

Popular Electronics

INCLUDING **Electronics World**

ELECTRONIC SYNTHESIZERS

ELECTRONICS IN WATER QUALITY CONTROL

RADIO AMATEUR 2-METER FM REPEATERS

COMPUTER ART AS A DESIGN TOOL

BUILD:

- Unique Binary Digital Clock
- Test Instruments for Digital Experiments
- Frequency-Selective Color Organ

TEST REPORTS:

- Archerkit Deluxe
Electronic Ignition Kit
- Lafayette SQA-50
Four-Channel Amplifier
- Electro-Voice 1711 & 1751 Microphones
- Pace Model 223 CB Transceiver
- Heath IM-1202

Digital VOM

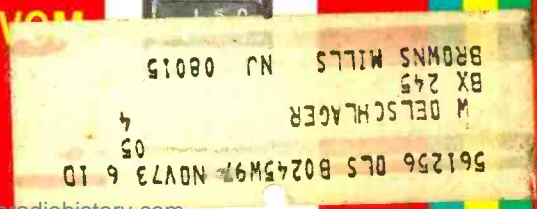

NOW you can train at home building a NEW 25" DIAGONAL Solid State Color TV engineered by NRI for learning and trouble-shooting

So much better for learning TV servicing than any hobby kit, because NRI designed and created it as an educational tool.

Unlike hobby kits which are designed for creating a TV set as the end product, NRI built its exclusive 25" Diagonal Solid State Color TV kit as a real training kit. You can introduce and correct defects . . . for trouble-shooting and hands-on experience in circuitry and servicing. The kits include a wide-band oscilloscope, color bar crosshatch generator, transistorized volt-ohmmeter and other valuable equipment that can soon have you earning \$5 to \$7 an hour servicing color sets in your spare time.

Handsome woodgrain cabinet, at no extra cost. (Offered only by NRI)

New square-cornered Sylvania picture tube

100% solid state chassis

6-position detented UHF channel selector



Modular construction with plug-in circuit boards

Automatic degaussing

Automatic fine tuning

Automatic tint control

Automatic color control



NRI FIRSTS make learning Electronics fast and fascinating—to give you priceless confidence

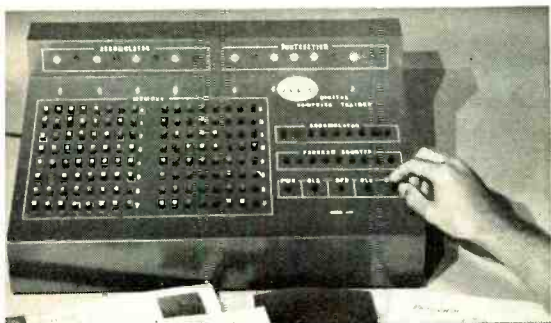

FIRST to give you a complete programmable digital computer, with memory, you build yourself... to learn organization, operation, trouble-shooting and programming. This remarkable computer is one of ten training kits you receive with the new NRI Complete Computer Electronics Course.

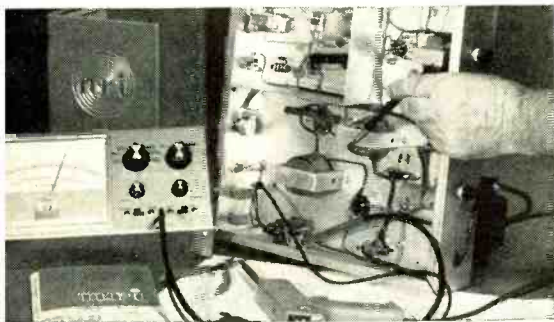

FIRST to give you true-to-life experiences as a Communications Technician. Every fascinating step you take in NRI Communications training, including circuit analysis of your own 15-watt, phone/cw transmitter, is engineered to help you prove theory and later apply it on the job. Studio equipment operation and trouble shooting become a matter of easily remembered logic.



FIRST to give you completely specialized training kits engineered for business, industrial and military Electronics Technology. Shown is your own training center in solid-state motor control and analog computer servo-mechanisms Telemetering circuits, solid-state multivibrators and the latest types of integrated circuits are included in your course.

The NRI color TV and digital computer kits are the latest in a long line of "firsts" for NRI. For more than fifty years, NRI has been providing unique 3-dimensional home-study training that has helped hundreds of thousands of students reach their goals quickly and easily.

What NRI provides is a combination of kits and bite-size texts that give you hands-on experience while you are learning. The texts average only 40 pages each, and they are fully illustrated. You are taken step-by-step from the first stages into the more advanced theory and techniques... with an expert instructor ready at all times to provide valuable guidance and personal attention. (The level of personal attention provided is more than you would receive in many classrooms.) Once you've grasped the fundamentals, you move with confidence and enthusiasm into new discoveries in the fascinating world of electronics.

You start out with NRI's exclusive Achievement Kit, containing everything you need to get moving fast. Lessons have been specifically written so that experiments build upon one another like stepping stones. You can perform a hundred experiments, build hundreds of circuits... as you learn to use the professional test equipment provided, building radios and TV sets, transmitter or computer circuits. It's the priceless "third dimension" in NRI training... practical experience.

Train with the leader—NRI

Compare training kits, texts, techniques and overall training... and you'll find that you get more for your money from NRI. Whatever your reason for wanting more knowledge of Electronics, NRI has an instruction plan that will meet your needs. Choose from major programs in Advanced Color TV Servicing, Complete Computer Electronics, Industrial Electronics and the other special courses designed to meet specific needs. With NRI home training, you can learn new skills while you're still working at your present job... and turn yourself into the man in demand.

GET FACTS ABOUT GI BILL

If you have served since January 31, 1955, or are in service now, check GI line on postage-free card.

Send for free NRI catalog

MAIL THE POSTAGE-FREE CARD FOR THE FREE NRI CATALOG IN THE FIELD OF YOUR CHOICE. YOU WILL BE UNDER NO OBLIGATION. NO SALESMAN WILL CALL.

If the card has been used, write direct to:



NRI TRAINING
3939 Wisconsin Ave.
Washington, D.C. 20016

Popular Electronics

WORLD'S
LARGEST-SELLING
ELECTRONICS MAGAZINE

INCLUDING **Electronics World**

FEATURE ARTICLES

- 26 ELECTRONICS AND WATER QUALITY CONTROL** *L. George Lawrence*
- 34 EFFECTIVE RADIATED POWER** *Gladden B. Houck, Jr.*
How to measure and improve your r-f output.
- 40 ELECTRONIC MUSIC SYNTHESIZERS** *Craig Anderton*
The way the "new music" is generated.
- 45 COMPARISON OF QUADRAPHONIC MATRIX DECODERS**
Julian D. Hirsch
- 48 COMPUTER ART AS A DESIGN TOOL** *David L. Heiserman*
- 51 THE MOSFET** *Adolph A. Mangieri*
How it works and some practical applications.
- 58 DO YOU KNOW YOUR DC CIRCUITS?** *Arthur H. Seidman*
First in a new series for study and reference.
- 67 UNDERSTANDING UNGROUNDED OSCILLOSCOPE MEASUREMENTS**
Raymond E. Herzog
- 84 AMATEUR 2-METER FM REPEATERS** *Willard R. Moody, WA3NFW*
- 86 BIOLOGICAL EFFECTS OF ELECTRICAL SHOCK** *John T. Frye*
- 90 FASTEST ELECTRONIC DEVICE**
A new solid-state switch.
- 100 UNDERSTANDING YOUR TRIGGERED SWEEP SCOPE** *Virgil A. Thomason*
- 110 ELECTRONICS IN HABILITATION AND REHABILITATION** *Al Yonovitz*
Projects help treat the handicapped.

CONSTRUCTION STORIES

- 31 UNIQUE DIGITAL CLOCK** *Glenn Young*
Has an unusual binary readout.
- 62 DESIGN YOUR OWN COLOR ORGAN** *Daryl Slaviero*
- 64 SIMPLE TEST INSTRUMENTS FOR DIGITAL CIRCUITS** *Frank Tooker*

ZIFF-DAVIS PUBLISHING COMPANY
Editorial and Executive Offices
One Park Avenue, New York, New York 10016
212 679-7200

William Ziff, President
W. Bradford Briggs, Executive Vice President
Hershel B. Sarbin, Senior Vice President and Secretary
Phillip Sine, Financial Vice President and Treasurer
Phillip T. Heffernan, Vice President, Marketing
Frank Pomerantz, Vice President, Creative Services
Arthur W. Butzow, Vice President, Production
Edward D. Muhlfield, Vice President, Aviation Division
Irwin Robinson, Vice President, Travel Division
George Morrissey, Vice President
Sydney H. Rogers, Vice President
Sidney Holtz, Vice President
Lawrence Sporn, Vice President, Circulation

POPULAR ELECTRONICS including ELECTRONICS WORLD, May, 1973, Volume 3, Number 5. Published monthly at One Park Ave., New York, NY 10016. One year subscription rate for U.S., U.S. Possessions and Canada, \$6.00; all other countries, \$7.00. Second class postage paid at New York, N.Y. and at additional mailing offices. Authorized as second class mail by the Post Office Department, Ottawa, Canada and for payment of postage in cash. Subscription service and Forms 3579: P.O. Box 2774, Boulder, CO 80302. Editorial offices for manuscript contributions, reader inquiries, etc.: One Park Ave., New York, NY 10016.

POPULAR ELECTRONICS including ELECTRONICS WORLD is indexed in the Reader's Guide to Periodical Literature.

Copyright © 1973 by ZIFF-DAVIS PUBLISHING COMPANY. All rights reserved.

POPULAR ELECTRONICS including Electronics World

EDGAR W. HOPPER

Publisher

WM. A. STOCKLIN

Editorial Director

MILTON S. SNITZER

Editor

LESLIE SOLOMON

Technical Editor

JOHN R. RIGGS

Managing Editor

EDWARD I. BUXBAUM

Art Director

ALEXANDER W. BURAWA

Associate Editor

ANDRE DUZANT

Technical Illustrator

JOHN T. FRYE

J. GORDON HOLT

RICHARD HUMPHREY

WALTER G. JUNG

MATT P. SPINELLO

Contributing Editors

JOSEPH E. HALLORAN

Advertising Director

JOHN J. CORTON

Advertising Sales

MADELEINE LITTMAN

Advertising Service Manager

STANLEY NEUFELD

Associate Publisher

FURMAN H. HEBB

Group Vice President

Electronics and Photographic

THE SCENES

- 12** STEREO SCENE *J. Gordon Holt*
- 76** HOBBY SCENE
- 91** TEST EQUIPMENT SCENE *Leslie Solomon*
- 94** SOLID-STATE SCENE *Walter G. Jung*
- 97** CB SCENE *Matt P. Spinello*
- 114** SURPLUS SCENE *Alexander W. Burawa*

PRODUCT TEST REPORTS

- 77** LAFAYETTE SQA-50 4-CHANNEL AMPLIFIER/DECODER
- 78** ELECTRO-VOICE MODELS 1711 and 1751 MICROPHONES
- 80** HEATH MODEL IM-1202 DIGITAL MULTIMETER KIT
- 82** PACE MODEL 223 CB TRANSCEIVER
- 83** ARCHERKIT DELUXE ELECTRONIC IGNITION SYSTEM

DEPARTMENTS

- 6** EDITORIAL *Milton S. Snitzer*
The Future of the "Floppy Disc"
- 8** LETTERS
- 22** NEWS HIGHLIGHTS
- 102** NEW PRODUCTS
- 111** ELECTRONICS LIBRARY
- 112** NEW LITERATURE

COMING NEXT MONTH

- Closed Box Speaker System Design*
- Evaluation of Cassette Tapes*
- Selecting an Electronic Organ*
- Model Rockets for the Experimenter*

Midwestern Office
The Pattis Group, 4761 West Touhy Ave.,
Lincolnwood, Illinois 60644, 312 679-1100
GERALD E. WOLFE, DICK POWELL
DICK GOVATSKI, MANLEY LUDWIG

Western Office
9025 Wilshire Boulevard, Beverly Hills, California 90211
213 273-8050; BRadshaw 2-1161
Western Advertising Manager, BUD DEAN

Japan: James Yagi
Oji Palace Aoyama; 6-25, Minami Aoyama
6 Chome, Minato-Ku, Tokyo 407-1930/6821

Ziff-Davis also publishes Boating, Car and Driver, Cycle, Flying, Modern Bride, Popular Photography, Skiing, and Stereo Review.

Forms 3579 and all subscription correspondence should be addressed to POPULAR ELECTRONICS including ELECTRONICS WORLD, Circulation Department, P.O. Box 2774, Boulder, CO 80302, Please allow at least eight weeks for change of address. Include your old address, as well as new—enclosing, if possible, an address label from a recent issue.

Editorial contributions must be accompanied by return postage and will be handled with reasonable care; however, publisher assumes no responsibility for return or safety of art work, photographs or manuscripts.



Member Audit Bureau of Circulations



Editorial

By Milton S. Snitzer, Editor

THE FUTURE OF THE "FLOPPY DISC"

We have talked previously about video cartridges and cassettes—and the problem of non-compatibility. These devices will play back and some will record pictures that can be displayed on one or more TV receivers. At that time we were thinking strictly about magnetic tape cartridges and cassettes. Nothing was said about video discs that would play back through your TV set. But the video disc is far from dead and several companies are working on it.

The people in the computer industry have been using disc storage for some time. Broadcasters have also used this technique for their "instant replay" in sporting events. However, these magnetic discs were bulky, rigid, and had to be made to very close mechanical tolerances.

Then, along came the "floppy disc" with magnetic material coated onto a thin, non-rigid disc made of Mylar plastic. The disc is slipped into what looks like a phono record jacket made of plastic; and the whole thing is inserted into a player. It is possible to record as well as play back these "floppy discs." The jacket mentioned above has an opening for the spindle hole in the center as well as a radial "window" for the tape head to make contact with the disc surface.

We saw a demonstration of one of these machines put out by Arvin Systems (Dayton, Ohio). The company uses the term "Discassette"™ for its record plus jacket disc. Instead of using a spiralled magnetic track, there are some 300 separate circular tracks on each side of the disc. Each track holds one TV frame (1/30 second), and the user can either play one frame repeatedly or the machine will advance from one band to another. The device is sort of like a slide projector and it is expected to be used in broadcast studios for titles, graphics, animation and freeze-frame effects. It can also be used anywhere in industry, schools, laboratories, hospitals, or any place where a series of black-and-white stills must be viewed. Since the machine meets professional broadcast standards with its 4.2-MHz bandwidth and has other very tight specs, the unit is not cheap, selling as it does for around \$4000.

It would seem to us that it is not entirely impossible to put the magnetic tracks on in a spiral rather than a series of concentric circles, add color to the unit, loosen the specs somewhat, and offer the whole thing as a recorder/player for the home TV set. Several companies are working along these lines right now and are claiming an under-\$500 price.

Our own feeling is that this is a good way to go for the mass consumer market, but that the tape cartridges and cassettes will continue to exist along with the disc. It's much like the hi-fi scene today where records and tapes are both used. So, we're waiting to see the first "floppy disc" home TV recorder/player.

The technology behind the BOSE 901.

In this article we would like to share with you the technology that produces the sound which has made the 901 the most highly reviewed speaker regardless of size or price.* There are five basic elements of this technology. Each element is important but it requires all five to produce the desired result.

1. An Optimum Combination of Direct and Reflected Sound

The combination of 11% direct radiation from the front of the enclosure with 89% radiation reflected at 30° angles from the rear wall, simulates in your listening room the spatial characteristics of the larger environment of the live performance. This is responsible for the "open" and "natural" sound that is immediately apparent in an A-B listening test of the 901 with any conventional speaker.

2. Multiplicity of Full-Range Drivers

The research that was presented at the Audio Engineering Society meeting in 1968 † revealed that the irregularities of the acoustical radiation inherent in the crossover range of any woofer-tweeter speaker could be overcome by the use of a multiplicity of full-range drivers. The 901 uses nine full-range drivers in each enclosure. The benefit of this approach is appreciated when you try to follow a single instrument through a heavily orchestrated passage.

3. Active Equalization

In the audio frequency range, precise tailoring of electronic circuits to match the characteristics of a speaker can achieve a far more accurate balance of radiated tones than can be achieved by the mechanical components of any speaker acting alone. The active equalizer in the 901 contains over one-hundred components and is precisely tailored to the characteristics of the 901 speaker. This precision tailoring of the equalizer to the 901 is responsible for the accurate musical timbre for which the 901 speaker is famous.

4. Flat Power Response

The concept of flat "frequency" response was sacred in the tradition of speaker design until the arrival of the 901. The research that gave birth to the 901 clearly showed that the reverberant acoustical field dominates the direct field in live performances. Flat frequency response would be appropriate only if the reverse were true. The basic patents covering the 901 are testimony to the importance of the discovery that flat "power" response is the correct criterion for speaker design. Flat power response combined with reflected sound enables the 901 to produce all overtones of musical instruments without the shrillness characteristic of direct radiating speakers.

5. The Technology of Quality Control

The sound of any loudspeaker depends on everything from the texture of the paper cone to the thickness of the glue joints. Unfortunately, the standard techniques for measuring loudspeakers are not adequate to guarantee that speakers with equal measurements will sound alike. The BOSE Research Department has worked on this problem for many years. The result is the SYNCOM™ speaker computer, introduced in 1972. This computer tests and selects every BOSE speaker to standards that mark a significant advance in your listening enjoyment. The SYNCOM computer, and the difference it makes, will be the subject of a future article.

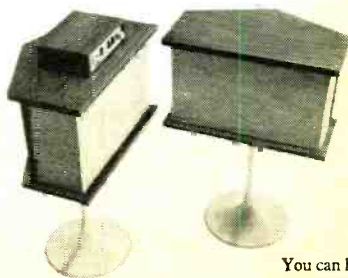
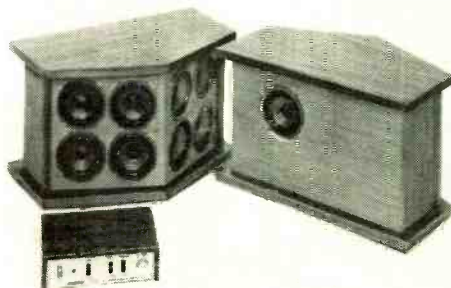

† Copies of the Audio Engineering Society paper, ON THE MEASUREMENT AND EVALUATION OF LOUSPEAKERS, by Dr. A.G. Bose, are available from Bose Corp. for fifty-cents each.

You can hear the difference now.

BOSE
Framingham, Massachusetts 01701

CIRCLE NO. 6 ON READER SERVICE CARD

take your pick

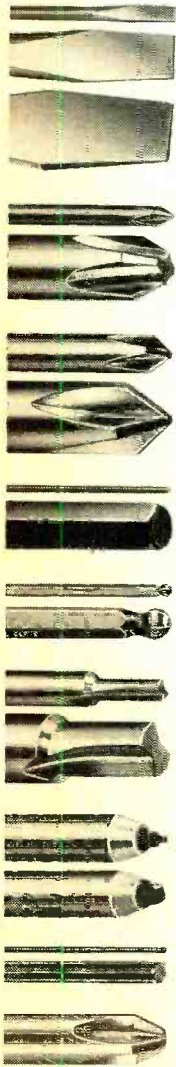

LARGEST RANGE, GREATEST VARIETY

What are you driving? Slotted, Phillips, Frearson, Reed & Prince, Allen hex, clutch head, Scrulox[®], Bristol Spline, or Pozidriv[®] screws? Xcelite makes screwdrivers for every type and size. Metrics, too.

- ⊕ from 2 1/8" miniatures to huge 2 footers.
- ⊕ .040" to 7/16" tip widths.
- ⊕ round or square blades.
- ⊕ tough, forged alloy steel or non-magnetic beryllium-copper.
- ⊕ nickel chrome, black oxide finish, or insulation coated.
- ⊕ fixed-handle or interchangeable and reversible blades.
- ⊕ straight and tee handles — regular and ratcheting types.
- ⊕ available individually or in handy kits and sets.

Made in U.S.A. to highest standards.

REQUEST FREE TOOL CATALOG 171
nationwide availability through
local distributors



professional screwdrivers

XCELITE, INC., 20 Bank St., Orchard Park, N. Y. 14127

Send complete tool catalog, which includes information on all Xcelite screwdrivers.

name _____

address _____

city _____ state & zip _____

In Canada contact Charles W. Pointon, Ltd.

CIRCLE NO. 39 ON READER SERVICE CARD

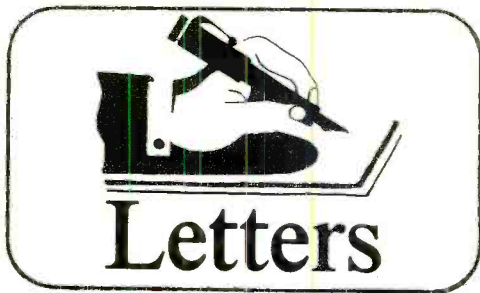

PLAY IT SAFE, USE LED'S

With regard to the "Semiconductor Junction Tester" (February 1973), the project will destroy transistors under test. Cold lamp bulbs typically draw between 12 and 15 times their steady-state currents; so, when the Junction Tester is used, large inrush currents will flow in the transistor under test. If, for example, a small 30-mA lamp were used, currents of up to 400 mA would flow through the transistor for several milliseconds. If this current were fed into the base of a signal transistor, it would in all likelihood destroy the transistor. I suggest that the lamps specified in the Parts List of the project be replaced with light-emitting diodes

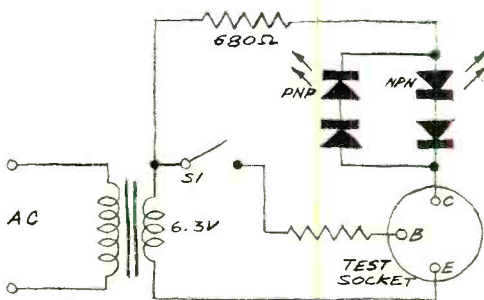

(LED's) as shown in the diagram. The LED's can be operated at a safe 5 or 10 mA.

RICHARD W. FOX
General Electric Application Engineering
Auburn, N.Y.

Many thanks for bringing this information to our and our readers' attention.

KR6 AND KR8 PREFIXES DELETED

The Amateur Radio Prefix/Country List given on pages 78 and 79 of the 1973 COMMUNICATIONS HANDBOOK is in error. Effective with the reversion of the Ryukyu Islands to the government of Japan on 15 May 1972, the amateur call signs KR6 and KR8 were removed from use and returned to the FCC's inactive list. Japanese amateurs use the JR6 call sign, while the U.S. Forces personnel use the KA6 call sign.

FRANK T. LAUGHNER, MSGT., USAF
APO San Francisco

GOT HIS WIRES CROSSED

I recently built the "Touch-Plate Power Switch" (August 1972) and encountered a problem that I believe many of your readers might be running into. Since I could not obtain an RCA 40673 MOSFET in my locality, I substituted a HEP F2004 unit. When the circuit did not work, I traced the problem down to the HEP substitute. Its gate leads are arranged in reverse order to those of the RCA MOSFET. So, I transposed the leads of the HEP device, slipping onto them insulating spaghetti to prevent their shorting to each other. Now my project works just fine.

GREGORY D. LONG
Albion, Iowa

A good solution to a substitution problem.

EXTEND A HELPING HAND

From time to time, we receive pleas from our readers for assistance that we cannot give for various reasons (mostly because we do not really have the time to enter into extensive research). So, we publish the requests in this column where other readers who can render the asked-for assistance will read it. This month, the following readers are asking for assistance:

Richard Baker (8 Valley View La., Newton Square, PA 19073) lost all of his issues of POPULAR ELECTRONICS and other magazines in

last year's flood and would like very much to replace them. Anyone willing to part with PE and other magazines and radio and TV schematics is invited to send Richard a list of what is being offered and the prices asked. Even if you do not want to sell, maybe you are willing to lend them to Richard for making copies.

Matt A. Muller (1134 Elm Ave., Landsdale, PA 19466) needs the construction manual for a Precise Development Corp. Model 300 oscilloscope.

M. Malinics (Bldg. A, Apt. 7, Oak Tree Dr., North Brunswick, NJ 08902) needs the service manual and/or schematic diagram for his Laboratory for Electronics Model 411 oscilloscope.

M. Pallas (4535 163 St., Flushing, NY 11358) needs four VT-5 vacuum tubes, a type C-65 interstage transformer, and a type I-44 filament ammeter for his 1928 Army Signal Corps Model BC-137 radio receiver.

Morriz Jagodowicz (622 Euclid Ave., Syracuse, NY 13210) needs the service manual for a Doric transistorized organ, Model or Serial No. 4528.

Ma Phuoc Hong Anh (411/19, Phan-Dinh-Phung, Saigon III, Republic of Vietnam) needs the spec. sheet and operating/service manual for a Sentinel Electronics, Inc., Model ME-26D/U vacuum-tube multimeter.

Anyone who can help is invited to write directly to these readers at the addresses given.



MAKING "WAVES"

CADENCE—the musical instrument speakers

Making better, clearer, amplified sound waves is the **THING** Cadence does . . . better than anything else in the industry. Cadence Speakers are built to withstand heat from sustained notes at a high power level and the vibrations and stresses which are continually placed upon them. Cadence is guaranteed **one full year** at the power level specified. This proven speaker family has been selected by the manufacturers of most of the world's fine amplified music instruments.

If making beautiful, clear sound waves is your thing, ask for **CADENCE SPEAKERS**. For complete information and the name of your Cadence Dealer, write:

utah 

UTAH ELECTRONICS DIVISION
Utah-American Corporation
1124 East Franklin Street
Huntington, Indiana 46750

CIRCLE NO. 37 ON READER SERVICE CARD

You get more "security" And it's all do-it-yourself.

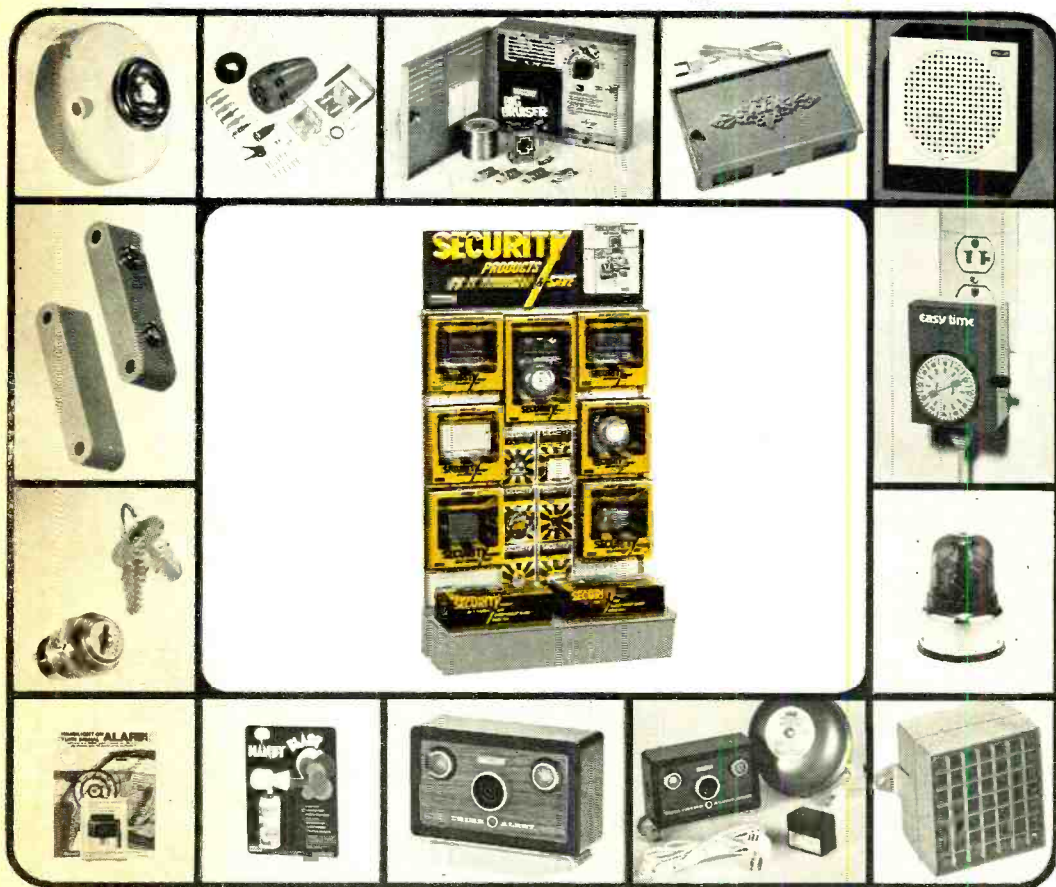

The Mallory line of security products is not only the most complete line you can get anywhere, it's also just about the easiest to hook up. It's genuinely a do-it-yourself line.

Especially the complete systems. From complete home intrusion alarm systems (plug-in or wire-in) to smoke alarms and car alarms.

And we have all the accessories you need to expand and adapt any of these

systems to your specific security needs.

Look for our security systems and accessories on display in their bright, new packages (with installation directions printed right on each package). It's all at your Mallory distributor's now.

In the meantime, look at the table on the right. It's everything we have in security products to date. A complete selection for one-stop security shopping.

from Mallory

THE MALLORY SECURITY LINE

WIRE-IN

COMPLETE ALARM SYSTEMS

Closed-Circuit Alarm System

Complete alarm system containing batteries, switches, wire, etc.

Crime Alert Ultrasonic Intrusion Alarm

Battery-operated, self-contained alarm. Also operates on AC.

Car Alarm

Alarm system containing siren, six switches, wiring, etc.

ACCESSORIES

DC Weatherproof Siren

DC Vibrating Bell

Magnetic Switches

Heat Sensors 135°F or 200°F

Panic Switch

Alarm Hook-Up Wire

Lockswitch Round or Flat Key

Mallory Batteries

Auto Headlight or

Turn Signal Alarm

Warning Decals

PERSONAL ALARMS

Bloc Alarm

Blocks doorways and warns if door is forced.

Handy Blast

Loud, piercing sound scares molesters away.

Handy Blast Refill

PLUG-IN

COMPLETE ALARM SYSTEMS

Smoke Alarm

Self-contained alarm to warn against smoke and fire.

Crime Alert Ultrasonic Intrusion Alarm

Self-contained alarm which detects intruders moving in an area of approximately 300 sq. ft.

Crime Alert Alarm System

Ultrasonically detects intruder. Transmits alarm signal over house wiring to signal activated bell. Simple plug-in installation.

Manual Alarm Pack

Manually summons help instantly by transmitting alarm signal over house wiring to signal activated bell when you push the button.

ACCESSORIES

Wood Cabinet for Crime Alert

Alarm Duration Timer for Crime Alert

Easy-Time 24-Hour Timer

Lockswitch Round or Flat Key

Power Failure Alarm

Mallory Batteries

AC Vibrating Bell

AC Weatherproof Horn

AC Weatherproof Siren

AC Rotating Red Light

SIGNAL ACTIVATED COMPONENTS

Transmit and receive alarm signal through house wiring.

Alarm Trigger—Transmits signal to:

Alarm bell

Weatherproof horn

Weatherproof siren

Outlet

Sonalert

Send for our new Security Systems catalog 9-654.
It describes every item listed here, explains how to use them.

MALLORY

MALLORY DISTRIBUTOR PRODUCTS COMPANY

a division of P. R. MALLORY & CO. INC.

Box 1284, Indianapolis, Indiana 46206; Telephone: 317-636-5353

CIRCLE NO. 24 ON READER SERVICE CARD



Stereo Scene

By J. Gordon Holt

AT THE professional running speed of 15 inches per second, discrepancies in the recorder's "setup" adjustments are less noticeable than at slower speeds. High frequencies are spaced a reasonable distance apart along the length of the tape, so there is little tendency for adjacent positive and negative magnetic polarities to erase one another. Also, the wavelengths involved put no critical demands on the magnetic gap dimensions in the record or play heads. As long as the equalization curves provided by the record and play circuits conform to industry standards, a single bias-current adjustment will yield pretty much flat response from just about any tape used on the recorder, despite the usual minor variations from one tape to another in coating thickness and coercivity (ease of recording).

But as soon as we start to run the tape at slower speeds, treble recording becomes increasingly difficult and, hence, increasingly affected by tape characteristics. At the slower speeds, the magnetic patterns representing high frequencies get jammed closer together on the tape, so each area of magnetic polarity comes more under the influence of adjacent areas of opposite polarity. One tends to erase the other, reducing treble output from the tape, and

requiring more treble boost while recording in order to obtain a flat high end. At the same time, the recorded wavelengths start to approach the practical minimum that can be designed into head gaps.

At cassette speed ($1\frac{1}{2}$ in./s), the demands of short wavelength recording are such that the recorder must be specifically and meticulously adjusted for the cassette tape being used if either is to approach its frequency-response specification. Even microscopic variations in oxide coating from one production batch to another of the same kind of tape can cause definitely audible differences between the original program material and the playback from the cassette. This, as I mentioned in a previous column, is why cassette-recorder owners feel so strongly, and disagree so sharply, about what are the best cassettes.

When they find that one brand and type of cassette causes muffled sound and another yields perfect record/play comparisons, it is not (usually) because the latter tape is better, but merely because it better matches the bias and equalization adjustments that the factory made on the cassette machine before it came off the assembly line. And it is the simple fact that *no* recorder can be precisely adjusted to one tape and work at its best with another that has given the cassette its reputation for being "still far inferior to open-reel tape." Some cassette recorders, carefully adjusted to a specific batch of cassettes, sound so much like a good open-reel machine that it takes a very good ear and top-notch playback components to detect any difference at all. If you bought one of the better cassette recorders, you can expect this kind of performance from your own machine, but only *if* you adopt a good tape as your quality standard (chromium dioxide or a premium low-noise tape), buy a carton of them, and

Do-It-Yourself Tape Recorder Setup

Now there's a CB radio with too much talk power.



Put punch in your voice, from a block away to the fringes of your range. New Dyna-Mike gain control puts out absolute modulation. So much talk power you'll have to turn it down.

An important feature, but only one that makes this fantastically low-priced CB radio the best CB value on today's market.

The Cobra 21 with crystal filter, dual conversion receiver; transmits and receives on all 23 AM channels. Features 60 dB adjacent channel rejection that completely eliminates bleedover.

Extra large Power S Meter let's you monitor your set's performance easily even when it's tucked under the dashboard.

And you get switchable automatic noise limiter, P.A./external speaker jack, large built-in speaker and detachable mike.

It's all wrapped up in a beautiful, compact cabinet only 6" wide x 2½" wide x 7½" deep. Meets FCC requirements.

Ask your CB Dealer for the Cobra 21. The radio with too much talk power for not much money.



\$119.95
with mike

COBRA 21
WITH EXCLUSIVE DYNA-MIKE

Product of DYNASCAN CORPORATION • 1801 W. Belle Plaine • Chicago, Illinois 60613

get your recorder adjusted for that kind of tape.

This is not to say that an open-reel recorder doesn't need careful adjustment to the tape of your choice, too. Even at 7½ in./s, a good ear can usually detect the high-end change when a different recording tape is used. But, whereas it is often possible to get acceptable performance from an open-reel machine just by trying some different tapes until you find one that works pretty well, it is usually *essential* that a cassette machine be specifically set up for the tape if it is to yield really good over-all results.

A factory service center for your recorder can usually do the job if you make it clear that you are an absolute fanatic for perfection and tell them to do every adjustment to within ± 0 dB. Any good tape-recorder serviceman can do the job, too, if he has a service manual for your machine, although you may have to pay for the manual. (He'll have to order it from the factory.) In any case, make it clear that you are finicky, and give the service people two tapes from the batch you'll be using for the service people to use in setting up the recorder.

Do It Yourself. A more satisfactory arrangement though, if you're the type, is to do the job yourself. First, there are a few items that you *must* have—either purchased or borrowed from various places. These are: a sensitive audio voltmeter, an audio oscillator providing a choice of, at least, 1,000 Hz and 8,000 or 10,000 Hz (some inexpensive miniature jobbies are available that will do fine), a standard playback-level tape for the speed and track configuration you use most often, and a service manual for your tape machine.

Most of the adjustments referred to subsequently will be internal adjustments, often accessible only after having removed the recorder from its case. Since the adjustments are rarely labeled in the recorder, the service manual will be necessary to identify them. And in many cases, the manual may also be needed to clue you in as to how to remove the case properly without damaging anything.

Many recorders, particularly the lower-priced models, will be found to lack some of the adjustments mentioned here. In this case you have no choice but to assume that those particular functions are okay and

proceed to the next. Also, you may find that your recorder cannot be adjusted right on the nose to certain figures called for in the service manual. (It may not yield more than 13 dB of record treble boost when the manual calls for 15, for example.) If both channels are approximately equal in their adjustment capability, set both adjustments the *same*, as close to the specified value as you can. You may then be able to compensate for the shortcoming in a later adjustment step. If the two channels are found to be markedly different in one respect, this suggests a defect in the recorder, and is a job for a qualified electronics service technician.

The service manual will generally describe the set-up procedure in some detail, and some of the details will vary from recorder to recorder. It is a great help, though, if you have some inkling of what you're doing and why, so let's run through the entire setup procedure on the basis that it will apply in general.

Since the only way really to evaluate what is going onto a tape is to play it back, the first step (after cleaning and degaussing heads and making the connections to the external test equipment) is to adjust the playback section. Start with the play (or record/play) head azimuth adjustment, using the appropriate high-frequency tone on the test tape.

Next, use the 1,000-Hz zero-VU "standard-level" tone on the test tape to adjust playback level or "play cal" to the value specified in the manual (and referred to as "Dolby level" in some recorders so equipped). If no value is specified, but a play level adjustment (*not* an external playback volume control, but internal adjustment) is provided, adjust the standard tape's test tone so that, with play level up full, the machine puts out the amount of signal specified in its performance spec listing. Adjusting to a standard play level gives a reference that we can use later to set the machine's *record* level to obtain minimum distortion and maximum signal/noise ratio.

Play Equalization. If there is an adjustment for playback equalization, do this next, according to the manual and the instructions for the test tape. The recorder is now set up to play any commercially made tape with proper output level and frequency response. Similarly, if we set up the

The best time to upgrade your component system is before you buy it.

If you're a typical reader of this magazine, you most likely have a sizeable investment in a component system. So our advice about upgrading might come a little late.

What you might have overlooked, however, is the fact that your records are the costliest and most fragile component of all. As well as the only one you will continue to invest in.

And since your turntable is the only component that handles these valuable records, advice about upgrading your turntable is better late than never.

Any compromise here will be costly. And permanent. Because there is just no way to improve a damaged record.

If the stylus can't respond accurately and sensitively to the rapidly changing contours of the groove walls, especially the hazardous peaks and valleys of the high frequencies, there's trouble. Any curve the stylus can't negotiate, it may lop off. And with those little bits of vinyl go the high notes and part of your investment.

If the record doesn't rotate at precisely the correct speed, musical pitch will be distorted. No amplifier tone controls can correct this distortion.

If the motor isn't quiet and free of vibration, an annoying rumble will accompany the music. You can get rid of rumble by using the bass control, but only at the expense of the bass you want to hear.

Experienced component owners know all this. Which is why so many of them, especially record reviewers and other music experts, won't play their records on anything but a Dual. From the first play on.

Now, if you'd like to know what several independent test labs say about Dual, we'll send you complete reprints of their reports. Plus a reprint of an article from a leading music magazine telling you what to look for in record playing equipment. Whether you're upgrading or not.

Better yet, just visit your franchised United Audio dealer and ask for a demonstration.

You'll find Dual automatic turntables priced from \$109.50 to \$225.00. That may be more than you spent on your present turntable, or more than you were intending to spend on your next one.

But think of it this way. It will be a long, long time before you'll need to upgrade your Dual.

Dual 1214, \$109.50

Dual 1215S, \$125.00

Dual 1218, \$169.50

Dual 1229, \$225.00



United Audio Products, Inc., 120 So. Columbus Ave., Mt. Vernon, N.Y. 10553

Exclusive U.S. Distribution Agency for Dual.

CIRCLE NO. 36 ON READER SERVICE CARD

machine's *record* section to produce proper level and flat response through its own play section, the resulting tapes will be fully compatible for playback on any other machine that has been set to industry playback standards.

A few machines also have other adjustments, such as for crosstalk rejection, in the play circuits. These should now be set, again according to the instructions given in the manual.

Now to the record section. Remove the standard test tape, load one of the tapes you'll be using for the most critical recording, and set any tape selector switches to the appropriate positions. Now, if the recorder has separate record and play heads, adjust the record head azimuth, observing the results of each adjustment via playback from the tape. With a single record/play head, setting play azimuth (which you have already done) will have automatically set record azimuth.

Next, adjust the ultrasonic recording bias current so that the observed playback at some middle frequency (1000 Hz, for example) is at maximum output or thereabouts. The "thereabouts" refers to the fact that some open-reel recorders function better at $7\frac{1}{2}$ in./s and faster if the bias current is increased to slightly beyond the peak-output point, to where the bias increase causes exactly a $\frac{1}{2}$ -dB drop in tape output. This "overbiased" condition will cause slight restriction of high-treble range, but the loss can usually be restored during adjustment of the record equalization, later on. The gain here is in slightly reduced distortion and a reduction in the audible dropout disturbance caused by minor tape-surface inconsistencies.

Whether you adjust bias for peak output or for slightly beyond peak, it is important that both channels be adjusted as closely as possible to the same bias point. Slight channel mismatching here will cause a peculiar condition in which some tapes have identical high-end response while others exhibit an audible difference in high-end response between channels, making it difficult to set stereo channel balance to satisfy the ears.

Recording Level. After bias adjustment, the record calibration should be adjusted so that the playback level is the same as that previously obtained from the standard tape's zero VU level. This will be the

maximum level that you should put onto any tape. Then, the VU meter calibrations should be adjusted so that the meters read zero VU when you're recording at that same level.

Now, reduce the recording input level until the VU meter reads 20 dB below zero VU (30 dB below with a cassette recorder). To avoid treble overload due to the record equalization, tape some 1000-Hz tone and then some 10,000-Hz tone, and play them both back. Note their relative outputs; and if they don't match within a dB, adjust the record equalization for the appropriate channel (or, in most cassette recorders, adjust the bias current), and repeat the 1000/10,000-Hz comparisons until the two frequencies are the same in playback level. Then, repeat the record equalization process in the other channel and at each of the recorder's other speeds, if any. At the cassette speed, bias current is so critical in its effect on high frequencies that it can be used to provide a wide range of high-end adjustment without having any perceptible effect either on mid-range output, distortion or noise.

If the recorder has a built-in Dolby, the foregoing adjustments will have automatically set up the Dolby adjustments. The machine is now also set up for use with an external Dolby, which must itself then be calibrated to match the recorder's own adjustments, to ensure that all input and output levels match precisely—a prerequisite for proper operation of any Dolby device.

And that does it, at least for your premium-use tape. Now, if your recorder has a tape selector switch, take a roll of your secondary tape type—the kind you'll be using for less-than-critical recordings—and go through all of the electrical setup steps that are adjustable separately from those for the premium tape. In some recorders, there are *no* adjustments specifically for the secondary tape.

Operating the tape selector switch merely changes the values of some fixed resistors or capacitors in the circuits by predetermined amounts, so if you want optimal results from your secondary tape, you'll have to try and find a kind of tape that best matches what the recorder provides after you've adjusted for your primary tape. But at least you'll know your recorder is working at its best with that particular tape, anyway. ♦

**Those also serve,
who test or measure
or protect or adapt
or sit around &
tell time.**

AC ADAPTER Equips any MITS 1200 Series pocket calculator for operation from 110 VAC \$6.95

DC4/DC6 DIGITAL CLOCKS

- 6 DIGIT [hours, minutes, seconds]
 DC6-E [electronics only] \$49.50
 DC6-K [complete kit] \$58.50
 DC6-M [assembled unit] \$99.50
- 4 DIGIT [hours, minutes, and 1 sec. pulsed colon]
 DC4-E [electronics only] \$39.50
 DC4-K [complete kit] \$48.50
 DC4-M [assembled unit] \$89.50
 Specify 12 or 24-Hour Operation on Assembled Units

PS-500 POWER SUPPLY

- Kit \$29.95
 Assembled \$39.95

ICT-1800 IC TESTER

- Kit \$119.95
 Assembled \$169.95

CARRYING CASES

- 1230/1240 Padded leatherette or rigid vinyl \$9.95
- 1200 Series High quality leatherette carrying case \$5.95



MITS®

WRITE OR MAIL COUPON FOR ADDITIONAL INFORMATION:

Micro Instrumentation & Telemetry Systems, Inc.

5404 Coal Ave., S.E., Albuquerque, New Mexico 87108
 505/265-7553

ENCLOSED IS A CHECK FOR \$ _____
 or BANK AMERICARD # _____
 or MASTER CHARGE # _____
 or PURCHASE ORDER # _____
 INCLUDE \$5.00 FOR POSTAGE AND HANDLING

MODEL # _____ KIT
 ASSEMBLED
 ELECTRONICS

PLEASE SEND INFORMATION ON ENTIRE MITS LINE.

NAME _____
 ADDRESS _____
 CITY _____
 STATE & ZIP _____
 MITS / 5404 COAL AVE. SE / ALBUQUERQUE, N.M. 87108

CIRCLE NO. 23 ON READER SERVICE CARD

USE IT ALL AS YOU GET READY FOR A NEW CAREER...

\$1,500.00 worth of two-way radio electronic communications equipment!

Bell & Howell Schools announces a new learn-at-home program that gives you "hands on" experience with commercial-grade equipment—as you prepare for a business of your own in two-way radio electronic communications servicing

You need "hands on" experience with a real, commercial-band FM transceiver and actual commercial-grade test equipment—to take full advantage of growing opportunities in electronic communications.

Two-way radio communications is a healthy growth area in electronics. And it's lucrative. Almost two million commercial two-way radio systems now serve as vital communications links for trucks, planes, boats and taxis. And the FCC requires each system to have its equipment serviced regularly by a licensed technician. That's where you come in. But you need career-oriented training—plus your FCC license.

Knowing how to put an amateur radio kit together won't help when you're "on the job"—servicing two-way radio systems for aircraft or advising trucking companies about their land-mobile communications system. For that, you need "hands on" experience with the real thing. This unique new Bell & Howell Schools learn-at-home program gives you just that. You can work with the equipment by attending one of our special "help sessions" or by dropping by one of the Bell & Howell resident schools. If neither of these plans

is convenient, you can have the equipment shipped to your home in return for a \$100 deposit, which is refundable when you return the equipment.

Find out more about this exciting new Bell & Howell Schools program. There's no obligation.

For free facts, mail attached card today!

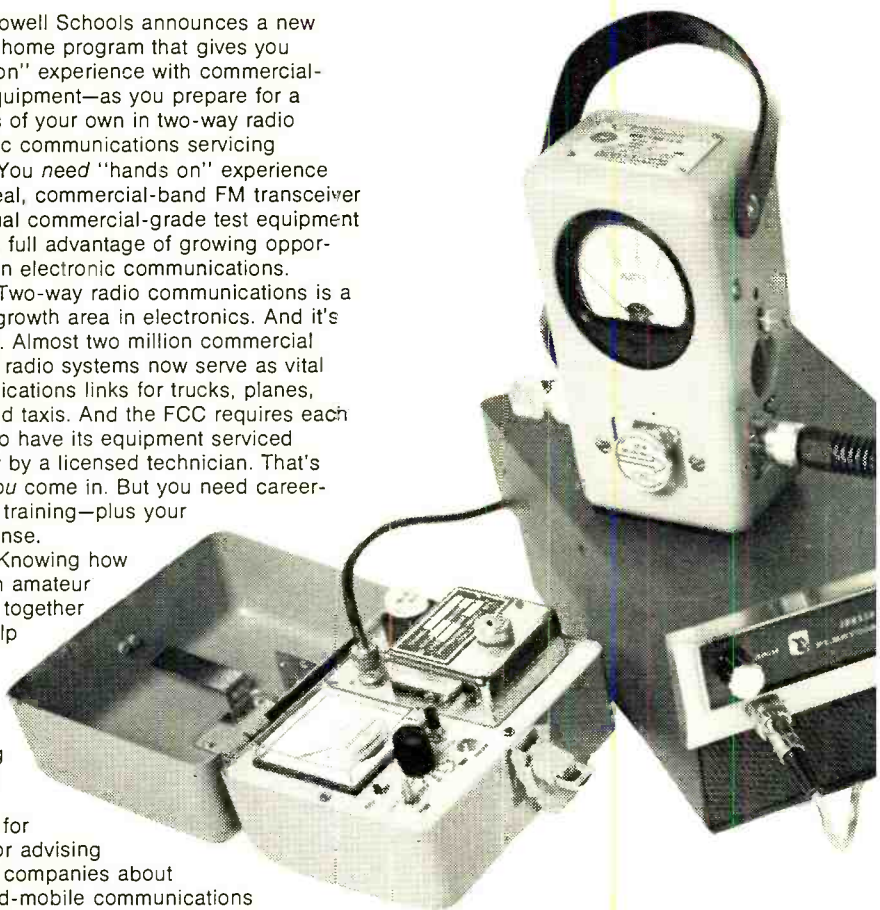

Let Bell & Howell Schools help you get ready for an exciting career or business of your own in two-way radio electronic communications!

Bell & Howell Schools has helped thousands of people prepare for careers—and businesses of their own—in electronics. You can have absolute confidence in the thorough training you get.

Expert instructors at Bell & Howell Schools plan each program to answer a single question: "What qualifications will you need to take advantage of *actual career opportunities* in electronics?" They then build each program to give you those exact qualifications.

To get ready for a business of your own in two-way radio, you need: 1) career-oriented training; 2) FCC License; 3) "hands on" experience with commercial-grade equipment. Bell & Howell Schools now offers this new at-home training program that gives you all three. (See FCC License Warranty on attached card.)

JUST LOOK AT ALL THE EQUIPMENT YOU'LL WORK WITH DURING YOUR TRAINING PROGRAM WITH BELL & HOWELL SCHOOLS!

Commercial-Band FM Transceiver . . . exactly the kind of two-way radio you'll service throughout your career



Deviation Meter

. . . model favored by many working technicians to check modulation of transmitted signal.

Frequency Meter

. . . highly sensitive instrument used to check signal frequency within precise tolerances established by government standards.

Power Output Meter

. . . meter used almost universally by trained and licensed technicians to check power output—or wattage—of signal.

Alignment Generator

. . . a custom-designed unit you use to generate test signals for transceiver alignment.



FCC REGULATIONS GIVE YOU THE OPPORTUNITY TO START YOUR OWN BUSINESS!

The Federal Communications Commission requires that all commercial two-way communications systems be checked and serviced by a licensed technician at regular intervals.

As a Bell & Howell Schools graduate, you'll have the technical know-how you need. With your FCC license, you can go out and eventually build your own business—signing contracts with companies that use two-way radio. FCC regulations could mean security and regular income for you!

BELL & HOWELL SCHOOLS OFFERS YOU THESE SPECIAL ADVANTAGES:

Help Sessions Scheduled regularly every few Saturdays at the Bell & Howell Schools and in many other cities throughout the U.S. and Canada. Top instructors give you personal help and guidance.

Transfer Privileges After completion, you can transfer to any of the resident schools for more advanced study, if you wish.

Lifetime National Placement Assistance Helps you locate a job after you complete your program — and throughout your career

Veterans' Benefits We are approved by the state approval agency for Veterans' Benefits.

Student Financial Aid We are an eligible institution under the Federally Insured Student Loan Program.

EXCLUSIVE ELECTRO-LAB®—YOURS TO KEEP!

To make sure you get practical experience with instruments used daily by professionals, we've integrated into your program three precision instruments you assemble yourself and keep:

Design Console Use this to rapidly "breadboard" circuits without soldering.

Oscilloscope Offers bright, sharp screen images, 3-way jacks for leads, plugs.

Transistorized Meter Registers current, voltage and resistance.

DETACH AND MAIL POSTAGE-FREE CARD TODAY! OR WRITE:

An Electronics Home Study School

DEVRY INSTITUTE OF TECHNOLOGY

ONE OF THE



BELL & HOWELL SCHOOLS

4141 Belmont, Chicago, Illinois 60641

406R3

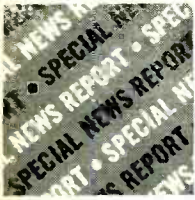

News Highlights

Engineers' Salaries Continue Gain

Results of the tenth biennial survey of engineers' salaries, just released by the Engineering Manpower Commission of Engineers Joint Council, indicate that the long-term rising trend was hardly affected by the unemployment crisis of the last two years. Only at the starting level for new graduates just entering employment were salaries noticeably held back, with an average annual increase of one percent. For more experienced engineers, salaries rose between 3.3 and 4.3 percent per year since 1970, thus keeping generally abreast of the rising consumer price index during the two-year period. The overall average annual salary for all engineers in 1972, without regard to age, type of employer, supervisory status, or degree level, was \$17,750. Half of all engineers' salaries were between the limits of \$20,350 and \$13,900.

Computerized Freeway Traffic Control

A computerized control station to transmit advisory traffic messages for an experimental freeway sign system has begun operating in Los Angeles. There are 35 special signs along an 11-mile stretch of the Santa Monica Freeway median strip. Data from roadway sensors and TV-equipped helicopters is transmitted to the control station and displayed on its console. The operator then selects appropriate advisory messages and displays them on signs. One hundred preset messages can be sent from the console, or the operator can type in additional messages by teletypewriter. The control system was designed and built by GTE Sylvania.

Consumer Products Show Increases in Imports and Exports

Television, home radio, phonographs and tape equipment all showed increases in imports in 1972 over imports in 1971, according to the Electronic Industries Association. Total television imports of 6,375,785 sets in 1972 were 17 percent over the 5,448,873 sets imported in 1971. Home radio imports of 40,159,210 sets in 1972 were up 29.6 percent over the 30,988,437 sets imported in 1971. Phonograph imports of 2,451,406 sets were up 27.3 percent over the 1,925,608 sets imported in 1971. Imports of tape equipment, transceivers, record changers and turntables also showed increases in 1972 over 1971. Exports of all categories of consumer electronics showed increases in 1972 over exports in 1971.

Sony to Build Picture Tube Factory in U.S.

The Sony Corp. announced that it will build a plant in suburban San Diego, California, to manufacture Trinitron color TV picture tubes. The tube plant will have about 170,000 square feet of floor space, and will be designed to allow for future expansion. The plant will incorporate advanced design, technology and production facilities. The tubes will be used exclusively in the company's TV sets assembled in Sony's existing San Diego facility which started operation last

August and is now assembling 6000 sets a month. Output is expected to increase to 20,000 units per month by the end of this year.

REACT Opposes FCC Plan to Boost CB License Fees

The FCC has proposed an increase in CB license fees from \$20 to \$25 for stations with up to five units. In addition an increased fee of \$1 per unit in excess of five units has been proposed by the FCC. REACT National Headquarters points out that 80 percent of their active teams have obtained a Team License for more efficient operation. Because of the large number of units in such teams, the \$1 per unit proposal will hit these teams hard and has been referred to as prohibitive, double taxation. The increase in basic license fee would, according to REACT, result in an increase in illegal, unlicensed operation on the CB band.

Electronics Technicians and Dealers Increase

According to a survey conducted by NEA (National Electronic Association) the number of TV service dealers (shops) has increased from 63,087 in 1970 to 74,000 in 1973. Some of this increase is due to the larger number of reporting states in the current survey. NEA's estimate of the total number of electronics technicians working in consumer electronics is now 204,000. Both full time and part time technicians are covered. There is an average of just under 3 technicians per service shop.

Minicomputer "Talks" to Blind

Over 5000 blind people in the Boston area have a new friend in a talking computer system that allows them to type letter-perfect correspondence, proofread manuscripts, calculate bookkeeping problems, and write computer programs. The first of these systems is operating at the Protestant Guild for the Blind in Watertown, Mass. It is built around a Data General minicomputer. A blind person types his information into the computer using ordinary telephone lines to carry the signals. The computer responds to the blind typist in words and sentences telling him precisely what he has typed or giving him the results of indicated commands or computations.

Two-Eyed Television Camera Tube

A new TV camera tube with two "eyes" or targets will enhance the performance and lower the cost of single-tube color TV cameras. The luminance (black and white) portion of the picture is projected onto one target and the chroma (color) information, in suitably encoded form, onto the second target. The tube, introduced by RCA, provides excellent registry between the luminance and chroma information without additional auxiliary coils because the beams generated by its two electron guns are controlled by a single magnetic focus and deflection system. These beams read out the stored picture information from the two targets and provide simultaneous output signals that can be superimposed with precision.

Tariff Commission Clears Japanese Color-TV Tubes

The Tariff Commission has notified the Secretary of the Treasury that an industry in the United States is not being and is not likely to be injured or prevented from being established by reason of imports from Japan of color television picture tubes sold at less than fair value. The merchandise is therefore not subject to special dumping duties.

It's fun to build quality. Heathkit Electronics

For full spectrum color, black & white

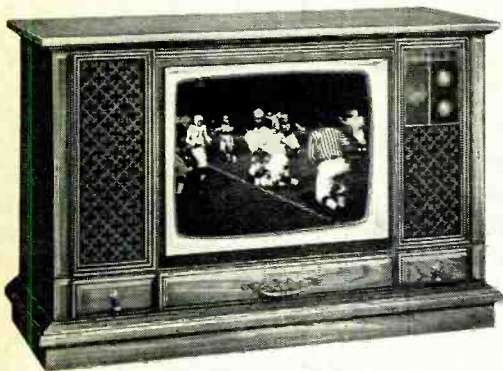

GR-900 **599⁹⁵***
(LESS CABINET)



New
GR-1900 **179⁹⁵***
(INCLUDES CABINET)

...and staying out of the red.



New
IC-2108
79⁹⁵*



New
IC-2009
92⁵⁰*

(INCLUDES CHARGER)

See them all at your Heathkit Electronic Center... or send for free '73 Heathkit Catalog.

HEATHKIT ELECTRONIC CENTERS

ARIZ.: Phoenix, 2727 W. Indian School Rd.; CALIF.: Anaheim, 330 E. Ball Rd.; El Cerrito, 6000 Potrero Ave.; Los Angeles, 2309 S. Flower St.; Pomona, 1555 Orange Grove Ave. N.; Redwood City, 2001 Middlefield Rd.; San Diego (La Mesa), 8363 Center Dr.; Woodland Hills, 22504 Ventura Blvd.; COLO.: Denver, 5920 W. 36th Ave.; CONN.: Hartford (Avon), 395 W. Main St. (Rte. 45); FLA.: Miami (Miami), 4705 W. 16th Ave.; GA.: Atlanta, 3265 Roswell Rd. (Rte. 40); ILL.: Chicago, 3462-66 W. Devon Ave.; Downers Grove, 224 Ogden Ave.; IND.: Indianapolis, 2112 E. 62nd Ave.; KANSAS: Kansas City (Mission), 19 1/2 Lamar Ave.; MD.: Baltimore, 1713 E. Joppa Rd.; Rockville, 5542 Nicholson Lane; MASS.: Boston (Wellesley), 165 Worcester St.; MICH.: Detroit, 19645 W. Eight Mile Rd. & 16149 E. Eight Mile Rd.; MINN.: Minneapolis (Hopkins), 101 Shady Oak Rd.; MO.: St. Louis, 9296 Gravois Ave.; N.J.: Fair Lawn, 35-07 Broadway (Rte. 41); N.Y.: Buffalo (Amherst), 3476 Sheridan Dr.; New York City, 25 W. 45th St.; Jericho, L.I., 15 Jericho Turnpike, Rochester, Long Ridge Plaza; OHIO: Cincinnati (Woodlawn), 10133 Springfield Pike, Cleveland, 5444 Pearl Rd.; PA.: Philadelphia, 6318 Roosevelt Blvd.; Pittsburgh, 3482 Wm. Penn Hwy.; TEXAS: Dallas, 2715 Ross Ave.; Houston, 3705 Westheimer; WASH.: Seattle, 221 Third Ave.; WIS.: Milwaukee, 5215 Fond du Lac.

Heathkit GR-900 25V Color TV with total-tuning convenience.

It's the most advanced TV circuitry you can build. Yet everything goes together with traditional Heathkit simplicity. And the built-in convergence board and test meter for at-home maintenance and self-service add further savings over the life of the set. With the GR-900 you pre-set any 12 UHF stations for positive pushbutton power tuning, and you can scan both UHF and VHF channels in either direction. An ultra-rectangular black matrix tube, voltage controlled varactor UHF tuner, MOSFET VHF tuner and an exclusive angular tint control for consistently better flesh tones combine to produce an absolutely brilliant color picture. There are four preassembled and finished cabinets to choose from, plus the Heathkit Wall Mount and wireless remote control option. Any way you look at it, the Heathkit GR-900 is one of the most rewarding kits you can build. Mailing weight, 125 lbs.

New Heathkit Solid-State B&W 19V Portable TV—a truly extraordinary set

The new Heathkit GR-1900 is like no other B&W portable! With advanced solid-state "modular" design — most circuitry mounts on just four plug-in boards. Dependable solid-state circuitry, including 23 transistors, 13 diodes, 2 ICs, and just 2 tubes; picture & high voltage. Total detent tuning on all 70 UHF channels as well as VHF. "Instant-On" for sound and pictures at a touch — plus other "big-set" front panel control features such as VHF/UHF fine tuning, brightness, contrast, master on/off, vertical hold, AGC, and height. New Ultrarectangular picture tube for a full 184 sq. in. viewing area. Automatic Vertical Linearity for rock-steady pictures — a feature usually found only on expensive color sets. Dual-Controlled AGC for improved picture/noise ratio — another "big-set" bonus feature. Extra-wide Video Bandwidth for theater-quality black-and-white pictures. Four circuits (most sets have only 3) in the grounded base VHF tuner for superior cross modulation in dense station areas. With all this, the GR-1900 is a kit even the novice can build. Both tuners come preassembled and aligned, transistors & ICs plug into sockets, and all chassis wiring is color coded. For truly extraordinary performance in B&W TV, you've got it all in the GR-1900. Mailing weight, 56 lbs.

New Heathkit Desk-top Calculator — an outstanding kit-form value.

The Heathkit IC-2108 features a sleek, low-profile case with bright 1/2" readout tubes in an 8-digit display — one of the largest, most legible in the industry. The color-coded keyboard is human engineered to slope down to the desk so you can rest your arm while using. And the IC-2108 is loaded with features: Four arithmetic functions. Floating and fixed decimal. Constant key. Chain calculation capability. Clear display key. Entry and result overflow indicators. Negative number indicator. 120/240 VAC operation. In addition, the IC-2108 is amazingly simple to build. Two spare evenings will do it. Kit IC-2108, 4 lbs.

New Heathkit "Pocketable" Calculator — you can service it yourself

The Heathkit IC-2009 is first a self-contained portable, weighing in at 11 oz. and small enough to fit in your coat pocket, but it's a desk-top calculator too. The internal Nickel-Cadmium battery gives five to eight hours use between charges. Or, the IC-2009 can be left connected to its charger for indefinite operation. And unlike other pocket calculators, the Heathkit IC-2009 is designed to be maintained by you. Plug-in keyboard and display boards, plus a complete troubleshooting section in the manual, make it easy — and economical. Add up the features for yourself: 8-digit capacity. Four arithmetic functions. Full floating decimal. Constant key. Chain calculation capability. Clear entry key. Entry and total overflow indicators. Negative answer indicator. Battery-saver circuitry. Low battery indicator. Tactile-feedback keyboard for positive entry indication. Order your IC-2009 now. You'll have it built in two or three evenings. Mailing weight, 3 lbs.

HEATH
Schlumberger



SEND FOR YOUR FREE 1973 HEATHKIT CATALOG
— it describes more than 350 Heathkit projects

HEATH COMPANY, Dept. 10-5
Benton Harbor, Michigan 49022

Please send FREE Heathkit Catalog.
Enclosed is \$ _____, plus shipping.

Please send model(s) _____

Name _____
Address _____
City _____ State _____ Zip _____

*Mail order prices; F.O.B. factory CL-464R



Heathkit 4-Channel Amplifier with Universal Decoder... 359.95*
(less cabinet)

You select discrete 4-channel, or switch-in the "Universal" decoder for reproduction of all the matrixed 4-channel discs now on the market, plus "derived" 4-channel from conventional stereo. Four solid-state amplifiers produce 200 watts (4x50 IHF) into 8 ohms, with power bandwidth on all channels from less than 5 Hz to greater than 45 kHz at 0.25% distortion. Kit AA2010, 37 lbs. AAA-2004-1, pecan cabinet, 7 lbs. 24.95*



Heathkit Universal Decoder for 4-channel conversion... 39.95*

Reproduces all matrixed discs, plus "derived" 4-channel from conventional stereo materials. Plug it into your receiver's tape monitor circuit, add a second stereo amp and speakers and you're set. Kit AD-2022, 4 lbs.



New Heathkit Ultrasonic Intrusion Alarm looks like a book... 49.95*

Disguised as an ordinary library book, this novel device fits unobtrusively anywhere in the home. Transmitter disperses a 41 kHz signal which bounces off walls and returns to the receiver where it's monitored for any change in amplitude. Triggers lights and any conventional alarm device — just plug them into AC outlets on the rear panel. Can be installed anywhere there's a 120 VAC outlet. An enjoyable 2-evening kit. Kit GD-39, 4 lbs.

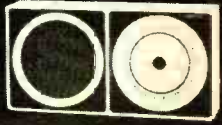

New Heathkit GR-1008 AM Radio can be built in one evening... 14.95*

A smartly styled, great sounding solid-state radio that makes a great introduction to Heathkit building. Eight-transistor circuitry mounts on one printed board, big 3 1/2" speaker mounts in high impact plastic case. If you've never built a kit before you can probably have this one together in one fun evening. Uses 9-volt battery (not supplied). Order the Heathkit GR-1008 for yourself or the kids. Kit GR-1008: 2 lbs.

CIRCLE NO. 20 ON READER SERVICE CARD

BY
L. GEORGE
LAWRENCE

Electronics and

How electronics is used to detect water pollution



Fig. 1. Skimming and aeration system at a water treatment plant.

LIFE and water are inseparable. There is no solvent substitute for water. Unfortunately, methods of controlling pollution of this precious liquid are grossly inadequate, inviting the invention and application of new engineering principles. We are fortunate, however, in having a good set of electronic instrumentation systems which provide valuable data on polluting contributors. Thus, *pre-prevention* of pollution can be as effective as pollution control "after the fact," so to speak. But much more work lies ahead. Let's see what has been and what can be done in this critical area.

The Federal government saw the writing on the wall early in 1948. It enacted the first water-pollution control act which had a five-year expiration date. The first permanent water-pollution control act (P. L. 84-660) became law in 1956. It has been strengthened several times. The Water Quality Act of 1965 emerged as a key feature of

the clean-water program because it required all states to establish water-quality standards for their interstate and coastal waters. Later, in 1968, the National Technical Advisory Committee to the Secretary of the Interior submitted its report on water-quality criteria. This 215-page document reflects, as shown in Table 1, the enormous difficulty of removing a dangerous family of agricultural and related pollutants from drinking water. The situation has become even more serious because of mercury and oil pollution of marine life. Here, if vital oxygen and food chains are disturbed, we must anticipate catastrophic consequences to our day-to-day existence.

The typical municipal water plant is not electronics-oriented, but devices such as thermistors, pH meters, and the like may be employed for general control purposes. To improve water quality, brute-power techniques such as skimming and aeration (Fig.

Water Quality Control

so that it can be readily prevented.

1), sedimentation, flocculation, and filtration are frequently employed to remove suspended materials. These may be augmented by methods of reducing water hardness and the application of disinfectants to improve bacteriological quality. The water is considered safe for consumption once it leaves the plant. Thus, for electronic and other quality controls to be effective, monitoring and anti-pollution measures must be installed and operated at plant feeders.

Water Parameters. We have a total of about fifteen measurable parameters of water. Some of these can be monitored electronically, while others lend themselves to chemical analyses only. Taken together, they are:

1. *Alkalinity:* Its measurement allows conclusions on the carbonate/bicarbonate concentration as distinguished from organic carbon.

2. *Chloride Ion:* Chloride at high levels is undesirable for health reasons.

3. *Conductivity:* Measurements discern the amount of dissolved solids (salts) in water. High levels indicate pollution by brines or inorganic chemicals, leaching of salts from watersheds, and the like.

4. *Dissolved Oxygen:* Perhaps the most important of water parameters. Organic pollution from sewage and certain industries can destroy oxygen concentration, making water totally useless; it cannot support aquatic life nor be used for recreational purposes.

5. *Flow Rate (Velocity):* Measurement is necessary to correlate, and perhaps explain, changes in other parameters.

6. *Fluoride Ion:* High fluoride concentrations cause tooth mottling. If fluorides are absent, dental caries increase. Industrial users of fluorides might leak excessive amounts into water supplies.

7. *Hardness:* Not desirable, because of treatment costs, especially if water is intended for domestic use.

8. *Nitrate:* Pollution arises from decomposing organic matter, agricultural fertilizers, and the like. Extremely dangerous to newborn children (causes methemoglobinemia or "blue baby").

9. *Oxidation Reduction Potential:* Measurements are designed to discern industrial wastes containing powerful reducing and oxidizing agents.

10. *pH:* A pH of 7.0 (pure water) is desired. Respective measurements provide data on sea-water (pH 8.2) leakage into water supplies, detect pollution from acidic or basic wastes entering feeder streams, etc. Data permits formulation of conclusions on stream quality, its corrosion potentials, and long-term forecasting of quality.

11. *Sodium Ion:* High-level sodium concentrations are undesirable for health reasons. Measurements can detect sea-water intrusion, dumping of brine wastes, etc.

12. *Sunlight:* Visible electromagnetic radiation from the sun is vital to production of algae which transform carbon dioxide back to oxygen. Thus, the recuperative power of organically polluted streams depends upon sunlight.

13. *Temperature:* Its measurement provides data on the pollution capacity and recovery potential of streams. Thermal pollution of the sea, especially where condensing systems of nuclear and other power plants are involved, must be monitored on behalf of marine and other life.

14. *Turbidity:* Its measurements is closely related to item #12, sunlight. Turbid water attenuates sunlight penetration and its beneficial actions, thus increasing cost of water treatment.

15. *Total Carbon Inventory:* In a stream, carbonaceous material directly relates to dissolved-oxygen levels.

No composite electronic instrument exists to measure all of these interrelated parameters simultaneously. Typical apparatus uses sensors, each of which has a purpose-designated function.

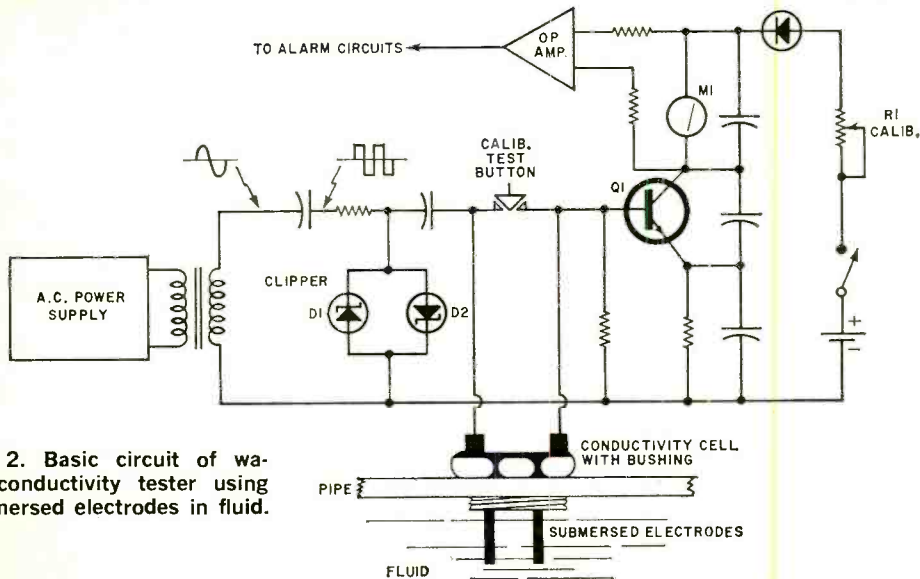

Fig. 2. Basic circuit of water conductivity tester using submersed electrodes in fluid.

Electronics. One of the simplest and most widely used methods for detecting water pollution is the electronic measurement of its conductivity. A typical testing device responds to the number of ions in a water sample, *i.e.*, atoms which carry a positive or negative electric charge due to having lost or gained an electron, respectively. Here, if a potential difference exists between two electrodes in a given solution, current flows, the magnitude of which is related to the conductivity (micromhos/cm) of the solution.

A basic, highly reliable instrument is shown schematically in Fig. 2. A sine-wave output voltage is provided by the ac power

supply, clipped in a zener-diode arrangement and fed, *via* submersed electrodes, to the base of transistor Q1. Meter M1 may be calibrated for a quiescent reading ("0") by depressing the calibration test button and setting the calibration potentiometer R1 accordingly. An operational amplifier, a dc op amp, is connected across M1 and provides drive currents for remote alarm circuits, a metering device, and the like. The instrument's meter and over-all net dc output can be calibrated against a standard conduction sample.

Fig. 3 represents a refinement of the circuit shown in Fig. 2. Again, the ac voltage is clipped (to provide a stable drive voltage

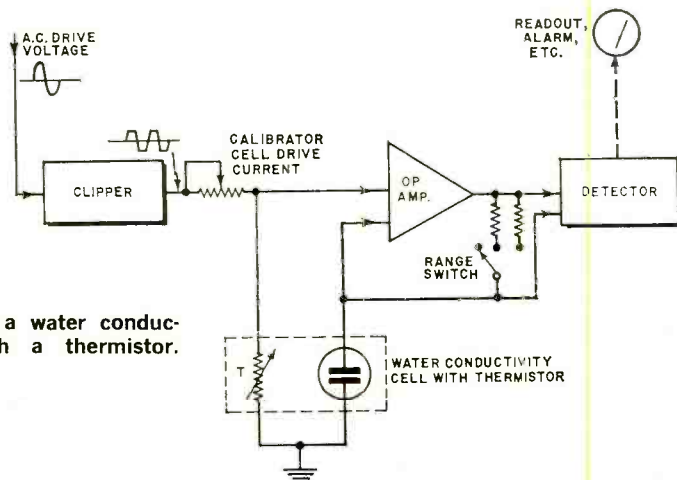

Fig. 3. Schematic of a water conductivity cell used with a thermistor.



Fig. 4. Commercial water conductivity meter.

regardless of line fluctuations) and fed via a calibrating potentiometer for the conductivity-cell drive current into an operational amplifier and the follow-up readout detector.

The voltage across the conductivity cell is varied according to the thermistor resistance, the thermistor compensating for the conductivity temperature dependence of the water being measured. If, for example, the water's temperature is 25°C, the meter will read the actual conductivity of the water directly. If the temperature differs from 25°C, the thermistor will cause the meter's sensitivity to change. Thus, 25°C becomes a *calibration constant*.

Fig. 4 shows a complete meter, the Balsbaugh Model 915. Like similar instruments, its tracking can be checked with a decade resistance box, using values of resistance obtained from the equation: *meter reading* (μmhos) = $(1/\text{megohms}) \times \text{cell constant}$. For example, a resistance of 4000 ohms will indicate 25 $\mu\text{mhos/cm}$ on a monitor which uses a conductivity cell constant of 0.1. Such cells may consist of titanium-palladium electrodes with Penton insulation, a Teflon-coated threaded stainless-steel bushing, with the thermistor potted in the center electrode for exact temperature re-

Fig. 5. Central water quality control room.

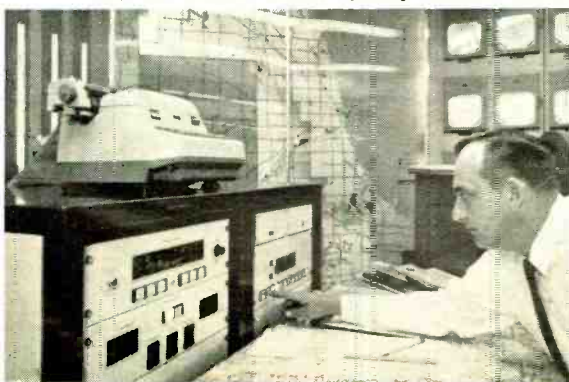

MAY 1973

sponse. Graphite electrodes may also be used, plus similar composition materials. It is important to remember that alternating current *must be used* in conductivity testers to avoid chemical changes, including electrolysis, in the solution next to the electrodes. "Polarization," as this phenomenon is termed, can generate galvanic error currents and introduce undesirable readout anomalies. As a general guide for obtaining quality data, the following water-conductivity figures are useful:

	Specific Resistivity (ohm/cm)	Specific Conductivity ($\mu\text{mho/cm}$)
Pure Water	20 megohms	0.05
Distilled Water	1 megohm	1.00
0.05% Salt	1000	1000.00
Sea Water	30	33,000.00

Electronics can replace the old "grab sample" method of obtaining water samples and subjecting them to analyses. Typically, in a large-city water-control system, raw

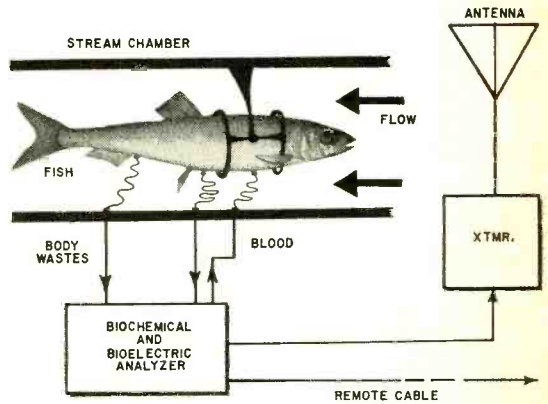

Fig. 6. Electronically monitored living fish is a new idea in quality control.

river water is pumped through a flow chamber to a plenum containing a series of small funnels. These funnels, filled and overflowing, pass water samples against sensors. Each of them provides low-voltage outputs (about 0-5 volts) proportional to the value of the variable being measured.

An excellent water-data acquisition system of this type is used by the Metropolitan Sanitary District of Greater Chicago (Chicago and). The District covers some 850 square miles and provides water and sewage services for a population of 5,500,000 plus an industrial equivalent to 3,000,000 peo-

ple. There are 71 miles of inland waterways under its jurisdiction. To provide and maintain superior water-quality control, the District uses eleven monitoring stations, three secondary receiving stations, and one central receiving station.

Fig. 5 shows Chicagoland's central control room. In the foreground is a Bristol Data-Master control data logger. The map

TABLE 1—WATER-QUALITY CRITERIA FOR PUBLIC WATER SUPPLIES

Constituent*	Permissible criteria (mg/l)	Desirable criteria (mg/l)
Total dissolved solids	500	200**
Sulfate	250	50**
Chloride	250	25**
Nitrate (as N)	10	Virtually absent
Insecticides		
Organic phosphates	0.1	Absent
Lindane	0.056	Absent
DDT	0.042	Absent
Heptachlor	0.018	Absent
Aldrin	0.017	Absent
Dieldrin	0.017	Absent
Toxaphene	0.005	Absent
Chlordane	0.003	Absent
Endrin	0.001	Absent
Herbicides		
2,4D plus 2,4,5-T plus 2,4,5-TP	0.1	Absent

*Conventional water treatment processes have little, if any, effect on these constituents.

**Less than.

in the background shows the area serviced. All eleven of the monitoring stations measure dissolved oxygen, conductivity, pH, water temperature, oxidation reduction potential (ORP), dissolved chlorides, and turbidity. Solar radiation intensity (SRI) is monitored at five stations. Sensor data is fed into voltage-to-frequency converters and sent by voice-grade telephone lines to readouts. The signals are audio tones transmitted over multiplexers. This insures maximum use of the lines, since several signals may be transmitted concurrently. Also featured are an integral test signal, a signal to indicate loss of water in the sampling flow chamber, and indication of signal failure.

Looking Ahead. What is the future for electronic water-quality monitoring and

control? At this moment, we have research trends in various areas. Biological-type sensors are a fascinating aspect of this R&D.

One basic idea of a biological-type sensor is shown in Fig. 6. Here, the organism of a living creature—a fish in this case—is envisioned as an ultra-effective and accurate control instrument. As shown, it is feasible to monitor a fairly complete set of the animal's organic reactions to environmental changes. If, for example, variations in water parameters occur, reactions will be triggered in both biochemical and bioelectric areas which are available for analysis by relatively simple electronic instruments and follow-up by traditional telemetry. Unfortunately, one of the big problems encountered here is how to sustain the life of the fish in *pure* water; that is, water which contains no nutrients of any kind. So this idea might have to be dropped in spite of its inherent promise.

However, excellent progress continues to be made in the *reverse-osmosis* process which provides water of exceptional quality.

Developed by Culligan International Co., the purification technique is based upon the age-old principle by which plants obtain their nourishment and human cells transport fluids. When two fluids are separated by a semipermeable membrane, there is a normal flow from the more dilute fluid to the more concentrated fluid—or osmosis. *Reverse osmosis* is just the opposite. In water technology, pressure furnished by a pump is applied to the more concentrated fluid (like brackish or saline water) which forces water to pass through the membrane. The latter is permeable to the water *per se*, but less permeable to water impurities. Result: The water is separated from its impurities.

Current capacities of the reverse-osmosis system range from 6000 to 60,000 gallons per day. While not an electronic machine as such, it provides high-quality water for the manufacture of transistors. The best quality of the distilled water used previously was 2 megohms. The reverse-osmosis system upgraded this value to 18 megohms! The ultra-pure water is used to rinse transistor wafers after each photo-resist and etching process.

In short, we are approaching an excellent state-of-the art. But much research and applied research need to be done to preserve a basic human right—the right to have pure water. It's a good sign, perhaps, that electronics is so well suited to maintain and improve the *status quo*. ♦

unique digital clock

TELLS TIME AND TEACHES BINARY ARITHMETIC

BY GLENN YOUNG Semiconductor Products Div., Motorola, Inc.

HAVING trouble learning binary arithmetic? How about learning to tell time on a clock that has a binary readout? It's the latest thing in digital clocks—and quite a conversation piece.

As shown in the schematic in Fig. 1, the input to Schmitt trigger *Q1* and *Q2* is the 60-Hz power-line frequency from the secondary of *T1*. The trigger converts the sinusoidal waveform into a rectangular wave of the same frequency to drive the digital counter made up of *IC1* through *IC3*. The circuit divides by 60 to produce one pulse per second. This pulse then drives the "seconds" LED flasher (*D1*) through *Q3* and also triggers another divide-by-60 counter (*IC4* through *IC6*) whose output is one pulse per minute.

Each of these division stages consists of an MFC6020, a dual T flip-flop that has a single input and output and produces one output pulse for every two input pulses. When cascaded together, the six flip-flops in *IC1* through *IC3* (and *IC4* through *IC6*) would divide by 64. However, the circuit is "fooled" by feedback to provide only 60 divisions. Each time this transition occurs, capacitor *C1* or *C2* injects a short pulse into the input of its associated divider. This pulse is counted just as if it were a normal input pulse. As four extra pulses are generated, the chain actually counts to 64 after receiving only 60 input pulses. Although this is an economical way to count, it cannot be decoded for use as a counter register because it does not contain the true count.

The minutes counter (*IC7-IC12*) is another form of divide-by-60 counter which uses AND gates (*IC9* and *IC11*) to decode the 60th count and reset the divider chain

(*IC7*, *IC8*, and *IC10*) through *IC12* to a zero count. The outputs of the divider, now containing the true count, are fed to *Q4-Q9* to drive the 1-2-4-9-16-32 minute LED indicators. The output of the minutes counter drives the hours counter (*IC13-IC16*), a divide-by-12 circuit decoded by *IC15* and reset to one through *IC16*. Transistors *Q10-Q13* drive the hour LED's.

Construction. There are two printed circuit boards in the clock; a large one that holds the IC's, transistors, etc., and a smaller one for the LED readouts. The large board pattern is shown in Fig. 2. Be sure all IC's are properly oriented—the dot on the IC indicates pin 1. Three resistors (*R1*, *R7*, and *R9*) are mounted vertically, with their upper ends serving as the circuit contacts.

The pattern for the LED board is also shown in Fig. 2. The LED's are polarized with the cathode leads (the ones going to the transistors) having square ends when viewed through the plastic case from the bottom. It is this lead that is soldered to the small pieces of foil next to each LED hole. The LED's are mounted with the glass tips protruding through the holes in the board, toward the non-foil side of the board.

The power supply can be built in any convenient place within the case, whose selection is left up to the builder. In the prototype, a sloping-front wooden enclosure was used, with the LED board forming the front (sloping) panel. The other PC board was mounted vertically in the enclosure. The actual clock face (the LED's protruding through the non-foil side of the board) was covered with black construction paper having holes for the LED's. The connections

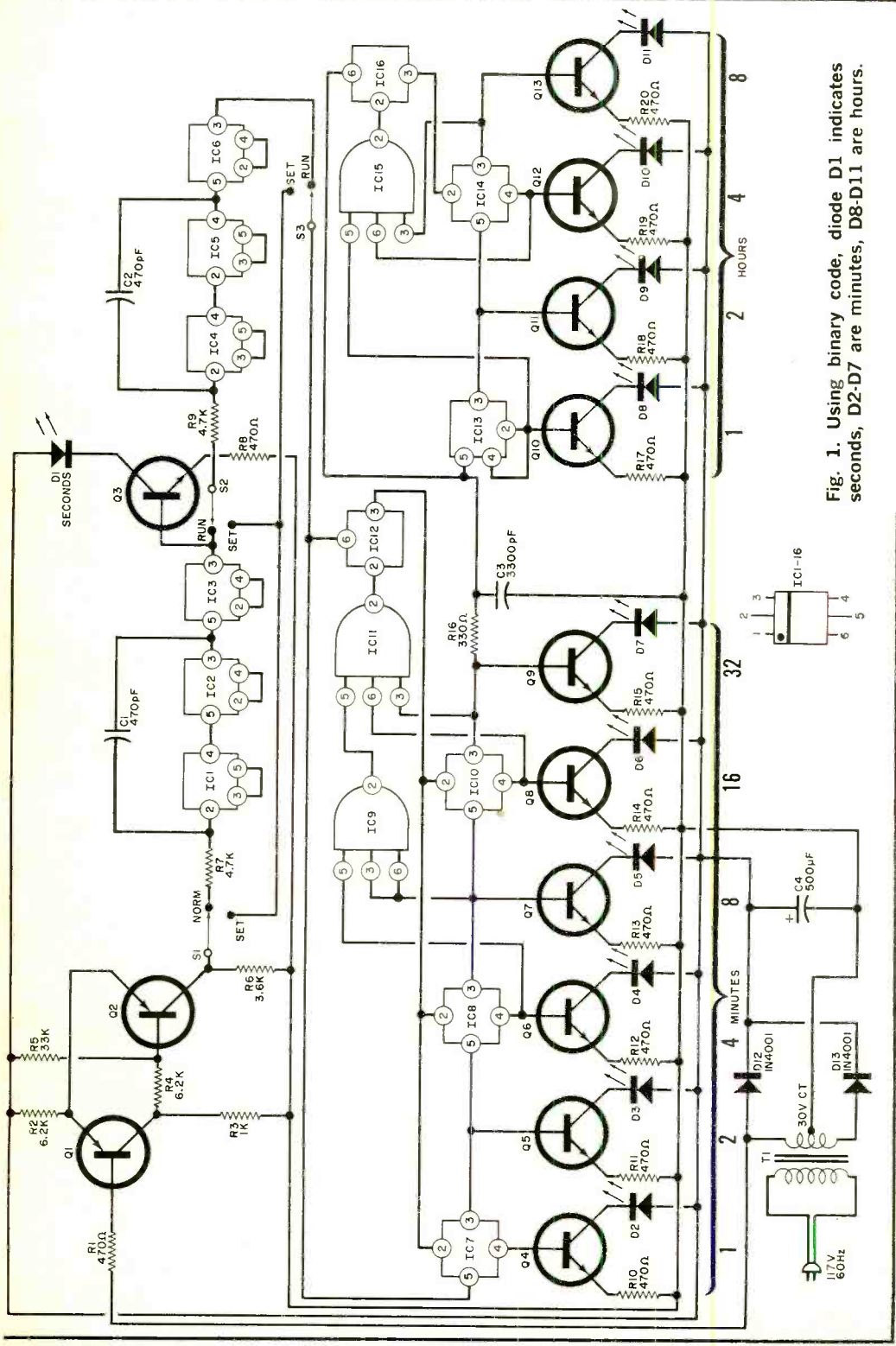

Fig. 1. Using binary code, diode D1 indicates seconds, D2-D7 are minutes, D8-D11 are hours.

PARTS LIST

C1,C2—470-pF disc capacitor
C3—3300-pF disc capacitor
C4—500- μ F, 50-volt electrolytic capacitor
D1-D11—MLED600 (Motorola)
D12,D13—1N4001 diode
IC1-IC6,IC13—MFC6020 (Motorola)
IC7,IC8,IC10,IC14—MFC6050 (Motorola)
IC9,IC11,IC15—MFC6060 (Motorola)
IC12,IC16—MFC6080 (Motorola)
Q1,Q2—MPSA70 (Motorola)
Q3-Q13—MPSA10 (Motorola)
R1,R8,R10-R15,R17-R20—470-ohm resistor
R2,R4—6200-ohm resistor
R3—1000-ohm resistor
R5—33,000-ohm resistor
R6—3600-ohm resistor
R7,R9—4700-ohm resistor
R16—330-ohm resistor
S1-S3—Spdt switch
T1—Transformer; secondary 30V CT, 1A
(Chicago-Stancor P-8609 or similar)
Misc.—Suitable enclosure, line cord, grommet, rubber feet (4).

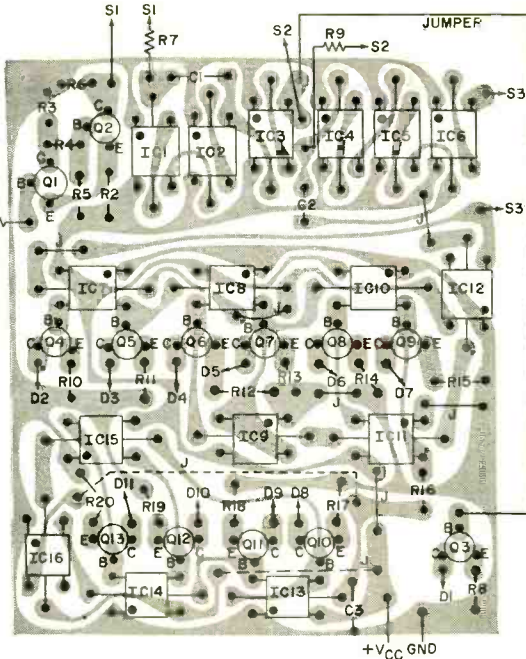
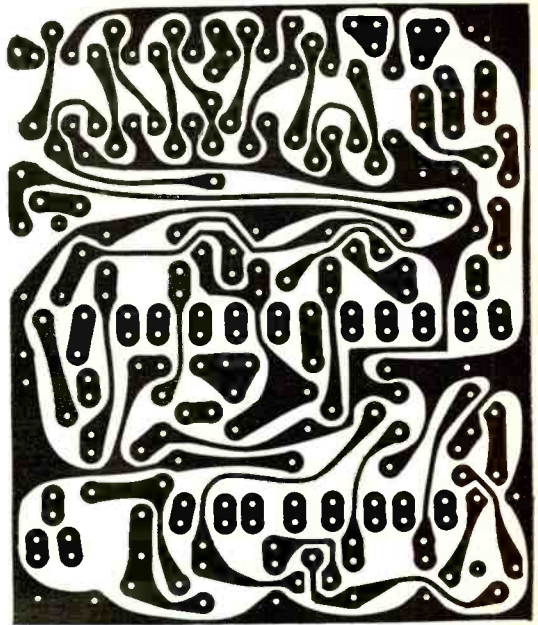
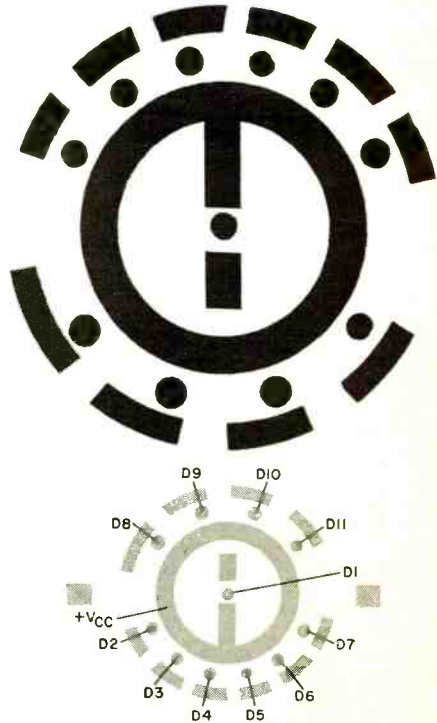

Fig. 2. Upper right are foil patterns.
 Component layouts above and at right.



between the two boards are made with #22 or #26 insulated wire.

Once the clock is assembled, place *S1* on SET and *S2* and *S3* on RUN. When power is applied, some LED's will come on. Putting *S2* on SET should cause the minutes LED's to cycle at about one per second in a binary

fashion. Placing *S3* on SET should cause them to cycle faster. Use both *S2* and *S3* to set the correct time on the clock. Then put them both on RUN and set *S1* to NORM. The seconds LED should blink at the proper one-per-second rate. The clock is now ready to operate. \diamond

EFFECTIVE RADIATED POWER

HOW TO CALCULATE ACTUAL R-F OUTPUT AND SOME WAYS TO IMPROVE IT

BY GLADDEN B. HOUCK, JR.

MAXIMUM effective radiated transmitter power is the aim of all CB and ham radio operators. This is evident from the fact that so much effort and money go into improving transmitter efficiency—matching devices, tuning couplers, SWR bridges, beam antennas, etc. There are many factors involved, actually, in the struggle to get maximum r-f output. Some are more important than others; but all are worth reviewing.

To start with, just how does one measure transmitter power output? One way is to use a commercial r-f wattmeter. An alternate method is to measure the voltage generated across a 50-ohm load with a conventional voltmeter using a high-frequency probe that will operate at the frequency of interest. This measured voltage can be converted into approximate r-f power for a 50-ohm load by using the curve in Fig. 1.

A less accurate method of determining r-f power output is to measure the dc power (voltage and current) supplied to the power amplifier when it is loaded by the proper antenna and tuned to resonance. The efficiency of this stage can be assumed to be about 60%, unless you have an actual figure supplied by the manufacturer. Thus, if the final stage in a CB rig has about 13.2 volts on the collector and the collector current is 380 mA, the legal dc input rating of 5 watts is obtained. With 60% efficiency, this would result in 3 watts of r-f at the output terminal.

To keep all computations in terms that point up the relative importance of any improvement, a dBW rating is used. By using

the scales in Fig. 1, we see that 3 watts is equivalent to 4.8 dBW. This approach is based on zero dB for one watt.

The least change in dB levels that the ear can notice is about 3 dB (a power level change of 2 to 1). If the transmitter described above had a 100% efficiency, its output would be 5 watts (7 dBW), less than twice the level of the original 4.8 dBW, a barely discernible improvement.

Line Losses. Transmission line losses are of two types: direct losses and reflected mismatch losses. Direct losses are easy to determine since they are proportional to the length of the transmission line, and they depend on the type of coaxial cable used. One of the common types of cable employed for connecting the transmitter to the antenna is RG-58/U. It has a loss rating of 0.022 dB per foot. If we assume that a typical base station uses about 60 feet of cable, this means a direct cable loss of -1.32 dB, where the minus sign indicates a loss. Using the same length of RG-8/U cable with a rating of only 0.01 dB per foot, the direct cable loss is -0.6 dB. This shows that the selection of coaxial cable can make a big difference in the transmitted signal level.

Reflected losses are measured by using an SWR bridge or an in-line wattmeter. The proper place to make these measurements is at the connection between the transmission line and the antenna. Measurements made at the transmitter end of the cable, although valid, are always lower due to the cable losses which attenuate both the direct and reflected signals to the bridge.

The chart in Fig. 2 provides a means of converting SWR and reflected power into dB losses. If a typical antenna system has a measured SWR of 2.0, Fig. 2 shows that the loss is -0.5 dB.

Antenna Gain. The gain of an antenna is specified by its manufacturer in terms of dB as compared to a standard dipole. Thus a simple whip antenna about 96" long has a gain of about $+2.15$ dB, while a multi-element beam antenna may have a gain of $+11$ dB or more. Since the gain of an antenna is difficult to measure without special equipment, it is usually necessary to take the manufacturer's word for it.

If we assume that a rig has 3 watts of r-f output at the transmitter, 60 feet of RG-58/U coaxial cable, an SWR of 2.0, and a beam antenna having $+11$ dB gain. These figures add up as follows: $(+4.8) + (-1.32) + (-0.5) + (+11) = +14$ dBW. Using Fig. 1, this converts to 25 watts of equivalent power.

Improvements in the transmission system by lowering the SWR or changing the cable to RG-8 U might raise the figure from $+14$ dBW to $+15$ dBW (effective radiated power of 32 watts). Note that this would only improve the received signal strength by

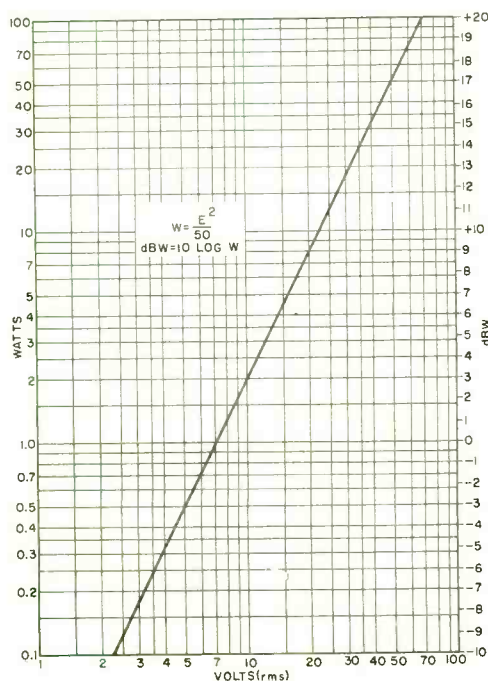

Fig. 1. Converting volts to watts and dBW.

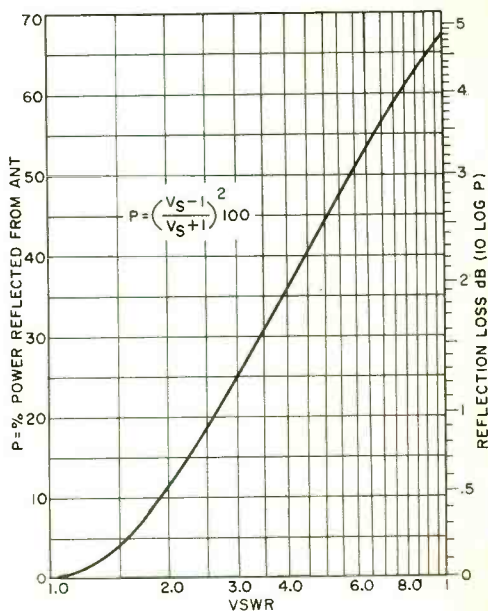

Fig. 2. Finding reflectance loss from SWR.

16% which is not enough to make that much difference, though every little bit helps.

For CB's and hams, the best thing to do is to use a directional high-gain multi-element beam antenna. Antennas of this type provide a dramatic improvement in transmission and also assist in reception. Since a beam antenna concentrates the energy (for both transmission and reception) in a "tear-drop" pattern, with the sharp end of the pattern at the antenna proper, it focuses most of the transmitted energy toward the receiver at which it is aimed and also provides much less pickup in the other directions. This means a considerable reduction in the pickup of unwanted signals. By properly aiming the antenna, distant transmission and reception are considerably improved.

In some situations, it is necessary to connect the SWR bridge at the junction of the transmission line and the transmitter. Indications obtained in this manner must be corrected for transmission line losses, with the curve in Fig. 2 used to convert SWR to dB of reflected power. Since the transmission line losses affect the SWR in both directions, the effect is to double the dB correction. Thus, if the SWR at the transmitter is 1.6, the reflected loss is 0.2 dB. If the line losses are 1.0 dB each way, the total for SWR correction is 2.2 dB. ♦

Confused by all the ads for home training in electronics?

Find out what it's really all about from RCA...

With RCA Institutes Home Training Programs you get:

- "Hands-On" training — with RCA Institutes home training, you get "hands-on" experience. You can build many valuable and useful pieces of electronics equipment that you can keep. In the Master TV Servicing Program you get as many as 21 valuable kits.
- The AUTOTEXT programmed method of learning electronics — the individualized, easier, faster way to learn.
- The CASSETTE SYSTEM — an optional extra — it's almost like having an instructor in your own home.
- Easy-pay tuition plans.
- FCC License Preparation — Money-back agreement assures you of your money back if you take, and fail to pass, the FCC examination within 6 months after completing the course.

Veterans: Train under new GI Bill. Accredited Member National Home Study Council I. Licensed by N.Y. State Education Dept. — courses of study and instructional facilities approved by the State Education Department. "Eligible Institution" under the Federally Insured Student Loan Program.

RCA INSTITUTES INC., 320 West 31st Street, New York, N.Y. 10001.

RCA



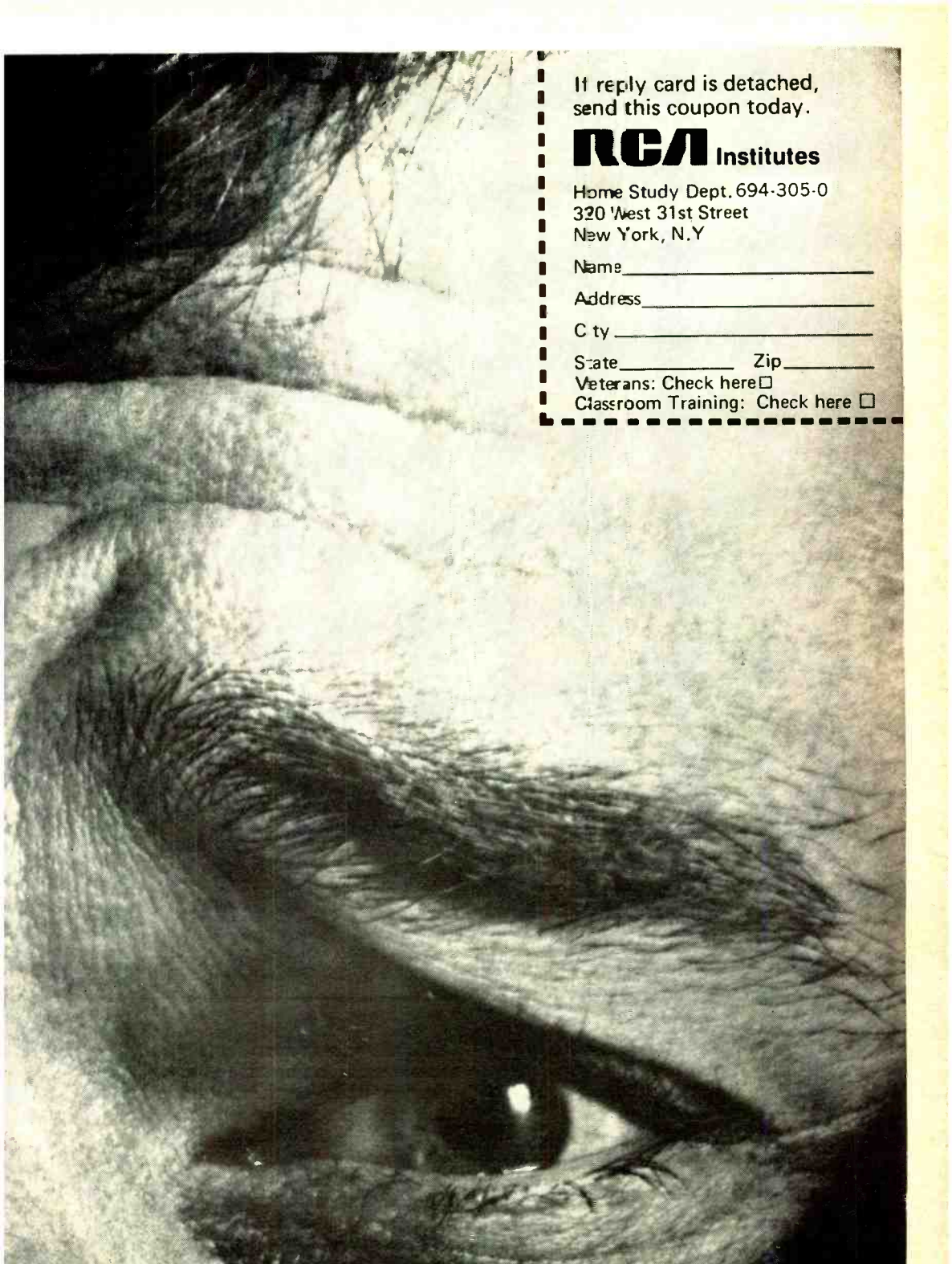

If reply card is detached,
send this coupon today.

RCA Institutes

Home Study Dept. 694-305-0
320 West 31st Street
New York, N.Y.

Name _____

Address _____

City _____

State _____ Zip _____

Veterans: Check here

Classroom Training: Check here

CIRCLE NO. 30 ON READER SERVICE CARD

WHILE a great many people have recently become interested in electronic music, few of them have any knowledge of just what goes into generating the sounds of this new music. In view of the fact that the first Moog synthesizers were made available only in 1964, this is not surprising. While electronic musical instruments consist of basically simple circuits, or building blocks, the instrument itself is usually a complex, sophisticated device.

Electronic musical instruments differ markedly from conventional or traditional musical instruments. Instead of reeds over which streams of air must be blown, strings which must be bowed or strummed, and diaphragms that must be tapped or beaten to produce sounds, electronic instruments use electrons to generate the signals that make up the sounds and speakers for sound propagation. In appearance, an electronic musical instrument resembles a computer more than a "musical" instrument. They are often as complex as a computer to operate as well, demanding of the composer and/or player an expertise beyond the knowledge of musicology.

In this article, we will be discussing the various electronic elements common to all electronic musical instruments. We will be approaching the subject from the operator/user point of view with only slight emphasis on circuit theory from the designer's end.

Typical Generators. Periodic or cyclic waveforms—sine, square, sawtooth, and triangle waves—form the backbone of electronic music generators (see Fig. 1). Most instruments (synthesizers) contain as many as several dozen oscillators, each capable of simultaneously providing some, and frequently all, of the basic waveforms. Each waveform has a distinctive sound quality all its own, an important feature in electronic music. It is necessary to have at least a basic understanding of overtones (harmonics) to understand why the waveforms have different characteristic sounds.

The sine wave is harmonically the least complex of waveforms. It contains no overtones. This means that a 200-Hz sine wave concentrates all of its energy at 200 Hz and no other frequency. A 200-Hz triangle wave, on the other hand, consists of the algebraic sum of many sine waves of different numerically related frequencies and amplitudes. The major portion of a triangle wave's energy is concentrated in the 200-Hz

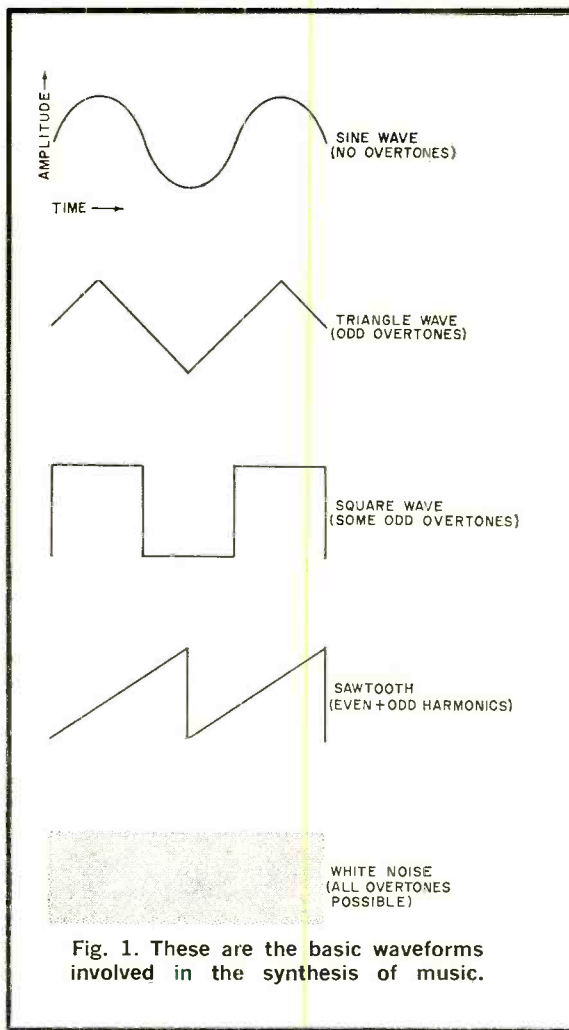

Fig. 1. These are the basic waveforms involved in the synthesis of music.

fundamental frequency. But since a triangle wave contains a number of odd harmonics, energy will also be channeled into the odd-harmonic frequencies (600, 1000, 1400 Hz, etc.). The higher the frequency, or harmonic, the smaller the amount of energy it receives. The third harmonic receives 11 percent of the energy contained in the fundamental, the fifth harmonic receives 4 percent, the seventh harmonic receives 2 percent, and the ninth harmonic receives only 1 percent.

by Craig Anderton

ELECTRONIC MUSIC SYNTHESIZERS

*How and where
do those
great sounds
originate?*



Square waves contain some odd harmonics, the content depending on whether the wave is perfectly square or rectangular. Sawtooth waves contain strong even and odd harmonics.

Waveforms with generous amounts of harmonics are easy to modify. By cutting out certain overtones, such as all harmonics above an arbitrary frequency, the essential nature and sound of the wave changes. Different waveforms can also be used to give "emotional" shading to a piece of music.

A sequence of notes consisting of sine waves will yield a different emotional response than would the same sequence of square-wave notes.

The "white-noise" generator is a type of special-purpose audio generator used in electronic music. In theory, it generates a wave that contains all possible frequencies with all possible relationships at the same time. It sounds like falling rain or escaping steam.

Basic Modifiers. Just as there are circuits that generate sounds, there are also circuits that modify or "process" those sounds. Two of the most basic processors in common use are the amplifier and the filter. The amplifier is extremely valuable in electronic music because it controls the dynamic aspect—crescendo and diminuendo—of a sound. The filter is a somewhat more complex circuit. It is an amplifier that controllably restricts the frequency response in one of three ways.

As a low-pass filter, it can cut off the high end of the audio spectrum. The high-pass configuration can be used when it is desired to cut off the low end of the spectrum. When both ends of the spectrum are to be cut off, a bandpass filter is used. As shown in Fig. 2, the cutoff frequency of a low-pass filter or a high-pass filter is the frequency at which the filter starts to attenuate the signal, while the resonant frequency of a bandpass filter is the frequency at which the greatest amount of boost (or minimum amount of cut) is present.

Because the timbre of a sound depends largely on its harmonic content, and since the desired harmonic content lies above the fundamental frequency of a signal, variable-cutoff low-pass filters that selectively attenuate certain overtones are used for modifying the timbre of various waveforms.

Enter Voltage Control. With the oscillator, amplifier, and filter, a sound can be specified according to waveform, pitch, timbre, and dynamic level. But without voltage control, a system consisting of these three building blocks has serious limitations. By using voltage control, the major parameters of the building blocks are made to respond to a dc or an ac voltage.

A voltage-controlled oscillator (vco) has its pitch controlled not by turning a potentiometer, but by applying to it a control voltage. The cutoff frequency of a filter (vcf)

or the gain of an amplifier (vca) can be similarly controlled by a variable dc voltage. For example, the amplifier shown in Fig. 3 has a conventional audio input, but instead of using a potentiometer level control, a voltage is applied to the input to control the gain. A -4 -volt potential is sufficient to cut off Q1 and reduce the gain to zero. By slowly making the control voltage less negative, the gain will increase until the amplifier is operating at full gain at 0 volt. (In the oscillators used in Moog and ARP synthesizers, a 1-volt change in control voltage causes a one-octave jump in frequency; so, by applying stepped increments of $1/12$ of a volt, the 12 tones of a conventional musical scale can be generated.)

Because it requires much technique to precisely specify frequency, amplifier gain, etc., simply by having the musician turn a potentiometer, most electronic music composers rely on voltage control to perform complex pitch, amplitude, and timbre changes. As a result, specialized circuits designed solely to generate control voltages have come into being. For example, a sub-audio triangle wave of, say, 0.5 Hz makes an excellent control voltage. For one second, the signal rises to peak amplitude (2 volts in Fig. 4). Then for another second it tapers off to zero amplitude. Applied to a voltage-controlled amplifier, this signal would be heard

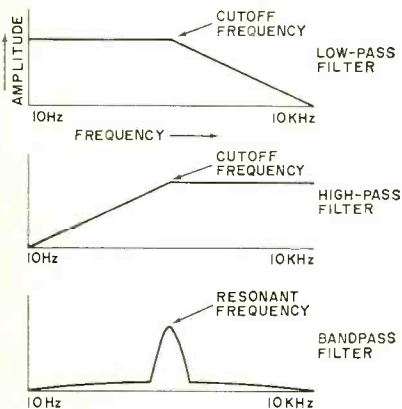

Fig. 2. Frequency characteristics of three basic types of filter circuits.

at the output as a linear increase and decrease of equal duration in each direction.

The common tremolo circuit found in guitar amplifiers and organs is simply a sine-wave-controlled vca. Vibrato is generally a vco that is controlled by a 6-Hz or so sine wave. Of course, any waveform can be used

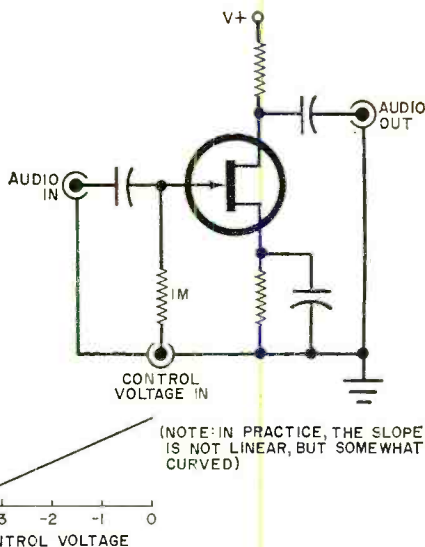

Fig. 3. Circuit of an amplifier with gain controlled by variable voltage.

to control a voltage-controlled system, but the problem with using only oscillators to generate the control voltages is that sometimes a non-repeating waveform is desired. This problem is overcome with the aid of an envelope generator, a device that can produce a control voltage with specified rise, on, and fall times.

Practical Envelope Generator. The "Timbre Gate" (April 1971), when broken down into a block diagram, can be illustrated as shown in Fig. 5. It consists of a voltage-controlled amplifier with an audio input and two audio outputs. An envelope generator with adjustable rise, on, and fall times generates the control voltage for the vca.

The envelope generator can be triggered manually or automatically to generate an envelope. The automatic triggering unit furnishes pulses that initiate the envelope. (Sometimes this type of pulse control system is referred to as a clock or a timer circuit.) Because of this timed feature, periodic control voltages of an unusual shape can be generated.

Although there are many types of control voltage generators, one of the most popular is the keyboard. It furnishes a string of control voltages to a control input, with the various voltages selected by pushbutton or key switches (see Fig. 6). In most commercial synthesizer keyboards, a pulse output is also available whenever a key is closed.

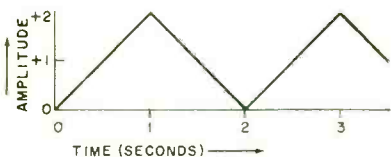

Fig. 4. Waveform of a triangle wave used to control output of amplifier.

Other Signal Modifiers. A system containing voltage-controlled oscillators, filters, and amplifiers represents a sophisticated electronic music setup. But there are other signal modifiers that are useful for specific functions and add a great deal of versatility to an electronic music studio. Some of these are:

Reverberators that artificially delay and decay a signal to simulate the effect of a sound bouncing off the walls of a large room. This effect can be accomplished in several ways but generally it is done by feeding the signal through springs or metal sheets coupled at both ends with special transducers.

Tape echo, a very precisely controlled delay system, bestows a sense of spaciousness, delay, or repetition upon electronic music. It also permits a musician to "accompany" himself.

Ring modulators have two inputs, one for an audio signal and another for a modulating (or carrier) signal. At the output of the modulator appears the algebraic sum of the input frequencies, but both original signals are suppressed.

Fuzztones and *waa-waa's* are also used as electronic modifiers. The fuzztone generates

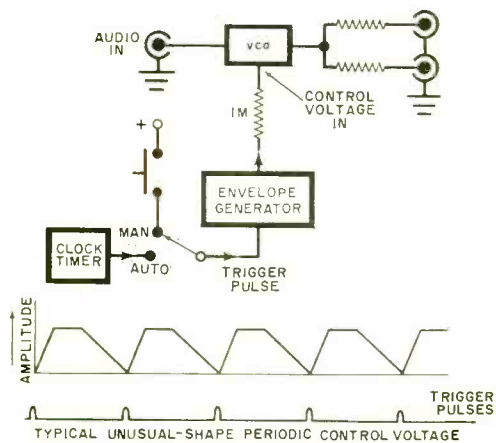

Fig. 5. Block diagram of a voltage-controlled amplifier with two outputs.

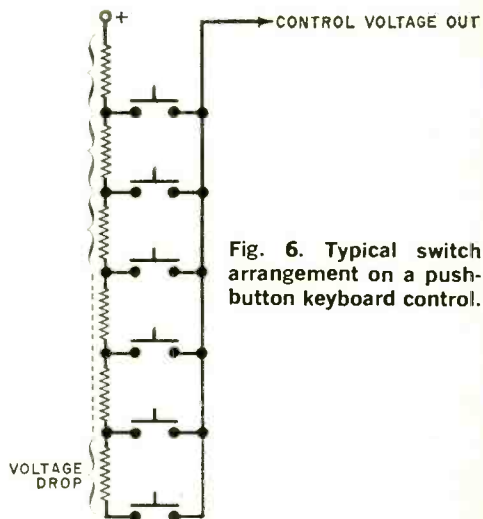

Fig. 6. Typical switch arrangement on a push-button keyboard control.

harmonics from a signal with otherwise low harmonic content. The waa-waa is a variable-bandpass filter, its resonant frequency controlled by a footpedal.

Mixers are not processors, but they are often used to adjust two or more signal levels to suitable proportions. They are also useful for adding together control voltages when control by more than one waveform is desired. Mixers can be sophisticated multi-input devices containing echo buses, switchable reverberation, filtering arrangements, and other convenience features.

Equalizers are basically batteries of filters that cover various parts of the audio

THE NON-TECHNICAL SIDE

Pioneers in the field of "new" music recognize that it has a deep spiritual basis. Electronic music is not simply another kind of music—like pop, country, etc.; it is a different kind—emphasizing pure sound in addition to themes, randomness with imposed order, and looseness as a complement to restricted thought. The fact that no one has yet devised a universal way to score this music is significant.

Even more significant is that electronic music encompasses many disciplines by combining different aspects of science, music, and philosophy—even theatre. People who look down on "music by machines" fail to realize that electronic music was not designed to replace humans; rather, it brings a powerful new tool to the hands of the musician.

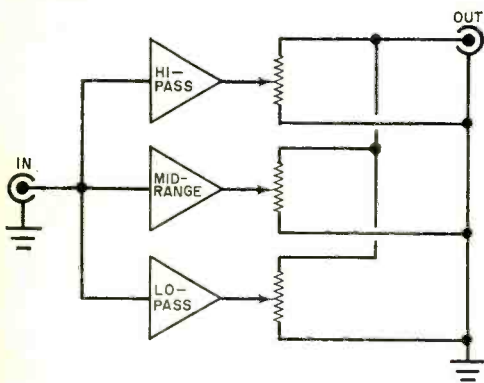

Fig. 7. Simplified equalizer diagram has 3 filters; 12 or 24 may be used.

spectrum, each output terminating in a level control. A simplified equalizer diagram is shown in Fig. 7. Here, only three filters are shown, but equalizers that divide the spectrum into 12 or 24 bands are not uncommon.

Compressors and *limiters* are functionally related to each other. The limiter's job is to maintain the maximum signal amplitude to a desired peak level. A compressor limits the peak amplitude of a signal but it also raises the low-level portions of the signal. When used with moderation, limiting and compression are hardly noticeable. However, with extreme limiting or compression, highly unusual effects are obtained.

Assembling a Synthesizer. A modern synthesizer contains most of the building blocks mentioned above. To give an idea of how these blocks might be put together to make a sound, Fig. 8 shows in block diagram form a representative method of interconnection (traditionally with the aid of patchcords). The heart of the system is the vco, its frequency determined primarily by the control voltage from the keyboard. By properly tuning the keyboard, it is possible to generate a chromatic scale. In addition, a 6-Hz sub-audio sine-wave control voltage vibrato-modulates the primary frequency.

The master vco has both square and sawtooth outputs. An envelope generator delivers a control voltage to a vca and a vcf. This combination modifies the square wave. The sawtooth wave is processed by an envelope generator/vca combination. Both waveforms, after being modified, are mixed down to one output, given some reverberation, and equalized to emphasize or cut any specific frequency components.

Striking a key initiates several events. First, a control voltage is applied to the vco to generate a tone of specific pitch. Simultaneously, a pulse triggers the two envelope generators. Envelope generator 1 is set for a long decay, while generator 2 is set for a short decay. By controlling a vcf, envelope generator 1 also changes the harmonic content of the square wave so that, as the signal decays, overtones are removed. The overall effect is a note of a certain pitch, modulated by vibrato, whose attack is mainly a burst of sawtooth wave followed by a slowly decaying square wave, the timbre of which changes as it decays.

Changing any part of the system yields a radically different sound. Any subtle changes can give dramatically different results. This is perhaps why so many people refer to electronic music as a medium of infinite potential. There are so many building blocks and their possible combinations so numerous that the problem for many composers is not what sounds to make, but what sounds not to make.

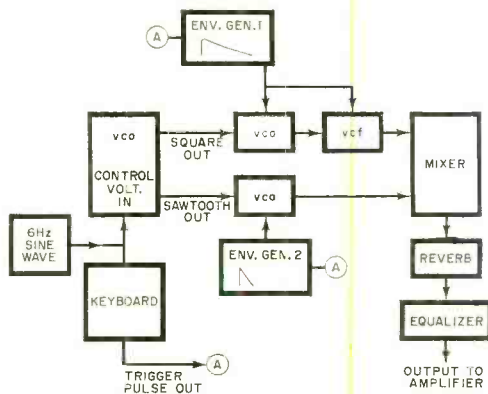

Fig. 8. One typical way of interconnecting blocks of synthesizer system.

Recommendations. This article presents the basics of electronic music. The next step is to translate the above into sounds, and for this, we recommend the *Nonesuch Guide To Electronic Music* (HC-73018) which contains the basic vocabulary of electronic music with an explanatory text. For current developments in electronic music, see *Electronotes* (60 Sheraton Dr., Ithaca, NY 14850), a monthly newsletter dealing primarily with the technical side, and *Source* (2101 22 St., Sacramento, CA 95818) which covers, twice a year, the avant garde side of electronic music. ♦



Electro-Voice EVX-44



Lafayette Radio Electronics SQ-L

COMPARISON OF QUADRAPHONIC MATRIX DECODERS

*Performance of three recent matrix decoders
for records using CBS SQ and Sansui QS matrices*

BY JULIAN D. HIRSCH *Hirsch-Houck Laboratories*

THE GENERAL acceptance of 4-channel sound for the home has been hindered by a lack of standardization among the competing systems on the market. In both open-reel and cartridge formats, 4-channel tapes enjoy a relatively stabilized condition. However, a limited recorded repertoire and high cost have worked against open-reel tapes, while the tape cartridge lacks both the quality and indexing ease required.

The largest potential market for quadra-

phonics lies in phonograph records. A major effort has gone into developing matrix systems that allow four channels of signals to be mixed down, or encoded, into two channels for recording through conventional stereo means. A playback decoder then recreates the original four channels from the two channels present on the stereo record by a process that allows it to separate the mixed-down signals.

In matrixing, each stereo channel carries

a blend of two or more quadraphonic channels. Each of the proposed matrix systems employs specific relative proportions and phase shifts between the four channels as they are encoded. In the decoding process, the left and right channels are each split and recombined, with the appropriate phase shifts and relative amplitudes, to generate the original 4-channel program.

Unfortunately, it is not possible to recover completely four independent channels from a two-channel matrixed program. There always exists a degree of crosstalk, with each channel appearing at a reduced level in one or more of the other outputs. In some cases, a constant-amplitude input signal will not be reproduced at the same level from any direction. Another problem is compatibility with stereo or monophonic playback since, with some matrix systems, instruments in a specific location (such as center-rear) can disappear when played in mono. Each system designer has selected matrix coefficients and other operating parameters that he feels can satisfy his goals. Of course, the recording engineer can avoid some of the possible problems with any system by proper instrument and microphone placement and mix-down.

The Contenders. At this time, the field has narrowed down to two major contenders in the encoder/decoder market. One is the CBS SQ system of matrixing; the other is the so-called "regular" matrix as defined by the Japanese electronics industry. The best-known example of the "regular" matrix in this country is Sansui's QS.

Most current quadraphonic amplifiers, receivers, and decoders are designed for use with the SQ matrix. Many also have additional matrices that are identified by a variety of names. Some of these are for "regular" matrix programs, while others do not appear to match any currently popular system.

One of the pleasant byproducts of matrixing is its ability to synthesize the rear channels, either from an ordinary 2-channel stereo program or from a differently encoded quadraphonic source. In general, rear-channel synthesis adds an "ambience" that almost always improves the sound of stereo programs, although it is not comparable to properly reproduced quadraphonic material.

With the aid of more than 50 recent quadraphonic record releases, a good 4-

channel music system, and a 4-channel display oscilloscope (Pioneer SD-1100), we have compared the performances of several representative matrix decoders. Since the recording matrix may not always match that used in the decoder, we also attempted to evaluate the performance of mismatched systems.

In its original form, the SQ system provided full channel separation from side to side but only about 3 dB from front to rear. Recent modifications include a cross-blending that slightly reduces the side-to-side separation, but improves the front-to-rear separation. A number of SQ decoders now feature "partial," or "front-to-rear," logic circuits. By sensing the spatial distribution of the quadraphonic program, these circuits can improve front-to-rear separation, altering the relative gains of the front and rear channels as required.

The so-called "full-logic" SQ decoder performs a similar function in all directions. If it determines that one channel carries a dominant signal, it shifts the gains to emphasize that channel. This action is continuous, dynamic, and fast enough to be undetectable under most listening conditions.

A full-logic SQ decoder is a complex device. With the discrete circuit components currently in use, it is correspondingly expensive. We tested the Sony SQD-2000 (\$300), the first model to become available. Not only does it have the necessary decoding circuits (more than 100 transistors), it also provides complete control flexibility for a 4-channel system. Each channel has its own level control and meter, plus a master volume control for all four channels. Like all decoders, the SQD-2000 is inserted into the tape monitoring path of a stereo amplifier or receiver that continues to drive the front speakers with the separated left and right front signals. It also provides decoded rear-channel outputs to a second stereo amplifier and the rear speakers.

Since the SQD-2000 contains bass and treble controls for the second amplifier, this need only be a basic amplifier. The decoder has tape recording and monitoring facilities for a 2-channel and a 4-channel tape deck, plus a mode switch that can reverse either the front or the rear outputs independently or cross-switch all outputs to rotate the sound pattern 180°. In addition, 2-channel stereo and mono operation, as well as ambience-recovery (MTX mode) are provided.

With some SQ records, the channel separation of the SQD-2000 has a truly discrete character with little or no detectable cross-talk. Since at this time there are no suitable test records or other program sources for judging quadrasonic matrix systems, we had to depend largely on our ears. However, the superiority of the decoder over less complex and less expensive decoders was unmistakable. It seems certain that, in the months to come, "full-logic" SQ decoders will become available at much lower prices to provide the most effective reproduction of SQ records.

The MTX position of the SQD-2000's mode switch was tried with QS-encoded records. It did not appear to provide anything more than a simple ambience enhancement. The total effect was considerably diminished, as compared to listening through a true "regular" matrix decoder.

A much less expensive decoder is the Electro-Voice EVX-44 (\$100) which is offered as a "universal" decoder. Its characteristics seem to match the SQ matrix very closely. The front-to-rear logic system appreciably attenuates the rear channels in the presence of a center-front program.

The EVX-44 contains a master volume control and an input selector for a 2-channel recorder and a 4-channel discrete source. Although it did a fine job with SQ discs, the decoder had limited front-to-rear separation along the sides of the room with SQ material. As a synthesizer, the EVX-44 worked very well, with the added advantage of locating a center-front soloist without the ambiguity sometimes introduced by a simple rear-channel synthesizer.

The last decoder we used was the Lafayette Radio Electronics SQ-L (\$80). It uses a switch to select discrete, SQ, Composer A, or Composer B, the latter two being synthesizer positions. A pushbutton switch replaces the normal program source with the

outputs of a 2-channel or a 4-channel tape deck. A master volume control is also provided.

The SQ circuits of the SQ-L contain a front-to-rear logic system. Our oscilloscope display, as well as our ears, indicated that the overall performance with SQ records was excellent, though not the equal of a full-logic system.

The composer B mode added a slight ambience to stereo programs, but Composer A was considerably more effective in this respect. When we played QS-encoded records through the decoder, we were surprised to find that Composer A was able to decode them in a virtually ideal manner. Because of this, we consider the Lafayette SQ-L to be the nearest thing to a truly "universal" decoder we have so far tested.

Conclusions. Any of the decoders mentioned above (and no doubt many others we were unable to include in our tests) can be used successfully to convert a stereo system to quadrasonic operation. A second stereo amplifier and an extra pair of speaker systems are needed.

It is difficult to guess at this time whether or not any of the systems will become truly "universal" in the near future. More amplifiers, receivers, and decoders include the SQ matrix than any other, but many of these also provide either a "regular" matrix or some form of synthesizer that can often deliver comparable results with suitable recordings.

Minor differences between recording and playback matrices may do little more than shift the apparent direction or level of some instruments. Since the listener usually does not know the recording engineer's intentions, his enjoyment of the program is not impaired. However, the "regular" or QS matrix and the SQ matrix are relatively incompatible. Neither can really do justice to a record encoded with the other.

From the listener's point of view, the differences between records (due principally to the techniques employed by the recording engineer) will usually outweigh any distinctions between competing matrix systems or their decoding hardware.

More than a year of constant exposure to quadrasonic sound has convinced us of its tremendous superiority over 2-channel stereo, whatever system is employed. It certainly should be tried—the results are amazing. ♦

EDITOR'S NOTE

At the time this report went to press, it was announced that Sony had discontinued manufacture of their Model SQD-2000 decoder. Currently being marketed in its place is the company's new Model SQD-2020 full-logic decoder (about \$250). Unfortunately, we did not have time to check out the new model at the time this report was being made up.

COMPUTER



Computer drawings such as this first prompted Bell Labs to consider computer art seriously.

ART AS A DESIGN TOOL

Computers can print out alpha- numerics and also draw illustrations.

BY DAVID L. HEISERMAN

ONE NIGHT late last October we paid a visit to a special computer laboratory located on the Ohio State University campus. It was a strange hour to be visiting a computer facility, but this was no ordinary lab. To all outward appearances, everything looked ordinary (to someone familiar with computer equipment, that is). There was the familiar array of computer consoles, plotters, card readers, and keypunch machines. Even the atmosphere was familiar with its bright diffused fluorescent lighting, almost antiseptic conditioned air, and sound-proofed walls and ceiling.

What made this computer lab different from most others was not the standard IBM interactive CRT graphics display. Seated in front of the 21" display, an operator was using a light pen and a series of pushbuttons to draw a picture on the screen. The figure being built up was not flat or sticklike—the sort of thing with which a bored lab man would doodle away the hours as he waited for something important or exciting to come his way. Quite the contrary. The picture was an excellent portrait of an attractive young woman. The operator was a graduate student in the College of Fine Arts, as were the

other people in this particular computer lab.

Apparently satisfied with the figure he had drawn on the screen, the operator-artist waved the light pen, punched a button, and watched his picture slowly zoom away into an imaginary third dimension. Then he moved the light pen in a spiral path and punched another button. The girl's smiling face tumbled into the foreground again, following the invisible spiral path just drawn. When the artist-operator punched another button, the portrait disappeared from the screen, becoming a group of thousands of coded binary words stored on a magnetic disc.

Engineers and draftsmen have been aware of the value of computer-generated artwork since the mid-1960's. At the Battelle Memorial Institute, for example, a group of researchers produced an animated film with the aid of a computer terminal. The film shows a line drawing of a proposed off-shore drilling rig going through twisting, bouncing, and swaying motions that represent its modes of vibration. As mathematically generated waves approach the rig, it stretches, twists, vibrates, and bends over. By entering engineering data concerning the

structure's materials and construction, the computer can make dynamic plots of stresses on every part and joint of the rig. Without having to build an expensive prototype or even scale model, engineers can determine the quality of a design and visually study its responses to different types of stresses.

In another case, an elaborately drawn picture of a helicopter appeared on the screen. The small blades on the tail were turning faster than the rotor (lift) blades, just as they do on a real-life helicopter. As we watched the screen, the helicopter "flew" across the CRT faceplate, turned its tail toward us, and went into an imaginary third dimension.

Unlike the drilling rig study, the helicopter presentation was not a film that was shot one frame at a time from statistically displayed figures on the screen. The helicopter was moving in real time. It would take a sharp mathematician the better part of an hour to solve all the equations for moving this complicated figure an inch across the screen. The computer was solving the same sets of equations, plus those needed for producing the effects of perspectives, thirty times each second. This computer was actually producing animated drawings on the spot; if he chose to do so, the operator could take full control of all of the motions.



Prof. Charles Csuri, head of Ohio State U. computer art group, controls flight of helicopter drawn on a CRT.

Computers In Animation. Traditional techniques for making animated films require a separate drawing for each frame of motion. At a typical film speed of 24 frames/second, a finished full-length cartoon uses more than 300,000 separate artwork setups. At best, it takes a skilled staff 2000 manhours just to shoot the film on an animation stand. It takes ten times longer to draw all of the pictures. At the present time, \$1500/minute of running time is an average price to pay for animated films produced by one-frame-at-a-time techniques.

Partial computerization of the animation process is already cutting production time and cost by as much as 60 percent. Most of the up-to-date Saturday morning TV cartoons are produced on computerized animation stands. Artists still have to draw at least one version of each background and one picture for each frame of non-repetitive motion. But a computerized animation stand eases the overall job by controlling the camera stand to produce background motion and give the figures different perspectives as they move.

A totally computer-generated animated film sequence made by Prof. Csuri.



Today's computers are not up to producing commercial-quality animations directly on the CRT screen. Although graphic computers can produce intricate patterns of motions for one or two detailed drawings, they lack the immense data handling capacity and high speeds required for putting several highly detailed cartoon characters through their motions against an elaborate moving background. As computer hardware and programming become more sophisticated, though, inexpensive full-color computer-generated animated films will become a reality.

Present & Future. The fact that artists inhabit the computer lab at Ohio State several hours a day makes it different from most other computer labs in the country. Engineers, of course, can create an air of excitement in a lab; but unlike engineers, who must deal with the problems of manipulating nature, artists deal with a humanistic understanding of nature. By blending artistic concepts of nature with computer technology, computer artists are able to convey ideas impossible to express by, or totally foreign to, engineers and artists of a somewhat more conventional variety.

Present-day computer artists are having some trouble gathering financial and moral support for their work. Much of the trouble is due to the rather unimpressive showing computer art made when it first appeared in the late 1950's and early 1960's. During that time, popular periodicals and a few of the more progressive art museums carried samples of computer-drawn figures. To most observers, the pictures appeared to be flat, lifeless, and far from human.

As far as the computer artists are concerned nowadays, the computer is something more than an expensive substitute for paintbrushes and animation stands. They maintain that the computer holds the key to an exciting new medium of artistic expression. For example, pioneer of computer art A. Michael Noll is working at Bell Laboratories on a technique for making truly three-dimensional impressions of figures drawn on a CRT screen. A computer program automatically splits the drawings, whether moving or stationary, into stereoscopic pairs. Viewing the screen through a stereo viewer, the observer perceives the figures as existing in three-dimensional space.

Instead of drawing on the screen with a light pen, the three-dimensional artist moves a "joystick" within a 1-cu-ft space. Moving the joystick up and down in the X-Y plane makes lines appear in a two-dimensional plane in the three-dimensional viewer. By moving the stick through paths that include the Z, or depth, axis, lines that appear to move in and out of the screen are produced. An artist can use this three-dimensional scheme to draw pictures in three dimensions. He can, in effect, produce three-dimensional sculptures.

Computer graphics and three-dimensional art, coupled with the upcoming technology of holography, will one day make it possible for artists to produce full-color moving electronic sculptures that appear to be suspended in space. Far from being a "fad" in art, the computer can—and will—expand the graphic arts horizons just as electronic music is firmly entrenching itself in that age-old artform. ♦

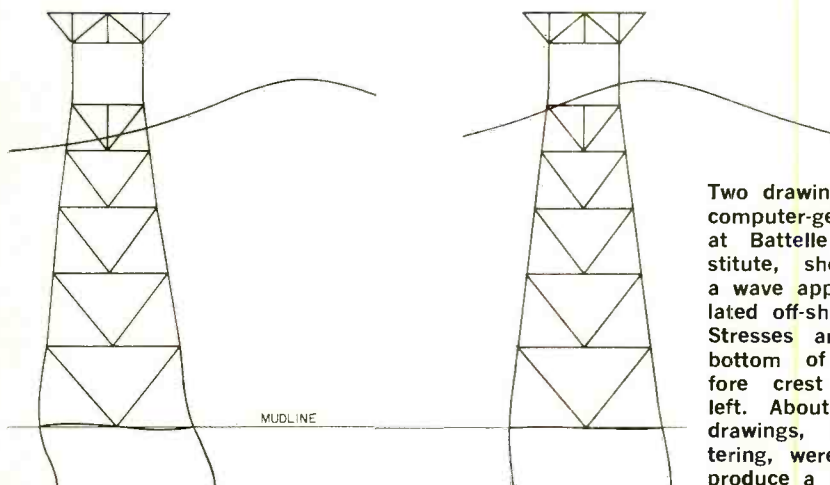

Two drawings, taken from computer-generated display at Battelle Memorial Institute, show effects of a wave approaching simulated off-shore drilling rig. Stresses are greatest on bottom of rig just before crest of wave, at left. About 14,000 such drawings, including lettering, were generated to produce a 10-minute film.

THE

mosfet

How it works and some practical applications

BY ADOLPH A. MANGIERI

A PPLICATIONS for and usage of the insulated gate field effect transistor (MOSFET, IGFET, or MOS transistor) are growing by leaps and bounds. Problems of high cost and frequency limitations which were initially encountered have been overcome by improvements in MOS technology and the IGFET is now competitive in price with other transistors both as discrete units and as parts of integrated circuits.

Micropower logic is made possible by complementary MOS circuitry with switching speeds suitable for many applications. Particularly adaptable to MSI and LSI digital circuits, the MOS transistor, long in the background, is now the focal point of accelerated research and development.

Fabrication and Operation. An n-channel MOS transistor is fabricated on one side of a silicon p substrate by the planar process. Two elongated strips of heavily doped, low resistivity n regions are diffused into the substrate to form the drain and source (Fig. 1). A very thin layer of insulating silicon dioxide (special glass) is formed over the entire surface. A portion of the insulator is then etched off to expose the source and drain elements. Next, an insulated gate electrode is formed over the channel and connections are made to source and drain by aluminum metalization. There are no rectifying junctions.

As shown in Fig. 2A, with drain-source voltage applied and gate voltage at zero, the pn junction at the drain is reverse biased. The drain current is near zero. When the gate voltage is increased from zero, the electric field within the oxide and semiconductor increases. When the gate voltage

exceeds a threshold, the electric field induces free electrons in a very thin layer at the top of the channel. Current may now flow from drain to source by means of free electrons or by n-type conductivity. In effect, the p channel has been inverted to n conductivity by the electric field. Although it has a p channel, the transistor is termed an enhancement mode n-channel IGFET or a type C FET.

Operation at a low drain voltage (Fig. 2B) produces a uniform inversion layer along the channel. This is operation in the linear region indicated on the static characteristics in Fig. 3A. In the linear region, the MOS transistor simulates a resistor whose value depends on the gate voltage. At higher drain voltages, the inversion layer is pinched off at or near the drain end (Fig. 2C). Channel current becomes dependent on gate voltage and nearly independent of drain-source voltage. This is operation in the current saturation region along the horizontal portions of the characteristics. This is the operation normally used for MOS amplifiers and constant-current sources.

The MOS transistor is then a square-law device showing curvature of the input-output

Fig. 1. How n-channel MOSFET is fabricated.

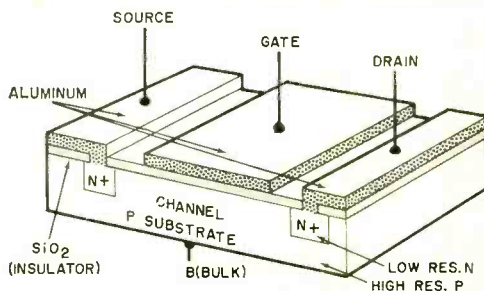

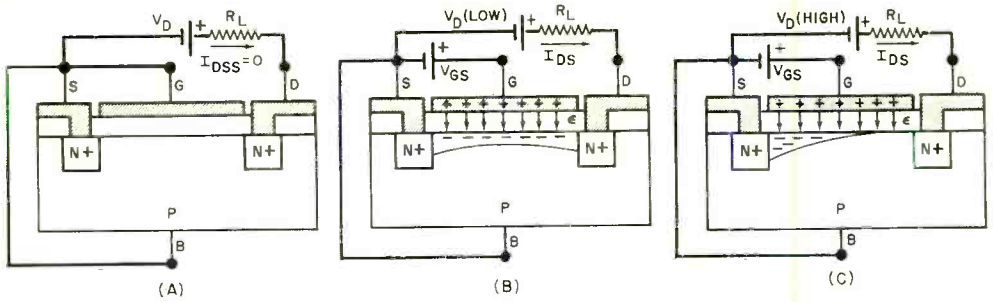

Fig. 2. Diagrams show how current in FET varies with changes in drain and gate voltage.

transfer characteristics (Fig. 3B). This is also suggested by the unequal spacings of the static characteristics. Junction field effect transistors (type A FET's) are similarly nonlinear.

A second type of MOSFET operates in the enhancement-depletion mode (type B FET). An n-channel depletion-mode MOS is similar to the enhancement device but also has an n region diffused into the surface of the channel. The n region bridges the source and drain and introduces a built-in layer of free electrons. As a result, the zero gate voltage drain current I_{DSS} is intermediate (Fig. 3B). Unlike type A and type C FET's, the type B can be operated with plus or minus gate polarity. The p-channel MOSFET is similar in construction and operation but uses n substrates and p source and drain regions. The polarities of operating voltages are reversed.

The very thin gate oxide layer is quite susceptible to puncture by static electricity. For this reason, MOSFET's have a shorting ring or wire on the leads. The shorting device is removed only after the transistor is installed. Some discrete and many IC MOS devices include a built-in diode to protect the gate.

Specifications for the MOSFET include

gate leakage current (I_{GSS}) which is in the nanoampere or picoampere range. Gate leakage resistance is extremely high—millions of megohms. Forward transconductance (Y_{fs}) is usually between 500 and 15,000 micromhos.

The frequency response of the MOS transistor is limited primarily by gate capacitance. Small-signal input capacitance is about 3 to 15 picofarads. The frequency response of available types extends to 400 MHz. Recently developed devices having very short channel lengths and lower parasitic capacitances have extended the usable frequency range up to 10 GHz.

Applications. Almost any application for the junction FET can also be handled by the MOS transistor. These include low-level audio and r-f amplifiers, oscillators, mixers, modulators, switching circuits, choppers, etc. A high input impedance audio pre-amplifier as shown in Fig. 4A uses an n-channel depletion mode MOS. Source resistor R_s provides gate bias voltage and negative feedback for improved linearity and stability. Unique applications of the MOS transistor rely on the fully insulated gate and high input resistance. The "infinite" impedance dc voltmeter shown in

Fig. 3. (A) Static characteristics of type C FET; (B) transfer characteristics of 3 types.

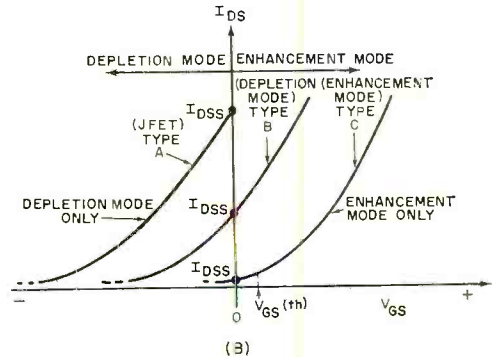
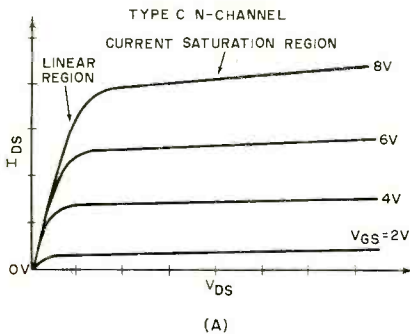

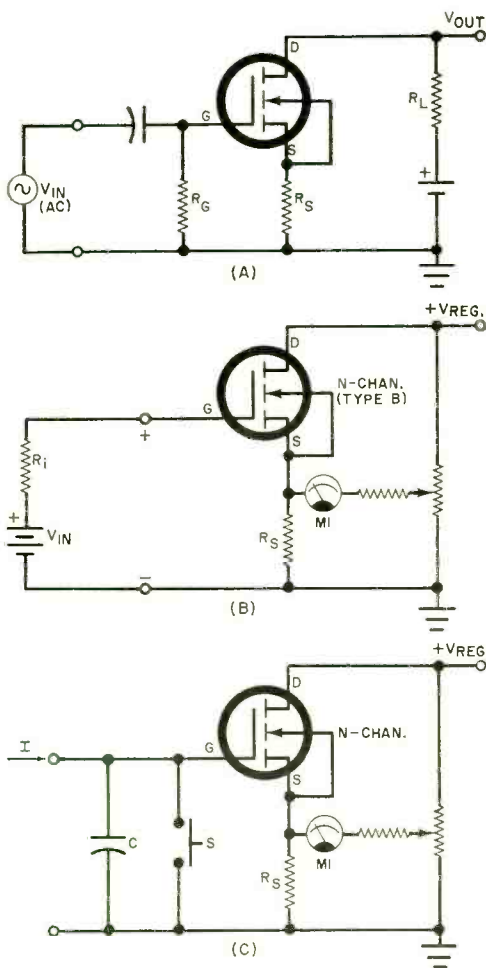

Fig. 4. Some typical MOSFET applications.

Fig. 4B is nonloading. The addition of a high-resistance input voltage divider and gate protection diode makes a practical voltmeter with input impedance from 10 to 100 megohms per volt.

By connecting a low leakage capacitor across the input, the voltmeter becomes a dc current integrator, a "read and hold" voltmeter, or an electrometer (Fig. 4C). The latter measures minute dc currents by accumulating a charge on the capacitor over a known time interval. The indication on the meter is proportional to the accumulated charge, allowing determination of the current charging the capacitor. An electrometer also serves as an electroscop to detect ionization levels of air or gases. The switch on the input allows resetting of the meter by discharging the capacitor. A familiar application of this circuit is the photographer's electronic flash meter.

When a suitable resistor is placed across the gate input in Fig. 4B, the circuit becomes a sensitive current meter. Full-scale indications of several nanoamperes can be obtained by using a 100-megohm resistor as a current shunt. Currents in the picoampere range (and lower) are measured using more complicated circuits, selected transistors, and highly insulated construction.

A very important application of the MOS transistor is in digital integrated circuits. MOS logic has high noise immunity because the gate voltage swings for turn-on are in the "volts" range. Of even greater importance is the remarkable reduction in power consumption afforded by complementary MOS micropower logic circuits, which utilize p- and n-channel transistors in a complementary circuit. The power consumption of the circuit is near zero on standby and very low when the circuit is switched.

A basic circuit in micropower logic is the complementary inverter shown in Fig. 5. Channels of the n-channel transistor and its p-channel complement are connected in parallel. Both are enhancement mode transistors, with Q1 requiring a positive gate voltage for turn on and Q2 a negative gate voltage. A logic one signal raises the input to $+V_s$ and a logic zero returns the gates to ground.

If V_{in} is zero, Q1 is off because V_{gs} of Q1 is zero; but V_{gs} of Q2 is minus, so it is on. Capacitor C (gates of following stages) charges up to $+V_s$ and current flow drops to I_{DSS} of Q1 (in the picoampere range). The output is high at logic one. When V_{in} is raised to V_s , Q2 turns off and Q1 turns on and the capacitor discharges rapidly to zero.

At present, complementary MOS switching speeds are under 10 MHz; recent developments assure higher speeds. ♦

Fig. 5. Low-power complementary inverter.

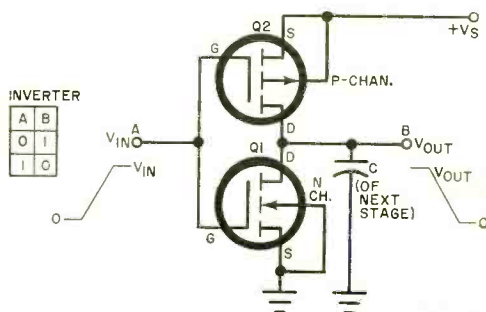



NTS Home-Training in Electronics was the start of something big for James Gupton

An NTS Graduate

James A. Gupton Jr. graduated from National Technical Schools with a diploma in TV & Radio Servicing. Today, he's a mighty important man in the world of Electronics!

Research associate with a major electronics corporation; author of numerous articles in electronics magazines; an inventor with five patent applications to his credit. In the field of electro-optics, he has perfected a revolutionary phosphor deposition technique for cathode ray tubes.

Quite a list of accomplish-

ments for a man who began his career with an NTS diploma and a job in TV & Radio servicing.

Any student can succeed

James Gupton is certainly an exceptional NTS graduate. He proves there's nothing to keep a determined man from becoming a success in Electronics. As he himself says, "Any student, properly motivated, can succeed in Electronics through home-training."

Every NTS Electronics Course is specially designed to keep you motivated from the time you

start building your first test instrument until you're ready to plug-in your solid-state Color TV or other advanced electronics equipment.

Exciting "Project Method" Training

NTS Project Method Training is the best way to learn electronics.

You build advanced equipment while you learn Electronics principles and applications.

Each week brings new excitement when you actually see the progress you've made.

NTS builds self-confidence.

For a man to become successful, like James Gupton, he must have confidence in himself.

As an NTS graduate you have this confidence. Your training is practical and thorough. You know Electronics from the bottom up. You enter a world of Electronics you're familiar with.

And if you have the drive and determination of a man like James Gupton, there are no limits on your success!

(James Gupton's address available upon request).

NTS COLOR TV SERVICING



Solid-state
315 sq. in.
Heath Color TV

Build and keep the largest, most advanced color TV made! Over-all solid-state design, ultra-rectangular screen, matrix picture tube, built-in self-servicing features, "Instant On," A.F.T., solid-state, 24-channel detent UHF/VHF power tuning, and much more! Also build and keep AM-SW Radio, solid-state Radio, FET Volt-Ohmmeter, and Electronic Tube Tester. Learn trouble-shooting, hi-fi, stereo, multiplex systems, radio, color and B&W TV servicing.

NTS B&W TV SERVICING

Learn sophisticated solid-state circuitry as you build this B&W TV Receiver, Lo-Silho "Superhet" Radio, FET Volt-Ohmmeter, solid-state Radio, Electronic Tube

Solid-state
B&W TV,
74 sq. in.
picture
(cabinet
included)



Big, Colorful NTS Guide to new opportunities in Electronics. Yours FREE!

NATIONAL TECHNICAL SCHOOLS
4000 S. Figueroa Street
Los Angeles, California 90037

Please rush me FREE Color NTS Electronics Guide & FREE lesson, plus information on course checked at right. No obligation. No salesman will call.

Checker, and Signal Generator. TV and all other equipment are yours to keep.

NTS ELECTRONIC & COMPUTER TECHNOLOGY

Solid-state Compu-Trainer 14 integrated circuits replace 198 Transistors!



Build and keep this exclusive NTS Compu-Trainer. It teaches you the same principles used in million-dollar systems. Contains 14 integrated circuits! All solid-state! You perform all wiring and patchcording. No shortcuts. No pre-wired circuit boards. Your training is complete! Also receive a FET Volt-Ohmmeter and a 5" wide-band solid-state Oscilloscope.

NTS ELECTRONIC COMMUNICATIONS

Gain the prestige and earning power of owning and F.C.C. First Class Radio-Telephone license. Two comprehensive NTS Courses cover the big opportunity field of transmitting and receiving.

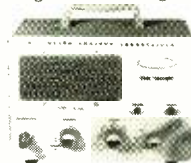

5-watt AM
Transmitter/
Receiver

You build and keep 14 kits, including this amateur phone 6-meter VHF Transceiver, NTS's exclusive 6-transistor solid-state Radio, and a fully transistorized Volt-Ohmmeter. Also, learn 2-way radio, Citizens Band Microwaves, and radar.

NTS INDUSTRIAL & AUTOMATION ELECTRONICS

Automation is the future of industry, and you can play an important part! Learn industrial controls by training on the NTS Electro-Lab (a complete workshop). You also build and operate this 5" solid-state

oscilloscope. And you perform experiments that involve regulating motor speeds, temperature, pressure, liquid level, and much more. All equipment is yours to keep.



All solid-state!

NTS AUDIO ELECTRONICS SERVICING

Learn sound theory — how it works in home radio, car tape decks, stereo multiplex component systems, and more! Set up a spectacular music system. Learn about sound distortion, amplification and control, loud-speaker baffles, problems of system installation, etc.

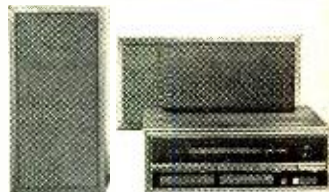

Build and keep this famous Heath Stereo Receiver and Speakers

Included is Volt-Ohmmeter, In-Circuit Transistor Tester and solid-state Radio. Prepare yourself for great opportunities in the Home Entertainment Industry!

CLASSROOM TRAINING AT LOS ANGELES

You can take classroom training at Los Angeles in sunny Southern California. NTS occupies a city block with over a million dollars in technical facilities. Check box in coupon below.

APPROVED FOR VETERAN TRAINING

Accredited Member: National Association of Trade and Technical Schools; National Home Study Council.

NATIONAL TECHNICAL SCHOOLS

World-Wide Training Since 1905
Resident & Home Study Schools
4000 S. Figueroa St., Los Angeles, Ca. 90037

Dept. 205-053

- MASTER COURSE IN COLOR TV SERVICING
- COLOR TV SERVICING (FOR ADVANCED TECHNICIANS)
- MASTER COURSE IN B&W TV & RADIO SERVICING
- MASTER COURSE IN ELECTRONIC COMMUNICATIONS
- PRACTICAL RADIO SERVICING
- FCC LICENSE COURSE
- MASTER COURSE IN ELECTRONICS TECHNOLOGY
- AUTOMATION & INDUSTRIAL ELECTRONICS
- COMPUTER ELECTRONICS
- BASIC ELECTRONICS
- AUDIO ELECTRONICS SERVICING

NAME _____ AGE _____

ADDRESS _____

CITY _____

STATE _____ ZIP _____

- Check if interested in Veterans Training under new G.I. Bill.
- Check if interested ONLY in Classroom Training at Los Angeles

DO YOU KNOW YOUR DC CIRCUITS?

PART 1 OF A 3-PART SERIES COVERING DC CIRCUIT ANALYSIS

BY ARTHUR. H. SEIDMAN, Prof. of Elect. Eng., Pratt Institute

1. Passive Elements.

A. Definition. An element is passive if it is only capable of accepting electrical energy. (A battery, for example, provides electrical energy and is therefore called an *active* element.) Examples of passive elements are resistors (R), capacitors (C), and inductors (L).

B. Ohm's Law. The current i (amps) in a resistor R (ohms) is equal to the voltage v (volts) across the resistor divided by the value of the resistance: $i = v/R$. This is the basic statement of Ohm's law. By algebraic manipulation, one can also write $v = iR$ and $R = v/i$.

C. Voltage and Current Relations for L and C. (1) The voltage across an inductor (L) is equal to the value of inductance (henrys) multiplied by the rate of change of current with respect to time (amperes second): $v = L(di/dt)$. If i is a direct current, it does not change with time; therefore $di/dt = 0$ and $v = 0$. (2) The current in a capacitor (C) is equal to the value of the capacitance (farads) multiplied by the rate of change of voltage across the capacitor with respect to time (volts/second): $i = C(dv/dt)$. If v is a direct voltage, it does not change with time; therefore, $dv/dt = 0$ and $i = 0$. This demonstrates that a capacitor blocks the flow of direct current. (3) The

charge q (coulombs) stored in a capacitor is $q = vC$.

2. Linear Elements.

A. Definition. A linear element is one that, if its input is increased by a given amount, responds with a proportional increase. For example, if the voltage across a linear resistor is doubled, the current flowing in the resistor is also doubled. A *nonlinear* resistor is shown in Fig. 1. Note that the value of the resistor, $R(v)$, depends on the voltage across it. (In this article we are concerned only with linear elements.)

B. Linear Circuits. A linear circuit contains only linear elements.

3. Notation.

For dc quantities, use upper-case letters for voltage (V), current (I), energy (W), and power (P). For time-varying quantities, use lower-case letters.

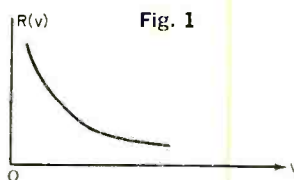

Fig. 1

4. Ideal Sources.

A. Definition. (1) An *ideal voltage source* is one whose voltage, V , is constant regardless of the current it supplies. (2) An *ideal current source* is one whose current, I , is constant regardless of the voltage across the element to which it supplies current.

B. Symbols. Symbols for ideal voltage and current sources are shown in Fig. 2.

Editor's Note: Whether you are an experienced designer and finished your formal education years ago or are just starting your first courses in electronics, here is an excellent opportunity to learn the fundamentals of dc circuit theory. Start now, and don't miss the second and third parts in succeeding issues. Other subjects to be covered in these series include transistors and diodes.

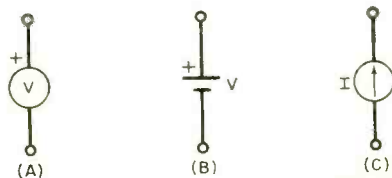

Fig. 2

5. Unit Step Function

A. Definition. A unit step function, $u_{-1}(t)$, is equal to 0 for t less than 0 and 1 for t greater than 0 (Fig. 3). This concept is useful in describing, for example, the application of a direct voltage (or direct current) to a circuit. If we let $v = Vu_{-1}(t)$, at t less than 0, $v = 0$ and at t greater than 0, $v = V$. If $i = Iu_{-1}(t)$, $i = 0$ for t less than 0 and $i = I$ for t greater than 0.

6. Circuits containing R & C and R & L Elements.

A. RC Circuits. To a direct current, a capacitor acts *initially* (time $t = 0$) like a *short circuit*. (1) The product of R and C is called the *time constant*, T , of the circuit: $T = RC$. (2) After a time of approximately $5T$, the circuit is considered to be in *steady state*, and the capacitor acts like an *open circuit*. (3) Steady state is symbolized by $t = \infty$.

Ex. 1. For the circuit in Fig. 4, determine I at (a) $t = 0$, $I(0)$ and (b) in steady state, $I(\infty)$. (c) What is the time constant of the circuit? *Sol.* (a) $I(0) = 10/100 = 0.1$ A. (b) $I(\infty) = 0$. (c) $T = RC = 100 \times 10 \times 10^{-6} = 10^{-3}$ s = 1 ms.

Ex. 2. For the circuit in Fig. 4, find the voltage across the capacitor, V_c , at (a) $t = 0$ and (b) $t = \infty$. *Sol.* (a) Because the capacitor acts like a short circuit at $t = 0$, $V_c(0) = 0$. (b) Because the capacitor acts like an open circuit in steady state, $V_c(\infty) = 10$ V.

B. Functions of Time. For times between $t = 0$ and $t = \infty$, the current and voltage as functions of time for the circuit in Fig. 4 may be expressed by:

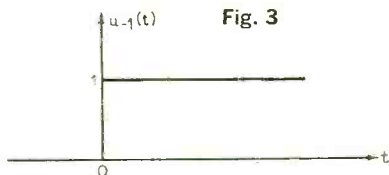

Fig. 3

$$i(t) = (V/R) e^{-t/RC} \text{ and } v_c(t) = V(1 - e^{-t/RC}).$$

C. RL Circuits. To a direct current, an inductor acts like an *open circuit* at $t = 0$ and as a *short circuit* at $t = \infty$. The time constant is $T = L/R$.

Ex. 3. Referring to Fig. 5, determine the current I at (a) $t = 0$ and (b) $t = \infty$. (c) What is the time constant for the circuit? *Sol.* (a) $I(0) = 0$. (b) $I(\infty) = V/R = 10/10 = 1$ A. (c) $T = L/R = 0.1/10 = 0.01$ s = 10 ms.

Ex. 4. For the circuit in Fig. 5, find the voltage across the inductor, at (a) $t = 0$ and (b) $t = \infty$. *Sol.* (a) Because the inductor acts like an open circuit at $t = 0$, $V_L(0) = 10$ V. (b) Because the inductor acts like a short circuit in steady state, $V_L(\infty) = 0$.

D. Functions of Time. For times between $t = 0$ and $t = \infty$, the current and voltage as functions of time for the circuit in Fig. 5 may be expressed by: $i(t) = (V/R)(1 - e^{-tR/L})$ and $v_L(t) = V e^{-tR/L}$.

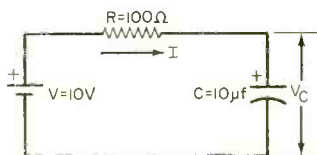

Fig. 4

7. Energy and Power.

A. Definitions. (1) Energy may be defined as the ability to do work. In the mks (meter, kilogram, second) system of units, the unit of energy is the newton-meter or joule. One joule is equal to one watt-second. (2) Power is the rate of doing work or the rate-of-change of energy with respect to time. Its unit is joules/second or watts. (3) Energy, w , is equal to the product of power, p , and time, t : $w = pt$. (4) For electrical circuits, $p = vi$. Since $i = v/R$ and $v = iR$, we can write $p = v^2/R = i^2R$. (5) Only resistors are capable of dissipating energy; capacitors and inductors store energy.

B. Energy Stored in Capacitor. The energy stored in a capacitor is $w_c = \frac{1}{2}Cv^2$, where v is the voltage across the capacitor.

C. Energy Stored in Inductor. The

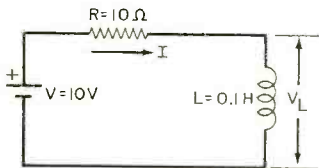

Fig. 5

energy stored in an inductor is $w_L = \frac{1}{2}Li^2$, where i is the current flowing in the inductor.

Ex. 5. A 200-watt light bulb is powered by a 120-volt dc source. Find (a) the current required by the bulb and (b) the energy consumed in lighting the bulb for 2 hours. Sol. (a) $I = P/V = 200/120 = 1.67$ A. (b) $W = Pt = 200 \times 2 \times 3600 = 1.44 \times 10^6$ joules.

Ex. 6. Determine the energy stored in (a) a 1-microfarad capacitor across which is 10 volts and (b) a 10-milli-henry inductor whose current is 4 A. Sol. (a) $w_c = \frac{1}{2} \times 10^{-6} (10)^2 = 0.5 \times 10^{-4}$ joules. (b) $w_L = \frac{1}{2} \times 10 \times 10^{-3} (4)^2 = 0.08$ joules.

Note: The circuit laws, theorems, and techniques reviewed here also apply, in general, to ac circuits.

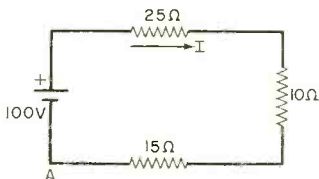

Fig. 6

8. Kirchhoff's Laws.

A. Kirchhoff's laws provide a formal method of finding currents and voltages in a circuit, regardless of its complexity. The laws apply to circuits energized by dc, ac, or time-varying voltage and currents.

B. Voltage Law. The voltage law states that the algebraic sum of voltages around a closed path is equal to zero. Mathematically, $\sum v(t) = 0$, where \sum is the Greek symbol for sum.

C. Series Circuit. A series circuit is a network where the same current flows in each element. An example of a series circuit is shown in Fig. 6.

Ex. 7. Using Kirchhoff's voltage law, find (a) the current in and (b) the

voltage across the 10-ohm resistor in the series circuit in Fig. 6. Sol. It is necessary to distinguish the direction of current flow and the polarity of voltage sources in the application of Kirchhoff's voltage law. The convention used here is: (1) A minus sign precedes a voltage quantity in going around a closed path from a low to a high potential or against the direction of indicated current flow.

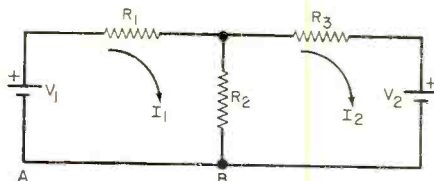

Fig. 7

(2) A plus sign precedes a voltage quantity in going around a closed path from a high to a low potential or with the direction of indicated current flow. (3) The assumed direction of current flow is arbitrary. (a) Referring to Fig. 6, assume that we start at point A and go around the closed path clockwise (with the direction of indicated current flow). Then, according to the voltage law and the conventions we have adopted, $-100 + (25 + 10 + 15)I = 0$ or $I = 100/50 = 2$ A. (b) From Ohm's law, the voltage across the resistor is $V = IR = 2(10) = 20$ V.

Ex. 8. Figure 7 shows a two-mesh or two-loop network with the assumed clockwise direction of current flow in each mesh indicated. Write the necessary equations to solve for the two currents. Sol. For the first mesh, beginning at point A, the voltages are $-V_1 + (R_1 + R_2)I_1 - R_2I_2 = 0$ (Eq 1). For the second mesh, starting at point B, $-R_2I_1 + (R_2 + R_3)I_2 + V_2 = 0$ or $-V_2 = -R_2I_1 + (R_2 + R_3)I_2$ (Eq 2). Equations (1) and (2) constitute a pair of simultaneous equations. Terms $R_1 + R_2$ and $R_2 + R_3$ are the self resistance of meshes 1 and 2, respectively; term R_2 is the mutual resistance linking the two meshes.

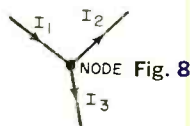

Fig. 8

Ex. 9. If, in Ex. 8, $R_1 = 1$ ohm, $R_2 = 2$ ohms, $R_3 = 4$ ohms, and $V_1 = V_2 = 6$ V, solve for I_1 , I_2 , and the voltage across each resistor. *Sol.* Substituting the given values in Eqs (1) and (2), we get $6 = 3I_1 - 2I_2$ (Eq 3) and $-6 = -2I_1 + 6I_2$ (Eq 4). Equations (3) and (4) may be solved for I_1 and I_2 in a number of ways. If, for example, we multiply Eq (3) by 3 and add the result to Eq (4), we have $12 = 7I_1$ or $I_1 = 12/7$ A. Substituting this value in Eq (4) and solving, $I_2 = -3/7$ A. The negative sign denotes that I_2 actually flows in a direction opposite to that assumed in Fig. 7. The voltage across R_1 is $V = (12/7)1 = 12/7$ V; across R_2 , $V = (12/7 + 3/7)2 = 30/7$ V; and across R_3 , $V = (-3/7)4 = -12/7$ V.

D. Current Law. Kirchhoff's current law states that the algebraic sum of currents leaving a node is equal to zero, or $\sum i(t) = 0$. A node is a junction of two

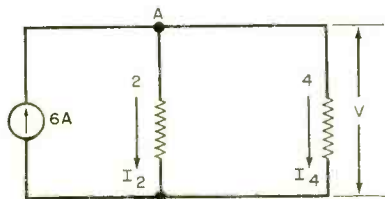

Fig. 9

or more elements. If currents flowing toward a node are taken as negative and currents flowing away as positive, then, for example, $-i_1 + i_2 + i_3 = 0$ in Fig. 8.

E. Parallel Circuits. A parallel circuit is a network where the voltage across each element is the same (Fig. 9).

Ex. 10. For the parallel circuit in Fig. 9, determine (a) the voltage across each resistor and (b) the current in each. *Sol.* (a) Applying Kirchhoff's current law at node A, we have: $-6 + V/2 + V/4 = 0$ or $6 = V(2 + 1)/4 = 3V/4$; and $V = 8$ V. (b) $I_2 = 8/2 = 4$ A; $I_4 = 8/4 = 2$ A.

F. Conductance. Conductance, G , is the reciprocal of resistance; thus $G = 1/R$. The unit for conductance is the mho, which is ohm spelled backwards.

Ex. 11. Referring to Fig. 10, write the necessary equations to solve for V_1 and V_2 . *Sol.* From Fig. 10, V_1 is taken

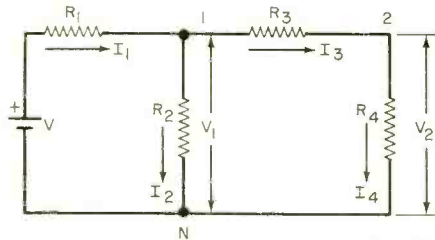

Fig. 10

between nodes 1 and N; with V_2 between nodes 2 and N. Node N is a common node and nodes 1 and 2 are independent nodes. Because we have two independent nodes, two nodal equations are necessary. With the assumed currents as shown, Kirchhoff's current law for node 1 gives: $-I_1 + I_2 + I_3 = 0$ (Eq. 5). At node 2: $-I_3 + I_4 = 0$ (Eq 6). Expressing Eqs (5) and (6) in terms of voltages and resistance, we have $-(V - V_1)/R_1 + V_1/R_2 + (V_1 - V_2)/R_3 = 0$, or $V/R_1 = V_1(1/R_1 + 1/R_2 + 1/R_3) - V_2/R_3$ (Eq 7); and $-(V_1 - V_2)/R_3 + V_2/R_4 = 0$ or $-V_1/R_3 + V_2(1/R_3 + 1/R_4) = 0$ (Eq 8). Equations (7) and (8) can be expressed in terms of conductances: thus, $G_1V = (G_1 + G_2 + G_3)V_1 - G_3V_2$ (Eq 9) and $-G_3V_1 + (G_3 + G_4)V_2 = 0$ (Eq 10). Terms $G_1 + G_2 + G_3$ and $G_3 + G_4$ are the self conductance of nodes 1 and 2, respectively; and G_3 is the mutual conductance between nodes 1 and 2.

Ex. 12. For the network in Fig. 11, determine V_1 and V_2 . *Sol.* At node 1, $-10 + 0.5V_1 + 0.5(V_1 - V_2) = 0$, or $10 = V_1 - 0.5V_2$ (Eq 11). At node

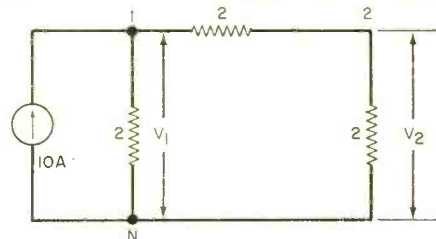

Fig. 11

2, $-0.5(V_1 - V_2) + 0.5V_2 = 0$, or $-0.5V_1 + V_2 = 0$ (Eq 12). From Eq (12), $V_1 = 2V_2$. Substituting this value in Eq 11, we have $10 = 2V_2 - 0.5V_2 = 1.5V_2$. Solving, $V_2 = 10/1.5 = 6.7$ V and $V_1 = 2V_2 = 2(6.7) = 13.4$ V.

(To be continued)

Design Your Own Color Organ

PICK YOUR OWN CHANNEL FREQUENCIES USING THIS SIMPLE DESIGN METHOD

BY DARYL SLAVIERO

Changing colored lights that keep time with the music—the color organ—are a natural accompaniment for a good stereo system. The possibilities are even greater with the newest quadraphonic systems—surround sound and surround light!

There are many types of multi-lamp color organs, ranging from simple LC or RC passive filter circuits to active filters driving SCR's or triacs. The passive filter is the less expensive but consumes audio power. Active filter circuits are preferable but they are often costly. They need not be, however, if you use the simplified circuit design

described here. If new parts are used in this design, a three-channel color organ should cost less than \$30. It will be less if some of the parts are available in the junk box.

How It Works. The circuit shown in Fig. 1 is for one channel only. Simplified design information will be given to add any number of channels for any center frequency within the audio range by changing three capacitors and adjusting a potentiometer.

The audio input signal is coupled to the color system through transformer *T1* and drives transistor *Q1*, a frequency selective amplifier. The amplitude of the output of this stage depends on the input frequency, if the input amplitude is held constant. However, the higher the input level is set (by *R1*), the more often the channel lamp will come on.

The output of *Q1* drives an SCR (or triac) through *Q2* which is used to buffer the output of *Q1* from the relatively high load of the SCR. Thus, although about 10 mA may be required to drive the SCR, only about 0.1 mA is required at the input to *Q2*. The SCR is turned off by using ac as the supply. Each time the ac voltage passes through zero, the SCR turns off and waits for the next trigger signal from *Q2*.

FILTER CALCULATIONS

Assume for *Q1*: $V_{CE} = 10 \text{ V}$, $I_c = 3 \text{ mA}$,
 $V_{CC} = 20 \text{ V}$, $\beta = 100$.

$$R4 = (V_{CC} - V_{CE}) / I_c = (20 - 10) / 0.003 \\ = 3333 \text{ ohms (use 3.3 kilohms)}$$

$$R3 = (V_{CE} - 0.6) / (I_c / 100) \\ = 9.4(100) / 0.003 = 313,333 \text{ ohms} \\ \text{(use 330 kilohms)}$$

$$C1, C2, C3 = 20 / f \\ = 20 / 80 = 0.25 \mu\text{F} \\ = 20 / 400 = 0.05 \mu\text{F} \\ = 20 / 1000 = 0.02 \mu\text{F} \\ = 20 / 4000 = 0.005 \mu\text{F}$$

Fig. 1. Active filter (Q1) is buffered by Q2 and drives the SCR to energize lamp connected to socket.

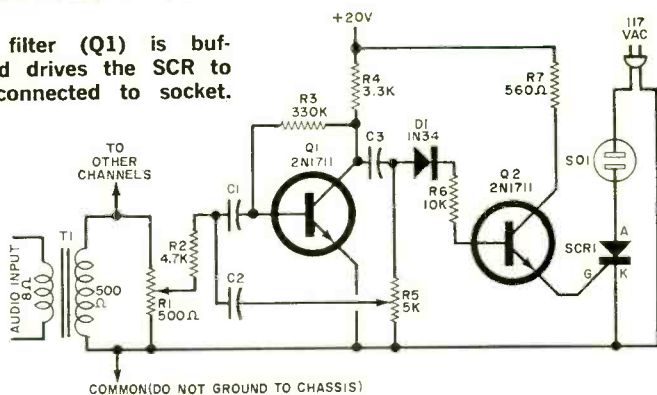

PARTS LIST

C1-C3—See text

D1—Small-signal diode (1N34 or similar)

Q1-Q2—2N1711 transistor (see text)

R1—500-ohm linear potentiometer

R2—4700-ohm resistor

R3—330,000-ohm resistor (see text)

R4—3300-ohm resistor (see text)

R5—5000-ohm linear taper potentiometer

R6—10,000-ohm resistor

R7—560-ohm resistor

SCR1—2.5 amperes, 200 PIV (see text)

SO1—117-volt panel receptacle

T1—Audio transformer; 8/500 ohms

Misc.—Suitable chassis, terminal strips, knob for R1, mounting hardware, etc.

Circuit Design. Almost any npn transistor can be used for Q1 and Q2 as long as the one for Q1 has a minimum beta of 50 and for Q2 a minimum beta of 100. The SCR should have sufficient power rating to operate the lamps to be used. If lamps with voltage ratings other than line voltage are used, the rating of the SCR may have to be changed. For very large loads, transistor Q2 should have a high output and R6 and R7 may have to be decreased in value to provide the extra drive.

Simplified calculations for the important elements of the active filter are shown in the box. Calculations for R3 and R4 are used if a transistor other than the 2N1711 is used. These equations also show a simple method of calculating the required value of the filter capacitors (C1, C2, and C3). The examples shown are for 80 Hz, 400 Hz, 1 kHz and 4 kHz, though any other center frequency can be selected. A typical 20-volt power supply is shown in Fig. 2.

Operation. For each stage of the color organ (as shown in Fig. 1.), when power is applied but without an input signal, potentiometer R5 is adjusted until the filter just starts to oscillate and the associated lamp is turned on. Then R5 is backed down until the lamp goes off. If desired, once the correct setting of R5 has been determined, the resistance values measured from the rotor to the ends can be used to determine fixed resistors to substitute for the potenti-

ometer. The channel is then fed a signal from the 8-ohm output of an audio amplifier.

If very high volume is required from the speaker, insert a resistance between 47 and 100 ohms in series with the input of T1 to remove the distorting effects of saturation of the transformer.

Lamp Power. If 117-volt line power is used for the lamps, an isolation transformer of the necessary wattage is suggested to prevent accidental shocks. In units such as this, where the power is ac, it is always best not to use a metal chassis; but if you do, make sure that all wiring is connected to insulated lugs of terminal strips. Under no conditions should the metal chassis be used as a common return.

If low-voltage lamps are used, a suitable heavy-duty filament transformer is ideal. Make sure that the total lamp wattage does not exceed the ratings of the SCR (or triac) and the transformer. ♦

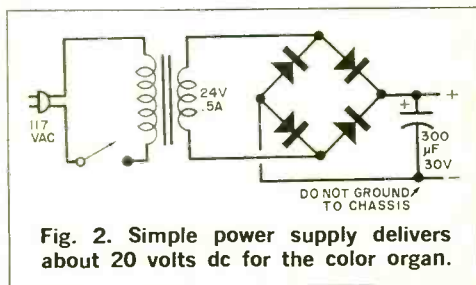

Fig. 2. Simple power supply delivers about 20 volts dc for the color organ.

SIMPLE TEST INSTRUMENTS FOR DIGITAL CIRCUITS

Manual or automatic slow clock and state indicator will come in handy.

BY FRANK TOOKER

IT ISN'T too difficult to design and assemble a digital counter or a scaler (frequency divider). What is difficult is to find out what is wrong if the thing doesn't work properly.

Because of their binary nature, digital instruments tend to be complicated due to the number of elements required to obtain a desired result. It is easy to make a mistake in wiring, and a single misconnection can cause a digital setup to do almost anything—from running wild to refusing to operate at all.

When faulty operation occurs, then, the first questions to be answered are: Is the setup wired properly? If it is, in what stage does the fault occur? Is this stage supplied with adequate drive, or is it just borderline?

To a large extent, it is not necessary to have expensive equipment to check out home-built digital circuits. All that is needed is a slow-speed repeating trigger with an instant stop and a pulse detector that can double as a pulse-coincidence detector. Amazingly simple, yet entirely adequate and reliable versions of these two RTL instruments are described here.

Slow-Speed Trigger. A slow-speed repeating trigger performs very much the same

service as a manual trigger, except that the operation is automatic. Pulses with fast rise and fall times are produced regularly at a repetition rate determined by the RC time constant of the components used. Speeds of one pulse every three to five seconds are adequate.

Fundamentally, a repeating trigger is an astable or free-running multivibrator. Two different circuits are shown in Figs. 1 and 2. They operate equally well, so the one you choose to build depends on your personal preference or the components you have on hand. Detailed assembly instructions are not given because anyone who can design and assemble a counter or a frequency divider can put together either of these simple circuits easily.

The circuit of Fig. 1 has a manual hold control as well as a hold input terminal. In either circuit, when the hold input is put at a logic 1 level (+3.6 volts), output 1 goes to the logic 0 level and remains there as long as the hold signal is applied. Simultaneously, output 2 goes to the logic 1 level and remains there.

The manual hold feature in the circuit of Fig. 1 can be eliminated by omitting the switch and the 1k resistor and grounding pin #10.

Fig. 1. An IC slow-speed square-wave generator provides one pulse every 3 seconds. Positive signal on hold input can be used to stop the oscillator.

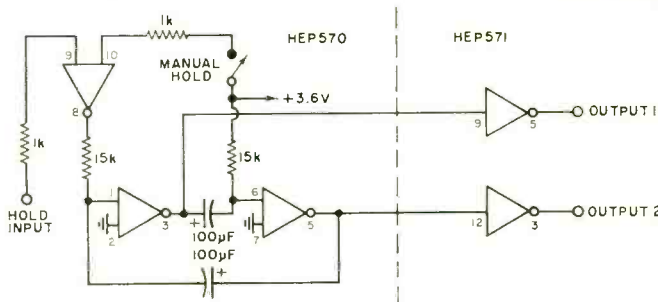

The circuit of Fig. 1 uses a quad 2-input gate (Motorola MC724P or HEP570) followed by a dual buffer (HEP571). With the components shown, the repetition rate is one pulse every three seconds.

The circuit of Fig. 2 uses a multifunction integrated circuit (Motorola MC787P or HEP C2503P) containing a JK flip-flop, an inverter, and two buffers. The buffers are interconnected to make up the astable multivibrator, the output of which is fed through a 3300-ohm resistor to the inverter input. The inverter operates to square the signal, while the 3300-ohm resistor reduces loading on the multivibrator. The output from the inverter feeds directly to the T input of the built-in JK flip-flop. Outputs Q and not Q of the flip-flop feed the two inputs of the dual buffer (Motorola HEP571).

The small figures at the inputs and outputs of the logic symbols in Figs. 1 and 2 indicate pin numbers on the integrated circuits. Pins 4, 7, and 10 of the MC787P are grounded. As usual, with these 14-pin IC's, pin 11 is to be connected to the +3.6-volt supply.

The repetition rate of the circuit of Fig. 2 is one pulse every five seconds.

A manual hold can be added to the circuit of Fig. 2 by feeding +3.6 volts through a spst switch to the hold input terminal (#5) of the JK flip-flop. Automatic control through the hold input terminal will be normal with the switch open.

A JK flip-flop with its T input connected to either output terminal of the repeating triggers of Figs. 1 or 2 will not be toggled by the opening or closing of the manual hold switches or by the application of a logic 1 signal to the hold input terminal. This is because a transient pulse at the hold or manual input cannot produce a clock pulse at the repeating trigger's output.

Slow-Speed Pulse Detector. The output of any digital logic device can be at either the logic 1 or 0 level. It does not, of its own accord, indicate its output state. So, when you are working with experimental setups, it is advantageous—if not essential—to have some form of simple readout device (a pulse-level indicator or detector) to tell you immediately when the output of your slow-speed repeating trigger or the output of any of the toggled flip-flops is at the 0 or 1 level at any moment.

You should also be able to connect such a device between the outputs of your JK flip-flops to determine if and when pulse coincidence occurs. In this case, the device is a pulse-coincidence detector. Such a device should consume so little power that it has little, if any, loading effect on the circuit.

The simple device shown in Fig. 3 fills this need effectively and inexpensively. It consists of a pair of 33,000-ohm resistors and a zero-center microammeter of the kind

Fig. 2. Variation of circuit shown in Fig. 1 uses JK flip-flop as shaper and hold gate. Outputs are buffered.

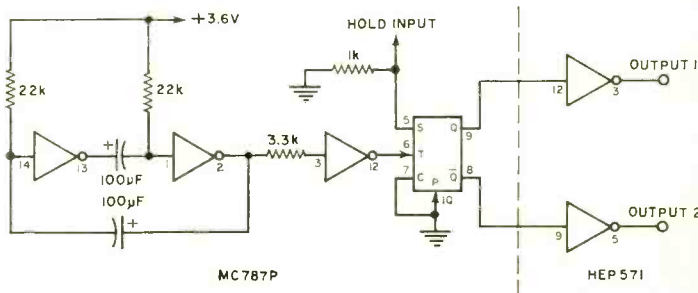

sold as stereo balance meters (such as Lafayette's 99F50346).

Since these meters are intended for rectified audio frequency applications without filtering, they are internally damped to a degree sufficient to prevent needle over-travel, even when the input signal level is enough to move the needle abruptly from one extreme to the other.

Current sensitivity of the meter should be 100 microamperes or less. The 33,000-ohm resistors are for a 100-microampere meter.

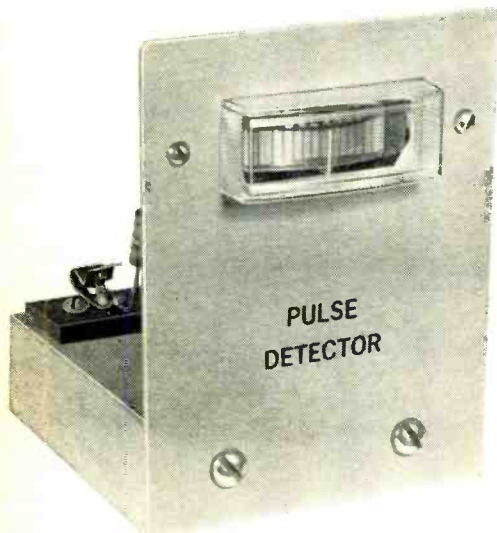

Fig. 3. Output state detector uses a zero-center stereo balance panel meter.

Using the Instruments. Obviously, the repeating trigger is connected ahead of your setup to feed a very slow signal into it. Connect ground to ground and either output of the trigger to the input of your counter or frequency divider. Output from either trigger is buffered so fan-out is adequate to drive any ordinary asynchronous or synchronous setup.

The pulse detector, or pulse-coincidence detector (depending on how you use it), can be connected across any two outputs in your setup to determine not only the rate of pulse recurrence or coincidence, but also (noting the extent of needle travel in either direction from zero) the pulse voltage level—indicative of the fan-out—at the point of measurement.

It is particularly true that in experimental counters and frequency dividers, erratic operation or failure to operate at all is due to inadequate drive at one or more of the

stages. Some JK flip-flops (Motorola MC-790P, for example) have a fan-out of 10, while others (Motorola MC791P) have buffered outputs and a fan-out of 16.

A quick check with the slow-speed trigger and the pulse detector will tell you if drive is adequate throughout your setup; and if it is not, in what stage or stages you should replace an MC790P with an MC791P to get the additional "push" needed. Pin connections on these two IC's are identical.

On the other hand, if you have designed and assembled a frequency divider that is operating smoothly but not giving the division ratio you want, use the meter as a pulse-coincidence detector. Then, using the truth table for the circuit you have designed, determine, across any two circuit points, one after the other, where pulse coincidence is occurring when it should and where it is occurring when it should not. The direction of the meter deflection will tell you immediately which side of your connection is at a logic 1 and which is at logic 0.

The hold control of the repeating triggers is used to stop the operation of a counter or a frequency divider at any desired point in its sequence of operations in order to determine the states of the flip-flops at that particular point.

It is best to try these two simple instruments using digital circuits that you know are operating properly. Once you have become familiar with the direction and extent of meter needle deflection, as far as proper digital circuit performance is concerned, you will be well on your way to tracking down faults in a matter of minutes. ♦

Editors Note: If you prefer an optical display of the output state, use the circuit shown below. Each time a positive signal appears at the input, the lamp will come on. This circuit is essentially nonloading for almost any type of logic block currently in use by the experimenter.

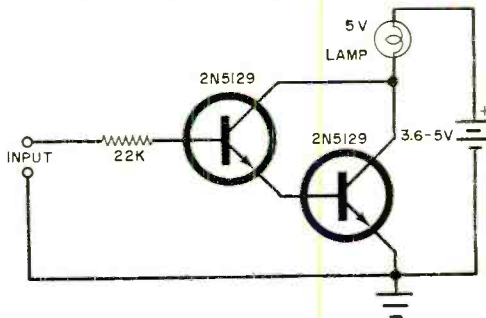

by Raymond E. Herzog

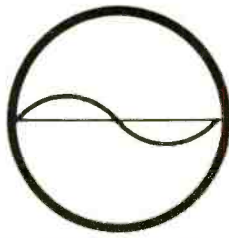

UNDERSTANDING UNGROUNDING OSCILLOSCOPE MEASUREMENTS

Making scope measurements across ungrounded components can present some problems. Here are the reasons—and some answers.

WHEN we measure a voltage in a circuit, we don't always take into account what we are actually measuring. For instance, we might say that a power supply's output is 50 V dc with 0.75 V ac ripple; or the output signal at a transistor amplifier's collector is 5 V ac. In these, and just about all voltage measurements, what we really mean is that the power supply's output is 50 V dc with respect to ground (or chassis common); the ripple is 0.75 V ac with respect to ground; and the amplifier output is 5 V ac with respect to ground. Thus, what we are really measuring is the voltage at a given point—with respect to a common point.

Since a voltage is the potential difference between two points, the two points have to be identified. For convenience, we generally use chassis ground as the second point.

But what if we want to measure the voltage across a component both sides of which are above ground? This presents a problem—many problems, in fact. Obviously, one difficulty is the lack of a convenient, easy-to-get-at chassis for a connecting point. More important, however,

are the possible bad effects of connecting both leads of a test instrument to ungrounded points.

Of course, occasions such as this do not occur often; but when they do, knowing the proper procedure can make the job easier and prevent undesirable effects such as overloaded circuits and noise pickup.

Not a Simple Test. Measuring a voltage between two ungrounded points is not always a simple matter. Assuming that an oscilloscope is being used, one does not merely connect the test probe and ground lead at opposite ends of the ungrounded component—certain precautions must be observed. Consider the following examples.

Assume that we have a conventional scope which has a three-wire power cord. For safety, the scope chassis is tied to the third wire and ground. Because the signal input "ground" terminal is also common with the chassis ground, it too is tied to the third wire in the power cord. Now, let's say we're testing an ac/dc radio or a transformerless TV receiver; the chassis being tested is tied to the low side (ground) of the power cord. So we have the situation

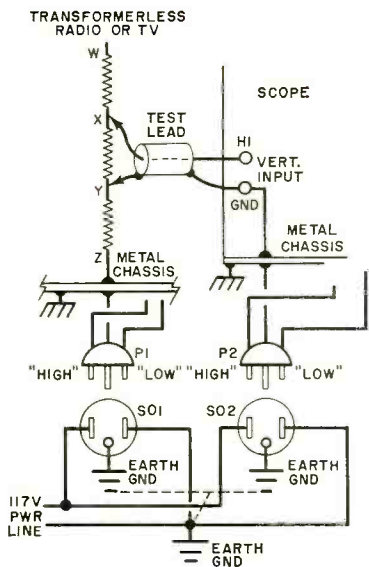

Fig. 1. In transformerless circuit, scope ground return on point Y can create a short across Y-Z element.

shown in Fig. 1. The chassis are tied together through the power line system.

As long as the scope's ground test lead is connected to the tested chassis (point Z in Fig. 1), the chassis are tied together, the grounds are tied, and we have a good, safe test setup. Notice, however, what happens when the scope's ground test lead is connected to a point above ground potential (point Y in Fig. 1). The portion of the circuit between Y and Z is effectively shorted out by the ground circuit through the two chassis and the power line ground.

This, of course, could severely disturb the circuit operation and possibly damage the components in the network. The same ground problem could also occur with a scope that has a 2-wire power cord if the low side is tied to chassis ground.

Now, assume that we have a scope with a three-wire power cord and we're testing a TV receiver with a power transformer and a conventional 2-wire ac connection. As shown in Fig. 2, the low side of the ac line is connected to the chassis through a large resistance (commonly 2.2 megohms). Of course, not all equipment have this resistance—some are entirely isolated—but it is important to know whether it is there or not. With the circuit shown in Fig. 2, there is an ac shunt effectively placed across part of the circuit under test.

The ac path inside the receiver is from point Z to the chassis, to the transformer secondary, through stray primary-to-secondary capacitance, to the transformer primary, to the ac line. This ac shunt can cause problems, especially with high frequency measurements. (For all of the above situations, tying the ac line to an ungrounded point can introduce noise into the circuit.)

Still another problem is encountered if the scope does not have its chassis tied to the power line ground. In this case, connecting the scope ground lead to a point above ground could make the chassis "hot."

So there are several undesirable effects that we want to avoid—dc shunt, ac shunt, noise pickup, hot scope, etc. Let's examine ways to make ungrounded measurements.

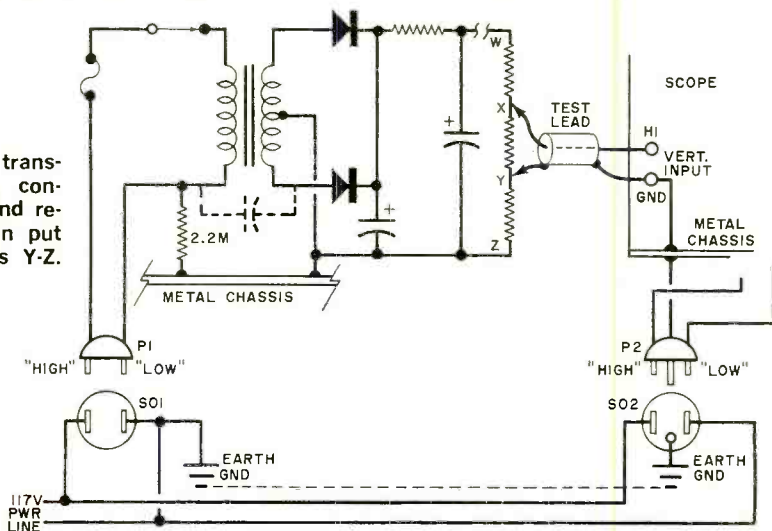

Fig. 2. With power transformer in circuit, connecting scope ground return to point Y can put an ac shunt across Y-Z.

Conventional Scopes. The only way to get ideal ungrounded measurements is with a special scope with a differential amplifier input. Next best is to use a scope with a dual-trace amplifier input and an "A-B" mode. But even with a conventional scope, there are ways to reduce some of the undesirable effects—if not completely eliminate them.

First, we must know our scope. Is the chassis grounded to the ac line? Also, note the grounding on the device under test. If it has been determined that the scope will not cause a dc shunt, we must realize that the circuit being tested can still be disturbed by the scope's ac loading. Noise and hum pickup should be taken into account. Even if the scope chassis is not directly tied to the line ground, it can put noise into the tested circuit; the scope's large metal cabinet acts as an antenna and picks up noise.

We can use an isolation transformer with the scope to prevent dc shunts. This also reduces the ac shunt; but because of the transformer's primary-to-secondary capacitance, ac loading and noise will still occur. However the capacitive reactance does reduce loading and noise—as compared to a direct line without a transformer. In using an isolation transformer, remember that the scope chassis can be hot when the signal ground lead is connected to an ungrounded point.

Oscilloscope Differential Amplifier. Because the output of a differential amplifier is the difference of its inputs, we can use it to measure the voltage across a component—which is a potential difference. The significance of a differential voltage measurement is that it can be used for an ungrounded component without encountering the bad effects noted above.

Figure 3 shows a simplified block diagram of a differential amplifier. It consists of two identical amplifiers. They have the same gain, but one inverts its input. The outputs are then combined by algebraic addition; and since one output is inverted, the total is $A - B$.

Differential measurements are less common than conventional single-input measurements so scopes with differential amplifier inputs are few. Many scopes of the plug-in type have differential amplifier inputs. The electronics enthusiast, experimenter, or service technician could build

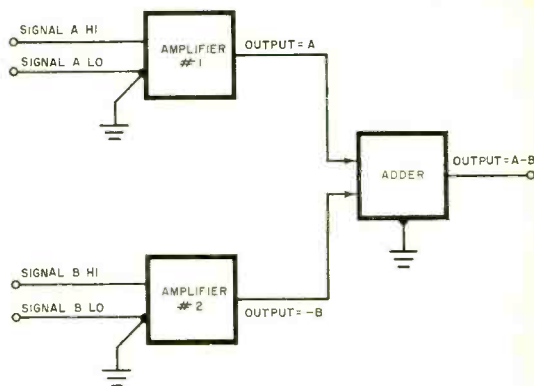

Fig. 3. Simple differential amplifier has inputs A and B and output $A - B$.

a differential amplifier to feed a conventional single-input scope.

In practice, the signal high leads are connected to the two points to be measured. No common ground connection is required so the two low leads are not used. Usually, they are shields on the test probes.

For safety reasons, however, the scope and device under test may be connected with a grounding wire. However, this connection must not be the signal low leads or the shields, to avoid ground loops.

It should be pointed out that the differential amplifier scope is not the same as a dual-trace scope. The latter has two amplifiers, each with its own input. Electronic switching alternately feeds the output of each amplifier to the scope's vertical deflection section. The result is a simultaneous display of the two inputs.

Under certain conditions, a dual-trace scope can provide some of the benefits of a differential amplifier scope. For instance, if there is an $A - B$ mode and the amplifiers are well matched, the difference of the two inputs is displayed. The scope manufacturer's operation manual will explain this function where applicable.

Making Differential Measurements. Let's see how differential scope measurements are made for ungrounded tests. In the circuit shown in Fig. 4, we want to measure the signal across load resistor R_{L1} . Only the high signal leads are connected to the circuit under test (at points X and Y). The shields are connected together and grounded; but they are not grounded at the tips. This connection reduces the impedance of the loop formed by the shields and equal-

Fig. 4. Using a differential scope to make a measurement across an ungrounded component.

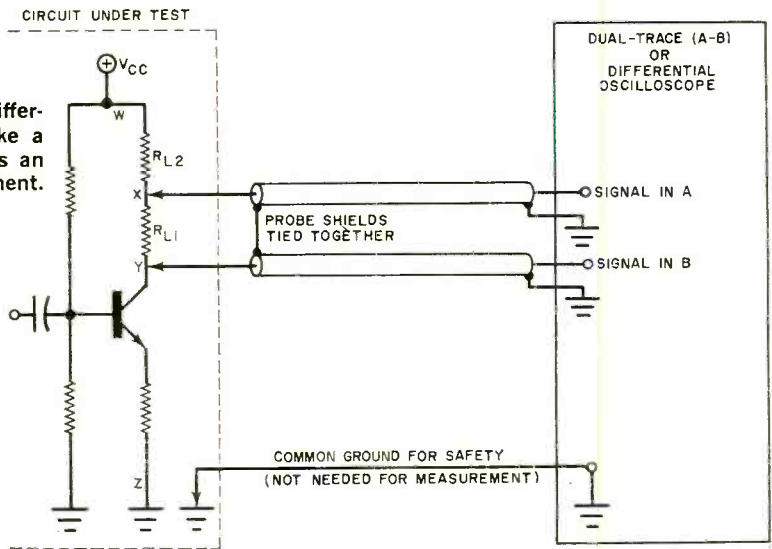

izes the currents through the loop, thereby allowing the differential amplifiers to nullify loop current effects by common mode rejection.

It is not correct to tie both shields together at the probe end and also connect them to the chassis. This makes a circuit for ground currents through the shield and can create measurement errors because of voltage difference at the scope. It would also be wrong to leave both shields unconnected at the probe ends. This would permit the shields to act like antennas to pick up noise.

The probe tips represent a high impedance to the circuit being tested and do not introduce excessive loading as did the conventional test circuits shown in Figs. 1 and 2. Since the scope chassis is not tied to a signal high point, there is no ac line noise introduced.

Reject Common Mode Signals. One of the more important uses of a differential measurement is to reduce the effects of a common mode signal such as hum. Common mode signals are identical with respect to amplitude and time. Since the output of a differential amplifier is the difference between its two inputs, a common (identical) signal on each input will be reduced (but not eliminated) in the output. There is a limit as to just how effective a differential amplifier can be. Its ability to reject common mode signals is known as common mode rejection. The ratio of the common

mode input signal amplitude to the amplitude of the difference signal displayed on the scope is known as the common mode rejection ratio. The higher the ratio, the better the differential amplifier.

Fig. 5. Conventional scope (A) displays both signal and hum, while a differential scope (B) displays only signal across the load resistor.

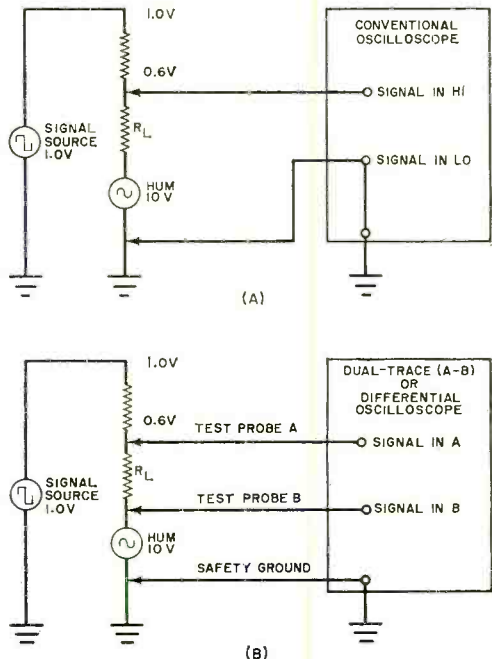

For example, if the common mode signal on both inputs is 10 volts and the signal produces a scope display of only 0.01 volt, the common mode rejection ratio is 10/0.01 or 1000.

Note what happens with a conventional scope measurement as shown in Fig. 5A. There is an unwanted 60-Hz hum signal in the circuit along with the desired signal. Assume the hum is 10 volts and the square wave source is 1 volt, of which, 0.6 volt appears across the component being tested. With the conventional scope setup, both the 0.6-volt signal and the 10-volt hum would be displayed, as in Fig. 6A. The desired signal rides on the bothersome hum, making the measurement difficult.

But notice what occurs when a differential scope is used as in Fig. 5B. In test probe A, is the combined signal and hum; while the hum alone is in probe B. The scope displays A minus B or only the desired signal across the resistor as shown in Fig. 6C. The amount of hum that is rejected depends on the scope's common mode rejection ratio; and if the latter is good, the resultant signal would have negligible hum.

As we have pointed out, the A - B mode

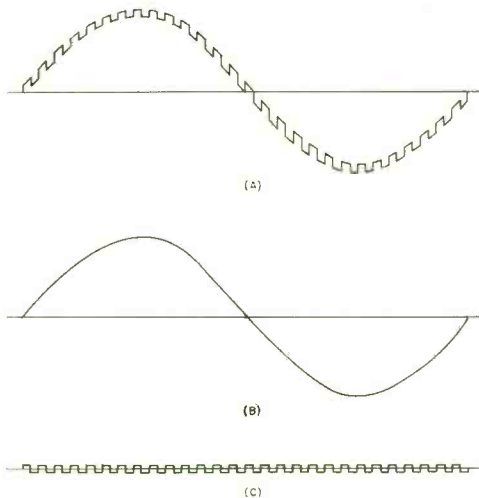

Fig. 6. (A) Signal with hum; (B) hum alone; (C) signal with hum rejected.

of a dual-trace scope can be used for differential measurements. The common mode rejection of such a scope, however, is less than that for a differential amplifier scope. Nevertheless, the ability to reduce common mode signals to even a small degree would be all that is needed for making a good measurement. ♦

SAVE MONEY!

A Delta Mark Ten Capacitive Discharge Ignition (CDI) System On Your Car Slashes Maintenance Costs And Increases Performance.

Put a Mark Ten on your car and save by eliminating 3 out of 4 tune-ups. Save as gasoline mileage increases (up to 20%). The Mark Ten CDI system also extends spark plug life, promotes more complete combustion and assures instant starts in all weather. It operates on any 6 or 12 volt negative or positive ground system.

The Mark Ten B affords additional money saving advantages by drastically reducing combustion contaminants and restoring power lost by the use of smog control devices. Equipped with handy switch for instant return to standard ignition, the Mark Ten B works with ANY 12 volt negative ground engine. Both systems install in ten minutes without rewiring.

Order your Mark Ten or Mark Ten B today. Save money while you enjoy low maintenance and increased performance.

Mark Ten (Assembled) \$44.95 ppd.

Mark Ten (Deltakit) \$29.95 ppd.

(Kits available in 12 volt only, positive or negative ground)

Mark Ten B \$59.95 ppd.

(12 volt negative ground only)

Superior Products at Sensible Prices

Mfg. in U.S.A.



DELTA PRODUCTS, INC.

P.O. BOX 1147 • GRAND JUNCTION, COLORADO 81501
PHONE: (303) 242-9000

Dept. PE

Please send me literature immediately:

Enclosed is \$ _____

Ship ppd. Ship C.O.D.

Please send: _____ Mark Ten B @ \$59.95 ppd.

___ Standard Mark Ten (Assembled) @ \$44.95 ppd.

___ 6 Volt: Neg. Ground Only ___ Positive Ground

___ 12 Volt: Specify ___ Negative Ground

___ Standard Mark Ten (Deltakit*) @ \$29.95 ppd.

(12 Volt Positive Or Negative Ground Only)

Car Year _____ Make _____

Name _____

Address _____

City/State _____ Zip _____

CIRCLE NO. 12 ON READER SERVICE CARD

From Cleveland Institute of Electronics

learn by doing!

Perform more than 200 exciting experiments
with CIE's fascinating **ELECTRONICS
LABORATORY PROGRAM!**

Put theory... into practice



You get your own 161-piece electronics laboratory... with authentic electronic components used by industry!

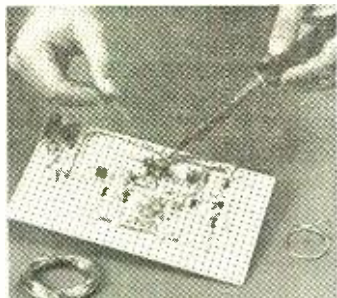

You learn how to construct circuits and connect them with a soldering iron, which is part of your CIE laboratory equipment. This "hands on" experience is extremely valuable in applying what you learn.



Testing and troubleshooting are an important part of your learning experience. Included in your laboratory is a precision "multimeter" to diagnose electrical and electronic troubles quickly and accurately.



Modern space-age components like this IC (integrated circuit) are professional quality and can be used again and again in many of your projects. Lesson by lesson, piece by piece your knowledge grows!

Prepare now for a high income career in Electronics...the Science of the Seventies.

Electronic miracles are changing today's world with breathtaking speed.

And with this growth in electronics technology has come a brand new need... a demand for thousands of electronics technicians, trained in theory and practice to build the products, operate them and service them during the Seventies.

Don't just wait for something to "happen" in your present job. Get ready now for a career you'll really enjoy with a good income and plenty of opportunity for advancement.

Experience with experiments is your best teacher

"Hands on" experience helps to reinforce basic theory. When you learn by doing, you discover the "how" as well as the "why." You'll find out for yourself the right way as well as the wrong way to use electronic components. How to construct your own circuits, to discover trouble spots and learn how to fix them. And with CIE's special Auto-Programmed® Lessons, you learn faster and easier than you'd believe possible.

CIE's fascinating course, Electronics Technology with Laboratory, teaches you Electronics by making it work before your eyes. And you do it yourself, with your own hands.

Importance of FCC License and our Money-Back Warranty

Many important jobs require an FCC License and you must pass a Government licensing exam to get one.

But, a recent survey of 787 CIE graduates reveals that better than 9 out of 10 CIE grads passed the FCC License exam.

That's why we can offer this famous Money-Back Warranty: when

you complete our Laboratory Course, which provides FCC License preparation, you'll be able to pass your FCC exam or be entitled to a full refund of all tuition paid. This warranty is valid during the completion time allowed for your course.

You get your FCC License — or your money back!

You'll have high paying job opportunities

Electronics is still young and growing. In nearly every one of the new exciting fields of the Seventies you find electronics skills and knowledge are in demand. Computers and data processing. Air traffic control. Medical technology. Pollution control. Broadcasting and communications. With a CIE Diploma and an FCC License you can choose the career field you want... work for a big corporation, a small company or even go into business for yourself.

Here's how two outstanding CIE students carved out new careers: After his CIE training, Edward J. Dulaney, President of D & A Manu-

facturing, Inc., Scottsbluff, Nebraska, moved from TV repairman to lab technician to radio station chief engineer to manufacturer of electronic equipment with annual sales of more than \$500,000. Ed Dulaney says, "While studying with CIE, I learned the electronics theories that made my present business possible."

Marvin Hutchens, Woodbridge, Virginia, says: "I was surprised at the relevancy of the CIE course to actual working conditions. I'm now servicing two-way radio systems in the Greater Washington area. My earnings have increased \$3,000. I bought a new home for my family and I feel more financially secure than ever before."

Send now for 2 FREE BOOKS

Mail the reply card or coupon for our school catalog *plus* a special book on how to get your FCC License. For your convenience, we will try to have a representative call. If coupon is missing, write: Cleveland Institute of Electronics, Inc., 1776 E. 17th St., Cleveland, Ohio 44114. Do it now!



Approved
under
G. I. Bill

All CIE career courses are approved for educational benefits under the G.I. Bill. If you are a Veteran or in service now, check box for G.I. Bill information.

CIE Cleveland Institute of Electronics, Inc.
1776 East 17th Street, Cleveland, Ohio 44114
Accredited Member National Home Study Council

Please send me your two FREE books:

1. Your illustrated school catalog, "Succeed in Electronics."
2. Your book, "How to Get a Commercial FCC License."

I am especially interested in: Electronics Technology with Laboratory
 Electronics Technology Industrial Electronics
 Electronic Communications First Class FCC License
 Broadcast Engineering Electronics Engineering

Name _____ Age _____
(PLEASE PRINT)

Address _____

City _____ State _____ Zip _____

Veterans and Servicemen: Check here for G.I. Bill information.

PE-45

CIRCLE NO. 7 ON READER SERVICE CARD

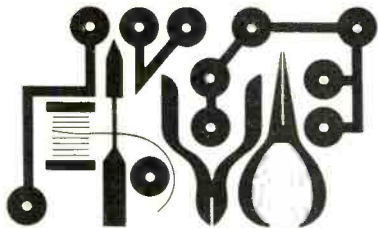

Hobby Scene

Beginner's Lie Detector

Q. I have often wanted to build one of those "emotion detectors" you have featured in the past. However, I am a beginner and don't feel I am up to building one with IC's so I haven't tried yet. Do you know of any simple type of lie detector that a beginner could try?

A. The circuit shown below is just about as basic as you can get. The two probes, which can be almost any kind of smooth metal rods, are held firmly in the palms of the hands, and the potentiometer is set for meter zero. When the subject is embarrassed or lies, the palms of the hands usually start to perspire, thus changing their resistance. This changes the transistor bias, and the meter deflects.

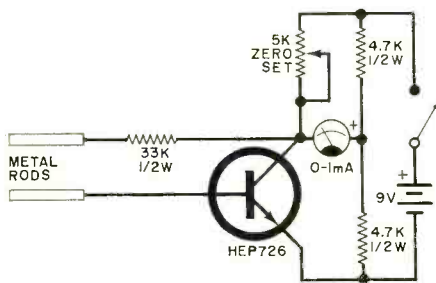

CMOS Logic Mini-Power

Q. I have been reading about CMOS (complementary metal oxide semiconductor) logic and still can't understand one thing. How can it work with such low power requirements?

A. Take a look at the schematic. Note that there are two MOSFET's in this typical CMOS gate—one a p channel and the other an n channel—connected in series between the positive supply and ground. When the input is low (ground), Q1 is off forming a very high resistance and Q2 is on making a very low resistance. Current flows only

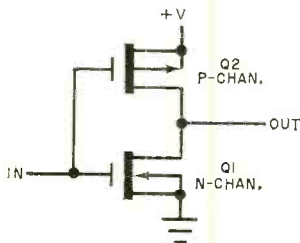

during the switching transition and this is very low. The output is then at the +V level. When the input goes high, Q1 turns on and Q2 turns off. Again only switching current flows and the output is virtually at ground. If the load is another MOS circuit, the latter will have a very high input resistance and require very little current. Only voltages are being switched. You can also guess that the actual value of +V is relatively unimportant so a well-regulated supply is not needed.

Battery Troubles

Q. I have a CB rig in my truck and often use it when the motor is not running. If I do this for very long, the battery won't start the truck. What can I do?

A. Other than using a separate battery, you could try the voltage monitor described in our August 1972 issue (p 58).

An Apology

Well it happened! We goofed. While gathering information for the March column, we found the so-called NASA voice filter. We hadn't tried it, but we thought it looked good and seemed to be the answer to the SWL's question. While the issue was being printed, and after it was too late to do anything about it, we tried the circuit and suddenly came to the dull realization that it would not work. It seems that some joker made a Xerox copy of the circuit with a NASA byline. We are very sorry that we propagated the joke.

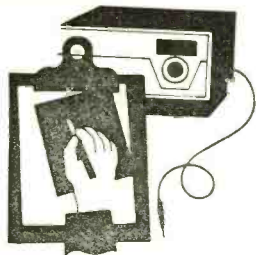

Product Test Reports

LAFAYETTE SQA-50 4-CHANNEL AMPLIFIER/DECODER (A Hirsch-Houck Labs Report)



THE LAFAYETTE Radio Electronics Model SQA-50 is an inexpensive (\$49.95), low-power 4-channel amplifier with a built-in matrix decoder section. It is designed principally for converting a stereo system to quadrasonic operation.

The amplifier/decoder is a compact and lightweight unit. It measures $9\frac{3}{4}'' \times 8\frac{1}{2}'' \times 3\text{-}3/16''$ and weighs a little more than 5 pounds. It contains four IC power amplifiers, a power supply, and a seven-transistor decoder circuit. Two quadrasonic matrices are provided. The first is for SQ-encoded material. The COMPOSER matrix synthesizes rear-channel information from the out-of-phase signals contained in most stereo program material. A third position on the mode switch shunts the four AUX inputs around the matrix circuits when discrete 4-channel tapes are played.

The separate front and rear channel amplifier gain controls are concentric pairs with slip-clutch action that permits the user to adjust each of the four channels independently. There are separate front and rear jacks on the front panel for use with 4-channel headphones. On the rear panel are all input and speaker output connectors (both groups phono types) and a line fuse.

The SQA-50 connects into an existing

stereo system in a rather unique manner. Two small input transformers are driven from the stereo amplifier's speaker outputs. Then the original front speakers are plugged into the front outputs, while a second pair of speakers is plugged into the unit's rear speaker outputs. After balancing the levels in each channel, the volume control of the stereo amplifier controls the levels in all four channels and its other controls select the program source and tone characteristics.

The amplifier/decoder carries a music power rating of 12 watts \pm 1 dB, or 3 watts/channel at 1000 Hz into 8-ohm loads. It is designed to drive only 8-ohm speakers of relatively high efficiency. The rated frequency response is 60-20,000 Hz -3dB, and hum is stated at -60 dB with the reference level unspecified.

Laboratory Tests. We tested the SQA-50 with all four channels driven into 8-ohm loads. Its output power at the clipping point was 1.4 watts/channel at 1000 Hz. The unit is not recommended for use with 4-ohm speakers, a provision that was immediately obvious when we measured only 0.185 watt/channel at the clipping level into 4-ohm loads.

At the recommended 12 o'clock volume control setting, the unit required 1.15 volts at its AUX inputs or 3.3 volts (equivalent to 1.35 watts) at its speaker inputs to drive the amplifier to full power output. According to the published specifications, at maximum gain, the driving source should be able to deliver at least 1.5 volts to the speaker inputs or 250 mV to the AUX inputs.

The frequency response met its specification, being down only 1 dB at 70 Hz and 20,000 Hz (-3 dB at 30 Hz) with the signal applied through the AUX inputs. The re-

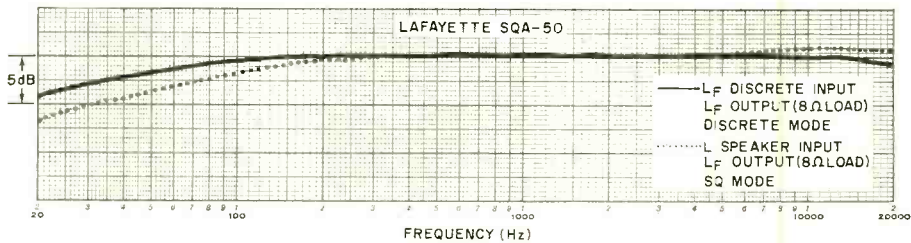

sponse was similar when the SQ matrix was switched into the circuit, the -3-dB point falling at 60 Hz.

The low-frequency power of the SQA-50 is very limited. But the 60-Hz distortion was a respectable 1.5-1.6 percent at output levels of either 0.1 watt or 1.0 watt. At frequencies from 1000 to 20,000 Hz, the distortion at 1 watt was between 0.073 and 0.27 percent. At 0.1 watt, it was slightly higher, ranging from 0.15 to 0.27 percent. The hum and noise output was low—about 65-69 dB below 1 watt at normal gain settings and 54-66 dB down at maximum gain, depending on the operating mode.

We were concerned about the ability of the tiny input transformers to handle the output of a fairly powerful amplifier. Our fears were groundless. From 60 Hz to 20,000 Hz, the equivalent of more than 50 watts at the input was required to produce significant distortion by core saturation. Even at 20 Hz, as much as 10 watts of drive could be applied without encountering serious distortion.

General Comments. The Lafayette Model

Circle No. 65 on Reader Service Card

SQA-50 amplifier/decoder was designed to convert low-powered stereo compacts and portable systems to quadraphonic operation. It would seem that it does this job quite satisfactorily since its low power is not much less than that of most portable or compact systems. (And the use of four channels goes a long way toward restoring any apparent loss of loudness.)

The input transformers electrically isolate the SQA-50 from its associated amplifier. Presumably, this would allow the unit to be used even with transformerless amplifiers without risking a shock hazard. Although it could be used with a stereo amplifier of almost any power rating, it is likely that the low power of the SQA-50 would unfavorably contrast with any amplifier rated at more than 15 watts rms of output power.

The successful use of this unit obviously depends on fairly efficient speaker systems for the rear channels. This reinforces its suitability for low-power systems which would already have efficient speakers. Small, efficient speakers characteristically have limited bass response, further complementing the characteristics of the SQA-50.

ELECTRO-VOICE MODELS 1711 AND 1751 MICROPHONES (A Hirsch-Houck Labs Report)



CONDENSER microphones are noted for their smooth, wide frequency response, a fact that makes them the finest recording mikes around. Also, their performance and

stability make them ideal for acoustics measurements; so, almost all loudspeakers are tested with condenser mikes. But condenser microphones also have their drawbacks, not the least of which are the high prices—often several hundred dollars—they demand.

A conventional microphone requires a dc polarizing voltage that can often exceed 100 volts. Since the condenser element must operate into a very high impedance, usually on the order of tens of megohms, an electronic impedance transforming circuit must be built in to provide a more conventional low-impedance output. At one time, this transformation required a vacuum-tube

cathode follower circuit powered by a bulky external power supply. Today, however, the same job can be done with a compact FET source follower circuit powered by a small battery, the whole of which can be fitted into the mike case or handle.

The development of practical electrets has radically changed the condenser mike stalemate. The electret is, in effect, a solid-state capacitor whose dielectric stores a permanent electrostatic charge. This eliminates the need for a dc polarizing voltage, making possible a practical, relatively low-cost condenser microphone for the consumer market.

Among the companies introducing electret condenser microphones is Electro-Voice. We selected (from their series) the Model 1711 omnidirectional mike selling for \$59.70 and the Model 1751 cardioid-pattern mike that sells for \$75. The models are similar in frequency response, dimensions, and external appearance.

The mikes have light aluminum anodized housings and weigh only 4.5 ounces, including battery. Not including the cable connector, they are 8 in. in overall length. The 7/8-in. diameter shank is suitable for hand-held use or for stand mounting via the clip-on plastic holder that is supplied. The microphone section itself measures 2 3/4 in. long by 1 3/8 in. in diameter. Its end is protected by a rugged wire mesh. An 18-ft two-conductor shielded cable with a three-pin audio connector that mates with the Switchcraft A3F socket built into the microphone handle comes with the mike.

The handle of the mike unscrews for snap-in installation of a single AA cell that powers the FET impedance-matching stage.

A slide switch on the side of the handle turns on and off the FET circuit. Failure to turn off the switch after use, however, will not quickly run down the battery. In fact, since the current drain during operation is only 0.4 mA, the battery should deliver its shelf life if left on continuously.

The two mikes have similar response ratings of 60 to 15,000 Hz. The 1751 cardioid version has about 7 dB greater output for the same sound pressure level (SPL). Both mikes have balanced outputs rated at 150 ohms.

Laboratory Tests. The microphones were tested in a reverberant field, located about 12 ft from a wide-range loudspeaker. The frequency response of the speaker was plotted with a sweeping signal generator and a graphic level recorder. Then a calibrated Altec 21BR150 condenser microphone was substituted for the microphone under test, after which the measurement was repeated. The differences between the two curves, added to the calibration curve of the reference microphone, yielded a response curve for the test microphone.

Since the reference mike is also omnidirectional, this technique is reasonably valid for the Model 1711 mike. In the case of the Model 1751 cardioid mike, sound reaching it from the sides or rear contributes very little to its total output. This would be expected to show a roll-off in response at high frequencies where cardioid directivity is most effective.

The Model 1711 had a very smooth extended-frequency response over our full measurement range. It was ± 4 dB from 55 to 15,000 Hz, rising at lower frequencies to

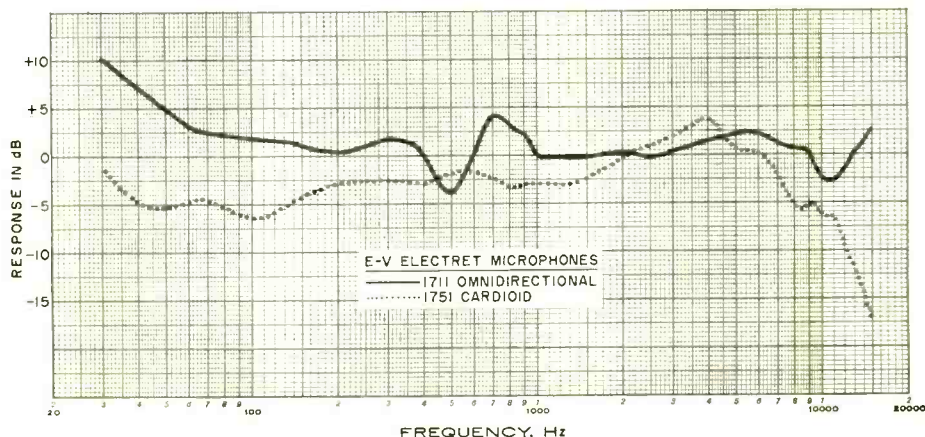

+ 10 dB at 30 Hz. The only significant irregularity in the curve was a dip and peak of about 4 dB (accounting for the greatest variation over the full range) at 500 Hz and 700 Hz.

The Model 1751 was flatter at low and middle frequencies (± 2.5 dB, 33-1500 Hz), with a broad rise of about 5 dB in the 4000-Hz region and a smooth roll-off at higher frequencies. This was expected because of the mike's directivity. Its output was 7 dB greater than that of the Model 1711 at the middle frequencies, as specified.

General Comments. Although the response curves clearly illustrated that the Electro-Voice electret mikes are first-rate performers, our ultimate test was to make tape recordings with each mike on one channel and our reference mike on the other channel of a stereo recorder. Both E-V mikes had smooth extended highs that closely matched the sound of the reference mike. The mid-range and lows seemed to lack a bit of

warmth, but our program material was limited to a male voice with which we would not consider this weakness as being significant. During the test, we checked the directivity of the Model 1751 mike and found it to be very effective.

The only really audible difference between the E-V and reference mikes (the latter rather expensive) was in the background noise levels. At high amplification, our reference mike exhibited some audible hum but virtually no hiss. The E-V mikes, being battery powered, had absolutely no hum but a somewhat more audible hiss level that was not audible at normal gain settings.

The mikes have effective "pop" filters and sound as good in close-up talking as they do at a distance. Their electret elements are rugged and are claimed to be impervious to humidity and to withstand temperatures of from 0° to 110° F. Best of all, their sound quality has a range and smoothness that we have not previously found except in much more expensive mikes.

Circle No. 66 on Reader Service Card

HEATH MODEL IM-1202 DIGITAL MULTIMETER KIT

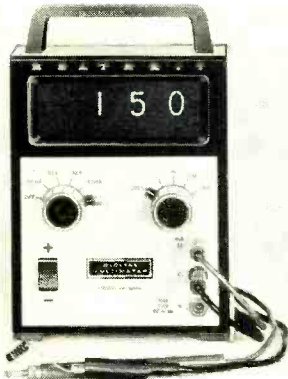

ABOUT three years ago in this department, we predicted the eventual demise of the traditional VOM as the then new transistor multimeter (TMM) was making its appearance in the test equipment market. Quite frankly, we called it wrong. The VOM is still going strong, while the TMM is taking a back seat to the up and coming digital instruments.

While practical digital multimeters (DMM's) have been available for several years, their prices have hardly been an inducement for the average experimenter and technician to rush out to buy them—until very recently. During the past couple of

years, manufacturer costs and supplier prices for all types of solid-state devices—including linear and digital IC's—have been steadily dropping. The result has been a considerable reduction in the prices demanded for DMM's. Even so, DMM's that sell for less than \$100 are still very rare. But the Heath Company has busted right through the \$100 price barrier with the introduction of their Model IM-1202 digital multimeter kit that sells for \$79.95.

The IM-1202 is a 2½-digit DMM providing accuracy and versatility that heretofore could be obtained only in much higher priced instruments. It is a true multimeter in the sense that it offers the user the full line of voltage, current, and resistance measuring functions in the most useful ranges for general-purpose bench servicing and experimenting.

At first glance, the IM-1202 might fool you into thinking that it is a conventional VOM. First of all, its case looks like that of a VOM, measuring 7¾" by 5-3/16" by 3¾" with a molded carrying handle. The layout of the front panel also adds strongly to the illusion; it contains the usual function, range, and polarity reversal switches and input banana jacks for test leads. It is only when one looks at the top of the front panel

that the illusion of an "ordinary" VOM vanishes. There is an oblong filter panel, behind which is located the instrument's readout display, where one would normally expect to find a meter movement.

Technical Data. The IM-1202's display consists of two Amperex gas-discharge 0-9 indicator tubes and a large "1" neon lamp that provide a 2½-digit capability. Another large neon lamp is used as an OVERRANGE indicator, while a pair of smaller lamps are "+" and "-" polarity indicators.

The function switch has positions for OFF, DCMA, DCV, ACV, ACMA, and K (200Ω). The five-position range switch is labelled (200Ω) 2, 20, 200, and 2000. A rocker switch labelled "+" and "-" on alternate positions is used for selecting the dc test polarity for voltage and current. The only other things on the front panel are three color-coded banana jacks labelled mA/Ω, C, and V (MAX. 1 KV DC OR PP).

The dc voltage measuring range of the DMM is from 10 mV to 1000 V with a full-scale accuracy of 1 percent, while the current range is from 10μA to 2000 mA (both ac and dc) with an accuracy of 1.5 percent. On ac, voltage measurements can be

made over a range from 10 mV to 700 V rms at a 1.5-percent full-scale accuracy. The frequency response for both ac voltage and current measurements is 25-10,000 Hz. The lower limit for resistance measurements is 1 ohm, going up to 2 megohms on the highest range, with full-scale accuracy of 2.0 percent. All quoted accuracies are in addition to a ±1-digit accuracy.

The input impedance/resistance is nominally 1 megohm on all voltage ranges. On the current ranges, the maximum drop is 2 volts. On all functions, the overrange capability is 25 percent. This last is within the maximum input limits of: 3 A into ac and dc mA; 700 V rms ac (140 V rms on 2-volt range); and 1000 V dc (200 V dc on 2-volt range).

Built into the kit's circuitry are full facilities for calibration of all functions and ranges. There are various test points on the main circuit board to which the test prod is touched while making the adjustments called for in the "Tests and Calibration" section of the assembly manual provided with the kit. No external test equipment is needed to get the instrument into working order, though external test equipment can be used if desired.

avanti's Astroplane gives CBer's Performance to brag about.

The unique construction features are exceptional.

4.46 db gain over isotropic is, and provides, a stronger transmit and a stronger receive.

To make use of the better signal, the Astroplane radiates the signal from higher up than other CB antennas and at a better angle. According to Dr. Alva Todd of the Midwest College of Engineering, "it possesses an unusually low angle of maximum radiation." This low angle of radiation means that your power is radiated at the horizon and not up into the clouds.

You'll also get long lasting, trouble-free performance because it is compact in design —without long drooping radicals, without coils to burn or

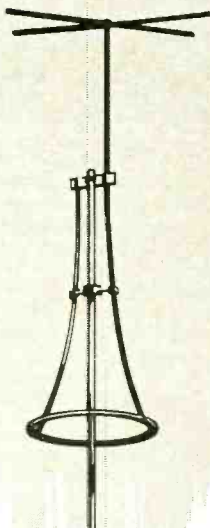

short out, and with direct ground construction for positive lightning protection and static dissipation.

\$29.95 Sugg. Retail

Gain 4.46 over isotropic
Power Capacity 2KW
Lightning protection D.C.
Ground
V.S.W.R. 1.2:1
Length 12 Ft.
Diameter 30 In.

Free 16 page color catalog

Write: Avanti, R & D, Inc.
35 W. Fullerton
Addison, Illinois 60101

avanti
RESEARCH AND DEVELOPMENT, INC.

CIRCLE NO. 2 ON READER SERVICE CARD

creators of the
famous



Comments. We assembled our kit in roughly 7½ hours, working at a slow pace to avoid making errors on the logic/readout board. The main circuit board required less care, due to its relatively uncluttered layout. So, in all, we had our multimeter ready to go in about 10 hours from the time we opened the carton to the point at which we fastened down the last screw.

Since we had at our disposal a precision

ac/dc voltage standard and a number of precision-tolerance resistors (some in the 0.1-percent range), we decided to find out exactly how accurate was our DMM. Needless to say, we were very satisfied with the results obtained from our tests based on using the kit's built-in calibration mechanism. We uncovered a couple of small errors that were well within the published accuracy specifications.

Circle No. 67 on Reader Service Card

PACE MODEL 223 CB TRANSCEIVER

ONE WOULD hardly expect to pay only \$110 for a completely equipped 23-channel, crystal-synthesized CB transceiver, yet that is what you get in Pace's new Model 223 transceiver. There are no extras to buy for that \$110, and it is a made-in-the-USA rig that carries a two-year performance guarantee.

Designed for mobile service where a 12-14-volt dc power source is available, the 223 has the usual features of compactness, an adjustable squelch, a full-time noise limiter, and a push-to-talk ceramic microphone with retractable coiled cord. There is no meter or "delta" tune, facilities that are not really needed in mobile installations, nor are there provisions for public address operation which is seldom used anyhow. The rig features just the essentials for getting the job done. But it has one unusual feature: a theft-proof mobile mounting bracket.

Technical Details. The receiver section of the 223 transceiver employs single conversion to a 455-kHz i-f with which an image rejection of 25 dB is obtained (better than usual for such a setup) and that provides an adjacent-channel selectivity checked out at 45 dB. The latter is made possible through the use of six tuned circuits in the i-f strip set up in a bandpass configuration.

The front end of the receiver contains the customary r-f amplifier and provides good sensitivity that we measured at 0.65 μV for 10 dB (S + N)/N. Included was an agc scheme that maintained an a-f output level within 5 dB with an input change of 10 dB (at 1-3 μV) and within 3 dB with an input variation of 70 dB (at 3-10,000 μV), making for relatively uniform output levels with widely differing input signals. The squelch



threshold was adjustable for a sensitivity of 1 to 1000 μV .

The a-f amplifier uses a power transistor in a single-ended circuit that delivers approximately 2 watts into an oval speaker located at the left side of the rig's case.

The transmitter section, operating up to the full legal input of 5 watts, is straightforward, with the crystal-synthesized carrier signals amplified and applied to the r-f power-output amplifier. The output circuit includes the customary network for matching to 50-ohm antenna loads and for minimizing harmonics. With operation from a 13.8-volt dc source, the 223's carrier output turned out to be 3.5 watts, while a 12-volt source reduced it to 2.5 watts. At an 80° F ambient temperature, the frequency tolerance held to 0.002 percent or less on all channels.

As usual, the receiver a-f power amplifier is used as the modulator for the transmitter. With our test unit, we obtained plenty of modulation, up to 100 percent with clipping. We also noted that the positive peak modulation was somewhat higher than on the negative peaks—even going a bit over 100 percent—resulting in an advantageous asymmetry that produced good upward modulation at a very high average level for a really hefty signal.

General Comments. The Pace 223 transceiver is an attractive rig, housed in a scuff-resistant case. The channel selector dial is

well illuminated for easy channel identification during night-time use.

The mobile mounting bracket clamps all the way around the transceiver case with the rig secured inside by a catch that pulls the bracket tightly together, making it impossible to slide the unit out of its bracket. A wing on the catch is provided with a hole for a padlock (supplied by the buyer) that prevents the catch from being opened.

Circle No. 68 on Reader Service Card

For added security, the mounting screws for the bracket are inaccessible when the rig is installed. While this system is a good deterrent against theft, removal of the lock enables the user to release the catch and loosen the grip on the transceiver without effort. On receive, the power drain at 13.8 volts is 1 ampere (unsquelched) and 150 mA squelched. On transmit, the drain is 1.8 amperes.

ARCHERKIT DELUXE ELECTRONIC IGNITION SYSTEM

OVER the years, we have read a considerable number of articles devoted to the various approaches used in obtaining electronic engine ignition and have become somewhat authoritative on the subject. We have also tested a few capacitive-discharge ignition systems that have later appeared as construction projects in these pages. Until now, however, we have had nothing to do with commercial systems.

Our introduction to the commercial product came from Radio Shack in a box containing all the parts needed for assembling their Archerkit Deluxe Capacitive Discharge Ignition system (\$40). We might add that the kit arrived at a rather opportune moment. We had been noticing that our four-year-old family car was losing its "zip" when we tried to pass slower moving vehicles. This wouldn't have been so bad if it weren't for the fact that the loss of pep created a potentially dangerous situation for us when trying to blend into expressway traffic. Repeated tune-ups did little to improve matters.

We were obviously interested in the Archerkit C/D ignition system. We became even more interested when we read what the new system was supposed to be able to do. According to the Archer people, it would develop 50 percent more spark energy for more complete combustion, and increase the spark magnitude by up to five times for better firing, especially in cold weather. Such an approach should also reduce the need for tune-ups by increasing point life from three to ten times and provide 10 to 20 percent better gas mileage.

The deluxe C/D ignition system can be used with any 4-, 6-, or 8-cylinder engine that operates from a 12-volt, negative-ground, electrical system. No rewiring of the engine's ignition system is required.

Circle No. 69 on Reader Service Card



Assembly. The kit went together in just about 4 hours, ending up in a compact weather-sealed case that measures 5" × 3½" × 3". Installation took only a few minutes, with most of the time spent in drilling three holes in an inside wheel well to accept the case's mounting screws. This done, we connected up the wiring to the appropriate points in the electrical system, guided all the way by an excellently prepared and illustrated manual included with the kit.

After installation, we checked the system's and engine's operation with a CRT ignition analyzer that let us see both the standard and new C/D system in operation. There was quite a difference in waveforms, particularly the high voltages delivered to the spark plugs. We were able to check engine performance with and without the C/D ignition system by operating a switch installed in the end of the case of the kit. Everything looked to be in order; so, we took the car out for a test drive.

After an hour or so of driving, in both passing and following situations, we noted that the engine was acting the way it did two years and 20,000 miles ago. There was a definite improvement in performance. Acceleration, specifically, was much improved.

Amateur 2-Meter FM Repeaters

BY WILLARD R. MOODY
WA3NFW

REPEATERS GREATLY EXTEND VHF RANGE.

THERE IS ONE PRESENTLY IN EARTH ORBIT.

A REPEATER is a modified transceiver that accepts an input r-f signal at one frequency and retransmits it at another r-f frequency. Usually mounted at points of excellent area coverage (on top of hills, towers, etc.), a number of amateur 2-meter band repeaters have greatly expanded the usage of this vhf band. One example of how far repeaters have advanced is the Oscar 6 amateur radio satellite now orbiting the earth. This really "far out" repeater has enabled 2-meter hams (144-148 MHz) to make clean contacts almost anywhere in the world where Oscar can be "seen" simultaneously by both parties. Several contacts have been made recently between 2-meter hams in the U. S. and Japan. Contacts of

over 1000 miles are not a rarity using this repeater.

The concept of the repeater has been in use for some time by commercial communication companies, as well as by the ham fraternity. With repeaters, hams going cross-country can greatly extend their operating range; and even hand-held portables can be heard as far away as a more powerful base station.

A block diagram of a typical repeater is shown in Fig. 1. In this case, the repeater transmitter operates at 146.34 MHz while the receiver is tuned to 146.94 MHz. Entry into the repeater is determined by a control circuit which may be as simple as a carrier-operated relay that turns on the repeater

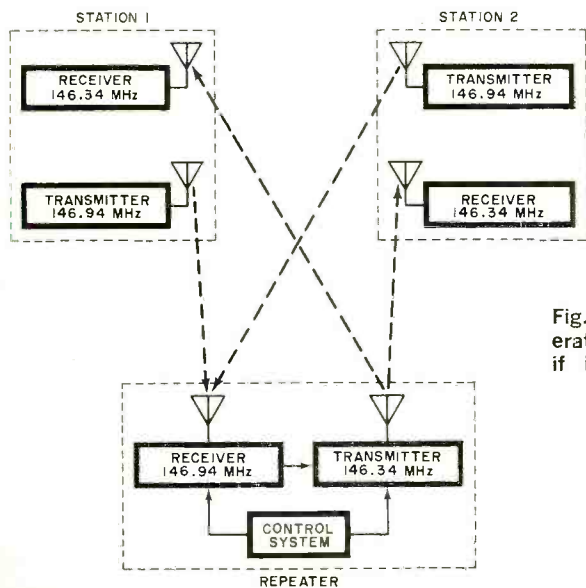

Fig. 1. Diagram of basic repeater operation. Control system determines if it is for general or private use.

when a received carrier (within the receiver's bandpass) exceeds some predetermined level. On the other hand, the control circuit may require a special series of audio tones (known only to club members) or it may have to be turned on remotely by one of the club members. Why only club members? Because a relatively sophisticated repeater may represent quite an investment of time and money on the part of the amateur radio club which operates it.

The two stations involved must have transmitters operating at the receiving frequency of the repeater and must be able to receive at the transmitted frequency of the repeater. Although the 2-meter frequencies previously mentioned are commonly used, other frequencies are possible—usually separated by about 600 kHz.

In the case of the Oscar satellite, a different approach is used (Fig. 2). The input frequencies to the satellite repeater are from 145.9 to 146 MHz, and it transmits on the 10-meter band from 29.45 to 29.55 MHz.

Potential Is Great. The potential use for space repeater systems is enormous. Hams have been experimenting for many years with moon bounce—using the moon as a passive reflector or mirror. However, transmission losses are very high due to the passive nature of the moon, and the radio waves are highly attenuated as they travel the long distance through space. With Oscar however, signal reinforcement produces a far better signal-to-noise ratio and greatly improves the performance. In fact, establishing contacts across the Atlantic or the Pacific is quite common—feats that

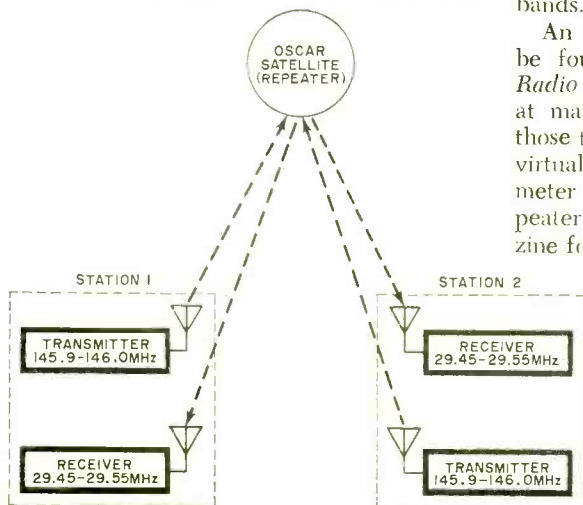

Fig. 2. The Oscar earth satellite repeater receives 2-meter transmission, transmits on 10 meters.

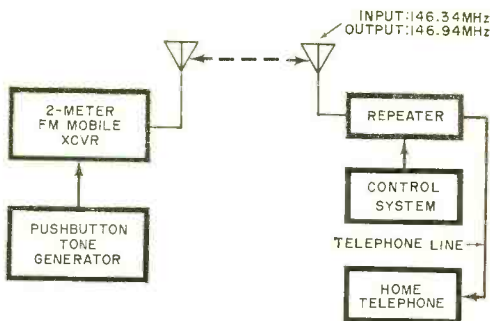

Fig. 3. Basic auto-patch communication system for the 2-meter amateur band.

were considered impossible only a few short years ago.

Another exciting aspect of amateur 2-meter FM and repeaters, is the use of the "auto patch" (Fig. 3). The mobile ham simply "calls" auto patch and operates a pushbutton tone generator (such as used in home phones) to get a land-line connection. In this case, the connection between the mobile and the remote phone is a radio link. This service is a great asset when traveling in remote areas or in the event of an emergency.

Repeater Locations. Each section of the country has its own repeater locations, determined by the club members who operate them. Local 2-meter hams are aware of these locations.

While 2-meter FM repeater operation is very popular, repeaters have also been used on the 6-meter ham band; and there seems to be great potential for use in the uhf bands.

An excellent treatment of repeaters can be found in the ARRL publication *The Radio Amateur's VHF Manual*. It is \$2.50 at many electronic distributors—especially those that handle ham gear. Frequencies for virtually all amateur operation in the 2-meter band and standard direct and repeater frequencies are given in *QST* magazine for May 1972. ♦



Biological Effects of Electrical Shock

By John T. Frye, W9EGV, KHD4167

MATILDA, office girl at Mac's Service Shop, paused in her typing to listen to the voices of her employer and his assistant coming through the open door of the service department. They were engaged in what Barney had solemnly assured her was going to be a "serious discussion."

"Okay, boss," Barney was saying, "I understand we're going to talk about what happens to the human body when it's exposed to various kinds and amounts of electricity, but where did this poop come from? Who dug it up?"

"The 'poop,' as you call it, represents the fruit of serious experiments by distinguished scientists in Russia, England, and this country, going back as far as 1775. On this card I've typed a list of some of the references I consulted while boning up on the subject, and I want you to read several of them. When through, you'll have a lot of respect for such names as Dalziel, Ferris, Lec, Kiselev, and Kouwenhoven. In our little talk, though, I do not intend to tie each finding to a certain experimenter. Instead I'll quote facts and figures that represent more or less a consensus, which will not be difficult because the separate findings lie reassuringly close together.

"Okay, how much voltage is safe?"

"We're not going to talk about voltage. Current is what affects the living organism, and current cannot be directly related to voltage applied to the human body because the resistance of the body varies so widely. For instance, dry skin has an average resistance of 100,000 to 500,000 ohms, but this falls to 1000 ohms when covered with perspiration and on down to 150 ohms when immersed in water. If areas are flayed so the electrodes are in contact with subcutaneous tissue, the resistance falls to only 100 ohms between the ears and to 500 ohms from flayed hand to flayed foot. Resistance also

varies greatly with the area in contact with the electrode. Since current equals voltage divided by resistance, this means the same voltage can produce a great range of current. For example, 110 volts ac can produce 1 mA through dry skin, 110 mA through perspiring skin, and 0.75 ampere when applied to a body in a bathtub or shower. This explains, in part, why people have been electrocuted with less than 50 volts, while others have survived contact with thousands of volts."

Direct and General Shock. "Before we get started on the effects of various amounts of current on the body, let's make a distinction between the direct effect of electric shock and general shock to the nervous system. The latter is evidenced by news stories in which a person dies of excitement while watching a football game, of fright in a fender-dimpling accident, or even of joy at the receipt of good news. For these people, no current they can feel and be startled by, no matter how slight, is safe and may result in a fatality; although the death should be charged to nervous system shock rather than to the primary effect of electric current.

"Over the years literally hundreds of men and women have been tested for their response to electrical currents. One of the first things experimenters established was the *threshold of perception current*. The subject usually held a small current-carrying wire in each hand or substituted a brass plate tapped with a forefinger for one of the wires while the available current was gradually increased until it could be felt. The mean current at this point was found to be about 1.1 mA for men and 0.7 mA for women. To be on the safe side, the 0.5 percentile value of these measurements, 0.5 mA, is generally established as the current level below which there is little likelihood that an electric current will be felt when applied to unbroken skin

of the hands. Some other areas of the body are more sensitive to electric current, the tongue being the most sensitive. Only 45 microamperes of current can be perceived by it, more in the way of a taste-bud stimulation than the usual sensation of shock."

"What happens when you increase the current?"

"The next thing the experimenters wanted to know was the *maximum let-go current*. As 60-Hz ac current is increased from the threshold value, the muscles begin to contract until finally voluntary control of them is lost. Beyond a certain value, called the let-go current, it is impossible for the subject to release a current-carrying electrode. Average values for this let-go current were found to be 16 mA for men and 10.5 mA for women. Again applying the 0.5 percentile values, these became 9 mA for men and 6 mA for women. Incidentally, this 3/2 ratio of current tolerance for men and women prevailed throughout most of the tests—if Women's Lib members will pardon the observation! It was also found that 60-Hz ac is four to five times more dangerous than dc because ac causes more severe muscular contractions and produces sweating that lowers the skin resistance. Let-go current increases with frequency. At 5000 Hz, the let-go current is more than three times the value at 60 Hz.

"Currents greater than about 18 mA contract the chest muscles and stop breathing during the shock, but breathing resumes when the current ceases. However if the current continues, collapse, unconsciousness, and death result in a few minutes from lack of oxygen to vital organs. Currents much above 20 mA are considered too dangerous to apply deliberately to human beings; so experiments must be conducted on animals and the data extrapolated to man. While this leaves much to be desired, it's not easy to recruit volunteers for destructive testing."

"I'd think not!" Barney muttered.

"Most tests on animals were directed toward determining the *maximum non-fibrillating current* in adults. Ventricular fibrillation is a medical term describing a usually fatal interference with the heart's electrical activity. Just as a car's ignition system keeps all the cylinders firing in a smooth and powerful sequence, so does the heart generate and conduct timed pulses of electrical current that contract ventricular muscle fibers in a coordinated and rhythmic fashion to produce maximum blood-pumping efficiency. An abnormal stimulation of the heart can

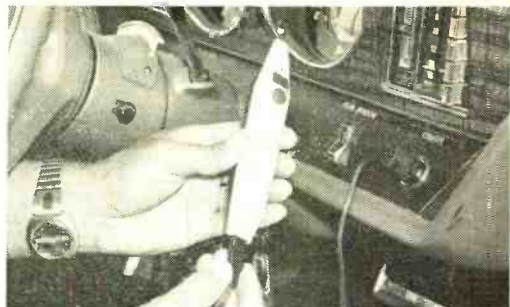

greatest advance in soldering since electricity!

WAHL Cordless SOLDERING IRON

Wahl "Iso-Tip" gives soldering heat in 5 seconds. Lets you solder up to 100 joints* unhindered by cord and plug anywhere! Recharger/converter plugs into 12V cigarette lighter. Safe to use on sensitive components. See your dealer or order direct.

7565 Kit with 12V Auto Charger **\$18.95**
7500 Kit with 120V AC Charger **\$19.95**

(* Depending upon wire size, temperature and atmospheric conditions.)

WAHL CLIPPER CORPORATION Dept. 2
2902 Locust St. • Sterling, Ill. 61081 (815) 625-6525
CIRCLE NO. 38 ON READER SERVICE CARD

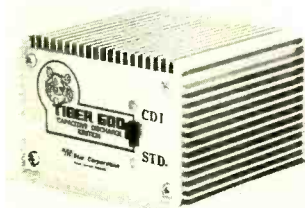

12 REASONS YOUR CAR NEEDS TIGER CDI

Instant starting in any weather - Eliminates tune-ups - Increases gas mileage - Increases horsepower 15% - Improves acceleration and performance - Spark plugs last up to 70,000 miles - Reduces engine maintenance expense - Amplifies spark plug voltage to 45,000 volts - Maintains spark plug voltage to 10,000 RPM - Reduces exhaust emissions - Dual ignition switch - An Unconditional LIFETIME GUARANTEE - Installs in 10 minutes on any car with 12 volt negative ground - No rewiring - Most powerful, efficient and reliable Solid State Ignition made.

SATISFACTION GUARANTEED or money back.
TIGER 500 assembled **\$49.95**
TIGER SST assembled **39.95**
TIGER SST Simpli-Kit **29.95**
Post Paid in U.S.A.

Send check or money order with order to:

Tri-Star Corporation

Dept. W, P. O. Box 1946
Grand Junction, Colorado 81501

DEALER INQUIRIES INVITED
CIRCLE NO. 35 ON READER SERVICE CARD

make it start acting as a car would if someone instantaneously scrambled the spark plug wires. Muscle fibers contract independently in an uncoordinated, asynchronous fashion that sets the heart to quivering and destroys entirely any effective pumping action. For all practical purposes, the heart stops and asphyxial death occurs in a few minutes. Once ventricular fibrillation starts in man, it rarely stops naturally before death."

Experimental Results. "Experimenters have electrocuted hundreds of animals including horses, calves, sheep, pigs, dogs, and smaller animals with gradually increasing 60-Hz current while monitoring the heart's action with an ECG to detect the onset of fibrillation. Were Matilda listening—which, of course, she isn't—I'd assure her the animals were anesthetized before the experiments." He paused, and Matilda's fingers began guiltily pecking away at the typewriter keys.

He went on. "Here are some conclusions reached: current through the heart—for example, from hand to hand or hand to foot—is needed to produce fibrillation. That's why, if you must work on a hot circuit, you should keep one hand in your pocket and make sure you're standing on insulating material. Whether or not fibrillation occurs depends on the weight of the subject, the strength and duration of the current, and *when* a short shock occurs with regard to the heart's cycle. Ventricular fibrillation is unlikely to occur in a normal adult if the shock intensity is less than $116/t^{1/2}$ mA, where t is in seconds. This means the maximum non-fibrillating current for a 1-second shock is 116 mA; but for a 4-second shock it is only half that value. As the weight goes down, so does the maximum non-fibrillating current. A value of current an adult can endure safely may electrocute a child."

"What does the timing of short shocks have to do with it?"

"There is a recovery period just after the ventricle has contracted when it is particularly susceptible to being triggered into fibrillation by stimulation. This corresponds with the 'T-wave' of the ECG display. If a random self-generated pulse of the heart, called a 'premature ventricular contraction,' falls on a T-wave, it can trigger fibrillation so that the heart, especially a diseased heart, can, in effect, electrocute itself. A pulse of external current penetrating the heart at this

sensitive moment can have the same effect.

"Currents of 100 to 200 mA are the values most likely to produce fibrillation when applied to the exterior of the body. Above 200 mA the heart muscles are clamped so tightly by the current that there is no movement, not even the quivering of fibrillation. A heavy current of short duration may well be less dangerous than one in the range of 100 to 200 mA. This also explains why fibrillation is stopped in a cardiac intensive care unit by a heavy-current counter shock that stops the random, ineffective activity of the heart completely and allows it 'to start all over' in the proper manner."

"But too much current actually sears tissue the way those electric hot dog cookers sear weiners," Barney pointed out.

"Right. It's a grisly subject, but we know a little about what heavy currents do to the human body from examination of the bodies of electrocuted criminals. In a typical electrocution, 2000 volts was fed to moistened, sponge-lined electrodes applied to the shaven skull and a leg. The voltage was immediately dropped to 500 volts and then raised and lowered between these two values of voltage every 30 seconds for two minutes. The current varied from 4 to 8 amperes. A temperature of 128°F was measured at the site of a leg electrode 15 minutes after the electrocution, and the blood was found to be profoundly altered electrochemically."

"Let's get off that subject," Barney said with a shiver. "A few years back, I remember reading stories in both *Time* and the prestigious *Wall Street Journal* quoting some authority as saying that 1200 patients were accidentally electrocuted in hospitals every year. Know anything about that?"

"That was in 1969, when Dr. Carl Waldemar Walter of Boston's Peter Bent Brigham Hospital and professor of surgery at the Harvard Medical School was alleged to have said that. His statement hit hard because Dr. Walter was chairman of the National Fire Protection Association that drafts safety codes for electrical devices. The figure was hotly disputed by many members of the AMA as being exaggerated and, to my knowledge, was never really proved true or false; but the story did serve to focus attention on this type of electrocution *that can and does happen*."

"Dr. Arbeit, writing in the June 19, 1972, issue of the *JAMA*, cites fifteen cases of accidental electric shocks delivered to hospital patients, at least five of which were fatal;

and an ECG machine or monitor was involved in fourteen of these cases. Such devices have normally grounded the patient to eliminate serious 60-Hz interference with the tracings. From our talk about leakage currents last month, we know a grounded body is a sitting duck for any current leaking out of any other line-current-operated device he touches, such as a bedside lamp, radio, TV, electric bed, or another diagnostic or therapeutic piece of equipment.

"Many hospital deaths, however, do not result from *macroshock currents*, applied to the exterior of the body. Instead they are caused by *microshock currents* that bypass the high-resistance skin layer and are delivered directly to the interior via wires or fluid-filled tubes inserted into one of the body orifices or through cuts made in the skin. Where such conductors enter the thorax and approach the heart, extremely small ac currents can cause death. Some medical authorities say currents as low as 20 microamperes can trigger fibrillation when applied directly to the heart by means of a pacemaker lead or through a diagnostic catheter inserted into the heart chambers. At this level, even static electricity becomes a threat.

"This accumulated knowledge about what happens to the body when it is exposed to electrical shock is beginning to bear fruit. In July of last year, the Underwriters' Laboratories finally brought out a realistic safety standard for medical and dental equipment, UL 544. We've already talked about established standards for leakage current in household appliances. Equipment manufacturers, finally provided by the medical fraternity with hard information regarding how much current is safe in a variety of situations, are designing and marketing equipment that should be harmless when properly used, as they always said they would." ♦

REFERENCES

- "The Effects of Electric Shock on Man," C. F. Dalziel, reprinted from IRE Transactions on Medical Electronics, May 1956. For sale by Supt. of Documents, U. S. Govt. Printing Office, Washington, DC. Price, 20¢.
- "Lethal Electric Current," C. F. Dalziel and W. R. Lee, IEEE Spectrum, February 1969.
- "Standards for Safety Medical and Dental Equipment," Underwriters' Laboratories, 1285 Walt Whitman Rd., Melville, NY 11746.
- "Controlling the Electrocutation Hazard in the Hospital," Sidney R. Arbeit, et al, Journal of American Medical Association, Vol. 220, No. 12, June 19, 1972.
- "Intensive Heart Care," Bernard Lown, Scientific American, Vol. 219, No. 1, July 1968.
- "American National Standard for Leakage Current for Appliances," #C101.1, American National Standards Institute, Inc., 1430 Broadway, New York, NY 10018.

TEST NEW CIRCUIT IDEAS, I.C.'s, DISCRETE COMPONENTS WITHOUT RISK!

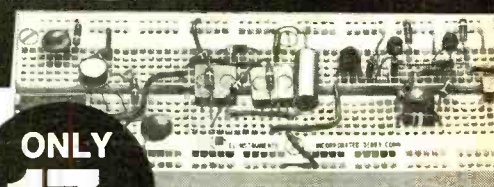

ONLY
17²⁵

**MONEY-BACK
GUARANTEE**

All you need are #4 mounting screws. Just plug-in 1/4 watt resistors, ceramic capacitors, diodes, I.C.s, transistors and more and your circuit is built! No special patch cords needed! Interconnect with any solid #22-26 gauge wire.

Try it with absolutely no risk for 5 days. If not satisfied, return your EL Socket and get a full refund. Trying is believing. How can you go wrong? **Send Check or M.O. today!**

- Nickel/silver plated terminals—low contact resistance
- Low insertion force • Mounts with #4 screws
- Initial contact characteristics beyond 10M insertions
- Vertical, horizontal interconnecting matrices
- Handles wide range of wire, leads from .015"-.032"

- Add 50c for postage, handling
- 25% deposit on C.O.D.s



ASK FOR NEW

FREE

**IDEA-PACKED,
ILLUSTRATED
CIRCUIT DESIGN
CATALOG!**



EL INSTRUMENTS, INC.
61 First St., Derby, Conn. 06418
Telephone: 203/735-8774

CIRCLE NO. 16 ON READER SERVICE CARD

Fastest Electronic Device

IN 1962, the English physicist Brian Josephson predicted that an insulator could behave like a superconductor (complete disappearance of electrical resistance at very low temperatures), provided it was thin enough and was sandwiched between two layers of superconductive metals.

Now, in 1973, scientists at the IBM Research Division have used the Josephson effect, combined with other experimental findings, to indicate that current could pass through an ultra-thin insulating barrier between superconductors in two different ways, to produce an electronic switch that can operate in less than 10 trillionths of a second (picoseconds). In performing this switching action, the device requires only about 1/10,000 the power of the best switching transistor.

This tiny power consumption means that the junctions generate very little heat and thus can be packed very closely together. Since an electrical impulse travels about 1 mm in the time that a Josephson junction

switches, dense packing is essential to avoid excessive delay as the signal travels from one circuit to the next.

At low current levels and with no magnetic field present, the current passes (or tunnels) through the insulator as if it were a superconductor. There is no voltage drop across the junction. If the current, or an applied magnetic field, is raised above a certain critical level, conduction through the insulating barrier is by the familiar form of electron tunneling similar to that found in a tunnel diode. The two differences—the presence or absence of a voltage drop—represents the 1 or 0 levels of digital computer logic.

The first Josephson junction switcher was reported in 1967 by Juri Matisoo of IBM, who measured a switching speed of less than 800 picoseconds. The higher speed is a result of the decreased size (1.25 by 3.1 microns), higher current density, and the sophisticated instrumentation developed for measuring such short switching intervals.

Drs. Wilhelm Jutzi (left) and Theodor Mohr, of IBM, check the new device.

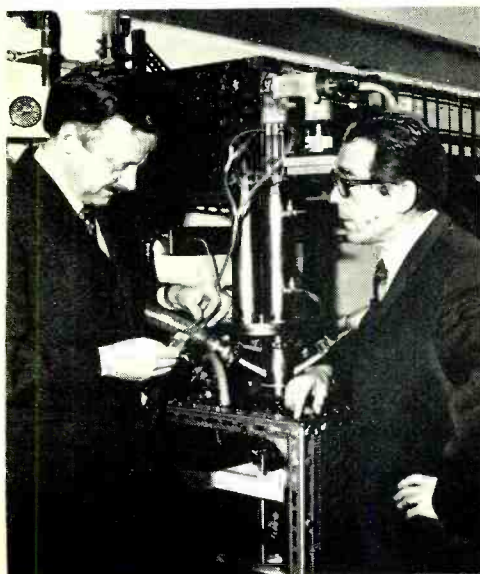

Small bounded oval at center of this photomicrograph is a Josephson junction, measuring 1.25 by 3 microns. Broad white areas are 50-ohm transmission lines connecting junction to the external time-measuring circuitry.

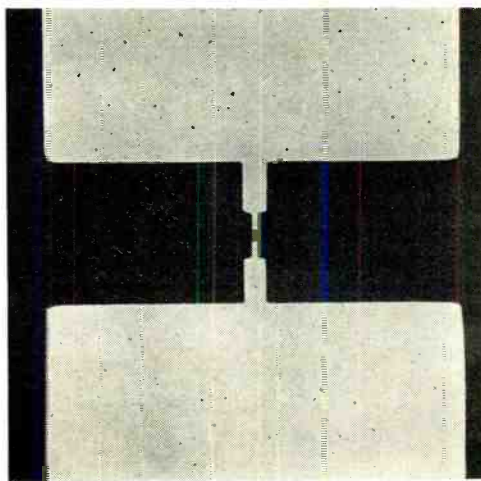

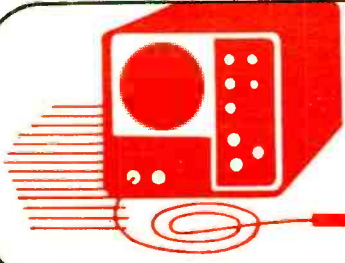

Test Equipment Scene

By Leslie Solomon, Technical Editor

NOW THAT digital logic, especially TTL, has come into wide use because its price has come down (or is it the other way around?), electronics hobbyists and technicians are starting to see more and more of this type of circuit. All of which probably accounts for the number of queries I have had recently concerning servicing of digital circuits and the types of test equipment that should be used.

Some engineers say that semiconductor devices do not have the mechanism to age or wear out, so that, theoretically, they should last forever, provided the applied voltage and signal parameters are not exceeded. However, we all know—or at least suspect—that gremlins exist and that their main talent is refuting the laws of physics. The chief gremlin is called “transient spike” and he can be stopped by the use of suitable suppressors judiciously connected to the circuit. Anyway, digital IC’s have been known to fail, and the chances are that, sooner or later, each of us will run into one that does.

As with conventional transistors, there are two ways to test digital IC’s. One is with the IC connected into the circuit; the other is with the IC off the board as a discrete unit. We will start with in-circuit tests.

Regardless of the type of digital circuit, the main intent is to have either a high (logic level 1) or low (logic level 0) output depending on the input signal conditions for the particular stage. In some cases, particularly timing circuits, the output of that stage is dependent on the values of the passive components connected to the IC. We must assume that these components are good. (If it is felt that this assumption is not valid, then the components should be checked.) For other circuits, all that is needed are the correct inputs to the IC and some means of detecting and indicating the 1 or 0 output state.

There are several digital “state” indicators on the market. Similar in appearance, they usually look like slightly chubby test probes and contain one or more lamps used as state indicators. Most derive their operating power from the PC board being tested, and the probe tip is used to check the state at the selected pins. Some testers use a single lamp to indicate a logic 1 (lamp on) and logic 0 (lamp off). Others use two lamps, one being on for logic 1 and the other for logic 0. Still other indicators have a third lamp (called a “pulse catcher”) that glows when a pulse of even a very short duration is detected. The latter is used when a narrow pulse does not have the duration to cause the logic 1 lamp to glow. There are even some state indicators that use an audio tone to signal the presence of a changing state, with one tone for logic 1 and another tone for logic 0. All of these probes are used to detect the signal present at one pin at a time.

Clip-On Testers. If you want to see the states of all of the pins at once, consider using a “clip-on” type of tester, which has a multi-contact, spring-loaded clip that fits over the IC package. The tester thus contacts all of the pins simultaneously and is connected by a flexible cable to an indicator chassis. The chassis usually has a 16-pin DIP outline with a pilot lamp at each pin

Testing Digital Circuits

Monitor Lo, Hi, UHF Simultaneously with PACE SCAN 308

only \$199.95
plus crystals

- weather alerts
- police messages
- fire alarms
- traffic advisory
- ambulance activity
- marine calls
- business action



The most advanced IC and FET designed, compact Monitor for mobile and home installation. The PACE SCAN 308 provides 16 channel capability.

Program switches on the rear panel select any 8 channel combinations of Hi or Lo VHF, or UHF FM frequencies. Lockout switches enable you to control channel monitoring in an instant. No need to rewire as in other monitors. Just plug into AC or 12v DC. Power cords, mobile and desk mounting material provided.

Manufactured in the U.S.A. with high grade U.S. components. PACE is the only supplier which backs up each product with a full 2-year warranty.

SEND FOR FREE CATALOG

((P)) PACE COMMUNICATIONS

Division of PATHCOM INC.

24049 So Frampton Avenue, Harbor City, California 90710

Your name _____

Street _____

City, State & Zip _____

Frequency or type of Monitor needed _____

CIRCLE NO. 28 ON READER SERVICE CARD

location. As the 1's and the 0's appear at each IC pin, the associated pilot lamp turns on and off. If you do any serious testing of digital circuits, you will need this type of instrument.

To see how handy a state indicator can be, build the simple circuit shown in the diagram. It is best not to have the probe

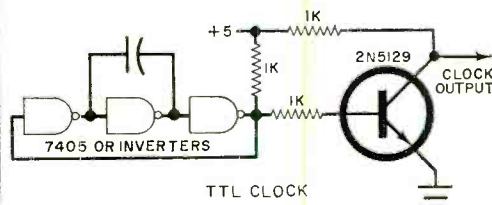
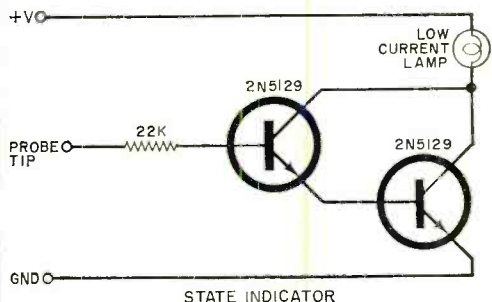

Two digital test circuits you can try.

input cable more than two feet long. You can use this state indicator for TTL, RTL, DTL, or even some MOS circuits. The Darlington circuit and input resistor assure a high input impedance (very low loading); and the lamp will glow when the input signal exceeds approximately 1.4 volts. Below this voltage, the lamp remains off. Both the +5 volts and ground are obtained from the circuit board under test. This circuit can be built into a narrow insulated tube, with the lamp at one end and a probe tip (which could be the resistor lead) protruding from the other. All you need is the +5-volt and ground leads coming out for the external connections. The circuit will also work with the 3.6 volts used for RTL.

If you also want to try a clock pulse generator, use the second schematic. This particular circuit uses a common type of TTL integrated circuit, and all you have to do is vary the value of the coupling capacitor to change the clock rate. The larger the capacitance value, the slower the clock.

If you purchase a number of TTL IC's from a surplus dealer (such as those advertised in this magazine), you may want

to check each piece before going through the trouble of soldering them into the board. It's pretty discouraging to discover, after installing a 14- or 16-pin IC (especially on a two-sided board), that the circuit doesn't work.

Build or Purchase. You can build your own digital IC tester using the circuits shown here (along with a power supply) or you can buy one of the many "breadboard" units currently available. The one we use is made by MITS. This handy unit is extremely flexible and contains a variable speed clock generator, a combination 14- and 16-pin IC socket with each pin having its own LED readout, a built-in 5-volt high-current power supply, and a unique method of switching each pin into the necessary configuration. You can test a wide variety of IC's with this tester. Using it is just like using a tube tester. All you do is look up the IC in the manual provided, set up the switches accordingly, plug in the IC, and watch the LED readouts.

Of course, the question always arises as to when to assume that the components and circuit design are OK and commit yourself to soldering the IC's to a PC board. Before taking this last step, most of us have already built a "breadboard" (if that's what you call that rat's nest of wires on the workbench). By the time we have arranged the sockets, power supply, readouts, and the required maze of interconnections, all it takes is a brief interruption to cause us to forget which lead went where and at what point we were in the design. If you have this type of problem, give some thought to the use of a professional type of breadboard. There are several on the market for both RTL and TTL/DTL circuits. Since TTL is getting to be more popular, we decided to use the Digi-Designer made by EL Instruments, Inc. This instrument contains a 5-volt power supply capable of handling a number of IC's, a set of LED readouts, some no-bounce switches, and a variable speed clock generator.

Once the kit is built, it can be used without making solder connections. All that is needed is some short lengths of #22 wire to make the necessary interconnections. The unique socket can hold a wide assortment of IC's, transistors, and accompanying passive components. It even has provisions for external inputs and outputs for any pin. ♦

If paging speakers all seem about alike to you...wait 'til you get to the top of the ladder to install them!



*Electro-Voice
Paging Speakers
... If you pay less
it may cost you more!*

How many trips up the ladder does it take you to finally install a paging speaker? (Be honest and include the times you drop hardware, and the extra trips to change level or positioning). Good news! E-V has made paging speaker installation easier and faster.

Now you need fewer tools and less time to get better sound. Speaker base removes for easy mounting, and it won't fall apart in your hands in the process. There are no screw terminals to short out, pigtailed are already attached, no transformer cover plates to unscrew, and final speaker positioning is simple and positive.

All this and great sound in the bargain. Plus competitive prices on every model. More than a dozen from which to choose. Write today for our catalog or see your nearby Electro-Voice sound merchant.

ELECTRO-VOICE, INC., Dept. 536P,
630 Cec 1 Street, Buchanan, Michigan 49117
In Europe: Electro-Voice, S.A. Romerstrasse 49, 2560 Nidau Switzerland
In Canada: EV of Canada, Ltd., Gananoune, Ontario

Electro-Voice®

**a Gulton
COMPANY**

CIRCLE NO. 17 ON READER SERVICE CARD

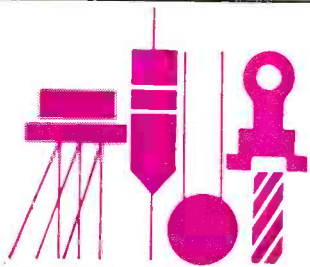

Solid-State Scene

By Walter G. Jung

OUR Solid-State Scene this month focuses on two key developments in the IC world—new types of quad comparators and op amps. Although these classes of devices serve different functions, they are in a sense related because both are members of the linear IC family and they operate by differential comparison. Further, they use some similar circuitry and are designed for building-block use in systems with single power supplies. Chances are that, once you become acquainted with these two new devices and what they can do, you'll find them useful additions to your bag of tricks.

New Quad Comparators. The op amp is probably familiar to most of us, but the comparator may be new to some. A comparator is simply a high-gain amplifier designed to "compare" two inputs. Like the op amp, a comparator has differential inputs, both inverting (-) and noninverting (+) with respect to a single output. Beyond this, however, the devices differ. A comparator is not used with negative feedback, whereas the op amp usually is. In a typical application for a comparator, a fixed (reference) voltage is applied to one input and a varying voltage (either ac or dc) to the other input. The output will then change states as the varying input voltage crosses the fixed reference level. The device answers the logic question, "Is the input *greater* or *less* than the reference?" The relative states of the

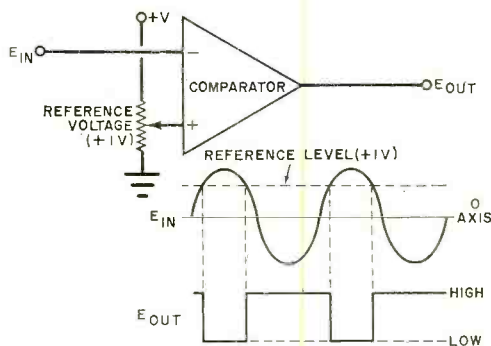

Fig. 1. Basic action of a comparator.

inputs are then indicated by the output—either high or low.

In the example shown in Fig. 1, a fixed 1-volt dc level is applied to the (+) input while a sine wave is applied to the (-) input. When E_{in} is less than +1 V, the output is high. As E_{in} rises and passes +1 V, the output switches states, going from high to low. Typically, a comparator is capable of a wide range of input levels (allowing it to be used with a wide range of input voltages) and its output is compatible with one or more forms of logic.

Applications for comparators include level detectors (such as Fig. 1), sine/square-wave converters, phase detectors, oscillators, multivibrators, and a host of other switching circuits based on the level-detection principle.

Multiplying a useful basic idea by four, Motorola and National Semiconductor have recently introduced quad comparators in single 14-pin packages. Motorola's chip is the MC3302P, while National has a series composed of LM139, LM239, and LM339 (the main difference among the three being temperature range).

What is unique about these devices as compared to previous ones? Well, they operate from single or dual power supplies

IC Comparators and Op Amps

over a wide range. They also have a very low power drain and their outputs can be used with all forms of logic. A very unusual feature is the pnp input stage (Fig. 2) which allows the input to be biased at ground level—even with a single power supply and no additional bias. Outputs of the comparators are open-collector npn stages—a handy feature for connecting a number of devices in parallel for combined logic functions.

All devices mentioned are available in 14-pin packages.

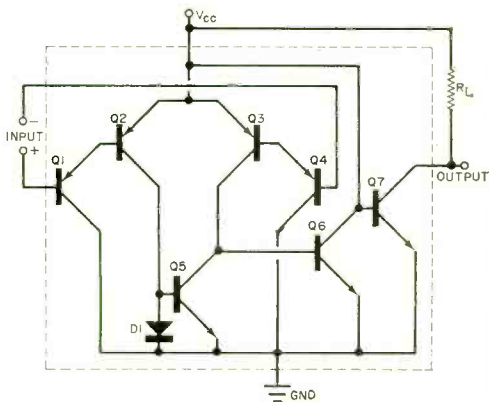

Fig. 2. One section of a quad comparator.

Quad Op Amps. We have mentioned a family relationship between the new comparators and op amps. National's new LM124, LM224, LM324, and LM2902 are the op amp relatives. They also feature that neat pnp input stage which allows such a wide range of input voltages. These devices are also designed for a single power supply (or a dual supply) and have low bias current.

These chips are in many respects like the popular 741, and for many applications, may be used as such. For instance their gain is about 100 dB; bandwidth is 1 MHz; and the amplifiers are internally compensated. All of these factors simplify their use considerably. Pin arrangement on these devices is different from the previously announced quad op amp (LM3900) and is shown in Fig. 3. This is a symmetrical layout with outputs at the four corners of the 14-pin package. The power supply pins are used as a screen between the two amplifier sets.

It has been said that the op amp is the most universal circuit component in existence. Now, universality acquires a new

The great new
Super Scanner
It scans 360° in milliseconds with 5.75 dB gain. Or beams an 8.75 dB gain signal where and when you want it—**instantaneously.** (Otherwise, it's just another beautiful base antenna.)

MODEL MS-119 Super Scanner electronic beam, incl. control console—sugg. price, \$99⁹⁵

the antenna specialists co.

Division of ORION INDUSTRIES, INC.
12435 Euclid Ave., Cleveland, Ohio 44106
Export: 2200 Shames Dr.,
Westbury, L.I., New York 11590
Canada: A. C. Simmonds & Sons, Ltd.

CIRCLE NO. 1 ON READER SERVICE CARD

ABOUT YOUR SUBSCRIPTION

Your subscription to POPULAR ELECTRONICS is maintained on one of the world's most modern, efficient computer systems, and if you're like 99% of our subscribers, you'll never have any reason to complain about your subscription service.

We have found that when complaints do arise, the majority of them occur because people have written their names or addresses differently at different times. For example, if your subscription were listed under "William Jones, Cedar Lane, Middletown, Arizona," and you were to renew it as "Bill Jones, Cedar Lane, Middletown, Arizona," our computer would think that two separate subscriptions were involved, and it would start sending you two copies of POPULAR ELECTRONICS each month. Other examples of combinations of names that would confuse the computer would include: John Henry Smith and Henry Smith; and Mrs. Joseph Jones and Mary Jones. Minor differences in addresses can also lead to difficulties. For example, to the computer, 100 Second St. is not the same as 100 2nd St.

So, please, when you write us about your subscription, be sure to enclose the mailing label from the cover of the magazine—or else copy your name and address exactly as they appear on the mailing label. This will greatly reduce any chance of error, and we will be able to service your request much more quickly.

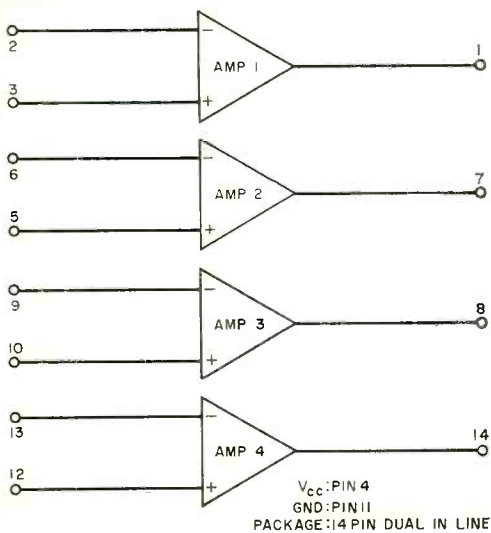

Fig. 3. Pin connections for op amps.

dimension—four universal components. Single-unit prices for the commercial grade comparators and op amps are: MC3302P, \$1.20; LM339N, \$5.70; LM324N, \$3.75.

Programmable Comparator. RCA has just introduced an interesting new IC: the CA3099E programmable comparator with memory. This chip is a combination of high- and low-voltage level sensors, a flip-flop (for memory), a driver, and a 150-mA output stage. It is capable of performing a variety of functions and has built-in voltage and current regulation. The device can be externally programmed for adjustment of performance and is designed as a control element for high-current loads such as thyristors, relays, lamps, etc. Applications include heater controllers, photosensitive relays, motor controllers, level detectors, time delays and one shots, and over-voltage, over-current and/or over-temperature protection. The device comes in a 14-pin dual in-line package.

Optic Couplers With 4N Classification. Have you ever been confused by the proliferation of numbers for LED (light-emitting diode) phototransistor electro-optic couplers? Motorola has recently taken a big step toward standardization of these devices by registration of former device numbers MOC1000, MOC1001, MOC1002, and MOC1003. The newly numbered devices are the 4N25, 4N26, 4N27, and 4N28. Isolation voltage ratings range from 500 V

(min) with the 4N28 to 2.5 kV (min) with the 4N25. Types 4N25 and 4N26 feature a 5-mA output current while the 4N27 and 4N28 achieve 3 mA, both ratings with a 10-mA input. All units are in 6-lead dual in-line packages with prices beginning at \$1.50 for the 4N28.

Power Transistors. Quite a number of new power transistors have been recently introduced by Texas Instruments. The devices cover a variety of packages and voltage ratings, both single transistor and power Darlington, in high voltage and complementary form.

The TIP620, TIP621, and TIP622 are npn power Darlington's with voltage ratings of 60, 80, and 100 V respectively. The pnp complements are TIP625, TIP626, and TIP627. All units can dissipate 100 watts, have a gain of 1000 at 3 A, and come in TO-3 metal packages.

For higher voltage applications, there are the plastic-packaged TIP55 through TIP58 (250, 300, 350, and 400 V), while the TIP554, TIP555, and TIP556 come in TO-3 metal packages with ratings of 200, 300, and 400 V. All units have a 125-watt dissipation rating. The plastic devices can handle 7.5 A, maximum, while the metal versions are rated at 5 A.

Nine high-voltage Darlington devices have also been introduced. The TIP150, 151, and 152 are in TO-66 plastic packages, rated at 2 A and 200, 300, and 400 V, respectively. The TIP160-162 come in TO-3 plastic packages, while the TIP660-662 come in TO-3 metal packages. Current ratings for these two sets are 5 A at 200, 300, and 400 V. The TIP150-152 have gains of 500 at 1.5 A, while the remaining units have the same gain at 3 A. Power ratings for the three different packages are 50, 125, and 150 watts.

Further Information. For further information on any of the devices mentioned above, write to their manufacturers at the following addresses:

- Motorola Semiconductor Products
P.O. Box 20912
Phoenix, AZ 85036
- National Semiconductor
2900 Semiconductor Dr.
Santa Clara, CA 95051
- RCA Solid State Division
Box 3200
Somerville, NJ 08876

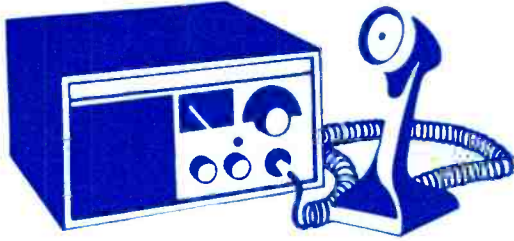

CB Scene

By Matt P. Spinello

AFTER five thousand miles of jet travel and seven consecutive days of additional wanderings, and after monitoring more than 1000 Citizens Radio calls and gathering statistics through CB, telephone, and in-person conversations in the field, the CB Scene is born!

Our CB Monitour (monitoring tour) was recently launched in 7 cities; and it will continue in the future with periodic visits to many areas heavily populated with CB users. We will be attending club gatherings throughout the U.S., recording CB'ers views on topics such as the present status of the service, its problems, probable solutions, and its future. The CB Scene will highlight various CB activities, including organizational make-up, public service, and emergency volunteer work during trying times such as floods, hurricanes, etc.

The majority of Citizens Radio's 878,000 licensees (utilizing approximately 4,000,000 CB transceivers) are enthusiastically involved, organized in great numbers, and concerned. Among other things, they want to know:

"What will it be—class D, class E, or both?"

"What about the proposed CB license fee increase?"

"What are the objective differences between the REACT and ALERT programs?"

"What constitutes a good CB club; and how do we organize one and keep it going?"

"Why does the majority of single-sideband activity seem to be locked in on channel 16?"

"Who's doing what to help CB beginners on the selection, installation, and operation of their CB systems?"

And, interestingly enough, a question that was raised at four different locations was, "When will manufacturers realize that there is a need and a definite market for a com-

pact, pocket-size walkie-talkie (like the old Morrow VP-100) that could be carried, concealed, inside a coat pocket or at the waist (a la Secret Service and local police)?" Presumably, the unit would have top controls and earphones without yards of antenna protruding over the shoulder, so that emergency personnel could monitor channel 9 at all times—at work or at play, or even at the country club dance.

These and several other subjects were discussed and debated, with the answers usually left in doubt, during our 7-city monitoring tour. The Citizens Radio Service's continual growth and unlimited applications make valid the users' "need to know," and that's what the CB Scene is all about!

This is your column! We look to CB clubs, teams and individuals to keep us posted on activity in their area and to supply us with emergency activity reports (with photos when available). Especially, we look forward to meeting with CB'ers in various parts of the country throughout the year. In the months to come, the CB Scene will delve into rule changes, services and activity, new products, single-sideband, and the problems and questions presented to us by our readers.

Monitour Report. CB Scene conducted its

Start of the Monitour

first POPULAR ELECTRONICS Monitor armed with a Johnson Messenger III and rechargeable battery pack. This and future reports gathered by actual on-the-air transmission monitoring and by discussions with area CB'ers is not meant to confirm the pattern by which 11-meter users conduct their transmissions on a 24-hour or year-round basis. It suggests, however, that a general idea of operating conditions can be determined from monitoring a minimum of 50 calls.

Washington, D.C. Heavy activity on most channels; orderly handling of emergency traffic involving minor accidents. Thanks to active cooperation of public service teams like REACT and ALERT, channel 9 remains relatively silent except for emergency traffic. An occasional "bandit" will make an attempt to lure "anybody" to answer; but he is quickly reminded by a monitor that the channel is reserved for emergency traffic. Rules violators are not absent from the FCC's back yard, but infractions are mild in comparison to other areas visited. Biggest D.C. area offender appears to be an operator labeled "Mad Dog." While frequently on the air breaking the squelch on every rig within range with deafening audio feedback and distortion, he never seems to raise anyone. Hopefully, the FCC will soon help him make contact.

New York, N.Y. By proclamation of a New York CB'er: "If you haven't monitored New York City, you ain't heard nothin' yet!" We monitored several base/mobile exchanges termed "necessary communications." In addition there was chit-chat mixed with skip: transmitters being tuned; an unannounced vocalist; and a matched set of he/she intellectuals (so they said) who took a stab at solving the problems of the world, including sex education in the schools, the after-effects of acupuncture,

and transcendental meditation. Channel 9, however, was professionally held together by David Getoff, KCK6194, serving as city-wide REACT monitor KDU0552. Dave handled traffic as quickly and efficiently as a veteran taxi dispatcher on New Year's Eve.

Detroit, Mich. Activity on channels 4, 7, 9, 11, 15, and 17. There were a considerable number of transmissions where callsigns were employed although the legality of the transmissions was questionable. A woman seemed to be in command of channel 9, issuing instructions, directions, and verbal hand-slappings for infringements; but she failed to use a callsign in her attempts to serve the area.

Kalamazoo, Mich. If monitoring is any judge, Kalamazoo has two distinctly different CB camps: one has charged itself with by-the-book communications and volunteer public service; while the other is out to capture the "tarnished-trophy-of-the-year award" for flagrant misuse of Citizens Radio channels.

During a landline conversation with Dr. James McCord, KFL7601, we learned that Community Radio Watch, founded in November of 1971 serves the Portage/Kalamazoo area. With a membership of 80, CRW monitors channel 9 on a voluntary basis from 6:00 a.m. to 12 midnight.

During a monitoring period which began at 11:00 p.m., CB Scene discovered Kalamazoo's other group, which continued non-stop for 90 minutes on channel 20. The clan consisted of "The Thousand Watt Mouth," "Polecat," "King Cole," "Jay-Jay," "Biz-E-Bee," "The Bald-Headed Beagle," "Banana Picker," "Big Red," "Gutter Ball," and "Red Fox." They apparently never heard of "Fox Charlie Charlie." With any luck, they may, soon! The exchange during

An outstanding offer for the engineer, student or hobbyist.

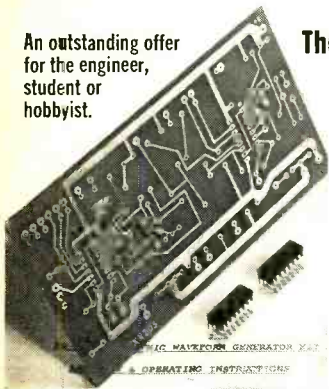

The XR205 monolithic **WAVEFORM GENERATOR KIT** Only \$28.00

Here's a highly versatile laboratory instrument for waveform generation at a fraction of the cost of conventional waveform or function generators. The Kit contains:

- 1) Two XR205 waveform generator IC's
- 2) Data sheet and applications notes
- 3) PC board (etched and drilled, ready for assembly)
- 4) Detailed assembly and hook-up instructions with parts list, schematic and layout diagram.

Immediate delivery.



EEP CORPORATION, 10180 W. JEFFERSON BLVD.,
CULVER CITY, CALIFORNIA 90230 (213) 838-1912

CIRCLE NO. 41 ON READER SERVICE CARD

the 90-minute "special" consisted mainly of "put-ons" attempting to out-do one another with corney one-liners.

Minneapolis, Minn. Legal activity on the air outshone the shenanigans in Michigan and New York. Excluding "Moonshiner" and "Spaghetti" who had a skip contact, Minneapolis's record for the monitoring period could be considered more legal than not. Channel chit-chat was not lengthy, was mild in content, and was at least conducted with licensed callsigns. Channel 9 was held in silent reserve for emergency use.

Kansas City, Mo. At Kansas City's new International Airport all CB monitoring frequencies were blocked by a solid, steady hum. Time did not allow investigation of the source—which kept our rig inoperable in the area. Monitoring from downtown Kansas City, we found that activity on the air paralleled that in Minnesota. Channels 7, 11, 15, 21, and 23 handled fairly routine and acceptable traffic, while channels 4, 17, 19, and 20 amplified chit-chat, attempts at skip contacts, and a discussion of the TV news that had just been aired.

Springfield, Va. Fairco REACT rides herd on channel 9. Its monitors are quick to ask would-be gabbers to leave the channel—even quicker to be of assistance to motorists in need. Fairco's membership of 21 is led by William Woodbury, president; Chuck Brown, vp; Bob Holzman, sec.; and George Rezac, treas. Fairco REACT encompasses the Fairfax County communities of Alexandria, Amandale, Arlington and Springfield. Code names in the area are few; chit-chat is confined generally to the uppermost portion of the band.

In the final analysis of Monitour's first on-site statistics gathering, CB Scene places the Minneapolis and Springfield, Va., areas in a tie for the cleanest, most legal operating areas of the seven monitored. Our next report will come from the states of Illinois, Wisconsin, and Colorado.

Monitour is finalizing plans for a month-long, cross-country motorhome tour of the U.S. in the month of July. Teams and clubs interested in meeting us along the way are urged to drop a note to the column, indicating a contact name, callsign, address, phone number, and club meeting day. Rush this information to Matt P. Spinello, CB Scene, Popular Electronics, One Park Ave., New York, NY 10016.

I'll CB'ing you. ◆

PRINTED CIRCUITS

FAST — EASY
with **DATAK's**

DIRECT ETCH SET

EASY—patterns rub down directly on the copper board and connect with rub-down lines or tapes supplied.

FAST—safe new etchants will etch a 2 oz. copper board in 30 minutes.

ACCURATE— $\pm .002$ " print tolerance so parts and connectors mate with no errors.

Circuit Made With ER-1

COMPLETE ER-1 SET contains hundreds of dry transfer DIP, flatpack, TO-5, IC, and transistor patterns; $\frac{1}{4}$ " and $\frac{1}{2}$ " etch resist tapes; 4 copper clad boards; $\frac{1}{4}$ lb. dry etch; tray and instructions. \$4.95 ppd.

IN STOCK AT ALLIED AND OTHER DISTRIBUTORS
WRITE FOR FREE CATALOG listing this and many other dry transfer marking sets.

The **DATAK Corporation**

85 Highland Avenue • Passaic, New Jersey 07055

CIRCLE NO. 9 ON READER SERVICE CARD



SPECIAL ALLIED CATALOG OFFER!

**Only for Readers
of this Magazine . . .**

It's the 1973 Allied Industrial Electronics Catalog, a giant 9x11", 420-page publication for everything in electronic parts and supplies. Originally sold and advertised for \$5.00—a printing overrun makes it available to you for just \$1 to help cover postage and handling. Lists over 50,000 separate stock items from more than 400 manufacturers with detailed specifications, descriptions and illustrations. Ideal for the hobbyist, student, repairman, Ham, CB'er—everyone in electronics, whether they need one part or a thousand! *Hurry, Quantity Limited!*

Here's my \$1—Please Send Catalog to:

Name _____

Address _____

City _____

State _____ ZIP _____

Mail Coupon to Dept. PE-2:

ALLIED ELECTRONICS Div. of
Tandy Corp.
2400 W. Washington, Chicago, Ill. 60612

Hurry, Quantity Limited!

CIRCLE NO. 43 ON READER SERVICE CARD

Understanding Your Triggered Sweep Scope

A BRIEF EXPLANATION OF THOSE PUZZLING TRIGGER CONTROLS

BY VIRGIL A. THOMASON

MOST technicians and electronics enthusiasts are familiar with the theory behind a triggered sweep scope. Others, however, still seem to be troubled by the special triggering controls used in this type of scope. Let's see if we can't clarify the uses of these sometimes baffling controls.

First, just what is a "trigger"? Remember that there are two different types of scope sweeps: recurrent and triggered. The recurrent sweep is always present on the CRT face and can be synchronized by a front-panel control appropriately marked. A triggered sweep is not recurring and usually is invisible until a trigger pulse comes along to start the sweep. In normal operation (before triggering), the invisible spot is at the left side of the CRT. The incoming trigger not only starts the trace, but also triggers an internal circuit that "unblanks" the beam for the duration of that sweep. Once the sweep has been initiated, a special "lock-out" circuit keeps any other trigger from affecting the sweep until that particular sweep is completed and the beam has returned to the left side of the CRT and is ready to accept another trigger. Therefore, any signal applied to the trigger circuit (usually from the vertical amplifier) will have no effect during the sweep time. This is what contributes so much to triggered sweep stability.

The controls for a typical scope triggering section are shown in Fig. 1. Your particular scope may have different names for these controls, but the principles are the same. Follow the signal flow shown in Fig. 2.

When the scope is to be used to view a

signal, the first step is to estimate the input signal level and set the vertical amplifier attenuator controls accordingly. Although a scope, unlike a VOM, cannot normally be damaged by excessive off-scale operation, it is good practice to make this signal level estimate—keeping in mind that the ac signal may have a dc component. If the latter is the case, set the vertical amplifier input selector to AC to begin with. If the scope is left in the DC mode, the desired ac signal may be riding on enough dc to cause the display to be so far off scale that it can't be seen. If you know that only an ac signal will be present, then you can use the DC mode of the vertical input selector.

The first trigger control encountered is the SOURCE selector. If you want to trigger the sweep at some point on the displayed waveform, use the INT (internal) position. This automatically picks up the signal from the vertical amplifier. The EXT (external) position allows the use of a trigger signal from outside the scope. If the displayed signal is related to the commercial power line frequency, then the LINE position will pick up a trigger signal from the power supply within the scope.

The next control is the trigger COUPLING selector. If you want to trigger at a particular dc level on the applied signal, use the DC position. To trigger from an ac signal use either AC position. If your scope has two AC positions, the one marked AC FAST uses a network that passes only the higher frequencies and is usually used to block any 60-Hz component that might be present on the triggering signal.

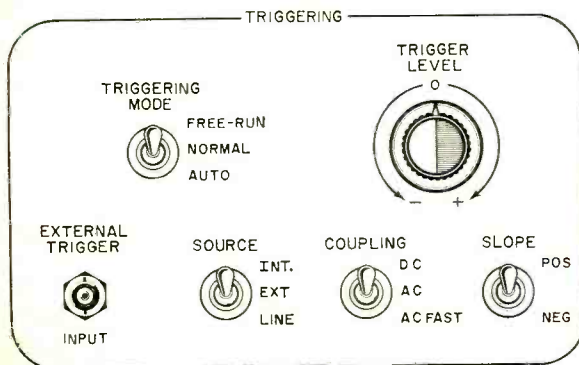

Fig. 1 Basic trigger controls for typical scope. Particular markings may differ from one scope to another but the principle is the same.

The SLOPE switch is used to pick a triggering point on either the positive or negative portion of the triggering waveform. The TRIGGERING LEVEL control is used to pick the actual point on either the positive- or negative-going portions at which you want the trigger to occur.

The TRIGGERING MODE switch usually has three positions. In FREE RUN, the sweep oscillator is made free-running, thus starting another sweep directly after the first is completed. This is similar to a conventional recurrent sweep scope. If your triggered sweep scope does not have this position, then the AUTO position may provide this feature, usually at some low frequency (in many cases, about 50 Hz). The selected trigger signal will override the 50 Hz to synchronize the sweep properly. In other words, the AUTO mode is the same as ac coupling, your choice of slope, and the exact center of the triggering level—provided the applied trigger is faster than 50 Hz. The NORMAL mode is used with the triggered sweep.

As a further aid to understanding these controls, try this little experiment. Use a filament transformer as the vertical input source to the scope. As a triggering source, you can

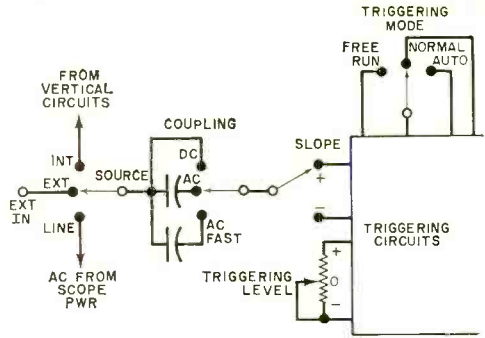

Fig. 2 This diagram shows the usual signal flow through triggered scope.

use either the LINE position of the SOURCE switch or you can feed the secondary of the transformer to the horizontal input also and use the external input as the trigger source. Use AC coupling and place the SLOPE switch on the positive position. The level potentiometer can now be adjusted to start the sweep on any portion of the positive-going sine wave being displayed. Changing the SLOPE switch to the negative position will now enable you to pick almost any point on the negative half cycle as the starting point. ♦

The Electronic Ignition that turns on Tom McCahill.

When Tom McCahill tested Gaylord's CompuSpark™ Capacitive Discharge Ignition, he said it flat out: "For my money, CompuSpark's a steal. Under 50 bucks. No moving parts. Fully electronic. Solid-state. And CD, too! "It's built like a brick out-house. They tried to wear one out and stopped at 270,000 miles when the car fell apart.

"What's in it for you? It virtually does away with point wear. Ends plug fouling hassles and puts plug wear way down the road. Often cuts your gas consumption by 20% and makes your engine run clean.

"The reasons for all this are as obvious as warts on a snake. A 60,000 volt spark is a helluva lot hotter than a stock ignition. CompuSpark — 'The Ignition System with a Brain'™ actually computes spark characteristics to engine RPM. You get the right spark at the right time and the right place. Darned things run great in Alaska or the tropics. Why not? All silicon, y' know. And the anti-theft lock really works!

"Another thing: CompuSpark is guaranteed one month longer than a Rolls-Royce: 37 months free repair or replacement. 30 day money back guarantee, too!

"Think of it this way: One skipped tune-up and CompuSpark has paid for itself. Two and you're money ahead. Plenty more where that came from — you're in clover, right? You bet.

"Order your CompuSpark now. It turned me on. I'm sure it'll turn you on, too!"

© 1973 CD Systems Division
Gaylord Electronics Inc. Dept. 24MY.
2314 Fourth St. Berkeley, Calif. 94710
415/849-0300

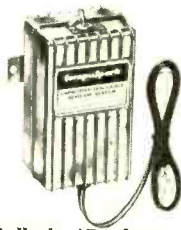

Installs in 15 minutes.

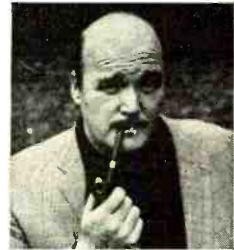

Rush me: CompuSpark ready to install. \$49.95
 Kit \$39.95
 CompuSpark brochure, free.

Car Year & Make _____

Name _____

Address _____

City, State, Zip _____

Enclosed: \$_____ Ship ppd. _____ Ship C.O.D. _____

Charge to my:

Master Charge BankAmericard American Express

For Credit Card orders supply all card information.

California residents, please include sales tax.

CIRCLE NO. 44 ON READER SERVICE CARD

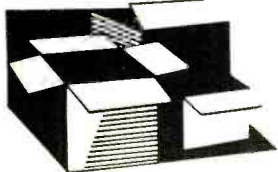

New Products

MIT'S DIGITAL IC TESTER

The MIT'S, Inc., Model ITC 1800 tester gives laboratories, service shops, and others the capability of testing IC's as quickly as they do tubes and discrete transistors. The professional-quality instrument contains a two-speed clock; 12 binding posts that allow connection with external equipment such as an oscilloscope, an oscillator, or an additional power source; 18 LED indicators that show the status of the IC

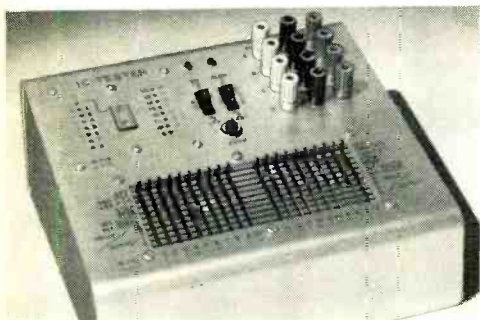

under test; and a pushbutton switch that permits counters, dividers, and shift registers to be advanced one step at a time. The most important feature is a 10 x 20 matrix switch used to program the functions and logic levels for the device under the test. It allows patch-in of any internal or external function to any pin or combination of pins. The tester is available in both wired and kit forms.

Circle No. 70 on Reader Service Card

BSR "TOTAL" TURNTABLE

BSR is featuring their top-of-the line Model 810X transcription series "Total Turntable," an advanced record-playing system consisting of the Model 810 turntable, a shure M91ED cartridge, and deluxe walnut base with dust cover. The heart of the 810X is BSR's unique



sequential cam drive mechanism, an advanced system that incorporates eight independent pre-programmed cams mounted on a central shaft that replaces the rotating eccentric plates and lightweight gears that other changers use. The tone arm is a low-mass tubular aluminum unit suspended in a ball-bearing race and balanced by a resiliently mounted counterweight.

Circle No. 71 on Reader Service Card

ANTENNA-CRAFT EXTREME-FRINGE ANTENNA

Sharp, true color plus clear black and white TV reception are provided by Antennacraft's Model CDX 1150 extreme-fringe antenna. Featuring 60 active elements, the antenna is said to be engineered to outperform all other antennas and provide the best possible reception in any TV/FM signal area. The CDX 1150 is designed with a patented flip-eze boom extension and cradle mount. The extension makes the 15½-ft boom easy to handle. For quick installation, the boom is folded and secured with one bolt. The cradle mount adds extra strength and stability and provides a low profile for

SEE...
COMPARE
SELECT!!

SBE

COMPLETE LINE OF
CB SUPER
CB STARS

Console

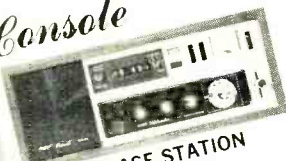

SSB/AM BASE STATION
SSB, 15W, p.e.p. input, AM, 5W input.
23 channels, no crystals to buy.
115VAC (will operate also from ext. 12V battery).

Catalina



AM MOBILE
23 channels, no crystals to buy.
Supplied w/dynamic mic/coil cord.

Cascade II



**5 WATT
PORTABLE**
6 channels, 5 watts
(reducible to 3W).
Battery operated.
All metal case.
Sturdy!

Sidekander II



SSB/AM MOBILE
SSB, 15W, p.e.p. input.
AM, 5W input, 23 channels,
no crystals to buy. Supplied
w/dynamic mic

WRITE FOR BROCHURE

SBE 220 Airport Blvd., Watsonville, CA 95076

CIRCLE NO. 31 ON READER SERVICE CARD

high wind resistance. Other features include a new ulf high-Q design and extra-heavy all-weather insulators.

Circle No. 72 on Reader Service Card

EDMUND SCIENTIFIC BIO-FEEDBACK MONITOR

The Edmund Scientific Co. Bio-Feedback Monitor/Trainer combines brain-wave, heart-rate, and skin-resistance feedback in a compact 2-pound unit. The head electrodes, hooked up to a high-gain amplifier, allow brain waves to be filtered to signal a beep for each alpha or theta wave passed. Wrist and finger electrodes monitor heartbeats and skin resistance responses, reproduced as an audible tone. The instrument comes with head, wrist, and finger electrodes, a threshold adjust, conducting solution, and full instructions.

Circle No. 73 on Reader Service Card

LAFAYETTE 4-CHANNEL HEADPHONES

The Lafayette Radio Electronics Model F-4400 4-channel stereo headphones feature a unique patented "baffle plate" that increases acoustic front-to-rear separation. The phones



consist of four separate 2½-in. speakers, each in its own acoustically isolated air-tight sealed chamber. Special switchable circuitry is built in for deriving 4-channel sound from conventional 2-channel stereo program sources through the ambience-recovery method. Each ear cushion is foam filled, as is the adjustable headband; both are covered with vinyl leatherette. The phones are supplied with a 10-ft cable terminated in two phone plugs.

Circle No. 74 on Reader Service Card

EMPIRE INDOOR/OUTDOOR SPEAKER SYSTEM

The first thing one notices when introduced to the new Empire Scientific Corp. Model 6500 Jupiter Series Speaker is a futuristic appearance. This three-way down-facing woofer wide-angle lens pedestal speaker system is made for today's indoor/outdoor way of life. With an enclosure made of a new indestructible space-age acoustic material and fully weatherproofed drivers, the Jupiter is tailor made for porch, patio, and pool-

MAY 1973



FREE

1973 LAFAYETTE CATALOG 730

Ready Now!

Your Complete Electronics Buying Guide

- Stereo/Hi-Fi Components • CB Transceivers & Walkie-talkies • PA Systems • Tools & Test Equipment
- Police/Fire Monitor Receivers • Antennas • Photography Equipment • Ham Gear • Books, Parts, and More!

Send Today!

Lafayette Radio Electronics
P.O. Box 10, Dept. 35053
Syosset, L.I., N.Y. 11791

NAME 35053 _____

ADDRESS _____

CITY _____

STATE _____ ZIP _____

CIRCLE NO. 21 ON READER SERVICE CARD

Amazing! THE QUARTZ SOLID STATE WATCH

with liquid crystal display.

This precision timepiece with no moving parts will show you the time of your life... The quartz crystal oscillates 32,768 times per second. A tiny CMOS chip with over 1200 transistors translates this oscillation into an equally precise digital display of time. Exact hour and minute is shown; colon oscillates once per second. Accuracy: 5 sec/month. Uses 1.5V battery. Guaranteed.



Order direct from: \$149.00
EEP CORPORATION
10180 W. JEFFERSON BLVD.
CULVER CITY, CA. 90230 213/838-1912

CIRCLE NO. 42 ON READER SERVICE CARD

side listening. When summer comes to a close, the speaker can be moved inside the home where its up-to-the-minute furniture design complements any room setting.

Circle No. 75 on Reader Service Card

COBRA AM/SSB CB TRANSCEIVER

Dynascan has introduced the Model 132 AM/SSB two-way mobile radio to their Cobra line of CB communication products. The 132 develops 15 watts of peak envelope power. It has 69-channel operation (23 AM, 46 SSB); 100 percent modulation with Cobra's exclusive Dyna-Boost compression circuit; better than 60-dB cross-modulation interference rejection; r-f gated noise blanker; three filters to prevent adjacent-channel interference; and drift-free ultra-stable Voice Lock. The transmitter features -40-dB SSB carrier suppression and unwanted sideband suppression, 350-2500 Hz frequency response, and an adjustable automatic load control. Receiver sensitivity on SSB is less than 0.25 μ V and on AM 0.5 μ V for 10 dB (S+N)/N at greater than 1 watt of audio.

Circle No. 76 on Reader Service Card

HEATHKIT ULTRASONIC INTRUSION DETECTOR

Between the bogus book covers of "The Informer" is the Heathkit Model CD-39, a sophisticated solid-state ultrasonic sensor that can trigger an alarm or turn on a light, or do both, should it detect movement in an area under

surveillance. To install it, the homeowner simply plugs The Informer into a convenient ac outlet; then he plugs the alarm and/or lamp into the receptacles provided in the rear of the unit. The Informer has adjustable sensitivity, automatic and manual reset, and a built-in 30-second delay circuit that allows the owner to enter a room and deactivate the alarm before it goes off.

Circle No. 77 on Reader Service Card

JVC 280-WATT 4-CHANNEL AMPLIFIER

JVC America, Inc., is currently selling their Model 4VN-990 patented SEA-Sound Effect Amplifier that permits complete freedom and control over sound in all five important fre-

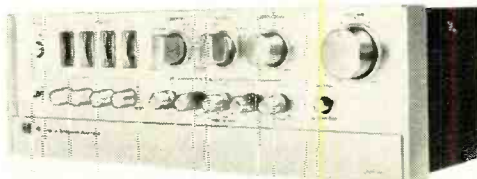

quency ranges. The amplifier provides 70 watts/channel in 4-channel use and 152 watts/channel when operated in the 2-channel mode. This high output power is possible due to a special power bridging circuit that enables the component to deliver a higher output when used

Gladiator SSB



For the man who knows CB, Courier has created Gladiator and Centurion SSB. Two rugged rigs with the sophistication of sideband and the durability of Courier. Full 15 watts p.e.p., 5 watts RMS, 23 AM, 23 USB and 23 LSB channels, ceramic filter on AM, crystal lattice filter on SSB and dual IF systems. Clarifier adjustment of receive and transmit frequencies over a 600 Hz range for perfect "netting." "ON THE AIR" pulsates red while unit is modulating. Separate green receive indicator, switchable noise blanker, noise limiter and plug-in mike. Complete with mike, crystals for all channels. Centurion also features digital clock and turn-on alarm.



Centurion SSB

CIRCLE NO. 40 ON READER SERVICE CARD



as a 2-channel system (conventional 4-channel amps do not use the rear channels when operating in the stereo mode). Built into the amplifier is a 4-channel matrix system that derives four channels of sound from any 2-channel signal source. It also allows perfect decoding of matrix-encoded records and broadcasts.

Circle No. 78 on Reader Service Card

TDK PROFESSIONAL-QUALITY TAPE REELS

TDK Electronics Corp. is currently offering a deluxe metal reel and library-shelf storage case for open-reel tape in a combination package designated the Model LR-7M. The professional-quality 7-in. reel with standard slotted hub is made of aluminum. Its precision warp-proof construction assures accurate alignment and perfect wrap-up of tape during recording, playback, rewind, and fast-forward operation. The storage case, made of polystyrene plastic, has a hinged cover with a self-locking latch.

Circle No. 79 on Reader Service Card

TOYO CARTRIDGE PLAYER/RECEIVERS

Two new 8-track cartridge player/receivers, designated the Models 680 and 682, have been announced by Toyo Radio Co. of America, Inc.



The Model 680 is said to be the first luxury component stereo system designed to provide the convenience of 8-track cartridges. It has automatic and pushbutton program selection, digital program lights, jacks for headphones, and external speakers. The AM/stereo FM receiver, with stereo beacon and afc, delivers 35 watts of music power into the two supplied speakers. The Model 682 is the same as the Model 680 except that it also contains a built-in four-speed automatic record changer.

Circle No. 80 on Reader Service Card

ARCHERKIT WIRELESS INTERCOM

The Archerkit Wireless Intercom available from Allied Radio and Radio Shack outlets need only be plugged into standard ac outlets in the same house or separate buildings that share the same power line transformer to provide instant communications. The units can be wall mounted or moved around as needed. They feature thumbwheel volume controls, pilot lights, "talk" buttons, and a lock button for hands-free conversation or monitoring.

Circle No. 81 on Reader Service Card

MAY 1973

Midwest Hifi

WHOLESALE & MAIL ORDER DIVISION

Protect your wallet.

Don't pay retail prices. Choose from over 100 name brands, and save on freight charges by ordering from the location nearest you.

Write today for our free catalog!
Midwest Hifi Wholesale & Mail Order Div.,
2455b Wisconsin Ave.
Downers Grove, Ill. 60515 (Attn Peter Eckart)
3309 E. J W Carpenter Frwy.,
Irving, Tex. 75060 (Attn Paul Eisner)

CIRCLE NO. 25 ON READER SERVICE CARD

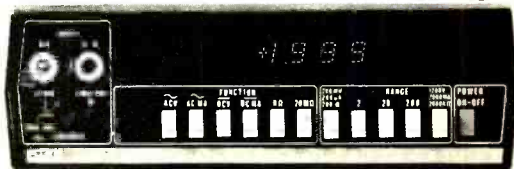

*New low cost digital multimeter \$299

- 26 ranges to measure ac/dc voltages from 100 microvolts to 1200 V, ac/dc currents from 100 nanoamperes to 2 amperes and resistance from 100 milliohms to 20 megohms.
- Guaranteed to stay within specifications for one full year. Fluke gives you the best specs and strongest warranty on the market today for the lowest cost of ownership ever.
- Wide choice of options including rechargeable battery pack, digital printer output, deluxe test leads, high-voltage probe, RF probe, 200-amp ac current probe, carrying case, dust cover and rack mounts.
- Unique self-zero feature eliminates offset errors.
- Rugged high-impact case with securely mounted internal electronics.
- Service centers throughout U.S., Canada, Europe and Far East for 48-hour turnaround repairs.



P.O. Box 7428,
Seattle, Washington 98133.

Get all the details from your nearest Fluke sales office. Dial toll-free 800-426-0361 for address of office nearest you.

CIRCLE NO. 18 ON READER SERVICE CARD

105

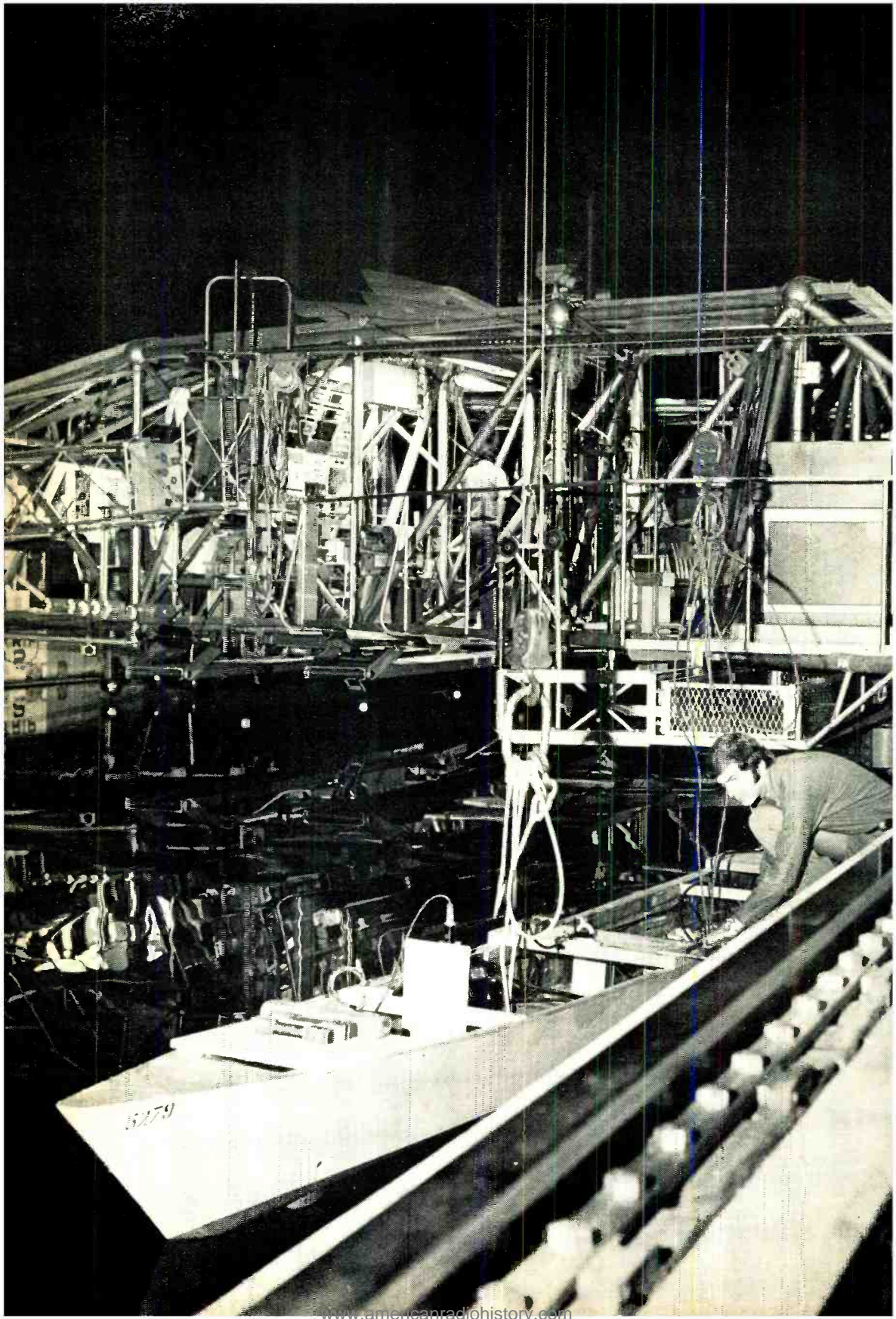

If you're looking for a career instead of a job in electronics...

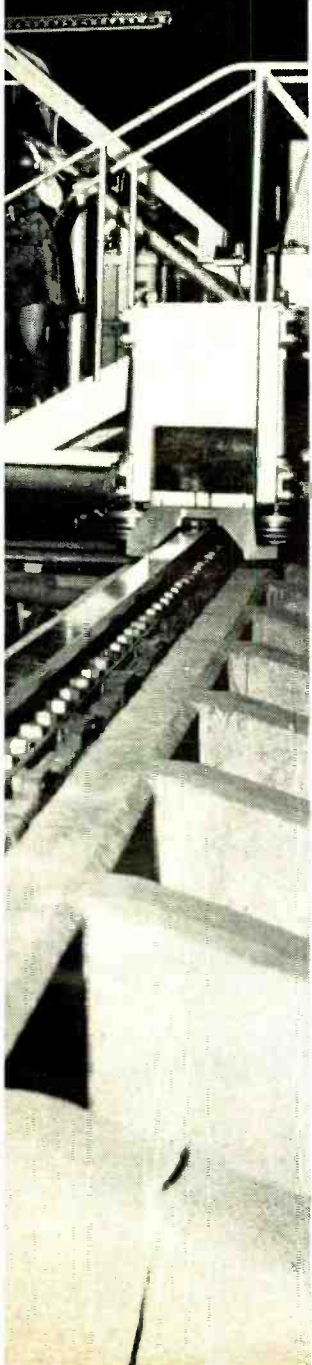

It costs millions of dollars to build modern ocean going vessels. The final design of such ships is based on extensive testing with sophisticated electronic measuring equipment using exact models as shown in the photo of the Naval Research and Development Center. The engineering technicians who check out, maintain and repair such equipment have to be experts. Their work is not only interesting and exciting, they also enjoy top pay in their field.

CREI offers Electronic Engineering Technology programs through home study. You have a choice of *eighteen* different program arrangements so you can specialize in exactly the area of electronics you want. All of the programs, except a brief introductory course, are college-level.

If you want to qualify for the highest paying level of technical employment in electronics, we invite you to consider the unique home study programs of CREI. Here is a list of just some of the CREI programs: *Communications Engineering • Computer Engineering • Missile & Spacecraft Guidance • Radar & Sonar • Television Engineering • Nuclear Instrumentation & Control • Digital Communications • Industrial Electronics • Electronic Systems Engineering • Microwave Communications • Satellite Communications • Cable Television Engineering*

For over 45 years, CREI programs have been recognized by leading technical organizations as effective home study training in advanced electronics.

Qualifications to Enroll. To qualify for enrollment in a CREI program, you must be a high school graduate (or equivalent). You should also be working in electronics or have previous training in this field.

Send for FREE book. If you are qualified, send for CREI's newly published book describing your career opportunities in advanced electronics. This full color book is filled with facts about career opportunities for you.

Capitol Radio Engineering Institute
A Division of McGraw-Hill Continuing Education Co.
 3939 Wisconsin Avenue, Washington, D. C. 20016



Accredited Member, National Home Study Council

CREI, Dept. E1205D
 3939 Wisconsin Avenue
 Washington, D. C. 20016

Rush me your FREE book describing my opportunities in advanced electronics. I am a high school graduate.

Name _____ Age _____

Address _____

City _____ State _____ ZIP _____

If you have previous training in electronics, check here

Employed by _____

Type of Present Work _____

Veterans and servicemen, check here for G. I. Bill information

CREI
CAPITOL
RADIO
ENGINEERING
INSTITUTE

WASHINGTON, D.C.

ELECTRONICS IN HABILITATION AND REHABILITATION

PE PROJECTS ARE HELPING IN THE TREATMENT OF HANDICAPPED CHILDREN

BY AL YONOVITZ

A COLOR organ usually finds its place in hi-fi music systems to provide a visual display in colored lights of the amplitude, pitch, and tempo of the music being played. But at the Mansfield Training School, a state institution for the mentally retarded located at Mansfield Depot in Connecticut, the Musette color organ (POPULAR ELECTRONICS, July 1966) is being used in a way that the designer probably never imagined. With the aid of a microphone and amplifier,

ning of this training involves the child's being able to discriminate gross sounds. For this purpose, the theremin, an electronic musical instrument, is an ideal teaching tool. By moving his hands toward and away from the pitch and volume antennas of the theremin, the child suddenly hears something more or less meaningful and he smiles. The auditory stimulation and happiness derived from this experience can help make more usable and meaningful what residual hearing the child has.



Modification of an early PE project demonstrated by a speech therapist. Bulb lights when the child speaks.

Another use for the theremin is an attempt to eliminate the rocking motion some retardedees continuously make. Here, the small antenna plates would be replaced by large metal screens toward and away from which the retardedee can rock, changing pitch and volume.

The goal of the Training Resource Center is to bridge the gap between electronics technology and special training in education. Toward this end, retardedees are taught certain skills that they can put to use in sheltered workshops. The devices mentioned above, plus others, are being made by retardedees for use at schools and other institutions. These devices are distributed at very fair cost on a non-profit basis. For more information, interested readers can write to the author at: Training Resource Center, Longley School, Mansfield Depot, CT 06251. ♦

the Musette has elicited speech from at least one retarded child. It has also supplied the necessary feedback to a deaf child, helping him to form better articulation in his speech.

It is a well-known medical fact that very few children with hearing impairments are actually totally deaf. These children commonly have very good hearing at frequencies between about 400 Hz and the lower end of the human speech range. For such children, a color organ can be used as a speech training device. By dividing the speech range into various channels and using a microphone-amplifier input, certain vowels and consonants will have distinct color patterns. In enunciating, the child attempts to match the color patterns of normal speech. The color organ is also quite beneficial in teaching accent and pitch control.

Hearing-impaired children also benefit greatly from auditory training. The begin-

Color organ is being used with speech and hearing impaired children. Various colored displays are employed.

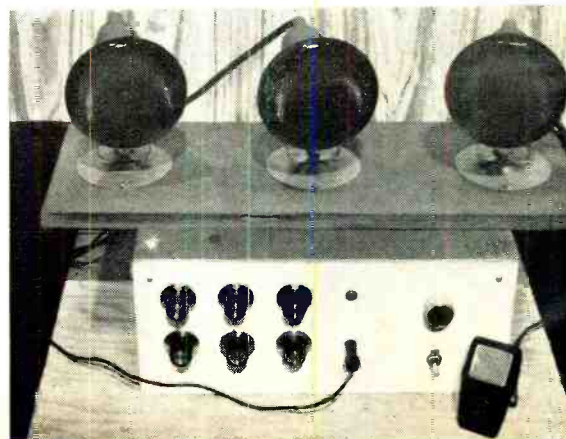

FREE McIntosh CATALOG and FM DIRECTORY

McIntosh Laboratory, Inc.
East Side Station P.O. Box 96
Binghamton, N.Y. 13904
Dept. 16-5

**SEND
TODAY!**

NAME _____

ADDRESS _____

CITY _____ STATE _____ ZIP _____

CIRCLE NO. 22 ON READER SERVICE CARD

Get all the news and latest information on the new McIntosh Solid State equipment in the McIntosh catalog. In addition you will receive an FM station directory that covers all of North America.



MX 113

AM FM/FM STEREO TUNER PREAMPLIFIER

RADIO HANDBOOK

by William I. Orr

This is a revised and updated 19th Edition designed to keep ham radio operators abreast of latest developments and equipment in the communications field. Detailed instructions for designing, building, and operating all types of radio communications equipment are provided. Theory and construction of modern circuitry, semiconductors, antennas, and power supplies are covered.

Published by Howard W. Sams & Co., Inc.,
4300 W. 62nd St., Indianapolis, Ind. 46268.
Hard cover. 946 pages. \$14.95.

BASIC ELECTRONIC CIRCUITS SIMPLIFIED

by Nelson W. Hibbs

This is an easily digested book with a conversational approach to electronics theory. Pertinent facts are interwoven with technical discussions so that theoretical expressions can be followed with only a rudimentary knowledge of electronics and a limited background in mathematics on the part of the reader. The book progresses from the very basics to the more complex aspects of electronics, including Thevenin's, Norton's, and Millman's theorems.

Published by Tab Books, Blue Ridge Summit,
PA 17214. 352 pages. \$8.95 hard cover; \$5.95 soft cover.



A COURSE IN RADIO FUNDAMENTALS, Fifth Edition

by George Grammer

This new edition of a popular book has undergone considerable revision, including modernizing the text and the introduction of much new material to increase its scope, almost doubling the number of pages over previous editions. Unlike the preceding editions that used *The Radio Amateur's Handbook* as a text, the new edition is a complete and independent study manual. Paced at an intermediate level, the text treatment is quantitative to the extent permitted by restricting mathematics to simple algebra.

Published by The American Radio Relay League, Inc., Newington, CT 06111. Soft cover. 184 pages. \$2.00.

Planning to move?

Let us know 6 to 8 weeks in advance so that you won't miss a single issue of **POPULAR ELECTRONICS INCLUDING ELECTRONICS WORLD**

Attach old label where indicated and print new address in space provided. Also include your mailing label whenever you write concerning your subscription. It helps us serve you promptly.

Write to: P.O. Box 2774, Boulder, Colo., 80302, giving the following information.

Change address only.

Extend subscription. Enter new subscription.

(1) 5 yrs. \$21 (2) 3 yrs. \$15 (3) 1 year \$6

Payment enclosed (1 extra issue per yr. as a BONUS)

Bill me later.

If you have no label handy, print OLD address here.

name _____ please print

address _____

city _____

state _____ zip-code _____

AFFIX LABEL

name _____ please print 0776

address _____

city _____ state _____ zip _____

Add'l postage: \$1 per year outside U.S., its possessions & Canada.

TUNER SERVICE

VHF, UHF, FM or IF Modules . . .

. . . All Makes

Fast **8** hr. Service!

1 YEAR GUARANTEE

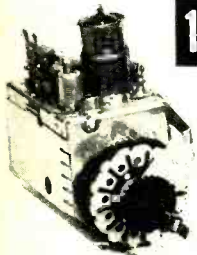

VHF-UHF-FM	\$ 9.95
UV-COMB.	\$16.95
IF-MODULE	\$12.50

Major Parts charged at Net Price
P.T.S. is overhauling more tuners for more technicians than any other tuner company in the world!

LIKE TO DO IT YOURSELF?

Send one Dollar (redeemable) for our 60 pages of top information

TUNER REPLACEMENT GUIDE AND PARTS CATALOG

For fastest service, send faulty tuner with tubes, shields and all broken parts to:

PTS ELECTRONICS, INC.

"Precision Tuner Service"



HOME OFFICE—
Box 272 • Bloomington, Ind. 47401 • Tel. 812. 824-9331
WEST—
Box 41354 • Sacramento, Calif. 95841 • Tel. 916. 482-6220
SOUTH—
Box 7332 • Longview, Tex. 75601 • Tel. 214. 753-4334
SOUTHEAST—
Box 6881 • Jacksonville, Fla. 32205 • Tel. 904. 389-9952
EAST—
Box 3189 • Springfield, Mass. 01103 • Tel. 413. 734-2737
MOUNTAIN—
Box 4245 • Denver, Colo. 80204 • Tel. 303. 244-2818

CIRCLE NO. 27 ON READER SERVICE CARD

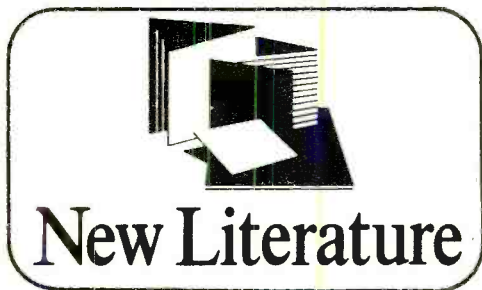

New Literature

PAIA ELECTRONIC PROJECTS CATALOG

Highlighted in the latest PAIA Electronics catalog (No. 1072) is the company's new Model 2720 synthesizer, an out-of-this-world electronic musical instrument based on a building-block approach. Other items included are: low-distortion sustain, ping-pong, waa-waa, attack delay unit, and foot switch (plastic molded in the shape of a real foot) for electric guitars; a rotating-speaker simulator; FM preamp; TV sports blackout eliminator; sound effects modules; and much more. Address: PAIA Electronics, Inc., P.O. Box 14359, Oklahoma City, OK 73114.

EDMUND SCIENTIFIC CATALOG

The first 1973 Edmund Scientific catalog, No. 731, is hot off the presses, listing more than 4000 unusual items, 400 of which are new to this latest edition. The 164-page catalog fully describes items for craft and hobby enthusiasts, gardening and workshop buffs, serious students, the scientifically minded, stargazers, and youngsters. Entries are listed according to such categories as optics, photographic attachments, black-light displays, model rockets, tools, etc. For the electronics buff, there are listings for a number of solid-state kits. Address: Edmund Scientific Co., 380 Edscorp Bldg., Barrington, NJ 08007.

SWITCHCRAFT AUDIO ADAPTER BULLETIN

For the audiophile who wants two separate outputs from a single miniature jack on his radio, TV, or tape recorder, a new miniature audio adapter is described in Product Bulletin No. 251 from Switchcraft. The 330T3P1 adapter has a Switchcraft "Tini-Plug" phone plug on one end and two molded "Tini-Extension Jax" on the other end. Address: Switchcraft, Inc., 5555 N. Elston Ave., Chicago, IL 60630.

SUPREME PUBLICATIONS MASTER INDEX

Supreme Publications is currently offering an up-to-date Master Index that covers all of the company's existing monochrome and color TV manuals and all radio manuals back to the 1926-38 issue. The index is a great convenience for looking up material in Supreme manuals and as an aid in determining the year of manufac-

Free!
1973 Eico catalog
OVER 200 INSTRUMENTS • KIT & WIRED!

NEW! TR-410 Solid State Triggered Sweep Scope
NEW! 300C "Clamp-On" Current Tester
NEW! TD-8 8 Track Stereo Tape Deck
NEW! SS-200 "Time Delay" Burglar Alarm System
NEW! ASA-300 Electronic Siren Auto Alarm

Build all-professional Eico Kits and save up to 50%. The more you know about electronics, the more you'll appreciate Eico. Over 2500 local Eico dealers offer you all the top brands, personal technical counsel, fast off-the-shelf service. Free catalog includes Test Equipment, Stereo, Eico-craft Projects, Burglar/Fire Alarm Systems and name of nearest Eico distributor, check reader service card or send 25¢ for first class mail service.

EICO, 283 Malta St., Brooklyn, N.Y. 11207
Leadership in creative electronics since 1945

CIRCLE NO. 14 ON READER SERVICE CARD

ture and comparing chassis and model numbers. Hints on using diagrams as a service aid are also given. Address: Supreme Publications, 1760 Balsam Rd., Highland Park, IL 60035.

CLEVELAND INSTITUTE SYMBOLS HANDBOOK

A new 22-page pocket-sized handbook illustrating more than 500 symbols commonly used in electronics is available from Cleveland Institute of Electronics. Titled "Electronic Symbols Handbook," the handy reference guide groups the symbols into 19 general classifications, each listed alphabetically by page reference number in a table of contents. An added feature is a 2-page Electronics Data Guide that covers conversion factors and constants; Ohm's law formulas; a resonant frequency, impedance and decibel table; and the color code. Address: Cleveland Institute of Electronics, Inc., 1776 East 17 St., Cleveland, OH 44114.

SIMPSON INSTRUMENTATION PRODUCTS

A 16-page catalog, No. 369, available from Simpson Electric Co. features a complete line of instruments for the lab and workbench. Among the listings are: digital electronic counters/timers, digital VOM's, solid-state electronic multimeters, a variety of miniature strip chart recorders, multi-range chart recorders, an RLC bridge, low-cost secondary standards, multi-range precision milliohmmeters, and

multi-range dc standards. Address: Simpson Electric Co., 5200 West Kinzie St., Chicago, IL 60644.

JENSEN TOOL CATALOG

More than 1900 individual items are described in Catalog No. 572 titled "Tools for Electronic Assembly and Precision Mechanics" currently being offered by Jensen Tools & Alloys. Section headings include: screwdrivers, wrenches, pliers, tweezers, files, shears, knives, microtools, relay tools, work holders, test equipment, etc. A solder section lists tin-lead alloys as well as eutectic alloys, copper-bearing solders, and more. Another important feature of the catalog is the inclusion of four pages of technical data on tool selection. Address: Jensen Tools & Alloys, 4117 N. 44 St., Phoenix, AZ 85018.

RUSSELL INDUSTRIES ANTENNA CATALOG

Russell Industries, manufacturers of a complete line of antenna rods, has announced the availability of a new information catalog. The 9-page catalog, No. AC-73, contains a cross-referenced center foldout that lists replacement rods for portable AM/FM radios and TV's, walkie-talkies, indoor FM, uhf, mobiles, and scanners. Illustrations for most rods and assemblies, plus an application chart, are included. Address: Russell Industries, Inc., 96 Station Plaza, Lynbrook, NY 11563.

*the tape that
turned the
cassette into
a high-fidelity
medium*



TDK SUPER DYNAMIC (SD) TAPE



CIRCLE NO. 34 ON READER SERVICE CARD

TDK

Until TDK developed *gamma ferric oxide*, cassette recorders were fine for taping lectures, conferences, verbal memos and family fun—but not for serious high fidelity.

TDK CASSETTE C-120SD

Today you can choose among high-quality stereo cassette decks.

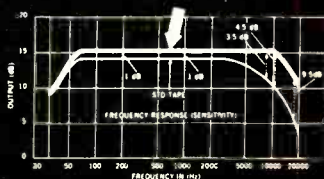

The new magnetic oxide used in **TDK Super Dynamic** tape distinctively differs from standard formulations in such important properties as coercive force, hysteresis-loop squareness, average particle length (only 0.4 micron!) and particle width/length ratio. These add up to meaningful performance differences: response capability from 30 to 20,000 Hz, drastically reduced background hiss, higher output level, decreased distortion and expanded dynamic range. In response alone, there's about 4 to 10 db more output in the region above 10,000 Hz—and this is immediately evident on any cassette recorder, including older types not designed for high performance. There's a difference in clarity and crispness you can hear.

Available in C30SD, C60SD, C90SD and C120SD length

TDK ELECTRONICS CORP.

LONG ISLAND CITY, NEW YORK 11103



Surplus Scene

By Alexander W. Burawa, Associate Editor

TIME TO ADD NEW NAMES TO YOUR DEALER LIST

To date, we have mentioned in this column only a very few of the total number of dealers doing business on the Surplus Scene. Most of the names we have mentioned were well-known (by anyone who is familiar with the surplus business) before they appeared in these pages. For those readers who have been keeping tally of the dealers we have mentioned (and from the mail received, we have no doubt that a great many of you are keeping tally), the following should be added to your lists.

East Coast Electronics (50 Scott St., Hamburg, NY 14075) states on the front page of the catalog they sent to us: "No fancy frills—just honest surplus bargains at the right prices." Looking through the listings in the catalog, we find that the statement is basically true. The company's stock in trade is parts—diodes, transistors, capacitors, coils, transformers, etc. But sandwiched into the listings are other items like power supplies; Rotron muffin fans; computer-type digital tape decks; and motor control, fire alarm, and burglar alarm kits.

Wonder of wonders, Colonel Wayne D. Russell (9410 Walhampton, Louisville, KY 40222) deals *exclusively* in Signal Corps surplus communication equipment. From the catalog pages we've seen, any ham or SWL who passes up sending for the catalog will be missing some of the best buys we've seen in government surplus gear.

Way out in the northwest, Star-Tronics (P.O. Box 17127, Portland, OR 97217) puts out a new catalog every month. To name just a few of the items listed in past catalogs, there were TS-505A/U military VTVM's, TS-452C/U military sweep generator/spectrum analyzers, and T-336/ARC-12 five-channel, crystal-controlled vhf transmitters. Regularly featured are test equipment manuals and discrete parts.

For hobbyists, experimenters, and do-it-yourselfers of both beginner and sophisticated levels, Cortlandt Electronics, Inc. (16 Hudson St., New York, NY 10013) claims that the listings in its current catalog comprise the lowest priced line of high-quality electronic kits and components in the industry. The kits include a light-activated relay, a car burglar alarm, a code-practice oscillator, and a variable time flasher. The parts listings range from resistors and capacitors to motors and relays.

While not exactly a "surplus" dealer, EEP Corp. (10180 W. Jefferson Blvd., Culver City, CA 90230) is a good source of hard-to-find solid-state parts and read-out devices. A nice lineup of National LM Series voltage regulator IC's is complemented by a wide variety of the new EXAR XR-0000 Series of transistor array, waveform generator, timing and decoder, and operational multiplier IC's and kits. Also listed are 1N4001-1N4007 diodes, 2N3055 transistors, red and green seven-segment display tubes, and LED panel lamps/illuminators.

Pardon Our Goof. In the February 1973 edition of the Surplus Scene, we mistakenly stated that specific model numbers of electronic gear are not listed in the catalogs put out by R.E. Goodheart Co., Inc. (P.O. Box 1220, Beverly Hills, CA 90213). We have been informed that the only thing arbitrary about the company's listings is the category number applied to their catalogs. Actually, the company does list specific items by type and model number, but you have to specify the catalog you want. (You don't have to know the category number; just tell them what type of equipment interests you and the company will send along the appropriate catalog.) ♦

ELECTRONICS MARKET PLACE

NON-DISPLAY CLASSIFIED: COMMERCIAL RATE: For firms or individuals offering commercial products or services, \$1.60 per word (including name and address). Minimum order \$16.00. Payment must accompany copy except when ads are placed by accredited advertising agencies. Frequency discount: 5% for 6 months; 10% for 12 months paid in advance. **READER RATE:** For individuals with a personal item to buy or sell, \$1.00 per word (including name and address.) No minimum! Payment must accompany copy. **DISPLAY CLASSIFIED:** 1" by 1 column (2 3/8" wide), \$200.00. 2" by 1 column, \$400.00. 3" by 1 column, \$600.00. Advertiser to supply cuts. For frequency rates, please inquire.

GENERAL INFORMATION: First word in all ads set in bold caps at no extra charge. All copy subject to publisher's approval. All advertisers using Post Office Boxes in their addresses **MUST** supply publisher with permanent address and telephone number before ad can be run. Advertisements will not be published which advertise or promote the use of devices for the surreptitious interception of communications. Closing Date: 1st of the 2nd month preceding cover date (for example, March issue closes January 1st. Send order and remittance to Hal Cymes. **POPULAR ELECTRONICS** Including **ELECTRONICS WORLD**, One Park Avenue, New York, New York 10016.

FOR SALE

FREE! bargain catalog. Fiber optics, LED's, transistors, diodes, rectifiers, SCR's, triacs, parts. Poly Paks, Box 942, Lynnfield, Mass. 01940.

GOVERNMENT Surplus Receivers, Transmitters, Snooperscopes, Radios, Parts, Picture Catalog 25¢. Meshna, Nahant, Mass. 01908.

LOWEST Prices Electronic Parts. Confidential Catalog Free. KNAPP, 3174 8TH Ave. S.W., Largo, Fla. 33540.

ELECTRONIC PARTS, semiconductors, kits. **FREE FLYER.** Large catalog \$1.00 deposit. BIGELOW ELECTRONICS, Bluffton, Ohio 45817.

WE SELL CONSTRUCTION PLANS. **TELEPHONE:** Answering Machine, Speakerphone, Carphone, Phonevision. Auto Dialer, Touch Button Dialer, Central Dial System. **TELEVISION:** \$35.00 Color Converter, Video Tape Recorder. \$25.00 Camera. **HOBBYIST:** Electron Microscope, 96 Hour Tape Music System, Ultrasonic Dishwasher, Radar-Oven. Plans \$4.95 each. **NEW ITEM:** \$75. Electronic Pocket Calculator, \$7.50. **COURSES:** Telephone Engineering \$39.50. Detective Electronics \$22.50, Integrated Circuit Engineering, \$49.50. **NEW SUPER HOBBY CATALOG** plus year's subscription to Electronic New Letter **AIRMAILED \$1.00.** Don Britton Enterprises, 6200 Wilshire Blvd., Los Angeles, Calif. 90048.

RADIO—T.V. Tubes—36¢ each. Send for free catalog. Cornell, 4213 University, San Diego, Calif. 92105.

SECORE, B&K Test Equipment Unbelievable Prices. Free Catalog and Price Sheet. Fordham Radio, 265 East 149th Street, Bronx, N.Y. 10451.

CONVERT any television to sensitive, big-screen oscilloscope. Only minor changes required. No electronic experience necessary. Illustrated plans. \$2.00. Relco-A33, Box 10563, Houston, Texas 77018.

METERS—Surplus, new, used, panel or portable. Send for list. Hanchett, Box 5577, Riverside, CA 92507.

PYROTECHNICAL chemicals, casings, tools, supplies, fuse, literature. Giant, illustrated catalogue/handbook includes formulas, instructions—50¢, with samples—\$1.00. Westech, Box 593, Logan, Utah 84321.

ELECTRONIC COMPONENTS—Distributor prices, Free catalog. Box 2581, El Cajon, California 92021.

ANTIGRAVITY, experiment and theory, Rushed—\$2.00. U.S. inquiries. Intertech 7A8, Box 5373, Station-F, Ottawa, Canada.

JAPAN HONG KONG DIRECTORY. World products information. \$1.00 today. Sekai Shobyō Anai, Hillyard, Washington 99207.

TEST EQUIPMENT, Aerospace-Laboratory Grade. Request your needs; will mail appropriate catalogs (we have 24 catalog categories). Only for Engineers, Businesses, Schools and advanced Technicians. Goodheart, Box 1220PE, Beverly Hills, Calif. 90213.

CONSTRUCTION PLANS: Laser . . . \$2.00. Missile Tracker . . . \$2.00. Catalog 25¢. ESP Experimenters Kit . . . \$2.00. Howard, P.O. Box 35271, Detroit, Michigan 48235.

BUILD YOUR OWN SPACE-AGE TV CAMERA



ONLY KNOWN SOLID-STATE CAMERA KIT! Ideal for experimenters, home, education, industry, etc. • High quality • Backed by over six years of lab & field testing • Fully Guaranteed • Converts to any TV set without modification • Step-by-step construction manual • Model XTCA, Series D complete with vidicon, \$19.99 postpaid anywhere in USA & Canada (less vidicon tube \$16.99)

PHONE OR WRITE FOR CATALOG.
DIAL 402-982-3771

Many other kits, parts and plans available including starter kits, focus-dial, coils, vidicon tubes, const. plans, audio subcarrier kit, etc.

1301 BROADWAY **ATV Research** DAKOTA CITY, NEBR. 68731

AMATEUR SCIENTISTS, Electronics Experimenters, Science Fair Students . . . Construction Plans—Complete, including drawings, schematics, parts list with prices and sources . . . Robot Man — Psychedelic shows — Lasers — Emotion/Lie Detector — Touch-Tone Dial—Quadrasonic Adapter—Transistorized Ignition — Burglar Alarm—Sound Meter . . . over 60 items. Send 25¢ coin (no stamps) for complete catalog. Technical Writers Group, Box 5994, State College Station, Raleigh, N.C. 27607.

REGULATED LABORATORY SUPPLY

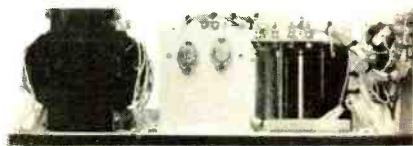

(cover open view)

This computer power supply delivers 5 highly regulated & filtered voltages. 24 volts @ 1.6 A., 26.5 volts @ 3.25 A., 18 volts @ 6.6 A., 14 volts @ 2.9 A., & 12 volts @ 1 A. Bench or 19" rack mount. A beautiful piece of equipment. 500 sold last year @ \$49.50. Weight 43 lbs.

STOCK NO. F5025 \$39.50 ea. 2/75.00

P & B POWER RELAY



Potter Brumfield PR7AL1 DPT power relay. 25 Amp. silver contacts. 1 set auxiliary contacts, 5 amps. SPST. 115 volt 60 Hz. Removed from new equipment.

STOCK NO. F9555 .75 ea. 3/2.00 5/3.00

NEW COMPUTER GRADE CAPACITORS

70,000 Mfd. 10 volts 1.75 ea. 6/9.00 No. J2118
32,000 Mfd. 40 volts 2.00 ea. 6/11.00 No. J2210
3,750 Mfd. 75 volts 1.75 ea. 6/9.00 No. J2116

Send for new 48 page catalog, loaded with new items. Please include sufficient postage. Excess will be refunded. **MINIMUM ORDER \$3.00**



DELTA ELECTRONICS CO.

BOX 1, LYNN, MASSACHUSETTS 01903
617-388-4705

CIRCLE NO. 10 ON READER SERVICE CARD

32 in One for \$5 ppd.



32 Surveillance Projects by means of 6 sub-assemblies plus parts & illustrated instructions & circuit diagrams—all in one kit, for only \$5 post-paid.

- Kit includes these sub-assemblies:
- Twin Photocells w/transistors
 - Sound-triggered SCR circuit
 - DPDT Relay; multi-voltage coil
 - Two glass-enclosed reed switches
 - Magnet & reed-switch coil
 - Pulse detector w/mike & SCR

Combine these ready-to-use units to make a variety of intrusion detectors. Using your imagination, toys, games, gadgets, etc. are also possible. A few of the 32 projects are: light-activated relay, light and/or sound switches, automatic telephone recording switch, all low battery powered trespasser & alarm systems.

Send check or M.O. 10-day money-back guarantee. Ask for free catalog.

CORTLANDT ELECTRONICS, Inc.

16 Hudson St. NYC 10013. 212-964-8044

CIRCLE NO. 8 ON READER SERVICE CARD

DIGITAL ELECTRONICS! Complete schematics, parts lists, theories—Discrete Component Digital Clock, \$3.00—Sound Sensitive Switch, \$1.50. Increase technical competence, hobby skills—Complete Course in Digital Electronics is highly effective, \$10.00. Free literature. DYNASIGN, Box 60A7, Wayland, Mass. 01778.

SURPLUS electronics for everyone. Free catalog. U.S. inquiries. ETCO, 464 McGill, Montreal, Canada.

FREE Catalog lists resistors, tubes, transistors, rectifiers, condensers, tools, tuners, etc. Hytron Hudson, Dept. PE, 2201 Bergenline Ave., Union City, N.J. 07087.

ELECTROENCEPHALOPHONE: brainwave monitor. Professional bio-feedback instruments. J&J, 8102-E, Bainbridge, Wash. 98110.

SOUND SYNTHESIZER kits—Surf \$11.95, Wind \$11.95, Wind Chimes \$16.95, Electronic Songbird \$6.95, musical accessories, many more. Catalog free. PAIA Electronics, Box J14359, Oklahoma City, OK 73114.

DIGITAL and analog computer modules. LED numeric display kits. FREE LITERATURE. Scientific Measurements, 2945 Central, Wilmette, Illinois 60091.

SHARE my Electronic Profits, your area! Free details! Hutson 23S, 1425 E. Madison, El Cajon, CA 92021.

WHOLESALE C.B., multiband receivers. Lowest prices. Catalog 25¢. G-Enterprises, Box 14P, O'Fallon, Ill. 62269.

ALPHA/THETA feedback instruments—\$25. Sensitive circuit of \$75 unit. Ultimate ease of use. Inner Space Electronics, Box 308PE, Berkeley, CA 94701.

FIREWORKS NEWS—Monthly magazine covering Fireworks, Construction, Sources of Supplies, New Firms-Products. Free Fireworks Catalogs with Subscriptions! \$9.00 per calendar year. Sample-Booklist \$1.00! Pyro Press, Box 1202N, Lexington, Kentucky 40501.

OSCILLOSCOPE improvement. Add trigger sweep and dual trace to any scope using low cost kits. HTP, Box 901, Cupertino, Calif. 95014.

FREE CATALOG

UP TO 50% OFF COMPARABLE KITS*

• BUY DIRECT • SAVE \$\$\$

FREE Catalog — Electronic Kits — Amplifiers — Preamps — Psychedelic Strobes — Burglar Alarms — Digital Tachometer — More: Free Catalog. SWTPC, Box A32040, San Antonio, Tex. 78284.

MECHANICAL, ELECTRONIC devices catalog 10¢. Greatest Values—Lowest Prices. Fertik's, 5249 "D", Philadelphia, Pa. 19120.

IGNITION SYSTEMS: Capacitor, Transistor. Information 10¢. Anderson Engineering, Epsom, N.H. 03239.

LASER Tube—\$9.50, Bargain Laser-Electronic Catalog—\$1.00 (Refundable). Plasma Systems, Box 3261, San Jose, CA 95116.

AUTHENTIC, INSTRUMENTED, FLYING ROCKETS for casual or serious experimenters. Over 80 scale, original, multi-stage or ready-to-fly models. Solid-propellant engines for safe, electric launch system liftoffs up to 2,500 feet. Measure altitude, temp. inversions, more. Real telemetry, electronic tracking, aerial still and movie photography with super-miniaturized equipment. New, detailed tech manual and full-color catalog, 25¢ from ESTES INDUSTRIES, Dept. 18J, Penrose, Colo. 81240.

FREE catalog. Surplus electronic parts. JK Products, P.O. Box 527-E, Norris, Tenn. 37828.

ELECTRONIC CDI Ignitions, VHF/UHF monitors, CB radios. Wholesale. Southland, Box 3591, Baytown, Texas 77520.

ALPHA/THETA brainwave biofeedback instruments. Unique digital filters for ultimate precision. BioScan, Box 14168E, Houston, Texas 77021.

116 POPULAR ELECTRONICS Including Electronics World

IC

FACTORY FIRSTS
NATIONALLY
KNOWN
BRANDS
SATISFACTION GUARANTEED

PRICES
SLASHED



	DIGITAL TTL		
7400N	32c	7453N	32c
7401N	32c	7454N	32c
7402N	32c	7472N	35c
7403N	32c	7473N	38c
7404N	32c	7474N	48c
7410N	32c	7475N	72c
7420N	32c	7476N	53c
7430N	32c	7486N	53c
7440N	32c	7490N	72c
7441N	\$1.50	7492N	72c
7442N	\$1.20	7493N	72c
7447N	1.15	7495N	\$1.20
7451N	32c	74107N	54c
		74121N	56c

709C TO-5 DIP or MINIOIP	38c	10 \$3.50
710C TO-5 or DIP	38c	10 \$3.50
723C TO-5	90c	10 \$8.25
741C TO-5 DIP or MINIDIP	40c	10 \$3.70
748C TO-5 DIP or MINIDIP	43c	10 \$3.95
558 (DUAL 741) MINIDIP	75c	10 \$6.75
558 (DUAL 741) TO-5	90c	10 \$8.25
LM309K TO-3	\$2.25	5 \$10.00

709C MINIDIP	40c	10 \$3.50
723C TO-5	90c	10 \$8.25
741C MINIDIP	50c	10 \$4.05
748C MINIDIP	55c	10 \$4.50
558C MINIDIP	88c	10 \$6.90
LM301 MINIDIP	45c	10 \$3.70
LM309K TO-3	\$2.50	5 \$11.00

The above full spec. first line TTL and Linear devices are also available with "Relaxed Specs." fully functional at discounts up to 50%. Use Reader's Service Card for Flyer.

1 AMP SILICON RECTIFIERS

1N4003 200PIV	12/\$1	100/\$6	1M/\$45
1N4005 600PIV	10/\$1	100/\$7	1M/\$65
1N4007 1000PIV	7/\$1	100/\$9	1M/\$75

SILICON SIGNAL DIODES

1N4148 (1N914 equiv.)	20/\$1	100/\$4	1M/\$30
-----------------------	--------	---------	---------

MOLEX IC SOCKET PINS

1000/\$1.00	200/\$1.80	300/\$2.60	500/\$4.20	700/\$5.80
1000/\$8.20 ea addn	1000/\$7.50			

READOUT TUBES

5 Volt 7 Segment Readout Tube \$3.75. Counting and Display Kit (Readout Tube +7490-7475+7447) \$5.75. 3 Kits for \$16.50

1/4 & 1/2 WATT 10% RESISTORS

1/4W 5c 30 \$1.20, 100 \$3.00, 500 \$13.75 as low as 1.7c ea in quantity-see catalog

1/2W 4c 30 90c, 100 \$2.50, 500 \$11.25 as low as 1c ea in quantity-see catalog

C.O.D. ORDERS ACCEPTED FOR SAME DAY SHIPMENT
CALL 218-681-6674

Free Catalog—Large Quantity Discounts—Orders Less Than \$10.00 Add 2%—Others Postpaid

PRICE PACESETTER FOR QUALITY IC'S
BOX 126K THIEF RIVER FALLS, MNS6701

DIGI-KEY

CIRCLE NO. 13 ON READER SERVICE CARD

ELECTRONIC ORGAN KITS, KEYBOARDS, Independent and divider tone generators. All diode keying. I.C. circuitry. Many components. With our kits you can build any type or size organ desired. 25¢ for catalog. DEVTRONIX ORGAN PRODUCTS, Dept. C, 5872 Amapola Dr., San Jose, Calif. 95129.

EXPERIMENTER and audiophile-test cables, chemicals, useful items-Free catalog. Technical Services, Box 687, Arlington, MN 55307.

1973 HOBBY ELECTRONICS DIRECTORY. \$1.50, Newcal, Box 323A, El Segundo, Cal. 90245.

POCKET Tele Microscope 3X telescope 30X Microscope Great for sports, hunting, stamp and coin collectors, \$2.20; 3 for \$6.25. Lherisson, 1365 St. Nicholas Ave., New York, N.Y. 10033. Free Catalog.

ELECTRONIC BOOKS Grab Bag, five different volumes, \$4.95. Fifteen, \$9.95. Publications, 1760 Balsam, Highland Park, Ill. 60035.

ELECTRONIC IGNITION (CDI) assembled, ready for twenty minute installation \$33. Request information or order from: ANALEKTA, Box 7340, Fort Worth, Texas 76111.

WHY NOT JAM UNWANTED NOISE WITH RELAXING PINK NOISE? Kit \$4.95, assembled \$6.95. Moneyback. Dealers inquire. Xenon 50W Fashtubes: 2/\$4.20, 10/\$17. Plans 75¢. Flyer. Mindlight, POB 2846PE, Van Nuys, CA 91404.

SURPLUS and **NEW** electronics for pros and serious amateurs. Computer memories, boards, I.C.S., semi-conductors. 2N2222, eight for \$1. Miniature 4V 40MA Lamp, eleven for \$1. Fifteen magnetic reads on board, \$1. Tri-Tek, Inc., P.O. Box 14206, Phoenix, Arizona 85063.

CALCULATOR owners: use your +—×÷ calculator to compute square roots, trigonometric functions, logarithms, exponentials, and more, quickly, accurately, easily. Instructions \$2.00. Mallmann Optics and Electronics, 836 South 113, West Allis, Wisconsin 53214.

INDUCTORS, mylar capacitors, coil bobbins, speakers. TSR, 3673W, 113th, Inglewood, California 90303.

QUALITY electronics parts: Free Flyer!, Box 475, Marysville, Washington 98270.

SOUND SYNTHESIZER kits—Surf \$11.95, Wind \$11.95, Wind Chimes \$16.95, electronic songbird, \$6.95, musical accessories, many more. Catalog free. PAIA Electronics, Box J14359, Oklahoma City, OK 73114.

BRAINWAVE TRANSLATOR. Revolutionary breakthrough in quality Biofeedback Instrumentation at low costs. HUMATECH INDUSTRIES, Drawer 1766-E, Fremont, California 94538.

FREE Bargain Catalog of Electronic Components. Chaney, Box 15431, Lakewood, Colorado 80215.

BRAIN WAVE CONTROL Biosone BF-2 Alpha Training Instrument. \$34.95 complete. Not a Kit. Fully Guaranteed. For information write. BIO-LOGIC DEVICES, Dept. A, Box 308, Stewartstown, Pa. 17363.

FREE CATALOG. Parts, circuit boards for Popular Electronics projects. PAIA Electronics, Box C14359, Oklahoma City, OK 73114.

BARGAINS: Surplus Electronics, free catalog. Atlantis-PE, Box 12654, Tucson, Arizona 85711.

TRIGGERED Oscilloscopes—\$129.00! Inquire. Bedford Electronics, 7741 Fir, Toledo, Ohio 43612.

LASER Parts Catalog, 60¢. Moynihan, 107 No. Brighton, Atlantic City, New Jersey 08401.

DIGITAL CLOCK PC \$11.00 pp. Build with your parts on our tested board, instructions included. ADRL, 14 Coachman, Freehold, N.J. 07728.

BURGLAR-FIRE alarm supplies and information. Free catalog. Protecto Alarm Sales, Box 357-G, Birch Run, Michigan 48415.

MAGNETS

MAGNETS. All types. Specials—20 disc magnets, or 2 stick magnets, or 10 small bar magnets, or 8 assorted magnets, \$1.00. Maryland Magnet Company, Box 192H, Randallstown, Maryland 21133.

LED MITY DIGITS "DCM'S" **9.99**

Will outperform any other DCM on the market today, not incandescent, but a device that will READ almost for life. MAN-4 Monsanto equal.

Kit includes: 3 x 2" printed ckt board, with fingers tool Side-mounting MAN-4 socket, resistors, 7448, 7476, 7490, booklet.

□ Digital Counting Modules at low prices.

"DIGITAL CLOCK ON A CHIP" □ Only **\$14.95**

MM56111 direct substitute to famous U.S. maker. 24 Pin DIP — IMAGINE ONE CHIP ELIMINATING 15 and other parts. Space Saver! Money saver! Latest in clock design. Features: 12 or 24 hr operation, 4 or 6 digits, 40 or 60 Hz operation. Internal digital multiplex oscillator, leading zero blanking, high output current for simple readout interface. Single power supply operation. Digit blanking for reduced current drain. 1 thru 19 volt range. Full MOS LSI. Sinc sheets included.

NEW Buy 3 Take 10%

NEW! 12-DIGIT "CALCULATOR ON A CHIP" **12.50**

Sorry, can't name U.S. maker! Type SD6001. Similar to Mastek 6012. Outperforms Texas Instruments 8-digit TMS-1802. Features: 40-pin DIP; not 5, not 3, but only single "calculator chip", 12-digit capacity; adds, subtracts, multiplies, divides, fixed point (0, 2, 3 or 4 decimal places), chain operations, leading zero blanking, 7-segment decoded display output, overflow lockout, and negative sign output. Drives incandescent fluorescent, Nixie, and LED readouts, 3 for \$35 with instruction booklet.

Includes: SN7490, decade counter; SN7475 latch, SN7441 BCD decoder driver, 0-to-9 Nixie tube, instructions.

"NIXIE" **LED READOUTS** □ 3 for \$10 **\$3.95**

MAN-4 EQUAL

0-9 plus letters, for SN-7448. Snaps in 14-pin DIP socket. 3/4" x 3/4" x 5V 10ma. with decimal point. Like MAN-1 □ Socket for above. 50c

35 WATT AUDIO □ **\$3.33** **AMPLIFIER BASIC 2 FOR STEREO 56**

For Class AB use. Basic includes: Signetec 540 100 transistor high power driver; TO-5 10C, with a pair of complementary 25-watt plastic transistors, i.e. 2N5296 npn and 2N6109 pnp. With schematics, printed circuit and parts board layouts.

This display is excellent for small portable electronics, such as DVM's, calculators, etc. Equivalent to Monsanto MAN 3A. Operates from 5V, 20 milliamperes, with 47 ohm dropping resistor.

LED READOUTS □ Buy 3 — Take 10% **\$2.95**

Linear Op Amps

Buy Any 3 PAKS Take 10% Discount

531	Hi low rate op-amp	\$2.50
532	Micro power 741 TO-5	2.50
533	Micro power 739 DIP	2.50
536	FET input op amp	3.95
537	Precision 741 TO-5	2.00
540	70W pwr driver	2.50
550	Precision 723 voltage reg.	1.17
555	Timer 2 uSecs to 1-hour	1.19
558	Dual 741 (mini DIP)	.48
560	Phase lock loops	3.25
561	Phase lock loop	3.25
562	Phase lock loop	3.25
563	Phase lock loops (A)	3.25
566	Function generator (mini DIP)	3.25
567	one decoder (Mini DIP)	3.25
595	Four quadrant multiplier	3.10
702C	Hi-gain, hi-imp. op. TO-5	3.64
703C	RF IF amp, 1 kcta, TO-5	1.00
709C	Operational amp (A)	.39
710C	Differential amp (A)	.39
711C	Dual diff. comp (A)	.39
723C	Voltage regulator (A)	.95
741C	Frequency compactor 709(A)	1.10
741CV	Frequency comp 709 (mini DIP)	.49
747C	Dual 741C, (A)	1.28
748C	Free ad. 741C (A)	1.10

Poly Paks Will Never Be Undersold!

LOWEST PRICES ON TTL IC'S Buy 3 — Take 10% Discount

No Gimicks On Pricing, Deliveries, or Quality! We're "The Only IC Advertiser" with MONEY BACK GUARANTEE!

Type	Price	Factory	Price	Price	Price		
SN7400	\$2.25	Marked	SN7489	3.50	SN74155	1.39	
SN7401	25		SN7490	1.00	SN74156	1.39	
SN7402	25	Factory	SN7491	1.00	SN74157	1.25	
SN7403	25		SN7492	7.11	SN74158	1.48	
SN7404	25	Guaranteed	SN7493	1.10	SN74160	1.79	
SN7405	25		SN7494	1.10	SN74161	4.10	
SN7406	45	Buy 100	SN7495	25	SN74162	1.79	
SN7408	25	Take 20%	SN7496	1.10	SN74163	1.79	
SN7409	25		SN7497	39	SN74164	1.10	
SN7410	25	SN7447	1.50	SN74100	1.41	SN74165	1.10
SN7411	25	SN7448	1.25	SN74101	49	SN74166	1.10
SN7412	25	SN7449	1.00	SN74102	49	SN74167	1.10
SN7413	75	SN7450	25	SN74103	49	SN74168	1.10
SN7414	48	SN7451	25	SN74104	49	SN74169	1.10
SN7417	48	SN7452	25	SN74105	49	SN74170	1.10
SN7420	45	SN7453	25	SN74106	49	SN74171	1.10
SN7421	25	SN7454	25	SN74107	49	SN74172	1.10
SN7422	32	SN7455	25	SN74108	49	SN74173	1.10
SN7423	32	SN7456	21	SN74109	49	SN74174	1.10
SN7424	30	SN7457	39	SN74110	49	SN74175	1.10
SN7425	30	SN7458	39	SN74111	49	SN74176	1.10
SN7426	30	SN7459	39	SN74112	49	SN74177	1.10
SN7427	30	SN7460	39	SN74113	49	SN74178	1.10
SN7428	30	SN7461	39	SN74114	49	SN74179	1.10
SN7429	30	SN7462	39	SN74115	49	SN74180	1.10
SN7430	30	SN7463	39	SN74116	49	SN74181	1.10
SN7431	30	SN7464	39	SN74117	49	SN74182	1.10
SN7432	30	SN7465	39	SN74118	49	SN74183	1.10
SN7433	30	SN7466	39	SN74119	49	SN74184	2.50
SN7434	30	SN7467	39	SN74120	49	SN74185	2.50
SN7435	30	SN7468	39	SN74121	49	SN74186	2.50
SN7436	30	SN7469	39	SN74122	49	SN74187	2.50
SN7437	30	SN7470	39	SN74123	49	SN74188	2.50
SN7438	30	SN7471	39	SN74124	49	SN74189	2.50
SN7439	30	SN7472	39	SN74125	49	SN74190	2.50
SN7440	30	SN7473	39	SN74126	49	SN74191	2.50
SN7441	30	SN7474	39	SN74127	49	SN74192	2.50
SN7442	1.12	SN7475	1.00	SN74128	49	SN74193	2.50
SN7443	1.21	SN7476	1.00	SN74129	49	SN74194	2.50
SN7444	1.21	SN7477	1.00	SN74130	49	SN74195	2.50
SN7445	1.21	SN7478	1.00	SN74131	49	SN74196	2.50
SN7446	1.50	SN7479	1.00	SN74132	49	SN74197	2.50
		SN7480	.65	SN74133	49	SN74198	2.50
		SN7481	1.10	SN74134	49	SN74199	2.50
		SN7482	.89	SN74135	49	SN74200	2.50
		SN7483	1.25	SN74136	49		
		SN7484	.49	SN74137	49		

Best Values for 18 years

Terms: add postage, cod's 25%. Retard: net 80

Phone Orders: Wakefield, Mass. (617) 245-3829

Retail: 16-18 Del Carmine St., Wakefield, Mass. (off Water Street) C.O.D.'S MAY BE PHONED IN

POLY PAKS P.O. BOX 942 Lynnfield, Mass 01940

PLANS AND KITS

ANTIGRAVITY DEVICE. Brochure rushed free. AGD, Box 3062-ZD, Bartlesville, Oklahoma 74003.

CDI PLANS—Proven design \$2.00. General Analog, 3014F S. Halladay, Santa Ana, Calif. 92705.

FREE KIT CATALOG

Why does every major College, University, Technical School, Research & Development Center buy from us? Because we have the highest quality and lowest prices. Free Catalog. SWTPC, Box H32040, San Antonio, Tex. 78284.

UPDATE Alarm System with camera, etc. Drawings and Details \$2.00. Julien's, 1237 Palm Ave., Beaumont, Calif. 92223.



Convert your transistor portable TV to project a giant 5'x6' PICTURE onto wall, sheet, or screen for under \$10.00. • Use with any transistor portable, up to 18" picture tube • Assemble in one evening, no experience necessary. • Removable in seconds for normal TV viewing. Kit contains detailed plans, complete inst. and precision Lens system . . . You supply wood and common mirror. Guaranteed to work or money refunded.

Complete kit including lens **\$12.95** Postage Paid
THE MACROCOMA CO. Dept. ED-5
WASHINGTON CROSSING, PENNA. 18977

SOLID STATE controlled auto alarm. Plans \$1.00. Mr. Walton, P.O. Box 10473, Ft. Worth, Texas 76114.

BUILD digital clock or freq. counter. Plans and PC boards, \$15.00, both \$27.50; plans only \$5.00 each. Mikra-D, Box 403, Holliston, Mass. 01746.

ACUPUNCTURE Electronic zone detector. Schematic \$2.00. ADZ, Box 2422, San Rafael, CA 94109.

LASER kit for the amateur scientist—complete optics, mirrors, crystal, tubing—write for instructions and free literature, Esco Products, 167 Oak Ridge Road, Oak Ridge, New Jersey 07438.

WANTED

QUICKSILVER, Platinum, Silver, Gold, Ores Analyzed. Free Circular. Mercury Terminal, Norwood, Mass. 02062.

MILITARY SURPLUS EQUIPMENT WANTED. ARC-34C, ARC-51BX, ARC-73, ARC-102, ARC-109, ARC-131, ARC-134, ARN-21C, ARN-52, ARN-65, GRC-106, VRC-12, URC-24, 618T, Also Bendix, Collins GR, HP, Tektronix needed, plus military test sets. We Buy or Trade. Sep Electronics, 2412 Highway 301, Ellenton, Florida 33532.

INSTRUCTION

LEARN ELECTRONIC ORGAN SERVICING at home all makes including transistor. Experimental kit—trouble-shooting. Accredited NHSC, Free Booklet. NILES BRYANT SCHOOL, 3631 Stockton, Dept. A, Sacramento, Calif. 95820.

LEARN WHILE ASLEEP, Hypnotize! Strange catalog free. Auto-suggestion, Box 24-ZD, Olympia, Washington 98501.

ASSOCIATE DEGREE IN ELECTRONICS through correspondence instruction. G.I. Bill approved. Free catalog. Grantham, 1509 N. Western, Hollywood, California 90027.

FCC First and Second Tests. \$8.95. Electronic Tutoring, Box 24190, Cleveland, Ohio 44124.

LOGIC trainers catalogs 50¢. UTI, POB 252, Waldwick, N.J. 07463.

HIGHLY effective college-level home study programs in Electronics Engineering and Engineering Mathematics. (Our 27th Year). Free Literature. Cook's Institute, Dept. 15, Box 10634, Jackson, Miss. 39209.

F.C.C. TYPE Exams Guaranteed to prepare you for F.C.C., 3rd., (\$7.00), 2nd., (\$12.00), 1st., (\$16.00), phone exams; Complete package, \$25.00. Research Company, Dept. A, Rt. 2, Box 448, Calera, Alabama 35040.

ON THE AIR announcer training at R.E.I. features individual realistic preparation for your Radio/TV career. R.E.I.'s engineering course features intensive training for the FCC First Phone! Complete either course in just five (5) weeks! Call 1-800-237-2251 toll free for brochure. Write: R.E.I., 1336 Main Street, Sarasota, Florida 33577.

SHORTCUTS To Success! Highly Effective, Profitable Short Courses. (75 Choices). Study At Home. Diploma Awarded. Our 27th Year. Free Literature. CIEE-D, Box 10634, Jackson, Miss. 39209.

AVIATION ELECTRONICS TECHNICIAN—Prepare for exciting career in new field of "Avionics." Train at nation's largest aeronautical school. Indicate if eligible for G.I. Benefits. Spartan Airschool, International Airport, Dept. MMW, Tulsa, Oklahoma 74151.

F.C.C. EXAM MANUAL
PASS FCC EXAMS! Memorize, study —"1973 Tests-Answers" for FCC First and Second class Radio-telephone licenses. Newly revised multiple-choice questions and diagrams cover all areas tested in FCC exams.—plus—"Self-Study Ability Test." \$9.95 postpaid.
COMMAND PRODUCTIONS RADIO ENGINEERING DIVISION P.O. BOX 26348-P SAN FRANCISCO, CALIF. 94126
Tests-Answers for FCC First and Second Class Commercial License

FCC FIRST CLASS LICENSE through tape recorded lessons with one week personal instruction. Radio License Training, 10600 Duncan, Manhattan Beach, Calif. 90266.

LEARN COMPUTER ELECTRONICS. Free homestudy details. Compukits, Box 4192M, Mountain View, California 94040.

TAPE RECORDING COURSE: Taught by studio engineers. Free information. NNA, Box 721R, Rye, New York 10580.

BEST Appliance Service Repair Guides—Major, \$5.95; Small \$4.95. Free Catalog. Tab Books, B.R.S., Pa. 17214.

COMPUTER ELECTRONICS! Complete course reveals basics of Logic Design, Digital Electronics, Highly Effective. Free Literature. DYNASIGN, Box 60C1, Wayland, Mass. 01778.

BE SAFE. In your car, plane or boat, you are much safer with reliable two-way communications aboard. Complete tape-recorded, no textbook Code and Theory license courses. Amateur Radio License School, 12217 Santa Monica Blvd., W. Los Angeles, Calif. 90025.

EXAMS, FCC first and second \$8.95. Specialty Shop, Box 1242E, Warren, Michigan 48090.

HYPNOTISM

"MALE-FEMALE Hypnotism" Exposed, Explained! "Secret Method"—They Never Know! \$2, Rushed. Guaranteed! Isabella Hall, Silver Springs, Florida 32688.

SLEEP learning. Hypnotic method. 92% effective. Details free. ASR Foundation, Box 7566EG, Fort Lauderdale, Florida 33304.

FREE Hypnotism. Self-Hypnosis. Sleep Learning Catalog! Drawer H400, Ruidoso, New Mexico 88345.

HYPNOTIZE STRANGERS in 30 seconds! Men or Women! Amazing hypnotic disk PULLS subjects into deep hypnosis!! Guaranteed! Send \$2 today!! Hypnodisk, 508 Mourning Dove, Dept. CM-5, Audubon, Pennsylvania 19407.

PRICES GOING UP!

INCREASED DEMAND FOR IC'S IN GENERAL AND TTL'S IN PARTICULAR HAS CAUSED SEVERE SHORTAGES AND SHARP INCREASES IN OUR COST. REGRETFULLY, WE ARE FORCED TO INCREASE OUR PRICES IN ORDER TO BE ABLE TO OBTAIN THESE PARTS FOR YOU. WE WILL, HOWEVER, ACCEPT ORDERS AT OUR PREVIOUSLY ADVERTISED PRICES IF POST-MARKED OR CALLED IN BY APRIL 20TH, 1973.

Catalog Number	Qty. (Per Pin) (Max)		Multiples of 10 (Per Pin) (Max)		Catalog Number	Qty. (Per Pin) (Max)		Multiples of 10 (Per Pin) (Max)	
	1-1000	1000-9999	1000	up 9900		1-1000	1000-9999	1000	up 9900
7400	.34	.32	.30	.28	74175	2.00	1.90	1.80	1.70
7401	.34	.32	.30	.28	74180	2.00	1.90	1.80	1.70
7402	.34	.32	.30	.28	74181	5.20	4.90	3.60	3.30
7403	.34	.32	.30	.28	74182	1.26	1.19	1.12	1.05
7404	.36	.34	.32	.30	74182	2.10	2.00	1.90	1.80
7405	.36	.34	.32	.30	74193	2.10	2.00	1.90	1.80
7406	.56	.53	.50	.47	74198	3.10	2.95	2.80	2.65
7407	.56	.53	.50	.47	74199	3.10	2.95	2.80	2.65
7408	.38	.36	.34	.32	SCHOTTKY TTL				
7409	.38	.36	.34	.32	74800	.88	.84	.79	.75
7410	.34	.32	.30	.28	74801	.88	.84	.79	.75
7411	.34	.32	.30	.28	74803	.88	.84	.79	.75
7413	.60	.57	.54	.51	74804	1.00	.95	.90	.85
7416	.54	.51	.48	.45	74805	1.00	.95	.90	.85
7417	.54	.51	.48	.45	74808	.88	.84	.79	.75
7418	.38	.36	.34	.32	74809	.88	.84	.79	.75
7420	.34	.32	.30	.28	74810	.88	.84	.79	.75
7421	.34	.32	.30	.28	74815	.88	.84	.79	.75
7423	.84	.80	.76	.72	74820	.88	.84	.79	.75
7425	.51	.48	.45	.42	74821	.88	.84	.79	.75
7426	.40	.37	.34	.31	74822	.88	.84	.79	.75
7430	.34	.32	.30	.28	74810	1.00	.95	.90	.85
7437	.56	.53	.50	.47	74850	.88	.84	.79	.75
7438	.36	.34	.32	.30	74851	.88	.84	.79	.75
7440	.34	.32	.30	.28	74860	.88	.84	.79	.75
7441	1.73	1.64	1.55	1.46	74861	.88	.84	.79	.75
7442	1.34	1.27	1.20	1.13	74862	.88	.84	.79	.75
7443	1.34	1.27	1.20	1.13	74865	.88	.84	.79	.75
7444	1.34	1.27	1.20	1.13	74873	1.82	1.73	1.64	1.54
7445	1.71	1.62	1.53	1.43	74874	1.82	1.73	1.64	1.54
7446	1.34	1.27	1.20	1.13	74807	1.82	1.73	1.64	1.54
7447	1.30	1.23	1.16	1.09	748112	1.82	1.73	1.64	1.54
7448	1.44	1.37	1.29	1.22	74811	1.82	1.73	1.64	1.54
7450	.34	.32	.30	.28	748110	1.00	.95	.90	.85
7451	.34	.32	.30	.28	LINEAR IC'S				
7453	.34	.32	.30	.28	NE201A	2.99	2.82	2.66	2.49
7454	.34	.32	.30	.28	NE201B	1.59	1.46	1.17	1.05
7459	.34	.32	.30	.28	NE531F	3.81	3.58	3.36	3.14
7460	.34	.32	.30	.28	NE536F	7.31	6.88	6.15	6.02
7470	.36	.34	.32	.30	NE540F	2.10	2.03	1.92	1.85
7472	.40	.38	.36	.34	SE3101	1.48	1.20	1.12	1.05
7474	.52	.49	.46	.43	NE550A	1.00	1.23	1.16	1.09
7475	.80	.76	.72	.68	NE555A	1.00	1.05	1.00	.95
7476	.58	.55	.52	.49	NE556A	2.10	1.95	1.80	1.65
7480	.80	.76	.72	.68	NE558A	1.00	.95	.90	.85
7482	1.10	1.05	1.00	.95	NE560B	3.57	3.36	3.15	2.94
7483	1.72	1.61	1.56	1.48	NE561B	3.57	3.36	3.15	2.94
7485	1.38	1.27	1.24	1.15	NE562B	3.57	3.36	3.15	2.94
7486	1.60	.57	.54	.51	NE565A	3.57	3.36	3.15	2.94
7490	.85	.80	.75	.70	NE566F	3.57	3.36	3.15	2.94
7491	1.48	1.41	1.34	1.27	NE567A	3.57	3.36	3.15	2.94
7492	.85	.80	.75	.70	NE567A	3.57	3.36	3.15	2.94
7493	.85	.80	.75	.70	NE511A	.99	.86	.82	.78
7494	1.32	1.26	1.20	1.14	NE595A	3.10	3.20	3.00	2.80
7495	1.32	1.26	1.20	1.14	NE596A	1.87	1.77	1.66	1.56
7496	1.32	1.26	1.20	1.14	7099	.50	.47	.44	.41
74100	1.80	1.70	1.60	1.50	710A	.50	.47	.44	.41
74101	.70	.67	.64	.61	711A	.55	.52	.49	.46
74105	.70	.67	.64	.61	723A	1.00	.95	.90	.85
74107	.54	.51	.48	.45	733A	1.90	1.80	1.70	1.60
74121	.60	.57	.54	.51	741F	.55	.52	.49	.46
74122	.74	.71	.68	.65	747A	1.10	1.04	.98	.92
74123	1.30	1.23	1.16	1.09	748F	.34	.31	.28	.25
74141	1.75	1.66	1.57	1.48	LM335	2.05	2.72	2.64	2.53
74145	1.50	1.43	1.36	1.29	LM336	3.85	3.66	3.46	3.27
74150	2.00	1.85	1.70	1.55	LM337	1.05	1.05	1.05	1.05
74151	1.30	1.24	1.18	1.12	TRANSISTORS AND DIODES				
74153	1.70	1.60	1.50	1.40	1N270	.45	.44	.43	.42
74154	2.75	2.55	2.35	2.05	1N911	.10	.09	.08	.07
74155	1.56	1.49	1.42	1.35	1N1001	.10	.09	.08	.07
74156	1.46	1.39	1.31	1.23	1N1002	.11	.10	.09	.08
74157	1.36	1.30	1.30	1.31	1N1003	.13	.12	.11	.10
74160	1.50	1.40	1.30	1.21	1N1006	.15	.14	.13	.12
74160	2.20	2.10	2.00	1.90	1N217A (10m)	.25	.22	.19	.16
74161	2.20	2.10	2.00	1.90	1N738A	.25	.22	.19	.16
74162	2.20	2.10	2.00	1.90	2N360	.25	.23	.21	.19
74163	2.20	2.10	2.00	1.90					
74164	2.20	2.10	2.00	1.90					
74166	2.30	2.20	2.10	2.00					

All IC's are supplied in 8-, 14-, or 24-pin DIP (Dual-in-line) plastic or ceramic package except for NE330, NE530, and SE330 which come in TO-3 package. Voltage Regulators LM335, LM336 and LM337 are supplied in TO-3 (Diamond) package.

We give FREE data sheets upon request, so ask for those data sheets that you NEED, even for those listed IC's that you are not buying.

LED 7-SEGMENT DISPLAY:

Solid State Systems has now expanded it's line of LED Displays and also reduced their cost. The following are now available from us at these prices:

	1-19	50-99	100-199	500-999	1,000 up
SSS-1	4.50	4.25	3.75	3.10	3.00
SSS-1C	1.75	1.50	1.00	3.65	3.25
SSS-2	4.50	4.25	3.75	3.10	3.00
SSS-3	7.75	7.30	7.00	6.75	6.50
SSS-4	7.75	7.50	7.00	6.75	6.50
SSS-7	3.50	3.25	3.00	2.75	2.50
SSS-9	3.50	3.25	3.00	2.75	2.50
Minitron*	3.00	2.75	2.50	2.25	1.90

The SSS-7 and SSS-9 are the common .33 in character height 7-segment and overflow display respectively, with decimal point on the left and wide-angle viewing. The SSS-1 and SSS-2 have the same physical dimensions as the SSS-7 and SSS-9 with increased life and slightly lower current requirement. The SSS-3C is the same as the SSS-3 except it has a colon instead of a decimal point, making it ideal for use in a digital clock. The SSS-3 and SSS-4 are the new giant .77 in character height 7-segment and overflow display respectively, with decimal point on the right and readability up to 40 feet. *Also included above is a new reduced price on our In-line-out 7-segment Display.

Package of 6, 1/4 watt current limiting resistors..... \$0.30

MOLEx IC SOCKET PINS: Use these economical pins instead of soldering your IC's to PC boards. Sold in continuous strips in multiples of 100 pins only.

100 Pin \$1.00	200 Pin \$1.80	300 Pin \$2.60	400 Pin \$3.10
500 Pin \$4.20	600 Pin \$5.00	700 Pin \$5.80	800 Pin \$6.60
900 Pin \$7.10	1000 Pin \$8.20	each additional 1,000 \$7.50	

Dual-in-line SOCKETS. Brand new with gold plated pins.

	1-19	50-99	100-199	500-999	1,000 up
14 Pin Solder	.50	.45	.40	.35	.25
16 Pin Solder	.55	.50	.45	.40	.30
14 Pin Wire Wrap	.55	.50	.45	.40	.30
16 Pin Wire Wrap	.60	.55	.50	.45	.35
14 Pin Closed Entry	.05	.05	.04	.04	.03
16 Pin Closed Entry	.05	.05	.04	.04	.03

STANGOR TRANSFORMERS: Ideal for use with LM series.

P-8180, 25-2VCT, 1 amp	\$3.00
P-6134, 6-3VCT, 1.2 amp	\$2.75

HEAT SINKS: Waterfield series 6100 circuit board coolers, 1 1/2" high with a dissipation up to 20 watts. Designed for use with TO-3 package.

	1-19	50-99	100-199	500-999	1000 up
Type 680-1, 25A	1.20	1.10	1.00	.90	.80

ALLEN-BRADLEY MIL-GRADE (45-hand) RESISTORS. Any of the 81 STANDARD 10% values from 2.2K to 22M 1/2 or 1/4 WATT. EATH..... \$0.05

CERAMIC DISC CAPACITORS. Type 56A-1000VDC. 5, 7.5, 10, 12, 15, 20, 22, 25, 27, 30, 33, 39, 50, 56, 68, 75, 82, 100, 150, 180, 200, 220, 250, 270, 300, 330, 360, 390, 470, 500, 560, 600, 680, 750, 820, 1000, 1200, 1500, 1800, 2000, 2200, 2500, 2700, 3000, 3300, 3900, 4700, 5000pF. EACH..... \$1.00
0.01uF. EACH..... \$1.11 0.02uF. EACH..... \$1.12

LOW VOLTAGE DIODES, Type 1K

1.0uF, 3V	\$2.25	0.47uF, 3V	\$2.25	0.2uF, 10V	\$2.20
1uF, 10V	\$4.12	2.2uF, 3V	\$4.30	0.01uF, 16V	\$4.10

ELECTROLYTIC CAPACITORS: All values are available in both, axial or upright (PC Board mount). Please indicate your choice.

10uF, 15V	\$1.00	30uF, 15V	\$2.20	30uF, 50V	\$4.10
30uF, 15V	\$1.00	50uF, 45V	\$2.20	10uF, 50V	\$1.15
50uF, 15V	\$1.00	100uF, 35V	\$2.20	20uF, 50V	\$2.20
100uF, 15V	\$1.00	500uF, 35V	\$4.40	50uF, 50V	\$2.20
220uF, 15V	\$1.15	1000uF, 35V	\$3.50	100uF, 50V	\$2.20
300uF, 15V	\$2.20	1uF, 50V	\$1.10	200uF, 50V	\$4.10
1000uF, 15V	\$2.30	2uF, 50V	\$1.10	300uF, 50V	\$5.55
20uF, 25V	\$1.15	3uF, 50V	\$1.10		

TERMS: Net 30 days. Net 30 days. Otherwise check or money order with order. BankAmericard and MasterCard are welcome. All invoicing is now done by computer therefore, the following standard charges will automatically be added to your order.

If you merchandise total is between:

	SPECIAL CHARGES
\$ 0.00 - \$ 1.99	add \$1.00 COD
\$ 2.00 - \$ 4.99	add \$0.75 Air Mail
\$ 5.00 - \$19.99	add \$0.50 Postal Insurance
\$ 20.00 - \$99.99	add \$0.25 Special Delivery
\$ 100.00 and up	add \$0.00

With this new system all shipments will be F.O.B. destination, via First Class or UPS (your choice). These charges include shipping, handling and insurance.

MISSOURI RESIDENTS: Please add 1% sales tax.

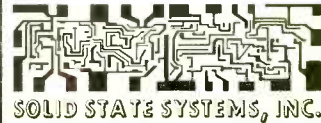

P. O. BOX 773 • COLUMBIA, MISSOURI 65201
TWX 910-760-1453 • PHONE 314-443-3673

Your
BANKAMERICARD
welcome here

ORDER DESK
(TOLL FREE)
1-800-325-2595

master charge
THE INTERBANK CARD

CIRCLE NO. 33 ON READER SERVICE CARD

NATIONAL MOS

DYNAMIC shift registers
 MM502 dual 50 25
 MM506 dual 100 bit 1.00
 MM506 dual 100 bit 1.00
 MM5013 1024 bit 1.50
 MM5017 dual 512 DIP 1.50
 MM5016 512 bit 1.00

STATIC shift registers
 MM504 dual 16 bit 1.00
 MM505 dual 32 bit 1.25

MM550 dual differential analog switch 2.00

CT5005

CALCULATOR ON A CHIP
 This chip has a full four function memory. Memory is controlled by four keys, +M (adds entry to memory), -M (subtract entry from memory), CM (clear memory—without clearing rest of registers), RM (read memory or use as entry).



12 DIGIT DISPLAY AND CALC. FIXED DECIMAL AT 0.1, 2, 3, 4, OR 5
 LEADING ZERO SUPPRESSION
 SEVEN SEGMENT MULTIPLEXED OUTPUT
 TRUE CREDIT SIGN DISPLAY
 SINGLE 28 PIN CHIP
 Chip and data—\$14.95
 Data only—1.00 (refundable)

MC1013 ECL 85mc ff 1.00
 MC1023 ECL driver 2.00
 MC1039 ECL-TTL interface 2.00
 8850, 9601—one shot multi-vibrator 1.00
 8269 Sigmatic is same as 8200 National 4 bit comparator 1.60
 MC853 dual JK DTL 30
 LU321 dual JK "Utilogic" 60
 SP629 RS/T Sigmatic 40
 SP659 dual 4 input buf. 25

7400 TTL DIP

7400-----\$.25
 7401-----35
 7402-----25
 7403-----25
 7404-----25
 7405-----25
 7406-----25
 7410-----25
 7411-----1.75
 7420-----25
 7421-----25
 7422-----25
 7423-----25
 7424-----1.30
 7425-----1.00
 7446-----1.50
 7448-----1.25
 7450-----25
 7451-----25
 7453-----25
 7454-----30
 7460-----25
 7472-----40
 7473-----55
 7474-----40
 7475-----50
 7476-----30
 7480-----25
 7481-----1.15
 7483-----1.15
 7486-----65
 7489-----3.00
 7492-----90
 7493-----90
 7495-----1.15
 74107-----55
 74154-----2.50
 74181-----3.50
 74193-----2.00
 74195-----1.00

ELECTRICAL SUPPLIES AND EQUIPMENT

PLATING Equipment, Portable Platers, Supplies and "Know-How." Build your own tanks for nickel, chrome, etc. Easy-to-install PVC liners. Rectifier components—all sizes. Schematics, parts lists, formulas, operating instructions for all plating. Guaranteed to save you 25%-75%. Some good units for sale. Write for details. Platers Service Company, 1511-PE Esperanza, Los Angeles, Calif. 90203.

HIGH FIDELITY

DIAMOND NEEDLES and Stereo Cartridges at Discount prices for Shure, Pickering, Stanton, Empire, Grado and ADC. Send for free catalog. All merchandise brand new and factory sealed. **LYLE CARTRIDGES**, Dept. P, Box 69, Kensington Station, Brooklyn, New York 11218.

SAVE your time and money. Get the lowest mail order price on stereo equipment. Free details, write **GOODJOHN**, P.O. Box 1018, Miami Beach, Fla. 33139.

TUBES

RADIO & T.V. Tubes—36¢ each. Send for free Catalog. Cornell, 4213 University, San Diego, Calif. 92105.

RECEIVING & INDUSTRIAL TUBES, TRANSISTORS. All Brands—Biggest Discounts. Technicians, Hobbyists, Experimenters—Request **FREE** Giant Catalog and **SAVE!** ZALYTRON, 469 Jericho Turnpike, Mineola, N.Y. 11501.

SAVE money on parts and transmitting-receiving tubes, foreign-domestic. Send 25¢ for giant catalog. Refunded first order. United Radio Company, 56-P Ferry Street, Newark, N.J. 07105.

TUBES "Oldies", latest. Lists free. Steinmetz, 7519 Maplewood, Hammond, Indiana 46324.

TUBES receiving, factory boxed, low prices, free price list. Translatericon, Inc., 1306 40th Street, Brooklyn, N.Y. 11218A, Telephone: 212-633-2800.

TUBES, ANTIQUE—Send list. P.O. Box 5570, Compton, Calif. 90224.

REPAIRS AND SERVICES

TV Tuners rebuilt and aligned per manufacturer's specification. Only \$9.50. Any make UHF or VHF Ninety day written guarantee. Ship complete with tubes or write for free mailing kit and dealer brochure. **JW Electronics**, Box 51C, Bloomington, Indiana 47401.

ELECTRONIC BUILD SERVICE. Experienced with equipment from miniature circuit boards to large control panels. Engineering, consultation, drafting. Multiple Electronics, Post Office Box 2319, Anderson, Indiana 46011. Phone 317-642-4973.

PERSONALS

MAKE FRIENDS WORLDWIDE through international correspondence. Illustrated brochure free. Hermes, Berlin 11, Germany.

DO-IT-YOURSELF

PROFESSIONAL ELECTRONIC PROJECTS—\$1.00 up. Catalog 35¢. PARKS, Box 15201A, Seattle, Wash. 98115.

BURGLAR-FIRE ALARM Supplies and Information. Free Catalog. EICO, Dept. PE, Box 215, Bklyn, N.Y. 11207.

3 CHIP CALCULATOR SET

This calculator set has eight digit floating point with left hand entry. It will add, subtract, multiply, and divide. Overflow and negative signals are provided.

Chips and data—\$6.95
 Data only—1.00 (refundable)

MV-50 red emitting 10-40ma @ 2v .40

MV502Z red LED .60

MV-10B Visible red 5-70ma @ 2v .75

SCHOTTKY TTL \$3.00 EACH

82530 8 input multiplexer
 82533 2 input 4 bit multiplexer
 82541 quad EX/OR element
 82542 4 bit comparator
 82562 9 bit parity gen./checker
 82567 2 input 4 bit multiplexer

5400 \$.75
 5411 1.00
 5420 .75
 5420 1.00
 5440 .75
 5440 1.00
 5451 1.00

LINEARS

LM100-----\$.80
 LM309H-----1.00
 LM309K-----2.50
 NE5556-----75
 NE5559-----1.00
 747(MINI DIP)-----45
 747-----1.10
 709-----30
 710-----40
 713-----40
 723-----1.00
 955(TIMER)-----75

CMOS

CD4001-----\$.75
 CD4002-----75
 CD4011-----75
 CD4012-----75
 CD4023-----75

8200 dual 5 bit buffer register 24 pin DIP-- 3.50
 8263 3 input 4 bit multiplexer 24 pin DIP-- 3.50
 8264 3 input 4 bit multiplexer 24 pin DIP-- 3.50
 All IC's are new and fully tested. Leads are plated with gold or solder. Orders for \$5 or more will be shipped prepaid. Add 35¢ for smaller orders. California residents add sales tax. IC orders are shipped with 24 hrs. COD's may be phoned in. Money back guarantee.

BABYLON ELECTRONICS
 P.O. Box 3 Carmichael, California 95608
 (916) 966-2111

CIRCLE NO. 4 ON READER SERVICE CARD

TAPE AND RECORDERS

RENT 4-Track open reel tapes—all major labels—3,000 different—free brochure. Stereo-Parti, 55 St. James Drive, Santa Rosa, Ca. 95401.

1930-1962 Radio Programs on tape. Huge Catalog! Sample Recordings! \$1.00 refundable!! AM Treasures, Box 192F, Babylon, N.Y. 11702.

SCOTCH MAGNETIC TAPE (USED)
 .150, .1 MIL POLYESTER, 3600 FT.
 ON 10 1/2 IN. FIBERGLASS REELS
 USED ONCE, \$1.99-1800 FT., 7 IN.
 REELS, 99¢-GUARANTEED TO PERFORM AS GOOD AS NEW OR MONEY REFUNDED. (BULK NO BOX) USED 10 1/2 IN. FIBERGLASS REELS (SMALL HOLDS) 50¢. NEW HINGED BOXES: 10 1/2 IN. 39¢. 7 IN. .9¢

Add 10% to Above Tape Prices for Shipping, handling, -5% Over \$80.00. (Extra Boxes, Reels, etc.—Please Include Funds for Weight and Distance)

SAXITONE TAPE SALES
 1776 Columbia Rd., N.W. Washington, D.C. 20009

BLANK 8-track Cartridges, Cassettes. Tremendous Discounts. Free Catalog. Exhibo West, Box 5174-PE, Mission Hills, CA 91340.

EMPLOYMENT INFORMATION

EXCITING Overseas jobs. Directory \$1.00. Research Associates, Box 889-E, Belmont, California 94002.

EMPLOYMENT OPPORTUNITIES

ELECTRONICS/AVIONICS EMPLOYMENT OPPORTUNITIES. Report on jobs now open. Details FREE. Aviation Employment Information Service, Box 240E, Northport, New York 11768.

INVENTIONS WANTED

PATENT Searches including Maximum speed, full airmail report and closest patent copies. Quality searches expertly administered. Complete secrecy guaranteed. Free Invention Protection forms and "Patent Information." Write Dept. 9, Washington Patent Office Search Bureau, Benjamin Franklin Substation, P.O. Box 7167, Washington, D.C. 20044.

FREE "Directory of 500 Corporations Seeking New Products." For information regarding development, sale, licensing of your patented/unpatented invention. Write: Raymond Lee Organization, 230-GR Park Avenue, New York City 10017.

INVENTORS: Protect your ideas! Free "Recommended Procedure." Washington Inventors Service, 422T Washington Building, Washington, D.C. 20005.

INVENTORS! Either I will sell your Invention before you do, (either through your own efforts or those of another firm) or I will pay you a cash bonus. For Free Invention Evaluation and information, write Gilbert Adams, Invention Broker, Dept. 20, 81 Wall St., New York, N.Y. 10005.

NEW PRODUCTS—INVENTIONS—IDEAS Developed/Marketed by professional organization. FREE INFORMATION "How to Market Inventions To Industry". Lawrence Peska Associates, 500-PE Fifth Avenue, New York City 10036.

FREE PAMPHLET: "Tips on Safeguarding Your Invention." Write: United States Inventors Service Company, 708-T Carry Building, Washington, D.C. 20005.

CASH-ROYALTIES for patented, unpatented inventions. Global Marketing Service, 2420-P 77th, Oakland, California 94605.

MOVIE FILMS

8MM-SUPER 8-16MM MOVIES! Biggest Selection! Lowest Prices! Free Catalog! Cinema Eight, Box 245-PE, N.Y.C. 10028.

BOOKS

FREE catalog aviation/electronic/space books. Aero Publishers, 329PE Aviation Road, Fallbrook, California 92028.

FREE book prophet Elijah coming before Christ. Wonderful bible evidence. Megiddo Mission, Dept. 64, 481 Thurston Rd., Rochester, N.Y. 14619.

PLASTICS

CASTOLITE pours like water, hardens like glass without heat. Crystal clear, colors. Embed natural flowers, other objects. Make fine gifts. Form flexible molds over any pattern, size. Reproduce your own designs in plastics, candle wax, metal, plaster, cement. Profitable. Illustrated Manual and Catalog Only \$1.00. CASTOLITE, Dept. 73E/PE, Woodstock, Ill. 60098.

GOVERNMENT SURPLUS

GOVERNMENT Surplus. How and Where to Buy in Your Area. Send \$2.00. Surplus Information, Headquarters Bldg., Box 30177-PE, Washington, D.C. 20014.

ELECTRONIC Equipment and Parts. Big 36 page Free Catalog. Send for your copy today! Fair Radio Sales, Box 1105-P, Lima, Ohio 45802.

JEEPS Typically from \$53.90 . . . Trucks from \$75.40 . . . Boats, Typewriters, Knives, Airplanes, Clothing, Multimeters, Oscilloscopes, Transceivers, Photographic, Electronics Equipment. Wide-variety, condition. 100,000 Bid Bargains direct from government nationwide. Complete sales directory and surplus categories catalog \$1.00 (Deductible on orders from separate included catalog). Surplus Service, Box 820-J, Holland, Michigan 49423.

MAY 1973



GREGORY ELECTRONICS
Reconditioned & Used
FM 2-WAY RADIO SAVINGS
Partial List—Send for New Catalog

MOTOROLA

U51GGT

40-50 MHz

12 volts, 60 watts.
Transistorized power supply. Narrow band complete with accessories
Private line (if available) add \$35.



\$188

Just Arrived! G-E. "Message Mates" High Band Receivers with Self-Call

G.E. PROGRESS LINE STRIPS, physically complete, AS IS!			
	LOW BAND	VHF	UHF
Power supply, 30 watts, less vibrator	MA/E13 MA/E16 MA/E33 MA/E36 MA/E42		
Power supply, 60 watts, less vibrator	\$20. \$20. \$20.		
TX narrow band			\$25. \$25.
less final tubes			
Note: MA/E42			
wide band	\$18. \$25. \$25. \$30. \$12.		
RX wide band			
less ovens	\$18. \$18. \$18. \$18. \$12.		
1 1/2" Progress Line Case, consisting of front basket and front plate with lock			\$10. \$10.
Low band dual front end, 2 freq. strip			\$20. \$20.



GREGORY ELECTRONICS CORP.
249-F Rt. 46, Saddle Brook, N.J. 07662
Phone: (201) 489-9000

CIRCLE NO. 19 ON READER SERVICE CARD

GOVERNMENT SURPLUS. Complete sales directory \$1.00. Surplus Publications, Box 26062Z, Los Angeles, Calif. 90026.

MANUALS for gov't surplus radios, test sets, scopes, teletype. List 50¢. Books, 7218 Roanne Drive, Washington, D.C. 20021.

SPORTS ACTION FILMS

SUPER 8 and 8mm color or B&W films for sale. Instant replay of NFL, Super Bowls, NHL Stanley Cup, NBA Basketball, Major League Baseball and All Boxing. Write for discount sports film catalog today. Elect. Dept., SPORTLITE, Box 500, Speedway, Indiana 46244.

RUBBER STAMPS

RUBBER address stamps. Free catalog. 45 type styles. Jackson's, Box 443F, Franklin Park, Ill. 60131.

PHOTOGRAPHY—FILM, EQUIPMENT, SERVICES

FREE! FREE! Bargain Book—Central Camera Co., Dept. 1051, 230 S. Wabash, Chicago, Ill. 60604.

MUSICAL INSTRUMENTS

30% DISCOUNT name brand musical instruments. Free Catalog. Freeport Music, 455N, Route 110, Melville, N.Y. 11746.

WHOLESALE! Professional Guitars, PA Systems, Altec Speakers, 240W RMS Amplifiers. Free Catalog, Carvin, Escondido, Calif. 92028.

We will equal any quantity discount for any IC or display offered by any surplus dealer advertising in this magazine

LIGHT EMITTING DIODES	
FLV 100 VIS. LED	\$.65
MT2 Photo Transistor	\$.90
MCT-2 Opto. Isolator	\$.149
MCD-2 Opto. Isolator	\$.149
MCS-1 Opto. Isolator	\$.195
MCA-2-30 Photo Relay	\$.195
MV5020 VIS. LED	\$.65
ME4 IR LED's	\$.65
MRD 148 Photo Cartridges	\$.65

7400	.25	7476	.60
7401	.25	7480	.65
7402	.25	7481	1.25
7403	.25	7483	1.25
7404	.28	7486	.60
7405	.28	7490	1.00
7408	.28	7492	.79
7410	.25	7493	.79
7411	.28	7495	.79
7420	.25	7494	1.10
7430	.25	7421	.70
7440	.25	74123	1.20
7441	1.30	74154	1.95
7442	1.25	74161	1.79
7446	1.50	74192	1.75
7447	1.50	74193	1.75
7448	1.25	74194	2.35
7450	.25	8570	1.90
7456	.25	8590	1.90
7472	.40	9309	1.65
7473	.75	9312	1.95
7474	.50	9322	1.95
7475	1.00	8280	1.40

VERIPAX PC BOARD
This board is a 1 1/16" single sided paper epoxy board 4 1/2" x 6 1/2" (standard veripax) DRILLED and etched, which will hold 21 single 14 pin IC's, or 8 16 or LSI DIP IC's with buses for power supply connections. It is also etched for a 22 pin connector. \$5.25 3 \$14.50

Send \$.20 for our Spring catalog featuring Transistors and Rectifiers

TRANSISTOR SPECIALS										
2N3584	NPN	Si	TO-66	35W	250V	2A	10MHz	100Hfe	\$1.50	
2N965	PNP	GE	TO-18	.15W	7V	.1A	.300	40	7/51.00	
2N1605	NPN	GE	TO-5	.15W	24V	.1A	14	125	5/51.00	
2N5324	PNP	GE	TO-3	60W	250V	10A	20	35	\$1.50	
2N1015D	NPN	Si	TO-82	150W	200V	7.5A	.025	10	\$1.45	
2N3724	NPN	Si	TO-5	.8W	30V	1.A	250	60	3/51.00	
2N3772	NPN	Si	TO-3	150W	60V	30A	2	30	\$1.25	
2N6109	PNP	Si	TO-220	36W	40V	4A	.8	60	50c	
2N5296	NPN	Si	TO-220	36W	40V	4A	.8	60	55c	
2N4898	PNP	Si	TO-66	25W	40V	4A	40	46	\$.60	
MJ2251	NPN	Si	TO-66	10W	225V	.5A	10	40	\$.70	
2N3055	NPN	Si	TO-3	115W	100V	15A	.2	44	\$1.00	

NIXIE TUBE
RAYTHEON 8754 WITH SOCKET AND DATA SHEET \$2.25 3/\$6.00
Printed circuit board 4 1/2" x 6 1/2" double sided fiber glass board 1 1/8" thick, unetched. \$.60 ea. 5 \$2.50

MAN-4 LED READOUT . \$4.50
MAN-3 LED READOUT . \$2.95

SV 1 Amp. regulated power supplies. These units are similar to analog devices encapsulated.
SE905 power supplies \$34.95

B223 Field Prog ROM . \$8.00
1101 256 Bit RAM . \$4.00

TRIACS				
PRV	1A	10A	15A	20A
100	.40	.70	1.00	1.20
200	.70	1.10	1.50	1.60
300	.90	1.35	1.90	2.00
400	1.10	1.60	2.30	2.40
500	1.50	2.00	2.70	2.80

© Press Fit

FULL WAVE BRIDGES			
PRV	2A	6A	
200	.95	1.25	
400	1.15	1.50	
600	1.35	1.75	

Silicon Power Rectifiers				
PRV	1A	3A	12A	50A
100	.06	.09	.30	.85
200	.07	.16	.35	1.25
400	.09	.20	.45	1.50
600	.11	.30	.70	1.30
800	.15	.40	.85	2.30
1000	.20	.55	1.10	2.75

Silicon Control Rectifiers				
PRV	6A	10A	20A	70A
100	.30	.45	1.00	3.50
200	.50	.75	1.25	6.50
300	.60	.90	1.50	
400	.70	1.10	1.75	9.50
500	.80	1.25	2.00	
600	.90	1.40	2.25	11.00

T1S43 UJT's .50
2N3819 N Channel FET's .50
D13T PROG. UJT's .60
ER 900 Trigger Diodes 4/\$1.00

8000 SERIES IC'S			
8230	...1.75	8284	...1.95
8233	...1.75	8713	...1.75
8242	...1.00	8714	...1.95
8250	...1.95	8716	...1.95
8251	...1.95	8722	...1.75
8262	...1.95	8723	...1.75
8270	...1.95	8724	...1.75
8271	...1.95	8726	...1.75
8275	...1.95	8780	...1.10
8280	...1.75	8790	...1.10

DECADE COUNTER KIT
Consisting of:
1-Nixie tube & socket (8754)
1-7490
1-7475
1-7441
3/\$15.00

PA231 1 Watt	\$.25
C Audio Amps	\$.15
LM 309K SV	\$.25
1 Amp Regulator	\$.25
741 OPER. AMP	\$.50
Dual 709	\$.95
723 Regulator	\$.75
TVR-2002 h/mh power 723	\$.100
703RF 1F Amp	\$.80
CA 15 FET Amp	\$.135
565 Phase Lock Loop	\$.325
566 Function Gen.	\$.325
567 Tone Decoder	\$.325
560 Phase Lock Loop	\$.325
561 Phase Lock Loop	\$.325
531 High Slew Oper Amp	\$.250
532 FET Input Oper Amp	\$.375
537 Precision 741	\$.250
540 70W Power Driver	\$.204
747 Dual 741	\$.125
1M208 Oper Amp	\$.195
5556 Oper Amp	\$.75
101 Oper Amp	\$.119
741CV Oper Amp	\$.55
320-SV Reg.	\$.175
320-15V Reg.	\$.175
424-Zero Voltage Switch	\$.125

Terms: FOB Cambridge, Mass. Send check or Money Order. Include postage. Average Wt. per package 1/2 lb. No C.O.D.'s. Minimum Order \$3.00. Rated companies 30 days net

SOLID STATE SALES

Post Office Box 74A

Somerville, Mass. 02143

Tel. (617) 547-4005

CIRCLE NO. 32 ON READER SERVICE CARD

BUSINESS OPPORTUNITIES

I MADE \$40,000.00 Year by Mailorder! Helped others make money! Start with \$10.00—Free Proof, Torrey, Box 318-N, Ypsilanti, Michigan 48197.

\$200.00 DAILY In Your Mailbox! Your opportunity to do what mail-order experts do. Free details. Associates, Box 136-J, Holland, Michigan 49423.

FREE CATALOGS. Repair air conditioning, refrigeration. Tools, supplies, full instructions. Doolin, 2016 Canton, Dallas, Texas 75201.

MAILORDER MILLIONAIRE helps beginners make \$500 weekly. Free report reveals secret plan! Executive (1K5), 333 North Michigan, Chicago 60601.

HIGHLY PROFITABLE ONE-MAN ELECTRONIC FACTORY

Investment unnecessary, knowledge not required, sales handled by professionals. Postcard brings facts about this unusual opportunity. Write today! Barta-DEPE, Box 248, Walnut Creek, CA 94597.

PIANO TUNING LEARNED QUICKLY AT HOME! Tremendous field! Musical knowledge unnecessary. GI approved. Information free. Empire School, Box 327, Miami 33145.

GROW RICH DRIVING YOUR CAR. Magnetic signs, Big Money, very, very easy. Copy Sign, 6644 Santa Monica Blvd., L.A., Calif. 90038.

FREE SECRET BOOK "2042 Unique, Proven Enterprises." Beat inflation with fabulous, successful "Little Knowns." Work home! Haylings-B9, Carlsbad, Calif. 92008.

START SMALL, highly profitable electronic production in your basement. Investment, knowledge unnecessary. Postcard brings facts. Barta-PEM, Box 248, Walnut Creek, California 94597.

MAILORDER: How to prepare your own catalog for pennies! Free Catalog! Obie-Q5, Brooklyn, New York 11219.

\$100.00 EXTRA weekly easy! Spare Time! Details, Beautiful Sample Free. Russell Products, Dept. BC174A, Columbia, Tennessee 38401.

TWO fantastically successful Mail Order Businesses—earns \$2000 monthly: Details: Tradewinds, 3401 W. Caracas, Tampa, Fla. 33614-PE.

TREASURE FINDERS

FREE—Valuable Treasure Finder catalog sent by return mail. Find Coins, Rings, Gold, Silver, Metals, Relics. Write today. JETCO, Dept. CPE, Box 26669, El Paso, Texas 79926.

TREASURE FINDER locates buried gold, silver, coins, treasures. 5 powerful models. \$19.95 up. Instant financing available. Free catalog. Relco, Dept. A-33, Box 10839, Houston, Texas 77018.

DISCOVER AMERICA'S FASTEST GROWING HOBBY. White's Electronics, Inc., would like to send you—absolutely FREE, their 42 page, fact-filled catalog on Mineral and Metal Locating Equipment. Amateurs or Professionals select from the world's largest line of metal detectors, priced as low as \$79.50, up. Detect Gold, Silver, Copper—Nuggets, Coins, Jewelry, etc. Budget terms available. For your convenience we have three major factory locations in the U.S. and Canada, as well as over 1,000 authorized dealers to serve you. See your local Yellow Pages, under "Metal Locating Equipment", or write: White's Electronics Inc., Room No. 391, 1101 Pleasant Valley Road, Sweet Home, Oregon 97386 —Elk-Air Industrial Park, Dexter Drive, East, Elkhart, Indiana 46514—or White's Electronics Ltd., 33784 Hazel Street, Abbotsford, British Columbia, Canada.

FISHER DETECTORS. You deserve the best. Free literature, FR-L, Dept. PE-5, P.O. Box 490, Belmont, CA 94002.

Popular Electronics

INCLUDING **Electronics World**

MAY 1973

ADVERTISERS INDEX

READER SERVICE NO.	ADVERTISER	PAGE NO.	READER SERVICE NO.	ADVERTISER	PAGE NO.
43	Allied Electronics	99	19	Gregory Electronics Corp.	121
1	Antenna Specialists Co., The	95	20	Heath Company	24, 25
2	Avanti Research and Development, Inc.	81	21	Lafayette Radio Electronics	103
4	Babylon Electronics	120	11	Lee Electronic Labs, Inc.	FOURTH COVER
	Bell & Howell Schools	18, 19, 20, 21	22	McIntosh Laboratory, Inc.	111
6	Bose	7	23	MITS Micro Instrumentation & Telemetry Systems, Inc.	17
	CREI Capitol Radio Engineering Institute	106, 107, 108, 109	24	Mallory Distributor Products Company	10, 11
7	Cleveland Institute of Electronics, Inc.	72, 73, 74, 75	25	Midwest Hi Fi Wholesale & Mail Order Div.	105
3	Cobra Communications, Dynascan Corporation	13		NRI Training	SECOND COVER, 1, 2, 3
8	Cortlandt Electronics, Inc.	116		National Technical Schools	54, 55, 56, 57
9	Datak Corporation, The	99	27	PTS Electronics, Inc.	112
10	Delta Electronics Co.	115	28	Pace Communications	92
12	Delta Products, Inc.	71	29	Poly Paks	117
13	Digi-Key	116	30	RCA Institutes, Inc.	36, 37, 38, 39
41	EEP Corporation	98	31	SBE	102
42	EEP Corporation	103	32	Solid State Sales	122
14	EICO	112	33	Solid State Systems, Inc.	119
15	Edmund Scientific Company	124	34	TDK Electronics Corp.	13
16	EI Instruments, Inc.	89	35	Tri-Star Corporation	87
17	Electro-Voice, Inc.	93	36	United Audio Products, Inc.	15
40	Fanon/Courier Corp.	104	37	Utah Electronics Division	9
18	Fluke	105	38	Wahl Clipper Corporation	87
44	Gaylord Electronics Inc.	101	39	Xcelite, Inc.	8
CLASSIFIED ADVERTISING			CLASSIFIED ADVERTISING		115, 116, 117, 118, 120, 121, 122, 123

REAL ESTATE

FREE . . . NEW . . . BIG . . . SUMMER CATALOG! Describes and pictures hundreds of farms, ranches, town and country homes, businesses coast to coast! Specify type property and location preferred. UNITED FARM AGENCY, 612-EP West 47th St., Kansas City, Mo. 64112.

MISCELLANEOUS

WINEMAKERS: Free illustrated catalog yeasts, equipment. Semplex, Box 12276P, Minneapolis, Minn. 55412.

HOME WATER DISTILLERS. Remove all impurities for pennies a gallon. Portable, no plumbing. Free details. United Vito-Way, Box 2216-V, Everett, Washington 98203.

EMERGENCY HORN—Hand-sized, self-powered. Perfect for emergencies. Can be heard up to one mile. Will also repel attackers or animals, without permanent harm. \$3.50 postpaid. J. Ross, Box 223, Jamaica, N. Y. 11431. Dept. PE.

YOUR LOW COST Classified or Display Classified Ad in these columns will be seen, read and responded to regularly by America's largest audience of Electronics Professionals and Hobbyists. For \$1.60 per word (minimum \$16.00) your Classified ad will produce sales results far in excess of the small amount you'll spend on advertising. If your product or service deserves more prominent exposure to this audience, then Display Classified is for you . . . and it's available in units of 1", 2" or 3" by one column at rates of \$200.00, \$400.00 or \$600.00 per insertion (even less if you sign up for a 6 or 12-time contract. For immediate action send copy and payment NOW to: Hal Cymes, Classified Advertising Manager, POPULAR ELECTRONICS including ELECTRONICS WORLD, One Park Avenue, New York, New York 10016.

LIVE IN THE WORLD OF TOMORROW... TODAY!

A BETTER LIFE STARTS HERE

ASTRONOMICAL TELESCOPE KITS



Grind your own mirror for powerful telescopes. Kit contains fine annealed pyrex mirror blank, tool, abrasives, diagonal mirror, and eyepiece lenses. Instruments you build range in value from \$75.00 to hundreds of dollars.

- Stock No. 70.003AV 4 1/2" diam. 3/4" thick \$10.75 Ppd.
- Stock No. 70.004AV 6" diam. 1" thick \$16.95 Ppd.
- Stock No. 70.005AV 8" diam. 1 1/4" thick \$24.50 Ppd.
- Stock No. 70.006AV 10" diam. 1 3/4" thick \$30 lbs. \$44.50 FOB
- Stock No. 70.007AV 12 1/2" diam. 2 1/4" thick 46 lbs. \$72.50 FOB

"FISH" WITH A GIANT MAGNET

Go Treasure Hunting On The Bottom!

Fascinating fun, and sometimes very profitable! Tie a line to our 5-pound Magnet—drop it overboard in bay, river, lake or ocean. Troll it along the bottom. Your "treasured" haul can be outboard motors, anchors, other metal valuables. Five-pound Magnet is war surplus—Alnico V Type that cost the Government \$50. It lifts over 150 pounds on land—much greater weights under water!



- Stock No. 70.571AV \$14.00 Ppd.
- Stock No. 70.570AV 3 1/2 lbs. \$8.75 Ppd.
- Stock No. 85.152AV 15 1/4 lbs. \$33.95 F.O.B.

PHOTOCELL RELAY SYSTEM BUY!

AVAILABLE AGAIN! SURPLUS PRICED!

Self contained unit adapted easily to operate burglar alarms; people, car, conveyor package counters; annunciators; garage door openers; warning systems, assemblyline control, etc. Orig. built for expensive copying machines. Incis cadmium sulphide photocell, single-pole double-throw relay, silicon rectifier, capacitor, resistor, 6.5v lamp, 75w 125v socket. Uses 110v AC Metal cased (1 1/2 x 3 3/4 x 3/4"). 11 1/2 oz. Instrs.



- Stock No. 60.622AV \$6.25 Ppd.

[And our FREE CATALOG is packed with exciting and unusual ecological & physical science items—plus 4,000 finds for fun, study or profit... for every member of the family.]

KNOW YOUR ALPHA FROM THETA!

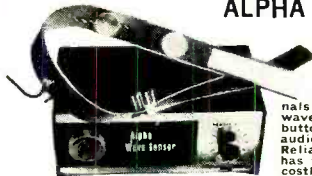

Learn to control your Alpha-Theta brainwaves for relaxation, improved memory, concentration. Electrode headband (w/ no messy creams, etc.) attach to amplifier filters brainwaves, signals beep for ca. Alpha or Theta wave passed. Spcl monitoring button to simulate Alpha sound: audio & visual (L.E.D.) feedback. Reliable, easy-to-use trainer unit has features comparable to many costlier models. Completely safe. Most people can learn in 8-12 hrs w/ incl instr. (8x3x4", 24 oz.) \$124.50 Ppd.

- No. 1635AV

NEW!

ELECTRONIC DIGITAL COMPUTER KIT

Solve problems, play games, predict weather, even play miniature chess, with this actual working model of giant electronic brains. Amazing new fun way to learn all about computer programming... logic, decimal, binary systems, Laws of Sets. Even do your own programming after completing the simplified, 116-page instruction booklet. Circuits are easily changed, readout is from an illuminated control panel. Requires 2 "D" batteries (not incl.).

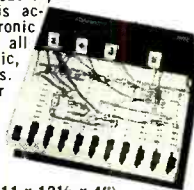

- Stock No. 71.434AV... \$31.50 Ppd. (11 x 12 1/2 x 4")

SEE THE STARS, MOON, PLANETS CLOSE UP!



3" ASTRONOMICAL REFLECTING TELESCOPE

60 To 180 Power. Famous Mt. Palomar Type

See the rings of Saturn, the fascinating planet Mars, Seas and Craters of the Moon, Star Clusters in detail. New improved, aluminized and overcoated 3" diameter f/10 primary mirror, ventilated cell. Equatorial mount with locks on both axes. Equipped with 60x finder telescope, hardwood tripod. Included FREE: VALUABLE "HOW TO USE YOUR TELESCOPE" book; "STAR CHART"

- Stock No. 85.050AV \$32.95 Ppd. 6" REFLECTOR TELESCOPE WITH DELUXE 3" REFLECTOR TELESCOPE
- Stock No. 80.162AV... \$61.50 Ppd. ELEC. CLOCK DRIVE
- Stock No. 85.086 \$239.50 F.O.B.
- 4 1/4" REFLECTOR TELESCOPE (45X TO 270X) Stock No. 85.105 \$99.50 F.O.B.

MAIL COUPON FOR GIANT FREE CATALOG!

164 PAGES • MORE THAN 4000 UNUSUAL BARGAINS!

Completely new Catalog. Packed with huge selection of telescopes, microscopes, binoculars, magnets, magnifiers, prisms, photo components, ecology and Unique Lighting items, parts, kits, accessories — many hard to get surplus bargains. 100's of charts, illustrations. For hobbyists, experimenters, schools, industry.

EDMUND SCIENTIFIC CO.
300 Edscorp Building, Barrington, N. J. 08007
Please rush Free Giant Catalog "AV"

Name _____
Address _____
City _____ State _____ Zip _____

COMPLETE & MAIL WITH CHECK OR M.O.

EDMUND SCIENTIFIC COMPANY
300 Edscorp Building, Barrington, N.J. 08007

How Many	Stock No.	Description	Price Each	Total

PLEASE SEND GIANT FREE CATALOG "AV" MERCHANDISE Total
HANDLING CHARGE \$1.00*
TOTAL \$ _____



I enclose check money order for \$ _____ *50¢ ON ORDERS OVER \$5.00

NAME _____
ADDRESS _____
CITY _____ STATE _____ ZIP _____

CIRCLE NO. 15 ON READER SERVICE CARD
Printed in U.S.A.

Popular Electronics

INCLUDING **Electronics World**

READER SERVICE

Here's an easy and convenient way for you to get additional information about products advertised or mentioned editorially (if it has a reader service number) in this issue. Just follow the directions below... and the material will be sent to you promptly and free of charge.

1
In the attached postage-free card, print or type your name and address in the lines indicated.

2
Circle the number (s) that corresponds to the key number (s) at the bottom or next to the advertisement or editorial mention that is of interest to you. (Key numbers for advertised products also appear in the Advertisers' Index.)

3
Simply cut out the card and mail. No postage required.

FREE INFORMATION

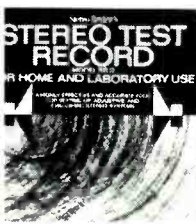

the **NEW STANDARD** in Stereo Testing!

Model SR12 STEREO TEST RECORD

The most complete...most sophisticated...
most versatile Test Disc available today.

Whether you're an avid audiophile, a casual listener or a professional technician... the new MODEL SR12 will be the most important disc in your entire collection.

MODEL SR12 has been produced by Stereo Review Magazine for music lovers who want immediate answers to questions about the performance of their stereo systems and how to get the best possible sound reproduction.

It's the most complete test record of its kind - containing widest range of checks ever included on one test disc.

Make these important stereo checks BY EAR... (no test instruments required)

Frequency response—a direct, warble-tone check of nineteen sections of the frequency spectrum, from 20 to 20,840 Hz, which will pinpoint any frequency response defects in your system.

Separation—an ingenious test which indicates whether you have adequate separation for good stereo.

Cartridge tracking—the most sophisticated tests ever devised for checking the performance of your cartridge, stylus and tone arm.

Channel balance—two broad-band, random-noise signals which permit you to eliminate any imbalances originating in cartridge, amplifier, speakers or room acoustics.

Hum and rumble—foolproof tests that help you evaluate the actual audible levels of rumble and hum in your system.

Flutter—a sensitive "musical" test to check whether your turntable's flutter is low, moderate, or high.

TESTS!
● Cartridge and Speaker Phasing ● Antialiasing Adjustment ● "Gun Shot Test" for Stereo Spread ● All-purpose Musician's "A" ● Equal-tempered Chromatic Scale ● Guitar-tuning Tones.

Attention Professionals... Model SR12 is also designed to be used as a highly efficient design and measurement tool. Tests below have been controlled to laboratory tolerances—affording accurate numerical evaluation when used with oscilloscope, chart recorder, output meter, intermodulation-distortion meter and flutter meter.

- 1,000-Hz square waves to test transient and high-frequency response of phono pickups.
- 500 to 20,000 Hz frequency-response sweep.
- Sine-wave tone-bursts to test transient response of pickup.
- Intermodulation test using simultaneous 400-Hz and 4,000-Hz signals.
- Intermodulation sweep to show distortion caused by excessive resonances in tone arm and cartridge.
- 1,000-Hz reference tones to determine groove velocity.
- 3,000-Hz tone for flutter and speed tests.

Sample waveforms—illustrating both accurate and faulty responses are provided in the Instruction Manual for comparison with the patterns appearing on your own oscilloscope screen.

FREE Instruction Manual Includes Detailed Instructions, Charts, Tables and Diagrams

HERE'S HOW TO ORDER YOUR SR12 STEREO TEST RECORD

CASH: Mail your order along with your name, address and remittance in the amount of \$5.98, postpaid.

CHARGE: Your American Express or BankAmericard account! Mail your order, name, address and credit card number. You will be billed at \$5.98, postpaid.

MAIL ALL ORDERS TO: RECORDS, ZIFF-DAVIS SERVICE DIVISION, 595 BROADWAY, NEW YORK, N.Y. 10012
OUTSIDE U.S.A. RECORDS ARE \$8.00, POSTPAID.



