

# Popular Electronics

INCLUDING **Electronics World**

## HOME SECURITY SYSTEMS

### BUILD:

- A Digital Logic Computer
- General Purpose Alarm
- Bass Reflex Enclosure

A GUIDE TO  
**HOME STUDY  
 EDUCATION**  
 in  
 Electronics

**TREASURE  
 DETECTORS  
 FOR  
 LAND USE**

### TEST REPORTS:

- Heath IC-2008 Calculator
- Dual 1218 Automatic Turntable
- James C-7535 Intrusion Alarm
- Production Devices  
 Transistor Tester
- Triplet 603 VOM

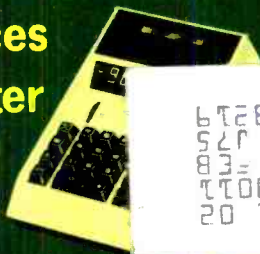

**SOLID-STATE  
 CIRCUITS**  
 for the  
 Electronics

3723219 RCMA 103FLOL 02  
 REGPC0225BPC1109 7001MB0011  
 RICHMOND PUB LIBR FEB  
 101 E FRANKLIN ST J75  
 RICHMOND VA 23219

# NOW you can train at home building a NEW 25" Solid State Color TV engineered by NRI for learning and trouble-shooting

*So much better for learning TV servicing than any hobby kit, because NRI designed and created it as an educational tool.*

Unlike hobby kits which are designed for creating a TV set as the end product, NRI built its exclusive 25" Solid State Color TV kit as a real training kit. You can introduce and correct defects . . . for trouble-shooting and hands-on experience in circuitry and servicing. The kits include a wide-band oscilloscope, color bar crosshatch generator, transistorized volt-ohmmeter and other valuable equipment that can soon have you earning \$5 to \$7 an hour servicing color sets in your spare time.

Handsome woodgrain cabinet, at no extra cost. (Offered only by NRI)

New square-cornered Sylvania picture tube

100% solid state chassis

6-position detented UHF channel selector



Modular construction with plug-in circuit boards

Automatic degaussing

Automatic fine tuning

Automatic tint control

Automatic color control

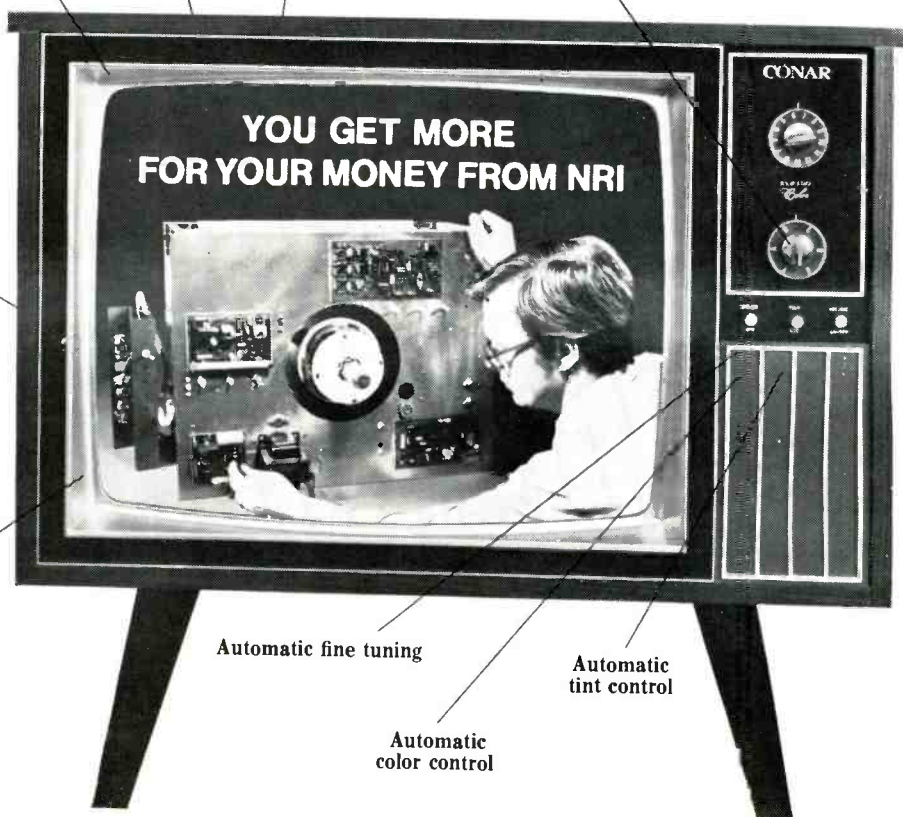

# NRI FIRSTS make learning Electronics fast and fascinating—to give you priceless confidence

The NRI color TV and digital computer kits are the latest in a long line of "firsts" for NRI. For more than fifty years, NRI has been providing unique 3-dimensional home-study training that has helped hundreds of thousands of students reach their goals quickly and easily.

What NRI provides is a combination of kits and bite-size texts that give you hands-on experience while you are learning. The texts average only 40 pages each, and they are fully illustrated. You are taken step-by-step from the first stages into the more advanced theory and techniques... with an expert instructor ready at all times to provide valuable guidance and personal attention. (The level of personal attention provided is more than you would receive in many classrooms.) Once you've grasped the fundamentals, you move with confidence and enthusiasm into new discoveries in the fascinating world of electronics.

You start out with NRI's exclusive Achievement Kit, containing everything you need to get moving fast. Lessons have been specifically written so that experiments build upon one another like stepping stones. You can perform a hundred experiments build hundreds of circuits... as you learn to use the professional test equipment provided, building radios and TV sets, transmitter or computer circuits. It's the priceless "third dimension" in NRI training... practical experience.

## Train with the leader—NRI

Compare training kits, texts, techniques and overall training... and you'll find that you get more for your money from NRI. Whatever your reason for wanting more knowledge of Electronics, NRI has an instruction plan that will meet your needs. Choose from major programs in Advanced Color TV Servicing, Complete Computer Electronics, Industrial Electronics and the other special courses designed to meet specific needs. With NRI home training, you can learn new skills while you're still working at your present job... and turn yourself into the man in demand.

### GET FACTS ABOUT GI BILL

If you have served since January 31, 1955, or are in service now, check GI line on postage-free card.

## Send for free NRI catalog

MAIL THE POSTAGE-FREE CARD FOR THE FREE NRI CATALOG IN THE FIELD OF YOUR CHOICE. YOU WILL BE UNDER NO OBLIGATION. NO SALESMAN WILL CALL.

If the card has been used, write direct to:



**NRI TRAINING**  
3939 Wisconsin Ave.  
Washington, D.C. 20016

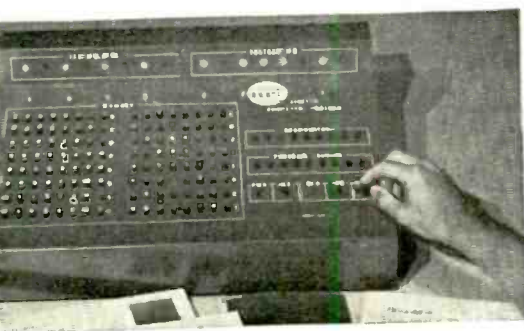

**FIRST** to give you a complete programmable digital computer, with memory, you build yourself... to learn organization, operation, trouble-shooting and programming. This remarkable computer is one of ten training kits you receive with the new NRI Complete Computer Electronics Course.

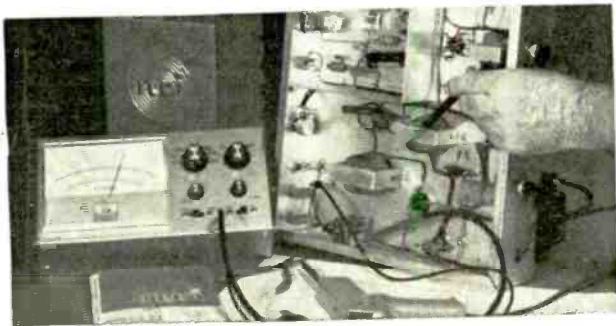

**FIRST** to give you true-to-life experiences as a Communications Technician. Every fascinating step you take in NRI Communications training, including circuit analysis of your own 15-watt, phone/cw transmitter, is engineered to help you prove theory and later apply it on the job. Studio equipment operation and trouble shooting become a matter of easily remembered logic.



**FIRST** to give you completely specialized training kits engineered for business, industrial and military Electronics Technology. Shown is your own training center in solid-state motor control and analog computer servo-mechanisms. Telemetering circuits, solid-state multivibrators and the latest types of integrated circuits are included in your course.

# Popular Electronics

WORLD'S  
LARGEST-SELLING  
ELECTRONICS MAGAZINE

INCLUDING **Electronics World**

## FEATURE ARTICLES

- 28 ELECTRONIC SECURITY SYSTEMS** *John T. Frye*  
*Alarm protection for your home.*
- 47 NOVEL USE FOR LED** *Roland J. McMahan*  
*An aid for the hard of hearing*
- 48 A GUIDE TO HOME STUDY EDUCATION IN ELECTRONICS**  
*Selecting a school and a course.* *Louis E. Frenzel, Jr.*
- 52 TREASURE DETECTORS FOR LAND USE** *L. George Lawrence*
- 60 HI-FI LOUDSPEAKERS: FACTS & FALLACIES (Part II)** *Victor Brociner*
- 66 SIMPLE SOLID-STATE CIRCUITS FOR THE EXPERIMENTER** *Jim Huffman*  
*Basic approach to amplifier design.*
- 72 CONTACT PROTECTS PANEL MARKINGS** *Richard A. Kunc*
- 86 NEW IN-LINE COLOR TUBE SIMPLIFIES CONVERGENCE**
- 87 NEW BREED OF TEST EQUIPMENT** *John T. Frye*  
*Diode junction tester has pizzazz.*
- 90 IDENTIFICATION BY INSTANT REPLAY TV**
- 107 EDUCATION AND OPPORTUNITIES** *David L. Heiserman*

## THE SCENES

- 12 STEREO SCENE** *J. Gordon Holt*  
*The discrete quadraphonic disc.*
- 96 COMMUNICATIONS SCENE** *Richard Humphrey*  
*Marine radio technicians and new regulations.*
- 100 TEST EQUIPMENT SCENE** *Leslie Solomon*  
*Proper probes for your oscilloscope.*
- 117 SURPLUS SCENE** *Alexander W. Burawa*

ZIFF-DAVIS PUBLISHING COMPANY  
Editorial and Executive Offices  
One Park Avenue, New York, New York 10016  
212 679-7200

William Ziff, President  
W. Bradford Briggs, Executive Vice President  
Hershel B. Sarbin, Senior Vice President and Secretary  
Phillip Sine, Financial Vice President and Treasurer  
Phillip T. Heffernan, Vice President, Marketing  
Frank Pomerantz, Vice President, Creative Services  
Arthur W. Butzow, Vice President, Production  
Edward D. Muhlfeld, Vice President, Aviation Division  
Irwin Robinson, Vice President, Travel Division  
George Morrissey, Vice President  
Sydney H. Rogers, Vice President  
Sidney Hottz, Vice President  
Lawrence Sporn, Circulation Director

POPULAR ELECTRONICS Including ELECTRONICS WORLD, September, 1972, Volume 2, Number 3. Published monthly at One Park Ave., New York, NY 10016. One year subscription rate for U.S., U.S. Possessions and Canada, \$6.00; all other countries, \$7.00. Second class postage paid at New York, N.Y. and at additional mailing offices. Authorized as second class mail by the Post Office Department, Ottawa, Canada and for payment of postage in cash. Subscription service and Forms 3579: P.O. Box 1096, Flushing, NY 11352. Editorial offices for manuscript contributions, reader inquiries, etc.: One Park Ave., New York, NY 10016.

POPULAR ELECTRONICS Including ELECTRONICS WORLD is indexed in the Reader's Guide to Periodical Literature.

Copyright © 1972 by ZIFF-DAVIS PUBLISHING COMPANY. All rights reserved.

POPULAR ELECTRONICS Including Electronics World

**EDGAR W. HOPPER**  
*Publisher*  
**WM. A. STOCKLIN**  
*Editorial Director*  
**MILTON S. SNITZER**  
*Editor*  
**LESLIE SOLOMON**  
*Technical Editor*  
**JOHN R. RIGGS**  
*Managing Editor*  
**EDWARD I. BUXBAUM**  
*Art Director*

**ALEXANDER W. BURAWA**  
*Associate Editor*  
**ANDRE DUZANT**  
*Technical Illustrator*  
**JUDITH L. HOGAN**  
*Editorial Assistant*  
**FOREST H. BELT**  
**JOHN T. FRYE**  
**DAVID L. WEISERMAN**  
**J. GORDON HOLT**  
**RICHARD HUMPHREY**  
*Contributing Editors*

**JOSEPH E. HALLORAN**  
*Advertising Director*  
**JOHN J. CORTON**  
*Advertising Sales*  
**MADELEINE LITTMAN**  
*Advertising Service Manager*  
**STANLEY NEUFELD**  
*Associate Publisher*  
**FURMAN H. HEBB**  
*Group Vice President*  
*Electronics and Photographic*

## CONSTRUCTION STORIES

- 32** BUILD BASS REFLEX ENCLOSURES THE EASY WAY *David B. Weems*  
**34** CONSTRUCTING PC BOARDS *Robert A. Sullivan and Robert S. Brodsky*  
*How to make your own professional-type boards.*  
**42** BUILD A DIGITAL LOGIC TRAINER *Jack Cazes*  
*Small computer performs 32 functions.*  
**64** BUILD A GENERAL-PURPOSE ALARM *Truett Brown*  
**70** AQUARIUM HEATER CONTROL FOR FISH FANCIERS *A. E. Donkin*  
**73** SLOW TURN-ON PROTECTS POWER SUPPLY *Frank Tooker*  
**91** LIGHT MINDER *Stephen J. Erst*

## PRODUCT TEST REPORTS

- 78** DUAL MODEL 1218 AUTOMATIC TURNTABLE  
**80** TRIPLETT MODEL 603 SOLID-STATE VOM  
**82** HEATHKIT MODEL IC-2008 DIGITAL CALCULATOR  
**83** PRODUCTION DEVICES MODEL 85 TRANSISTOR TESTER  
**84** JAMES MODEL C-7835 INTRUSION DETECTOR

## DEPARTMENTS

- 6** EDITORIAL *Milton S. Snitzer*  
*The New/Com Show*  
**8** LETTERS  
**25** NEWS HIGHLIGHTS  
**102** NEW PRODUCTS  
**114** ELECTRONICS LIBRARY  
**116** NEW LITERATURE  
 READER SERVICE CARD ON BACK COVER

## COMING NEXT MONTH

*How Good Are Audio Cassettes?*  
*Multiset Coupling for TV Antennas*  
*Electronics Helps*  
*Prevent Car Collisions*  
*Public Address Questions & Answers*

Midwestern Office  
 The Pattis Group, 4761 West Touhy Ave.,  
 Lincolnwood, Illinois 60644, 312 679-1100  
 GERALD E. WOLFE, DICK POWELL  
 DICK GOVATSKI, MANLEY LUDWIG

Western Office  
 9025 Wilshire Boulevard, Beverly Hills, California 90211  
 213 273-8050; BRadshaw 2-1161  
 Western Advertising Manager, BUD DEAN

Japan: James Yagi  
 Oji Palace Aoyama; 6-25, Minami Aoyama  
 6 Chome, Minato-Ku, Tokyo 407-1930/6821

Ziff-Davis also publishes Boating, Car and Driver, Cycle, Flying, Modern Bride, Popular Photography, Skiing, and Stereo Review.

Forms 3579 and all subscription correspondence should be addressed to POPULAR ELECTRONICS Including ELECTRONICS WORLD, Circulation Department, P.O. Box 1096, Flushing, NY 11352, Please allow at least eight weeks for change of address. Include your old address, as well as new—enclosing, if possible, an address label from a recent issue.

Editorial contributions must be accompanied by return postage and will be handled with reasonable care; however, publisher assumes no responsibility for return or safety of art work, photographs or manuscripts.



Member Audit Bureau  
 of Circulations



# Editorial

By Milton S. Snitzer, Editor

## THE NEW/COM SHOW

Recently we returned from sunny, hot Las Vegas where we spent several days at the New/Com '72 show. New/Com (National Electronics Week/Components) is a trade show attended by manufacturers of electronic equipment that is sold through parts distributors. The show is sponsored by the Electronic Industries Association, Western Electronic Manufacturers Association, Association of Electronic Manufacturers, National Electric Distributors Association, and Electronic Representatives Association.

The show is important to you since the business transacted there partly determines which components, test equipment, tools, CB rigs, antennas, and semiconductors you will find on the shelves of your local distributor.

This year's show occupied about 20 percent more space than the 1971 show which was held in Miami Beach. In all there were 195 exhibitors, compared to about 180 last year. There were 253 display booths and 30 conference suites for a total of 283 exhibit spaces at the big Las Vegas Hilton hotel.

Almost without exception, all the exhibitors we talked to were excited and enthusiastic about the amount of business they were able to conduct with distributors and sales reps. Sales quotas were toppled and some exhibitors told us they simply didn't have enough personnel on hand to conduct all the business that was being written at the show.

Not only did we see a number of new pieces of equipment but we saw lots of attractively packaged components of all kinds. There were resistors, capacitors, diodes, transistors, integrated circuits, printed circuit kits, and more, all in self-showing packages that hang on sales racks or on the walls of the distributor's store.

What the show means is that there will be a greater variety and better quality of items that you will be able to buy from your electronic parts distributors. Here is a group that is really catering to the needs of the electronics experimenter, especially those of you who write to us asking where you can buy this part or that item for one of our construction projects.

# The best time to upgrade your component system is before you buy it.

If you're a typical reader of this magazine, you most likely have a sizeable investment in a component system. So our advice about upgrading might come a little late.

What you might have overlooked, however, is the fact that your records are the costliest and most fragile component of all. As well as the only one you will continue to invest in.

And since your turntable is the only component that handles these valuable records, advice about upgrading your turntable is better late than never.

Any compromise here will be costly. And permanent. Because there is just no way to improve a damaged record.

If the stylus can't respond accurately and sensitively to the rapidly changing contours of the groove walls, especially the hazardous peaks and valleys of the high frequencies, there's trouble. Any curve the stylus can't negotiate, it may lop off. And with those little bits of vinyl go the high notes and part of your investment.

If the record doesn't rotate at precisely the correct speed, musical pitch will be distorted. No amplifier tone controls can correct this distortion.

If the motor isn't quiet and free of vibration, an annoying rumble will accompany the music. You can get rid of rumble by using the bass control, but only at the expense of the bass you want to hear.

Experienced component owners know all this. Which is why so many of them, especially record reviewers and other music experts, won't play their records on anything but a Dual. From the first play on.

Now, if you'd like to know what several independent test labs say about Dual, we'll send you complete reprints of their reports. Plus a reprint of an article from a leading music magazine telling you what to look for in record playing equipment. Whether you're upgrading or not.

Better yet, just visit your franchised United Audio dealer and ask for a demonstration.

You'll find Dual automatic turntables priced from \$109.50 to \$199.50. That may be more than you spent on your present turntable, or more than you were intending to spend on your next one.

But think of it this way. It will be a long, long time before you'll need to upgrade your Dual.

**Dual**

Dual 1215 S. \$109.50

Dual 1218. \$155.00

Dual 1229. \$199.50

United Audio Products, Inc., 120 So. Columbus Ave., Mt. Vernon, N.Y. 10553  
Exclusive U.S. Distribution Agency for Dual

**CIRCLE NO. 38 ON READER SERVICE CARD**

# versatile new 14-Piece, 1/4" Sq. Drive socket wrench set drives fasteners 7 different ways



**REVERSIBLE RATCHET** — Precision made, long life, fully enclosed mechanism. Short handle swing for close quarter work.

**UNIQUE SPINNER/EXTENSION** — 5-3/4" overall. Plastic (UL) handle with 1/4" sq. drive socket insert for ratchet. Use also as regular nutdriver.

**2" DRIVE EXTENSION** — Fits on ratchet or either end of spinner/extension.

**RUGGED, HEAT TREATED, ALLOY STEEL SOCKETS** — Nine for hex sizes 3/16" thru 1/2". Two dual purpose for hex and square sizes 1/4" and 5/16".

**FREE STICK-ON INITIALS** personalize the sturdy plastic case and help prevent loss or mix-up.

REQUEST  
BULLETIN N770

No. 1001 SET



Made in U.S.A.

nationwide availability  
through local distributors

## XCELITE

XCELITE, INC. • 20 BANK ST., ORCHARD PARK, N. Y. 14127  
Send Bulletin N770 on 1/4" Square Drive Socket Wrench Set.

name \_\_\_\_\_  
address \_\_\_\_\_  
city \_\_\_\_\_ state & zone \_\_\_\_\_

**CIRCLE NO. 41 ON READER SERVICE CARD**

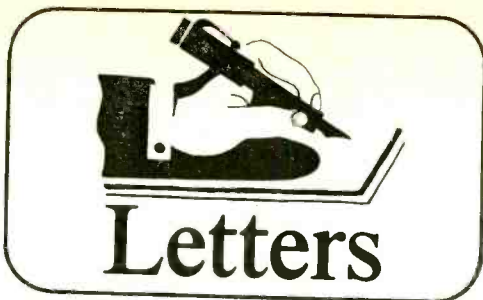

### KEEP THE ETCHING GUIDES

Marvin Jones (Letters, June 1972) may not know why you publish etching and drilling guides, but he speaks only for himself. I use the guides regularly, as I am sure many other readers do.

WALTER E. SCHMID  
Carbondale, Ill.

I don't like the time it takes between submitting an order and the delivery of my commercial PC boards. Furthermore, commercial boards leave no room for me to modify them should I wish to do so. I vote you keep the etching guides.

JAMES THIEL  
Kentucky

A great many of us experimenters take pleasure in being able to say that we built a project from scratch. Leaving out the guides, putting us at the mercy of commercial suppliers, would change us into assemblers instead of builders. Please don't discontinue publishing the etching and drilling guides.

DANIEL L. SANDERS  
Spokane, Wash.

It is obvious that Marvin Jones has never had to pay import duties for the items he uses in his electronics hobby. For most of us who live outside the U.S.A., it is necessary to add at least one-third more to the cost of any item purchased outside our countries. If we have PC guides, at least we can save some money by buying materials locally and making our own boards. Those published guides come in mighty handy in such cases.

RICHARD CAMERON  
Ontario, Canada

*Enough said. The above is only a small sampling of the flood of letters received—all asking us to continue publishing our etching and drilling guides. There was not one letter of dissent. The guides will remain.*

### ANOTHER COUNTY HEARD FROM

In "News Highlights" (June 1972) mention was made of RCA's new "Electronics For Law



Enforcement" system. It was stated that the dispatcher can blow the horn of any vehicle when the driver is away. Well, here in Palm Beach County, the Sheriff's Office has what they call a "Recall" system. It is an electronic gadget located near the radio. Not only does it operate the car's horn, but it also turns on the blue lights on the roof.

PAUL S. COLOMBO  
Lake Worth, Fla.

## A WORD TO CB'ERS

After reading "The Case For A National CB Organization (February 1972), I came to the following conclusion: If the CB'ers ever did organize a nationally accepted group, it would have quite a job on its hands. To convince the F.C.C. that the CB operators were worthy of the 220-222-MHz ham band, this organization would first have to clean up the present CB bands. That in itself would be quite a miracle.

As I listen in on the CB frequencies from time to time, I note that the majority of operators do not even have licenses. Emergency channel 9 is being used the same as any other channel, and I dread to think what might happen if a real emergency ever came up. Another thing I noticed was the profanity used by CB'ers; it has never before been equalled by any other broadcasting group.

My conclusion is that before the F.C.C. even considers giving a ham band to CB'ers, the CB operators themselves should clean up their present bands.

DAVID J. SHUCH, WB2BOH  
President  
H.B. Thompson Ham Radio Club  
Syosset, N.Y.

## SATISFIED POP MUSICIAN

While researching material for a music synthesizer, I happened across your "Touchtone" circuit (March 1970). Since I run light shows for rock groups, I'm always on the lookout for circuits which can be assembled to improve my shows. So, I incorporated the Touchtone into another circuit. My combination works fine. Thanks for a great idea.

MICHAEL B. CARROLL  
Kendallville, Ind.

## SOMETHING FOR VACUUM TUBE BUFFS

I am glad to see that you have not forgotten your readers who experiment with vacuum tubes. I am speaking of the story "Transmitter For the Neglected Band" in the January issue. I hope you will have more projects using tubes.

ROBERT ROLAND  
San Jose, Calif.

*Have you seen "Tuner For the Neglected Band" in the February issue?*

SEPTEMBER 1972

# Dreaming about a pair of \$300 condenser microphones?

## Think seriously about these: \$39.75\* each!

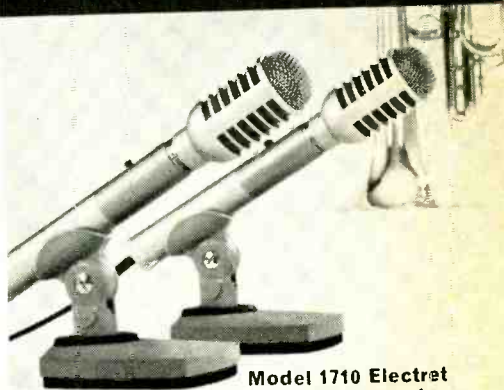

Model 1710 Electret  
Condenser Omnidirectional Microphone

All of the great condenser advantages are here without compromise. Flat, extended range, excellent transient response, high output, low noise, and ultra-clean sound. But the new E-V electret condenser microphones need no high voltage power supply. Just an AA penlite battery to operate the built-in FET impedance converter. The result is studio performance without complications and at a dramatically lower price.

There are 4 new E-V electret microphones, including cardioid models, from \$39.75 to just \$75.00, audiophile net. Second-generation designs with unusually high resistance to heat and humidity. Hear them today at your nearby Electro-Voice soundroom. Or write for details.

**More U. S. recording studios use Electro-Voice microphones than any other brand.**

\*Suggested retail price. Microphones shown on Model 421 Desk Stand. \$12.00 each.

**Electro-Voice®** a Gulton  
COMPANY

ELECTRO-VOICE, INC., Dept. 922P  
630 Cecil Street, Buchanan, Michigan 49107  
In Europe: Electro-Voice, S.A., Römerstrasse 49,  
2560 Nidau, Switzerland

**CIRCLE NO. 12 ON READER SERVICE CARD**

# Get a little in the Navy.

## **More job.**

If you qualify, we can guarantee you any one of 68 job fields. What's more, we'll send you to a school that will make you a real pro. That way, you get more jobs in the Navy and when you get out, you've got somewhere to go.

## **More choice.**

There's a new 3 year Navy enlistment. So you can come in for 6 years or 4 years or now, 3 years.

## **More guarantees.**

You can be guaranteed East or West Coast and choice of sea duty or airman recruit work.

## **More travel.**

See Africa. See Europe. See Japan. Join the Navy and see the world. (It's still true.)

## **More bread.**

New guys now earn \$288 a month. (Congress gave us a raise.)

# more

## More hair.

You can wear a beard (nicely trimmed) if you want to. It's a Naval tradition. It's also a brand new Navy.

## More freebies.

Besides free travel and free education and that \$288 a month, you get free food and free clothing and free housing and free health care and 30 paid vacation days per year.

If you think you've got what it takes to make it in the new Navy,

**Call:**  
**800-424-8880**

It's toll free, there's no obligation, and a real live Navy recruiter will answer all your questions 24 hours a day, seven days a week. In Washington, D. C. call 433-2000.

**Or:**

See your Navy man right now. He's listed in your phone book under U.S. Government, Navy. He's got all the answers—or he knows where to find them.

**Or:**

Send to: Captain Donald E. Oglevee  
Building 157, Fourth Floor,  
Washington Navy Yard,  
Washington, D.C. 20390

102

I want to know more about:

- More job, training, education.
- The new 3 year enlistment.
- More travel.
- Guaranteed East or West Coast home port.
- More bread.
- Enlisting now, reporting 6 months later.
- I want to know more right away. Call me.  
My phone No. (\_\_\_\_\_).

■ If you really don't want to wait, call us toll free right now at: **800-424-8880**  
In Washington, D. C. call: 433-2000

Name \_\_\_\_\_ Age \_\_\_\_\_

Address \_\_\_\_\_

City \_\_\_\_\_

State \_\_\_\_\_ Zip \_\_\_\_\_



# Stereo Scene

By J. Gordon Holt

**S**OME REASONS why video cassettes have not yet brought about the revolution in viewing that was predicted for them are that there are at least a half a dozen different video cassette systems being proposed these days. None of the players can use cassettes made for any other player, and some of them don't work very well anyway. These strike me as being very good reasons why the video public has not yet leaped in with both feet and embraced video cassettes with both arms. They are also very good reasons why the audio public has not yet been eager to embrace 4-channel stereo, for much the same situation prevails in quadraphony as in video cassettes.

A quick count at the time of this writing reveals that there are at least eight different systems being proposed for quadraphonic reproduction from discs. Of these, five are matrixing systems of various kinds, where signal phases and amplitudes are juggled to produce what has been described as "a tolerable substitute for the real thing," at its best, and as "hopelessly inadequate" at its worst. The "real thing," of course, is discrete quadraphony: four separate recording and reproducing channels. Test after test has shown that the discrete approach outperforms every other one in every respect. Some discrete quadraphonic record-

ings have been made available from several manufacturers on open-reel tape and on 8-track cartridges from RCA and Ampex.

The commercial success of these discrete 4-channel tapes is still by no means assured. Each format uses for its rear-channel signals two of the tape tracks that formerly provided half of the tape's total 2-channel playing time. This halves the amount of music that can be accommodated on them. Some early 2-channel stereo recording systems were rejected by the buying public largely for the same reasons, because they cost more and gave only half as much music for the extra money. In addition, even though sales of prerecorded tapes on cassettes and cartridges have been burgeoning during the past year or so, most people still prefer recordings on discs. And discrete 4-channel sound on a disc seemed beyond the capabilities of current technology.

Then the Japanese Victor Company announced, rather modestly, that they had found a practical way of recording discrete quadraphony on a disc.

The basic technique for doing this was not new: It had been proposed back in the mid-1950's (by Jerry Minter, of Components Corporation, if memory serves me) as a means of recording 2-channel stereo on a disc. It involved using a frequency-modulated ultrasonic signal recorded on the disc along with the usual monophonic (L + R) lateral modulations. The ultrasonic signal carried the stereo difference information (L - R), and after a playback demodulator converted the ultrasonic FM into audio frequencies, a simple matrixing circuit mixed the difference signal with the sum signal to extract from them the two original stereo signals.

Most audio experts were aghast at the idea. "Why, the first time the record is played," they predicted direly, "the pickup

## The Discrete Quadraphonic Disc

# Twelve years — Five major advances



**BOSE 901\***



**BOSE 501\***

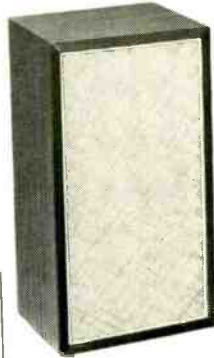

**CONVENTIONAL  
SPEAKER**



	BOSE 901*	BOSE 501*	CONVENTIONAL SPEAKER	YOUR SPEAKER ?
<b>1</b>	YES	NO	NO	
<b>2</b>	YES	NO	NO	
<b>3</b>	YES	YES	NO	
<b>4</b>	YES	YES	NO	
<b>5</b>	YES	YES	NO	

The twelve years of university research† that led to the design of the BOSE 901 and BOSE 501 DIRECT/REFLECTING® speaker systems revealed five design factors which optimize speaker performance:—

**1** The use of a multiplicity of acoustically coupled full-range speakers — to provide a clarity and definition of musical instrument sounds that can not, to our knowledge, be obtained with the conventional technology of woofers, tweeters and crossovers.

**2** The use of active equalization in combination with the multiplicity of full-range speakers — to provide an accuracy of musical timbre that can not, to our knowledge, be achieved with speakers alone.

**3** The use of an optimum combination of direct and reflected sound — to provide the spatial fullness characteristic of live music.

**4** The use of flat power response instead of the conventional flat frequency response — to produce the full balance of high frequencies without the shrillness usually associated with Hi-Fi.

**5** Acoustical coupling to the room — designed quantitatively to take advantage of adjacent wall and floor surfaces to balance the spectrum of radiated sounds.

To appreciate the benefits of these five design factors, simply place the BOSE 901 directly on top of the largest and most expensive speakers your dealer carries and listen to the comparison.

**You can hear the difference now.**

NATICK, MA. 01760

**BOSE®**

\* Patents issued and applied for  
† Copies of the Audio Engineering Society paper, "ON THE DESIGN, MEASUREMENT AND EVALUATION OF LOUSPEAKERS", by Dr. A. G. Bose, are available from Bose Corp. for fifty cents.

**CIRCLE NO. 3 ON READER SERVICE CARD**

will wipe off the ultrasonic carrier, and what's left will be so noisy it'll be unlistenable." "Not so," said the FM system's promoters, but they were never able to prove their point. The 45-45 matrixing system for stereo came along, and its utter simplicity and potential (and it was *only* a potential, then) for high-quality sound made it the logical way to go.

**No Simple Answer.** It seems to me, though, that matrixing is not going to provide the neat, simple answer for 4-channel that it provided for 2-channel disc recording. JVC resurrected the ultrasonic carrier system, added a few refinements and innovations, and right or wrong (for everyone concerned), managed to persuade RCA that this is the way to go. Today, RCA is getting ready to release a number of the JVC discrete 4-channel discs, and the necessary playback equipment is being marketed in the U.S. by JVC and Panasonic.

The JVC system—which they call CD4—differs from the 2-channel carrier system in that there are two ultrasonic carriers modulating the groove in the usual 45-45-degree stereo axes. Thus, the playback pickup must maintain adequate separation as well as frequency response well up into the ultrasonic range. If it does, it will produce two separate carrier outputs along with the usual two stereo outputs. The CD4 resembles the early 2-channel system in that it records the stereo sum signals directly and the difference signals on the ultrasonic carrier, and for the same reasons. This allows the carrier to operate over a narrower frequency range (stereo separation is of negligible significance below about 200 Hz) and, more important, it yields a disc that is compatible with the 2-channel disc.

In the CD4 system, all signal information is recorded in the usual way as 45/45-degree modulations (Fig. 1). Modulations in one 45-degree axis carry all left-hand information, those in the other 45-degree axis carry all right-hand information. Thus, if the disc is played on a 2-channel stereo system, the left front and left rear sounds will all come from left front, and right front and right rear signals from right front. All instruments are heard in their proper balance, whereas matrixed discs always exhibit some attenuation of sounds coming from certain directions when played on a 2-channel system. The CD4 disc is perfectly compatible with 2-channel repro-

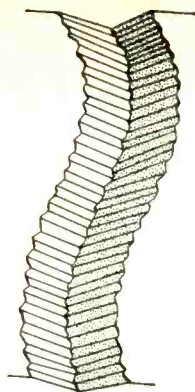

**Fig. 1. Audio signal (large undulation) and ultrasonic carrier (small undulations) in a single disc groove.**

ducers, yet all it takes to separate the left and right-channel signals into left front, left rear, right front, and right rear, is the appropriate demodulator unit.

The demodulator is, essentially, a pair of stereo FM detectors. The ultrasonic carrier on the disc has a center frequency of around 30 kHz (its frequency in the absence of any front/rear difference information). When a difference signal is present, the frequency of the carrier shifts above or below its 30-kHz center. The frequency is modulated by the difference signal. The higher the amplitude of the signal, the more the carrier changes frequency, within a limit of 20 to 45 kHz for the loudest signal. Remember, though, that the 25-kHz frequency range is *not* the range of audio frequencies that can be handled by the carrier. The carrier frequency represents signal amplitude or intensity. Frequency information is represented only by the number of times per second that the carrier changes frequency.

Once the demodulator has converted the two FM carrier signals into audio difference signals, they are matrixed against the left-channel and right-channel sum signals from the disc to yield the four discrete quadraphonic signals. And that's it, in theory (Fig. 2).

How does it work, in practice? People who have heard the system report that it outclasses any of the simple matrixing systems, and seems indistinguishable from a 4-channel playback directly from four discrete tape tracks.

But the question of stylus erasure of the carrier signals has yet to be answered to

# our fourth generation



## introducing the 1440: a powerful addition to our quality family of kit calculators priced from \$99.50

The first of its kind available anywhere, the 1440 was developed by MITS — the original kit calculator company — to answer the need for a high caliber calculator at an easily affordable price.

Using only the highest quality components from such American manufacturers as AMP, IRC, National Semiconductor, Sprague, and TI, the 1440 follows the tradition of the 816 (featured on the cover of *Popular Electronics* in November, 1971).

Design standards assure customer satisfaction when 5% resistors; fully interconnected, double sided, plated through PC boards; extra large LED's; individual mounting sockets for all IC's; pre cut, stripped, and tinned wire; and double-injected, feather touch keyboards are the rule.

Comprehensive, detailed instructions covering Theory of Operation (with complete schematics and logic diagrams), Step by Step Assembly, Troubleshooting, and Applications make assembling a MITS calculator as easy as it is enjoyable. And a full 90 day warranty (1 year on assembled units) insures that you'll get a product you can count on long after you buy it.

You can even increase the 1440's capacity to that of a small desktop computer by the addition of completely compatible printing and programming units (available summer '72) to the interfacing that's already there — so your needs will never outgrow its capability, and with six functions (+, -, x, ÷,  $x^2$ ,  $\sqrt{x}$ ) and two memories (a constant and an independent data memory) that's a lot of power.

A reasonable price was the only remaining factor in the 1440's design. We think that \$199.95 (assembled \$249.95) is fair, and we hope you'll agree. To make ordering yours simple, we accept MasterCard and Bank Americard. Why not give us a call today?



Our four function 816's (with 'computerizing' interfaces) and the single chip 808 have undergone design improvement too. They're available at: \$99.50 (808), \$149.95 (816A), and \$159.95 (816B).

**MITS**

**Micro Instrumentation & Telemetry Systems, Inc.**

2016 San Mateo NE, Albuquerque, New Mexico 87110 505 - 266-2330

Dealer Inquiries Invited

**CIRCLE NO. 20 ON READER SERVICE CARD**

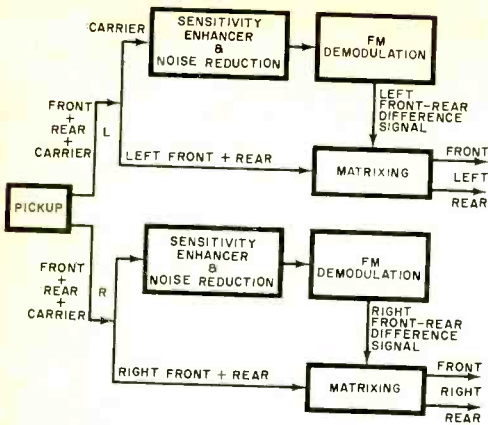

Fig. 2. Diagram of CD4 playback system.

everyone's satisfaction. It is obvious, from the theory of the system, that it wouldn't take much in the way of carrier signal to convey all the necessary difference-signal information, because it is the frequency of the carrier and not its intensity which is of importance. Mistracking distortion, as might result from severe wear of the carrier modulations, is primarily impulse noise, which is amplitude modulation. The FM demodulators can be made to be insensitive to these noises just as an FM tuner can be made insensitive to the amplitude modulations of static. But JVC has not been willing or able to furnish data about just how little carrier signal or how much noise it takes to produce how much of what kinds of degradation in performance.

It is equally obvious, nonetheless, that JVC foresaw carrier erasure as a potential weakness of the CD4 system, for they put a great deal of effort into seeing that this would not become a problem. The demodulator units that are now being marketed by JVC and Panasonic in the U.S. incorporate special circuitry for enhancing their sensitivity to the carrier while reducing whatever noise would otherwise develop as a result of the enhancement. RCA (handling the disc end of the system) did their bit by coming up with a new record material which they claim to be five times more resistant to wear than the usual vinyl material. A spokesman for RCA told me that their tests had satisfied them that the new disc material, plus the enhancing circuits in the demodulators, would allow more than 100 plays on a typical 2-channel stereo phonograph. And, as he pointed out, very, very few people will ever play a disc 100 times.

**The Shibata Stylus.** But that isn't all. Along with the enhancing circuits and RCA's new disc material, JVC uses as part of their system a new type of stylus called the Shibata stylus. This stylus resembles an elliptical stylus, except that its front side is faceted in a manner similar to that of the rear face of a cutting stylus. The outer edges of the facets, where they contact the groove walls, are at the same vertical angle as the outer edges of the facets on the cutting stylus, so the former is supposed to fit neatly into the high-frequency modulations cut by the latter. This is intended to accomplish two things. It should greatly improve the "resolution" of the playback stylus—due to its ability to follow the tiny undulations instead of just rattling along over the tops of them. And it should do this without reducing the area of contact between the stylus and groove walls, as would be the case were the same resolving power to be obtained merely by using extremely small side radii on an ordinary elliptical stylus. Thus, the resolution would be improved without a significant increase in record wear.

The success of this, however, presupposes that the vertical angle of the facets on the playback stylus be the same as that of the cutting facets. This may be hard to achieve in practice, as a pick-up's vertical tracking angle can vary appreciably according to tracking force, the age of the stylus, the number of discs in a record-changer stack, and even the amount of warpage on a disc. Only time, and experience, will show whether the typical exigencies of actual use will give the Shibata stylus any real advantage over designs that are potentially less perfect but also less demanding of ideal conditions.

So here is a discrete 4-channel disc system which does appear to be practical. It can apparently provide everything in the way of performance that 4-track tape can, without halving the available playing time. The un-demodulated signals can even be broadcast over FM and reconstituted at home, although there is no way at present of committing them to 2-channel tape, either in the home or on commercial duplicating machines. Taping quadraphony still requires four tracks or the use of one of the matrixing systems. So while CD4 works well, and yields discs that are fully compatible with 2-channel discs and players, total compatibility is not within reach. ♦



# WHICH WAY FOUR CHANNEL ?

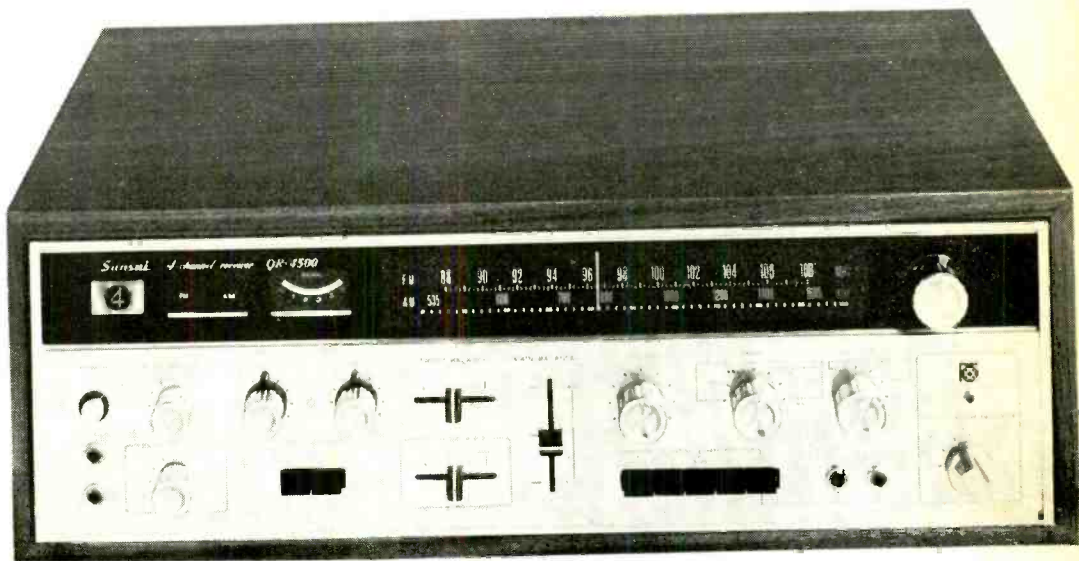

## THIS WAY

If the four-channel merry-go-round has you confused, you have lots of company. Discrete or matrixed. Compatible or non-compatible. This system or that one.

Now Sansui offers you total-capability QR Receivers that will transport you into the four-channel world to day and can handle every variation to the four-channel game that anyone's dreamed up for tomorrow.

Take the QR4500 AM/FM Two-Channel and Four-Channel Stereo Receiver-Synthesizer-Decoder-Amplifier-and-Control-Center. It can decode any compatibly matrixed four-channel recording or FM broadcast, or it can synthesize two rear channels from any two-channel source. Exclusive Sansui phase-shift matrixing prevents the sound dropouts and false dislocations that plague many matrixed systems. And exclusive phase modulators duplicate the live sound field.

It can handle any tape or other discrete source and accepts adaptors, converters or other accessories for any four-channel technique anyone's hinted at.

It boasts 240 watts of total IHF power (continuous power per channel of 38 watts at 4 ohms, 27 watts at 8 ohms) with less than 0.5% TH or IM distortion at rated output and normal response of 20 to 30,000 Hz  $\pm$ 1dB. In a walnut cabinet, \$599.95.

You'll find the same universal four-channel versatility in all Sansui QR Quadphonic Receivers, including the QR1500, with 100 watts of total IHF power (20 watts continuous per channel at 4 ohms). With walnut cabinet, \$299.95.



**Sansui**



### SANSUI ELECTRONICS CORP.

Woodside, New York 11377 • Gardena, California 90247

ELECTRONIC DISTRIBUTORS (Canada), Vancouver 9, B.C.

SANSUI ELECTRIC CO., LTD., Tokyo, Japan • Sansui Audio Europe S. A., Antwerp, Belgium

© COPYRIGHT BY SANSUI

**CIRCLE NO. 29 ON READER SERVICE CARD**

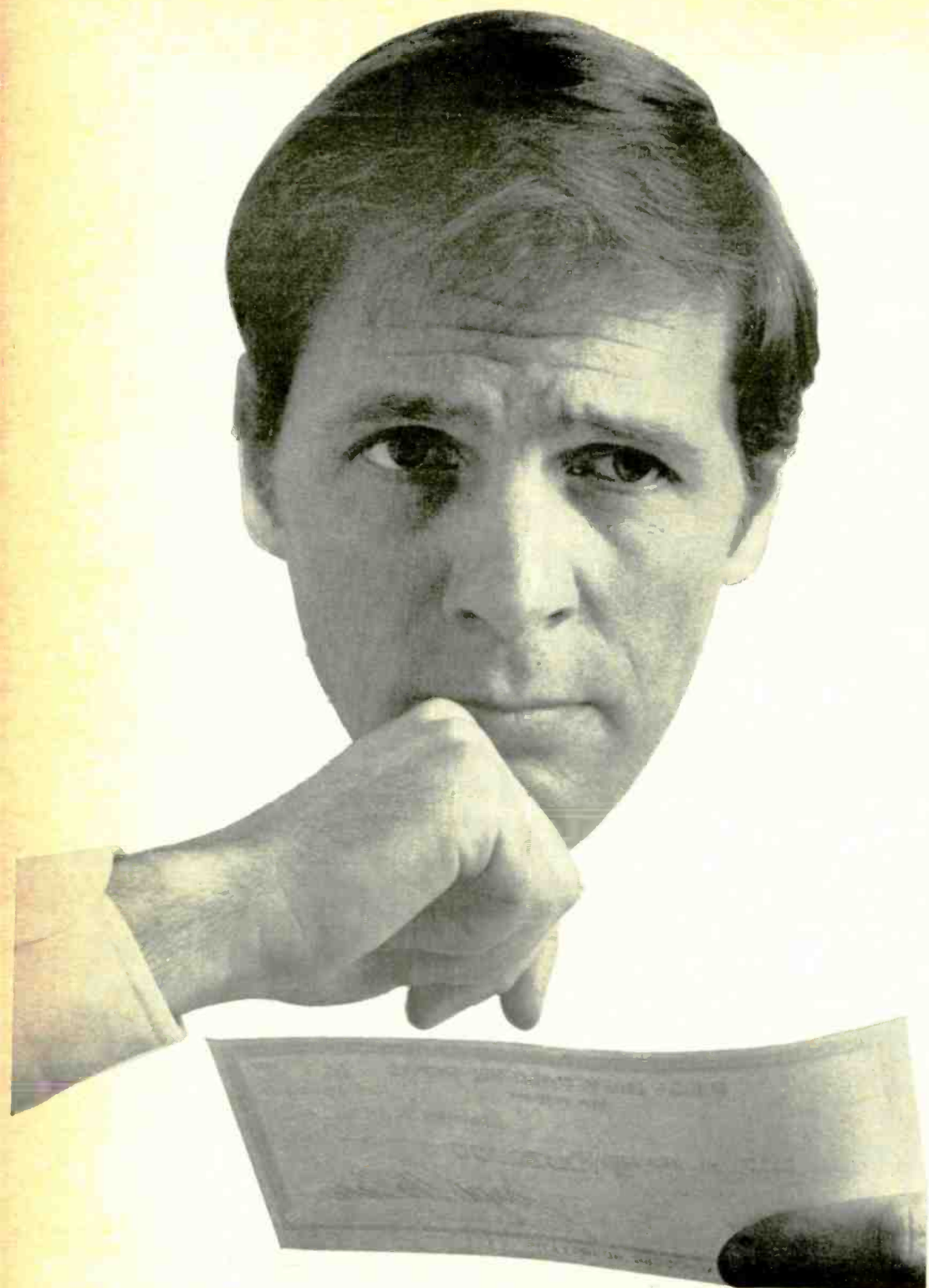

# Your paycheck says a lot about you

It tells you more than how much you make. It tells you how far you've come. And if your paycheck looks very much the same as it did last year, or the year before, it simply means that you look very much the same as you did last year and the year before.

But times change, and you should be changing with them. Old dull jobs are disappearing. New exciting ones are being created. There are challenging fields that need electronics technicians... careers such as computers, automation, television, space electronics where the work is interesting and the earnings are good.

RCA Institutes can get you started even if you've had no previous training or experience because RCA has developed a faster, easier way for you to gain the skills and the knowledge you need for a fascinating, rewarding electronics career. And you don't have to quit work and go back to school. With RCA Institutes Home Study Plan you can do both. You set your own pace depending on your schedule.

Check over these RCA Institutes benefits:

- You get Hands-On Training — as many as 21 kits in RCA's Master TV/Radio Servicing Program.
- You get RCA's unique "Autotext" method of learning — individual programmed instruction, the easy, faster, simplified way to learn!
- You get the widest choice of electronics courses and programs—everything from Basic Electronics right up to Communications and Digital Electronics.
- You get a choice of low-cost tuition plans!

Sounds great, and it is! For complete information, without obligation, send in the attached postage paid card... or return the coupon below. That will say a lot about you.

Veterans: Train under new GI Bill. Accredited Member National Home Study Council. Licensed by N.Y. State—courses of study and instructional facilities approved by the State Education Department.

RCA Institutes, Inc. is a Subsidiary of RCA Corporation

<b>RCA Institutes</b>	
Home Study Dept. 694-209-0 320 West 31st Street, New York, N.Y. 10001	
Please rush me FREE illustrated catalog. I understand that I am under no obligation.	
Name _____	Age _____
(please print)	
Address _____	
City _____	State _____ Zip _____
Veterans: Check here <input type="checkbox"/>	

If reply card is detached—send this coupon today

CIRCLE NO. 25 ON READER SERVICE CARD

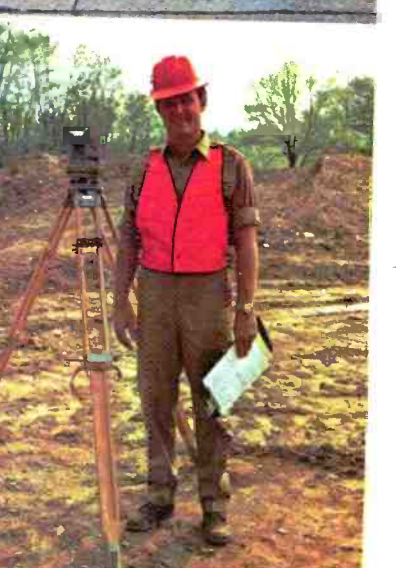
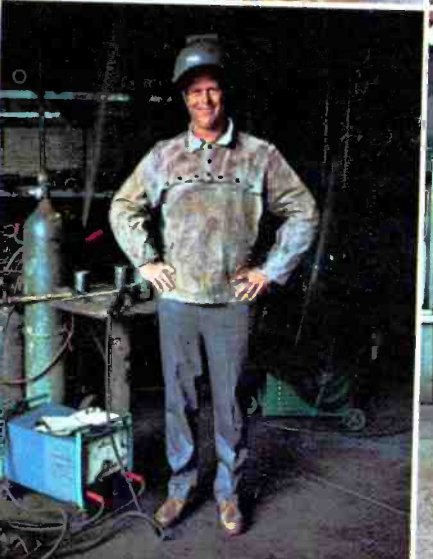
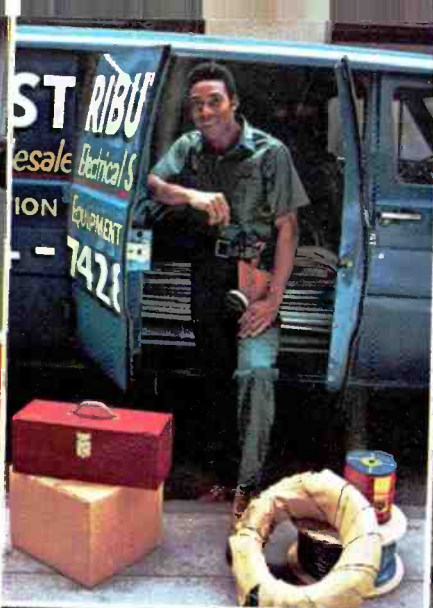

# Lots of people have jobs we taught them.

Think of today's Army as the world's largest technical school and you'll realize why we have so many successful alumni.

You see, there are over 300 occupations in today's Army that aren't too unlike corresponding civilian jobs. So when you learn a job with us you have a skill when you get out.

You get to pick that skill, too, before you enlist. And if you're qualified, you'll get the training to perform it like a professional.

Which means intensive, in-depth, on-the-job training along with classroom instruction.

While you learn you get paid. Starting at \$288 a month. And with 30 days paid vacation a year, free meals, free housing, free clothing, and free medical and dental care, your take-home pay goes a long way.

Send the coupon or see your Army Representative about job-training opportunities in today's Army. You'll pick up skills that will benefit us now, **Today's Army** and yourself later.

**wants to join you.**

Army Opportunities Dept. 200, Hampton, Va. 23369	Date _____	2PE 9-72
Please send me information on job training and opportunities in today's Army.		
Name _____	Date of birth _____	
Address _____		
City _____	County _____	
State _____	Zip _____	Phone _____
Education _____		

**EVEN IF THEY NEVER SEE  
YOUR SLEEK NEW COBRA 135, THEY'LL  
KNOW YOU HAVE THE BEST.**



They'll know by listening. Because you'll send with all the power allowed—15 watts P.E.P. input. Plus the extra authority of 100% modulation with Dynaboost speech compression.

You'll transmit on 23 AM and 46 SSB modes. Two separate transmitters give you the best of each, with overload protection.

Your own ears will confirm what we say. This Cobra has the crispest, cleanest

sound ever. Over 60 dB cross modulation interference rejection completely eliminates bleedover.

Cobra's drift-free Voice Lock lets you locate and lock-in sideband signals over a wide range. Three filters—one crystal, two ceramic—keep adjacent channels under wraps.

And Cobra's noise blanker really punches holes in noise, both AM and SSB.

The control console has everything. Adjustable AM/SSB RF gain control. Backlit RF output/SWR/S meter. 24-hour digital-leaf clock. Illuminated mode selector. And full-function controls.

Both talking and listening, it's the first base station to combine all the features you want in one package. And as for looks—wow!

Ask your CB dealer to show you the best. Cobra 135.

**COBRA 135**  
**AM/SSB**  
**\$419<sup>95</sup>**

microphone included

Product of Dynascan Corporation, 1801 West Belle Plaine Avenue, Chicago, Illinois 60613

**CIRCLE NO. 2 ON READER SERVICE CARD**

POPULAR ELECTRONICS Including Electronics World



# News Highlights

## **Columbia Records and Electro-Voice Reach 4-Channel Patent Accord**

Columbia Records and Electro-Voice have reached an agreement for an exchange of patent rights and technology related to their respective 4-channel quadrasonic disc systems. Such rights and technology will also be made available to others. Columbia introduced its SQ quadrasonic disc system in June of last year; Electro-Voice has marketed its own quadrasonic system under the brand name Stereo-4 since February 1971. Under the new agreement, E-V will be able to produce a new, modified IC designed to decode records for the SQ system. In turn, Columbia's equipment licensees will be able to obtain access to E-V's patent privileges and technical know-how. Included in this exchange are rights to the recently issued U.S. patent to Peter Scheiber for matrixing techniques.

## **Big U.S. Trade Deficit in Electronics**

We are still importing more than we are exporting in electronics and communications products. The unfavorable U.S. balance of trade reached minus \$570 million in 1971—more than three times the minus \$181 million figure in 1970. The major problem remains in the consumer electronic products area, which ran an unfavorable balance of more than \$1.3 billion last year. Radios, TV sets and tape recorders accounted for 65 percent of this deficit and most of these imports come from Japan. The balance of trade in other communications-electronic products, while still favorable overall, continued to decline in 1971.

## **Grants for Cable Technicians**

Colorado Electronic Technical College is making available 12 full-tuition scholarships for its CATV course to be offered to men and women of minority groups. The college, located in Manitou Springs, Colo., is offering the six-week course free to blacks and other minority group students who will be selected by minority group organizations. In addition, the school is offering to any cable system that wishes to participate the opportunity to send a minority group member to the school for the course at reduced tuition. More than 400 CETC graduates are working in CATV systems throughout the U.S.

## **Electronics Key to Future Education**

The Carnegie Commission on Higher Education recently recommended that the U.S. government spend between \$100 million and \$200 million a year for the next seven years to develop and promote the use of electronics for education. The commission said that videotape cassettes, computers, and cable television should be in general use at the colleges by the year 2000. The new technology will not replace the book and the teacher but will serve to enrich and supplement them.

## **Supreme Court Backs FCC on CATV**

By a vote of five to four, the Supreme Court has upheld the 1969 FCC rule requiring cable TV systems with at least 3500 subscribers

to originate programming. The court overturned a St. Louis U.S. Court of Appeals decision handed down last year in the Midwest Video Corp. case. Midwest had challenged the authority of the FCC to require origination, and the St. Louis court agreed that the commission had overstepped its charter. Initial reaction from the cable industry appears to be a mixture of support for the clarification of the FCC's authority to regulate cable, and relief of the anxiety and uncertainty that comes from regulation by an agency whose authority appears to be in doubt.

### **Almost Half FM Stations are Stereo Equipped**

Of the 3260 FM radio stations in North America, a total of 1560, or 48 percent are equipped for stereo. Totals for the U.S. are 3043 commercial and educational FM stations, of which 1480, or 49 percent have stereo. These figures are taken from a recently completed study conducted by Dr. Bruce F. Elving, publisher of "FM Station Atlas" (Box 24, Adolph, MN 55701). The study also shed light on the use of vertical polarization by the broadcasters. FM stations which send out a vertically polarized signal as well as the usual horizontally polarized signal are better able to serve car radio listeners and persons having small portables and line-cord antennas.

### **Electronics Future Looks Bright**

Taking a look at the audio electronics industry, General Electric's Richard T. Galton (general manager of Audio Electronics Products Dept.) predicted that this industry would grow about 40 percent over the next five years. Stereo components will be the fastest growing segment of the business. Industry sales of color TV picture tubes are expected to reach a new all time high in 1972, according to John B. Farese (executive vice president) of RCA Electronic Components. In the U.S. domestic market, industry color TV set sales in the first quarter continue to run at a rate about 25 percent ahead of last year and 8 million color sets for the year is a distinct possibility.

### **Postal Service to Continue Mailgram Service**

The U.S. Postal Service and Western Union have signed a long-term, open-ended agreement providing continuation of the Mailgram. The service combines the convenience of mail delivery with the speed of electronic transmission. Mailgram uses the Telegraph Company's facilities for acceptance and electronic transmission of messages for next business day delivery nationwide by postal carriers. Teleprinters are located at selected post offices. Since the experiment began January 1, 1970, the system has gained increasing public acceptance, reaching a level of over 20,000 messages transmitted daily nationwide.

### **Electronics in the Supermarket**

A new voice-activated checkout system for the supermarket industry has been demonstrated by Threshold Technology Inc. The system recognizes the spoken word and shows the word to the customer in a lighted display at the checkout stand. At the conclusion of the transaction the customer is provided with a printed receipt similar to the one now in use. The system permits the cashier to bag at the same time prices are entered by voice. Checkout stations are programmed for the voice characteristics of the individual cashier at the station. Since the system is adaptive to the speech of the individual it can be used by any speaker regardless of language, vocabulary, dialect, accent or pronunciation. Also in the supermarket, there are now to be seen the new digital-display scales that show the unit price and total price for the item being weighed.



# FIVE VITAL COMPONENTS

## FOR KNOWLEDGE... FOR PROFIT... FOR SHEER MUSIC AND ELECTRONICS ENJOYMENT!



### 1972 STEREO DIRECTORY & BUYING GUIDE

Listen to this... and you'll hear better! It has a lot of information to give you about all the latest stereo systems and components—Amplifiers • Tuners • Receivers • Hi-Fi Systems • Changers and Turntables • Speaker Systems • Phono Cartridges and Arms • Cassette, Cartridge and Reel-to-Reel Tape Machines. More than 1500 products in all, listed by manufacturer, each with model number, complete specifications, description and price. Plus a complete, shop-at-home Buyer's Guide loaded with expert information on what to look for, what to avoid, how to decide what's best for you at a price you can afford. Now you can know what you want before you visit the dealer and what to listen for when you get there.

### 1972 TAPE RECORDER GUIDE — Spring

The age of quadronics is all spelled out for you with a complete feature on 4-Channel Sound including directories of 4-channel components, matrix discs and discrete 8-track tapes.

In addition, Tape Recorder Guide delivers everything you tape-recording heart desires—like The Dolby Noise-Reduction System—Tips For Buyers of Cassette Machines—Home Video Tape Machines—Facts on Reel-to-Reel Tape Recorders—the "Compact" Stereo System—the Cassette Tape Recorder—Microphones—Headphones—the works! Plus—there's a complete buyers guide for reel-to-reel tape, cassette and 8-track tape machines, raw tape, microphones, headphones and accessories! All the advice, all the equipment, all the expertise you need to get more out of your present rig... get more when you trade up... right here in this all new edition.



**TAPE RECORDER GUIDE 1972**  
NOW PUBLISHED TWICE A YEAR!



### 1971 ELECTRONIC EXPERIMENTER'S HANDBOOK — SPRING EDITION

20 electronics construction projects in the Spring 1971 Electronic Experimenter's Handbook. All lab-tested by the Editors, with parts list, easy "How-To-Do-It, How-It-Works" instructions—many with actual size PC foil patterns! Experimenter's Laser • Ten-Watt PA Amplifier • A Pair Of Loaded Dice • Automatic Vehicle Burglar Alarm • "No-Fooling" Fence Alarm • The Thumpa-Thumpa Box • Electric Aquarium Heater • Beginner's Signal Generator • Plus 12 others and these informative features: Caution-Laser... Rally Round The Reflex... Engineering Level Opportunities For You... Strange Power of Air Ions.

### 1972 ELECTRONIC EXPERIMENTER'S HANDBOOK — WINTER EDITION

Join in this big semi-annual projects festival! You'll get 33 electronics construction projects, each one lab tested by the editors, complete with parts list, easy "how-to-do-it, how-it-works" instructions, and many with actual size PC foil patterns and I. C. diagrams! Build these brain-busters for home and car, for experience, for fun—The Frisky Four Speaker System • Automatic Lightning Protector • Super Flash • Remote Camera Shutter Release • Design Your Own Printed Circuits • Laser Beam Communicator • Modify Your Electric Guitar Sound • Electronic Overload Protection • Electronic Combination Ignition Lock • Build A Low-Cost Relay • Photocell Motor Control Demonstrator • Wire Music • Super Substitution Box—Plus 20 More.

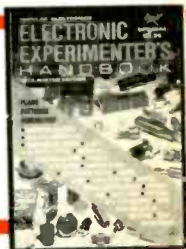

### 1972 COMMUNICATIONS HANDBOOK

Tunes you in on everything you need to know about CB, SWL or HAM.

Here it is in one single package—the combined knowledge and experience of the top men in each field. Citizens Radio, Short Wave Listening and Amateur Radio. It's a whole book full of up-to-the-minute data to help you get greater value, greater enjoyment out of every minute that you spend with your equipment. Special bonus—includes TV DX'ing, ABC's Broadcast Listening and complete listings of frequencies used by Police, Fire and Public Safety agencies as well as UHF and VHF.

### BACK ISSUES AVAILABLE!

If you've missed any of these previously published Annuals, a wide selection is still available. To place your order, circle the corresponding numbers on the coupon on this page.

Tape Recorder Guide: 1972 Winter #56, 1971 #19

Communications Handbook: 1969 #86, 1970 #10, 1971 #37

Electronic Experimenter's Handbook: 1970 Winter #97, 1970 Spring #14, 1971 Winter #33

### USE THIS COUPON TO ORDER YOUR COPIES TODAY!

ZIFF-DAVIS SERVICE DIVISION • Dept. W • 595 Broadway, New York, N.Y. 10017

P.E. 972

Please send me the Annuals I've checked below:

- 1972 Tape Recorder Guide—Spring, \$1.50  1971 Electronic Experimenter's Handbook—Spring, \$1.50  
 1972 Electronic Experimenter's Handbook—Winter, \$1.25  1972 Communications Handbook, \$1.25  
 1972 Stereo Directory & Buying Guide—\$1.50

Also, I have circled the numbers below of the additional Annuals I wish to receive:

\$1.50 each 10 86 97 \$1.50 each 14 19 33 37 56

I am enclosing a total of \$\_\_\_\_\_ for the Annuals ordered above. I've enclosed an additional 35¢ per copy for postage and handling. (For orders outside the U.S.A. all Annuals are \$2.50 per copy, postpaid.)

print name \_\_\_\_\_  
 address \_\_\_\_\_  
 city \_\_\_\_\_ state \_\_\_\_\_ zip \_\_\_\_\_

• PAYMENT MUST BE ENCLOSED WITH ORDER •

# ELECTRONIC SECURITY SYSTEMS



PROTECT YOUR HOME  
WITH ONE OF THESE ALARMS

BY JOHN T. FRYE

**I**N A RECENT survey, *Life* magazine found that 78% of the respondents felt unsafe in their homes and 43% were victims of crime during 1971. On August 31, 1971, an FBI crime report indicated that a burglary was committed every 15 seconds in the United States. The average loss to the victim was \$310. Professional burglars, joined by amateurs, carried off some \$407 million in valuables. More than half of the burglaries were in the daylight.

The rate of crimes against personal property rose 14% between 1960 and 1970. Still more frightening is the fact that the rate of violent crimes which often accompany unauthorized entry into the home rose 126% during the same period.

It is no wonder then that many Americans are seeking protection for themselves and their property beyond that which the

various law enforcement agencies have to offer. Many people find confidence in the dozens of electronic home security systems available on the market.

**Turning to Electronics.** Modern electronics is making practical home security a reality. Projected figures indicate that Americans will spend about \$1 billion a year on electronic security equipment by 1975. The private citizen wishing to safeguard his home can find a wide range of prices, versatility, sophistication, and ease of installation in the electronic security equipment presently on the market.

Three basic perimeter protection schemes are illustrated in Fig. 1. In A, the parallel-connected normally open switches cause no standby drain on the battery and are unlikely to sound a false alarm. The wires running to the various switches, however, must be heavy enough to carry the entire bell current. Also, the system can be disabled simply by cutting one of the control wires. Nor is there any holding action; simply by closing the door behind him, the burglar can cause the alarm to stop sounding.

By providing a relay to handle the heavy bell current, the circuit in B permits the running of small wire which carries only the light relay current to the switches. The relay latches to provide holding action. But an intruder still can disable the alarm by cutting a switch wire.

A slightly more sophisticated circuit, employing normally closed switches connected in series with the battery and relay



(Artwork courtesy the Heath Co.)

coil is shown in C. With *SI* in position 1, the system is shut down; in position 2, the bell circuit is tested; in position 3, the relay is energized, opening the bell circuit; and in position 4, the system is fully activated with the resistor being used to reduce battery current just enough to hold the relay energized but not sufficient to pull the armature back if a detector switch is briefly opened and closed. This provides holding action. The circuit is also failsafe in that cutting a wire sets off the alarm. On the negative side, this circuit draws current while it is activated, and a poor contact along the detector line or jarring the relay can set off a false alarm.

**Modern Intrusion Alarms.** By contrast, modern intruder alarms are usually more elaborate and sophisticated than the elementary ones described above. In sophisticated systems, alarm bells, Klaxon horns, or sirens are installed inside *and* outside the covered



**Telectronics sonic wall alarm has delayed action arming key. With key on, owner has 2 minutes to leave premises.**

**Fig. 1. Basic electric alarm systems.**

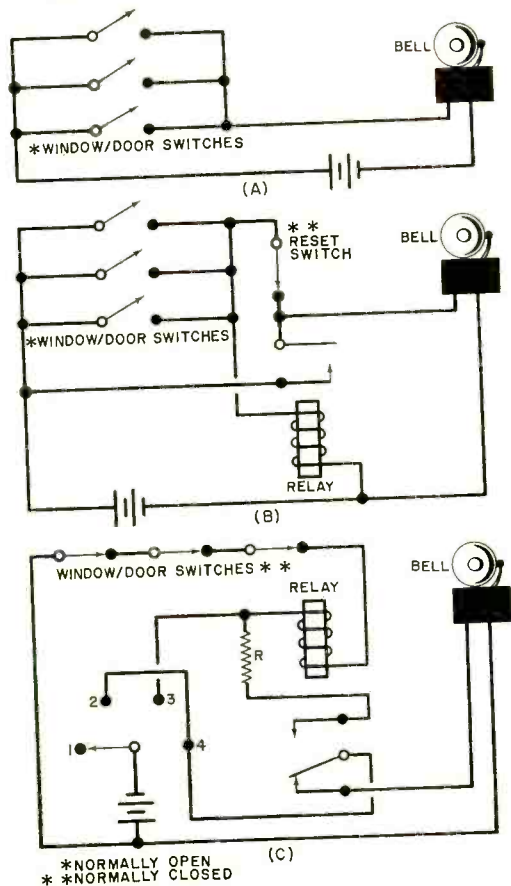

premises. There may be a mechanism which dials the police department or a security agency and delivers a taped call for help. Panic buttons strategically placed around the house can be wired so that they trip the alarm even when the rest of the system is not active, permitting a call for help in an emergency.

Window and door switches take many forms. Magnetic reed switches mounted on frames with controlling magnets on movable members are popular—as are mercury switches and pull-traps. The latter operate when a clip attached by fine wire or fish-line to a window sash or door is pulled loose.

Pressure mats and vibration detectors can be wired into an alarm circuit. Detectors for smoke, fire, basement flooding or freezer and furnace failure can be used to double the usefulness of the system. To guard against bypassing the system by breaking a window pane, metallic tape can be cemented to the glass so that breaking the glass fractures the tape and trips the alarm.

Many perimeter systems now employ a vibration-proof SCR or a similar solid-state device which permits the controlling current through the sensors to be reduced to a very low value. This reduces battery drain and allows long runs of very small wires to the detectors.

Various intruder detector systems supply exit and entry facilities. A time delay on the key-controlled activating switch permits the homeowner to turn on the system and leave quickly by the door without setting

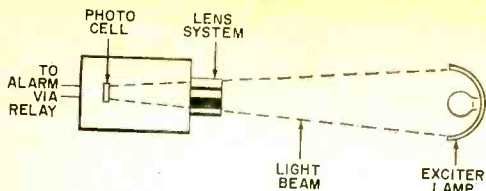

Fig. 2. Operation of photocell system.

off the alarm. On return, entry can be made promptly with a key used to switch off the system before the alarm sounds. Some systems employ an "electronic" key. For example, Dialalarm's Model 1200 system has a small wireless FM transmitter which acts as a portable panic button for tripping the alarm anywhere within 150 feet of the control unit. But with the control unit switched to an alternate mode, the hand-held transmitter can be used to arm and disarm the system in much the same manner as the key described above.

Other systems, such as one made by Heath, have protecting switches and detectors connected to a wired-wireless transmitter which puts a special signal on the house wiring when triggered. The receiver/control unit is a portable device which can be plugged into any ac outlet. When a signal from the transmitter is detected, the alarm sounds until the signal ceases and a reset switch is operated. If ac power fails, a battery in the control unit starts the alarm.

The entire Heath system consists of two transmitters and a control unit. One transmitter has self-contained smoke and fire detectors and facilities for connecting other remote fire detectors. The "utility" transmitter has multiple inputs which accommodate both normally open and normally closed sensors as well as those that change resistance within certain specified limits. The latter are useful with normally open freeze-and-thaw detectors exposed to moisture.

**Optical and Ultrasonic Systems.** The more exotic systems employ photocells with in-

One of 3 units in Heath alarm system.

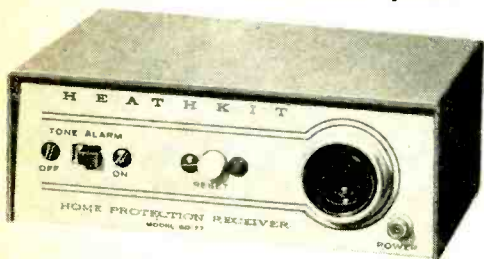

candescent, infrared, ultraviolet, or pulsed light sources. Even laser beams are being tried for possible use as photocell exciters. In Fig. 2 is shown the basic setup for a so-called "electric eye" alarm system. Light from the exciter is focused onto a photocell. An intruder passing between exciter and cell interrupts the light path and causes a relay controlled by the photocell to sound the alarm.

When a simple incandescent lamp is used as the exciter, the intruder can see the beam and defeat the system by focusing



Mallory ultrasonic alarm. Transducers are at top, Sonalert alarm in center.

his flashlight beam onto the photocell as he passes through the exciter's beam path. Employing infrared or ultraviolet light, invisible to the intruder, makes defeating the system very difficult. Pulsing the exciting light at some critical frequency increases that difficulty. (The passive infrared system does not employ an exciting lamp. Instead, infrared radiation given off by the intruder's body trips a sensor.)

Light-sensitive intruder alarm systems are used chiefly to guard a small area in which an intruder may be expected to appear, such as a doorway or a corridor. More exotic systems, employing ultrasonic sound, microwaves, or radar to detect the presence of an intruder, are used to guard larger areas. Most such systems operate on the Doppler principle (see Fig. 3), whereby waves from a transducer or antenna flood the protected area and are reflected in a stable manner from stationary objects to a receiver. Any moving object in the covered area causes changes in frequency, amplitude, and phase of the received signal so that the detector/reference circuit develops an output to trigger an alarm.

The Mallory Crime Alert® is a good

example of a self-contained ultrasonic alarm. It is placed in operation simply by facing it into the area to be protected and plugging it in. With a switch set to **MANUAL RESET**, the user has 15 to 20 seconds to leave the area before setting off the alarm. After that, any movement in the area will cause the built-in alarm (and any accessory device) to sound until the switch is moved to **STANDBY**. Setting the switch to **INSTANT RESET** allows the alarm to sound each time something moves in the area but stop when the movement stops.

The Aerospace Research Advisor V™ is designed to avoid false alarms caused by blowing curtains, vibrating walls, air turbulence, and power-line interference. Signals received by a corner-mounting transceiver are processed so that the alarm can be tripped only by a net change in range on the part of the intruder, a technique used by the military to detect intruders amid a jungle of swaying trees.

Another example is the Defender intrusion alarm marketed by the Bourns Security Systems, Inc. It incorporates both an inconspicuous microwave antenna sensor and an ambient light sensor. Electronic logic analysis is used with microwave and light systems to verify human intrusion before activating the alarm. Each system can be used independently, or the command logic module can be set so that both must be triggered to set off an alarm.

Still another example is the Model 307

**Fig. 3. Doppler effect systems detect moving objects from reflected waves.**

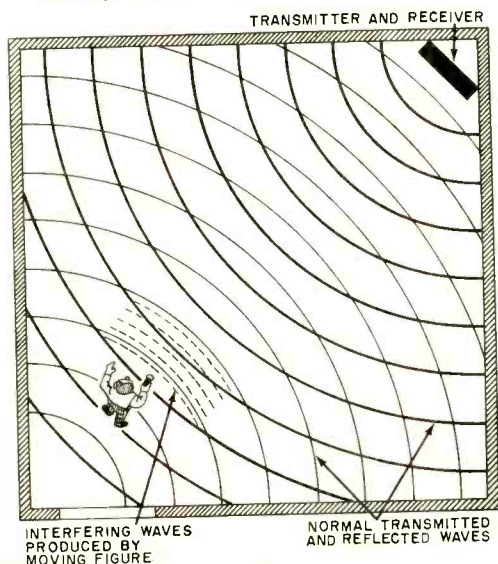

**Control unit for the Eico system.**

radar intrusion detector marketed by Detec-tron Security Systems. When a 915-MHz radar field radiated by a ground-plane antenna is disturbed, a relay closes. The relay contacts can be wired into any perimeter system. The area to be protected can measure up to 40 feet in diameter by setting a built-in sensitivity control as needed.

**Security Information.** It should be understood that the systems mentioned by name in this article are merely illustrative examples of the many types of equipment available. The annual "Security Products Directory Issue" of *Security World*, published each year in July-August (at 2630 South Cienega, Los Angeles, CA 90034), lists literally hundreds of manufacturers, addresses, and products in the security area. The Mountain West Alarm Supply Co. (4215 North 16 St., Phoenix, AZ 85016) publishes an excellent catalog called "Space Age Security." You might also investigate various magazines for advertising by burglar and intruder alarm companies to see what is available and at what prices. ♦



**Detec-tron unit has antenna on case.**

# *Build Bass Reflex Enclosures the Easy Way*

SOME HINTS  
ON SUCCESSFUL  
DESIGN  
AND CONSTRUCTION

BY DAVID B. WEEMS

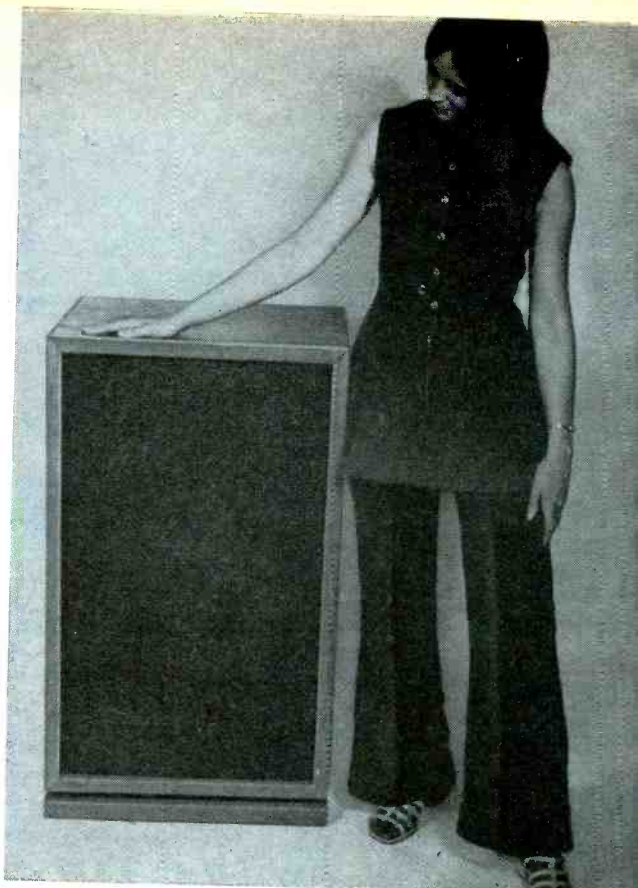

**T**HE bass reflex speaker enclosure is a perennial favorite of home hi-fi builders. Perhaps one reason for its popularity is that most of the hi-fi component speakers sold are designed for bass reflex operation. But a ported enclosure also offers a more interesting project than does a simple box. Even the name of the system suggests something special in bass performance. This appeal sometimes inspires reckless application of reflex theory which can result in a mistuned "boom box."

It is not easy—but far from impossible—for the experimenter to successfully design his own bass reflex enclosure. First he must face a myriad of decisions. He must decide at the outset if he wants to emphasize bass output and range or concentrate on obtaining optimum transient response.

Of the questions he will most likely ask himself, one is should the box be tuned to control the cone at the speaker's free-air resonance or to some lower frequency to

minimize cone travel and distortion at the bottom of the reproduced frequency range? Then again, he might ponder whether or not to tune the box at the higher frequency of the speaker plus box (before porting) system resonance. Each of these methods of tuning is used by various manufacturers.

The experimenter with unusual tastes in sound can, by stressing the quality he desires, end up with a system that is not only more original but more satisfying to his ear than the typical commercial system. As one loudspeaker engineer points out, the amateur speaker system builder is sometimes a "strange bird." Perhaps his urge to be creative is stronger than the desire to obtain good sound.

**Some Simple Do's.** The home builder can obtain optimum performance from his loudspeaker, as defined by those who ought to know, by following the design booklets published by the manufacturer. Data sheets are packed right in the speaker's shipping

carton; so, one needs only to buy the speaker before beginning work on the enclosure.

Ports can be used with boxes of various sizes, but the principle is particularly useful for full-size systems. Typical of the kind of component speaker available for bass reflex operation is the Electro-Voice Model LT15, a 15" three-way loudspeaker for which the enclosure shown in the photos was designed.

Three-way speakers offer several advantages for the home builder. Most obvious is the simplified installation in a single speaker cutout. But, more important, the concentric mounting of all reproducing elements eliminates the problem of where to mount the midrange and/or tweeter reproducers for minimum phase distortion at the crossover frequencies.

Our speaker system was put together without the need for cut-and-try efforts. Its very satisfactory performance can be described with one word—smooth. The enclosure dimensions chosen were the greatest of the three sets of figures given on the Electro-Voice data sheet that accompanied the speaker. This brings up a useful rule of thumb: Choose the largest possible enclosure

**When installing speaker, do not over-tighten hardware. Note duct behind the port which permits use of larger port.**



**Read information sheet packed in with speaker first. If size range is suggested, choose largest one possible.**

size that is specifically recommended by the manufacturer to obtain the best results.

Here are some more construction hints that will help smooth the way. Use  $\frac{3}{4}$ "-thick plywood with tight cores. Except for the removable rear panel, glue and screw together all joints. Use solid wood for glue blocks at the corners and for the cleats that hold the screws for the speaker and rear panels. Reinforce the panels, particularly the large ones, with braces. Mount the speaker off-center if possible to reduce standing waves in the enclosure. Install a 1"-or-greater thickness of fiberglass wool or other acoustical damping material on the rear panel and walls inside the enclosure to absorb the midrange and high-frequency sound and prevent its reflection through the speaker cone or the port. Guard against air leaks.

The only possible need for experimentation is in the amount of fiberglass to use. A fiberglass collar, stapled over the speaker, sometimes improves speaker damping.

The quality of a bass reflex enclosure depends upon proper design and sturdy construction. The loudspeaker manufacturer provides the design parameters. The audiophile who follows it need only concern himself with careful carpentry to prevent panel vibration and air leaks. A flair for originality can be expressed in external style and finish. ♦

# CONSTRUCTING PC BOARDS

## USEFUL TECHNIQUE TO MAKE PROFESSIONAL-LIKE PRINTED CIRCUITS

BY ROBERT A. SULLIVAN & ROBERT S. BRODSKY

**M**AKING your own printed circuit board has never been a particularly easy job; but the rewards of doing so are great. You save time and money; and you get a real feeling of satisfaction from having accomplished the task. Not, of course that it's all that difficult. A number of kits for making PC boards are available commercially—varying as to the degree of complexity involved in the technique and the quality of the final result.

It is not always necessary, however, to have a complicated layout to make a good PC board. Described here is a technique that combines many of the best features of different kit manufacturers. The non-camera photographic technique (generally agreed upon as the best approach) requires a minimum investment in equipment and is virtually "goof-proof."

The procedure involves five basic steps: laying out the etching guide, making a film positive of the layout, printing the negative pattern on a sensitized PC board blank, and etching and drilling the board. The procedure is much less complicated than it sounds and you will be able to make a commercial-quality board on your first try.

**Basic Materials Needed.** Before you can begin making a printed circuit board, you must have on hand a few basic items. Table I lists the most important. In addition, not listed in Table I but a basic necessity is a

supply of sensitized PC board blanks (see Table II). There are three types available. Epoxy fiberglass has the best electrical and

Fig. 1. Reproduction of printed page shows how patterns are presented in magazine, making the first step easy.

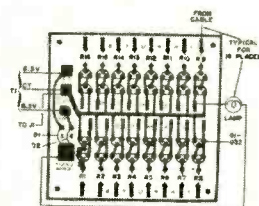
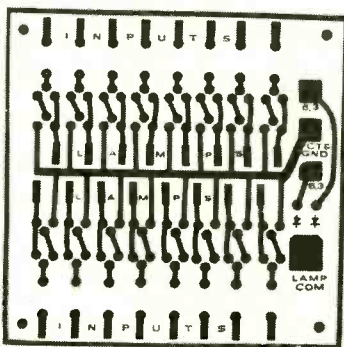

Fig. 2. Actual size foil pattern (above) and component installation (left) for a 16-terminal tester. If you need only 14 terminals, two end circuits are removed and two leads remain from 16-wire cable.

$\frac{1}{2}$ " centers with the two rows  $1\frac{1}{2}$ " apart. Drill the lamp holes just large enough for a press fit with the lamp assembly. Determine which way the display is to be observed and make a conspicuously large dot at the number 1 lamp (pin). You can also outline the lamps with an IC layout, being sure to include the

notch between pin 1 and pin 14. Use permanent black ink. With the lamps installed, solder one end of each lamp to the common ground solder pad on the foil pattern. Then, being very careful, solder the other leads to their respective solder pads that are connected to the transistors.



mechanical properties, but it is also the most expensive by a wide margin. Polyester boards can yield electrical properties as good as the epoxy-fiberglass type, but they tend to warp—a difficulty which can be overcome by storing them flat. The phenolic board is the least expensive. It is adequate for all but the most critical projects. Its tendency to chip during drilling (which applies to the polyester board to a lesser degree) can be circumvented by careful and patient work.

For almost all projects, a  $\frac{3}{16}$ "-thick board blank with 1-ounce copper cladding on one side will suffice. Buy fairly large board blanks, which cost less per square inch.

A photo reversing kit (such as the one from Kepro) is needed to make the film negative. The kit generates a total of 480 square inches of film negative for about \$7.00. Film and developer are available separately. (The developer supplied with the photo reversing kit is expensive, however 70% methyl-NOT propyl-alcohol works just as well and costs considerably less.) Very carefully read and follow all instructions which you will find on a sheet packed with the film.

You will also need a solution for developing the exposed PC board. Purchase this in gallon quantities if you plan on doing a lot of PC work.

Etchant is used to remove the unwanted copper from the developed board blank. This solution contains ferric chloride which permanently stains virtually anything it touches and corrodes most metals. Handle it with care. Again, buy by the gallon.

Layout materials come next. They include self-adhering black dots and black tape, dry-transfer decals which can be used to title and number component locations on the board (an option you can do without if you are on a tight budget), and sheet acetate for the layout base. For the latter, select clear, untreated acetate in a medium or heavy weight.

Kepro recommends that you use a No. 2 photoflood lamp for exposing the negative and board blank, but if you cannot find this item, a standard 150-watt reflector lamp, available at any drug store, can be substituted. Add to your shopping list two  $9" \times 5\frac{1}{2}" \times 2"$  Pyrex dishes, to be used for developing and etching the board, and a small plastic funnel for replacing reusable chemicals in their containers.

Filter paper is an option which can pay for itself in the long run. Use it to periodically filter the accumulation of photoresist out of

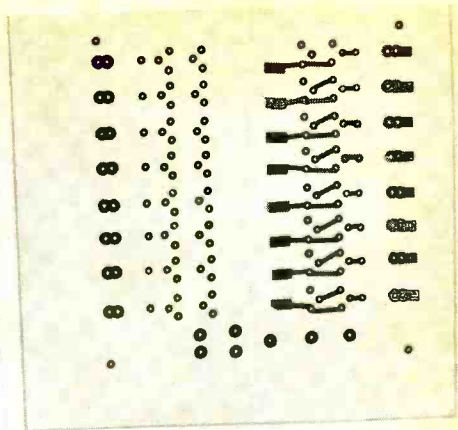

Fig. 2. Typical pattern on plastic sheet. Remaining lines must be added.

the developer. Cotton swabs with long wooden handles are a must. They are required for developing the film negative, and the handles can be used to lift the board out of the etchant.

A black ink designed for touching up photographic film can be used to correct layout errors on the film negative. And for errors caught before the board is etched, you should have on hand a supply of rub-on resist and a bottle of paint-on resist for corrections.

Finally, you will need No's. 60 and 67,  $\frac{1}{16}$ ", and  $\frac{1}{8}$ " drills, all of them high-speed types. The No. 67 drill is particularly useful for drilling IC lead holes.

**Step-By-Step Procedure.** You will most likely be interested, at least at first, in duplicating an actual size PC board from a magazine etching guide. In this case, the hard job of laying out the conductor pattern (see Fig. 1) has been done for you. Lay a piece of acetate sheet over the etching guide and fix it in place with masking tape or staples. You are now ready to make the film positive.

Begin your layout by pasting solder pads on the acetate, matching the dot sizes reasonably close as shown in Fig. 2. After all the pads are in place, put a piece of paper over the layout and use the back of a spoon to burnish them down.

Next, use the black crepe tape to interconnect the pads according to the published layout, again matching widths. It is also a good idea to make a border with the tape (see Fig. 3) to assist in trimming the board after it is etched. When positioning the tape strips, allow  $\frac{1}{16}$ " of width for each 5 amperes of current they must handle and  $\frac{1}{32}$ " minimum

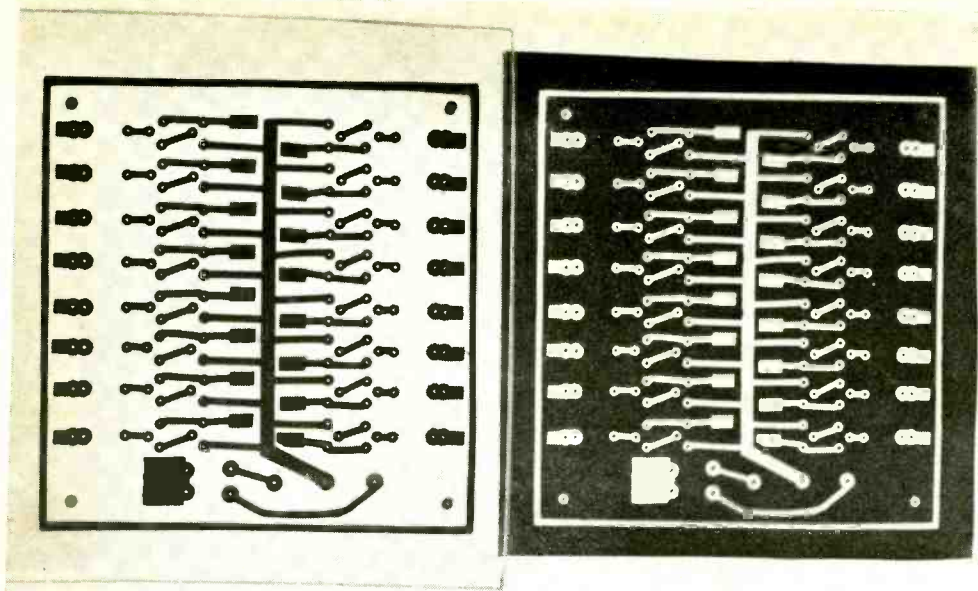

Fig. 3. At the left, the lines and border needed for Fig. 2 have been added to the plastic sheet. Then negative is made by photographic process (right).

spacing between strips. Burnish down the strips.

Remove the acetate positive from the layout and very carefully compare the two for accuracy. A mistake now is difficult to correct later. This done, turn off all fluorescent lighting, if any, in your work area. Place a lamp equipped with a 15-watt bulb and shade (to diffuse the light) 8 feet or more away from the work area. Turn on the lamp and extinguish all other lighting in the room. From now until you finish developing the board, this is the only lighting there should be in your work area.

Open the reversing film container and remove the instruction sheet packed inside. Carefully read the instructions provided. Then, remove the reversing film and cut off enough to make your negative. Immediately return the rest of the film to its light-tight container and seal the container with masking tape.

Place the reversing film, emulsion side down on a sheet of clear glass. Over this, place and center your positive. Complete the sandwich with another sheet of glass. If you are using the No. 2 photoflood lamp, expose the negative as instructed. But if your exposing medium is a 150-watt reflector lamp, exposure time will be about 3½ minutes at a distance of 12 inches.

After exposing the film for the recommended time, shut off the exposing lamp.

TABLE I—MATERIALS REQUIRED

Material	Cat. No.*	Price
PC Board Developer		
1 pint	D-1PT(K)	\$1.15
1 gallon	D-1G(K)	5.50
Etchant (Ferric Chloride)		
1 pint	E-1PT(K)	0.85
1 gallon	E-1G(K)	3.50
Resist Paint (Black)		
1 pint	R-1PT(K)	2.25
Photo Reversing Kit	FK-701(K)	7.20
Photo Reversing Film		
10" × 24"	RF-1024(K)	3.00
20" × 24"	RF-2024(K)	5.40
Reversing Film Developer		
1 pint	RFD-1PT(K)	2.25
Layout Pads		
250 (0.293 × 0.031)	D137(B)	3.00
250 (0.100 × 0.031)	D101(B)	3.00
250 (0.156 × 0.031)	D103(B)	2.00
IC Pads		
250 (14-pin DIP)	6014(B)	7.55
Black Tape		
20 yd (0.125" wide)	T201/.125(B)	0.75
20 yd (0.062" wide)	T201/.062(B)	0.75
20 yd (0.031" wide)	T201/.031(B)	0.75

\*Catalog numbers followed by (K) are available from Kepro Circuit Systems, Inc., 3630 Scarlet Oak Blvd., St. Louis, MO 63122; those followed by (B) are available from Bishop Graphics Inc., 7300 Radford Ave., North Hollywood, CA 91605. Items are also available from distributors such as Allied Electronics and Newark Electronics.

**TABLE II—BOARD BLANKS**

Material	Cat. No.*	Price
Phenolic Base		
3" x 3"	S1-33	\$0.58
3" x 6"	S1-36	0.90
4" x 6"	S1-46	1.06
6" x 6"	S1-66	1.52
7" x 10"	S1-710	2.72
12" x 12"	S1-1212	5.36
Polyester Base		
3" x 3"	S1-33M	0.60
3" x 6"	S1-36M	0.94
4" x 6"	S1-46M	1.12
6" x 6"	S1-66M	1.62
7" x 10"	S1-710M	2.88
12" x 12"	S1-1212M	5.72
Epoxy Base		
3" x 3"	S1-33G	0.84
3" x 6"	S1-36G	1.44
4" x 6"	S1-46G	1.66
6" x 6"	S1-66G	2.58
7" x 10"	S1-710G	4.80
12" x 12"	S1-1212G	9.64

\*Kepro Circuit Systems, Inc., 3630 Scarlet Oak Blvd., St. Louis, MO 63122.

Note: All are 1/16" thick, clad on one side only with 1-ounce copper with photosensitized resist coating.

Next, use a swab and the film developer to remove all unwanted emulsion as shown in Fig. 4. Move the swab back and forth, using enough developer to keep the film wet. In a few seconds, the unwanted green coating will begin to dissolve. Continue swabbing until all of the exposed emulsion has dissolved; wash and hang the negative up to dry.

If your board blank must be trimmed to size before being exposed, sandwich it between two sheets of heavy, opaque paper and seal the edges with masking tape. Then use a nibbling tool to trim the blank to size. Immediately seal with masking tape the ex-

**Fig. 4. Remove the exposed emulsion with a swab and developer solution.**

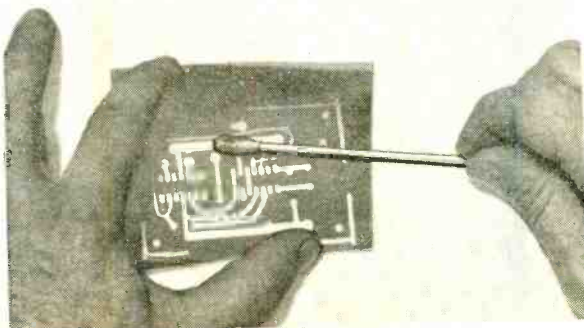

posed edges of the portion to be saved and return it to its light-tight envelope.

Now, sandwich the board (copper side up) and film negative between the two sheets of glass, and expose the board according to Kepro's instructions for the No. 2, or for 3½ minutes at 12" for the reflector lamp.

Pour board developer to a depth of ½" into both Pyrex dishes. Handling it carefully only by edges, place the board into the developer and gently rock the dish back and forth for 2 minutes. Still handling it by its edges, remove the board from the dish and lay it on a protected flat surface where the developer on it can evaporate undisturbed. Meanwhile, pour the used developer into a non-plastic (preferably glass) container labelled "used developer." Thoroughly rinse the dish.

When the board is completely dry, inspect it to see if the developer has done its work. You should be able to see clearly the photoresist pattern on the copper. If necessary, place the board into the dish containing the clean developer and rock the dish for 45 seconds. Remove the board and again allow it to dry undisturbed. You can now turn on the regular lighting in the room. When it has dried completely, carefully inspect the board's resist pattern. Repair any messy or incomplete areas with rub-on or paint-on resist.

The board is now ready to be etched. To do this, pour etchant to a depth of ½" for small and ¾"-1" for medium to large boards into a Pyrex dish. Float the board, copper side down, in the resist. It will take about an hour for the etchant to completely remove the unwanted copper, but you should check the progress every 10 or 15 minutes. Do not rinse the board until the entire etching process is complete. When the etching process is complete, however, thoroughly rinse the etchant off under running water. Then remove the resist with fine steel wool and follow up with a cleaning in soapy water.

Do not try to economize on etchant. Once used, it should be discarded by pouring it in a slow, lazy stream down the drain with plenty of running water. Let the water continue to run for about 15 seconds after all the etchant is gone and the dish has been thoroughly cleaned.

The final steps in fabricating your PC board are drilling component lead and mounting holes and trimming to final size. If desired, you can rub onto the component side of the board dry-transfer legends to identify component locations. ♦

From Cleveland Institute of Electronics

# learn by doing!

Perform more than 200 exciting experiments  
with CIE's fascinating **ELECTRONICS  
LABORATORY PROGRAM!**

Put theory... into practice

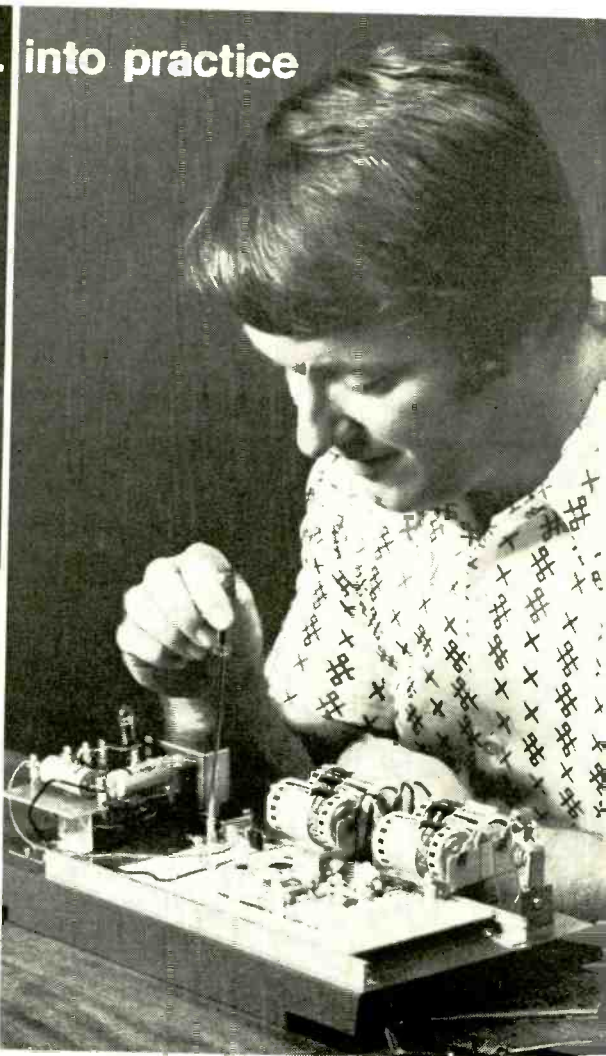

# You get your own 161-piece electronics laboratory... with authentic electronic components used by industry!

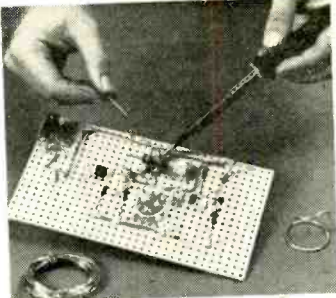

You learn how to construct circuits and connect them with a soldering iron, which is part of your CIE laboratory equipment. This "hands on" experience is extremely valuable in applying what you learn.

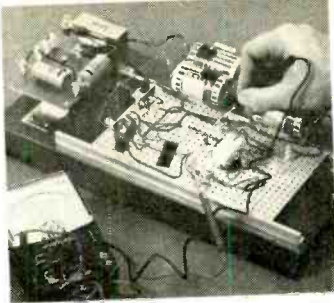

Testing and troubleshooting are an important part of your learning experience. Included in your laboratory is a precision "multimeter" to diagnose electrical and electronic troubles quickly and accurately.

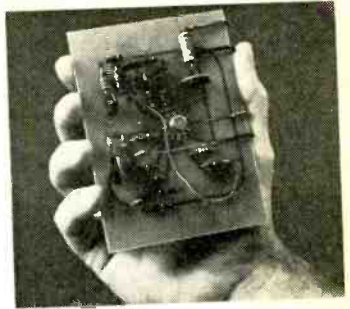

Modern space-age components like this IC (integrated circuit) are professional quality and can be used again and again in many of your projects. Lesson by lesson, piece by piece your knowledge grows!

## Prepare now for a high income career in Electronics...the Science of the Seventies.

Electronic miracles are changing today's world with breathtaking speed.

And with this growth in electronics technology has come a brand new need... a demand for thousands of electronics technicians, trained in theory and practice to build the products, operate them and service them during the Seventies.

Don't just wait for something to "happen" in your present job. Get ready now for a career you'll really enjoy with a good income and plenty of opportunity for advancement.

### Experience with experiments is your best teacher

"Hands on" experience helps to reinforce basic theory. When you learn by doing, you discover the "how" as well as the "why." You'll find out for yourself the right way as well as the wrong way to use electronic components. How to construct your own circuits, to discover trouble spots and learn how to fix them. And with CIE's special Auto-Programmed® Lessons, you learn faster and easier than you'd believe possible.

CIE's fascinating course, Electronics Technology with Laboratory, teaches you Electronics by making it work before your eyes. And you do it yourself, with your own hands.

### Importance of FCC License and our Money-Back Warranty

Many important jobs require an FCC License and you must pass a Government licensing exam to get one.

But, a recent survey of 787 CIE graduates reveals that better than 9 out of 10 CIE grads passed the FCC License exam.

That's why we can offer this famous Money-Back Warranty: when

you complete our Laboratory Course, which provides FCC License preparation, you'll be able to pass your FCC exam or be entitled to a full refund of all tuition paid. This warranty is valid during the completion time allowed for your course.

You get your FCC License — or your money back!

### You'll have high paying job opportunities

Electronics is still young and growing. In nearly every one of the new exciting fields of the Seventies you find electronics skills and knowledge are in demand. Computers and data processing. Air traffic control. Medical technology. Pollution control. Broadcasting and communications. With a CIE Diploma and an FCC License you can choose the career field you want... work for a big corporation, a small company or even go into business for yourself.

Here's how two outstanding CIE students carved out new careers: After his CIE training, Edward J. Dulaney, President of D & A Manu-

facturing, Inc., Scottsbluff, Nebraska, moved from TV repairman to lab technician to radio station chief engineer to manufacturer of electronic equipment with annual sales of more than \$500,000. Ed Dulaney says, "While studying with CIE, I learned the electronics theories that made my present business possible." Marvin Hutchens, Woodbridge, Virginia, says: "I was surprised at the relevancy of the CIE course to actual working conditions. I'm now servicing two-way radio systems in the Greater Washington area. My earnings have increased \$3,000. I bought a new home for my family and I feel more financially secure than ever before."

### Send now for 2 FREE BOOKS

Mail the reply card or coupon for our school catalog plus a special book on how to get your FCC License. For your convenience, we will try to have a representative call. If coupon is missing, write: Cleveland Institute of Electronics, Inc., 1776 E. 17th St., Cleveland, Ohio 44114. Do it now!



Approved under  
G. I. Bill

All CIE career courses are approved for educational benefits under the G. I. Bill. If you are a Veteran or in service now, check box for G. I. Bill information.

**CIE** Cleveland Institute of Electronics, Inc.  
1776 East 17th Street, Cleveland, Ohio 44114  
Accredited Member National Home Study Council

Please send me two FREE books:

1. Your illustrated school catalog, "Succeed in Electronics."
2. Your book, "How to Get a Commercial FCC License."

I am especially interested in:  Electronics Technology with Laboratory  
 Electronics Technology  Industrial Electronics  
 Electronic Communications  First Class FCC License  
 Broadcast Engineering  Electronics Engineering

Name \_\_\_\_\_ Age \_\_\_\_\_

Address \_\_\_\_\_

City \_\_\_\_\_ State \_\_\_\_\_ Zip \_\_\_\_\_

Veterans and Servicemen: Check here for G. I. Bill information.

PE-34

**CIRCLE NO. 4 ON READER SERVICE CARD**

# Build a DIGITAL LOGIC TRAINER



BABY COMPUTER PERFORMS 32 FUNCTIONS  
AND TEACHES BOOLEAN ALGEBRA

BY JACK CAZES

**T**HERE have been quite a number of articles appearing in various magazines covering digital logic. In most cases, they dealt with simple applications of logic in clocks, frequency counters, or digital multimeters. However, there are very few articles covering the use of digital logic in computation—such as the construction of real digital computers.

The digital logic computer described here is an arithmetic/logic function generator that can perform 16 binary arithmetic operations including addition, subtraction, decrement, and straight transfer and 16 logic functions including AND, NAND, OR, NOR, Exclusive-OR, and comparator. Not only will this combination allow you to learn and use binary arithmetic, it will also enable you to study logic and Boolean algebra.

To use the computer, all you do is set the appropriate selector switches and enter the data as two 4-bit words. There is no re-wiring or patching required for any of the 32 available functions.

The computer is designed around a medium-cost IC (75 equivalent gates on a single chip) and a multi-contact rotary switch.

**Construction.** There are no special construction techniques required and lead dress is not critical. Of course, neat layout of the leads will result in a more esthetically appealing unit as well as one that is easier to troubleshoot, should the need arise. In the prototype shown in the photographs, many of the leads (those interconnecting the IC, the function

selector switch, the binding posts, the lamp-driver board, the output lamps, and the bank of data input switches) were tagged with  $\frac{1}{8}$ "-wide numbered wire markers.

The computer is housed in a 7"  $\times$  5"  $\times$  3" aluminum case, with the 16-position function selector switch mounted horizontally at one end. All other switches, lamps, and binding posts are located on the front. The case should be drilled, painted, and marked, using dry transfer lettering, before mounting the components.

The function selector switch, *S1*, should be wired first, as shown in Fig. 1. It is convenient to complete this wiring outside the

Fig. 1. Wire *S1* as shown here with connections to the IC, BP1 and BP2.

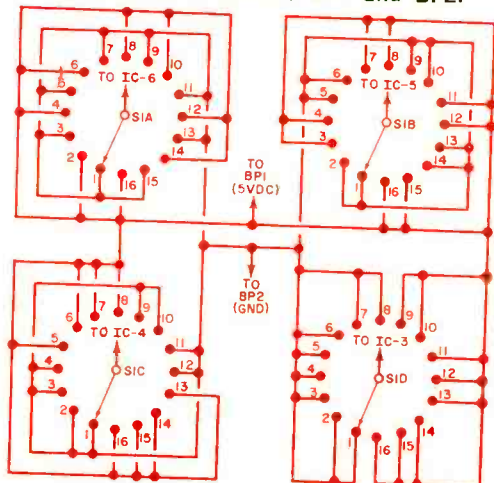

case, leaving leads 8 or 10 inches long, to be connected to the IC and *BP1* and *BP2*. Label these leads appropriately and mount the switch in the case.

Insert the 24-pin IC socket in the center of a 2" x 2" piece of perforated phenolic board (hole spacing, 0.100"). It is advisable to use a socket for the integrated circuit to prevent possible heat damage resulting from soldering directly to the IC. Connect the four leads from the rotors of *S1A*, *S1B*, *S1C*, and *S1D* to the IC socket according to Figs. 1 and 2. Connect long leads to all other IC socket pins except #15 and #17, marking them with their respective pin numbers, and then mount the board in the case.

Wire the six lamp-driver circuits as shown in Fig. 3. Here again, it's convenient to use

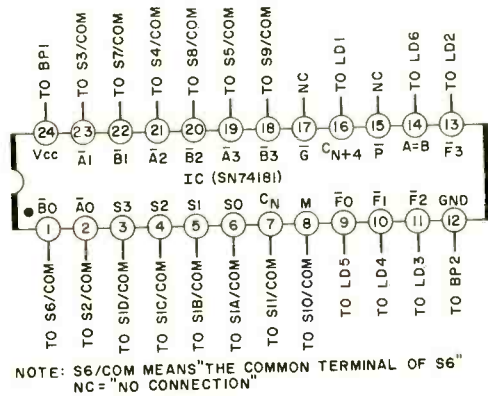

Fig. 2. Top view of connections to the IC. It is best to use a socket.

a small piece of perf board to mount the resistors and transistors. The lamp assemblies are mounted in the front of the case and then wired to the driver circuits inside the case.

Using Fig. 4 as a guide, install all of the wiring that interconnects *S2* through *S11*. The leads running from the IC socket to *S2* through *S11* should now be connected. The only remaining task is to connect all leads going to the two binding posts and the lamp-driver circuits (*LD1-LD6*) from *S1*, *S2* through *S11*, and the IC socket. Wiring is now complete. Check all of your wiring carefully and, when you're sure all is correct, plug in the integrated circuit. You're now ready to try out your computer.

**Testing and Operation.** Connect a regulated 5-volt dc supply to *BP1* (pos.) and *BP2* (neg.). This will provide supply voltage to the IC and the lamp-driver circuits, and

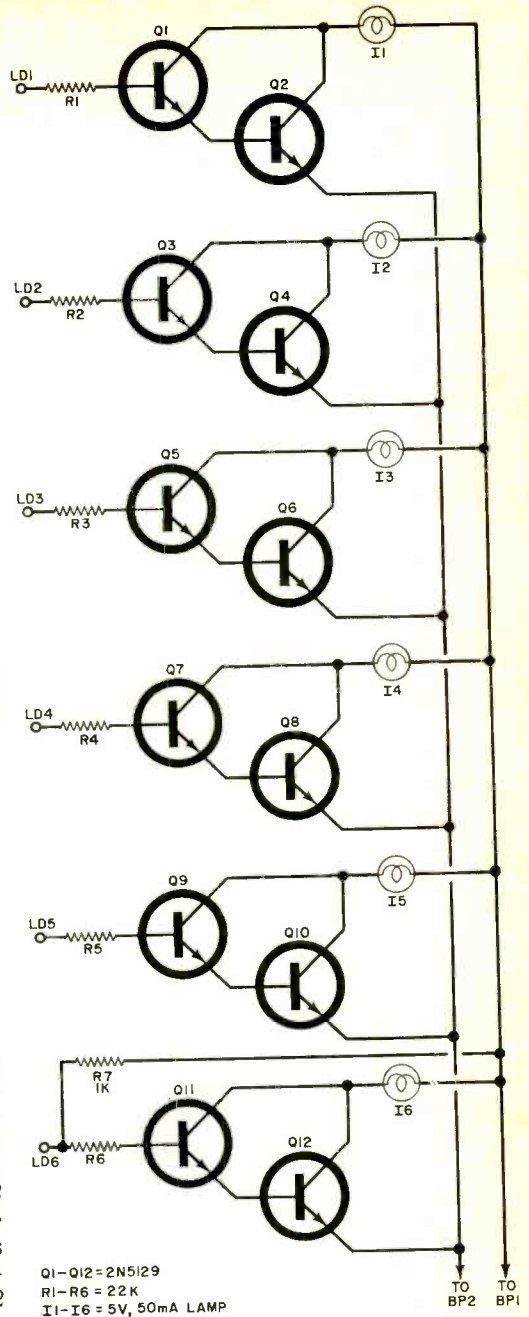

Fig. 3. Lamp drivers with high input impedance display the final result.

logic 1 level voltage to the input and function selector switches. Internal grounding represents the logic 0 state at the various inputs. In actual operation, outputs at a logic 0 level will be near zero volts, whereas outputs at a logic 1 level will be well above zero (3 volts).

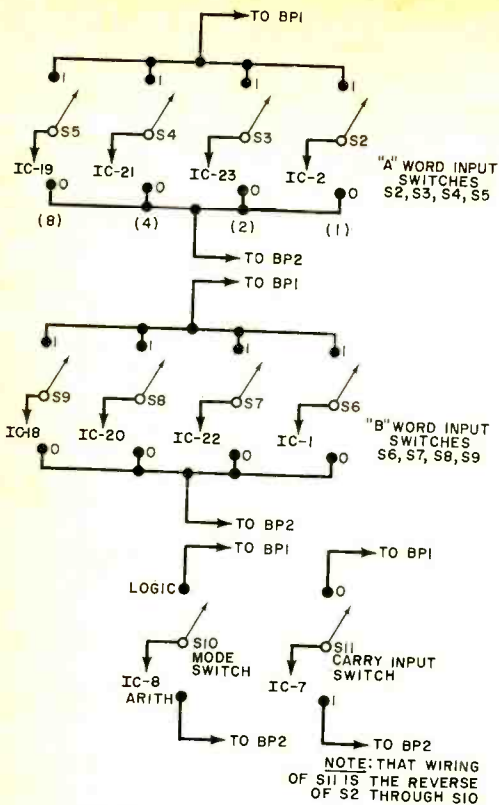

Fig. 4. Wiring of mode of operation switches and those for word inputs.

A logic 0 state will result in an unlit lamp, whereas a 1 state will turn the lamp on.

Arithmetic functions are obtained by setting *S10* to ARITH and *S11* to the logic 0 position. The desired function is then selected from Table I and function selector *S1* is set to the appropriate position.

For logic functions, *S10* must be set to the LOGIC position. Setting of *S11* is irrelevant in this case. The desired logic function is selected from Table II and *S1* is set to the appropriate position. In this mode of operation, the internal carry is disabled. Thus, one can enter four different combinations of input conditions and observe their respective outputs simultaneously.

Exhaustive testing of the computer would require going through each of the 32 available functions, setting the "A" and "B" input switches to all of their possible combinations and seeing that the result is what it should be. This would be beyond the scope of this article and is probably unnecessary. However, using Tables III and IV as guides to typical operation, set the input

TABLE I—ARITHMETIC FUNCTIONS

S1 Position	Function
1	A
2	A + B
3	A plus $\overline{A}B$
4	Minus 1*
5	A + $\overline{A}B$
6	(A + B) plus $\overline{A}B$
7	A minus B minus 1**
8	$\overline{A}B$ minus 1
9	A plus AB
10	A plus B
11	(A + $\overline{B}$ ) plus AB
12	AB minus 1
13	A plus A***
14	(A + B) plus A
15	(A + $\overline{B}$ ) plus A
16	A minus 1

General Note: Plus signs are logic OR functions (as in positions 1, 2, and 3 of switch *S1*). Arithmetic functions are spelled out.

\*Displayed as its 2's complement.

\*\*Also used for comparator function, A=B.

\*\*\*Each bit in binary A shifts to the next more significant position.

switches as shown and check to see that your output levels correspond to those given in the tables.

The expressions shown in Tables I through IV are written in Boolean algebra. Let's briefly review the notational system used:

1. A "high" or "yes" logic level is written as 1, whereas a "low" or "no" logic level is written as 0. An exception to this notation is at the CARRY OUT. Here, because of the way in which the IC was designed, the reverse is true. Thus, when CARRY OUT is 0, its voltage level is high, (lamp turned on),

TABLE II—LOGIC FUNCTIONS

S1 Position	Function
1	$\overline{A}$ (Inversion of A)
2	$\overline{A + B}$ (NOR)
3	$\overline{AB}$
4	Logic 0
5	$\overline{AB}$ (NAND)
6	$\overline{B}$ (Inversion of B)
7	A ⊕ B (Exclusive OR)
8	$\overline{AB}$
9	$\overline{A + B}$
10	$\overline{A \oplus B}$
11	B
12	AB (AND)
13	Logic 1
14	A + $\overline{B}$
15	A + B (OR)
16	A



**TABLE III—  
ARITHMETIC FUNCTION TESTS  
(Set S10 to ARITH, S11 to 0)**

S1	Input		Output		
	A 8421	B 8421	Carry	8421	A=B
1	1010	0101	1	1010	0
2	0011	1010	1	1011	0
3	0011	1010	1	0111	0
4	0000	0000	1	1111	1
5	1111	1111	1	1111	1
6	1111	0000	0	1110	0
7	0101	0100	1	0110	0
8	0000	0000	1	1111	1
9	1000	0011	0	0100	0
10	0011	1000	1	1010	0
11	0000	0000	1	1111	1
12	0110	1001	1	1100	0
13	1000	1100	0	0100	0
14	1110	1001	0	0110	0
15	1111	1011	0	1010	0
16	0101	0000	1	1010	0
17	0100	0001	1	1001	0
18	0100	0001	0	0010	0
19	1000	0000	1	1111	1

and vice versa. If this becomes annoying, you can reverse the output by inserting an inverter stage between pin 15 of the SN74181 and LD1.

2. A line over an expression means "not." Thus,  $\bar{A}$  is read as not A, and  $\bar{B}$  is read as not B. If A = 1, then  $\bar{A}$  = 0, and vice versa.

3. AB is read as A and B.  $\overline{AB}$  is read as A and not B.

4.  $A + B$  is read as A or B.  $A + \bar{B}$  is read as A or not B.

5.  $A \oplus B$  is read as exclusively A or B.

**TABLE IV—LOGIC FUNCTION TESTS  
(Set S10 to Logic, S11 irrelevant)**

S1	Input		Output		
	A 8421	B 8421	Carry	8421	A=B
1	0101	0000	1	1010	0
2	1001	1100	1	0010	0
3	1010	0011	1	0001	0
4	0000	0000	1	0000	0
5	1111	1111	1	0000	0
6	1001	1010	1	0111	0
7	0000	1111	1	0000	0
8	0000	0000	1	1111	1
9	0101	0110	1	0011	0
10	0101	0110	0	0001	0
11	1100	1010	0	1011	0
12	1100	1010	0	1001	0
13	0101	1001	1	1001	0
14	0101	1001	0	0001	0
15	0101	1001	1	1111	1
16	0101	1001	0	1101	0
17	1100	1010	0	1101	0
18	0101	1001	1	1101	0
19	0101	1001	0	0101	0

6. Arithmetic addition and subtraction are written as "plus" and "minus", respectively.

**Using the Computer (Addition).** Binary addition of two 4-bit numbers is accomplished by entering them as A and B and reading the result directly. If the result is greater than 15 there will be a "carry out" (CARRY OUT = 1, lamp off). Thus:

```

  1 0 1 1 A (BINARY 11)
  0 0 1 1 B (BINARY 3)
  -----
  1 1 1 0 SUM (NO CARRY OUT)
  
```

```

BUT  1 0 1 1 A (BINARY 11)
     1 1 0 0 B (BINARY 12)
     -----
     0 1 1 1 SUM (WITH CARRY OUT)
  
```

CARRY

**Subtraction.** Enter the two numbers with which subtraction is to be performed into A and B inputs. The result, for Function 7 in Table I, will be A minus B minus 1, rather than only A minus B. The reason for this can be understood by examining the procedure by which subtraction is performed within the integrated circuit. We must first, however, define a couple of terms.

1. If each bit in a binary number is inverted (i.e., zeroes changed to ones, and vice versa) the result is known as the "1's complement" of the number. For example, given the binary number 1 1 0 1, its 1's complement would be 0 0 1 0. Note that the sum of a binary number and its 1's complement is always a binary number composed of all ones (1 1 0 1 plus 0 0 1 0 = 1 1 1 1). A number can be converted to its 1's complement in the computer with S1 in logic position 1 for a binary number entered into A and with S1 in logic position 6 for a binary number entered into B. Set your computer for LOGIC with S1 on 1. Enter binary 1100 into A and observe that the output reads 0 0 1 1, the 1's complement of the entered number.

2. If the 1's complement of a number is increased by one (i.e., add 1 to it) the result is called the 2's complement. Thus, the 2's complement of 1 1 0 1 would be

```

  1 1 0 1 GIVEN NUMBER
  0 0 1 0 1'S COMPLEMENT
  -----
  PLUS 1 ADD 1
  -----
  0 0 1 1 2'S COMPLEMENT
  
```

Now let's return to the mechanism by which subtraction is performed. To subtract B from A, the 1's complement of B is added

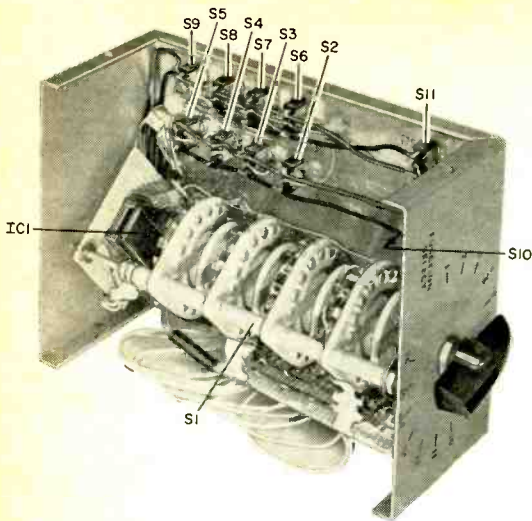

This shows how the prototype was assembled. Note mounting of IC board.

to A. This is done internally, within the IC. We've already seen, however, that the result of this type of subtraction is not A minus B, but rather A minus B minus 1, which is one less than the result we want. Some larger machines automatically correct this result by a technique known as an "end-around" or "forced" carry. Let's follow what happens, for example, in subtracting 3 from 8:

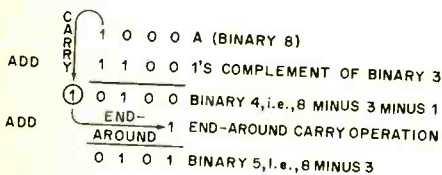

With this computer, this end-around carry must be performed externally. It can be simulated by simply switching S11 to the 1 position, thus adding 1 to the result. Don't forget to switch S11 back to 0 for normal arithmetic operation!

We have seen that the 1's complement method of subtraction is a two-step procedure. Most larger computers use a different, one-step method that is more economical in terms of time required and makes use of the 2's complement of the subtrahend. Two's complement subtraction involves conversion of the subtrahend to its 2's complement, followed by its addition to the other number. Thus, 3 from 11 is:

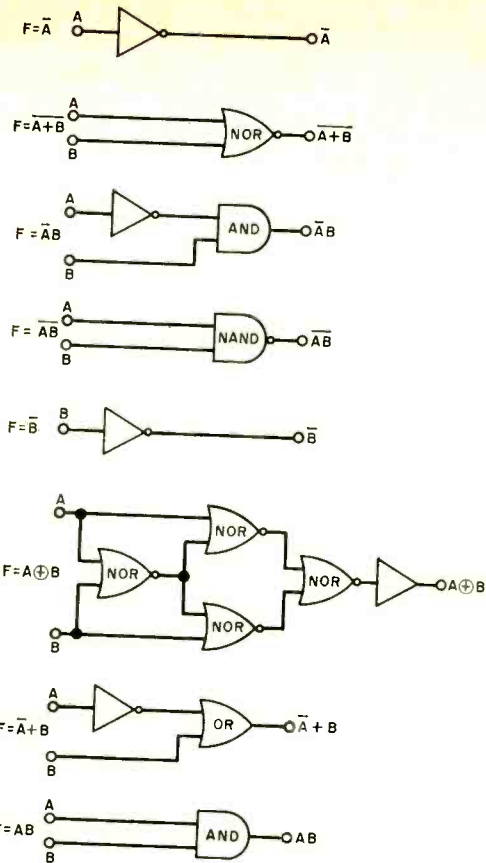
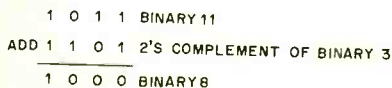

Fig. 5. Logic functions performed by the computer are represented here in symbolic "electronic shorthand" form.

### PARTS LIST

- 11-16—5-V, 50-mA miniature lamp assembly, with plastic cap (Southwest Technical Products, Inc., Box 16297, San Antonio, TX 78216, Part 57ASP-007)
  - IC1—Integrated circuit (TI SN74181)
  - BP1-BP8—4-way binding post (H. H. Smith Type 1517)
  - Q1-Q12—Transistor (National 2N5129)
  - R1-R6—22,000-ohm, 1/4-watt resistor
  - R7—1000-ohm, 1/4-watt resistor
  - S1—4-pole, 16-position rotary switch, non-shorting (Centralab PA-3007)
  - S2-S11—Spdt, miniature toggle switch (Alco MST-105D)
  - Misc.—Aluminum case (7" x 5" x 3") (Bud CU2108A or Premier PMC-1008); 24-pin IC socket; phenolic perf board (2) (2" x 2" and 1 1/2" x 4") with 0.100" hole spacing.
- Note: A set of twelve 2N5129 transistors and one SN74181 integrated circuit is available from Electronics Co. Inc., Box 278, Cranbury, NJ 08512 for \$15.25, postpaid.

**Comparator Functions.** To use the A = B comparator function, set the computer up for subtraction (S10: ARITH; S11: 0; S1: 7). Whenever A is equal to B, the A=B output will be in a 1 logic state (lamp on). A second comparator function works as follows. With S10 on ARITH and S1 on 7, there are four possible conditions: (1) with S11 = 0 and CARRY OUT on, A is less than or equal to B; (2) with S11 = 1 and CARRY OUT on, A is less than B; (3) with S11 = 0 and CARRY OUT off, A is greater than B; and (4) with S11 = 1 and CARRY OUT off, A is equal to or greater than B.

**Logic Functions.** The sixteen available logic functions shown in Table II as Boolean algebra expressions will accept four different sets of input conditions and provide the four resultant outputs simultaneously; this is because when the computer is set up in the logic mode, the internal carry is disabled.

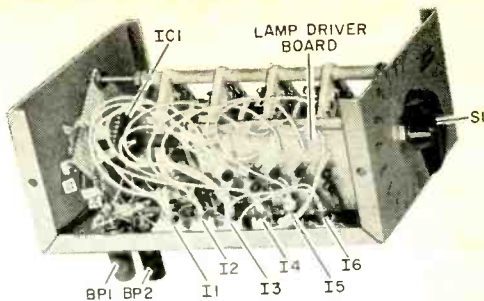

The computer is simple to build when wired in sections as in Figs. 1 to 4.

Equivalent logical block diagrams are shown in Fig. 5 for some of the available functions. To use them, set S10 to LOGIC and S1 to the desired function. Enter input conditions via A and B, as required by the function selected; up to four conditions may be entered simultaneously. Observe the resultants at the four outputs. ♦

# NOVEL USE for LED

AN AID FOR THE HARD OF HEARING

BY ROLAND J. McMAHAN

Light-emitting diodes (LED's) are now widely used as power-on indicators or state readouts, or in other reasonably complex indicator circuits. However, an LED can also be fun and very handy when used in some non-critical and unusual circuits.

A typical LED operates in the potential range between 1.2 and 3 volts and requires a maximum current of about 20 mA. Considering its small size, it can generate a surprising amount of useful light.

The voltage required for the one watt of power for a conventional 8-ohm speaker is within the LED range. Try clipping an LED across the speaker voice coil and watch the light flicker with the program material. With LED's available in different colors, here is a chance to make the world's simplest and smallest color organ.

**For the Handicapped.** If you connect an LED to the speaker terminals of a telephone amplifier, it makes an interesting and helpful item for the deaf. With the phone in

the amplifier cradle, the LED will glow steadily if the volume is brought up and there is a dial tone. A busy signal is indicated by a fast flashing; ringing by a long steady, intermittent glow; and a received voice produces a variable-strength glow. Deaf people have easily recognized the signal difference between "no" and "OK." Thus, by judicious questioning, they can find out if their spoken message has been understood. If the deaf person is also mute, a buzzer or an audio oscillator at each end of the line permits Morse code conversation over the telephone easily and without assistance.

An LED connected to the speaker terminals of a record player, in conjunction with a Morse code record, has been successfully used to teach the code to a group of deaf people. One deaf student will soon have her novice license; and with an LED at the audio output of her receiver, will have no problem holding conversations with other hams all over the world. ♦

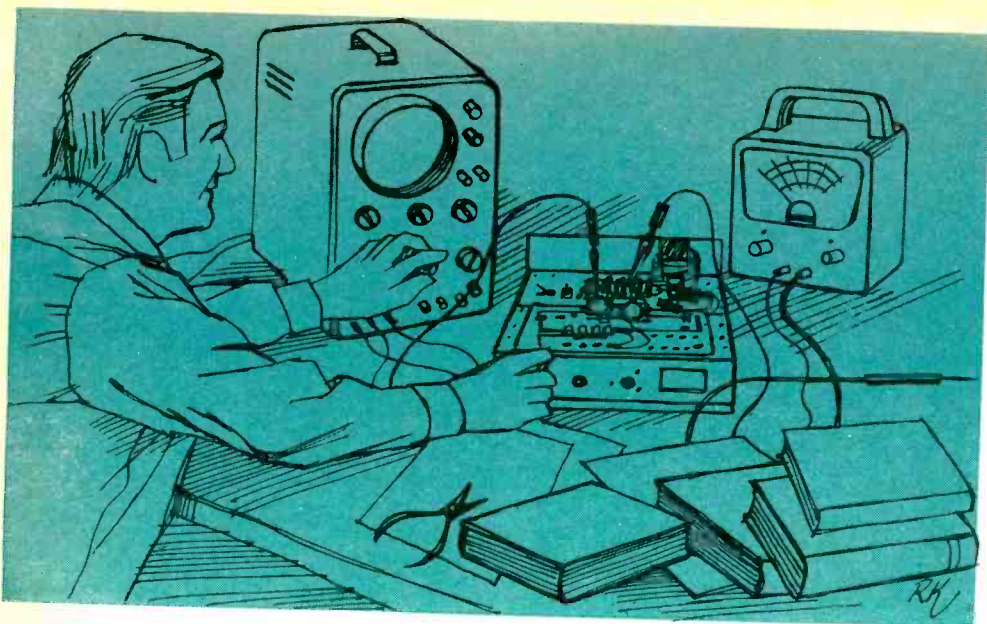

# A GUIDE TO **Home Study** **Education in Electronics**

THIS ARTICLE WILL HELP YOU MAKE UP YOUR MIND ABOUT WHICH SCHOOL TO SELECT FOR YOUR NEEDS

BY LOUIS E. FRENZÉL, JR.

**S**UCCESS in electronics, whether it is your career or simply an avocation, is almost always directly traceable to a good understanding of electronics fundamentals. This understanding is, in turn, usually the result of a good education in electronics; and one of the most efficient ways to get this basic education is through home study.

However, correspondence schools and their home study courses seem to be an enigma to some people, despite their wide appeal and popularity for many others. If you've considered taking a home study course, but can't make up your mind, perhaps we can help you decide.

## **Putting Home Study in Perspective.**

Home study is an excellent learning method. It is widely recognized in govern-

ment, business, and industry because of its effectiveness. It is also the lowest in cost and most convenient method of education in existence today.

It costs many thousands of dollars to complete a college or resident technical school education, but the cost of a good home study course is usually in the \$100 to \$1,000 range. Compared to resident classes, that's a real bargain.

Home study is also the most convenient method of education. The school comes to you. When you enroll, the school sends you all of the materials you need to learn the subject. You study the lesson texts and work with the other training materials, such as kits and audio/visual devices, to learn the subject matter. You study on your own schedule and by your own method.

## Home Study vs Self Study.

Many people say, "Why should I enroll for a formal home study course in electronics and pay several hundred dollars when I can go to the public library, check out the books that I need, and learn the material from them myself?" The fact is, you can; self study does work. It is quite possible to find the appropriate books, study, and learn the subject yourself. However, it is probably the most difficult and demanding method of education. It can be difficult to find textbooks or other materials that cover the subject matter adequately. Should you be lucky enough to find suitable material at the library or a bookstore, there is the problem of disciplining yourself to sit down, read the material, and work appropriate problems. Very few people have the perseverance it takes to do this.

A home study course is similar in many ways to self study in that you read and study the material yourself. However, the formal home study course has quite a bit more going for it. First, the course is a formal package of educational materials planned to teach you a particular subject at a specific level. It is put together by technically qualified educators who know the subject matter and know how to present it for best results. The school provides you with all of the study materials necessary.

A formal home study course also helps to motivate you. Because you have paid a certain amount of money for the course, you feel some incentive and obligation to study and complete it.

The home study school provides many additional services and benefits not available in the self study method. Qualified instructors are on hand to answer your technical questions about the course and usually about related subjects as well. In addition, upon completion of the course your achievement is recognized by the awarding of an appropriate diploma which carries a certain amount of weight and prestige. Some schools even have alumni associations, periodic magazines or newsletters, and job location assistance. All of these are things that you do not get with self study. Although self study works, you will learn your subject faster and more thoroughly with a formal home study program.

As for resident schools, you wouldn't ordinarily think that home study schools would compete, but in reality there are many cases where they do.

For example, what happens if you can't get into the college or resident technical school of your choice for academic or other reasons? What if there isn't a college or appropriate school available where you live? What if there is an appropriate school in your area but it does not offer night courses, the only type of course that you can take because you work full time? What if you cannot afford the cost of the school? If you are prevented from attending a college or resident technical school for any one of these reasons, then you should consider a home study course.

## Why Take a Home Study Course?

So now that you are thinking about taking a course, you want to know what's really in it for you. Let's take a look at some of the benefits that you might obtain.

1. You will obtain a greater knowledge of your specialty. A good home study course in electronics is going to give you a good background in electronics fundamentals. You will learn theory that will open your mind and give you new insights into your work. A lot of things that you may have worked with before but not fully understood will finally become perfectly clear.

2. Your increased knowledge of electronics will permit you to do a better job. You will be more competent and will, therefore, have a greater confidence in your work. This could possibly lead to a raise or a promotion with its increased responsibility and the need for greater technical knowledge.

3. Your newly gained knowledge could qualify you for a different and better job. You may find that, with your increased knowledge and confidence, your present job is no longer suitable or satisfying. A new job could bring you even greater success.

4. Your increased knowledge may permit you to meet some special goal which you have set for yourself. For example, you may want or need a first class radio telephone license. The course you take may qualify you to pass the FCC exam for this license. Then again, your improved competency could help you pass the test for a particular job or for that important service promotion that you have been wanting.

5. Last, and perhaps the most important benefit of all, is the fact that completing a home study course and gaining the knowledge it contains will give you greater confidence and self respect, two characteristics

that will help you to move ahead more than anything else.

Although all of these things can result from taking a correspondence course, you should also have the proper attitude about it. Most employers will recognize such work since it shows perseverance, a desire to get ahead, and a certain level of education and competence. But you may also find that some employers virtually fail to recognize it at all. They are not aware of its benefits; but that is their loss. Don't be discouraged if you run across this attitude. Maintain your confidence and keep going. The benefits of a home study education are more subtle than bold and obvious.

### **Which Course Should You Take?**

Once you have decided that you are going to take a home study course, the next step is to set yourself a specific goal that you wish to achieve. You have to know what you want to do before you can determine which course to take. You may wish to review basic electronics to ensure your knowledge of fundamentals. Then again, you may just want specialized advanced training in some subject area such as computers, communications, or mathematics. Try to determine your specific goal before you choose a school and course.

Once you have set your goal you can proceed to locate a school offering the course you want. The table accompanying this article gives a list of home study schools offering courses in electronics and related areas. Simply drop a post card to those schools in the list. Don't overlook the postage-paid insert cards accompanying the ads for some schools in this magazine. Each of them will gladly send you a catalog and complete information on their school and its courses. Accumulate all of this information first and study it carefully. You will find some schools that meet your specific goals and others that do not. Narrow the choice down to possibly one or two schools. Then study each of these schools and their course selections carefully. Find the one best suited to your needs. If the catalog information sent to you by the school does not answer all your questions, by all means write the school with your specific questions. Be absolutely sure that the course and school are right for you before you make the investment.

Some schools employ sales representatives. Instead of getting a catalog from the

school, you may receive a call from a salesman. The salesman will give you complete details on the school and the various courses. Just remember that these representatives are salesmen and will encourage you to enroll promptly. Take your time, however, and study each school carefully before you make a decision.

### **Courses with Kits.**

When you are investigating the schools and courses, you will find a number of the courses include kits. These kits will teach you to solder, build and use various pieces of electronic equipment, run experiments, make tests, collect data and draw conclusions. You may even build and use several very interesting and useful end products, such as test equipment, a TV set, or a digital computer.

Kits in a course can be extremely beneficial, especially if you are not experienced in handling electronic hardware. They permit you to put theory into practice. After all, as a technician or an engineer, you will be working with hardware. Nothing is better than actual experience with real hardware.

On the other hand, if you have had some experience in electronics and have worked with hardware, tools, instruments, and components, then you may wish to take a course without kits, and save some time and money.

### **College Home Study Courses.**

The home study schools and courses listed in the table are private schools. The courses they offer are modern, up-to-date, and very effective. However, often overlooked as sources of home study education are the colleges and universities themselves. Many of the larger state universities offer home study courses for college credit. In most cases these courses duplicate the same courses offered in residence at the college or university. If the course is completed satisfactorily, standard college quarter credits or semester hour credits are awarded. In many instances you can achieve from one-fourth to one-half of all of the college credits needed for a Bachelor's degree by correspondence. The exact requirements vary depending upon the subject area and the college in which you do your work. Generally speaking, however, the first two college years can be completed through correspondence.

For more information on this subject, send fifty cents to the National University Extension Association, 900 Silver Spring Avenue, Silver Spring, Maryland 20910 and ask for their bulletin "A Guide to Correspondence Study in Colleges and Universities." This will give you complete information on all the colleges and universities offering courses for college credit.

### PRIVATE HOME STUDY SCHOOLS

School	Price Range	Kits	Accreditation*	Sales Reps.
Bell & Howell Schools 4141 Belmont Ave. Chicago, IL 60641	\$750— \$1275	Yes	NHSC	Yes
Capitol Radio Engineering Institute Wisconsin at Tilden Washington, DC 20016	\$90— \$675	No	NHSC	Yes
Cleveland Institute of Electronics 1776 East 17th St. Cleveland, OH 44114	\$450— \$725	Yes	NHSC	Yes
Cook's Institute of Electronic Engineering PO Box 10634 Jackson, MS 39209	\$45— \$570	No	ACTS	No
Grantham School of Engineering 1505 North Western Ave. Hollywood, CA 90027	\$370— \$390	Yes	NHSC	No
International Correspondence Schools Scranton, PA 18515	up to \$1195	Yes	NHSC	Yes
National Radio Institute 3939 Wisconsin Ave. Washington, DC 20016	\$60— \$631	Yes	NHSC	No
National Technical Schools 4000 S. Figueroa St. Los Angeles, CA 90037	\$185— \$995	Yes	NHSC	No
RCA Institutes 320 W. 31st St. New York, NY 10001	\$90— \$1150	Yes	NHSC	No
United Technical Institute Career Academy 611 E. Wells St. Milwaukee, WI 53201	\$1098	Yes	NHSC	Yes

\*The National Home Study Council (NHSC) is designated by the U.S. Office of Education as a nationally recognized accrediting agency. Write them at 1601 18th St., N.W., Washington DC 20009, for specific information on accreditation. The Association of Career Training Schools (ACTS) is a trade association of home study schools that sets standards for member schools. All of above schools are VA approved meaning that the Veterans Administration will pay for the entire course for you if you are eligible for benefits under the G.I. Bill.

### Starting and Finishing a Course.

Once you have decided upon a course and school, the next step is to enroll. This is generally a very easy procedure since it only involves filling out a simple form and sending it in with the necessary money. With a small down payment you can get started immediately. Reasonable monthly payments can then be made over a period of two to three years, the time limit generally given in which to complete your course. Keep in mind that when you enroll in most schools you are signing a contract. This contract obligates you to make the payments monthly whether you study the course or not. It is your obligation to see that you get your money's worth.

There are many hundreds of thousands of successful correspondence course graduates, but there are probably thousands of others who have started a home study course and not completed it.

Most people are quite enthusiastic about a home study course when they first enroll. They get right to work when the course materials arrive. However, this initial enthusiasm can taper off if you don't stay with it. If you study regularly, you won't lose interest.

No doubt there are many who enrolled in a home study course at one time or another but dropped out or discontinued studies for some reason. Maybe you weren't aware of the effort involved in completing such a course. Perhaps the course is not what you expected. Just remember that your failure to complete the course is generally your fault rather than that of the school. Most schools want you to complete the course and will make every effort to help you do so. If you are having trouble understanding the material or developing the proper study habits, don't hesitate to write the school and tell them about it. They have dealt with these problems for years and are experienced in handling them.

It is always a good idea to try to complete what you start. It will give you great personal satisfaction.

In addition, it will give you the self-respect and confidence that are so important to success in electronics. You won't know what this satisfaction is really like until you experience it. In many ways this self-satisfaction and confidence in your own ability may be a more important factor than the actual education in electronics obtained from the course. ♦

# TREASURE DETECTORS for LAND USE

WHAT TO LOOK FOR IN SELECTING  
A METAL DETECTOR AND WHAT'S AVAILABLE

BY L. GEORGE LAWRENCE

**T**REASURE hunting equipment—or, more accurately, metal locators—has improved considerably in the last few years. Today's gear offers the hunter much greater success in locating buried "treasure" than was ever before possible. The current crop of detectors combines light weight (for comfort) with greater range capabilities and easier operation. Best of all, the latest devices are priced about the same as their predecessors.

Metal detector electronics have been improved to the point where they are virtually drift free. Better packaging offers more utility. For example, one detector can accommodate several different types of search heads. With miniature extension heads, it is now possible to explore deep crevices; and even detectors designed for underwater use have undergone dramatic changes.

**Depth of Detection.** The prospective buyer generally has two questions foremost in his mind. First, of course, he wants to know how deep any given device will detect a buried object. Next, he wants to know which of the various offerings is the easiest to use.

A beat-frequency detector with a large search head is well suited for finding objects buried directly underground. But the head is much too bulky for exploring in small angled crevices in caves where real

treasure might be buried. Obviously, if you plan your adventures over a wide variety of terrains, it would be a good idea to obtain a detector with several interchangeable search heads. Two different detectors with fixed heads—each designed for a different job—could also be used, in which case the redundancy gives good insurance in case one detector breaks down in the middle of nowhere. A second benefit is that two detectors allow you to work faster.

A unit's depth-detection ability is always important and can characterize the quality

**Fig. 1. One of latest depth finders is Gardiner unit with 3-ft searcher.**





of the instrument. Data of this type is always difficult to obtain from commercial sources, especially when different detectors, each equipped with different search heads, are to be compared side-by-side. Fortunately, there are rules-of-thumb to guide you.

When searching for small objects buried just beneath the surface, smaller search heads usually provide stronger indications. They will also locate large objects, but they lack the detection capability of a large head. Large search coils spread the magnetic field over larger areas. This reduces flux density; yet the field extends much deeper into the ground.

Gardiner's Model 181 detector with a 3-foot search head (Fig. 1) is a good depth-ranging unit. It has pushbutton and automatic electronic tuning, plus a 219-hour continuous-operation battery life and it is carefully counterbalanced to minimize fatigue while toting it.

The Fisher Explorer II (Fig. 2) represents one of the very latest concepts in detector design. Its electronics package is housed in a separate box which is hung around the user's neck. The Explorer II, has a telescoping search rod, interchangeable search heads, both meter and audio indicators, and a headphone jack.

Another new development in detectors is in the Yukon series of metal-mineral detectors made by Compass Electronics (Fig. 3). They feature balancing and setting circuits, including a wide-scan search loop which permits excellent control of the unit when searching for concealed metals and minerals under soil, water, cement, rock, snow, or ice. They weigh less than 4 lb and were designed in accordance with military specifications to resist shock, vibration, and humidity.

**What To Look For.** Unfortunately, there are no universal guides to aid everyone in selecting equipment that satisfies all needs and preferences. But there are some points which should be given serious consideration: The equipment should be easy to operate. Good depth range and resolution are even more important, which means that a choice of two or more search heads should be considered.

The instrument you choose should have little ground pickup. It must be as free as possible of false detections from tree roots, changes in moisture content of the ground,



Fig. 2. In Fisher Explorer II, the electronics is carried by strap suspended around the prospector's neck.

salt water, etc. The less sensitivity the instrument has to false detections, the less unnecessary digging you will have to do.

Look for convenient electronic tuning. The best units have either pushbutton-operated or fully automatic electronic tuning. And, while you are at it, check the current drain and type of batteries used. The lower the drain, the better. Batteries should be the types commonly used in electronic gear (AA, C, D, or 9-volt transistor batteries) which can be obtained almost anywhere you happen to be.

Since the detector is a field instrument, look for rugged design coupled with functional simplicity. Do not be misled by fancy carrying cases or pretty looks. What counts is performance.

If your plans include making searches at great depths (say 20 feet) with hand-carried gear, somewhat different considerations arise. Searches this deep put you into the geophysical league and require a degree of foresight and professionalism. But the rewards are correspondingly high.

One of the best all-around depth detectors is the Fisher M-Scope and its cousins. Gemini, Fisher's latest model, shown in Fig. 4, is a dual system which carries a

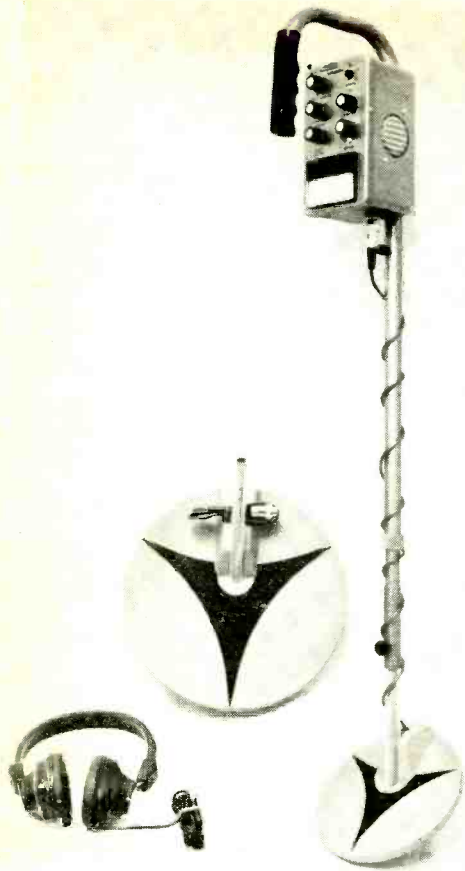

Fig. 3. Compass Electronics Yukon units.

pulsed r-f transmitter at one end of an adjustable bar and a receiver at the other end. Under average soil conditions, a metallic object, buried for about two years, can be detected as follows: 4 sq in. to 14" deep; 0.5 sq ft to 42" deep; 1 sq ft to 6' deep; 4 sq ft to 10' deep; 1 sq yd to 14' deep; and 2 sq yd to 22' deep.

You can either use the M-Scope's built-in speaker, its meter, or its headphones. Electronically, the transmitter pumps about 65 mW of power into the loop under test

conditions. The output frequency is  $82 \text{ kHz} \pm 5 \text{ kHz}$ . Power to both the transmitter and receiver is furnished by conventional 9-volt batteries.

Your fancy might also turn toward so-called "treasure canes" or the custom-made "goldfinger." The treasure cane is a "diagnostic" metal detector. It is suited for locating objects buried at shallow depths or hidden away in narrow crevices. Looking like a cane (all electronics inside), it is well liked by beachcombers who do not wish to call attention to their treasure hunting.

The goldfinger is another crevice tool. The detector looks like a simple walking stick, but it contains a small search head at one end. Signals are monitored by earphone, with the phone cord strung from the unit up the searcher's sleeve.

Aside from the assembled commercial detectors described above, you might wish to consider a kit or home-built instrument. The Heath Company has a kit available; or, for do-it-yourself projects, refer to the Winter 1968 and Spring 1970 editions of *POPULAR ELECTRONICS' ELECTRONIC EXPERIMENTER'S HANDBOOK*. (Back issues of the Handbook are available directly from Ziff-Davis Service Div., 595 Broadway, New York, NY 10012. Include \$1.65 to cover postage and handling for each issue.)

**Going Professional.** The professional treasure hunter's objectives are not restricted to traditional "treasures." He explores ore bodies, knows how to deal with decoys, and has a fair knowledge of geophysical techniques and geology. One basic method of investigating noble metals, including gold and silver, is shown in Fig. 5. Once a vein's outcrop is determined by examination, use is made of the vein's direct or semiconductance by feeding an r-f noise into it. A suitable noise generator can be made of little else than a power source, buzzer, capacitor, and coupling transformer as shown.

Fig. 4. Fischer's Gemini has a pulsed r-f transmitter and receiver at opposite ends.

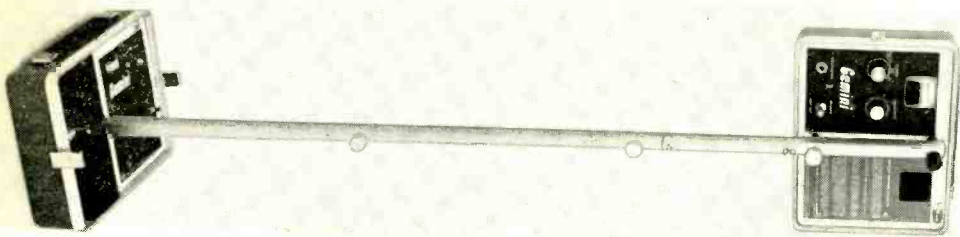

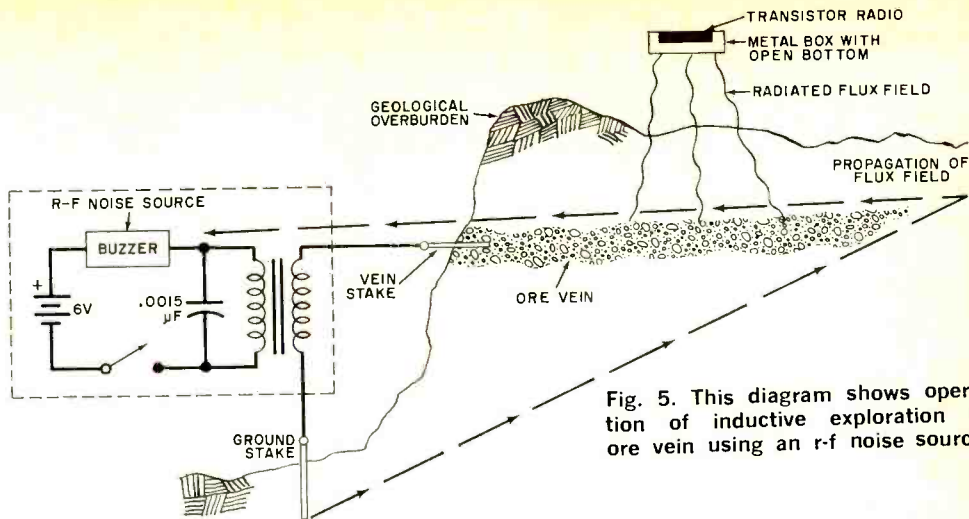

Fig. 5. This diagram shows operation of inductive exploration of ore vein using an r-f noise source.

The direction or dip of the vein can be monitored by a small transistor radio mounted in an open-bottom metal box. The strongest noise output will be obtained when the radio is in the vein's proximity. It is good practice, however, to examine samples of the materials you are looking for so that you can identify them in their natural ore forms.

Unlike amateur treasure hunters, professionals are quick to recognize decoys such as metal cans and other metallic junk that is heaped, usually in layers, atop a real buried treasure. The decoy's purpose is to

discourage novice treasure hunters, for once the detector gives off an indication and the decoys are discovered, the amateur usually abandons the "dig." The professional, however, keeps on testing and digging. Decoyed pits often have special terrain markers such as stones arranged in symmetrical patterns. Watch for them.

The electronic magnetometer is a professional detector. It senses geomagnetic distortions in the earth's ambient magnetic field and indicates the presence of large objects like sunken ships, large treasure chests, meteorites, ferromagnetic ore bodies, inclines having possible oil accumulations, etc.

Magnetometers are sensitive instruments. They come in many different shapes, price ranges, and capabilities. White Electronics makes a convenient model for hand use. It costs about \$650. Used magnetometers are also excellent buys. One fine surplus unit is the EPL Mark I, a rotating search coil unit whose spinning coil cuts through the earth's flux field to generate a minute electrical current by dynamo action. This small current is carefully processed and furnished with a reference voltage supplied by a tachometer generator coupled to the coil's drive motor. Data is expressed in magnetic gammas. If a treasure-type body exists at the magnetometer's field station, the instrument will respond to the earth's distorted magnetic flux field and produce a given indication with reference to a base station value. However it is advisable to consult textbooks on professional geophysics to fully understand and use the enormous capabilities of the magnetometer. ♦

### TREASURE DETECTORS\*

Manufacturer	Model	Coil	Price
D-Tex Electronics P.O. Box 451 Garland, TX 75040	Professional	6"	\$229.50
	Professional	12"	229.50
Fisher Research Labs. Palo Alto, CA 94303	Metalert 70	11"	158.50
Gardiner Electronics Co., Inc. 4729 N. Seventh Ave. Phoenix, AZ 85013	190	11"	210.00
	200	11"	115.00
Garrett Electronics 2814 National Dr. Garland, TX 75040	Hunter	5"	229.50
	Hunter	8"	229.50
	Hunter	12"	229.50
Jetco Electronic Ind. P.O. Box 26669 El Paso, TX 79926	Treasure Hawk 990	6"	189.50
	Treasure Hawk 990	12"	189.50
Relco Ind. P.O. Box 10839 Houston, TX 77018	Frontiersman	6"	129.50
	Frontiersman	12"	129.50
White's Electronics, Inc. Pleasant Valley Rd. Sweet Home, OR 97386	66T	7½"	269.50
	66T	11"	269.50

\*A sampling of the many excellent detectors available.



# NTS Home-Training in Electronics was the start of something big for James Gupton

## An NTS Graduate

James A. Gupton Jr. graduated from National Technical Schools with a diploma in TV & Radio Servicing. Today, he's a mighty important man in the world of Electronics!

Research associate with a major electronics corporation; author of numerous articles in electronics magazines; an inventor with five patent applications to his credit. In the field of electro-optics, he has perfected a revolutionary phosphor deposition technique for cathode ray tubes.

Quite a list of accomplish-

ments for a man who began his career with an NTS diploma and a job in TV & Radio servicing.

## Any student can succeed

James Gupton is certainly an exceptional NTS graduate. He proves there's nothing to keep a determined man from becoming a success in Electronics. As he himself says, "Any student, properly motivated, can succeed in Electronics through home-training."

Every NTS Electronics Course is specially designed to keep you motivated from the time you

start building your first test instrument until you're ready to plug-in your solid-state Color TV or other advanced electronics equipment.

## Exciting "Project Method" Training

NTS Project Method Training is the best way to learn electronics.

You build advanced equipment while you learn Electronics principles and applications.

Each week brings new excitement when you actually see the progress you've made.

# NTS builds self-confidence.

For a man to become successful, like James Gupton, he must have confidence in himself.

As an NTS graduate you have this confidence. Your training is practical and thorough. You know Electronics from the bottom up. You enter a world of Electronics you're familiar with.

And if you have the drive and determination of a man like James Gupton, there are no limits on your success!

(James Gupton's address available upon request).

## NTS COLOR TV SERVICING



Solid-state  
315 sq. in.  
Heath Color TV

Build and keep the largest, most advanced color TV made! Over-all solid-state design, ultra-rectangular screen, matrix picture tube, built-in self-servicing features, "Instant On," A.F.T., solid-state, 24-channel detent UHF/VHF power tuning, and much more! Also build and keep AM-SW Radio, solid-state Radio, FET Volt-Ohmmeter, and Electronic Tube Tester. Learn trouble-shooting, hi-fi, stereo, multiplex systems, radio, color and B&W TV servicing.

## NTS B&W TV SERVICING

Learn sophisticated solid-state circuitry as you build this B&W TV Receiver, Lo-Silho "Superhet" Radio, FET Volt-Ohmmeter, solid-state Radio, Electronic Tube

Solid-state  
B&W TV,  
74 sq. in.  
picture  
(cabinet  
included)



Big, Colorful NTS Guide to new opportunities in Electronics. Yours FREE!

**NATIONAL TECHNICAL SCHOOLS**  
4000 S. Figueroa Street  
Los Angeles, California 90037

Please rush me FREE Color NTS Electronics Guide & FREE lesson, plus information on course checked at right. No obligation. No salesman will call.

Checker, and Signal Generator. TV and all other equipment are yours to keep.

## NTS ELECTRONIC & COMPUTER TECHNOLOGY

Solid-state  
Compu-Trainer  
14 integrated  
circuits  
replace 198  
Transistors!

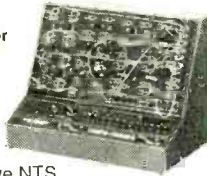

Build and keep this exclusive NTS Compu-Trainer. It teaches you the same principles used in million-dollar systems. Contains 14 integrated circuits! All solid-state! You perform all wiring and patching. No shortcuts. No pre-wired circuit boards. Your training is complete! Also receive a FET Volt-Ohmmeter and a 5" wide-band solid-state Oscilloscope.

## NTS ELECTRONIC COMMUNICATIONS

Gain the prestige and earning power of owning and F.C.C. First Class Radio-Telephone license. Two comprehensive NTS Courses cover the big opportunity field of transmitting and receiving.



5-watt AM  
Transmitter/  
Receiver

You build and keep 14 kits, including this amateur phone 6-meter VHF Transceiver, NTS's exclusive 6-transistor solid-state Radio, and a fully transistorized Volt-Ohmmeter. Also, learn 2-way radio, Citizens Band Microwaves, and radar.

## NTS INDUSTRIAL & AUTOMATION ELECTRONICS

Automation is the future of industry, and you can play an important part! Learn industrial controls by training on the NTS Electro-Lab (a complete workshop). You also build and operate this 5" solid-state

oscilloscope. And you perform experiments that involve regulating motor speeds, temperature, pressure, liquid level, and much more. All equipment is yours to keep.



All solid-state!

## NTS AUDIO ELECTRONICS SERVICING

Learn sound theory — how it works in home radio, car tape decks, stereo multiplex component systems, and more! Set up a spectacular music system. Learn about sound distortion, amplification and control, loud-speaker baffles, problems of system installation, etc.

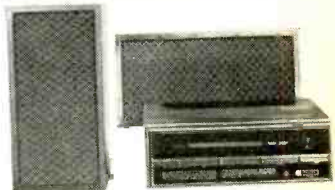

Build and keep this famous Heath Stereo Receiver and Speakers

Included is Volt-Ohmmeter, In-Circuit Transistor Tester and solid-state Radio. Prepare yourself for great opportunities in the Home Entertainment Industry!

## CLASSROOM TRAINING AT LOS ANGELES

You can take classroom training at Los Angeles in sunny Southern California. NTS occupies a city block with over a million dollars in technical facilities. Check box in coupon below.

## APPROVED FOR VETERANS

Accredited Member: National Association of Trade and Technical Schools; National Home Study Council.

## NATIONAL TECHNICAL SCHOOLS

Resident & Home Study Schools  
World-Wide Training Since 1905  
4000 S. Figueroa St., Los Angeles, Ca. 90037

Dept. 205-092

NAME \_\_\_\_\_ AGE \_\_\_\_\_  
ADDRESS \_\_\_\_\_  
CITY \_\_\_\_\_  
STATE \_\_\_\_\_ ZIP \_\_\_\_\_

- Check if interested in Veterans Training under new G.I. Bill.  
 Check if interested ONLY in Classroom Training at Los Angeles

- MASTER COURSE IN COLOR TV SERVICING  
 COLOR TV SERVICING (FOR ADVANCED TECHNICIANS)  
 MASTER COURSE IN B&W TV & RADIO SERVICING  
 MASTER COURSE IN ELECTRONIC COMMUNICATIONS  
 PRACTICAL RADIO SERVICING  
 FCC LICENSE COURSE  
 MASTER COURSE IN ELECTRONICS TECHNOLOGY  
 AUTOMATION & INDUSTRIAL ELECTRONICS  
 COMPUTER ELECTRONICS  
 BASIC ELECTRONICS  
 AUDIO ELECTRONICS SERVICING

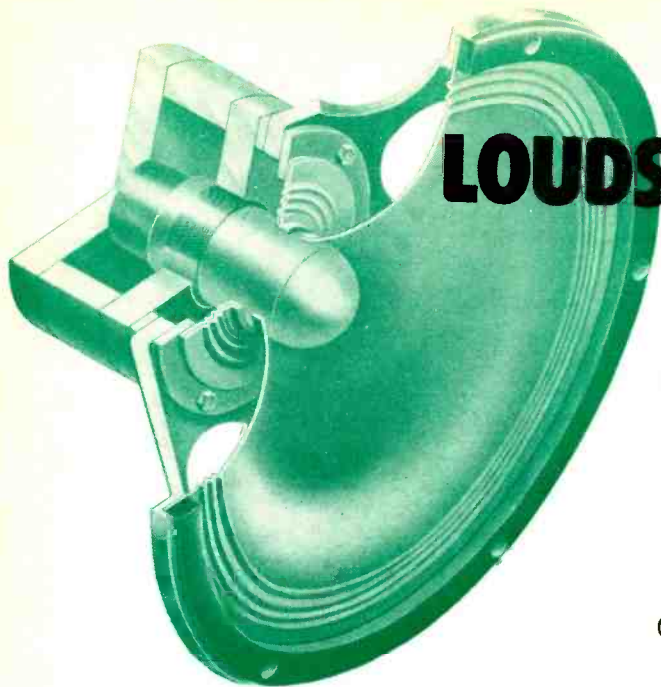

# HI-FI LOUDSPEAKERS: FACTS & FALLACIES

PART II

UNRAVELLING MORE OF  
THE MYSTERIES  
OF SPEAKER OPERATION

BY VICTOR BROCIER

**L**AST MONTH, in Part I of this article, we discussed a number of facts and fallacies having to do with hi-fi loudspeakers and speaker systems. Here are some more:

26. *The number of speakers used in a system is a sign of the system's quality.*

**Fallacy:** Many poor-quality speakers are not better than one excellent quality speaker. Multiple-speaker systems have advantages only if the speakers are of high quality and are designed to work together. The better hi-fi systems use two or more complementary speakers.

27. *A "high-compliance" speaker produces better bass sound than does a low-compliance speaker.*

**Fallacy:** Most hi-fi systems employ high-compliance woofers because a loudspeaker must be highly compliant to properly reproduce bass sounds. However, the speaker must also have a heavy cone and voice coil to reproduce deep bass sounds. (The heavy moving system is the reason for the low efficiency of systems capable of really good bass response.)

28. *A low resonance frequency is necessary for a speaker to have extended bass response.*

**Fact:** Below resonance, the response of

the direct-radiator drops off rapidly, but this is not necessarily true of the horn-type speaker. Since almost all bass range speakers are direct radiators, the generalization is reasonably accurate.

29. *Good bass response cannot be obtained by designing a speaker so that its low-frequency characteristic drops off progressively and compensating for this by shaping the amplifier's response curve to make up for this deficiency.*

**Fallacy:** There is no objection to the use of frequency equalization to obtain the desired overall response.

30. *If a loudspeaker is operated in free air, the rear wave cancels out most of the front wave in the bass range and the resulting sound lacks "body."*

**Fact:** When a speaker cone moves forward, creating a compression wave in the air, its rear face creates a reduced pressure wave which is free to flow around the speaker to cancel the front wave in the bass range. This does not happen at higher frequencies where the speaker is directional.

31. *Enclosing the back of a loudspeaker in an air-tight box of sufficient size contains the rear wave, preventing cancellation and improving bass response.*

**Fact:** The key phrase is "of sufficient

size." If the box is too small, the air within acts like a spring which reduces cone travel and compliance, raises the resonant frequency, and reduces bass response.

32. *A box enclosing the back of a speaker can be made to act larger than its true size.*

**Fact:** If the box is filled with loosely packed material like fiberglass wool, its reaction on the speaker is reduced, making it act like a larger box.

33. *A system in which the back of the speaker is enclosed by an air-tight box is called an acoustic or air suspension system.*

**Fallacy:** With a speaker mounted in a closed box, the suspension of the cone and the air in the box determine system compliance. The term "acoustic suspension" applies only when the air compliance is appreciably less than the speaker's compliance.

34. *The back wave from a speaker can be used to assist the front wave instead of cancelling it.*

**Fact:** When suitably proportioned, the combination of the air's compliance in the bass reflex or ported enclosure and the mass of the air in and around the extra opening comprises an additional resonant element which creates a reinforcement wave over a limited frequency range.

35. *Bass reflex enclosures sound "boomy."*

**Fallacy:** A correctly designed bass reflex box produces smooth, extended bass without peaks. The box and speaker must be matched, however. Poor design can well result in peaked bass response which sounds "boomy."

36. *If distortion occurs in a speaker operated in the bass range, the only result is the creation of harmonics.*

**Fallacy:** Harmonics are multiples of the fundamental signal frequency. When distortion occurs, there are also intermodulation products when two signal frequencies are present at one time. These products generally bear no musical relationship to the fundamental and are far more objectionable to the ear than are the harmonics.

37. *Speakers which operate through reflection of a large portion of their sound output from the wall in back of them are made more nearly omnidirectional by the reflected sound.*

**Fact:** The ear receives sound from a speaker through two paths (see Fig. 3)—the sound arriving directly from the speaker and the sounds which arrive after one or more reflections. The ear judges the directional characteristics of the source by evaluating the ratio between the direct and reflected sounds.

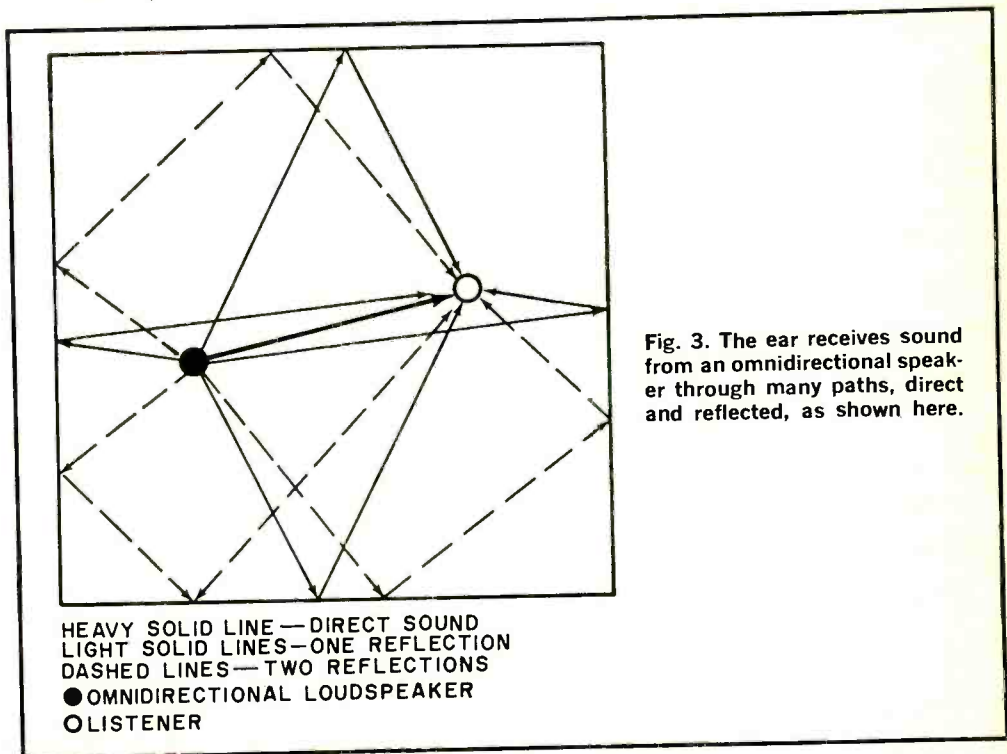
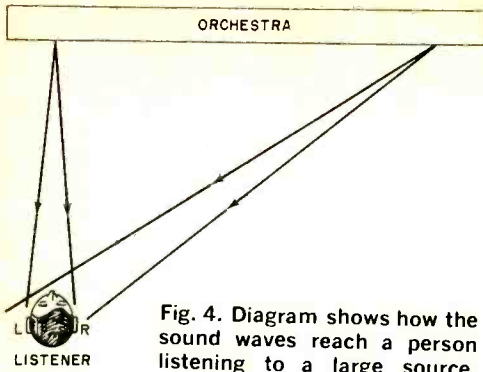

Fig. 3. The ear receives sound from an omnidirectional speaker through many paths, direct and reflected, as shown here.



**Fig. 4.** Diagram shows how the sound waves reach a person listening to a large source.

38. *Direct/reflecting speaker systems make the source (speaker) sound larger than its physical size.*

**Fact:** If you are listening to an orchestra as in Fig. 4, an instrument at the left produces equal-intensity sounds which arrive at both ears simultaneously. Now, if an instrument at the extreme right is played, the sound behaves differently, arriving slightly earlier and slightly louder at the right ear than at the left. The hearing mechanism interprets this in terms of direction.

To make the sound source appear to be larger than it really is, it is necessary to have different kinds of sound coming from different parts of the apparent source. A direct/reflecting speaker system which accomplishes this is shown in Fig. 5. The sound from speaker A is reflected from the wall, behaving as though it originated from phantom speaker A' located behind the wall. The reflected sound is somewhat attenuated and changed in frequency response because the wall does not absorb all frequencies equally. The direct sound from speaker A also reaches the listener, as shown by the curved lines. The noncircular shapes of the curves indicate that the midrange is less intense off the axis of speaker A—the high frequencies are attenuated even more. (Reflecting speaker B behaves in a manner similar to that of speaker A except that its sound is slightly different in character.) Direct speaker C operates like any other conventional speaker.

The paths traversed by the sounds reaching the listener are of different lengths, causing differences in arrival times among them and between the left and right ears. The combination of differences in intensity, frequency response, and time combine to give the listener a sense of a broad source of sound.

39. *Reflecting speaker systems have an*

*effective frequency response that is highly dependent on the reflecting qualities of the walls behind them.*

**Fallacy:** This type of speaker system is usually equipped with equalization controls which permit the user to compensate for the high-frequency absorption of the wall behind the speaker. Most wall coverings increasingly absorb treble as the frequency increases so that a smoothly rising equalization curve is easily adjusted to produce an effectively uniform frequency response.

40. *A defective loudspeaker can produce a humming noise.*

**Fallacy:** A loudspeaker is incapable of originating sound. It can only reproduce electrical signals fed to it. If hum exists, look to the equipment preceding the speaker system for the trouble.

41. *Decorative grilles on the front of a speaker enclosure can exert a detrimental effect on frequency response and directional characteristics.*

**Fact:** Grilles with a very large percentage of openings have very little effect. Any solid materials wider than about  $\frac{1}{8}$ "-wide can block off some high frequencies if located in front of a midrange speaker or tweeter. They can also create "dead" or "hot" spots at various listening angles.

42. *All obstructions in front of a loudspeaker are undesirable.*

**Fallacy:** Acoustic lenses consist of obstructions such as spaced and shaped bars or a series of holes in a plate which are

**Fig. 5.** This diagram shows how the direct-reflecting loudspeaker works.

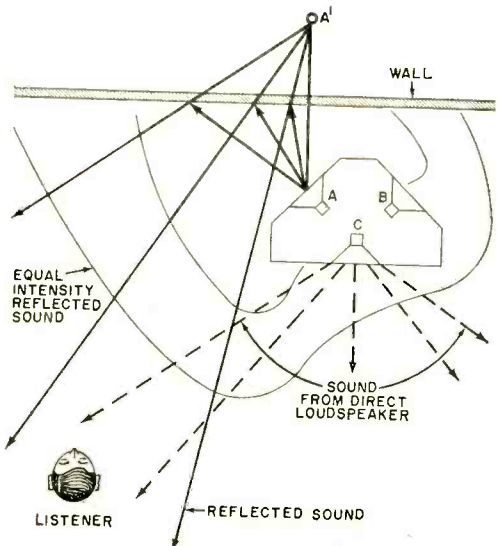



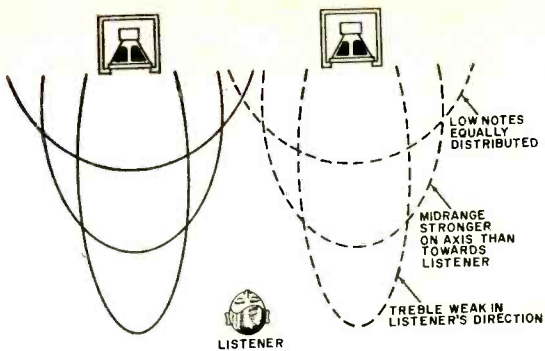

Fig. 6. Effects of directional speakers.

designed to improve the directional characteristics of a loudspeaker.

43. A good speaker system is usually rather heavy.

**Fact:** High-quality speaker systems generally require heavy materials like iron, copper, and lumber. However, weight alone does not guarantee quality.

44. Electrostatic speaker systems exhibit less distortion than do dynamic speaker systems.

**Fallacy:** There is no virtue inherent in any given type of speaker system.

45. Speaker systems are sometimes designed to create the impression of good bass response when in fact they reproduce little deep bass.

**Fact:** A region of elevated response around an octave below middle-C results in a deep-throated "boomy" sound which simulates bass response. This trick is perhaps justifiable when really good bass response is difficult to attain, as in automobile speakers, but it does not belong in hi-fi reproducing systems. The artificial effect is easily detected, especially when a male voice is reproduced.

46. Speaker systems for stereo should be directional.

**Fallacy:** In the average listening room, it is best for speaker systems to be as non-directional as possible. The ideal listener location is midway between the speakers and some distance forward, placing the listener considerably off-axis as shown in Fig. 6. The speakers must distribute sound uniformly throughout the frequency spectrum. Any loss of highs (which play the principal role in establishing the location of a source in stereo) will reduce the stereo effect.

47. Four-channel sound reproduction requires full power and frequency range in the rear speaker systems.

**Fact:** While it is true that the hall reverberation reproduced by the rear channels usually has less high-frequency content and is lower in intensity than the direct sound, modern music is taking advantage of "surround sound" which can have as many as four groups—one on each channel—playing. These applications require full power and full range on all four channels.

48. Speaker measurements are all very good, but final judgments must be made by means of listening tests.

**Fact:** It is probably true that a speaker system with a perfect frequency response, ideal distribution pattern throughout its range, and low distortion would sound great. Unfortunately, real speakers fall far short of this ideal. When compromises must be made, it is extremely difficult to evaluate the results of measurements. Speaker frequency response curves have numerous peaks and valleys. The height, broadness, and locations of these have various effects on the sound quality and it is not possible to predetermine exactly how one speaker system will sound compared to another simply by observing the deviations from a flat response.

49. Measurements cannot be used as a guide to the performance of a speaker system.

**Fallacy:** In a negative sense, performance curves permit the evaluation of the quality of a speaker system, mainly because they are useful in revealing defects. Good results imply the probability of good aural performance, but they are not definitive except with speaker systems of very high quality.

50. Response curves are not published because they usually indicate poor performance

**Fallacy:** Test results require a lot of skill and experience for proper interpretation. The average buyer lacks such expertise. So, it is because of potential false conclusions on the part of the buyer that the manufacturer opts not to publish response curves.

**In Conclusion.** We do not pretend that our presentation is as comprehensive as it could be if given unlimited space. Nor is it conceivable that all questions about loudspeakers and speaker systems have been answered for all time. Our sole purpose has been to decrease the number of fallacies popularly associated with an, at best, controversial subject. ♦

# Build a GENERAL-PURPOSE ALARM

SIREN-LIKE WAIL CAN BE TRIGGERED BY A NUMBER OF SOURCES

BY TRUETT BROWN

**T**HERE ARE many different types of intrusion alarms. They all have one purpose—to detect the presence of an intruder and sound the alarm.

However, there are many applications for alarms that do not involve an intruder. These include signalling the presence of unwanted moisture or liquids, the presence or absence of light, the removal of a small object, and the unwanted opening of a door by a child or animal. What is needed then, is a general-purpose alarm that can be triggered by a variety of stimuli.

The circuit for a basic alarm is shown in Fig. 1. Transistors Q1 and Q2 form an audio oscillator with the speaker representing the collector load for Q2. The frequency of oscillation is determined by C4 and the voltage across C3. The charge on C3 comes from the positive line through R3, R4, and

R5. When the dc voltage across C2 reaches a level determined by the spring adjustment of K1, the relay pulls in allowing the contacts to open so that both C2 and C3 discharge. As C3 discharges, it causes the audio tone to go down in frequency. As the voltage across C2 drops, the point is reached where the relay contacts close to repeat the cycle. As C2 and C3 charge and discharge, the oscillator frequency simulates the rising and falling wail of a siren.

The circuit is triggered into operation only when SCR1 is in a conducting mode. This, of course, means that some positive going voltage must be applied to the gate input connector of TBI (positive with reference to the neg input). Figure 2 shows some examples of how such toggling can be obtained.

In Fig. 2A (a break-wire trigger), when

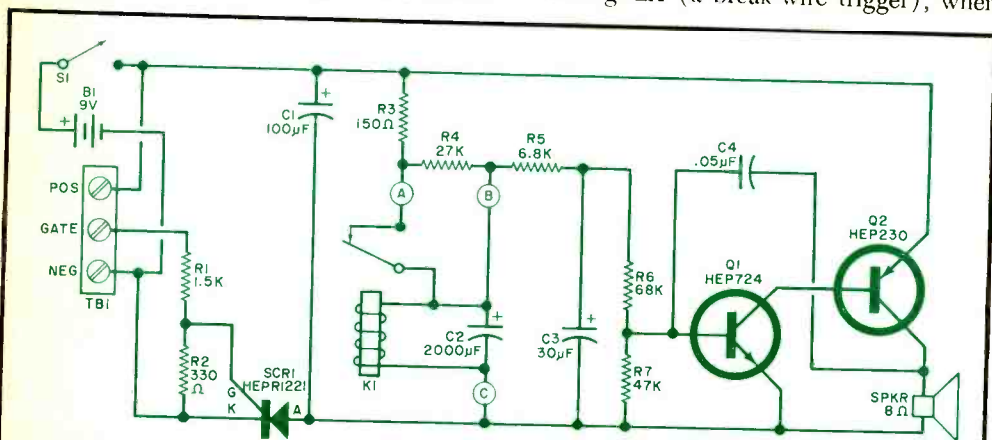

Fig. 1. The siren-like wail is produced by the changing voltage on capacitor C3, which is controlled by the operation of K1. Operation of SCR1 turns on the system.

## PARTS LIST

B1—9-volt battery  
 C1—100- $\mu$ F, 10-volt electrolytic capacitor  
 C2—2000- $\mu$ F, 15-volt electrolytic capacitor  
 C3—30- $\mu$ F, 6-volt electrolytic capacitor  
 C4—0.05- $\mu$ F ceramic disc capacitor  
 K1—1000-ohm, 50-mW sensitive relay  
 (Sigma 11F-1000-G/SIL or similar)  
 Q1—2N2712, HEP724 transistor  
 Q2—HEP230 transistor  
 R1—1500-ohm,  $\frac{1}{2}$ -watt resistor  
 R2—330-ohm,  $\frac{1}{2}$ -watt resistor

R3—150-ohm,  $\frac{1}{2}$ -watt resistor  
 R4—27,000-ohm,  $\frac{1}{2}$ -watt resistor  
 R5—6800-ohm,  $\frac{1}{2}$ -watt resistor  
 R6—68,000-ohm,  $\frac{1}{2}$ -watt resistor  
 R7—47,000-ohm,  $\frac{1}{2}$ -watt resistor  
 S1—Spst switch  
 SCR1—HEP R1221 silicon controlled  
 rectifier  
 SPKR—8-ohm speaker (see text)  
 TBI—Three-lug terminal strip  
 Misc.—Battery clip, mounting hardware,  
 suitable chassis, etc.

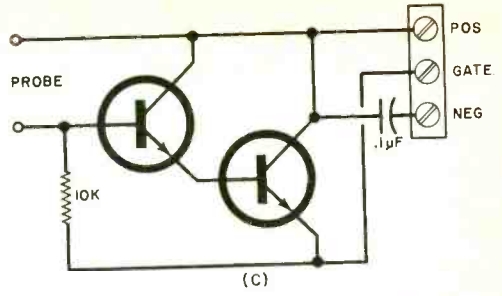
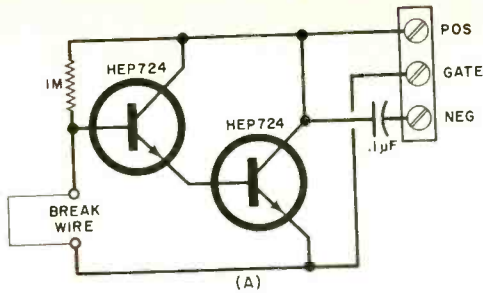
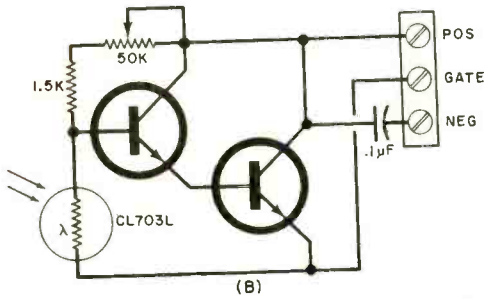

Fig. 2. Three typical trigger circuits. (A) is for break-wire; (B) is light controlled; (C) is water level sensor.



the wire is opened, a positive-going pulse is applied to the gate of SCR1. This circuit can be used for closet doors, toy chests, etc. If desired, a magnet-operated, normally open reed switch can be used. Since it is battery-operated, this system can be mounted over a hotel or motel door to signal the opening of the door.

The photo-trigger sensor shown in Fig. 2B can be used to signal the presence of unwanted light in an unattended photography darkroom or the illicit turning on of a light in any room. The potentiometer is used as the sensitivity control. The water-level sensor shown in Fig. 2C can be used in basements, boat bilges, etc. to sound the siren-like wail when water gets above a predetermined level.

You can also connect a simple normally open switch between the positive and gate

terminals of TBI to turn on the alarm when the switch is closed. There are any number of mechanical arrangements for this application. In an automobile, the alarm can be powered from the vehicle battery and used to signal the presence of voltage on any desired line—turn signals, parking lights, backup lights, etc. If wired to the dome light with the siren output capacitor coupled to an audio amplifier, the circuit serves as a burglar alarm.

**Construction.** Although any type of construction can be used, the foil pattern and layout shown in Fig. 3 provide a good, trouble-free arrangement. Note that K1 and C2 are mounted off the board.

In the prototype, an 8-ohm speaker was connected to the board, but you can increase the volume somewhat if you use a conventional transistor output transformer, with the secondary matched to the speaker impedance. For coupling to an audio amplifier, interconnect the common negatives and use capacitor coupling from the collector of Q2. Adjust the pull-in spring of the relay so that it cuts in and out at the upper and lower voltages (charge on C2) desired. ♦

Fig. 3. Foil pattern and component layout. K1 and C2 are not on board.

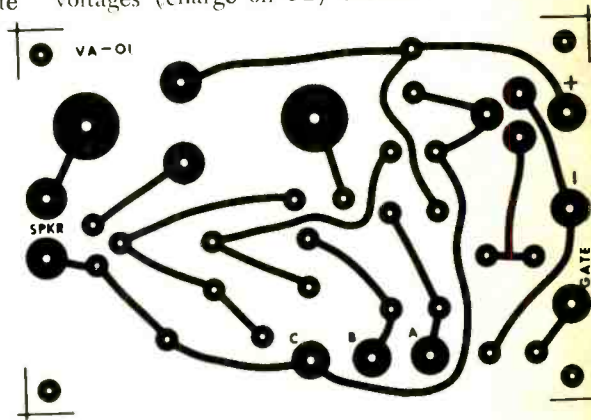
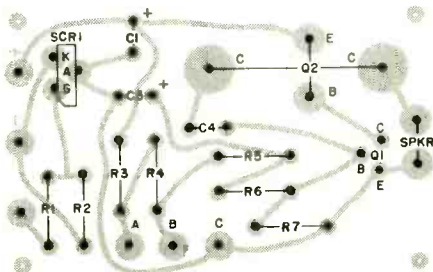

# SIMPLE SOLID- STATE CIRCUITS for the Experimenter

BASIC APPROACH ENABLES  
ANYONE TO "ROLL HIS  
OWN" AMPLIFIER

BY JIM HUFFMAN

**YOU DON'T** have to be a mathematical genius to design a simple solid-state amplifier. All you have to do is follow some basic rules, cut-and-try a little, test the circuit, and there it is! The mathematics involved in complete, top-level circuit design require the knowledge of a graduate engineer; but, unless the circuit is critical, there are some shortcuts that can be used by the serious electronics experimenter. These shortcuts yield "ballpark" figures that work well with components having 5% or 10% tolerances.

To explain what we mean by shortcuts and simplicity, we will use as an example the design of a microphone preamplifier. In this design, math is at the high school level, and Ohm's Law is the most complicated formula involved. All the designer has to

do is "plug in" the numbers necessary for his particular application.

**Preamplifier Design.** Suppose you want a microphone preamplifier that will match a low-impedance dynamic mike to a modulator or power amplifier with an input impedance of one megohm. (In other words, you want to make the dynamic mike "look" like a crystal mike.) Note, however, that the same procedure described here could be used for matching an input device of any impedance to any circuit impedance simply by changing the necessary figures and using the appropriate transistor.

The design is accomplished in eight easy steps:

- 1. Write down all the pertinent facts about the circuit (see Fig. 1). It was de-

#### CIRCUIT FACTS:

1. MUST USE A 9-VOLT POWER SUPPLY
2. INPUT IMPEDANCE IS 3000 OHMS (DYNAMIC MIKE)
3. OUTPUT IMPEDANCE MUST BE 1 MEGOHM
4. FREQUENCY IS RANGE FROM 100 TO 3000 HZ

Fig. 1. Write down basic circuit facts.

termined (by tests) that the output of a crystal mike hits a maximum of 0.5 volt (roughly that of a crystal phonograph pickup). The dynamic mike was connected to a VTVM, and a no-load output voltage of 0.1 volt was measured when speaking loudly, so a normal level of 0.05 volt was used. Thus, the voltage gain required of the amplifier is about 10 (0.5/0.05). Since these are very rough approximations, a final voltage gain of at least 20 was decided upon.

#### SEMICONDUCTOR FACTS:

2N697

SILICON

NPN

$\beta = 40-120$  AT 150 mA

$V_{CE} = 40$  VOLTS

$f_T = 40$  MHz

OPER. FREQ =  $\frac{40}{\beta(\text{HIGH})} = \frac{40}{120} =$

0.33 MHz (COMMON EMITTER)

Fig. 2. Consider transistor characteristics.

- 2. Write down all available facts about the transistor. Since we have a 2N697 in our junk box, we decide to try it (see Fig. 2). The 2N697 is silicon, so it is stable with temperature. It is an npn and has a beta between 40 and 120 when the current is 150 mA. Usually, we use the lowest beta

$Z_{IN} \geq 3000 \Omega$   
 $Z_{OUT} \leq 1 \text{ MEGOHM}$   
 VOLTAGE GAIN  $\geq 10$

- CAN'T USE  $\rightarrow$  1. COMMON COLLECTOR (EMITTER FOLLOWER) - NO GAIN  
 CAN'T USE  $\rightarrow$  2. COMMON BASE - LOW INPUT  $Z$   
 3. COMMON EMITTER  
 4. COMMON COLLECTOR - HI  $Z$

Fig. 3. These are circuit parameters.

figure, but since the 150 mA specified for the 2N697 is considerably more than we need, we use a beta of 50. Since we are using a nine-volt supply and the breakdown voltage,  $V_{CE}$ , is 40, the device should be safe.

The gain-bandwidth product,  $f_t$ , for the 2N697 is 40 MHz. Dividing this value by the highest beta (120) gives a maximum frequency of 330 kHz, when the device is used in the common-emitter configuration. This is well above the 3-kHz maximum frequency required.

- 3. Decide on a configuration, using the facts in Fig. 1. The parameters selected are shown in Fig. 3. The input impedance may be hard to achieve with a common-base amplifier; and since the voltage gain is more

Fig. 4. Two circuit configurations.

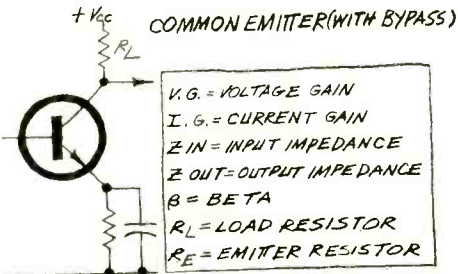

$V.G. \cong (R_L / Z_{IN}) \beta$   
 $I.G. \cong 0.9 \beta$   
 $Z_{IN} \cong \beta (26 / I_E \text{ (MAX)})$   
 $Z_{OUT} \cong R_L$  (A)

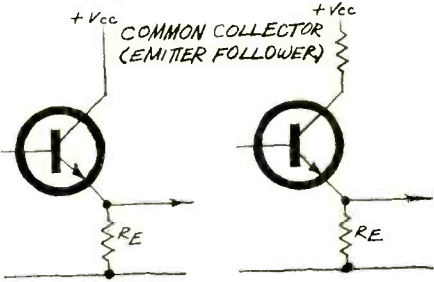

$V.G. \cong 1$   
 $I.G. \cong 0.9 \beta$   
 $Z_{IN} \cong \beta R_E$   
 $Z_{OUT} \cong Z_{IN} / \beta$  (B)

than unity, the common-collector approach can't be used. The common emitter (Fig. 4A) looks good except that the input impedance is higher than that normally associated with a common-emitter circuit. So we have to add another stage (emitter follower) to raise the input impedance (Fig. 4B).

- 4. Now we can draw a preliminary design, such as that shown in Fig. 5. The battery supply is included, capacitors are marked for polarity, and components are numbered for reference.

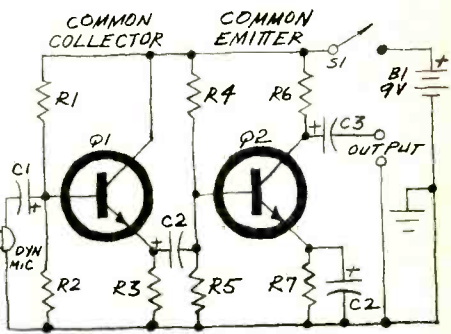

Fig. 5. Draw basic circuit diagram.

Note that single-battery bias is used. This bias method provides better results as far as temperature stability and other factors are concerned. Also, contrary to some beliefs, this is the easiest system to design.

- 5. Calculate the data as shown in Fig. 6, using the data supplied in Fig. 4A for the common emitter stage and Fig. 4B for the emitter follower.

The most critical parameter for the emitter follower is the output impedance. The latter is approximately equal to the input impedance divided by beta, or 3000/50. So the output impedance (or the emitter resistance) should be 60 ohms or more. This is easy to achieve since the input impedance of the next stage is probably greater than 60 ohms. The actual emitter resistor is  $R_3$ , and to avoid as little loss as possible, we choose it to be ten times the 60 ohms decided on for the emitter resistance. Thus,  $R_3 = 600$  ohms or more. The "or more" tells us which way to go if we have to use other than a 600-ohm resistor.

For stability,  $R_2$  should be about 10 times  $R_3$  or 6000 ohms.

The value of  $R_1$  depends on the value of bias current chosen. Since the stage is a voltage amplifier, and since a 9-volt supply is used, there should be about 4 volts across  $R_3$  (including a 1-volt drop across the

transistor). Thus, the voltage at the base of the emitter follower should be four volts when there is no input signal. To achieve this drop across  $R_2$ ,  $R_1$  has to be 7500 ohms.

For the common emitter stage,  $R_7$  is a non-critical value in most cases and can be "picked out of the air." If the wrong value is chosen, we will find out later in the design. A good value to choose for  $R_7$  is 1000 ohms.

In this stage, as before,  $R_5$  is 10 times  $R_7$  or 10,000 ohms.

The value for  $R_6$ , which must be chosen before  $R_4$  can be determined, will be approximately equal to the output impedance of the amplifier. The modulator or power amplifier input is a voltage amplifier because of the high impedance. Since the output of the preamp is required to be a voltage generator, the output impedance can be much less than the input impedance of the modulator or power amplifier. The stage need not transfer maximum power, only maximum volts, so the impedances need not match. Essentially, the entire output voltage from the common emitter stage will be felt at the input of the amplifier if the output impedance is less than about 1/10 of the input impedance of the amplifier. In fact, 1/100 would be a better figure, so  $R_6$  is chosen to be 10,000 ohms. Normally, at

Fig. 6. Determine the resistor values.

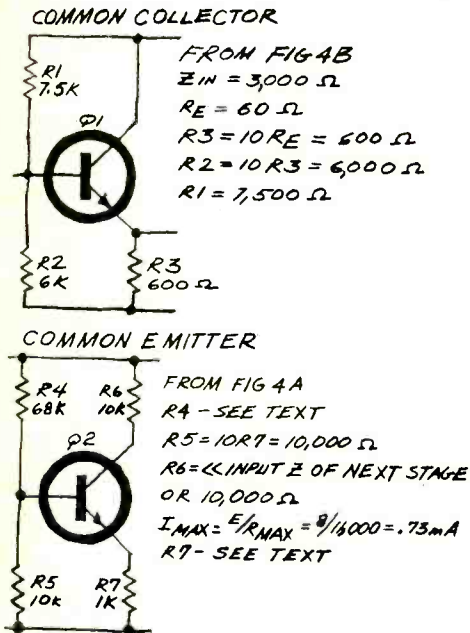

this time,  $R_6$  would be considered in regard to the desired voltage gain. A quick check shows that the 10,000-ohm value provides a gain of over 20.

To make sure that the output of the amplifier is class A (and since  $Q_2$  is a current amplifier,) the bias through  $R_6$  is chosen to be half of its maximum value. The maximum current through  $R_6$  will be

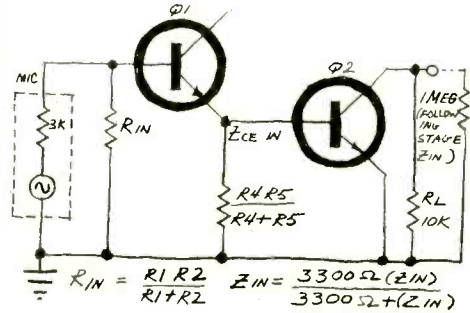

Fig. 7. Convert to equivalent ac design.

about 0.73 mA (1-volt drop in the transistor) or about 0.36 mA at the class A bias point.

Resistor  $R_4$  is selected to provide the 0.36-mA bias current. There should be about 0.36 volt across  $R_1$  with bias current flowing. Since this is a small voltage, we must take into account the 0.8-volt drop at the base-emitter junction of the transistor. Thus the voltage at the base of the transistor must be  $0.8 + 0.36$  or 1.16. Resistor  $R_4$  is chosen to provide 1.16 volts across  $R_5$ . This turns out to be about 68,000 ohms.

• 6. To calculate the ac values, redraw the circuit showing all bypassed resistors as shorts to ac and the input impedance of the following stage as resistors (Fig. 7). Note that  $R_1$  and  $R_2$  in parallel form  $R_{in}$ , which is in parallel with  $Z_{in}$  of the emitter follower to form the amplifier input impedance. Since the input impedance of the emitter follower is dependent on the input impedance of the common emitter, we must determine the latter from Fig. 4A. Since  $I_b = 0.36$  mA and beta is 50, the input impedance is 3600 ohms. The latter is in parallel with  $R_4$  and  $R_5$ , the bias resistors. The parallel value of  $R_4$  and  $R_5$  is approximately 8800 ohms, which, in parallel with 3600, comes to about 2560 ohms.

The 2560 ohms is paralleled by the emitter follower's own  $R_3$  so the emitter sees about 500 ohms. The emitter follower input impedance becomes 500 times the beta or 25,000 ohms.

The input impedance of the entire amplifier is  $R_{IN}$  (3600) in parallel with 25,000 or 3000 ohms, which is what is desired. If the values were found to yield an overall input impedance which was not 3000 ohms, the components would have to be adjusted appropriately.

The voltage gain of the amplifier depends on the gain of the common emitter stage, which, from Fig. 4A, is about 140. Thus the amplifier meets the gain requirement of at least 20.

Capacitor values are chosen so that the response at 100 Hz is -3 dB. So, we lump the impedances associated with a particular capacitor and solve for an equivalent  $X_C$ . Since the input impedance is 3000 ohms,  $X_{C1} = 3k$  and  $C1$  is  $0.5 \mu F$  ( $X_C = 1/2\pi fC$ ). Keep in mind that, if you cannot hit this value, a larger capacitance will only lower the response and probably won't be undesirable.

Bypass capacitor  $C4$  is associated with a 1000-ohm resistor and its value will be close to  $2 \mu F$ . Capacitor  $C3$  and the 10,000-ohm output impedance combine for a value of  $0.2 \mu F$ ; and the reactance of  $C2$  must be 500 ohms so its value is about  $3 \mu F$ .

Insert all of the above figures into the circuit as shown in Fig. 8.

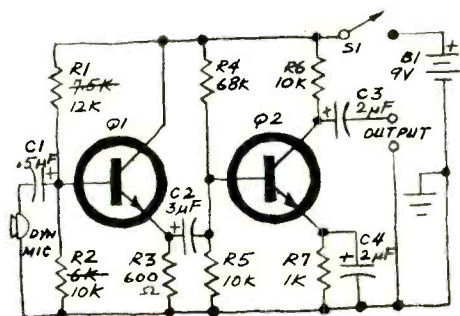

Fig. 8. This is the final circuit layout.

• 7. Breadboard the circuit. When substituting resistor values, keep the same ratio between the values and increase or decrease until you come close to something you have. For instance, assume you do not have a 7500- or 6000-ohm resistor for  $R1$  or  $R2$ . You know the values can go up, so find the ratio of  $R1/R2$ —which is 1.25. An increase in both values will merely raise the input impedance, which is not objectionable. Thus, as shown in Fig. 8,  $R1$  and  $R2$  were changed to 12k and 10k, respectively, since they were readily available.

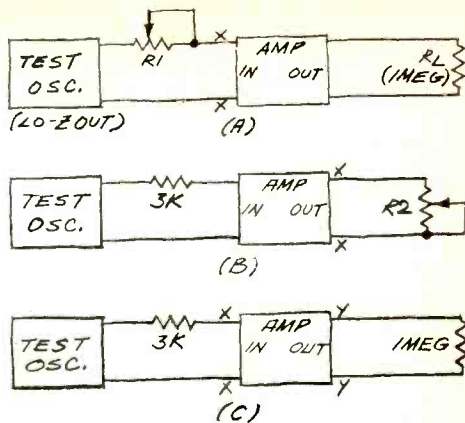

Fig. 9. Testing input/output impedances.

If you want to change the value of  $R3$ , you will have to go higher, since lowering its value would lower the 3000-ohm input impedance. Keep in mind that, in some applications, the impedance may not be allowed to be different from that calculated.

Now we can build the circuit, apply power and check the voltage levels at the emitters of both transistors. This tells us whether the bias values are correct. It also tells us whether or not the circuit will operate. Then we connect it to the other devices (mike and power amplifier) to see if the whole thing works.

• 8. You may not wish to perform this last step, but if you have an audio generator, use the hookups shown in Fig. 9 to measure the important parameters of the circuit. Figure 9A is used to measure input impedance. Adjust  $R1$  until the voltage at the input is half its maximum value. (The value of  $R1$  should be greater than the estimated input impedance of the amplifier. Then remove  $R1$  and measure its rotor-to-end resistance.

This value will be approximately the same as the input impedance of the amplifier.

The output impedance is measured in the same way by adjusting  $R2$  in Fig. 9B. The voltage gain is found by using the circuit in Fig. 9C and dividing the output by the input. Frequency response is found by adjusting the frequency until two points are obtained at which the output is 0.707 times the maximum. These are the upper and lower 3-dB power-loss points.

Now the design is complete. The checks should show any values that need adjusting. Parts can now be purchased, printed circuit boards can be etched, etc., etc. ♦

# Aquarium Heater Control for Fish Fanciers

AND PHOTOGRAPHERS,  
CHEMISTS, AND ANYONE ELSE  
WHO NEEDS STABLE,  
PRECISE TEMPERATURE CONTROL

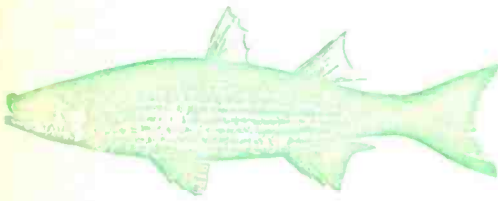

**W**HILE virtually all IC's were originally designed for commercial applications, quite a few have filtered down to the hobbyist and experimenter. One of the more interesting IC's to follow this route is RCA's CA3059 trigger circuit for the control of thyristors. Almost by itself, this IC is a complete electronic control system for immersible and non-immersible heaters. This means that the tropical fish keeper, the amateur and professional photographer, and the chemist can now have an inexpensive, highly accurate heater control.

The CA3059 eliminates the instabilities present in the typical bimetallic thermostatic heater by replacing the mechanical contacts with a triac and em-

ploying a totally electronic interface. Among its many features, the IC includes zero-voltage switching; which means that triggering for the triac is provided only at the points where the 60-Hz line power voltage crosses the zero axis. Hence, rf noise is eliminated without having to resort to bulky and expensive line filters.

The electronic heater control described here will maintain any preset temperature within its range of control to very tight limits. With the components specified, the system will handle output loads (heaters) rated at up to 200 watts. However, a higher power triac can be substituted to cope with higher power requirements.

**Theory of Circuit Design.** The CA3059 is a fairly unique integrated circuit. In addition to its triggering circuit, the IC also contains a power supply and a differential amplifier. This minimizes the external circuitry to a handful of components as can be seen in Fig. 1.

The only external components needed are thermistor temperature sensor *TH1*, temperature control resistor and potentiometer *R1* and *R2*, triac *Q1*, and the dropping resistor and filter capacitor *R3* and *C1* for the power supply. The power line is fused by *F1* as a safety measure, and neon lamp/resistor assembly *I1/R4* are optional items that give a visual indication of the operational status of *Q1*.

In operation, the heater to be used with the system is plugged into *SO1* and the line cord is plugged into any convenient 117-volt ac receptacle. Both temperature sensor *TH1* and the heater are then immersed in the same water or solution (but no less than 2" apart), and *R2* is adjusted to the position that will maintain the water at the desired temperature.

Assuming that the water was originally cooler than desired, the system should trigger on as soon as the heater and *TH1* are immersed and power is applied to the circuit. While the system is active and triggering *Q1* into conduction, *I1* will light to show that power is being applied to the heater.

At some time during the heating process, the water will attain the desired temperature, at which time *TH1* will initiate action to stop the IC from trigger-

BY A. E. DONKIN



## PARTS LIST

*C1*—100- $\mu$ F, 35-volt electrolytic capacitor

*F1*—2-ampere fuse

*11*—NE2 neon lamp

*IC1*—CA3059 integrated circuit (RCA)

*Q1*—40532 triac (RCA)—see text

*R1*—2200-ohm,  $\frac{1}{2}$ -watt resistor

*R2*—2500-ohm, linear-taper potentiometer

*R3*—10,000-ohm, 2-watt resistor

*R4*—47,000-ohm,  $\frac{1}{2}$ -watt resistor

*SO1*—Chassis-mounting ac receptacle

*TH1*—Fenwall JA3311 thermistor

*Misc.*—8"-long glass tube; perforated phenolic board and push-in solder clips; Bakelite chassis box; fuse holder; ac line cord with plug; solid and stranded hookup wire; lamp bezel with lens for 11; insulating tubing and air hose; solder; hardware; etc.

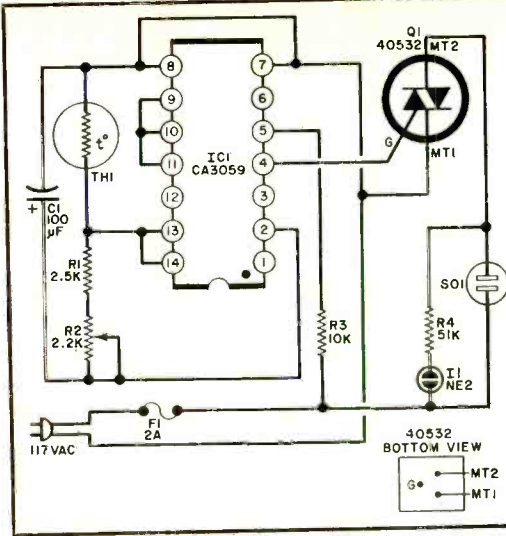

Fig. 1. Only a few external components are needed with IC1 to make control.

ing *Q1* into conduction and shut off the heater. As long as the water temperature remains constant at the preset level, the system will remain passive. However, if the water temperature should fall below the preset level, *TH1* will sense the event and initiate the process for resuming triggering *Q1* and turning on the heater.

**Assembly.** There is nothing critical about the layout and wiring of the main circuit just as long as proper soldering precautions are exercised. In Fig. 2 can be seen how the prototype was assembled using a small piece of perforated phenolic board and push-in solder clips.

Fig. 2. Simplicity of circuit is responsible for easy layout of components on perforated board. Note that, since line voltages are exposed in several places in circuit, insulating Bakelite box should be used for the chassis enclosure.

Interconnecting wiring was routed along the bottom side of the board.

The sensing element probe assembly consists of a 0.01"-diameter disc thermistor mounted inside a glass tube one end of which is sealed. To make this assembly, use a high-heat flame to bring the end of the glass tube to red-hot temperature and draw out the softened glass until it seals itself. Then hold the sealed end of the tube in the flame again until the sharp point rounds off.

Twist together two 36" lengths of flexible stranded hookup wire. Slip a 3" length of insulated sleeving over the end of one wire, and solder both conductors at this end to the thermistor leads. Slide

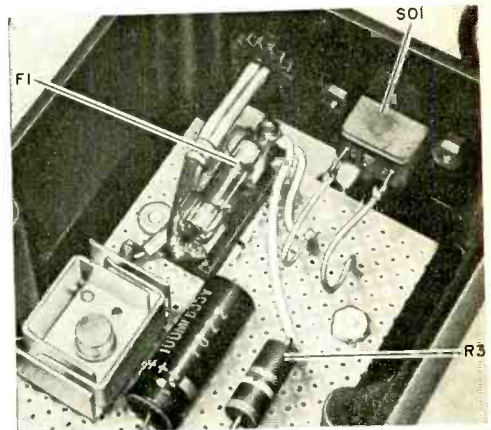
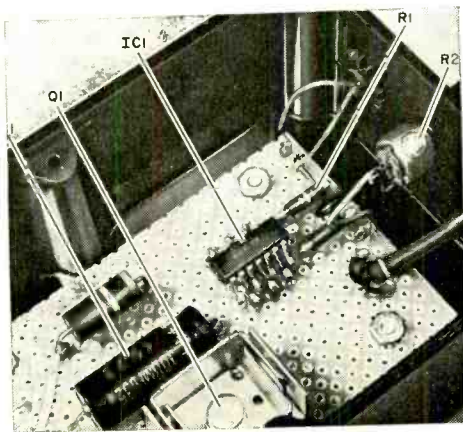

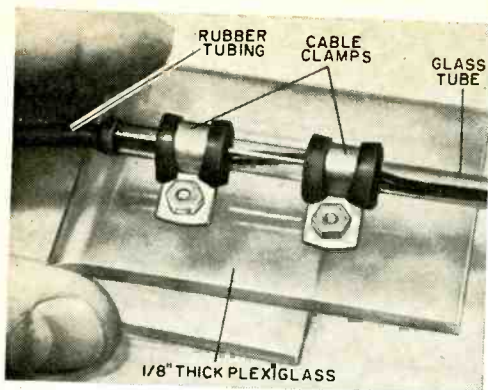

Fig. 3. Sensing probe assembly mounts on plastic bracket with cable clamps and #6 hardware. Do not overtighten clamps or the glass tube will break.

the sleeving down over the thermistor lead. Then check to make sure that the thermistor's leads do not short out against each other with the sleeving in place.

Now, carefully slide the thermistor into the open end of the tube until it sits against the closed end. Fashion a mounting bracket for the probe assembly from  $\frac{1}{8}$ "-thick Plexiglass and mount the probe assembly to it with a pair of plastic-lined cable clamps as shown in Fig. 3. Then slip a 6" length of plastic or rubber air hose over the free end of the twisted wires and force it down over the open end of the glass tube for about  $\frac{1}{4}$ " as shown. Connect and solder the free ends of the wires to the appropriate points on the circuit board.

**Test and Use.** After the control system

is assembled, an easy test to check out its operation can be performed with the aid of a 40- or 60-watt incandescent lamp as the load. (Note: Since line voltage is used at several points in the circuit, exercise extreme caution when working with the circuit without the cover on.) Turn up the heat control, R2, until the lamp lights.

Bring the sensing probe near the lighted lamp; after a short lag, the lamp should extinguish as a result of the heat transfer from the lamp to the thermistor. Keep the probe assembly near the lamp after it goes out, and a few seconds later, the lamp should again trigger on. If the probe is held near the lamp for a considerable time, the lamp should cycle on and off.

Now you are ready to put the control system into service. If you already have a bimetallic thermostatic heater, turn its control up for a high temperature. Plug it into SO1 on the control box. (If you do not have a heater, use one of the non-controlled submersible heaters found in pet stores.)

Advance the heat control to the desired setting, making sure that the probe and heater are both immersed in water. Wait until the water temperature stabilizes before making any small adjustments of the control.

If the control system is to be used just for tropical fish aquariums, rough setting of R2 will suffice. However, for more critical photography bath and chemical solutions, it is advisable to calibrate the control setting with the aid of an accurate thermometer. ♦

## CONTACT PROTECTS PANEL MARKINGS

Dry-transfer lettering kits have made a simple job of prettying up front panels of home-made projects. But keeping the markings from wearing away or scratching off is a big problem. However, there is a simple way of ruggedizing the markings to bear up under even extra-heavy usage. After finishing off the front panel and applying the lettering and markings, cut some transparent Contact (a flexible adhesive-backed vinyl) to dimensions  $\frac{1}{2}$ " larger than the length and width of the panel.

Strip off the protective backing and tack the Contact, adhesive side up, on a flat surface. Now, carefully lower the front panel onto the Contact, roughly centering it. Do not attempt to lift the Contact off the panel from this point on or the lettering and markings will be destroyed. Remove the tacks and firmly burnish down the Contact, pricking any air bubbles with a sharp pin as you proceed. Finally, use a sharp knife to trim away the excess Contact flush with the panel edges. —Richard A. Kunc

# Slow Turn-On Protects Power Supply

BY FRANK TOOKER

ORDINARILY, when a power supply is switched on from a cold start, the instantaneous voltage drop across the filter capacitor is zero. Hence, at the instant of turn-on, the rectifier and power transformer "see" a short circuit. Not until the filter capacitor becomes charged does the power supply operate normally.

Although solid-state rectifiers can absorb a very high momentary current surge without breaking down, it would be better all around if the turn-on could be delayed to eliminate the instantaneous surge.

The schematic diagram shows how to add the simple delaying network to an existing power supply circuit. Notice that the delay network is installed between the rectifier and filter capacitor.

The operation of the network is simple and virtually foolproof. Capacitor *C1* has no voltage drop across it when no voltage is applied to the power supply. So, the voltage at the base of *Q1* is zero at the instant of turn-on. Now, when the power supply is switched on, *C1* begins to charge up through *R1*. The rate of charge depends on the values of *C1* and *R1*; the higher the values, the slower will be the charging rate.

As the voltage across *C1* increases, current begins to flow from *Q1*'s collector to its emitter, charging the supply's filter capacitor. The rate of charge for the filter follows the rate of charge on *C1* almost exactly. A charging rate of from 0.5 to 1.0 second, from zero to full charge, has been found to be more than adequate for most applications. ♦

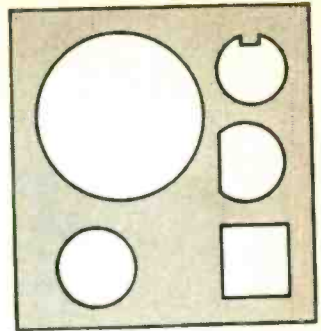
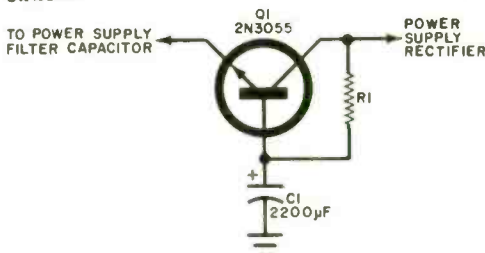

## Put more punch in your work.

With a Greenlee Chassis Punch you can punch clean, true holes in seconds. Round, square, key or D. In 16-ga. metal, hard rubber, plastic or epoxy. Available at radio and electronics parts dealers. Write for catalog E-730. Greenlee Tool Co, 1764 Columbia Ave., Rockford, Ill. 61101.

**GREENLEE TOOL CO**

A Unit of Ex-Cell-O Corporation 

**CIRCLE NO. 44 ON READER SERVICE CARD**

An amazing new miniature torch brazes, welds, solders and heats with surprising precision. You solder any appliance electrical part. You weld auto parts, braze household devices and toys easily, with professional accuracy, at half the normal cost. The Little Torch welds any size metal from tiny .002" wire to 1/6 gauge steel. Is economical to use, easy to operate—an invaluable addition to your home and workshop tools. Send for your FREE brochure telling all about the Little Torch, today.

**Tescom**  
CORPORATION  
Instrument

(U.L. APPROVED)

DEPT. 9-33

2600 NIAGARA LANE NO., MINNEAPOLIS, MINN. 55441  
**CIRCLE NO. 43 ON READER SERVICE CARD**

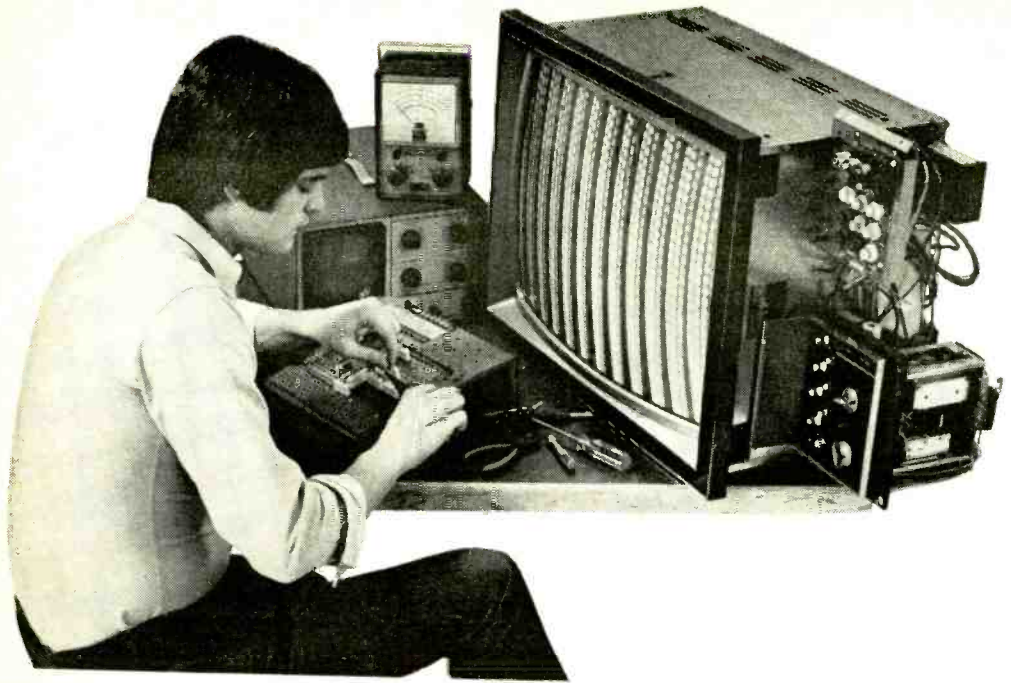

# **BUILD YOUR OWN BELL & HOWELL SOLID STATE 25-INCH COLOR TV!**

Learn new skills  
that could lead to  
a business of your own  
—full or part time—  
in home entertainment  
electronics.

For free information,  
fill out  
postage-paid reply card,  
detach and mail today!



# Earn extra money part time... or start a full time business of your own!

Bell & Howell Schools has helped many thousands of people start new careers or businesses of their own in electronics. You may earn extra money—or start a business of your own in color TV servicing—with the skills you acquire through this exciting new program.

## Not just a "kit"—a complete at-home learning program in home entertainment electronics!

You'll enjoy the challenge of this new learn-at-home program from Bell & Howell Schools. Not just a "kit"—a complete learning program prepared by skilled instructors.

## Enjoy the personal satisfaction of building your own color TV

You'll find it especially absorbing to build this superb color TV set. And you'll take pride in it because *you did it yourself!*

## Follow simple, step-by-step instructions

This color TV project is part of a complete step-by-step program prepared by skilled instructors. If you'd like some personal advice, attend a special "help session" and meet a Bell & Howell Schools instructor *in person!*

## Master the most up-to-date solid-state circuitry

As color TV moves more and more in the direction of total solid-state circuitry, you'll be thoroughly familiar with the most advanced "trouble-shooting" techniques for these sophisticated circuits.

## Fix stereo systems . . . FM-AM radios . . . phonographs . . . tape recorders

The thorough knowledge of electronics you gain from completing this course and building your own color TV set will be more than enough to service any type of home entertainment electronic device.

## Exclusive Electro-Lab®—yours to keep!

To make sure you get practical experience with instruments used daily by professionals, we've integrated into your program three precision instrument kits you assemble yourself and keep: a Design Console, an Oscilloscope and a Transistorized Meter. (See details at right.)

## CONSIDER THESE ADVANTAGES:

**Help Sessions** Scheduled regularly every few Saturdays at the Bell & Howell Schools and in many other cities throughout the U.S. and Canada. Top instructors give you personal help and guidance.

**Resident Study** After you complete your program, you can transfer to any of the resident schools for more advanced study, if you wish.

**Lifetime National Placement Service** When you complete your course, we help you locate a position in the field of Electronics that fits your background and interests. This unique service is available at any time—now or in the future—at no additional cost.

**Veterans' Benefits** We are approved by the state approval agency for Veterans' Benefits. Check the box for details.

**Student Financial Aid** We are an eligible institution under the Federally Insured Student Loan Program. Check the box for details.

Detach postage-paid reply card below and mail today for free information about . . .



■ **Bell & Howell solid-state 25-inch color TV** Ultra-rectangular 25-inch diagonal with full 315 sq. inch screen. Lets you view more of the transmitted image. 25,000 volts . . . 45

transistors . . . 55 diodes . . . 4 advanced IC's . . . 3-stage solid state IF . . . solid state VHF, UHF tuners . . . automatic fine tuning and many other quality features.

■ **Design Console** Use this to rapidly "bread-board" circuits without soldering. Equipped with built-in power supply . . . test light . . . speaker . . . patented plug-in modular connectors.

■ **Oscilloscope** Portable 5-inch wide-band oscilloscope offers bright, sharp screen images . . . calibrated for peak-to-peak voltage and time measurements . . . 3-way jacks for leads, plugs, wires.

■ **Transistorized Meter** Combines most desired features of vacuum-tube voltmeter and quality multi-meter. Registers current, voltage and resistance measurements on a large, easily-read dial. Features sensitive, 4-inch, jewel-bearing d'Arsonval meter movement.

## For Free Information, Mail Card Today!

If card has been removed, write:

DEVRY INSTITUTE OF TECHNOLOGY  
ONE OF THE



**BELL & HOWELL SCHOOLS**

4141 Belmont, Chicago, Illinois 60641

331

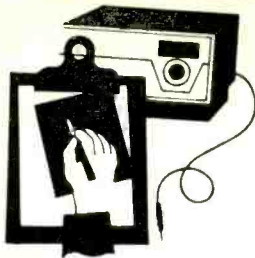

# Product Test Reports

## DUAL 1218 AUTOMATIC TURNTABLE (A Hirsch-Houck Lab Report)

**T**HE Model 1218 is a new member of Dual's line of high-quality automatic turntables. It replaces the former Model 1209. In features and performance, the 1218 closely resembles the top-of-the-line Model 1219—at a considerably lower cost of \$139.50. (An optional walnut base is available for \$10.95.)

The Model 1218 is a three-speed turntable with a vernier adjust control which provides a total range of about 6 percent at each of the nominal speeds. The synchronous motor drives a 10 $\frac{1}{2}$ "-diameter, 4-pound non-ferrous cast platter. (This is one of the points of difference between the 1218 and 1219; the latter has a larger and heavier platter.)

The tonearm, supported on gimbal bearings (like the 1219), is balanced by a rotating threaded counterweight which is isolated from the arm by an elastic damping section. A coiled spring within the pivot assembly applies the downward tracking force; a dial, calibrated at 0.25-gram intervals from 0.25 to 5.5 grams, is used for setting the force. A separate knob on the motorboard is provided for setting the anti-skating correction. It has separate scales for conical and elliptical styli calibrated to match the tracking-force dial.

To maintain an approximately correct 15-degree vertical tracking angle whether playing a single disc or a stack of up to six discs, the turntable has a tilting cartridge mount. A small knob on the side of the slide-on plastic cartridge holder is marked S for single and M for multiple play. It can be used to set cartridge tilt so that the cartridge is parallel to the disc's surface when the turntable is operated in the single-play mode. In automatic operation, the cartridge is parallel to the surface of the center discs, and the stylus deviates negligibly from the correct vertical angle through-



out the stack of discs with the knob set to M.

The basic operating control of the turntable is a single lever. In manual operation, it is moved to the left to start the motor and index the tonearm. Moving the lever to the right returns the arm to its rest and shuts off the motor. A separate record-size selector indexes the arm for 7-in., 10-in., and 12-in. disks. For purely manual operation, one merely lifts the arm from its rest, which starts the motor, and places it on the disc. A silicone damped cueing control gently raises and lowers the arm at any point on the record's surface.

The metal turntable is covered by a ribbed anti-static mat which contacts the record only at its outer diameter. Two interchangeable spindles are provided: a short one which rotates with the turntable to eliminate any center hole wear when using the 1218 for single play, and an automatic one which accommodates up to six discs of the same size and speed.

**Laboratory Measurements.** At low-force settings, the calibration of the tracking force dial was very accurate. At a 3-gram setting, the maximum error was 0.1 gram; at the 4-gram setting, actual force was 4.5 grams; and at a 5-gram setting, it was 5.7 grams. At the 1-gram setting, the tracking force



# FREE

## Heathkit Catalog

### Build and save on over 350 kits

Your free 1972 Heathkit catalog describes more kits than ever... over 350...all designed to give you fine performance and save you money when you buy and when you use. Choose solid state color TV, stereo, marine, automotive, test instruments, amateur radio, short-wave, home appliances, and more! Send for your free copy today.

### NEW Solid-State Heathkit Color TV — the best TV kit ever offered

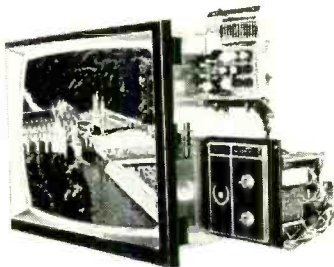

25" diagonal matrix tube, 24-position UHF/VHF detent power tuning, varactor UHF tuner, MOSFET VHF tuner, tint switch. New performance and convenience. Detent tuned UHF & VHF. Preselect any 12 favorite UHF stations, then power pushbutton (or remote) tune all 24 channels in either direction. New angular tint control switch selects normal or wide angle color to reduce tint changes between stations. Exclusive Heath MTX-5 ultra-rectangular black matrix tube has brighter pictures, better contrast. "Instant-On." Automatic fine tuning. Adjustable tone control. Automatic chroma control. Adjustable video peaking. More sensitive tuners. Transformer operated. Built-in dot generator and volt-ohm meter. Choice of cabinet styles from \$81.95\*.

- Kit CR-900, less cabinet ..... \$599.95\*
- Kit GRA-900-6, remote control ..... \$79.95\*

### NEW Heathkit Digital FM Tuner



Another Heathkit "first" in consumer electronics. Pure digital computer design including digital frequency synthesizer tuning employing phase-lock-loop techniques. FET varactor FM RF front end, digital discriminator and readout result in performance specs and tuning convenience that already are the talk of the audio world: channel frequency accuracy better than 0.005%; less than 1.8 uV sensitivity; distortion levels of 0.1%; selectivity and IF rejection better than 95 dB; image & spurious rejection better than 90 dB; S/N ratio better than 65 dB; separation better than 40 dB. One of a kind, the AJ-1510 "computer tuner" is the only tuner offering you 3 distinct tuning modes; keyboard, computer-type punch cards (up to 3), plus automatic band scanning with variable speed and stereo-only capability. The 55 ICs, 50 transistors and 50 signal diodes mount on 10 modules with 7 plugging into a master board for optimum computer modularity & ease of assembly. Join the computer generation of audio equipment — order your AJ-1510 today.

- Kit AJ-1510, Tuner only ..... \$539.95\*
- Cabinet ..... \$24.95\*

### NEW Heathkit Solid-State Ignition Analyzer

Analyzes standard, transistor, or capacitive discharge systems on 3, 4, 6, or 8 cyl. engines to find bad plugs, points, wiring or distributor parts, incorrect dwell time, coil, condenser, transistor or CD circuitry problems. Built-in tach. 0-1000 & 0-5000 rpm ranges for carb. adjustments. Constant width patterns, primary or secondary, parade or superimposed, plus expanded. Optional 12VDC supply for road checks, \$24.95\*.

- Kit CO-1015 ..... \$129.95\*

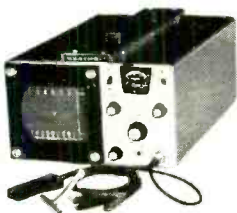

### NEW Heathkit 4-Channel Amplifier

Brings you 200 versatile watts for discrete or matrixed 4-channel sound, and stereo or mono. Built-in matrix circuitry decodes matrixed 4-channel recordings or broadcasts, lets you use your existing stereo equipment as well as enhancing your present stereo records and tapes. As discrete 4-channel media grows the AA-2004 is ready... with four amplifiers producing 260 watts into 4 ohms (4x65), 200 watts into 8 ohms (4x50), 120 watts into 16 ohms (4x30), and controls for every source, mode and installation. Amplifier sections are controlled in pairs with one complete stereo system for left and right front speakers and another for left and right rear — so it can be used to power two complete 4-channel systems (up to 8 speakers)... or, four separate-source mono systems if desired. Easy circuit board assembly.

- Kit AA-2004, amplifier only ..... \$349.95\*
- Cabinet ..... \$24.95\*



### NEW Heathkit 8-Digit Calculator

Adds, subtracts, multiplies, divides, chain or mixed functions, and constant. Floating or selectable 7 position decimal. Plus, minus, and overflow indicators. Overflow protection of most significant 8 digits. Clear-display key to correct last entry. Standard keyboard. American LSI circuitry. Bright 1/2" red digits. 120 or 240 VAC operation. Desktop black & white cabinet, 3 1/2" h x 6" w x 10 1/4" d.

- Kit IC-2008 ..... \$129.95\*

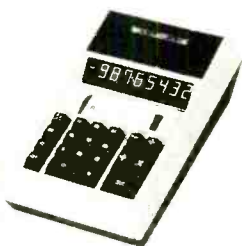

### NEW Heathkit Solid-State FET VOM

Dual FET portable multimeter with lab grade accuracy, 10 megohm input and the ranges you really need. 9 DCV & ACV ranges, 0.1 to 1000 v, ± 2% accuracy. 6 DC & AC current ranges, 10 microamps. to 1 amp. 7 resistance ranges, X1 (10 ohm center) to X1 Meg. 9 dB ranges, —40 to + 62. 1% precision metal-film dividers. 4 1/2", 100 uA, ruggedized taut-band meter, diode & fuse protected. Battery check.

- Kit IM-104, less batteries, \$79.95\*.



See them all at your Heathkit Electronic Center... or fill out the coupon below

HEATHKIT ELECTRONIC CENTERS — ARIZ: Phoenix, 2727 W. Indian School Rd.; CALIF: Anaheim, 330 E. Ball Rd.; EL Cerrito, 6000 Potrero Ave.; Los Angeles, 2309 S. Flower St.; La Pomona, 1555 Orange Grove Ave. N.; Redwood City, 2001 Middlefield Rd.; San Diego (La Mesa), 8363 Center Dr.; Woodland Hills, 22504 Ventura Blvd.; D.D.L.: Denver, 5940 W. 38th Ave.; FLA: Miami (Hialeah), 4705 W. 16th Ave.; GA: Atlanta, 5285 Roswell Rd.; ILL: Chicago, 3462-65 W. Devon Ave.; MD: Rockville, 5542 Nicholson Lane; MASS: Boston City Mission, 165 Worcester St.; MICH: Detroit, 18645 P. Eight Mile Rd. & 18149 E. Eight Mile Rd.; MINN.: Minneapolis (Hopkins), 101 Shady Oak Rd.; MO: St. Louis, 9296 Gravois Ave.; N.J.: Fair Lawn, 35-07 Broadway (Rte. 4); N.Y.: Buffalo (Amherst), 3476 Sheridan Ave.; N.Y.: New York, 35 W. 45th St.; Jersey, L.I., 15 Jericho Turnpike; Rochester, Long Ridge Dr.; OHIO: Cincinnati (Woodlawn), 10133 Springfield Pike, Cleveland, 5444 Pearl Rd.; PA.: Philadelphia, 6318 Roosevelt Blvd.; Pittsburgh, 3482 Wm. Penn Hwy.; TEXAS: Dallas, 2715 Ross Ave.; Houston, 3705 Westheimer; WASH.: Seattle, 2221 Third Ave.; WIS.: Milwaukee, 5215 Fond du Lac.

HEATHKIT  
Schlumberger

HEATH COMPANY, Dept. 10-9  
Benton Harbor, Michigan 49022

Please send FREE Heathkit Catalog. \_\_\_\_\_, plus shipping.

Enclosed is \$\_\_\_\_\_

Please send model(s) \_\_\_\_\_

Name \_\_\_\_\_

Address \_\_\_\_\_

City \_\_\_\_\_ State \_\_\_\_\_ Zip \_\_\_\_\_

Prices & specifications subject to change without notice.  
\*Mail order prices; F.O.B. factory. CL-434R

CIRCLE NO. 15 ON READER SERVICE CARD

increased by 0.15 gram at the top of a 1/2" disc stack.

When a cartridge was carefully installed using the plastic jig supplied with the 1218, the tonearm's tracking error was very small, measuring less than 0.4 degree per inch of radius over the entire disc and typically about 0.2 degree per inch or less. We found it necessary to set the anti-skating force slightly higher than indicated, especially at low tracking forces. However, this is not a critical setting, and one could safely use it with the anti-skating dial matching the setting of the tracking force dial.

The turntable speed could be varied over a range of +4.5 percent to -3 percent at 33 1/3 rpm. The correct speed on our test unit was obtained with the vernier control set slightly below the indicated nominal speed point. A stroboscopic disc is supplied for making this adjustment. The speed was unaffected by line voltage changes or different record loads. Wow and flutter were very low, the latter being 0.04 percent at all speeds and the former 0.04 percent at 33 1/3 rpm and 0.025 percent at the two faster speeds.

The unweighted NAB rumble was 32 dB down and dropped to -36 dB when vertical components were cancelled by paralleling the cartridge outputs. With the CBS

RRLL weighting, which correlates better with rumble audibility, the measurement was -54 dB, a typical figure for a good turntable.

We found no detectable arm/cartridge resonance in the 10-500-Hz range, using an Empire 1000ZE/X cartridge. The change cycle took 12 seconds at 33 1/3 rpm and 7 seconds at 78 rpm.

**Comments.** As with all Dual turntables we have used, the 1218 operated silently, smoothly, and reliably. It is apparent that in all important respects it is very similar to the 1219.

The low-friction arm bearings are equal to the task of carrying any cartridge made at the lowest tracking force of which it is capable (we had no difficulty operating at 0.5 gram). The damped cueing system operated very smoothly, and when the anti-skating force was set to match the tracking force, it returned the stylus to the same point at which it left the record. If tracking forces of less than 1 gram are used, and if the anti-skating force is set to an optimum value, there is some outward drift of the pickup during descent. But since few cartridges can (or should) be operated at less than 1 gram of tracking force, this is unlikely to present any difficulties.

Circle No. 65 on Reader Service Card

### TRIPLETT MODEL 603 SOLID-STATE VOM

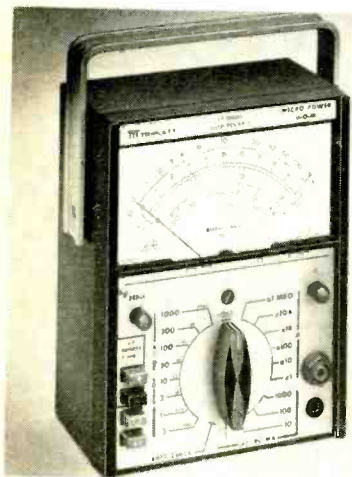

ic power shut-off device to prevent battery rundown if the instrument were inadvertently left on after use.

With the introduction of their latest solid-state multimeter, the Model 603 FET VOM which retails for \$150, Triplett has not only silenced us on the subject of automatic shut-off, but they have added a couple of arm twisters in the way of further improving this new VOM. Using an approach called "TMP" (for Triplett Micro Power), the Model 603's total current drain is so low that the carbon-zinc batteries used for powering the electronics package approach their shelf life. This feature alone could eliminate the need for a power switch, but the switch is there just the same. If you forget to turn off the instrument after use, no matter when you come back a day or a week later, the batteries will still have plenty of life in them.

Some of the other changes include a 70-mV low-power ohms measurement circuit

**B**ACK in September 1970, we reviewed the Triplett Model 602 VOM. At the end of the review, we suggested that the one improvement needed was an automat-



which permits making in-circuit resistance measurements without biasing or burning out delicate semiconductors or other low-power devices that are making their appearance in many radio and TV receivers. Conventional resistance measurements are still possible by switching to the normal resistance mode in which a 1.5-volt D cell is used.

Another very useful feature is a built-in automatic-polarity circuit which enables the user to measure both positive and negative dc voltages without having to go through the contortions of swapping test leads or flipping a switch. Other switches permit determination of either positive or negative voltages should the polarity need to be known. We found the auto-polarity feature ideal for making null adjustments. All the user has to do is tune the circuit for null, watching the pointer of the Model 603's meter movement drop toward zero. If he goes too far, the pointer will begin to swing up-scale. Consequently, there is no need to view the meter head-on to remove the possibility of parallax error.

Only two scales are used for all dc and ac voltage and current ranges. Separate scales are used for resistance and dB readings. This makes for a clean, easy-to-interpret scale. Only one function switch and one set of probe connectors are used for all 44 meter ranges and functions.

The ranges for both dc and ac voltage are: 0.3, 1, 3, 10, 30, 100, 300, and 1000 volts full-scale. Accuracy is 3 percent on all ranges. Input resistance is set for a minimum of loading on the circuit under test. On dc, it is 11.12 megohms, on ac it is 10 megohms. The frequency response for all ac ranges up to 100 volts is 20-10,000 Hz.

The ohmmeter function has the usual RX1 to RX1-megohm range spread in six steps. The user has a selection of either conventional or low-power ohms measurements.

Both ac and dc currents can be measured from 1 mA to 1 ampere full-scale in four ranges. The dB ranges go from -30 db to +62 db. Accuracy is 3 percent, and 0 db is equal to 0.776 volt (1 mW across 600 ohms).

The Model 603's electronics are housed in a 6½" × 5¾" × 3¾" high-impact plastic molded case. The instrument weighs a mere 2½ pounds, including batteries. A metal carrying handle, which doubles as a tilt stand, is provided. Three conventional

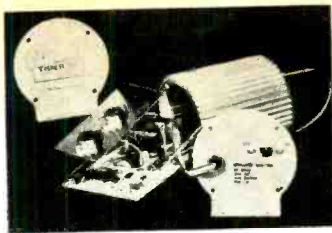

### FROM KIT TO CAR IN 80 MINUTES!

Electronic ignition is "in". Update your car with the TOPS in power, efficiency and reliability — the TIGER SST capacitive discharge ignition (CD).

The TIGER delivers everything other CD's promise — and more: quicker starting, more power, more gas mileage, tune-ups eliminated, lifetime plugs and points, reduced repairs and pollution.

The TIGER can be built and installed in your car in 80 minutes. The TIGER is unique! Errors in construction or incorrect installation will not harm the TIGER or the engine. The TIGER will not operate under either condition.

The TIGER comes with a switch for TIGER or standard ignition for 12V negative ground only.

SATISFACTION GUARANTEED  
or Money Back.

Simpli-Kit \$29.95 — Assembled \$39.95  
POST PAID

WE ACCEPT:  
Mastercharge or BankAmericard.  
Send check or money order with order to:

**Tri-Star Corporation**

DEPT. W, P. O. Box 1946  
Grand Junction, Colorado 81501

**CIRCLE NO. 36 ON READER SERVICE CARD**

## ANOTHER SUPERB VALUE from Olson

Electronics

ONLY

**\$12**

**DELUXE  
TRANSISTOR  
CHECKER**



Compact, self-contained, self-powered dynamic transistor checker. Test may be made "in circuit" or out of circuit. Identifies and checks PNP and NPN types, plus power. Complete with instruction manual, service tips and transistor drawings.

Olson Electronics, Dept. 19, 260 S. Forge St.,  
Akron, Ohio 44327

- I enclose \$12, plus \$1 for postage and handling.  
Send me the TE-199 Transistor Checker.
- Write for the new Olson Annual Catalog. It's  
**FREE**

Name \_\_\_\_\_  
Address \_\_\_\_\_  
City \_\_\_\_\_  
State \_\_\_\_\_ Zip \_\_\_\_\_

**CIRCLE NO. 21 ON READER SERVICE CARD**

batteries—two 9-volt and one 1½-volt D cell—needed to power the instrument are supplied.

You need no tools to get inside the case to replace batteries. A rather heavy ⅜"-diameter knurled screwhead is all that holds the back on—quite solidly, we hasten to add. The entire interior of the meter case is lined with sheet brass which makes electrical contact with the ground on the printed circuit board. All high-quality components are employed, and the three batteries are securely held in place by a removable plastic bar. (Incidentally, the range/function switch also has a battery-test position

which allows the user to keep tabs on the condition of the batteries.)

The manual which accompanies the Model 603 FET VOM is very complete. Not only does it contain the usual information on how to use and maintain the instrument, but it also outlines the calibration procedure to use if and when the need for it arises.

After using the Model 603 for a couple of weeks, we can state that it is a first-class solid-state VOM which is certain to find favor as the workhorse instrument for the busy bench technician and electronics hobbyist.

Circle No. 66 on Reader Service Card

### HEATHKIT MODEL IC-2008 DIGITAL CALCULATOR

**A** DIGITAL electronic calculator is an excellent device to have around for solving mathematical problems and calculating parameters in circuit design. Having used a number of calculators with different capabilities in the past, we were especially interested in the new Heathkit Model IC-2008 calculator kit which lists for \$129.95.

The IC-2008 is a desk-top calculator, but it is very compact and lightweight, measuring 10¼" × 6" × 3½" overall and weighing 3½ pounds. Since it is so light, four non-skid pads are attached to the bottom of the case to hold it in place.

The usual complement of 11 keys is provided for feeding in the numbers from 0 through 9 and the decimal point. Five arithmetic function keys are to the right of the number keyboard: add, subtract, multiply, divide, and equals. To the left of the number keyboard are four more keys. One clears the logic at the start of calculations. A second clears only an erroneous entry (obviating the need for re-doing an entire equation when only the last entry is incorrect). The third key programs the logic for constant-factor calculations. The fourth key, though not unique, is not often found on arithmetic calculators; it is used to change the display from positive to negative and vice versa.

Two controls are provided. One is a rocker-type power switch. The other is a thumb-wheel switch which is used to set the decimal point (up to seven trailing decimal positions). The decimal point can also be left floating.

With the IC-2008, calculations can be chained or done in sequence. A fixed constant can be used when performing long calculations.

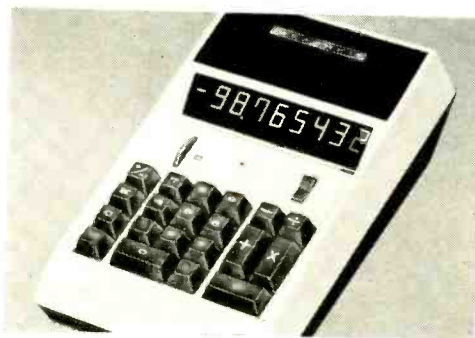

The overall range of the calculator is from 0.0000001 to 99999999. If the instrument's capability is exceeded—either during entry or during totalling—the keyboard automatically locks out, and the extreme left readout displays an E.

The seven-segment gas-discharge readout display in the IC-2008 is one of the most legible and largest we have seen. Even with the dense, polarized filter placed in front of it, the display is very bright. While the calculator is operating, there is no zero blanking. Instead, a series of lower-case leading zeroes is displayed to indicate unused readouts.

We assembled the IC-2008 in about seven hours. The work consists essentially in wiring two printed circuit boards: a small one for mounting the readouts and a mother board for the rest of the electronics. Carefully following the instructions given in the well-illustrated assembly/operating manual supplied with the kit, we encountered no difficulties. Extreme care must be exercised when inserting the 28-pin LSI chip into its socket.

The various switches which make up the

keyboards are mounted in a novel manner. The operation makes mechanical alignment between the switch pushrods and metal mounting bracket a sure-fire thing.

Heath supplies with the kit a small neon-lamp tester for checking out the various high-voltage points to insure that the voltages are present when needed but absent at other points. Hence, the assembler does not have to have a VOM or VTVM on hand when working on the calculator. We turned on our calculator immediately after it was assembled; and it worked beautifully.

The assembly/operating manual does not spend much time discussing the amazing 28-pin American-made LSI chip which does all the work. But it must be pretty complex to perform as it does.

Circle No. 67 on Reader Service Card

### PRODUCTION DEVICES MODEL 85 TRANSISTOR TESTER

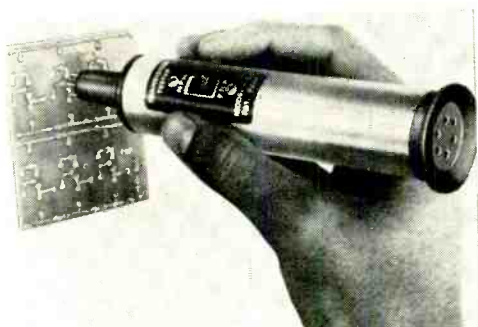

**L**IKE a lot of you, we dread the thought of having to find a malfunction on a printed circuit board assembly containing dozens of transistors. Just the idea of having to unsolder a number of leads—and possibly doing more damage with the soldering iron—leaves us cold. It is either unsolder the suspected transistor and test it off the board, or use an in-circuit tester while performing an acrobatic-like balancing act to keep the probes on the appropriate transistor solder pads while observing a meter.

One day a few months ago, there came in the mail a package from Production Devices. Opening the box, we found the company's new Model 85 in-circuit transistor tester which has, in just a short time, dispelled most of the distaste we used to have for troubleshooting a transistor circuit.

The Model 85 is a handy little self-powered tester. It is about the size of an over-stuffed scope probe. Inside is a complete

## Technical excellence in electronics

On our small, friendly campus the emphasis is on Living as well as Learning. Extra-curricular social activities, student clubs, a student operated radio station, student government, new dormitory and a full sports program help provide a world of your own in which to prepare for tomorrow. Associate Degree in Engineering Electronics. B.S. obtainable. G.I. approved.



VALPARAISO TECHNICAL INSTITUTE  
Dept. PE, Yellowstone Trail, Valparaiso, Indiana 46383

CIRCLE NO. 40 ON READER SERVICE CARD

## THE ONE WORD FOR PERFORMANCE AND RELIABILITY IN ELECTRONIC IGNITION JUDSON

**YOU CAN HAVE  
TOMORROW'S  
IGNITION ON  
YOUR CAR TODAY**



Don't accept "as good as" there are none.

Write Today for Literature

**JUDSON**  
RESEARCH AND MFG. CO  
CONSHOHOCKEN PA. 19428



CIRCLE NO. 16 ON READER SERVICE CARD

test circuit, a conventional 9-volt transistor battery, and a tiny speaker. The business end of the probe consists of three stiff, sharpened metal prods arranged in the familiar triangular TO-5 configuration. The base lead is clearly identified by its gold color, making it a simple job to jab the prods into the solder pads of a suspected transistor.

A small switch on the side of the tester is marked PNP/NPN. With the prods firmly contacting the transistor's solder pads and the switch set to the proper position, the tiny speaker emits a clear tone if the transistor is good. The absence of a tone in either switch position indicates that the transistor is either shorted or open. Regardless of the switch position, there is no danger to the semiconductor under test because the maximum voltage applied to the base-emitter junction is only 0.8 volt.

Because standby current is only a few microamperes, no on/off power switch is provided. In operation, current consumption is only a couple of milliamperes.

For testing transistors in other than the familiar TO-5 configuration, the tester is

provided with an extender cable which plugs onto the prod end of the instrument. The test end of the cable is equipped with color-coded alligator clips, one each for the base, emitter, and collector leads.

We used the Model 85 tester on some very crowded PC boards used in imported radio receivers. Finding "dud" transistors was a cinch. However, while working with the tester, we found that leaving it on the workbench sometimes allowed the three probe tips to come into contact with metal tools and other objects usually found in a busy work area. As a result, the probe tips can short together, putting a 90-mA current drain on the tester's battery. Although when a short-circuit condition like this takes place the speaker gives off a loud click to alert you to the situation, we recommend that before you lay down the instrument you push the probe tips into an eraser. Other than this minor inconvenience, the Model 85 tester is certain to become one of the handiest tools around for the technician and experimenter who regularly works with transistor circuits, especially since it is priced at only \$17.45.

Circle No. 68 on Reader Service Card

## JAMES MODEL C-7535 INTRUSION DETECTOR

**I**INTRUSION alarms can be divided into two major categories or types. The "hard-wired" multi-point perimeter version employs some form of mechanically operated sensor at each entry point within the protected area. The second category takes advantage of the "area protection" approach in which only a certain portion of a room or other enclosed area needs an alarm system. If your concern is area protection—because you do not want to go through the bother of wiring up your house, or because you feel that protecting only one area, such as a door or window, is sufficient—then you should look into the available small ultrasonic alarm offerings. One of these is the James Model C-7535 Doppler-Sonic Intrusion Detector which sells for \$159.95 fully wired and tested.

The James intrusion alarm is an attractive but unobtrusive device. Its electronics are housed in an oiled wood enclosure, the front of which is covered with a color-coordinated grille cloth. At first glance, the detector looks like a small 11"-long by 4"-square shelf loudspeaker system.

Using both Doppler shift and amplitude modulation, this unit is insensitive to false

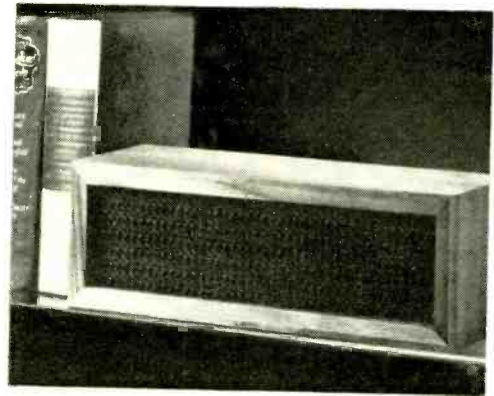

triggering from air currents, high-frequency sounds, fluorescent ballast noise, and can be adjusted to disregard the motions of small animals in the protected area. The detector covers an operational area of about 180 square feet in a cone which extends 18 feet out and 10 feet across the base. Any motion within this area will be sensed by the system.

Power for the James alarm can be taken from the ac line or from a 12-volt dc source; so, the system is equally at home in

a private home, a business establishment, or in just about any enclosed vehicle. If the system is operated on both ac and battery power sources, it normally operates from the ac source but automatically switches over to battery in the event of either a deliberate or accidental power failure without any loss in protection. Of course, in this application, the external alarm must also be battery powered.

Two sets of screw-terminal contacts are provided on the rear panel. One pair is for remote control of 117-volt ac alarms, while the other pair is used to energize battery-powered alarms. Provisions are also made on the rear panel for remote detectors and a key-operated remote control unit which can be located anywhere that is convenient to the user. (A number of accessory detectors are also available from James.)

We tested the C-7535 in its simplest form, with the intrusion detector plugged into a 117-volt ac power source and the remote relay operating a light bulb alarm "sounder." The maximum range we obtained was about 25 feet by opening a door directly in the beam path. Human motion triggered

the system within 15 to 18 feet from the detector. Air conditioner blasts and smoke had no effect on the system.

There is a screwdriver-adjust response control on the rear panel. It allows variation of the amount of time that a motion must be present before the alarm triggers. This permits "normal" motions such as that produced by air currents, bells having a 40-kHz ultrasonic component, and small animals to be blanked out if the duration is between 0.5 and 5 seconds. The range is adjustable between the two stated times. If these random motions do not persist for more than the preset time, they will be ignored. But any motion which exceeds the preset time will cause the alarm to trigger.

Because a number of animals are sensitive to sounds in the ultrasonic range and many TV receiver remote control devices operate around 40 kHz, we checked the system out for these effects. The animals responded, of course, but not with discomfort. In our case, the C-7535 turned up the chroma on our TV receiver; but this effect is not too important since it would be rare for both the TV and detector to be on at the same time.

Circle No. 69 on Reader Service Card

# SAVE MONEY!

**A Delta Mark Ten Capacitive Discharge Ignition (CDI) System On Your Car Slashes Maintenance Costs And Increases Performance.**

Put a Mark Ten on your car and save by eliminating 3 out of 4 tune-ups. Save as gasoline mileage increases (up to 20%). The Mark Ten CDI system also extends spark plug life, promotes more complete combustion and assures instant starts in all weather. It operates on any 6 or 12 volt negative or positive ground system.

The Mark Ten B affords additional money saving advantages by drastically reducing combustion contaminants and restoring power lost by the use of smog control devices. Equipped with handy switch for instant return to standard ignition, the Mark Ten B works with ANY 12 volt negative ground engine. Both systems install in ten minutes without rewiring.

Order your Mark Ten or Mark Ten B today. Save money while you enjoy low maintenance and increased performance.

**Mark Ten (Assembled) \$44.95 ppd.**

**Mark Ten (Deltakit) \$29.95 ppd.**  
(Kits available in 12 volt only,  
positive or negative ground)

**Mark Ten B \$59.95 ppd.**  
(12 volt negative ground only)

Superior Products at Sensible Prices

Mfg. in U.S.A.



**DELTA PRODUCTS, INC.**

P.O. BOX 1147 • GRAND JUNCTION, COLORADO 81501  
PHONE (303) 242-9000

Dept. PE

Please send me literature immediately:

Enclosed is \$ \_\_\_\_\_  
 Ship ppd.     Ship C.O.D.  
 Please send: \_\_\_\_\_ Mark Ten B @ \$59.95 ppd.  
 \_\_\_\_\_ Standard Mark Ten (Assembled) @ \$44.95 ppd.  
 \_\_\_\_\_ 6 Volt: Neg. Ground Only \_\_\_\_\_ Positive Ground  
 \_\_\_\_\_ 12 Volt: Specify \_\_\_\_\_ Negative Ground  
 \_\_\_\_\_ Standard Mark Ten (Deltakit) @ \$29.95 ppd.  
 (12 Volt Positive Or Negative Ground Only)

Car Year \_\_\_\_\_ Make \_\_\_\_\_  
 Name \_\_\_\_\_  
 Address \_\_\_\_\_  
 City/State \_\_\_\_\_ Zip \_\_\_\_\_

CIRCLE NO. 9 ON READER SERVICE CARD

# NEW "IN-LINE" COLOR TUBE SIMPLIFIES CONVERGENCE

**A** NEW color CRT, introduced by RCA uses an in-line, triple-beam gun structure, and a line-focus-type of static toroidal deflection yoke that eliminates the need for dynamic convergence. The shadow mask has vertically oriented slit-shaped apertures with the phosphor array forming vertical green, red, and blue lines. Dynamic convergence magnets are not required.

The three-gun assembly is arranged horizontally and is about half the size of the conventional delta layout.

A single static convergence and purity device is included in the yoke assembly which is bonded to the neck of the CRT.

The new approach produces a 1.8" shorter tube, 2½ lb lighter than present 90° systems. The new tubes will be available in 15", 17", and 19" sizes. RCA is also working on a 13" version.

Standard Delta System

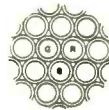
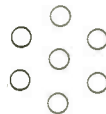
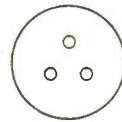

Electron Gun

Shadow Mask

Screen (Operating)

RCA Precision In-Line System

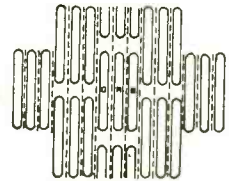
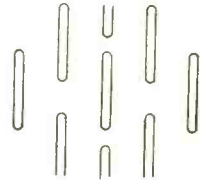

**New tube and in-line gun (left) has all deflection and convergence elements bonded to neck. It is smaller, lighter, and easier to set up than conventional tube (right).**

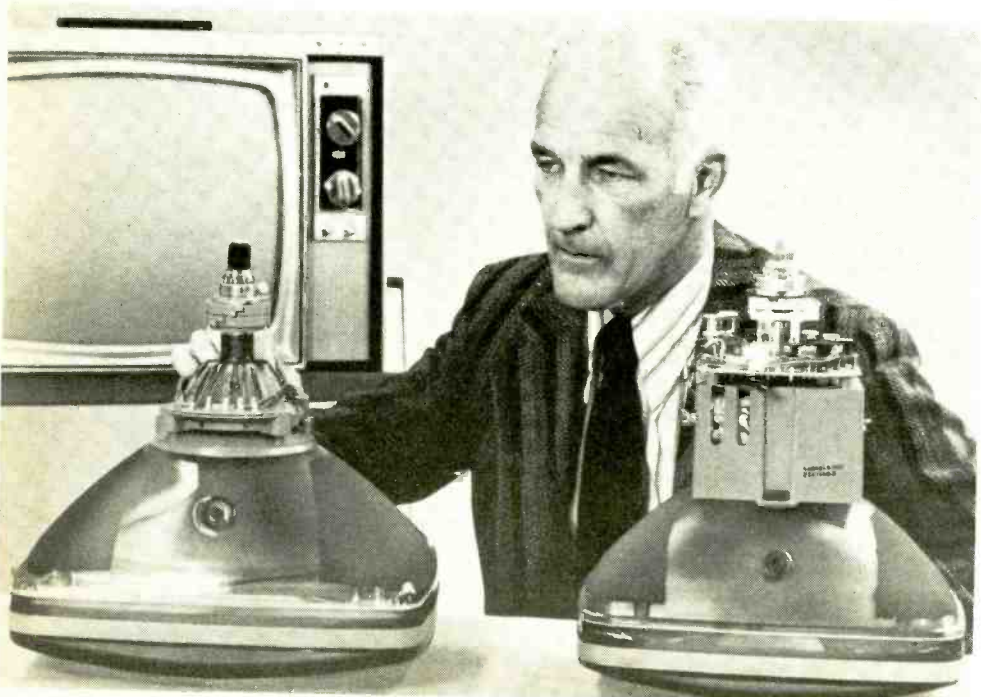



# New Breed of Test Equipment

By John T. Frye, W9EGV, KHD4167

"**M**AN!" Barney exclaimed, stopping short in the doorway of the service department, "I knew we had lots of business, but I didn't think we'd have to install a traffic light on the service bench."

Mac, the owner of the shop, looked around with a grin and then turned back to the little (4 $\frac{1}{4}$ " x 4 $\frac{1}{4}$ " x 2 $\frac{1}{4}$ ") blue-cased instrument resting on a tilt bail on the bench so its brushed aluminum panel looked up at him. That panel contained only an on-off switch on the left, two binding posts at the bottom center, a red one on the left and a green one on the right, and directly above these two large cut-outs in the panel in the form of opposite-directed diode symbols. Both were flashing on and off at a rate of three or four times a second. The bottom one with the arrow pointing to the right was flashing a bright green; the top one with the arrow pointing to the left was flashing a bright red, giving rise to Barney's comment.

"Junction Verifier, Electronics Division, Kurz-Kasch, Inc., Dayton, Ohio," Barney read from the little panel over Mac's shoulder. "What the heck is a 'junction verifier'?" (Kurz-Kasch, Inc., Electronics Div., 1421 S. Broadway, Dayton, OH 45401)

"Just what it says: a device to verify the operating condition of any junction in most solid-state, semiconducting junction-type electronic devices in use today, including silicon, germanium, or selenium diodes, zeners, bridge rectifier assemblies, npn and pnp transistors, LED's, FET's, and tunnel diodes. With this defective diode you see I have connected to the binding post terminals, both displays are flashing to indicate no rectification is taking place across the shorted junction and current is flowing in both directions. You get the same display

by simply putting a piece of wire between the binding posts. When I remove the shorted diode and replace it with an open-circuited diode, like so, neither display flashes because current cannot pass in either direction across the open junction."

"Does that thing only give you the bad news? How about the good news?"

"I'm coming to that. Let's connect this good diode with the marked cathode to the green binding post and the anode to the red post. That is the normal way to connect a junction to the instrument: anode to the red post, cathode to the green post. Notice now only the bottom green display is flashing, verifying that the junction is good and that the diode is properly marked resulting in 'conventional' current flow from left to right. But now let's reverse the diode so the cathode is connected to the red post and the anode to the green post. See, now only the red display is flashing. This indicates the junction is still good, but the current is flowing from right to left. That is what would happen if we tried to test a diode with the cathode improperly marked."

"I get it," Barney said. "The verifier tells you four things about a diode: (1) if the diode is shorted, (2) if the diode is open, (3) if the diode is rectifying, and (4) which way current is flowing through the diode. Right?"

**Checking Transistors.** "Right as far as you go. The verifier actually tells you these four things about almost *any* semiconductor junction, no matter if that junction constitutes a simple diode rectifier or is one of several junctions contained in a single solid-state device. Let me show you what I mean," he said, attaching matching test leads to the red and green five-way binding

posts of the verifier and removing the back of an inexpensive little transistorized radio lying on the bench.

"Suppose we want to check the transistors in this Japanese receiver for which we have no service data. The transistors, which we do not recognize, are soldered in. I touch the green lead to the collector and the red lead to the base of a transistor. The green display starts to flash, and I immediately know two things: the collector-base junction of the transistor is good, and the transistor is a pnp type in which the collector voltage is supposed to be negative with respect to the base.

"Next, I shift the green lead to the base and the red one to the emitter. Again the flashing of the green arrow tells me the junction I am testing, the emitter-base junction, is good and that the base is properly the cathode of this junction. If, in our first test, the red arrow had started flashing instead of the green one, I should have known

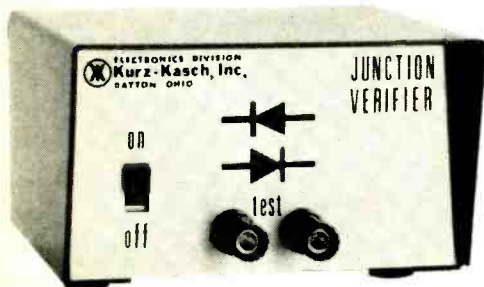

we were dealing with an npn type transistor that requires a positive voltage on the collector. If both displays had flashed simultaneously, I would know the junction was shorted. Had neither arrow flashed, I could be sure the junction was open. In either case, the transistor would be bad. So you see the verifier serves as a transistor tester and a transistor-type identifier."

**In-Circuit Tests, Too.** "What impresses me," Barney observed, "is that you made these tests with the transistor wired into the circuit. Can you always do that?"

"Almost always. A junction may be tested in-circuit as long as the parallel resistance is 1500 ohms or more or the parallel circuit capacitance is 10 microfarads or less, which is practically almost always the case. Lower parallel resistance or greater parallel capacitance may cause the verifier to indicate erroneously a shorted junction."

"A couple of times you said the instru-

ment would test 'almost' any junction. What are the exceptions?"

"It will not test junctions having more than 2 volts forward voltage drop. About the only place you find these is in high-voltage rectifier stacks. Neither will it reliably test junctions having reverse voltage drops less than 4 volts. That means it will not test low-voltage zeners, such as the 3-volt type. Finally, some voltage reference diodes, such as the 1N821 and the 1N937, are designed to operate in a forward conducting mode, in contrast to zener and avalanche diodes. To insure their correct circuit application, these devices are banded on their anode ends, as opposed to cathode banding on true zener and conventional forward-conducting diodes. Such reference diodes rated in excess of 2 volts will appear as open elements on the junction verifier because tests with an ohmmeter will show normal forward resistance of about 10,000 ohms and infinite reverse resistance."

"Do you know how the junction verifier works?"

"Only in general terms. It is said to use a unique digital technique that sends pulses of current, not exceeding 5 mA, in both directions through the junction, samples both forward and reverse currents, compares the two, and displays the result on the diode symbol screens of the front panel. I may as well admit I peeked inside and saw two IC's and a host of discrete components mounted on a glass epoxy board. Since the circuit is a new one for which a patent has been applied, it is naturally not published."

"What does the thing cost?"

"This ac model, the JV-1505, costs \$44.95. A battery model, using four 'C' batteries, the JV-1506, is priced at \$30.95. But actually the interesting thing to me about the junction verifier is that it typifies a new line of service instruments coming on the market—instruments designed to meet the problems of the *modern* technician and to impress favorably his customer."

"Why do you accent the word 'modern'?"

**New Types of Testers.** "In the old days the work was done almost entirely in the shop. It mattered little how bulky, heavy, and hard to understand the instruments were. They were only seen by the technician, and he knew what they said. But today much of the work is done in the home. Those instruments have to go out into society, and they should have what the auto



industry calls 'pizzazz,' or flair. They should please the eye of the customer and impress him with their performance.

"Note, for example, the compactness and light weight of this little junction verifier. Every ounce and every cubic inch of space counts when you have to take the instruments to the receiver. Also look at the attractive, textured, chip-resistant blue case and the brushed aluminum panel. Above all, though, notice how movement and color are employed in the readout. Those flashing colored arrows catch the eye of the customer just as they caught your eye when you came through the door. That is showmanship.

"But the showmanship is backed up with solid utility for the technician. The instrument has versatility that insures it against obsolescence. Just as a crescent wrench is always useful, no matter how many box sockets and end wrenches you have on the bench, so will an instrument that speedily checks a single junction always be in demand. And it is speedy. You can check junctions as fast as you can apply the test probes."

"You might say the same thing about the new digital voltmeters," Barney observed.

"They are rugged, easy to read, and are bound to impress the customer with the computer-fast speed with which their display changes."

"Right you are, and I'm glad you used that adjective 'computer-fast.' That is the key to what I am talking about. The important thing is the association that takes place in the mind of the customer when he sees some of the modern service instruments working. That DVM readout reminds him of the displays he has seen during rocket launches, and he knows that the space program incorporates the best there is in electronics.

**Other Examples.** "The new, compact, solid-state scopes are another example of the same thing. The customer is always intrigued by the moving patterns seen on a scope screen. After all, he has seen these instruments used in science laboratories and in the operating room, and he equates their use with precision and technical excellence. It is most reassuring to him to see his TV set adjusted with the use of a scope. But, again, a modern dc scope is the most versatile instrument a technician can take into the home. It can serve as an ac or



## MAKING "WAVES"

**CADENCE—the musical instrument speakers**

Making better, clearer, amplified sound waves is the THING Cadence does... better than anything else in the industry. Cadence Speakers are built to withstand heat from sustained notes at a high power level and the vibrations and stresses which are continually placed upon them. Cadence is guaranteed **one full year** at the power level specified. This proven speaker family has been selected by the manufacturers of most of the world's fine amplified music instruments.

If making beautiful, clear sound waves is your thing, ask for **CADENCE SPEAKERS**. For complete information and the name of your Cadence Dealer, write:



**UTAH ELECTRONICS DIVISION**  
Utah-American Corporation  
1124 East Franklin Street  
Huntington, Indiana 46750

CIRCLE NO. 39 ON READER SERVICE CARD

# TYMETER®

"Time At A Glance"

DIGITAL CLOCKS

Since 1935



MADE IN U.S.A.

\$16.50

Plus  
\$1.00  
Postage

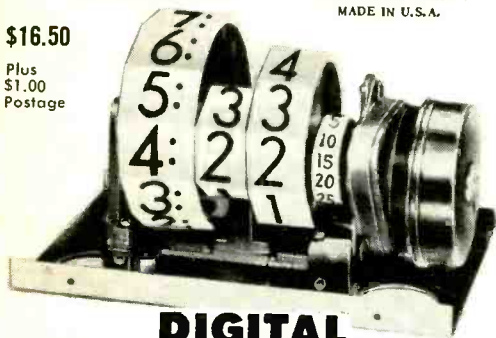

## DIGITAL CLOCK MOVEMENTS

#130..12 HOUR #131..24 HOUR

DIGITS RESETTABLE INDIVIDUALLY

Available in 50, 60 cy., all voltages, AC. UL approved motor, cord. One Year Guarantee.

Complete Line of Count-Up and  
Count-Down Digital Computers

CATALOG ON REQUEST

**PENWOOD NUMECHRON CO.**

DIVISION OF LCA CORPORATION

7749 FRANKSTOWN AVE

PITTSBURGH, PA. 15208

CIRCLE NO. 23 ON READER SERVICE CARD

## IT'S EASY TO ASSEMBLE A SCHOBER ORGAN!

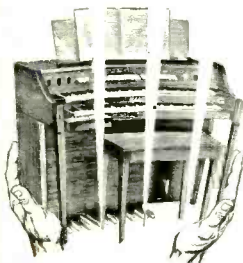

**CONSOLE II  
ORGAN  
\*\$1040**

\*Includes easy to  
assemble walnut  
console kit.  
Amplifier, speaker  
system, optional  
accessories extra

You can learn to play it. And you can build it, from Schober kits, world famous for ease of assembly without the slightest knowledge of electronics or music.

There has never been an organ of the Console II's graceful small size with 22 such pipelike, versatile voices, five-octave big organ keyboards, and 17 pedals! Highest praise from musicians everywhere. Send for free catalog featuring five Schober Organ models, beginning at \$499.50.

The *Schober* Organ Corp., Dept. PE-44  
43 West 61st Street, New York, N.Y. 10023

Please send me Schober Organ Catalog.

Enclosed please find \$1.00 for 12-inch L.P.  
record of Schober Organ music.

NAME \_\_\_\_\_

ADDRESS \_\_\_\_\_

CITY \_\_\_\_\_ STATE \_\_\_\_\_ ZIP \_\_\_\_\_

CIRCLE NO. 30 ON READER SERVICE CARD

dc voltmeter, a signal tracer, a distortion analyzer, a curve tracer, a phase-shift detector, a frequency meter, or what have you. A modern scope gives real meaning to that common phrase: 'the usefulness is limited only by the ingenuity of the owner.'

"Why are we getting these new instruments now?"

"I think the major debt is to the space program and the computer industry. For example, I am sure this junction verifier came about through the research Kurz-Kasch did in developing their digital logic testing probes which they claim will replace wide-band scopes and DVM's now used for this purpose. The readout of these low-cost probes is in the form of three colored lights. And we know that IC applications in space age instruments and computers have lead to the DVM's and the solid-state scopes."

"Well," Barney said as he got into his shop coat, "I just hope the space and computer boys continue throwing an occasional glance toward our needs. Service instrumentation can stand some 'pizzazz' as you call it."

## IDENTIFICATION BY INSTANT REPLAY TV

An "instant replay" video disc system for controlling access to high security areas has been introduced by Ampex Corporation. The TVID (television identification) system employs the same rapid access TV disc record and playback techniques developed for instant replay of sports action. It enables guards to replay previously recorded television pictures of personnel on a television screen with a maximum access time of two seconds. The guard can also add new recordings to the file in seconds with the television camera.



POPULAR ELECTRONICS Including Electronics World

# LIGHT MINDER

ALERTS YOU TO TURN OFF CAR LIGHTS WHEN ENGINE IS SHUT DOWN

BY STEPHEN J. ERST

**R**EPLACING a dead battery resulting from having left your car lights on overnight is an expensive and time-consuming proposition. Detroit has remedied the "forgotten ignition key syndrome" with a buzzer; now you can remedy the "forgotten light syndrome" with a similar alerting system. With a Light Minder installed in your car, you

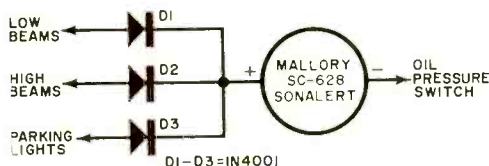

will be alerted to turn off parking and headlights whenever you turn off the engine without first switching off the lights.

As shown in the schematic, the Light Minder—consisting of three isolation diodes and a Sonalert tone generator—takes advantage of the operational positions of the oil pressure switch. The oil pressure switch is normally closed when the engine is not running, providing a convenient current path from chassis ground through the Sonalert and the appropriate diode to battery positive via the switched on lamp or lamps. Consequently, until the lamps are switched off, the Sonalert will continue to sound an alert.

When the engine is running, the oil pressure switch is normally open, breaking the current path through the Sonalert. This gives you a side benefit: if your lights are on while driving, the Sonalert will sound should there be a loss of oil pressure.

When installing the Light Minder into your car's electrical system, it is best to locate the Sonalert in the glove box or some other out of the way location. After making hookups, cover all joints with electrical tape to insulate and waterproof them. ♦



*The best of two worlds...*



**Short Wave Listening**

**Communications Radio**



**Drake**  
MODEL  
**SW4-A**



**Drake**  
MODEL  
**SPR-4**

## International Shortwave Broadcast Receiver

- Precision tuning dial eliminates guesswork, permits Direct Frequency Dialing on SW and standard AM Broadcast
- Crystal lattice filter for adjacent station rejection and good AF response
- Dual conversion
- Solid state AF output
- S-meter
- Preselector gives superior sensitivity by peaking antenna and RF stages
- Crystal-controlled H. F. Oscillator stability
- Amplified AVC constant AF output.

**\$335.00**

## Programmable Communications Receiver

- Programmable to suit any interest: SWL, Amateur, Laboratory, Broadcast, Marine Radio, etc.
- All solid state
- Direct Frequency Dialing: 150-500 kHz plus any (23) 500 kHz ranges, .500 to 30 MHz
- FET Circuitry
- Linear dial, 1 kHz readout
- 3 bandwidths: 0.4 kHz, 2.4 kHz, and 4.8 kHz for: CW, SSB, AM
- Power: 120 VAC, 220 VAC, and 12 VDC
- Crystals supplied for LW, BC and seven SW bands.

**\$499.95**

**R. L. DRAKE COMPANY**



540 Richard Street  
Miamisburg, Ohio 45342

CIRCLE NO. 10 ON READER SERVICE CARD

# You don't have to get a college in electronics

Next to a willingness to work, nothing will improve your chances of success in electronics more than a college-level education. But family obligations and the demands of your job may make it very difficult for you to attend classes. That doesn't mean you have to forget about getting ahead. CREI makes it possible for you to get the college-level education you need without going back to school.

## Learn at home

At your own pace, your own schedule . . . without giving up your present job. CREI lessons are written to be clearly understood without the presence of a teacher. Your problems are anticipated. Your instructors will work with you in a very personal manner and give you all the individual attention you need. Many men learn far more readily through home study than they ever did in the classroom.

## Not for beginners

CREI programs are written for men familiar with basic electronics, but who want to

get the advanced, specialized knowledge they must have to move up to engineering-level positions and engineering-level pay. All CREI training material is developed with the help of top engineers and scientists from private industry and government laboratories. Each of these men is an expert in his field of electronics. He knows exactly what level of specialized knowledge a man needs to work successfully in that particular field today. This is your assurance that what you learn from your CREI study can be applied on the job.

## You can have confidence in CREI

Since 1927, CREI has helped tens of thousands of men move ahead in every phase of the electronics industry. You'll find CREI graduates and students in key jobs wherever up-to-date knowledge of electronics is demanded. Leading companies recognize the quality of CREI education. Many pay all or part of CREI tuition for their employees.

## CREI education is up-to-date education

CREI courses are continually being revised. New developments are included as quickly as they occur. Right

now, CREI students are getting the latest information on cable TV, LSI chips, microminiaturization, lasers and masers, telemetry systems, servomechanisms and data links. If it's new in electronics, CREI—and you—will know about it.

## Send for free book with complete information on CREI programs

Use postpaid card—no stamp needed. If card is detached use coupon or write: CREI, Dept. E1209C, 3939 Wisconsin Ave., N.W., Washington, D.C. 20016



Founded 1927  
Accredited Member of  
the National  
Home Study Council

# to go to college -level education



## Capital Radio Engineering Institute



This certifies that  
**Robert Denney, Jr.**  
 has satisfactorily completed the Course of Study in  
**Electronic Engineering Technology**  
 Majoring in  
**Computers**  
 and upon the recommendation of the Board of Directors is granted this  
**Diploma**  
 In Testimony Whereof, we have affixed our signatures



*B. A. Costello*

**CREI, A Division of the McGraw-Hill  
 Continuing Education Company**

Dept. E 1209C, 3939 Wisconsin Ave., N.W.,  
 Washington, D.C. 20016

Please send me free book with full information about  
 CREI Programs.

Name \_\_\_\_\_ Age \_\_\_\_\_

Address \_\_\_\_\_

City \_\_\_\_\_ State \_\_\_\_\_ Zip \_\_\_\_\_

Employed by \_\_\_\_\_

Type of Present Work \_\_\_\_\_

I am interested in:  Computers  Electronic Engineering  
 Technology  Nuclear Engineering Technology  
 Industrial Electronics  Electronics Systems  
 Engineering  Television Engineering  Non-Technical  
 Course in Computer Programming  New! Cable TV

APPROVED FOR TRAINING UNDER NEW GI BILL





# Communications Scene

By Richard Humphrey

**M**ANY words have been written explaining the massive changes in marine communications regulations to the average pleasure boater and the average commercial ship owner. But little attention has been paid to the man who is electronically knowledgeable and who wants more in-depth information. This especially applies to the FCC-licensed technician who's going to be installing, maintaining and repairing this equipment. New FCC Rules & Regulations, radio techniques new to the marine community and an ever-growing number of radio-equipped vessels have all conspired to extend a golden carrot with one hand to those earning a living in marine radio and, at the same time, swat them in the chops with a cast iron copy of new laws and technical requirements with the other hand.

Since January 1, 1972, new installations of double sideband (DSB) AM marine radiotelephones in the 2-3-MHz band have been prohibited. This means the FCC won't license them—therefore they're illegal. All new installations must be single sideband

(SSB) equipment capable of A3J (SSB with the carrier suppressed at least 40 dB below PEP, peak effective power), A3A (SSB with carrier 16 dB,  $\pm$  2 dB, below PEP), and A3H (SSB with the carrier between 3 and 6 dB below PEP). In all cases, the upper sideband shall be used.

Before a new installation of SSB equipment will be licensed, there must be a validly licensed vhf/FM (156-162 MHz) marinephone installation on board.

Double sideband AM marinephones may be installed and licensed *only* if the set is owned by someone who has sold his boat, bought another, and is transferring the 2-3-MHz DSB radio to his new boat. And then only if the DSB radio was licensed from *before* January 1, 1972 *past* January 1, 1972. In this case, the old license and the application are submitted to the FCC and the radio will be relicensed, but no longer than January 1, 1977. DSB marinephones licensed prior to January 1, 1972 in the 2-3-MHz band and retained on the same vessel may be licensed and used until January 1, 1977.

If someone buys a boat *after* January 1, 1972 and it is equipped with a 2-3-MHz DSB radiophone, he may *not* license the equipment even though the radio was properly licensed before that date and the license is still valid. The FCC has ruled that an *original* owner is entitled to amortization relief but no one may "inherit" this privilege.

**New 2-3-MHz Frequencies.** Listed in the Table are the new SSB frequencies authorized June 16, 1970. These are all limited to A3J and A3A SSB emission. The frequencies that have long been standbys in the 2-3-MHz band—2003, 2142, 2638, 2670, 2738 and 2830 kHz—permit A3, A3A, A3H and A3J with A3 (DSB) out as of January 1, 1977. On 2182 kHz, the

## New Regulations and the Marine Radio Technician

international calling and distress frequency, A3 and A3H *only* are permitted until January 1, 1977 with A3H *only* after that date.

Installing, maintaining and servicing radio equipment aboard commercial vessels is a highly specialized field involving stand-by power supplies, vessel tonnages, the number of passengers carried, r-f indicating devices, transmit-position lighting, U.S. Coast Guard regulations and a host of other considerations never found in pleasure boat work. Anyone considering a career in commercial marine electronics—and it's extremely well-paying—must have an intimate knowledge of the Communications Act of 1934, as amended, and Volume IV of FCC Rules & Regulations.

### The vhf/FM (156-162 MHz) Band.

The bulk of a marine communication technician's work is going to be with vhf/FM equipment, and aboard pleasure boats. About the only field instrument necessary is an SWR bridge. Even this isn't vital since FCC regulations permit frequency and modulation checks into a dummy load to be made on the service bench.

Since channels 6 (156.3 MHz) and 16 (156.8 MHz) are mandatory, most sets come from the manufacturer with these crystals installed. Most radios also have the receive-only National Weather Service crystal (162.55 MHz). This last will probably eventually be replaced with channel 15 (156.75 MHz), the environmental channel, which will have weather broadcasts tailored expressly for marine interests. Presently, however, channel 15 is operational only in Florida waters.

Many questions have been asked about channel 16, the national distress, safety and calling frequency. Being a distress frequency, it must be monitored at all times by coast and ship stations during their hours of service. For most vessels this means from the time the set is turned on until the time it is turned off. What precisely is meant by "national"? Usually it means waters inside the three-mile limit. For fishing, our national waters extend out 12 miles. "National" insofar as it applies to the vhf/FM marine band has not yet been defined. However, it has been tacitly agreed that the vhf/FM boundary is 20 miles from shore. The regulations permit mandatorily equipped passenger vessels carrying over six passengers to satisfy the law by using vhf/FM equip-

# TUNER SERVICE

VHF, UHF, FM or IF Modules . . .

. . . All Makes

## Fast 8 hr. Service!

### 1 YEAR GUARANTEE



VHF-UHF-FM	\$ 9.95
UV-COMB.	\$16.95
IF-MODULE	\$12.50

Major Parts charged at Net Price  
P.T.S. is overhauling more tuners for more technicians than any other tuner company in the world!

**LIKE TO DO IT YOURSELF?**  
Send one Dollar (redeemable) for our 60 pages of top information

**TUNER REPLACEMENT GUIDE AND PARTS CATALOG**

For fastest service, send faulty tuner with tubes, shields and all broken parts to:

## PTS ELECTRONICS, INC.

"Precision Tuner Service"



HOME OFFICE—  
Box 72 • Bloomington, Ind. 47401 • Tel. 812. 824-9331  
WEST—  
Box 41354 • Sacramento, Calif. 95841 • Tel. 916. 482-6220  
SOUTH—  
Box 7332 • Longview, Tex. 75601 • Tel. 214. 753-4334  
SOUTHEAST—  
Box 6881 • Jacksonville, Fla. 32205 • Tel. 904. 389-9952  
EAST—  
Box 1189 • Springfield, Mass. 01103 • Tel. 413. 734-2737  
MOUNTAIN—  
Box 4245 • Denver, Colo. 80204 • Tel. 303. 244-2818

**CIRCLE NO. 22 ON READER SERVICE CARD**

## Planning to move?

Let us know 6 to 8 weeks in advance so that you won't miss a single issue of **POPULAR ELECTRONICS INCLUDING ELECTRONICS WORLD**

Attach old label where indicated and print new address in space provided. Also include your mailing label whenever you write concerning your subscription. It helps us serve you promptly.

Write to: P.O. Box 1096, Flushing, N.Y. 11352, giving the following information.

If you have no label handy, print OLD address here.

name please print

---

address

---

city

---

state zip-code

AFFIX LABEL

- Extend subscription.**       **Change address only.**       **Enter new subscription.**
- (1) 5 yrs. \$21 (2) 3 yrs. \$15. (3) 1 year \$6
- Payment enclosed (1 extra issue per yr. as a BONUS)**       **Bill me later.**      0709

name please print

---

address

---

city state zip

Add'l postage: \$1 per year outside U.S., its possessions & Canada.

ment instead of 2-3-MHz marinephones if the vessel is always operated within 20 nautical miles of a U.S. Coast Guard or public coast (marine operator) station.

**International Differences.** At intervals of approximately seven years, the International Telecommunications Union holds a World Administrative Radio Conference—usually in Geneva—to lay down broad general agreements in radio matters. Signatory nations reserve the right to alter agreements if special conditions warrant. The U.S. has a pleasure boating situation faced by no other nation. There are about 200,000 radio-equipped recreational crafts in this country while the entire nation of France has less than 500.

The main difference between U.S. and international policies in marine communications is one of dates. In the 2-3-MHz band, the U.S. transition from DSB AM to SSB is January 1, 1972 to January 1, 1977. Internationally, the transition dates are January 1, 1973 to January 1, 1982. The vhf/FM scene has stabilized—once the initial shock wore off—and there are no major differences between U.S. and international policies with the exception that channel 16 (156.8 MHz) is a safety and calling frequency internationally and not officially designated a distress frequency.

**Misunderstood Areas.** There are two areas where misunderstandings exist: signing the ship's radio log, and on-the-air radio checks. You are required to list the carrier frequency; the percent of modulation and the output power (when the manufacturer's rated transmitter power exceeds the legal maximum by more than 120%); when the initial installation is made; and when

any adjustments, changes or repairs are made which affect the transmitted signal. The details of any repairs must also be listed along with your name, your address, the class and serial number of your license, and its expiration date. This same certification must also be made on installation. Incidentally, local FCC Field Office engineers appreciate your telephone number when you sign the log. In this way, slight bobbles on your part can be corrected by a phone call rather than by mail.

This satisfies the FCC, but the boat-owner needs different treatment. This means on-the-air checks to demonstrate that the radiophone works. Public correspondence (marine operator) stations are good starters on both vhf/FM and 2-3 MHz since you're usually within their primary coverage areas and it's nice to have a "loud and clear" on your first try. Next in line should be one or more U.S. Coast Guard Stations in your area. Here you may run into some difficulty due to a misinterpretation of FCC rules and regulations in some USCG Districts. Be sure to refer to your 2-3-MHz radio check as a "technical test." If the USCG unit comes back with "radio checks with Coast Guard Stations are forbidden by FCC rules," you can do one of two things: accept the comeback as a signal report of sorts, or refer him to Section 83.356(a) (4) which specifically authorizes technical (FCC-licensed technicians) or FCC personnel radio checks with U.S. Coast Guard units on 2182 kHz.

The same section authorizes radio checks on 2182 kHz with other vessels. Section 178(c) authorizes general ("any boat for a radio check") calls to other vessels. There are no restrictions on radio checks, Coast Guard or otherwise, on channel 16 (156.8 MHz) in the vhf/FM band.

Then checks should be made on two or more of the ship's working frequencies. *Always* use the vessel name and radio call-sign. If the boat is operating on an interim license, you must give the owner's name and the vessel's name when identifying.

Last, but most important, if you are a First or Second Class commercial licensee or intend to become one, get copies of the Communications Act of 1934, as amended, with all effective supplements and Volume IV, FCC Rules & Regulations. Both are available from the Government Printing Office, Washington 20402. Get to know them well. ♦

### NEW 2-3-MHZ FREQUENCIES

Frequency (kHz)	Conditions of use
2065.0	Assignment to ship and coast stations will be subject to coordination with Canada.
2079.0	Same as above.
2082.5	Available to ship stations primarily for intership safety communications in the maritime mobile service.
2086.0	Available to ship and coast stations operating in the Mississippi River System.
2093.0	Available to ship stations for intership communications aboard vessels engaged in commercial fishing.
2096.5	Available for use by limited ship coast stations.
2203.0	Available in the Gulf of Mexico only for assignment to ship stations other than those aboard vessels engaged in commercial fishing.



# “Easy Buy” time payment plan for Sams Photofact®

Free tool set if you act now!



PS130 Xcelite screwdriver, nutdriver set, with 60 sets.

Vaco tool luggage case. 33 tools, with 500 sets.

Fill in the gaps in your Photofact® library and bring your service coverage up to date.

Purchase a minimum of 60 Photofact® sets and pay for them in easy monthly installments through the Easy Buy Time Payment Plan.

**If you act now you get a bonus. Choice of tool sets FREE, with orders of 60, 100, 300 or 500 Photofact® sets!**

And, as usual, you get a single drawer file cabinet with every 60 sets, or a 4-drawer file cabinet with every 100 sets.

But act now and send for your Easy Buy order form. Bonus offer expires December 31, 1972.

PE-092

 **HOWARD W. SAMS & CO., INC.**  
4300 West 62nd Street, Indianapolis, Indiana 46268

Please send me Photofact Coverage Chart, Easy Buy order form and bonus tool offer.

Name \_\_\_\_\_

Address \_\_\_\_\_

City \_\_\_\_\_ State \_\_\_\_\_ Zip \_\_\_\_\_

**CIRCLE NO. 28 ON READER SERVICE CARD**

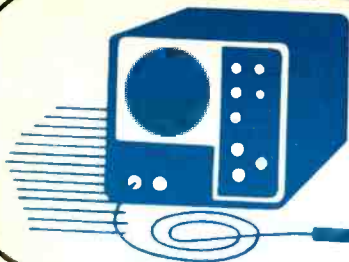

# Test Equipment Scene

By Leslie Solomon, Technical Editor

**I**T APPEARS to be an axiom among technicians and experimenters that, unless a scope comes with a probe already attached, any old length of insulated wire lying around the bench can be used to get the signal from the circuit under test into the scope. If that is your feeling, check the answers to the following questions.

*What's wrong with a piece of wire?*

Unfortunately, once you get away from simple dc transmission, where only the minuscule dc resistance of the wire is involved, things get very complicated. As the lead meanders across the benchtop on its way to the scope, it usually passes near or lies on anything that happens to be there. This produces a stray capacitance between the wire in the lead and the other object, with the lead's insulation as a dielectric medium.

Since the reactance of a capacitor goes down as the frequency goes up, a lower impedance is offered to the signal path. As this capacitance varies when the lead is moved around, there is no way of knowing the reactance of the lead at any given frequency or any given time. Now, just visualize what the high frequencies are going through: they don't know whether to be bypassed or not, nor by how much!

*What if I only work at low frequencies?*

This is fine as long as you are looking at

## Probes for Servicing

a simple sine wave. Just remember that anything other than a simple sine wave involves various quantities of higher-frequency harmonics; and they determine the actual waveshape seen on the scope. Also, keep the "antenna effect" in mind. Just visualize a high-gain, high-input impedance scope having an antenna hooked to the front end and a working TV set or radio transmitter in the neighborhood. Before you hook the probe to the scope, there is already a complex waveform present, and the viewed results will be a happy (or mostly unhappy) combination of the two.

*Will it be OK if I use coax cable?*

If you want to kill external interference, it will be. Unfortunately, the solution isn't really that easy. Look up the specifications of the coax you expect to use and check its capacitance per foot. Then calculate the reactance at the upper end of the frequency of the scope you are using. You paid good money for the scope's bandwidth. Now you will realize that you have a scope with a 5-MHz bandwidth with a built-in, front-end bypass capacitor that may now allow the upper audio frequencies to come through.

*What is the simplest probe?*

The simplest probe that could be used from dc to about 10 kHz would consist of a length of coax cable terminated at the tip by about 10,000 ohms. Because of the scope's high input impedance (1 megohm or more), the added resistance has no effect. Such probes are called "isolation" types and many commercial versions are available.

*What about units for higher frequencies?*

There are two approaches here. The first

is shown in Fig. 1A. The coax cable picks up a voltage from a two-resistor divider, which is designed for a 10:1 reduction. Note the presence of a small-valued trimmer capacitor ( $C1$ ). What has to be taken into account is the capacitance of the coax cable ( $C2$ ) and the input capacitance of

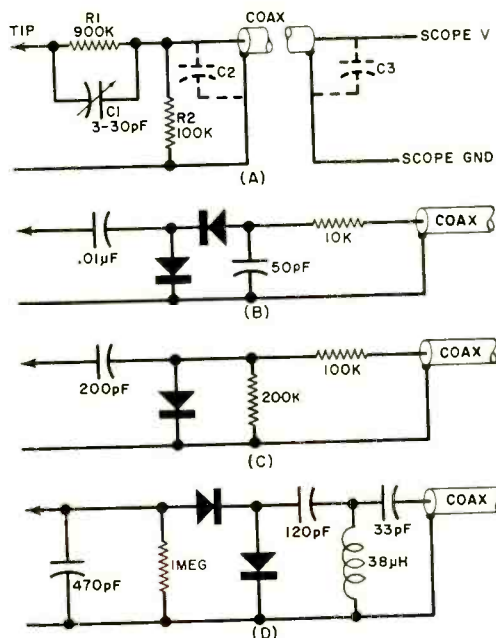

Fig. 1. Circuits of various probe types.

the scope ( $C3$ ). Assume that the combination of  $C2$  and  $C3$  adds up to 50 pF. When a 10-kHz square wave is applied to the input of the probe, the reactance of  $C2$  and  $C3$  will be about 300,000 ohms. However, all square waves have certain rise and fall times—important characteristics. If the rise time is, say, 10  $\mu$ s, it would take a scope bandpass of 35 kHz to show a decent square wave. Unfortunately, the reactance of  $C2 + C3$  is only about 85,000 ohms at 35 kHz; so the high-frequency components of the square wave will be attenuated more than the fundamental. This is what gives rise to the rounded edges on displayed waveforms.

Fortunately, since  $R2$  is shunted by 50 pF, series resistor  $R1$  can be shunted by a small capacitance ( $C1$ ) for compensation using the same ratio of capacitor reactance to resistance. The value of  $C1$  is made adjustable to compensate for varying lengths of coax cable and scope input capacitances. To calibrate this probe, simply apply a square wave and adjust  $C1$  until the scope

shows a clean square wave with no rounding (too little capacitance) or overshoot (too much capacitance) on the edges. Once compensated, the probe will be relatively insensitive to frequency variations. Some scopes use their own input resistance instead of fixed resistor  $R2$ .

#### What is a demodulator probe?

An oscilloscope can be used to examine modulation waveforms in the r-f and i-f portions of a TV, FM, or AM receiver, even though the upper frequency limit of the scope is only a couple of hundred kHz while the signal is many MHz. This is done by using the demodulator probe with a voltage doubler as shown in Fig. 1B or a half-wave version as in Fig. 1C. Essentially, what we have here is a broadband crystal detector with a little r-f filtering on the output. The half-wave approach has about half the signal level of the doubler version; but, in most cases, the former has a higher frequency response (less stray capacitance to bypass the r-f input). Many commercial demodulator probes can easily extract the signal from a carrier up to 250 MHz.

#### Are there specialized probes?

If you take a look at most manufacturers' catalogs, you can find probes for just about any purpose under the sun. The circuit of one probe (RCA WG-499A) is shown in Fig. 1D. It is frequency sensitive and is specially designed for 4.5-MHz trap alignment in TV receivers.

Then there are high-voltage probes for VTVM's (and scopes) for examining the range of 20,000 to 30,000 volts on CRT's. Some companies also make a current probe to measure either ac or dc current flowing in a wire without cutting the wire. There are, of course, many others—you will find them in your distributor's catalogs and shelves.

#### Who Makes What?

Just about every manufacturer who makes a scope or VTVM (TVM) also has a line of probes to be used with that instrument. Among these are RCA, B & K, Heath, Eico, Simpson, Leader, Pomona, and Mercury. Many of the larger electronic parts distributors also have a line of probes of their own brand listed in their catalogs. All you have to do is look over the line, pick the one you can use. And get rid of that hunk of insulated wire! ♦

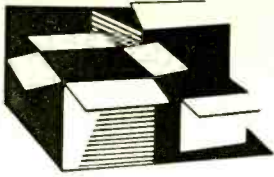

## New Products

### ONKYO STEREO RECEIVER

The Model TX-666, rated at 140 watts into 8 ohms, solid-state AM/stereo FM receiver is the newest entry into the hi-fi market by *Onkyo Sales*. The receiver has directly coupled and



differential amplifier circuitry in addition to automatic protection against speaker damage and dc leakage. Another feature is a transient killer for power-on/power-off overload protection. Built-in is a microphone mixing feature which allows the user to mix sounds from different sources, such as a turntable and tape recorder.

Circle No. 70 on Reader Service Card

### CRAIG 8-TRACK TAPE PLAYER SYSTEM

Recently introduced by *Craig Corp.* is the Model 3212 AM/stereo FM eight-track tape player system which comes complete with a pair of matched speaker systems. The tape player section is designed to play all presently-available eight-track stereo endless loop cartridges. Program switching is fully automatic but can be overridden for manual track selection. A front panel phone jack provides for private listening. A stereo record player equipped with a high-level ceramic cartridge can be used as an external signal source.

Circle No. 71 on Reader Service Card

### PIONEER 100-WATT SPEAKER SYSTEM

*U.S. Pioneer Electronics Corp.* recently released details on its new Model CS-99A speaker system which features the company's free-heating cone paper. The system employs a well-damped 15" woofer, 5" and 4" cone-type midrange drivers, multicellular horn-type tweeter, and a pair of ½" dome-type tweeters. The system is set in a specially designed air-suspension walnut enclosure. Impedance is 8 ohms; maximum power input is 100 watts; frequency range is 25-22,000 Hz; and crossovers are at 800, 2000, 5000, and

10,000 Hz. The unusual cone paper in the CS-99A is made of plant and animal fibers that are beaten—not cut—which results in a lighter but stronger cone.

Circle No. 72 on Reader Service Card

### RAY JEFFERSON DEPTHSOUNDER

An all new recorder/flasher depthsounder which charts bottom topography, finds fish, and indicates water depth has been introduced by *Ray Jefferson*. The Model 5270 has circuitry which prevents engine or ignition noise from disturbing the normal operation of the system without sacrificing sensitivity. As a result, the 5270 provides deep-burn, unusually sharp, high-contrast readings which give a detailed accurate picture of bottom topography. The unit traces on a moving chart the contour of the bottom under the boat, gives simultaneous flashing-light indication of depth, and shows all intervening objects. Separate motors for the flasher and chart drive are provided. Depth soundings are to 270 feet.

Circle No. 73 on Reader Service Card

### PRE-FINISHED SPEAKER ENCLOSURE

*National Tel Tronics* has developed a new idea in prefabricated speaker enclosures. The kit is designed to just fold together in 12 min or less to create a sturdy, hi-fi quality enclosure. No tools, cutting, or screws or nails are required during assembly. Completely prefabricated, the enclosure is walnut-veneer finished. The walls are of ¾"-thick wood to provide an airtight acoustic-suspension enclosure designed to assure performance in the range of 10-25,000 Hz. Two models are available: the CK 20-2 is for 2-way systems and accommodates a 2½" tweeter and an 8" woofer; the CK 20-3 is for 3-way systems and accommodates the same speakers as the CK 20-2 plus a 5" midrange driver. The company is also marketing two NTT/Peerless speaker kits for use in the enclosures.

Circle No. 74 on Reader Service Card

### MARANTZ AM/STEREO FM TUNER

The *Marantz Co., Inc.*, Model 105 stereo tuner incorporates many of the features found in its more expensive counterparts. These include exclusive Gyro-Touch tuning, illuminated tuning meter, dial pointer and blackout dial, and a gold-anodized front panel to match other Marantz components. A signal strength tuning meter assures accurate tuning for optimum reception, and FM muting eliminates interstation noise when

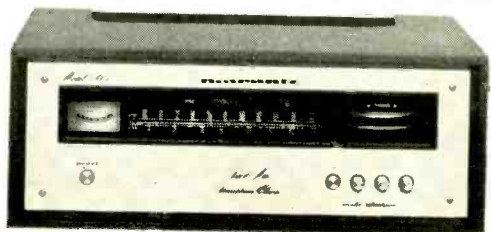

POPULAR ELECTRONICS Including Electronics World

# Look for the PTC *Please The Customer* Semiconductor Mart at your Mallory Distributor's.

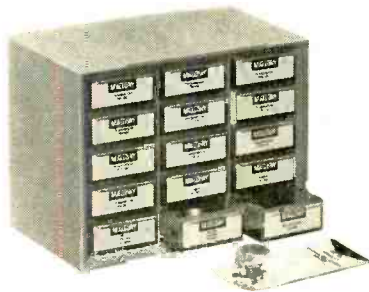

**THE FAMOUS MALLOBIN WAREHOUSE.**  
With the semiconductors most needed by service technicians.



**THE SEMICONDUCTOR MART.** He's the quick, easy way to get the replacements you need. It's the best assortment of the hottest semiconductors around. Transistors, diodes, multiple diode packages, zener diodes and integrated circuits included.

**FREE** copies of the very latest cross-referenced Semiconductor Product Guide.

Clear, concise product data on the packages makes your choice easy. And Mallory quality, versatility, and dependability make every choice a good one.

## You know what you need. Now you know where to find it.

**MALLORY**



**MALLORY DISTRIBUTOR PRODUCTS COMPANY**  
a division of P. B. MALLORY & CO. INC.  
Box 1284, Indianapolis, Indiana 46206; Telephone: 317-636-6363

**CIRCLE NO. 19 ON READER SERVICE CARD**

DELUXE  
**MAGAZINE CASES**  
*Designed Exclusively for*  
**POPULAR ELECTRONICS**

● The ideal way to save your valuable copies, keep them well protected and make it easy for you to refer to any issue at any time. Both decorative and attractive enough to enhance the decor of any room, each case holds a full year's copies. Constructed of reinforced fiberboard, these durable cases are covered in a rich-textured leatherette. The gold embossed back adds to its elegance and makes each case a welcome addition to your bookshelf or cabinet.

Magazine cases are available for any of your favorite magazines. They're only \$4.20 each, 3 for \$11.60, in any combination of titles ordered. Add 50c per case for postage and handling. Outside U.S.A. add \$1.00 per case ordered.

 **CHARGE YOUR AMERICAN EXPRESS OR UNI-CARD ACCOUNT.** 

Ziff-Davis Pub. Co., Dept. 23, 1 Park Avenue, New York 10016

My remittance in the amount of \$ \_\_\_\_\_ is enclosed. Please send magazine cases for the titles indicated below.

CHARGE:  American Express  Uni-Card

Account # \_\_\_\_\_

Signature \_\_\_\_\_

PE-972	TITLE	QUANTITY

Check One:  All Black  Maroon Back, Black Sides

Print Name \_\_\_\_\_

Address \_\_\_\_\_

City \_\_\_\_\_ State \_\_\_\_\_ Zip \_\_\_\_\_

**PAYMENT MUST ACCOMPANY ORDER**

tuning. The rear panel contains 300-ohm unbalanced and 75-ohm balanced antenna inputs, AM ferrite antenna, and an accessory ac outlet.

**Circle No. 75 on Reader Service Card**

**SHURE IMPROVES M91E PHONO CARTRIDGE**

Augmenting their M91 phono cartridge series, *Shure Brothers, Inc.*, has introduced the Model M91ED which offers trackability second only to the company's V-15 Type II (Improved) cartridge. The new cartridge delivers significantly improved high-frequency trackability over the present M91E, made possible by design advances in the stylus assembly. The M91ED features an elliptical stylus. For those who prefer a spherical stylus, Shure is offering the M91GD cartridge. Also, owners of M91E cartridges can upgrade their present system by purchasing an N91ED (elliptical) stylus.

**Circle No. 76 on Reader Service Card**

**E.F. JOHNSON CB TRANSCEIVER**

An improved version of their most popular 23-channel base station CB transceiver has been introduced by *E.F. Johnson Co.* Called the Messenger 123A, it features completely new solid-state circuitry with a ceramic selectivity filter designed to reject adjacent-channel interference even from strong nearby signals. Another feature



is an "acoustically isolated" speaker and special audio circuitry which has a frequency-tailored response for clearer voice reproduction and suppression of noise. An accessory external speaker is also available for use under exceptionally noisy conditions. Other accessories available include a power pack with rechargeable batteries for portable operation and a power supply base for desktop use on 117-volt ac power.

**Circle No. 77 on Reader Service Card**

**TRIPLETT PORTABLE INSTRUMENT KITS**

To meet the electrical measurement needs of schools, test labs, experimenters, and hobbyists who custom design their own portable test instruments, *Triplett Corp.* is marketing four new instrument kits. The G/P Series 10-2189 through 10-2192 kits consist of unbreakable molded phenolic cases with 5-way binding posts and a metal front plate assembly which accommodates 3 1/2" panel meters. The panel can be punched, drilled, painted, legend inscribed, or used for adding

**free TRIGGER**  
**MONEY-SAVING CATALOG**  
**FOR THE MAN IN ELECTRONICS**



**SEE**  
**TRIGGER'S GREAT SELECTIONS**  
 Send for this reliable buying guide to carefully selected:  
 Amateur Gear • Stereo Hi-Fi • Electronic Kits • CB Radio • Tape Recording • Electronic Parts • Antennas • Tubes • Transistors • Tools • Books • Test Gear  
 Count on TRIGGER for the best in electronics. Write for FREE Catalog today.

**SEND FOR IT TODAY!**

TRIGGER Electronics, Dept. 12-ST  
 7361 North Ave., River Forest, Ill. 60305

Send FREE TRIGGER Catalog

Name \_\_\_\_\_  
 PLEASE PRINT

Address \_\_\_\_\_

City \_\_\_\_\_ State \_\_\_\_\_ Zip \_\_\_\_\_

**CIRCLE NO. 37 ON READER SERVICE CARD**

**FREE Catalog**

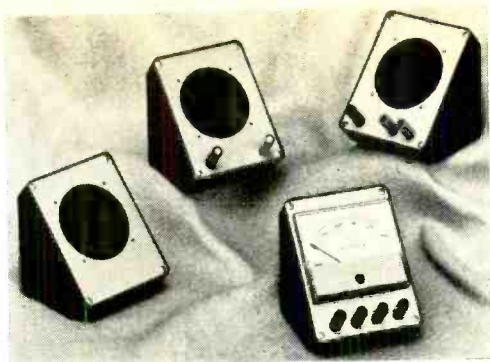

controls. The No. 10-2192 kit contains a case and metal panel without binding posts; No. 10-2191 is the same but also includes one red and one black binding post; No. 2190 is similar and has an extra red binding post; and No. 10-2189 consists of case, metal plate, and three red and one black binding posts.

**Circle No. 78 on Reader Service Card**

#### ANTENNA SPECIALISTS CB BASE ANTENNA

A new 27-MHz omnidirectional base station antenna described as a major breakthrough in basic antenna design has been introduced by *Antenna Specialists Co.* The Model M-400 Starduster half-wave dipole incorporates a vertical radiator and three ultra-low-angle active radial elements

which create a full aperture and extremely low radiation angle. The result is a measured gain of 5 dB over the standard ground-plane reference and 6.85 dB over an isotropic source. The antenna has a weatherproof feedpoint in the form of a diecast center hub which accommodates standard 1" threaded pipe or 1 1/4" steel antenna mast.

**Circle No. 79 on Reader Service Card**

#### HEATHKIT DIGITAL MULTIMETER KIT

New to the *Heath* line of test instrument kits is their Model IM-102 digital multimeter which features a 3 1/2-digit display and lab-calibrated ac-

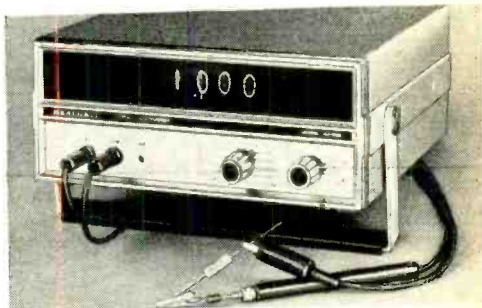

curacy to 0.1% on dc volts. The instrument accurately measures both ac and dc voltages from 100  $\mu$ V to 500 volts, ac and dc current from 100 nA



When you stop to think about it, the claims made for some headphones seem to border on the ridiculous.

You've read about phones that supposedly go from the subsonic to the ultrasonic, some that employ woofers, tweeters and crossover networks and still others that are tested on and certified by dummies.

But the truth is that there is no completely reliable instrument method for testing headphones or substantiating a manufacturer's performance claims.

So what's the prospective headphone buyer to do?

At Beyer, we've found the only reliable answer is to trust your own ears.

And to help make it easier for you, we've reprinted an independent, completely unbiased article called, "The Truth About Headphones," which we'll be happy to send you. It describes the difficulties involved in testing headphones and goes on to tell you how to compare and evaluate headphone performance for yourself.

Once you've had a chance to compare Beyer to the rest, we think you'll end up buying Beyer.

Because, the truth about Beyer headphones is...what you hears is what you gets.

Revox Corporation, 155 Michael Drive, Syosset, New York 11791  
**CIRCLE NO. 26 ON READER SERVICE CARD**

to 2 amperes, and resistances from 0.1 ohm to 20 megohms. Resolution on the 200-mV range is 100  $\mu$ V, and on the 1000-volt range, 1 volt. The IM-102 automatically switches to accommodate either dc polarity, displaying either a + or a - on the readout strip, thus eliminating the need to change probe leads. Input impedance is approximately 1600 megohms on the 2-volt range, and 10 megohms on all higher ranges.

Circle No. 80 on Reader Service Card

### FANON INTERCOM STARTER PACK

Fanon is offering three 5-station intercom masters and two 50' multiconductor cables in a convenient "all-master" starter pack. The ac-operated Model IN-603 masters install in minutes. Using plug-in connectors, the system expands to five-station operation with ease by adding Model IN-600 masters (which include cables). The system is fully selective. Stations can call one or more other stations and conduct conference calls. Two separate station-to-station calls can proceed simultaneously.

Circle No. 81 on Reader Service Card

### PATHCOM SCANNING MONITOR RECEIVER

A programmable three-band scanning monitor receiver which covers the 25-50 MHz, 140-174 MHz, and 450-470 MHz bands simultaneously is available from Pace Communications. The Scan

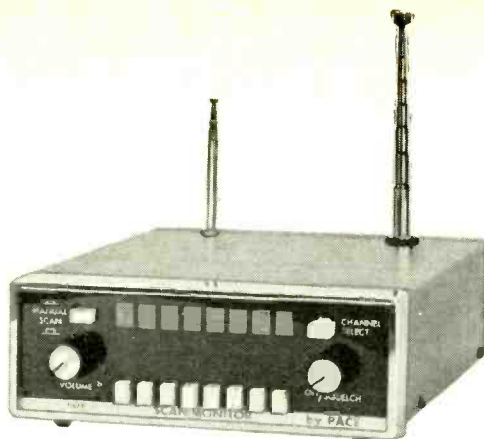

308 receiver uses a switching network which can be programmed easily for monitoring any combination of eight channels in the high and low VHF and the UHF bands. Capacity is up to 16 different channels. Unless specified, the receiver comes tuned to the most generally used 35-45 MHz, 152-164 MHz, and 450-462 MHz segments of the bands. Rear-panel programming switches are used to select bands and choose the desired combination from 16 internal crystal sockets. The Model 308 can be powered on either 12 volts dc or 117 volts ac.

Circle No. 82 on Reader Service Card



## TDK ANNOUNCES THE ONLY 3 HOUR 180 MINUTES 4-ALBUM CASSETTE

**The TDK C-180LN Cassette.** For the first time in any recording medium, a full three hours of unbelievable listening pleasure—the equivalent of four (or more) full disc albums—has been concentrated into a package you can slip into a pocket or cradle in the palm of your hand.

The package is the familiar cassette that has revolutionized tape recording, but the running time is new—and *exclusively* available from TDK, with the same reliability warranty that covers all dependable TDK cassettes. And the tape it carries is TDK's Deluxe Low-Noise, a quality product that surpasses most other high-performance types.

Yesterday—TDK Super Dynamic (SD) cassette tape—"the tape that turned the cassette into a high-fidelity medium."

Today—The *exclusive* TDK C-180LN three-hour, four-album, extra-long-playing cassette.

Tomorrow—Who knows what we are going to turn you on with?



# TDK

TDK ELECTRONICS CORP.

23-73 48TH STREET, LONG ISLAND CITY, N. Y. 11103 • 212-721-6881

*Purity in Sound*



CIRCLE NO. 42 ON READER SERVICE CARD

POPULAR ELECTRONICS Including Electronics World



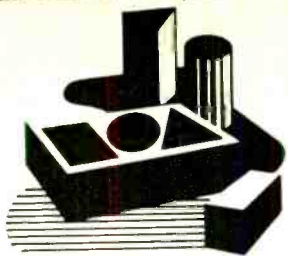

# Education & Opportunities

By David L. Heiserman

## Developing Good Self-Study Habits

*I hold a BSET degree from a local tech college, and I work as an electronics engineering technician. Within a few months I will have an opportunity to move up to a junior engineer's position. My problem is that we do a lot of R&D work that require an understanding of differential equations. I would like to teach myself more about this subject, but my past efforts at self teaching have not been very successful. I have plenty of good textbooks, but I can never seem to stick with the program. Do you have any helpful suggestions?*

• Yes—develop the self-teaching habit. Setting out to teach yourself what you want to know is a lot like starting up a physical fitness program. Physical fitness buffs know that the best way to stick to their exercises is to get into the fitness habit. This means setting aside a certain amount of time every day just for exercising, jogging or pressing weights. After a while, people on a physical fitness program get guilt feelings if they even think about skipping a session. Self-teaching programs work the same way.

Set aside a certain time of day for study—two hours in the early evening seems to suit most people, but some like to get up a couple of hours earlier in the morning to study. I know of one self teacher who decided to start a physical fitness and a self-teaching program at the same time. He got up every day at 5:30 a.m., exercised for about twenty minutes in the brisk morning air, then studied electronics and math two hours before going to work. Three years later, he passed the Professional Engineering exams in his state (he doesn't have a college degree) and he ran the mile in 4:45.

The amount of time you study every day is important, too. Set a time, such as two hours, and stick to it—study no more and no less. When the studies aren't going well, the time will seem to drag on forever, and it isn't hard to knock off when the time is up. Other times, though, you're all fired up and tempted to go past the allotted study time. I suggest you don't. Save some of that enthusiasm as

starting fuel for the next study period when you might need it.

Finding a special place for studying is also important. Although some people have no choice, the kitchen table isn't the best place to study if you have a family around. Kitchens are the traditional center of a lot of family activity; so, unless you are there at 5:30 a.m., you're bound to get included in some of the distracting activities. The ideal study place is a special study room or unused bedroom. There you can close the door and maintain a semblance of peace and privacy.

Don't exclude the idea of setting up a study place in an attic or basement. These places might not be the neatest and most comfortable ones in the home, but at least you can say, "This place is all mine for two hours a day."

Once you find a place to study, try to stay there. A special study place soon takes on a certain kind of psychological feeling that makes you want to study as soon as you enter the room.

Some people find they can stay with a self-teaching program if they have a study partner. This trick is all right in some ways, but there are some hazards, too. People who share good study habits can help each other quite a bit, but any bad study habits they have in common can wreck the relationship—and the study program—in a short time.

Developing good study habits is one big key to successful self teaching. Without them, you can't get anywhere. With them, you can master any subject you choose.

## Small Appliance Sales and Service

*I see a lot of ads promising big incomes for people operating small appliance sales and service shops. Can you give me an unbiased opinion about the opportunities in such a business?*

• There is a good potential in the small appliance service and sales business; but, as with any kind of private electrical or electronics business, your ultimate success or failure depends on your abilities as both a businessman and a technician.

The U. S. Small Business Administration has

NEW  
for  
'72



**TECHNI-TOOL INC.**  
1218 ARCH ST. PHILA., PENNA. 19107  
215 568-4457, 4482 TELX 60-7783

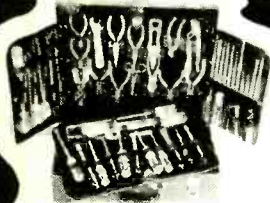

**FREE**  
New 1972  
Catalog

Tools & Tool Kits — Over 5000 Items

**TECHNI-TOOL, INC.**

1218 ARCH ST., PHILADELPHIA, PENNA.  
ZIP: 19107 1 (215) 568-4457-4482

CIRCLE NO. 35 ON READER SERVICE CARD

## ABOUT YOUR SUBSCRIPTION

Your subscription to POPULAR ELECTRONICS is maintained on one of the world's most modern, efficient computer systems, and if you're like 99% of our subscribers, you'll never have any reason to complain about your subscription service.

We have found that when complaints do arise, the majority of them occur because people have written their names or addresses differently at different times. For example, if your subscription were listed under "William Jones, Cedar Lane, Middletown, Arizona," and you were to renew it as "Bill Jones, Cedar Lane, Middletown, Arizona," our computer would think that two separate subscriptions were involved, and it would start sending you two copies of POPULAR ELECTRONICS each month. Other examples of combinations of names that would confuse the computer would include: John Henry Smith and Henry Smith; and Mrs. Joseph Jones and Mary Jones. Minor differences in addresses can also lead to difficulties. For example, to the computer, 100 Second St. is not the same as 100 2nd St.

So, please, when you write us about your subscription, be sure to enclose the mailing label from the cover of the magazine—or else copy your name and address exactly as they appear on the mailing label. This will greatly reduce any chance of error, and we will be able to service your request much more quickly.

put together a report called "Selling and Servicing Household Appliances and Radio-TV." This report, based upon a survey by the National Appliance and Radio-TV Dealers Association, shows the owner of an appliance sales and service shop can take home \$11.68 out of every \$100 in gross receipts, not including a profit of \$4.63 which the owner can pocket or invest in the business.

For further information about setting up and operating a household appliance sales and service shop, visit your nearest SBA office. You can get a free copy of the report cited above by writing the SBA for "Small Business Bibliography No. 57." The address is U. S. Small Business Administration, Washington, DC 20416.

### Opportunities in Civil Avionics

*How do I go about finding a job as a civil avionics technician and what are the special qualifications for such a job?*

- Civilian avionics (aviation electronics), like so many other specialized fields of modern electronics, is suffering from a shortage of truly competent technicians. Central repair shops for major airlines, and private aircraft sales and service shops are nearly always looking for more men with the right kind of training and education.

The qualifications for an avionics technician vary somewhat from one shop to another. Of course, they all demand an educational background in electronics with, preferably, special emphasis on communications. Technicians with military avionics experience and a commercial FCC or pilot's license generally rank high on the list of "most desirables," but the airlines and private shops are just as anxious to find people who can combine a little bit of experience with a lot of enthusiasm and willingness to learn on the job. In fact, most of the old pros and supervisors in the avionics business today started out with only a general background in electronics and worked their way up by learning aviation electronics on the job.

The commercial airline companies do not maintain staffs of avionics technicians at every airport they service. Instead, they rely on their flight engineers to spot troubles; and they train their line crews to switch "black boxes" on the spot. The faulty equipment all goes to large central repair shops located in several major cities around the country.

The wages at these central repair shops are generally quite good, and the working conditions range from good to outstanding. These airline maintenance centers, by the way, are among the few places an electronics technician can encounter a union shop.

Local passenger service offices can give you the addresses of their regional personnel offices and, perhaps, supply you with some employment brochures and job application forms.

If the idea of working in a large airline

repair center doesn't appeal to you, you can find a job at one of the smaller avionics shops that specialize in selling, installing and servicing equipment for private aircraft owners. Just about every municipal airport supports at least one of these shops, and the employment opportunities are generally quite good.

In a typical avionics sales and service shop, a dozen or so technicians work in the hangar, pinpointing faulty "black boxes" and pulling them out of the aircraft. Bench technicians troubleshoot the boxes and make the necessary repairs.

Working as an avionics technician in one of these shops is challenging and demanding. For one thing, the technicians have to work on a wide variety of equipment. They have to know how to service old vacuum-tube equipment as well as new IC gear; and they have to keep up with new developments and be prepared to cope with them *before* the equipment comes into the shop. There is also a sense of urgency around a good avionics shop. A homeowner can live with a broken TV for a weekend, but a businessman-pilot stranded out of town with faulty radio equipment cannot afford to wait around two days for a straight 9-to-5 shop to open. The avionics shops that do the best business, then, are those staffed with conscientious, hard-working, and competent technicians. There's no room for deadbeats in aviation electronics.

### A New Ground-Floor Specialty —Minicomputer Technology

*I work as an electronics technician in a petroleum processing plant. The company recently installed a minicomputer data acquisition and control system; and, although I am not responsible for working on any part of the new system, I am interested in learning more about minicomputers and their applications. I would also like to know more about possible careers as a "minicomputer technician."*

- Minicomputers are bringing about a revolution in industrial control, and there is a whole new world of career opportunities for electronics technicians with the training and experience required for assembling and testing minicomputer data acquisition and control systems.

With the exception of an occasional special amplifier for the interface circuits, virtually all parts of a minicomputer data acquisition and control system are off-the-shelf items. Assembling such a system, then, is largely a matter of planning the job, writing the programs, assembling all the basic building blocks, wiring the interface circuits, and testing and troubleshooting the completed system. Minicomputer technicians often help engineers specify the hardware and make up the wiring diagrams. The technicians are wholly responsible for as-

sembling all the building blocks and wiring the interface circuits. With the help of the engineers, technicians also run thorough performance tests, do most of the troubleshooting, and install the system at the customer's facility.

Technicians specializing in minicomputer work must have an unusually broad working knowledge of electronics. At the present time, however, there is no one course of instruction from a home study or resident school that can give a minicomputer technician all the working knowledge he needs. Thus, the technician has to back up his general courses in electronics technology with special courses in digital electronics, control systems, and systems programming.



This minicomputer system uses a Digital Equipment Corp. unit with various other types of peripheral equipment.

Minicomputer work demands a special kind of competence and determination; and, although there is a shortage of minicomputer specialists, finding the jobs demands some patience and perseverance. Minicomputer systems are most often one-of-a-kind affairs, and only small electronics firms with a low overhead can afford to assemble them. Thus, most of the minicomputer systems now reaching into nearly every phase of modern industry come from small engineering and consulting firms scattered all over the country.

Perhaps the best sources of leads for jobs in the minicomputer business are the field offices for major minicomputer manufacturers listed in the "Yellow Pages." The people at these offices can tell you who is buying minicomputer building blocks in your area. Of course a good employment agency or your State Employment Service can be helpful, too. ♦



**HIS EYE  
IS ON THE  
FUTURE...**

**and a  
DEGREE in  
ELECTRONICS**

**Grantham School of Engineering**

• Established in 1951 •

1505 N. Western Ave.  
Hollywood, Calif. 90027

*Telephone:*  
**(213) 469-7878**



**What's in YOUR future? Where will you be one year from today — or in two years, or five years?**

Your future is shaped by the steps you take today. Keep your eye on the future as you plan. Take steps that should bring greater enjoyment and satisfaction in your work and greater financial rewards. Move ahead in ELECTRONICS — the Science of the Seventies — by

## STUDYING AT HOME

Grantham offers a college-level home-study program in *Electronics Engineering Technology*, consisting of series of four separate correspondence courses (called correspondence semesters) which logically follow each other, preparing you for different levels of employment as you advance in your electronics career. Upon completion of the four correspondence semesters (and a two-week seminar held at the School), you are awarded the A. S. E. T. Degree — the *Degree of Associate in Science in Engineering Technology* — with a major in electronics.

## WHO IS GRANTHAM?

Grantham School of Engineering is a college-level institution, teaching mainly by correspondence, *authorized* under the laws of the State of California to grant academic degrees, *approved* for veterans and servicemen under the G. I. Bill, *accredited* by the Accrediting Commission of the National Home Study Council, and an *eligible institution* under the Federally Insured Student Loan Program. We are "the college that comes to you." Mail the postcard or coupon for our free bulletin which contains complete information.

**Grantham School of Engineering** PE-9-72

1505 N. Western Ave., Hollywood, Cal. 90027

Please send me your free Bulletin which explains how the Grantham educational program can prepare me for a *degree* in electronics.

- I am a beginner in electronics.  
 I am an experienced electronics technician.

Name \_\_\_\_\_

Address \_\_\_\_\_

City \_\_\_\_\_ State \_\_\_\_\_ Zip \_\_\_\_\_

# PRINTED CIRCUITS

**FAST — EASY**  
with DATAK's

# DIRECT ETCH SET

**EASY**—patterns rub down directly on the copper board and connect with rub-down lines or tapes supplied.

**FAST**—safe new etchants will etch a 2 oz. copper board in 30 minutes.

**ACCURATE**— $\pm .002$ " print tolerance so parts and connectors mate with no errors.

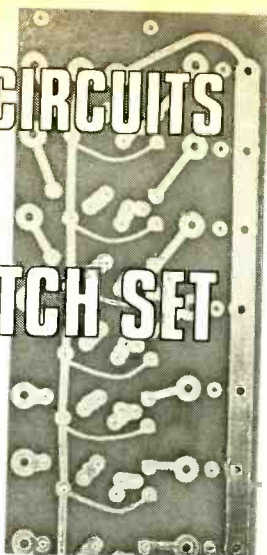

Circuit Made With ER-1

**COMPLETE ER-1 SET** contains hundreds of dry transfer DIP, flatpack, TO-5, IC, and transistor patterns;  $\frac{1}{8}$ " and  $\frac{1}{2}$ " etch resist tapes; 4 copper clad boards;  $\frac{1}{4}$  lb. dry etch; tray and instructions. \$4.95 ppd.

**IN STOCK AT ALLIED AND OTHER DISTRIBUTORS**  
WRITE FOR FREE CATALOG listing this and many other dry transfer marking sets.

The **DATAK Corporation**

85 Highland Avenue • Passaic, New Jersey 07055  
**CIRCLE NO. 7 ON READER SERVICE CARD**



## Earn Your Degree

### ELECTRONICS ENGINEERING

#### through HOME STUDY

**HIGHLY EFFECTIVE HOME STUDY COURSES IN:**  
• ELECTRONICS ENGINEERING TECHNOLOGY  
• ELECTRONICS ENGINEERING MATHEMATICS

Earn your Associate in Science Degree in Electronics Engineering and upgrade your status and pay to the engineering level. Complete college level courses in Electronics Engineering. We're a forward looking school. Outstanding lesson material—thorough and easy to understand. Engineering taught on the basis of application and understanding rather than on the basis of memorization. Up to date in every respect. Acquire the knowledge and ability that means the difference between a low paying technician job and a high paying engineering position. Low tuition cost with low monthly payments. Free engineering placement service for our graduates. Write for free descriptive literature. Ask for bulletin J, no salesman will call on you.

**COOK'S INSTITUTE of Electronics Engineering**



Forest Hill Road  
P. O. Box 10634  
Jackson, Miss. 39209

Established 1945

Formerly Cook's School of Electronics

**CIRCLE NO. 5 ON READER SERVICE CARD**

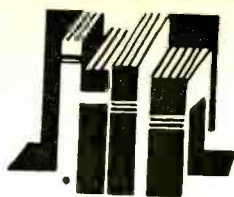

## Electronics Library

### ELECTRONIC FUNDAMENTALS FOR TECHNICIANS

by Robert L. Schrader

A functional course in electronic devices and circuits with their system applications at a basic electronics level is offered in this companion and followup to the author's famous "Electronic Fundamentals." Written for vocationally oriented technician programs, the text enables students to grasp the fundamentals of circuit and device operation with a minimum of mathematics. The text itself is supplemented by a semi-programmed question technique which aids comprehension and enables the student to check his progress.

Published by McGraw-Hill Book Co., 330 West 42 St., New York, NY 10036. Hard cover. 416 pages. \$11.95.

### HOW TO BUILD PROXIMITY DETECTORS & METAL LOCATORS, Second Edition

by John Potter Shields

This updated edition contains valuable information on the principles and circuits used in proximity detectors, metal locators, and the closely related theremin. It begins with a simple explanation of the basic types and functions of proximity detectors and metal locators. Then the more complicated and advanced electronic projects containing special devices are discussed. Among the advanced devices discussed are the Hall-effect metal detector and the FM-discriminator proximity detector. Build-them-yourself projects are included, each thoroughly tested before publication.

Published by Howard W. Sams & Co., Inc., 4300 West 62 St., Indianapolis, IN 46268. Soft cover. 160 pages. \$3.95.

### 25 SOLID-STATE PROJECTS

by R. F. Graf & G. J. Whalen

Hobbyists, experimenters, hams, and car buffs will find a variety of useful and interesting projects in this new book. Covering a wide range of devices such as a sequential-turn signal system, a rally-mate timepiece, a shortwave r-f pre-selector, and electronic dice, all projects presented were designed to serve a specific function. All contain a bit of design novelty to start the reader thinking of new circuits and

# FREE McIntosh CATALOG and FM DIRECTORY

Get all the newest and latest information on the new McIntosh Solid State equipment in the McIntosh catalog. In addition you will receive an FM station directory that covers all of North America.



**MX 114** FM/FM STEREO TUNER and STEREO PREAMPLIFIER

**CIRCLE NO. 18 ON READER SERVICE CARD**

## SEND TODAY!

McIntosh Laboratory Inc.  
2 Chambers St., Dept. PT-972  
Binghamton, N.Y. 13903

NAME \_\_\_\_\_  
ADDRESS \_\_\_\_\_  
CITY \_\_\_\_\_ STATE \_\_\_\_\_ ZIP \_\_\_\_\_

projects of his own. In addition to providing schematics, photos, and illustrations, the authors include a parts list which tells where to obtain hard-to-find components and a table of voltage and resistance readings for each project.

Published by Hayden Book Co., Inc., 116 W. 14 St., New York, NY 10011. Soft cover. 120 pages. \$3.95.

### INTRODUCTION TO THE UNIFIED THEORY OF ELECTROMAGNETIC MACHINES

by M.G. Say

The traditional way to teach the student of electrical engineering about electrical machines has been to treat a few common machines in terms of their steady-state characteristics. This approach is no longer adequate, and in this book the author treats the subject by regarding all electromagnetic conversion devices—limited motion as well as rotary—as variants on the common theme of gap energy. He employs the systems concept, with its accent on dynamic rather than steady-state conditions. In effect, this book bridges the gap between the simple magnetic circuit and the advanced generalized theory so that sophisticated treatments can be more readily understood.

Published by Harper & Row, 49 East 33 St., New York, NY 10016. Hard cover. 198 pages. \$8.00.

### ELECTRONIC CIRCUIT ANALYSIS

by Benjamin Zeines

Introduced here are the basic concepts and mathematical techniques used in today's electronics. Divided into two parts, the first half presents the essential principles of dc circuit theory, while the second half is devoted to ac theory. Taken together, the two halves represent a comprehensive, unified approach to and comprehension of the fundamentals of electronics.

Published by Reston Publishing Co., Inc., Reston, VA 22070. Hard cover. 422 pages. \$15.00.

### BASIC ELECTRONICS COURSE

by Norman H. Crowhurst

This is a modern self-study textbook for the novice, hobbyist, and student. The content covers the entire field of electronics from electricity and magnetism right on up to semiconductors and microelectronics. Extensive use of schematic diagrams and graphs aids the reader in quickly absorbing the theory discussed in the text.

Published by Tab Books, Blue Ridge Summit, PA 17214. 368 pages. \$8.95 hard cover, \$5.95 soft cover.

## DUAL BAND VHF/UHF LF/VHF 10 CHANNEL FM MONITOR RECEIVERS



- ★ Dual Channel non-restrictive programming of channels allows any combination of preselected channels to fit your needs
  - ★ Priority channel-locks out all other signals
  - ★ Any channel may be switched out of scanning sequence
  - ★ Carrier Delay—You may hear mobile callbacks
- A sophisticated professional automatic scanning monitor with the most reliable circuitry ever conceived. Has more power, more audio and more features than other monitors. New ceramic filter provides excellent adjacent channel operation in urban areas. All solid state. 2 watts of "Voice Fidelity," easy access plug in crystals. Dual purpose power supply for 117VAC and 12VDC, negative ground only.

#### designed for:

- Police, Fire and Municipal Depts.
- County, State & Federal agencies
- Commercial & Industrial applications
- Other unlimited uses

FR-2526 VHF/UHF **189<sup>95</sup>**  
FR-2528 LF/VHF

FR-2525—UHF only \$179.95  
Comes with AC and DC power cables, mounting bracket, less crystals. Crystals \$5.00 ea.

SONAR RADIO CORP., 73 Wortman Ave., Bklyn, N.Y. 11207  
Please send information on SONAR-SCAN FM Monitor Receivers.

Name \_\_\_\_\_ Dept. 702  
Address \_\_\_\_\_  
City \_\_\_\_\_ State \_\_\_\_\_ Zip \_\_\_\_\_

**CIRCLE NO. 34 ON READER SERVICE CARD**

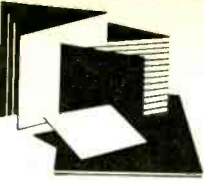

# New Literature

## DATA SHEETS FOR MOTOROLA HEP PRODUCTS

Engineering and design data sheets are now available for many *Motorola* HEP semiconductor products. These descriptive sheets contain complete and comprehensive information on the specified devices, including design curves rating charts, and application schematics. Copies of the data sheets and additional information can be obtained from HEP representatives or from: *Motorola Inc.*, Semiconductor Products Div., 5005 E. McDowell Rd., Phoenix, AZ 85036.

## NEW-TRONICS CB & MONITOR ANTENNA CATALOG

*New-Tronics* recently announced the availability of their new 24-page *Citizens Band And Monitor Antenna Catalog*. Included in the listings are complete descriptions and illustrations of new and improved antenna models, including the *Discone*, *Power Multiplier Beans*, fiberglass assemblies, high-efficiency short antennas, *Monitor-Match*, etc. Address: *New-Tronics Corp.*, 15800 Commerce Park Dr., Brookpark, OH 44142.

## MALLORY ELECTROLYTIC CAPACITOR GUIDE

An *Electrolytic Capacitor Guide*, edited for the electronics technician, is currently available from *Mallory*. This 32-page brochure tells how to find a good capacitor replacement for an original equipment capacitor of a given rating, size, and shape. More than 4500 capacitors, including singles, duals, triples, and quad types are listed. Address: *Mallory Distributor Products Co.*, 101 S. Park Ave., Indianapolis, IN 46201.

## HALLICRAFTER SW/HAM EQUIPMENT CATALOG

An illustrated four-page short-form catalog titled "You Should Be Talking With A Hallicrafters" features the entire line of shortwave and professional amateur radio equipment marketed by *The Hallicrafters Co.* The catalog lists a 2000-watt PEP transceiver and power supply, remote VFO/SWR console, keyer, AM/CW/SSB receivers, and accessories. Address: *The Hallicrafters Co.*, Dept. PR-300, 600 Hicks Rd., Rolling Meadows, IL 60008.

## TURNER MICROPHONES CATALOG

New product listings in the latest *Turner* microphone catalog (No. 2720) include four models of multi-port cardioid dynamic mikes for use in professional recording, broadcasting, and entertainment. Included in the listings is *Turner's* full line of communication, sound system, professional entertainment, and recording microphones, plus mike cartridges, stands, and accessories. Address: *Turner Division*, 909 17 St., N.E., Cedar Rapids, IA 52402.

## ATLAS SOUND LOUDSPEAKER BROCHURE

The first eight-page color brochure devoted exclusively to their line of loudspeakers has just been released by *Atlas Sound*. Subdivided into individual sections detailing paging and intercom speakers, projector horns and drivers, mobile and industrial communication units, hi-fi and sound columns, the new catalog provides complete information and technical data for more than 100 individual models of loudspeakers and accessories. Address: *Atlas Sound*, 10 Pomeroy Rd., Parsippany, NJ 07054.

## RCA THYRISTOR/RECTIFIER CATALOG

A completely revised catalog which lists and describes *RCA* thyristors and rectifiers is available from *RCA Solid State Division*. Titled "Thyristors/Rectifiers," publication No. THC-500B reflects the wide selection of triacs, SCR's, diacs, and rectifiers available from *RCA*. Also included is information on applications of *RCA* thyristors. Address: *RCA Solid State Div.*, Box 3200, Somerville, NJ 08876.

SEE...  
COMPARE  
SELECT!!

**SBE**  
CB  
SUPERSTARS

*Catalina*



**23 CHANNEL AM MOBILE TRANSCEIVER**  
All crystals supplied • 5 watts • Hi-level modulation • Speech clipper and filter for higher average talk power • Exclusive SBE dynamic mic w/coil cord • Noise limiter • Squelch • Unique back-lighted dial has largest channel readout ever • Silicon semiconductors throughout.

WRITE FOR BROCHURE

**99<sup>95</sup>**



**SBE** 220 Airport Blvd., Watsonville, CA 95076  
CIRCLE NO. 27 ON READER SERVICE CARD  
POPULAR ELECTRONICS Including Electronics World





SALE

# Surplus Scene

By Alexander W. Burawa, Associate Editor

## WHAT'S AVAILABLE IN TEST EQUIPMENT

EVERY column in this magazine receives mail addressed to it, but the Surplus Scene of late has received more than its fair share. Interestingly enough, as the letters indicate, requests on where to get what test instruments run second in popularity only to the subject of transistors and other solid-state devices. What is even more surprising is the fact that most of the writers are asking about precision laboratory test gear made by such manufacturers as Hewlett-Packard, Sperry, Tektronix, etc. Either you experimenters are a lot more sophisticated than general-purpose instrument manufacturers give you credit for or there are some companies out there using this column as a clearinghouse. We suspect the former since most letters are on plain stationery and written by hand.

This month, we will explore the entire range of test equipment as it applies to the Surplus Scene. And since there seems to be so much interest in lab-type test and measurement equipment, we will start with the dealers who offer such devices. According to the listings given in the various catalogs and flyers, Baynton Electronics Corp. (2709 N. Broad St., Philadelphia, PA 19132) seems to have the greatest diversity in equipment types by more major manufacturers in the "for-sale" market. Typical of some of their offerings are: Airborne Instrument Lab's Model 390A-3 portable microwave crystal tester for \$40; a whole raft of Bird devices ranging in price from a low of \$25 for the Model 5247 low-pass filter to a high of \$450 for the Model 8890 r-f coaxial load resistors; and a Dumont Model 404 pulse generator for \$160. Other names to look for are Hewlett-Packard, Tektronix, Fluke, General Radio, Minneapolis-Honeywell, Polarad, and so on.

Herbach & Rademan, Inc. (401 E. Erie

Ave., Philadelphia, PA 19134) is another big supplier of lab-type equipment. Examples of past offerings include such items as: the Leeds & Northrop Model 5305 resistance bridge for \$95; General Radio Type 1106-A-B-C frequency transfer unit for \$109.50; and Monsanto Model 506A dc lab power supply for \$79.50.

If you are starting out small and need the best in test equipment but cannot justify the expense of purchasing your own, you are in luck. There are at least two companies catering to the rental market. One is Leasametric (822 Airport Blvd., Burlingame, CA 94010) which sells and leases test instruments. The other is Rental Electronics, Inc. (16600 Oakmont Ave., Gaithersburg, MD 20760) which—according to the catalog—only leases equipment.

For most readers of this column, rugged general-purpose test equipment is more than adequate. If you fall into this category, surplus military test equipment is always a good bet. All such equipment is extremely rugged (most built according to U.S. Army Signal Corps standards) and most provide good accuracy when properly calibrated. Every dealer who carries military surplus gear features some type of test equipment. For example G&G Radio Supply Co. (45 Warren St., New York, NY 10007) features the TS-155C/UP general-purpose signal generator for \$69.50 brand new and the BC-906 portable absorption-type frequency meter, also new, for \$12.95. Fair Radio Sales Co. (1016 E. Eureka St., Lima, OH 45802) is another military surplus dealer which has been catering to ham radio and experimenter interest for years. Among the various types of instruments they offer are the TS-505/U VTVM type multimeter for \$40 and the BC-221 frequency meter for \$95, including calibration book. ♦

# ELECTRONICS MARKET PLACE

**NON-DISPLAY CLASSIFIED: COMMERCIAL RATE:** For firms or individuals offering commercial products or services, \$1.50 per word (including name and address). Minimum order \$15.00. Payment must accompany copy except when ads are placed by accredited advertising agencies. Frequency discount: 5% for 6 months; 10% for 12 months paid in advance. **READER RATE:** For individuals with a personal item to buy or sell, \$1.00 per word (including name and address.) No minimum! Payment must accompany copy. **DISPLAY CLASSIFIED:** 1" by 1 column (2 5/8" wide), \$185.00, 2" by 1 column, \$370.00. 3" by 1 column, \$555.00. Advertiser to supply cuts. For frequency rates, please inquire.

**GENERAL INFORMATION:** First word in all ads set in bold caps at no extra charge. All copy subject to publisher's approval. All advertisers using Post Office Boxes in their addresses **MUST** supply publisher with permanent address and telephone number before ad can be run. Closing Date: 1st of the 2nd month preceding cover date (for example, March issue closes January 1st). Send order and remittance to Hal Cymes. **POPULAR ELECTRONICS** Including **ELECTRONICS WORLD**, One Park Avenue, New York, New York 10016.

## FOR SALE

**FREE!** bargain catalog. Fiber optics, LED's, transistors, diodes, rectifiers, SCR's, triacs, parts. Poly Paks, Box 942, Lynnfield, Mass. 01940.

**GOVERNMENT** Surplus Receivers, Transmitters, Snooperscopes, Radios, Parts, Picture Catalog 25¢. Meshna, Nahant, Mass. 01908.

**ROCKETS:** Ideal for miniature transmitter tests. New illustrated catalog. 25¢. Single and multistage kits, cones, engines, launchers, trackers, rocket aerial cameras, technical information. Fast service. Estes Industries, Dept. 18-K, Penrose, Colorado 81240.

**LOWEST** Prices Electronic Parts. Confidential Catalog Free. **KNAPP**, 3174 8TH Ave. S.W., Largo, Fla. 33540.

**ELECTRONIC PARTS**, semiconductors, kits. **FREE FLYER**. Large catalog \$1.00 deposit. **BIGELOW ELECTRONICS**, Bluffton, Ohio 45817.

**WE SELL CONSTRUCTION PLANS. TELEPHONE:** Answering Machine, Speakerphone, Carphone, Phonevision, Auto Dialer, Touch Button Dialer, Central Dial System. **TELEVISION:** \$35.00 Color Converter, Video Tape Recorder, \$25.00 Camera. **HOBBYIST:** Electron Microscope, 96 Hour Tape Music System, Ultrasonic Dishwasher, Radar-Oven. Plans \$4.95 each. **NEW ITEM:** \$75. Electronic Pocket Calculator, \$7.50. **COURSES:** Telephone Engineering \$39.50, Detective Electronics \$22.50, Integrated Circuit Engineering, \$49.50. **NEW SUPER HOBBY CATALOG** plus year's subscription to Electronic New Letter **AIRMAILED \$1.00**. Don Britton Enterprises, 6200 Wilshire Blvd., Los Angeles, Calif. 90048.

**RADIO—T.V. Tubes—**36¢ each. Send for free catalog. Cornell, 4213 University, San Diego, Calif. 92105.

**CONVERT** any television to sensitive, big-screen oscilloscope. Only minor changes required. No electronic experience necessary. Illustrated plans. \$2.00. **Relco-A33**, Box 10563, Houston, Texas 77018.

**MECHANICAL, ELECTRONIC** devices catalog 10¢. Greatest Values —Lowest Prices. Fertik's, 5249 "D", Philadelphia, Pa. 19120.

**SENCORE**, B&K Test Equipment Unbelievable Prices. Free Catalog and Price Sheet. Fordham Radio, 265 East 149th Street, Bronx, N.Y. 10451.

**ELECTRONIC** Ignition. Various Types. Information 10¢. Anderson Engineering, Epsom, N.H. 03239.

**METERS—**Surplus, new, used, panel or portable. Send for list. Hanchett, Box 5577, Riverside, CA 92507.

**PYROTECHNICAL** chemicals, casings, tools, supplies, fuse, literature. Giant, illustrated catalogue/handbook includes formulas, instructions—50¢, with samples—\$1.00. Westech, Box 593, Logan, Utah 84321.

## BUILD YOUR OWN SPACE-AGE TV CAMERA

**ONLY KNOWN SOLIDSTATE CAMERA KIT!** Ideal for experimenters, hobby, education, industry, etc. • High quality • Backed by over six years of lab & field testing • Fully Guaranteed • Contracts to any TV set without modification • Step-by-step construction manual • Model XT1A, Series D complete with vidicon \$149.50 postpaid anywhere in USA & Canada (less vidicon tube \$116.95 pp)

**PHONE or WRITE for CATALOG.**  
DIAL 808-887-3777

Many other kits, parts and plans available including starter kits, focus-defl. coils, vidicon tubes, const. plans, audio subcarrier kit, etc.

1301 BROADWAY **ATV Research** DAKOTA CITY, NEBR. 68731

**ELECTRONIC IGNITION:** Improves performance, Eliminates tune-ups, Boosts spark voltage. Only \$14.95 postpaid. Box 2002, Huntington Beach, California 92647.

**SUPREME** twenty different radio-television volumes. \$50 value, only \$19.95, postpaid. **Supreme Publications**, 1760 Balsam, Highland Park, Illinois 60035.

**DIAGRAMS—**Radios \$1.50, Television \$3.00. Give make and model. **Diagram Service**, Box 1151PE, Manchester, Conn. 06042.

**ELECTRONIC COMPONENTS—**Distributor prices, Free catalog. Box 2581, El Cajon, California 92021.

**GREGORY ELECTRONICS**  
**Reconditioned & Used**  
**FM 2-WAY RADIO SAVINGS**  
Partial List—Send for New Catalog

**MOTOROLA U44BBT**  
450-470 MHz  
12 volt, 15 watts transistor  
power supply.

\$48

With accessories ..... add \$30.00

<p style="text-align: center;"><b>MA/E13</b> 30-50 MHz 6/12 volt, 30 watts, vibrator power supply</p> <p style="text-align: center; font-size: 2em; font-weight: bold;">\$48</p> <p style="font-size: 0.8em;">With accessories, add \$30. (Earlier serial number, \$28. plus \$30. for accessories)</p>	<p style="text-align: center;"><b>MA/E33</b> 150-170 MHz 6/12 volt, 30 watts, vibrator power supply</p> <p style="text-align: center; font-size: 2em; font-weight: bold;">\$68</p> <p style="font-size: 0.8em;">With accessories, add \$30. (Earlier serial number, \$48. plus \$30. for accessories)</p>
---	---

15,000 2-way FM mobile units in stock!  
Send for new 1972 catalog

**GREGORY ELECTRONICS CORP.**  
249-F Rt. 46, Saddle Brook, N.J. 07662  
Phone: (201) 489-9000

CIRCLE NO. 14 ON READER SERVICE CARD



## INVENTORY CLEARANCE PRICES SLASHED

### LINEARS

709	TO-5 op amp	.40
710	TO-5 comparator	.50
723	TO-5 volt. reg.	1.00
741	TO-5 comp. 709	.45
809	DIP op amp	.45
5558	DIP dual 741	1.00

**NE 565 Phase Locked Loop 3.50**

### READOUT TUBES

ZM1000	2.00
8754	3.10
CK 1907 plus and minus sign tube	3.10

### DIODES

1N914	100 for 3.00
1N4001	60 for 3.00
1N4004	40 for 3.00
1N4007	25 for 3.00
1N4729A	15 for 3.00
1N4734A	15 for 3.00

Min. order \$3.00. On orders less than \$10.00 enclose .50 for postage and handling. Send check or M.O. Send for our free flyer on many other bargains.

## EDWARDS ELECTRONICS

The John Edwards Electronics Co.  
P.O. Box 465, Glen Ellyn, Ill. 60137

**CIRCLE NO. 45 ON READER SERVICE CARD**



## REGULATED POWER SUPPLY

This supply has five

regulated voltages. 24 vdc @1.6 amps, 26.5 vdc @ 3.25 amps, 18 vdc @6.6 amps., 14 vdc @2.9 amps, 12 vdc @ 1 amp. Highly regulated and filtered, all voltages fused, Rack or bench mount. Designed for leading computer mfg. Original cost over \$250. Complete with data sheets, circuit diagram etc.  
STOCK NO. F5025 49.50 ea.

## "VISIBLE" LIGHT EMITTING DIODES

Micro min. axial leads STOCK NO. F5020

.95 ea. 6/5.00 25/19.00

Jumbo TO-18 STOCK NO. F5021

.95 ea. 6/5.00 25/19.00

## POWER TRANSISTOR/HEAT SINK ASSEMBLY



Westinghouse 1561-0404 (similar to 2N3055, mounted on double ribbed heat sink, with TO-3 socket and .2 ohm emitter resistor. 75 watts. A pair makes an entire amplifier output stage.

STOCK NO. F5022 1.35 ea. 2/2.50 8/9.00

### COMPUTER GRADE CAPACITORS (BRAND NEW)

40,000 mfd. 10 volts 1.25 ea. 6/7.00 Stk. No. F2026  
70,000 mfd. 10 volts 1.75 ea. 6/9.00 Stk. No. F2118  
6000 mfd. 55 volts 1.50 ea. 7/9.00 Stk. No. F2117  
3,750 mfd. 75 volts 1.75 ea. 6/9.00 Stk. No. F2116

### MINIMUM ORDER \$3.00

Many other items—send for new 40 page catalog. All merchandise guaranteed. Please include postage. Excess will be refunded.



## DELTA ELECTRONICS CO.

BOX 1, LYNN, MASSACHUSETTS 01903

**CIRCLE NO. 8 ON READER SERVICE CARD**

**SCIENCE TEACHER:** Theory, models, kits. Sercolab, P.O. Box 78H, Arlington, Mass. 02174.

**SIGNAPROBE**—the signal tracer you carry in your pocket like a pen. \$29.95 postpaid. Details 8¢ stamp. Bitting Radio, Box 13, New Cumberland, Pa. 17070.

**DIGITAL** and analog computer modules. LED numeric display kits. FREE LITERATURE. Scientific Measurements, 2945 Central, Wilmette, Illinois 60091.

**ELECTRONIC ORGAN KITS, KEYBOARDS** for music synthesizers and organs. Every component for organ circuitry. 25¢ for catalog. Devtronix Organ Products, 5872 Amapola Drive, San Jose, Calif. 95129.

**AUTOMOBILE BURGLAR SYSTEM** with system connected even HOT WIRING will not start motor \$7.95 complete. VANSONS MFG. & SALES, 10175 Breidt, Tujunga, Calif. 91042.

**OSCILLOSCOPE** improvement. Add trigger sweep and dual trace to any scope using low cost kits. HTP, Box 901, Cupertino, Calif. 94014.

**WE SELL CONSTRUCTION PLANS**—gold recovery unit!—silver recovery unit—infra-red scope—x-ray fluoroscope—alternator adapter—200 watt inverter—electronic insect trap—burglar alarm system—chemical formulary (home products)—electroplater—plans \$5.00—plus many more!—ask for FREE catalog—creative products, 1551 east loop 820, Dept. E-972, fort worth, texas 76112.

**LEARN** the secrets of the experts. Protect against industrial espionage and snooping by illegal wiretaps and eavesdropping devices. For your booklet, "The Walls May Have Ears" send \$2.00 to East Coast Research and Development, 1408 Concord Pl., Elizabeth, New Jersey 07208.

**OSCILLOSCOPE** improvement. Add trigger sweep and dual trace to any scope using low cost kits. HTP, Box 901, Cupertino, California 95014.

**SCOPES, Counters, Meters, Bridges, Precision Instrumentation Components.** Industrial and Government Surplus. G-R, Tektronix, H-P, Weston and others. Many "one of a kind" specials. Send name and address for free "Bargain Bulletins" to: Lawrence Instruments, P.O. Box 744, Sunbury, Pa. 17801.

**CDI Ignitions**—3 models. Southland, Box 3591, Baytown, Texas 77520.

**THE most unusual electronic kits available.** Surf Synthesizer \$11.95 ppd., Electronic Steam Whistle \$8.95 ppd., electronic music accessories, many more. Catalog free. PAIA Electronics, Box J14359, Oklahoma City, OK 73114.

**SAVE \$100.** Electronic Digital Calculator, Special Sale. Famous brands. Office, Personal. Also calculator kits, Electronic digital clock kits. Write: Hope Electronics, P.O. Box 181, Brooklyn, N.Y. 11210.

**FINALLY!** Realistically priced high quality telephone recording device. Size 3x1 1/2x1". Plugs into tape recorder with standard miniature plug. Special plugs (specify) no extra charge. Easy to follow instructions, fully guaranteed. Only \$9.75. California residents add 5% tax. Viking International, Box 632, Newhall, Calif. 91321.

**RESISTORS:** Carbon Composition brand new. All standard values stocked. 1/2 Watt 10% 50/\$1.00; 1/4 Watt 10% 40/\$1.00. 10 resistors per value please. Minimum order \$5.00. Postpaid. PACE ELECTRONIC PRODUCTS, Box 161-P, Ontario Center, New York 14520.

**COMPUTER ELECTRONICS**—Complete course teaches basic of Logic Design, Handy devices you can build! Free details. DYNASIGN, Box 60-A2, Wayland, Mass 01778.

**BURGLAR-FIRE** alarm supplies and information. Free catalog. Protecto Alarm Sales, Box 357-G, Birch Run, Michigan 48415.

**TELEPHONES**—parts. Literature 10¢. Comet Communications, Dept. D, 639 50th Street, Brooklyn, New York 11220.

**LATEST** snooping countermeasures: Manual \$10.00. Negeye, Box 1036X, Anderson, Indiana 46015.

**TELEPHONE PICK-UP** for cassette recorders: \$2.00. Monitor ear-phone; \$1.00. Mardon Enterprises, Box 97, Rockwood, Michigan 48173.

**UNIQUE** and unusual electronic project plans. Free information send Design Systems, Box 386, Endicott, New York 13760.

## PLANS AND KITS

**FREE Kit Catalog:** Why does every major College, University, Technical School, Research & Development Center buy from us? Because we have the highest quality and lowest prices. Free catalog. SWTPC, Box H32040, San Antonio, Tex. 78284.

**FREE Kit Catalog:** Amazing new Universal Digital Instruments with plug-ins as featured in Popular Electronics. Unbeatable prices. SWTPC, Box D32040, San Antonio, Tex. 78284.

**FREE Kit Catalog:** Digital Microlab \$29.95. Also Segmented and Nixie Readouts, Timebases, Scaler, Electronic Digital Clocks (all featured in Popular Electronics) SWTPC, Box C32040, San Antonio, Tex. 78284.

**TRIGGERED Sweep conversion kits** for EICO 460 or Heath 10-102. Details write: HW Electronics, Bloomfield, Ontario, Canada. U.S. Inquiries.

**PLANS:** Profitable electronic devices. Literature free. Barta-PAE, Box 248, Walnut Creek, Calif. 94596.

**ANTIGRAVITY DEVICE.** Brochure 35¢. AGD, Box 3062-ZD, Bartlesville, Oklahoma 74003.

## WANTED

**QUICKSILVER,** Platinum, Silver, Gold, Ores Analyzed. Free Circular. Mercury Terminal, Norwood, Mass. 02062.

**QUICK CASH . . .** for Electronic Tubes, Semi-Conductors, Equipment (Receivers, Transmitters, Scopes, Vacuum Variables etc.) Send Lists now! Write: Barry Electronics, 512 Broadway, New York, NY 10012. (212) 925-7000.

## ELECTRICAL SUPPLIES AND EQUIPMENT

**PLATING Equipment,** Portable Platers, Supplies and "Know-How." Build your own tanks for nickel, chrome, etc. Easy-to-install PVC liners. Rectifier components—all sizes. Schematics, parts lists, formulas, operating instructions for all plating. Guaranteed to save you 25%-75%. Some good units for sale. Write for details. Platers Service Company, 1511-PE Esperanza, Los Angeles, Calif. 90023.

## TUBES

**RADIO & T.V. Tubes—36¢ each.** Send for free Catalog. Cornell, 4213 University, San Diego, Calif. 92105.

**ELECTRONIC TUBES,** Semiconductors, Equipment, Telephones, Public Address, Intercoms, CB, Walkie-Talkies, etc. Quality Merchandise Only! Serving Engineers, Purchasing Agents, TV/Hi-Fi Servicemen and Hams for 28 years, Domestic and Exnort. Write for Catalog or call (212) 925-7000. **BARRY ELECTRONICS,** 512 Broadway, New York, N.Y. 10012.

**RECEIVING & INDUSTRIAL TUBES, TRANSISTORS.** All Brands—Biggest Discounts. Technicians, Hobbyists, Experimenters—Request **FREE** Kit Catalog and **SAVE!** ZALYTRON, 469 Jericho Turnpike, Mineola, N.Y. 11501.

**SAVE money on parts and transmitting-receiving tubes,** foreign-domestic. Send 25¢ for giant catalog. Refunded first order. United Radio Company, 56-P Ferry Street, Newark, N.J. 07105.

**TUBES "Oldies",** latest. Lists free. Steinmetz, 7519 Maplewood, Hammond, Indiana 46324.

**TUBES receiving,** factory boxed, low prices, free price list. Transletronic, Inc., 1306 40th Street, Brooklyn, N.Y. 11218A, Telephone: 212-633-2800.

## ELECTRONIC CALCULATOR COMPLETELY WIRED



Only \$119.

**NEW For 1973**

**Home, Office, Shop, Student, School**

\* Uses single Texas Instrument "Chip" Features found in more expensive units

Never before offered at this price! You've seen them at \$175, \$149 . . . but now at a price calculator users can't afford. EIGHT-DIGIT fluorescent display has 16-digit capacity. Adds! Subtracts! Multiplies! and Divides! In chain or mixed calculations. Includes MINUS indicator showing negative credit balance. OVERFLOW sign. MEMORY switch. Floating decimal of 2, 3, 4, 5 decimal points as required. (CE) key clears calculator of just entry error. Automatic loading and trailing zero suppression. LSI (Large Scale Integration) equivalent to more than 8,000 transistors. Calculation speed adds and subtracts 10,000th of a second. Keyboard is REED SWITCH assembly for extensive trouble-free operation. Separate power switch. Removable 115 VAC line cord. Feet 110-120 VAC 50-60 cycles. Wt. 3 lbs. Handsome black molded cabinet with silver trim, size: 9 1/2" x 5 7/8" x 2 1/4". Completely ready-to-use-to-understand. **THE ONLY FACTORY GUARANTEED CALCULATOR BY A MAIL ORDER ADVERTISER. Gift Packed!**



## DIGITAL CLOCK KIT Buy 3 — Take 10%

Smaller more compact 8" x 5 1/2" x 3" case

Only \$57. WITH CASE

By Scientific Devices

The lowest priced digital clock kit (with cabinet) as far as we can see in U.S.A. Scientific Devices' engineering dept. took extra patience in designing to give you the finest digital clock kit using the latest techniques in an easy-to-understand booklet. The cabinet-making section gives it the "interior decorating" touch so that it may fit into any room at home, shop or office. Walnut laminated tapered front cabinet with gold-line front. Tapered legs for easy viewing. Large clear, 7-segment fluorescent "blue-green" polaroid display, completely etched and thru plated circuit board. All IC's. Includes LCD outputs for use with timer options. may be wired for 12 or 24 hour display. Indicates HOURS, MINUTES, SECONDS. 115 VAC 60 cy. Gift packed. Wt. 3 lbs.

Type	Description	Size
531	Hi slew rate op-amp	3.58
533	Micro power 709	4.50
535	FEET input op amp	3.25
540	70W pwr driver amp	2.04
550	Precision 723 voltage reg.	1.17
560	Phase lock loops (A)	3.25
561	Phase lock loops (A)	3.25
562	Phase lock loops (A)	3.25
565	Phase lock loops (A)	3.25
566	Function generator (A)	3.25
567	Tone decoder (A)	1.00
568	Dual 741 (mini DIP)	3.10
595	Four quadrant multiplier	3.10
702C	Hi-gain, DC amp, TO-5	2 for 1.00
703C	RIF. amp, 1.4 GHz, TO-5	1.00
709C	Differential amp (A)	.39
710C	Operational amp (A)	.39
711C	Dual diff. comp (A)	.95
723C	Voltage regulator (A)	.41
741C	Frequency compensator 709	.41
747C	Dual 741C, TO-5	1.00
748C	Freq. adj. 741C (A)	1.00
709-709	Dual stereo preamp	1.98
739-739	Dual stereo preamp	1.98
741-741	Dual 741C (mini DIP)	1.00
749-749	Dual channel amp	1.98

(A) TO-5 or DIP dual in line pak

**BRAND NEW Linear Op Amps**

Buy Any 3 PAKS Take 10% Discount

Timer 2 uSec to 1-1hr

555 . . . 1.19

FACTORY MARKED  
FACTORY TESTED  
FACTORY GUARANTEED

Buy 100 — Take 20%

FACTORY MARKED  
Factory Guaranteed!

Type	Price	Type	Price	Type	Price		
SN7400	.24	SN7443	1.21	SN7481	1.50	SN74120	1.55
SN7401	.25	SN7444	1.21	SN7482	1.49	SN74121	1.15
SN7402	.25	SN7445	1.17	SN7483	1.49	SN74122	1.55
SN7403	.25	SN7446	1.17	SN7484	.95	SN74123	1.39
SN7404	.27	SN7447	1.10	SN7485	1.35	SN74124	1.39
SN7405	.27	SN7448	1.37	SN7486	.76	SN74125	1.48
SN7406	.49	SN7449	1.17	SN7487	1.09	SN74126	1.79
SN7407	.49	SN7450	.24	SN7488	1.09	SN74127	1.79
SN7408	.29	SN7451	.24	SN7489	.76	SN74128	1.39
SN7409	.29	SN7452	.24	SN7490	.76	SN74129	1.48
SN7410	.25	SN7453	.24	SN7491	1.09	SN74130	1.48
SN7411	.27	SN7454	.24	SN7492	.76	SN74131	1.48
SN7412	.55	SN7455	.24	SN7493	1.09	SN74132	1.79
SN7413	.49	SN7456	.24	SN7494	1.09	SN74133	1.79
SN7414	.49	SN7457	.24	SN7495	1.09	SN74134	1.79
SN7415	.49	SN7458	.24	SN7496	1.09	SN74135	1.79
SN7416	.25	SN7459	.24	SN7497	1.09	SN74136	1.79
SN7417	.25	SN7460	.24	SN7498	1.09	SN74137	1.79
SN7418	.25	SN7461	.24	SN7499	1.09	SN74138	1.79
SN7419	.25	SN7462	.24	SN7500	1.09	SN74139	1.79
SN7420	.25	SN7463	.24	SN7501	1.09	SN74140	1.79
SN7421	.25	SN7464	.24	SN7502	1.09	SN74141	1.79
SN7422	.25	SN7465	.24	SN7503	1.09	SN74142	1.79
SN7423	.25	SN7466	.24	SN7504	1.09	SN74143	1.79
SN7424	.25	SN7467	.24	SN7505	1.09	SN74144	1.79
SN7425	.25	SN7468	.24	SN7506	1.09	SN74145	1.79
SN7426	.25	SN7469	.24	SN7507	1.09	SN74146	1.79
SN7427	.25	SN7470	.24	SN7508	1.09	SN74147	1.79
SN7428	.25	SN7471	.24	SN7509	1.09	SN74148	1.79
SN7429	.25	SN7472	.24	SN7510	1.09	SN74149	1.79
SN7430	.25	SN7473	.24	SN7511	1.09	SN74150	1.79
SN7431	.25	SN7474	.24	SN7512	1.09	SN74151	1.79
SN7432	.25	SN7475	.24	SN7513	1.09	SN74152	1.79
SN7433	.25	SN7476	.24	SN7514	1.09	SN74153	1.79
SN7434	.25	SN7477	.24	SN7515	1.09	SN74154	1.79
SN7435	.25	SN7478	.24	SN7516	1.09	SN74155	1.79
SN7436	.25	SN7479	.24	SN7517	1.09	SN74156	1.79
SN7437	.25	SN7480	.24	SN7518	1.09	SN74157	1.79
SN7438	.25			SN7519	1.09	SN74158	1.79
SN7439	.25			SN7520	1.09	SN74159	1.79
SN7440	.25					SN74160	1.79
SN7441	.25					SN74161	1.79
SN7442	.25					SN74162	1.79
SN7443	1.21					SN74163	1.79

**Poly Paks Will Never Be Undersold!**

**LOWEST PRICES ON TTL IC'S** Buy 3 — Take 10% Discount

No Gimmicks on Pricing, Deliveries, or Quality! We're "The Only IC Advertiser" with **MONEY BACK GUARANTEE!**

Best Values for 18 years

Terms: add postage, cod's 25% **Rated:** net 30  
Photo-Orders: Wakefield, Mass. (617) 245-3829  
Retail: 211 Albion St., Wakefield, Mass.  
C.O.D.'S MAY BE PHONED IN

**POLY PAKS** P.O. BOX 942 E  
Lynnfield, Mass. 01940

**CIRCLE NO. 24 ON READER SERVICE CARD**

## HIGH FIDELITY

**DIAMOND NEEDLES** and Stereo Cartridges at Discount prices for Shure, Pickering, Stanton, Empire, Grado and ADC. Send for free catalog. All merchandise brand new and factory sealed. **LYLE CARTRIDGES**, Dept. P, Box 69, Kensington Station, Brooklyn, New York 11218.

**STEREO** Components at lowest prices. Send for free catalog. Carston, Box 1094-A, Danbury, Conn. 06810.

**FREE Kit Catalog.** Amplifiers: Lil Tiger \$11.10, Universal Tiger \$30.00. Preamp \$44.50 (Featured in Popular Electronics) Mixer-6 input \$13.75. SWTPC, Box A32040, San Antonio, Tex. 78284.

**TAKE SOUND OFF** your Cassette or Cartridge with "ERASETTE". Our exclusive electronic wash (-65db O-VU) gives you a like new Cassette or Cartridge in an instant. Less than 1—lb. self contained, 4—"AA" battery powered. \$12.50 postpaid. Calif. residents add sales tax. Magnesonics Corp., Box 127, Northridge, California 91324.

**McGEE RADIO COMPANY**  
World's Best Selection of Speakers  
Almost Every Size From 1½ to 18"  
**WOOFERS — TWEETERS — CROSSOVERS**  
**MANY HIGH FIDELITY KITS.**  
*McGee's Speaker Catalog*  
*Sent Free Upon Request*  
**NORELCO HI-FI SPEAKERS**  
An Added Full Line of Norelco Hi-Fi Speakers  
For The System Builder  
**McGEE RADIO COMPANY,**  
1901 McGee Street PE,  
Kansas City, Missouri 64108

## TAPE AND RECORDERS

**STEREO TAPE RENTAL** for particular people. Free catalog. Gold Coast Tape Library, Box 2262, Palm Village Station, Hialeah, Fla. 33012.

**OLD Radio Programs** on cassettes or reels. High quality, low prices, thousands to choose from, professional equipment, catalog 50¢. Remember Radio Inc., Box 2513, Norman, Okla. 73069.

**RENT 4-Track open reel tapes**—all major labels—3,000 different—free brochure. Stereo-Parti, 55 St. James Drive, Santa Rosa, Ca. 95401.

**MEMOREX** recording tape, audio & video lowest prices, write for free information. Bergetz Systems Co., Box 1181, Melrose Park, Ill. 60161.

## REPAIRS AND SERVICES

TV Tuners rebuilt and aligned per manufacturers specification. Only \$9.50. Any make UHF or VHF Ninety day written guarantee. Ship complete with tubes or write for free mailing kit and dealer brochure. JW Electronics, Box 51C, Bloomington, Indiana 47401.

## INSTRUCTION

**LEARN ELECTRONIC ORGAN SERVICING** at home all makes including transistor. Experimental kit—trouble-shooting. Accredited NHC, Free Booklet, **NILES BRYANT SCHOOL**, 3631 Stockton, Dept. A, Sacramento, Calif. 95820.

**LEARN WHILE ASLEEP**, Hypnotize! Strange catalog free. Auto-suggestion, Box 24-ZD, Olympia, Washington 98501.

**HIGHLY effective home study courses** in Electronics Engineering Technology and Electronics Engineering Mathematics. Earn your Degree. Write for Free Descriptive Literature. Cook's Institute of Electronics Engineering, (Dept. 15), P.O. Box 10634, Jackson, Miss. 39209. (Established 1945).

**ASSOCIATE DEGREE IN ELECTRONICS** through correspondence instruction. G.I. Bill approved. Free catalog. Grantham, 1509 N. Western, Hollywood, California 90027.

**FCC First and Second Tests.** \$8.95. Electronic Tutoring, Box 24190, Cleveland, Ohio 44124.

**LOGIC** trainers catalogs 50¢. UTI, POB 252, Waldwick, N.J. 07463.

**EARN College Degrees** at home. Many Subjects. Florida State Christian College, Post Office Box 1674, Fort Lauderdale, Fla. 33302.

**HIGHLY Effective, Profitable Short Courses.** (75 Choices). Study At Home. Diploma Awarded. Our 27th Year. Free Literature. CIEE-D, Box 10634, Jackson, Miss. 39209.

**AVIATION ELECTRONICS TECHNICIAN**—Prepare for exciting career in new field of "Avionics". Train at nation's largest aeronautical school. Indicate if eligible for G.I. Benefits. Spartan Airschool, International Airport, MM, Tulsa, Oklahoma 74151.

**AMATEUR RADIO.** For getting your General Class or higher license in the shortest possible time, complete correspondence tape-recorded no textbook license courses. Amateur Radio License School, 12217 Santa Monica Boulevard, Los Angeles, Calif. 90025.

**DRAFTING**—Blueprint Reading (Mechanical, Electronic, Architectural). Home Courses \$25.00. Send \$2.00 first lesson. Prior Inc., 23-09 169th Street, Whitestone, New York 11357.

**F.C.C. TYPE Exams** Guaranteed to prepare you for F.C.C., 3rd., (\$7.00), 2nd., (\$12.00), 1st., (\$16.00), phone exams; Complete package, \$25.00. Research Company, Rt. 2, Box 448, Calera, Alabama 35040.

**HIGH SCHOOL DIPLOMA** for adults. Earn State Diploma. Accepted by Civil Service, business, colleges. Low cost. No tedious study. Money-back guarantee. Details: H-S Program, Suite 2504, 1221 Avenue of Americas, New York, N.Y. 10020.

**ON THE AIR** announcer training at R.E.I. features individual realistic preparation for your Radio/TV career. R.E.I.'s engineering course features intensive training for the FCC First Phone! Complete either course in just five (5) weeks! Call 1-800-237-2251 toll free for brochure. Write: R.E.I., 1336 Main Street, Sarasota, Florida 33577.

**LEARN RECORDING FROM STUDIO ENGINEERS.** Free literature. Write: NNA, Box 721-F, Rye, New York 10580.

**F.C.C. EXAM MANUAL**

The Original Test-Answers exam manual that prepares you at home for FCC First and Second class licenses. Includes Updated multiple choice tests and Key Schematic diagrams. PLUS - "Self-Study Ability Test." -- ONLY: \$9.95 Postpaid!

Test-Answers for FCC First and Second Class Commercial License

COMMAND PRODUCTIONS P.O. BOX 26348-P  
RADIO ENGINEERING DIVISION SAN FRANCISCO, CALIF. 94126

## DO-IT-YOURSELF

**ORNAMENTAL FOUNTAINS BY RAIN JET** Provide "Showers of Diamonds." Patented. Our "Junior Jet Set" includes various fountain heads for use with your pump in your pool. From \$17.75 plus tax. Send for brochure with do-it-yourself fountain items. Rain Jet Corp., 301 Flower St., Dept. FYA, Burbank, California 91503.

**PROFESSIONAL ELECTRONIC PROJECT BUSINESS** to advanced technicians and engineers only. Very reasonable. PARKS, 7544 23rd Ave., NE, Seattle, Wash. 98115.

POPULAR ELECTRONICS Including Electronics World

**LOWEST PRICES: ON BRAND NEW FULLY TESTED & GUARANTEED IC'S  
BEST SERVICE: 10% DISCOUNT ON ALL ITEMS NOT SHIPPED IN 24 HOURS  
MOST CONVENIENT: ORDER DESK 1-800-325-2395 (TOLL FREE)**

**PLEASE NOTE: To qualify for prices in the last three columns, you must order in EXACT  
Multiples of 10 per item for all IC items on your order.**

Catalog Number	Any Quantity Per Item (Mix)			Multiples of 10 Per Item (Mix)			Catalog Number	Any Quantity Per Item (Mix)			Multiples of 10 Per Item (Mix)		
	1-99	100-999	1000 up	100-999	1000-9999	10000 up		1-99	100-999	1000 up	100-999	1000-9999	10000 up
7400	.26	.25	.23	.22	.21	.20	7474	.50	.48	.45	.43	.40	.38
7401	.26	.25	.23	.22	.21	.20	7475	.80	.76	.72	.68	.64	.60
7402	.26	.25	.23	.22	.21	.20	7476	.56	.53	.50	.48	.45	.42
7403	.26	.25	.23	.22	.21	.20	7480	.76	.72	.68	.65	.61	.57
7404	.28	.27	.25	.24	.22	.21	7482	.99	.94	.88	.83	.78	.72
7405	.28	.27	.25	.24	.22	.21	7483	1.63	1.55	1.46	1.38	1.29	1.20
7406	.52	.50	.47	.44	.42	.39	7485	1.42	1.35	1.27	1.20	1.12	1.05
7407	.52	.50	.47	.44	.42	.39	7486	.58	.55	.52	.49	.46	.44
7408	.32	.30	.29	.27	.26	.24	7490	.80	.76	.72	.68	.64	.60
7409	.32	.30	.29	.27	.26	.24	7491	1.43	1.35	1.28	1.20	1.13	1.05
7410	.26	.25	.23	.22	.21	.20	7492	.80	.76	.72	.68	.64	.60
7411	.28	.27	.25	.24	.22	.21	7493	.30	.27	.22	.20	.17	.15
7413	.58	.55	.52	.49	.46	.44	7494	1.13	1.12	1.05	.99	.93	.87
7416	.52	.50	.47	.44	.42	.39	7495	1.13	1.12	1.05	.99	.93	.87
7417	.52	.50	.47	.44	.42	.39	7496	1.13	1.12	1.05	.99	.93	.87
7420	.26	.25	.23	.22	.21	.20	74100	1.52	1.44	1.36	1.28	1.20	1.12
7421	.26	.25	.23	.22	.21	.20	74107	.52	.49	.47	.44	.42	.39
7423	.30	.27	.26	.24	.22	.21	74121	.56	.53	.50	.48	.45	.42
7425	.50	.48	.45	.43	.40	.38	74122	.70	.67	.63	.60	.56	.53
7426	.34	.32	.31	.29	.27	.26	74123	1.21	1.06	1.00	.94	.89	.83
7430	.26	.25	.23	.22	.21	.20	74141	1.63	1.55	1.46	1.38	1.29	1.20
7437	.36	.33	.30	.28	.25	.24	74145	1.41	1.33	1.26	1.18	1.11	1.04
7438	.36	.33	.30	.28	.25	.24	74150	1.63	1.55	1.46	1.38	1.29	1.20
7440	.26	.25	.23	.22	.21	.20	74151	1.20	1.13	1.07	1.01	.95	.89
7441	1.73	1.64	1.55	1.46	1.37	1.27	74153	1.63	1.55	1.46	1.38	1.29	1.20
7442	1.27	1.21	1.14	1.07	1.01	.94	74154	2.43	2.30	2.16	2.03	1.89	1.76
7413	1.27	1.21	1.14	1.07	1.01	.94	74155	1.46	1.39	1.31	1.23	1.16	1.08
7414	1.27	1.21	1.14	1.07	1.01	.94	74156	1.46	1.39	1.31	1.23	1.16	1.08
7415	1.71	1.62	1.53	1.44	1.35	1.26	74157	1.56	1.48	1.39	1.31	1.23	1.15
7416	1.24	1.17	1.11	1.04	.98	.91	74158	1.56	1.48	1.39	1.31	1.23	1.15
7417	1.16	1.10	1.04	.98	.92	.85	71161	1.89	1.79	1.68	1.58	1.47	1.37
7448	1.44	1.37	1.29	1.22	1.14	1.06	74164	1.89	1.79	1.68	1.58	1.47	1.37
7450	.26	.25	.23	.22	.21	.20	74166	1.93	1.85	1.76	1.65	1.54	1.43
7451	.26	.25	.23	.22	.21	.20	74180	1.20	1.13	1.07	1.01	.95	.88
7453	.26	.25	.23	.22	.21	.20	74181	5.20	4.90	4.59	4.28	3.98	3.67
7451	.26	.25	.23	.22	.21	.20	74182	1.20	1.13	1.07	1.01	.95	.88
7460	.26	.25	.23	.22	.21	.20	74192	1.93	1.87	1.76	1.65	1.54	1.43
7470	.42	.40	.38	.36	.34	.32	74193	1.93	1.87	1.76	1.65	1.54	1.43
7472	.38	.36	.34	.32	.30	.29	74198	2.81	2.65	2.50	2.34	2.18	2.03
7473	.50	.48	.45	.43	.40	.38	74199	2.81	2.65	2.50	2.34	2.18	2.03

**TRANSISTORS AND DIODES**

1N270	.15	.14	.13	.12	.11	.10	1N4003	.43	.42	.41	.40	.39	.38
1N751A	.30	.28	.26	.24	.22	.20	1N4006	.15	.14	.13	.12	.11	.10
1N914	.10	.09	.08	.07	.06	.05	1N154	.15	.14	.13	.12	.11	.10
1N1001	.10	.09	.08	.07	.06	.05	2N3060	.25	.23	.21	.19	.17	.15
1N4002	.11	.10	.09	.08	.07	.06							

**SUPER FAST SCHOTTKY TTL**

Types 74S00, 74S01, 74S03, 74S08, 74S09, 74S10, 74S15, (Three input AND with open collector), 74S20, 74S21, 74S50, 74S61, 74S64, 74S64, (4-2-3-2 input AND-OR-INVERT gate), 74S65 (open collector 74S64); your six column prices are:

1.14	1.08	1.02	0.96	0.90	0.84
------	------	------	------	------	------

Types 74S04, 74S05, 74S10, 74S140 (Dual 4-input NAND Line Driver); your six column prices are:

1.37	1.30	1.22	1.15	1.08	1.01
------	------	------	------	------	------

Types 74S73, 74S74, 74S76, 74S78, 74S107, 74S112, 74S113, 74S114; your six column prices are:

1.98	1.87	1.76	1.65	1.54	1.43
------	------	------	------	------	------

ALL IC'S are supplied in 8-, 14-, 16-, or 24-pin DIP (Dual-in-Line) plastic package. We give FREE data sheets upon request, so ask for those data sheets that you NEED, even for those listed IC that you are not buying.

**Solid State Systems, Inc.**  
P.O. Box 773  
Columbia, Mo. 65201

Phone 314-443-3673  
TWX 910-760-1453

TERMS: RATED FIRMS NET 30 DAYS. Others CHECK or MONEY ORDER with order. Add 3% in orders under \$5.00 for postage & handling. For UPS or FIRST CLASS add .45 and for AIR MAIL add 65% to your order; we pay the balance. If you are served by UPS in your area, we strongly recommend this service with its built-in \$100 insurance. COD orders are FOB Columbia with 65 COD fee additional. Canadian residents please add 5% for INSURANCE.

MISSOURI RESIDENTS: Please add 4% Sales Tax.

WRITE OR CIRCLE READER SERVICE CARD FOR OUR CATALOG OF PARTS & SERVICES. IT'S FREE.

**CIRCLE NO. 33 ON READER SERVICE CARD**

**LED 7-SEGMENT DISPLAY**



\$4.95 Each

50-99  
100-999  
1000-70

\$4.75  
\$4.50  
\$4.25

Large 1/2" 7-segment LED readout similar to the popular MAN-1 but with improved brightness. Has left-hand decimal point. Fits in a DIP socket. Expected life: Over 100 Yrs. Regularly \$12.95 in single Lots. These are BRAND NEW with full data sheet and 4-page MULTIPLEXING Application Note. Needs a 7417 for driver and ONE CURRENT-LIMITING RESISTOR PER SEGMENT. We can supply you with one or ten thousand FROM STOCK. Also available, 21 OVERFLOW digit at the same price. Mixing of Regular & Overflow digit allowed.

Package of R. 1/4W Limiting R's ..... 30¢

Incandescent Type of 7-segment display. With right-hand decimal point. Rated 8mA per segment at TTL supply of 5V. Design life of 50,000 hours. Needs a 7417 as a driver. In DIP Package. Each \$3.25



MOLEX IC SOCKET PINS: Use these economical pins instead of soldering your IC's to PC boards. Sold in continuous strips in multiples of 100 pins only.

100 for \$1.00; 200 for \$1.80; 300 for \$2.60  
400 for \$3.40; 500 for \$4.20; 600 for \$5.00  
700 for \$5.80; 800 for \$6.60; 900 for \$7.40  
1000 for \$8.20. Each Additional 1000 \$7.50



CERAMIC DISC CAPACITORS Type 56A-16000VWDC.  
5, 7.5, 10, 12, 15, 20, 22, 25, 27, 30, 33, 39, 50, 56, 68, 75, 82, 100, 120, 150, 180, 200, 220, 250, 270, 300, 330, 360, 390, 470, 500, 560, 680, 750, 820, 1000, 1200, 1500, 1800, 2000, 2200, 2500, 2700, 3000, 3300, 3900, 4700, 5000µdF.

1µF ..... 10¢  
0.01µF EACH ..... 1¢  
0.02µF EACH ..... 12¢

LOW VOLTAGE DISCS, Type UK.  
1.0µF, 3V ..... 25¢  
1.0µF, 10V ..... 12¢  
0.47µF, 3V ..... 25¢  
0.01µF, 16V ..... 10¢

ELECTROLYTIC CAPACITORS:  
All values are available in both axial or upright (PC Board) mount. PLEASE INDICATE YOUR CHOICE.

10µF, 15V	..... 10¢	1000µF, 35V	..... 50¢
30µF, 15V	..... 10¢	1µF, 50V	..... 10¢
50µF, 15V	..... 10¢	2µF, 50V	..... 10¢
100µF, 15V	..... 10¢	3µF, 50V	..... 10¢
220µF, 15V	..... 15¢	5µF, 50V	..... 10¢
500µF, 15V	..... 20¢	10µF, 50V	..... 15¢
1000µF, 15V	..... 30¢	20µF, 50V	..... 20¢
20µF, 25V	..... 15¢	50µF, 50V	..... 20¢
30µF, 15V	..... 20¢	100µF, 50V	..... 20¢
50µF, 35V	..... 20¢	200µF, 50V	..... 40¢
100µF, 35V	..... 20¢	500µF, 50V	..... 55¢
500µF, 35V	..... 40¢		

VOLTAGE REGULATORS: Internally-set, overload and short-circuit proof regulators need no external components to set. With data sheet and application notes. 10-3 Package.  
LM335, 5V, 600mA ..... \$2.85  
LM335, 12V, 500mA ..... \$3.85  
LM337, 15V, 450mA ..... \$4.05  
20 Watt PC-Board Type HEAT SINK ..... \$1.20

STANCOR P4180, 25.2 VOLT, 1-Amp Transformer. Ideal for use with LM series. Each ..... \$3.00

ALL-EN-BRADLEY MIL-GRADE (5-band) RESISTORS. Any of the 84 STANDARD 10% values from 2.752 to 22MΩ 1/4 or 1/2 WATT. EACH ..... \$5

DUAL-IN-LINE Wire-Wrap Type IC Sockets. BRAND NEW with gold plated pins.

1-99	100-249	250-999	1000-4999	5K-UP
14-PINS 0.40	0.35	0.30	0.25	0.20
16-PINS 0.75	0.70	0.65	0.60	0.55

## PERSONALS

**MAKE FRIENDS WORLDWIDE** through international correspondence. Illustrated brochure free. Hermes, Berlin 11, Germany.

**MAKE** friends for travel, matrimony, fishing, etc. Send age and \$1 for bulletin "Introductions." Amity, P.O. Box 2471, Detroit, Michigan 48231.

**BUGGED???** . . . Electronic Detector locates hidden transmitters. Literature 25¢. Security Devices, Box 671, Westwood, New Jersey 07675.

## INVENTIONS WANTED

**INVENTIONS** wanted. Patented: unpatented. Global Marketing Service, 2420-P 77th, Oakland, Calif. 94605.

**INVENTORS!** Don't sell your invention, patented or unpatented, until you receive our offer. Eagle Development Company, Dept. 9, 79 Wall Street, N.Y., N.Y. 10005.

**PATENT** Searches including Maximum speed, full airmail report and closest patent copies. Quality searches expertly administered. Complete secrecy guaranteed. Free invention Protection forms and "Patent Information." Write Dept. 9, Washington Patent Office Search Bureau, Benjamin Franklin Substation, P.O. Box 7167, Washington, D.C. 20044.

**FREE** "Directory of 500 Corporations Seeking New Products." For information regarding development, sale, licensing of your patented/unpatented invention. Write: Raymond Lee Organization, 230-GR Park Avenue, New York City 10017.

**INVENTORS:** Protect your Ideas! Free "Recommended Procedure". Washington Inventors Service, 422T Washington Building, Washington, D.C. 20005.

**FREE PAMPHLET:** "Tips on Safeguarding Your Invention." Write: United States Inventors Service Company, 708-T Carry Building, Washington, D.C. 20005.

## BOOKS

**FREE** catalog aviation/electronic/space books. Aero Publishers, 329PE Aviation Road, Fallbrook, California 92028.

**FREE** book prophet Elijah coming before Christ. Wonderful bible evidence. Megiddo Mission, Dept. 64, 481 Thurston Rd., Rochester, N.Y. 14619.

## RECORDS

**CHAPEL** Records Club—Free catalog. 1000-B Richmond, China Lake, Calif. 93555.

## GOVERNMENT SURPLUS

**GOVERNMENT** Surplus. How and Where to Buy in Your Area. Send \$1.00. Surplus Information, Headquarters Bldg., Box 30177-PE, Washington, D.C. 20014.

**ELECTRONIC** Equipment and Parts. Big 36 page Free Catalog. Send for your copy today! Fair Radio Sales, Box 1105-P, Lima, Ohio 45802.

**JEeps** Typically from \$53.90 . . . Trucks from \$78.40 . . . Boats, Typewriters, Knives, Airplanes, Clothing, Multimeters, Oscilloscopes, Transceivers, Photographic, Electronics Equipment. Wide-variety, condition. 100,000 Bid Bargains direct from government nationwide. Complete sales directory and surplus categories catalog \$1.00 (Deductible on orders from separate included catalog). Surplus Service, Box 820-J, Holland, Michigan 49423.

**GOVERNMENT SURPLUS.** Complete sales directory \$1.00. Surplus Publications, Box 26062Z, Los Angeles, Calif. 90026.

**MANUALS** for gov't surplus radios, test sets, scopes, teletype. List 25¢. Books, 4905 Roanne Drive, Washington, D.C. 20021.

## BUSINESS OPPORTUNITIES

**I MADE** \$40,000.00 Year by Mailorder! Helped others make money! Start with \$10.00—Free Proof. Torrey, Box 318-N, Ypsilanti, Michigan 48197.

**\$200.00 DAILY** In Your Mailbox! Your opportunity to do what mail-order experts do. Free details. Associates, Box 136-J, Holland, Michigan 49423.

**START** small, highly profitable electronic production in your basement. Investment, knowledge unnecessary. Postcard brings facts. Barta-PEB, Box 248, Walnut Creek, California 94597.

**FREE CATALOGS.** Repair air conditioning, refrigeration. Tools, supplies, full instructions. Doolin, 2016 Canton, Dallas, Texas 75201.

**MAILORDER MILLIONAIRE** helps beginners make \$500 weekly. Free report reveals secret plan! Executive (1K9), 333 North Michigan, Chicago 60601.

**FREE BOOK** "999 Successful, Little-Known Businesses." Work home! Plymouth BGI, Brooklyn, New York 11218.

**MAKE** \$1.00 per sale selling engraved metal Social Security plates. **FREE SALES KIT.** Engraving plates, Box 10460-200, Jacksonville, Florida 32207.

**400,000 BARGAINS** Below Wholesale! Many free! Liquidations . . . Closeouts . . . Job lots . . . Single Samples. Free details. Bargainhunters Opportunities, Box 730-J, Holland, Michigan 49423.

**CB DISTRIBUTORS WANTED**—Reliable CB units can build your profits. SILTRONIX, a Cubic Corporation company, is in the process of expanding its nation wide distribution network for Citizen-Band equipment. If you have aggressive dealers eager to sell quality products in this lucrative market, contact Bob Miller for details of our profit building plan. Call (714) 757-8860, today. SILTRONIX, 221 Via El Centro, Oceanside, Calif. 92054.

**PIANO TUNING** learned quickly at home. Tremendous field! Musical knowledge unnecessary. GI Approved. Information Free. Empire School, Box 327, Miami, Florida 33145.

## Up Your OWN! Organization!

by Donald M. Dible

A complete guide on how to start and finance a business.  
Send for free brochure. Entrepreneur Press, Dept. A-95  
Drawer 2759, Santa Clara, Ca 95051.



**FREE BOOK** "2042 Unique, Proven Enterprises." Largest successful, moneymaking Collection in world! Fabulous ways to beat inflation! Work home . . . sparetime! Haylings-B, Carlsbad, Calif. 92008.

## TREASURE FINDERS

**FISHER DETECTORS.** You deserve the best. Free literature, FRI, Dept. PE-9, P.O. Box 490, Belmont, CA 94002.

**TREASURE** Hunters! Prospectors! Rockhounds! Hobbyists! Find gold, silver, relics with world famous Detector Metal Detectors. Free information. Delivery immediate. Detectors, Dept. 9-PE, Box 243, San Gabriel, Calif. 91778.

**TRANSISTORIZED** detectors—\$19.95 to \$79.95. Family fun and fortune. Catalog write: Treasureprobe PE 25, Tennent, N.J. 07763.

POPULAR ELECTRONICS Including Electronics World



### 50 MEGAHERTZ LOW COST COUNTER



Here is a new item, featured because of numerous customer suggestions.

We have taken the basic power supply, chassis and cover from our clock kit, and by substituting a new front panel and printed circuit board, have made a

- lowest cost frequency counter. The unbelievable low cost is due to our use of our large stock of unused surplus nixies, the new 74196 50 MHz decade counter, and the commonality of parts with our other kits. Readout is to six decades, time base is 1 second, 0.1 seconds, or external. Design is modular, for ease of construction, compactness, and expandability.
- 50 MHz six digit counter, using line frequency as time base, complete except for cover \$97.50
  - Optional crystal controlled time base plug in conversion \$23.50
  - Cover, blue or black anodized \$ 4.50

### BUILD YOUR OWN ELECTRONIC CALCULATOR FOR ONLY \$108.00!



A complete calculator kit, complete with self contained power supply and case. Indispensable in the home, office or school. Simple enough for a child to build. Some of the features of the calculator are as follows:

- MOS integrated circuits (extra large scale integration) reduce the number of components to a minimum.
- Easy assembly • Displays eight digits on large size seven segment displays • Full function complement keyboard features addition, subtraction, multiplication, division, alternate display, multiplication by a constant, clear all, clear entry, and decimal point set. • Sixteen digit entry and sixteen digit results are possible with alternate display key. • Leading zeros suppressed • Chain operation • All integrated circuits and diodes are socket mounted and replaceable.

So reliable and simple to build, we can make this guarantee: If for any reason you cannot succeed in getting your calculator to function properly after completing construction, for a flat handling fee of \$10.00, B and F will repair and ship back your calculator anywhere in the USA. This applies regardless of the age of the assembler, barring gross negligence or the use of acid core solder in construction.

### DIGITAL CLOCK KIT WITH NIXIE DISPLAY

We have well over 20,000 surplus nixies in stock, and because of this bargain purchase we can sell a complete digital clock kit for less than the usual cost of the display tubes only. We provide a complete etched and thru-plated circuit board, all integrated circuits, complete power supply, display tubes, I.C. sockets and a nice front panel with polaroid view. We have never seen anyone offer this kit for less than \$100.00 before. Includes 8CD output display. Indicates hours, minutes, seconds.

- Clock Kit, complete less outside cover \$57.50
- Aluminum blue or black anodized cover (specify) \$ 4.50
- SHRINK TUBING SPECIAL. Assortment of 200 pieces of shrink tubing, diameters 1/8" to 1/2", length 1/2" to 2" \$1.25
- Price \$1.25

### KEYBOARDS

- Three keyboards are available: 20 key calculator keyboard, 40 key alphanumeric, and 12 key touch tone. All have separate contacts carried out to edge connector.
- Touch Tone Keyboard \$ 9.50
  - Calculator Keyboard \$14.50
  - Alphanumeric Keyboard \$29.00

### LIGHT EMITTING DIODE NUMERIC DISPLAY



This display is excellent for small portable electronics, such as DVM's, calculators, etc. Equivalent to Monsanto MAN 3A. Operates from 5 volts, 20 milliamperes, with 47 ohm dropping resistor.

- \$3.25 Each
- 10 For \$27.50
- Complete counter kit, 7490, 7475 latch 7447, printed circuit board, led readout \$9.50

### LATEST HARD-TO-GET SEMICONDUCTORS

- MUS 4988 silicon unilateral switch. Useful for voltage sensitive switch, switch generators, etc. \$1.00
- MIS A64 PNP high current Darlington transistor. Super high gain in small package. \$21.00
- MPS A14, same as above, NPN. \$21.00

### THIS MONTHS FEATURE ITEM

#### POCKET CALCULATOR KIT



This is the kit you have been waiting for. So compact it actually fits in a shirt pocket: (3-13/16 x 4-5/8 x 1-1/4). It performs every function you would expect in a desk calculator, including constant and chain operation, and full floating decimal. The unit is powered by self contained batteries, and uses 8 digit LED displays. The calculations are performed by a single 40 pin integrated circuit, which can truly be called large scale integration (LSI). As a student, engineer, salesman, accountant, or anyone who would like fast accurate answers, this calculator fits the bill, and at a price that unquestionably makes this the lowest price high quality calculator available.

- Pocket Calculator Kit \$75.00

#### RECHARGEABLE BATTERY/CHARGER KIT

This option allows the throw-away alkaline battery to be replaced with a nicad battery, and includes a charger to recharge this battery. The unit may be run during the recharge cycle.

- Battery/Charger Kit \$17.50

#### LOGIC AND OPERATIONAL AMP SUPPLIES



- Figure A, potted logic supply, 5 Volts at 1 Ampere, short circuit proof, ultra high regulation, ultra low ripple \$16.00
- Figure A, potted Op Amp supply, +15 Volts, and -15 Volts at 0.5 Amperes. Mfg. by Analog Devices similar to their model 902. Short circuit proof, ultra high performance. \$29.00
- Figure B, 5 Volt 1 Amp supply, reg. lated by Fairchild 9305, short circuit protected \$9.75
- Same as above, in kit form \$7.75
- Mating connector for above \$1.00
- 5 Volt 5 Amp regulated supply, by Bluline, (not shown) \$29.00

#### LIGHT EMITTING DIODES

- Montanto MV 50 or equivalent LED's. Now less expensive than filamentary bulbs. At this price we wire them into logic circuits as status indicators, build low cost counters or use them as panel lites. Rated at 10-40 Ma @2V.
- 10 LED's \$3.00
  - 100 LED's \$25.00
  - 1000 LED's \$200.00

#### LOUDSPEAKER SYSTEM COMPONENT SPECIAL!!

- We have made an excellent purchase of an excess inventory of a local manufacturer's speaker systems although we aren't allowed to mention the manufacturer's name, the specs should make it self evident. The woofer is a 12" free edge (acoustic suspension) unit, with 2" voice coil and 2 lb. magnet. The midrange is a 5" unit and the tweeter is of the dome type, for best high frequency dispersion. Crossover between woofer and midrange is by an R-L-C network, while high frequency crossover is by an R-C network. Balance controls are provided for both mid-range and tweeter. Plans for a suitable enclosure are provided.
- Speaker System \$29.00 ea./2 for \$55.00

#### CALCULATOR CHIP SPECIAL

B and F has purchased a quantity of MOS large scale integration chips for calculators. We are not allowed to mention the manufacturer's name, however, the specs should make them self-evident.

- Set "X" Four 24 pin I.C.'s, BCD output, 16 digit, fixed automatic decimal point, possible memory expansion, constant \$29.00
- Set "Y" Single 40 pin 7 segment output, 12 digit, fixed automatic decimal, no constant \$15.00
- Set "Z" Single 40 pin I.C., 7 segment output, 8 digit, floating point, constant \$19.50

#### LINEAR DEVICES, OP AMPS, REGULATORS

- 709 High performance Op-Amp \$5.00
- 711 Dual Comparator \$5.00
- 723 Regulator \$1.25
- 741 Compensated Op-Amp \$5.00
- 558 Dual 741 \$1.00
- LM309 5 Volt 1 amp Regulator, TO-3 \$2.25

#### FAIRCHILD VOLTAGE REGULATOR

- Fairchild UGH7805 5 Volt 1 amp voltage regulator. Perfect for logic supplies, very compact \$1.95

### SANKEN HYBRID AUDIO AMPLIFIER MODULES



We have made a fortunate purchase of Sanken Audio Amplifier Hybrid Modules. With these you can build your own audio amplifiers at less than the price of discrete components. Just add a power supply, and a

chassis to act as a heat sink. Brand new units, in original boxes, guaranteed by B and F. Sanken and the Sanken U.S. distributor. Available in three sizes: 10 watts RMS (20 watts max power), 25 watts RMS (50 watts M.P.) and 50 watts RMS (100 watts M.P.) per channel. 20 page manufacturers instruction book included. Sanken amplifiers have proved so simple and reliable, that they are being used for industrial applications, such as servo amplifiers and wide band laboratory amplifiers.

- SI1010 10 watt RMS amplifier, industrial grade \$4.75
- SI1025A 25 watt RMS amplifier, industrial grade \$14.75
- SI1050A 50 watt RMS amplifier, industrial grade \$23.50
- SI1025E 25 watt RMS amplifier, entertainment grade \$14.00
- SI1050E 50 watt RMS amplifier, entertainment grade \$21.00
- Transformer for stereo 10 watt amplifiers (2 lbs.) \$3.95
- Transformer for stereo 25 or 50 watt amplifiers (3 lbs.) \$5.95
- Set of (3) 2000 microfarad capacitors for 10 watt stereo \$1.00
- Set of (3) 2200 microfarad 75V capacitors for 25 or 50 watt amplifiers \$5.00
- 1 Amp Bridge Rectifier, suitable for all amplifiers \$2.00
- Complete kit for 100 watt RMS stereo amplifier (200 watt output) including two 50 watt Sanken hybrids, all parts, instructions, and nice 1/16" thick black anodized and punched chassis \$88.00
- Same for 50 watt RMS stereo amplifier, includes two 25 watt Sanken, etc. \$58.00
- Same for 20 watt RMS stereo, includes two 10 watt Sanken, etc. \$30.00

#### SGS-THA 621 AUDIO AMPLIFIER

1. C audio amplifier in 14 pin DIP package, provides up to 4 watts power with proper heat sink and 28 watt supply. Can be used at 12 Volts with reduced output power. - \$1.95 \$6 for 100

#### HIGH POWER SCR'S

SCR's - invaluable for high power applications, motor speed controls, lighting circuits, welding controls, etc. Never before at this low price. Brand new packaged devices, complete with data sheet and 21 page consumer applications manual.

- 2N5062 Plastic 100V 1 amp \$3.50
- 2N5064 Plastic 200V 1 amp .40
- 2N4169 100V/1 amp stud 1.45
- 2N4170 200V/8 amp stud 1.65
- 2N4172 400V/8 amp stud 1.95
- 2N3525 400V/3 amp press fit .95
- 2N1772/C15A 100V/8 amp stud 1.75
- 2N1774/C15B 200V/8 amp stud 1.95
- 2N1777/C15D 400V/8 amp stud 2.50
- 2N1844/C20A 200V/12 amp stud 1.75
- 2N1836/C20B 200V/20 amp stud 1.95
- 2N5169 500V/20 amp stud 3.75
- 2N5170 500V/20 amp stud 4.75
- 2N5171 700V/20 amp stud 6.75
- 2N3896/C30A 100V/25 amp stud 3.95
- 2N3897/C30B 200V/25 amp stud 3.95
- 2N3899/C30E 500V/25 amp stud 4.95

#### SANKEN HIGH POWER, HIGH PERFORMANCE HYBRID VOLTAGE REGULATORS

These hybrid regulators are easy to use, requiring no external components. Excellent for operational amplifier supplies, logic supplies and other high performance applications. All regulators have less than 50 millivolts ripple and better than 1% line and load regulation, some models far exceeding this specification.

- SI3120E 12 Volts, 1 Ampere \$2.25
- SI3150E 15 Volts, 1 Ampere \$2.25
- SI3240E 24 Volts, 1 Ampere \$2.25
- SI3050E 5 Volts, 1 Ampere \$2.25
- SI3554H 5 Volts, 3 Amperes \$7.00

#### ALL ITEMS WHERE WEIGHT NOT SPECIFIED

POSTAGE PAID IN THE U.S.A.  
Phone in charges for (617) 531-5774 or (617) 532-2323.  
BankAmericard - Mastercharge, \$10.00 minimum. No C.O.D.'s please.



#### B. & F. ENTERPRISES

Phone (617) 532-2323  
P.O. Box 44, Haverhill, Massachusetts 01937

**LEDS**

FLV 100 VIS LED'S	\$.65
GAAS IR LED'S	\$.65
MRD 148 Photo darlington's	\$.65

**VARIABLE CAPACITANCE DIODES**

(Similar to 1N5463A) used to tune VHF, color TV, & FM broadcast sets \$ .95

7400	.25	7475	.80
7401	.25	7476	1.00
7402	.25	7480	.75
7404	.28	7481	1.25
7410	.25	7483	1.25
7413	.75	7486	.57
7420	.25	7490	.79
7430	.25	7492	.80
7440	.25	7493	.75
7441	1.15	7495	.75
7447	1.15	74107	.85
7450	.25	74121	.55
7460	.25	74192	1.95
7472	.50	8570	1.50
7473	.50	8590	1.50
7474	.50		

MINIATURE 7 segment cold cathode readout MG-19F \$2.85

**TANTULUM CAPACITORS**

4.7 MFD AT 20V	\$ 1.00
10 MFD AT 20V	\$ 1.00
4.7 MFD AT 100V	\$ .50
11 MFD AT 100V	\$ .75

2N3584 250 Vceo NPN 2A Silicon Trans.	\$1.70
2N3055 7 amp NPN Silicon Transistor	\$1.00

Send \$ .20 for our Latest catalog featuring Transistors and Rectifiers: 325 Elm St., Cambridge, Mass.

These regulated power supplies have been designed to provide complementary power for Operational Amplifiers, Functional Modules, A-D & D-A Converters and Digital Logic.

The supplies are completely self contained (no external parts required). Epoxy encapsulation provides properties close to a true hermetic seal.

**FEATURES**

- Short Circuit Protected
- Compact Size
- No Derating Over Specified Operating Range



MODEL	SE904	SE902	SE903	SE905
Output Voltage (VDC)	±15	±15	5	5
Output Current (MA)	50	100	500	1000
Line (105-125 VAC)	\$18.95	\$26.95	\$22.95	\$34.95

NE 565 PHASE LOCK LOOPS \$3.95

MINIATURE TRIM POTS 500 OHM, 10K, 20K, 25K, 50K or 3 for \$2.00

400 PRV 5A Full Wave Bridge \$1.40  
200 PRV 15A Full Wave Rectifier \$ .95

**TRIACS**

PRV	1A	10A	15A	20A*
100	.40	.70	1.00	1.20
200	.70	1.10	1.50	1.60
300	.90	1.35	1.90	2.00
400	1.10	1.60	2.70	2.40
500	1.50	2.00	3.20	2.80

\*Press Fit  
TIS43 UJT's \$ .50  
2N3819 N Channel FET's \$ .45  
D13T PROG. UJT's \$ .75

**Silicon Power Rectifiers**

PRV	1A	3A	12A	50A
100	.06	.09	.30	.85
200	.07	.16	.35	1.25
400	.09	.20	.45	1.50
600	.11	.30	.70	1.30
800	.15	.40	.85	2.30
1000	.20	.55	1.10	2.75

**Silicon Control Rectifiers**

PRV	3A	7A	20A	70A
100	.30	.45	1.00	3.50
200	.50	.75	1.25	6.50
300	.60	.90	1.50	
400	.70	1.10	1.75	9.50
500	.80	1.25	2.00	
600	.90	1.40	2.25	11.00

IN4886 POWER VARIATORS \$4.95

**TEST EQUIPMENT SPECIALS**  
(Used in good condition)

TEKTRONIX 545A with CA plug-in	\$800.00
NJE RCU36-15, 0-36V at 0-15A power supplies	\$195.00
POWER DESIGN 3240, 1-32V at 6A power supplies	\$95.00
POWER DESIGN 1210, 1-12V at 10A power supplies	\$95.00
Dumont 304A scopes	\$ .95
Tektronix 531 with B or K plug-in	\$475.
HP 521C counter	\$125.
HP 400D voltmeter	\$95.
Ballantine 314 voltmeter	\$95.

**DECADE COUNTER KIT**

Consisting of:  
1-Nixie tube & socket (8754)  
1-7490  
1-7475  
1-7441

**\$4.75**

709C OPER. AMP	\$ .50
741 OPER. AMP	\$ .50
748 Adjust 741	\$ .95
Dual 709	\$1.39
723	\$ .75
TVR-2002 high power 723	\$1.00

**NIXIE TUBES**

Similar to Raytheon  
8754, with socket & data sheet \$1.85

Terms: FOB Cambridge, Mass. Send check or Money Order. Include postage. Average Wt. per package 1/2 lb. No C.O.D.'s.

Minimum Order \$3.00  
Rated companies 30 days net

# SOLID STATE SALES

Post Office Box 74A

Somerville, Mass. 02143

Tel. (617) 547-4005

**CIRCLE NO. 32 ON READER SERVICE CARD**

**FREE**—Valuable Treasure Finder catalog sent by return mail. Find Coins, Rings, Gold, Silver, Metals, Relics. Write today. JETCO, Dept. CPE, Box 26669, El Paso, Texas 79926.

**TREASURE FINDER** locates buried gold, silver, coins, treasures. 5 powerful models. \$19.95 up. Instant financing available. Free catalog. Relco, Dept. A-33, Box 10839, Houston, Texas 77018.

**DISCOVER AMERICA'S FASTEST GROWING HOBBY.** White's Electronics, Inc., would like to send you—absolutely FREE, their 42 page, fact-filled catalog on Mineral and Metal Locating Equipment. Amateurs or Professionals select from the world's largest line of metal detectors, priced as low as \$79.50, up. Detect gold, Silver, Copper—Nuggets, Coins, Jewelry, etc. Budget terms available. For your convenience we have three major factory locations in the U.S. and Canada, as well as over 1,000 authorized dealers to serve you. See your local Yellow Pages, under "Metal Locating Equipment", or write: White's Electronics Inc., Room 10, 391, 1101 Pleasant Valley Road, Sweet Home, Oregon 97386—Elk-Air Industrial Park, Dexter Drive, East, Elkhart, Indiana 6514—or White's Electronics Ltd., 33784 Hazel Street, Abbotsford, British Columbia, Canada.

**BUILD** your own treasure finder. Build a \$129.00 treasure finder for under \$20.00. Easy to follow plans. Parts list \$3.00. Century Radio, P.O. Box 1712, Sanford, Florida 32771.

**BUILD** transistor treasurefinders for \$1 each. Tremendous Profits. Complete business setup, plans, instruction, sources—\$5. Satisfaction guaranteed! Barta—PEE, Box 248, Walnut Creek, California 94596.

**RUBBER STAMPS**

**RUBBER** Address Stamps \$2.00. Signature \$3.50. Free Catalog. Jackson's, Box 443-G, Franklin Park, Illinois 60131.

**NEW!** Three line pocket rubber stamp. \$1.25. Renlee, 215E Golf ne, Hewlett Harbor, NY 11557.

**HYPNOTISM**

"MALE-FEMALE Hypnotism" Exposed, Explained! "Secret Method"—They Never Know! \$2, Rushed. Guaranteed! Isabella Hall, Silver Springs, Florida 32688.

**SLEEP** learning. Hypnotic method. 92% effective. Details free. ASR Foundation, Box 7545PL, Fort Lauderdale, Florida 33304.

**FREE** Hypnotism. Self-Hypnosis. Sleep Learning Catalog! Drawer H400, Ruidoso, New Mexico 88345.

**PRINTING**

**PRINTED** Envelopes. Samples, Price List. Anderson Envelope Co., P. O. Box 606A, Anderson, Indiana 46015.

**EMPLOYMENT INFORMATION**

**EXCITING** Overseas jobs. Directory \$1.00. Research Associates, Box 889-E, Belmont, California 94002.

**ELECTRONICS/AVIONICS** Employment Opportunities. Report on jobs now open. FREE details. Aviation Employment Information Service, Dept. EW, Box 240, Northport, N.Y. 11768.

**REAL ESTATE**

**FREE . . . NEW . . . FALL CATALOG!** Describes and pictures hundreds of farms, ranches, town and country homes, businesses coast to coast! Specify type property and location preferred. UNITED FARM AGENCY, 612-EP West 47th St., Kansas City, Mo. 64112.

## MOVIE FILMS

**MOST MEN ENJOY** Our Sports Films . . . you can become a collector, too, by ordering films from our **FREE 8mm/Super 8** Catalog. Clip this ad and save \$1.00 on the first film you order. **SPORTLITE**, Elect. Dept., Box 500, Speedway, Indiana 46224.

## MAGAZINES

**ADVERTISERS** try one ad in **THE BUCCANEER** magazine. 8¢ a word. 15,000 circulation. Subscription \$2.00. Copy 25¢. Martin's Service, 1148F Martinsville, Virginia 24112.

## MUSICAL INSTRUMENTS

**30% DISCOUNT** name brand musical instruments. Free Catalog. Freeport Music, 455N, Route 110, Melville, N.Y. 11746.

**FREE** Catalog. Electronic musical accessory kits. **PAIA Electronics**, Box A14359, Oklahoma City, OK 73114.

**WHOLESALE!** Professional Guitars, PA Systems, Altec Speakers, 240W RMS Amplifiers. Free Catalog. Carvin, Escondido, Calif. 92028.

## PLASTICS

**CASTOLITE** pours like water, hardens like glass without heat. Crystal clear, colors. Embed natural flowers, photos, coins, anything; in paperweights, keytags, desksets; for gifts, profits. Make flexible molds of your own designs over any pattern, any size. Reproduce them in Castolite, candlewax, plaster, cement. New Manual, 300 photographs, only \$1.00 postpaid. Dept. 72K/PE, Castolite, Woodstock, Ill. 60098.

## MAGNETS

**MAGNETS.** All types. Specials—20 disc magnets, or 2 stick magnets, or 10 small bar magnets, or 8 assorted magnets, \$1.00. Maryland Magnet Company, Box 192H, Randallstown, Maryland 21133.

## RESORTS AND TRAVEL

**SAILHO!** Rent new sailboats. Instructions. Inexpensive. Box 20773, St. Petersburg, Florida 33742.

## MUSIC



### SONGWRITERS! POETS!

Spiritual and religious poems and songs wanted for recording by the Chapel Symphony Orchestra and Choir. We pay all recording costs.

**Information: Write Dept. PE  
CHAPEL RECORDING CO.  
P.O. Box 162, Wollaston, Ma. 02170**

## MISCELLANEOUS

**WINEMAKERS:** Free illustrated catalog yeasts, equipment. Semplex, Box 12276, Minneapolis, Minn. 55412.

## POPULAR ELECTRONICS

Including **Electronics World**

SEPTEMBER 1972

## ADVERTISERS INDEX

READER SERVICE NO.	ADVERTISER	PAGE NO.
1	B. & F. Enterprises	125
	Bell & Howell Schools	74, 75, 76, 77
3	Bose	13
	CREI, A Division of the McGraw-Hill Continuing Education Company	92, 93, 94, 95
4	Cleveland Institute of Electronics	38, 39, 40, 41
2	Cobra Communications, Dynasean Corporation	24
5	Cooks Institute of Electronics Engineering	114
6	Cortlandt Electronics Inc.	119
7	Datak Corporation, The	114
8	Delta Electronics Co.	120
9	Delta Products, Inc.	85
10	Drake Company, R.L.	91
11	Edmund Scientific Co.	128
45	Edwards Electronics	120
12	Electro-Voice, Inc.	9
	Grantham School of Engineering	110, 111, 112, 113
44	Greenlee Tool Co.	73
14	Gregory Electronics Corp.	118
15	Heath Company	79
16	Judson Research and Mfg. Co.	83
17	Lafayette Radio Electronics	129, 130
18	McIntosh Laboratory Inc.	115
19	Mallory Distributor Products Company	103
20	MIT'S Micro Instrumentation & Telemetry Systems, Inc.	15
	National Radio Training	SECOND COVER, 1, 2, 3
	National Technical Schools	56, 57, 58, 59
21	Olson Electronics	81
22	PTS Electronics, Inc.	97
23	Pennwood Numechron Co.	90
24	Poly Paks	121
25	RCA Institutes, Inc.	18, 19, 20, 21
26	Revox Corporation	105
27	S B E	116
28	Sams & Co., Inc., Howard W.	99
29	Sansui Electronics Corp.	17
30	Schober Organ Corp., The	90
31	Shure Brothers Inc.	FOURTH COVER
32	Solid State Sales	126
33	Solid State Systems, Inc.	123
34	Sonar Radio Corp.	115
42	TDK Electronics Corp.	106
35	Techni-Tool, Inc.	108
43	Teseon Corporation	73
36	Tri-Star Corporation	81
37	Trigger Electronics	104
	U.S. Army	22, 23
	U.S. Navy	10, 11
38	United Audio Products, Inc.	7
39	Utah Electronics Division	89
40	Valparaiso Technical Institute	83
41	Xcelite, Inc.	8
	CLASSIFIED ADVERTISING	118, 119, 120, 121, 122, 124, 126, 127

# LIVE IN THE WORLD OF TOMORROW... TODAY! NEW PRODUCTS, NEW MATERIALS, NEW IDEAS!

## UNUSUAL ECOLOGICAL SCIENCE BOYS

### UNIQUE HARD-TO-FIND BARGAINS FOR FUN, STUDY OR PROFIT

#### HI-VOLTAGE ELECTROSTATIC GENERATOR



Van De Graaf low-amp type, 200,000 volt potential, yet completely safe. Demonstrates lightning, St. Elmo's fire, repulsion of charges, electrostatic dust collection, many other electrical wonders. Meter, 100, 60 cycle, AC, 10-25 microamps. Aluminum base, frame and charge collector. Unbreakable plastic insulating column, 17" height. From full instructions.

Stock No. 70.260AV ..... \$3.75 Ppd.  
 STATIC ELECTRICITY GENERATOR  
 Stock No. 70.070AV ..... \$19.50 Ppd.

See moon shots, orbits, stars, phases of Venus, planets close up, 60 to 180 diam. 10 primary mirror, coated, 600 lines. Equatorial mount with locks on both axes. 60X eyepiece and mounted Barlow lens. 35 inches telescope, horizontal tripod. FREE "Star Chart." How to Use Your Telescope.

Stock No. 85.050AV ..... \$32.95 Ppd.  
 DELUXE 3" TELESCOPE  
 Stock No. 80.162AV ..... \$59.50 Ppd.  
 Stock No. 85.105AV ..... \$94.50 FOB  
 Stock No. 85.086AV ..... \$239.50 FOB



#### ASTRONOMICAL TELESCOPE KITS



Grind your own mirror for powerful telescopes. Kit contains fine abraded pyrex mirror blank, tool, abrasives, diamond mirror, and eyepiece lenses. Instruments you build range in value from \$75.00 to hundreds of dollars.

Stock No. 70.003AV ..... \$10.75 Ppd.  
 4 1/4" dia. x 3 1/4"  
 Stock No. 70.005AV ..... \$16.95 Ppd.  
 5" dia. x 4 1/4"  
 Stock No. 70.006AV ..... \$24.50 Ppd.  
 8" dia. x 1 3/4"  
 Stock No. 70.007AV ..... \$44.50 FOB  
 10" dia. x 1 3/4" 30 lbs  
 12 1/2" dia. x 2 1/4" ..... 46 lbs. \$72.50 FOB

Big surplus bargain—fine electrical pressure switch activated by 1/2 to 1/2 PSI air or 1 1/2" or less water pressure. Single pole, normally open, 10ma DC contact rating. 3W AC 160 v. loads require sensitive relay or solid state control. Use as sensor, switch, control, timer, edge trigger, instrument alarm. Long life (1,000,000 operations), impervious to extreme shock, vibration. 1/2" sq. polycarbonate case. 1 1/2" diam. extra barbed pressure ports. W-10 frame. ORIGINAL COST \$11.50.

Stock No. 41.623AV ..... \$3.95 Ppd.



#### \$8.95 ELECTRONIC STROBE



Hand-sized solid state electronic strobe light at fantastically low price. Produces bright psychedelic effects like larger, far more expensive Xenon strobes. Yet it's just 2 1/4 x 4 x 1 3/8" thick. Adjustable flash rate approx. 10 to 3-10 flashes per second. Make stop motion effects, posters come alive. Great to take with you to parties, dances, parties, etc. Requires 2 dry transistor batts (not incl), instructions.

Stock No. 41.443AV ..... \$8.95 Ppd.  
 4 REPLACEMENT LAMPS ..... 1.00 Ppd.  
 P-41.444AV

#### NEW! ELECTRONIC DIGITAL COMPUTER KIT!

Solve problems, play games, predict weather with this actual working model of giant electronic brains. Amazing new fun way to learn all about computer programming—logic, decimal, binary systems. Laws of self, build your own programming after completing simplified 116 page instructive booklet. Includes step-by-step assembly diagrams. Circuits easily changed. Readout from illuminated control panel. Rec. 2 1/2" batt (not incl) w/ model we've seen—for home, school, industry.

Stock No. 71.434AV ..... (11"X12 1/2" X 4") \$31.50 Ppd.



#### UNIQUE LIGHTING HANDBOOK



100 information packed pages! Fully explains latest in psychedelic lighting equipment, techniques, diagrams. Covers all facets of psychedelic light-show production including strobes, back lights, projectors, crystals, organic slides, mirrors, color organs, polarized color, light boxes, MusicVision, etc. Shows how to "psychedelize" parties, musical groups, shows or how to set up "electric trips" for private gatherings. 8 1/2" x 11" looseleaf paper for 3 rings.

Stock No. 9100AV ..... \$3.00 Ppd.  
 P-41.444AV

#### GO TREASURE HUNTING ON THE BOTTOM!

Fascinating fun & sometimes profitable! Tie a line to our 5 lb. Magnet—drop it overboard in bay, river, lake or ocean. Trawl it along bottom—your "treasured" haul can be inbound motors, anchors, other metal valuables, etc. Magnet is war surplus—Alnico V Type—Gov't. cost \$50. Lifts over 150 lbs. on land—much greater weights under water.

Stock No. 70.571AV ..... 5 1/2 lbs. ..... \$14.00 Ppd.  
 Stock No. 60.215AV ..... 1 1/2 lbs. ..... \$5.75 Ppd.  
 Stock No. 70.570AV ..... 3 1/2 lbs. (40 lbs.) ..... \$8.75 Ppd.  
 Stock No. 85.152AV ..... 15 3/4 lbs. (350 lbs.) ..... \$33.95 F.O.B.

#### "FISH" WITH A MAGNET



#### HELIUM BALLOONS MAKE A "BALL"



Anytime there's a balloon the air is festive. Especially when the "ball" is helium which makes a balloon party and fun—20 various colored balloons or 4, 5, or 6" diameter when inflated. With one pressurized (300 lbs. sq. in.) then 20 various colored balloons or 4, 5, or 6" diameter when inflated. With one containing 20 liters of helium inflate all 20. For adults or kids' parties, give-aways, bazaars or just demonstrate "hotter than air." Helium is a safe non-toxic inert gas.

Stock No. 71.289AV ..... \$3.00 Ppd.

#### AMAZING NEW Wankel Engine Kit!

Thrill to the fun of building your own revolutionary motorized model of revolutionary pistonless type engine. For which GM recently paid \$50 million. Only engine experts think economically modifiable to meet new emission standards. Replaces piston, cylinder, crank assemblies with rotating discs (sections removed for firing chambers). Smaller than conventional; fewer parts, greater reliability. Same speed w/ less horsepower. Feet: flashing plugs, rubber fan belt, stick-shift on-off switch. Runs 2 1/2 AA batt. (not incl).

Stock No. 71.424AV (41" X 5 1/2" X 9") \$6.75 Ppd.  
 510 Page Wankel Engine Book  
 Stock No. 9.439AV ..... \$15.25 Ppd.



### MAIL COUPON FOR GIANT FREE CATALOG!

**164 PAGES • MORE THAN 4000 UNUSUAL BARGAINS!**

Completely new Catalog. Packed with huge selections of telescopes, microscopes, binoculars, magnets, magnifiers, prisms, photo components, ecology and Unique Lighting items, parts, kits, accessories—many hard-to-get surplus bargains. 100's of charts, illustrations. For hobbyists, experimenters, schools, industry.

**EDMUND SCIENTIFIC CO.**

300 Edscorp Building, Barrington, N.J. 08007  
 Please rush Free Giant Catalog "AV"

Name \_\_\_\_\_  
 Address \_\_\_\_\_  
 City \_\_\_\_\_ State \_\_\_\_\_ Zip \_\_\_\_\_

#### GIANT WEATHER BALLOONS

"Balls of fun" for kids, traffic stoppers for stores, terrific for amateur meteorologists. Create a neighborhood sensation. Great backyard fun. Exhilarating beach attraction. Amateur meteorologists use to measure cloud heights, wind speed and temp. Made of heavy duty neoprene. Inflate with vacuum cleaner or auto air hose. Locally available helium for high rise.

Stock No. 60.568AV (8' size) ..... \$2.00 Ppd.  
 Stock No. 60.632AV (16' size) ..... \$7.00 Ppd.



#### BETTER BUG TRAP—BLACK LIGHT!

Feel free outdoors with a genuine "black light" trap—a 10 times more alluring to insects than simulated light. Long-wave black light lamp scientifically attracts fire-flies, a watery death. Weatherproof easily cleaned unit is effective up to 1/2 acre of cleared lawn (patio, pool, stable, golf courses, etc.). Free standing or hang where needed. Just plug into grounded electrical outlet. Inc. 2 yr. bulb, powerful motor & fan, 110v., 26 watts.

Stock No. 71.657AV ..... \$39.95 Ppd.  
 12" x 7 1/2" x 9 1/2"



## EDMUND SCIENTIFIC CO.

ORDER BY STOCK NUMBER • SEND CHECK OR MONEY ORDER • MONEY-BACK GUARANTEE

# 300 EDSCORP BLDG. BARRINGTON, NEW JERSEY 08007

CIRCLE NO. 11 ON READER SERVICE CARD  
 Printed in U.S.A.  
 CIRCLE NO. 17 ON READER SERVICE CARD  
 POPULAR ELECTRONICS Including Electronics World

# Popular Electronics

INCLUDING **Electronics World**

## READER SERVICE **FREE** INFORMATION.

Here's an easy and convenient way for you to get additional information about products advertised or mentioned editorially (if it has a reader service number) in this issue. Just follow the directions below . . . and the material will be sent to you promptly and free of charge.

1. On the attached postage-free card, print or type your name and address on the lines indicated.
2. Circle the number(s) that corresponds to the key number(s) at the bottom or next to the advertisement or editorial mention that is of interest to you. (Key numbers for advertised products also appear in the Advertisers' Index.)
3. Simply cut out the card and mail. No postage required.



## Get the All-New Model SR12 STEREO TEST RECORD

### Who Needs the New Model SR12?

Whether you're an avid audiophile who'll settle or nothing but peak performance from his stereo components . . . a casual listener who'd like more insight into the challenging world of stereo reproduction . . . or a professional technician who needs precise standards for lab testing . . . the MODEL SR12 will be the most important disc in your entire collection.

### You'll make these important stereo checks BY EAR... (no test instruments of any kind required)

**Frequency response**—a direct warble-tone check of nineteen sections of the frequency spectrum, from 20 to 20,540 Hz, which will pinpoint any frequency response defects in your system.

**Separation**—an ingenious test which indicates whether you have adequate separation for good stereo.

**Cartridge tracking**—the most sophisticated tests ever devised for checking the performance of your cartridge, stylus and tone arm.

**Channel balance**—two broad-band, random-noise signals which permit you to eliminate any imbalances originating in cartridge, amplifier, speakers or room acoustics.

**Hum and rumble**—foolproof tests that help you evaluate the actual audible levels of rumble and hum in your system.

**Flutter**—a sensitive "musical" test to check whether your turntable's flutter is low, moderate, or high.

- Cartridge and Speaker Phasing
- Anti-Skating Adjustment
- "Gun Shot Test" for Stereo Spread
- Multi-purpose Musician's "A"
- Equal-tempered Chromatic Octave
- Guitar-tuning Tones.

### AND, for the ultimate in stereo testing, 7 critical TEST EQUIPMENT checks . . .

Attention professionals: Stereo Review's new Model SR12 Stereo Test Record is also designed to be used as a highly efficient design and measurement tool. In the following tests, recorded levels, frequencies, etc. have been controlled to laboratory tolerances—affording accurate numerical evaluation when used with oscilloscope, chart recorder, output meter, intermodulation-distortion meter and flutter meter.

- 1,000-Hz square waves to test transient and high-frequency response of phono pickups.
- 500 to 20,000 Hz frequency-response sweep.
- Sine-wave tone-bursts to test transient response of pickup.
- Intermodulation test using simultaneous 400-Hz and 4,000-Hz signals.
- Intermodulation sweep to show distortion caused by excessive resonances in tone arm and cartridge.
- 1,000-Hz reference tones to determine groove velocity.
- 3,000-Hz tone for flutter and speed tests.

Sample waveforms—illustrating both accurate and faulty responses are provided in the Instruction Manual for comparison with the patterns appearing on your own oscilloscope screen.

### FREE Instruction Manual Includes Detailed Instructions, Charts, Tables and Diagrams.

**SEND NO MONEY.** Use the postage-paid order card located at the top of the flap to the right to order your Test Record. In the event the card has already been detached, you can also place your order by circling #91 on the Information Service Card to the right. Either way, the record will be mailed to you along with an invoice for only \$5.98 plus 35¢ for postage and handling.

**ENCLOSE PAYMENT—SAVE MONEY.** You can save postage and handling charges by sending your order and payment in the amount of \$5.98 to Records, Ziff-Davis Service Division, 595 Broadway, New York, N.Y. 10012.

**Do not use the Reader Service Card for cash orders.**

**AN EXTRA SERVICE FOR YOU—CHARGE YOUR RECORD ORDER TO YOUR AMERICAN EXPRESS OR BANKAMERICARD ACCOUNT. USE THE POSTAGE-PAID ORDER CARD.**



SSB-ers:

## increase talk power, cut "splatter"



Our 444 base station microphone not only gives you increased talk power, but cuts "splatter" (and QRM complaints) to an absolute minimum! It has superbly tailored response, with sharp cutoffs below 300 and above 3,000 Hz and a rising response characteristic for maximum intelligibility. The 444's rugged, reliable Controlled Magnetic element has been proved in safety communications, and other tough professional communications applications. It delivers a clean signal to the transmitter at levels as high as crystal units! (And, unlike crystal and ceramic units, the element is totally immune to the effects of temperature and humidity.) The 444 also features an adjustable height stand that makes for comfortable "ragchewing" sessions, an optional-locking bar for push-to-talk or VOX operation, and a practically indestructible Armo-Dur® case. Write:

Shure Brothers Inc.,  
222 Hartrey Ave., Evanston, Ill. 60204



CIRCLE NO. 31 ON READER SERVICE CARD