

# Popular Electronics

INCLUDING **Electronics World**

## MOBILE CB TRANSCEIVERS

Special Product Directory & Specifications

**THE DOLBY  
TECHNIQUE**

**ELECTRONICS  
AT  
DISNEY WORLD**

**LOUDSPEAKERS:** Facts & Fallacies

### **BUILD:**

- Touch-Plate Power Switch
- Preamplifier for your Scope
- Auto Battery Voltage Monitor

### **TEST REPORTS:**

- Hitachi IA-1000 Amp
- Heath IO-103 & IO-105 Oscilloscopes
- Bird 4350 R-f Wattmeter
- Dynascan Cobra 130 CB Transceiver
- Eico SS-500 Security





# **firsts** make learning Electronics at home fast and fascinating— give you priceless confidence.

Some NRI **firsts** in training equipment

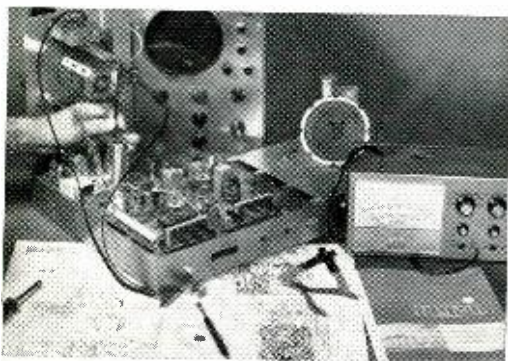

**first** to give you Color Television training equipment engineered specifically for education—built to fit NRI instructional material, *not* a do-it-yourself hobby kit. The end product is a superb Color TV receiver that will give you and your family years of pleasure. You “open up and explore” the functions of each color circuit as you build.



**first** to give you a unique, exciting digital computer *with memory* built especially for home training. You learn organization, trouble shooting, operation, programming as you build and use it. Performs the same functions as commercial computers. Lessons stress computer repair. You conduct a hundred experiments, build hundreds of circuits. A solid-state VTVM is included among ten training kits.

## NRI's "discovery" method is the result of over half a century of leadership simplifying and dramatizing training at home

The FIRSTS described below are typical of NRI's half century of leadership in Electronics home training. When you enroll as an NRI student, you can be sure of gaining the in-demand technical knowledge and the priceless confidence of "hands-on" experience sought by employers in Communications, Television-Radio Servicing and Industrial and Military Electronics. Everything about NRI training is designed for your education . . . from the much-copied, educator-acclaimed Achievement Kit sent the day you enroll, to "bite-size" well-illustrated, easy to read texts programmed with designed-for-learning training equipment.

### YOU GET YOUR FCC LICENSE OR YOUR MONEY BACK

There is no end of opportunity for the trained man in Electronics. You can earn \$6 or more an hour in spare time, have a business of your own or qualify quickly for career positions in business, industry, government. And if you enroll for any of five NRI courses in Communications, NRI prepares you for your FCC License exams. *You must pass* or NRI refunds your tuition in full. No school offers a more liberal money-back agreement. The full story about NRI leadership in Electronics training is in the new NRI Catalog. Mail postage-free card today. No salesman is going to call.  
NATIONAL RADIO INSTITUTE, Washington, D.C. 20016

**APPROVED UNDER NEW GI BILL** If you have served since January 31, 1955, or are in service, check GI line on postage-free card.

## designed from chassis up for your education

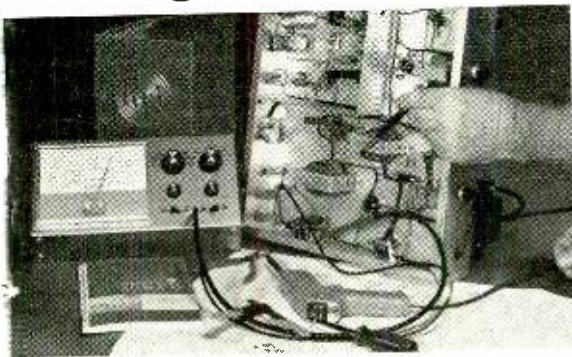

**first** to give you true-to-life experiences as a communications technician. Every fascinating step you take in NRI Communications training, including circuit analysis of your own 25-watt, phone/cw transmitter, is engineered to help you prove theory and later apply it on the job. Studio equipment operation and troubleshooting become a matter of easily remembered logic.

**first** to give you completely specialized training kits engineered for business, industrial and military Electronics. Shown above is your own training center in solid state motor control and analog computer servo-mechanisms. Telemetry circuits, solid-state multi-vibrators, and problem-solving digital computer circuits are also included in your course.

# Popular Electronics

WORLD'S  
LARGEST-SELLING  
ELECTRONICS MAGAZINE

INCLUDING

# Electronics World

## FEATURE ARTICLES

- 12** COLOR CODE CHARTS
- 26** DIRECTORY OF MOBILE CB TRANSCEIVERS *Gladden B. Houck, Jr.*
- 30** LASER MACHINING PRODUCES ELECTRONIC CIRCUITS
- 31** THE DOLBY TECHNIQUE FOR REDUCING NOISE *Mannie Horowitz*  
*Special circuit for solving the tape-noise problem.*
- 34** BATTERY-POWERED LOCATOR BEACON FOR AIRCRAFT
- 35** SOLID-STATE RADIOGRAPHIC SCREENS
- 40** HI-FI LOUDSPEAKERS: FACTS & FALLACIES *Victor Brociner*  
*Solving some of the common misunderstandings.*
- 44** ELECTRONICS AT DISNEY WORLD *Edward A. Lacy*
- 53** TEST YOUR KNOWLEDGE OF SEMICONDUCTORS *William R. Shippee*
- 60** RISE-TIME MEASUREMENTS *Raymond E. Herzog*
- 62** THE FIELD SERVICE REPRESENTATIVE *Stephen A. Kallis, Jr.*  
*What he does in the computer industry.*
- 68** SHELF LIFE OF CAPACITORS AND BATTERIES *John T. Frye*  
*How long to keep them and why they go bad.*
- 76** THE FIELD-EFFECT TRANSISTOR *William R. Shippee*  
*The semiconductor that has revolutionized electronics.*
- 77** NEW HOLOGRAM CRYSTALS PERMANENTLY STORE IMAGES

## THE SCENES

- 14** STEREO SCENE *J. Gordon Holt*  
*Choosing the sound you want.*
- 65** COMMUNICATIONS SCENE *Richard Humphrey*  
*Automatic identification of transmitters*
- 97** SURPLUS SCENE *Alexander W. Burawa*

ZIFF-DAVIS PUBLISHING COMPANY  
Editorial and Executive Offices  
One Park Avenue, New York, New York 10016  
212 679-7200

William Ziff, President  
W. Bradford Briggs, Executive Vice President  
Hershel B. Sarbin, Senior Vice President and Secretary  
Philip Sine, Financial Vice President and Treasurer  
Phillip T. Heffernan, Vice President, Marketing  
Frank Pomerantz, Vice President, Creative Services  
Arthur W. Butzow, Vice President, Production  
Edward D. Muhlfield, Vice President, Aviation Division  
Irwin Robinson, Vice President, Travel Division  
George Morrissey, Vice President  
Sydney H. Rogers, Vice President  
Sidney Holiz, Vice President  
Lawrence Sporn, Circulation Director

POPULAR ELECTRONICS including ELECTRONICS WORLD, August 1972, Volume 2, Number 2. Published monthly at One Park Ave., New York, NY 10016. One year subscription rate for U.S., U.S. Possessions and Canada, \$6.00; all other countries, \$7.00. Second class postage paid at New York, N.Y. and at additional mailing offices. Authorized as second class mail by the Post Office Department, Ottawa, Canada and for payment of postage in cash. Subscription service and Forms 3579: P.O. Box 1096, Flushing, NY 11352. Editorial offices for manuscript contributions, reader inquiries, etc.: One Park Ave., New York, NY 10016.

POPULAR ELECTRONICS including ELECTRONICS WORLD is indexed in the Reader's Guide to Periodical Literature.

Copyright © 1972 by ZIFF-DAVIS PUBLISHING COMPANY. All rights reserved.

POPULAR ELECTRONICS Including Electronics World

**EDGAR W. HOPPER**  
*Publisher*  
**WM. A. STOCKLIN**  
*Editorial Director*  
**MILTON S. SNITZER**  
*Editor*  
**LESLIE SOLOMON**  
*Technical Editor*  
**JOHN R. RIGGS**  
*Managing Editor*  
**EDWARD I. BUXBAUM**  
*Art Director*

**ALEXANDER W. BURAWA**  
*Associate Editor*  
**ANDRE DUZANT**  
*Technical Illustrator*  
**JUDITH L. HOGAN**  
*Editorial Assistant*  
**FOREST H. BELT**  
**JOHN T. FRYE**  
**DAVID L. HEISERMAN**  
**J. GORDON HOLT**  
**RICHARD HUMPHREY**  
*Contributing Editors*

**JOSEPH E. HALLORAN**  
*Advertising Director*  
**RICHARD J. HALPERN**  
*Advertising Manager*  
**MADELEINE LITTMAN**  
*Advertising Service Manager*  
**STANLEY NEUFELD**  
*Associate Publisher*  
**FURMAN H. HEBB**  
*Group Vice President*  
*Electronics and Photographic*

## CONSTRUCTION STORIES

- 47 A PREAMPLIFIER FOR YOUR SCOPE** Imre Gorgenyi  
*X10 amplification to increase scope usefulness.*
- 50 TOUCH-PLATE POWER SWITCH** Jay Nunley  
*Build a switch to control up to 1400 watts.*
- 58 AUTO BATTERY VOLTAGE MONITOR** Charles and John Morris  
*Lets you know when your battery needs charging.*

## PRODUCT TEST REPORTS

- 78 HITACHI IA-1000 INTEGRATED STEREO AMPLIFIER**
- 80 HEATHKIT IO-103 AND IO-105 TRIGGERED-SWEEP OSCILLOSCOPES**
- 82 DYNASCAN COBRA 130 CB TRANSCEIVER**
- 84 BIRD HAM-MATE 4350 R-F WATTMETER**
- 86 EICO SS-500 SECURITY ALARM SYSTEM**

## DEPARTMENTS

- 6 EDITORIAL** Milton S. Snitzer  
*Apollo Without Electronics*
- 8 LETTERS**
- 23 NEWS HIGHLIGHTS**
- 88 NEW PRODUCTS**
- 94 ELECTRONICS LIBRARY**
- 96 NEW LITERATURE**
- READER SERVICE CARD ON BACK COVER

## COMING NEXT MONTH

- Treasure Detectors for Land Use*
- Home Electronic Security Systems*
- Build an Alarm System for Cars*
- Construct Digital Logic Computer*

Midwestern Office  
The Pattis Group, 4761 West Touhy Ave.,  
Lincolnwood, Illinois 60644, 312 679-1100  
GERALD E. WOLFE, DICK POWELL  
DICK GOVATSKI, MANLEY LUDWIG

Western Office  
9025 Wilshire Boulevard, Beverly Hills, California 90211  
213 273-8050; Bradshaw 2-1161  
Western Advertising Manager, BUD DEAN

Japan: James Yaagi  
Oji Palace Aoyama; 6-25, Minami Aoyama  
6 Chome, Minato-Ku, Tokyo 407-1930 6821

Ziff-Davis also publishes Boating, Car and Driver, Cycle, Flying, Modern Bride, Popular Photography, Skiing, and Stereo Review.

Forms 3579 and all subscription correspondence should be addressed to POPULAR ELECTRONICS Including ELECTRONICS WORLD, Circulation Department, P.O. Box 1096, Flushing, NY 11352. Please allow at least eight weeks for change of address. Include your old address, as well as new—enclosing, if possible, an address label from a recent issue.

Editorial contributions must be accompanied by return postage and will be handled with reasonable care; however, publisher assumes no responsibility for return or safety of art work, photographs or manuscripts.



Member Audit Bureau  
of Circulations



# Editorial

By Milton S. Snitzer, Editor

## APOLLO WITHOUT ELECTRONICS

By the time this appears in print, any excitement that may have been generated by the successful flight of Apollo 16 to the moon and back will have been dissipated. Even while the flight was going on, all it meant to most people was reading a couple of newspaper headlines or watching briefly the TV coverage. But how blasé can we get? Maybe it's just the enormity of the achievement or because men have walked on the moon before. Or, maybe it's because there were more important things to be concerned about at the time. Whatever the reason, most people simply accepted the moon flight as a matter of course.

However those of us who are interested in electronics, either professionally or as hobbyists, should pause for a minute or two. Would it all have been possible without electronics?

There would have been no Saturn countdown computers monitoring more than 3000 parameters during the countdown leading to the takeoff. There would have been no inertial guidance system to keep Saturn on course. We would not have been able to track the flight from beginning to end using ground and shipboard radars.

We would not have been able to monitor the astronauts on the moon without the color-TV camera assembly which was controlled on the earth. There would have been no lunar communications relay unit to transmit voice, telemetry and color TV from the surface of the moon and receive transmissions from the earth. What about the lunar module communications system which transmitted and received voice, telemetry, biomedical data, commands, ranging signals and television to and from the earth on a microwave carrier a little above 2000 MHz, and to and from the command module orbiting overhead on a little under 300 MHz?

There would have been no vhf ranging system to tell the distance between the lunar module and the command module. And no backpack radios for the astronauts to use while exploring the moon's surface. And no rendezvous radar/transponder, and no lunar module landing radar. And on and on the list goes.

We are not saying that the electronics was the most important thing on the flight, but we are saying that without it, the flight as we knew it would have been impossible. And that goes for the upcoming flight of Apollo 17 too.

# Sams guides you through the highways and byways of electronics

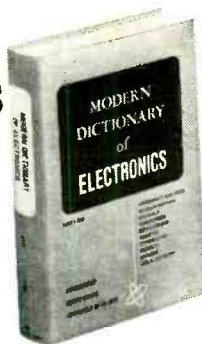

**MODERN DICTIONARY OF ELECTRONICS** 4th Edition  
by Rudolf F. Graf  
Completely updated definitions of approximately 18,500 terms used in the fields of communications, microelectronics, fiber-optics, semiconductors, reliability, computers, and medical electronics. Over 2000 terms have been added, and hundreds of definitions have been updated. An invaluable reference.  
No. 20852 \$12.95

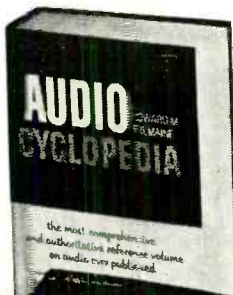
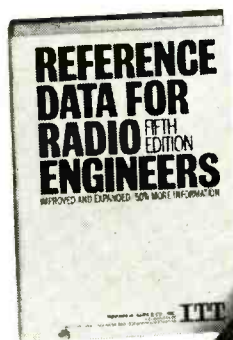

**REFERENCE DATA FOR RADIO ENGINEERS** 5th Edition

Covers transistors, electroacoustics, microminiature electronics, space communication, navigation aids, quantum electronics, reliability and life testing. Completely revised by over 100 experts. 50% more data than previous edition. Over 400,000 copies in use. 1696 pgs., 1350 illustrations.  
No. 20678 \$20.00

**AUDIO CYCLOPEDIA** 2nd Edition

by Dr. Howard M. Tremaine  
The most comprehensive and authoritative reference text on audio ever published. 1758 pages, over 3500 topics, and 1800 illustrations devoted to the fields of acoustics, recording and reproduction. Completely updated.  
No. 20675 \$29.95

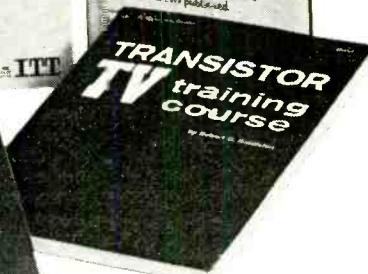

**ABC'S OF ELECTRONICS** 2nd Edition

by Earl J. Waters  
Clearly explains the principles of electricity, functions of atoms and electrons, magnetic forces and their relationship to electronics; basic components and their applications; fundamental electronic circuits and how they work. Latest information on solid state devices.  
No. 20865 \$3.95

**TRANSISTOR TV TRAINING COURSE** 2nd Edition

by Robert G. Middleton  
This training course in solid-state tv circuitry is a valuable guide for both the technical student and the experienced tv technician. It includes such late developments as integrated circuits, dual-gate MOSFETS and SCR sweep circuits, and the most recent innovations in solid state color tv circuitry.  
No. 20882 \$4.50

**STUDY GUIDE FOR CET EXAMINATIONS**

by J. A. Wilson, CET and Dick Glass, CET

A programmed text giving full coverage of typical questions encountered in the CET examination, together with the answers. For background information, the chapters are keyed to the two Sams television courses described at the right.

No. 20834 \$5.95

**COLOR TV TRAINING MANUAL** 3rd Edition

by the Howard W. Sams Editorial Staff

A step-by-step education in the intricacies of color-tv. Its explanation of the basic principles of each circuit leads to a clear understanding of the overall function of the set. A widely used text for schools and self study, it embraces modern developments in color-tv circuitry.

No. 20736 \$6.95



**PHOTOFACT TELEVISION COURSE** 3rd Edition

by the Howard W. Sams Editorial Staff

This basic and comprehensive explanation of black-and-white television has helped thousands become proficient in television theory and servicing. Includes timely information on transistor circuits.

No. 20595 \$4.95



Order from your Electronics Parts Distributor, or mail to Howard W. Sams & Co., Inc., 4300 West 62nd St., Indianapolis, Ind. 46268.

Send books checked below. \$\_\_\_\_\_ enclosed. Please include sales tax where applicable. Canadian prices slightly higher.

Send FREE 1972 Sams Book Catalog

Name \_\_\_\_\_

Address \_\_\_\_\_

City \_\_\_\_\_

State \_\_\_\_\_

Zip \_\_\_\_\_

20852  20678  20675  20865  20882  20834  20736  20595

CIRCLE NO. 31 ON READER SERVICE CARD

# the EL SOCKET



Test new circuit ideas...

I.C. circuits...

discreet components...

at no risk!

Money back guarantee!

**\$17<sup>25</sup>**

All you need are #4 mounting screws . . . just plug-in components . . . like 1/4 watt resistors, ceramic capacitors, diodes, I.C.s, transistors and more . . . and your circuit's built! No special patch cords needed! Components interconnected with any solid No. 22-26 gauge wire.

And you can try it with absolutely no risk for 5 days. If not satisfied, just return your EL Socket and receive a full refund. Trying is believing. How can you go wrong? Order your EL Socket now!

- Nickel/silver plated terminals — very low contact resistance
  - Low insertion force
  - Mounts with #4 screws
  - Initial contact characteristics beyond 10,000 insertions
  - Vertical, horizontal interconnecting matrices
  - Accommodates wide range of wire and component leads from .015"-.032"
- Send check or M.O. today!
- Add 50¢ for postage and handling
  - 25% deposit on C.O.D.s



**EL INSTRUMENTS, INC**  
61 First St., Derby, Conn. 06418  
Telephone: 203/735-8774

**CIRCLE NO. 15 ON READER SERVICE CARD**

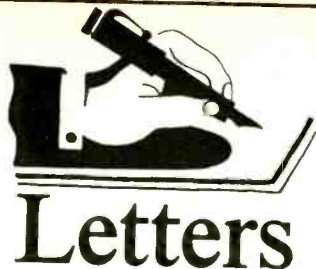

## ON THE INSIDE LOOKING OUT

Enclosed you will find a copy of a check for a subscription to POPULAR ELECTRONICS which appears to have been deposited in June of last year. Now, that's a long time to be without PE! The judge so far (while making of me a bonafide "convict") has made me do without girls for ten years, but being without POPULAR ELECTRONICS for five months constitutes "cruel and unusual punishment." Please do something to relieve this situation before I have to take the matter up with a higher court.  
Name Withheld

*Higher courts notwithstanding, we have had to go to a lower authority to put things to rights. By the time you read this, you should be wallowing in PE's.*

## GOING BEYOND THE BASICS

"What Makes The Transistor Tick?" (November 1971) has several misconceptions in the text which need clarification. The statement that ". . . In their pure states, germanium and silicon crystals are electrically inert and behave in the manner of an insulator" is quite vague and, I believe, misleading. Intrinsic Ge and Si are classed as semiconductors—not insulators.

Later, discussing a pn junction, the author states: "With no voltage applied to the diode, no voltage difference exists between the two types of material." This is incorrect. At equilibrium, a pn junction does have a voltage drop across it. Because of the migration of majority carriers across the junction, a potential barrier is formed, on the order of a few tenths of a volt. Attempts to observe this potential with a voltmeter fail because of the contact potentials formed between the meter and diode leads.

L. ARTHUR A. READ  
Physics Dept.  
Waterloo Lutheran University  
Waterloo, Ontario, Canada

*Both points made by Mr. Read are, in essence, technically correct. However, for purposes of the published article, aimed as it was toward the novice to solid-state electronics,*



the discussion presented was more than adequate. No statement was made to the effect that Ge and Si are insulators—only that they behave that way when in their pure states. Regarding the potential barrier across the pn junction, discussion of the potential difference is best left to technician and engineering level texts.

### A SATISFIED CALCULATOR OWNER

In response to those critics (Letters, March 1972) of the November 1971 Electronic Desk Calculator, I would like to state that I am most satisfied with my kit purchase of the MITS calculator. I assembled the kit without a hitch; the parts were all of excellent quality; and the assembly instructions were perhaps the very best I have ever seen.

CARL E. DOYLE  
Duarte, Calif.

### DOCTOR LENDS HIS SUPPORT

In response to your poll on a home study course in medical electronics (Letters, March 1972), let me state that I am definitely interested in lending my support. If some school can devise such a course, and make it really worthwhile, I will be one of the first to subscribe.

I am a psychiatrist who feels that medical electronics offers some great opportunities for breakthroughs in definitive treatment approaches. In putting together a home study course in medical electronics, I feel that it should offer some information on building instruments such as a brainwave detector. I know that this might appear to be a bit farfetched, but it would be folly to underestimate the ability and determination of the student.

PAUL A. SAXON, M.D.  
Clinical Director  
Wyoming State Hospital  
Evanston, Wyo.

*Most of the responses to our poll have been enthusiastic, to say the least. But we have some bad news to report. At the time of this writing no more than 30 responses have been received; and of that 30, six were from medical electronics engineers and technicians and practicing physicians. This is hardly a figure with which to approach a home study school.*

### A HELPFUL HINT

With all the cables and connectors used in the average hi-fi/stereo system, there is a very real need for keeping them identified. My solution in the past has been to use the small plastic "tags" used to close plastic bread wrappers and the like. These tags can be marked with any waterproof marker then slipped over the cable lead.

CARL S. BLUM  
Ames, Iowa

AUGUST 1972



**PACE**  
makes  
another  
**BREAKTHROUGH**



### 23 CHANNEL CB TRANSCEIVER

- ALL crystals supplied
- 5 Watts of Transmit
- Pace plus modulation
- Ceramic microphone
- Locking latch rack

### Pace Model 223



\$109.95

From the PACE U. S. Engineering Team that introduced the first all transistor CB transceiver, the Model 223 offers another breakthrough in both Price and Quality. Taking advantage of U. S. mass production techniques and engineering knowhow, the PACE Model 223 provides the truly great bargain for today's CB operator who wants performance and price with the quality guarantee of a U. S. manufacturing firm. With a NO compromise design approach the PACE engineers built a double conversion receiver with a full 6 section tuned filter network for maximum receiver performance even under adverse conditions - we can guarantee performance for 2 years because we shake every one in the roughest QC test procedure ever designed for 2 way radios.

If you compare before you buy you'll join the Proud Pace owner's club!

### ((P)) PACE COMMUNICATIONS

Division of PATHCOM INC. 24049 South Frampton Ave.  
Harbor City, California 90710 • (213) 325-1290  
Export: 2200 Shames Drive, Westbury, New York 11590

**CIRCLE NO. 25 ON READER SERVICE CARD**

# Get a little in the Navy.

## **More job.**

If you qualify, we can guarantee you any one of 68 job fields. What's more, we'll send you to a school that will make you a real pro. That way, you get more jobs in the Navy and when you get out, you've got somewhere to go.

## **More choice.**

There's a new 3 year Navy enlistment. So you can come in for 6 years or 4 years or now, 3 years.

## **More guarantees.**

You can be guaranteed East or West Coast and choice of sea duty or airman recruit work.

## **More travel.**

See Africa. See Europe. See Japan. Join the Navy and see the world. (It's still true.)

## **More bread.**

New guys now earn \$288 a month. (Congress gave us a raise.)

# more

## More hair.

You can wear a beard (nicely trimmed) if you want to. It's a Naval tradition. It's also a brand new Navy.

## More freebies.

Besides free travel and free education and that \$288 a month, you get free food and free clothing and free housing and free health care and 30 paid vacation days per year.

If you think you've got what it takes to make it in the new Navy,

**Call:**  
**800-424-8880**

It's toll free, there's no obligation, and a real live Navy recruiter will answer all your questions 24 hours a day, seven days a week. In Washington, D. C. call 433-2000.

**Or:**

See your Navy man right now. He's listed in your phone book under U.S. Government, Navy. He's got all the answers—or he knows where to find them.

**Or:**

Send to: Captain Donald E. Oglevee  
Building 157, Fourth Floor,  
Washington Navy Yard,  
Washington, D.C. 20390

76

I want to know more about:

- More job, training, education.
- The new 3 year enlistment.
- More travel.
- Guaranteed East or West Coast home port.
- More bread.
- Enlisting now, reporting 6 months later.
- I want to know more right away. Call me.  
My phone No. (\_\_\_\_\_)\_\_\_\_\_.
- If you really don't want to wait, call us  
toll free right now at: **800-424-8880**  
In Washington, D. C. call: 433-2000

Name \_\_\_\_\_ Age \_\_\_\_\_

Address \_\_\_\_\_

City \_\_\_\_\_

State \_\_\_\_\_ Zip \_\_\_\_\_

# COLOR CODE CHARTS

## COLOR BAND SYSTEM



Resistors With Black Body Color Are Composition, Non-Insulated.  
Resistors With Colored Bodies Are Composition, Insulated.  
Wire-Wound Resistors Have the 1st Digit Color Band Double Width.

## RESISTOR CODES (RESISTANCE GIVEN IN OHMS)

COLOR	DIGIT	MULTIPLIER	TOLERANCE
BLACK	0	1	±20%
BROWN	1	10	±1%
RED	2	100	±2%
ORANGE	3	1000	±3%
YELLOW	4	10000	GMV*
GREEN	5	100000	±5% (EIA Alternate)
BLUE	6	1000000	±5%
VIOLET	7	10000000	±12.12%
GRAY	8	.01 (EIA Alternate)	±30%
WHITE	9	.1 (EIA Alternate)	±10% (EIA Alternate)
GOLD		1 (JAN and EIA Preferred)	±5% (JAN and EIA Preferred)
SILVER		.01 (JAN and EIA Preferred)	±10% (JAN and EIA Preferred)
NO COLOR			±20%

\*GMV = guaranteed minimum value, or -0.100% tolerance.  
±3, 6, 12, 1, 2, and 30% are ASA 40, 20, 10, and 5 step tolerances.

## BODY-END-DOT SYSTEM

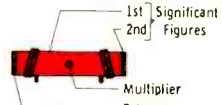

## BODY-END BAND SYSTEM

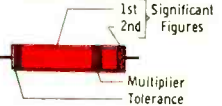

## DISC CERAMICS (5-DOT SYSTEM)

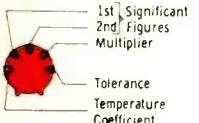

## DISC CERAMICS (3-DOT SYSTEM)

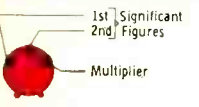

## CERAMIC CAPACITOR CODES (CAPACITY GIVEN IN pF)

COLOR	DIGIT	MULTIPLIER	TOLERANCE	TEMPERATURE COEFFICIENT	EXTENDED RANGE		
					10 pF or LESS	10 pF or MORE	TEMP. COEFF. SIGNIFICANT FIGURE
BLACK	0	1	±2.0 pF	±20%	0(NP0)	0.0	-1
BROWN	1	10	±0.1 pF	±1%	-33(N033)		-10
RED	2	100		±2%	-75(N075)	1.0	+100
ORANGE	3	1000		±2.5%	-150(N150)	1.5	-1000
YELLOW	4	10000			-220(N220)	2.2	-10000
GREEN	5		±0.5 pF	±5%	-330(N330)	3.3	-1
BLUE	6				-470(N470)	4.7	-10
VIOLET	7				-550(N550)	7.5	+100
GRAY	8	.01	±0.25 pF		-30L(P30)		-1000
WHITE	9	.1	±1.0 pF	±10%	General Purpose		
SILVER					Bypass & Coupling		
GOLD					+100 (P100, JAN)		

Voltage ratings are standard 500 volts for some manufacturers, but 1000 volts for other companies.

## HIGH CAPACITY TUBULAR CERAMIC

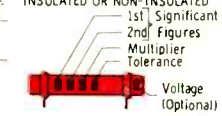

## TEMPERATURE COMPENSATING TUBULAR CERAMICS

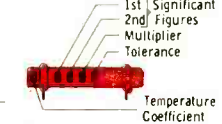

## EXTENDED RANGE T. C. TUBULAR CERAMICS

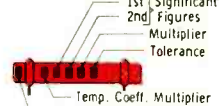

## FEED-THRU CERAMICS

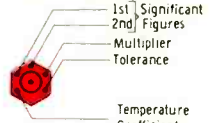

## MOLDED-INSULATED AXIAL LEAD CERAMICS

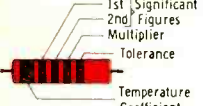

## TYPOGRAPHICALLY MARKED CERAMICS

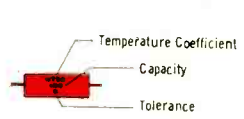

JAN LETTER	TOLERANCE
C	±0.2 pF
D	±0.5 pF
F	±1.0 pF
G	±2.0 pF
J	±5%
K	±10%
M	±20%

## BUTTON CERAMICS

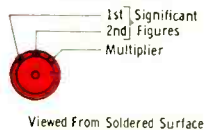

## STAND-OFF CERAMICS

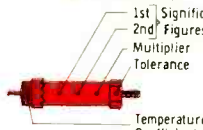

## MOLDED CERAMICS Using Standard Resistor Color Code



## MOLDED MICA CAPACITOR CODES (Capacity Given In pF)

COLOR	DIGIT	MULTIPLIER	TOLERANCE	CLASS OR CHARACTERISTIC
BLACK	0	1	20%	A
BROWN	1	10	1%	B
RED	2	100	2%	C
ORANGE	3	1000	3%	D
YELLOW	4	10000		E
GREEN	5		5% (EIA)	F(JAN)
BLUE	6			G(JAN)
VIOLET	7			H(EIA)
GRAY	8			I(EIA)
WHITE	9			J(EIA)
GOLD		.1	5% (JAN)	
SILVER		.01	10%	

Class or characteristic denotes specifications of design involving Q factors, temperature coefficients, and production test requirements.  
All axial lead mica capacitors have a voltage rating of 300, 500, or 1000 volts.  
\*or ±1.0 pF whichever is greater.

## MOLDED PAPER CAPACITOR CODES (Capacity Given In pF)

COLOR	DIGIT	MULTIPLIER	TOLERANCE
BLACK	0	1	20%
BROWN	1	10	
RED	2	100	
ORANGE	3	1000	
YELLOW	4	10000	
GREEN	5	100000	5%
BLUE	6	1000000	
VIOLET	7		
GRAY	8		
WHITE	9		
GOLD			10%
SILVER			5%
NO COLOR			20%

## MOLDED PAPER TUBULAR

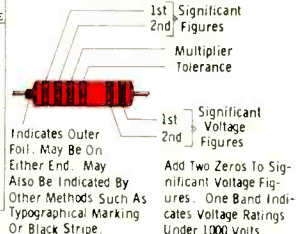

## CURRENT STANDARD JAN AND EIA CODE

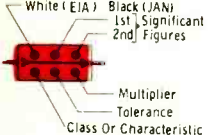

## BUTTON SILVER MICA

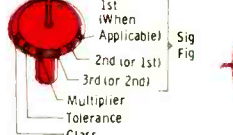

## MOLDED FLAT PAPER CAPACITORS (COMMERCIAL CODE)

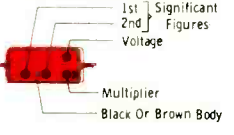

## MOLDED FLAT PAPER CAPACITORS (JAN CODE)

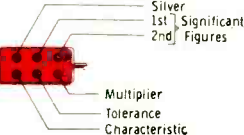



## Ecstasy. At a price that won't cause too much agony.

Before the ecstasy of listening to your new stereo equipment comes, alas, the agony of shopping for it—the frustration of wanting this feature, and that spec. and finding that your budget won't quite cover it.

Sony has something to ease the pain. The STR-6036. An FM Stereo/AM-FM receiver for the man with a small room, a small budget, but big ears nonetheless.

It's an inexpensive receiver that doesn't sacrifice performance, specifications, control flexibility, sound quality, or even looks.

What it does sacrifice, of course, is just a bit of power. The STR-6036 delivers 50 clean watts of IHF dynamic power at 4 ohms\*. That's quite enough to drive even most low-efficiency "bookshelf" speakers, even if it's not enough to rival the power company.

or to let you bust your buttons bragging about it.

The tuner, though, makes no concessions: It has a sensitive, overload-proof FET front end. And ceramic i.f. filters that increase selectivity and never need realignment. Plus a tuning meter for both AM and FM.

The controls have all the flexibility you'd expect from Sony: tape monitor, main/remote speaker selector, switchable loudness, even front-panel microphone input jacks.

And the control feel is typical Sony, too—firm, silky-smooth and positive. So the pleasure begins at your fingertips, even before your ears can start

enjoying. Your pleasure will deepen to ecstasy when you hear the low price. As will your dealer's when you buy one. Sony Corporation of America, 47-47 Van Dam Street, Long Island City, N.Y. 11101.

\*IHF standard constant supply method.

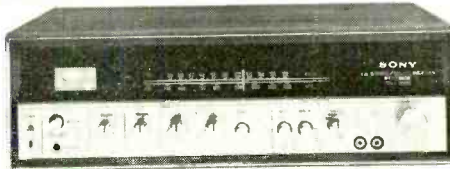

## The **SONY**® 6036 Stereo Receiver

CIRCLE NO. 35 ON READER SERVICE CARD



# Stereo Scene

By J. Gordon Holt

**I**N MY LAST "Stereo Scene," we saw how your personality type—introvert or extrovert, sensitive or cloddish—might affect the kind of reproduced sound you like. This time, we'll consider how to choose a system that sounds that way.

If you've done any amount of component auditioning, in stores or in friends' homes, you will have noticed that loudspeakers differ more in sound from model to model than any other component in the audio chain. There are audible differences between pickups and tape decks, too; and even amplifiers and preamplifiers exhibit audible, although less conspicuous, differences. But since loudspeakers are the most highly colored and thus distinctive-sounding components, your choice of speakers will determine, to a major extent, how your audio system will sound.

We can divide loudspeakers into three basic sonic types, on the basis of the apparent distance that they seem to place between you and the sound. Some put the sound very close, giving the impression that the reproduced instruments are right in the room with you. Others have a noticeably distant perspective, giving the illusion of a good balcony seat in an auditorium, while others have a neutral perspective, making the instruments sound as far away from you as they were from the recording mikes. Most systems fall somewhere between the extremes of ultra-close and ultra-distant.

## Choosing the Sound You Want

(You can vary the apparent distance of many speakers by adjusting the tweeter balance controls.) In terms of absolute fidelity, we can argue that the most neutral reproducers are the most accurate. But the absolutely accurate system may not produce the best illusion or reality for you, for a couple of reasons.

First, if you have a preference for a close listening seat at a live concert, close-up sound will be your criterion for reality, and the more distant sound of a neutral loudspeaker won't seem natural to you. Conversely, if you prefer and are accustomed to the kind of richness and breadth that you hear from a balcony seat at a live performance, close-up sound won't be realistic to you, either. You may find a few recordings whose miking makes them sound sufficiently distant or close to suit your taste, but most recordings aren't this extreme in either direction, so you're better off letting the speakers provide the perspective you prefer.

Second, there is the matter of the *appropriateness* of the reproduced sound's apparent distance. There are some kinds of musical performances that *could* conceivably take place right in your living room. A six-piece combo, a folk singer with guitar, or a string quartet *could* fit into a larger-than-average living room. So there is nothing unnatural about reproducing this kind of music with extreme closeness, giving the impression that the musicians are out in the room in front of the loudspeakers. A neutral loudspeaker cannot do this, for it maintains the original mike-to-instrument distances, and these distances can never be less than zero feet. Thus, the neutral system could place instruments that are miked extremely close right behind the loudspeakers, but could never bring them out into the listening room. Of course, you don't have to bring small performing groups right into the room with you, but the option

# Introducing the expensive dual-trace scope that doesn't cost a lot.

The B&K Precision Model 1470.

A solid-state 5-inch scope that combines dual-trace triggered sweep with vectorscope capability.

Our DC to 10 MHz bandwidth with 10 mV/cm sensitivity makes the 1470 exceptionally versatile. And its TV-H and TV-V positions are a special plus.

Dual-trace lets you observe input and output wave forms simultaneously in the same circuit. And 16-position triggered sweep, from 1 sec/cm to 0.2sec/cm lets you sync them instantly.

On the other hand, you might prefer our Model 1465 single-trace, triggered-sweep scope at \$359.95. It has many of the same features and our patented CALI-BRAIN® automatic voltage readout system.

Everything about our scopes is expensive —except their price.

For complete technical data, call your local B&K distributor. Or write Dynascan Corporation.

Very good equipment **B&K**  
at a very good price.

Product of Dynascan Corporation  
1801 West Belle Plaine Avenue, Chicago, Illinois 60613

## \$499<sup>95</sup>

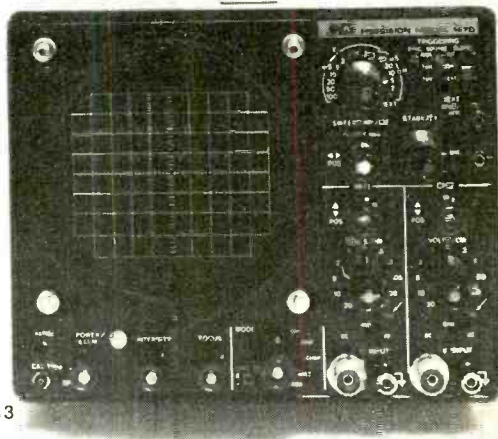

CIRCLE NO. 7 ON READER SERVICE CARD

is there, and the effect would not stretch one's credibility too much.

**No Room for an Orchestra.** But consider a full symphony orchestra, with maybe a 200-voice chorus thrown in to add interest. By no stretch of the imagination could this assemblage be squeezed into your living room, and to attempt to create a right-in-the-room illusion here would be ludicrous. For large performing groups, the object is to try to transport the listener into the concert hall, rather than bringing the instruments into the living room. Consequently, the apparent perspective of the loudspeakers should be such that they give an illusion of listening from a distance, either from a close seat in the auditorium or (according to your preference) a more distant seat.

Whichever you choose, bear in mind that closeness in a loudspeaker goes hand-in-hand with coloration, and extreme closeness means extreme coloration. This will impress itself on the instrumental sounds themselves and may change their quality enough to constitute a gross distortion of the original musical sounds. So, after you've found some speakers whose apparent closeness or distance seems to suit you, listen to them for naturalness of sound, using familiar program material.

The typical advice to the hi-fi shopper—that he listen and then buy what sounds “good” to him—is worthless to anyone who is looking for a semblance of fidelity in a system. “Good” is a value judgement, and what you feel to be good may be nothing more than what you are accustomed to hearing, or what your mind's ear thinks of as high fidelity. It takes a very well-trained ear to tell whether reproduced music sounds like live music, because most of us who get to hear live music enjoy it for its over-all effect, rather than listening analytically to its sonic details. This is not the case with natural sounds however.

Ever since birth, our brains have been storing recognition clues about the sounds that are part of our lives until, by early adulthood, we are able to tell the approximate size and weight of an object merely from the noise it makes landing on the floor in another room. We can even guess what the object was made of, or whether or not it broke. Our ears can tell us the size of a stream, the distance of a train, and (by the sounds of tires on the street) whether it is hot, cool, or raining outside. Our ears can

also tell us, very easily, whether or not a natural sound *sounds* natural. For this reason, good sound-effects recordings can often give an instant and accurate impression of the fidelity of a reproducing system. Of course, you should still base your final decision on how the system sounds with music, but sound effects such as street traffic, fizzing soda pop, and hammering and sawing (for example) can usually be used to weed out the dross of the system and allow you to narrow the final choices to two or three likely contenders.

**How Much Noise Do You Want?** If your demands for audio quality are very high, there is much to be said for buying a high-power amplifier even if you don't plan to use your system for rattling windows. Even at low power levels, high-power amplifiers are usually better—that is, lower in distortion—than low-power ones, simply because they are generally designed to more stringent standards. If you plan to do a substantial amount of your listening at high to very high levels, a high-power amplifier is mandatory, as is a loudspeaker that will handle the kind of power you must feed it in order to produce the necessary listening levels.

If you're looking for live in-the-room listening levels, you should be wary of speakers with very low efficiency. These may burn out if driven loudly for protracted periods of time. Speakers aren't usually rated in terms of efficiency, but if you do need efficient speakers you can spot them instantly in a listening comparison in your dealer's showroom. Without changing the volume-control level, switch to each of the speakers whose other qualities you feel you could live with, and choose the one that sounds the loudest over the entire audio range. (Some “efficient” speakers are that way only throughout their middle range, and may have low efficiency at low frequencies.) Then choose an amplifier whose continuous power output rating is no greater than the signal or program power rating of the speaker. Huge, brute force amplifiers may be safe to use for a while, but unless you exercise constant caution, there is always the possibility of their demolishing your loudspeakers. (Of course, you can always fuse the loudspeaker.)

For extremely high listening levels, you should probably not even consider buying conventional hi-fi speakers. Special loud-



speaker systems are made for high-quality, high-level use, and if that's what you have in mind, you're best off buying a pair.

**Are You a Diddler or a Listener?** While we all pay lip service to the idea that high-fidelity equipment is intended for listening to music, there are many audiophiles to whom the possession and manipulation of hi-fi equipment is the primary interest. So, before jumping in with both feet and buying an expensive system with hosts of knobs, flashing colored lights and myriads of screwdriver adjustments to diddle, consider for a moment just what you want from your system.

Are you an inveterate knob twiddler, who spends his evenings trying different loudspeaker placements and checking the phasing of his tweeters? If so, then by all means consider a complex system with all the controls you can pay for. If you have a good listening ear as well, and hear a lot of things in commercial recordings that you don't like, you might even include in your system one of those multi-band equalizer devices that divide the audio range into 9 or 10 segments and allow you to control each one independently.

Your diddling proclivities, or lack of them, should influence your choice of a primary music medium, too. Discs are simple to use, but the louder you play your system, the more audible their surface noise will be, and it takes care to keep disc surfaces in new condition. They must be handled with scrupulous care (no fingers on the grooves and no grit in the sleeves) and kept perfectly free from dust while playing.

It takes a persnickety person indeed to observe the cleaning rituals that are necessary to keep a disc in mint condition, and if you are not so inclined, you're better off with one of the tape formats, none of which have quite the potential for top fidelity that discs have and all of which have somewhat higher hiss than discs. Generally speaking, open-reel tape offers the best fidelity of the tape formats, but many people like the tape-threading ritual even less than the disc-cleaning ritual; and, for them, cassettes are probably the best choice (unless they wish to plunge into 4-channel sound with RCA's Q-8 cartridges). Bear in mind, though, that at present, discs still offer by far the widest variety of available program material, so this factor alone may outweigh the other disadvantages of the disc medium. ♦

# THE MOST ADVANCED FULLY AUTOMATIC LOCKING SYSTEM ON THE MARKET TODAY!

UNLOCKS ON APPROACH . . .  
. . . LOCKS ON WITHDRAWAL OF  
TRANSMITTER

## PROX-LOCK<sup>®</sup>

MODEL 161/171  
Patent Applied For Receiver



(Transmitter Carried by User Weighs Only 2 1/4 Oz.)

"FAIL SAFE" Design

### A PROVEN LOCKING SYSTEM

USED SUCCESSFULLY ON:

- AUTOMOBILES  
(car must have electric locks)
- BEVERAGE TRUCK DOORS
- BANK CASH DRAWERS
- CASH REGISTERS
- ANYWHERE YOU FIND A  
NEED FOR SECURITY

SECURITY THROUGH THE USE OF  
PULSE-CODING

NICAD BATTERY POWERED  
TRANSMITTER

ONLY

**\$179.95**  
Complete

with installation  
instructions and  
1 year warranty

PULSE DYNAMICS MFG. CORP.  
FULTON & DEPOT STREETS  
COLCHESTER, ILLINOIS 62326



- Please send the PROX-LOCK with complete installation instructions.
- Check  Money Order enclosed for \$179.95
- Please send additional information on the Model 161/171

Name \_\_\_\_\_

Address \_\_\_\_\_

City \_\_\_\_\_ State \_\_\_\_\_ Zip \_\_\_\_\_

CIRCLE NO. 28 ON READER SERVICE CARD

# You don't have to get a college in electronics.

Next to a willingness to work, nothing will improve your chances of success in electronics more than a college-level education. But family obligations and the demands of your job may make it very difficult for you to attend classes. That doesn't mean you have to forget about getting ahead. CREI makes it possible for you to get the college-level education you need without going back to school.

## Learn at home

At your own pace, your own schedule . . . without giving up your present job. CREI lessons are written to be clearly understood without the presence of a teacher. Your problems are anticipated. Your instructors will work with you in a very personal manner and give you all the individual attention you need. Many men learn far more readily through home study than they ever did in the classroom.

## Not for beginners

CREI programs are written for men familiar with basic electronics, but who want to

get the advanced, specialized knowledge they must have to move up to engineering-level positions and engineering-level pay. All CREI training material is developed with the help of top engineers and scientists from private industry and government laboratories. Each of these men is an expert in his field of electronics. He knows exactly what level of specialized knowledge a man needs to work successfully in that particular field today. This is your assurance that what you learn from your CREI study can be applied on the job.

## You can have confidence in CREI

Since 1927, CREI has helped tens of thousands of men move ahead in every phase of the electronics industry. You'll find CREI graduates and students in key jobs wherever up-to-date knowledge of electronics is demanded. Leading companies recognize the quality of CREI education. Many pay all or part of CREI tuition for their employees.

## CREI education is up-to-date education

CREI courses are continually being revised. New developments are included as quickly as they occur. Right

now, CREI students are getting the latest information on cable TV, LSI chips, microminiaturization, lasers and masers, telemetry systems, servomechanisms and data links. If it's new in electronics, CREI—and you—will know about it.

## Send for free book with complete information on CREI programs

Use postpaid card—no stamp needed. If card is detached use coupon or write: CREI, Dept. E 1208C, 3939 Wisconsin Ave., N.W., Washington, D.C. 20016

**CREI** Founded 1927  
Accredited Member of  
the National  
Home Study Council

# to go to college level education

## Capitol Radio Engineering Institute



This certifies that  
**Robert Denay, Jr.**  
has satisfactorily completed the Course of Study in  
**Electronic Engineering Technology**

Majoring in  
**Computers**

and upon the recommendation of the Board of Directors is granted this  
**Diploma**  
In Testimony Whereof, we have affixed our signatures

*B. A. Costello*

CREI, A Division of the McGraw-Hill  
Continuing Education Company

Dept. E 1208C, 3939 Wisconsin Ave., N.W.,  
Washington, D.C. 20016

Please send me free book with full information about  
CREI Programs.

Name \_\_\_\_\_ Age \_\_\_\_\_

Address \_\_\_\_\_

City \_\_\_\_\_ State \_\_\_\_\_ Zip \_\_\_\_\_

Employed by \_\_\_\_\_

Type of Present Work \_\_\_\_\_

I am interested in:  Computers  Electronic Engineering  
Technology  Nuclear Engineering Technology  
 Industrial Electronics  Electronics Systems  
Engineering  Television Engineering  Non-Technical  
Course in Computer Programming  New! Cable TV

APPROVED FOR TRAINING UNDER NEW GI BILL



# Twelve years — Five major advances

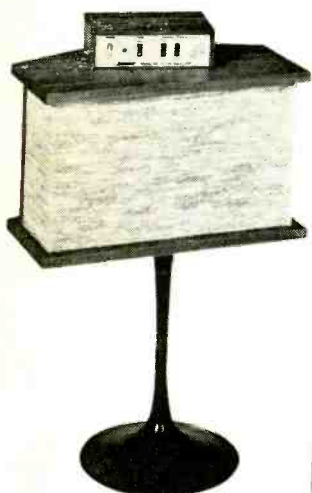

**BOSE 901\***

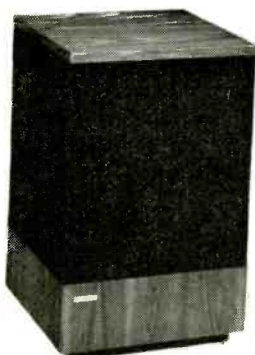

**BOSE 501\***

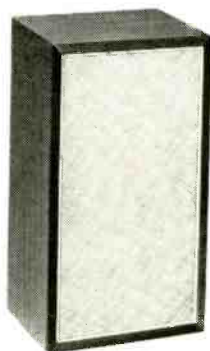

**CONVENTIONAL  
SPEAKER**

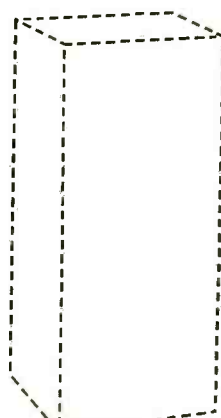

**YOUR  
SPEAKER  
?**

<b>1</b>	YES	NO	NO	
<b>2</b>	YES	NO	NO	
<b>3</b>	YES	YES	NO	
<b>4</b>	YES	YES	NO	
<b>5</b>	YES	YES	NO	

The twelve years of university research† that led to the design of the BOSE 901 and BOSE 501 DIRECT/REFLECTING® speaker systems revealed five design factors which optimize speaker performance:—

- 1** The use of a multiplicity of acoustically coupled full-range speakers — to provide a clarity and definition of musical instrument sounds that can not, to our knowledge, be obtained with the conventional technology of woofers, tweeters and crossovers.
- 2** The use of active equalization in combination with the multiplicity of full-range speakers — to provide an accuracy of musical timbre that can not, to our knowledge, be achieved with speakers alone.
- 3** The use of an optimum combination of direct and reflected sound — to provide the spatial fullness characteristic of live music.

**4** The use of flat power response instead of the conventional flat frequency response — to produce the full balance of high frequencies without the shrillness usually associated with Hi-Fi.

**5** Acoustical coupling to the room — designed quantitatively to take advantage of adjacent wall and floor surfaces to balance the spectrum of radiated sounds.

To appreciate the benefits of these five design factors, simply place the BOSE 901 directly on top of the largest and most expensive speakers your dealer carries and listen to the comparison.

**You can hear the difference now.**

NATICK, MA. 01760

**BOSE®**

\* Patents issued and applied for

† Copies of the Audio Engineering Society paper, "ON THE DESIGN, MEASUREMENT AND EVALUATION OF LOUDSPEAKERS", by Dr. A. G. Bose, are available from Bose Corp. for fifty cents.

**CIRCLE NO. 5 ON READER SERVICE CARD**



# News Highlights

## More Quartz Crystal Wristwatches

Ever since the announcement by Bulova some months ago of a \$395 quartz crystal wristwatch, other companies have been rushing to announce their versions. One of these is the Waltham Watch Co., which has announced the marketing of a quartz crystal controlled watch at under \$200. Unlike the Bulova version with its conventional moving hands, the Waltham version uses a liquid crystal digital display to show the time. The liquid crystal segments forming the numerals become reflective when a low voltage is applied to them. Since there is little or no current flow, this type of display is very economical of battery power. The colon between the hours and minutes numerals blinks once a second to show the passage of time. Accuracy of the watch is within five seconds a month.

Also announced recently was a line of electronic watches by Ebauches S.A., Switzerland, with cooperation from the company's partner, the Longines Watch Co. Ebauches S.A. has quartz crystal controlled watches with moving hands display or with liquid crystal digital display. These watches not only show the hours and minutes but also the seconds and the date as well. The company does not sell watches directly to the consumer but sells movements to watch manufacturers. Retail prices are expected to be below \$300. Watches from both companies use IC's as frequency dividers for the crystal oscillators. Replaceable batteries operate the watches for at least a year.

## TV Receiver with Memory Vision

A double-screen television receiver that permits instant, pushbutton freezing of action without interrupting normal viewing has been announced by Hitachi. The basic chassis is a standard black and white TV receiver with a 13-in. picture screen. To the left of this is a second smaller (9 in.) picture tube. Both CRT's are housed in a single cabinet. When a pushbutton is pressed, the image on the main screen at that moment is transferred to the second screen, frozen and locked in indefinitely until the pushbutton is pressed again. Normal viewing of the main picture tube goes on without interruption. Heart of the stop-motion system is a 4-in. rotating magnetic disc on which the video signal is constantly being recorded.

## Russian Bank Orders U.S. Computers

The national bank of the U.S.S.R., Gosbank, has ordered two large-scale Honeywell computer systems, valued at approximately \$5 million. The computers will be installed at Gosbank's computation center in Leningrad and will service the three main branches of the state-operated bank—the bank of foreign trade, the savings branch, and the industrial, agricultural and administrative branch. The order includes 100 terminals, which will be linked by telephone lines to the computer center from branch offices within a 180-mile radius.

## Electronic Manufacturers Support Metric System

U.S. electronic manufacturers continue to be in favor of efforts currently underway to convert this country to the metric system of

measurement. According to a membership survey completed by the Electronic Industries Association, manufacturers overwhelmingly approve of House Joint Resolution 1092 which states that the policy of the U.S. will be to facilitate and encourage the substitution of metric measurement units for customary measurement units in all sectors of the economy with a view toward making metric units predominant. Most responders favor a plan that calls for government legislation with targeted changeover dates and voluntary industry participation in the changeover.

### **First Ham to Slow Scan Color Globally**

William DeWitt (W2DD) recently transmitted a color photo by means of slow scan television (SSTV) to another ham in South Africa, who then recorded the signal and transmitted it back to DeWitt's Fairport, N.Y. station. For color SSTV, the picture to be transmitted is scanned by a camera through red, green and blue filters. The resulting monochrome information is translated into audio tones which modulate an SSB FM transmitter. To playback the picture, the receiving station photographs the sequential images through color decoding filters. For color image reproduction, a triple exposure of the three filtered images is made onto appropriate Kodak color films. Then processing is required to reconstitute the color photograph.

### **GE Files with FCC for Four-Channel Broadcasting System**

The General Electric Audio Electronics Products Dept. has filed a technical report with the FCC covering field testing of its four-channel discrete FM broadcasting system. The tests were conducted at the company's FM station, WGFN, at Schenectady, N.Y., during non-broadcast hours. The transmission is compatible with existing monophonic and stereophonic receivers and music systems. The system transmits four discrete full-frequency 30-to-15,000-hertz audio channels by adding an ultrasonic subcarrier above the present stereo subcarrier used for stereo FM broadcasting.

### **Equipment Announced for Discrete Four-Channel Disc**

The discrete four-channel disc developed by Victor Co. of Japan has three proponents so far. They are subsidiary JVC America, as well as Panasonic, and RCA Records. RCA has already announced the release of a four-channel disc, with more to come. Now the other two manufacturers are announcing their equipment to play the disc. JVC is offering a demodulator at \$100, a special cartridge at \$70, and a combination record changer with built-in demodulator and cartridge at \$190. Panasonic is making available a demodulator at \$135 and a combination record changer with demodulator at \$200.

### **Satellite Helps Save Two Patients**

An earth-orbiting ATS (Applications Technology Satellite) recently helped save the life of one woman in Alaska and relieve another seriously ill patient on the same day. The satellite is functioning as a switchboard-in-the-sky in a statewide Alaskan communications experiment under a cooperative program between NASA, the State of Alaska, and the Lister-Hill National Center for Biomedical Communications (HEW). Some 26 terminals located in remote villages and hospitals equipped with vhf transmitters and receivers use the satellite for communication to central locations in Alaska. During a routine educational program, the two emergency medical problems were reported. The satellite was kept in operation continuously while a doctor at the District Medical Center in Tanana, Alaska, provided instructions to the local nurse and an aide on the emergency treatment of the two patients.

# Watch, listen, calculate, tune-up, or test with 8 great new kits from Heath

## NEW Solid-State Heathkit Color TV — the best TV kit ever offered

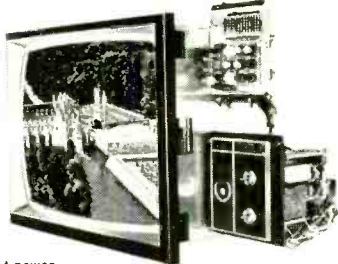

25" diagonal matrix tube, 24-position UHF/VHF detent power tuning, varactor UHF tuner, MOSFET VHF tuner, tint switch. New performance and convenience. Detent tuned UHF & VHF. Preselect any 12 favorite UHF stations, then power pushbutton (or remote) tune all 24 channels in either direction. New angular tint control switch selects normal or wide angle color to reduce tint changes between stations. Exclusive Heath MTX-5 ultra-rectangular black matrix tube has brighter pictures, better contrast. "Instant-On." Automatic fine tuning. Adjustable tone control. Automatic chroma control. Adjustable video peaking. More sensitive tuners. Transformer operated. Built-in dot generator and volt-ohm meter. Choice of cabinet styles from \$81.95\*.

- Kit GR-900, less cabinet ..... \$599.95\*
- Kit GRA-900-6, remote control ..... \$79.95\*

## NEW Heathkit component-quality stereo for cars



Mobile FM stereo tuner features clean 7 watts (3.5 W per channel) with less than 2% THD, frequency response  $\pm 1$  dB, 3 Hz to 15 kHz, 3 uV sensitivity, 60 dB selectivity, 40 dB min. separation. Stereo cassette deck offers hi-fi stereo cassette entertainment plus single-channel dictation while you drive. Single stereo amp powers either or both units. Choice of 5" door mount or 6" x 9" rear deck speakers (19.95\* the pair).

- Kit CR-1000, tuner, 6 lbs. .... \$64.95\*
- Kit CT-1001, cassette deck, 9 lbs. .... \$89.95\*
- Kit CRA-1000-1, amplifier, 3 lbs. .... \$29.95\*

## NEW Heathkit 8-Digit Calculator

Adds, subtracts, multiplies, divides, chain or mixed functions, and constant. Floating or selectable 7 position decimal. Plus, minus, and overflow indicators. Overflow protection of most significant 8 digits. Clear-display key to correct last entry. Standard keyboard. American LSI circuitry. Bright  $\frac{1}{2}$ " red digits. 120 or 240 VAC operation. Desktop black & white cabinet,  $3\frac{1}{2}$ " h x 6" w x  $10\frac{1}{4}$ " d.

- Kit IC-2008 ..... \$129.95\*



## NEW Heathkit Digital FM Tuner

Another Heathkit "first" in consumer electronics. Pure digital computer design including digital frequency synthesizer tuning employing phase-lock-loop techniques, FET varactor FM RF front end, digital discriminator and readout result in performance specs and tuning convenience that already are the talk of the audio world: channel frequency accuracy better than 0.005%; less than 1.8 uV sensitivity; distortion levels of 0.1%; selectivity and IF rejection better than 95 dB; image & spurious rejection better than 90 dB; S/N ratio better than 65 dB; separation better than 40 dB. One of a kind, the AJ-1510 "computer tuner" is the only tuner offering you 3 distinct tuning modes: keyboard, computer-type punch cards (up to 3), plus automatic band scanning with variable speed and stereo-only capability. The 55 ICs, 50 transistors and 50 signal diodes mount on 10 modules with 7 plugging into a master board for optimum computer modularity & ease of assembly. Join the computer generation of audio equipment — order your AJ-1510 today.

- Kit AJ-1510, tuner only ..... \$539.95\*
- AJA-1510-1, cabinet ..... \$24.95\*



## NEW Heathkit FET Tester

Tests transistors, diodes, FETs, SCRs, triacs, uni-junction transistors in or out of circuit. 5 current ranges measure leakage as low as 1 uA and collector currents as high as 1A. Gain (DC Beta), transconductance (GM), and leakage values read directly on large meter face. Special battery testing circuit gives meter indication of self-contained power supply.

- Kit IT-121, 6 lbs. .... \$49.95\*



## NEW Heathkit Timing Light

Features extra bright daylight-use flash and an all new triggering method. Special low-voltage inductive trigger pickup coil lets you connect light while engine is running, eliminates direct connections to spark plug, prevents interference with other test instruments connected to engine. High-impact, shock-proof plastic case.

- Kit CI-1040, 4 lbs. .... \$29.95\*



## NEW Heathkit Solid-State FET VOM

Dual FET portable multimeter with lab grade accuracy, 10 megohm input and the ranges you really need, 9 DCV & ACV ranges, 0.1 to 1000 v,  $\pm 2\%$  accuracy. 6 DC & AC current ranges, 10 microamps. to 1 amp. 7 resistance ranges, X1 (10 ohm center) to X1Meg. 9 dB ranges,  $-40$  to  $+62.1\%$  precision metal-film dividers.  $4\frac{1}{2}$ ", 100 uA, ruggedized tauband meter, diode & fuse protected. Battery check.

- Kit IM-104, less batteries, \$79.95\*.



See them all at your Heathkit Electronic Center... or fill out the coupon below

HEATHKIT ELECTRONIC CENTERS — ARIZ.: Phoenix, 2727 W. Indian School Rd.; CALIF.: Anaheim, 330 E. Ball Rd.; El Cerrito, 6000 Potrero Ave.; Los Angeles, 2309 S. Flower St.; Pomona, 1555 Orange Grove Ave. N.; Redwood City, 2001 Middlefield Rd.; San Diego (La Mesa), 8363 Center Dr.; Woodland Hills, 22504 Ventura Blvd.; COLO.: Denver, 5940 W. 98th Ave.; CONN.: Avon, 395 W. Main St.; FLA.: Miami (Mialeah), 4705 W. 16th Ave.; GA.: Atlanta, 5285 Roswell Rd.; ILL.: Chicago, 3452-66 W. Devon Ave.; Downers Grove, 224 Cgden Ave.; IND.: Indianapolis, 2112 E. 62nd St.; KANSAS: Kansas City (Mission), 5960 Lamar Ave.; MD.: Baltimore, 1713 E. Joppa Rd.; Rockville, 5542 Nicholson Lane; MASS.: Easton (Wellesley), 165 Worcester St.; MICH.: Detroit, 18645 P. Eight Mile Rd.; 18149 E. Eight Mile Rd.; MINN.: Minneapolis (Hopkins), 101 Shady Oak Rd.; MO.: St. Louis, 9296 Sheridan Dr.; N.J.: Fair Lawn, 35 W. 45th St.; Jericho, L.I., 15 Jericho Turnpike; Rochester, Long Ridge Plaza; OHIO: Cincinnati (Woodlawn), 10133 Springfield Pike; Cleveland, 5444 Fears Rd.; PA.: Philadelphia, 6318 Roosevelt Blvd.; Pittsburgh, 3482 Wm. Penn Hwy.; TEXAS: Dallas, 2715 Ross Ave.; Houston, 3705 Westheimer; WASH.: Seattle, 2221 Third Ave.; WIS.: Milwaukee, 5215 Fond du Lac.

HEATHKIT Schlumberger	
HEATH COMPANY, Dept. 10-8 Benton Harbor, Michigan 49022	
<input type="checkbox"/> Please send FREE Heathkit Catalog.	
<input type="checkbox"/> Enclosed is \$ _____, plus shipping.	
Please send model(s) _____	
Name _____	State _____ Zip _____
Address _____	
City _____	State _____ Zip _____
Prices & specifications subject to change without notice.	
* Mail order prices; F.O.B. factory.	
CL-436R	

CIRCLE NO. 18 ON READER SERVICE CARD

*A summary of the important specs to look for when you are selecting a CB rig*

# Directory of Mobile

**A**NY motorist who travels the expressway system of this country can make good use of a class D Citizens Band (CB) radio transceiver. Easy to acquire and operate, CB is a fast and convenient means of summoning aid for yourself or any other motorist in an emergency. Channel 9 is being used for this purpose. Many groups such as REACT (Radio Emergency Associated Communications Teams) monitor this channel to provide emergency communications. Other uses are numerous—from home you can keep in touch with the family car; from the store, you can contact the delivery van.

A class D Citizens Band license is for citizens who are over 18 years old. The other requirements are covered by the filing of a simple form with the FCC and paying the fee of \$20.00. No written test is required. The application form is usually included with the transceiver and may also be obtained from any local FCC office.

The accompanying chart covers many models of mobile AM CB transceivers. Units that are designed for base use with 12-volt supply capability are not included. They tend to be too large for most mobile appli-

cations. Units that cover less than the full 23 channels are not included.

All figures given in the chart were supplied by the manufacturers. Where a manufacturer did not answer our questionnaire or followup phone calls, his products were not included.

Since space in the chart is at a premium, code letters often provide the desired data. Typical codes are "C" for calibrated, "N" for not available, "S" for switched, "V" for variable or adjustable, and "Y" for available. A question mark means the data were not supplied.

**1. Manufacturer and Model.** Among the models listed, the price and the number and quality of features offered in each model can help in your selection of a satisfactory unit.

**2. Price.** The price is given in even dollars and in all cases is the manufacturer's net. It includes the cost of a full set of crystals where they must be ordered separately. With crystal synthesis it is possible to provide 23 channels of transmit and receive with only 11 crystals. This makes

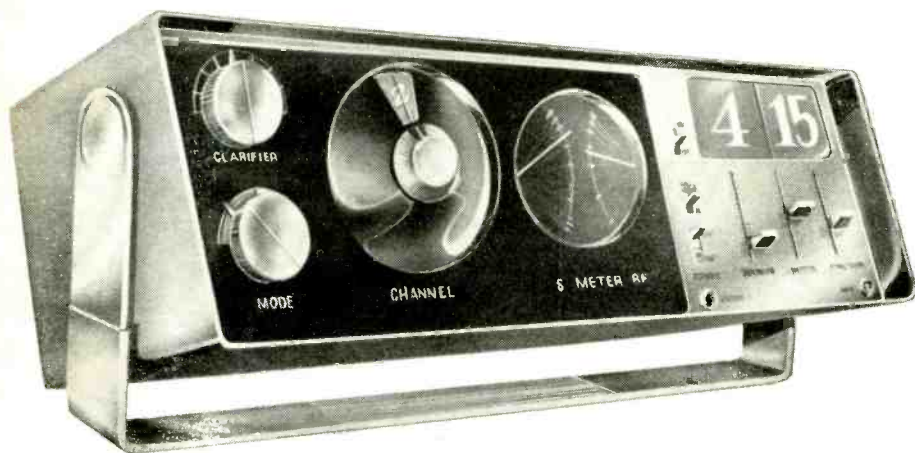



# CB Transceivers

the set more economical than the sets which use a separate crystal for each transmit and receive channel. The 36 extra crystals would cost about \$75 more.

**3. Dimensions.** As an aid in determining where this equipment will fit into your car, the height, width and depth are given in inches. A box built to these dimensions will help you to check for mounting in your glove compartment, next to your stereo, or other handy location.

Other necessary installation data includes the location of the mike connector and whether the speaker grill opens right or left, up or down. Code letters "L", "R", "U", "D", "M", and "S" represent left, right, up, down, mike and speaker.

**4. Meter.** A meter is available on many units to indicate the received signal strength "S" and the relative r-f power output "R" of the transceiver. The received signal may be calibrated. In this case, we give the number of microvolts input required to read S9. There is no standard requirement so the value can be whatever the designer chooses. The application to mobile units is to aid in selecting a site for transmitting since the signal strength can vary enough over a few feet to help in a marginal condition.

For the transmitter power the "R" indicator serves to monitor the output. The meter reading will be affected by load variations that may occur if the antenna is damaged. The power output on most models is also affected by the battery voltage. Where the scale is not calibrated the "I" is used. For example, "55RI" means the S meter is calibrated for S9 at 55 microvolts and the meter indicates relative r-f output.

**5. Power Supply.** The current drawn while transmitting and the receiver standby current are given. The "±" before the first

reading tells that the unit can be operated on positive ground systems. All can be used on common negative ground. If your car has a positive ground, this may be an important feature.

**6. R-F Power (Min. Watts).** This is a measure of how well you are transmitting. The FCC rules limit the maximum power output of the transmitter to 4 watts. If the power input to the final amplifier is measured, the limit is 5 watts. The difference between a 3-watt and a 4-watt output results in a negligible difference in signal. The effective range would be increased only by about 10% for this power increase. More important is the protection of the output transistors from overload. If the unit is so protected a "P" comes after the power reading.

**7. Automatic Modulation Control (AMC).** One method of legally improving the effective output is to keep the percentage of modulation as high as possible. However, overmodulation (more than 100%) produces distortion and interference with other stations, which, incidentally, is illegal. For this reason an automatic modulation control is an important feature of a transceiver. Some units have a light on the panel to indicate modulation. An "I" is indicative of this feature.

**8. Output Filters.** The rules of the FCC require that the harmonics and other frequencies outside of the CB channel be limited to 50 dB below the on-frequency output. The figure thus presented should equal or exceed -50 dB.

The output filters used to accomplish the required attenuation may also be used to match the antenna impedance to the output transistors. The "P" stands for the pi type of low-pass filter, while "T" stands for trap type used to filter one frequency.

## 23-CHANNEL MOBILE AM CB TRANSCEIVERS

1. Manufacturer and Model	2. Price (\$)	3. Height (in.)	Width	Depth	Mounting Code	4. Meter	5. Transmitter (A)	Receiver (A)	6. R-F Watts	7. AMC	8. Filters	- dB Out	9. Sensitivity ( $\mu$ V)	10. Image (dB)	I-F Rejection	Spurious	Blocking (V)	11. Select. - 6 dB (kHz)	At 10 kHz (dB)	12. Delta Tune (kHz)	13. Noise Limiters	
<b>Allied-Radio Shack</b>																						
Mini-23 TRC-50	110	1.5	5.25	7.9	SD	N	0.7	0.12	3.5	YI	2P	-50	0.5	-75	?	?	?	?	N	G		
TRC-24	150	1.75	6	7	SD	SIRI	0.95	0.14	3.5	NI	2P	-50	0.5	-85	?	?	?	?	N	G		
<b>Browning</b>																						
SST	170	2.4	6.5	8.2	MLSU	16RC	$\pm 1.8$	0.85	3.5P	YI	2P	-55	0.3	-50	-80	-50	0.5	4	-60	V1.5	G	
<b>Courier</b>																						
Traveler II	140	1.9	7.75	6.25	SD	100	1	0.2	3.0P	YI	PT	-50	0.4	-40	-50	-50	?	3	-40	N	SG	
Classic II	200	2.5	7	9.5	SL	100	1	0.2	3.0P	YI	PT	-50	0.3	-40	-50	-50	?	4	-50	S1.3	SG	
Chief 23	200	2.75	7	9.5	SD	N	1.35	0.25	3.0P	YI	PT	-50	0.3	-40	-50	-50	?	4	-40	N	SG	
<b>Dynascan</b>																						
Cobra 20	140	2.4	6	8.5	MLSD	SIRC	1.8	1.3	3.0	Y	2P	-50	0.5	-40	-40	-40	?	4	-40	N	G	
Cobra 28	170	2.4	6	8.5	MLSD	RC	1.8	1.3	3.0	Y	2P	-50	0.5	-40	-40	-40	?	4	-40	S?	G	
<b>Fannan</b>																						
Fanfare 200	110	2.0	5.5	7.5	?	SCR1	1.2	0.25	3.0P	NI	?	-52	0.5	-40	-70	-50	0.1	3	-40	N	G	
Fanfare 700	190	4.5	13.75	8.5	?	SCR1	2.0	0.4	3.0P	NI	?	-55	0.3	-50	-70	-55	0.1	2.5	-78	N	G	
<b>Heath</b>																						
GW-14A	160	2.9	7	11	MLSD	100RI	0.75	0.12	3.0	N	2PT	-50	0.5	?	?	?	?	?	?	N	G	
<b>Ray Jefferson</b>																						
CB-405	150	1.5	6	8.0	SD	SIRI	?	?	?	?	?	-50	1.5	?	?	?	?	?	?	N	G	
<b>E. F. Johnson</b>																						
123	140	2.5	6.2	8.75	MRSL	50RI	$\pm 0.85$	0.35	3.0P	Y	2P	?	0.5	?	?	-47	?	3	?	N	G	
323M	290	2.5	8	9.5	MRSL	50RI	$\pm 1$	0.3	3.0P	Y	2P	?	0.5	?	?	-50	?	3.5	-60	N	G	
<b>Kris</b>																						
T-23	140	2.0	6.25	7.5	MLSD	SIRI	1	0.18	3.3	Y	?	-50	0.5	-68	?	-50	?	2.5	-50	V5	SG	
<b>Lafayette</b>																						
Micro 23	104	1.75	5	7.5	MLSD	N	$\pm 0.8$	0.1	3.5	Y	PT	?	0.7	-50	?	-50	?	4	-40	N	G	

HB-23A	128	2.25	6	7.75	SD	63RC	±1	0.5	3.0P	Y	PT	?	1.1	-46	?	-50	?	4	-45	N	G
HB-525E	150	2.4	6.25	8	MLSD	100RC	+0.7	0.5	3.8P	YI	PT	?	0.6	-38	?	-50	?	2.5	-45	N	G
HB-625A	190	2.5	6.5	8.5	MLSD	100RC	+0.7	0.5	3.0P	YI	PT	?	0.6	-88	?	-50	?	2.5	-45	S2	GSB
Telsat-50-150	170	2.5	6.5	8	MLSD	N	±1	0.5	3.5	Y	P	?	0.6	-50	?	-50	?	4	-45	N	G
<b>Mark Products</b>																					
Invader-23	170	2	6	9	MLSD	SIRI	1.5	0.2	3.0	Y	2P2T	-50	0.5	?	?	-50	?	?	?	N	G
Lanser-23	140	2.5	8.75	9.5	SD	SIRI	1.5	0.3	3.0	Y	2P2T	-50	0.5	?	?	-50	?	?	-50	N	G
<b>Messenger</b>																					
TR-18M	130	2.5	5.9	?	MDSU	50RI	1.2	0.1	3.8	YI	PT	-50	0.7	-30	?	-50	?	?	-40	N	G
<b>Midland</b>																					
13-870	150	2	5.9	8.25	SD	SIRI	1.5	0.3	2.5P	Y	3P	-50	1	-40	?	?	?	?	-40	N	G
<b>Paticom (Pace)</b>																					
123	130	2	6.5	7	MLSD	SIRI	?	?	3.5	Y	?	-50	0.4	?	?	-50	?	3	?	N	G
2376	150	2.5	6.75	8.5	MLSD	N	?	?	3.5	?	?	-50	0.3	?	?	?	?	?	-50	N	G
2300	199	2.5	8.5	6.75	MLSD	SC	?	?	3.5	?	?	-50	0.25	?	?	?	?	?	-50	N	G
<b>Pearce Simpson</b>																					
Puma 23	115	2	5.75	8.6	?	N	1.2	0.18	2.9P	YI	3PT	-60	0.5	-50	?	-60	0.5	2.5	-50	N	G
Bobcat 23	150	2	5.9	8.1	MLSD	N	0.75	0.25	2.9P	YI	3P	-60	0.5	-60	?	-56	0.5	2.4	-50	N	G
Tiger 23	165	2.4	6.75	8.1	SD	N	1.0	0.25	2.9P	YI	2PT	-60	0.5	-65	?	-60	0.5	2.5	-50	S	SG
Cougar 23	190	2.6	7	8.1	SD	100RI	1.1	0.35	2.9P	YI	3PT	-60	0.5	-71	?	-75	0.5	2.4	-50	V	GSB
<b>Regency</b>																					
Sprint 23	139	2.25	6	7.25	SD	50RC	±1.1	0.75	2.9	Y	2PT	-50	0.5	-45	?	-120	?	5	-50	N	G
GT-523	189	2.25	5.5	7.5	MLSD	SI	1.2	0.6	3.0	Y	PT	-50	0.8	-60	?	-60	?	4	-60	S1	G
<b>Robyn Int.</b>																					
J123	115	2	5.75	7.1	?	N	±1	0.25	3.5P	Y	2PT	-50	0.7	-50	?	?	?	?	-50	N	SG
K123	130	1.9	5.75	6.6	?	SIRC	±1.1	0.25	3.5P	N	2PT	-60	0.5	-50	?	?	?	?	-50	N	G
TR123C	140	2	6	7.75	SD	SIRC	±1.1	0.15	3.5P	YI	3PT	-60	0.5	-60	?	?	?	2	-50	V1.5	SG
<b>SBE Linear Systems</b>																					
Catalina	100	1.5	6.5	7.5	M <sup>1</sup> SD	N	1.5	0.25	3.0	YI	2P	-50	1	-40	?	-60	1.0	2.5	-40	N	G
Coronado	163	2.5	5.75	8	?	N	1.2	0.25	3.5	YI	3P	-50	1	-50	?	-60	0.5	3	-40	N	G
<b>Sharp</b>																					
CBT-58	120	2.25	6.25	7.5	MSL	100RC	?	?	2.3	Y	2P	-50	1	-40	?	-45	0.1	2.25	-50	S1.5	G
<b>Sonar</b>																					
J-23	240	3.5	6.5	8.5	SL	N	1	0.25	3.2	N	2PT	-55	1	-75	?	-80	0.5	?	?	N	SC

Abbreviations:  
 B—Blanker, noise  
 C—Calibrated  
 D—Down

M—Mike  
 N—None, or not available  
 P—Pi network, protected

R—Right, relative output power  
 S—Speaker, switched,  
 received signal strength

T—Trap  
 U—Up  
 V—Variable, or adjustable

Y—Yes, or available  
 ?—Information not supplied

Sometimes more than one section is used; for example, 2PT stands for two pi sections and one trap.

**9. Sensitivity.** No single figure will describe just how weak a signal the receiver will pick up. Noise and interference from other signals have a lot to do with reception of a weak signal. However, a figure can be given in microvolts required to make the signal plus noise 10 dB stronger than the noise alone. Thus, a low figure indicates a more sensitive receiver.

**10. Spurious Responses.** The reception of signals not on the desired channel can present problems that limit the use of the CB set. Signal image and i-f are the worst offenders. Other spurious signals may be a problem if the offending transmitter is close. The greater the minus dB figure on these values, the better. The blocking of the front end of the receiver from very strong signals is very bad when an r-f noise blanker is used. If it is turned off, the reception may improve. Blocking also appears as distortion of very strong signals. The higher the blocking voltage, the better.

**11. Selectivity.** The audio frequencies transmitted are less than 3 kHz. Actually 2 kHz is adequate. For this reason the -6 dB points should be at least  $\pm 2$  kHz. If one considers that the stations can be legally off frequency by as much as 0.005% (1.35 kHz), it is obvious that a bit more bandwidth is needed for the worst case. If delta

tuning is available, this can be used to compensate for the frequency tolerance.

The second figure is the amount of attenuation for a frequency 10 kHz from the center. This is indicative of how well a station on the next channel can be eliminated. Ceramic or mechanical filters are usually used for this purpose.

**12. Delta Tune.** This is sometimes called a clarifier as it is used to make the signal clearer. Since the previous paragraph indicates that the transmitter can be as much as 1.35 kHz off the center frequency, this frequency shifter can be quite useful. It also can be used to enhance the amount of adjacent channel rejection. "V" is for the variable control, "S" is for step or switched control. The number is the frequency change from the center.

**13. Noise Limiters.** The best method of eliminating noise is to suppress it at its source. When the transceiver is installed, ignition suppressors and generator filters are installed to reduce the impulse type of noise generated in your car. This still leaves the other vehicles around to cause interference. For this reason every mobile CB set has some type of built-in impulse noise limiter. The most common is the series diode gate "G", although some sets also have circuits that blank out the set momentarily during noise peaks. These r-f blankers "B" are very helpful. They must be switched out "S" if a strong local station is present or they will blank each time the station comes on. ♦

## LASER MACHINING PRODUCES ELECTRONIC CIRCUITS

A new laser "machining" process devised by Bell Laboratories engineers is capable of forming tiny electronic circuit patterns directly onto ceramic substrates. The new process, still in the experimental stages, makes use of a laser assisted by information stored in a computer that is programmed to describe the type of circuit pattern to be machined. In the process, substrates coated with a thin film of metal are mounted on a circular drum; and as the drum rotates, each substrate is successively exposed to a focused laser beam that is modulated, or switched on or off. Thus microscopic areas of the metal are either vaporized or left intact. A mirror steers the beam from line to line

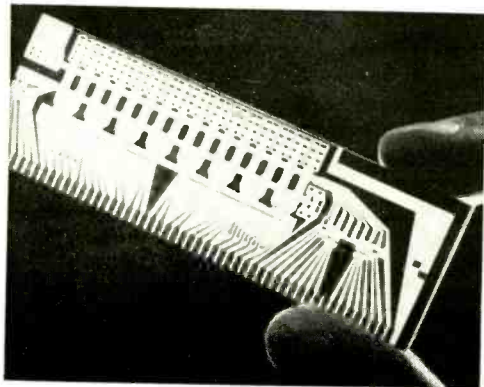



# THE DOLBY TECHNIQUE FOR REDUCING NOISE

by *Mannie Horowitz*

Eico Electronic Instrument Co., Inc.

SEVERAL COMPANIES ARE SOLVING THE TAPE-NOISE PROBLEM WITH SPECIAL CIRCUITS IN THEIR RECORDERS. HERE'S HOW ONE OF THE MOST SUCCESSFUL SYSTEM WORKS.



**N**OISE can be defined as any undesired transmission which accompanies a desired signal. Should the amount of noise be minute when compared with the signal, it is unobtrusive and considered negligible. However, even when it is not at all comparable in magnitude to the intelligence to be reproduced, it will interfere with the program material. Hence, noise must be reduced to the smallest possible levels.

Noise may be due to various factors. Radio and tape recordings occasionally suffer from noise generated by radiation or induction from electrical equipment. More important than this, the coating on the tape used for recording consists of tiny closely packed particles. Although they are almost identical in size and magnetic characteristics, there are variations in the number of particles at different places on the tape. These variations are of all frequencies, but are most obviously reproduced as high-frequency noise or "tape hiss."

Theoretically uniform noise is known as "white noise." Interference of this type appears as a hiss and identical power is delivered at all frequencies. Tune your FM receiver between channels and the sound you hear, if your receiver does not have a

quieting circuit and you can disable the de-emphasis circuit, is similar to white noise.

In addition to noise due to tape, the semiconductors in a tape recorder are the source of two types of noise. One, *partition noise*, is caused by the irregular division of the total transistor emitter current between the elements (base and collector) in the device. The second important source of noise in the transistor is *shot noise*. This is due to the discrete particle nature of electricity and the statistical variations in the motion of these electrical particles as they pass through the semiconductor device.

Noise interference is a wide-band phenomenon. The ear responds to noise at all audible frequencies but the most annoying is high-frequency hiss, above about 5000 Hz. Elimination or reduction of noise present in the top octave of the audio range is a desirable goal and various circuits have been designed to accomplish this.

**Schemes To Minimize Noise.** Before any method is applied to reduce noise, the amplifier must be designed so that it will be as noise-free as possible. Once circuit noise is minimized, the next step is to reduce noise originating from tapes or from any

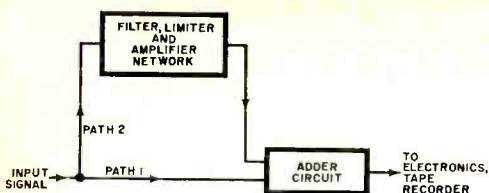

Fig. 1. Input to Dolby network for a tape recorder goes through two paths, one being the special filter network.

other medium used to reproduce program material.

One of the most widely used methods to minimize the reproduction of high-frequency noise employs a low-pass passive filter. Low frequencies are passed freely to the output of the amplifier while the upper portion of the audio band is attenuated. A common arrangement consists of one resistor and one capacitor in a circuit designed to reduce high frequencies, letting them roll off at the eventual rate of 6 dB per octave. That is to say, every time the frequency doubles, the gain of the circuit is reduced by an additional 6 dB. If, for example, you wish to reduce noise by 10 dB at 5000 Hz, noise will be reduced by about another 6 dB at 10,000 Hz when the filter is used.

However, not only is the interfering noise reduced at these frequencies the desirable music or program content is reduced as well and high-fidelity qualities are lost. In fact, some attenuation begins to become quite evident at the frequency where the gain is reduced by 3 dB, or at 1600 Hz in this case.

The situation is improved by using two resistor-capacitor networks so that the eventual rolloff is at the rate of 12 dB per octave (twice the 6-dB-per-octave rolloff rate of one network). If the gain at 5000 Hz is reduced by 10 dB with such a circuit, the frequency at which the attenuation becomes evident (circuit gain reduced by 3 dB) is now about 2100 Hz. This is an improvement over the previous case, but the output from the amplifier is still badly limited in bandwidth.

One method used to improve the signal-to-noise ratio when recording on tape is to "ride the gain." A maximum limit on the size of the signal that can be fed to the record preamplifier is set by the distortion or saturation characteristics of the tape. Weak signals which might be lost within the tape noise can be increased manually

before being fed to the record amplifier. These signals can be boosted sufficiently before being recorded so that they can later override the noise during playback. Average and high-level signals can be manually limited in amplitude when fed to the recorder so that they will not saturate the tape. These signals are usually sufficient to mask any tape or record playback amplifier noise similar to them in frequency.

A variation of this procedure uses an electronic compressor to limit the output as the gain increases. The relative output-level difference between the loud and soft passages of music is reduced. Extremely loud passages of music are subdued so as not to overload the tape or tape amplifiers, while relatively low intensities of sound are recorded at comparatively higher levels. The opposite of the compressor—the expander—is placed at the output of the tape recorder to restore normal amplitude relationships.

One big drawback to this system is the time it takes for the compressor and expander to go into action. Another defect is "breathing" or noise modulation. Background noise is alternately increased and decreased, producing very annoying listening conditions.

Another very successful means of improving the signal-to-noise ratio uses pre-emphasis and de-emphasis in the recording and playback processes, respectively. Standard curves specify that the high frequencies be emphasized a fixed amount while recording on tape. These same frequencies are reduced by an equal amount during the playback process so that the overall frequency response is level. Noise is overridden by the large high-frequency signals placed on the tape in the record process and is reduced during playback due to attenuation of the high end of the band. This system is used on all tapes and playback equipment that is currently available on the market.

**The Dolby System.** Perfecting the procedure just described, and adding some additional brilliant features, Dr. Ray Dolby evolved an excellent method of reducing noise and hiss, along with any other type of undesirable low-level material found on tapes.

First, let us state the one thing this method of noise reduction *cannot* do. It cannot eliminate noise already recorded on the tape.

Similar to the compressor/expander and pre-emphasis/de-emphasis methods, the program material must be processed before it enters the recorder electronics and after it emerges. Here is how the Dolby B-type system used in home recording equipment works.

However annoying, noise on tape is usually at a much lower level than the music or other program material. On loud passages, noise is masked by the program material. You do not hear the noise which may be 40 or 50 dB below the level of the desired sound.

During quiet passages, however, the level of noise is comparable to the level of the music. It is quite objectionable. The Dolby noise-reduction system discriminates between loud and soft passages and attenuates noise only when it can be annoying, as is the case when low levels of material are being reproduced.

Tape hiss, being a high-frequency phenomenon, is poorly masked by the low frequencies in the program material, even when the amplitude of the signal is high. Therefore, the Dolby system separates the high-frequency band from the low frequencies. Large signals at low frequencies will not keep the high-frequency noise from being attenuated. Only high-frequency am-

Fig. 2. These are record process characteristics. Playback is the inverse.

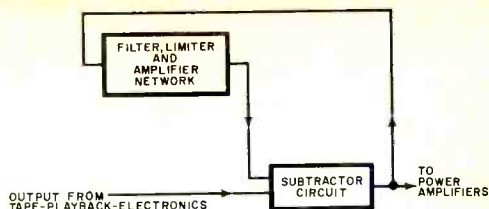
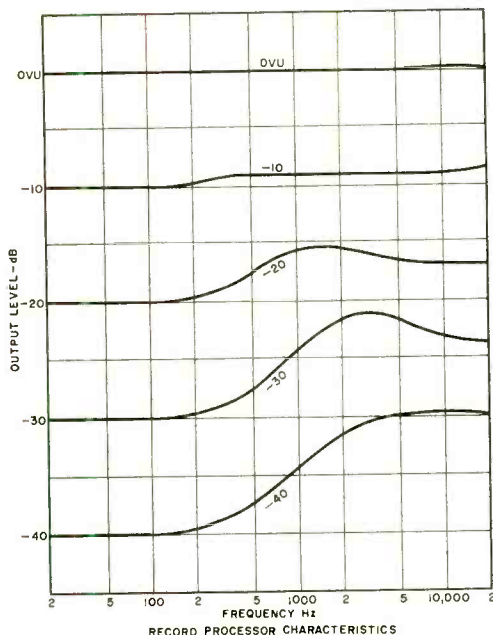

Fig. 3. Dolby output network from recorder has one path through feedback.

plitudes determine when noise will or will not be reduced.

Should fixed-filter circuits be used to determine or separate the high-frequency band from the low frequencies, breathing can become evident. Instead of a fixed filter, a variable type is used. The frequency characteristic automatically adjusts itself, by use of a feedback circuit, for the best performance.

Briefly, the input to the tape recorder takes the form shown in Fig. 1. The input signal follows two paths in the Dolby circuit before being fed to a summing or adder network. One path is directly to the adder. The second path is through a network which separates the high-frequency but low-level input signals from the rest of the material to be recorded. The output of the network is significant above 1 kHz, rising to its maximum level at 5 kHz and above. The selected signals are amplified and fed to the adder. The sum of the direct signal and the amplified low-level, high-frequency signals, is then fed to the input of the tape recorder.

Let us say that the high-frequency filter, for those frequencies above 5000 Hz, and the level-selective network are actuated when any signal over 5000 Hz falls to 1% or less of the maximum input signal. This low-amplitude signal will then actuate the level-selective network and all frequencies of 5000 Hz and above are then amplified 2.16 times. The low-amplitude portion of the signal, instead of being 1% or less of the maximum input signal, is now 1% + 2.16% or 3.16% which is equivalent to increasing the low-amplitude signals by 10 dB. A compressor-type action is accomplished here as the low and high levels of the signal feeding the tape recorder approach each other in amplitude. Even though a wide gap exists between maximum and minimum amplitudes, the difference is narrowed by a factor of 3.16 or 10 dB. (See Fig. 2)

It should now be obvious that any signal 1% or less over 5000 Hz will be increased 10 dB while those signals over 1% will be allowed to pass through without any Dolby action. The direct opposite will be true on playback. Any signal that is of 10 dB level or below will again actuate the level-selective network and, in this case, attenuate all high frequencies to their previous normal level.

The simple description above implies that the circuit has a sharp threshold at the 1% level. In practice, as the high-frequency signals rise above the 1% level, so the amount of boost introduced falls progressively from the 2.16 times. At levels of -20 dB and above, the boost is negligible, avoiding any over-modulation produced by higher peak signal levels than normally used.

The output from the preamplifier stages of the tape recorder feeds a network with frequency characteristics similar to the one at the input (Fig. 3). However, this time the path is through a subtractor. All the

factors added to the signal by the network in Fig. 1 are now reduced by an equal amount. The original program material is restored in proper amplitude proportion, expanding the difference between the high- and low-amplitude portions of the signal. However, noise introduced by the tape and electronics is reduced by about 10 dB over what it would have been without the intervening Dolby circuits. The amplified high-frequency signals introduced at the input of the recorder are capable of overriding much of the noise normally generated while recording. Reducing gain of these frequencies at the output also diminishes the audible noise.

Although the system is complex, it can be made as a relatively simple and inexpensive circuit. The 10-dB reduction in hiss and noise makes it quite worthwhile. When playing back a Dolbyized tape through conventional equipment, it is only necessary to reduce the treble response somewhat, using the tone control. ♦

## BATTERY-POWERED LOCATOR BEACON FOR AIRCRAFT

**A** NEW crash locator beacon for aircraft is being used to help speed search and rescue operations in airplane accidents. Called the "Pointer," the battery-powered device is a self-contained crash-proof unit which automatically sends out signals from downed aircraft, regardless of the pilot's condition. Designed for survivable and non-survivable accidents, the Pointer can also be manually operated.

The line-of-sight transmission range of the

Pointer is up to 125 miles at an altitude of 10,000 feet; at 25,000 feet, the range increases to 200 miles. The operating frequencies of the unit are 121.5 and 243.0 MHz. Reliable operation is obtainable over a -40° F to +150° F temperature range.

The Pointer is made by Aero Electronics of Phoenix, Arizona. It employs as a power source a Mallory "Duracell" 8.10-volt mercury battery which has a storage life rating of two years. ♦





# Solid-State Radiographic Screens

It only takes a moment to have an X-ray taken. However, it takes quite a bit longer to have the film developed and ready for observation. If multiple X-ray photos are required, the time can really stretch out. Recently, the Westinghouse Electric Corp., Electronic Tube Division, came up with two new solid-state radiographic screens that can convert X-ray images to visible images without significant time delay, but with energy gain and either storage or non-storage features.

Essentially, this means that X-rays can now be used for inspection or non-destructive testing at almost any time. Not only is the radiation exposure time greatly reduced, relieving one major medical problem, but the resulting picture will have a much higher "readability." Resolution is about 6 to 8 lines per mm, while the contrast sensitivity easily meets the specs for non-destructive testing.

One screen, used for storage, displays its visible image for several hours, or until it is electrically erased. If a permanent record is required, the screen can be conventionally photographed.

The non-storage screen is a direct replacement for existing fluoroscopic screens and provides up to 10 times the brightness, three times the contrast, and about three times better resolution than the conventional screen. Having a fast response, the non-storage screen is effective for both static and dynamic X-ray images. Its main application will be in production-line inspections and non-destructive testing. The non-storage screen can also be photographed if a permanent record is required. The speed of either screen is equivalent to that of high-contrast, high-resolution photographic film.

The photoconductor-electroluminescent (PC-EL) screens have a photoconductive portion which is sensitive to X-rays. The EL layer provides the visible image and is deposited on top of the PC layer to form a sandwich. A voltage is applied across the sandwich and, when the PC layer is ex-

posed to X-rays, its electrical resistance decreases. This causes more of the applied voltage to be dropped across the EL layer, thus causing it to emit more light. The resulting light pattern exactly corresponds to the pattern of the incident X-rays.

The new amplifier screens are thin, lightweight, and shock resistant; and their development was supported, in part, by NASA. ♦

**Dr. Zoltan Szepesi, of the Electronic Tube Division of Westinghouse Electric Corporation, shows how the contents of a woman's purse appear on a new type of radiographic amplifier storage screen for viewing X-rays.**



# CIE graduate builds two-way radio service business into \$1,000,000 electronics company!

**How about YOU? Growth of two-way transmitters creates demand for new servicemen, field and system troubleshooters. Licensed experts can make big money. Be your own boss, build your own company. And you don't need a college education.**

Two-way radio is booming. There are already nearly seven million two-way transmitters for police cars, fire department vehicles, taxis, trucks, boats, planes, etc., and Citizens Band uses. And the number keeps growing by the thousands every month. Who is going to service them? You can — if you've got the know-how!

## Why You'll Earn Top Pay

One reason is that the United States Government doesn't permit anyone to service two-way radio systems unless he's *licensed* by the FCC (Federal Communications Commission).

Another reason is that when two-way radio men are needed, they're *really* needed! A two-way radio *user* must keep those transmitters operating at all times. And, they *must* have their frequency modulation and plate power input checked at regular intervals by licensed personnel to meet FCC requirements.

As a licensed man, working by the hour, you would usually charge at least \$5.00 per hour, \$7.50 for each mobile evenings and Sundays, plus travel expenses.

Or you could set up a regular monthly retainer fee with each customer. Your fixed charge might be \$20 a month for the base station and \$7.50 for each mobile station. Studies show that one man can easily maintain at least 135 stations — averaging 15 base stations with 120 mobiles! This would add up to at least \$12,000 a year.

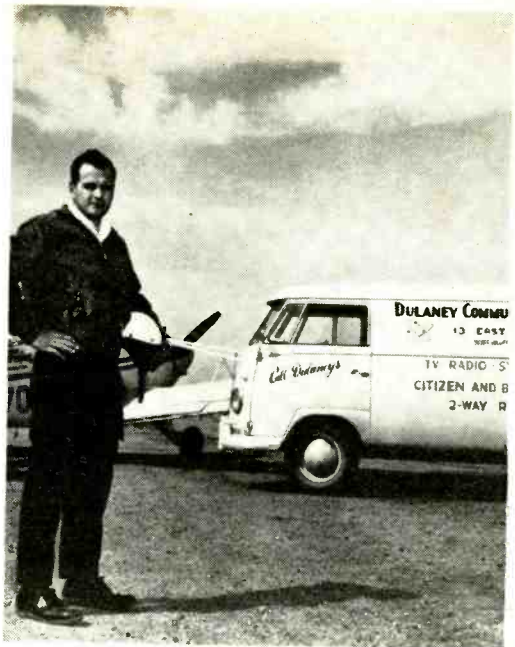

Edward J. Dulaney, Scottsbluff, Nebraska, (above and at right) earned his CIE Diploma in 1961, got his FCC License and moved from TV repairman to lab technician to radio station Chief Engineer. He then founded his own two-way radio business. Now, Mr. Dulaney is also President of D & A Manufacturing, Inc., a \$1,000,000 company building and distributing two-way radio equipment of his own design. Several of his 25 employees are taking CIE courses. He says: "While studying with CIE, I learned the electronics theories that made my present business possible."

## Be Your Own Boss

There are other advantages, too. You can become your own boss — work entirely by yourself or gradually build your own fully staffed service company. Of course, we can't promise that you will be as successful as Ed Dulaney, or guarantee that you'll establish a successful two-way radio business of your own, but the opportunities for success are available to qualified, licensed men in this expanding field.

## How To Get Started

How do you break in? This is probably the best way:

1. Without quitting your present job, learn enough about electronics fundamentals to pass the Government FCC exam and get your Commercial FCC License.
2. Then get a job in a two-way radio service shop and "learn the ropes" of the business.
3. As soon as you've earned a reputation as an expert, there are several ways you can go. You can move *out* and start signing up and servicing your own customers. You might become a franchised service representative of a big manufacturer and then start getting into two-way radio sales.

Cleveland Institute of Electronics has been successfully teaching Electronics for over 37 years. Right at home, in your spare time, you learn Electronics step by step.

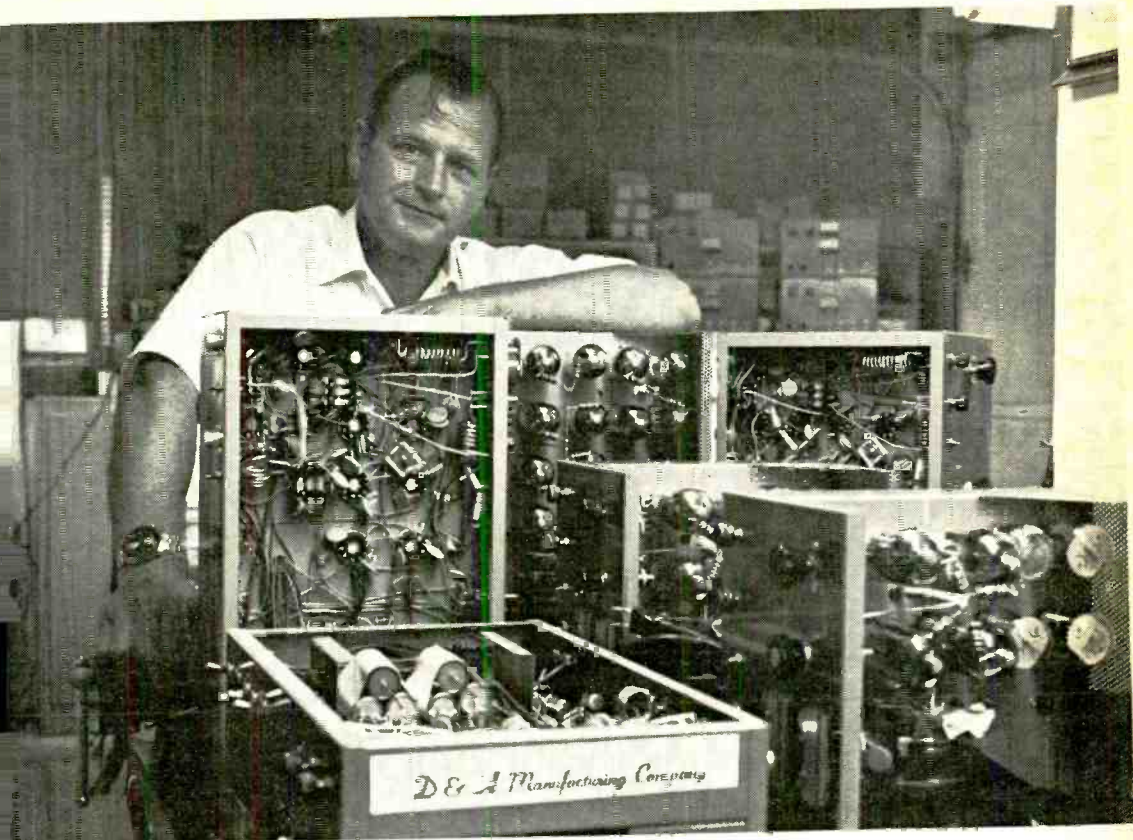

CIE's AUTO-PROGRAMMED® Lessons remove the roadblocks by using simple, concise examples. You learn in small, compact steps — each one building on the other!

You'll learn not only the fundamentals that apply to all electronics design and servicing, but also the specific procedures for installing, troubleshooting, and maintaining two-way mobile equipment.

### You Get Your FCC License... or Your Money Back!

By the time you've finished your CIE course, you'll be able to pass the FCC License exam. A recent survey of 787 CIE graduates reveals that better than 9 out of 10 CIE grads passed the FCC License exam. That's why we can offer our famous Money-Back Warranty: when you complete any CIE licensing course, you'll get your FCC License or be entitled to a full refund of all tuition paid. This warranty is valid during the completion time allowed for your course. You get your FCC License — or your money back!

### It's Up To You

Mail the reply card for two FREE books, "Succeed in Electronics" and "How To Get A Commercial FCC License." If card has been removed, mail coupon or write: Cleveland Institute of Electronics, 1776 E. 17th Street, Cleveland, Ohio 44114.

### APPROVED UNDER G. I. BILL

All CIE career courses are approved for educational benefits under the G.I. Bill. If you served on active duty since January 31, 1955, OR are in service now with more than 180 days of active duty, check box for G.I. Bill information.

## CIE Cleveland Institute of Electronics

1776 East 17th Street, Cleveland, Ohio 44114

Please send me your two FREE books:

1. Your book on "How To Get A Commercial FCC License."
2. Your new catalog "Succeed In Electronics" describing the job opportunities in Electronics today, and how your courses can prepare me for them.

I am especially interested in:

- |   |  |
|---|--|
| <input type="checkbox"/> Electronics Technology                 | <input type="checkbox"/> Electronic Communications |
| <input type="checkbox"/> Broadcast Engineering                  | <input type="checkbox"/> Industrial Electronics    |
| <input type="checkbox"/> First Class FCC License                | <input type="checkbox"/> Electronics Engineering   |
| <input type="checkbox"/> Electronics Technology with Laboratory |  |

Name \_\_\_\_\_ (Please Print)

Address \_\_\_\_\_

City \_\_\_\_\_

State \_\_\_\_\_ Zip \_\_\_\_\_ Age \_\_\_\_\_

Veterans & Servicemen: Check here for G. I. Bill information  
Accredited Member National Home Study Council

PE-33

**CIRCLE NO. 6 ON READER SERVICE CARD**

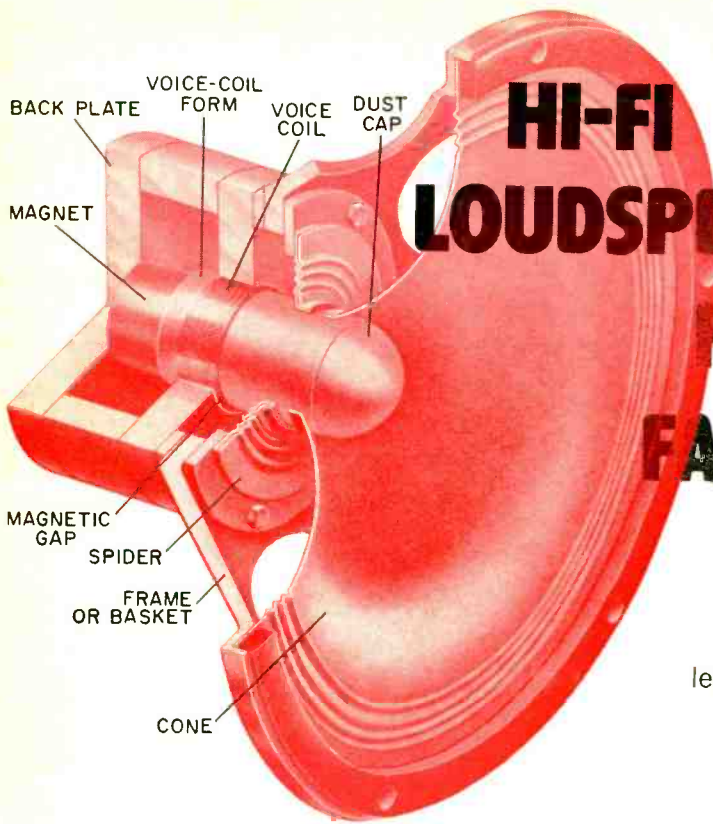

# HI-FI LOUDSPEAKERS: FACTS & FALLACIES

PART I

The mystery of how  
a speaker works  
leads to many fallacies.  
Here are the facts.

BY VICTOR BROCHNER

**T**HE LOUDSPEAKER is a relatively simple electro-mechanical device. But for most people, the manner in which it operates presents a mystery which has given rise to and perpetuated a number of peculiar fallacies. To describe a loudspeaker, we need very few words: It consists of a magnet assembly with a voice coil which drives a cone. The cone is elastically suspended in a metal frame in a manner which centers the voice coil/cone assembly in the magnet assembly's air gap. Try describing the typical hi-fi receiver in as few words. It can't be done.

In spite of their complexity, receivers are fairly well understood. The same cannot be said of the loudspeaker. There are two reasons for this state of affairs. The first is that the input and output of a receiver are electrical signals which can be measured with a meter and observed with an oscilloscope. While the input to a loudspeaker is an electrical signal, its output is an acous-

tical (sound) wave which radiates into the listening room in all directions and is reflected many times before it dies out. How then does one go about measuring the sound wave?

The second reason for the prevalence of false conclusions regarding loudspeaker design lies in the fact that the difficulty in grasping the theory encourages intuition and experimentation. Unfortunately, intuition is frequently pursued along the wrong lines. As for experimenting—a loudspeaker will operate in some fashion in any kind of a housing, short of being imbedded in concrete; and someone may well like the resulting sound. This may account for some of the "revolutionary" developments that have appeared, the claims for which contradict some of the basic laws of physics.

In this article, we will be dealing with 50 of the most popular facts and fallacies pertaining to loudspeakers and speaker system designs. To cover as much ground as

possible, the article is being presented in two parts: Part I here; Part II next month.

The first facts and fallacies have to do with the function that a loudspeaker is meant to perform.

1. *A loudspeaker should "sound good."*

**Fallacy:** The function of a loudspeaker is to reproduce, as acoustic energy, the electrical energy fed into it. It must be neutral, neither adding to nor subtracting from the original signal.

2. *If I want to modify the sound to suit my own preferences, I have a perfect right to do so.*

**Fact:** Your preferences may vary from time to time and for different types of program material. It would make more sense to modify the sound by means of the amplifier's tone controls.

3. *The Fletcher-Munson curves (see Fig. 1) show that the ear is less sensitive to the bass than it is to the midrange audio frequencies. Hence, loudspeakers should boost bass to make up for the characteristic.*

**Fallacy:** A good look at the curves reveals that human hearing has less sensitivity to low frequencies at moderate or low sound levels. But if the same is true when listening to a live performance, it makes no sense at all to design a speaker with bass boost in an attempt to make up for the ear's deficiency when listening to a recording.

4. *The previous statement implies that sound should always be reproduced with all frequencies amplified equally (flat response).*

**Fallacy:** If we listen to reproduced sound at the same loudness level as that of the original, the frequency response should be flat. But a lower loudness level alters tonal balance as shown in Fig. 1. Suppose the original sound was at level A where the ear requires 2 dB more power at 50 Hz than at 1000 Hz for a given loudness sensation. If the reproduced sound level were at B, 50 Hz requires 12 dB more power than 1000 Hz for equal loudness. There is now a deficiency of 10 dB, and the reproduction appears to be deficient in bass response. To restore tonal balance, 50 Hz must be boosted 10 dB as with a compensated loudness network. Since the amount of boost required is dependent on the volume level, the loudness compensation network should not be built into the loudspeaker where it would have a fixed characteristic. Also, loudspeakers should not be compensated to make up

for the deficiencies of human hearings as is so often stated.

Another set of facts and fallacies has to do with loudspeaker size and shape and the material used to make the enclosure.

5. *Musical instruments that produce low tones are large; therefore loudspeakers must be large to produce good bass.*

**Fallacy:** The analogy is incorrect; musical instruments depend on resonance to produce low tones and they must be reasonably efficient so that they can be heard. Loudspeakers do not generate sound in this sense; they reproduce it, and efficiency is rather unimportant. A small loudspeaker can be designed to have bass response that extends as low as a large loudspeaker.

6. *Large loudspeakers have advantages for bass reproduction.*

**Fact:** Although this sounds contradictory to the preceding explanation, large speakers can be played louder without excessive distortion. They have higher efficiency so that they require less amplifier power.

7. *Horn loudspeakers are better in the bass range than are direct radiators.*

**Fact:** This is true only if the horn speaker is large enough, however. By this we mean that the horn speaker must have several times the cubic volume of a large direct-radiator speaker.

8. *Loudspeakers should be shaped like the instruments whose sound they reproduce.*

**Fallacy:** Ideally, perhaps something like this is true, at least for monophonic reproduction. The directional characteristic of reproduced sound might well be made to match that of the instrument sound reproduced, but when several different types of instruments are playing at once, the principle is not practicable.

9. *The shape of the loudspeaker should match that of the ear.*

**Fallacy:** There is no conceivable basis in physics to support this statement. One might well ask, why not shape it like the mouth which at least produces sounds?

10. *The type of wood used in making the enclosure has an important effect on loudspeaker performance.*

**Fallacy:** The only requirement is that the enclosure be rigid and massive enough to prevent its walls from vibrating. The sole function of the box is to contain or provide a separate path for the sound wave coming from the back of the speaker.

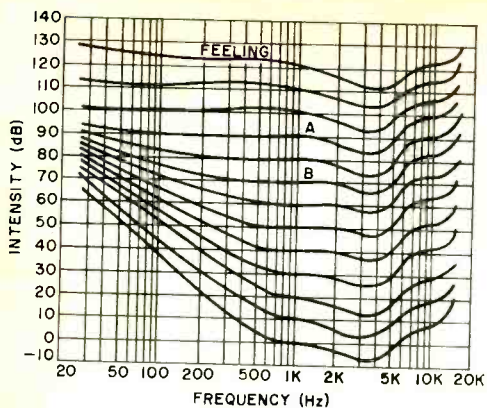

Fig. 1. Fletcher-Munson equal loudness curves pertain to human hearing.

11. An elliptical speaker or linear array of speakers has wider sound distribution in the plane of its long axis.

**Fallacy:** According to Huygen's principle, each point of a sound radiator can be considered as a point source producing spherical waves with the combined wavefront tangent to these spherical wavelets. In Fig. 2 is shown how an array of small sources produces a narrow beam of sound. This effect is used in sound reinforcement speakers (columns and line loudspeakers) to restrict the vertical spread of sound. The distribution angle is narrowed only for frequencies above the range in which the wavelength is comparable to the length of the source. So, for better horizontal distribution, stand an elliptical speaker so that its long axis is vertical.

12. The shape of a speaker enclosure has an important effect on its frequency response.

**Fact:** Reflections inside the cabinet can reinforce or reduce response in many narrow bands of frequencies, producing uneven response. A long narrow box can act like an organ pipe, causing undesirable resonances. Overhanging front edges produce diffraction effects whereby sound waves following different paths interfere with each other. So can decorative grilles. The ideal shape for the front of a speaker box is something like a hemisphere—not exactly a shape to excite decorators or enclosure designers.

Regarding loudspeaker operation.

13. A loudspeaker has to move a lot of air, especially for good bass reproduction.

**Fallacy:** Speakers do not move air. What they do is cause local air molecules to vibrate back and forth, producing a wave-

front which spreads out and away from the speaker. There is no air flow.

14. High frequencies are inherently directional, while low frequencies are omnidirectional.

**Fallacy:** Omnidirectional waves are created by vibrating objects which are small compared to the wavelength of the sound being produced. If the dimensions of the vibrating object are several times that of a wavelength, the wave produced is nearly plane and progresses in a straight line without much spreading out. Since frequency is inversely proportional to wavelength, high-frequency waves are short in wavelength compared to ordinary speaker dimensions. Hence, the high notes tend to be directional. The converse is true for low frequencies.

15. A point source is associated with directionality.

**Fallacy:** A theoretical point source radiates sound equally in all directions.

16. We can determine the location of a loudspeaker in a room because that is where the sound is coming from.

**Fallacy:** When listening to a typical speaker in the average room at a distance of, say, 8', our ears actually receive most of the sound after it has been reflected one or more times from the floor, walls, and ceiling. The reason we can detect the location of the sound source is that sounds coming directly from the source reach our ears before the reflected sounds arrive. This is known as the Precedence Effect.

17. The ideal loudspeaker is one which behaves like a perfect piston at all frequencies.

**Fallacy:** A uniformly vibrating diaphragm becomes directional in response in the upper midrange, and its output power drops off markedly. A perfect 10"-diameter piston would be usable only up to about 800 Hz, which may be acceptable for a low-frequency driver but not for a wide-range speaker. Even a 3" tweeter would be good only to about 3000 Hz. Speaker cones are designed so that their outer regions are progressively "decoupled" as the frequency increases, allowing smaller and smaller portions of the cone to vibrate while the rest of the cone area stands still as frequency goes up. In this manner, the speaker becomes effectively smaller to permit both response and directional characters to remain good. The upper frequency limit is extended to about four times the piston range.

18. A speaker placed at a junction of a wall and the floor has more bass output than one in the center of the floor or wall, and bass output is still further increased by locating the speaker in the corner of a room.

**Fact:** In the bass range, the reflections from the room surfaces occur in such a way that they are in phase with and reinforce the direct wave from the speaker. For higher frequencies, the times of travel along different paths differ in a random manner which does not permit this degree of reinforcement.

19. Some speakers must be driven hard to sound good.

**Fallacy:** The frequency response, directional characteristics, and distortion of speakers are never worse at low volume levels than when driven hard. Of course, a speaker that is somewhat deficient in bass response will sound even more so at low volume, but this is because of the Fletcher-Munson loudness characteristic of the ear and not as a result of a property of the speaker.

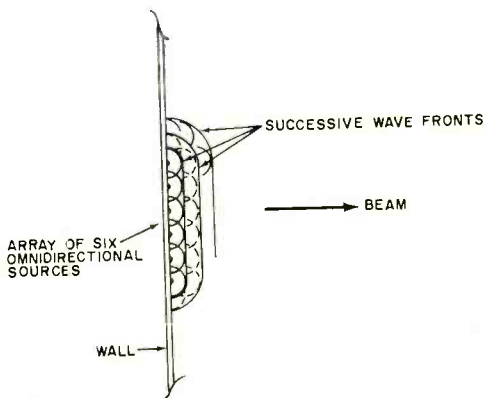

Fig. 2. Each point of a line type of radiator produces a spherical wave, with the latter combining to produce a narrow beam at high frequencies.

20. High efficiency is desirable in a speaker.

**Fact:** A high-efficiency speaker demands less power from the amplifier for a given loudness than does a low-efficiency speaker. But high-efficiency direct-radiator speakers tend to have less bass response than does the low-efficiency speaker.

21. Speakers work best with amplifiers which have very high damping factors.

**Fallacy:** Damping factor is a measure of the ability of an amplifier to keep the speaker cone from continuing to vibrate after the

signal has stopped. Very high damping factors can make some speakers lose bass response, especially high-efficiency direct radiators. In theory, there is an optimum damping factor for each speaker design. But most speakers will work well with amplifiers which have moderately high damping factors, say about 10. Nothing is gained by increasing the damping factor, and, in fact, amplifiers with very high damping factors tend to be somewhat unstable.

22. Speakers can be rated in terms of the minimum power required to drive them.

**Fact:** But this does not mean what it at first appears to mean. Speakers do not require some minimum power to produce sound. As power is reduced, the sound simply becomes less loud. So, minimum power refers to the minimum power required to drive a speaker to a loudness corresponding to average listening levels in an average listening room without excessive amplifier distortion on peaks. Although vague, the minimum-power rating is useful in guiding the user in choosing an amplifier; it is not the maximum power the speaker can withstand, which is expressed in terms of maximum power handling capacity. Actually, a speaker can be safely driven by an amplifier whose power output exceeds this rating provided the volume control is never turned up to full capacity.

23. The power rating of a speaker indicates the maximum permissible power rating of the amplifier with which it is used.

**Fact:** This was pointed out above.

24. Horn-type speakers are more efficient than are direct radiators.

**Fact:** A horn acts somewhat like the transmission in an automobile. It enables the speaker to operate under more favorable conditions.

25. Because they are more efficient, horn-type speakers take up less space than do direct radiators.

**Fallacy:** Efficiency has nothing to do with size. It involves only the ratio of power output to power input. It happens that for a given frequency range horn-type speakers are more bulky than are direct radiators. This is one of the prices paid for higher efficiency.

This ends Part I of our discussion about speakers. In Part II, we will discuss 25 more facts and fallacies relating to this most of-  
ten misunderstood device. ♦

**I**N THE CENTER of Florida, about 15 miles southwest of Orlando, Walt Disney Productions has created what it calls the "Vacation Kingdom of the World." Its official name is Walt Disney World. In an area three miles wide and more than two miles long, Disney has built a complete theme park with resort hotels, water sports, and numerous other outdoor recreation activities.

While some of the 35 major attractions in the park will be familiar to the more than 100-million people who have visited Disneyland in California, many more are unique to Disney World. The park is the largest recreation enterprise ever undertaken by a single company, costing \$300-million as of the opening date. It permanently employs 10,700 people. Its parking lot capacity is 12,000 cars; and there are 225 campsites, 4.5 miles of beaches, and two 18-hole golf courses.

Disney World has many unique technological features also. For example, it has the nation's first officially designated STOL-port designed for exclusive use by short takeoff and landing planes. And it has an all-electric elevated monorail transportation system which interconnects major areas, attractions, and accommodations.

Two major hotels or theme resorts are attractions in themselves. The 1057-room Contemporary and the 500-room Polynesian Village were built by U.S. Steel from pre-assembled rooms. The Contemporary is shaped like a hollow Mayan pyramid and has a gigantic lobby appropriately called the "Grand Canyon Concourse." Monorail trains travel directly through this lobby to pick up and debark hotel guests. Closed-circuit TV keeps conventioners accommodated in the hotels in touch with business proceedings and schedule changes.

**Information-Communication System.** As you might expect, the electronic systems in operation in Disney World range from the conventional to the futuristic. RCA, the prime electronics contractor, has worked with the Disney people to plan and build the "first 21st Century information-communication system," providing instantaneous information on activities. Designed to serve both guests and park personnel, this electronic system—called WEDCOMM—blends computer, telephone, automatic monitoring and control, mobile communications,

television, and wide-band systems into one totally integrated system.

One coaxial cable carries telephone traffic, automatic monitoring and control system signals, computer data, and the audio and control signals for the attractions.

#### **Telephone & Mobile Communications.**

With the exception of a few miniature relays, the telephone system (built by Strom-

Copyright Walt Disney Productions



berg Carlson) is the nation's first all-electronic network. Some of its features, either currently in use or planned, include: call-back to tell you when a busy phone is free; 2- or 3-digit abbreviated dialing for numbers most frequently called; automatic transfer or following which allows calls to be transferred to any neighbor's phone while you are away; three-party calls; and utility meter reading by remote control.

Mobile communications equipment supplied by RCA includes six fixed stations, 50 mobile units, and 150 portable personal size units. The equipment operates on five channels between 450 and 470 MHz with duplex service.



**Hotel Room TV Receivers.** Hotel TV receivers are connected to a unique master antenna television (MATV) system called DISCADE, built especially for Disney World by Ameco. In this system, a guest dials the channel he wants. That channel and no other is transmitted to his receiver over a 6-MHz bandwidth coaxial line from a central switching system. (By restricting the cable bandwidth in this manner, dis-

instance, he could check out at any one of the data terminals located in the hotel lobbies merely by punching his room number into the terminal keyboard. The terminal would then automatically print out an itemized statement for payment at the cashier's window.

Presently, the terminals are connected by telephone line to RCA Spectra 70/45 computers in Burbank, Calif.

A computerized automatic monitoring and control system built by RCA monitors the operating conditions of everything from fire alarms to golf course sprinklers. Should an equipment malfunction or an alarm condition such as a fire hazard occur, the system will identify the problem by flashing a coded message on video data terminals located at two fire stations, two security locations, and the maintenance console in the main service area.

**Audio Animatronics.** "Audio Animatronics," a patented Disney invention, is not part of WEDCOMM, but it is just as futuristic. Certainly, it is one of Disney's most important and popular contributions to the entertainment world. In this system, voices, music, and sound effects are electronically combined and synchronized with life-like movements of three-dimensional objects ranging from birds and flowers to humans.

Eight major attractions use Audio Animatronics—the Mickey Mouse Revue, the 36 Presidents in Liberty Square's Hall of Presidents, Country Bear Jamboree, Haunted Mansion, Sunshine Pavilion, Flight to the Moon, It's a Small World, and Peter Pan's Flight.

Essentially, the character movements are hydraulically actuated from electronic signals on magnetic disks. Characters in the foreground obviously are the most sophisticated and have the most elaborate circuits and functions. Mickey Mouse, for example, has 38 functions and even keeps time with the music.

In a typical 45-minute show, there can be up to 1000 analog functions—character movements, stage effects, and sound effects. Signal routing is accomplished through the use of 250 binary addresses. To compose a show, an animator sits at the programming console of the digital animation control system which uses a general-purpose computer with a 32,000-bit memory and activates the functions he wants. This informa-

# Electronics at Disney World

HOW ELECTRONICS IS  
HELPING TO MAKE DISNEY  
WORLD A SUCCESS

BY EDWARD A. LACY

tribution amplifiers are simpler and more care-free.)

Guests now have a choice of four channels, but the system can be expanded to 30. Three of the channels provide local area TV programs; the fourth channel gives hotel information.

The color TV receivers, built by RCA for Disney World, do not have r-f tuners since down-converting is not necessary.

**Computers & Automatic Monitoring.** Video data terminals are planned for the Contemporary and Polynesian hotels to handle guest reservations, registrations, and checkouts. As a guest prepares to leave, for

tion is recorded on magnetic tape. Data on this tape is then copied on magnetic discs (up to four per show) which are used to play back the complete show. The tape itself is sent to Disney headquarters to be kept in a safe.

**Future Plans.** As exciting as these systems are, it should be noted that they are just the beginning. "We have additional projects and concepts on the boards for many years ahead," says Donn B. Tatum, President of Walt Disney Productions. "We can confidently say that there will always be something new for families to see and enjoy on future visits to Walt Disney World."

RCA, for example, is building a multimedia show to depict future advances in electronics and communications as they will serve the consumer at home and away. The show, which will be in Tomorrowland, will feature Audio-Animatronic figures, movies, cartoons, three-dimensional effects, and holographic-type techniques.

Phase one of the master plan calls for development of the vacation resort over a five-year period. Later phases include a leisure-oriented residential community, a showcase industrial park, and, finally, EPCOT—the Experimental Prototype Community of Tomorrow.

EPCOT is planned to be a "living blue-

**Programmers at work before a console that is used to control some 30 separate movements. ©Walt Disney Prod.**



**With Magic Castle in background, RCA engineer checks mobile radio system.**

print of the future," a complete community of more than 20,000 population. Here, new concepts and technologies will be introduced and tested, years ahead of their application elsewhere.

To make it possible for Disney to do this, the Florida legislature has passed 500 pages of special legislation, giving the Reedy Creek Improvement District, which covers the Disney property, many of the powers of a county government, including zoning, building codes, and the like.

Actually, the complete Disney site is the size of a small county. It takes in 43 square miles, an area roughly the size of San Francisco, or twice the size of Manhattan Island. The Magic Kingdom, hotels, golf courses, beaches, and campsites take up just a small part of the Disney acreage.

"There's enough land here to hold all the ideas and plans we can possibly imagine," said Walt Disney back in 1964. "With the technical know-how of American industry and the creative imagination of the Disney organization, I'm confident we can build a living showcase that more people will talk about and come to look at than any other area in the world." ♦

# A PREAMPLIFIER for your SCOPE

BUILD THIS

X10 AMPLIFIER TO INCREASE SCOPE USEFULNESS

**F**REQUENTLY, when using an oscilloscope to check low-level signals, we wish that our scope had more gain. Suppose, for instance, that the scope's maximum vertical sensitivity is 50 mV (peak-to-peak) per inch or centimeter. With a typical low-capacitance probe (10 megohms, 8-35 pF) which has an attenuation of 10:1, one scope division may represent half a volt. Of course, the gain can be increased by using a straight-through probe instead of the low-capacitance probe. Unfortunately, this may be impractical with a high source impedance or at high frequencies.

So how do we get higher gain? We use a scope preamplifier. The low-cost preamp whose schematic is shown in Fig. 1 can be used to fill the probe-sensitivity gap. It has a voltage gain of 10 and a bandwidth of about 5 MHz; and it can be used with any scope. The integrated circuit used was developed for the 45-MHz i-f range in TV

and has high gain and low noise. With careful layout and choice of components, the bandwidth can easily be extended to 30 MHz or more. The IC also has automatic gain control, which can be adjusted.

**How It Works.** The input connector (*J1*) should fit the probe you are going to use with the preamp. The output connector (*J2*) is a BNC type, which should be used on the scope vertical input if it is not already there. If your scope uses a pair of banana jacks, now is the time to upgrade it with a good shielded coaxial connector.

The input stage is a field-effect transistor. It may be necessary to add extra capacitance (*C2A*) at the input, as discussed later under "Alignment." The signal at the source of *Q1* is connected to the input of *IC1* through *C3*. Resistors *R4* and *R5* are the load resistors for the IC, and the output signal is taken from the non-inverting output

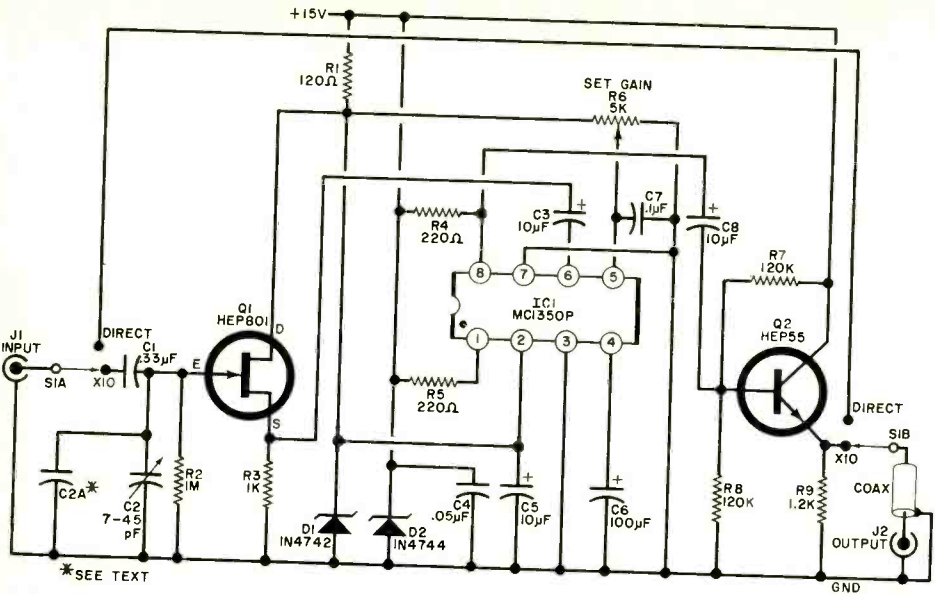

Fig. 1. Preamplifier circuit uses a commercial, high-quality 45-MHz IC amplifier, with a FET input stage. The gain is adjusted by varying R6.

#### PARTS LIST

- |   |  |
|---|--|
| <p>C1—0.33-<math>\mu</math>F, 200-volt capacitor<br/>         C2—7.45-pF trimmer capacitor<br/>         C3, C5, C8—10-<math>\mu</math>F, 25-volt electrolytic capacitor<br/>         C4—0.05-<math>\mu</math>F capacitor<br/>         C6—100-<math>\mu</math>F, 15-volt electrolytic capacitor<br/>         C7—0.1-<math>\mu</math>F capacitor<br/>         C9—500-<math>\mu</math>F, 50-volt electrolytic capacitor<br/>         C10—25-<math>\mu</math>F, 25-volt electrolytic capacitor<br/>         D1—1N4742, HEP105<br/>         D2—1N4744, HEP607<br/>         IC1—MC1350P, HEP6059P<br/>         J1—BNCUG-625/U connector<br/>         J2—BNCUG-260/U connector<br/>         Q1—2N5459, HEP801, MPF105<br/>         Q2—MPS6515, HEP55</p> | <p>R1—120-ohm, <math>\frac{1}{2}</math>-watt, 5% resistor<br/>         R2—1-megohm, <math>\frac{1}{2}</math>-watt, 5% resistor<br/>         R3—1000-ohm, <math>\frac{1}{2}</math>-watt, 5% resistor<br/>         R4, R5—220-ohm, <math>\frac{1}{2}</math>-watt, 5% resistor<br/>         R6—5000-ohm potentiometer<br/>         R7, R8—120,000-ohm, <math>\frac{1}{2}</math>-watt, 5% resistor<br/>         R9—1200-ohm, <math>\frac{1}{2}</math>-watt, 5% resistor<br/>         R10—430-ohm, 2-watt resistor<br/>         RECT1—MDA920-1, HEP175<br/>         S1—Dpdt slide or toggle switch<br/>         T1—Power transformer; secondary: 25V, 100mA<br/>         Misc.—Mounting hardware, PC board, coax cable, line cord, chassis (see text), 14-pin in-line IC socket, etc.</p> |
|---|--|

at pin 8. Transistor Q2 has a high input and a low output impedance and is used to couple the amplifier to the scope. The low output impedance helps to reduce the frequency limiting effect of the capacitance of the coaxial cable. The length of the output cable should be less than four inches—even less if you want to have a bandwidth of 30 MHz.

The dc voltage at pin 5 of IC1 determines the gain and, therefore, must be carefully adjusted. The upper end of R6 is held at 12 volts by zener diode D1, but a variation of only a few millivolts on pin 5 will change the gain of the preamp. So it may be necessary, after the unit is con-

structed to make adjustments easier by reducing the value of R6 and adding a fixed resistor on either side of the potentiometer. To do this, once the final gain has been adjusted, get an accurate measurement of the voltage needed at pin 5. Then use a 500-ohm potentiometer for R6 and add end resistors to make the total value 4000 or 5000 ohms. Since the IC supply is stabilized by D2, the gain setting is stable at normal line voltage fluctuation.

**Construction.** The preamp is built in two separate sections: the amplifier in one shielded box and the power supply (Fig. 2) in another. The circuit shown in Fig. 1 is

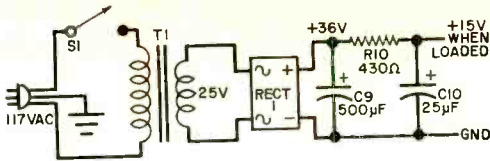

Fig. 2. The 15-volt, 85-mA supply to be used if not available elsewhere.

built on a  $3\frac{1}{2}'' \times 1\frac{1}{4}''$  piece of printed circuit board. To minimize circuit capacitances, wiring is without pins. The IC socket is mounted on the non-foil side of the board after first drilling the necessary holes. With the exception of pins 3 and 7, all holes should have the copper cleared from around them. Use a larger bit (manually) to do the scraping. Note that IC1 only uses pins one through four and 11 through 14 of a conventional 14-pin in-line socket. Solder socket pins 3 and 13 (IC1 pin 7) to the foil. All the other components are mounted on the foil side using point-to-point wiring of the component leads and the foil as ground.

The completed board is mounted with standoffs in a  $4'' \times 2\frac{1}{8}'' \times 1\frac{1}{8}''$  metal enclosure. Before installing the board, drill holes for input jack *J1*, selector switch *S1*, and the power leads and coaxial cable. The last two holes must be fitted with grommets.

The power supply shown in Fig. 2 is optional if the required 15 volts at 85 mA is available elsewhere. However, if this supply is used, do not turn it on unless it is connected to the amplifier. Without *D2*, the supply can reach about 36 volts, which

might damage electrolytic capacitor *C10*.

**Alignment.** Using a 10:1 probe as the input to the preamplifier, supply power and connect the probe to a source of 1 volt, peak-to-peak, at about 1 kHz. Adjust *R6* to obtain a 1-volt peak-to-peak indication on the scope.

Now connect the probe to a 0.5-volt peak-to-peak square wave and place *S1* in the DIRECT position. You should see a 50-mV square wave on the scope. Adjust the probe frequency-compensation trimmer capacitor for sharp corners without overshoot. Switch *S1* on the preamp to the X10 position and adjust *C2* to obtain a clean square wave without overshoot. If *C2* cannot be adjusted for the desired effect, add another small capacitor (*C2A*) in parallel—try 33 pF. In some cases, the scope vertical input compensation trimmer may also have to be adjusted.

If you now replace the 10:1 probe with a direct probe, a 50-mV signal will produce a 0.5-volt deflection on the scope. The direct output of a magnetic cartridge (approximately 5 mV) can be seen easily on the 50-mV input position of the scope's vertical input.

Do not allow the dc voltage at the input of the preamplifier to exceed the voltage rating of *C1* and do not apply more than 1 volt, peak-to-peak, to the probe if *S1* is in the X10 position.

If desired, the preamp can be built directly into the scope, with the scope's vertical gain switch changed accordingly. ♦

The power supply is in one chassis (left) and the preamplifier in another. Note how component leads in the preamp are soldered together for mounting.

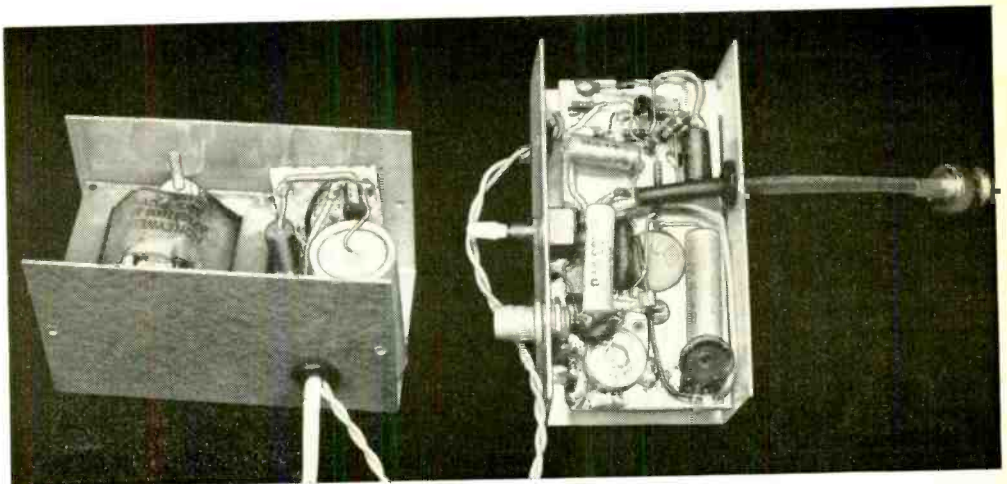

# TOUCH-PLATE POWER

# SWITCH

BY JAY NUNLEY

CONSTRUCTION OF  
A SWITCH THAT CONTROLS  
UP TO 450 WATTS AT  
THE TOUCH OF A FINGER

ONE of the best features of electronics experimenting is acquiring the ability to make useful household devices. The Touch-Plate Switch described here is particularly interesting since it can be used to turn power on or off merely with a touch of the finger—or the elbow, if a person's hands are full. The switch is activated by the ac field potential that is normally found on the human body—picked up from the power-controlled environment in which we live. This is the same field that shows up as a sine wave when you touch the vertical input of an oscilloscope or that makes an ac hum when you touch the input connector of an audio amplifier. Although the signal can have a high voltage level, the associated current is extremely low.

Depending on the type of SCR used, the touch switch can handle from a few watts to several thousand watts. This also makes it very useful for stage lighting control where sharp on-off transitions are required.

**Circuit Operation.** Transistor *Q1* (see Fig. 1) is an insulated-gate MOSFET having an extremely high input impedance. Voltage gain is not required in this circuit, but current gain and impedance transformation are. When the touch plate is contacted, the ac signal on the body is passed through the high resistance of *R4* to one gate of *Q1*. Resistor *R5* completes the input voltage divider. The total of *R4* and *R5* is about 20 megohms.

The source of *Q1* is connected to a voltage divider (*R3*, *D3*, and *R2*) at a point

that is about 4 volts positive. This makes the gate four volts negative with respect to the source so that, in the absence of an input signal, *Q1* is fully cut off. The drain load (*R6*) supplies the trigger pulse for the toggle input of *IC1* and holds the T input at about +2.5 volts. When the touch plate is contacted, the 60-Hz field is applied to the gate of *Q1*. The positive peaks cause *Q1* to conduct at 60 Hz, with a negative pulse on the drain. Filter capacitor *C3* integrates the pulse to a smooth dc to toggle the IC.

The J, K, and clear inputs of *IC1* are connected to the common point because placing a logical zero on these inputs is the most direct way of setting up the flip-flop for simple toggling. Note however that the ground pin (4) of the IC is taken to the anode of *D3* in the voltage divider. The cathode of this diode is at the same voltage level as the source of *Q1*; and, because the forward breakover voltage of *D3* is about 0.6 volt, this biases the source of *Q1* negative with respect to the ground pin of *IC1*. The negative-going trigger pulses are thus assured of falling to zero or slightly below to provide a clean toggle.

Both the Q and not-Q of *IC1* are loaded by electrolytic capacitors *C4* and *C5*. This is necessary for two reasons. First, the fall time of the input pulse is no faster than the 60-Hz signal used to drive the toggle input and is far too slow to trigger the flip-flop. The capacitors provide reliable toggling, even at a low rate. Second, since the power supply is not regulated, the capacitors give the flip-flop some immunity to power-line transients.

The Q output drives the gate of SCR1 through R8, while the cathode of SCR1 is connected through R9 to the not-Q output. Resistor R7 slightly biases the Q output to meet the worst-case SCR triggering requirements. Thus, when the not-Q output is low and Q is high, the gate of SCR1 is forward biased and the SCR is on. The next toggle pulse (when the touch plate is contacted) toggles IC1 so that not-Q goes high and Q goes low to turn off SCR1. Since the fan-out of IC1 is limited, an SCR with a sensitive gate must be used for SCR1. Even so, up to

1400 watts of 120-volt ac power can be controlled, depending on the SCR used.

When SCR1 is on, it applies power to the load and charges C2 through D2. During the next (reverse) half cycle, C2 discharges through R1 and the gate and cathode of SCR2. Thus SCR1 and SCR2 supply power during alternate half cycles to provide full-wave ac power, up to 450 watts.

**Construction.** So that the touch switch can be installed within a conventional 3" × 2" × 2" metal junction box (such as wall

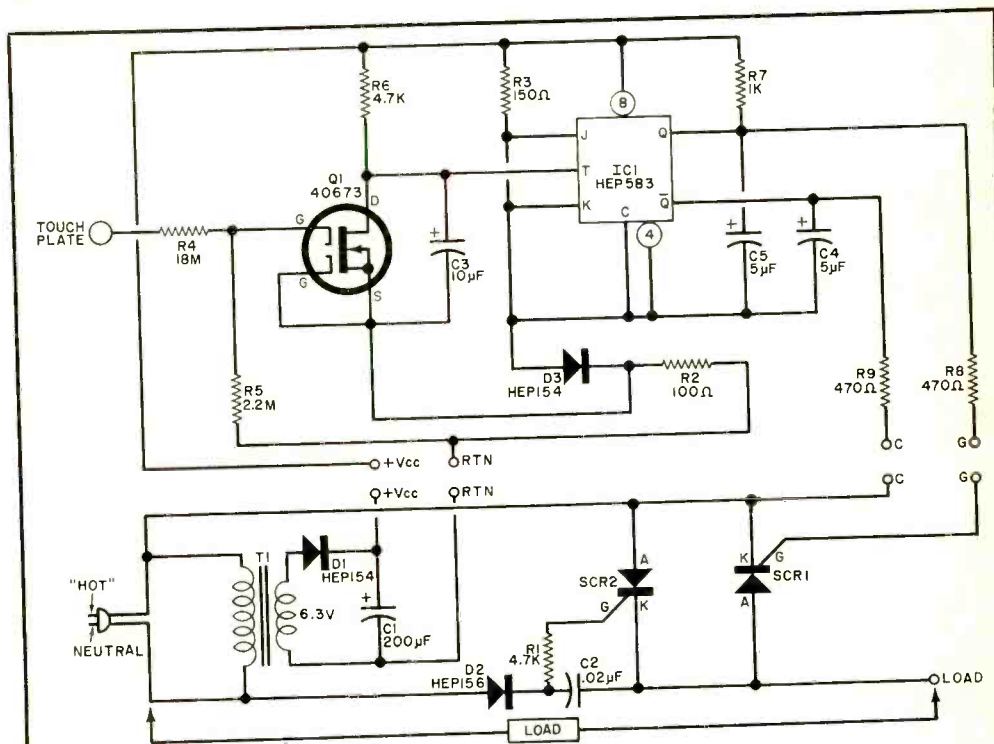

Fig. 1. In switch circuit, the flip-flop in IC1 is triggered by MOSFET Q1 which has high input impedance. Two SCR's supply load power on alternate half cycles.

#### PARTS LIST

- C1—200- $\mu$ F, 10-volt electrolytic capacitor
- C2—0.02- $\mu$ F, 200-volt capacitor
- C3—10- $\mu$ F, 10-volt electrolytic capacitor
- C4,C5—5- $\mu$ F, 10-volt electrolytic capacitor
- D1,D3—HEP154 diode
- D2—HEP156 diode
- IC1—HEP583 integrated circuit
- Q1—RCA-40673 MOSFET
- R1,R6—4700-ohm resistor
- R2—100-ohm resistor
- R3—150-ohm resistor
- R4—18-megohm resistor
- R5—2.2-megohm resistor
- R7—1000-ohm resistor
- R8,R9—470-ohm resistor

- SCR1,SCR2—1R106B1 (Allied Stock No. 779-3008) or similar, 200 PRV, 0.5mA gate current silicon controlled rectifier
- T1—Filament transformer; secondary: 6.3V at 300mA (Radio Shack 273-1384)
- Misc.—Aluminum bar  $\frac{3}{4}$ " wide x  $\frac{1}{8}$ " thick x  $3\frac{1}{4}$ " long, transistor mounting insulation and silicone grease, mounting hardware, #4-40 screws and nuts,  $\frac{1}{2}$ " insulated spacer (2), suitable metal touch plate, plastic junction box cover.

Note: Etched and drilled printed circuit boards are available from Metrotec Electronics, Inc., 33 Cain Dr., Technical-Industrial Park, Plainview, NY 11803, at \$2.25 each board.

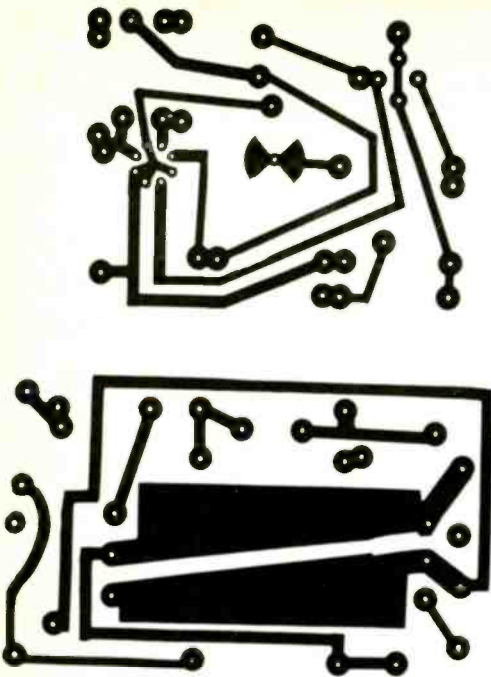
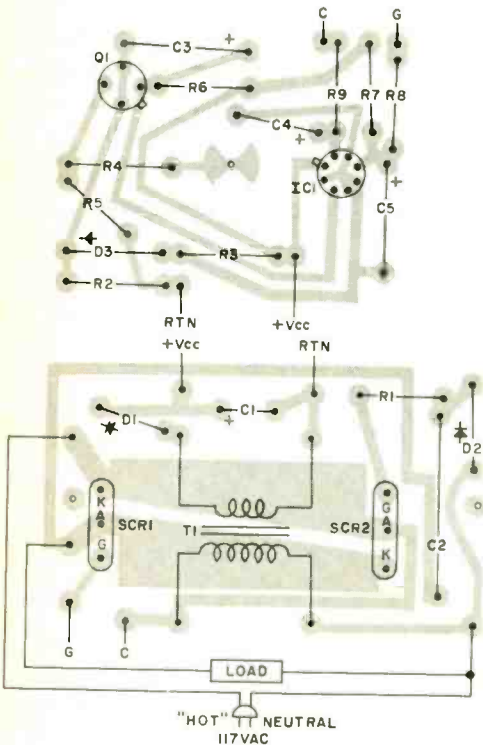

Fig. 2. Foil patterns for two printed circuit boards are shown above with component layouts below. Touch plate mounts in the center of small board.



switches are in), two PC boards are used. These are shown in Fig. 2, with component mounting details.

The smaller board is built first, taking care that the electrolytic capacitors and semi-conductors are properly installed. Although most MOSFET's must be specially handled, the one called for in the Parts List has internal protection so it can be treated as any other transistor. Use a low-power soldering iron and fine solder. Before installing any components, be sure there is a small hole drilled through the board at the center for the touch plate mounting and contact screw (size 4-40).

After installing components on the larger board, make a heat sink for the two SCR's. Use a 3 1/2" long piece of 3/8" wide by 1/8" thick aluminum bar (available at most hardware stores) and bend it into a C shape so that it contacts each tab on the SCR's and clears the transformer shell. Drill holes in the aluminum bar exactly opposite the SCR tab holes. Use conventional power transistor insulation and silicone grease to attach the two SCR's to the ends of the heat sink.

The two boards can now be interconnected with short lengths of wire (just enough slack to permit board mounting) between similarly marked terminals. Connect conventional ac leads to the neutral, hot, and load terminals.

Obtain a plastic cover for the junction box and drill a hole (for a 4-40 screw) at the center. Drill two more holes 2 1/4" apart along the center line and centered on the first hole. The touch plate can be any of a number of metal plates, medallions, etc. It must be metal, and any protective plastic coating must be removed. Use a 4-40 screw long enough to pass through the touch plate, the plastic cover, and into the PC board. Since the electrical contact to the touch plate will be on the under side of the small PC board, fix the touch plate screw in place and use a nut to make the actual electrical contact. Another small nut is used to secure the small board in place.

Cut a small piece of cardboard or plastic sheet to cover the components on the small board. Mount the larger board over the smaller one (over the insulation just installed) using 4-40 hardware through the other two holes in the plastic cover. Use 1/2" insulated spacers. Check that the board-to-board interconnections are still good.

**Test and Installation.** Wire the unit in ac-



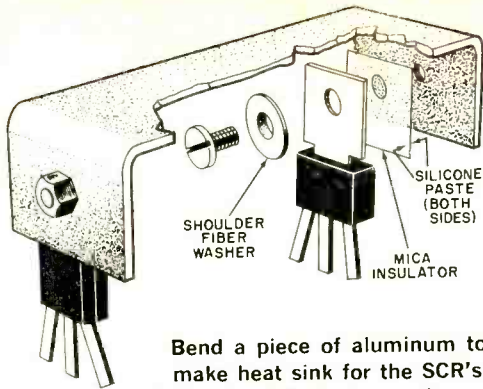

Bend a piece of aluminum to make heat sink for the SCR's.

cordance with Fig. 1, with the hot and neutral lines to the ac source and the load line to a 117-volt lamp or similar load. Be sure that all exposed ac line connections are thoroughly insulated to prevent shorting or contacting.

When the touch plate is contacted, the load should go on. When the plate is contacted again, the load should go off. If this does not happen, reverse the connections to the ac line.

When the touch control works properly, it can be installed in a standard wall conduit box. Before installation, be sure to shut off the power on that circuit by removing fuses

or throwing the circuit breaker. The existing wiring must be opened, with the touch switch installed—fully insulated—in accordance with your local electrical code. When you remove the wallbox plate, you will find a pair of wires coming from the main source, with the switch in series with the hot lead. With all power removed from the circuit, remove the two wires from the switch, noting which one goes to the load and which goes to the main source. The one from the main source is the hot connection point. The one to the lamp is the load connection. If you open the other pair, usually secured and insulated with a plastic nut, this is the neutral line. If there is no other pair, connection to the metal box itself will provide the neutral side of the circuit.

If you have any doubt about the wiring conditions in your home or the proper way to install the touch switch, consult a professional, licensed electrician. Attempts to do it yourself, unless you are sure, at this point may lead to physical harm in case of shock and/or negation of fire insurance.

In operation, the unit may run slightly warm. This is normal. The heat is similar to that generated by many power dimmers found in modern lighting installations. ♦

## TEST YOUR KNOWLEDGE OF SEMICONDUCTORS

BY WILLIAM R. SHIPPEE

- Transistor  $H_{FE}$  remains steady regardless of temperature.  
(a) True (b) False
- Which of these elements used to dope semiconductor materials is an acceptor or p type?  
(a) Phosphorous (b) Arsenic  
(c) Antimony (d) Indium
- In a class A output stage, dissipation is always highest when there is no ac power output.  
(a) True (b) False
- Mesa and planar epitaxial transistors give high-speed switching and good saturation characteristics at relatively high voltage ratings.  
(a) True (b) False
- The configuration used most often for a transistor switching circuit is:  
(a) Common collector (b) Common base  
(c) Common emitter
- Many mesa and planar transistors exhibit negative resistance after breakdown voltage is reached.  
(a) True (b) False

7. Voltage feedback from the collector of a transistor stage tends to increase the output impedance of that stage.

- (a) True (b) False
- Below (top) is schematic symbol for:  
(a) Unijunction (b) SCR  
(c) Tetrode (d) Nnpn transistor
  - Below (left) is schematic symbol for:  
(a) FET (b) SCR  
(c) SCS (d) Nnpn transistor
  - Below (right) is schematic symbol for:  
(a) Symmetrical zener (b) SCS  
(c) Nnpn transistor (d) SCR

(Answers below)

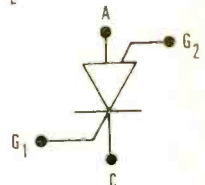
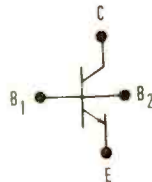

1. b 2. d 3. a 4. a 5. c 6. a 7. b 8. c 9. a 10. b

# 10 Reasons why RCA Home Training is your best investment for a rewarding career in electronics:

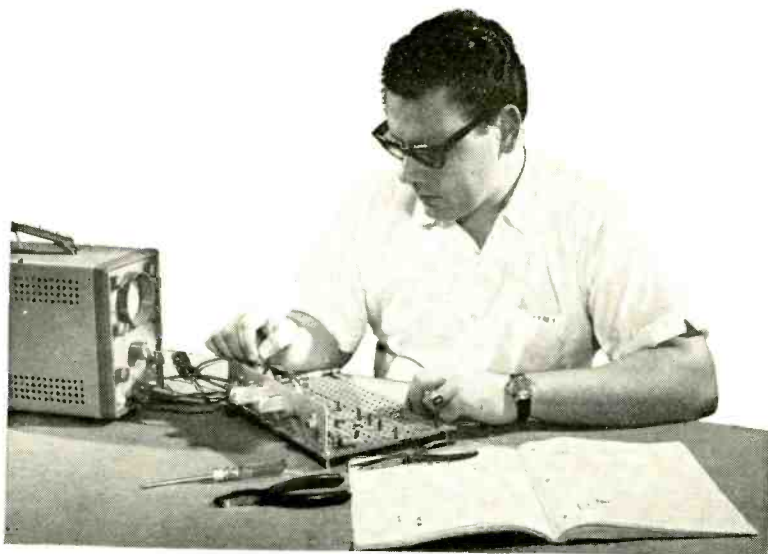

Performing transistor experiments  
on programmed breadboard — using  
oscilloscope

## 1 LEADER IN ELECTRONICS TRAINING

When you think of electronics, you immediately think of RCA... a name that stands for dependability, integrity, and pioneering scientific advances. For over half a century, RCA Institutes, Inc., a subsidiary of RCA, has been a leader in technical training.

## 2 RCA AUTOTEXT TEACHES ELECTRONICS FASTER, EASIER, ALMOST AUTOMATICALLY

Beginner or refresher. AUTOTEXT, RCA Institutes' own method of programmed Home Training will help you learn electronics more quickly and with less effort, even if you've had trouble with conventional learning methods in the past.

## 3 WELL PAID JOBS ARE OPEN TO MEN SKILLED IN ELECTRONICS

RCA Institutes is doing something positive to help men with an interest in electronics to qualify for rewarding jobs in this fascinating field. There are challenging new fields that need electronics technicians... new careers such as computers, automation, television, space electronics where the work is interesting and earnings are greater.

## 4 WIDE CHOICE OF CAREER PROGRAMS

Start today on the electronics career of your choice. On the attached card is a list of "Career Programs", each of which starts with the amazing AUTOTEXT method of programmed instruction. Look the list over, pick the one best suited to you and check it off on the card.

## 5 SPECIALIZED ADVANCED TRAINING

For those already working in electronics or with previous training, RCA Institutes offers advanced courses. You can start on a higher level without wasting time on work you already know.

## 6 PERSONAL SUPERVISION THROUGHOUT

All during your program of home study, your training is supervised by RCA Institutes experts who become personally involved in your efforts and help you over any "roughspots" that may develop.

## 7 HANDS-ON TRAINING

To give practical application to your studies, a variety of valuable RCA Institutes engineered kits are included in many programs. Each kit is complete in itself. You never have to take apart one piece to build another. They're yours to keep and use on the job.

## 8 FCC LICENSE TRAINING—MONEY BACK AGREEMENT

Take RCA's Communications Career program—or enter with advanced standing and prepare immediately for your 1st, 2nd, or 3rd class FCC Radio Telephone License examinations. RCA Institutes money-back agreement assures you of your money back if you fail to pass the FCC examination taken within 6 months after completing the course.

## 9 CONVENIENT PAYMENT PLANS

You get a selection of low-cost tuition plans. And, we are an eligible insti-

tution under the Federally Insured Student Loan Program.

## 10 RCA INSTITUTES IS FULLY ACCREDITED

RCA Institutes is an accredited member of the National Home Study Council. Licensed by N. Y. State—courses of study and instructional facilities are approved by the State Education Department.

**VETERANS: TRAIN  
UNDER NEW GI BILL**

**SEND ATTACHED POSTAGE PAID CARD TODAY! FREE DESCRIPTIVE BOOK YOURS WITHOUT OBLIGATION!**

If reply card is detached, send this coupon today.

RCA INSTITUTES, INC.  
DEPT. 694-208-O  
320 W. 31 ST.  
NEW YORK, N. Y. 10001

Please send me FREE illustrated career catalog. I understand that I am under no obligation.

Name \_\_\_\_\_

Address \_\_\_\_\_

City \_\_\_\_\_

State \_\_\_\_\_ ZIP \_\_\_\_\_

Age \_\_\_\_\_

Veterans: Check here

# RCA

Construction of Multimeter.

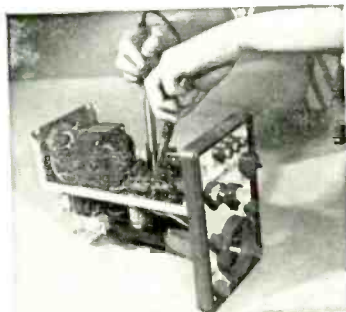

Construction of Oscilloscope.

Temperature experiment with transistors.

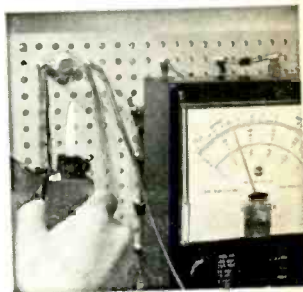

# Auto Battery Voltage Monitor

LETS YOU KNOW  
WHEN YOUR BATTERY  
NEEDS CHARGING

BY CHARLES AND JOHN MORRIS

**H**OW MANY times have you used mobile radio equipment for long periods of time and then tried to start the car engine only to find the battery dead or nearly so. This is a problem not too uncommon to members of communications nets or ham field-day operators. One of two things can be done to avoid this problem: you can keep the engine running all the time (which can be dangerous if you are inside with the windows closed) or you can run the engine intermittently just enough to keep the battery charged. The latter is preferable, but how do you know when it is necessary?

The electronic device whose schematic is shown in Fig. 1 is a battery voltage-level detector that can be preset to turn on a warning light when it is time to start the car engine for battery recharging. The unit is designed around a low-cost quadruple 2-input positive NAND gate IC having open collector outputs. Three of the gates in the IC are used with the level detector; the fourth can be used to operate a low-power relay for an acoustic alarm if desired. The voltage monitor can be built for under \$15.00 if all parts are purchased new—much less if a well-stocked junk box is on hand.

The voltage monitor can be made to op-

erate with either negative or positive ground 12-volt systems.

**Circuit Operation.** A conventional series-pass regulator (Q1) controlled by a zener diode is used to supply +5 volts for the detector and indicator lamp. Potentiometer R4 is used to adjust the detector operating level. When the junction of R2 and R3 is more than 6 volts but less than 9 volts, and with R4 set to minimum resistance, pins 2 and 3 of IC1A is at low voltage or logic

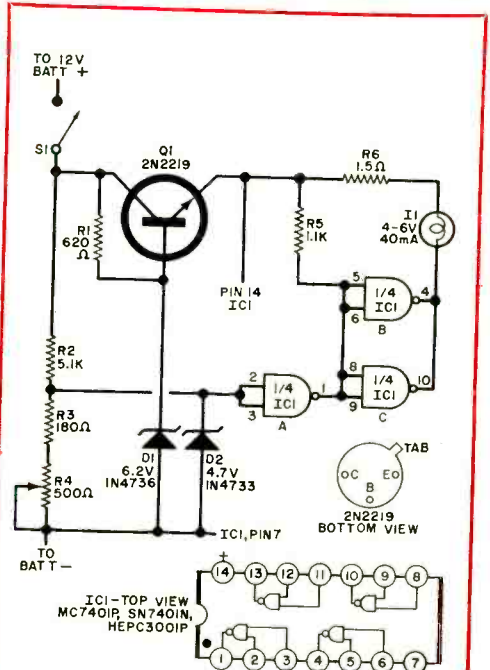
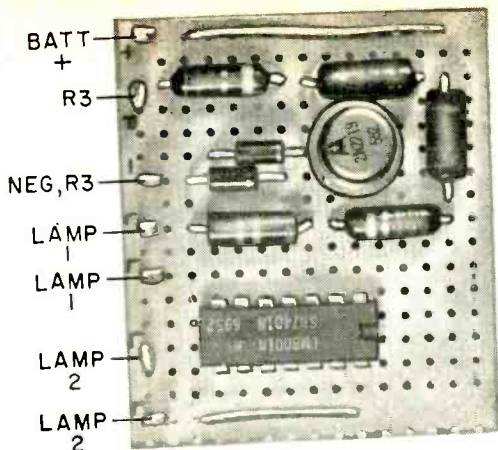

Fig. 1. When level at R2/R3 drops below 1.7 volts, warning light goes on.

## PARTS LIST

- D1—1N4736, 6.2V, 1W zener diode
  - D2—1N4733, 4.7V, 1W zener diode
  - I1—4-6-volt, 40mA pilot lamp
  - IC1—MC7401P, SN7401N, or HEPC3001P
  - Q1—2N2219 or HEPS3001 transistor
  - R1—620-ohm, 1/2-watt resistor
  - R2—5100-ohm, 1/2-watt resistor
  - R3—180-ohm, 1/2-watt resistor
  - R4—500-ohm potentiometer
  - R5—1100-ohm, 1/2-watt resistor
  - R6—1.5-ohm, 1/2-watt resistor
  - S1—Sps slide or toggle switch (optional)
  - Misc.—Transistor socket (optional), 14-pin DIP IC socket, transistor heat sink (Wakefield NF209 or similar), perf board, terminals, chassis, lamp lens (red), mounting hardware, etc.
- Note—A set of all four semiconductors is available for \$3.00 from Semiconductors Corp., 265 Canal St., New York, NY 10013.



The fourth gate in the IC can be used to drive a second lamp or other alarm.

zero. Pin 1 of *IC1A*, as well as pins 5 and 6 of *IC1B* and 8 and 9 of *IC1C* are at a higher voltage causing a lower voltage at pins 4 and 10. In this case, current flows through *I1* causing it to light. Sections B and C of the IC are in parallel to permit sufficient current drive for the lamp.

When the voltage at *R2/R3* goes above 9 volts (battery charged up) or if the resistance of *R4* is increased so that the voltage on pins 2 and 3 exceeds about 1.7 volts, then the states of the gates are reversed and the output at pins 4 and 10 is high so that no current flows through the lamp.

Resistor *R3* serves to prevent shorting the IC input to ground if *R4* is set to minimum resistance. Diode *D2* is provided to insure that the IC input voltage never exceeds 5 volts since a higher voltage could damage the IC, especially over long periods of time. Since the IC is of the open collector type, resistors *R5* and *R6* serve as pull-up resistors to maintain proper switching action of the IC.

**Construction.** The prototype was built on perf board as shown in the photo, though any other type of construction could be used. The board assembly was then mounted in a small chassis box having holes for the adjustment of *R4* and for the lamp. The board assembly should be isolated from the chassis box unless the car battery system is negative ground, in which case the box can be used as ground and must be firmly connected to the vehicle ground. Do not do this if the system has a positive ground.

It is important that a suitable socket be

used for the IC since its leads are short and heating them for soldering can cause damage. All of the components are soldered and wired in place before the IC and *Q1* are installed. The transistor can be soldered direct if each lead is heat-sinked (with long-nose pliers) while soldering. The same technique is used in soldering *D1* and *D2*. Be sure to use the heat sink called for in the parts list for *Q1*.

**Installation and Adjustment.** The voltage monitor can be mounted in any convenient location—just so the lamp can be seen. If switch *S1* is used, it and the lamp can be mounted separately with the rest of the unit tucked away out of sight. Another idea is to mount these components on the radio equipment panel so that, when the equipment is on, the monitor is also on.

Connect the monitor positive lead as directly as possible to the battery positive or to ground if the system has a positive ground. Connect the negative lead similarly. Of course, if *S1* is used, the ungrounded detector lead goes through the switch first. The detector can be permanently connected and on all the time since current drain is very low.

The voltage monitor is adjusted by using a variable dc power supply with an output of at least 12 volts. Connect the supply to the monitor as if it were the car battery. Using a voltmeter across the supply, reduce the voltage to what you consider to be the maximum battery voltage drop that would still allow you to start the engine. The prototype was set at 11.5 volts which worked well for engine starting. Then, adjust potentiometer *R4* to the point where warning lamp *I1* comes on. If the warning lamp comes on prior to adjustment of *R4*, adjust *R4* until the lamp goes out. Set the power supply voltage again, and adjust *R4* again until the lamp comes back on. When the adjustment is satisfactory, either lock the potentiometer shaft or touch it with a bit of glue to keep it from moving.

As the car battery runs down to the monitor's triggering level, the warning lamp will turn on, telling you to start the engine to recharge the battery. Note that as soon as the engine starts, the lamp will go out since the charging system is at a higher voltage level. Either watch the car's ammeter or (if there is no ammeter) run the car for 10 to 15 minutes at a slightly fast idle to recharge the battery. ♦

# Rise-Time Measurements

WHAT YOU SEE MAY NOT BE WHAT YOU'VE REALLY GOT

**S**UPPOSE you feed the output of a pulse generator through a probe to an oscilloscope. You adjust the scope time base for a fast sweep. (This is the typical setup for measurement of rise time.) The result is the easily recognized rise-time waveform shown in Fig. 1.

**Question:** If the time base is set for a sweep of 50 nanoseconds per division, what is the rise time of the generator's output pulse—ignoring any inherent scope inaccuracies.

"That's easy," you say, quickly multiplying 50 ns/div times the two divisions covered by the pulse's leading edge. "100 ns is the rise time of the pulse. Right?"

Maybe yes; and maybe no!

Although 100 ns is the correct reading of the scope display, this value may not be the true rise time of the pulse. So ignoring scope inaccuracies, what other reason is there for suspecting that the measurement is not the real rise time?

Basically it is that, when the pulse passes through the probe, the scope amplifier, and even the scope CRT, it suffers rise time deterioration. Thus, the displayed waveform can't represent the true, original signal.

Although this is an unfortunate circumstance, it has one saving grace: it can be predicted. So, if you erroneously said that the rise time in the example was 100 ns, it should be both interesting and informative to learn how to determine what the error might be.

**Fig. 1. Pulse rise time is measured between the 10% and 90% points on the leading edge of oscilloscope trace. In this case, rise time is 100 nanosec.**

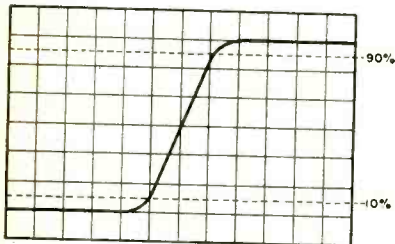

**Rise-Time Formula.** True rise time can be determined by the use of the tongue-twisting formula known as "the square root of the sum of the squares." In mathematical terms:

$$T_{RG} = \sqrt{T_{RD}^2 + T_{RP}^2 + T_{RO}^2}$$

where  $T_{RG}$  = true signal generator rise time

$T_{RD}$  = displayed rise time

$T_{RP}$  = probe rise time

$T_{RO}$  = oscilloscope (amplifier and CRT) rise time

For a low- to medium-priced general-purpose oscilloscope, a typical rise time is 35 ns.

For a standard probe, rise time is 5 or 10 ns. Putting these values into the formula, we get

$$T_{RG} = \sqrt{100^2 + 35^2 + 10^2} = 93.1 \text{ ns}$$

Thus, the actual rise time of the generator pulse is 93.1 ns and not the 100 ns displayed on the scope; and the measurement was in error by 7.4%.

It is important, therefore, to keep in mind that the displayed rise time is greater than the actual rise time. The amount of error is shown in Fig. 2, where per cent of error is plotted against the ratio of the input signal's rise time to test equipment rise time. In our example, this rise time ratio would be 93.1 divided by the square root of  $35^2 + 10^2$  or 2.56.

Knowing that the measurement devices do introduce an error and with the aid of Fig. 2, you can determine just what error to expect. Conversely, to make a measurement within a given accuracy, Fig. 2 can be used to find what rise time response is needed in the test equipment.

**More About Rise Time.** We often concern ourselves with only the frequency response of an oscilloscope or an amplifier when, as we have seen, rise time is also important.

In using Fig. 1, we measured rise time between the 10% and 90% points of peak value on the leading edge of the pulse. These two points are used as standards for waveform measurement in the industry.

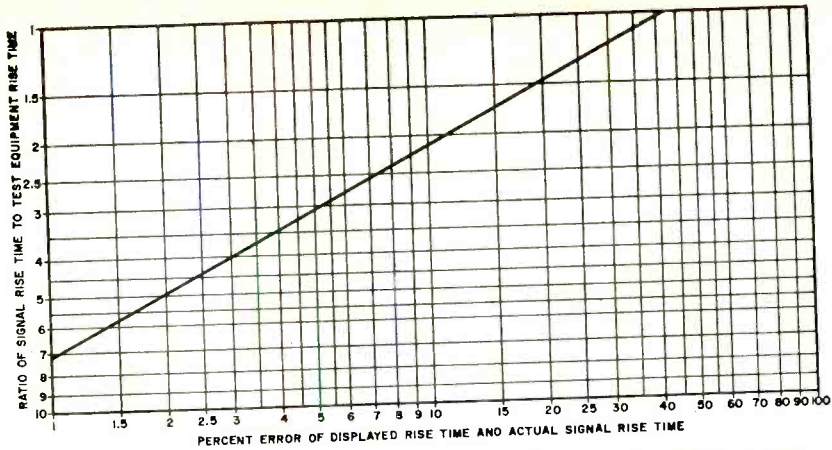

Fig. 2. Measurement error is inversely proportional to the rise-time ratio.

Looking at Fig. 1 again, you will note that the pulse rises linearly from the 10% voltage level to the 90% level. Such a characteristic is known as a Gaussian response. When an ideal unit step pulse (one with zero rise time) is applied to an amplifier (or cascaded amplifiers) whose frequency response is RC limited, the response is Gaussian. For a Gaussian response, there is a relationship between rise time and frequency (also called bandwidth):

$$0.35 = t_r \times bw$$

where  $t_r$  = rise time in microseconds

$bw$  = frequency bandwidth in MHz

Oscilloscope vertical amplifiers consist of cascaded RC stages so the above formula applies. For instance, if a scope has a 10-MHz bandwidth, its corresponding rise time would be 0.035 microseconds or 35 ns.

The 0.35 constant in the formula results from a combination of two factors:

$$RC \text{ rise time} = t_r = 2.2RC$$

$$-3 \text{ dB frequency} = F_c = 1/(2\pi RC)$$

Consider first the 2.2RC factor and look at the universal time constant curve in Fig. 3. This curve will readily be recognized as the capacitor charging voltage in a series RC network with an applied ideal step pulse. Recalling that, in rise time measurements, the 10% and 90% points were used, we find the corresponding RC value for these two points: namely 0.1 RC and 2.3 RC. Taking the difference between these two values, we get 2.2RC—the time in which rise time is resolved.

But wait just a moment! The curve in Fig. 3 is not Gaussian, so how can it be used in our calculations? Well, irrespective of Gaussian—or whatever—the universal time constant curve serves only as a reference

for the 2.2 RC value. It is not the signal pulse to be measured (as in Fig. 1) and thus does not have to be Gaussian.

Remember that what we did say about Gaussian response was that it pertained to an amplifier stage whose frequency response is RC limited.

This brings us to the second factor in the 0.35 constant: the -3-dB frequency, or the frequency at which an amplifier's gain is down 3 dB from mid-frequency gain. The influence of the stage's resistance and capacitance is shown in the -3-dB frequency formula:  $F_c = 1/(2\pi RC)$ .

Having defined these two factors, let's see how they determine the 0.35 constant. First, transpose  $F_c = 1/(2\pi RC)$  into  $RC = 1/(2\pi F_c)$ . Then from  $t_r = 2.2RC$ , we get  $t_r = 2.2 [1/(2\pi F_c)] = 0.35/F_c$ . Finally,  $0.35 = t_r \times F_c$ . Or since frequency response is bandwidth,  $0.35 = t_r \times bw$ . ♦

Fig. 3. This is time constant curve for charging capacitor in series RC circuit.

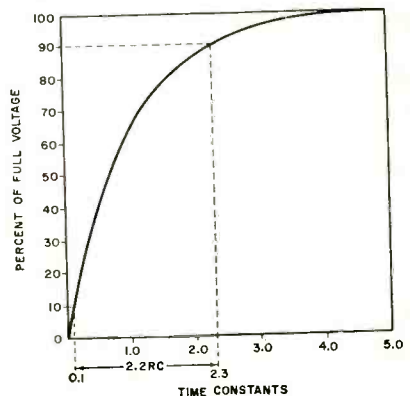

# The FIELD SERVICE REPRESENTATIVE

A VOCATION PROFILE OF AN IMPORTANT MEMBER  
OF THE COMPUTER FAMILY

BY STEPHEN A. KALLIS, JR. *Digital Equipment Corp.*

**B**ARRY OTT is a field service representative for *Digital Equipment Corporation*, or *DEC*, a major manufacturer of electronic computers. With approximately 18,500 computers manufactured by DEC located throughout the Free World, and on the high seas, it is important for the company to have a trained staff of specialists who can service the computers. Ott works at a DEC field service facility, one of 120 located across the U.S., through most of Western Europe, and in Canada, Japan, and Australia.

DEC's computers can be found in a wide variety of environments, from sedate air-conditioned business offices to oil fields, luxury ocean liners, steel mills, or baseball stadiums. Consequently, Ott's equipment is compact and highly portable. When he goes on a job, he generally takes a tool kit in a small suitcase-size carrier, a portable oscilloscope, a set of solid-state components capable of being used to repair the majority of DEC modules (logic cards) in the field, spare modules, and a set of computer tapes to permit him to run performance checks at the computer site.

The range of different situations that Ott encounters is quite large, primarily because his company's customers vary in degrees of sophistication. Some customers can perform maintenance without outside aid. They call

for a field service representative only when something major happens to the system.

By contrast, most customers are less knowledgeable about computers. Many view computers as "black box" solutions to their problems. And even among those who have programming experience, the ability to repair their computers is limited. Just as the average user of a tape recorder or TV receiver does not need a detailed understanding of the "works" to operate it effectively, many users of computers are in the dark when it comes to knowing just how the system operates.

**A Professional Consultant.** There are two ways that a man who is called in to correct a malfunction can be viewed: as a repairman or as a professional consultant. The field service representative belongs in the latter category. Before a man can become a field service representative at DEC, he is screened carefully. He must have at least an Associate degree or the equivalent. Further, he must have broad experience in some phase of related electronic activity, preferably with experience in such items as computer core memories, magnetic tape units, disk storage systems, etc.

The screening process also includes a written examination on basic computer tech-



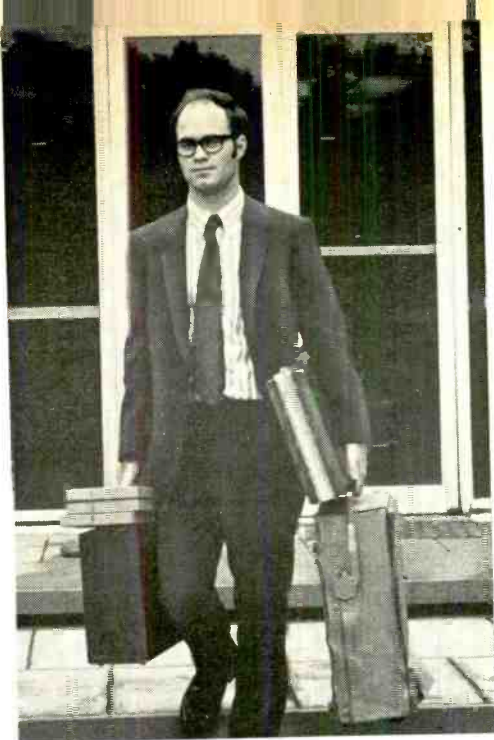

Starting out on a typical field service call, the representative carries all the tools of his trade to his car. In his right hand are three boxes containing component parts to repair computer logic modules and his tool kit. An attache case with the computer programs and a portable oscilloscope make the rest of the load.

Compact tool kit contains variety of items for mechanical inspection, assembly, and disassembly. In addition to tools, there are lubricants, etc. Probes and leads are in box at right.

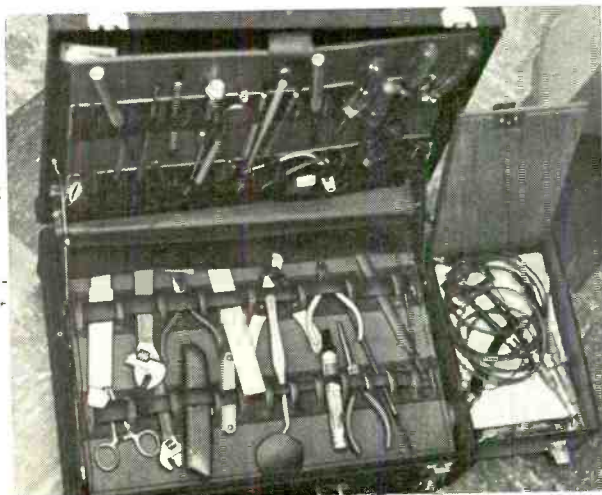

nology, covering number systems, Boolean algebra, and basic circuits—in short, the aspects that a field service man must be familiar with to function effectively as a computer professional.

The applicant for a field service position is interviewed and evaluated in several ways. In addition to a session with the personnel department, he is interviewed by a field service office manager and by a technical specialist. It is important to determine whether or not he really knows what the job entails and that he has the aptitude to perform the tasks required of a field service man. Also, the interviewers are interested in how the applicant reacts under pressure, his attitude toward working long hours on a particular job, and his willingness to travel.

Barry Ott is an example of the type of person who finds field service work exciting. A graduate of high school and technical school, he had six years of technical service in the U.S. Navy. He worked on analog and digital computers, with an assignment to maintain 24-bit general-purpose computers. During his 15 months of Navy training, he achieved a standing of 86 percent in his class. By the time he applied to DEC, he had a thorough understanding of computers and their peripheral devices.

**Special Problems.** Although the vast majority of problems is well within the ability of a field service man to cope with, there is a small percentage of problems which requires special training. The company realizes this, and it backs its field service representatives with field service support specialists. A support specialist has an intimate knowledge about a particular computer type or system configuration. It is his job to tackle the problems that defy ordinary servicing. A field service representative like Ott might wish to become a field service support specialist as he progresses within the company.

DEC also backs up the field service support specialist. If there is a need, the company will bring in as consultants the engineers who were responsible for designing the computer system. Although this is extremely rare, it has happened. Thus, when a field service representative like Barry Ott represents his company, he does so knowing that he can be supported on those occasions when the problem he encounters is beyond the scope of his expertise.

Unlike the support specialist, Ott is a

"generalist," with an understanding of a wide variety of computers and peripheral devices. Even though a generalist learns about a lot of different computers, he tends to lean more toward certain machines than others, as his interests dictate. Thus, if he wishes to specialize, he may find himself in a position to train to become a field service support specialist in those computers which interest him.

**A Typical Day.** A typical day in the life of Barry Ott starts at about 8:15 a.m. when he checks the status board at the field service office to determine what is scheduled for the day. Knowing with what machines he will be involved, he checks to make sure that he has the correct programs and servicing manuals for the job. He then makes sure that he has all the hardware and tools necessary.

For all practical purposes, all the computers and systems that Ott will be called upon to service are located geographically close to him. This is true for most field service representatives. Only in a region of sparse population where the field service regional territory is naturally larger, or in a region that does not normally have a field service office, will a representative be asked to travel any appreciable distance.

One interesting example of an unusual case was when several minicomputers were installed aboard ships that had to leave port before the complete maintenance routine could be completed. For the next day or so, the field service representative found himself at sea while he finished up. Thus, a field service representative has what amounts to his own territory. In Barry Ott's case, it is the greater Boston area.

With regard to his future, if Ott decides to become a support specialist, he will be required to do more extensive traveling since there is no one territory that will be likely to contain sufficient models of any machine or machines to justify an exclusive support specialist.

Ott understands the characteristics of the computers within his territory. As a result, he knows many of the things to expect when visiting his well-established customers. This in turn helps him to plan his schedule to permit him to work at maximum efficiency.

A routine call generally lasts 2-3 hours, permitting Ott to perform preventive maintenance to ensure that the computer will not malfunction at a critical time and allowing him to make minor repairs should these be necessary. In addition to looking



**In the event that a completely assembled logic module is not available in stock at the field service office, the components kit permits representative to repair the majority of modules in the field. Because of the tight and compact packaging of parts, soldering must be performed carefully.**

at the computer itself, Ott must look after the entire system, including teletypewriters, storage and display devices, and line printers.

The field service representative performs a very useful function. His annual salary ranges from \$8000 to \$12,000, and he generally gets time-and-a-half for any work performed in excess of 40 hours per week. The field service support specialist or field service engineer, who generally specializes in one particular type of equipment, is salaried at \$9000-\$14,000 a year. A slightly higher technical level product support engineer is salaried at \$10,000-\$16,000 a year.

Most of the computers which a field service representative works with are used in a variety of jobs that are "on line;" that is, they are connected directly to an instrument or process. When a computer is being used to monitor the vital processes of a patient in an intensive care ward of a hospital, or when a computer is used to switch messages between aircraft in flight, the owner cannot afford to have it malfunction. By using men like Barry Ott who have an enthusiasm for working on computer systems, DEC's field service organization can be assured that the company's computers will always be working at the peak of their performance capabilities. And the field service representative finds himself in a highly satisfying line of work. ♦



# Communications Scene

By Richard Humphrey

IF REPUTABLE sources can be believed, the Federal Communications Commission will release shortly a proposal which will require all transmitters, including CB amateur, marine, aeronautical, etc., to have a tamper-proof, permanently installed, integrated-circuit module which will automatically identify a station without the operator's even being aware of it.

The identifier module will be mounted in a 24-pin plastic package  $1.2'' \times 0.6'' \times 0.185''$  and will transmit every thirty seconds a three-letter, four-number, "coded-for-computer" binary "blip" lasting 5-7 milliseconds. This seven-character identifier is capable of over 78 billion combinations.

Obviously aware of possible adverse reactions from the communications community the FCC has been emphatically denying it plans to release a Notice of Proposed Rule Making making automatic identification of transmitters mandatory. Unfortunately, the FCC—excellent at supervising the airwaves—has trouble hiding its tracks.

*Item:* In June of 1970, Daniel K. Child (Chief, Aviation & Marine Division, FCC) told the writer "we are presently looking for an automatic identification system to be used in the maritime mobile service."

*Item:* On July 17, 1970, Curt Plummer, Chief of the FCC's Field Bureau said: "Identification of two-way radio stations must, in the long run, be taken out of the hands of the individual operator."

He then went on to discuss in depth the automatic ID methods the Commission was studying (the "continual running" ID using frequencies of 40 to 300 Hz keyed at a 25 word-per-minute rate; the "burst" method triggered when the microphone is keyed) and the problems the FCC was encountering.

*Item:* Without exception, manufacturers of integrated circuits—among them, Texas Instruments, Motorola and Sylvania—have

admitted that the FCC has been in contact with them for assistance in developing an automatic ID system.

**Two Important Discoveries.** Then—on March 20, 1972—two important discoveries were made. One was a document which discussed in detail the FCC intention of amending certain rules and regulations "to provide a mandatory system for automatic identification of transmitters (ATIS) used for radiotelephony other than those used for radionavigation." The other was a photograph of what will probably be the 24-pin integrated circuit module.

The document—dated July 9, 1972—states that "the Commission has developed the system for rapid automatic identification of transmitters" and that it will be "binary coded in USA Standard Code for Information Interchange (USASCII) which (will be) transmitted automatically at the end of each transmission, or at intervals of approximately thirty seconds in the case of longer transmissions, at a rate of 600 bits per second."

The FCC, says the document, is using only a portion of the USA Standard Code grid. The letter "K" in the USASCII would

## Automatic Identification of Transmitters

be transmitted as "1001011(1)". The number in parenthesis is the "parity bit" which is transmitted to give an odd number of 1's so that the computer will accept the signal as being valid.

An FCC monitor station or prowl car will—when the system is operational—record the binary ID of a violator, feed the information into its computer, and come up with the name and address of the licensee in a matter of seconds. The entire signal sequence will consist of the prefix "SYN" sent twice (this synchronizes the computer to the ID signal), then the seven-place identifier. Finally, "ETB" (End of Transmission Block) is sent twice. Each bit pattern will have a parity bit added. Thus, the automatic ID signal of the mythical call "WBN-2703" in binary form would be:

SYN	0010110(0)
SYN	0010110(0)
W	1010111(0)
B	1000010(1)
N	1001110(1)
2	0110010(0)
7	0110111(0)
0	0110000(1)
3	0110011(1)
ETB	0010111(1)
ETB	0010111(1)

One of the suggestions offered by the industry is that "ETB" be changed to "ETX" (0000011(1))—End of Text—to make it more distinctive and avoid computer confusion. Since the prefix and suffix symbols will appear in all automatic ID signals, they will probably be permanently programmed into each IC by the semiconductor maker. The three-letter, four-number portion will undoubtedly be programmed into the IC by the manufacturer of the transmitter since the FCC document calls for the identifier to "be installed in each transmitter by the manufacturer of the transmitter".

**Comments from Manufacturers.** Here's what's facing the transmitter manufacturers in this program. They will have to: buy the integrated circuit; buy the equipment to program the IC; train personnel to do the programming; program and install the IC; assume the responsibility of correctly matching—by card or plate attached to the transmitter or by some other foolproof means—the transmitter to the ID code; and apply for type-acceptance of their transmitters and describe "the measures em-

ployed to limit or preclude the capability of field or servicing personnel to adjust the . . . functions or to change the . . . identifier."

Comments from equipment manufacturers interviewed ranged from, "We think the FCC is out of its mind," through, "It'll be a mountain of paperwork but I suppose we'll have to do it," to, "We intend to file a comment in support of the measure".

There's nothing much facing the semiconductor manufacturers except deciding whether they want the money in large bills or small ones. With basic research already behind them and a potential multi-million unit market, they aren't complaining.

**What About the End-User?** Here's what's facing the end-user: an inevitable increase in equipment cost. One industry source says that any cost to a manufacturer is usually reflected by a 3.2 increase in the over-the-counter price. This means that if the automatic ID integrated circuit costs a transmitter manufacturer \$10 including installation, equipment amortization, etc., the man who buys a CB set or a ham rig or what-have-you will pay \$32. In a \$100 piece of equipment, this represents a 32% increase in price.

Reactions from user groups are as varied as those encountered from equipment manufacturers. An increase in equipment cost irked those interested in lower-priced units (CB'ers, many hams). After all, a \$32 increase in a \$100 CB rig is quite different from a \$32 increase in a \$900 transceiver. The commercial marine vessel owners welcomed the news as did land-mobile operators. These groups seldom give their callsigns because of the press of business but would just as soon be legal. Operating procedures of airline and private pilots wouldn't be changed. They've got to voice-identify to keep one another sorted out. Pleasure boat owners were the most reactionary ("I'll tear the damned thing out! I dare 'em to put me in jail!").

**Tamper-Proofing Problems.** Tamper-proofing will present problems. Technicians who have no qualms about "hopping up" a CB set for \$10 under-the-counter aren't about to be fazed by a programmable read-only-memory IC. The semiconductor industry offered two programming methods to the request the FCC didn't make. One uses the "fuzable link" technique which, once programmed, cannot be changed. The

other method uses an electrically implanted negative charge which acts as a barrier (giving a "0") in a so-called "floating gate". The advantage of this method is that the IC can be completely tested prior to use. Then it is erased and sent on to the equipment manufacturer. The only trouble: The IC can be erased by merely exposing it to ultraviolet light or X-rays—an open invitation to the unscrupulous technician.

With all these problems it's no wonder the FCC doesn't want anyone to know about its no-Notice of Proposed Rule Making. If it thinks the refusal of an engineer for a major semiconductor firm to work on the project ("It smacks of Big Brotherism.") or the opinion of a major communications equipment manufacturer ("It makes about as much sense as gun control laws: the violators will go on violating while the rest of us have given up some more of our rights!") are jibes from a small group, wait until the general communications public hears about it. This is the public that's going to be footing the bill for this trip into 1984. ♦

### LOW-BUDGET RADIOTHERAPY UNIT

Radiation therapy technician Cain Chan of Memorial Hospital, Modesto, Calif., makes an adjustment of a Varian Associates Clinac (TM) 4 linear accelerator for cancer radiation therapy, which was recently installed at the small community hospital. Advanced microwave techniques and solid-state electronics have been used to provide a fully mechanized, easily operated unit, specially designed for small hospitals and treatment centers. Radiation intensity is up to 350 rads/minute.

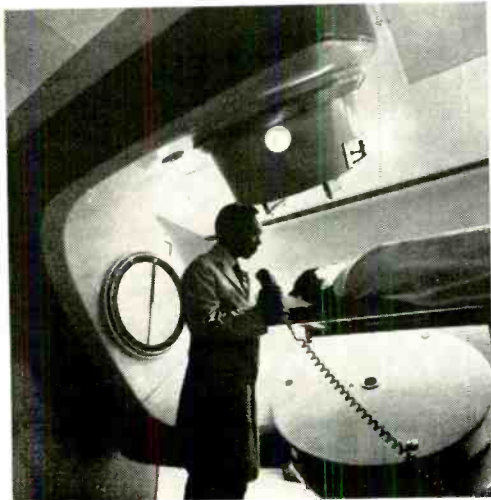



# Earn Your DEGREE

**Learn Electronics Technology thru HOME STUDY . . .**

Earn your Associate in Science DEGREE, and work as an electronics engineering technician. Grantham School of Engineering is a college-level institution, teaching mainly by correspondence, authorized by the California State Dept of Education to grant degrees, and approved for veterans under the G.I. Bill.

If you are a high school graduate, write for information *Bulletin P-72*. It's free.

## GRANTHAM

### School of Engineering

1505 N. Western Ave.  
Hollywood, Calif. 90027

## Planning to move?

Let us know 6 to 8 weeks in advance so that you won't miss a single issue of **POPULAR ELECTRONICS INCLUDING ELECTRONICS WORLD**

Attach old label where indicated and print new address in space provided. Also include your mailing label whenever you write concerning your subscription. It helps us serve you promptly.

Write to: P.O. Box 1096, Flushing, N.Y. 11352, giving the following information.

If you have no label handy, print OLD address here.

name please print

---

address

---

city

---

state zip-code

AFFIX LABEL

- Change address only.
- Extend subscription.  Enter new subscription.
- (1)  5 yrs. \$21 (2)  3 yrs. \$15. (3)  1 year \$6
- Payment enclosed (1 extra issue per yr. as a BONUS) 0701
- Bill me later.

name please print

---

address

---

city state zip

Add'l postage: \$1 per year outside U.S., its possessions & Canada.



# Shelf Life of Capacitors & Batteries

By John T. Frye, W9EGV, KHD4167

MAC was so busily engaged in what he was doing at the workbench that he actually jumped when he heard the voice of Barney, the second banana of the shop, who had entered quietly and was standing behind him.

"So! You sneaked out and bought something new!" Barney was saying accusingly as he levelled a finger at the impressive little black instrument, bristling with push-buttons, dials, switch knobs, a magic eye tube, and a large meter sitting on the bench surrounded by all sizes and shapes of capacitors. "What is it?"

"A *Sprague* Model TO-6 Tel-Ohmike Capacitor Analyzer," Mac answered. "The other day I replaced a 0.1- $\mu$ F coupling capacitor in a tape recorder with one from our stock and found the new one had less insulation resistance than the one replaced. I tried three more of our capacitors, and every one showed objectionable leakage, but a fourth was fine. Right then I decided we needed an accurate method of evaluating capacitors we planned to install in critical locations. The fact that a capacitor is unused obviously does not mean it is good. Moreover, many surplus capacitors can be purchased today at such tempting prices that they represent bargains—if we have a means of separating the sheep from the goats. This little instrument is just the ticket for telling us all we need to know about surplus capacitors or the ones we get from our jobber.

"It measures capacitance from 1 pF to 2000  $\mu$ F, and the applied voltage is low enough that capacitors rated at 3V can be tested without damage—an important point with capacitors designed for transistorized equipment. The power factor and leakage current of electrolytics can be accurately measured at their exact rated working voltage. Finally the insulation re-

sistance of paper, ceramic, and mica capacitors can be read directly on a meter with two ranges: one up to 10,000 megohms at 30 V for low-voltage capacitors and the other up to 50,000 megohms at 150 V for higher voltage types. Incidentally, those leaky paper capacitors of ours have insulation resistance of less than 2 megohms, while they should have a minimum resistance, when new, of 5000 megohms. This is according to data given in the TO-6 operating manual as to what constitutes minimum insulation resistance for all types and values of paper, mica, silver mica, ceramic, oil-filled, subminiature capacitors, etc."

"We must have got a bum batch of 0.1- $\mu$ F capacitors, huh?"

"I doubt it. Those capacitors were probably OK when new but simply deteriorated in the bin. I have no idea how long they've been there. We don't use many 0.1- $\mu$ F 600-V units any more, and I have the bad habit of ordering new paper capacitors when any one type is running low and dumping the new ones in on top of the old. Then I use the new ones off the top of the pile and leave the old ones down at the bottom; and I do this over and over. We're going to quit that."

"You think paper capacitors go sour on the shelf?"

"Nothing good nor bad lasts a hundred years," the Spanish say. All things deteriorate with time—except service technicians, of course! At any rate, I became curious about the shelf life of several items we use regularly and dashed off letters to capacitor, battery, tube, and solid-state manufacturers asking them for information as to the shelf life I could reasonably expect from their products, what conditions affected shelf life, and what recommendations they had regarding storage.

Returns are still coming in, but I already have a good response from capacitor and battery manufacturers. After all, they know that customer satisfaction and confidence comes from installing components when they are new and fresh. Trying to use an over-age, gone-sour component breeds dissatisfaction, no matter how unfair that feeling may be."

**Shelf Life of Capacitors.** "Okay, so what have you learned about capacitors?"

"I've learned the normal shelf life for paper tubular capacitors used in TV/radio is about five years, as is the normal shelf life for micas (both dipped and molded) and small ceramic capacitors. The decrease in insulation resistance with time takes place chiefly in the dielectric material. Heat and moisture are great villains in this regard. Every effort is made to seal moisture out of the capacitors, and modern techniques do a good job of this; but if the capacitors are exposed to temperature cycling under conditions of high humidity, some moisture is eventually bound to penetrate the seals and degrade the insulating quality of the dielectric."

"Then these capacitors should be stored away from heat and moisture."

"Right. As one capacitor manufacturer wrote me, 'I suppose that one way of looking at it would be for you to keep the capacitors under conditions similar to that under which your wife would keep spices—not near any heat, such as a stove or radiator, and as dry as possible.' You and I can believe this because we both know that when we get a radio in for service that has been stored in an attic or basement, we are certain to find several leaky capacitors in it."

"How about dry electrolytics? Should they be stored under the same conditions?"

"As far as keeping them away from high temperature, yes; but here we are not so much concerned with keeping the moisture out as keeping it in. Let me explain. A dry electrolytic really might be called a 'damp' electrolytic because the electrolyte inside it is in the form of a moist paste. The actual dielectric is a very thin oxide film that normally forms through the combined action of an applied voltage and the chemical action of the electrolyte. The anode constitutes one plate of the capacitor, the electrolyte forms the other. Therefore the drying out of the electrolyte

The great new  
**Super Scanner**  
It scans 360° in milliseconds with 5.75 dB gain. Or beams an 8.75 dB gain signal where and when you want it—instantaneously. (Otherwise, it's just another beautiful base antenna.)



MODEL MS-11F Super Scanner electronic beam, inc. control console—sugg. price, \$99.



**the antenna specialists co.**

Division of THE ALLEN GROUP INC  
2435 Electric Ave., Cleveland, Ohio 44106

Export: 2201 Charles Dr., Westbury, L.I., New York 11590  
Canada: A. C. Simmonds & Sons, Ltd.

**CIRCLE NO. 3 ON READER SERVICE CARD**

**ELECTRONICS and AVIATION Go "Hand in Hand" Be an "AVIONICS" Technician!**

*Combine Your Interest in Electronics With the Opportunities in Aviation*



**AVIATION ELECTRONICS offers you a whole new career opportunity: Exciting! Fast-growing! High Pay!**

**FREE**

**"Aviation Career Kit"**

I earn how you can train—in 12 months—to repair, maintain and calibrate sophisticated electronic navigation, control, environmental and communications systems now used in modern aircraft. Mail Coupon for Free "Career Kit" on AVIONICS.

.....  
 • SPARTAN SCHOOL OF AERONAUTICS Dept 22918  
 • International Airport, 8820 E. Pine St., Tulsa, Okla. 74151  
 • Rush me full information on your AVIONICS course.  
 .....  
 Name \_\_\_\_\_ Age \_\_\_\_\_  
 Address \_\_\_\_\_  
 City \_\_\_\_\_ State \_\_\_\_\_ Zip \_\_\_\_\_  
 .....  
**CIRCLE NO. 36 ON READER SERVICE CARD**

destroys the capacitor, and the presence of heat speeds up this drying process.

"Manufacturers seem to agree that the normal shelf life for dc electrolytics is one to two years. However the drying up of the electrolyte is not the limiting factor here as much as is the gradual deterioration of the dielectric film under the eroding action of the electrolyte when no polarizing voltage is present to maintain that film. The life of an electrolytic capacitor on the shelf can be materially extended if a polarizing voltage is applied to it through a current-limiting resistor every few months. Heat increases the chemical action of the electrolyte on the oxide film under storage conditions and shortens the normal shelf life."

"What happens if the capacitor is stored at extreme low temperatures?"

"The series resistance goes up and the capacitance goes down due to ionic immobility because of the freezing of the ionizing agent. Capacitors that have been out of service at extreme low temperatures react as though open circuited at first but start returning to normal with the temperature rise of the equipment."

**What About Batteries?** "Okay, now tell me about the shelf life of batteries. Transistorized equipment has made this an important subject."

"I'm indebted to *Union Carbide*, maker of Eveready Batteries, and to RCA for the information I have on this subject. Union Carbide defines the shelf life as the period of time, at a storage temperature of 70° F, after which a given battery retains 90% of its original energy content. Shelf life is reduced by high temperatures because of wasteful zinc corrosion and side chemical reactions within the cells and because of moisture loss from the cells through evaporation. The shelf life of a battery stored at 90° F may be 1/3 that of one stored at 70° F.

"RCA has conducted some interesting tests on the effect of temperature on shelf life of carbon-zinc cells. For example, an A-size carbon-zinc cell stored at 70° for 24 months retained only 50% of the rated capacity, but cells stored at 45° F and 0° F retained 70% and 90%, respectively, of their rated capacity. Other tests showed carbon-zinc cells stored at 48° F were in better condition at the end of five years

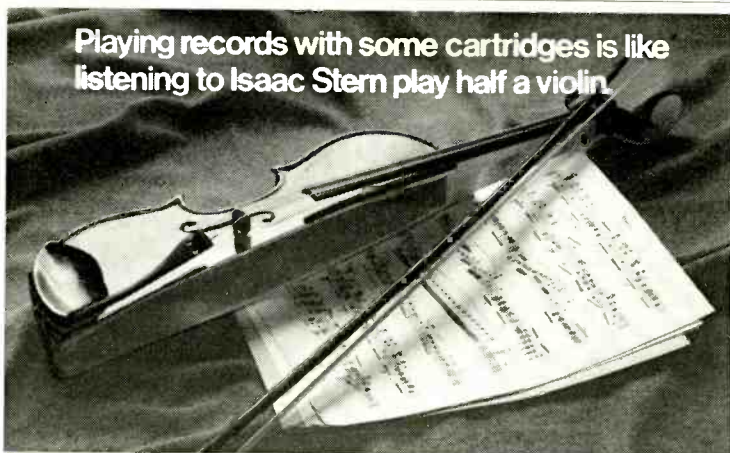

**Playing records with some cartridges is like listening to Isaac Stern play half a violin.**

In the important upper audio frequencies, some cartridges suffer as much as a 50% loss in music power.

So, there's a lack of definition in the reproduction of violins, oboes, pianos, and other instruments which depend on the overtones and harmonics in the upper frequencies for a complete tonal picture.

The Pickering XV-15 cartridge delivers 100% Music Power 100% of the time. Which is why we call it "The 100% Music Power Cartridge." At 100% Music Power,

all the instruments are distinct and clear, because Pickering XV-15's have no music-robbing output drop anywhere in the audio spectrum.

Pickering XV-15 stereo cartridges are priced from \$29.95 to \$65.00, and there's one to fit anything you play records with. For more information write: Pickering & Co., Inc., Dept. E, 101 Sunnyside Blvd., Plainview, L.I., N.Y. 11803.

 **PICKERING**

*"for those who can hear the difference"*

All Pickering cartridges are designed for use with all 2 and 4-channel matrix derived compatible systems.

**CIRCLE NO. 26 ON READER SERVICE CARD**



than those stored at 104° F at the end of one year.

"UC says the shelf life, as defined previously, of silver-oxide, mercury, or alkaline batteries is one year. The shelf life of carbon-zinc batteries is slightly less than that. Other types of batteries mentioned do not benefit as much from cold storage as do the carbon-zinc cells.

"RCA, on the other hand, while agreeing on the shelf life of silver-oxide cells, finds mercury cells have a shelf life of two years and that alkaline cells have a shelf life almost as good. RCA further states that the shelf life of mercury cells can be extended by storing them at lower than room temperature, *provided suitable precautions are followed*. Since both companies concur in these precautions, let me list them: (1) Don't handle frozen batteries any more than necessary and be gentle with them to avoid cracking the internal and external seals which may become brittle at low temperatures. (2) Allow the cells to reach room temperatures in the containers in which they are stored to avoid excessive condensed moisture, which will generally destroy the jackets and increase electrical leakage. (3) Do not put the cells into service until they have reached room temperature."

"How about recharged primary cells? Is their shelf life as good as it was originally?"

"Definitely not. RCA says such recharged cells have a very poor shelf life and should be put into service immediately after recharging."

"Well," Barney said, "this certainly has convinced me that capacitors and batteries should be purchased from a source that moves these items rapidly and keeps a close tab on how long they have been on the shelf. By the same token, we should buy in small enough quantities that they will not be long on our shelves. And we should work on a first-in-first-out basis. But now tell me about the tubes and transistors."

"I'm afraid that is going to have to wait," Mac said, starting to put the capacitors he had finished testing back into their bins. "I haven't heard from all the people I wrote to in those fields yet, and it is high time we got to work. But I promise that someday soon we'll talk about the shelf life of tubes, transistors, IC's, etc." ♦

AUGUST 1972

## Technical excellence in electronics

On our small, friendly campus the emphasis is on Living as well as Learning. Extra-curricular social activities, student clubs, a student operated radio station, student government, new dormitory and a full sports program help provide a world of your own in which to prepare for tomorrow. Associate Degree in Engineering Electronics. B.S. obtainable. G.I. approved.



VALPARAISO TECHNICAL INSTITUTE  
Dept. PE, Yellowstone Trail, Valparaiso, Indiana 46383

CIRCLE NO. 38 ON READER SERVICE CARD

### ANOTHER SUPERB VALUE from **Olson**

Electronics



ONLY

# \$19<sup>95</sup>

## ELECTRIC EYE WARNING SWITCH

Multi-purpose warning system for business, home, warehouse or industry. Electric Eye is used to signal or count someone entering or breaking the beam. You need only plug in a bell, buzzer, counter or any other device.

Olson Electronics, Dept. 18, 260 S. Forge St.,  
Akron, Ohio 44308

- I enclose \$19.95 plus \$1 for postage and handling. Send me the SW-364 Electric Eye Warning Switch.
- Send me the next seven issues of the Olson Catalog, without cost or obligation. **FREE**

Name \_\_\_\_\_  
Address \_\_\_\_\_  
City \_\_\_\_\_  
State \_\_\_\_\_ Zip \_\_\_\_\_

CIRCLE NO. 23 ON READER SERVICE CARD

# Changes come fast in electronics.

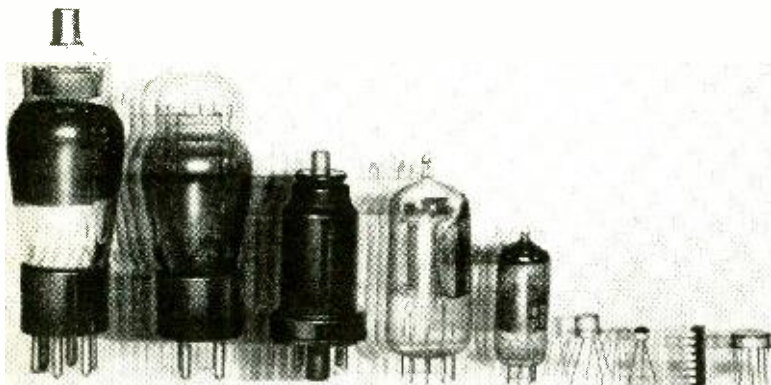

From  
tube  
to  
LSI

Take a look at the race in circuit technology. In the 1960's the tubes at the left made way for the transistors at the right. Today, transistors are surpassed by the large scale integrated circuit (LSI) at the far right. This circuit, less than a quarter inch square, replaces over 6000 transistors!

There's big money to be made by the men who stay ahead of this technology race. Put yourself

ahead with NTS Home Training! You get the latest, most advanced equipment (at no extra cost). More solid-state units, and more advanced technology. Plenty of training with integrated circuits, too! As an NTS graduate, you enter a world of electronics you're familiar with. You have a thorough working knowledge of solid-state circuitry. You're ready to tackle bigger jobs at higher pay!

## NTS COLOR AND B & W TV SERVICING



**Solid-state  
315 sq. in.  
Heath color TV**

Build and keep the largest, most advanced color TV made! Over-all solid-state design, ultra-rectangular screen, matrix picture tube, built-in self-servicing features, "Instant On," A.F.T., solid-state, 24-channel detent UHF/VHF power tuning, and much more! Also build and keep AM-SW Radio, Solid-State Radio, FET Volt-Ohmmeter, and Electronic Tube Tester. Learn trouble-shooting, hi-fi, stereo, multiplex systems, radio, color and B & W TV servicing.

Learn sophisticated solid-state circuitry as you build this B & W TV receiver. Lo-Silho "Superhet" Radio, FET Volt-Ohmmeter, Solid-State Radio, Electronic Tube Checker, and Signal Generator. TV

and all other equipment are yours to keep.

**Solid-state  
B & W TV,  
74 sq. in.  
picture  
(cabinet  
included)**

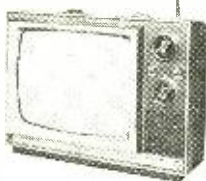

## NTS ELECTRONICS & COMPUTER TECHNOLOGY

Build and keep this exclusive NTS Compu-Trainer. It teaches you the

**Solid-state  
Compu-Trainer  
14 integrated  
circuits replace  
198 transistors!**



same principles used in million-dollar systems. Contains 14 inte-

grated circuits! All Solid-State! You perform all wiring and patchcording. No shortcuts. No pre-wired circuit boards. Your training is complete! Also receive an FET Volt-Ohmmeter and a 5" wide-band Solid-State Oscilloscope.

## NTS ELECTRONICS COMMUNICATIONS

Gain the prestige and earning power of owning an F.C.C. First Class Radio-Telephone License. Two comprehensive NTS courses cover the big opportunity field of transmitting and receiving.

You build and keep 14 kits, including this amateur phone 6-meter VHF Transceiver, NTS's exclusive 6-transistor Solid-State Radio, and a fully transistorized Volt-Ohmmeter. Also, learn 2-way radio, Citizens Band microwaves, and radar.

**5-watt AM  
transmitter/  
receiver**

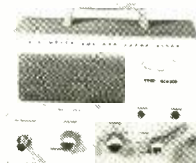

# NTS Home Training puts you in the lead.

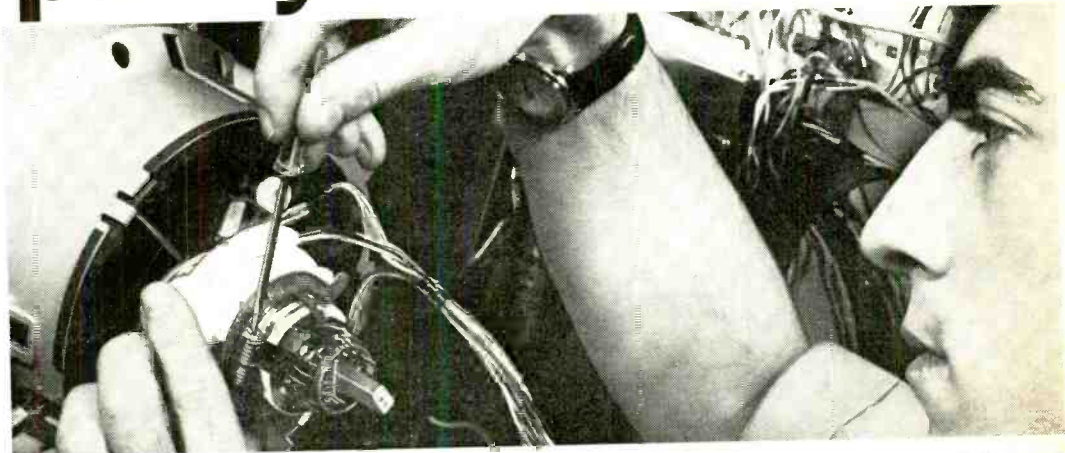

## NTS INDUSTRIAL & AUTOMATION ELECTRONICS

Automation is the future of industry and you can play an important part! Learn industrial controls by training on the NTS Electro-Lab (a complete workshop). You also build and operate this 5' Solid-State oscilloscope. And you perform experiments that involve regulating motor speeds, temperature, pressure, liquid level, and much more. All equipment is yours to keep.

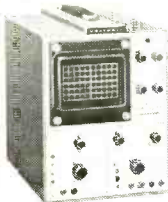

## NTS AUDIO ELECTRONICS SERVICING

Learn basic sound theory—how it works in home radio, car tape

decks, stereo multiplex component systems, and more! Set up a spectacular music system. Learn about



Build and keep this famous Heath Stereo Receiver and Speakers.

sound distortion, amplification and control, loud-speaker baffles, problems of system installation, etc. Included is Volt-Ohmmeter, In-Circuit Transistor Tester, and Solid-State

Radio. Prepare yourself for great opportunities in the Home Entertainment Industry!

## CLASSROOM TRAINING AT LOS ANGELES

You can take classroom training at Los Angeles in sunny Southern California. NTS occupies a city block with over a million dollars in technical facilities. Check box in coupon below.

## NATIONAL TECHNICAL SCHOOLS

WORLD-WIDE TRAINING SINCE 1905

4000 S. Figueroa Street  
Los Angeles, California 90037

## APPROVED FOR VETERANS

Accredited Member: National Association of Trade and Technical Schools; National Home Study Council.

Dept. 205-082

Big, Colorful NTS Guide to new opportunities in Electronics. Yours FREE!



NATIONAL TECHNICAL SCHOOLS  
4000 S. Figueroa Street  
Los Angeles, California 90037

Please rush me FREE Color NTS Electronics Guide & FREE lesson, plus information on course checked at right. No obligation. No salesman will call.

- MASTER COURSE IN COLOR TV SERVICING
- COLOR TV SERVICING (FOR ADVANCED TECHNICIANS)
- MASTER COURSE IN B&W TV & RADIO SERVICING
- MASTER COURSE IN ELECTRONIC COMMUNICATIONS
- PRACTICAL RADIO SERVICING
- FCC LICENSE COURSE
- MASTER COURSE IN ELECTRONICS TECHNOLOGY
- AUTOMATION & INDUSTRIAL ELECTRONICS
- COMPUTER ELECTRONICS
- BASIC ELECTRONICS
- AUDIO ELECTRONICS SERVICING

NAME \_\_\_\_\_ AGE \_\_\_\_\_

ADDRESS \_\_\_\_\_

CITY \_\_\_\_\_

STATE \_\_\_\_\_ ZIP \_\_\_\_\_

- Check if interested in Veterans Training under new G.I. Bill.
- Check if interested ONLY in Classroom Training at Los Angeles

# The Field-Effect Transistor

WHAT IT IS AND HOW IT HAS

REVOLUTIONIZED ELECTRONICS

BY WILLIAM R. SHIPPEE

**E**VER since its introduction, the field-effect transistor has been creating quite a stir in electronics. Devices and systems heretofore impossible to produce with bipolar transistors had to be built around vacuum tubes—if at all. Now, the FET is changing the situation.

The FET has many of the qualities and advantages of both the vacuum tube triode and the bipolar transistor. It is as compact as most small-signal transistors. It operates at low voltages, thus eliminating most of the bulk and expense of the power supply. Its input impedance can be rigged to fall into the desirable multi-megohm category. Recent developments have produced FET's which are capable of dissipating several watts of power; and since they exhibit the property of having a negative temperature coefficient, it is hard to make them succumb to thermal runaway.

Viewed as a design element, the FET is a semiconductor device which behaves in the manner of a variable resistor. As shown in Fig. 1, current flow between the source and drain is controlled by the gate voltage which is applied to both p sections simultaneously. As the reverse bias increases, the space charge area starts to pinch off, causing the source-to-drain current to fall almost to zero. Thus, the gate "field" has a direct "effect" on the source-to-drain current—hence the term "field-effect" transistor.

Fig. 1. FET acts as variable resistor in which the gate field has a direct effect on source-to-drain current flow.

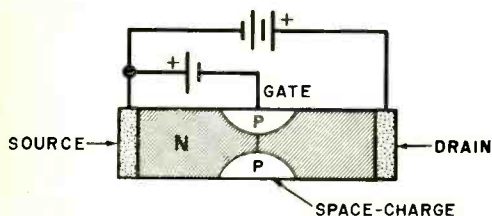

**Types of FET's.** There are basically two types of field-effect transistors in regular use today. The most common is the junction field-effect transistor, or JFET, which has a direct ohmic contact at the gate. The MOSFET, or metal-oxide field-effect transistor (sometimes known as an IGFET for insulated-gate field-effect transistor) has an electrically isolated gate.

In the JFET category, there are p- and n-channel types (see Fig. 2). The n-channel FET is very similar in voltage polarities and biasing to the vacuum tube triode as shown in Fig. 3.

The MOSFET, a long-needed semiconductor device, even more closely approximates the input impedance of the typical vacuum tube. It can be fabricated to yield gate impedances well into the several hundred megohm region—beyond the usual capabilities of the common JFET. As shown in Fig. 4, there are currently two types of MOSFET's available. The one on the left is a single-gate type, while the one on the right has two gates.

The MOSFET's substrate is usually connected internally to the source; if not, the substrate is externally connected to the source or to ground. Great care must be exercised in handling the MOSFET since the gate input impedance is so high and the gate insulation is so thin that any static charge introduced at the gate can perforate

Fig. 2. Shown here are the schematic symbols for a p-type (left) and an n-type junction field-effect transistor.

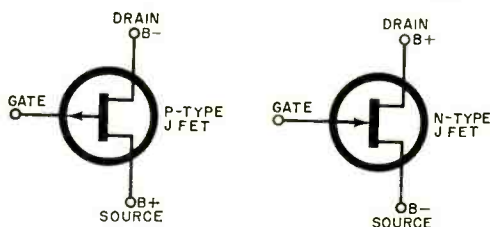

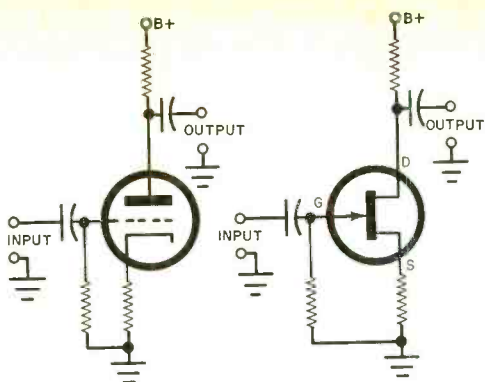

Fig. 3. Biasing arrangements for n-type JFET and vacuum tube triode are same.

the oxide insulator barrier and destroy the device.

The dual-gate MOSFET finds its most popular application as the mixer stage in AM, FM, and TV tuners where it provides a convenient means of "beating" two frequencies in a nonlinear device while maintaining isolation between the two signals. Also the MOSFET appears to exhibit less noise and crossmodulation problems than do conventional transistors and vacuum tubes.

Virtually all MOSFET's produced for large current conditions are contained in single packages—not integrated circuits. The reason for this is that the FET needs roughly ten times the active area required by bipolar transistors to provide the same current capabilities.

It is well to note that as r-f amplifiers, FET's are immune to strong-signal overloads. Some FET's are so symmetrically

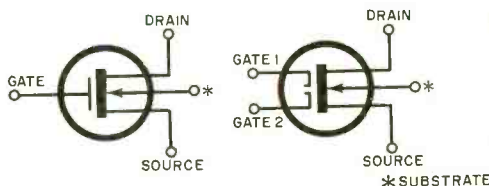

Fig. 4. Schematic symbols for single-gate and dual-gate MOSFET's are shown here.

constructed that their drain and source leads are interchangeable.

The past few years have witnessed some remarkable developments in the semiconductor scene. It will be interesting to see which directions research and development will take in the future. ♦

## NEW HOLOGRAM CRYSTALS PERMANENTLY STORE IMAGES

**D**EVELOPMENT of a crystal capable of storing hologram images as atomic patterns which can be read out, one by one, by slow rotation in a laser beam has been announced by RCA. The development may ultimately lead to a new document storage system in which files of statistics, engineering drawings, computer data, and other graphic material are permanently stored in crystals the size of sugar cubes.

The significance of the announcement is that crystals 500 times more sensitive than ever before and a system for permanently "fixing" images stored in them have been developed. Though holograms have been stored in crystals before, a very powerful laser was required and the holograms tended to erase during the readout process.

The RCA holograms can be retrieved relatively easily by the same low-power gas laser used during the storage process. Furthermore, a display from such a hologram can be 15 times brighter than that from a conventional photographic-film negative.

Metallic impurities in the lithium niobate

and barium niobate crystals are responsible for the increased sensitivity. Storage capacity is theoretically a trillion bits per cubic centimeter of crystal. ♦





# Product Test Reports

## HITACHI MODEL IA-1000 INTEGRATED STEREO AMPLIFIER (A Hirsch-Houck Lab Report)

**H**ITACHI, a major Japanese manufacturer of electronic equipment, has entered the consumer hi-fi component market in the United States with a deluxe integrated stereo amplifier, their Model IA-1000. This handsomely styled unit, sporting a brushed aluminum, satin-finish panel with rosewood side trim plates retails for \$319.95.

The IA-1000 has a number of interesting design and construction features. It has a 140-watt IHF music power rating into 8-ohm loads. This works out to 55 watts per channel continuous power with one channel driven. Its tone controls are true step-type switches, unlike the mechanically detented potentiometers used in some amplifiers and receivers. The balance control, a potentiometer, also has a slight detent at its center-of-rotation position.

The input FUNCTION SELECTOR has positions for two high-level inputs, a tuner, and two magnetic phono cartridges. Three different input sensitivities on PHONO can accommodate almost any magnetic stereo cartridge ever made. The nominal sensitivities of the two phono inputs are 5 mV and 2 mV with 50,000-ohm impedances, but the latter can be converted to an input for moving-coil cartridges simply by flipping a switch located on the amplifier's rear apron. This increases the sensitivity to a nominal 0.25 mV at 200 ohms impedance. Most moving-coil cartridges which normally require step-up input transformers with all but a very few amplifiers can be connected directly into this input circuit of the IA-1000. A single hybrid integrated circuit, manufactured by Hitachi, is used in each phono preamplifier channel.

The MODE switch has positions for both normal and reversed stereo and for driving both speaker systems with the L (left), R (right), or both channel signals in the mono mode. A microphone input jack, located on



the front panel with its own level control/on-off switch, mixes a single microphone signal into both channels, together with any other program source. This microphone signal, however, does not appear at the tape recording outputs.

A number of lever-type switches is used for power on/off, activating either or both of two pairs of speaker systems independently, switching in and out low and high filters and the loudness compensation, reducing the output level by 20 dB (a convenience when answering the telephone or doorbell), and controlling the tape monitoring function. A headphone jack located on the front panel is always energized.

A distinctive feature of the Hitachi IA-1000 is its pair of softly illuminated VU meters which are used to monitor the output signal levels. A switch allows selection of HIGH, MEDIUM, or LOW meter ranges in addition to allowing the meters to be switched out of the circuits altogether.

The rear apron of the amplifier contains all the usual preamplifier/amplifier inputs and outputs, including a DIN-type recorder input/output connector, center-channel output, and preamplifier-out/main-amplifier-in jacks which are normally connected together electrically. An adjacent slide switch allows the user to break this connection for inserting an equalizer or other accessory into the signal path.

The insulated speaker output connectors are spring-loaded, eliminating the need for a screwdriver when making the hookups. There are three ac outlets, two of which are

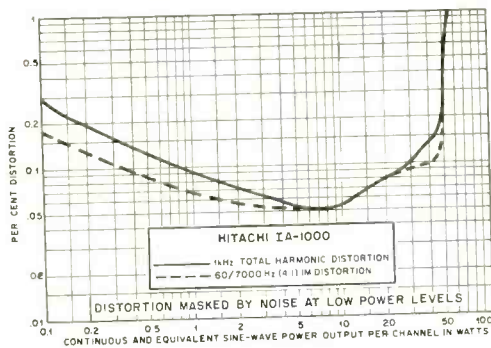
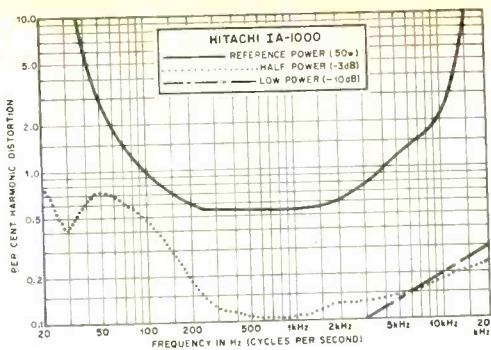

Distortion in Hitachi IA-1000 receiver is shown at various power levels and frequencies in the above graphs.

switched. Two fast-acting fuses protect the output transistors in the event an overload situation occurs, while a slow-blow fuse is used in the ac power line.

**Lab Test Results.** Our measurements on the Hitachi IA-1000 showed the per-channel clipping power output at 1000 Hz with both channels driven to be 46 watts into 8 ohms, 51 watts into 4 ohms, and 32 watts into 16 ohms. The harmonic distortion, masked by noise at very low power levels, was 0.055 percent at 10 watts, 0.1 percent at 30 watts, and 0.25 percent at 50 watts per channel. The IM distortion levels were generally similar.

Using 50 watts per channel as a reference full-power output, distortion was below 0.6 percent in the midrange, rising to 1.0 percent at 100 Hz and 4000 Hz. Although the distortion curves would have looked better with a lower full-power level, we felt that 50 watts was a realistic choice for the relatively undistorted midrange output. At half power, or 25 watts per channel, distortion was 0.75 percent at 20 Hz, fell to about 0.1 percent at frequencies between 300 and 2000 Hz, and rose gradually to 0.24 percent

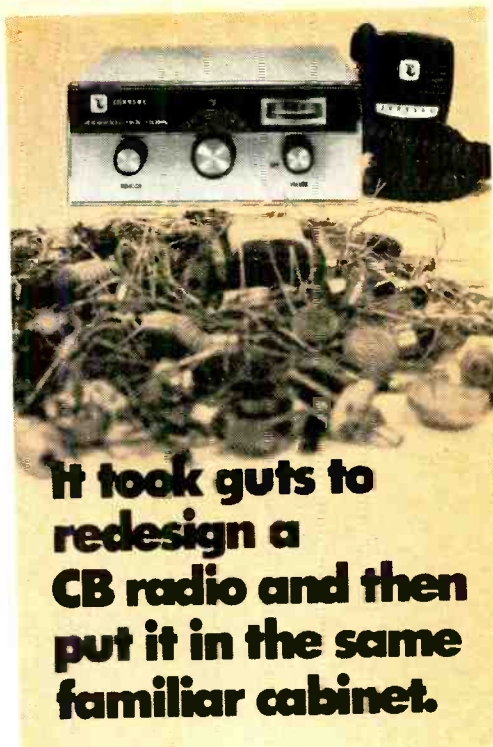

**It took guts to redesign a CB radio and then put it in the same familiar cabinet.**

We know today's CBER is looking for real value. So we redesigned our Messenger 123 where it counts—on the inside. Our engineers gave the model "A" new improved circuitry. With a new acoustically isolated speaker and voice-tailored audio that cuts noise—increases clarity. Plus a new ceramic selectivity filter that rejects adjacent channel chatter. And, of course it has built-in electronic speech compression for famous Johnson "talk power." At \$149.95, the Messenger 123A is a real value. And come to think about it, it's still a great looking CB radio just the way it is.

**Messenger 123A.**  
**New where it counts:**  
**Inside.**



**JOHNSON**  
 Waseca, Minnesota 56093



Full 1-year parts and labor warranty—backed by over 550 authorized service centers nationwide.

**CIRCLE NO. 19 ON READER SERVICE CARD**

at 20,000 Hz. At one-tenth power, the distortion was less than 0.1 percent from 20 Hz to several thousand hertz, rising to 0.29 percent at 20,000 Hz.

The tone controls had excellent characteristics, with a sliding inflection point on the bass control which allowed useful correction at frequencies less than 100 Hz with negligible effect on the higher frequencies. The loudness compensation circuit boosted both the low and high frequencies at reduced volume levels. The filters had a desirable 12-dB per octave slope, with the -3-dB points being at 90 Hz on the low end and 4000 Hz on the upper end. The RIAA phono equalization was accurate to within  $\pm 0.5$  dB from 50 Hz to 15,000 Hz and was down 3 dB at 30 Hz. Measurements for the RIAA equalization were taken at the tape outputs.

For an output of 10 watts, the required inputs were 68 mV on AUX, 2.25 mV on PHONO 2, and 0.94 or 0.25 mV on PHONO 1, this last depending on the setting of the moving-magnet/moving-coil cartridge selector switch. Phono overloading occurred at 165 mV, 68 mV, and 21 mV for the three phono input sensitivities, providing complete assurance against overdriving the preamplifier from any properly installed phono cartridge. The noise level, relative to 10 watts output, was 65 to 67 dB down on the phono

inputs and 71 dB down on the high-level inputs. The microphone input required 1 mV for 10 watts output for a -56-dB noise level at maximum gain.

We measured the VU meter calibration against power output, basing our results on the use of 8-ohm loads. The two meters differed in their readings by 1 to 3 dB at the same power levels. In the HIGH range, 0 dB corresponded to 50 watts and -6 dB to 10 watts. The MID range read 0 dB at 10 watts and was down 7 to 8 dB at 1 watt. The LOW range read about -2 dB at 1 watt and -10 dB to -15 dB at 0.1 watt. Although the calibrations are not accurate enough for any critical level setting purposes, they do provide an interesting insight into the actual power output required for different listening levels.

The construction of the IA-1000, both internally and externally, was excellent. Its finely finished metal knobs and switch levers operated with a smooth, positive feel. Sound reproduction was excellent, even when driving some rather power-hungry speaker systems. With just about every feature one could expect in a stereo control amplifier, coupled with a very attractive appearance, the Hitachi Model IA-1000 integrated amplifier is a worthy entry into the stereo component market.

Circle No. 65 on Reader Service Card

## HEATHKIT SOLID-STATE TRIGGERED-SWEEP OSCILLOSCOPES MODEL IO-103 SINGLE-TRACE AND MODEL IO-105 DUAL-TRACE

IN THE recent past, such niceties as wide bandwidth, fast rise time, and triggered sweep could be found only in multi-thousand-dollar oscilloscopes designed for R&D laboratories. Now, however, there are two low-priced scope offerings featuring these and many other characteristics. They are both made by Heath and are designated as the Model IO-105 (dual-trace) and the Model IO-103 (single-trace). Respectively, they are listed in the catalog at \$429.95 and \$229.95. For these prices, you get scopes that are just as at home in general-purpose use as they are on the lab bench.

Leading off with the IO-105, we can state that this is the scope kit to end all scope kits. With respect to functions and technical specifications, this scope is comparable in performance to many of the higher-priced commercial units presently being used in R&D labs. Yet, its low cost puts it within the reach of the serious experimenter and service technician.



The IO-105 features two broadband channel inputs, each having a frequency response



from dc to 15 MHz, rise time of 24 ns, nine-position attenuator in a 1-2-5 sequence providing a range of from 0.05 V/cm to 20 V/cm, ac/dc coupling, and the choice of either channel 1 or channel 2 or both in alternate and chop modes. Each channel is fully independent of the other, with its own gain, ac/dc input switch, and trace positioning control.

The time base, which is common to both input channels, is a true triggered sweep system which has 18 calibrated rates from 0.2  $\mu$ s to 100 ms/division in a 1-2-5 sequence with a continuously variable rate which can be switched in as desired. Sweep triggering can be accomplished from either channel, and the user can select the "auto" mode in which the sweep is triggered at the average dc voltage of the input signal or the "normal" mode where a front-panel trigger level control permits starting the trace at almost any point desired. A conventional stability control permits "fine tuning" of the triggered sweep.

Additionally, there are an X-Y mode in which the two inputs are coupled in a vector-scope fashion with channel 1 on the vertical axis and channel 2 on the horizontal axis, and a TTL-compatible blanking input and gate output, this last located on the rear apron.

The IO-103 general-purpose scope is only slightly less sophisticated than the IO-105. A single-trace, triggered-sweep affair, its frequency response extends from dc to 10 MHz at 3 cm deflection (dc-8 MHz at 6 cm deflection). Sensitivity is specified at 50 mV, while rise time is 50 ns. Like the IO-105, the IO-103's attenuator has nine positions in the 1-2-5 sequence; it yields a range of from 0.05 V/cm to 20 V/cm. The time base sweep is a seven-position switching arrangement which covers a range of from 100 ns/cm to 100 ms/cm. At one of the front panel jacks, there is available a 1-volt peak-to-peak, 60-Hz reference/test signal which is used for calibrating the IO-103's vertical deflection circuits and, later, for whatever you have in mind.

**Similar Yet Different.** There are some basic similarities between the IO-105 and IO-103 scopes. First, of course, is that they are both all solid-state (except the CRT). Each has a variable-intensity/off calibrated graticule over the flat screen of the CRT, held in place by a rectangular camera-mount bezel. Aside from the usual complement of



IO-103

scope controls, each model has a series of switches which are used to select internal or external source triggering, ac or dc coupling arrangement, + or - triggering slope, and normal or automatic triggering.

Both the IO-105 and IO-103 have display expansion; in the IO-105 the magnification factor is X5, while in the IO-103, it is X2. This welcome feature allows the user to examine critically any waveform displayed. In the IO-105, the magnifier function is on an independent switch, while in the IO-103 it is an attachment on the horizontal positioning control and is activated by pulling out the control knob. In both cases, the magnifier is defeatable.

The input connectors on both scopes are BNC female types. The coaxial input cables have mating male-type BNC connectors on one end and alligator clips on the other end. (Heath also makes available their Model PKW-101 high-frequency compensated probe for use with both scopes at \$23.95. It comes completely assembled and has a bandwidth of dc to 30 MHz.)

The differences between the two scopes are mostly subtle. Aside from the obvious differences in frequency response, rise time, magnifier figure, and input channel capabilities, the two are different mainly in cosmetics. For example, while the two are almost the same size—the IO-105 measures 15"  $\times$  12"  $\times$  10" and the IO-103, 16"  $\times$  12"  $\times$  9"—the dual-tracer is a block-like affair with projections only on the front panel, while the single-tracer has a raised ridge along the top, topped off by the carry-

ing handle and a rear-projecting plastic cup over the neck of the CRT, in addition to the front panel projections. (On the IO-105, the handle is recessed into the case top.)

The graticule on the IO-103 has a  $6 \times 10$ -cm grid, while the IO-105 has an  $8 \times 10$ -cm grid. For reasons which will become obvious, the control grouping on both scopes is different, but in neither case are the controls difficult to find or awkward to use.

The IO-105 is designed along the traditional lines of the laboratory scope. Hence, it is really a two-part system, consisting of a basic main frame containing the CRT, associated controls, and power supply, and a "plug-in" input module containing the separate channel preamps and processors. Interconnections between the two assemblies are made via appropriate connectors. (Incidentally, with this plug-in arrangement, we assume that the Heath people have other input modules in mind for use with the main frame section. It would not be difficult to replace the dual-trace module with, say, a curve tracer, spectrum analyzer, etc.)

**Assembly and Calibration.** It is difficult to believe that, after building either of these oscilloscopes, they are such highly sophisticated test instruments. The IO-105 and IO-

103 kits are actually *easy* to assemble, even if the builder has only limited experience in assembling kits. This is due in large part to the fact that almost all components mount on printed circuit boards which are interconnected with factory-prepared wiring harnesses, and to the excellently written and illustrated assembly manual.

The IO-105, due to its higher order of sophistication and complexity, took the longer of the two kits to assemble. Using careful assembly techniques, total building time was 27 hours. The IO-103 took just under 18 hours. The initial checkout and calibration, requiring the aid of only a VTVM or TVM, ate up another 30 minutes for the IO-103 and about 45 minutes for the IO-105.

Once we had our scopes in operating order, we could not resist the temptation to compare the manufacturer's published specifications with actual performance tests. To do this, we used laboratory-standard equipment of known accuracy. We can now categorically state that both scopes performed well within their published specifications. In fact, in most of the vital areas, the published specifications were very conservative, which is not really surprising in light of the fact that the Heath people traditionally publish conservative ratings.

Circle No. 66 on Reader Service Card

## DYNASCAN COBRA 130 CB TRANSCEIVER



**T**HE Dynascan Cobra 130 is a synthesized 23-channel CB transceiver designed for use on conventional AM or on SSB (upper or lower sideband). It is a solid-state unit designed primarily for mobile use with power derived from a 12-volt negative-ground dc source.

The operating features of the Cobra 130 are those which are now becoming more or less standard with this type of transceiver. They include r-f and a-f gain controls; a selector switch with positions for AM, SSB/USB, and SSB/LSB; adjustable squelch; voice-lock (fine tune); AM noise limiter and SSB noise blanker; built-in

speaker; jack for external speaker with receiver for PA operation; detachable microphone; and a transmitter-on/modulation indicator lamp.

**Technical Notes.** No schematic diagram was supplied with our test unit, but we were otherwise able to determine the following: The 130 employs three FET's, 32 bipolar transistors, an integrated circuit, and 62 diodes. Double conversion is used on receive for AM with 7.3 MHz and 455 kHz for the first and second i-f's, respectively. Ceramic filters provide the required selectivity at the second i-f, whereby a 6-dB band-pass of 5 kHz is obtained with a rated adjacent-channel rejection of 50 dB. In our test unit, however, the selectivity response was found to be somewhat unsymmetrical, resulting in an adjacent-channel rejection of 20 dB on the low-frequency side and 80 dB on the upper side.

A separate i-f section at 7.8 MHz is engaged

for single conversion on SSB with selectivity and sideband selection obtained with a 2.1-kHz bandpass crystal filter. Since this filter provides all the selectivity required (with the unwanted-sideband rejection measured as 60 dB at 1 kHz), there is no need to go to a second conversion at a lower i-f.

A product detector is engaged for SSB, an envelope detector for AM. DSB, suppressed-carrier signals can also be copied in the SSB mode. Adjustable squelch operation is provided for each mode of operation with a threshold sensitivity down to less than  $0.5 \mu\text{V}$ .

The same "front end" (r-f input amplifier and mixer) is employed for both modes of reception with the separate conversion sections and detectors switched in individually for SSB or AM. The setup provides a measured sensitivity of  $0.15 \mu\text{V}$  on SSB and  $0.5 \mu\text{V}$  on AM for a 10-dB (S + N)/N. The circuitry, plus the following i-f, provided an image rejection of 80 dB.

Individual series-gate type noise blankers can be switched into the system independently for SSB or AM to ensure optimum performance in each case. Anyone who has handled gear with a good noise blander,

such as the ones used in the 130, will appreciate how much more effective this method of noise silencing is over the usual type of noise limiter.

Combinations of frequencies obtained from a crystal-controlled frequency synthesizer provide the heterodyning signals at the mixers as needed for the particular conversion. A "voice-lock" control at one group of crystals is designed to permit the receiver frequency to be varied 600 Hz either side of the center frequency, enabling the receiver to be tuned exactly to the received signal for proper demodulation on SSB.

**Transmitter Section.** The initial carrier for the transmitter is produced at 7.8 MHz with the frequency synthesizer signals used for conversion to the channel frequency. SSB signals are generated with the initial carrier using a balanced modulator and a crystal-lattice filter. Different groups of crystals are engaged at the synthesizer for either lower- or upper-sideband operation on the various channels. The SSB signals are brought up to a 15-watt PEP input at the r-f power-output amplifier with a measured PEP output of 8 watts into 50 ohms with

**Full Featured 5-Watt,  
23-Channel Base Station**  
Digital clock. Power meter.  
Model 13-864 \$179.95



**Compact 5-Watt, 23-Channel  
Mobile.** Power meter. Switch-  
able ANL. PA/CB switch. All  
hardware. 13-869 \$109.95

*Prices are suggested retail*

**MIDLAND**  
ELECTRONICS COMPANY  
P.O. Box 19032, Kansas City, Mo. 64141

5-Watt Mobile,  
6 Channels.  
13-856 \$79.95



# tough talkers!

**3 Mean CB Machines with  
Hard-to-Beat Prices . . .  
Brand New from Midland!**

**FREE! Write Today  
for Colorful New  
CB Brochure**

**CIRCLE NO. 22 ON READER SERVICE CARD**

operation from a 13.6-volt dc source (normal battery potential when a vehicle's engine is running). With a 12-volt source, it drops to 6 watts output.

The unwanted-sideband suppression at 1 kHz was found to be 50 dB and the carrier suppression, 60 dB. The second- and fifth-order distortion products were 25 and 40 dB down, respectively; better than the manufacturer's rating of 20-25 dB and than that usually found with solid-state CB transceivers.

There is an automatic level control (alc) system designed in to maintain relatively uniform modulating levels and prevent power amplifier overdrive; however, flat-topping of the SSB signal (which increases the distortion products) can still occur at high speech levels.

The voice-lock control at the synthesizer also varies the transmitter frequency, automatically placing the transmitter on exactly the same frequency as that of a received SSB signal properly tuned in. For our money, this is the preferred arrangement as opposed to others where only the receiver section's frequency can be shifted.

The synthesizer crystals are held to a closer tolerance than usual in order that the maximum possible deviation with the voice-lock will maintain the transmitter frequency within the legal tolerance. With our test unit, the maximum possible deviation from the exact frequency on any channel was -900 to +1350 Hz, thus holding to within the required 0.005 percent limit.

**AM Operation.** For AM, the SSB-producing section of the transmitter is disabled and the r-f driver and PA are modulated by

the receiver a-f power-output amplifier. The AM input runs up to 5 watts with a measured carrier output of 3.75 watts using a 13.6-volt dc power source. Good modulation up to 100 percent was attainable with clipping at this point for a hefty-sounding signal.

When the AM carrier is on, a red lamp comes on and blinks brighter when modulation is applied. With SSB, because of the suppressed carrier, the lamp does not come on until modulation is applied, at which time it lights to a brilliance determined by the modulation peaks.

When a loudspeaker is plugged into the external speaker jack, it cuts off the built-in speaker and permits the signal to be heard only on the external speaker. A PA/CB switch on the front panel cuts off the receiver output and sets up the transceiver for PA service using an external speaker at another jack. We measured the a-f output as a good 3.5 watts into 8 ohms.

**Performance.** The preceding discussion contains much data on what to expect from the Cobra 130 in the way of performance. In addition, the agc holds the a-f output to within 10 dB and 2 dB with an r-f input change of 20 dB (1-10  $\mu$ V) and 60 dB (10-10,000  $\mu$ V), respectively. On the other hand, there is sometimes not sufficient control to prevent overload with distortion on strong local SSB signals. However, this can be alleviated by turning down the r-f gain control.

The Cobra 130 is a good-looking, easy-to-use and operate transceiver made in Japan. It measures 11 $\frac{3}{4}$ "  $\times$  9"  $\times$  2 $\frac{1}{2}$ " and weighs 6 $\frac{1}{2}$  pounds. It is list-priced at \$349.95.

Circle No. 67 on Reader Service Card

### BIRD "HAM-MATE" MODEL 4350 R-F WATTMETER (A Hirsch-Houck Lab Report)

**T**HE widely used Bird "ThruLine" r-f directional wattmeters employ plug-in sensing elements for different power and frequency ranges. The elements rotate in their sockets to read forward or reflected power in a coaxial transmission line. Elements are available for full power ranges from 1 watt to 10,000 watts, covering frequencies from 450 kHz to 2200 MHz.

The relatively high price—typically \$150 or more—of the commercial Bird ThruLine r-f wattmeters has limited their use in amateur radio stations. Now, however, the

Bird "Ham-Mate" Series 4350 r-f directional wattmeters have brought the basic performance of the commercial instruments to the amateur radio market in terms of cost.

The Bird 4350 is a compact, self-contained unit, measuring 5 $\frac{3}{4}$ "  $\times$  4"  $\times$  3 $\frac{3}{4}$ ". It weighs 1 $\frac{3}{4}$  pounds. The meter face is slanted for easy viewing. On each side of the case, there is a female SO-239 ulf connector, one of which goes to the transmitter while the other goes to the antenna or dummy load rated at between 50 and 52 ohms. The meter can be left permanently con-



capacitively coupled to the inner conductor of the rigid coax.

The Ham-Mate has two power ranges (200 watts and 2000 watts) which can be alternately selected according to the positioning of the slider on a HIGH-LOW switch. The sensing element is not removable, but is turned by a knob to read forward or reflected power. The rated frequency range is from 1.8 MHz to 30 MHz. A similar unit to the Model 4350, the Model 4351, has a 1000-watt HIGH range instead of 2000 watts, and another, the Model 4352, has ranges of 40 watts and 400 watts and a frequency range of 50 MHz to 150 MHz. All models carry the same \$79 price tag. And all have a published rated accuracy of  $\pm 8$  percent full-scale.

nected in the transmission line since it has no effect on the transmission system's performance.

The Model 4350 contains a 4" section of rigid air-dielectric coaxial line coupler which is designed for an accurate 50-ohm impedance. The rotating sensing element is inserted into the side of the coupler and is

**Comparison Tests.** Lacking an accurate r-f standard wattmeter, we were unable to verify the accuracy of the Bird 4350 Ham-Mate in a rigorous manner. However, we did make substitution measurement comparisons between it and another popular r-f wattmeter designed for the amateur market, using a Heath "Cantenna" 50-ohm dummy load and several antenna systems. The signal source was a Heath Model SB-400 exciter

# SAVE MONEY!

**A Delta Mark Ten Capacitive Discharge Ignition (CDI) System On Your Car Slashes Maintenance Costs And Increases Performance.**

Put a Mark Ten on your car and save by eliminating 3 out of 4 tune-ups. Save as gasoline mileage increases (up to 20%). The Mark Ten CDI system also extends spark plug life, promotes more complete combustion and assures instant starts in all weather. It operates on any 6 or 12 volt negative or positive ground system.

The Mark Ten B affords additional money saving advantages by drastically reducing combustion contaminants and restoring power lost by the use of smog control devices. Equipped with handy switch for instant return to standard ignition, the Mark Ten B works with ANY 12 volt negative ground engine. Both systems install in ten minutes without rewiring.

Order your Mark Ten or Mark Ten B today. Save money while you enjoy low maintenance and increased performance.

**Mark Ten (Assembled) \$44.95 ppd.**

**Mark Ten (Deltakit) \$29.95 ppd.**

(Kits available in 12 volt only, positive or negative ground)

**Mark Ten B \$59.95 ppd.**  
(12 volt negative ground only)

**Superior Products at Sensible Prices**  
Mfg. In U.S.A.



**DELTA PRODUCTS, INC.**

P.O. BOX 1147 • GRAND JUNCTION, COLORADO 81501  
PHONE: (303) 242-9000

Dept. PE

Please send me literature immediately:

Enclosed is \$ \_\_\_\_\_

Ship ppd.  Ship C.O.D.

Please send: \_\_\_\_\_ Mark Ten B @ \$59.95 ppd.

\_\_\_\_\_ Standard Mark Ten (Assembled) @ \$44.95 ppd.

\_\_\_\_\_ 6 Volt: Neg. Ground Only \_\_\_\_\_ Positive Ground

\_\_\_\_\_ 12 Volt: Specify \_\_\_\_\_ Negative Ground

\_\_\_\_\_ Standard Mark Ten (Deltakit®) @ \$29.95 ppd.

(12 Volt Positive Or Negative Ground Only)

Car Year \_\_\_\_\_ Make \_\_\_\_\_

Name \_\_\_\_\_

Address \_\_\_\_\_

City/State \_\_\_\_\_ Zip \_\_\_\_\_

**CIRCLE NO. 12 ON READER SERVICE CARD**

and, when necessary, a Heath Model SB-200 linear amplifier.

On the 14-MHz amateur band, where Bird suggests calibrating their Model 4350, the two meters agreed very closely at power levels from 10 watts to 200 watts. The total "spread" between the two units never exceeded 10 percent of their average readings and was usually much less. On the high power ranges, the differences were greater, typically 15-20 percent. Since the accuracy rating of the Bird 4350 is  $\pm 8$  percent of *full-scale*, which would permit an error of 160 watts at any point on the HIGH range, no firm conclusions can be drawn as to the accuracy of either unit. On the other hand, if either was considered to be the reference standard, the other was also within *its* published accuracy specification. In all cases, the reflected power reading was zero, as would be expected with the 50-ohm dummy load used.

To check the Ham-Mate under the less-than-ideal conditions of an antenna load with an appreciable standing wave ratio (SWR), we again compared the two units on the 10-, 20-, 40-, and 80-meter amateur bands. On 10 meters, the Bird and comparison units indicated, respectively, 75 watts and 78 watts with both showing 1 watt of reflected power. On 20 meters, both

indicated 120 watts forward and 12 watts reflected power. On 40 meters, with a badly mismatched antenna, the Bird indicated 190 watts forward and 100 watts reflected power, while the comparison unit indicated 200 watts forward and 110 watts reflected power. The net radiated power (90 watts) was identical as measured with both instruments. The corresponding SWR's, calculated from the power readings, were 6.4 with the Bird and 6.8 with the comparison unit—certainly close enough for any practical purpose. On 80 meters, both units indicated 120 watts forward, while the reflected powers were 8 watts for the Bird and 6 watts for the comparison unit. Since the latter readings were near the bottoms of the meter scales, no significance can be attached to the small discrepancy.

Even though our tests could hardly be considered a proof or disproof of any of the Bird specifications, we have not the slightest doubt that the 4350 does exactly what is claimed for it, probably with an error much smaller than its ratings would allow. At about half the price of the commercial Thru-line r-f directional wattmeters, the Model 4350 does practically the same job, with very nearly the same accuracy, over the range of power levels and frequencies encountered in h-f ham communication.

Circle No. 68 on Reader Service Card

## EICO SS-500 SECURITY ALARM SYSTEM

**I**T MAY take many hours of searching through various catalogs to piece together a security system to suit your particular needs. After looking at the various sensors, bells, buzzers, and switches, you may start to wonder just how such a system can be integrated and how it will work. What with ac and dc bells, normally open and normally closed switches, fire and smoke sensors, and the multitude of window and door sensors available in various configurations, putting together a system can become, at best, a difficult task.

Now, for the do-it-yourselfer, Eico has come out with their Model SS-500 security alarm system retailing for \$99.95. This system includes the company's assembled Model FC-100 security control center containing all the electronics for monitoring the intrusion or fire warning system and the Model A-75 ac power supply in a compact wall-mounted security box. The Model SD-10 door-window magnetic contact reed

switches supplied are two-piece units consisting of a normally open reed switch encased in a plastic housing. A bar magnet for controlling the open/close conditions of the switch is encapsulated in a similar plastic housing.

As long as the magnet is kept close to the reed switch, the switch contacts are held closed magnetically. When the magnet is moved far enough away from the reed switch so that its magnetic field is weakened considerably, the contacts spring open. The distance by which the magnet needs to be removed from the reed switch to cause the contacts to open is very small to insure proper security.

When the contacts of the reed switch open, the FC-100 security control center senses the interruption and the alarm system activates.

The SD-20 fire sensors included in the system are designed for a normally open circuit condition. When heated to their

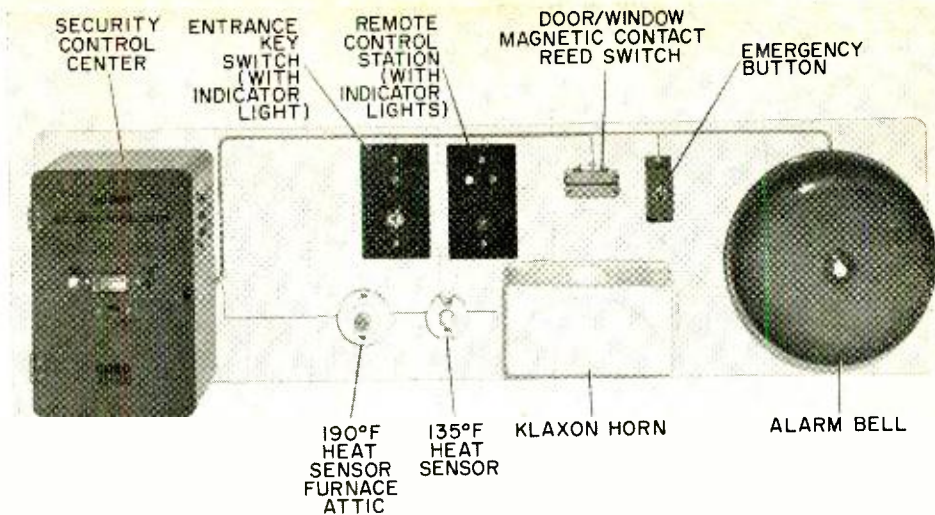

Photo shows various items which can be integrated into Eico's security system.

operating temperature (135° F or the optional 190° F level) they automatically close, arming the independent fire-warning system and sounding the associated Klaxon horn.

The SD-40 door cords supplied with the SS-500 system are 12"-long flexible leads used to connect a movable door or window to its contacts on the adjoining jamb. SD-50 tamper switches are provided for mounting on the control center or the external bell housing to sound the alarm automatically if either of these units is moved from its preset mountings.

Two control stations (Model A-65 remote and Model A-45 entrance) have lamps to indicate the state of the system and provide means of entering the protected areas using the special key provided. A-45 emergency buttons, sometimes called "panic buttons," allow operation of the alarm from any location within the house and override the other sensors. Besides these and other sensors, 250' of hookup wire is also supplied.

Available separately for \$2.95 is the A-95 "Home Security Handbook" which illustrates the various methods which can be used to protect a house or other premises. If you are considering putting in your own alarm system, take a look at this informative manual.

There are also available a number of optional accessories to the basic security system. These include additional remote stations, Klaxon horns, high-temperature

(190° F) heat sensors, freeze-up and water flood sensors, and window tape. All of these can be seen on your local Eico dealer's display rack. If you do not want to purchase a complete SS-500, you can pick and choose from among the components displayed according to your needs.

**Installing the System.** We found that installing the security system is easy, and the only tools we needed were a screwdriver and a knife. We picked an arrangement from the manual, suitable to our needs, and went to work. In a matter of hours, the job was completed. Using the instructions supplied with the SS-500, the system was tested and found to operate properly as each protected door and window was opened. The alarm bell's clanging was reassuring. The fire alert system was tested using kitchen matches. It, too, operated with reassuring promptness. We had no real need for the "panic buttons," but we could well see how such a button placed at bedside could offer the bedridden, elderly, or infirm some consolation when they are home alone.

The intrusion and fire alerts are two completely independent systems. When the intrusion alarm is disabled—as it usually is when the family is at home—the protection of the fire alarm system remains in readiness at all times.

The Model FC-100 control center is available separately. Alone, it retails for \$49.95.

Circle No. 69 on Reader Service Card

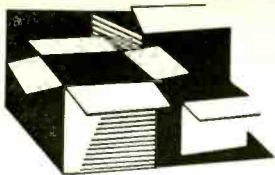

## New Products

### XCELITE COMPACT DRIVER SETS

Just added to their tool line of "compact convertibles" are three new all-purpose *Xcelite* screwdriver/nutdriver sets. Each consists of an assortment of color-coded midjet tools and a unique "piggyback" torque amplifier handle. The PS-6 screwdriver set includes miniature drivers for No. 00, 0, and 1 Phillips: 3/32", 1/8", and 5/32" slotted screws. The PS-140 screwdriver and nutdriver set contains a popular assortment of drivers for No. 0, 1, and 2 Phillips screws; 3/32", 1/8", 3/16" and 1/4" slotted screws; and 1/4", 5/16", and 3/8" hex nuts. Finally, the PS-130 screwdriver and nutdriver set is similar to the PS-140 with a larger assortment of nutdrivers, including 3/16", 1/4", 5/16", 11/32", and 3/8" hex sizes, plus drivers for No. 1 and No. 2 Phillips screws and 1/8" 3/16", and 1/4" slotted screws.

Circle No. 70 on Reader Service Card

### METROTEC UNIVERSAL DECODER/AMPLIFIER

*Metrotec's* Model SD4A-Q is a truly "universal" 4-channel stereo decoder/amplifier on a single chassis. Capable of fully and faith-



fully decoding CBS, SQ, and Electro-Voice encoded records, it also provides 4-channel ambience recovery from any 2-channel source. The SD4A-Q is the first synthesizer to retain full bass response in the rear channels by utilizing a special 300-Hz turnover in the matrix/phase-shift circuit. The low-distortion, full-response rear channel amplifier has 10 watts rms/channel and provisions for discrete tape and 4-channel headphones.

Circle No. 71 on Reader Service Card

### REALISTIC VHF SCANNING RECEIVER

The Realistic Patrolman PRO-9 vhf scanning and tunable receiver from *Radio Shack* automatically scans up to seven crystal-controlled

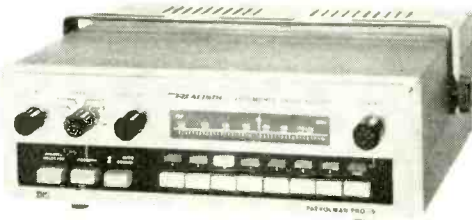

channels plus one selected eighth channel in the 148-174-MHz band. It is said to be the first and only professional vhf scanning monitor with both crystal control and full-band coverage tuning. Any one of eight channels can be selected as a priority channel on which constant check is maintained. At the touch of a button, any channel can be instantly locked out of scan and skipped over. A 2-second delay prevents missing call-backs. There is also a channel selector button, and illuminated indicators show which channel is being monitored. Scanning rate is 10 channels per second.

Circle No. 72 on Reader Service Card

### SIMPSON SOUND LEVEL METER

The Model 885 sound level meter made by *Simpson* quickly and accurately measures noise and sound levels anywhere in accordance with

SEE...  
COMPARE  
SELECT!!

*Console*



SSB/AM BASE STATION  
SSB, 15W, p.e.p. input, AM, 5W input.  
23 channels, no crystals to buy.

115VAC (will operate also from ext. 12V battery).

SSB/AM MOBILE

SSB, 15W, p.e.p. input.  
AM, 5W input. 23 channels.  
no crystals to buy. Supplied  
w/dynamic mic

*Catalina*



AM MOBILE

23 channels, no crystals to buy.  
Supplied w/dynamic mic/coil cord.

*Cascade II*



5 WATT  
PORTABLE

6 channels, 5 watts  
(reducible to 3W).  
Battery operated.  
All metal case.  
Sturdy!

**SBE**  
COMPLETE LINE OF  
CB SUPER  
STARS

WRITE FOR BROCHURE

CIRCLE NO. 30 ON READER SERVICE CARD

SBE 220 Airport Blvd., Watsonville, CA 95076



the Occupational Safety and Health Act of 1970 and Walsh-Healey requirements. It is simple to operate, with solid-state reliability. Full coverage is provided from 40 dB to 140 dB with A, B, and C weightings. The input transducer is a rugged calibrated ceramic microphone element. Also provided is an output jack which permits the sound level meter to be used with recorders and analyzers.

Circle No. 73 on Reader Service Card

### ANTENNA SPECIALISTS MOBILE CB ANTENNA

A new mobile antenna, guaranteed not to burn out in CB installations, is now available from *Antenna Specialists Co.* The Model M-410 antenna is designed around an industrial type loading coil twice the size and weight of the conventional CB type and a stainless-steel whip employing an exclusive new copper and nickel coating process which provides super conductivity. The high-capacity design offers increased efficiency and, thus, more effective signal radiation. The antenna is equipped with the company's "Quick-Grip" mount for a no-hole trunk installation with the cable completely hidden.

Circle No. 74 on Reader Service Card

### FOURTH GENERATION MITS CALCULATOR KIT

*MITS*, the original manufacturer of kit electronic calculators, recently announced their latest kit, the Model 1440. Easily assembled in less than 10 hours, the 1440 provides outstanding computational versatility with straightforward operational procedure. Its 15

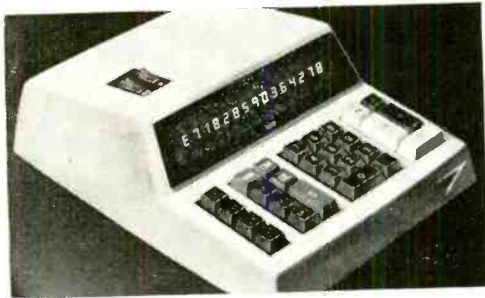

LED readouts (14-digit entry and readout) and powerful computational decimal system provide high accuracy. In addition to the four basic arithmetic functions, the 1440 has square and square-root functions, and an independent data memory which can store complex equation elements for later recall. The 1440 is also available factory assembled.

Circle No. 75 on Reader Service Card

### LAFAYETTE POLICE & FIRE RECEIVER

*Lafayette Radio Electronics Corp.* recently introduced a custom-styled 3-band UHF/VHF/HF Public Service communications receiver with crystal control or tunable frequency selection. Designated the Model PF-300, it provides FM

AUGUST 1972

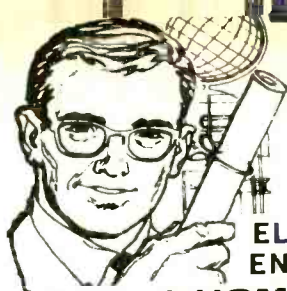

# Earn Your Degree

## ELECTRONICS ENGINEERING

### through HOME STUDY

HIGHLY EFFECTIVE HOME STUDY COURSES IN:  
 • ELECTRONICS ENGINEERING TECHNOLOGY  
 • ELECTRONICS ENGINEERING MATHEMATICS

Earn your Associate in Science Degree in Electronics Engineering and upgrade your status and pay to the engineering level. Complete college level courses in Electronics Engineering. We're a forward looking school. Outstanding lesson material—thorough and easy to understand. Engineering taught on the basis of application and understanding rather than on the basis of memorization. Up to date in every respect. Acquire the knowledge and ability that means the difference between a low paying technician job and a high paying engineering position. Low tuition cost with low monthly payments. Free engineering placement service for our graduates. Write for free descriptive literature. Ask for bulletin J, no salesman will call on you.

**COOK'S INSTITUTE** of Electronics Engineering  
 Forest Hill Road  
 P. O. Box 10634  
 Jackson, Miss. 39209  
 Established 1945  
 Formerly Cook's School of Electronics

CIRCLE NO. 8 ON READER SERVICE CARD

## Thinking 4-Channel?

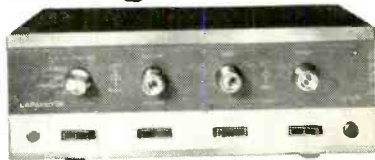

The LA-524 SQ Decoder/Amplifier

Think  
**LAFAYETTE**  
**4**-CHANNEL  
 ★ Receivers ★ Amplifiers  
 ★ SQ Decoders  
 ★ Adapters plus more!

NOW ON PRESS!! NEW 1973 Catalog 730  
 The Only Complete Guide To "Everything In Electronics"

Lafayette Radio Electronics, Dept. 35082  
 P.O. Box 10, Syosset, L.I., N.Y. 11791

Please send FREE 1973 Catalog 730: 35082

Name \_\_\_\_\_

Address \_\_\_\_\_

City \_\_\_\_\_ State \_\_\_\_\_ Zip \_\_\_\_\_

CIRCLE NO. 20 ON READER SERVICE CARD

coverage of 30-50 MHz, 144-174 MHz, and 450-470 MHz segments used by police, fire, and public service utilities, U.S. Weather Bureau, and amateur radio operators. Adjustable broad and sharp selectivity is available on all bands, while 1  $\mu$ V sensitivity is typical. Features include a multiple selector switch for a choice of two crystal positions on each band, or tunable operation; variable squelch; rear-panel accessories (including tape recording output jack); etc.

Circle No. 76 on Reader Service Card

### COURIER SSB/AM CB TRANSCEIVER

Courier has entered the SSB field with their compact high-performance "Gladiator" trans-

ceiver. High sensitivity and selectivity in both SSB and AM receive modes assure positive



pick-up of distant on-channel signals and provide freedom from adjacent-channel interference. A lattice crystal filter in the SSB receive mode virtually eliminates interference, while a mechanical ceramic filter in AM receive performs a similar function.

Circle No. 77 on Reader Service Card

### SONY PORTABLE CASSETTE RECORDER

The Sony Model CF-350 is an extremely compact ac/dc cassette recorder with a combination AM/FM receiver. Introduced by *Superscope*, the CF-350 features a built-in condenser microphone as well as a microphone jack. It also has differential-balanced flywheels which stabilize the sound quality when recording or playing back, automatic shut-off, and a variable sound monitor which permits the user to adjust the speaker volume without affecting the recording level. The CF-350 Cassette-Corder has a servo-controlled motor which maintains accurate tape speed.

Circle No. 78 on Reader Service Card

### CONCORD CASSETTE RECORDER

The newest of the Concord solid-state cassette tape recorders available from *Benjamin Electronic Sound* is the monaural Model F-21 which weighs only 3 lb, yet delivers up to 1 watt of high-quality output. The F-21 features pushbutton controls, remote-control microphone, auxiliary input jack, and automatic level control. It has a capstan drive with dual-track recording and playback. A 2 1/4" loud-speaker assures that the recording capabilities of the F-21 are faithfully reproduced during playback.

Circle No. 79 on Reader Service Card

## TUNER SERVICE

VHF, UHF, FM or IF Modules . . .

. . . All Makes

*Fast* **8 hr. Service!**

**1 YEAR GUARANTEE**

VHF-UHF-FM	\$ 9.95
UV-COMB.	\$16.95
IF-MODULE	\$12.50

Major Parts charged at Net Price

P.T.S. is overhauling more tuners for more technicians than any other tuner company in the world!

LIKE TO DO IT YOURSELF?

Send one Dollar (redeemable) for our 60 pages of top information

TUNER REPLACEMENT GUIDE AND PARTS CATALOG

For fastest service, send faulty tuner with tubes, shields and all broken parts to:

**PTS ELECTRONICS, INC.**

"Precision Tuner Service"



HOME OFFICE—  
Box 272 • Bloomington, Ind. 47401 • Tel. 812. 824-9331  
WEST—  
Box 41354 • Sacramento, Calif. 95841 • Tel. 916. 482-6220  
SOUTH—  
Box 7332 • Longview, Tex. 75601 • Tel. 214. 753-4334  
SOUTHEAST—  
Box 8881 • Jacksonville, Fla. 32205 • Tel. 904. 389-9952  
EAST—  
Box 3189 • Springfield, Mass. 01103 • Tel. 413. 734-2737  
MOUNTAIN—  
Box 4245 • Denver, Colo. 80204 • Tel. 303. 244-2818

CIRCLE NO. 24 ON READER SERVICE CARD

**\$SAVE  
MORE  
BY MAIL  
FROM DIXIE!**

**ON NATIONALLY ADVERTISED  
STEREO HI-FI COMPONENTS**

SAVE ON NATIONALLY ADVERTISED BRANDS!  
**Write Today for Our FREE 28-page  
Wholesale Audio Catalog**

CHECK THE FACTS: 1. Dixie's Reputation—Over 12 years of great savings & reliable service; 2. Only top brands—Choose the Stereo components & accessories you want; 4. Everything shipped brand new and factory sealed; 5. Quotes answered by return mail; 6. No Membership Fee Required—Write today for FREE Wholesale Catalog.

**DIXIE HI-FI WHOLESALERS**

Dept. P E-8  
10128/30 Bacon Drive  
Beltsville, Md. 20705  
Phone: 1-301-937-3090

Exclusive!  
Master Charge/  
BankAmericard  
Honored on  
Mail Orders.



CIRCLE NO. 13 ON READER SERVICE CARD

# Your key to a brighter future in electronics:

the exclusive Bell & Howell Schools Electro Lab®. It's a complete electronics laboratory-in-the-home you build and keep as you prepare for a new career or color TV servicing business of your own!

For free information about how you can build and keep the Electro Lab — and a 25-inch color TV — detach and mail postage-free card opposite.

Here's your chance to get into one of the fastest-growing fields in industry today — electronics. Your key to a brighter future is *career-oriented training*. Find out now how you can get that training from Bell & Howell Schools using the exclusive Electro Lab® electronics laboratory-in-the-home!

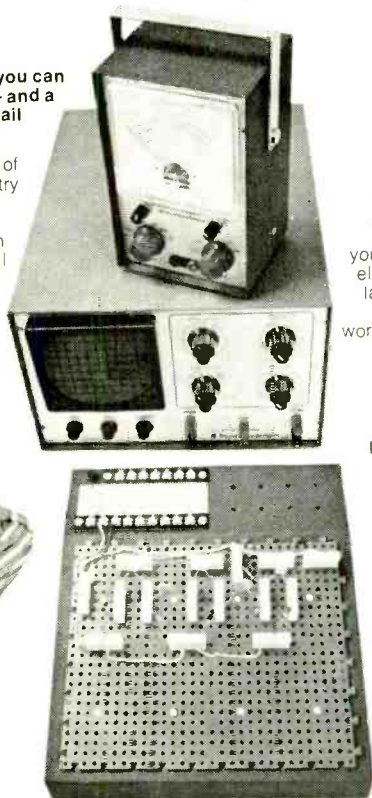
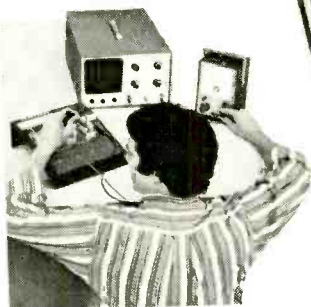

**Exclusive Electro Lab gives you practical experience at home — two ways!** First, you build your home electronics laboratory yourself — with sixteen shipments of top-quality electronic components. As you assemble your lab, you learn electronics theory ... build new manual skills ... learn how each instrument works so you can maintain and repair it yourself.

Second, you actually use your Electro Lab® as the "tools of your trade" while you build your Bell & Howell solid-state 25-inch color TV. You gain experience using these instruments as they're used daily by professional technicians. And you'll continue to use them throughout your career.

**No need to give up your present paycheck!** With your Bell & Howell Schools Electro Lab®, you can prepare for growing opportunities in electronics right in your own home. You don't have to leave your present job or travel miles to classes. Everything comes to you by mail. You build your own lab ... use it to help you assemble a 25-inch color TV ... then start a new career or business of your own in color TV servicing.

## Here's what you build and keep:

**Design Console** Use this to rapidly "breadboard" circuits and perform over 300 electronics experiments. No wiring or soldering. You simply plug and unplug modular units to create different circuit designs. The fast, easy up-to-the-minute way to master basic electronics.

**Oscilloscope** This is standard equipment for professionals in electronics. Once you've built it, you'll use it throughout your career. Helps you assemble, wire test and check electronic equipment. Offers bright, sharp screen images calibrated for peak-to-peak voltage and time measurements.

**Transistorized Meter** After you've assembled this sensitive instrument, you'll use it to measure current, voltage and resistance. Registers measurements on a large, easily-read dial. Combines most desired features of a vacuum-tube voltmeter and a quality multimeter. It's portable, too!

**YOU ALSO BUILD AND KEEP A BELL & HOWELL SOLID-STATE 25-INCH COLOR TV.**

FOR FREE INFORMATION,  
MAIL POSTAGE-FREE CARD  
OPPOSITE

IF CARD HAS BEEN  
REMOVED, WRITE:

DE VRY INSTITUTE OF TECHNOLOGY 501  
ONE OF THE  
**BELL & HOWELL SCHOOLS**  
4141 Belmont, Chicago, Illinois 60641

CONTROLLED  
QUALITY  
CRYSTALS by



**CRYSTEK**



The "On-Channel" Crystals

FOR

**CITIZEN BAND**

23 Channels and "Mars"

**HAM OPERATORS**

**Commercial 2-Way**

**Marine-Monitor**

See your Distributor for Speedy  
"Zip Certificates"



**CRYSTEK**

formerly Texas Crystals  
Div. of Whitehall Electronics Corp.

1000 Crystal Drive 4117 W. Jefferson Blvd.  
Fort Myers, Florida 33901 Los Angeles, California 90016

**CIRCLE NO. 10 ON READER SERVICE CARD**

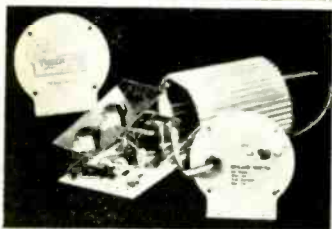

### FROM KIT TO CAR IN 80 MINUTES!

Electronic Ignition Is "in". Update your car with the TOPS in power, efficiency and reliability — the TIGER SST capacitive discharge Ignition (CD).

The TIGER delivers everything other CD's promise — and more: quicker starting, more power, more gas mileage, tune-ups eliminated, lifetime plugs and points, reduced repairs and pollution.

The TIGER can be built and installed in your car in 80 minutes. The TIGER is unique! Errors in construction or incorrect installation will not harm the TIGER or the engine. The TIGER will not operate under either condition.

The TIGER comes with a switch for TIGER or standard Ignition for 12V negative ground only.

**SATISFACTION GUARANTEED**  
or Money Back.

Simpli-Kit \$29.95 — Assembled \$39.95  
POST PAID

WE ACCEPT:  
Mastercharge or BankAmericard.  
Send check or money order with order to:

**Tri-Star Corporation**

DEPT. W, P. O. Box 1946  
Grand Junction, Colorado 81501

**CIRCLE NO. 37 ON READER SERVICE CARD**

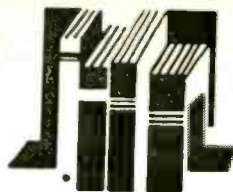

## Electronics Library

### ABC'S OF ELECTRONIC POWER

by Rufus P. Turner

The text in this book clearly explains just what electronic power is and how it is measured. The first chapter deals with fundamental ideas of power in resistive and reactive circuits. Dc power, being much simpler than ac power, is allotted one chapter. Ac power, having the added considerations of power factor, single phase and polyphase, and audio and radio frequency measurements, is given three chapters for discussion.

Published by Howard W. Sams & Co., Inc.,  
4300 West 62 St., Indianapolis, IN 46268.  
Soft cover. 96 pages. \$3.50.

### THE RADIO AMATEUR'S HANDBOOK, 49th Edition

This latest edition of the amateur radio operator's "bible" contains the most extensive revision and update ever attempted. Thirteen chapters have been rewritten to cover new devices and techniques, and the material has been completely reorganized to make individual material easier to find. Among the new sections are discussions of digital logic devices, linear IC's, hf and vhf antennas, broadband amplifiers, filter networks, converter designs, and SSB techniques. A new 28-page chapter on frequency modulation and repeaters is also included, and 200 new drawings and charts have been used to present the current state of the art in all areas of amateur communications.

Published by American Radio Relay League,  
Inc., Newington, CT 06111. Soft cover. 704  
pages. \$1.50.

### UNDERSTANDING RADIO ELECTRONICS Fourth Edition

by Milton Kaufman et al

In this extensively revised edition of a popular book, updated to include solid-state concepts, the authors provide complete coverage of the communication electronics field. The book itself is designed for either self-study or classroom use and is specifically written for vocationally oriented high school or community college students with little or no previous training in electricity or electronics. Included are 300 new illustrations and self tests to help students re-

POPULAR ELECTRONICS Including Electronics World

# DUAL BAND VHF/UHF LF/VHF 10 CHANNEL FM MONITOR RECEIVERS



- ★ Dual Channel non-restrictive programming of channels allows any combination of preselected channels to fit your needs
- ★ Priority channel-locks out all other signals
- ★ Any channel may be switched out of scanning sequence
- ★ Carrier Delay—You may hear mobile callbacks

A sophisticated professional automatic scanning monitor with the most reliable circuitry ever conceived. Has more power, more audio and more features than other monitors. New ceramic filter provides excellent adjacent channel operation in urban areas. All solid state. 2 watts of "Voice Fidelity," easy access plug in crystals. Dual purpose power supply for 117VAC and 12VDC, negative ground only.

**designed for:**

- Police, Fire and Municipal Depts.
- County, State & Federal agencies
- Commercial & Industrial applications
- Other unlimited uses

FR-2526 VHF/UHF **189<sup>95</sup>**  
 FR-2528 LF/VHF  
 FR-2525—UHF only \$179.95  
 Comes with AC and DC power cables, mounting bracket, less crystals. Crystals \$5.00 ea.

SONAR RADIO CORP., 73 Wortman Ave., Bklyn, N.Y. 11207  
 Please send information on SONAR-SCAN FM Monitor Receivers.

Name \_\_\_\_\_ Dept. 602  
 Address \_\_\_\_\_  
 City \_\_\_\_\_ State \_\_\_\_\_ Zip \_\_\_\_\_

**CIRCLE NO. 34 ON READER SERVICE CARD**

view important material and increase their comprehension.  
 Published by McGraw-Hill Book Co., 330 West 42 St., New York, NY 10036. Hard cover. 732 pages. \$10.95.

### SHORTWAVE LISTENER'S HANDBOOK

by Norman Fallon

This book offers the beginning listener a complete introduction to shortwave equipment and techniques and many valuable tips for even the experienced SWL. Topics covered include descriptions of the full range of SWL equipment, evaluation of all types of receivers and antennas, tuning and logging stations, coping with listening conditions, hunting weak signals, and getting reception reports, station schedules, and other useful data. The world's major SW broadcast stations are listed by country and frequency. There is a glossary of SWL terms and a unique selection of 10 do-it-yourself projects complete with parts lists and diagrams.

Published by Hayden Book Co., Inc., 116 West 14 St., New York, NY 10011. Soft cover. 144 pages. \$3.95.

### COMMERCIAL RADIO OPERATOR THEORY COURSE

by Martin Schwartz

A complete course in radio theory, this book

is written in a simple style, supported by numerous diagrams, that requires no technical background. It begins with the basic concepts of electricity, and proceeds to transmission and reception. At the end of each lesson, an exam, based on questions presented in exactly the same manner as they are on the FCC exams, tests the reader's comprehension of the material covered. Two final exams—one for the First and another for the Second Class license—are also provided.

Published by Ameco Publishing Corp., 314 Hillside Ave., Williston Park, NY 11596. Soft cover. 448 pages. \$5.95.

### SOLID STATE ELECTRONIC DEVICES

by Ben G. Streetman

Electrical engineers and scientists, as well as newcomers to electronics, constantly need updated understanding of electronic devices. This book provides the background for this type of continuing study. Beginning with second-year college physics, the text develops techniques for keeping up to date on future electronic devices and applications. The reader becomes better equipped to gather new data from current periodicals and professional literature in the electronics field.

Published by Prentice-Hall, Inc., Englewood Cliffs, NJ 07632. Hard cover. 463 pages. \$13.95.

## FREE McIntosh CATALOG and FM DIRECTORY

Get all the newest and latest information on the new McIntosh Solid State equipment in the McIntosh catalog. In addition you will receive an FM station directory that covers all of North America.



**MX 114** FM/FM STEREO TUNER and STEREO PREAMPLIFIER

**CIRCLE NO. 21 ON READER SERVICE CARD**

## SEND TODAY!

McIntosh Laboratory Inc.  
 2 Chambers St., Dept. PT-872  
 Binghamton, N.Y. 13903

NAME \_\_\_\_\_

ADDRESS \_\_\_\_\_

CITY \_\_\_\_\_ STATE \_\_\_\_\_ ZIP \_\_\_\_\_

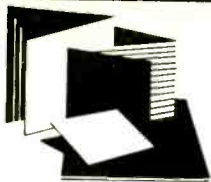

## New Literature

### AVANTI ANTENNA CATALOG

Avanti's new Citizens Band Communications Catalog features the company's complete line of base station, mobile, and marine antennas, trunk lid and deck mounts, and co-phasing harness kit and accessories. The catalog is in full color, and each entry is fully described both electrically and mechanically. Address: Avanti Research & Development, Inc., 33-37 W. Fullerton Ave., Addison, IL 60101.

### STANCOR CROSS REFERENCE GUIDE

The new 64-page Stancor Color and Monochrome Television Parts Replacement Guide is now available from *Essex Controls Div.* It lists more than 500 Stancor transformer and deflection components for 200 TV receiver brands, providing the technician with replacement data for more than 14,000 original parts. A separate section covers the Stancor line of flybacks, deflection yokes, vertical outputs, filter chokes, power, and output transformers. Address: Essex Int'l., Inc., Controls Div., Stancor Products, 3501 W. Addison St., Chicago, IL 60618.

### MOTOROLA HEP CROSS-REFERENCE GUIDE

Approximately 38,000 semiconductor devices are cross-referenced to HEP replacements in the new 1972 *Motorola HEP Semiconductor Cross-Reference Guide & Catalog*. Included in the listings are 1N, 2N, 3N, JEDEC, manufac-

turers' regular and special "house" numbers, and many international devices. Some 467 HEP items are listed, including hardware, accessories, technical manuals, and hobby project books. The catalog is free at local HEP dealers, or write to: Motorola Inc., Semiconductor Products Div., 5005 E. McDowell Rd., Phoenix, AZ 85036.

### ATLAS SOUND MIKE STAND BROCHURE

A four-page brochure exclusively devoted to its line of microphone stands, stand accessories, adaptors, and fittings has just been released by *Atlas Sound*. It outlines the functional and mechanical details for 14 commercial and professional floor stand models, 12 desk stands, four boom stands, and more than 50 stand accessories. For a copy of Form 7201, write to: Sales Dept., Atlas Sound, 10 Pomeroy Rd., Parsippany, NJ 08054.

### IRC CROSS REFERENCE AND DATA BOOK

The Spring Edition of *International Rectifier's "Semiconductor Cross Reference and Transistor Data Book"* contains more than 35,000 listings, including 10,000 not previously shown, making it one of the most comprehensive cross-reference books in the industry. Listings include transistors, diodes, zener diodes, capacitors, rectifiers, and SCR's. Copies of the 64-page book, No. JD-451, can be obtained from authorized IRC dealers or by writing to: Semiconductor Div., International Rectifier Corp., 233 Kansas St., El Segundo, CA 90245.

### METROLOGIC LASER CATALOG

A new illustrated catalog available from *Metrologic Instruments, Inc.*, lists and describes seven laser models, including a new modulated type, and a wide range of accessories to extend their use for education and research. In addition to six ready-to-use models, the catalog describes low-cost educational kits which capitalize on laser light to teach optics and light theory. Other listings include holographic equipment, laser kits, accessories, and optics bench equipment. Address: Metrologic Instruments, Inc., 143 Harding Ave., Bellmawr, NJ 08030.

## CALECTRO

GC ELECTRONICS  
Rockford, Ill. 61101

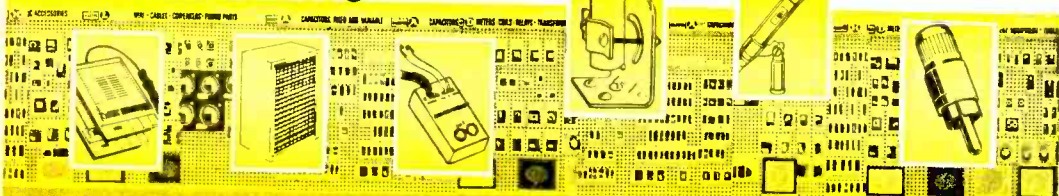

# YOUR ELECTRONICS SUPERMARKET

CIRCLE NO. 16 ON READER SERVICE CARD

POPULAR ELECTRONICS Including Electronics World

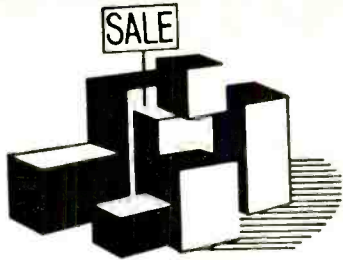

# Surplus Scene

By Alexander W. Burawa, Associate Editor

## IN THE BATTLE FOR FIRST PLACE, THE BUYER WINS

AS ELECTRONICS hobbyists, we are accustomed to thinking in terms of numbers. We measure parameters which have numerical quantities and design circuits and networks which require manipulations with numbers. But perhaps the most important numbers we deal with are the dollar and cents figures which ultimately control the degree of our involvement in the electronics hobby. To put our designs into practice requires spending our hard-earned cash for parts and equipment. Obviously, the less we spend for a given project, the more projects we can build. It is fortunate that military, government and commercial obsolescence as well as production overruns have created a Surplus Scene which can save us a great deal of money on parts expenditures.

Keeping abreast of which company happens to hold the number one spot with the lowest price for any given electronic device at any given moment is no easy task. The market is currently so competitive that the dealer with the lowest prices this week may well have the second or even third lowest prices next week. With what appears to be a price "war" on, the buyer—you and I—are the big winners. In the past few months alone, there has been a marked reduction in both unit and quantity cost of various items ranging from transistors, MSI and LSI integrated circuits, and all types of numeric readout indicators to the basic items like resistors, capacitors, switches, relays, transformers, and controls. In some respects, the price reductions have reversed the late inflationary trends of the economy—today, your dollar buys more than it did this time last year, but only if you are a smart shopper.

Some of the most stimulated competition has been in all types of solid-state devices. Among the top contenders for the "mostest

for the leastest" are such companies as *Solid-State-Systems, Inc.* (Box 773, Columbia, MO 65201), *B. & F. Enterprises* (Box 44, Hathorne, MA 01937), and *Poly-Paks* (Box 942E, Lynnfield, MA 01940). All three companies are strong on diodes and transistors but excel in their diversity of IC's especially the 7400 series of digital TTL integrated circuits and their compatible read-out indicators.

On the balance sheet, *John Meshna, Jr.* (19 Allerton St., Lynn, MA 01904) and *Delta Electronics Co.* (P.O. Box 1, Lynn, MA 01903) are also close contenders for the low-price top spot in the semiconductor area. Their offerings are just a bit less diverse in the very popular digital IC line.

For switches, resistors, potentiometers, capacitors, relays, transformers, and the like, *Meshna, Delta*, and *Poly-Paks* seem to share the laurels with the widest assortment of offerings.

For test equipment and communication gear, we shouldn't pass up *Fair Radio Sales Co.* (P.O. Box 1105, Lima, OH 45802), *Surplus Center* (P.O. Box 82209, Lincoln, NB 68501) *R. E. Goodheart Co., Inc.*, (Box 1220, Beverly Hills, CA 90213), and *Baynton Electronics Corp.* (2704 North Broad St., Philadelphia, PA 19132). Incidentally, *Baynton* stocks perhaps the widest selection of professional commercial test equipment available anywhere.

Now that the trend toward lower parts and equipment prices has been set, can we expect the market to improve even more? The answer is a qualified "Yes." While it is quite possible that the day is not long into the future when you will be able to buy IC's by the dozen, diodes by the hundred, etc., for only a dollar or so, the real improvement will come in the form of state-of-the-art items filtering down to the consumer parts markets. ♦

# ELECTRONICS MARKET PLACE

**NON-DISPLAY CLASSIFIED; COMMERCIAL RATE:** For firms or individuals offering commercial products or services, \$1.50 per word (including name and address). Minimum order \$15.00. Payment must accompany copy except when ads are placed by accredited advertising agencies. Frequency discount: 5% for 6 months; 10% for 12 months paid in advance. **READER RATE:** For individuals with a personal item to buy or sell, \$1.00 per word (including name and address.) No minimum! Payment must accompany copy. **DISPLAY CLASSIFIED:** 1" by 1 column (2 5/8" wide), \$185.00. 2" by 1 column, \$370.00. 3" by 1 column, \$555.00. Advertiser to supply cuts. For frequency rates, please inquire.

**GENERAL INFORMATION:** First word in all ads set in bold caps at no extra charge. All copy subject to publisher's approval. All advertisers using Post Office Boxes in their addresses **MUST** supply publisher with permanent address and telephone number before ad can be run. Closing Date: 1st of the 2nd month preceding cover date (for example, March issue closes January 1st). Send order and remittance to Hal Cymes, **POPULAR ELECTRONICS** Including **ELECTRONICS WORLD**, One Park Avenue, New York, New York 10016.

## FOR SALE

**FREE!** bargain catalog. Fiber optics, LED's, transistors, diodes, rectifiers, SCR's, triacs, parts. Poly Paks, Box 942, Lynnfield, Mass. 01940.

**GOVERNMENT** Surplus Receivers, Transmitters, Snooperscopes, Radios, Parts, Picture Catalog 25¢. Meshna, Nahant, Mass. 01908.

**ROCKETS:** Ideal for miniature transmitter tests. New illustrated catalog. 25¢. Single and multistage kits, cones, engines, launchers, trackers, rocket aerial cameras, technical information. Fast service. Estes Industries, Dept. 18-K, Penrose, Colorado 81240.

**INVESTIGATORS,** latest Electronics Aids. Free literature. Clifton, 11500-L NW 7th Ave., Miami, Florida 33168.

**LOWEST** Prices Electronic Parts. Confidential Catalog Free. **KNAPP,** 3174 8TH Ave. S.W., Largo, Fla. 33540.

## ALPHA-NUMERIC NIXIE TUBE

**BURROUGHS B-7971, GIANT NIXIE** (Alphanumeric) 15 segment tube, makes all digits and alphabet. An \$18.00 value. Complete with socket, data sheet, and information for making simple diode decoder.

STOCK NO. F5015  
3.50 ea., 3/10.00 10/25.00



## "VISIBLE" LIGHT EMITTING DIODES

Micro min. axial leads STOCK NO. F5020  
.95 ea. 6/5.00 25/19.00  
Jumbo TO-18 STOCK NO. F5021  
.95 ea. 6/5.00 25/19.00

## POWER TRANSISTOR/HEAT SINK ASSEMBLY

Westinghouse 1561-0404 (similar to 2N3055, mounted on double ribbed heat sink, with TO-3 socket and 2 ohm emitter resistor. 75 watts. A pair makes an entire amplifier output stage.

STOCK NO. F5022 1.35 ea. 2/2.50 8/9.00

### COMPUTER GRADE CAPACITORS (BRAND NEW)

40,000 mfd. 10 volts 1.25 ea. 6/7.00 Stk. No. F2026  
70,000 mfd. 10 volts 1.75 ea. 6/9.00 Stk. No. F2118  
6000 mfd. 55 volts 1.50 ea. 7/9.00 Stk. No. F2117  
3,750 mfd. 75 volts 1.75 ea. 6/9.00 Stk. No. F2116

### MINIMUM ORDER \$3.00

Many other items—send for new 40 page catalog. All merchandise guaranteed. Please include postage. Excess will be refunded.



**DELTA ELECTRONICS CO.**

BOX 1, LYNN, MASSACHUSETTS 01903

CIRCLE NO. 11 ON READER SERVICE CARD

**WE SELL CONSTRUCTION PLANS. TELEPHONE:** Answering Machine, Speakerphone, Carphone, Phonevision, Auto Dialer, Touch Button Dialer, Central Dial System. **TELEVISION:** \$35.00 Color Converter, Video Tape Recorder. \$25.00 Camera. **HOBBYIST:** Electron Microscope, 96 Hour Tape Music System, Ultrasonic Dishwasher, Radar-Oven. Plans \$4.95 each. **NEW ITEM:** \$75. Electronic Pocket Calculator, \$7.50. **COURSES:** Telephone Engineering \$39.50. Detective Electronics \$22.50, Integrated Circuit Engineering, \$49.50. **NEW SUPER HOBBY CATALOG** plus year's subscription to Electronic New Letter **AIRMAILED \$1.00.** Don Britton Enterprises, 6200 Wilshire Blvd., Los Angeles, Calif. 90048.

**ELECTRONIC PARTS,** semiconductors, kits. **FREE FLYER.** Large catalog \$1.00 deposit. **BIGELOW ELECTRONICS,** Bluffton, Ohio 45817.

**RADIO—T.V. Tubes—36¢ each.** Send for free catalog. Cornell, 4213 University, San Diego, Calif. 92105.

**CONVERT** any television to sensitive, big-screen oscilloscope. Only minor changes required. No electronic experience necessary. Illustrated plans. \$2.00. **Relco-A33,** Box 10563, Houston, Texas 77018.

**MECHANICAL, ELECTRONIC** devices catalog 10¢. Greatest Values—Lowest Prices. **Fertik's,** 5249 "D", Philadelphia, Pa. 19120.

**SENCORE, B&K** Test Equipment Unbelievable Prices. Free Catalog and Price Sheet. **Fordham Radio,** 265 East 149th Street, Bronx, N.Y. 10451.

**ELECTRONIC Ignition.** Various Types. Information 10¢. **Anderson Engineering,** Epson, N.H. 03239.

**CONSTRUCTION PLANS:** Laser . . . \$2.00. Investigation Aids—2-FM Microphone Transmitters . . . \$1.00. FM Telephone Transmitter . . . \$3.00. Sound Telescope . . . \$3.00. Infinity Amplifier . . . \$5.00. Free catalog. **Howard,** 2681 Peterboro Rd., Orchard Lake, Michigan 48033.

**NOW!** Enjoy the great outdoors in comfort with your pocket size electronic Skeeter Skat mosquito repeller. \$9.95 postpaid USA. Satisfaction guaranteed. **Detectron,** Dept. G-8, P.O. Box 243, San Gabriel, Calif. 91778.

**METERS—**Surplus, new, used, panel or portable. Send for list. **Hanchett,** Box 5577, Riverside, CA 92507.

**PYROTECHNICAL** chemicals, casings, tools, supplies, fuse, literature. Giant, illustrated catalogue/handbook includes formulas, instructions—50¢, with samples—\$1.00. **Westech,** Box 593, Logan, Utah 84321.

## BUILD YOUR OWN SPACE-AGE TV CAMERA



**ONLY KNOWN SOLID-STATE CAMERA KIT!** Ideal for experimenters, home, education, industry, etc. \* High quality \* Backed by over six years of lab & field testing \* Fully Guaranteed \* Converts to any TV set without modification \* Step-by-step construction manual \* Model XT1A Series D complete with vidicon \$149.50 postpaid anywhere in USA & Canada (this vidicon tube \$118.50pp).

PHONE or WRITE for CATALOG.

DIAL 402-963-3771

Many other kits, parts and plans available including starter kits, floppy-disk, coils, vidicon tubes, const. plans, audio amplifier kit, etc.

1301 BROADWAY

**ATV Research**

DAKOTA CITY, NEBR. 68731



**ELECTRONIC COMPONENTS**—Distributor prices, Free catalog. Box 2581, El Cajon, California 92021.

**ANTIGRAVITY**, experiment and theory, Rushed—\$2.00. U.S. Inquiries, Intertech 7A11, Box 5373, Station-F, Ottawa, Canada.

**JAPAN HONG KONG DIRECTORY**. World products information. \$1.00 today. Sekai Shogyo Annai, Hillyard, Washington 99207.

**EUROPEAN** and Japanese bargains catalogs. \$1 each. Dee, P.O. Box 9308, North Hollywood, Calif. 91609.

**BURGLAR ALARM SYSTEMS**. We manufacture intruder-fire detection systems, radar and perimeter types. Accessories available.

Free literature. Inquiries for dealership and wholesale prices must be on letterhead. U.S. and Canada only. Microtech Associates, Inc., Box 10147, St. Petersburg, Florida 33733.

**GET "Music Only" FM Programs**. SCA Adaptor fits any FM tuner or receiver. Free list of stations with order. Kit \$14.50 (with Squelch \$19.50) Wired and Tested \$25.00 (with Squelch \$29.95). All plus postage and insurance. Thousands Sold. SWTPC, Box E32040, San Antonio, Tex. 78284.

**BURGLAR Alarm Systems** equipment, dealers and private. Write: United Security, Box 2428, Dublin, Calif. 94566.

**FREE Kit Catalog**: Shortproof powersupply \$39.50. Ultrasonic Alarm \$37.25. SWTPC, Box B32040, San Antonio, Tex. 78284.

**FREE catalog** new electronic devices! World's smallest transmitter \$19.95! Telephone Answerer \$49.50! Telephone Recording Device \$19.95! Lie Detector \$19.95! Many more! Sonic Devices, 69-29E Queens Blvd., New York 11377.

**FREE Catalog**. Parts, circuit boards for Popular Electronics projects. PAIA Electronics, Box C14359, Oklahoma City, OK 73114.

## FIRE & BURGLAR ALARMS

### 1972 Handbook & Catalog

# Save Hundreds of Dollars



Learn the cost of Professional Alarm Equipment. Know how it is installed. Discover how you can save Hundreds-Of-Dollars by installing your own system. See the latest in technology such as **LASER BEAMS, INFRARED BODY HEAT DETECTORS and ELECTRONIC SIRENS**. 1972 "Handbook & Catalog" 84 pages. just \$1.00 postage and handling. \$1.00 is credited to first order.

### ALARM COMPONENT DISTRIBUTORS

33 New Haven Ave., Dept. P.E., Milford, Conn. 06460

**FREE Kit Catalog**: Color Organs \$11.00. Psychedelic Strobes \$17.50. Professional quality-lowest prices. SWTPC, Box F32040, San Antonio, Tex. 78284.

**TEST EQUIPMENT**, Aerospace-Laboratory Grade. Request your needs; will mail appropriate catalogs (we have 24 catalog categories). Only for Engineers, Businesses, Schools and advanced Technicians. Goodheart, Box 1220, Beverly Hills, Calif. 90213.

**AMATEUR SCIENTISTS**, Electronics Experimenters, Science Fair Students . . . Construction Plans—Complete, including drawings, schematics, parts list with prices and sources . . . Long-Range "Sound Telescope"—This amazing device enables you to hear conversations, birds and animals, other sounds hundreds of feet away. Very directional. Transistorized. uses 9v battery—\$3.00 . . . Robot Man—Psychedelic shows—Lasers—Emotion/Lie Detector—Touch-Tone Dial—Quadrasonic Adapter—Transistorized Ignition—Burglar Alarm—Sound Meter . . . over 60 items. Send 25¢ coin (no stamps) for complete catalog. Technical Writers Group, Box 5994, State College Station, Raleigh, N.C. 27607.

**SURPLUS electronics** for everyone. Free catalog. U.S. inquiries. ETCO, 464 McGill, Montreal, Canada.

## LIGHT-ACTIVATED RELAY

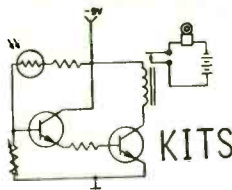

**KITS**

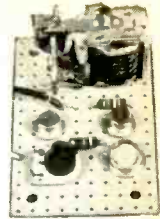

For **ALARM, SIREN, FLOODLIGHT or NIGHT LIGHT**: battery operated. Kit includes:— Includes a **Clairrex Photocell** and a **Pot** to reduce the sensitivity of the photocell. **Low battery drain**. A regular flashlight at a distance of 30 feet triggers the relay. Relay contacts carry two amperes at 120 volts AC. **only \$3.85**

1 Battery clip and colored wires  
Perforated mounting board and a booklet of complete wiring, mounting and operating instructions.

## REED SWITCH with RELAY \$2.85

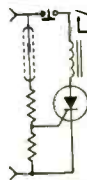

The slightest momentary contact of the reed switch will latch the Silicon Controlled Rectifier and activate the relay until power is turned off. Wire up a store, factory or home with any number of these reed switches—on windows or doors—set the magnet at any height so windows may be partially opened. Extra strong magnet included. Booklet of wiring instructions and suggestions included. Extra ALNICO MAGNET & SW. 39c

## AUTOMOBILE BURGLAR ALARM

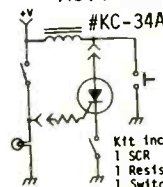

**SWITCH with key for both these alarms \$2.40 extra**

Kit includes:  
1 SCR  
1 Resistor  
1 Switch  
10 ft wire

**\$1.50**

This alarm is activated by a hidden switch (or key switch) under a mudguard. When the car door is opened the horn blows and stays on until the switch is turned off. The SCR is the important component in this circuit.

The added feature of this alarm is that it is NOT activated when the door is opened, but when the motor is started. The switch may be hidden inside the car—Under dashboard. Two additional capacitors included plus parts shown at left.

Kit #KC-34B

Both kits include booklet of instructions.



## GE READOUT \$1.95 EACH

Sharp, bluish-green fluorescent digital display; 7/16" numeric characters in 3/8" glass envelope. Filament: 1.5 volts at 45 mA. Plate: 25 volts at about 5 mA. Long, 1.5" leads. No socket required.

## BURROUGHS NIXIE B-7971 \$1.95 EACH

As used on stock-market quotation boards. All alpha and digital characters are 2 1/2" high. Overall height is 4 1/2". The fifteen-segment neon tube operates at 170 volts dc. Instead of sockets, we supply contacts that fit on the pins (no extra charge).



Terms: Net cash w/order. Write for catalog.

## CORTLANDT ELECTRONICS INC.

16 Hudson St. New York, N.Y. 10013

**CIRCLE NO. 9 ON READER SERVICE CARD**

**WE SELL CONSTRUCTION PLANS, Kits and Wired Units**—silver recovery unit—x-ray fluoroscope machine—chemical formulary (home products)—200 watt inverter (12vdc-120vac)—coin cleaner/electroplater—plans \$5.00 each—alternator adapter (produce 120 volts from ANY alternated vehicle!) plans \$6.95—PLUS MANY MORE—ask for FREE catalog—Creative Products, Department EH, 1551 East Loop 820, Fort Worth, Texas 76112.

**MAGNETIC PICKUP** CD ignition plans. Write SES Enterprises, Box 607, Ferndale, Wash. 98248.

**SEMICONDUCTORS** at industrial discount prices. Catalog \$1.00. Box 24395, San Jose, California 95134.

**BURGLAR-FIRE** alarm supplies and information. Free catalog. Protecto Alarm Sales, Box 357-G, Birch Run, Michigan 48415.

**PARTS! CORNELL TUBES!**  
FREE Send For FREE  
CORNELL'S  
New Color  
Catalog  
48 Pgs. New Items  
**33¢** per tube  
**36¢** per tube  
ORDER FREE  
IF NOT SHIPPED  
IN 24 HOURS!  
IN LOTS OF 100  
4219 UNIVERSITY AVE. SAN DIEGO, CALIF. 92105

**AMPEX FR100B** 14 channel recorder \$2900. Weber, 4205 Sherrod, Pittsburgh, Pa. 15201.

**SKILL-RATED** construction plans. Free catalog. Systems-Mart, Box 25280, Portland, Oregon 97225.

**WRITE** for our free 32 page catalog. It lists resistors (14 different types, in kits and singly), 1542 tube types, 3024 different transistor types, many transistor kits, rectifiers in kits and singly, condensers of various types, tools, wire, antennae, phonograph cartridges and needles, speakers, CRT boosters, controls, switches, T.V. tuners, yokes, fly-backs, etc. Hytron Hudson, Dept. PE, 2201 Bergenline Ave., Union City, N. J. 07087.

**CONDENSER MICROPHONES** in easy to build kits. Free details. Write: Electronics Enterprises, 3305A Pestana Way, Livermore, California 94550.

**LASER-PARTS** and supplies for sale, all types: Gas Crystal Dye etc. George Panos, 13009 Fairford Ave., Norwalk, Calif. 90650.

**250 SELECTED RESISTORS**—1/2 Watt, 10% Carbon composition. 5 each of 50 different values between 10 Ohms and 22 Megohms. \$34 retail for \$9.00. Send check to Electro-Harmonix, 15 West 26th Street, N.Y., N.Y. 10010. Dept. EHC.

**RESISTORS, Capacitors.** Best prices on small quantities. Same day service. Free list. Hammond Wells, Box 7451, Jacksonville, Florida 32210.

**TELEGRAPH** keys, traditional manual type, heavy duty, by Winslow Electronics. 5 1/2" x 2 3/4". Originally \$18.50, Sale \$12.95. BILLYBUMPER, Box 125, Newark, New York 14513.

**ELECTRONIC ORGAN KITS,** keyboards, oscillator coils, I.C. tone generators, every component for electronic organ assembly, 25¢ for catalog. Devtronix Organ Products, 5872 Amapola Dr., San Jose, Calif. 95129.

**SOIL-CEMENT.** Make pathways, patios, play areas from Soil-Cement. Durable, economical. Instructions \$2.00. Alvey's Acre, Box 42 PE, Brookhaven, MS. 39601.

**HOBBYISTS!** Logic IC project kits. Combination Lock, \$5.95. Catalog free. John Huntley, 1351 Mahoney, Rodeo, Calif. 94572.

**HAM, CB** equipment, super discount prices. Write, Goodies List, Specific Quotes. Madison Electronics, 1508 McKinney, Houston, Texas 77002. (713) 224-2668.

**FREE** Electronics plans and kit catalog. McCord Electronics, Box 41, Sylvania, Ohio 43560.

**RESISTORS, Op Amps.** Free Flyer, Kingtree, Box 3092, Columbus, Ohio 43210.

**FINALLY!** Realistically priced high quality telephone recording device. Size 3 x 1 1/2 x 1". Plugs into tape recorder with standard miniature plug. Special plugs (specify) no extra charge. Easy to follow instructions, fully guaranteed. Only \$9.75. Calif. residents add 5% tax. Viking International, Box 632, Newhall, Cal. 91321.

**ELECTRONIC Ignitions**—3 models. Southland, Box 3591, Baytown, Texas 77520.

**UNIQUE** and unusual electronic project plans. Free information send Design Systems, Box 386, Endicott, New York 13760.

**HAMMOND ORGAN** string bass. Simple installation. ETEC Electronics Company, PO 402, San Luis Obispo, Calif. 93401.

**FOR SALE** 3 new Shibaden Model HV-50 TV cameras less lens. List price \$395.00; Sell for \$210.00 each. One PANASONIC TV camera with lens. List \$360.00 new; Sell for \$275.00. Roy Salecker, Conco Inc., 5632 Northwest Highway, Chicago, Illinois 60646. (312) 763-7433.

**ELECTROENCEPHALOPHONE:** brainwave monitor. Professional bio-feedback instruments. J&J, 8102-E, Bainbridge, Wash. 98110.

## PLANS AND KITS

**FREE** Kit Catalog: Why does every major College, University, Technical School, Research & Development Center buy from us? Because we have the highest quality and lowest prices. Free catalog. SWTPC, Box H32040, San Antonio, Tex. 78284.

**COMPUTER,** high speed general purpose with stored program. Most adaptable and easily understood type. Build with surplus integrated circuits. Plans \$5.00. Buckley Electronics, 927 Marco Pl., Venice, Calif. 90291.

**FREE** Kit Catalog: Amazing new Universal Digital Instruments with plugins as featured in Popular Electronics. Unbeatable prices. SWTPC, Box D32040, San Antonio, Tex. 78284.

**FREE** Kit Catalog: Digital Microlab \$29.95. Also Segmented and Nixie Readouts, Timebases, Scaler, Electronic Digital Clocks (all featured in Popular Electronics) SWTPC, Box C32040, San Antonio, Tex. 78284.

**PLANS:** Profitable electronic devices. Literature free. Barta-PED, Box 248, Walnut Creek, California 94596.

**RECHARGE** flashlight batteries using new technique. Plans \$2.00. P.O. Box 37, Postal Station C, Winnipeg, Manitoba, R3M3S3. U. S. Inquiries.

## WANTED

**QUICKSILVER,** Platinum, Silver, Gold, Ores Analyzed. Free Circular. Mercury Terminal, Norwood, Mass. 02062.

**QUICK CASH** . . . for Electronic Tubes, Semi-Conductors, Equipment (Receivers, Transmitters, Scopes, Vacuum Variables etc.) Send Lists now! Write: Barry Electronics, 512 Broadway, New York, NY 10012. (212) 925-7000.

## ELECTRICAL SUPPLIES AND EQUIPMENT

**PLATING** Equipment, Portable Platers, Supplies and "Know-How." Build your own tanks for nickel, chrome, etc. Easy-to-install PVC liners. Rectifier components—all sizes. Schematics, parts lists, formulas, operating instructions for all plating. Guaranteed to save you 25%-75%. Some good units for sale. Write for details. Platers Service Company, 1511-PE Esperanza, Los Angeles. Calif. 90023.

## HIGH FIDELITY

**DIAMOND NEEDLES** and Stereo Cartridges at Discount prices for Shure, Pickering, Stanton, Empire, Grado and ADC. Send for free catalog. All merchandise brand new and factory sealed. LYLE CARTRIDGES, Dept. P, Box 69, Kensington Station, Brooklyn, New York 11218.

### 50 MEGAHERTZ LDW COST COUNTER



Here is a new item, featured because of numerous customer suggestions. We have taken the basic power supply, chassis and cover from our clock kit, and by substituting a new front panel and printed circuit board, have made a

lowest cost frequency counter. The unbelievable low cost is due to our use of our large stock of unused surplus nixies, the new 74196 50 MHz decade counter, and the compactness of parts with 0.1 other kits. Readout is to six decades, time base is 1 second, 0.1 seconds, or external. Design is modular, for ease of construction, compactness, and reparability.

- 50 MHz six digit counter, using line frequency as time base, complete except for cover \$97.50
- Optional crystal controlled time base plus in conversion \$23.50
- Cover, blue or black anodized \$4.50

### BUILD YOUR OWN ELECTRONIC CALCULATOR FOR ONLY \$108.00!



A complete calculator kit, complete with self contained power supply and case, indispensable in the home office or school. Simple enough for a child to build. Some of the features of the calculator are as follows:

- MOS integrated circuits (extra large scale integration) reduce the number of components to a minimum for easy assembly
- Displays eight digits on large size seven segment displays
- Full function complement keyboard features addition, subtraction, multiplication, division, alternate display, multiplication by 10
- Sixteen digit entry and sixteen digit results are possible with alternate display key
- Leading zeros suppressed
- Chain operation
- All integrated circuits and displays are socket mounted and replaceable

constant, clear all, clear entry, and decimal point set. Sixteen digit entry and sixteen digit results are possible with alternate display key. • Leading zeros suppressed • Chain operation • All integrated circuits and displays are socket mounted and replaceable.

So reliable and simple to build, we can make this guarantee: If for any reason you cannot succeed in getting your calculator to function properly after completing construction, for a flat function fee of \$10.00, B and F will repair and ship back your calculator anywhere in the USA. This applies regardless of the age of the assembler, barring gross negligence or the use of acid core solder in construction.

### DIGITAL CLOCK KIT WITH NIXIE DISPLAY

We have well over 20,000 surplus nixies in stock, and because of this bargain purchase we can sell a complete digital clock kit for less than the usual cost of the display tubes only. We provide a complete etched and thru-plated circuit board, all integrated circuits, complete power supply, display tubes, I.C. sockets and a nice front panel with polaroid view. We have never seen anyone else kit for less than \$100.00 before. Includes BCD outputs for use as timer option. May be wired for 12 or 24 hour display. Indicates hours, minutes, seconds.

- Clock Kit, complete less outside cover \$57.50
- Aluminum tube or black anodized cover (specify) \$4.50
- SHRINK TUBING SPECIAL. Assortment of 200 pieces of shrink tubing, diameters 1/8" to 1/2", length 1/2" to 2" \$1.25

Price \$125.00

### KEYBOARDS



Three keyboards are available: 20 key calculator keyboard, 40 key alphanumeric, and 12 key touch tone. All have separate contacts carried out to edge connector.

- Touch Tone Keyboard \$9.50
- Calculator Keyboard \$14.50
- Alphanumeric Keyboard \$29.00

### LIGHT EMITTING DIODE NUMERIC DISPLAY

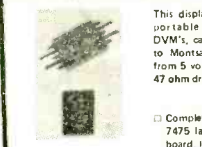

This display is excellent for small portable electronics, such as DVM's, calculators, etc. Equivalent to Monsanto M2000. Operates from 5 Volts, 20 milliamperes, with 47 ohm dropping resistor.

- \$3.25 Each
- 10 For \$27.50
- 7475 latch 7447, printed circuit board, led readout \$9.50

### LATEST HARD-TO-GET SEMICONDUCTORS

- MJS 4988 silicon uni-lateral switch. Useful for voltage sensitive switch, sweep generators, etc. \$1.00
- MIS A64 PNP high current Darlingtion transistor. Super-high gain in small package. 2/51.00
- MPS A14, same as above, NPN. 2/51.00

### THIS MONTHS FEATURE ITEM



### POCKET CALCULATOR KIT

This is the kit you have been waiting for. So compact it actually fits in a shirt pocket! It performs every function you would expect in a DESR calculator, including constant and chain operation, and full floating decimal. The unit is powered by self contained batteries, and uses 8 digit LED displays. The calculations are performed by a single 40 pin integrated circuit, which can truly be called large scale integration (LSI).

As a student, engineer, salesman, accountant, or anyone who would like fast accurate answers, this calculator fills the bill, and at a price that unquestionably makes this the lowest priced high quality calculator available this month.

- Pocket Calculator Kit \$75.00

### RECHARGEABLE BATTERY/CHARGER KIT

This option allows the throw-away alkaline battery to be replaced with a nicad battery, and includes a charger to recharge this battery. The unit may be run during the recharge cycle.

- Battery/Charger Kit \$17.50

### LOGIC AND OPERATIONAL AMP SUPPLIES

- Figure A, potted logic supply, 5 Volts at 1 Ampere, short circuit proof, ultra high regulation, ultra low ripple \$16.00
- Figure A, potted Dp Amp supply, +15 Volts, and -15 Volts at 0.5 Amperes. Mig. by Analog Devices, similar to their model 902. Short circuit proof, ultra high performance \$29.00
- Figure B, 5 Volt 1Amp supply, regulated by Fairchild 9305, short circuit protected \$9.75
- Same as above, in kit form \$7.75
- Matching connector for above \$1.00
- 5 Volt 5 Amp regulated supply, by Bluyline (not shown) \$29.00

### LIGHT EMITTING DIODES

Monsanto MV 50 or equivalent LED's. Now less expensive than filamentary bulbs. At this price we make them into logic circuits as status indicators, build low cost counters using them as panel lights. Rated at 10 - 40 Ma @2V.

- 10 LED's \$3.00
- 100 LED's \$25.00
- 1000 LED's \$200.00

### LOUDSPEAKER SYSTEM COMPONENT SPECIAL!!

We have made an excellent purchase of an extensive inventory of a local manufacturer's speaker systems although we aren't allowed to mention on the manufacturer's spec sheet the specs should make it self evident. The woofer is a 12" free edge (acoustic suspension) unit, with 2" voice coil and a 2 lb. magnet. The mid range is a 5" unit with a 1.5" voice coil and a 1 lb. magnet. The tweeter is of the dome type, for best high frequency dispersion. Crossover between woofer and mid range is by an R-L-C network, while high frequency crossover is by an R-C network. Balance controls are provided for both mid-range and tweeter. Plans for a suitable enclosure are provided.

- Speaker System \$29.00 ea./2 for \$55.00



### CALCULATOR CHIP SPECIAL

B and F has purchased a quantity of MOS large scale integration chips for calculators. We are not allowed to mention the manufacturer's name, however, the specs should make them self-evident.

- Set "X": Four 24 pin I.C.'s, BCD output, 16 digit, fixed automatic decimal point, possible memory expansion, constant \$129.00
- Set "Y": Single 40 pin, 7 segment output, 12 digit, fixed automatic decimal, no constant \$115.00
- Set "Z": Single 40 pin I.C., 7 segment output, 8 digit, floating point, constant \$119.50

### LINEAR DEVICES, OP AMPS, REGULATORS

- 719 High performance Op-Amp \$5.00
- 711 Dual Comparator \$5.00
- 723 Regulator \$11.25
- 741 Compensated Op-Amp \$5.50
- 558 Dual 741 \$11.00
- LM309 5 Volt 1 amp Regulator, TO-3 \$22.25

### FAIRCHILD VOLTAGE REGULATOR

Fairchild UCH7805 5 Volt 1 amp voltage regulator. Perfect for logic supplies, very compact \$1.95

### SANKEN HYBRID AUDIO AMPLIFIER MODULES



We have made a fortunate purchase of Sanken Audio Amplifier Hybrid Modules. Buy these you can build your own audio amplifiers at less than the price of discrete components. Just add a power supply, and

chassis to act as a heat sink. Brand new units, in original boxes, guaranteed by B and F Sanken and the Sanken U.S. distributor. Available in three sizes: 10 watts RMS (20 watts music power), 25 watts RMS (50 watts M.P.), and 50 watts RMS (100 watts M.P.) per channel. 20 page manufacturer's instruction book included. Sanken amplifiers have proved so simple and reliable, that they are being used for industrial applications, such as stereo amplifiers and wide band laboratory amplifiers.

- SI1010Y 10 watt RMS amplifier, industrial grade \$4.75
- SI1025A 25 watt RMS amplifier, industrial grade \$14.75
- SI1050A 50 watt RMS amplifier, industrial grade \$22.50
- SI1025E 25 watt RMS amplifier, entertainment grade \$14.00
- SI1050E 50 watt RMS amplifier, entertainment grade \$21.00
- Transformer for stereo 10 watt amplifiers (2 lbs.) \$1.95
- Set of (3) 2000 mfd 50V capacitors for 10 watt stereo \$4.40
- Set of (3) 2200 mfd 75V capacitors for 25 or 50 watt amplifiers \$5.00
- 4 Amp Bridge Rectifier, suitable for all amplifiers \$2.00
- Complete kit for 100 watt RMS stereo amplifier (200 watt music) including two 50 watt Sanken hybrids, all parts, instructions, and nice 1 1/2" thick black anodized and punched chassis \$100.00
- Same for 50 watt RMS stereo amplifier, includes two 25 watt Sankens, etc. \$58.00
- Same for 20 watt RMS stereo, includes two 10 watt Sankens, etc. \$30.00

### SGS 1A4 621 AT AUDIO AMPLIFIER

11 C audio amplifier in 14 pin DIP package, provides for 4 watts power with proper heat sink, and 28 Volt supply. Can be used at 12 Volts with reduced output power. \$1.95

### HIGH POWER SCR'S

SCR's - invaluable for high power applications, motor speed controls, lighting circuits, welding controls, etc. Never before at this low price. Brand new packaged devices, complete with data sheet and 24 page consumer applications manual.

- 2N5062 Plastic 100V 1 amp \$1.35
- 2N5064 Plastic 200V 1 amp \$1.40
- 2N4169 100V/8 amp stud 1.45
- 2N4170 200V/8 amp stud 1.65
- 2N4172 400V/8 amp stud 1.95
- 2N3525 400V/3 amp press fit .95
- 2N1772/C15A 100V/8 amp stud 1.75
- 2N1774/C15B 200V/8 amp stud 1.95
- 2N1775/C15H 400V/8 amp stud 2.50
- 2N1844/C20A 100V/12 amp stud 1.75
- 2N1846/C20B 200V/12 amp stud 1.95
- 2N5169 200V/20 amp stud 3.75
- 2N5170 50V/20 amp stud 4.75
- 2N5171 100V/20 amp stud 6.75
- 2N3896/C30A 100V/25 amp stud 2.95
- 2N3897/C30B 200V/25 amp stud 3.95
- 2N3899/C30E 300V/25 amp stud 4.95

### SANKEN HIGH POWER, HIGH PERFORMANCE HYBRID VOLTAGE REGULATORS

These hybrid regulators are easy to use, requiring no external components. Excellent for operational amplifier supplies, logic supplies and other high performance applications. All regulators have less than 50 millivolts ripple and better than 1% line and load regulation, some models far exceeding this specification.

- SI3120E 12 Volts, 1 Ampere \$2.25
- SI3150E 15 Volts, 1 Ampere \$2.25
- SI3240E 24 Volts, 1 Ampere \$2.25
- SI3505E 5 Volts, 1 Ampere \$2.25
- SI3554M 5 Volts, 3 Amperes \$7.00

### ALL ITEMS WHERE WEIGHT NOT SPECIFIED

POSTAGE PAID IN THE U.S.A.  
Phone in charges to (617) 531-5774 or (617) 532-2323.  
BankAmericard - Mastercharge, \$10.00 minimum. No C.O.D.'s please.



\$10.00 Minimum Charge

### B. & F. ENTERPRISES

Phone (617) 532-2323  
P. O. Box 44, Haltham, Massachusetts 01937

**LEDS**

FLV 100 VIS LED'S	.....	65
GaAs IR LED'S	.....	65
MRD 148 Photo darlington	.....	65

**VARIABLE CAPACITANCE DIODES**

(Similar to 1N5463A) used to tune VHF, color TV, & FM broadcast sets ..... \$ .95

7400	.....25	7475	.....80
7401	.....25	7476	.....1.00
7402	.....25	7480	.....75
7404	.....28	7481	.....1.25
7410	.....25	7483	.....1.25
7413	.....75	7486	......57
7420	.....25	7490	......75
7430	.....25	7492	......80
7440	.....25	7493	......75
7441	.....1.30	7495	......75
7447	.....1.15	74107	.....85
7450	.....25	74121	.....55
7460	.....25	74192	.....95
7472	.....50	8570	.....1.75
7473	.....50	8590	.....1.50
7474	.....50		

**TANTULUM CAPACITORS**

4.7 MFD AT 20V	.....	5	\$1.00
10 MFD AT 20V	.....	4	\$1.00
4.7 MFD AT 100V	.....	5	.50
11 MFD AT 100V	.....	5	.75
2N3584 250 Vceo			
NPN 2A Silicon Trans.	.....	1	\$1.70
2N3055 7 amp NPN			
Silicon Transistor	.....	1	\$1.00

These regulated power supplies have been designed to provide complementary power for Operational Amplifiers, Functional Modules, A-D & D-A Converters and Digital Logic.

The supplies are completely self contained (no external parts required). Epoxy encapsulation provides properties close to a true hermetic seal.

**FEATURES**

- Short Circuit Protected
- Compact Size
- No Derating Over Specified Operating Range



MODEL	SE904	SE902	SE903	SE905
Output Voltage (VDC)	-15	-15	5	5
Output Current (MA)	50	100	500	1000
Line (105-125 VAC)	\$18.95	\$26.95	\$22.95	\$34.95

NE 565 PHASE LOCK LOOPS ..... \$3.95

MINIATURE TRIM POTS  
500 OHM, 10K, 20K, 25K, 50K ..... or 3 for \$2.00  
400 PRV 5A Full Wave Bridge ..... \$1.40  
200 PRV 15A Full Wave Rectifier ..... \$ .95

**TRIACS**

PRV	1A	10A	15A	20A
100	.40	.70	1.00	1.20
200	.70	1.10	1.50	1.60
300	.90	1.35	1.90	2.00
400	1.10	1.60	2.70	2.40
500	1.50	2.00	3.20	2.80

Press Fit  
TI543 UJT's ..... .50  
2N3819 N Channel FET's ..... .45  
D13T PROG. UJT's ..... .75

**Silicon Power Rectifiers**

PRV	1A	3A	12A	50A
100	.06	.09	.30	.85
200	.07	.16	.35	1.25
400	.09	.20	.45	1.50
600	.11	.30	.70	1.30
800	.15	.40	.85	2.30
1000	.20	.55	1.10	2.75

**Silicon Control Rectifiers**

PRV	3A	7A	20A	70A
100	.30	.45	1.00	3.50
200	.50	.75	1.25	6.50
300	.60	.90	1.50	
400	.70	1.10	1.75	9.50
500	.80	1.25	2.00	
600	.90	1.40	2.25	11.00

IN4886 POWER VARIATORS \$4.95

**TEST EQUIPMENT SPECIALS**

(Used in good condition)  
Dumont 304A scopes ..... \$ .95  
Tektronic 531 with B or K plug-in ..... \$475.  
HP 521C counter ..... \$125.  
HP 400D voltmeter ..... \$95.  
Ballantine 314 voltmeter \$95.  
Lepel T-5N-3, 12.5 KVA induction heater ..... \$1295.

**DECADE COUNTER KIT**

Consisting of:  
1—Nixie tube & socket (8754)  
1—7490  
1—7475  
1—7441  
**\$5.25**

709C OPER. AMP ..... \$ .50  
741 OPER. AMP. .... \$ .50  
748 Adjust 741 ..... \$ .95  
Dual 709 ..... \$1.39  
723 TVR-2002 high power 723 ..... \$1.00

**NIXIE TUBES**

Similar to Raytheon 8754, with socket & data sheet ..... \$1.85

MINIATURE 7 segment cold cathode readout MG-19F ..... \$2.85

Terms: FOB Cambridge, Mass. Send check or Money Order. Include postage. Average Wt. per Package 1/2 lb. No C.O.D.'s.

Minimum Order \$3.00 Rated companies 30 days net

Send \$ .20 for our Latest catalog featuring Transistors and Rectifiers: 325 Elm St., Cambridge, Mass.

**SOLID STATE SALES**

Post Office Box 74A

Somerville, Mass. 02143

Tel. (617) 547-4005

**CIRCLE NO. 32 ON READER SERVICE CARD**

**STEREO** Components at lowest prices. Send for free catalog. Carston, Box 1094-A, Danbury, Conn. 06810.

**FREE Kit Catalog.** Amplifiers: Lil Tiger \$11.10, Universal Tiger \$30.00. Preamp \$44.50 (Featured in Popular Electronics) Mixer-6 Input \$13.75. SWTPC, Box A32040, San Antonio, Tex. 78284.

**TAKE SOUND OFF** your Cassette or Cartridge with "ERASETTE". Our exclusive electronic wash (-65db 0-VU) gives you a like new Cassette or Cartridge in an instant. Less than 1—lb: self contained, 4—"AA" battery powered. \$12.50 postpaid. Calif. residents add sales tax. Magnesonics Corp., Box 127, Northridge, California 91324.

**STEREO CARTRIDGES,** Stereo Phones, Stereo Equipment, Blank Tape. Write for quotes: Custom Stereo, 124 Adams Street, Fairmont, West Virginia 26554.

**J. GORDON HOLT** publishes a magazine, too. For free sample back issue, write STEREOPHILE, Box 47P, Elwyn, Pa. 19063.

**TUBES**

**RADIO & T.V. Tubes**—36¢ each. Send for free Catalog. Cornell, 4213 University, San Diego, Calif. 92105.

**ELECTRONIC TUBES,** Semiconductors, Equipment, Telephones, Public Address, Intercoms, CB, Walkie-Talkies, etc. Quality Merchandise Only! Serving Engineers, Purchasing Agents, TV/Hi-Fi Servicemen and Hams for 28 years. Domestic and Export. Write for Catalog or call (212) 925-7000. **BARRY ELECTRONICS,** 512 Broadway, New York, N. Y. 10012.

**RECEIVING & INDUSTRIAL TUBES, TRANSISTORS.** All Brands—Biggest Discounts. Technicians, Hobbyists, Experimenters—Request **FREE** Giant Catalog and **SAVE!** **ZALYTRON,** 469 Jericho Turnpike, Mineola, N.Y. 11501.

**SAVE** money on parts and transmitting-receiving tubes, foreign-domestic. Send 25¢ for giant catalog. Refunded first order. United Radio Company, 56-P Ferry Street, Newark, N.J. 07105.

**TUBES "Oldies",** latest. Lists free. Steinmetz, 7519 Maplewood, Hammond, Indiana 46324.

**TUBES** receiving, factory boxed, low prices, free Price list. Transleteronic, Inc., 1306 40th Street, Brooklyn, N.Y. 11218A, Telephone: 212-633-2800.

**TAPE AND RECORDERS**

**STEREO TAPE RENTAL** for particular people. Free catalog. Gold Coast Tape Library, Box 2262, Palm Village Station, Hialeah, Fla. 33012.

**OLD** Radio Programs on cassettes or reels. High quality, low prices, thousands to choose from, professional equipment. catalog 50¢. Remember Radio Inc., Box 2513, Norman, Okla. 73069.

**RENT** 4-Track open reel tapes—all major labels—3,000 different—free brochure. Stereo-Parti, 55 St. James Drive, Santa Rosa, Ca. 95401.

**MEMOREX** recording tape, audio & video lowest prices, write for free information. Bergetz Systems Co., Box 1181, Melrose Park, Ill. 60161.

**RENT** Stereo Tapes, open reel cartridges, cassettes. Complete catalogue \$0.75. Write: Caltape, P. O. Box 5716, Redwood City, Calif. 94063.

**NEW** revolving tape storage rack. Heavy duty ball-bearing base. Real wood furniture construction. Walnut finish. Holds 48. Specify 8-track or cassette. \$14.95 ppd. Money-back guarantee. FT Products, Box 236PE, Brooklyn, New York 11204.

**DO-IT-YOURSELF**

**PROFESSIONAL ELECTRONICS PROJECTS**—\$1.00 up. Catalog 25¢. PARKS, Box 25665A, Seattle, Wash. 98125.

POPULAR ELECTRONICS Including Electronics World

## REPAIRS AND SERVICES

TV Tuners rebuilt and aligned per manufacturers specification. Only \$9.50. Any make UHF or VHF Ninety day written guarantee. Ship complete with tubes or write for free mailing kit and dealer brochure. JW Electronics, Box 51C, Bloomington, Indiana 47401.

## INSTRUCTION

**LEARN ELECTRONIC ORGAN SERVICING** at home all makes including transistor. Experimental kit—trouble-shooting. Accredited NHSC, Free Booklet. **NILES BRYANT SCHOOL**, 3631 Stockton, Dept. A, Sacramento, Calif. 95820.

**LEARN WHILE ASLEEP**, Hypnotize! Strange catalog free. Auto-suggestion, Box 24-2D, Olympia, Washington 98501.

F. C. C. 1st phone license training in 5 weeks. R.E.I.'s intensive training produces outstanding results. For information and free brochure call toll free: 1-800-237-2251, or write home office, Radio Engineering Incorporated Schools, 1336 Main Street, Sarasota, Florida 33577. Florida residents call (813) 955-6922.

**HIGHLY** effective home study courses in Electronics Engineering Technology and Electronics Engineering Mathematics. Earn your Degree. Write for Free Descriptive Literature. Cook's Institute of Electronics Engineering, (Dept. 15), P.O. Box 10634, Jackson, Miss. 39209. (Established 1945).

**ASSOCIATE DEGREE IN ELECTRONICS** through correspondence instruction. G.I. Bill approved. Free catalog. Grantham, 1509 N. Western, Hollywood, California 90027.

**F.C.C. TYPE EXAM** . . . Guaranteed to prepare you for F.C.C. 3rd, 2nd, and 1st phone exams, 3rd class, \$7.00; 2nd class, \$12.00; 1st class, \$16.00; complete package, \$25.00. Research Company, Rt. 2, Box 448, Calera, Alabama 35040.

**FCC First and Second Tests**. \$8.95. Electronic Tutoring, Box 24190, Cleveland, Ohio 44124.

**LOGIC** trainers catalogs 50¢. UTI, POB 252, Waldwick, N.J. 07463.

**EARN** College Degrees at home. Many Subjects. Florida State Christian College, Post Office Box 1674, Fort Lauderdale, Fla. 33302.

**HIGHLY** Effective, Profitable Short Courses. (65 Choices) Free Literature, CIEE-D, Box 10634, Jackson, Mississippi 39209.

**FREE** Bible course! Degree! Request information! 708 Bragg, Monroe, North Carolina 28110.

**F.C.C. EXAM MANUAL**

The Original Test-Answers exam manual that prepares you at home for FCC First and Second class licenses. Includes Updated multiple choice tests and key Schematic diagrams. PLUS "Self-Study Ability Test." — ONLY: \$9.95 Postpaid.

**COMMAND PRODUCTIONS**  
RADIO ENGINEERING DIVISION **P.O. BOX 26348-P**  
**SAN FRANCISCO, CALIF. 94126**



## PERSONALS

**INVESTIGATORS**, Latest Electronics Aids. Free Literature. Clifton, 11500-K NW 7th Ave., Miami, Florida 33168.

**MAKE FRIENDS WORLDWIDE** through international correspondence. Illustrated brochure free. Hermes, Berlin 11, Germany.

## INVENTIONS WANTED

**INVENTIONS** wanted. Patented; unpatented. Global Marketing Service, 2420-P 77th, Oakland, Calif. 94605.

AUGUST 1972

**GREGORY ELECTRONICS**  
Reconditioned & Used  
**FM 2-WAY RADIO SAVINGS**  
Partial List—Send for New Catalog

**MOTOROLA U44BBT**  
450-470 MHz  
12 volt, 15 watts transistor  
power supply.

\$48

With accessories ..... add \$30.00

<p style="text-align: center; font-weight: bold;">MA/E13</p> <p style="text-align: center;">30-50 MHz 6/12 volt, 30 watts, vibrator power supply</p> <p style="text-align: center; font-size: 2em; font-weight: bold;">\$48</p> <p style="font-size: 0.8em;">With accessories, add \$30. (Earlier serial number, \$28, plus \$30. for accessories)</p>	<p style="text-align: center; font-weight: bold;">MA/E33</p> <p style="text-align: center;">150-170 MHz 6/12 volt, 30 watts, vibrator power supply</p> <p style="text-align: center; font-size: 2em; font-weight: bold;">\$68</p> <p style="font-size: 0.8em;">With accessories, add \$30. (Earlier serial number, \$48, plus \$30. for accessories)</p>
--	--

15,000 2-way FM mobile units in stock!  
Send for new 1972 catalog



GREGORY ELECTRONICS CORP.

249-F Rt. 46, Saddle Brook, N.J. 07662  
Phone: (201) 489-9000

CIRCLE NO. 17 ON READER SERVICE CARD

**INVENTORS!** Don't sell your invention, patented or unpatented, until you receive our offer. Eagle Development Company, Dept. 9, 79 Wall Street, N.Y., N.Y. 10005.

**PATENT** Searches including Maximum speed, full airmail report and closest patent copies. Quality searches expertly administered. Complete secrecy guaranteed. Free Invention Protection forms and "Patent Information." Write Dept. 9, Washington Patent Office Search Bureau, Benjamin Franklin Substation, P.O. Box 7167, Washington, D.C. 20044.

**FREE** "Directory of 500 Corporations Seeking New Products." For information regarding development, sale, licensing of your patented unpatented invention. Write: Raymond Lee Organization, 230-GR Park Avenue, New York City 10017.

**INVENTORS:** Protect your ideas! Free "Recommended Procedure". Washington Inventors Service, 422T Washington Building, Washington, D.C. 20005.

**FREE PAMPHLET:** "Tips on Safeguarding Your Invention." Write: United States Inventors Service Company, 708-T Carry Building, Washington, D.C. 20005.

## BOOKS

**FREE** catalog aviation/electronic/space books. Aero Publishers, 329PE Aviation Road, Fallbrook, California 92028.

**FREE** book prophet Elijah coming before Christ. Wonderful bible evidence. Megiddo Mission, Dept. 64, 481 Thurston Rd., Rochester, N.Y. 14619.

## RECORDS

**CHAPEL** Records Club—Free catalog. 1000-B Richmond, China Lake, Calif. 93555.

## GOVERNMENT SURPLUS

**GOVERNMENT Surplus.** How and Where to Buy in Your Area. Send \$1.00. Surplus Information, Headquarters Bldg., Box 30177-PE, Washington, D.C. 20014.

**ELECTRONIC** Equipment and Parts. Big 36 page Free Catalog. Send for your copy today! Fair Radio Sales, Box 1105-P, Lima, Ohio 45802.

**JEEPS** Typically from \$53.90 . . . Trucks from \$78.40 . . . Boats, Typewriters, Knives, Airplanes, Clothing, Multimeters, Oscilloscopes, Transceivers, Photographic, Electronics Equipment. Wide-variety, condition. 100,000 Bid Bargains direct from government nationwide. Complete sales directory and surplus categories catalog \$1.00 (Deductible on orders from separate included catalog). Surplus Service, Box 820-J, Holland, Michigan 49423.

**GOVERNMENT SURPLUS.** Complete sales directory \$1.00. Surplus Publications, Box 26062Z, Los Angeles, Calif. 90026.

## BUSINESS OPPORTUNITIES

**I MADE \$40,000.00** Year by Mailorder! Helped others make money! Start with \$10.00—Free Proof. Torrey, Box 318-N, Ypsilanti, Michigan 48197.

**\$200.00 DAILY** In Your Mailbox! Your opportunity to do what mail-order experts do. Free details. Associates, Box 136-J, Holland, Michigan 49423.

**START** small, highly profitable electronic production in your basement. Investment, knowledge unnecessary. Postcard brings facts. Barta-PEB, Box 248, Walnut Creek, California 94597.

**PIANO TUNING** learned quickly at home. Tremendous field! Musical knowledge unnecessary. GI Approved. Information Free. Empire School, Box 327, Miami Florida 33145.

**FREE CATALOGS.** Repair air conditioning, refrigeration. Tools, supplies, full instructions. Doolin, 2016 Canton, Dallas, Texas 75201.

**MAILORDER MILLIONAIRE** helps beginners make \$500 weekly. Free report reveals secret plan! Executive (1K8), 333 North Michigan, Chicago 60601.

**FREE BOOK** "999 Successful, Little-Known Businesses." Work home! Plymouth BGH, Brooklyn, New York 11218.

**HOME WORKERS** wanted! For details, send 16¢ stamps. Mike Boorman, 729½ "L" Street, West Palm Beach, Florida 33401.

**311 FAST,** easy ways to make money! Free! Rush name, address, zip. Perry, 13263W Ventura Blvd., Studio City, Calif. 91604.

**MAILORDER**—How to prepare your own catalog for pennies. Free catalog! Obie-BGG, Brooklyn, New York 11219.

## GUIDE TO EARNING EXTRA INCOME

A Ziff-Davis Publication



All new—first time ever published! Everything you need to know about full and part time money-making. How to start your own mail order business • 22 proven and profitable home business ideas • How to earn extra \$'s • Franchising • Vending machines • Advice on cutting living costs. Only 75¢.

Order from Ziff-Davis Service Division, 595 Broadway, New York, New York 10012.

Enclose an additional 25c for postage and handling.

**400,000 BARGAINS** Below Wholesale! Many free! Liquidations . . . Closeouts . . . Job lots . . . Single Samples. Free details. Bargainhunters Opportunities, Box 730-J, Holland, Michigan 49423.

**MAKE \$1.00** per sale selling engraved metal Social Security plates. **FREE SALES KIT.** Engravplates, Box 10460-200, Jacksonville, Florida 32207.

## Up Your OWN! Organization!

by Donald M. Dible

A complete guide on how to start and finance a business. Send for free brochure. **Entrepreneur Press, Dept. A-95**  
Drawer 2759, Santa Clara, Ca 95051.



## RUBBER STAMPS

**RUBBER** Address Stamps \$2.00. Signature \$3.50. Free Catalog. Jackson's, Box 443-G, Franklin Park, Illinois 60131.

**PICTURE** catalog free. Lowest prices. Newton's, 1071 Prosser Ave., Prosser, Washington 99350.

## TREASURE FINDERS

**FISHER DETECTORS.** You deserve the best. Free literature, FRL, Dept. PE-8, P.O. Box 490, Belmont, CA 94002.

**TREASURE** Hunters! Prospectors! Rockhounds! Hobbyists! Find gold, silver, relics with world famous Detectron Metal Detectors. Free information. Delivery immediate. Detectron, Dept. 8-PE, Box 243, San Gabriel, Calif. 91778.

**TRANSISTORIZED** detectors—\$19.95 to \$79.95. Family fun and fortune. Catalog write: Treasureprobe PE 24, Tennent, N.J. 07763.

**FREE**—Valuable Treasure Finder catalog sent by return mail. Find Coins, Rings, Gold, Silver, Metals, Relics. Write today. JETCO, Dept. CPE, Box 26669, El Paso, Texas 79926.

**TREASURE FINDER** locates buried gold, silver, coins, treasures. 5 powerful models. \$19.95 up. Instant financing available. Free catalog. Relco, Dept. A-33, Box 10839, Houston, Texas 77018.

**BUILD** transistor treasurefinders for \$1 each. Tremendous Profits. Complete business setup, plans, instruction, sources—\$5. Satisfaction guaranteed! Barta-PEC, Box 248, Walnut Creek, California 94596.

## MAGAZINES

### ELECTRONIC EXPERIMENTER'S HANDBOOK



148 pages of the most fascinating and challenging construction projects for the electronic hobbyists. All with complete schematics, illustrations, parts list, and easy-to-follow instructions.

1972 Winter edition . . . \$1.25 . . . #40  
1971 Spring edition . . . \$1.50 . . . #26  
1971 Winter edition . . . \$1.50 . . . #33  
1970 Spring edition . . . \$1.50 . . . #14  
1970 Winter edition . . . \$1.35 . . . #97  
1968 Spring edition . . . \$1.25 . . . #84

Order by number from

Ziff-Davis Service Div., 595 Broadway • N.Y., N.Y. 10012  
Enclose an additional 35¢ per copy for postage and handling.  
(Outside U.S.A. all magazines are \$2.50 per copy, postpaid.)

**PAYMENT MUST BE ENCLOSED WITH ORDER**

POPULAR ELECTRONICS Including Electronics World

**LOWEST PRICES: ON BRAND NEW FULLY TESTED & GUARANTEED IC'S  
BEST SERVICE: 10% DISCOUNT ON ALL ITEMS NOT SHIPPED IN 24 HOURS  
MOST CONVENIENT: ORDER DESK 1-800-325-2595 (TOLL FREE)**

PLEASE NOTE: To qualify for prices in the last three columns, you must order in EXACT Multiples of 10 per item for all IC items on your order.

Catalog Number	Any Quantity Per Item (Mix)						Multiples of 10 Per Item (Mix)						
	1-99	100-999	1000-9999	10000-99999	100000-999999	1000000-9999999	Catalog Number	1-99	100-999	1000-9999	10000-99999	100000-999999	1000000-9999999
7400	.26	.25	.23	.22	.21	.20	7473	.50	.48	.45	.43	.40	.38
7401	.26	.25	.23	.22	.21	.20	7475	.80	.76	.72	.68	.64	.60
7402	.26	.25	.23	.22	.21	.20	7476	.56	.53	.50	.48	.45	.42
7403	.26	.25	.23	.22	.21	.20	7480	.76	.72	.68	.65	.61	.57
7404	.28	.27	.25	.24	.22	.21	7482	.99	.91	.88	.83	.78	.72
7405	.28	.27	.25	.24	.22	.21	7483	1.63	1.55	1.46	1.38	1.29	1.20
7406	.52	.50	.47	.44	.42	.39	7485	1.42	1.35	1.27	1.20	1.12	1.05
7407	.52	.50	.47	.44	.42	.39	7486	.58	.55	.52	.49	.46	.44
7408	.32	.30	.29	.27	.26	.24	7490	.80	.76	.72	.68	.64	.60
7409	.32	.30	.29	.27	.26	.24	7491	1.43	1.35	1.28	1.20	1.13	1.05
7410	.26	.25	.23	.22	.21	.20	7492	.80	.76	.72	.68	.64	.60
7411	.28	.27	.25	.24	.22	.21	7493	.80	.76	.72	.68	.64	.60
7413	.58	.55	.52	.49	.46	.44	7494	1.18	1.12	1.05	.99	.93	.87
7416	.52	.50	.47	.44	.42	.39	7495	1.18	1.12	1.05	.99	.93	.87
7417	.52	.50	.47	.44	.42	.39	7496	1.18	1.12	1.05	.99	.93	.87
7420	.26	.25	.23	.22	.21	.20	7498	1.52	1.44	1.36	1.28	1.20	1.12
7421	.26	.25	.23	.22	.21	.20	7499	.52	.49	.47	.44	.42	.39
7423	.80	.76	.72	.68	.64	.60	7499	.56	.53	.50	.48	.45	.42
7425	.50	.48	.45	.43	.40	.38	7499	.70	.67	.63	.60	.56	.53
7426	.34	.32	.31	.29	.27	.26	74123	1.21	1.06	1.00	.94	.89	.83
7430	.26	.25	.23	.22	.21	.20	74111	1.63	1.55	1.46	1.38	1.29	1.20
7437	.56	.53	.50	.48	.45	.42	74145	1.41	1.33	1.26	1.18	1.11	1.04
7438	.56	.53	.50	.48	.45	.42	74150	1.46	1.39	1.31	1.23	1.16	1.08
7440	.26	.25	.23	.22	.21	.20	74157	1.56	1.48	1.39	1.31	1.23	1.15
7441	1.73	1.64	1.55	1.46	1.37	1.27	74158	1.63	1.55	1.46	1.38	1.29	1.20
7442	1.27	1.21	1.14	1.07	1.01	.94	74154	2.43	2.30	2.16	2.03	1.89	1.76
7443	1.27	1.21	1.14	1.07	1.01	.94	74155	1.46	1.39	1.31	1.23	1.16	1.08
7444	1.27	1.21	1.14	1.07	1.01	.94	74156	1.46	1.39	1.31	1.23	1.16	1.08
7445	1.71	1.62	1.53	1.44	1.35	1.26	74157	1.56	1.48	1.39	1.31	1.23	1.15
7446	1.24	1.17	1.11	1.04	.98	.91	74158	1.56	1.48	1.39	1.31	1.23	1.15
7447	1.16	1.10	1.04	.98	.92	.85	74161	1.89	1.79	1.68	1.58	1.47	1.37
7448	1.44	1.37	1.29	1.22	1.14	1.06	74164	1.89	1.79	1.68	1.58	1.47	1.37
7450	.26	.25	.23	.22	.21	.20	74166	1.98	1.87	1.76	1.65	1.54	1.43
7451	.26	.25	.23	.22	.21	.20	74180	1.20	1.13	1.07	1.01	.95	.88
7453	.26	.25	.23	.22	.21	.20	74181	5.20	4.90	4.59	4.28	3.98	3.67
7454	.26	.25	.23	.22	.21	.20	74182	1.20	1.13	1.07	1.01	.95	.88
7460	.26	.25	.23	.22	.21	.20	74192	1.98	1.87	1.76	1.65	1.54	1.43
7470	.42	.40	.38	.36	.34	.32	74193	1.98	1.87	1.76	1.65	1.54	1.43
7472	.38	.36	.34	.32	.30	.29	74198	2.81	2.65	2.50	2.34	2.18	2.03
7473	.50	.48	.45	.43	.40	.38	74199	2.81	2.65	2.50	2.34	2.18	2.03

**TRANSISTORS AND DIODES**

1N270	.15	.14	.13	.12	.11	.10	1N4003	.13	.12	.11	.10	.09	.08
1N751A	.30	.28	.26	.24	.22	.20	1N4006	.15	.14	.13	.12	.11	.10
1N914	.10	.09	.08	.07	.06	.05	1N4154	.15	.14	.13	.12	.11	.10
1N4001	.10	.09	.08	.07	.06	.05	2N3860	.25	.23	.21	.19	.17	.15
1N4002	.11	.10	.09	.08	.07	.06							

**SUPER FAST SCHOTTKY TTL**

Types 74S00, 74S01, 74S03, 74S08, 74S09, 74S10, 74S15, (Three input AND with open collector), 74S20, 74S22, 74S50, 74S51, 74S60, 74S64, (4-2-3-2 input AND-OR-INVERT gate), 74S65 (open collector 74S64); your six column prices are:

1.14	1.08	1.02	0.96	0.90	0.81
------	------	------	------	------	------

Types 74S04, 74S05, 74S10, 74S110 (Dual 4-input NAND line Driver); your six column prices are:

1.37	1.30	1.22	1.15	1.08	1.01
------	------	------	------	------	------

Types 74S73, 74S74, 74S76, 74S78, 74S107, 74S112, 74S113, 74S114; your six column prices are:

1.98	1.87	1.76	1.65	1.54	1.43
------	------	------	------	------	------

All IC's are supplied in 8-, 14-, 16-, or 24-pin DIP (Dual-in-Line) plastic package. We give FREE data sheets upon request, so ask for those data sheets that you NEED, even for those listed IC that you are not buying.

**Solid State Systems, Inc.**  
P.O. Box 773  
Columbia, Mo. 65201

Phone 314-443-3673  
TWX 910-760-1453



TERMS: RATED FIRMS NET 30 DAYS. Others CHECK or MONEY ORDER with order. Add 3% to orders under \$5.00 for postage & handling. For UPS or FIRST CLASS add 4% and for AIR MAIL add 6% to your order. We strongly recommend this service with its built-in \$100 insurance. COD orders are FOB Columbia with 6% COD fee additional. Canadian residents please add 5% for MISSOURI RESIDENTS: Please add 4% Sales Tax.

WRITE OR CIRCLE READER SERVICE CARD FOR OUR CATALOG OF PARTS & SERVICES. IT'S FREE.

**CIRCLE NO. 33 ON READER SERVICE CARD**



**LED 7-SEGMENT DISPLAY**

\$4.95 Each

50-99	\$4.75
100-999	\$4.50
1000-70	\$4.25

Large 7-segment LED readout similar to the popular MAN-1 but with improved brightness. Has left-hand decimal point. Fits in a DIP socket. Expected life: Over 100 Yrs. Regularly \$12.95 in single Lots. These are BRAND NEW with full data sheet and 4-page MULTIPLEXING Application Note. Needs a 7447 for driver and ONE CURRENT-LIMITING RESISTOR PER SEGMENT. We can supply you with our or ten thousand FROM STOCK. Also available: 54 OVERFLOW digit at the same prices. Mixing of Regular & Overflow digit allowed.

Package of 8, 5W Limiting R's

306

Manufacture Type of 7-segment display. With right-hand decimal point. Rated 80mA per segment at TTL supply of 5V. Design life of 50,000 hours. Needs a 7447 as a driver. In DIP Package. Each \$3.25



**MOLEX IC SOCKET PINS:** Use these economical pins instead of soldering your IC's to PC boards. Sold in continuous strips in multiples of 100 pins only.

100 for \$3.00; 200 for \$1.80; 300 for \$2.60  
500 for \$3.10; 500 for \$4.20; 600 for \$5.00  
700 for \$3.80; 800 for \$6.60; 900 for \$7.40  
1000 for \$8.20. Each Additional 1000 \$7.50



**CERAMIC DISC CAPACITORS, Type 56A-10000WVDC.**  
5, 7.5, 10, 12, 15, 20, 22, 25, 27, 30, 33, 39, 50, 56, 68, 75, 82, 100, 120, 150, 180, 200, 220, 250, 270, 300, 330, 360, 390, 470, 500, 560, 680, 750, 820, 1000, 1200, 1500, 1800, 2000, 2200, 2500, 2700, 3000, 3300, 3900, 4700, 5000µF.

0.01µF, EACH	10¢	0.02µF, EACH	12¢
10W VOLTAGE DIS'S, Type-1K.			
1.0µF, 3V	25¢	2.2µF, 3V	30¢
1.0µF, 10V	12¢	0.2µF, 10	20¢
0.47µF, 3V	25¢	0.01µF, 16V	10¢

**ELECTROLYTIC CAPACITORS:**  
All values are available in both axial or upright (PC Board) mount. PLEASE INDICATE YOUR CHOICE.

10µF, 15V	10¢	1000µF, 35V	50¢
30µF, 15V	10¢	1µF, 50V	10¢
50µF, 15V	10¢	2µF, 50V	10¢
100µF, 15V	10¢	3µF, 50V	10¢
220µF, 15V	15¢	5µF, 50V	10¢
500µF, 15V	20¢	10µF, 50V	15¢
1000µF, 15V	30¢	20µF, 50V	20¢
20µF, 25V	15¢	50µF, 50V	20¢
30µF, 35V	20¢	100µF, 50V	20¢
50µF, 35V	20¢	200µF, 50V	40¢
100µF, 35V	20¢	500µF, 50V	55¢
500µF, 35V	40¢		

**VOLTAGE REGULATORS:** Internally-set, overload and short-circuit proof regulators need no external components to set. With data sheet and application notes. TO-3 Package.

LM335, 5V, 60mA	\$2.85
LM336, 12V, 50mA	\$3.85
LM337, 15V, 450mA	\$4.05
20 Watt PC-Board Type DEVI SINK	\$1.20

**STANCO P-R100, 25.2 VOLT, 1-Amp Transformer.**  
Ideal for use with LM-series. Each \$3.00

**ALLEN-BRADLEY MIL-GRADE (5-hand) RESISTORS:** Any of the 84 STANDARD 10% values from 2.752 to 22MΩ ¼ or ½ WATT, EACH \$5

**DUAL-IN-LINE Wire-Wrap Type IC Sockets:** Brand NEW with gold plated pins.

1-99	100-219	250-999	1000-1999	5K-UP
14-PINS 0.40	0.35	0.30	0.25	0.20
16-PINS 0.75	0.70	0.65	0.60	0.55

## 12-DIGIT "CALCULATOR ON A CHIP"

Sorry, can't name U.S. maker! Type SD5001. Similar to Mostek 6012. Outperforms Texas 8-digit TMS-1802. Features: 40-pin DIP; not 5, not 9, but only single "calculator chip". 12-digit capacity; adds, subtracts, multiplies, divides, fixed point (0, 2, 3 or 4 decimal places), chain operations, leading zero blanking, 7-segment decoded display output, overflow lockout, and negative sign output. Drives incandescent, fluorescent, Nixies, and LED readouts, complete with instruction booklet.



Only **24.95**

### Poly Paks Will Never Be Undersold! LOWEST PRICES ON TTL IC'S

Buy 3 — Take 10% Discount  
No Gimmicks On Pricing, Deliveries, or Quality! We're "The Only IC Advertiser" with MONEY BACK GUARANTEE!

Buy 100 — Take 20%			
<input type="checkbox"/> SN7450	.24	<input type="checkbox"/> SN74107	.49
<input type="checkbox"/> SN7451	.24	<input type="checkbox"/> SN74121	.79
<input type="checkbox"/> SN7453	.24	<input type="checkbox"/> SN74122	.87
<input type="checkbox"/> SN7454	.24	<input type="checkbox"/> SN74123	1.06
<input type="checkbox"/> SN7456	.24	<input type="checkbox"/> SN74141	1.55
<input type="checkbox"/> SN7470	.40	<input type="checkbox"/> SN74145	1.33
<input type="checkbox"/> SN7472	.36	<input type="checkbox"/> SN74150	1.55
<input type="checkbox"/> SN7473	.45	<input type="checkbox"/> SN74151	1.13
<input type="checkbox"/> SN7474	.45	<input type="checkbox"/> SN74153	1.55
<input type="checkbox"/> SN7475	.53	<input type="checkbox"/> SN74154	2.30
<input type="checkbox"/> SN7476	.49	<input type="checkbox"/> SN74155	1.39
<input type="checkbox"/> SN7480	.72	<input type="checkbox"/> SN74156	1.39
<input type="checkbox"/> SN7481	1.50	<input type="checkbox"/> SN74157	1.48
<input type="checkbox"/> SN7482	.99	<input type="checkbox"/> SN74158	1.48
<input type="checkbox"/> SN7483	1.49	<input type="checkbox"/> SN74160	1.79
<input type="checkbox"/> SN7486	.55	<input type="checkbox"/> SN74161	1.79
<input type="checkbox"/> SN7489	.76	<input type="checkbox"/> SN74162	1.79
<input type="checkbox"/> SN7491	1.35	<input type="checkbox"/> SN74163	1.79
<input type="checkbox"/> SN7492	.76	<input type="checkbox"/> SN74180	1.13
<input type="checkbox"/> SN7493	.76	<input type="checkbox"/> SN74181	1.90
<input type="checkbox"/> SN7494	1.09	<input type="checkbox"/> SN74182	1.13
<input type="checkbox"/> SN7495	1.09	<input type="checkbox"/> SN74192	1.87
<input type="checkbox"/> SN7496	1.09	<input type="checkbox"/> SN74193	1.87
<input type="checkbox"/> SN74100	1.44	<input type="checkbox"/> SN74195	1.49

## ALPHA-NUMERIC 7-SEG. READOUTS

<input type="checkbox"/> MINI-7 — Fluorescent Blue-Green Socket — 50c	Buy any 3 for \$6.	<b>2.50</b>	<input type="checkbox"/> MINI-7	<input type="checkbox"/> SLIM-7
<input type="checkbox"/> SLIM-7 — Fluorescent Blue-Green Socket — 50c			<input type="checkbox"/> MINI-7	<input type="checkbox"/> SLIM-7
H Characters	W Characters	Filament V.		
MINI-7: 1.75" x 1.75"	.360 x .570"	1.5V AC/DC 42 mils		
SLIM-7: 1.6" x 0.375"	.40 x .20"	1.5V AC/DC 42 mils		

\*Compatible to 7-segment driver IC's. 0-9 numerals, decimals and letters.

## BRAND NEW LINEAR IC AMPS

Type	Description	SALE	1c MORE
703 RF-IF, 14 Hookups	TO-5	\$.79	2 for \$.80
709C Operational Amps*		\$.59	2 for .60
710C Differential Amps*		\$.59	2 for .60
711C Memory, Sats., Amps*		\$.59	2 for .60
723A Voltage Regulator*		1.49	2 for 1.60
TVR-2000 Hi-power 723s		1.59	2 for 1.60
741C Freq. Comp. 709		.89	2 for .90
748C Freq. Adjustable 741*		.89	2 for .90
709-709 Dual 709's (DIP)		1.49	2 for 1.50
741-741 Dual 741's (Mini DIP)		1.79	2 for 1.80

\*State 1st, 2nd choice — Dual in Line, TO-5.

## NEW OP AMPS & PHASE LOCKS

Type	Description	Sale
531 HI slow rate op-amp		\$3.58
533 Micro power 709		3.58
536 FEY input op amp		4.50
540 70W pwr driver amp		2.04
565 Phase lock loop (A)		3.55
566 Function generator (A)		3.55
567 Tone decoder (A)		3.55

(A) TO-6 or DIP dual in line pak

## LED READOUTS

0-9 plus letters for SN7446 or SN7447. Snaps in 14-pin DIP socket. $\frac{1}{4} \times \frac{3}{8} \times \frac{3}{8}$ ". Characters: $\frac{1}{8} \times \frac{3}{8}$ ". 5V. 20-mils per seg. characters: $\frac{1}{8} \times \frac{3}{8}$ ". Famous W.A.N. 1 type. Sockets .50 ea.	<b>4.50</b>	3 for \$12.	3 for \$24
--	-------------	-------------	------------

## LED READOUT COUNTING SYSTEM

<input type="checkbox"/> 7480	
<input type="checkbox"/> 7447	
<input type="checkbox"/> 7475	
<input type="checkbox"/> 567	
<input type="checkbox"/> LED	

## ALLEN BRADLEY'S 'MICRO-POTS'

Ohms	2 for \$1		
<input type="checkbox"/> 75	<input type="checkbox"/> 2.0K	<input type="checkbox"/> 7.5K	<input type="checkbox"/> 25K
<input type="checkbox"/> 100	<input type="checkbox"/> 2.5K	<input type="checkbox"/> 10K	<input type="checkbox"/> 75K
<input type="checkbox"/> 500	<input type="checkbox"/> 5.0K	<input type="checkbox"/> 20K	<input type="checkbox"/> 5 M

We stock Locknut Bushing & Screwdriver Types at same low prices.

## 'JUMBO' LEDS

Buy Any	2 for \$1
<input type="checkbox"/> Infra-Red	
<input type="checkbox"/> "Invisible"	
<input type="checkbox"/> RED "Visible"	

Best Values for 18 years

Terms: add postage, cod's 25%. Rated: net 30  
Phone Orders: Wakefield, Mass. (617) 245-3829  
Retail: 211 Albion St. Wakefield, Mass.  
C.O.D.'S MAY BE PHONED IN

**POLY PAKS** P.O. BOX 942 E  
Lynnfield, Mass. 01940

CIRCLE NO. 27 ON READER SERVICE CARD

## MOVIE FILMS

PRO SPORTS FILMS for Instant Replay. Including '71 NHL Record-Breakers and '71 World Series—both just out! 8mm or Super 8, \$14.95 Color; \$7.95 B&W Delivered. Free Catalog. SPORTLITE, Dept. Elect., 20 North Wacker Drive, Chicago, Illinois 60606.

## HYPNOTISM

"MALE-FEMALE Hypnotism" Exposed, Explained! "Secret Method" —They Never Know! \$2. Rushed. Guaranteed! Isabella Hall, Silver Springs, Florida 32688.

SLEEP learning. Hypnotic method, 92% effective. Details free. ASR Foundation, Box 7545PL, Fort Lauderdale, Florida 33304.

FREE Hypnotism. Self-Hypnosis. Sleep Learning Catalog! Drawer H400, Ruidoso, New Mexico 88345.

## PRINTING

PRINTED Envelopes. Samples, Price List. Anderson Envelope Co., P. O. Box 606A, Anderson, Indiana 46015.

## EMPLOYMENT INFORMATION

EXCITING Overseas jobs. Directory \$1.00. Research Associates, Box 889-E, Belmont, California 94002.

ELECTRONICS/AVIONICS Employment Opportunities. Report on jobs now open. FREE details. Aviation Employment Information Service, Dept. EW, Box 240, Northport, N.Y. 11768.

## REAL ESTATE

FREE . . . Big . . . 248-page CATALOG! Describes and pictures hundreds of farms, ranches, town and country homes, businesses coast to coast! Specify type property and location preferred. UNITED FARM AGENCY, 612-EP West 47th St., Kansas City, Mo. 64112.

## MUSICAL INSTRUMENTS

30% DISCOUNT name brand musical instruments. Free Catalog. Freeport Music, 455N, Route 110, Melville, N.Y. 11746.

## MUSIC

## SONGS — POEMS

Wanted for publishing and recording consideration.

Accepted songs will be published & recorded at our expense - for information write to Talent, 17-PE Longwood Rd., Quincy, Mo. 02169

**POEMS & LYRICS** OF RELIGIOUS. REVERANT & INSPIRED NATURE WANTED FOR IMMEDIATE RECORDING. WE ARE ONLY INTERESTED IN SONGS OF HOPE, GOD'S LOVE, THE COMFORT OF HIS WORDS AND WISDOM. SEND TO:

**CATHEDRAL RECORDING CO.**  
P.O. BOX 78, STUDIO PE  
NO. WEYMOUTH, MASS. 02191



## MISCELLANEOUS

**WINEMAKERS:** Free illustrated catalog yeasts, equipment. Semplex, Box 12276, Minneapolis, Minn. 55412.

### AMAZING INVENTION!



- Non-Electric!
- Interchangeable Tips — 8 Irons in 1!
- Heats To 862° Within Seconds!
- No External Heat Of Any Kind!

"Quick-Shot" Cartridge Heated Soldering Iron. Used commercially for years — now available to you for the first time. 1001 uses — Indispensable where electric power is unavailable — where a torch can't be used — anywhere. 8 tips gives you the right tool for any soldering job at 1/3 the price of an additional iron. Cartridge activates in seconds — is non-flammable, non-explosive, emits no fumes, shelf life exceeds 4 years. It's the tool you can't afford to be without. Complete kit includes Soldering Iron, 1/4" Tip, Cartridges — Only \$19.95 Post-paid. Send order & payment to Kemode Manufacturing Co., Dept. E, 409 Railroad Ave., Westbury, N.Y. 11590.

**MONEY BACK GUARANTEE.**

YOUR Classified or Display Classified Ad in these columns will be seen, read and regularly responded to by America's largest audience comprising Electronics Professionals and Hobbyists. Cost is low, results high (most advertisers repeat 12 times each year). Send copy and payment now to address indicated at beginning of **ELECTRONICS MARKET PLACE.**

## ABOUT YOUR SUBSCRIPTION

Your subscription to **POPULAR ELECTRONICS** is maintained on one of the world's most modern, efficient computer systems, and if you're like 99% of our subscribers, you'll never have any reason to complain about your subscription service.

We have found that when complaints do arise, the majority of them occur because people have written their names or addresses differently at different times. For example, if your subscription were listed under "William Jones, Cedar Lane, Middletown, Arizona," and you were to renew it as "Bill Jones, Cedar Lane, Middletown, Arizona," our computer would think that two separate subscriptions were involved, and it would start sending you two copies of **POPULAR ELECTRONICS** each month. Other examples of combinations of names that would confuse the computer would include: John Henry Smith and Henry Smith; and Mrs. Joseph Jones and Mary Jones. Minor differences in addresses can also lead to difficulties. For example, to the computer, 100 Second St. is not the same as 100 2nd St.

So, please, when you write us about your subscription, be sure to enclose the mailing label from the cover of the magazine—or else copy your name and address exactly as they appear on the mailing label. This will greatly reduce any chance of error, and we will be able to service your request much more quickly.

## POPULAR ELECTRONICS

Including Electronics World

AUGUST 1972

### ADVERTISERS INDEX

READER SERVICE NO.	ADVERTISER	PAGE NO.
3	Antenna Specialists Co. The	69
4	B. & F. Enterprises	101
7	B&K Division, Dynascan Corporation	15
	Bell & Howell Schools	91, 92, 93
5	Bose	22
	CREI, A Division of the McGraw-Hill Continuing Education Company	18, 19, 20, 21
6	Cleveland Institute of Electronics	36, 37, 38, 39
8	Cooks Institute of Electronics Engineering	89
9	Cortlandt Electronics Inc.	99
10	Crystek	94
11	Delta Electronics Co.	98
12	Delta Products, Inc.	85
13	Dixie Hi-Fi Wholesalers	90
14	Edmund Scientific Co.	108
15	EI Instruments, Inc.	8
1	Electro-Voice, Inc.	FOURTH COVER
2	Electro-Voice, Inc.	FOURTH COVER
16	GC Electronics	96
	Grantham School of Engineering	67
17	Gregory Electronics Corp.	103
18	Heath Company	25
19	Johnson	79
20	Lafayette Radio Electronics	89
21	McIntosh Laboratory Inc.	95
22	Midland Electronics Company	83
	National Radio Institute	SECOND COVER, 1, 2, 3
	National Technical Schools	72, 73, 74, 75
23	Olson Electronics	71
24	PTS Electronics, Inc.	90
25	Pace Communications	9
26	Pickering & Co., Inc.	70
27	Poly Paks	106
28	Pulse Dynamics Mfg. Corp.	17
29	RCA Institutes, Inc.	54, 55, 56, 57
30	S B E	88
31	Sams & Co., Inc., Howard W.	7
32	Solid State Sales	102
33	Solid State Systems, Inc.	105
34	Sonar Radio Corp.	95
35	Sony Corporation of America	13
36	Spartan School of Aeronautics	69
37	Tri-Star Corporation	94
	U.S. Navy	10, 11
38	Valparaiso Technical Institute	71
<b>CLASSIFIED ADVERTISING</b>		
98, 99, 100, 102, 103, 104, 106, 107		

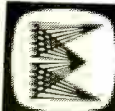

LIVE IN THE WORLD OF TOMORROW... TODAY! NEW PRODUCTS, NEW MATERIALS, NEW IDEAS!

# UNUSUAL ECOLOGICAL SERVICE BOYS

UNIQUE HARD-TO-FIND BARGAINS FOR FUN, STUDY OR PROFIT



## DIGITAL COMPUTER LOGIC LAB



Fascinating new way to learn computer types. Binary systems, truth tables, logic. Make ring counter, shift register and binary counters. Play with reaction time, electronic coin flipper. Experiment with memory, counting. Experiments: clock, solid-state hand gates, flip-flop, display, 20 hand gates for 100's of circuits, 23 computer experiments. No electronic know-how needed! 74 pg. illust. manual explains all. Req. 6v batt. (not incl.)

Stock No. 71.403AV ..... \$39.75 Ppd.

See moon shots, orbits, stars, phases of Venus, planets close up, 60 to 180 power. Amazed! oversized 35-diam. f 10 primary mirror, ventilated cell. Equatorial mount with locks on both axes. 60x objective and mounted Barlow lens. 4x field telescope, hardwood tripod. FREE! "Star Chart." How to Use Your Telescope.

Stock No. 85.050AV ..... \$32.95 Ppd.  
 DELUXE 18" TELESCOPE ..... \$59.50 Ppd.  
 Stock No. 80.162AV ..... \$59.50 Ppd.  
 No. 85.105AV ..... \$94.50 Ppd.  
 No. 85.086AV ..... \$239.50 Ppd.

## 3" ASTRONOMICAL TELESCOPE



## ASTRONOMICAL TELESCOPE KITS



Grind your own mirror for powerful telescopes. Kit contains fine unground pyrex mirror blank, tool, abrasives, diamond mirror, and eyepiece lenses. Instruments you build range in value from \$75.00 to hundreds of dollars.

Stock No. 70.003AV ..... \$10.75 Ppd.  
 4 1/4" dia. X 3" ..... \$10.75 Ppd.  
 Stock No. 70.004AV ..... \$16.95 Ppd.  
 5" dia. X 3" ..... \$16.95 Ppd.  
 Stock No. 70.005AV ..... \$24.50 Ppd.  
 8" dia. X 13" ..... \$24.50 Ppd.  
 Stock No. 70.006AV ..... \$44.50 Ppd.  
 10" dia. X 13" ..... \$44.50 Ppd.  
 Stock No. 70.007AV ..... \$72.50 Ppd.  
 12 1/2" dia. X 21" ..... \$72.50 Ppd.

## ULTRA LOW PRESSURE SENSOR

Big surplus! cheap—tiny electrical pressure switch activated by only 0.02 psi air or 1/2" or less water pressure. Single pole, normally open. 10ma DC contact rating. 30v AC 1/2 amp load. Requires sensitive relay or solid state control. Use as sensor, switch, control, timer, or alarm. Excellent alarm. Long life (1,000,000 operations), impervious to extreme shock, vibration, 1750 psi polyurethane case. 30 watt or barbed pressure ports. Wt—10 grams. ORIGINAL COST \$11.50

Stock No. 41.623AV ..... \$3.95 Ppd.

## NEW! ELECTRONIC DIGITAL COMPUTER KIT!



Solve problems, play games, predict weather with this actual working model of giant electronic brains. Another new way to learn all about computer programming... logic, decimal, binary systems. Laws of sets, logic. Do your own programming after completing simplified 113 page instructive booklet. Includes step-by-step assembly diagrams. Circuits easily changed. Readout from illuminated control panel. Req. 2 "C" batt. (not incl.) Best you've seen—for home, school, industry.

Stock No. 71.434AV ..... \$31.50 Ppd.

## 58.95 ELECTRONIC STROBE



Hand-sized solid state electronic strobe priced at fantastically low price. Produces bright psychedelic effects like larger, far more expensive Xenon strobes. Set it's just 2 1/2" X 4" X 1 1/2" thick. Adjustable flash rate, approximately 3-10 flashes per second. Make sign motion effects, posters come alive. Great to take with you to parties, dances, outings, etc. Requires 2 9v transistor batt. (not incl.). Instructions.

Stock No. 41.443AV ..... \$8.95 Ppd.  
 4 REPLACEMENT LAMPS ..... 1.00 Ppd.  
 P-41.444AV

## UNIQUE LIGHTING HANDBOOK

100 information packed pages! Fully explains latest in psychedelic lighting equipment, techniques, developments. Covers all facets of the electronic light-show production including strobes, black lights, projectors, crystals, organic slides, mirrors, color organs, polarized color, light boxes, MusicVision, etc. Shows how to "psychedelicize" parties, musical groups. Shows or how to set up "electric trips" for private gatherings. 8 1/2" X 11" loose-leaf paper for 3 rings.

Stock No. 9100AV ..... \$3.00 Ppd.

## "FISH" WITH A MAGNET



Go treasure hunting on the bottom! Fascinating fun & sometimes profitable! Tie a line to our 50-oz. Magnet—drop it overboard in bay, river, lake or ocean. Troll it along bottom—your "treasure" haul can be outboard motors, anchors, other metal valuables. 27-oz. Magnet is war surplus—Army V Type—low cost \$70. Lifts over 150 lbs. on land—much greater weights under water.

No. 70.571AV ..... \$12 lbs. ..... \$14.00 Ppd.  
 No. 60.215AV ..... 11 1/2 lbs. ..... \$5.75 Ppd.  
 No. 70.570AV ..... 3 1/2 lbs. (40 lbs.) ..... \$6.75 Ppd.  
 Stock No. 85.152AV ..... 15 3/4 lbs. (350 lbs.) ..... \$33.95 Ppd.

## HELIUM BALLOONS MAKE A "BALL"



Anything there's a balloon the air is festive. Especially when the "air" is helium which makes a balloon party and adventures. Now here's 24 times the fun—20 various colored balloons of 4, 6 or 8" diameter when inflated. With them, a pressurized 300 lbs./sq. in. can containing 20 liters of helium to inflate all 20. For adults or kids' parties, giveaways, bazaars or just demonstrating "lighter than air". Helium is a safe non-toxic inert gas.

Stock No. 71.289AV ..... \$3.00 Ppd.

## AMAZING NEW Wankel Engine KIT!

Thrill to the fun of building your own see-through motorized model of revolutionary pistonless type engine, rights for which GM recently paid \$40 million! Only engine experts think economically modifiable to meet new pollution standards. Replaces piston engine. Crank assemblies with rotating discs (sections removed for firing chambers). Smaller than conventional power plants, greater reliability, same speed w less horsepower. Fast flashing plugs, rubber fan belt, stock-shif on/off switch. Req. 2-1.5V batt. (not incl.)

Stock No. 71.424AV (4 1/2" X 5" X 9") ..... \$6.75 Ppd.  
 116 Page Wankel Engine book ..... \$15.25 Ppd.  
 Stock No. 9.439AV

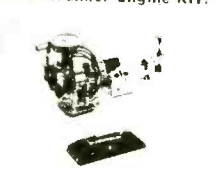

**MAIL COUPON FOR GIANT FREE CATALOG!**

148 PAGES • MORE THAN 4000 UNUSUAL BARGAINS!

Completely new Catalog. Packed with huge selection of telescopes, microscopes, binoculars, magnifiers, prisms, photo compass, ecology and Unique Lighting items, parts, kits, accessories—many hard-to-get surplus bargains. 100's of charts, illustrations. For hobbyists, experimenters, schools, industry.

**EDMUND SCIENTIFIC CO.**  
 300 Edscorp Building, Barrington, N.J. 08007  
 Please rush Free Giant Catalog "AV"

Name \_\_\_\_\_  
 Address \_\_\_\_\_  
 City \_\_\_\_\_ State \_\_\_\_\_ Zip \_\_\_\_\_

## NEW \$99.50 HELIUM-NEON LASER!

Completely assembled. Instant-starting w 3X power output of comparable models. Steady, ripple-free light of moderate (safe) power. Excellent collimation. Simple and safe to use. 4 1/2 lb. unit reaches 757' power in 2 secs. 100% typically 0.5 milliwatt (0.5 mW minimum) in 2 mins. Beam divergence 2 milliradians—2 cms at 40 ft.

Stock No. 79.004AV ..... \$99.50 Ppd.  
 Laser Goggles ..... \$20.00 Ppd.  
 Stock No. 60.854AV



## BETTER BUG TRAP—BLACK LIGHT!

Feel free outdoors with a genuine "black light" trap—3 to 10 times more effective on insects than simulated kind. Long-wave black light lamp scientifically attracts bite-flies, mosquitoes, etc. Weatherproof easily cleaned unit effective up to 2 1/2 acres of cleared area (patio, pool, stable, golf course, etc.). Free-standing or hang where needed. Just plug into grounded electrical outlet. Includes 2 v. batt. powerful motor & fan. 110v. 26 watts.

Stock No. 71.657AV ..... \$39.95 Ppd.



**EDMUND SCIENTIFIC CO.**

ORDER BY STOCK NUMBER • SEND CHECK OR MONEY ORDER • MONEY-BACK GUARANTEE

**300 EDSCORP BLDG. BARRINGTON, NEW JERSEY 08007**

CIRCLE NO. 14 ON READER SERVICE CARD

Printed in U.S.A.

# Popular Electronics

INCLUDING **Electronics World**

## READER SERVICE **FREE INFORMATION.**

Here's an easy and convenient way for you to get additional information about products advertised or mentioned editorially (if it has a reader service number) in this issue. Just follow the directions below . . . and the material will be sent to you promptly and free of charge.

- 1.** On the attached postage-free card, print or type your name and address on the lines indicated.
- 2.** Circle the number(s) that corresponds to the key number(s) at the bottom or next to the advertisement or editorial mention that is of interest to you. (Key numbers for advertised products also appear in the Advertisers' Index.)
- 3.** Simply cut out the card and mail. No postage required.



### THE **'STORAGE PROBLEM' SOLVERS** DELUXE MATCHING STORAGE CASES FOR YOUR 12" RECORDS, 7" REELS, CASSETTES AND 8-TRACK CARTRIDGES.



- (A) 60-unit cassette case. 13½" h. x 12¾" d. x 5½" w. Compartments are tilted back to prevent spillage. Includes pressure sensitive labels for titling. \$14.75 each. 3 for \$42.00.
- (B) 30-unit cassette case. 13½" high x 6½" deep x 5½" wide. Tilted compartments, labels included. \$8.40 each. 3 for \$24.00.
- (C) 12-unit cartridge case. 13¼" high x 6½" deep x 4¼" wide. Tilted compartments, labels included. \$5.25 each. 3 for \$13.75.
- (D) 6-unit 7" reel case. 8" high x 7½" deep x 5" wide. Holds reels in original boxes. \$4.75 each. 3 for \$12.65.
- (E) 20-unit 12" record case. 13¼" high x 12½" deep x 3½" wide. Holds records in original jackets. \$5.25 each. 3 for \$13.75.

Here's the ideal solution to the problem of keeping all your records and tapes stored neatly, safely, conveniently and attractively. A complete set of matched storage cases, designed by the editors of STEREO REVIEW magazine, for your records and all your tapes: cassette, cartridge and 7" reel. Now you can keep them side-by-side on your bookshelf or cabinet, easy to identify and readily available.

These cases are sturdily constructed and covered in a handsome leatherette. The outer case is elegantly embossed in gold and comes in your choice of three popular decorator colors — black, brown and green — so that they lend themselves readily to the decor of any room.

STEREO REVIEW large capacity storage cases are just what you've been looking for — they're the ideal solution to keeping your records and tapes neatly stored for easy use.



AN EXTRA SERVICE FOR YOU—  
CHARGE YOUR STORAGE CASE ORDER  
TO YOUR AMERICAN EXPRESS  
OR UNI-CARD ACCOUNT.

Use the postage-paid order card located at the top of the flap to the right to order your Storage Cases.

To get more from  
your high fidelity  
system...put more  
of yourself in it.



In these days of instant everything, the idea behind Electro-Voice Custom Loudspeakers is a refreshing change of pace.

The custom loudspeaker concept asks you to do more than buy. It suggests that you participate directly in choosing the very best speaker system for your own special listening needs, speaker by speaker.

There's a complete, logical range of woofers, tweeters, mid-range drivers and accessories. And, with the help of your E-V dealer, you create the performance that suits you best.

You have the option of installing the speakers in new or existing furniture, or building them into walls, closets, or wherever.

Write today for our literature and list of E-V Custom Loudspeaker dealers.

## Can the EVX-4 4-Channel Decoder face up to records encoded for Columbia SQ, Sansui, Dyna, and all the rest?

Yes. Listen. Play "their" best demonstration records through the EVX-4 or the E-V 1244X add-on decoder/stereo amplifier.

In most cases you'll hear little or no difference. Some records may even sound better to you through our decoder than through theirs! How can this be? Because you're listening to music... not ping-pong or algebra. And our decoding is basic.

STEREO-4™ decoders can do the best job at the lowest cost for all 4-channel matrix records and FM broadcasts. Not to mention how well they enhance your present stereo records, tapes, and FM.

But don't take our word for it. Listen carefully. Make your own discovery that "their" records can make the best case for "our" decoders!

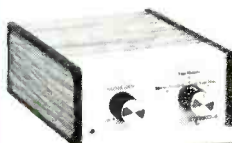

EVX-4  
Stereo Decoder  
\$59.95 suggested resale



E-V 1244X  
Decoder/Stereo Amplifier  
\$149.95 suggested resale

CIRCLE NO. 1 ON READER SERVICE CARD

CIRCLE NO. 2 ON READER SERVICE CARD

ELECTRO-VOICE, INC., Dist. #247P 630 Cecil Street, Buchanan, Michigan 49107  
In Europe: Electro-Voice, S.p.A. Rome - Italy - Tel. 06/374111. See us here.  
In Canada: EV of Canada, Ltd., Toronto, Ontario

a **Gulton**  
COMPANY

**Electro-Voice**