

HOW TO SELECT A LOUDSPEAKER SYSTEM

# Popular Electronics

FIFTY CENTS / DECEMBER 1971

## Distortionless Audio Compressor For Tape, PA, CB and Ham Rigs

GIANT BILLBOARD ANTENNAS  
FOR SPACE-AGE RADARS

WHAT'S HAPPENED TO  
EDUCATIONAL TV?

BUILD:

Mini-Pyramidal UHF TV Antenna  
VHF Converter  
Intruder/Fire Alarm

PRODUCT TESTS:

Pioneer SX-2500 Stereo Receiver  
Lafayette 4-Channel Adapter  
Unilarm Speaker Enclosure Kit  
Heathkit Frequency Scaler

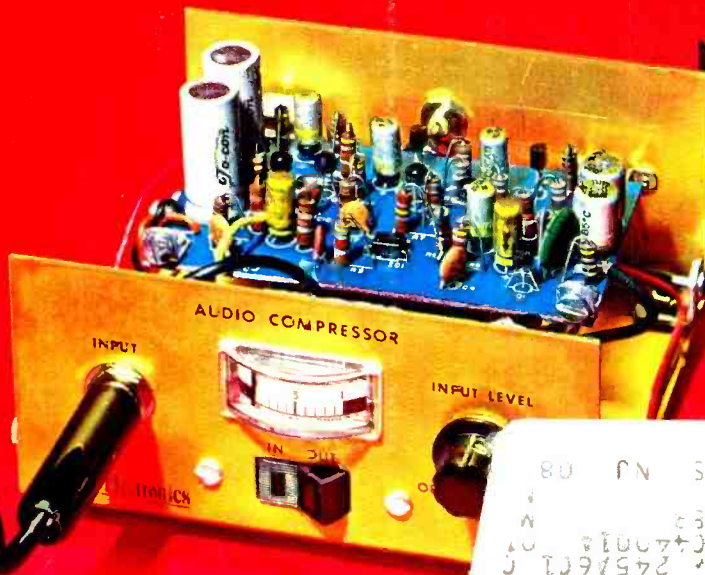

372818 CLC 245A6C1  
PFC00046261C42001A  
M  
4 CFCFLD02  
BX 245  
BRONS MILLS NJ 08

All this is yours—from Achievement Kit to the only Color TV specifically designed for training—when you enroll for NRI's TV-Radio Servicing course. Other courses are equally complete. But NRI training is more than kits and "bite-size" texts. It's also personal services which have made NRI a 50 year leader in the home-study field. Mail the postage-free card today.

**Approved under GI BILL**

If you served since Jan. 31, 1955, or are in service, check GI line in postage-free card.



# You get more for your money from NRI—

## America's oldest and largest Electronic, Radio-Television home-study school

Compare. You'll find — as have so many thousands of others — NRI training can't be beat. From the delivery of your first lessons in the remarkable, new Achievement Kit, to "bite size," easily-read texts and carefully designed training equipment . . . NRI gives you more value.

Shown below is a dramatic, pictorial example of training materials in *just one* NRI Course. Everything you see below is included in low-cost NRI training. Other major NRI courses are equally complete. Text for text, kit for kit, dollar for dollar—your best home-study buy is NRI.



## NEW COLOR TV



### **GET A FASTER START WITH NRI'S NEW EXCLUSIVE ACHIEVEMENT KIT**

The day your enrollment is received your Achievement Kit will be on its way to you. It contains everything you need to make an easy, fast start in the Electronics training of your choice. This attractive, new starter kit is an outstanding, logical way to introduce you to home-study the way NRI teaches it . . . backed by a dedicated staff and the personal attention you should expect of a home-study school. It is your first special training aid . . . designed to make your adventure into Electronics absorbing, meaningful. Your Achievement Kit contains your first group of lesson texts; rich vinyl desk folder to hold study material; the industry's most complete Radio-TV Electronics Dictionary; valuable reference texts; lesson answer sheets; envelopes; pencils, pen; engineer's ruler—even postage. No other school has anything like it.

OVER 50 YEARS OF LEADERSHIP



### **LEARNING BECOMES AN ABSORBING ADVENTURE WITH NRI TRAINING KITS**

What better way to learn than by doing? NRI pioneered and perfected the "home lab" technique of learning at home in your spare time. You get your hands on actual parts and use them to build, experiment, explore, discover. Electronics come alive! NRI invites comparison with training equipment offered by any other school. Begin NOW this exciting, practical program. It's the best way to understand the skills of the finest technicians—and make their techniques your own. Whatever your reason for wanting to increase your knowledge of Electronics . . . whatever your field of interest . . . whatever your education . . . there's an NRI instruction plan for you, at low tuition rates to fit your budget. Get all the facts about NRI training plans, NRI training equipment. Fill in and mail the attached postage-free card today.

NATIONAL RADIO INSTITUTE, Washington, D.C. 20016.

IN ELECTRONICS TRAINING

Accredited by the Accrediting Commission of the National Home Study Council

# Popular Electronics

WORLD'S LARGEST-SELLING ELECTRONICS MAGAZINE

## FEATURE ARTICLES

- |   |           |                                  |
|---|-----------|----------------------------------|
| <b>DISTORTIONLESS AUDIO COMPRESSOR</b><br><i>For hams, CB'ers, and tape recording fans</i>  | <b>25</b> | <i>Charles Caringella, W6NJV</i> |
| <b>WHAT'S HAPPENED TO EDUCATIONAL TV?</b><br><i>Public and instructional TV</i>   | <b>31</b> | <i>Forest H. Best</i>            |
| <b>BUILD A MINI-PYRAMIDAL UHF TV ANTENNA</b><br><i>improve reception anywhere</i>   | <b>40</b> | <i>George J. Manser</i>          |
| <b>GIANT BILLBOARD ANTENNAS FOR SPACE-AGE RADARS</b><br><i>Stationary, closed array; move the beams</i>   | <b>44</b> | <i>Edward A. Lacy</i>            |
| <b>THE ELECTRONICS BOOKSHELF, PART 2</b><br><i>General theory and hobby books</i>   | <b>48</b> | <i>Carl C. Drumeller, W5JJ</i>   |
| <b>VHF FREQUENCY CONVERTER</b><br><i>Add service bands to your car radio</i>  | <b>52</b> | <i>Lyman E. Greenlee</i>         |
| <b>HI-FI AMPLIFIER MODULE</b><br><i>New unit simplifies construction</i>  | <b>59</b> | <i>Art Trauffer</i>              |
| <b>PROFESSIONAL INTRUDER/FIRE ALARM</b><br><i>Solid-state commercial-type system</i>  | <b>61</b> | <i>George Meyerle</i>            |
| <b>STEREO SCENE</b><br><i>Selecting a speaker system</i>  | <b>66</b> | <i>J. Gordon Holt</i>            |
| <b>WORLD ADMINISTRATIVE RADIO CONFERENCE</b><br><i>An eyewitness report</i>   | <b>69</b> | <i>Richard G. Gould</i>          |
| <b>ADHESIVE STENCIL TECHNIQUE FOR PC BOARDS</b><br><i>A new do-it-yourself approach</i>   | <b>71</b> | <i>Thomas Anderson</i>           |
| <b>OPPORTUNITY AWARENESS</b>  | <b>79</b> | <i>David L. Heiserman</i>        |
| <b>COMMUNICATIONS</b>   | <b>81</b> | <i>Leslie Solomon</i>            |
| <b>THE PRODUCT GALLERY</b><br><i>Pioneer SX-2500 Stereo Receiver</i><br><i>Lafayette QD-4 Four-Channel Adapter</i><br><i>Unilarm Kab Kif Speaker Enclosure</i><br><i>Heathkit 1B-102 Frequency Scaler</i> | <b>83</b> |                                  |
| <b>SOLID STATE</b><br><i>Christmas shopping list</i>  | <b>88</b> | <i>Lou Garner</i>                |

## DEPARTMENTS

- |  |               |                          |
|--|---------------|--------------------------|
| <b>DIRECT &amp; CURRENT</b>                | <b>7</b>      | <i>Milton S. Snitzer</i> |
| <b>INTERFACE</b>                           | <b>8</b>      |                          |
| <b>NEW LITERATURE</b>                      | <b>14</b>     |                          |
| <b>READER SERVICE PAGES</b>                | <b>15, 97</b> |                          |
| <b>ELECTRONICS LIBRARY</b>                 | <b>16</b>     |                          |
| <b>NEW PRODUCTS</b>                        | <b>22</b>     |                          |
| <b>INDEX TO VOLUME 35 (JULY-DEC. 1971)</b> | <b>100</b>    |                          |

POPULAR ELECTRONICS is Indexed  
in the Reader's Guide  
to Periodical Literature

Copyright © 1971 by ZIFF-DAVIS PUBLISHING COMPANY. All rights reserved.

William Ziff, President; Hershel B. Sarbin, Senior Vice President and Secretary; Philip Sine, Financial Vice President and Treasurer  
**POPULAR ELECTRONICS**, December 1971, Volume 35, Number 6. Published monthly at One Park Ave., New York, N.Y. 10016.  
One year subscription rate for U.S., U.S. Possessions and Canada, \$6.00; all other countries, \$7.00. Second class postage paid  
at New York, N.Y., and at additional mailing offices. Authorized as second class mail by the Post Office Department, Ottawa,  
Canada and for payment of postage in cash. Subscription service and Forms 3579; P.O. Box 1096, Flushing, N.Y. 11352.  
Editorial offices for manuscript contributions, reader inquiries, etc.: One Park Ave., New York, N.Y. 10016.

This month's cover photo by  
**Justin Kerr**

# 50% off on FET experimenter kits and the Siliconix FET handbook



**The Handbook:** The ink is barely dry on this one. It takes you from basic FET principles and manufacture through characterization and biasing to audio and RF amplifiers, VCRs, current limiters, switches, chopper and analog gates . . . just to mention a few. More than 30 practical circuits are shown. Additional references are included for those who want to go deeper into a given subject.

*KIT #1*

2N3368 Amplifier	1.40
2N4223 VHF Amplifier	1.50
E300 VHF Amplifier	1.40
U183 Amplifier	1.40
VCR7N VCR	2.25
CL2210 Current Limiter	3.25
and new FET Handbook	2.50
VALUE	\$13.70

LIMITED-TIME PRICE

*Only \$16.50*

*KIT #2*

2N3368 Amplifier	1.40
2N3437 Amplifier	1.90
E101 Amplifier	2.20
E300 VHF Amplifier	1.40
U202 Switch	2.95
VCR7N VCR	2.25
CL1020 Current Limiter	3.25
U234 Matched Dual FET	5.00
and new FET Handbook	2.50
VALUE	\$22.85

LIMITED-TIME PRICE

*Only \$11.50*

*KIT #3*

2N3370 Amplifier	2.15
2N5398 UHF Amplifier	4.50
E101 Amplifier	2.20
U184 HF Amplifier	2.75
U241 10 Ohm Switch	9.70
CL1020 Current Limiter	3.25
U234 Matched Dual Fet	5.00
LM201H Op. Amplifier	6.50
and new FET Handbook	2.50
VALUE	\$38.55

LIMITED-TIME PRICE

*Only \$16.50*

## ORDER NOW FOR CHRISTMAS

**Siliconix**  
incorporated

2201 Laurelwood Rd. • Santa Clara, Calif. 95054  
(408) 246-8000 Ext. 201 • TWX: 910-338-0227

### SILICONIX INCORPORATED

P.O. Box 185, Agnew Station—Santa Clara, Calif. 95054

Please send items as checked below, for which payment is enclosed. (Sorry, no Purchase Orders or CODs.)

Add 50¢ for postage and handling

- |                                 |         |   |         |
|---------------------------------|---------|---|---------|
| <input type="checkbox"/> Kit #1 | \$ 6.50 | <input type="checkbox"/> Kit #1 Less Handbook | \$ 5.00 |
| <input type="checkbox"/> Kit #2 | \$11.50 | <input type="checkbox"/> Kit #2 Less Handbook | \$10.00 |
| <input type="checkbox"/> Kit #3 | \$16.50 | <input type="checkbox"/> Kit #3 Less Handbook | \$15.00 |
|                                 |         | <input type="checkbox"/> Handbook only        | \$2.50  |

Name \_\_\_\_\_  
Address \_\_\_\_\_  
City \_\_\_\_\_ State \_\_\_\_\_ Zip \_\_\_\_\_

(California residents add 5% sales tax)  
Offer expires December 31, 1971



Premium-Quality

LIGHT EMITTING DIODES

priced for the  
hobbyist/experimenter



Here's your chance to get the 'Cadillac' of the LEDs... visible light sources, indicator lamps, alphanumeric readouts, photo-sensors, opto-isolators.

Sprague L.E.D. devices open up a new world of electronic experimentation. Projects such as intruder alarms, smoke detectors, light communicators, counters, controls, clocks, optical tachometers, computer readouts, Xmas light displays, etc. are *naturals* for these fantastically long-life, solid-state devices. Fully compatible with ICs, this new Sprague series includes replacements for conventional miniature lamps, as well as devices completely interchangeable with other leading makes of LEDs.

For complete data, write to Sprague Products Co., 395 Marshall St., North Adams, Mass. 01247. If you'd like to see these tiny LEDs in a working display, drop a note to our Mr. Guy Ezelle for the location of your nearest Sprague distributor.

\*another exciting product from Monsanto



CIRCLE NO. 18 ON READER SERVICE PAGE

# Popular Electronics

LAWRENCE SPORN  
*Publisher*

MILTON S. SNITZER  
*Editor*

LESLIE SOLOMON  
*Technical Editor*

JOHN R. RIGGS  
*Managing Editor*

EDWARD I. BUXBAUM  
*Art Director*

ALEXANDER W. BURAWA  
*Associate Editor*

ANDRE DUZANT  
*Technical Illustrator*

JUDITH L. HOGAN  
*Editorial Assistant*

J. GORDON HOLT  
L. E. GARNER, JR.  
DAVID L. HEISERMAN  
*Contributing Editor*

RICHARD J. HALPERN  
*Advertising Manager*

MADELEINE LITTMAN  
*Advertising Service Manager*

STANLEY NEUFELD  
*Associate Publisher*

FURMAN H. HEBB  
*Group Vice President*

*Electronics and Photographic*

ZIFF-DAVIS PUBLISHING COMPANY  
Editorial and Executive Offices  
One Park Avenue, New York, New York 10016  
212 679-7200

Midwestern Office  
The Patis Group, 4761 West Touhy Ave.,  
Lincolnwood, Illinois 60644, 312 679-1100  
GERALD E. WOLFE, DICK POWELL

Western Office  
9025 Wilshire Boulevard, Beverly Hills, California 90211  
213 Crestview 4-0265; BRadsHaw 2-1161  
Western Advertising Manager, BUD DEAN

Japan: James Yagi  
Oji Palace Aoyama; 6-25, Minami Aoyama  
6-Chome, Minato-Ku, Tokyo 407-1930/6821

Circulation Office  
P.O. Box 1096, Flushing, N.Y. 11352

William Ziff, President  
W. Bradford Briggs, Executive Vice President  
Hershel B. Sarbin, Senior Vice President and Secretary  
Stanley R. Greenfield, Senior Vice President  
Philip Sine, Financial Vice President and Treasurer  
Walter S. Mills, Jr., Vice President, Circulation  
Phillip T. Heffernan, Vice President, Marketing  
Frank Pomerantz, Vice President, Creative Services  
Arthur W. Butzow, Vice President, Production  
Edward D. Muhlfeld, Vice President, Aviation Division  
Irwin Robinson, Vice President, Travel Division  
George Morrissey, Vice President  
Sydney H. Rogers, Vice President

Ziff-Davis also publishes Airline Management, Boating, Business & Commercial Aviation, Car and Driver, Cycle, Electronics World, Flying, Modern Bride, Popular Photography, Skin-Sensation, Street News, Skiing Trade News, Stereo Review, and David Weekly.

For 1977 and all subsequent correspondence should be addressed to POPULAR ELECTRONICS, Circulation Department, P.O. Box 1096, Flushing, N.Y. 11352. Please allow at least eight weeks for change of address. Include your old address, as well as new—enclosing if possible an address label from a recent issue.

EDITORIAL CONTRIBUTIONS must be accompanied by return postage and will be handled with reasonable care; however, publisher assumes no responsibility for return or safety of art work, photographs or manuscripts.



Member Audit Bureau of Circulations

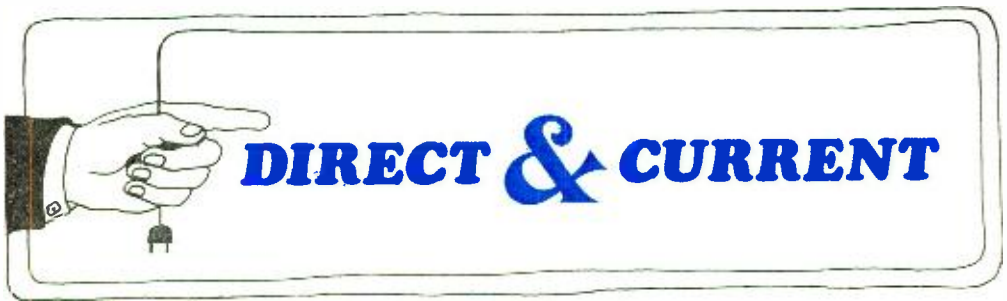

By Milton S. Snitzer, Editor

## A BIGGER AND BETTER POPULAR ELECTRONICS

Next month, POPULAR ELECTRONICS will be bigger and better than ever. Effective with our January issue, PE, the world's largest selling electronics magazine, will have merged with it—and will include some of the best features and editorial coverage of—our sister magazine, ELECTRONICS WORLD.

PE readers will also be pleased with other changes we are planning for January. These include not only more pages to serve our additional readers, but also improved graphic design, cleaner, easier-to-read type, and the addition of a number of new columns and other editorial features. For example, the popular Stereo Scene column will share our pages with new Communications, Test Equipment, Television, and Surplus Scene columns covering these important areas of interest to our readers.

In addition to our usual construction projects, we will include more tutorial, state-of-the-art stories, articles on how things electronic work, and items of interest on new products and developments. What is more, we plan to enlarge our coverage of new products by using, testing, and reporting on more new audio and test equipment, communications gear, and tools and accessories than we have been able to do before.

There are several good reasons for including the features and coverage of ELECTRONICS WORLD in the pages of POPULAR ELECTRONICS. We will elaborate on these in next month's Editorial. But for now, let us say that PE, which actually was born out of the pages of ELECTRONICS WORLD (then called RADIO & TV NEWS) in 1954, has been growing up with its readers and with their increasing knowledge of and sophistication in electronics. Hence, it no longer makes sense for us to maintain a separate identity for the two publications which were, in fact, drawing closer and closer together. The main difference between the two magazines was that while PE concentrated on electronic construction projects, EW emphasized general and tutorial articles. By offering a bigger, combined publication, we hope to cover both areas for our readers.

We are still getting letters from our readers commenting on our "new look" which we began some time ago. We expect even more comments on our still newer look which you will see starting with our January issue. We know you won't want to miss the new PE, starting with our next issue. Watch for it.

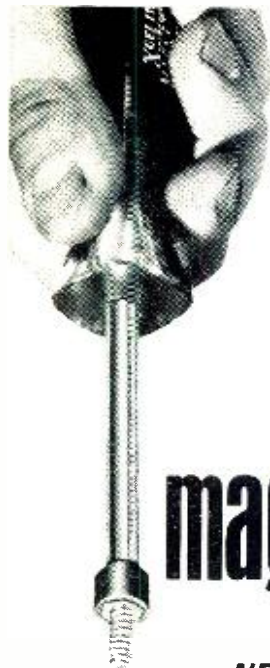

**we've  
gone  
magnetic!**

**NEW NUTDRIVERS  
STOP FUMBLING, SAVE TIME**

Exclusive with Xcelite, 1/4" and 5/16" hex socket magnetic nutdrivers offer the ultimate in convenience for starting, driving, or retrieving screws, bolts, or nuts.

All types: Midget Pocket Clip, Regular, Extra Long, Super Long fixed handle...also interchangeable shanks for Series "99" handles.

Permanent Alnico magnet. Sockets remain demagnetized. Won't attract extraneous matter or deflect against metal surfaces.

New comfort-contour, color-coded handle makes one-hand driving easy, identifies tools as magnetic.

Sockets specially treated and hardened for use with hex head, self-tapping screws. Finished in black oxide for dimensional control and added identification.

REQUEST DESCRIPTIVE LITERATURE

*nationwide availability through  
local distributors*



Made in U.S.A.



XCELITE, INC., 20 BANK ST., ORCHARD PARK, N.Y. 14127

Please send descriptive literature on Xcelite  
Magnetic Nutdrivers.

name \_\_\_\_\_

address \_\_\_\_\_

city \_\_\_\_\_ state \_\_\_\_\_ zip \_\_\_\_\_

**CIRCLE NO. 20 ON READER SERVICE PAGE**

**INTERFACE**

**CONGRATULATIONS AND THEN SOME**

I would like to extend my congratulations on David Heiserman's "Opportunity Awareness" column. It is just great. The column fills a definite need in answering non-technical questions about the many job, career, and educational opportunities available today. Right on. Keep it going.

I do, however, have a negative remark to make with reference to the column. In the June 1971 column, Mr. Heiserman comments on the BSET degree programs. His comments are a bit incorrect and incomplete. These are fantastic new programs, and I would not want someone to get the wrong idea about them. Not all of the new programs lead to a Bachelor of Science in Engineering Technology. Other names are Bachelor of Engineering Technology (BET), Bachelor of Technology (BT), Bachelor of Science in Industrial Technology, and a few others. My degree is a Bachelor of Applied Science (BAS).

Mr. Heiserman is incorrect in stating that students in such programs spend less time in the courses and receive little or no instruction in the humanities. All BSET programs take four years to complete. In addition, BSET students take as many humanities courses as any other Bachelor of Science degree student receives.

About the only difference between the BSET and standard BSEE programs is that BSEE students take a number of engineering courses outside their majors (chemical, mechanical, and civil engineering). The BSEE program is usually more science and theory oriented, while the BSET program goes more heavily on practical design and applications training.

Louis E. Frenzel, Jr.  
Silver Spring, Md.

**TWO-PERSONALITY INTEGRATED CIRCUIT**

While you publish a very good magazine, I believe I have caught a rather unfortunate error. In the "Fil-Oscillator" story (May 1971), dual in-line  $\mu$ A748 IC's were specified.



# new Heath-gift ideas



## Meet the second generation AR-15 ...new Heathkit AR-1500!

From the AR-15, hailed at the time of its introduction in 1967 as the most advanced receiver of its kind, comes the AR-1500... with impressive improvements in every critical area! **180 Watts Dynamic Music Power**, 90 watts per channel (8 ohm load); 120 watts dynamic music power per channel under 4 ohm load, with less than 0.1% intermod distortion, less than .25% harmonic distortion. A 14-lb. power transformer and massive output transistor heat sink are mute testimony to the power at your command. Direct coupled output and drive transistors are protected by limiting circuitry that electronically monitors voltage and current. **FM selectivity greater than 90 dB**, better phase linearity, separation, and less distortion are the result of two computer-designed 5-pole LC Filters. An improved 4-gang 6-tuned circuit front end offers better stability, 1.8  $\mu$ V sensitivity, 1.5 dB capture ratio, and 100 dB image and IF rejection. Four ICs are used, three in the IF and one in the Multiplex. Patented automatic FM squelch is both noise and deviation activated, fully

adjustable for sensitivity. **Vastly Superior AM**, an "also ran" with many receivers, has two dual-gate MOSFETs in the RF and Mixer stages, one J-FET in the oscillator, 12-pole LC Filter in the IF, and broad-band detector. Result: better overload characteristics, better AGC action, and no IF alignment. **Greatly simplified kit construction**. Ten plug-in circuit boards, two wiring harnesses and extensive use of pre-cut wiring with installed clip connections make the AR-1500 a kit builder's dream. Built-in test circuitry uses signal meter to make resistance and voltage checks before operation. **Other advanced features** include Black Magic panel lighting that hides dial markings when set is not in use; flywheel tuning; pushbutton function controls; outputs for two separate speaker systems, bi-amplification, oscilloscope monitoring of FM multipath; inputs for phono, tape, tape monitor and aux. sources — all with individual level controls. **Versatile installation** in optional new low-profile walnut cabinet, in a wall, or black-finish dust cover included. Join the "NOW" Generation in audio technology...order your Heathkit AR-1500 today!

**Kit AR-1500**, less cabinet, 42 lbs. .... **349.95\***  
**ARA-1500-1**, walnut cabinet, 6 lbs. .... **24.95\***

### New Heathkit Stereo Cassette Recorder



**119.95\***

Frequency response of  $\pm 3$  dB, 30-12 kHz, brings your stereo system into the cassette age. Features built-in bias adjustment to accommodate the new chromium dioxide tape; counter; automatic motor shutoff; preassembled and aligned transport mechanism. The AD-110 offers fidelity recording and playback of stereo or mono when used with your stereo system.

**Kit AD-110**, 10 lbs. .... **119.95\***

### New Heathkit Stereo-4 Decoder



**29.95\***

Compatible with your present stereo system and FM receiver, lets you hear all Stereo-4 material currently being broadcast by a number of stations across the country. Additionally, imparts a 4-channel effect to your existing stereo library. Requires second amplifier and 2 speaker systems for installation with conventional stereo system.

**Kit AD-2002**, 5 lbs. .... **29.95\***

### New Heathkit Stereo Phonograph with AM Radio



**109.95\***

Gets it together in a portable package with a purple plum snakey skin that's as far out as today's sounds. Solid-state 18-watt amplifier, fold-down 4-speed automatic changer and swing-out high compliance speakers. Speakers can be separated up to 5'. A flip of the mode switch and you're into AM radio! 45 spindle adapter included.

**Kit GD-111**, 50 lbs. .... **109.95\***

# there's a Heathkit present



229.95\*

## New Heathkit Solid-State Digital Multimeter...

Here's a breakthrough in instrumentation. The new Heathkit IM-102 gives you a true digital multimeter for about half what you'd pay for comparable wired DMM's! And with an accuracy that's better than many wired digital units on the market... decidedly superior to most analog type instruments. This great new meter measures AC and DC voltages and currents, and resistance with no need to change probes or switch for changes in DC polarity. Automatically displays a positive or negative DC voltage and current, indicating the correct amplitude and polarity. Five overlapping ranges measure voltage from 100  $\mu$ V to 1000 V on DC (either polarity), five ranges cover 100  $\mu$ V to 500 V on AC; 10 ranges measure 100 nanoamperes to 2 amperes on AC or DC, and six ranges show resistance from .1 ohm to 20 megohms. Input impedance is exceptionally high — approximately 1000 megohms on 2V range (10 megohm on higher ranges), with overload protection built-in on all ranges. Decimal point is automatically placed with range selection and over-range is indicated by a front panel light.

**Ends parallax and interpolation errors!** There's no mistaking a digital display — everyone reads it the same way. High quality precision components, 3½ digits and ease of calibration contribute to the IM-102's lab-grade accuracy. Analog to digital conversion is accomplished by a patented, dependable Dual Slope Integrator that does not depend on a stable clock frequency for accuracy. A Heath-designed and assembled precision DC calibrator is furnished with each IM-102. An internal circuit and transfer method provides accurate AC voltage calibration. The all solid-state design incorporates cold cathode readout tubes and a "memory" circuit to assure stable, non-blinking operation. Features include detachable 3-wire line cord (no batteries needed), dual primary power transformer, isolated floating ground and completely enclosed, light-weight aluminum cabinet with die-cast zinc front panel and tinted viewing window. Kit includes standard banana jack connectors complete with test leads. Assembles in approximately 10 hours. The new Heathkit IM-102 Digital Multimeter will be the pride of your bench!

Kit IM-102, 9 lbs., mailable ..... 229.95\*

## New Heathkit Vector Monitor...



49.95\*

Designed for use with the Heathkit IG-28 Pattern Generator or similar units which display either "rainbow" (offset carrier) or NTSC patterns, the IC-1128 vector display helps you perform fine tuning, static and dynamic convergence,

purity, 3.58 oscillator, reactance coil, phase detector transformer, demodulator angle check, and chroma bandpass adjustments. Represents exactly the color signals fed to CRT guns.

Kit IC-1128, 10 lbs. .... 49.95\*

## New Heathkit Electronic Switch... 39.95\*

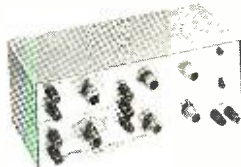

Provides simultaneous visual display of 2 input signals on a single trace oscilloscope. Has DC coupling and DC-5 MHz  $\pm$ 3 dB frequency response. Conventional binding posts permit fast

hook-up. Can be left connected to scope. Ideally suited for digital circuit work: amplifier input and output for gain and distribution checks; simultaneous monitoring of 2 stereo channels.

Kit ID-101, 6 lbs. .... 39.95\*

# for every age, every hobby!

## New Heathkit "Minimizer" kitchen waste compactor...

Today's most modern refuse handling method in easy-to assemble kit form! Now you can own the most exciting kitchen appliance on the market for less than you'd pay for any other comparable compactor. The Heathkit Minimizer lets Mom throw out the unsightly waste baskets and garbage cans for the latest in clean, convenient, odor-free disposal. The Minimizer handles all normal household trash — food wastes, glass and plastic containers, tin cans, wrappings, boxes, floor sweepings, light bulbs, etc. The packing ram descends with 2,000-lb. force to reduce refuse to almost 1/4 of its original size, packing the material in a strong disposable bag — one bag holds an entire week's trash for a family of four! When the bag's full, Mom simply folds over the top and removes a neat, dry package for normal rubbish pickup. And the Minimizer deodorizes the contents each time the drawer is opened and closed. The sanitation man will love Minimizer, too!

Simple, safe operation! To use, Mom merely inserts a Minimizer plastic-lined bag in the drawer and starts the compacting cycle. In less than a minute the ram forces down the trash, returns to its normal position, and the Minimizer shuts itself off. For maximum safety, the Minimizer uses a key lock switch and an interlock which automatically turns unit off if drawer is not fully closed or is accidentally opened during cycling. Your Heathkit Minimizer can be built-in under the kitchen counter or left free-standing. Its bright white enamel finish with marble-tone vinyl-clad top complements any decor. And you can build it yourself in 6 to 10 hours. Has long-life 1/3 hp motor, plugs into 110-120 VAC conventional household outlet. Kit includes 5 plastic-lined bags, one 9 oz. aerosol can of deodorant. Minimizer measures 34 3/8" H x 15" W x 25 1/2" D.

Kit GU-1800, 203 lbs. .... 199.95\*  
 GUA-1800-1, 15 plastic-lined bags, 5 lbs. .... 4.99\*



199.95\*

## New Heathkit Slotless 1/32-Scale Raceway

129.95\*



You race up to 4 GT cars — each with independent acceleration, deceleration and steering! Make all the maneuvers of real high-speed drivers. You can even turn around completely and backtrack. Kit includes track sections for 8'x4' oval, power transformer, 2 cars and controllers.

Kit GD-79, 13 lbs., available ..... 129.95\*  
 Kit GDA-79-1, extra car and controller, 3 lbs., available ..... 21.95\*

## New Heathkit Electronic Workshops

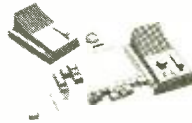

Completely self-contained electronics labs teach youngsters the basics of electronics.

Each contains basic electronic components in easy-to-work-with module form. Kids simply follow the instructions, arrange the blocks on the board to form actual working circuits for code flashers, timers, alarms, etc.

Kit JK-1033, 36 experiments, 11 lbs. .... 29.95\*  
 Kit JK-1022, 25 experiments, 8 lbs. .... 24.95\*  
 Kit JK-1011, 12 experiments, 6 lbs. .... 19.95\*

## SEE THESE KITS AT YOUR LOCAL HEATHKIT ELECTRONIC CENTER... or send for FREE catalog!

CALIF.: Anaheim, 330 E. Ball Road; El Cerrito, 6000 Potrero Avenue, La Mesa, 8363 Center Drive; Los Angeles, 2309 S. Flower St., Redwood City, 2001 Middlefield Rd.; Woodland Hills, 22504 Ventura Blvd.; COLO.: Denver, 5940 W. 38th Ave.; GA.: Atlanta, 5285 Roswell Road; ILL.: Chicago, 3462-66 W. Devon Ave.; DOWNERS GROVE, 224 Ogden Ave.; MD.: Rockville, 5542 Nicholson Lane; MASS.: Wellesley, 165 Worcester St.; MICH.: Detroit, 18645 W. Eight Mile Rd.; MINN.: Hopkins, 101 Shady Oak Rd.; MO.: St. Louis, 9296 Gravois Ave.; N.J.: Fair Lawn, 35-07 Broadway (Rte. 4); N.Y.: Jericho, L.I.: 15 Jericho Turnpike; New York, 35 W. 45th Street; OHIO: Cleveland, 5444 Pearl Rd.; Woodlawn, 10133 Springfield Pike; PA.: Philadelphia, 6318 Roosevelt Blvd.; Pittsburgh, 3482 William Penn Hwy.; TEXAS: Dallas, 2715 Ross Avenue; Houston, 3705 Westheimer; WASH.: Seattle, 2221 Third Ave.; WIS: Milwaukee, 5215 Fond du Lac.

Retail Heathkit Electronic Center prices slightly higher to cover shipping, local stock, consultation and demonstration facilities. Local service also available whether you purchase locally or by factory mail order.

HEATHKIT Schlumberger	
HEATH COMPANY, Dept. 10-12 Benton Harbor, Michigan 49022	
<input type="checkbox"/> Enclosed is \$_____ , plus shipping.	
Please send model(s) _____	
<input type="checkbox"/> Please send FREE Heathkit Catalog.	
Name _____	
Address _____	
City _____	State _____ Zip _____
*Mail order prices; FOB factory. Prices & specifications subject to change without notice. CL-422R	

CIRCLE NO. 11 ON READER SERVICE PAGE



**INTERFACE** (Cont'd. from page 8)

but the schematic diagram shows pin connections for a round IC. The pin connections for the 14-lead DIP are completely different from those of the 8-lead round IC. To make the pins correspond properly, the following table must be used:

ROUND	DIP
1	3
2	4
3	5
4	6
5	9
6	10
7	11
8	12

I hope this clears up any problems that many readers might have.

Larry A. Thiel  
Forest Lake, Minn.

Many thanks from the editorial staff and readers for clearing up the discrepancy.

**WHERE'S THE VOLUME CONTROL?**

The "dream" transceiver pictured on the front cover of the August issue had all the

features anyone could wish for. But it didn't have one feature that a few people might find useful—a volume control!

Mike Centore III  
Edison, N.J.

*Perhaps it has one of those sophisticated circuits that senses the ambient noise level and automatically adjusts the transceiver's volume so that it can be heard clearly? Actually, the only explanation for the oversight is that our artist isn't an engineer and our engineer-editors aren't artists.*

**WHAT HAPPENED TO CHICAGO'S KWO-39?**

On page 81 of the August 1971 issue I believe you omitted from the "Radio Weather" listing in the Communications column Chicago's National Weather Service radio station, KWO-39. Tsk. tsk. It was one of the first in the country.

Ken Greenberg  
Chicago, Ill.

*Not so! While KWO-39 was indeed one of the first NWS radio stations, it certainly was not listed in the U.S. Department of Commerce news release dated May 6, 1971 and numbered NOAA 71-63. All of the information given in our listing was taken directly from the release.*



**Short Wave Listening**



**Drake**  
MODEL  
**SW4-A**

**International Shortwave Broadcast Receiver**

- Precision tuning dial eliminates guesswork, permits Direct Frequency Dialing on SW and standard AM Broadcast
- Crystal lattice filter for adjacent station rejection and good AF response
- Dual conversion
- Solid state AF output
- S-meter
- Preselector gives superior sensitivity by peaking antenna and RF stages
- Crystal-controlled H. F. Oscillator stability
- Amplified AVC constant AF output.

**\$299.00**



**Communications Radio**



**Drake**  
MODEL  
**SPR-4**

**Programmable Communications Receiver**

- Programmable to suit any interest: SWL, Amateur, Laboratory, Broadcast, Marine Radio, etc.
- All solid state
- Direct Frequency Dialing: 150-500 kHz plus any (23) 500 kHz ranges, .500 to 30 MHz
- FET Circuitry
- Linear dial, 1 kHz readout
- 3 bandwidths: 0.4 kHz, 2.4 kHz, and 4.8 kHz for: CW, SSB, AM
- Power: 120 VAC, 220 VAC, and 12 VDC
- Crystals supplied for LW, BC and seven SW bands.

**\$499.95**

**R. L. DRAKE COMPANY**



540 Richard Street  
Miamisburg, Ohio 45342

# FREE!

1972 LAFAYETTE  
CATALOG 720

**JUST OFF THE PRESS!!  
SEND FOR YOUR EXCITING COPY NOW!**



Our 51st Year

**YOUR 1st GUIDE TO  
EVERYTHING IN  
ELECTRONICS**

1972  
LAFAYETTE  
CATALOG  
720



## The Latest in 4-Channel Stereo Sound

- ★ CITIZENS BAND 2-WAY RADIO
- ★ STEREO/HI-FI COMPONENTS
- ★ MUSICAL INSTRUMENTS AND AMPLIFIERS
- ★ PUBLIC ADDRESS
- ★ AMATEUR RADIO
- ★ TEST EQUIPMENT
- ★ PARTS
- ★ PORTABLE AND TABLE RADIOS
- ★ PHOTO EQUIPMENT
- ★ TOOLS-BOOKS
- ★ AUTO ACCESSORIES
- ★ EDUCATIONAL AND OPTICAL
- ★ TV AND ANTENNAS

Your Complete Buying Guide to Everything in Electronics

LAFAYETTE Radio ELECTRONICS  
Dept. 35 121 P.O. Box 10  
Syosset, L.I., N.Y. 11791

Send me the FREE 1972 LAFAYETTE Catalog 35 121

Name .....

Address .....

City ..... State .....

Zip .....  
(please include your Zip Code No.)

**Mail the Coupon Today  
for your FREE Lafayette  
Catalog**

CIRCLE NO. 12 ON READER SERVICE PAGE

# Every record you buy is one more reason to own a Dual.

If you think of your total investment in records—which may be hundreds, even thousands of dollars—we think you'll agree that those records should be handled with the utmost care.

Which brings us to the turntable, the component that actually handles your precious records and tracks their impressionable grooves with the unyielding hardness of a diamond.

For many years serious music lovers have entrusted their records to one make of automatic turntable Dual. In fact, nearly all professionals, including record reviewers, use a Dual in their own stereo component systems.

If you'd like to know why, just write. We'll send you an article from a leading music magazine that tells you what to look for in record playing equipment. We'll also send you a series of independent test reports on Dual.

When you read them, you'll know why Dual has made an impression on the experts and none on their records.



United Audio Products, Inc.  
120 So. Columbus Avenue, Mt. Vernon, New York 10553.

Circle No. 19 on Reader Service Page

CIRCLE NO. 19 ON READER SERVICE PAGE



To obtain a copy of any of the catalogs or leaflets described below, fill in and mail the Reader Service Page 15 or 97.

A new consumer integrated circuits bulletin (No. CB-134) is available from *Texas Instruments, Inc.* The four-page bulletin provides a selection of 39 IC's ideal for use in the various sections of AM/FM radio-phono and color TV systems. Type numbers and descriptions are given for six audio output amplifiers, four dual-channel and stereo IC's, six chroma circuits, seven complex TV functions, three voltage regulators for Varactor tuners, 12 IC circuits for radio and TV, and a power supply regulator. Block diagrams are shown for the radio/phono and color TV systems. IC applications for each subsystem are noted in color.

Circle No. 75 on Reader Service Page 15 or 97

A booklet that serves as a "primer" to the application of nickel-cadmium storage batteries for emergency lighting is available from *NIFE Inc.* Included are answers to such questions as: what type of battery should be used for emergency lighting; what a NiCad battery is; what pocket plate construction is and why it is important; what the performance advantages of NiCad batteries are; how battery reliability is measured. A brief description of the state requirements regarding emergency lighting is also included.

Circle No. 76 on Reader Service Page 15 or 97

The big feature in the 1972 *Lafayette Radio Electronics* catalog, No. 720, is equipment for 4-channel sound reproduction. As always, the catalog is devoted to products for a wide range of interests. Listings include audio/hi-fi equipment, communications gear, TV receivers, home appliances, parts and accessories, experimenter kits, and many more items. Also included in the listings are watches and chronographs, weather forecasting instruments, cameras and projectors, microscopes and telescopes, and a variety of manual and power tools.

Circle No. 77 on Reader Service Page 15 or 97



# Popular Electronics

## READER SERVICE PAGE

### free information service:

Here's an easy and convenient way for you to get additional information about products advertised or mentioned editorially (if it has a "Reader Service Number") in this issue. Just follow the directions below... and the material will be sent to you promptly and free of charge.

**1.** On coupon below, circle the number(s) that corresponds to the key number(s) at the bottom or next to the advertisement or editorial mention that is of interest to you. (Key numbers for advertised products also appear in the Advertisers' Index.) Print or type your name and address on the lines indicated.

**2.** Cut out the coupon and mail it to: POPULAR ELECTRONICS, P.O. Box 8391, Philadelphia, PA 19101.

**note:** If you want to write to the editors of POPULAR ELECTRONICS about an article on any subject that does not have a key number, write to POPULAR ELECTRONICS, One Park Avenue, New York, N.Y. 10016. Inquiries concerning circulation and subscriptions should be sent to POPULAR ELECTRONICS, P.O. Box 1096, Flushing, N.Y. 11352.

# Popular Electronics

12 71-1  
Void after January 31, 1972

P.O. BOX 8391  
PHILADELPHIA, PA. 19101

1 2 3 4 5 6 7 8 9 10 11 12 13 14 15 16 17 18 19 20  
21 22 23 24 25 26 27 28 29 30 31 32 33 34 35 36 37 38 39 40  
41 42 43 44 45 46 47 48 49 50 51 52 53 54 55 56 57 58 59 60  
61 62 63 64 65 66 67 68 69 70 71 72 73 74 75 76 77 78 79 80  
81 82 83 84 85 86 87 88 89 90 91 92 93 94 95 96 97 98 99 100

NAME (Print clearly) \_\_\_\_\_

ADDRESS \_\_\_\_\_

CITY \_\_\_\_\_ STATE \_\_\_\_\_ ZIP CODE \_\_\_\_\_

## AR guarantees its published specifications

At Acoustic Research we believe that the publication of complete performance data on our high fidelity components is obligatory. Otherwise, our guarantee would have little meaning.

Find out just what AR guarantees that its products will do. Mail the coupon below, and detailed technical literature will be sent to you free of charge.



**Acoustic Research, Inc.**  
24 Thorndike Street  
Cambridge, Mass. 02141  
Dept. PE-12

Please send measured performance data on AR products to

Name \_\_\_\_\_

Address \_\_\_\_\_

**CIRCLE NO. 1 ON READER SERVICE PAGE**

## Hear your police and firemen in action!

Listen on these channels, too...



WEATHER  
TRAFFIC  
UTILITY  
BUSINESS  
MARINE  
CIVIL DEFENSE

### WITH ALL-NEW **Bearcat III**

#### The Only Monitor Receiver You'll Ever Need

Meets present and future needs in any locality. Scans 1 to 8 FM emergency and business channels you select, in any 1 or 2 bands—low, high, UHF. Stops for any transmission, then resumes search. Plug-in interchangeable RF module for each band. Built-in front speaker. Complete band coverage. Comes with one or two RF modules, mobile mount and cords for AC and DC. American built by Electra, originator of the scanning receiver. At better dealers.

**\$139.95** WITH RF MODULE FOR ANY 1 BAND

**\$159.95** WITH RF MODULES FOR ANY 2 BANDS

Plus plug-in crystals at \$5 each. Additional modules \$20 each.

**Electra CORPORATION**  
CUMBERLAND, INDIANA 46229

**CIRCLE NO. 10 ON READER SERVICE PAGE**



### LABORATORY MANUAL FOR INTEGRATED COMPUTER CIRCUITS

by Robert F. Coughlin

The study of electronics is incomplete without actual supportive laboratory experience. This clearly written textbook is one of the very few really good lab manuals available. It explores both digital (logic) and operational amplifier (linear) circuits. The book is divided into two parts called Principal Problems. The first part deals with digital to analog conversion, basic logic elements, and an electronic organ. The second part, titled "Design and Build an Analog Computer," introduces the reader to passive analog computing circuits and op-amp theory and operation.

Published by Prentice-Hall, Inc., Englewood Cliffs, NJ 07632. Soft cover. 152 pages. \$5.95.

### BASIC ELECTRONICS, Third Edition

by Bernard Grob

An introductory course in electrical principles, electron tubes, and transistors needed for all electronic circuits. Electrons and the atom are first discussed, followed by dc circuits, meters, magnetism, ac circuits, tubes, semiconductors, and transistors. This third edition contains a new and more detailed chapter on RC and RL time constants. In addition, the chapter on transistors, including FET's, has been updated and expanded. Coverage now includes theory of semiconductors, diode rectifiers and power supplies, transistor theory and amplifiers, including load line analysis. Separate chapters are devoted to Kirchoff's laws and network theorems.

Published by McGraw-Hill Book Co., 330 West 42 St., New York, NY 10036. Hard cover. 764 pages. \$12.95.

### 1972 POPULAR TUBE/TRANSISTOR SUBSTITUTION GUIDE

There can be little doubt that among the extremely useful electronics handbooks, the transistor and/or tube substitution guides (Continued on page 99)

Announcing the **NEW STANDARD** in Stereo Testing!

# Get the All-New Model SR12 STEREO TEST RECORD

The most complete...most sophisticated...most versatile  
Test Disc available today... **For Just \$5.98!**

## Who Needs the New Model SR12?

If you've read this far, you do. Whether you're an avid audiophile who'll settle for nothing but peak performance from his stereo components... a casual listener who'd like more insight into the challenging world of stereo reproduction... or a professional technician who needs precise standards for lab testing... the new MODEL SR12 will be the most important disc in your entire collection.

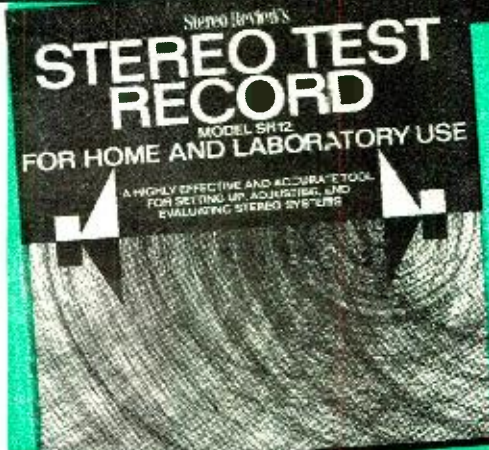

Like its predecessor Model 211, MODEL SR12 has been produced by Stereo Review Magazine (formerly HiFi/Stereo Review) as a labor of love — by music lovers... for music lovers who want immediate answers to questions about the performance of their stereo systems and how to get the best possible sound reproduction.

Now greatly expanded and updated with the most modern engineering techniques, MODEL SR12 is the most complete test record of its kind — containing the widest range of checks ever included on one test disc. An ear-opener for every serious listener!

**AND, for the ultimate in stereo testing, 7 critical TEST EQUIPMENT checks...**

## You'll make these important stereo checks BY EAR... (no test instruments of any kind required)

Frequency response—a direct warble-tone check of nineteen sections of the frequency spectrum, from 20 to 20,840 Hz, which will pinpoint any frequency response defects in your system.

Separation—an ingenious test which indicates whether you have adequate separation for good stereo.

Cartridge tracking—the most sophisticated tests ever devised for checking the performance of your cartridge, stylus and tone arm.

Channel balance—two broad-band, random-noise signals which permit you to eliminate any imbalances originating in cartridge, amplifier, speakers or room acoustics.

Hum and rumble—foolproof tests that help you evaluate the actual audible levels of rumble and hum in your system.

Flutter—a sensitive "musical" test to check whether your turntable's flutter is low, moderate, or high.

- Cartridge and Speaker Phasing
- Anti-Skating Adjustment
- "Gun Shot Test" for Stereo Spread
- Multi-purpose Musician's "A"
- Equal-tempered Chromatic Octave
- Guitar-tuning Tones.

**Don't waste another minute on less-than-perfect stereo—Order Your Model SR12 Stereo Test Record NOW!**

Consider the hundreds—even thousands—you've spent on your set-up and you'll agree \$5.98 is a small price to pay for the most valuable performance tool ever made. So to be sure your order is promptly filled from the supply available, mail the coupon at right with your remittance... today!

Attention professionals: Stereo Review's new Model SR12 Stereo Test Record is also designed to be used as a highly efficient design and measurement tool. In the following tests, recorded levels, frequencies, etc. have been controlled to laboratory tolerances—affording accurate numerical evaluation when used with oscilloscope, chart recorder, output meter, intermodulation-distortion meter and flutter meter.

- 1,000-Hz square waves to test transient and high-frequency response of phono pickups.
- 500 to 20,000 Hz frequency-response sweep.
- Sine-wave tone-bursts to test transient response of pickup.
- Intermodulation test using simultaneous 400-Hz and 4,000-Hz signals.
- Intermodulation sweep to show distortion caused by excessive resonances in tone arm and cartridge.
- 1,000-Hz reference tones to determine groove velocity.
- 3,000-Hz tone for flutter and speed tests.

Sample waveforms—illustrating both accurate and faulty responses are provided in the Instruction Manual for comparison with the patterns appearing on your own oscilloscope screen.

## FREE Instruction Manual Includes Detailed Instructions, Charts, Tables and Diagrams.

Nothing is left to chance... or misinterpretation. Every segment of every band is fully, clearly, graphically explained. You'll know exactly what responses to listen for in each test. Which sounds and patterns indicate accurate performance... which ones spell trouble... as well as the cause of trouble and precise corrective measures to follow and help you pinpoint, analyze and cure your stereo headaches!

RECORDS • Ziff-Davis Service Division SK-12-71  
595 Broadway • New York, N.Y. 10012

Please send \_\_\_\_\_ test records at \$5.98 each, **postpaid**.

My check (or money order) for \$ \_\_\_\_\_ is enclosed.  
(Outside U.S.A. please send \$8.00 per record ordered.) N. Y. State residents please add local sales tax.

Print Name \_\_\_\_\_

Address \_\_\_\_\_

City \_\_\_\_\_

State \_\_\_\_\_ Zip \_\_\_\_\_

**PAYMENT MUST BE ENCLOSED WITH ORDER**



# Does your mother-in-



# law call you a meatball?

Does your boss?

Maybe even your wife? On payday.

Know what? If you have read this far, you are not meatball material. Because meatballs don't face the present, the future, the facts. They stay put. Dreaming and talking. And today, more than ever staying put means falling behind. Pretty tragic in a time when people with specific aptitudes are so necessary in so many interesting fields.

Today huge industries depend on people with electronics training.

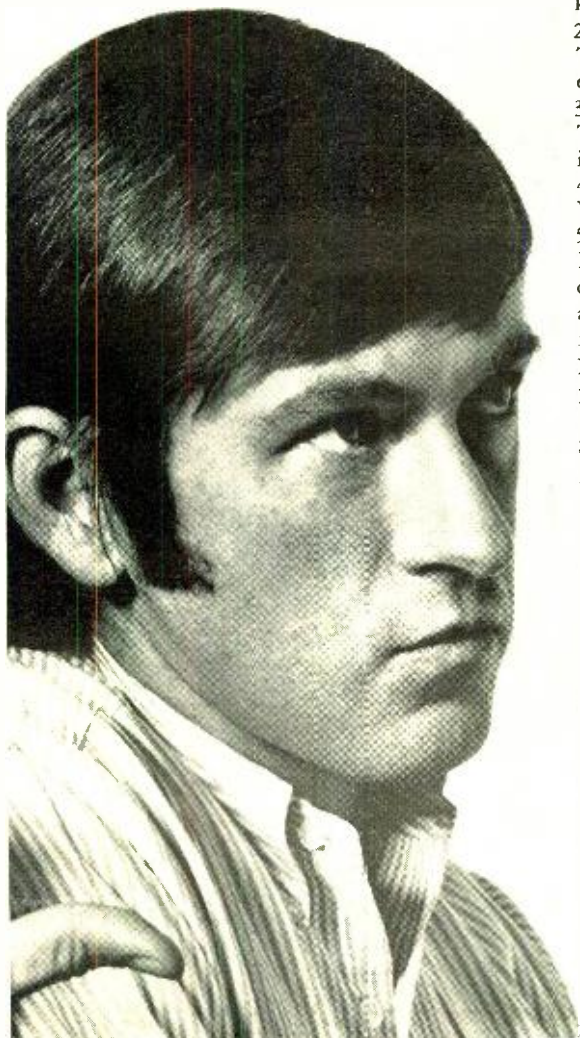

Today there is a course of action that may lead you toward these well-paying, vital positions. It is RCA Institutes.

RCA Institutes is not for meatballs. RCA Institutes trains you for the fields where the action is: Computers • Color TV • Automation • Communications • Industrial Electronics • And more.

RCA Institutes not only has years of experience, it has an exclusive line-up of tested methods:

**1. Hands-On Training**

Over 250 interesting experiments. As many as 22 kits with some of the programs.

**2. RCA Autotext**

The easy-way-to-learn method that gets you started easier, faster.

**3. Wide choice of courses and programs**

Training in electronics fundamentals right up to solid state technology and communications electronics.

**4. Low-Cost Tuition Plans**

You'll find the one just made to fit your own budget.

**5. FCC License Training Money-Back Agreement**

RCA Institutes' money-back agreement assures you of your money back if you fail to pass the FCC examination taken within six months after completing RCA Institutes' FCC course.

RCA Institutes gets your training started even if you've not had previous experience or training. Just bring us your interest.

Set your own pace depending on your schedule.

If you like to tinker, fiddle, fix, put that ability to work to do a real repair job on your future now.

Don't wait. Get complete information right now. No obligation. Except to yourself. Send us the attached postcard. Or return the coupon.

Veterans: Train under GI Bill. Accredited Member National Home Study Council. RCA Institutes, Inc. is licensed by—and its courses of study and instruction facilities approved by—the N.Y. State Education Department.

## **RCA Institutes**

Home Study Department  
320 W. 31 Street, New York, N.Y. 10001

Please rush me FREE illustrated electronics career catalog. I understand that I am under no obligation.

NAME \_\_\_\_\_

ADDRESS \_\_\_\_\_

CITY \_\_\_\_\_ STATE \_\_\_\_\_ ZIP \_\_\_\_\_

694-112-0

Veterans check here

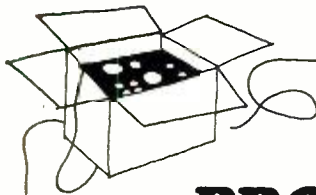

# NEW PRODUCTS

Additional information on products described in this section is available from the manufacturers. Each new product is identified by a corresponding number on the Reader Service Page. To obtain additional information on any of them, circle the number on the Reader Service Page, fill in your name and address, and mail it in accordance with the instructions.

**KENWOOD AM/STEREO FM RECEIVER**—Eighty watts of IHF output power and modern circuit design give the Kenwood Electronics, Inc., Model KR-4140 stereo receiver top quality sound reproduction in a middle-of-the line receiver. The FM tuner section incorporates a two-FET, 4-gang front end and a two-IC and mechanical filter i-f section to deliver 55 dB IHF selectivity, 1.8  $\mu$ V IHF sensitivity, and 2.5 dB IHF capture ratio. Frequency response of the audio sections is 20-40,000 Hz,  $\pm 1.5$  dB, power bandwidth is 18-30,000 Hz, and distortion is less than 0.5 percent at rated output. A full complement of controls and input and output jacks is provided. Price \$259.95; optional walnut cabinet \$19.95.

Circle No. 78 on Reader Service Page 15 or 97

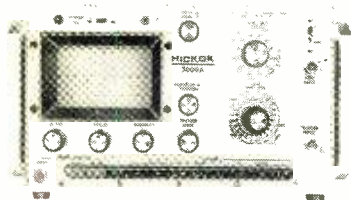

**HICKOCK 25-MHz OSCILLOSCOPE**—The Hickock Electrical Instrument Co. Model 5000A wideband oscilloscope offers wide dynamic range and 10 mV/div. sensitivity at an economical price. Vertical bandwidth is dc-25 MHz at the  $-3$  dB point. An ultra-stable triggering circuit provides solid waveform displays to beyond 50 MHz. Either positive or negative slope can be selected to initiate sweep. A built-in vertical delay line provides 50 ns of display prior to the trigger point on the input waveform. Input impedance is 1 Megohm, 30 pF. Overload protection is 600 V on all but the most sensitive range, where it is 300 V. Rise time is 14 ns. Price \$595.

Circle No. 79 on Reader Service Page 15 or 97

**JENSEN MODEL 5 SPEAKER SYSTEM**—The Model 5 speaker system manufactured by Jensen Sound Laboratories incorporates "Total Energy Response" to produce the best musical balance throughout a listening room. The four-driver, three-way system employs a 12" woofer, two complementary 5" direct radiating mid-range speakers and an ultra-tweeter. Special crossover networks are designed to provide optimum smoothness and tonal blending. The woofer coil has four layers; there is a Tuned Isolation Chamber on each midrange driver; and the ultra-tweeter will respond to sounds well beyond the audible range. Overall frequency range is 32-30,000 Hz. Impedance is 8 ohms. Price \$147.00

Circle No. 80 on Reader Service Page 15 or 97



**DYNACO 4-CHANNEL STEREO DEMO DISC**—A 4-channel stereo demonstration record containing Vanguard Recording Society library selections can be obtained from Dynaco dealers. It is designed for playback through systems incorporating Dynaco's "Quadaptor" circuitry.



Played through a 4-channel system, it provides the front-to-back and left-to-right directionality distinctive of the concert hall. Selections include a Moog synthesized adaptation of the "Flight of the Bumblebee," an excerpt from the Berlioz *Requiem*, and the final movement of Tchaikovsky's 4th Symphony (conducted by Leopold Stokowski). Disc #SVP-7 retails for \$2.95

Circle No. 81 on Reader Service Page 15 or 97

**CRAIG MINIATURE ELECTRONIC CALCULATOR**—Craig Corp. is currently marketing an economy-priced miniature electronic calculator with an 8-digit readout and floating decimal point operation. The Model 4501 calculator measures 5" x 3" x 1" and weighs approximately 14 ounces. It employs easy-to-read light-emitting diode (LED) numeric readouts for long-life operation. The calculator operates on either self-contained NiCad rechargeable batteries (more than 3 hours of use per charge) or directly from the ac line. All arithmetic functions—addition, subtraction, multiplication, and division—can be performed separately and in long chains.

Circle No. 82 on Reader Service Page 15 or 97



**AUDIOTEX WIRELESS INTERCOMS**—Designed for 117-volt ac operation GC Electronics' new Audiotex wireless intercom No. 30-6024 requires no special cables or wires. The ac line not only supplies the operating power for the intercoms, but it also acts as the transmitting and receiving cable. The intercom operates on a carrier current frequency of 140 kHz. Each intercom features a lock button for continuous operation when used for baby-sitting, surveillance, etc. Price is \$49.95 per pair.

Circle No. 83 on Reader Service Page 15 or 97

**HALLICRAFTERS 4-BAND TABLE RECEIVER**—A new, improved version of the popular S-120 Series AM/SW table receivers has been engineered by *The Hallicrafters Co.* The Model S-125, called "Star-Quest II," provides the listener with an all-transistor, completely self-contained AM general-coverage shortwave receiver with many built-in features and frequency coverage found only in far more costly receivers. These include an improved dial legend for simplified SW tuning, greater sensitivity, better calibration, and coverage of 76 SW services out to 30 MHz in four tuning ranges. Although designed for the novice SWL, DX'er, etc., as a table receiver, the S-125 has an external power jack that permits use from a battery source. Price is \$59.95.

Circle No. 84 on Reader Service Page 15 or 97

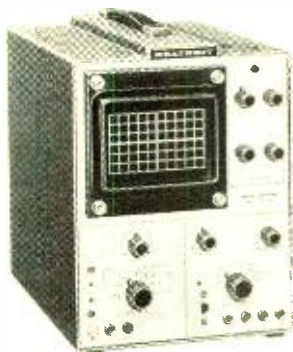

**HEATHKIT SOLID-STATE 5" OSCILLOSCOPE**—The *Heath Co.* now has available their Model IO-102, a new solid-state oscilloscope suitable for general service and design work in audio, TV, and radio receiver circuitry. Vertical channel response is dc to 5 MHz with switch-selectable ac or dc coupling for extra versatility. A frequency-compensated 3-position attenuator accommodates varying input levels. FET input provides high input impedance to prevent circuit loading. Input sensitivity is 30 mV/cm and rise time is 80 ns. A recurrent automatic sync type sweep generator provides 5 sweep ranges from 10 Hz to 500 kHz.

Circle No. 85 on Reader Service Page 15 or 97

**CAN'T FIND  
PARTS FOR  
SOLID-STATE  
PROJECTS?**

**RCA Integrated Circuit Project Kits  
eliminate that problem for  
hobbyists, educators, technicians, hams.**

Stop running all over town trying to hunt up a part for your solid-state projects! Get RCA IC Project Kits—complete with active and passive components, predrilled printed-circuit boards, and easy-to-follow instructions.

As a matter of fact, RCA IC Project Kits are a convenient and inexpensive source for all kinds of circuits: from intruder- and fire-alarms to a 3-V regulated power supply, from amplifiers to marine-bank converters.

See your RCA Distributor for the IC Project Kit of your choice. And while you're there, purchase the 358-page RCA Solid-State Hobby Circuits Manual, HM-91—it details over 60 interesting circuits, and includes a section on theory and operation of solid-state circuits.

RCA | Electronic Components | Harrison, N.J. 07029.

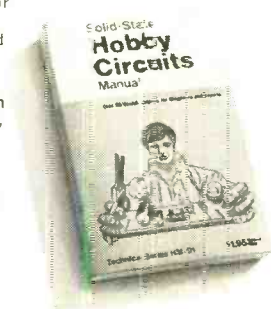

**RCA**

POPULAR ELECTRONICS



## **Distortionless Audio Compressor**

JUST THE THING FOR HAMS, CB'ers,  
AND TAPE RECORDING FANS

BY CHARLES CARINGELLA, W6NJV

**T**HE AUDIO COMPRESSOR is an important engineering instrument in every recording, television, and radio studio. By holding the output of a device at a given level for a given increase in input signal level, the compressor assures a smooth listenable product, without booms and overloading distortion. You can see how valuable a contribution a compressor would make to your own audio equipment—be it tape recorder, amateur radio or CB transmitter.

Once set up to operate with a tape recorder, the audio compressor will hold the recording level constant, without introducing noise or distortion. You can ignore the recording level meter on your recorder and there is no need to "ride" the recorder gain control. The compressor is particularly valuable when recording lectures, press conferences, family groups, etc. Smooth, professional results can be achieved when making stereo or multiple channel recordings. All it takes is one compressor in each channel and the work is done for you.

When used with amateur radio and CB transmitters, an audio compressor can provide as much as a 10-dB increase in signal strength at the receiving end. This is the next best thing to adding a kilowatt linear amplifier to your transmitter! The automatic limiting action also prevents overmodulation, without adding distortion to the transmitted signal.

Still another application for the audio compressor is with public address amplifiers. Here, the output of the system can be held constant regardless of input variations due to difference in voice levels and distance from the microphone. The unit also minimizes annoying feedback.

You can build your own audio compressor for less than \$50 and it will be the equivalent of commercial units costing 4 or 5 times as much. Although the compressor is somewhat complex in theory, it is easy to build and use. It is simply installed between the microphone and the equipment. There is no need to dig into the equipment circuitry.

Besides having a large dynamic com-



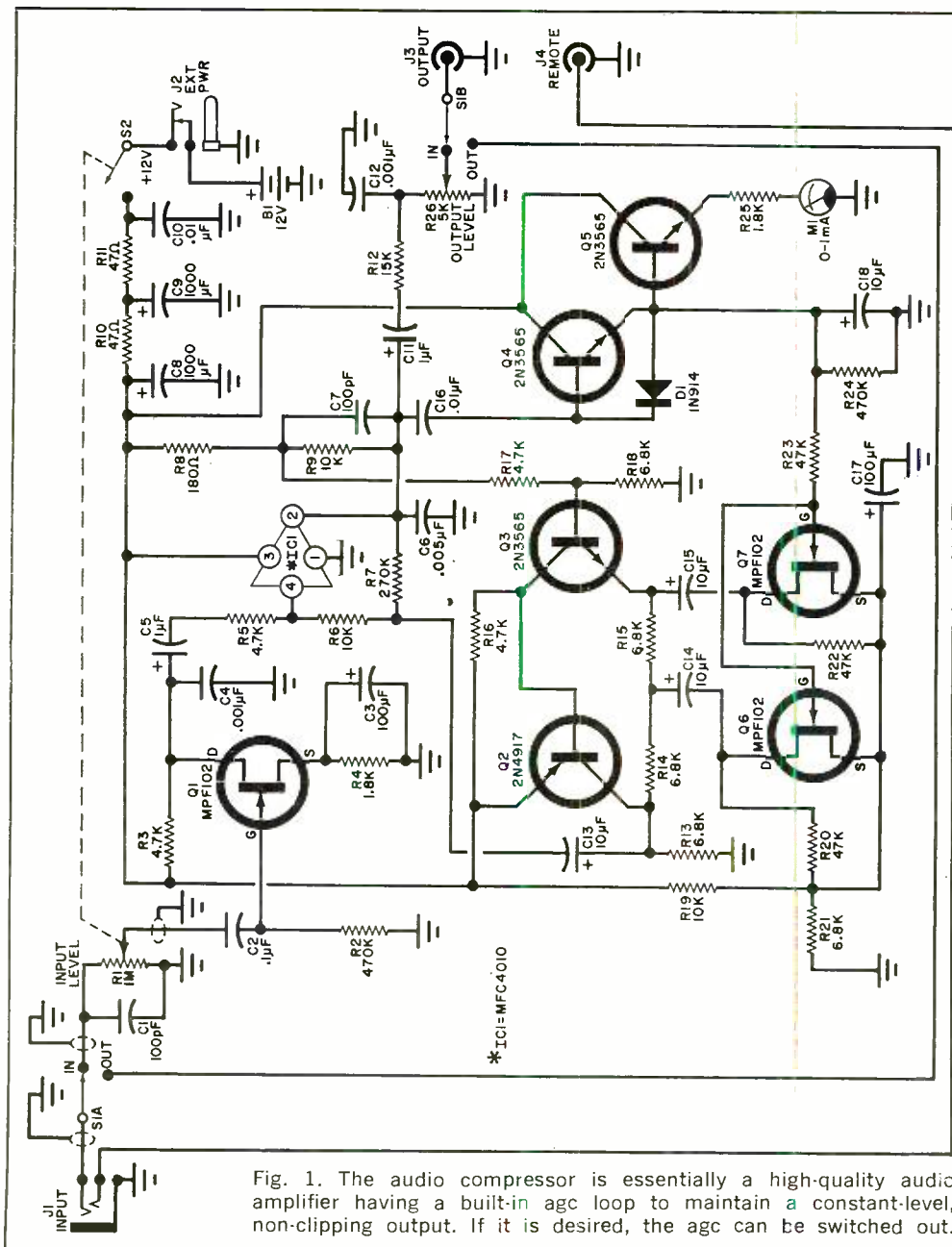

Fig. 1. The audio compressor is essentially a high-quality audio amplifier having a built-in agc loop to maintain a constant-level, non-clipping output. If it is desired, the agc can be switched out.

pression range (45 dB or more), the compressor described here also serves as a high gain preamplifier with approximately 46 dB of gain. This permits the use of practically any type of microphone, from low-impedance dynamics (200 ohms or more) to high-impedance crystal, ceramic, and dynamic types. An FET input provides a very low noise figure.

The completed unit, housed in a cabinet 5" x 2½" x 4½", can be operated from an internal 12-volt mercury battery for portable applications or any other 12-volt external supply.

**Theory of Circuit Design.** The compressor is basically an audio amplifier with an automatic gain control (agc) feedback

## PARTS LIST

- B1—12-volt mercury battery (Mallory 289 or similar)  
 C1,C7—100-pF ceramic disc capacitor  
 C2—0.1- $\mu$ F miniature ceramic disc capacitor  
 C3,C17—100- $\mu$ F, 12-volt miniature printed circuit electrolytic capacitor  
 C4, C12—0.001- $\mu$ F ceramic disc capacitor  
 C5,C11—1- $\mu$ F, 12-volt miniature printed circuit electrolytic capacitor  
 C6—0.005- $\mu$ F ceramic disc capacitor  
 C8,C9—1000- $\mu$ F, 12-volt miniature printed circuit electrolytic capacitor  
 C10,C16—0.01- $\mu$ F ceramic disc capacitor  
 C13,C14,C15,C18—10- $\mu$ F, 12-volt miniature printed circuit electrolytic capacitor  
 D1—1N914 silicon diode  
 IC1—Amplifier integrated circuit (Motorola MFC4010)  
 J1—3-way phone jack  
 J2—Closed-circuit coaxial power jack  
 J3,J4—Phono jack  
 M1—Milliammeter, 0.1 mA, 2800-ohm coil (Emico Model 12)  
 Q1,Q6,Q7—FET, n-channel (Motorola MPF102)  
 Q2—Pnp transistor (Fairchild 2N4917)  
 Q3,Q4,Q5—Npn transistor (Fairchild 2N3565)  
 R1—1-megohm potentiometer with spst switch for S2  
 R2,R24—470,000-ohm,  $\frac{1}{2}$ -watt 10% resistor  
 R3,R5,R16,R17—4700-ohm, " " "  
 R4,R25—1800-ohm " " "  
 R6,R9,R19—10,000-ohm " " "  
 R7—270,000-ohm " " "  
 R8—180-ohm " " "  
 R10,R11—470-ohm " " "  
 R12—15,000-ohm " " "  
 R13,R14,R15,R18,R21—6800-ohm " "  
 R20,R22,R23—47,000-ohm " " "  
 R26—5000-ohm potentiometer  
 S1—Dpdt rocker-type slide switch  
 S2—Spst switch, part of R1  
 Misc.—Chassis (5" x 2 $\frac{1}{2}$ " x 1 $\frac{1}{2}$ " ), knob, angle brackets (6), battery clips (2), rubber feet (4), hardware, wire solder, etc.  
 Note: The following are available from Caringella Electronics, Inc., P.O. Box 327, Upland, CA 91786; etched and drilled printed circuit board at \$5.95; complete kit of parts less battery but including PC board, chassis, assembled power supply, and all hardware at \$49.95. All prices postpaid. California residents, add 5% sales tax.

loop (see Fig. 1). The feedback provides a very fast attack time and a slow decay time. The fast attack means that the compressor can respond to a 20-dB increase in signal at 1 kHz in less than 1 millisecond. At 10 kHz, the attack time response is less than 100 microseconds. The fast attack time results in no loss of information at the beginnings of words or sounds.

More important, since there is no "overshoot" of the signal associated with the attack, there is no evidence of popping or clicks in the audio signal, which is a drawback in many compressors.

Compression is accomplished by a form of negative feedback, part of the output signal being fed back out of phase with the input. The amount of negative feedback increases as the signal level goes up and vice versa. The net result is that the compressor output remains constant as the input signal varies.

Field effect transistor Q1 provides a high input impedance (on the order of 0.5 megohm) and keeps the "front end" noise to an almost unmeasurable level so that there is none of the "rushing" sound commonly associated with transistor amplifiers. The input level control is adjusted by potentiometer R1.

Integrated circuit IC1 is a high-gain amplifier with low output noise. The IC package contains three npn transistors and five resistors. The audio signal from the output of IC1 is coupled to the output level control, R26. The combination of R12 and C12 provides high frequency roll off above 20,000 Hz.

Part of the output signal is also fed to the base of transistor Q3. Resistors R8, R9, R17, and R18 set the forward bias for Q3 and also divide the output signal so that it is at the proper level. Transistors Q2 and Q3 form a variable gain amplifier whose output provides negative feedback to the input of IC1. The gain of the feedback amplifier is varied by changing the effective resistance in series with bypass capacitors, C14 and C15. This resistance is provided by Q6 and Q7, which are controlled by a dc voltage that is a function of the output signal.

Part of the output is fed to diode D1 and transistor Q4 through capacitor C16. The diode and transistor form a voltage doubling rectifier (with very low output impedance) which controls Q6 and Q7. The time constant of R24 and C18 determines the decay time of the compressor.

Transistor Q5 serves as a dc current amplifier to drive the compression indicating meter. The meter indicates only during compression and not when the circuit is amplifying in the linear region.

Capacitors C8 and C9 and resistors R10 and R11 provide filtering for the 12-volt supply so that a simple transformer and

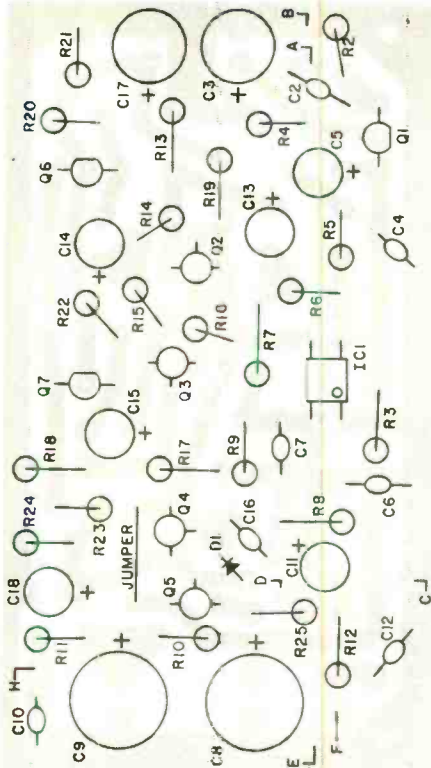
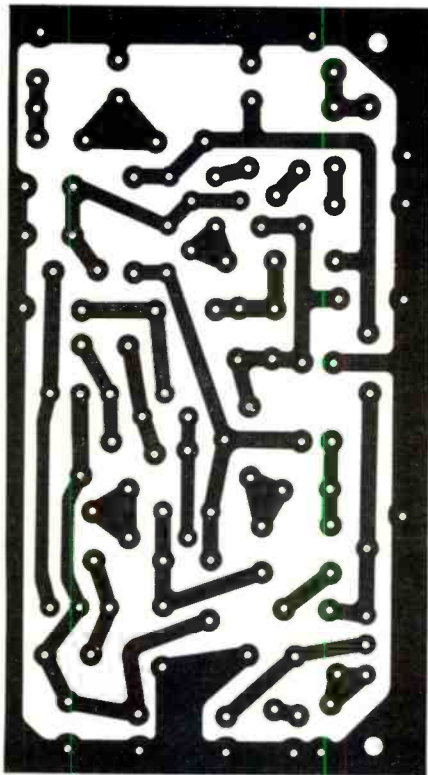

Fig. 2. Actual size foil pattern and component installation for the audio compressor. Observe the current polarity of electrolytic capacitors and all semiconductors including IC audio amplifier.

full-wave rectifier can be used as a supply instead of the battery. Capacitor C10 provides r-f bypassing when the compressor is used in conjunction with transmitting equipment.

A 3-way jack is used for the input connection. The remote line, running to J4, is used for push-to-talk operation. The compressor can be bypassed by placing S1 in the OUT position.

Although the compressor is rated at 45 dB compression range, it is capable of producing as much as 50 dB. Total harmonic distortion is extremely low and must be measured with sophisticated laboratory equipment. It cannot be seen on an oscilloscope.

**Construction.** All of the circuit components, with the exception of C1, are mounted on a circuit board whose foil pattern is shown in Fig. 2. Capacitor C1 (r-f bypass) is mounted directly across the input level control R1, as shown in Fig. 3.

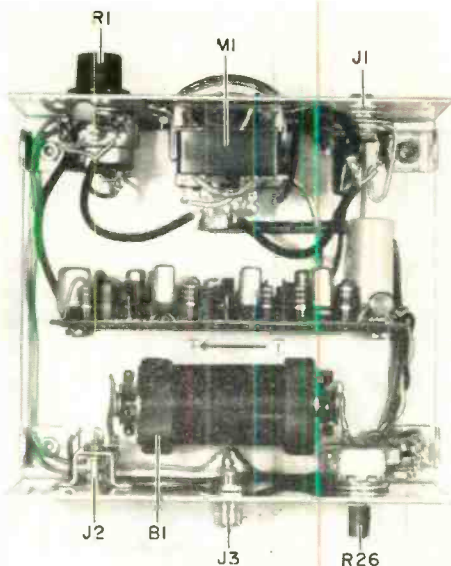

Fig. 3. Although any method of installation may be used, this is a view of prototype.



## HIRSCH-HOUCK LABORATORIES Project Evaluation

As claimed, this is a nondistorting compressor. The maximum output level was too low for us to make distortion measurements, but visually it looked perfect on a scope no matter what the degree of compression.

The gain in the linear portion is very good, 45 microvolts being required for 10 millivolts output—about 46 dB. Compression begins at about 300 microvolts. The maximum output at full compression is 60 millivolts.

We passed a 10-kHz tone burst through the compressor to measure the attack time. It would seem to be about 100 microseconds.

When the input level control is set below maximum (the usual condition), the frequency response is quite flat—down 1.5 dB at 35 Hz and 20 kHz. However, at maximum input level, the highs rise and keep rising to a maximum of +9 dB at 30 kHz. The rather high input impedance seems to be responsible for the rolloff, which is of little practical importance since one would hardly use it "wide open."

We made tape recordings of voice with the compressor, and they sounded fine—no distortion, just a bit of "breathing" on extreme compression.

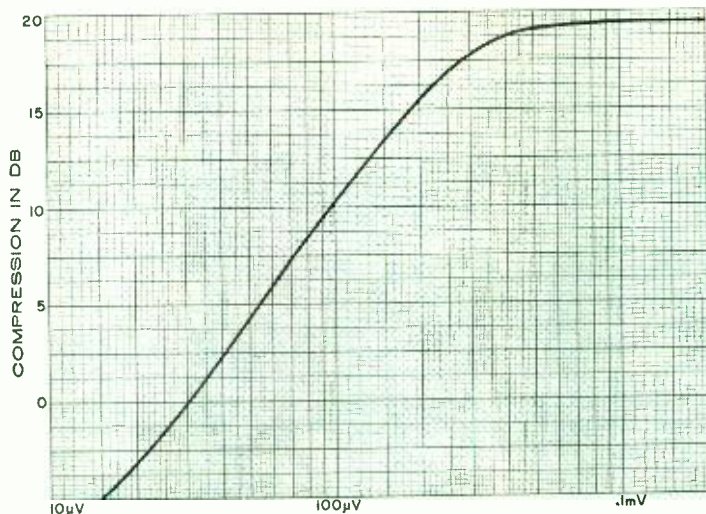

Input versus compression showing the smooth curve of an excellent no-distortion setup.

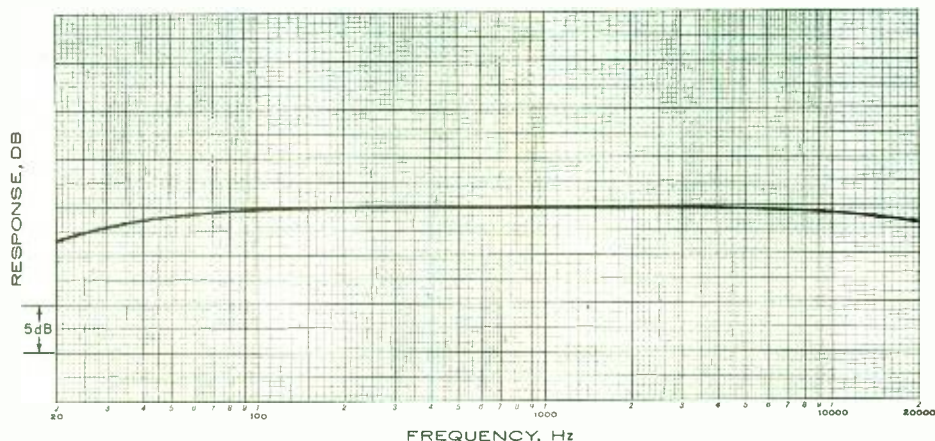

The frequency response of the compressor is just as good as most high-quality audio systems so that it is top notch for musical recordings.

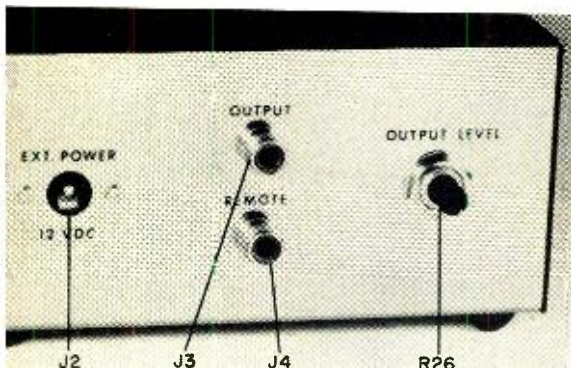

The rear apron of the compressor chassis showing the jack for external power supply input, terminals, and output level control.

Mount all of the transistors first. Space each one about  $\frac{1}{4}$ " away from the board and make sure they are properly oriented. The IC should rest flat against the board. Mount *D1* vertically. Use a heat sink on all semiconductor leads during the soldering operation.

The capacitors should be flush against the board. Observe the polarities of electrolytics. All of the resistors are mounted vertically with one end flush against the board. Use shielded wire between *J1* and *S1* and between *S1* and *R1*.

Attach all the connecting leads to the board before installing it in the cabinet. Use shielded wire for the input line.

The prototype cabinet was made of two pieces of 0.050" sheet aluminum, though a standard chassis box can be used. The circuit board was mounted vertically using two angle brackets. Due to the high gain and high input impedance of the circuit, it is extremely important that the entire circuit be completely shielded in a metal box. This is important if you plan

#### TECHNICAL SPECIFICATIONS

- Compression Range:** 45 dB minimum
- Sensitivity:** Approximately 300 microvolts for compression
- Frequency Response:** -3 dB at 20 Hz, -1.5 dB at 20,000 Hz, in linear region of amplification and in compression region
- Total Harmonic Distortion:** At 1 kHz, 0.1% in linear region, 1.5% in compression
- Input Impedance:** 0.5 megohm
- Output Impedance:** 5000 ohms
- Attack Time:** Less than 1 millisecond for 20 dB change at 1kHz
- Release Time:** Approximately 2 seconds

to use the compressor in a custom installation or within existing equipment.

Use shielded cable for the input and output connections.

**Use.** With a 12-volt battery installed, or some other 12-volt supply attached, plug a microphone into the compressor and connect the compressor output to the equipment to be used. Place *S1* in the OUT position to bypass the compressor. Talk into the microphone at close range and set the gain control on your equipment for the proper operating level. If you are using a tape recorder, you will be watching the recording level meter; if you are using a transmitter, you will probably be watching a modulation indicating meter.

Now, turn on *S2* but leave *R1* and *R26* fully counterclockwise. Place *S1* on the IN position. While speaking into the mike, advance *R1* until the compression meter begins to kick upward. Now advance the output level control, *R26*, until the meter on your equipment reads the same as when the compressor was bypassed. Flip *S1* back and forth to see how the signal looks with and without compression.

The compression meter not only indicates the fact that the signal is being compressed, but also when the signal is overdriving the compressor. In that case the meter reads off scale. Compression will begin at an input of about 300 microvolts; and the compressor will be overdriven when the input exceeds about 60 millivolts. When the meter on your recorder or transmitter indicates the presence of a signal but there is no indication on the compression meter, the compressor is simply acting as an amplifier.

While operating the compressor, adjust the input level control (*R1*) for the amount of sensitivity required. This will vary according to the type of microphone used, background noise, etc. A 200-ohm dynamic mike will drive the unit into compression but is not as sensitive as a high-impedance dynamic mike or a crystal or ceramic one. If you need more sensitivity from a low-impedance mike, use a step-up transformer on the input to the compressor.

Telephone conversations can be recorded by hooking the input of the compressor either directly to the phone line or to a telephone pickup coil. ◆

# What's Happened To Educational TV?

BY FOREST H. BELT

## PUBLIC TV AND INSTRUCTIONAL TV HAVE TAKEN OVER FROM WHAT WAS ONCE CALLED ETV

**P**UBLIC TV and instructional TV, are the new words that have displaced "educational television" and they are more than mere semantic dress-up. The two terms redefine divergent trends in the field of ETV.

*Public television* or PTV has been called "that dramatic and cultural stuff no one watches." The tag is not altogether true. Lately, nearly 35 million viewers a week watch the nation's 204 noncommercial stations. That's almost 20% of the entire television audience. And PTV viewers see more than just "cultural stuff."

*Instructional TV* is the other "new" face of ETV. The fact is, classroom instruction was the original intent of ETV. A few people raved that TV would revolutionize American education; but that idea dropped into limbo ages ago. However, ITV is alive and well and fulfilling some of the early hopes.

**Good TV for Everyone.** One TV executive likes to quote this description: "Public television doesn't belong to anybody—it belongs to everybody."

For a few years, PTV didn't seem to belong to anybody—period. Sporadic and usually bland local programming attracted few viewers. Even nationally produced PTV shows suffered the maladies ascribed to commercial TV (pointless news, tedious drama, specious talent). Public TV was as much an experiment in "how-nice-TV-would-be-without-commercials" as anything else. Repeated inoculations of money from the Ford Foundation and other angels failed to ward off the doldrums. Stingy appropriations from Congress only kept the idea of public television from dying completely.

But a little more than a year ago, public TV began showing life again. The medium isn't out of the valley yet, but its trend is upward. Most important, new attitudes have surfaced:

(1) In keeping with its "community TV" nickname, PTV is learning social responsibility. Public stations increasingly explore sensitive problems in their localities. Public Broadcasting Service (PBS), the national PTV network, expounds on matters of concern in the nation and world: poverty, minorities, the war, ecology, foreign relations, and the like.

(2) A new respect for the audience helps. PTV officials have come to realize viewers want entertainment with their doses of quality. A few new programs this fall reflect a more sensitive outlook.

(3) Public TV seeks innovation, with





Something new and different is what is promised on the public television stations—as exemplified in this shot from a program called “Apollo,” which explores new music.

no intent to be avant garde. Theoretically free of advertiser influence, PTV is a logical showcase for unproved talent, experimental ideas, and fanciful concepts. Public TV gave us “Sesame Street,” the children’s show that exhibits outstanding technical imagination. “Masquerade,” new this season, tests a fresh idea: giving some inventive twists to familiar folk tales, myths, and nursery rhymes. Another PBS program, “Apollo,” promises

attention to new dance, new music, and new artists.

(4) Public TV planners claim responsibility for adult education. Consequences are scattered. Chicago City College transmits lectures to more than 250,000 viewers over WTTW-TV, in many instances for credit. Schools offer a few courses by PTV. Usually, though, “adult education” boils down to bridge, cooking, and guitar lessons.

Opportunities abound to provide great service. For instance, between 10 and 15 million adult Americans can’t read. Children’s Television Workshop has begun a televised reading program for children ages 7-10 on PBS. Concepts in “The Electric Company” could be toned up for a PBS series to end adult illiteracy.

Narrow thinking still pervades public TV, particularly on the local level. Stations need money. Those not affiliated with schools are desperate. Officials tend to lean on gimmicks for financing, which proves unstable and sometimes demeaning. Station executives too frequently lose sight of why PTV exists. Their own

#### PARTIAL, TENTATIVE PBS SCHEDULE

##### Sunday

- 7:00 Civilisation
- 8:00 Firing Line (political interviews)
- 9:00 Masterpiece Theater (classic movies)
- 10:00 Apollo (new—musical “magazine”)

##### Monday

- 8:00 Special of the Week
- 9:30 Book Beat

##### Tuesday

- 8:00 Masquerade (new—family dramas)
- 8:30 The Advocates
- 9:30 Black Journal

##### Wednesday

- 8:00 French Chef
- 8:30 This Week (new—news story)
- 9:00 Great American Dream Machine

##### Thursday

- 8:00 Thirty Minutes With—
- 8:30 Washington Week
- 9:00 Hollywood Theater (original dramas)
- 10:00 World Press
- 10:45 Critic-at-large (arts)

Some public TV stations have equipment and crews to produce professional shows, like this one at Louisiana State U. Same technical personnel usually work on ITV programs.

*(Photo courtesy Telemation, Inc.)*



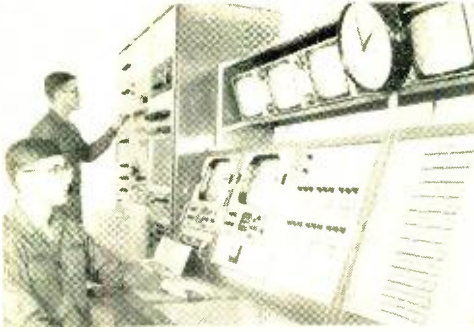

(Photo courtesy of Audio Engineering, Inc.)

Educational TV is used at many U. S. Army training centers. This elaborate facility also includes remote controlled switching.

productions (if they have any) can't hold audiences, and hometown support—financial and other—goes down the drain. To prosper, community-oriented television needs a more perceptive brand of thinking.

**Teaching by Television.** Classroom TV triggers debate over (1) whether the medium can actually educate and (2) whether it is worth the money it costs. Various surveys support both sides of both arguments. But dig a little deeper and you uncover factors that influence answers to both questions.

For one thing, many telecourses fall short of even modest educational goals. Material is often outdated, inadequately prepared, sparsely illustrated, impractically demonstrated, and monotonously explained. Production is frequently inept and erratic. On-screen teachers need lessons themselves, in TV technique and camera manner (acting).

Seen last spring: the teacher on screen knew science well, but the camera turned away from his "talking head" only for odd moments of sketchy drawings accompanied by his dull voice-over. At another extreme, one geography teacher bounced around and gushed so childishly that her junior-high viewers fidgeted and drew doodles.

Exceptions stand out. The same afternoon, a robed young black led a session in Afro rhythms and chants. His patient enthusiasm, and the beguiling smile by which he cued his drummers and his audience, won attention and participation at several age levels.

Consistently mediocre TV lessons turn kids off. So the teacher turns the TV off. And parents assume television simply can't teach. Yet, surveys show that students prefer TV teaching when the programs are fact-laden, illustrated, and smooth, and provided room teachers are not against ITV.

The U.S. Army knows TV can teach: 20% of basic training is now televised. So do mothers whose toddlers learn numbers, letters, words, and even abstract ideas from "Sesame Street." Japan runs a high-school-at-home entirely by television, and plans a whole TV university soon. One expert in the U.S. is convinced that half or more of the instruction leading to a master's degree can be televised. The remainder is guided self-education, and television and computers can initiate and direct even that.

Several school systems use an efficient large-class concept. As many as 400 students gather in a televiewing room. A teacher trained in the psychology and logistics of managing large classes prepares the students for the next lesson. After the telecast, she and her aides guide discussion. They suggest and approve related individual study.

Buildings expressly for large-class ITV handle up to 50% more students than traditional construction. They occupy less real estate, and are cheaper to build. Even ordinary buildings absorb larger en-

Young students in booths can intercommunicate with their teacher during a lesson. System shown in this photo has only audio recorders, but other versions include video units.

(Photo courtesy of Shikaden Corp.)





rollments when a portion of the curriculum is shifted to large ITV classes.

Reaching more students (sometimes with more and better instruction) is economical. In one large school system where music education is a requirement, covering grades 3-6 in 90 schools kept 12 music specialists on the run. Classes were hurried and skimpy. In 1968, one top specialist was allotted a budget to put together music telecourses. The job took more than a year. Now, broad music training goes by television to all grade levels. Total cost—including video-tape production and telecasting—is only one-tenth the cost before ITV.

TV-study modules offer an individual approach. Each booth has a monitor, headset, video player, and controls. If desired, a pupil can pursue his own studies either from a video prerecording in the booth or by dialing the lesson from a bank of video tapes. In one system, a whole video/audio text can be transferred to a memory disc in about 60 seconds; the disc is in the student's booth.

A sophisticated version of the "module" idea involves a computer. The booth includes a typewriter-like keyboard. The pupil sits down and types his student number. The computer greets him by name (typing or talking) and in a few milliseconds finds where that student left off last time. The computer manages what telecourse lessons are shown, asks questions, judges the student's typed responses, and shows supplemental material when needed. A TV intercom carries requests for help to a central-staff expert in the subject. The student picks homework from computer suggestions. When the session is over, the computer says "goodbye" and sends a performance and progress report to Student Data Central.

Variants of this utopian system operate already. Initial cost is high; but applied to the school lives of thousands of students, electronically complex teaching systems may ultimately be the most economical.

Despite technology, the argument continues. To say ITV can truly educate demands a definition of education. In the broad sense, education must prepare an individual to think, to learn and to keep learning his whole life long. Instructional

TV can serve that goal only as an efficient tool and sweeping stimulus.

**How ITV Works Today.** One day a teacher was home sick. The school principal got a cheap closed-circuit TV camera and put it where another teacher was holding class. He ran some wire down the hall to a TV set on the absent teacher's desk. Her class spent that day watching the first closed ITV system.

Today, closed-circuit ITV still suits many colleges and universities. A closed-circuit teach-at-home system being tried in Kansas and in Illinois uses two-way TV, so the teacher can see the pupil. The Illinois setup works on a digitalized-TV principle so voice-grade phone lines can be used instead of expensive cable or microwave.

Hospitals prefer the privacy of CCTV for medical instruction and consultation. One pharmaceutical company already sponsors production of medical tele-

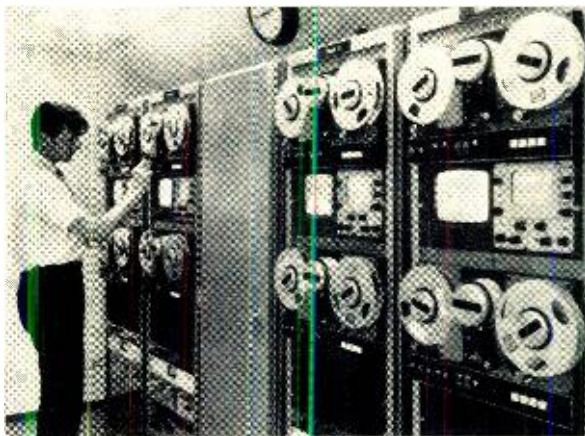

(Photo courtesy International Video Corp.)

Video tapes store television course lessons. Banks of players can then be loaded and the individual lessons are dialed by students.

courses. The American Medical Association proposes a national microwave or cable network of medical TV. Even the most remote doctor would have access to advanced study and to help with diagnosis and treatment.

The simplest open-circuit ITV arrangement is an ordinary VHF or UHF station. It's one-way only, but for large



areas or many reception points, it's economical. Public TV stations generally share facilities with ITV. It's not uncommon for students to run the station for both operations.

Schools can get a license for Instruc-



*(Photo courtesy North American Philips)*

Camera in operating theater feeds closed-circuit ITV system. Surgery is often video recorded for later study by both students and surgeons. Zoom lens moves for closeups.

tional Television Fixed Service (ITFS) stations. There are between 200 and 300 of these open-circuit systems. They operate at microwave frequencies, around 2500 MHz. Many channels are available to a single ITFS station. Equipment is usually less costly than for a VHF or UHF TV station.

Some ITV stations telecast technical and business courses. Local companies pay a fee so employees can study right in the company plant. Four-channel ITFS carries telecasts from certain Colorado universities to participating companies. Employees get college credit. Around Dallas, electronics company employees earn credits toward graduate degrees by special ITFS instruction; and a voice tie-in lets students and teacher converse.

Some ITFS operates two-way. The Stanford University system can, although it is seldom used that way because it takes two channels. Stanford programs in-plant training for several San Francisco companies, and telecasts noncredit courses after business hours.

Law enforcement agencies also use ITV. The St. Louis police department trains recruits in its police academy by

ITFS link. Receivers in district stations also pick up occasional advancement classes for patrolmen. Boston ITV station WGBH-TV sometimes broadcasts police courses to departments in other New England towns.

Among the newer ITV hardware are remote control systems. A psychiatrist at Massachusetts General Hospital in Boston interviews patients 30 miles away at the Veterans Administration hospital in Bedford. They can see each other on two-way TV. But the doctor can also pan, tilt, and zoom the camera that views the patient. He can command full-length shots or closeups on hands, facial tics, etc.

At a nursing school in Indiana, 20 cameras are remote controlled from 3 miles away over a single phone line. In PTV/ITV studios, remote controls save staff time.

The University of Illinois has PLATO (Programed Logic for Automated Teaching Operations), a digitalized two-way ITV system by microwave. PLATO IV, to be finished in a couple years, uses plain phone lines. Commanded by a computer, PLATO IV can bring ITV classes to as many as 4000 widely dispersed students simultaneously.



*(Photo courtesy North American Philips)*

Students operate instructional stations, and often produce telecourses or recordings of student activities for future reference.

ITV and PTV continue to grow more complex, yet simpler to operate. The important thing is that they do continue to grow. That's about all ETV can expect of her offspring. ♦

# Join "THE TROUBLESHOOTERS"

They get paid top salaries  
for keeping today's  
electronic world running

Suddenly the whole world is going electronic! And behind the microwave towers, push-button phones, computers, mobile radio, television equipment, guided missiles, etc., stand THE TROUBLESHOOTERS—the men needed to inspect, install, and service these modern miracles. They enjoy their work, and get well paid for it. Here's how you can join their privileged ranks—without having to quit your job or go to college in order to get the necessary training.

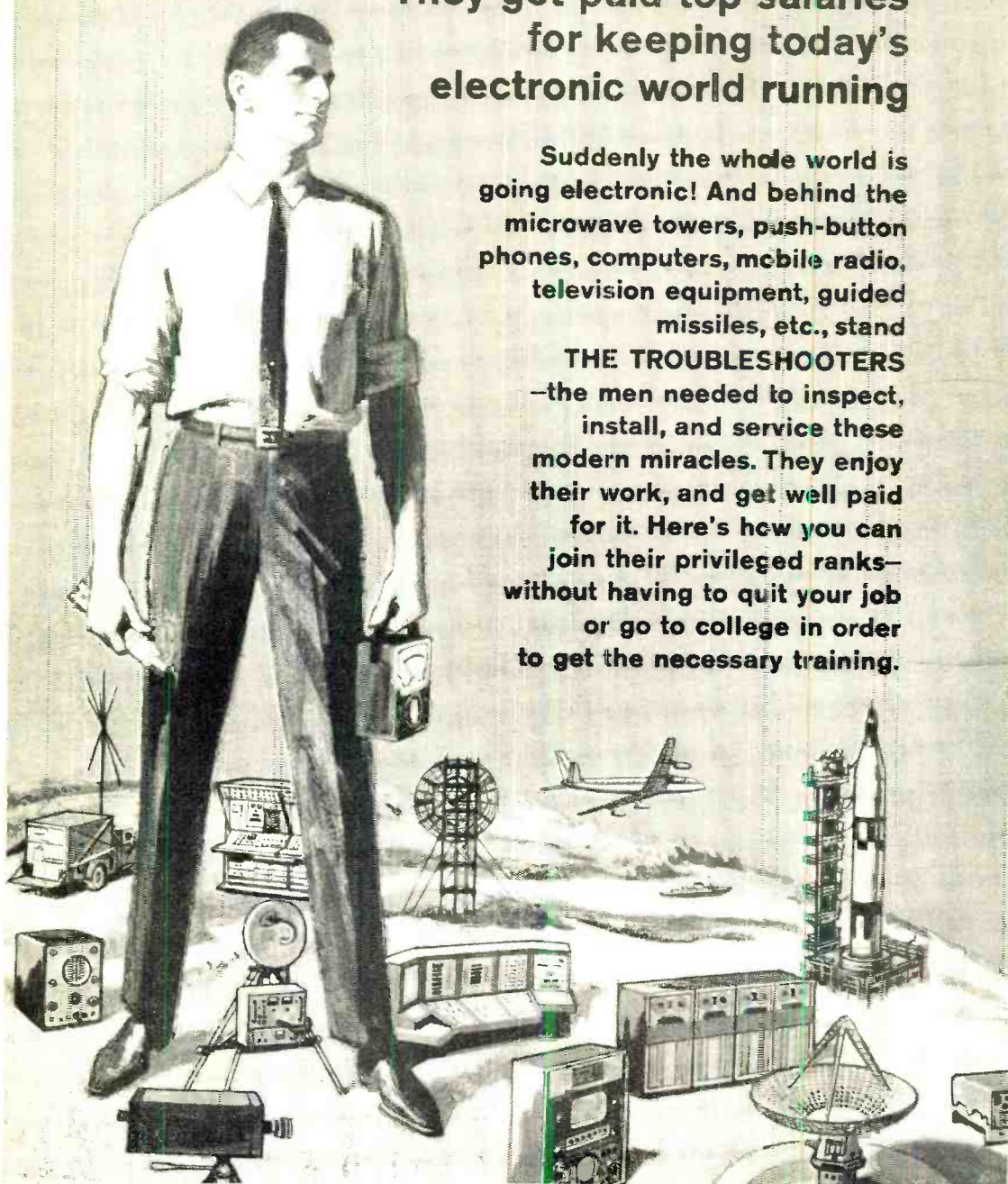

**J**UST THINK how much in demand you would be if you could prevent a TV station from going off the air by repairing a transmitter...keep a whole assembly line moving by fixing automated production controls...prevent a bank, an airline, or your government from making serious mistakes by servicing a computer.

Today, whole industries depend on Electronics. When breakdowns or emergencies occur, someone has got to move in, take over, and keep things running. That calls for one of a new breed of technicians—The Troubleshooters.

Because they prevent expensive mistakes or delays, they get top pay—and a title to match. At Xerox and Philco, they're called Technical Representatives. At IBM they're Customer Engineers. In radio or TV, they're the Broadcast Engineers.

What do you need to break into the ranks of The Troubleshooters? You might think you need a college degree, but you don't. What you need is know-how—the kind a good TV service technician has—only lots more.

### Think With Your Head, Not Your Hands

As one of The Troubleshooters, you'll have to be ready to tackle a wide variety of electronic problems. You may not be able to dismantle what you're working on—you must be able to take it apart "in your head." You'll have to know enough Electronics to understand the engineering specs, read the wiring diagrams, and calculate how the circuits should test at any given point.

Learning all this can be much simpler than you think. In fact, you can master it without setting foot in a classroom...and without giving up your job!

For over 30 years, the Cleveland Institute of Electronics has specialized in teaching Electronics at home. We've developed special techniques that make learning easy, even if you've had trouble studying before. Our AUTO-PROGRAMMED\* lessons build your knowledge as easily and solidly as you'd build a brick wall—one brick at a time. And our instruction is personal. Your teacher not only grades your work, he analyzes it to make sure you are thinking correctly. And he returns it the same day received, while everything is fresh in your mind.

### Always Up-To-Date

To keep up with the latest developments, our courses are constantly being revised. This year CIE students are

getting new lessons in Laser Theory and Application, Microminiaturization, Single Sideband Techniques, Pulse Theory and Application, and Boolean Algebra.

In addition, there is complete material on the latest troubleshooting techniques including Tandem System, Localizing through Bracketing, Equal Likelihood and Half-Split Division, and In-circuit Transistor Checking. There are special lessons on servicing two-way mobile radio equipment, a lucrative field in which many of our students have set up their own businesses.

### Your FCC License—or Your Money Back!

Two-way mobile work and many other types of troubleshooting call for a Government FCC License, and our training is designed to get it for you. But even if your work doesn't require a license, it's a good idea to get one. Your FCC License will be accepted anywhere as proof of good electronics training.

And no wonder. The licensing exam is so tough that two out of three non-CIE men who take it fail. But our training is so effective that 9 out of 10 CIE graduates pass. That's why we can offer this famous warranty with confidence: If you complete a license preparation course, you get your FCC License—or your money back.

### Mail Card for 2 Free Books

Want to know more? Send for our 44-page catalog describing our courses and the latest opportunities in Electronics. We'll send a special book on how to get a Government FCC License. Both are free—just mail the bound-in postpaid card. If card is missing, use coupon below.

### ENROLL UNDER NEW G.I. BILL

All CIE courses are available under the new G.I. Bill. If you served on active duty since January 31, 1955, or are in service now, check box on card or coupon for G.I. Bill information.

## CIE Cleveland Institute of Electronics

1776 East 17th Street, Cleveland, Ohio 44114

### Cleveland Institute of Electronics

1776 East 17th Street, Cleveland, Ohio 44114

Please send me without cost or obligation:

1. Your 44-page book "How to Succeed in Electronics" describing the job opportunities in Electronics today, and how your courses can prepare me for them.

2. Your book on "How to Get A Commercial FCC License." I am especially interested in:

- |  |   |  |
|--|---|--|
| <input type="checkbox"/> Electronics Technology    | <input type="checkbox"/> Broadcast Engineering  | <input type="checkbox"/> First Class FCC License |
| <input type="checkbox"/> Electronic Communications | <input type="checkbox"/> Industrial Electronics | <input type="checkbox"/> Electronics Engineering |

Name \_\_\_\_\_ (PLEASE PRINT)

Address \_\_\_\_\_

City \_\_\_\_\_ State \_\_\_\_\_ Zip \_\_\_\_\_

Check here for G. I. Bill information.

PE-23

## NEW COLLEGE-LEVEL COURSE IN ELECTRONICS ENGINEERING

for men with prior experience in Electronics. Covers steady-state and transient network theory, solid state physics and circuitry pulse techniques, computer logic and mathematics through calculus. A college-level course for men already working in Electronics.

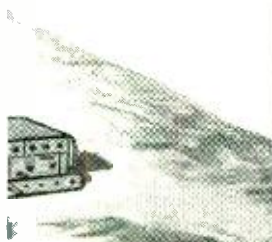

CIRCLE NO. 2 ON READER SERVICE PAGE





# BUILD A MINI- PYRAMIDAL UHF TV ANTENNA



GET SHARP, GHOST-FREE RECEPTION LOCALLY,  
IN FRINGE AREAS, AND EVERYWHERE IN BETWEEN

BY GEORGE J. MONSER

**T**HE LOWLY UHF TV ANTENNA has been almost lost in the shuffle for bigger, better, and more complex VHF arrays. Yet, the UHF antenna is somewhat of a phenomenon. Roughly one-tenth the size of its VHF counterpart, the UHF antenna is a great deal simpler to install and use. The question is: How well does the properly designed UHF antenna operate?

To find the answer, a VHF log periodical antenna of known operating ability ("Build The Pyramidal TV FM Antenna," July 1969) was trimmed down for operation in the UHF band. Since the new antenna retained the "pyramidal" shape, it was dubbed the "Mini-Pyramidal UHF TV Antenna." Performance-wise, it excels.

In initial tests, the Mini-Pyramidal antenna pulled in two UHF channels from San Diego, a distance of about 185 miles from where it was set up in Santa Barbara. On less distant and local stations, reception was clear and sharp. There can be little doubt that the 10-dB log

Mini-Pyramidal antenna will cover the entire UHF TV band with nearly constant gain. The antenna is well matched to 300-ohm twin-lead cable and, therefore, will provide ghost-free reception if set up within about 190 miles of a UHF station.

**Construction.** Building the Mini-Pyramidal UHF TV antenna is a simple procedure, requiring the use of only a drill, a hacksaw, and a screwdriver. The raw materials needed for the various parts that make up the antenna are available from any well-stocked hardware store.

The first step is to prepare the aluminum U-channel booms and Plexiglass supports. After cutting these parts to the dimensions specified in the Bill of Materials, refer to Fig. 1 and mark the locations for the holes that will be used to mount the elements and attach the down-lead to the booms. Slip one of the booms onto a support as shown. Then use a  $\frac{1}{8}$ " drill to bore through the boom and support at each marked hole loca-

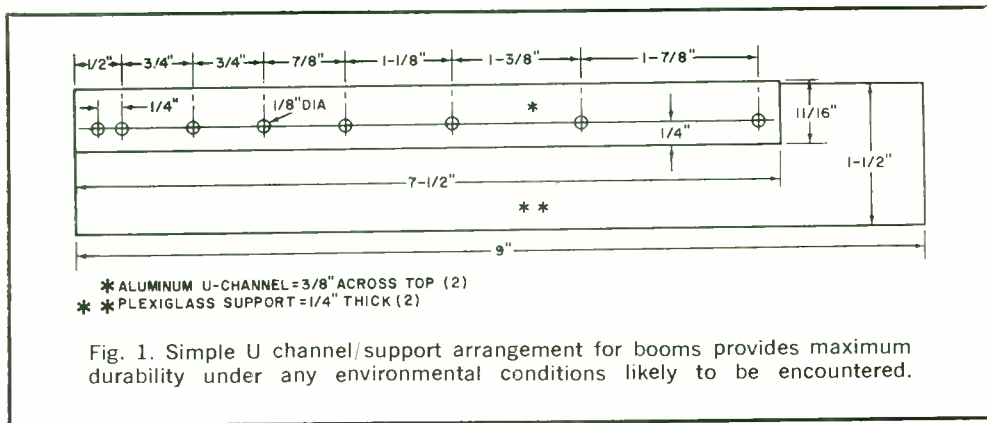

Fig. 1. Simple U channel/support arrangement for booms provides maximum durability under any environmental conditions likely to be encountered.

tion. Repeat this procedure for the remaining boom and support.

Next, fabricate the antenna elements from 1/2" x 1/2" aluminum stripping (do not attempt to substitute narrower stripping or tubing for the elements since neither will provide the proper bandwidth for color reception), referring to Fig. 2 for fabrication details and a table of element lengths. Note that two elements of each length are required and that the lengths listed include the 1/2" of stripping used for the element mounting tabs. The actual element lengths will be 1/2" shorter than the dimensions given in the second column in the table.

Now, referring to Fig. 3, arrange the boom assemblies so that they form a 50° throat angle. Drill a pair of 1/8" holes at the throat. Then drill a 1/8" hole through each boom support at the ends opposite the throat. The first pair of holes will be used to anchor the booms at the proper throat angle, while the second pair of holes will be used for mounting the antenna to a mast. Use 6-32 x 3/4" machine screws and nuts to fasten together the boom supports at the throat.

Starting from the throat end of one of the booms, slip the mounting tab of one of the shortest elements between the boom and support (see Fig. 4). Align the tab hole with the second hole in the boom and use a 6-32 x 5/8" machine screw and the appropriate lockwasher and nut to anchor the pieces together. In the same manner, mount at the third hole location on the boom one of the second shortest elements on the opposite side of the boom. Working on alternate sides of the

boom, mount one of each successive length element in place.

Again starting at the throat end of the antenna, mount the second set of elements as described above. However, when mounting these elements, they must be located on the opposite sides of the boom from those on the first boom. For example, if element No. 1 on the first boom projects to the left, element No. 1 on the second boom must project to the right.

Pass a 6-32 x 3/4" machine screw through each of the unoccupied holes near the throat end of each boom. Place on each screw a lockwasher (preferably steel or bronze) and follow up with a 6-32 nut. Securely tighten each screw so that the lockwashers bite deeply into the metal booms without cracking the Plexiglass supports. Loosely screw on a pair of nuts. The antenna is now ready for installation and testing.

ANTENNA ELEMENT LENGTHS	
Element No.	Element length in inches*
1	2"
2	2 1/2"
3	2 7/8"
4	3 1/4"
5	4 1/8"
6	4 5/8"
7	5 3/8"

\*Overall dimension; actual element length is 1/2" shorter than dimensions given.  
 Note: two of each length are required

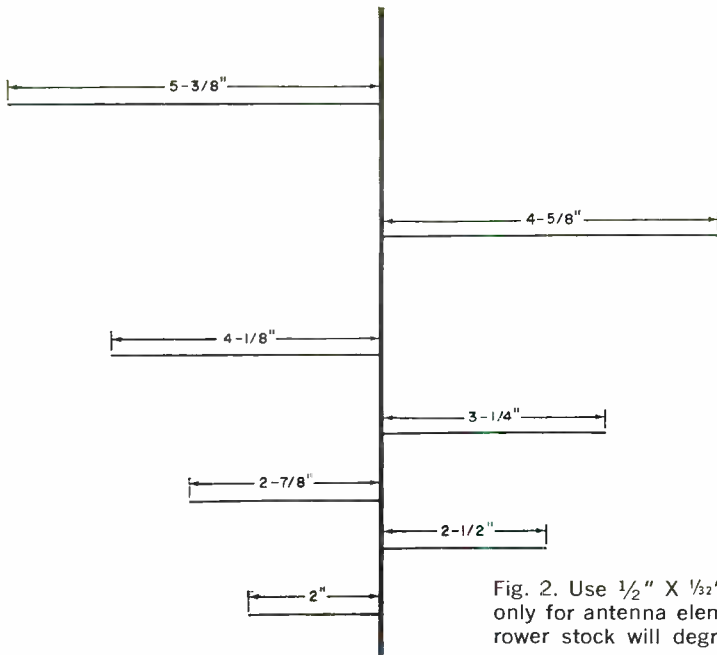

Fig. 2. Use 1/2" X 1/2" aluminum stock only for antenna elements; use of narrower stock will degrade performance.

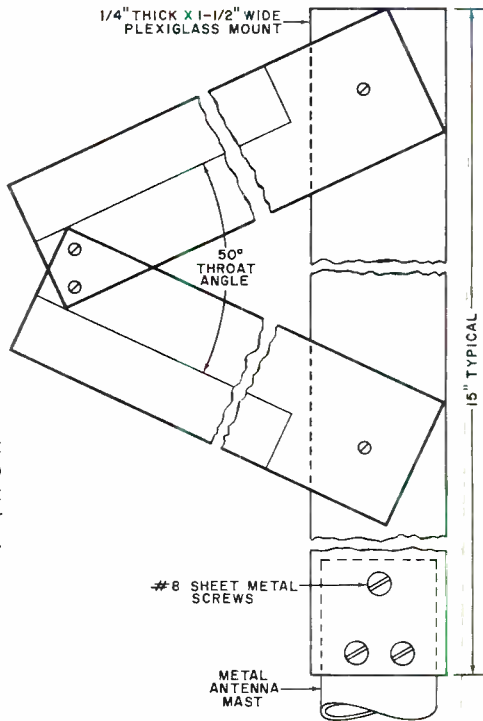

Fig. 3. Use non-metallic mount (Plexiglass or fiberglass) to fasten antenna to mast. Do not substitute metal for mount or mount antenna directly to mast.



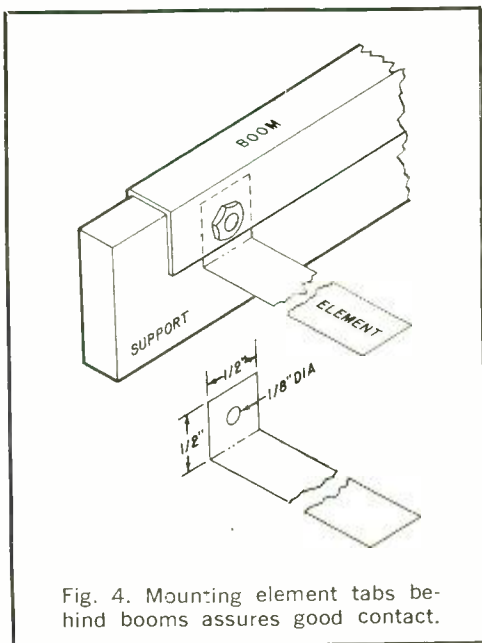

Fig. 4. Mounting element tabs behind booms assures good contact.

**Installation.** The Mini-Pyramidal UHF TV Antenna is designed for outdoor use. If you already have a VHF antenna mounted on a mast the UHF antenna can be mounted above—NOT below—it with a simple Plexiglass mounting arrangement as shown in Fig. 3. Use #6 x  $\frac{3}{8}$ " sheet metal screws to anchor the Plexiglass antenna mount to the metal antenna mast.

Once the antenna is mounted, attach 300-ohm twin-lead cable to it by wrap-

### BILL OF MATERIALS

2—10" x 1 $\frac{1}{2}$ " pieces of  $\frac{1}{4}$ " Plexiglass for boom supports  
 1—15" x 1 $\frac{1}{2}$ " piece of  $\frac{1}{4}$ " Plexiglass for antenna mount  
 1—60" length of  $\frac{1}{2}$ " x  $\frac{1}{32}$ " aluminum molding strip for antenna elements  
 2—8 $\frac{1}{2}$ " lengths of  $\frac{5}{8}$ " x  $\frac{1}{4}$ " (inside dimensions) aluminum U-channel for booms  
 Misc.—300-ohm twin-lead cable; 6-32 machine hardware (see text); #6 x  $\frac{3}{8}$ " sheet metal screws for mounting antenna; etc.

ping the cable conductors around the screws at the throat and tightening down on the nuts. Connect the other end of the twin-lead to the UHF antenna terminals on your TV receiver. Turn on the receiver and tune across the UHF band while observing the TV screen. At various points across the band, depending on the number of stations within the range of the antenna, you should observe pictures pop in and out. Tune for the strongest station (sharpest picture and color and least distorted sound). If you have a rotor in your antenna system, try repositioning the Mini-Pyramidal antenna for improved reception.

Now tune for a weaker, snowy station and reposition the antenna for the clearest reception. You will soon realize that there are more UHF TV stations within range of your antenna than can be picked up by conventional UHF antennas. The pictures will be sharper, the colors more vivid, and the sound clearer. ♦

### NEW INFRARED NIGHT-IMAGING SYSTEM

A new forward-looking infrared system, described as one of the most advanced night-imaging systems ever developed, has been delivered to the U. S. Air Force by Hughes Aircraft Company. Designated MAFLIR (for Modified Advanced Forward-Looking IR), the system is shown here installed in the belly turret of a C-131 for flight testing. The MAFLIR is said to have greatly improved resolution and, as a result, should extend operational ranges significantly. The Air Force will test the equipment to determine its suitability for high-speed weapon delivery against ground targets as well as high-altitude application. The MAFLIR was developed under cognizance of the Air Force Avionics Laboratories, Wright-Patterson Air Force Base, Ohio.



## STATIONARY "PHASED ARRAYS" MOVE THE BEAMS

**C**ONVENTIONAL radar installations, with their spiderwork parabolic antennas and block-house-like equipment structures, are easy to spot and identify. Even the "golf ball" domes that are used to protect radar antennas from the elements are of no help in hiding the identity of a radar installation. However, today there is a new crop of radar that is so unobtrusive and adaptable to almost any type of architecture that recognizing a radar installation can be rendered almost impossible.

The story dates back more than half a decade when the Air Force was faced with a mounting problem: The number of satellites and amount of junk orbiting the Earth over the United States could not be

reliably tracked with conventional radars. What was needed was a system that could track all of these objects and any additional ones that would be put into orbit. So, the engineers put their heads together and devised a whole new radar system to meet the Air Force's needs.

Thus emerged the phased array (or electronically steerable array) radar. The phased array radar is unique in that it contains no moving parts. Instead of a rotating parabolic dish antenna to steer the radar beam, the beam itself is positioned and repositioned through a system of electronics only.

The new phased array radars have been

# GIANT BILLBOARD ANTENNAS FOR SPACE-AGE RADARS

BY EDWARD A. LACY

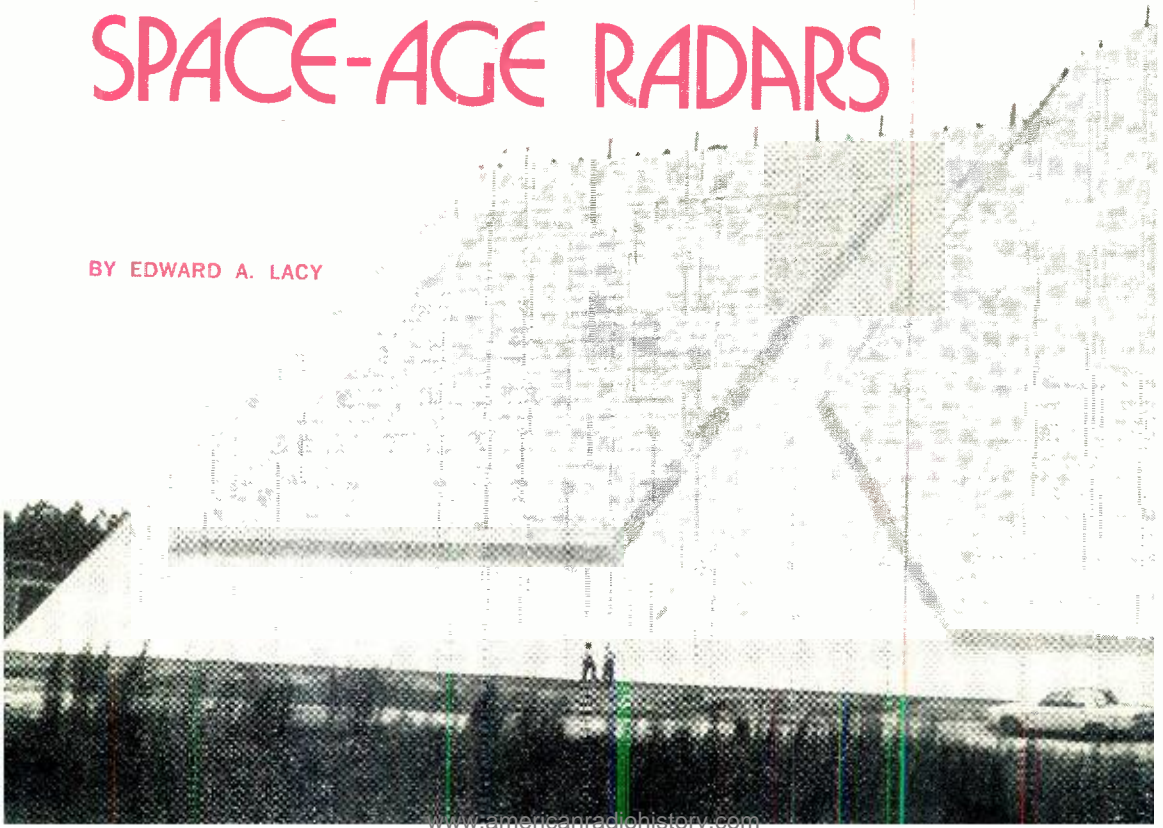

functioning for quite a while now. The biggest one, the AN/FPS-85, (below) located at Eglin Air Force Base, was designed to meet the need for space tracking. Built by Bendix Corp., the radar is housed in a wedge-shaped building the size of a football field. Seen from either end, the building has the shape of a right triangle. Its sloping roof contains the individual transmitting and receiving modules. Head-on, the building looks more like a giant billboard instead of a radar installation.

The Army's use of phased array radar includes an installation at the White Sands Missile Range known as HAPDAR (Hard Point Demonstration Array Radar) which was designed and installed by Sperry Corp. for the Army Missile Command. A more recent phased array radar installation under the auspices of the

Army is located at Kwajalein Island, in the West Pacific.

Nor has the Navy been dragging its feet, although so far, the carrier *Enterprise* is the only place in which the Navy is employing phased array radar.

At present, and after some six years of operational tests, phased array radars are still classified as experimental. But it won't be long before these radars become regular inventory items by the various services.

**In a typical** phased array radar system, one set of antennas is used for transmitting, another for receiving. Each system consists of hundreds, even thousands, of separate antennas. The AN/FPS-85, for example, contains 5776 transmitting and 19,500 receiving antennas.

The antenna sets can be subdivided

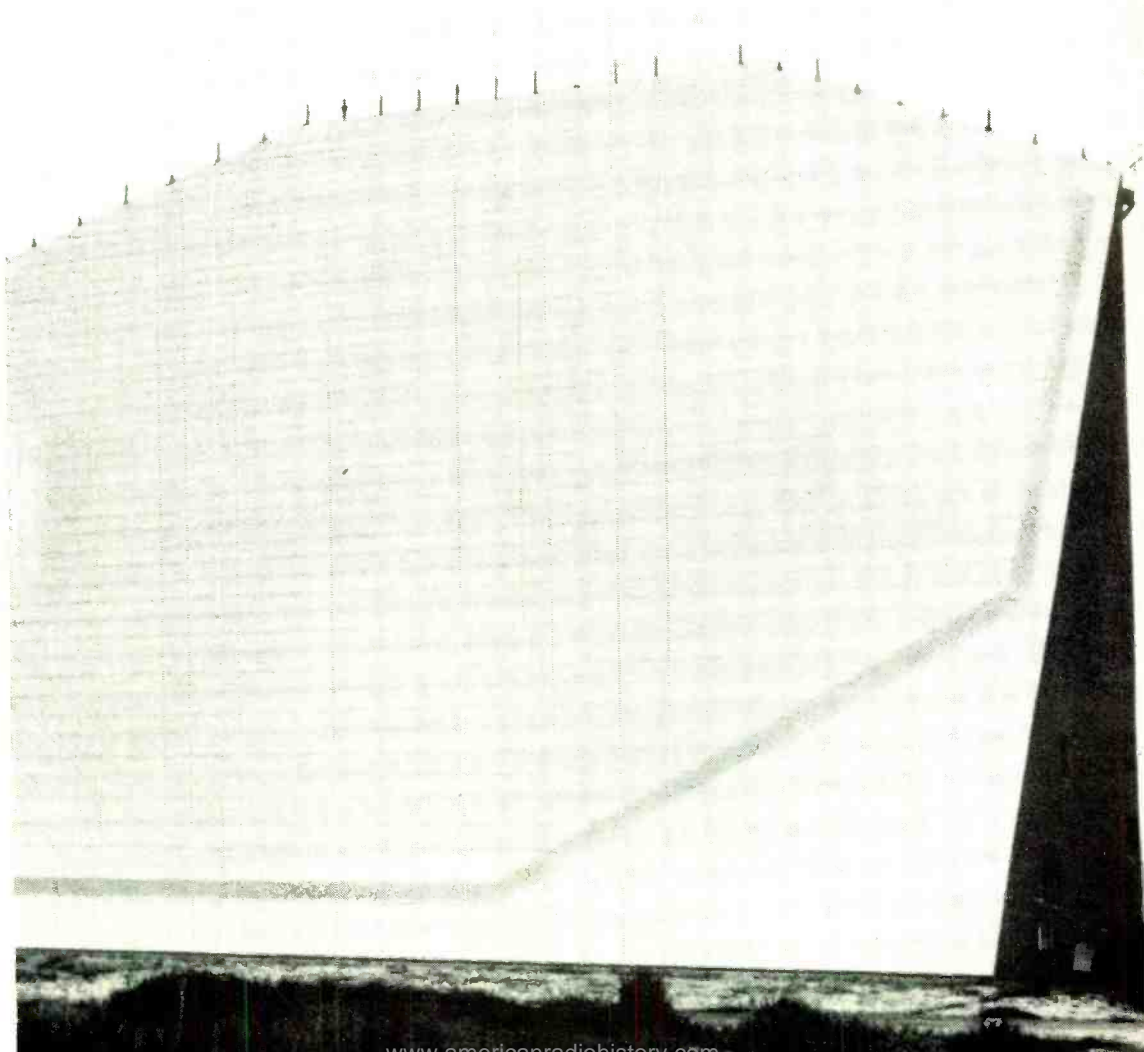



into subsets, with each subset connected to a receiver or transmitter. In some cases, each antenna is coupled to its own transmitter or receiver.

All of the transmitters in a phased array system are on the air simultaneously when a pulse is being transmitted. Since the output power of each transmitter is additive, theoretically an unlimited amount of output power can be generated and radiated.

To move the radar beam from one point to another, it is only necessary to change the phase of the signal delivered to each antenna. The antenna itself remains stationary. The result of all-electronic beam steering is inertialess tracking. Hence, the beam can be steered from point to point in microseconds.

To provide the proper phase shift to each antenna at the high speeds required, computers are used. In the case of the AN/FPS-85, three IBM computers are employed, while HAPDAR employs a Univac computer.

Radar users are continually demanding more power, larger antennas, greater receiver sensitivity, and the ability of the radar to keep track of the multitude of high-velocity flying and orbiting objects. Such demands are mostly beyond the capabilities of conventional radar techniques—but not beyond the capabilities of the phased array.

Parabolic radar antennas must conform to hard-to-meet mechanical tolerances and are so heavy that enormous, impractical drive systems are required to overcome

Hughes Aircraft Co. ADAR phased array radar has antenna with space-age "hair-do" look.



the inertia involved in moving and re-positioning them fast enough to search for incoming targets and simultaneously keep track of those targets already spotted.

Also, the waveguide that feeds the parabolic antenna limits the peak power that can be transmitted by the system. Exceeding the power-handling capacity of the waveguide results in inevitable breakdown. But even before this happens, the generation and control of high voltages required to operate the super-power klystrons in radar systems become serious problems.

The phased array radar overcomes another of the disadvantages of conventional radars. Its thousands of active transmitters preclude system failure even if dozens of transmitters are out of operation. (It has been estimated that in a given day, as many as 100 transmitter modules fail in the AN/FPS-85 alone.) If a transmitter fails, it can simply be unplugged and replaced by an identical unit.

Another important advantage of the phased array system is that virtually any surface will accommodate it. In aircraft, consequently, better aerodynamic stability and less crowding in the nose can be achieved when the radar is flush-mounted in the fuselage. In space satellites, balance stability is obtained from the phased array due to its lack of moving parts.

**The basic principle** of the phased array is not new. In fact it has been known for many years that a directional beam can be formed with an array of antennas. Only the technique of electronically varying the phase of the signal at each antenna to obtain inertialess beam steering is new.

In operation, the signals from each antenna in a phased array form a wavefront close to the array. Farther out, the wavefront forms a directional beam. Beam shaping is determined by the number of antennas and their spacing within the array. For the narrow beam essential to satellite tracking, a large number (the larger the better) of antennas must be used. Conversely, for a broad-beam surveillance radar, a few antennas are sufficient.

When the antenna elements are excited in phase with each other, the direc-

tion of the beam is broadside to the face of the array. By introducing a different phase displacement in the current delivered to each antenna, however, the beam can be moved almost instantaneously from one position to another.

The phase shifter consists of a ferrite rod that is placed inside the waveguide as shown in the drawing. This rod forms the center of a solenoid which is wrapped around the waveguide. By varying the current through the solenoid coil, the permeability of the ferrite rod is changed, thereby changing the velocity of propagation through the shifter system. The result is that the delay in propagation causes a phase shift in the transmitter's signal.

With a high-speed computer in control of the changes in current through the solenoid coil, it is possible to create an almost unlimited variety of beam scanning patterns. For example, the computer can be programmed to produce a beam that will "skip" a nearby mountain but scan on both sides of the mountain for targets. Furthermore, the high speed of the computer and low inertia of the radar beams make possible tracking any number of objects in several different directions while at the same time scanning for new targets coming into range.

Obviously, ponderous conventional radars with their enormous inertia cannot do the job effectively. They are limited to the number of objects they can track simply because they have to "pause" between pulse transmissions to wait for the return echo before moving on. In the interim, they must remain idle.

Conventional radars (Western Electric's DEW Line system shown) are easy to identify.

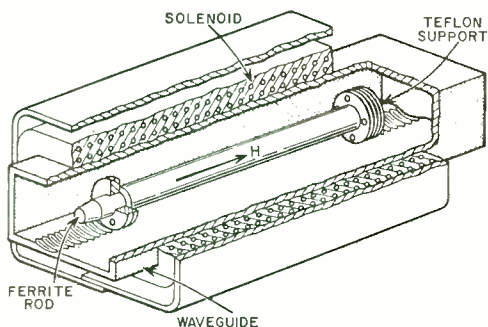
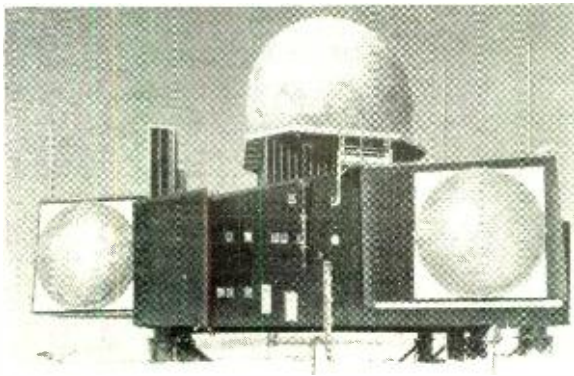

Phase shifter consists of a ferrite rod in waveguide. (Courtesy of Bell Laboratories)

A phased array radar, on the other hand, can transmit a pulse, move on to other positions to transmit more pulses, and return to "listen" for the echoes from each target spotted. Naturally, the closest targets are spotted first. During the receiving phase, the appropriate amount of phase shift is applied to the signals being received so that the signals add coherently. In effect, the received beam is "steered" in a manner not unlike the steering of the transmitted beam.

**Inertialess beam steering** is not obtained without difficulty. Mutual coupling between the radiating elements of the antennas in the array is a major problem. Then, too, as the beam is steered or scanned away from boresight, spurious multiple beams—commonly known as grating lobes—appear, giving the array a tendency toward tunnel vision instead of the 180° scan angle it has in theory.

To scan a full 360°, it is necessary to use three or four phased array radar systems—a factor that can multiply overall systems cost well beyond so-called practical cost/use limits. Phased array radars, after all, are not inexpensive. The total reported cost of the AN/FPS-85 is \$62,000,000. But this figure also includes the cost of rebuilding the original system which was destroyed by fire in 1965 shortly before it was to undergo operational tests.

The new techniques and devices (especially the use of IC's) just might cut the cost of phased array radars dramatically. For example, RCA's Missile and Surface Radar Division has already developed a solid-state phased array antenna design

(Continued on page 98)

**T**HE BOOKS devoted to technical school level electronics are innumerable, ranging in price from very inexpensive to impressively expensive. As pointed out in Part I of this story (see last month's issue, page 44), book selections should be made intelligently if you expect to get maximum value out of your studies. The book or books you choose should treat fully the subject areas in which you have an interest.

Since no useful and definitive guidelines are available to help the buyer make intelligent selections, here is a list of books that have proven their worth.

Many technical school students and many people using self study for preparation at a similar level need to acquire a thorough understanding of electronic fundamentals. Some otherwise excellent textbooks make the error of assuming that the reader is already versed in the basic fundamentals and, therefore, treats the fundamentals only as review. No greater mistake can be made. The fundamentals must be truly mastered before the more complex applications can be absorbed. The recommended book for this study is *Principles Of Electronic Technology* (\$9.95) published by McGraw-Hill.

This entire book is devoted to the basic building blocks of electronics and treats them with a degree of thoroughness that ensures complete understanding. The reader is given the proper preparation to recognize the functions performed by the basic electronic elements, no matter how complex a circuit he may find them in during later studies. At the end of each chapter, there are a summary and review questions. Many drawings, charts, graphs, and tables are employed to make certain of the reader's full mastery of the fundamentals. Although this book contains a synoptic review of the math needed for the study of fundamentals, most students will profit by additional math study.

For many years, the recognized authoritative textbook has been *Basic Mathematics For Electronics* (about \$10.00). This book wastes no pages on phases of math not needed by an electronics technician. It is not an engineering book—although it graces many an engineer's bookshelf—but it provides in detail and

BY CARL C. DRUMELLER, W5JJ

# The Electronics Bookshelf

PART 2

GENERAL THEORY AND  
HOBBY BOOKS

SOME PERSONAL  
EVALUATIONS AND  
RECOMMENDATIONS  
FOR BUYING  
ELECTRONICS BOOKS

clarity those applications of math needed for a thorough comprehension of electronics technology.

Once past the fundamentals, the student is ready for a purview of the applications of electronics technology. These recommendations are limited to aspects of electronic communication. Of the many good books on this subject, *Electronic Communication Systems* (\$13.95) stands out as preeminent. The book gives full treatment to each system discussed. Yet the book is kept to reasonable length without neglecting a portion of the subject matter. This has been accomplished by omitting the obsolete and retaining only the current systems. Few textbooks approach either the scope or thoroughness of this one.

No study of electronics would be complete without an in-depth study of solid-



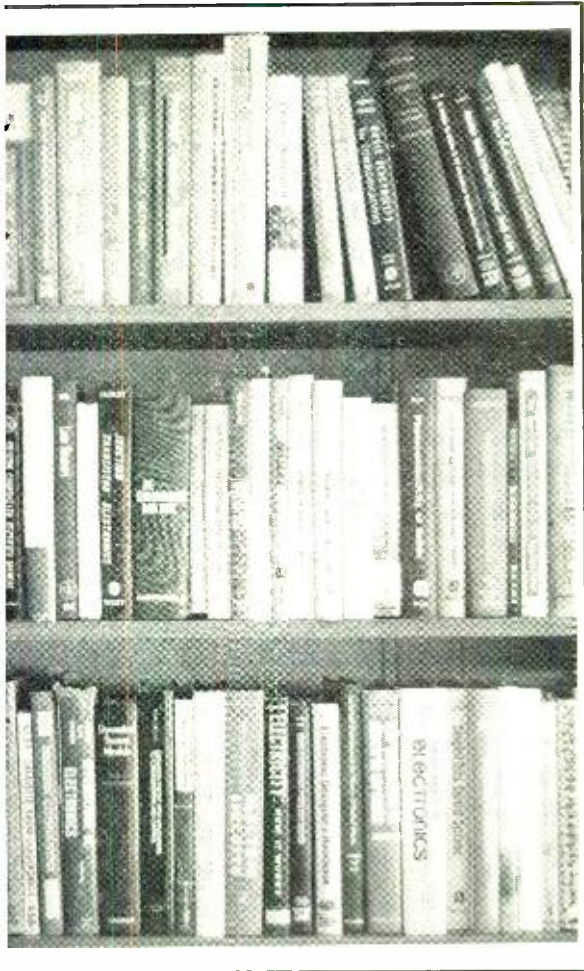

state devices. However, books on transistors are almost endless in number. Some waste many pages in going into detail on manufacturing techniques; others attempt to tutor by describing how to build projects that merely test the reader's ability to run wires between components. And some go into tedious detail on the mathematical computation of bias, load, and coupling parameters. A very few strike a medium that offers practical worth and useful information. One of these is *Transistor Circuit Action* (\$7.50).

This book follows the usual pattern: starting with semiconductors, progressing through junctions, and then getting into transistor action. But the outline only hints at the real worth of this book, which lies in the manner in which the material is presented. Text, drawings, tables, study questions, graphs, curves,

and charts present a unified combination to develop a true understanding of how a bipolar transistor functions. Once this is established, the use of transistors in circuits is treated with an equal thoroughness. Unijunction (UJT) and unipolar (field-effect or FET) transistors are also covered, but in less detail. The lightness with which the FET is treated is the only weak point of the book.

**Hobby-type** books cover so many subjects that a comprehensive review is not practical. Nor can meaningful recommendations be made for every category. Some guidelines, however, can be given for making selections.

If you wish to gain an understanding of how electronic devices work, plus associated theory, *ABC's Of Electronics* (\$2.50) is one of the better choices. It uses simple analogies to develop the theory and provides a very good explanation of the behavior of electronic components and circuits. A surprising amount of knowledge about electronics can be gained from this book's 96 pages.

To go deeper into circuit action, high recommendation can be accorded to the series written by Thomas M. Adams, each volume of which sells for \$3.50 (or \$19.95 for the entire 7-volume set). This series, published by Howard W. Sams, is segmented by subject, giving the reader the flexibility to select only those volumes which interest him. The use of multi-color diagrams in the series is very effective in explaining circuit action. The reading is easy, but the theory of circuit operation is presented in full depth and detail.

**Manufacturers' manuals** and booklets are highly valuable for the study of the various special aspects of electronics. Among these are the *RCA Transistor, Thyristor, And Diode Manual* (\$2.50); *GE Transistor Manual* (\$2.00) and *Electronic Components Hobby Manual* (\$1.50); *Motorola Semiconductor Power Circuits Manual* (\$2.25); and *RCA Silicon Power Circuits Manual* (\$2.00). Each of these manuals represents a high return for your dollar value. And each requires careful reading (with the exception of the GE Hobby Manual) since they are written as handbooks to be consulted for obtaining detailed and authoritative infor-

mation. Taken together, the manuals provide a solid basis for deep understanding of a wide scope of solid-state theory and applications.

The field-effect transistor, both junction and insulated-gate types—has excited much interest, generating a rash of books, some to explain the theory of operation, others to describe projects to build. The two areas, however, are combined neatly in *FET Principles, Experiments, And Projects* (\$4.95). The first 222 of its 272 pages are devoted to general device theory and more detailed theory relating to specific applications. This is quite comprehensive; yet it involves only a minimum of math. Construction projects consume 42 pages, and they are designed to give the builder the "feel" of the FET, enhancing his confidence in the fullness of his understanding of the related theory.

Tube, diode, transistor and IC manuals are extremely valuable in circuit design work.



The one great weakness of these specialized manuals and construction books is the rate of obsolescence. Their appeal is based on newness, their exposition of some phase of electronics that has not become commonplace. Often, by the time the book has been written, published, and distributed, another new phase has become popular.

**Experimenting** with novel projects is a popular pastime among hobbyists, and many project books have come out to cater to and stimulate an interest in electronics as a hobby.

Among the more worthy titles in this category are *Electronic Hobbyists IC Project Handbook* (\$3.95) which contains details on 50 projects, and *Amateur Radio Construction Projects* (\$3.25) which, although a bit dated, is a cut above the ordinary. Details concerning each project are given, schematic diagrams are supplemented by pictorials, lists of parts required are supplied, and theory and operating instructions are furnished.

*Ham Antenna Construction Projects* (\$3.95) is an easy-to-read exposition on building a number of antennas suitable for amateur and SWL use. It is prepared as a guide for the beginner, although a few of the projects are rather ambitious.

#### TECHNICIAN LEVEL BOOK TITLES

**Principles of Electronic Technology** (McGraw-Hill) by Carl B. Weick. Hard cover. 372 pages.

**Basic Mathematics for Electronics** (McGraw-Hill) by Nelson M. Cooke, updated by F. R. Adams. Hard cover.

**Electronic Communication Systems** (McGraw-Hill) by George Kennedy. Hard cover.

**Transistor Circuit Action** (McGraw-Hill) by Henry C. Veach. Hard cover.

#### HOBBY-TYPE:

**ABC's of Electronics** (Sams) by Earl J. Waters. Soft cover. 96 pages.

**Circuit Action Series** (Sams) by Thomas M. Adams. 7 individual volumes. Soft cover.

**Transistor, Thyristor, and Diode Manual** (RCA). Soft cover. 656 pages.

**Transistor Manual** (GE). Soft cover. 660 pages.

**Electronic Components Hobby Manual** (GE). Soft cover. 199 pages.

**Semiconductor Power Circuits Handbook** (Motorola). Soft cover. 252 pages.



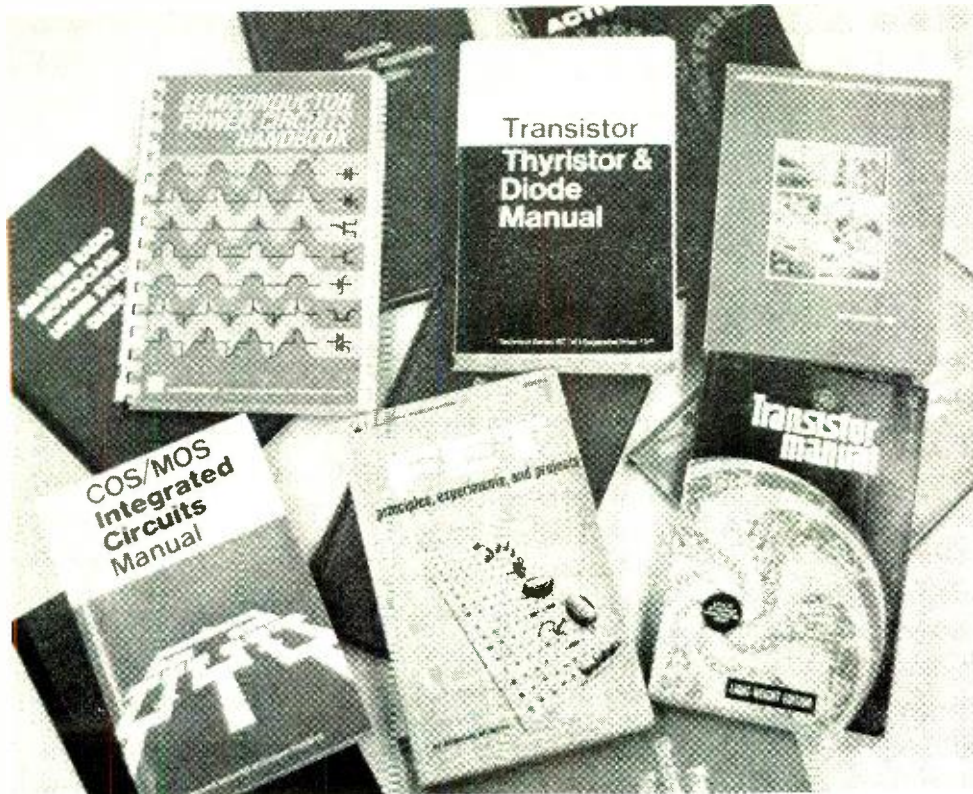

Manuals and hobby books (foreground) have soft covers and are very inexpensive for the amount of information provided. The textbooks (rear) are hard covered and more costly.

**Silicon Power Circuits Manual** (RCA).  
Soft cover. 416 pages.

**FET Principles, Experiments, and Projects**  
(Sams) by Edward M. Noll. Soft cover.  
272 pages.

**Electronic Hobbyists IC Project Hand-  
book** (Tab) by Brown & Kneitel. Soft  
cover.

**Amateur Radio Construction Projects**  
(Sams). Soft cover.

**Ham Antenna Construction Projects**  
(Sams). Soft cover.

#### PUBLISHERS & SUPPLIERS

General Electric, Advertising & Sales  
Promotion, 3800 N. Milwaukee Ave.,  
Chicago, IL 60641

McGraw-Hill Book Co., 330 West 42  
St., New York, NY 10036

Motorola Semiconductor Products Inc.,  
Box 20912, Phoenix, AZ 85036

RCA Distributor Products, Harrison, NJ  
07029

Howard W. Sams & Co., Inc., 4300 West  
62 st., Indianapolis, IN 46268

Tab Books, Blue Ridge Summit, PA  
17214

Much information on construction and tuning techniques is given, making the book of unquestioned worth.

It is worthwhile to note at this point that, because of the rapidly changing focus of interest in hobby projects, it is hardly necessary to consider the purchase of expensive, hard-cover hobby books. But if you are interested in electronic gadgetry, by all means leaf through the hobby books you find to determine if they contain projects of interest to you. Remember that the directions your hobby takes are formulated by your own personal interests.

No attempt has been made in this article to evaluate or recommend college-level engineering and reference books. The reason for this is that such books are intended for study in connection with formal training and/or by the practicing engineer who wishes to brush up on his chosen specialty. Generally, reference works are for the practicing engineer and are considerably expensive. ♦



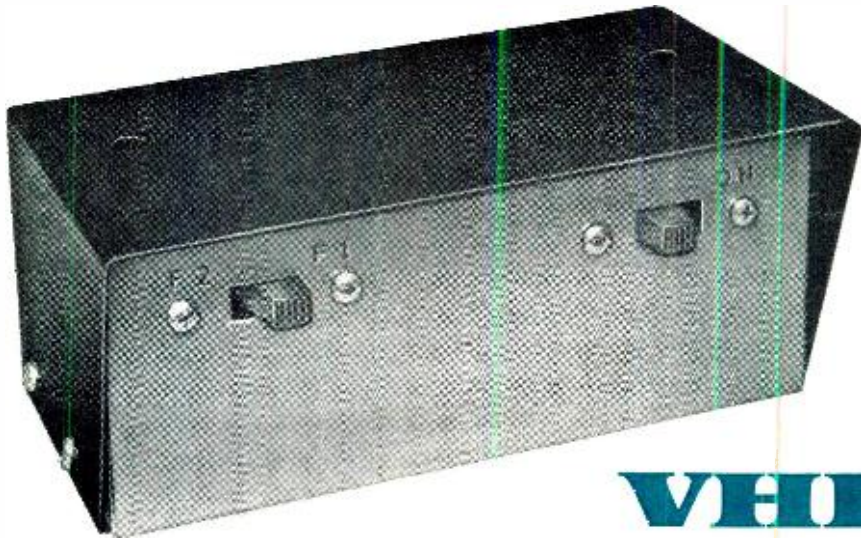

# VHF FREQUENCY CONVERTER

ADD SERVICE BANDS TO YOUR CAR RADIO

BY LYMAN E. GREENLEE

**F**OR THE PERSON interested in monitoring the various service bands (volunteer fire, police, CD, CAP, etc.) installing a vhf receiver in his automobile can be an expensive proposition. It is much less costly and easier to install a frequency converter so that the regular BCB car radio can be used; and the prospects are even brighter if the simple one-IC converter circuit described here is used. This crystal-controlled converter is powered by the vehicle's 12-volt battery and can be set accurately to the desired frequency (between 25 and 225 MHz) so that the BCB receiver need only be tuned to one particular spot on the dial. If the vehicle receiver has push-button tuning one button can be used for the desired vhf station. The conventional vehicle antenna can be used, or a special vhf antenna can be installed to feed both the converter and the BCB receiver.

Many vhf-to-BCB converters use manu-

ally tuned oscillators. This presents a problem in a moving vehicle. Drift, accidental tuning movement due to vibration, and the usual short duration of vhf transmissions make manual tuning impractical. With crystal control, only the vehicle's BCB radio need be adjusted and crystals are relatively immune to vibration problems.

**Construction.** The basic circuit of the frequency converter is shown in Fig. 1 and the component values for the various frequencies are given in the Table. The layout shown in Fig. 2 should be followed for best results. All connecting leads, especially those carrying r-f must be kept short. Be sure to observe the polarities of the diodes and the pin locations on the IC. Some type of clamp (or spring) must be used to keep the crystal holder seated. Note that the IC is mounted on standoff clips with the leads fanned out.

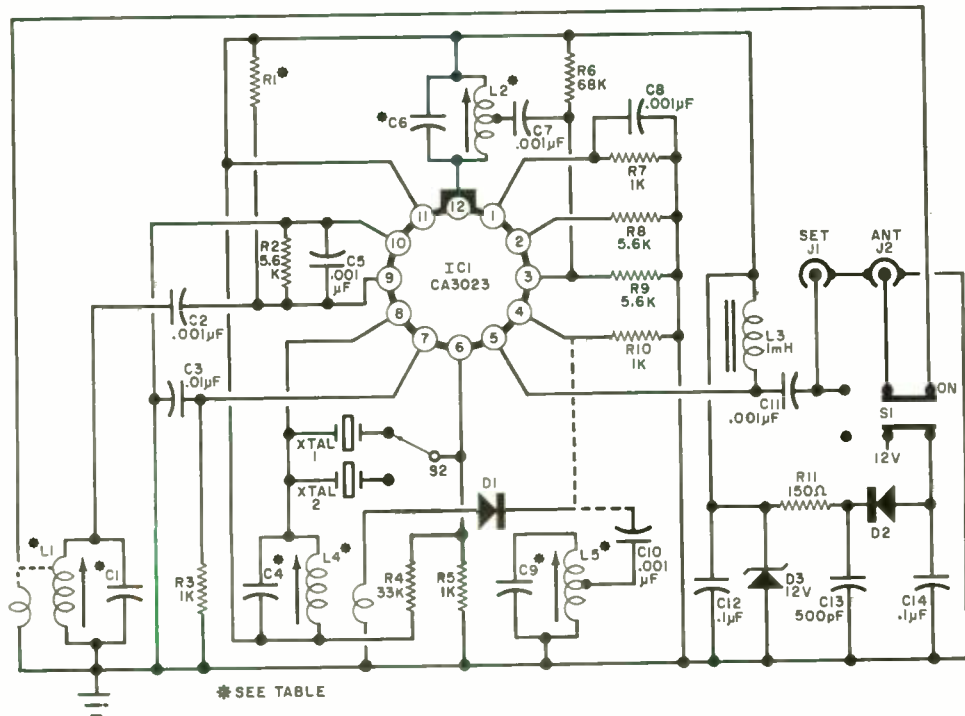

Fig. 1. This one-IC vhf converter is used with a conventional vehicle radio enabling monitoring of CAP, CD, volunteer fire and police bands.

### PARTS LIST

C1, C4, C6, C9—See table  
 C2, C5, C7, C8, C10, C11—0.001- $\mu$ F disc capacitor  
 C3—0.01- $\mu$ F disc capacitor  
 C12, C13—0.1- $\mu$ F capacitor  
 C15—500-pF capacitor  
 D1—Signal diode  
 D2—Rectifier diode: 1A, 100V  
 D3—Zener diode: 12V, 1W  
 IC1—Integrated circuit (RCA-CA3023)  
 J1, J2—Shielded antenna connector  
 L1, L2, L5—See table  
 L3—1-mH r-j choke  
 L4—12 and 3 turns, #24 enameled wire  
 R1—See table

R2, R8, R9—5600-ohm,  $\frac{1}{2}$ -watt resistor  
 R3, R5, R7—1000-ohm,  $\frac{1}{2}$ -watt resistor  
 R4—33,000-ohm,  $\frac{1}{2}$ -watt resistor  
 R6—68,000-ohm,  $\frac{1}{2}$ -watt resistor  
 R10—10,000-ohm,  $\frac{1}{2}$ -watt resistor  
 R11—150-ohm,  $\frac{1}{2}$ -watt resistor

S1, S2—Dpdt slide or toggle switch

Misc.—Suitable board, mounting terminals, crystal socket, knobs, spacers, enclosure, mounting hardware, etc.

Note—Complete kit of parts, less crystal, is available for \$39.95, postpaid, from Mobil Electronics, Inc., P.O. Box 1132, Anderson, IN 46015 (USA only). The M6970 (similar to RCA CA3023) integrated circuit is also available for \$3.50, postpaid.

### COMPONENT TABLE

Frequency MHz	L1 Turns	L2 Turns	L5 Turns	C1 pF	C4 pF	C6 pF	C9 pF	R1 Kilohms
25-35	12&3	12	—	15	56	33	—	220
35-55	12&3	12	—	10	33	15	—	220
60-80	6	6	6	86	43	33	33	68
80-110	5	5	5	15	10	10	10	68
150-170	3	3	3	25	10	10	10	68
200	2	2	2	22	10	12	12	68

Note: Use #24 enamelled wire for the 12 and 3 turns on L1; #18 buss wire on all other inductors. Antenna connects to 3-turn winding on L1 when there are two windings and directly to winding when there is only one.



**Train on this  
315 sq. in.  
picture  
color TV  
and get the  
skills that  
mean a  
high-paying  
career!**

# Solid-State — the newest development

**Count on NTS training to always  
feature the latest electronic equipment.**

Now included in two exciting NTS color TV courses, this set is the largest, most advanced color television made. Guided by the NTS "Lab-Project Method" of combining professional kits and easy-to-follow lessons, you build this color TV step by step — learning TV Servicing as you go! NTS has successfully trained thousands of men at home for rewarding careers as electronics technicians. Prepare for the great opportunity fields of TV-Radio Servicing, Computers, Communications, and Automation.

**This solid-state color set contains:** 45 transistors, 55 diodes, 2 silicon controlled rectifiers, and 4 advanced integrated circuits representing an addi-

tional 46 transistors and 21 diodes. The first solid-state color TV this large — yours to keep! It features Automatic Fine Tuning; "Instant On"; an Ultra-Rectangular Screen (25 in. diagonal measurement) that lets you see the complete transmitted image for the first time — a full 315 square inches; exclusive built-in Self Servicing features which eliminate the need to buy costly test equipment; exclusive design Solid-State VHF Tuner with an MOS Field Effect Transistor; 3-stage Solid-State IF; Automatic Chroma Control, Adjustable Noise Limiting and Gate Automatic Gain Control, High Resolution Circuitry; Matrix Picture Tube; and a specially formulated Etched Face Plate that eliminates unwanted glare, and heightens contrast. Colors are more vivid,

fresh tones more natural, and the picture is sharper than ever before. By training on this unique color TV, you'll gain the most up-to-date skills possible in TV Servicing!

**Other valuable equipment you build and keep** includes an AM SW Radio, Solid-State Radio, FET Volt-Ohmmeter, and Electronic-Tube Tester. All included in your tuition. You learn troubleshooting, hi-fi, multiplex systems, stereo, and color TV servicing. Step right into a technician's job at top pay or open a business of your own! For complete details on all NTS electronics courses, mail the coupon today for the full-color NTS Catalog. No obligation. No salesman will call.



**Build this set  
and learn  
solid-state  
circuitry—the  
electronics  
of today!**

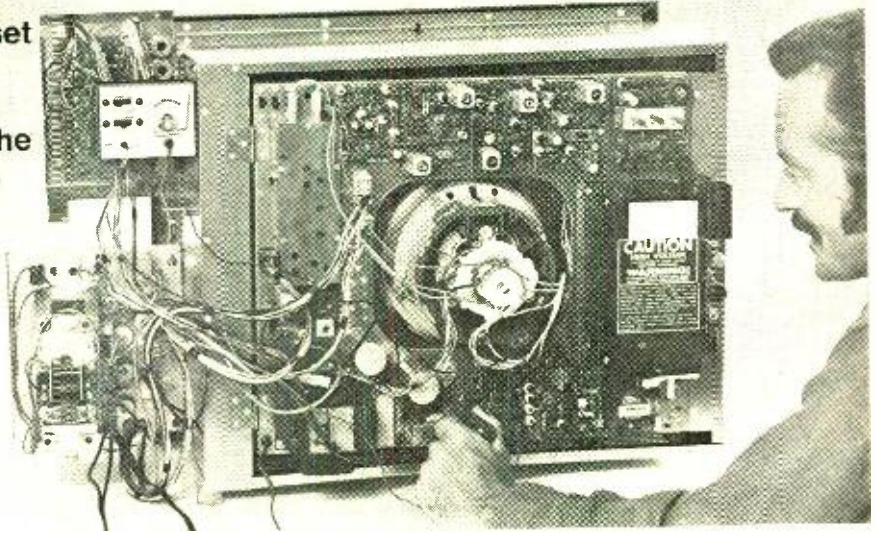

# in color TV — comes to home training.

## NTS ELECTRONICS & COMPUTER TECHNOLOGY

Build this exclusive NTS Compu-Trainer! Loaded with integrated circuits, it shows you the how, what, and why of computers. Learn this exciting field faster, more thoroughly. You also assemble and learn to operate an FET Volt-Ohmmeter and 5" wide-band Oscilloscope.



## NTS BLACK & WHITE TV AND RADIO SERVICING

Learn all phases of television, radio, stereo, and hi-fi. You receive this 74 sq. in. picture Solid-State B&W TV, Lo-Silho "Superhet" Radio, FET Volt-Ohmmeter, Solid-State Radio, Electronic Tube Checker, and Signal Generator. Start earning extra money even before you complete the course!



## NTS ELECTRONICS COMMUNICATIONS & F.C.C.

Gain the security and prestige of owning an F.C.C. First Class Radio-Telephone License! Two comprehensive NTS courses cover the big opportunity field of transmitting and receiving. You build 14 kits, including a 5 watt AM Transceiver, 6 Transistor Pocket Radio, and FET Volt-Ohmmeter. Learn 2-way radio, Citizens Band, micro-waves and radar.



## NTS INDUSTRIAL & AUTOMATION ELECTRONICS

Automation is the future of industry and you can play an important part! Learn industrial controls by training on the NTS Electro-Lab — a complete workshop. You also build and operate this 5" wide band Oscilloscope. And you perform experiments that involve regulating motor speeds, temperature, pressure, liquid level, and much more.

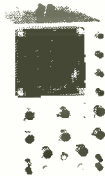

**Classroom Training at Los Angeles.** You can take classroom training at Los Angeles in sunny Southern California. NTS occupies a city block with over a million dollars in technical facilities. Check box in coupon.

**APPROVED FOR VETERANS**  
Accredited Member: National Association of Trade & Technical Schools; National Home Study Council.

**NATIONAL TECHNICAL SCHOOLS**  
WORLD-WIDE TRAINING SINCE 1905  
4000 South Figueroa Street, Los Angeles, Calif. 90037

Please rush Free Color Catalog and Sample Lesson, plus Information on course checked below. No obligation. No salesman will call.

**NATIONAL TECHNICAL SCHOOLS**  
NEW! ON SELF-TRAINING

**National Technical Schools**  
4000 S. Figueroa St.  
Los Angeles, Calif. 90037

Master Course in Color TV Servicing  
 Color TV Servicing (For Advanced Technicians)  
 Master Course in B&W TV & Radio Servicing  
 Master Course in Electronic Communication  
 Practical Radio Servicing  
 FCC License Course  
 Master Course in Electronics Technology  
 Industrial and Automation Electronics  
 Computer Electronics  
 Basic Electronics  
 High School at Home Dept. 205-121

Name \_\_\_\_\_ Age \_\_\_\_\_

Address \_\_\_\_\_

City \_\_\_\_\_ State \_\_\_\_\_ Zip \_\_\_\_\_

Check "Interests" in Veterans Training Under New G.I. Bill.  
Check "Interests" only in Classroom Training at Los Angeles.

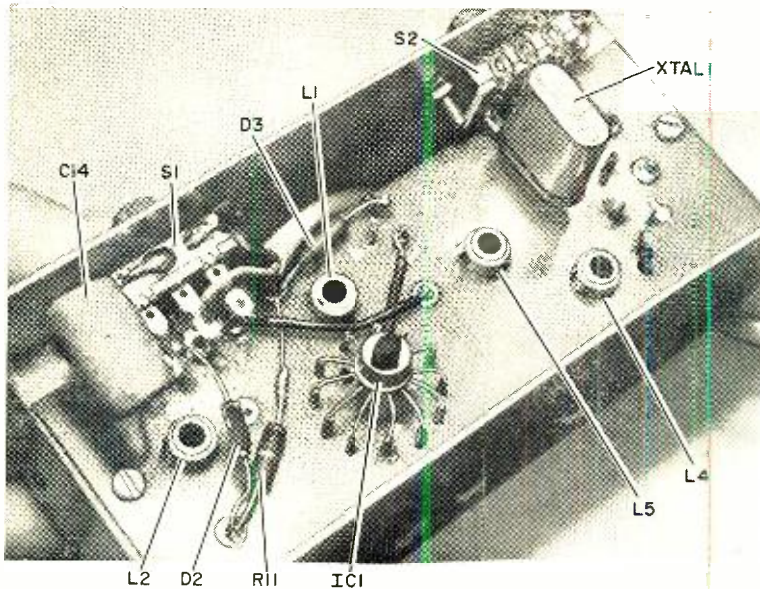

Fig. 2. Perf board construction was used in the prototype, observing good vhf wiring practice. Any connecting leads carrying r-f must be kept as short as possible. An etched board can also be designed and used. Note how IC leads are fanned out and soldered to standoff clips. Although only one crystal is shown, the other fits into a socket adjacent to XTAL1. More crystals may be used within same frequency range.

Any type of board can be used to assemble the circuit, with the board mounted in a small metal enclosure that fits easily in the vehicle. The antenna bypass switch and the crystal selector switch (if used) should be mounted on the front of the enclosure so that they are accessible. When the antenna switch is in the bypass position, power is removed from the converter and the antenna is connected directly to the BCB radio.

The connections to D1 and C9 are shown as dashed lines in Fig 1. For the frequency range between 25 and 55 MHz, L5 can be omitted and diode D1 connected directly to pin 4 of the IC. With L5 omitted, C9 can also be left out. For other frequencies, both L5 and C9 are used.

In selecting a crystal choose one whose harmonic is between 600 to 1600 kHz different from the desired frequency. The frequency between 600 and 1600 kHz is the intermediate frequency to which the BCB receiver is tuned. If possible, work backwards. That is, pick a spot on the radio dial that is quiet, with no strong signals nearby, and then pick

a crystal whose frequency is that amount different from the desired vhf frequency. Two crystals (switch selectable) can be used in the converter if the two signals are not more than 4 MHz apart in the same band.

**Alignment.** Connect the converter (through J1) to the antenna input of the vehicle receiver, using shielded line to avoid pickup. Connect the vehicle antenna to J2 on the converter. For the best reception, the antenna height should be about 42". Place S1 in the on position and tune the vehicle receiver to the correct frequency on the standard broadcast band between 600 and 1600 kHz.

Connect a high impedance dc voltmeter between pin 7 (+) on IC1 and ground. Using an insulated alignment tool, adjust L4 for a maximum indication, then back off one to two turns. The voltage should be about 4 to 6 volts. Connect the voltmeter between pin 4 (+) on IC1 and ground, and adjust L5 for a maximum indication. Remove the voltmeter. Adjust L1 and L2 for a maximum signal from a station or signal generator at the desired frequency. ♦

# HI-FI AMPLIFIER MODULE

NEW COMMERCIAL UNIT SIMPLIFIES CONSTRUCTION

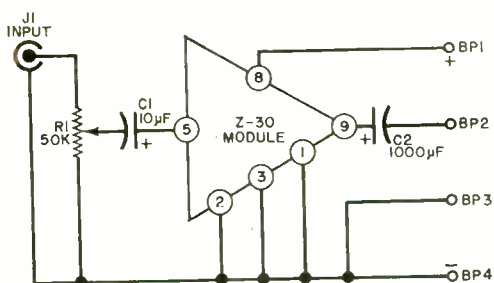

Fig. 1. Complete amplifier contains only module, two capacitors, and potentiometer.

### PARTS LIST

- BP1-BP4—Five-way binding post
- C1—10- $\mu$ F, 10-volt electrolytic capacitor
- C2—1000- $\mu$ F, 35-volt electrolytic capacitor
- IC1—Sinclair Model Z-30 audio amplifier module (available from Audionics, Inc., 8600 Northeast Sandy Blvd., Portland, Or. 97220, \$15.95.)
- J1—Phono jack
- R1—50,000-ohm audio taper potentiometer

most any AM or FM tuner or with a ceramic phono cartridge. It is also useful as a signal tracer or in a number of other audio applications.

The module (on a printed circuit board) can be made into a complete amplifier with the addition of a couple of capacitors and a volume control as shown in Fig. 1. It is only necessary to solder six wire "lugs" to the module terminals as shown in Fig. 2. Use heavy-

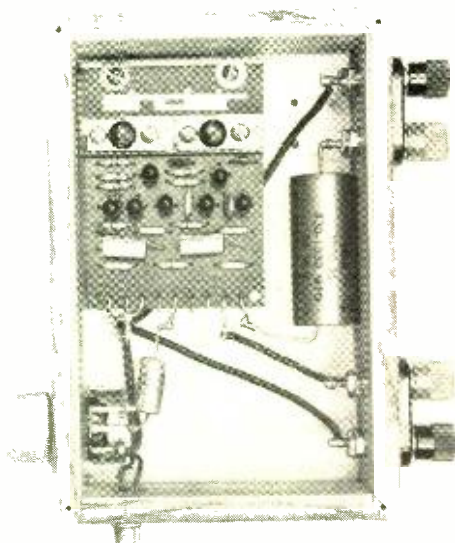
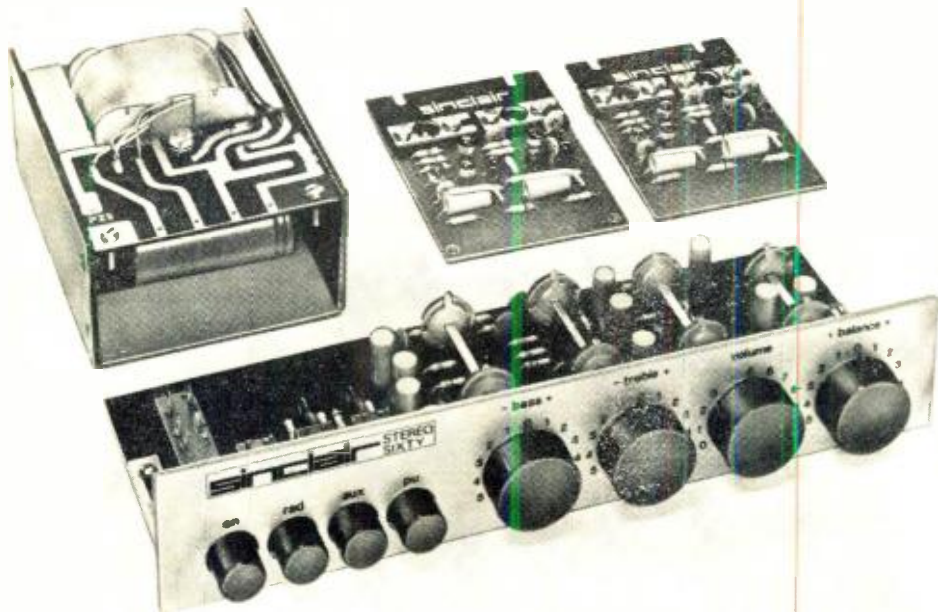

Fig. 2. The module can be mounted easily in a small case with other components attached.

**W**HEN doesn't it pay to design and build your own solid-state hi-fi amplifier? When you can buy a better one than you can design—for less money than it takes to build one. This was the reaction upon seeing the specifications of the Sinclair Model Z-30 audio amplifier presently being imported from England.

This excellent general-purpose audio amplifier module can be housed in a small enclosure and can be used with al-





To complement the Z-30, Audionics also has made available a suitable power supply, and a preamplifier/control unit that includes all the necessary tone and balance controls, with pushbuttons for selecting the various inputs. As shown above, this combination is called the "Stereo 60." In addition, there are also available a high- and low-pass active filter unit for scratch and rumble attenuation, a 50-watt amplifier module similar to the Z-30 unit, and a new IC having an output of 6 watts

rms continuous (12 watts peak). Another addition is a new concept in FM tuners which uses a phase-locked loop system. For a complete catalog of all of these devices, write to Audionics, Inc., 8600 Northeast Sandy Blvd., Portland, OR 97220. This equipment is manufactured in England, but most of the transistors are made in America. The units are small enough to fit into small chassis and come with finished, neat front panel designs. A line of matching loudspeakers will be added.

## TECHNICAL SPECIFICATIONS

**Power output:** 15 watts continuous sine wave (30 watts peak) into 8 ohms with regulated 35-volt supply; 20 watts rms into 3-4 ohms with regulated 30-volt supply

**Frequency response:** 30-300,000 Hz  $\pm$ 1 dB

**Distortion:** 0.02% or less up to and including full output at 8 ohms

**Sensitivity:** 250 mV into 100,000 ohms

**Signal-to-noise ratio:** -70 dB unloaded with class AB output

**Power requirements:** 8-35 volts dc regulated (power output level decreases with decrease in supply voltage)

duty solid wire and let them overlap the end of the board about  $\frac{1}{4}$ ". All ground leads are soldered to one point.

The power supply for the amplifier module can be between 8 and 35 volts dc. The amplifier shown in Fig. 2 was built to have an external power supply, but the supply could easily be incorporated in the same enclosure.

A loudspeaker of 8 or 16 ohms is recommended. If you want to use a 3.2-ohm speaker, be sure that the power supply is not over 25 volts and that the module has adequate heat sinking.

The Z-30 amplifier module comes with a comprehensive operating manual, which should be consulted for further operating instructions. ◆

# Professional Intruder/Fire ALARM

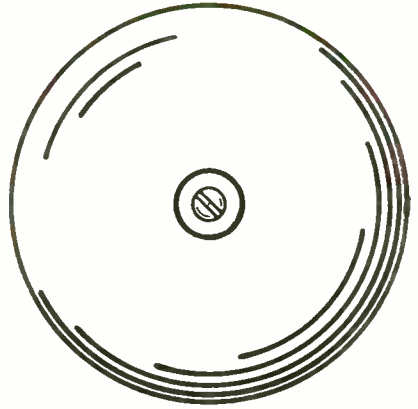

SELF-POWERED SOLID-STATE SYSTEM

HAS FEATURES OF A COMMERCIAL ALARM

BY GEORGE MEYERLE

**D**O YOU read an article about a burglar alarm kit with an inclination to say, "Oh, no, not another one of those things"—and move on to something else? Well, hold your horses and take a second look.

True, the alarm described here doesn't use a lot of new gadgets for detection devices or involve sophisticated things like ultrasonics or microwaves. Actually, it operates with breakwires and switches just as do most commercial units. The advantages of the alarm are in the circuit design itself—advanced solid-state features not found in most systems.

In addition, the alarm operates on lantern batteries for power, eliminating the possibility of having the wires cut to silence the alarm. Power consumption in the standby mode is extremely low so that almost shelf life can be obtained from the battery. This makes the system ideal for use in areas where primary power is not readily available.

In most commercial systems, a constant current flows through the closed protection loop to keep the various switch contacts in good condition. In this alarm, however, there is no wasteful loop current: the switch contacts are kept clean by a pulse of current which flows through the loop each time the system is activated.

In addition to intruder detection, the system can be used as a fire alarm. In this case, fire (actually heat) sensors are connected to the circuit to sound the alarm. It is also a simple matter to include such features as mat switches to indicate when anyone enters an open door or uses a staircase; and manual pushbuttons can be included to operate as panic alarms.

A 5-to-50-second delay is used to allow the owner to enter through any one selected door. Entry in any other way will cause the alarm to sound. For this type of use, the control panel must be located out of sight but convenient enough for

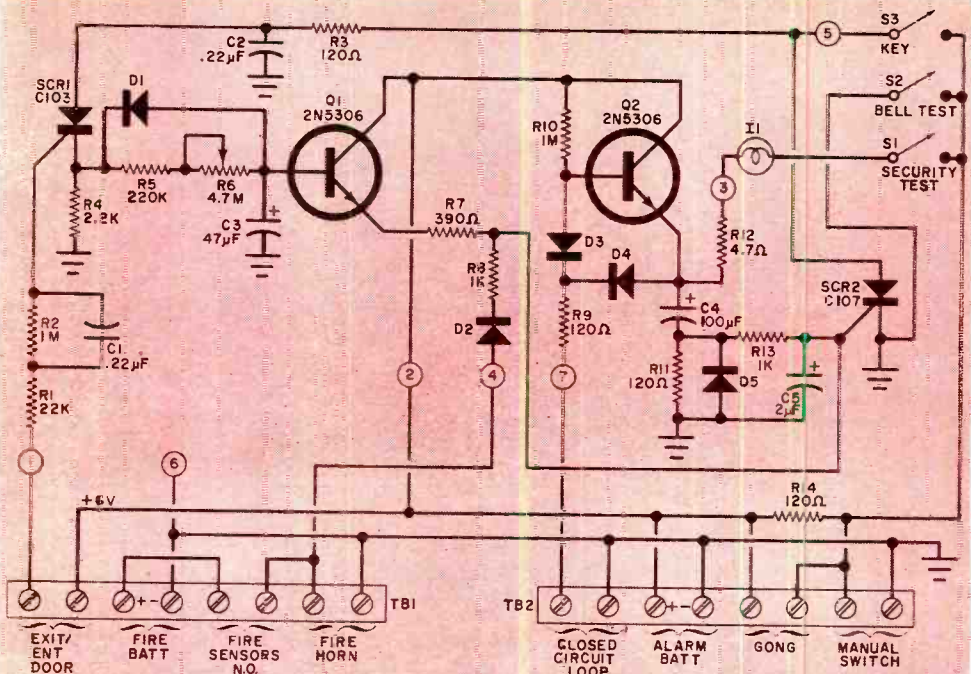

Fig. 1. Unlike other alarms, this one features a 5- to 50-second delay to allow legitimate entry without ringing the gong. This same circuit is also used for fire warning when used with the appropriate sensors.

### PARTS LIST

- C1, C2—0.22- $\mu$ F capacitor
- C3—47- $\mu$ F, 20-volt, tantalum capacitor
- C4—100- $\mu$ F, 15-volt electrolytic capacitor
- C5—2- $\mu$ F, 25-volt, electrolytic capacitor
- D1-D5—1-ampere, 600-volt silicon diode
- I1—6-volt, low-current incandescent lamp
- Q1, Q2—2N5306 (Darlington) transistor
- R1—22,000-ohm,  $\frac{1}{2}$ -watt resistor
- R2, R10—1-megohm,  $\frac{1}{2}$ -watt resistor
- R3, R9, R11, R14—120-ohm,  $\frac{1}{2}$ -watt resistor
- R4—2200-ohm,  $\frac{1}{2}$ -watt resistor
- R5—220,000-ohm,  $\frac{1}{2}$ -watt resistor
- R6—1.7-megohm PC potentiometer
- R7—390-ohm,  $\frac{1}{2}$ -watt resistor
- R8, R13—1000-ohm,  $\frac{1}{2}$ -watt resistor
- R12—17-ohm,  $\frac{1}{2}$ -watt resistor
- S1, S2—Normally open pushbutton switch
- S3—Key switch assembly

SCR1—Silicon controlled rectifier (GE C103YY)

SCR2—Silicon controlled rectifier (GE C107F12)

TB1, TB2—Eight-pin barrier strip

Misc.—Suitable chassis, lantern batteries (6-volt), battery connectors, mounting hardware, etc.

Note—The following are available from Metrotec Industries, Technical & Industrial Park, 33 Caine Dr., Plainville, NY 11803, etched and drilled PC board #602, \$2.00; control panel, chassis, key lock, PC board, all electrical and mechanical components, #60F, \$29.95 plus \$1.60 postage; 10" gong, #607, \$15.95; fixed temperature heat sensors (specify 135° or 190°), \$1.90. The same firm can supply switches, breakwires, etc., used in professional alarms.

the legitimate user to shut down the system by operating a key switch once he is inside. Both the control box and the gong enclosure can be fitted with normally open switches in the protective loop so that if anyone tries to remove either of these units from the wall, the alarm sounds.

**Construction.** The schematic of the elec-

tronic portion of the alarm is shown in Fig. 1. Assemble the circuit using the foil pattern and layout guide shown in Fig. 2. Silicon controlled rectifier SCR2 is mounted on the metal chassis and connected to the PC board terminals through three lengths of insulated wire. Be sure to get the polarities on the electrolytics and semiconductor correct. Use a low-power soldering iron and fine solder. Note that



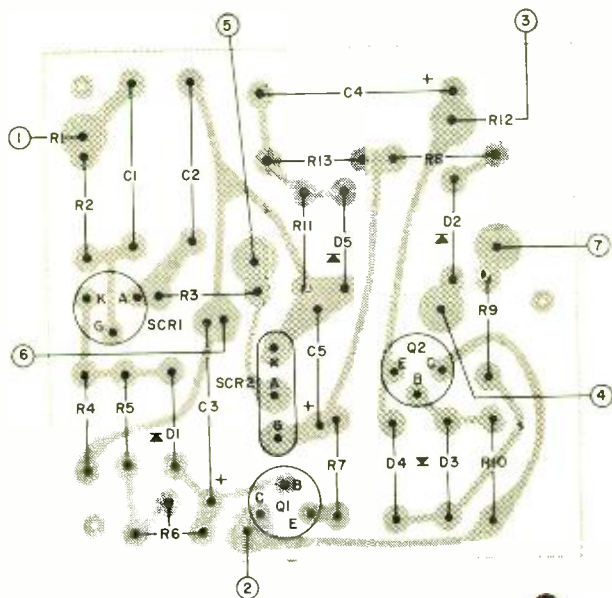
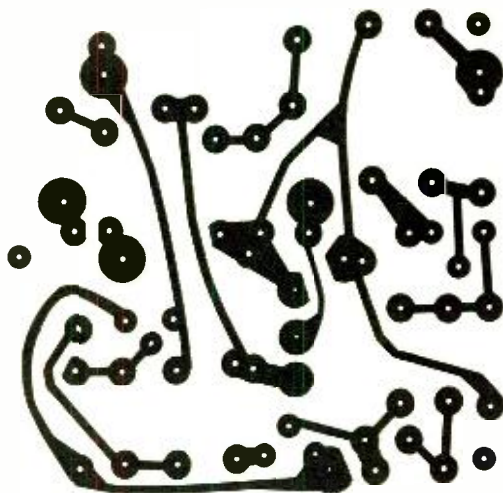

Fig. 2. The actual size foil pattern (right) and component installation (above). Note that SCR2 is mounted on the chassis and connected to its terminals via lengths of insulated wire. It should also be pointed out that both Q1 and Q2 are Darlingtons for high input impedance.



R1 and R12 are mounted vertically with their top terminals serving as terminals 1 and 3 respectively. Terminals 2 and 4 through 7 on the board are made from L-shaped pieces of stiff copper wire inserted in the appropriate holes and soldered to the foil on the bottom.

Components such as the security test lamp I1, security test switch S1 bell test switch S2, and key switch S3 should be mounted on the front panel of the enclosure and connected to the board with insulated wire.

Mount the components in a suitable enclosure similar to that shown in the photo. If the PC board is mounted on in-

ulated spacers SCR2 need not be isolated electrically from the metal chassis. If the board is metallically connected to the chassis, an insulating transistor mounting kit must be used, with silicone grease added to insure heat conduction.

Use some form of press-on type to identify the controls on the front panel. Connections to the outside circuit are made with insulated wiring passed through a hole punched on the side of the chassis.

**Installation.** When selecting a location for the control panel, remember that it should be mounted where it can be

## THEORY OF CIRCUIT DESIGN

With the closed-loop protection circuit connected to the control panel, the emitter of *Q2* is at ground potential and *C4* is discharged. When the loop is broken in any way, *C4* is charged up to +6 volts through *Q2*. The positive voltage developed across *R11* during this charging period is applied to the gate of *SCR2*, turning it on. This completes the gong circuit through terminal 5 and the key switch.

To keep the alarm from sounding when the owner leaves or enters the premises, a unique 5-to50-second delay is used. The switch on the exit/entrance door is open when the door is closed and closed when the door is opened. One side of the switch is connected to the battery supply.

Under normal conditions, before leaving, key switch *S3* is open so that, when the door is opened, the positive voltage applied to *C1* through *R1* cannot fire *SCR1* because there is no positive voltage on its anode. Capacitor

*C1* discharges through *R2*. Now the key switch is closed and exit is made, closing the door. The next time the exit/entrance door is opened (the switch closes) *C1* is charged up and fires *SCR1*. The positive pulse across *R1* puts a charge on *C3* through *R5* and *R6*. As a result *Q1* is turned on and once it saturates, a positive pulse is applied to the gate of *SCR2*, turning on the alarm. The amount of time that it takes *C3* to charge up and turn on *Q1* is determined by the setting of *R6*.

The fire alarm system is a simple series circuit consisting of the heat sensor, the fire horn, and the fire battery. When the heat sensor closes, it completes the horn circuit. When the fire horn sounds off, a positive voltage at the junction of the fire sensor and the battery feeds through *D2* and *R8* to turn on *SCR2* and activate the intruder gong as well.

Diodes *D3* and *D4* protect the circuit from lightning spikes picked up on the relatively long closed loop. Diode *D5* removes the negative spike from the *SCR2* gate circuit when *C4* is discharged.

reached within 5 to 50 seconds (depending on the preset delay) after entering the premises. However, it should not be visible from outside the area being guarded. Also keep in mind that a number of leads have to be connected to the control panel, so be sure that you have cabling access.

Since the purpose of the system is to let you know when something happens, you should use a good, large, loud gong for the alarm. If mounted outside, the gong should be in a weatherproof louvered enclosure. The enclosure should have two normally open switches (one on the door and one between the enclosure and the wall) wired in series with the remainder of the closed-circuit loop. Mount and wire the switches so that if the gong enclosure is opened or it is removed from its mounting, one of the switches will open and cause the alarm to sound.

**Intrusion Protection.** Determine which door is to be used as the main entrance and exit. Fit the door with a switch that is open when the door is shut and closed when the door is open. This switch is connected to appropriate terminals on *TB1*. Determine the other points of entry that are to be protected and select the appropriate switch for each. In all cases, the switches must be normally closed

when all is OK, but open in the event of an intrusion. Connect them in series to form a closed-loop system to be connected to the appropriate terminals on *TB2*.

There are many different types of switches that can be used for this purpose. Some are spring-loaded and are held down by a finger arrangement attached to the door or window. In this way the switch opens when the door or window is opened. There are also magnetically operated switches, with the magnet attached to the door or window to keep the switch closed. Switches with mechanical variations can be obtained for doors and windows with unusual configurations and circumstances.

Large glass areas can be protected with self-adhering conductive frangible tape that can be very easily torn (open circuited) if a crack occurs in the glass. Electrical contact is made to the tape with a self-adhering contactor.

After all switches have been selected and properly installed—along with other protective devices—they must all be connected in series and brought to the appropriate terminals on *TB2*. To test the circuit, an ohmmeter should show a very low resistance for the entire loop when all doors and windows are closed. The resistance should go to infinity if any part of the loop is opened.

In the exit door circuit, the opposite is true. The circuit should be open when the door is closed and closed when the door is open.

To provide a manual alarm, connect a normally open pushbutton switch to the appropriate terminals on TB2. The switch can be mounted in any convenient location. Floor mat switches, if used, are connected to the same terminals on TB2.

**Fire Protection.** This alarm system also makes an excellent fire or smoke alarm, when wired to suitable heat sensors. There are three basic sensors. One operates at a temperature of 135°F for use

normally open heat sensors are connected in parallel to the suitable terminals on TB1.

**Test and Operation.** To check the security of the system, with the key switch turned off, open any protected door or window as an intruder would. Depress the security test switch (S1) and note that the security test lamp (I1) comes on.

To test the closed circuit loop with the gong, make sure that the loop is closed and the key switch turned on. When any part of the closed loop is broken, the gong should ring until the key switch is turned off.

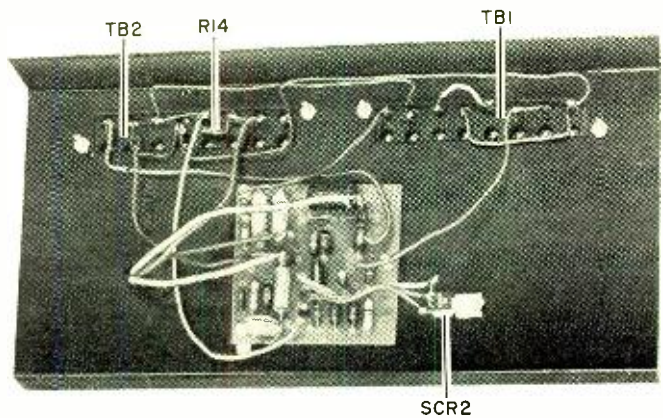

The PC board and the two barrier strips are shown mounted on the shelf that comes with the enclosure (see Parts List). Note how SCR2 is mounted to the metal shelf using a transistor insulator mounting kit.

in living areas; another switches on at 190°F for use in boiler rooms and attics; while a third is a rate-of-temperature-rise sensor that operates when there is a sudden change in the ambient temperature. The latter is what happens when a fire suddenly sweeps into a room. These

To check out the exit/entrance door system, open that door prior to turning the key switch on. Turn the key switch on and then close the door. The alarm should go off between 5 and 50 seconds after the door is opened again. The timing is set by adjusting R6. ♦

### SOLID-STATE LIGHTER IS A PRODUCT OF THE SPACE AGE

Space-age electronics and the harnessing of electricity to create tiny bolts of lightning is the key to the ignition system of the new Maruman "solid-state" butane cigar and cigarette lighter which is being distributed in the U.S. by Consolidated Cigar Corp.

The patented electronic mechanism is based on the piezoelectric principle. When the piezo hammer puts pressure on a cam, the hammer excites the piezo

element, producing a spark between the positive electrode and the gas nozzle. This ignition system eliminates the need for flint, striking wheels, wicks, and constant cleaning. And the lighter does not require a battery for ignition—it's all done by striking a piezoelectric crystal.

Maruman states that 30 years from the time of purchase, the lighter will still be producing a spark every time.





Sixteenth in a Monthly Series by J. Gordon Holt

## CHOOSING A SPEAKER SYSTEM

**O**F ALL the letters I receive in connection with testing equipment, by far the most common asks the question, "What loudspeaker should I buy?" When I can dig up the time to reply to such questions individually (usually I can't), my answer is normally a polite put-off—not because I am disinclined to answer the question, but because in truth I can't really answer it.

I can tell you what a few of the best loudspeakers are. The Infinity Servostatic I, the IMF Studio, and the KLH Nine are but three that come to mind, although there are a number of others. But there is no single best speaker system. Even the top-of-the-pile systems excel in some respects and fall short in others. So the best one for you is purely a matter of which aspects you are most picky about, and in which aspects you are willing to tolerate some short-comings.

The most common advice given to loudspeaker shoppers is "Attend a few concerts, then go into your local hi-fi shop and choose loudspeakers that sound the most like what you heard in the concert hall."

This isn't quite unmitigated tripe, but it comes close to it. To begin with, only a trained hi-fi ear can retain an impression of the sound of live music long enough to make valid comparisons between it and the canned variety. And if your ears are trained, there is no need to ask other people what loudspeaker to buy. You'll be able to make up your own mind.

A second thing that makes the live-versus-canned comparison rather academic is the fact that most commercial recordings do not really sound like live music because they aren't intended to. It is an article of faith among recording engineers these days that a recording is a work of art unto itself, and should stand on its own musical merits without having to bear comparison with concert-hall sound. This is arguable, but for the record buyer, the recording companies are City Hall, and you needn't bother to fight them. They think they know what you want to hear better than you do.

Okay, so you can't remember what live music sounds like, and it wouldn't matter if you could. Where does that leave you? It leaves you to find other ways of picking your perfect loudspeaker, and there are several.

**Loudspeaker Colorations.** Every loudspeaker, even the very best, has a tendency to "color" reproduced sound in certain ways. These colorations stem mainly from the speaker's deviations from perfect transient performance and absolutely flat response, and your job as a buyer is to find the one(s) whose colorations annoy you the least. Or, if you're lucky, one whose colorations you actually like. Of course, every loudspeaker manufacturer likes to think of his products as having "flat" response—well, almost every one. Some cunningly build in response boosts in the mid-bass boom range (for "fatness") and in the presence range (for "projection"). But even the systems that are supposed to be flat have certain response deviations due to inescapable resonances, crossover network imperfections and so on. The best that any speaker has been able to achieve to date is a measured response of plus or minus 2 dB throughout most of its range, and while this is extraordinarily good for a loudspeaker, it nevertheless leaves room for a conspicuously audible 4-dB variation throughout the working range. And this is where you come in. With that much possible variation from one speaker system to another (and the variation is usually much greater), the best you can do is find out which speaker's variations suit you the best.

If you are simply out to find a system that will make music sound the way you think it should sound, and to heck with literal realism, your job is somewhat easier. You just take a few favorite records to your local dealer(s), sample them through the various speakers that are set up for demonstration, and pick the system that turns you on. Then you arrange to take the speakers home for a trial period. (Many dealers will go along with this if they think you're seriously inter-

ested in buying and aren't just playing games.) If you're still happy with them after a week of listening to a variety of program material, they're probably your cup of tea.

**The Hair-Splitting Perfectionist.** This simplistic "I-like-what-I-like" approach will suffice for most people. But if you are a borderline perfectionist, or have even crossed the border, this approach probably will *not* satisfy you. In which case, you will have to start doing some hair-splitting.

Most perfectionists have learned that the equipment ahead of a loudspeaker can have almost as much effect on its sound as the speaker itself. For this reason, the associated equipment used for loudspeaker auditioning in a store should either be familiar to the buyer or should have a reputation for having certain qualities. This does not mean you can say "Well, it's made by the celebrated Acme Products Company, therefore it must be good." Celebrated audio manufacturers, like their uncelebrated brethren, sometimes "bomb out" on a design, and the product doesn't usually get its reputation for being a loser until it is just about obsolete anyway. So go on the reputation of the specific products, not on their brand names.

Some ideal amplifiers for loudspeaker auditioning (and of course for listening at home too) include the Harman-Kardon Citation 12, the Crown DC-300, and the SAE Mark III. There are others, of course. The Citation 12, because of its lower power, will tend to produce more low end with a bit less detail from most speakers, some of which will sound at their best that way, others of which may sound bottom-heavy. The DC-300 and SAE do the opposite, and thus may produce too little bass, but with superb detail, from some speakers. Finally, the SAE normally tends to make most speakers sound a bit more forward than the other two amplifiers. But all three are excellent.

As for preamps, the Citation 11, the Infinity One, and the Audio Research SP-2C (if you can find a dealer who carries it) are among the best-sounding preamps currently available. With poorer preamps, your sound may range from slightly grainy to very hard and brittle, so bear that in mind too when auditioning your speakers. Many pickups are so variable in sound that your best bet is to either use one exactly like the one you own, or use an excellent one like the Stanton 681A.

**What to Listen to.** It should not be necessary to point out that most conventional test records are of dubious value in selecting loudspeakers. The ear will respond much more acutely to colorations in reproduced sound than it will to changes in the perceived level of test tones. So listen to nat-

ural sounds, not warble tones. And I mean *natural* sounds, like sound effects.

There are some excellent recordings of natural sounds available on disc; the Elkra series of sound-effects records is particularly good for subjective speaker evaluation. The reason for using them may not be immediately evident, though. All of us, golden ears or not, have certain preferences about musical sound. These legitimate differences in individual taste (as well as the price of the ticket) are what make one concert-goer choose a balcony seat and another choose a close seat in the orchestra section. But we have no such preferences for natural sounds—the sounds we hear around us when we are not listening to music. We have grown up with these natural sounds, we have learned through the years to orient ourselves in our environment by means of them, and we are acutely aware of when they don't sound "right." Thus, the sound of a rushing stream, street traffic, or rain on the pavement either sounds real to us or it doesn't. And our personal preferences have nothing to do with it.

For this reason, nothing can reveal mid-range coloration in a loudspeaker quite as dramatically as the reproduction of these sounds. The metallic clack of shotgun bolt (in the skeet-shooting sequence) or the clink of ice in a glass are definitive indicators of treble response, while it takes a system with extraordinary smoothness and transient response to reproduce the individual bursts of the bubbles in the soda-pop sequence. Thunder will reveal low-frequency range, while the ability to reproduce street traffic without excessive low-frequency rumble can confirm the fact that that deep bass is being well damped.

Of course, you can't use the sound effects



to the complete exclusion of recorded music, because you will, after all, be listening to more music than anything else. So, once the sound effects have indicated how smooth and wide-range the system is, you should then use some music recordings to determine whether those inevitable colorations will help or hinder your enjoyment of musical reproduction.

For example, do massed violins sound steely and brittle? Some recordings are made to sound that way, but if a sampling of Deutsche-Grammophon discs does, then look for another speaker. Try listening to a solo violin. Is it sweet, or steely? Does piano sound there, even if at a distance? Or is there a velvet veil between it and you? Can you feel the bass drum in the pit of your stomach, or does it just go "whoomp"? It should "thud". Trombones should blat, cellos should "zuzz" or "zoop", double-basses should "vroom" when bowed and "thud" when plucked. And you should be able to listen at the volume you like, without the sound starting to become hard, muddy or shattery. Be realistic about your listening levels, though. If you like your music really loud, then get a high-efficiency speaker system with at least 50 watts program-power input capability, and don't consider a low-efficiency speaker. If acid rock is your bag, don't even buy high-fidelity components. Buy

ones that are designed for hard rock use, and kiss goodbye to your hearing.

**What Do You Prefer?** Finally, you might consider your listening preferences. The foregoing checks should allow you to locate a speaker system that is at least free from sharp peaks and dips. If you can afford the \$300 to add a multi-band equalizer like the Sound-Craftsmen 20-12, you can make practically any smooth speaker system sound the way you want it, and you could cease your speaker hunting there. Otherwise, take note of whether the speaker of your choice seems to move all sounds fairly close to you or whether it consistently gives the impression of listening from a distance. This is one of the major differences between even top-of-the-line speaker systems, and will ultimately have a profound influence on whether you find the speaker eminently good to live with or a constant source of mild frustration. Here, you must choose what you like. Nobody else can advise you, any more than you could seek advice about the woman you should marry. Despite all your efforts, you could still end up with a speaker (or spouse) that you feel leaves something to be desired. But then, anything can be improved. There will always be a better one over there, so the least anyone can do is get one he can live with. ♦

### A \$25,000 SUNDIAL?

Ever since man first became consciously aware of the passage of time, he has attempted to segment his day by the "clock." One of the earliest such clocks was the sundial. The desk clock shown in the photo has one thing in common with the sundial—it contains no moving parts. This unique timepiece was built by the Motorola Semiconductor Products Division, Central Research Laboratories, at a developmental cost of \$25,000.

The timepiece represents three departures from the conventional clock design. First, in place of moving hands, it employs 72 light-emitting diodes (LED's) to indicate seconds, minutes, and hours. Second, the mechanical movement has been replaced by tiny integrated circuits that turn on the hour, minute, and second LED's. (Only three LED's are on at any given time, allowing the clock to operate for about a year on two small batteries.) Third, the timing device is an extremely accurate quartz crystal instead of a mechanical tuning fork or balance staff.

Although the timepiece is only in the research phase, it is almost certain that the electronics inside will be commercially adopted in both clocks and wrist watches before long. Expectations are that a full integrated clock will exist within the year.

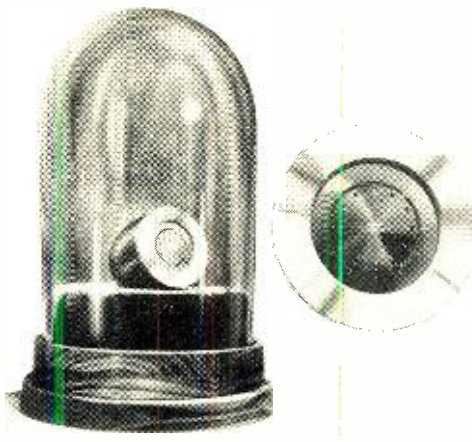



# A Report on the WORLD ADMINISTRATIVE RADIO CONFERENCE

BY RICHARD G. GOULD

## NEWLY PROPOSED WARC REGULATIONS EMPHASIZE SATELLITES

**T**HE WARC is over. Representatives of 101 countries attended. The United States sent a 50-man delegation headed by an ambassador. The WARC lasted for six weeks, including one marathon session that ran around the clock from Saturday morning till dawn on Sunday. WARC stands for the World Administrative Radio Conference, and was typical of such conferences held about every eight years to revise the Radio Regulations and the Table of Frequency Allocations.

Did we get what we wanted? Can we use the new frequencies that were allocated? What kinds of new space services and systems are now possible?

When the Final Acts of the WARC take effect on January 1, 1973, satellites may be used by the space counterparts of many existing services such as the Amateur, Maritime and Aeronautical Mobile and Radionavigation, Meteorological Aids and the Broadcasting Services. In addition, frequencies were allocated to two completely new services: Earth Exploration and Inter-Satellite. The previous Conference allocated frequencies up to 40 GHz. This one extended the Table to 275 GHz.

**Broadcasting Satellite Service.** While all the new allocations don't agree exactly with the ones the United States had proposed, every service got frequencies in or near most of the bands we wanted.

One surprising and gratifying result was the allocations made to the Broadcasting Satellite Service. The Conference agreed on primary allocations for space broadcasting in the bands from 2500 to 2690 MHz, 11.7 to 12.2 GHz, 41 to 43 GHz and 84 to 86 GHz, the last two bands being exclusive and the rest shared with other services. (A primary allocation means that a user can't cause interference to other primary users, and they can't interfere with you. A secondary allocation means you can't cause interference, but others can cause you interference.)

In the uhf band, space TV broadcasting will be permitted between 630 and 790 MHz (that is, on channels 40 through 67) on a "footnote basis". This means that the service is not listed in the Table of Allocations itself, but mentioned in a footnote. This footnote also specifies the precautions that must be taken, including the statement that broadcasting can only take place "subject to agreement among administrations concerned . . . and affected." In other words, the other services come first and space broadcasting cannot interfere with them. Still, it brings a little closer the day when people may be able to dial the satellite on their TV receiver at home. The 2500-MHz band is also attractive. Although there are no receivers built for TV at these frequencies now, sets could be designed to sell at reasonable prices. Among the uses seen for this band is service to remote

areas of the United States, such as Alaska, for both television and telephone to small settlements in the bush.

The other frequencies above 10 GHz allocated to space broadcasting will be more difficult and expensive to use because of the increased complexity of receivers for these bands: but they have been allocated and will be available as the need for space broadcasting develops and as we learn how to build less expensive equipment for these bands.

**Fixed Satellite Service.** The Communication Satellite Service, renamed the Fixed Satellite Service, got some new frequencies: most of them shared with other services, but some of them exclusive. For example it will now share a portion of the 2500-MHz band with the Broadcasting Satellite Service mentioned above, as well as with the Fixed and Mobile Services.

Communications satellites were also added to the bands from 10.95 to 11.2 GHz, 11.45 to 11.7 GHz and 12.5 to 12.75 GHz where they must share with the Fixed and Mobile Services, and in the band from 11.7 to 12.2 GHz which they must also share with Broadcasting satellites.

Fixed satellites were also added to one other band below 10 GHz for down-link transmissions, and to the band from 14.0 to 14.5 GHz for up-links. The new down band, 6625 to 7125 MHz, is particularly desirable because rain attenuation effects are not as severe there as they are above 10 GHz. However, it may be difficult to use this band with the new 14-GHz band because of harmonic interference problems. We hadn't proposed the 14-GHz band, suggesting instead a band around 13 GHz, that is not harmonically related to the 7-GHz frequencies, but 14 GHz was the only one all nations could agree on.

Communications satellites also got 12 more bands between 17.7 and 275 GHz. These, of course, are subject to the high attenuation caused by precipitation and would undoubtedly have to be used with space diversity earth stations. Space diversity, long used on the ground to overcome the effects of fading on microwave systems, becomes much more expensive when communicating with satellites. On the ground, antenna separations of up to

80 feet on the same tower are adequate. Thus, one only need add a second antenna and receiver. To combat rain attenuation in satellite systems, entire duplicate earth stations must be built, located up to 20 miles apart, and interconnected by microwave or cable systems on the ground.

**Amateur and Other Satellites.** In the case of the other existing services, satellite techniques will now be permitted in many bands that had been assigned to those same services. For example, all amateur bands that had been allocated exclusively on a world-wide basis, can now be used for transmitting from amateur satellites. Actually, a group of amateurs has been working for several years to build these satellites, to arrange for their launch, and to work for the establishment of the Amateur Satellite Service and the allocation of frequencies to it.

Amateurs first banded together in California during 1960 to form the Project Oscar Association. This group was responsible for four satellites between 1961 and 1965. Amsat, the Amateur Radio Satellite Corporation, was formed in 1969 as a non-profit corporation to continue the work of Project Oscar. To date, this new organization has arranged for the launch of one satellite, Australis Oscar-5, a 40 pound spacecraft built by students in Australia. Amsat is now working towards the 1972 launch of another Oscar satellite which, according to plans, will contain three transponders. The organization has also formally proposed to NASA to provide an amateur package called Syncart (Synchronous Amateur Radio Transponder) on the ATS-G satellite, scheduled for launch in 1975. Licensed amateurs and others interested in amateur radio can learn more about Amsat, and how they can participate, by writing to P.O. Box 27, Washington, D.C. 20044.

As another example of space tech-waves being added to existing services, the band from 1540 to 1660 MHz, long allocated to aeronautical radionavigation, has been extended down to 1535 MHz and then split into several pieces, some of which are still allocated only for airborne radars, but now satellites may be used to assist in air navigation. Other pieces of this band were allocated to maritime mobile and aeronautical mobile

*(Continued on page 78)*



# ADHESIVE STENCIL TECHNIQUE FOR PC BOARDS

BY THOMAS ANDERSON

GET PROFESSIONAL QUALITY  
FROM MAGAZINE FOIL PATTERNS

**T**HE ELECTRONICS HOBBYIST often has to prepare printed circuit boards from actual size etching guides published in magazines. This process involves point-by-point transfer of dimensions from the printed page to the copper foil on the board blank, a tedious process to say the least. And, even though his intentions may be good, the results of his efforts have more often than not yielded rather untidy PC boards made by the easiest method available—free-hand application of resist.

Until now, to obtain a professional-looking board, either dry-transfer resist or photographic techniques had to be used, neither of which is economical and both of which employ materials with limited storage lives. Clearly, a faster, more convenient, and less expensive method of making professional-quality PC boards is in order.

This article describes a new adhesive-stencil ("Ad-Sten") technique of preparing blank boards for etching. The tech-

nique is suitable for all but very intricate patterns. And you can, if desired, use the same stencil to make multiple copies of the same PC board. Inexpensive materials, available from any dime store, are used throughout. These materials also have unlimited storage lives.

With the "Ad-Sten" (for Adhesive-Stencil) technique described in these pages, a typical PC board can be readied for etching in less than an hour at a cost of only 15¢, exclusive of the board blank. To top it off, the finished product will have the appearance of being professionally made, even though the point-by-point transfer of dimensions has been completely eliminated.

**Basic Materials & Tools.** It would be pointless to describe the Ad-Sten technique of making printed circuit boards without first enumerating what materials and tools you will need. In the category of materials needed, there are "Con-"  
(Text continued on page 78)



# 1200 Radio Shack stores have electronic kits that build easy—yet aren't kid's stuff!



**Stereo Headset.** Low-cost hi-fi for nightowls—only YOU hear the music! Very lightweight, very comfortable. 6' cord & plug included.

**7<sup>95</sup>**

**"Custom Design" Speaker Kits.** Finest woofers & tweeters, 3/4" hardwoods, decorator-inspired grille cloths. With cross-over network, wiring—everything—even a walnut finishing kit. For floor or shelf.

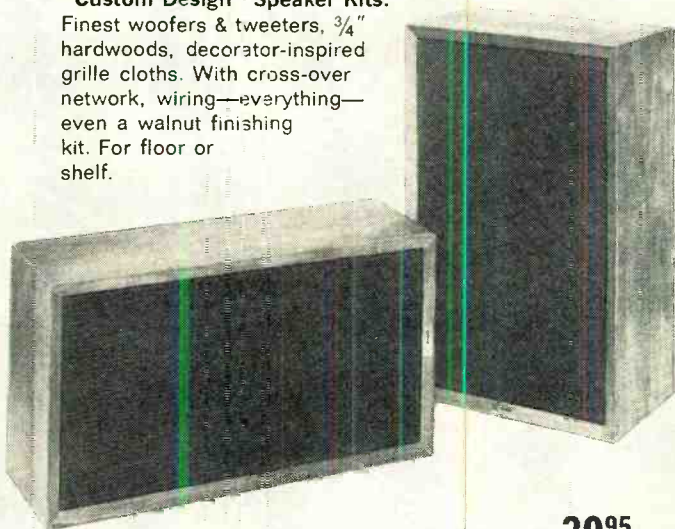

8" Two-Way System, 45-18,000 Hz **39<sup>95</sup>**

10" Three-Way System, 40-18,000 Hz **49<sup>95</sup>**

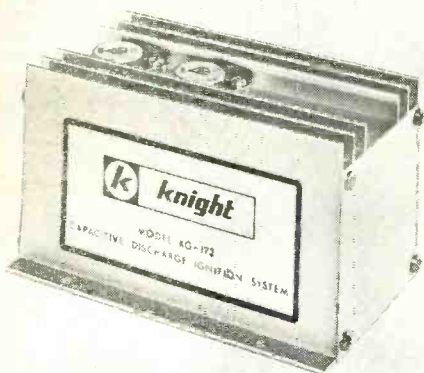

**Capacitive-Discharge Auto Ignition System.** Just like the '72 factory-option systems costing twice as much or more! Improves gas mileage, plug life. Assembles in one evening, installs in 10 minutes. No rewiring needed.

**29<sup>95</sup>**

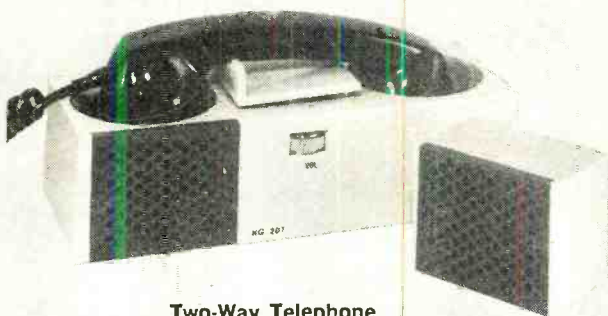

**Two-Way Telephone Amplifier.** For family or business calls. Frees hands for writing or working while you phone. Everyone in the room can talk 'n listen! Earphone included, aids hard-of-hearing. Separate speaker, earphone. Battery operated—no warm-up needed!

**12<sup>95</sup>**

# \$7.95 to \$49.95. Cheap! And just great! No wonder our kits are America's favorites!



**"3-D" Color Organ.** Adds ever-changing musical lights in vivid reds, blues, greens to any hi-fi system. Sliding color controls, walnut-grain vinyl cabinet. Guaranteed to brighten-up any party!

**29<sup>95</sup>**



**"Globe Patrol" Radio.** Tune in the world with 3 bands of fascinating shortwave—plus AM! Fun-'n-easy to assemble. Complete with speaker, earphone, manual. Battery-powered—use it anywhere!

**19<sup>95</sup>**



**Metal Locator.** Strike it rich! Discover buried treasure. Find lost jewelry, coins, relics—anything metallic. Locates pipes in walls or underground, too. Includes expandable shaft (to 36"), volume & pitch controls, stethoscope earphones. Happy hunting!

**19<sup>95</sup>**

**Adjustable Strobe Light.** "Freezes" the action for stop-motion effects. Create stunning displays at parties & get-togethers. 100's of hobby & mechanical uses, too!

**19<sup>95</sup>**



**ALLIED RADIO SHACK**

A TANDY CORPORATION COMPANY

Check the Yellow Pages for our store near you! Or we'll ship postpaid—add your state, local taxes; address below.

**Ask for FREE Catalog!**

**2725 W. 7th Street, Fort Worth, Texas 76107**



## THE 7-STEP "AD-STEN" TECHNIQUE

On these two pages are illustrated the seven steps required to translate an actual size etching guide on a printed page to a finished printed circuit board that can hardly be distinguished from a commercially made board. The procedure flows from left to right across both pages, first along the top and then along the bottom. The steps shown are of a general nature and apply to all board layouts. Special cases are discussed in detail on page 78. The quality of the work you do depends on the care you take in preparing the stencil. So, take your time and work in a well-lighted area.

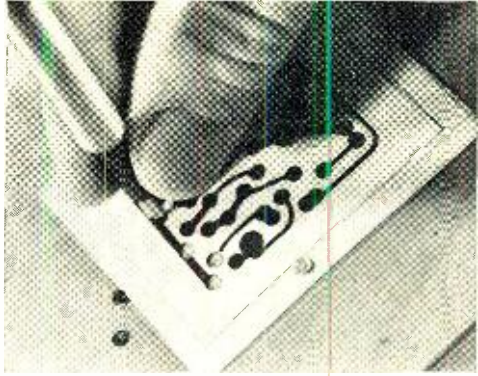

The first step in the Ad-Sten procedure is to make an actual size copy of the etching guide from the printed page. This is best done with the aid of tracing paper and a soft-lead pencil. Since the etching guide will be destroyed in the following steps, it is not advisable to use the original guide here. Once the tracing is made, use rubber cement to adhere it to an oversize piece of Con-Tact. Tape this to your soft-wood working surface and use your circle cutter or punch to cut out the solder pads. It is essential that you cut cleanly and completely through the stencil in this step.

The board blank to be used with the stencil should be no less than  $\frac{1}{4}$ " more in length and width than the finished printed circuit board is to be. Furthermore, it must be scoured to completely remove all traces of dirt, grease, and oil. Once the copper surface is cleaned, do not handle it with your bare hands. Now, starting at one corner, and taking care to prevent any folds or air bubbles, apply the stencil to the bare copper. Then, with your finger wrapped in a soft, clean cloth, firmly go over the entire stencil to securely fix the Con-Tact's adhesive backing to the raw copper surface.

Next, liberally apply the nail polish resist to all exposed copper surfaces, working it into every bend and corner until it completely covers the copper. There is no need to be artistic or neat since the stencil will assure a well-defined and accurate resist pattern. Allow the nail polish to set for at least 20 minutes. Then use a very sharp knife to score the resist around all edges of the stencil, and slowly peel off the stencil. Take care not to tear the stencil if you wish to make multiple copies of the same board. If you do not plan to reuse the stencil, discard it after removal.

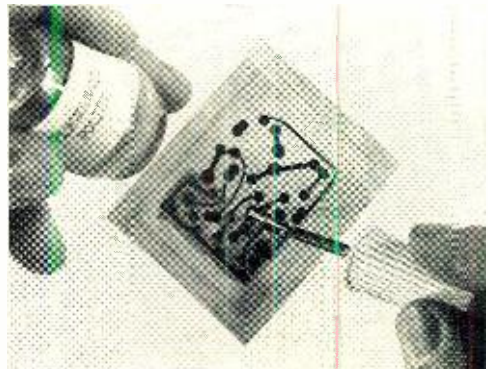
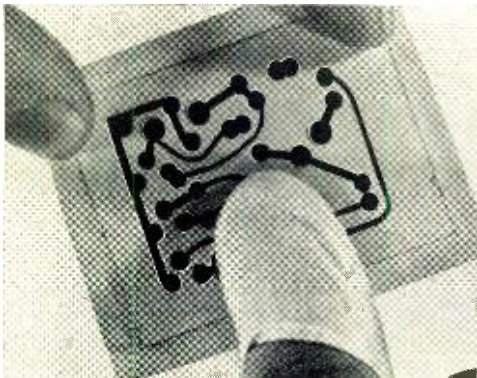



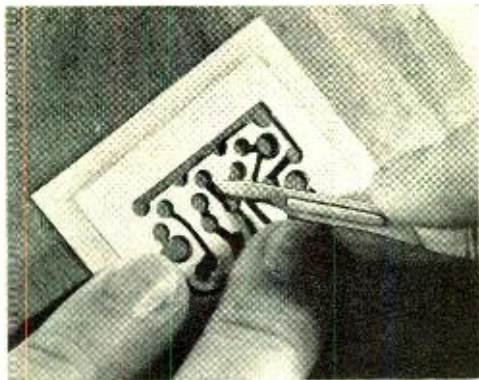

Once the solder pads are made, use a very sharp hobby knife to cut away the material to make the interconnections between the pads. Go slowly at first until you get the "feel" of the cutting process. Make very short cuts along the edges of the outlines, cutting no more than  $\frac{1}{8}$ " at a stroke. In this manner you will soon find that you can easily and accurately cut curves and intricate patterns with little effort. Do not give in to the temptation to rush; haste at this point will almost certainly result in a torn or ragged stencil that will defeat your purposes. All lines must be smooth.

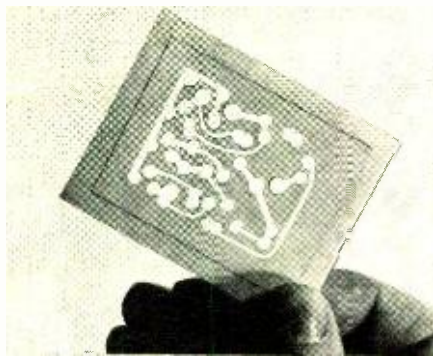

When all cutting is completed, check the stencil against the original etching guide on the printed page to make sure that you have not missed anything. Be especially observant of those short conductors between closely spaced solder pads. This is also a good time to clean up any fuzzy areas with the hobby knife. Now, remove the stencil from your working surface. On close inspection, the stencil should very closely resemble, if not exactly duplicate, the original etching guide. You can check this out by laying the stencil over the published etching guide and aligning the patterns.

Do not be alarmed if, after removing the stencil, you notice that a great deal of adhesive has been left behind. The adhesive must be removed before etching, but the job is simplified by the fact that lighter fluid makes a good solvent. After the nail polish has completely dried, moisten a tissue with the lighter fluid and clean away the adhesive. When working with lighter fluid, practice extreme caution. Work in a well-ventilated area where no open flame or burning ember exists. Lighter fluid is extremely flammable, and careless handling can quickly result in an uncontrollable fire.

After etching the board in the conventional manner, you can remove the nail-polish resist either by scouring it away with a medium-grade steel wool or with nail polish remover. Use the first method only if the nail polish has been laid on fairly thin. If the coat of polish is thick, it is better to use the latter method and follow up with a good cleaning in soap and water to remove the moisturizer left behind by the remover. Then, after drilling component lead holes and making any necessary cutouts, trim the board to size with a nibbling tool or other suitable cutter to prevent cracking.

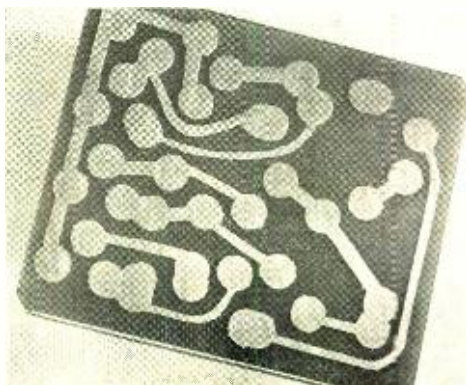

## **ADHESIVE STENCIL** (Continued from page 71)

Tact" (an adhesive-backed vinyl sheet commonly used for shelf covering; the pattern or color are unimportant), rubber cement, tracing paper and pencil, tape, soft-wood working surface, nail polish and nail polish remover, and one or more grades of steel wool. You do not have to buy the "best" or top-rated brands; just get the least expensive materials that will assure a good job.

In the category of tools, there are just two items. The first is a set of circle punches or cutters for making component-lead solder pads in the stencil. These can be homemade or store bought. The homemade punches, for which you will also need a small hammer to drive home, can be made from lengths of telescoping antenna elements of various diameters. The punches are cut to a length of about 5" then chucked into a drill and sharpened with a file. A set of circle cutters, ranging in diameter from 1/8" to 1/4", can be purchased from most art or drafting supply stores. The homemade punches, however, are less expensive, easier and faster to work with, and, if well sharpened, produce a cleaner hole in the stencil.

The second tool you need is a good hobby knife. When buying the knife, be

sure to stock up on extra cutting blades. The best blades to obtain are those that come to a very sharp point.

**Special Cases.** One special case that might arise is a PC board which contains one or more conductors completely surrounded by other continuous conductors. Obviously, in a case like this, your stencil will have to consist of two or more pieces. This is no problem, however. Unlike other stencils, the Ad-Sten's adhesive will keep all pieces in place regardless of their number. Care in positioning the pieces relative to each other is required. Additionally, in cases where shielding is unnecessary or unimportant, you can redesign the conductor pattern to eliminate surround conductors.

Another special case is that of a PC card designed to plug into an edge connector. The trick here is not to cut the stencil slots for the matching conductor stripes right to the edge of the stencil. Make the conductor cutouts that will mate with the connector contacts just long enough to extend slightly beyond the edge of the finished board. You can trim the conductors to the desired length at the same time you finalize the dimensions of the PC card. ♦

---

## **REPORT ON WARC** (Continued from page 70)

satellites. As a consequence, satellites may eventually supply voice and data circuits, not only to the officers of ships and planes for necessary communications while crossing the oceans, but for commercial telephone service to passengers.

One of the new services, for earth exploration, was added to many bands. It is now a secondary service in the band from 1525 to 1535 MHz, a primary service sharing with other users in the bands from 8025 to 8400 MHz and 21.2 to 22 GHz, as well as in two bands above 51 GHz, and lastly, on a footnote basis in three more UHF bands. In the future, these satellites will both receive transmissions of data from remote, unmanned sensing stations around the world, and take pictures of the earth, sending all their output to centrally located stations for processing and analysis. Among the satellites that have already been put to

these purposes are the Tiros and Nimbus.

The other new service was established to provide for relaying of signals between satellites. Called the Inter-Satellite Service, it was given several allocations between 54.25 and 190 GHz. These frequencies are difficult to use for space-to-earth links because of the high attenuation due to precipitation and to absorption phenomena in the atmosphere, but they are well suited to transmissions wholly outside the earth's atmosphere.

Although the Final Acts of the WARC will be in force internationally in 1973, they must be ratified by the President with the advice and consent of the Senate, before we will be bound by them. Assuming that this ratification takes place without a hitch, the FCC will then be able to revise its rules so that domestic users can take advantage of these new frequencies. ♦



Twentieth in a Monthly Series by David L. Heiserman

**Experience Helps—  
Even in the Classroom**

*I am an insurance salesman during the day and attend a two-year technical college in the evening. I get good grades in every subject except my major—electronics. I seem to be at a disadvantage because I don't have a job in electronics; the fellows who do get all the top grades. Any suggestions?*

- Get to work building some of the projects that appear in POPULAR ELECTRONICS—and that's not just a plug for the magazine. Buy some kits and put them together. Try fixing that broken radio, TV, or record player that you stored away somewhere. The idea is to get some of the experience that the other guys have.

Of course, you aren't alone with this problem. A good share of the students enrolled in evening technical colleges are already working in the field of their choice. They are in school (often at their employer's expense) to upgrade their knowledge. It isn't that they are smarter or already know everything about electronics theory; but by working every day with electronics problems, they have a chance to apply what they learned the night before. All of your knowledge and experience with electronics is coming from textbooks and a few artificial situa-

tions in the laboratory. These are no substitute for practical experience.

So, unless you are willing to give up your present job to take one in electronics, you'll have to create your own opportunities for applying what you are learning. Build some projects, assemble some kits, and try fixing some electronic devices. Obviously you are already very busy; but you can find the time if you think of it as a vital part of your learning process. When you suddenly find theories making more sense and see your grades inching up, you'll realize it was worth the extra trouble and expense.

**Education for Jobs in Electronics**

*Would you please publish a complete summary of the principal jobs in electronics and the amount of education required for each?*

- We have received a number of requests of this type; but, since a full treatment of the subject would most likely fill an entire issue of the magazine, we've had to tackle the job piecemeal. Since a picture can say a thousand (or more) words, we've come up with a chart that gives a fairly complete idea in a small space.

The chart, adapted from an IEEE bulletin

Adapted from an IEEE publication, this chart shows the education levels required for various positions in electronics. Note that the job categories overlap on education levels.

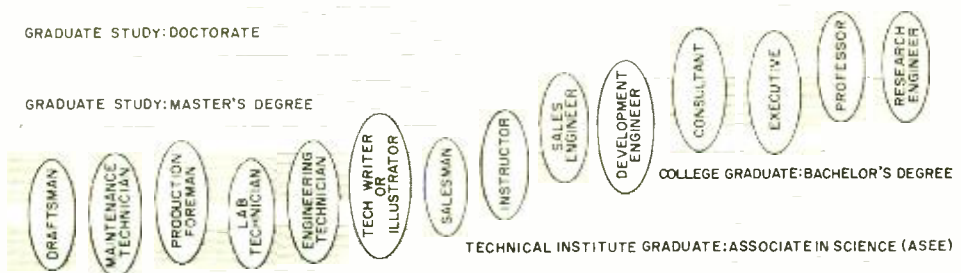



entitled "Your Challenge in Electrical Engineering," shows fourteen main job classifications for technicians and engineers working in electronics today. The horizontal bars indicate the amount of education required for each job. As an example of how to use the chart, a lab technician should have at least a little bit of technical school training and, preferably, a couple of years of college. By contrast, a consultant must have at least a bachelor's degree and, preferably, some graduate training at the PhD level.

## Electronics—Industrial & Communications

*I am a first-year student in a two-year technical college, majoring in electronics. Next year I have to decide whether to specialize in communications or industrial electronics. There are a number of industrial electronics firms in my home town, but I would like to know more about opportunities in communications electronics, and the difference between the two.*

- There are some big differences between industrial and communications electronics: in the equipment, in the design problems, and, when you get right down to it, in the basic philosophies. Even though a technician may have a lot of training and years of experience in industrial electronics, for instance, he will most likely have to take some home study courses in communications before he can qualify for a job in that field. Thus, electronics technicians have a tendency to go into either industrial or communications electronics and stay there. This means that your decision to be made next year is an important one.

The two charts show the relative numbers of electronics technicians now employed in industrial and communications electronics. They also show three main areas of specialization within the two major fields; and, furthermore, they show the relative numbers of technicians working at four different kinds of jobs within each specialty. By studying the charts, which represent a fairly complete and accurate occupational profile for electronics technicians in the U.S., you may be able to get a better idea of the kind of electronics work that interests you and determine the range of opportunities available.

In communications electronics, there are three main areas of specialization: consumer electronics, broadcasting, and military electronics. The first includes the whole world of electronic equipment, for the home: TV and radio receivers, audio equipment, and a host of other minor gadgets that use electronic parts and circuits. Broadcasting represents the other end of the communica-

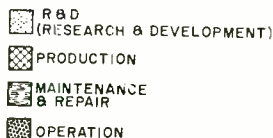
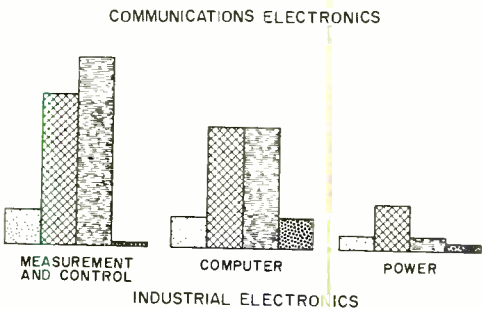
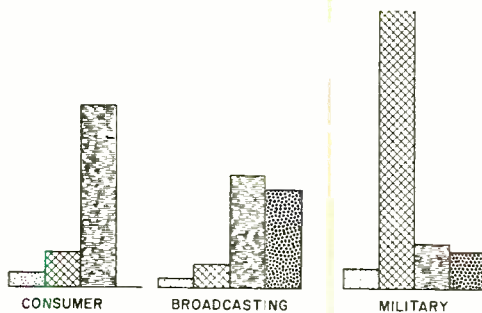

Relative numbers of technicians working in six different areas and four kinds of jobs.

tions link—TV and radio transmitting equipment and sound recording systems. Today, most technicians working in communications electronics have jobs somehow related to radio, radar, navigation or guidance systems for military use.

Specialization in industrial electronics includes: measurement and control instruments, computers, and industrial power equipment. Most of the work in measurement and control involves sensors, activators, and logic systems for industrial automation. Computer specialization deals with digital systems for business, industry and scientific research; while the relatively new industrial power specialization includes emergency standby power systems, inverters, and many different kinds of high-power control devices.

The four job divisions within each area of specialization give you some idea of the kind of work done. Research and development (R & D) jobs involve planning, designing, prototyping, and testing new electronic devices and circuits. The production jobs range from assembly line work to testing and quality control. Maintenance

(Continued on page 98)



# COMMUNICATIONS

By Leslie Solomon, Technical Editor

## GEOALERT WARNINGS IN ENGLISH

If you have a need to know any of the following: the solar terrestrial factors of the past 24 hours, the solar flux (amount of energy radiated from the sun at a frequency of 2800 MHz), the A-index (an approximate measure of the geomagnetic storm activity), the degree of solar activity, the conditions of the geomagnetic field, the coordinates and time of major solar and proton flares, the occurrence of flare-related proton events observed on satellites, polar cap absorption events, and other varied and sundry solar goings-on—then you are in luck. This data is now being compiled at the National Oceanic and Atmospheric Administration, Space Environment Services Center at Boulder, Colorado, and messages are being transmitted in English (rather than Morse code) during the 18th minute of each hour on WWV and during the 45th minute of each hour from WWVH (Hawaii). You also get a 24-hour forecast at the same time.

## REALLY HIGH AIR TRAFFIC CONTROL

*Atlantic airline crossings are not without their problems—there are no visual or electronic checkpoints and some planes spend as long as three hours in a communications blackout. As a result, present peak-hour traffic is 85 planes, each assigned a flight corridor 120 miles wide, with planes spaced 15 minutes apart.*

*The communications people at Bell Aerospace are working up a satellite relay air traffic control experiment for NASA. Known as PLACE (Position Location Aircraft Communications Equipment), the system gives pilots both voice and data communication with their control center, and provides data on the aircraft's altitude and location. It is hoped that air traffic lanes can be reduced to a width of 30 miles with 5-minute spacing. With this system, the plan is to have 250 aircraft crossing the Atlantic during peak hours.*

## LICENSES FOR THE BLIND

The FCC has announced rule changes to provide for issuance of "all classes of radiotelephone licenses" to blind persons. Examinations are to be given orally, and applicants must make appointments to take the tests at least two weeks in advance. The rules, the Commission said, "... require endorsement of licenses of blind operators to prohibit use in the public safety radio services and to require that any transmitter operated by a blind person be adapted by the station licensee for such operation." This practice, it said, "will be continued for sightless persons obtaining higher grade licenses."

## CATV GOES UP IN FREQUENCY

Most present microwave links transmitting CATV signals use amplitude modulation, are usually limited to one r-f channel per carrier, and can only transmit in four directions at once. Recently, the Laser Link Corp. patented and is making available a whole new approach. They have come up with a transmitter operating at 12.7 to 12.95 GHz enabling them to put up to 18 individual TV carriers on one transmitter. Having

20 watts r-f output (compared to the tenth of a watt of conventional microwave rigs), up to 21 antennas, each pointing in a different direction, can be used. The plan is to create small CATV packages, each serving a small area (though miles apart from each other) and each fed by a central transmitter complex. In this way, many miles of coax cable are eliminated and all the complexities of long-haul cable (with repeater amplifiers, etc.) are eliminated.

## TIME SIGNALS VIA SATELLITE

*For all of you WWV listeners, there is now a new service at your disposal. The National Bureau of Standards, in conjunction with NASA, is operating an experimental time and frequency service via satellite. At 135.625 MHz, these signals are available to North and South America, and major portions of the Atlantic and Pacific Oceans. A format of voice announcements, ticks, tones, and time code is included. This experimental service operates only between the hours of 1700 to 1715 and 2145 to 2200 GMT.*

## RAILROAD RADIOS

As of May 1971, there were almost 117,000 radio transmitter licenses in the railroad radio service. They included 114,869 transmitters, 803 speedmeters, and 1050 fixed stations (some microwave). The U.S. rail system has 23,947 route miles of microwave operational, with another 602 miles under construction. In Canada, there are 11,569 route miles of microwave with another 228 miles being built.

## COMMUNICATIONS AND OTHER SATELLITES

*Usually the only time we hear about those fantastic space satellites is when the TV networks are carrying a show that originates in remote areas of the world. Recently, a few relatively unknown facts about satellites have come to light: for instance, in 1971, 10 million trans-oceanic phone calls were made via satellite. Costing only \$5.40 for a 3-minute call from New York to London, the deal is pretty good. The satellites also offer more than 10,000 trans-oceanic circuits, about three times the number available with underwater cable service.*

*In the near future, air traffic controllers will be using satellites to guide planes from all over the world, thus greatly reducing the risk of mid-air collisions. Not only will we have a new and better navigational system, but pretty soon, there will be direct satellite broadcasting to remote areas of the world. (Experiments are being conducted now in Brazil and India.) On the weather side, one Nimbus satellite makes the equivalent of 10,000 daily balloon or rocket soundings.*

## INSTANT AIRPORT TOWERS

As you travel past almost any busy airport, you undoubtedly notice the large tower used by flight controllers to monitor the air traffic. Most of these towers took a long time to build and some are construction wonders.

Now, if you happen to have an old, abandoned air strip or a nice, smooth, grassy field, all you need is the latest RCA AN/TSW-7 portable air traffic tower to convert your landing strip into a high-capacity airfield. The portable tower is only 12 x 7 x 7 ft., but it holds three air traffic controllers, four vhf and five uhf radios, a radio direction finder, wind speed and direction sensors, signal light guns, air conditioning and telephones. Also included is a separate rechargeable battery supply and gas-driven generator. When combined with a portable radar, you are set up to inaugurate your own international airport.

Presently, only the military can get their hands on these units; and because they are easily transportable by aircraft, ship, rail, or truck, they are being deployed around the world wherever the boys in blue need an air strip in a hurry.



# THE PRODUCT GALLERY

Sixteenth in a Monthly Series by "The Reviewer"

PIONEER SX-2500

STEREO RECEIVER

(Hirsch-Houck Lab Report)

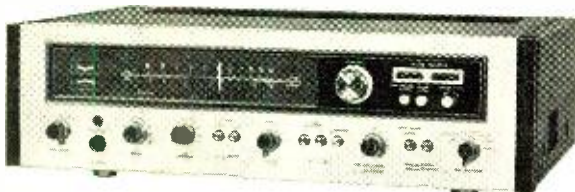

The SX-2500 is the most advanced stereo receiver made by Pioneer Electronic Corp. It features auto tuning through a motorized signal-seeking scan device on both the AM and FM broadcast bands and permits the user to control tuning and volume levels from a small remote unit as well as at the receiver itself.

The receiver has a "black-out" tuning dial which is nearly opaque when power is turned off. With power on, the dial scales and zero-center and relative signal strength meters are softly lit. Illuminated legends identify the signal source in use and also indicate when a stereo FM station is being received. The always visible clear plastic dial pointer lights up when an FM station is properly tuned in.

A tuning knob and the auto tuning controls duplicate those on the remote control unit. Small green arrows light up to show the direction in which the scan is moving, and another green light comes on when a station is finally tuned in.

The source selector has positions for AM, FM, MONO, FM AUTO (automatically switches to stereo when pilot carrier is received), PHONO, and two high-level AUX inputs. Two separate magnetic phono inputs are also included, but they are selected by operating another switch on the front panel. An easily installed optional plug-in transformer is available for use with low-output moving-coil cartridges.

Remote control of volume is a rarity in home receivers due to hum pickup and the loss of high frequencies resulting from the capacitances of other cables. Pioneer has solved these problems in the SX-2500 with a pair of cadmium-sulfide cells shunt-

ing the normal volume controls. Two cells and a single lamp control both channels simultaneously, with the remote volume control varying a direct current through the lamp to change the cells' resistances and, thus, the sound level out of the receiver. The signal path never leaves the receiver; so there is no chance of performance degradation when using the remote control.

The tone controls which operate on both channels simultaneously are eight-position switch arrangements that eliminate the ambiguity in determining the true "flat" response setting. In the center position, the tone controls are out of the system.

The rear apron of the SX-2500 contains all the input and output connectors required. The preamplifier outputs and power amplifier inputs are brought out separately, with a slide switch to bridge them for normal operation. An accessory equalizer, electronic crossover, etc., can be connected to these jacks without interrupting other normal functions.

The speaker outputs are brought out through polarized jacks, for which special plugs are provided, to make accidental short circuits and incorrect speaker phasing an unlikely possibility. The output stages are protected by internal electronic circuits and by fuses which are accessible on the rear apron. An ac power selector allows operating the receiver with line voltages ranging from 110 to 240 volts ac.

**Test Results.** The audio performance of the Pioneer SX-2500 met or exceeded all of its key specifications. At the point of output waveform clipping, we measured 77 watts/channel into 8 ohms with both channels

driven. Into 16 ohms, the output was 46 watts, and into 4 ohms, it was an impressive 115 watts/channel!

At 70 watts, the harmonic distortion was less than 0.1 percent from 75 to 3000 Hz and increased to the rated 0.5 percent at 32 Hz and 20 kHz. At half power or less, distortion was typically less than 0.05 percent and did not exceed 0.15 percent between 20 and 20,000 Hz.

The 1000-Hz distortion was 0.2 percent at 0.1 watt output and decreased to less than 0.03 percent for outputs between 15 and 40 watts. It reached 0.1 percent at the rated 72-watt output. IM distortion behaved in a similar manner, decreasing from 0.45 percent at 0.1 watt to 0.07 percent in the 15-40-watt range, reaching 0.5 percent at the rated output.

Hum and noise were inaudible and tested out to be 74-78 dB below 10 watts on the PHONO and AUX inputs. The high-gain phono preamplifiers required only 1.3 mV to deliver a 10-watt output, but they did not overload until 90 mV was applied. RIAA equalization was accurate to within 1 dB from 30 to 15,000 Hz. The high- and low-cut

filters had gradual 6 dB/octave slopes beginning at 3000 and 90 Hz, respectively.

The tone controls had excellent characteristics. Most of the settings provided substantial boost and cut at the frequency extremes without affecting the midrange. Only at the extreme settings was there any modification of the midrange response.

The usable IHF sensitivity of the FM tuner measured 2.1  $\mu$ V. Although this was not quite as good as the rated sensitivity, the limiting action was very effective, and signals of 4  $\mu$ V and greater were fully quieted. For all practical purposes, therefore, the SX-2500 is about as sensitive as any receiver on the market. FM distortion at 75,000 Hz deviation was 0.8 percent. In stereo, channel separation was about 30 dB from 100 to 4000 Hz, reducing to 21 dB at 30 Hz and 15 dB at 15,000 Hz.

The FM frequency response was flat within 1 dB from 30 to 15,000 Hz, but the almost total absence of 19 kHz and 38 kHz components in the outputs testified to the very effective filtering in the multiplex section. FM signal-to-noise ratio was 71 dB, image rejection was 83.5 dB, and AM re-

Graphs show harmonic distortion and THD (below left and right), and frequency response and crosstalk (bottom) for Pioneer's SX-2500 receiver.

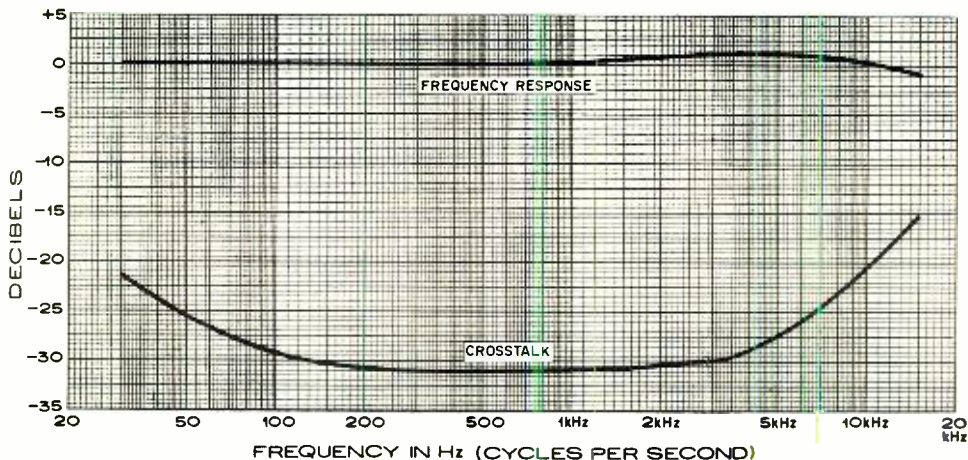
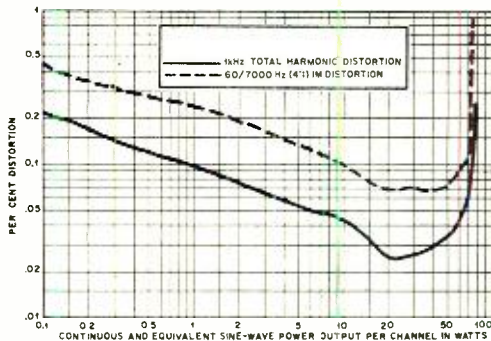
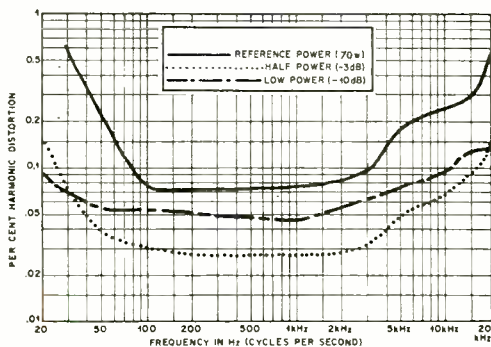

jection was 51 dB. The capture ratio tested out at 3.5 dB.

Selectivity, though not measured, was very good, and the receiver was able to separate weak stations adjacent to relatively strong local ones by virtue of the two crystal filters in the FM i-f strip. No measurements were made on the AM tuner, but it sounded as good as most we have heard in recent years.

**User Comments.** The Pioneer SX-2500 operated with impressive smoothness and freedom from bugs. Needless to say, it sounded first rate—it could hardly have done otherwise with its performance on the test bench.

We especially liked the auto scan system. Other automatically tuned receivers we have used were fully electronic and employed silicon voltage-variable capacitors for tuning. This approach, though attractive from a design viewpoint, makes no allowance for tuning dial calibration. Frequency calibration in the all-electronic systems is usually in the form of approximations on a small meter. Then, too, the voltage-variable capacitors are also subject to thermal drift unless afc is used.

In contrast, the SX-2500 employs a motor for tuning a conventional variable capacitor.

It can scan the entire band in about 9 seconds (assuming no signals are present), but normally stops and locks onto any signal encountered. Tuning is smooth and noiseless, and the audio is muted until a station is tuned in.

Since the dial pointer moves, it is easy to identify a station from its position. Also, the receiver setting remains the same when power is switched off and then reapplied. Finally, the auto tuning works on AM as well as on FM, and the muting between AM stations can be equally advantageous.

The remote volume control was also much appreciated. It seems to us that remote frequency control without a volume control facility is, at best, a half-way measure. This is, in a real sense, a remotely operated receiver as contrasted to a remotely tuned one. There is a noticeable time lag in the remote volume adjustment. This is due to the thermal time constant of the lamp in the CdS subassembly. But one soon becomes accustomed to it.

All in all, the SX-2500 impresses us as an exceptionally well-thought-out design, with performance to match. Its price of \$549.95 places it well up in the rarified class of "deluxe" receivers, but it is worth every cent. The price, incidentally, includes the cabinet and remote control unit.

Circle No. 86 on Reader Service Page 15 or 97

### LAFAYETTE FOUR-CHANNEL ADAPTER (Model QD-4) (Hirsch-Houck Lab Report)

Although four-track tapes and "Q-8" cartridges are the "purest" form of four-channel stereo program material, most people will continue to depend on discs and FM broadcasts for the bulk of their listening. Considerable effort has gone into developing compatible four-channel systems which can be broadcast over FM as well as recorded on discs. These can be heard as full two-channel programs on conventional stereo equipment, and as a complete mono program on single-channel systems.

Compatible four-channel systems employ matrixing in which the four channels are combined in various phase and amplitude relationships to form two stereo channels which are then recorded and broadcast in the usual manner. The playback system has a decoder which applies an inverse operation to recreate the original four-channel program.

Although four-channel matrixing systems differ somewhat in specific details, they generally do not have the distinct channel separation of discrete systems such as four-track tape or Q-8 cartridges. Their principal

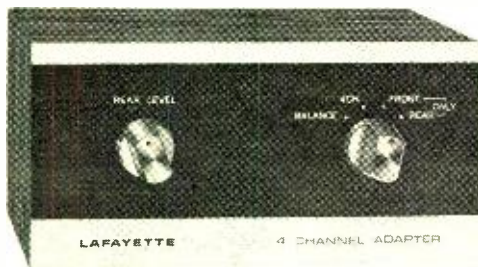

purpose is to restore a sense of ambience, bringing the liveliness of the concert hall into the listening room, and they do this very effectively. They can also provide a distinctly different program content between front and rear speakers in addition to the usual left-to-right stereo separation.

The Lafayette Radio Electronics Model QD-4 four-channel adapter is a passive matrix unit using the method proposed by David Hafler of Dynaco. (A similar unit, with different packaging, is also available from Dynaco.) The adapter is a small box measuring only 5½" x 4½" x 2⅞". It has a mode switch, for playing through all four speakers or through only the front or the rear speakers. A balance position is provided for initial setup using a monophonic signal. There is also a rear speaker level control.



All cables for connecting the adapter to the amplifier and four speakers are provided.

Unlike other matrix systems, the adapter does not require a second stereo amplifier for driving the rear speakers. It is connected between the standard two-channel stereo amplifier outputs and the four speakers. In effect, the stereo amplifier becomes part of the matrixing circuit. Although best results are obtained when four identical speakers are employed, it is possible to use different speakers in the rear from those in the front. All speakers, however, should be 8-ohm types, and the rear speakers should be at least as efficient as the front speakers.

The adapter does not affect the separation between the front-channel outputs. If a signal is present in only one input, it appears at full strength in the corresponding front speaker and is reduced by 3.7 dB in the rear speaker. In the diagonally opposite rear speaker, the level is down 8.7 dB, resulting in a rear side-to-side separation of 5 dB.

A mono signal is reduced by 11 dB in the rear speakers. On the other hand, an out-of-phase signal between the two inputs appears at full strength in all speakers but

subjectively seems to come from the rear because of the phase relationships between the various outputs.

Since there is little program material specifically encoded for the adapter system, it is chiefly used for recovering the ambience information which is present in most stereo programs in the form of out-of-phase signals. Practically all two-channel stereo program sources are dramatically enhanced when played through the adapter, often with some instruments heard from the rear and others from the front.

With material encoded for this system, the results are even more impressive, giving the listener a sense of being surrounded by the sound. A number of discs are now available that are encoded for the Electro-Voice matrix system; these can be played quite successfully through the adapter.

Selling for \$29.95, with all cables included, the Lafayette four-channel adapter is the least expensive and actually one of the best ways to introduce four-channel sound into your home. We used rear speakers ranging in price from \$20 to \$200, and although the more expensive ones naturally sounded better, even the least expensive speakers added a worthwhile effect.

Circle No. 87 on Reader Service Page 15 or 97

### UNILARM "KAB KIT" SPEAKER ENCLOSURE

Kits have become the mainstay of the economy-minded hi-fi enthusiast. It is conservative to state that there are presently in use in the United States tens of thousands of amplifiers, preamplifiers, tuners, receivers, and speaker systems that all had their beginnings as kits. Now along comes *Unilarm, Inc.*, with their "Kab Kit" at \$16.95 for the hi-fi buff who wants a really economy-priced speaker enclosure kit to which he can add the driver of his choosing.

**Description.** The Kab Kit's shell consists of 1/2-in. thick particle board with walnut-finished vinyl exterior. The grille cloth, already cut and mounted to the speaker board, is a dark brown open-weave burlap that pleasantly complements the dark walnut finish. The entire enclosure measures only 15" x 8 7/8" x 8", making it suitable for use as a true bookshelf speaker system.

In addition to the basic shell, the Kab Kit is supplied with all the hardware you will need to assemble the enclosure and mount the speaker and input terminal strip (the latter is included in the kit), sufficient fiberglass wool for acoustic lining, glue and glue blocks, and a 12-in. length of two-conductor zip cord. A welcome feature is the four galvanized steel straps included; these

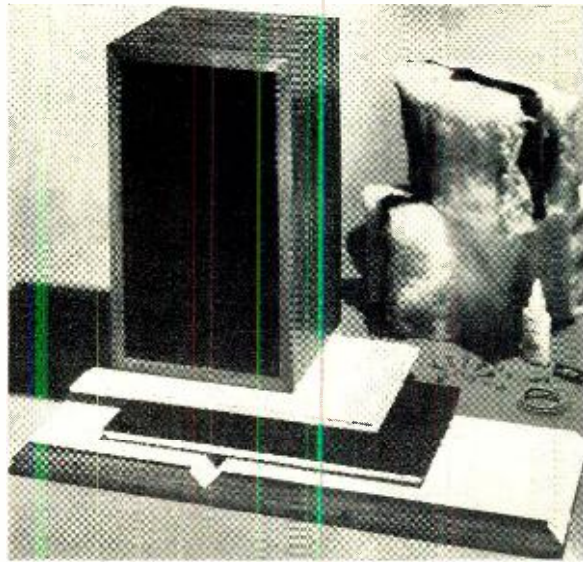

are used to adapt speakers that measure less than 8" in diameter or 6" x 9" oval.

Assembling the Kab Kit, with the aid of the clearly written and well-illustrated instructions provided, was a snap. In terms of actual labor, less than an hour is required. However, due to the fact that the glue takes approximately 24 hours to com-

pletely set, the Kab Kit is not immediately ready to use.

**Use Tests.** We tried out our Kab Kit with an inexpensive 8" round speaker and were impressed. Although there was no very deep bass response, there was no notable lack of response in the low bass region, either. In the mid- and upper-midrange, the sound was smooth. This was hardly surprising considering the fact that our test speaker was designed to respond smoothly be-

tween 800 and about 12,500 Hz. We did not try to install an oval speaker in the Kab Kit, nor did we think it advisable to use a smaller than 8-in. round speaker since in the latter case the integrity of the air seal would have been sacrificed.

From listening tests with our 8-in. speaker we concluded that the Kab Kit with a fairly decent driver is a "listenable" system. We recommend the Kab Kit and a good driver for first speaker, center channel, and rear channel (in 4-channel stereo) uses.

Circle No. 88 on Reader Service Page 15 or 97

## HEATHKIT FREQUENCY SCALER (Model IB-102)

After building the Heathkit IB-101 frequency counter (reviewed in April 1971), we found this excellent digital instrument to be a very handy piece of test gear on our bench. Unfortunately, it was limited to use with audio, low-frequency r-f, and digital equipment since the highest frequency it could reach was about 15 MHz. However, in its role, it has done yeoman service; so that, for the first time, we really knew exactly what frequencies we were working with.

Now the folks at Heath have come up with a physical and electrical complement to the IB-101 (or almost any other low-frequency digital counter you have). This is the IB102 frequency scaler and it is \$99.95 in kit form. Once we got the scaler wired up and hooked to the IB-101, we found that we could reach 175 MHz—permitting use with CB, business radio, and a couple of ham rigs with no strain.

The frequency scaler is essentially a switch-selectable divider with three push-buttons on the front panel to permit dividing the input frequency by 1, 10, or 100. This makes the IB-101 capable of resolving to 175 MHz with no trouble. Of course, you have to keep a mental "eye" on the decimal point.

With a 50-ohm input impedance in the divide-by-10 or -100 positions, the unit requires only about 30 mV at 100 MHz to permit triggering. Input impedance in the divide-by-1 position is the same as the frequency counter being used. A front panel sensitivity control and a built-in meter can be used to adjust the input signal for maximum sensitivity. You simply tune until the meter needle goes into the green area. The output signal is 1 volt across a 1-megohm, 20-pF load, which is typical of most frequency counters. Rise and fall times are 20 and 10 ns respectively—good enough to toggle any decent frequency counter.

Mechanically, the IB-102 is up to the



usual Heath standards. It is all solid-state, with eight IC's and seven transistors (including one FET), and it has an excellent built-in regulated power supply. It has the same dimensions as the IB-101 counter—8¼" wide, 9" deep, and 3¾" high. It weighs seven pounds and fits nicely on top of (or under) the counter.

Using a heavy-duty aluminum case, with a combination handle/tilt-stand, the IB-102 can take a lot of physical punishment. It has been transported many a mile in our service truck.

Putting it together is reasonably simple. Everything goes on one PC board using connector strips for mounting the IC's, and the job is easy when you follow the manual. Assembly took about seven hours and the scaler worked the first time it was turned on. Even if you goof, Heath's foresight in providing an excellent voltage checkout chart, along with a detailed troubleshooting table, will put you straight.

There was a time not too long ago when we would have balked at paying a couple of hundred dollars for a fancy digital frequency counter and another hundred for an add-on that would let us go to 175 MHz; but after building the two Heath units, noting the quality of components and mechanical detail in them, and then putting them to actual use, we found them well worth the price.

Circle No. 89 on Reader Service Page 15 or 97



One Hundred Eighty-sixth in a Monthly Series by Lou Garner

**T**AKE A DASH of imagination, add to it a good measure of generosity, an overflowing cup of thoughtfulness, a modest pocketbook, and a copy of the latest catalog issued by one of the broad line distributor-manufacturers, such as Allied Radio Shack (2615 West 7th St., Fort Worth, TX 76107) or Lafayette Radio Electronics (111 Jericho Turnpike, Syosset, L.I., NY 11791). Blend well and you should be able to select a suitable solid-state gift within your budget for virtually everyone on your shopping list except, perhaps, for infants and those rare individuals who "have everything." With luck, you might even be able to find something new for the latter—a novelty that they have not, as yet, acquired for themselves.

A sub-teen on your list? A small radio is always a good choice and, for something different, you might take a look at Allied Radio Shack's new Lunavox (Cat. No. 12-180), an AM receiver with a transparent back panel to reveal its "inner works." If your budget is limited, both Lafayette and Allied Radio Shack offer pocket-sized portables for under \$5.00.

Should your sub-teen be a budding scientist or engineer, then you might choose from any of a variety of Allied Radio Shack's Science Fair kits, from a Bell/Buzzer Code Key outfit at \$1.95 (Cat. No. 28-112) to a 100-in-1 Electronic Project Kit at \$21.95 (Cat. No. 28-220). A precocious sub-teen might enjoy Allied Radio Shack's Digi-Count IC Binary Counter Kit (Cat. No. 28-136); at only \$7.95, this interesting kit features a pair of DTL IC's, lamp readouts, and a solar cell sensor.

Cassette tape recorders are "in" with the teen age set. Here, again, the choice is wide. If your finances are limited, you might choose Lafayette's Model RK-65 (Cat. No. 99 R 15828L) at \$19.95. On the other hand, if your pocketbook is bulging with bread, you could get that "someone special" a really deluxe unit such as Allied Radio Shack's Model CTR-9 (Cat. No. 14-867) at \$74.50.

A combination FM-AM Radio/Recorder is an excellent gift for adults as well as teens—Allied Radio Shack's Model CTR-18 (Cat. No. 14-876) at \$69.95 is a good choice, as is Lafayette's Model RK-166 (Cat. No. 27 R 01159L) at \$59.95. Both instruments have an AM/FM receiver with slide rule dial, a recording level/battery condition meter, an integral cassette recorder, and ac as well as battery operation. For an extra gift, blank tape cassettes make excellent stocking stuffers.

The "lady of the house," be she wife or mom, probably would appreciate a step-saving intercom system. Lafayette offers a two-station wired system (Cat. No. 99 R 46245) for only \$8.95, or you might prefer a wireless system such as Allied Radio Shack's "Plug'N Talk" two-station intercom (Cat. No. 43-210) at \$29.95. If your home already has an intercom, then your lady might like a "Hands-Free" Telephone Amplifier, such as Allied Radio Shack's No. 43-230, offered at \$15.95.

There are, literally, dozens of solid-state gifts suitable for the "old man"—dad, pop, grandpa, husband, uncle, business associate, or boy friend.

A sports enthusiast might enjoy an up-to-date AM/FM receiver, such as Allied Radio Shack's new "IC-72" (Cat. No. 12-5051), a compact \$29.95 portable with a FET front end, AFC, vernier tuning, a whip antenna, and an advanced IC design.

A multiband receiver is a fine choice if the donor can afford a higher price tag. Lafayette offers a 4-band AM/FM/SW/Marine portable receiver (Cat. No. 17 R 02323L) for \$34.95, or you might go "all out" with Allied Radio Shack's *Astronaut 8* (Cat. No. 12-751), an 8-band set covering the AM, FM, police, fire, aircraft, marine and SW bands at \$99.95. Both sets are designed for ac as well as built-in battery operation.

CB "walkie-talkies" are great for the outdoorsman—the hunter, hiker, camper, or fisherman. The choice is wide, limited only by the size of one's bank account and the



measure of his generosity. Lafayette offers their limited range Model HA-70D (Cat. No. 99 R 32138L) at only \$5.99 each, but you can pay as much as \$119.95 for Allied Radio Shack's TRC-101 (Cat. No. 21-137), a 5-watt, 23-channel instrument with a dual-conversion receiver and a battery/r-f power meter.

Another good choice for the outdoorsman is a metal detector such as Allied Radio Shack's Knight-Kit KG-366 (Cat. No. 29-3382). Who knows? Perhaps the recipient will find another gift himself—buried treasure or lost jewelry.

Automotive gifts are fine and the variety large, from a simple burglar alarm to a moderately expensive capacitive discharge ignition system, such as Allied Radio Shack's Knight-Kit KG-397 (Cat. No. 29-3202) at \$44.95. Or you could give an auto tape player, a reverb amplifier system, such as Lafayette's Cat. No. 99 R 85193 at \$9.95, or a piece of automotive test equipment.

Perhaps you'd prefer to select a gift to complement your recipient's hobby or interests.

Does he like shop work? Then consider Allied Radio Shack's Motor Speed Control Kit (Cat. No. 28-170), a solid-state control capable of handling 117-volt ac loads of up to 6 amperes.

Photography? Lafayette offers a transistorized strobe flash, Cat. No. 99 R 71128, for only \$9.95.

Is she a musician? Take a look at Allied Radio Shack's new Electronic Metronome, Knight-Kit KG-386 (Cat. No. 29-3392), a solid state instrument which can deliver either an audible beat note or flashing tempo light at any rate from 40 to 120 beats per minute.

Is he interested in electronics? Test

equipment, power supplies, new construction kits, accessories and even an assortment of new components are all good choices.

Whatever your selections, remember that your thoughtfulness in selecting the most appropriate gift for each person on your list is far more important than the gift's monetary value.

All prices mentioned are the distributor's published catalog prices. Shipping, local sales taxes, and accessories, if required, are extra. Individual item prices at local retail outlets may be slightly higher.

**Useful Circuits.** Fascinated by Busse's electronic combination lock (see "Build A Cryptolock" by James G. Busse, POPULAR ELECTRONICS, January 1971), reader Walt Isengard (Box 511, Grove City College, Grove City, PA 16127), an electrical engineering student, studied the circuit in some detail. Walt finally concluded that the lock would operate if the proper three combination switches were depressed simultaneously. If a potential thief had read the magazine article, then, he would be able to operate the lock in less than ten minutes, assuming that he tried all possible combinations and allowed for the maximum penalty delay after each wrong combination. With only average luck, a thief would be able to "break" the combination in half that time.

Undeterred, Walt decided to modify Busse's original circuit to reduce its vulnerability, while still retaining its basic operational characteristics, minimal switch requirements, and overall simplicity of design. His circuit is shown in Fig. 1.

Fig. 1. Based on a circuit originally appearing in January, 1971, this variation carries the electronic lock one step further and makes it even more burglar-proof.

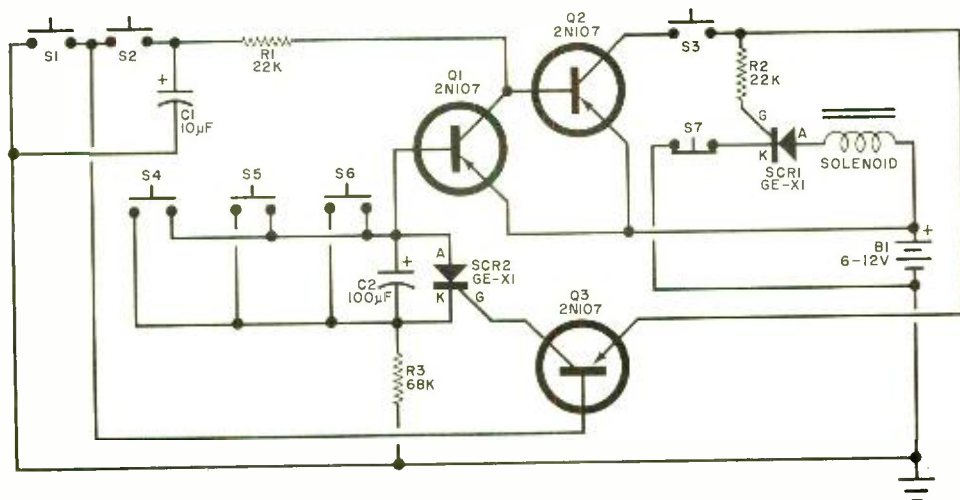

# Let Bell & Howell Schools help you get ready for a rewarding Color TV Service Business of Your Own

This new Program brings you a series of Bell & Howell Schools materials that are fully integrated with the Heathkit components you will receive a step at a time. The Color TV kit offers an ultra-rectangular 25" diagonal picture tube with 315-sq. inch screen. Lets you view more of the transmitted image. 25,000 volts. 45 transistors, 55 diodes, 4 advanced IC's, 3-stage, solid-state IF. Solid-state VHF/UHF tuners. Automatic fine tuning and many other quality features.



**BUILD, KEEP, USE ALL FOUR OF THESE PRECISION QUALITY KITS**

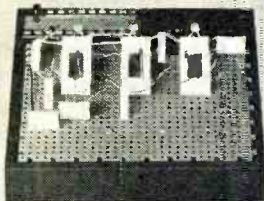

**INCLUDES—**  
Design Console with built-in power supply, test light and speaker. Plus patented plug-in Modular Connectors.



**INCLUDES—**  
Portable 5-inch, wide-band oscilloscope calibrated for peak-to-peak voltage and time measurements.



**INCLUDES—**  
Transistorized Meter combines most desired features of vacuum-tube voltmeter and quality multimeter. Measures very small current values.

**FREE! MAIL CARD TODAY FOR ALL THE FACTS**  
No Postage Needed

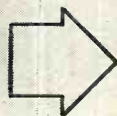

# YOU'LL BE READY FOR COLOR TV . . . B&W AND MOST HOME ENTERTAINMENT ELECTRONICS DEVICES

This exciting new program offers you the *first* 315-sq. inch Solid-State Color TV available for at-home training.

As you follow the simple, step-by-step assembly procedures, you become thoroughly familiar with the most advanced solid-state TV circuitry. And as you build this kit you'll prepare yourself for a profitable Color TV service business of your own—either full or part time.

## Why Color TV pays better.

Today, Color TV is the big seller. As Color Television goes completely solid-state, the man who has mastered this type of circuitry will be in demand. Obviously, this is where the money is going to be made.

This new Bell & Howell Schools program will also give you an in-depth knowledge of the basics as well as TV circuit theory and analysis. You'll get the theory and practical experience you need to handle radios, hi-fis, stereos, and tape recorders.

You will also receive three precision quality instrument kits which you assemble and keep. These are highly sensitive professional instruments which you'll use constantly.

**EXCLUSIVE ELECTRO-LAB®  
IS YOURS TO KEEP, USE**

This unique at-home laboratory comes to you in 16 shipments and includes a remarkably instructive *design console*. You can rapidly "breadboard" a great variety of circuits without soldering. The *Oscilloscope* offers 3-way jacks to handle test leads, wires, plugs. Images on screen are bright, sharp. Your *Transistorized Meter* is fully portable, features a sensitive, 4-inch, jewel-bearing d'Arsonval meter movement. It registers the slightest power surge or lag on a large, easily read dial.

## CONSIDER THESE ADVANTAGES:

Bell & Howell Schools' Electro-Lab-at-Home Plan gives you the most thorough background possible in solid-state Color TV. Everything

Note: TV picture is simulated.

comes to you by mail and you go at your own speed. You'll be prepared not only for a service business of your own but for many positions in the Electronics and Television industries. All without missing a paycheck!

When you have completed your program our *Lifetime National Employment Service* will help you locate in an area that interests you. This service is available at any time—now or in the future.

**Approved for G.I. Benefits**

If you've had six months continuous active duty, you're probably eligible for Veterans' Benefits. If you're a Vet, check the appropriate space in the card at left for full details. Our programs are approved for Veterans' Benefits.

## Student Loans now available

If you are a non-veteran and need financial assistance, you may qualify for Student Loans, which are also available.

**Special Help Sessions.** These are scheduled regularly (Saturdays) at seven Bell & Howell Schools and in many other cities. Here you can get expert guidance by top instructors to help you over the rough spots.

Bell & Howell Schools offer you even more. Once you have finished your program at home, you may decide you want more advanced preparation. In this case, you may transfer to any one of our seven schools which are located all across the country.

Mail the postage-free card today for all the facts. There is no cost or obligation of any kind.



# BELL & HOWELL SCHOOLS

4141 Belmont, Chicago, Illinois 60641

324



**FREE! MAIL CARD TODAY FOR ALL THE FACTS**  
No Postage Needed



He has eliminated the electromagnetic relays used in the original design, adding an additional transistor and SCR. As in Busse's circuit, S1, S2 and S3 are the "combination" switches, S4, S5, and S6 the "penalty" switches, and S7, located within the protected area, the "reset" switch. Its basic operation also is similar to the original—S1 and S2 are depressed together momentarily, with S3 depressed within 2 seconds after S1 and S2 are released. Unlike the original, the lock will not operate if all three combination switches are depressed simultaneously. Switches S4, S5 and S6 will deactivate the lock circuit for about 20 seconds if depressed accidentally.

Altogether, then, Walt's basic circuit offers even a knowledgeable thief 60 possible combinations, with an automatic delay introduced each time the incorrect combination is chosen. With a few additional penalty switches and one or two extra combination switches added in series with S1 or S2, the number of possible combinations would run into the hundreds, and the average time to "break" into many hours, even assuming that the potential thief knew the principle of lock operation.

Walt has used standard components in his version of the lock circuit. Switches S1 through S6 are normally open, momentary contact spst pushbutton switches, while S7 is normally closed. All resistors are half-watt units, and C1 and C2 are 15-volt electrolytic capacitors. A 6- to 12-volt battery is used for B1, depending on the solenoid lock's requirements.

With neither layout nor lead dress critical, the electronic lock circuit may be assembled on a suitable etched board, on a small chassis using point-to-point wiring, or on perf board. For maximum protection, the operational circuit should be located at some distance from the key switch panel and the solenoid latch. According to Walt, there is only one critical component in the circuit, SCR1's series gate resistor, R2. He suggests that its value may have to be adjusted for optimum performance, depending on the supply voltage used and on the characteristics of both Q2 and SCR1.

Another interesting and potentially useful circuit is illustrated in Fig. 2. Abstracted from Application Note AN-527, *Theory, Characteristics and Applications of the Programmable Unijunction Transistor*, published by Motorola Semiconductor Products, Inc. (Box 20912, Phoenix, AZ 85036), the design features a junction FET (Q1) and a programmable unijunction transistor (or PUT, Q2) and can provide time delays of up to 20 minutes. It can be used, typically, in process control equipment, delayed alarm systems, photographic timers and similar applications.

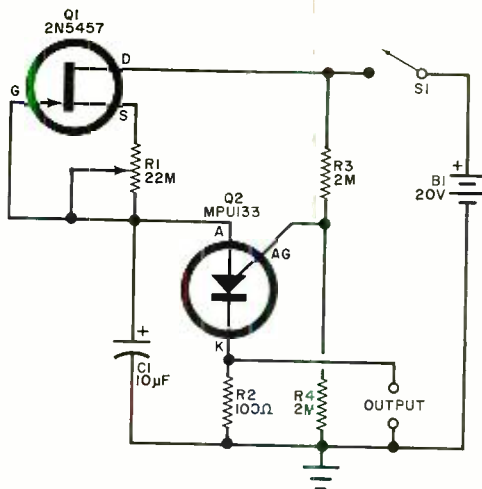

Fig. 2. Using a PUT and a FET, you can make a timer delivering an output pulse of a few seconds to 20 minutes.

In operation, C1 is charged slowly by B1 through Q1's high source-drain impedance and R1. During this period, Q2 acts essentially as an open circuit. When C1's charge reaches Q2's peak point fringing voltage, as "programmed" by gate voltage-divider R3-R4, the PUT switches to a conducting state, discharging C1 through R2 and developing an output pulse. The circuit then repeats the charging cycle.

Standard commercial components are specified for the circuit. For optimum performance, C1 must be a low-leakage device, such as a Mylar film capacitor.

Neither parts placement nor the wiring arrangement are critical and the long duration timer circuit may be assembled using any preferred construction method for experimental tests.

With the introduction of Model 556 IC by Signetics, a number of new circuit ideas spring to mind. Among the many uses for the voltage controlled oscillator IC is the test generator shown in Fig. 3. Driven by a conventional 9-volt battery, the circuit can be used in a number of testing applications since it delivers square waves, triangle waves, and both positive- and negative-going spikes. The fact that it has separate outputs for square waves (5V p-p), triangular waves (1.5V p-p) and both positive and negative spikes (1.5V p-p) increases its versatility. Although it is not designed to operate into low-impedance loads, a transistor buffer can be used to provide the proper interface.

**A Unique Coupler.** If you own a solid-state tape recorder, there's a better than 50-50 chance you also own an induction pick-up for use when recording telephone

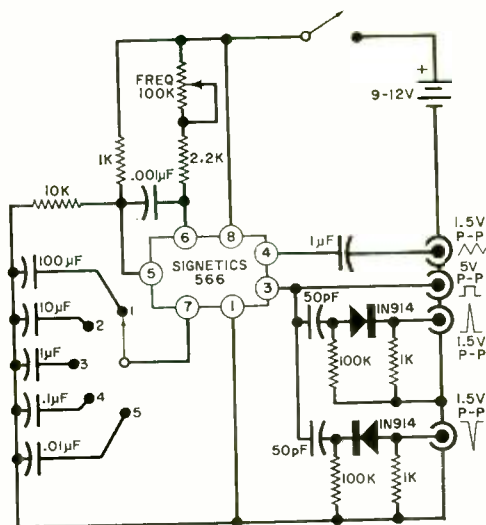

1. 1 PER 30 SEC, TO 1 PER SEC
2. .2-10Hz
3. 10-50Hz
4. 100-1000Hz
5. 250Hz-9kHz

Fig. 3. A commercial-grade variable-frequency waveform generator can be made using this latest low-cost IC.

conversations. Available from a number of sources in a variety of styles, most of these inexpensive units work rather well when used in accordance with their published instructions.

But what do you do when you want to play a recording over the telephone? Hold the telephone's microphone against the recorder's loudspeaker? Turn up the volume and hope? These are the usual techniques

This unique telephone coupler can be used as both an induction pickup and transmission coupler. It is an induction

and, as any who has tried them can testify, they result in transmission of rather poor quality.

A Midwestern firm, Trinetics, Inc. (807 West 3rd St., Mishawaka, IN 46544) has developed a solution for this problem—a simple device which can be used both as an induction pickup and a transmission coupler. Identified, appropriately, as a Telephone Transmit/Receive Coupler, Model PC-48, the unit is essentially an induction coil mounted in a pliable ring which can be slipped over a telephone's earpiece.

In operation, the PC-48 is connected to the tape recorder's earphone or speaker output jack for the transmission of recorded material, and to the microphone or input jack for use as a pickup. The PC-48 is available directly from the manufacturer on a satisfaction guaranteed basis for \$9.95 each, but is also stocked by some local outlets.

**Device News.** New from Britain are solid-state panel indicator lamps with integral amplifiers which may be switched directly by logic circuits at currents as low as 15 µA at 3 V. Manufactured by I.C.S. Components Ltd. (78 Clarke Rd., Northampton NN1 4QE, England), the gallium phosphide light emitting diodes require only 10 mA at 5 V. Identified as the series MPAG Logics-lamps, the units measure only 1" long by 3/16" diameter, and can be mounted in a 1/4" panel hole. The firm's U. S. representative is the Hamos Co. (7th floor, 242 West 30th St., New York, NY 10001).

RCA's Solid State Division (Route 202, Somerville, NJ 08876) has announced a variety of new devices, including a new microwave transistor, seventeen additional IC's in



## IMPEDAVERTER™ IMP I

• IMPROVES MICROPHONE PERFORMANCE •



1. Converts high to low impedance.
2. Use cables to 500 feet with minimum loss of response, and minimum hum.
3. Switchable gain/loss and phase.
4. Quick disconnect, stand clamps provided.

**\$22.95**  
\$1.25 postage



## RUSSOUND | FMP

DEPT. P  
P.O. BOX 204  
STRATHAM, N.H. 03865



## MULTI-MIXER™ TMS-1

HANDLES UP TO THREE RECORDERS



1. Record or play back any or all simultaneously.
2. Eliminates jury-rig multiple connections.
3. Establishes a main control system for multiple usage, and monitoring
4. MTG BKTS provided for permanent installation.

INTRODUCTION  
PRICE  
**\$19.95**  
\$1.25 postage

WRITE DEPT. P  
FOR NEW PRODUCT RELEASES

CIRCLE NO. 16 ON READER SERVICE PAGE

DELUXE

## MAGAZINE CASES

*Designed Exclusively for*

### POPULAR ELECTRONICS

● The ideal way to save your valuable copies, keep them well protected and make it easy for you to refer to any issue at any time. This bold new design is both decorative and attractive enough to enhance the decor of any room. Each case holds a full year's copies.

Constructed of reinforced fiberboard, these tough and durable cases are covered in a rich textured, leather-like fabric. The gold embossed back adds to its elegance and makes each case a welcome addition to your bookshelf, end table, desk—or for that matter, anywhere in your home or office.

In addition to Popular Electronics, cases are available for any of your favorite magazines. They're only \$3.95 each, 3 for \$11.00, 6 for \$21.00, in any combination of titles ordered. Add 50¢ per order for postage and handling. Outside U.S.A. add \$1.00 per case ordered.

Ziff-Davis Pub. Co., Dept. 23, 1 Park Ave., N.Y., N.Y. 10016

Enclosed is \$ \_\_\_\_\_ Please send Magazine Cases for the titles indicated below @ \$3.95 each, 3 for \$11.00, 6 for \$21.00. Add 50¢ per order for postage and handling. Outside U.S.A. add \$1.00 per case ordered.

TITLE  
**POPULAR ELECTRONICS**

PE-12-71  
QUANTITY

Check One:  All Black  Maroon Back  Black Sides

Print Name \_\_\_\_\_

Address \_\_\_\_\_

City \_\_\_\_\_

State \_\_\_\_\_

Zip \_\_\_\_\_

PAYMENT MUST ACCOMPANY ORDER

its popular COS/MOS line, a number of pnp and npn power transistors, and a group of developmental liquid crystal readouts.

The new RCA microwave transistor, designated type TA7995, features overlay multiple-emitter-site construction and integral emitter-ballasting resistors. Assembled in a special stripline package, the device can furnish up to 7 dB gain while delivering 10 watts at 2 GHz.

Three pnp and five npn power transistors are among RCA's latest offerings. Intended as complements for the npn 2N3585 series, the pnp devices, designated types 2N6211, 2N6212, and 2N6213, may be used in converters, power-switching circuits, inverters, and similar switching and amplifier applications, as well as in complementary-symmetry designs. Breakdown voltage ratings range from 225 to 350 volts, depending on type, and all three devices are assembled in JEDEC TO-66 packages.

Identified as types 410, 411, 413, 423 and 431, RCA's new npn transistors have power dissipation ratings of 125 watts, and are intended for use in inverters, deflection circuits, switching regulators, high-voltage bridge amplifiers, ignition circuits, and other high-voltage applications. The 410 is rated at 200 volts, the other types at 325 volts. All five transistors have collector-current ratings of 10 amperes peak and 7 amperes continuous, and are in TO-3 packages.

Six devices make up RCA's new line of developmental liquid crystal numeric display readouts. Designed to interface with COS/MOS IC's, the readouts feature exceptionally low power requirements and very high readability, even under extreme ambient light conditions, such as direct sunlight or floodlight. Both reflective (TA8034) and transmissive (TA3032) types are included in the line. The reflective cells utilize a mirrored area on the inner surface of the back plates to enhance contrast, and are used in front lighting display applications. The transmissive cells, on the other hand, have both conductive surfaces transparent and are used in applications where back or edge-lighted readouts are desirable.

Types TA8040 through TA8043 are 4-digit, 7-segment readouts developed to indicate performance capability in equipment designs. The TA8041 and TA8043 are transmissive types, the TA8040 and TA8042 reflective types. Types TA8040 and TA8041 have decimal points before each digit for use in numeric readout applications, while types TA8042 and TA8043 have colons between the 2nd and 3rd digits to fit them for clock and timing circuits.

Available only on special order, the developmental liquid crystal displays are priced at \$25.00 each for the single-digit units; \$75.00 each for the 4-digit types. ♦

POPULAR ELECTRONICS



# Popular Electronics

## READER SERVICE PAGE

### free information service:

Here's an easy and convenient way for you to get additional information about products advertised or mentioned editorially (if it has a "Reader Service Number") in this issue. Just follow the directions below... and the material will be sent to you promptly and free of charge.

**1.** On coupon below, circle the number(s) that corresponds to the key number(s) at the bottom or next to the advertisement or editorial mention that is of interest to you. (Key numbers for advertised products also appear in the Advertisers' Index.) Print or type your name and address on the lines indicated.

**2.** Cut out the coupon and mail it to: POPULAR ELECTRONICS, P.O. Box 8391, Philadelphia, PA 19101.

**note:** If you want to write to the editors of POPULAR ELECTRONICS about an article on any subject that does not have a key number, write to POPULAR ELECTRONICS, One Park Avenue, New York, N.Y. 10016. Inquiries concerning circulation and subscriptions should be sent to POPULAR ELECTRONICS, P.O. Box 1096, Flushing, N.Y. 11352.

12 71-2

Void after January 31, 1972

## Popular Electronics

P.O. BOX 8391  
PHILADELPHIA, PA. 19101

1 2 3 4 5 6 7 8 9 10 11 12 13 14 15 16 17 18 19 20  
21 22 23 24 25 26 27 28 29 30 31 32 33 34 35 36 37 38 39 40  
41 42 43 44 45 46 47 48 49 50 51 52 53 54 55 56 57 58 59 60  
61 62 63 64 65 66 67 68 69 70 71 72 73 74 75 76 77 78 79 80  
81 82 83 84 85 86 87 88 89 90 91 92 93 94 95 96 97 98 99 100

NAME (Print clearly) \_\_\_\_\_

ADDRESS \_\_\_\_\_

CITY \_\_\_\_\_ STATE \_\_\_\_\_ ZIP CODE \_\_\_\_\_

# free TRIGGER

MONEY-SAVING 1972 CATALOG  
FOR THE MAN IN ELECTRONICS



**SEE**

## TRIGGER'S GREAT SELECTIONS

Send for this reliable buying guide to carefully selected:  
**Amateur Gear • Stereo Hi-Fi • Electronic Kits • CB Radio • Tape Recording • Electronic Parts • Antennas • Tubes • Transistors • Tools • Books • Test Gear**

Count on TRIGGER for the best in electronics. Write for Free 1972 Catalog today

SEND FOR IT TODAY!

TRIGGER Electronics, Dept. PE-12  
7361 North Ave., River Forest, Ill. 60305

Send FREE 1972 TRIGGER Catalog

Name \_\_\_\_\_  
PLEASE PRINT

Address \_\_\_\_\_

City \_\_\_\_\_ State \_\_\_\_\_ Zip \_\_\_\_\_

**FREE Catalog**

CIRCLE NO. 22 ON READER SERVICE PAGE

## OPPORTUNITY AWARENESS

(Continued from page 80)

and repair and operation are concerned with actual equipment.

Although it is generally quite difficult to switch from industrial to communications electronics, most technicians find it rather easy (and often desirable) to change specializations within their field. And changing job titles within a given specialization is even easier and more desirable—the latter because it generally means more responsibility and more pay.

These charts show only the popularity of different kinds of jobs in electronics—not the amount of training required or the going salaries. With the notable exception of military communications electronics, jobs in communications generally pay less than those in industrial electronics. And, because of the special skills required, R&D jobs generally pay more than the other three.

Keep in mind that the charts represent the national picture—job opportunities for electronics technicians vary widely from one part of the country to another. ♦

## SPACE-AGE RADAR

(Continued from page 47)

## AT LAST! PROFESSIONAL HOME PROTECTION EVERYONE CAN INSTALL AND AFFORD.

Model FC-100  
**\$34.95**  
WIRED

- Start your custom Burglar/Hold-up/Fire Alarm System with the FC-100. Add on Sensors, Alarms and Accessories to suit your own needs.
- "Do-it-Yourself" Installers Handbook included. No technical knowledge needed—No soldering.
- 100% Professional in Design, Reliability, Performance.



**'Fail Safe'-SYSTEM BY EICO**

A New Concept in "Do-it-Yourself" Home Protection

### FREE 32 PAGE EICO CATALOG

For latest catalog on EICO Test Instruments, Stereo, EICOCRAFT Projects, Environmental Lighting, Burglar/Fire Alarm Systems, and name of nearest EICO Distributor, check Reader Service Card or send 25¢ for First Class mail service.

EICO, 283 Malta Street, Brooklyn, N.Y. 11207



CIRCLE NO. 7 ON READER SERVICE PAGE

technique which is said to yield power densities 100 times those of conventional radars. Texas Instruments Inc. has developed a microradar so small that a complete transmitter, receiver, and antenna can fit into the palm of a hand. And other companies—Sperry Rand, Raytheon, RCA, Hughes Aircraft—are working feverishly to develop compact, reliable, and low-cost phased array radars.

No matter what the cost of the phased array radar, it does a job that no other type of radar can approach. For satellite tracking, defense surveillance, and insuring air traffic safety, the phased array radar is a must. Bear in mind, however, that no plans are on the drawing board to substitute the phased array where a conventional radar will suffice. The conventional radars will be with us for a long time to come, but they will eventually have to give way to the Space Age Radar—the phased array—which has already proved itself. ♦

## LIBRARY

(Continued from page 16)

stand very high among the top ten. This new updated and expanded edition of the only 2-in-1 substitution guide available lists the best substitutes for all popular tubes and transistors, even the foreign ones. The guide lists 99 percent of the tubes and transistors which normally need replacing in home-entertainment equipment. Moreover, only readily available and comparably priced substitutes are listed. This new guide is one of the most practical everyday aids for the serviceman ever published.

Published by Tab Books, Blue Ridge Summit, PA 17214. 256 pages. \$4.95 soft vinyl cover; \$2.95 soft paper cover.

## ADVANCED ELECTRONIC INSTRUMENTS AND THEIR USE

by Sol D. Premsky

Sophisticated general-purpose laboratory test instruments in current use in industry and research are the subject of this book. The book covers each major instrument group, discussing basic electronic principles and illustrating practical applications. Representative instruments are discussed to enable the reader to become familiar with the capabilities and limitations. In addition to practical information on specific instruments, standardization and calibration procedures are emphasized.

Published by Hayden Book Co., Inc., 116 West 14 St., New York, NY 10011. 208 pages. \$9.50 hard cover, \$6.95 soft cover.

## ELECTRONIC DESIGNER'S HANDBOOK Second Edition

by T. K. Hemingway

Circuit design in a depth required for practical engineering is discussed in this timely book. The new edition presents changes in and additions to the text. More important is the fact that more than 70 diagrams that appeared in the first edition have been updated to reflect the state of the art. Part I deals with the transistor as a switch and small-signal amplifier. Several circuits that are rather unusual appear in Part II, accompanied by descriptions on how different circuits can be modified and synthesized to serve in a number of practical applications. Topics in Part III include bootstrapping techniques and prototype testing.

Published by Tab Books, Blue Ridge Summit, PA 17214. Hard cover. 294 pages. \$9.95.

DECEMBER 1971



**KITS FEATURED IN**  
**POPULAR ELECTRONICS**  
**AND FROM OTHER SOURCES**

Psychedelic Strobe Light	\$17.50
"UT" Stereo Amplifier	\$80.00
FET Preamp	\$44.50
SCA Adaptor	\$14.50
Ultrasonic Alarm	\$37.25
Regulated Power Supply	\$39.50

Prices plus postage and insurance

Also:  
Psychedelia I Color Organ, Sonolite, Nixie Readouts, Frequency Counters, Sports Timers, Ultrasonic Alarm, etc.

**WRITE FOR FREE CATALOG**  
**Southwest Technical Products**  
219 (PE) W. Rhapsody  
San Antonio, Texas 78216

CIRCLE NO. 17 ON READER SERVICE PAGE

## ABOUT YOUR SUBSCRIPTION

Your subscription to POPULAR ELECTRONICS is maintained on one of the world's most modern, efficient computer systems, and if you're like 99% of our subscribers, you'll never have any reason to complain about your subscription service.

We have found that when complaints do arise, the majority of them occur because people have written their names or addresses differently at different times. For example, if your subscription were listed under "William Jones, Cedar Lane, Middletown, Arizona," and you were to renew it as "Bill Jones, Cedar Lane, Middletown, Arizona," our computer would think that two separate subscriptions were involved, and it would start sending you two copies of POPULAR ELECTRONICS each month. Other examples of combinations of names that would confuse the computer would include: John Henry Smith and Henry Smith; and Mrs. Joseph Jones and Mary Jones. Minor differences in addresses can also lead to difficulties. For example, to the computer, 100 Second St. is not the same as 100 2nd St.

So, please, when you write us about your subscription, be sure to enclose the mailing label from the cover of the magazine—or else copy your name and address exactly as they appear on the mailing label. This will greatly reduce any chance of error, and we will be able to service your request much more quickly.



# INDEX

## TO VOLUME 35

---

### JULY-DEC. 1971

#### COMMUNICATIONS

CB and the Coast Guard (Humphrey).....	42 Sept.
Communications	
70 Aug., 69 Sept., 71 Oct., 79 Nov., 81 Dec.	
Crystal Calibrator for the Ham and SWL (Blair)	59 Aug.
Distortionless Audio Compressor (Caringella)...	25 Dec.
Receiver Noise Figure and Sensitivity,	
Understanding (West).....	33 Nov.
Single Sideband for CB Is Now (Friedman).....	25 Aug.
VHF Frequency Converter (Greenlee).....	52 Dec.
World Administrative Radio Conference (Gould)	69 Dec.

#### CONSTRUCTION

Add Triggered Sweep to your Scope (Garland & Melen).....	52 July
Adhesive Stencil Technique for PC Boards (Anderson) .....	71 Dec.
Amplifier Module, Hi-Fi (Trauffer).....	59 Dec.
Combination Lock, Electronic (Nunley).....	51 Aug.
Combination Lock, SCR (Fahnstack).....	53 Nov.
Continental Speaker System, The (Weems).....	41 Aug.
Crystal Calibrator for the Ham and SWL (Blair)	59 Aug.
Distortionless Audio Compressor (Caringella)...	25 Dec.
Drummer Boy, The (Simonton).....	25 July
Electronic Desk Calculator You Can Build, An (Roberts) .....	27 Nov.
Four-Channel Decoder, Build a (Meyerle).....	52 July
Intruder Fire Alarm, Professional (Meyerle)....	61 Dec.
Low-Voltage Remote Power Control (Johnson)...	69 July
Mini-Pyramidal UHF TV Antenna, Build a (Monser) .....	40 Dec.
Plastic Tiger Audio Power Amplifier, The (Meyer).....	27 Oct.
Solid-State Bird, The (Simonton).....	58 Sept.
Solid-State Laser for the Experimenter (Mims)...	46 Oct.
Sports Amplifier, All American (Cooper).....	29 Sept.
Stereo Decoder, Unique (Reich).....	53 Oct.
Underground Survey Meter, An (Pallatz).....	63 Aug.
Underwater Fish Finder (Green).....	48 Aug.
VHF Frequency Converter (Greenlee).....	52 Dec.
Voltage Monitor (Hammes).....	63 Nov.

#### DEPARTMENTS

Direct & Current	
Global Broadcasting.....	7 July
Truck Hijacking and Electronics.....	7 Aug.
The Electronics Parts Distributor.....	7 Sept.
A Typical Technician.....	7 Oct.
Electronics and Noise Pollution.....	7 Nov.
A Bigger and Better Popular Electronics.....	7 Dec.
Out of Tune	
Princes Puzzle (May '71).....	94 July
Drummer Boy, The (July '71).....	100 Oct.
Vox Gain Rider (June '71).....	100 Oct.
Solid State (Garner)	
79 July, 87 Aug., 87 Sept., 86 Oct., 82 Nov., 88 Dec.	
Tips & Techniques.....	90 Nov.

#### DIGITAL ELECTRONICS

Add Triggered Sweep to your Scope (Garland & Melen).....	52 July
Digital Japan (Mann).....	50 Aug.
Electronic Desk Calculator You Can Build, An (Roberts).....	27 Nov.

#### EDUCATION

Electronics Bookshelf (Part 1) (Drumeller).....	44 Nov.
Electronics Bookshelf (Part 2) (Drumeller).....	48 Dec.
Opportunity Awareness (Heiserman)	
69 July, 77 Aug., 76 Sept., 78 Oct., 72 Nov., 79 Dec.	

#### ELECTRONIC MUSIC

Drummer Boy, The (Simonton).....	25 July
----------------------------------	---------

#### FEATURES

4-Channel Stereo is Here (Burawa).....	47 July
Are Modern Military Radars Infallible? (Judd)...	45 Sept.
Can an Amplifier Tube have Zero Transconductance? (Bailey).....	42 Nov.
CB and the Coast Guard (Humphrey).....	42 Sept.
Continental Speaker System, The (Weems)....	41 Aug.
Destiny and Geomagnetism (Garrison).....	41 July
Digital Japan (Mann).....	50 Aug.
Don't Bypass the Hobby Shop (Tooker).....	50 Oct.
Electronic Desk Calculator You Can Build, An (Roberts).....	27 Nov.
Electronics Bookshelf (Part 1) (Drumeller).....	44 Nov.
Electronics Bookshelf (Part 2) (Drumeller).....	48 Dec.
Electronics Fights Noise Pollution (Silver).....	61 Oct.
Giant Billboard Antennas for Space-Age Radars (Lacy) .....	44 Dec.
Operational Amplifier (Part 1), The (Tenny)....	30 Aug.
Operational Amplifier (Part 2), The (Tenny)....	61 Sept.
Plastic Tiger Audio Power Amplifier, The (Meyer).....	27 Oct.
Portable Radar Becomes a Reality (Humphrey)...	67 July
Quiz, True-False Logic (Bell & Kish).....	102 Nov.
Receiver Noise Figure and Sensitivity, Understanding (West).....	33 Nov.
Single Sideband for CB is Now (Friedman).....	25 Aug.
Solid-State Laser for the Experimenter (Mims)...	46 Oct.
Solid-State Laser, Understanding the (Mims)....	35 Oct.
Sports Amplifier, All American (Cooper).....	29 Sept.
Substitute for Meters in Bridge Circuits, A (Friedman).....	62 Nov.
Testing Power Supplies (Demas).....	67 Sept.
Understand the System (Buchsbaum).....	52 Sept.
What Makes the Transistor Tick? (Wood).....	49 Nov.
What's Happened to Educational TV? (Belt)....	31 Dec.
World Administrative Radio Conference (Gould)	69 Dec.
<b>HOME HI-FI/STEREO</b>	
4-Channel Stereo is Here (Burawa).....	47 July
Amplifier Module, Hi-Fi (Trauffer).....	59 Dec.
Continental Speaker System, The (Weems)....	41 Aug.
Distortionless Audio Compressor (Caringella)...	25 Dec.
Four-Channel Decoder, Build a (Meyerle).....	52 July
Plastic Tiger Audio Power Amplifier, The (Meyer).....	27 Oct.
Stereo Decoder, Unique (Reich).....	53 Oct.
Stereo Scent (Holt)	
What is High Fidelity?.....	71 July
Ten Hi-Fi Fallacies.....	70 Aug.
All About Adjustments.....	84 Sept.
Setting Up a Tape Recorder.....	67 Oct.
Answering Reader Mail.....	70 Nov.
Selecting a Speaker System.....	66 Dec.

### NEW DEVELOPMENTS IN ELECTRONICS

- Operational Amplifier (Part 1), The (Tenny)... 30 Aug.
- Operational Amplifier (Part 2), The (Tenny)... 61 Sept.
- Portable Radar Becomes a Reality (Humphrey)... 67 July
- Single Sideband for CB is Now (Friedman) ... 25 Aug.
- Solid-State Laser for the Experimenter (Mims)... 46 Oct.
- Solid-State Laser, Understanding the (Mims)... 35 Oct.

### PRODUCT GALLERY

- Avanti AV-527 CB Antenna..... 80 Oct.
- B & K Model 1460 Oscilloscope..... 82 July
- Calgon Heat Sink Paste..... 78 Sept.
- Chapman Ratchet-Offset Kit..... 82 Aug.
- Garrard Zero 100 Turntable..... 82 Aug.
- Harman-Kardon CAD-5 Cassette Deck..... 80 Oct.
- Heathkit GR-169 Color TV..... 82 July
- Heathkit HM-102 RF Wattmeter..... 78 Sept.
- Heathkit IB-102 Frequency Scaler..... 83 Dec.
- Heathkit IM-105 VOM..... 80 Oct.
- Heathkit IR-18M Chart Recorder..... 65 Nov.
- J & J Electronics Transistor Tester..... 80 Oct.
- Lafayette Guardian-6000 6-band Receiver..... 80 Oct.
- Lafayette QD-4 Four-Channel Adapter..... 83 Dec.
- Lafayette Telsat 924 CB Transceiver..... 65 Nov.
- Lendell Quick-Pick Tools..... 80 Oct.
- Magnecord 2001 Tape Deck..... 78 Sept.
- Mid-Line Frequency Standard..... 82 Aug.
- Pioneer SX-2500 Stereo Receiver..... 83 Dec.
- Simpson Electronics Model A Transceiver..... 82 Aug.
- Stanton Dynaphase I Headphones..... 82 July
- Teac A-24 Stereo Cassette Deck..... 65 Nov.
- Unilarm Kab Kit Speaker Enclosure..... 83 Dec.

### SCIENCE FAIR

- Drummer Boy, The (Simonton)..... 25 July
- Solid-State Bird, The (Simonton)..... 58 Sept.
- Solid-State Laser for the Experimenter (Mims)... 46 Oct.
- Underwater Fish Finder (Green)..... 48 Aug.

### TEST EQUIPMENT

- Add Triggered Sweep to your Scope  
(Garland & Melen)..... 52 July
- Crystal Calibrator for the Ham and SWL (Blair) 59 Aug.
- Substitute for Meters in Bridge Circuits,  
A (Friedman)..... 62 Nov.
- Testing Power Supplies (Demas)..... 67 Sept.
- Voltage Monitor (Hammes)..... 63 Nov.

### TUTORIAL

- Are Modern Military Radars Infallible? (Judd)... 45 Sept.
- Can an Amplifier Tube have Zero Trans-  
conductance? (Bailey)..... 42 Nov.
- Destiny and Geomagnetism (Garrison)..... 41 July
- Don't Bypass the Hobby Shop (Tooker)..... 50 Oct.
- Electronics Bookshelf, (Part 1), The (Drumeller)... 44 Nov.
- Electronics Fights Noise Pollution (Silver)..... 61 Oct.
- Operational Amplifier (Part 1), The (Tenny)... 30 Aug.
- Operational Amplifier (Part 2), The (Tenny)... 61 Sept.
- Receiver Noise Figure and Sensitivity,  
Understanding (West)..... 33 Nov.
- Solid-State Laser, Understanding the (Mims)... 35 Oct.
- Understand the System (Buchsbaum)..... 52 Sept.
- What Makes the Transistor Tick? (Wood)..... 49 Nov.

### USEFUL HOUSEHOLD PROJECTS

- Combination Lock, Electronic (Nunley)..... 51 Aug.
- Combination Lock, SCR (Fahnstock)..... 53 Nov.
- Low-Voltage Remote Power Control (Johnson)... 69 July
- Sports Amplifier, All American (Cooper)..... 29 Sept.
- Underground Survey Meter, An (Pallatz)..... 63 Aug.
- Voltage Monitor (Hammes)..... 63 Nov.



FREE

COLOR  
**CATALOG**

from

ECHO

Full of bargains on communications,  
electronics, and other special equipment.

### ECHO COMMUNICATIONS, INC.

1038 S. Washington Ave., Cedarburg, Wis. 53012  
PHONE 414 377-5050

Please send me Echo's free catalog today.

Name .....

Address .....

City ..... State .....

Zip .....

**CIRCLE NO. 8 ON READER SERVICE PAGE**

## POPULAR ELECTRONICS SUBSCRIBER SERVICE

Please include an address label when writing about your subscription to help us serve you promptly.

Write to: P.O. Box 1096, Flushing, N.Y. 11352

**CHANGE OF ADDRESS:** Please let us know you are moving at least six to eight weeks in advance. Affix magazine address label in space below and print new address in space provided. If you have a question about your subscription, attach address label to your letter.

If you have no label handy, print OLD address here.

name \_\_\_\_\_ please print

address \_\_\_\_\_

city \_\_\_\_\_

state \_\_\_\_\_ zip-code \_\_\_\_\_

**TO SUBSCRIBE:** Check these boxes:  New  Renewal  
 5 years \$21  3 years \$15  1 year \$6  
**SPECIFY:**  Payment enclosed—You get 1 extra issue per year as a BONUS!  Bill me later.

0574

name \_\_\_\_\_ please print

address \_\_\_\_\_

city \_\_\_\_\_ state \_\_\_\_\_ zip \_\_\_\_\_

Add'l postage: \$1 per year outside U.S., its possessions & Canada.

# Popular Electronics Market Place

**NON-DISPLAY CLASSIFIED: COMMERCIAL RATE:** For firms or individuals offering commercial products or services, \$1.25 per word (including name and address). Minimum order \$12.50. Payment must accompany copy except when ads are placed by accredited advertising agencies. Frequency discount: 5% for 6 months; 10% for 12 months paid in advance. **READER RATE:** For individuals with a personal item to buy or sell, 80¢ per word (including name and address.) No Minimum! Payment must accompany copy. **DISPLAY CLASSIFIED:** 1" by 1 column (2 5/8" wide), \$185.00. 2" by 1 column, \$370.00. 3" by 1 column, \$555.00. Advertiser to supply cuts. For frequency rates, please inquire.

**GENERAL INFORMATION:** First word in all ads set in bold caps at no extra charge. All copy subject to publisher's approval. All advertisers using Post Office Boxes in their addresses **MUST** supply publisher with permanent address and telephone number before ad can be run. Closing Date: 1st of the 2nd month preceding cover date (for example, March issue closes January 1st). Send order and remittance to Hal Cymes, **POPULAR ELECTRONICS**, One Park Avenue, New York, New York 10016.

## FOR SALE

**FREE!** bargain catalog. Fiber optics, LED's, transistors, diodes, rectifiers, SCR's, triacs, parts. Poly Paks, Box 942, Lynnfield, Mass. 01940.

**GOVERNMENT** Surplus Receivers, Transmitters, Snooperscopes, Radios, Parts, Picture Catalog 25¢. Meshna, Nahant, Mass. 01908.

**ROCKETS:** Ideal for miniature transmitter tests. New illustrated catalog, 25¢. Single and multistage kits, cones, engines, launchers, trackers, rocket aerial cameras, technical information. Fast service. Estes Industries, Dept. 18-K, Penrose, Colorado 81240.

**LOWEST** Prices Electronic Parts. Confidential Catalog Free. **KNAPP**, 3174 8TH Ave. S.W., Largo, Fla. 33540.

**WE SELL CONSTRUCTION PLANS. TELEPHONE:** Answering Machine, Speakerphone, Carphone, Phonevision, Legal Connector, Auto Dialer, Central Dial System. **TELEVISION:** \$35.00 Color Converter, Tape Recorder, 3DTV. \$25.00 Camera. **HOBBYIST:** Electron Microscope, 96 Hour Tape Music System, Ultrasonic Dishwasher, Radar-Oven, Electronic Tranquilizer. Plans \$4.95 each. **COURSES:** Telephone Engineering \$39.50. Detective Electronics \$22.50, Anti-Detective Electronics \$27.50, **NEW SUPER HOBBY CATALOG AIRMAILED** \$1.00. Don Britton Enterprises, 6200 Wilshire Blvd., Los Angeles, Calif. 90048.

**MECHANICAL, ELECTRONIC** devices catalog 10¢. Greatest Values—Lowest Prices. Fertik's, 5249 "D", Philadelphia, Pa. 19120.

**SENCORE, B&K** Test Equipment Unbelievable Prices. Free Catalog and Price Sheet. Fordham Radio, 265 East 149th Street, Bronx, N.Y. 10451.

**ELECTRONIC** Ignition. Various Types. Information 10¢. Anderson Engineering, Epsom, N.H. 03239.

**BUILD YOUR OWN SPACE-AGE TV CAMERA**

ONLY KNOWN SOLID-STATE CAMERA KIT! Ideal for experiments, home, industry, security, etc. • High quality • Features to meet the needs of lab & field practice • Fully Guaranteed • Converts to any TV set without modification • Simply plug construction manual • Model #1114, serial D complete with video \$169.95 postpaid anywhere in USA • **CamView** (best version) \$119.95 postpaid

PHONE or WRITE FOR CATALOG  
DIAL 400-664-3371

Many other kits, parts and plans available including starter kits, focus-adj. cells, video cam, video camera, video scanner kit, etc.

1301 BROADWAY **ATV Research** DAKOTA CITY, NEBR. 68731

**ELECTRONIC COMPONENTS**—Distributor prices, Free catalog. Box 2581, El Cajon, California 92021.

**FREE** Kit Catalog: Shortproof Powersupply \$39.50. Ultrasonic Alarm \$37.25. SWTPC, Box B32040, San Antonio, Tex. 78216.

**AMATEUR SCIENTISTS, Electronics** Hobbyists, Experimenters, Students . . . Construction Plans—all complete, including drawings, schematics, parts lists with prices and sources . . . Radar—Build your own ultrasonic doppler radar. Detect motion of people, automobiles, even falling rain drops. Transistorized, uses 9 volt transistor battery—\$4.50 . . . Long-Range "Sound Telescope"—This amazing device can enable you to hear conversations, birds and animals, other sounds hundreds of feet away. Very directional. Transistorized. Uses 9V battery—\$3.50 . . . Robot Man—Moves hands and arms—\$3.50 . . . Or send 25¢ coin (no stamps) for complete catalog. Other items include Psychedelic strobes, light shows, lasers . . . 46 different projects. Technical Writers Group, Box 5994, State College Station, Raleigh, N.C. 27607.

**DEALERS WANTED!** Citizens Band, AM, SSB, Two-way Radios & Accessories. USA and Export models. We ship around the world. Send letterhead to: Baggy's Radio P.O. Box 778, 6391 Westminster Ave., Westminster, Ca. 92683. 714-894-3301.

**CITIZENS BAND**—Shortwave Listener-Ham equipment from Amrad Supply, Inc. Free Flyer. 1025 Harrison St., Oakland, Calif. 94607.

**PSYCHEDELIC** Strobe Kit: Complete with 110w/sec. tube, reflector, chassis and cabinet \$17.50 plus postage and insurance. 2 lbs. (Extra tubes \$3.50) SWTPC, Box E32040, San Antonio, Texas 78216.

**ANTIGRAVITY**, experiment and theory; Rushed—\$2.00. U.S. Inquiries. Intertech 7A3, Box 5373, Station-F, Ottawa, Canada.

**LEARN** the facts of electronics and your privacy. Send for the Tron-X Manual. P.O. Box 38155, Hollywood, CA 90038. \$5.95.

**JAPAN HONG KONG DIRECTORY.** World products information. \$1.00 today. Sekai Shogyo Annai, Hillyard, Washington 99207.

**INTEGRATED CIRCUITS**—Factory Prices, Catalog 10¢. Silling, Box 6257, Seattle. Washington 98188.

**JETCO ELECTRONIC INDUSTRIES, INC.**  
Dept. PEC, 3933 Barranca Dr., El Paso, Texas 79935.

**FIND COINS-GOLD-RELICS-TREASURE metal locators by JETCO!**

- Lightweight
- Easy to Use
- Comes Complete
- Made in USA
- 5 yr. Guarantee
- Immediate Delivery!
- Write for FREE Catalog.

priced from **\$39.95**



**WEBBER LAB'S** Police & Fire Converters. Catalog 25¢. 72 Cottage Street, Lynn, Mass. 01905.

**INVESTIGATORS**, latest Electronics Aids. Free Literature. Clifton, 11500-L NW 7th Ave., Miami, Florida 33168.

**ELECTRONIC PARTS**, semiconductors, kits. **FREE FLYER.** Large catalog \$1.00 deposit. **BIGELOW ELECTRONICS**, Bluffton, Ohio 45817.

**RADIO**—T.V. Tubes—36¢ each. Send for free catalog. Cornell, 4213 University, San Diego, Calif. 92105.

**NEW SEMICONDUCTOR LIGHT EMITTING DIODES**—bright red lights replace light bulbs. Typical life 100 years. Operate at 1.65 volts, 50 milliamps. Order 2 for \$2.98 **NOW.** Data sheet and instructions included. Monsanto Company, Hobby Section, 10131 Bubb Road, Cupertino, California 95014.

**CONVERT** any television to sensitive, big-screen oscilloscope. Only minor changes required. No electronic experience necessary. Illustrated plans, \$2.00. Reico-A33, Box 10563, Houston, Texas 77018.



## DEALERS WANTED!

CITIZENS BAND, AM, SSB, Two-way Radios & Accessories. USA and export models. We ship around the world. Send letterhead to:

### BAGGY'S RADIO

P.O. Box 778, 6391 Westminster Ave.,  
Westminster, California 92683  
714-894-3301

**FREE Kit Catalog:** Color Organs \$11.00, Psychedelic Strobes \$17.50, Professional quality—lowest prices. SWTPC, Box F32040, San Antonio, Texas 78216.

**EUROPEAN and Japanese bargains catalogs.** \$1 each. Dee, P.O. Box 9308, North Hollywood, Calif. 91609.

**BURGLAR ALARM SYSTEMS.** We manufacture intruder-fire detection systems, radar and perimeter types. Accessories available. Free Literature. Inquiries for dealership and wholesale prices must be on letterhead. U.S. and Canada only. Microtech Associates, Inc., Box 10147, St. Petersburg, Florida 33733.

## "LISTEN IN" TO POLICE-FIRE RADIO CALLS IN YOUR CAR!

WORKS with ANY CAR—Portable or HOME RADIO! Just PLUGS in—No wiring—3 minute hookup! Switch instantly from regular to ALL POLICE-FIRE-EMERGENCY-COMMERCIAL-TAXICAB-STATE-CITY-GOV'T 2-way Radio calls in YOUR AREA. DUAL-HI-LOW BANDS—OVER a MILLION Radio Cars stations. USE Everywhere—anytime—always works!

Send \$0.99 for cash, (Ck., M.O.) and pay post. man \$7.99 plus COD post. or send \$9.99 for ppd Del in USA. COMPLETE, ready to use with Instructions. One Year service Warranty—10 DAY MONEY BACK TRIAL (if ret'd). AMAZING OFFER good only by mail!

**WESTERN RADIO Dept. BPE-12 KEARNEY, NEBR. 68847**



**CONSTRUCTION PLANS:** Laser . . . \$2.00. Investigation Aids—2-FM Microphone Transmitters . . . \$1.00. FM Telephone Transmitter . . . \$2.00. Sound Telescope . . . \$2.00. Space Monitor—Missile Tracker . . . \$2.00. Free equipment and kit catalog. Howard, 20174 Ward, Detroit, Michigan 48235.

**POLICE-FIRE Radio dispatcher callbooks!** Exclusive official listings: Callsigns, frequencies! Nationwide. Send 8¢ stamp for catalog. Communications, Box 56-PE, Commack, N.Y.

OVER 1,000 new electronic parts, list \$240.00, yours \$19.95. 28 Music pages \$1.25. All postpaid. Hobbytronics, 921 East 19th, San Angelo, Texas 76901.

**FREE catalog, parts, circuit boards for POPULAR ELECTRONICS projects.** PAIA ELECTRONICS, Box C14359, Oklahoma City, Ok. 73114.

**DIAGRAMS—Radios \$1.50, Television \$3.00.** Give make and model. Diagram Service, Box 1151PE, Manchester, Conn. 06042.

**SCREWDRIVER** with built-in light eases the strain. 4 blades Order now—only \$1.75. Valley Sales, Dept. 11C1, 235 Lloyd, Livermore, Calif. 94550.

**1972 ELECTRONICS Catalog 25¢.** McCord Electronics, Box 412, Sylvania, Ohio 43650.

**ALPHA—Theta-wave Biofeedback.** Relaxed awareness, meditation, body control. Inner Space Electronics, Box 319PE, Fairfax, Calif. 94930.

**PYROTECHNICAL, rocketry, laboratory supplies:** chemicals, tubes, tools, igniters, colored smoke tracers. Illustrated catalogue/handbook includes formulas, instructions—50¢. Westech, Salt Lake City, Utah 84108.

**REPAIRS—Complete Course Details, 12 Repair Tricks, Plans, Two Lessons, all for \$1.** Refundable. Frank Bocek, 333, Redding, Calif. 96001.

**SEMICONDUCTORS:** Buy from single source. Serving experimenters, hobbyists. No minimums. SN 7400N, \$1.95; MC724P, \$1.19, etc. RLabs, Box 253, Burlington, Ma. 01803.

**TUBE Testers—Mercury Model 204 \$95.00,** write: Bob Greber, 10144 Dunbarton Dr., El Paso, Texas 79925.

**PULSE GENERATORS,** oscillators, logic modules, booklets, and plans. Free Literature. Scientific Measurements, 2945 Central, Wilmette, Illinois 60091.

**COUNTER Power Supply—Input 115VAC—Output 180VDC 20ma and 5VDC 500ma—Load Regulation 25mV—Ripple 1mV—5X2" PC Board—PC transformer—LM309K IC regulator—Heatsink—Satisfaction or money back (Kit) \$17.95.** Key Telemetry Products, 3853 Garden Terrace, Owensboro, Ky. 42301.

## FIRE & BURGLAR ALARMS 1972 Handbook & Catalog

### Save Hundreds of Dollars



Professional equipment famous manufacturers, not readily available from local sources. **NEW & EXPANDED** to include laser photo-electronic systems, dialers, electronic sirens, perimeter controls, and a **NEW RADIO ACTUATED SYSTEM THAT** installs in less than 2 hours. Also includes switches, bells, control panels, wire and hardware. Save up to 75%. This handbook is a must for every homeowner and businessman. Just \$1 cash, check or M.O. \$1 refunded with first order.

### ALARM COMPONENT DISTRIBUTORS

33 New Haven Ave., Dept. P.E., Milford, Conn. 06460

**BURGLAR Alarms, Wholesale.** Rose Alarms, 509 5th Avenue, New York, New York 10017.

**BUILD your own Electronic Desk Calculator.** Catalog \$0.25. Digital Concepts, Box 5424, Charlottesville, Virginia 22903.

**SHORT-WAVE-LOG 1972.** Transmitting times for all stations. \$2.00 Airmail \$2.50. Sample Club Magazine 21RC. Swedish Radioklubb, Box 5083, Stockholm, Sweden.

**NOW!** Enjoy the great outdoors in comfort with your pocket size electronic Skeeter Skat mosquito repeller. \$9.95 postpaid USA. Satisfaction guaranteed. Detectron, Dept. G-12, P.O. Box 243, San Gabriel, Calif. 91778.

**STEREO headphones** individual volume controls, limited quantity available, \$12.95 + \$1.25 mailing and handling, N.C. residents add 3% sales tax. Neal's Enterprises, 2703 Belmar St., Greensboro, N.C. 27407.

**ELECTROENCEPHALOPHONE** teaches alphawave control. J&J Enterprises, 24120-E 3rd West, Bothell, Wash. 98011.

**HOBBYISTS—Programmable electronic combination lock kit.** Five IC's, plans, theory. \$5.95. Catalog free. John Huntley, 1351 Mahoney, Rodeo, Calif. 94572.

**FREE ELECTRONICS Catalog.** Tremendous bargains. Edu-Kits, Department C-708-D, Hewlett, New York 11557.

**WE SELL CONSTRUCTION PLANS, KITS AND WIRED UNITS—**alternator adapter, 110 volts at 3,000 watts from ANY alternated vehicle!—silver recovery unit—x-ray fluoroscope machine—ultra sensitive metal detector—auto theft guard—golfers range finder—hypnotic disc—electronic deodorizer—birth control pill!—instant fish kit—automatic wheel balancers—lifetime match—make your own hand soap, laundry detergent, hair oil, cologne at a fraction of the cost you're paying now—ask for our FREE catalog—Creative Products, 1708-E Tierney Road, Fort Worth, Texas 76112.

**CLEARANCE SALE** rectifiers, transistors, 1000's other items. Catalog 15¢. General Sales Company, 254 Main, Clute, Texas 77531.

## PLANS AND KITS

**FREE Kit Catalog:** Digital Microlab \$29.95. Also Segmented and Nixie Readouts, Timebases, Scalers, Electronic Digital Clocks (all featured in Popular Electronics) SWTPC, Box C32040, San Antonio, Tex. 78216.

**FREE Kit Catalog.** Why does every major College, University, Technical School, Research & Development Center buy from us? Because we have the highest quality and lowest prices. Free catalog. SWTPC, Box H32040, San Antonio, Tex. 78216.

**KITS—Color organs, synchronizers, strobes.** Workshop, Box 3932, Bethpage, New York 11714.

**KITS AND EQUIPMENT—**FM Wireless microphone transmitters, FM Telephone transmitters, Infinity transmitters. Security Electronics, P.O. Box 265, Huntington, W. Va. 25707.

**FREE** kit Catalog: Amazing new Universal Digital Instruments with plugins as featured in **Popular Electronics**. Unbeatable prices. SWTPC, Box D32040, San Antonio, Tex. 78216.

**STATE** of the Art Color Organ kit, four 1,000 watt channels, OpAmp buffered stereo inputs. Leo photoisolation \$75.00. f.o.b. Norton Media, 311 West 37th, Austin, Texas 78705.

**"DISTANCE** Crystal Set Construction" Handbook—50¢. "Coil Winding"—50¢. Catalog. Laboratories, 745-L Cordone, Reno, Nevada 89502.

**MAKE** your own printed circuit boards. New easy method. Send \$2.00, Box 6802, Glendale, Calif. 91205.

**BOX** turns Amp off when turntable records finish, cable tester; plans \$1; McCreary, P.O. Box 667, Berkeley, Calif. 94701.

**AUTOMATIC** Morse Code Copying Machine. Featured in Ham Radio Magazine this fall. Copy up to 120 wpm without knowing CW! Simply hook to your receiver's audio and read printout. Send \$14.95 for detailed construction plans. VMG Electronics, 2138P, West Sunnyside, Phoenix, Arizona 85029.

**TESLA COIL**—40" Sparks! Plans \$7.50. Information 75¢. Huntington Electronics, Box 9-P, Huntington, Conn. 06484.

**CONVERT** your eight track player to a player/recorder. Plans three dollars. Sound Four, 4534 50th, San Diego, CA. 92115. Dept. PC1.

**PLANS 'N' KITS.** Detailed plans with schematics, parts lists. Complete, easy-to-build kits. **AUDIO;** Amplifiers, generators, arc loudspeaker. **RADIO;** FM telephone transmitter, converters, de-buggers. **PSYCHEDELIC;** Strobes, color organs, phonelescope. **UNUSUAL:** Electric candles, lighting-bolt generator, X-Ray generator. **MANY MORE.** Plans from 50¢. Complete catalog, 50¢. TA, Box 1266, S. Lake Tahoe, CA. 95705.

**SUPER** sensitive, economical, balanced induction metal detector plans. \$2.00. Box 643, Plano, Texas 75074.

**COLOR ORGAN** Kits \$7.50. IC's .25¢. Catalog. Murphy, 204 Roslyn Ave., Carle Place, New York 11514.

## HIGH FIDELITY

**TAPE RECORDERS,** Hi-Fi, components, Sleep Learning Equipment, tapes. Unusual Values. Free Catalog. Dressner, 1523R, Jericho Turnpike. New Hyde Park, N.Y. 11040.

**FREE** Kit Catalog. Amplifiers: Lil Tiger \$11.10, Universal Tiger \$30.00, Preamp \$44.50 (Featured in **Popular Electronics**) SCA Adaptors \$14.55 SWTPC, Box A32040, San Antonio, Tex. 78216.

**DIAMOND NEEDLES** and Stereo Cartridges at Discount prices for Shure, Pickering, Stanton, Empire, Grado and ADC. Send for free catalog. All merchandise brand new and factory sealed. LYLE CARTRIDGES, Dept. P, P.O. Box 69, Kensington Station, Brooklyn, New York 11218.

**HEGEMAN "OMNI-DIRECTIONAL" SPEAKERS** \$100 Creighton Audio Labs, Haven Pl., Linden, N.J. 07036.

**McGEE RADIO COMPANY**  
World's Best Selection of Speakers  
Almost Every Size From 1½ to 18"  
**WOOFERS — TWEETERS — CROSSOVERS**  
**MANY HIGH FIDELITY KITS.**  
*McGee's 176 Page Catalog*  
*Sent Free Upon Request*  
**NORELCO HI-FI SPEAKERS**  
An Added Full Line of Norelco Hi-Fi Speakers  
For The System Builder  
**McGEE RADIO COMPANY,**  
1901 McGee Street PE,  
Kansas City, Missouri 64108

## WANTED

**CASH PAID!** Unused tubes, electronic equipment. Barry, 512 Broadway, NYC 10012.

**QUICKSILVER,** Platinum, Silver, Gold, Ores Analyzed. Free Circular. Mercury Terminal, Norwood, Mass. 02062.

**HELP** Handicapped people in Israel. Everything Accepted. Everything Appreciated. Be Generous Give Now. Handicapped Workers, Olivewood Crafts, 43 Chefetz-Chaim, Petahtitwa, Israel.

## TUBES

**RECEIVING & INDUSTRIAL TUBES, TRANSISTORS.** All Brands—Biggest Discounts. Technicians, Hobbyists, Experimenters—Request **FREE** Giant Catalog and **SAVE!** **ZALYTRON**, 469 Jericho Turnpike, Mineola, N.Y. 11501.

**RADIO & T.V. Tubes**—36¢ each. Send for free Catalog. Cornell, 4213 University, San Diego, Calif. 92105.

**TUBE** Headquarters of World! Send 10¢ for Catalog (tubes, electronic equipment) Barry, 512 Broadway, N.Y.C. 10012.

**SAVE** money on parts and transmitting-receiving tubes, foreign-domestic. Send 25¢ for giant catalog. Refunded first order. United Radio Company, 56-P Ferry Street, Newark, N.J. 07105.

**2,000 TUBES,** 90% off list. Rhodes, Box 806, Watervliet, Michigan 49098.

**TUBES** "Oldies", latest. Lists free. Steinmetz, 7519 Maplewood, Hammond, Indiana 46324.

## TAPE AND RECORDERS

**STEREO TAPE RENTAL** for particular people. Free catalog. Gold Coast Tape Library, Box 2262, Palm Village Station, Hialeah, Fla. 33012.

**STEREO TAPE TRANSPORT**—7" reel—2 speeds—pause control—made for famous manufacturer—50 to 15,000 Hz—with rec/play and erase heads, without case. Send m.p. or check for \$19.50 to Alsheimer Audio Electronics, 218 Columbia St., Utica, N.Y. 13502. \$2.50 for prepaid shipping and insurance.

**RENT** 4-Track open reel tapes—all major labels—3,000 different—free brochure. Stereo-Parti, 55 St. James Drive, Santa Rosa, Ca. 95401.

**BARGAIN MUSIC,** Tape, Equipment Catalog, 25¢. Saxitone, 1776 Columbia Road, Washington. D.C. 20009.

**BUY** Irish Tape Open Reel & Cassettes & 8-Track Blanks at Discount Prices. Write: Direct Mail Cassette Corp., Box 71, Plainview, N.Y. 11803.

**RECORDING TAPE** made by top American manufacturer, guaranteed not "seconds" or "white box"; 2400' mylar, \$2.29; 1800' mylar \$1.69; 1200' acetate \$ .79. Send for information and quantity pricing. Alsheimer Audio Electronics, 218 Columbia Street, Utica, New York 13502.

**NOSTALGIC** Radio Programs on tape. Six hours \$7.00, catalogue 25¢. Nostalgic Radio, Box 29P, Peoria, Ill. 61601.

**PROFESSIONAL** quality eight track blank cartridges. Specify length 30 to 60 minutes. \$1.00 each. Orders under \$10 \$1.00 handling. California residents add 5¢ tax. Quantity count available. Sound Four, box 665, Monrovia, CA

**RECORDING TAPE:** Blank Cassettes, 8 track, reel. \$ Write: NNA, Box 721F, Rye, New York 10580.

**RECORDING? DUBBING? EDITING?** Use the "Dubie" segregate two or more recorders into your music system, tangled cables, ruined tapes. Brochure D-5, Dubie Co., Oklahoma, Norman, Okla. 73069.

**FREE** Stereo Tapes brochure. Music Society, Box 27815, Los Angeles, Calif. 90027.

**AUDIO TAPE.** Most brands available at wholesale prices. Recording Tape Wholesalers, Box 844, Orange, Conn. 06477.

**OLD** Radio Programs on cassettes or reels. High quality, low prices, thousands to choose from, professional equipment, catalog 50¢. Remember Radio Inc., Box 2513, Norman, Okla. 73069.

**OLD** Radio Programs. Catalog \$1.00. (Refundable). Radio Vault, Box 9032, Wyoming, Michigan 49509.

## REPAIRS AND SERVICES

TV Tuners rebuilt and aligned per manufacturers specification. Only \$9.50. Any make UHF or VHF Ninety day written guarantee. Ship complete with tubes or write for free mailing kit and dealer brochure. JW Electronics, Box 51C, Bloomington, Indiana 47401.

**COILS** Made; Parts machined to your Specs. Electro-Wire Products, 2805 E. 117th Street, Cleveland, Ohio 44120.

**HAMS**—experimenters—hobbyists: printed circuit boards from your 1:1 artwork—70¢ square inch—shipped COD dealer inquiries invited—GAM Circuits, Box 551, Galion, Ohio 44833.

**SPEAKERS** rebuilt, Hi-Fi foreign instrument amplifier. Speakers, 2409 1/2, W. Colorado, Colorado Springs 80904.

## PERSONALS

**MAKE FRIENDS WORLDWIDE** through international correspondence. Illustrated brochure free. Hermes, Berlin 11, Germany.

**INVESTIGATORS**, Latest Electronics Ads. Free Literature. Clifton, 11500-K NW 7th Ave., Miami, Florida 33168.

## INVENTIONS WANTED

**INVENTIONS** wanted. Patented: unpatented. Global Marketing Service, 2420-P 77th, Oakland, Calif. 94605.

**INVENTORS!** Don't sell your invention, patented or unpatented, until you receive our offer. Eagle Development Company, Dept. 9, 79 Wall Street, N.Y., N.Y. 10005.

**PATENT** Searches including Maximum speed, full airmail report and closest patent copies. \$6.00. Quality searches expertly administered. Complete secrecy guaranteed. Free Invention Protection forms and "Patent Information." Write Dept. 9, Washington Patent Office Search Bureau, 734 15th St. N.W., Washington, D.C. 20005.

**FREE** "Directory of 500 Corporations Seeking New Products." For information regarding development, sale, licensing of your patented/unpatented invention. Write: Raymond Lee Organization, 230-GR Park Avenue, New York City 10017.

**INVENTORS:** Protect your ideas! Free "Recommended Procedure". Washington Inventors Service, 422T Washington Building, Washington, D.C. 20005.

**FREE PAMPHLET:** "Tips on Safeguarding Your Invention." Write: United States Inventors Service Company, 501-H Thirteenth Street N.W., Washington, D.C. 20004.

## INSTRUCTION

**DIY ORGAN SERVICING** at home all makes included. Experimental kit—trouble-shooting. Accredited Booklet. NILES BRYANT SCHOOL, 3631 Stockton, Dept. N, Sacramento, Calif. 95820

**LEARN WHILE ASLEEP**, Hypnotize! Strange catalog free. Auto-suggestion, Box 24-ZD, Olympia, Washington 98501.

**FREE** brochure self-improvement books. Eldon McEray, 412 Arthur Street, Huntsville, Ala. 35805.

**DEGREE** in electronics Engineering earned mostly by correspondence. Free brochure. Dept. G-9, Grantham School of Engineering, 1505 N. Western Ave., Hollywood, California 90027.

**F. C. C.** 1st phone license training in 5 weeks. R.E.I.'s intensive training produces outstanding results. For information and free brochure call toll free: 1-800-237-2251, or write home office. Radio Engineering Incorporated Schools, 1336 Main Street, Sarasota, Florida 33577. Florida residents call (813) 955-6922.

**HIGHLY** effective home study courses in Electronics Engineering Technology and Electronics Engineering Mathematics. Earn your Degree. Write for Free Descriptive Literature. Cook's Institute of Electronics Engineering, (Dept. 15), P.O. Box 10634, Jackson, Miss. 39209. (Established 1945).

**F.C.C. TYPE EXAM** . . . Guaranteed to prepare you for F.C.C. 3rd, 2nd, and 1st phone exams. 3rd class. \$7.00; 2nd class, \$12.00; 1st class, \$16.00; complete package, \$25.00. Research Company, 3206 Bailey Street, Sarasota, Florida 33580.

**PRINTED CIRCUITS.** Design and process your own photo-etched printed circuits. Order book—complete instructions—illustrated. \$1.00 pp. ORR, 4223 Tideland Drive, Bridgeton, Mo. 63044.

**FCC "TESTS-ANSWERS"** . . . Original exam manual for F.C.C. First and Second Class License—plus—"Self-Study Ability Test." Proven! \$9.95. Satisfaction Guaranteed. Command, Box 26348-P, San Francisco 94126.

## GOVERNMENT SURPLUS

**GOVERNMENT** Surplus. How and Where to Buy in Your Area. Send \$1.00. Surplus Information, Headquarters Bldg., Box 30177-PE, Washington, D.C. 20014.

**JEEPS** Typically from \$53.90 . . . Trucks from \$78.40 . . . Boats. Typewriters, Knives, Airplanes, Clothing, Multimeters, Oscilloscopes, Transceivers, Photographic, Electronics Equipment. Wide variety, condition. 100,000 Bid Bargains direct from government nationwide. Complete sales directory and surplus categories catalog \$1.00 (Deductible on orders from separate included catalog). Surplus Service, Box 820-J, Holland, Michigan 49423.

**GOVERNMENT SURPLUS.** Complete sales directory \$1.00. Surplus Publications, Box 26062Z, Los Angeles, Calif. 90026.

**MANUALS** for surplus electronics. List 25¢. Books, 4905 Roanne Drive, Washington, D.C. 20021.

## BOOKS

**FREE** catalog aviation electronic space books. Aero Publishers, 329PE Aviation Road, Fallbrook, California 92028.

**FREE** book prophet Elijah coming before Christ. Wonderful bible evidence. Megiddo Mission, Dept. 64, 481 Thurston Rd., Rochester, N.Y. 14619.

## HYPNOTISM

"**MALE-FEMALE** Hypnotism!" Exposed. Explained! "Secret Method"—They Never Know! \$2. Rushed. Guaranteed! Isabella Hall, Silver Springs, Florida 32688.

**SLEEP** learning. Hypnotic method, 92% effective. Details free. ASR Foundation, Box 7545PL, Fort Lauderdale, Florida 33304.

**HYPNOSIS** News Annual. Articles by physicians, hypnotists, dentists. Information, brain wave synchronizer, societies, seminars, journals, etc. \$3.00 postpaid. Hypno, Box 448, Gulfport, Miss. 39501.

## PHOTOGRAPHY—FILM, EQUIPMENT, SERVICES

**SCIENCE** Bargains Request Free Giant Catalog "CJ"—148 pages—Astronomical Telescopes, Microscopes, Lenses, Binoculars, Kits, Parts. War surplus bargains. Edmund Scientific Co., 300 Edscorp Bldg., Barrington, New Jersey 08007.



---

## RECORDS

**POPULAR** organ albums factory direct. Concert Recordings, Lynwood, Calif. 90262.

**THE LONE RANGER** and other complete old radio programs available on L.P. records. Radio, Box 844, Orange, Conn. 06477.

---

## RUBBER STAMPS

**RUBBER** Address Stamps \$2.00. Signature \$3.50. Free Catalog. Jackson's, Box 443-G, Franklin Park, Illinois 60131.

---

## EMPLOYMENT OPPORTUNITIES

**RECORDISTS.** Make records. We train, equip, provide exclusive territory. Modest investment. Director Group, Englewood, Ohio 45322.

---

## EMPLOYMENT INFORMATION

**EXCITING** Overseas jobs. Directory \$1.00. Research Associates, Box 942-E, Belmont, California 94002.

---

## MAGAZINES

**JAPAN PUBLICATIONS GUIDE** Business, pleasure, education. \$8.00. INTERCONTINENTAL, CPO 1717. Tokyo 100-91.

**OVER 2,000,000** backdate magazines! Specify needs. Midtown, Box 917-PE. Maywood, New Jersey 07607.

---

## SPORTS COLOR FILMS

**AN UNUSUAL CHRISTMAS GIFT**—Pro Football, Hockey. Auto Racing and Baseball. Super 8/8mm. Catalog. **SPORTLITE**, Elec. Dept., Box 24-500, Speedway, Indiana 46224.

---

## BUSINESS OPPORTUNITIES

**I MADE \$40,000.00** Year by Mailorder! Helped others make money! Start with \$10.00—Free Proof. Torrey, Box 318-N, Ypsilanti, Michigan 48197.

**FREE BOOK** "999 Successful Little Known Businesses" Work home, Plymouth 445-P, Brooklyn, N.Y. 11216.

**\$200.00 DAILY** In Your Mailbox! Your opportunity to do what mail-order experts do. Free details. Associates, Box 136-J, Holland, Michigan 49423.

**MAILORDER!** Make big money working home. Free report reveals millionaire's trade secrets! Executive (1K12), 333 North Michigan, Chicago 60601.

**\$1000 DAY**—150% Profit. Selling by mail. No investment in inventory. Part time—full time. Unlimited potential. Complete details \$1.00. National, Box 7212S, Chicago, Illinois 60680.

**START small**, highly profitable electronic production in your basement. Investment, knowledge unnecessary. Postcard brings facts. Barta-Electronics, Box 248, Walnut Creek, California 94597.

**FREE CATALOGS.** Repair air conditioning, refrigeration. Tools, supplies, full instructions. Doolin, 2016 Canton, Dallas, Texas 75201.

**PIANO TUNING** learned quickly at home. Tremendous field! Musical knowledge unnecessary. GI Approved. Information Free. Empire School, Box 327, Miami, Florida 33145.

**INEXPENSIVE, Home**—Auto Fire, Burglar Alarms, Extinguishers. 200% Profits. Nation's Watchdog, Williamsburg, Ohio 45176.

**GUARANTEED \$100.00** in advance for mailing 100 letters. Instructions \$2.00. FJD, P.O. Box 538, Camarillo, Ca. 93010.

**BIG EARNINGS** selling Hertel Bibles. New 3-dimension cover, finest reference edition sells fast. Demonstrator furnished. Big commissions. International Book, Dept. PE, Box 118, Wichita, Kansas 67201.

**MAILORDER MONEYMAKING KIT.** Home Business. Valuable lists, concrete information, detailed steps. Capital unnecessary. Free Details, Pictures. Prudential, Box 327-PEC, Boston 02199.

**CASH IN ON SHOPLIFTING:** Simulated closed circuit T.V. camera with red light, looks like real thing. Sends shoplifters elsewhere. Complete with decal. Easy seller. Sample unit \$23.80 or details \$1.00. Nautilus Security, Dept. CCTV, Box 240, Brooklyn, New York 11224.

---

## TREASURE FINDERS

**GOLD, Silver, Relics!** Located with powerful Detectron Metal Detectors. Free information. Terms, Detectron, Dept. PE12, Box 243, San Gabriel, California 91778.

**TREASURE FINDER** locates buried gold, silver, coins, treasures. 5 powerful models. \$19.95 up. Free catalog. Relco-A33. Box 10839, Houston, Texas 77018.

**FREE:** Jetco Electronics 24-page Treasure Finder Catalog. Find Gold, Silver, Coins, Metals, Minerals, relics. Jetco, Dept. PEC, 3933 Barranca, El Paso, Texas 79935.

**FISHER DETECTORS** introduces new 1972 models! Free literature. FRL Dept. PE-12, Palo Alto, CA. 94303.

---

## REAL ESTATE

**FREE... 256-page CATALOG!** Describes and pictures hundreds of farms, ranches, town and country homes, businesses coast to coast! Specify type property and location preferred. Zip Code, please. United Farm Agency, 612-EP West 47th St., Kansas City, Mo. 64112.

---

## MUSICAL INSTRUMENTS

**30% DISCOUNT** name brand musical instruments. Free catalog. Freeport Music, 127-N Sunrise Highway, Freeport, N.Y. 11520.

**WHOLESALE!** Professional Amplifiers, PA Systems, Guitars. Free Catalog. Carvin, Escondido, Calif. 92028.

**30% TO 50% DISCOUNT!** Guitars, Amps, Drums. Free catalog. Warehouse PE-1, BOX 9352, Fort Worth, Texas 76107.

**SWISS** Musical Movements. Electrical. Mechanical. Spielman, 55 West 42nd, New York, New York 10036.

**I'LL teach you** to read music in one evening! Guaranteed method. Free details. Noyes Enterprises, 44 Bucksport Rd., Orrington, Maine 04474.

**FREE** song selling information. Peerless Publications, Box 193-F, Bloomfield, Conn. 06002.

---

## DO-IT-YOURSELF

**BURGLARY-Fire Protection.** Free Catalog. (Citation Manual loaned Free upon request). Sa 11th Street, Brooklyn, New York 11235.

---

## MISCELLANEOUS

**WINEMAKERS:** Free illustrated catalog yeasts, equipment, Box 12276. Minneapolis, Minn. 55412.

**WINE RECIPES** and Catalog, 25¢. Country Winemaker, Box 191E, RFD 1, Mattapoisett, Massachusetts 02739.

POPULAR ELECTRONICS

DECEMBER 1971

ADVERTISERS INDEX

R.S. NO.	ADVERTISER	PAGE NO.
1	Acoustic Research, Inc.	16
	Allied Radio Shack	72, 73, 74, 75
	Bell & Howell Schools	90, 91, 92, 93
2	Cleveland Institute of Electronics	36, 37, 38, 39
3	Cobra Communications. DYNASCAN CORP.	THIRD COVER
5	Crystek	107
6	Drake Company. R.L.	12
7	EICO Electronic Instrument Co., Inc.	98
8	Echo Communications	101
9	Edmund Scientific Co.	108
10	Electra Corp.	16
4	Electro-Voice, Inc.	FOURTH COVER
11	Heath Company	9, 10, 11
12	Lafayette Radio Electronics	13
	National Radio Institute	SECOND COVER, 1, 2, 3
	National Technical Schools	54, 55, 56, 57
14	Olson Electronics	107
15	RCA Electronic Components & Devices	24
	RCA Institutes, Inc.	18, 19, 20, 21
16	Russound FM	96
21	Siliconix, Inc.	5
17	Southwest Technical Products	89
	Products Co.	6
	Electronics	96
19	United Audio Products (DUAL)	14
20	Xcelite, Inc.	8

CLASSIFIED ADVERTISING: 102, 103, 104, 105, 106

CONTROLLED  
QUALITY  
CRYSTALS by



**CRYSTEK**



The "On-Channel" Crystals  
FOR  
**CITIZEN BAND**  
23 Channels and "Mars"

**HAM OPERATORS**  
**Commercial 2-Way**

**Marine-Monitor**

See your Distributor for Speedy  
"Zip Certificates"



**CRYSTEK**

formerly Texas Crystals  
Div. of Whitehall Electronics Corp.

1000 Crystal Drive 4117 W Jefferson Blvd.  
Fort Myers, Florida 33901 Los Angeles, California 90016

CIRCLE NO. 5 ON READER SERVICE PAGE

**ANOTHER SUPERB VALUE**  
from

**Olson**

Electronics

ONLY \$300



**TV SYSTEM**  
with **INTERCOM**

Compact camera and monitor is equipped for 2-way sound that offers new dimension in all-round protection for your family, home, business or industry. Simple plug-in installation. Complete - nothing else to buy.

Olson Electronics, Dept. IX, 260 S. Forge St.,  
Akron, Ohio 44308

I enclose \$300 plus \$1 for postage and handling. Send me the TV-300 TV System.

Send me the next seven issues of the Olson Catalog, without cost or obligation. **FREE**

Name \_\_\_\_\_

Address \_\_\_\_\_

City \_\_\_\_\_

State \_\_\_\_\_ Zip \_\_\_\_\_

CIRCLE NO. 14 ON READER SERVICE PAGE

# KEEP PACE WITH SPACE AGE! SEE MOON SHOTS—LANDINGS, SPACE FLIGHTS, CLOSE-UP!

## AMAZING SCIENCE BUYS

for FUN, STUDY or PROFIT

### HELIUM BALLOONS MAKE A "BALL"



Helium is a safe non-toxic inert gas.  
Stock No. 71.289AV

Anytime there's a balloon the air is festive. Especially when the "air" is helium which makes a balloon perkier and adventurous. Now here's 25 times the fun—25 various colored balloons of 4, 5, or 6" diameter when inflated. With them, a pressurized (300 lbs./sq. in.) can containing 21 liters of helium to inflate all 25. For adults or kids' parties, giveaways, bazaars or just demonstrating "lighter than air".

\$3.00 Ppd.

### NUMERICAL INDICATOR TUBES



Socket for above: No. 41.666AV  
TUBE W/ DEC. TO LEFT: No. 41.618AV  
Socket for above: No. 41.617AV

Designed as direct line, side-view readout devices for basic counter and computer circuits, gas filled cold-cathode numerical readout tubes use common anodes. 11 cathodes in shapes of numbers 0-9. Also give visual digital display of volts, cycles, etc. High reliability, long life, wide-angle viewing with brightness and stability.

**TUBE W/ O DECIMAL:**  
No. 41.593AV \$5.95 Ppd.  
80c Ppd.  
**TUBE W/ DEC. TO LEFT:**  
No. 41.618AV \$5.95 Ppd.  
80c Ppd.

### \$8.95 ELECTRONIC STROBE



Hand-sized solid state electronic strobe light at fantastically low price. Produces bright psychedelic effects like larger, far more expensive Xenon strobes. Yet it's just .284 X 4 X 1.34" thick. Adjustable flash rate, approximately 3-10 flashes per second. Make stop motion effects, posters come alive. Great to take with you to parties, dances, outings, etc. Requires 2 1/2 AA transistor batt. (incl.). Instructions. Stock No. 41.443AV \$8.95 Ppd.  
4 REPLACEMENT LAMPS AV 1.00 Ppd.  
P. 41.44

### BLACK-LIGHT MIGHTY MITES



Relatively small (12") fixtures give surprisingly bright black-light. Mirror-finished reflector makes instant starting. 8-watt high-intensity bulb look like 40-watter. Up to 5,000 hours of safe, long-wave (3600A) black-light to really turn on parties, light & theatrical shows, psychedelic decors, holiday decorations. Shockproof end-caps remove for safe, easy replacement of bulb and starter. Stands upright or horizontal. Aluminum case.

Stock No. 71.274AV \$14.95 Ppd.  
**DELUXE OUTDOOR INDOOR MODEL**  
Stock No. 71.299AV \$19.95 Ppd.

### PSYCHEDELIC LIGHTING HANDBOOK



100 information packed pages! Fully explains latest in psychedelic lighting equipment, techniques, developments. Covers all facets of psychedelic light-show production including: strobes, black lights, projectors, crystals, organic slides, mirrors, color organs, polarized color, light boxes. Music/vision, etc. Shows how to "psychedelize" parties, musical groups, shows or how to set up "electric trine" for private gatherings. 8 1/2" x 11" looseleaf paper for 3 rings.

Stock No. 9100AV \$3.00 Ppd.

Order by Stock No.—Check or M.O.—Money-Back Guarantee  
EDMUND SCIENTIFIC CO., 300 EDSCORP BLDG., BARRINGTON, N.J. 08007

### WRITE FOR GIANT FREE CATALOG "AV"



Completely new edition. New items, categories, illustrations. 148 easy-to-read pages, packed with 4000 unusual items. Dozens of electrical and electro-mechanical accessories. Enormous selection of Astronomical Telescopes, Microscopes, Binoculars, Magnifiers, Magnets, Lenses, Lasers, Prisms. Many war surplus items; for hobbyists, experimenters, workshops, factory. Write for catalog "AV."

### See moon shots, orbits, stars, craters!

## NEW 3" ASTRONOMICAL REFLECTOR TELESCOPE

60 to 180X

### DE-LUXE FEATURES AT ECONOMY PRICE

Amazingly priced Apollo 8-size Explorer brings the wonders of the universe up close. 3" aluminum & overcoated f 10 mirror. Exceeds theoretical limits of resolution & definition. 60X standard size 1 1/4" O.D. eyepiece. 1.6" 2X adjustable barlow. 6X finder telescope; high impact-resistant tubular mount w/ positive locking, 36" hardwood tripod. Included FRIE: 273, Handbook, Star Chart, Instructions. Best value ever!

Stock No. 80.162AV \$59.50 Ppd.  
**REG. 3" REFLECTOR TELESCOPE** \$34.50 Ppd.  
Stock No. 85.050AV \$34.50 Ppd.  
**4 1/2" ASTRONOMICAL REFLECTOR TELESCOPE** \$94.50 Ppd.  
Stock No. 85.105AV \$94.50 Ppd.  
**6" ASTRONOMICAL REFLECTOR TELESCOPE** \$239.50 F.O.B.

### SPECIAL VISUAL EFFECTS PROJECTOR SET

Dazzling, avant-garde visual effects. Fantastic variety. Incredibly beautiful. Special package offer contains all necessary apparatus. Creative lighting, exciting, fiery bursts of color like "Symphony of Splashes," "Chromalite Starbursts," "Crystal Starburst." Features 3.5mm 500 W. fan cooled projector—produces high mag. at short distance, accepts 1/2" diam. wheels (Dro Kaleidoscope & Hexadecscope), 2 cylindrical accessories (6" Colored Clouds & Hexidroscope w/ six internal mirrored walls). Perfect for entertaining, parties, photography.

Stock No. 71.212AV \$79.50 Ppd.  
Stock No. 71.295AV Deluxe Model \$99.50 Ppd.

### NEW! ELECTRONIC DIGITAL COMPUTER KIT!

Solve problems, play games, predict weather with this giant working model of giant electronic brains. Amazing new fun way to learn all about computer programming. Logic, decimal, binary systems. Laws of Sets—even do your own programming after completing simplified 116 page instructive booklet. Includes step-by-step assembly diagrams. Circuits easily changed. Readout from illuminated control panel. Req. 2 1/2" batt. (incl.). Best model we've seen—for home, school, industry. Stock No. 71.434AV (11"X12 1/2"X4") \$31.50 Ppd.

### AMAZING NEW Wankel Engine KIT!

Thrill to the fun of building your own see-through motorized model of revolutionary pistonless type engine, rights for which GM recently paid \$50 million! Only engine experts think economically infeasible to meet new pollution standards. Inplaces piston, cylinder, crank assemblies with rotating discs (sections removed for firing chambers). Smaller than conventional; fewer parts, greater reliability, same speed w/ less horsepower. Great: washing plugs, rubber fan belt, LGV batt. (not incl.).

Stock No. 71.424AV (4 1/2"X5"X9") \$6.75 Ppd.

### NEW LIGHT-EMITTING-DIODE KIT

Bargain kit ideal for economical experimenting with amazing L.E.D.s, the tiny solid state monochromatic lamps that use low voltage DC, last up to 10M hrs. Used in card-tape readers, character recognition, hi-speed electronics, a wide range of electro-optical applications. Kit includes 3 L.E.D.s: gallium arsenide (6400 Å), AlGaIn (630 Å), 2 visible red emitting (6600 Å), 1 infra-red emitting (9000 Å); 6 resistors; 1 20mm plastic fibre optic light pipe; Inst. Stock No. 41.597AV

EDMUND SCIENTIFIC CO. 300 EDSCORP BLDG. BARRINGTON, NEW JERSEY 08007

CIRCLE NO. 9 ON READER SERVICE PAGE

PRINTED IN U.S.A.

POPULAR ELECTRONICS



# Why buy a CB radio that butts in on your conversation?

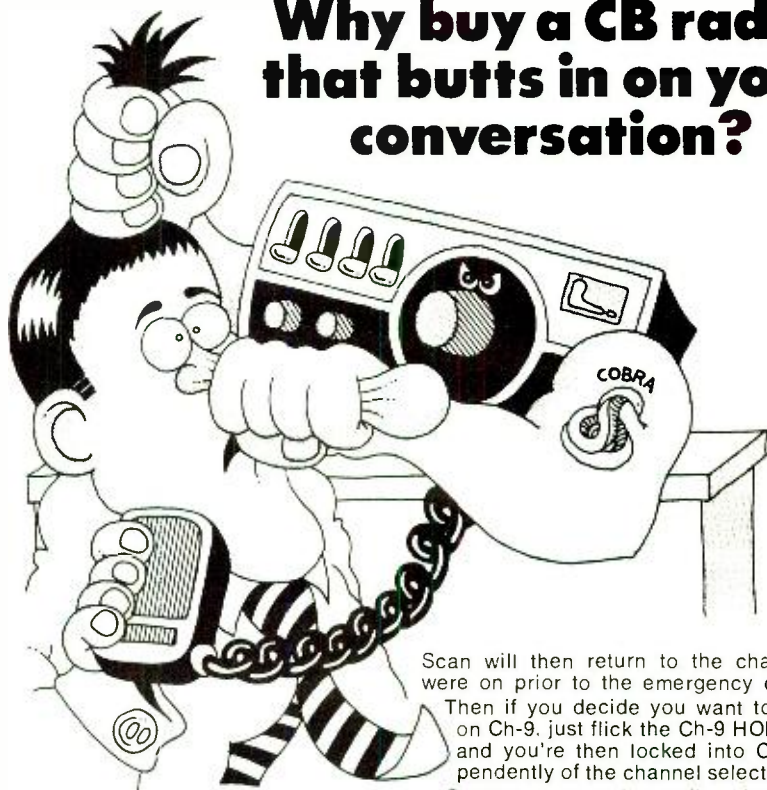

Because emergencies don't wait to happen. They interrupt.

That's why we created the new Cobra 28 Citizen's Band radio. With the Cobra 28, if a distress call comes in on emergency Channel-9, it's going to butt in on you. No matter what channel you're operating on. You can be transmitting or receiving on any one of the Cobra 28's other 22 channels and still be monitoring Ch-9 at the same time.

This practical new feature is called the Emergency Channel-9 Scan-Alert, and you get it on the Cobra 28.

Here's how the Scan-Alert works. Just slide the Ch-9 Scan switch to "scan" position. Then if you're operating on any of the other 22 CB channels and an emergency call comes in on Ch-9, it'll cut right in on whatever frequency you're already on. After the call has been received, the

Scan will then return to the channel you were on prior to the emergency call.

Then if you decide you want to transmit on Ch-9, just flick the Ch-9 HOLD switch and you're then locked into Ch-9 independently of the channel selector switch.

So now you can transmit and receive on Ch-9 without resetting the channel selector.

Of course, the Ch-9 Scan-Alert is switchable. Just turn the Scan switch to the "off" position if you don't want Ch-9 to butt in on you.

Also included in the new Cobra 28: Full 5 watts power with Dynabooast speech compression, RF Noise blanker, automatic noise limiter, PA system output, Delta tune control, ANL/NB switch, channel indicator lights, PWR/S Meter and many other features that make the Cobra 28 the most complete Mobile CB radio at a fantastic price.

This new Cobra is the perfect way to help with emergencies in your area.

So butt in on your local CB dealer and ask to see the new Cobra 28. Or write us direct for more information.

**23 Channel CB Radio with Ch-9 Scan-Alert \$169.95**



## COBRA 28

Product of DYNASCAN CORPORATION • 1801 W. Belle Plaine • Chicago, Illinois 60613

CIRCLE NO. 3 ON READER SERVICE PAGE

# 4-CHANNEL SOUND

## Electro-Voice takes the first practical step:

**EV STEREO-4™**  
compatible four channel

*Being more a progress report than an advertisement.*

### The Promise

Thousands of people have heard 4-channel stereo reproduction at hi-fi shows and special demonstrations in the last few years. Others have read about this fascinating and rewarding technique that promises more faithful reproduction of musical performances. Early experiments have also shown 4-channel to be an effective tool in creating new sonic environments for both serious and popular musical forms. The concept has met with almost universal critical acclaim, and strong general approval.

### The Problem

But alas only a handful of enthusiasts can actually enjoy this advance today. Because only a few 4-channel tapes have been produced for sale. The problem is simple, but basic: 4-channel means just that—four separate signals. And to reproduce it properly demands four of everything, right down the line.

Using four amplifier channels and adding four speakers is easy. Even creating a 4-channel tape recorder is practical (although expensive). But the stumbling block has been finding a way to put four completely independent signals in a record groove, or broadcast them over a standard stereo FM station.

And if you can't buy a 4-channel disc, or hear it on FM, the market is limited to a precious few 4-channel tape owners. But their numbers are so small that record companies just can't afford to release four

channel material. So they continue to produce 2-channel stereo that you *can* play (and that they can sell in volume).

### The Way Out

Now Electro-Voice has moved to break the impasse. With a system that can offer the significant advantages of discrete 4-channel, yet is compatible with present record playing equipment and present FM broadcasting. It is called STEREO-4.

STEREO-4 is a system that encodes four channels into a stereo signal that *can* be transmitted over FM or recorded on a disc. In the home you add a STEREO-4 decoder, plus another stereo amplifier and a pair of rear speakers. The result is reproduction that closely rivals the original 4-channel sound. Four different signals from your speakers, with a feeling of depth and ambiance you have never before heard from any record.

Admittedly, STEREO-4 is not quite the equal of 4 discrete signals. But while there is some loss of stereo separation, there is no reduction in frequency response or overall fidelity. We might note that this reduced separation actually seems to aid the psycho-acoustic effect for many listeners in normal listening situations. And on the plus side, STEREO-4 offers an advantage that even discrete 4-channel cannot provide.

### The Remarkable Bonus

Playback of almost all of your present 2-channel stereo library is greatly enhanced when fed through the STEREO-4 decoder. It's the result of multi-microphone recording techniques that include a remarkable amount of 4-channel information on ordinary stereo discs and tapes. Adding STEREO-4 releases this hidden information for you to enjoy.

### The Details

A STEREO-4 Model EVX-4 Decoder costs just \$59.95. And with it, plus 4 speakers and dual stereo amplifiers,

you're equipped for almost any kind of sound available. Encoded 4-channel, enhanced stereo, regular stereo, and discrete 4-channel (assuming suitable source equipment). Even mono. So you have the one system that is completely compatible with the past, present, and foreseeable future.

### The Present

And what about encoded 4-channel discs and broadcasts? Well, recording companies have already started mastering STEREO-4 records, and more are joining in. And STEREO-4 is now being broadcast in many major cities around the country.

### The Future

Like you, we hope for the day when discrete 4-channel sound will be commonplace on records and FM, and your STEREO-4 decoder will be relegated to enhancing your present library. But that day will have to wait until some very knotty design problems are solved. And probably after a host of new FCC regulations define an utterly new system. Indeed, there is serious question whether these problems can be solved at all.

In the meantime, the STEREO-4 system is getting 4-channel recordings into the marketplace in increasing numbers, in a form that people can enjoy. Hear STEREO-4 at your E-V soundroom soon. And ask your local FM station for a schedule of STEREO-4 broadcasts. Or write us for complete information. It's not too soon to start planning for tomorrow.

ELECTRO-VOICE, INC., Dept. 1214P,  
630 Cecil Street, Buchanan, Michigan 49107  
In Europe: Electro-Voice, S.A., Lyss-Strasse 55,  
2550 Nidau Switzerland

**Electro-Voice®**  
a GULTON subsidiary



EVX-4 Stereo-4 Decoder

CIRCLE NO. 4 ON READER SERVICE PAGE  
www.americanradiohistory.com