

GETTING THE BEST FROM YOUR TAPE RECORDER

Popular Electronics

FIFTY CENTS / OCTOBER 1971

Plastic Tiger Audio Power Amplifier

UNDERSTANDING
SOLID-STATE LASERS

DON'T BYPASS THE HOBBY SHOP

ELECTRONICS FIGHTS
NOISE POLLUTION

BUILD: SOLID-STATE LASER,
UNIQUE STEREO DECODER

PRODUCT TESTS: HARMAN-KARDON
CAD-5 CASSETTE DECK, HEATHKIT
VOM, LAFAYETTE MULTIBAND
RECEIVER, AVANTI CB ANTENNA

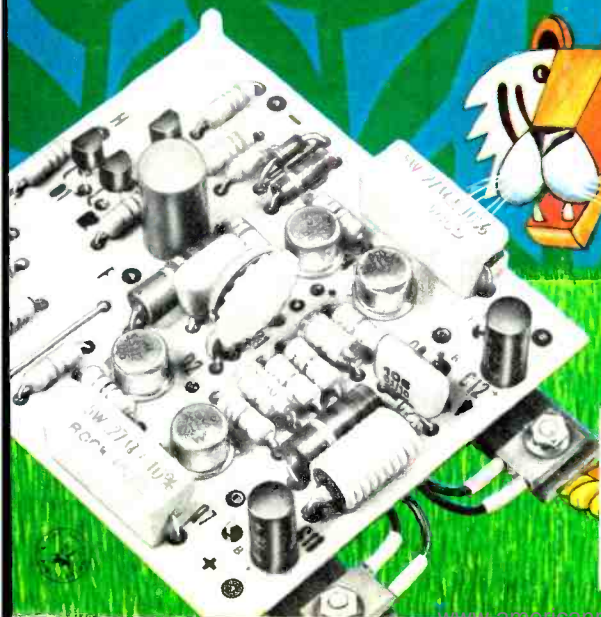

3708015 DLGM 245A601 01
REG00046261044001A 012
M DELSCHLAGER MAR
BX 245 K72
BROWNS MILLS NJ 08015

Kit for kit, text for text, dollar for dollar, your best home training buy is NRI

NRI "hands on" method gives you as much as 2 years of on-the-job experience. Pick your field and enroll now!

After over 55 years of training men for Electronics in their homes, NRI knows that theory alone is not enough. That's why NRI concentrates so heavily in the development of special training equipment. Your hands must be trained as well as your head, and NRI gives you both kinds of training in a manner no other school can match.

You get your hands on professional parts and demonstrate theory you read in NRI's unique "bite-size" texts. You build designed-for-learning Electronic circuits and complete, operating equipment. You use what you build to prove out what you read. Electronics comes alive in the most valuable, practical manner. You experiment with the same kinds of solid-state and transistorized and tube circuits you'll find on the job—not hardware or breadboard hobby kits.

NRI prepares you for your choice of careers in Color TV Servicing, Communications, Industrial Electronics and the growing field of Computer Electronics. Many NRI graduates start earning \$5 to \$7 an hour extra soon after they enroll, fixing home Electronic equipment for friends and neighbors in spare time. NRI's remarkable teaching method simplifies, organ-

izes, dramatizes subject matter so that any ambitious man, regardless of his education, can effectively learn and profit from the Electronics course of his choice—and NRI gives you 15 training plans to choose from.

Over three-quarters of a million men have enrolled with NRI since 1914. Proof of the value and experience you get when you choose NRI for your Electronics training . . . proof of why NRI continues to be the country's largest Electronics home-study school. Discover for yourself how easy it is to move into Electronics and move up in a rewarding career. Mail the postage-free card for the new NRI Catalog. There is no obligation. No salesman will call on you because NRI does not employ salesmen. NATIONAL RADIO INSTITUTE, Washington, D.C. 20016.



If postage-free card is missing, write to:
NATIONAL RADIO INSTITUTE
Washington, D.C. 20016

GET FACTS ABOUT GI BILL

If you have served since January 31, 1955, or are in service now, check GI line on postage-free card.



...first and only school to include training equipment designed from chassis up for your education

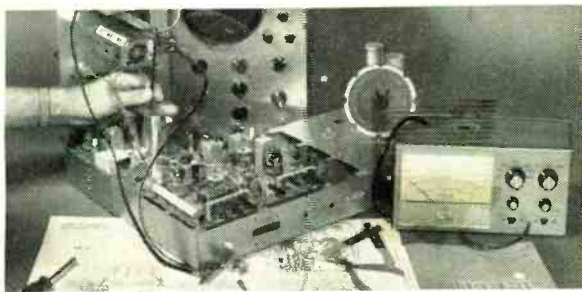

Earn \$5 to \$7 an hour spare or full time in COLOR TV SERVICING

It's easy to learn as you build, stage-by-stage, the only custom designed Color TV receiver engineered specifically for training purposes. You grasp a professional understanding of all color circuits through logical demonstrations never before presented. The end product is a superb Color TV set that will give you and your family years of viewing pleasure. NRI gives you the option of selecting either Color or black-and-white training equipment.

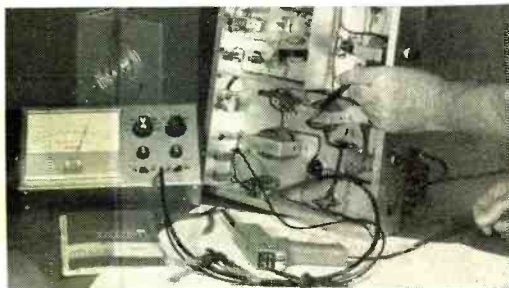

There's glamour, success awaiting Technicians in COMMUNICATIONS

NRI gives you the experience you need to qualify for jobs in TV broadcasting stations, or operating and servicing mobile, marine, aviation communications equipment. You build and use a solid-state voltohmmeter; perform experiments on transmission lines and antenna systems, even build your own 25-watt, phone-cw amateur transmitter band. In all NRI Communications courses, *you must pass your FCC exams—or you get your money back.*

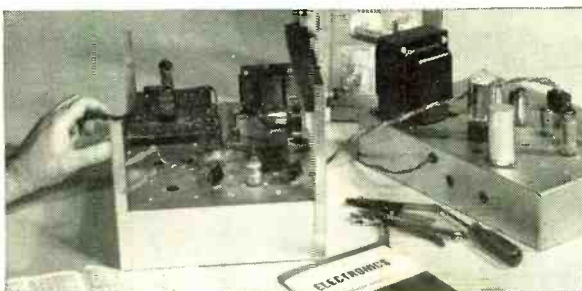

Fill technical jobs without a degree in INDUSTRIAL ELECTRONICS

NRI's Electronics Technology course gives you completely specialized training kits engineered for business, industrial and military Electronics fields. On completing this training, competent technical ability can be instantly demonstrated by you. As you learn, you actually build and use your own training center in solid-state motor control and analog computer servo-mechanisms. Telemetering circuits, solid-state multi-vibrators, even the latest integrated circuits are included in your home training program.



Prepare quickly for a high pay career in COMPUTER ELECTRONICS

This may well be the most unique and exciting educational aid ever developed for home training—a digital computer *with memory* you build and use to learn organization, trouble shooting, operation and programming. It performs the same functions as commercial computers you encounter on the job. Lessons stress computer repair. You perform a hundred experiments, build hundreds of circuits. Your own solid-state voltohmmeter is included among the ten training kits you receive.

OVER 50 YEARS OF LEADERSHIP IN ELECTRONICS TRAINING

Popular Electronics

WORLD'S LARGEST-SELLING ELECTRONICS MAGAZINE

FEATURE ARTICLES

- THE PLASTIC TIGER AUDIO POWER AMPLIFIER** 27 *Daniel Meyer*
An easy way to add two channels of sound
- UNDERSTANDING THE SOLID-STATE LASER** 35 *Forrest M. Mims*
Explains how it works
- SOLID-STATE LASER FOR THE EXPERIMENTER** 46 *Forrest M. Mims*
Tells how to build one
- DON'T BYPASS THE HOBBY SHOP** 50 *Frank H. Tooker*
Many things for electronics
- UNIQUE STEREO DECODER** 53 *Seymour Reich*
Update your FM receiver
- ELECTRONICS FIGHTS NOISE POLLUTION** 61 *Sidney L. Silver*
How industrial noise is being checked
- STEREO SCENE** 67 *J. Gordon Holt*
Setting Up a Tape Recorder
- COMMUNICATIONS** 71 *Leslie Solomon*
Finding lost souls
- OPPORTUNITY AWARENESS** 78 *David L. Heiserman*
- THE PRODUCT GALLERY** 80
Harman-Kardon CAD-5 Cassette Deck
Lafayette Guardian-6000 6-band Receiver
Avanti AY-527 CB Antenna
J & J Electronics Transistor Tester
Lendell Quick-Pick Tools
Heathkit IM-105 VOM
- SOLID STATE D-MOST transistors** 86 *Lou Garner*

DEPARTMENTS

- DIRECT & CURRENT** 7 *Milton S. Snitzer*
- INTERFACE** 8
- NEW LITERATURE** 12
- ELECTRONICS LIBRARY** 14
- READER SERVICE PAGES** 15, 99
- NEW PRODUCTS** 24
- OUT OF TUNE** 100
"The Drummer Boy" (July 1971)

POPULAR ELECTRONICS is Indexed
 In the Reader's Guide
 to Periodical Literature

Copyright © 1971 by ZIFF-DAVIS PUBLISHING COMPANY. All rights reserved.

William Z.H. President; Hershel B. Sarbin, Senior Vice President and Secretary; Philip Sine, Financial Vice President and Treasurer
 POPULAR ELECTRONICS, October 1971, Volume 35, Number 4. Published monthly at One Park Ave., New York, N.Y. 10016.
 One year subscription rate for U.S., U.S. Possessions and Canada, \$6.00; all other countries, \$7.00. Second class postage paid
 at New York, N.Y. and at additional mailing offices. Authorized as second class mail by the Post Office Department, Ottawa,
 Canada and for payment of postage in cash. Subscription service and Forms 3579: P.O. Box 1096, Flushing, N.Y. 11352.
 Editorial offices for manuscript contributions, reader inquiries, etc.: One Park Ave., New York, N.Y. 10016.

This month's cover art by
 Robert Korn

YOUR SOLDERING GUN IS OBSOLETE

Ungar's New #6760 makes it so!

Now Ungar gives you the better gun to tackle the most critical soldering jobs... the kind of jobs demanded by today's sophisticated electronics.

Here's why it's better. You get total electrical isolation—We grounded the gun—with a 3 wire NEMA plug and cord... so your sensitive I.C.s and densely packed components are safe from static electricity and stray currents. (It's also safer for you too.) The Isolated Grounded Tip—a simple idea that protects both you and your circuitry.

But we didn't stop there. We designed an entirely new soldering gun for you. Instead of the usual heavy, transformer you get reliable advanced circuitry. It makes this new gun a feather-light five ounces! Now you can accurately pinpoint solder in hard-to-get-to-spots without hand fatigue.

Next we added versatility. You get two heat ranges (500° and 900°F approx.)—all with the same gun. And, you have a choice of three thread-on replaceable tips that won't give or bend in constant use—select the shape that fits your needs best. For greater accessibility, you can easily lock the tip to the exact angle needed for your job.

A few other standard bonuses you get only with Ungar's new trigger-activated #6760: a virtually shatter-proof case—U.L. listed—a guarantee of excellence on each and every gun—and separately replaceable parts. But don't just take our word for it. Try one... or ask another pro who has one. Then make up your own mind.

Prove for yourself that in the age of solid state, Ungar really outguns the heavyweights.

Ungar®
Division of
Eldon Industries, Inc.



meet the metrics

Xcelite's where the Metrics are!

A great variety of tools and sets to help you turn most any Metric fastener or adjusting screw you're likely to encounter . . . hex socket set screws and cap screws, hex nuts, hex head cap screws, and whatever.

All tools precision made for exact fit. Bright nickel chrome nutdriver shafts and protective black oxide finished hex socket screwdriver blades. Plastic (UL) handles shaped for perfect grip and balance.

FIXED HANDLE NUTDRIVERS



NUTDRIVER SHANKS & HEX SOCKET SCREWDRIVER BLADES for use interchangeably in Series 99 plain and ratchet type handles.

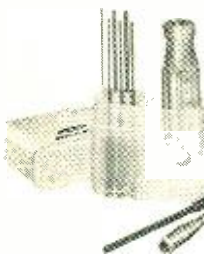

COMPACT SETS
No. 99-PS-41-MM
(7 Metric hex socket blades, extension and handle)



No. 99-PS-51-MM
(10 Metric nutdriver shafts, extension and handle)

nationwide availability through local distributors



XCELITE, INC.,
20 BANK ST., ORCHARD PARK, N. Y. 14127

Send Catalog with information on Xcelite Metric Tools.

name _____
address _____
city _____ state & zip _____

CIRCLE NO. 30 ON READER SERVICE PAGE

Popular Electronics

LAWRENCE SPORN
Publisher

MILTON S. SNITZER
Editor

LESLIE SOLOMON
Technical Editor

JOHN R. RIGGS
Managing Editor

EDWARD I. BUXBAUM
Vrt Director

ALEXANDER W. BURAWA
Associate Editor

ANDRE DUZANT
Technical Illustrator

JUDITH L. HOGAN
Editorial Assistant

J. GORDON HOLT
L. E. GARNER, JR.

DAVID L. HEISERMAN
Contributing Editors

RICHARD J. HALPERN
Advertising Manager

MARGARET DANIELLO
Advertising Service Manager

STANLEY NEUFELD
Associate Publisher

FURMAN H. HEBB
Group Vice President
Electronics and Photography

ZIFF-DAVIS PUBLISHING COMPANY

Editorial and Executive Offices

One Park Avenue, New York, New York 10016

212 679-7200

ALAN WASSERMAN, Sales

Midwestern Office

The Pattis Group, 4761 West Touhy Ave.,
Lincolnwood, Illinois 60644, 312 679-1100

GERALD E. WOLFE, DICK POWELL

Western Office

9025 Wilshire Boulevard, Beverly Hills, California 90211

213 Crestview 4-0265; BRadshaw 2-1161

Western Advertising Manager, BUD DEAN

Japan: James Yagi

Oji Palace Aoyama; 6-25, Minami Aoyama
6-Chome, Minato-Ku, Tokyo 407-1930/6821

Circulation Office

P.O. Box 1096, Flushing, N.Y. 11352

William Ziff, President
W. Bradford Briggs, Executive Vice President
Hershel B. Sarbin, Senior Vice President and Secretary
Stanley R. Greenfield, Senior Vice President
Philip Sine, Financial Vice President and Treasurer
Walter S. Mills, Jr., Vice President, Circulation
Phillip T. Heffernan, Vice President, Marketing
Frank Pomerantz, Vice President, Creative Services
Arthur W. Butzow, Vice President, Production
Edward D. Muhlfield, Vice President, Aviation Division
Irwin Robinson, Vice President, Travel Division
George Morrissey, Vice President
Sydney H. Rogers, Vice President

Ziff-Davis also publishes Airline Management, Boating, Business & Commercial Aviation, Car and Driver, Cycle, Electronics World, Flying, Modern Bride, Popular Photography, Skiing, Skiing Area News, Skiing Trade News, Stereo Review, and Travel Weekly.

Forms 3579 and all subscriptions correspondence should be addressed to POPULAR ELECTRONICS, Circulation Department, P.O. Box 1909, Flushing, N.Y. 11352. Please allow at least eight weeks for change of address. Include your old address, as well as new—enclosing if possible an address label from a recent issue.

EDITORIAL CONTRIBUTIONS must be accompanied by return postage and will be handled with reasonable care; however, publisher assumes no responsibility for return or safety of art work, photographs or manuscripts.



Member Audit Bureau of Circulations

POPULAR ELECTRONICS



By Milton S. Snitzer, Editor

A TYPICAL TECHNICIAN

Recently we sent one of our reporters to visit John Lizza, a sightless electronics technician, who lives in Carle Place, Long Island, N. Y. If there's anyone whose entire life is wrapped up in electronics, it's John. For 17 years, he had been employed at Reeves Instruments until his layoff last year when the company moved to Florida.

John is actively looking for a job, but in the meantime, like so many of our readers, he is busy with his avocational interest in electronics. Our reporter found a house full of tape recorders, phono equipment, test instruments, and ham gear. Some of the test equipment was special, using audible rather than visual readouts, but the audio and ham equipment were the same kind the rest of us use. He has a Drake receiver and a couple of Heathkit transmitters that he built himself. One of his audible meters parallels the plate-current meter in the Heath transmitter so that he can tune it up and put it on the air. He keeps a Weller soldering gun close at hand, for any soldering that has to be done.

Mr. Lizza also services his own equipment, as well as the radio and TV sets of his friends and neighbors. Did you ever try to adjust a TV set's hold control by listening to the sound made by the sweep oscillators in a transistor radio held near the picture tube?

After listening to our reporter's tape recording of the interview, we realized that John never lets his blindness keep him from doing what he wants to do. Like many of our readers, he is worried about a job, yet he optimistically makes plans for the future. He is sustained by his abiding interest in and love for electronics as a hobby, and is always learning more about it through his continuous, active participation. The rest of us can learn a lesson from the example of John Lizza.



INTERFACE

THANKS FROM RUSSIA

Many thanks to Mr. Ferrell and Mr. Solomon for helping me obtain components for assembling the "Waa-Waa" (January 1970) and Attack Delay Unit ("Modify Your Electronic Guitar Sound," June 1970). And my sincerest thanks go to John S. Simonton, Jr., whose construction projects for electronic music are much appreciated.

Vladimir Bolgov
Zaporozye, USSR

BASS AMPLIFIER DILEMMA

I was much impressed with Mr. Weems's "The Case For The Single Woofer" in the May 1971 issue of POPULAR ELECTRONICS. Since reading the article, I have decided to build my new system as suggested in the

story. Having already acquired the midrange speakers and tweeters and housed them in suitable enclosures, I am now turning my attention to the woofer. And here is where I have encountered a problem.

I have elected to pursue the method using a network to feed a speaker output signal to a bass amplifier (Fig. 2A in the article). Now I would like to know where I can obtain a bass amplifier for this application.

Peter B. Mann
Avondale Estates, Ga.

Any good instrument amplifier (available at music shops or through Heathkit, Lafayette Radio, Allied Radio Shack, etc.) will serve your purposes. However, any audio amplifier with a good response down to 15 Hz or less will also fill the bill. You can probably pick up one of these latter amplifiers very cheaply as a used item in hi-fi centers.

CRITICISM AND PRAISE

A few days ago I wrote to you to criticize the policy of making too many POPULAR ELECTRONICS construction projects dependent on components available only from Southwest Technical Products Corp. At that time, I had been waiting a considerable

True 4 Channel Sound

[\$42.50 per 20 watt channel]

There are several components on the market today that will give you true 4-channel sound. All are expensive. Except ours.

We call ours QAUDIO. It's an amplifier and player with 4 discrete channels. And we designed it primarily to play the new 8-track 4-channel cartridges.

But it will also play ordinary 8-track stereo cartridges, and make them sound fuller and richer than they ever have before.

Of course it takes a specially recorded 4-channel cartridge to give you the real QAUDIO experience.

You can experience it today—at a price that's almost as unbelievable as the sound: \$169.95. (That's \$169.95 for a true 4-channel amplifier-player with 80 watts of total music power.) A unit for car/boat is just \$129.95.

A free call to **800-631-1971** (in N.J. 800-962-2803) will give you the names of stores where you can experience a Qaudio demonstration.

For brochure: Toyo Radio Co. of America, Inc., 1842B W. 169th St., Gardena, Calif. 90247.



QAUDIO
BY TOYO

A SHOCKING EXPERIENCE IN SOUND

CIRCLE NO. 26 ON READER SERVICE PAGE

CIRCLE NO. 9 ON READER SERVICE PAGE →

NOW-PICK UP THAT DISTANT TV STATION

and enjoy the blacked out PRO games!

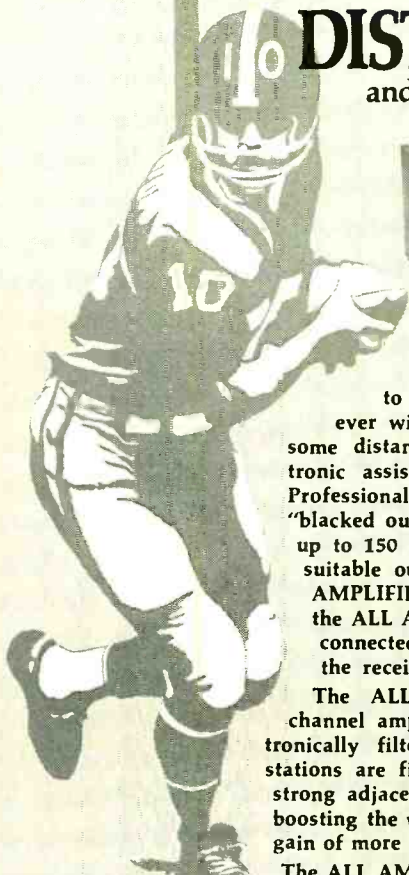

The ALL AMERICAN SPORTS AMPLIFIER® is a totally unique device for the television fan who wants to pick up TV programs from stations 75 to 150 miles distant. This means everyone who has ever wished they could "tune-in" programs from a station some distance away now has a truly "state-of-the-art" electronic assistant; the ALL AMERICAN SPORTS AMPLIFIER. Professional football, hockey, basketball and other events "blacked out" in your town, but carried on distant TV stations up to 150 miles away, can now be viewed. All you need is a suitable outdoor antenna and the ALL AMERICAN SPORTS AMPLIFIER. If you already have a suitable outdoor antenna, the ALL AMERICAN SPORTS AMPLIFIER installs in minutes, connected to your lead in line at the TV receiver, just before the receiver.

The ALL AMERICAN SPORTS AMPLIFIER is a single channel amplified filter. The single channel of interest is electronically filtered so only that channel remains. Strong, local stations are filtered out in the filtering circuit and this includes strong adjacent channels too! Then the amplifier goes to work boosting the weak distant channel signal by 22 to 25 db; a voltage gain of more than 10,000!

The ALL AMERICAN SPORTS AMPLIFIER utilizes newly created (patent pending) etched inductor amplified filter techniques. Hundreds of units were extensively field tested in CATV systems all across the United States and Canada for nearly 18 months before this unit was released to the public. For the complete story on this amazing electronic device, see the September 1971 issue of POPULAR ELECTRONICS magazine.

The ALL AMERICAN SPORTS AMPLIFIER is offered direct to you by the factory, tuned to the single channel of your choice. This is a fully wired and tested unit, ready to plug in and operate. Full installation instructions, including antenna installation instructions, are included with each unit.

As featured in September PE...



CADCO SYSTEMS
4444 Classen Blvd.
Oklahoma City,
Oklahoma 73118

Please send me ALL AMERICAN SPORTS AMPLIFIER(s) tuned for channel . My check/money order for \$97.50 (for each unit) is attached.

Name _____

Address _____

City _____ State _____ Zip _____

All units are shipped via insured parcel post. Sorry, NO COD orders accepted.

Save over \$47 on a Cobra



Cobra 25 CB Base Station

Reg. \$228⁰⁰ less microphone

Now \$189.95
with microphone

As if we weren't famous enough already. Now we're a household word.

Why? Because we've come up with everything you've been asking for in a CB radio designed for the home (or for that matter, any place a base station is used).

It's called the Cobra 25. You have to see it to believe it. Hear it and you'll be convinced.

Ultramodern new solid state circuit design gives you the biggest talk power in the industry—full 5 watts input, maximum legal output up to 4 watts.

And exclusive Dynaboost speech compression puts your message through crisp and sharp, even when others are garbled and unclear.

The word is spreading fast about the new big talking Cobra 25. Shouldn't you have one for your household or communications center?

**FACTORY-AUTHORIZED
LIMITED-TIME SALE**

Other selected models also on sale!

See your CB dealer today!



Product of Dynascan Corporation
1801 W. Belle Plaine
Chicago, Illinois 60613

CIRCLE NO. 7 ON READER SERVICE PAGE

INTERFACE (Cont'd. from page 8)

length of time for delivery of my first order from SWTPC.

Since my earlier letter, I have received my order and I find myself more than pleased with the contents. I was pleasantly surprised to find that my kit contained nearly every conceivable piece of hardware necessary to assemble the project, as well as wire, solder, and very detailed assembly instructions.

I feel the wait for delivery was well worth it, and I withdraw all previous remarks about SWTPC-based construction articles.

John W. Holland
Lincoln, Neb.

THE "REVIEWER" CHALLENGED

In the July 1971 "The Product Gallery" a few confused statements were made about headphone design. The statement: "By their very nature, stereo headphones are a design compromise since piping hi-fi sound into your ears directly is a far cry from listening in your listening room to the same sound bouncing off the walls and ceiling" is the exact opposite of the real situation.

Speaker systems are destroyed by room reflections. The finest speaker system in the world will sound no better than the room in which it is used. Headphones are free from room reflection and polar response and isolation problems.

The statement: "Headphones, unlike speaker systems that strive to attain a flat frequency response have 'sculptured' response curves—which is a polite way of saying that a headphone manufacturer has problems achieving wide range response (50-15,000 Hz) using transducers small enough to fit into an earpiece" irritates me. This not only implies that all headphones have poor response but that the manufacturers are not even striving to achieve it. My Koss ESP-9 headphone response is guaranteed to be 15-15,000 Hz, ± 2 dB. Show me a speaker system that can match the response of the ESP-9 in a normal room anywhere!

The Reviewer obviously dislikes headphones. That's his problem. But I hate to see such a wealth of misinformation go by unchallenged. I don't know whether the Stanton "Dynaphase I" phones reviewed were good or bad, but it seems unfair to preface their review with such an anti-headphone bias.

David Danby
Winnetka, Ill.



Just a few of the projects for which we've got solid state devices. All in one package For only \$4.95

If you bought the semiconductors for any one of these projects separately, they'd cost about seven bucks. Be our guest for \$4.95. And treat yourself to an easy, really fun electronic project with a really useful product on the other end.

The electronic timer is in great demand for darkroom and photography work, at sports events, etc. The automatic "porch" light and burglar alarm are, shall we say, quite timely. The TV commercial killer works off a regular flashlight, for stay-seated dousing of objectionable commercial audio. The code practice oscillator, the garage door switch, the alarm clock — all are excellent projects you'll be proud to have completed.

This project package (HEK-4) includes all five semiconductors needed, and a brochure with directions and circuit schematics for all projects (plus bonus project). Look for it. At your HEP supplier now.

Happy soldering.



MOTOROLA HEP® Semiconductors

P. O. Box 20924, Phoenix, Arizona 85001

CIRCLE NO. 22 ON READER SERVICE PAGE

www.americanradiohistory.com

Premium-Quality

LEDs

LIGHT EMITTING DIODES

priced for the
hobbyist/experimenter

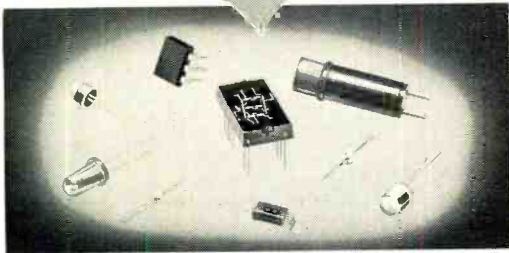

Here's your chance to get
the 'Cadillac' of the LEDs
... visible light sources, indicator lamps, alpha-
numeric readouts, photo-sensors, opto-isolators.

Sprague L.E.D. devices open up a new world of electronic experimentation. Projects such as intruder alarms, smoke detectors, light communicators, counters, controls, clocks, optical tachometers, computer readouts, Xmas light displays, etc. are *naturals* for these fantastically long-life, solid-state devices. Fully compatible with ICs, this new Sprague series includes replacements for conventional miniature lamps, as well as devices completely interchangeable with other leading makes of LEDs.

For complete data, write to Sprague Products Co., 395 Marshall St., North Adams, Mass. 01247. If you'd like to see these tiny LEDs in a working display, drop a note to our Mr. Guy Ezelle for the location of your nearest Sprague distributor.

*another exciting product from Monsanto

SPRAGUE[®]
THE MARK OF RELIABILITY

60-11179R1

CIRCLE NO. 25 ON READER SERVICE PAGE

12



To obtain a copy of any of the catalogs or leaflets described below, fill in and mail the Reader Service Page 15 or 99.

An expanded and up-to-date edition of a comprehensive Twist-Lok[®] and Print-Lok[®] Electrolytic Capacitor Replacement Manual has just come off the Sprague Products Co. presses. Expanded to include more suppliers than in the previous edition, Manual K110 now covers more than 300 different makes from Admiral to Zenith, including TV receivers as well as home and auto radios, hi-fi equipment, and CB stations manufactured from 1947 through December 1970. This 40-page manual lists original part numbers for each manufacturer and includes ratings, recommended Sprague capacitor replacements, and list prices. More than 2500 electrolytic capacitors are in the listing.
Circle No. 75 on Reader Service Page 15 or 99

There is plenty for every member of the family in the new 1971 catalog available from Edmund Scientific Co. This 148-page catalog is crammed full with intriguing buys for hobbyists, experimenters, students, and workshop enthusiasts. The more than 4000-item listing includes games, puzzles, rockets, tools, microscopes, telescopes, binoculars, photo attachments, ultra-violet light equipment, and the country's largest selection of unique lighting items.
Circle No. 76 on Reader Service Page 15 or 99

A new catalog containing all new entries in GC Electronics' expanded Audiotex product line has just been published. The 52-page, two-color catalog includes items for use in all phases of home electronics, from hi-fi listening in the living room to stereo accessories in the car. Included in the catalog are a variety of TV antenna installation hardware items and a comprehensive cable-connector-adaptor line for stereo equipment applications. Catalog No. FR-71-A lists more than 350 items for the music listener and hobbyist.

Circle No. 77 on Reader Service Page 15 or 99

POPULAR ELECTRONICS

University Premier Speakers put all of their eggs in one basket — on purpose.



Speaker components must be properly protected to assure long life and trouble-free operation. University's Premier Speakers are housed in award-winning, heavy-duty one piece die-cast baskets. Special cone assembly reproduces the

lowest bass frequencies without distortion and coloration. All five models of Premier Speakers are outstanding for clarity and depth of performance over the full frequency range. Don't settle for anything less if you want precise sound.

U UNIVERSITY SOUND DELIVERS!

ALTEC Division of LTV Ling Altec, Inc.

1515 S. Manchester Avenue, Anaheim, California 92803

Write for free detailed University Sound Components Catalog

CIRCLE NO. 29 ON READER SERVICE PAGE

CALL ME!



24 HOURS A DAY... 7 DAYS A WEEK

I'll send you 2 FREE BOOKS describing career opportunities in Electronics. Call me TOLL FREE: **800-321-2155**
(in Ohio, call 800-362-2105)

For details about the famous CIE home-study courses in Electronics, see our ad on page 18

Cleveland Institute of Electronics
1776 East 17th Street, Cleveland, Ohio 44114

AR guarantees its published specifications

At Acoustic Research we believe that the publication of complete performance data on our high fidelity components is obligatory. Otherwise, our guarantee would have little meaning.

Find out just what AR guarantees that its products will do. Mail the coupon below, and detailed technical literature will be sent to you free of charge.

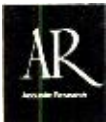

Acoustic Research, Inc.
24 Thorndike Street
Cambridge, Mass. 02141
Dept. PE-10

Please send measured performance data on AR products to

Name _____

Address _____

CIRCLE NO. 1 ON READER SERVICE PAGE



BASIC SLIDE RULE OPERATION Second Edition

by W.S. Mittelstadt

The slide rule is one of the most important tools available to the student and practicing scientist and engineer. The proper interpretation and manipulation of the scales on the slide rule are of paramount importance, and this self-instruction book will aid the reader in gaining familiarity with the rule. The text focuses on the basic operations: multiplication, division, and decimal placement; short cuts for longer problems in multiplication; special applications of multiplication and division; and squares, square roots, cubes, and cube roots. This is an extremely useful book for the beginner.

Published by McGraw-Hill Book Co., 330 West 42 St., New York, NY 10036. Soft cover. 235 pages. \$4.50.

STUDY GUIDE FOR CET EXAMINATIONS

by J.A. Wilson & Dick Glass

Written to give the veteran technician a sound and comprehensive review of the material covered by the Certified Electronics Technician exams, this book also serves as an excellent guide to help the technician pass a state or local licensing exam and serves as a review for anyone applying for a position in the electronics field. The scope is limited to radio-TV servicing—the areas in which current state legislation for technician certification is most vigorous.

Published by Howard W. Sams & Co., Inc., 4300 West 62 St., Indianapolis, IN 26468. Soft cover. 272 pages. \$5.95.

FIRE & THEFT SECURITY SYSTEMS

By Byron Wels

Today's increasing crime rate threatens virtually everyone and not just those who live in metropolitan areas. Criminals are more "mobile" than ever before—capable of striking at any time, anywhere. A secluded rural area is safer than the big city by only a precious small margin. And, of course,

Popular Electronics

READER SERVICE PAGE

free information service:

Here's an easy and convenient way for you to get additional information about products advertised or mentioned editorially (if it has a "Reader Service Number") in this issue. Just follow the directions below... and the material will be sent to you promptly and free of charge.

1. On coupon below, circle the number(s) that corresponds to the key number(s) at the bottom or next to the advertisement or editorial mention that is of interest to you. (Key numbers for advertised products also appear in the Advertisers' Index.) Print or type your name and address on the lines indicated.

2. Cut out the coupon and mail it to: POPULAR ELECTRONICS, P.O. Box 8391, Philadelphia, PA 19101.

note: If you want to write to the editors of POPULAR ELECTRONICS about an article on any subject that does not have a key number, write to POPULAR ELECTRONICS, One Park Avenue, New York, N.Y. 10016. Inquiries concerning circulation and subscriptions should be sent to POPULAR ELECTRONICS, P.O. Box 1096, Flushing, N.Y. 11352.

Popular Electronics

10/71-3
Void after November 30, 1971

P.O. BOX 8391
PHILADELPHIA, PA. 19101

1 2 3 4 5 6 7 8 9 10 11 12 13 14 15 16 17 18 19 20
21 22 23 24 25 26 27 28 29 30 31 32 33 34 35 36 37 38 39 40
41 42 43 44 45 46 47 48 49 50 51 52 53 54 55 56 57 58 59 60
61 62 63 64 65 66 67 68 69 70 71 72 73 74 75 76 77 78 79 80
81 82 83 84 85 86 87 88 89 90 91 92 93 94 95 96 97 98 99 100

NAME (Print clearly) _____

ADDRESS _____

CITY _____ STATE _____ ZIP CODE _____

Every record you buy is one more reason to own a Dual.

If you think of your total investment in records—which may be hundreds, even thousands of dollars—we think you'll agree that those records should be handled with the utmost care.

Which brings us to the turntable, the component that actually handles your precious records and tracks their impressionable grooves with the unyielding hardness of a diamond.

For many years serious music lovers have entrusted their records to one make of automatic turntable Dual. In fact, nearly all professionals, including record reviewers, use a Dual in their own stereo component systems.

If you'd like to know why, just write. We'll send you an article from a leading music magazine that tells you what to look for in record playing equipment. We'll also send you a series of independent test reports on Dual.

When you read them, you'll know why Dual has made an impression on the experts and none on their records.



United Audio Products, Inc.

120 So. Columbus Avenue, Mt. Vernon, New York 10553.

Exclusive U.S. Distribution Agency for Dual.

CIRCLE NO. 28 ON READER SERVICE PAGE

LIBRARY (Continued from page 14)

no one is completely safe from fire, regardless of locality. How can you protect your family, property, and possessions? What type of systems are best and most economical for each purpose? What equipment is needed, and how elaborate should a system be? The answers to these and many other vital questions are contained in this book.

Published by Tab Books, Blue Ridge Summit, PA 17214. 176 pages. \$7.95 hard cover, \$4.95 soft cover.

ESSENTIALS OF ELECTRONICS

by G.J. Wheeler & A.L. Tripp

This one-volume guide to the practical principles and methods associated with active electronic devices places emphasis on applications and troubleshooting techniques. Enough theory is included to provide the reader with a basic understanding of how devices and circuits operate, forming the essential foundation for later, more advanced, treatment of communication or computer theory. Separate chapters are devoted to power supplies, electric current, three-element devices, bias, linear and r-f amplifiers, signal-flow graphs, etc. The level of the text requires familiarity with only basic algebra and trigonometry.

Published by Prentice-Hall, Inc., Englewood Cliffs, NJ 07632. Hard cover. 436 pages. \$17.35 (\$12.95 in study edition).

NORTH AMERICAN RADIO AND TV STATION GUIDE, Seventh Edition

by Vane A. Jones

Contained in this Guide are listings for all of the nearly 10,000 radio and television broadcast stations in the U.S., Canada, Mexico, and West Indies. The 5500 AM, 3000 FM, and 1200 TV stations presently in operation, scheduled to start operation soon, or temporarily off the air are each listed by geographical location, frequency or channel, and call letters. This book is more than just a listing of stations; important statistics such as power by day and night, height of antennas, and sharing of time with other stations are given. Also listed is the network affiliation of each station. Educational and stereo FM stations are so designated.

Published by Howard W. Sams & Co., Inc., 4300 West 62 St., Indianapolis, IN 46268. Soft cover. 160 pages. \$3.95.

a
**remarkable
 listening
 experience**

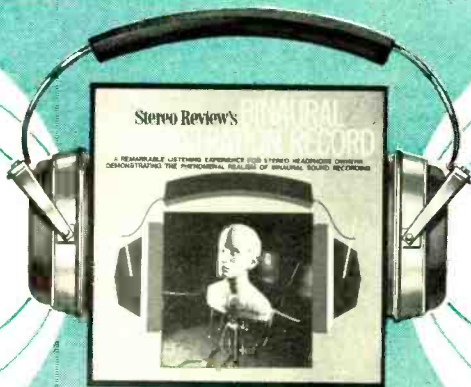

for
**stereo
 headphone
 owners!**

*The phenomenal realism
 of binaural sound recording
 is demonstrated by Stereo Review's*

AMAZING NEW BINAURAL DEMONSTRATION RECORD

Created specifically for playback through stereo headphones, this unique record presents the listener with sound of unsurpassed realism. It recreates at each of the listener's ears the precise sound that each ear would have heard—independently—at the original scene.

Binaural recording re-creates the directions, distances, and even the elevations of sounds better than any other recording method. The super-realism of binaural recording is accomplished by recording the acoustical input for each ear separately, and then playing it back through stereo headphones. Thus the sound intended for the left ear cannot mix together with the sound for the right ear, and vice versa. This technique eliminates all acoustical problems in playback, such as the effects of "dead" rooms, over-reverberant rooms, variations in stereo perspective caused by changes in sitting position, and variations in frequency response due to changes in speaker positioning.

Binaural recording offers the listener the identical acoustical perspective and instrument spread of the original. The sound reaching *each ear* is exactly the same as would have been heard at the live scene. The Stereo Review Binaural Demonstration Record is the only record of its kind; there is nothing else like it. It provides a unique listening experience that you will want to share with your friends.



"MAX"—GENIE OF BINAURAL RECORDING. More than a year of intense effort was devoted to the preparation of this recording. "Max," a specially constructed dummy head, was modeled by a professional sculptor, then cast in silicone rubber. Super-precision capacitor microphones were installed in Max's ears so that each microphone would pick up exactly what each human ear would hear. The two separate sound channels were then fed into an ultra-low-noise electronics system and then recorded on an advanced-design tape recorder operating at 30 inches per second.

In making location recordings for the demonstration side of the record, a recording technician taped miniature capacitor microphones into his ears, so his head would serve its normal acoustical role as an absorber and reflector of sound. The result is a demonstration of phenomenal recorded sound.

STARTLING REALITY. The Binaural Demonstration Record offers 45 minutes of sound and music of startling reality. Side 1 introduces you to binaural recording via a narrated demonstration in nine sequences, taking you through a variety of situations that show off the remarkable depth and natural perspective of binaural recording.

You'll marvel at the eerie accuracy with which direction and elevation are re-created as you embark on a street tour in binaural sound—Sounds Of The City...Trains, Planes & Ships... a Basketball Game, a Street Parade, a Steel Fabrication Plant, The Bird House at the Zoo—all demonstrating the incredible realism of binaural sound reproduction.

MUSIC IN BINAURAL. With "Max" acting as your extension ears, the musical performances presented on the Binaural Demonstration Record transport you to the concert hall for a demonstration of a wide variety of music. Selections total 23 minutes, and include examples of jazz, rock, organ, and chamber music.

A highlight of the record is the first recording of *Space Virgin*, a new jazz work by noted composer Ronnie Roullier. Insiders have already called it one of the most exciting jazz recordings ever made. The organ recordings, with Frederic Swann at the keyboard of the majestic Riverside Church organ, have been hailed for reproducing the whole range of organ sonorities totally without distortion, and are among the most memorable listening experiences of a lifetime.

The Stereo Review Binaural Demonstration Record is the ultimate in sound reproduction. It has been made without compromise for the owner of stereo headphones. If you own stereo headphones, this record is a *must*.

Note: Although headphones are necessary to appreciate the near-total realism of binaural recording, the record can also be played and enjoyed on conventional stereo systems.

Order your Stereo Review Binaural Demonstration Record today. **ONLY \$5.98.**

RECORDS, Ziff-Davis Service Division, 595 Broadway, N.Y., N.Y. 10012

Please send _____ Binaural Demonstration Records at \$5.98 each, postpaid. My check (or money order) for \$_____ is enclosed. (Outside U.S.A. please send \$8.00 per record ordered.) N.Y. State residents please add local sales tax. PE-10-71

Print Name _____

Address _____

City _____

State _____

Zip _____

PAYMENT MUST BE ENCLOSED WITH ORDER



This important job (and its big income) is reserved for a qualified electronics technician. It can be you!

It's a fact. There are *thousands* of jobs like this one available *right now* for skilled electronics technicians. What's more, these men are going to be in even *greater* demand in the years ahead. But how about you? Where do you fit into the picture? Your opportunity will never be greater... so act *now* to take advantage of it. The first step? Learn electronics fundamentals... develop a practical understanding of transistors, trouble-shooting techniques, pulse circuitry, micro-electronics, computers and many other exciting new developments in this growth field. Prepare yourself now for a job with a

bright future... unlimited opportunity with lasting security... prestige and a steadily growing paycheck.

Cleveland Institute of Electronics courses have been stepping stones to good jobs in electronics for thousands of ambitious men. Why not join them? You can learn at home, in your spare time, and tuition is remarkably low. Read the important information on the facing page. Then fill out the postage-free reply card and drop it in the mail today. Without obligation we'll send you all the details. But act now... and get *your* high-paying job just that much sooner.

How You Can Succeed In Electronics

... Select Your Future From Seven Career Programs

The "right" course for your career

Cleveland Institute offers not one, but seven different and up-to-date Electronics Home-Study Programs. Look them over. Pick the one that is "right" for you. Then mark your selection on the bound-in reply card and send it to us. In a few days you will have complete details... without obligation.

1A. Electronics Technology

A comprehensive program covering Automation, Communications, Computers, Industrial Controls, Solid-State Devices, and preparation for a 1st Class FCC License.



1B. Electronics Technology with Laboratory

Includes all areas of Course 1A including 1st Class FCC License preparation. In addition, student receives 161-piece Electronics Laboratory and 17 "lab" lessons for "hands-on" experience.



2. Broadcast Engineering

Here's an excellent studio engineering program which will get you a 1st Class FCC License. Now includes Video Systems, Monitors, FM Stereo Multiplex, Color Transmitter Operation and Remote Control.



3. First Class FCC License

If you want a 1st Class FCC ticket quickly, this streamlined program will do the trick and enable you to maintain and service all types of transmitting equipment.



4. Electronic Communications

Mobile Radio, Microwave and 2nd Class FCC preparation are just a few of the topics covered in this "compact" program. Highly recommended for jobs with telephone companies.



5. Industrial Electronics & Automation

This exciting program includes many important subjects such as Computers, Electronic Heating and Welding, Industrial Controls, Servomechanisms and Solid-State Devices.



6. Electronics Engineering

A college-level course for men already working in Electronics... covers Steady-State and Transient Network Theory, Solid-State Physics and Circuitry, Pulse Techniques, Computer Logic and Mathematics through Calculus.



An FCC License... or your money back!

In addition to providing you with comprehensive training in the area indicated, programs 1A, 1B, 2, 3 and 4 will prepare you for a Commercial FCC License. In fact, we're so certain of their effectiveness, we make this **exclusive** offer:

The CIE courses described here will prepare you for the FCC License specified. Should you fail to pass the FCC examination after completing the course, we will refund all tuition payments. You get an FCC License... or your money back!

CIE's **AUTO-PROGRAMMED** Lessons help you learn faster and easier

Cleveland Institute uses the new programmed learning approach. Our Auto-Programmed Lessons present facts and concepts in small, easy-to-understand bits... reinforce them with clear explanations and examples. Students learn more thoroughly and faster through this modern, simplified method. You, too, will absorb... retain... advance **at your own pace.**

Lifetime job placement service for every CIE graduate... at no extra cost

Once enrolled with CIE, you will get a bi-monthly listing of the many high-paying, interesting jobs available with top companies throughout the country. Many CIE students and graduates hold such jobs with leading companies like American Airlines, AT&T, General Electric, General Telephone and Electronics, IBM, Motorola, Penn Central Railroad, Raytheon, RCA, Westinghouse and Xerox... to name a few.

CIE Lessons are always up-to-date

Only CIE offers new, up-to-the-minute lessons in all of these subjects: Logical Trouble-shooting, Laser Theory and Application, Microminiaturization, Single Sideband Techniques, Pulse Theory and Application, Boolean Algebra and Solid-State Devices.

New Revised G.I. Bill Benefits:

All CIE courses are approved for full tuition reimbursement under new G.I. Bill. If you served on active duty since January 31, 1955, OR are in service now, check box on reply card or coupon for latest G. I. Bill information.

CIE Cleveland Institute of Electronics
1776 East 17th Street, Cleveland, Ohio 44114

If card has been removed, mail this coupon for 2 FREE BOOKS

Cleveland Institute of Electronics
1776 East 17th Street, Cleveland, Ohio 44114

Please send me without cost or obligation:

1. Your 44-page book, "How To Succeed in Electronics."
2. Your book on "How To Get a Commercial FCC License."

I am especially interested in:

- | | | |
|---|--|--|
| <input type="checkbox"/> Electronics Technology | <input type="checkbox"/> Broadcast Engineering | <input type="checkbox"/> Electronic Communications |
| <input type="checkbox"/> Electronics Technology with Laboratory | <input type="checkbox"/> First Class FCC License | <input type="checkbox"/> Industrial Electronics & Automation |
| | <input type="checkbox"/> Electronics Engineering | |

Name _____ Age _____
(please print)

Address _____

City _____ State _____ Zip _____

Veterans & Servicemen:
check here for G.I. Bill information.

PE-21

Accredited Member National Home Study Council.



We'll make you expert at whatever turns you on.

Today's Army can make you an expert at whatever you like best. And do best.

We can teach you all there is to know about tearing down an engine, fixing a television set, forecasting the weather.

We have more horsepower than the Motor City. Cameras that can take a portrait of a bird a half-mile away. Electronic equipment so new it hasn't even been named yet.

With more than 300 job-training courses to choose from, today's Army can take that favorite talent of yours and turn it into a rewarding lifetime career. And if you qualify, we'll guarantee your choice of training in writing. Before you enlist.

If you'd like to learn more about the opportunities to learn a skill in today's Army, see your nearest Army representative. Or just send the coupon.

Today's Army wants to join you.

Army Opportunities		Date	_____
Dept 200, Hampton, Va 23369		2 PE 10-71	
I'd like to know more about the job training courses in today's Army			
Send me your free book			
Name	_____	Date of Birth	_____
Address	_____		
City	_____	County	_____
State	_____	Zip	_____
Phone	_____		

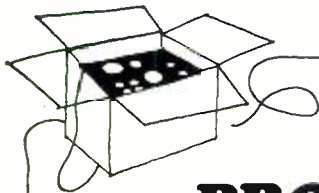

NEW PRODUCTS

Additional information on products described in this section is available from the manufacturers. Each new product is identified by a corresponding number on the Reader Service Page. To obtain additional information on any of them, circle the number on the Reader Service Page, fill in your name and address, and mail it in accordance with the instructions.

ADVENT CASSETTE TAPE DECK—The Advent Model 201 cassette tape deck combines the important characteristics of high-performance open-reel tape recorders with the convenience of cassettes. The new deck employs the Dolby Noise Reduction System to provide recordings of exceptionally wide frequency and dynamic range without obtrusive tape noise. In addition, the Model 201 combines a new heavy-duty transport mechanism and newly designed low-noise record/playback electronics. Its recording meter circuitry is specially compensated to provide full indication of high-frequency signal strength, and its equalization characteristic is switchable to allow for both conventional tape formulations and the greater potential of DuPont's "Crolyn" (chromium-dioxide) formulation. Price \$280 for 201 deck, \$20 for special optional microphone preamplifier.

Circle No. 78 on Reader Service Page 15 or 99

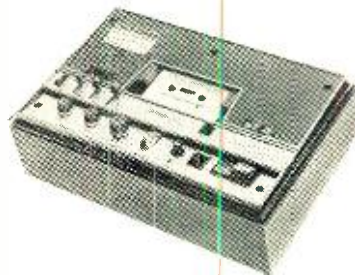

ALTEC "SANTIAGO" SPEAKER SYSTEM—Altec Lansing has just announced the availability of their Model 878A "Santiago," the latest entry into the company's Dynamic Force Speaker line. The Santiago uses "Voice of the Theatre" components: a 15" woofer with 3" voice coil and 17-lb magnetic structure for more control over cone movement; and an 18" high-frequency sectoral horn that provides smooth response up to 90° off axis. A dividing network provides crossover at 800 Hz with complete control of the high-frequency output by a continuously variable shelving control (an electronic crossover at 800 Hz is also available). The Santiago has a continuous power rating of 60 watts, an impedance of 8 ohms, and low-distortion frequency range of 20-20,000 Hz. Price \$399.

Circle No. 79 on Reader Service Page 15 or 99

EDI HIGH-VOLTAGE SOLID-STATE RECTIFIERS—Electronic Devices, Inc., recently announced a major development in the silicon rectifier field with the introduction of the company's new "Solid-Tube" solid-state high-voltage rectifier for direct field replacement of vacuum-tube rectifiers in color TV receivers. No electrical or mechanical changes are required for the replacements. Solid-Tube number R-3A3 replaces vacuum-tube types 3A3, 3AW3, 3B2, 1B3, 1G3, 1K3, and 1J3. Type R3AT2 is the solid-state replacement for the 3AT2 vacuum tube. Since there is no thermionic electron emission from the EDI rectifiers, the theoretical life expectancy of the Solid-Tube is infinite.

Circle No. 80 on Reader Service Page 15 or 99



DYNAMIC INSTRUMENT BATTERY CHARGER—A charging system that recharges sealed nickel-cadmium fast-rate cells to full charge level in an hour has been announced by *Dynamic Instrument Corp.* Partial charges can be given by the Model 3-1672A charger in proportionate time periods: half-charge in 30 minutes, quarter charge in 15 minutes, etc. The Model 3-1672A is the first of a complete series being developed which will ultimately charge as many as 12 Ni-Cad cells simultaneously. The Model 3-1672A itself recharges two series-connected 450-mA-hr rated cells to full capacity. The charger is available in two configurations: one with the transformer housed in the plug, the other with the transformer located within the product.

Circle No. 81 on Reader Service Page 15 or 99



GONSET HI-BAND VHF PORTABLE RECEIVER—The Gonset Division of Aerotron, Inc., recently announced the availability of the Model 6RP high-band VHF personal portable receiver for monitoring the range of frequencies between 146 and 160 MHz. The 6RP is a high-performance, true FM narrow-band "pocket" type receiver. It has a built-in antenna, and options include a two-frequency capability. The monitor also features an adjustable signal-to-noise ratio squelch, and can be used for monitoring police, fire, industrial, civil defense, amateur FM, and many other land-mobile services. Housed in a durable plastic case, the monitor measures only 5 $\frac{1}{8}$ " X 2 $\frac{1}{2}$ " X 1 $\frac{3}{16}$ ".

Circle No. 82 on Reader Service Page 15 or 99

WELTRON FUTURISTIC ENTERTAINMENT CENTER—Innovative in design, the *Weltron Co.* Model 2001 eight-track stereo tape player and AM/stereo FM receiver is modular in design. It features a 12" diameter spheroid cabinet. On one side of the cabinet are located all controls, selectors, dials, and cartridge insertion slot. In keeping with the futuristic design, the slide-type volume, tone, and balance controls are set into a black face for night time selection ease. The speakers follow the spheroid design of the player/receiver. The portable all-solid-state 2001 develops 3 watts of music power/channel. It can be operated on batteries, 12-volt auto supply, or line power. Price \$160.

Circle No. 83 on Reader Service Page 15 or 99



TRAVEL-TRON MOBILE TV ANTENNA—A new TV antenna, Model AC-700K, has been designed by *Antenna Corporation of America* especially for easy installation on campers, trailers, mobile homes, and boats. Called the Travel-Tron, the antenna operates in a manner similar to an umbrella. By simply pushing it up, powerful reception in color and monochrome on all VHF and UHF channels is obtained. In just seconds, the antenna snaps down and is completely enclosed in a weatherproof tube, ready for traveling. The Travel-Tron rotates fast to pick up stations in all directions.

Circle No. 84 on Reader Service Page 15 or 99

The RCA portable color bar generator



Performs like the big ones Costs only \$75*

- Provides color bar, dot, cross hatch, and blank raster patterns
- All solid state circuitry including ICs
- Pattern signals, RF output frequency and color subcarrier all crystal-controlled
- Battery operated, AC adapter available

- Lightweight — less than 20 oz., only 6½" wide x 4" deep x 3" high

For all the technical specs get in touch with your RCA Distributor. RCA | Electronic Components | Harrison, N.J. 07029.

* Optional User Price

RCA

CIRCLE NO. 24 ON READER SERVICE PAGE

POPULAR ELECTRONICS

FOR THE HI-FI BUFF who demanded outstanding performance in a high-power amplifier, there was the Universal Tiger ("Assembling a Universal Tiger," October 1970). But if your power requirements are more conservative with no lessening in the demand for quality, now there is the "Plastic Tiger," second cousin to the Universal Tiger.

Except for a more conservative output power capability (30 watts as opposed to the Universal Tiger's 80 watts into 8 ohms), the Plastic Tiger has virtually the same outstanding performance of its bigger cousin. By using plastic complementary output transistors capable of more than enough power for the average listening room, the Plastic Tiger is simpler in design and more economical.

The circuit of the Plastic Tiger is completely stable with any type of input or output termination. The output stage is protected against excessive current drain by the same unique circuit used in the Universal Tiger. This circuit protects the amplifier against any loading condition from an open circuit to a dead short at any frequency in the audio range. The amplifier is also safe to use with a parallel capacitive load of up to 1- μ F across an 8-ohm load at any frequency in the audio range.

The frequency response, distortion, noise, etc., characteristics are good enough to qualify the Plastic Tiger for use in

The Plastic Tiger Audio Power Amplifier

A SIMPLE WAY TO ADD
2 MORE CHANNELS OF
HIGH-QUALITY AUDIO

COVER STORY
BY DANIEL MEYER

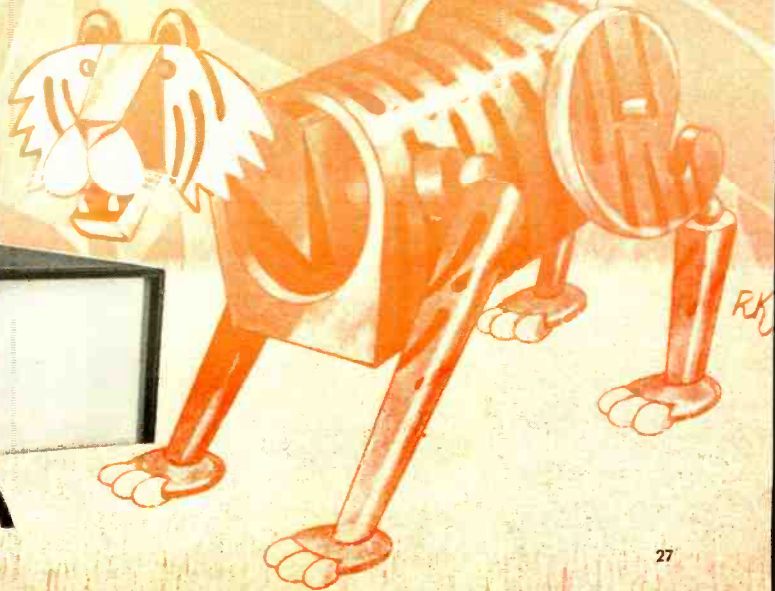
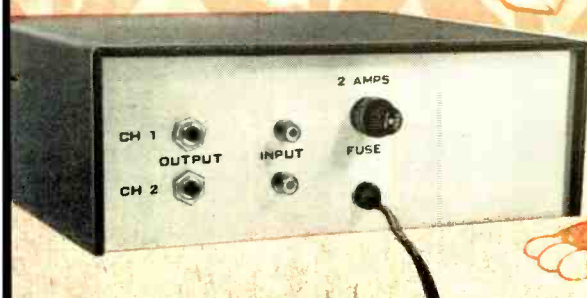

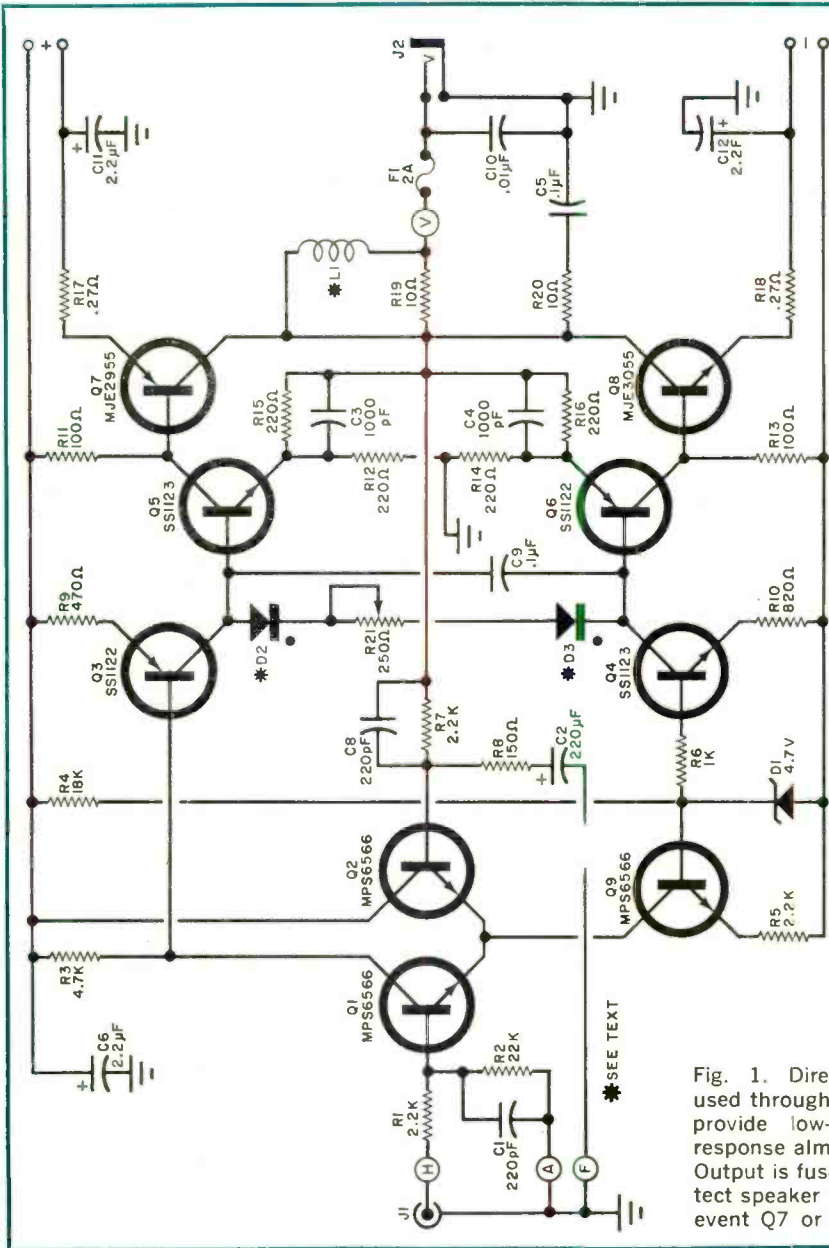

Fig. 1. Direct coupling is used throughout amplifier to provide low-end frequency response almost down to dc. Output is fused by F1 to protect speaker from damage in event Q7 or Q8 should fail.

even a "super" system. It is very unlikely, for example, that it would be possible to detect the difference between this amplifier and an amplifier with better performance with anything but a distortion analyzer. Further, the Plastic Tiger produces no detectable "coloration" to amplified sounds

Theory of Circuit Design. The circuit of

the Plastic Tiger is shown in Fig. 1. The input stage consists of a differential amplifier with the input signal applied to the base of Q1 and the feedback applied to the base of Q2. Current source transistor Q9 provides controlled emitter current. The high impedance to the signal input point provided by the current source decouples the signal from any hum or noise existing on the -40-volt bus.

PARTS LIST

- C1,C8—220-pF capacitor
 C2—220- μ F, 6-volt electrolytic capacitor
 C3,C4—1000-pF capacitor
 C5,C9—0.1- μ F capacitor
 C6,C11,C12—2.2- μ F, 50-volt electrolytic capacitor
 C7—Not used
 C10—0.01- μ F capacitor
 D1—1.7-volt, 1-watt zener diode (1N4732 or similar)
 D2, D3—Compensating diodes (see text)
 F1—2-ampere standard fuse
 J1—Phono jack
 J2—Single-circuit phone jack
 L1—Single layer of #26 wire close-wound on body of R19
 Q1,Q2,Q9—MPS6566 transistor (Motorola)
 Q3,Q6—SS1122 transistor (Motorola)
 Q4,Q5—SS1123 transistor (Motorola)
 Q7—MJE2955 transistor (Motorola)
 Q8—MJE3055 transistor (Motorola)
 R1,R5,R7—2200-ohm, $\frac{1}{2}$ -watt 10% resistor
 R2—22,000-ohm " " "
 R3—4700-ohm " " "
 R6—1000-ohm " " "
 R8—150-ohm " " "
 R9—470-ohm " " "
 R10—820-ohm " " "
 R11,R13—100-ohm " " "
 R12,R14,R16—220-ohm, $\frac{1}{2}$ -watt, 10% resistor
 R4—18,000-ohm, 1-watt, 10% resistor
 R19,R20—10-ohm, 1-watt, 10% resistor
 R17,R18—0.27-ohm, 5-watt, 10% resistor
 R21—250-ohm potentiometer
 Misc.—Fuse holder; printed circuit board; chassis box; $\frac{1}{4}$ " spacers; #18 or #20 hookup wire; mica insulators for Q7 and Q8; heat-transferring silicone paste; 4-40 machine hardware; solder; etc.
 Note—The following items are available from Southwest Technical Products Corp., 219 W. Rhapsody, San Antonio, TX 78216: Circuit board No. 185b for \$2.35; kit of parts for one channel, including circuit board but minus chassis and power supply, for \$18.50 plus postage on 1 lb.; complete kit of parts for two channels plus power supply and chassis for \$55.00 plus postage on 10 lb.

The output signal from Q1 drives the base of Q3 which is the positive half of the bidirectional current driver. The negative half of the current driver is the Q4 circuit. Transistors Q3 and Q4 provide the output driver transistors, Q5 and Q6, with a high-impedance current source drive signal.

Diodes D2 and D3, actually base-emitter junctions of silicon transistors, plus

potentiometer R21 provide enough bias voltage to just turn on the driver transistors. A gain of two is provided by Q5 and Q6 operating class AB. This gain is a function of the ratio between R15/R12 and R16/R14.

Current source driver Q9 and a large amount of feedback eliminate any trace of crossover distortion. The load, or speaker system, is driven by the signal present at the collectors of output transistors Q7 and Q8. The lag network made up of R20 and C5 determines the high-frequency roll-off point in the feedback loop as is normally the case with this type of amplifier. Coil L1 decouples the load at high frequencies to insure that the feedback loop cannot be shorted by an external capacitance and cause high-frequency oscillation. Capacitor C10 simply provides r-f bypassing at the load terminals.

In Fig. 2 are shown amplitude and phase plots. The upper plot is for frequencies from 20 Hz on down, while the lower plot is for frequencies 20,000 Hz on up. The frequency and phase plots between 20 and 20,000 Hz form straight lines.

The low-frequency curves show that the amplifier is down 1 dB at 5 Hz with gain approaching unity at dc. The phase shift plot shows that a maximum low-frequency phase shift of about 60° occurs at approximately 0.7 Hz and then gradually approaches 0° again near the dc point.

The high-frequency curves show the amplifier to be down 1 dB at approximately 100,000 Hz, while the unity gain point occurs at 1.3 MHz. The phase plot shows that the amplifier has approximately a 40° phase margin, enough to insure stability under any operating conditions.

A plot of output impedance versus frequency is given in Fig. 3. The wiring resistance is on the order of 0.05 ohm and is included in this plot which was taken at the amplifier's output terminals. The output impedance is quite low over the majority of the audio range and begins a slow rise beyond 5000 Hz. It reaches a maximum of 0.2 ohm at 20,000 Hz. This is about what would normally be expected from the amount of feedback and the bandwidth of the circuit.

Oscilloscope waveform photos of the square-wave response of the amplifier at

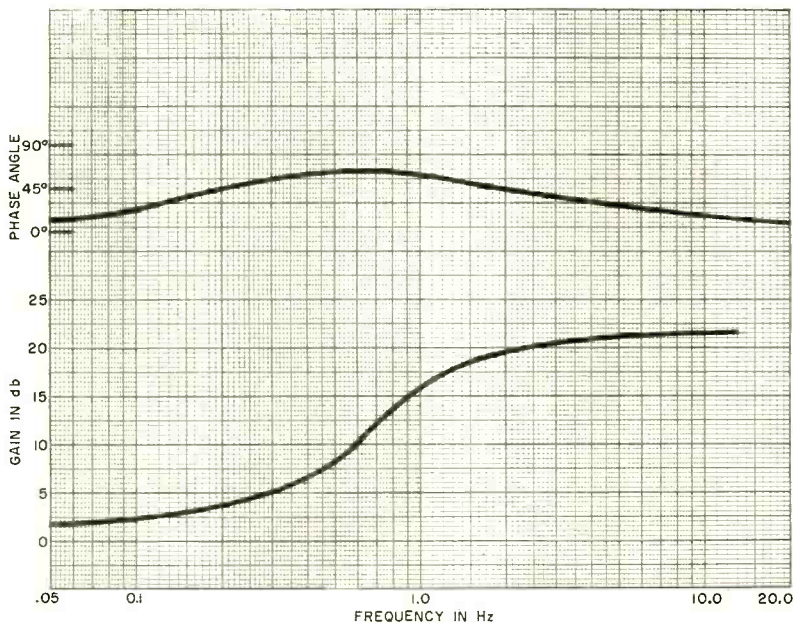
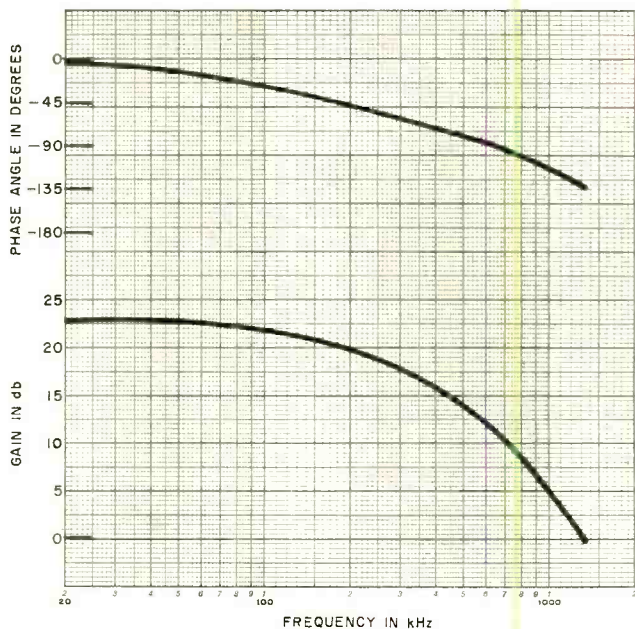

Fig. 2. Shown here are amplitude and phase plots for 20 Hz on down (above) and 20 kHz to 2 MHz (right). Frequency and phase plots for 20-20,000 Hz form straight lines.



10,000 and 100,000 Hz are given in Fig. 4. The 10,000-Hz photo was taken only because this frequency is commonly used in amplifier testing. It is actually too low a frequency for testing an amplifier such as the Plastic Tiger. The 100,000-Hz response photo shows clearly the rise time of approximately $2.5 \mu\text{s}$ and the complete absence of "ringing" when driven with a step input. (Caution: Performing this test

is not recommended for most amplifiers and should not be performed on the Plastic Tiger by the layman.)

Assembly. The majority of the components that make up the Plastic Tiger are to be mounted on a printed circuit board. If you plan to etch and drill your own board, an actual size etching and drilling guide and a components placement dia-

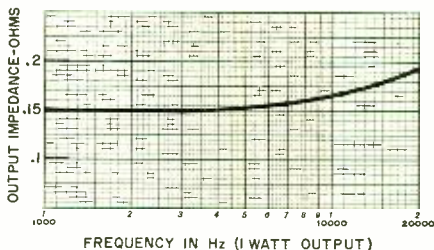

Fig. 3. Output impedance is quite low over audio range, rising to 0.2 ohm at 20 kHz.

gram are provided in Fig. 5. For those who prefer to purchase a ready-made board, refer to the Parts List for source information. Mount the components on the board and solder their leads to the foil pattern.

Power transistors Q7 and Q8 are to be mounted on the bottom of the board with their leads extending up through the holes drilled to accommodate them. To mount the transistors, first bend the outer leads up $\frac{1}{4}$ " from the case and the center leads $\frac{7}{16}$ " from the case. When these leads are correctly bent, the metal side of the transistor cases will be facing down. Insert the transistor leads in the appropriate holes in the circuit board. Squarely position the transistors so that their bottom surfaces are parallel to and $\frac{1}{4}$ " from the foil side of the board. Solder the leads to the foil pattern. If the mounting procedure is not done carefully, Q7 and Q8 will not lie flat on the chassis and heat sinking will not work properly.

Coil L1 is made up of #26 insulated hookup wire close wound in a single layer along the body of R19. The exact value of this coil is not critical, and 8-10 turns

will be the average number you can wind on the resistor. Strip away the insulation from both ends of the coil and solder the exposed wires to the leads of R19. Then mount the L1/R19 assembly in the appropriate location on the circuit board.

Bias diodes D2 and D3 are made from a pair of 2N4918 transistors after first cutting away the collector (center) leads. Use the emitter leads for the cathodes, soldering them to 3" lengths of hookup wire and the free ends of the hookup wire to the holes near the dots on the board. The base leads go to the unidentified anode holes via 3" wires.

Solder color-coded 10" lengths of hookup wire to the foil pattern at holes A, F, and H. Twist these wires together in a neat bundle. Solder one end of a 10" length of #18 or #20 wire to hole G, and 6" lengths of the same wire to both + and both - holes and hole V. Temporarily set the board aside.

Almost any power supply capable of delivering 2 amperes of current and with +40 and -40 volt sources will adequately power the Plastic Tiger. An example of such a power supply is given in Fig. 6.

The photos in Fig. 7 show an assembled stereo version of the Plastic Tiger. The same assembly procedures apply to both mono and stereo versions. Now, with the exception of the filter capacitors and their mounting clips, mount the power supply components on the chassis as shown. Power switch S1, if used, should be mounted on a 4-lug terminal strip with the center, or common ground, lug not used (the rectifier bridge assembly simply bolts directly to the chassis floor).

After mounting the input and output

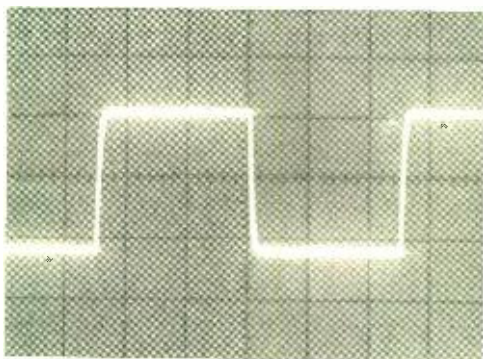
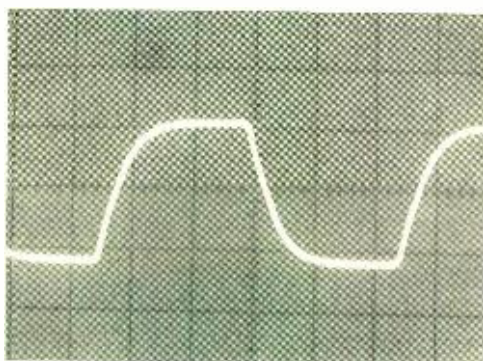

Fig. 4. Square wave output waveforms from amplifier show virtually zero distortion



at 10,000 Hz (above left) and absence of ringing at 100,000 Hz (above) and beyond.

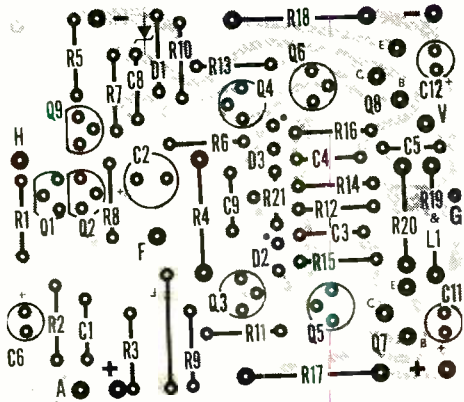

Fig. 5. Actual size etching and drilling guide at left is supplied for those who wish to make their own PC boards. Diagram above shows locations and orientations of components on PC board.

HIRSCH-HOUCK LABORATORIES Project Evaluation

The 30-watt output power rating of the Plastic Tiger amplifier seems to be justified, although its power supply limitations keep it from realizing this power below 300 Hz. At 30 watts/channel, the distortion is only 0.084% at 300 Hz, but is 7% at 100 Hz and far greater with decreasing frequency. Otherwise, the distortion at any power level up to 30 watts/channel is typically well below 0.1% from 20 to 20,000 Hz. At normal listening levels, the distortion is less than 0.07% at any frequency, qualifying the Plastic Tiger as a first-rate high-fidelity amplifier.

The 1000-Hz harmonic distortion remains less than 0.09% from 0.1 watt to 30 watts, clipping rapidly at higher power levels. Intermodulation distortion follows a similar characteristic, but it is slightly greater—typically less than 0.3% up to 30 watts output.

At the point of visual waveform clipping, the output power into 8 ohms was 40.5 watts/channel; into 4 ohms, 33 watts/channel; and into 16 ohms, 25 watts/channel. The 8-ohm clipping level was also checked at low frequencies: at 50 Hz, it was 22 watts; at 20 Hz, it was 18.7 watts.

All of the preceding measurements were made with the Plastic Tiger's bias control set as received. The control was subsequently adjusted for minimum distortion at low power output levels (it is interesting to note that waveform notching could not be observed at any setting of the control). This produced a substantial reduction (two to five times) in both harmonic and IM distortion at power levels below 1 watt but had negligible effect at higher power levels. The optimum setting was with the control at one extreme. No measurements were made on idling currents under this condition, but it is possible that transistor dissipation would be undesirably high. If so, there is no point to the optimization of distortion since it is adequately low at almost any control setting.

The frequency response of the Plastic Tiger was flat across the audio spectrum, down 0.2 dB at 15 Hz and 50,000 Hz, and down 1.7 dB at the lower measurement limit of 5 Hz. The high-frequency output was down 3 dB at 190,000 Hz. Square-wave rise time was 2 μ s, while noise was 83 dB below 10 volts.

Although the entire amplifier became quite hot during our tests, this was not the case during normal listening usage. In all, the Plastic Tiger is certainly a compact, low-cost powerhouse.

jacks on the front panel, mount the circuit board as follows. Spread a film of heat transferring silicone paste on both sides of four mica insulators; then place the insulators over the appropriate holes in the chassis. Lower the circuit board onto the chassis, aligning the mounting holes of the power transistors with the holes in the insulators and chassis. Press the transistors firmly into the paste. Place the metal sides of the diodes against the respective transistor cases—D2 atop Q7 and D3 atop Q8—and orient them as shown. Fasten the diode/transistor pairs to the chassis with 4-40 machine hardware. Then, at the opposite end of the board, anchor the circuit assembly firmly in place with 4-40 hardware and 1/4" spacers.

Locate the twisted-together wires coming from the circuit board and route them to J1 along the side of the chassis away from the power transformer. Connect and solder the wire coming from hole A to the

signal, or center, contact of J1. Connect and solder the remaining two wires in the bundle to the ground lug on J1. Use two separate wires coming from holes A and F as directed, grounding them only at the input jack.

Bolt the speaker fuse holder to the floor of the chassis with 4-40 hardware. Also, mount the capacitor clips to the rear apron of the chassis and slip into them the filter capacitors. Wire together the power supply components, referring to Fig. 6. The common (COMM) line from the power supply connects to the circuit ground by running a length of #18 or #20 wire from the junction between C1 and C2 in the power supply to the ground lug on J2. If the stereo version of the amplifier is being built, run a separate wire from the capacitors to the respective jack ground lugs. (Note: Do not solder any connection to J2 or the speaker fuse holder lugs until directed to do so.)

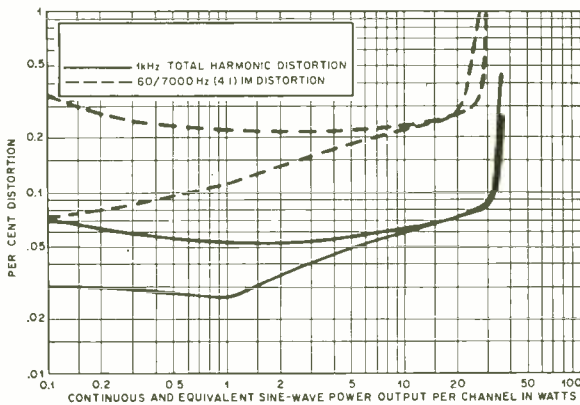

With R21 set as received upper broken and upper solid curves indicate measured distortion. Remaining curves were obtained when R21 was set for minimum distortion.

Curves show extremely low harmonic distortion over entire audio range at various power levels.

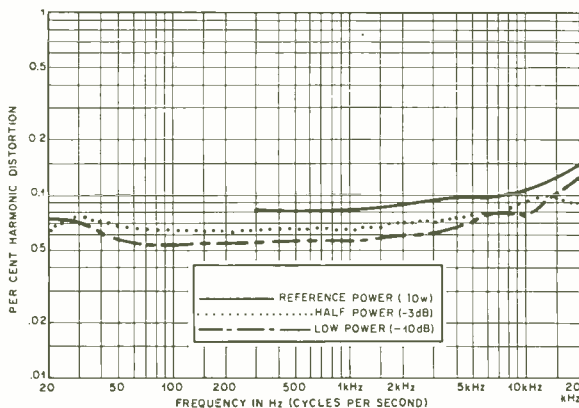

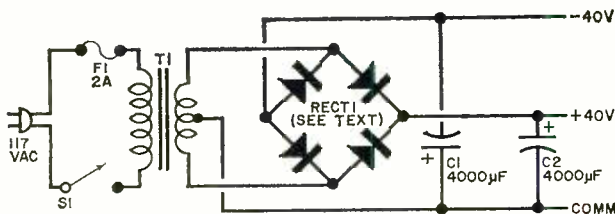

Fig. 6. In typical power supply for Plastic Tiger amplifier, RECT1 can be discrete diodes or rectifier assembly.

PARTS LIST POWER SUPPLY

C1, C2—4000- μ F, 50-volt electrolytic capacitor
 F1—2-ampere fuse
 RECT1—Four 200 PIV, 3-ampere silicon diodes or substitute Motorola MDA962-3 full-wave bridge rectifier assembly

S1—Spst switch (optional)
 T1—12- to 45-volt, center-tapped, 2-ampere power transformer
 Misc.—Fuse holder; 4-lug terminal strip; line cord with plug; hookup wire; solder; hardware; etc.

Locate the free end of the wire from hole G. Route this wire across the center of the chassis and connect and solder it to the lower hole in the ground lug on the terminal strip. Connect the free end of the wire from hole V to the near lug on the speaker fuse holder; then connect a length of #18 or #20 wire from the other fuse holder lug to the signal contact lug on J2. Lastly, connect C10 to the lugs of J2 and solder all lug connections to the output jack and the speaker fuse holder. All that is left of the wiring is to connect and solder the two wires from the - holes on the board to the negative side of C2 and the two wires from the + holes to the positive side of C1.

Carefully check your wiring, especially in the power supply, against Fig. 1 and Fig. 6 for errors. When you are satisfied that your wiring is correct, use an ohmmeter to check the resistance from each lead of the biasing diodes and output transistors to chassis ground. Reverse the ohmmeter leads and perform the tests again. In all cases, the readings obtained should be several megohms to infinity. If you obtain a short-circuit indication or a very low resistance reading, the component in question is not properly insulated from the chassis and will have to be dismantled and resealed until insulation integrity is obtained.

(Continued on page 100)

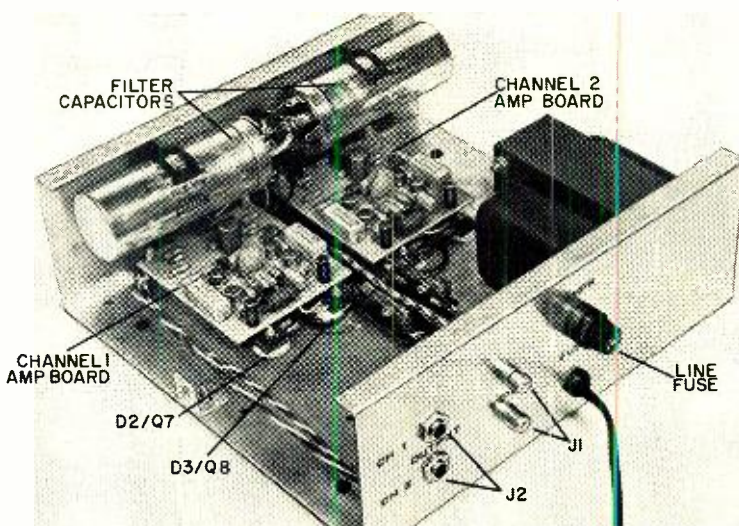

Fig. 7. In photo of completed two-channel version of Plastic Tiger, note the special mounting arrangement given to D2/Q7 and D3/Q8.



UNDERSTANDING SOLID-STATE LASERS

TRUE LASERS AS SMALL AS THE HEAD OF A PIN, OPERATE FROM CONVENTIONAL BATTERIES, YET DELIVER COHERENT, MONOCHROMATIC LIGHT

BY FORREST M. MIMS

WOULD YOU BELIEVE that there are lasers smaller in size than the proverbial grain of sand? Well, semiconductor lasers like the one in the photo at left have been around since 1962; but few people have even heard of them. This tiny laser promises to make important contributions to communications, crime prevention, and even ultra-fast computers in which wire interconnections are replaced by beams of light. Like all other new and specialized electronic components, these lasers are relatively expensive; but a recent price cut by one major manufacturer makes the semiconductor laser by far the least expensive of all lasers and entirely within the budget of many electronics experimenters.

The history of the semiconductor laser is filled with difficult technological and theoretical accomplishments—flavored with a dash of serendipity. Even before Theodore Maiman's first ruby laser was constructed in 1960, physicists had made predictions about the possibility of laser action in a semiconductor. In the late 1950's and early 1960's, rapid advances

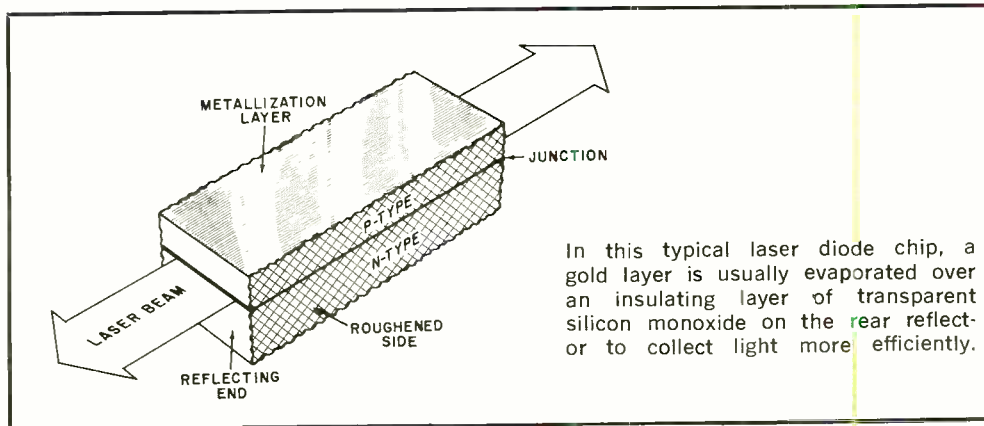

In this typical laser diode chip, a gold layer is usually evaporated over an insulating layer of transparent silicon monoxide on the rear reflector to collect light more efficiently.

were made in the development of semiconductor light-emitting diodes (LED's) and most scientists working in the field realized that laser action was within reach. In 1962 a Soviet researcher reported that the output of an LED became purer when the diode was stimulated by very high current pulses. This was an important clue since theory had not predicted the very high current levels which would eventually be needed for true laser action in a semiconductor diode.

Researchers at several important laboratories went right to work in a highly competitive race to develop the first laser diode. In the fall of 1962, GE, IBM, and MIT all announced the development of lasers made from specially modified LED's.

The laser diode development immediately touched off a major research effort. Since the laser diode converted electricity directly into light, it was far more efficient than any other laser at that time. And, even now, only certain types of gas lasers are more efficient.

The first diode lasers were made from gallium arsenide (GaAs); and, though lasing has been observed in numerous other semiconductors, nearly all semiconductor laser research centers around this material. Diodes are commonly used, but since some semiconductors cannot be given a junction, bulk material is sometimes bombarded by high energy electrons to produce laser action. This technique can result in beams of intense visible light.

Since GaAs lasers normally emit infrared and must be operated at very low temperatures to produce visible light,

there is strong interest in materials which produce visible light at room temperatures.

Both GE and IBM went on to produce commercial lasers for civilian and military applications, but RCA has made perhaps the biggest contribution to the field. Having had considerable experience with GaAs (as a result of years of work with radiation resistant solar cells and tunnel diodes) RCA was in an excellent position to jump into the laser field, and they perfected new techniques for fabricating efficient solid-state lasers. General Electric eventually dropped out of commercial production due to the limited market, but RCA and IBM have competition now in the form of several other laser producing companies.

How They Operate. The LED readily emits light when stimulated by very small amounts of electricity. In the case of the laser, we require that such a medium be placed between two mirrors to fulfill a fundamental requirement for laser action. So, why can't we fabricate an LED so that it has two parallel mirrors? We can—very conveniently—since the index of refraction of most semiconductors is sufficiently high that their surfaces act as partially reflecting mirrors. GaAs is a crystal and since a crystal cleavage surface is very flat and they can be made parallel to each other, it is very easy to make a GaAs LED into a laser diode merely by cleaving two opposite sides. It is actually very easy to cleave GaAs and the operation is often accomplished with nothing more than a razor blade; but for many reasons, the process used

is not that simple, so fabrication becomes an important subject.

Fabrication of Laser Diodes. The LED can be a very simple device. In fact, even a conventional silicon or germanium diode will produce infrared light—though very inefficiently. GaAs LED's are often merely a wafer of p-type material into which has been diffused a thin layer of n-type material. Light emission occurs at the junction of the p and n layers when electrons, propelled over the junction barrier by the diode's forward voltage, fall back to their normal unexcited state. In the process, most of the electrons give up a good deal of their stored energy in the form of light.

Although this process of light generation is basic to the diode laser, its fabrication is far more specialized. Before the GaAs crystal is cleaved to form the parallel, reflecting sides, it is prepared in wafer form. Very thin wafers which

have been sliced from the bulk crystal by a diamond saw are given a pn junction by either the diffusion or epitaxial process. In the case of diffusion, an n-type wafer is baked under carefully controlled conditions in the presence of zinc or other p-type materials. After a suitable period, the wafer is removed from the furnace, cleaned, and metallized on both sides with tin, gold, or some other contacting material.

The metallizing process is the same for epitaxial lasers, but the junction formation process is far different. There are several techniques; but usually the wafer, after being brought to a high polish, is immersed in molten p-type GaAs. A very thin section of the polished surface melts and, when the furnace is slightly cooled, a layer of GaAs literally grows on the wafer. The process results in extremely uniform pn junctions—a very important factor in the operation of the diode laser.

The fabrication process from here on

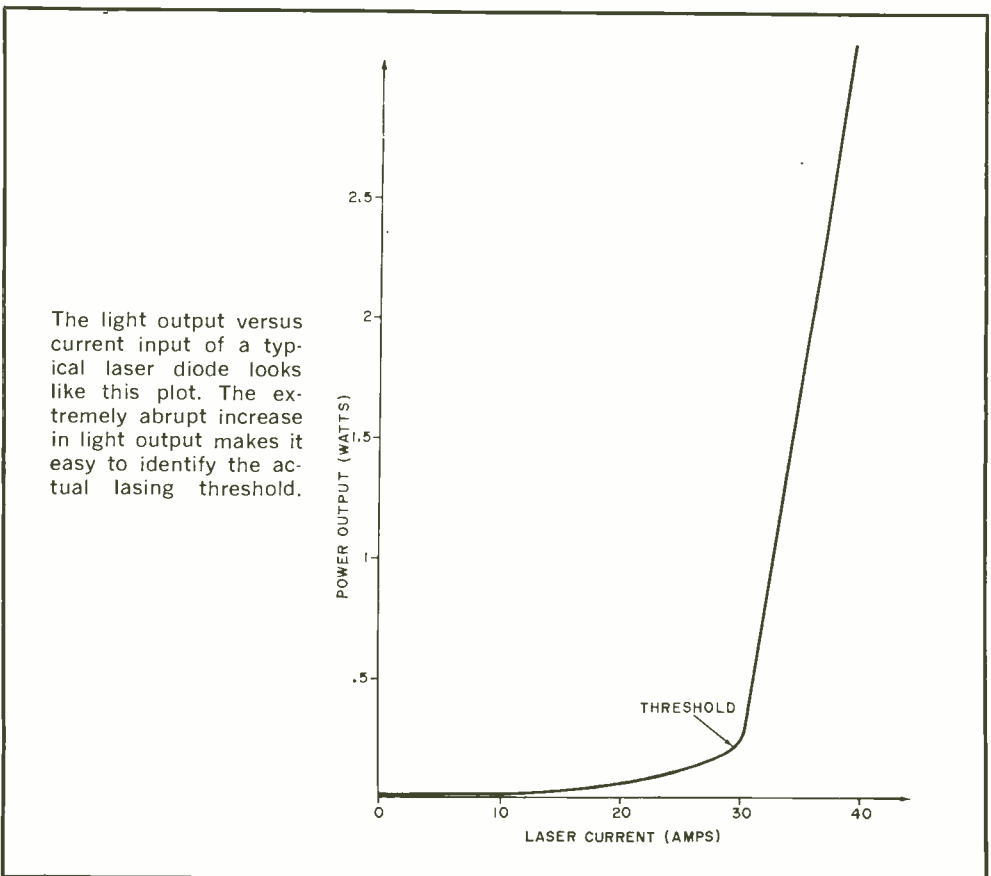

Does your mother-in-



law call you a meatball?

Does your boss?

Maybe even your wife? On payday.

Know what? If you have read this far, you are not meatball material. Because meatballs don't face the present, the future, the facts. They stay put. Dreaming and talking. And today, more than ever staying put means falling behind. Pretty tragic in a time when people with specific aptitudes are so necessary in so many interesting fields.

Today huge industries depend on people with electronics training.

Today there is a course of action that may lead you toward these well-paying, vital positions. It is RCA Institutes.

RCA Institutes is not for meatballs. RCA Institutes trains you for the fields where the action is: Computers • Color TV • Automation • Communications • Industrial Electronics • And more.

RCA Institutes not only has years of experience, it has an exclusive line-up of tested methods:

1. Hands-On Training

Over 250 interesting experiments. As many as 22 kits with some of the programs.

2. RCA Autotext

The easy-way-to-learn method that gets you started easier, faster.

3. Wide choice of courses and programs

Training in electronics fundamentals right up to solid state technology and communications electronics.

4. Low-Cost Tuition Plans

You'll find the one just made to fit your own budget.

5. FCC License Training Money-Back Agreement

RCA Institutes' money-back agreement assures you of your money back if you fail to pass the FCC examination taken within six months after completing RCA Institutes' FCC course.

RCA Institutes gets your training started even if you've not had previous experience or training. Just bring us your interest.

Set your own pace depending on your schedule.

If you like to tinker, fiddle, fix, put that ability to work to do a real repair job on your future now.

Don't wait. Get complete information right now. No obligation. Except to yourself. Send us the attached postcard. Or return the coupon.

Veterans: Train under GI Bill. Accredited Member National Home Study Council. RCA Institutes, Inc. is licensed by—and its courses of study and instruction facilities approved by—the N.Y. State Education Department.

RCA Institutes

Home Study Department
320 W. 31 Street, New York, N.Y. 10001

Please rush me FREE illustrated electronics career catalog. I understand that I am under no obligation.

NAME _____

ADDRESS _____

CITY _____ STATE _____ ZIP _____

694-110-0

Veterans check here

PHYSICS OF LASER DIODES

An essential requirement for a laser is two mirrors, one on either side of an optically active medium. The process of laser action begins when electrons in the active medium are excited to a higher than normal energy level by the application of optical or electrical energy. The electrons have a tendency to remain at the higher level for a brief period of time, and then they begin to fall back to their normal level, in the process giving off the energy absorbed from the excitation source in the form of heat or light. If photon emissions predominate and if a very large number of electrons are in the excited state, a condition will exist where an emitted photon from one electron may stimulate the emission of a photon from another. This process, which obviously can become a chain reaction, is called stimulated emission of radiation.

Since the active medium is between two facing, parallel mirrors, a feedback mechanism is provided to encourage the stimulated emission of very large numbers of photons. Like water sloshing back and forth in a basin, the oscillating photon beam quickly builds in intensity until a portion penetrates the more transmissive of the two mirrors.

This process of light generation occurs in one form or another in all types of lasers. But a full understanding of the laser diode requires a consideration of electrical and optical properties. A detailed explanation of the generation of light in a semiconductor will be found in the November 1970 issue of POPULAR ELECTRONICS. Briefly, light is generated in some types of semiconductor diodes when electrons which have been raised to a higher than normal energy level in order to penetrate the junction fall into holes. Since the laser diode has semi-mirrored ends, the essential requirement for laser action is realized and a quasi-coherent beam of light is emitted from the junction region. Because the junction is very thin, the light is far more divergent than the beam produced by most lasers. The spreading is identical to that which occurs when any beam of light passes through a narrow slit and is diffracted outward.

While the GaAs LED emits a fairly uniform spectrum of light about 300 Angstroms wide, the spectral output of the GaAs laser usually consists of an envelope of extremely narrow spikes. Total width of the envelope is 20 to 40 Angstroms, but individual spikes may be extremely narrow. The spikes result from definite optical modes within the laser and indicate, as does other evidence, the existence of some coherence in the emitted beam. But, unfortunately, the laser diode is not nearly as coherent as most other lasers.

Though the discussion so far applies generally to all GaAs laser diodes, various junction formation techniques can cause a wide variation in device efficiency, current requirements, and lifetime. Considering current required to reach the lasing threshold, for example, simple diffused junction lasers have a typical threshold of 100,000 amperes per square centimeter. Then, the threshold of a laser chip 0.5 mm x 0.1 mm would be 50 amperes. Epitaxial GaAs lasers which have much flatter junctions typically require 40,000 A/sq cm to reach the lasing threshold. For the same size chip described above, the threshold would be 20 A. Single heterojunction lasers of GaAs and aluminum, or GaAlAs-GaAs, have thresholds of 8000 A/sq cm (4 A for the above chip), and double heterojunction lasers of GaAlAs-GaAs-GaAlAs have the lowest threshold of all—about 1 A for the chip. The latter structure was used by Bell Labs for the first laser diode to operate continuously at room temperature.

Power efficiency (power in to power out) for the various types of GaAs lasers ranges from about 1% for diffused devices to over 12% for some single heterojunction diodes. Lifetime improvement is equally good. Diffused lasers sometimes last only a hundred hours or less before losing most of their output power; some single heterojunction lasers have shown lifetimes of several thousand hours.

The major reason for advances in GaAs lasers is improvement in junction formation. Several years ago it was noticed that the optical index of refraction

varies slightly at the junction of simple diffused lasers. Since light leaving a medium of one index of refraction and going to a medium of another index tends to be reflected at the interface, a waveguiding effect takes place. This waveguiding helps keep laser light in the junction where it belongs. The effect is enhanced in simple epitaxial lasers, partly because of the improved planarity of the junction.

Junction tailoring led to the development of the single heterojunction laser, where a material of a much higher index of refraction, GaAlAs, is grown directly adjacent to one side of the junction. The GaAlAs layer confines both optical and electrical activity to a region only about 2 microns thick. The close confinement results in the lower threshold described earlier. Of course, the next logical step was the double heterojunction device with a very thin layer of GaAs between two of GaAlAs. The extremely good confinement results in a very low threshold, but the very thin junction, only about one micron thick, causes the emitted beam to be about twice as divergent as that of a typical laser diode.

There are two major classes of laser diode degradation: gradual and catastrophic. The former is greatly reduced in lasers with a low threshold because the degradation mechanism seems to be directly related to the density of electrical current (as well as imperfections in the laser structure). Catastrophic degradation is a mechanical phenomenon very similar to that which causes chips to fly from the ends of ruby and glass lasers operated at extremely high power levels. In a diode laser, this type of degradation leaves a row of chips at both ends of the junction and therefore destroys the lasing cavity. For GaAs, the maximum range of power densities which can be safely extracted from a laser range from several watts to about half a watt per mil of junction width. Since the allowable power density depends in part on junction thickness, lasers with very thin junctions cannot produce as much optical power as lasers the same size but with thicker junctions.

is very similar for both diffused and epitaxial lasers. Cleaving is accomplished with a razor blade or by scribing parallel lines across the wafer with a sharp instrument and then rolling a glass rod over the wafer. Gentle pressure applied to the rod results in the formation of a series of long bars with parallel sides. After cleaving, the individual bars are coated on one of the two parallel sides with a layer of silicon monoxide and gold, the former for insulation, the latter for 100% reflection.

Next the bars are separated into individual chips, typically between 3 and 50 mils wide. The separation can not be done by cleaving as this would result in four parallel surfaces—a condition which tends to quench laser action. So usually chips are made using a diamond or wire saw.

Individual chips are cleaned and then soldered to the heat sink block of a special header. The chip can be soldered to the block and given a positive electrode at the same time. A technician orients the header in a jig under a microscope so that the block faces up and then puts a tiny square of tin on the heat sink. Next come the laser chip, another square of tin, and the wire electrode. A drop of flux is added and then heat is applied. As soon as the tin begins to melt, the heat is turned off and the laser is ready for installation of a protective cap—with a glass window.

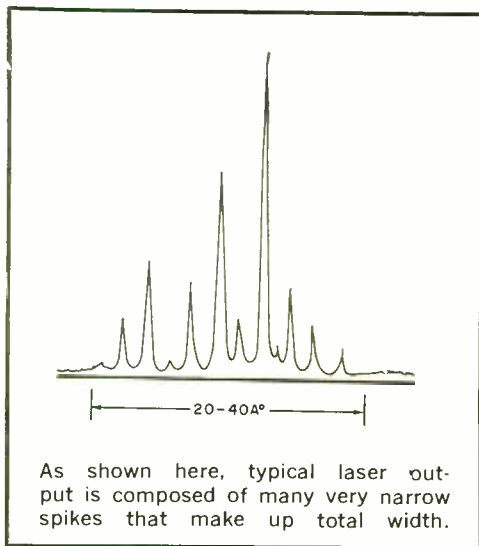

In another fabrication process used by some companies, an indium plated chip is pressed between two similarly plated copper strips. The soft indium provides good thermal and electrical contact. Lasers produced in this manner are sometimes difficult to work with, but their excellent heat sinking characteristics permit much higher duty cycles than lasers mounted on a header.

Since it takes time to saw individual laser chips from GaAs bars, saws with as many as 75 wires are often used. Not only does this result in an important production shortcut, it also facilitates the fabrication of arrays of lasers. Normally a single chip is affixed to a header as described above, but if a great deal of optical power is required, a large number of chips will be needed. Rather than use many separate laser containers, manufacturers often attach a long bar of GaAs with its built-in diode junction to a substrate, saw it (but not the substrate) into separate chips, and connect the chips together in series with tiny wires. The technique provides a sturdy array of as many as 75 lasers which can be put in a package not larger than an ordinary transistor. Such an array may produce 300 or more watts of peak optical power! For applications where even more power is required, such as in covert illumination systems for the military, a dozen or more array strips may be used.

How They Operate. Now that we have a laser diode, or perhaps a laser array, how is it operated and what are the characteristics of the emitted light beam? Nearly all other types of lasers are stimulated into laser action indirectly. A very attractive feature of the diode laser is that it can be driven directly and efficiently by an electrical current. Though Bell Labs has very recently developed a laser diode which can be operated continuously at room temperature, the lasers available to us now must be operated only in a pulsed mode to prevent catastrophic destruction. A typical laser diode may be operated at a repetition rate of up to 10 kHz with an absolute maximum width per pulse of 0.2 microseconds.

Since the laser diode requires relatively high currents, the design of a suitable pulse generator can be a little tricky. Due to their very fast switching characteris-

tics, SCR's, avalanche transistors, and miniature thyatrons are often used. Since very fast pulse rise times are essential for efficient operation, lead dress is fairly critical.

Several things happen when a single pulse is applied to a laser diode. At first, incoherent light is emitted and the chip acts as an LED. As the current increases and reaches the lasing threshold, laser action suddenly begins. An examination of the beam pattern would reveal a bright distinct pattern on a surrounding field of relatively uniform light. The uniform field represents the incoherent output of the laser and remains relatively constant. The distinct pattern becomes extremely brilliant as the current pulse continues to rise to the peak.

However, another interesting thing is going on: the chip is heating up. Since the output is directly related to chip temperature, the wavelength begins to shift. For a typical laser operating at room temperature, the shift in wavelength is about 2.5 Angstroms per degree Centigrade. Since the temperature of a chip may rise about 2°C during a single pulse, the wavelength may shift 5 Angstroms.

As the current pulse reaches a peak and begins to decrease, the threshold

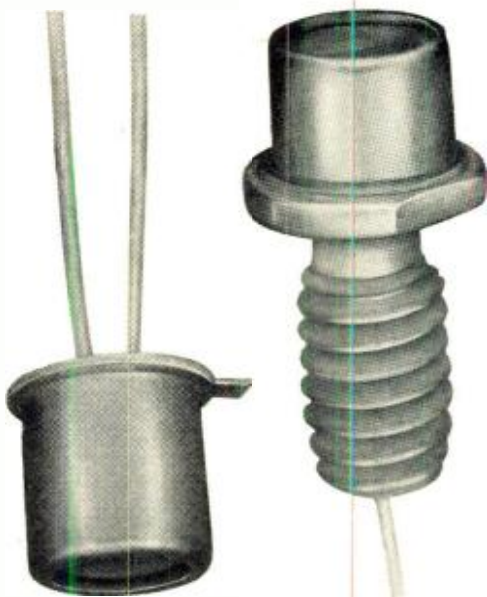

Two styles of laser diodes. The RCA version (right) includes heat sinking and mounting.

Laser diode chips are soldered to heat sink blocks within the header. Actual size of header is similar to that for transistors. Reflected light from the camera obliterates the chip in device on the left.

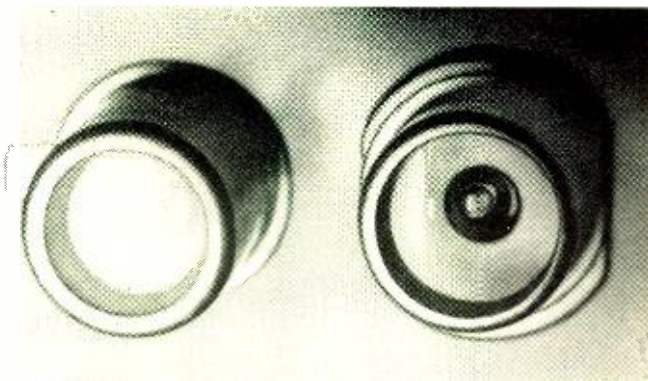

value is again reached and the light output drops sharply. Below threshold, the chip again functions as an LED. While the pulse drive recycles for the next pulse, the laser literally cools off in preparation for it.

Lasers vs LED's. Just what does the laser have over the LED? Because of the stringent requirements imposed on the operation of the diode laser, it may appear that the LED can do the same job with less trouble. Often this is true. For example, in communications, the LED is presently far more efficient than the laser. Also, in any application that requires a continuous beam or a pulse longer than a few tenths of a microsecond, the LED is a must. Still another plus for the LED is that relatively slow phototransistors can be used to detect the beam. Since the laser diode output is such a very brief pulse, efficient detection requires a fast photodetector. While readily available, these devices are generally much less sensitive than phototransistors.

But there are certain overwhelming advantages that make the laser diode a must for some important applications. First, the output power of a single laser diode is easily more than 1000 times that of the LED on a pulse-for-pulse basis. While both devices, in general, have about the same average power, the high peak power of the laser makes it very attractive for pulsed applications such as ranging. Another significant factor in favor of the laser is the extremely small size of the chip. Since light is emitted from a spot only a few microns thick and from 3 to 50 thousandths of an inch

wide, it is very simple to focus it into an extremely narrow beam. A simple convex lens with a focal length and diameter of about an inch will produce a beam which diverges only a fraction of a degree. Narrow beams are important for communications over long distances, range finding, and covert illumination.

Applications. Communications and ranging are perhaps the most promising applications for the diode laser. The recent development at Bell Labs of the diode laser which operates continuously at room temperature is a major step forward in communications since total utilization of the diode laser's properties requires a continuous source.

For more limited communications and ranging, a pulse laser is perfectly adequate. In ranging, for example, a very brief pulse of laser light is sent toward a distant object whose range is unknown. At the same moment, a high-frequency counter is activated. When a sensitive detector circuit on the unit receives the reflected pulse, the counter is deactivated and the range is read directly from a digital display.

Another use of the pulsed laser diode is in mobility aids for the blind. LED's have also been used for this purpose, but the laser offers several advantages. Since the laser is such a tiny source of light, it is very easy to focus its output into a narrow beam with a very small lens system. With its high peak power and narrow pulse width, the laser makes for a very sensitive, noise immune system.

A very important potential application
(Continued on page 102)

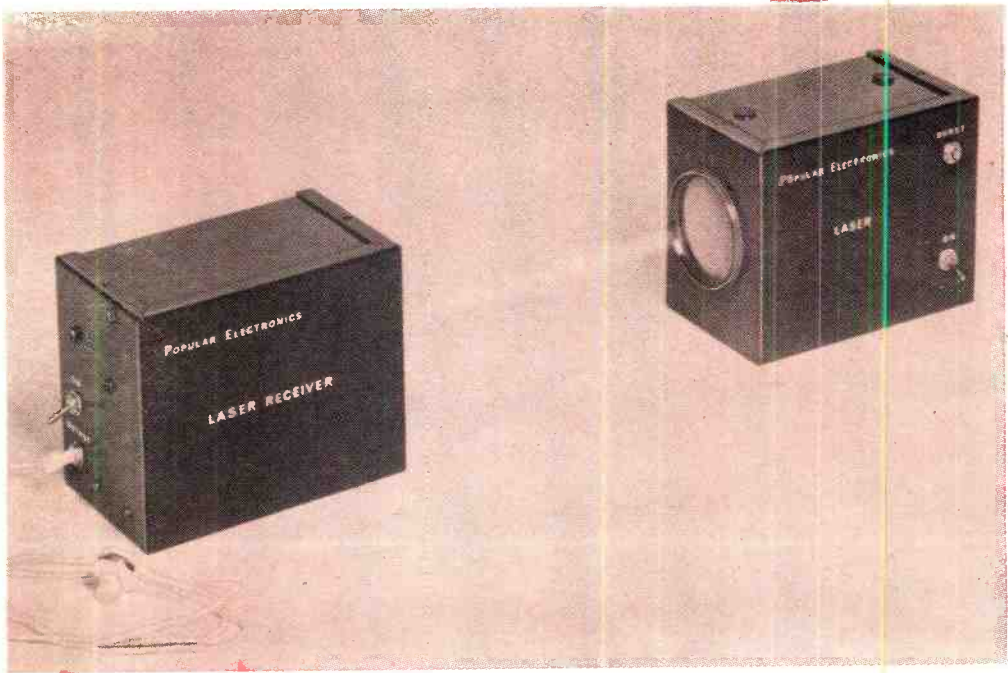

SOLID-STATE LASER FOR THE EXPERIMENTER

SAFE SEMICONDUCTOR
DIODE MAKES
AN IDEAL
SECRET COMMUNICATOR

BY FORREST M. MIMS

THANKS to a recent breakthrough in semiconductor (laser) technology, the serious electronics experimenter can now work with a solid-state gallium arsenide (GaAs) laser costing less than \$20. (One of the very first lasers suitable for experimentation was the HeNe device described in these pages in December 1969.)

Operating at 9050 Angstroms (see the article on page 35 for an explanation of how a solid-state laser works), the laser beam is totally invisible—even when shone onto a sheet of white paper. It is suitable for many applications, including secret communications and intrusion detectors. Because both the transmitter and the receiver operate from self-contained

batteries, any system using the solid-state laser can be completely independent of the commercial power line.

Transmitter. The solid-state laser used here requires a current pulse of at least 5 but not more than 10 amperes to reach the lasing threshold. If the maximum current rating is exceeded, the laser will be destroyed. Since the laser chip is only 3 X 9 mils, the current pulse must be very short (about 200 nanoseconds) to prevent damaging buildup of heat.

The circuit of the transmitter is shown in Fig. 1. Transistor Q1 can be any one of a number of switching transistors (such as HEP50) but it must be tested in

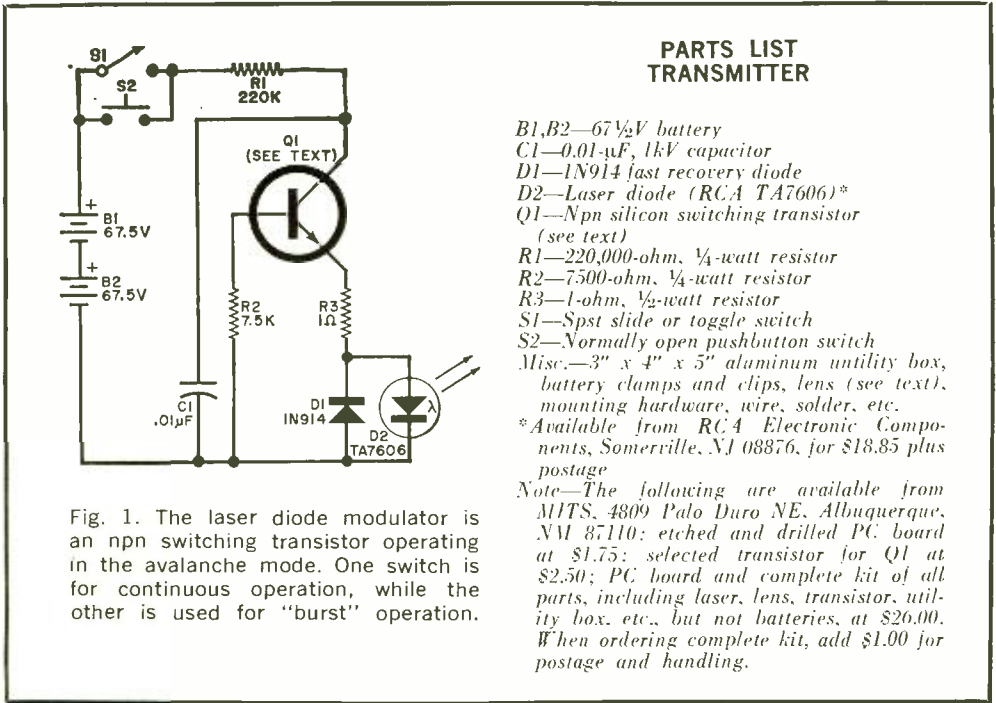

**PARTS LIST
TRANSMITTER**

- B1, B2—67 1/2V battery
 - C1—0.01-µF, 1kV capacitor
 - D1—1N914 fast recovery diode
 - D2—Laser diode (RCA TA7606)*
 - Q1—Npn silicon switching transistor (see text)
 - R1—220,000-ohm, 1/4-watt resistor
 - R2—7500-ohm, 1/4-watt resistor
 - R3—1-ohm, 1/2-watt resistor
 - S1—Spst slide or toggle switch
 - S2—Normally open pushbutton switch
 - Misc.—3" x 4" x 5" aluminum utility box, battery clamps and clips, lens (see text), mounting hardware, wire, solder, etc.
- *Available from RCA Electronic Components, Somerville, NJ 08876, for \$18.85 plus postage
- Note—The following are available from MITS, 4809 Palo Duro NE, Albuquerque, NM 87110: etched and drilled PC board at \$1.75; selected transistor for Q1 at \$2.50; PC board and complete kit of all parts, including laser, lens, transistor, utility box, etc., but not batteries, at \$26.00. When ordering complete kit, add \$1.00 for postage and handling.

Fig. 1. The laser diode modulator is an npn switching transistor operating in the avalanche mode. One switch is for continuous operation, while the other is used for "burst" operation.

the circuit to make sure that it avalanches properly. Capacitor C1 is charged up through R1 until the collector-to-emitter breakdown voltage of Q1 is reached. When Q1 break down (avalanches), the energy in C1 flows through Q1, R3, D1, and D2. To determine whether a transistor is avalanching, replace the laser diode (D2) with a conventional silicon rectifier. With a 135-volt source applied to the circuit, connect a scope across C1. When

the circuit is oscillating (a small percentage of transistors may not), the amplitude of the displayed pulses is the breakdown voltage of the transistor. Do not use a transistor with a breakdown voltage greater than 45 volts since any higher voltage will provide more than 10 amperes to the laser.

A foil pattern and component layout for the transmitter are shown in Fig. 2. Mount Q1, R1, R3, and C1 flush against

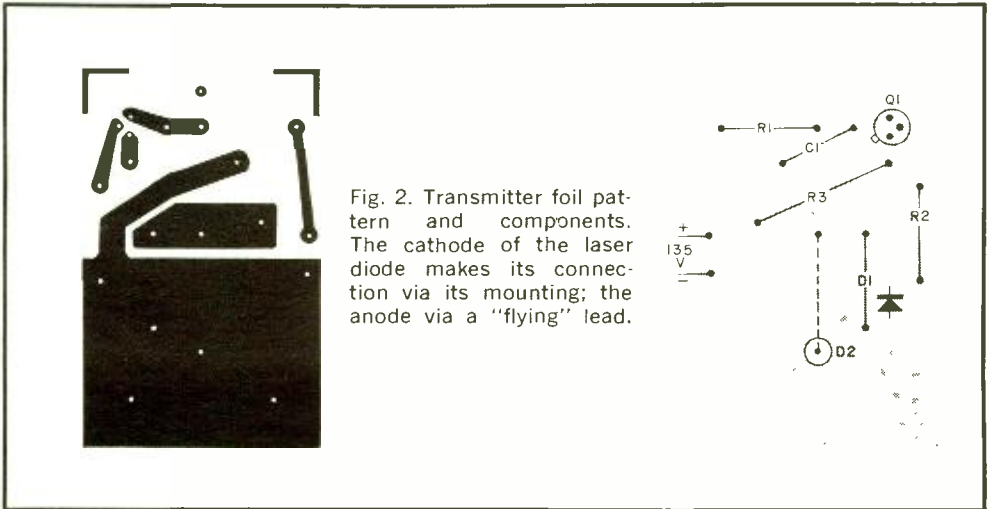

Fig. 2. Transmitter foil pattern and components. The cathode of the laser diode makes its connection via its mounting; the anode via a "flying" lead.

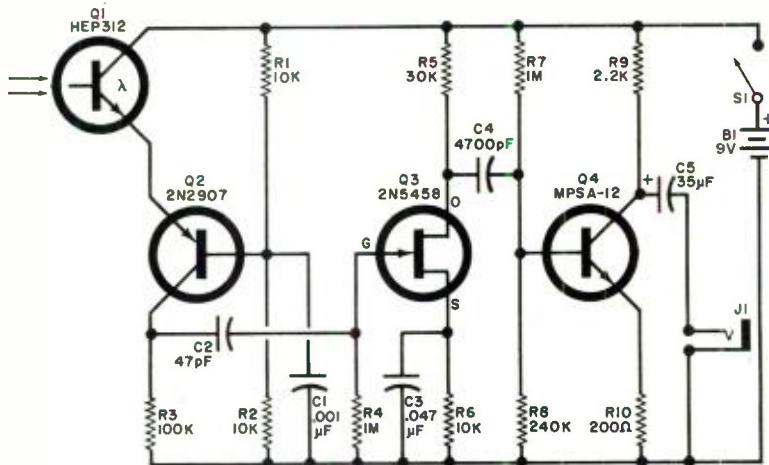

Fig. 3. The receiver is essentially a phototransistor driving a conventional audio system. Any phototransistor may be used as long as it will respond to the 9000-Angstrom laser output.

**PARTS LIST
RECEIVER**

- B1—9-volt battery
- C1—0.001- μ F, 10-volt capacitor
- C2—47-pF, 10-volt capacitor
- C3—0.047- μ F, 10-volt capacitor
- C4—4700-pF, 10-volt capacitor
- C5—35- μ F, 10-volt electrolytic capacitor
- J1—Earphone jack and plug
- Q1—HEP-312 phototransistor
- Q2—2N2907 transistor
- Q3—2N5458 or HEP801 FET
- Q4—Darlington transistor (Motorola MPSA12)
- R1, R2, R6—10,000-ohm, $\frac{1}{4}$ -watt resistor

- R3—100,000-ohm, $\frac{1}{4}$ -watt resistor
 - R4, R7—1-megohm, $\frac{1}{4}$ -watt resistor
 - R5—30,000-ohm, $\frac{1}{4}$ -watt resistor
 - R8—240,000-ohm, $\frac{1}{4}$ -watt resistor
 - R9—2200-ohm, $\frac{1}{4}$ -watt resistor
 - R10—200-ohm, $\frac{1}{4}$ -watt resistor
 - S1—Spst slide or toggle switch
 - Misc.—3" x 4" x 5" aluminum utility box, battery holder, lens (see text), mounting hardware, wire, solder, earphone, etc.
- Note—The following are available from MITS, 4809 Palo Duro NE, Albuquerque, NM 87110: etched and drilled PC board at \$1.95; PC board and complete kit of all parts, including, lens, utility box, etc., at \$9.70. When ordering complete kit, add \$1.00 for postage and handling.

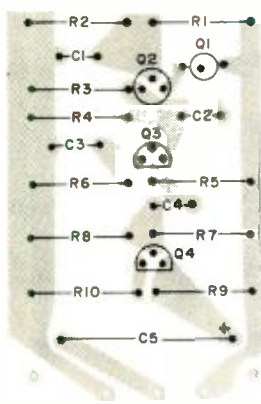
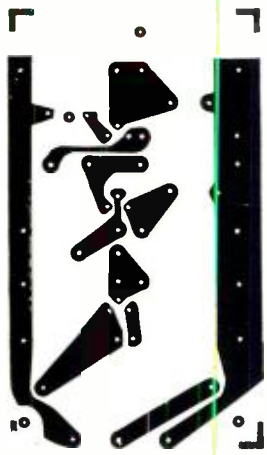
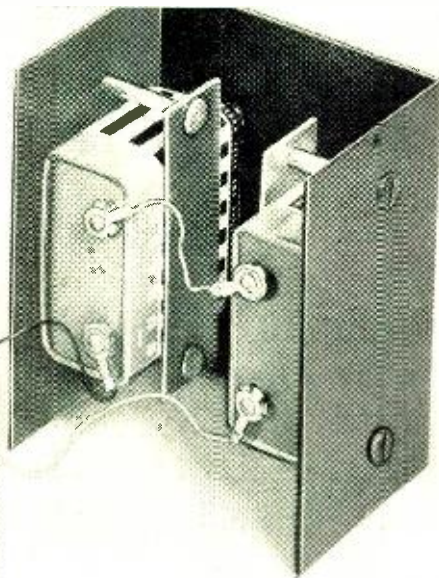
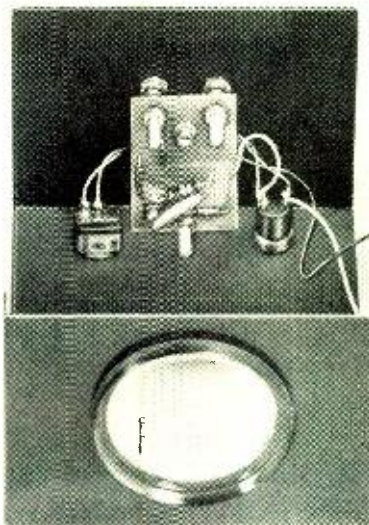

Fig. 4. The receiver foil pattern and component installation. Note that Q1 has only two leads, the light from the laser acts as the base input signal.





When mounting the transmitter, make sure the laser diode sits at the focal point of the lens. Three adjustable spacers are used to make this adjustment.

the board to reduce stray inductance. Despite its low value, do not omit R3. It

limits the laser current. Drill a $\frac{3}{8}$ " hole at the spot where D2 is to be mounted and use a hex nut to secure it in place. Its flat sides must be parallel to the narrow end of the board. Be careful when connecting the laser anode lead to its hole in the foil.

To test the transmitter, place it close to an operating AM radio and depress the burst switch, S2. A tone of approximately 1 kHz should be heard from the radio.

Receiver. The circuit of the receiver (Fig. 3) is essentially a phototransistor (Q1) driving a conventional audio system. A foil pattern and component layout are shown in Fig. 4. The phototransistor is mounted on the foil side of the board and protrudes through a hole in the board. Clip the excess lead length from it before soldering it in place and make sure that it is level.

To test the receiver, turn it on and aim the phototransistor at a fluorescent lamp. Various noises will be heard as the receiver is aimed at different areas along the lamp.

Mounting and Optics. Using a 3" X 4" X 5" utility box, cut a 2" diameter hole
(Continued on page 102)



In the receiver, the phototransistor mounts at the focal point of the lens. In this case, the receiver, battery, switch and phone jack are mounted on one end of metal enclosure.

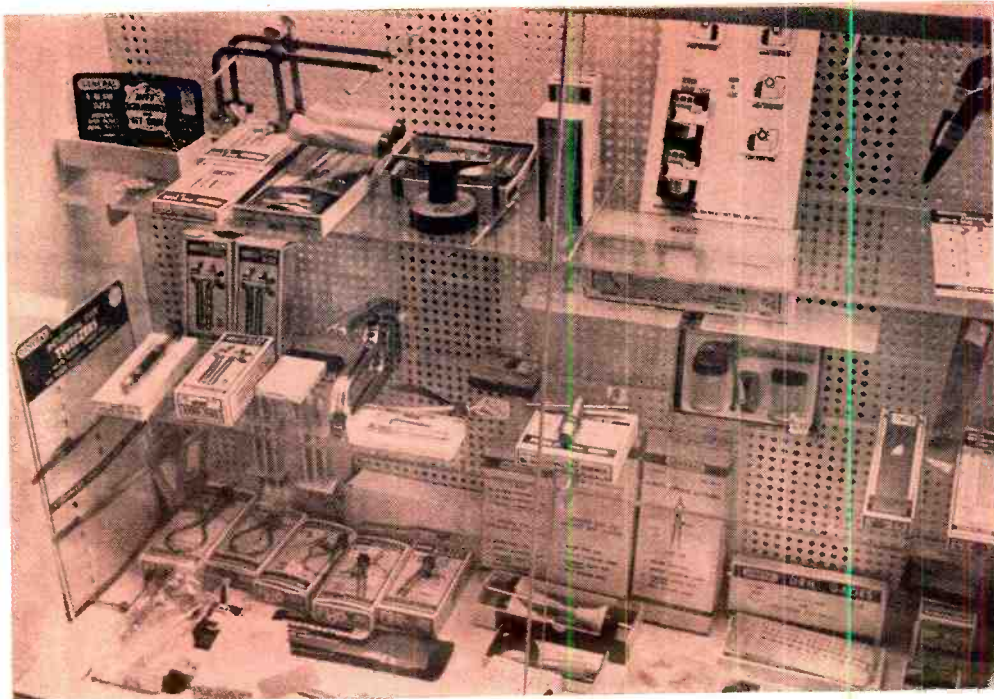

DON'T BYPASS THE HOBBY SHOP

A GOLD MINE OF HARD-TO-FIND TOOLS

AND MATERIALS

FOR THE ELECTRONICS EXPERIMENTER

BY FRANK H. TOOKER

YOUR HOBBY interests may not extend to model railroading, airplanes, or ships, but that is no reason for you to pass right by the model hobby shop when you are out shopping for items for your electronics hobby. When you browse around a modern, well-stocked hobby shop, you will be amazed at the variety of items you find that are useful in electronics.

Materials and tools that are obtainable only with difficulty or perhaps not at all from electronics suppliers and hardware stores are right there on display in the hobby shop. To give you an idea of what you can expect to find, let's discuss some examples.

Basic Materials. Precision-made telescoping brass tubing, round or square, is a standard item in any hobby model shop. Available in a wide variety of diameters and square dimensions, these tubes fit one inside another so precisely that they can be used anywhere as bearings.

Short lengths of tubing can be used to increase control shaft diameters—say, from $\frac{1}{8}$ " to $\frac{1}{4}$ "—to allow the use of readily available knobs. And the tubing can be used as extension shafts, too; the extensions are lightweight, yet sufficiently strong, for most electronics applications.

The tubing can be quickly formed to



Useful hobby shop offerings for experimenters include wide variety of sizes of brass, aluminum, and plastic round and square tubing, angles, strips, and sheets.

make attractive handles for projects. Tubing benders for this purpose are probably right there on the same shelf with the tubing.

Available diameters for brass tubing cover a range of from 1/16" to 1/2" with a 1/64" wall thickness. And you can obtain the tubing either plain or nickel plated. Small-diameter aluminum and plastic tubing are also available in hobby shops. Most of the better places have both 12" and 36" lengths.

Looking for sheet metal for any purpose from shim stock to a small chassis? The hobby shop is the place to get it. Brass, copper, aluminum, even light-weight magnesium sheet stock are there for the picking. And don't forget the various thicknesses of plastic sheets and brass, aluminum, and plastic angle stock.

Model hobby shops also carry "music wire" in a wide range of diameters. This is a very high-quality steel wire preferred by industry for making coil springs. And you know how difficult it is to buy a spring with just the right tension and dimensions even for standard dial cord assembly replacement. With a reasonable selection of music-wire sizes, you can actually make small coil springs to order for just about any application. (NOTE:

Do not attempt to cut music wire with diagonal cutters; you will only damage the cutters. Instead, use a carbide saw or grinding wheel to cut the wire.)

Maybe you need some especially tiny screws, nuts, and washers. You will not find them in a hardware store or an electronics parts supply store. But the hobby shop has them in abundance in dozens of sizes—some so small you need a jeweler's loop and screwdriver to work with them.

Have you ever looked high and low for small pulleys for stringing dial cords in a home-brewed project? If so, you already know that such a basic item is often the hardest thing to find. Excellent "pulleys" (known to the modeler as "sheaves") can be had from any hobby store in 3/32", 1/8", 3/16", and 5/16" diameters. You won't find much use for the first two sizes, but the latter two are really handy.

This is by no means the end of the list of materials you can find in hobby shops that you can put to good use in electronics project building. There are dozens and dozens of other materials you have probably long since given up on trying to find.

Special Tools. The model hobby store excels in its variety of special-purpose tools. Don't be misled into believing that modeling tools are cheaply made, inaccurate, and made of poor quality mate-

The photographs in this article were taken by Ed Buxbaum in, and with the kind cooperation of, Polk's Hobbies, Fifth Ave., New York, N.Y.

rials. While there are certainly some "cheap" tools available for the infrequent user, serious modelers own and use some of the finest hand tools you'll find anywhere.

What most significantly distinguishes modeling tools from most others is that the former are designed to do small, fine work accurately. (Just think of some of the really close work you have had to do in some of your most recent projects, and you'll appreciate how handy modeling tools can really be.)

Modelers work in miniature, so their tools are often miniature in size. Such tools, of course, can be obtained from jewelers' supply houses, but for a one-place source, the hobby shop is the place to go.

A simple but pressing example of a tool that is desperately needed for modern electronics work is a No. 67 drill. This drill is extensively used in making component lead holes in printed circuit boards. Some hardware stores handle this size drill, but *all* hobby stores have it as a standard item. When buying such fine drills, add the extra few cents and get the high-speed steel ones; they are well worth the extra cost.

Now you will need a device to let you use such a small drill with a standard drill chuck. Get a collet-type pin vise when you pick up the drill. A word of caution: Don't try to use fine drills in your portable electric drill (a drill press is okay); you will just bend or break them one after another.

When working with fine drills, invest



Many items on peg-board displays are packaged in clear plastic bags so contents can easily be seen, simplifying buyer selections.

in a geared-type cordless electric drill, another hobby shop standard. Your \$6 or \$7 investment in the drill will more than pay for itself in drills and reduced labor when drilling many holes.

(Continued on page 104)

Small items, among them hardware, tools, cutters, etc., are generally kept in glass display cases under counters to afford browsers and buyers easy view of offerings.



UNIQUE STEREO DECODER

A BRAND-NEW IC AND
A HANDFUL OF PARTS,
MAKE A FIRST-CLASS
MULTIPLEX DECODER

BY SEYMOUR REICH

RCA Linear Applications

NOW IS THE TIME to update your FM receiver to include multiplex stereo—or to improve your present stereo FM receiver with the latest circuit advances. Why now? Because there is a new integrated circuit component which needs only 12 other low-cost standard components (13 if you want an indicator light) to make up a complete stereo decoder. The decoder circuit using the new RCA SK3078 IC, can be made operational without any instrumentation and requires only one adjustment that can be adequately set by an off-the-air signal.

The decoder circuit, shown in Fig. 1, has a single tuned circuit made up of capacitor C2 and inductance coil L1 tuned to 76 kHz. A built-in phase locked loop places minimum reliance on the accuracy of the initial adjustment of the oscillator, obviating the need for elaborate alignment procedures. Characteristics of the decoder circuit include:

- Automatic switching from monaural to stereo.
- Automatic energizing of the indicator light when stereo is present.
- Operation over a range of power supply voltages from 10 to 16 volts.
- Internally regulated power supply with current drain (typically 22 mA) virtually independent of supply voltage.
- Typical output (with 200 mV input) of 400 mV across 10,000-ohm load—sufficient to drive most output stages.
- System gain of 6 dB.
- Nominal 40-dB channel separation without necessity for decoder balance adjustment.
- Small size—IC is in a 16-lead quad in-line plastic package.

Theory of Circuit Design. The functions performed in the SK3078 IC are shown in the block diagram in Fig. 2. The composite signal is applied to pin 1 of the low distortion preamplifier. The amplified composite signal is then applied to the 19-kHz detectors, the 38-kHz L-R detector and the matrix circuits. The L-R detector and the lamp driver amplifier are normally off unless energized by the Schmitt trigger.

A local VCO (voltage controlled oscillator) is adjusted, by means of an external coil, for free running at 76 kHz and this signal is fed to a divide-by-two counter. The 38-kHz output from this stage is fed to the L-R detector and to the divide-by-two counters that provide 19 kHz. (Two of the latter counters are required because the phase relationships of the reference signals required by the two detectors must be different. The reference for the phase lock detector must differ from the pilot by 90°, while the reference for the pilot presence detector must be in phase with the pilot.)

The 19-kHz pilot carrier, contained in the composite signal from the preamplifier is compared to the locally generated 19-kHz signal in the phase lock detector. A phase difference results in a dc output voltage that is impressed on a reactance control network within the 76-kHz VCO that corrects the discrepancy. Similarly, a dc output from the pilot presence detector activates the Schmitt trigger, enabling the L-R detector and energizing the lamp driver.

The matrix circuit mixes the L+R (monaural) information with the L-R (demodulated 38-kHz signals) to provide the

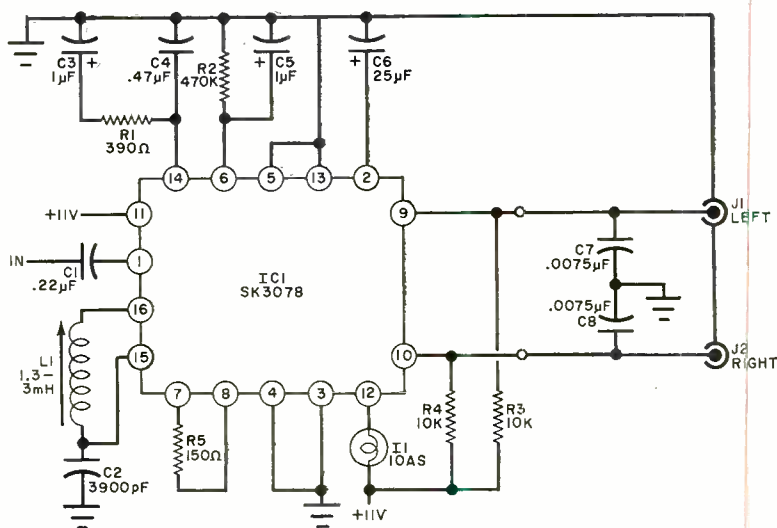

Fig. 1. The high-quality, yet very simple multiplex adaptor can be aligned from an off-the-air signal, and includes a stereo-on lamp.

PARTS LIST

C1—0.22- μ F Mylar disc capacitor
 C2—3900-pF silver mica capacitor
 C3, C5—1- μ F, 12-volt Mylar or tantalum capacitor
 C4—0.47- μ F, 25-volt Mylar capacitor
 C6—25- μ F, 25-volt electrolytic capacitor
 C7, C8—0.0075- μ F disc capacitor
 IL—10-volt, 10-mA pilot lamp (Sylvania 10AS or similar, see text)

IC1—SK3078 integrated circuit (RCA)
 J1, J2—Phono connector
 L1—1.3-3-mH adjustable inductor (Miller 9059-1 or similar)
 R1—390-ohm, $\frac{1}{4}$ -watt resistor
 R2—470,000-ohm, $\frac{1}{4}$ -watt resistor
 R3, R4—10,000-ohm, $\frac{1}{4}$ -watt resistor
 R5—150-ohm, $\frac{1}{4}$ -watt resistor
 Misc.—Printed circuit board, wire, solder, etc.

left and right outputs. The matrix circuit passes only monaural in the absence of the 19-kHz pilot carrier (no output from the 38-kHz L-R detector). Hence, the system automatically switches between stereo and monaural. The difference in output level when switching takes place is about 0.1 dB, and the circuit design eliminates the annoying "thumping" frequently detected in stereo systems during the automatic stereo-monaural switch-over.

Construction. The decoder prototype was built on a PC board using the foil pattern and component layout shown in Fig. 3. Note that the 75-microsecond de-emphasis network, which is capacitors C7 and C8, is not mounted on the PC board. The PC board is not an absolute necessity; discrete wiring to the integrated circuit is entirely feasible.

When assembly is complete, the only adjustment required is to set L1 so that the free-running frequency of the VCO is close to 76 kHz. With the pilot present, the phase-lock detector captures the VCO and locks it in on frequency if the free-running frequency is within 6 kHz of 76 kHz. Of course, capture performance is optimal when the VCO is properly adjusted to begin with. This can be done easily by connecting a frequency measuring instrument to pin 15 through an isolation resistor of greater than 47,000 ohms and adjusting L1 to get 76 kHz. If you don't have the proper instrumentation for this, you can use one of the two following procedures:

An accurate alignment can be achieved by using a signal generator and an oscilloscope having an input impedance over 1 megohm. The output of the 76-kHz oscillator is then compared with

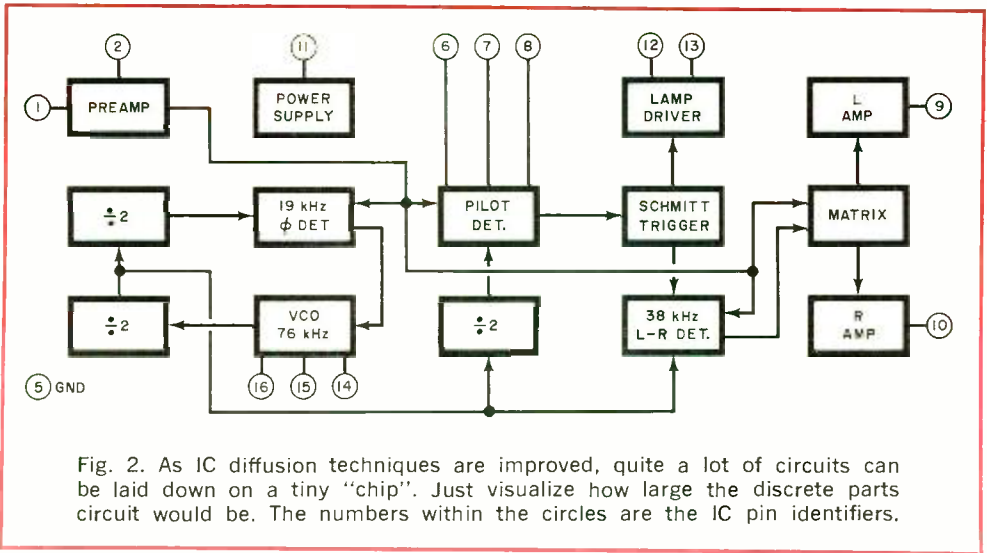

that of the signal generator by connecting pin 15 through a 47,000-ohm isolation resistor to the vertical input of the scope and the signal generator to the horizontal input. Set the signal generator to the lowest obtainable multiple of 76 kHz (76, 152, or 228), and adjust *L1* to obtain the appropriate Lissajou pattern on the scope. (Since the two frequencies are not synchronized some drift in the pattern can be expected.) Greater accuracy can be obtained by calibrating the signal generator with the 19-kHz pilot and then touching up the VCO using the calibrated generator. This is done by driving the decoder from an on-air stereo

signal with oscilloscope and signal generator connected as described above. If the pilot light comes on, the VCO is phase locked to 76 kHz. Now adjust the signal generator to get the proper Lissajou pattern on the scope. This means the signal generator is calibrated for 76 kHz and the free-running VCO can be adjusted with the on-air signal removed.

The second method of adjusting the VCO uses only the on-air signal. If the stereo indicator light is on, rotate *L1* counterclockwise until the light goes off. Then rotate *L1* clockwise and note the exact position where the pilot light comes on. Continue to advance the slug in

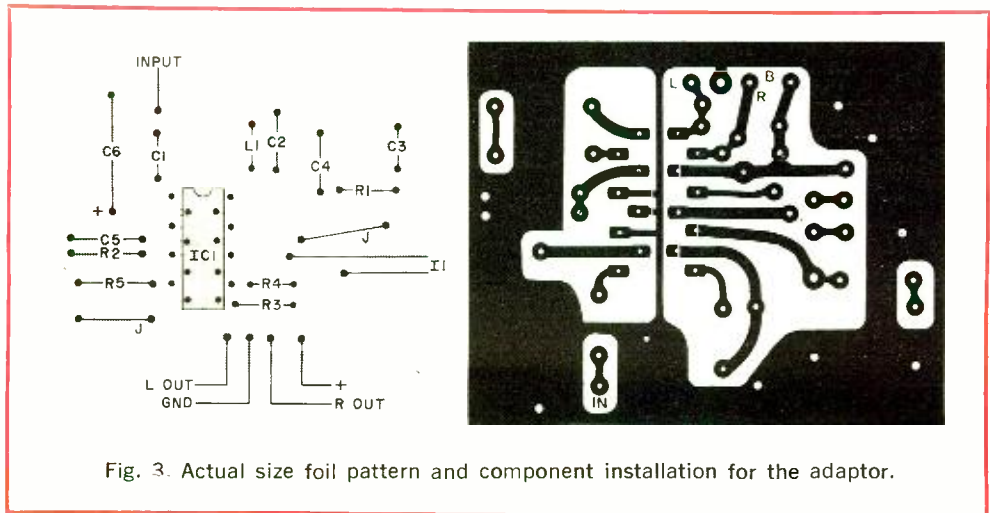



How to prepare for today's competitive job market, tomorrow's new opportunities in electronics

Competition for jobs and promotions is severe in the electronics industry today. But experts say that exciting new electronic products will create thousands of new jobs in the next few years.

One thing is certain: in good times or bad, the best opportunities come to the man with an advanced, specialized knowledge of electronics. He has a better chance of survival in a recession and will profit more in times of prosperity than the man with ordinary qualifications.

But how can you get the additional education in electronics you need to protect your future—and the future of your family? Going back to school isn't easy for a man with a job and family obligations.



College Credits for CREI Students

Recently CREI affiliated with the New York Institute of Technology for the express purpose of making it possible for CREI students to earn college credits for their studies. The New York Institute of Technology is fully accredited by the Middle States Association of Colleges and Universities and is chartered by the New York State Board of Regents.

For the many CREI students who are not interested in college credits, but simply in improving their knowledge of advanced electronics, this affiliation with NYIT will provide additional assurance of the high quality of CREI home study education.

If you want to know more about earning college credits for CREI study, check the appropriate box when you mail the postpaid card for complete information on CREI Programs.

Founded 1927
CREI
 Accredited Member of the
 National Home Study Council



Free book tells all about CREI programs. For your copy, tear out and mail postpaid card or write: CREI, Dept. E1210B Wisconsin Ave. & Tilden St., Washington, D.C. 20016

CREI Home Study Programs offer you a practical way to get more education without going back to school. You study at home, at your own pace, on your own schedule. And you study with the assurance that what you learn can be applied on the job immediately to make you worth more money to your employer.

You're eligible for a CREI Program if you work in electronics and have a high school education. Our FREE book gives complete information. Mail postpaid card for your copy. If card is detached, use coupon or write: CREI, Dept. E1210B, Wisconsin Ave. & Tilden St., Washington, D.C. 20016.

CREI, A Division of the McGraw-Hill Continuing Education Company

Dept. E1210B, Wisconsin Ave. & Tilden St., Washington, D.C. 20016

Please mail me free book describing CREI Programs. I am employed in electronics and have a high school education.

Name _____ Age _____

Address _____

City _____ State _____ Zip Code _____

Employed by _____

Type of Present Work _____ G.I. Bill

- I am interested in: College credits for CREI study. Space Electronics
 Electronic Engineering Technology Computers Industrial Electronics
 Nuclear Engineering Technology Electronics Systems Engineering
 Non-technical course in computer programming. CATV Engineering

APPROVED FOR TRAINING UNDER NEW G.I. BILL

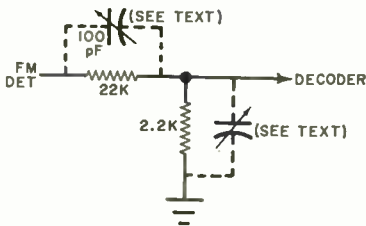

Fig. 4. This compensation network added to the FM detector output can greatly improve the results.

L1 clockwise until the light again goes off. Record the total number of turns of the L1 slug from light on to light off. Rotate the L1 slug counterclockwise and count the number of turns before the light goes on. Subtract this number from the number for clockwise adjustment. Divide this difference by two to determine the slug position required for centering L1 in the VCO pull-in range. Continue to advance the slug counterclockwise to reach the desired position.

Additional Factors. The typical 40-dB stereo channel separation that can be provided by the IC used in this decoder may be adversely affected by improper bandpass characteristics in the FM tuner detector. Most FM detectors have a 1-dB rolloff at 38 kHz and this is the design criterion for the decoder IC. If the decoder is to be used with an FM detector having different characteristics, the compensation network shown in Fig. 4 should be used.

If the characteristic curve is flat to above 38 kHz, then the trimmer capacitor should be connected across the 2200-ohm resistor; if there is a rapid falloff at 38 kHz, then the trimmer should be connected across the 22,000-ohm resistor. In either case, the trimmer capacitor is adjusted until the detector output curve shows about 1 dB drop at 38 kHz. Though it is not an absolute necessity, the compensation network should be used when circumstances warrant.

The stereo outputs are intended to drive audio amplifiers that incorporate the required 75-microsecond de-emphasis networks. If your amplifier(s) is not so equipped, add C7 and C8 as shown in Fig. 1. Failure to use a de-emphasis network will create excessive high-frequency levels.

The circuit shown in Fig. 1 requires a composite input signal of 150 to 200 mV. If it is desired to widen the dynamic range, remove resistor R5 and substitute a series tuned LC network consisting of a 4.7-mH coil and a 0.015- μ F capacitor. This change permits the input signal to range from 30 to 400 mV.

If it is desired to add a "high-power" pilot light to act as a stereo signal detector, connect pin 12 directly to the positive side of the supply, disconnect pin 13 from ground and connect it to the base of an npn transistor (such as 2N32-41). Ground the emitter of this transistor and hook a 10-volt, 50-to-150-mA pilot lamp between the collector and the positive side of the power supply. Provision for this change is included in the board in Fig. 3. \diamond

Taxi Group Uses New Silent Alarm

Members of an independent taxi association in New York City will be the nation's first cab drivers to use a new RCA radio system to flash a silent alarm to their headquarters in case of robbery or other emergency. By pressing a hidden switch, a driver for the Dial Taxi Owners Guild will be able to signal, without a passenger's knowledge, that an emergency exists. The radio dispatcher, after consulting a log of the cab's earlier assignments to determine its general location, can summon help by calling the police or radioing other cab near the one in distress.

The RCA "Voice-PLUS" alarm is part of a two-way radio system which relays messages in number code as well as by voice. When a driver presses the switch, automatic equipment in headquarters prints out a log showing the cab's identifying number, the time the message was received, and sounds a bell alert.

Aside from emergencies, the RCA mobile radios will be used routinely to advise the dispatcher via an instantaneously coded message that a cab is available to pick up a passenger. The system also automatically transmits a return signal from the dispatcher that lights an "acknowledge" lamp on the cab's dashboard.

ELECTRONICS FIGHTS NOISE POLLUTION

HERE'S HOW INDUSTRIAL NOISE
IS BEING KEPT IN CHECK
WITH ELECTRONICS

BY SIDNEY L. SILVER

THERE is nothing quite so peaceful and relaxing as a few minutes spent at the edge of a shallow stream babbling over rocks deep in a mountainous woodland. There is no pollution in the stream or on the ground; and—perhaps best of all—there is no noise pollution in the air. There are very few places where one can earn one's daily bread these days without being constantly bombarded by noise—sounds of all degrees of loudness and frequencies. To get away from them is a great source of relaxation. Noise pollution is, in fact, becoming a major ecological problem—consider what happened to the SST!

Industrial noise, in particular, is recognized as a serious form of pollution, and public hostility toward it has focused attention on the need for a better understanding of the impact of excessive noise on the human environment. This has not always been the case. For years after the Industrial Revolution created the sources of so much noise, it was taken for granted that noisy surroundings were an unavoidable consequence of most production operations. Constructive action to suppress acoustical noise was extremely limited, mainly because of the difficulty of estab-

lishing precisely what constituted dangerous noise levels. Moreover, the existing noise control techniques were based largely on trial-and-error experimentation, and very little progress was made on the problem of interrelating acoustical principles with practical means of noise abatement.

Today, however, significant advances are being made to bridge the gap between the physical aspects of sound propagation and the psychological and physiological effects of noise pollution. And electronic techniques and instrumentation are playing important roles in analyzing and controlling the problem.

How Much Can We Take? To meet the high production needs of today's economy, modern machinery runs at very high speeds, requiring high-strength materials to withstand the greater stresses. Such materials have little inherent damping and create high noise levels due to vibration. In addition, these powerful machines impose high impact forces on bearings, gears, etc., thereby inducing further noise.

Depending on the type of noise and the individual involved, initial exposure to

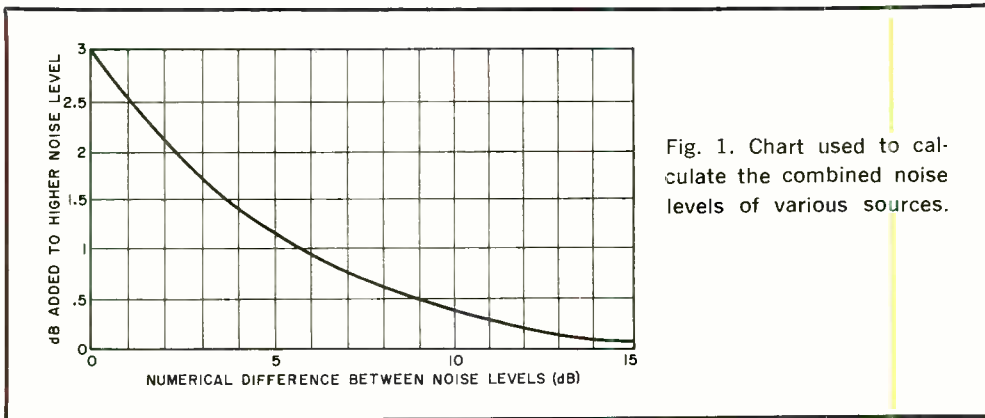

Fig. 1. Chart used to calculate the combined noise levels of various sources.

these excessive noise levels can produce a temporary hearing loss which is recovered after a short interval away from the noise. Repeated or prolonged exposure to high-intensity noise levels, however, can lead to a permanent hearing loss, which is irreversible and does not respond to any treatment known to modern medical science.

Moderate noise levels, on the other hand, which are not loud enough to cause hearing impairment, can degrade the working environment by limiting the ability of individuals to communicate vocally with each other. This noise can affect occupational accident rates by distracting a person's attention from voice instructions or by masking audible alarm signals. Continuous exposure to moderate noise levels can also promote irritability, annoyance, and fatigue; and although these are highly individualized phenomena which cannot be easily measured, they are part of the cause for the current increase in concern with noise pollution.

Fundamentals of Noise Perception. According to the currently acceptable definition, acoustic noise is an unwanted sound. The degree of "unwantedness" is determined by the effect a specific sound has on a particular listener and also by the characteristics of his auditory system. Noise may be objectionable because of its intensity, pitch, intermittent nature, or by any combination of these factors when related to a particular time and place.

Obviously, the point at which useful sound becomes noise is a highly subjective matter, and varies from one person

to another. To some, sound is undesirable if it carries no essential information and tends to interfere with useful sound, such as speech.

Objectively, acoustic noise is simply a rapidly changing air pressure, the magnitude of which can easily be determined by a suitable measuring instrument. The hearing process, however, is so complex that no simple and unique relationship exists between the physical measurement of a sound pressure level and its perception by a human. This makes it difficult to devise a scale of loudness since the ear does not respond equally to all frequencies. Nor does it perceive an increase in sound pressure as a proportionate rise in apparent loudness.

Based on many psychoacoustic tests, it has been established that the risk of noise-induced hearing damage is directly related to the sound intensity, frequency, and duration of exposure, with the high frequency components representing the greatest potential hazard. At moderate, constant levels, noise in the midrange (between 1 and 4 kHz) appears louder than that at either end of the audio spectrum. For weak signals, the ear is relatively insensitive to low frequencies; but at very high levels, the ear is almost equally sensitive to all frequencies. An even more significant peculiarity of the ear is its response to the bandwidth of the noise—the broadband sound of a jet engine appears much louder than a narrowband noise of the same amplitude from some other source.

One of the most remarkable properties of the human ear is its extremely high sensitivity to sound pressure variations,

ranging from levels that are barely audible to those that are millions of times greater in intensity. Due to the large dynamic range involved, it is convenient to express noise amplitudes as a logarithmic ratio using decibel notation. Thus, a sound pressure scale of 1 to 10,000,000 is reduced to a decibel scale from a reference level of 0 dB to 140 dB, the threshold of pain. (The reference quantity corresponds to an absolute sound pressure level of 0.0002 microbars, the weakest sound, at 1 kHz, audible to a person with normal hearing in a very quiet location.)

There are many situations where it is necessary to compute the overall noise level of several different sources, or to predict the effect of adding a source of noise to an already noisy environment. The desired result, however, cannot be obtained simply by adding the individual sound pressure levels (in dB) because of the logarithmic nature of the decibel scale. Instead, the chart shown in Fig. 1 is used. The numerical difference between two noise levels is located on the horizontal axis and the value read off from the curve on the vertical axis is then added to the higher of the two original noise levels.

As an example, if a machine with a noise level of 90 dB is operated near a machine producing 95 dB, the difference is 5 dB, the corresponding value on the vertical axis is 1.2 dB, and the overall noise level is 96.2 dB. Similarly, if two noise sources each produce 85 dB (zero difference), the cumulative noise level is 88 dB. In combining more than two noise levels, the two highest ones are considered first, and the process is continued to each level. If one machine, however, is substantially noisier than the others (greater than 10 dB), it "masks" the others and there is no significant increase in the total level.

Origins of Noise. Noise levels in an enclosed building are usually a complex combination of direct and reflected sounds which radiate to the surrounding air and reach the listener from many sources. Inside a building, noise decreases at about 3 to 6 dB for each doubling of the distance from the source. However, because of the reflecting surfaces, the decrease may be only 0 to 2 dB for each doubling at locations away from

Table I. Comparative noise levels encountered in industry and daily life.

Sound Level (decibels)	Source (long-term average)
140	Threshold of pain
130	Drop-forge hammer (3')
125	Diesel engine room
120	Threshold of discomfort
115	Pneumatic riveter (3')
110	Punch press (3')
100	Metal cutter (3')
95	Electric power station
90	Textile loom (3')
85	Printing press
80	Lathe (3')
75	Office with tabulators
70	Average street noise (50')
65	Busy restaurant
60	Conversational speech (3')
55	Private business office
50	Noisy residence
40	Quiet residence
35	Soft whisper (5')
30	Broadcast studio
20	Electric clock
0	Threshold of hearing

the source. It is easy to see, then, why the problem of hearing loss is most acute where high noise levels are generated in close quarters.

In addition to noise transmitted through the air, there is structure-borne noise produced by machine vibrations. These vibrations are conducted through foundations, columns, beams, etc. to other parts of the building where they are radiated as airborne noise. Table I compares the various sound pressure levels of common environments and machines.

Table I. Maximum exposure measured on meter using A-weighting network.

Noise Level (dBA)	Maximum Permissible Exposure (hr/day)
90	8
92	6
95	4
97	3
100	2
102	1½
105	1
110	½
115	¼

Clearly, the noise intensity reaching a listener depends on the strength of the sound levels leaving the source, the distance from the source, and the physical layout of the area. The potential risk of hearing damage is influenced by how rapidly the noise occurs, whether it is steady or intermittent, whether it is impulsive or continuous, and whether it begins abruptly or gradually. Steady noise, for example, is characterized by sound pressure levels which do not fluctuate rapidly with time, and include the noise produced by rotating machinery. Sometimes the noise consists of unpitched sounds ranging over a wide band of frequencies, such as duct noise in air-handling systems. The releasing of compressed air through a nozzle is a very noisy operation and the predominant noise is made up of high frequency components—the worst kind for human ears. High impact noises are produced by punch presses, riveting guns, drop hammers, and the like. A related class of noise is the repeated explosions resulting from the testing of internal combustion engines and the ground checking of jet aircraft engines.

Noise Exposure Standards. Under the terms of the Walsh-Healey Public Contracts Act of 1936, the Department of La-

bor was given the right to establish standards to protect the safety and health of industrial workers. However, due to the limited information available regarding the nature and amount of noise that would cause hearing impairment, nothing concrete was done for many years to implement the provisions of the law relating to noise problems. Finally, in 1969, the Labor Dept. adopted regulations specifying the maximum permissible noise levels to which employees could be exposed in industries selling goods in excess of \$10,000 or services over \$2500 to the Federal Government. The recently enacted Occupational Safety and Health Act has extended these standards to industries engaged in interstate commerce. Under these regulations, industries must first try to reduce the noise to acceptable levels and, if that cannot be accomplished, some form of ear protection must be provided.

Noise levels and periods of maximum exposure are given in Table II. In this table, the dBA designation refers to the sound levels indicated on a standard sound-level meter, using the A-scale at slow response. Here, an A-weighting network makes the meter less sensitive to low frequencies, in the same way that the ear is less responsive to low-frequency sounds, thus providing a fairly accurate



Fig. 2. Sound-level meter (General Radio 1565) being used to investigate noise produced by a braiding machine. Note protective earmuffs worn by sound surveyor and machine operator.

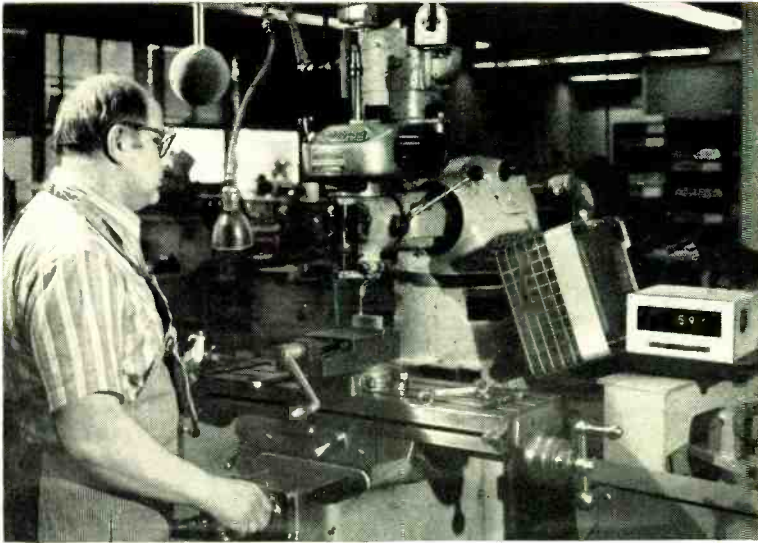

Fig. 3. Milling machine operation is monitored by General Radio 1934 noise exposure meter. Mike is in windscreen right of operator's head.

index of the human response to noise. In Fig. 2, a typical sound-level meter is being used to check machine noise.

An important consideration is that industrial noise does not generally stay constant during the working day so that the cumulative exposure consists of varying noise levels with different durations. Each level and duration must then be measured and added to the others to obtain the true daily exposure. Under these conditions, the requirements imposed by the noise-exposure criteria make the use of the sound-level meter a time-consuming operation, involving some lengthy calculations to determine the total noise exposure.

A number of instruments have been developed to compute, automatically, noise exposure levels in accordance with requirements of the Walsh-Healey Act. These devices accept noise information from a microphone, calculate the data, and display, in digital form, noise exposure as a function of elapsed time. Some types of equipment operate on batteries (with an attached microphone) and can be worn by the worker as he moves in and out of various noise fields. Other types are installed in a fixed location with the microphone mounted at the work position.

Figure 3 shows a noise exposure meter being used to monitor the noise exposure

at a milling machine. The operator starts the measurement by selecting the number of hours that the plant is in operation and then logs the total noise exposure readings at the end of the day. When he has to leave his work station during the day, he activates a "pause" button which stops the measurement until he returns. At the end of the preselected measurement period, the instrument stops, holding the elapsed time and the noise in a memory bank. As soon as the information is logged, the operator pushes a reset button and the instrument is ready for a new measurement. Electrical outputs are also provided to feed the noise exposure data to strip-chart recorders or other auxiliary equipment to make a permanent record of times of high exposure levels. In this way, noise reduction efforts can be directed toward machines that operate during peak noise periods.

According to the Walsh-Healey regulations, a cumulative noise level of 100% or under is acceptable, but if the exposure is over 100%, steps must be taken by the employer to reduce the noise level.

Noise Control Techniques. In the perception of noise, there are three basic factors to be considered: a source, a transmission path, and a receiver. Noise control problems, therefore, can be handled (see Fig. 4) by reducing noise at the

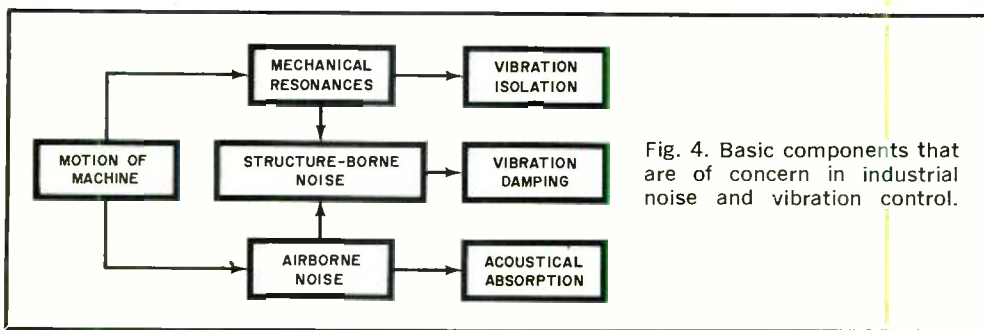

Fig. 4. Basic components that are of concern in industrial noise and vibration control.

origin, interrupting or modifying the transmission path, attenuating the noise level at the listener's ear, or by some combination of these methods.

In industrial cases, noise pollution can be reduced by changing the technique used in the work process. For example, compression riveting can be substituted for pneumatic riveting and, in some cases, welding can replace the entire riveting process. But the most widely used method of controlling excessive noise is by isolation—mounting the machine or equipment on coil springs, resilient pads, etc. This keeps the vibration of the machine from transmitting mechanical energy to the surrounding area. Another way of controlling high-level noise is to dissipate the vibrational energy (in the form of heat) before it is converted into acoustical noise. An efficient damping material, such as molded rubber, is applied to the surface of the structure.

In addition to isolation and damping, the use of porous sound absorbing material on walls, floors, and ceilings is effective in reducing noise, provided the sound arriving at the operator's ears is reflected and not radiated directly from the source.

In many instances, where sources and transmission paths cannot be controlled, hazardous noise levels in confined areas may be reduced by enclosing the noisy machines in acoustical barriers, or silencing enclosures. When this is impractical, an isolation booth may be installed near the machine so that the operator can control the machine under safe conditions. In a completely automatic operation, the production processes are supervised by remote-control positions in a noise-free environment. Machine operation is handled by mechanical devices under computer control while the operator receives information through closed-circuit television. ♦

ORBITAL SCANNER TO TELL IF MOTHER EARTH IS SICK OR WELL

A Multi-Spectral Scanner (MSS) designed to tell whether the nation's resources are well or ailing has been developed by Hughes Aircraft Co. for tests with NASA's Earth Resources Technology Satellite (ERTS-A) to be launched next year. An MSS model is being tested at General Electric Co. under direction of NASA's Goddard Space Flight Center.

The Scanner will detect and record (in photo-like images) the light "signature" of solar energy emitted by agricultural crops, forests, and rivers to indicate their environmental health, and to pinpoint underground deposits of mineral and oil. The 100-pound MSS will scan a swath of earth 100 nautical miles wide during each orbital pass of the ERTS. Management and conservation of resources is eventual goal.

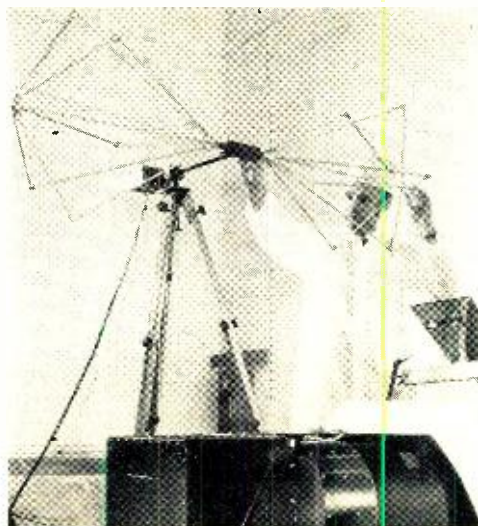



STEREO SCENE

Fourteenth in a Monthly Series by J. Gordon Holt

SETTING UP A TAPE RECORDER

LAST MONTH, we discussed the sorry state of affairs regarding adjustable audio components—that is, components that call for factory adjustments prior to delivery to the customer. We pointed out that, while FM tuners (and similar components) can often be improved by a careful touch-up of their alignments, they are usually delivered in pretty fair shape; but tape recorders usually are not. Finally, we suggested that it is worthwhile for any tape recorder owner to learn to do his own setups, so he doesn't have to trot his recorder down to the local audio shop every time he changes tape brands or types. This month, we'll expand on that suggestion by giving a practical, hopefully succinct description of how to go about doing your own recorder setup adjustments.

First of all, how do you know whether or not your recorder needs adjustment? That's simple. If you can hear any difference between an original signal and the playback from a tape of that signal, chances are your recorder needs work.

One of the most common misconceptions among amateur tape recorder fans holds that one tape is better than another because it *sounds* better. This is only a half truth. To understand why, consider for a moment the FM tuner.

Broadcasters of FM must adhere to very stringent standards (established by the FCC) with regard to frequency accuracy (on the dial), bandwidth, modulation levels, and the frequencies and intensities of the piggy-back signals that convey storecast and stereo-signal material. Since all stations adhere to the same set of standards, a perfectly aligned tuner receives them all equally well, at least within the limits of its capabilities.

Not so a tape recorder! Recording tapes adhere to certain dimensional standards, but their magnetic characteristics differ rather widely from one brand to another and even from one type to another within a brand line. Consequently, there cannot be a perfectly

adjusted recorder. The best one can hope to achieve is adjustments that are perfect for one specific kind of tape. Other kinds of tape will then perform strictly in relation to how similar their magnetic properties are to those of the tape for which the recorder was set up. A new tape that is substantially different from that used for the recorder setup will make the recorder behave very poorly, even though the new tape may be potentially better. This is why simply trying different tapes on your recorder will not indicate which tape is best; it will merely show which one (if any) your recorder was adjusted for at the factory. And since setups done at the factory are rarely as accurate as they could be, we shall now see how to go about doing them yourself.

You will need a test tape for a machine having the same head configuration as yours. That is, a 4-track tape for a 4-track machine, or full-track tape for a mono or two-track stereo machine or for a quadriphonic machine. Suitable tapes are available from Ampex Corp. or any Ampex dealer. Next, you'll need an ac VTVM sensitive enough to read full scale with 10 millivolts input. You may be able to rent or borrow one from a local audio or TV repair shop, or you may purchase one of the less-expensive versions made by Heath, Eico, Lafayette, or Allied-Radio Shack. Finally, you'll need a source for midfrequency and high-frequency sine waves. This too can be rented or borrowed, but a very inexpensive one (called the "Mini-Gen") may be purchased for \$15 from Century General Corp., 570 Seventh Ave., New York, NY 10018. You will also probably need several sizes and kinds of screwdrivers, but the only way to find out just which ones is to start the job.

The Better, the More. Generally, the better the recorder, the more internal adjustments it has. Generally, also, you can ignore most of them. For setup purposes, all you'll

need to find are these (one per channel): Bias Adjust, Record Level, Meter Calibration, Record Equalization (one per speed), Play Equalization, and, in semi-professional machines or those equipped with Dolby, Playback Level. Some recorders have fewer adjustments; some have more. (You may have, for instance, a tape selector switch to select two sets of perfect adjustments for two kinds of tape.)

The cardinal rule of all equipment diddling is this: If you don't know what something adjusts, leave it alone. Do not, under any circumstances, adjust something unless you know what it is supposed to do and have some means of observing what it does. There are no exceptions to this rule, so don't try looking for one.

The first step, then, in a tape recorder setup is to locate and identify all the necessary adjustments; and the best way to do this is by using the service manual for your recorder. Usually, you can buy one of these from the factory at a price which the manufacturer assumes will scare off anyone who who doesn't run a service center. Pay the

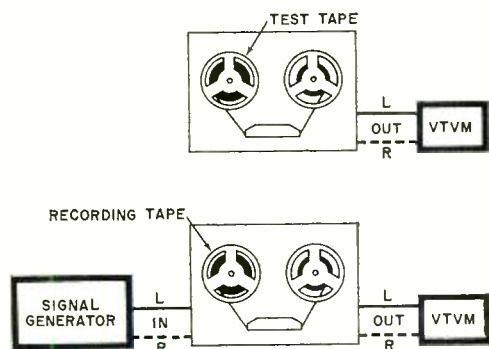

Instrumentation setups for playback (above) and record-circuit alignment procedures.

price anyway. If the manufacturer refuses to sell you a manual, your local audio shop may allow you to peruse theirs for long enough to find out how to expose the adjustments and to make a sketch showing their locations.

Some service manuals don't tell you how to get at the internal adjustments. If they don't, it's probably because getting at the adjustments is simple and straightforward, usually requiring nothing more than removal of the cabinet. To do this, unplug everything from the recorder, including any little plugs that don't seem to do anything. (Fuse caps count as plugs; so remove them, usually with a slight counterclockwise rotation.) If you think you'll have problems re-locating any of the connections later, make a sketch of what goes where before yanking them out.

Next, put a pillow on the floor and set

the recorder, face down, on the pillow. If the only screws on the bottom (or back) of the case are those in the centers of the rubber feet, remove them. If there are four or more others visible, remove them instead. Now, gently work the cabinet up off the recorder, being careful not to force it. If it encounters an obstacle that you can't work around, you probably forgot to unplug something. Let the cabinet go back to its original position and remove the offending object before trying again to lift off the cabinet. If it still won't come off, give up. Replace it, and put the screws back in. Don't overtighten the screws; use your fingers, not the palm of your hand to turn the screwdriver.

Assuming you get the cabinet off, now locate all the adjustments you have to work with. In some instances, it will be necessary to remove a metal shield to get at them. Drop all screws into an empty tin can as you take them out so they won't get lost, and note the length of each as you remove it. Some with identical heads may be longer than others and must be put back in the right place—make a rough sketch as a guide for reassembly.

Now, since you're going to have to be making adjustments while the tape is running, prop the recorder up on your work table so that all the internal adjustments are accessible and the deck is positioned in such a way that its reels will stay in place while turning.

The Purpose of It All. Briefly, here's what you'll be doing. First, you'll adjust the playback circuits so that a full-volume signal recorded equally on both stereo tracks will reproduce at full level and in proper balance. Then, you'll check to make sure a tape recorded with industry-standard equalization—a commercially pre-recorded tape for instance—will play back with the requisite flat frequency response. You'll use the test tape for both of these checks.

Then, going to the record circuits, you will first set the bias current for the recording tape you'll be using and then adjust the recording equalization so that the tape gets exactly the signal it needs in order to reproduce properly through the play section you have just set up to the industry standard.

Next, if your machine has Dolby or provisions for monitoring off the tape while recording, you will adjust the recording level so that input and output signals are at the same volume level. Finally, you will trim up the meter calibrations so that the meters indicate maximum recording level when the tape is actually being recorded at maximum level.

The playback adjustments are essentially the same for all tape machines, since the

object is to make the recorder respond predictably to any tape made according to the industry standards for that speed and format. If you have a service manual, follow all of the setup instructions described therein. If not, proceed as follows.

Connect the VTVM to either of the recorder's Line Output receptacles. Demagnetize and clean the heads, load the test tape, and locate on it the middle-frequency tone (400 to 1000 Hz) identified as "Normal Maximum or Zero VU" level. If there is a playback volume control (or two) with a knob on it, turn it (or them) up full. Then play the zero-level test tone and adjust the internal Play Level or Output Level pot until you measure 1.2 volts on the VTVM. Do this for each channel. If there are no internal Play Level adjustments, use the main Play Volume control(s) to produce that output figure. Leave them at these settings for the remainder of the procedure.

Next, check the playback frequency response by means of the test tape, adjusting the Play Equalization control (if there is one) to obtain the flattest possible response. Don't touch head alignment unless the high-end response falls below specifications by more than one dB or so. Even then, head alignment should be approached with caution since it can be tricky—especially if you don't know which screw to adjust. Follow the service manual.

Test-tape equalization tests are recorded at 10 to 15 dB lower than the zero maximum so change the VTVM's range accordingly. If it is not possible to get absolutely flat response from the test tape by means of the equalization pots, the best compromise is to match the level at 7 to 8 kHz to the level at 400 or 1000 Hz. That completes the play adjustment, and if you did it right, it should not have to be adjusted again until the play head is replaced. Let the test tape wind all the way through at play speed (rather than rewinding it) and then remove and store it.

The technique for the record setup will depend on whether or not you have a service manual and whether or not your recorder has the separate play head necessary to monitor from the tape while recording. If you have a manual, follow it, regardless of what kind of recorder you have. If you don't have a manual, but you do have a three-headed recorder, here's how to do the setup.

Connect the VTVM to either Line Output, load a tape of the kind you will be recording on most of the time, and feed a mid-range (400 to 1000 Hz) signal into the appropriate Line Input, adjusting level until the recorder's volume indicator reads zero or thereabouts. Then start recording at the machine's high

speed and switch the monitor selector to Tape. Adjust the record level a bit if necessary in order to get a VTVM reading directly on one of the meter's decibel calibrations near the right end of the 1-volt scale.

Bias Adjustments. Some recorders have adjustments for Bias Purity or Waveform, Bias Traps, Bias Frequency, and so on. Leave these strictly alone. Find the one identified as Bias Current or, simply, Bias.

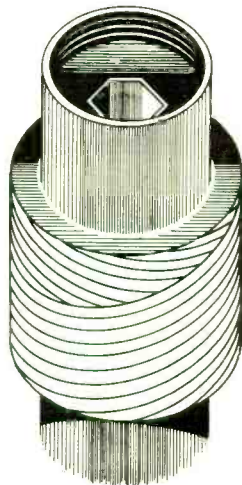

Some equalization adjustments are made on a coil with hexagonal hole in molded slug.

for the channel you are adjusting, and slowly rotate the screw until the measured output from the tape is maximum.

Reduce the input signal to a level 10 dB below the Zero point, switch the oscillator to 10,000 Hz, and watch the measured output from the tape as you slowly adjust the Bias screw clockwise. If 10,000 Hz diminishes in level, make a note to yourself that "Clockwise Bias is Increase." If it increases, make a note that "Clockwise Bias is Decrease." This is so you will know which way to turn the screw when the next step calls for increasing the bias.

Go back to the midfrequency from the oscillator, bring the record level meter reading back up to Zero, and adjust the VTVM's range switch so that the meter is on-scale to the right. Once more, adjust the Bias for maximum output from the tape and again adjust the Input level until the VTVM reads right on one of its decibel calibrations near the right end of the 1-volt scale. Then, very slowly, turn the Bias screw in the direction to increase it. You will observe that the measured output from the tape will decrease as you increase the bias. Increase bias until the measured output has

decreased by exactly $\frac{1}{2}$ dB (1 dB in a machine with 15-ips speed). Now, repeat the above steps for the other channel using the same speed.

You will probably notice, now, that there is a change in volume when you change the tape monitor switch from Input to Tape and vice versa. The next adjustment will fix that. Still feeding the midfrequency tone to the tape, adjust the Record Calibrate or Record Level pot for the channel you have the VTVM connected to until there is less than $\frac{1}{2}$ dB of measured difference when you operate the monitor switch. Then connect the VTVM and signal generator to the other channel and repeat the procedure.

With some recorders, the VU meters will be automatically calibrated by the time you have completed the procedure thus far. To check this, record the midfrequency signal on your blank tape at an input level necessary to get back (in Play mode) the same level you got from the Zero-dB part of your test tape. This recording level should coincide with the Zero-VU indications on the recorder's own meter. If it doesn't, adjust the internal Meter Calibrate pot for each channel.



Here are two varieties of plastic adjustment tools for coils: hex (above) and oval.

Record Equalization adjustments must be made for each of the recorder's speeds. Because of the substantial amount of treble boosting that normally takes place when recording (to compensate for inherent losses of the medium), response measurements at high frequencies must be made at a level considerably below zero dB. For adjustment purposes, a level of -10 dB (below zero) can be used for a speed of $7\frac{1}{2}$, while -15 and -20 dB are appropriate for $3\frac{3}{4}$ and $1\frac{1}{8}$ ips, respectively. Measurement of the actual high-end range of a machine will usually necessitate using even lower levels.

Record Equalization. To set Record Equalization, select a midfrequency tone, set the monitor switch to Input, and adjust the input level until the VTVM at the Line Output reads about the requisite amount below the 1.2-volt zero-dB level. Select a high-frequency tone, adjust the input level if necessary for the same low level, and switch the monitor back and forth between Tape and Input, adjusting the appropriate Record Equalization until the Input and Output

levels match. Then do the same for the other channel and other speeds.

One important note: some recorders use a molded "slug" threaded into a coil form for equalization adjustments. Unlike potentiometer adjustments, which cover their full range in less than a full revolution, these slugs may need several turns. Many of them cannot be adjusted with an ordinary screwdriver. Some have a hexagonal hole in them and require a special plastic tool of the kind sold in radio supply stores for TV i-f transformer adjustment. Others have a roughly oval hole and require yet another kind of tool. It is essential, though, not to try to use anything other than the proper tool. A small screwdriver may look as if it would work, but it may split the slug in half, making it impossible to adjust from then on. Then the entire coil has to be replaced.

A final note about two-headed recorders. Without the ability to monitor from the tape while recording, all recording circuit adjustments in these machines must be made with a tedious record—rewind—play procedure. One way of getting around this is to use two machines side by side, with the one being adjusted doing the recording (with its capstan bypassed) and the other pulling the tape and playing it back as the adjustments are made on the first machine.

With cassette recorders, the very slow running speed makes it possible to adjust the high-frequency response by varying the bias current; and this is the way it should be done. Service manuals for cassette machines usually specify that record equalization be set by measuring the equalization itself rather than by measuring its effect on tape playback. Once this is set, "equalization" adjustment is a simple matter of recording a midfrequency tone and then a high-frequency one of the same amplitude, playing them back, and making appropriate adjustments of the bias each time until both play back at the same level. Watch the input level, though. This must be at least 15 dB below the normal maximum Zero level indicated on the record meter.

Of course, no amount of care in setup can make any recorder perform better than its inherent potential, so don't expect an inexpensive machine to produce playbacks that are indistinguishable from the original signals. But if yours is a machine for which the manufacturer claims really high-quality performance, careful setup can make it truly difficult to distinguish between the original and the playback. Even if there is a difference, though, it's nice to know the recorder is doing its best for you, and that you aren't at the mercy of the local audio repair shop every time you want to switch to a different kind of recording tape. ♦



COMMUNICATIONS

By Leslie Solomon, Technical Editor

WHERE AM I?

It won't be long now before it will be almost impossible to get lost no matter where you are on the earth's surface. The army is experimenting with some portable receivers that work in conjunction with the Navy Navigation Satellite System to provide measurements accurate to a couple of yards and is unaffected by weather, time of day, or geographical location.

The Navy Navigation Satellite System is a group of satellites that continuously orbit the earth broadcasting their positional data. The first use for this system will be in land surveying but it is hoped that further development will lead to accurate position-finding gear which can be used anywhere in the world.

I SEE YOU

The District of Columbia has petitioned the FCC for a microwave frequency to operate a mobile TV system which will enable the Mayor to see what is going on in the streets as a result of civil disturbance, severe weather situations, traffic tieups, fire, serious accidents, or any other occurrence that should be brought to his attention. The plan is to mount the camera and microwave transmitter in a truck and use a downtown tower to carry the receiving equipment. This, in turn, will relay the signals to an antenna located on the Municipal Building.

HERE I AM

When you have a large number of busses or a fleet of vehicles covering a variety of streets and avenues in a large urban area, how do you know just where each one is at any given time? Sure, you just look at the printed schedule. Unfortunately, there are any number of circumstances that can foul up such schedules. Now, if RCA has its way, an automatic vehicle monitoring system (AVM) will keep tabs on all errant busses and public conveyances. In the system, miniature low-power transmitters are placed on signposts at intersections and other selected points. Each signpost transmits a unique code which identifies that specific point. As a bus, or other "signpost" vehicle passes within range of that transmitter, a small receiver in the vehicle picks up and stores the code. When it comes within range of another signpost, it stores the new code. When interrogated by radio from control center the vehicle's receiver automatically sends back the stored code number. A computer remembers these facts and can locate any selected vehicle to within several hundred feet of its true position on any signpost street. Now, if there were only some way that the rain-soaked potential rider could find out when the overdue bus is coming.

(More Communications Overleaf)

FREEZE

RCA has just announced a new silicon CRT that can store an individual TV frame and display it on demand. It is hoped that such a tube could be used in a home TV center so that a viewer could "freeze" one picture by pushing a button. This would allow a housewife, for example, to copy a recipe or select from a list of supermarket items that would be displayed on a cable TV system. In the actual console, a conventional CRT would display the continuing program and the silicon tube would store the selected frame when desired.

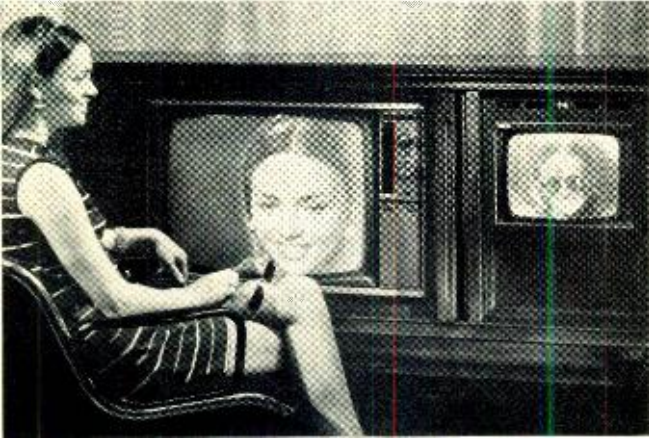

The lovely model is being monitored on TV and has removed her sunglasses, but before she did, one picture was "frozen" on the screen at the right.

Engineers also point out that, by using a system of remote control coding, a certain feature, such as stock market quotations or sports scores, could be automatically frozen when it came over the cable. The cable system operator would identify each feature with a code, and the subscriber having punched his selected code into the system, would find the feature waiting for him when he gets home.

GANGWAY, HERE I COME

If you live, or drive, in a large urban area, you have probably seen the frightening sight of an emergency vehicle, siren and lights going, trying to get through an intersection already crowded with traffic. In some areas, the drivers of these vehicles fervently hope that the optical and acoustical racket will be sufficient to clear the intersection without letting them plow into something. Not too long ago, someone came up with a system that changed the lights for traffic perpendicular to the emergency vehicle's travel. Evidently, that wasn't enough, for now the FCC has authorized one company to experiment with a radio device that will control all four lights at any selected intersection. A small antenna on the light control box, located at strategic corners, receives signals from a 3-watt transmitter located on the emergency vehicle. We assume that an emergency vehicle in this case is an ambulance, police, or fire truck bound on urgent life-saving business, and hope that this is the limit and that the privileges won't be extended down the political pecking order.

SATELLITE TV

All present-day satellites are essentially "private" in that they relay signals from one earth station (government or private) to another. It has now been learned that Applications Technology Satellite "F", due to be launched in May of 1973 will be used to explore the technical, economic, and educational practicality of regular TV transmissions to low-cost ground receivers in remote areas of the country. As planned,

the experiment will begin with educational and health programs to school and public health receivers distributed in the Rocky Mountains and Alaska. Consideration is also being given to installations in the Appalachians.

NASA is designing the 15-watt transmitters, operating in the 2500-2690-MHz band. The band is considered appropriate for this type of application.

OPERATOR? GET ME WWV, PLEASE

After July 1, 1971, it was possible to dial (303) 499-7111 (Boulder, Colo.) and hear the audio portion of the WWV transmissions loud and clear, with no fading or interference. This service is supplied by the U. S. Department of Commerce. The signals include a voice announcement of the GMT time, plus the usual audio tones and special announcements of interest to geophysicists and navigators. In continental U.S., the time signals should be accurate to 30-40 milliseconds.

AL UNSER USES MOBILE RADIO

Al Unser's big win this year in the Indianapolis 500 race in a car equipped with radio has focused the racing world's attention on mobile radio as a way to make the sport more competitive and safer for the driver. These conclusions were reached after watching the RCA miniature radio system at work in two cars (driven by Unser and Joe Leonard) from the track's pit area. When Unser pushed a button on his steering wheel, he could talk to his pit crew chief, instantly advising him of any developing problem. Thus alerted, the pit crew was able to save Unser 22.48 seconds in pit stops—his margin of victory was just under 23 seconds.



Indy 500 pit action shows this year's winner, Unser, making fast stop for fuel and giving instructions to pit crew chief over a mobile radio system. Engine noise and helmets make voice communication impossible during pit stop.

Unser continued to use the radio system during the time the car was in the pit, even though he and his crew chief were only feet apart. They agreed that the radio was far better than hand signals normally used in the pit where engine noise and helmets make voice communication virtually impossible.

With recent improvements in mobile equipment, it should be feasible for the driver to receive as well as transmit messages, which would enable the driver to learn of accidents ahead or other problems that might exist and to respond quickly. He could also receive such information as his position in the race, the lap he is on, and the number of laps to go.



**Train on this
315 sq. in.
picture
color TV
and get the
skills that
mean a
high-paying
career!**

Solid-State — the newest development

Count on NTS training to always feature the latest electronic equipment.

Now included in two exciting NTS color TV courses, this set is the largest, most advanced color television made. Guided by the NTS "Lab-Project Method" of combining professional kits and easy-to-follow lessons, you build this color TV step by step — learning TV Servicing as you go! NTS has successfully trained thousands of men at home for rewarding careers as electronics technicians. Prepare for the great opportunity fields of TV-Radio Servicing, Computers, Communications, and Automation.

This solid-state color set contains: 45 transistors, 55 diodes, 2 silicon controlled rectifiers, and 4 advanced Integrated Circuits representing an addi-

tional 46 transistors and 21 diodes. The first solid-state color TV this large — yours to keep! It features Automatic Fine Tuning; "Instant On"; an Ultra-Rectangular Screen (25 in. diagonal measurement) that lets you see the complete transmitted image for the first time — a full 315 square inches; exclusive built-in Self Servicing features which eliminate the need to buy costly test equipment; exclusive design Solid-State VHF Tuner with an MOS Field Effect Transistor; 3-stage Solid-State IF; Automatic Chroma Control; Adjustable Noise Limiting and Gate Automatic Gain Control; High Resolution Circuitry; Matrix Picture Tube; and a specially formulated Etched Face Plate that eliminates unwanted glare, and heightens contrast. Colors are more vivid,

fresh tones more natural, and the picture is sharper than ever before. By training on this unique color TV, you'll gain the most up-to-date skills possible in TV Servicing!

Other valuable equipment you build and keep includes an AM SW Radio, Solid-State Radio, FET Volt-Ohmmeter, and Electronic-Tube Tester. All included in your tuition. You learn troubleshooting, hi-fi, multiplex systems, stereo, and color TV servicing. Step right into a technician's job at top pay or open a business of your own! For complete details on all NTS electronics courses, mail the coupon today for the full-color NTS Catalog. No obligation. No salesman will call.

**Build this set
and learn
solid-state
circuitry—the
electronics
of today!**

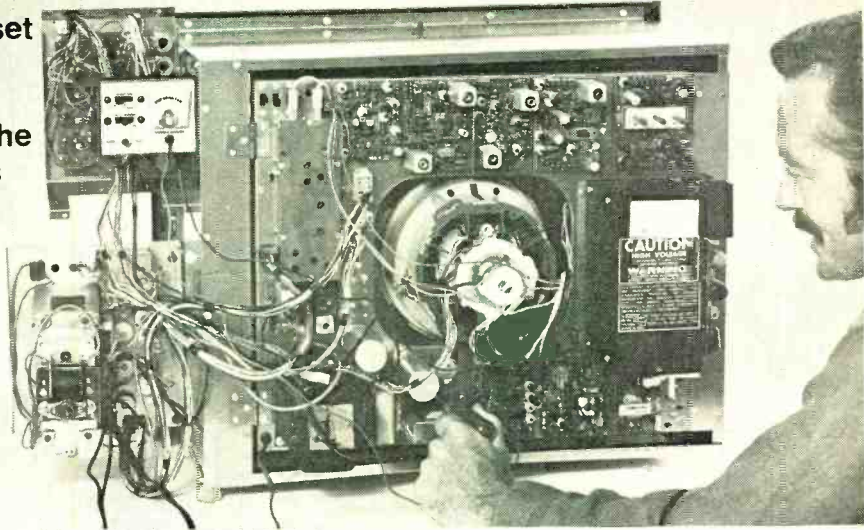

in color TV — comes to home training.

NTS ELECTRONICS & COMPUTER TECHNOLOGY

Build this exclusive NTS Compu-Trainer! Loaded with integrated circuits, it shows you the how, what, and why of computers. Learn this exciting field faster, more thoroughly. You also assemble and learn to operate an FET Volt-Ohmmeter and 5" wide band Oscilloscope.

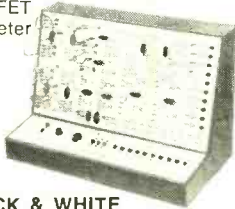

NTS BLACK & WHITE TV AND RADIO SERVICING

Learn all phases of television, radio, stereo, and hi-fi. You receive this 74 sq. in. picture Solid-State B&W TV, Lo-Silho "Superhet" Radio, FET Volt-Ohmmeter, Solid-State Radio, Electronic Tube Checker, and Signal Generator. Start earning extra money even before you complete the course!

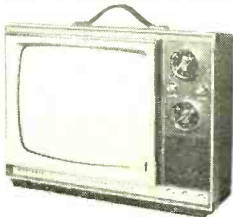

NTS ELECTRONICS COMMUNICATIONS & F.C.C.

Gain the security and prestige of owning an F.C.C. First Class Radio-Telephone License! Two comprehensive NTS courses cover the big opportunity field of transmitting and receiving. You build 14 kits, including a 5 watt AM Transceiver, 6 Transistor Pocket Radio, and FET Volt-Ohmmeter. Learn 2-way radio, Citizens Band, micro-waves and radar.



NTS INDUSTRIAL & AUTOMATION ELECTRONICS

Automation is the future of industry and you can play an important part! Learn industrial controls by training on the NTS Electro-Lab — a complete workshop. You also build and operate this 5" wide band Oscilloscope. And you perform experiments that involve regulating motor speeds, temperature, pressure, liquid level, and much more.

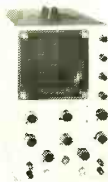

Classroom Training at Los Angeles. You can take classroom training at Los Angeles in sunny Southern California. NTS occupies a city block with over a million dollars in technical facilities. Check box in coupon.

APPROVED FOR VETERANS
Accredited Member: National Association of Trade & Technical Schools; National Home Study Council.

NATIONAL TECHNICAL SCHOOLS
WORLD-WIDE TRAINING SINCE 1905
4000 South Figueroa Street, Los Angeles, Calif. 90037

Please rush Free Color Catalog and Sample Lesson, plus information on course checked below. No obligation. No salesman will call.



National Technical Schools
4000 S. Figueroa St.
Los Angeles, Calif. 90037

- Master Course in Color TV Servicing Color TV Servicing (For Advanced Technicians)
 - Master Course in B&W TV & Radio Servicing
 - Master Course in Electronic Communication
 - Practical Radio Servicing
 - FCC License Course
 - Master Course in Electronics Technology
 - Industrial and Automation Electronics
 - Computer Electronics
 - Basic Electronics
- High School at Home Dept: 205-101

Name _____ Age _____
Address _____
City _____ State _____ Zip _____

Check if interested in Veteran Training under new G.I. Bill
Check if interested in Classroom Training at Los Angeles



OPPORTUNITY AWARENESS



Thoughtful Reflections On Your Future

Eighteenth in a Monthly Series by David L. Heiserman

Tips on Successful Home Study

I have just signed up for a home study program in electronics technology. Do you have any special suggestions about study habits that might help me get through the course successfully?

● The usual answer to this kind of question is, "Study hard and stick to the program." Considering the growing number of intelligent, hard-working individuals now signing up for home study programs, however, it seems that a more detailed and meaningful reply is in order.

Mr. Milton Gussow, Vice President for Academic Affairs at CREI, has supplied us with the following study tips that are valuable to home study "pros" as well as beginners: "The student should, to whatever extent he can, arrange a good study environment—a comfortable desk and chair, absence of distractions, adequate light; texts, notebook, paper and pencil conveniently placed—all these help, but the lack of any of them is not an insurmountable handicap. Our students, like all ambitious men and women, study under whatever circumstances they can. They study on trains and busses, aboard submarines on patrol, in messrooms and wardrooms at sea, and, almost literally, in foxholes in Vietnam. Environment is important, but not all-important.

"The greatest single factor making for success in correspondence study, even more than in college, is *regularity*. Many of our students have found—usually after a rather skeptical trial—that the best way they can study in peace is to get up an hour earlier every morning and spend that hour on their lessons. At that time, the student's surroundings are usually quiet, his mind is refreshed and receptive, and he has the advantage of being able to think over during the day what he studied that morning. The lost sleep can be made up—though many people do not

find it necessary—by skipping the late show and going to bed an hour early.

"More than an hour a day, if it can be arranged regularly, is undoubtedly helpful. Most students, however, find themselves pleasantly surprised by the progress they can make by just that early-morning hour five days a weeks. It is much more effective than twice the time devoted to cramming sessions on weekends.

"It sometimes happens that an idea or a statement that puzzles a student early in a lesson is clarified by something that comes later. If the student has skimmed through the entire assignment at the beginning, he may well recognize that the puzzling idea comes up again a little later. He can thus proceed without wasting time on the immediate problem. If a student really finds himself unable to understand some part of a lesson, he should not spend time over it uselessly. He should write to his correspondence school at once and be as specific as possible about his problem.

"Each student should keep a notebook in which he can write outlines of his assignment. He should use part of the notebook for formulas so that he can find them easily when he needs them. He should develop the habit of marking up his text pages using colored pencils for emphasizing, underlining and marginal notes. After all, these texts are his; he should make them as useful as he can. This is especially true of diagrams showing polarities, current directions, and the like."

Mr. Rhynie F. Hollitz, Director of Education for the Cleveland Institute of Electronics, suggests an important "don't" for home study scholars:

"The independent study course includes an examination at the end of each lesson. This is an 'open book' examination. The student can always refer to the text whenever he is not sure that he knows the answer to a unique question. This is a continuation

of the teaching process and helps the student to acquire a firmer understanding of the concepts. The student should never get into the habit of starting with the exam questions and then going to the text to search for the answer. This does not help, but seriously affects the development of his capacities. The home study course is designed to develop his capacity for memory, logical thinking, and creative ability."

Engineering Societies Library

I have heard that the world's largest engineering library is located somewhere in New York City. Supposedly, this library offers a number of special services to the public and loans books by mail. Can you give me more information about the library and its services?

● You must be referring to the Engineering Societies Library. Containing 225,000 books and a running list of 4400 periodicals, ESL is, indeed, the largest engineering library in the free world. The library offers a complete range of photocopy, microfilm, literature search, and translating services to the public.

Although the reading rooms are open to the public, the ESL loans out books only to special members and members of several major engineering societies, so if you are an IEEE member, you can take out books in person or request them by mail.

For more information about the ESL, write or visit:

Engineering Societies Library
United Engineering Center
345 E. 47th Street
New York, NY 10017

Getting Ahead— With or Without a College Degree

I believe that you are misleading your younger readers by implying that they do not need a college degree to get ahead in electronics ("The Sacred Club of Engineers," Opportunity Awareness, November, 1970). I missed my chance at a college education 25 years ago, and I've been paying for it ever since. I have been working as an electronics technician all this time and I know that young fellows today can get a degree in electrical engineering and start out ahead of where I am now.

● What I have suggested several times here is that not all people, no matter how brilliant they may be, can survive (for one reason or another) the stress of college academics. I do not consider such people unfortunate or disadvantaged—there are too many fine home study and two-year tech-

nical schools that can provide all the basic training these people need.

Those who happen to have the right temperament should, by all means, get as much formal college education as possible. As you say, college graduates start out far ahead of nongraduates. And, on the average, graduate engineers go a lot farther and earn much more money than do technicians. The important word here is "average." It is a plain fact of life that it is possible to beat the averages. A technician, in other words, doesn't always have to take a second seat in electronics all his life.

College degree or not, the people who really move ahead of the crowd are those with the right kind of talent, nerve, brains, and energy. College experience can go a long way toward developing these personality traits, but so can experience, some basic training, and a lot of hard work.

OK, LADIES, MAKE IT WORK

"The feminine concern for detail and for wanting everything working properly in its place makes television a natural vocation for women," says Sandra Schaffner. Mrs. Schaffner, shown below in her workshop, has organized a new, nationwide club for women engaged in professional electronic servicing. It's called LITES (Ladies in Technical Electronic Servicing) and it seeks to encourage women to enter the field by providing for exchange of ideas through national yearly meetings and a regular newsletter. Mrs. Schaffner works with her husband, Len Schaffner, in their shop, Kings Magnavox, 1209 Los Angeles Ave., Simi Valley, Calif.

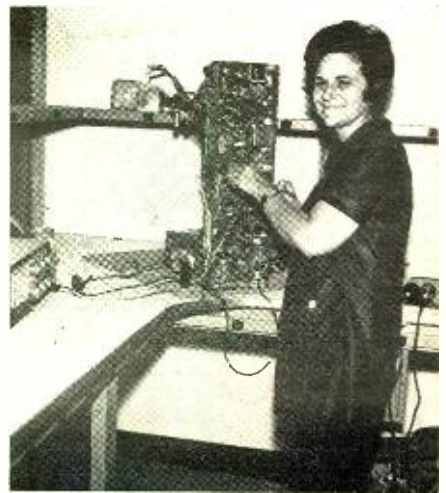

THE PRODUCT GALLERY

Fourteenth in a Monthly Series by "The Reviewer"

HARMAN-KARDON CASSETTE DECK (Model CAD-5) (Hirsch-Houck Lab. Report)

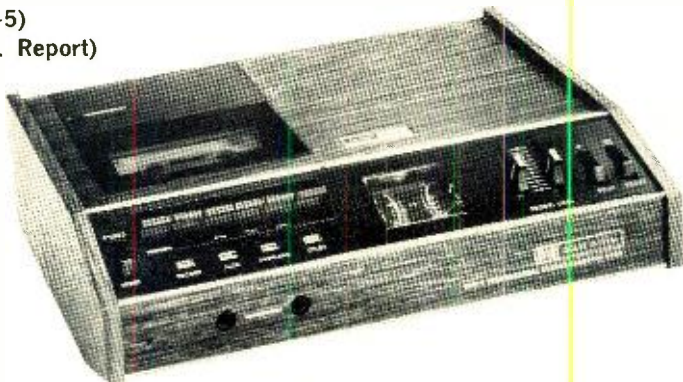

Recently, much has been heard about the Dolby Noise-Reduction System and its significance to the hi-fi enthusiast. The Dolby system has been widely used in the recording industry for some time now, but only during the past year has it appeared in home-entertainment products.

The Dolby "B" system (the simplified type used in home entertainment tape and cassette decks) increases the high-frequency response when recording low-level signals and reduces the highs in a complementary fashion when playing them back. Any noise originating in the recording and playback process is decreased by as much as 10 dB, while the overall frequency response is unaffected. The action is instantaneous and automatic (once certain critical standardized output and input levels have been established), and only the lower hiss level reveals the presence of the noise-reduction system.

One of the major limitations of the cassette tape medium resulting from the narrow track width and slow speed is its often marginal signal-to-noise ratio. Anyone who has listened to cassettes—either of his own taping or commercially reproduced—on a wide-range system, is aware of the constant audible hiss. Obviously, then, the cassette recorder is a prime candidate for a noise-reduction system such as the one designed by Ray Dolby.

Description. Harman-Kardon's CAD-5 cassette deck is one of the few Dolbyized decks available. Externally, it closely resembles the CAD-4, its predecessor. However, the CAD-5 is a completely new machine. A row of "piano-key" levers operates the transport. They are mechanically interlocked so that the STOP lever must be operated before going from PLAY or RECORD to FAST FORWARD or REWIND, or vice versa. A RECORD interlock lever must be depressed together with the PLAY/RECORDER lever to make a recording. Pressing the PAUSE lever stops the tape motion instantly (without releasing the RECORD interlock). A second press of the lever starts the tape moving again.

Two slider-type controls are used for adjusting the recording levels which are shown on twin illuminated meters. The meters also indicate the line output levels during playback. Rocker-type switches control power, stereo/mono recording, and the Dolby circuits. On the top of the deck is a pushbutton reset index counter and the tape loading slot which has a tinted plastic window.

Four signal lights below the control levers show the operating status of the CAD-5. The RECORD and DOLBY lights show that the respective circuits are in use. The AUTO light goes on when the tape is in motion.

When the end of the tape is reached, the mechanism stalls and in a few seconds a protective circuit removes power from the motor and extinguishes the AUTO light. The mechanism must be shut off manually via the STOP lever to disengage the pinch roller.

On the rear of the deck are two sets of recording inputs for high- and low-level signals and output jacks. A slide switch sets the bias and equalization for optimum results with a "standard" tape (TDK SD is recommended for best results), or for one of the chromium-dioxide tapes now available from several manufacturers.

The other rear-panel controls are associated with the Dolby system, allowing the user to calibrate the recorder for the tape being used. A DOLBY test button records a standard-level tone, and the REC CAL screwdriver adjustments are set for playback at 0 VU in each channel. This procedure must be followed when changing brands of tape. (The CAD-5 is shipped from the factory adjusted for TDK SD tape). There are a pair of PLAY CAL adjustments, which normally do not require readjustment. If readjustment is necessary, a special Dolby test-level cassette is available from Harman-Kardon for \$5.95.

Test Results. In our laboratory tests, the record/playback frequency response of the Harman-Kardon CAD-5 was an outstanding ± 1.5 dB from about 50 Hz to 15,000 Hz. When using the Dolby circuits, there was an additional 1 dB of output at all frequencies beyond 2000 Hz. The playback frequency response from a BASF test tape was within ± 2 dB, 31.5-10,000 Hz.

Circle No. 85 on Reader Service Page 15 or 99

Wow and flutter were, respectively, 0.10 percent and 0.24 percent. Distortion was 3 percent at -3 VU recording level, increasing rapidly at higher levels and reducing to 2.2 percent at -6 VU. Incidentally, Harman-Kardon recommends a maximum recording level of -2 VU.

The signal-to-noise ratio, referred to the -2 VU recording level, was 45 dB without the Dolby—a normal figure for a good cassette deck. Switching the Dolby system into the circuit improved the S/N ratio to 53 dB, comparable to good-quality open-reel tape recorders.

Subjectively, the CAD-5 added only a minute hiss level to disc records which were dubbed on to cassettes and played back for comparison with the original program. There was no audible change of frequency response in the record/playback process. When taping stereo FM broadcasts, there was no discernible change from the original program to the playback of the recorded program. The normal residual noise in stereo FM reception was at least as high as the recorder's noise level. Care must be used to prevent program peaks from exceeding -2 VU since audible distortion can result from levels between 0 and +3 VU which some non-Dolby recorders can accommodate without difficulty.

In summary, the Harman-Kardon CAD-5 cassette deck is an excellent recorder by any standards applicable to a home-entertainment machine. Until recently, only the better 7½ in./s open-reel decks were capable of as much fidelity as this cassette recorder delivers at 1½ in./s. It is a lot of recorder for \$229.95.

LAFAYETTE GUARDIAN-6000 PORTABLE 6-BAND RECEIVER

There are portables and there are portables, but the Guardian-6000 receiver from Lafayette is one of the most interesting. At \$79.95, it is actually six radios in one; and, with its DF (direction finding) capability, it also makes a fine addition to any small boat.

To start at the beginning, the 6000 has six ranges: the long-wave (LW) band from 180 to 380 kHz; the conventional BCB (AM) from 540 to 1600 kHz; a medium short-wave (MB) band from 1.6 to 4.0 MHz; the standard FM band from 88 to 108 MHz; the aircraft (AIR) band from 108 to 136 MHz; and the public service (PSB) band that includes both weather and police/fire frequencies from 147 to 174 MHz. That's quite a handful for any receiver.

(Continued on page 82)



The LW, AM, and MB ranges use a large, externally mounted, rotatable ferrite antenna which doubles as the direction finder. Used in conjunction with an easy-to-read meter (which also indicates battery condition), this feature permits listening to the long-wave weather broadcasts as well as using the long-wave beacons to locate yourself at sea. The same DF capability is available on the AM and MB bands. The antenna includes an optical sighting arrangement for making visual bearing sights.

A built-in agc can be used to vary the sensitivity of the receiver and tuning meter for more accurate DF purposes.

The PSB range covers the new VHF/FM marine band and also includes the 162.55-MHz weather broadcasts, making the 6000 even more valuable for the marine enthusiast. The only use I found for the AIR band was snooping on aircraft reporting to the local airport. Incidentally, it was on this receiver that I heard the complete story of an actual aircraft hijacking while it was taking place. The MB range is useful for listening to the 2.5-MHz WWV transmis-

sions as well as the local marine radio-telephone band.

Using readily available, conventional C batteries, or operated from the ac power line, the all solid-state receiver has instant turn on and a pushbutton controlled pair of "grain-of-wheat" lamps to illuminate the dial when needed.

The FM, AIR, and PSB ranges use a collapsible built-in whip antenna, and a squelch control is included for operation on these VHF bands. Among the other features are an external antenna jack, an earphone outlet, a slide-rule dial for accurate resetting, a 4" speaker with good tonal quality, and a collapsible steel carrying handle.

After using the 6000 for a couple of weeks, I found it real handy, especially when I wanted to check the weather during the day (on 162.55 MHz), listen to music on the FM band, or switch to AM for the news. On my small boat, when used with a local marine map, I found the DF capabilities of the 6000 pretty good and was able to locate myself reasonably closely to a known marker buoy 15 miles offshore.



1000	AM	MB	FM	AIR	PSB	LOG
	540	1.8		126	147	-0-
160		1.7	88	112		-1-
500	600		95	115	152	-2-
	700	2		118		-3-
850		2.5	85	120	155	-4-
	800		100		160	-5-
900	1000	3		125		-6-
		S.E.			165	-7-

The DF peepsight (upper left) of the 6000 can be used in conjunction with the compass ring for accurate position location. The large meter (above) indicates battery condition, signal strength, and the minimum signal strength required for accurate DF requirements. The large, clear frequency numbering on the six bands is shown at the left. A logging scale is included for resetting. A front-panel pushbutton switch can be operated to turn on the dial illuminators.

Circle No. 86 on Reader Service Page 15 or 99

AVANTI MOBILE CB ANTENNA (Model AV-527)

Having tried a couple of short antennas in the last few years—without much success—I have always returned to the good old reliable 108" whip. Of course, this tall thing can be annoying (especially under trees, garages, and underpasses), but I lived with it because it got my signal out.

Recently, however, I tried out a new short antenna, the Avanti AV-527. Unlike many other shorties, this one gave excellent results and comparative tests between this and the tall monster showed very little difference in signal strengths for separations between stations of quite a number of miles.

For those who have new cars and don't feel like drilling holes or having wild antennas strapped to shiny new bumpers, there is real cheer. The AV-527 comes with a very nice trunk-lip support to hold the antenna securely without drilling. Using our Eico 715 Test Set, we found that it also produces a good polar diagram and the VSWR can be set to a minimum very easily.

The antenna is a base-loaded type having an "acrylonitrile-butadiene-styrene" cover over the base and loading coil. This material is as tough as it sounds; and, besides looking good, it protects the silver-coated (for high Q) coil and base from extremes of heat, cold, and humidity. A heavy-duty spring enables the AV-527 to bend with contact, reducing breakage problems.



All in all, the AV-527 (consisting of the AV-327 antenna and AV-521 No-Hole Trunk Lip Mount) is a good-looking, high-performance CB antenna that doesn't make a car look ugly (my touchy wife doesn't mind it), and yet gives the performance of the old-fashioned whip.

Circle No. 87 on Reader Service Page 15 or 99

J & J ELECTRONICS Q-CHECK (Model 100A Transistor Tester)

Since you can't tell by looking at a transistor whether it is good or bad, it is almost a necessity to test each one before soldering it into a circuit. There are many ways of checking a transistor: some people use an ohmmeter (always a dangerous move because excessive current may destroy a good junction); and others use one of the many transistor checkers that are currently available. Most of the transistor checkers have a meter readout that must be interpreted or they perform functions that are not really of prime importance when the object is to determine whether or not the unit is good.

The J & J Electronics Laboratories recently introduced their Model 100A Q-Check Transistor Tester (\$169.50) which has a 1" CRT as the readout. This 6½" x 8" x 8" unit has a transistor socket and element connectors on the front panel and requires only the plugging in of any type of semiconductor (except FET's) and noting the CRT display. All indications are automatic.



The basic circular display changes its format in accordance with the type of semiconductor being tested (nnp, pnp, SCR, diode, zener) and shows whether or not there is

anything wrong. The illustrated material supplied with the tester shows the patterns that should occur with good units, and the patterns that will occur if there are inter-element shorts or opens and the amount of leakage between various elements.

The Q-Check does not indicate the values

of beta, leakage, etc., but does tell the user what type of device he has plugged in and what, if anything, is wrong with it.

If you handle a lot of semiconductors and have a need to know rapidly whether you have good units or bad, then the Model 100A is just the thing to have on the bench.

COMPARISON CHART

	NPN	PNP	SCR	DIODE	ZENER	
GOOD						
SHORT E-B						
SHORT C-B						
SHORT C-E						
OPEN						
LEAKAGE C-E						
LEAKAGE C-B						
LEAKAGE E-B						

NOTE: FOR SCR'S, C IS ANODE, B IS CATHODE AND E IS CATHODE

J&J ELECTRONIC LAB
NEW CITY, N.H. 10956

Circle No. 88 on Reader Service Page 15 or 99

At left is a facsimile of the information supplied with the transistor tester to show the user the various oscilloscope traces that can be expected for various devices, whether good or defective.

LENDELL "QUICK-PICK" COMPONENT REMOVAL TOOLS

After many years of building kits and homemade projects, and servicing those tiny imported radio and TV sets, there is one thing that always bothered the heck out of me. How to remove a faulty transistor, electrolytic, etc., from an already crowded PC board when I couldn't possibly get my fingers in there—or even a pair of needle-nose pliers. Up to now, it has meant much sweat, tears, and some profanity. But my whole attitude changed recently when I got my hands on a unique new set of tools—the "Quick-Pick," made by Lendell Products Co.

The package of seven tools (costing \$9.95) consists of clamplike tubes of different diameters to fit over 25 outlines of transistor and capacitor cases. The tools are just 0.028" wider than the part that they are to remove so that you get a good snug fit. The tube of the correct size is simply placed over the



part and an outer sleeve is slid down. This causes the slotted tube to grab the component firmly. The component is then unsoldered, and the Quick-Pick enables you to pull it off the board neatly and easily once the leads are free.

Besides making parts removal a snap, the Quick-Pick also helps greatly when it comes

time to insert the replacement part. All you do is grab the part in the tube with the correct diameter, affix the grip, and insert. Besides acting as a "third hand," the tool also acts as a neat sink during soldering. Each of the seven non-magnetic tools has a colored plastic tip and they range from 0.185" to 0.335" in diameter.

Circle No. 89 on Reader Service Page 15 or 99

HEATHKIT VOLT/OHM/MILLIAMETER (Model IM-105)

The traditional volt/ohm/milliammeter may have been overshadowed by more sophisticated solid-state instruments in recent years, but it is still very much in evidence on workbenches and in field service work. For ruggedness and convenience, the VOM is hard to beat. So, it was no surprise that the people at Heathkit decided to add a new VOM kit (Model IM-105) to their line.

The IM-105, selling for \$47.50, is no ordinary VOM, though it does everything required of a conventional VOM. This is an extraordinarily rugged instrument, employing a very tough high-impact Lexan® case and a ruggedized taut-band movement. Inside and out, the IM-105 shows its quality. Fuse protection, quality metal-film low-tolerance resistors, epoxy-glass printed circuit boards, and thermistor compensation combined with the rugged case and meter movement allow the IM-105 to bounce back from physical and electrical abuse.

Range selection for the IM-105 has been designed for maximum convenience and utility. A continuous-rotation 20-position range/function switch provides eight dc voltage ranges from 0.25 to 5000 volts full-scale; seven ac ranges from 2.5 to 5000 volts full-scale; six dc current ranges from 0.05 mA to 10 amperes full-scale; and five resistance ranges from X1 to X10K with a center-scale factor of 20. Accuracy on all dc voltage and current ranges is 3 percent (on ac, 4 percent) full-scale. For audio voltage measurements, there is a -10 to ± 50 -dB measuring capability in five ranges.

Building the kit presented no difficulty, considering that the usually explicit assembly instructions provided by the Heathkit people were up to their usual standard. The whole job—mechanical assembly, electrical wiring and calibration—consumed just slightly more than four hours. Because this is a precision instrument, requiring the use of sophisticated test and calibration gear to obtain maximum accuracy, the calibration

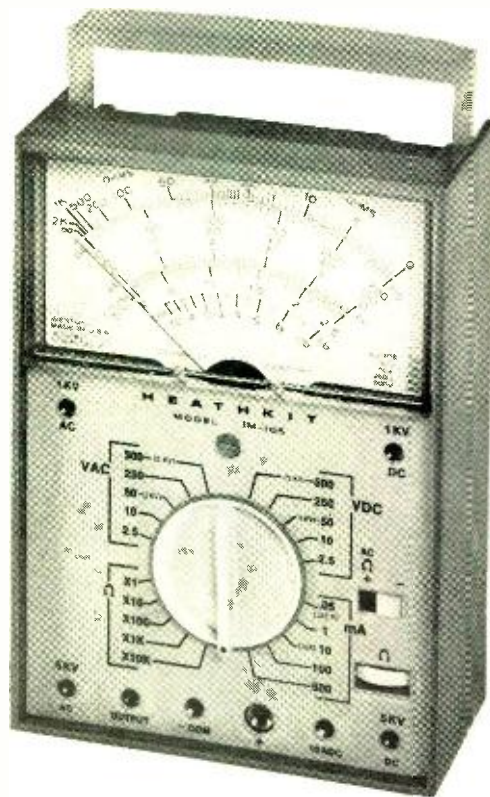

section in the manual outlines two procedures: one with the appropriate test instruments and another for general accuracy without the aid of special instruments. The general procedure provides adequate accuracy for most applications.

The IM-105 is, first and foremost, an accurate, very versatile field instrument designed for those people who require ruggedness of their equipment. It is an ideal VOM for the workbench as well as in the field servicing kit.

Circle No. 90 on Reader Service Page 15 or 99



One Hundred Eighty-fourth in a Monthly Series by Lou Garner

LOWER semiconductor prices may be but one of the beneficial results of a new manufacturing process developed after three years of research by scientists and engineers of the Signetics Corporation (811 E. Arques Ave., Sunnyvale, CA 94086), a subsidiary of the Corning Glass Works. Dubbed "D-MOST," for Double-diffused Metal-Oxide Semiconductor Technology, the new production method is a relatively simple and inexpensive technique which can be used to fabricate discrete devices, such as individual diodes and transistors, as well as both linear and digital integrated circuits. It can be used effectively in turning out both small signal and high power units and is of particular value in the low-cost production of high performance VHF and UHF devices.

Currently, there are two popular techniques for producing semiconductor IC's—the bipolar and MOS (Metal-Oxide Semiconductor) methods. Within the MOS technology itself, there are several individual

processes, including n-channel, p-channel, ion implantation, nitride, complementary, and silicon gate techniques. Bipolar circuits, in general, feature high operational speeds; but MOS circuits are more compact and require less power, although traditionally slower than bipolar.

Signetics' new D-MOST devices, on the other hand, have exhibited speeds five times faster than standard n-channel MOS units and at least ten times faster than devices made by the p-channel MOS process. D-MOST devices, in fact, are comparable in speed to fast bipolar transistors, but retain the advantages of high density, low power consumption, and low cost. Sample D-MOST digital devices exhibit a typical rise time of only 210 pico-seconds.

High frequency microwave devices can be produced using the new process as well as logic circuits and computer memory elements. Experimental D-MOST microwave transistors, for example, operate at frequen-

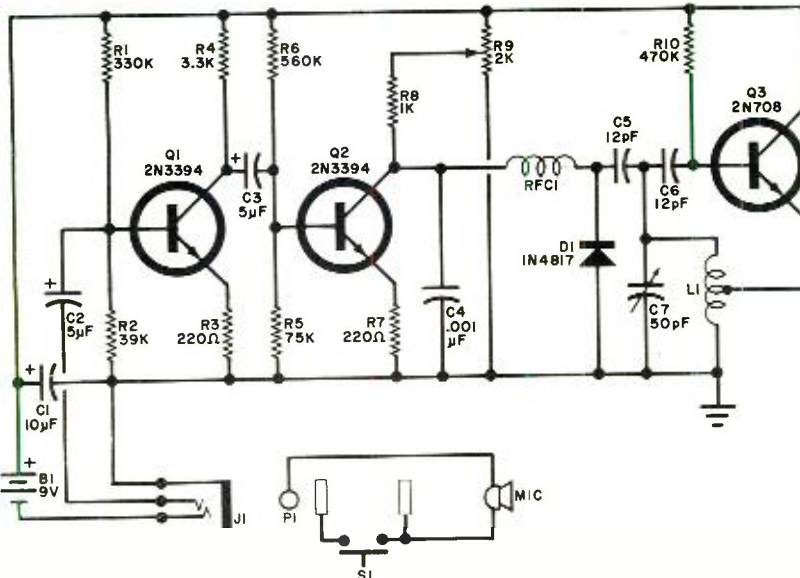

Fig. 1. This simple FM wireless microphone circuit uses the audio voltage to vary the junction capacitance of a conventional rectifier diode.

cies up to 10 GHz, with a typical noise figure of only 4.5 dB at 1.0 GHz, and a maximum gain of between 10 and 15 dB at that frequency. Even at 2 GHz, 7-dB gain is feasible. D-MOST transistors also outperform junction FET's, exhibiting very low feedback capacitance, low distortion, less cross modulation, lower parasitics, and greater linearity.

In practice, the speed of MOS-type digital circuits is determined by the length of the "channel" beneath the gate and situated

between the source and drain electrodes. Transfer time is reduced and speed increased as channel length is shortened. In the conventional MOS process, however, this has the undesirable effect of lowering breakdown voltage, a problem which is eliminated with the D-MOST technique. Since breakdown voltage is not dependent on channel length with the new process, high voltage capability can be designed independently of channel length, thereby retaining high-frequency performance.

D-MOST transistors have been fabricated with channel widths of only 1 micron (millionth of a meter). Signetics has successfully assembled 1-GHz, 300-volt devices, and has also made other units with breakdown voltages as high as 600 volts, using two micron channels. The basic D-MOST process is essentially an optimum blend of bipolar and MOS techniques.

Useful Circuits. Featuring a novel modulation method, the FM wireless microphone circuit illustrated in Fig. 1 was submitted by reader Thomas Duncan (4240 N. E. 23rd Ave., Lighthouse Point, FL 33064). Instead of a conventional reactance stage, saturable inductor, or oscillator bias control, Tom has used a standard rectifier diode as his modulator, operating it as a varactor across the oscillator's tuned circuit. With the limited

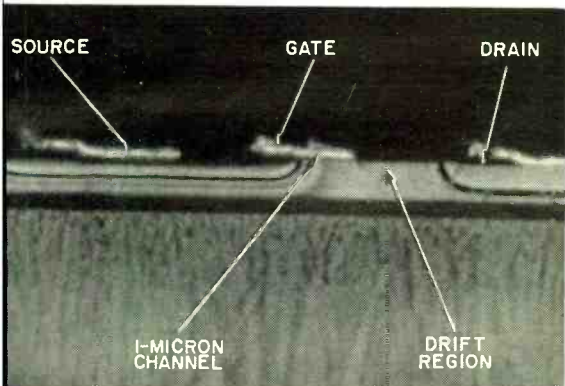

In D-MOST transistor, narrow control channel under gate increases speed of operation.

READ THIS!!

FAMOUS Marshall BRAND

COMPONENT COLOR ORGANS

NOW AT ★★ INCREDIBLE ★★ NEW PRICES:

<p>REG. \$40. Three Channel NOW ▶ 18⁵⁰</p>	<p>HERE'S HOW IT IS DONE:</p>
---	-------------------------------

- ★ True frequency selective, amplitude modulated 3 channel color organ, with front panel indicator lamps for bass, mid, & treble.
- ★ 900 WATTS! That's EIGHTEEN 50 watt bulbs: Do YOU need more than that?
- ★ Solid half inch thick walnut finished pre-constructed cabinet. 12x3" front panel.

2 YEAR GUARANTEE! WIRES TO ANY SOUND SYSTEM! NO LONG WAITING: ORDERS PROCESSED IN ONE DAY!

Please **RUSH** my color organ(s) as follows
 ___ kits at 18.50 + 1.85 postage; handling.

Paid in full. 5.00 deposit enclosed:

Send C.O.D. for balance + postage.
 maryland residents: add 4% sales tax

Marshall Electronic:

Name _____

Address _____

City, State _____ Zip _____

Rm 104, 101w. read st.
baltimore, md. 21201

range required of unlicensed transmitters, the unit is intended for household use with standard FM broadcast band receivers.

Resistance-coupled amplifiers Q1 and Q2 serve as the audio preamp for the microphone. Base bias for Q1 is established by voltage-divider R1-R2 in conjunction with emitter resistor R3, with R4 serving as the collector load. Similarly, Q2's base bias is established by R5-R6 and emitter resistor R7. Resistor R8 and a portion of diode bias control R9 serve as Q2's collector load. Capacitors C2 and C3 provide audio coupling, C5 and C6 r-f coupling, C1 power supply bypass, and C4 r-f filtering. Transistor Q3 serves as a modified Hartley oscillator, with its basic operating frequency established by tuned circuit L1-C7, and base bias supplied through R10. Circuit dc power is furnished by B1, controlled by spst push-to-talk switch S1.

In operation, a fixed dc bias is applied to diode D1 through R9, R8 and RFC1. The instantaneous bias changes, however, in accordance with the amplified audio signal delivered by Q2, causing corresponding changes in its effective anode-cathode capacitance. Since D1 is essentially in parallel with L1-C7, the tuned circuit's frequency

changes accordingly, generating an FM r-f signal.

Except for hand-wound coil L1, standard components are used in the instrument. The coil consists of 4 turns of #18 wire, 1/4" in diameter and 1" long, with a tap on the second turn from ground.

Tom writes that the design is well-suited to pref board or etched circuit construction, and that neither layout nor lead dress is overly critical, except in the oscillator/varactor circuit, where good VHF wiring practice should be observed. After assembly and check-out, trimmer C7 should be adjusted so that the instrument's signal is picked up at a "dead" spot (where there is no local station) on the dial of a nearby FM receiver. Afterwards, R9 should be adjusted for optimum modulation and best clarity, with C7 retuned as necessary.

Another interesting circuit is illustrated in Fig. 2—a touch control switch which can be used to operate lights, bells, buzzers, fans, household appliances, small motors, or any similar electrical devices. The circuit was abstracted from the instruction folder furnished with Motorola's HEP Field Effect Transistor Experimenter Kit Model HEK-2. An inexpensive kit consisting of a pair of

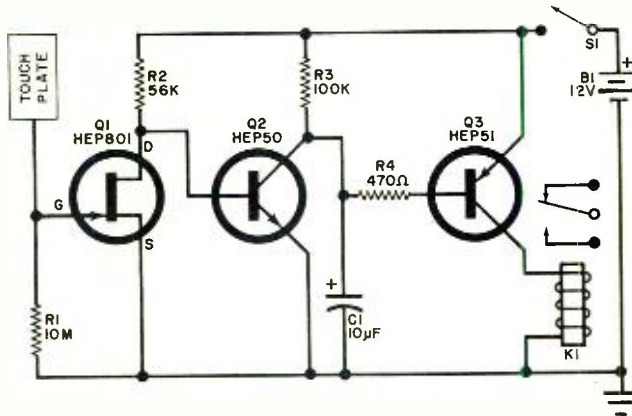

Fig. 2. Simple touch switch can be used to operate almost any type of alarm or low-power appliance. It can be built from the readily available Motorola HEK2, FET Experimenter's Kit.



DIRECT FREQUENCY DIALING

International Short-Wave Broadcast RECEIVER



No more guesswork in identifying stations. Set dial at a station's frequency and if conditions permit you'll hear it everytime...

- Ultra-precision tuning dial accuracy, SW and standard AM Broadcast
- Crystal lattice filter for adjacent station rejection and good AF response
- Dual conversion • Solid state AF output • S-meter • Preselector gives superior sensitivity by peaking antenna and RF stages • Crystal-controlled H. F. Oscillator stability • Amplified AVC constant AF output • Price \$299.00

Write for free Brochure

R. L. DRAKE COMPANY • Miamisburg, Ohio 45342

CIRCLE NO. 12 ON READER SERVICE PAGE

n-channel FETs and both npn and pnp silicon transistors, the HEK-2 may be used in a variety of projects. Among the other circuits featured in the folder are a timer, moisture detector, light activated relay, 2-meter preamp, microphone/phonograph preamp, audio amplifier, sound activated relay, and broadband r-f amplifier. Additional components are required for all of the projects, for the basic kit includes only the semiconductor devices.

A straightforward design, the Motorola touch switch circuit features a high input impedance FET preamp, Q1, followed by a two-stage complementary dc amplifier/detector, Q2-Q3, controlling an electromagnet-relay, K1. Resistor R1 serves as Q1's gate return and R2 as its drain load, while R3 acts as Q2's collector load, C1 as a filter, and R4 as a current limiting resistor.

In practice, electrical signals picked up by the operator's body are transferred through the touch plate to Q1. After amplification and detection, the resulting base bias control signal, filtered by C1, is applied to Q3 through R4, causing a change in Q3's collector current and actuating the relay. The relay's contacts, in turn, are used as a simple switch to operate external circuitry or electrical equipment.

The active devices used are, of course, from the HEK-2 kit, with the relay a moderately sensitive type with a 12-volt dc coil. Although a spdt type is shown, latching, time delay, or stepping relays may be used here, as needed for special control applications. Either a line-operated power supply or 12-volt battery may be used for B1. Finally, the touch plate can be any small piece of metal or foil.

Layout and lead dress are not overly critical and, therefore, any desired construction technique may be used for duplicating the circuit. Polarities must be observed, of course, and the touch plate should be mounted as close to Q1's gate terminal as is feasible for optimum performance.

Logic Lab Revisited. Back in December, 1970, we described an inexpensive introductory course in computer logic which included a basic logic circuit lab in addition to a detailed educational workbook. Offered by Scientific Measurements, Inc. (2945 Central, Wilmette, IL 60091), the \$39.00 Comp-U-Kit, Logic Lab I, Model 10, apparently struck a responsive chord among our readers, for the manufacturer later wrote that he had "received an amazing number of orders and inquiries referencing the column."

Scientific Measurements has now introduced a follow-up design which may be used to expand the capability and applications of their original Logic Lab 1. Identified as the Comp-U-Kit Logic Lab 2, the new

When you go 23-channels ...go *First Class*



First Class design. At Johnson we build two-way radio equipment for more kinds of users (including industrial, police, and government) than any other company in America. Engineering experience that results in the most advanced CB radios you can buy! **First Class construction.** Here in Waseca, Minnesota, our patient and skilled people assure you of top construction standards. We even manufacture many parts others must buy from outside suppliers—so we can be sure of top reliability. **First Class service.** Only Johnson has 400 authorized service centers nationwide. Fast warranty and repair service is nearby wherever you live—and parts are always available. **First Class value.** Compare features. Compare on-the-air performance. Compare price. Compare Johnson, made right here in Waseca, Minnesota, USA with equipment made *anywhere* else.

MESSENGER 123
23-channel mobile

\$139⁹⁵

MESSENGER 223
23-channel base

\$199⁹⁵



E. F. JOHNSON COMPANY
WASECA, MINNESOTA 56093

CIRCLE NO. 18 ON READER SERVICE PAGE

DELUXE

MAGAZINE CASES

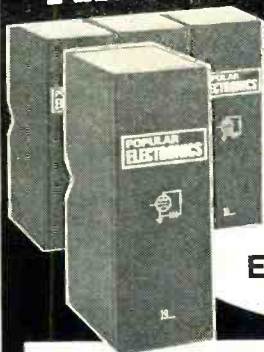

Designed Exclusively for
POPULAR ELECTRONICS

● It's the new look in Magazine Cases! The ideal way to save your valuable copies, keep them well protected and make it easy for you to refer to any issue at any time. This bold new design is both decorative and attractive enough to enhance the decor of any room—and each case is specially designed to hold a full year's copies.

Constructed of reinforced fiberboard to guard your magazines against soiling and tearing, these tough and durable cases are covered in a rich textured, leather-like fabric. They're available in either all black or attractive maroon back with black sides. The gold embossed back adds to its elegance and makes each case a welcome addition to your bookshelf, end table, desk—or for that matter, anywhere in your home or office.

In addition to Popular Electronics, cases are available for any of your favorite magazines. They're only \$3.95 each, 3 for \$11.00, 6 for \$21.00, in any combination of titles ordered. Add 50c per order for postage and handling. Outside U.S.A. add \$1.00 per case ordered.

Ziff-Davis Pub. Co., Dept. 23, 1 Park Ave., N.Y., N.Y. 10016

PE-10-71

Enclosed is \$..... Please send Magazine Cases for the titles indicated below @ \$3.95 each, 3 for \$11.00, 6 for \$21.00. Add 50c per order for postage and handling. Outside U.S.A. add \$1.00 per case ordered.

TITLE	QUANTITY
POPULAR ELECTRONICS	_____
_____	_____
_____	_____

Check One: All Black Maroon Back • Black Sides

Print Name _____

Address _____

City _____

State _____ Zip _____

PAYMENT MUST ACCOMPANY ORDER

version is designed so that it can be attached to the original Logic Lab 1 with extender rails to form a more powerful and versatile experimental lab.

The new Logic Lab 2 consists of a number of individual circuit modules assembled on PC boards. These are attached to support rails which also serve as power supply busses. The new version includes 2-input NOR gates, flip-flops, 4-input AND gates, and a 3-bit lamp display with built-in transistor driver amplifiers. As in Logic Lab 1, the circuits are designed for operation on a 6-volt dc source, and module interconnections are made using plug-in jumpers.

Scientific Measurements' Comp-U-Kit Logic Lab 2 sells for \$39.00, postpaid.

Achtung Audiophiles! The Signetics Corporation (811 East Arques Ave., Sunnyvale, CA 94086) and Dolby Laboratories, Inc. (London, England) have announced that they are collaborating on the development of a microcircuit version of the famous Dolby noise reduction system for consumer equipment. The announcement was made by Jack E. Halter, Signetics Vice President.

Discussed in February Stereo Scene column in this magazine, the Dolby system is a technique for reducing noise in high quality audio transmission and recording. It is effective in attenuating such noise as rumble, hum, buzzing, pops, clicks, hiss, crosstalk, and print-through.

Signetics will develop and produce the Dolby system in the form of a monolithic semiconductor integrated circuit, according to Mr. Halter. After a brief period of maintaining exclusive commercial rights to the IC version, Signetics will make all technical information available to the integrated circuit industry. The information and materials are expected to be available to Dolby licensees sometime in 1972.

As a kind of technical ambassador, Mr. Hans R. Camenzind, President of Interdesign, Inc. (Sunnyvale, CA), played an important role in negotiations between Signetics and Dolby, and will serve as a consultant to Signetics on the development of future applications of the Dolby circuit, especially in the areas of FM broadcasting and recording of computer data. Interdesign specializes in the design and development of custom linear integrated circuits. Mr. Camenzind is best known for developing Signetics' versatile monolithic phase-locked loop.

The Battle of the Giants? RCA has recently introduced 33 new all solid-state color TV sets, with the announced goal of selling more tubeless chassis color sets than all other domestic manufacturers combined. With the 33 new models, some 65 percent

of the total RCA color TV line will consist of solid-state versions. Eventually, according to William H. Anderson, Division Vice President, Marketing, RCA Consumer Electronics, all RCA color TV sets will be powered by tubeless chassis with advanced modular circuitry.

Naturally, Motorola's very popular *Quasar* TV sets were not mentioned in the RCA announcement, but *Quasar* has captured a substantial share of the market.

Interestingly, in another area, Motorola Semiconductor Products, Inc. has announced the development and production of a number of new logic circuits as (in Motorola's own words) "a springboard toward leadership in the off-the-shelf Complementary Metal Oxide Semiconductor (CMOS) marketplace." Again, the Motorola announcement did not identify RCA's rapidly expanding COS/MOS line, but the implication is clear.

There was a time when such competitive moves by opposing industrial firms might have led to profit-killing price cuts, bitter feelings, and, in some cases, even a few cracked skulls. In today's business climate, however, competition is healthy, and the RCA/Motorola "battle" probably will be a gentlemanly skirmish with three winners—the public, RCA, and Motorola.

Literature Up-Date. Utilizing material from

sources in industry, the government, the IEEE, and the IEC, the Engineering Department of the Electronic Industries Association (EIA) has published an authoritative dictionary of terms and definitions in the area of micro electronics. Entitled *Glossary of Microelectronic Terms, Definitions, and Symbols*, the publication contains sections on physical terms, electrical terms, and definitions applicable to all microcircuits, digital, linear, and hybrid. Identified as JEDEC Engineering Bulletin No. 1-B, the new glossary is available at \$2.15 per copy from the Electronic Industries Association, 2001 Eye St., N. W., Washington, DC 20006.

Describing RCA's wide selection of thyristors (triacs and SCR's), rectifiers, and diacs, the new 28-page catalog, publication No. THC-500A, includes data on the 1N and 2N (JEDEC) types, the -4000 series, and developmental (TA) devices. Data for each type of device are arranged by series.

Carrying an optional list price of 35 cents, RCA's "Top-of-The-Line" *Solid State Replacement Guide* is a 72-page, 8½ X 11, punched booklet covering all 96 semiconductor devices in the firm's popular SK-Series product line. Included are a Quick Selection Chart, basic specifications and performance data in tabular form, outline drawings, terminal diagrams, a technical discussion of operational considerations,

ELECTRONIC PARTS PARADISE

AT OVER 1000 RADIO SHACK STORES

"The Parts Place" for Builders and Hobbyists. You Name It, We've Got It!
1000's of Things That Make It Easy to "Do-It-Yourself." A Few Samples:

PRINTED CIRCUIT KIT- EVERYTHING INCLUDED!

A Only **6⁹⁵**

(A) Design & make real PC boards. Two blank boards, all chemicals, pen, drill bit. Fun, safe, easy.

(B) Pre-punched hole pattern for "pro" parts & transistor mounting and terminal connections. Copper clad. 6x3½".

(C) For most miniature components and connectors. 6x3½ x ¼" thick. ¼" dia. holes. Use with or without PERFBX.

(D) Removable 3½ x 6" Perf-Board front, bakelite case, rear pre-drilled for speaker, side-hole for wire entry. Very versatile. 3¾ x 6 1/8 x 2".

PATTERNED PERF-BOARDS

B 2 for **1⁹⁸**

5-PIECE PANEL SET

C 3 Perf-Boards, 1 Aluminum & 1 Bakelite Panel **1⁶⁹**

D PERFBX®

1⁶⁹

"PUSH-IN" TERMINALS **100 for 1⁵⁹**
For Perf-Boards

**FREE!
Parts
Catalog**

At Your
Nearby
Store
or by
Mail

Find Us in Your Phone Book

ALLIED RADIO SHACK
A TANDY CORPORATION COMPANY

2725 West 7th Street Fort Worth, Texas 76107

CIRCLE NO. 1 ON READER SERVICE PAGE

Announcing 16 exciting new Heathkit projects for wintertime kitbuilding fun!

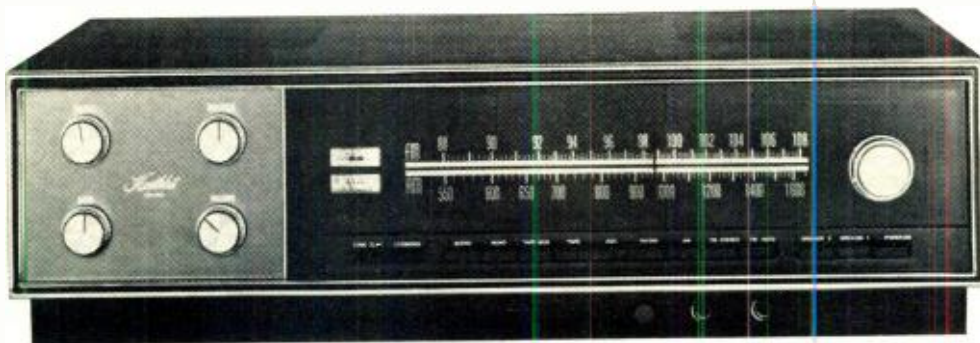

Meet the second generation AR-15 ...new Heathkit AR-1500!

From the AR-15, hailed at the time of its introduction in 1967 as the most advanced receiver of its kind, comes the AR-1500... with impressive improvements in every critical area! **180 Watts Dynamic Music Power**, 90 watts per channel (8 ohm load); 120 watts dynamic music power per channel under 4 ohm load, with less than 0.1% intermod distortion, less than .25% harmonic distortion. A 14-lb. power transformer and massive output transistor heat sink are mute testimony to the power at your command. Direct coupled output and drive transistors are protected by limiting circuitry that electronically monitors voltage and current. **FM selectivity greater than 90 dB**, better phase linearity, separation, and less distortion are the result of two computer-designed 5-pole LC Filters. An improved 4-gang 6-tuned circuit front end offers better stability, 1.8 uV sensitivity, 1.5 dB capture ratio, and 100 dB image and IF rejection. Four ICs are used, three in the IF and one in the Multiplex. Patented automatic FM squelch is both noise and deviation activated, fully

adjustable for sensitivity. *Vastly Superior AM*, an "also ran" with many receivers, has two dual-gate MOSFETs in the RF and Mixer stages, one J-FET in the oscillator, 12-pole LC Filter in the IF, and broad-band detector. Result: better overload characteristics, better AGC action, and no IF alignment. *Greatly simplified kit construction*. Ten plug-in circuit boards, two wiring harnesses and extensive use of pre-cut wiring with installed clip connections make the AR-1500 a kit builder's dream. Built-in test circuitry uses signal meter to make resistance and voltage checks before operation. *Other advanced features* include Black Magic panel lighting that hides dial markings when set is not in use; flywheel tuning; pushbutton function controls; outputs for two separate speaker systems, bi-amplification, oscilloscope monitoring of FM multipath; inputs for phono, tape, tape monitor and aux. sources — all with individual level controls. *Versatile installation* in optional new low-profile walnut cabinet, in a wall, or black-finish dust cover included. Join the "NOW" Generation in audio technology...order your Heathkit AR-1500 today!

Kit AR-1500, less cabinet, 42 lbs. 349.95*
ARA-1500-1, walnut cabinet, 6 lbs. 24.95*

New Heathkit Stereo Cassette Recorder



119.95*

Frequency response of ± 3 dB, 30-12 kHz, brings your stereo system into the cassette age. Features built-in bias adjustment to accommodate the new chromium dioxide tape; counter; automatic motor shutoff; preassembled and aligned transport mechanism. The AD-110 offers fidelity recording and playback of stereo or mono when used with your stereo system.

Kit AD-110, 10 lbs. 119.95*

New Heathkit Stereo-4 Decoder



29.95*

Compatible with your present stereo system and FM receiver, lets you hear all Stereo-4 material currently being broadcast by a number of stations across the country. Additionally, imparts a 4-channel effect to your existing stereo library. Requires second amplifier and 2 speaker systems for installation with conventional stereo system.

Kit AD-2002, 5 lbs. 29.95*

New Heathkit Stereo Phonograph with AM Radio



109.95*

Gets it together in a portable package with a purple plum snakey skin that's as far out as today's sounds. Solid-state 18-watt amplifier, fold-down 4-speed automatic changer and swing-out high compliance speakers. Speakers can be separated up to 5'. A flip of the mode switch and you're into AM radio! 45 spindle adapter included.

Kit GD-111, 50 lbs. 109.95*

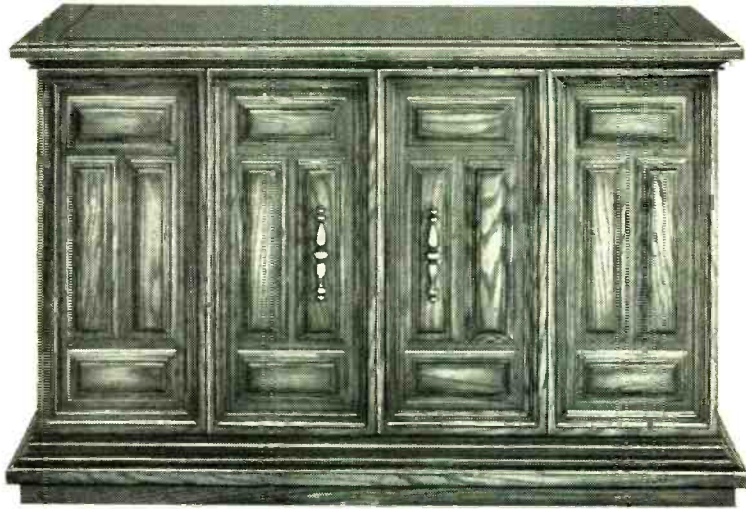

Now Heath's finest color TV package comes wrapped in a handsome new optional cabinet!

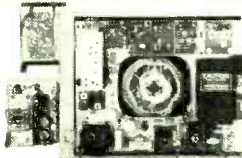

Here's the inside story: ...the Heathkit 25" solid-state color TV with exclusive MTX-5 ultra-rectangular tube to bring you the largest color picture in the industry! The etched, bonded tube face cuts glare, increases contrast for sharper picture,

purper colors, more natural flesh tones. But the true story of color TV reliability starts in the solid-state modular circuitry ... 45 transistors, 55 diodes, 2 silicon-controlled rectifiers, 4 ICs containing another 46 transistors, 21 diodes, and just two tubes (picture and high-voltage rectifier). Major circuit functions are contained on individual plug-in glass epoxy boards (see chassis inset above) to simplify assembly, service and adjustment. And, of course, only Heathkit color TV offers you the money-saving advantages of home-serviceability...with the built-in dot generator and tilt-out convergence panel to let you perform the periodic adjustments required of all color receivers.

Other advanced design features include solid-state VHF tuner with MOSFET for greater sensitivity, lower noise and cross modulation; solid-state UHF tuner with hot-carrier diode design for greater sensitivity; 3-stage solid-state IF for higher gain and superior picture quality; Automatic Chroma Control for constant color quality under different signal conditions; adjustable video peaking; adjustable noise limiting and gated AGC; "Instant-On"; VHF power tuning on 13 channels plus one preselected UHF channel; Automatic Fine Tuning; Tone-Control; and an output to your stereo/hi-fi system for the ultimate in sound reproduction.

And to wrap it all up ... your Heathkit GR-371MX is available in a magnificent new Mediterranean cabinet with doors that transform your home television theater back into an attractive center of decor. This finest cabinet in the Heathkit line features deep-grained pecan veneers on hand rubbed furniture grade hardwood solids. Two beautifully scalloped double-hinged bi-fold doors hide the TV screen when it's not in use, fold neatly to the cabinet sides when opened. Ornate brass "Canterbury Antique" handles add the perfect finishing touch. Measures 29 5/8" H x 56 1/4" W x 22 3/8" D.

Kit GR-371MX, TV less cabinet, 125 lbs. **579.95***
 GRA-404-25, assembled cabinet, 87 lbs. **139.95***

New Heathkit Solid-State Wireless Intercom

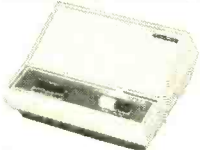

29.95*

Plug two of them into standard 105-130 VAC outlets for 2-way communications. Three channels let you carry on 3 conversations in a 6-unit system, call one unit without disturbing the others in a 3-unit network. Intercoms have channel selectors, spring loaded "talk" button, slide-action volume control, and "dictate" for extended one-way communication.

Kit GD-113, 5 lbs. each **29.95***

New Heathkit Solid-State Shortwave Receiver

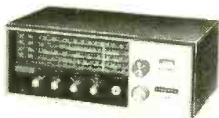

59.95*

Four over-lapping bands provide continuous coverage from 550 kHz to 30 MHz, giving you local AM plus international, amateur, marine & weather and citizens band broadcasts. Features band-spread tuning for close station separation; BFO control for receiving code; signal meter; front-panel headphone jack; noise limiter; built-in AM antenna.

Kit SW-717, 10 lbs. **59.95***

New Heathkit Automatic Battery Charger...



Charges 12-volt batteries automatically. 10 amp max. charge rate. Impossible to hook up wrong. No charge setting to make ... can be left hooked up indefinitely. Meter monitor charge. Kit GP-21, 13 lbs. **29.95***

New Heathkit Automotive Timing Light...



Completely self-contained. Bright flash lets you work in sunshine. Adapter for connecting to distributor. Hi-impact plastic case.

Kit CI-1020, 2 lbs. **19.95***



399^{95*}

New Heathkit DC-15 MHz Dual Trace Solid-State Oscilloscope...

The new Heathkit IO-105 is a high-performance scope designed to give you a wide range of measurements for use in instrumentation courses, engineering, R&D and electronics...at a fraction of the cost of comparable scopes! The IO-105 brings you complete dual trace and X-Y capability, allowing comparison of input/output for such parameters as loss, gain, phase shift and distortion. You can display two separate input signals in Channel 1 or Channel 2 modes of operation. Direct comparison of both signals is possible in alternate and chopped modes. In the alternate mode, both signals are alternately displayed on successive sweeps...at faster sweep speeds they are retained on the screen for time relationship comparison. In the chop mode, both signals are sampled at 100 kHz and appear as a function of the same time base. In X-Y, both channels are displayed as a function of each other...channel 1 controlling the vertical (Y) axis and channel 2 controlling the horizontal (X) axis. Both input channels are precision balanced for 5% or less phase shift to 50 kHz. Switch selected AC or DC coupling lets you trigger the time base at a given point on the signal or at a preselected

DC level. Flipping a switch gives you automatic triggering at the crossover (O) point. You can also switch select positive or negative slope triggering. Internal, External and Line trigger inputs are provided. The convenient 18-position time base switch in a 1, 2, 5 sequence provides sweep rates from 100 msec/cm to 0.2 usec/cm. The separate vernier control with a calibrated position gives you continuous control between settings, while a 5-times magnifier switch allows detailed trace viewing. The DC-15 MHz bandwidth capability and 24 nsec rise time make possible analysis of high frequency signals and transient waveforms. Full bandwidth is featured from 20 V/cm to 50 mV/cm in 1, 2, 5 sequence. For special applications, a rear panel Sweep Gate output delivers a 3.5V pulse in sync with the sweep. A TTL-compatible external blanking input is also provided. Other features include a CRT bezel incorporating standard camera mount dimensions...flush mounted handle for easy stacking...easily-removable side panels for quick accessibility...compact, 15" depth for bench installation instead of cart. If you want to expand your analysis capability while holding the budget line, order your new Heathkit IO-105 now! Or send for more information and complete specification sheet.

Kit IO-105, 35 lbs. 399.95*

New Heathkit Vector Monitor...

49^{95*}



Designed for use with the Heathkit IG-28 Pattern Generator or similar units which display either "rainbow" (offset carrier) or NTSC patterns, the IO-1128 vector display helps you perform fine tuning, static and dynamic convergence,

purity, 3.58 oscillator, reactance coil, phase detector transformer, demodulator angle check, and chroma bandpass adjustments. Represents exactly the color signals fed to CRT guns.

Kit IO-1128, 10 lbs. 49.95*

New Heathkit Electronic Switch... 39^{95*}



Provides simultaneous visual display of 2 input signals on a single trace oscilloscope. Has DC coupling and DC-5 MHz ± 3 dB frequency response. Conventional binding posts permit fast

hook-up. Can be left connected to scope. Ideally suited for digital circuit work; amplifier input and output for gain and distribution checks; simultaneous monitoring of 2 stereo channels.

Kit ID-101, 6 lbs. 39.95*

New Heathkit "Minimizer" kitchen waste compactor...

Today's most modern refuse handling method in easy-to-assemble kit form! Now you can own the most exciting kitchen appliance on the market for less than you'd pay for any other comparable compactor. The Heathkit Minimizer lets Mom throw out the unsightly waste baskets and garbage cans for the latest in clean, convenient, odor-free disposal. The Minimizer handles all normal household trash — food wastes, glass and plastic containers, tin cans, wrappings, boxes, floor sweepings, light bulbs, etc. The packing ram descends with 2,000-lb. force to reduce refuse to almost 1/4 of its original size, packaging the material in a strong disposable bag — one bag holds an entire week's trash for a family of four! When the bag's full, Mom simply folds over the top and removes a neat, dry package for normal rubbish pickup. And the Minimizer deodorizes the contents each time the drawer is opened and closed. The sanitation man will love Minimizer, too!

Simple, safe operation! To use, Mom merely inserts a Minimizer plastic-lined bag in the drawer and starts the compacting cycle. In less than a minute the ram forces down the trash, returns to its normal position, and the Minimizer shuts itself off. For maximum safety, the Minimizer uses a key lock switch and an interlock which automatically turns unit off if drawer is not fully closed or is accidentally opened during cycling. Your Heathkit Minimizer can be built-in under the kitchen counter or left free-standing. Its bright white enamel finish with marble-tone vinyl-clad top complements any decor. And you can build it yourself in 6 to 10 hours. Has long-life 1/3 hp motor, plugs into 110-120 VAC conventional household outlet. Kit includes 5 plastic-lined bags, one 9 oz. aerosol can of deodorant. Minimizer measures 34 3/8" H x 15" W x 25 1/2" D.

Kit GU-1800, 203 lbs. 199.95*
GUA-1800-1, 25 plastic-lined bags,
2 aerosol cans, 6 lbs. 10.95*

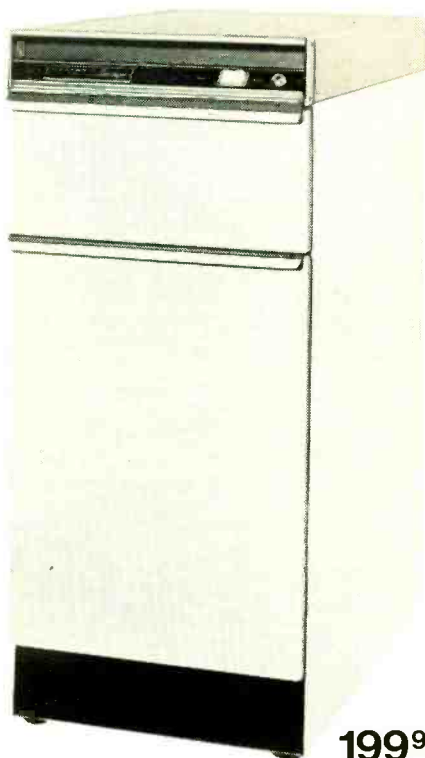

199.95*

New Heathkit Thermo Spotter



24.95*

Seeks out the temperature where your favorite fish live. Includes submersible sensing element, 100' of strong nylon cord, battery-powered solid-state meter circuitry... in high-impact plastic take-up reel case.

Kit MI-104, 3 lbs. 24.95*

New Heathkit Digital Depth Sounder



139.95*

Gives accurate, digital depth readings to 199'. Red warning light alerts you to shoals of 10' or less. Automatic noise rejection and range switching.

Kit MI-101-1 (w/thru-hull trans.)
6 lbs. 139.95*
Kit MI-101-2 (w/transom-mount
trans.) 8 lbs. 139.95*

New Heathkit Economy Garage Door Opener



99.95*

Deluxe features include husky 1/4 hp motor, heavy-duty chain drive, automatic safety reversing, automatic light. Preassembled transmitter & solid-state receiver.

Kit GD-309A, 43 lbs. 99.95*
Kit GD-309B (w/2 trans.)
43 lbs. 114.95*

SEE THESE KITS AT YOUR LOCAL HEATHKIT ELECTRONIC CENTER... or send for FREE catalog!

CALIF.: Anaheim, 330 E. Ball Road; El Cerrito, 6000 Potrero Avenue; La Mesa, 8363 Center Drive; Los Angeles, 2309 S. Flower St.; Redwood City, 2001 Middlefield Rd.; Woodland Hills, 22504 Ventura Blvd.; COLO.: Denver, 5940 W. 38th Ave.; GA.: Atlanta, 5285 Roswell Road; ILL.: Chicago, 3462-66 W. Devon Ave.; Downers Grove, 224 Ogden Ave.; MD.: Rockville, 5542 Nicholson Lane; MASS.: Wellesley, 165 Worcester St.; MICH.: Detroit, 18645 W. Eight Mile Rd.; MINN.: Hopkins, 101 Shady Oak Rd.; MO.: St. Louis, 9296 Gravois Ave.; N.J.: Fair Lawn, 35-07 Broadway (Rte. 4); N.Y.: Jericho, L.I., 15 Jericho Turnpike; New York, 35 W. 45th Street; OHIO: Cleveland, 5444 Pearl Rd.; Woodlawn, 10133 Springfield Pike; PA.: Philadelphia, 6318 Roosevelt Blvd.; Pittsburgh, 3482 William Penn Hwy.; TEXAS: Dallas, 2715 Ross Avenue; Houston, 3705 Westheimer; WASH.: Seattle, 2221 Third Ave.; WIS: Milwaukee, 5215 Fond du Lac.

Retail Heathkit Electronic Center prices slightly higher to cover shipping, local stock, consultation and demonstration facilities. Local service also available whether you purchase locally or by factory mail order.

HEATH COMPANY, Dept. 10-10
Benton Harbor, Michigan 49022

HEATH
Schlumberger

Enclosed is \$ _____, plus shipping.

Please send model(s) _____

Please send FREE Heathkit Catalog.

Name _____

Address _____

City _____ State _____ Zip _____

*Mail order prices; FOB factory.

Prices & specifications subject to change without notice. CL-415

CIRCLE NO. 17 ON READER SERVICE PAGE

Keep your big sound PURE!

Come through loud and clear; get with the *preferred* speakers by CTS. Used in more musical instrument amplifiers than any other brand. So upgrade, customize, or replace with your choice of eight big power CTS speakers up to 220 watt peaks.

Free Brochure lists them at factory-to-you prices.



Cut out
High Speaker Costs
right now ...

CTS of Paducah, Inc. Dept. PE
1565 N. 8th St. • Paducah, Ky. 42001
Please send me your action-packed
sound Catalog.

Name _____
Address _____
City _____ State _____ Zip _____

CIRCLE NO. 8 ON READER SERVICE PAGE

QUICK-PICK Pat. Pend.

- Makes removal of transistors and capacitors from a "forest" of parts easy

Precision Tools

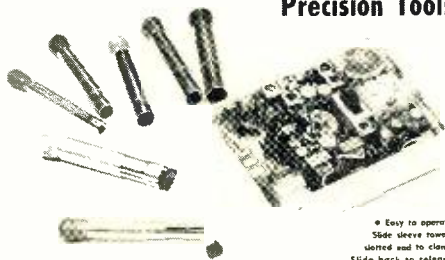

• Easy to operate.
Side sleeve toward
solder and to clamp.
Side back to release.

- Seven (7) tools clamp on over 25 different outlines of transistors or can capacitors. *Therefore*, it can be used on hundreds of types of transistors and capacitors.
- Makes an excellent heat sink while unsoldering or replacing parts.
- Permits more attention to be given the soldering operation. *Will leave both hands free to unsolder the leads. A slight pull on the Quick-Pick will remove the part when the leads are free.*
- Colored handles permit Quick size selection.
- Packaged in an attractive carrying case.

995

Lendell Products set of 7 tools postpaid
939 S. 7th St. DeKalb, Illinois 60115
CIRCLE NO. 20 ON READER SERVICE PAGE

service hints, an extensive replacement directory, and a battery interchangeability chart.

Device News. A versatile operational amplifier is the first device in Motorola Semiconductor Products' (P.O. Box 20912, Phoenix, AZ 85036) new beam lead linear series. Providing a significant improvement in reliability compared to standard IC devices using fragile connection wires, the beam lead units utilize cantilevered gold structures extending from the chip and bonding readily to the substrate to supply both mechanical and electrical connections. Two electrically identical versions of the new op amp are available—the MCBC1709, which is a beam lead chip suitable for hybrid circuits, and the MCB1709F, which is housed in a flat package. Other devices to be offered in the near future include beam lead versions of the 1741 op amp, 1710 comparator and 1596 modulator.

Among the devices recently introduced by the RCA Solid State Division (Route 202, Somerville, NJ 08876) are a new silicon triac and a half-dozen IC's, including an AM Receiver Subsystem, a Stereo Multiplex Decoder, an FM-IF Subsystem, and three voltage regulators.

Intended for use with ac loads in 220-volt applications such as light dimmers (300 to 1440 watts), heating controls, and power-switching systems, the new triac, type 40842, is rated at 6 amperes rms and 450 volts peak. Its unique plastic package permits simple mounting on a chassis or printed circuit board and presents a low thermal impedance.

The AM Receiver Subsystem IC, type CA3088, includes the functions of an AM converter, i-f amplifier, detector, and audio preamp in a single package. Designated type CA3090, the Stereo Multiplex Decoder is designed for use in FM stereo multiplex systems and requires the use of only one low-inductance tuning coil, hence only one adjustment for complete alignment. Finally, the type CA3089, includes an i-f amplifier, quadrature detector, preamp, and specific circuits for agc, afc, and muting (squelch, and tuning meter). All three devices are furnished in 16-lead packages.

RCA's new voltage regulators are silicon monolithic IC's providing regulation at output, from 1.7 to 46 volts at currents up to 100 mA. Designated types CA3085, CA3085A and CA3085B, they operate with unregulated inputs ranging from 7.5 to 50 volts, and incorporate such important features as short-circuit protection, temperature-compensated reference voltage, current limiting, and adjustable output voltage. The CA3085 Series is supplied in the hermetic 8-lead TO-5 style package. ♦

Popular Electronics

READER SERVICE PAGE

free information service:

Here's an easy and convenient way for you to get additional information about products advertised or mentioned editorially (if it has a "Reader Service Number") in this issue. Just follow the directions below... and the material will be sent to you promptly and free of charge.

1. On coupon below, circle the number(s) that corresponds to the key number(s) at the bottom or next to the advertisement or editorial mention that is of interest to you. (Key numbers for advertised products also appear in the Advertisers' Index.) Print or type your name and address on the lines indicated.

2. Cut out the coupon and mail it to: POPULAR ELECTRONICS, P.O. Box 8391, Philadelphia, PA 19101.

note: If you want to write to the editors of POPULAR ELECTRONICS about an article on any subject that does not have a key number, write to POPULAR ELECTRONICS, One Park Avenue, New York, N.Y. 10016. Inquiries concerning circulation and subscriptions should be sent to POPULAR ELECTRONICS, P.O. Box 1096, Flushing, N.Y. 11352.

10/71—2

Void after November 30, 1971

Popular Electronics

P.O. BOX 8391
PHILADELPHIA, PA. 19101

1 2 3 4 5 6 7 8 9 10 11 12 13 14 15 16 17 18 19 20
21 22 23 24 25 26 27 28 29 30 31 32 33 34 35 36 37 38 39 40
41 42 43 44 45 46 47 48 49 50 51 52 53 54 55 56 57 58 59 60
61 62 63 64 65 66 67 68 69 70 71 72 73 74 75 76 77 78 79 80
81 82 83 84 85 86 87 88 89 90 91 92 93 94 95 96 97 98 99 100

NAME (Print clearly) _____

ADDRESS _____

CITY _____ STATE _____ ZIP CODE _____

Put it to Work!

NEW AND ONLY FROM EICO—THE INDUSTRY'S LOWEST-PRICED PROFESSIONAL FET-VM.

Model 239

\$39.95
KIT



Use the battery powered Solid State EICO 239 on your bench or in the field. Check semiconductor and vacuum tube circuits. 11 Megohm DC input impedance. Read AC rms and DC voltages in seven steps from 1 to 1000 volts on large 4½" meter. Measure and read peak-to-peak AC to 2800 volts. Check resistance from 0.2Ω to 1000MΩ on seven ranges. Provides a total of 28 useful ranges on 12 accurate scales. Automatic battery check. Includes exclusive DC/AC ohms InProbe™. Factory Assembled, \$59.95.

FREE 32 PAGE EICO CATALOG

For latest catalog on EICO Test Instruments, Stereo, EICOCRAFT Projects, Environmental Lighting, Burglar/Fire Alarm Systems, and name of nearest EICO Distributor, check Reader Service Card.

EICO, 283 Malta Street, Brooklyn, N.Y. 11207



CIRCLE NO. 13 ON READER SERVICE PAGE

PLASTIC TIGER

(Continued from page 34)

Setup and Use. Plug the line cord into a convenient 117-volt ac outlet and close S1. Check the dc voltages with reference to chassis ground; they should be between 30 and 35 volts in both polarities. Now, check the voltages across R11 and across R13. Typically, there should be little or no measurable voltage across R11. In no case is there to be more than 0.5 volt across R13 if the amplifier is to operate properly. Make a final voltage check from point V to chassis ground; you should read 0.1 volt or less if everything is operating normally. If any of the transistors or other parts become warm or hot when there is no input signal or load on the amplifier, immediately shut down the power and find the source of the trouble before proceeding.

Now, if you have the appropriate instruments available, you can adjust bias control R21 for optimum amplifier performance. First, connect an 8-ohm load to the Plastic Tiger via J2 and drive the amplifier at J1 with a 10,000-Hz sine wave signal of sufficient amplitude to provide a 1-watt output from the amplifier. Observing the wave-form of the output signal on an oscilloscope screen, rotate R21 clockwise (viewed from the input end of the circuit board) until the small cross-over notches disappear at the waveform's zero crossing points. If you do not have the appropriate instruments available, just set R21 for a three-quarter clockwise rotation. ♦

IMPOSSIBLE? BARGAINS IN SURPLUS

THIS MONTH'S SUPER SPECIAL:



7 Segment Readout: Two sizes are available: a large size model with wire leads for P.C. Board Mounting illustrated at (A) and a small size low current version in a Dual In-Line type package for multibay battery operated instruments illustrated at (B).
Large Size Readout (100, 01) \$3.95
Low Current Version (100, 01) \$3.75



Composite counter kit including 7490 decade counter, 7447 decoder and printed circuit board, and choice of either readout.
Price \$8.75
Complete counter kit alone with 7475 latch for storage Price \$10.75

Complete Bi-directional counter with 74197 instead of 7490, for up/down counting \$11.75
Complete Bi-directional counter with latch for storage (74197 7475 7447) \$12.75

SPECIAL SALE ON DIODES AND TRANSISTORS

The recession in the electronics industry is the gain of the electronics enthusiast. Discrete components are now available at prices that are a fraction of the large volume price. Every unit listed is a brand new device with full lead length and original manufacturer's boxes. Guaranteed 100% or exceed manufacturer's specifications.

ZENER DIODES, 5% Tolerance, Mips. List \$1.71 each	
1N746A	3.3 Volt
1N747A	3.6
1N748A	3.9
1N749A	4.3
1N750A	4.7
1N751A	5.1
1N752A	5.6
1N753A	6.2
Special Number	3 for \$1.00, 10 for \$2.50, 100 for \$225.00
	Mix or Match

DIODES	
1N6400	400 PIV, 1 Amp
1N6401	400 PIV, 2 Amp
1N6402	400 PIV, 3 Amp
1N6403	400 PIV, 4 Amp
1N6404	400 PIV, 5 Amp
1N6405	400 PIV, 6 Amp
1N6406	400 PIV, 7 Amp
1N6407	400 PIV, 8 Amp
1N6408	400 PIV, 9 Amp
1N6409	400 PIV, 10 Amp
1N6410	400 PIV, 11 Amp
1N6411	400 PIV, 12 Amp
1N6412	400 PIV, 13 Amp
1N6413	400 PIV, 14 Amp
1N6414	400 PIV, 15 Amp
1N6415	400 PIV, 16 Amp
1N6416	400 PIV, 17 Amp
1N6417	400 PIV, 18 Amp
1N6418	400 PIV, 19 Amp
1N6419	400 PIV, 20 Amp
1N6420	400 PIV, 21 Amp
1N6421	400 PIV, 22 Amp
1N6422	400 PIV, 23 Amp
1N6423	400 PIV, 24 Amp
1N6424	400 PIV, 25 Amp
1N6425	400 PIV, 26 Amp
1N6426	400 PIV, 27 Amp
1N6427	400 PIV, 28 Amp
1N6428	400 PIV, 29 Amp
1N6429	400 PIV, 30 Amp
1N6430	400 PIV, 31 Amp
1N6431	400 PIV, 32 Amp
1N6432	400 PIV, 33 Amp
1N6433	400 PIV, 34 Amp
1N6434	400 PIV, 35 Amp
1N6435	400 PIV, 36 Amp
1N6436	400 PIV, 37 Amp
1N6437	400 PIV, 38 Amp
1N6438	400 PIV, 39 Amp
1N6439	400 PIV, 40 Amp
1N6440	400 PIV, 41 Amp
1N6441	400 PIV, 42 Amp
1N6442	400 PIV, 43 Amp
1N6443	400 PIV, 44 Amp
1N6444	400 PIV, 45 Amp
1N6445	400 PIV, 46 Amp
1N6446	400 PIV, 47 Amp
1N6447	400 PIV, 48 Amp
1N6448	400 PIV, 49 Amp
1N6449	400 PIV, 50 Amp
1N6450	400 PIV, 51 Amp
1N6451	400 PIV, 52 Amp
1N6452	400 PIV, 53 Amp
1N6453	400 PIV, 54 Amp
1N6454	400 PIV, 55 Amp
1N6455	400 PIV, 56 Amp
1N6456	400 PIV, 57 Amp
1N6457	400 PIV, 58 Amp
1N6458	400 PIV, 59 Amp
1N6459	400 PIV, 60 Amp
1N6460	400 PIV, 61 Amp
1N6461	400 PIV, 62 Amp
1N6462	400 PIV, 63 Amp
1N6463	400 PIV, 64 Amp
1N6464	400 PIV, 65 Amp
1N6465	400 PIV, 66 Amp
1N6466	400 PIV, 67 Amp
1N6467	400 PIV, 68 Amp
1N6468	400 PIV, 69 Amp
1N6469	400 PIV, 70 Amp
1N6470	400 PIV, 71 Amp
1N6471	400 PIV, 72 Amp
1N6472	400 PIV, 73 Amp
1N6473	400 PIV, 74 Amp
1N6474	400 PIV, 75 Amp
1N6475	400 PIV, 76 Amp
1N6476	400 PIV, 77 Amp
1N6477	400 PIV, 78 Amp
1N6478	400 PIV, 79 Amp
1N6479	400 PIV, 80 Amp
1N6480	400 PIV, 81 Amp
1N6481	400 PIV, 82 Amp
1N6482	400 PIV, 83 Amp
1N6483	400 PIV, 84 Amp
1N6484	400 PIV, 85 Amp
1N6485	400 PIV, 86 Amp
1N6486	400 PIV, 87 Amp
1N6487	400 PIV, 88 Amp
1N6488	400 PIV, 89 Amp
1N6489	400 PIV, 90 Amp
1N6490	400 PIV, 91 Amp
1N6491	400 PIV, 92 Amp
1N6492	400 PIV, 93 Amp
1N6493	400 PIV, 94 Amp
1N6494	400 PIV, 95 Amp
1N6495	400 PIV, 96 Amp
1N6496	400 PIV, 97 Amp
1N6497	400 PIV, 98 Amp
1N6498	400 PIV, 99 Amp
1N6499	400 PIV, 100 Amp

80 PAGE CATALOG - Free with any order or send \$0.25

ALL ITEMS POSTAGE PAID IN THE U.S.A.
Change Order/Res. AutoCancel. Maximum \$100.00/mo.
B. & F. ENTERPRISES
Phone (631) 532-2323
P.O. Box 44, Hephorn, Massachusetts 01937

CIRCLE NO. 6 ON READER SERVICE PAGE

OUT OF TUNE

"Vox Gain Rider," June 1971. Change IC1 in Fig. 1 and Parts List to read MFC4010P—not MC4010P

"The Drummer Boy," July 1971. Although the circuit shown in Fig. 1 will operate properly (with two minor changes) if wired point-to-point, it does not match the PC diagrams in Fig. 5. The

coupling capacitors and resistors between stages are reversed in Fig. 1, compared to the way they are on the board. This, of course, has no bearing on the operation. The waltz switches (S2B, S3B, and S4B) should be connected between Q2 and Q3 as shown in the corrected diagram below, not between Q4 and Q5.

Also in Fig. 1, point 4 should be on the base of Q7, not the base of Q9. The collector of Q12 should be connected to the shift buss instead of point 7.

In Fig. 2, connect the line coming down from S14B to point M, not the clave contact on S18. Connect the line from S15B to the clave contact on S18, not point M. There should be no connection between point M and the clave switch.

In the Parts List on page 28, add C29, C30, C50, 0.001-microfarad capacitors.

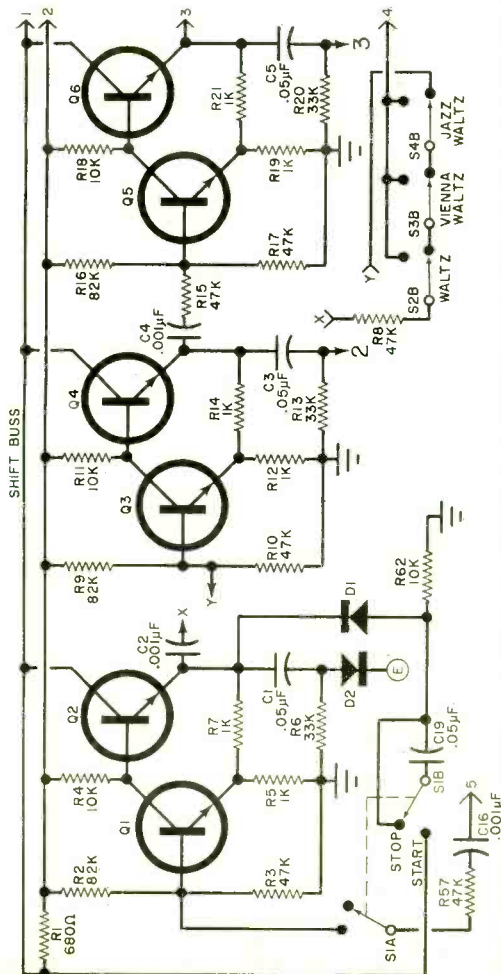

24 HOURS A DAY... 7 DAYS A WEEK

I'll send you 2 FREE BOOKS describing career opportunities in Electronics. Call me TOLL FREE: **800-321-2155**
(in Ohio, call 800-362-2105)

For details about the famous CIE home-study courses in Electronics, see our ad on page 18

Cleveland Institute of Electronics
1776 East 17th Street, Cleveland, Ohio 44114

ANOTHER SUPERB VALUE from Olson Electronics



ONLY
\$12
DELUXE
TRANSISTOR
CHECKER

Compact, self-contained, self-powered dynamic transistor checker. Test may be made "in circuit" or out of circuit. Identifies and checks PNP and NPN types, plus power. Complete with instruction manual, service tips and transistor drawings.

Olson Electronics, Dept. IV, 260 S. Forge St., Akron, Ohio 44308

- I enclose \$12, plus \$1 for postage and handling. Send me the TE-199 Transistor Checker.
- Send me the next seven issues of the Olson Catalog, without cost or obligation. **FREE**

Name _____
Address _____
City _____
State _____ Zip _____

Circle No. 23 on Reader Service Page

ALLIED RADIO SHACK

ISSUES A NEW AND DIFFERENT CATALOG!

The new buying Guide for kit builders, Hams, hobbyists, do-it-yourselfers, "fix-it men"! Lists thousands of handy and wanted "little things" most stores don't stock. Like tubes and transistors, cables and plugs, adapters and antennas—you name it—the things that keep equipment working. Or make it work even better. Or DO MORE. If you own anything electronic or electrical, you need this catalog!



UNDERSTANDING LASERS

(Continued from page 45)

of laser diodes will be as active elements in an optical computer. When one laser is illuminated by another, extremely rapid switching effects are observed. For example, various types of gates can be made by fabricating several lasers in a single GaAs chip. If the lasers are properly arranged and appropriate contacts are applied, switching speeds of well under a nanosecond can be obtained. In fact, the switching speed of the laser is so rapid that it is difficult to design circuitry with which to exploit it.

A laser application which has resulted in a large number of military contracts—and consequent advances in the state of the art—is covert illumination. In conjunction with image converters (devices which make infrared light visible to the human eye) powerful laser diode searchlights are important battlefield devices. Over a thousand individual laser chips may be used in an illuminator, which is artificially cooled to permit operation at a high duty cycle with a resultant increase in average power of up to 30 watts or more.

A commercial application of the laser diode is in intrusion alarms. The narrow beam characteristic of the focussed laser permits long path lengths to protect large areas. ♦

ALLIED RADIO SHACK

Dept. PE-9

SEND, ORDER ON ENVELOPE

2725 W. 7th St., Fort Worth, Texas 76107

Send me your FREE Spring/Summer Cat. 212

Name (print) _____

Route No. _____ Box No. _____

Street _____ Apt. No. _____

City _____ State _____ Zip _____

CIRCLE NO. 3 ON READER SERVICE PAGE

CONTROLLED
QUALITY
CRYSTALS by



CRYTEK



The "On-Channel" Crystals
FOR
CITIZEN BAND
23 Channels and "Mars"

HAM OPERATORS

Commercial 2-Way

Marine-Monitor

See your Distributor for Speedy
"Zip Certificates"



CRYTEK

formerly Texas Crystals
Div. of Whitehall Electronics Corp.

1000 Crystal Drive 4117 W. Jefferson Blvd
Fort Myers, Florida 33901 Los Angeles, California 90016

CIRCLE NO. 10 ON READER SERVICE PAGE

SOLID-STATE LASER

(Continued from page 49)

for the lens in one narrow end. (See photographs.) Select a lens whose focal point is about 1/2" from the other end of the chassis. This can be done by using light from a distant source and moving a white card behind the lens until the distant light is focused. Make a note of this distance and, with the lens cemented to the chassis, mount the transmitter circuit board on the rear wall of the chassis using spacers so that the laser is at the focal point of the lens. Tighten the mounting and spacers but make sure that the laser anode lead does not touch the chassis.

Follow the same procedure with the

SAFETY CONSIDERATIONS

The GaAs laser diode used here has a peak optical output of about 1 watt per pulse. That's a lot of light compared to the low-power helium-neon laser previously described in POPULAR ELECTRONICS, but since the optical pulses are so brief, the average power is far less than that of the helium-neon device.

It is impossible to operate a laser diode in a manner which will yield more than the rated power. Current pulses higher than the specified maximum cause heating effects which raise the laser's temperature. The temperature rise, which occurs almost instantly because of the laser's tiny physical dimensions, significantly increases the laser's lasing threshold and therefore reduces optical output. Very high, one-shot current pulses produce the same heating effect and usually destroy the laser chip.

According to the Air Force School of Aerospace Medicine, GaAs lasers ten times more powerful than the RCA TA7606 used here are not capable of producing ocular damage. In fact, the TA7606 output is far below the threshold for such damage. There are several reasons for this: absorption of the infrared in the eye's vitreous humor, imperfect focusing of the infrared, and the laser's low average power. But the main reason a single laser diode is incapable of inflicting ocular damage is that the power density at the retina is too far below the damage threshold.

Nevertheless, follow a few basic precautions to insure utmost safety:

1. As with any source of bright light, do not look directly into the laser beam.
2. Avoid pointing the laser at very shiny surfaces (mirrors, unpainted metal, etc.).
3. Turn off the laser when it is not in use. (This preserves the lives of the batteries and the laser also.)

receiver, placing Q1 at the focal point of the lens.

Operation. To make a low-power cw transmitter/receiver system, aim the two units at each other (lenses facing). Transmission can be over quite a distance, depending on the lenses used and the ambient light.

To make an intrusion alarm, omit C5 and the earphone and replace R9 with a low-power relay to drive an externally mounted alarm. ♦

ELECTRONICS KNOW-HOW

1972 ELECTRONIC EXPERIMENTER'S HANDBOOK—WINTER EDITION

Join in this big semi-annual projects festival! You'll get 33 electronics construction projects, each one lab tested by the editors, complete with parts list, easy "how-to-do-it, how-it-works" instructions, and many with actual size PC foil patterns and I. C. diagrams! Build these brain-busters for home and car, for experience, for fun—The Frisky Four Speaker System ■ Automatic Lighting Protector ■ Super Flash ■ Remote Camera Shutter Release ■ Design Your Own Printed Circuits ■ Laser Beam Communicator ■ Modify Your Electric Guitar Sound ■ Electronic Overload Protection ■ Electronic Combination Ignition Lock ■ Build A Low-Cost Relay ■ Photocell Motor Control Demonstrator ■ Wire Music ■ Super Substitution Box—Plus 20 More!



1971 COMMUNICATIONS HANDBOOK 1971



1971 COMMUNICATIONS HANDBOOK

tunes you in on everything you need to know about CB, SWL or HAM

Completely updated and revised. Also features Police and Fire Dispatcher Frequencies of 250 cities.

Here it is in one single package—the combined knowledge and experience of the top men in each field—Citizens Radio (CB), Shortwave Listening and Amateur Radio. Everything you need to know about getting licenses . . . equipment to buy and how to set it up . . . efficient operations . . . a whole bookful of up-to-the-minute data to make your listening hours more enjoyable! Fact-filled with time charts . . . station data . . . maps . . . country lists . . . awards . . . and much more. Photos galore.

Plus: BUYER'S GUIDE of CB and HAM RADIO GEAR. SPECIAL SECTION on LONG RANGE TV RECEPTION.

Copies of the Spring 1971 Electronic Experimenter's Handbook are still available. This edition includes 20 challenging electronics construction projects. Use the coupon below to order your copy.

ZIFF-DAVIS SERVICE DIVISION—Dept. W
595 Broadway, New York, N.Y. 10012

Please send me the annuals I've checked below:

- 1972 ELEC. EXPERIMENTER'S HANDBOOK — Winter, \$1.25
- 1971 ELEC. EXPERIMENTER'S HANDBOOK — Spring, \$1.50
- 1971 COMMUNICATIONS HANDBOOK, \$1.50

In U.S.A., add 35c for postage and handling for each copy ordered. PE-10-71

Outside U.S.A., copies are \$2.50 each postpaid.

TOTAL ENCLOSED \$ _____

print name _____

address _____

city _____

state _____

zip _____

PAYMENT MUST BE ENCLOSED WITH ORDER

POPULAR ELECTRONICS SUBSCRIBER SERVICE

Please include an address label when writing about your subscription to help us serve you promptly.

Write to: P.O. Box 1096, Flushing, N.Y. 11352

CHANGE OF ADDRESS: Please let us know you are moving at least six to eight weeks in advance. Affix magazine address label in space below and print new address in space provided. If you have a question about your subscription, attach address label to your letter.

If you have no label handy, print OLD address here.

name _____ please print

address _____

city _____

state _____ zip-code _____

AFFIX LABEL

TO SUBSCRIBE: Check these boxes: — New — Renewal
 5 years \$21 3 years \$15 1 year \$6

SPECIFY: Payment enclosed—You get 1 extra issue per year as a BONUS! Bill me later.

0560

name _____ please print

address _____

city _____ state _____ zip _____

Add'l postage: \$1 per year outside U.S., its possessions & Canada.

Hey!

Hams, Engineers, Hobbyists

**MARK LIKE
MAGIC**



Any surface *
can be marked with
**DATAK'S
DRY TRANSFER**
titles and symbols.
The results are
professional,
it looks like the
finest printing!

Write for your **FREE
SAMPLE** and Catalog,
listing hundreds of
letter sheets and
symbol sets.

Order from your distributor
or directly from:

**THE DATAK
CORPORATION**

* From #K-64 1/4" letters
and numerals ... \$1.50
Also available #9581
professional title
set for electronic
equipment ... \$5.95

85 Highland Ave. / Passaic, New Jersey 07055

Circle No. 11 on Reader Service Page

HOBBY SHOP

(Continued from page 52)

Most electronics supply houses now have jewelers' screwdrivers, but in the hobby shop you can also get wrenches and nutdrivers for hardware as fine as No. 00. You can also buy a saw with a fine Swedish-steel blade that is only 0.008" thick (that's roughly half of 1/64"!)

Look around in the hand



Tools are available individually and in kits. Example of modeler's tool kit is shown above.

tool section, and you'll find a wide variety of miniature pliers and cutters and tweezers that seem to be just made to order for your electronics workbench.

Visit Your Local Hobby Shop. But take along only the amount of money you intend spending. This is no light admonition. The vast array of materials and tools (not to mention model kits) are too tempting to pass up.

Here's a good idea: Make your first trip a browsing visit in which you familiarize yourself with the items available. Don't buy; just look. Then come back another day to make your purchases. Either way, allot a good four hours for your first visit; more if the hobby shop is really first class. You'll need that much time to just look.

If you live in an area not serviced by a well-stocked model hobby shop, you can do your browsing and purchasing by mail. You will have to pay for a catalog, but it is well worth the nominal investment. ♦

Popular Electronics Market Place

NON-DISPLAY CLASSIFIED: COMMERCIAL RATE: For firms or individuals offering commercial products or services. \$1.50 per word (including name and address). Minimum order \$15.00. Payment must accompany copy except when ads are placed by accredited advertising agencies. Frequency discount: 5% for 6 months; 10% for 12 months paid in advance. **READER RATE:** For individuals with a personal item to buy or sell. \$1.00 per word (including name and address). No Minimum! Payment must accompany copy. **DISPLAY CLASSIFIED:** 1" by 1 column (2 5/8" wide), \$185.00. 2" by 1 column, \$370.00. 3" by 1 column, \$555.00. Advertiser to supply cuts. For frequency rates, please inquire.

GENERAL INFORMATION: First word in all ads set in bold caps at no extra charge. All copy subject to publisher's approval. All advertisers using Post Office Boxes in their addresses **MUST** supply publisher with permanent address and telephone number before ad can be run. Closing Date: 1st of the 2nd month preceding cover date (for example, March issue closes January 1st). Send order and remittance to Hal Cymes, **POPULAR ELECTRONICS**, One Park Avenue, New York, New York 10016.

FOR SALE

FREE! bargain catalog. Fiber optics, LED's, transistors, diodes, rectifiers, SCR's, triacs, parts. Poly Paks, Box 942, Lynnfield, Mass. 01940.

GOVERNMENT Surplus Receivers, Transmitters, Sniperscopes, Radios. Parts, Picture Catalog 25¢. Meshna, Nahant, Mass. 01908.

ROCKETS: Ideal for miniature transmitter tests. New illustrated catalog. 25¢. Single and multistage kits, cones, engines, launchers, trackers, rocket aerial cameras. Technical information. Fast service. Estes Industries, Dept. 18-K, Penrose, Colorado 81240.

LOWEST Prices Electronic Parts. Confidential Catalog Free. **KNAPP**, 3174 8TH Ave. S.W., Largo, Fla. 33540.

WE SELL CONSTRUCTION PLANS. TELEPHONE: Answering Machine, Speakerphone, Carphone, Phonevision, Legal Connector, Auto Dialer, Central Dial System. **TELEVISION:** \$35.00 Color Converter, Tape Recorder, 3DTV. \$25.00 Camera. **HOBBYIST:** Electron Microscope, 96 Hour Tape Music System. Ultrasonic Dishwasher, Radar-Oven, Electronic Tranquilizer. Plans \$4.95 each. **COURSES:** Telephone Engineering \$39.50. Detective Electronics \$22.50. Anti-Detective Electronics \$27.50. **NEW SUPER HOBBY CATALOG AIRMAILED \$1.00.** Don Britton Enterprises, 6200 Wilshire Blvd., Los Angeles, Calif. 90048.

FIND COINS-GOLD-RELICS-TREASURE metal locators by JETCO!

- Lightweight
- Easy to Use
- Comes Complete
- Made in USA
- 5 yr. Guarantee
- Immediate Delivery!
- Write for FREE Catalog.

priced from

\$39.95



JETCO ELECTRONIC INDUSTRIES, INC.

P. O. BOX 132, PE HUNTSVILLE, TEXAS 77340
PHONE ORDER TO: 713/295-5422

WEBBER LAB'S Police & Fire Converters. Catalog 25¢. 72 Cottage Street, Lynn, Mass. 01905.

INVESTIGATORS, latest Electronics Aids. Free Literature. Clifton, 11500-L NW 7th Ave., Miami, Florida 33168.

ELECTRONIC PARTS, semiconductors, kits. **FREE FLYER.** Large catalog \$1.00 deposit. **BIGELOW ELECTRONICS**, Bluffton, Ohio 45817.

RADIO—T.V. Tubes—36¢ each. Send for free catalog. Cornell, 4213 University, San Diego, Calif. 92105.

CLEARANCE SALE rectifiers, transistors. 1000's other items. Catalog 15¢. General Sales Company, 254 Main, Clute, Texas 77531.

MECHANICAL, ELECTRONIC devices catalog 10¢. Greatest Values—Lowest Prices. Fertik's, 5249 "D", Philadelphia, Pa. 19120.

SENCORE, B&K Test Equipment Unbelievable Prices. Free Catalog and Price Sheet. Fordham Radio, 265 East 149th Street, Bronx, N.Y. 10451.

ELECTRONIC Ignition. Various Types. Information 10¢. Anderson Engineering, Epsom, N.H. 03239.

NEW SEMICONDUCTOR LIGHT EMITTING DIODES—bright red lights replace light bulbs. Typical life 100 years. Operate at 1.65 volts, 50 milliamps. Order 2 for \$2.98 **NOW**. Data sheet and instructions included. Monsanto Company, Hobby Section, 10131 Bubb Road, Cupertino, California 95014.

CONVERT any television to sensitive, big-screen oscilloscope. Only minor changes required. No electronic experience necessary. Illustrated plans, \$2.00. Relco-A33, Box 10563, Houston, Texas 77018.

SPACE-AGE TV CAMERA KITS & PLANS



BE A PIONEER IN HOME TELECASTING! Build your own TV CAMERA, Model XT-1A, Series D, \$116.95 pp. Solid-State. Step-by-step construction manual. High quality. Connects to any TV without modification. Ideal for home, experiments, education, industry, etc.

PHONE or WRITE for CATALOG.
DIAL 402-967-3779

Many other kits, parts and plans available including starter kits, focus/defl. coils, vidicon tubes, const. plans, etc.

1301 N. BROADWAY • **ATV Research** DAKOTA CITY, NEBR. 68731

ELECTRONIC COMPONENTS—Distributor prices, Free catalog. Box 2581, El Cajon, California 92021.

FREE Kit Catalog: Shortproof Powersupply \$39.50. Ultrasonic Alarm \$37.25. SWTPC, Box B32040, San Antonio, Tex. 78216.

AMATEUR SCIENTISTS, Electronics Hobbyists, Experimenters, Students . . . Construction Plans—all complete, including drawings, schematics, parts lists with prices and sources . . . Radar—Build your own ultrasonic doppler radar. Detect motion of people, automobiles, even falling rain drops. Transistorized, uses 9 volt transistor battery—\$4.50 . . . Long-Range "Sound Telescope"—This amazing device can enable you to hear conversations, birds and animals, other sounds hundreds of feet away. Very directional. Transistorized. Uses 9V battery—\$3.50 . . . Robot Man—Moves hands and arms—\$3.50 . . . Or send 25¢ coin (no stamps) for complete catalog. Other items include Psychedelic strobes, light shows, lasers . . . 46 different projects. Technical Writers Group, Box 5994, State College Station, Raleigh, N.C. 27607.

DEALERS WANTED! Citizens Band, AM, SSB. Two-way Radios & Accessories. USA and Export models. We ship around the world. Send letterhead to: Baggy's Radio P.O. Box 778, 6391 Westminster Ave., Westminster, Ca. 92683. 714-894-3301.

CITIZENS BAND Shortwave Listener-Ham equipment from Amrad Supply, Inc. Free Flyer, 1025 Harrison St., Oakland, Calif. 94607.

PSYCHEDELIC Strobe Kit: Complete with 110w/sec. tube, reflector, chassis and cabinet \$17.50 plus postage and insurance. 2 lbs. (Extra tubes \$3.50) SWTPC, Box E32040, San Antonio, Texas 78216.

SEMICONDUCTORS: Buy from single source. Serving experimenters, hobbyists. No minimums. SN 7400N, 1.95; MC724P, \$1.19, Etc. RLabs, Box 253, Burlington, Ma. 01803.

ANTI GRAVITY, experiment and theory; Rushed—\$2.00. U.S. Inquiries. Intertech 7A1, Box 5373, Station-F, Ottawa, Canada.

LEARN the facts of electronics and your privacy. Send for the Tron-X Manual, P.O. Box 38155, Hollywood, CA 90038. \$5.95.

JAPAN HONG KONG DIRECTORY. World products information. \$1.00 today. Sekai Shogyo Annai, Hillyard, Washington 99207.

INTEGRATED CIRCUITS—Factory Prices, Catalog 10¢. Silling, Box 6257, Seattle, Washington 98188.

DEALERS WANTED!

CITIZENS BAND, AM, SSB, Two-way Radios & Accessories. USA and export models. We ship around the world. Send letterhead to:

BAGGY'S RADIO

P.O. Box 778, 6391 Westminster Ave.,
Westminster, California 92683
714-894-3301

FREE Kit Catalog: Color Organs \$11.00, Psychedelic Strobes \$17.50, Professional quality—lowest prices. SWTPC, Box F32040, San Antonio, Texas 78216.

EUROPEAN and Japanese bargains catalogs. \$1 each. Dee, P.O. Box 9308, North Hollywood, Calif. 91609.

BURGLAR ALARM SYSTEMS. We manufacture intruder-fire detection systems, radar and perimeter types. Accessories available. Free Literature. Inquiries for dealership and wholesale prices must be on letterhead. U.S. and Canada only. Microtech Associates, Inc., Box 10147, St. Petersburg, Florida 33733.

"LISTEN IN" TO POLICE-FIRE RADIO CALLS IN YOUR CAR!

WORKS with ANY CAR—Portable or HOME RADIO! Just PLUGS in—No wiring—3 minute hookup! Switch instantly from regular to ALL POLICE-FIRE-EMERGENCY-COMMERCIAL-TAXICAB-STATE-CITY-GOV'T 2-way Radio calls in YOUR AREA. DUAL—HI-LOW BANDS—OVER a MILLION Radio Cars/stations. USE Everywhere—anytime—always works!

SEND ONLY \$2.00 (cash, Ck. M.O.) and pay post-man \$7.99 plus \$3.99 COD pstg or send \$9.99 for pnd Del in USA. COMPLETE, ready to use with instructions. One Year warranty—10 DAY MONEY BACK TRIAL (if retnd). AMAZING OFFER good only by mail—WESTERN RADIO Dept. BPE-10 KEARNEY, NEBR. 68847



CONSTRUCTION PLANS: Laser . . . \$2.00. Investigation Aids—2-FM Microphone Transmitters . . . \$1.00. FM Telephone Transmitter . . . \$2.00. Sound Telescope . . . \$2.00. Space Monitor—Missile Tracker . . . \$2.00. Free equipment and kit catalog. Howard, 20174 Ward, Detroit, Michigan 48235.

GERMAN AND JAPANESE tubes, transistors, and parts price list \$1.00. Matthews TV, 1413 Lee, Lawton, Oklahoma 73501.

FREE! 1972 Electronics Catalog. McCord Electronics, Box 41-P, Sylvania, Ohio 43650.

ALL BAND TRAP ANTENNA!

Reduces Noise on All Makes Short Wave Receivers. Makes World-Wide Reception Better. Complete with 96 ft. 72 ohm feeding. Sealed resonant traps. For novice and all class radio amateurs! Eliminates 5 separate antennas with excellent performance on all 80-40-20-15-10 meter bands. Complete 102 ft. \$19.95. 40-20-15-10 meter bands. 54 ft. (best for world-wide short wave reception) \$18.95. Send only \$3.00 (cash, ck, mo) and pay postman balance COD plus postage on arrival or send full price for post-paid delivery. Complete instructions included.

For ALL Amateur Transceivers. Guaranteed for 1000 Watts Power. Inconspicuous—Efficient! MADE IN U.S.A.

110 VOLTS at 3,000 watts of power from any vehicle with an alternator! Operate AC lights, AC Drills, portable saws and many more AC devices! Build adapter for \$7.95 kit form or \$9.95 wired. Add 50¢ for postage, send check to, Creative Products, 1708-EE Tierney Road, Fort Worth, Texas 76112.

8TR Car players, \$32.50; Speakers, \$8 pr.; Hit Tapes, \$3.49. Baco, P.O.B. 686, Salem, Va. 24153.

BARGAIN Prices on Precision Resistors—100 for \$1.99 plus 10¢ for postage. R&R Electronics, 311 E. South St., Indianapolis, Ind. 46225.

MAKE \$25.00 more a day while you sleep! Build this fantastic silver recovery unit! Complete construction plans. Send \$5.00 to, Creative Products, 1708-E Tierney Road, Fort Worth, Texas 76112.

PYROTECHNICAL, rocketry, laboratory supplies: chemicals, tubes, tools, igniters, colored smoke tracers. Illustrated catalogue/handbook includes formulas, instructions—50¢. Westech, Salt Lake City, Utah 84108.

POLICE-FIRE Radio dispatcher callbooks! Exclusive official listings: Callsigns, frequencies! Nationwide. Send 8¢ stamp for catalog. Communications, Box 56-PE, Commack, N.Y.

LIGHTBAR KITS

LBK-1 (kit) \$ 9.95
LBK-E (kit) \$ 6.95
LBK-1 (wired) \$12.95
LBK-E (wired) \$ 9.95

FOR ADDITIONAL INFORMATION WRITE TO

DATE

P.O. Box 5203, Fullerton, California 92633

OVER 1,000 new electronic parts, list \$240.00, yours \$19.95. 28 Music pages \$1.25. All postpaid. Hobbytronics, 921 East 19th, San Angelo, Texas 76901.

FREE catalog, parts, circuit boards for POPULAR ELECTRONICS projects. PAIA ELECTRONICS, Box C14359, Oklahoma City, Ok. 73114.

CAMERA FANS: Build quality Phototronic Project SA-4 Shutter Speed Meter, Precision Calibrator about \$25-\$50 parts. Seven linear millisecond ranges. Plans, pictorials—\$5.45. Brochure 15¢. A. Mangieri, 1170 Seventh Street, New Kensington, Pa. 15068.

BUILD your own Electronic Desk Calculator. Catalog 25¢. Digital Concepts, Box 5424, Charlottesville, Va. 22903.

BURGLAR ALARM. Complete instructions \$2.50 each. Mike, 5908 Esplanade, Montreal, Quebec, Canada.

TWI-007 TELEPHONE recorder-actuator \$22.85, automatic recorders, transmitters. Catalog 15¢. Twilight Electronics, Box 11562, St. Louis, Missouri 63105.

DIGITAL IC Interchangeability guide, \$1.00. Davis, 5021½ Second, SE, DC, 20003.

TVTUNER REPAIRS—Complete Course Details, 12 Repair Tricks, Many Plans, Two Lessons, all for \$1. Refundable. Frank Bocek, Box 833, Redding, Calif. 96001.

SUPERGAIN Transistor. DC current gain 200,000 at 100 MA output. Two for \$1.10 postpaid with complete data and schematics. Campbell, 2425 Bradley Road, Rockford, Ill. 61107.

ELECTRONICS HOBBYIST and professional builders love our 3¢ film resistors; 16¢ electrolytics and 1¢ micas. Great catalog 35¢. Electrovalue-America, Box 27C, Swarthmore, Pa. 19081.

SOLDERING TOOLS



DIRECT FROM
FACTORY
SAVE BY MAIL

WALL BRAND
Since
1864

Industrial quality—ideal for shop, home. World's finest soldering gun: #214LT, probe light, wattage 400/150, lightweight (no transformer), 1/4" tip, reg. \$21.95. just \$16.50. Two slim pencil irons with cool unbreakable handles: #614XLS, 1/4" tip, 40 watts, 120v, 85° F, reg. \$16.69, just \$12.50. #864, 3 oz w/o cord, 3/16" tip, 40 watts, AC/DC 125v, reg. \$10.69, just \$7.95. Satisfaction guaranteed. Postage paid. Send check or money order for selected tool; print name and address clearly.

WALL MFG. Co. Dept. PE-101 Box 3349 Kinston, N.C. 28501
WHOLESALE Burglar alarm supplies. Catalog \$1.00 (refundable) Eilin, 161 Bonad, Chestnut Hill, Mass. 02167.

PHONE PATCH—EASY TO INSTALL



A Phone Patch PHP-1 hooked up to your phone in conjunction with a recorder will automatically engage the recorder upon picking up your telephone receiver. Your recorder is now ready to record the entire conversation. Upon completion of the call and replacement of the telephone receiver, the recorder automatically shuts off and you have an audio record of what has been said. Ideal for confirming orders or statements. Perfect for confirming messages taken by your answering service.

NET: \$19.95

TELECO, 1351 Pearl Street, Santa Monica, CA 90405

DIAGRAMS—Radios \$1.50, Television \$3.00. Give make and model. Diagram Service, Box 1151PE, Manchester, Conn. 06042.

TELEPHONES . . . Modern, Continental, components. Free brochure. Comet Communications Co., Dept-B, 639 50th St., Brooklyn, New York 11220.

FIRE ALARM System for your home complete with control unit, 8 sensors, wiring and alarm bell. Easy installation instructions. Satisfaction guaranteed: \$69.50. Electronic Signal Systems, Dept. A-2, 713 Rebecca Drive, Tallahassee, Florida 32303.

FREE ELECTRONICS Catalog. Tremendous bargains. Edu-Kits, Department C-706 D, Hewlett, New York 11557.

PLANS AND KITS

FREE Kit Catalog: Digital Microlab \$29.95. Also Segmented and Nixie Readouts, Timebases, Scalers, Electronic Digital Clocks (all featured in Popular Electronics) SWTPC, Box C32040, San Antonio, Tex. 78216.

AUTOMATIC Morse Code Copying Machine. Featured in Ham Radio Magazine this fall. Copy up to 120 wpm without knowing CW! Simply hook to your receiver's audio and read printout. Send \$14.95 for detailed construction plans. VMG Electronics, 2138P West Sunnyside, Phoenix, Arizona 85029.

FREE kit Catalog: Amazing new Universal Digital Instruments with plug-ins as featured in **Popular Electronics**. Unbeatable prices. SWTPC, Box D32040, San Antonio, Tex. 78216.

FREE Kit Catalog. Why does every major College, University, Technical School, Research & Development Center buy from us? Because we have the highest quality and lowest prices. Free catalog. SWTPC, Box H32040, San Antonio, Tex. 78216.

ELECTRIC BICYCLE. Ride all day for nickel. Complete plans \$3.00. Electro, Box 27203-E, Indpls., Ind. 46227.

PARTS Bargain—Save 50% on parts package: 10 Semi-conductors, 52 Resistors, Capacitors, Audio Transformer. 4 PDT Switch. Over 70 parts total. No "junk" parts. All first quality of U.S. manufacture. \$8.90 P.P. with schematics for ten safe projects based on a 9 Volt Battery (not included). The Hall Company, P.O. Box 38158, Urbana, Ohio 43078.

A.I.L.P.—What's AILP? Argon Ion Laser Plans. What Else? Illustrated—Send Now. Only \$2.00. Bill, 273B Jessie Lane, Mountain View, Calif. 94040.

"DISTANCE Crystal Set Construction" Handbook—50¢. "Coil Winding"—50¢. Catalog. Laboratories, 745-L Cordone, Reno, Nevada 89502.

STATE of the Art Color Organ Kit, four 1,000 watt channels, OpAmp buffered stereo inputs. Leo photoisolation \$75.00, F.O.B. Norton Media, 311 West 37th, Austin, Texas 78705.

HOBBYISTS—Programmable electronic combination lock kit. Five IC's, plans, theory, \$5.95. Catalog free. John Huntley, 1351 Mahoney, Rodeo, Calif. 94572.

ANALOG Computers, Plans, Op-Amps, Economical. Catalog \$1.00 (refundable). Fernwood, Box 2005E, Lynwood, Wash. 98036.

COLOR Organs, Strobes, plans, brochure, 10¢. Raeco, P.O. Box 14, Readville, Mass. 02187.

WANTED

CASH PAID! Unused tubes, electronic equipment. Barry, 512 Broadway, NYC 10012.

QUICKSILVER, Platinum, Silver, Gold, Ores Analyzed. Free Circular. Mercury Terminal, Norwood, Mass. 02062.

AMATEUR Gear and equipment wanted for handicapped people in Israel. Everything Accepted. Send to Handicapped Workers, Bernard Weinstein, 43 Chefetz Chaim, Petah Tiawa, Israel.

PRE-1930 Phonographs, Radios, Telephones. Will pay up to \$25.00 plus shipping. Erickson, 40 Ridge, Glen Rock, N. J. 07452.

TUBES

TUBES "Oldies", latest. Lists free. Steinmetz, 7519 Maplewood, Hammond, Indiana 46324.

RECEIVING & INDUSTRIAL TUBES, TRANSISTORS, All Brands—Biggest Discounts. Technicians, Hobbyists, Experimenters—Request **FREE** Giant Catalog and **SAVE!** ZALYTRON, 469 Jericho Turnpike, Mineola, N.Y. 11501.

RADIO & T.V. Tubes—36¢ each. Send for free catalog. Cornell, 4213 University, San Diego, Calif. 92105.

TUBE Headquarters of World! Send 10¢ for Catalog (tubes, electronic equipment) Barry, 512 Broadway, N.Y.C. 10012.

SAVE money on parts and transmitting-receiving tubes, foreign-domestic. Send 25¢ for giant catalog. Refunded first order. United Radio Company, 56-P Ferry Street, Newark, N.J. 07105.

HIGH FIDELITY

TAPE RECORDERS, Hi-Fi. components, Sleep Learning Equipment, tapes. Unusual Values. Free Catalog. Dressner, 1523R, Jericho Turnpike, New Hyde Park, N.Y. 11040.

LOW, Low quotes: all components and recorders, HiFi. Roslyn, Penna. 19001.

FREE Kit Catalog. Amplifiers: Lil Tiger \$11.10, Universal Tiger \$30.00, Preamp \$44.50 (Featured in **Popular Electronics**) SCA Adaptors \$14.55. SWTPC, Box A32040, San Antonio, Tex. 78216.

DIAMOND NEEDLES and Stereo Cartridges at Discount prices for Shure, Pickering, Stanton, Empire, Grado and ADC. Send for free catalog. All merchandise brand new and factory sealed. LYLE CARTRIDGES, Dept. P, P.O. Box 69, Kensington Station, Brooklyn, New York 11218.

the **Quadpod**

decodes new four channel sound from your present stereo. A small, easy IC kit (AC powered) provides rear signals for a second small stereo amplifier and two small rear speakers. (LV and Dyna compatible) QUADPOD B: tape ENCODER soon available. Free prospectus. Guaranteed, postpaid kit...

OLD COLONY-Box 21A Swarthmore PA 19081 \$11.50

AMPLIFIER, miniature, stereo/hi-fi. Transistorized. No distortion. Easily-assembled kit. Free details. Danville Engineering, 881-PE Danville Boulevard, Danville, Calif. 94526.

TAPE AND RECORDERS

OLD radio programs on tape. 6 hours for \$8.00. Catalog 50¢. Don Maris. 1926 Cherokee, Norman, Okla. 73069.

STEREO TAPE RENTAL for particular people. Free catalog. Gold Coast Tape Library, Box 2262, Palm Village Station, Hialeah, Fla. 33012.

STEREO TAPE TRANSPORT—7" reel—2 speeds—pause control—made for famous manufacturer—50 to 15,000 Hz—with rec/play and erase heads. without case. Send m.o. or check for \$19.50 to Alshemer Audio Electronics, 218 Columbia St., Utica, N.Y. 13502. \$2.50 for prepaid shipping and insurance.

RENT 4-Track open reel tapes—all major labels—3,000 different—free brochure. Stereo-Parti, 55 St. James Drive, Santa Rosa, Ca. 95401.

BARGAIN MUSIC, Tape, Equipment Catalog, 25¢. Saxitone, 1776 Columbia Road, Washington, D.C. 20009.

RECORDING TAPE made by top American manufacturer, guaranteed not "seconds" or "white box"; 2400' mylar, \$2.29; 1800' mylar \$1.69; 1200' acetate \$.79. Send for information and quantity pricing. Alshemer Audio Electronics, 218 Columbia Street, Utica, New York 13502.

BUY Irish Tape Open Reel & Cassettes & 8-Track Blanks at Discount Prices. Write: Direct Mail Cassette Corp., Box 71, Plainview, N.Y. 11803.

GERMAN and Japanese tape recorders and stereos converted and repaired. Dual, Grundig, Sansui, Akai, Teac and others. Matthews T.V., 1413 Lee Blvd., Lawton, Okla. 73501.

REMAILING SERVICES

HOUSTON Remails 25¢. Monthly \$3.00. Fast forwarding. Box 12263, Houston, Texas 77017.

REPAIRS AND SERVICES

TV Tuners rebuilt and aligned per manufacturers specification. Only \$9.50. Any make UHF or VHF Ninety day written guarantee. Ship complete with tubes or write for free mailing kit and dealer brochure. JW Electronics, Box 51C, Bloomington, Indiana 47401.

TELEVISION Tuners, any make VHF or UHF, cleaned, repaired and realigned per manufacturer's specifications \$9.50. One year guarantee. Quality Tuner Repair, 526 West Busby Street, Lebanon, Indiana 46052.

PERSONALS

MAKE FRIENDS WORLDWIDE through international correspondence. Illustrated brochure free. Hermes, Berlin 11, Germany.

INVESTIGATORS, Latest Electronics Aids. Free Literature. Clifton, 11500-K NW 7th Ave., Miami, Florida 33168.

SECRET LOANS BY MAIL. Borrow \$100 to \$1500 for any good reason in absolute privacy. No interviews, no endorsers, no cosigners. Fast service. Write Dial Finance Co., Dept. K-593, 410 Kilpatrick Bldg., Omaha, Nebraska 68102.

INSTRUCTION

LEARN ELECTRONIC ORGAN SERVICING at home all makes including transistor. Experimental kit—trouble-shooting. Accredited NHSC, Free Booklet. NILES BRYANT SCHOOL, 3631 Stockton, Dept. A, Sacramento, Calif. 95820.

LEARN WHILE ASLEEP, Hypnotize! Strange catalog free. Auto-suggestion, Box 24-ZD, Olympia, Washington 98501.

DEGREE in electronics Engineering earned mostly by correspondence. Free brochure. Dept. G-9, Grantham School of Engineering, 1505 N. Western Ave., Hollywood, California 90027.

WANT AN F.C.C. 1st CLASS LICENSE? WANT TO BECOME A DISC-JOCKEY? REI has a school near you VA approved. Call toll free: 1-800-237-2251 or write REI, 1336 Main St., Sarasota, Florida 33577, Florida Residents call: 813-955-6922.

HIGHLY effective home study courses in Electronics Engineering Technology and Electronics Engineering Mathematics. Earn your Degree. Write for Free Descriptive Literature. Cook's Institute of Electronics Engineering, (Dept. 15), P.O. Box 10634, Jackson, Miss. 39209. (Established 1945).

FREE brochure self-improvement books. Eldon McBrayer, 412 Arthur Street, Huntsville, Ala. 35805.

FCC RADIOTELEGRAPH LICENSE through tape recorded lessons. Radio License Training, 1060D Duncan, Manhattan Beach, Calif. 90266. Phone 379-4461.

EARN College degree at home. Many subjects, Ministerial Studies, High School Equivalency Diploma. Florida State Christian College, Post Office Box 1674, Fort Lauderdale, Florida 33302.

F.C.C. TYPE EXAM . . . Guaranteed to prepare you for F.C.C. 3rd, 2nd, and 1st phone exams. 3rd class, \$7.00; 2nd class, \$12.00; 1st class, \$16.00; complete package, \$25.00. Research Company, 3206 Bailey Street, Sarasota, Florida 33580.

FCC First and second tests. \$8.95. Electronic Tutoring, Box 24190, Cleveland, Ohio 44124.

AMATEUR RADIO. Complete correspondence tape-recorded license courses. AMATEUR RADIO LICENSE SCHOOL, 12217 Santa Monica Blvd., Los Angeles, Calif. 90025.

DRAFTING—Blueprint Reading (Mechanical, Electronic, Architectural). Home Courses, \$25.00. Send \$2.00 first lesson. Prior, Inc., 23-09 169th Street, Whitestone, New York 11357.

MEMORIZE STUDY: "1971 Test-Answers" for FCC First and Second Class License—plus—"Self-Study Ability Test." Proven! \$9.95. Satisfaction guaranteed. Command, Box 26348-P, San Francisco 94126.

INVENTIONS WANTED

INVENTIONS wanted. Patented; unpatented. Global Marketing Service, 2420-P 77th, Oakland, Calif. 94605.

INVENTORS! Don't sell your invention, patented or unpatented, until you receive our offer. Eagle Development Company, Dept. 9, 79 Wall Street, N.Y., N.Y. 10005.

PATENT Searches including Maximum speed, full airmail report and closest patent copies, \$6.00. Quality searches expertly administered. Complete secrecy guaranteed. Free Invention Protection forms and "Patent Information." Write Dept. 9, Washington Patent Office Search Bureau, 711 14th Street, N.W., Washington, D.C. 20005.

FREE "Directory of 500 Corporations Seeking New Products." For information regarding development, sale, licensing of your patented/unpatented invention. Write: Raymond Lee Organization, 230-GR Park Avenue, New York City 10017.

INVENTORS: Protect your ideas! Free "Recommended Procedure". Washington Inventors Service, 422T Washington Building, Washington, D.C. 20005.

FREE PAMPHLET: "Tips on Safeguarding Your Invention." Write: United States Inventors Service Company, 501-H Thirteenth Street N.W., Washington, D.C. 20004.

GOVERNMENT SURPLUS

JEeps Typically From \$53.90 . . . Trucks From \$78.40 . . . Boats, Typewriters, Airplanes, Multimeters, Oscilloscopes, Transceivers, Electronics Equipment. Wide Variety, Condition. 100,000 Bid Bargains Direct From Government Nationwide Complete Sales Directory and Surplus Catalog \$1.00. (Deductible First \$10.00 Order). Surplus Service, Box 820-J, Holland, Michigan 49423.

GOVERNMENT Surplus. How and Where to Buy in Your Area. Send \$1.00. Surplus Information, Headquarters Bldg., Box 30177-PE, Washington, D.C. 20014.

MANUALS for surplus electronic equipment. List 25¢. Books, 4905 Roanne Drive, Washington, D.C. 20021.

BOOKS

FREE catalog aviation/electronic/space books. Aero Publishers, 329PE Aviation Road, Fallbrook, California 92028.

FREE book prophet Elijah coming before Christ. Wonderful bible evidence. Megiddo Mission, Dept. 64, 481 Thurston Rd., Rochester, N.Y. 14619.

MAGAZINES

JAPAN PUBLICATIONS GUIDE Business, pleasure, education. \$8.00. INTERCONTINENTAL, CPO 1717, Tokyo 100-91.

OVER 2,000,000 backdate magazines! Specify needs. Midtown, Box 917-PE, Maywood, New Jersey 07607.

PHOTOGRAPHY—FILM, EQUIPMENT, SERVICES

SCIENCE Bargains Request Free Giant Catalog "CJ"—148 pages—Astronomical Telescopes, Microscopes, Lenses, Binoculars. Kits, Parts. War surplus bargains. Edmund Scientific Co., 300 Edscorp Bldg., Barrington, New Jersey 08007.

HYPNOTISM

"MALE-FEMALE Hypnotism" Exposed, Explained! "Secret Method"—They Never Know! \$2. Rushed. Guaranteed! Isabella Hall, Silver Springs, Florida 32688.

SLEEP learning. Hypnotic method, 92% effective. Details free. ASR Foundation, Box 7545PL, Fort Lauderdale, Florida 33304.

RECORDS

POPULAR organ albums factory direct. Concert Recording, Lynwood, Calif. 90262.

RUBBER STAMPS

RUBBER Address Stamps \$2.00. Signature \$3.50. Free Catalog. Jackson's, Box 443-G, Franklin Park, Illinois 60131.

STAMPS

FREE! 88 DIFFERENT COUNTRIES!! An incredible Collection of genuine postage stamps . . . from Afghanistan to Zambia, all around the world! Stamps from the North and South Poles. British, French, Portuguese, Spanish Colonies. Ancient Stamps. New Issues, Airmails, Commemoratives. Moon and Outer Space Stamps—from 88 Countries! Also, other exciting stamps for free examination. Buy any or none, return balance, cancel privilege any time. Plus Big Introductory Catalog. Send 10¢ for mailing. H.E. Harris, Dept. SS-12, Boston, Mass. 02117.

EMPLOYMENT OPPORTUNITIES

RECORDISTS. Make records. We train, equip, provide exclusive territory. Modest investment. Director Group, Englewood, Ohio 45322.

EMPLOYMENT INFORMATION

EXCITING Overseas jobs. Directory \$1.00. Research Associates, Box 942-E. Belmont, California 94002.

JOB opportunities in California—send \$1.00—California Information Service, Drawer AP, Los Altos, Ca. 94040.

TREASURE FINDERS

GOLD, Silver, Relics! Located with powerful Detectron Metal Detectors. Free Information. Terms, Detectron, Dept. PE10, Box 243, San Gabriel, California 91778.

TREASURE FINDER locates buried gold, silver, coins, treasures. 5 powerful models. \$19.95 up. Free catalog. Relco-A33. Box 10839, Houston, Texas 77018.

FREE: Jetco Electronics Free 24 page Treasure Finder catalog. Find metals, minerals, gold, silver, coins and relics, Jetco, Box 132 PE. Huntsville, Texas 77340.

FISHER DETECTORS has something new! Free literature. Fisher Research, Dept. PE-10, Palo Alto, CA 94303.

MUSICAL INSTRUMENTS

30% DISCOUNT name brand musical instruments. Free catalog. Freeport Music, 127-N Sunrise Highway, Freeport, N.Y. 11520.

WHOLESALE! Professional Amplifiers, PA Systems, Guitars. Free Catalog. Carvin, Escondido, Calif. 92028.

CHORD Sounds and pictures. Guitar self instruction for the beginner only \$2.95. Post paid. Quality Distributor, 920 South Main, Kokomo, Indiana 46901.

OCTOBER 1971

SPORTS ACTION FILMS

ALL MAJOR SPORTS . . . for your selection and enjoyment. Free Catalog. Super 8/8mm, B&W, COLOR. SPORTLITE, Elec. Dept., Box 24-500, Speedway, Indiana 46224.

BUSINESS OPPORTUNITIES

I MADE \$40,000.00 Year by Mailorder! Helped others make money! Start with \$10.00—Free Proof. Torrey, Box 318-N, Ypsilanti, Michigan 48197.

FREE BOOK "999 Successful Little Known Businesses" Work home, Plymouth 445-M, Brooklyn, N.Y. 11216.

\$200.00 DAILY In Your Mailbox! Your opportunity to do what mail-order experts do. Free details. Associates, Box 136-J, Holland, Michigan 49423.

BIG EARNINGS selling Hertel Bibles. New 3-dimension cover, finest reference edition sells fast. Demonstrator furnished. Big commissions. International Book, Dept. PE, Box 118, Wichita, Kansas 67201.

MAILORDER! Make big money working home. Free report reveals millionaire's trade secrets! Executive (1K10), 333 North Michigan, Chicago 60601.

TWELVE Sensational money makers. Inexpensive Fire, Burglar Alarms, Extinguishers, Locks. Special Offer. Watchdog Marketing, Williamsburg, Ohio 45176.

MAIL GALORE! Money-making opportunities! Name on nationwide mailing lists, 35¢. Three months, 50¢. Sullins, Box 206-PE, Forsyth, Georgia 31029.

MAILORDER Moneymaking Kit. Home Business. Valuable lists, concrete information, detailed steps. Capital unnecessary. Free details, pictures. Prudential, Box 327-PEA, Boston, Mass. 02199.

PIANO TUNING learned quickly at home. Tremendous field! Musical knowledge unnecessary. GI Approved. Information Free. Empire School, Box 327, Miami, Florida 33145.

INVENTOR Introducing home "sonic" perimeter burglar alarm system. Detects before entry! Entrance-Exit time delays. Resets electronically. Covers glass no foiling. Seeking dealers. \$1.00 for details. King, Box 2, Maywood, Ill. 60153.

\$1000 DAY—150% Profit. Selling by mail. No investment in inventory. Part time—full time. Unlimited potential. Complete details \$1.00. National, Box 7212S, Chicago, Illinois 60680.

REAL ESTATE

FREE . . . New 256-page Fall catalog! Describes and pictures hundreds of farms, ranches, town and country homes, businesses coast to coast! Specify type property and location preferred. Zip Code, please. United Farm Agency, 612-EP West 47th St., Kansas City, Mo. 64112.

MISCELLANEOUS

WINEMAKERS: Free illustrated catalog yeasts, equipment. Semplex, Box 12276, Minneapolis, Minn. 55412.

WINE RECIPES and Catalog, 25¢. Country Winemaker, Box 191E, RFD 1, Mattapoisett, Massachusetts 02739.

YOUR Classified or Display Classified Ad in these columns will be seen, read and regularly responded to by America's largest audience of Electronics Hobbyists. The cost is low—the results are high! Plan your campaign now by sending copy and payment to: Hal Cymes, Classified Advertising Manager, POPULAR ELECTRONICS, One Park Avenue, New York, New York 10016.

1000'S OF UNUSUAL SCIENTIFIC BARGAINS including...
SPECIAL UNIQUE PSYCHEDELIC LIGHTING
 Get Fine Project Effects!

HELIUM BALLOONS MAKE A "BALL"



Helium is a safe non-toxic inert gas.
 Stock No. 71.289AV \$3.00 Ppd.

Anytime there's a balloon the air is festive! Especially when the "air" is helium which makes a balloon perky and adventurous. Now here's 25 times the fun—25 various colored balloons of 4, 5, or 6" diameter when inflated. With them, a pressurized (300 lbs sq. in.) can containing 21 liters of helium to inflate all 25. For adults or kids' parties, give-aways, bazaars or just demonstrating "lighter than air".

3-CHANNEL COLOR ORGAN BARGAIN!

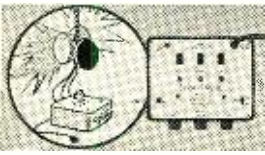

setting plastic case, 6 ft. cord. Including complete instructions.
 Stock No. 71.223AV \$44.50 Ppd.

Create tremendous variety of unusual & beautiful lighting effects with this low-cost top-quality 1500-Watt unit (500 W per channel). Compare with others selling for twice the price. Has pilot light, plus individual sensitivity controls and channel indicator lights. Can operate ten 150 W "spots" or 200 Christmas lights. Uses reg. house current—attaches to audio source w/RCA-type phone plug. 1 1/2" x 2 1/2" x 2 1/2" lbs. Thermal

\$8.95 ELECTRONIC STROBE



BLACK-LIGHT MIGHTY MITES

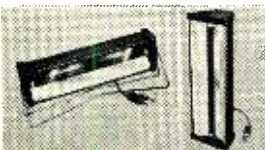

Stock No. 71.274AV
 DELUXE OUTDOOR/INDOOR MODEL
 Stock No. 71.299AV \$19.95 Ppd.

Hand-sized solid state electronic strobe light at fantastically low price. Produces bright psychedelic effects like larger, far more expensive Xenon strobes. Yet it's just 2 3/4 x 4 x 1 3/8" thick. Adjustable flash rate, approximately 3-10 flashes per second. Make stop motion effects, posters come alive. Great to take with you to parties, dances, outings, etc. Requires 2 W transistor batt. (not incl.). Instructions. Stock No. 41.443AV \$8.95 Ppd. 4 REPLACEMENT LAMPS AV 1.00 Ppd. P-41.444

Relatively small (12") fixtures give surprisingly bright black-light. Mirror-finished reflector makes instant starting 8-watt, high-intensity bulb look like 40-watt. Up to 5,000 hours of safe, long-wave (3660A) black-light to really turn on parties, light & theatrical shows, psychedelic decors, holiday decorations. Shockproof end-caps remove for safe, easy replacement of bulb and starter. Stands upright or horizontal. Aluminum case. Stock No. 71.274AV \$14.95 Ppd.

PSYCHEDELIC LIGHTING HANDBOOK



paper for 3 rings.
 Stock No. 9100AV \$3.00 Ppd.

100 Information packed pages! Fully explains latest in psychedelic lighting equipment, techniques, developments. Covers all facets of psychedelic light-show production including strobes, black lights, projectors, crystals, organic slides, mirrors, color organs, polarized color, light boxes, MusicVision, etc. Shows how to "psychedelize" parties, musical groups, shows or how to set up "electric trips" for private gatherings. 8 1/2" x 11" looseleaf

NEW LIGHT-EMITTING-DIODE KIT

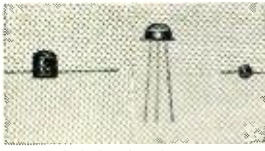

fiber optic light pipe; instrs.
 Stock No. 41.597AV \$5.95 Ppd.

Bargain kit ideal for economical experimenting with amazing L.E.D.s, the tiny solid state monochromatic lamps that use low voltage DC, last up to 1MM hrs. Used in card-tape readers, character recognition, hi-speed detectors, all kinds of electronic applications. Kit incl's 3 L.E.D.s; Gallium arsenide (MLED 600, MV 50, MLED 920); 2 visible red emitting (6600 A°); 1 infra-red emitting (9000 A°); 6 resistors: 1" 20mm plastic

WRITE FOR GIANT FREE CATALOG "AV"

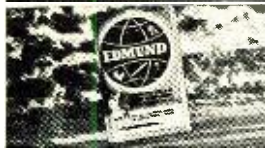

Completely new edition. New items, categories, illustrations, 148 easy-to-read pages packed with 4000 unusual items. Dozens of electrical and electro-magnetic parts, accessories. Enormous selection of Astronomical Telescopes, Microscopes, Binoculars, Magnifiers, Magnets, Lenses, Lasers, Prisms. Many new surplus items for hobbyists, experimenters, workshops, factory. Write for catalog "AV".

EDMUND SCIENTIFIC CO. 300 EDSCORP BLDG. BARRINGTON, NEW JERSEY 08007
 ORDER BY STOCK NUMBER - SEND CHECK OR MONEY ORDER - MONEY-BACK GUARANTEE

POPULAR ELECTRONICS

OCTOBER 1971

ADVERTISERS INDEX

R.S. NO.	ADVERTISER	PAGE NO.
1	Acoustic Research, Inc.	14
2	Allied Radio Shack	91
3	Allied Radio Shack	102
6	B & F Enterprises	100
8	CTS of Paducah, Inc.	98
	CREI, Home Study Div., McGraw-Hill Book Co.	56, 57, 58, 59
9	Cadco Systems	9
5	Cleveland Institute of Electronics	14, 18, 19, 20, 21, 101
10	Crystek	102
11	Datak Corp., The	104
12	Drake Company, R.L.	88
7	Cobra Div., DYNASCAN CORP.	10
13	EICO Electronic Instrument Co., Inc.	100
14	Edmund Scientific Co.	110
4	Electro-Voice, Inc.	FOURTH COVER
17	Heath Company	92, 93, 94, 95, 96, 97
18	Johnson Company, E.F.	89
19	Lafayette Radio Electronics	111, 112
20	Lendell Products	98
21	Marshall Electronic	87
22	Motorola (HEP)	11
	National Radio Institute	SECOND COVER, 1, 2, 3
	National Technical Schools	74, 75, 76, 77
23	Olson Electronics	101
24	RCA Electronic Components & Devices	26
	RCA Electronic Components & Devices	THIRD COVER
	RCA Institutes, Inc.	38, 39, 40, 41
25	Sprague Products Co.	12
26	Toyo Radio Co. of America, Inc.	8
	U.S. Army	22, 23
27	Ungar, Div. of Eldon Industries, Inc.	5
28	United Audio Products (DUAL)	16
29	University Sound	13
30	Xcelite, Inc.	6

CLASSIFIED ADVERTISING 105, 106, 107, 108, 109

CIRCLE NO. 14 ON READER SERVICE PAGE

CIRCLE NO. 19 ON READER SERVICE PAGE

Printed in U.S.A.

----- Mail This Card Today-->

LAFAYETTE 1972 Catalog 720 Our 51st Year

FREE!

Your Complete Buying Guide to
Everything in Electronics



468
Pages

**BETTER
THAN
EVER**



Use LAFAYETTE'S Budget Plan

- ★ Radios ★ Cassette recorders ★ Stereo
- Hi-Fi ★ Citizens Band ★ Tape Recorders
- ★ Cameras ★ Photographs and More

--- Mail This Card Today for Your Friend-->

STORE LOCATIONS

52 Convenient Store Locations in ten states:

- | | | |
|---------------|--------------|----------|
| NEW YORK | CONNECTICUT | VIRGINIA |
| NEW JERSEY | PENNSYLVANIA | MARYLAND |
| MASSACHUSETTS | OHIO | GEORGIA |
| | ILLINOIS | |

Associate Stores From Coast-To-Coast. Visit the Lafayette store nearest you for fast personalized service. Watch For New Grand Openings.

Mail the Coupon today for your
FREE 1972 Lafayette Catalog 720

LAFAYETTE Radio **ELECTRONICS**
Dept. 15091 P.O. Box 10
Syosset, L.I., N.Y. 11791

Please Send the FREE 1972 LAFAYETTE CATALOG 720

Name

Address

City State Zip

(Please Give Your Zip Code No.)



MAIL THIS CARD
TODAY FOR YOUR

FREE!

1972 LAFAYETTE
CATALOG 720

Dept. 15091

Name

Address

City

State Zip



MAIL THIS CARD
TODAY FOR YOUR

FREE!

1972 LAFAYETTE
CATALOG 720

Dept. 15091

Name

Address

City

State Zip

LAFAYETTE
RADIO ELECTRONICS
 P.O. BOX 10
 SYOSSET, L.I., N.Y. 11791

PLACE
 STAMP
 HERE

LAFAYETTE
RADIO ELECTRONICS
 P.O. BOX 10
 SYOSSET, L.I., N.Y. 11791

PLACE
 STAMP
 HERE

Mail This Card Today For Your

FREE!

LAFAYETTE 1972 Catalog 720



468
 Pages

Our 51st Year

Shop At the "World's Hi-Fi
 & Electronics Center"
 For Widest Selection, Low Prices

Stereo Hi-Fi • Citizens Band • Ham Gear • Tape
 Recorders • Test Equipment • TV and Radio
 • Phonographs, Accessories • Intercoms and PA
 • Closed Circuit TV • Tubes and Parts • Cameras
 • Auto Accessories • Musical Instruments • Tools
 • Books



Award Winning LR-1500TA
 IC Solid State Receiver



Micro 12
 Solid State 2-Way Radio
 For Home and Car



Citizens Band
 Dyna Com
 Super Series
 Walkie Talkie



Musical Instruments
 and Accessories

Do A Friend A Favor . . .

Have a friend interested in hi-fi or electronics? Send us his name and address and we will send him his own personal copy of the 1972 LAFAYETTE CATALOG 720

FREE! MAIL THE CARD TODAY!

----- Mail This Card Today-->
 LAFAYETTE 1972 Catalog 720 Our 51st Year

FREE!

Your Complete Buying Guide to
 Everything in Electronics



468
 Pages

**BETTER
 THAN
 EVER**



Use LAFAYETTE'S Budget Plan

- ★ Radios ★ Cassette recorders ★ Stereo Hi-Fi
- ★ Citizens Band ★ Tape Recorders
- ★ Cameras ★ Photographs and More

--- Mail This Card Today for Your Friend-->
STORE LOCATIONS

52 Convenient Store Locations in ten states:

- | | | |
|---------------|--------------|----------|
| NEW YORK | CONNECTICUT | VIRGINIA |
| NEW JERSEY | PENNSYLVANIA | MARYLAND |
| MASSACHUSETTS | OHIO | GEORGIA |
| | ILLINOIS | |

Associate Stores From Coast-To-Coast. Visit the Lafayette store nearest you for fast personalized service. **Watch For New Grand Openings.**

Mail the Coupon today for your
FREE 1972 Lafayette Catalog 720

LAFAYETTE Radio ELECTRONICS
 Dept. 15091 P.O. Box 10
 Syosset, L.I., N.Y. 11791

Please Send the FREE 1972 LAFAYETTE CATALOG 720

Name

Address

City State Zip

(Please Give Your Zip Code No.)



**MAIL THIS CARD
 TODAY FOR YOUR**

FREE!

**1972 LAFAYETTE
 CATALOG 720**

Dept. 15091

Name

Address

City

State Zip



**MAIL THIS CARD
 TODAY FOR YOUR**

FREE!

**1972 LAFAYETTE
 CATALOG 720**

Dept. 15091

Name

Address

City

State Zip

LAFAYETTE
RADIO ELECTRONICS
 P.O. BOX 10
 SYOSSET, L.I., N.Y. 11791

PLACE
 STAMP
 HERE

LAFAYETTE
RADIO ELECTRONICS
 P.O. BOX 10
 SYOSSET, L.I., N.Y. 11791

PLACE
 STAMP
 HERE

Mail This Card Today For Your

FREE!

LAFAYETTE 1972 Catalog 720



468
 Pages

Our 51st Year

Shop At the "World's Hi-Fi
 & Electronics Center"
 For Widest Selection, Low Prices

Stereo Hi-Fi • Citizens Band • Ham Gear • Tape
 Recorders • Test Equipment • TV and Radio
 • Phonographs, Accessories • Intercoms and PA
 • Closed Circuit TV • Tubes and Parts • Cameras
 • Auto Accessories • Musical Instruments • Tools
 • Books



Award Winning LR-1500TA
 IC Solid State Receiver

Micro 12



Solid State 2-Way Radio
 For Home and Car



Citizens Band
 Dyna Com
 Super Series
 Walkie Talkie



Musical Instruments
 and Accessories

Do A Friend A Favor . . .

Have a friend interested in hi-fi or electronics? Send us his name and address and we will send him his own personal copy of the 1972 LAFAYETTE CATALOG 720

FREE! MAIL THE CARD TODAY!

Cut arc-back in TV damper circuits with RCA tubes...

6AF3

6AY3B

6BS3A

6CG3/6BW3

6CJ3/6CH3

6CL3

6DW4B

17AY3A

17BE3/17BZ3

17BS3A/17DW4A

All have the pre-coated cathode!



These are the 10 most popular industry types for TV damper circuits. The cathodes in these RCA tubes are pre-coated to reduce arcing.

A special manufacturing process pre-coats the cathode and pressure-welds the coating. This produces a smooth, uniform surface that virtually eliminates arcing.

In every way, the quality that goes into these tubes backs up your reputation for quality work. Systematic

parts inspection, tough environmental testing, sample life testing ... these are some of the ways we build quality in and then check it out.

See your RCA tube distributor for the complete line of RCA tubes for damper circuits, high-voltage circuits and all your other tube needs.

RCA | Electronic Components | Harrison, N.J. 07029.

RCA

A superb condenser microphone for just \$39.75. What's the trick? Brilliant engineering.

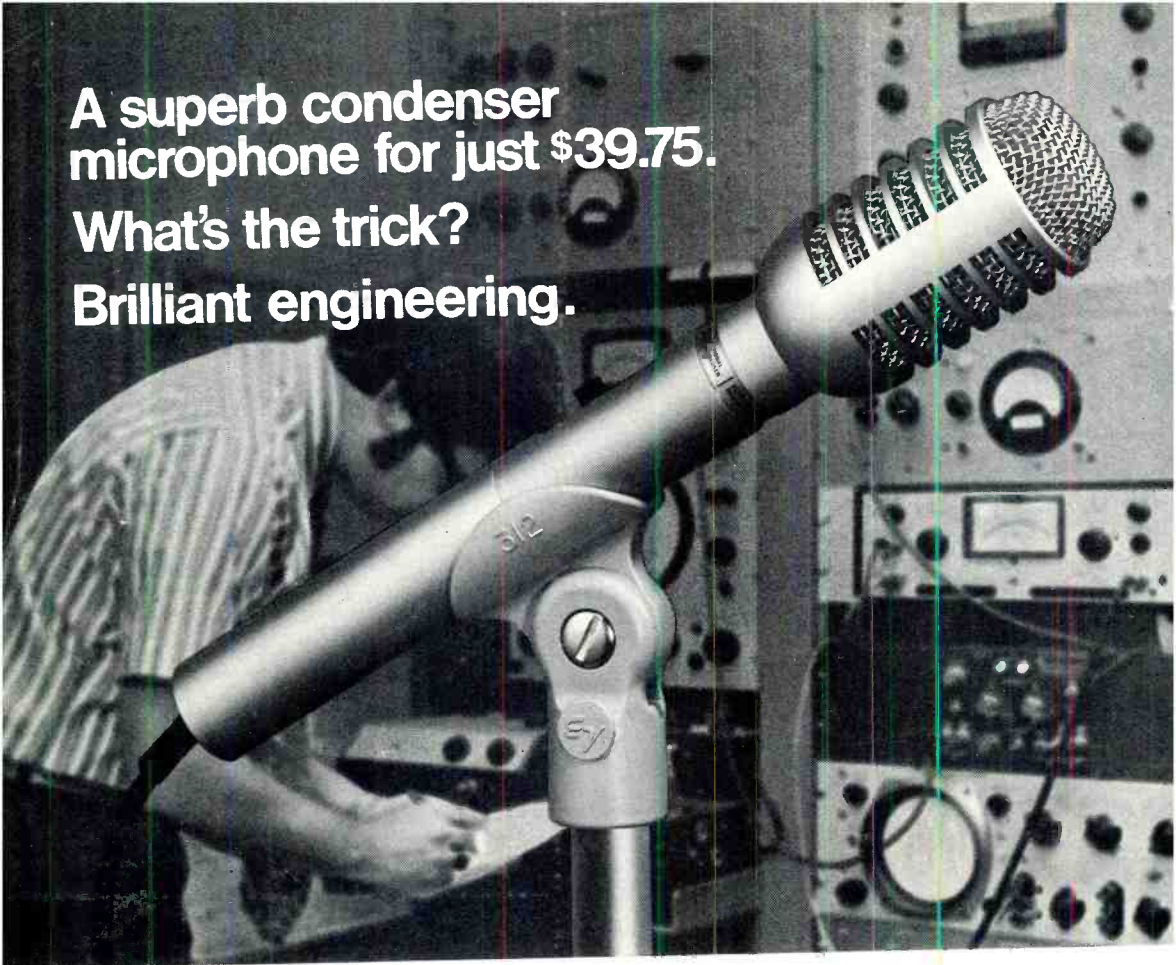

Condenser microphones have long been known for their sound...and their cost, and their complexity. Now Electro-Voice introduces a series of genuine condenser microphones that provide sound embarrassingly close to the most expensive studio models, without the high cost and complexity.

A big problem with conventional condenser microphones has been the need for a high voltage power supply to polarize the diaphragm. E-V has eliminated it completely with its new *electret* condensers. We've found a way to permanently trap this voltage right on the surface of the diaphragm, thus doing away with the need for bulky, expensive power supplies.

How do the new Electro-Voice electrets sound? Response is clean, flat, and transparent, with very high output for full recording volume. It's just what you would expect from condenser microphones costing much more, and by far the best sound-per-dollar you've ever heard.

A simple FET circuit inside each E-V electret microphone matches both professional and home tape recorder inputs with equal quality. This low-noise, high-output circuit operates from a single "AA" penlite battery for as long as 1200 hours of use.

Choose either omnidirectional or Single-D cardioid types. The chart shows the prices, and some of the reasons for the difference in cost. Whichever model you choose will give you excellent transient response, high sensitivity, and uniform polar response. Our "second-generation" electret design offers vastly improved protection against extremes of humidity and temperature. And the ruggedness of E-V electret condensers is rivaled only by E-V dynamic models. All-in-all, new E-V condensers are a significant improvement over less sophisticated condenser microphones (electret or otherwise).

If your goal is to record natural sound, or natural music—try an E-V electret. But don't tell your listeners how much you paid for your new microphones. They'll never believe you!

ELECTRO-VOICE, INC., Dept. 1011P
630 Cecil Street, Buchanan, Michigan 49107
In Europe: Electro-Voice, S.A., Lyss-Strasse 55,
2560 Nidau, Switzerland



MODEL 1710
Omnidirectional
80-13,000 Hz response.
Unbalanced 150 ohm output.
—50 dB output level*.
\$39.75



MODEL 1750
Single-D Cardioid
80-13,000 Hz response.
Unbalanced 150 ohm output.
—43 dB output level*
\$45.00



MODEL 1711
Omnidirectional
60-15,000 Hz response.
Balanced 150 ohm output.
Professional cable connector.
—50 dB output level*.
\$59.70



MODEL 1751
Single-D Cardioid
60-15,000 Hz response.
Balanced 150 ohm output.
Professional cable connector.
—43 dB output level*.
\$75.00

*Output level ref. to 1 mw/10 dynes/cm
The smaller the number, the better
Prices shown are suggested retail

Electro-Voice[®]
a GULTON subsidiary