

YOU CAN HAVE FOUR-CHANNEL STEREO NOW

Popular Electronics

FIFTY CENTS / JULY 1971

Rhythm Maker For Musical Instruments

**ARE EARTH'S POLES
REVERSING?**

TRIGGERED SCOPE SWEEP

NEW HAND-HELD RADARS

**EASY-TO-INSTALL
REMOTE CONTROL**



7454601 71
401 A 010
MAR 210
672
08015
BROWNS MILLS NJ
P. 245
SCHLAGER
401 A 010
7454601 71

**NRI “hands-on” training in
Television, Communications,
Electronics and Computers
can give you as much
as 2 years of on-the-job
experience.**

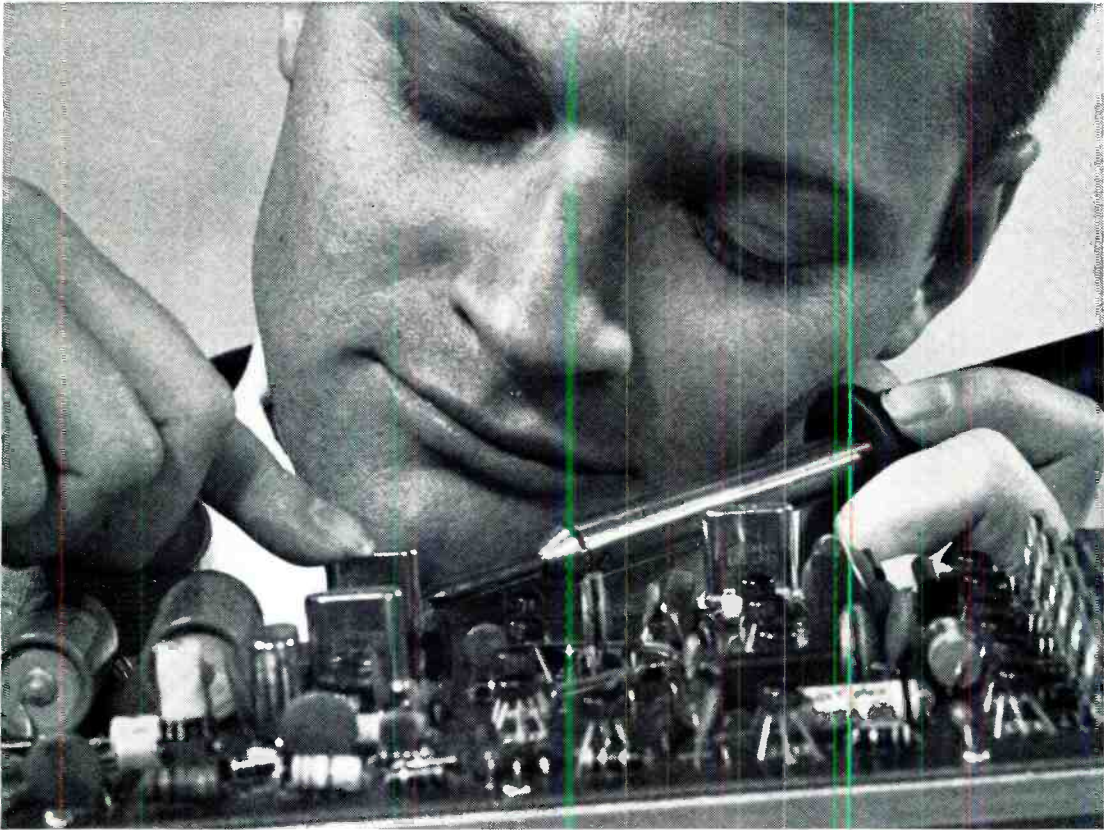

EARN YOUR FCC LICENSE – OR YOUR MONEY BACK

NRI Communications training programs will qualify you for a First Class Commercial Radiotelephone License issued by the FCC. If you fail to pass the FCC examinations for this license after successfully completing an NRI Communications course we will, on request, refund in full the tuition you have paid. This agreement is valid for the period of your active student membership and *for six months* after completion of your training. No school offers a more liberal FCC License agreement.

Experience is still your best teacher

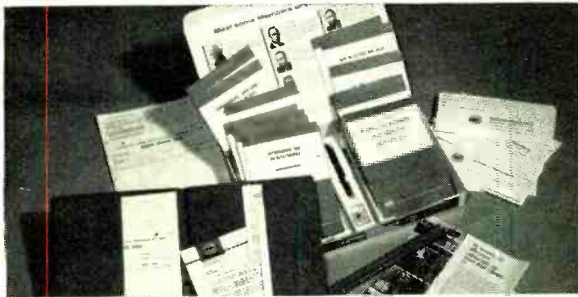

NRI Achievement Kit is educator-acclaimed and the original "starter" kit in home study training. Imitated but never duplicated, this kit is designed and personalized for you and your training objective. It has one purpose — to get you started quickly and easily.



"Bite-Size" Texts average an easily-digested 40 pages of well-illustrated, scientifically prepared subject matter in the course of your choice. Questions in each book are carefully hand-graded and returned to you with helpful instructional notes. You get unlimited personal help from the day you enroll.

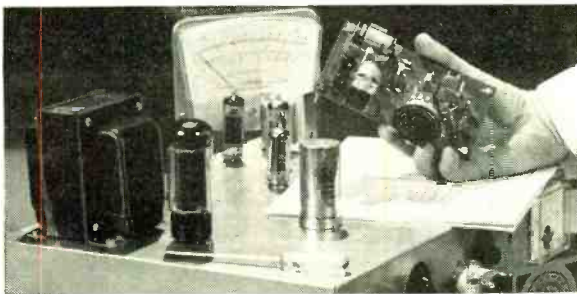

Designed-For-Learning Equipment

Like this phone-cw transmitter (Kit #7 in the Communications course) is engineered from chassis up to demonstrate principles you must know. NRI does not use modified hobby kits for training, but the finest parts money can buy, professionally and educationally applied.

...here's how you get it with unique NRI training at home

Ask any teacher, job counselor, engineer, technician or prospective employer about the need for practical application of theory in Electronics. He'll tell you Electronics is as much a "hands-on" profession as dentistry or chemistry. That's how you learn at home with NRI. You prove the theory you read in "bite-size" texts, by actual experimentation with the type of solid-state, transistor and tube circuits you'll find on the job today — *not* hardware or hobby kits. You introduce circuit defects, analyze results, discover quickly the kind of trouble-shooting and design techniques that will make you employable in Electronics.

Train with the leader — NRI

NRI lab equipment is designed from chassis up for effective, fascinating training — not for entertainment. The fact that end results are usable, quality products is a bonus. In Communications, for example, you build and analyze, stage by stage, your own 25-watt phone/cw transmitter. It's suitable for use on the 80-meter amateur band, if you have an interest in ham radio. In TV-Radio Servicing your practical training gives you your choice of monochrome or color TV sets. All training equipment is included in the low tuition — you pay nothing extra. Discover for yourself the ease, excitement and *value* of NRI training. Mail postage-free card today for new NRI Catalog . . . or use the coupon below. No obligation. No salesman will call on you. NATIONAL RADIO INSTITUTE, Washington, D.C. 20016.

APPROVED UNDER NEW GI BILL

If you have served since January 31, 1955, or are in service now, check GI line on postage-free card or in coupon.

MAIL THIS COUPON IF CARD IS GONE



NATIONAL RADIO INSTITUTE

Washington, D.C. 20016

1-071

Please send me your new NRI Catalog. I understand no salesman will call and there is no obligation.

Name _____ Age _____

Address _____

City _____ State _____ Zip _____

Check for facts on new GI Bill

ACCREDITED MEMBER NATIONAL HOME STUDY COUNCIL

Popular Electronics

WORLD'S LARGEST-SELLING ELECTRONICS MAGAZINE

FEATURE ARTICLES

- | | | |
|--|-----------|--------------------------------|
| THE DRUMMER BOY
<i>Rhythm accompaniment for music</i> | 25 | John S. Simonton, Jr. |
| DESTINY AND GEOMAGNETISM
<i>Are earth's magnetic poles reversing?</i> | 41 | Webb Garrison |
| 4-CHANNEL STEREO IS HERE
<i>What's available now and for the future</i> | 47 | Alexander W. Burawa |
| BUILD A FOUR-CHANNEL DECODER
<i>Versatile controls with unique IC</i> | 52 | George Meyerle |
| ADD TRIGGERED SWEEP TO YOUR SCOPE
<i>Make your scope more useful</i> | 61 | Harry Garland
& Roger Melen |
| PORTABLE RADAR BECOMES A REALITY
<i>Two new models for small boats</i> | 67 | Richard Humphrey |
| LOW-VOLTAGE REMOTE POWER CONTROL
<i>Two-way low-cost switching system</i> | 69 | Neil Johnson |
| STEREO SCENE
<i>What is high fidelity?</i> | 71 | J. Gordon Holt |
| OPPORTUNITY AWARENESS
<i>The radio/TV broadcast technician</i> | 77 | David L. Heiserman |
| SOLID STATE
<i>New imaging device</i> | 79 | Lou Garner |
| THE PRODUCT GALLERY
<i>B&K Model 1460 Oscilloscope</i>
<i>Heathkit GR-169 Color TV</i>
<i>Stanton Dynaphase I Headphones</i> | 82 | |

DEPARTMENTS

- | | | |
|------------------------------------|---------------|-------------------|
| DIRECT & CURRENT | 7 | Oliver P. Ferrell |
| INTERFACE | 8 | |
| NEW LITERATURE | 14 | |
| READER SERVICE PAGES | 15, 95 | |
| ELECTRONICS LIBRARY | 16 | |
| NEW PRODUCTS | 22 | |
| OUT OF TUNE | 94 | |
| <i>"Princes Puzzle" (May 1971)</i> | | |

POPULAR ELECTRONICS is Indexed
in the Reader's Guide
to Periodical Literature

Copyright © 1971 by ZIFF-DAVIS PUBLISHING COMPANY. All rights reserved.

William Ziff, President; Hershel B. Sarbin, Senior Vice President and Secretary; Philip Sine, Financial Vice President and Treasurer
 POPULAR ELECTRONICS, July 1971, Volume 35, Number 1. Published monthly at One Park Ave., New York, N.Y. 10016.
 One year subscription rate for U.S., U.S. Possessions and Canada, \$6.00; all other countries, \$7.00. Second class postage paid
 at New York, N.Y. and at additional mailing offices. Authorized as second class mail by the Post Office Department, Ottawa,
 Canada and for payment of postage in cash. Subscription service and Forms 3579: P.O. Box 1096, Flushing, N.Y. 11352.
 Editorial offices for manuscript contributions, reader inquiries, etc.: One Park Ave., New York, N.Y. 10016.

This month's cover art by
Robert Korn



NEW IR-18M solid-state 12-speed chart recorder kit

NEW GR-371MX 25" square-corner solid-state color TV kit

NEW GD-29 microwave oven kit

NEW IB-101 solid-state 15 MHz frequency counter kit

NEW IQ-102 solid-state 5" scope kit

NEW IM-105 solid-state VOM kit

NEW IB-102 175 MHz solid-state frequency scaler kit

Seven new Heathkit® improvement ideas for home or shop

NEW! Heathkit IR-18M 10" chart recorder kit provides 12 different chart speeds...instant pushbutton selection from 5 sec/in. to 200 min/in. Digital logic delivers accuracy unobtainable with ordinary gear trains. Two input ranges permit accurate measurements from 0-1 & 0-10 mV full scale. Hi-Z input minimizes loading. 3-terminal floating input. Light-operated modulator eliminates problems of a mechanical chopper...operates at 240 Hz to reduce 60 Hz noise. Internal temperature-stabilized reference voltage eliminates troublesome reference battery. Coarse & Fine zero controls allow fast, accurate pen positioning. Other features: versatile pen holder that accepts virtually any writing instrument & hinged top for easy paper loading. For the best value going in a chart recorder, order your IR-18M now. Kit IR-18M, 15 lbs., **149.95***

NEW! GR-371MX 25" solid-state ultra-rectangular color TV. Check out the competition for standard features like these: 25" square corner Matrix picture tube for the biggest, brightest, sharpest color picture ever...high resolution circuitry plus adjustable video peaking...Automatic Fine Tuning...pushbutton channel advance..."Instant-On"...Automatic Chroma Control...factory assembled 3-stage solid-state IF and VHF & UHF tuners for superior reception, even under marginal conditions...adjustable noise limiting & gated AGC...adjustable tone control...hi-fi sound output to internal speaker or your hi-fi system. Plus your choice of installation in one of the three beautiful Heath cabinets or custom wall mounting capability. And the exclusive Heath self-service features let you do all normal adjustment & servicing, saving hundreds of dollars in service costs. If you want the finest, this is it...order your 371MX now. Kit GR-371MX, 125 lbs. **579.95***

NEW! GD-29 microwave oven...the most modern way to prepare food. Cooks up to 70% faster with better vitamin retention. Cooks on glass, ceramics, even paper plates. Low profile design fits under cupboards easily, yet has one of the largest oven capacities in the industry. Operates anywhere on standard 120 VAC current. Kit includes specially prepared cookbook. Kit GD-29, 97 lbs. **399.95*** Roll-around cart gives even easy mobility. Model GDA-29-1, **24.95***

NEW! IB-102 Scaler and IB-101 Frequency Counter combination give you frequency measurement capability to 175 MHz at low, low cost. IB-101 counts from 1 Hz to over 15 MHz. Hz/kHz ranges & over-range indicator let you make an 8-digit measurement down to the

last Hz in seconds. 5-digit cold-cathode readout...extremely low input triggering...all solid-state with 26 ICs, 8 transistors. NEW IB-102 Frequency Scaler can be used with virtually any counter on the market to extend your measurement capability well into the VHF range...at a price far below the cost of a 175 MHz counter. 10:1 and 100:1 scaling ratios give resolution down to 10 Hz...1:1 ratio provides straight-thru counting for frequencies in range of counter. Exclusive Heath input circuit triggers at very low levels...at 100 MHz less than 30 mV is needed. A handy Test switch gives a quick, accurate check of proper operation. All solid-state; fully regulated supplies; convenient carrying handle/tilt stand. Extend your frequency measurement capability now with these two new kits. Kit IB-101, 7 lbs. **199.95*** Kit IB-102, 7 lbs. **99.95***

NEW! IQ-102 solid-state 5" scope ideally suited for general purpose service & design work. Features wide DC-5 MHz response, 30 mV/cm sensitivity and 80 ns rise time. Switch-selected AC or DC coupling for greater versatility. Frequency-compensated 3-position attenuator. FET input provides hi-Z to minimize circuit loading. Recurrent, automatic-sync type sweep provides five ranges from 10 Hz to 500 kHz with vernier. External horizontal and sync inputs are also provided. One volt P-P output provides an accurate comparison voltage source. Additional features include a big 5" CRT with high visibility trace; 6x10 cm ruled graticule that can be replaced with a standard camera mount; solid-state zener-regulated supplies for extra display stability and 120/240 VAC operation. An excellent all-around scope that belongs on your bench now. Kit IQ-102, 29 lbs., **119.95***

NEW! IM-105 solid-state portable VOM...an extremely rugged, highly accurate, low cost meter for hundreds of applications. High impact Lexan® case and ruggedized diode & fuse protected taub-band meter movement will suffer extreme abuse and still maintain specifications. 95° wide viewing area provides high resolution. 3% DC accuracy; 4% AC accuracy; 3% DC current accuracy. Temperature compensated, 8 DCV ranges from 0.25 to 5000 V full scale...7 ACV ranges from 2.5 to 5000 V full scale...6 DC current ranges from 0.05 mA to 10 A full scale...5 ohms ranges from x1 to x10k with center scale factor of 20...5 dB ranges from -10 to +50 dB. Other features include DC polarity reversal switch; front panel thumbwheel ohms zero; self-storing handle and fast, easy assembly. A lot of meter at a little cost...that's the new IM-105. Order yours now. Kit IM-105, 7 lbs., **47.95***

See these kits at your local Heathkit Electronic Center... or Send for Free Catalog



CALIF.: Anaheim, 330 E. Ball Road, El Cerrito, 6000 Potrero Avenue, La Mesa, 8363 Center Drive, Los Angeles, 2309 S. Flower St., Redwood City, 2001 Middlefield Rd., Woodland Hills, 22504 Ventura Blvd., COLO.: Denver, 5940 W. 38th Ave., GA.: Atlanta, 5285 Roswell Road, ILL.: Chicago, 3462-66 W. Devon Ave., Downers Grove, 224 Ogden Ave., MD.: Rockville, 5542 Nicholson Lane, MASS.: Wellesley, 165 Worcester St., MICH.: Detroit, 18645 W. Eight Mile Rd., MINN.: Hopkins, 101 Shady Oak Rd., MO.: St. Louis, 9296 Gravois Ave., N.J.: Fair Lawn, 35-07 Broadway (Rte. 4), N.Y.: Jericho, L.I., 15 Jericho Turnpike, New York, 35 W. 45th Street, OHIO: Cleveland, 5144 Pearl Rd., Woodlawn, 10133 Springfield Pike, PA.: Philadelphia, 6318 Roosevelt Blvd., Pittsburgh, 3482 William Penn Hwy., TEXAS: Dallas, 2715 Ross Avenue, Houston, 3705 Westheimer, WASH.: Seattle, 2221 Third Ave., WIS.: Milwaukee, 5215 W. Fond du Lac.

Retail Heathkit Electronic Center prices slightly higher to cover shipping, local stock, consultation and demonstration facilities. Local service also available whether you purchase locally or by factory mail order.

HEATH COMPANY, Dept. 10-7
Benton Harbor, Michigan 49022 a Schlumberger company

Enclosed is \$ _____, plus shipping.

Please send model (s) _____

Please send FREE Heathkit Catalog. Please send Credit Application.

Name _____

Address _____

City _____ State _____ Zip _____

*Mail order prices; F.O.B. factory.
Prices & specifications subject to change without notice. CL-411R

CIRCLE NO. 11 ON READER SERVICE PAGE

Save \$30 on a Cobra



Cobra 24 Reg. \$169.95

Now \$139.95

The Cobra 24 strikes through garbage and static everytime. All you get is a crisp and clear message on all 23 crystal-controlled channels (no extra crystals needed).

Thanks to:

- A Dynascan exclusive full 5-watts of clear message with DYNABOOST speech compression.
- All solid-state plus FET and integrated circuitry for stability and dependability.
- Selective, dual-conversion, superhet receiver with ceramic filter to give superior selectivity and gain.
- Operates on 12 volts DC. Meets FCC requirements.
- Positive/negative ground operation without internal wiring changes needed—with reverse polarity protection.

The Cobra 24 also features a dynamic push-to-talk microphone, an illuminated channel selector and "S" meter for night transmission and a PA/CB switch with adjustable volume. Plus many more features that make the Cobra 24 the most powerful and dependable radio in its class.

FACTORY-AUTHORIZED LIMITED-TIME SALE

Other selected models also on sale!
See your CB dealer today!



Product of Dynascan Corporation
1801 W. Belle Plaine
Chicago, Illinois 60613

CIRCLE NO. 8 ON READER SERVICE PAGE

Popular Electronics

LAWRENCE SPORN

Publisher

OLIVER P. FERRELL

Editor

LESLIE SOLOMON

Technical Editor

JOHN R. RIGGS

Managing Editor

EDWARD I. BUXBAUM

Art Director

ALEXANDER W. BURAWA

Associate Editor

ANDRE DUZANT

Technical Illustrator

PATTI MORGAN

Assistant Editor

JUDITH L. HOGAN

Editorial Assistant

J. GORDON HOLT

L. E. GARNER, JR.

DAVID L. HEISERMAN

Contributing Editors

STANLEY NEUFELD

Associate Publisher

RICHARD J. HALPERN

Advertising Manager

MARGARET DANIELLO

Advertising Service Manager

FURMAN H. HEBB

*Group Vice President
Electronics and Photographic*

ZIFF-DAVIS PUBLISHING COMPANY

Editorial and Executive Offices

One Park Avenue, New York, New York 10016
212 679-7200

Midwestern Office

The Pattis Group, 4761 West Touhy Ave.,
Lincolnwood, Illinois 60464, 312 679-1100
GERALD E. WOLFE, DICK POWELL

Western Office

9025 Wilshire Boulevard, Beverly Hills, California 90211
213 CRestview 4-0265; BRadshaw 2-1161
Western Advertising Manager, BUD DEAN

Japan: James Yagi

Oji Palace Aoyama; 6-25, Minami Aoyama
6-Chome, Minato-Ku, Tokyo 407-1930/6821

Circulation Office

P.O. Box 1096, Flushing, N.Y. 11352

William Ziff, President

W. Bradford Briggs, Executive Vice President
Hershel B. Sarbin, Senior Vice President and Secretary
Stanley R. Greenfield, Senior Vice President
Philip S. ne, Financial Vice President and Treasurer
Walter S. Mills, Jr., Vice President, Circulation
Phillip T. Heffernan, Vice President, Marketing
Frank Pomerantz, Vice President, Creative Services
Arthur W. Butzow, Vice President, Production
Edward D. Muhlfield, Vice President, Aviation Division
Irwin Robinson, Vice President, Travel Division
George Morrissey, Vice President
Sydney H. Rogers, Vice President

Ziff-Davis also publishes Airline Management and Marketing Including American Aviation, Boating, Business & Commercial Aviation, Car and Driver, Cycle, Electronics World, Flying, Modern Bride, Popular Photography, skiing, Skiing Area News, Skiing Trade News, Stereo Review, and Travel Weekly.

Forms 3570 and all subscriptions correspondence should be addressed to POPULAR ELECTRONICS, Circulation Department, P.O. Box 1096, Flushing, N.Y. 11352. Please allow at least eight weeks for change of address. Include your old address, as well as new—enclosing if possible an address label from a recent issue.

EDITORIAL CONTRIBUTIONS must be accompanied by return postage and will be handled with reasonable care; however, publisher assumes no responsibility for return or safety of art work, photographs or manuscripts.



Member Audit Bureau
of Circulations

POPULAR ELECTRONICS



Eleventh in a Monthly Series by Oliver P. Ferrell, Editor

GLOBAL BROADCASTING

In the latter part of April, I attended the Ohio State University Symposium on Global Broadcasting: Dimensions, Problems and Promises. This Symposium was part of the OSU Centennial Program and was conducted in cooperation with the Association for Professional Broadcasting Education, the Corporation for Public Broadcasting, and the National Association of Educational Broadcasters. It was a three day program and featured speakers from numerous foreign countries.

Global broadcasting—voice or television broadcasting beyond one's own borders—has had tremendous impact on the emerging nations in Africa and Asia. Much of the impact has not been evaluated and the results from increased programming have often not been what broadcasters or educators might have expected. It was obvious from the Symposium that there remains great potential in broadcasting—particularly of the educational variety—but the technology has far outstripped our ability to make use of the facilities currently available.

There was a certain mystique at this Symposium attached to educational broadcasting from satellites. Particular regard was paid to the Indian Satellite Experiment and to the recently signed agreement between NASA and the Canadian Department of Communications for experimental educational transmissions to outlying northern areas. Oddly enough, not too much attention was paid to international shortwave broadcasting. Some of this attitude was strictly American and concurred with views recently expressed in this column about shortwave listening.

I feel that the day is not too distant when international attention will be focused on shortwave broadcasting should either the Soviet Union or the People's Republic of China decide to orbit a relay satellite transmitting in the international 16-meter broadcast band. With the declining sunspot count making skywave transmission in this band more difficult, the appeal of an orbiting 50-to-100-watt, 16-meter transmitter becomes that much greater.

FOR EVERYONE WHO NEEDS WEATHER INFO

Allied Radio Shack

Invents the
World's
1st and Only

Instant Weather Radio

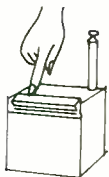

Touch—
It's ON

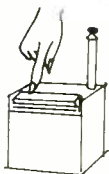

Touch—
It's OFF

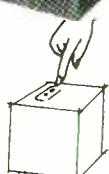

Pre-Set
Controls

Unique 3" Square
"Talking Barometer"

14.95
Post
Paid

From your desk or deck — monitor the new U.S. Government 24-hour VHF weathercasts, in 29 cities* on 162.55 MHz with a palm-size cube radio that's battery-powered and PRE-SET for instant automatic listening. Invented by 50-year-old Allied Radio Shack for its brilliant "Realistic" line. Volume, fine-tuning controls hidden under the set. Just touch the Play Bar to turn on and off. Simulated rosewood-grain. Solid state. An unusual, inexpensive gift.



AT OVER 950 STORES COAST TO COAST



**Free Parts &
Accessory Catalog**

Electronics for Everyone

2725 West 7th Street Fort Worth, Texas 76107

- Weather radios @ 14.95 Postpaid
- Free Allied Radio Shack '71 Catalog

Name (print) _____

Apt. No. _____ Route _____ Box _____

Street _____

City _____ State _____ Zip _____

*In These Cities: Atlantic City, Baton Rouge, Boston, Brownsville, Buffalo, Charleston, Akron, Chicago, Cleveland, Corpus Christi, Galveston, Honolulu, Jacksonville, Kansas City, Mo., Lake Charles, L. Angeles, Miami, N. London, N.Y., N. Orleans, Norfolk, Portland, Me., Portland, Or., Sandusky, S. Francisco, Seattle, St. Louis, Tampa, Wash., D.C.



INTERFACE

TOMPKINS "MOBILINK"

We appreciate the review of the Mobilink relay transmitter receiver that appeared on page 80 of your April issue. Please be advised that the antenna is now a wire whip that is flexible and that the "insecure" mounting has been redesigned and replaced. There is also a 9-volt jack input to the receiver provided for use of the equipment over longer periods of time.

HERBERT SALCH
Woodsboro, Texas

SELLING INVENTIONS

I think you could have given your reader more information than that contained in Opportunity Awareness, p 84, February, 1971 issue. I have experienced the same difficulty in selling an invention, but I feel you should have pointed out that a new service has been offered to inventors through the U.S. Department of Commerce, Patent Office, Washington, DC 20231. This service is described in a pamphlet titled, "Disclosure Document Program."

The service provides a means for an inventor to describe his invention in detail, have it witnessed, send it to the patent office and have the material held in confidence for a period of two years. The service costs \$10.

The inventor can then describe his invention to possible manufacturers without fear of loss of his patent rights, since he has conclusive proof of his patent office disclosure.

A. S. DUBUAR
Toms River, N.J.

EXTENDED TWILIGHT OF THE SWL

Somewhere in your March 1971 editorial, "Twilight of the Short-Wave Listener," it appears you have some negative feedback. Hallicrafters, for one, maintains more than a minor interest in this hobby. We currently offer no less than five SWL table-type radios ranging in price from \$60 to \$550. We think it is a viable market with good growth potential. We do agree that this industry needs direction and promotion and we're taking
(Continued on page 12)

POPULAR ELECTRONICS

a
 remarkable
 listening
 experience

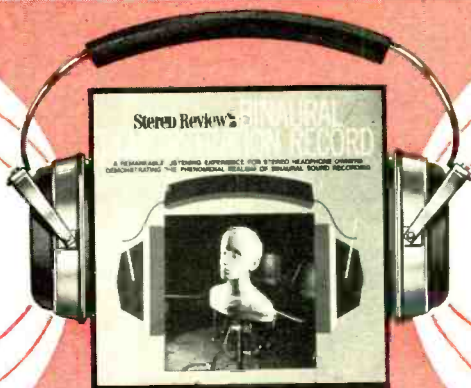

for
 stereo
 headphone
 owners!

*The phenomenal realism
 of binaural sound recording
 is demonstrated by Stereo Review's*

AMAZING NEW BINAURAL DEMONSTRATION RECORD

Created specifically for playback through stereo headphones, this unique record presents the listener with sound of unsurpassed realism. It recreates at each of the listener's ears the precise sound that each ear would have heard—independently—at the original scene.

Binaural recording re-creates the directions, distances, and even the elevations of sounds better than any other recording method. The super-realism of binaural recording is accomplished by recording the acoustical input for each ear separately, and then playing it back through stereo headphones. Thus the sound intended for the left ear cannot mix together with the sound for the right ear, and vice versa. This technique eliminates all acoustical problems in playback, such as the effects of "dead" rooms, over-reverberant rooms, variations in stereo perspective caused by changes in sitting position, and variations in frequency response due to changes in speaker positioning.

Binaural recording offers the listener the identical acoustical perspective and instrument spread of the original. The sound reaching *each ear* is exactly the same as would have been heard at the live scene. The Stereo Review Binaural Demonstration Record is the only record of its kind; there is nothing else like it. It provides a unique listening experience that you will want to share with your friends.



"MAX"—GENIE OF BINAURAL RECORDING. More than a year of intense effort was devoted to the preparation of this recording. "Max," a specially constructed dummy head, was modeled by a professional sculptor, then cast in silicone rubber. Super-precision capacitor microphones were installed in Max's ears so that each microphone would pick up exactly what each human ear would hear. The two separate sound channels were then fed into an ultra-low-noise electronics system and then recorded on an advanced-design tape recorder operating at 30 inches per second.

In making location recordings for the demonstration side of the record, a recording technician taped miniature capacitor microphones into his ears, so his head would serve its normal acoustical role as an absorber and reflector of sound. The result is a demonstration of phenomenal recorded sound.

STARTLING REALITY. The Binaural Demonstration Record offers 45 minutes of sound and music of startling reality. Side 1 introduces you to binaural recording via a narrated demonstration in nine sequences, taking you through a variety of situations that show off the remarkable depth and natural perspective of binaural recording.

You'll marvel at the eerie accuracy with which direction and elevation are re-created as you embark on a street tour in binaural sound—Sounds Of The City...Trains, Planes & Ships... a Basketball Game, a Street Parade, a Steel Fabrication Plant, The Bird House at the Zoo—all demonstrating the incredible realism of binaural sound reproduction.

MUSIC IN BINAURAL. With "Max" acting as your extension ears, the musical performances presented on the Binaural Demonstration Record transport you to the concert hall for a demonstration of a wide variety of music. Selections total 23 minutes, and include examples of jazz, rock, organ, and chamber music.

A highlight of the record is the first recording of *Space Virgin*, a new jazz work by noted composer Ronnie Roullier. Insiders have already called it one of the most exciting jazz recordings ever made. The organ recordings, with Frederick Swann at the keyboard of the majestic Riverside Church organ, have been hailed for reproducing the whole range of organ sonorities totally without distortion, and are among the most memorable listening experiences of a lifetime.

The Stereo Review Binaural Demonstration Record is the ultimate in sound reproduction. It has been made without compromise for the owner of stereo headphones. If you own stereo headphones, this record is a *must*.

Note: Although headphones are necessary to appreciate the near-total realism of binaural recording, the record can also be played and enjoyed on conventional stereo systems.

Order your Stereo Review Binaural Demonstration Record today. **ONLY \$5.98.**

RECORDS, Ziff-Davis Service Division, 595 Broadway, N.Y., N.Y. 10012

Please send _____ Binaural Demonstration Records at \$5.98 each, postpaid. My check (or money order) for \$_____ is enclosed. (Outside U.S.A. please send \$8.00 per record ordered.) N.Y. State residents please add local sales tax. **PE-7-71**

Print Name _____

Address _____

City _____

State _____ Zip _____

PAYMENT MUST BE ENCLOSED WITH ORDER

Free... ANY 3 STEREO LP's or WITH ABSOLUTELY NO OBLIGATION



67519 STEPPENWOLF
GOLD
Dunhi LP, 8TR, CASS



68023 WOODSTOCK
TWO (2 record set)
Cotil LP



66738 NEIL DIAMOND
Tap Root Manuscript
Uni LP, 8TR, CASS



65793 BREWER &
SHIPLEY Tarkio
KamSu LP, 8TR, CASS



30618 DIANA ROSS
Motow LP, 8TR, CASS



41152 WHO Tommy
(2 record set)
Decca LP



38376 CANNED HEAT
'N JOHN LEE HOOKER
(2 record set) Liber LP



33065 JOAN BAEZ
David's Album
Vangu LP, 8TR, CASS



39089 5TH DIMENSION
Greatest Hits
SouGi LP, 8TR, CASS

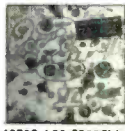

42780 LEO ZEPPELIN
III
Atlan LP, 8TR, CASS



42988 ROGER WILLIAMS
Love Story
Kapp LP, 8TR, CASS



66764 ELTON JOHN
Tumbleweed Connection
Uni LP, 8TR, CASS



44411 '55T OF
GOR FOOT
UniAr LP, 8TR, CASS



42911 MAN OF LA
MANCHA Original Cast
Kapp LP, 8TR, CASS



65784 MELANIE
Leftover Wine
Budda LP, 8TR, CASS



44753 TRAFFIC
John Barleycorn
Must Die
UniAr LP, 8TR, CASS

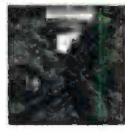

65796 CAL TJADER
Tjader-Ade
Budda LP, 8TR, CASS



33182 SUSAN SINGS
SESAME STREET
Scept LP, 8TR, CASS



43871 STATER BROS.
Bed of Roses
Mercu LP, 8TR, CASS



21537 TCHAIKOVSKY
1812 Overture
Yorks LP, 8TR, CASS



37838 FLIP WILSON
Flipped Out
Sunse LP, 8TR



28082 GREGORIAN
CHANT TREASURY
Yorks LP, 8TR, CASS



33183 B.J. THOMAS
Most of All
Scept LP, 8TR, CASS



33134 B.J. THOMAS
Greatest Hits Vol. 1
Scept LP, 8TR, CASS



75002 JACKSON 5
Maybe Tomorrow
Motow LP, 8TR, CASS



66709 DRSON WELLES
Begatling of The
President Media LP



66735 VERY BEST OF
THE LOVIN' SPONDFUL
KamSu LP, 8TR, CASS



66826 BOBBY SHERMAN
Portrait of Bobby
Metro LP, 8TR, CASS



21597 RIMSKY-KORS-
AKOV Scheherazade
Yorks LP



42784 STEPHEN
STILLS
Atlan LP, 8TR, CASS



21633 RED ARMY
ENSEMBLE
Yorks LP



37833 ROD MCKUEN
In The Beginning
Sunse LP, 8TR



21551 BEETHOVEN
Piano Sonatas
Yorks LP



48800 B.B. KING
Live, Cook County Jail
ABC LP, 8TR, CASS



33099 PDG BACH
Stoned Guest
Vangu LP



41213 JESUS CHRIST
Superstar
(2 record set)
Decca LP



38373 IKE & TINA
TURNER Workin'
Together
Liber LP, 8TR, CASS



50506 BUFFY
SAINT-MARIE
Wanna Be A Ballerina
Vangu LP, 8TR, CASS



33185 JOSEPH & THE
AMAZING TECHNICOLOR
OREAMCOAT
Scept LP, 8TR, CASS



33179 DIONNE WAR-
WICK I'll Never Fall
In Love Again
Scept LP, 8TR, CASS



68030 CROSBY, STILLS,
NASH & YOUNG
Four Way Street
(2 record set) Atlan LP



67517 THREE DOG
NIGHT Golden
Biscuits
Dunhi LP, 8TR, CASS



44726 FERRANTE &
TEICHER 10th
Anniversary Album
(2 record set) UniAr LP



44746 DUKE ELLING-
TON 70th Birthday Con-
cert (2 record set)
Solst LP

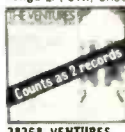

38368 VENTURES
10th Anniversary
Album (2 record set)
Liber LP



41217 BERT KAEMP-
FERT Orange Colored
Sky
Decca LP, 8TR, CASS



33092 BEST OF BUFFY
SAINT-MARIE
(2 record set)
Vangu LP



33184 DIONNE
WARWICK Very
Dionne
Scept LP, 8TR, CASS



33093 JAN & SYLVIA
Greatest Hits
(2 record set)
Vangu LP

RECORD CLUB OF AMERICA—The World's Largest Record and Tape Club

ANY 1 TAPE Cartridge or Cassette SHOWN HERE Worth up to \$20.94 TO BUY ANYTHING EVER!

Yes, take your pick of these great hits right now. Choose any 3 Stereo LPs (worth up to \$20.94) or any 1 Stereo Tape (cartridge or cassette, worth up to \$6.98) FREE... as your welcome gift from Record Club of America when you join at the low lifetime membership fee of \$5.00. We make this amazing offer to introduce you to the only record and tape club offering guaranteed discounts of 33 1/3% to 79% on all labels—with no obligation or commitment to buy anything ever. As a member of this one-of-a-kind club you will be able to order any record or tape commercially available, on every label—including all musical preferences: jazz, rock, classical, country & western, opera, popular, soul, foreign, etc. No automatic shipments, no cards to return. We ship only what you order. Money back guarantee if not satisfied.

See for yourself why over 1 1/2 million record and tape collectors paid \$5 to join Record Club of America when other record or tape clubs would have accepted them free.

Compare and see!	Classical Record Club	Columbia Cartridge Service	Capitol Record Club	Columbia Record Club	RCA Stereo & Tape Club	RECORD CLUB OF AMERICA
CAN YOU CHOOSE FROM ALL LABELS? LPs OR TAPES INCLUDING CARTRIDGE AND CASSETTE TAPES?	NO	NO	NO	NO	NO	YES!
MUST YOU BUY A MINIMUM NUMBER OF RECORDS OR TAPES? HOW MANY?	12	12	12	10	6	NONE!
HOW MUCH MUST YOU PAY TO FULFILL YOUR OBLIGATION?	\$59.76 to \$71.75	\$83.76 to \$95.40	\$59.76 to \$71.75	\$49.80 to \$59.80	\$41.70 to \$47.70	ZERO DOLLARS
CAN YOU BUY ANY RECORD OR TAPE YOU WANT AT A DISCOUNT?	NO	NO	NO	NO	NO	ALWAYS!
DO YOU EVER RECEIVE UNWANTED RECORDS OR TAPES?	YES	YES	YES	YES	YES	NEVER!
HOW LONG MUST YOU WAIT FOR SELECTIONS TO ARRIVE?	5 to 6 weeks	5 to 6 weeks	5 to 6 weeks	5 to 6 weeks	5 to 6 weeks	NO LONG WAITS!

Choose any LP or tape on any label! No exceptions! Over 200 different manufacturers including Capitol, Columbia, RCA, etc.
No obligations. No yearly quota! Time as long as you like. No minimum. As few or as many as you like. No "add-on" charges.
You don't have to spend a penny. Because you're not legally obligated to buy even a single record or tape!
Your discount up to 79%! Guaranteed never less than 1/3 off! No exceptions!
There are no cards which you must return! Only the records and tapes you want are sent and one when you ask us to send them.
Your order processed same day received. No shipping on credit.

TYPICAL "EXTRA DISCOUNT" SALE

\$4.98 LPs average as low as \$1.96
 \$5.98 LPs average as low as \$2.25
 \$6.98 LPs average as low as \$2.56

Savings of 63% or more from recent club sales up to \$4.42 per LP. Start these giant savings now... not after you fulfill your obligation like the other clubs.

Average Club Price	List Price
Andy Williams—Love Story	Colum 5.98
Anne Murray	Capit 5.98
Ed Ames—This Is 2001—A Space Odyssey	RCA 6.98
Mary Travers—Mary	MGM 6.98
Credence Clearwater	Warner 4.98
Revival—Pendulum	Fanta 4.98
Miles Davis—Bitches Brew	Colum 5.98
Love Story—Soundtrack	Para 5.98
Perry Como—It's Impossible	RCA 5.98
Blackrock—3	Capit 5.98

NOW YOU CAN CHARGE IT, TOO!

RECORD CLUB OF AMERICA
 CLUB HEADQUARTERS
 YORK, PENNSYLVANIA 17405 V050

Yes—Rush me a lifetime Membership Card, Free Giant Master LP & Tape Catalog, and Disc & Tape Guide at this Special Membership Offer. Also send me the 3 FREE LPs or 1 FREE tape which I have indicated below (with a bill for a small mailing and handling fee. I enclose my \$5.00 lifetime membership fee. This entitles me to buy any LPs or tapes at discounts up to 79%, plus a small mailing and handling charge. I am not obligated to buy any records or tapes—no yearly quota. If not completely delighted I may return items above within 10 days for immediate refund of membership fee.

3 FREE LPs
 or 1 FREE TAPE

8 track
 cassette
 or Deferr Selection—send expanded list.

Mr. _____
 Mrs. _____
 Miss _____
 Address _____
 City _____ State _____ Zip _____

All Servicemen write Soc. Sec. # _____

CHARGE IT to my credit card. I am charging my \$5.00 membership (mailing and handling fee for each FREE LP and tape selected will be added).

Check one: Diners Club Master Charge
 American Express BankAmericard

Acct. # _____ Expiration Date _____
 Signature _____

Canadians: mail coupon to above address. Orders to be serviced from Canada.

AT LAST A RECORD AND TAPE CLUB WITH NO "OBLIGATIONS"—ONLY BENEFITS!

Ordinary record and tape clubs make you choose from a few labels—usually their own! They make you buy up to 12 records or tapes a year—usually at list price—to fulfill your obligation. And if you forget to return their monthly card—they send you an item you don't want and a bill for \$4.98, \$5.98, \$6.98, or \$7.98! In effect, you may be charged almost double for your records and tapes.

BUT RECORD CLUB OF AMERICA ENDS ALL THAT!
 We're the largest all-label record and tape club in the world. Choose any LP or tape (cartridges and cassettes), including new releases. No exceptions! Take as many, or as few, or no selections at all if you so decide. Discounts are GUARANTEED AS HIGH AS 79% OFF! You always save at least 33 1/3%. You get best sellers for as low as 99¢.

NO AUTOMATIC SHIPMENTS
 With our Club there are no cards which you must return to prevent shipment of unwanted LPs or tapes (which you would have to return at your own expense if you have failed to send written notice not to ship). We send only what you order.

HOW CAN WE BREAK ALL RECORD AND TAPE CLUB RULES?
 We are the only major record and tape club NOT OWNED, NOT CONTROLLED, NOT SUBSIDIZED by any record or tape manufacturer anywhere. Therefore, we are not obliged by company policy to push any one label. Nor are we prevented by distribution commitments from offering the very newest LPs and tapes.

SPECIAL INTRODUCTORY MEMBERSHIP OFFER
 Join RECORD CLUB OF AMERICA now and take advantage of this special Introductory Membership Offer. Choose any 3 LPs or any 1 tape shown here (worth up to \$20.94) and mail coupon with check or money order for \$5.00 membership fee (a small handling and mailing fee for your free

(LPs or tapes will be sent later). If you can't find 3 LPs or 1 tape here, you can defer your selection and choose from expanded list later. This entitles you to LIFETIME MEMBERSHIP—and you never pay another club fee. Your savings have already more than made up for the nominal membership fee.

NOW YOU CAN CHARGE IT
 If you prefer, you may charge your membership to one of your credit cards. We honor four different plans. Check your preference and fill-in your account number on the coupon.

- LOOK WHAT YOU GET**
- FREE Lifetime Membership Card—guarantees you brand new LPs and tapes at discounts up to 79%... Never less than 1/3 off.
 - FREE Giant Master LP and Tape Catalog—lists all readily available LPs and tapes (cartridges and cassettes) of all labels (including foreign)... all musical categories.
 - FREE Disc and Tape Guide—The Club's own Magazine, and special Club sale announcements which regularly bring you news of just-issued new releases and "extra discount" specials.
 - FREE Any 3 Stereo LPs or any 1 Tape shown here (worth up to \$20.94) with absolutely no obligation to buy anything ever!

GUARANTEED INSTANT SERVICE
 All LPs and tapes ordered by members are shipped same day received (orders from the Master Catalog may take a few days longer). ALL RECORDS AND TAPES GUARANTEED—factory new and completely satisfactory or replacements will be made without question.

MONEY BACK GUARANTEE
 If you aren't absolutely delighted with our discounts up to 79%... return items within 10 days and membership fee will be returned AT ONCE! Join over one and one-half million budget-wise record and tape collectors now.

RECORD CLUB OF AMERICA—The World's Lowest Priced Record and Tape Club

CIRCLE NO. 17 ON READER SERVICE PAGE

ANOTHER SUPERB VALUE

from **Olson**

Electronics

ONLY

\$12

**DELUXE
TRANSISTOR
CHECKER**



Compact, self-contained, self-powered dynamic transistor checker. Test may be made "in circuit" or out of circuit. Identifies and checks PNP and NPN types, plus power. Complete with instruction manual, service tips and transistor drawings.

Olson Electronics, Dept. 1S, 260 S. Forge St., Akron, Ohio 44308

- I enclose \$12, send me the TE-199 Transistor Checker.
- Send me the next seven issues of the Olson Catalog, without cost or obligation.

Name _____
 Address _____
 City _____
 State _____ Zip _____

CIRCLE NO. 14 ON READER SERVICE PAGE

WANTED

THE RARE OR UNUSUAL TOOL YOU HAVE BEEN SEARCHING FOR.

**SPECIALISTS
IN TOOLS FOR
INTEGRATED
CIRCUITRY**

**24 HOUR
DELIVERY ON
MOST ITEMS**

**MORE THAN
5000 ITEMS**

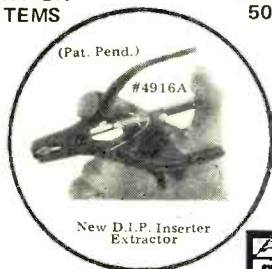

New D.I.P. Inserter Extractor



FREE 1971
(160 Page)
CATALOG AND SUPPLEMENT

TECHNI-TOOL, INC.

1218 ARCH ST., PHILA., PENNA.

ZIP CODE: 19107-(215) LO 8-4457

CIRCLE NO. 19 ON READER SERVICE PAGE

INTERFACE (Continued from page 8)

positive steps to strengthen the Hallicrafters line and develop this market—not commiserating over what has not been done.

J. C. MATHEWS, JR.
Hallicrafters Co.

TAPE HEAD CLEANERS

I hope your readers are not misled by the Ampex Tape Head Cleaner (Ampex Part No. 087-007 with a red label). This is to be used only on Ampex tape heads. It is specifically not recommended for general use. It contains Xylene which will dissolve some of the plastics used in making many tape heads. The Ampex General Purpose Head Cleaner (Ampex Part No. 050-104 with a brown label) contains a type of Freon that is suggested for general use.

R. W. JAVINS
Washington, D.C.

PROBLEMS WITH DISTRIBUTORS

After rereading your December, 1970 Direct & Current editorial (It Takes All Kinds!) about electronic suppliers, I thought I would tell you of a few of my pet peeves.

There is one concern that regularly issues "credit certificates" for items that are not shipped and are supposedly out of stock. Nevertheless, this poor stocking situation doesn't stop the same concern from regularly advertising products they never have. This same outfit will also send prepaid orders C.O.D.—which you must admit is pretty cute.

A midwest mail order supplier has a peculiar trick all its own. After ordering an antenna from them, I received a Railway Express shipping notice. Then, 30 days later, I received a bill and subsequently phone calls, letters and threats about nonpayment. Oddly enough, I never received the merchandise, although this supplier claimed that they had proof of delivery!

Another supplier that is guaranteed to wear out anyone's patience claims that they will replace defective components—they sell distress or surplus components. However, if you mark the components you return for replacement, you can be 100% sure of getting them back!

My last beef is about a company in Texas that is so tardy in shipping orders that it is unbelievable. If you get merchandise in two months, you are lucky; and you had better retain a copy of your original order since mail orders are seldom complete.

S. L. BURNEY, IV
Columbia, S.C. 29209

Leslie® Speakers Add A New Dimension of Sound To Organs and Amplified Musical Instruments



The **Leslie** brand name means products engineered to the highest standards of musical excellence... products which animate the music and add a new dimension of sound. Leslie speaker cabinets, for example, combine advanced electronic/electro-mechanical techniques and spinning rotors into a unique speaker system. The result: a majestic stereophonic sound that enhances any amplified musical instrument.

All Leslie brand products... speaker systems, space generators, amplifiers, relays and other accessories... share one common goal: to create a truly memorable musical experience for everyone who appreciates fine quality sound reproduction.

Leslie
SPEAKERS

Electro Music/CBS Musical Instruments,
A Division of Columbia Broadcasting System, Inc., Bin 30, Arroyo Annex, Pasadena,
California 91109, Leslie is a Registered trademark of CBS, Inc.

CIRCLE NO. 21 ON READER SERVICE PAGE

ALLIED RADIO SHACK ISSUES A NEW AND DIFFERENT CATALOG!

ELECTRONICS
FROM A-Z
ANTENNAS
BATTERIES
CAPACITORS
DIODES
EDUCATIONAL KITS
FIBER OPTICS
GRILLE CLOTH
HI-FI SPEAKERS
IC'S · JACKS
KNOBS · L-PADS
MIKES · NEEDLES
OSCILLOSCOPE · P-BOXES
QUADRACS · RESISTORS
SEMICONDUCTORS
TELEPHONES
ULTRASONIC ALARMS
VHF ANTENNAS · WIRE
XENON STROBE LIGHT
"Y" ADAPTERS
ZENER DIODES
AND MUCH MORE!



a valuable "FIRST EDITION"
...and it's **FREE!**

The new buying Guide for kit builders, Hams, hobbyists, do-it-yourselfers, "fix-it men"! Lists thousands of handy and wanted "little things" most stores don't stock. Like tubes and transistors, cables and plugs, adapters and antennas—you name it—the things that keep equipment working. Or make it work even better. Or DO MORE. If you own anything electronic or electrical, you need this catalog!

At 950 Stores Nationwide

Dept. PE-2

2725 W. 7th St., Fort Worth, Texas 76107

Send me your FREE Spring/Summer Cat. 212

Name (print) _____

Route No. _____ Box No. _____

Street _____ Apt. No. _____

City _____ State _____ Zip _____



To obtain a copy of any of the catalogs or leaflets described below, fill in and mail the Reader Service blank on page 15 or 95.

A 20-page multicolor catalog detailing more than 50 test instruments and accessories is now available from *Leader Instrument Corp.* Featured are five digital color bar/pattern generators; solid-state oscilloscopes/vector scopes; sweep marker, sine-wave, and r-f wideband signal generators; voltmeters; FET multimeters; a field-strength meter and CRT high-voltage probe and meter; transistor checker/tracer; etc. Technical specifications for each instrument and accessory listed are also provided.

Circle No. 75 on Reader Service Page 15 or 95

A 10-year index of articles and features that have appeared in *POPULAR ELECTRONICS* for the years 1961 to 1970 can be obtained for \$2.00 from *Periodical Indexes*, Box 178, San Luis Obispo, CA 93401. The Index is arranged in alphabetical order according to major interest areas (amplifiers, communications, lasers . . . , etc.). Each entry is key-coded to tell what type of article it is (tutorial, construction, etc.) the length of the article, and the issue and page on which the article appeared.

In 32 pages of the 1971 catalog just released by *EICO Electronic Instrument Co.* are described 250 kit and wired products in nine different lines. The listing includes hi-fi kits, audio color organs, 2-hour project kits, test equipment, strobilites, etc. Each product is fully described through rundowns of technical specifications.

Circle No. 76 on Reader Service Page 15 or 95

A new general catalog (No. FR-71-72) just published by *GC Electronics* lists more than 14,000 products from all of the company's various divisions. The 312-page catalog contains listings for chemicals, tools, printed circuit materials, servicing aids, automotive hardware, replacement electronic parts, antennas, etc.

Circle No. 77 on Reader Service Page 15 or 95

Popular Electronics

READER SERVICE PAGE

free information service:

Here's an easy and convenient way for you to get additional information about products advertised or mentioned editorially (if it has a "Reader Service Number") in this issue. Just follow the directions below... and the material will be sent to you promptly and free of charge.

1. On coupon below, circle the number(s) that corresponds to the key number(s) at the bottom or next to the advertisement or editorial mention that is of interest to you. (Key numbers for advertised products also appear in the Advertisers' Index.) Print or type your name and address on the lines indicated.

2. Cut out the coupon and mail it to: POPULAR ELECTRONICS, P.O. Box 8391, Philadelphia, PA 19101.

note: If you want to write to the editors of POPULAR ELECTRONICS about an article on any subject that does not have a key number, write to POPULAR ELECTRONICS, One Park Avenue, New York, N.Y. 10016. Inquiries concerning circulation and subscriptions should be sent to POPULAR ELECTRONICS, P.O. Box 1096, Flushing, N.Y. 11352.

7/71-1

Void after August 31, 1971

Popular Electronics

P.O. BOX 8391
PHILADELPHIA, PA. 19101

1 2 3 4 5 6 7 8 9 10 11 12 13 14 15 16 17 18 19 20
21 22 23 24 25 26 27 28 29 30 31 32 33 34 35 36 37 38 39 40
41 42 43 44 45 46 47 48 49 50 51 52 53 54 55 56 57 58 59 60
61 62 63 64 65 66 67 68 69 70 71 72 73 74 75 76 77 78 79 80
81 82 83 84 85 86 87 88 89 90 91 92 93 94 95 96 97 98 99 100

NAME (Print clearly) _____

ADDRESS _____

CITY _____ STATE _____ ZIP CODE _____

FIGHT INFLATION!

Still the greatest value in CB base antenna history...

The Magnum

MODEL M-117 \$32.95

Suggested resale price

- The original omnigain antenna—3.75 solid dB gain!
- "Hi-Q" phasing transformer, weatherproof construction!
- ¼ wave length radials!
- More CBers own Magnums than any other base station antenna!



Be an "antenna specialist!" These great, top-quality jackets available only from your A/S dealer — just \$8.95.

the antenna specialists co.



"Stripes of Quality"

Div. of **allen** Electric & Equipment Co.
12435 Euclid Avenue • Cleveland, Ohio 44106
EXPORT: 220 Shames Drive Westbury, L.I., New York 11690
CANADA: A. C. Simmonds & Sons, Ltd.
CIRCLE NO. 2 ON READER SERVICE PAGE



ESTIMATION THEORY WITH APPLICATIONS TO COMMUNICATIONS AND CONTROL

by Sage & Melsa

The authors have succeeded in writing a comprehensive textbook that covers estimation theory, including decision theory, in its entirety. The scope is broad, beginning with basic non-time-dependent linear problems and progressing to time-dependent linear problems. In addition, material is devoted to stochastic processes, Gauss Markov processes and stochastic differential equations, and the optimum linear filter.

Published by McGraw-Hill Book Co., 330 West 42 St., New York, NY 10036. Hard cover. 529 pages. \$16.50.

HANDBOOK OF ELECTRONIC TEST EQUIPMENT

by John D. Lenk

Represented in this book is a one-volume source of the basic principles and operating procedures for all types of test equipment. The book describes to the technician what types of test instruments are available, what they do, how they operate, their basic operating principles, and general calibration procedures. An entire section is devoted to basic logic circuits, explaining how digital circuits are used in test equipment.

Published by Prentice-Hall, Inc., Englewood Cliffs, NJ 07632. Hard cover. 460 pages. \$15.00.

ELECTRONIC EXPERIMENTERS CIRCUIT MANUAL

This new book details 44 different practical projects for the beginner and intermediate electronics hobbyist/experimenter. The projects described cover a wide range of interests, and each is accompanied by a circuit diagram, complete parts list, component layout diagram, and a photo of the finished project. Also included are notes on advanced theory, care and handling of components, safety precautions, r-f interference data, troubleshooting tips, component specifications, and

(Continued on page 99)



NEW PRODUCTS

Additional information on products described in this section is available from the manufacturers. Each new product is identified by a corresponding number on the Reader Service Page. To obtain additional information on any of them, circle the number on the Reader Service Page, fill in your name and address, and mail it in accordance with the instructions.

AKAI TAPE DECK WITH NEW HEAD—Two new models (GX-280D and GX-220D) of stereo tape decks introduced by *Akai Electric Co., Ltd.* incorporate what the company claims to be a significant advance in head design. The core of the GX head is made of single crystal ferrite, and the inner circumference of the head shield is mounted and set in glass. As a result the head is free of magnetic dust, and wear and abrasion are almost completely eliminated. All of which leads the manufacturer to guarantee a head life of 150,000 hours. The head has a "focused" magnetic bias field which they claim improves the frequency response (± 3 dB from 30 to 24,000 Hz at $7\frac{1}{2}$ ips). The 280D contains other refinements such as a servo controlled capstan drive, which make it the more "deluxe."



Circle No. 81 on Reader Service Page 15 or 95

CROWN STEREO AMPLIFIER—Delivering 40 watts per channel RMS output into 40 ohms at 0.05% THD, the *Crown International* Model D-40 is said to be ideal for driving electrostatic headphones. Frequency response is ± 1 dB from 20 to 20,000 Hz at any level up to 30 watts into 8 ohms. The all-silicon components include 18 transistors, 14 diodes and 4 zener diodes. Front panel volume controls for each channel are included and the price is \$229.



Circle No. 82 on Reader Service Page 15 or 95

A/S ANTENNAS AND ACCESSORIES—For the serious monitor on the high-band and VHF ranges. *The Antenna Specialists Co.* has some interesting new antennas and a very helpful accessory device, known as the "Signal Splitter" (Model MON-22). The latter permits simultaneous monitoring of low- and high-band receivers from a single combination-frequency antenna. It is \$13.95. The Model MON-20 antenna, for base station applications, is stainless steel with 6" radials (\$32.95). Then there are two 3-dB gain models in the 118-174-MHz range: mobile Model MON-16 with Quick Grip mounting and stainless steel shock spring, and Model MON-17, base station unit (\$21.95 and \$29.95, respectively).

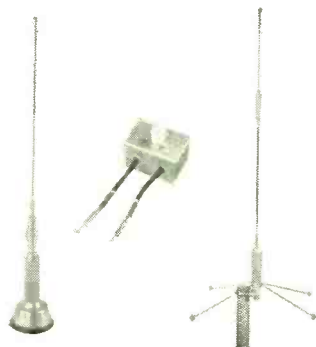

Circle No. 83 on Reader Service Page 15 or 95

HEATHKIT SPEAKER SYSTEM USES AR-3a—The new *Heath Co.* AS-103 speaker system uses three Acoustic Research AR-3a drivers in a sealed acoustic suspension
(Continued on page 22)

NEW!

Announcing the CIE "LEARNING LABORATORY"

Light-years ahead of any
other way to learn electronics.

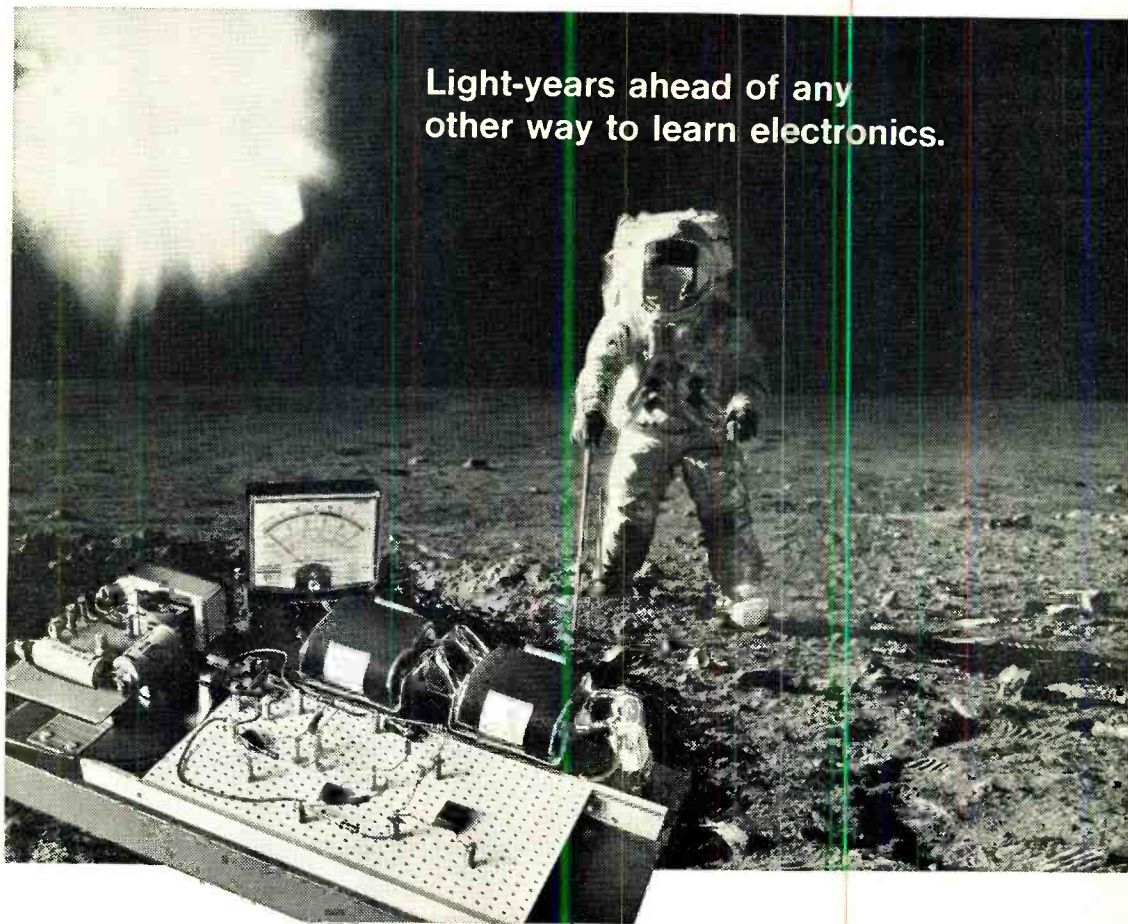

Electronic "kits" are out!

Now you can have your own electronics laboratory.

You'll perform hundreds of exciting experiments like these with authentic electronic components used by industry.

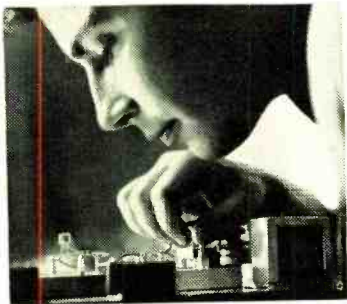

Working with basic single transistor circuit—Student learns best installation and troubleshooting techniques. He has constructed a basic single transistor circuit, first step toward understanding more complex solid-state circuitry.

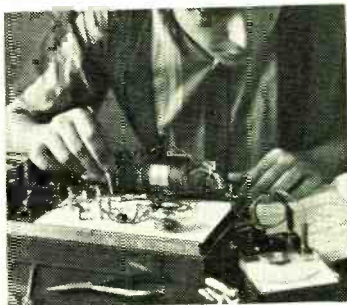

Observing transistor operating as shunt-fed amplifier—Student has installed an oscillator and shunt-fed amplifier. He takes various measurements and observes the transistor operating as an amplifier. This is a typical solid-state circuit.

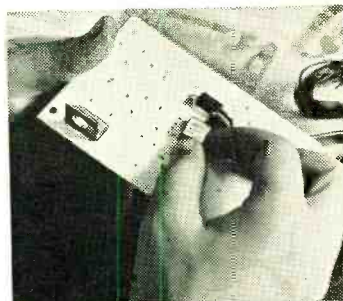

Assembling integrated circuit on a printed circuit board—Circuit is identical to one used in latest IBM System 360 computers. Student is constructing an oscillator combined with a Darlington pair output amplifier.

Prepare now for a high income career in the fast growing field of electronics.

Electronic miracles are changing today's world with breathtaking speed.

And with this electronics explosion has come a brand new need... a demand for thousands of electronic technicians, trained in theory and practice to build the products, operate them and service them.

Don't wait for something to "happen" in your present job. Start working right now to get ready for a career you'll really enjoy... at \$10,000... \$12,000 or more a year.

Experience with experiments is your best teacher

Step-by-step learning cannot compare with learning-by-doing. Now you can learn "why" as well as "how." You'll find out for yourself the right way as well as the wrong way to use electronic components, to construct your own circuits, to discover trouble spots and learn how to fix them.

This new CIE course, Electronics Technology with Laboratory, teaches you electronics by making it work before your eyes. And you do it yourself, with your own hands.

Importance of FCC License and our money-back warranty

An FCC License is a legal requirement for many important jobs. And it is not easy to get!

But more than 9 out of every 10 CIE graduates who take the Government licensing exam pass it!

We are so certain that our Laboratory Course will successfully prepare you for a First Class FCC License examination, with Radar Endorsement, that if you fail the exam we will refund all tuition payments.

You get your FCC License, or you get your money back!

You'll have high-paying job opportunities

Electronics is in its infancy. Everywhere you turn you find new products and equipment using space-age circuitry. Computers. Improved radar for air traffic control. Mobile microwave communications. These and many more examples of electronic technology have created thousands of new jobs—in companies like American Airlines, American Telephone and Telegraph, General

Electric, IBM, North American Rockwell, Raytheon and Westinghouse.

Once you're enrolled with CIE you will get a bi-monthly listing of many high-paying, interesting jobs open in designing, manufacturing, testing, operating and repairing.

More and more jobs will be created in the next few years. Start today to get ready for an exciting, new career in electronics... the industry of tomorrow.

Don't put it off. Send now for 2 FREE BOOKS

Mail the postpaid reply card for our School Catalog *plus* a special book on how to get your FCC License. If card is missing, use the coupon below, or write to: Cleveland Institute of Electronics, 1776 East 17th Street, Cleveland, Ohio 44114. But do it now!



Approved under new G.I. Bill

All CIE courses are approved under the new G.I. Bill. If you served on active duty since January 31, 1955, or are in service now, check box on card or coupon for G.I. Bill information.

CIE Cleveland Institute of Electronics
1776 East 17th Street, Cleveland, Ohio 44114

Please send me without cost or obligation:
1. Your 44-page book, "How to Succeed in Electronics."
2. Your book, "How to Get a Commercial FCC License."

I am especially interested in: Electronics Technology with Laboratory
 Electronics Technology Industrial Electronics
 Electronic Communications First Class FCC License
 Broadcast Engineering Electronics Engineering

Name _____ Age _____
(please print)

Address _____

City _____ State _____ Zip _____

Check here for G.I. Bill information. Accredited Member National Home Study Council
A Leader in Electronics Training... Since 1934 PE-18

CIRCLE NO. 6 ON READER SERVICE PAGE

NEW PRODUCTS (CONTINUED FROM PAGE 17)

enclosure to provide virtually flat response from 30 to 20,000 Hz. Midrange and tweeter level controls are provided on the rear of the cabinet, which measures 25" x 14" x 11 $\frac{3}{4}$ ".

Circle No. 84 on Reader Service Page 15 or 95



SHERWOOD STEREO CENTER—Economy of space is the byword in the new Model S-4100 from *Sherwood Electronic Labs., Inc.* It incorporates an AM/FM tuner, pre-amplifier, 100-watt power amplifier (25 watts per channel rms at 8 ohms), a 4-speed automatic turntable with cueing, anti-skate control, and a Shure stereo cartridge. There is also a dust cover. Only speakers need to be added.

Circle No. 85 on Reader Service Page 15 or 95

AKG DYNAMIC HEADPHONE—"Subjectively controllable sound" is the term given to the latest development in stereo headphones by AKG (distributed by *North American Phillips Corp.*). The acoustically effective auditory volume (air volume between headphone driver and ear entrance) may be infinitely varied by turning the adjustment knob. This moves the headphone driver back and forth within the cup and permits the selection and adaptation of the sound to individual physiological acoustic taste. Price is \$69.00.



Circle No. 86 on Reader Service Page 15 or 95



SHURE PREAMPLIFIER—The voltage gain, equalization, and impedances necessary for magnetic phono cartridges and tape playback heads are available in the Model M64 preamplifier made by *Shure Brothers Inc.* A slide switch selects RIAA equalization for phono cartridges, NAB for tape heads, or flat for microphone (or use as a buffer amplifier). Output can be high-level, high-impedance or low-level, low-impedance and there is a minimum of 50 dB isolation between channels. The M64 operates on 117-volt, 50/60-Hz power. Model M64-2E is identical but operates on 240 volts, 50/60 Hz.

Circle No. 87 on Reader Service Page 15 or 95

MARANTZ STEREO RECEIVER—With an eye on the moderate-price stereo component field, the *Marantz Co.* has introduced the Model 28 AM/FM receiver, priced at \$229. In addition to its exclusive Gyro-Touch Tuning, the receiver uses all silicon transistors (plus IC's and FET's), has high and low filters and loudness compensation for low-level listening. It delivers a continuous stereo rms output of 20 watts into 8 ohms with a frequency range from 40 to 15,000 Hz. Total harmonic distortion is less than 0.5%.



Circle No. 88 on Reader Service Page 15 or 95

LEADER COLOR TV ALIGNER—Service technicians will be able to use to advantage the new Model LSW-330 post-injection sweep marker/generator from Leader Instruments Corp. It provides all signals for circuit alignment of chroma, sound and video i-f stages and has a 10.7-MHz sweep for use with FM i-f. Constant amplitude is assured through an automatic limit control; crystal control helps deliver accurate frequency markings. Triangular waveform voltage facilitates sweep linearity; discriminator adjustment is made easy with 1-kHz modulation.

Circle No. 89 on Reader Service Page 15 or 95

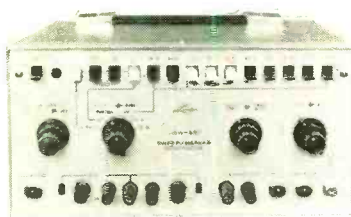

REGENCY AIRCRAFT RADIO SCANNER—For those who have to, or just want to, know what's going on up there in the skies, Regency Electronics, Inc. now has an automatic 8-channel scanning receiver. Up to 8 plug-in crystals for wanted frequencies can be installed in the solid-state circuitry. The radio automatically scans each of the frequencies for an active signal and stops when one is received. Pushbutton controls for each of the 8 channels enable the operator to activate or de-activate any channel from the scan process.

Circle No. 90 on Reader Service Page 15 or 95

FANON WIRELESS PA SYSTEM—Flexibility and mobility in a PA system for any purpose are available in the WA-100 system from Fanon Electronics. Operating on commercial line power or batteries, the audio output is 10 or 5 watts respectively. FM frequency is either 40.68 MHz or 47.27 MHz, depending on the locality (with wireless microphone selected for the particular frequency). The speaker/amplifier can also be programmed into any existing high-power PA system and still provide freedom of movement by eliminating mike cables.

Circle No. 91 on Reader Service Page 15 or 95

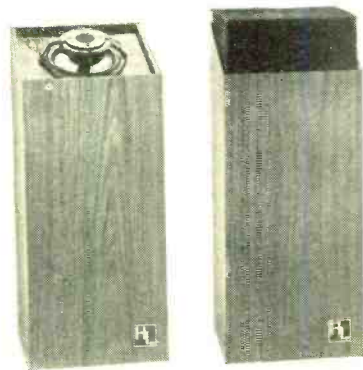

HEGEMAN OMNIDIRECTIONAL SPEAKER—Coaxially mounted, the "Hegeman I" two-way system (Hegeman Laboratories, Inc.) is housed in a floor-standing closed-box baffle. Omnidirectional dispersion is achieved by tilting the plane of the drivers so that sound bounced against the wall projects out into the room rather than back into the speaker. A full-range high-compliance 6½" driver uses a drawn aluminum cone and aluminum voice-coil form to obtain linear transient response. Front loading by a shaped tweeter housing creates a basic toroidal distribution pattern. The domed super-tweeter with a crossover at 5 kHz is loaded in the same manner. The system is \$180 per pair.

Circle No. 92 on Reader Service Page 15 or 95

The RCA portable color bar generator



Performs like the big ones Costs only \$75*

- Provides color bar, dot, cross hatch, and blank raster patterns
- All solid state circuitry including ICs
- Pattern signals, RF output frequency and color subcarrier all crystal-controlled
- Battery operated, AC adapter available
- Lightweight — less than 20 oz., only 6½" wide x 4" deep x 3" high

For all the technical specs get in touch with your RCA Distributor. RCA | Electronic Components | Harrison, N.J. 07029.

* Optional User Price

RCA

CIRCLE NO. 16 ON READER SERVICE PAGE

POPULAR ELECTRONICS

BY JOHN S. SIMONTON JR.



The Drummer Boy

**RHYTHM IS THE
NAME OF THE GAME—
WALTZ TO FUNK
BASS DRUM TO CONGA**

WHETHER you are an amateur organist, a guitar freak, or just get your kicks with a comb and a piece of paper, there have probably been times when you were really wailing and felt that the only thing separating you from the pro's was the extra "push" that a rhythm section provides.

So what held you back? Probably the \$150 or more that a commercially available electronic rhythm section costs. In that case, the "Drummer Boy" is for you. For about a third of the money, you can build a rhythm section that has the features of a commercial unit—and you'll get some valuable electronics training experience in the process.

JULY 1971

25

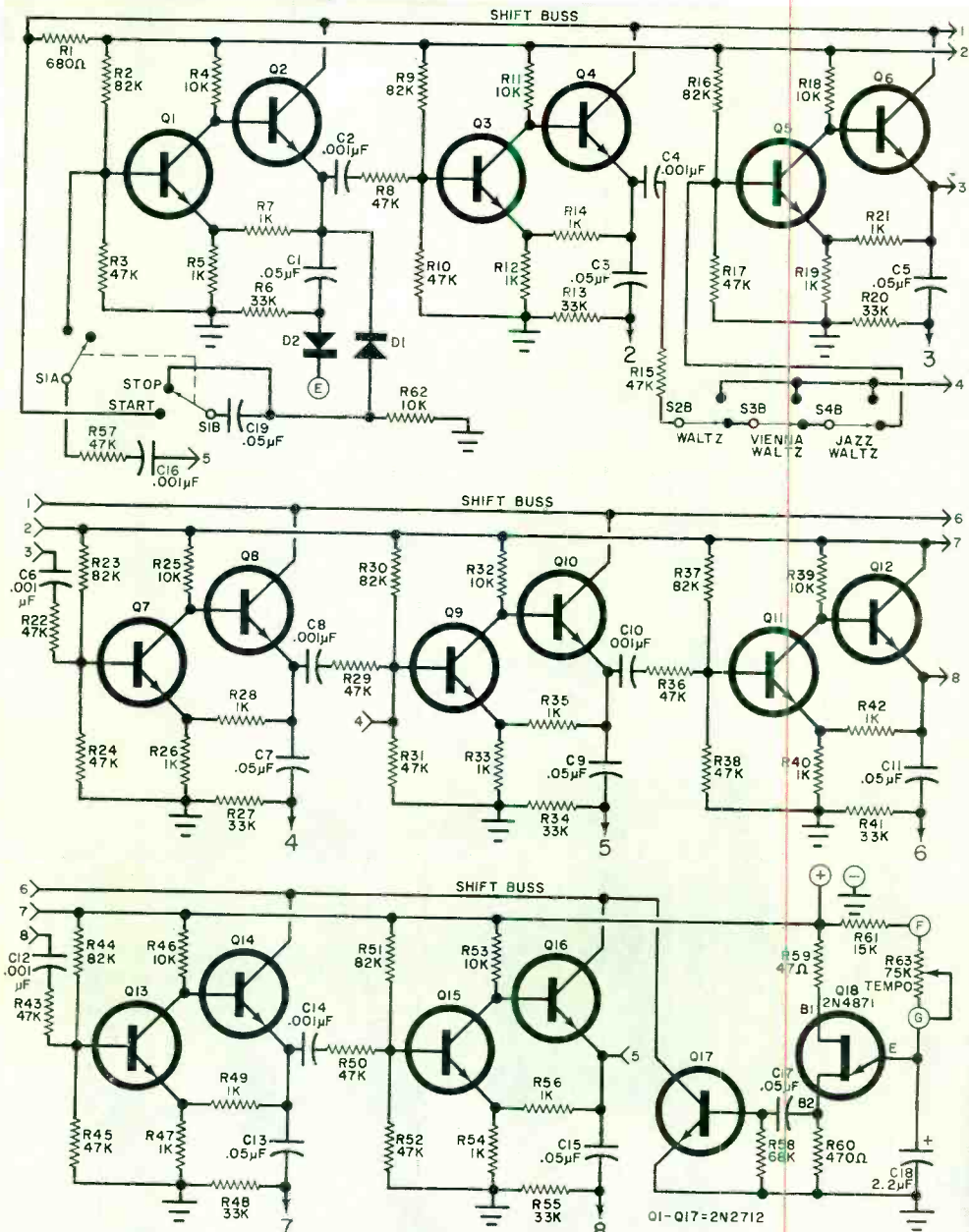

Fig. 1. Generated by Q18, the shift pulses are passed down the counter.

**PARTS LIST
RING COUNTER AND
SWITCHING CIRCUITS**

- C1, C3, C5, C7, C9, C11, C13, C15, C17, C19—
0.05-µF disc capacitor
- C2, C4, C6, C8, C10, C12, C14, C16—0.001-µF disc
capacitor
- C18—2.2-µF, 15-volt electrolytic capacitor
- D1-D41—1N918 diode (or similar)

- Q1-Q17—2N2712 transistor
- Q18—2N4871 transistor
- R1—680-ohm, ½-watt resistor
- R2, R9, R16, R23, R30, R37, R44, R51—32,000-
ohm ½-watt resistor
- R3, R8, R10, R15, R17, R22, R24, R29, R31, R36,
R38, R43, R45, R50, R52, R57—47,000-ohm,
½-watt resistor
- R4, R11, R18, R25, R32, R39, R46, R53, R62—
10,000-ohm, ½-watt resistor

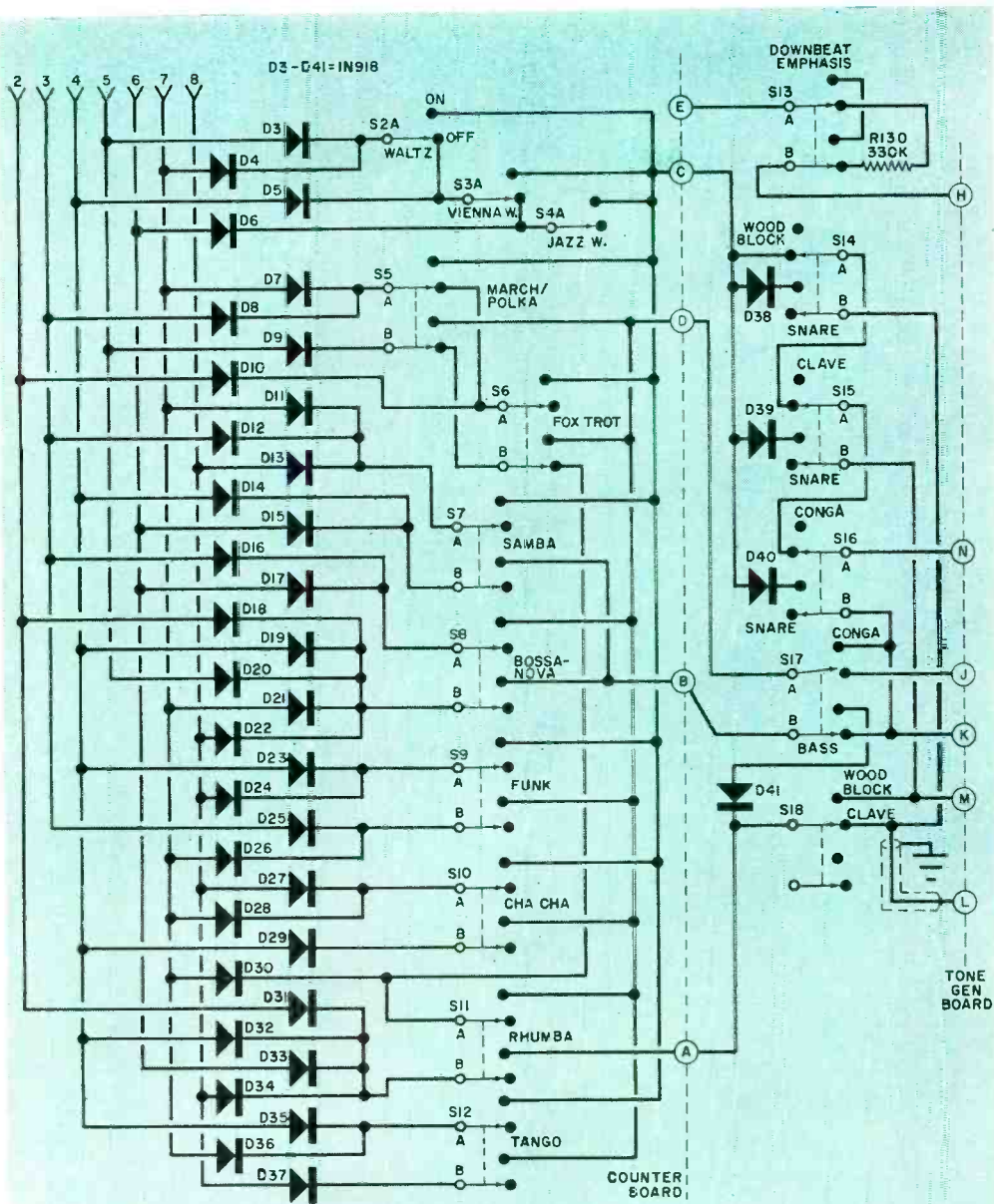

Fig. 2. The diode matrix determines the number and spacing of the pulses and after selection, the groups are passed to the tone generator.

- R5, R7, R12, R14, R19, R21, R26, R28, R33, R35, R40, R42, R47, R49, R54, R56—1000-ohm, 1/2-watt resistor
 R6, R13, R20, R27, R34, R41, F48, R55—33,000-ohm 1/2-watt resistor
 R58—68,000-ohm, 1/2-watt resistor
 R59—47-ohm, 1/2-watt resistor
 R60—470-ohm, 1/2-watt resistor
 R61—15,000-ohm, 1/2-watt resistor

- R63—75,000-ohm, reverse audio taper potentiometer
 R130—330,000-ohm, 1/2-watt resistor
 S1-S18—Dpdt rocker switch
 Misc.—Switch mounting brackets (2), mounting hardware, two-lug terminal strip, etc.
 Note—An etched and drilled PC board is available (#7701A) at \$5.00, postpaid, from the address given in Parts List for Fig. 3.

Essentially, the Drummer Boy is a variable speed digital counter that has 11 different beats—ranging from a slow waltz to a fast cha-cha—played either by a bass drum, wood block, clave, conga, snare drum, or a combination. Self-powered and having both variable tempo and volume control, the Drummer Boy is easily connected to an instrument power amplifier.

On the other hand, if you construct only the tone generator board and couple it to a finger-operated switch system (also described here), you can simulate an entire rhythm section with one hand—in any type of beat.

Ring Counter. The circuit of the Drummer Boy can be divided into three sections: an eight-stage ring counter, a switching and decoding system, and an electronic tone generator.

In the ring counter (see Fig. 1), the basic timing is provided by Q18, a conventional UJT relaxation oscillator whose frequency is determined by capacitor C18 and by the setting of the tempo control, R63. Each time the UJT fires, a positive pulse is generated across R60. The pulse turns on Q17, which momentarily causes the shift buss to be shorted to ground.

With the exception of a modification in the start circuit of stage 1 (Q1,Q2), the eight ring counter stages are identical. With switch S1 off, Q1 is biased on by the combination of R2 and R3; and Q2 is off. When S1 is turned to start, the momentary surge of charging current on C19 causes a voltage spike across R62. This positive-going spike is passed through D1 to the emitters of Q1 and Q2 causing them to change their states. As long as Q2 is on, the current flow through the common emitter resistors, R7 and R5, keeps Q1 off.

When a pulse from Q17 occurs on the shift buss, the collector of Q2 is effectively grounded and the emitter of Q1 is lowered to the point where it turns on. Simultaneously, while Q2 was on, C2 accumulated a charge so that, when Q2 turns off, C2 discharges through R5 and R7 and the biasing resistor on Q3. This causes Q3 to turn off. When the shift buss returns to normal (Q17 not triggered), Q2 will not turn on because Q1 is saturated. At the same time, Q3 is off and Q4 is on.

PARTS LIST TONE GENERATOR

- C20,C22,C26,C31,C36,C39,C40,C41—0.05- μ F disc capacitor
 C21,C27,C32,C37,C42—0.1- μ F disc capacitor
 C23,C24,C33,C43,C48,C49—0.01- μ F disc capacitor
 C25,C28,C34,C35,C44,C45—0.005- μ F disc capacitor
 C38,C57—0.22- μ F, Mylar capacitor
 C46—0.1- μ F, Mylar capacitor
 C47,C51—2.2- μ F, 6-volt electrolytic capacitor
 C52,C53—30- μ F, 10-volt electrolytic capacitor
 C54,C55—30- μ F, 15-volt electrolytic capacitor
 C56—100- μ F, 15-volt electrolytic capacitor
 D42—1N918 diode (or similar)
 J1—Open-circuit phone jack
 Q19-Q29,Q31-Q34—2N2712 transistor
 Q30—2N5139 transistor
 R64—270,000-ohm, $\frac{1}{2}$ -watt resistor
 R65,R74,R79,R80,R83,R93,R102,R122—68,000-ohm, $\frac{1}{2}$ -watt resistor
 R66,R75,R84,R88,R89,R94,R98,R99,R103,R118—39,000-ohm, $\frac{1}{2}$ -watt resistor
 R67,R73,R76,R85,R95,R104,R117—1-megohm, $\frac{1}{2}$ -watt resistor
 R68,R77,R86,R96,R105—4700-ohm, $\frac{1}{2}$ -watt resistor
 R69,R70,R71,R78,R87,R106,R107,R108—100,000-ohm, $\frac{1}{2}$ -watt resistor
 R72,R81,R90,R100,R109,R115—50,000-ohm trimmer potentiometer, printed circuit type
 R82,R92—470,000-ohm, $\frac{1}{2}$ -watt resistor
 R91—150,000-ohm, $\frac{1}{2}$ -watt resistor
 R97,R121—47,000-ohm, $\frac{1}{2}$ -watt resistor
 R101,R116—330,000-ohm, $\frac{1}{2}$ -watt resistor
 R110,R112,R113,R120—10,000-ohm, $\frac{1}{2}$ -watt resistor
 R111,R125—2200-ohm, $\frac{1}{2}$ -watt resistor
 R114,R124—6800-ohm, $\frac{1}{2}$ -watt resistor
 R119—680-ohm, $\frac{1}{2}$ -watt resistor
 R123—15,000-ohm, $\frac{1}{2}$ -watt resistor
 R126,R127—330-ohm, $\frac{1}{2}$ -watt resistor
 R128—100-ohm, $\frac{1}{2}$ -watt resistor
 R129—5000-ohm potentiometer with spst switch (S1)
 T1—Miniature driver transformer 10K:2K; secondary not used

Note—The following are available from PAIA Electronics, Inc., PO Box 14359, Oklahoma City, OK 73114; etched and drilled tone generator board (#7701B) at \$4.25 postpaid; complete kit of parts for tone generator at \$17.75, plus postage for 1 lb; complete kit for Drummer Boy including circuit boards, hardware, and finished case (#7701K) at \$55.00, plus postage for 10 lb. Oklahoma residents, add 2% sales tax.

Each time a pulse occurs on the shift buss, this same procedure is repeated down the string of eight counters. Thus, a pulse appears to walk down the outputs numbered 2 through 8 on Fig. 1. When the last stage is reached, the output goes through switch S1 back to the first stage and the counting continues. The process continues until S1 is turned off, which

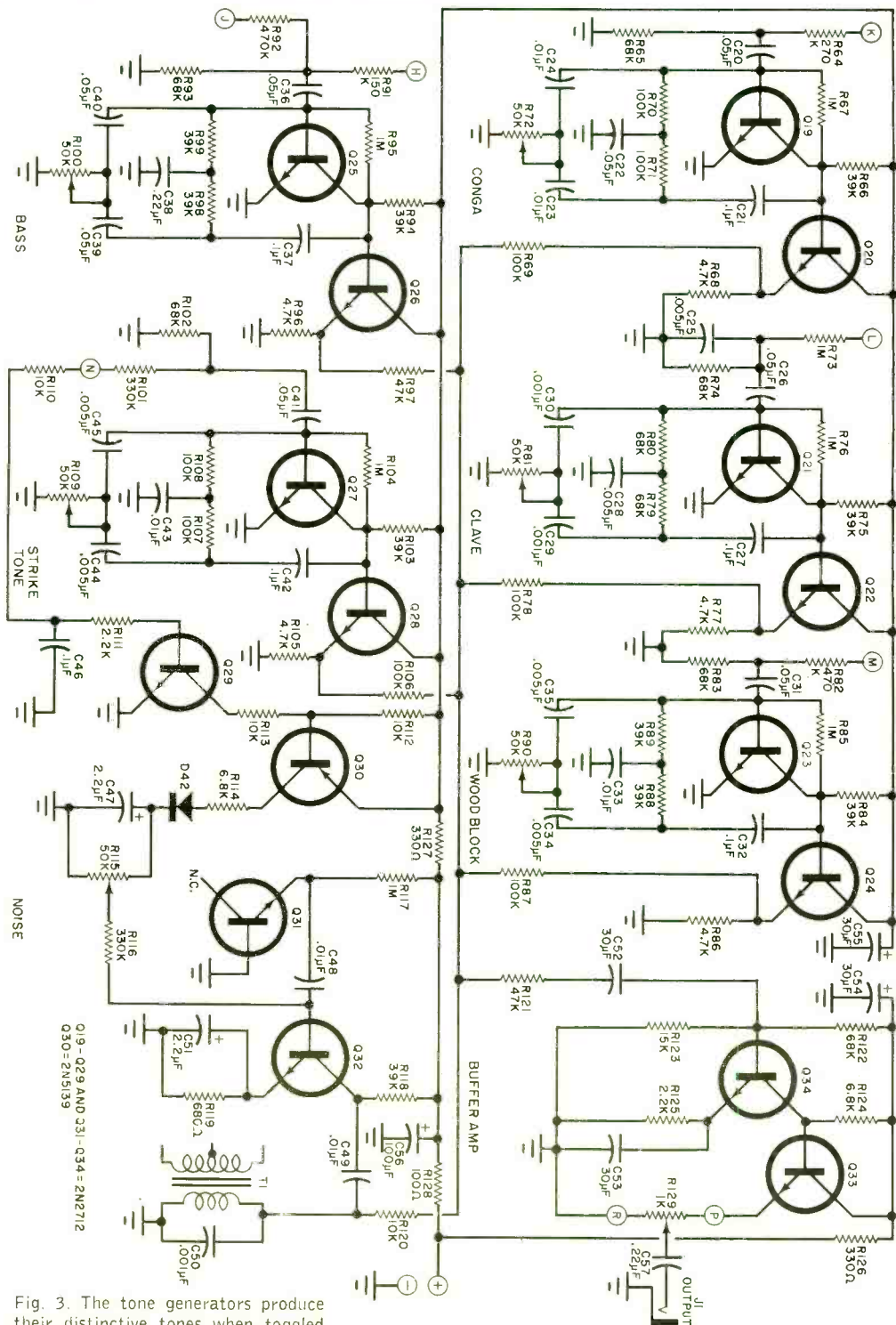

Fig. 3. The tone generators produce their distinctive tones when toggled by the switch-selected pulse groups.

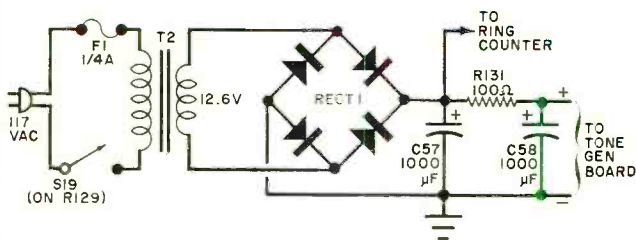

Fig. 4. The power supply, which is chassis mounted, provides a smoother dc to the tone generator than to the pulse counter.

PARTS LIST POWER SUPPLY

C57, C58—1000- μ F, 25-volt electrolytic capacitor
F1— $\frac{1}{4}$ -ampere fuse and holder

R131—100-ohm, $\frac{1}{2}$ -watt resistor
RECT1—50-volt, 1.5-ampere bridge rectifier (Motorola MDA942A-1 or similar)
S19—Spst switch (on R129)
T2—Filament transformer; secondary, 12.6 volts, 300 mA

also shorts out C19 to insure that it will be completely discharged for the next sequence.

An RC differentiating network is connected to the output of each pair (for example, C3 and R13 for Q3 and Q4) to convert the square-wave output to spikes. These are used in the diode matrix to decode the selected rhythm patterns and trigger the various tone oscillators.

Since the ring counter normally counts in eight beats, a waltz tempo using six beats is obtained by bypassing stages three and four with the closing of switch S2, S3 or S4.

Decoding and Switching. The output from stage one of the ring counter (terminal E) is the downbeat signal and is processed in a special way which will be described later. The other seven outputs (2 through 8) are coupled to the diode matrix shown in Fig. 2. The diodes are arranged to pick up the correct beats for the selected rhythm. (The use of diode coupling permits more than one ring counter output to be tied to a single tone generator without intercoupling.) Rocker switches S2 through S12 are used to select the desired rhythm, while switches S14 through S18 and their associated coupling diodes select the tones. Switch S13 permits emphasis on the downbeat when desired and couples the first ring stage to the bass tone generator.

Tone Generator. When a percussion instrument is struck, it generates a tone which is dependent on the instrument's size and the material out of which it is

made. The tone then dies away. A similar effect can be obtained electronically by applying a sharp pulse to a parallel-T audio oscillator that is normally just below the point of oscillation. Once triggered, the circuit oscillates at its resonant frequency, with the oscillation decaying just as in a musical instrument. By selecting suitable time constants for the oscillator circuits, almost any tone can be simulated. Those used in the Drummer Boy are shown in Fig. 3.

As an example, note that in the conga drum circuit, the oscillator consists of a single high-gain transistor (Q19) stabilized by feedback through R67. A second feedback loop consisting of a parallel-T RC notch filter made up of R70, R71, R72, C22, C23, and C24 is used. Normally,

CONTROL IDENTIFICATIONS

S1	Start/Stop
S2	Waltz
S3	Vienna Waltz
S4	Jazz Waltz
S5	Polka (March)
S6	Fox Trot
S7	Samba
S8	Bossa Nova
S9	Funk (Watusi)
S10	Cha-Cha
S11	Rhumba
S12	Tango
S13	Downbeat Emphasis/Off
S14	Wood Block/Snare
S15	Clave/Snare
S16	Conga/Snare
S17	Conga/Bass
S18	Wood Block/Clave
R63	Tempo/Off
R129	Volume

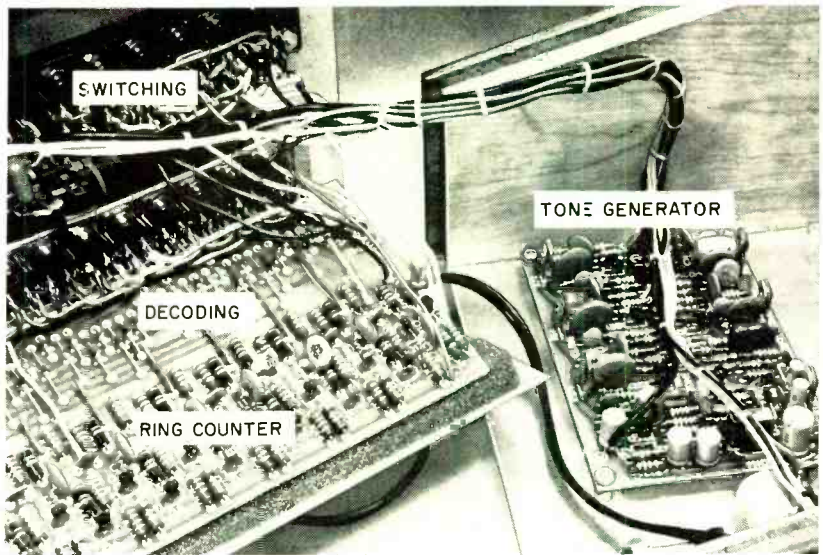

The prototype was assembled within a sloping-front chassis with the layout shown here. The decoding and ring counter board is soldered directly to the lugs of the associated switches. The other end is cemented to a length of conventional rubber strip.

the circuit is quiescent. When a voltage spike appears at the input, it passes through R64 and the R65/C20 combination to put the circuit into oscillation. The spike is brief so that the circuit starts to oscillate quickly and dies away rapidly. The frequency of oscillation is determined by the component values in the parallel-T circuit. The "lossiness" of the circuit is preset by R72. Emitter follower Q20 couples the output to the common audio line.

Circuits for the clave, wood block and bass drum are similar but the snare drum presents a special problem. In this case, we need the sound of the striking of the drumhead by the stick and also the sound of the snares striking the bottom drumhead. This problem is solved by using "white noise", which is similar to the interstation hiss heard on an FM receiver.

There are six transistors (Q27 through Q32) in the snare drum circuit. Transistor Q31, the white noise generator, is used as a reverse-biased pn junction operated above its breakdown potential. As the junction avalanches, the resulting shot noise closely approximates the Gaussian distribution of white noise. The noise is amplified by Q32, which is normally biased off. A voltage spike at input N excites a ring from the parallel-T oscillator

Q27 and Q28 to generate the drum striking tone and also turns on Q29 and Q30. Due to the action of capacitor C46, both Q29 and Q30 stay on long enough to accumulate a charge on C47 and a resulting voltage envelope across R115. This envelope biases, Q32 to turn it on and transmit the white noise to a voicing circuit consisting of C50 and the primary of T1. The time constants of the triggering envelope and T1 and C50 are selected to achieve the desired sound of the snares.

Each tone generator is coupled to the common audio line through an isolating resistor and the outputs are amplified by Q34, with Q33 acting as an emitter follower for coupling.

A power supply consisting of a bridge rectifier and suitable filters for the Drummer Boy is shown in Fig. 4.

Construction. The major portion of the Drummer Boy is assembled on two printed circuit boards whose foil patterns and layouts are shown in Fig. 5 and 6. Be sure to align the semiconductors properly; get the proper polarities on the electrolytic capacitors; and use a low-power soldering iron and fine solder.

The accompanying photos show how the prototype was assembled; though any arrangement can be used. In the proto-

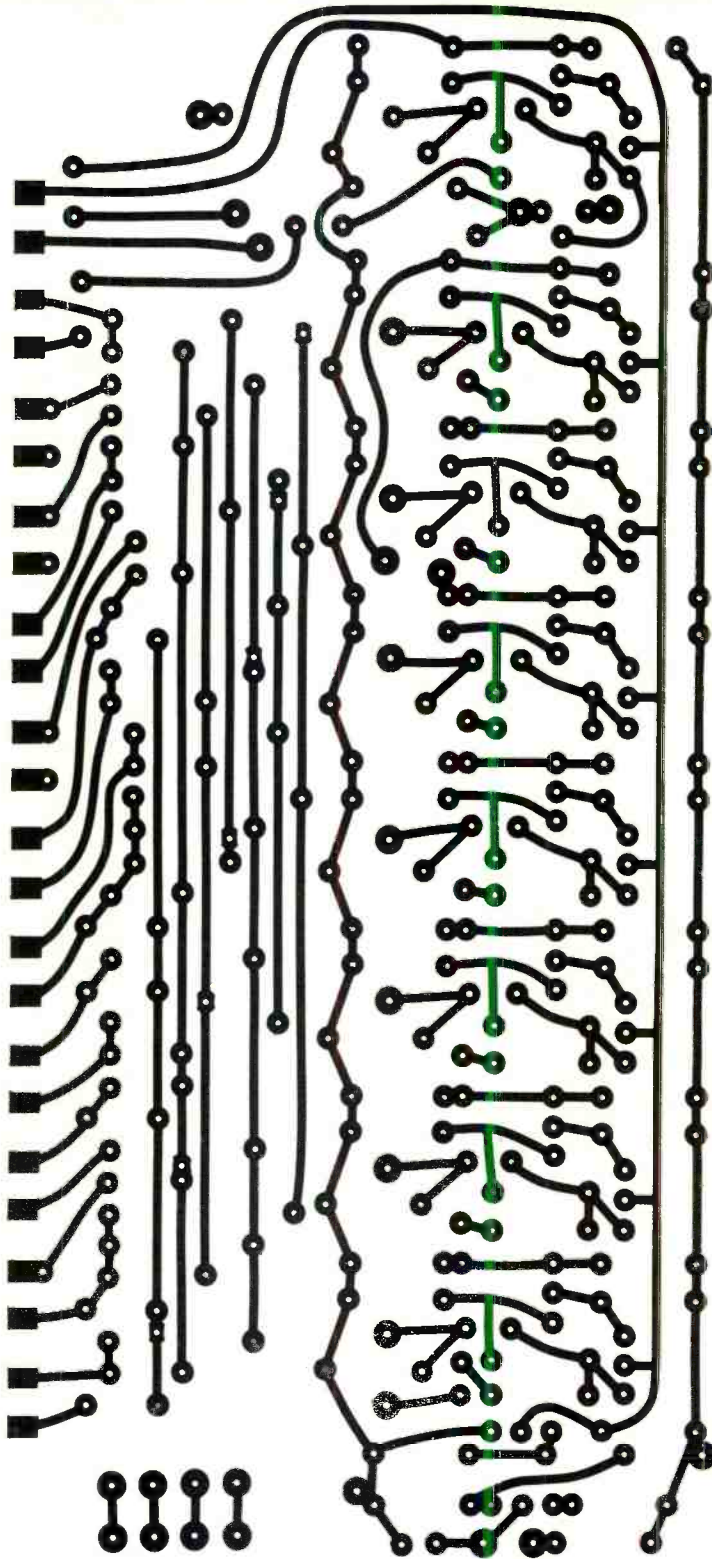
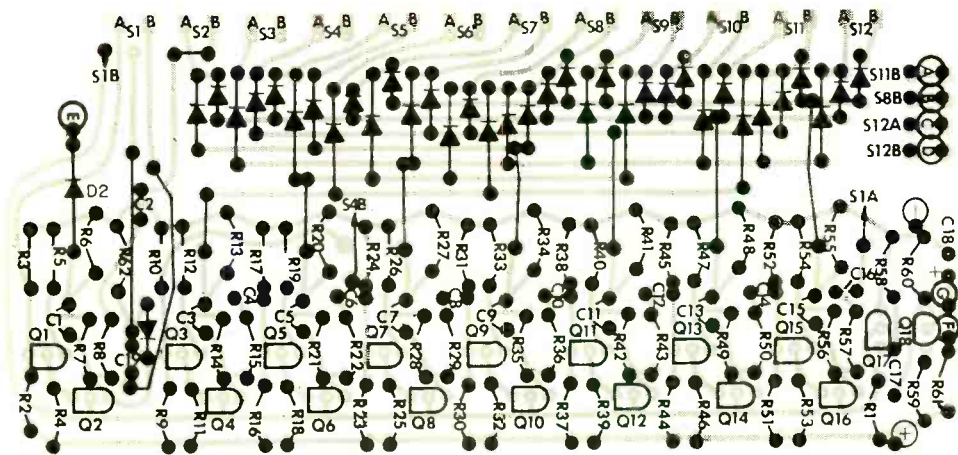

Fig. 5 (Above and opposite top right). Actual size foil pattern for pulse generator and diode matrix.



Component installation and external connections to the pulse generator.

type, a bracket was constructed to hold the 11 rocker switches (S2 through S12) that select rhythms and S1 the start-stop switch. The physical arrangement of these switches is such that the edge connector pads for the ring counter board may be soldered directly to the pertinent switch contacts to form the support for the board. To make a good mechanical connection, bend the center solder lugs on the switches 90 degrees. The various jumpers between the top row of switch contacts are made of insulated wire with connections to the appropriate tie points on the circuit board.

Another support bracket was made

to hold the six instrument selection switches (S13 through S18) and the tempo and volume controls (R63 and R129). The switches are interconnected as shown in Fig. 2 with resistor R130 and diodes D38 through D41 soldered directly to the switch lugs. Secure a two-lug terminal strip (one grounded) to the bracket adjacent to R129. Use the ungrounded lug to mount one end of C57 and the grounded lug for the ground on the output coaxial cable to J1.

In the prototype, the tone generator board was mounted on four spacers on the bottom of the chassis and the power supply components were mounted beside

The power supply can be mounted in any convenient place within the chassis. A terminal strip is used to mount the rectifier, and terminate the electrolytics, and the power line connections.

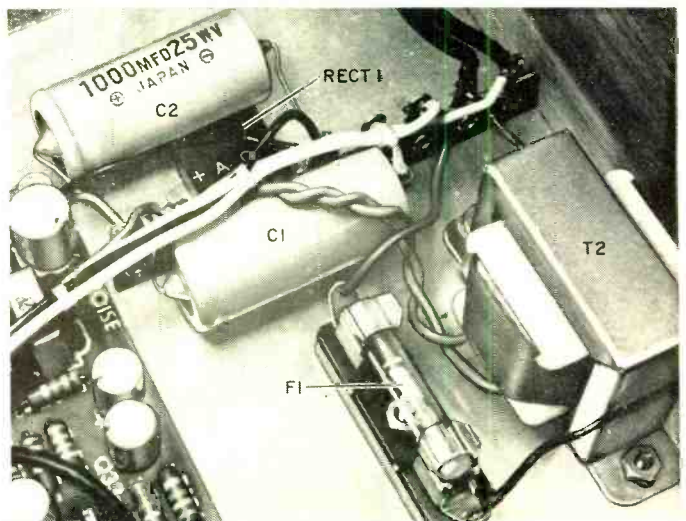

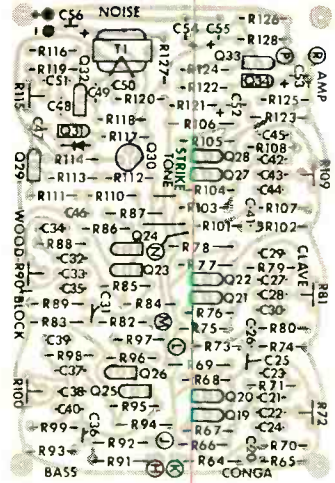
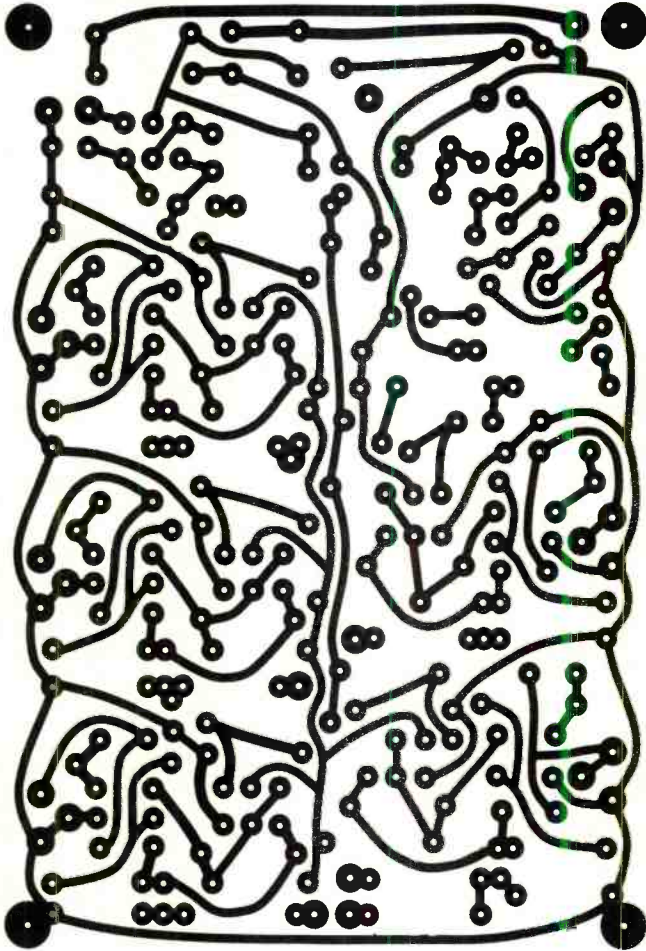

Fig. 6. Actual size foil pattern for the tone generator, and the component installation (above).

it, with a nine-lug terminal strip for the small components.

Once the mechanical assembly is complete, interconnect the four major sub-assemblies (counter, tone generator, switches, and power supply). Although the wiring from the six tone selector switches to the tone generator may be bundled and laced together to make a neat appearance, don't bundle the leads from the rhythm selector switches to the ring counter. There is always the possibility of mutual coupling between these leads and a trigger pulse intended for one tone generator can accidentally activate another. Note also that small diameter coaxial or other shielded audio cable is used to connect S18 to the clave oscillator. Because of its relatively high frequency and long sustain, this oscillator

is particularly susceptible to erroneous triggering.

Shielded audio cable or small-diameter coaxial cable should be used to make the connection between output capacitor C57 and connector J1.

When completed, check all wiring and check printed circuit boards for solder bridges and cold solder joints.

Using press-on type or some other form of lettering, identify the various switches and controls as shown in the Table. Note that S14, S15, and S16 have a common "snare" designation. The lettering for the rhythm selectors should be located at the on position of the switches.

Checkout and Tuning. Connect the Drummer Boy to a suitable audio amplifier and speaker. Place all tone generator

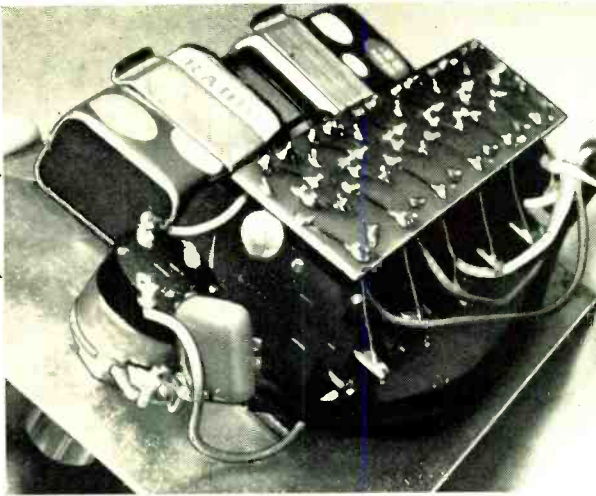

If you want to control the tone generator manually, a set of independent normally open switches can be used and connected directly to the tone generator. A typical switching circuit is shown at upper right.

controls in the full counterclockwise position (looking into the PC board). Turn on the power switch (through the Tempo control) and advance the volume until sounds are heard in the audio amplifier system. All rhythm selector switches should be off.

Using a small screwdriver, slowly advance each trimmer potentiometer (except R115 for noise) until a tone is heard. Then back the control off slightly until

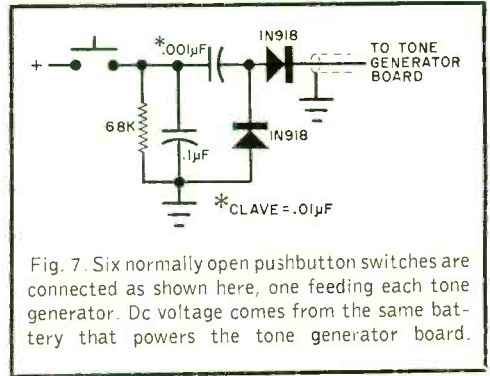
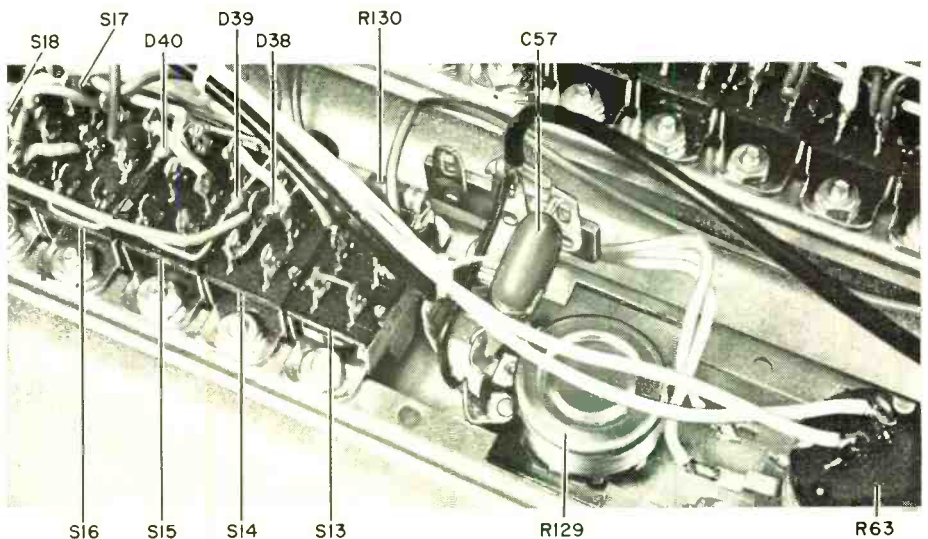

Fig. 7. Six normally open pushbutton switches are connected as shown here, one feeding each tone generator. Dc voltage comes from the same battery that powers the tone generator board.

the tone just disappears. The bass drum may continue to come through at this point. The tempo control can be adjusted as desired.

If a tone cannot be heard at all, look for trouble in the audio preamplifier (Q33, Q34) or the power supply. If one of the individual oscillators fails to operate, the problem is within that stage.

Once all the oscillators are operating, place S14, S15, and S16 in the snare position, S2 on waltz and S1 on start. You should hear the familiar waltz rhythm, with the tempo adjustable through R63. You should also hear the bass drum on the downbeat and probably a distorted snare drum on the other two beats. Adjust both R109 and R115 to get a true snare drum sound. The level of the bass downbeat can be changed by switching S13.



The author's prototype used a pair of metal brackets to support the various switches and controls.

10 Reasons why RCA Home Training is your best investment for a rewarding career in electronics:

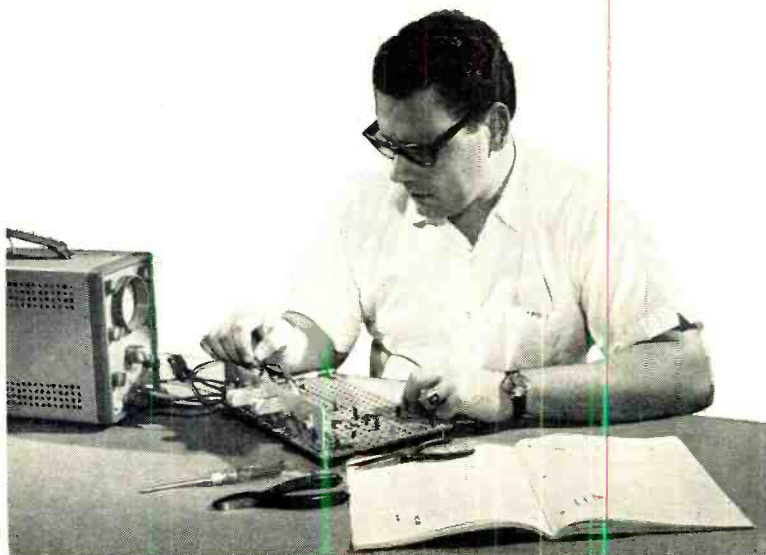

Performing transistor experiments on programmed breadboard — using oscilloscope

1 LEADER IN ELECTRONICS TRAINING

When you think of electronics, you immediately think of RCA... a name that stands for dependability, integrity, and pioneering scientific advances. For over half a century, RCA Institutes, Inc., a subsidiary of RCA, has been a leader in technical training.

2 RCA AUTOTEXT TEACHES ELECTRONICS FASTER, EASIER, ALMOST AUTOMATICALLY

Beginner or refresher, AUTOTEXT, RCA Institutes' own method of programmed Home Training will help you learn electronics more quickly and with less effort, even if you've had trouble with conventional learning methods in the past.

3 WELL PAID JOBS ARE OPEN TO MEN SKILLED IN ELECTRONICS

RCA Institutes is doing something positive to help men with an interest in electronics to qualify for rewarding jobs in this fascinating field. There are challenging new fields that need electronics technicians... new careers such as computers, automation, television, space electronics where the work is interesting and earnings are greater.

4 WIDE CHOICE OF CAREER PROGRAMS

Start today on the electronics career of your choice. On the attached card is a list of "Career Programs", each of which starts with the amazing AUTOTEXT method of programmed instruction. Look the list over, pick the one best suited to you and check it off on the card.

5 SPECIALIZED ADVANCED TRAINING

For those already working in electronics or with previous training, RCA Institutes offers advanced courses. You can start on a higher level without wasting time on work you already know.

6 PERSONAL SUPERVISION THROUGHOUT

All during your program of home study, your training is supervised by RCA Institutes experts who become personally involved in your efforts and help you over any "rough spots" that may develop.

7 HANDS-ON TRAINING

To give practical application to your studies, a variety of valuable RCA Institutes engineered kits are included in your program. You get over 250 projects and experiments and as many as 22 kits in some programs. Each kit is complete in itself. You never have to take apart one piece to build another. They're yours to keep and use on the job.

8 FCC LICENSE TRAINING—MONEY BACK AGREEMENT

Take RCA's Communications Career program—or enter with advanced standing and prepare immediately for your 1st, 2nd, or 3rd class FCC Radio Telephone License examinations. RCA Institutes money-back agreement assures you of your money back if you fail to pass the FCC examination taken within 6 months after completing the course.

9 CONVENIENT PAYMENT PLANS

You get a selection of low-cost tuition plans. And, we are an eligible insti-

tution under the Federally Insured Student Loan Program.

10 RCA INSTITUTES IS FULLY ACCREDITED

RCA Institutes is an accredited member of the National Home Study Council. Licensed by N. Y. State—courses of study and instructional facilities are approved by the State Education Department.

VETERANS: TRAIN UNDER NEW GI BILL

SEND ATTACHED POSTAGE PAID CARD TODAY! FREE DESCRIPTIVE BOOK YOURS WITHOUT OBLIGATION!

If reply card is detached, send this coupon today.

RCA INSTITUTES, INC.
DEPT. 694-007-1
320 W. 31 ST.
NEW YORK, N. Y. 10001

Please send me FREE illustrated career catalog. I understand that I am under no obligation.

Name _____

Address _____

City _____

State _____ ZIP _____

Age _____

Veterans: Check here

Construction of Multimeter.

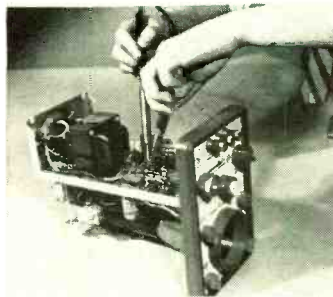

Construction of Oscilloscope.

Temperature experiment with transistors.

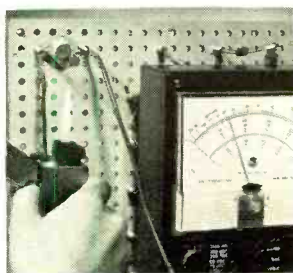

As the rhythm switches are frequently operated, they should be mounted as firm as possible.

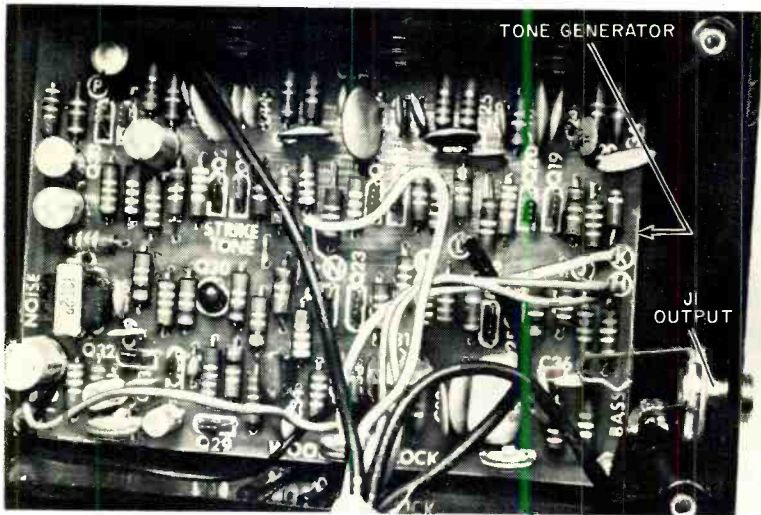
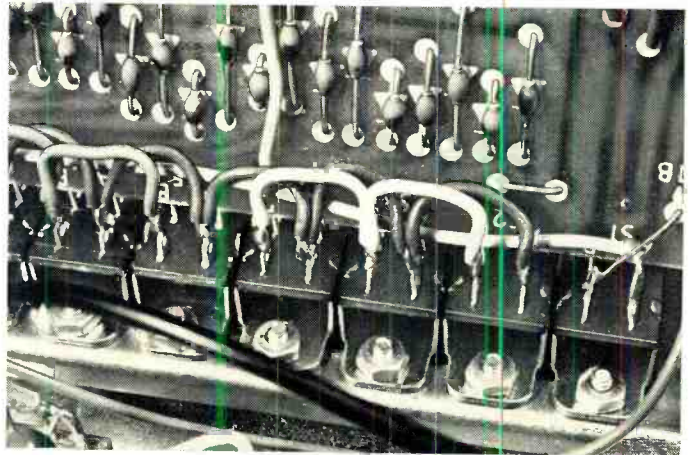

In the hand-held unit, tone generator board will fit snugly in a conventional plastic utility case.

With the waltz rhythm still operating, set S14 to the wood block position, and then adjust R90 on the tone generator to get the best wood block sound. (Note also that taking either S14, S15 or S16 off the snare position removes the snare completely.) With S14 back on snare, set S15

(Continued on page 97)



The six finger-operated rhythm pushbuttons are mounted to the top panel with the volume control, while the output jack is mounted on one side. The batteries fit inside.

DESTINY AND



GEOMAGNETISM

HOW MUCH DO WE KNOW OF THE
“INFLUENCES” ON OUR LIVES?

BY WEBB GARRISON

“EVERYTHING that is, or that happens, in the sky is felt in some hidden fashion by earth and nature . . .”

Jeane Dixon? Zolar? The astrologer in the next block who has a standing cut-rate price of \$2 per reading? Who said that?

Actually, that testimony of belief in the influence of the sun, moon, and other heavenly bodies came from the lips of the astronomer-mathematician Johannes Kepler, who formulated the three basic laws

of planetary motion. Kepler rejected the notions of astrology. But more than 300 years elapsed before hard scientific evidence was found to support his intuitive theory that movements of heavenly bodies have a profound influence on creatures on earth.

Kepler's theory, greatly refined, provides a clue to the special character of this wonderful spaceship called Earth. Most or all passengers aboard this craft probably do receive some type of elec-

tronic or geomagnetic signals from space. These signals from beyond our atmosphere help guide metabolism, reproduction, navigation, migration, and many other basic activities.

Fifty years ago, all this would have sounded like nonsense. True, an occasional man with ideas before his time had suggested that many activities are governed by biological clocks. In 1759, J. G. Zinn found that some plants he studied showed the same rhythm of activity and "sleep" regardless of variations in light and temperature. Records dating from 292 BC supported the rather preposterous idea that some species of bamboo produce flowers and seeds at intervals of 32 years.

Logic to the contrary, California fishermen swore that grunion know the precise days and hours at which tides are highest. Years of observation showed that grunion invariably spawn at high tide. They time their arrival at favorite beaches to coincide precisely (not approximately) with the crest of the tide.

Biological Clocks. Long-range cycles of pinpoint accuracy, it was found, are more spectacular but much less common than daily cycles. Dr. Franz Halberg of the University of Minnesota coined *circadian*

to designate those biological rhythms that are "about a day" in length.

The reality of biological clocks that precisely govern circadian and other rhythms proved a stimulus to new inquiries. Are the "clocks" intrinsic and wholly contained within organisms that include them? Or, do they get the signals which govern them from an outside (extrinsic) source or sources?

Most early believers in the reality and importance of biological clocks considered them to be intrinsic. That viewpoint seemed logical, but some puzzling cycles didn't fit into the behavior patterns that would be expected of self-contained "clocks." At Yale, Dr. Burr found that, when opposite sides of a tree are connected by means of a wire, a difference in potential causes a flow of current. Sometimes it flows in one direction, sometimes the other. Burr studied massive records, but could find no clue to these phenomena except in movements of the moon and sun. His findings weren't taken very seriously however; how could movements of heavenly bodies have any connection with wholly self-regulating activities of trees?

L. C. Cole, a vociferous critic of early theories about possible outside sources of signals received by biological clocks, believed that statistical errors were involved. He joked that by juggling numbers he had "discovered the exogenous rhythm of the unicorn." But he was not joking when he underscored his verdict that "so-called exogenous rhythms are as imaginary as the unicorn itself."

Long before the controversy was settled, an extraordinary man, Frank A. Brown, Jr., had turned his attention to the riddle of biological clocks. Brown had earned his Ph.D. at Harvard in the field of biology. After brief terms at Harvard and Illinois, he joined the faculty of Northwestern University in 1937 at the age of 29. He investigated such matters as conditioned behavior in lower animals, color perception in fishes, and plumage changes in birds.

Some of the phenomena he studied were dependent upon existence of biological clocks. Much evidence suggested that just as humans periodically set their clocks by means of information from radio time signals, so organisms receive



Dr. Frank A. Brown, Jr., spent years searching for a biological clock or "timer" before finding positive evidence that signals are from outside.

signals from points beyond their immediate environment.

Brown probed the activities of organisms ranging from potato sprouts to oysters. Then he found a particularly valuable experimental animal—the fiddler crab that goes through elaborate daily cycles of change in color.

In nature, fiddler crabs are pale silvery gray at sunset. Next morning when the sun rises they begin to grow darker. Color changes, plotted on a chart, show astonishing regularity. And crabs maintained in a photographic darkroom continue for weeks to change color in synchrony with others of their kind exposed to the day-night pattern of nature.

Cosmic Radiation Effects? A major break came in 1954. By chance, Brown noticed that the chart showing daily metabolic changes in the fiddler crab was almost an exact mirror image of charts showing the intensity of cosmic rays for the same period.

Correlations such as this are extremely rare. They do not constitute proof of a cause-and-effect relationship. Brown was interested—and puzzled. He was well aware that primary cosmic radiation seldom gets within miles of the Earth's surface. That being the case, how could particles from the sun and distant space have any effect on color changes of crabs?

For practical purposes a natural "electronic ear," would have to be extremely sensitive. It would have to be capable of responding to lunar cycles, solar cycles, sunspots, and possibly many other phenomena.

The Earth's natural magnetic field met all these requirements. But the strength of the geomagnetic field is puny compared with fields produced in laboratories. It had always been assumed that Earth's magnetism couldn't possibly affect living things—to say nothing of feeding intricate information to them about positions of the moon, sun and other bodies.

Frank Brown decided to embark on a series of daring experiments. Instead of using very strong magnetic fields, he worked with weak fields.

The results were hard to believe. Slow moving slug-like mollusks (*Nassarius*) forced to leave a "corral" in single file proved sensitive to changes in magnetic

fields. By the time thousands of slugs had been observed, Brown and his colleagues reached a clear conclusion. The *Nassarius* is equipped to "measure" the lunar month as accurately as instruments used by geophysicists!

Additional experiments with flatworms (*Planaria*) confirmed and amplified these findings. When orientation of a field was artificially changed, worms could still ascertain the geomagnetic field within 15°.

Thousands (not simply hundreds) of experiments have been made since then. To the satisfaction of most (but not all) specialists, it has been shown that practically all organisms on Earth have a built-in capacity to sense changes in the magnetic field.

This capacity had been overlooked, partly because of the ever-present and totally pervasive nature of this feature of our environment; and partly because experiments with relatively strong fields have proved futile—by exceeding reaction levels to the point where "flooding" resulted.

Today it is generally recognized that creatures ranging from insects to men really do perceive both strength and direction of geomagnetic fields. These fields are constantly involved in complex cycles of change. Earth's magnetism at

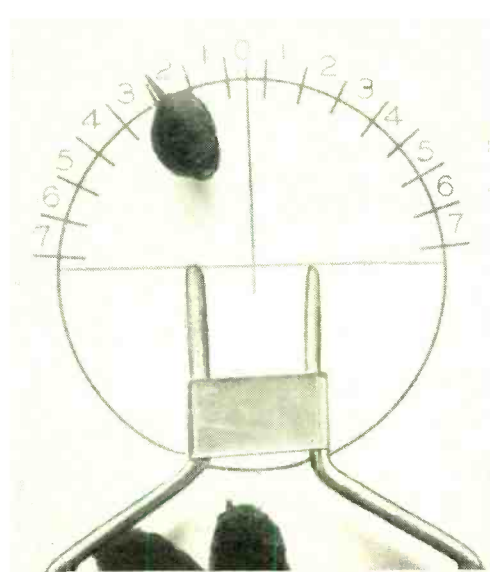

Mud snail emerging from gate pointed to magnetic south pole veers to the left at noon. Morning and evening he goes to right. (Courtesy Dr. F. Brown.)

a given point at a particular moment is affected by the solar wind, position of the moon, position of the sun, and many other factors. As a result, the geomagnetic field is continually monitoring signals from space, literally (not simply figuratively) *talking* to slugs, birds, worms, oysters, men, and even bean sprouts.

The Electronic Ear. Just how this natural "electronic ear" feeds information into bio-electric systems, no one knows. There are several theories, each of which may contain a bit of truth. Liquid crystals (abundant in many living organisms) are so sensitive that they may respond to magnetic fields of low strength. Many, or most, "higher organisms" probably have elaborate dc systems whose sensitivity to magnetism is largely masked by extraneous electrical activity.

Until comparatively modern times, no one knew that a geomagnetic environment existed. William Gilbert, the 16th-century English physician who discovered it, thought the Earth's interior might include an enormous bar magnet. This naive notion was soon quashed, but the precise systems that operate to give our planet a vast magnetic shield are still unknown. Turning on its axis, the planet may operate as a dc generator. James Van Allen (for whom the Van Allen radiation belts are named) supports this theory. According to him, the "generator effect" has a potential of approximately 50,000 volts.

On the morning side of the earth, thinks Van Allen, protons are extracted from the solar wind. At the same time, electrons are exiting from the evening side.

Instead of being stable, the geomagnetic field varies from hour to hour and even from minute to minute. The shape of the field that reaches about 40,000 miles into space is greatly influenced by movements of the moon and the Earth. An immense magnetic tail trails behind the Earth, somewhat like the tail of a comet. Until unmanned satellites were put into orbit, the contemporary concept of the geomagnetic field was undeveloped.

Unconsciously monitoring the celestial movements that affect the shape and strength of the geomagnetic field, earth-bound organisms are given time coordinates. This information fosters navigation by birds, fishes, and insects. It is an essential factor in seasonal migration (which may involve a 2000-mile trek to a target destination that is very small). It fosters reproduction by telling creatures when it is time to mate—and how to reach the mating grounds of the species.

Other cues and clues (from light, temperature, relative humidity, and the like) are fed into the "organic computer" that is ceaselessly receiving and analyzing magnetic data. Geomagnetic signals, alone, do not account for the myriad complex rhythms of nature. But they seem to be essential ingredients in the complex that forms a foundation for life.

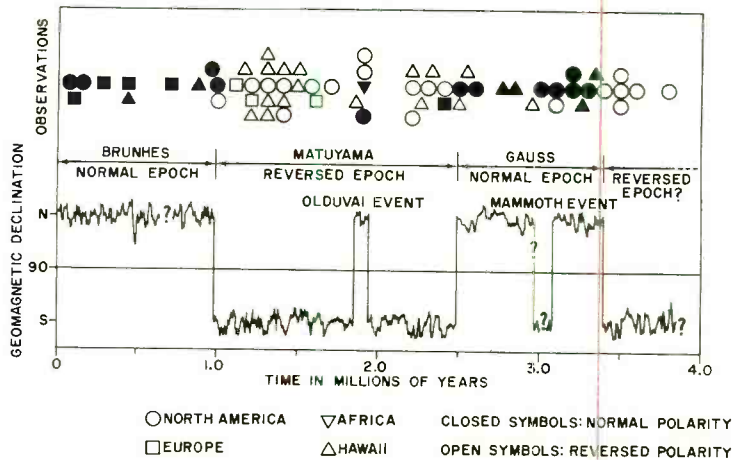

Magnetic polarities of 64 volcanic rocks and their potassium-argon ages. Geomagnetic declination for moderate latitudes is indicated schematically. (A. V. Cox, et al., from the magazine *Science*, 144:1541, used here with permission.)

The stream of evolution itself may have been profoundly affected by our planet's natural magnetic field—and changes in it.

For more than 30 years it has been known that the vast Pilandsberg dyke system in South Africa (1290 ± 180 million years old) is reversely magnetized. Geologists now recognize that, when ferromagnetic minerals in lava cool below their Curie points, they acquire thermoremanent magnetization.

During the last decade, the study of paleomagnetism has become worldwide. Evidence from every part of the globe confirms early hints that the Earth's magnetic poles have repeatedly reversed themselves. This reversal has taken place at least nine times in the past 3.6 million years.

Polarity Reversals. Duration of geomagnetic epochs varies widely. All known reversals of polarity have occurred during relatively brief periods—10,000 years or so. Several theories seek to account for sudden switching of the poles; none is supported by conclusive evidence.

Whatever the cause, paleomagnetic evidence indicates that life on Earth has been greatly affected by influences that accompany pole reversal. Sedimentary cores recovered from deep-sea drilling show a striking correlation between the last reversal (about 700,000 years ago) and disappearance of many forms of life.

At Columbia University's Lamont-Doherty Geological Observatory, Dr. James D. Hays has pinpointed seven instances in which extinction of *radiolaria* (marine plankton) has been linked with magnetic reversals.

Geomagnetic field strength presumably diminishes over a period of centuries (a mere instant, in terms of planetary history). For a thousand or so years, our whirling space ship has no magnetic field at all. During such a period, primary cosmic radiation is no longer deflected or modified by the magnetosphere. Whether this relatively sudden shower of powerful radiation serves to bring about genetic changes is a subject still widely debated.

Even if no genetic changes are involved, the weakening, disappearance, and subsequent reversal of the natural magnetic field could have profound effects. Creatures dependent on signals received by

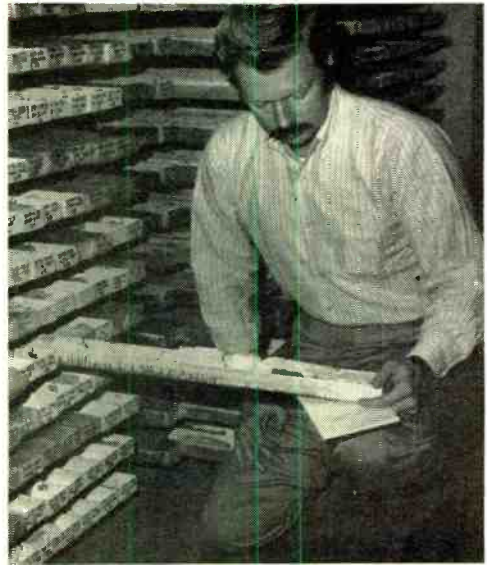

Dr. James D. Hays, Lamont-Doherty Geological Observatory checks deep-sea sediment in his study of magnetic reversals. (Photo by H. C. Wehner.)

way of that field could become completely disoriented—in time, space, and bodily function. This factor alone could account for the puzzling fact that animal extinction (and emergence of new families) has proceeded by periodic bursts rather than along a gradual curve.

If reversal of geomagnetic polarity, with accompanying drop in field strength, really does test the survival capacity of organisms, men of the future may face severe challenges.

A Reversal Coming? The Earth's magnetic moment is now decreasing. Physicist Keith McDonald estimates that it has dropped 15% in the last three hundred years. If the present rate of decrease continues, our planet will become nude (in terms of its magnetosphere) about 4000 AD. The Earth's surface is likely to be pelted with protons—known to be capable of splitting atoms and causing genetic mutations. In the absence of our geomagnetic signals, hundreds of human bodily rhythms may be affected.

Long before this magnetic Doomsday, we are likely to know a great deal more about its potential impact. Once we begin truly long-distance space flights (as opposed to neighborhood jaunts such as flights to the moon) aerospace scientists

Physicist Keith McDonald of the Environmental Science Services Administration points to magnetic map indicating drop in field intensity from 1835 to 1965. With Robert Gunst of the U. S. Coast and Geodetic Survey, McDonald has calculated that if the rate of drop continues, the earth's magnetic field will fade away completely by year 3991. (This photo courtesy ESSA.)

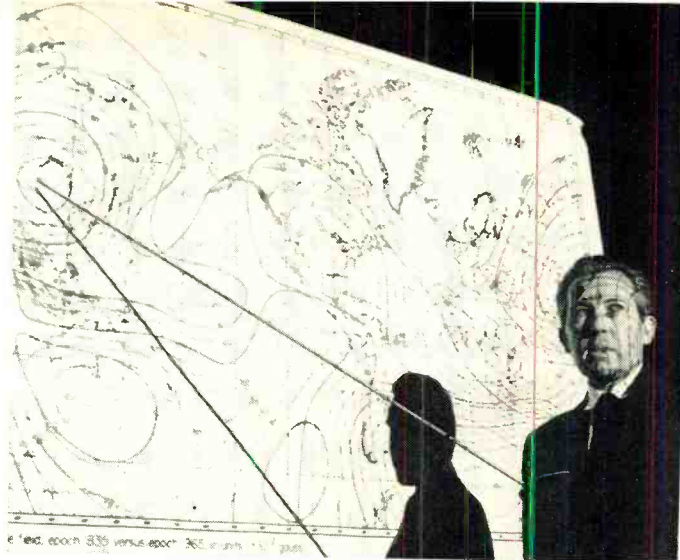

will have new data about effects of lengthy stays in environments that lack magnetic clues.

We know a little—a very little—about this matter already. On journeys to the moon, astronauts have found that some bodily cycles change significantly. Others, such as the all-important cycle marking daily excretion of potassium, remain constant or practically constant for the duration of brief flights.

Astronauts have the tremendous (and perhaps vital) advantage of being able to receive information through man-made channels. Lacking radio and TV contact, members of a crew would quickly lose all sense of time. How effectively even highly trained persons could function in such a chaotic, formless environment is open to serious question.

Your own body is affected by hundreds of cycles that are guided by biological clocks. One of the most conspicuous of these cycles is body temperature—which is about 2°F lower at midnight than it is at noon. Sweating of the palms, rise and fall of blood pressure, reflex time, excretion of sodium, and great numbers of equally complex activities are “set” to follow daily, or circadian, cycles.

Other cycles are longer and more puzzling. There is at present no direct causal relationship between length of the lunar month and the 28-day menstrual cycle of women. But is the correlation accidental? Does it represent a biological carry-over from the infancy of the race, during which the moon set the clock that governs fertility? Positive evidence is lacking

—but the recent discovery that human males have 28-day cycles of sex hormone production strengthens the theory that movements of the moon, monitored by the geomagnetic field, may have permanently molded man.

Frank A. Brown minces no words, “The evidence at hand suggests strongly that diurnal, or 24-hour rhythmicity is as fundamental a characteristic of life on the Earth as are respiration, reproduction, growth, differentiation and excitability.”

Indisputable evidence suggests that most or all creatures on Earth “listen” to electronic signals fed into their system by the geomagnetic field and—in the absence of all other information—can remain biologically informed about days, months, years, tides, and other factors.

Results obtained from space probes suggest that this state of affairs doesn't prevail on other planets of our solar system. Earth's dipole moment ranges slightly above or below 8×10^{25} gauss cm³. That of Venus is only about 3.4% as strong and Mars only 0.3%.

Earth, then, is unique among known heavenly bodies. Passengers on it are protected by a vast and complex magnetosphere. Because it is subject to periodic cataclysmic change, it may have played a major role in eliminating or modifying many forms of life. Now in a period of rapid decline in strength, it may give space-age man one of his biggest tests. Meanwhile, the magnetosphere (along with light, temperature and other factors) “is an omnipresent factor with which life steadily interacts.” ♦

4-CHANNEL STEREO

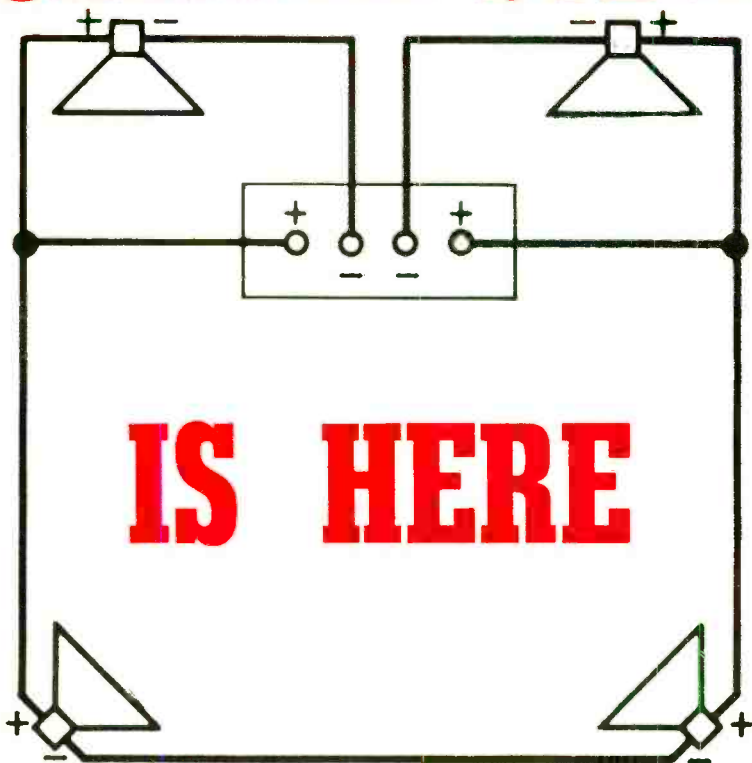

REFLECTIONS ON HOW QUADRIPHONICS CAME ABOUT—
AND ITS FUTURE

BY ALEXANDER W. BURAWA
ASSOCIATE EDITOR

STEREO BUFFS will remember 1971 as the year four-channel stereo made it into the home. At about the time you read this, a dozen or so manufacturers will be promoting four-channel stereo devices designed specifically for the home entertainment market. But there are complications: although four-channel stereo has arrived, it is appearing in several guises.

Each of the available four-channel (properly known as quadriphonic or quadrisonic sound) devices employs one of three basic approaches to the reproduction of the new sound, although they have a more or less common goal. Which device or devices is best for you depends largely on what you want in the way of

performance and to a lesser extent on your present stereo system and how much money you are willing to invest to get four-channel sound.

So that you don't have to wander around your local hi-fi center blind, we have surveyed the four-channel stereo market to find out what equipment and accessories are currently for sale. In the following pages, are discussed the various approaches to four-channel sound with a list of brand-name equipment presently on the market in each category.

Why Quadriphonic Sound? Before discussing either the equipment or techniques used to achieve four-channel

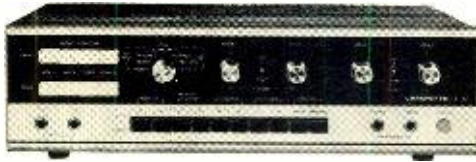

Lafayette Radio's LA-44 four-channel amplifier with built-in ambience recovery circuitry (above) and RK-48 two- and four-channel cartridge player (below) are billed as companion pieces. Both items are fully compatible with the existing two-channel stereo sources and sound reproducing equipment.



sound reproduction, it is appropriate first to put quadriphonic sound into focus. Four-channel stereo is a legitimate and long-overdue step forward in sound reproduction. It is not a gimmick thought up by greedy equipment manufacturers to squeeze a few extra bucks out of stereo enthusiasts. The innovators of four-channel stereo are sincerely motivated to bring into being a real technical advance.

Two-channel directed-sound reproduction, commonly identified as "stereo," was a logical advance beyond the limitations of monophonic sound. And four-channel stereo is the logical step beyond two-channel sound. To understand why, it is necessary to take a moment to re-

view the acoustical conditions that exist during a live music performance.

Most live performances are conducted within the confines of a volume of space enclosed by walls, a floor, and a ceiling—in other words, a certain acoustical environment. This environment has a fixed size and shape; its walls, ceiling, and floor possess sound reflecting and absorbing characteristics. Together, they influence the sounds heard by a listener sitting within the environment. This influence, consisting to a great extent of reflected sound, is known as "ambience."

It is ambience which gives the listener the ability to aurally distinguish—quite apart from any visual effects—the difference between a large environment and one of lesser volume. In fact, it is even possible to distinguish acoustically between environments of the same volume but constructed in different configurations.

Here is how ambience works. Assume you are seated in the "perfect" listening location in an ideal acoustical environment. You will, of course, hear sounds coming directly from the performers. In addition, you will hear the same sounds after they have been reflected from the walls, floor, and ceiling—ambience. The reflected sounds will arrive at your ears delayed, diminished in intensity, and at various phase angles.

The larger the volume of space in the environment, the longer will it take for the reflected sound waves to reach your ears. This long delay creates what our ear interprets as "spaciousness." The phase angle displacements of the reflected sound waves are dependent on

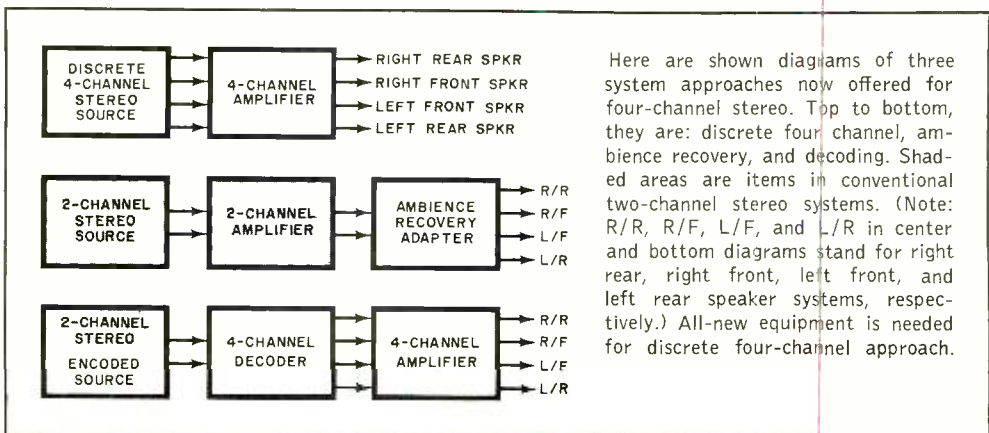

both the time it takes for the echo to reach you and the frequency of the sound itself.

Monophonic recordings and radio broadcasts suffer from a notable deficiency in the ambience information that existed during the live performances. Hence, mono sound reproduction is almost totally lacking in the original acoustical environment's character. Short of artificially doctoring the monophonic signal (adding "reverb"), little can be done to recreate even a semblance of the live-performance character during reproduction. In effect, your listening room with all of its limitations in size, shape, and characteristics, becomes the acoustical environment.

Two-channel stereo, on the other hand, contains a considerable amount of ambience information and, so, presents some interesting possibilities. In addition to providing the ability to localize the positions of predominant instruments along a panorama extending from left to right in front of the listener, the ambience information adds depth to the sound—though certainly not as much as is heard during a live performance.

Extracting More Ambience. The existence of ambience information in conventional two-channel stereo discs or tapes, offers the exciting possibility of recovering this information and reproducing it in the home. This is exactly what David Hafler of Dynaco proposed and demonstrated almost two years ago.

It is recognized that if four-channel stereo is going to work as a home entertainment medium, it must be fully compatible with existing two-channel stereo equipment, discs and tapes, and stereo FM broadcasting. Any medium which will make obsolete today's stereo equipment and require the replacement or duplication of tape and disc libraries will undoubtedly meet consumer resistance.

With this in mind, let us review the various approaches now being proposed in the equipment already on the market. The most obvious approach (and the first to appear in a marketable item) employed four related but independent signal sources to drive as many amplifier/speaker systems.

The discrete four-channel approach to reproducing four-channel stereo sound

has the advantages of superior between-channel separation, low distortion, and maximum programming flexibility. Its most telling disadvantage is that it will not reproduce the four-channel effect from any two-channel material—even if such material is encoded for quadriphonic sound. On the other hand, discrete four-channel equipment will accept and reproduce single- and two-channel material in the ordinary manner.

The discrete four-channel approach is typically a tape medium. It is a simple matter to modify a tape player/recorder made for two-channel stereo simply by substituting four-channel stereo tape heads for the existing two-channel stereo heads and adding two extra channels of electronics. Each of four separate tracks on the magnetic tape are then used simultaneously as signal sources.

Among the four-channel stereo open-reel tape recorders and/or players you



Distinctive feature of Sansui's QS1 decoder is VU meter for each channel. QS1 functions in manner similar to EVX-4 decoder made by Electro-Voice.

will find on the market are: Panasonic Model RS-736; Teac Model TCA-42; Wollensack Model 6250; and Crown International Model CX844. The available cartridge players include: "Mark 8" by RCA; "Quad-8" by Motorola; Model RK-48 from Lafayette Radio Electronics; Fisher Model CP100; and "Qaudio CS-721" from Toyo of Japan.

The second approach to four-channel stereo, proposed by David Hafler of Dynaco, involves a system of ambience "recovery." This technique simply recovers ambience information already present on two-channel stereo signals.

The ambience recovery technique is the least expensive way of obtaining

FOUR-CHANNEL STEREO THE EASY WAY

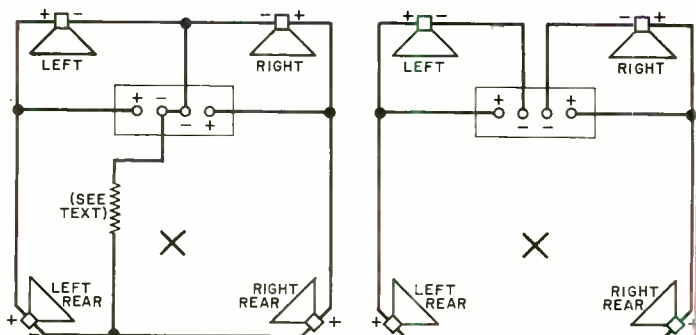

If you have an extra pair of speaker systems handy, you can set up your present two-channel stereo system to provide quad sound through ambience recovery. First study your operating manual to determine whether or not the common terminals on the outputs of your amplifier can be safely tied together as one. If so, wire the extra speakers into your system as shown in the left drawing above. The value of the resistor shown will depend on the impedance of the added (rear) speakers. If the speakers have a 4-ohm impedance, use a 4-ohm, 10-watt resistor; if 8 ohms, use an

8-ohm, 10-watt resistor; if 16 ohms, use a 16-ohm, 10-watt resistor.

For all other amplifiers, even those which are doubtful, use the right drawing to wire in the extra speakers. In this case, there will be no feedback line and no resistor will be needed.

In both diagrams, the added speaker systems are those identified as the "rear" speakers. These will, if properly wired into the system, reproduce only the ambience information. The X marks in the diagrams merely indicate an appropriate listening position.

something approximating four-channel stereo. It requires only a simple passive network and two extra speaker systems to set up. In the original Hafler setup, the speakers were arranged in a diamond configuration—to the left and right and center front and center rear of the listener. Most recent setups show four-corner placement. There is no special tape player, decoding device, synthesizer, or extra stereo amplifier.

The Dynaco ambience recovery technique has the advantage of being compatible with all existing two-channel stereo equipment and program sources. It is designed to supplement an existing stereo system.

Presently only Dynaco (a kit) and Lafayette Radio Electronics (wired) are marketing equipment, under the name of "Dynaquad," employing the ambience recovery technique.

The final approach to providing four-channel stereo takes advantage of the compatibility of the Hafler system in that the ambience of standard two-channel recordings can be brought out and it also makes use of an electronic encoding and decoding process. Encoding four signal channels down to two is the responsibility of the record and tape manufacturers

and stereo FM broadcasters. The listener becomes involved in the process only after the material is encoded.

Now, if the listener's system is equipped with the appropriate decoder, he can electronically reconstruct the four original signal channels. This means that although the listener can retain his present stereo tape and record players and FM tuner, he must still add a second stereo amplifier and two more speaker systems to obtain four-channel reproduction.

It can be said, then, that the signal-coding process lies somewhere between the discrete four channel and the ambience recovery techniques in both system cost and program flexibility.

The coded-signal approach is fully compatible with existing two-channel stereo signal sources and equipment. When two-channel stereo material is passed through the decoder, it will emerge with an enhanced sound effect (most people who hear it describe the effect as "presence"), simulating ambience to some varying degree from little to superb.

Coded-Signal techniques are employed in two separately evolved equipment designs. Here in the United States, Feldman and Fixler designed encoding and decod-

ing equipment for Electro-Voice. The Model EVX-4 decoder is being marketed by Electro-Voice and through Allied Radio Shack under the name "Stereo-4." Heathkit is selling the same item in kit form (Model AD-2002), with Metrotec Industries selling a modified version in both kit (see construction article starting on page 52) and wired forms under E-V's Stereo-4 trademark. (It is interesting to note that Peter Scheiber, one of the early innovators of the coding technique for quadriphonic sound, and Electro-Voice have now joined forces.)

Over in Japan, two equipment manufacturers have been busy developing encoding/decoding systems for four-channel stereo. Japan Victor's Model CD-4 decoder is said to provide greater separation than the EVX-4 and the ambience recovery systems. Sansui's QS1 decoder employs a complicated system of phase shifting in addition to the type of decoding employed in E-V's "Stereo-4" decoder.

Not to be forgotten are the various support devices for four-channel stereo sound reproduction. Fisher Radio's Model 701 receiver combines an AM/stereo FM tuner and a four-channel integrated amplifier on a single chassis (the receiver simulates four-channel sound from two-channel stereo program material). The four-channel amplifier offerings include H. H. Scott's Model 499 "Quadrant," one by Harman-Kardon (no model number or name assigned at press time), and Lafayette Radio's Model LA-44.

All of the available amplifiers can be used with any of the four-channel stereo devices currently on the market (and, as a bonus, can double as two completely separate two-channel stereo systems if desired). Lafayette's LA-44 has an interesting "composer" feature which switches into the system an ambience recovery network. The network is located in the preamplifier section and, so, provides four signals to drive all four amplifier channels.

And, finally, there are the discs, tapes, and cartridges containing four-channel stereo signals. Unfortunately, the offerings are limited to a only few artists and selections. And while there are many stereo FM stations experimenting with quadriphonic sound broadcasts, they are still comparatively few and are located only in urban areas.



Electro-Voice EVX-4 and Heathkit (shown) "Stereo-4" decoders are identical in electronic details and performance and almost identical in appearance. E-V's decoder is available only wired, while Heathkit decoder is available only in kit form.

The Outlook. The future of four-channel stereo as a home entertainment medium is probably assured. The most important question seems to be: Which approach to quadriphonic sound reproduction will prevail to become the standard? Record and tape manufacturers, the most potent deciding force, are reluctant to commit themselves to any one technique at this stage. Evidently, they feel that it is up to the consumer. Conversely, it is likely that the consumer just might not care to invest in quadriphonic sound until he has a considerable variety of tapes and discs from which to choose. Ultimately, the first-year market trends will be the deciding factor. ♦

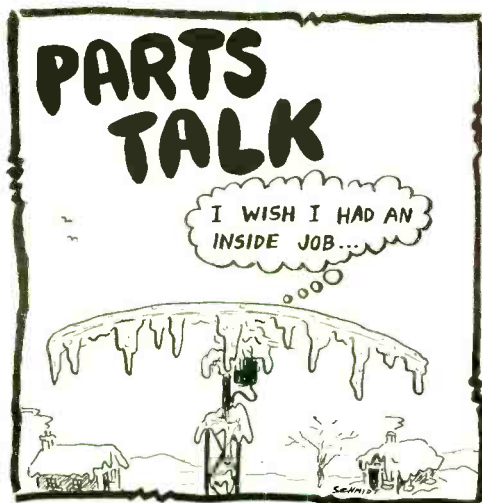

BUILD A

FOUR-CHANNEL STEREO DECODER

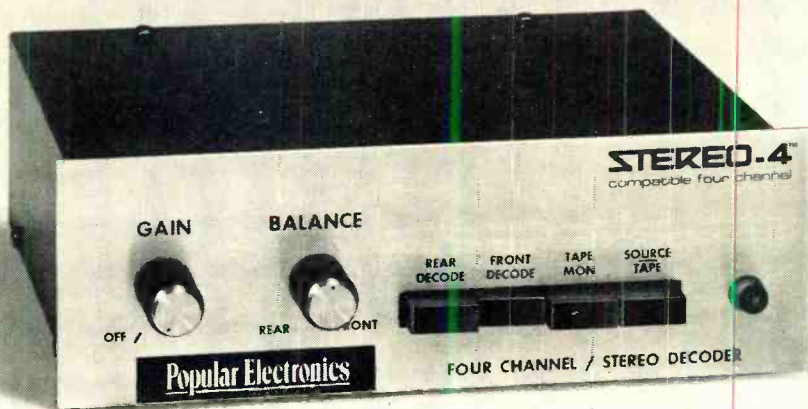

REAL QUADRIPHONIC SOUND
USING UNIQUE INTEGRATED CIRCUIT

BY GEORGE MEYERLE

VARIOUS METHODS of encoding and decoding in order to matrix four channels of information in the same medium as two-channel stereo are attracting national attention. As the story on page 47 of this issue explains, Electro-Voice has begun a massive market program to introduce the Fixler/Feldman system into recording studios, broadcasting stations, and the homes of stereo enthusiasts. Electro-Voice Stereo-4® decoders are being marketed for home use and the single integrated circuit—which is the heart of the decoder—is being offered to numerous manufacturers and kit builders.

This article describes a variation of the E-V four-channel decoder to incorporate features that some builders may find of value. The system is connected to a reproduction system between the pre-amplifier and power amplifier—with two output channels supplying the existing

stereo amplifier and the other two feeding a second stereo amplifier for two rear speakers. Connections for an integrated receiver with tape input, output, and monitor jacks are shown in the Table, as are connections for a discrete components system.

Since no two recordings are similar in every respect, it was felt important to add as much flexibility to the decoding as possible. Thus the system is designed so that, when playing conventional stereo recordings, the front channels can be either regular stereo or decoded stereo (with a slight loss in channel separation, while the rear channels can be either in parallel with the front ones or decoded to create four channels. A special balance control was added to permit the desired adjustment between front and rear signals without changing the master gain control.

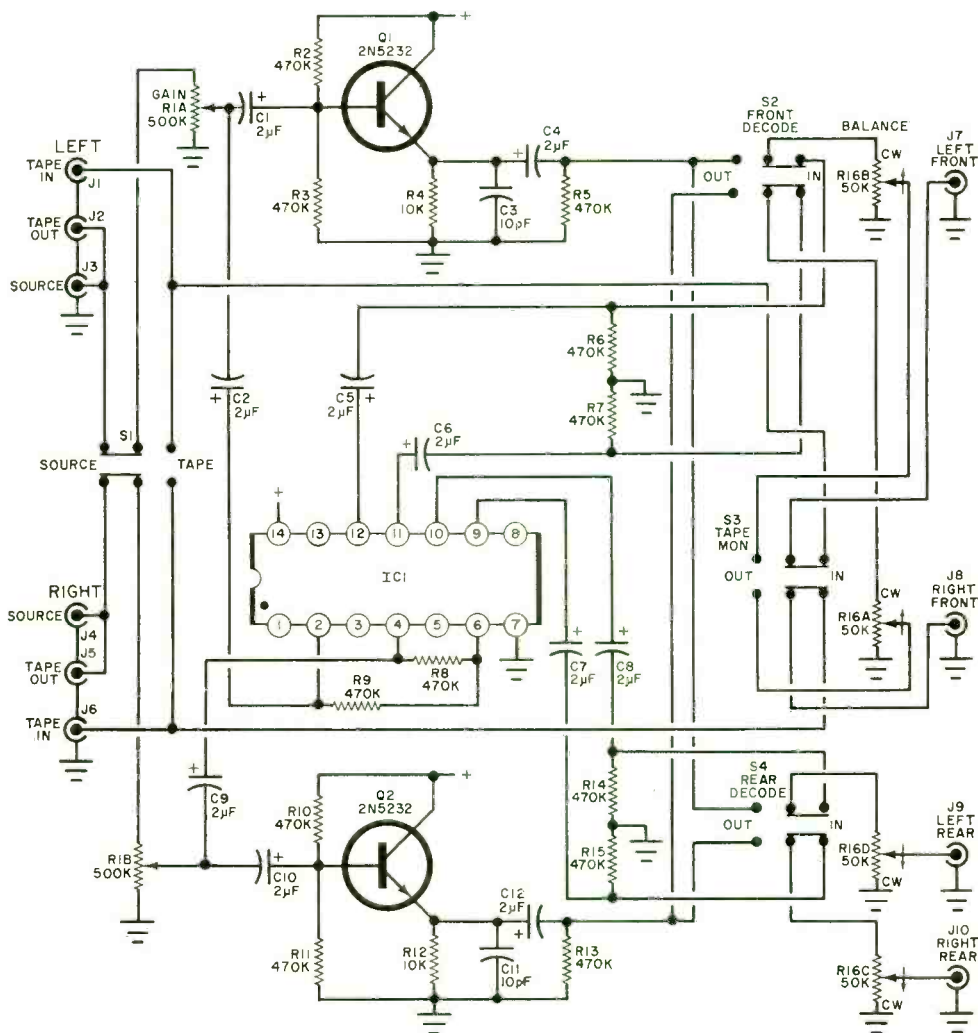

Fig. 1. This circuit offers the maximum flexibility for four-channel sound using the E-V chip.

PARTS LIST

C1,C2,C4-C10,C12—2- μ F, 25-volt electrolytic capacitor
 C3,C11—10-pF disc capacitor
 C13,C14—150- μ F, 35-volt electrolytic capacitor
 D1,D2—100-volt, 1-ampere diode
 D3—20-volt, 1-watt zener diode
 I1—117-volt neon power-on indicator assembly
 IC1—Matrix logic IC (see note)
 J1-110—Phono jack
 Q1-Q3—2N5232 transistor
 R1—500,000-ohm audio-taper dual potentiometer
 R2,R3,R5-R11,R13-R15—470,000-ohm, $\frac{1}{2}$ -watt resistor
 R4,R12—10,000-ohm, $\frac{1}{2}$ -watt resistor
 R16—4-section, 50,000-ohm potentiometer
 R17—2700-ohm, $\frac{1}{2}$ -watt resistor
 R18—1200-ohm, $\frac{1}{2}$ -watt resistor

S1-S4—Dpdt pushbutton switch
 S5—Spst slide or toggle switch
 T1—Power transformer; secondary, 40V, 30mA
 Misc.—Chassis, line cord, grommet, rubber feet (4), mounting hardware, etc.
 Note—The following are available from Metrotec Industries, Technical & Industrial Park, 33 Cain Dr., Plainview, NY 11803: etched and drilled PC board, #702 at \$3.00; IC1, #701 at \$15.00; complete kit including brushed anodized screened front panel, punched chassis, cover, switches, controls, etc., #703 at \$39.95 (plus \$1.25 postage and handling); wired and tested unit, #704 at \$59.95 (plus \$1.25 postage and handling). Residents of New York state, add 5% tax. This source also has available a selection of 4-channel discs.



The best way to get electronics into your head

No book ever written can give you the "feel" of electronics.

This is why every NTS course in Electronics includes the most modern, professional training equipment in kit form.

Putting equipment together, kit by kit, can teach you more about electronics than a whole library of bone-dry theory.

Each kit contains illustrated instructions.

You look at the pictures, then you apply what you see as you assemble or service your equipment.

What could be simpler? Or more fun? You'll enjoy every profitable minute.

Here's just some of the equipment you get to build and what you will learn.



Square-Corner
25" Diagonal picture.

NTS COLOR AND B&W TV SERVICING

You receive a big screen color TV with many unique features, including self-servicing equipment so you can make all normal test operations. You also get an AM-SW radio, solid-state radio, field-effect transistor, Volt-Ohmmeter and electronic tube tester. You learn about electronic principles, trouble-shooting, hi-fi, multiplex systems, stereo and color TV servicing.

Solid-state
B&W TV
74 sq. in.
picture
(cabinet
included)

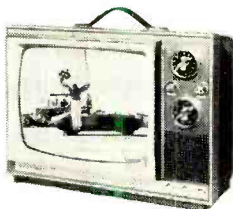

The B&W TV receiver features the latest in *solid-state circuitry*, making your TV training the most modern, most advanced available.

NTS COMPUTER ELECTRONICS

One of the 10 important kits included is this remarkable Compu-Trainer® — an NTS exclusive. It's a fully operational computer logic trainer — loaded with integrated circuits. It introduces you quickly to the how, what, when, and why of computers. This unit is capable of 50,000 operations per second.

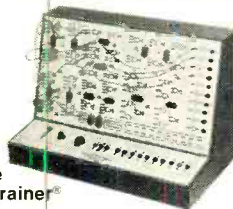

Exclusive
Compu-Trainer®

NTS ELECTRONICS COMMUNICATIONS

Two exciting courses in the big-paying fields of transmitting and receiving equipment. Either one qualifies you for your FCC First Class Radio-

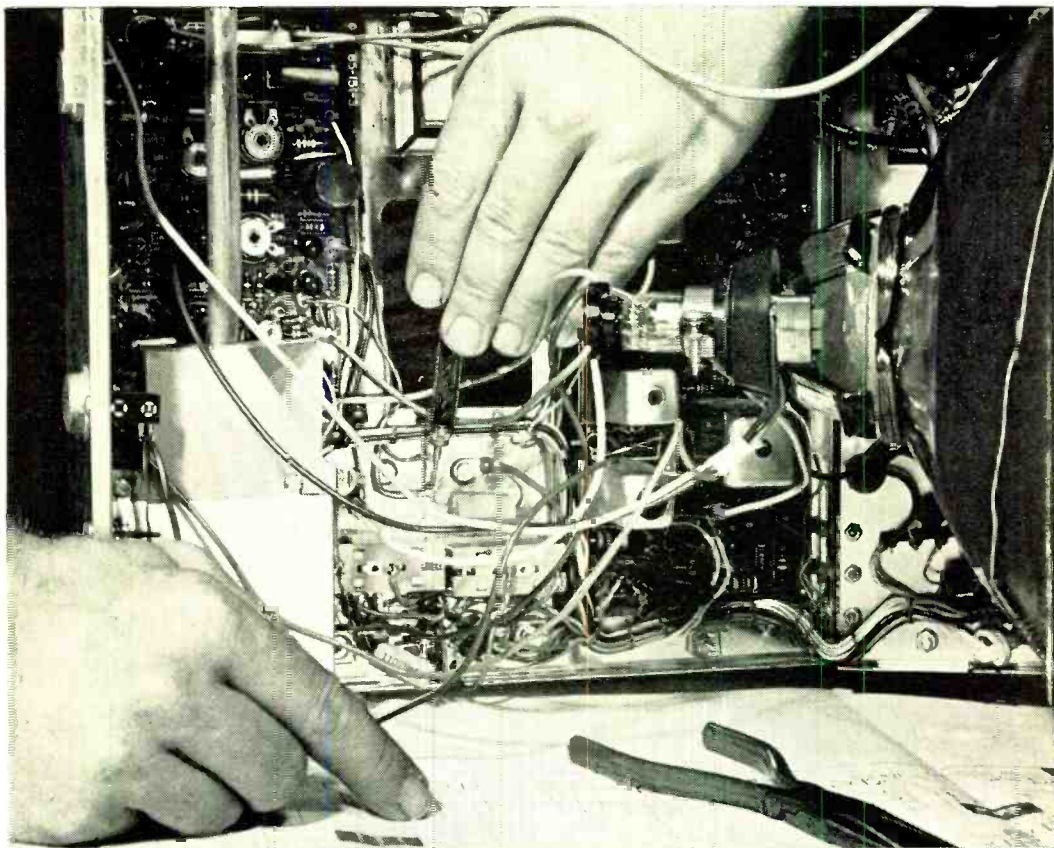

is to have the actual equipment in your hands.

Telephone License. *NTS assures you will pass this FCC exam within 6 months after successfully completing your course — or your tuition is refunded.* You receive 14 kits to build an amateur phone 6 meter VHF transceiver plus NTS' exclusive 6 transistor solid-state radio and a fully transistorized volt-ohmmeter.

5 watt AM transmitter/receiver.



NTS AUTOMATION/ INDUSTRIAL ELECTRONICS

Let NTS put you into the age of electronic controls. Systems automation is rapidly becoming the emphasis of modern industry. NTS training includes equipment like a 5" wide band oscilloscope. You also get the new, exclusive NTS Electro-Lab — a

complete workshop that lets you build five industrial controls to regulate motor speed, temperatures, pressure, liquid level, smoke, and much more.

5" Oscilloscope



Mail card today for free, full-color catalog that details what each training program offers. (Or if card is missing, send coupon.) No obligation. No salesman will call.

Remember, the best way to get electronics into your head is to have the actual equipment in your hands. The sooner you mail the card, the sooner you'll get your hands on the finest, most advanced electronics home training ever offered.

CLASSROOM TRAINING

AT LOS ANGELES You can take classroom training at Los Angeles in sunny California. NTS occupies a city block with over a million dollars in facilities devoted exclusively to technical training. Check box in coupon.

APPROVED FOR VETERANS

Accredited Member: National Association of Trade and Technical Schools; National Home Study Council.

NATIONAL TECHNICAL SCHOOLS

WORLD-WIDE TRAINING SINCE 1905

4000 S. Figueroa St., Los Angeles, Calif. 90037

If card is missing check coupon and mail for free color catalog and sample lesson. Now.

Please rush Free Color Catalog and Sample Lesson, plus information on course checked below. No obligation. No salesman will call.



National Technical Schools

4000 S. Figueroa St., Los Angeles, Calif. 90037

- Master Course in Color TV Servicing
- Color TV Servicing
- Master Course in TV & Radio Servicing
- Practical TV & Radio Servicing
- Master Course in Electronic Comm.
- FCC License Course
- Master Course in Electronics Tech.
- Industrial and Automation Electronics
- Computer Electronics
- Basic Electronics

Dept. 205-071

Name Age

Address

City State Zip

Check if interested in Veteran Training under new G.I. Bill
 Check if interested only in Classroom Training at Los Angeles

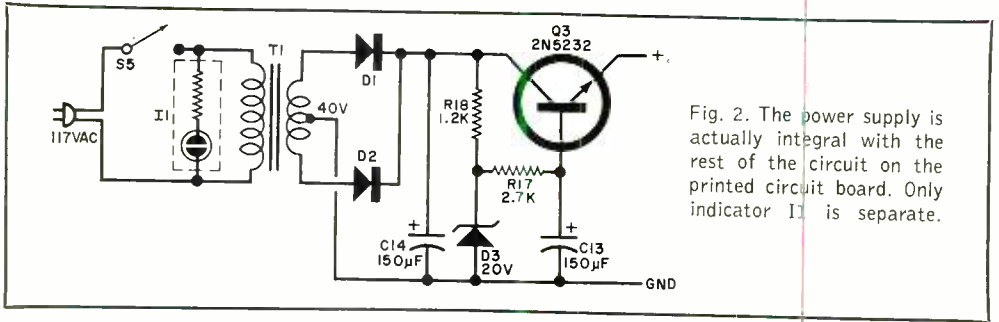

Fig. 2. The power supply is actually integral with the rest of the circuit on the printed circuit board. Only indicator I1 is separate.

Controls R1 and R16 and the switches S1 through S4 are mounted on the printed circuit board with their shafts extending through the front panel. Be sure to drill the holes in the front panel large enough.

CONNECTIONS FOR STEREO-4 For Integrated Receiver

Left Channel

- J3—Receiver tape output
- J2—Tape recorder input (if used)
- J1—Tape recorder output (if used)
- J7—Receiver tape monitor input
- J9—Rear stereo amplifier

Right Channel

- J4—Receiver tape output
- J5—Tape recorder input (if used)
- J6—Tape recorder output (if used)
- J8—Receiver tape monitor input
- J10—Rear stereo amplifier

For Discrete Preamplifier and Power Amplifier

Left Channel

- J3—Preamplifier
- J1, J2—Not used
- J7—Power amplifier
- J9—Rear stereo amplifier

Right Channel

- J4—Preamplifier
- J5, J6—Not used
- J8—Power amplifier
- J10—Rear stereo amplifier

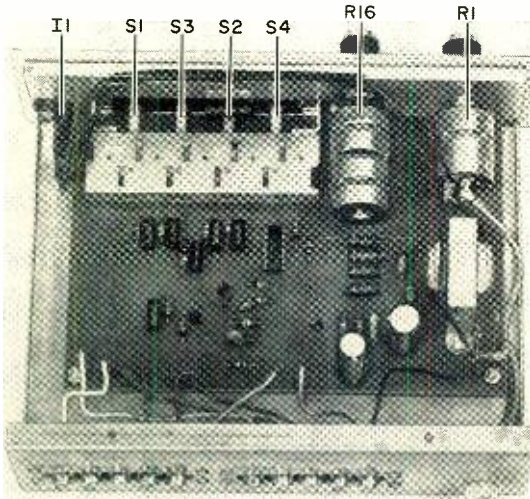
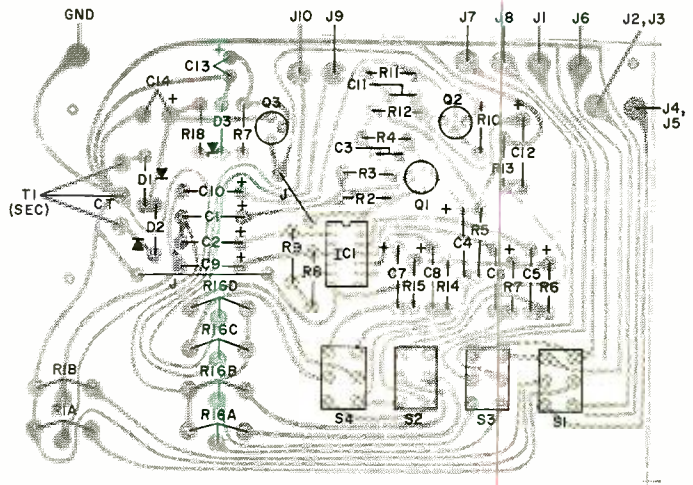
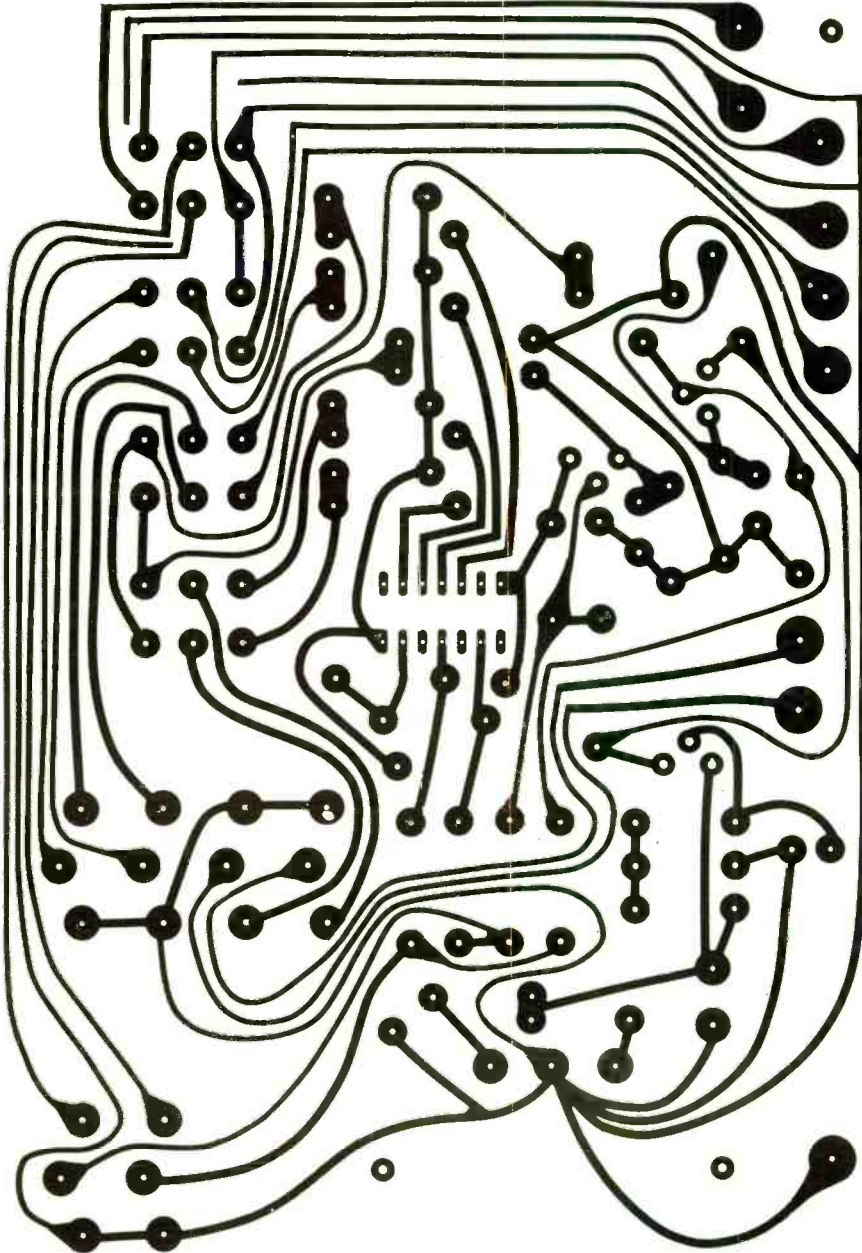

Fig. 3. After making the board, using the actual size pattern (opposite), install the components as shown here. Observe the polarities of all the components, especially IC1.



Construction. The schematic of the circuit for the Stereo-4 is shown in Fig. 1. The power supply schematic is shown in Fig. 2. All of the components are mounted on a single PC board such as that in Fig. 3. Observe the polarities of the elec-

trolytics, the integrated circuit and the other semiconductors when installing. Use a low-power soldering iron and fine solder. The two potentiometers (R1 having two sections) and R16 (four sections) and the four pushbutton switches are



HIRSCH-HOUCK LABORATORIES

Project Report

One big advantage of this unit (compared to E-V's Model EVX-4) is that it has provisions for decoding the front and rear channels independently. Thus signals with a strong L + R—such as a center soloist—do not lose front separation when the front is not decoded. Alternatively, when the signal is fully decoded, and the main front program is concentrated on one side, the sound appears to "smear" along the side of the room. By decoding the front but not the rear, this effect is largely eliminated; yet, with some enhancement from the rear.

With the decoding off, the crosstalk between L and R was in the noise, which was an impressively low 82 dB below 1 volt output at 1000 Hz. The frequency response was absolutely flat to 5 Hz and to well beyond 20 kHz. It was down 3 dB at 85 kHz. Distortion was 0.022% at 1 volt output and 0.1% at 2.5 volts output.

With the decoding on and 1 volt into the L input at 1000 Hz, the left front output was down 14.2 dB. Both outputs were 180 degrees out of phase with the input. The left rear output was at -3 dB, also out of phase. However, the right front output was at -5 dB and in phase with the input. In other words, the rear separation was 8 dB from a single channel input. Driving both inputs in phase (L + R), the rear outputs (either one) were at -17.7 dB.

In the diagram, we have shown the various signal paths with relative signal levels and phase relationships. The front speakers have a 14.2 dB separation, with 8 dB separation for the rear but the latter are essentially 180° out of phase with the front. This last has no meaning when considering stereo programs but does describe the single-signal behavior of the system.

With an essentially monophonic signal, the front-to-rear separation is 17.7 dB, with the rear speakers

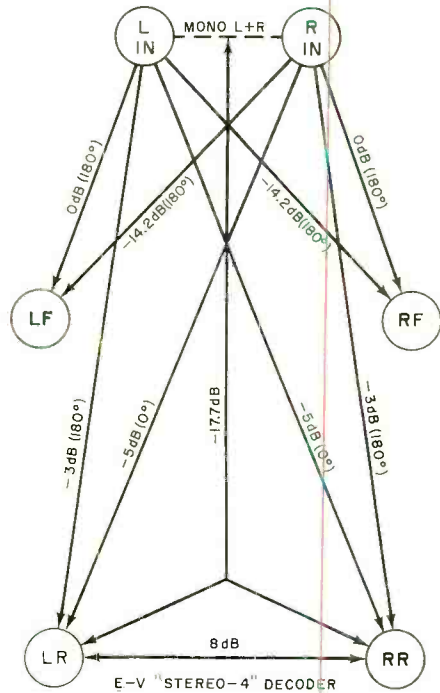

in phase with each other and out of phase with the front.

With the proper source material, the achievable effect can be described only as "great." Directionality is usually rather vague, but you can sense that it is different from all four speakers.

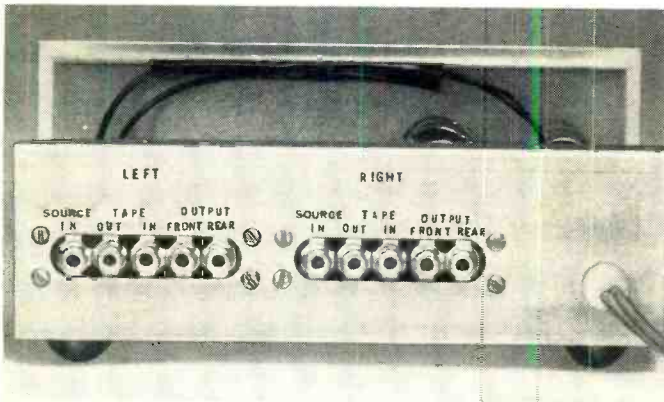

The output jacks look just like those of a preamplifier, except that there are both front and rear outputs. Obviously, another stereo system is added.

mounted directly on the board as shown.

The board is mounted on spacers in a suitable metal chassis, with a grommeted hole for the line cord. When drilling the front panel for the controls, make sure that the switch holes are large enough to permit the switches to operate

properly. After board installation, label each control and switch using suitable press-on type.

Once the master gain has been set, using *R1*, the balance control, *R16*, is adjusted for the desired effect in the listening area. ♦

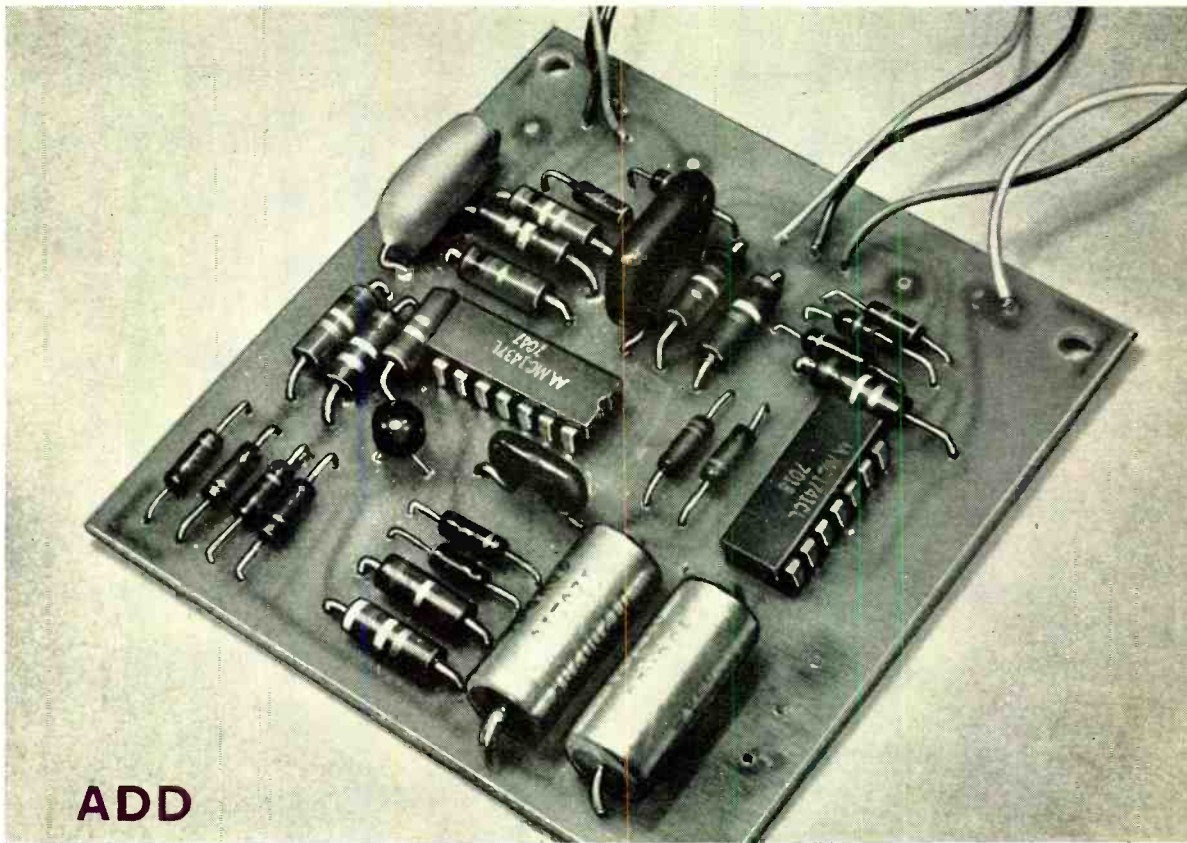

ADD

TRIGGERED SWEEP TO YOUR SCOPE

NEW LIFE, NEW USES FOR INEXPENSIVE SCOPES

BY HARRY GARLAND AND ROGER MELEN

ONE OF THE BEST features of expensive oscilloscopes is that they usually have a built-in triggered sweep. Without a triggered sweep—using only the conventional free-running time base found in lower-priced scopes—it is very frustrating to try to get some waveforms to stand still. Built-in triggering also eliminates erratic multi-triggering; and, due to the extremely good linearity found in triggered sweep circuits, accurate time and/or frequency measurements may be made along the horizontal axis. Once a signal is displayed on the scope, it can easily be expanded horizontally without losing sync.

In any triggered sweep system, the sweep does not start until the reference signal (usually the signal to be displayed on the vertical axis), reaches some predetermined level. Once triggered into operation, the sweep becomes immune to any other input signal for the duration of that trace. After retracing, the sweep is once again triggered and the process is repeated. Since the horizontal sweep is then very linear, the trace can be calibrated in microseconds, milliseconds, or seconds per division, enabling time and frequency measurements to be made during the display period. Nonperiodic wave-

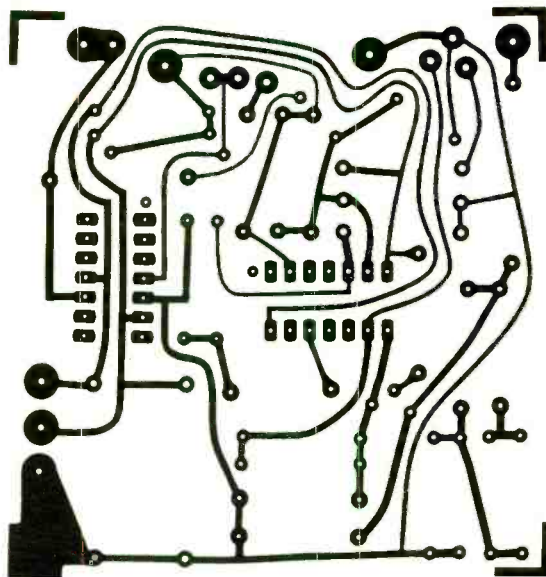
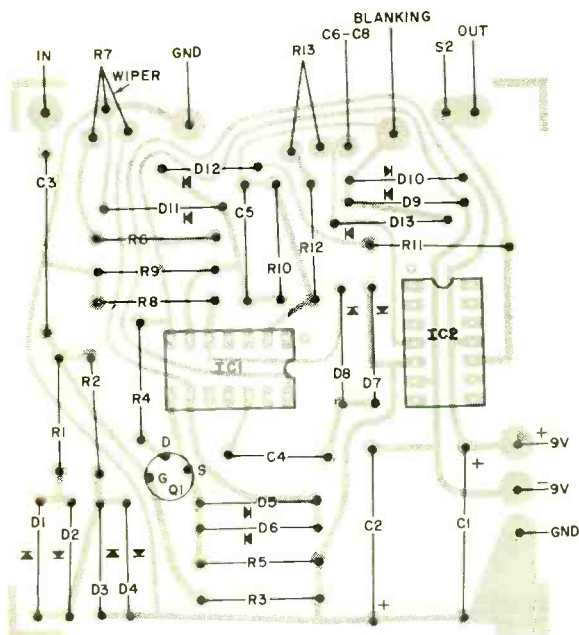

Fig. 2. The actual size foil pattern above can be used to make a printed circuit board, with the components mounted on it as shown at left. Control components S2 (with C6, C7, and C8), R7, and R13 are located off the circuit board.



forms, such as those found in many digital pulse circuits can be displayed properly only on a triggered sweep scope.

The triggered-sweep generator whose schematic is shown in Fig. 1 has a high input impedance, a 100-mV triggering sensitivity, three switch-selected sweep rates with provisions for vernier control, and a sweep linearity of better than 0.01%.

Construction. The circuit can be assembled on a printed circuit board such as that shown in Fig. 2. Be sure to observe the coding on the IC's and use a low-wattage soldering iron and fine solder for installing all components.

There are two ways of mounting the board. A small chassis can be used with three operating controls (sweep switch S2, sweep vernier R13, and sensitivity

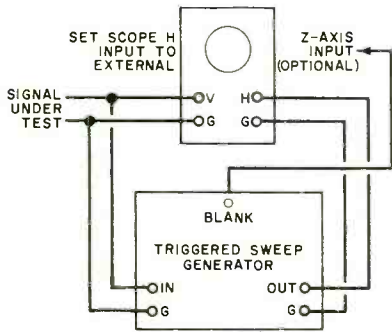

Fig. 3. When sweep generator is assembled outside of scope, make connections to scope as shown here.

control R7) mounted on the front panel and with another switch used to turn the power on and off. A pair of 9-volt batteries can be used for power in this case. The sweep generator is connected to the scope as shown in Fig. 3.

The second approach is to mount the sweep generator directly in a scope, locating the printed circuit board in any suitable spot (away from heat if the scope uses vacuum tubes). A pair of silicon rectifier diodes and filter capacitors may be used to obtain the necessary dc operating voltages from the scope filament supply, or if the scope is all solid state, a look at the schematic will show where the suitable voltages can be picked off.

The input to the sweep generator may be derived from the existing scope input or from the scope sync leads. In the latter case, the high-input impedance FET stage may be omitted and the circuit shown in Fig. 4 used for the input. The 100,000-ohm potentiometer in this circuit is used as the sensitivity control. The blanking output may be connected to the scope blanking circuit if desired.

Operation. With the desired input signal connected (using an audio generator for testing), and the triggered sweep not turned on, only a vertical trace will be seen on the scope. Adjust the height to some convenient value. When the triggered sweep is turned on, a horizontal trace may appear. If it does, adjust both the sweep rate selector switch, S2 and sweep vernier R13 until the display shows some multiple stationary signals. If the trace does not appear, adjust the

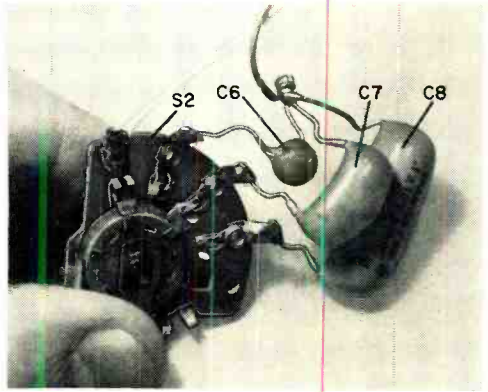

Shown here is method of attaching capacitors C6, C7, and C8 to the sweep rate selector switch S2.

sensitivity control, R7, until it does. Lower the input level from the generator and keep adjusting the sensitivity control until the sweep triggers at some low level. Once the lowest trigger level is established, the sensitivity control may be left alone. The scope horizontal gain control determines sweep length.

With a steady signal now displayed, note that manipulation of the sweep vernier and sweep rate switch produces a stationary signal from a small part of a sine wave to any desired number of sine waves, without losing sync lock at any time. Also, with a single sine wave displayed, it is possible to adjust the audio frequency generator over a wide range of frequencies without losing sync lock.

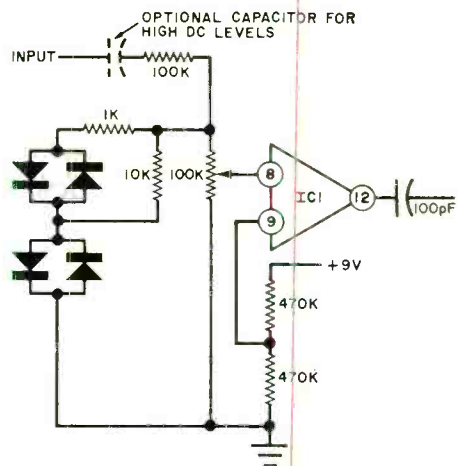

Fig. 4. If scope sync leads are used for sweep input, omit Q1 and use this circuit for first stage.

THEORY OF CIRCUIT DESIGN

To avoid loading the input circuit (which is also applied to the scope), the first stage of the sweep generator uses a field-effect transistor. Resistors *R1* and *R2* and diodes *D1* through *D4* provide automatic range selection. As the input voltage rises, the diodes conduct to shunt the input and reduce the signal applied to the FET. If high-level inputs are used constantly, a series resistor will reduce the loading effect.

The output of the FET source follower is coupled to the first op amp which is half of *IC1*. The sweep cycle begins when the signal to pin 8 exceeds the bias set by the threshold potentiometer *R7* at pin 9. The high-gain op amp amplifies the difference signal until its output is +9 volts. The positive output of the first op amp appears at the minus input of the second op amp, causing its output to swing to -9 volts. This level is held to -9 volts by the feedback action of *R10*. The next stage (*IC2*) is known as a Miller integrator and produces an ultra-linear ramp voltage when the negative signal is applied to pin 4. The speed of the sweep is determined by the value of the switch-selected feedback capacitor (*C6*, *C7*, or *C8*) and the value of *R13*.

When the sweep voltage ramp reaches its maximum value, the feedback signal through *R11* and *D12* causes the output of the second op amp to change from -9 to +9 volts. Diode *D13* is then forward biased and the selected feedback capacitor is rapidly discharged. During the discharge of the capacitor, the scope trace returns to the left side of the screen, where it remains until the trigger cycle starts again.

Calibration. If you want to calibrate sweep vernier *R13* and sweep rate *S2*, an accurate source of frequencies must be available. To calibrate the horizontal graticule, apply a known frequency to the input and establish a steady trace. Adjust the scope horizontal shift to start the trace at some known mark on the

The sweep switch *S2*, with *C6*, *C7*, and *C8*, sensitivity control *R7*, and sweep vernier *R13* are connected by wires of suitable length to appropriate points on PC board. Note that leads from *R7* are twisted together.

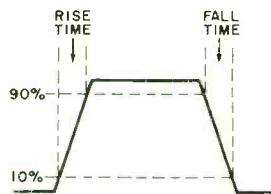
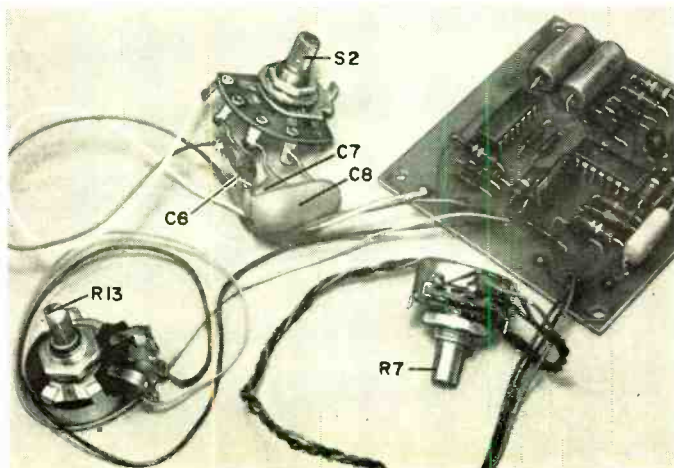
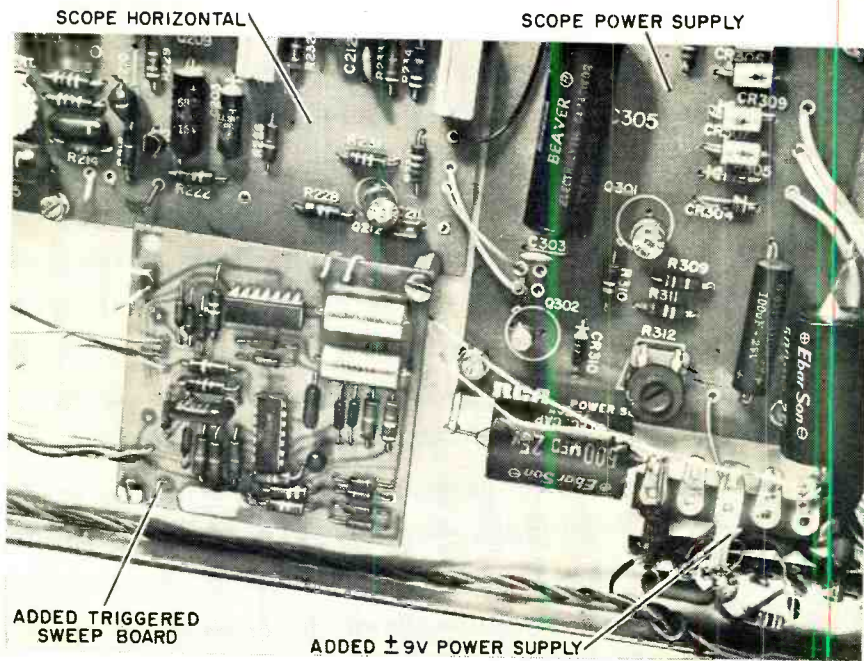

Fig. 5. To measure rise or fall time of an applied pulse, count time between 10% and 90% points.

left side of the horizontal graticule. Adjust the scope horizontal gain until the trace reaches another known mark on the right side of the screen. Determine the time period of the input frequency by using the equation $T = 1/f$, where *T* is the period and *f* is the frequency. For example, using a 100-kHz sine wave, each cycle is 10 microseconds long. Adjust *R13* until one cycle occupies exactly one division on the scope graticule. Mark the knob position on *R13* 10 $\mu\text{s}/\text{div}$. Other points on either *R13* or *S2* can be found using the same technique. For example, 60 Hz is 16.66 milliseconds and 15,750 Hz (TV line frequency) is 63.6 microseconds. If desired, a series of fixed resistors and trimmer pots may be used for *R13* (with a selector switch).

Once calibration is complete, it is easy to determine the frequency of an applied waveform or to measure the rise or fall time of an applied pulse. In the latter case, note that measurement is made between the 10% and 90% points of the waveform (see Fig. 5). Adjust the triggered sweep for at least one complete pulse. The rise (or fall) time is calculated by determining how many divisions and parts of a division lie between the two



This is a typical installation of triggered sweep generator in a scope. Location is not critical but it should be away from heat if the scope uses tubes. In the case illustrated here, a 9-volt power supply was added.

In the installation shown here, the "phase," "sync," and "sweep" controls on the front of the existing scope were removed and replaced by three controls for the sweep generator. Blanking output can be connected if desired.

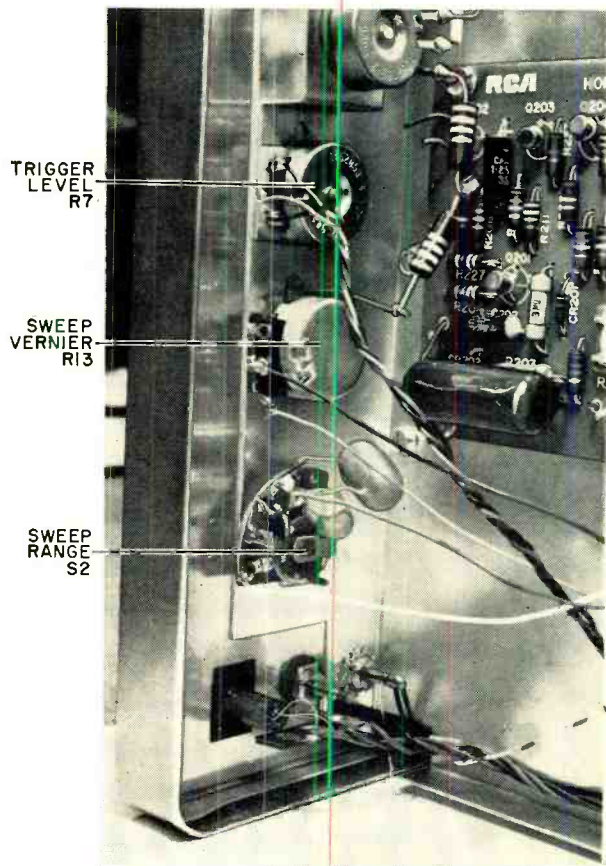



PORTABLE RADAR BECOMES A REALITY

TWO NEW SETS FOR THE SMALL BOAT OWNER

BY RICHARD HUMPHREY

MANY TIMES in the past, I have flapped out of the office, climbed into my High Dither and gone screaming across the countryside to track down the latest rumor of a "portable" or "hand-held" radar. And every time, I was disappointed. However, on my latest try, I think I found not one, but two. What's more they both work better, in some respects, than their manufacturers claim.

The first (shown in the photo above) is truly a hand-held radar. Called the Whistler," it is 6" × 10" × 13", weighs under seven pounds and resembles a thick briefcase. The case is made of high impact plastic which is "easily cleaned with soap and water" and is waterproofed

(floats if dropped overboard). Aimed squarely at the pleasure boat market, Whistler is priced at \$595. Kimball Products Company claims a two-mile maximum range for the Whistler and a minimum range of 50 feet. When I worked with the unit, I copied a shoreline nearly three miles away. It wasn't possible to get a reading on small buoys at this distance, but I did get sharp returns from them at 2 miles and 2.3 miles. We also "read" large wooden pilings at approximately 35 feet; so, as far as range is concerned, Whistler performs better than advertised. The 70-milliwatt output feeds a parabolic antenna with a 3° horizontal and 10° vertical beamwidth. We found this sharp



The Whistler is being used here by Roger Merrill of Kimball Products. There is one knob for on/off control and the meter is calibrated in tenths of a mile. Neck strap provides safety in handling.

enough to give good target separation throughout the entire range (distinct echoes from a nun buoy and can buoy marking a channel 50' wide at a distance of 1.7 miles, for instance).

Purists will miss the cathode ray tube display of conventional radar. Whistler, however, is intended to take over where traditional radar leaves off: in the two-

mile-and-under range. To use the Whistler radar, you connect the power cable to either the boat's 12-volt dc supply (power consumption, 0.5 A) or to a rechargeable NiCad TV battery, plug in the ear-phones, turn the unit on and adjust the sensitivity knob until you get a good "sky return" while aiming the Whistler upwards. Then merely sweep the horizon slowly until you hear a definite change in intensity and pitch. (An adjustable neck strap is provided.) Then you've found a target. A quick comparison with the boat's compass will give you the relative bearing. Distance can either be "guesstimated" from the pitch of the echo—the farther away the target, the higher the pitch; the closer the target, the lower the pitch—or by reading directly from the distance meter. On our prototype, the meter read only to one mile, and it wasn't properly calibrated. We found an error of approximately 0.2 mile. (A lighted buoy ½ mile away showed 0.3 mile on the meter.) Despite these minor shortcomings, I read the surroundings (using a chart of the area) as quickly and as accurately as I could have with conventional radar. In fact, it was better, since conventional radar begins to get myopic at minimum ranges.

Along more conventional lines is the Bonzer SR-20 small boat radar made by Bonzer, Inc. While not "hand-held" like
(Continued on page 98)

Though it is a more or less conventional radar, the Bonzer SR-20 is still small enough to be taken off the boat for safe keeping. It has an on/off sensitivity control and a range switch. Maximum range is 2500 yards; minimum 30 feet.

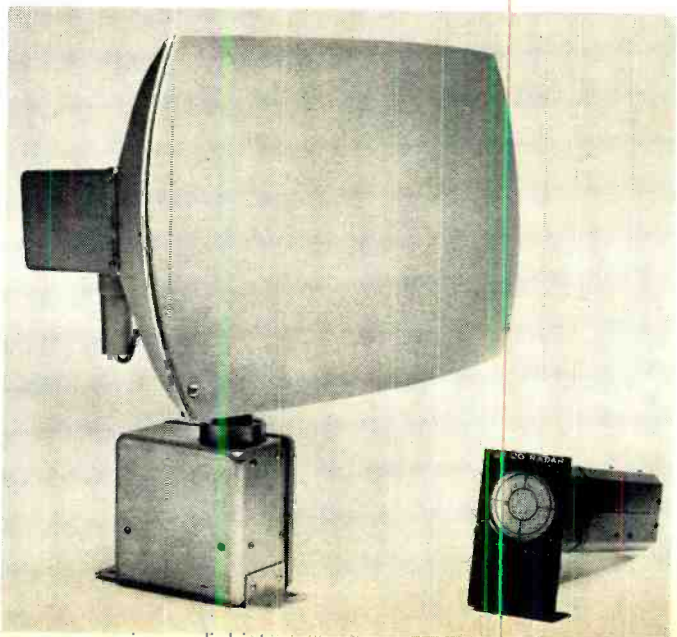

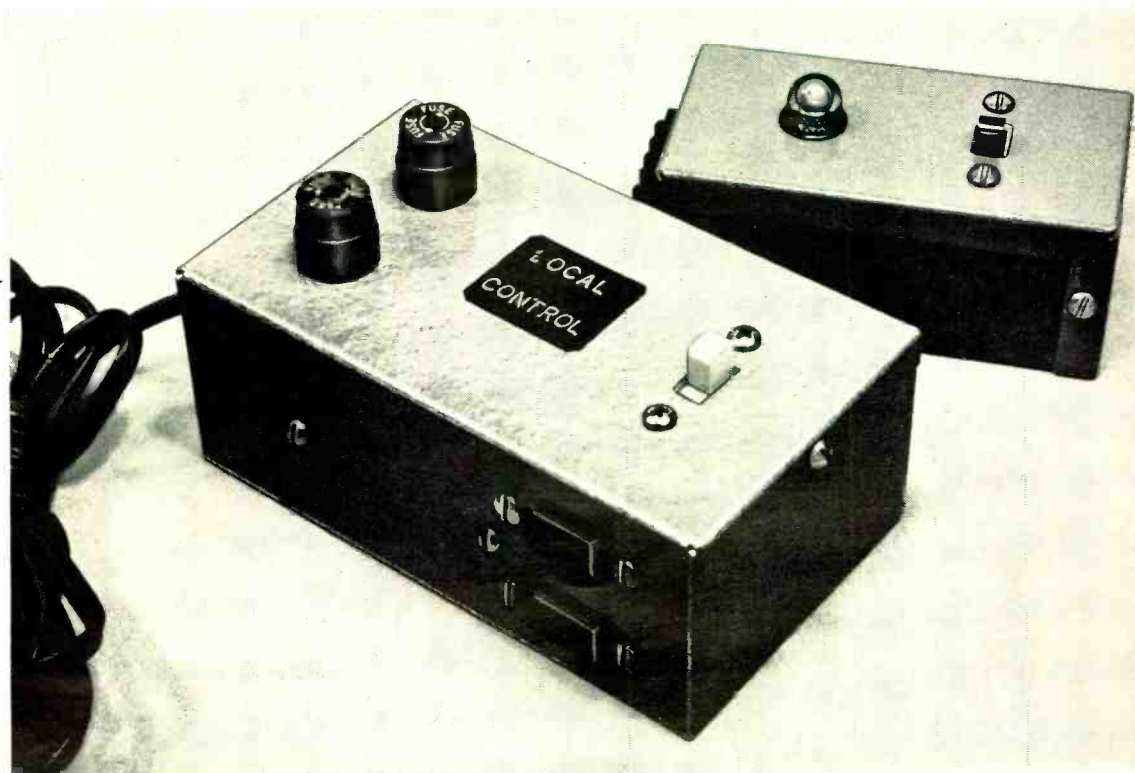

LOW-VOLTAGE Remote Power Control

AVOID SAFETY PROBLEMS AND COSTLY REWIRING

BY NEIL JOHNSON

MOST HOUSES and apartments come with an adequate (if you're lucky) wiring system already concealed within the walls and floors. There usually comes a time, however, when what you have isn't enough and you need a two-way switching system for remote control.

The first thing that comes to mind is a conventional two-way circuit that involves running a pair of power-carrying leads from the remote to the local switching point—sort of a super extension cord. Such a system is definitely out, since you are creating a real safety hazard, not to mention violating the National Electrical Code and running the risk of making your insurance man very unhappy.

Of course, you can always hire an electrician and do the thing properly; but you may not want to spend that much money—and there is a way out, for less than \$10.

The secret of this remote power switching unit is a step-down transformer that also contains a relay. It is perfectly safe to run low-voltage, low-current wiring around the house without elaborate protection—the high-power portion of this system is located as close as possible to the 117-volt outlet. A typical circuit using the transformer relay is shown in Fig. 1. The relay contacts can handle up to 600 watts at 120 volts ac, but the control winding is safely isolated from the power

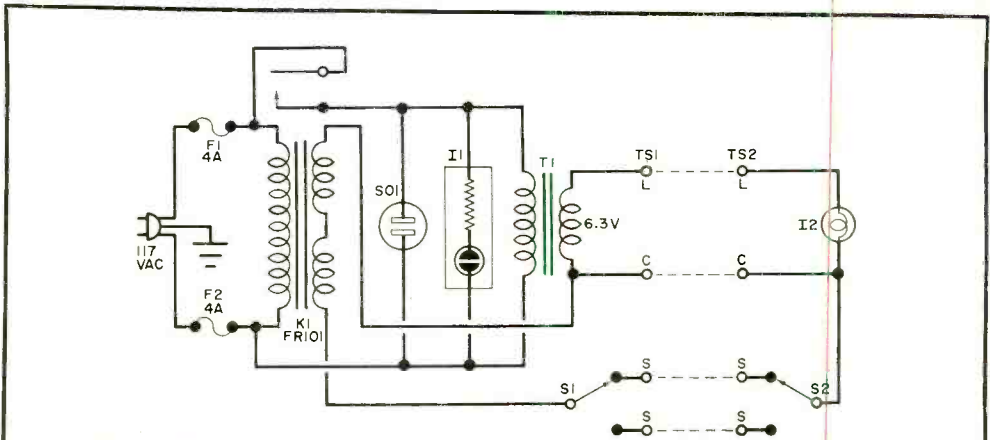

Fig. 1. Relay K1 also contains a step-down transformer. Wiring to I2 and S2 is low-voltage type. Power can be switched from either end of circuit.

PARTS LIST

F1, F2—4-ampere fuse and holder
 I1—117-volt neon indicator lamp
 I2—6.3-volt indicator lamp
 K1—Remote control isolation relay (ALCO FR-101, Lafayette 30F12002)

S1, S2—Spdt slide or toggle switch
 SO1—120-volt ac chassis mounted outlet
 T1—6.3-volt, 1-ampere filament transformer
 TS1, TS2—4-terminal barrier strip
 Misc.—Suitable enclosures (2), length of 4-wire cable (Belden 8741 or similar). 3-lead ac power line, mounting hardware.

line. When the control winding has a very low resistance in its circuit, there is sufficient pull-in power in the relay winding to close the contacts.

The system is divided into two sections: (1) the high-power circuit with transformer, relay contacts and the com-

ponent to be controlled (plugged into SO1); and (2) the low-power remote section containing a switch and indicator lamp. A conventional 4-wire intercom cable can be used for the connections to the remote circuit. If 4-wire intercom cable

(Continued on page 96)

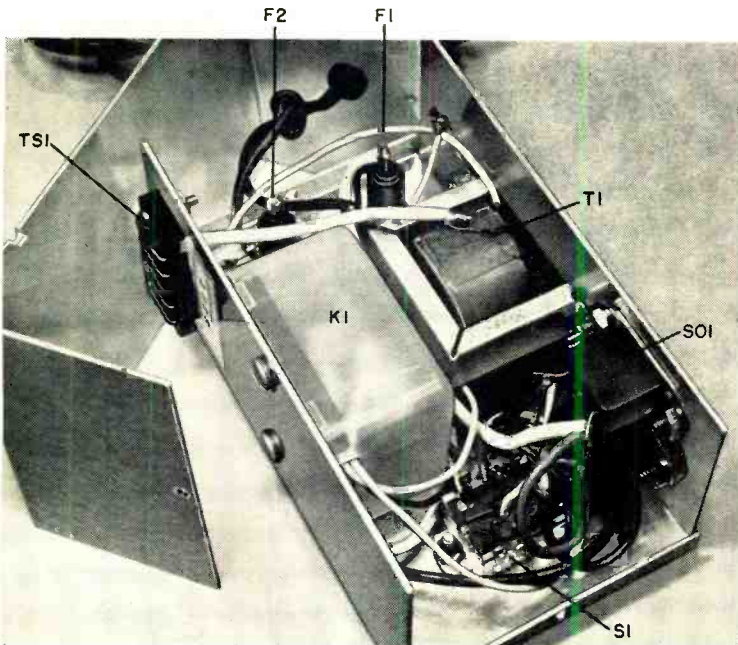

Enclosure for power unit must be either non-metallic or units must be properly insulated to avoid contact. Both sides of power line are fused with ground conductor connected to chassis.



Eleventh in a Monthly Series by J. Gordon Holt

OK! WHAT IS HIGH FIDELITY?

SOME MONTHS AGO, I heard screams of outrage from readers of *The Stereo Scene* when I dared to imply that so-called pop music is irrelevant to high fidelity. Since I intend in this column to state my case, I expect my mail to be even more plentiful and tasty; but I also hope to put the recorded music scene in a sane perspective for those readers who are not emotionally committed exclusively to either the pop scene or the classical field.

Regardless of how you may feel about the classics, this music was the original justification for the whole high-fidelity movement. All of the early advances in sound recording and reproduction were lavished first on symphonies and operas; and the success of each new development was judged on the basis of its effectiveness in reproducing the sound of large performing groups—orchestras and choruses.

The fact that the same technical developments also made the contemporary pop recordings sound better was a welcome by-product, but the idea of trying to make realistic recordings of pop music was a late-comer. Prior to the 1950's, audio developments were concentrated on the hardware—better mikes with smoother, wider range and lower distortion, better amplifiers, better pickups, better tape, and all of the other concomitant improvements in recording and reproducing equipment.

As long as his tools of the trade—the microphones, amplifiers, and disc cutters—were audibly imperfect, the recording engineer aimed for realism. But by the early 1950's, when technological advances made literal realism a genuine possibility, the simple microphone setups, which allowed the instruments, the conductor and the hall acoustics to determine the recorded sound, were being phased out in favor of the more versatile, sophisticated multi-miking techniques. Such techniques gave the recording director con-

siderable control over instrumental timbres and balances, and, via artificial reverberation, over the apparent quality of the acoustics. As multi-miking gave the recording engineers more control, the criterion of the "live performance" sound became subject to more interpretation. The engineer's goal was to place the listener in a hypothetical "best seat in the house," which was supposedly a better listening location than any actual seat in the recording studio. It was then a logical step to the current concept of the recording as a creation unto itself, having no necessary relationship to anything one might hear from any seat in any concert hall.

Regardless of whether current practices choose to acknowledge the fact, there is still some standard of comparison between classical music recordings and "the real thing." The seat at a live concert does affect the sound you hear. While we may not like what we hear from a second balcony seat, we can scarcely deny that it is realistic—because it is the real thing.

The Recording Generation. There appears to be a whole generation of music lovers who, having cut their teeth on recordings, have come to prefer reproduced sound to the real thing. Obviously, this is wholly subjective since what we like or don't like has no bearing on reality. The photography magazines are full of color photographs where the rendition, while pleasing to the eye, cannot be compared with the colors of the original scene.

A convenient and popular way of dismissing any argument about "reality" is to claim that, because our perceptions are personal, different people perceive different things in different ways. The implication that fidelity is purely a matter of taste, and that my taste is as good as yours, is a fallacy. Different people elect, probably unconsciously, to listen to different aspects of the total sound.

"Bell & Howell Schools' proven programs turn out the kind of men we want,"



Say men who do the hiring for top firms in computer, aerospace, television-radio and automation electronics.

A leading computer company: "He has some appreciated abilities not found in graduates of other programs. He has a knowledge of oscilloscopes of any size and complexity—how to use them, repair and service them. His circuit analysis is above average for a man with this experience."

An electronics company: "Perhaps the most valuable asset these 30 men have is the ability to adapt to new work projects with little hesitancy. Their training has enabled them to efficiently perform a variety of tasks and (thus) increase their potential for advancement."

A top TV-radio manufacturer: "I have personally been pleased to note that the men you have sent us show Bell & Howell Schools have consistently kept up with the times in the electronics field."

A major aerospace firm: "It has been our experience that your men have been able to stay abreast of the rapidly changing technical picture in the aerospace industry. They have been able to meet the challenge and consequently maintain an excellent competitive position."

Why you'll become "the man they want"

There are advantages to getting your Electronics training from Bell & Howell School's Proven Programs.

Most importantly, you receive what key executives in business and industry recognize as the most up-to-date, practical and thorough-going preparation for a career in Electronics available.

One of the major reasons for this is that we invest more than \$100,000 yearly—simply to keep our programs in step with

what is going on in the constantly changing world of Electronics.

Electro-Lab-at-home plans offer you many unusual advantages

Bell & Howell Schools offers you four different Electro-Lab-at-Home Plans—two of which are new and expanded. The first covers Computer Control as well as basics.

This program recognizes the expanding need for skilled Electronics Operations

Technicians in a variety of automated industrial processes. You'll understand how the computer *controls* these manufacturing operations . . . be able to help design, install and maintain this highly sophisticated equipment. You'll get a sound background in industrial electronics and instrumentation—with special emphasis on digital computer-controlled systems.

Any man who completes this program can expect a secure, rewarding career with plenty of opportunity for growth.

HEES. This is our newly expanded *Home Entertainment Electronics Systems* program. It offers the *first* 315-sq. inch solid-state Color TV for at-home training.

You'll build, keep this famous name 25" solid-state Color TV set as you prepare yourself for a profitable Service Business of your own. You will be completely familiar with the most advanced solid-state circuitry. And, as the name of the program suggests, you'll be well prepared to handle B & W Television, AM-FM Radio, HiFi, Tape Recorders and most other home entertainment equipment.

These and other Programs are based on valuable experience gained from our own nation-wide technical colleges—information available nowhere else.

This is why we are able to present the most modern theory. And that theory is reinforced by the latest and most useful applications. You'll also receive personal guidance from exceptionally well qualified instructors—men with considerable practical experience and the ability to really "get-it-across."

Our exclusive Electro-Lab®. This includes a remarkably instructive, self-contained circuit design console. It enables you to rapidly "breadboard" a great variety of circuits—like those you'll encounter in today's real world of Electronics.

You'll also receive 16 big shipments of components—including everything you

need to build your own portable, 5-inch, wide-band oscilloscope and a fully transistorized volt meter. You will have two of the best precision instruments money can buy—professional quality gear you'll want to keep and use throughout your career in Electronics.

We provide 8 films to help make the more complicated (yet basic) information easier to understand. These films simplify by picturing what happens—a step at a time. We also lend you a projector so you can run each film as often as you want!

Lifetime national employment service. Whatever your interest, or your experience, we will help you locate the better paying positions in Electronics—and this service is available to you at *any* time—now or in the future.

APPROVED FOR VETERANS' BENEFITS

If you're an ex-serviceman, check the space on the card for the good news about your Veteran's Benefits. Bell & Howell Schools programs are approved under the G.I. Bill.

Student Loans now available. If you're a non-veteran and need financial assistance you may qualify for a student loan. This may enable you to *learn now . . . and repay later.*

Special Help Sessions are scheduled regularly (on Saturdays) at eight Bell & Howell Schools and in many other cities. Here you can get expert guidance by top instructors . . . who will help you over any rough spots.

Why not take advantage of your interest and ability *and the pent up demand in the field of Electronics* by expanding your knowledge and experience now?

Mail the card today for complete information about planning and choosing a profitable career in Electronics. There is no cost or obligation of any kind. 323

FREE! MAIL CARD
NOW FOR COMPLETE
INFORMATION

No Postage Needed



**BELL & HOWELL
SCHOOLS**

4141 Belmont, Chicago, Illinois 60641

But if you recreate exactly the same air vibrations in your home as existed at the site of the original performance, every listener will hear an accurate replica of the live sound.

To most people, high fidelity is not a descriptive term, it is a noun. To them, a record player does not have high fidelity, it is a hi-fi; and when the two-channel record player came along, it became a stereo, simply to distinguish it from a hi-fi. Ask the average person how hi-fi his stereo is, and he'll give you a blank look, as though you had asked him why he doesn't stop beating his wife. Joe Public learned all about stereo and hi-fi from articles and advertisements in the Sunday supplements, so most people can be forgiven for their ignorance. The prevalence of misconceptions scarcely changes the fact that fidelity is faithfulness, and a high-fidelity reproduction is one that is highly faithful to the original. All of which now brings us to the contentious pop field.

Of all the links in the reproducing chain, loudspeakers introduce the most coloration to sound and, for this reason, vary the most from one brand and model to another. All other links, from power amplifier back to the microphone, can be made so close to theoretical perfection (defined as the ability to pass the signal without subtracting or adding to it) that they color the sound only slightly and thus tend to be rather similar. A recording made "straight," using excellent microphones and with no attempt at sonic enhancement, would sound as realistic as the playback loudspeakers permit. But, as soon as a loudspeaker appears at some point in the chain between the recording mikes and the home reproducing system, fidelity starts to go out the window.

Every loudspeaker colors the sound in its own unique fashion and it colors the listener's judgement of the sound. This is no less true of the monitor loudspeakers in the recording studio than it is of the home hi-fi system. When a recording engineer adds tonal corrections and adjusts his balance by listening to the sound through the monitors, he is enhancing the sound as *heard through those speakers only*. The more "perfect" he makes it sound through those monitor speakers, the less perfect it will sound when heard from speakers having a different flavor—and this is the major hitch with today's pop recordings.

Mechanical Classics. The sound of the music we usually think of as classical is produced by purely mechanical means. No amplifiers or loudspeakers (hopefully) are ever involved. The sounds come from vibrating strings, air columns, reeds, and so forth. There are generally accepted "standards" for what violins, trombones and clarinets should

sound like. There are good instruments and poor instruments, bright instruments and mellow instruments, but the range of variation is small enough to enable us to think in terms of "a violin sound" or "a trombone sound." We have, in other words, fairly definitive criteria for assessing the faithfulness of a reproduction of these instruments—regardless of the kind of music they are playing. In a live performance, the acoustics and the listening location modify the sounds of the individual instruments, but the range of modification is narrow enough to permit us to think in terms of "a live performance sound" and to apply this criterion to a reproduction of the sound.

A live, in-person rock performance differs from most other performances in that the audience is not expected to listen! It is expected to participate—loudly—and whatever it hears of the musicians is determined solely by the power and efficiency of the sound reinforcement system. There is a live performance sound, but even if record buyers could stand a diet predicated on the uproar of a Woodstock, the better rock groups would not be interested in being virtually buried by the background sound.

My division here of music into classical and popular is merely a convenience for the purposes of this dissertation, since it is not at all that easy to divide them musically. Some classical folk singers perform "popular" folk music, and some classical compositions for voice and guitar are played by "pop" folk singers. There are even symphony orchestras that play pop tunes and some rock groups occasionally play adaptations of classical compositions. The distinction is not clear-cut, but what does set them apart is the matter of original performance. Was there a performance that an audience could have enjoyed, or did the performance come to fruition on a recording? The answer determines whether or not we can apply standards of fidelity to the reproduction.

The Record Maker's View. Equally pertinent to this subject, although in a different vein, is the attitude of the record manufacturers. They may or may not respect the classical record buyer, but they respect his taste enough to provide high standards of musicality and sound. The manufacturers have found little or no reason to respect the pop buyer's taste. Filthy, distorted rock recordings of performers whose virtuosity would get them laughed off the stage at any Amateur Hour compete with the best sounds of the Beatles. The record manufacturers' understandable reaction is simply, "Okay, if this garbage sells, we'll sell garbage, because it costs less to produce." There are rock record buyers who value musicality and good sound,

(Continued on page 93)



OPPORTUNITY AWARENESS



Thoughtful Reflections On Your Future

Fifteenth in a Monthly Series by David L. Heiserman

The Radio/TV Broadcast Technician

I have been a television repair technician for three years and have nearly completed an electronics engineering home study course. I also have a First-Class Radiotelephone license. Now I would like to get into TV broadcasting. What kind of a job could I get?

● It appears that you have the qualifications for a good job as a broadcast technician in the engineering department of a radio or television station. The kind of work broadcast technicians do is mainly concerned with operating, maintaining, and repairing all the electronic equipment in the station. In a small broadcast station, you might operate a camera, repair a piece of sound equipment, run a routine maintenance check on a transmitter, give the station's call letters when the regular announcer gets a catch in his throat, or sweep the floors! In a larger station, however, you would most likely be assigned to a particular section of the engineering department where your duties would be more specialized and consistent.

According to the National Association of Broadcasters (NAB), the minimum require-

ments for broadcast technicians are a high school diploma and some kind of formal electronics training. Several years' experience with TV or radio maintenance, repair, or production is helpful; and an FCC license is a must for better salaries and faster advancement.

People with no formal electronics training can sometimes get technicians' jobs in broadcasting, but their responsibilities are limited to routine operation of noncritical equipment such as sound booms, lighting, etc. Recent developments in broadcast automation are making these routine jobs obsolete.

Fill out a resume and send it to several radio or television stations, directed to the Chief Broadcast Engineer. When you visit the station for a job interview, take along your high school diploma, FCC license, and the diploma from your home study school. If you're still taking a course in electronics, take along some of the completed lessons to show how well you're doing.

The NAB publishes several free booklets on careers in TV and radio broadcasting. Write for "Careers in Radio" or "Careers in Television" to: National Association of Broadcasters, 1771 N St., NW, Washington, DC 20036. The NAB also publishes a list of

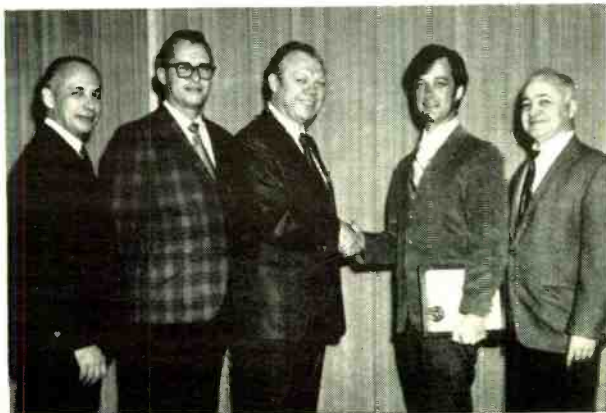

The first accredited degree in engineering to be granted by a correspondence school was awarded to Clayton L. Hallmark, Cincinnati, Ohio. Donald J. Grantham, President of Grantham School of Engineering awarded the degree of Associate in Science in Electronics Engineering. Looking on, from left, are Wilfred Denny, Dean of Students, John Doyle, Dir. of Educational Services, and Harold Tornheim, the Chief Teaching Correspondent.

universities and junior colleges that offer courses in broadcasting.

Three home study schools (approved by the National Home Study Council) offer specialized courses in radio and TV broadcasting:

- Career Academy
825 N. Jefferson St.
Milwaukee, WI 53202
- Grantham School of Engineering
1505 N. Western Ave.
Hollywood, CA 90027
- RCA Institutes, Inc.
320 W. 31 St.
New York, NY 10001

Multiple Factory Authorization For Service Shops

I have been working as a technician in two-way radio and TV repair shops for 12 years. Now I would like to open my own shop, but I want to handle both types of equipment. How will two different manufacturers react when I apply for factory-authorized service for two different kinds of equipment. Perhaps I should avoid the problem by skipping factory authorization altogether.

● It seems that every manufacturer has his own set of standards concerning factory-authorized service shops. Some won't tolerate authorization from any other firm at all, while some don't care as long as the other authorizations don't create a conflict of interests. In the latter case, chances are that you can find some TV manufacturers and two-way radio companies that don't regard each other's products as competitive. The only way to find out is to contact the Service Divisions of the companies concerned.

It is possible, as you mentioned, to get around the problem by running the shop without any factory authorizations. I don't recommend it, though. As Mr. Robert D. Coonley, Advertising Manager of the E. F. Johnson Company puts it, "The reputable manufacturer can offer many advantages to the full-time authorized service shop. In addition to the promotional material and service aids that are made available at either a low cost or no cost, the authorized service shop has the advantage of using the expertise of the factory people with whom he can readily consult from time to time. He is also assured of staying up to date on all the latest service manuals and bulletins—which add further to his efficiency. He need not search for the solution to service problems that others have already encountered."

Mr. Coonley notes another important advantage of factory authorization: "Not to be overlooked is the advantage of low-cost education. Major manufacturers conduct fac-

tory training for service people—either at the factory, in the field, or both."

Opportunities in CB Repair

I have a First-Class FCC license and work as a technician in a two-way radio shop, which specializes in business-band FM equipment. Often individuals come to us with their CB equipment, but they are turned away. These potential customers complain that the only way they can get their equipment repaired is by sending it back to the factory—a process which often takes 6 to 10 weeks. What opportunities would there be for me on my own in the part-time CB repair business?

● I'm sorry I can't give you a simple, straight-to-the-point answer on this. Like any other service business, the opportunities in CB repair depend on the local market, the amount of cash you can invest in spare parts and test equipment, and—above all—your abilities as both a technician and a businessman. However, perhaps the following comments and notes of advice from CB equipment manufacturers will help:

Carl E. Mosley (WOFQY), President and Manager of Mosley Electronics, Inc., says, "In order to conduct a business of this kind, a fellow would have to be in the right neighborhood. The activity in CB varies in different areas. He would also have to be liked by CB'ers and he would have to be operating a station from which he would be in close contact with others."

Mr. Mosley also believes you have the right idea about going into the CB repair business on a part-time basis. "I think that, at the present time, most of the businessmen who try to make a living in the repair of CB equipment operate on a part-time basis. I don't think they depend on a CB repair shop for their entire income."

Robert D. Coonley, Advertising Manager of E. F. Johnson Co., doesn't quite agree with Mr. Mosley about the part-time opportunities: "Success in the field of servicing CB products is—as in most private enterprises—directly related to the investment. As a part-time venture, most would find it difficult to justify the investment in spare parts and test equipment needed to do an efficient job."

Mr. Coonley also says that, "Efficiency is largely the factor that makes the difference between a profitable and a losing business."

I agree, but I still suggest you work your way into the CB repair business a little at a time. To start with, you may have difficulty obtaining wiring schematics for CB transceivers—in case the owner doesn't have his original (and how many do?) You should check Howard Sams to see what they have

(Continued on page 94)



One Hundred Eighty-second in a Monthly Series by Lou Garner

SCIENTISTS and engineers at Bell Telephone Laboratories (Mountain Avenue, Murray Hill, NJ 07974) have developed a new solid-state device which, one day, may provide an exciting new field for the serious experimenter and hobbyist. Using charge-coupling techniques, the device scans printed matter, drawings or photographs line-by-line, converting variations in light intensity into electrical signals. If transmitted to remote locations over telephone lines or by radio broadcast, these signals can be used to reproduce high resolution images of the original material.

The new imaging device is a 2-mm by 4.5-mm chip of homogenous p-type silicon semiconductor with an insulating layer of silicon dioxide overlaying the silicon and a linear array of 288 separate metal electrodes deposited on the oxide surface a mere 12.5 microns apart. These 288 electrodes are connected electrically into three groups: one

consists of the 1st, 4th, 7th, etc., electrodes; another the 2nd, 5th, 8th, etc; and the last the 3rd, 6th, 9th, etc., electrodes. The first three electrodes operate as a single light-sensitive element, as do each subsequent group of three, for a total of 96 elements.

In operation, a lens is used to focus an image on the surface of the silicon chip. Light from the document or other material releases negatively charged minority carriers (electrons) within the silicon, with more charges generated where the light is brighter, fewer where the light is dimmer.

Within each sensing element, the center electrode is connected to a more positive voltage with respect to the silicon substrate than the other two, as illustrated in Fig. 1A. Charges generated by the light near that element collect at the surface of the silicon under the center electrode. Since the number of collected charges at each element is proportional to the light flux falling on the sili-

Fig. 1. How signal charges are kept and moved on in Bell Lab.'s charge-coupled imaging device. Charge storage is shown at A, while B shows how charge transfers when an adjacent electrode is raised to a higher positive potential. It would appear that an all solid-state TV camera using the device may not be too far off.

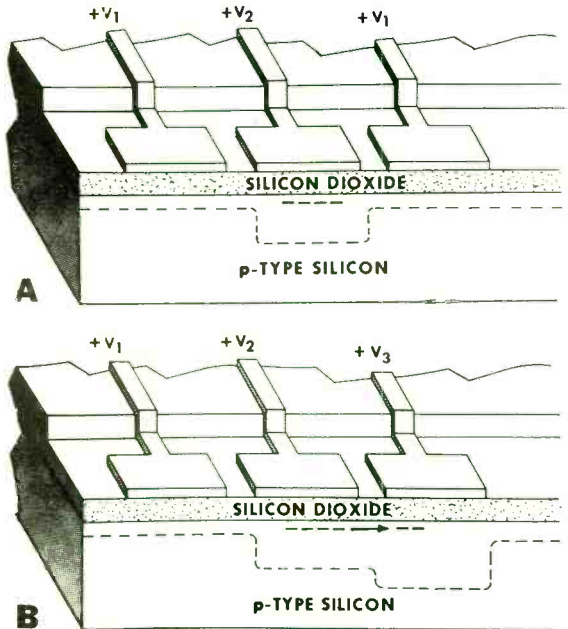

con at that point during the accumulation (storage) period, the resulting concentration of charges is a linear measure of the light and dark areas on the original material. In the experimental device assembled at Bell Labs, the charge pattern is accumulated in only 2.5 milliseconds.

At the end of the accumulation period, the groups of stored charges are transferred along the surface of the silicon by successively applying a more positive voltage to the electrode adjacent to the one holding the charge, while decreasing the voltage on the electrode over the charge region, as shown in Fig. 1B. This causes the charge to move from under one electrode to under the next electrode. Called charge coupling, this transfer process is repeated sequentially until each charge packet has passed along the array of electrodes to the end of the device.

When they reach the last electrode, the charges are collected by an output electrode connected to a small n-type diffusion in the p-type substrate at the end of the structure. A positive voltage is applied to this electrode, reverse biasing the p-n junction and developing an electrical field within the silicon which attracts the charges to the n-type region, thus generating an electrical current whose fluctuations represent variations in light intensity along a line of the original image. Signal read-out from the device requires only about 96 microseconds.

Since the imaging device handles but a single line along one dimension, the document being scanned must be moved relative to the device either optically or physically to

develop a two-dimensional image signal. In the initial experimental system, then, the basic set-up included a light source to illuminate the document, a lens to focus its image on the sensor's surface, a drive mechanism to move the document from line to line as it is scanned, the silicon image sensor, and, of course, the necessary electronic circuitry to develop charge packet transfer and read-out.

Despite the experimental nature of the initial system, the images are of exceptional quality. Bell expects even better resolution and definition as the imaging sensor's design is refined and fabrication techniques are improved.

Still in its developmental stage, Bell's new solid-state image sensor probably will not be available as a commercial device for many months. When offered on the general market, however, it should be useful in a variety of interesting projects, ranging from low-cost facsimile systems to reading aids for the blind, from industrial comparison instruments to image decoders, and from slow-scan television to electronic locks. One day, perhaps, the new device might even find an application in an automatic fingerprint analyzer, thus joining other electronic devices in the never-ending war on crime.

Reader's Circuit: Demonstrating uncommon creative ability, reader Guy C. Sheatz (612 McIntyre Road, Rockville, MD 20851) has broken a long established precedent by submitting two acceptable reader's circuits in succession. Last month, you may recall, we featured his "state-of-the-art" audio ampli-

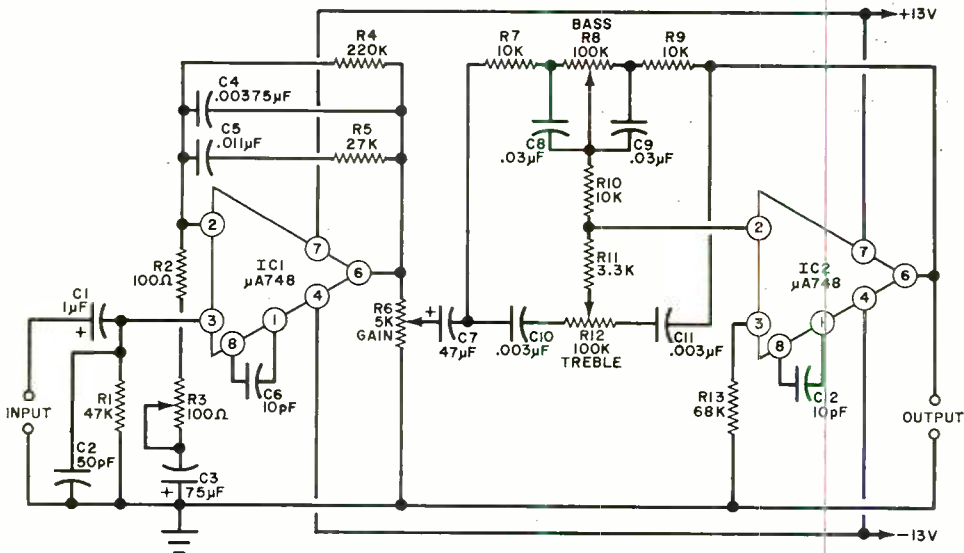

Fig. 2. This two-IC phono preamplifier mates with IC power amplifier submitted last month by Sheatz.

fier, an interesting design utilizing an integrated circuit predriver and complementary power Darlington output devices. This month, we offer Guy's "all IC" phono preamp as a companion design to his power amplifier. According to Guy, his circuit, illustrated in Fig. 2, will furnish more than adequate drive for his power amplifier when used with high-quality phono cartridges.

Guy developed his design around a pair of high performance operational amplifiers. IC1 and IC2. Each amplifier is a monolithic silicon device comprising 20 transistors and 12 resistors, thus providing an overall performance equivalent to a discrete device circuit using 40 active devices.

In operation, feedback network R4-C4-C5-R5 establishes RIAA equalization for IC1, while a different network is used with IC2 to furnish fully adjustable bass and treble control. With the component values listed, bass control R8 will furnish up to 20 dB boost or -20 dB cut at 20 Hz, with a smooth roll-off to the turn-over frequency of 1 kHz. Similarly, treble control R12 can supply up to 19 dB boost or -19 dB cut at 20 kHz, again with a smooth roll-off to the 1 kHz turn-over frequency. Capacitors C1 and C7 provide dc blocking; R1, shunted by C2, establishes the amplifier's input impedance; and R6 is the gain control.

Standard commercial components are specified for the circuit with R3, R8 and R12 being linear potentiometers, while R6 is a logarithmic (volume control) type. Capacitor C3 should be a solid tantalum electrolytic, with C1 and C7 conventional electrolytics.

Although neither lead dress nor circuit layout are overly critical, good audio wiring practice should be followed when duplicating the design, with all signal carrying-leads kept short and direct, and care taken to provide adequate separation between input and output circuitry. Any construction method may be used. Guy assembled his original model on perf board but, of course, a suitably designed etched circuit board could be used, if desired. While a dual 13-volt, well filtered dc power supply is suggested for optimum performance, the circuit's quiescent current is only 3 mA, making battery operation feasible.

Several modifications may be made in the basic design to adapt it to individual needs. With the circuit values specified, IC1's nominal input impedance is quite high and R1, shunted by C2, is included simply to insure a good impedance match for standard 50K phono cartridges. Other R-C combinations may be used here, if needed to match special pick-ups. If NAB equalization for tape recordings is preferred to RIAA, change C4 to 0.0016 μ F, C5 to 0.015 μ F, and R5 to 3600 ohms.

Manufacturer's Circuits. A number of useful semiconductor switching and control circuits are described in a series of informative application bulletins published by the Unitorde Corporation (580 Pleasant St., Watertown, MA 02172). Entitled *New Design Idea*, the series is directed toward design engineers, but could be of real value to advanced experimenters and serious hobbyists. Selected from various issues, the interesting circuits illustrated in Figs. 3 and 4 are typical of those discussed in the bulletins.

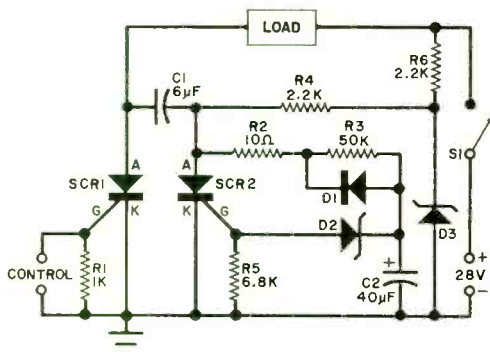

Fig. 3. Novel interval timer will provide three amperes for 1 sec. when toggled by control signal.

Suitable for use in programmers, automatic testing, temperature cycling, process control, and similar applications, the interval timer circuit given in Fig. 3 will supply up to 3 amperes for a period of 1 second when triggered by an external signal, switching off automatically and remaining off until retriggered by another pulse.

In operation, the timing cycle is initiated by applying a positive-going pulse to SCR1's gate, switching this device to a conducting state and supplying power to the load. At the same time, SCR2 is switched "off" through C1's commutating action, permitting timing capacitor C2 to be charged slowly through R2, R3 and R4 by the constant voltage source established by zener diode D3 in conjunction with series resistor R6. When C2's increasing voltage exceeds series zener diode D2's rating sufficiently to permit adequate conduction through SCR2's gate, the latter device is switched "on," discharging both C1 and C2 (through R2 and D1), removing SCR1's anode voltage and, through C1's commutation, switching the device back to a non-conducting state. With SCR1 "off" and C2 discharged, the load current is cut off and the circuit is ready for recycling.

Relatively few components are needed for circuit assembly. Silicon controlled rectifier SCR1 is an SSPI type 3B3060 controlled switch and SCR2 an SSPI type AA100; D2 (Continued on page 87)



THE PRODUCT GALLERY

Eleventh in a Monthly Series by "The Reviewer"

IN THE SIXTH COLUMN of this series (February 1971) considerable emphasis was placed on what now appears to be the age of better bench test equipment for the engineer, technician, or serious electronics experimenter. At the time the discussion centered around a new, imported, modestly priced oscilloscope featuring triggered sweep. As your Reviewer might have expected, no sooner had the sixth column appeared in print than another test equipment manufacturer brought to our attention the fact that they were also importing a triggered sweep oscilloscope that quite possibly might be slightly better and with a shade more flexibility.

B&K SOLID-STATE OSCILLOSCOPE (Model 1460)

Your Reviewer has discussed the advantages of triggered sweep before on these pages. In a triggered sweep system, the oscilloscope trace instantly locks on to either the positive or negative (operator selected) edge of the waveform and remains locked despite variations in either amplitude or even reasonable frequency changes in the signal. Once the oscilloscope trace starts, it remains immune to further triggering until the trace is completed. The triggered sweep is stable and once the operator finds how useful it can be there is absolutely no desire to return to the old-fashioned free running oscilloscope.

There are other advantages to triggered sweep and probably the most important is the fact that the sweep itself can be made extremely linear and the horizontal base line calibrated in time or frequency. This permits the oscilloscope to become the device that it always should have been—an excellent frequency/time instrument.

The B & K Model 1460 is a fine example of a reasonably priced triggered sweep oscilloscope with all the characteristics worthy of any precision instrument costing several times as much. The vertical amplifier response is flat from dc to about 10 MHz and appears to be substantially useful well beyond that range. There are 11 ranges of ver-

tical calibration (compared with 9 or less for some other scopes) offering from 20 volts to 0.01 volt per graticule division. The horizontal sweep portion offers 19 ranges starting from the nominally low 0.5 second per graticule division to 0.5 microsecond per division. This range is more than adequate to present some of the very slow waveforms found in medical electronics to the extraordinarily high speeds used in some types of digital logic circuits. Triggering is either manual or automatic and can be selected with either the positive or negative going edges of the applied waveform. There is also a $\times 5$ expander to enable a closer look at some selected portion of the waveform. For the television servicemen there are three additional items: a fixed sweep for TV horizontal circuits, a fixed sweep for the vertical interval, and simple provisions for converting the Model 1460 to a vectorscope.

Mechanically, the Model 1460 looks a little different than the usual 5" CRT oscilloscope—presumably it might be called a low-profile instrument since it measures only 8½" high. The panel of the Model 1460 is black and all controls are clearly identified including a front panel controlled variable graticule illumination, a built-in 5-volt calibrator, and an arrangement to add a camera adapter for recording waveforms. There is an input for intensity modulation and the probe supplied by the manufacturer has thumb switching for either direct input or a 10:1 attenuation.

Performance Tests. The Model 1460 was subjected to our more or less standard tests using the "Time Base Calibrator" construction project described in the January 1971 issue of this magazine (p 33). As expected, the accuracy of the triggered sweep was excellent and a supplemental test to check the vertical calibration using the Heath EU-80A voltage calibrator proved to our satisfaction that here again we had a scope that was right on the money.

Obviously, once you have established that the scope accuracy leaves little or nothing to be desired, there isn't too much more that

**B & K OSCILLOSCOPE
(Model 1460)**

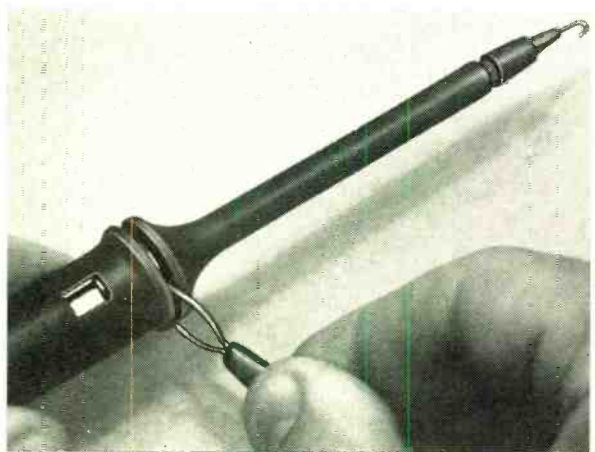
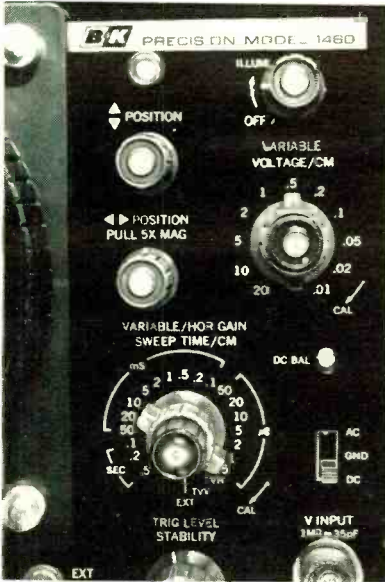

On the main operating controls there are 19 values of sweep (plus a variable control), 11 values of vertical sensitivity (plus a variable control), and the X5 switch on the horizontal position pot.

The ground connection to the circuit under test is made from a clip on the probe. This eliminates a trailing lead on the bench. The scope comes with a couple of different screw-on probe tips, with the hooked version shown installed here. The small window indicates either direct or 10:1 probe hookup.



To change the probe from direct to 10:1, simply pull out the probe end, rotate it, and re-install.

If you have to move the scope around very much, a hollow chamber is provided to stow the line cord.

you can say. In comparative tests with a well-known laboratory type scope, the Model 1460 handled—with relative ease—some of the trickiest waveforms you are likely to encounter in a laboratory workbench. From a purely subjective view, I like the black panel and white lettering, the “squat” construction, and particularly the thoughtfulness of providing a pocket in the rear skirt of the scope to stuff the ac power cord.

HEATHKIT PORTABLE COLOR TV (Model GR-169)

The folks at Heathkit recently added three more kits to their line of solid-state color TV receivers. The new kits cover the range of popular sizes from a 25” ultra-rectangular console with all the trimmings (GR-371MX) to an 18” compact (GR-269) to a handy 14” portable (GR-169). We felt that the portable receiver would be of most interest; so, we decided to check out the GR-169.

This is a non-nonsense receiver, obviously designed for the viewer who wants console performance with carry-all convenience. At first glance, the \$349.95 asking price for the kit might appear to be a little steep when compared with other small-screen receivers on the market. But consider what the GR-169 has to offer—it is a miniature version of the GR-370 console on which we reported in this column in January 1971.

The common design lineage of the two receivers bestows upon the GR-169 an uncommonly fine picture quality and excellent color fidelity owing to the fact that both models share the same VHF and UHF tuners and three-stage i-f strip. There are other similarities that will not go unnoticed: epoxy-fiberglass plug-in circuit board modules, built-in servicing functions and exclusive volt/ohmmeter tester, and the instant on feature. Comparing the schematic diagrams for both receivers, it is also obvious that, in designing the GR-169, only minor changes have been made in the original GR-370 circuit; and the changes reflect the lower power requirements of the portable receiver.

The assembly/operating manual that accompanies this receiver kit consists of four volumes. Book 1 and Book 2 deal with circuit board assembly and chassis assembly, respectively. Book 3 details simple-to-perform adjustments and operating instructions, while Book 4 is devoted to troubleshooting and technical data. All four books are excellently written and illustrated, but Book 2 deserves special mention since it continues the two-color assembly instructions introduced with the GR-370 manuals. This new format simplifies chassis wiring while at the same time virtually eliminating the possibility of wiring errors.

The GR-169 kit went together in less than 20 hours with your reviewer working at a deliberately leisurely pace. Most of the time was spent in mounting and soldering the components to the nine printed circuit cards. Chassis wiring and mechanical assembly, normally the most time-consuming operations, are much easier to perform than a veteran kit builder has a right to expect. In fact, they are so easy that the GR-169 ranks as one of the simplest of any kind of electronic kit to assemble.

Owing to the small size of the receiver, purity, gray-scale, and convergence adjustments are ridiculously easy to perform. Just stand behind the receiver peering into a mirror that shows the entire face of the picture tube, and all of the controls are well at hand.

In slightly less than 21 hours, the GR-169 was ready for a Saturday afternoon of ballgame viewing. And what an afternoon that was. Sitting there watching this little receiver, measuring only 14” diagonally, the sharp picture and excellent color fidelity soon left me with the illusion that I was viewing a large-screen console.

The areas where the GR-169 differs from the GR-370 are minor. Aside from size and weight, the major differences are the absence of AFT, automatic degaussing, and remote control features in the portable receiver. But, after all, there is really no need for these features in a receiver that is designed to be carried from room to room. Degaussing is accomplished manually with a switch that is spring-loaded in a normally off position.

The GR-169 is an excellent color TV receiver to supplement your console. But where it really shines is as a “first color receiver” with its superb performance.

STANTON STEREPHONIC HEADPHONES (Dynaphase I)

Ownership of stereo headphones among stereo buffs is undeniably on the increase (see POPULAR ELECTRONICS, April 1971, p 44). And so is performance, if the user can evaluate this in terms of fidelity, low distortion and power handling ability. By their very nature stereo headphones are a design compromise since piping hi-fi sound into your ears directly is a far cry from listening in your living room to the same sound bouncing off the walls and ceiling. Headphones, unlike speaker systems that strive to attain a flat frequency response have “sculptured” response curves—which is a polite way of saying that a headphone manufacturer has problems achieving wide range response (50-15,000 Hz) using transducers small enough to fit in an earpiece.

Your reviewer shares the opinion of some

**HEATHKIT PORTABLE
COLOR TV
(Model GR-169)**

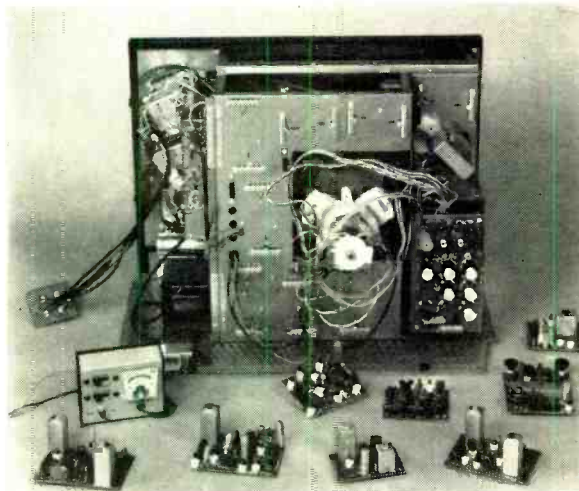
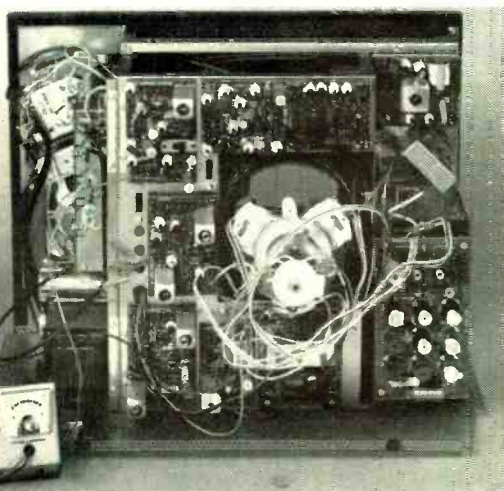
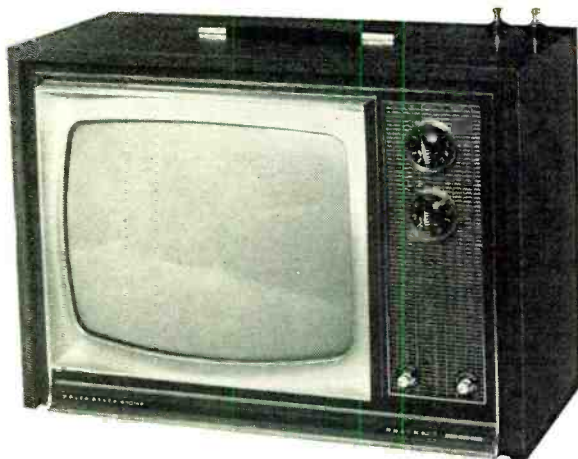

Color TV receiver kit from Heathkit employs eight epoxy-fiberglass plug-in circuit board assemblies. Shown above is assembled receiver, minus cabinet; above right, plug-in boards are shown arranged around basic chassis. VOM that comes with kit can

be seen at lower left in both photos. In photo of fully assembled receiver (top right) can be seen retracted built-in telescoping antenna elements. Not apparent in photo is fact that all secondary controls are located behind trim panel at bottom.

audio experts that stereo headphone response curves are not only difficult to obtain qualitatively, but deceptive and misleading. Curve excursions of ± 6 to 8 dB are not uncommon and even Stanton does not claim a response better than ± 6 dB for the Dynaphase I in the range of 30-18,000 Hz. Unlike many things in hi-fi, the proof of the pudding in stereo headphones is in the listening—not the technical specs.

A half-dozen listeners were used to test

the Stanton Dynaphase I headphones (ranging in age from 14 to 50 years) and each commented favorably on the fidelity and well balanced sound. This, in itself, is quite an achievement considering the gradual aging of people's hearing as they grow older. In addition, listeners that used the Dynaphase I headphones for several hours reported an absence of listening fatigue which can safely be taken to mean that its distortion is very low.

There are two minor disadvantages observable during use of the Dynaphase I. The soft white plastic of the headband and ear cups has an alarming tendency to pick up dirty fingerprints. Although they are easily removed, this reviewer wonders if a colored headband and ear cup might have been more attractive. The overall weight of the Dynaphase I headphone is just under 28 oz. which, according to information in this reviewer's hands makes them just about the

heaviest stereo headphones on the market. Of course, this fact in itself was no secret to the manufacturer and great effort has obviously been made to construct a very comfortable headband and ear piece. Your reviewer has the suspicion that Stanton may have analyzed the median time period that stereo headphones are in use and made a trade off favoring the additional weight in combination with better than average bass reproduction and full range sound.

FOR MORE INFORMATION

B & K Oscilloscope—Circle No. 78 on Reader Service Page 15 or 95
Heathkit Color TV—Circle No. 79 on Reader Service Page 15 or 95
Stanton Headphones—Circle No. 80 on Reader Service Page 15 or 95

**STANTON STEREO
HEADPHONES
(Dynaphase I)**

We found the Dynaphase I stereo headphones to produce some of the best wide-range sound. Each headphone has a separate miniature dynamic woofer and tweeter. The soft, very pliable, white plastic ear cups fit snugly around the listener's ear. Note the letter R indicating the right-hand earpiece.

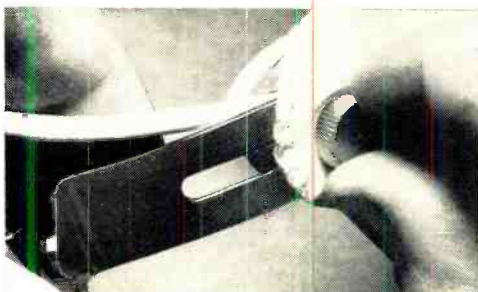
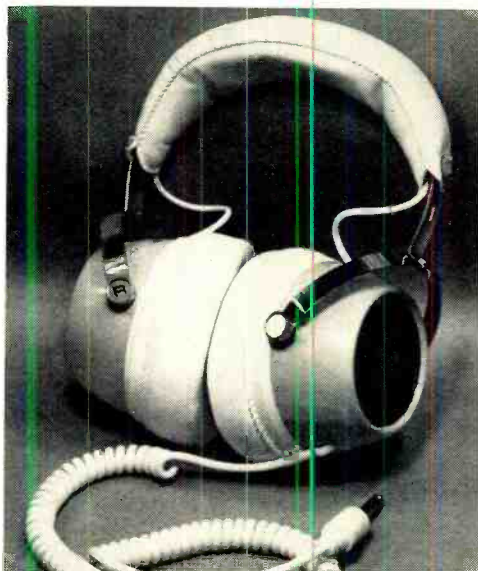

The headphone cord on the Dynaphase I is coiled and can be stretched to 7 feet. Cable is molded to the insulated headphone plug with "spacers" to virtually eliminate possibility of cable breakage.

Comfortable headband is easily adjusted to fit normal sizes. Sound reproduction is exceptionally pleasing, but the weight is somewhat disturbing and headband tends to show dirt due to the color.

SOLID STATE

(Continued from page 81)

is a 6.8-volt zener, type 1N710A, D3 an 18-volt zener, type 1N720A, and D1 a type 1N483 silicon diode. Capacitor C1 is a 30-volt electrolytic, C2 a 10-volt type; and all resistors are 1/4-watt units.

With the component values specified and a 28-volt dc power supply, a trigger pulse of at least 1-volt amplitude and a minimum duration of at least 5 microseconds is required to start the timing cycle. The load current will

be supplied for approximately 1 second before automatic shut-off occurs, but this interval may be increased by increasing C2's value, or vice versa.

Control system designers often encounter the problem of switching power to two loads in complementary sequence—that is, so that one or the other load is always powered, but not both at the same time. A complementary switch of this type might be used, for example, to energize indicator lamps to identify ON-OFF, HIGH-LOW, GO-NO GO, or SAFE-DANGER conditions in electrical or mechanical equipment. Similarly, complementary switches could be used to actuate solenoid valves in processing systems, fail-safe con-

Fig. 4. Circuit A uses two silicon controlled switches to operate complementary loads—with one off, the other on, and vice versa. Circuit B is high-speed version of triac switch.

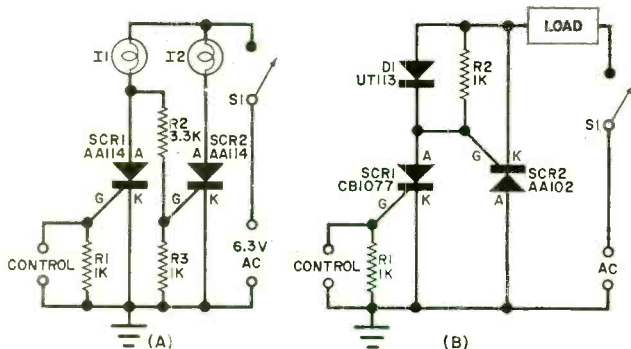

NEW DELUXE COLOR ORGAN CIRCUITS! UP TO 35,000 WATTS

A.P.M. SYSTEMS CORP., MANUFACTURERS OF THE FINEST
COLOR ORGANS IN THE WORLD, NOW OFFER YOU THE MOST
ADVANCED AND POWERFUL COLOR ORGAN CIRCUITS.

AVAILABLE IN 3 AND 4 CHANNEL KITS FEATURING:

- Solid State (easy to assemble printed circuit).
- All UL listed components.
- 3 channel circuit - 2,670 watts - easily converted to handle up to 26,250 watts.
- 4 channel circuit - 3,556 watts - easily converted to handle up to 35,000 watts.
- Electronically balanced circuitry permits one step tuning.
- Wires to any popular sound system in the same manner as a speaker.
- 2 year unconditional guarantee on all parts.
- Easy to assemble kit form.

SEND TODAY

FREE color brochure
with each kit order.

A.P.M. SYSTEMS, INC.
1551 Almaden Rd.
San Jose, Calif. 95125

PLEASE RUSH ME MY A.P.M. COLOR ORGAN KIT, AS INDICATED BELOW:

Check box to indicate choice.

- 3 Channel Kit - \$37.95
- 4 Channel Kit - \$54.95
- 3 Channel Plans - 26,250 watts - \$2.00
- 4 Channel Plans - 35,000 watts - \$2.00
- Color brochure on water swirls and living walls - \$.50

Check one box to indicate manner of payment.

- I enclose full payment. Ship kit postpaid.
- I enclose \$5.00 deposit. Ship kit C.O.D. for balance plus postage.

Name _____
Address _____
City & State _____ Zip _____
California residents add 5% sales tax

A.P.M. SYSTEMS, INC. Dept. M15
P.O. Box 9159, San Jose, Calif. 95117

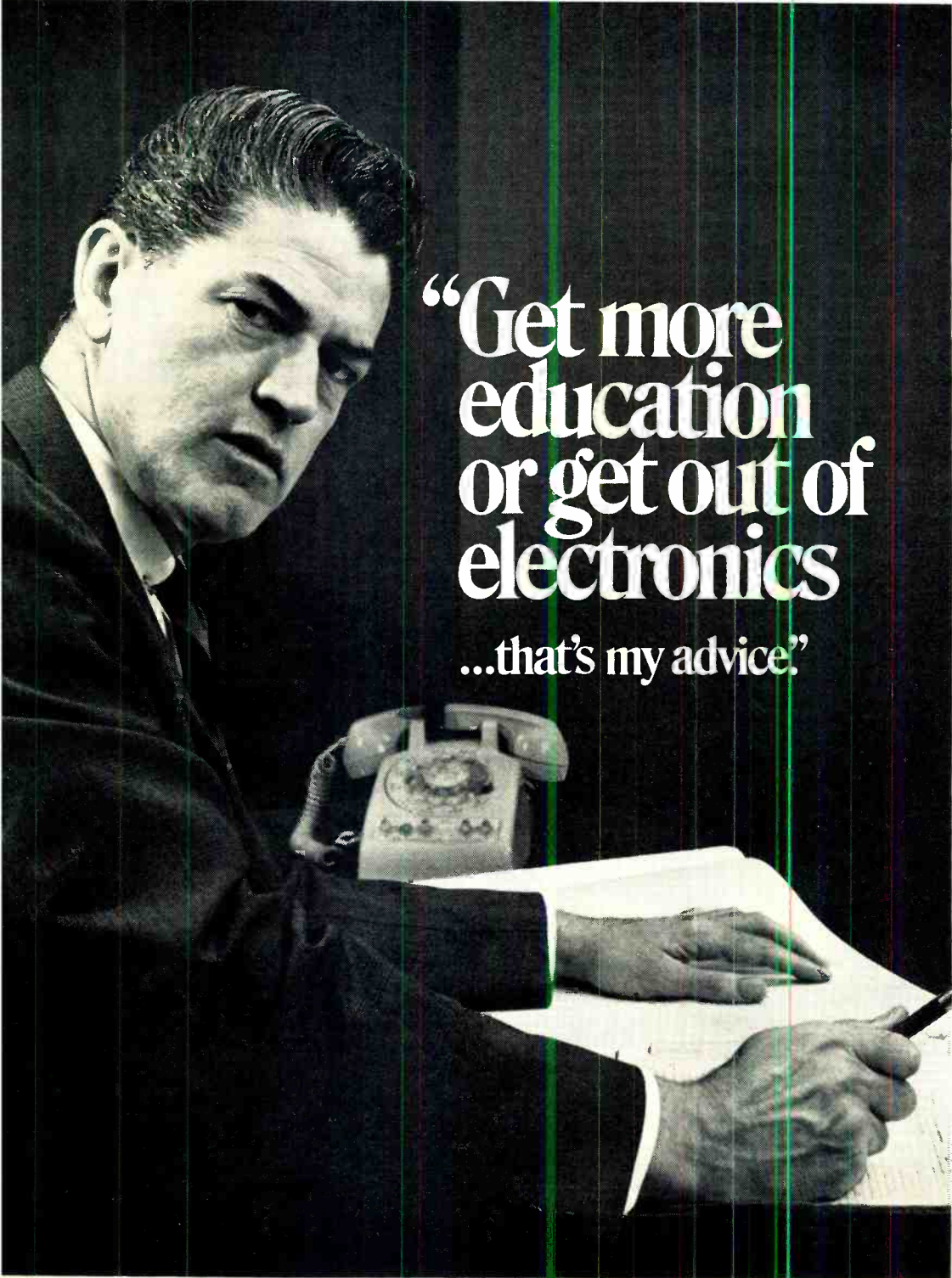

“Get more
education
or get out of
electronics
...that’s my advice.”

Ask any man who really knows the electronics industry.

Opportunities are few for men without advanced technical education. If you stay on that level, you'll never make much money. And you'll be among the first to go in a layoff.

But, if you supplement your experience with more education in electronics, you can become a specialist. You'll enjoy good income and excellent security. You won't have to worry about automation or advances in technology putting you out of a job.

How can you get the additional education you must have to protect your future—and the future of those who depend on you? Going back to school isn't easy for a man with a job and family obligations.

CREI Home Study Programs offer you a practical way to get more education without going back to school. You study at home, at your own pace, on your own schedule. And you study with the assurance that what you learn can be applied on the job immediately to

make you worth more money to your employer.

You're eligible for a CREI Program if you work in electronics and have a high school education. Our FREE book gives complete information.

Mail postpaid reply coupon today or write:
CREI, Dept. E1207B, 3224 Sixteenth St., N.W.
Washington, D. C. 20010.

Founded 1927

Accredited Member of the National Home Study Council

CREI

SEND FOR FREE BOOK

Cut out entire business reply envelope below. Fill in coupon. Fold over, seal (paste or tape) and mail today.

NO STAMP NECESSARY.



Cut along dotted line—Seal (paste or tape) and mail

**CREI, A Division of the McGraw-Hill
Continuing Education Company**
3224 Sixteenth St., N.W.
Washington, D.C. 20010

CREI

Postage will be paid by

BUSINESS REPLY MAIL
No Postage Stamp Necessary If Mailed in The United States

FIRST CLASS
Permit No. 288-R
Washington, D.C.

Do not cut here—just fold over, seal and mail—No stamp needed

NO STAMP NEEDED—

This entire fold-over coupon forms a postpaid envelope.

Please mail me FREE book describing CREI Programs. I am employed in electronics and have a high school education.

E 1207B

NAME _____ AGE _____

ADDRESS _____

CITY _____ STATE _____ ZIP _____

EMPLOYED BY _____

TYPE OF PRESENT WORK _____

I am interested in: Electronic Engineering Technology Space Electronics Computers Nuclear Engineering Technology Industrial Electronics **NEW!** Electronics Systems Engineering **NEW!** Non-Technical Course in Computer Programming.

Approved for training under new G.I. Bill

Johnson put it all together.

□ low band and high band channels in any combination □ base and mobile operation with built-in power supply □ auto-scan with push-button "lock out" plus manual "lock in"

new
Duo-Scan™
\$169⁹⁵

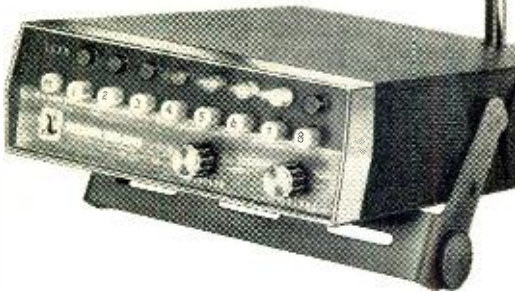

Eight VHF FM channels, in any combination of high and/or low band, keep you on top of all the action. Operates mobile or base with performance features previously found only in professional public safety radio equipment. Two ceramic filters give unsurpassed adjacent channel rejection. Integrated circuit symmetrical limiting makes it really quiet. 0.4 μ V sensitivity lets you hear what others miss. Powerful transistor audio produces clear, undistorted sound. The new Duo-Scan puts it all together, for just \$169.95 (less crystals).



E. F. JOHNSON COMPANY

WASECA, MINNESOTA 56093

1214

CIRCLE NO. 23 ON READER SERVICE PAGE

trols in heavy machinery, or heating and cooling elements in temperature sensitive areas. Featuring a pair of controlled silicon switches, the circuit illustrated in Fig. 4A may be used in such applications.

A positive-going control signal applied to SCR1's gate will energize this device, supplying power to I1 on the ac source's positive half-cycles; SCR2 cannot conduct during this period, for insufficient gate voltage is available through voltage-divider R2-R3. If the control signal is removed, however, SCR1 switches to a non-conducting state and I1 is de-energized. With virtually full supply voltage available at SCR1's anode, adequate gate voltage is applied to SCR2 through R2-R3, energizing this device on alternate half-cycles and furnishing power to load I2.

The controlled silicon switches, SCR1 and SCR2, are both type AA114. The indicator lamps may be any standard 6-volt type (typically, #44), while S1 is a familiar toggle or slide switch.

Normally, an input signal of approximately 1 volt at 1 mA is required to actuate the circuit. The indicator lamps will operate at about 1/3 normal brightness if a 6.3-volt ac source is used, but can be raised to full brightness by employing a 9-volt ac source. If desired, other loads may be substituted for the lamps, such as relays or control solenoids.

Widely used in both consumer and industrial equipment, the bi-directional Triac generally is designed for medium to high power, low-frequency applications and, as a result, is somewhat insensitive and has a relatively slow response time. The circuit given in Fig. 4B, abstracted from Unitrode's *New Design Idea* No. 20, can be used as a high-speed, low-level replacement for a Triac static switch. If combined with a suitable pulse generator, it also can be used as an ac proportional control.

In operation, a positive input signal applied to SCR1's gate causes the device to conduct on the ac source's positive half-cycles, but to switch off during negative periods. On negative half-cycles, however, a small reverse anode current can flow through SCR1 which, blocked by series diode D1, flows into SCR2's gate, triggering this device into conduction. Since SCR2 is connected with reverse polarity compared to SCR1, it conducts during negative half-cycles, thus furnishing full-wave ac to the load.

Standard components are specified for the design; SCR1 is type CB1077, SCR2 type AA102, and D1 type UT113. The resistors are half-watt types and S1 a toggle, slide or rotary switch. A conventional 117-volt, 60-Hz ac power source is used, but the circuit will operate at ac frequencies of up to 20 kHz.

In practice, the switching circuit may be used to drive loads requiring from as little as

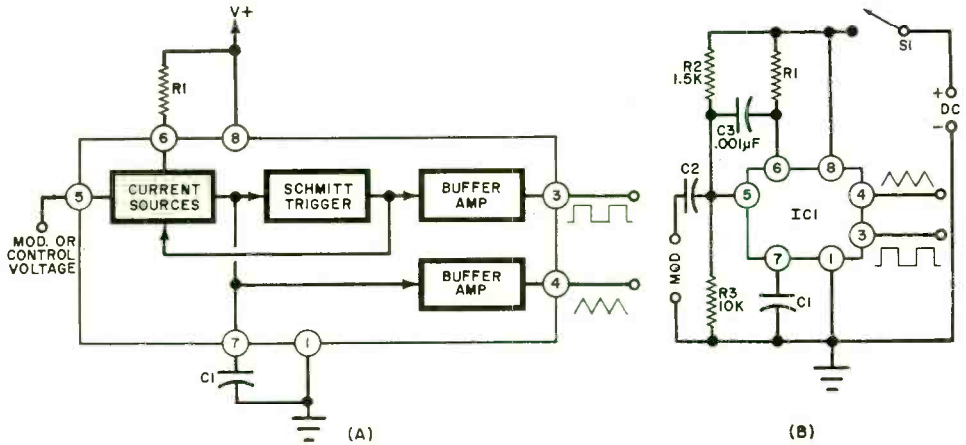

Fig. 5. This new VCO IC can deliver triangle or square wave outputs from 1 Hz to 1 MHz. Frequency is determined by R1 and C1, with modulation applied via pin 5.

1 mA up to 1 ampere. A positive control signal of only 3 mA is needed for operation or, for proportional control, variable-time positive-going pulses of similar amplitude.

Device News. Suitable for use in Touch Tone® encoding, frequency-shift keying, FM modulators, and tone, clock, signal and function generators, a new voltage-controlled IC oscillator of exceptional stability and linear-

ity has been introduced recently by the Signetics Corporation (811 E. Arques Ave., Sunnyvale, CA 94086). Designated the type SE/NE 566 Function Generator, the monolithic device produces two outputs simultaneously: a highly accurate buffered square wave and a very linear buffered triangular wave. Its frequency stability is on the order of 100 ppm/°C.

The SE/NE 566 is offered in both an 8-pin

WHY

Aren't You Listening to the 2 EXTRA CHANNELS in Your Stereo Records, Tapes, and FM Broadcasts?

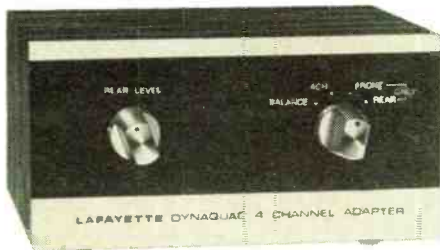

Only **29⁹⁵**

There are four stereo channels already present on your stereo records, tapes, and FM broadcasts but you're listening to only two of them! Add the Lafayette Dynaquad* 4-Channel Adapter to your present stereo receiver or amplifier and two additional speakers and you'll experience the exciting difference of four channel sound NOW!

The Lafayette Dynaquad Adapter recovers and separates the existing stereo sound components and directs them selectively to all 4 speakers. This dramatic new sound dimension is achieved with all existing stereo program sources without the need for any additional amplifiers!

So... why listen to only two channels when you can hear music the way it was meant to be heard with FOUR CHANNEL STEREO from LAFAYETTE?

Send me FREE Lafayette Catalog 714

35071

Name

Address

City

State Zip

LAFAYETTE®

Lafayette Radio Electronics, Dept. 35071
P.O. Box 10, Syosset, L. I., N. Y. 11791

LONG DISTANCE CB MOBILE ANTENNAS

Our fiberglass "Racers 4 & 6" have tunable tips so you can tune your SWR to 1.1:1 and get the most distance out of your mobile transceiver. Extra strong, non-fraying military grade fiberglass . . . fits all standard $\frac{3}{8}$ "-24 thread mounts. The prices are right, too.

Racer 6.....6' length.....\$11.95
Racer 4.....4' length.....\$11.25
Racer Mounts.....\$ 4.95

See your local CB dealer.

TUNABLE TIP
FOR LOWEST
POSSIBLE SWR

avanti

Avanti Research & Development, Inc.
Addison, Illinois 60101

CIRCLE NO. 5 ON READER SERVICE PAGE

Express Yourself
in creative electronics

FREE!

32-page
25th Anniversary
Catalog.

KITS & WIRED



Build all-professional Eico Kits and save 50%. The more you know about electronics, the more you appreciate Eico. Over 2500 local Eico dealers offer you all the top brands, personal technical counsel, fast off-the-shelf service.

- **SOUND N' COLOR®** high fidelity color organs, transmitters, strobes.
- **TEST EQUIPMENT:** new solid state instruments guaranteed 5 years.
- **CORTINA®** solid state stereo receivers, amplifiers, tuners.
- **EICOCRAFT®** solid state jiffy project electronic kits.

Write for **FREE** catalog to: EICO Electronic Instrument Co., Inc., 283 Malta Street, Brooklyn, N.Y. 11207.

CIRCLE NO. 9 ON READER SERVICE PAGE

dual-inline package and a TO-style case. Its "SE" and "NE" versions are similar except for temperature characteristics, with the "SE" type intended for more critical applications.

As shown by the block diagram given in Fig. 5A, the SE/NE 566 includes controlled-current sources, a Schmitt trigger, and a pair of buffer amplifiers. In operation, its frequency of oscillation is determined by an external resistor (R_1), an external capacitor (C_1), and the voltage applied to a special control terminal. The oscillator can be programmed over a 10:1 frequency range by the proper selection of external resistance value and modulated over a similar 10:1 range by the control voltage. It can deliver signals from less than 1 Hz to approximately 1 MHz.

The use of the SE/NE 566 as a simple function generator is illustrated in Fig. 5B. Components R_1 and C_1 are chosen for the desired operating frequency, with R_1 greater than 2K but less than 20K, and C_1 between 0.0001 and 10 μ F. The larger the RC values used, the lower the operating frequency. The circuit's dc supply voltage is not critical as long as maximum ratings (26 volts) are observed. With a nominal 12-volt source, the triangular wave at pin 4 will have a peak-to-peak amplitude of approximately 2 volts across a 50-ohm source, while the square wave at pin 3 will have a peak-to-peak amplitude of about 6 volts, again across a 50-ohm source.

In addition to its new Function Generator, Signetics also has announced a family of four new linear IC's which it has dubbed "third generation" operational amplifiers. The four new units include the SE/NE 537 Precision "Punch Through" Operational Amplifier, the SU 536 FET Input Operational Amplifier, the SE/NE 533 Micropower Operational Amplifier, and the SE/NE 531 High Slew Rate Operational Amplifier. Among the several unique features of the new devices, the SE/NE 537 offers a maximum differential input voltage of ± 30 volts as compared to only 1 volt for early devices, the SU 536 features a high-impedance FET input stage with a typical input offset current of only 2 picoamperes, the SE/NE 533 offers a power dissipation of as little as 100 microwatts.

COS/MOS Manual. If you—as are your editors—are intrigued by RCA's low-power COS/MOS logic circuits as discussed briefly in our April column, you'll want to get a copy of the industry's first manual describing the basic principles of the design and application of these exciting devices. Entitled the "RCA COS/MOS Integrated Circuits Manual," the book covers the fundamentals of physics, device construction, and theory of

operation for monolithic IC's containing both p-channel and n-channel MOS transistors on a single chip.

The manual is organized into separate sections dealing with COS/MOS fundamentals, basic circuits, series CD4000A (3-volt) and CD4000 (6-volt) devices, performance characteristics for both series, logic system design, counters and registers, astable and monostable oscillators, 32-bit adders, linear biasing of COS/MOS inverters, and crystal oscillators. Ratings and parameters are included for many types of individual devices, while such general design considerations as noise immunity, power supplies, interfaces with other logic forms, design criteria and procedures, and typical circuits are discussed in detail.

Although prepared specifically to meet the needs of equipment design engineers, the manual could be of real value to educators, technicians, students, radio amateurs, serious experimenters, hobbyists and others interested in solid-state devices and circuits.

Designated publication No. CMS-270, the 160-page paperback manual carries a nominal price of \$2.50 per copy. It is available from most RCA franchised semiconductor distributors or may be ordered directly from RCA Commercial Engineering, Harrison, NJ 07029. ♦

STEREO SCENE

(Continued from page 76)

though, and it is fortunate for them that the rock groups of outstanding musicality are usually able to persuade their recording producers to give them fairly good sound.

Good musicians, classical and/or pop, want to be heard, and with the rock groups, the sound's the thing. At a recording session they call on the full arsenal of equalizers,

mixers and reverb devices to help create the sound they want. Each instrument is miked separately and taped on its own track. Some players will double on another instrument to add a few new sound tracks and the original master may consist of up to 16 tracks. The sounds made in the studio were "original sounds," but they aren't a performance. They are merely the raw materials of the performance. Each taped track is individually equalized, laced with an appropriate amount of artificial reverb, and mixed down to a two-channel master with "pan-pot" controls used to position each monophonic signal on the stereo stage. The final result is assessed on the monitor speakers in the studio—and that is about as close as it ever comes to a "live" performance.

The subsequent playback in the record buyer's home may be judged to be good or bad sound and no one can argue with that judgement. But the fidelity of the playback—its faithfulness to the original—should be gauged not by how accurately his sound system reproduces, but how closely its particular idiosyncrasies and colorations approach those of the studio monitors. Since different recording studios use different monitors, no single pair of home loudspeakers can provide equally faithful playback of all pop recordings.

The best for which anyone can hope is to assemble a playback system that strikes a balance between the normal range of variation expected from the sounds of the studio monitors. That is, a system whose sound is as neutral as possible. It may never make a pop recording sound exactly as it did in the studio, but it will avoid the situation where a third of the recordings sound fine, another third of the recordings sound too bright, and the last third sound impossibly shrill. The neutral reproducer will make each recording sound the way it actually is, including classical recordings that were intended to sound like live concert hall performances. And if this isn't a high-fidelity system, I don't know what is. ♦

FREE McIntosh CATALOG and FM DIRECTORY

Get all the newest and latest information on the new McIntosh Solid State equipment in the McIntosh catalog. In addition you will receive an FM station directory that covers all of North America.



MX 114

FM/FM STEREO TUNER
and STEREO PREAMPLIFIER

SEND TODAY!

McIntosh Laboratory Inc.
2 Chambers St., Dept. PT-771
Binghamton, N.Y. 13903

NAME _____

ADDRESS _____

CITY _____

STATE _____

ZIP _____

OPPORTUNITY AWARENESS

(Continued from page 78)

available. Otherwise, you'll have to get info from the manufacturers. The test equipment required for CB repair is not too big a deal. Some of it you probably already have, but the whole setup shouldn't be more than \$600-\$750.

At any rate, to start with, spend a couple of evenings a week on CB repair and see how costs and earnings balance out. If you are in a good market area (and that's a big "if") you can increase your working time and your earnings.

Chemistry to Electronics

After ten years as a chemical technician in a refining plant that is being converted to electronic process control, how could I go about getting a position on the electronics end of the business? I completed a home study course in TV and radio repair 8 years ago and have a Third Class FCC ticket. My job is secure but I'd like to get in on the other side of the operation.

● This is an interesting question because it could have come from any number of people now working in traditionally non-electronic industries that are converting to process control and automation.

Unless you've been doing a lot of homework, chances are that the new electronics technicians will know more about modern solid-state circuits, computers, etc. than you do. You have the advantage, however, of knowing all about the chemical processes that go on in your plant. So you should have little trouble getting one of the new jobs once you start updating your electronics know-how.

I suggest you discuss your situation with your employer. Tell him you already know a

little bit about electronics and that you're willing to take some home study courses in modern electronics technology, industrial electronics, and automation. Who knows? He might even be willing to pay part of your tuition.

When talking to him, stress the fact that you can serve as a valuable liaison between the electronics and chemistry branches; and, as your studies progress, you should become even more valuable to both departments.

To get a good start right away, write to the National Home Study Council for a free up-to-date listing of accredited private home study schools. The pamphlet they send you will contain an index of schools offering the courses you want. The address is: 1601 Eighteenth St., NW, Washington, DC 20029.

You may run into one particular snag: if you are valuable in your present position, your immediate superior may not want to release you. In that case, you have to persuade management that an electronics technician who knows a lot about chemistry is more valuable to the company than a chemical technician who knows a little about electronics.

OUT OF TUNE

"Princept Puzzle." May 1971. Diode D11 in Fig. 1 is shown installed incorrectly. The cathode and anode leads of the diode should be interchanged. The diode is shown installed with the correct polarity in the components layout diagram in Fig. 2.



MODEL
SPR-4
\$499⁹⁵
NET

COMMUNICATIONS RECEIVER

A general purpose receiver, the SPR-4 may be programmed to suit any interest: SWL, Amateur, Laboratory, Broadcast, Marine Radio, etc. Frequency Coverage: 150-500 KHz plus any (23) 500 KHz ranges, 500 to 30 MHz.

FEATURES: ● Linear dial with 1 KHz readout ● 4-pole crystal filter in first IF ● 4-pole LC filter in second IF ● Three bandwidths: 0.4 KHz, 2.4 KHz, and 4.8 KHz for: CW, SSB, AM ● Superior cross-modulation and overload performance ● Power: 120 VAC, 220 VAC, and 12 VDC ● Crystals supplied for LW, BC and seven SW bands ● Built-in speaker ● Notch Filter.

ACCESSORIES: 100 KHz calibrator, noise blander, transceiver adapter (T-4XB), DC power cord, loop antenna, crystals for other ranges.

- Direct Frequency Dialing • All Solid State
- Programmable Coverage • FET Circuitry

For more details write: **R. L. DRAKE COMPANY** 540 Richard St., Miamisburg, Ohio 45342

CIRCLE NO. 7 ON READER SERVICE PAGE

Popular Electronics

READER SERVICE PAGE

free information service:

Here's an easy and convenient way for you to get additional information about products advertised or mentioned editorially (if it has a "Reader Service Number") in this issue. Just follow the directions below... and the material will be sent to you promptly and free of charge.

1. On coupon below, circle the number(s) that corresponds to the key number(s) at the bottom or next to the advertisement or editorial mention that is of interest to you. (Key numbers for advertised products also appear in the Advertisers' Index.) Print or type your name and address on the lines indicated.

2. Cut out the coupon and mail it to: POPULAR ELECTRONICS, P.O. Box 8391, Philadelphia, PA 19101.

note: If you want to write to the editors of POPULAR ELECTRONICS about an article on any subject that does not have a key number, write to POPULAR ELECTRONICS, One Park Avenue, New York, N.Y. 10016. Inquiries concerning circulation and subscriptions should be sent to POPULAR ELECTRONICS, P.O. Box 1096, Flushing, N.Y. 11352.

7/71-2

Void after August 31, 1971

Popular Electronics

P.O. BOX 8391
PHILADELPHIA, PA. 19101

1 2 3 4 5 6 7 8 9 10 11 12 13 14 15 16 17 18 19 20
21 22 23 24 25 26 27 28 29 30 31 32 33 34 35 36 37 38 39 40
41 42 43 44 45 46 47 48 49 50 51 52 53 54 55 56 57 58 59 60
61 62 63 64 65 66 67 68 69 70 71 72 73 74 75 76 77 78 79 80
81 82 83 84 85 86 87 88 89 90 91 92 93 94 95 96 97 98 99 100

NAME (Print clearly) _____

ADDRESS _____

CITY _____ STATE _____ ZIP CODE _____

REMOTE CONTROL

(Continued from page 70)

is not available use 4-conductor cable such as that used for antenna rotators.

Construction. The power circuit should be constructed in a non-conductive housing to avoid any chance of making contact with the power line. If a metal housing is used, the components must be mounted to avoid accidental contact with the enclosure. Make sure that the power line ground lead is directly connected to the metal enclosure. Mount a 4-terminal barrier strip, socket(s) *SO1*, local power indicator *I1* and local on-off switch *S1* on the power unit chassis. The fuses should be mounted on insulated holders and the power line should have a grommited hole in the chassis.

The remote control unit can be mount-

ed in any small enclosure, insulated or not, since no appreciable power flows through it. Mount a 4-terminal barrier strip, remote on-off switch *S2*, and remote indicator *I2* on this enclosure.

Operation. Plug the main unit into the commercial power line. Note that *I1* is not lit and there is no power at *SO1*. Remove the power. Connect the 4-wire cable to the power unit, noting which lead is which and then connect it to the remote control unit. Plug the power cord in again. Either switch *S1* or *S2* can now be operated to apply or remove power from *SO1*. Try to keep the total resistance of the four-wire cable within several hundred ohms to get reliable operation. The indicator lamps, one at each end, give visual indication that the system is working properly.

When the remote and local units are in place and the wiring between the two has been installed carefully and securely, recheck the entire system with a load plugged into *SO1*. ♦

*the tape that
turned the
cassette into
a high-fidelity
medium*



TDK SUPER DYNAMIC (SD) TAPE

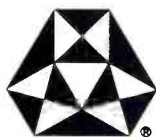

CIRCLE NO. 20 ON READER SERVICE PAGE

TDK

Until TDK developed *gamma ferric oxide*, cassette recorders were fine for taping lectures, conferences, verbal memos and family fun—but not for serious high fidelity.

Today you can choose among high-quality stereo cassette decks.

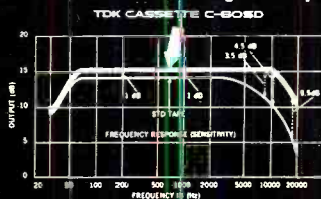

The new magnetic oxide used in TDK Super Dynamic tape distinctively differs from standard formulations in such important properties as coercive force, hysteresis-loop squareness, average particle length (only 0.4 micron!) and particle width/length ratio. These add up to meaningful performance differences: response capability from 30 to 20,000 Hz, drastically reduced background hiss, higher output level, decreased distortion and expanded dynamic range. In response alone, there's about 4 to 10 db more output in the region above 10,000 Hz—and this is immediately evident on any cassette recorder, including older types not designed for high performance. There's a difference in clarity and crispness you can hear.

Available in C60SD and C90SD lengths.

TDK ELECTRONICS CORP.

LONG ISLAND CITY, NEW YORK 11103

DRUMMER BOY

(Continued from page 40)

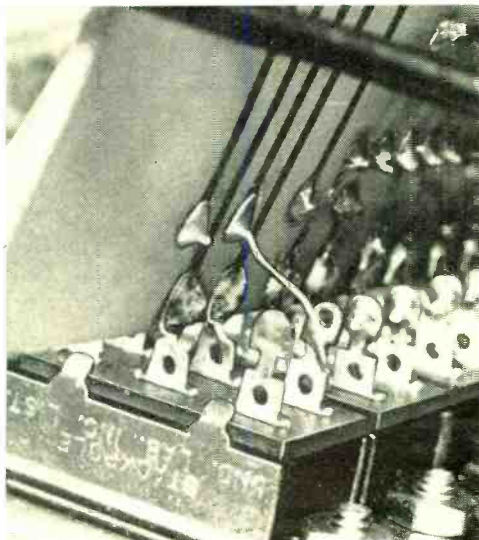

Lugs of the switches associated with the decoder-matrix board are bent 90 degrees so that they can be soldered directly to the pads on the boards.

to the clave position and adjust R81 for the best clave sound. Put S15 back to snare and set S16 for conga. Adjust R72 to get the best conga sound. All the tone generators have now been adjusted.

Turn off the waltz switch and turn on each rhythm switch one at a time. Note that the rhythms are properly generated.

Turn off the main switch and see if the pattern in progress completes itself before stopping.

Operation. Obviously, the best thing to do is experiment. Bear in mind that more than one of the rhythm switches can be used at a time to produce unusual beats. Operating either of switches S14, S15, and S16 removes the snare and substitutes the wood block, clave, or conga, respectively. However, neither of the switches takes precedence over the others.

The conga-bass switch (S17) allows the substitution of a conga for the bass on any beat except the downbeat, where the bass drum is permanent. At the same time that the conga-bass switch substitutes the conga for the bass in a pattern, it also substitutes for the conga either the clave or wood block as selected by S18.

The tone generator can be used by itself and operated manually by using the circuit shown in Fig. 7. Six similar circuits are needed for all of the tone functions. The switches are normally open with snap action. The circuits are identical except for the snare drum which uses a 0.01- μ F series capacitor instead of the 0.001- μ F capacitor shown in the diagram.

Both this board and the tone generator board may be driven by a pair of 9-volt transistor radio batteries in series. The tone generator board can then be connected to the main audio amplifier through a length of audio cable. The manual toggle, the tone generator, and the batteries can be put in a small case and connected to the amplifier.

NEW! CB Transceiver SOLID STATE Pre-Amp

INTERCHANGEABLE 12VDC & 117VAC

- For mobile or base stations
- Improves receiver performance
- Works on tube or transistor equipment
- No modification to CB unit — Also works on SSB
- CQ-THE-AIR sign automatically lights when transmitting



Model PCB1 with universal built-in power supply, transfer relay, AC & DC connecting cables, domestic manufacture, wired & tested.

Write for free literature to —

GONSET/Division of AEROTRON, INCORPORATED
P.O. Box 6527 • Raleigh • North Carolina 27608



CIRCLE NO. 1 ON READER SERVICE PAGE

HAND-HELD RADAR

(Continued from page 68)

the Whistler, the SR-20 is small enough and light enough to be taken off the boat easily and carried home under one arm. The transceiver/antenna is 12" x 24"; the rotator 6" x 6" x 4"; the display unit (a 3" CRT) 3 1/4" x 3 1/4" x 10"; and the total weight of all three is 13 pounds. Simple to operate, the SR-20 has just two controls: an on-off/sensitivity switch and a range switch (2500, 250 and 50 yards). Maximum range is 2500 yards, minimum 30 feet. The Bonzer (an Australian word meaning "very good" if you're interested) isn't choosy about its power source; anything between 10 and 35 volts dc keeps it happy. It draws approximately 2 amperes; the peak power is 10 watts; and the antenna rotates at 20 rpm. A price tag of \$1495 makes the Bonzer SR-20 the least expensive conventional radar on the market today.

Installation is also less—around \$150 would be a good ballpark figure—than

other radars which are generally \$400 to \$450. As a matter of fact, the average boatowner could probably do the physical installation himself: make two connections for power; install the transceiver/antenna and rotator units on a mast, pole or cabin top; plug in the 20' pre-wired connecting cable which comes with the radar; and call in an FCC-licensed technician to check the installation for a minimum fee.

Both the Bonzer and the Whistler have a common ancestor: the radar altimeter which is standard equipment on most aircraft. The Bonzer operates at 5500 MHz while the Whistler is on the 14,000-14,050-MHz band recently authorized by the FCC for continuous-wave FM small-boat radar. (The conventional "X-Band" marine radar operates at 9,000 MHz.)

Both companies—Kimball Products Company which makes the Whistler and Bonzer, Inc. which makes the SR-20—will be concentrating on this year's pleasure boating season. Kimball said it would be in "limited production" by June, while Bonzer claimed "delivery in March." ♦

True 4 Channel Sound

[\$42.50 per 20 watt channel]

There are several components on the market today that will give you true 4-channel sound.

All are expensive. Except ours.

We call ours QAUDIO*. It's an amplifier and player with 4 discrete channels. And we designed it primarily to play the new 8-track 4-channel cartridges.

But it will also play ordinary 8-track stereo cartridges, and make them sound fuller and richer than they ever have before.

Of course it takes a specially recorded 4-channel cartridge to give you the real QAUDIO experience.

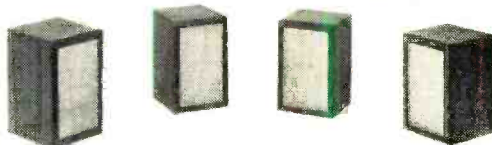

You can experience it today—at a price that's almost as unbelievable as the sound: \$169.95. (That's \$169.95 for a true 4-channel amplifier-player with 80 watts of total music power.) A unit for car/boat is just \$129.95.

We'll be happy to send you the names of dealers near you demonstrating QAUDIO, together with a brochure describing it in detail.

Write to Toyo Radio Company of America, Inc., 1842B W. 169th St., Gardena, Calif. 90247.

QAUDIO
BY TOYO

A SHOCKING EXPERIENCE IN SOUND

*PRONOUNCED "KWAH-DIO". THE NAME QAUDIO IS BASED ON THE GENERIC "QUADRIPHONIC".

CIRCLE NO. 22 ON READER SERVICE PAGE

LIBRARY

(Continued from page 16)

two pages of electronic device symbols and connections.

Published by General Electric Co., 316 East 9 St., Owensboro, KY 42301. Soft cover. 252 pages. \$2.00.

CIRCUIT PROBLEMS AND SOLUTIONS

by Gerald Lippin

Each book in this three-volume set has been written for students at the technical school and junior college levels. Volume 1 covers "Elementary Methods;" Volume 2, "Network Theorems;" and Volume 3, "Transistor and Tube Circuits." With the object of providing a brief review of circuit theory, the volumes are designed to be used in conjunction with a standard course textbook.

Published by Hayden Book Co., 116 West 14 St., New York, NY 10011. Soft cover. Volume 1, 190 pages; \$3.95. Volume 2, 126 pages; \$3.95. Volume 3, 92 pages; \$3.55.

ELECTRONIC CIRCUITS: PHYSICAL PRINCIPLES, ANALYSIS, AND DESIGN

by Paul M. Chirlian

Written for college juniors and seniors, this textbook provides a thorough understanding of the physical principles of electronic devices and the operation of their circuits. Both integrated and discrete circuits are discussed in depth. And a unified treatment of transistors and field-effect transistors and vacuum tube circuits is given wherever possible.

Published by McGraw-Hill Book Co., 330 West 42 St., New York, NY 10036. Soft cover. 863 pages. \$15.50.

ABC'S OF INTEGRATED CIRCUITS

by Rufus P. Turner

Students, hobbyists, and others with some knowledge of transistors and similar semiconductor devices will find this book ideal for getting acquainted with the IC. It is an elementary introduction to the IC, its construction, behavior, and uses. Theory and math have been purposely kept to a minimum; the approach is descriptive and practical.

Published by Howard W. Sams & Co., Inc., 4300 West 62 St., Indianapolis, IN 46268. Soft cover. 96 pages. \$2.95.

LABORATORY MANUAL FOR TRANSISTOR AND SEMICONDUCTOR DEVICES

by R.F. Coughlin, et al.

Prepared by Wentworth Institute, the book shows the reader how to put into practice the things learned in theory. While it is not restricted solely to solid-state circuits as its title implies, it is definitely a transistor and diode book.

Published by Prentice-Hall, Inc., Englewood Cliffs, NJ 07632. Soft cover. 148 pages. \$7.95.

UNDERSTANDING SOLID-STATE CIRCUITS

by Norman H. Crowhurst

All the information anyone might need to become acquainted with practical solid-state circuits is contained within the pages of this book. The pertinent details are explained without resort to electromechanical physics. Everything from the lowly diode through sophisticated IC's is dealt with.

Published by Tab Books, Blue Ridge Summit, PA 17214. 192 pages. \$7.95 hard cover; \$4.95 soft cover.

Sonar SENTRY VHF MONITOR RECEIVERS WITH ADJUSTABLE SQUELCH



With Battery, Earphone, & Jess Crystals \$5.00 ea.

\$49.95 SOLID STATE
With ADJUSTABLE SQUELCH
POCKET SIZE
3 CHANNELS

FR-103SA (150-175 MHz) | FR-106SA (IN FOUR 30-50 MHz FREQ.)

LISTEN TO: POLICE, FIRE, & WEATHER REPORTS!

for Industrial, Commercial, Utility & Govt. Use

3 CHANNELS • BROADCAST BAND • CRYSTAL CONTROLLED

Designed and engineered for simplicity of operation, compact enough to fit a shirt pocket yet powerful enough to deliver a clear clean signal—it's dependable • Operates on three crystal controlled VHF channels plus broadcast band • Adjustable squelch • Completely solid state for long life use • Visible battery indicator to show battery condition at all times • Built in antenna • 5 7/8" H x 2 1/2" W x 1 3/4" D. Wt. 11 oz.

SONAR RADIO CORP., 73 Wortman Ave., Bklyn, N.Y. 11207

Please send information on VHF Monitor Receivers.

Dept. 301

Name _____
Address _____
City _____ State _____ Zip _____

CIRCLE NO. 18 ON READER SERVICE PAGE

ELECTRONICS MARKET PLACE

NON-DISPLAY CLASSIFIED: COMMERCIAL RATE: For firms or individuals offering commercial products or services, \$1.25 per word (including name and address). Minimum order \$12.50. Payment must accompany copy except when ads are placed by accredited advertising agencies. Frequency discount: 5% for 6 months; 10% for 12 months paid in advance. **READER RATE:** For individuals with a personal item to buy or sell. 80¢ per word (including name and address). No Minimum! Payment must accompany copy.

DISPLAY CLASSIFIED: 1" by 1 column (2 5/8" wide), \$110.00. 2" by 1 column, \$215.00. 3" by 1 column, \$320.00. Advertiser to supply cuts.

GENERAL INFORMATION: First word in all ads set in bold caps at no extra charge. All copy subject to publisher's approval. Closing Date: 1st of the 2nd month preceding cover date (for example, March issue closes January 1st). Send order and remittance to Hal Cymes, **POPULAR ELECTRONICS**, One Park Avenue, New York, New York 10016.

FOR SALE

FREE! bargain catalog. Fiber optics, LED's, transistors, diodes, rectifiers, SCR's, triacs, parts. Poly Paks, Box 942, Lynnfield, Mass. 01940.

GOVERNMENT Surplus Receivers, Transmitters, Snooperscopes, Radios, Parts, Picture Catalog 25¢. Meshna, Nahant, Mass. 01908.

ROCKETS: Ideal for miniature transmitter tests. New illustrated catalog. 25¢. Single and multistage kits, cones, engines, launchers, trackers, rocket aerial cameras, technical information. Fast service. Estes Industries, Dept. 18-G, Penrose, Colorado 81240.

LOWEST Prices Electronic Parts. Confidential Catalog Free. **KNAPP**, 3174 8TH Ave. S.W., Largo, Fla. 33540.

WE SELL CONSTRUCTION PLANS. TELEPHONE: Answering Machine, Speakerphone, Carphone, Phonevision, Legal Connector, Auto Dialer, Central Dial System. **TELEVISION:** \$35.00 Color Converter, Tape Recorder, 3DTV. \$25.00 Camera. **HOBBYIST:** Electron Microscope, 96 Hour Tape Music System, Ultrasonic Dishwasher, Radar-Oven, Electronic Tranquillizer. Plans \$4.95 each. **COURSES:** Telephone Engineering \$39.50. Detective Electronics \$22.50. Anti-Detective Electronics \$27.50. **NEW SUPER HOBBY CATALOG AIRMAILED \$1.00.** Don Britton Enterprises, 6200 Wilshire Blvd., Los Angeles, Calif. 90048.

WEBBER LAB's Police & Fire Converters. Catalog 25¢. 72 Cottage Street, Lynn, Mass. 01905.

INVESTIGATORS, latest Electronics Aids. Free Literature. Clifton, 11500-L NW 7th Ave., Miami, Florida 33168.

ELECTRONIC PARTS, semiconductors, kits. **FREE FLYER.** Large catalog \$1.00 deposit. **BIGELOW ELECTRONICS**, Bluffton, Ohio 45817.

RADIO—T.V. Tubes—36¢ each. Send for free catalog. Cornell, 4213 University, San Diego, Calif. 92105.

CLEARANCE SALE rectifiers, transistors, 1000's other items. Catalog 15¢. General Sales Company, 254 Main, Clute, Texas 77531.

MECHANICAL, ELECTRONIC devices catalog 10¢. Greatest Values—Lowest Prices. Fertik's, 5249 "D", Philadelphia, Pa. 19120.

SENCORE, B&K Test Equipment Unbelievable Prices. Free Catalog and Price Sheet. Fordham Radio, 265 East 149th Street, Bronx, N.Y. 10451.

ELECTRONIC Ignition. Various Types. Information 10¢. Anderson Engineering, Epsom, N.H. 03239.

NEW SEMICONDUCTOR LIGHT EMITTING DIODES—bright red lights replace light bulbs. Typical life 100 years. Operate at 1.65 volts, 50 milliamps. Order 2 for \$2.98 NOW. Data sheet and instructions included. Monsanto Company, Hobby Section, 10131 Bubb Road, Cupertino, California 95014.

CONVERT any television to sensitive, big-screen oscilloscope. Only minor changes required. No electronic experience necessary. Illustrated plans, \$2.00. Relco-A33, Box 10563, Houston, Texas 77018.

FREE catalog, parts, circuit boards for **POPULAR ELECTRONICS** projects. **PAIA ELECTRONICS**, Box C14359, Oklahoma City, OK 73114.

ELECTRONIC COMPONENTS—Distributor prices, Free catalog. Box 2581, El Cajon, California 92021.

FREE Kit Catalog: Shortproof Power supply \$39.50. Ultrasonic Alarm \$37.25. **SWTPC**, Box B32040, San Antonio, Tex. 78216.

AMATEUR SCIENTISTS, Electronics Hobbyists, Experimenters, Students . . . Construction Plans—all complete, including drawings, schematics, parts lists with prices and sources . . . Radar—Build your own ultrasonic doppler radar. Detect motion of people, automobiles, even falling rain drops. Transistorized, uses 9 volt transistor battery—\$4.50 . . . Long-Range "Sound Telescope"—This amazing device can enable you to hear conversations, birds and animals, other sounds hundreds of feet away. Very directional. Transistorized. Uses 9V battery—\$3.50 . . . Robot Man—Moves hands and arms—\$3.50 . . . Or send 25¢ coin (no stamps) for complete catalog. Other items include Psychedelic strobes, light shows, lasers . . . 46 different projects. Technical Writers Group, Box 5994, State College Station, Raleigh, N.C. 27607.

WOULD YOU SPEND 25¢ to save \$25.00 or more? Citizens Band, AM and SSB 2-way radios, USA and export models. Send 25¢ for catalog to: **BAGGY'S RADIO**, 6391 Westminster Avenue, Westminster, CA 92683. Dealer Inquiries Invited.

FIND COINS-GOLD-RELICS-TREASURE metal locators by JETCO!

- Lightweight
- Easy to Use
- Comes Complete
- Made in USA
- 5 yr. Guarantee
- Immediate Delivery!
- Write for FREE Catalog.

priced from

\$39.95



Jetco ELECTRONIC INDUSTRIES, INC.

P. O. BOX 132, PE HUNTSVILLE, TEXAS 77340
PHONE ORDER TO: 713/95-5422

CITIZENS BAND—Shortwave Listener-Ham equipment from Amrad Supply, Inc. Free Flyer, 1025 Harrison St., Oakland, Calif. 94607.

PSYCHEDELIC Strobe Kit: Complete with 110w/sec. tube, reflector, chassis and cabinet \$17.50 plus postage and insurance. 2 lbs. (Extra tubes \$3.50) **SWTPC**, Box B32040, San Antonio, Texas 78216.

SEMICONDUCTORS: Buy from single source. Serving experimenters, hobbyists. No minimums. SN 7400N, \$1.90; MC724P, \$1.10, Etc. RLabs, Box 253, Burlington, Ma. 01803.

ANTIGRAVITY, experiment and theory. Rushed—\$2.00. U.S. Inquiries. Intertech 7A10, Box 5373, Station-F, Ottawa, Canada.

LEARN the facts of electronics and your privacy. Send for the Tron-X Manual, P.O. Box 38155, Hollywood, CA 90038. \$5.95.

SPACE-AGE TV CAMERA KITS & PLANS



BE A PIONEER IN HOME TELECASTING! Build your own TV CAMERA. Model XT-1A Series D \$116.95 pp. S&H. Steels. Step-by-step construction manual. High quality. Connects to any TV without modification. Ideal for homes, experimenters, education, industry, etc.

PHONE or WRITE for CATALOG.

DIAL 402-987-3771

Many other kits, parts and plans available including starter kits, focus/detf. coils, vidicon tubes, const. plans, etc.

1301 N. BROADWAY **ATV Research** DAKOTA CITY, NEBR. 68731

POPULAR ELECTRONICS

WOULD YOU SPEND 25¢

to save \$25.00 or more? Citizens Band, AM and SSB 2-way Radios, USA and Export Models. Send 25¢ for catalog to:

BAGGY'S RADIO

P. O. Box 778, 6391 Westminster Avenue
Westminster, CA 92683
Dealer Inquiries Invited

JAPAN HONG KONG DIRECTORY. World products information. \$1.00 today. Sekai Shogyo Annai, Hillyard, Washington 99207.

PRINTED CIRCUITS Quick. Free Estimates. Industrial Photo B-18, Oakhurst, N. J. 07755.

EUROPE's top quality electronic parts, ridiculous prices. Catalog 35¢. Electrovalue-America, Box 27A, Swarthmore, Pa. 19081.

INTEGRATED CIRCUITS—Factory Prices, Catalog 10¢. Silings, Box 6257, Seattle, Washington 98188.

duo-band • auto search Monitor Receiver



pei 8-channel scanning monitor HL-44 locks on active channel,

then resumes search when channel goes quiet. Program scanning speed, any number of high or low band channels by plugging in crystals. **NO WIRING CHANGES.** Use it on your desk or in your car.

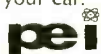

Write for free literature.

PETERSEN ELECTRONICS, INC.

1000 South Main — Council Bluffs, Iowa 51501

FREE Kit Catalog: Color Organs \$11.00, Psychedelic Strobes \$17.50, Professional quality—lowest prices. SWTPC, Box F32040, San Antonio, Texas 78216.

"ACHTUNG! Das machine is nicht fur Gerfingeroken and Mit-tengrabben"-etc. on **GOLD CARDS.** \$1.00 for 6. JMH Enterprises, 1208 S.E. Seventh, Portland, Oregon 97214.

FREE! Giant Electronics Catalog. McCord Electronics, Box 41-P, Sylvania, Ohio 43560.

PULSE GENERATORS, oscillators, logic modules, booklets, and plans. **FREE LITERATURE.** Scientific Measurements, 2945 Central, Wilmette, Illinois 60091.

ELECTRONIC Gummies new guaranteed. Monarch KW SWR relative power dualmeter antenna bridge \$16.45 postpaid. Quote industrial, amateur, CB. Madison Electronics, 1508 McKinney, Houston, Texas 77002. (713) 224-2668.

STORAGE pockets heavy vinyl self-adhering. 8 individual (4½" x 5½") compartments per sheet (11½" x 13½"). Uses: probes, small parts, components, messages, index cards included. 50¢ per sheet. 3 for \$1.00, 10 for \$3.00. Tech Electronics Supply Co., 7320 Lubao Ave., Canoga Park, Calif. 91306.

SHURE-AKG-Turner-Electro Voice Microphones. Prices? Randall's, Box 8097, Milwaukee, Wis. 53223.

EUROPEAN and Japanese bargains catalogs. \$1 each. Dee, P.O. Box 9308, North Hollywood, Calif. 91609.

BRAINWAVE FEEDBACK. Electroencephalophone teaches alpha-wave control. Information 10¢. J & J Enterprises 8102-E Bainbridge, Wash. 98110.

QUALITY components and Hi-Fi Equipment at excellent prices. Our large catalogue 10¢. Gust & Company, Box 24081, Edina, Minnesota 55424.

BATTERIES costing you a fortune? Tape Recorder Batteries don't seem to last? NICAD Rechargeable Batteries will solve your Battery problems. They can be recharged 500 times. They carry a full year warranty. All sizes in stock. Phone, write or come in. Advance Electronics, 54 West 45th St., New York, New York 10036. (212) 661-0124.

FREE Electronics Catalog. Tremendous bargains. Edu-Kits, Department C-701 D, Hewlett, New York 11557.

"LISTEN IN" TO POLICE-FIRE RADIO CALLS IN YOUR CAR!

WORKS with ANY CAR—Portable or HOME RADIO! Just **PLUGS in**—No wiring—3 minute hook-up! Switch instantly from regular to **ALL POLICE-FIRE-EMERGENCY-COMMERCIAL-TAXICAB-STATE-CITY-GOV'T** 2-way Radio calls in **YOUR AREA. DUAL-HI-LOW BANDS**—**OVER a MILLION** Radio Cars/stations. **USE** Everywhere—anytime—always works!
SEND ONLY \$2.00 (cash, Ck., M.O.) and pay post-man \$7.99 plus **COD** pstg or send \$9.99 for **ppd Del in USA. COMPLETE,** ready to use with instructions. One Year Service Warranty—**10 DAY MONEY BACK TRIAL** if return. **AWAZING OFFER** good only by mail—**WESTERN RADIO Dept. BPE-7 KEARNEY, NEBR. 68847**



BURGLAR ALARM SYSTEMS. We manufacture intruder-fire detection systems, radar and perimeter types. Accessories available. Free Literature. Inquiries for dealership and wholesale prices must be on letterhead. U.S. and Canada only. Microtech Associates, Inc., Box 10147, St. Petersburg, Florida 33733.

CONSTRUCTION PLANS: Laser . . . \$2.00. Investigation Aids—2-FM Microphone Transmitters . . . \$1.00. FM Telephone Transmitter . . . \$2.00. Sound Telescope . . . \$2.00. Space Monitor—Missile Tracker . . . \$2.00. Free equipment and kit catalog. Howard, 20174 Ward, Detroit, Michigan 48235.

RADAR, Fire, Burglar Alarms, Electronics. New, 256 pages profusely illustrated, \$4.95. Harvey Electronics, 3846 Greenville, Wilmington, Del. 19807.

TV TUNER REPAIRS—Complete Course Details, 12 Repair Tricks, Many Plans, Two Lessons, all for \$1. Refundable. Frank Boeck, Box 833, Redding, Calif. 96001.

TOOLS—Woodcarvers Supply, catalog 25¢, 3112 West 28th, Minneapolis, Minn. 55416.



BARGAIN HUNTING?

SEND 10¢ TO DEPT 6
FOR BARGAIN CB CATALOG!

HENSHAW'S

3617 TROOST, KANSAS CITY, MO

PLANS AND KITS

FREE Kit Catalog: Digital Microlab \$29.95. Also Segmented and Nixie Readouts, Timebases, Scalers, Electronic Digital Clocks (all featured in Popular Electronics) SWTPC, Box C32040, San Antonio, Tex. 78216.

FREE kit Catalog: Amazing new Universal Digital Instruments with plugins as featured in **Popular Electronics.** Unbeatable prices. SWTPC, Box D32040, San Antonio, Tex. 78216.

FREE Kit Catalog. Why does every major College, University, Technical School, Research & Development Center buy from us? Because we have the highest quality and lowest prices. Free catalog. SWTPC, Box H32040, San Antonio, Tex. 78216.

TELEVISION Training Kits, Parts, Plans. \$2.99. Free Flyer. Aline, 434 West 4th Street, West Islip, New York 11795.

CONVERT your scope. Dual trace FET switch, \$10.00. Trigger-sweep \$24.95. Kits include semiconductors, boards, instructions. HAMLIN TECHNICAL PRODUCTS, Box 901, Cupertino, Calif. 95014.

COLOR organ. Construction plans for three-channel color organ. \$2.00. Pacinfo, Box 153M, Clovis, Calif. 93612.

BURGLAR alarms super-sonic plans with parts list. Homes, factories \$5.00. Refundable on parts. Security, 14 East Jackson, Chicago 60604.

COLOR organs, strobes, plans, brochure 10¢. Raeco, P.O. Box 14, Readville, Mass. 02187.

ANALOG Computers, plans, economical. Catalog \$1.00 (refundable). Fernwood, Box 2005E, Lynnwood, Wash. 98036.

HIGH FIDELITY

TAPE RECORDERS, Hi-Fi, components, Sleep Learning Equipment, tapes. Unusual Values. Free Catalog. Dressner, 1523R, Jericho Turnpike, New Hyde Park, N.Y. 11040.

LOW, Low quotes: all components and recorders. HiFi, Roslyn, Penna. 19001.

FREE Kit Catalog. Amplifiers: Lil Tiger \$11.10, Universal Tiger \$30.00, Preamp \$44.50 (Featured in **Popular Electronics**) SCA Adaptors \$14.55. SWTPC, Box A32040, San Antonio, Tex. 78216.

DIAMOND NEEDLES and Stereo Cartridges at Discount prices for Shure, Pickering, Stanton, Empire, Grado and ADC. Send for free catalog. All merchandise brand new and factory sealed. LYLE CARTRIDGES, Dept. P, P.O. Box 69, Kensington Station, Brooklyn, New York 11218.

DAZZLING color organs. Other great electronic kits too. Free catalog. Korly Co., Box 143E, Cranford, New Jersey 07016.

WANTED

CASH PAID! Unused tubes, electronic equipment. Barry, 512 Broadway, NYC 10012.

QUICKSILVER, Platinum, Silver, Gold, Ores Analyzed. Free Circular. Mercury Terminal, Norwood, Mass. 02062.

TUBES

TUBES "Oldies", latest. Lists free. Steinmetz, 7519 Maplewood, Hammond, Indiana 46324.

RECEIVING & INDUSTRIAL TUBES, TRANSISTORS. All Brands—Biggest Discounts. Technicians, Hobbyists, Experimenters—Request **FREE** Giant Catalog and **SAVE!** ZALYTRON, 469 Jericho Turnpike, Mineola, N.Y. 11501.

RADIO & T.V. Tubes—36¢ each. Send for free catalog. Cornell, 4213 University, San Diego, Calif. 92105.

TUBE Headquarters of World! Send 10¢ for Catalog (tubes, electronic equipment) Barry, 512 Broadway, N.Y.C. 10012.

TUBES—Lowest prices. Foreign-American. Obsolete, receiving, special purpose, transmitting tubes. Send for tube, parts catalog. United Radio Company, 56-P Ferry St., Newark, N.J. 07105.

TAPE AND RECORDERS

OLD radio programs on tape. 6 hours for \$8.00. Catalog 50¢. Don Maris, 1926 Cherokee, Norman, Okla. 73069.

STEREO TAPE RENTAL for particular people. Free catalog. Gold Coast Tape Library, Box 2262, Palm Village Station, Hialeah, Fla. 33012.

RENT 4-Track open reel tapes—all major labels—3,000 different—free brochure. Stereo-Parti, 55 St. James Drive, Santa Rosa, Ca. 95401.

BARGAIN MUSIC, Tape, Equipment Catalog, 25¢. Saxitone, 1776 Columbia Road, Washington, D.C. 20009.

TRADE Stereo tapes, \$1.25 each postpaid. Minimum three. Tape-trade, Box 2181, La Jolla, Ca. 82037.

STEREO TAPE TRANSPORT—7" reel—2 speeds—pause control—made for famous manufacturer—50 to 15,000 Hz—with rec/play and erase heads, without case. Send m.o. or check for \$19.50 to Alshemer Audio Electronics, 218 Columbia St., Utica, N.Y. 13502. \$2.50 for prepaid shipping and insurance.

RECORDING TAPE. Most brands available at lowest prices anywhere. Recording Tape Wholesalers, Box 844, Orange, Conn. 06477.

RECORDING TAPE made by top American manufacturer, guaranteed not "seconds" or "white box"; 2400' mylar, \$2.29; 1800' mylar \$1.69; 1200' acetate \$.79. Send for information and quantity pricing. Alshemer Audio Electronics, 218 Columbia Street, Utica, New York 13502.

OLD Radio Programs Catalog \$1.00 (refundable). Radio Vault, 1533 50th S.W., Wyoming, Michigan 49509.

REPAIRS AND SERVICES

TV Tuners rebuilt and aligned per manufacturers specification. Only \$9.50. Any make UHF or VHF Ninety day written guarantee. Ship complete with tubes or write for free mailing kit and dealer brochure. JW Electronics, Box 51C, Bloomington, Indiana 47401.

INSTRUCTION

LEARN ELECTRONIC ORGAN SERVICING at home all makes including transistor. Experimental kit—trouble-shooting. Accredited NHSC, Free Booklet. NILES BRYANT SCHOOL, 3631 Stockton, Dept. A, Sacramento, Calif. 95820.

LEARN WHILE ASLEEP, Hypnotize! Strange catalog free. Auto-suggestion, Box 24-ZD, Olympia, Washington 98501.

DEGREE in electronics Engineering earned mostly by correspondence. Free brochure. Dept. G-9, Grantham School of Engineering, 1505 N. Western Ave., Hollywood, California 90027.

WANT AN F.C.C. 1st CLASS LICENSE? WANT TO BECOME A DISC-JOCKEY? REI has a school near you VA approved. Call toll free: 1-800-237-2251 or write REI, 1336 Main St., Sarasota, Florida 33577, Florida Residents call: 813-955-6922.

HIGHLY effective home study courses in Electronics Engineering Technology and Electronics Engineering Mathematics. Earn your Degree. Write for Free Descriptive Literature. Cook's Institute of Electronics Engineering, (Dept. 15), P.O. Box 10634, Jackson, Miss. 39209. (Established 1945).

FREE brochure self-improvement books. Eldon McBrayer, 412 Arthur Street, Huntsville, Ala. 35805.

FCC LICENSE through tape recorded lessons. Radio License Training, 1060D Duncan, Manhattan Beach, Calif. 90266.

FCC TYPE EXAMS . . . Guaranteed to prepare you for FCC 3rd, 2nd, and 1st phone exams. 3rd class \$7.00, 2nd class \$12.00, 1st class \$16.00, complete package \$25.00. Due to demand, allow 3 weeks for mailing. Research Company, Box 22141, Tampa, Florida 33622.

AMATEUR RADIO. Correspondence Sight-and-Sound no-textbook courses for GENERAL, ADVANCED and EXTRA Class licenses, complete Code and Theory. These are Not memory courses. AMATEUR RADIO LICENSE SCHOOL, 12217 Santa Monica Blvd., W. Los Angeles, Calif. 90025.

SERVICING course complete in one book: "Electronic Servicing for the Beginner." Covers troubleshooting TV, Radio, Stereo, Ham, plus homemade gear. Includes building projects. Only \$3.95 at parts stores selling "Sams" publications (catalog number 20090). Or order autographed copy direct from author: J. Stanley, 855-J, South Fillmore Street, Denver, Colorado 80209. Add 25¢ handling.

MEMORIZE STUDY: "1971 Tests-Answers" for FCC First and Second Class License—plus—"Self-Study Ability Test." Proven! \$9.95. Satisfaction guaranteed. Command, Box 26348-P, San Francisco 94126.

FREE circular self-improvement books. Cazin, 526 Maple, Redwood City, California 94063.

INVENTIONS WANTED

INVENTIONS wanted. Patented; unpatented. Global Marketing Service, 2420-P 77th, Oakland, Calif. 94605.

PATENT Searches including Maximum speed, full airmail report and closest patent copies, \$6.00. Quality searches expertly administered. Complete secrecy guaranteed. Free Invention Protection forms and "Patent Information." Write Dept. 9, Washington Patent Office Search Bureau, 711 14th Street, N.W., Washington, D.C. 20005.

INVENTORS! Don't sell your invention, patented or unpatented, until you receive our offer. Eagle Development Company, Dept. 9, 79 Wall Street, N.Y., N.Y. 10005.

FREE "Directory of 500 Corporations Seeking New Products." For information regarding development, sale, licensing of your patented/unpatented invention. Write: Raymond Lee Organization, 230-GR Park Avenue, New York City 10017.

INVENTORS: Protect your ideas! Free "Recommended Procedure". Washington Inventors Service, 422T Washington Building, Washington, D.C. 20005.

FREE PAMPHLET: "Tips on Safeguarding Your Invention." Write: United States Inventors Service Company, 501-H Thirteenth Street N.W., Washington, D.C. 20004.

GOVERNMENT SURPLUS

JEeps Typically From \$53.90 . . . Trucks From \$78.40 . . . Boats, Typewriters, Airplanes, Multimeters, Oscilloscopes, Transceivers, Electronics Equipment. Wide Variety, Condition. 100,000 Bid Bargains Direct From Government Nationwide Complete Sales Directory and Surplus Catalog \$1.00. (Deductible First \$10.00 Order). Surplus Service, Box 820-J, Holland, Michigan 49423.

GOVERNMENT Surplus. How and Where to Buy in Your Area. Send \$1.00. Surplus Information, Box 30177-PE, Washington, DC 20014.

MANUALS for surplus electronics. List 25¢. Books, 4905 Roanne Drive, Washington, D.C. 20021.

BOOKS

FREE catalog aviation/electronic/space books. Aero Publishers, 329PE Aviation Road, Fallbrook, California 92028.

FREE book prophet Elijah coming before Christ. Wonderful bible evidence. Megiddo Mission, Dept. 64, 481 Thurston Rd., Rochester, N.Y. 14619.

MAGAZINES

JAPAN PUBLICATIONS GUIDE Business, pleasure, education. \$8.00. INTERCONTINENTAL, CPO 1717, Tokyo 100-91.

OVER 2,000,000 backdate magazines! Specify needs. Midtown, Box 917-PE, Maywood, New Jersey 07607.

ELECTRONIC EXPERIMENTER'S HANDBOOK



148 pages of the most fascinating and challenging construction projects for the electronic hobbyists. All with complete schematics, illustrations, parts list, and easy-to-follow instructions.

1971 Winter edition . . .	\$1.50	#33
1971 Spring Edition . . .	\$1.50	#26
1970 Winter edition . . .	\$1.35	#97
1970 Spring edition . . .	\$1.50	#14
1968 Spring edition . . .	\$1.25	#84

Order by number from
Ziff-Davis Service Div., 595 Broadway • N.Y., N.Y. 10012
Enclose an additional 35¢ per copy for postage and handling.
(Outside U.S.A. all magazines are \$2.50 per copy, postpaid.)

PAYMENT MUST BE ENCLOSED WITH ORDER

AUTHORS' SERVICES

AUTHORS! Learn how to have your book published, promoted, distributed. **FREE** booklet "ZD," Vantage, 516 West 34 St., New York 10001.

PERSONALS

MAKE FRIENDS WORLDWIDE through international correspondence. Illustrated brochure free. Hermes, Berlin 11, Germany.

SECRET LOANS BY MAIL. Borrow \$100 to \$1500 for any good reason in absolute privacy. No interviews, no endorsers, no co-signers. Fast service. Write Dial Finance Co., Dept. G-593, 410 KilPatrick Bldg., Omaha, Nebraska 68102.

INVESTIGATORS, Latest Electronics Aids. Free Literature. Clifton, 11500-K NW 7th Ave., Miami, Florida 33168.

HYPNOTISM

"**MALE-FEMALE Hypnotism!**" Exposed, Explained! "Secret Method"—They Never Know! \$2, Rushed. Guaranteed! Isabella Hall, Silver Springs, Florida 32688.

SLEEP learning. Hypnotic method. 92% effective. Details free. ASR Foundation, Box 7021PE HC Station, Lexington, Ky. 40502.

MAGNETS

MAGNETS. All types. Specials—20 disc magnets, or 2 stick magnets, or 10 small bar magnets, or 8 assorted magnets, \$1.00. Maryland Magnet Company, Box 192H, Randallstown, Maryland 21133.

PHOTOGRAPHY—FILM, EQUIPMENT, SERVICES

SCIENCE Bargains Request Free Giant Catalog "CJ"—148 pages—Astronomical Telescopes, Microscopes. Lenses, Binoculars, Kits. Parts. War surplus bargains. Edmund Scientific Co., 300 EdsCorp Bldg., Barrington, New Jersey 08007.

RECORDS

POPULAR organ albums factory direct. Concert Recording, Lynwood, Calif. 90262.

SPECIAL interest records available, produced by the editors of the world's leading special interest magazines. Send for free catalog. Record Catalog-PE, Ziff-Davis Publishing Company, One Park Avenue, New York, N.Y. 10016.

RUBBER STAMPS

RUBBER Address Stamps \$2.00. Signature \$3.50. Free Catalog. Jackson's, Box 443-G, Franklin Park, Illinois 60131.

BUSINESS OPPORTUNITIES

I MADE \$40,000.00 Year by Mailorder! Helped others make money! Start with \$10.00—Free Proof. Torrey, Box 318-N, Ypsilanti, Michigan 48197.

FREE BOOK "999 Successful Little Known Businesses" Work home, Plymouth 445-G, Brooklyn, N.Y. 11216.

\$200.00 DAILY In Your Mailbox! Your opportunity to do what mail-order experts do. Free details. Associates, Box 136-J, Holland, Michigan 49423.

HOW to make \$1,000,000 in only ten years! Start with \$10! Details Free! International Service, (PE), Box 11796, Atlanta, Georgia 30305.

FREE CATALOGS. Repair air conditioning, refrigeration. Tools, supplies, full instructions. Doolin, 2016 Canton, Dallas, Texas 75201.

PIANO TUNING learned quickly at home. Tremendous field! Musical knowledge unnecessary. GI Approved. Information Free. Empire School, Box 327, Miami, Florida 33145.

200% PROFIT. Inexpensive fire, burglar alarms. Watchdog Systems, Williamsburg, Ohio 45176.

SELL HERTEL BIBLES—Part Time. Finest reference Bible available. Demonstrator and supplies furnished. Excellent commissions. Write International Book, Dept. PE, Box 118, Wichita, Kansas 67201.

START small, highly profitable electronic production in your basement. Investment, knowledge unnecessary. Postcard brings facts. Barta-GRA, Box 15083, San Francisco, Cal. 94115.

\$\$\$\$ in your mailbox from mailorders. Opportunity to make money working at home. Details \$2.00. Refundable. TELMART. Box 5244, Charlotte, N.C. 28205.

MAILORDER imports. Report reveals foreign drop-ship sources. World traders digest. Ideal mailorder items. \$1.00, Cazin, 526 Maple, Redwood City, California 94063.

MAIL GALORE! Money-making opportunities! Name on nationwide mailing lists, 25¢. Three months, 50¢. Sullins, Box 206-PE, Forsyth, Georgia 31029.

TREASURE FINDERS

GOLD, Silver, Relics! Located with powerful Detectron Metal Detectors. Free information. Terms, Detectron, Dept. PE7, Box 243, San Gabriel, California 91778.

TREASURE FINDER locates buried gold, silver, coins, treasures. 5 powerful models. \$19.95 up. Free catalog. Relco-A33, Box 10839, Houston, Texas 77018.

FREE: Jetco Electronics Free 24 page Treasure Finder catalog. Find metals, minerals, gold, silver, coins and relics, Jetco, Box 132 PE, Huntsville, Texas 77340.

FISHER DETECTORS has something new! Free literature. Fisher Research, Dept. PE-7, Palo Alto, CA 94303.

MUSIC

FREE Song Selling information. Peerless Publications, Box 193-F, Bloomfield, Conn. 06002.

MUSICAL INSTRUMENTS

30% DISCOUNT name brand musical instruments. Free catalog. Freeport Music, 127-N Sunrise Highway, Freeport, N.Y. 11520.

WHOLESALE! Professional Amplifiers, PA Systems, Guitars. Free Catalog. Carvin, Escondido, Calif. 92028.

REAL ESTATE

FREE . . . 240-PAGE SUMMER CATALOG! Describes and pictures hundreds of farms, ranches, town and country homes, businesses coast to coast! Specify type property and location preferred. Zip Code, please. **UNITED FARM AGENCY**, 612-EP West 47th St., Kansas City, Mo. 64112.

SPORTS ACTION FILMS

\$1.00 OFF EACH PRINT on First Order! Immediate Delivery. 25¢ Catalog, 8 and Super 8. **SPORTLITE**, Elect. Dept., 20 North Wacker, Chicago 60606.

PRINTING

ADDRESS LABELS, 1000 Gummed \$1.25; 500 Golden \$2.25; 500 Pressure Stick \$2.25 postpaid. Alan Smith, Dept. PE71, P.O. Box 1551, Anniston, Alabama 36201.

BUSINESS cards, envelopes and letterheads. Free samples. Stewart Printing, P.O. Box 19284, Dallas, Texas 75219.

MISCELLANEOUS

WINEMAKERS: Free illustrated catalog yeasts, equipment. Semplex, Box 12276, Minneapolis, Minn. 55412.

LIGHT bulbs, thousands sizes, specify—Jetronics, Box 67015ZD, Century City, Calif. 90067.

HYPNOTIZE ELECTRONICALLY . . . or money-back! Television repairman's accidental discovery. Uses television set. \$2. Elton's, Box 12167-PE, St. Petersburg, Florida 33733.

WINE RECIPES and Catalog, 25¢. Country Winemaker, Box 191E, RFD 1, Mattapoisett, Massachusetts 02739.

YOUR Classified or Display Classified Ad in these columns will be seen, read and regularly responded to by America's largest audience of Electronics Hobbyists. The cost is low—the results are high! Plan your campaign now by sending copy and payment to: Hal Cymes, Class. Adv. Mgr., **POPULAR ELECTRONICS**, 1 Park Ave., New York, N. Y. 10016.

ABOUT YOUR SUBSCRIPTION

Your subscription to **POPULAR ELECTRONICS** is maintained on one of the world's most modern, efficient computer systems, and if you're like 99% of our subscribers, you'll never have any reason to complain about your subscription service.

We have found that when complaints do arise, the majority of them occur because people have written their names or addresses differently at different times. For example, if your subscription were listed under "William Jones, Cedar Lane, Middletown, Arizona," and you were to renew it as "Bill Jones, Cedar Lane, Middletown, Arizona," our computer would think that two separate subscriptions were involved, and it would start sending you two copies of **POPULAR ELECTRONICS** each month. Other examples of combinations of names that would confuse the computer would include: John Henry Smith and Henry Smith; and Mrs. Joseph Jones and Mary Jones. Minor differences in addresses can also lead to difficulties. For example, to the computer, 100 Second St. is not the same as 100 2nd St.

So, please, when you write us about your subscription, be sure to enclose the mailing label from the cover of the magazine—or else copy your name and address exactly as they appear on the mailing label. This will greatly reduce any chance of error, and we will be able to service your request much more quickly.

POPULAR ELECTRONICS

JULY 1971

ADVERTISERS INDEX

READER SERVICE NO.	ADVERTISER	PAGE NO.
	A.P.M. Systems, Inc.	87
1	Aerotron Inc., Gonset, Inc.	97
	Allied Radio Shack	8, 14
3	Ampex	THIRD COVER
2	Antenna Specialists Co., The	16
5	Avanti Research & Development Co., Inc.	92
	Bell & Howell Schools	72, 73, 74, 75
	CREI, Home Study Div., McGraw-Hill Book Co.	88, 89
6	Cleveland Institute of Electronics	18, 19, 20, 21
7	Drake Company, R.L.	94
8	Communications Div., DYNASCAN CORP.	6
9	EICO Electronic Instrument Co., Inc.	92
10	Edmund Scientific Co.	105
11	Heath Company	5
23	Johnson Company, E. F.	90
4	KLH Research & Development	FOURTH COVER
12	Lafayette Radio Electronics	91
21	Leslie Speakers	13
13	McIntosh Labs	93
	National Radio Institute	SECOND COVER, I, 2, 3
	National Technical Schools	54, 55, 56, 57
14	Olson Electronics	12
15	Progressive "Edu-Kits", Inc.	106
16	RCA Electronic Components & Devices	24
	RCA Institutes, Inc.	36, 37, 38, 39
17	Record Club of America	10, 11
18	Sonar Radio Corp.	99
20	TDK Electronics Corp.	96
19	Techni-Tool, Inc.	12
22	Toyo Radio Co. of America, Inc.	98
CLASSIFIED ADVERTISING 100, 101, 102, 103, 104		

1000% OF UNUSUAL SCIENTIFIC BARGAINS including SPECIAL UNIQUE PSYCHELIC LIGHTING for Fun, Proof, Effects

HELIUM BALLOONS MAKE A "BALL"



Helium is a safe non-toxic inert gas.

Anytime there's a balloon the "air" is festive. Especially when the "air" is helium which makes a balloon perky and adventurous. Now here's 25 times the fun—25 various colored balloons of 4, 5, or 6" diameter when inflated. With them a pressurized (300 lbs. in.) can containing 21 liters of helium to inflate all 25. For adults or kids' parties, give-aways, bazars or just demonstrating "lighter than air".

\$3.00 Ppd.

HI-VOLTAGE ELECTROSTATIC GENERATOR



Stock No. 70.264AV
STATIC ELECTRICITY GENERATOR
Stock No. 70.070AV

Van De Graaff low-amp type, 2,000,000 volt potential, yet completely safe. Demonstrates lightning, St. Elmo's fire, repulsion of charges, electrostatic dust collection, many other electrical wonders. Metal, 100-v. 60-cycle AC. Humidity range, 0-100%. Current, 1.5 to 2.5 microamps. Aluminum base, frame and charge collector. Unbreakable plastic. Insulating column, 11" dia. 63 1/2". Full instructions.

\$53.75 Ppd.
\$19.50 Ppd.

1st LOW-COST XENON STROBE!



Stock No. 71.342AV
DELUXE OUTDOOR STROBE KIT
Stock No. 71.343AV

Price breakthrough in bright, reliable electronic strobes. 50W/Second xenon tube. Variable flash rate—60 to 500 per minute. Long life—more than 1,000,000 flashes. Printed circuit board design. Safely mounted bulb. Plastic shield. 6 1/4 X 3 1/2 X 2 1/4 oz. Perfect for psychedelic, stop-action lighting effects for home light shows, parties, displays.

\$24.95 Ppd.
\$19.95 Ppd.

BLACK-LIGHT MIGHTY MITES

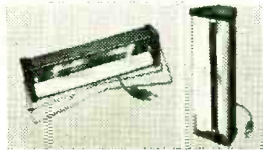

Stock No. 71.274AV
DELUXE OUTDOOR INDOOR MODEL
Stock No. 71.299AV

Relatively small (12") fixtures give surprisingly bright black-light. Mirror-finished reflector makes instant starting. 8-watt, high-intensity bulb look like 40-watt. Up to 5,000 hours of safe, long-life (3000) black-light to really turn on parties, light & theatrical shows, psychedelic decor, holiday decorations. Shockproof end-caps remove for safe, easy replacement of bulb and starter. Stands upright or horizontal. Aluminum case.

\$14.95 Ppd.
\$19.95 Ppd.

PSYCHELIC LIGHTING HANDBOOK



paper for 3 rings.
Stock No. 9100AV

100 information packed pages! Fully explains latest in psychedelic lighting equipment, techniques, development. Covers all facets of psychedelic light-show production including strobes, blacklights, projectors, systems, organic slides, mirrors, color organs, polarized color, light boxes, music-visualization, etc. Shows how to "psychedelize" parties, musical groups, shows or how to set up "electric trips" for private gatherings. 8 1/2" x 11" looseleaf

\$3.00 Ppd.

LONG-WAVE BLACKLIGHT FIXTURE



Stock No. 70.364AV
Stock No. 60.124AV

Extremely versatile, compactly designed, long wave (3200-4000 angstroms) black light (ultra-violet) fixture. Has 6-watt, 110-V lamp with built-in filter—eliminates harmful shorter wave ultra-violet rays. Use to identify minerals, fungi, bacteria—check for surface flaws, oil and gas leakage—perfect for displays with fluorescent paper, paints, chalk, crayons, trace powder, incl. adjustable aluminum reflector. Mount vert., hor., or on corner. 10" L., 1 1/2" W., 1 1/4" H.

\$12.50 Ppd.
\$4.75 Ppd.

Order by Stock No.—Check or M.O.—Money-Back Guarantee
EDMUND SCIENTIFIC CO., 300 EDSCORP BLDG., BARRINGTON, N.J. 08007

WRITE FOR GIANT FREE CATALOG "AV"



Completely new edition. New items, categories, illustrations, 148 easy-to-read pages packed with 4000 unusual items. Dozens of electrical and electromagnetic parts, accessories. Enormous selection of Astronomical Telescopes, Microscopes, Binoculars, Magnifiers, Magnets, Lenses, Lasers, Prisms. Many war surplus items; for hobbyists, experimenters, workshops, factory. Write for catalog "AV."

EDMUND SCIENTIFIC CO. 300 EDSCORP BLDG., BARRINGTON, NEW JERSEY 08007
ORDER BY STOCK NUMBER - SEND CHECK OR MONEY ORDER - MONEY-BACK GUARANTEE

BILL 20 RADIO

and Electronics Circuits

PROGRESSIVE HOME RADIO-T.V. COURSE

Now Includes

- ★ 12 RECEIVERS
- ★ 3 TRANSMITTERS
- ★ SQ. WAVE GENERATOR
- ★ SIGNAL TRACER
- ★ AMPLIFIER
- ★ SIGNAL INJECTOR
- ★ CODE OSCILLATOR

"EDU-KIT" NOW INCLUDES

- ★ TRANSISTOR (Solid State) CIRCUITS
- ★ VACUUM TUBE CIRCUITS
- ★ PRINTED CIRCUITS
- ★ HAND WIRED CIRCUITS



Reg. U.S. Pat. Off.

Training Electronics Technicians Since 1946

YOU DON'T HAVE TO SPEND HUNDREDS OF DOLLARS FOR A RADIO COURSE

The "Edu-Kit" offers you an outstanding PRACTICAL HOME RADIO COURSE at a rock-bottom price. Our Kit is designed to train Radio & Electronics Technicians, making use of the most modern methods of home training. You will learn radio theory, construction practice and service. This is a COMPLETE RADIO COURSE IN EVERY DETAIL. You will learn how to build radios, using regular schematics; how to wire and solder in a professional manner; how to service radios. You will work the standard type of punched metal chassis as well as the latest development of Printed Circuit chassis. You will learn the basic principles of radio. You will construct, study and work with RF and AF amplifiers and oscillators, detectors, rectifiers, test equipment. You will learn and practice Code, using the Progressive Code Oscillator. You will learn and practice trouble-shooting, using the Progressive Signal Tracer, Progressive Signal Injector, Progressive Dynamic Radio & Electronics Tester, Square Wave Generator and the accompanying instruction manual.

You will receive training for the Novice, Technician and General Classes of F.C.C. Radio Amateur Licenses. You will build Receiver, Transmitter, Square Wave Generator, Code Oscillator, Signal Tracer and Signal Injector Circuits, and how to operate them. You will receive an excellent background for television, Hi-Fi and Electronics. Absolutely no previous knowledge of radio or science is required. The "Edu-Kit" is the product of years of teaching and engineering experience. The "Edu-Kit" will provide you with a basic education in Electronics and Radio, worth many times the low price you pay. The Signal Tracer alone is worth more than the price of the kit.

THE KIT FOR EVERYONE

You do not need the slightest background in radio or science. Whether you are interested in Radio & Electronics because you want an interesting hobby, or you are paying business or a job with a future, you will find the "Edu-Kit" a worth-while investment. Many thousands of individuals of all ages and backgrounds have successfully used the "Edu-Kit" in more than 79 countries of the world. The "Edu-Kit" has been carefully designed, step by step, so that you cannot make a mistake. The "Edu-Kit" allows you to teach yourself at your own rate. No instructor is necessary.

PROGRESSIVE TEACHING METHOD

The Progressive Radio "Edu-Kit" is the foremost educational radio kit in the world, and is universally accepted as the standard in the field of electronics training. The "Edu-Kit" uses the modern educational principle of "Learn by Doing." Therefore you construct, learn schematics, study theory, practice trouble shooting—all in a closely integrated program designed to provide an easily-learned, thorough and interesting background in radio. You begin by examining the various radio parts of the "Edu-Kit." You then learn the function, theory and wiring of these parts. Then you build a simple radio. With this first set you will enjoy listening to regular broadcast stations, learn theory, practice testing and trouble-shooting. Then you build a more advanced radio, learn more advanced theory and techniques. Gradually, in a progressive manner, and at your own rate, you will find yourself constructing more advanced multi-tube radio circuits, and doing work like a Professional Radio Technician.

Included in the "Edu-Kit" course are Receiver, Transmitter, Code Oscillator, Signal Tracer, Square Wave Generator and Signal Injector Circuits. These are not unprofessional "breadboard" experiments, but genuine radio circuits, constructed by means of professional wiring and soldering on metal chassis, plus the new method of radio construction known as "Printed Circuitry." These circuits operate on your regular AC or DC house current.

THE "EDU-KIT" IS COMPLETE

You will receive all parts and instructions necessary to build twenty different radio and electronics circuits, each guaranteed to operate. Our Kits contain tubes, tube sockets, variable, electrolytic, mica, ceramic and paper dielectric condensers, resistors, tie strips, hardware, tubing, punched metal chassis, Instruction Manuals, hook-up wire, solder, selenium rectifiers, coils, volume controls and switches, solid state materials, etc.

In addition, you receive Printed Circuit materials, including Printed Circuit chassis, special tube sockets, hardware and instructions. You also receive a useful set of tools, a professional electric soldering iron, and a self-powered Dynamic Radio & Electronics Tester. The "Edu-Kit" also includes Code Instructions and the Progressive Code Oscillator, in addition to F.C.C. Radio Amateur License training. You will also receive lessons for servicing with the Progressive Signal Tracer and the Progressive Signal Injector, a High Fidelity Guide and a Quiz Book. You receive Membership in Radio-TV Club, Free Consultation Service, Certificate of Merit and Discount Privileges. You receive all parts, tools, instructions, etc. Everything is yours to keep.

Progressive "Edu-Kits" Inc., 1189 Broadway, Dept. 702D, Hewlett, N. Y. 11557.

UNCONDITIONAL MONEY-BACK GUARANTEE

- Please rush my Progressive Radio "Edu-Kit" to me, as indicated below:
- Check one box to indicate choice of model
- Deluxe Model \$31.95.
 - New Expanded Model \$34.95 (Same as Deluxe Model plus Television Servicing Course and valuable Radio & TV Tube Checker).
- Check one box to indicate manner of payment
- I enclose full payment. Ship "Edu-Kit" post paid.
 - I enclose \$5 deposit. Ship "Edu-Kit" C.O.D. for balance plus postage.
 - Send me FREE additional information describing "Edu-Kit."

Name

Address

PROGRESSIVE "EDU-KITS" INC.

1189 Broadway, Dept. 702D, Hewlett, N. Y. 11557

FREE EXTRAS SET OF TOOLS

- SOLDERING IRON
- ELECTRONICS TESTER
- PLIERS-CUTTERS
- VALUABLE DISCOUNT CARD
- CERTIFICATE OF MERIT
- TESTER INSTRUCTIONS MANUAL
- HIGH FIDELITY GUIDE & QUIZZES
- TELEVISION BOOK & RADIO TROUBLE-SHOOTING BOOK
- MEMBERSHIP IN RADIO-TV CLUB: CONSULTATION SERVICE & FCC AMATEUR LICENSE TRAINING
- PRINTED CIRCUITRY

SERVICING LESSONS

You will learn trouble-shooting and servicing in a progressive manner. You will practice repairs on the sets that you construct. You will learn symptoms and causes of trouble in home, portable and car radios. You will learn how to use the professional Signal Tracer, the unique Signal Injector and the Dynamic Radio & Electronics Tester. While you are learning in this practical way, you will be able to do many a repair job for your friends and neighbors, and charge fees which will far exceed the price of the "Edu-Kit." Our Consultation Service will help you with any technical problems you may have.

FROM OUR MAIL BAG

J. Statistis, of 25 Poplar Pl., Waterbury, Conn., writes: "I have repaired several sets for my friends and made money. The 'Edu-Kit' paid for itself. I was ready to spend \$240 for a course, but I found yours and sent for your Kit."

Ben Valerio, P. O. Box 21, Magna, Utah, writes: "The Edu-Kits are wonderful. Here I am sending you the questions and also the answers for them. I have been in Radio for the last seven years, but like to work with Radio Kits, and like to build Radio Tuning Equipment. I enjoyed every minute I worked with the different kits; the Signal Tracer works fine. Also like to let you know that I feel proud of becoming a member of your Radio-TV Club."

Robert L. Sluff, 1534 Monroe Ave., Huntington, W. Va., writes: "I would drop you a few lines to say that I received my Edu-Kit, and was really amazed that such a bargain can be had at such a low price. I have already started repairing radios and phonographs. My friends were really surprised to see me get into the swing of it so quickly. The trouble-shooting Tester that comes with the Kit is really swell and finds the trouble, if there is any to be found."

PRINTED CIRCUITRY

At no increase in price, the "Edu-Kit" now includes Printed Circuitry. You build a Printed Circuit Signal Injector, a unique servicing instrument that can detect many Radio and TV troubles. This revolutionary new technique of radio construction is now becoming popular in commercial radio and TV sets.

A Printed Circuit is a special insulated chassis on which has been deposited a conducting material which takes the place of wiring. The various parts are merely plugged in and soldered to terminals.

Printed Circuitry is the basis of modern Automation Electronics. A knowledge of this subject is a necessity today for anyone interested in Electronics.

CIRCLE NO. 15 ON READER SERVICE PAGE
 CIRCLE NO. 3 ON READER SERVICE PAGE

Printed in U.S.A.

"Very Heavy." That's the recording artist's hip way of expressing satisfaction after a recording session because every single sound has been captured exactly as it was created. Ultimate fidelity. Audio perfection. And chances are it was achieved on Ampex sound equipment. Which is why Ampex is in 90% of the world's recording studios.

Now for the first time, you can experience virtually this same studio versatility and quality at home. We created the AX-300 for the man who has a passion for true, pure sound. The audio perfectionist. And because the AX-300 has more professional innovations than others, we dubbed it the 45 Lb. Studio. You'll soon see... and hear... why it warrants this distinction.

The AX-300 is a six head bi-directional stereo tape deck. The Ampex Deep-Gap heads are symmetrically located so that tape is always pulled over heads in either direction for better tape-to-head interface. 3 motor drive system. Heavy duty hysteresis synchronous capstan motor assures steady, even tape motion regardless of voltage fluctuations.

Symmetrically arranged push-buttons control all tape motion functions thru positive action solenoid operation.

Exclusive motion sensing controlled solid-state logic circuit prevents tape stretch, breaks and spills, even when changing from fast wind directly to play.

Built-in studio 4 line mixer. 4 separate controls let you mix 4 independent sources for mono,

THE AMPEX 45 lb. STUDIO



or 2 stereo sources for stereo recording.

Function programmer. Operates independently of mixer panel and allows total recording and playback convenience

with choice of stereo operation, channel 1 mono, channel 2 mono, sound-on-sound or sound-with-sound. All programmed internally without external patching.

Stereo echo effect. Allows addition of controlled feedback in both channels without the use of external patchcords.

Controlled bandwidth. Built-in active filtering limits the bandwidth to allow full bias, provides extremely clean recordings throughout the audio spectrum. Provides extremely high signal-to-noise ratio, virtually eliminates intermodulation distortion and dropouts.

Externally adjustable bias and VU meter calibration. Automatic reverse and repeat play Pause/edit control. Variable noise reduction filter. Source/tape monitoring. 6 solid state pre-amps Auto shut-off. 3-speed operation. Optional remote control. Plus many more features we simply don't have room to list

AX-300 means studio innovations, studio capabilities for the audio perfectionist. One of the most technically versatile decks you can buy. Yet it's a breeze to operate. We built in everything you need. And nothing you don't.

For in-depth coverage of all the features of the AX-300, order the AX-300 instruction manual. Just send \$1.00 to cover postage and handling to Ampex, Dept. 300, 2201 Lardmeier Road, Elk Grove Village, Illinois 60007. Or stop by your audio dealer and ask him about the AX-300. And be prepared to do a lot of listening.

The 45 Lb. Studio
Very Heavy, Indeed!



Very Heavy



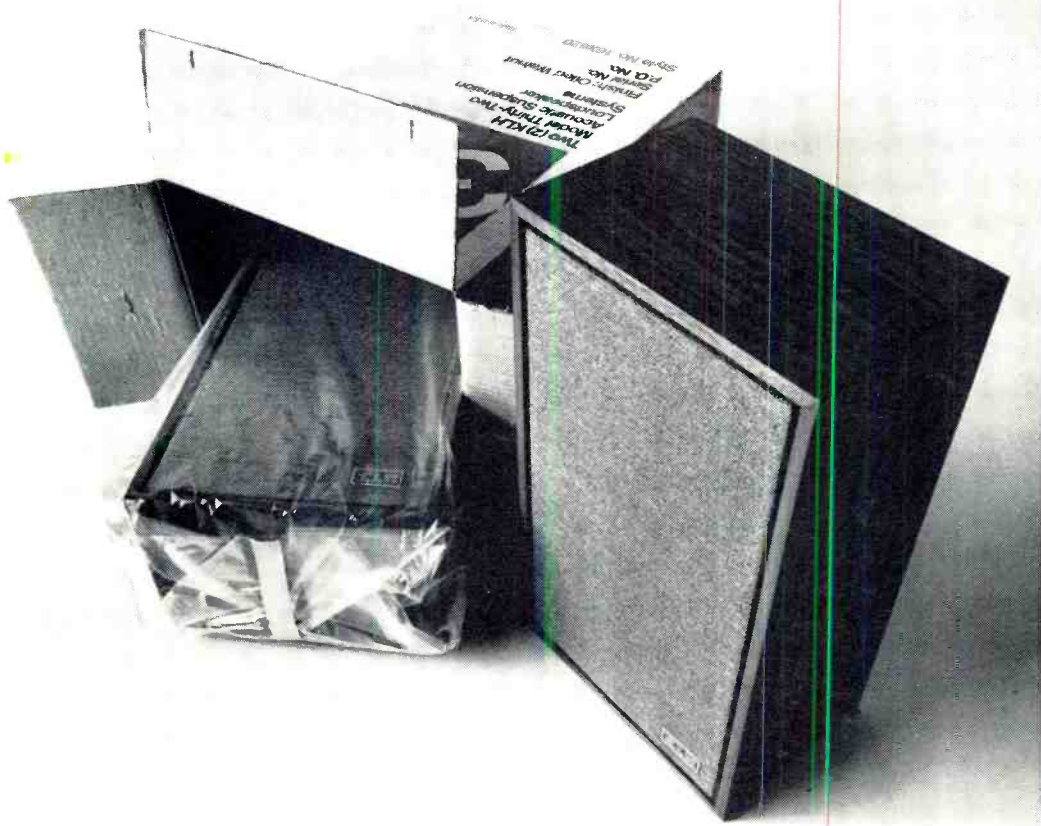

The \$95 Misunderstanding.

It seems there's been some confusion about the price that appeared in our first ad for the new KLH Model Thirty-Two loudspeakers. To clear up any misunderstanding, the price is, indeed, \$95 the pair (\$47.50 each). †

If you're wondering how we could make a KLH loudspeaker for \$47.50, it's really quite simple.

We had two choices.

Either we could make a fair speaker and a lot of profit. Or we could make a lot of speaker and a fair profit.

We chose the latter. We always do. That's why KLH speakers sound like KLH speakers.

Of course our Model Thirty-Two won't deliver as

much bass response as, say, our Model Seventeen. But the basic listening quality of the new KLH Thirty-Two is superb by any standard. In fact, we'll match the Thirty-Two against any speaker in its price class, even against most speakers costing twice its price. For when it comes to making reasonably-priced speakers that deliver an inordinate amount of sound, that's really what KLH is all about.

And about that, there can be no misunderstanding.

For more information on the Model Thirty-Two, write to KLH Research and Development, 30 Cross St., Cambridge, Mass. 02139. Or visit your KLH dealer.

†Suggested retail price. Slightly higher in the west.

*A trademark of The Singer Company



KLH RESEARCH AND DEVELOPMENT
A Division of The Singer Company

CIRCLE NO. 4 ON READER SERVICE PAGE