

MORE EXPERIMENTS IN ELECTRO-CULTURE

Popular Electronics

FIFTY CENTS / JUNE 1971

How To Pick A Phono Cartridge

VOICE-CONTROLLED AMPLIFIER

LAB BENCH POWER SUPPLY

BUILD THE COLOSSAL WOOFER

DIGITAL THERMOMETER MODULE

MORE ABOUT RTL IC's

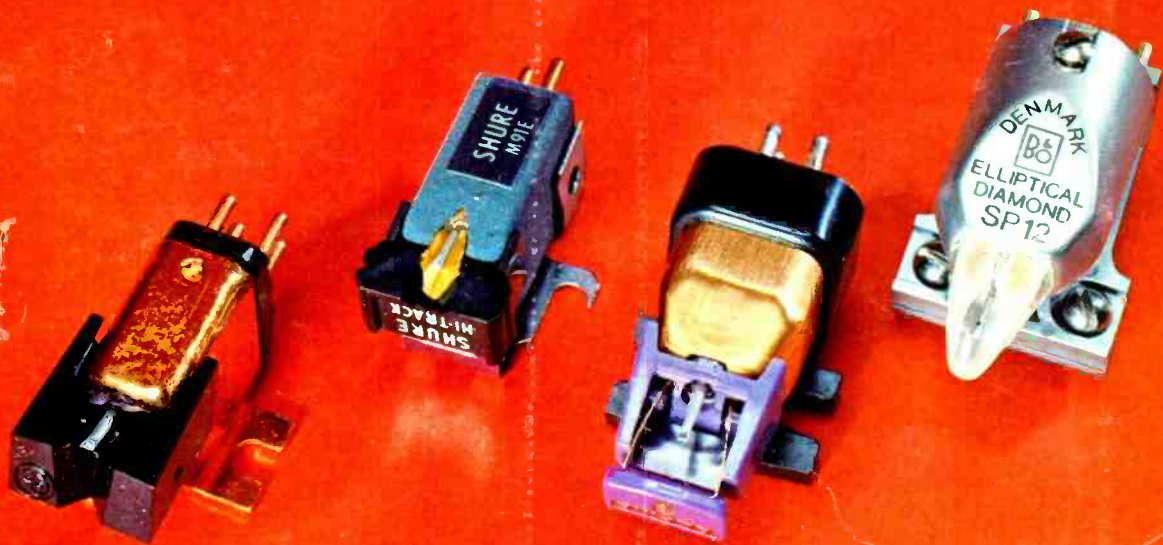

Retailers: Notice of display-allowance plan is within last three pages.

Kit for kit, text for text, dollar for dollar, your best home training buy is NRI

NRI "hands on" method gives you as much as 2 years of on-the-job experience. Pick your field and enroll now!

After over 55 years of training men for Electronics in their homes, NRI knows that theory alone is not enough. That's why NRI concentrates so heavily in the development of special training equipment. Your hands must be trained as well as your head, and NRI gives you both kinds of training in a manner no other school can match.

You get your hands on professional parts and demonstrate theory you read in NRI's unique "bite-size" texts. You build designed-for-learning Electronic circuits and complete, operating equipment. You use what you build to prove out what you read. Electronics comes alive in the most valuable, practical manner. You experiment with the same kinds of solid-state and transistorized and tube circuits you'll find on the job—not hardware or breadboard hobby kits.

NRI prepares you for your choice of careers in Color TV Servicing, Communications, Industrial Electronics and the growing field of Computer Electronics. Many NRI graduates start earning \$5 to \$7 an hour extra soon after they enroll, fixing home Electronic equipment for friends and neighbors in spare time. NRI's remarkable teaching method simplifies, organ-

izes, dramatizes subject matter so that any ambitious man, regardless of his education, can effectively learn and profit from the Electronics course of his choice—and NRI gives you 15 training plans to choose from.

Over three-quarters of a million men have enrolled with NRI since 1914. Proof of the value and experience you get when you choose NRI for your Electronics training . . . proof of why NRI continues to be the country's largest Electronics home-study school. Discover for yourself how easy it is to move into Electronics and move up in a rewarding career. Mail the postage-free card for the new NRI Catalog. There is no obligation. No salesman will call on you because NRI does not employ salesmen. NATIONAL RADIO INSTITUTE, Washington, D.C. 20016.



If postage-free card is missing, write to:

NATIONAL RADIO INSTITUTE
Washington, D.C. 20016

GET FACTS ABOUT GI BILL

If you have served since January 31, 1955, or are in service now, check GI line on postage-free card.



...first and only school to include training equipment designed from chassis up for your education

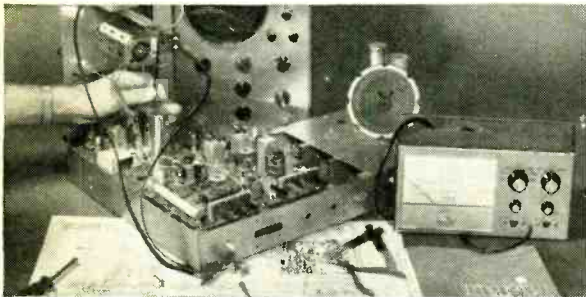

Earn \$5 to \$7 an hour spare or full time in COLOR TV SERVICING

It's easy to learn as you build, stage-by-stage, the only custom designed Color TV receiver engineered specifically for training purposes. You grasp a professional understanding of all color circuits through logical demonstrations never before presented. The end product is a superb Color TV set that will give you and your family years of viewing pleasure. NRI gives you the option of selecting either Color or black-and-white training equipment.



There's glamour, success awaiting Technicians in COMMUNICATIONS

NRI gives you the experience you need to qualify for jobs in TV broadcasting stations, or operating and servicing mobile, marine, aviation communications equipment. You build and use a solid-state voltohmmeter; perform experiments on transmission lines and antenna systems, even build your own 25-watt, phone-cw amateur transmitter band. In all NRI Communications courses, you must pass your FCC exams—or you get your money back.

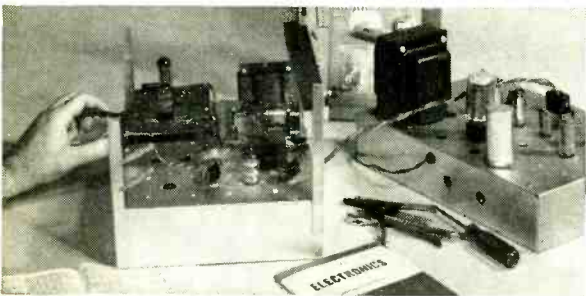

Fill technical jobs without a degree in INDUSTRIAL ELECTRONICS

NRI's Electronics Technology course gives you completely specialized training kits engineered for business, industrial and military Electronics fields. On completing this training, competent technical ability can be instantly demonstrated by you. As you learn, you actually build and use your own training center in solid-state motor control and analog computer servo-mechanisms. Telemetering circuits, solid-state multi-vibrators, even the latest integrated circuits are included in your home training program.

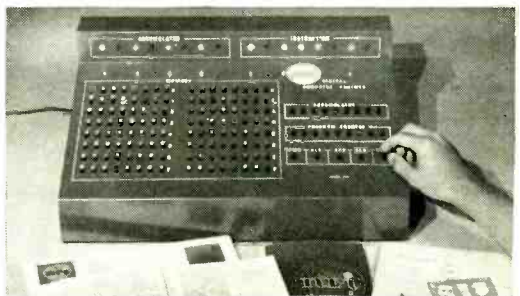

Prepare quickly for a high pay career in COMPUTER ELECTRONICS

This may well be the most unique and exciting educational aid ever developed for home training—a digital computer *with memory* you build and use to learn organization, trouble shooting, operation and programming. It performs the same functions as commercial computers you encounter on the job. Lessons stress computer repair. You perform a hundred experiments, build hundreds of circuits. Your own solid-state voltohmmeter is included among the ten training kits you receive.

OVER 50 YEARS OF LEADERSHIP IN ELECTRONICS TRAINING

Popular Electronics

WORLD'S LARGEST-SELLING ELECTRONICS MAGAZINE

FEATURE ARTICLES

- 15 THINGS WE DO KNOW ABOUT PHONO CARTRIDGES** **25** J. Gordon Holt
What to look for; how to recognize it
- LABORATORY IC POWER SUPPLY** **31** Richard J. Valentine
Low-cost regulation: 0-20 V, 0-2 A
- EQUIVALENCY IN RTL CIRCUITS** **39** Frank H. Tooker
Part 2: The lowdown on flip-flops
- THE COLOSSAL WOOFER** **47** David B. Weems
A 30-inch separate bass
- BUILD A VOX GAIN RIDER** **58** David W. Beaty
Voice operated microphone
- MORE EXPERIMENTS IN ELECTRO-CULTURE** **63** L. George Lawrence
Check your plant's emotions
- DIGITAL THERMOMETER MODULE** **68** Daniel Meyer
For the Digital Measurements Lab
- COMMUNICATIONS** **76**
- THE PRODUCT GALLERY** **78**
CTD IC Logic Design Program
Industrial Inventions Logico BPL-10
- STEREO SCENE** **81** J. Gordon Holt
Those redundant volume controls
- OPPORTUNITY AWARENESS** **84** David L. Heiserman
Educational benefits from employers
- SOLID STATE** **85** Lou Garner
Tone and frequency decoder

DEPARTMENTS

- DIRECT & CURRENT** **7** Oliver P. Ferrell
- INTERFACE** **8**
- NEW LITERATURE** **12**
- ELECTRONICS LIBRARY** **14**
- READER SERVICE PAGES** **15, 95**
- NEW PRODUCTS** **22**
- OUT OF TUNE** **97**
"Build a Timbre Gate" (April 1971)
- INDEX TO VOLUME 34 (JAN.-JUNE 1971)** **98**

POPULAR ELECTRONICS is Indexed
in the Reader's Guide
to Periodical Literature

This month's cover photo by
Justin Kerr

Copyright © 1971 by ZIFF-DAVIS PUBLISHING COMPANY. All rights reserved.

William Ziff, President; Hershel B. Sarbin, Senior Vice President and Secretary; Philip Sine, Financial Vice President and Treasurer
POPULAR ELECTRONICS, June 1971, Volume 34, Number 6, Published monthly at One Park Ave., New York, N.Y. 10016,
one year subscription rate for U.S., U.S. Possessions and Canada, \$6.00; all other countries, \$7.00. Second class postage paid at
New York, N.Y., and at additional mailing offices. Authorized as second class mail by the Post Office Department, Ottawa, Canada
and for payment of postage in cash. Subscription service and Forms 3579; P.O. Box 1096, Flushing, N.Y. 11352. Editorial offers
for manuscript contributions, reader inquiries, etc.: One Park Ave., New York, N.Y. 10016.

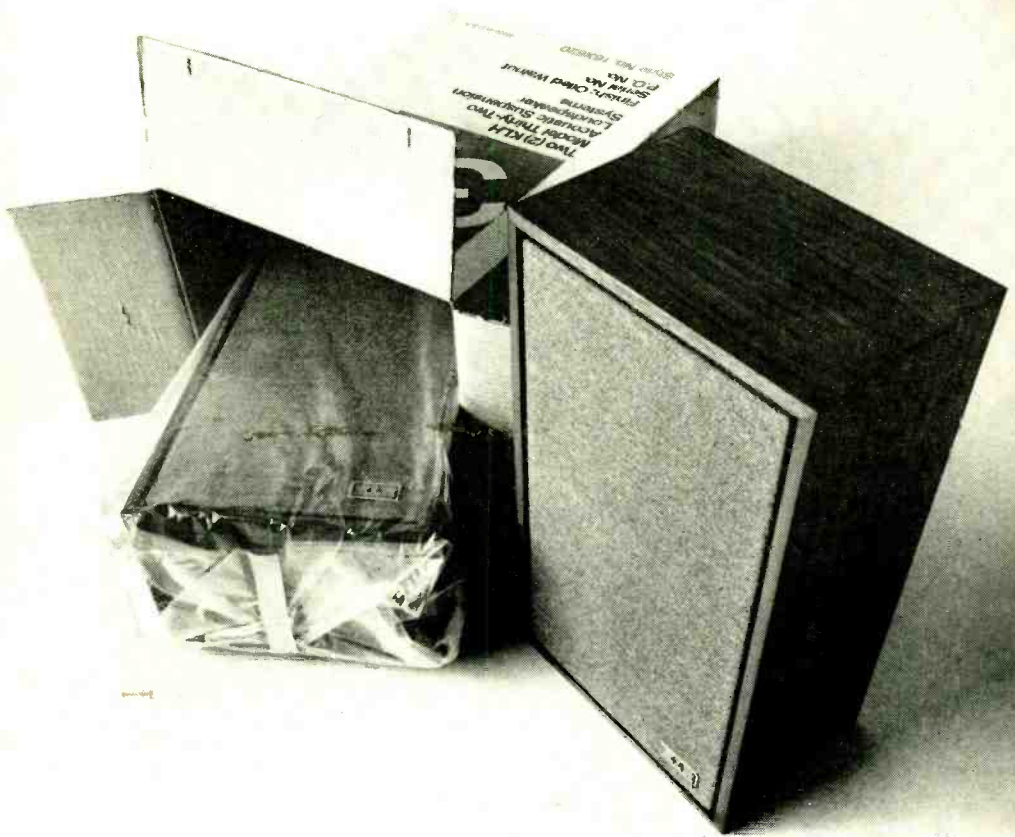

The \$95 Misunderstanding.

It seems there's been some confusion about the price that appeared in our first ad for the new KLH Model Thirty-Two loudspeakers. To clear up any misunderstanding, the price is, indeed, \$95 the pair (\$47.50 each).[†]

If you're wondering how we could make a KLH loudspeaker for \$47.50, it's really quite simple.

We had two choices.

Either we could make a fair speaker and a lot of profit. Or we could make a lot of speaker and a fair profit.

We chase the latter. We always do. That's why KLH speakers sound like KLH speakers.

Of course our Model Thirty-Two won't deliver as

much bass response as, say, our Model Seventeen. But the basic listening quality of the new KLH Thirty-Two is superb by any standard. In fact, we'll match the Thirty-Two against any speaker in its price class, even against most speakers costing twice its price. For when it comes to making reasonably-priced speakers that deliver an inordinate amount of sound, that's really what KLH is all about.

And about that, there can be no misunderstanding.

For more information on the Model Thirty-Two, write to KLH Research and Development Corporation, 30 Cross St., Cambridge, Mass. 02139. Or visit your KLH dealer.

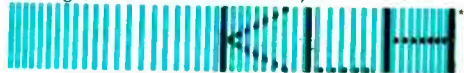

KLH RESEARCH AND DEVELOPMENT
A Division of The Singer Company

[†]Suggested retail price. Slightly higher in the west.

*A trademark of The Singer Company.

CIRCLE NO. 13 ON READER SERVICE PAGE



Now, there's absolutely no reason you shouldn't own a PE automatic turntable

At \$99.95, the PE-2035 has many of the exclusive features of the top-rated PE-2040. Ultra-gentle, fingertip cueing control . . . Fail safe stylus protector . . . Automatic record scanner . . . Single lever control for all modes of operation . . . Continuous record repeat, and much more. Visit your PE dealer for a demonstration of PE Perfection in Performance. Or, fill in the coupon and receive the complete story of why the PE-2035 is your inevitable choice of an automatic turntable around \$100. Other PE models from \$70 to \$155.



ELPA MARKETING INDUSTRIES, INC.
New Hyde Park, N.Y. 11040

Please send additional information on the PE-2035 as well as the complete line of PE automatic turntables.

NAME _____

ADDRESS _____

CITY _____

STATE _____ ZIP _____

CIRCLE NO. 10 ON READER SERVICE PAGE

Popular Electronics

LAWRENCE SPORN
Publisher

OLIVER P. FERRELL
Editor

LESLIE SOLOMON
Technical Editor

JOHN R. RIGGS
Managing Editor

EDWARD I. BUXBAUM
Art Director

ALEXANDER W. BURAWA
Associate Editor

ANDRE DUZANT
Technical Illustrator

PATTI MORGAN
Assistant Editor

JUDITH L. HOGAN
Editorial Assistant

J. GORDON HOLT
L. E. GARNER, JR.
DAVID L. HEISERMAN
Contributing Editors

STANLEY NEUFELD
Associate Publisher

RICHARD J. HALPERN
Advertising Manager

ROBERT UR
Marketing Manager

MARGARET DANIELLO
Advertising Service Manager

FURMAN H. HEBB
Group Vice President
Electronics and Photographic

ZIFF-DAVIS PUBLISHING COMPANY
Editorial and Executive Offices
One Park Avenue, New York, New York 10016
212 679-7200

Midwestern Office
The Parris Group, 4761 West Touhy Ave.,
Lincolnwood, Illinois 60066, 312 679-1100
GERALD E. WOLFE, DICK POWELL

Western Office
9025 Wilshire Boulevard, Beverly Hills, California 90211
213 Crestview 4-0265; Bradshaw 2-1161
Western Advertising Manager, BUD DEAN

Japan: James Yagi
Oji Palace Aoyama; 6-25, Minami Aoyama
6-Chome, Minato-Ku, Tokyo 407-1930/6821

Circulation Office
P.O. Box 1096, Flushing, N.Y. 11352

William Ziff, President
W. Bradford Briggs, Executive Vice President
Hershel B. Sarbin, Senior Vice President and Secretary
Stanley R. Greenfield, Senior Vice President
Phillip Sine, Financial Vice President and Treasurer
Walter S. Mills, Jr., Vice President, Circulation
Phillip T. Heffernon, Vice President, Marketing
Frank Pomerantz, Vice President, Creative Services
Arthur W. Butzow, Vice President, Production
Edward D. Muhlfield, Vice President, Aviation Division
Irwin Robinson, Vice President, Travel Division
George Marrissey, Vice President
Sydney H. Rogeis, Vice President

Ziff-Davis also publishes *Airline Management and Marketing*, *Incubating America's Aviation*, *Boating*, *Business & Commercial Aviation*, *Car and Driver*, *Cycle*, *Electronics World*, *Flying*, *Modern Bride*, *Popular Photography*, *Skating*, *Skating Area News*, *Skating Trade News*, *Stereo Review*, and *Travel Weekly*.

Forms 3579 and all subscription correspondence should be addressed to POPULAR ELECTRONICS, Circulation Department, P.O. Box 1096, Flushing, N.Y. 11352. Please allow at least six weeks for change of address. Include your old address, as well as new—enclosing if possible an address label from a recent issue.

EDITORIAL CONTRIBUTIONS must be accompanied by return postage and will be handled with reasonable care; however, publisher assumes no responsibility for return or safety of art work, photographs or manuscripts.



Member Audit Bureau
of Circulations



Tenth in a Monthly Series by Oliver P. Ferrell, Editor

SOMETHING GOOD ABOUT CB—AFTER ALL!

It's doubtful whether radio amateurs would be willing to admit it, but isn't the current flood of interest in 2-meter FM mobile operation a direct result of CB? Wouldn't it be strange if, after all the complaints and name calling, radio amateurs have CB'ers to thank for the first dramatic innovation in their hobby since the introduction of SSB?

Mobile operation on 2 meters has been around for the past two decades. Until a few years ago the majority of mobiles were AM. Then someone discovered that commercial narrow-band FM equipment for the 152-174-MHz band was easily converted to 2 meters and simultaneously some notable progress was made in extending the operating range through the use of repeaters—also a technique similar to that employed by the commercials. After it looked like the surplus commercial equipment market might either dry up or limit growth of 2-meter mobiles, a half-dozen ham equipment manufacturers introduced transceivers looking deceptively like CB units. They were compact, powered by 12 volts dc, were solid-state, had crystal-controlled channels (receive and transmit) and were just a little more powerful than CB transceivers. To make the story complete, 2-meter FM mobile is now the "in" thing for amateur radio—while SSB is getting ready to make a massive invasion in the CB market!

A PEEK AROUND THE CORNER

I have received hundreds of letters and postcards commenting on the "new look" in POPULAR ELECTRONICS. One advantage to the change in format that is not immediately obvious to the reader has been the fact that the editorial staff can now engage in some very long-range planning. Much of the editorial content for POPULAR ELECTRONICS that will be published in the next six issues is now either being proof-built, tested, or polished up for the best possible presentation. A few things you may find of interest are the construction projects for the Electro-Voice 4-Channel Decoder scheduled for July or the September issue's unusual TV preselector/preamplifier that builds up the strength of a TV signal on one channel while suppressing the two adjacent channels—guess what that's for! In November, we will present plans for building a desk calculator!

Discover the power
of your own voice!

Take our free voice analysis

Find out if you can be trained
as a newscaster, sportscaster,
disc jockey or announcer.

Now, find out—FREE—if you have a voice that can be trained for broadcasting. Just mail in the coupon for information about our free voice test. It was created with the help of John Cameron Swayze, Curt Gowdy, Fran Allison, and other members of the faculty of Career Academy's Division of Famous Broadcasters.

If you qualify for training, you can study at one of the Academy's many studios, or at home, in your spare time. Either way, your Career Academy Certificate prepares you for a Federal Communications Commission Third Class Operator's License with Broadcast Endorsement—in as little as a few months.

MAIL COUPON NOW...

for details on your
free voice analysis,
plus a free record
and colorful booklet.
There's absolutely
no obligation.



CAREER ACADEMY'S

DIVISION OF FAMOUS BROADCASTERS
International Headquarters School
611 E. Wells Street, Dept. N087227
Milwaukee, Wisconsin 53201

I want to know if I have broadcasting talent worth developing. Please rush me more information. I am interested in:

Home Study Studio Training

Name _____
(please print)

Address _____

City _____

State/
Province _____ Zip _____

Phone _____ Age _____
(Home, Business, or Neighbor)

Year of high school graduation _____

Check here if eligible for Veteran's Benefits
Accredited by the NATTS and NHSC.

CIRCLE NO. 5 ON READER SERVICE PAGE

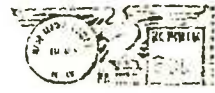

INTERFACE

THE PROJECT BUILDER SPEAKS

I rarely write to magazines, but wanted to express my appreciation for the March issue. I was beginning to lose interest in POPULAR ELECTRONICS, but I like to find a number of under-\$20 state-of-the-art projects. I hope the March issue is the beginning of a trend in that direction.

L. LAURENCE
Hat Creek, Calif.

Just a note to tell you how much I enjoy the caliber and type of articles you're now carrying in POPULAR ELECTRONICS. It's better than ever! Your test equipment building sections have been received warmly. In particular, I am waiting for all of the follow-up sections to the Digital Lab readout equipment series. Thanks for maintaining a periodical of superior quality.

D. D. Holtz, WB2HTH
Rochester, N.Y.

MUSINGS AT TWILIGHT

I hope that what you say in your editorial, "Twilight of the Shortwave Listener," March, 1971, is not true. I have found considerable pleasure in listening to broadcasts from other countries—especially those in the English language. Shortwave broadcasting is a mess, not because of the listener, but because of the selfish interests of the broadcasters. The number of shortwave listeners would undoubtedly increase if the countries involved would put their own houses in order and realize the vital importance of communicating to the rest of the world.

A. SCHOLL
Brant Lake, N.Y.

I tune shortwave for its news value and for the human interest of hearing the distant or the unusual. It is a hard game and I've never made a convert. You have to have been an SWL for DX reasons to know how to tune shortwave. The stations are little help and there is little real news (except for the BBC). If some of the stations end their transatlantic service, it's okay with me—less is more! There's too much propaganda and lack of planning.

H. BOX
Brooklyn, N.Y.

About two years ago I decided to set up a listening post and purchased a well-known

POPULAR ELECTRONICS

NOW! THIRD VOLUME AVAILABLE!

Color-TV Field-Service Guides

These invaluable guides have been compiled to enable the technician to service color-TV more efficiently in the customer's home. Charts provide chassis layouts showing type, function, and location of all tubes and/or transistors used in a particular chassis, ratings and locations of fuses and circuit breakers, location of service controls and adjustments, etc. Specific field-adjustment procedures are shown on page opposite chassis layout. Index provides instant reference to the proper chart for any particular TV chassis. Each volume contains 80 diagrams covering over 3000 chassis.

- Volume 1. Order 20796, only \$4.95
- Volume 2. Order 20807, only \$4.95
- Volume 3. Order 20847, only \$4.95

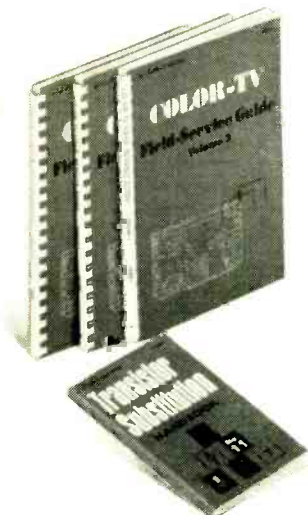

Television Broadcasting: Equipment, Systems, and Operating Fundamentals

by HAROLD E. ENNES. This book is a valuable treatise on the entire television broadcast system. It is not only a practical and basic course for new and prospective television broadcast technicians, but it serves also as a useful source of reference information for practicing technical personnel. Presents the basics of the NTSC color system, reinforced by a special detailed exercise section. Describes the fundamentals of camera chains, sync generators, television recording systems, and transmitters. Each chapter is accompanied by exercises to help reinforce understanding of the subjects covered. Hardbound. Order 20786, only \$14.95

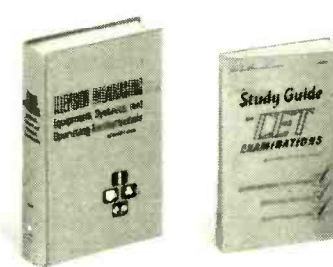

Study Guide for CET Examinations

by J. A. WILSON, CET and DICK GLASS, CET. Here is an invaluable study guide for those who want to qualify for a Certified Electronic Technician (CET) license or for a required state or local license. The material assumes that the reader is already competent to service home entertainment equipment. The book places special emphasis on recent developments and uses of such special devices as FET's and variable voltage capacitors. Includes keyed study assignments in the two Howard W. Sams books, Photofact® Television Course, and Color-TV Training Manual. Covers the important basic concepts that are likely to be encountered in the CET and other exams. Programmed questions and answers, as well as practice tests and their answers, appear in the back of the book. Order 20834, only \$5.50



Important New SAMS Books



New 11th Edition

Transistor Substitution Handbook

by the HOWARD W. SAMS ENGINEERING STAFF. Fully updated to include over 100,000 substitutions. Covers all manufacturers and gives proper substitutions for all types of bipolar transistors: U. S. and foreign, home-entertainment and industrial. Computer-compiled for accuracy. Also includes manufacturers' recommendations for general-replacement transistor substitutions. Tells how and when to use substitute transistors. An invaluable reference book for everyone in electronics.

Order 20835, only \$2.25

Replacement Control Guide

1971 Edition

by the HOWARD W. SAMS ENGINEERING STAFF. Shows replacement controls manufactured by Centralah, CTS-IRC, and Mallory for television sets: home, auto, CB radios; and tape recorders and tape players. Covers replacements for over 70,000 models manufactured from 1955 through 1970. Lists over 28,000 parts numbers in an alphabetical numerical index system using industry numbers. Provides quick, easy selection of proper replacement controls. Order 06401, only \$1.50

Electronic Organ Servicing Guide

by ROBERT G. MIDDLETON. Provides a complete understanding of the basic circuitry of the individual units employed in an electronic organ and explains how they function together. Once these principles are grasped, the servicing of electronic organs is fairly easy to accomplish. The book explains in detail how to diagnose and repair troubles in each section of the organ, how to practice preventive maintenance, how to make required adjustments and how to master tuning techniques. Order 20826, only \$4.95

101 Questions and Answers About Electricity

by LEO C. SANDS. This book is a valuable reference source for experimenters and students, or for anyone who wants a basic understanding of electricity and its applications. Answers the most frequently asked questions about electricity in easily understood terms. Especially noteworthy are the explanations of the practical aspects of electricity which are presented with a minimum of theory. All topics are covered with extreme clarity for easy understanding. Order 20806, only \$3.50

HOWARD W. SAMS & CO., INC.

Order from your Electronic Parts Distributor, or mail to Howard W. Sams & Co., Inc., Dept. PE-061 4300 W. 62nd St., Indianapolis, Ind. 46268

Send books checked at right. \$_____ enclosed (please include sales tax where applicable).

Send FREE 1971 Sams Book Catalog

Name _____
Address _____
City _____ State _____ Zip _____

- 20796 20835
- 20807 20826
- 20847 20806
- 20786 06401
- 20834

receiver. The roadblock I have found is in locating a few good technicians and dealers interested in the SWL market.

R. L. DAVENPORT
Raleigh, N.C.

BATTLE SUMMARY

Your feature article ("Battle of the Giant

Brains," April, 1971, p 39) on the early history of computers was interesting and informative. How about a follow-up article on the history of analog computers many of which still use intricate mechanical devices such as integrators and differentiators to great advantage?

R. LIEBMAN
Flushing, N.Y.

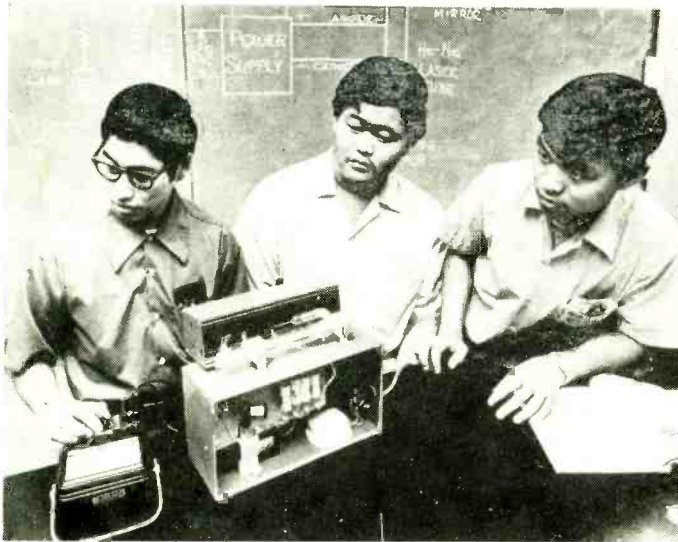

HAWAIIAN LASER

After a year, working one afternoon a week, students in Electronics Technology Program completed building optically safe HeNe gas laser which will be used in Science Department physics classes at Honolulu Community College. Laser operates on wavelength of 6328 Angstroms while generating 0.4 mW output power. Laser, based on POPULAR ELECTRONICS article was \$60 to build. Students involved in project, left to right, are Roy Araki, Shelton Goto, and Don Tang. Students study laser in physics course "Sound, Light, and Electricity" as a major.

*the tape that
turned the
cassette into
a high-fidelity
medium*

TDK

Until TDK developed *gamma ferric oxide*, cassette recorders were fine for taping lectures, conferences, verbal memos and family fun—but not for serious high fidelity.

Today you can choose among high-quality stereo cassette decks.

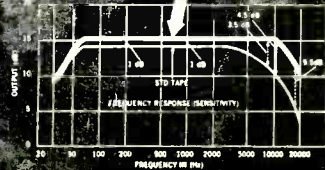

The new magnetic oxide used in TDK Super Dynamic tape distinctively differs from standard formulations in such important properties as coercive force, hysteresis-loop squareness, average particle length (only 0.4 micron!) and particle width/length ratio. These add up to meaningful performance differences: response capability from 30 to 20,000 Hz, drastically reduced background hiss, higher output level, decreased distortion and expanded dynamic range. In response alone, there's about 4 to 10 db more output in the region above 10,000 Hz—and this is immediately evident on any cassette recorder, including older types not designed for high performance. There's a difference in clarity and crispness you can hear.

Available in C60SD and C90SD lengths.

TDK ELECTRONICS CORP.
LONG ISLAND CITY, NEW YORK 11103



TDK SUPER DYNAMIC (SD) TAPE



CIRCLE NO. 25 ON READER SERVICE PAGE

ALLIED RADIO SHACK ISSUES A NEW AND DIFFERENT CATALOG!

...a valuable "FIRST EDITION"...and it's **FREE!**

1000'S OF ITEMS,

100'S OF
EXCLUSIVES!

PREVIEWS OUR COMPLETE
SCIENCE FAIR® AND
KNIGHT-KIT® LINES FOR '72!

950 STORES NATIONWIDE!
EVERYTHING IN THIS BOOK
AVAILABLE FAST & EASY!

First & Only Catalog of its kind . . . The new Buying Guide for kit builders, hobbyists, Hams, experimenters, all "do-it-yourselfers" and "fix-it men"! Lists 1000's of handy but hard-to-find "little things" (and lots of not-so-little things) most stores don't stock. Like tubes and transistors, cables and plugs, adapters and antennas—you name it—the pieces and part and accessories that make equipment keep working after you've bought it. Or work even better. Or **DO MORE!** If you own anything electronic or electrical, you need this catalog.

A newer, easier way to shop . . . Use this book at home, unhurried, to find exactly what you need. Then go to your neighborhood Allied Radio Shack store and purchase your selections. It's that simple! Combines the best features of catalog and in-person shopping. If we don't have a store near you (unlikely!) you may order by mail.



ALLIED RADIO SHACK

A TANDY CORPORATION COMPANY

2725 West 7th Street
Fort Worth, Texas 76107
Dept. PE-1

Send me your FREE Spring/Summer Cat. 212

Name _____ Apt. No. _____

Route _____ Box _____

Street _____

City _____ State _____ Zip

POPULAR ELECTRONICS SUBSCRIBER SERVICE

Please include an address label when writing about your subscription to help us serve you promptly.

Write to: P.O. Box 1096, Flushing, N.Y. 11352

CHANGE OF ADDRESS: Please let us know you are moving at least six to eight weeks in advance. Affix magazine address label in space below and print new address in space provided. If you have a question about your subscription, attach address label to your letter.

If you have no label handy, print OLD address here.

name _____		please print	
address _____			
city _____			
state _____		zip code _____	

AFFIX LABEL

TO SUBSCRIBE: Check these boxes: — New — Renewal

5 years \$21 3 years \$15 1 year \$6

SPECIFY: Payment enclosed—You get 1 extra issue per year as a BONUS! Bill me later.

0521

name _____ please print

address _____

city _____ state _____ zip _____

Add'l postage: \$1 per year outside U.S., its possessions & Canada.

ABOUT YOUR SUBSCRIPTION

Your subscription to POPULAR ELECTRONICS is maintained on one of the world's most modern, efficient computer systems, and if you're like 99% of our subscribers, you'll never have any reason to complain about your subscription service.

We have found that when complaints do arise, the majority of them occur because people have written their names or addresses differently at different times. For example, if your subscription were listed under "William Jones, Cedar Lane, Middletown, Arizona," and you were to renew it as "Bill Jones, Cedar Lane, Middletown, Arizona," our computer would think that two separate subscriptions were involved, and it would start sending you two copies of POPULAR ELECTRONICS each month. Other examples of combinations of names that would confuse the computer would include: John Henry Smith and Henry Smith; and Mrs. Joseph Jones and Mary Jones. Minor differences in addresses can also lead to difficulties. For example, to the computer, 100 Second St. is not the same as 100 2nd St.

So, please, when you write us about your subscription, be sure to enclose the mailing label from the cover of the magazine—or else copy your name and address exactly as they appear on the mailing label. This will greatly reduce any chance of error, and we will be able to service your request much more quickly.



To obtain a copy of any of the catalogs or leaflets described below, fill in and mail the Reader Service blank on page 15 or 95.

Literature describing the Ensign and Ensign II VHF-FM marine radiotelephones and accessories can be obtained on request from *RF Communications Inc.* Included along with the specifications for the items listed, including antennas, is a complete price list.

Circle No. 75 on Reader Service Page 15 or 95

A Digital Multimeter priced at only \$195.50 is described in Form DM 3550-1(171) from *Esterline Angus*. The four-color pamphlet indicates that the Digital Multimeter has 21 switch-selectable ranges for ac and dc voltage and current and resistance.

Circle No. 76 on Reader Service Page 15 or 95

A new line of modular "Designer Series" extruded aluminum instrument cases is illustrated in Bulletin No. 171 available from *Buckeye Stamping Co.* The pamphlet describes how these new Bord-pak cases are assembled with concealed fastenings and how, by assembling the matching extruded shapes, it is possible to achieve an extremely broad range of case sizes—including standard rack panel heights.

Circle No. 77 on Reader Service Page 15 or 95

Multi-function furniture and wall decorations with built-in full-spectrum color lighting and geometric patterns or abstract designs in ever-changing motion are listed in "Chromatic Fantasy," a catalog available from *Control Research Inc.* Featured are light columns, Plexiglass cubes, and speaker lites that double as color organs.

Circle No. 78 on Reader Service Page 15 or 95

Digital panel meters are the subject of Form 101570-25M, a two-color, six-page catalog from *Triplet Corp.* Listed is the company's full line of 2-, 2½-, 2¾-, 3-, and 3½-digit panel meters. In addition to providing the complete electrical, physical and mounting specifications for each meter, the catalog also contains a comprehensive specification selection guide.

Circle No. 79 on Reader Service Page 15 or 95



Seven new Heathkit® improvement ideas for home or shop

NEW! Heathkit IR-18M 10" chart recorder kit provides 12 different chart speeds...instant pushbutton selection from 5 sec/in. to 200 min/in. Digital logic delivers accuracy unobtainable with ordinary gear trains. Two input ranges permit accurate measurements from 0-1 & 0-10 mV full scale. Hi-Z input minimizes loading. 3-terminal floating input. Light-operated modulator eliminates problems of a mechanical chopper...operates at 240 Hz to reduce 60 Hz noise. Internal temperature-stabilized reference voltage eliminates troublesome reference battery. Coarse & Fine zero controls allow fast, accurate pen positioning. Other features: versatile pen holder that accepts virtually any writing instrument & hinged top for easy paper loading. For the best value going in a chart recorder, order your IR-18M now. Kit IR-18M, 15 lbs., 149.95*

NEW! GR-371MX 25" solid-state ultra-rectangular color TV. Check out the competition for standard features like these: 25" square corner Matrix picture tube for the biggest, brightest, sharpest color picture ever...high resolution circuitry plus adjustable video peaking...Automatic Fine Tuning...pushbutton channel advance...Instant-On...Automatic Chroma Control...factory assembled 3-stage solid-state IF and VHF & UHF tuners for superior reception, even under marginal conditions...adjustable noise limiting & gated AGC...adjustable tone control...hi-fi sound output to internal speaker or your hi-fi system. Plus your choice of installation in one of the three beautiful Heath cabinets or custom wall mounting capability. And the exclusive Heath self-service features let you do all normal adjustment & servicing, saving hundreds of dollars in service costs. If you want the finest, this is it...order your 371MX now. Kit GR-371MX, 125 lbs. 579.95*

NEW! GD-29 microwave oven...the most modern way to prepare food. Cooks up to 70% faster with better vitamin retention. Cooks on glass, ceramics, even paper plates. Low profile design fits under cupboards easily, yet has one of the largest oven capacities in the industry. Operates anywhere on standard 120 VAC current. Kit includes specially prepared cookbook. Kit GD-29, 97 lbs. 399.95* Roll-around cart gives oven easy mobility, Model GDA-29-1, 24.95*

NEW! IB-102 Scaler and IB-101 Frequency Counter combination give you frequency measurement capability to 175 MHz at low, low cost. IB-101 counts from 1 Hz to over 15 MHz. Hz/kHz ranges & over-range indicator let you make an 8-digit measurement down to the

last Hz in seconds. 5-digit cold-cathode readout...extremely low input triggering...all solid-state with 26 ICs, 8 transistors. NEW IB-102 Frequency Scaler can be used with virtually any counter on the market to extend your measurement capability well into the VHF range...at a price far below the cost of a 175 MHz counter. 10:1 and 100:1 scaling ratios give resolution down to 10 Hz...1:1 ratio provides straight-thru counting for frequencies in range of counter. Exclusive Heath input circuit triggers at very low levels - at 100 MHz less than 30 mV is needed. A handy Test switch gives a quick, accurate check of proper operation. All solid-state; fully regulated supplies; convenient carrying handle/tilt stand. Extend your frequency measurement capability now with these two new kits. Kit IB-101, 7 lbs. 199.95* Kit IB-102, 7 lbs. 99.95*

NEW! IO-102 solid-state 5" scope ideally suited for general purpose service & design work. Features wide DC-5 MHz response, 30 mV/cm sensitivity and 80 ns rise time. Feature-selected AC or DC coupling for greater versatility. Frequency-compensated 3-position attenuator. FET input provides hi-Z to minimize circuit loading. Recurrent, automatic-sync type sweep provides five ranges from 10 Hz to 500 kHz with vernier. External horizontal and sync inputs are also provided. One volt P-P output provides an accurate comparison voltage source. Additional features include a big 5" CRT with high visibility trace; 6x10 cm ruled graticule that can be replaced with a standard camera mount; solid-state zener-regulated supplies for extra display stability and 120/240 VAC operation. An excellent all-around scope that belongs on your bench now. Kit IO-102, 29 lbs., 119.95*

NEW! IM-105 solid-state portable VOM...an extremely rugged, highly accurate, low cost meter for hundreds of applications. High impact Lexan® case and ruggedized diode & fuse protected taunt-band meter movement will suffer extreme abuse and still maintain specifications. 95° wide viewing area provides high resolution. 3% DC accuracy; 4% AC accuracy; 3% DC current accuracy. Temperature compensated. 8 DCV ranges from 0.25 to 5000 V full scale...7 ACV ranges from 2.5 to 5000 V full scale...6 DC current ranges from 0.05 mA to 10 A full scale...5 ohms ranges from x1 to x10k with center scale factor of 20...5 dB ranges from -10 to +50 dB. Other features include DC polarity reversal switch; front panel thumbwheel ohms zero; self-storing handle and fast, easy assembly. A lot of meter at a little cost...that's the new IM-105. Order yours now. Kit IM-105, 7 lbs., 47.95*

See these kits at your local Heathkit Electronic Center ... or Send for Free Catalog

CALIF.: Anaheim, 330 E. Ball Road; El Cerrito, 6000 Potrero Avenue; La Mesa, 8363 Center Drive; Los Angeles, 2309 S. Flower St.; Redwood City, 2001 Middlefield Rd.; Woodland Hills, 22504 Ventura Blvd.; COLO.: Denver, 5940 W. 38th Ave.; GA.: Atlanta, 5285 Roswell Road; ILL.: Chicago, 3462-66 W. Devon Ave.; Downers Grove, 224 Ogden Ave.; MD.: Rockville, 5542 Nicholson Lane; MASS.: Wellesley, 165 Worcester St.; MICH.: Detroit, 18645 W. Eight Mile Rd.; MINN.: Hopkins, 101 Shady Oak Rd.; MO.: St. Louis, 9296 Gravois Ave.; N.J.: Fair Lawn, 35-07 Broadway (Rte. 4); N.Y.: Jericho, L.I., 15 Jericho Turnpike; New York, 35 W. 45th Street; OHIO: Cleveland, 5444 Pearl Rd.; Woodlawn, 10133 Springfield Pike; PA.: Philadelphia, 6318 Roosevelt Blvd.; Pittsburgh, 3482 William Penn Hwy.; TEXAS: Dallas, 2715 Ross Avenue; Houston, 3705 Westheimer; WASH.: Seattle, 2221 Third Ave.; WIS.: Milwaukee, 5215 W. Fond du Lac.

Retail Heathkit Electronic Center prices slightly higher to cover shipping, local stock, consultation and demonstration facilities. Local service also available whether you purchase locally or by factory mail order.



HEATH COMPANY, Dept. 10-6
Benton Harbor, Michigan 49022
a Schlumberger company

Enclosed is \$ _____, plus shipping.

Please send model (s) _____

Please send FREE Heathkit Catalog. Please send Credit Application.

Name _____

Address _____

City _____ State _____ Zip _____

*Mail order prices; F.O.B. factory.
Prices & specifications subject to change without notice. CL-411R

CIRCLE NO. 11 ON READER SERVICE PAGE

Johnson announces DRC*

**Now you can monitor
two channels
simultaneously**



***DUAL RECEIVE
CAPABILITY**

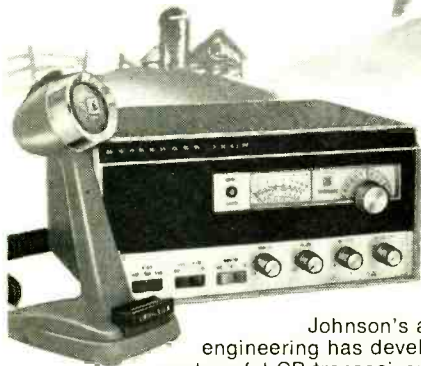

Johnson's advanced engineering has developed the most useful CB transceiver function since the introduction of full 23-channel operation. It's **DRC**—Dual Receive Capability.

While you operate the transceiver normally, on any channel you choose, separate receiver circuitry monitors either of two selected channels (such as your local calling frequency or Emergency Channel 9). When a call is transmitted on the monitored channel, you'll know instantly! First, the signal is detected by the DRC circuits and automatically an indicator light is flashed on the front panel. You see the call! Then with the DRC switched to the fully automatic mode, it interjects the message through your speaker. You *hear* the call! (DRC can also be switched to a "signal light only" mode, if you don't want your normal operation interrupted.) Separate squelch controls provide you with total convenience and versatility!

AVAILABLE NOW AT YOUR DEALER!

New Messenger 124-M complete with 23-channel master control and a Channel 9 crystal for the DRC monitor. (Additional DRC monitor crystal and base station microphone, optional extras.)
\$339.50



E. F. JOHNSON CO.

Waseca, Minnesota 56093

1112

CIRCLE NO. 12 ON READER SERVICE PAGE

14

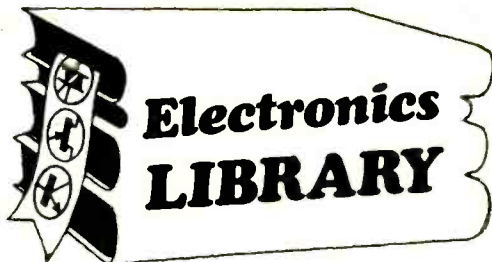

ELECTRIC ENERGY SYSTEMS THEORY

by Olle I. Elgerd

The newest addition to the McGraw-Hill Electrical and Electronic Engineering Series represents possibly the finest modern textbook on power systems to come along in years. The author presents the main objectives of a power system against a background of the national energy situation, future power trends, and ecological and economical considerations.

Published by McGraw-Hill Book Co., 330 West 42 St., New York, NY 10036. Hard cover. 564 pages. \$16.50.

AN INTRODUCTION TO LASERS AND MASERS

by A. E. Siegman

Intended for use in an introductory course in lasers and masers at the senior or first-year graduate level, this book combines basic principles with examples of practical applications. The text contains descriptions of many simple and inexpensive experiments and demonstrations that illustrate the basic principles or important device characteristics. In the tradition of a textbook, each chapter concludes with a set of problems and a list of selective references for further reading.

Published by McGraw-Hill Book Co., 330 West 42 St., New York, NY 10036. Hard cover. 520 pages. \$18.50.

ELECTRONIC DESIGN DATA BOOK

by Rudolph F. Graf

This book simplifies the task of locating essential design data. A single encyclopedic source, it contains a wealth of timely, practical information, presented in ready-to-use formulas, nomograms, tables, and charts. Ready answers to problems are provided without lengthy derivations and proofs.

Published by Van Nostrand Reinhold Co., 450 West 33 St., New York, NY 10001. Hard cover. 312 pages. \$17.95.

FIRST-CLASS RADIOTELEPHONE LICENSE HANDBOOK, Third Edition

by Edward M. Knoll

This book has two major objectives: to help the reader obtain a license, and to prepare him for the responsibility of operating and maintaining broadcast equipment on the job. Third edition has been completely revised to

POPULAR ELECTRONICS

Popular Electronics

READER SERVICE PAGE

free information service:

Here's an easy and convenient way for you to get additional information about products advertised or mentioned editorially (if it has a "Reader Service Number") in this issue. Just follow the directions below... and the material will be sent to you promptly and free of charge.

1. On coupon below, circle the number(s) that corresponds to the key number(s) at the bottom or next to the advertisement or editorial mention that is of interest to you. (Key numbers for advertised products also appear in the Advertisers' Index.) Print or type your name and address on the lines indicated.

2. Cut out the coupon and mail it to: POPULAR ELECTRONICS, P.O. Box 8391, Philadelphia, PA 19101.

note: If you want to write to the editors of POPULAR ELECTRONICS about an article on any subject that does not have a key number, write to POPULAR ELECTRONICS, One Park Avenue, New York, N.Y. 10016. Inquiries concerning circulation and subscriptions should be sent to POPULAR ELECTRONICS, P.O. Box 1096, Flushing, N.Y. 11352.

Popular Electronics

6/71-3
Void after July 31, 1971

P.O. BOX 8391
PHILADELPHIA, PA. 19101

1 2 3 4 5 6 7 8 9 10 11 12 13 14 15 16 17 18 19 20
21 22 23 24 25 26 27 28 29 30 31 32 33 34 35 36 37 38 39 40
41 42 43 44 45 46 47 48 49 50 51 52 53 54 55 56 57 58 59 60
61 62 63 64 65 66 67 68 69 70 71 72 73 74 75 76 77 78 79 80
81 82 83 84 85 86 87 88 89 90 91 92 93 94 95 96 97 98 99 100

NAME (Print clearly) _____

ADDRESS _____

CITY _____ STATE _____ ZIP CODE _____

The best base station microphone in the world.



Turner +3

Modern styling. Transistorized pre-amp. Volume control. Modu-Gard™: a compression amplifier circuit that guarantees you cannot over-modulate. Clear signal, always. No interference with adjacent channels, regardless of volume setting. 300-3,000 Hz frequency response for best voice transmission. Relay or electronic switching. Push-to-talk bar. Lock lever. The Best. At your local dealers, list price \$75.00.

The TURNER Company, Inc.

A subsidiary of Conrac Corporation
909 17th St. N.E., Cedar Rapids, Iowa 52402

CIRCLE NO. 21 ON READER SERVICE PAGE

LIBRARY (Continued from page 14)

contain all of the new material included in the recently revised FCC Study Guide. To accomplish its aims, the text follows an informal question-and-answer format that has proven very effective for digesting the essential information.

Published by Howard W. Sams & Co., Inc., 4300 West 62 St., Indianapolis, IN 46268. Soft cover. 416 pages. \$6.50.

COMPUTER DATA HANDLING CIRCUITS

by Alfred Corbin

Most formal electronics courses contain much material that is unnecessary or only remotely related to a practical understanding of the subject. This handy one-volume course in digital circuit analysis has eliminated the nonessentials.

Published by Howard W. Sams & Co., Inc., 4300 West 62 St., Indianapolis, IN 46268. Soft cover. 176 pages. \$4.95.

ANALOGUE AND ITERATIVE METHODS

by B. R. Wilkins

Starting with the classical techniques of analog computation, the text leads to a discussion of asynchronous control of computer systems which allow optimization and other problems to be solved by iterative (successive approximation) methods.

Distributed by Barnes & Noble, Inc., 105 Fifth Ave., New York, NY 10003. Hard cover. 273 pages. \$11.25.

RCA PHOTOMULTIPLIER MANUAL, PT-61

This manual was written to provide designers and users of electro-optical equipment a thorough understanding of today's photomultiplier tubes. In addition to explaining photomultiplier tube theory, photometric units, photometric-to-radiant conversion, radiant energy sources, and spectral response are dealt with.

Published by RCA Electronic Components, Harrison, NJ 07029. Soft cover. 192 pages. \$2.50.

COMPUTER CIRCUITS & HOW THEY WORK

by Byron Wels

Everyone associated with electronics should have at least a rudimentary understanding of computers. The field of computer technology is broken down into bite-size areas. Then, in step-by-step fashion, descriptions and functions of various parts of the computer are explained.

Published by TAB Books, Blue Ridge Summit, PA 17214. 192 pages. \$7.95 hard cover; \$4.95 soft cover.

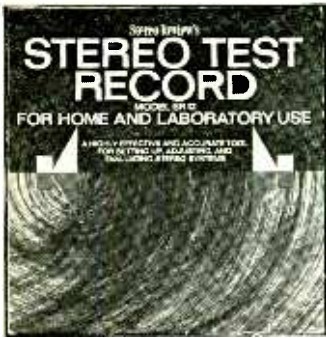

**THE
2 MOST
IMPORTANT
RECORDS IN
YOUR ENTIRE
COLLECTION!**



New Standard in Stereo Testing! The All-New Model SR12 STEREO TEST RECORD
The most complete . . . most sophisticated . . . most versatile Test Disc available today!

The Most Spectacular Sound Exhibition of STEREO FIDELITY Ever Available on one Disc.

Whether you're an avid audiophile who'll settle for nothing but peak performance from his stereo components . . . a casual listener who'd like more insight into the challenging world of stereo reproduction . . . or a professional technician who needs precise standards for lab testing . . . the new MODEL SR12 will be the most important disc in your entire collection. SR12 has been produced by Stereo Review Magazine for music lovers who want immediate answers to questions about the performance of their stereo systems and how to get the best possible sound reproduction. SR12 is the most complete test record of its kind—containing the widest range of checks ever included on one test disc.

MAKE THESE IMPORTANT STEREO CHECKS BY EAR . . . (NO INSTRUMENTS OF ANY KIND REQUIRED)

FREQUENCY RESPONSE — a direct warble-tone check of nineteen sections of the frequency spectrum, from 20 to 20,840 Hz ● **SEPARATION** — indicates whether you have adequate separation for good stereo ● **CARTRIDGE TRACKING** — devised for checking the performance of your cartridge, stylus and tone arm ● **CHANNEL BALANCE** — two broad-band, random-noise signals which permit you to eliminate any imbalances originating in cartridge, amplifier, speakers or room acoustics ● **HUM AND RUMBLE** — foolproof tests that help you evaluate the actual audible levels of rumble and hum in your system ● **FLUTTER** — a sensitive "musical" test to check whether your turntable's flutter is low, moderate, or high ● **PLUS:** Cartridge and Speaker Phasing ● Anti-Skating Adjustment ● "Gun Shot Test" for Stereo Spread ● Multi-purpose Musician's "A" ● Equal-tempered Chromatic Octave ● Guitar-tuning Tones.

FOR THE ULTIMATE IN STEREO TESTING, 7 CRITICAL TEST EQUIPMENT CHECKS . . .

Attention professionals: Model SR12 is also designed to be used as a highly efficient design and measurement tool. In the following tests, recorded levels, frequencies, etc. have been controlled to laboratory tolerances—affording accurate numerical evaluation when used with oscilloscope, chart recorder, output meter, intermodulation-distortion meter and flutter meter.

● 1,000-Hz square waves to test transient and high-frequency response of phono pickups. ● 500 to 20,000 Hz frequency-response sweep. ● Sine-wave tone-bursts to test transient response of pickup. ● Intermodulation test using simultaneous 400-Hz and 4,000-Hz signals. ● Intermodulation sweep to show distortion caused by excessive resonances in tone arm and cartridge. ● 1,000-Hz reference tones to determine groove velocity. ● 3,000-Hz tone for flutter and speed tests. ● **Sample waveforms** — illustrating both accurate and faulty responses are provided in the Instruction Manual for comparison with the patterns appearing on your own oscilloscope screen.

This record is the result of two years of intensive research in the sound libraries of Deutsche Grammophon Gesellschaft, Connoisseur Society, Westminster Recording Company and Cambridge Records Incorporated. The Editors of Stereo Review have selected and edited those excerpts that best demonstrate each of the many aspects of the stereo reproduction of music. **The record offers you a greater variety of sound than has ever before been included on a single disc.** It is a series of independent demonstrations, each designed to show off one or more aspects of musical sound and its reproduction. Entirely music, the Record has been edited to provide self-sufficient capsule presentations of an enormous variety of music arranged in a contrasting and pleasing order. It includes all the basic musical and acoustical sounds that you hear when you listen to records, isolated and pointed up to give you a basis for future critical listening.

WIDE RANGE OF DEMONSTRATIONS

● Techniques of Separation & Multiple Sound Sources ● Acoustic Depth ● Ambiance of Concert Hall ● Sharp Contrasts of Dynamics ● Crescendo & Diminuendo ● Very High & Very Low Pitched Musical Sounds ● Polyphony (2 or more melodies at once) With Both Similar & Contrasting Instruments ● Tonal Qualities of Wind, String & Percussion Instruments ● Sounds of Ancient Instruments ● Sounds of Oriental Instruments ● Sound of Singing Voice, Both Classically Trained and Untrained ● Plus a Large Sampling of Finger Snapping, Hand Clapping, Foot Stamping & Other Musical & Percussive Sounds.

13 SUPERB SELECTIONS

STRAUSS: Festive Prelude, Op. 61 (excerpt) DGG.
DEBUSSY: Feux d'artifice (excerpt), Connoisseur Society.
BEETHOVEN: Wellington's Victory (Battle Symphony) (excerpt from the first movement) Westminster Records.
MASSAINO: Canzona XXXV à 16 (complete) DGG Archive.
CORRETTE: Concerto Comique Op. 8, No. 6, "Le Plaisir des Dames" (third movement) Connoisseur Society.
KHAN: Raga Chandranandan (excerpt) Connoisseur Society.
RODRIGO: Concert—Serenade for Harp and Orchestra (excerpt from the first movement) DGG.
MANITÁS DE PLATA: Gypsy Rhumba (complete) Conn. Soc.
MARCELLO: (arr. King): Psalm XVII "The Heavens are Telling" (complete) Connoisseur Society.
PRAETORIUS: Terpsichore: La Bourrée XXXII (complete) DGG Archive.
BERG: Wozzeck (excerpt from Act III) DGG.
BARTÓK: Sonata for two pianos and Percussion (excerpt from the first movement) Cambridge Records.
BEETHOVEN: Wellington's Victory (Battle Victory) (excerpt from the last movement) Westminster.

FREE 8 Page Instruction Manual includes detailed instructions, charts, tables and diagrams.

Only \$5.98 each

FREE Descriptive Booklet Enclosed includes discussion of the selections on the record, plus a complete description of each selection and the purpose behind its demonstration.

NOTE — THE STEREO DEMONSTRATION RECORD ONLY IS AVAILABLE IN YOUR CHOICE OF 33 1/3 RPM OR 45 RPM

Both the Model SR12 Stereo Test Record and Stereo Demonstration Record are processed and pressed on a newly developed, improved vinyl. It is permanently anti-static, repels dust and dirt and promotes longer stylus wear. The use of this material is conducive to low surface noise and contributes to the production of full dynamics and frequency range. The record continually looks new, sounds new and wears longer.

<p>RECORDS • Ziff-Davis Service Division 595 Broadway • New York, N.Y. 10012</p> <p>My check (or money order) for \$ _____ is enclosed. Please send: _____ Stereo Review Stereo Demonstration Records at \$5.98 each, postpaid. Check one: <input type="checkbox"/> 33 1/3 RPM <input type="checkbox"/> 45 RPM _____ Model SR12 Stereo Test Records at \$5.98 each, postpaid. (Outside U.S.A. please send \$8.00 per record ordered.) New York State residents Please add local sales tax.</p>	<p style="text-align: right;">PE-6 71</p> <p>Print Name _____</p> <p>Address _____</p> <p>City _____</p> <p>State _____ Zip _____</p> <p style="text-align: center;">PAYMENT MUST BE ENCLOSED WITH ORDER</p>
--	---

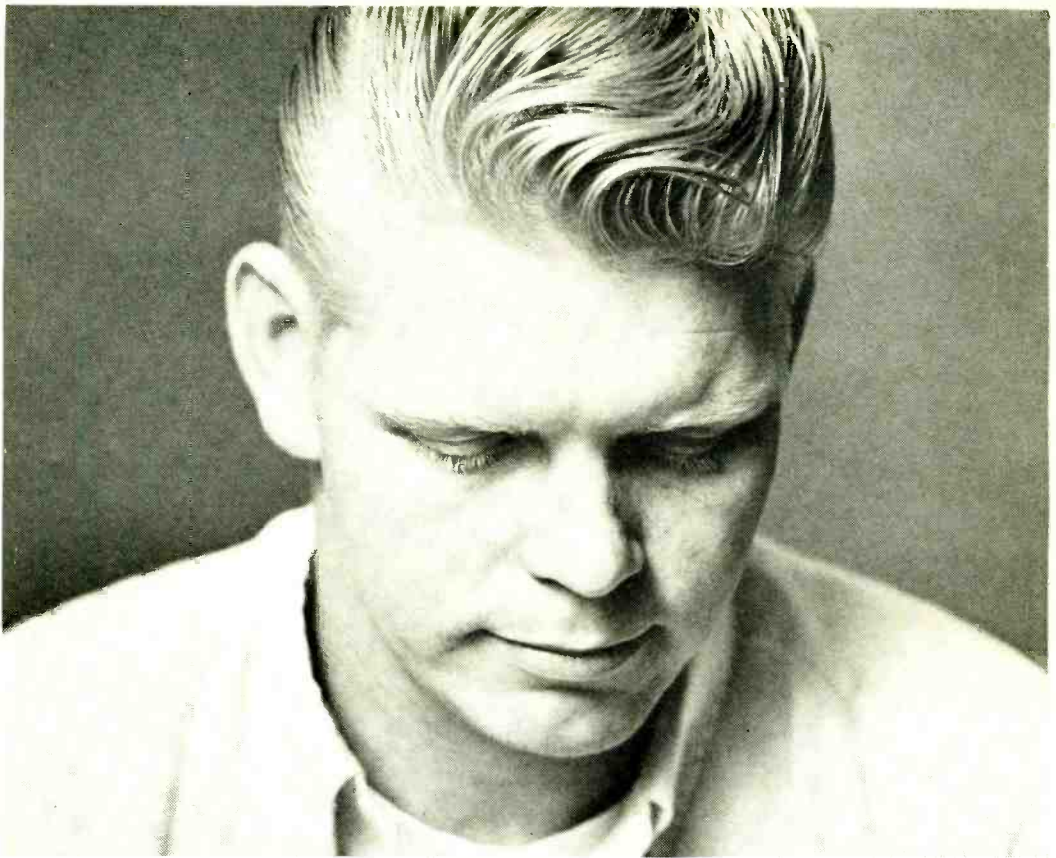

The best way to get electronics into your head

No book ever written can give you the "feel" of electronics.

This is why every NTS course in Electronics includes the most modern, professional training equipment in kit form.

Putting equipment together, kit by kit, can teach you more about electronics than a whole library of bone-dry theory.

Each kit contains illustrated instructions.

You look at the pictures, then you apply what you see as you assemble or service your equipment.

What could be simpler? Or more fun? You'll enjoy every profitable minute.

Here's just some of the equipment you get to build and what you will learn.

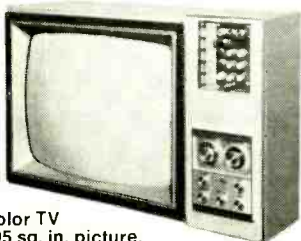

Color TV
295 sq. in. picture.

NTS COLOR AND B&W TV SERVICING

You receive a big screen color TV with many unique features, including self-servicing equipment so you can make all normal test operations. You also get an AM-SW radio, solid-state radio, field-effect transistor, Volt-Ohmmeter and electronic tube tester. You learn about electronic principles, trouble-shooting, hi-fi, multiplex systems, stereo and color TV servicing.

Solid-state
B&W TV
74 sq. in.
picture
(cabinet
included)

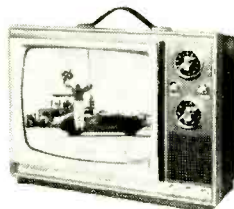

The B&W TV receiver features the latest in *solid-state circuitry*, making your TV training the most modern, most advanced available.

NTS COMPUTER ELECTRONICS

One of the 10 important kits included is this remarkable Compu-Trainer® — an NTS exclusive. It's a fully operational computer logic trainer — loaded with integrated circuits. It introduces you quickly to the how, what, when, and why of computers. This unit is capable of 50,000 operations per second.

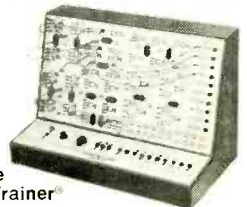

Exclusive
Compu-Trainer®

NTS ELECTRONICS COMMUNICATIONS

Two exciting courses in the big-paying fields of transmitting and receiving equipment. Either one qualifies you for your FCC First Class Radio-

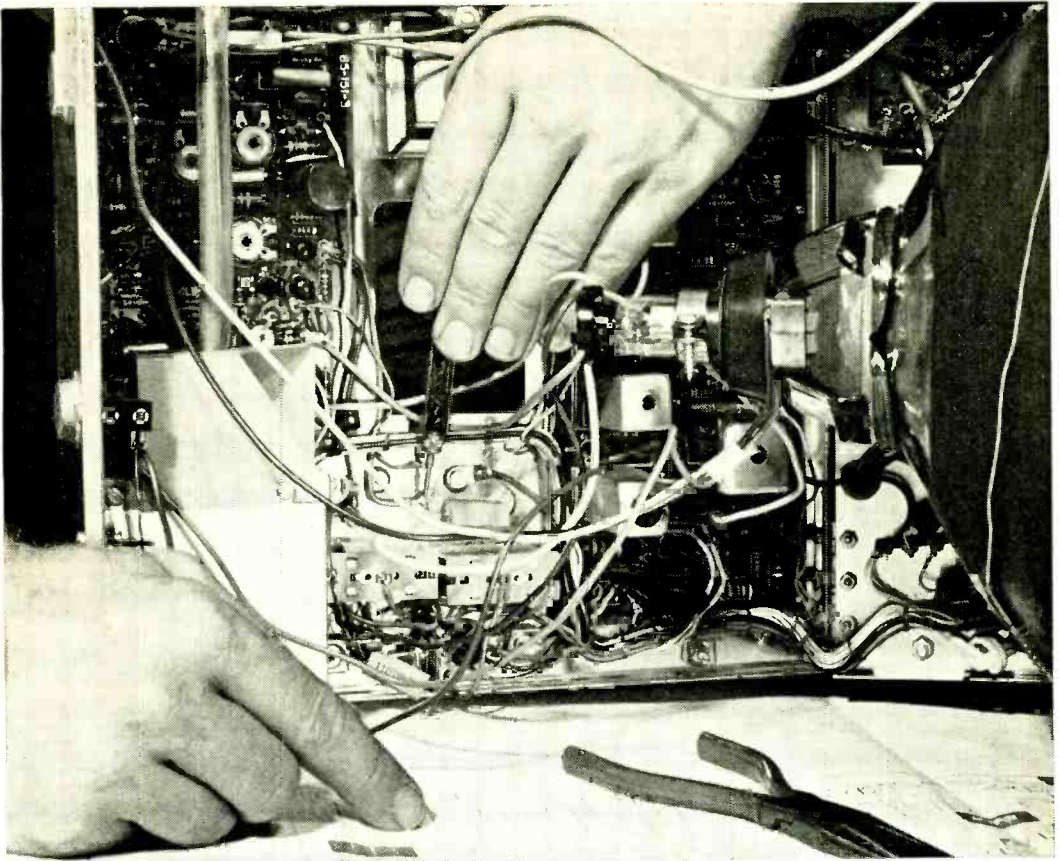

is to have the actual equipment in your hands.

Telephone License. *NTS assures you will pass this FCC exam within 6 months after successfully completing your course — or your tuition is refunded.* You receive 14 kits to build an amateur phone 6 meter VHF transceiver plus NTS' exclusive 6 transistor solid-state radio and a fully transistorized volt-ohmmeter.

5 watt AM transmitter/receiver.



NTS AUTOMATION/ INDUSTRIAL ELECTRONICS

Let NTS put you into the age of electronic controls. Systems automation is rapidly becoming the emphasis of modern industry. NTS training includes equipment like a 5" wide band oscilloscope. You also get the new, exclusive NTS Electro-Lab — a

complete workshop that lets you build five industrial controls to regulate motor speed, temperatures, pressure, liquid level, smoke, and much more.

5" Oscilloscope

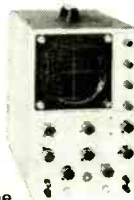

Mail card today for free, full-color catalog that details what each training program offers. (Or if card is missing, send coupon.) No obligation. No salesman will call.

Remember, the best way to get electronics into your head is to have the actual equipment in your hands. The sooner you mail the card, the sooner you'll get your hands on the finest, most advanced electronics home training ever offered.

CLASSROOM TRAINING AT LOS ANGELES You can take classroom training at Los Angeles in sunny California. NTS occupies a city block with over a million dollars in facilities devoted exclusively to technical training. Check box in coupon.

APPROVED FOR VETERANS

Accredited Member: National Association of Trade and Technical Schools; National Home Study Council.

NATIONAL TECHNICAL SCHOOLS

WORLD-WIDE TRAINING SINCE 1905
4000 S. Figueroa St., Los Angeles, Calif. 90037

If card is missing check coupon and mail for free color catalog and sample lesson. Now.

Please rush Free Color Catalog and Sample Lesson, plus information on course checked below. No obligation. No salesman will call.



National Technical Schools

4000 S. Figueroa St., Los Angeles, Calif. 90037

- Master Course in Color TV Servicing
- Master Course in Color TV Servicing
- Master Course in TV & Radio Servicing
- Master Course in Practical TV & Radio Servicing
- Master Course in Electronic Comm.
- FCC License Course
- Master Course in Electronics Tech.
- Industrial and Automation Electronics
- Computer Electronics
- Basic Electronics

Dept. 205-061

Name _____ Age _____

Address _____

City _____ State _____ Zip _____

Check if interested in Veteran Training under new G.I. Bill.
 Check if interested only in Classroom Training at Los Angeles

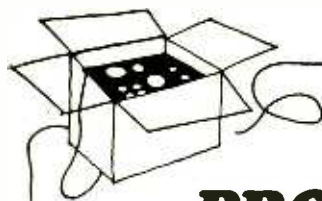

NEW PRODUCTS

Additional information on products described in this section is available from the manufacturers. Each new product is identified by a corresponding number on the Reader Service Page. To obtain additional information on any of them, circle the number on the Reader Service Page, fill in your name and address, and mail it in accordance with the instructions.

HARMAN-KARDON OMNIDIRECTIONAL SPEAKER SYSTEM

—Audiophiles will be wanting to try the new Citation 13 system from *Harman-Kardon, Inc.* Three 7" low-frequency drivers are loaded by a double-chambered enclosure which brings bass response down to 30 Hz without doubling. All of the drivers are fastened to a mounting board which is tilted at 14° off the horizontal in the top section of the baffle. By tuning the double chamber's an octave apart, the higher frequency creates acoustic loading in the middle bass, while the lower frequency maintains loading down to a suitable low-frequency limit. Specifications on the \$295 speaker system are available at Harman-Kardon dealers.

Circle No. 80 on Reader Service Page 15 or 95



LAMPKIN THREE-WAY INSTRUMENT—Versatility has been achieved by *Lampkin Laboratories, Inc.* in the Type 107A Digital Frequency Meter/Synthesizer/Signal Generator. As a heterodyne frequency meter, it will measure carrier frequencies of nearby transmitters or signals picked up on a receiver—AM, FM, TV, SSB or CW—from 10 kHz to above 500 MHz. As a synthesizer, frequencies from 1000 to 9,999.9 Hz can be generated in steps of 100 Hz. Finally, as a signal generator, the 107A provides CW, amplitude- or frequency-modulated signals on fundamental frequencies as described for the synthesizer up to 10 MHz. From 10 MHz to above 500 MHz, harmonics are employed. Dials are direct reading in MHz and kHz.

Circle No. 81 on Reader Service Page 15 or 95

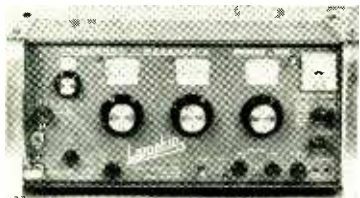

TOYO FOUR-CHANNEL TAPE DECK—One of the first four-channel tape cartridge players is the Qaudio CH-702, available from *Toyo Radio Co. of America, Inc.* With a master volume control for all four channels, there are also balance controls for left/right and rear speakers. Four illuminated VU meters monitor all the channels. Frequency response extends beyond 10,000 Hz with a total of 20 watts rms output to 4-ohm speaker loads for 80 watts peak power. S/N is 50 dB, wow and flutter is less than 0.35 percent at 3 kHz, and distortion at 1 kHz is 2 dB.

Circle No. 82 on Reader Service Page 15 or 95



HEATHKIT FREQUENCY SCALER—Experimenters and technicians can measure into the VHF range with the new IB-102 Frequency Scaler from *Heath Co.*, which will di-

vide input frequencies from 2 MHz to 175 MHz. The scaled output can be fed to any frequency counter with a 1-megohm input. The kit contains 8 IC's, 6 transistors, 1 FET, 11 diodes and fully regulated power supplies. Front panel switches allow selection of 10:1 or 100:1 scaling ratios, with counter resolution down to 10 Hz when used with a counter having a 1-second time base.

Circle No. 83 on Reader Service Page 15 or 95

RAYMER SPEAKER LINE TESTER—Sound installers and servicemen can use the Raymer Model LTS-1 to check the wattage requirement of any 25- or 70-volt speaker line up to 200 watts, determine the wattage drawn by a speaker with a 25- or 70-volt transformer, and measure the impedance of a speaker voice coil. Made by *Trutone Electronics, Inc.*, the LTS-1 has an illuminated sensitive meter for null detection. Operation is direct read-out with no graphs or charts necessary.

Circle No. 84 on Reader Service Page 15 or 95



KOSS STEREO HEADPHONES—New dynamic "stereo-phone," the "Red Devil" from *Koss Electronics, Inc.* weighs 12 oz and retails at \$29.95. Frequency range is 20 to 20,000 Hz and the phones are usable with low-impedance jacks or direct speaker output taps. Headband is flexible, high-strength polypropylene with neoprene foam ear cushions.

Circle No. 85 on Reader Service Page 15 or 95

RAMECO AUDIO SWEEP GENERATOR—Designed to display the response characteristics of either active or passive circuits on a standard scope, the Model ASG-1 Sweep Generator from *Rameco Corp.* has a frequency range of 0 to 100 kHz. Both swept and CW modes of operation are provided and output is adjustable for 0 to 5 volts peak-to-peak. Sweep time is variable from 20 milliseconds to 20 seconds. Generator blanking pulses are available for triggered operation.

Circle No. 86 on Reader Service Page 15 or 95



SONY SUPERSCOPE CASSETTE DECK—Said to be the first true high-fidelity stereo cassette deck on the market the Model 160 marketed by *Superscope* compares favorably in features and performance with the most expensive cassette decks currently available. Yet, it is priced in the under \$200 range. The deck incorporates several engineering advances, including Closed-Loop Dual Capstan Tape Drive which eliminates modulation distortion and reduces wow and flutter to 0.1 percent; built-in Peak Limiter which reduces high-level transients to 0-VU level to prevent tape saturation and distortion without altering the dynamic range of the recording; an illuminated Tape Pilot indicator for the operating mode; and a Headphone Level switch which adjusts the playback volume level when monitoring.

Circle No. 87 on Reader Service Page 15 or 95

The RCA portable color bar generator



Performs like the big ones Costs only \$75*

- Provides color bar, dot, cross hatch, and blank raster patterns
- All solid state circuitry including ICs
- Pattern signals, RF output frequency and color subcarrier all crystal-controlled
- Battery operated, AC adapter available
- Lightweight — less than 20 oz., only 6½" wide x 4" deep x 3" high

For all the technical specs get in touch with your RCA Distributor. RCA | Electronic Components | Harrison, N.J. 07029.

* Optional User Price

CIRCLE NO. 19 ON READER SERVICE PAGE

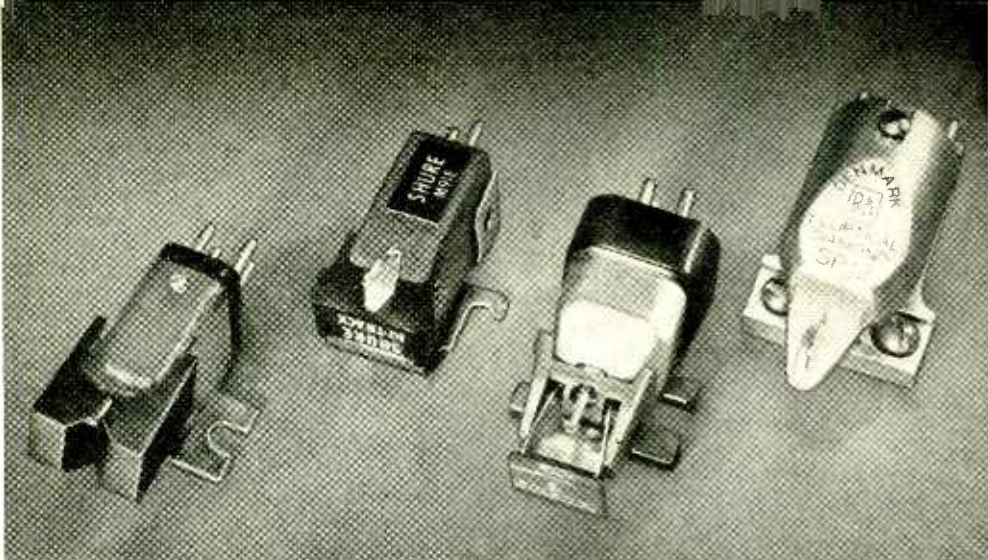

15 Things We Do Know About Phono Cartridges

HOW TO INTERPRET MANUFACTURERS' SPECS

BY J. GORDON HOLT

WHIO WAS the first person to suspect that it was impossible for a phono cartridge to track perfectly the indentations in a tiny groove on a recording? Possibly it was Edison since he undoubtedly encountered the problem. (Though the mechanical arrangement and materials he used were quite different from those we know today.) At any rate, through the years it has been calmly accepted that perfect tracking is impossible.

For a while, designers of reproduction systems simply made the stylus do what they wanted it to by increasing the tracking force until the stylus *had* to stay put in the groove. This had its obvious disadvantages; and, though today they still recognize the fundamental dilemma, designers have been learning what the problems are and finding better ways of circumventing them than by the use of brute force.

Improvements in cartridge design are by no means the least important in the changes that have been made to get better tracking. While no cartridge is yet perfect, the past few years have seen an end to the worst imperfections that made disc reproduction an

audiophile's headache. However, in picking a cartridge, be aware that they are not all the same—and not all equally good. So check yourself out on these fifteen points (arranged alphabetically for ready reference):

Compliance. As the stylus rides in the groove of a record, there is a great deal of actual contact pressure between the two. This pressure is a result of nothing more than the applied tracking force (which see) in an *un*-modulated groove. When the groove starts pushing the stylus around, contact pressures can rise considerably above 24 tons per square inch and the amount of rise depends on how much the stylus resists the groove's efforts to move it. When the resistance to movement is significant, groove destruction does take place, and the stylus starts to rattle around between the groove walls to produce the familiar shatter of tracking distortion.

For many years, cartridge designers were convinced that both record wear and tracking distortion stemmed from excessive stiffness of the stylus's flexible mounting. Manufacturers tried to "out-compliance" one another until

some styli were barely rigid enough to keep the tone arm following the stylus movement. Today, compliance is no longer the limiting factor in trackability of most cartridges—although some designs intended for use in second-rate tone arms are made to have less compliance than the top-flight precision products. High compliance didn't solve the trackability problem anyway; it just helped. Obviously, something else was involved, and the culprit now seems to be stylus inertia or moving mass (which see).

Distortion. One of the difficulties in evaluating cartridge performance is the lack of meaningful measurements for audible distortion. Audio testing organizations customarily publish harmonic and intermodulation distortion figures, but these do not gauge what we hear as tracking distortion. They only measure things which usually (but not always) accompany it. Trackability measurements are more to the point, but these too are useful only for comparisons between different cartridges, since it is possible for one pickup that is tracking better than another to *sound* as though it were tracking worse—purely as a result of differences in other aspects of the reproduced sound.

Very small amounts of amplifier distortion can make tracking distortion sound much worse than it really is, as can high-frequency peaks in the cartridge and/or loudspeakers; while a response dip in the upper frequency range can make a cartridge sound as if it were tracking *more* cleanly than it actually is.

Durability. Few good cartridges will withstand a clumsy "finger-dusting", but the days when an initially excellent pickup would go to pot in a few months because of hardening of the flexible stylus suspension seem largely behind us. With today's stylus-saving low tracking forces, though, many cartridges will start to sound sour for this reason long before the stylus shows audible signs of wear. This is a bit of an annoyance but it is better than having a worn stylus chewing up discs before the wear becomes audible. Styli should be checked once a year anyway—just to make sure.

Elliptical Styli. The elliptical stylus was a result of observations that, while high-frequency modulations are best followed by an extremely small-radius stylus, radii below a certain size tend to ride in the bottom of the groove instead of staying propped up be-

tween the groove walls. Combining small side radii with large front and back radii produced the elliptical tip.

Ellipticals do generally sound cleaner in the inner grooves of "difficult" discs (compared to spherical styli), but the gain is not achieved without some losses. Because the stylus/groove contact area of an elliptical is smaller, contact pressure at a given tracking force is considerably higher. Reducing the tracking force can help to offset this, but it cannot cause a concomitant decrease in contact pressure against the walls of a *modulated* groove since the compliance and moving mass figures of an elliptical cannot be made any better than those of a spherical. As a consequence, the 0.7×0.2 -mil elliptical that is tracking cleanly at around 1 gram will do more damage than a 0.7-mil spherical tracking at 3 grams.

Only when the spherical is starting to mis-track on passages where the elliptical is clean will their rate of record wear be about the same. And a good spherical will track the vast majority of discs of serious music as cleanly as a good elliptical. So light tracking force alone is no guarantee of low record wear; the tracking force must be equated with groove/stylus contact area.

Frequency Response. Of the qualitative measurements that can be made on cartridges, a check of frequency response reveals the most information about how a cartridge actually sounds—or how it makes the record sound. The sound should, of course, be as much as possible like that from the master tape from which the disc was cut, but the recent mania for improved trackability has tended to obscure the fact that most current designs do not produce sounds like those from the tape. And much of the blame for this lies with the elliptical stylus.

Because of the differences in groove-contact characteristics, ellipticals tend to have a broad response dip in the "brilliance" range that sphericals do not. Thus ellipticals sound rather muted and "soft" by comparison. One of the most highly respected top-priced ellipticals, noted for its clean tracking, has a substantial dip in the brilliance range which, apart from making it sound dull, makes it sound cleaner tracking than it is.

A second factor which is somewhat against ellipticals results from the fact that recording studios use spherical cartridges in judging what they're putting on their discs. The improved high-frequency tracing of the ellipti-

cal causes a rising high end on discs that were cut to sound flat.

Some ellipticals do sound quite "tapey," though two of the most accurate disc reproducers available (Decca 4RC and Stanton 681A) are spherical.

Magnetic Attraction. This was a problem when some cartridges (Ortofon, Deccas) were used with iron or steel turntable platters and the cartridge's magnet would draw it toward the platter causing a drastic and inconsistent increase in tracking force. It is seldom a problem today since virtually all transcription turntables and many record changers have aluminum platters. If in doubt, check the platter before using it with a cartridge that has its magnet or pole pieces close to the stylus tip.

Moving Mass. This is another term for inertia—which is the mechanical characteristic that makes any object "want to" retain its present state of motion (or rest). When a disc groove is undulating 20,000 times per second (half cycle of a 10,000-Hz signal), it takes little stylus inertia to make the groove's task an impossible one. The lighter the stylus and its supporting member, the more readily it follows the groove's high frequency undulations, the less record wear there will be, and the cleaner the sound will be. Unfortunately, lightness entails fragility, so a practical stylus assembly must be a compromise. This is one area in which different cartridges have significantly different attributes and trackabilities.

Noise. Until the vinyl disc was invented, subtleties of noise like amplifier hum and hiss were usually covered by the noise of the shellac record surface. Today's disc is virtually noiseless (when new), so the temptation to play it at high listening levels reveals hum tendencies that might have gone unnoticed as recently as five years ago. In response to this, cartridges and turntables now have better shielding than ever before so that, with a few notable exceptions, it is no longer necessary to "mate" cartridge and turntable for minimum hum.

Price. The picture here has changed from what it was a few years ago when you had to pay top price for a cartridge that wouldn't butcher your discs. Prices at the top are still about what they were five years ago, but the money buys you a better cartridge. And of

course, now you can buy a high-compliance, low mass light-tracking cartridge (such as the Goldring G-850) for under \$10.

Record Wear. Low tracking force in itself is not what makes a cartridge easy on record grooves. What is important is the ability to track with a low force without incurring mistracking during loud passages since this is an indication that the stylus compliance is high enough and its moving mass is low enough to offer minimum resistance to the groove's thrusts.

Obviously, stylus-to-groove contact pressure is lowest on each groove when the total applied force is equally divided between the two contact points. When the stylus encounters a modulation it can't follow readily, it tends to press more heavily against that groove wall and less heavily against the other. There still may not be serious groove damage, though, since vinyl is resilient enough to spring back somewhat after such an assault. But when the stylus meets a really impossible modulation, it tends to plow right in and lose momentary contact with the other wall of the groove. Each time it regains contact, it does so with tremendous pressure and an audible click. It is a rapid succession of these clicks that causes the shattering sound of acute mistracking. And the groove can't take this kind of abuse. Each click is a sign that the stylus has plowed too deeply into the modulation for the vinyl to recover and the resulting permanent indentations in the groove will continue to sound fuzzy under any condition.

Since the groove is V-shaped, high tracking force helps to overcome the tendency toward momentary losses of contact with either groove wall, thus making the sound cleaner. But if the stylus is still plowing into modulations, fairly clean tracking is no assurance that the record isn't being damaged.

It is the *ability* to track cleanly at a low force that is important, rather than the actual tracking force. A high tracking force accelerates record wear to a degree but the damage is not usually as great as that incurred when a cartridge is allowed to mistrack on an occasional disc. That is why, even though a cartridge may be able to track most discs cleanly at $\frac{3}{4}$ of a gram, record wear may be less when tracking force is higher—perhaps 1 gram.

Separation. Nearly all modern stereo phono cartridges with pretensions to fidelity have more than the 25 dB of separation through the mid-frequency range that is

GETTING THE CARTRIDGE MOUNTED

All four of the stereo phono cartridges shown on this month's cover use slightly different mounting techniques. Manufacturers have refined the process of cartridge mounting to virtually eliminate tracking error and still insure ease and convenience in performing what was once a nuisance undertaking. At right is the Empire 999VE/X, one of the more highly rated cartridges in \$79 (list) price bracket. Two sizes of molded plastic screws are provided to secure cartridge clip to special mounting bracket (not shown). Cartridge is then easily snapped in place and leads connected. Stylus removal is also quite simple and nameplate guard shown in photo protects stylus in transit. Practically every cartridge you buy includes mounting hardware and some form of stylus protection.

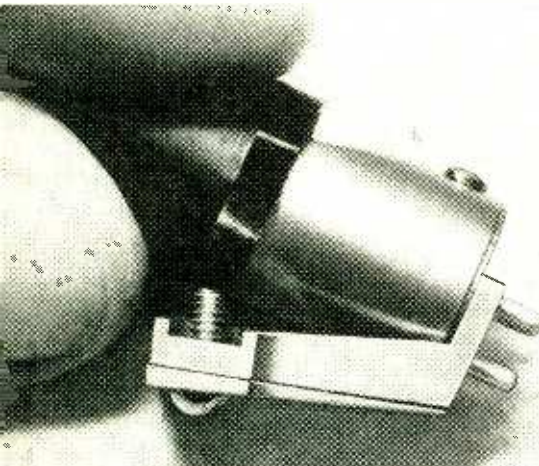
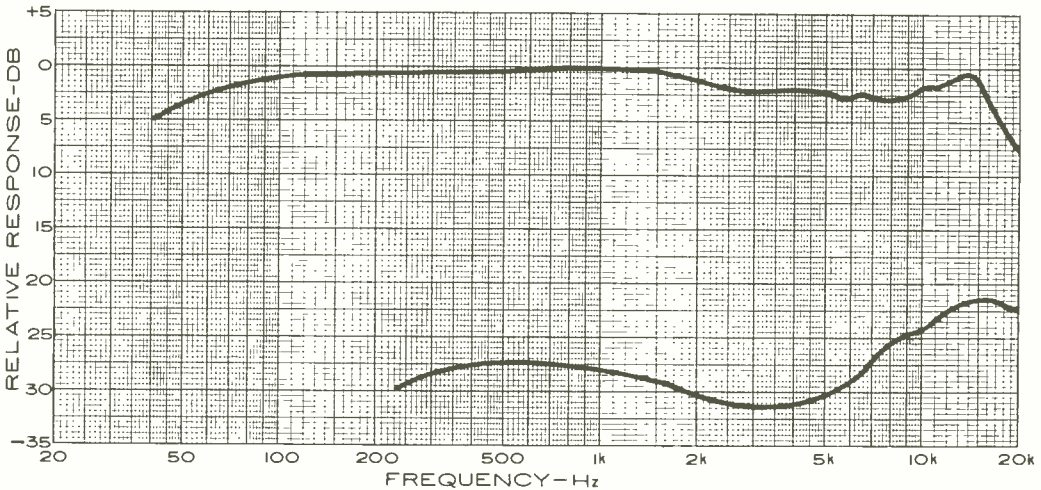
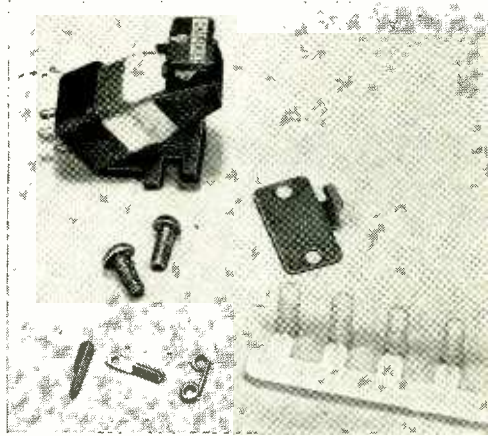

Frequency response graph above was made from test measurements on an Empire 999VE/X. Note the relatively smooth top curve which indicates the overall left channel response. The lower curve shows response in the right channel due to crosstalk from the left channel—indicating stereo separation. A graph of phono cartridge response is usually published in magazine evaluation reports.

Cartridge at left is the Danish import from B&O labelled SP 12 and selling for \$69.95 (list). Like the Empire above it has an elliptical stylus. Note the removable wedge supplied by the manufacturer to correct cartridge mounting in a record changer where the record stacking would drastically alter the preferred 15-degree vertical tracking angle.

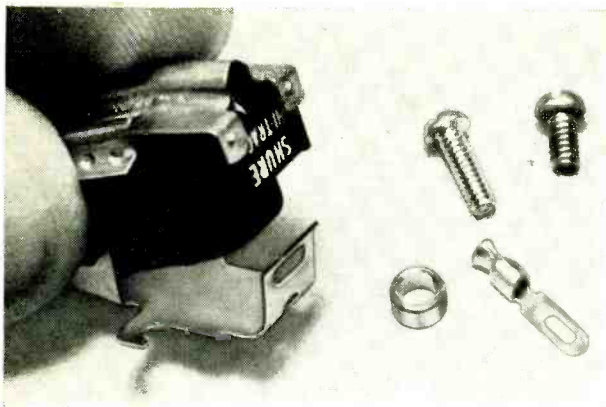

The Shure M91E cartridge (left) has an elliptical stylus with a metal guard—shown here under the photographer's index finger. Cartridge is partially disengaged from "Easy-Mount" snap-in bracket which would normally be attached to tone arm head or plug-in shell. As mentioned elsewhere, cartridges are supplied with a variety of mounting hardware and a few examples are shown here—mounting screws (two types with American and British threads), washer/spacers, and lead clips. Most record players and changers are sold with clips soldered to the fine wire leads passing through the tone arm—and color-coded to boot. Mounting has been simplified by standardizing on $\frac{1}{2}$ " (12.7 mm) center-to-center for the two retaining screws that hold the mounting bracket to tone arm shell.

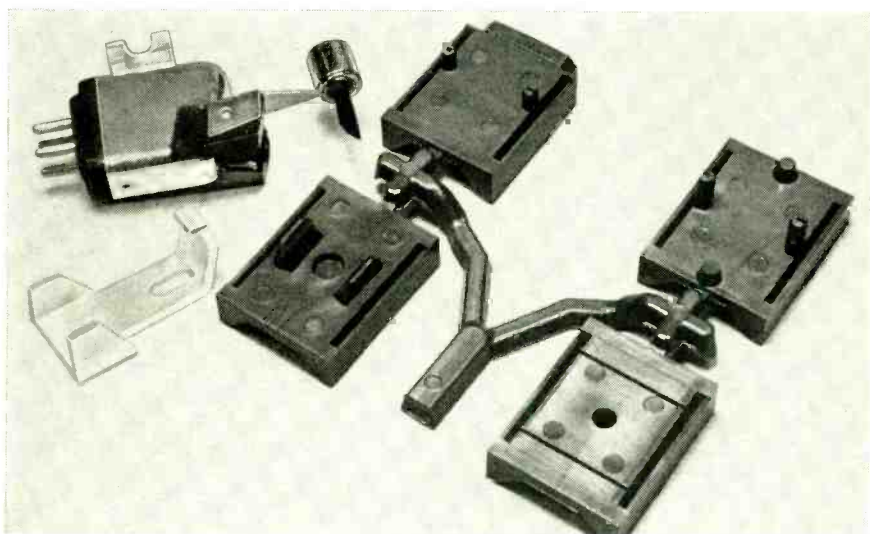

Pickering and Company has carried phono cartridge mounting ease one step further by supplying the buyer a variety of individualized "Snap-In-Mounts" cast from plastic (shown above with connecting plastic still in place). Starting from lower left and going clockwise, the mounts are for Dual, BSR, Garrard, and BSR Single Hole Heads. The cartridge itself is snapped into place on reverse side of each mount. Stylus guard has been removed and is seen near the cartridge. Note also the dust brush that is attached to cartridge. This is Pickering's model XV-15/750E cartridge selling for \$65, list.

Paralleling the efforts of cartridge manufacturers to simplify mounting, record player/changer manufacturers frequently provide additional information, mounting hardware, or even a special plastic guide. This is the tone arm cartridge mounting shell for a Dual 1219—note the clips soldered to connecting wires. The guide (upper right in photo) is used to align accurately the depth and the stylus overhang to provide minimum tracking error.



needed to achieve subjectively total channel isolation. When separation appears to be less, it is usually that way on the disc. Cartridges do still vary rather widely in high-end separation, and those with substantially less than 15 dB separation at 10 kHz can be expected to exhibit some wandering or lack of specificity in directional information.

Stereo separation is a touchy subject among manufacturers, so advertised claims are often more optimistic than factual. This information is best gotten from test reports in magazines.

Signal Output. A source of noise in some early stereo cartridges was their extremely low signal output. Most preamps have a certain amount of hum and/or hiss, which may become audible if the volume control has to be turned up to make the signal loud enough. The answer in most cases was to feed the low-output cartridge through a step-up transformer, which was itself a potent source of hum and frequently gave such a high output level that the preamp was driven to the verge of overload.

Most cartridge designers now recognize the limitations of preamps and provide a nominal cartridge output of about 1 millivolt (per cm/sec of recorded signal velocity). It is still wise, though, to check a cartridge's rated output before buying to anticipate potential noise or overload problems. There is no status value in output ratings so manufacturers' specifications are usually accurate.

Tone Arms. The advantages, shortcomings, or incompatibilities in a tone arm influence the performance of any cartridge. With the exception of Acoustic Research, manufacturers of pivoted tone arms now seem to agree that bias compensation is necessary for optimum cartridge performance—though there is less consensus as to the proper amount of compensation that is needed. (Generally, it is best set experimentally.)

Otherwise, there have been surprisingly few developments in tone arms in recent years. Most manufacturers seem to feel there is no room for improvement—which has been proved wrong by the few really improved designs that have appeared. One eminently successful approach has been the viscous-damped "unipivot" arrangement typified by the Audio & Design and Decca "International" tone arms. Both have many audible advantages and some purely mechanical disadvantages and have not proved to be as

popular as they deserve to be. The former has been discontinued; the latter is available through several sources in the U.S. or directly from dealers in England.

Trackability. This is a term widely used by Shure Bros. in their promotional material after they devised a scheme by which tracking ability could be measured. A trackability test shows, usually in the form of a graph, how much recorded level a cartridge can handle (at a given tracking force) throughout the audio range before it starts to lose intimate groove contact. It is thus an indirect measure of both compliance (affecting trackability at all frequencies) and moving mass (affecting mainly high-frequency trackability), in terms that matter the most to the user: tracking cleanness and record wear. Obviously the two do go hand in hand.

Tracking Force. It has long been known that tracking force was directly related to record wear; but only in the last few years have researchers been learning just how it is possible for a "featherweight" 2-gram cartridge to wear grooves. The trouble, it seems, is that while we think in terms of force, the groove must contend with *pressure*.

Since the groove wall is (nominally) a flat surface and the stylus tip is round, they contact one another at a microscopic point (actually two points—one on each side of the groove). Pressure is force per unit area, so if these contact points were true points, with zero area, the contact pressure (force per unit area) from that 2 grams would be infinitely high! Fortunately, the vinyl is flexible enough to let the stylus sink into it at the contact points, making each point about 3/10,000 of an inch in diameter (with 0.7-mil stylus at 2 grams force). This reduces the contact pressure against each groove wall to a mere 48,000 lb (24 tons) per square inch!

Since vinyl normally collapses when applied pressure exceeds 14,000 lb/sq in., nobody has yet been able to explain how a disc can survive a single play; but the prevailing attitude of researchers seems to be: "Accept it and be thankful."

What's In Store? There are no breakthroughs in cartridge development in sight. The best we can look forward to is even lighter (and more fragile) stylus assemblies that will give cleaner tracking and more transparent, open sound. Perfect tracking is still not in the cards.

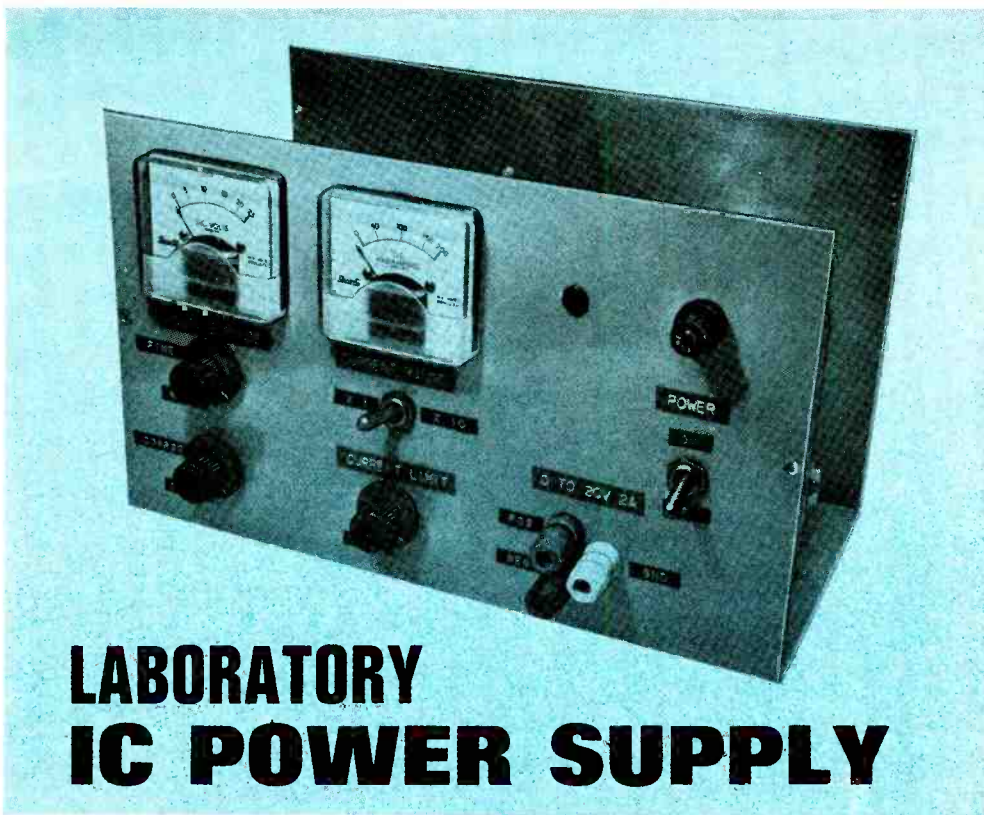

LABORATORY IC POWER SUPPLY

Low-cost regulation: 0-20 volts, 0-2 amperes

BY RICHARD J. VALENTINE

LABORATORY-TYPE power supplies that include both voltage and current regulation usually come at a pretty high price. You can build one for yourself, however, that will hold its own against most commercial units; and it will cost you only about \$50. Specifications for the supply are given in the Table so you can see how good it is.

Designed around a new regulator IC, the power supply has floating positive and negative outputs and can be adjusted from zero to 20 volts with fine and coarse voltage controls. The current range can be controlled continuously up to 2 amperes, and a short circuit on the output will not damage the supply. In addition, by setting the voltage output for maximum and adjusting the current limit for the desired level, you have a constant-current supply.

Construction. The schematic diagram of the power supply is shown in Fig. 1. Assemble

the components on a printed circuit board as shown in Fig. 2. For the prototype shown in the photos, a 7" x 12" x 5 $\frac{3}{4}$ " chassis was used. The circuit board was mounted vertically at one end of the chassis, with the heavy components, including *RECT1*, on the bottom. Power transistor *Q2* and its heat sink are on the rear panel. Operating controls and meters are mounted on the front panel. Construction is simple, but make sure that ample ventilation is provided for *T1* and *Q2*. Use at least #18 wire for connections to *RECT1*, *C9*, *Q2*, *M1*, *S2*, and the output jacks.

It is important to use the heat sink prescribed in the Parts List since it may be necessary to dissipate as much as 50 watts under certain short circuit conditions. To provide maximum heat transfer, apply silicone grease to *Q2*, the mica insulator, and the portion of the heat sink covered by the insulator. A piece of plastic sheet can be used to keep the case of the transistor from shorting to ground

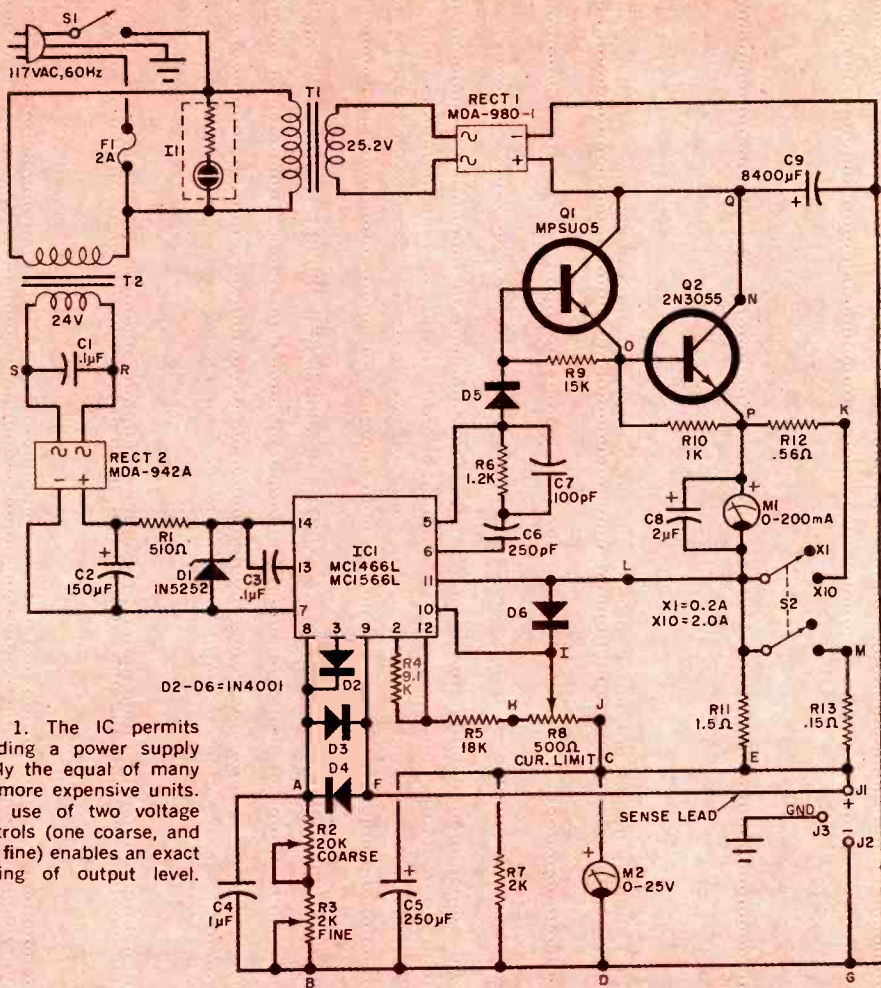
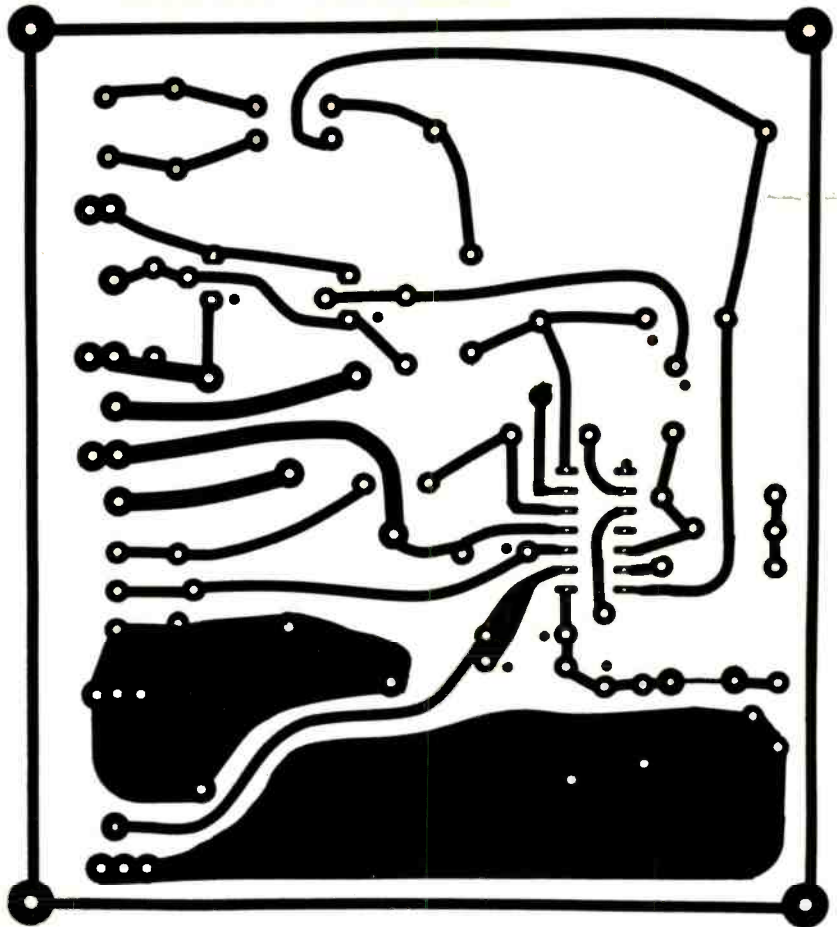

Fig. 1. The IC permits building a power supply easily the equal of many far more expensive units. The use of two voltage controls (one coarse, and one fine) enables an exact setting of output level.

PARTS LIST

C1,C3,C4—0.1- μ F, 50-volt disc capacitor
 C2—150- μ F, 50-volt electrolytic capacitor
 C5—250- μ F, 50-volt electrolytic capacitor
 C6—250-pF mica capacitor
 C7—100-pF mica capacitor
 C8—2- μ F, 50-volt electrolytic capacitor
 C9—8400- μ F, 50-volt electrolytic capacitor
 D1—1N5252, 24-volt, 500-mA zener diode
 D2-D6—1N4001, 1-A, 50-volt silicon diode
 F1—2-A fuse and holder
 I1—117-volt neon indicator
 IC1—Integrated circuit (Motorola MC1466L or MC1566L)
 J1-J3—Five-way binding post (red, black, and white)
 M1—0-200-mA meter (Shurite 8309)
 M2—0-25-volt meter (Shurite 8109)
 Q1—Transistor (Motorola MPSU05)
 Q2—2N3055 or HEP704 transistor
 R1—510-ohm, $\frac{1}{2}$ -watt 5% resistor
 R2—20,000-ohm wirewound potentiometer

R3—2000-ohm wirewound potentiometer
 R4—9100-ohm, $\frac{1}{4}$ -watt 5% resistor
 R5—18,000-ohm, $\frac{1}{4}$ -watt 5% resistor
 R6—1200-ohm, $\frac{1}{4}$ -watt 5% resistor
 R7—2000-ohm, 2-watt 10% resistor
 R8—500-ohm wirewound potentiometer
 R9—15,000-ohm, $\frac{1}{4}$ -watt 10% resistor
 R10—1000-ohm, $\frac{1}{2}$ -watt 10% resistor
 R11—1.5-ohm, 2-watt 5% resistor
 R12—0.56-ohm, 2-watt 5% resistor (see text)
 R13—0.15-ohm, 2-watt 5% resistor
 S1—Spst slide or toggle switch
 S2—Dpst slide or toggle switch
 T1—Power transformer: secondary 25.2V, 2A (Triad F41X or similar)
 T2—Power transformer: secondary 24V, 0.035A (Triad F94X or similar)
 Misc.—14-pin in-line IC socket (optional), chassis (Bud SC-3030 or similar), knobs (3), 2°C/W heat sink (Thermalloy 6403B or Wakefield NC421A), mica insulator, silicone grease, mounting hardware, etc.



through accidental contact with other objects.

If you use a meter other than that specified for *M1*, shunt resistor *R12* must be changed to match the meter's internal resistance. The value of the shunt resistance can be determined by multiplying the meter's internal resistance by 0.11.

Operation. With the current limit control set to maximum (rotor at the *R5* end), adjust both voltage controls until the front panel voltmeter (*M2*) indicates the desired voltage. When the load is connected, the current meter will indicate the current being drawn by the load. When the current range switch *S2* is in the X1 position, the meter will indicate to 200 mA. In the X10 position, the indication is to 2 amperes.

If the desired load current is known or must be limited to a safe value, set the current-limit potentiometer to maximum, adjust the two voltage-level controls to the desired voltage level and place a short circuit across

Fig. 2. Actual size foil pattern (above) can easily be fabricated from one of readily available commercial etching kits now sold by most distributors. Install various components as illustrated below.

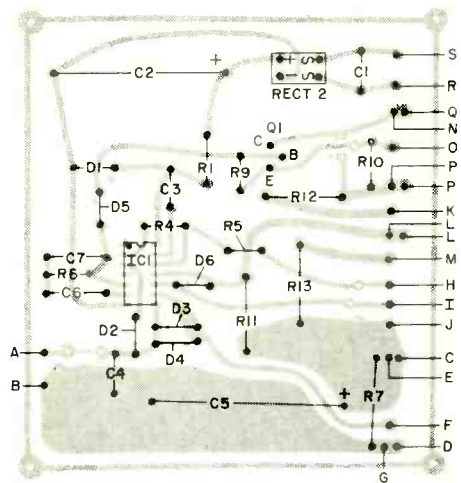

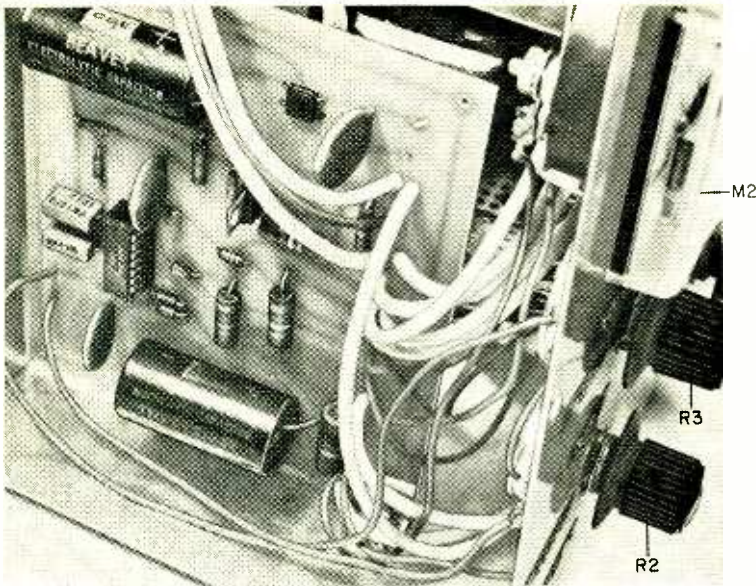

Construction is not critical so any layout may be used. Don't forget to use heavy-gauge wire in all the current-carrying portions to avoid lead heating.

the output terminals. Adjust the current-limit potentiometer for the desired current level. Remove the short and note that the voltmeter goes back to the predetermined voltage.

By setting both voltage controls to maximum and adjusting the current limit for the desired level, the power supply can act as a constant-current source.

Theory of Circuit Design. The rectified power from *RECT1* is fed to the output through transistor *Q2*, which is controlled by *Q1*. The output is fed back through a sense lead to a differential amplifier which is part of *IC1*. The other side of this differential amplifier is supplied with a constant current through pin 14, while the two voltage control

HIRSCH-HOUCK LABORATORIES Project Evaluation

The supply seems to do just what the designer claims. The output voltage is adjustable from essentially zero to 21.3 volts, which is close enough to the rated 20 volts. The short circuit current is limited to 2.0 amperes with the current control set at maximum. The current limiting action is smoothly adjustable from zero to 2 A. With the coarse and fine voltage controls, it was easy to set the voltage as required. Of course, the meters on the prototype are rather crude—the ammeter reads about 10 to 15% high on the high range.

Set for constant current operation into a 4-ohm load, the ripple was about 0.4 millivolt at currents from 0.5 A to 2 A. In constant voltage operation, with

an 8-ohm load, ripple was between 0.120 and 0.127 millivolt for currents from 0.5 to 2 A. The ripple seems to be largely 60 Hz, not the expected 120 Hz, perhaps due to rectifier unbalance or internal pickup.

With a constant 120-volt line input and an 8-ohm load, the regulation was better than 0.01 volt at 15 volts out, from no load to 2 A. From full load with 108 volts input to no load with 128 volts, we could detect no output change. The specification of 0.03% would be a 5-millivolt change—about half the minimum we could detect.

When operating at 16-volt output with a 2-ampere load, for about 15 minutes, the temperature of the pass transistor case seemed to stabilize at 146°F (105°C), which is apparently within its safe operating range.

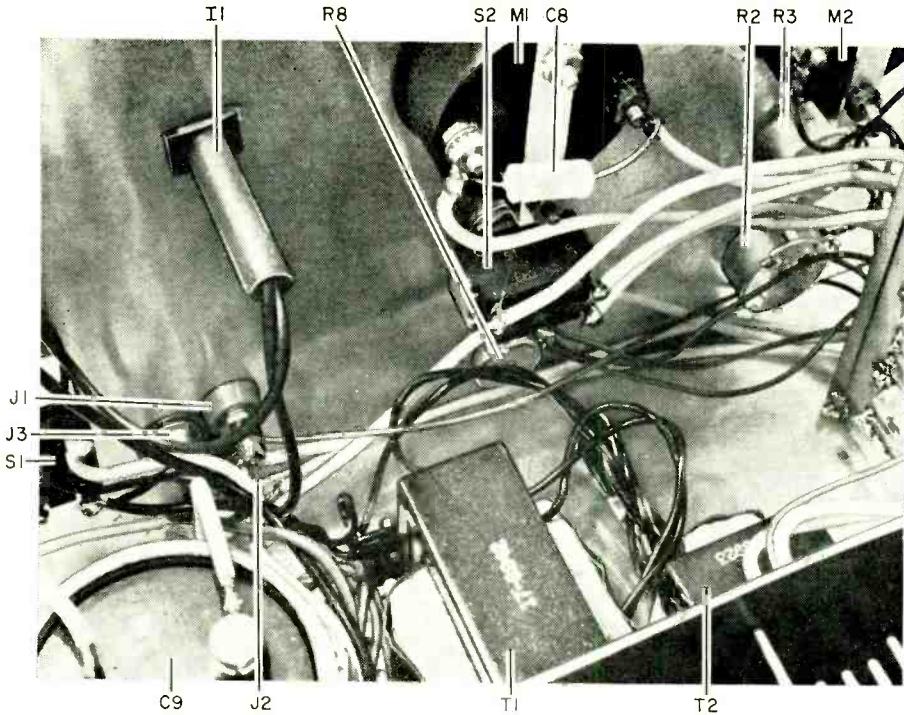

Note the large amount of room within the chassis. This, plus ventilation holes, permits the supply to run cool under almost all operating conditions.

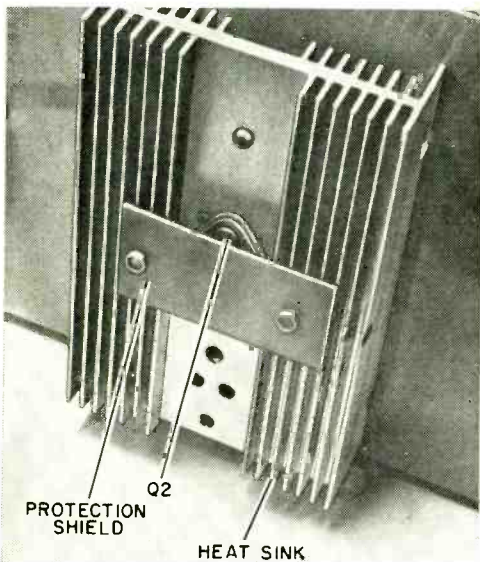

Covering the metal case of the power transistor with a plastic shield reduces the possibility of accidental shorts from the rear of the supply.

POWER SUPPLY SPECIFICATIONS

Voltage range	0 to +20 volts
Current range	0 to 2 amperes
Voltage regulation	0.03% (108 volts on line with 2 amperes load to 128 volts on line with no load)
Current regulation	0.2% in constant-current mode
Noise and ripple	Less than 0.0005 volt (0.001 volt in constant-current mode)
Short circuit protection	Output may be shorted at any voltage or current without supply failure

potentiometers (*R2* and *R3*) determine what the preset voltage should be. When the preset voltage is the same as the output voltage, the differential amplifier maintains the level of *Q1* and *Q2*.

However, if a load is placed across the output and the voltage starts to go down, the differential amplifier allows *Q2* to provide more voltage at the output. The opposite action takes place if the line voltage goes up. Resistors *R11* and *R13* provide current feedback for the IC and potentiometer *R8* is set to fix the maximum load current.

**Do you work in electronics?
Find out how CREI can give
you the specialized technical
knowledge you need for
better pay, more security.**

**Mail postpaid card for
FREE book and complete
information.**



“Stop kidding yourself about your future in electronics.”

You've been working in electronics long enough to know the facts. Companies are more selective in hiring and promoting men now than ever before. The result: plenty of opportunities for men with good technical qualifications; almost none for those without them.

Make yourself one of the specialists who will enjoy good pay and excellent security in the years ahead. Supplement your experience with more education in electronics. You won't have to worry about automation or advances in technology putting you out of a job.

CREI Home Study Programs offer you a practical way to get more education without going back to school. You study at home, at your own pace, on your own schedule. And you study with the assurance that what you learn can be applied on the job immediately to make you worth more money to your employer.

You're eligible for a CREI Program if you work in electronics and have a high school education. Our FREE book gives complete information. Mail postpaid card for your copy today.

In-depth coverage of solid state electronics . . . including integrated circuits!

E1206B

FREE BOOK

Please mail me FREE book describing CREI Home Study Programs. I am employed in electronics and have a high school education.

I am interested in:

- Electronic Engineering Technology
- Space Electronics
- Computers
- Nuclear Engineering Technology
- Industrial Electronics
- NEW! Electronics Systems Engineering
- NEW! Non-technical Course in Computer Programming



Name _____

Age _____

Address _____

City _____

State _____

Zip _____

Employed by _____

Type of Present Work _____

G.I. Bill

APPROVED FOR TRAINING UNDER NEW G.I. BILL

“Stop kidding yourself about your future in electronics.”



Men without advanced technical education will find few opportunities in electronics in the years ahead. But industry will offer exciting work, good pay and excellent security to men who become specialists in these key areas:

- Electronic Engineering Technology
- Aeronautical & Navigational
- Television
- Communications
- Nuclear Instrumentation & Control
- Missile & Spacecraft Guidance
- Radar & Sonar
- Nuclear Engineering Technology
- Automatic Control
- Industrial Electronics
- Computers
- Digital Communications
- Electronics Systems Engineering

Take the advice of men who know the electronics industry. Make yourself a specialist in one of the key areas of electronics. Then stop worrying about how cutbacks, layoffs and contract terminations will affect you and your family. If you have up-to-date specialized knowledge of electronics, you can look forward to security and excellent earnings when men with ordinary qualifications are let go.

But to become a specialist, you must supplement your experience in electronics with

more technical education. CREI Home Study Programs offer you an opportunity to get that additional education without going back to school.

You're eligible for a CREI Program if you work in electronics and have a high school education. Free book gives complete information. Mail postpaid card for your copy today.

CREI

APPROVED FOR TRAINING UNDER NEW G.I. BILL

FIRST CLASS
Permit No. 288-R
Washington, D.C.

BUSINESS REPLY MAIL

No Postage Necessary If Mailed In The United States

Founded 1927

CREI

Accredited Member of the National Home Study Council

CREI, A Division of the McGraw-Hill Continuing Education Company

3224 16th St., N.W.,
Washington, D.C. 20010

Free book tells all about CREI programs. For your copy, tear out and mail postpaid card or write:

CREI, Dept. E1206B,
3224 16th St., N.W.
Washington, D.C. 20010



EQUIVALENCY

IN RTL

CIRCUITS

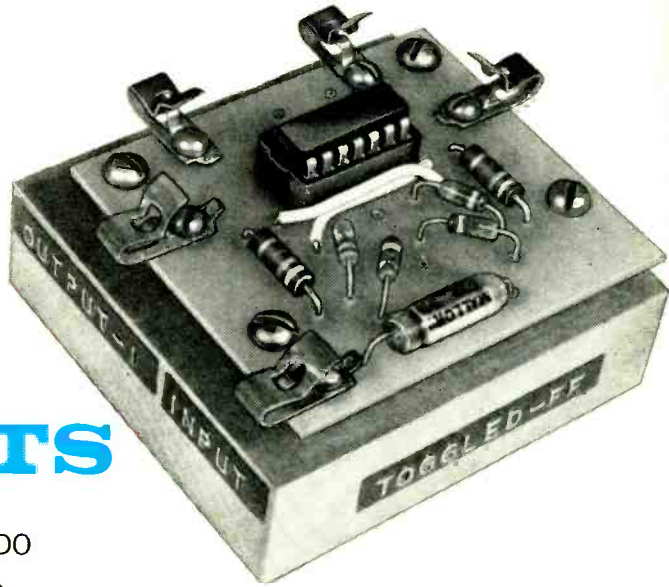

WHAT TO DO WITH FLIP-FLOPS— T OR JK

IN THE FIRST part of this article ("Equivalency in RTL Circuits," February, p 49), we focused on the one-input gate (inverter) and the RS flip-flop. Now we are prepared to deal with the more versatile T or toggled flip-flop, which will lead us finally to the sophisticated JK flip-flop.

As in the first part of the story, we use a two-pronged approach to breadboarding RTL logic elements. Four of the schematic diagrams are designed to be assembled with only discrete components. The remaining seven circuits employ both IC elements and discrete components. However, if you want to use only discrete components throughout, you can easily substitute logic gates made from discrete components for the same IC elements.

The T or toggled flip-flop resembles the RS flip-flop in that it employs two logic gates with the output of one connected directly to the input of the other. This type of circuit remains indefinitely in the state to which it is triggered, held there by its own cross-coupled feedback until a pulse is received to make it

change state. The similarity between the circuits ends here, however.

The RS flip-flop requires two inputs: one to set it to a certain state, and another to set it to the complementary, or opposite, state. One input is termed the *set* input, the other the *reset* input (which accounts for the origin of the RS designation).

The toggled flip-flop, on the other hand, has a *single* input terminal. One pulse applied to this terminal triggers the circuit into a certain output state. The next pulse triggers the circuit into the complementary state. A series of input pulses toggles the output of the circuit alternately between the two states.

The input waveform to a RS flip-flop is not especially critical. But quite the opposite is true of the conventional T flip-flop which requires "clock-pulse quality" waveforms that have either a very sharp rise or a very sharp fall time, depending on the type of logic used. Typically, a clock pulse has both sharp rise and fall times.

In T flip-flops which toggle on a negative pulse, a rapid transition from a logic 1 to a

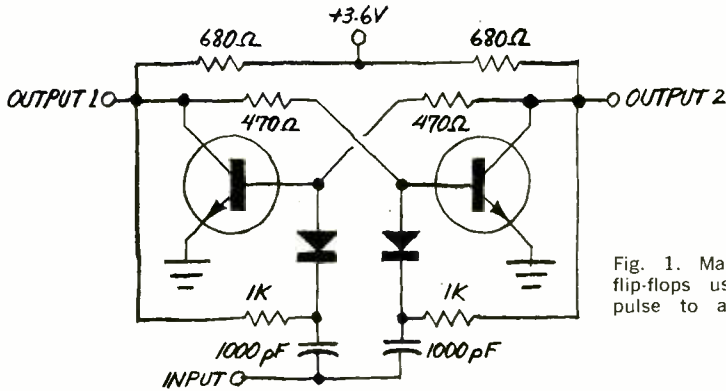

Fig. 1. Many early types of toggled flip-flops used diodes to steer input pulse to appropriate side of circuit.

logic 0 (fast fall time) is required. Those circuits which toggle on a positive pulse through a rapid transition from 0 to 1 require a fast rise time. All circuits in this article employ negative-going logic with triggering taking place on the "trailing edge" of the waveform.

The rate of transition of the input signal from one to the other logic level most significantly describes a clock pulse. Usually, this transition must occur within 100 nS (0.1 μ S). A slower rate might cause the circuit to operate erratically; a much slower rate might prevent any toggling.

Obtaining waveforms with fall times on the order of 0.1 μ S is not as difficult as it appears. The output of a Schmitt trigger, for example, will adequately "shape" the waveform.

It should be understood from the outset that the "T" designation is not shorthand for the term "toggled." Rather, the vertical bar symbolizes the single input and the terminations of the horizontal bar symbolize the two outputs of the flip-flop. In this respect, all single-input flip-flops are of the T type, although only simple circuits are so designated.

The circuit shown in Fig. 1, one of the oldest of toggled flip-flops, requires an input trigger pulse of a very brief duration. It also provides a means for "steering" the trigger pulse from the input to first one and then the other side of the circuit as successive pulses are received. This is accomplished by feeding the output of one side of the circuit back through a 1000-ohm resistor to the cathode of the diode associated with its input. Since both sides of the circuit are identical, the transistor that is cut off back-biases its respective diode, while the conducting transistor forward biases its diode.

The negative-going trigger pulse follows the path of least resistance and biases off the conducting transistor. This allows the transistor that was originally cut off to saturate by virtue of the circuit's cross-coupling. Switching from one to the other state occurs rapidly, requiring a trigger transit of very brief duration.

Transistors used in the circuits in this article, unless otherwise specified, can be 2N2475's, HEP56's, or any npn silicon type

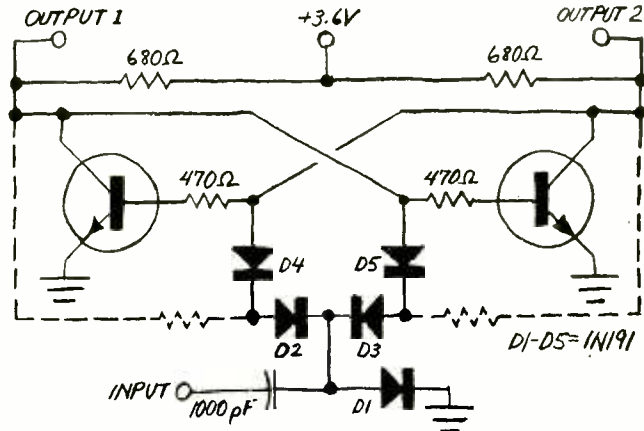

Fig. 2. Transition rate of c pulse at input is critical. circuit fails to toggle, in 1000-ohm resistors as indica

with computer-grade switching characteristics. Similarly, unless otherwise specified, diodes can be 1N191's, HEP134's, or similar types. The capacitors must be silver-mica or polystyrene types. When breadboarded with the specified components, all circuits are capable of operating at input trigger speeds of 100,000 operations per second (100,000 Hz).

The Fig. 2 circuit is a variation of the circuit given in Fig. 1. The method of input pulse steering used here may not be immediately apparent. What has been done is to forward bias the diodes associated with the saturated transistor to allow the combined potential hills of the series-connected diodes in the opposite side of the circuit to take care of the back-biasing. As before, the trigger pulse simply takes the path of least resistance and forces into cutoff the saturated transistor.

This circuit operates satisfactorily *only* when 1N191, or similar, diodes are used. These diodes are of the point-contact variety and have the appropriate forward voltage drop for this circuit. Junction diodes, such as the HEP134, will not allow the circuit to toggle.

Circuit toggling is on the negative-going transition (1-to-0) of the input clock pulse. As a result of the forward biasing of the diodes that are alternately active, the Fig. 2 circuit tends to have a somewhat faster operating speed than that of the previous circuit. Correspondingly, the transition rate of the clock pulse at the input is somewhat more critical.

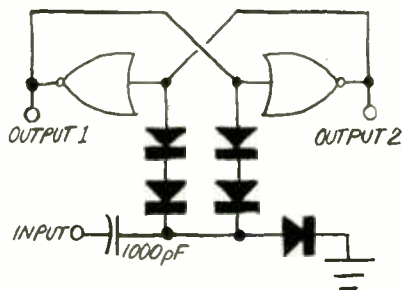

Fig. 3. IC inverters can be substituted for discrete components in T flip-flops.

If the circuit is too critical of the clock-pulse transition, adding a 1000-ohm resistor to each side of the circuit (dashed line sections) will sometimes relieve this condition, although the resistors are not ordinarily used. (This circuit lends itself to the use of integrated-circuit, one-input gates, rather than discrete components, as shown in Fig. 3.)

The purpose in gating a T flip-flop is to steer the clock pulse to the side of the circuit where it will be effective in toggling the system. In the preceding circuits, this was accomplished with diodes and resistors or with forward-biased diodes only. Steering, however, can also be accomplished with transistors and resistors and with logic gates in the manner shown in Fig. 4. Any and all of the logic gates can be replaced with their discrete-component equivalents.

This circuit is unique because it does not necessarily require a clock pulse for toggling. In fact, when set up for the purpose, it will even toggle when a sine-wave signal is applied to the input!

At the instant of toggling, the circuit consists of three interconnected latches. One latch is made up of $G1$ and $G2$, another of $G1$ and $G3$, and the third of $G2$ and $G1$. Gates $G1$ and $G2$ of the principal latch are shared, and capacitors C can be considered as offering high conductance to the trigger pulse.

One of the $G3$ inputs is connected directly to one of the $G1$ inputs, with both inputs connected in common to the output of $G5$. When both inputs to $G3$ or $G1$ are near ground potential (logic 0), one of the inputs to the other gate is positive, or at a logic 1 level.

The circuit toggles on that side of the system where both gate inputs are at logic 0. Assume that this is $G3$. The next time the input goes to 0, the output of $G5$ goes to 1, sending the output of $G3$ to 0 to cut off $G1$. Initially, $G1$ had to be conducting since, at the outset, both inputs to $G3$ were assumed to be at logic 0. With $G1$ conducting, $G2$ had to be cut off, putting one of the inputs of $G1$ at logic 1. So, triggering could not occur in $G1$ simultaneously with triggering in $G3$.

With $G1$ at cutoff, $G2$ is conducting. Now, both inputs to $G1$ can be at logic 0, and triggering can occur through $G1$ while it is inhibited in $G3$. Toggling in the $G1$ - $G3$ and $G2$ - $G1$ sections is the result of regeneration and, hence, occurs rapidly. The system can be thought of as generating its own trigger pulse, first on one side and then on the other side of the circuit. Consequently, the system will toggle even when the input to $G5$ is a sinusoidal wave.

The values of the capacitors depend on the shape of the waveform the input signal takes and the clock pulse rate. When the input signal is of clock pulse quality, the system operates excellently at all frequencies up to 100,000 Hz if the values of both capacitors are identical and between 220 pF and 470 pF.

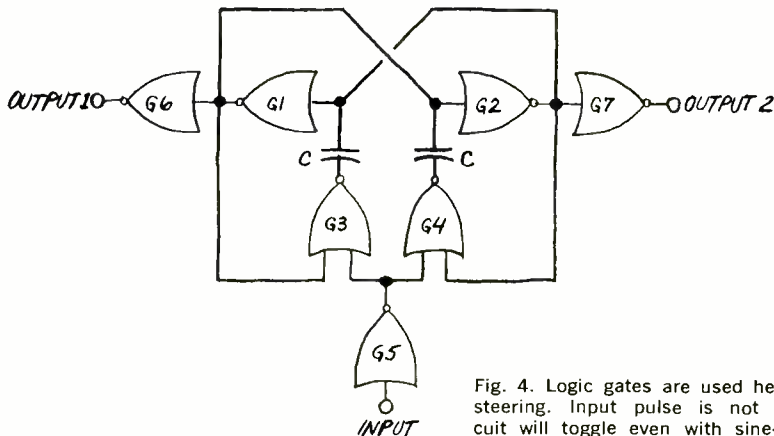

Fig. 4. Logic gates are used here for pulse steering. Input pulse is not critical; circuit will toggle even with sine-wave input.

When the input signal is a pure sine wave, use identical values of about $0.1 \mu\text{F}$ for frequencies between 40 Hz and 400 Hz; $0.01 \mu\text{F}$ for frequencies between 400 Hz and 4 kHz; 1000 pF for frequencies between 4 kHz and 40 kHz; and 470 pF for frequencies greater than 40 kHz. The signal level at the input should be 1.5-3 volts in all cases.

Inverters are used at the input (G5) and the two outputs (G6 and G7) to serve as buffers and to provide a fan-in of 3 and a fan-out—at each output—of 16.

Another advantage of this circuit is that no capacitor is directly associated with the input terminal. This is important because neither these toggled circuits nor some JK flip-flops in integrated circuits will directly drive a capacitive load.

When the input is a clock pulse, the output is a clock pulse. For a sine-wave input, the output waveform will be rectangular and have fast rise and fall times. It will *not*, however, be up to clock-pulse quality. But if two

such circuits are connected with the output of one going directly to the input of the next, the output from the last circuit will usually be a clock pulse when the input to the first is a sine wave.

The logic diagram for a flip-flop using cross-coupled (or follow-through) transistor gating is given in Fig. 5. The capacitor values given are for a clock-pulse input.

A flip-flop is made to toggle alternately between states by the release of energy from a storage element. The energy is released rapidly and entirely in a single burst so that the trigger has a spike-pulse waveform. In the circuits thus far described, it was convenient to use a capacitor as the storage element. However, it is possible and practical to use the energy present in a p-n junction as the storage element. An npn transistor has two such junctions. One is between the emitter and base, the other between the base and collector. In conventional use, the base-collector junc-

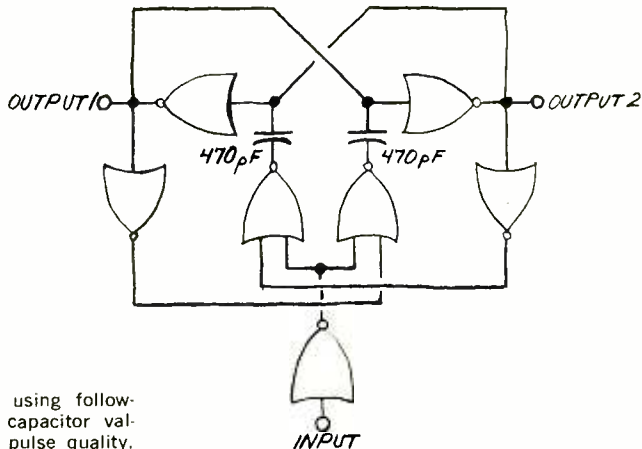

Fig. 5. Logic diagram for flip-flop using follow-through transistor gating specifies capacitor values to be used when input is clock pulse quality.

tion is reverse-biased. If it is operated in forward-bias, however, current carriers are present at, and flowing through, the junction.

If the polarity were suddenly reversed (reverse-bias), the current carriers would rapidly move away from the junction, clearing the junction. In a high-speed transistor, the base-collector junction might clear in a few nanoseconds. During the clearing interval, the movement of current carriers away from the junction constitutes a current flow which takes the form of a burst of energy. This burst of energy assumes the waveform of a positive-going spike at the emitter of the transistor. It is of sufficient amplitude to saturate the off transistor of a flip-flop.

Now, if a pair of transistors is used in this manner, and a pair of gates is added to con-

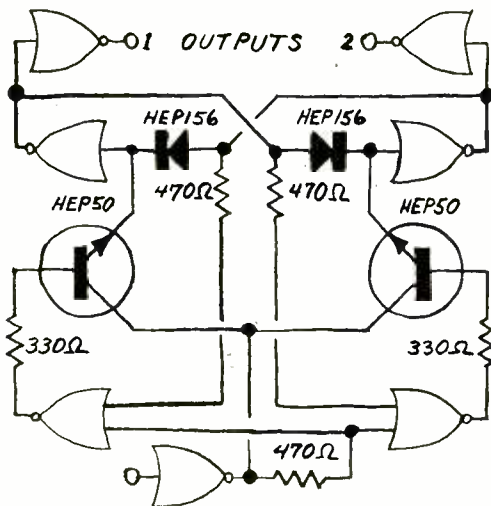

Fig. 6. Instead of using diodes, base-to-collector junctions in transistors serve as storage elements.

control the charging of the base-collector junctions, you have a toggled flip-flop which operates as well as if capacitors were used as the storage elements. Such a circuit setup is shown in Fig. 6. This circuit represents the principles used in the fabrication of many JK flip-flop IC's.

A single toggled flip-flop divides by two. For each output pulse, two clock pulses are required at the input. If division by four is desired, two toggled flip-flops can be connected in series with either output of one going to the input of the other element. Add another flip-flop in series, and you obtain a divide-by-eight system, and so on. One very important point to bear in mind is that either

ALSO AVAILABLE

A line of easily assembled digital logic kits is available from Electronic Designers, Inc., 33 Cain Dr., Plainview, NY 11803 for \$8.95 each. The six available kits include astable (free-running), bistable, and monostable multivibrators, an inverter, a flip-flop, and an AND/OR gate. Readout lamps are provided, eliminating the need for external equipment. Each kit comes with a fully detailed assembly/instruction booklet.

output of these elements must not be connected to the input of another element of the same kind of circuits in Figs. 1-3, or the setup will not operate. The reason for this is that the direct outputs of a toggled flip-flop will not operate into a capacitive load and all of these circuits have capacitive inputs.

The use of buffers at the outputs of T flip-flops will overcome the capacitive loading shortcoming. The output from a buffer drives a capacitive load quite satisfactorily.

The buffers required need not be high-current-gain types. A simple inverter is adequate for the majority of applications. You can do the job with discrete components, or you can use a pair of IC inverters as shown in Fig. 7 and Fig. 8, respectively.

As for interfacing with RTL-type JK flip-flops, Motorola's MC791P will drive capacitor-input toggled circuits, but the HEP572 will not. This is because the MC791P has built-in buffered outputs. Of course, all of the toggled circuits will drive the RTL-type JK flip-flops.

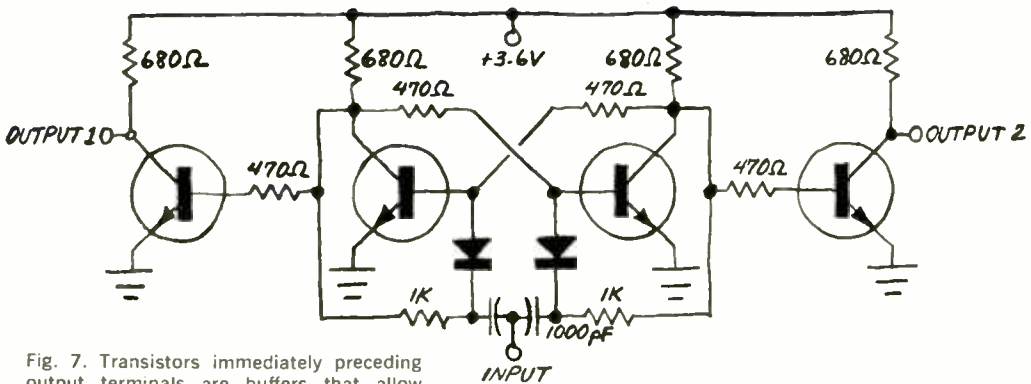

Fig. 7. Transistors immediately preceding output terminals are buffers that allow capacitive input circuits to be cascaded.

Adding pre-clear and preset inputs to a toggled circuit is simply a matter of assembling a RS flip-flop and using the two outputs obtained to perform these functions. The toggle components are connected in exactly the same manner as in the preceding circuits. For examples, Fig. 9 shows how pre-clear and preset inputs are added to the circuit in Fig. 4 and Fig. 10 shows how these inputs are added to the circuit in Fig. 8.

Note that in Fig. 9 and Fig. 10, the input terminals are labeled T, while output 1 is labeled Q and output 2 is labeled \bar{Q} (said not-Q). The bar or vinculum in the Q symbol simply indicates that the output at this terminal is the opposite, or complement, of the output at the Q terminal.

Pre-clear and preset inputs perform functions identical to the inputs of a RS flip-flop (see Part I of this article). A logic 1 signal applied to the pre-clear input promptly sends the Q output to 0 and the \bar{Q} output to 1. Similarly, a logic 1 signal applied to the preset input sends the Q output to 1 and the \bar{Q} output to 0. Logic 1 inputs are not normally applied to pre-clear and preset simultaneously.

The majority of IC dual-JK flip-flops, such as the MC791P and HEP572, have a pre-clear input, but neither is provided with a preset input. After all the other necessary inputs and outputs are provided for on these 14-pin IC's, no pin is left for preset inputs. Actually, this is not really too bad since a preset input is not needed nearly as often as is a pre-clear input.

For those occasions when a preset input is needed, you can add one to an IC JK flip-flop—provided its outputs are *not* internally buffered—by connecting the collector of an expander (see part one) to the \bar{Q} output as shown in Fig. 11. The HEP572 or any similar

IC can have a preset input added in this manner. But the MC791P cannot; its outputs are internally buffered.

The difference between a simple toggled flip-flop and the sophisticated JK flip-flop is primarily the clear and set inputs incorporated into the latter. These inputs perform functions similar to those performed by pre-clear and preset inputs, except that the clear or set function can take place only upon application of a clock pulse at the T input, while the pre-clear or preset function occurs promptly upon application of a signal to the prescribed input terminal.

The schematic diagram for breadboarding a JK flip-flop is given in Fig. 12. This circuit is essentially the same as the one in Fig. 6, with S and C (set and clear) and preset and pre-clear inputs added.

Assume that $Q = 0$ and $T = 1$. Since the Q output transistor operates as an inverter, $Q = 0$ indicates that *G1* is off with both tran-

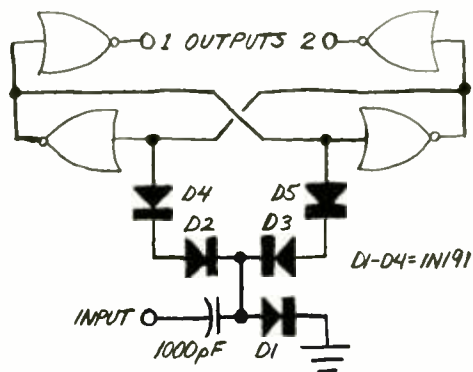

Fig. 8. In this logic diagram of a toggled flip-flop circuit, the output gates serve as buffers.

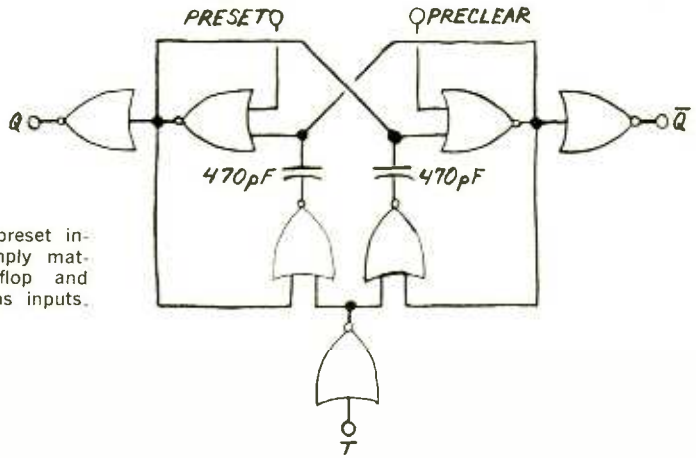

Fig. 9. Adding preclear and preset inputs to toggled circuit is simply matter of assembling RS flip-flop and using outputs thus obtained as inputs.

sistors in this gate at cutoff. With $T = 1$, the output of $G1$ is at logic 0, and the collectors of toggling transistors $Q1$ and $Q2$ are near ground potential. Also, all inputs to $G2$ are at logic 0; so the base of $Q1$ is at logic 1. This makes the base of $Q1$ positive with respect to its collector. Hence, the collector junction, being forward biased, is conducting. No significant amount of current flows in the emitter junction since the potential hill of the transistor in $G4$ is higher than the collector-to-emitter potential of the transistor in $G1$.

Now, send the T input from logic 1 swiftly to logic 0. The output of $G1$ goes positive, making one input of $G2$ also positive. Consequently, the output of $G2$ goes to logic 0 and sends the base of $Q1$ to near ground potential.

Simultaneously, when the output of $G1$ goes positive, the collectors of $Q1$ and $Q2$ also go positive. The collector junction of $Q1$ becomes reverse-biased, and the charge which existed in the previously forward-biased collector junction is expelled in the form of a

positive-going spike pulse at the emitter. This pulse turns $G4$ on and $G5$ off as a result of cross-coupling in the circuit. The result is that the output of $G4$ goes to logic 0 and the Q output goes to logic 1.

When the next clock pulse is received at T , a similar sequence of events takes place, but this time involving the right side of the circuit, and the Q output is toggled back to the logic 0 level.

If you examine the circuit, you will see that HEP156 diodes are employed in the cross-coupling networks. These diodes, together with the emitter junctions of the HEP50 transistors, form OR gates at the inputs of $G4$ and $G5$. The OR gates are needed because there is no way to get directly to the bases of the transistors in the IC 2-input gates (the input resistors built into these gates intervene). In a discrete-component setup, the emitters of the HEP50's connect directly to the bases of the gate transistors and the input resistors replace the diodes.

In Fig. 12, if a logic 1 is applied to C when $Q = 0$, the base of $Q1$ is maintained at

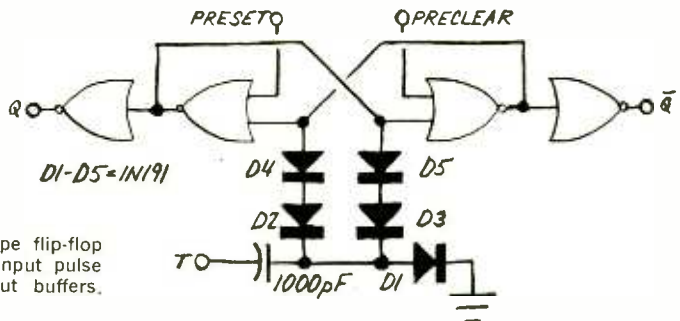

Fig. 10. Logic diagram of JK-type flip-flop shown here employs diode-type input pulse steering and inverters for output buffers.

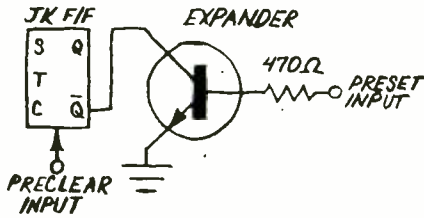

Fig. 11. Expander circuit can be used to provide preset input to IC JK flip-flop not so equipped.

near ground potential and, hence, the collector junction of *Q1* cannot charge. Triggering in this side of the circuit is inhibited, and *Q* remains at 0 as long as the logic 1 is maintained at *C*. The circuit is unresponsive to clock pulses at *T*.

On the other hand, if a logic 1 is applied to *C* when *Q* = 1, the circuit will toggle when the next clock pulse is received at *T* and

send *Q* to 0 where it will remain until *C* is sent to 0. Similarly, if a logic 1 is applied to *S*, *Q* will go to 1 on the next clock pulse at *T*, or it will remain at 1 if already there.

Unlike the preclear and preset inputs, signals may be applied to the set and clear inputs simultaneously. If this is done, both sides of the circuit will be inhibited, preventing toggling in either direction. The outputs merely remain in the states they had at the time the inputs were applied simultaneously to *S* and *C*.

Waveform requirements at the *S* and *C* inputs are not especially critical. It is essential only that either or both inputs be well established at the time the following clock pulse arrives.

The truth table that accompanies the circuit lists all possible *S* and *C* inputs and the *Q* outputs they produce before and after a clock pulse (*CP*) arrives at *T*. The \bar{Q} outputs are not listed since it is understood that these are simply the opposite or complementary states of the *Q* outputs. Nor are preclear and preset inputs listed for the simple reason that they perform identical functions to those of an RS flip-flop and can be easily determined from the information provided in the first part of this article.

IF Q IS:	AND PRIOR TO CP C IS:	AFTER CP S IS:	Q WILL BE
0	0	0	1
1	0	0	0
0	1	0	0
1	1	0	0
0	0	1	1
1	0	1	1
0	1	1	0
1	1	1	1

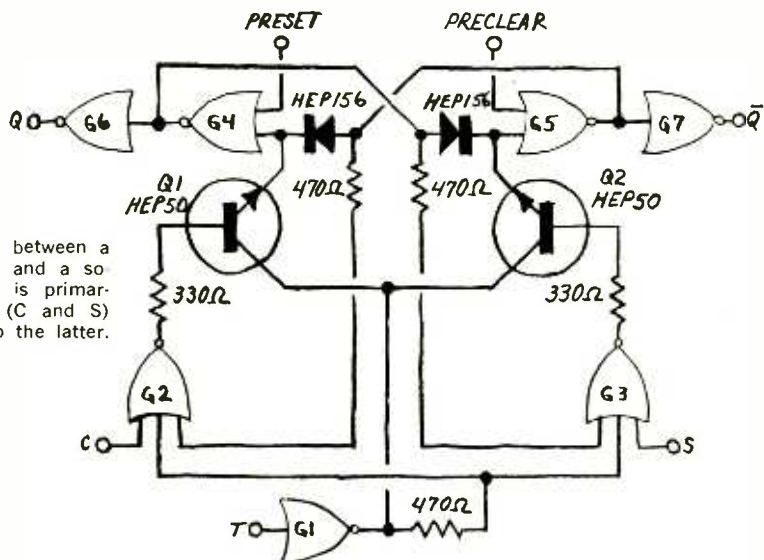
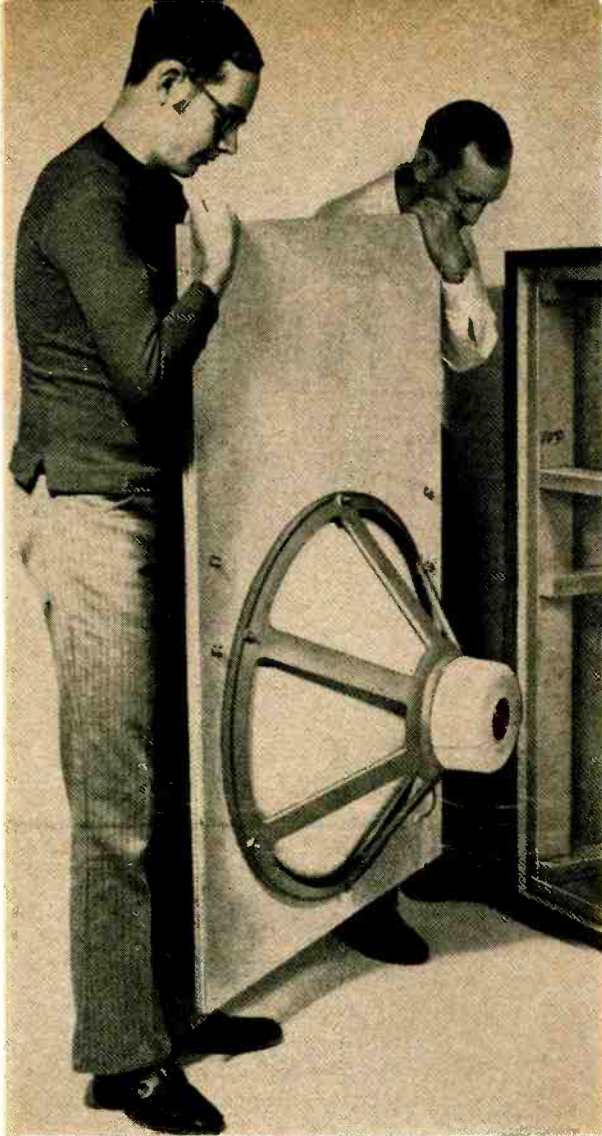

Fig. 12. The difference between a simple toggled flip-flop and a so sophisticated JK flip-flop is primarily the clear and set (*C* and *S*) inputs incorporated into the latter.

The COLOSSAL WOOFER

*You
want
bass?*

This is it!



LAST MONTH, in "The Case for the Single Woofer" we discussed the benefits that can be obtained from using a mixed-signal woofer in a stereo system. The article made no mention of the relative quality of the speaker to be used, leaving its choice to the reader. However, if you want to try a really "different" mixed-signal woofer, you might investigate the Electro-Voice Model 30W woofer—a Super Colossal speaker measuring 30 in. in diameter. But if you do, have a second amplifier handy and be prepared to surrender about 27 cubic feet of space in your listening room.

The technical specifications for the 30W are as unusual as its size. For example, power handling capacity is listed at 100 watts with 200 watts peak. The frequency range is an

uncommon 15-300 Hz. with a free air resonance of about 15 Hz. The Electro-Voice people also recommend setting the crossover at 100 Hz.

When the 30W is installed in the phase loaded box, described here, and the box is properly located with respect to one wall of the room, system resonance is about 30 Hz.

About the Woofer. The challenge of producing a response that is flat down to the lowest limits of the audio band has inspired several different approaches to ultra-low-frequency propagation of sound waves. The approach taken by Electro-Voice in designing the 30W for their top-of-the-line "Patrician" speaker system was to make the cone large

enough to handle the lowest audio frequencies effortlessly.

The design of a woofer the size of the 30W presented some problems, particularly with respect to the material to be used for the cone. Paper, the conventional material, could not be used. A 30-in. cone made of paper stiff enough for bass piston action without cone break-up would have been too heavy for acceptable transient response. So the 30W cone is fashioned from low-mass bead foam polystyrene. This material does not exhibit cone breakup at frequencies below 250 Hz.

Impaired transient response can become a major disadvantage with woofers exceeding 15 in. in diameter due to the fact that large cones cannot be accelerated (controlled) as easily as smaller cones. In the 30W, the use of polystyrene helps to alleviate the problem of cone mass. Also, since transient response becomes less of a problem with decreasing frequency, employing the lower than normal recommended crossover frequency reduces the response of the 30W to a range in which transient response is not problematical.

On the bright side, the large size of the 30W's cone has an inherent advantage. A bass frequency output level that would require a 12-in. cone to move $1\frac{3}{4}$ " could be duplicated by a 30-in. cone with only $\frac{1}{4}$ " of cone travel. It should be noted that distortion increases in proportion to the length of cone travel. Since the 30W requires a much shorter cone travel for a given output level, it stands to reason that distortion is considerably reduced as a consequence.

Woofer Box Assembly. The wall material recommended for the woofer box is 1"-thick plywood which is not generally available. As an alternative, the walls can be fabricated from $\frac{3}{4}$ " fir plywood covered with $\frac{1}{4}$ " hardwood plywood. (If 1" plywood is available in your area and you choose to use it, you will have to make the appropriate dimension changes for the plywood sheets.)

Another thing to watch out for is the 2" x 4" framing stock. For years, 2" x 4" actually meant $1\frac{5}{8}$ " x $3\frac{5}{8}$ "—but on September 1, 1970, a new national softwood lumber stand-

BILL OF MATERIALS

- 1—Electro-Voice Model 30W woofer (available on special order at E-V dealers)
- 5—19" lengths of 2" x 1" pine for studs
- 1—36 $\frac{1}{2}$ " length of 2" x 4" pine for footing
- 4—34 $\frac{1}{2}$ " lengths of 2" x 4" pine for front and rear plates and sills
- 1—31 $\frac{1}{2}$ " length of 2" x 4" pine for rear cross brace
- 6—22" lengths of 2" x 4" pine, notched at ends, for spacers
- 2—20 $\frac{1}{2}$ " lengths of 2" x 4" pine for footing
- 7—15" lengths of 2" x 4" pine for front and rear braces and side sills
- 2—52" x 34 $\frac{1}{2}$ " sheets of $\frac{3}{4}$ " fir plywood for front and rear interior panels
- 2—52" x 23 $\frac{3}{4}$ " sheets of $\frac{3}{4}$ " fir plywood for side interior panels
- 2—36" x 23 $\frac{3}{4}$ " sheets of $\frac{3}{4}$ " fir plywood for top and bottom interior panels
- 1—52" x 36" sheet of $\frac{1}{4}$ " hardwood plywood for front exterior panel
- 1—52" x 34 $\frac{1}{2}$ " sheet of $\frac{1}{4}$ " hardwood plywood for rear exterior panel
- 2—53 $\frac{1}{2}$ " x 24" sheets of $\frac{1}{4}$ " hardwood plywood for side exterior panels
- 2—36 $\frac{1}{2}$ " x 24" sheets of $\frac{1}{4}$ " hardwood plywood for top and bottom exterior panels
- 1—38" x 5 $\frac{1}{2}$ " piece of 1" hardwood trim, ends miter cut at 45°, for front interior base molding
- 2—24 $\frac{3}{4}$ " x 5 $\frac{1}{2}$ " piece of 1" hardwood trim, one end of each miter cut at 45°, for side interior base molding
- 1—39 $\frac{1}{4}$ " x 3 $\frac{1}{2}$ " piece of 1" hardwood trim, ends miter cut at 45°, for front exterior base
- 2—25 $\frac{1}{4}$ " x 3 $\frac{1}{2}$ " piece of 1" hardwood trim,

- one end of each miter cut at 45°, for side exterior base
- 2—48" x 2 $\frac{1}{2}$ " piece of 1" hardwood trim, one edge of each miter ripped at 45°, for front vertical corner trim
- 1—38" x 2" piece of 1" hardwood trim, ends miter cut at 45°, for front top molding
- 2—24 $\frac{3}{4}$ " x 2" pieces of 1" hardwood trim, one end of each miter cut at 45°, for side top molding
- 2—48" x 1 $\frac{3}{4}$ " pieces of 1" hardwood trim, one edge of each ripped at 45°, for side vertical corner trim
- 2—48" x 1 $\frac{3}{4}$ " pieces of 1" hardwood stock for rear edge side trim
- 4—48" lengths of 1" x 1" hardwood stock for center panel trim
- 60—#12 x 3" flathead wood screws for frame assembly
- 200—#10 x 1 $\frac{1}{2}$ " flathead wood screws for mounting $\frac{1}{4}$ " plywood panels to frame
- 50—#10 x 2" flathead wood screws for retaining rear panel
- 165—#8 x $\frac{1}{4}$ " flathead wood screws for fastening $\frac{1}{4}$ " panels in place
- 1 gal—Wood glue
- 2—Heavy-duty garage door pulls
- 8 sets—1 $\frac{1}{2}$ " x $\frac{1}{4}$ " round-head bolts, washers, and lugs for installing handles
- 6 sets—2 $\frac{1}{2}$ " x $\frac{1}{4}$ " round-head bolts, washers, and lugs for installing woofer
- 1—Two-lug screw-type terminal block or strip
- 1 qt—Contact cement for fastening hardwood panels to enclosure walls
- Misc.—Six-penny finishing nails for fastening trim in place; silicone rubber compound; Celotex; speaker wire; etc.

ard became effective with the new dimensions fixed at $1\frac{1}{2}'' \times 3\frac{1}{2}''$. Some lumberyards may have in stock both the old and new standard $2'' \times 4''$ stock. So, check the measurements of your framing stock before cutting it to size, particularly those pieces which are to be notched to receive another member.

Bearing in mind the varying dimensions, cut your $2'' \times 4''$ framing stock to the dimensions specified in the Bill of Materials. Drill $\frac{3}{4}''$ shank holes. Then clamp the pieces into position to drill $\frac{3}{8}''$ pilot holes in the proper locations to receive #12 \times 3" wood screws. Stagger the holes at the corners so that screws from two directions do not meet in the wood.

Start assembly by joining the members that make up the front frame, referring to Fig. 1. Use glue liberally on *every* joining operation with the single exception of mounting in place the back plate.

Next, assemble the corner pieces by attaching a length of plain $2'' \times 4''$ stock to the un-notched section of four of the notched pieces of lumber. If possible, use C clamps to hold the pieces together while seating the screws.

Then anchor the corner pieces to the front frame. Finally, attach the corner pieces to the rear frame (assembled as shown in Fig. 2) in the same manner and add the center side braces. This completes the assembly of the frame.

Cut the front panel to size as specified. Attach this panel in place on the front of the frame with glue and #10 \times $1\frac{1}{2}''$ flathead wood screws as follows. Lay the frame on its back on a level, flat surface and lower onto it the front panel. Use C clamps to prevent the panel from sliding around. Now, strike a line about 1" in from each edge of the panel. Locate and strike the center lines for the center braces as well. Making absolutely certain that the panel will not slip, use a $\frac{1}{16}''$ drill to sink $1\frac{1}{4}''$ -deep holes at 4" to 6" intervals along each line. (Note: Do not start at the corners; rather, start about 3" away from the points where the lines cross.)

Loosen the clamps and slide the panel off the frame assembly. Lay the panel on a flat surface and use a $\frac{5}{32}''$ drill to widen all holes drilled through the plywood. Then use a coun-

Fig. 1. Enclosure frame consists of $2'' \times 4''$ pine solidly anchored together with wood glue and 3" screws.

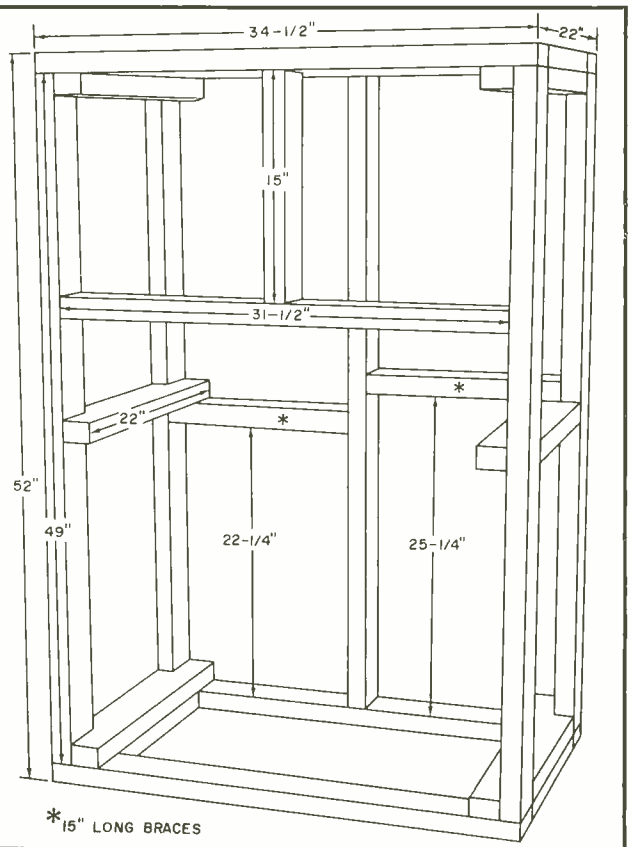

Use cardboard speaker mask from carton in which 30W arrived as template for drawing speaker cutout on rear panel.



tersink to finish off the holes to a depth of about $\frac{1}{4}$ ".

Liberaly bead all front surfaces of the frame, including the center braces, with glue. Lower onto the frame the plywood panel so that each pair of holes is properly aligned. Tightly screw down the panel until the screw heads are flush with—or just slightly below—the level of the surface of the front panel. This is a rather time- and energy-consuming operation; so if you have a brace or electric drill with the proper screwdriving attachment, better haul it out.

After cutting the side panels to size, install them on the frame in the same manner described above. Take into account that the front edges of the panels should sit flush with the front surface of the front panel. This means that the center lines for the screws must be located $2\frac{1}{4}$ " in from the front and rear edges of the side panels if they are to bite into the frame. The top and bottom center lines are still 1" in from the edges.

Once the top and bottom panels are cut to size, strike a line $2\frac{1}{4}$ " in from each side edge, 3" in from the rear edge, and $2\frac{1}{2}$ " in from the front edge of each panel. Use the same procedures to fasten these panels to the frame.

The $\frac{1}{4}$ " hardwood panels, if used, are to be installed in the same sequence used for the plywood panels—front, sides, and bottom. Delay mounting the top panel, for now.

Before installing the front panel, use a pencil to strike lines to locate straight rows of #8 \times $\frac{3}{4}$ " screws which you will later cover with trim. Indent the lines 1" from each edge. Then strike two evenly spaced lines down the

middle of the panel, locating them so that the distance between vertical trim pieces will be equal. The distances between the vertical lines will be about $11\frac{3}{8}$ ".

Place the enclosure box on its back and set onto its front surface the hardwood panel. Use masking tape to hold the panel in place on the box while drilling. Chuck a $\frac{3}{64}$ " drill into your electric drill and sink pilot holes through the hardwood panel and about $\frac{1}{2}$ " deep into the plywood panel every 4" to 6" along each line. Remove the hardwood panel and use a $\frac{7}{64}$ " drill to ream through the already drilled holes in this panel. Finish up with a countersink, but avoid going clear through the holes.

Brush glue onto both surfaces to be joined, spreading the glue as evenly as possible. Then lower the hardwood panel onto the glued box surface and carefully align the hole pairs. Press down on the hardwood panel until the excess glue bleeds out along the edges and through the screw holes. Use a dampened clean cloth rag to remove the excess glue. Fasten the panel down with #8 screws until the screw heads are flush with the surface of the hardwood.

Set the box, hardwood side down, on a flat, level surface and weight it with any heavy items you have around the shop until the glue sets solidly. If the surface on which the box rests is too rough to insure against marring the hardwood panel, a sheet of Celotex laid down first will provide the necessary protection.

Cut the side panels, which should overlap the side edges of the front panel, to size.

Strike a line 1" in from both the top and bottom edges, $\frac{1}{2}$ " in from the front and rear edges, and $12\frac{3}{8}$ " in from the rear edges of both panels. Then proceed to fasten the hardwood panels to the sides of the box. Completely finish the first side before proceeding to work on the next side.

On the bottom panel, strike lines from front to rear for four rows of screws. Locate the front, rear, and side lines $\frac{1}{2}$ " in from the edges of the paneling. Then attach the panel to the bottom of the box with screws and glue.

Invert the box onto its unfinished plywood top and install with glue and $\#12 \times 3$ " flat-head woodscrews a $2" \times 4$ " footing flush with the front and side edges of the box. Glue strips of heavy felt to the bottom surfaces of the footing to protect the floor on which the box will be used.

While the box is inverted, cut the six base molding pieces to size from 1"-thick (actual dimension is $\frac{3}{4}$ ") hardwood stock, mitering the front edges of the side pieces and both ends of the front pieces at 45° to provide "invisible" joints. Smoothly sand all but the rear surfaces of the molding. Then attach the pieces flush with the bottom of the box with glue and six-penny finishing nails. Set the box in its upright position.

Cut to size the hardwood paneling and, using only contact cement, fasten it to the top of the box. Carefully follow the instructions supplied with the cement, and heavily and evenly weight the panel until the cement sets. Meanwhile, prepare the top molding pieces, cutting the appropriate ends at 45° to provide invisible joints. Smoothly sand the bottom surfaces.

After the contact cement has thoroughly set, use glue and six-penny nails to attach the top molding to the box. Rip two $2\frac{1}{2}$ "-wide pieces of hardwood trim at 45° and cut to exact length to fit between the top and bottom molding at the front edge of each corner of the box. Also, rip two $1\frac{3}{4}$ " pieces at 45° to complete the corners. Fasten these pieces to the box with glue and finishing nails.

Now, rip the two $1\frac{3}{4}$ "-wide pieces of hardwood for the side rear edges of the box and cut to length the four $1" \times 1$ " center side and front trim. Again, attach these pieces in place with glue and finishing nails after first sanding each piece. Stain and finish the box as desired.

Use the round pattern from the woofer's shipping carton to outline the speaker cutout as shown in Fig. 3. The pattern diameter is $27\frac{5}{8}$ " which is somewhat smaller than the cutout specified in the instruction sheet supplied

with the 30W. But the specified diameter would be $\frac{1}{4}$ " larger than the diameter of the woofer gasket. By sawing along the outside edge of the drawn circle, the cutout obtained with the pattern will be about $27\frac{3}{4}$ "—which is just about right.

Tightly clamp together the hardwood and plywood sheets that make up the speaker mounting board. Then use a sabre saw to make the speaker cutout, and drill holes for the speaker and handle mounting bolts. While the panels are clamped together, strike lines $\frac{3}{4}$ " in from the edges of the sheets and drill $\frac{3}{16}$ " shank holes along the lines, spacing the holes at 4" intervals. Then drill shank holes for each brace.

Separate the panels and drill seven holes for "clamping" screws to hold the panels together while gluing. These holes ($\frac{7}{64}$ " shank in the $\frac{1}{4}$ " panel and $\frac{3}{64}$ " pilot in the $\frac{3}{4}$ " panel) should be located along a horizontal line 10" from and parallel to the top edges of the panels.

Coat the mating surfaces of the panels with glue and fit the glued surfaces together, aligning all hole pairs. Install the seven clamping screws ($\#8 \times \frac{3}{4}$ "). Place clamps around the circumference of the woofer cutout as well as along the outer edges of the panels. If too few clamps are available, the handles and their bolts and the mounting bolts for the 30W can be installed to serve as clamps. But do *not* install the 30W itself at this point.

Mount a terminal strip with heavy-duty lugs and screw-type connectors in either lower corner, no less than 3" from the bottom or side edges. Use silicone rubber compound around the terminal strip to assure an airtight seal. You can locate the crossover components inside the box if external connections are provided for each crossover terminal so that changes in the wiring can be made without removing the 50 screws which secure the rear plate.

Set the speaker board temporarily into place in the rear of the speaker box and sink $\frac{3}{64}$ " pilot holes into the box frame through the perimeter holes already drilled through the board. Then lay the board on a flat surface and mount the 30W over the cutout with the bolts supplied. Practice extreme care when handling the woofer and when tightening down the nuts on the mounting bolts. Test the speaker wiring and, if it is all right, install the rear panel in the speaker box.

No acoustical treatment of the inside of the box is necessary if a low-frequency (100 Hz or less) crossover point is used. Most damp-

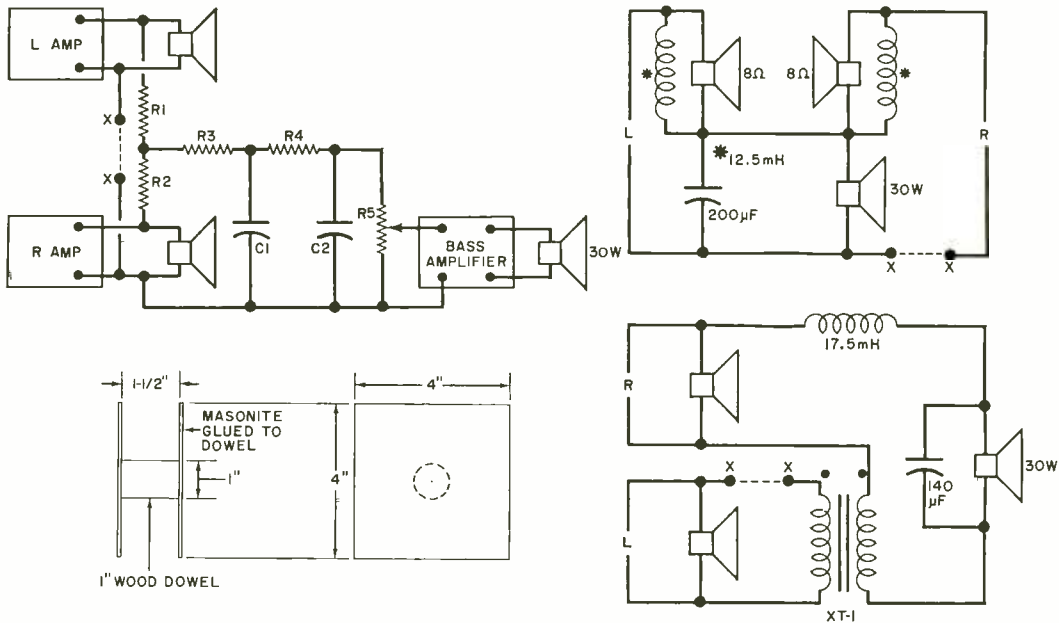

Fig. 2. Separate bass amplifier scheme is shown top left. Insert 500- μ F capacitor between X's if filter input is connected to solid-state amplifier. Wind 750 and 864 turns of #18 Formvar magnet wire onto spool (above left) for 12.5- and 17.5-mH coils, respectively, in diagrams above right.

ing materials are virtually transparent, having little or no effect, at such low frequencies.

If it is possible that the rear plate will be removed several times while testing, use #8 or #9 screws for the first installation. Reserve the #10 screws for the final assembly. If during testing, you find that the box is not airtight around the rear plate, remove the plate and apply a thick bead of silicone rubber compound to the frame members to which the panel fastens. Allow the compound to set completely before replacing the plate on the rear of the box. The silicone rubber will then serve as an air-tight gasket.

Finally, tack a piece of grille cloth, open-weave burlap, etc., over the speaker opening. This is not required for any aesthetic reason since the woofer itself faces the wall and is out of sight. The covering simply serves to keep the dust and dirt away from the cone.

Phase Loading. In tests performed after the system was assembled, resonance was about 45 Hz with the box located in the center of a room. Moved to a position 10 in. from a wall, the system exhibited a 40-Hz resonance which dropped to 35 Hz at 4 in. from the wall. In the proper listening position, 2 in. from the wall, resonance fell to 31 Hz.

More important than the frequency of the

resonance is the fact that the resonant peak was much less pronounced with the system located near the wall. In fact, the difference in sound quality between the middle of the room and near the wall locations was significant; a somewhat "boomy" low bass was changed by "phase loading" to a smooth response.

When placed 2 in. from a typical modern construction wall (gypsum dry wall), there was more vibration from the wall than from the panels of the box. However, the materials specified in the Bill of Materials should be taken as the minimum thickness for the box walls. If panel vibration is a problem, it can be dampened by gluing and screwing pieces of Celotex to the inside surfaces of the plywood panels in the areas not covered by the frame. And if you want to add acoustical treatment to the inside of the box anyway, it will do no harm.

For most speaker systems, the trick of obtaining correct polarity is accomplished by observing the polarity of each voice coil terminal and connecting positive to positive terminals. With the Super Colossal Woofer, the problem is complicated by the unorthodox position of the woofer in the box, the possibility of an unusual location for the box in the room, and perhaps phase shift in some kinds of crossover networks that might be used.



Woofer cone faces rear of enclosure. Grille cloth is used solely to protect cone from dust and dirt.

Instead of attempting to analyze the phase relationships of a particular installation, it is much easier and more accurate to switch the leads to the woofer and choose that connection which produces the best bass response. If a frequency source such as a test record or an audio generator is available, use 100 Hz as the test frequency and listen for the greater output level at that frequency.

Woofer Hookup. The successful integration of the 30W system into a stereo setup requires attention to three problems: correct polarity of the woofer; proper balance between the woofer and the other speaker systems; and the choice of a circuit that is compatible with your amplifier.

The most flexible method of connecting the woofer to a stereo system is the use of a separate amplifier with an exceptionally good low frequency response. If the volume control on the bass amplifier is accessible, the output of the woofer can easily be matched to that of the full-range speaker systems. Also, the problem of an improper load on the stereo amplifier is avoided.

The bass amplifier requires a filter to roll off the response above 100 Hz. A passive filter, shown in the upper left diagram in Fig. 2

is the least expensive approach. Resistors $R1$ and $R2$ are 47 ohms, $R3$ is 390 ohms, $R4$ is 3900 ohms, and $R5$ is 50,000 ohms. Capacitor $C1$ is 4 μF , and $C2$ is 0.4 μF . A possible disadvantage of this type of filter is insertion loss, which might necessitate an extra stage of amplification. Hookups that do not require a separate bass amplifier are shown to the right in Fig. 4. These, however, might require the use of pads on the full-range speakers to adjust their sound levels to that of the woofer.

The tendency at first is to adjust the volume level of the woofer too high. But in so doing, the whole system can sound "mushy." If used properly, the woofer adds a new depth that seems to improve the mids and highs. With a little experience and a careful hand on the volume control, the depth will become apparent.

At high power levels, objects that are not nailed down in the listening room begin to move around. In fact, acoustical feedback will require a damping pad under your turntable when playing records to prevent the feedback from making itself felt. But unless you live in the Mojave Desert or some equally isolated location, you will most likely get feedback from your neighbors before you reach the object-moving level. —50—

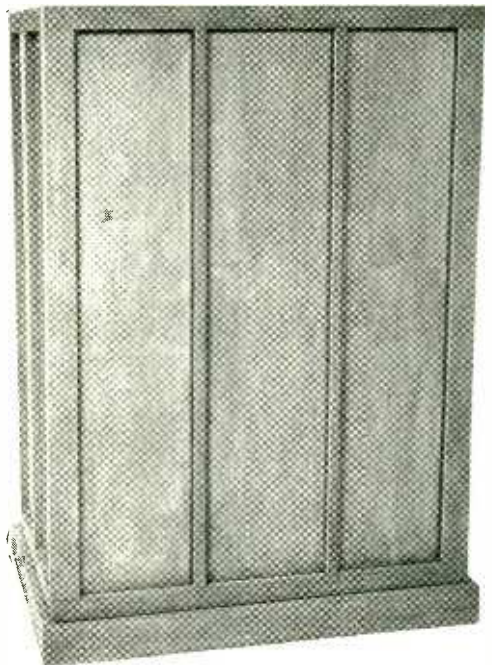

Enclosure sports modern design. Decorative molding covers screws that fasten wall panels together.

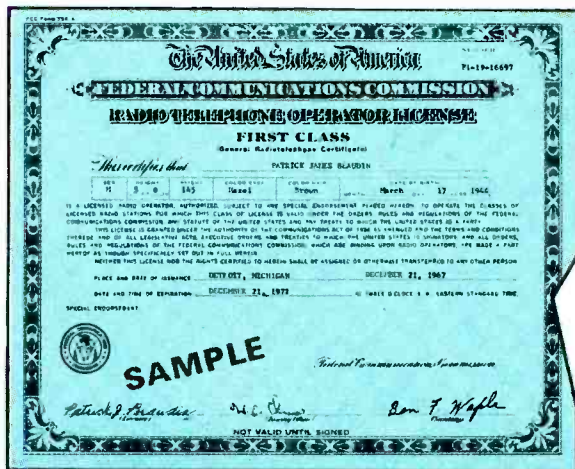

Cleveland Institute of Electronics

MONEY-BACK WARRANTY

of success in obtaining a Government FCC License

The Cleveland Institute of Electronics hereby warrants that upon completion of the Electronics Technology, (with or without Lab), Broadcast Engineering, or First-Class FCC License course, you will be able to pass the FCC examination for a First Class Commercial Radio Telephone License (with Radar Endorsement);

OR upon completion of the Electronic Communications course you will be able to pass the FCC examination for a Second Class Commercial Radio Telephone License;

AND in the event that you are unable to pass the FCC test for the course you select, on the very first try, you will receive a **FULL REFUND** of all tuition payments.

This warranty is valid for the original completion time allowed for the course selected.

G. O. Allen

Dr. G. O. Allen
President

You can earn more money if you get an FCC License

...and here's our famous CIE warranty that you will get your license if you study with us at home

NOT SATISFIED with your present income? The most practical thing you can do about it is "bone up" on your electronics, pass the FCC exam, and get your Government license.

The demand for licensed men is enormous. Ten years ago there were about 100,000 licensed communications stations, including those for police and fire departments, airlines, the merchant marine, pipelines, telephone companies, taxicabs, railroads, trucking firms, delivery services, and so on.

Today there are over a million such stations on the air, and the number is growing constantly. And according to Federal law, no one is permitted to operate or service such equipment without a Commercial FCC License or without being under the direct supervision of a licensed operator.

This has resulted in a gold mine of new business for licensed service technicians. A typical mobile radio service contract pays an average of about \$100 a month. It's possible for one trained technician to maintain eight to ten such mobile systems. Some men cover as many as fifteen systems, each with perhaps a dozen units.

Coming Impact of UHF

This demand for licensed operators and service technicians will be boosted again in the next 5 years by the mushrooming of UHF television. To the 500 or so VHF television stations now in operation, several times that many UHF stations may be added by the licensing of UHF channels and the sale of 10 million all-channel sets per year.

Opportunities in Plants

And there are other exciting opportunities in aerospace industries, electronics manufacturers, telephone companies, and plants operated by electronic automation. Inside industrial plants like these, it's the licensed technician who is always considered first for promotion and in-plant training programs. The reason is simple. Passing the Federal government's FCC exam and getting your license is widely accepted proof that you know the fundamentals of electronics.

So why doesn't everybody who "tinkers" with electronic components get an FCC License and start cleaning up?

The answer: it's not that simple. The government's licensing exam is tough. In fact, an average of two out of every three men who take the FCC exam fail.

There is one way, however, of being pretty certain that you will pass the FCC exam. And that is to take one of the FCC home study courses offered by the Cleveland Institute of Electronics.

CIE courses are so effective that better than 9 out of every 10 CIE-trained graduates who take the exam pass it. That's why we can afford to back our courses with the iron-clad Warranty shown on the facing page: you get your FCC License or your money back.

There's a reason for this remarkable record. From the beginning, CIE has specialized in electronics courses designed for home study. We have developed techniques that make learning at home easy, even if you've had trouble studying before.

In a Class by Yourself

Your CIE instructor gives his undivided personal attention to the lessons and questions you send in. It's like being the only student in his "class." He not only grades your work, he analyzes it. Even your correct answers can reveal misunderstandings he will help you clear up. And he mails back his corrections and comments the same day he receives your assignment, so you can read his notations while everything is still fresh in your mind.

It Really Works

Our files are crammed with success stories of men whose CIE training has gained them their FCC "tickets" and admission to a higher income bracket.

Mark Newland of Santa Maria, Calif., boosted his earnings by \$120 a month after getting his FCC License. He says: "Of 11 different correspondence courses I've taken, CIE's was the best prepared, most interesting, and easiest to understand."

Once he could show his FCC License, CIE graduate Calvin Smith of Salinas, California, landed the mobile phone job he'd been after for over a year.

Mail Card for Two Free Books

Want to know more? The postpaid reply card bound-in here will bring you free copies of our school catalog describing opportunities in electronics, our teaching methods, and our courses, together with our special booklet, "How to Get a Commercial FCC License." If card has been removed, just mail the coupon at right.

1. **ELECTRONICS TECHNOLOGY with LABORATORY** . . . teaches you the fundamentals. With a 161-piece laboratory you apply the principles you learn by analyzing and trouble-shooting electronics equipment.
2. **ELECTRONICS ENGINEERING** . . . Covers steady-state and transient network theory, solid state physics and circuitry, pulse techniques, computer logic and mathematics through calculus. A college-level course for men already working in Electronics.

2 NEW CIE CAREER COURSES

CIE Cleveland Institute of Electronics
1776 East 17th Street, Cleveland, Ohio 44114

Accredited Member
National Home Study Council

CIRCLE NO. 6 ON READER SERVICE PAGE

THESE CIE MEN PASSED THE FCC LICENSE EXAM... NOW THEY ARE EARNING MORE MONEY

From Tugboat to Television

"When I started my CIE electronics training, I was working in the engine room of a tugboat. Before finishing, I passed my First Class FCC License exam and landed a job as a Broadcast Engineer at KDFM-TV in Beaumont. I was able to work, complete my CIE course and get two raises . . . all in the first year of my new career in broadcasting. The course was interesting and well written."—Richard L. Kihn, Anahuac, Texas.



New Job with 40% More Pay

"CIE has taken me from a dull low-pay job with little chance for advancement to one with challenge and a good future. I'm now an Engineering Specialist with National Radio Company, Inc. testing prototype equipment. CIE training gave me the electronics technology I needed to pass the exam for First Class FCC License. I'm already earning 40% more than I could without my CIE training."—Joseph E. Perry, Cambridge, Mass.



NEW REVISED G.I. BILL BENEFITS: All CIE courses are approved for full tuition reimbursement under new G.I. Bill. If you served on active duty since January 31, 1955, OR are in service now, check box on reply card or coupon for G.I. Bill information.

Cleveland Institute of Electronics
1776 East 17th Street, Cleveland, O. 44114

Please send me without cost or obligation:

Your illustrated 44-page book, "How To Succeed in Electronics."

Your book on, "How To Get a Commercial FCC License."

I am especially interested in:

- Electronics Technology Electronic Communications
- Broadcast Engineering Industrial Electronics
- First Class FCC License Electronics Engineering
- Electronics Technology with Laboratory

Name _____ (PLEASE PRINT)

Address _____

City _____

State _____ Zip _____ Age _____

Veterans & Servicemen: check here for latest G.I. Bill information. PE-17

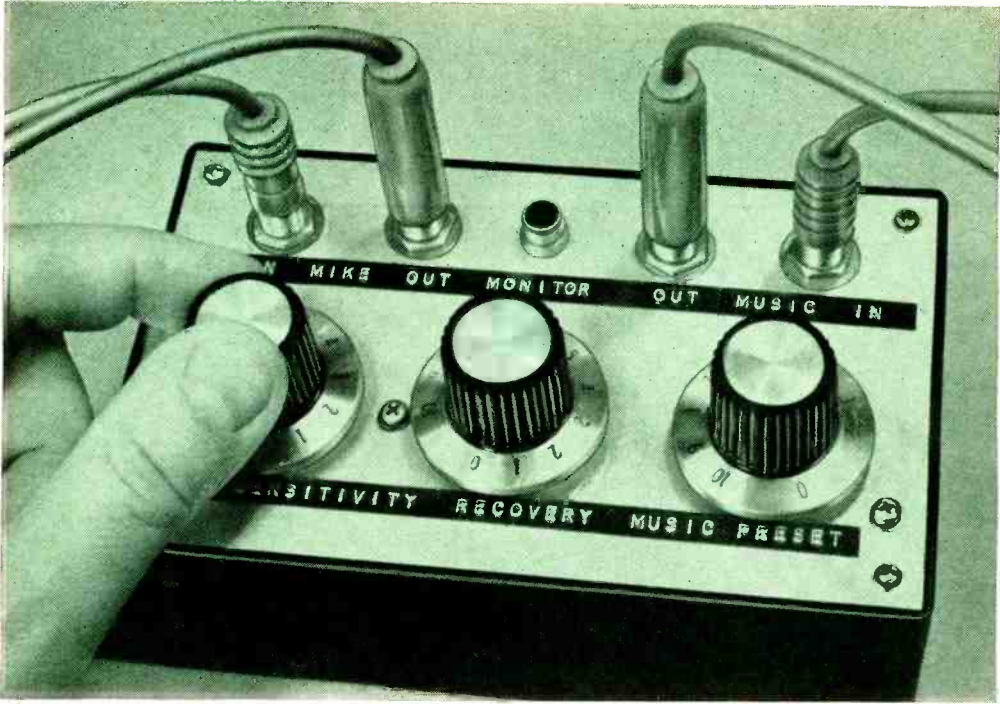

BUILD A VOX GAIN RIDER

VOICE-CONTROLLED MIKE MAKES MUSIC MURMUR

BY DAVID W. BEATY

ONE SURE WAY to spoil a good party is to interrupt the music—live or canned—to make an announcement and have the volume all wrong for speech, with acoustic feedback that shatters everyone's eardrums and entirely too long a delay just to let people know that "soup's on." All of this can be avoided if you equip your sound system with a "VOX Gain Rider." It's a simple circuit that responds to a voice input to a microphone and automatically lowers the volume of the music. This permits you to make your announcement easily and effectively—and the music will continue at its former level as soon as you are finished.

The VOX Gain Rider is battery-powered for portability and can be used in conjunction

with any sound system and a high-impedance microphone. In fact, there are a number of ways in which it can be used: to turn off your hi-fi system when the telephone rings; to lower the volume when the baby cries upstairs; to cut down the din in the recreation room when you want to get a message through to the kids; or any suitable situation where one signal can take precedence over another.

Theory of Circuit Design. The schematic of the Gain Rider circuit is shown in Fig. 1. The audio signal from a high-impedance microphone—or similar source—is coupled to the circuit through *T1* which provides impedance matching. The proper amount of signal is taken from the arm of potentiometer *R1*

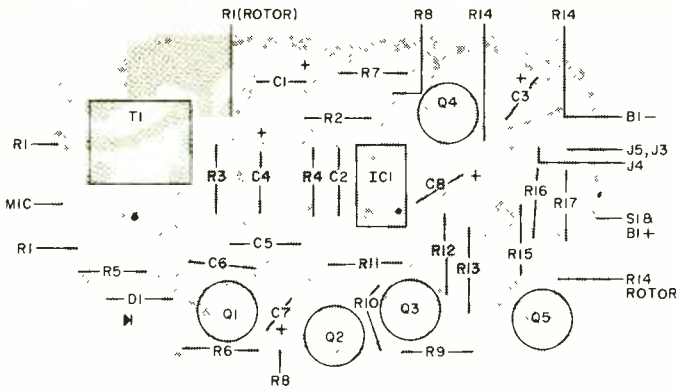
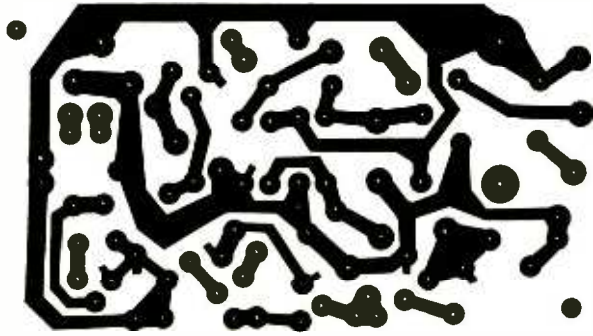
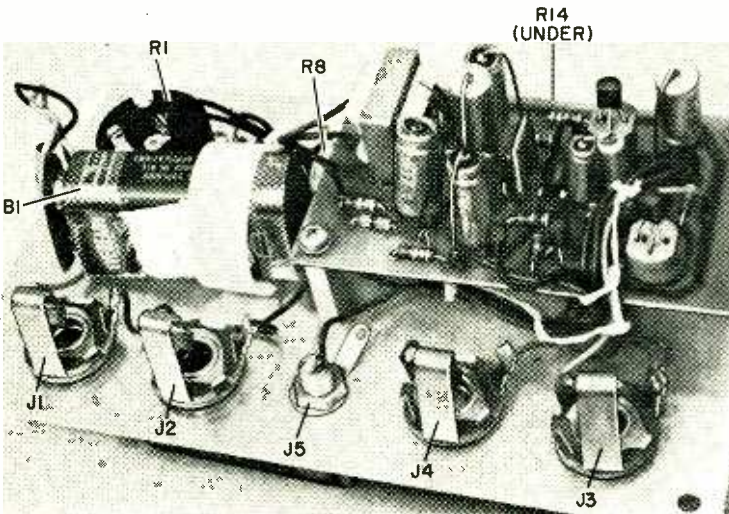

Fig. 2. Actual size PC board etching and drilling guide (right) and component layout and orientation (above). Observe the polarity of IC1, transistors, and electrolytic capacitors.



and applied to *IC1*, an audio amplifier module. The IC raises the signal level enough to saturate transistor *Q1* on each positive half cycle. This permits *C7* to discharge at a rate determined by the time constant of *R6* and

C7. Capacitor *C7* receives its charge through *R7* and *R8*, the RECOVERY potentiometer. When a sufficient number of input cycles have occurred to allow *C7* to be discharged below the threshold of Schmitt trigger *Q2* and *Q3*,



Although the prototype used phone jacks, any other suitable type of connector may be used. A short length of plastic strip supports the 9-volt battery.

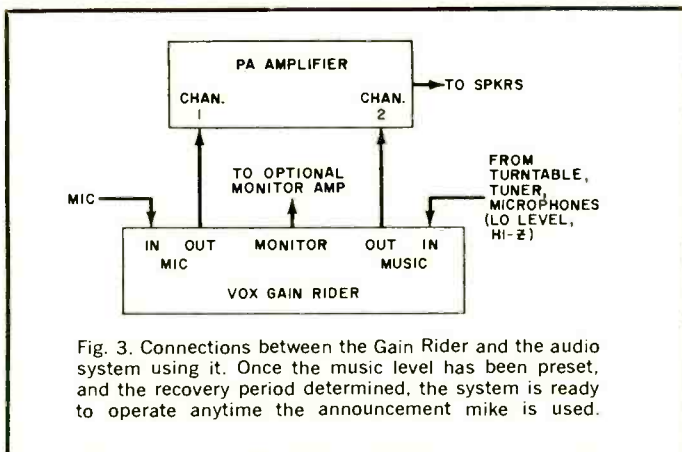

the latter saturates. This causes $Q4$ to conduct and places its collector at approximately the level of the supply voltage. Occasional narrow noise pulses on the input are not sufficient to allow $C7$ to discharge enough to fire the Schmitt trigger.

With $Q4$ conducting, the potential at the wiper of $R14$ is raised to a maximum of 9 volts, depending on its setting. This provides the gate signal for field effect transistor $Q4$. The latter acts as a voltage-variable resistor to reduce the level of the signal between $J3$

and $J4$. The signal from the microphone thus cuts off the music signal and takes over the amplifier system. When the microphone signal is removed, transistor $Q1$ is not saturated and capacitor $C7$ is recharged through resistors $R7$ and $R8$.

Construction. The circuit is built up on a printed circuit board using the foil pattern and component layout shown in Fig. 2. Note that the various electrolytic capacitors are mounted "standing up" with one lead soldered

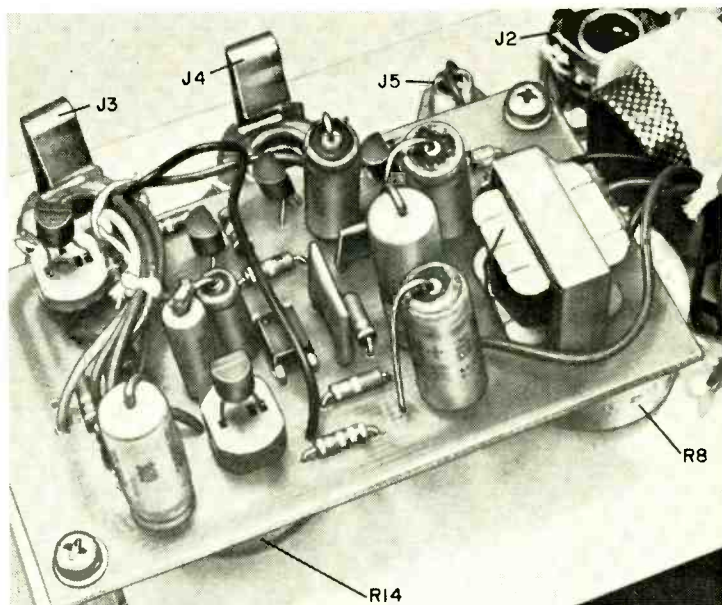

To conserve board space, note that the capacitors are mounted "on end." The use of transistor sockets is optional, as is the type of phone jacks shown.

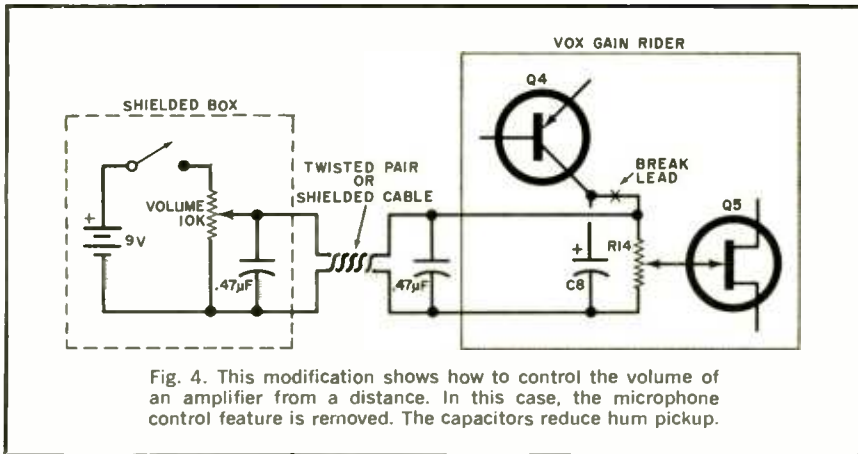

Fig. 4. This modification shows how to control the volume of an amplifier from a distance. In this case, the microphone control feature is removed. The capacitors reduce hum pickup.

directly into its hole and the other lead bent over to reach the other hole. To conserve space, $\frac{1}{4}$ -watt resistors are suggested; though, if you make your own board layout and have the room, you may substitute $\frac{1}{2}$ -watt resistors. Observe the location coding for *IC1*; and when installing this and the other semiconductors, use a low-power soldering iron and fine solder.

The prototype shown in the photos was built on the metal cover plate of a 6" \times 3 $\frac{1}{2}$ " \times 2" plastic box. The three potentiometers and five input/output jacks were mounted across the top of the panel and suitably marked. The battery was held in place by a plastic band attached to the chassis. A conventional 9-volt transistor radio battery can be used since the drain is only 6 milliamperes.

Testing and Operation. All connections to and from the Gain Rider circuit should be made with shielded audio cable to reduce 60-Hz hum. Connect a turntable, AM/FM tuner, or any other low-level high impedance audio source to the music input jack *J3*. Connect an amplifier and speaker to the music output jack *J1*. Set the amplifier controls for the desired sound level. Set the Gain Rider SENSITIVITY control *R1* for minimum and connect a high-impedance microphone to *J1*. Connect an audio cable from the microphone output jack *J2* to the other channel on the amplifier. All of the above connections are shown in Fig. 3.

Set *R11* (MUSIC PRESET) and *R8* (RECOVERY) to minimum (should be maximum counterclockwise). Then adjust the amplifier gain control for a sound level slightly higher than that normally used.

While speaking slowly into the microphone,

advance the SENSITIVITY control until the music level drops suddenly. Continuing to speak slowly into the microphone, advance *R1* until the music level drops suddenly with each word. It may be necessary to pause between words to allow the music level to recover. Record this setting of *R1* for future reference.

Speaking into the microphone at normal level, adjust *R8* (RECOVERY) until the music level does not recover between normally spaced words, but does recover in a suitable time after you stop speaking. Record the setting of *R8*.

Obtain the desired level of music while you are talking by adjusting *R11* (MUSIC PRESET).

Once the three potentiometers are set as described above, the VOX Gain Rider is ready for use.

Remote Control. The VOX Gain Rider can be used to control the level of a sound system from a remote location by using the modification circuit shown in Fig. 4. The remote control unit is connected to the system through a reasonable length of twisted pair or shielded cable. The capacitance value may have to be increased if the amount of stray pickup is too high.

Helpful Hints. Note that the setting of *R1* (SENSITIVITY) depends on the type of input—electric guitars, organs, FM receivers may take different settings. It should also be noted that when used with live performances, the ambient noise level may be sufficient to trigger the circuit unless a good cardioid microphone or a "close-speaking" type is used. If a permanent installation is desired, any well-filtered 9-volt dc power supply may be used to replace the battery.

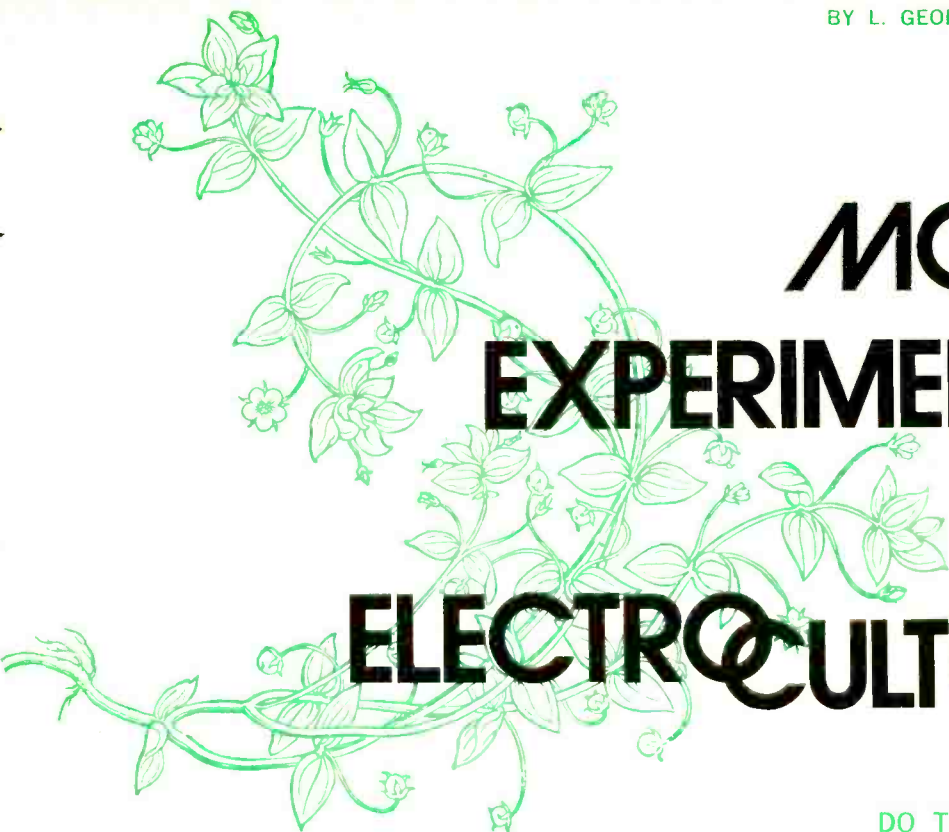

MORE EXPERIMENTS IN ELECTRO CULTURE

DO THEY REALLY
KNOW IF YOU CARE?
FIND OUT ELECTRONICALLY

EXPERIMENTING on living organisms is exciting and—as history shows—often rewarding. But there just aren't many people, dogs, birds, fish, etc., that you can (or would want to) subject to tests to determine such things as emotional reactions, nervous response, or sensorial perception. So, how about plants? They are after all, living things, and there are many indications that when stimulated, they have sensitive, sensible reactions which can be measured on ordinary electronic equipment. Before going into the details of the equipment (which you can build for yourself), let's get to know a little more about plants and how they tick.

Do They Just Sit? On first thought, plants appear to be quite remote from life as we know it. Their sedentary existence stands in strong contrast to energetic animals, which are endowed with a massive inventory of sen-

sory capacities, fast reflex movements, and many active organs.

However, recent research has revealed that many of the same environmental factors and stimulations that affect animals also affect plants. Of course, here we find modified abilities to sense, feel, and react. Also, since a plant cannot run away from a threat to its existence, it would appear that special internal forces are set in motion to protect the organism from shock and possible death. These phenomena are akin to states of anxiety in animals and are evidenced by changes in the plant's psychogalvanic or electric states which occur in threatening situations. The recently discovered "Backster Effect," seems to provide evidence that plants have some ability to function in a mode of supersensory perception. This, of course, invites a host of exciting and unique investigations.

However, prior to engaging in plant-ori-

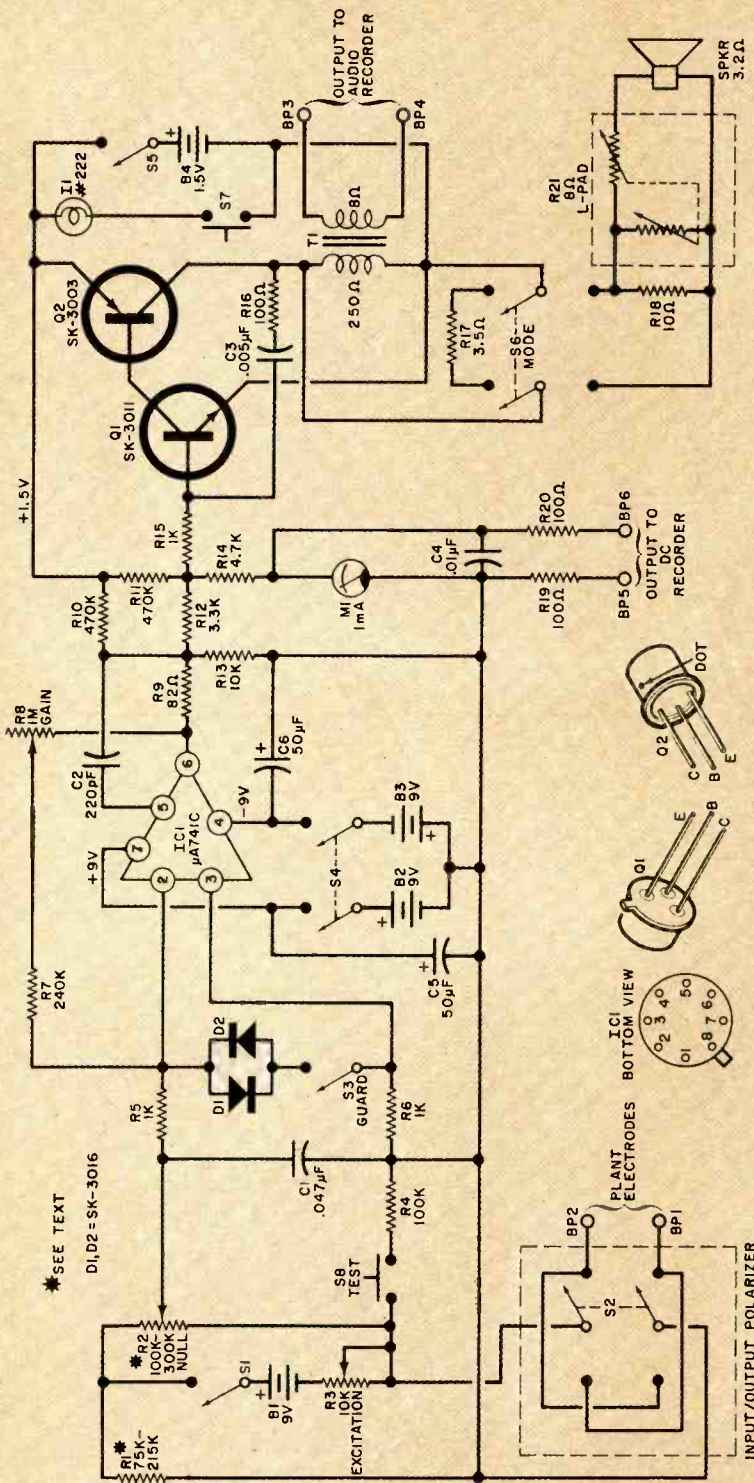

Fig. 1. If desired, the circuit can be terminated at meter M1 if you just want meter readout, or you can drive the audio oscillator with headphones connected to the 8-ohm output and the meter out of the circuit. However, for maximum versatility, the entire circuit can be built and both an audio and dc recorder used.

ented experiments, you should realize that living systems frequently produce maverick results. While a plant may be regarded as an organic semiconductor having variable resistance and self-generating properties, it also has elements of apparent cellular consciousness. Electronic and mechanical response profiles are not uniform.

Some plants (such as the *Mimosa Pudica*) react rapidly; others give no discernible reactions to stimuli and still others exhibit strangely delayed responses. Remember that typical electrical signals provided by plants are in the low millivolt/microampere range. The equipment described here for making experiments should give you a good start, but

TRANSMITTER EFFECT

The behavior of plants in strong r-f fields has been studied only superficially. Although excessive energy levels induce heating and death and although plants are (electrically speaking) dc-oriented organisms, they nevertheless incorporate mechanisms which allow them to survive in the immediate vicinity of high-power radio transmitters of all types. To our knowledge, no tests have been performed to detect psychogalvanic behavior in plants under these conditions.

for some extremely sensitive tests, you should avail yourself of an ultra-high-gain electrometer with input impedances of 10^{10} ohms or higher.

Another factor to remember is the importance of repetition. If, for example, a plant specimen is stimulated continuously, badly injured by burns or cuts, infrequently watered, etc., it is bound to tire quickly, perhaps lapse into shock and die. Terminal conditions are indicated by wilting, and discoloration usually forecasts death. Depending on the plant's overall chemistry and the amount of moisture retained in leaves and stem structures, a dead specimen is little else than a simple conductor of the carbon type and no psychogalvanic response of any kind should be expected. In short, be gentle and allow plants to recuperate after they have served your purpose.

Some 350,000 plant species are known to science. At this time, we have no concise information as to which group is psychogalvanically superior to others. In general, however, it has been discovered (Lund, 1931) that the distribution of gradients of electrical potentials in large plants (such as trees) is more complex than in small plants. Apparently, each individual cell in a plant is electrically polarized and acts as a tiny, variable battery. The electrical potentials occurring in tissues are summation effects of the potentials of individual cells which may act either in series or in parallel (Rosene, 1935). Various mechanisms of correlation are involved here; but, as you are bound to discover, there is no complete uniformity from one specimen to the next, either in looks or reactions.

Plant Response Detector. The basic instrument for plant experimentation is a response detector whose schematic is shown in Fig. 1. The detector has both visual (meter) and acoustical (speaker) indications of plant reaction. The audio tone output can also be

PARTS LIST

- B1-B3—9-volt battery
 B4—1.5-volt D battery
 BP1-BP6—Five-way binding post
 C1—0.047- μ F capacitor
 C2—220-pF capacitor
 C3—0.005- μ F capacitor
 C4—0.01- μ F capacitor
 C5,C6—50- μ F, 10-volt electrolytic capacitor
 D1,D2—Silicon diode (RCA SK-3016)
 I1—2.2-volt lamp (222)
 IC1—Op amp IC (Fairchild μ A741C)
 M1—1-mA dc meter (Calestro D1-912 or similar)
 Q1—Transistor (RCA SK3011)
 Q2—Transistor (RCA SK3003)
 R1—75,000-ohm resistor (see text)
 R2—100,000-ohm linear potentiometer (see text)
 R3—10,000-ohm linear potentiometer
 R4—100,000-ohm resistor
 R5,R6,R15—1000-ohm resistor
 R7—210,000-ohm resistor
 R8—1-megohm linear potentiometer
 R9—82-ohm resistor
 R10,R11—470,000-ohm resistor
 R12—3300-ohm resistor
 R13—10,000-ohm resistor
 R14—4700-ohm resistor
 R16,R19,R20—100-ohm resistor
 R17—3.5-ohm, 1-watt resistor
 R18—10-ohm resistor
 R21—8-ohm potentiometer L pad
 S1,S3,S5—Spst switch
 S2,S6—Dpdt switch
 S4—Dpdt switch
 S7,S8—Normally open pushbutton switch
 T1—Audio transformer; 250/8-ohm, 200-mW (Calestro D1-726 or similar)
 Misc.—Suitable chassis and cabinet, battery holders, pilot-lamp mounting assembly, clamp support, machine clamp, clamp insulators, metal electrodes, twin shielded lead, rubber feet, plastic pot for plant, knobs, mounting hardware, etc.
 Note—The μ A741C op amp is available from PolyPaks, PO Box 942W, Lynnfield, MA 01940, for \$2.98.

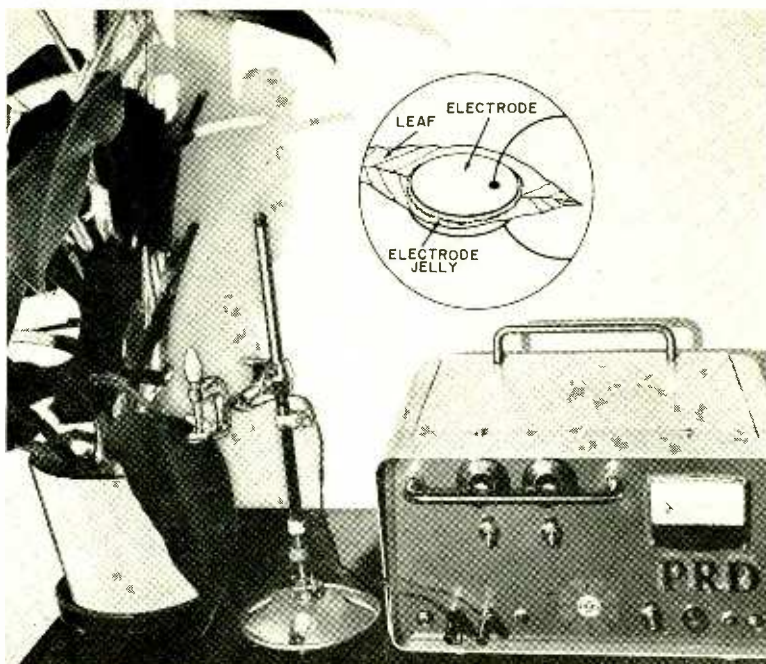

Fig. 2. Leaf contact is made through a highly conductive metal disc and electrode jelly of the same type used by physicians to make medical electronic tests. Take care not to crush the leaf when making the contact, and use a stable support system.

connected to a conventional audio tape recorder and a pen-type recorder can be connected to the dc amplifier output to make permanent records of results.

The schematic is divided into four operational sections: the Wheatstone bridge input with exciter and input-output polarizer; an op amp guard circuit having a disabling feature; a high-gain dc operational amplifier; and an audio tone generator whose frequency varies with the potential generated in the plant. The op amp used has a large-signal gain of 100,000 and has built-in short circuit protection.

The circuit can be assembled on perf board or a printed circuit board. Be careful to avoid heat damage when soldering the IC and other semiconductors. Observe the polarity of the electrolytic capacitor. Either a well-filtered dual 9-volt power supply or 9-volt batteries may be used for the power source. Use a suitable metal chassis to house the detector, with the meter and all controls on the front panel.

Connections to Plant. The pickup electrodes which are attached to the plant (see Fig. 2) can be of almost any shape and any

metal that has good conductivity. Stainless steel or silver electrode pairs will work very well. Use of dissimilar metals can cause undesirable electrolysis. The effective size of the electrodes can be determined experimentally, but normally would be less than one inch in diameter. If it is found that the leaf resistance is very high, a larger diameter on the electrodes is required. If the plant has thin, moist, semi-opaque leaves, a smaller electrode is used. Leaf conductance can be enhanced by using electrocardiographic electrode contact cream, such as ECG KONTAX (Cat. No. 391, Birtcher Corp., Los Angeles, CA 90032). It is water soluble and should be wiped off plant leaves after the experiment is complete. Give the leaf a good rinse after that. Connections to the electrodes are made through a shielded pair cable. The electrodes are insulated from the metal clamp by pieces of plastic with the leaf gently compressed between the electrodes. Using the bridge resistor values shown in Fig. 1, the resistance between the electrodes should not exceed 250,000 ohms. Also keep in mind that the plant generates a small current of its own which, depending on the setting of switch S2, is superimposed on the excitation current flowing in the circuit.

Theory of Circuit Design. The resistance of the plant leaf, connected to $BP1$ and $BP2$, forms part of a Wheatstone bridge with the other arms formed by $R1$ and the two portions of $R2$. Power for the bridge is supplied by $B1$ controlled by $R3$. The final values of $R1$ and $R2$ are determined by the type of plant leaf being used. The resistances must be increased when the leaf is thin and sensitive to avoid over-excitation and undesirable side effects.

The input/output polarizer switch $S2$ permits reversal of the current applied to the plant leaf since living matter tends to saturate and gradually cease to function as an organic resistor.

The offset signal from the bridge is amplified in $IC1$, which is guarded by diodes $D1$ and $D2$. When $S3$ is closed, these diodes limit the input voltage to the op amp and protect it from large signals. However, once the circuit is operational and maximum sensitivity is required after $M1$ has been nulled, $S3$ can be opened. The output of the de amplifier

MAGNETO-TROPICISM

This phenomenon was discovered by Dr. L. J. Audus, of Bedford College, London, in 1959, and reported by him in "Nature" in 1960. This report clearly showed that plants are highly susceptible to electromagnetic fields.

In tests, a viable seed of any plant is inserted in a small plastic container which is then placed between the poles of a strong magnet (of the magnetron type). For control purposes, another similar seed and container are placed far away from the magnet but with all other conditions being the same.

The "magnetized" seedling should show some bending effects plus a more emphatic growth than the control specimen.

It is also possible to "quick-ripen" fruit with a 900-gauss magnet. For example, a number of tomatoes placed at various distances around the magnet poles (anywhere from 3 to 17 inches away) will show varying rates of ripening. Those closest to the magnet will be the first to turn red. Horticulturists at the University of Utah believe that the earth's magnetic field activates an enzyme system inside fruits and vegetables causing them to ripen and that a similar thing is caused artificially when the fruit is placed near a powerful magnet.

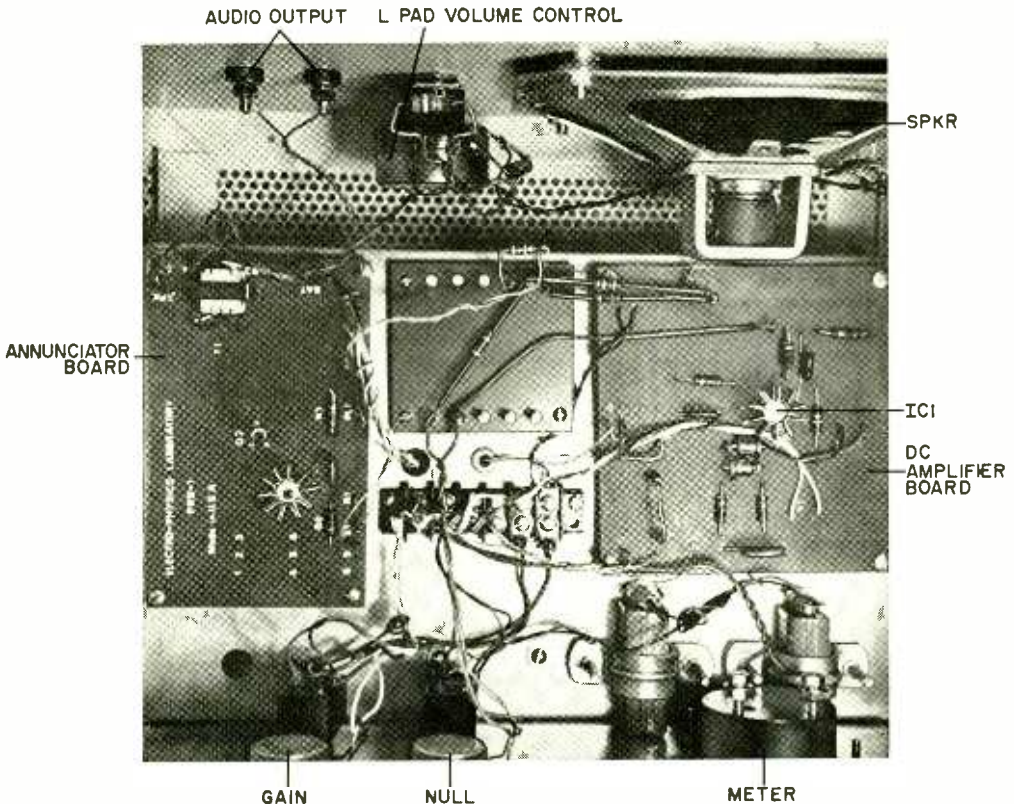

The prototype was constructed in sections on independent circuit boards, but any other physical arrangement may be used as well as any type of cabinet.

is indicated on a meter and can be used to drive a dc pen recorder if a permanent record is desired. The output also drives an audio oscillator ($Q1$ and $Q2$) whose frequency is a function of the dc signal. Transformer $T1$ couples the audio tone to an optional audio tape recorder and to an internal speaker. Capacitor $C3$ and resistor $R16$ provide feedback for the oscillator.

The circuit is sensitive to a few microamperes of input current, and when this current changes as a result of plant stimulation, the bias on $Q1$ changes to alter the pitch of the oscillator. Indicator lamp $I1$, momentarily activated by pushbutton switch $S7$, permits intermittent tests of battery voltage and provides for the injection of cue markers on a tape recorder since the pitch increases when $S7$ is activated. Power to the audio oscillator is controlled by switch $S5$.

Transformer $T1$ provides an audio output for the tape recorder at all times regardless of the position of $S6$. In one position of $S6$, $R17$ serves as a load; while in the other position, $R21$, an 8-ohm pad, is the load. Volume control is essential since the beep in the audio tone produced by $S7$ is annoying to listen to and can produce an undesired stimulus to the plant.

While performing a particular experiment, the audio signal can be fed to one channel of a conventional stereo tape recorder, while the other channel is supplied with time markers (from WWV or CHU) or vocal announcements. This permits recording of vocal stimulus to the plant as well as the plant's response.

DC BOOSTER

In tests performed on a tree by the U. S. Department of Agriculture at the University of California in 1964, the application of about 58 volts dc (negative electrode high in the tree, positive attached to stainless steel nail driven in the base of the trunk) showed that leaf density on the electrified branches increased substantially after 28 days. Over a much longer period of time, the leaf growth was 300% over that on the non-electrified branches.

It was also noticed that when a sensitive dc voltmeter was connected between two conductors driven into a living branch (one at the center of a cut-off portion; the other in the layer just under the bark), cutting twigs or branches in any other part of the tree produced a sudden fluctuation on the meter. Even burning a leaf produced a noticeable effect. Not only did the natural voltage rise and fall; at times it even reversed polarity. There is no explanation for this effect.

THE BACKSTER EFFECT

Cleve Backster, one of this country's leading authorities on the polygraph (lie detector) connected a pair of electrodes to a leaf of a *dracaena massangeana* while it was being watered. Surprisingly, the plant's psychogalvanic reaction pattern resembled that of a human subject exposed to emotional stimulation.

In further tests, Backster decided to ignite a match and burn the leaf to which the electrodes were attached. At the instant that the thought image occurred in his mind, a dramatic change appeared on the plant's polygraph readout. Tests were carried out on other living matter including paramecium, fresh fruits and vegetables, amoeba, mold cultures, scrapings from the roof of a human mouth, and yeast. All showed similar results. It would appear that there is an unknown communication between all living things, outside the orthodox electromagnetic spectrum. For example, placing plants in lead-lined, Faraday-screened cages, fails to suppress the phenomenon.

It also appears that plants form some sort of emotional attachment to their owners. Cleve Backster has reported that one plant responded to his emotional attitude at a distance of over 1000 miles. Obviously, much work remains to be done in this area.

Conducting Tests. In connecting the electrodes to the leaf, apply just enough pressure to make a good contact with the leaf without crushing it. Place the guard switch ($S3$) in the closed position to protect the IC from an excessive input signal.

When $S1$ is turned on, power is applied to
(Continued on page 93)

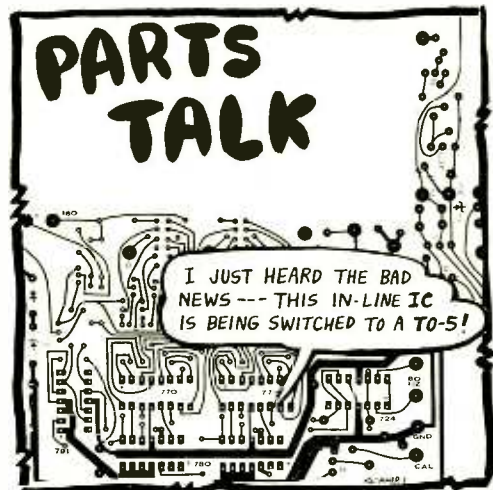

Digital Thermometer Module

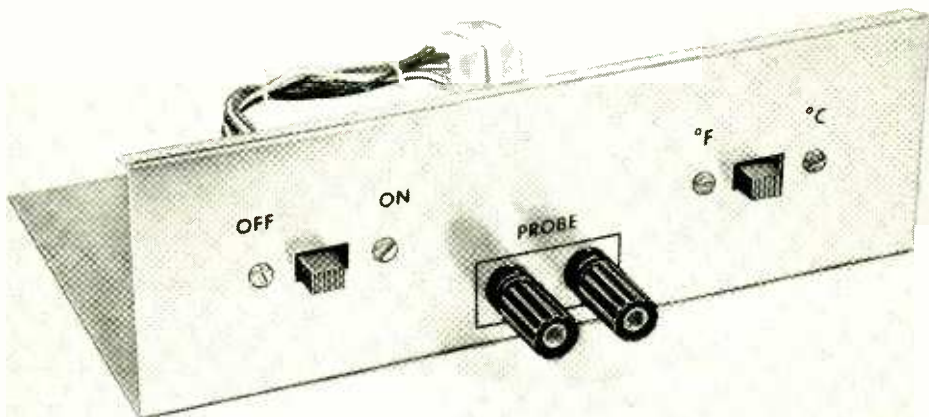

for the Digital Measurements Lab

FROM FREEZING TO BOILING—

FAHRENHEIT OR CENTIGRADE

BY DANIEL MEYER

THE CONSTRUCTION PROJECT this month for the Digital Measurements Lab is a Digital Thermometer plug-in module. Capable of measuring temperatures between the freezing and boiling points of water in °C and °F, the module is essentially a variable frequency oscillator that converts resistance changes that result from temperature variations into frequency changes that can be used by the lab's main frame. (See Nov. 1970)

The Thermometer's sensing element is a Texas Instruments Sensistor[®] silicon resistor. The Sensistor has a linear positive temperature coefficient. Its resistance increases linearly with increasing temperature. Sealed in a glass tube, the Sensistor can be mounted in any location and wired to the plug-in module via a cable and banana jack assembly.

If a reasonable wire length is used to connect the sensor to the module, the temperature readings will be unaffected. Wire lengths up to several thousand feet can be used if the

circuit is calibrated with the wire length you plan to use for your measurements.

Theory of Circuit Design. The resistance change of sensing resistor R_{21} (see Fig. 1) is converted to a frequency change by the oscillator circuit built around unijunction transistor Q_6 . The frequency of oscillation in this circuit is a direct function of the value of C_2 and the level of the current supplied to the oscillator by transistor Q_5 . The voltage level at the base of Q_5 , and thus the current through the transistor, are controlled by the combined resistances of R_{11} , either R_{12} or R_{13} (depending on the position of S_1), and R_{21} .

The current supplied to Q_6 is a linear function of the resistance of R_{21} just as long as this current does not have to go completely to zero. The linearity is arranged by the Q_3 circuit which acts as a current sink and draws a constant 100 μA from the collector of Q_5 .

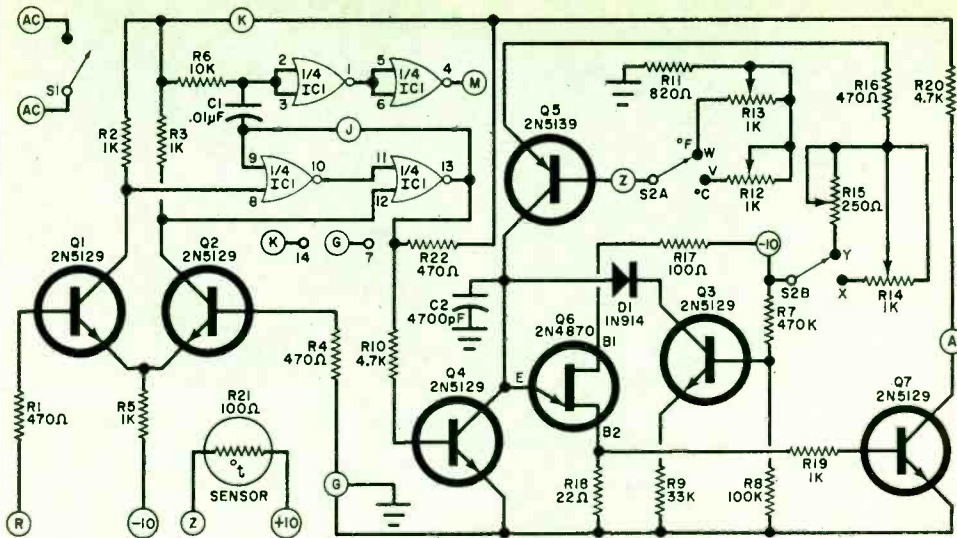

IC1=7402

Fig. 1. Variations in temperature cause corresponding variations in output frequency of oscillator Q6 as result of changing RC control component (sensor R21/C2). Gating is controlled by 60-Hz reference, differential amplifier Q1/Q2, and integrated circuit IC1.

PARTS LIST

- C1—0.01- μ F disc capacitor
 C2—4700-pF disc capacitor (see text)
 D1—1N914 diode
 IC1—7402 quad two-input gate integrated circuit
 Q1-Q4, Q7—2N5129 bipolar transistor
 Q5—2N5139 bipolar transistor
 Q6—2N4870 or 2N4871 unijunction transistor
 R1, R4, R16, R22—470-ohm
 R2, R3, R5, R19—1000-ohm
 R6—10,000-ohm
 R7—470,000-ohm
 R8—100,000-ohm
 R9—33,000-ohm
 R10, R20—4700-ohm
 R11—820-ohm
 R17—100-ohm
 R18—22-ohm

All resistors
 1/2 watt,
 10% tolerance

- R12-R14—1000-ohm trimmer potentiometer (Type IRC-CTS X-201 or similar)
 R15—250-ohm trimmer potentiometer (Type IRC-CTS X-201 or similar)
 R21—100-ohm Sensistor (Texas Instruments No. TC1/8 silicon resistor)
 S1—Spst switch (part of power supply in main frame)
 S2—Dpst switch
 1—15-contact Molex connector to mate with connector in main frame
 Misc.—Printed circuit board; five-way binding posts (2); chassis; spacers; hardware; solid and stranded hookup wire; solder; etc.
 Note: The following are available from Southwest Technical Products Corp., 219 W. Rhapsody, San Antonio, TX 78216: etched and drilled printed circuit board No. THR-1b for \$2.15; complete kit of parts including chassis, connector, and hardware No. THR-1C for \$16.50 plus postage on 5 lb and insurance.

The value of C2 will be affected to some extent by the characteristics of Q6. It can vary between 3900 pF and 5600 pF.

The output pulse from Q6 is amplified by the Q7 circuit to provide a high enough output level to drive virtually any type of read-out system you may wish to use. All that is necessary now is to gate the oscillator off and discharge C2 at the end of each conversion period. Since a 60-Hz signal is available from the power line (via the transformer in the main frame's power supply), and this rate is

high enough so that flicker will not be present, a 60-Hz gate system is used in the Thermometer module.

The 60-Hz signal from the transformer is amplified and squared by the differential amplifier made up of Q1 and Q2. The resulting signal at the collectors of these two transistors is used to operate a set-reset flip-flop, or latch, circuit. The SR flip-flop is made up of two of the gates in IC1.

This system is not affected by line voltage variations or by line noise due to the high

Fig. 2. At right is shown actual size etching/drilling guide for fabricating printed circuit board. When installing components on circuit board (see below), carefully orient transistors and IC1.

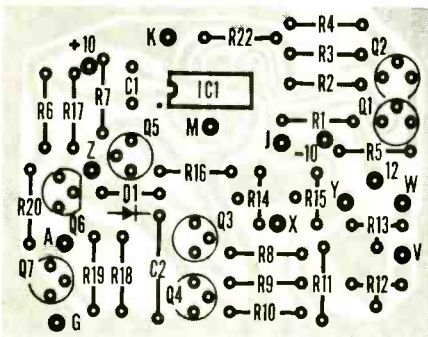
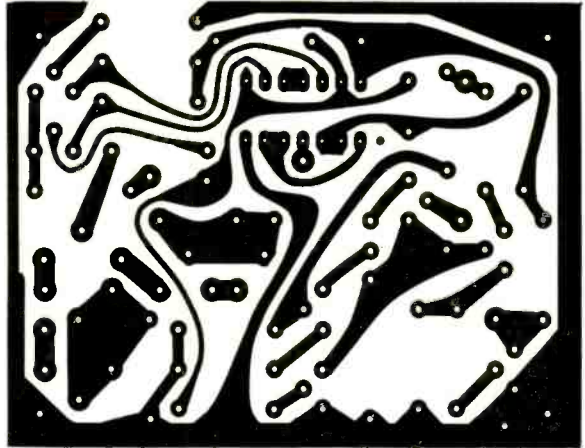

gain and the use of a latch system to generate the gate signal. The output from the latch drives $Q1$ which, in turn, shorts the emitter of $Q6$ to ground for 8.33 milliseconds and then allows the circuit to oscillate for another 8.33 milliseconds.

During the time that the oscillator is running, point J—which is connected to the blanking input of the readout—is at a logic "0" and the display readouts are off. As soon as the conversion cycle is complete, the blanking input returns to a logic "1" and the total number of pulses that occurred in this cycle is displayed by the readout tubes in the main frame. Connected to the fourth gate in $IC1$, $C1$ and $R6$ cause a reset pulse to be generated, resetting the display to zero at the beginning of each conversion portion of the cycle.

Construction. Assembling the Thermometer module is quite simple. Most of the components mount on a compact printed circuit board, the actual size etching guide and components placement and orientation diagram for which are shown in Fig. 2. Be careful to orient the transistors and integrated circuit

properly on the board before soldering them to the foil pattern. Use a low-wattage, fine-pointed soldering iron and work carefully to avoid solder bridges between closely spaced foil conductors.

Next, mount the five-way binding posts and $S1$ and $S2$ on the front panel of the module chassis (see Fig. 3). Then wire the post and switch lugs, circuit board, and a 15-contact connector together (see connector wiring diagram in "Digital Measurements Lab," Nov. 1970). Point Z on the circuit board does not go to the connector; solder a wire from this point to the wiper of $S2A$.

(Continued on page 96)

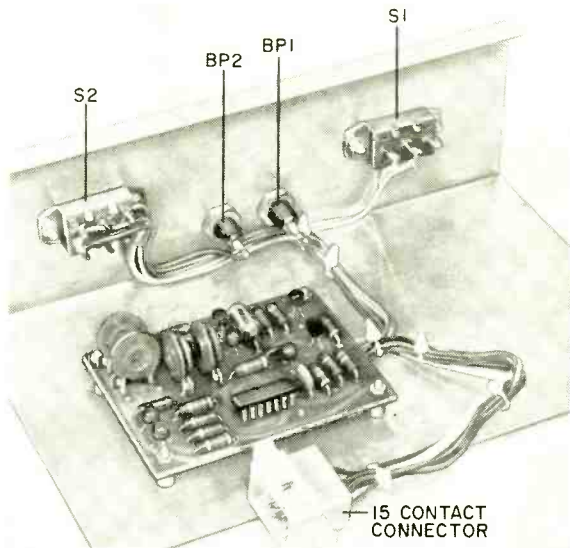
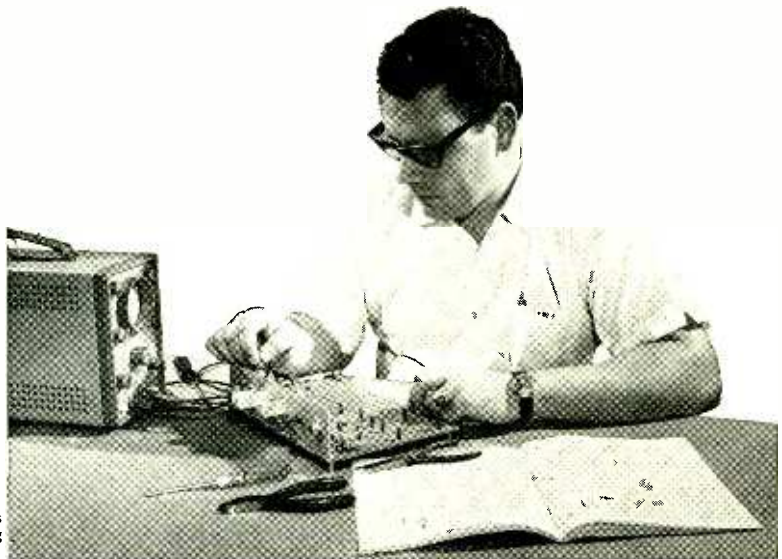

Fig. 3. Interconnections between circuit board and connector should be made with stranded hookup wire. When wiring is complete, use 4-40 machine hardware and $1/4$ " spacers to mount circuit board.

10 Reasons why RCA Home Training is your best investment for a rewarding career in electronics:



Performing transistor experiments on programmed breadboard — using oscilloscope

1 LEADER IN ELECTRONICS TRAINING

When you think of electronics, you immediately think of RCA... a name that stands for dependability, integrity, and pioneering scientific advances. For over half a century, RCA Institutes, Inc., a subsidiary of RCA, has been a leader in technical training.

2 RCA AUTOTEXT TEACHES ELECTRONICS FASTER, EASIER, ALMOST AUTOMATICALLY

Beginner or refresher, AUTOTEXT, RCA Institutes' own method of programmed Home Training will help you learn electronics more quickly and with less effort, even if you've had trouble with conventional learning methods in the past.

3 WELL PAID JOBS ARE OPEN TO MEN SKILLED IN ELECTRONICS

RCA Institutes is doing something positive to help men with an interest in electronics to qualify for rewarding jobs in this fascinating field. There are challenging new fields that need electronics technicians... new careers such as computers, automation, television, space electronics where the work is interesting and earnings are greater.

4 WIDE CHOICE OF CAREER PROGRAMS

Start today on the electronics career of your choice. On the attached card is a list of "Career Programs", each of which starts with the amazing AUTOTEXT method of programmed instruction. Look the list over, pick the one best suited to you and check it off on the card.

5 SPECIALIZED ADVANCED TRAINING

For those already working in electronics or with previous training, RCA Institutes offers advanced courses. You can start on a higher level without wasting time on work you already know.

6 PERSONAL SUPERVISION THROUGHOUT

All during your program of home study, your training is supervised by RCA Institutes experts who become personally involved in your efforts and help you over any "rough spots" that may develop.

7 HANDS-ON TRAINING

To give practical application to your studies, a variety of valuable RCA Institutes engineered kits are included in your program. You get over 250 projects and experiments and as many as 22 kits in some programs. Each kit is complete in itself. You never have to take apart one piece to build another. They're yours to keep and use on the job.

8 FCC LICENSE TRAINING—MONEY BACK AGREEMENT

Take RCA's Communications Career program—or enter with advanced standing and prepare immediately for your 1st, 2nd, or 3rd class FCC Radio Telephone License examinations. RCA Institutes money-back agreement assures you of your money back if you fail to pass the FCC examination taken within 6 months after completing the course.

9 CONVENIENT PAYMENT PLANS

You get a selection of low-cost tuition plans. And, we are an eligible insti-

tution under the Federally Insured Student Loan Program.

10 RCA INSTITUTES IS FULLY ACCREDITED

RCA Institutes is an accredited member of the National Home Study Council. Licensed by N. Y. State—courses of study and instructional facilities are approved by the State Education Department.

VETERANS: TRAIN UNDER NEW GI BILL

SEND ATTACHED POSTAGE PAID CARD TODAY! FREE DESCRIPTIVE BOOK YOURS WITHOUT OBLIGATION!

If reply card is detached, send this coupon today.

RCA INSTITUTES, INC.
DEPT. 694-006-1
320 W. 31 ST.
NEW YORK, N. Y. 10001

Please send me FREE illustrated career catalog. I understand that I am under no obligation.

Name _____

Address _____

City _____

State _____ ZIP _____

Age _____

Veterans: Check here

RCA

Construction of Multimeter.



Construction of Oscilloscope.

Temperature experiment with transistors.



GUINEA, REP.—Since the state of emergency over last fall's "invasion," *Radio Conakry* has been almost constantly on the air with marches and rabble-rousing sloganry. Listen especially to the all-night service on 9.650 and 7.115 MHz, often talking in English to "African freedom-fighters everywhere" around 0300-0600. Two 60-meter outlets are now in use: the old 4.910 and the new 4.970 MHz: watch for these at the 0600 sign-on of regular daily programs. . . **INTERNATIONAL WATERS**—Anchored off the Dutch coast, *Radio North Sea International* is back in its familiar slot of 6.205 MHz just outside the 49-meter band. East Coasters should hear it around 2200-0800, while throughout the country it should peak at 0700. . . **LEBANON**—*Radio Beirut* to North America has adjusted slightly from 11.780 MHz to 11.775, at 0130 to 0400, with English at 0230-0300.

MOZAMBIQUE—Hard rock music, singing identifications and jingles in English. . . no, that sound on 11.780 MHz around 0300-0500 isn't an image from your local AM station, but "*LM Radio*," beamed to the South Africa commercial outlet in Lourenco Marques, now heard with fine strength though listed as 10 kW and verifying as 7.5. A short way up the band, on 11.820, you can hear the same style of programming, but in Portuguese. Watch for it when BBC Ascension Island there signs off at 0415. . . **NORWAY**—*Radio Norway*'s English "Norway This Week," beamed to North America for Sunday-evening listening, is putting all its eggs in the 31-meter basket. At 0400-0430 (Monday, GMT), you can choose between 9.550, 9.610, and 9.645 MHz; at 0600-0630, 9.550 or 9.645 MHz.

SOUTH AFRICA—Avoiding a long-standing clash with Nicaragua on 11.875 MHz, *Radio RSA* has moved to 11.970 MHz; trouble there is jamming directed against *Radio Liberty*. In parallel during the North American services at 2325-0320 are 15.220, 9.705 and 9.695 MHz. . . **SOUTH YEMEN**—Strong contender for the longest name among active stations, the *People's Democratic Republic of South Yemen Broadcasting Service*, in Arden, is making up a backlog of unverified reports, so now's the time to write. Sign-on is 0330 on 5.060 MHz, all in Arabic. Don't confuse with Tirana from its 0430 sign-on there. (Submitted by Richard E. Wood)

FEDERAL REGULATIONS

Radiation Safeguards—Overseas visitors planning to bring a foreign-made TV receiver into the United States must be sure that the receiver bears a label certifying compliance with U.S. Department of Health, Education, and Welfare limitations on X-ray emissions. Definitive information on the new HEW regulations are available from the Bureau of Radiological Health, Office of Information, 12720 Twinbrook Parkway, Rockville, Maryland 20822, under the title, "Electronic Product Import Information" (BRH/P1). People returning from overseas must provide information on declaration forms regarding the safety of imported devices and bonds must be filed if a device is declared as not meeting the standards. Labelling requirements apply now to TV receivers, but standards will be established in October for microwave cooking ovens.



THE PRODUCT GALLERY

Tenth in a Monthly Series by "The Reviewer"

IT'S FAIRLY DIFFICULT to be in hobby or experimental electronics without being exposed to the brand new world of gates and flip-flops. Digital logic and digital circuits are being used in all manner of systems ranging from electronic construction projects to commercial test equipment. Incidental to the development of digital logic is the appearance of a new kind of schematic—the logic diagram. In this new look, instead of illustrating a circuit in discrete components, there are groups of elements that perform a particular function and that are then combined within a distinctive outline and given a name such as gate, flip-flop, etc. The necessity to use this new look becomes fairly obvious when we imagine how enormous would be a wiring schematic that had to include all of the transistors, diodes, and resistors contained in the logic elements.

The uninitiated technician is finding it difficult to "believe" that it is no longer necessary to know what is actually inside the black box. The "need to know" is actually very minimal since the circuit contained within an integrated circuit cannot be repaired. All that remains is to be able to identify the "family" that the logic symbol belongs to, and this is done by identifying the box outline. In a way, this can be thought of as a form of electronic shorthand.

Besides being able to recognize the logic family by the outline shape of the symbol, the electronics technician or experimenter should know what happens to the output signal when certain actions are taken on the various input lines. Once this knowledge is gained, even a complex logic circuit, representing possibly hundreds of transistors and their associated passive components can be readily understood.

IC LOGIC DESIGN PROGRAM CENTER FOR TECHNICAL DEVELOPMENT

A working knowledge of digital logic may be obtained from a variety of sources. One interesting "do-it-yourself" study program that recently crossed your reviewer's desk was the IC Logic Design Program (LDP-1) offered by the Center for Technical Development. The Program consists of three elements; a loose-leaf textbook, an assembled electronics breadboard and a programmed "self-testing" outline.

The well written and illustrated text is divided into four major sections: logic elements, minimizing techniques, memory elements, and pulse forming. The section on logic elements covers all details of the various types of gates encountered in digital logic circuits and describes the various types of logic (RTL, TTL, etc.) used in present-day electronics.

The section on minimizing techniques covers Boolean algebra, de Morgan's theorem and Karnaugh maps, which explain the rules of logic and enable the user to reduce long complex statements of logic to much simpler forms (thereby reducing the component count). Memory elements deals with the design, operation, and characteristics of the different types of electronic flip-flop circuits, while the pulse forming section covers the design of many of the commonly used digital circuits for shaping pulses.

The battery operated, electronic breadboard comprises 7 IC's, 4 lamp drivers and lamps, and a set of 4 operational switches to introduce the logic levels. The board provides access to 28 functions including four OR gates four AND gates, six NOT (inverter) stages, four NOR gates, and 10 NAND gates.

CENTER FOR
TECHNICAL DEVELOPMENT
IC LOGIC
DESIGN PROGRAM

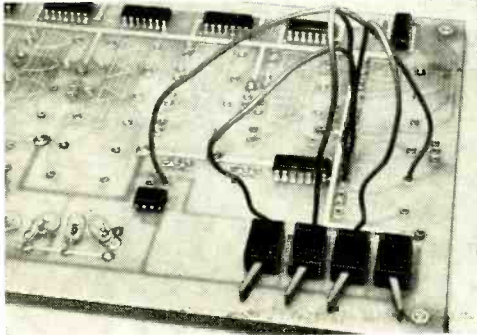
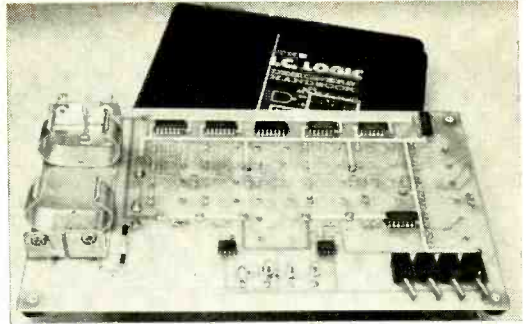

Small enough to fit easily on a shelf directly over the workbench, the Logico has 10 inputs connected to the logic board under test through conventional test leads. The circuit is almost nonloading in that the threshold voltages are 0.9 volt for turn on, 0.7 volt for turn off with only $2 \mu\text{A}$ drain from the most positive level and $125 \mu\text{A}$ from the most negative. Tests showed that the Logico does not affect the circuit under test and can be used with RTL, DTL, TTL, and ECL logic, either IC's or discrete circuitry, and provides positive indication of all logic circuit action.

INDUSTRIAL
INVENTIONS
LOGICO BPL-10

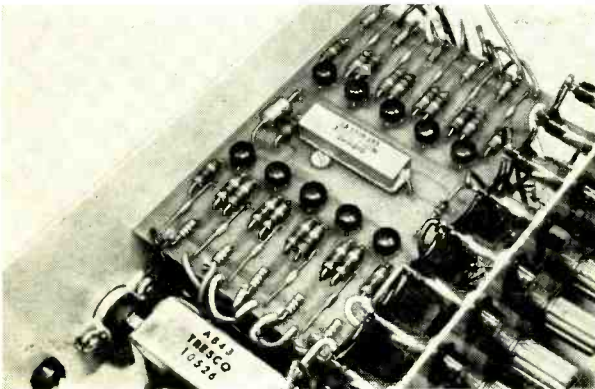

Reading about logic and trying to confirm the many truth tables of various types of gates is one thing, but actually being able to set up the different system configurations and observe the operations on lamp readouts is something else. Just a couple of minutes in wiring, and throwing switches brings a lot of things into vivid clarity. Keyed to the written material, the electronic breadboard can also be used to set up the various types of oscillators, flip-flops, and pulse forming circuits. It is even possible to design simple digital projects on the versatile breadboard.

These functions are more than adequate to set up any logic lesson in the text and probably enough to experiment with many logic circuits found in other publications. The circuits are interconnected with clip-on wires and the output state is determined by an indication of one of the four lamps.

Once you have performed all of the instructions detailed in the textbook and feel that you know what makes a logic circuit tick, you can work on the programmed "self-test." If you want to, return your test results to the manufacturer; and if you pass, you will receive a Certificate of Achievement.

Although this reviewer feels that the LDP-1 course is moderately expensive, there is no denying that this is an excellent way to learn the basics of digital logic at the newcomer's own pace. Being able to set up the experiments described in the book and confirm the operation of a particular circuit greatly improves the learning process. And, having a breadboard that is almost completely indestructible (electronically) enables "doodling" to satisfy the newcomer's curiosity about other logic arrangements—even circuits that are not mentioned in the book.

DIGITAL MONITOR (LOGICO BPL-10)

The expanding trend toward the use of digital circuits has necessitated the development of new types of test equipment. Because digital circuits usually have a number of discrete on/off states, specialized units are replacing the voltohmmeter and the oscilloscope (see POPULAR ELECTRONICS, March 1971, p 41). A convenient method of checking integrated circuits in operation is through the use of on/off neon lamps. The Logico Digital Monitor is an example of this new crop of test instruments.

In the Logico BPL-10, the neon lamps are

used to indicate the state of any 10 selected inputs. The device's reference terminal is connected to the most negative point in the system and the 10 inputs are connected to the particular circuit points to be checked. The input current for each input stage is only 125 μ A (maximum) so that the loading of the test circuit is always minimal. Each of the 10 inputs is independent and once the common reference line is attached, the inputs can be connected to various points in the digital chain. The pertinent lamps will then indicate logic state "1" (on) or logic state "0" (off).

Testing of the Logico BPL-10 in the POPULAR ELECTRONICS laboratory was performed according to the manufacturer's instructions. Testing of a countdown chain was easy and sure. The 10 monitor inputs of the BPL-10 were hooked up in serial fashion; i.e., input #1 examined the input to the first counter, input #2 was hooked to its output, input #3 went to the output of the second stage, etc., etc. In this way, the progress of a pulse through the digital countdown was easy to observe. There were no problems and the system appeared to be compatible with RTL, DTL, TTL, ECL, or even discrete component circuits.

Logico (company name Industrial Inventions, Inc.) also manufactures a Logalog strobe labeling monitor to indicate the logic levels at 10 different points. In this way, the operation of a high-speed logic system can be checked at some selected point in time. Another device is the "Cricket 4" Audible Digital Monitor that automatically monitors four circuit points with an audio tone. A different audio tone (and associated indicator lamps) is connected to each point in the digital circuit. The particular sequence of digital signals being monitored will produce a characteristic tone pattern. Any change in the tone pattern is immediately evident and the system can be used where it becomes difficult to keep an eye on the digital tester.

FOR MORE INFORMATION

Logic Design Program—Circle No. 88 on Reader Service Page 15 or 95.
Logico BPL-10—Circle No. 89 on Reader Service Page 15 or 95.



Tenth in a Monthly Series by J. Gordon Holt

THOSE REDUNDANT VOLUME CONTROLS

EVERYONE knows what a volume control is. It's that little knob on the front of the radio or TV that you turn clockwise to get more noise and counterclockwise to get less. Learning to use it properly takes little or no practice. But what if there is a *second* volume control that seems to behave almost, but not quite, the same as the first? Then indecision becomes the name of the game.

The average person can learn to live with two volume controls. He just messes with both of them until the volume is right and then forgets about it. However, the ardent audiophile is a born worrier. He knows instinctively that there must be some *reason* for having two apparently redundant volume controls and assumes that the reason has something to do with the sound of his system. He's right. And when he's confronted by three or even four volume controls, all of which seem to do exactly the same thing, he may begin to feel like the laboratory rat faced with the choice of hunger or an electric shock.

In a typical component system, every component in the chain—the tuner, tape recorder, preamp, power amp—may have its own volume controls. (Some preamps have a number of them on the rear panel, a main one on the front, and a second one on the front marked Loudness.) Any one of the controls, from tuner to power amp, can be used to raise or lower the volume, but it is customary to use the one(s) at the front of the preamp to control the system volume. So where do we set the others? All the way down? Obviously not; that would kill the sound. But should they be halfway up, full up, or somewhere in between? Only you can decide, because the optimum setting of each component's volume control depends on all the others.

Transistors (and tubes) being what they are, there is a definite range of signal levels that they can handle properly. Feed them too strong a signal, and they overload. Feed them too feeble a signal, and their back-

ground noise will cover the signal. The multiplicity of controls in a high-quality reproducing system simply permits the signal levels to be set safely between these high and low limits.

A typical tuner, for instance, has one amplifying stage following its own volume control. If you set this control near the bottom of its range, the tuner's output signal will be very weak and certainly in no danger of overloading the final stage. *But*, in order to drive your loudspeakers to adequate volume, you have to give them a sufficient signal; and when you try to do this at any later stage in the system, the tuner's final-stage noise will be amplified along with the signal. Eventually, the noise will become conspicuously audible. Now, we've set one practical limit.

The more signal the tuner supplies to the preamp, the less amplification you'll have to add subsequently to drive the speakers properly—and the less audible will be the tuner's output noise. *But*, if you turn the tuner's volume control up full, you run the risk of overloading its own final stage or, at best, driving it hard enough to produce too much distortion. That's the other limit.

Happy Medium. The object of volume or level-set adjustment is to strike a happy medium between the two limits—to drive each component's output stage as gently as possible without bringing its noise up the level of audibility. Here's how to do it.

If the loudspeakers have their own tweeter-level controls, set these at or somewhat above their "normal" positions (determined by listening to program material), and turn all other volume and level-set controls all the way down. Now turn the controls on the power amplifier (if it has them) all the way up and listen for hum or hiss. Do this from your usual listening location—not with your ear in the speaker. If there is no change in the noise level, leave the power amplifier controls all the way up. Otherwise, turn

them down bit by bit (by the same amount in a stereo system to retain balance) until the noise has just ceased to be audible. If you have to turn them down more than about $\frac{1}{3}$ of the full rotational range (that is, to less than $\frac{2}{3}$ of wide open), you may have a defective preamp or hum-loop problems—about which I'll have more to say some other time.

Set all controls on the main preamp to their normal positions for discs (tone controls flat, mode switch on stereo phono, loudness compensation off, balance at mid-setting, etc.), but leave the main volume control turned down. Now, the next step depends on what, if any, provision your preamp has for phono level adjustment.

If the preamp has Hi-Mag and Lo-Mag input receptacles, plug the phono into the Hi-Mag ones. Play a conservatively cut disc (a Vanguard, for instance) and advance the main volume control until the sound is a bit louder during crescendos than you would ever be likely to want. Note the volume control setting, turn it all the way down, and then take the cartridge off the record and

shut off the turntable. If you were unable to get adequate volume with the control turned all the way up, transfer the phono connections to the Lo-Mag inputs.

If there was enough volume, advance the main volume control to the previously determined setting and listen for hiss or sputtering noises only. Ignore any hum you may hear. Next turn the volume control off, unplug the cartridge leads from the preamp and return to the previous control setting, listening this time for hum only. (This two-fold approach avoids misleading observations due to the fact that the cartridge itself may introduce hum unrelated to the phono preamp, while the absence of the cartridge will often magnify preamplifier hiss and other noises.) A certain amount of both types of noise is normal with most preamps, but if either is clearly audible under the conditions of the test—loud enough to compete with the quiet-groove noise of a disc—you should switch the phono to the Lo-Mag connections (with the volume turned down again, of course).

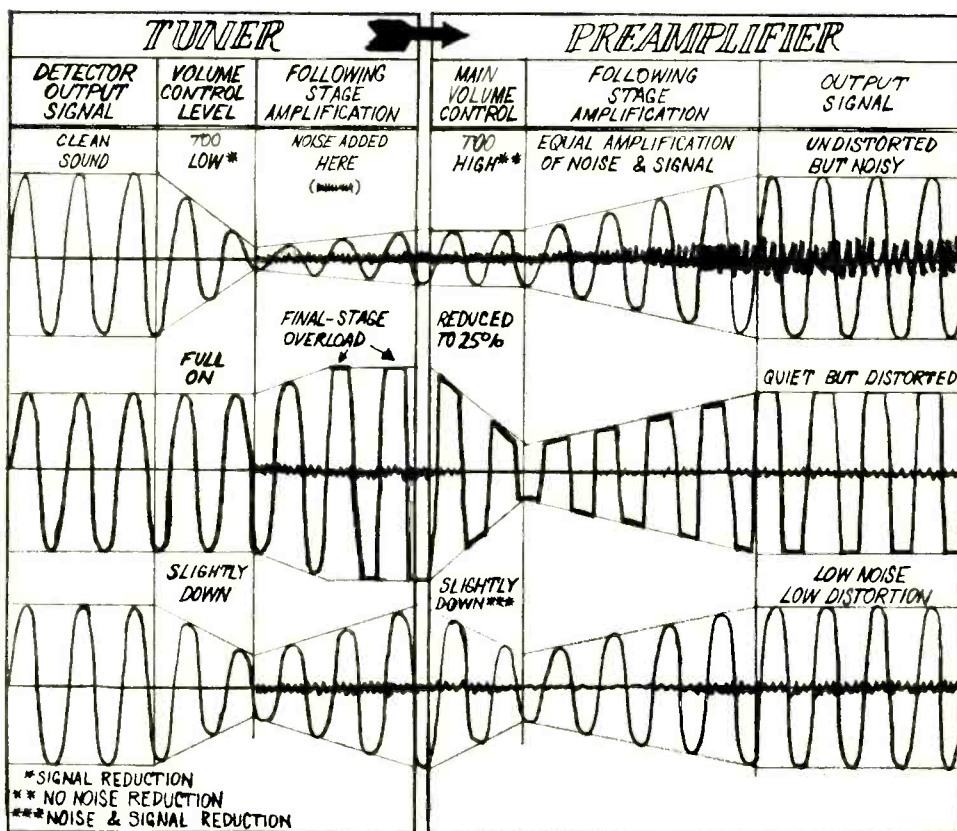

Shown in chart are effects obtained in hi-fi system as result of various settings of tuner and preamplifier volume controls. Knowledgeable adjustment of the controls will yield optimum performance.

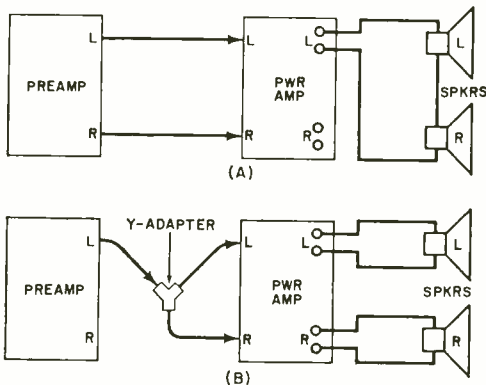

Good stereo is obtained by balancing speaker systems (top) and power amplifier (immediately above).

If the preamp has level-set controls at the rear for phono, start with these all the way down and advance the main volume control until you hear noise (hum or hiss) or until the control is full up. If noise appears, back the control off (but no more than $\frac{1}{3}$ down from full) until the noise is faintly audible and leave it there. Select a disc with conservative cutting levels and listen to it while advancing the rear-panel phono level controls until the volume on crescendos is a bit louder than you would ever want. Both controls should end up at about the same setting.

No Control at All. If your preamp has no means of adjusting phono level, don't worry about it unless you have annoyingly high background noise on phono (no record playing) or find you have to operate the main volume control at settings below about 9 o'clock in order to get moderate listening levels. If either is the case, you should consider another cartridge; yours may be incompatible with the preamp.

Audio and electronic outlets have available several types of Y adapters which can be used in performing balance tests and adjustments on power amplifier. You can also make up your own from individual parts.

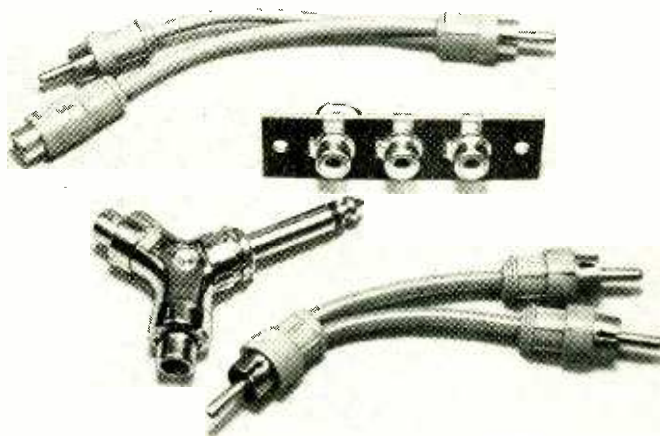

Once the phono level has been set, the remaining level-set controls for the tuner, tape recorder, etc., should be used to match their signal levels to that from the phono so you can switch sources without causing drastic changes in volume. Again, the same basic procedure is followed.

If the preamp has rear-panel level sets for high-level sources, first switch to each source in turn and advance its preamp level sets until they are either full up or just below the point where noise becomes audible (with the main volume control set at its previously determined position). Then switch back and forth between phono and the other sources, using their volume controls or (lacking this) level sets on the preamp to match volumes to that of the phono.

If the preamp has no level-set adjustments for high-level sources, the final step consists merely of the level-matching to the phono, using each source's volume control. An exception here is the occasional tape recorder whose playback level is adjustable only with a screwdriver. These adjustments should be left strictly alone unless you are qualified and equipped to do a complete recorder setup job. If a recorder doesn't have a playback volume knob somewhere on it, you'll either have to use the preamp's rear-panel level sets (if any) for matching volume to the phono or just forget about it.

Finally, you may want to go back and trim up some of the adjustments for proper stereo channel balance. If your speakers have tweeter level controls, start by balancing them for a centered sound image with the two speaker systems connected in series and to one amplifier output. Then reconnect the two speakers normally, use a Y-adapter to connect both power amplifier inputs to one preamp output, and adjust the power amplifier controls for a centered sound image. If there is appreciable imbalance to start with,

(Continued on page 94)



OPPORTUNITY AWARENESS

Thoughtful Reflections On Your Future

Fourteenth in a Monthly Series by David L. Heiserman

Educational Benefits from Employers

I have been working as an electronics technician for nearly six years, but my boss refuses to offer financial assistance or time off toward my taking resident courses in electronics engineering technology. I would like to know what kinds of educational assistance plans are available—or generally offered—by some of the more "enlightened" employers.

● Over the past several years alert employers have become aware of how important it is to encourage continued education for their employees. Such programs upgrade employee performance and morale and attract ambitious new people to the company.

Educational benefits vary from one employer to another, although they seem to fall into three general categories: financial aid, time off from work, and in-house company-sponsored classrooms. Some employers offer just one of the three, others two of the three and some all three.

Employers that offer financial assistance for continuing education generally pay a percentage of your tuition. The actual amount may depend on whether or not the employer thinks the courses you are taking are relevant to your job. Thus the percentage may range from 50% or lower to full tuition. A few employers base the percentage of tuition payment upon the course grades—a sort of incentive.

There are also employers that deduct a small amount from your paycheck to build up an education fund and there are those employers who will frown upon the practice of time away from the job. On occasion, employers in the latter category may even ask you to make up the lost time during your lunch hour, in the evenings, or even on weekends.

Attending classes on company time amounts to an increase in your hourly rate of pay. Five paid hours away from the job each week amounts to a 12½% increase in your hourly pay. Many employers also find that

time away from the job disrupts the working day and frequently induces hostility toward the company and toward the "favorite" employee from the remaining employees.

Classes that are held in-house can be either a curse or a blessing. Some training programs are so badly organized and poorly presented that they are a waste of time. Many of the larger employers operate in-house training programs that are far superior to anything you can find on the outside. Almost without exception, in-house company training programs operate at the company's expense and mostly on company time.

The best compromise appears to be a resident course taken after working hours with employer financial assistance—in the ballpark between 50 and 75%.

Employers involved in technical work should always encourage their employees to continue their education. An employer that doesn't do this is either badly managed or getting into financial hot water—two warning signs to look for when considering a job change.

About BSET Degrees

In your February, 1971, column you mentioned "the new BSET program." This appears to be a cut above the 2-year Associate degree I am now pursuing. Please tell me more about it. How much of my work toward an Associate degree could I transfer? Where can I find a list of schools granting BSET degrees?

● The BSET (Bachelor of Science in Engineering Technology) meets the needs of people who want to take on engineering responsibilities but don't have the time, money, or aptitude for all of the humanities courses required for a regular Bachelor of Science degree in engineering. A BSET program is actually a 4- or 5-year university program scaled down to 3 or 4 years. The technical content of a BSET program is much the

(Continued on page 97)

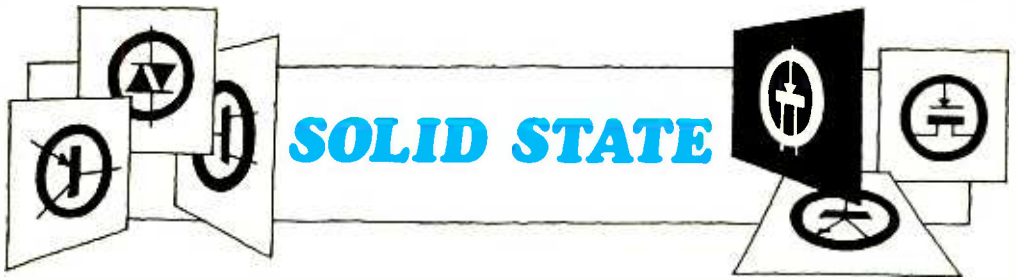

One Hundred Eighty-first in a Monthly Series by Lou Garner

EXPERIMENTERS and hobbyists should find a number of exciting applications for an interesting new device recently introduced by the Signetics Corporation (811 East Arques Ave., Sunnyvale, CA 94086). A versatile tone and frequency decoder version of the phase-locked loop (or PLL, see this column, January 1971), the new unit is designed for such commercial applications as AT&T's Touch-Tone® telephone decoding, carrier-current remote control, frequency monitoring, ultrasonic control, communications paging, frequency control, wireless intercoms, and signal or pulse generation. A phase detector, a current controlled oscillator, a quadrature phase detector and two multi-stage amplifiers are all included within the single IC device (see Fig. 1).

Designated the type SE/NE 567 Tone Decoder, the device will deliver output currents of up to 100 mA when driven by sustained input signals of as little as 25 mV rms within its detection band. It is capable, therefore, of furnishing direct drive to relays, lamps, and TTL logic elements. Both its center frequency and detection bandwidth are ad-

justable independently by means of four external components. In practical circuits, its center frequency may be adjusted from 0.01 Hz to 500 kHz, while its detection bandwidth is adjustable from 1 to 14 percent of its center frequency.

A monolithic IC fabricated on a silicon chip measuring only 57×61 mils, the SE/NE 567 comprises 62 transistors and 50 resistors. Offered in both 8-pin TO ("T") and dual-in-line ("V") packages, the new device is designed for nominal operation on a standard 5-volt dc source, but will perform satisfactorily on supplies furnishing from 4.5 to 9 volts. Its maximum quiescent current at 5 volts is 8 mA, while its minimum "on" current is 13 mA, plus the load current.

Used as a tone decoder, the SE/NE 567 will respond to input signals from as low as 25 to as high as 1000 mV rms. Its acceptance bandwidth is essentially independent of input amplitude with input levels of 200 mV or more, depending solely upon the values of an external capacitor and resistor. At input levels below 200 mV, however, its bandwidth depends upon signal amplitude as well as

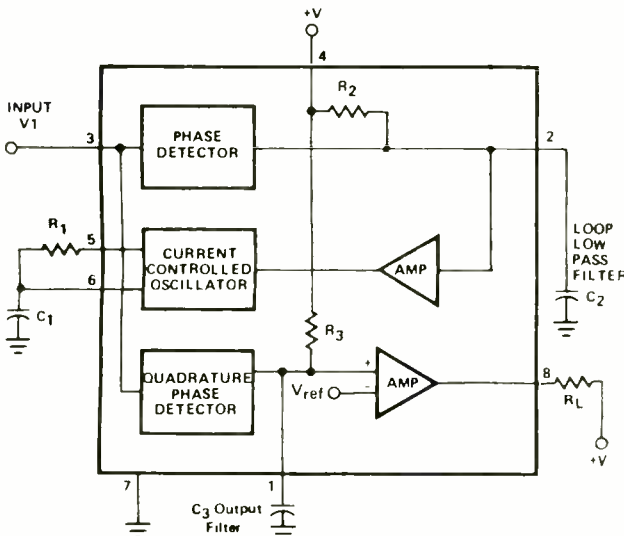

Fig. 1. This IC plus a few external components makes a reasonably high-Q filter covering the range from 0.01 Hz to about 500 kHz. Because bandwidth can be between 1 and 14% of the center frequency, a number of them can be used in parallel. It is a natural for radio control use.

capacitance, thus improving its rejection of noise and crosstalk from adjacent channels at low signal levels.

An unusually adaptable device, the SE/NE 567 can be used effectively in a variety of hobbyist projects ranging from ultrasonic, radio and carrier-current remote controls and communications systems to test equipment and musical instruments.

In a frequency or tone selective remote control or communications system, for example, all that is needed for signal decoding is the SE/NE 567 and a few external resistors and capacitors. The detection-band center frequency is established with one RC network, the detection bandwidth with a second capacitor, while a third capacitor is used for smoothing the audio output. Add a relay, lamp, or other output device requiring up to 100 mA for operation, and the basic system is "go," whether used to operate remote controls on a model plane or vehicle, to switch various home appliances from a central location (with different tones used for each appliance position), or to switch different intercoms or paging receivers selectively for private communications.

Quite aside from the unit's potential applications as a tone decoder, its integral current-controlled oscillator can be used independently as a wide-range signal source for test equipment such as waveform or pulse generators or in such musical instruments as electronic organs.

Three typical applications for the SE/NE 567 are illustrated in Fig. 2—a carrier-current remote control or intercom at (A), a dual-frequency square-wave oscillator at (B), and a variable-width pulse generator at (C). All three circuits were abstracted from the technical applications and specifications brochure for the device published by Signetics.

Reader's Circuit. Using the latest semiconductor devices, the simple power amplifier circuit illustrated in Fig. 3 was submitted by reader Guy C. Sheatz (612 McIntyre Road, Rockville, MD 20851). Capable of delivering better than 35 watts to loudspeaker loads when powered by a dual 18-volt dc source, the amplifier has a frequency response beyond audibility and has more than adequate sensitivity for use with conventional preamplifiers. It can be used in PA equipment, phonographs, tape players, receivers, modulators, paging systems, or virtually any equipment design requiring moderate audio power levels.

Guy uses complementary power Darlington $Q1$ and $Q2$ in a symmetrical push-pull output stage, with monolithic operational amplifier $IC1$ serving as the driver. Diode coupling ($D1$ to $D8$) is used between the driver and output stages in conjunction with base resistors $R3$ and $R5$ to establish proper biasing, while overall feedback via $R6$, $R2$ and $C2$ insures excellent gain stability, mini-

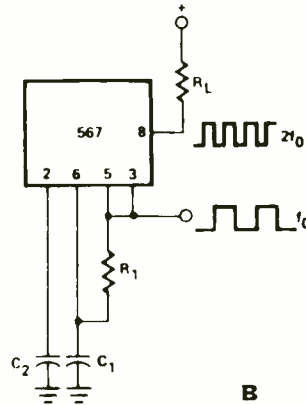
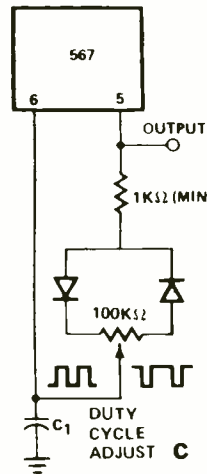
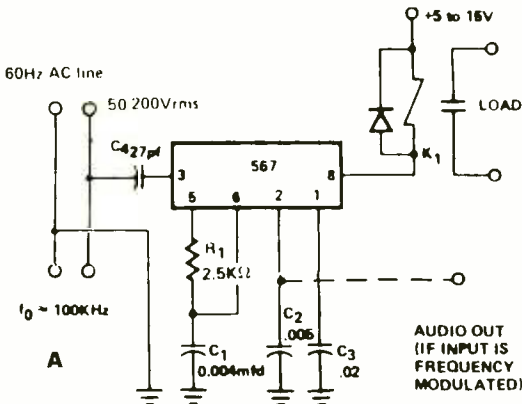

Fig. 2. Three typical uses for the 567. A wireless intercom or remote control is shown at A; a dual-frequency square-wave oscillator at B; and a variable width pulse generator at C.



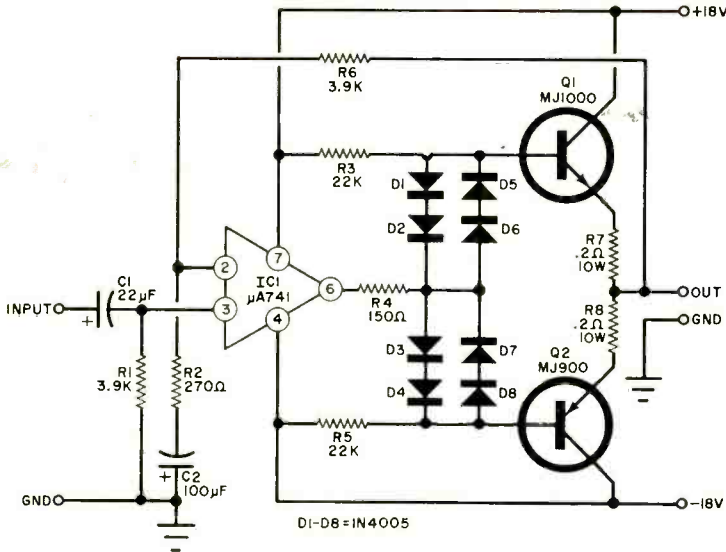

Fig. 3. Operational amplifier driving a pair of power Darlington's makes excellent 35-watt universal audio system according to designer Guy C. Sheatz.

imum distortion, and good frequency response. Unbypassed emitter resistors R_7 and R_8 are included to maintain output stage balance, R_4 serves as IC_1 's output load limiter, R_1 provides input bias, and C_1 acts as the input coupling capacitor.

Although circuit layout and lead dress are not overly critical, good audio wiring prac-

tice should be observed when assembling the amplifier, with all signal carrying leads kept short and direct and care taken to provide reasonable separation between the input and output circuits. Adequate heat sinks should be provided for Q_1 and Q_2 if the amplifier is to be used at moderate or high power levels.

Guy indicates that he used a dual 18.5-volt

New Cortina 2 Stereo Kits

The lowest priced component quality high fidelity!
EICO 3780 50-Watt Silicon Solid State FET AM-FM Stereo Receiver.
Kit \$109.95. Wired \$169.95.
Separate Tuner, 50-Watt Amplifier, each:
Kit \$69.95. Wired \$109.95.

Express Yourself

IN CREATIVE ELECTRONICS
Save up to 50% with EICO KITS & WIRED EQUIPMENT

New EICO-CRAFT®

The electronic science project kits for beginners, sophisticates, educators. 42 kits to date.
FM Wireless Mike \$9.95

New Automotive Electronics

EICO 889 Solid State Capacitive Ignition System.
Boosts gas mileage up to 25%; life of points, plugs to 100,000 miles. Kit \$29.95. Wired \$39.95.
EICO 886 Solid State Universal Engine Analyzer. Tunes and trouble-shoots your car/boat engine, the totally professional way.
Kit \$49.95. Wired \$69.95.

New "Treasure Hunter"

Kit finds metals, pipes, several inches underground. Locates iron, steel, tin, gold, silver, copper, etc. Beep pitch increases as you near object.
Eico Model TH-30, battery-operated, \$29.95.

8 New Eicocraft Kits

Automotive "LIGHT-GUARD" • "VARIVOLT" DC Power Supply • "MOODLITE" Light Dimmer Control • "VARASPEED" Motor Speed Control • "LIGHTSHOW" Sound/Lite Translator • "SUPER MOODLITE" Remote Control Dimmer • "ELECTROPLATER" From \$2.50 to \$14.95.

NEW SOLID STATE TEST INSTRUMENTS

The first and only solid state test equipment guaranteed for 5 years!

EICO 240 Solid State FET-TVM. Kit \$59.95. Wired \$79.95.
EICO 379 Solid State Sine/Square Wave Generator. Kit \$69.95. Wired \$94.50.
EICO 242 Solid State FET-TVOM. Kit \$69.95. Wired \$94.50.
EICO 150 Solid State Signal Tracer. Kit \$49.95. Wired \$69.95.
EICO 330 Solid State RF Signal Generator. Kit \$59.95. Wired \$84.50.

SOUND N' COLOR

Now see the music you hear! Color Organs by EICO transform sound waves into moving synchronized color images.
Model 3450 Giant (30" x 12" x 10") 4-Channel. Kit \$79.95. Wired \$109.95. Others from \$19.95.
Translators create audio-simulated light displays.
From Kit \$24.95. Wired \$39.95.
New Model 3477 Cube Strobe creates white light flashes in rhythm with audio with 3 colored lens filters \$29.95.

FREE 1971 SILVER ANNIVERSARY EICO CATALOG

Fill out Reader Service Card for FREE catalog of 200 best buys offered by 2500 local EICO dealers who give you top brands, technical counsel, off-the-shelf service.
25 Years of Leadership in Creative Electronics
EICO Electronic Instrument Co. Inc.,
283 Maita St., Brooklyn, N.Y., 11207.
(212) 949-1100.

CIRCLE NO. 24 ON READER SERVICE PAGE

5 VITAL COMPONENTS

FOR KNOWLEDGE . . . FOR PROFIT . . . FOR SHEER
MUSIC AND ELECTRONICS ENJOYMENT!



1971 STEREO/HI-FI DIRECTORY

The most complete, reliable guide to getting the best quality—the best buy—for your money. Accurate, reliable facts on amplifiers, tuners, receivers, changers, tape machines—cartridge, cassette and reel-to-reel, speakers, cabinets, compact hi-fi systems, cartridges, arms, accessories!

1971 TAPE RECORDER ANNUAL

Your own personal expert on tape recorders and tapes. Complete guide to what's available . . . and how to choose what's best for you. Complete buyer's guide to the brands and models on the market. Expert tips on equipment: What to buy—How to use it—Tape tactics—PLUS a round-up of the best pre-recorded tapes of the year.



1971 ELECTRONIC EXPERIMENTER'S HANDBOOK—SPRING EDITION

148 pages containing 20 of the most exciting electronics construction projects for the electronics hobbyist. All laboratory tested by the editors, complete with parts list, easy "How-To-Do-It, How-It-Works" instructions and many with actual size PC Foil Patterns!



1971 ELECTRONIC EXPERIMENTER'S HANDBOOK—WINTER EDITION

Another big package containing more challenging, fun-to-build electronics projects ever! Be sure to order this one today!



1971 COMMUNICATIONS HANDBOOK

1971 COMMUNICATIONS HANDBOOK

Everything you want to know—need to know—about Citizens Band, Amateur Radio, Short Wave Listening. The world's most complete guide to communications. Designed to help you get greater value, greater enjoyment out of every minute you spend with your equipment.



ZIFF-DAVIS SERVICE DIVISION • Dept. W PE-6-71
595 Broadway, New York, N.Y. 10012

Please send me the annuals I've checked below:

- 1971 Stereo/Hi-Fi Directory—\$1.50
 1971 Tape Recorder Annual—\$1.50
 1971 Electronic Experimenter's Handbook—Spring—\$1.50
 1971 Electronic Experimenter's Handbook—Winter—\$1.50
 1971 Communications Handbook—\$1.50

I am enclosing \$_____. My remittance includes an additional 35c per copy for postage and handling. (Outside U.S.A. all magazines are \$2.50 per copy, postpaid.)

print name _____

address _____

city _____

state _____ zip _____

PAYMENT MUST BE ENCLOSED WITH ORDER

dc source for power, but that higher or lower operating voltages may be used without difficulty as long as maximum ratings are observed. The integrated circuit has a maximum rating of ± 22 volts, while $Q1$ and $Q2$ have maximum collector-emitter ratings of 60 volts. In general, the higher the supply voltage, within limits, the greater the maximum output power, and vice versa. Although a regulated dc source is preferred, Guy reports good results with a well-filtered conventional power supply using a bridge type full-wave rectifier.

Manufacturer's Circuit. Another interesting circuit application for power Darlington is illustrated in Fig. 4. Described in an applications sheet published by Motorola Semiconductor Products, Inc. (Box 20912, Phoenix, AZ 85036), this short-circuit protected voltage regulator can furnish 5 volts output regulated to within 0.08 percent from no-load to full-load conditions when driven by a 13-volt unregulated dc source. It can handle load currents of up to 10 amperes.

In operation, power Darlington $Q1$ serves as a series pass device, controlled by functional voltage regulator $IC1$ which, in turn, samples the output voltage, comparing this to an internal reference voltage and automatically adjusting $Q1$'s base bias as needed to maintain a fixed output level. Short-circuits are sensed through coupling diode $D1$ and $Q1$'s base bias is readjusted to prevent damage.

The basic circuit can be used for designs furnishing maximum currents of 3, 5, or 10 amperes, depending on $Q1$'s specifications. For load currents of up to 3 amperes, $Q1$ should be type MJ1000, with type MJ3000 used for 5-ampere operation and MJ4033 for outputs of up to 10 amperes. Corresponding Rsc values are 0.41, 0.11 and 0.08 ohms, respectively.

With neither parts placement nor wiring dress critical, the voltage regulator may be assembled using any construction method. For optimum performance at full loads, however, $Q1$ should be equipped with a heat sink comparable to Motorola's type MS-10. Forced air cooling is recommended for continuous operation at maximum power levels.

On the Medical Front. Solid-state electronics is rapidly becoming an important adjunct to the medical profession and one day may rank along with pathology, pharmacology, and biochemistry.

Medically oriented electronics research and development work is being conducted by major manufacturers, universities and research foundations, while technical sessions on biomedicine were presented at the International Solid-State Circuits Conference held in Philadelphia earlier this year for the

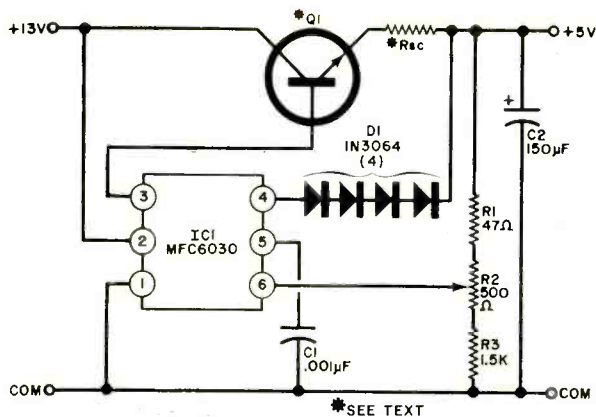

Fig. 4. Using a power Darlington in conjunction with a regulator IC results in a power supply having 0.08% regulation from no load to full, and it can handle up to 10 amperes with short circuit protection. The diodes making up D1 sense the short circuit and adjust the bias on Q1 accordingly.

first time in the eighteen-year history of this annual affair.

At the Bell Telephone Laboratories in Murray Hill, New Jersey, physicists Donald L. White and Michael R. Rocchi, working with Drs. Peter J. K. Starek and C. Walton Lillehei of the New York Hospital-Cornell Medical Center, have developed an experimental pacemaker that obtains its operating power indirectly from the heart itself, thus eliminating the need for periodic battery replacement. The experimental unit employs piezoelectric discs to convert variations in

blood pressure into electrical pulses, which are then stored in a capacitor and used to furnish power to the microwatt solid-state signal generator which serves to trigger heart operation.

Research scientists J. W. Spickler and N. S. Razor at the Cox Heart Institute in Dayton, Ohio, have designed a solid-state pacemaker so small that it can be inserted into a vein in the neck by minor surgery, passed into the heart, then attached to the heart's inner wall with a simple pinlike clip. The device, including its long-life radioactive

MIDLAND INTERNATIONAL VHF / FM MONITOR

VOLUME SQUELCH

OFF F

MAN. SCAN.

13-925

1 2 3 4 5 6 7 8

Mobile mounting bracket and hardware included.

Midland's New Hi-Lo Scanning Monitor has "RANGEMATIC" Intermix!

The first scanner offering any combination of hi-lo VHF frequencies without internal rewiring!

MIDLAND COMMUNICATIONS COMPANY

E.S.S.A. (162.55 MHz) weather band crystal installed. Built-in speaker. Operates on AC and 12-volt DC (all power cords included.) Individual channel lockout. Automatic squelch in scan mode. 13-925

For further information, write: P.O. Box 19032, Kansas City, Mo. 64141

flameless 1000° heat

Instant, precise heat for 1001 uses — shrink tubing, soldering-desoldering, forming, bonding, deburring, drying, setting adhesives. World's most complete line. Models from 200-1000°F. Send for new free Catalog 75.



U.L. listed

you can hold in your hand

MASTER HEAT GUNS

1745 FLETT AVE., RACINE, WI 53403

CIRCLE NO. 15 ON READER SERVICE PAGE

DELUXE
MAGAZINE CASES

Designed Exclusively for
POPULAR ELECTRONICS

● The ideal way to save your valuable copies, keep them well protected and make it easy for you to refer to any issue at any time. This bold new design is both decorative and attractive enough to enhance the decor of any room. Each case holds a full year's copies.

Constructed of reinforced fiberboard, these tough and durable cases are covered in a rich textured, leather-like fabric. The gold embossed back adds to its elegance and makes each case a welcome addition to your bookshelf, end table, desk—or for that matter, anywhere in your home or office.

In addition to Popular Electronics, cases are available for any of your favorite magazines. They're only \$3.95 each, 3 for \$11.00, 6 for \$21.00, in any combination of titles ordered. Add 50c per order for postage and handling. Outside U.S.A. add \$1.00 per case ordered.

Ziff-Davis Pub. Co., Dept. 23, 1 Park Ave., N.Y., N.Y. 10016
Enclosed is \$_____ Please send Magazine Cases for the titles indicated below @ \$3.95 each, 3 for \$11.00, 6 for \$21.00. Add 50c per order for postage and handling. Outside U.S.A. add \$1.00 per case ordered. PE-6-71

TITLE	QUANTITY
POPULAR ELECTRONICS	_____
_____	_____
_____	_____

Check One: All Black Maroon Back • Black Sides
Print Name _____
Address _____
City _____ State _____ Zip _____

PAYMENT MUST ACCOMPANY ORDER

battery, is a scant 1/4" in diameter and 3/4" long.

In another area, scientists and engineers at Stanford University have developed a unique reading aid ("Optacon") for the blind. Featuring a planar array of micro-miniature silicon phototransistors as an artificial "eye," the device converts the optical images of individual letters of printed text into a vibratory mechanical motion which can be "read" through touch in much the same way that Braille impressions can be interpreted by a trained reader.

At the International Solid-State Circuits Conference, the major emphasis in the biomedicine session was on the application of implantable devices utilizing integrated circuits.

Among the technical papers offered was one entitled "A Catheter-Type Semiconductor Radiation Detector for Medical Applications." Presented by a team of six Japanese scientists, the paper discussed the development of a solid-state detector for beta-ray counts in the human body during tracer studies.

Another paper, presented by a group of three scientists from Northeastern University in Boston, discussed the problem of short battery life in implanted devices. The paper, "A Unique Hybrid Transformerless DC-to-DC Converter for Long-Term Nuclear Power," described the design of a tiny hybrid solid-state converter suitable for boosting the output of a 0.4-volt nuclear cell to 1.35-volts, thus providing the electrical equivalent of a mercury cell with an effective life of several years.

Looking to the future, we anticipate a continuing expansion of semiconductor applications in medicine, with, perhaps, the development and introduction of such unusual devices as implantable hearing aids and special sensors to add "touch" and "feel" to artificial limbs.

Brochures and Booklets. The Signetics Corporation has published the first volume in a new series of useful handbooks discussing the performance and application of their DCL Series 8000 devices. Entitled "DCL-Designer's Choice Logic Specifications Handbook, Vol. 1, Logic Elements," the punched, paperback 8 1/2 x 11 booklet should be of real value to anyone working with digital logic circuits. After a short introduction, the volume's five major sections cover Design Considerations, Electrical Characteristics, AC Testing, Applications, and SURE Program. Exceptionally well illustrated, the new Signetics publication includes package outlines, terminal connections, schematic and logic diagrams, and numerous tables and graphs.

"Understanding and Designing with FET's" is the title of a valuable plastic-bound loose-leaf booklet issued by Motorola Semiconductor Products, Inc. In addition to a half-dozen multi-page Application Notes, the booklet includes a short introductory section which describes the field effect transistor, gives a brief history of the device, and discusses its advantages and disadvantages as compared to vacuum tubes and bipolar transistors. Another section covers the various FET classes and outlines their general use in different circuit functions, while Motorola FET specifications are presented in tabular form as an easy-to-use "Selector Guide."

The TRW Semiconductor Division (14520 Aviation Blvd., Lawndale, CA 90260) has announced the availability of a new brochure which describes their line of communications devices. Entitled "TRW RF Communications Technology 1 MHz to 3 GHz," the brochure discusses TRW's rf power and CATV transistors, integrated circuits, amplifiers and microelectronic linear broadband rf amplifiers.

Copies of the publications listed may be obtained by writing to the manufacturers or, in some cases, by contacting local representatives or franchised distributors of the manufacturer's products.

Device News. Siliconix, Inc. (2201 Laurelwood Road, Santa Clara, CA 95054) has recently introduced a number of new devices, including a 2-channel monolithic MOS switch, type DGM111BK, a series of n-channel FET's designed for low-noise applications in small signal, wideband amplifiers, and a family of six dual FET's.

The DGM111BK includes an integral driver and has the capability to switch analog signals up to 20 volts peak-to-peak in industrial service. Furnished in a TO-116 ceramic dual inline package, the device features p-channel normally off MOSFET's, with all gates protected by integral zener diodes. It is designed to interface with most 5-volt IC logic, including RTL, DTL, and TTL.

Identified as the U273/A-U275/A family, the new FET's are silicon junction devices packaged in standard TO-72 cases. With low gate leakage currents and ultra-low capacitance, the devices have minimum transconductance figures of 500, 600 and 800 μ mhos, depending on type number.

Suitable for use in differential amplifiers, the new dual FET's, types U280 through U285, have low noise characteristics, high common-mode rejection ratios, and matched parameters. All six devices are packaged in TO-71 cans.

A new series of developmental-type thyristors with current carrying capacity of 80



Automatic Cross Band Monitoring

only in the fantastic **Hi/Lo**

MONITORADIO / Scanner

A computer patch board matrix, coupled with push button program control, allows automatic scanning of any combination of High or Low Band frequencies.

You can use any mixture of 30-50 or 144-174 MHz crystals . . . it makes no matter to our busy little radio. It details the signal search with fascinating read-out lights. Upon a signal detection, in either band, our radio stops to bring the entire transmission . . . then resumes its search.

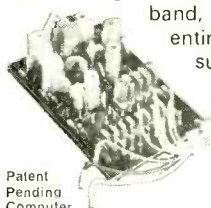

Patent Pending
Computer
Patch board matrix

Push button control enables you to program for both sides of complex base/mobile networks. Each channel has a push button for placing the frequency in or out of service. Push button, too, for manual or automatic operation.

It's compact! It performs base or mobile. And it has a built in 4" speaker and detachable, telescope antenna.

The Hi/Lo Scanner is a bargain at \$169.00 plus crystals at \$4.95 each. See it to believe it . . . at your favorite Regency retailer.

Regency ELECTRONICS, INC.
7900 Pendleton Pike
Indianapolis, Indiana 46226

CIRCLE NO. 23 ON READER SERVICE PAGE

pliers pliers



ALL THE TYPES YOU NEED IN A FULL RANGE OF SIZES.

From 4" miniature electronics to 10" utility. Precision made in USA. Forged alloy steel construction. Cleanly milled, perfectly aligned jaws. Hand-honed, mated cutting edges. Most with Cushion Grip handles.

NOW INCLUDING



- 5" Bent Thin Chain Nose. For handling fine wires in close quarters. No. 79CG
- 5 1/2" Thin Needle Nose. For firm gripping and looping of wires. No. 57CG
- 4" Full Flush Cutting Diagonals. Snap cuts to the extreme tip. No. 84CG
- 5" Midget Slip Joint. Narrow jaws for close quarters. 3 openings to 1/2". No. 50CG

nationwide availability through local distributors



XCELITE, INC. • 20 BANK ST., ORCHARD PARK, N. Y. 14127
Send Catalog with information on Xcelite Pliers.

name _____
 address _____
 city _____ state & zip _____

CIRCLE NO. 22 ON READER SERVICE PAGE

SOLID STATE

(Continued from page 91)

amperes (double that of most commercially available triacs) has been introduced by the RCA Solid State Division (Somerville, NJ 08876). Designated as the TA7757 series, the new devices are capable of handling power loads up to 22 kW at ac line voltages up to 277 volts. With blocking voltages of 200, 400, and 600 volts, depending on type, the units are suitable for such heavy-duty industrial applications as heater and welding control, motor control, high intensity lamp control and power switching.

Motorola Semiconductor Products, Inc. has announced substantial price reductions for its three popular light emitting diodes—MLED50, MLED600 and MLED630. All three are pn gallium arsenide phosphide devices emitting visible red light which peaks at approximately 6600 Angstroms. Typical brightness levels range from 750 fL for the MLED50 to 1100 fL for the MLED630. The new prices, as little as 49 cents each for the MLED50 in lots of 1000, could lead to an increased use of these devices in automotive and appliance applications.

Now that IC voltage regulators are commonly used, Lambda Electronics Corp. (515 Broad Hollow Rd., Melville, NY 11746) has decided to go even farther and recently introduced its LAS2000 line of hybrid voltage regulator packages with dissipations of up to 85 watts. Occupying about 2.5 cu in., the packages completely replace all the transistors, diodes, resistors, capacitors, and circuit boards of present-day regulators. Available in 22 different models delivering from 5 to 28 volts and up to 5 amperes, the basic regulator has 0.2% line or load regulation. 0.007%/°C temperature coefficient, internal thermal protection, and electrical isolation from its case. It can be programmed remotely if desired. Mechanically the package will fit in conventional TO-3 power transistor mounting holes.

Another company, Airpax Electronics (Box 8488, Fort Lauderdale, FL 33310) is also introducing a pair of new hybrid circuits. These are high-power audio modules: the SI-1025A capable of delivering 25 watts and the SI-1050A rated at 50 watts. Useful for various types of audio systems, the amplifiers have single-ended output, can withstand a 5-second output short circuit, and have a claimed distortion of less than 1/2% at 25 and 50 watts and a response within 1/2 dB from 20 Hz to 100 kHz. The modules are complete and require only an input, power supply, and speaker. —Lou

ELECTRO-CULTURE

(Continued from page 68)

the bridge circuit at a level determined by *R3*. Then turn on *S4* to activate the op amp IC. Potentiometer *R2* is adjusted for a meter null indication. This null may have to be re-adjusted when the plant is in a non-stimulated condition. Note the pitch of the audio tone coming from the speaker when the plant is quiescent. A change in pitch, as well as in the meter indication, may result when the plant's well being is threatened.

The amount of excitation (via *R3*), and the state of the input/output polarizer switch *S2* must be determined by actual use. Obviously, the gain control (*R5*) can be adjusted to obtain more or less sensitivity, and *S3* can be opened to increase the gain of the de-amplifier.

There is very little more to be said about the use of the response detector. Patience and repetition are the key words. Obviously, also, controlled conditions are a must. The area in which the plant lives must be quiet so that stimuli can be applied. There should be a minimum of power-line noise to avoid fluctuations in the audio and meter indications. There should be no r-f transmitters in the vicinity to cause faulty indications. —30—

References

- Electrophysiological Methods in Biological Research*, J. Bures, Academic Press, New York, 1967.
- Plant Response as a Means of Physiological Investigations*, J. C. Bose, Longmans, Green & Co., London, 1924.
- The Nervous Mechanism of Plants*, J. C. Bose, Longmans, Green & Co., London, 1926.
- Die Elektrophysiologie der Pflanzen*, K. Stern, Springer, Heidelberg, 1924.
- "Build a Psych-Analyzer," R. E. Devine, POPULAR ELECTRONICS, February 1969.
- Plant Physiology*, Second Edition, E. C. Miller, McGraw-Hill, New York, 1938.
- "Electric Correlation between Living Cells in Cortex and Wood in the Douglass Fir," E. J. Lund, *Plant Physiology*, 6:631-652, 1931.
- "Proof of the Principle of Cell E.M.F.'s," H. F. Rosenc, *Plant Physiology*, 10:209-224, 1935.
- "Evidence of a Primary Perception in Plant Life," C. Backster, *International Journal of Parapsychology*, 10:4, Winter 1968.
- "Electronics and the Living Plant," L. G. Lawrence, *Electronics World*, October 1969.
- "Experimental Electro-Culture," L. G. Lawrence, POPULAR ELECTRONICS, February 1971.
- "Magnetotropism: A New Plant Growth Response," L. J. Audus, *Nature*, Jan. 16, 1960.
- "Plants Are Only Human," W. McGraw, *Argosy*, June 1969.
- "Electricity in Plants," B. I. H. Scott, *Scientific American*, October 1962.

be a private



bowman converter MOD-U-KITS

Assemble your way to airwave sleuthing. Listen in on police, fire, shortwave and weather casting on your existing radio. Simply add a Bowman Converter Mod-U-Kit — all parts supplied, except standard 9 volt battery — and tune in. All converters are handsomely encased in 2-piece vinyl, gold anodized, silk screened enclosure.



MODEL PWF-3 — for fire, VHF, marine & weather broadcasts, by tuning FM to a quiet spot on the band. Added feature: special squelch control. \$7.95

MODEL SWC-3 — for shortwave signals in 25, 31 & 41 meter bands, 7 - 12 MHZ. Simply tune AM to 1600KC. \$6.95

MODEL PFC-2 — for police and fire calls by tuning AM to 1600KC. 30 - 40 MHZ. \$6.95

MODEL VAC-1 — for aircraft and airport tower broadcasts in the 118 - 130 MHZ band. \$6.95

These are just a few of Bowman's many Mod-U-Kits, created for all levels of hobbyists — from beginner to the pro. All are useful and educational. Why not find out more today?

B BOWMAN LEISURE INDUSTRIES
Garwood, New Jersey

Send me your complete catalog of MOD-U-KITS and the location of my nearest Bowman Dealer.

Name _____

Address _____

City _____ State _____ Zip _____

CIRCLE NO. 2 ON READER SERVICE PAGE



FREE!

Lafayette's 1971 Golden Jubilee Catalog

50th
anniversary

Your 1st Guide To
Everything in Electronics

- Stereo/Hi-Fi Components
 - Musical Instruments and Amplifiers
 - Photography Equipment
 - Ham and CB Gear
 - Public Address Systems
 - Tools and Test Equipment
 - Educational and Optical Equipment
 - Black and White/Color Televisions
 - Police and Fire Monitor Receivers
 - Books and Parts
- Plus Thousands of Additional Items

Lafayette Radio Electronics Dept. 35061
P. O. Box 10, Syosset, L. I., N. Y. 11791

Send Me the Free Lafayette Golden Jubilee 1971 Catalog 710 35061

Name

Address

City

State Zip

(Please include your zip code)

CIRCLE NO. 14 ON READER SERVICE PAGE

CONTROLLED
QUALITY
CRYSTALS by



The "On-Channel" Crystals
FOR

CITIZEN BAND

23 Channels and "Mars"

HAM OPERATORS

Commercial 2-Way

Marine-Monitor

See your Distributor for Speedy
"Zip Certificates"



formerly Texas Crystals
Div. of Whitehall Electronics Corp.

1000 Crystal Drive 4117 W. Jefferson Blvd.
Fort Myers, Florida 33901 Los Angeles, California 90016

CIRCLE NO. 7 ON READER SERVICE PAGE

STEREO SCENE

(Continued from page 83)

turn the louder channel down and the softer one up until they match. Now reconnect the power amplifier normally to the preamp.

Select any program source and switch the preamp's mode switch to Mono A + B. With the balance control at mid-setting, the sound image should be centered throughout the most used rotational range of the main volume control. If there is a consistent tendency toward imbalance in either direction, use one of the power amp's controls to correct it, choosing that control whose correction will bring it closer to the setting you arrived at during the initial level-setting procedure. If you have an imbalance, but no means of correcting for it at the preamp outputs or the power amp inputs, forget it for the time being.

Now check for phono balance by playing a monophonic disc with the preamp's mode switch set for stereo. If there is some imbalance now, you may be able to correct it with the phono input level-set controls at the rear of the preamp or lacking these, with the power amp's input controls. Either way, the object is to try and get the system in audible balance with the balance control at the middle of its range. But if neither the preamp nor the power amp has correction facilities, give up and use the balance control. If the proper setting turns out to be far from center, you may have a defective component in the system. If there are no defects, you can remove the balance knob and replace it so that its pointer indicates the midposition.

Finally, still using the stereo mode, feed a mono signal from the tuner and then the tape recorder into the system and balance these out to center the signal image—if they have provision for doing so. That's all, brother.

Loudness Controls. Most of these are just like the main volume control, except that, when used to reduce the volume, they also introduce bass boost to correct for the ear's bass losses at low listening levels. The bass-boosting action depends on the setting of the control: the lower the setting, the more the boost, regardless of the actual volume of the sound. No bass boost is needed when the listening volume is high. So if the system is producing high levels when the control is below maximum, the superfluous bass boost will make the sound excessively boomy. For proper operation, the loudness control must be balanced out against another uncompensated volume control, so that no bass boost is taking place when you are listening at fairly high volume levels.

-30-

Popular Electronics

READER SERVICE PAGE

free information service:

Here's an easy and convenient way for you to get additional information about products advertised or mentioned editorially (if it has a "Reader Service Number") in this issue. Just follow the directions below... and the material will be sent to you promptly and free of charge.

1. On coupon below, circle the number(s) that corresponds to the key number(s) at the bottom or next to the advertisement or editorial mention that is of interest to you. (Key numbers for advertised products also appear in the Advertisers' Index.) Print or type your name and address on the lines indicated.

2. Cut out the coupon and mail it to: POPULAR ELECTRONICS, P.O. Box 8391, Philadelphia, PA 19101.

note: If you want to write to the editors of POPULAR ELECTRONICS about an article on any subject that does not have a key number, write to POPULAR ELECTRONICS, One Park Avenue, New York, N.Y. 10016. Inquiries concerning circulation and subscriptions should be sent to POPULAR ELECTRONICS, P.O. Box 1096, Flushing, N.Y. 11352.

6/71-4

Void after July 31, 1971

Popular Electronics

P.O. BOX 8391
PHILADELPHIA, PA. 19101

1 2 3 4 5 6 7 8 9 10 11 12 13 14 15 16 17 18 19 20
21 22 23 24 25 26 27 28 29 30 31 32 33 34 35 36 37 38 39 40
41 42 43 44 45 46 47 48 49 50 51 52 53 54 55 56 57 58 59 60
61 62 63 64 65 66 67 68 69 70 71 72 73 74 75 76 77 78 79 80
81 82 83 84 85 86 87 88 89 90 91 92 93 94 95 96 97 98 99 100

NAME (Print clearly) _____

ADDRESS _____

CITY _____ STATE _____ ZIP CODE _____

OUR STORE
AT YOUR DOOR

Olson
ELECTRONICS
FREE
Catalog

Fill in coupon for a FREE One Year Subscription to OLSON ELECTRONICS' Fantastic Value Packed Catalog — Unheard of LOW, LOW PRICES on Brand Name Speakers, Changers, Tubes, Tools, Stereo Amps, Tuners, CB, and other Values. Credit plan available.

NAME _____
ADDRESS _____
CITY _____ STATE _____
GIVE ZIP CODE _____

If you have a friend interested in electronics send his name and address for a FREE subscription also.

OLSON ELECTRONICS

Dept. IR, 260 S. Forge Street Akron, Ohio 44308

CIRCLE NO. 17 ON READER SERVICE PAGE

GATOR WHIP MEANS LONG DISTANCE

THE TUNABLE TIP DOES IT . . . makes Avanti's Gator whip the super long distance CB mobile antenna. Exclusive full 9' length . . . 5' of super tough Gator Glass and 4' of tapered stainless steel whip . . . all stainless steel set screws and brass fittings give years of reliable use.

Tunes to lowest possible SWR
Adjustable—25 to 40 MHz
Standard 3/8"-24 thread
mounting

High power handling
capacity

for business use

ONLY \$15.95

at your CB dealer.

Write for Catalog

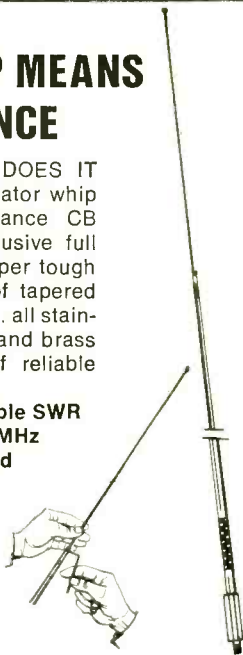

avanti Avanti Research &
Development, Inc.

33-35 W. FULLERTON • ADDISON, ILLINOIS 60101

CIRCLE NO. 1 ON READER SERVICE PAGE

THERMOMETER

(Continued from page 71)

The sensing resistor can be mounted on a lug strip at the desired monitor location, or you can make it into a probe by covering or coating the resistor package and the resistor leads with a waterproofing material. If you coat the resistor, keep the coating material as thin as possible so that the time required to reach a stable temperature reading does not become excessive.

Calibration. After assembling the Thermometer module, plug it into the main frame via the connector assembly and turn on the system. The readout should immediately indicate some numerical value which should change slightly if you hold the probe in your hand.

Since no two Sensistors will have exactly the same value or respond in exactly the same way to temperature changes, the Thermometer circuit must be calibrated with the resistor you intend to use if you expect maximum accuracy. The most accurate calibration will be obtained if you use a thermometer that is known to be accurate to within 1% of its reading. However, if such a thermometer is not readily available, you can obtain fairly accurate calibration with a cup of crushed ice and a pan of boiling water.

Using the second method of calibration, proceed as follows. First push the probe into the crushed ice. After the temperature has had a minute or two to stabilize, adjust trimmer pot *R12* for a "1" numeric readout in the °C position of *S2*. Flip *S2* to °F, and adjust *R13* for a reading of 32. Now, plunge the probe into boiling water and adjust *R15* for a reading of 212 with *S2* set to °F and adjust *R14* for a reading of 100 with *S2* set to °C.

Go back to the ice with the probe and recheck calibration on the low end. The controls interact slightly; so, calibration will be more accurate if performed more than once.

The Sensistor's resistance change with temperature is not absolutely linear so the instruments should be calibrated to be correct at the high and low extremes of temperature that you wish to measure for best accuracy. It will be within ±1% over any 60° to 70°F range selected. Over the full 0° to 212°F range, accuracies of ±3% would be typical. —30—

OPPORTUNITY AWARENESS

(Continued from page 84)

same, if not more rigorous, than that of a regular BS curriculum.

Just as in any BS program, the BSET candidate specializes in a particular branch of engineering such as chemistry, aeronautics, electronics, etc. The required courses provide a thorough look at general engineering principles—including physics, mathematics, drafting, and an introductory course along the lines of "engineering principles." There are, of course, some required courses in the humanities and business: history, English, psychology, foreign languages, economics, etc.; but the number of hours spent in these courses is about half of what it is in a normal BS program.

The student's elective courses, mostly in engineering, determine his specialty. If you are working for a BSET in electronics, you will spend about half of your time in electronics electives. You'll also get a thorough background in electrical engineering—including strong doses of both theory and laboratory work.

Schools that have BSET programs usually have the Associate curriculum as well—in which case, you could move smoothly from the Associate program in the BSET work. The educational standards of schools offering Associate degrees vary so widely, however, that I can't tell you how much credit another school would accept toward a BSET if you transfer. Ask the admissions director of the school you want to attend.

You can find a listing of schools that offer BSET programs in Volume 4 of *Barrow's College Blue Book* or in *Lovejoy's College Guide*. Your local library should have at least one of these in its reference department. If you have access to a good engineer-

ing school library, you can find a brief up-to-date list of BSET schools on page 446 of the February, 1971, issue of the magazine *Engineering Education*.

Listings of Electronics Home Study Schools

Would you please publish a complete list of good home study schools that offer courses in electronics?

● The National Home Study Council presently lists 19 accredited home study schools offering complete courses in electronics. Rather than list them all here, I suggest you write to the NHSC for a free copy of "Directory of Accredited Home Study Schools—1971." This pamphlet contains a general subject index which you can use to get the names and addresses of all schools offering subjects that interest you.

The NHSC has another free service that will save you a lot of time and postage. The "Directory" contains a postcard which, when returned to NHSC with your name, address and subject you want to study, will bring you information from any or all of the 19 electronics schools.

The NHSC address is:

National Home Study Council
1601 Eighteenth St., NW
Washington, DC 20009

OUT OF TUNE

"Build A Timbre Gate" (April 1971). In Fig. 2 on page 31, input capacitor $C4$ is incorrectly shown connected to the top of timing capacitor $C1$. The input capacitor should be connected *after* $R3$, directly to the gate lead of $Q1$.



DIRECT FREQUENCY DIALING International Short-Wave Broadcast RECEIVER



No more guesswork in identifying stations. Set dial at a station's frequency and if conditions permit you'll hear it everytime...

- Ultra-precision tuning dial accuracy, SW and standard AM Broadcast
- Crystal lattice filter for adjacent station rejection and good AF response
- Dual conversion • Solid state AF output • S-meter • Preselector gives superior sensitivity by peaking antenna and RF stages • Crystal-controlled H. F. Oscillator stability • Amplified AVC constant AF output • Price \$299.00

Write for free Brochure

R. L. DRAKE COMPANY • Miamisburg, Ohio 45342

CIRCLE NO. 8 ON READER SERVICE PAGE

INDEX

TO VOLUME 34

JAN.-JUNE 1971

AUTOMOTIVE ELECTRONICS

Auto Emergency Flasher, Rugged (Ives)..... 67 May
 Voltage Regulator, VR 12 (Ball)..... 65 Apr.

COMMUNICATIONS

Communications
 79 Jan., 82 Feb., 80 Mar., 71 Apr., 70 May,
 76 June

QRP Thing, The (Olson) 39 Feb.
 10.7-MHz Signal Generator (Lewis) 61 Mar.

CONSTRUCTION

Auto Emergency Flasher, Rugged (Ives)..... 67 May
 Charge Now, Build the (Mangieri) 53 Apr.
 Colossal Woofer, The (Weems) 47 June
 Cryptolock, Build a (Busse)..... 42 Jan.
 Decimal Counter, Ultimate (Meyer) 45 Feb.
 Digital Thermometer Module (Meyer) 69 June
 Digi-Viewer, Build a (Lancaster) 41 Mar.
 Digi-Vista, Six-Digit Popular Electronics (Meyer &
 Kay) 71 Jan.
 Electro-Culture, More Experiments in (Lawrence)..... 63 June
 Electronic Clinical Thermometer, Build an
 (Laughlin) 75 Jan.
 Electro-Culture, Experimental (Lawrence) 66 Feb.
 Fil-Oscillator, Build the (Melen & Garland) 58 May
 Five Forty Power Amplifier, Build the (Meyer) 49 May
 EL Panel Driver (Huffnagle) 43 May
 In-Out Annunciator, The (Simonton) 48 Apr.
 Laboratory IC Power Supply (Valentine) 31 June
 Leslie Effect Simulator (Simonton)..... 51 Mar.
 Light-Operated Bi-Stable Switch (Conner) 70 Mar.
 Millivoltmeter for FET Circuits (Tooker)..... 45 Jan.
 Moisture Sensor, Build a (St. Laurent)..... 67 Mar.
 Princeps Puzzle, The (Cuccia) 26 May
 Psych-Tone, Build the (Lancaster) 25 Feb.
 QRP Thing, The (Olson) 39 Feb.
 Resistance Decade, The Different (Fred)..... 64 Mar.
 Timbre Gate, Build a (Anderton) 29 Apr.
 Time Base Calibrator, Build a (Valentine)..... 33 Jan.
 Time-Period Module (Meyer) 63 Jan.
 Transistor Tester, Non-Destructive (Keith)..... 47 Mar.
 Voltage Regulator, VR 12 (Ball)..... 65 Apr.
 Vox Gain Rider, Build a (Beaty)..... 58 June
 Wheatstone Bridge/Substitution Box, Build a (Callas)
 62 Feb.
 2XY Calibrator, Building and Using the (Windolph) 34 Mar.
 10.7-MHz Signal Generator (Lewis)..... 61 Mar.

DEPARTMENTS

Communications
 79 Jan., 82 Feb., 80 Mar., 71 Apr., 70 May,
 76 June

Direct & Current (Ferrell)
 Under Another Guise 7 Jan.
 Putting the Cards on the Table 7 Feb.
 Twilight of the Shortwave Listener..... 7 Mar.
 Hopefully, Not a Second Time Around..... 7 Apr.
 Begrudging—But True 7 May
 Something Good About CB—After All!..... 7 June

Electronics Library
 16 Jan., 14 Feb., 16 Mar., 16 Apr., 16 May,
 14 June

Interface
 8 Jan., 8 Feb., 8 Mar., 8 Apr., 8 May, 8 June

New Literature
 14 Jan., 12 Feb., 14 Mar., 14 Apr., 14 May,
 12 June

New Products
 22 Jan., 22 Feb., 22 Mar., 22 Apr., 17 May,
 22 June

Out of Tune
 Reflex Enclosure Dimensions (Dec. '70) 100 Feb.
 Electronics Self Study Course (Dec. '70) 12 Mar.
 Electronic Clinical Thermometer (Jan. '71)..... 12 Mar.
 Non-Destructive Transistor Tester (Mar. '71)..... 10 May
 Wheatstone Bridge & Substitution Box (Feb. '71) 10 May
 Build the Psych-Tone (Feb. '71) 10 May
 The QRP Thing (Feb. '71) 10 May
 Chemicals for Electronics (Apr. '71) 10 May
 Build a Timbre Gate (Apr. 1971, p. 29) 97 June

Solid State (Garner)
 83 Jan., 85 Feb., 84 Mar., 86 Apr., 71 May,
 85 June

DIGITAL ELECTRONICS

In-Out Annunciator, The (Simonton)..... 48 Apr.
 Decimal Counter, Ultimate (Meyer) 45 Feb.
 Digital Thermometer Module (Meyer)..... 69 June
 Digi-Viewer, Build a (Lancaster) 41 Mar
 Digi-Vista, Six-Digit Popular Electronics
 (Meyer & Kay) 71 Jan.
 Equivalency in RTL Circuits (Tooker)..... 49 Feb.
 Equivalency in RTL Circuits (Tooker)..... 39 June
 Fil-Oscillator, Build the (Melen & Garland) 58 May
 Princeps Puzzle, The (Cuccia) 26 May
 Psych-Tone, Build the (Lancaster)..... 25 Feb.
 Time Base Calibrator, Build a (Valentine) 33 Jan.
 Time-Period Module (Meyer) 63 Jan.

EDUCATION

Opportunity Awareness (Heiserman)
 Home Study in Medical Electronics 81 Jan.
 Selling Inventions 84 Feb.
 Getting into Computer Servicing 78 Mar.
 Your Wages vs Average 85 Apr.
 Armed Services Electronics Schools 84 May
 Educational Benefits From Employers 84 June

ELECTRONIC MUSIC

Psych-Tone, Build the (Lancaster)	25 Feb.
Leslie Effect Simulator (Simonton)	51 Mar.
Timbre Gate, Build a (Anderton)	29 Apr.

FEATURE ARTICLES

Acoustic Surface-Wave Devices (Fisk)	27 Mar.
Battle of the Giant Brains (Dill)	39 Apr.
Cable FM, A Bonus for CATV Subscribers: (Lacy).....	60 Jan.
Chemicals for Electronics (Cantor)	25 Apr.
Chemicals for Electronics (Cantor)	63 May
Cryptolock, Build a (Busse).....	42 Jan.
Digi-Viewer, Build a (Lancaster).....	41 Mar.
Digi-Vista, Six-Digit Popular Electronics (Meyer & Kay).....	71 Jan.
Electricity & Physiology (Garrison)	27 Jan.
Electro-Culture, Experimental (Lawrence)	66 Feb.
Electro-Culture, More Experiments in (Lawrence).....	63 June
Electronic Clinical Thermometer, Build an (Laughlin)	75 Jan.
EL Panel Driver (Huffnagle).....	43 May
Equivalency in RTL Circuits (Tooker)	49 Feb.
Equivalency in RTL Circuits (Tooker).....	39 June
Five Forty Power Amplifier, Build the (Meyer).....	49 May
Leakage Current & Electrical Shock (Jarrett)	46 Mar.
Leslie Effect Simulator (Simonton)	51 Mar.
Millivoltmeter for FET Circuits (Tooker)	45 Jan.
Moisture Sensor, Build a (St. Laurent)	67 Mar.
Phono Cartridges, 15 Things We Do Know About (Holt)	25 June
Princes Puzzle, The (Cuccio).....	26 May
Psych-Tone, Build the (Lancaster)	25 Feb.
Quiz, Switching Logic (Balin).....	50 Mar.
Quiz, What Do You Know About Capacitors (Balin)	32 Jan.
Single Woofer, Case for the (Weems)	33 May
Stereo Headphones, Pick and Choose Among (Steele)	44 Apr.
Timbre Gate, Build a (Anderton).....	29 Apr.

HOME HI-FI/STEREO

Colossal Woofer, The (Weems)	47 June
Five Forty Power Amplifier, Build the (Meyer)	49 May
Phono Cartridges, 15 Things We Do Know About (Holt)	25 June
Single Woofer, Case for the (Weems).....	33 May
Stereo Headphones, Pick and Choose Among (Steele)	44 Apr.
Stereo Scene (Holt)	
Is It Music or Sound?	68 Jan.
All About Dolby.....	71 Feb.
It Was a Very Good Year.....	71 Mar.
The Best of Everything	82 Apr.
Where the Music Sounds Best	86 May
Those Redundant Volume Controls.....	81 June
Vox Gain Rider, Build a (Beaty).....	58 June

NEW DEVELOPMENTS IN ELECTRONICS

Acoustic Surface-Wave Devices (Fisk)	27 Mar.
Chemicals for Electronics (Cantor)	25 Apr.
Chemicals for Electronics (Cantor)	63 May
EL Panel Driver (Huffnagle).....	43 May

PRODUCT GALLERY

Acoustic Research AR-6	78 May
CTD IC Logic Design Program	78 June
Edsyn Saldavac	82 Mar.
Heathkit GD-29 Microwave Oven	78 May
Heathkit GR-370 Color TV	86 Jan.
Heathkit IB-101 Counter	76 Apr.
Industrial Inventions Logic BPL-10	78 June
Lafayette RK-890 Recorder.....	76 Apr.
Leader LBO-501 Oscilloscope.....	78 Feb.
Russell Antenna Booster	78 Feb.
Ten-Tec RX-10 Receiver	78 May
Tompkins Mobilink	76 Apr.
U.S. Magnet Extendo-Mag	78 Feb.
Winegard Sensor Antenna.....	82 Mar.

SCIENCE FAIR

Electro-Culture, Experimental (Lawrence)	66 Feb.
Electro-Culture, More Experiments in (Lawrence)	63 June
Electronic Clinical Thermometer, Build an (Laughlin)	75 Jan.
In-Out Annunciator, The (Simonton).....	48 Apr.
Princes Puzzle, The (Cuccio)	26 May

TEST EQUIPMENT

Chemicals for Electronics (Cantor)	25 Apr.
Decimal Counter, Ultimate (Meyer)	45 Feb.
Digi-Viewer, Build a (Lancaster)	41 Mar.
Fil-Oscillator, Build the (Melen & Garland)	58 May
Laboratory IC Power Supply (Valentine).....	31 June
Millivoltmeter for FET Circuits (Tooker)	45 Jan.
Resistance Decade, The Different (Fred).....	64 Mar.
Time Base Calibrator, Build a (Valentine).....	33 Jan.
Time-Period Module (Meyer)	63 Jan.
Transistor Tester, Non-Destructive (Keith)	47 Mar.
Wheatstone Bridge/Substitution Box, Build a (Callas)	62 Feb.
2XY Calibrator, Building and Using the (Windolph)	34 Mar.
10.7-MHz Signal Generator, Low-Cost (Lewis)	61 Mar.

TUTORIAL

Electricity & Physiology (Garrison)	27 Jan.
Equivalency in RTL Circuits (Tooker)	49 Feb.
Equivalency in RTL Circuits (Tooker).....	39 June
Leakage Current & Electrical Shock (Jarrett).....	46 Mar.

USEFUL HOUSEHOLD PROJECTS

Charge Now, Build the (Maglieri).....	53 Apr.
Cryptolock, Build a (Busse)	42 Jan.
Digi-Vista, Six Digit Popular Electronics (Meyer & Kay)	71 Jan.
Electronic Clinical Thermometer, Build an (Laughlin)	75 Jan.
In-Out Annunciator, The (Simonton)	48 Apr.
Light-Operated Bi-Stable Switch (Conner).....	70 Mar.
Moisture Sensor, Build a (St. Laurent).....	67 Mar.
Vox Gain Rider, Build a (Beaty)	58 June

ELECTRONICS MARKET PLACE

NON-DISPLAY CLASSIFIED: COMMERCIAL RATE: For firms or individuals offering commercial products or services, \$1.25 per word (including name and address). Minimum order \$12.50. Payment must accompany copy except when ads are placed by accredited advertising agencies. Frequency discount: 5% for 6 months; 10% for 12 months paid in advance. **READER RATE:** For individuals with a personal item to buy or sell, 80¢ per word (including name and address). No Minimum! Payment must accompany copy.

DISPLAY CLASSIFIED: 1" by 1 column (2 1/2" wide), \$110.00. 2" by 1 column, \$215.00. 3" by 1 column, \$320.00. Advertiser to supply cuts

GENERAL INFORMATION: First word in all ads set in bold caps at no extra charge. All copy subject to publisher's approval. Closing Date: 1st of the 2nd month preceding cover date (for example, March issue closes January 1st). Send order and remittance to: Hal Cymes, **POPULAR ELECTRONICS**, One Park Avenue, New York, New York 10016.

FOR SALE

FREE! Bargain catalog. Fiber optics, LED's, transistors, diodes, rectifiers, SCR's, triacs, parts. Poly Paks, Box 942, Lynnfield, Mass. 01940.

GOVERNMENT Surplus Receivers, Transmitters, Snooper scopes, Radios, Parts. Picture Catalog 25¢. Meshna, Nahant, Mass. 01908.

ROCKETS: Ideal for miniature transmitter tests. New illustrated catalog. 25¢. Single and multistage kits, cones, engines, launchers, trackers, rocket aerial cameras, technical information. Fast service. Estes Industries, Dept. 18-E, Penrose, Colorado 81240.

LOWEST Prices Electronic Parts. Confidential Catalog Free. **KNAPP**, 3174 8th Ave. S.W., Largo, Fla. 33540.

WE SELL CONSTRUCTION PLANS. TELEPHONE: Answering Machine, Speakerphone, Carphone. Phonevision, Legal Connector, Auto Dialer, Central Dial System. **TELEVISION:** \$35.00 Color Converter, Tape Recorder, 3DTV, \$25.00 Camera. **HOBBYIST:** Electron Microscope, 96 Hour Tape Music System, Ultrasonic Dishwasher, Radar-Oven, Electronic Tranquilizer. Plans \$4.95 each. **COURSES:** Telephone Engineering \$39.50, Detective Electronics \$22.50, Anti-Detective Electronics \$27.50. **NEW SUPER HOBBY CATALOG AIRMAILED \$1.00.** Don Britton Enterprises, 6200 Wilshire Blvd., Los Angeles, Calif. 90048.

WEBBER LAB's. Police & Fire Converters. Catalog 25¢. 72 Cottage Street, Lynn, Mass. 01905.

INVESTIGATORS, LATEST ELECTRONICS AIDS. FREE LITERATURE. CLIFTON, 11500-L NW 7th Ave., MIAMI, FLORIDA 33168.

ELECTRONIC PARTS, semiconductors, kits. FREE FLYER. Large catalog \$1.00 deposit. **BIGELOW ELECTRONICS**, Bluffton, Ohio 45817.

RADIO—T.V. Tubes—36¢ each. Send for free catalog. Cornell, 4213 University, San Diego, Calif. 92105.

CLEARANCE SALE rectifiers, transistors, 1000's other items. Catalog 15¢. General Sales Company, 254 Main, Clute, Texas 77531.

MECHANICAL, ELECTRONIC devices catalog 10¢. Greatest Values—Lowest Prices. Fertik's, 5249 "D", Philadelphia, Pa. 19120.

BURGLAR ALARM SYSTEMS and accessories. Controls, bells, sirens, hardware, etc. **OMNI-GUARD** radar intruder detection system, kit form or assembled. Write for free catalog. Microtech Associates, Inc., Box 10147, St. Petersburg, Florida 33733.

SENCORE, B&K TEST EQUIPMENT UNBELIEVABLE PRICES. FREE CATALOG AND PRICE SHEET. FORDHAM RADIO, 265 EAST 149TH STREET, BRONX, N.Y. 10451.

ELECTRONIC COMPONENTS—Distributor prices. Free catalog, Box 2581, El Cajon, California 92021.

FREE Kit Catalog: Shortproof Powersupply \$39.50. Ultrasonic Alarm \$37.25. SWTPC, Box B32040, San Antonio, Tex. 78216.

AMATEUR SCIENTISTS, Electronics Hobbyists, Experimenters, Students . . . Construction Plans—all complete, including drawings, schematics, parts lists with prices and sources . . . Radar—Build your own ultrasonic doppler radar. Detect motion of people, automobiles, even falling rain drops. Transistorized, uses 9 volt transistor battery—\$4.50 . . . Long-Range "Sound Telescope"—This amazing device can enable you to hear conversations, birds and animals, other sounds hundreds of feet away. Very directional. Transistorized. Uses 9V battery—\$3.50 . . . Robot Man—Moves hands and arms—\$3.50 . . . Or send 25¢ coin (no stamps) for complete catalog. Other items include Psychedelic strobes, light shows, lasers . . . 46 different projects. Technical Writers Group, Box 5994, State College Station, Raleigh, N.C. 27607.

DIAGRAMS—Radios \$1.50. Television \$3.00. Give make and model. Diagram Service, Box 1151PE, Manchester, Conn. 06042.

ELECTRONIC Ignition. Various Types. Information 10¢. Anderson Engineering, Epsom, N.H. 03239.

SENSABELL: Ideal auxiliary annunciator for workshop, playroom, garage. Sounds simultaneously with your present chimes. Inexpensive circuit connects directly across existing bell transformer. No other wires or pushbuttons necessary: Plans \$1.00. Totaltron, 36 Quirk Street, Watertown, Mass. 02172.

POLICE-FIRE RADIO DISPATCHER CALLBOOKS! EXCLUSIVE, OFFICIAL LISTINGS: CALLSIGNS, FREQUENCIES! LATEST REVISIONS, NATIONWIDE. CATALOG, SEND STAMP. COMMUNICATIONS, BOX 56-PE, COMMACK, N.Y. 11725.

WOULD YOU SPEND 25¢

to save \$25.00 or more? Citizens Band, AM and SSB 2-way Radios, USA and Export Models. Send 25¢ for catalog to:

BAGGY'S RADIO

P. O. Box 778, 6391 Westminster Avenue
Westminster, CA 92683
Dealer Inquiries Invited

NEW SEMICONDUCTOR LIGHT EMITTING DIODES—bright red lights replace light bulbs. Typical life 100 years. Operate at 1.65 volts, 50 milliamps. Order 2 for \$2.98 NOW. Data sheet and instructions included. Monsanto Company, Hobby Section, 10131 Bubb Road, Cupertino, California 95014.

CONVERT any television to sensitive, big-screen oscilloscope. Only minor changes required. No electronic experience necessary. Illustrated plans. \$2.00. Relco-A33, Box 10563, Houston, Texas 77018.

FREE catalog, parts, circuit boards for **POPULAR ELECTRONICS** projects. **PAIA ELECTRONICS**, Box C14359, Oklahoma City, OK 73114.

MATRIX ARRAY COMPONENT UNITS; needed in experimenter laboratory and repair shop, catalog 10¢. **CUHINCO**, 2404 Stratton Drive, Rockville, Maryland 20854.

CITIZENS Band-Shortwave Listener-Ham equipment from Amrad Supply, Inc. Free Flyer, 1025 Harrison St., Oakland, Calif. 94607.

PSYCHEDELIC Strobe Kit: Complete with 110w/sec. tube, reflector, chassis and cabinet \$17.50 plus postage and insurance. 2 lbs. (Extra tubes \$3.50) SWTPC, Box E32040, San Antonio, Texas 78216.

CONSTRUCTION PLANS: Laser . . . \$2.00. 2-FM microphone transmitters . . . \$1.00. FM telephone transmitter . . . \$2.00. Sound telescope . . . \$2.00. Space monitor-missile tracker . . . \$2.00. Equipment and kits available. Howard, 20174 Ward, Detroit, Michigan 48235.

FREE Kit Catalog: Color Organs \$11.00, Psychedelic Strobes \$17.50, Professional quality—lowest prices. SWTPC, Box F32040, San Antonio, Texas 78216.

ANTIGRAVITY, experiment and theory; Rushed—\$2.00. U.S. Inquiries, Intertech 7A9, Box 5373, Station-F, Ottawa, Canada.

HOBBYISTS—Electronic components at huge savings. Transistors 6/25¢, resistors 5¢, capacitors 10¢. Thousands of items. Catalogue free. SASCO Electronics, 1009 King Street, Alexandria, Va. 22314.

LEARN the facts of electronics and your privacy. Send for the **Tron-X Manual**, P.O. Box 38155, Hollywood, CA 90038. \$5.95.

TV TUNER REPAIRS—Complete Course Details, 12 Repair Tricks, Many Plans, Two Lessons, all for \$1. Refundable. Frank Boeck, Box 833, Redding, Calif. 96001.

duo-band • auto search Monitor Receiver



pei 8-channel scanning monitor
HL-44 locks on active channel,

then resumes search when channel goes quiet. Program scanning speed, any number of high or low band channels by plugging in crystals. NO WIRING CHANGES. Use it on your desk or in your car.

Write for free literature.
pei PETERSEN ELECTRONICS, INC.
1000 South Main— Council Bluffs, Iowa 51501

WOULD YOU SPEND 25¢ to save \$25.00 or more? Citizens Band, AM and SSB 2-way radios, USA and export models. Send 25¢ for catalog to: BAGGY'S RADIO, 6391 Westminster Avenue, Westminster, CA 92683. Dealer Inquiries Invited.

FIND COINS-GOLD-RELICS-TREASURE metal locators by JETCO!

- Lightweight
- Easy to Use
- Comes Complete
- Made in USA
- 5 yr. Guarantee
- Immediate Delivery!
- Write for FREE Catalog.

priced from

\$39.95



JETCO ELECTRONIC INDUSTRIES, INC.
P. O. BOX 132, PE. HUNTSVILLE, TEXAS 77340
PHONE ORDER TO: 713/294-5422

BRAINWAVE Feedback Electroencephalophone. Send 10¢, J. & J. Enterprises, 8102E, Bainbridge, Wash. 98110.

ELECTRICAL MULTIMETERS, New, high quality, very reasonable. Request details. Newera, 4480 Broadview, Cleveland, Ohio 44109.

FREE Electronics Catalog. Tremendous bargains. Edu-Kits, Department C-699 D, Hewlett, New York 11557.

SPACE-AGE TV CAMERA KITS & PLANS



BE A PIONEER IN HOME TELECASTING! Build your own TV CAMERA. Model TE-1A. Series D. \$16.95. Ship. Insured. One-day construction manual. High quality. Connects to any TV without modification. Used in home, experimenters, education, industry, etc.

PHONE OR WRITE FOR CATALOG.
DIAL 400-989-5371

Many other kits, parts and plans available including stereo kits, lasers, ball, coils, Wilson tubes, coast plans, etc.

1300 N. BROADWAY • **ATV Research** DAKOTA CITY, NEBR. 68731

JAPAN HONG KONG DIRECTORY. World products information. \$1.00 today. Ippano Kaisha Ltd., Hillyard, Washington 99207.

PRINTED CIRCUITS Quick. Free Estimates. Industrial Photo B-18, Oakhurst, N. J. 07755.

EUROPE's top quality electronic parts, ridiculous prices. Catalog 35¢. Electrovalue-America, Box 27A, Swarthmore, Pa. 19081.

INTEGRATED CIRCUITS—Factory Prices, Catalog 10¢. Silling, Box 6257, Seattle, Washington 98188.

HOOSIER ELECTRONICS Authorized dealers for Regency, Scanners and CB, also Midland, Hy-Gain, Drake, Ten-Tec, Galaxy, Hallcrafters. All equipment new and fully guaranteed. Write today for our low quote. Hoosier Electronics, Dept. F, R. R. 25, Box 403, Terre Haute, Indiana 47802.

SEE in total darkness with infrared snooperscope. Complete plans and schematics \$3.00. Don Moore, 7902 Oak Knoll, Houston, Texas 77028.

NEW used Surplus parts equip. 50¢. WI, P.O. Box 5132, Oxnard, California 93030.

FREE! Giant Electronics Catalog. McCord Electronics, Box 41-P, Sylvania, Ohio 43560.

NEW and Used CB Radios & Equipment all types, new TR-44 Rotors—\$58.00! Free lists. David Driver Electronics, P.O. Box 1163, Lexington, N.C. 27292.

SEMICONDUCTORS: Buy from single source. Serving experimenters, hobbyists. No minimums. SN 7400N, \$1.90; MC724P, \$1.10, Etc. RLabs, Box 253, Burlington, Ma. 01803.

QUALITY Components at reasonable prices. Catalogue 10¢. Send name to GUST & Company, Box 24081, Edina, Minnesota 55424.

POCKET-SIZE COMPUTER. Free details. Write: Technical Equipment, Box 391, Upland, Calif. 91786.

NEW ELECTRONIC COMBINATION LOCK Solid State Logic Circuits, 5600 possible combinations (easily changed), Security and Convenience, fully assembled, tested and guaranteed. Made in U.S.A. Only \$54.50. DIGILOCK ENGINEERING, Box 616, SM Branch, Miami, Florida 33143.

"ACHTUNG! Das machine is nicht fur Gerfingerpoken und Mit-tengrabben"-etc. on GOLD CARDS. \$1.00 for 6. JMH Enterprises, 1208 S.E. Seventh, Portland, Oregon 97214.

INVESTIGATORS—Detectives—Industrial Security Officers. Latest subminiature electronic equipment. Catalog 50¢. Jack, Box 19422, Sacramento, Calif. 95819.

4-CHANNEL SOUND for under \$10.00 Newly developed matrix adapter enables you to electronically separate any standard 2-channel record, tape or FM broadcast into four channels using your present stereo amplifier or receiver. No electronic experience needed. For completely illustrated plans and parts list send \$3.00 to Techni-Sketch #1, P.O. Box 1151, Sun Valley, Calif. 91352.

NOW! . . . Visible and Infrared Light Emitting Diodes, Matching Receiving Photodiodes, Comprehensive Plans . . . You can build inexpensive secret communications, alarm, control devices! Catalog including \$1.00 discount certificate. 25¢. Lundart, University Station 4008-E7, Tucson, Arizona 85717.

ELECTRONIC Deodorizer, eliminate odors instantaneously. \$24.95 pp. guaranteed. Holmes Distributor, 6244 Oakland, St. Louis, Mo. 63139.

PULSE GENERATORS, oscillators, logic modules, booklets, and plans. Free Literature. Scientific Measurements, 2945 Central, Wilmette, Illinois 60091.

TRACTOR RADIOS perfect for Auto, Boat, Truck, etc. weather proof case used, excellent working condition. Originally \$69.95, closeout \$15.95 postpaid. VGRS Electronics Dept., 2239 East 55th Street, Cleveland, Ohio 44103.

FOUR TRACK auto tape players as is repairable. Originally \$49.95 now \$4.95 postpaid. VGRS, Electronics Dept., 2239 East 55th Street, Cleveland, Ohio 44103.

FCC TYPE EXAMS . . . Guaranteed to prepare you for FCC 3rd, 2nd, and 1st phone exams. 3rd class \$7.00, 2nd class \$12.00, 1st class \$16.00, complete package \$25.00. Due to demand, allow 3 weeks for mailing. Research Company, Box 22141, Tampa, Florida 33622.

LASER Flashlamp, with instructions, send \$3.00, ZDF, Box 3261, San Jose, Calif. 95116.

SURPLUS ELECTRONICS. Parts, equipment. Catalog 25¢. Jeff-Tronics, 4252-P Pearl Rd., Cleveland, Ohio 44109.

LOWEST prices, printed circuit boards. Metal & Plastic Rods-Sheets Tubes. Post Paid. Free List. Fowler, 1605 Quill Street, Indianapolis, Ind. 46203.

PARTS! CORNELL TUBES!

FREE Send For FREE

CORNELL'S
New Color
Catalog
40 Pgs. New Items

33¢ per tube

36¢ per tube

ORDER FREE
IF NOT SHIPPED
IN 24 HOURS!

4219 UNIVERSITY AVE. SAN DIEGO, CALIF. 92105

PLANS AND KITS

FREE Kit Catalog: Digital Microlab \$29.95. Also Segmented and Nixie Readouts, Timebases, Scalars, Electronic Digital Clocks (all featured in Popular Electronics) SWTPC, Box C32040, San Antonio, Tex. 78216.

PSYCHEDELIC LIGHTING MANUAL! Make strobes, kaleidoscopes, organs, etc. Send \$2.95. Lightrays, 1315-D Weaver, Philadelphia, Pa. 19150.

FREE kit Catalog: Amazing new Universal Digital Instruments with plugins as featured in Popular Electronics. Unbeatable prices. SWTPC, Box D32040, San Antonio, Tex. 78216.

FREE Kit Catalog. Why does every major College, University, Technical School, Research & Development Center buy from us? Because we have the highest quality and lowest prices. Free catalog. SWTPC, Box H32040, San Antonio, Tex. 78216.

TELEVISION Training Kits, Parts, Plans. \$2.99. Free Flyer. Aline, 434 West 4th Street, West Islip, New York 11795.

BRUSHLESS MOTOR, Electronic Pendulum Transistor Devices SERCOLAB, P.O. Box 78B, Arlington, Mass. 02174.

INTEGRATED CIRCUITS new, best prices, \$1 for three DIP SN7402N quad two input nor gates and flyer listing Kits, TTL, DTL and Linear IC's. Babylon Electronics, 5942G Don Way, Carmichael, Calif. 95628.

CONVERT your scope. Dual trace FET switch, \$10.00. Triggersweep \$24.95. Kits include semiconductors, boards, instructions, HAMLIN TECHNICAL PRODUCTS, Box 901, Cupertino, Calif. 95014.

SCR (electronic switch) Hobbyist Kit. SCR's, many plans, circuit theory. \$4.95. Catalog free. John Huntley, 909 Wisconsin, San Francisco, CA. 94107.

T.V. Cameras kits. \$1.00 information. 9036 Pauhaska, Apple Valley, Calif. 92307.

ELECTRONIC organ kit, spinet, two manual, transistorized, SASE for details. Lloyd Hanson, RR2B52A, Angola, Indiana 46703.

COLOR organ kits \$7.50. IC's 25¢. Catalog. Murphy, 204 Roslyn Ave., Carle Place, N.Y. 11514.

TESLA COIL—40" SPARKS! Plans \$7.50. Information 50¢. Huntington Electronics, Box 9-P, Huntington, Conn. 06484.

COLOR Organ Kit Three Channel Tone Controlled \$8.95. Includes parts and instructions. Kustom House Electronics, 8530 Westminster Ave., Westminster, Calif. 92683.

BUILD your own reflective-sound, omni-directional speakers. Previously unpublished plans use nine low-cost 5" speakers per enclosure. Sound radiates 360° when placed near any wall. Use with or without equalizer. For detailed instructions and parts list, send \$3.00 to Modtronics (Plan #901-A), P.O. Box 1144, Sun Valley, Calif. 91352.

ENJOY Clearer (Snow-Free) Television! build plan 200 Super-Log Antenna. Complete instructions. Rush \$3.00 (no stamps), GJM Electronics, Dept. PE, Box 218, Goleta, Calif. 93017.

HIGH FIDELITY

TAPE RECORDERS. Hi-Fi. components, Sleep Learning Equipment, tapes. Unusual Values. Free Catalog. Dressner, 1523R, Jericho Turnpike, New Hyde Park, N.Y. 11040.

LOW, Low quotes: all components and recorders, HiFi, Roslyn, Penna. 19001.

FREE Kit Catalog. Amplifiers: Lil Tiger \$11.10, Universal Tiger \$30.00. Preamp \$44.50 (Featured in Popular Electronics) SCA Adaptors \$14.55. SWTPC, Box A32040, San Antonio, Tex. 78216.

DIAMOND NEEDLES and Stereo Cartridges at Discount prices for Shure, Pickering, Stanton, Empire, Grado and ADC. Send for free catalog. All merchandise brand new and factory sealed. LYLE CARTRIDGES, Dept. P, P.O. Box 69, Kensington Station, Brooklyn, New York 11218.

ELECTRONIC Turntable Speed Changer. For AR. \$25.00 postpaid Box 176, Brooklyn 11205.

WANTED

CASH PAID! Unused tubes, electronic equipment. Barry, 512 Broadway, NYC 10012.

QUICKSILVER, Platinum, Silver, Gold, Ores Analyzed. Free Circular. Mercury Terminal, Norwood, Mass. 02062.

TUBES

TUBES "Oldies", latest. Lists free. Steinmetz, 7519 Maplewood, Hammond, Indiana 46324.

RECEIVING & INDUSTRIAL TUBES, TRANSISTORS. All Brands—Biggest Discounts. Technicians, Hobbyists, Experimenters—Request **FREE** Giant Catalog and **SAVE!** ZALYTRON, 469 Jericho Turnpike, Mineola, N.Y. 11501.

RADIO & T.V. Tubes—36¢ each. Send for free catalog. Cornell, 4213 University, San Diego, Calif. 92105.

TUBE Headquarters of World! Send 10c for Catalog (tubes, electronic equipment) Barry, 512 Broadway, N.Y.C. 10012.

CLASSIFIED ADVERTISING ORDER FORM

Please refer to heading on first page of this section for complete data concerning terms, frequency discounts, closing dates, etc.

1	2	3	4	5
6	7	8	9	10
11	12	13	14	15
16	17	18	19	20
21	22	23	24	25
26	27	28	29	30
31	32	33	34	35

_____ Words { @ 80¢ (Reader Rate) } = \$ _____
 { @ \$1.25 (Commercial Rate) }

Insert _____ time(s) Total Enclosed \$ _____

NAME _____

ADDRESS _____

CITY _____ STATE _____ ZIP _____

Signature _____

WORD COUNT: Include name and address. Name of city (Des Moines) or of state (New York) counts as one word each. Zip Code numbers not counted. (Publisher reserves right to omit Zip Code if space does not permit.) Count each abbreviation, initial, single figure or group of figures or letters as a word. Symbols such as 35mm, COD, PO, AC, etc., count as one word. Hyphenated words count as two words.

PE671

TUBES—Lowest prices. Foreign-American. Obsolete, receiving, special purpose, transmitting tubes. Send for tube, parts catalog. United Radio Company, 56-P Ferry St., Newark, N.J. 07105.

TAPE AND RECORDERS

OLD radio programs on tape. 6 hours for \$8.00. Catalog 50¢. Don Maris. 1926 Cherokee. Norman. Okla. 73069.

STEREO TAPE RENTAL for particular people. Free catalog. Gold Coast Tape Library. Box 2262. Palm Village Station, Hialeah, Fla. 33012.

RENT 4-Track open reel tapes—all major labels—3,000 different—free brochure. Stereo-Parti. 55 St. James Drive. Santa Rosa, Ca. 95401.

BARGAIN MUSIC, Tape, Equipment Catalog, 25¢. Saxitone, 1776 Columbia Road, Washington, D.C. 20009.

RADIO shows. 4 hours \$6.50. Catalog 25¢. Box 724, Redmond, Wash. 98052.

EIGHT TRACK Recorder Amplifier or Deckkit or complete manufacture closeout. Details 50¢. Do-It-Yourself Leather Goods, Special Kits, Belts, Purses, etc. Transmex Industries, Box 745, Newport Beach, Calif. 92661.

WOULD you like to buy nationally advertised blank open reel tapes, cassettes, 8 track? Write: Direct Mail Cassette Corp., Box 71, Plainview, N.Y. 11803.

TRADE Stereo tapes. \$1.25 each postpaid. Minimum three. Tape-trade. Box 2181, La Jolla, Ca. 82037.

REPAIRS AND SERVICES

TV Tuners rebuilt and aligned per manufacturers specification. Only \$9.50. Any make UHF or VHF Ninety day written guarantee. Ship complete with tubes or write for free mailing kit and dealer brochure. JW Electronics, Box 51C, Bloomington, Indiana 47401.

INSTRUCTION

LEARN ELECTRONIC ORGAN SERVICING at home all makes including transistor. Experimental kit—trouble-shooting. Accredited NHSC. Free Booklet. **NILES BRYANT SCHOOL**, 3631 Stockton, Dept. A, Sacramento, Calif. 95820.

LEARN WHILE ASLEEP, Hypnotize! Strange catalog free. Auto-suggestion, Box 24-ZD, Olympia, Washington 98501.

DEGREE in Electronics Engineering earned mostly by correspondence. Free brochure. Dept. G-9, Grantham School of Engineering, 1505 N. Western Ave., Hollywood, California 90027.

WANT AN F.C.C. 1st CLASS LICENSE? WANT TO BECOME A OISC-JOCKEY? REI has a school near you VA approved. Call toll free: 1-800-237-2251 or write REI, 1336 Main St., Sarasota, Florida 33577. Florida Residents call: 813-955-6922.

HIGHLY effective home study courses in Electronics Engineering Technology and Electronics Engineering Mathematics. Earn your Degree. Write for Free Descriptive Literature. Cook's Institute of Electronics Engineering, (Dept. 15), P.O. Box 10634, Jackson, Miss. 39209. (Established 1945).

FREE brochure self-improvement books. Eldon McBrayer. 412 Arthur Street, Huntsville, Ala. 35805.

FCC LICENSE through tape recorded lessons. Radio License Training, 10600 Duncan, Manhattan Beach, Calif. 90266.

BE MATH EXPERT. Order "Ten Second Check" for addition, multiplication, division, square root \$1.75. Stranahan, Box 111, Harwinton, Conn. 06790.

AMATEUR RADIO. Correspondence Sight-and-Sound no-textbook courses for GENERAL, ADVANCED and EXTRA Class licenses, complete Code and Theory. These are NOT memory courses. **AMATEUR RADIO LICENSE SCHOOL**, 12217 Santa Monica Blvd., W. Los Angeles, Calif. 90025.

MEMORIZE STUDY: "1971 Tests-Answers" for FCC First and Second Class License—plus—"Self-Study Ability Test." Proven! \$9.95. Satisfaction guaranteed, Command, Box 26348-P, San Francisco 94126.

INVENTIONS WANTED

INVENTIONS wanted. Patented: unpatented. Global Marketing Service. 2420-P 77th, Oakland, Calif. 94605

PATENT Searches including Maximum speed, full airmail report and closest patent copies. \$6.00. Quality searches expertly administered. Complete secrecy guaranteed. Free Invention Protection forms and "Patent Information." Write Dept 9 Washington Patent Office Search Bureau, 711 14th Street, N.W., Washington, D.C. 20005.

INVENTORS! Don't sell your invention, patented or unpatented, until you receive our offer. **Eagle Development Company**, Dept. 9, 79 Wall Street, N.Y., N.Y. 10005.

FREE "Directory of 500 Corporations Seeking New Products." For information regarding development, sale, licensing of your patented/unpatented invention. Write: Raymond Lee Organization, 230-GR Park Avenue, New York City 10017.

PATENT SEARCHES, including copies of related United States Patents. Inventors, attorneys, manufacturers use our "World-Wide" Airmail service Free: "Invention Record" form and "Information Every Inventor Needs", Hayward Company, 898-HR National Bldg., Washington, D.C. 20007.

INVENTORS: Protect your ideas! Free "Recommended Procedure". Washington Inventors Service, 422T Washington Building, Washington, D.C. 20005.

FREE PAMPHLET: "Tips on Safeguarding Your Invention." Write: United States Inventors Service Company, 501-H Thirteenth Street N.W., Washington, D.C. 20004.

GOVERNMENT SURPLUS

JEeps Typically From \$53.90 . . . Trucks From \$78.40 . . . **Boats**, Typewriters, Airplanes, Multimeters, Oscilloscopes, Transceivers, Electronics Equipment. Wide Variety, Condition. 100,000 Bid Bargains Direct From Government Nationwide Complete Sales Directory and Surplus Catalog \$1.00. (Deductible First \$10.00 Order). Surplus Service, Box 820-J, Holland, Michigan 49423.

GOVERNMENT Surplus. How and Where to Buy in Your Area. Send \$1.00. Surplus Information, Box 30177-PE, Washington, DC 20014.

MANUALS for surplus electronics equipment. List 25¢. Books, 4905 Roanne Drive, Washington, D.C. 20021.

BOOKS

FREE catalog aviation/electronic/space books. Aero Publishers, 329PE Aviation Road, Fallbrook, California 92028.

FREE book prophet Elijah coming before Christ. Wonderful bible evidence. Megiddo Mission, Dept. 64, 481 Thurston Rd., Rochester, N.Y. 14619.

MAGAZINES

JAPAN PUBLICATIONS GUIOE Business, pleasure, education. \$8.00. INTERCONTINENTAL. CPO 1717. Tokyo 100-91.

OVER 2,000,000 backdate magazines! Specify needs. Midtown, Box 917-PE, Maywood, New Jersey 07607.

ELECTRONIC EXPERIMENTER'S HANDBOOK



148 pages of the most fascinating and challenging construction projects for the electronic hobbyists. All with complete schematics, illustrations, parts list, and easy-to-follow instructions.

1971 Winter edition . . . \$1.50. #33
1971 Spring Edition . . . \$1.50. #26
1970 Winter edition . . . \$1.35. #97
1970 Spring edition . . . \$1.50. #14
1968 Spring edition . . . \$1.25. #84

Order by number from

Ziff-Davis Service Div., 595 Broadway • N.Y., N.Y. 10012
Enclose an additional 35¢ per copy for postage and handling.
(Outside U.S.A. all magazines are \$2.50 per copy, postpaid.)

PAYMENT MUST BE ENCLOSED WITH ORDER

HYPNOTISM

"MALE-FEMALE HYPNOTISM" EXPOSED, EXPLAINED! "SECRET METHOD"—THEY NEVER KNOW! \$2, RUSHED, GUARANTEED! ISABELLA HALL, SILVER SPRINGS, FLORIDA 32688.

SLEEP Learning. Hypnotic method. 92% effective. Details free. ASR Foundation, Box 7021PE HC Station, Lexington, Ky. 40502.

PHOTOGRAPHY—FILM, EQUIPMENT, SERVICES

SCIENCE Bargains Request Free Giant Catalog "CJ"—148 pages—Astronomical Telescopes. Microscopes, Lenses. Binoculars, Kits, Parts. War surplus bargains. Edmund Scientific Co., 300 Edscorp Bldg., Barrington, New Jersey 08007.

RECORDS

POPULAR organ albums factory direct. Concert Recording, Lynwood, Calif. 90262.

SPECIAL interest records available, produced by the editors of the world's leading special interest magazines. Send for free catalog. Record Catalog-PE, Ziff-Davis Publishing Company, One Park Avenue, New York, N.Y. 10016.

RUBBER STAMPS

RUBBER ADDRESS STAMPS \$2.00. SIGNATURE \$3.50. FREE CATALOG. JACKSON'S, BOX 443-G, FRANKLIN PARK, ILLINOIS 60131.

BUSINESS OPPORTUNITIES

I MADE \$40,000.00 Year by Mailorder! Helped others make money! Start with \$10.00—Free Proof. Torrey, Box 318-N, Ypsilanti, Michigan 48197.

FREE BOOK "999 Successful Little Known Businesses" Work home, Plymouth 445-L, Brooklyn, N.Y. 11216.

\$200.00 DAILY In Your Mailbox! Your opportunity to do what mail-order experts do. Free details. Associates, Box 136-J, Holland, Michigan 49423.

HOW to make \$1,000,000 in only ten years! Start with \$10! Details Free! International Service, (PE), Box 11796, Atlanta, Georgia. 30305.

MAILORDER! Make big money working home. Free report reveals millionaire's trade secrets! Executive (1K6), 333 North Michigan, Chicago 60601.

I MADE \$2,000.00 Monthly by Mailorder—Evenings only. You can too! Free Proof! Kingman, Box 7227ZB, Erie, Penn. 16510.

FREE CATALOGS. Repair air conditioning, refrigeration. Tools, supplies, full instructions. Doolin, 2016 Canton, Dallas, Texas 75201.

UNUSUAL lucrative home business. Small basement production. Investment, skill unnecessary. Amazing literature free. Barta-ZIDA, Box 15083, San Francisco, Calif. 94115.

MAILORDER MONEYMaking KIT. Start home. Capital unnecessary. Free Details, Pictures. Prudential, Box 327-PE3, Boston 02199.

CHINCHILLA income guaranteed. Terms: 25¢, bulletin \$1.00. Rainbow, Port Richey, Fla. 33568.

BIG EARNINGS selling Hertel Bibles. New 3-dimension cover, finest reference edition sells fast. Demonstrator furnished. Big commissions. International Book, Dept. PE, Box 118, Wichita, Kansas 67201.

PIANO TUNING learned quickly at home. Tremendous field! Musical knowledge unnecessary. GI Approved. Information Free. Empire School, Box 327, Miami, Florida 33145.

200% PROFIT. Inexpensive fire, burglar alarms. Watchdog Systems, Williamsburg, Ohio 45176.

TREASURE FINDERS

FREE TREASURE GUIDE! Fact-filled collectors edition; send 50¢ for postage. Also request free literature on ultrasensitive, professional Fisher Detectors. FISHER RESEARCH, Dept. PE-6, Palo Alto, California 94303.

GOLD, Silver, Relics! Located with powerful Detectron Metal Detectors. Free Information. Terms, Detectron, Dept. PE6, Box 243, San Gabriel, California 91778.

TREASURE FINDER locates buried gold, silver, coins, treasures. 5 powerful models. \$19.95 up. Free catalog. Relco-A33, Box 10839, Houston, Texas 77018.

FREE: Jetco Electronics Free 24 page Treasure Finder catalog. Find metals, minerals, gold, silver, coins and relics, Jetco, Box 132 PE, Huntsville, Texas 77340.

MUSICAL INSTRUMENTS

30% DISCOUNT name brand musical instruments. Free catalog. Freeport Music, 127-N Sunrise Highway, Freeport, N.Y. 11520.

WHOLESALE! Professional Amplifiers, PA Systems, Guitars. Free Catalog, Carvin, Escondido, Calif. 92028.

REAL ESTATE

FREE . . . NEW 240-PAGE SUMMER CATALOG! Describes and pictures hundreds of farms, ranches, town and country homes, businesses coast to coast! Specify type property and location preferred. Zip Code, please. UNITED FARM AGENCY, 612-EP West 47th St., Kansas City, Mo. 64112.

PERSONALS

MAKE FRIENDS WORLDWIDE through international correspondence. Illustrated brochure free. Hermes, Berlin 11, Germany.

INVESTIGATORS, LATEST ELECTRONIC AIDS, FREE LITERATURE. CLIFTON, 11500-K NW 7th AVE., MIAMI, FLORIDA 33168.

SECRET LOANS BY MAIL. Borrow \$100 to \$1500 for any good reason in absolute privacy. No interviews, no endorsers, no co-signers. Fast service. Write Dial Finance Co., Dept. F-593, 410 Kilpatrick Bldg., Omaha, Nebraska 68102.

STAMPS

NEW Stamp Club fills your Worldwide Stampbook blanks each month. Trial subscription: \$6.50, Satisfaction guaranteed. Martin Stamp, Box 122-B, Brooklyn, New York 11223.

PRO ACTION SPORTS FILMS

START AN INDY "500" FILM COLLECTION. \$2.00 off your first color print (choice of 1962 thru 1970). 8 and Super 8. Catalog. SPORTLITE, Elect. Dept., 20 North Wacker, Chicago 60606.

MISCELLANEOUS

WINEMAKERS: Free illustrated catalog of yeasts, equipment. Semplex, Box 12276, Minneapolis, Minn. 55412.

LIGHT bulbs, thousands sizes, specify—Jetrronics, Box 67015ZD, Century City, Calif. 90067.

YOGURT MAKER, \$8.95—Delicious, economical. Free brochure. FOODKITS, BX 111, Monmouth Junction, New Jersey 08852.

RETAIL DISPLAY PLAN

All magazine retailers in the United States and Canada interested in earning an allowance for the display and sale of a minimum of five publications of the Ziff-Davis Publishing Company, to be paid quarterly on the basis of ten per cent of the cover price of each sold copy, assuming that all terms and conditions of the contract are satisfied, are entitled to do so and are invited to write for full details and copies of the contract to

Mr. J. Robert Gallicano

Single Copy Sales Director

ZIFF-DAVIS PUBLISHING COMPANY

One Park Avenue, New York, New York 10016

POPULAR ELECTRONICS

JUNE 1971

ADVERTISERS INDEX

READER SERVICE NO.	ADVERTISER	PAGE NO.
	Allied Radio Shack	11
1	Avanti Research & Development Co.	96
3	B & K Div., DYNASCAN CORP.	THIRD COVER
2	Bowman Leisure Industries	93
	CRI, Home Study Div., McGraw-Hill Book Co.	36, 37, 38
5	Career Academy	8
6	Cleveland Institute of Electronics	54, 55, 56, 57
7	Crystek	94
8	Drake Co., R.L.	97
24	EICO Electronic Equipment Co., Inc.	87
9	Edmund Scientific Co.	105
4	Electro-Voice, Inc.	FOURTH COVER
10	Elpa Marketing Industries, Inc.	6
11	Heath Company	13
12	Johnson Company, E.F.	14
13	KLH Research & Development Corp.	5
14	Lafayette Radio Electronics	94
15	Master Appliance Corp.	91
16	Midland Communications Co.	89
	National Radio Institute, SECOND COVER, 1, 2, 3	
	National Technical Schools	18, 19, 20, 21
17	Olson Electronics	96
18	Progressive "Edu-Kits", Inc.	106
19	RCA Electronic Components & Devices	24
	RCA Institutes, Inc.	72, 73, 74, 75
23	Regency Electronics, Inc.	91
20	Sams, Howard W. & Co., Inc.	9
25	TDK Electronics Corp.	10
21	Turner Microphone Co., The	16
22	Xcelite, Inc.	92
	CLASSIFIED ADVERTISING 100, 101, 102, 103, 104	

1000'S OF UNUSUAL SCIENTIFIC BARGAINS including... SPECIAL UNIQUE PSYCHEDELIC LIGHTING for Fun, Profit, Effects

HELIUM BALLOONS MAKE A "BALL"



Anytime there's a balloon the air is festive. Especially when the "air" is helium which makes a balloon perk and adventurous. Now here's a tip—the fun—25 various colored balloons of 4, 5, or 4" diameter when inflated. With them a pressurized (700 lbs./sq. in.) can containing 21 liters of helium to inflate all 25. For adults or kids' parties, giveaways, bazaars or just demonstrating "lighter than air".

Helium is a safe non-toxic inert gas.
Stock No. 71,289AV

\$3.00 Ppd.

HI-VOLTAGE ELECTROSTATIC GENERATOR



Van De Graaff low-amp type, 2,000,000 volt potential, yet completely safe. Demonstrates lightning. St. Elmo's fire, repulsion of charges, electrostatic dust collection, many other electrical wonders. Meter 110v, 60-cycle, AC. Humidity range, 0-80%. Current, 1.5 to 2.5 microamps. Aluminum base, frame and charge collector. Unbreakable plastic. In-slating column. 17" dia. 6 1/2". Full instructions.

Stock No. 70,264AV

STATIC ELECTRICITY GENERATOR

Stock No. 70,070AV

\$53.75 Ppd.

\$19.50 Ppd.

ASTRONOMICAL TELESCOPE KITS



Grind your own mirror for powerful telescopes. Kits contain fine annealed pyrex mirror blank, tool, abrasives, diagonal mirror, and objective lenses. Instruments you build range in value from \$75 to hundreds of dollars.

4 1/2" DIAMETER—3 1/2" Thick

Stock No. 70,003AV \$10.75 Ppd.

6" DIAMETER—1 1/2" Thick

Stock No. 70,004AV \$13.95 Ppd.

8" DIAMETER—1 1/2" Thick

Stock No. 70,005AV \$21.50 Ppd.

10" DIAMETER—1 1/2" Thick

Stock No. 70,006AV \$21.50 FOB

BLACK-LIGHT MIGHTY MITES

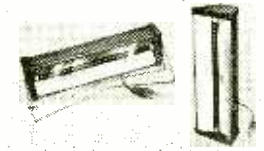

Relatively small (12") fixtures give surprisingly bright black-light. Mirror-finished reflector makes instant starting 8-watt, high-intensity bulb look like 40-watt. Up to 2,000 hours of safe, long-wave (3600Å) black-light to readily turn on parties, light & theatrical shows, psychedelic decors, holiday decorations. Shockproof end-caps remove for safe, easy replacement of bulb and socket studs.

In retail or horizontal. Aluminum case.

Stock No. 71,274AV

DELUXE OUTDOOR INDOOR MODEL

Stock No. 71,299AV

\$14.95 Ppd.

\$19.95 Ppd.

PSYCHEDELIC LIGHTING HANDBOOK



100 information packed pages! Fully explains latest in psychedelic lighting equipment, techniques, developments. Covers all facets of psychedelic light-show construction including strobes, black lights, projectors, crystals, organic slides, mirrors, color organs, polarized color, light boxes, MusicVision, etc. Shows how to "psychedelize" parties, musical groups, shows or how to set up "electric trips" for private gatherings. 8 1/2" x 11" mosaic paper for 3 rings.

Stock No. 9100AV

\$3.00 Ppd.

LONG-WAVE BLACKLIGHT FIXTURE



Extremely versatile, compactly designed, long wave (3200-4000 angstroms) black light (ultraviolet) fixture. Has 6-watt, 110-V lamp with built-in filter—eliminates harmful shorter wave ultraviolet rays. Use to identify minerals, fungi, bacteria—check for surface flaws, oil and gas leakage—perfect for displays with fluorescent paper, paints, chalk, crayons, trace powder, etc. Adjustable aluminum reflector. Mount vert., hor., or on corner. 10" L. 1 1/2" W. 1 1/2" H.

Stock No. 70,364AV

Stock No. 60,124AV

\$12.50 Ppd.

REPLACEMENT BULB \$4.75 Ppd.

Order by Stock No.—Check or M.O.—Money-Back Guarantee

EDMUND SCIENTIFIC CO., 380 EDCORP BLDG., BARRINGTON, N.J. 08007

WRITE FOR GIANT FREE CATALOG "AV"



Completely new edition. New 1185 categories, illustrations, 148 easy-to-read pages packed with 4000 unusual items. Dozens of electrical and electromagnetic parts, accessories. Enormous selection of Astronomical telescopes, Microscopes, Binoculars, Magnifiers, Magnets, Lenses, Lasers, Prisms. Many way surplus items; for hobbyists, experimenters, workshops, factory. Write for catalog "AV"

EDMUND SCIENTIFIC CO. 380 EDCORP BLDG. BARRINGTON, NEW JERSEY 08007

ORDER BY STOCK NUMBER—SEND CHECK OR MONEY ORDER—MONEY-BACK GUARANTEE

CIRCLE NO. 9 ON READER SERVICE PAGE

BILLBOARD 20 RADIO

and Electronics Circuits

Reg. U.S.
Pat. Off.



Training Electronics Technicians Since 1946

PROGRESSIVE HOME RADIO-TV COURSE

Now Includes

- ★ 12 RECEIVERS
- ★ 3 TRANSMITTERS
- ★ SQ. WAVE GENERATOR
- ★ SIGNAL TRACER
- ★ AMPLIFIER
- ★ SIGNAL INJECTOR
- ★ CODE OSCILLATOR

"EDU-KIT" NOW INCLUDES

- ★ TRANSISTOR (Solid State) CIRCUITS
- ★ VACUUM TUBE CIRCUITS
- ★ PRINTED CIRCUITS
- ★ HAND WIRED CIRCUITS

YOU DON'T HAVE TO SPEND HUNDREDS OF DOLLARS FOR A RADIO COURSE

The "Edu-Kit" offers you an outstanding PRACTICAL HOME RADIO COURSE at a rock-bottom price. Our Kit is designed to train Radio & Electronics Technicians, making use of the most modern methods of home training. You will learn radio theory, construction practice and servicing. THIS IS A COMPLETE RADIO COURSE IN EVERY DETAIL. You will learn how to build radios, using regular schematics; how to wire and solder in a professional manner; how to service radios. You will work the standard type of punched metal chassis as well as the latest development of Printed Circuit chassis. You will learn the basic principles of radio. You will construct, study and work with RF and AF amplifiers and oscillators, detectors, rectifiers, test equipment. You will learn and practice code, using the Progressive Code Oscillator. You will learn and practice trouble-shooting, using the Progressive Signal Tracer, Progressive Signal Injector, Progressive Dynamic Radio & Electronics Tester, Square Wave Generator and the accompanying instructional material. You will receive training for the Novice, Technician and General Classes of F.C.C. Radio Amateur Licenses. You will build Receiver, Square Wave Generator, Code Oscillator, Signal Tracer and Signal Injector circuits, and learn how to operate them. You will receive an excellent background for television, Hi-Fi and Electronics. Absolutely no previous knowledge of radio or science is required. The "Edu-Kit" is the product of many years of teaching and engineering experience. The "Edu-Kit" will provide you with a basic education in Electronics and Radio, worth many times the low price you pay. The Signal Tracer alone is worth more than the price of the kit.

THE KIT FOR EVERYONE

You do not need the slightest background in radio or science. Whether you are interested in Radio & Electronics because you want an interesting hobby, a well paying business or a job with a future, you will find the "Edu-Kit" a worthwhile investment. Many thousands of individuals of all

ages and backgrounds have successfully used the "Edu-Kit" in more than 79 countries of the world. The "Edu-Kit" has been carefully designed, step by step, so that you cannot make a mistake. The "Edu-Kit" allows you to teach yourself at your own rate. No instructor is necessary.

PROGRESSIVE TEACHING METHOD

The Progressive Radio "Edu-Kit" is the foremost educational radio kit in the world, and is universally accepted as the standard in the field of electronics training. The "Edu-Kit" uses the modern educational principle of "Learn by Doing." Therefore you construct, learn schematics, study theory, practice trouble shooting—all in a closely integrated program designed to provide an easily-learned, thorough and interesting background in radio. You begin by examining the various radio parts of the "Edu-Kit." You then learn the function, theory and wiring of these parts. Then you build a simple radio. With this first set you will enjoy listening to regular broadcast stations, learn theory, practice testing and trouble-shooting. Then you build a more advanced radio, learn more advanced theory and techniques. Gradually, in a progressive manner, and at your own rate, you will find yourself constructing more advanced multi-tube radio circuits, and doing work like a professional Radio Technician. Included in the "Edu-Kit" course are Receiver, Transmitter, Code Oscillator, Signal Tracer, Square Wave Generator and Signal Injector Circuits. These are not unprofessional "breadboard" experiments, but genuine radio circuits, constructed by means of professional wiring and soldering on metal chassis, plus the new method of radio construction known as "Printed Circuitry." These circuits operate on your regular AC or DC house current.

THE "EDU-KIT" IS COMPLETE

You will receive all parts and instructions necessary to build twenty different radio and electronics circuits, each guaranteed to operate. Our Kits contain tubes, tube sockets, variable, electrolytic, mica, ceramic and paper dielectric condensers, resistors, tie strips, hardware, tubing, punched metal chassis, Instruction Manuals, hook-up wire, solder, selenium rectifiers, coils, volume controls and switches, etc., solid state materials, etc. In addition, you receive Printed Circuit materials, including Printed Circuit chassis, special tube sockets, hardware and instructions. You also receive a useful set of tools, a professional electric soldering iron, and a self-powered Dynamic Radio and Electronics Tester. The "Edu-Kit" also includes Code Instructions and the Progressive Code Oscillator, in addition to F.C.C. Radio Amateur License training. You will also receive lessons for servicing with Progressive Signal Tracer and Signal Injector, a Progressive Signal Tracer, a High Fidelity Guide and a Quiz Book. You receive Membership in Radio-TV Club. Free Consultation Service, Certificate of Merit and Discount Privileges. You receive all parts, tools, instructions, etc. Everything is yours to keep. Progressive "Edu-Kits" Inc., 1189 Broadway, Dept. 700D, Hewlett, N. Y. 11557.

UNCONDITIONAL MONEY-BACK GUARANTEE

- Please rush my Progressive Radio "Edu-Kit" to me, as indicated below:
- Check one box to indicate choice of model
- Deluxe Model \$31.95.
 - New Expanded Model \$34.95 (Same as Deluxe Model plus Television Servicing Course and valuable Radio & TV Tube Checker).
- Check one box to indicate manner of payment
- I enclose full payment. Ship "Edu-Kit" post paid.
 - I enclose \$5 deposit. Ship "Edu-Kit" C.O.D. for balance plus postage.
 - Send me FREE additional information describing "Edu-Kit."

Name
Address

PROGRESSIVE "EDU-KITS" INC.
1189 Broadway, Dept. 700D, Hewlett, N. Y. 11557

FREE EXTRAS

- SET OF TOOLS
- SOLDERING IRON
- ELECTRONICS TESTER
- PLIERS-CUTTERS
- VALUABLE DISCOUNT CARD
- CERTIFICATE OF MERIT
- TESTER INSTRUCTIONS MANUAL
- HIGH FIDELITY GUIDE & QUIZZES
- TELEVISION BOOK & RADIO TROUBLE-SHOOTING BOOK
- MEMBERSHIP IN RADIO-TV CLUB
- CONSULTATION SERVICE & FCC AMATEUR LICENSE TRAINING
- PRINTED CIRCUITRY

SERVICING LESSONS

You will learn trouble-shooting and servicing in a progressive manner. You will practice repairs on the sets that you construct. You will learn symptoms and causes of trouble in home, portable and car radios. You will learn how to use the professional Signal Tracer, the unique Signal Injector and the dynamic Radio & Electronics Tester. While you are learning in this practical way, you will be able to do many a repair job for your friends and neighbors, and charge fees which will far exceed the price of the "Edu-Kit." Our Consultation Service will help you with any technical problems you may have.

FROM OUR MAIL BAG

J. Stataitis, of 25 Poplar Pl., Waterbury, Conn., writes: "I have repaired several sets for my friends, and made money. The "Edu-Kit" paid for itself. I was ready to spend \$20 for a course, but I found your ad and sent for your Kit." Ben Valerio, P. O. Box 21, Magna, Utah: "The Edu-Kits are wonderful. Here I am sending you the questions and also the answers for them. I have been Radio for the last seven years, but like to work with Radio Kits, and like to build Radio Testing Equipment. I enjoyed every minute I worked with the different kits; the Signal Tracer works fine. Also like to let you know that I feel proud of becoming a member of your Radio-TV Club." Robert L. Shuff, 1534 Monroe Ave., Huntington, W. Va.: "Thought I would drop you a few lines to say that I received my Edu-Kit, and was amazed that such a bargain can be had at such a low price. I have already started repairing radios and phonographs. My friends were really surprised to see me get into the swing of it so quickly. The Trouble-shooting Tester that comes with the Kit is really swell, and finds the trouble, if there is any to be found."

PRINTED CIRCUITRY

At no increase in price, the "Edu-Kit" now includes Printed Circuitry. You build a Printed Circuit Signal Injector, a unique servicing instrument that can detect many Radio and TV troubles. This revolutionary new technique of radio construction is now becoming popular in commercial radio and TV. A Printed Circuit is a special insulated chassis on which has been deposited a conducting material which takes the place of wiring. The various parts are merely plugged in and soldered to terminals. Printed Circuitry is the basis of modern Automation Electronics. A knowledge of this subject is a necessity today for anyone interested in Electronics.



B&K
Precision
Model 1460
Triggered
Sweep Scope
\$389.95

B & K Precision's new 1460 Triggered Sweep Scope... The one that's been worth waiting for.

You won't believe how easy it is to sync TV-V and TV-H signals until you've actually tried it.

Trouble shooting complex TV circuits takes enough time without having to fiddle with dials and controls to adjust to the proper wave form.

That's why the new B&K Triggered Sweep Scope features the TV-H and TV-V positions. These are the two new positions you've always needed for quick one-knob selection of horizontal or vertical TV signals. Exclusive sync separator circuit. No complicated and time-consuming adjustments . . . just flick a single knob.

Fully automatic triggered sweep lets you view the entire complex TV signal or any part of it. Including the VITS (vertical interval test signal).

And the "back porch" of the horizontal sync pulse, with color burst information. All locked in rock steady.

All solid state with 5 FETs. Runs coolest. Vertical sensitivity (10mV/cm) and writing speed of 0.1 microsecond/cm (using 5X multiplier). Features usually found in expensive lab scopes. Complete with direct/10 to 1 probe. 19 sweep speeds and 11 voltage calibrated ranges, DC to 10 MHz.

Pinpoint your problems quickly and accurately with the new 1460 Triggered Sweep Scope. The only thing you'll have to adjust to is having more time on your hands. Write for further information.

There is a difference in test equipment—ours works!



Product of DYNASCAN CORPORATION
1801 W. Belle Plaine / Chicago, Illinois 60613

CIRCLE NO. 3 ON READER SERVICE PAGE

7 arguments in favor of building your own speaker system from scratch.

The easiest way to buy high fidelity speakers may not always be the best. Because a complete pre-packaged system may be far from what you need. Consider some of the advantages of separate component loudspeakers:

1. You choose from an almost infinite variety of sizes and levels of performance. Your system will exactly reflect your specific listening preferences.
2. You save space by building speakers into walls, ceilings, closet doors, even in floors! Or use existing cabinets or custom-built enclosures that better suit your decor than any mass-produced system.
3. You enhance the illusion of "live" music by hiding or disguising the sound source. You listen to the music — not the speakers.
4. You can up-date your component system as often as you wish to meet advances in the state of the art.
5. You save money by paying only for performance.

6. You end the conflict between fine sound and handsome decor by making the speaker system an integral part of the room or the furniture.

7. You can use the building-block method of planned improvement as your budget permits. There's no problem of being "stuck" with a compact that fits today's budget but can't meet your ultimate listening goals.

Take a few minutes to study the variety of Electro-Voice component speakers. 21 models from \$20.00 to \$275.00. From super-tweeters to giant 30" woofers. Consider how they can aid in creating a speaker system that uniquely expresses your musical needs. And ask your Electro-Voice high fidelity specialist for his recommendation. Finally, take the time to listen carefully.

Freedom of choice. It's at the very nub of high fidelity.

ELECTRO-VOICE, INC., Dept. 6 1 4 P,
630 Cecil St., Buchanan, Michigan 49107

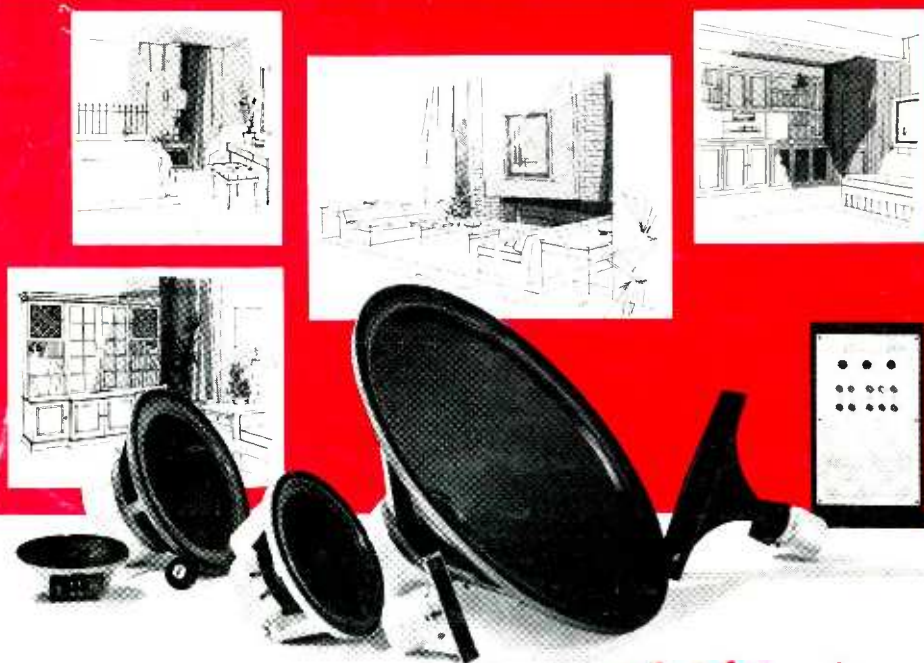

Electro-Voice[®]

A SUBSIDIARY OF GULTON INDUSTRIES, INC.

CIRCLE NO. 4 ON READER SERVICE PAGE