

SOLID-STATE AUTO VOLTAGE REGULATOR

Popular Electronics

FIFTY CENTS / APRIL 1971

Chemicals & Cleaners for Bandswitches TV Tuners & Controls

TIMBRE GATE

Re-Shapes Musical Notes

BATTLE OF GIANT BRAINS

ENIAC, Bell V and Harvard I

IN/OUT ANNUNCIATOR

Photocells Sense Direction

STEREO HEADPHONES

Which Ones and Why



3708015 QLCM 245A601 01K
 SP300046261 5827 A 012K
 M GELSCHLAGER XMAR
 BX 245 D72
 BRDMNS MILLS NJ 08015



NRI "hands-on" training in TV-Radio, Electronics can give you as much as 2 years of on-the-job experience.

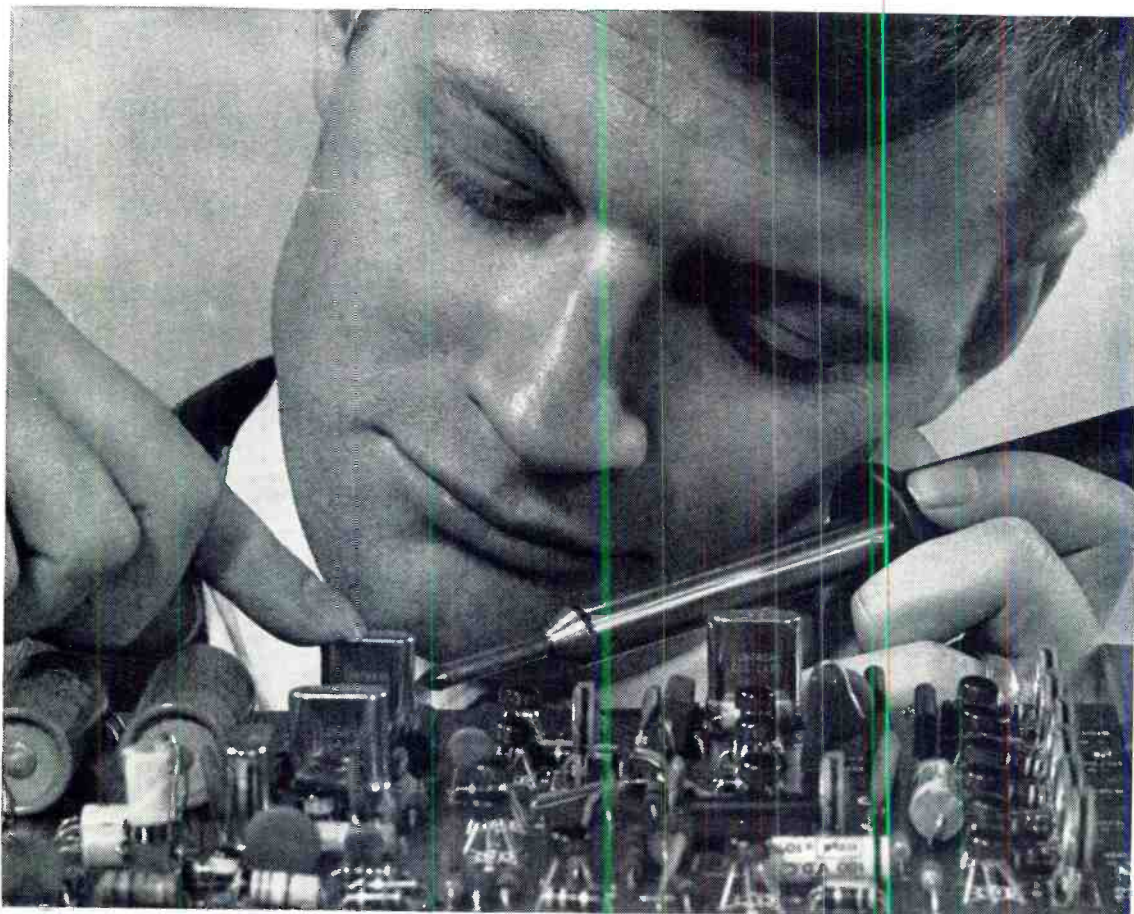

EARN YOUR FCC LICENSE – OR YOUR MONEY BACK

NRI Communications training programs will qualify you for a First Class Commercial Radiotelephone License issued by the FCC. If you fail to pass the FCC examinations for this license after successfully completing an NRI Communications course we will, on request, refund in full the tuition you have paid. This agreement is valid for the period of your active student membership and for six months after completion of your training. No school offers a more liberal FCC License agreement.

Experience is still your best teacher

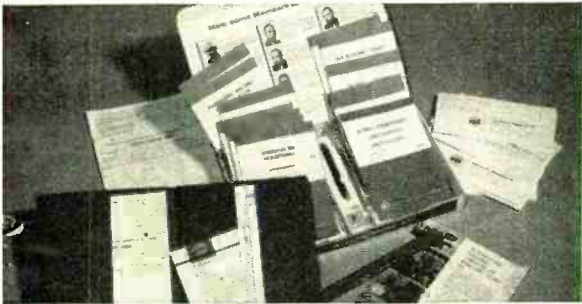

NRI Achievement Kit is educator-acclaimed and the original "starter" kit in home study training. Imitated but never duplicated, this kit is designed and personalized for you and your training objective. It has one purpose — to get you started quickly and easily.



"Bite-Size" Texts average an easily-digested 40 pages of well-illustrated, scientifically prepared subject matter in the course of your choice. Questions in each book are carefully hand-graded and returned to you with helpful instructional notes. You get unlimited personal help from the day you enroll.



Designed-For-Learning Equipment

Like this phone-cw transmitter (Kit #7 in the Communications course) is engineered from chassis up to demonstrate principles you must know. NRI does not use modified hobby kits for training, but the finest parts money can buy, professionally and educationally applied.

...here's how you get it with unique NRI training at home

Ask any teacher, job counselor, engineer, technician or prospective employer about the need for practical application of theory in Electronics. He'll tell you Electronics is as much a "hands-on" profession as dentistry or chemistry. That's how you learn at home with NRI. You prove the theory you read in "bite-size" texts, by actual experimentation with the type of solid-state, transistor and tube circuits you'll find on the job today — *not* hardware or hobby kits. You introduce circuit defects, analyze results, discover quickly the kind of trouble-shooting and design techniques that will make you employable in Electronics.

Train with the leader — NRI

NRI lab equipment is designed from chassis up for effective, fascinating training — not for entertainment. The fact that end results are usable, quality products is a bonus. In Communications, for example, you build and analyze, stage by stage, your own 25-watt phone/cw transmitter. It's suitable for use on the 80-meter amateur band, if you have an interest in ham radio. In TV-Radio Servicing your practical training gives you your choice of monochrome or color TV sets. All training equipment is included in the low tuition — you pay nothing extra. Discover for yourself the ease, excitement and *value* of NRI training. Mail postage-free card today for new NRI Catalog or use the coupon below. No obligation. No salesman will call on you. NATIONAL RADIO INSTITUTE, Washington, D.C. 20016.

APPROVED UNDER NEW GI BILL

If you have served since January 31, 1955, or are in service now, check GI line on postage-free card or in coupon.

MAIL THIS COUPON IF CARD IS GONE



NATIONAL RADIO INSTITUTE

Washington, D.C. 20016

1-120

Please send me your new NRI Catalog. I understand no salesman will call and there is no obligation.

Name _____ Age _____

Address _____

City _____ State _____ Zip _____

Check for facts on new GI Bill

ACCREDITED MEMBER NATIONAL HOME STUDY COUNCIL

Popular Electronics

WORLD'S LARGEST-SELLING ELECTRONICS MAGAZINE

FEATURE ARTICLES

- CHEMICALS FOR ELECTRONICS** 25 *Lon Cantor*
Degreasers, cleaners, and polishers
- BUILD A TIMBRE GATE** 29 *Craig Anderton*
Envelope generator for new sounds
- BATTLE OF THE GIANT BRAINS** 39 *Frank Y. Dill*
Electronics conquers all
- PICK & CHOOSE AMONG STEREO HEADPHONES** 44 *John Steele*
What do they have to offer?
- THE IN-OUT ANNUNCIATOR** 48 *John S. Simonton, Jr.*
Gets them coming and going
- BUILD THE CHARGE NOW** 53 *A. A. Mangieri*
Recharge most any battery
- VR12 VOLTAGE REGULATOR** 65 *C. R. Ball, Jr.*
Solid-state dependability for your car
- COMMUNICATIONS** 71
- THE PRODUCT GALLERY** 76
Heathkit 18-101 Counter
Lafayette RK-890 Recorder
Tompkins Mobilink
- STEREO SCENE** 82 *J. Gordon Holt*
The best of everything
- OPPORTUNITY AWARENESS** 85 *David L. Heiserman*
Your wages vs average
- SOLID STATE** 86 *Lou Garner*
Digital counting grows up

DEPARTMENTS

- DIRECT & CURRENT** 7 *Oliver P. Ferrell*
- INTERFACE** 8
- NEW LITERATURE** 14
- READER SERVICE PAGES** 15, 95
- ELECTRONICS LIBRARY** 16
- NEW PRODUCTS** 22

POPULAR ELECTRONICS is Indexed
in the Reader's Guide
to Periodical Literature

This month's cover photo by
Conrad Studios

Copyright © 1971 by ZIFF-DAVIS PUBLISHING COMPANY. All rights reserved.

William Ziff, President; Hershel B. Sarbin, Senior Vice President and Secretary; Philip Sine, Financial Vice President and Treasurer
POPULAR ELECTRONICS, April 1971, Volume 34, Number 4, Published monthly at One Park Ave., New York, N.Y. 10016.
One year subscription rate for U.S., U.S. Possessions and Canada, \$6.00; all other countries, \$7.00. Second class postage paid at
New York, N.Y. and at additional mailing offices. Authorized as second class mail by the Post Office Department, Ottawa, Canada
and for payment of postage in cash. Subscription service and Forms 3579: P.O. Box 1096, Flushing, N.Y. 11352. Editorial offices
for manuscript contributions, reader inquiries, etc.: One Park Ave., New York, N.Y. 10016.

ELECTRONICS TECHNICIANS:

If you really want
to go places in this
Age of Electronics...

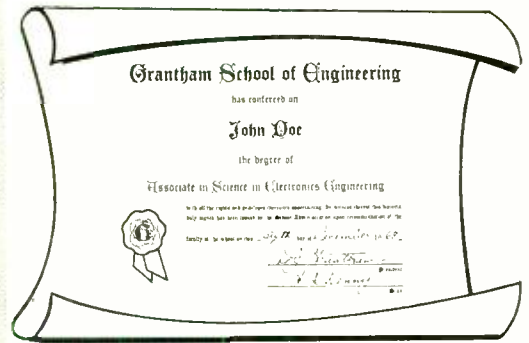

EARN YOUR DEGREE

AND GET INTO ELECTRONICS ENGINEERING!

Advance beyond the technician level. Become an engineer. If you are a high school graduate and have a good aptitude for electronics and mathematics, you can earn the Degree of Associate in Science in Electronics Engineering

MOSTLY BY STUDYING AT HOME

while you remain on your present job. Grantham School of Engineering (GSE) offers a home-study program, followed by a two-week class, for the ASEE Degree. This degree is accredited by the Accrediting Commission of the National Home Study Council.

In this college-level program (presented at the same level as resident-college engineering courses), the lessons have been prepared especially for *home study*. They have been written, revised, added-to, revised, expanded, revised, re-oriented, revised, etc., over a period of many years, by home-study experts in the teaching of engineering, with the one objective of providing a *better way* for technicians to learn engineering.

This *accredited* ASEE Degree program includes: review of basic electronic circuits and systems, a thorough coverage of applied engineering mathematics (including algebra, trigonometry, and calculus), classical and modern physics, technical writing, computer science, electrical networks, and semiconductor circuit analysis and design.

We award the *associate* rather than the bachelor's degree because our educational program covers only engineering and engineering-related subjects and does not cover general subjects such as English, History, Foreign Languages, etc. Notice, however, that the ASEE is a degree in *engineering* rather than the usual junior-college kind of associate degree.

We Teach Better Because We Specialize

The main purpose of the GSE educational program is to *upgrade* electronics technicians to the *engineering level*. Therefore, as a GSE student, you are not, for example,

studying math with accounting students or studying physics with medical students. Instead, all of the lessons covering all subjects are written for students just like yourself — for electronics technicians upgrading to the engineering level. This method allows electronics engineering examples and applications to be tied in with the study of all subjects in the curriculum.

Since all of our students have backgrounds similar to yours and the same professional objective as yours, we can teach all of the required subjects more directly to the point — the way they should be taught (for maximum advantage) specifically to electronics technicians who are upgrading to the engineering level — not generalized to the extent that they apply equally well to a dozen different professions! So *our way* of teaching electronics engineering is more applicable to *your need*.

— G.I. Bill Approved —

- Mail the coupon below for our free Bulletin ●

Grantham School of Engineering PE-4-71
1505 N. Western Ave., Hollywood, Calif. 90027

Gentlemen:

I have been in electronics for _____ years. I am interested in the Grantham degree program in Electronics Engineering. Please send me your free bulletin.

Name _____ Age _____

Address _____

City _____ State _____ Zip _____

CIRCLE NO. 14 ON READER SERVICE PAGE

Tools of the TV Serviceman



TUN-O-BRITE
Cleans, Brightens
& Lubricates Tuner
Contacts

The only tuner spray with built-in polishing action. Won't harm precious metal plating. Heavy-duty lubricant keeps tuners working better, longer.

SUPER FROST AID
Pin-Points Thermal
Intermittents

Isolates defective, heat affected components in TVs and radios. A must for every serviceman. Saves hours of probing and testing for intermittents.

TUN-O-WASH
Tuner Cleaner &
Degreaser

The TUN-O-WASH power spray melts away "gunk", dirt and corrosion. Like an ultrasonic bath in a can, it gets tuners really clean.

Spray chemicals and cleaners are among the most important tools of professional TV servicemen. TUN-O-BRITE, SUPER FROST AID and TUN-O-WASH are three such tools. Each is formulated to do a specific job, and is guaranteed to do it better and easier. Avoid costly callbacks. Build customer satisfaction . . . make more money servicing. Available at your local distributor.

CHEMTRONICS INC.

1260 Ralph Avenue, Brooklyn, New York 11236
CIRCLE NO. 5 ON READER SERVICE PAGE

Popular Electronics

LAWRENCE SPORN
Publisher

OLIVER P. FERRELL
Editor

LESLIE SOLOMON
Technical Editor

JOHN R. RIGGS
Managing Editor

EDWARD I. BUXBAUM
Art Director

ALEXANDER W. BURAWA
Associate Editor

ANDRE DUZANT
Technical Illustrator

PATTI MORGAN
Assistant Editor

JUDITH L. HOGAN
Editorial Assistant

J. GORDON HOLT
L. E. GARNER, JR.
DAVID L. HEISERMAN
Contributor Editors

J. ROYCE RICHARD
Assistant Publisher

RICHARD J. HALPERN
Advertising Manager

ROBERT UR
Marketing Manager

MARGARET DANIELLO
Advertising Service Manager

FURMAN H. HEBB
Group Vice President
Electronics and Photographic

ZIFF-DAVIS PUBLISHING COMPANY
Editorial and Executive Offices
One Park Avenue, New York, New York 10016
212 679-7200

Midwestern Office

The Patis Group, 4761 West Touhy Ave.,
Lincolnwood, Illinois 60466, 312 679-1100
GERALD E. WOLFE, DICK POWELL

Western Office

9025 Wilshire Boulevard, Beverly Hills, California 90211
213 CResview 4-0265; BRadshaw 2-1161
Western Advertising Manager, RUD DEAN

Japan: James Yagi

Oji Palace Aoyama; 6-25, Minami Aoyama
6-Chome, Minato-Ku, Tokyo 407-1930/6821

Circulation Office

P.O. Box 1096, Flushing, N.Y. 11352

William Ziff, President

W. Bradford Briggs, Executive Vice President
Hershel B. Sarbin, Senior Vice President and Secretary
Stanley R. Greenfield, Senior Vice President
Philip Sine, Financial Vice President and Treasurer
Walter S. Mills, Jr., Vice President, Circulation
Phillip T. Heffernan, Vice President, Marketing
Frank Pomerantz, Vice President, Creative Services
Arthur W. Butzow, Vice President, Production
Edward D. Muhlfeld, Vice President, Aviation Division
Irwin Robinsan, Vice President, Travel Division
George Morrissey, Vice President
Sydney H. Rogers, Vice President

Ziff-Davis also publishes Airline Management and Marketing including American Aviation, Boeing, Business & Commercial Aviation, Car and Driver, Cycle, Electronics World, Flying, Modern Bride, Popular Photography, Skinning, Skiing Area News, Skiing Trade News, Stereo Review, and Travel Weekly.

Forms 3579 and all subscriptions correspondence should be addressed to POPULAR ELECTRONICS, Circulation Department, P.O. Box 1096, Flushing, N.Y. 11352. Please allow at least six weeks for change of address. Include your old address, as well as new-enclosing if possible an address label from a recent issue.

EDITORIAL CONTRIBUTIONS must be accompanied by return postage and will be handled with reasonable care; however, publisher assumes no responsibility for return or safety of art work, photographs or manuscripts.



Member Audit Bureau
of Circulations



Eighth in a Monthly Series by Oliver P. Ferrell, Editor

HOPEFULLY, NOT A SECOND TIME AROUND

If you haven't noticed, the audiophiles have a new vocabulary. All their serious discussions now involve words and phrases such as: ambiance, encoder, L-R, total compatibility, etc. It all has to do with either getting something for nothing or making an attempt to compress four channels of music information into the same track width or groove depth that last year was occupied by two channels—in other words, surround quadriphonic stereo.

This editorial is not a progress report on four-channel sound—simply because events in this field are moving so rapidly that, in the relatively short time between the writing and publication of an editorial, there is almost certain to be the birth of another new idea or innovation—and more new words. Also, I find it difficult to stifle a nagging sensation that all is not right with four channel. Has the hi-fi industry turned its engineers loose to run amuck and stimulate business through new product developments, or is there a “call” for four channels? Does good listening really require total immersion of the listener or are the first four-channel demonstrations minimizing musical values for electronic showmanship?

It's fascinating from an engineering point of view to see and hear what a relatively simple decoder—such as that used in the Electro-Voice system—reveals to be hidden away on present disc or tape stereo recordings. But simultaneously, it's musically unnerving to be bombarded with sound from all directions.

There's a good chance that properly used (whatever that might be) four-channel reproduction has some very desirable advantages for the serious, or even the background music, listener. However, at the moment, it is difficult to believe that four channel is of great interest to anyone other than the devotee of modern pop and rock music. Certainly my teenagers—more than I—would find four channel to their liking—although that affinity might well be due to the fact that four channel sounds louder and gets the listener more “involved.”

The outboard gadgets, the doubling up of amplifiers and speakers, recall the introduction of the stereo disc in 1958. Hopefully, the hi-fi industry recalls the confusion created then after the first flush of success. I think that four channel is on the threshold of something big. Whether it's in the techniques of recording or playback remains to be seen; but, gentlemen, don't make us go around again.



INTERFACE

ELECTRONICS SELF-STUDY PROGRAM

I would like to congratulate the author and the staff of POPULAR ELECTRONICS for the very fine article in the December, 1970 issue on page 45. Unfortunately, of the 12 manuals that I have ordered, only five have been delivered and there is an indication that four will be sent within the future and three seem to be permanently out of stock.

W. STROH III
Short Hills, N.J.

Reader response to the "Electronics Self-Study Program" article far exceeded our best estimates. The Government Printing Office apparently received over 1000 orders for the electronics training manuals mentioned in the story and soon found that stocks of certain manuals had been depleted. Our apologies to those readers who didn't get their

orders into the GPO in time to receive the full complement of manuals.

THOSE HARD-TO-FIND PARTS

Your Direct & Current editorial (February issue, p 7) emphasizes a very annoying problem. However, I believe the blame lies more with the manufacturers than the distributors. Here are some of the reasons the local store may not have the "latest and greatest":

1. New devices are announced months before they can be made available. This is a deliberate sales policy to feel out the market.

2. Manufacturing the device runs into trouble and after products have been announced they cannot be manufactured.

3. There are frequent minor mechanical or electrical parameter changes and/or the numbering may be changed.

4. Many manufacturers bring out devices first under their "house" numbers and after they become popular the same device is assigned a new, but standard, EIA number. Conversion lists from house numbers to standard EIA numbers are hard to come by.

5. For many uses, there may be devices that are equally suitable and many manufacturers offer "replacement" devices. However, sometimes replacements do not work and the original number would have been preferred in the article—in other words, how does the magazine reader without access to a full list of standard numbers replace a replacement?

I agree that it would be good business to



The does-it-all turntable at a do-it-yourself price.

It's the BSR McDonald 310/X, and it's the best buy in automatic turntables. Anywhere.

This is no "little brother" turntable, either. It's got a full-size platter, cue and pause control, low mass tone arm system and a visible stylus pressure indicator.

And because it's a famous BSR Total Turntable, it comes complete with a tinted dust cover, custom molded base and a Shure M-75 magnetic cartridge—all factory-installed and balanced and included in the low price.

The BSR McDonald 310/X. It's perfect for people who want the best, no matter how little it costs.

Send for free full color catalog on all our automatic turntables. BSR (USA) Ltd., Blauvelt, N.Y. 10913

BSR
McDONALD

CIRCLE NO. 2 ON READER SERVICE PAGE

POPULAR ELECTRONICS

NEW KITS

CONTAINING THE LATEST STATE OF THE ART ELECTRONIC COMPONENTS FROM THE NATION'S LEADING MANUFACTURERS OF SOLID STATE SEMICONDUCTORS

Logiconcepts is dedicated to linking the latest electronic hardware to the practical understanding of its function by actual use of the product. Our volume purchase practices, industry knowledge and our

association with top electronic engineers keeps our designs and kits up-to-date. State of the art hardware, latest circuitry and design . . .

. . . that's Logiconcepts.

PSYCHEDELIC LIGHTS

A bright, colorful, 6 bulb audio activated light. Volume control for variable sensitivity, 3 channel light system. Solid state circuitry. Walnut base with diffused pattern translucent plastic cover. Easy to assemble kit. Arrange lights in variable configurations. 13 inches high. Complete kit and instructions. . . **\$24.95**



DIGITAL CLOCK

A totally solid state clock. Trouble free, sharper clearer display with R.C.A. Numitron 7 segment read-out tubes. MSI-TTL Logic on one simple circuit board. New design eliminates line noise common in other digital clocks. Displays hours, minutes and seconds. Assemble a 12 or 24 hour version.

Cost on complete kit. **\$79.95**
Walnut cabinet **\$9.95 extra.**



POWER SUPPLIES

MODEL D-200 DUAL POWER SUPPLY: A bench type regulated supply featuring 2 independent outputs. Ideal for testing all IC or Semi circuits. Independent output adjustments. 0 to 22 VDC at 750 MA. 10 MV RMS max. ripple.

Complete kit w/instructions. . . **\$69.95**

MODEL S-100 SQUARE WAVE GENERATOR & POWER SUPPLY: Bench type. TTL compatible. 10HZ to 1 MHZ. 5V at 1 amp. digital supply. Continuous variable clock outputs. Fixed supply, short circuit protected.

Easy to assemble kit. **\$44.95**

DUAL POWER SUPPLY



SQUARE WAVE GENERATOR

VERSATILE BARRY SPRINGBOARDS FOR QUICK, EASY CIRCUIT SET UP



A positive way to develop circuits, experimental or permanent. No soldering necessary, reusable. Spring action, positive connections. Assemble, rearrange, disassemble easily. Can be linked for more complex circuits. Regular model: **\$8.95** Deluxe model: **\$9.95**

LOGICONCEPTS has several advanced project educational kits featuring latest components and circuitry.

WRITE FOR DETAILS.

SEND CHECK OR MONEY ORDER TODAY OR WRITE FOR DETAILS ON KITS

Advancing electronics with practical kits that utilize the latest electronic components.

LOGICONCEPTS, INC.

22513 SO. NORMAND E AVE. • TORRANCE, CALIF. 90501
PHONE: (213) 328-5031/775-3613

*California residents add 5½% sales tax

Gentlemen: Enclosed is my check for \$ _____ to cover the cost of _____

Send me details on: _____

Send information on your Educational Kits.

Name: _____

(PLEASE PRINT)

Street: _____

City: _____

State: _____ Zip: _____

CIRCLE NO. 18 ON READER SERVICE PAGE

April, 1971

9



...the new Heathkit® 25" ultra-rectangular TV color picture is that perfect.

"Picture postcard perfect"...an apt description for the quality of color reproduction in the new Heathkit GR-371MX 25" ultra-rectangular solid-state color TV. And the reasons are as clear as the expanded 315 sq. in. view:

New Heath MTX-5 ultra-rectangular matrix picture tube. Developed in conjunction with leading domestic tube manufacturers to produce a sharper picture, purer colors, more natural flesh tones. Specially formulated etched face plate cuts out unwanted glare, increases contrast without sacrificing brightness. Matrix screen around phosphor dots eliminates reflected light, allows use of higher transmission glass for greater light output. New square-corner rectangular design opens up the largest picture in the industry...25" diagonal measurement, a full 315 sq. in. of viewing enjoyment. New shape allows complete transmitted image to be seen for the first time. Pictures don't wrap around sides of tube as before. And 25,000 volt high voltage assembly assures optimum picture quality.

Unique solid-state design: 45 transistors, 55 diodes, 2 silicon controlled rectifiers; 4 advanced ICs containing another 46 transistors and 21 diodes; and just 2 tubes (picture and high voltage rectifier) combine to deliver performance and reliability unobtainable in conventional tube sets.

Other plus-performance features include: High resolution circuitry for improved picture clarity, plus new adjustable video peaking that lets you select the degree of sharpness and resolution you desire; an exclusive solid-state VHF tuner with MOS Field Effect Transistor for superior reception even under marginal conditions; Memory Fine Tuning; 3-stage solid-state IF, factory-assembled and aligned; Automatic Fine Tuning; VHF power tuning; "Instant-On"; Automatic Chroma Control; adjustable noise limiting and gated AGC; adjustable tone control; hi-fi sound output to your stereo or hi-fi system.

Exclusive owner-service capability...only Heath offers you this money-saving advantage: built-in dot generator and tilt-out convergence panel let you do periodic dynamic convergence adjustments required of all color TVs. Modular plug-in glass-epoxy circuit boards with transistor sockets permit fast, easy service

and adjustment. Volt-Ohm meter supplied for detailed troubleshooting right down to the smallest part.

Available in choice of factory-assembled, pre-finished cabinets: Mediterranean, Early American, Contemporary...or without cabinet for custom installation.

Kit GR-371MX, 125 lbs., (less cabinet) 579.95*

Choose from the complete line of Heathkit solid-state Color TVs... for every size and budget requirement:



14" portable solid-state color TV

Kit GR-169, 69 lbs., including cabinet 349.95*

20" solid-state color TV

Kit GR-270, 109 lbs., less cabinet 489.95*

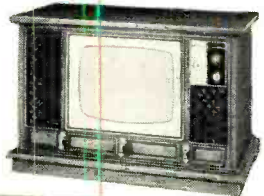

23" solid-state color TV

Kit GR-370, 124 lbs., less cabinet 539.95*



A New 25-pedal
"Legato"
1,495*

C New solid-state
amateur receiver
319.95*

B
New
microwave
oven
399.95*

D New 15 MHz
frequency counter
199.95*

And while you're at it, picture these Heathkit newsmakers in your den, kitchen, ham shack or shop.

A New Heathkit solid-state "Legato" 25-pedal Theater Organ

One of the world's most versatile musical instruments...now in money-saving kit form. Designed exclusively for Heath by Thomas Organ craftsmen. All solid-state. Features 15 manual voices, 4 pedal voices...any or all at the flip of a tab. 25-note heel & toe pedal board, range 16' & 8' C0 to C3. Color-Glo® key lights and comprehensive organ course supplied have you playing like a pro in minutes. Two 44-note keyboards; accompaniment range 8'...F1 to C5. Solo manual 16', 8', 4', 2'...F1 to C7. 200 watts peak power from two solid-state amplifiers...one for the 2-speed rotating Leslie speaker and one for the two 12" speakers. Tape record/playback jack on amplifier. Band Box & Playmate accessories available.

Kit TO-101, 299 lbs.1,495*

B New Heathkit microwave oven

The cooking revolution of tomorrow, here today in easy-to-build kit form...saving you hundreds of dollars over comparable electronic ovens. Exclusive patent-pending Heath double door interlock system provides absolute safety...oven cannot be turned on if door is open. Prepares meals in minutes, not hours. Cooks on china, glass, even paper plates in spacious, roast-size oven cavity.

Low-profile, countertop design fits unobtrusively into kitchen decor. Portable convenience, too...can be used on patio, at poolside, etc...wherever a 120 VAC grounded outlet is provided. Give your wife a break from kitchen drudgery...with this new miracle of microwave cooking.

Kit GD-29, 97 lbs.399.95*

C New Heathkit solid-state 80-10 meter amateur receiver

All the quality you'd expect in a new Heathkit receiver...and solid-state to boot. Tunes USB, LSB, AM, CW & RTTY, 80-10M. 15 MHz WWV coverage. 100 & 25 kHz calibration. Dual gate MOSFET front end for greater dynamic range. Solid-state factory-assembled & aligned linear master oscillator for rock-solid tuning with 1 kHz readout. 1/4 µV sensitivity for 10 dB S+N/N. 2.1 kHz selectivity with built-in SSB crystal filter...optional AM & CW crystal filters available.

Kit SB-303, 21 lbs.319.95*

D New Heathkit solid-state 15 MHz frequency counter

Another Heathkit first...highly accurate frequency measurement at a price you can afford to pay. Delivers stable, accurate counting from 1 Hz to over 15 MHz. All integrated circuitry for top performance, high reliability. Automatic trigger level for wide range input without adjustment. Five digit cold-cathode readout with Hz/kHz ranges and overrange indicators give 8-digit capability. Input Z 1 megohm shunted by less than 20 pF for low circuit loading.

Kit IB-101, 7 lbs.199.95*

See these and 300 other Heathkit suggestions at one of the following Heathkit Electronic Centers:

CALIFORNIA: Anaheim, 92805, 330 E. Ball Road, El Cerrito, 94530, 6000 Potrero Avenue, La Mesa, 92041, 8363 Center Drive, Los Angeles, 90007, 2309 S. Flower St.; Redwood City, 94063, 2001 Middlefield Rd.; Woodland Hills, 91364, 22504 Ventura Blvd.; COLORADO: Denver, 80212, 5940 W. 38th Ave.; GEORGIA: Atlanta, 30305, 3285 Roswell Road; ILLINOIS: Chicago, 60645, 3462-66 W. Devon Ave.; Downers Grove, 60515, 224 Ogden Ave.; MARYLAND: Rockville, 20852, 5542 Nicholson Lane; MASSACHUSETTS: Wellesley, 02181, 165 Worcester St.; MICHIGAN: Detroit, 48219, 13645 W. Eight Mile Rd.; MINNESOTA: Hopkins, 55343, 101 Shady Oak Rd.; MISSOURI: St. Louis, 63123, 9296 Gravois Ave.; NEW JERSEY: Fair Lawn, 07410, 35-07 Broadway (Rte. 4); NEW YORK: Jericho, L.I., 11753, 15 Jericho Turnpike; New York, 10036, 35 W. 45th Street; OHIO: Cleveland, 44129, 5444 Pearl Rd.; Woodlawn, 45215, 10133 Springfield Pike; PENNSYLVANIA: Philadelphia, 19149, 6318 Roosevelt Blvd.; PITTSBURGH, 15235, 3482 William Penn Hwy.; TEXAS: Dallas, 75201, 2715 Ross Avenue; Houston, 77027, 3705 Westheimer; WASHINGTON: Seattle, 98121, 2221 Third Ave.; WISCONSIN: Milwaukee, 53216, 5215 W. Fond du Lac

Retail Heathkit Electronic Center prices slightly higher to cover shipping, local stock, consultation and demonstration facilities. Local service also available whether you purchase locally or by factory mail order.

HEATHKIT
a Schlumberger Company

HEATH COMPANY, Dept. 10-4
Benton Harbor, Michigan 49022

Enclosed is \$....., plus shipping.

Please send model (s)

Please send FREE Heathkit Catalog. Please send Credit Application.

Name _____

Address _____

City _____ State _____ Zip _____

*Mail order prices: F.O.B. factory.
Prices & specifications subject to change without notice. CL-403R

CIRCLE NO. 15 ON READER SERVICE PAGE



Regency
Monitoradio Scanner
Model TMR-8U

Scanningly New and Field Tested for Automatic, Positive, and Clear Reception of the Intricate UHF Band

Push the buttons. They're there to give you program control over your choice of eight UHF crystal controlled frequencies —450-470 MHz.

Program it to hear both sides of two-way conversations, even though they may be on different frequencies. Operate it automatically or manually. Each of 8 channels has a push button for placing the frequency in or out of service. Hear what's happening on all or any combination of channels. Fascinating scanning lights detail over busy receiver's signal search. It stops to hear all of an active message. . . . then resumes search for a return or other signal.

Our new monitoradio/scanner has been developed and tested to perform in areas of high density interference. With Regency, you get the result of exacting performance: .05 second per channel scan rate and 0.7 microvolt sensitivity @ 20 db.

It comes complete with AC and DC cords, mobile mounting bracket, detachable telescope antenna, built-in 4" speaker plus terminals for external speaker and remote antenna. All for only \$159.00. Crystals \$4.95 each. Also single channel Model TMR-1U \$119.00. See them at your favorite Regency retailer all over the country.

 **Regency ELECTRONICS, INC.**

American Made
One Year Warranty
Patent Pending

7900 Pendleton Pike • Indianapolis, Indiana 46226
CIRCLE NO. 23 ON READER SERVICE PAGE

14



Blonder-Tongue Labs., Inc., recently made available their No. 70-72 "Home Products Catalog." The catalog contains specifications and photos for mast-mounted preamplifiers, broadband amplifiers, amplified signal dividers, UHF converters, antenna rotors, antennas, and miscellaneous home TV system accessories.

Circle No. 75 on Reader Service Page 15 or 95

More than 150 current and forthcoming titles are listed in the Winter 1970 Catalog of Electronic, Electrical & Hobbyist Books recently issued by *Tab Books*. The 20-page catalog covers schematic/servicing manuals, broadcasting, basic technology, CATV, electronics engineering, reference, audio, TV and radio, hobby and experiment topics, to cite just a few. Some of the forthcoming titles featured are "Computer Circuits & How They Work," "Electronic Musical Instruments," and "TV Trouble Diagnosis Made Easy."

Circle No. 76 on Reader Service Page 15 or 95

A six-page catalog (No. C171) available from *Bell P/A Products Corp.* gives detailed specifications and descriptions of the company's broad line of commercial sound components and special-purpose sound systems. The catalog covers amplifiers, tuners, boosters, mixers, turntables and record changers, carrying cases and cabinetry. Complete specifications and photographs of the Bell P/A Mod Series, the Carillon Series, the Transistor Power Amplifier Series, and the SLA Series of automatic limiting amplifiers.

Circle No. 77 on Reader Service Page 15 or 95

More than 25,000 American, European, and Japanese semiconductors are cross-referenced to HEP equivalents in *Motorola's* new replacement guide/catalog No. HEP HMA-07. Listings for thousands of manufacturers' regular and "house" numbers are also included. The semiconductor cross-reference guide features the company's full-line HEP product catalog which gives minimum and maximum ratings and electrical characteristics for 285 HEP devices. The devices are listed by type number with a packaging index, dimension drawing, and selection guide information.

Circle No. 78 on Reader Service Page 15 or 95

POPULAR ELECTRONICS

Popular Electronics

READER SERVICE PAGE

free information service:

Here's an easy and convenient way for you to get additional information about products advertised or mentioned editorially (if it has a "Reader Service Number") in this issue. Just follow the directions below... and the material will be sent to you promptly and free of charge.

1. On coupon below, circle the number(s) that corresponds to the key number(s) at the bottom or next to the advertisement or editorial mention that is of interest to you. (Key numbers for advertised products also appear in the Advertisers' Index.) Print or type your name and address on the lines indicated.

2. Cut out the coupon and mail it to: POPULAR ELECTRONICS, P.O. Box 8391, Philadelphia, PA 19101.

note: If you want to write to the editors of POPULAR ELECTRONICS about an article on any subject that does not have a key number, write to POPULAR ELECTRONICS, One Park Avenue, New York, N.Y. 10016. Inquiries concerning circulation and subscriptions should be sent to POPULAR ELECTRONICS, P.O. Box 1096, Flushing, N.Y. 11352.

4/71-1
Void after May 31, 1971

Popular Electronics

P.O. BOX 8391
PHILADELPHIA, PA. 19101

1 2 3 4 5 6 7 8 9 10 11 12 13 14 15 16 17 18 19 20
21 22 23 24 25 26 27 28 29 30 31 32 33 34 35 36 37 38 39 40
41 42 43 44 45 46 47 48 49 50 51 52 53 54 55 56 57 58 59 60
61 62 63 64 65 66 67 68 69 70 71 72 73 74 75 76 77 78 79 80
81 82 83 84 85 86 87 88 89 90 91 92 93 94 95 96 97 98 99 100

NAME (Print clearly) _____

ADDRESS _____

CITY _____ STATE _____ ZIP CODE _____



Electronics LIBRARY

RADIO SPECTRUM HANDBOOK

by James M. Moore

A reviewer is inevitably faced with one nagging question when a new book appears on his desk: Why was this written and published? Sometimes the answer is self-evident, but on occasion a book arrives concerning a subject that was never covered in print before and that defies rational explanation as to why it should be covered. That, unfortunately, is the case with Mr. Moore's *Radio Spectrum Handbook*.

This is an imposing collection of data on radio frequency assignments and usage, bit-by-bit and channel-by-channel from 10 kHz to 40,000 MHz. It is extraordinarily well-done, in an orderly, detailed fashion—with ample illustrations. But, who needs, requires, or wants this sort of information? Although there appears to be no similar collection of data available to the public, each piece of information in the book is readily available

from the proper source for the asking. Since no one would envy Mr. Moore the task he undertook, he must be congratulated on the reduction of so much data to such a palatable format. This is a reference work and hopefully will find its way into many technical libraries and possibly the hands of a few SWL's who tune between the broadcast bands.

Published by Howard W. Sams & Co., Inc., 4300 West 62 St., Indianapolis, IN 46268. Hard cover. 192 pages. \$7.95

AMATEUR RADIO TECHNIQUES

by J. P. Hawker, G3VA

The British, and in particular The Radio Society of Great Britain, are favored by the presence of J. P. Hawker, G3VA, on the editorial scene. Pat (what else is there to call him) has the talent for wading through a jungle of schematics and finding the crucial circuits. Once he has located them, Pat employs what must be one of the world's most underrated photographic memories to point out what is different, new, unusual, or worthwhile. It is a constant amazement to those of us who look forward to reading his monthly "Technical Topics" column in *Radio Communication* how one man can know so much about so many aspects of electronics.

This book is a nicely put together collection of several hundred "Topics" columns arranged in categories such as: components, receivers, audio, power supplies, antennas, etc.

(Continued on page 94)

*the tape that
turned the
cassette into
a high-fidelity
medium*



TDK SUPER DYNAMIC (SD) TAPE



CIRCLE NO. 24 ON READER SERVICE PAGE

TDK

Until TDK developed gamma ferric oxide, cassette recorders were fine for taping lectures, conferences, verbal memos and family fun—but not for serious high fidelity.

Today you can choose among high-quality stereo cassette decks.

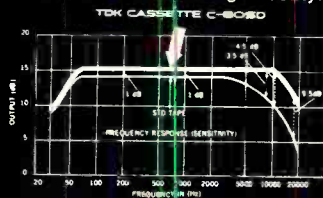

The new magnetic oxide used in TDK Super Dynamic tape distinctively differs from standard formulations in such important properties as coercive force, hysteresis-loop squareness, average particle length (only 0.4 micron!) and particle width/length ratio. These add up to meaningful performance differences: response capability from 30 to 20,000 Hz, drastically reduced background hiss, higher output level, decreased distortion and expanded dynamic range. In response alone, there's about 4 to 10 db more output in the region above 10,000 Hz—and this is immediately evident on any cassette recorder, including older types not designed for high performance. There's a difference in clarity and crispness you can hear.

Available in C60SD and C90SD lengths.

TDK ELECTRONICS CORP.

LONG ISLAND CITY, NEW YORK 11103

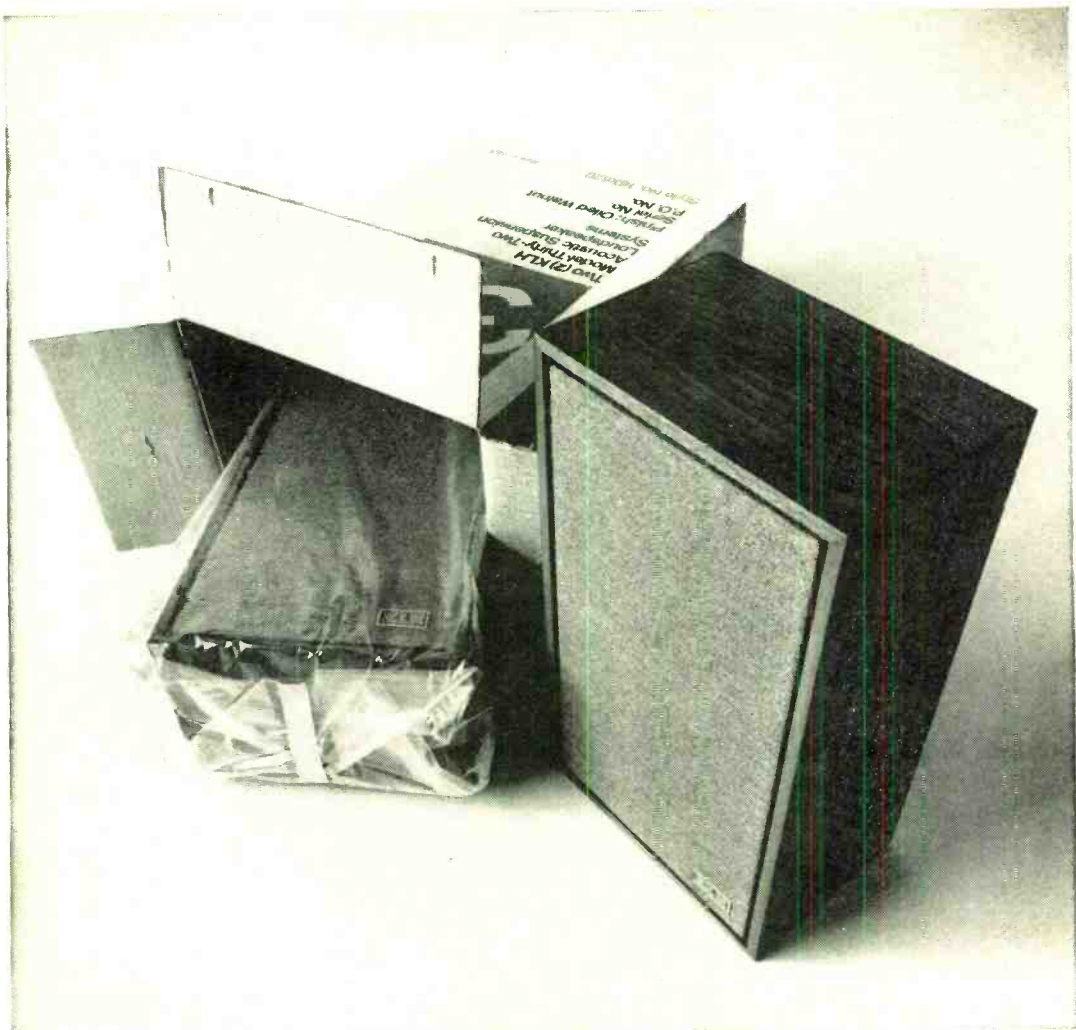

The new KLH Thirty-Two is the best speaker you can buy for the money.

Bravado has never been our bag. But after carefully comparing the new model Thirty-Two with our competitor's best-selling loudspeaker, we're going to break our rule.

Our product is superior.

You see, the Thirty-Two sounds like a very close relative of our now famous Model Six.

With good reason.

It's designed like a Six. It's built like a Six. And it shares many of the Six's finest listening qualities. Bass response that curts your toes. A mid-range that seduces you with its smoothness. And an overall sound quality that finally puts an end to listening fatigue.

But the Thirty-Two not only sounds like an expensive speaker, it looks like one, too. It is unquestionably the

best looking loudspeaker in its price range.

The price?

Almost as amazing as the sound. Just \$47.50 (\$95 the pair).†

Make sure you hear—and see—the new KLH Thirty-Two soon. And compare it with the best-known speaker in its price range. We are sure you will agree that there's never been anything like it for the money.

Anybody's money.

For more information on the Model Thirty-Two, write to KLH Research and Development Corporation, 30 Cross St., Cambridge, Mass. 02139. Or visit your KLH dealer.



Hunting for a better job?

**Here's the
license
you need
to go after
the big ones**

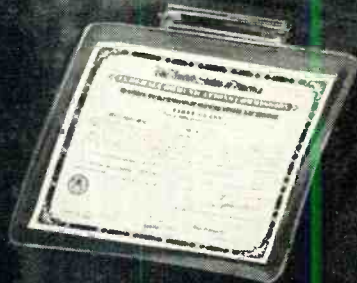

A Government FCC License can help you bring home up to \$10,000, \$12,000, and more a year. Read how you can prepare for the license exam at home in your spare time—with a passing grade assured or your money back.

IF YOU'RE OUT TO BAG A BETTER JOB in Electronics, you'd better have a Government FCC License. For you'll need it to track down the choicest, best-paying jobs that this booming field has to offer.

Right now there are 80,000 new openings every year for electronics specialists—jobs paying up to \$5, \$6, even \$7 an hour... \$200, \$225, \$250, a week... \$10,000, \$12,000, and up a year! You don't need a college education to make this kind of money in Electronics, or even a high school diploma.

But you *do* need knowledge, knowledge of electronics fundamentals. And there is only one nationally accepted method of measuring this knowledge... the licensing program of the FCC (Federal Communications Commission).

Why a license is important

An FCC License is a legal requirement if you want to become a Broadcast Engineer, or get into servicing any other kind of transmitting equipment—two-way mobile radios, microwave relay links, radar, etc. And even when it's not legally required, a license proves to the world that you understand the principles involved in *any* electronic device. Thus, an FCC "ticket" can open the doors to thousands of exciting, high-paying jobs in communications, radio and broadcasting, the aerospace program, industrial automation, and many other areas.

So why doesn't everyone who wants a good job in Electronics get an FCC License and start cleaning up?

The answer: it's not that simple. The government's licensing exam is tough. In fact, an average of two out of every three men who take the FCC exam fail.

There is one way, however, of being pretty certain that you will pass the FCC exam. And that is to take one of the FCC home study courses offered by Cleveland Institute of Electronics.

CIE courses are so effective that better than 9 out of 10 CIE graduates who take the exam pass it. That's why we can back our courses with this iron-clad Warranty: Upon completing one of our FCC courses, you must be able to pass the FCC exam and get your license—or you'll get your money back!

They got their licenses and went on to better jobs

The value of CIE training has been demonstrated time and again by the achievements of our thousands of successful students and graduates.

2 NEW CIE CAREER COURSES

1. BROADCAST (Radio and TV) ENGINEERING... now includes Video Systems, Monitors, FM Stereo Multiplex, Color Transmitter Operation.

2. ELECTRONICS ENGINEERING... covers steady-state and transient network theory, solid state physics and circuitry, pulse techniques, computer logic and mathematics through calculus. A college-level course for men already working in Electronics.

Ed Dulaney, Scottsbluff, Nebraska, for example, passed his 1st Class FCC License exam soon after completing his CIE training... and today is the proud owner of his own mobile radio sales and service business. "Now I manufacture my own two-way equipment," he writes, "with dealers who sell it in seven different states, and have seven full-time employees on my payroll."

Daniel J. Smithwick started his CIE training while in the service, and passed his 2nd Class exam soon after his discharge. Four months later, he reports, "I was promoted to manager of Bell Telephone at La Moure, N.D. This was a very fast promotion and a great deal of the credit goes to CIE."

Eugene Frost, Columbus, Ohio, was stuck in low-paying TV repair work before enrolling with CIE and earning his FCC License. Today, he's an inspector of major electronics systems for North American Aviation. "I'm working 8 hours a week less," says Mr. Frost, "and earning \$228 a month more."

Send for FREE book

If you'd like to succeed like these men, send for our FREE 24-page book "How To Get A Commercial FCC License." It tells you all about the FCC License... requirements for getting one... types of licenses available... how the exams are organized and what kinds of questions are asked... where and when the exams are held, and more.

With it you will also receive a second FREE book, "How To Succeed In Electronics." To get both books without cost or obligation, just mail the attached postpaid card. Or, if the card is missing, just mail the coupon below.

ENROLL UNDER NEW G.I. BILL. All CIE courses are available under the new G.I. Bill. If you served on active duty since Jan. 31, 1955, or are in service now, check box on reply card for complete details.

CIE Cleveland Institute of Electronics

1776 E.17th St., Cleveland, Ohio 44114

Accredited Member National Home Study Council
A Leader in Electronics Training... Since 1934



Cleveland Institute of Electronics
1776 East 17th Street, Cleveland, Ohio 44114

Please send me without cost or obligation:
Your 44-page book "How to Succeed In Electronics" describing job opportunities in Electronics today, and how your courses can prepare me for them.
Your book on "How To Get A Commercial FCC License."

I am especially interested in:

| | |
|--|--|
| <input type="checkbox"/> Electronics Technology | <input type="checkbox"/> Electronic Communications |
| <input type="checkbox"/> Broadcast Engineering | <input type="checkbox"/> Industrial Electronics |
| <input type="checkbox"/> First Class FCC License | <input type="checkbox"/> Electronics Engineering |

Name _____ (PLEASE PRINT)
Address _____
City _____
State _____ Zip _____ Age _____

Check here for G.I. Bill information **PE-15**

CIRCLE NO. 6 ON READER SERVICE PAGE

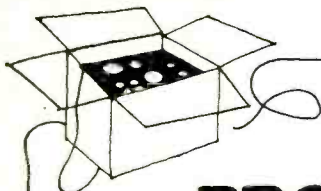

NEW PRODUCTS

Additional information on products described in this section is available from the manufacturers. Each new product is identified by a corresponding number on the Reader Service Page. To obtain additional information on any of them, circle the number on the Reader Service Page, fill in your name and address, and mail it in accordance with the instructions.

ESTERLINE ANGUS DIGITAL MULTIMETER—Priced just under \$200, the new *Esterline Angus* multimeter has eight ac voltage and current ranges, eight dc voltage and current ranges and five ohm ranges. It measures in 10-mV and 10- μ A steps on the lowest voltage and current ranges. Accuracy on linear readings is 1% with a 10% over-range on all scales. Three-digit display has automatic positioning of decimal point.

Circle No. 79 on Reader Service Page 15 or 95

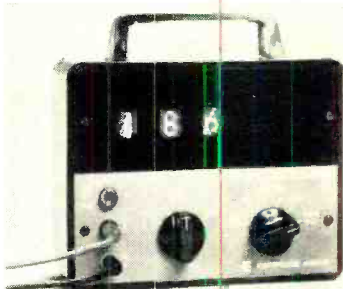

JBL BOOKSHELF SPEAKERS—Originally developed for recording studios where high quality but small size (1.5 cu. ft.) were necessary, the L100 Century speaker system is now available from *James B. Lansing Sound, Inc.* Though small in size each unit still contains 3 speakers: a long-excursion 12" woofer, a 4" midrange for 2500 to 7500 Hz, and a direct radiator for the top notes. Tonal balance can be controlled from the front of the unit. Note the three-dimensional grille material, which is reportedly better than cloth.

Circle No. 80 on Reader Service Page 15 or 95

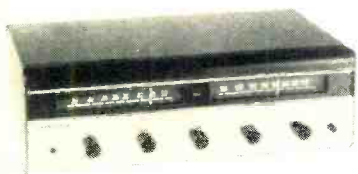
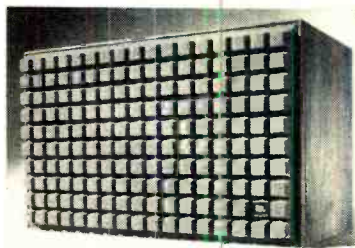

LAFAYETTE DUAL-BAND RECEIVER—Monitoring the police and fire frequencies is made easier by *Lafayette Radio Electronics Corp.*'s new Model PF200, covering 30 to 50 and 144 to 174 MHz. It uses 19 transistors, 9 diodes, 1 IC and 3 ceramic i-f filters for \pm 325 kHz, 60 dB selectivity and 1 microvolt sensitivity. There are two crystal positions on each band as well as squelch, built-in speaker, tape recording output jack and external speaker jack.

Circle No. 81 on Reader Service Page 15 or 95

SCOTT 125-WATT AM/STEREO FM RECEIVER—The exclusive Perfectune automatic tuning circuit—which provides a visual indication when FM tuning is optimum—is one of the features of the *H. H. Scott* Model 636 receiver. Another is the use of field effect transistors in the front end (to get the most stations with the least distortion) and in the tone control for maximum range. All the controls and input and output jacks are there too—at a price of \$249.95, including the case.

Circle No. 82 on Reader Service Page 15 or 95

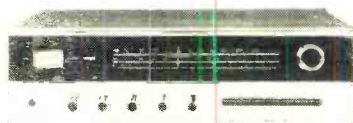

CROWN PREAMPLIFIER—You can do just about anything in the way of mixing and controlling with *Crown's* new IC-150 preamplifier. A 7-position stepped program selector accommodates 2 phonos, 2 tape recorders, 1 tuner, and 2 auxiliaries; plus controls for balance, panorama,

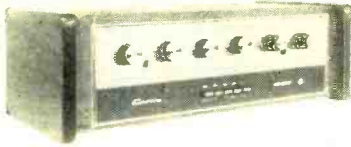

AR FM TUNER—In the last 2 or 3 years, *Acoustic Research* has been building up a line of electronic components to go with their speakers and turntables. (A receiver and an amplifier are already on the market.) Now they are introducing a stereo multiplex FM tuner. It is all solid state and has a FET front end with 4-section variable capacitor, multisection phase-linear i-f filter and integrated circuit i-f amplifiers. Guaranteed distortion is less than 0.5% IM or THD—a good feature for off-the-air recording.

Circle No. 84 on Reader Service Page 15 or 95

loudness compensation, tone control cancel, rumble and scratch filters, and tape monitors for 2 recorders. Rated output is 2.5 volts with unmeasurable THD, IM under 0.01%, and 90 dB minimum S.N.

Circle No. 83 on Reader Service Page 15 or 95



SONY CASSETTE/RECEIVER SYSTEM—As if we needed proof that the cassette is here to stay, *Superscope, Inc.* has introduced a new line of Sony systems which include a stereo cassette recorder, an AM/stereo FM receiver, and two speakers. Top of the line is the CF-620 (at \$299.95) which features a tape select switch to optimize performance for both standard and chromium dioxide cassettes, straight-line volume and tone controls, and FET tuner. Other models (CF-610 and CF-500) vary in packaging and sophistication of controls at somewhat lower prices.

Circle No. 85 on Reader Service Page 15 or 95



B&K COLOR GENERATOR—The professional TV repairman and the do-it-yourself-at-home guy can choose between two new IC digital color generators available from *B&K-Dynascan*. Deluxe Model 1246 (pictured) has crystal-controlled picture carrier oscillators for channels 3 and 4, a 4.5-MHz unmodulated carrier, and red, blue, and green color killers. It provides 9 patterns including center dot. More modest Model 1243 has 6 patterns and is tunable to channels 3, 4 or 5 but factory set to channel 3.

Circle No. 86 on Reader Service Page 15 or 95



COURIER CB TRANSCEIVER/FM MONITOR—There's a new combination for CB'ers who would like to monitor the VHF/FM band from 150 to 175 MHz. *Courier Communications'* Chief 23 is a 23-channel mobile transceiver combined with a 3-channel monitor for police, fire, weather, and industrial frequencies. All 23 crystals are supplied for the CB channels and all the necessary controls are included. In addition, an auxiliary speaker-phone jack and built-in PA system with volume control.

Circle No. 87 on Reader Service Page 15 or 95



SONAR BATTERY ADAPTER—Combining a battery charger and audio booster, *Sonar's* Model CH2913 Mobile Adapter provides mobile capability for any 2300 series FM transmitter receiver. The nickel-cadmium battery charger and 5-watt amplifier are all solid-state for low power consumption and can be used in any vehicle having a 12-volt dc, negative-ground, system. There is a fast charging rate (12-14 hours) and an indefinite trickle.

Circle No. 88 on Reader Service Page 15 or 95

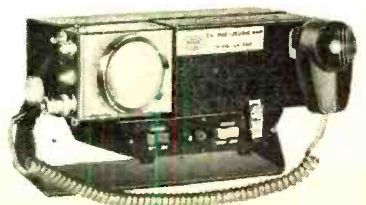

and stable in use. Freon 11 is a selective solvent meaning that it dissolves oils and greases, yet will not affect most metal contacts, common plastics, or carbon-type potentiometers. In cleansing action Freon 11 ranks above hydrocarbons and just below chlorinated solvents.

Besides dissolving oils and greases, Freon 11 also provides a "washing" action, especially if sprayed on the target area under high pressure. The high density and low surface tension of Freon 11 enables this solvent to thoroughly wet the surface of most materials thereby washing away dirt and "gunk."

The Allied Chemical name for a solvent roughly equivalent to Freon 11 is Genesolv-D. In fact, Genesolv-D has the same mouthful of a name as Freon—trichlorotrifluoroethane. The Dow Chemical Company sells two similar types of chemicals used by some manufacturers in the electronics industry—Chlorothene XU and Dow Clene EC.

The above basic chemicals are blended by the various manufacturers of electronic cleansing chemicals to produce commercial products. None of these manufacturers is willing to reveal the formulation of its cleaners, so it is impossible to know—by true chemical definition—exactly what you're buying. Nevertheless, any cleaner incorporating any of the above mentioned chemicals is good. The problem in electronics is to avoid the cheaper products which use kerosene, benzene, or denatured alcohol as solvents. You can usually

detect any of these products by the smell. They are also flammable and should be so identified on the can or bottle. These products may also be cheaper, but you pay for this cost saving through detuned circuits and deformation of soft plastic parts. For every experimental application you are better off to pay a little more money for a better and safer cleaner.

To Lubricate or Not to Lubricate. Aside from the cleansing action, some electronic aerosol chemicals also include lubricants. Lubricants not only reduce the friction of moving contacts, they may also minimize arcing and provide a protective coating to inhibit further corrosion.

Lubrication, however, is not an undisguised and unmixed blessing. A heavy residue of a lubricant can detune a critical circuit and for this reason, most electronics technicians prefer non-lubricating cleaners for work around critical tuned circuits.

Until the late 1960's, hydrocarbon lubricants were seen in most cleaning solutions incorporating a lubricant. Since hydrocarbon lubricants are organic, they are not particularly long lasting or known for their chemical stability. In addition, the hydrocarbon lubricant is itself flammable.

Today, some of the newer electronic chemical cleaners use silicone lubricants. Organic lubricants are hydrocarbon polymers, but silicone lubricants are derived from silicon-



This is exactly what you want a cleaner in an aerosol can NOT to do—be flammable. Though spectacular, a test like this is relatively safe in a wide open area.



CAUTION: Contents under pressure, do not puncture, throw into fire or store in direct sunlight or in temperatures above 120°F. Avoid prolonged breathing of the vapors. Do not spray open flames as the contents can decompose and produce toxic gases. Not to be taken internally. **KEEP AWAY FROM CHILDREN.**

Read the label before buying. For most cleansing operations around tuned circuits you will probably be better off with a non-flammable chemical that leaves no residue. Look for a possible warning about use around plastics and if in doubt check as described on the next page. As with all aerosol cans, be circumspect about disposing the empty can.

DIRECTIONS: Spray all tuner contacts with Spra-Lube . . . rotate tuner several times in both directions. **NON-DRIFT, WILL NOT DE-TUNE TV TUNERS.** This formula contains a solvent used and approved by the National Aeronautics and Space Administration and appears in Military Specification Number MSFC Spec. 237A.

oxygen linkages which should give this sort of lubricant better high temperature capabilities. Silicone lubricants generally last longer and are inert. Whereas hydrocarbon lubricants sometimes break down under application of high voltage or heat, leaving a carbon residue, synthetic silicone lubricants seem to withstand greater variation of voltage and temperature without noticeable ill effects.

Polishing. Recently a new dimension has been added to switching contact sprays: polishing. In addition to cleansing and lubrication, these new products attempt chemically to assist the polishing of switching contacts through the normal wiping action of the switch itself. However, cleaners containing polishing compounds must be used with care. Many switch contacts in electronic equipment use a precious metal plated on a base metal. It is quite possible for the polishing agent—if it is abrasive—gradually to scrape away the thin precious metal plating—along with the dirt. Once the base metal is exposed, it tends to corrode rapidly, ruining the contact.

Various manufacturers are currently emphasizing the incorporation of polishing compounds in their cleaners. One manufacturer calls polishing, "the continuous cleaning method," while another emphasizes the non-abrasive polishing agent in his cleaner. Regardless of the advertising claims, all cleaners that clean, lubricate and polish have particular applications. The basic ground rule calls for a moderately thick permanent lubricant that is less likely to "run" into adjacent circuitry. These cleaner/polishers must be applied with considerable care—just on the contacts—and in the case of TV tuners or band switching components in receivers or transmitters—never near capacitive, sensitive devices.

Making Your Own Tests. A few "recommendations" prepared by the Editors of POPULAR ELECTRONICS appear in conjunction with this article. However, if you encounter an unknown chemical cleaner, here's a quicky test you can use to get an idea of just what you have bought:

1. Spray the cleaner onto a clean piece of

white paper. Smell it carefully to see if you can detect the odor of alcohol, kerosene, or camphor. If any of these odors are detected, use this cleaner **ONLY** on equipment that you can sacrifice.

2. Feel the paper you have just sprayed with your fingertips. If the product is advertised as including a lubricant, you should be able to feel it. Rub the paper between your thumb and forefinger to see if there is any decrease in lubricating action. Simultaneously, if the product is supposed to contain a polishing agent, you should be able to feel an initial grittiness. This grittiness should disappear after a few rubs. If the grittiness persists, this product should be rejected or used with care.

3. If in doubt as to the action of the unknown cleaner on plastic, lightly spray it on several types of scrap plastic. A good cleaner will have no effect on plastic—neither dissolving it or making it turn cloudy.

4. As illustrated in the photograph on page 26, carefully spray the unknown cleaner directly at a lighted match. There should not be a “flame thrower” effect and if the product supports combustion it should be rejected. However, certain reputable products will decompose in a flame and produce toxic gases. Do this experiment last—and do it carefully.

Chemicals for Audio Equipment Maintenance.

Chemicals can be very useful in



For effective spraying many aerosols have hollow extension tubes that plug into the release button.

WHAT TO USE WHERE

| Work to Be Performed | Suggested Products |
|---------------------------------------|--|
| Cleaning (washing) around rf circuits | Chemtronics Tun-O-Wash Miller-Stephenson Freon TF Degreaser “No Noise” Super Spray Bath Rawn Power Degreaser Tech Spray Blue Shower |
| Cleaning bandswitches | Chemtronics Tun-O-Brite CRC Contact Cleaner GC Magic Vista Krylon Tuner Cleaner “No Noise” Super Lube Quietrole Tech Spray Blue Stuff |
| Cleaning noisy potentiometers | Chemtronics Contact Kleen Miller-Stephenson Contact Re-Nu Workman Lubrite |
| Cleaning relay contacts | Chemtronics Super Trol Aid GC Spru Kleen “No Noise” Spray Lube |
| Cleaning tape heads | Ampex Tape Head Cleaner Chemtronics Tape Head Cleaner GC Audio/Video Magnetic Tape Head Cleaner Miller-Stephenson Magnetic Head Cleaner Tech Spray Tape Head Spray |
| Cleaning PC Boards | Miller-Stephenson Flux Remover Print-Kote Solvent Tech Spray Rosin Flux Remover |

maintaining hi-fi and stereo equipment. The most obvious use is in cleaning. Aerosol chemicals can be used to wash away dust and dirt from records and a few chemicals leave an antistatic charge which tends to repel the accumulation of future dust. It pays to clean your discs before use.

Record changers and turntables should be cleaned with a good washing type degreaser that leaves no residue. Spindles on changers often “gunk up” and refuse to drop records properly, but this problem is easily resolved with an application of a good Freon 11 or equivalent spray.

One of the more important uses of chemicals for audio is to clean tape recorder heads.

(Continued on page 91)

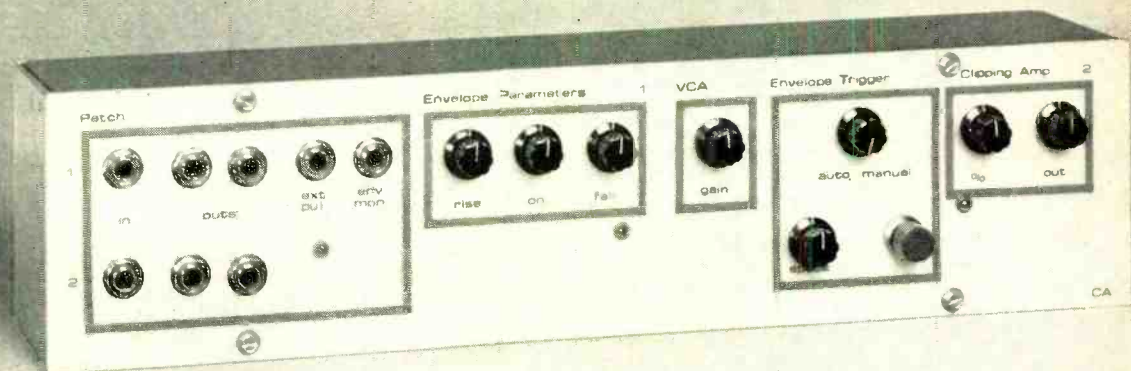

BUILD A TIMBRE GATE

ENVELOPE GENERATOR FOR GREAT NEW SOUNDS

BY CRAIG ANDERTON

WHAT is the quality that distinguishes the sound of one musical instrument from another? The answer, of course, is timbre; and timbre is determined primarily by the geometry of the sound wave generated by the instrument—be it mechanical, electronic, or human.

Electronic synthesizers have added new dimensions to the creation of music because they can generate sounds of many different timbres—some closely resembling known instruments, others previously unknown. They do this by producing amplitude envelopes of various shapes and sizes. The "Timbre Gate" described here is an envelope generator that creates any number of different timbre qualities and will be a valuable addition to your sound setup at a fraction of the cost of commercially available generators.

As shown in Fig. 1, the amplitude envelope of a musical note consists of an imaginary line drawn from $T = 0$ across the peaks of

each successive cycle of the note. The amplitude envelope shows rise time (time required for the envelope to go from initial zero to maximum), on time (envelope remains at maximum), and fall time (envelope goes from maximum to zero). These three parameters—rise, on, and fall times—geometrically describe the shape of the amplitude envelope and, hence, the timbre of the sound.

Theory of Circuit Design. The schematic diagram of a strictly manual version—which can be used where economy is important and complexity is unimportant—is given in Fig. 2. Field effect transistor $Q1$ operates as a voltage-controlled amplifier where the gain of the stage is a function of the magnitude of the bias voltage. Applying a negative bias to the gate of $Q1$ allows the stage to conduct until at about -4 volts bias, $Q1$ ceases to conduct current from source to drain. This cutoff action is the key to envelope generation.

With momentary-action switch $S1$ in its normal position (shown), negative bias current flows through $R1$ and is stored in $C1$.

In addition to his writing, Craig Anderton is electronic musician for the group "Anomali."

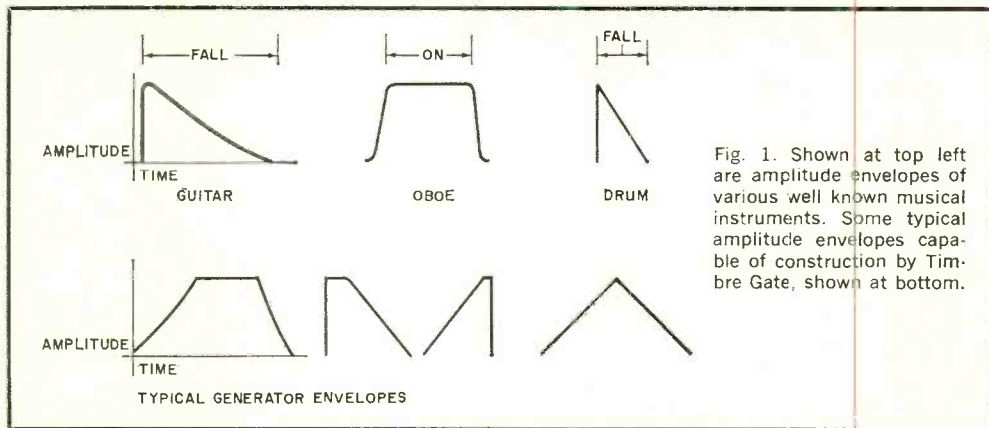

Fig. 1. Shown at top left are amplitude envelopes of various well known musical instruments. Some typical amplitude envelopes capable of construction by Timbre Gate, shown at bottom.

The charge on $C1$ maintains $Q1$ at cutoff. Depressing $S1$ to its alternate position allows the charge on $C1$ to be dumped to ground through $R2$. The resistance setting of $R2$ determines the amount of time required for $C1$ to lose its negative charge and thus controls the rise time of the envelope. With $R2$ set at maximum resistance rise times of a few seconds are obtained.

For the duration of the time $S1$ is in its depressed position, there will be no negative bias on $Q1$ and the stage will operate at full gain. Consequently, the length of time $S1$ remains in this position determines the duration of the on time of the envelope being generated.

Releasing $S1$ allows $C1$ to again charge up to the -4 volt level required to cut off $Q1$ and reduce stage gain to zero. The larger the resistance setting of $R1$ through which the charging current for $C1$ flows, the longer will be the fall time of the envelope. Consequently, simply by depressing and releasing $S1$, a complete envelope can be generated. Of course, as has just been demonstrated, the geometry of the envelope must be constructed by setting $R1$ and $R2$ and holding depressed $S1$ for a discrete interval of time.

When pitch and level controls must be operated, having to operate a switch to generate the envelope as well can become a bother. To alleviate this problem, the trigger process section shown in Fig. 3 which allows a single short-duration pulse to initiate the envelope action was designed. The trigger processor is used in conjunction with the basic generator circuit. Connected to the generator via a relay, $K1$, which replaces $S1$, the processor provides both automatic and manual modes of operation. Here, AUTO/MANUAL switch $S2$ is used to select the desired mode of operation.

In the MANUAL mode momentary-action pushbutton switch $S3$ is briefly depressed to initiate envelope generation. The pulse delivered by closing this switch charges $C5$ which, in turn, applies a bias voltage to $Q2$. With the bias applied, $Q2$ cuts off and de-energizes $K1$, allowing the upper contact circuit to be completed and initiating the rise and on time characteristics of the envelope. The charge on $C5$ now slowly discharges through on time control $R9$ until sufficient bias is removed from $Q1$ to allow $K1$ to again energize and initiate the fall time characteristic, thus completing the cycle.

Setting $S2$ to the AUTO position allows pulses to be developed at the $B1$ terminal of unijunction transistor $Q3$ to provide the trigger. The speed of the pulse generator, with the component values specified, is adjustable over a wide range.

A second optional attachment that can be used with the envelope generator system is shown schematically in the box on page 33. This circuit consists of a dual-gate IC and operates as a fuzz box used with guitars.

Construction. Straightforward design makes assembling the envelope generator, trigger processor, and clipper a relatively uncomplicated operation. As shown in the photos, the circuits were assembled on perforated phenolic boards. But if you are enterprising, you might want to design printed circuit boards for your project.

Since the prototype shown in the photos employed all three subassemblies, one board was used for mounting both the generator and trigger processor, while the clipper was assembled on a separate board. If you plan to use perf board, mount the components and make connections—from the under side of the

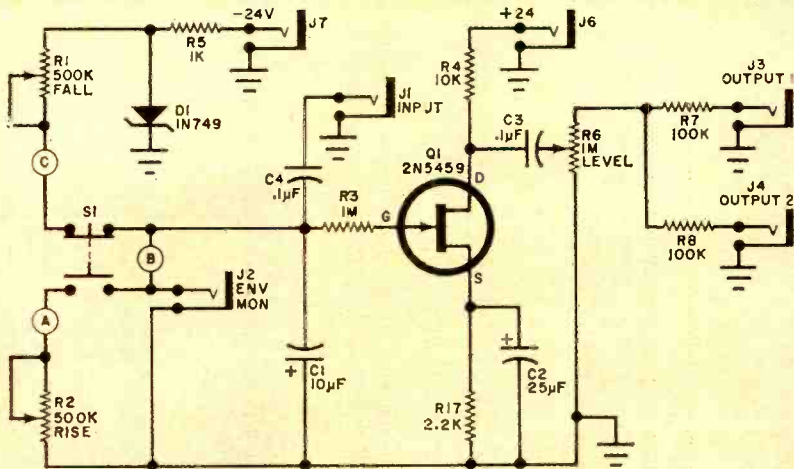

Fig. 2. Fall and rise times of the envelope are controlled by R1 and R2, respectively; on time is determined by the time S1 is in alternate position.

PARTS LIST

- C1—10- μ F, 10-volt electrolytic capacitor
- C2—25- μ F, 20-volt electrolytic capacitor
- C3, C4—0.1- μ F ceramic disk capacitor
- C5, C6—20- μ F, 20-volt electrolytic capacitor
- C7—200- μ F, 20-volt electrolytic capacitor
- D1—1N749 zener diode (see text)
- D2—1N914 or similar silicon diode
- J1-J7—Single circuit phone jack
- K1—4.5-volt spdt relay with 1000-ohm, 3.5-mA coil (Calectro D1-962 or similar)
- Q1—2N5459 field effect transistor
- Q2—Bipolar transistor (Motorola MPS2926)
- Q3—Unijunction transistor (General Electric)
- R1, R2—500,000-ohm linear-taper potentiometer
- R6—1-megohm logarithmic-taper potentiometer
- R9—100,000-ohm linear-taper potentiometer
- R15—50,000-ohm linear-taper potentiometer

- R3—1-megohm
- R4—10,000-ohm
- R5—1000-ohm
- R7, R8—100,000-ohm
- R10—4700-ohm
- R11—1500-ohm
- R12—100-ohm
- R13—470-ohm
- R14—3300-ohm
- R16, R17—2200-ohm

All resistors
1/2 watt 10%
tolerance

- S1—Spdt switch (see text)
- S2—Spdt switch
- S3—Spst normally-open momentary-action pushbutton switch
- S4—Spst switch (part of R15)
- Misc.—Perforated phenolic board with flea clips; 17" x 4" x 3" aluminum chassis; cover for chassis (see text); control knobs; machine hardware; hookup wire; solder; etc.

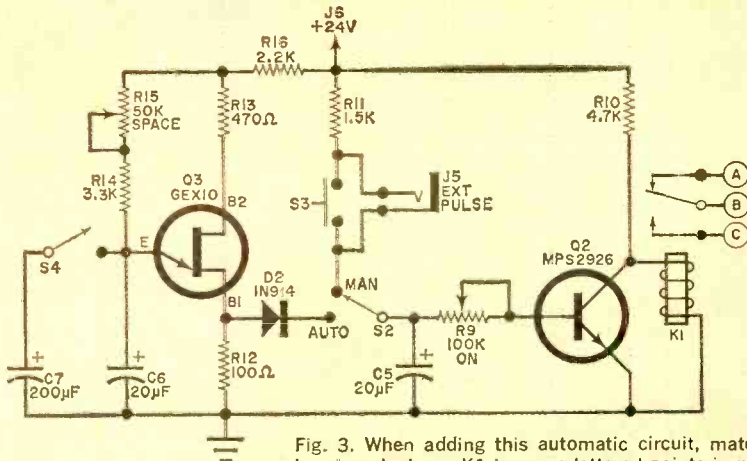
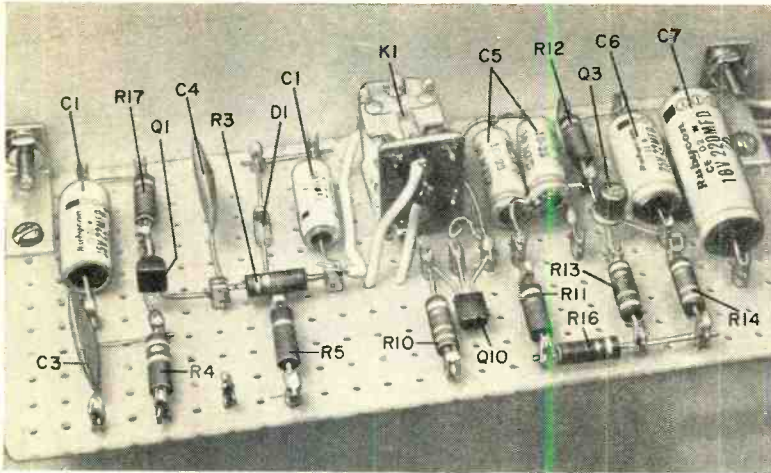

Fig. 3. When adding this automatic circuit, match lettered contacts on K1 to same lettered points in manual circuit and eliminate S1. Use S3 to initiate envelope.



Single piece of perforated board was used in prototype to accommodate all parts (except jacks and controls) in basic circuit and auto/manual add-on.

board—via flea clips. And be as neat as you possibly can when laying out the components.

Certain precautions must be exercised when soldering transistors and diodes into the circuit. Use a low-wattage soldering iron with a clean tip and a heat sink. Remember that excessive heat can damage solid-state components rather easily. So, use the heat sink on all transistor and diode leads and apply the iron tip long enough only for the solder to flow over the connection.

The prototype project was built into a 17" x 4" x 3" aluminum chassis, fitted with a white Plexiglass® front panel on which were mounted all controls and input, output, and monitor jacks. This size chassis is more than adequate to accommodate all of the components. If you wish, you can considerably reduce the size of the chassis required.

Setup and Use. Connect a suitable power supply to the circuit. If a dual-polarity 24-volt de power supply cannot be obtained, a single-polarity 24-volt supply will provide

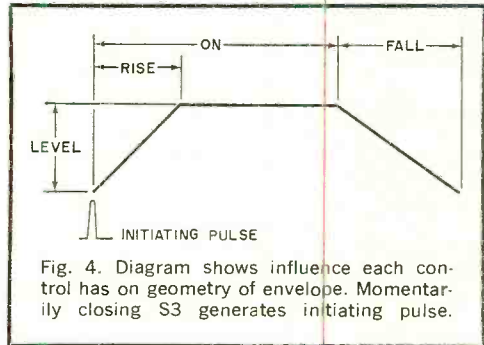

Fig. 4. Diagram shows influence each control has on geometry of envelope. Momentarily closing S3 generates initiating pulse.

most of the voltages needed, and a 9-volt transistor battery can be used to supply the negative voltage required for biasing *Q1*.

Connect the output of the envelope generator to an instrument or hi-fi amplifier. Then feed into *J1* a signal from an electric guitar or audio generator. Set the AUTO/MANUAL switch to the MANUAL position and the RISE, ON, and FALL time controls to zero. With the LEVEL control set for midposition,

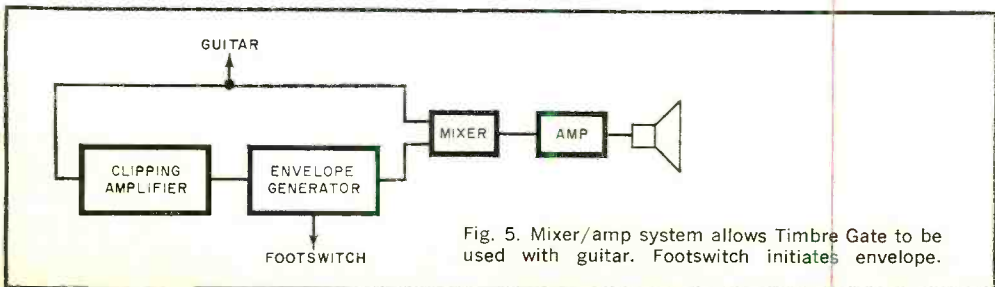
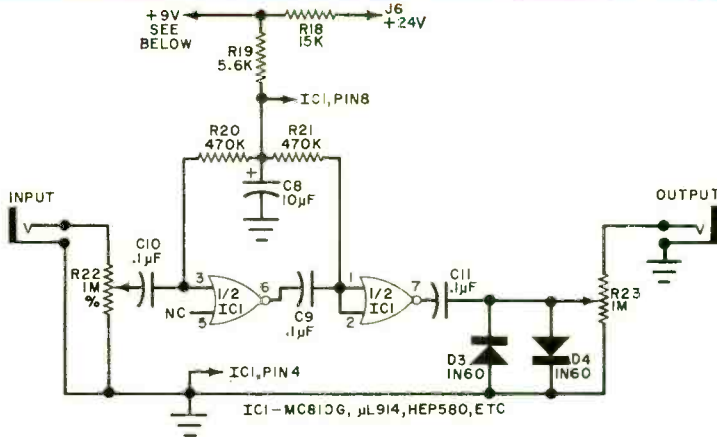

Fig. 5. Mixer/amp system allows Timbre Gate to be used with guitar. Footswitch initiates envelope.



CLIPPING AMPLIFIER

In its simplest form, the envelope generator consists of the circuit shown in Fig. 2. Incorporating the circuit in Fig. 3 merely adds an automatic/manual feature. For additional signal processing, the clipping amplifier shown here can greatly increase the versatility of the system. The clipping amplifier is similar to the fuzztone circuits often used with electric guitars and can, in fact, be used separate from the envelope generator by having a 9-volt battery at the point indicated instead of the 24-volt supply.

The clipping amplifier consists of an inexpensive dual two-input gate RTL integrated circuit, IC1, in which each of the gates is biased into linear operation. The gates are then cascaded. The output from the second gate is clipped by D3 and D4.

Two controls are provided in the clipping amplifier. Potentiometer R22 allows you to adjust the percent of clipping you desire,

while potentiometer R23 lets you adjust the output signal level from the subassembly.

When the clipping amplifier is connected at the output of the envelope generating system, the percent (%) control can be adjusted so that clipping occurs only after a certain amplitude has been exceeded. Hence, the signal would start clean, but past a certain level would start to sound "fuzzy." If, however, the clipping amplifier were connected at the input of the envelope generator, the signal from the input source should be clipped regardless of amplitude. Then it would be given an envelope.

When assembling the clipping amplifier, use the same techniques employed with the two circuits that make up the envelope generator. Be particularly careful when installing IC1 to make the proper orientation of the indexing tab. Also, use caution when soldering the IC leads in place.

Operation of system is greatly simplified when rise, on, and fall controls (R2, R9, and R1) are grouped together as shown.

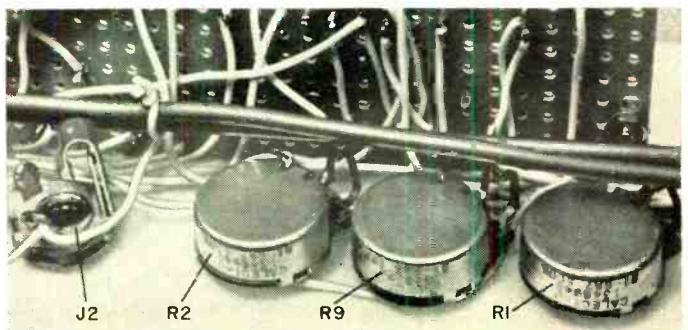

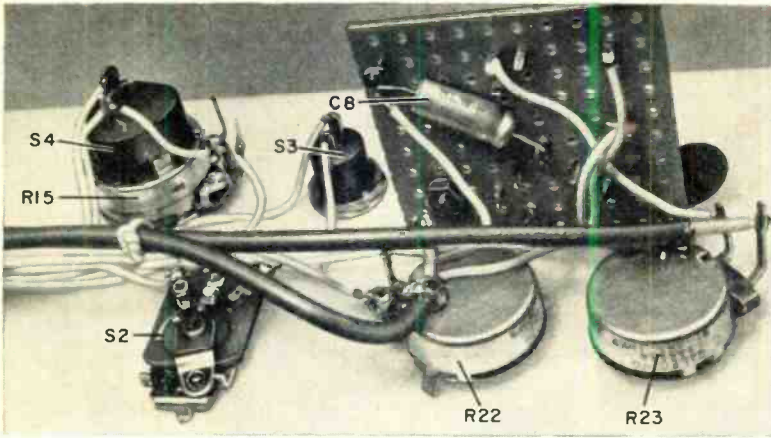

Solder shields of audio cables to the housings of potentiometers R22 and R23. Also note that capacitor C8 mounts on the bottom of clipper amp circuit board.

there should be no sound coming out of the system. If Q1 is not being overloaded and you hear sound, not enough bias is available to cut off Q1; use a higher voltage zener diode for D1 in this case.

Depress and hold down S3; you should hear whatever signal is connected to the input of the system. In Fig. 4 are shown the effects the various controls have on the shape of the envelope being generated. Bear in mind that the on and rise times overlap.

Try various adjustments until you become familiar with each control. Plug into J2 an oscilloscope or VTVM if you have either of these items, and you can monitor the effect

each control has on the envelope. Set S2 to AUTO and the RATE control fully clockwise. You should now hear a pulsing sound. (Note: if the on or fall time is longer than the period of the pulse generator, the signal will remain on indefinitely.)

External pulse jack J5 is another handy built-in feature of the envelope generator. It allows you to use a footswitch to initiate the envelope generating cycle while your hands are busy playing your musical instrument. This feature is typically used with a guitar setup as shown in the block diagram in Fig. 5. The straight sound of the guitar feeds to one input of a two-input mixer, while

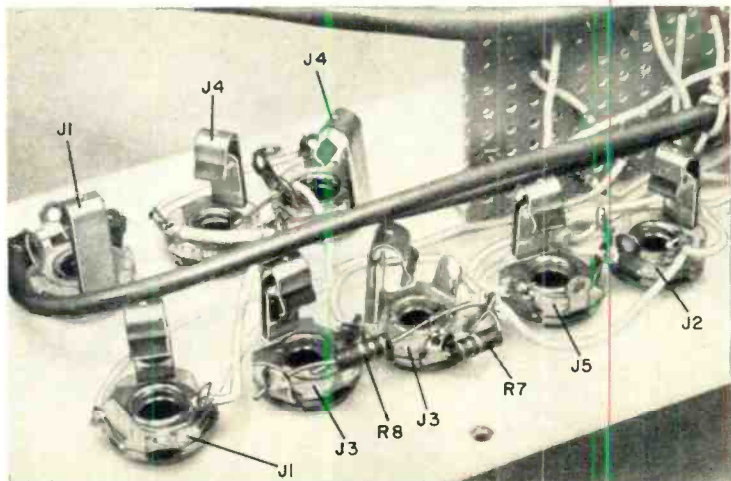

For operating convenience, all jacks (except those used for power) are best located in a group. Power jacks J6 and J7 can be located on side of box.

Wired clipper amp board fastens to front panel with 4-40 machine hardware and small L bracket. Wires connecting sub-assembly into system are soldered to terminals on the bottom side of the circuit board.

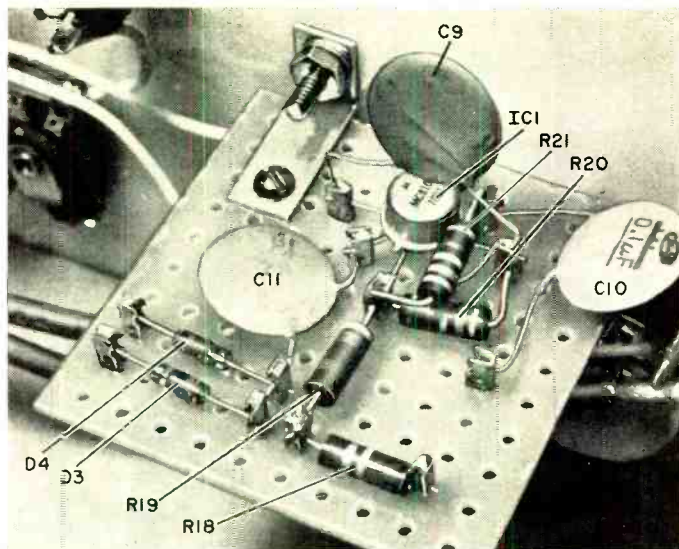

the output of the envelope generator connects to the second mixer input. When the envelope generator is triggered, a slowly rising wave of fuzz can be initiated—or, for that matter, a burst of fuzz can be initiated by presetting a fall time with zero rise and on times.

The system can also be set in the automatic cycling mode, with rise and fall times adjusted so that the end of a fall coincides with the beginning of a rise. Under these conditions, the sound generated is like a super tremolo with adjustable amplitude slope.

Sometimes the slowest pulse generator range will appear not to be working at the low end. To remedy this, turn the space control fully clockwise for a few seconds. Then return the control to the low end again.

The values of certain key components in the envelope generator can be changed to tailor the system to your needs. To double the maximum rise and fall times, $R2$ and $R1$ can be increased in value to 1 megohm. Increasing $C5$ to 50- μF will yield on times of up to 20 seconds. Lastly, if the low end of the pulse generator is too slow for your particular application, reduce $C7$ to 100 μF .

Several controls interact in the envelope generator. So, if at first the system does not seem to be operating correctly, make sure that the problem is not a misadjusted control or switch or an incorrectly installed diode, transistor, or electrolytic capacitor.

Space limits the description of what can be done with the envelope generator when a little imagination and a lot of experimenting are applied. So far, the system has been used

successfully with guitar, organ and bass—as well as both commercial and homemade music synthesizers. Even an audio oscillator can become a musical instrument with the aid of the envelope generator.

Remember that an electronic musical instrument is really no different from the more conventional musical instruments with which you are familiar. The more practice you put in, the better will be your technique. The number of controls on the envelope generator means that it may take you several hours just to figure out how everything works. But at the end of that time, you will feel the effort well worth while.

-30-



**Do you work in electronics?
Find out how CREI can give
you the specialized technical
knowledge you need for
better pay, more security.**

**Mail postpaid card for
FREE book and complete
information.**

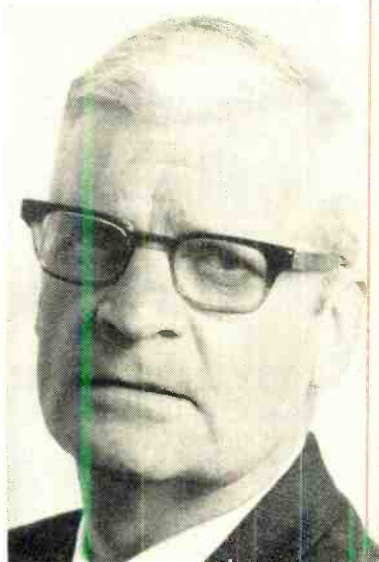

“Stop kidding yourself about your future in electronics.”

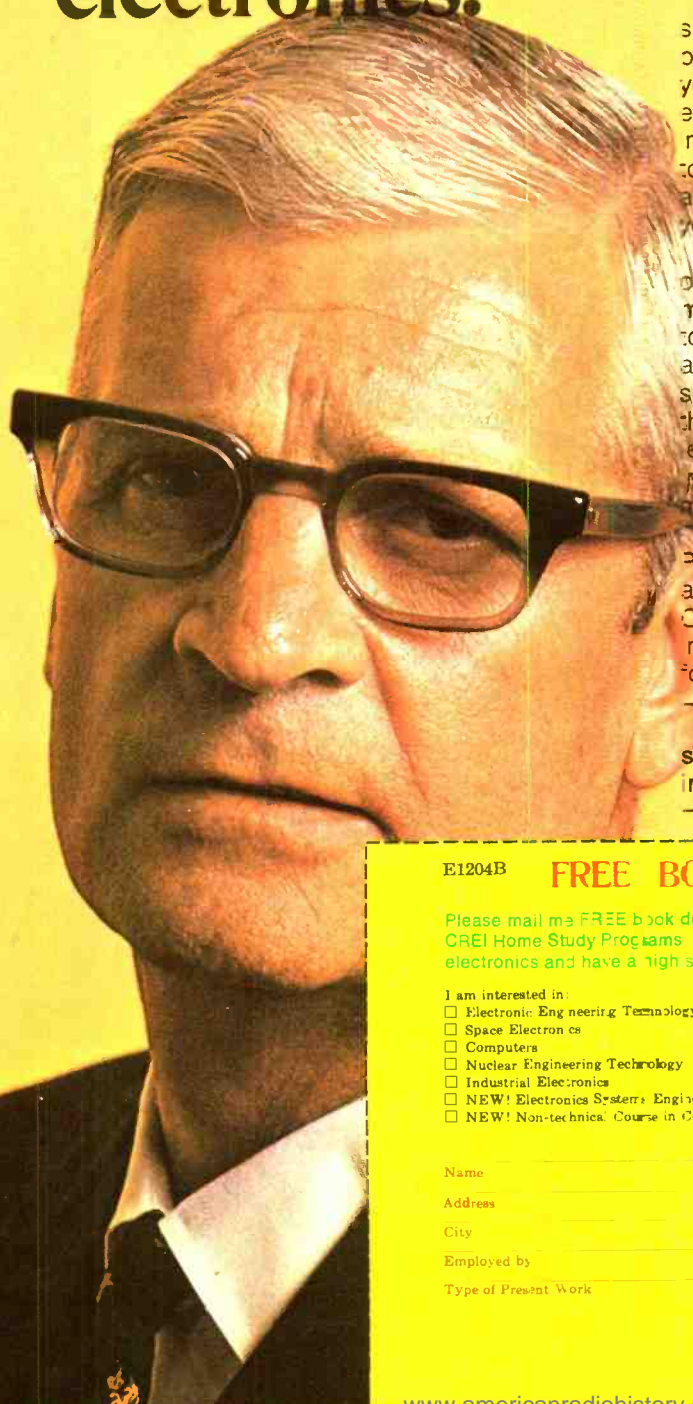

You've been working in electronics long enough to know the facts. Companies are more selective in hiring and promoting men now than ever before. The result: plenty of opportunities for men with good technical qualifications; almost none for those without them.

Make yourself one of the specialists who will enjoy good pay and excellent security in the years ahead. Supplement your experience with more education in electronics. You won't have to worry about automation or advances in technology putting you out of a job.

CREI Home Study Programs offer you a practical way to get more education without going back to school. You study at home, at your own pace, on your own schedule. And you study with the assurance that what you learn can be applied on the job immediately to make you worth more money to your employer.

You're eligible for a CREI Program if you work in electronics and have a high school education. Our FREE book gives complete information. Mail postpaid card for your copy today.

In-depth coverage of solid state electronics . . . including integrated circuits!

E1204B

FREE BOOK

Please mail me FREE book describing CREI Home Study Programs. I am employed in electronics and have a high school education.

I am interested in

- Electronic Engineering Technology
- Space Electronics
- Computers
- Nuclear Engineering Technology
- Industrial Electronics
- NEW! Electronics Systems Engineering
- NEW! Non-technical Course in Computer Programming



Name _____

Age _____

Address _____

City _____

State _____

Zip _____

Employed by _____

Type of Present Work _____

G.I. Bill

APPROVED FOR TRAINING UNDER NEW G.I. BILL

“Stop kidding yourself about your future in electronics.”



Men without advanced technical education will find few opportunities in electronics in the years ahead. But industry will offer exciting work, good pay and excellent security to men who become specialists in these key areas:

- Electronic Engineering Technology
- Aeronautical & Navigational
- Television
- Communications
- Nuclear Instrumentation & Control
- Missile & Spacecraft Guidance
- Radar & Sonar
- Nuclear Engineering Technology
- Automatic Control
- Industrial Electronics
- Computers
- Digital Communications
- Electronics Systems Engineering

Take the advice of men who know the electronics industry. Make yourself a specialist in one of the key areas of electronics. Then stop worrying about how cutbacks, layoffs and contract terminations will affect you and your family. If you have up-to-date specialized knowledge of electronics, you can look forward to security and excellent earnings when men with ordinary qualifications are let go.

But to become a specialist, you must supplement your experience in electronics with

more technical education. CREI Home Study Programs offer you an opportunity to get that additional education without going back to school.

You're eligible for a CREI Program if you work in electronics and have a high school education. Free book gives complete information. Mail postpaid card for your copy today.



APPROVED FOR TRAINING UNDER NEW G.I. BILL

Free book tells all about CREI programs. For your copy, tear out and mail postpaid card or write:

CREI, Dept. E1204B,
3224 16th St., N.W.
Washington, D.C. 20010



FIRST CLASS
Permit No. 288-R
Washington, D.C.

BUSINESS REPLY MAIL

No Postage Necessary if Mailed In The United States

Founded 1927



CREI, Continuing Education Division

McGraw-Hill, Inc.

3224 Sixteenth Street, N.W.

Washington, D.C. 20010

BATTLE of the GIANT BRAINS

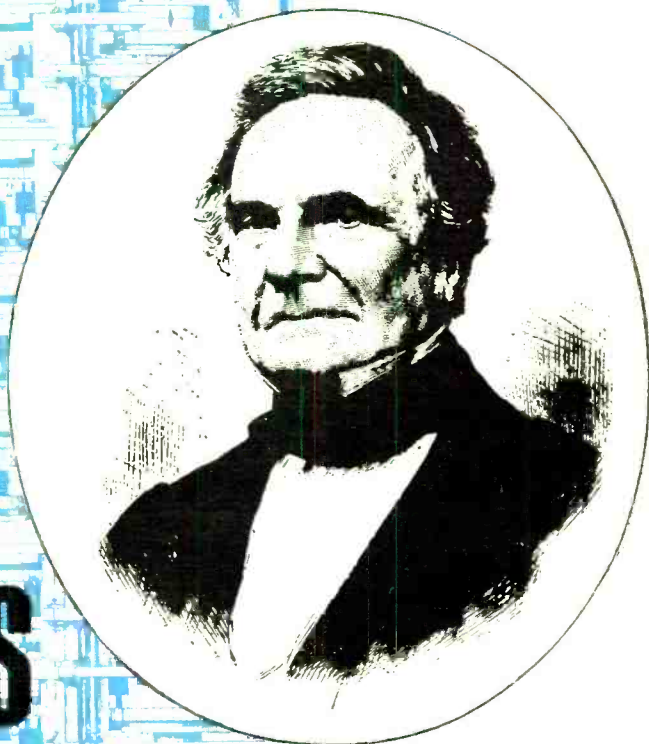

or Electronics Conquers All

A STARTLING REVELATION OF THE
EARLY DAYS OF DIGITAL COMPUTERS

CONSIDER for a moment the hardware that goes to make up a digital computer. Could any way of implementing digital functions be better or more natural than the use of electronic components? Our first reaction is to say "no"—conditioned as we are by a

Frank Y. Dill is a freelance writer specializing in computers and electronics. Above are copies of old engravings of Charles Babbage and his plans for the Difference Engine.

quarter of a century of electronic computers and an \$8 billion (annually) computer manufacturing industry. It happens, however, that this has not always been the case. In the late 1930's, the question of how to design a digital computer was very much up in the air.

For more than a century after its theoretical invention, the digital computer was an idea in search of realization through suitable technology. Electronics, while it was used in some limited precision analog devices, was

generally overlooked for digital applications. Designers were still thinking of representing discrete quantities in terms of rotating wheels, punched cards, and relays. These devices had shown great promise as far as reliability was concerned and had proven workable in small-scale digital machines. Thus, when the first large-scale digital computers were being designed over 40 years ago, they used non-electronic devices.

Unchallenged success of these non-electronic "giant brains" would have set important design precedents. Fortunately, however, before this could happen construction of an electronic digital computer was begun. Actually, a three-way contest developed between two electromechanical designs and one electronic. The electronic project was at a disadvantage due to the head start enjoyed by its rivals. However, the fate of electronics in computers rested on the success of this project. If this machine were to fail to operate at all or to be not competitive in reliability and overall cost, the future of electronics would be greatly damaged.

Where It All Began. Before witnessing this three-way design race, let's see where the idea of digital computation began. In September 1834, an Englishman named Charles Babbage, hoping to free mathematicians from the drudgery of calculating tables and to rid the tables of the mathematicians' errors, made the first drawings for what he called an "Analytical Engine." These plans contain many of the basic modern computing principles: punched card input, multiple reg-

isters to store intermediate results, automatic sequencing of control, sequencing based on both calculated results and original instructions, and direct mechanical printout of results.

Babbage's device was an extension of the then two-century-old adding and multiplying machines in that it included multiple step calculations whose sequence was controlled by the machine itself. The older machines used a wheel with teeth to advance an adjacent wheel for an arithmetic carry. Similar wheels were to be used in the Analytical Engine to store one thousand numbers of fifty decimal digits each. Calculations and control were to be accomplished by a combination of metal cams, rods, shafts, and levers capable of coupling and decoupling as the program demanded.

Unfortunately, the Analytical Engine was never built. Its construction—like that of twentieth century digital computers—required considerable financial support. The most likely sponsor, the British Government, had already spent £17,000 on an uncompleted, 10-year project of Babbage's called the "Difference Engine." This project had encountered unexpected delays since the machinist's art, lacking modern alloys and mechanical drawing conventions, was unable to fashion Babbage's ideas into metal. So, when Babbage asked the government whether he should continue work on the older project or begin the more powerful and complex Analytical Engine, they, in typical bureaucratic fashion, deliberated for nine years and then said, "neither."

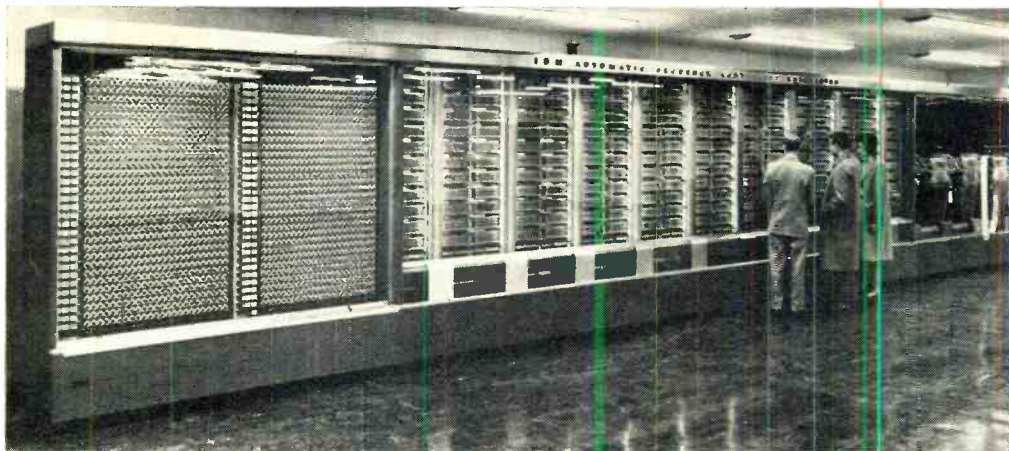

The IBM Automatic Sequence Controlled Calculator, also called the Harvard Mark I, was the first electro-mechanical, general-purpose digital computer. Neat in appearance, it used counter wheels and relays, had relatively small size, required little maintenance, but computations were slow. (Photo courtesy IBM)

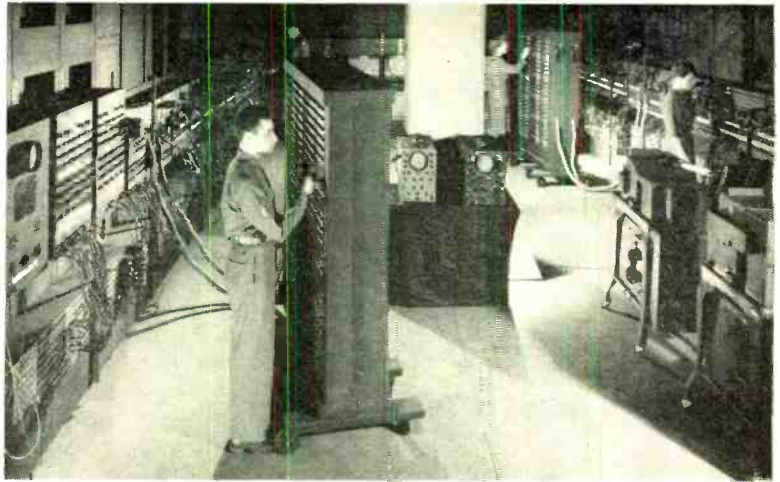

First electronic general-purpose computer was developed by University of Pennsylvania for the Army Ballistic Research Lab. Not mini in size, it solved the speed problem and was predecessor of many electronic computers. (Photo courtesy U. of Penn.)

Unable to obtain financial support, Charles Babbage spent the remainder of his life (until 1871) trying to improve the mechanical technology of the period. The general purpose digital computer remained unbuilt for more than a century after Babbage conceived his plans. However, it was a fruitful period for electromechanical technology and the advances obtained led to the design in the twentieth century of the first large-scale computer.

Babbage Is Vindicated. In 1937, Howard H. Aiken, of Harvard University, aware of the school's need for computational facilities, wrote a paper describing the connection between Babbage's ideas and machines then being produced by International Business Machines.¹ It turned out that IBM was willing to build such a machine, believing that many of their existing mechanisms could be used with little or no modification.

The project was begun in 1939 at Endicott, N.Y., and was officially called the IBM Automatic Sequence Controlled Calculator. Computer jargon was not tolerant of such long names, of course, so it is now usually referred to as the IBM A.S.C.C. or the Harvard Mark I, depending on the speaker's industrial or academic background.

In this first electromechanical project (as in Babbage's machine), variable numbers were stored on ten-position metal wheels. They were rotated by a shaft connected to a 4-hp motor and were engaged by a magnetically controlled clutch. Unlike the Analytical

Engine, numbers were not transferred mechanically, but electrically through a buss. Relays controlled access to the buss and provided for arithmetic carries and borrows. Mechanical wheels and relays were used to implement the mathematical functions.

The Second Project. Proceeding concurrently with the IBM-Harvard effort was a computer design originated by George R. Stibitz of Bell Telephone Laboratories. Not surprisingly, this design relied heavily on existing telephone and teletype devices. The fundamental computing device was the ordinary telephone relay, which was so reliable that it could be expected to operate continually for years without failure. An added advantage was that standard telephone practice already included design and maintenance procedures necessary to keep the computer in order.

A series of six computer models was eventually built by Bell Labs. The success of each provided incentive and design experience which contributed to the next. The Model I, called the Complex Computer, was put into operation in January 1940. It contained 450 relays and was used to perform the arithmetic of complex numbers for the Labs. In the Models II, III, and IV, which followed, 440, 1400, and 1425 relays were used, respectively. Finally in 1944, Bell Labs had gained enough experience to attempt to build a 9000-relay general-purpose computer—the Model V.

Electromechanical technology was used in

both of the projects just described. The main difference was that the IBM-Harvard computer used some purely mechanical devices for number storage and for implementing the arithmetic operations. The need for a mechanical drive system however placed severe spatial restrictions on the design. The Bell Labs machines, using only relays, eliminated these space problems, but speed was not greatly improved. This problem was a fundamental one, involving the inertial mass of the moving parts. Even the short time required to close the relay contacts was an important factor.

Solving the Speed Problem. Events leading to a solution of the speed problem were taking place at the same time. Soon after the start of World War II, the Army's Ballistic Research Laboratory needed more capacity for handling ballistic tables. It had been using a differential analyzer (an analog computer) designed by the Moore School of Electrical Engineering, University of Pennsylvania. Since the Moore School had a larger analyzer, the BRL contracted to use it and the combination developed into what was probably the largest scientific computing group in the world.

Unfortunately, the results were still unsatisfactory. More than a hundred desk calculators were needed to supplement the analog computers. The Army needed, as soon as possible, a better way of producing firing tables, each of which involved 250,000 to 500,000 mathematical operations.

In the spring of 1943, Dr. John W. Mauchly, a professor at the U. of Pennsylvania, circulated a report which offered a solution to the Army's computing problem. In 1941, he had visited Iowa State College to study

the Atanasoff-Berry computer.² This 300-tube electronic computer was being built to solve algebraic equations. It was never finished but it reinforced Mauchly's belief that electronic high-speed computing devices were feasible. His report advocated building such a machine. An appendix to the report by J. Presper Eckert, Jr., gave explicit suggestions for implementing Mauchly's ideas in electronic hardware.

The Army's need at that time justified taking a chance on the project and \$61,700 was allocated in 1943 for six months of research and development on Project PX, Mauchly's electronic digital computer. The project later became known as ENIAC, an acronym which originally stood for Electronic Numerical Integrator and Computer, though the last word has since been incorrectly reported as Calculator.

During those six developmental months, the most challenging electronic problems ever encountered in a single design were tackled. Since the reliability of a computer is all-important and since the reliability of the whole is no better than that of its individual parts, component reliability was the first major technical consideration.

The most likely component to fail was the vacuum tube. While a single tube had a life expectancy of many thousands of hours, a total of 18,000 tubes were to be used. This meant that the probability of a single tube failure at any particular time was rather high. Prior to this, the largest electronic system was a radar set with 400 tubes, and the problem was important even then.

The solution was to use proven standard tubes and to operate them well below their normal ratings. Filaments were run at 5.7 volts instead of 6.3 and they were rarely

COMPARISON OF EARLY COMPUTERS⁷

| | IBM A.S.C.C. Harvard Mark I | Bell Labs Model V | ENIAC |
|---|------------------------------------|----------------------|---------------------|
| Construction | Electromechanical | Relay | Electronic |
| Major Components | 2200 Counter wheels 3300 Relays | 9000 Relays | 18,000 vacuum tubes |
| Floor space | 240 sq. ft. | 1150 sq. ft. | 1800 sq. ft. |
| Weight | 5 tons | 10 tons | 30 tons |
| Percentage of time needed for repair | 8% | 3% | 25.6% |
| Maintenance staff | 3 men | 1 man | 11 men |
| Addition time | 1/3 sec. | 1/3 sec. | 1/5000 sec. |
| Multiplication time | 6 sec. | 1 sec. | 1/350 sec. |

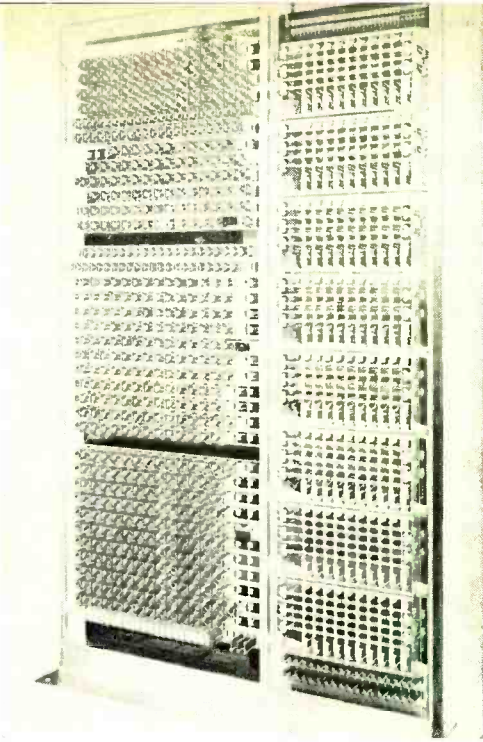

Relay panel from Bell Labs Model I Complex Computer, first of series of 6 relay computers using standard telephone apparatus. (Photo courtesy Bell Labs.)

turned off to increase their life.³ Plate and screen powers were limited to 25% of rated values.

It is easy to see how the heat generated by all those tubes provided another problem. There were 70,000 resistors and 10,000 capacitors in the system which could be damaged by excessive heat. Of the 150 kW of power consumed by the ENIAC, 80 kW was dissipated by the tubes and another 20 kW was used to drive cooling fans. In addition, each panel of the machine was protected by a thermostat which would shut off that panel if the temperature got over 115°F.

Another problem encountered in the design of the computer was synchronization. Control pulses of two to five microseconds were repeated in cycles. Still other pulses were generated by the computing process. Although the idea of gating is now fundamental to computer design, one of the first applications of a "gating tube" was in the ENIAC computer.⁴

For storage, the ENIAC used the Eccles-Jordan trigger circuit commonly called a flip-flop. The arrangement of the flip-flops to represent decimal digits was rather unusual in terms of modern design. Ten flip-flops were used to represent a single digit.

This resulted in a very expensive main memory. Eckert estimated that the average cost of storage was \$15.00 per decimal digit. By comparison if the largest main memory of a modern computer like the IBM System 370 Model 165 used such a memory, the 3 million bits would cost in excess of one hundred million dollars.

The Race Quickens. When the ENIAC project was just a year old, the complete electromechanical Mark I was unveiled in a public dedication ceremony on August 7, 1944. Its impressive 51-foot, neatly encased exterior was in sharp contrast to the jumble of wire and panels that were to comprise the ENIAC. Actually the Mark I had been tested prior to the start of ENIAC and it had undergone a complete debugging while operating in secret. The age of digital computers had arrived and the Mark I operated around the clock with a down-time record that was impressive by modern standards.

Thus the Mark I posed a real threat to electronic computers. The total need for computers had been greatly underestimated. In fact, a prediction had been made that the entire computing requirements of the U. S. could be satisfied by six computers.⁵ So the Army might have been justified in cancelling the ENIAC in favor of a Mark I type of machine, especially if unexpected delays or expenses were encountered. Such loss of sponsorship had happened to Babbage a century before.

An even more direct challenge to ENIAC came from the Bell Labs Model V. The same Army group that had contracted for ENIAC, hedging on its gamble, had also ordered one of the two Model V's being built. However, the hedge was not needed since ENIAC was completed and shown to the public in February 1946, after 30 months and \$486,804.22 in the making.

(Continued on page 99)

References

1. "Proposed Automatic Calculating Machine," H. H. Aiken, *IEEE Spectrum*, August 1964, p 64.
2. *Electronic Digital Systems*, R. K. Richards, John Wiley & Sons, New York, 1966.
3. "Electronic Computing Circuits of the ENIAC," A. W. Burks, *Proceedings of the IRE*, August 1947, p 757.
4. *A Report on the ENIAC*, Staff of the Moore School, Univ. of Pennsylvania, Philadelphia, 1946.
5. "An Interview with Eckert and Mauchly," H. Bergstein, *Datamation*, April 1962, p 26.
6. *Theory and Techniques for Design of Electronic Digital Computers*, Staff of the Moore School, Univ. of Pennsylvania, Philadelphia, 1947.
7. *Survey of Automatic Digital Computers*, Office of Naval Research, 1953.

BUYERS' GUIDE TO STEREO HEADPHONES

The list below is a sampling of stereo headphones available for a listening check at the time this article was prepared. Most manufacturers offer a variety of models ranging from the economical to those guaranteed to stretch your budget. All of the headphones have the ability to generate sound at very low distortion levels and up to sound pressure levels far beyond that that any listener can tolerate. Frequency balance differs notably from manufacturer to manufacturer and the listener interested in securing top quality reproduction should always try two or three different headphones before finalizing a purchase. A trial run is also desirable to find out how comfortable the headphones are to the listener—since this is an individual matter.

Use the tone controls on your amplifier as a means of achieving optimum frequency balance. Start any trial with the tone controls in the flat position, but correct the controls to suit your hearing. Don't forget that many headphones must be tightly coupled to your ear since air leakage around the rim of the ear-set will attenuate the bass. This does not mean that the headphones must exert pressure against the listener's head, but that the earphone pads must be settled snugly.

All of the headphones listed (except the Sennheiser HD-414) are low impedance and must be used at the amplifier's speaker terminals or plugged into the headphone jacks now a part of the package of most amplifiers and receivers. High impedance headphones may be driven from a preamplifier or from a tape recorder with a high impedance headphone jack. High impedance headphones are considered those at 600 ohms and up. Low impedance headphones used in high impedance circuits will produce some sound with a slight loss in bass response, but this is not considered a satisfactory arrangement. Most of the headphones listed are dynamics which in effect means that each earpiece is a miniature loudspeaker. The exceptions are the Koss ESP series and the Stanton 770 which are electrostatics.

AKG-60 (Div. of North American Phillips Co.). Good balanced sound with extended clean high end. Seven foot cord. Less than \$40. The AKG-120 is similar and less expensive.

Beyer DT-48 (Gotham Audio). Used mostly by professionals. Notable presence and high end. Ten foot cord. Less than \$100.

Bogen EP10 "Row 10" (Lear Siegler). Good overall balanced sound with strong bass response. Six foot cord. Under \$30.

Clark 100A (David Clark Co.). Smooth response with good balance and strong bass. Ten foot cord. High impedance models available. About \$50.

Fisher HP-100 (Fisher Radio Corp.). Well balanced sound with strong presence and high end. Extremely light and outstanding in comfort. Eight foot cord. Under \$40.

Koss Pro-4AA (Koss Electronics). Excellent low bass response with extended highs—possibly one of the best available. Ten foot cord. About \$60.

Koss ESP-9 (Koss Electronics). Electrostatic headphones with separate energizer that must be connected to amplifier speaker terminals. Extremely wide, flat frequency response with superior sound reproduction. Ten foot cord. About \$150.

Lafayette F990 (Lafayette Radio Electronics). Smooth response with good bass and clean high end. Seven foot cord. Under \$40.

Pioneer SE-50 (Pioneer Electronics). Two reproducers in each earpiece with tone and volume controls permitting independent earpiece adjustment. Flat response. Sixteen foot cord. Under \$50.

Sennheiser HD-414 (Sennheiser Electronics Corp.). Good to excellent balance with strong presence and high end. Appears similar to Fisher HP-100. High impedance (2000 ohms). Fifteen foot cord. Under \$30.

Sharpe 660 (Sharpe Audio, Div. Scintrex). Good low end with very dominant presence and high range. Ten foot cord. About \$65.

Stanton Model 770 (Stanton Magnetics Corp.). Electrostatic design with separate energizer connected to amplifier speaker terminals. Very light and comfortable. Very wide range with smooth response. Ten foot cord. About \$150.

Telex Studio 1 (Telex). Smooth response with individual tone and volume controls on each earpiece. Fifteen foot cord. Under \$100.

negative aspects of using headphones and on some people headphones may be physically bothersome or downright uncomfortable. However, the comfort index has also shot upward in the past few years and there are many headphones that now sit lightly—almost imperceptibly—on the user's head and put

only a small measure of pressure on each ear. Don't be fooled by the bulky shape of some headphones. Frequently the bulky headphones—probably because of weight distribution—are more comfortable over a long period of time than some of the smaller minute—almost stethoscopic—headphones.

The Road to Success. Keeping room and environmental noise out of the music you want to hear is more than reducing an annoyance. Headphones may well be a positive contribution to improved fidelity because room noise can, in effect, diminish the frequency response of a good audio system by masking the highs or lows, or both. Room noise can also be so intense at a particular frequency that it may punch a hole in the response of an otherwise good system—or even create a sort of intermodulation distortion.

Naturally, no one is going to buy just headphones and forget about his speaker system. We will always use speakers. Headphones have simply added a wonderful, convenient additional way to listen to recorded music.

If you want to give your friends a quick impressive dose of headphone listening, play for them *Stereo Review's* "Binaural Demonstration Record,"* which, in effect, takes each of your ears back to the scene of the original recording. This particular record, designed specifically to be listened to with headphones, provides the truest reproduction of the original acoustic environment since the recording microphones were literally "installed" in the ears of a life-sized dummy head. The sounds reaching the microphones have been reflected and refracted by the head, just as real sounds are at a real head: all of the directionality and spacing cues are those of actual listening.

The New Experience: Pro and Con. If you are one of the few that hasn't listened to one of your favorite recordings through a top-quality pair of headphones (driven by a first-rate audio system) you will be stunned by the immediacy and super-fidelity of all instrumental sounds. This experience is not likely to be a first-contact thrill that gradually fades away with further listening. Headphones have an addictive quality; you rapidly become acclimated to the freedom from noise, plus the concentration and closeness of the music.

The best headphones rival the performance characteristics of the best stereo speakers. You can obtain headphones where the frequency response is excellent without peakiness or hills and dales from the bottom of the bass range to the top treble notes. In fact, the bass range can sometimes be smoother than that heard via speaker systems because the headphones are free of room reflections and

resonances. These resonant effects often cause large and uncontrollable unevenness in bass response. Since the amplifier power that must be handled by the headphones is very small, distortion can be extraordinarily low and the heavy damping used to produce a smooth response with excellent transient handling qualities in the middle and high audio frequencies.

There is one area in headphones performance that may not be to your liking. This is the abnormality evident in certain American stereo discs manufactured in the mid-1960's. The acoustics of the recording space—as reproduced by the headphones—may seem strange. Instruments heard right-of-center through speakers will, through headphones, be far, far out on the right; and those left-of-

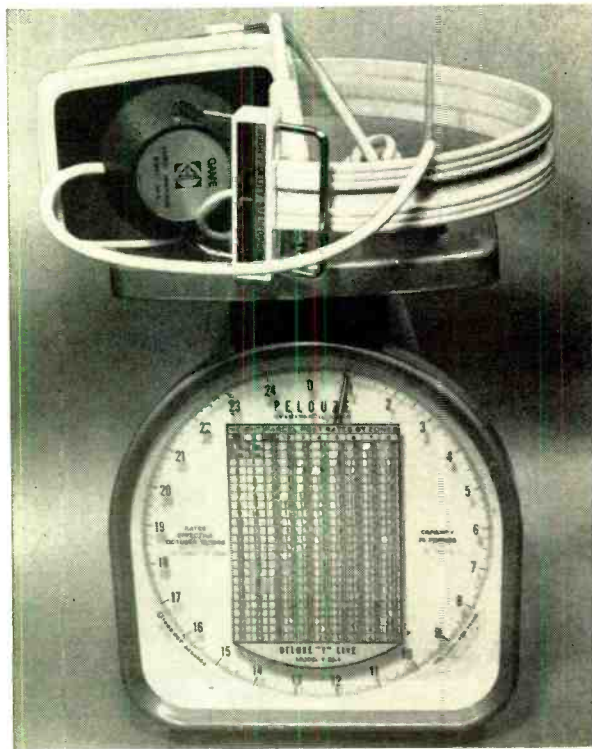

All stereo headphones are lightweight and average less than 1 lb. These new headphones are from Game.

center will be way out on the left. Reverberation effects are frequently unreal.

These disc and tape effects resulted from the spread-microphone recording technique that was so popular in the '60's. This technique makes stereo playback in rooms through

(Continued on page 96)

*Available from Ziff-Davis Service Division, 595 Broadway, New York, NY 10012. Price \$5.98.



The In-Out Annunciator

GETS THEM COMING AND GOING

BY JOHN S. SIMONTON, JR.

THE ELECTRIC "EYE" has been a faithful, reliable workhorse in all sorts of burglar alarms and counting systems since before the word "electronics" was coined. Even today, it is extensively used in these applications. But too often it is used in circuits that are far from up-to-date.

The "In-Out Annunciator" described here is, in fact, an electric eye system—using a highly sophisticated circuit. Designed for the special case where it is not enough to know simply that someone or something has interrupted the beam of light, the Annunciator tells you whether the person was entering or leaving the passage-way covered.

Uses of the Annunciator include monitoring one-way-only garage doors, operating automatic doorbells or chimes that do not sound when a visitor is leaving, guarding high-secu-

rity areas, and discriminating sizes of objects. It also makes an interesting, attention-getting Science Fair project.

Two inexpensive resistor-transistor logic IC's are at the heart of the Annunciator, containing enough electronics to provide the amplification needed for good sensitivity in high ambient light areas and the logic necessary to distinguish between objects passing in either of two directions.

Theory of Circuit Design. Before going into a detailed examination of the operation of the Annunciator's circuit, it is useful to point out that gate pairs $G1/G3$ and $G2/G4$ in $IC1$, as shown in Fig. 1, are wired with regenerative feedback through resistors $R1$ and $R2$, respectively. This feedback arrangement adds hysteresis to the response of the circuit so that slight changes in ambient light level will not be misinterpreted by the circuit and generate "false" counts. Capacitors $C3$ through $C6$, by rolling off the high-frequency

John S. Simonton, Jr. is a graduate electrical engineer who now spends most of his time developing unusual projects.

response of *IC1*, reduce the sensitivity of the circuit to transients. Also, *G3* and *G4* are cross-coupled to form a set-reset latch.

The steady-state outputs of the NOR gates with both *LDR1* and *LDR2* fully illuminated are: *G1* and *G2*, high; *G3* and *G4*, low; *G5* and *G6*, high; and *G7* and *G8*, low.

Now, suppose the light source is interrupted on first *LDR1* and then on *LDR2*. By darkening *LDR1*, its internal resistance increases and causes a high input to be presented to *G1*. In turn, the output of *G1* goes to low. Since both inputs to *G3* are now low, the output of this gate goes to high and is then inverted by *G5*. The output of *G3* is also applied to one of the inputs of *G4* to guarantee that this gate's output will remain low.

Gate *G7* now has one of its inputs at low and the input from *G2* at high; so, its output it still low. When *LDR2* is darkened, the output of *G2* goes to low, applying a second input to *G7* and causing the output of *G7* to go to high. As a result, *Q1* conducts and energizes *K1*. The state of *G4* does not change because the output of this gate is held low by the high output of *G3*.

As the light again illuminates *LDR1*, the state of the circuit does not change by virtue of feedback from *G7* which holds the output of *G1* at low. When the light illuminates fully *LDR2*, the output of *G2* goes to high and, consequently, the output of *G7* goes to low, unlocking the loop formed by *G1*, *G3*, and *G5*.

Objects passing between the light source

and the system so that *LDR2* is darkened first, followed by the darkening of *LDR1*, generate a similar chain of events to energize *K2*.

Construction. Since integrated circuits are used in the Annunciator, printed circuit board construction is the only realistic approach to assembly. You can etch and drill your own circuit board by carefully following the actual size etching guide provided in Fig. 2, or you can purchase a ready-to-use board from the source given in the Parts List.

Begin assembly by mounting the components on the board (see Fig. 2). Be careful to orient properly polarized components, and use heat from a 35-watt soldering iron sparingly. Also, as you solder, take pains to avoid solder bridges between closely spaced foil conductors—particularly around the IC solder pads.

Mount *K1* and *K2* on the circuit board with 4-40 machine hardware. Then use insulated jumper wires to connect the relay coils to the appropriate solder points on the foil pattern of the circuit board.

When mounting trimmer pots *R5* and *R6*, bend their leads to position the adjustment slot directly over the $\frac{1}{4}$ "-diameter holes in the circuit board. This allows the system to be adjusted through access holes in the plastic cabinet once final assembly is complete.

A standard $6\frac{1}{4} \times 3\frac{3}{4} \times 2$ " Bakelite case makes for an exceptionally compact project. However, steps must be taken to keep



All components except power transformer, on/off switch, and LDR's mount on printed circuit board. Spacers and 4-40 machine hardware fasten circuit board to case top.

Fig. 1. Two quad two-input gate digital IC's supply all functions for proper bidirectional operation of Annunciator system. Relays control counters and/or signalling devices.

PARTS LIST

- C1, C2—100- μ F, 15-volt electrolytic capacitor*
C3-C6—0.1- μ F disc capacitor
IC1, IC2—Integrated circuit (Motorola MC-724P)
K1, K2—12-volt, 1640-ohm relay (Sigma No. 65F1A-12Dc or similar)
LDR1, LDR2—Light-dependent resistor (Clairex No. CL703L or similar)
Q1, Q2—2N2712 transistor

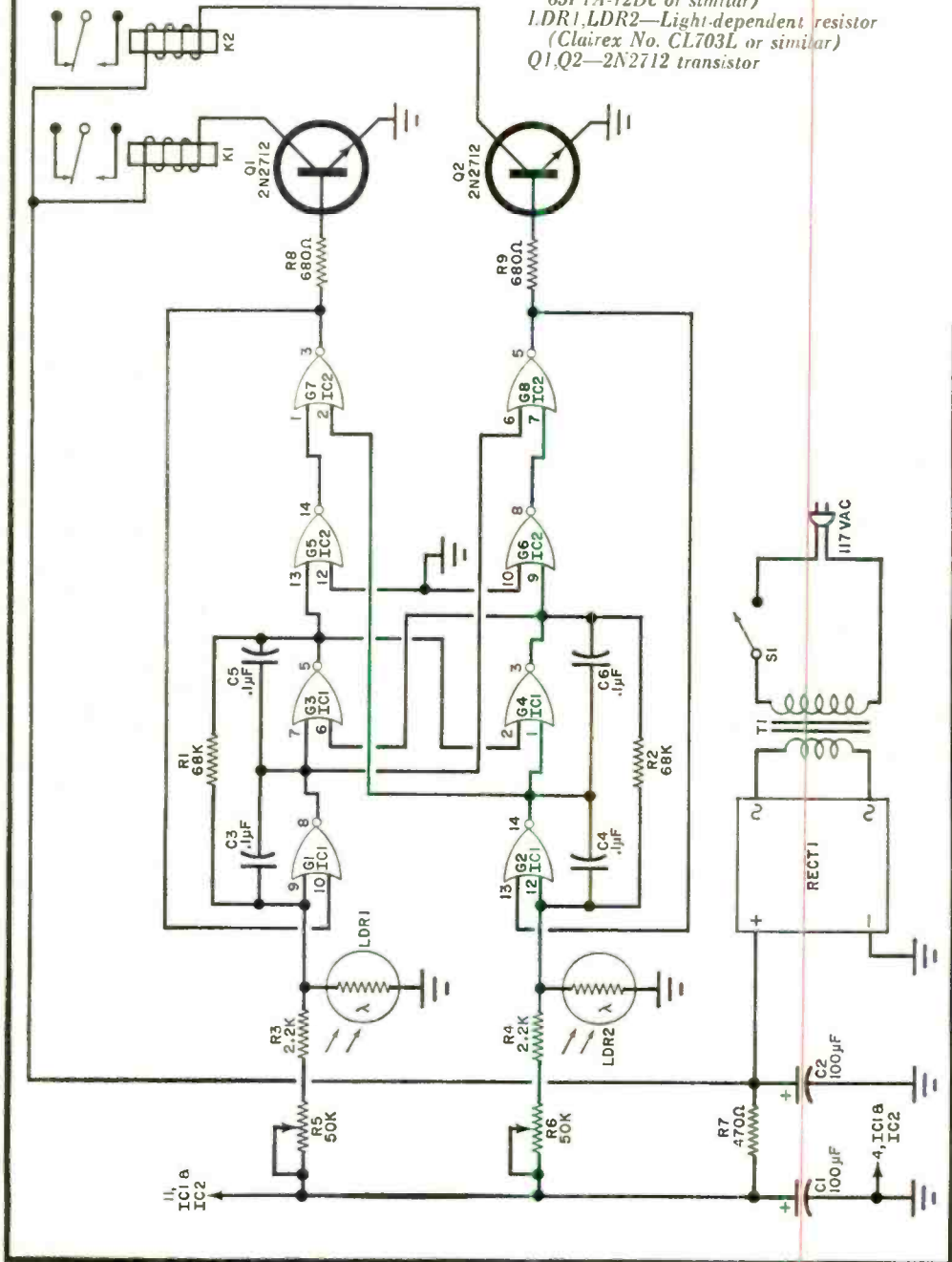

R1,R2—68,000-ohm }
 R3,R4—2200-ohm } All resistors, 1/2-watt,
 R7—470-ohm } 10% tolerance
 R8,R9—680-ohm }
 R5,R6—50,000-ohm trimmer potentiometer
 RECT1—50 PIV, 1-ampere rectifier bridge
 assembly (Motorola MD.A942A-1 or similar)
 S1—Spst switch
 T1—12.6-volt, 300-mA filament transformer

Misc.—Printed circuit board, terminal strips
 (2), line cord and strain relief; 3/4" long
 spacers; 6 1/4" x 3 3/4" x 2" plastic or Bake-
 lite box; 5-dram pill containers (2); hook-
 up wire; 4-40 hardware; solder; etc.

Note: The following items can be obtained
 from PATA Electronics, Inc., P.O. Box
 14359, Oklahoma City, OK 73114; etched
 and drilled circuit board No. 5701pc for
 \$3.50 postpaid; complete kit of all parts,
 including circuit board and unfinished case,
 No. 5701K for \$19.75 plus insurance and
 postage on 2 lb.

components and assemblies from interfering
 with each other. The following general as-
 sembly sequence should be followed as closely
 as possible.

Begin mechanical assembly by drilling the
 mounting holes for transformer T1. Locate
 the transformer so that it is in contact with
 one of the long sides of the case. (Note that
 the same machine hardware used to fasten
 T1 in place is also used to anchor the terminal
 strips which serve as tie points for the leads
 of the LDR's.)

Position the light shields (5-dram pill con-
 tainers) at opposite ends of the transformer,
 and use a pencil or scoring tool to mark their
 outlines on the Bakelite case. Then remove
 and set aside the shields. Locate the centers
 of the light shield outlines and slowly and
 carefully drill first a 1/16" hole, following it
 up with a 1/4" bit to enlarge the holes. At this
 point, you can use a multiple-drilling tech-

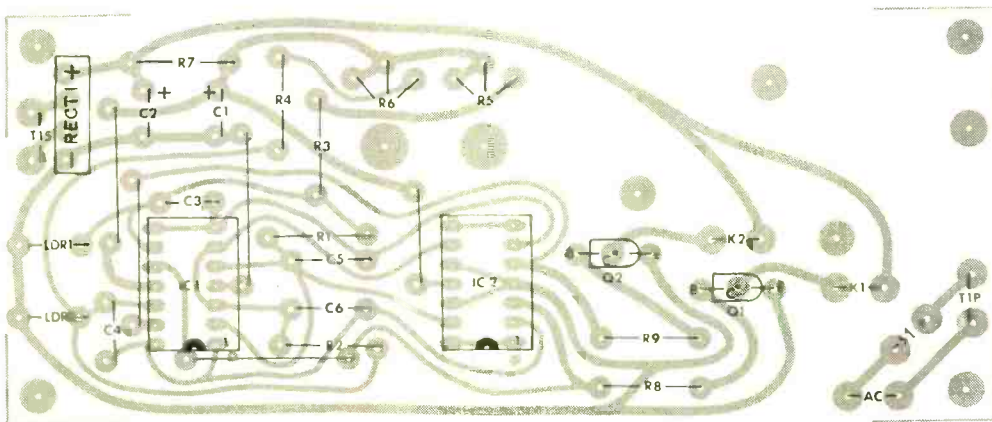
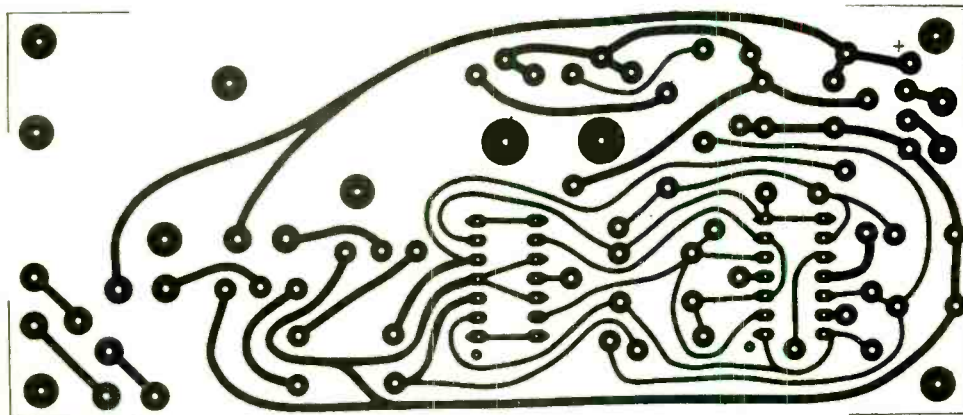

Fig. 2. At top is given actual size etching and drilling guide for fabricating the printed circuit board. In the component location and orientation guide (above) note particularly orientations of IC's.

nique, a nibbling tool, or a chassis punch to enlarge the holes or cutouts so that they are slightly larger in diameter than the shields.

The mounting holes for power switch *S1* and the circuit board, and the access holes for the slots of *R5* and *R6* trimmer pots can now be accurately located and drilled. Position the circuit board as close as possible to the front of the case to obviate any possibility of the lugs on *S1* from contacting *T1*.

When all front-panel holes are drilled, paint and label the panel as desired. Allow sufficient time for the paint to dry; then drill a hole for and mount the line cord—via its strain relief—and the terminal block on the rear of the case.

Drill two #60 holes, about 30° apart and as close as possible to the bottom of each pill container. Then use flat black paint to coat the interior surfaces of both containers. When the paint dries, use a pin to clear the #60 holes of paint. Insert the leads of the LDR's through the holes, daub a drop of epoxy cement on the undersides of the LDR's, and press the LDR's to the bottoms of the containers.

Slip the light shield assemblies into their respective cutouts, taking care not to tear off the LDR leads. Run a thin bead of epoxy cement around the lip of each shield; then seat the shields squarely in their cutouts and allow the cement to set at least overnight.

Interconnect all components and assemblies as shown. Then mount the circuit board inside the case with 4-40 machine hardware and 1/4"-long spacers.

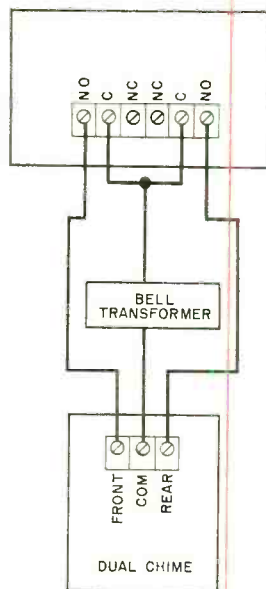
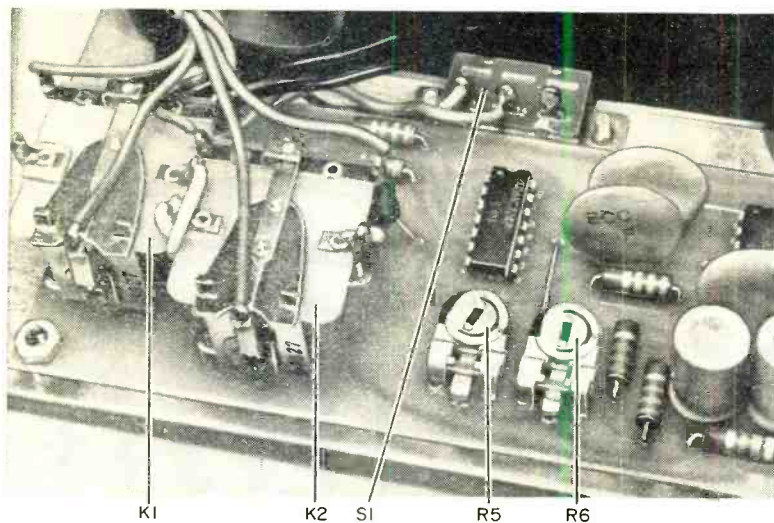

Fig. 3. When wiring dual chimes into system, use only normally open and common contacts on relays.

Setup and Use. Rotate *R5* and *R6* fully clockwise (viewed from the component side of the board). Point the LDR's at a relatively bright light source, plug the power cord into a convenient ac outlet, and close *S1*. Use a piece of opaque cardboard to completely cover *LDR1*; neither relay should be energized. With *LDR1* still covered, place another piece
(Continued on page 92)



Access to contacts on *K1* and *K2* is through solder lugs mounted on small phenolic boards which are on relay frames facing toward on/off switch *S1* in photo.



Build the Charge Now

RECHARGES ANY NICKEL-CADMIUM OR
ALKALINE AA, C, OR D CELL

BY A. A. MANGIERI

NAME your battery charging problem! The "Charge Now" solves them all—with some added extras. With a Charge Now in your workshop or lab, you have all the advantages of an expensive commercial unit—at much less cost.

Here are some of the uses to which you can put the Charge Now. It provides dc currents in values from less than 1 mA to 1 A in ten ranges for recharging nickel-cadmium cells. It recharges any alkaline AA, C, or D cell in fourteen hours using voltage-limited, tapered charging to automatically prevent overcharging. With a well-filtered dc output available at a pair of binding posts, the charger serves as a fully adjustable constant-current source

for testing semiconductors and many other components and circuits. And with a zener diode across the output, a well-regulated, low-voltage source is available for other testing.

Construction. The schematic of the battery charger is shown in Fig. 1. Wiring and layout are not critical. In the prototype shown in the photos, a piece of perf board $3\frac{1}{2}'' \times 4''$ was used to support most of the components. Layout is shown in Fig. 2. Optional transistor sockets were used in the prototype. Note that the metal cases of *R27*, *R28*, and *R29* provide negative return to terminal ZZ.

Another piece of perf board $2'' \times 2''$ was mounted directly on the meter terminals to hold all of the components directly associated with the meter circuit. Terminals on the board should be identified for making connections.

A. A. Mangieri, when not developing projects or writing articles, is an amateur radio operator.



Your paycheck says a lot about you

It tells you more than how much you make. It tells you how far you've come. And if your paycheck looks very much the same as it did last year, or the year before, it simply means that *you* look very much the same as *you* did last year and the year before.

But times change, and you should be changing with them. Old dull jobs are disappearing. New exciting ones are being created. There are challenging new fields that need electronics technicians...new careers such as computers, automation, television, space electronics where the work is interesting and the earnings are greater.

RCA Institutes has one of the nation's largest and most respected home study schools devoted to electronics. They can get you started even if you've had no previous training or experience. RCA Institutes has developed a faster, easier way for you to gain the skills and the knowledge you need for a fascinating, rewarding electronics career. And you don't have to quit work and go back to school. With RCA Institutes Home Study Plan you can do

both. You set your *own* pace depending on *your* schedule.

Check over these RCA benefits:

- You get Hands-On Training—over 300 experiments and as many as 25 kits with some programs.
- You get RCA's unique "Autotext" method of learning—individual programmed instruction, the *easy, faster*, simplified way to learn!
- You get the widest choice of electronics courses and programs—everything from Electronics Fundamentals right up to Solid State Technology and Communications Electronics.
- You get a selection of low-cost tuition plans!

Sounds great, and it is! For complete information, without obligation, send in the attached postage paid card...or return the coupon below. That will say a lot about you.

Veterans: Train under new GI Bill. Accredited Member National Home Study Council. Licensed by N.Y. State—courses of study and instructional facilities approved by the State Education Department.

RCA Institutes

Home Study Dept. 694-004-1
320 West 31st Street, New York, N. Y. 10001

Please rush me FREE illustrated catalog.
I understand that I am under no obligation.

Name _____ Age _____
(please print)

Address _____

City _____ State _____ Zip _____

Veterans: Check here

If reply card
is detached—
send this
coupon today

PARTS LIST

- C1—5500- μ F, 25-volt electrolytic capacitor
 C2—0.22- μ F disc capacitor
 C3—25- μ F, 25-volt electrolytic capacitor
 D1-D6—1-ampere, 50-PIV silicon diode (HEP154 or similar)
 F1—1-ampere fuse and holder
 I1—117-volt ac neon lamp
 J1, J2—Five-way binding post (one red, one black)
 M1—1-mA dc milliammeter
 (Allied Radio Shack 701-0020 or similar)
 Q1, Q3—Transistor (HEP53 or similar)
 Q2—Transistor (HEP247 or similar)
 Q4, Q5—Transistor (HEP51 or similar)
 R1—2200-ohm
 R2—17-ohm
 R3, R4—1000-ohm
 R5—33,000-ohm
 R6, R7—5.6-ohm
 R8, R9—1-ohm
 R10—150-ohm
 R11—22-ohm (see text)
 R12—6.8-ohm (see text)
 R13—3.3-ohm (see text)
 R14—1000-ohm
 R15—270-ohm
 R16—130-ohm
 R17—56-ohm
 R18—22-ohm
 R19—11-ohm, 2-watt resistor
 R20—6.8-ohm, 2-watt resistor
 R21—2-ohm, 5-watt resistor
 R22—1-ohm, 5-watt resistor
 R23—3.6-ohm, 2-watt 5% resistor
 R24—0.68-ohm, 2-watt, 5% resistor
 R25—0.22-ohm, 2-watt, 5% resistor
 R26—1200-ohm, 1-watt resistor
 R27, R28—1.5-ohm, 2-watt, wirewound potentiometer (Centralab V-1.5 or similar)
 R29—600-ohm, 2-watt wirewound potentiometer (Centralab V-600 or similar)
 R30—100-ohm, 2-watt wirewound potentiometer (Centralab V-100 or similar)
 R31—1000-ohm, wirewound potentiometer (Centralab WW-102 or similar)
 RECT1—1-ampere, 200-PIV rectifier (HEP176 or similar)
 S1—Spst slide or toggle switch
 S2—Double-pole triple-throw slide switch (Wirt SP3T8, Allied Radio Shack 759-5580, or similar)
 S3—6-pole, 6-position non-shorting rotary switch (Centralab PA-2023, Allied Radio Shack 747-2023, or similar)
 S4—One-pole, 10-position, non-shorting rotary switch (Centralab PA-1001, Allied 747-1001, or similar)
 T1—12-volt, 2-ampere filament transformer
 Misc.—Heat sink and mounting kit (Motorola HEP500 or similar), plastic case with cover for cell holder, 2" corner braces, perf board, eye bolts, springs, capacitor mounting bracket, lug strips, thin sheet brass or stainless steel, line cord, mounting hardware, copper sheet for RECT1 mounting, $\frac{1}{2}$ " wood V blocks, vinyl tape, solder lugs, etc.

All resistors $\frac{1}{2}$ -watt

All resistors 1-watt

When assembling the power supply within the chassis, make sure that filter capacitor C1 is completely insulated from the metal chassis by a plastic sleeve. The rectifier (RECT1) is mounted on four heat sinks, one attached to each leg, so that sufficient heat is conducted away during use with 1 ampere drain. The heat sinks were made of four copper L brackets mounted on perf board with the bottom of the L up. The leads of the rectifier were then soldered to their respective heat sinks. Also on this perf board was the fuse holder.

The large heat sink for Q2 can be mounted on the rear wall of the chassis using four insulated shoulder washers for support. It is then possible to omit the usual mica washer, but use silicone grease between the transistor and the heat sink. The transistor was fitted into a socket on the other side of the heat sink and a three-lug terminal strip was mounted on one of the heat sink nuts for connections to the transistor. Include some vent holes if the rear wall of the chassis is solid metal.

Cell Holders. Before building the chassis, determine what type of cell holders you prefer. Obviously, conventional holders for AA, C, and D cells may be used. In this case, sim-

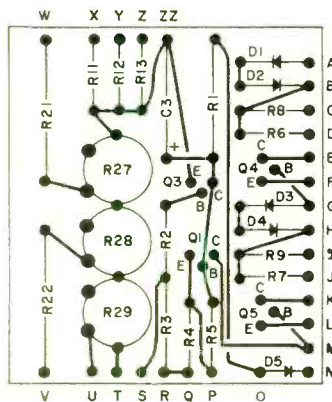

Fig. 2. Component installation on the perf board. The dark lines duplicate the insulated wire connections made between the various mounting clips.

ply mount the cell holders to an outboard wooden frame and connect them to the charger through short lengths of insulated wire. To duplicate the prototype, a special cell holder must be made as follows.

Obtain a $1\frac{1}{2}$ " deep \times $2\frac{5}{8}$ " \times $3\frac{3}{4}$ " plastic utility box with plastic cover. Cut two holes in the rear of the box as shown in Fig. 3.

Two-inch steel corner braces must be made

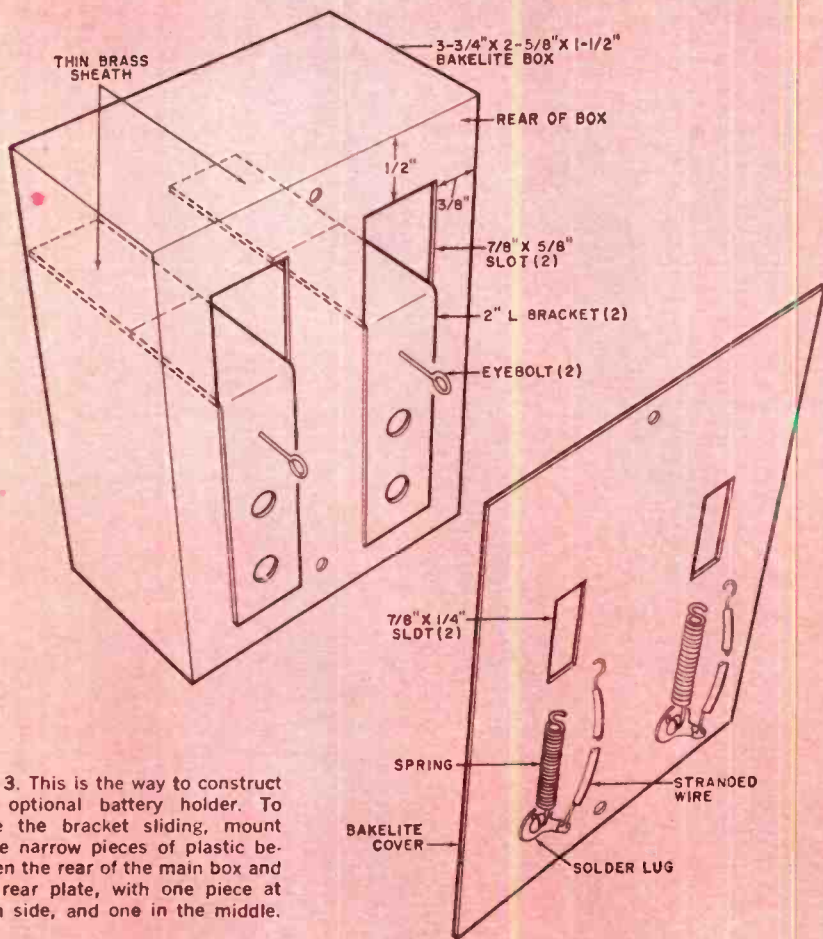

Fig. 3. This is the way to construct the optional battery holder. To ease the bracket sliding, mount three narrow pieces of plastic between the rear of the main box and the rear plate, with one piece at each side, and one in the middle.

and filed smooth; also make a thin brass or stainless steel cover for the arm that protrudes into the case. Make sure that both braces slide smoothly up and down in their slots. Swage a conventional solder eyebolt to the rear of each slide as shown. Cut two slots in the plastic cover so that the eyebolts can slide up and down to the maximum travel of the steel braces. Then secure a pair of solder lugs to the bottom of the cover directly under each slot. Use small spacers to attach the cover to the rear of the box so that, when assembled, the two braces can slide up and down unhindered. Mount a spring to each soldering lug and attach the other end to the eyebolt. The electrical connection is made through a short length of insulated wire.

The interior of the case is fitted with wood V blocks faced with black vinyl tape. These

blocks are cemented in place after test aligning a cell. Use double-sided tape to attach the blocks while aligning them. Then use cement or epoxy for final mounting.

With an AA cell in place on the V blocks and with the steel braces partially up in their slots (the rear spring providing tension), locate the lower minus contact button and use 6-32 x 3/4 hardware and a spacer to mount it. With a cell in place, the brace should automatically clamp the cell between the brace and lower minus contact.

Because of different cell diameters, two sets of minus contacts should be provided for each side of the cell holder. Electrical connections to these contacts are made through a soldering lug at each minus contact. Identify the cell holders as B1 and B2 and identify the PLUS and MINUS sides of the holder.

The face of meter *M1* must be retouched to add two more scales. The original 0-1 scale will be used for the 1000-mA range. Using some form of press type, add the numbers 50, 100, 150, 200, and 250 over the original indications for .2, .4, .6, .8, and 1.0 respectively. This is the 250-mA scale. Similarly, add 10, 20, 30, 40, and 50 for the 50-mA scale. When making these additions, take care not to damage the meter movement or the needle.

The front panel of the charger is shown in the photographs. Note the cutout for the plastic cell holder, which is supported by four mounting screws. Switch *S3* is marked for VLTC (voltage-limited tapered charge) on three positions and CC (constant current) on two positions. The CC positions are further

identified by a line going to the *R31* (FINE) and *S4* (COARSE) controls. This aids in setting up the correct switches.

Note the placement of the other switches and controls on the panel and inside the chassis. Since lead length and placement are not critical, it is not necessary to duplicate the prototype exactly; but the arrangement has been found to be convenient.

Adjustment. Before making any adjustments, connect a 5-to-10-watt, 20-ohm resistor between the plus of the power supply and the remainder of the circuit to test the VLTC ranges and check the CC mode for positions 1 through 9 of *S1*. For position 10 of *S1*, use a 10-to-15-ohm resistor.

Set *R29* for a resistance of about 300 ohms

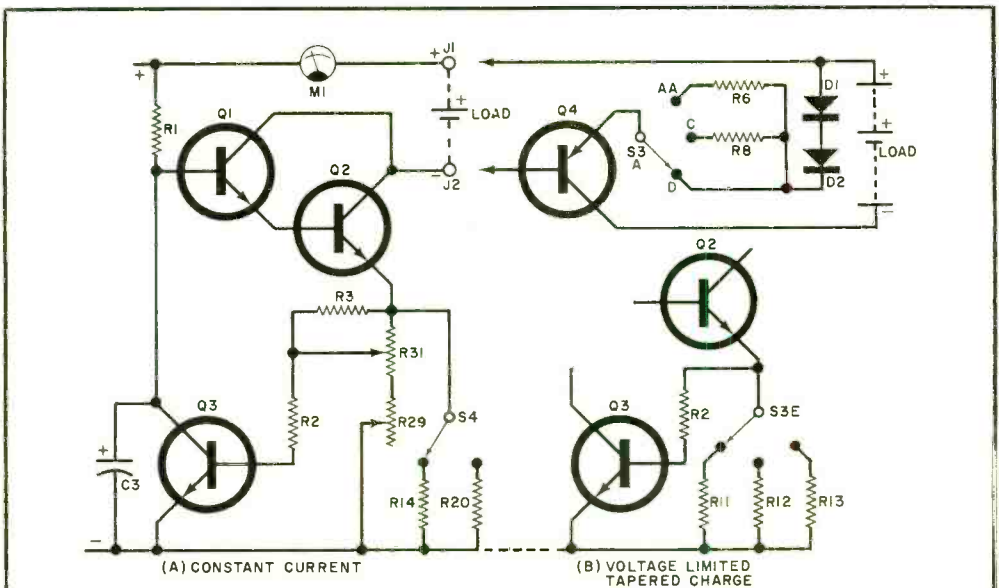

THEORY OF CIRCUIT DESIGN

The schematic shown here is a simplification of the Charge Now circuit. Section A illustrates the constant-current (CC) mode. The load is on the collector circuit of the *Q1-Q2* Darlington pair. The emitter circuit includes *S4* which selects the various current range shunts. The constant-current adjustment circuit (*R31*, *R3*, and *R29*) is a voltage divider on the base of *Q3*. Resistor *R1* in the collector circuit of *Q3* also supplies base drive for the Darlington pair. If the emitter current of *Q2* rises, *Q3* receives more base drive and reduces the drive to *Q1* correcting for the change (and vice versa). With high loop gain through *Q1*, *Q2*, and *Q3*, the current through the load is regulated very closely.

In the voltage-limited tapered-current

(VLTC) mode, two series-connected shunt voltage clamps are switched into the circuit of *Q2*. (See section B.) The CC adjust circuit and *S4* are replaced by a current shunt made up of *R11*, *R12*, or *R13*, which are selected by *S3E*. Diodes *D1* and *D2* and transistor *Q1* are matched so that, with the cell out of the holder, the open-circuit voltage is 1.7 to 1.75 volts. With a discharged cell (about 1 volt) connected between *J1* and *J2*, the voltage clamp does not conduct and current is supplied to the cell. As the cell voltage builds up, the voltage clamp begins to shunt current around the cell, thereby providing the voltage-limited tapered charging.

Resistor *R3*, which is used in the constant-current mode and shorted out in the VLTC mode, insures base drive to *Q3* under all conditions when non-shorting switch *S3* is used.

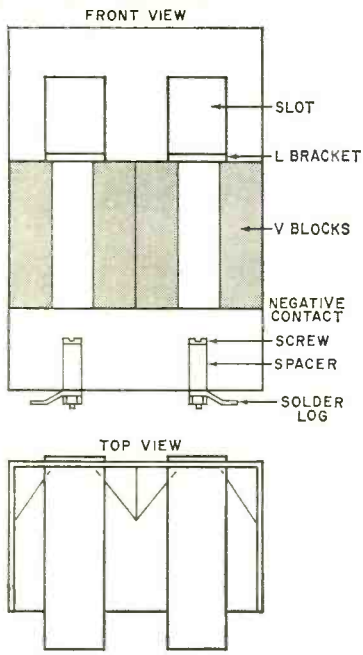

The V-blocks are used to center the cells in the holder so that good contact is made between the two electrical connectors. After final positioning, cover the wood blocks with black plastic tape.

and R_{27} , R_{28} , and R_{30} for maximum resistance. Place S_3 in the CC mode, S_4 in the first LO position, and S_2 on 1000.

Connect a multi-range milliammeter be-

tween J_1 and J_2 and turn on the power. As S_4 is advanced from position 1 to position 9, observe an increasing output current from less than 1 mA to several hundred mA with variable control through R_{31} in each position. Set the output current to 200 mA, place S_2 on 250 and adjust R_{30} until the meter on the front panel indicates 200 mA.

With R_{31} set for low current, place S_4 on HI. Adjust R_{28} until the meter indicates 400 mA. Shut down the power and replace the external 20-ohm resistor with a 10-ohm resistor. Turn on the power, and slowly advance R_{31} and R_{29} until the meter indicates one ampere with R_{31} fully clockwise. Repeat these steps until R_{31} controls the current from 400 to 1000 mA. Then set S_4 to position 9 and adjust R_{27} until R_{31} covers the range up to 500 mA. Check that all lower ranges have a slight overlap.

Check that the meter on the charger tracks the external milliammeter on the three major ranges of S_4 . Potentiometer R_{30} is used to make any necessary scale adjustments. It may be advantageous to set R_{30} so that the high range (1000 mA) is correct, and then trim the shunts of the lower ranges (R_{23} - R_{25}) for reasonably close meter indications.

In the VLTC mode, diodes are paired off with Q_4 and Q_5 and resistors R_{11} through R_{13} are sized to set the charge rates indicated in the Table. Use a 20-ohm resistor in the plus lead of the power supply and re-

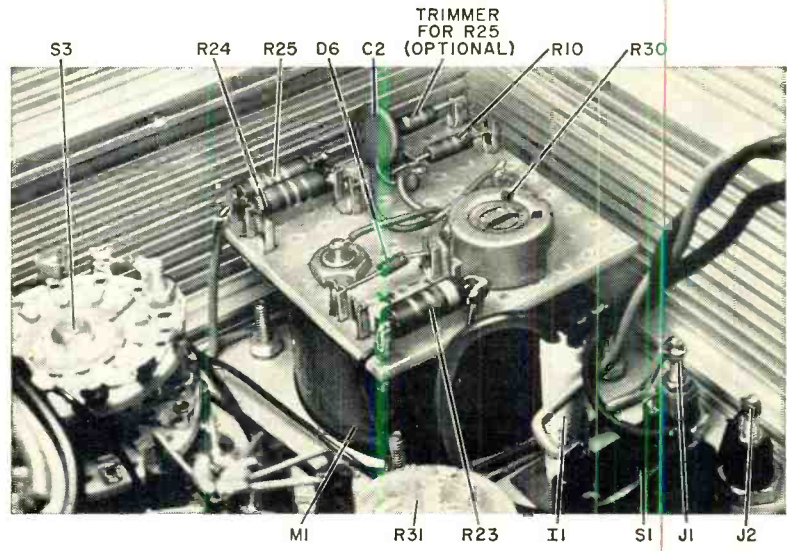

The various components that are associated with the meter circuit are mounted on a small piece of perf board, that in turn, is mounted on the meter terminals.

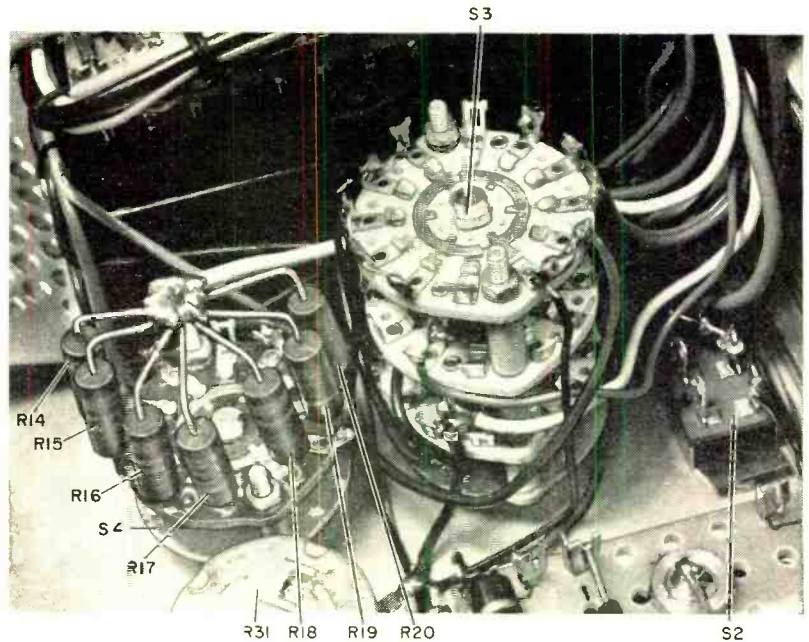

Arrangement of the resistors associated with S4 shows an easy method of mounting.

move the outboard meter from *J1* and *J2*. Allow a 5-to-10-minute warmup for the diodes and transistors.

Accuracy is more important in setting the voltage limit than in measuring the charge rate. Check the accuracy of the low-voltage de range (5 volts) of the external VOM you are going to use.

Place *S3* on position 5 (VLTC-D) and, if necessary change the value of *R13* until *M1* indicates 200 mA. Then measure the voltage across the B1 and B2 holders. It should be about 1.7 volts. The diodes in each circuit may be interchanged to get a better match. If the voltage is less than 1.7, increase the charge rate using *R13*. If the matched volt-

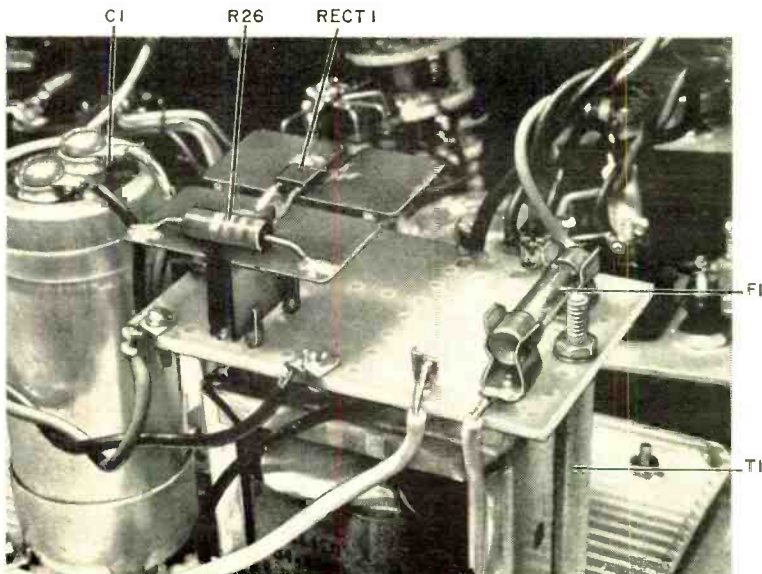

Each terminal of the rectifier is soldered to a copper plate that acts as a heat sink during heavy power consumption. Each segment is individually mounted. Capacitor C1 is insulated from chassis by a plastic wrap.

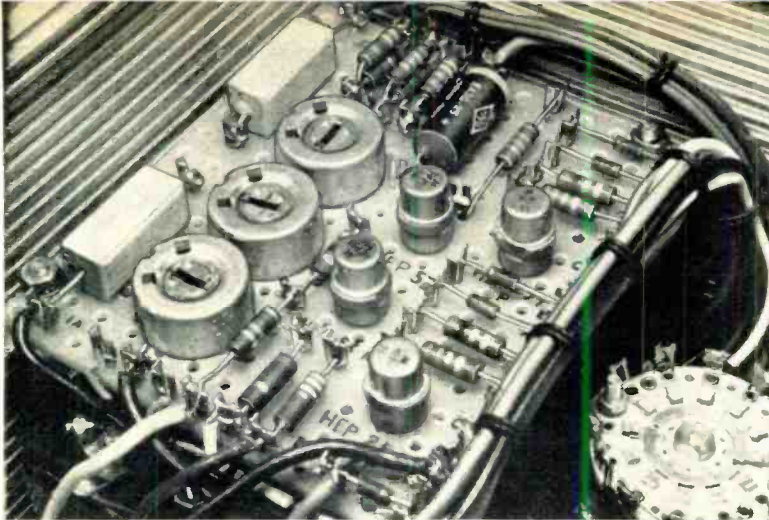

Although the author used sockets for the transistors, they are optional. To avoid wiring errors, clearly identify each terminal and component. To create a neat appearance, leads going to a common area are bundled together to form a wiring harness.

CURRENT AND VOLTAGE LIMITS VLTC MODE

| Mallory Type | Rated Capacity (mA-hr) | Charging Rate (mA) |
|--------------|------------------------|--------------------|
| SA-15AA | 300 | 30-37.5 |
| SA-14C | 1000 | 100-115 |
| SA-13D | 2000 | 200-230 |

Charge open-circuit voltage limits (volts): 1.7-1.75.

same. If not, interchange or change the values of $R8$ and $R9$. To increase the voltage, it is preferable to raise the charge rate rather than use higher resistances.

Follow the same procedure with $S3$ in position 3 (VLTC-AA). In this case, it will probably be necessary to set the charge rate toward the high limit of the Table.

Application. To charge a single nickel-cadmium cell, set $S3$ to position 1 (CC-B1) and place the cell in the B1 holder. For two identical cells, place $S3$ in position 2 (CC B1+B2). Recharge nickel-cadmium cells at the rate and for the time marked on the cell or as specified by the manufacturer. Both $S4$ and $R31$ can be adjusted for the correct values, with the current indicated on $M1$. If the charging information is not specified, but the milliamper-hour rating is known, divide this rating by 10 and charge at that rate for 14

(Continued on page 97)

ages are above 1.75, set the charge rate slightly under 200 mA or select other diodes. Just make sure that the voltages on the B1 and B2 holders are matched.

Set $S3$ to position 4 (VLTC-C) and adjust the value of $R12$ to obtain 100 mA on $M1$. The voltage on the holders should remain the

Power transistor Q2 is mounted directly to its heat sink, and the heat sink is insulated from the metal chassis. Vent holes allow cooling air to circulate within the closed container.

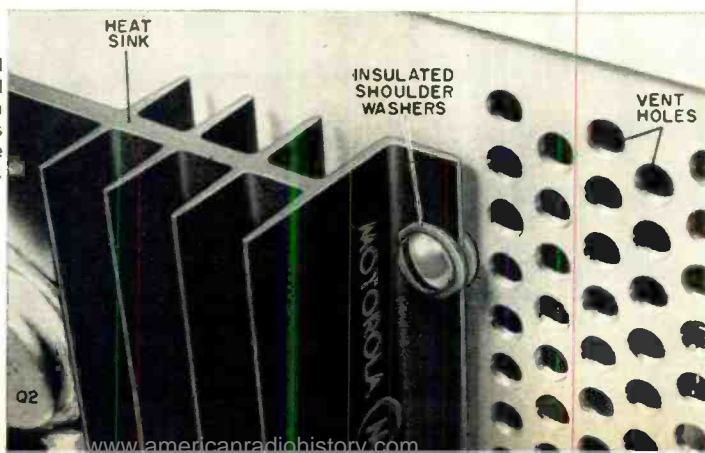

VR12 VOLTAGE REGULATOR

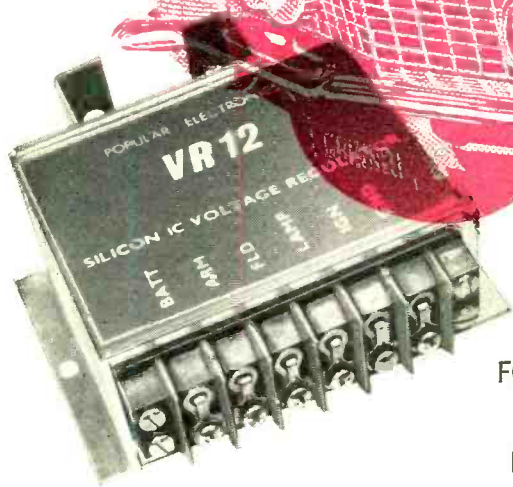

FOR YOUR CAR

SOLID-STATE DEPENDABILITY
BEATS MECHANICAL IRREGULARITY

BY C. R. BALL, JR.

MECHANICAL contacts in electrical circuits are known for their tendency to arc, wear, chatter, and gradually change spacing with use. Sooner or later, every car owner becomes cognizant of the two most important electrical contacts in his automobile—the “points” in the distributor and the voltage regulator in the generator/alternator circuit.

While some minor resetting of the contacts in the voltage regulator is always possible, there is a tendency among automobile mechanics to discard the regulator and replace it with a brand-new unit.

The voltage regulator performs more tasks than its name would imply. Mechanical relays in this device monitor the battery charging voltage and current and effectively control the operation of the generator/alternator so the battery is kept properly charged. Although

mechanical regulators have been considerably improved in recent years, there is an obvious question in the minds of many electronics hobbyists and experimenters as to why in this day of integrated circuits it is necessary to put up with a temperamental mechanical product?

This all-silicon IC and solid-state regulator provides a solution to all problems created by the mechanical regulator. This device has been use-tested for nearly two years and is considered completely safe, can cause no external damage to the automotive electrical system, and at very most requires one additional wire to be added to the average American car. If the suggestions are followed as to the size and insulation requirements of the hookup wire, your installation should be as safe as that of the original automotive equipment manufacturers. The device is temperature compensated and can be constructed for under \$18.

C. R. Ball, started on his own in TV repair, was inspired to be a little more creative, got his BSEE and wound up a design engineer.

Charging Systems. The only major

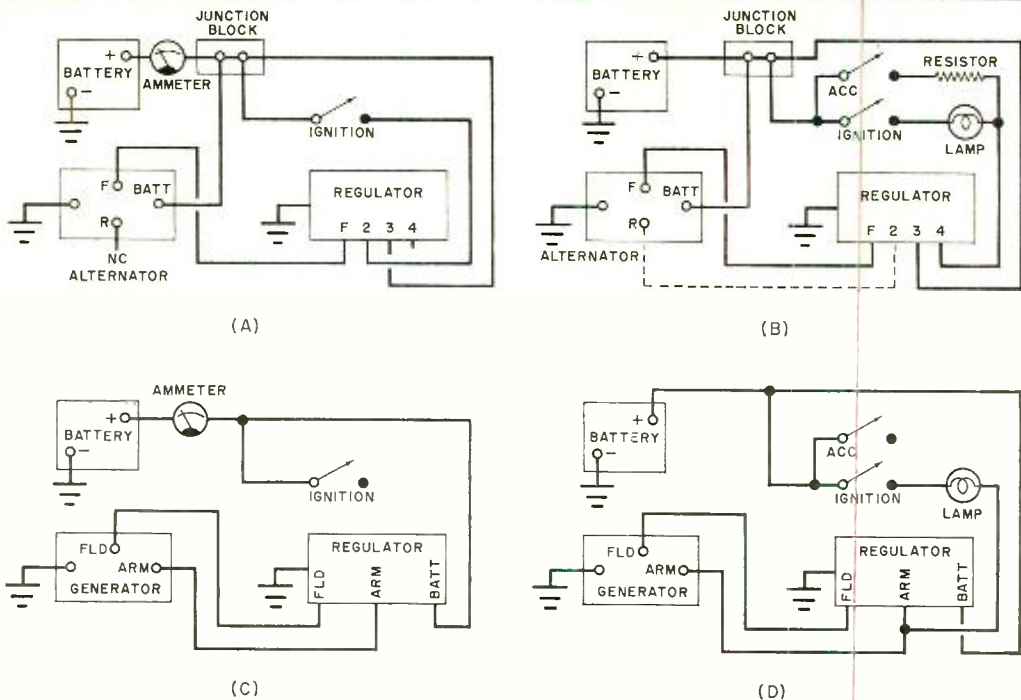

Fig. 1. The four common types of charging circuits are shown here. The two at the top are for an alternator system, while the two at the bottom are for a generator system. The two at the left are for meter circuits, while the two at the right are for those vehicles using a pilot lamp as charge indicator.

change in automotive battery charging systems in the last 15 years has been the switch from the dc generator to the ac alternator systems.

The old-style generator uses mechanical commutation to generate the necessary dc to charge the battery and as a result requires the use of a relay to disconnect the armature when the automobile ignition is turned off. The generator also requires over-current protection in order to prevent its own self-destruction in a high charge condition.

The ac alternator incorporates heavy-duty silicon diodes to act as rectifiers and to block current flow back through the alternator when it is in a no-charge condition. The alternator is inherently a self-limiting device in current and requires no over-current outboard protection.

Four common types of charging circuits are shown in Fig. 1. The four are obvious combinations of generator with lamp or ammeter and alternator with lamp or ammeter. The VR12 Voltage Regulator, whose basic schematic is shown in Fig. 2, can be used in any of the four arrangements.

Construction. Before constructing the regulator, use Fig. 1 to determine which configuration fits your needs and refer to Fig. 3 for the proper connections for the VR12.

The main part of the regulator uses the foil pattern and component layout shown in Fig. 4. Use an epoxy glass board for the PC. In installing the components, be sure that the IC is properly oriented. If power transistor Q8 is used (for lamp circuits), it must be thermally connected to a length of metal which is bolted to the chassis wall as shown in the photographs. Transistor Q5 is thermally mounted to the rear wall of the chassis. Solder leads of adequate length to the board terminal points. Excess solder flux should be removed and the board inspected for correct component installation and clean solder joints. Spray the board with a moisture-resistant, non-conductive spray.

For generator systems, the resistor pattern shown in Fig. 5 must be made (following the pattern exactly) on a 2-oz copper-clad board to provide current-sensing resistor R14. The resistance is 0.02 ohms and it can regulate 30 amperes.

PARTS LIST

- C1—82-pF disc capacitor
 D1—1N1183 diode
 IC1—Integrated circuit (CE P4230)
 Q1, Q4, Q6, Q9—2N3638 transistor
 Q2, Q7—T transistor (Motorola MFS6566)
 Q3—T transistor (Motorola MM4005)
 Q5—2N3055 transistor (Motorola MJE3055)
 Q8—2N4921 transistor
 R1—2200-ohm, 5% resistor
 R2—15-ohm thermistor (Fenval JD12/4 or similar)
 R3, R5—560-ohm, 10% resistor
 R4, R10—100-ohm, 10% potentiometer
 R6—330-ohm, 10% resistor

- R7, R8, R12—1000-ohm, 10% resistor
 R9—620-ohm, 10% resistor
 R11—390-ohm, 10% resistor
 R13—470-ohm, 10% resistor
 R14—0.02-ohm resistor (see text)
 Misc.—Heat sink for D1 (Delco 7270725), case, oil-proof flame-retardant wire, 6-terminal barrier block, moisture-proofing spray, mounting hardware.

Note—The following are available from BECO Solid State Systems, P.O. Box 686, Salem, VA 24153: etched and drilled glass-epoxy PC board (820-036) at \$2.25; R14 circuit board at \$1.75; extruded aluminum case at \$2.60; treated heat sink for D1 at \$1.10. All prices plus postage. Residents of Virginia, add 4% sales tax. A complete kit of parts for any of the four configurations is available, as are assembled and tested units. Write for prices.

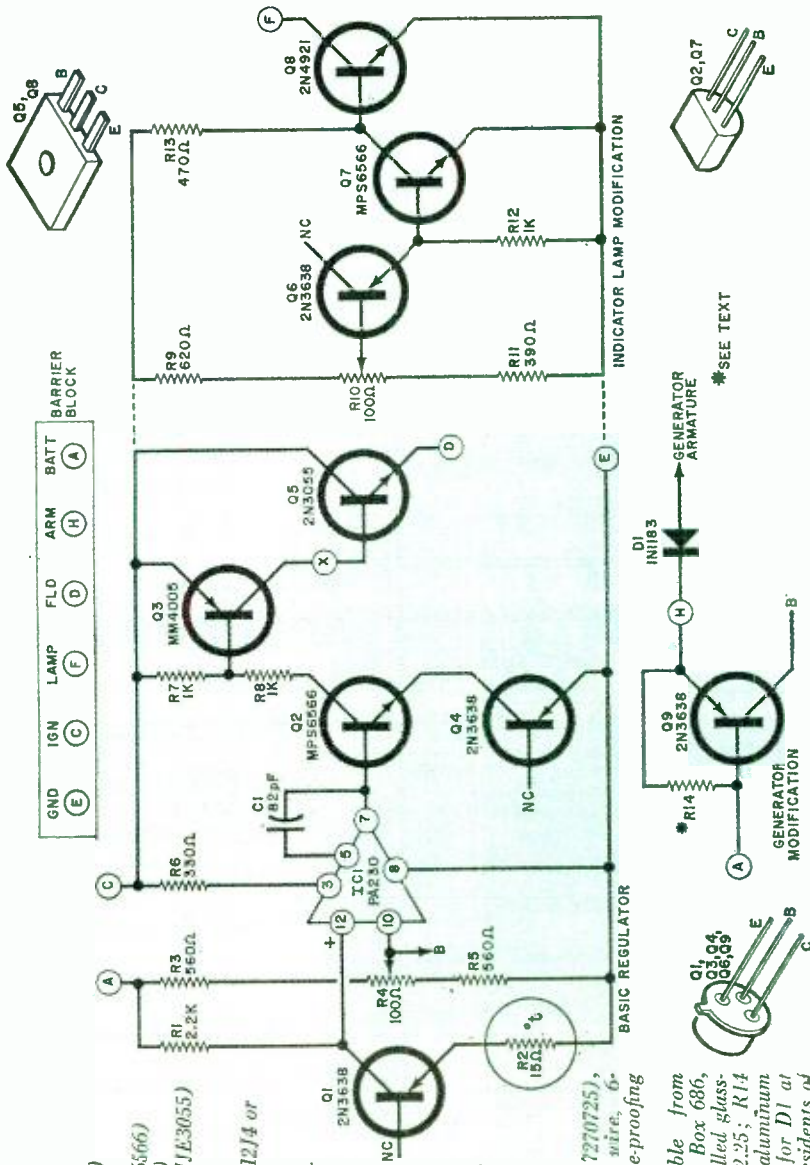

Fig. 2. Basic circuit for the regulator showing both the lamp option (on the right), and the generator modification (at the bottom). Resistor R14 is created from foil pattern.

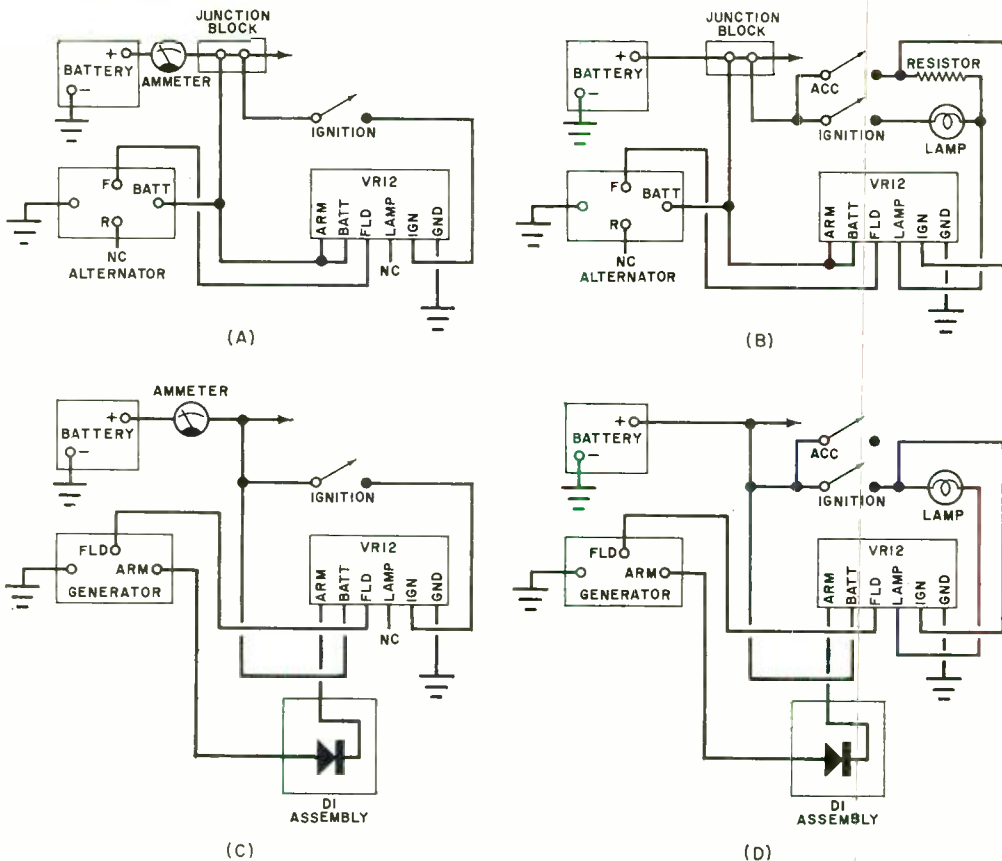
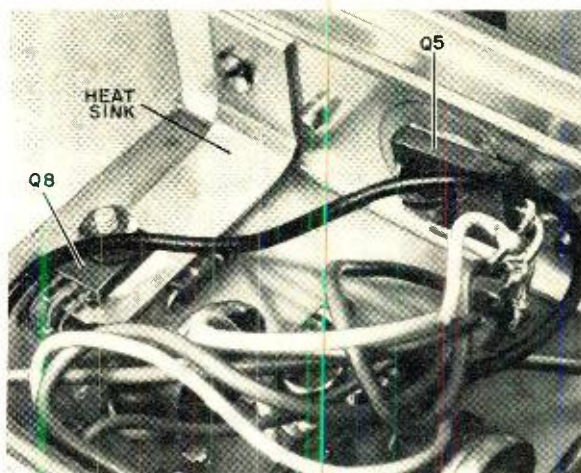

Fig. 3. This shows the four possible charging systems when using the VR12. Select the one that fits your requirements and wire the vehicle accordingly.

The printed circuit board is mounted in a heavy-duty closed metal chassis. (The one shown in the photographs was made of extruded aluminum.) Shock mounts are not required. Mount the six-terminal barrier strip on the chassis and connect the leads to the appropriate terminals. Make sure that each terminal on the outer side of the barrier strip is clearly identified.

An additional small heat sink will be required for diode *D1* for generator systems. All physical mountings must be made with lockwashers to prevent loosening due to vibration.

Adjustment. Before making any adjustments on the VR12 Regulator, the dc voltage at the present regulator must be measured and recorded. This must be done after the engine has been running for a while and the



Transistor Q8 has its own heat sink, while Q5 is thermally, but not electrically connected to the metal chassis, via a grease-covered mica washer.

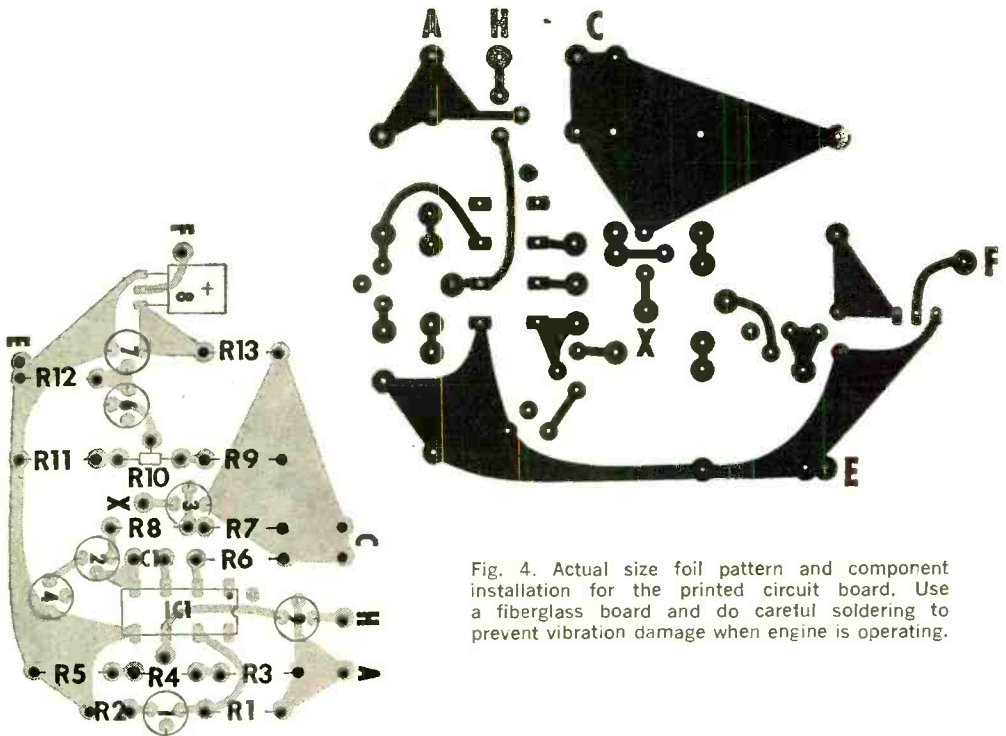

Fig. 4. Actual size foil pattern and component installation for the printed circuit board. Use a fiberglass board and do careful soldering to prevent vibration damage when engine is operating.

battery is fully charged. Failure to measure this voltage may result in a mis-adjustment of the solid-state regulator and faulty charging of the battery.

Connect the VR12 to a power supply as shown in Fig. 6A. Set the dc power supply to deliver the exact voltage which was measured in the preceding paragraph. Adjust *R4* on the regulator until the voltmeter indicates this

voltage. Increasing the power supply output slightly should cause the voltmeter to drop to zero.

If a lamp indicator is to be used, set up the circuit shown in Fig. 6B, with the output of the power supply set for 13 volts. Adjust *R10* on the regulator until the test lamp goes out. Decreasing the power supply output slowly should cause the lamp to come on. This ad-

Fig. 5. To make R14, a 0.02-ohm resistor able to regulate up to 30 amperes, follow this actual size foil pattern layout. A 2-oz copper-clad board must be used. As a substitute, use a plain board of the same size with 8 feet of #14 PVC insulated wire wound neatly around the board.

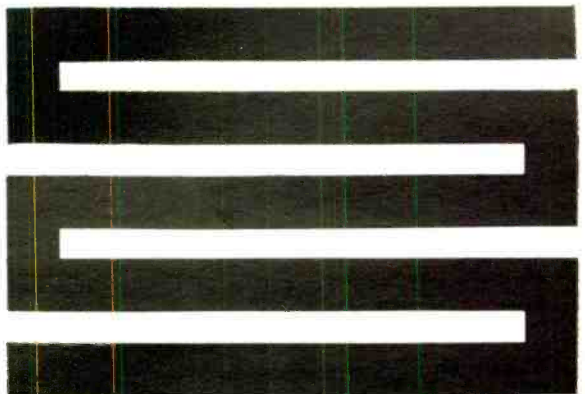

THEORY OF CIRCUIT DESIGN

In the basic circuit, the combination of *R1*, *Q1* (acting as a zener diode), and thermistor *R2* provides a reference voltage for the non-inverting input of the differential operational amplifier *IC1*. The thermistor provides temperature compensation.

The voltage sensing network consisting of *R3*, *R4*, and *R5* comes into operation when the ignition is on. The wiper of *R4* provides an adjustable sensing point for the inverting input of *IC1*.

If the alternator (generator) output voltage increases, the input to *IC1* from *R4* increases. This causes *Q5* to go toward cutoff, reducing the field current to the generator and causing the output voltage to decrease. The voltage at point A is stabilized at the value preset by *R4*.

In the indicator lamp circuit, as long as the wiper of *R10* is at a sufficient level to fire *Q6* (corresponding to a correctly charging system) transistor *Q7* is held on and *Q8* is cut off. If the input voltage drops so that *R10* does not supply enough voltage to *Q6* (acting as a zener diode), *Q8* turns on and the lamp is lit.

The generator modification consists of blocking diode *D1*, which prevents current flow back into the generator when the battery is not being charged. If the voltage across *R14* exceeds the base-emitter drop of *Q9*, this transistor turns on bringing the voltage at point B close to that at point A and causing the regulator to reduce its output. This, in turn, forces the generator to decrease its output.

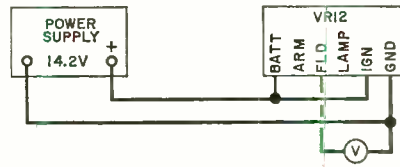

(A)

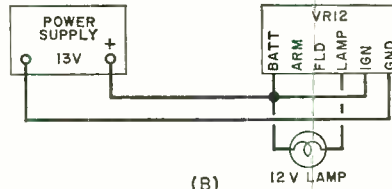

(B)

Fig. 6. Test circuit for the voltage (A), and the charge lamp (B). A metered bench dc power supply is used to make these tests.

adjustment will have to be re-checked when the regulator is mounted in the vehicle to insure that the lamp is on when the ignition is on (but the engine is not running) and goes off when the engine is charging the battery.

This indicating circuit is much more sensitive than the conventional system and the lamp may remain on for as much as a minute after the engine is started—depending on the

(Continued on page 98)

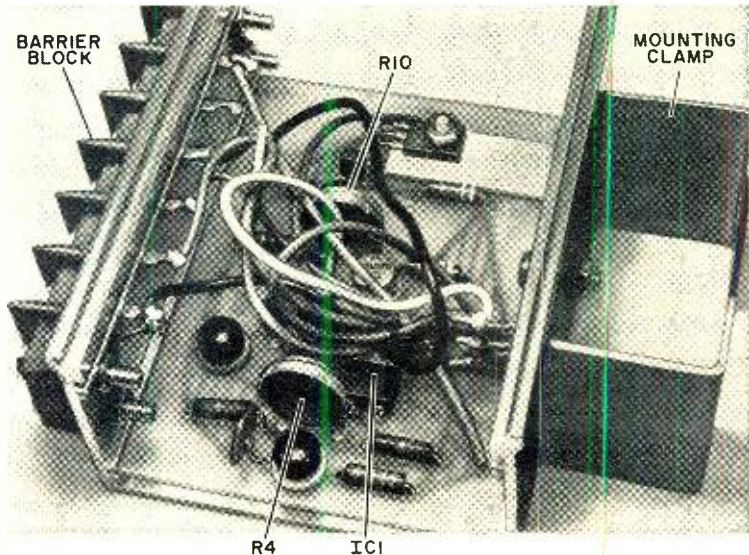

The VR12 may be mounted within any small, but substantially built chassis, capable of withstanding vehicle vibration. Use lockwashers on all mounting hardware.



MOBILE RADIO

Comparative Tests—*Motorola has been given a license for experimental/developmental station KB2XWL to compare radio communications on the 900-MHz band with the 450-MHz band. The tests will be made in the northern part of Chicago on 451.65 and 956.1 MHz, usually during daylight with various widths of narrow-band FM and approximately 100 watts of output power. Results may enable greater development of mobile radio in the 900-MHz band.*

CITIZENS RADIO (CB)

Two CB Projects—In cooperation with the Community Council, a CB base station has been installed in the headquarters of the 24th Police Precinct, 100th St. and Amsterdam Ave., Manhattan, New York City. Manned by REACT members, the station will monitor channel 9 and hopefully will be a successful and useful experiment in convincing the police force of a major city that they could make greater use of CB. Volunteers are being sought for this program and CB'ers in the area should contact Patrolman Tom Kelly . . . Meanwhile, the Louisiana Sabine River Authority has requested the FCC for permission to use channel 9 for "distress calls" on the 60-mile long Toledo Bend Lake, extending from Leesville to Logansport, La. The Authority hopes to install 24-hour CB stations along the lake and to require manning similar CB stations at sites leased by the state.

TELEVISION

The Vertical Interval—*There's a lot more information being transmitted in conjunction with your TV picture than ever appears on the screen. To see for yourself, adjust the vertical hold on your receiver until the black blanking bar appears. Especially on network relay transmissions, you'll see a line of white dots and bars that appear to be modulating the first few lines just above the top of the picture. Besides controlling various test patterns for both monochrome and color, these signals contain the white level reference, facsimile (called Homefax by RCA), time signals (sometimes courtesy of the National Bureau of Standards), and any number of other experimental things. Most TV viewers are unaware that the last 12 lines of each scanned field—each line having the capability of a 12,000-Hz channel—are technically available for special signals.*

CITIZENS RADIO (CB)

More Uses for Channel 9—Designation of channel 9 for emergencies has not been without headaches and problems. The Pennsylvania League of Emergency Associations (PLEA) has petitioned the FCC for "looser" controls as to who should or should not use channel 9. PLEA asked the FCC to permit use of channel 9 in non-emergency cases to maintain control of their mobile units on the road. In addition, PLEA feels that "broadcasts" should be made periodically (not oftener than every half hour) to motorists to assure them that channel 9 is being monitored. PLEA says looser rules would ultimately provide greater road safety.



The best way to get electronics into your head

No book ever written can give you the "feel" of electronics.

This is why every NTS course in Electronics includes the most modern, professional training equipment in kit form.

Putting equipment together, kit by kit, can teach you more about electronics than a whole library of bone-dry theory.

Each kit contains illustrated instructions.

You look at the pictures, then you apply what you see as you assemble or service your equipment.

What could be simpler? Or more fun? You'll enjoy every profitable minute.

Here's just some of the equipment you get to build and what you will learn.

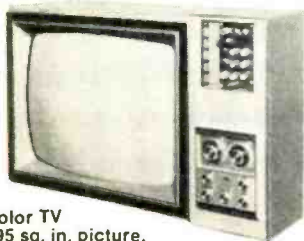

Color TV
295 sq. in. picture.

NTS COLOR AND B&W TV SERVICING

You receive a big screen color TV with many unique features, including self-servicing equipment so you can make all normal test operations. You also get an AM-SW radio, solid-state radio, field-effect transistor, Volt-Ohmmeter and electronic tube tester. You learn about electronic principles, trouble-shooting, hi-fi, multiplex systems, stereo and color TV servicing.

Solid-state B&W TV
74 sq. in. picture (cabinet included)



The B&W TV receiver features the latest in *solid-state circuitry*, making your TV training the most modern, most advanced available.

NTS COMPUTER ELECTRONICS

One of the 10 important kits included is this remarkable Compu-Trainer® — an NTS exclusive. It's a fully operational computer logic trainer — loaded with integrated circuits. It introduces you quickly to the how, what, when, and why of computers. This unit is capable of 50,000 operations per second.

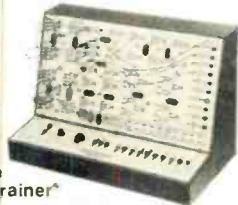

Exclusive Compu-Trainer®

NTS ELECTRONICS COMMUNICATIONS

Two exciting courses in the big-paying fields of transmitting and receiving equipment. Either one qualifies you for your FCC First Class Radio-

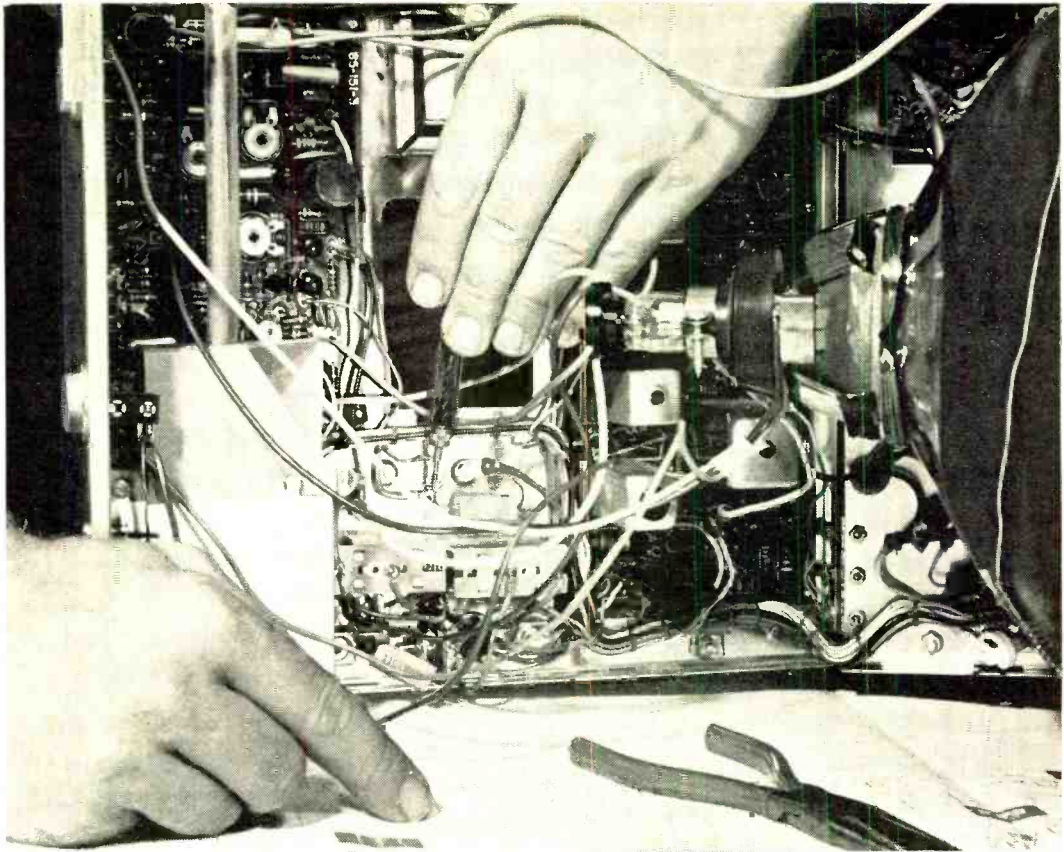

is to have the actual equipment in your hands.

Telephone License. *NTS assures you will pass this FCC exam within 6 months after successfully completing your course — or your tuition is refunded.* You receive 14 kits to build an amateur phone 6 meter VHF transceiver plus NTS' exclusive 6 transistor solid-state radio and a fully transistorized volt-ohmmeter.

5 watt AM transmitter/receiver.



NTS AUTOMATION/ INDUSTRIAL ELECTRONICS

Let NTS put you into the age of electronic controls. Systems automation is rapidly becoming the emphasis of modern industry. NTS training includes equipment like a 5" wide band oscilloscope. You also get the new, exclusive NTS Electro-Lab — a

complete workshop that lets you build five industrial controls to regulate motor speed, temperatures, pressure, liquid level, smoke, and much more.

5" Oscilloscope

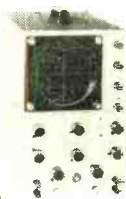

Mail card today for free, full-color catalog that details what each training program offers. (Or if card is missing, send coupon.) No obligation. No salesman will call.

Remember, the best way to get electronics into your head is to have the actual equipment in your hands. The sooner you mail the card the sooner you'll get your hands on the finest, most advanced electronics home training ever offered.

CLASSROOM TRAINING AT LOS ANGELES You can take classroom training at Los Angeles in sunny California. NTS occupies a city block with over a million dollars in facilities devoted exclusively to technical training. Check box in coupon.

APPROVED FOR VETERANS

Accredited Member: National Association of Trade and Technical Schools; National Home Study Council

NATIONAL TECHNICAL SCHOOLS

WORLD-WIDE TRAINING SINCE 1905

4000 S. Figueroa St., Los Angeles, Calif. 90037

If card is missing check coupon and mail for free color catalog and sample lesson. Now.

Please rush Free Color Catalog and Sample Lesson, plus information on course checked below. No obligation. No salesman will call.

National Technical Schools

4000 S. Figueroa St., Los Angeles, Calif. 90037

- Master Course in Color TV Servicing
- Color TV Servicing
- Master Course in TV & Radio Servicing
- Practical TV & Radio Servicing
- Master Course in Electronic Comm.
- FCC License Course
- Master Course in Electronics Tech.
- Industrial and Automation Electronics
- Computer Electronics
- Basic Electronics

Dept. 205-041



Name _____ Age _____

Address _____

City _____ State _____ Zip _____

Check if interested in Veteran Training under G. Bill.
 Check if interested only in Classroom Training at Los Angeles



THE PRODUCT GALLERY

Eighth in a Monthly Series by "The Reviewer"

A LOOK at the workbench of a serious electronics hobbyist and experimenter shows a variety of test equipment that only a few years ago was only to be found in the most advanced laboratories. Digital readout multimeters, super-clean waveform generators, triggered-sweep oscilloscopes, etc. are readily available to any experimenter, technician, or engineer with a modest budget. Until a few months ago, the only area not covered was frequency measurement. Of course digital readout frequency counters have been around for years, but always at a price!

There are a multitude of obvious uses for a frequency counter. Audio frequencies can be determined by eye straining interpretation of Lissajous figures—assuming that the reference frequency is correct. If you test audio systems using some form of audio generator or pre-recorded tones; how do you know that the tape deck or the disc player is on frequency? In the case of audio generators, there is always the chance of significant error due to warm-up drift and dial accuracy even if the unit is one with switch-selected frequencies.

When it comes to r-f alignments, there is little chance that a manually tuned oscillator can ever be placed exactly on frequency. In digital circuits, especially in long countdown stages, a frequency counter is the easiest way to check for proper operation. There are also uses for frequency counters in ham radio equipment, designing filters, etc. In general, knowing the exact frequency invariably saves a lot of headaches.

HEATHKIT FREQUENCY COUNTER MODEL IB-101

Once again, the Benton Harbor Rangers have come to the rescue. This time it's the Heathkit IB-101 counter currently offered at a price just under \$200. This is a solid-state, five Nixie® tube readout device that actually produces the equivalent of eight-digit accu-

racy. The frequency range is from 1 Hz to slightly over 15 MHz with an accuracy of plus or minus one count within the crystal-controlled time base stability. Sensitivity is well under 100-mV up to 1 MHz and substantially less than 250 mV from there on up to 15 MHz. The IB-101 has automatic triggering and an input impedance of 1 megohm shunted by less than 20 pF.

Assembly. The circuit for the IB-101 is assembled on a single fiberglass double-sided printed circuit board and total construction time—including mounting the Nixies and switches should be about 7 hours. However, one word of caution: that figure assumes that you have had some previous experience assembling a digital circuit kit and have a narrow-tipped, low-wattage soldering iron available. Heath provides $\frac{1}{32}$ " diameter solder with details on how to convert your heavy soldering iron tip to a more usable tip for working with pins of the digital IC's.

As usual, if you follow the well illustrated Heathkit manual, you should have no problems assembling the IB-101. Your reviewer has found that it saves a lot of troubleshooting time (if necessary) to go over a PC board with snugly mounted components using a small magnifying lens. Look for cold solder connections and whisker solder bridges between adjacent foil sections.

Operation. Once assembled, the IB-101 is self-calibrating. There is no secret to the unit's operation and if you attempt to make a kilohertz reading while on the hertz scale, the "overflow" light comes on. Your reviewer would suspect that most advanced experimenters and technicians after using the IB-101 for a few weeks will find that they have it ready to be attached to a signal generator and used as a "tuning dial" rather than depend on the accuracy of the mechanical dial on the instrument itself. Psychologically, there's a nice glow of confidence in

FREQUENCY COUNTER (Heathkit IB-101)

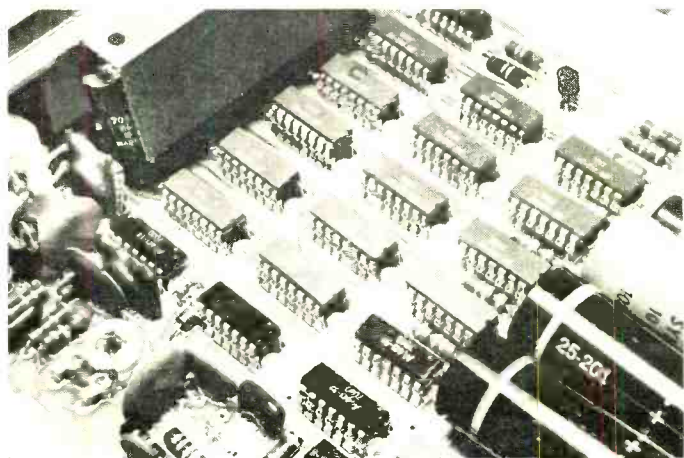

Heathkit IB-101 Frequency Counter is built around 26 in-line integrated circuits, 8 transistors and 5 cold-cathode display tubes. The IC's plug into special strips of IC pin connectors. The component density is rather high and the builder must exercise great care not to form solder bridges on board. Glow tubes are hidden by light shield in upper left-hand corner.



Handle on IB-101 swings through a 180° arc and is used for carrying and instrument tilt on workbench. Handle action is controlled by spring-loaded square detent visible in photo above. Also in this shot is back of overrange light

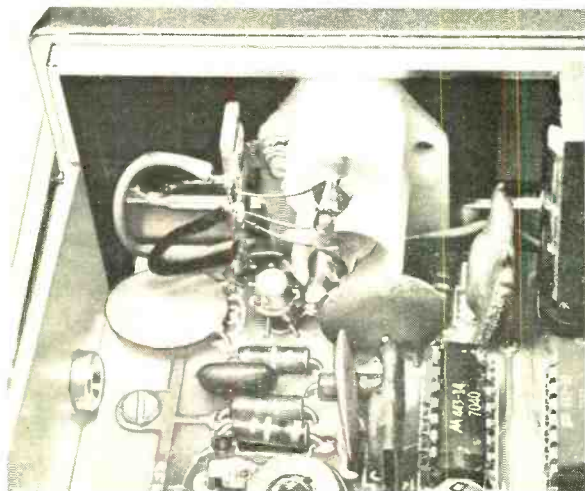

Discrete component wiring density is particularly bad under the two range lamps. There are about 20 different components within range of this photo. The input sensitivity potentiometer can barely be seen at bottom. Sensitivity and calibration can be established without resorting to laboratory test instruments.

knowing that you are on the right frequency.

This reviewer had only two minor objections to the operation of the IB-101. For some reason, there appears to be no provision for protecting the input circuit from a reasonably high dc voltage. This can happen if the IB-101 is used to measure a frequency from the plate of a vacuum tube oscillator or from a high voltage output transistor. A blocking capacitor between the board and input terminal of the IB-101 is an easy and ready cure to this problem. There is plenty of room to install this component. Also, in the hertz position, the IB-101 takes a couple of "bites" at the frequency and requires three or four seconds to settle down. This is a slight annoyance—especially to those familiar with instruments that read on a "one and only one" basis.

LAFAYETTE RK-890 CARTRIDGE RECORDER/PLAYER

The 8-track cartridge has a tenacious foothold in the field of stereo playback for automobiles. Having arrived on the scene before full-fidelity cassettes, cartridges are probably here to stay for a long time. However, pre-recorded cartridges are expensive and this reviewer sees a trend toward home-recording—either off the air or off of discs and tapes that the car owner has available. If this recording can be done on a decent piece of equipment at a respectable price, the monetary saving can be substantial. In our travels, we have noticed advertisements for a reasonably priced 8-track cartridge recorder/player tape deck that might prove of interest to readers with tape cartridge players in their cars.

The RK-890 is a household tape deck with all the essential features of a 1971 open reel or cassette tape deck—modified by the special requirements of the 8-track tape medium. It allows recorded material to be played in the home through your stereo system and, perhaps more important, it makes recordings on blank cartridges for playback while driving.

The RK-890 has separate AUX and MIC inputs with individual channel level controls, concentrically mounted—for recording. The two sources can be mixed and each channel has an illuminated recording level meter—which also functions on playback.

Operation. Most of the routine functions—once the gain level has been set—are push-button controlled. The pushbuttons are for: EJECT, RECORD (lock), STOP, PLAY, and FAST FORWARD (FF). There is no "pause" button and the stopping action of the RK-890 is not quite instantaneous, since although the mo-

tor power is shut off, the internal fly wheels keep the tape advancing for a couple of seconds. The FAST FORWARD (FF) operation is by no means as fast as you find on a cassette player or open reel deck. Using FF, you can move to any portion of a 32-minute cartridge within about 90 seconds.

The EJECT button clears all other controls and literally pops the cartridge out of the slot. Ideally, this sort of interlock arrangement should prevent a cartridge from remaining in the machine with the rubber drive wheel engaged when the power is shut off. However, this disengagement does not take place if the cartridge is in place and the line cord is pulled out. There is also an AUTO EJECT switch, which can be set to play (or record) in sequence 1, 2, 3, or 4 tracks of the cartridge, and to eject the cartridge after the selected number of tracks has been played. With this switch in the OFF position, the recorder plays through all four tracks (in stereo) and then repeats the procedure indefinitely until either the EJECT or STOP button is actuated.

A manual pushbutton in the lower left-hand corner advances the RK-890 by one track each time the button is pressed. The number of the stereo track in use is always illuminated above the cartridge loading slot. This is a useful function in attempting to provide instant access to any track at any part of the cartridge. Obviously, there is really no way of determining what part of the track is being played, except at the tape splice, which triggers the automatic advance to the next track.

Test Results. The Lafayette RK-890 has a very respectable record/playback frequency response. Using BASF tape, the response was measured to be within ± 3.5 dB from 22 Hz to 12 kHz. Nominal playback output was but 0.7 volts. At 1000 Hz, stereo crosstalk was -27 dB. The signal-to-noise ratio was also very good and, in a 22-kHz bandwidth, was measured at 49 dB. On record, the RK-890 required a 90-mV input at the AUX input and 0.85 mV at the MIC input.

Flutter was measured at 0.33% and although slightly higher than that of the better grade of cassette or open reel tape machines was not obvious on most program material. Wow was measured at 0.03% and distortion was measured at 2% at 0 dB, 1.8% at -3 dB, and 2.4% at $+3$ dB.

A Few Final Words. If you have become addicted to cartridge-player stereo in your car, the Lafayette RK-890 will soon pay for itself. The surprisingly high cost of pre-recorded tape cartridges makes this machine a worthwhile investment. The RK-890 can be used to make recordings on blank tape car-

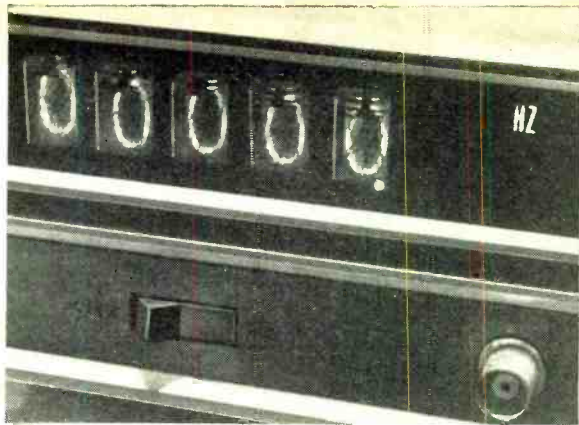

HEATHKIT IB-101 (Cont'd)

The five-digit readout enables accurate readings to be made into the megahertz range. The right-hand digit is always within plus or minus 1 count. Decimal point in the lower right corner of the glow tube showing most significant digit is always "on." The range lamps indicate the frequency in either KHZ or MHZ.

Builder assembling the IB-101 must be very careful soldering the IC pin connector strips. If a fine-tip soldering iron is not available (such as the Ungar "Princess" shown here), Heath recommends shaping up a piece of large bare wire into a tip extension for an ordinary 25-watt soldering iron. Inspect the soldered connections with a magnifying glass to see if any cold joints or bridges might have been made.

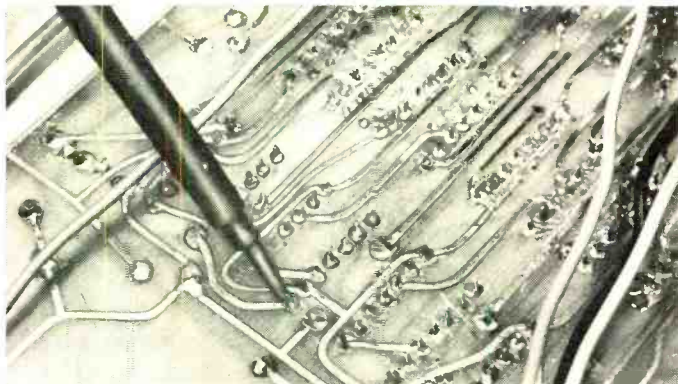

CARTRIDGE RECORDER / PLAYER (Lafayette RK-890)



This 8-track stereo record/player deck makes a nice addition to household setups that make use of cartridges. The owner can record off-the-air, tapes and discs on blank cartridges for playback in his car. Operation of the RK-890 is simple and all of the important record and playback controls are seen here. On/Off pushbutton is under the operator's thumb. Microphone and Aux inputs may be mixed at the operator's pleasure.

tridges for subsequent playback in your car. In other words, you could take material off the air, or tape your favorite disc or open reel tape. The RK-890 is non-critical as to recording level and any program material that does not consistently drive the recording level meters to full scale should be recorded with satisfactory quality.

Of course, higher flutter seems to be inherent in the endless loop tape cartridge, but this also appears to vary widely between different brands of blank tape cartridges—and possibly even within each brand.

As a clincher, you will find your home-recorded cartridges sound much better than commercially recorded cartridges. If you don't believe this is possible, ask someone who has similar equipment and has tried it.

TOMPKINS "MOBILINK"

In the beginning, CB was proclaimed the "everyman's two-way radio system" and the air was filled with visions of instant short-range radio communications. Things didn't turn out as expected and many plans to make more and better use of CB were dropped. Not so for one accessory that recently arrived on my desk. It is called a "Mobilink" and is manufactured by Tompkins Radio Products and distributed by Herbert Salch & Company. It is a simple gadget consisting of a separate miniature transmitter and receiver. The transmitter is wired to the CB transceiver speaker and broadcasts signals picked up via CB to a pocket receiver that may be carried by the user. The range possible between this "extra" transmitter and receiver varies from 100 to 900-1000 feet depending on location of the transmitter and the surrounding terrain.

The Mobilink package received by your reviewer consisted of a crystal-controlled transmitter set on 27.264 MHz with a power input of about 90 mW. The pocket receiver was the shape and size of an ordinary broadcast-band AM receiver. The receiver itself is obviously an AM i-f strip with a new crystal-controlled mixer/oscillator stage in the spot normally occupied by the ferrite antenna. There is no tuning adjustment, only an on/off switch and volume control, plus a short collapsible antenna. The transmitter is apparently USA-made and consists of four

transistors, a crystal control circuit, and a type 131 pilot bulb strapped across the input for volume limiting. The Mobilink transmitter is inoperative until an audio signal is received. The installation literature accompanying our test prototype indicated that the transmitter had VOX control, although we did not see a wiring diagram and it was difficult to disassemble the transmitter for circuit analysis.

Some Test Results. The Mobilink package was used with several CB transceivers and very satisfactory re-transmission of CB was noted from our laboratory workbench out to a range of just under 200 feet. Of course, everything audible on the base station CB was fed down the pipe and out through the Mobilink. Obviously, for a satisfactory type of "Page Call" relay the squelch control must be adjusted to eliminate as much background interference as possible. For maximum receiving range the short antenna on the receiver had to be extended, although more than adequate reception within 50-75 feet of the laboratory was obtained with the antenna partially collapsed.

The instructions supplied by the manufacturer of the mobilink recommend that the user try to cut into the CB transceiver at the speaker terminals. We found this rather inadvisable and prefer to drive the Mobilink transmitter from the "EXT SPKR" phono jack on the back of the transceiver (an output that is available on at least three out of every five units).

Comment. Because of its low cost, it is difficult to fault the Mobilink, although the manufacturer could have given more thought to the physical design of the transmitter. An RCA phono input would be preferred. The antenna out the top of the Mobilink is rather insecurely mounted and subject to breakage at the insulated base where it enters the transmitter package.

It's also worth mentioning that the manufacturer or distributor neglected many other uses for the Mobilink—including ham radio and SWL'ing. Tying the Mobilink transmitter to a communications receiver enables the operator or listener to be somewhere else in his own home or backyard while monitoring a specific channel or frequency. Undoubtedly, other uses could be dreamed up for this surprisingly handy little item. -30-

FOR MORE INFORMATION

Heathkit IB-101—Circle No. 91 on Reader Service Page 15 or 95.
Lafayette RK-890—Circle No. 92 on Reader Service Page 15 or 95.
Tompkins Mobilink—Circle No. 93 on Reader Service Page 15 or 95.

LAFAYETTE RK-890 (Cont'd)



TRACK advance pushbutton and AUTO EJECT rotary switch add to flexibility of the RK-890 cartridge tape deck. Switch may be set to play or record, in sequence, 1, 2, 3, or 4 tracks. Pushbutton advance is indicated by the illuminated numeral (1 is visible) on panel above cartridge. Frequency response (below) shows test results from Hirsch-Houck Laboratories. See text for details.

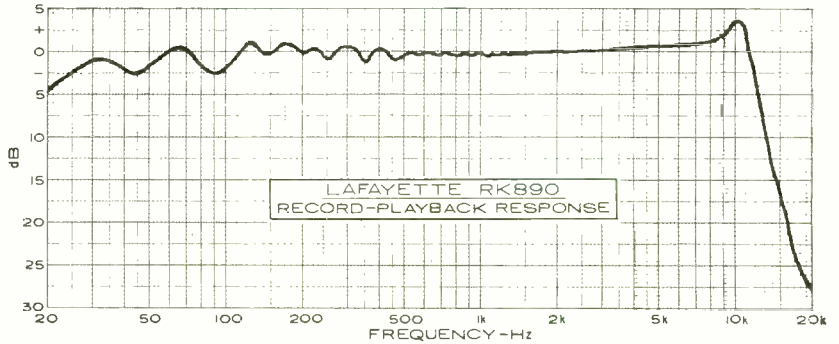

MOBILINK

(Tompkins Radio Products)

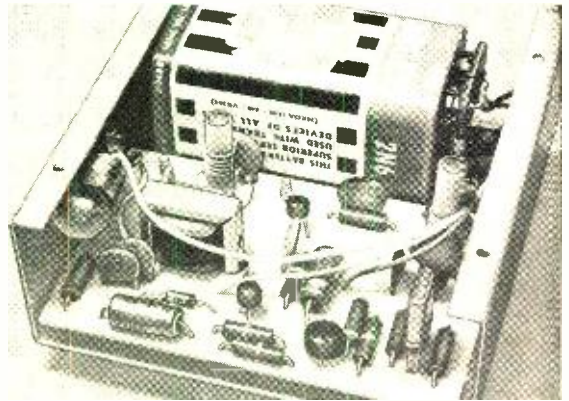

Two components of Mobilink are seen in the upper left photo. Above, transmitter is shown upside down. Lamp for volume limiting is soldered to the input terminal strip. At left, the open receiver shows how the AM mixer/oscillator, tuning capacitor and ferrite antenna have been eliminated and replaced by a miniature PC board, containing the crystal-controlled mixer on 27.264 MHz.





STEREO SCENE

Eighth in a Monthly Series by J. Gordon Holt

THE BEST OF EVERYTHING

GET TO LISTEN to a lot of stereo equipment that I could never hope to buy. Some of it I wouldn't care to have around the house even if I could, but things have changed since those halcyon days when a four-figure price tag was no guarantee of anything except a designer's delusion of grandeur. Today, top price usually means top quality.

This is not to say that a speaker costing \$1234 is \$34 better than a speaker costing \$1200. In fact, in performance the more expensive speaker may not be as good, but in most cases, the price tag is a fairly good guarantee that that system will be substantially better than a \$500 speaker. Or, at least, I would personally judge it to be better—and not on the basis of price alone.

For some people catalog-perusing is not the fun it is for most serious audiophiles; it has become an agonizing chore. When you get down to it, these people do not *want* to choose; they want to be told what is The Best, preferably by a bonded, licensed Expert. For the benefit of those unhappy souls, let me say that the words below are going to disappoint them. I'm going to talk about some equipment that *could* be The Best, but I'm not going to name the very best equipment simply because I can't. I don't think anyone can, and here's why.

Is There A Best? Going at things in a typically backward fashion, let's consider loudspeakers. The Altec A-7-500 system isn't in the top price category, but it is certainly capable of reproducing cleanly almost any sound at absolutely ear-shattering levels. It also has excellent blending between the woofer and tweeter. But, the A-7-500 has a distinct coloration that says "horn" all over it. It puts you, the listener, in a seat close to the orchestra. It has rolled-off response at both ends of the audio range although it's fine between 60 and 10,000 Hz. The A-7-500 beams the high frequencies and as a result

seriously restricts the stereo listening area.

An entirely different type of loudspeaker—the KLH Nine full-range electrostatic—sells at a bit over \$1000 for a stereo pair and offers the closest thing to a perfectly clear window on sound that money can buy. It has a stupendous transient response, but it is as inefficient as the Altec is efficient and will overload or blow its fuses before you can get anything like "row A" concert hall volume out of it. On the minus side of the ledger, the KLH Nine also beams its high frequencies and has a somewhat restricted low end that's effective down to about 60 Hz. It produces a slightly remote sound and is devilishly sensitive to listening room characteristics. Since it is an electrostatic speaker, its heavily capacitive load throws most power amplifiers into hysterics. If money presents no barriers, you can use four Model Nine panels coupled two per channel. This carries the bottom end down to a healthy 35 Hz and slightly increases the maximum volume capability. All of the other problems will remain, but this sort of four-panel setup is one of my favorite systems.

Of course, given unlimited funds, I might pick the Infinity Servo-Static I, which sells for \$2000 for the complete system. Said system includes two large electrostatic panels, a rather large cube-shaped bass "commode" and a combination of electronic crossover and bass range amplifier. It also takes two stereo preamplifiers to drive the SS-I, so the total may come to well over \$2700. Although the SS-I has much of that window-on-the-sound characteristic of the KLH Model Nine (plus better treble distribution and better stereo imaging), it's low end goes just a shade deeper than the four panels of the Model Nine and it is a much closer-sounding system but without the marked coloration of the Altec A-7-500. To my ear it seems to have more detail than the KLH and the Altec; and the SS-I can deliver something approaching close seat concert hall volume

into a typical listening room if you have enough amplifier power. Nevertheless, the SS-1 has certain colorations that the Model Nine doesn't have—including a slight lower mid-range hollowness and a subtle high-end hardness that sometimes becomes annoyingly sharp when abetted by the performance of the usual top-quality solid-state amplifier.

So nothing's really perfect, but to my taste—I emphasize that this is strictly a personal view—the SS-1 is the most nearly perfect system that I have heard to date. All of this assumes that you don't demand discotheque listening levels and don't have the patience or desire to experiment maybe for weeks or months with various room placements. Although like the Model Nines, the SS-1 panels are *very* critical as to room placement.

Have I actually heard all the contenders for top speaker rating? Of course not. I have never heard an L. W. Erath, or a BBC Monitor, or the new Canadian Dayton-Wright. I have heard the J. B. Lansing Paragon which I felt sounded raucous, bass-shy, and somewhat dull at the top end. And, for all of their magnificent spaciousness, the Bose 901 setup strikes me as being a bit flabby at the low end and too steely at the top. Analogous to electrostatic speakers, the 901's have a reputation for being hard to place optimally in the listening room.



The Audio Research Dual 50 is an all-vacuum-tube power amplifier with impressive figures for output, distortion, frequency response, hum and noise.

The speakers designed and manufactured by Paul Klipsch have an enviable reputation among audiophiles striving to obtain the very best. His new Klipschorns may be excellent, but I will probably never know, since I was not overwhelmingly impressed with some earlier models and Mr. Klipsch apparently feels that my ears are not adequate to judge his speakers.

The Question of Amplifiers. The preamplifier is probably the easiest component to evaluate sonically and I can make that qualification because, when it comes to the matter of "features," personal taste is going

to rule the roost. Some audiophiles will never be happy unless they can control every aspect of the sound—from separation to distortion and for these few a preamplifier with basic controls will have little or no appeal—even if it is a perfect piece of equipment. Most preamplifiers have enough diddling adjustments to satisfy the audiophile, but performance is always something else again and this is one field in which high price is *not* a guarantee.

I believe it was Julian Hirsch who first said, in describing the perfect preamplifier, that it should be nothing more than a "straight wire with gain." In other words a device that amplifies and does absolutely nothing more. You can check this yourself by setting the controls to have minimal effect on the program material, then switching the preamplifier in and out of the signal circuit—in other words, bypassing it—and noting the audible difference. Whether or not the preamplifier sounds "good" or "bad" is irrelevant, since if the preamplifier changes the sound in *any* way, it isn't a perfect piece of equipment.

To my knowledge, the most expensive preamplifier currently available is the Audio Research Model SP-1 currently selling at about \$750. Oddly enough, it does not pass the bypass test, but neither do any of the preamplifiers selling at somewhat lower prices. The frustrating thing is that some preamplifiers do extremely well in half of their circuitry—the phono preamplifier stage—and less well in the high level circuits—the tone controls and outputs.

The Model SP-1, and its less costly cousin the SP-2, have the most nearly perfect phono preamplification sections of any preamp I've heard, but fare less well through the latter stages. The Harman-Kardon Citation 11, selling at just under \$300, has a superb high-level section and by comparison to the Audio Research units, a less than successful phono preamp. The SAE preamplifier (weighing in at about \$500) has an excellent front end, but the high-level stages lack some of the transparency of the Citation. I haven't heard the Infinity preamplifier, but users have told me that some of the early samples sounded hard and had a tendency to blow the opamp modules, but later samples now sound as good as anything available—if not better.

Power amplifiers are harder to assess because they don't lend themselves to the "straight-wire-with-gain" bypass test. The best you can do and hope for when evaluating a power amplifier is to make laboratory measurements and then listen to them on a variety of speakers that have elicited the "best" sound from previous amplifiers that have been tested. If this all sounds like cir-

cular logic, it is. The technique does work most of the time and amplifiers that I have judged to be "best" are usually ones preferred by other finicky listeners. The most expensive stereo power amplifier is another Audio Research product—the Dual 100 (meaning 100 watts rms per channel) that sells for a mere \$2000. There is a cheapskate model—the Dual 50B—that only costs \$440 and like their matching preamplifiers, the two Dual models are *not* solid-state—they are all vacuum tubes! Over most of the audio range, the Dual 50B sounds a shade better to my ears than any solid-state amplifier and even the 100-watt model is a smidgen better, although I will not stick my neck out to claim that it is worth an additional \$1600. When it comes to controlling the speaker's low end, neither of these power amplifiers can touch the performance of the better solid-state units.

The Crown Model DC-300 (at just under \$700) produces a much deeper and tighter low end—probably due to its very high power and exceedingly high damping factor. In fact, the DC-300 may be overdamped for some speakers and even cause a thinning out at the bottom. The DC-300 is not quite as transparent in the upper range as the Citation 12 which has a comparatively modest price (\$300—or \$225 in kits).

An Easy One. When discussing an FM tuner, there's really no contest—the Marantz 10B was and still is the best that money could buy. Unfortunately, money may not be able to buy it, since it's been discontinued and used Model 10B tuners now cost more than they did when brand new. Of course, there is the question whether or not the 10B is worth the money since there's only one FM station in the country—WFMT in Chicago—that transmits a signal clean enough to justify the price of the 10B tuner. The only saving grace is the 10B won't exaggerate the distortion that the average FM station is transmitting.

My personal choice for a solid-state tuner that stands out as conspicuously as the 10B is the Heath AJ-15. Not only is the Heath nearly \$800 cheaper, but the performances of the two are closely matched.

Players, Turntables, and Pickups. For the man who probably wants the best of the most, the Thorens TD-125 turntable is probably as good a choice as any. If you don't insist on three speeds and a vernier speed adjustment, the Acoustic Research Model XA offers equally good performance at a mere \$87. The XA comes with its own tone arm—about which the less said, the better. I always advise replacing it and it's worth investigating the Rabco Model SL8E which

has become available with an adapter kit for installation on the AR turntable. If you opt for the Thorens you will be pleased to note that the Rabco arm matches the styling of the Thorens turntable so closely that they look as though they were made for each other.

Of course, the Rabco has problems and you can hear the servo system's vibration coming through the speakers when the audio gain is cranked way up. Unfortunately, the pivots are rarely adjusted for optimum performance when you buy the arm. In addition, there is no damping to the arm at all and this can lead to acoustic feedback problems. The Decca International arm has a superb damping system and is as feedback-resistant as anything you can get, but it just can't be mounted on most modern turntables—simply because it requires over 4" of depth under the motor board.

Finally, we come to the beginning of the system—the phono cartridge or pickup. And, if you say, "Why, of course, the Shure V-15-II is the best pickup," I'll argue with you. I grant that it does track splendidly, but trackability isn't the only criterion for judging a phono cartridge. A cartridge should be able to make good discs sound as much as possible like master tapes, and this is the one thing that the Shure pickup does not do—thanks to a rather peculiar response dip through the "brilliance" range. Personally, I've only found two pickups that really approach that master-tape sound and it may be heresy to add that both of them are spherical-stylus models—not ellipticals. These pickups are the Decca 4RC and the Stanton 681A. The Decca sounds a bit better than a Stanton, but it hums with some turntables and has a fierce magnetic pull toward ferrous platters. Decca's quality control is certainly nothing to cheer about and the 4RC is best pre-tested before buying. The Stanton, on the other hand, has no problems—it just doesn't sound *quite* as good as a hand-selected Decca. But then, how can anyone say which pickup is best?

Lastly, in discussing tape recorders, I won't even try to name the contenders—because there is really no audiophile ceiling in tape equipment. Quality and price range all the way up to the big professional machines costing nearly \$5000 and there is no line of demarcation between the professional and the audiophile tape deck. In truth, some obvious machines for home playback like the Revox A-77 perform with higher fidelity than the studio machines, but the studio machines are more consistent and dependable and infinitely more rugged.

Now that you've heard the ifs, buts, and ands, what is the best of everything? You tell me.

-30-



OPPORTUNITY AWARENESS



Thoughtful Reflections On Your Future

Twelfth in a Monthly Series by David L. Heiserman

Wages—Yours vs Average

How can I find out whether or not my wages are in line with other electronic technicians working in my part of the country?

● The statistics division of your state employment bureau compiles the most complete and impartial wage statistics for your part of the country. These annual reports break down the wage figures according to occupation, type of business or industry, and city or geographic area.

You can generally get a free copy of the report—or at least see one—by visiting your nearest state employment office. If that doesn't work, write directly to your state's division of labor statistics.

Also, your local library should have a recent copy of *Employment and Earnings Statistics for States and Areas*. This book, published by the U.S. Department of Labor's Bureau of Labor Statistics, is a collection of all the wage reports submitted by the states.

Engineering College Drop-Out

I am in my third year of study at a 5-year engineering college. Although the VA is helping me, I am finding it more and more difficult to be a responsible family man and full-time engineering student at the same time. So I will be dropping out of college at the end of this term to get a full-time job. I have four years of experience as a Navy Electronics Technician and three full years of college behind me. How can I use this background to help me get a good job in electronics?

You may think your three years of college add to your value as an employee; and strictly speaking, you're right. However, without some kind of diploma in your hand, you'll most likely find yourself making some tough compromises at job interviews. You certainly won't be able to get a graduate engineer's position and salary, for instance, but you should be able to do better than a man who has no higher education at all. You'll find yourself being classified

somewhere in a murky gray area between a technician and an engineer. The question is "where?" Unless you can get some kind of diploma or know someone who can vouch for your abilities, you'll probably have to start out more on a technician level.

A transcript of grades might help convince prospective employers you have the potential for becoming a good engineer or engineering technician. Unless your grades are exceptionally good, however, displaying them at a job interview may do more harm than good.

It's a sad fact of life that a college dropout with an "A" or "B" average has a tough time commanding the same kind of respect granted a college graduate with a "C" average.

You may have guessed by now that my advice is to stay in college—at least on a part-time basis. If you don't have the money or time for part-time college work, I suggest you transfer your credits to a two-year technical school and attend evening classes. You might be able to get a degree in Electrical Engineering Technology in less than a year.

The point is to get some formal credentials. You'll still have to work hard for what you want, but formal credentials will give you a better foothold at the start.

Out-Of-Town Jobs

In our October 1970 column, we suggested that readers looking for jobs in distant localities, should contact the headquarters of Snelling and Snelling (a nationwide employment agency) in Paoli, Penn. Since they have 540 offices in 45 states, the agency tells us that they can serve you better if you contact your local office or the one in the nearest large city. (See the white pages of the telephone book.) A list of these offices may be obtained by writing to the Public Relations Dept. of Snelling and Snelling, Inc., 2 Industrial Blvd., Paoli, PA 19301, but resumes should be sent to local offices.



One Hundred Seventy-Ninth in a Monthly Series by Lou Garner

DIGITAL counting is growing up. For the last three years, this magazine has been featuring the latest in digital readout circuits, usually involving separate pulse counters, latches, decoders and readout devices for each decade. We have often wondered why some semiconductor manufacturer didn't package the whole "works" in one IC. It would appear logical (no pun intended) since the counter/decoder/readout always go together anyway.

Now, Motorola (Box 20924, Phoenix, AZ 85036) has brought us part of the way home with the introduction of their MC4050 IC. The unit, shown schematically in Fig. 1, contains a single MSI chip that includes a decade counter, a four-bit latch, a seven-segment decoder, and display driver transistors able to handle 15 volts with up to 40 mA of collector current, which is more than enough for most seven-segment readouts. Provisions are also made for lamp blanking to suppress leading zeroes in a display, and for a lamp

test to check that all seven segments of the readout are operating properly.

Present cost is around \$10 per unit. The TTL logic used is good to 35 MHz, making it very attractive for the serious electronics experimenter or engineer.

All that remains now is to add another layer on the IC and include a solid-state seven-segment readout under a transparent cover. How about it Motorola?

Other Digitals. Hewlett-Packard has been manufacturing logic-readout devices for quite a while, primarily for very high quality instruments and government projects. Now they are mounting a major push into the display market with their 5082-7300 logic/readout package. At this stage, the 7300 costs \$10 per digit and includes a decoder/driver on the same chip as the LED 7-segment readout. With any kind of large orders, H-P hopes to bring this price down to about \$5 per decade within two years. That's some-

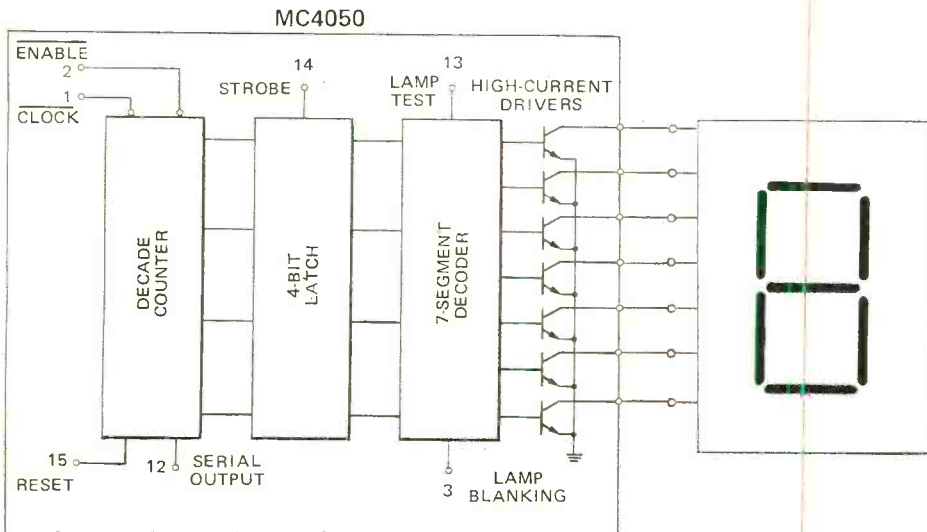

Fig. 1. Because they are always used together, having the counter, latch, and readout driver in the same package makes for smaller and neater readouts using a much simpler PC board.

thing to look forward to. A spokesman for Monsanto, another manufacturer of LED 7-segment readouts, calls \$5 per decade a reachable target by the end of this year, even though their present readout (MAN-1) now sells at \$11. Meanwhile, back on the East Coast, the president of Opcoa (Edison, N.J.) claims that his company's present \$8 readout could conceivably drop to \$2 each in large quantities.

On the other side of the coin, Burroughs, which manufactures the world-famous Nixie® tube has a contender of its own. The Panaplex, a multi-digit gas discharge readout with up to 14 decades in a single tube, now averages about \$3 per digit including drive circuits.

No matter what happens now, it would appear that the day of the analog meter is just about over.

On a slightly different subject but still in the digital world—when we used to use RTL logic, we were accustomed to providing a supply of 3.6 volts at several hundred milliamperes. When we graduated to TTL, we found that 5 volts of power was needed but at slightly less current. It now comes as a pleasant surprise to learn that a new class of logic, called COS/MOS by RCA, operates from a 1.5-volt supply with microwatt power dissipation. Some of the new devices are the TA5987, which can be used as an ultra-low-power crystal oscillator, NAND/NOR gate, triple inverter, dual transmission gate, etc.; the TA5938, a 14-stage ripple carry binary counter-divider; and the TA5939, an oscillator plus 14-stage ripple carry binary counter-divider that also includes an input inverter. This kind of power reduction is almost like a quantum jump for an old fogie like me.

Reader's Circuit. While acknowledging that Vincent Wood's PLL SCA adapter ("Build an SCA Adapter for FM Reception," POPULAR ELECTRONICS, December 1970, p 53) does a fine job, reader Allen R. Jackson (2334B Riverside Dr., Beloit, WI 53511) was disappointed, nonetheless, in the unit's lack of interstation muting. Of course

he hadn't seen the squelch circuit we presented in last month's column, but he designed one (see Fig. 2), which has merit of its own.

Allen employed a three-stage direct-coupled amplifier to control $Q2$'s emitter bias, adding a zener diode to provide a reference voltage for comparison with PLL's ($IC1$) output. In operation, removal of the SCA subcarrier, as between stations or when cut off by the broadcaster, is sensed by the control circuit, which then effectively grounds $Q2$'s emitter cutting off both this stage and the emitter follower output. When the subcarrier returns, $Q2$'s emitter bias is restored and normal operation resumes.

Relatively few inexpensive components are required for the muting circuit. All three transistors are general purpose audio silicon devices. Except for the potentiometer, the resistors are conventional half-watt types, while $D1$ is a low-to-medium wattage (actual rating not critical) 9-volt zener diode (although another voltage rating may be required if other than a 12-volt power supply is used with the SCA adapter). The correct zener value is 1 volt less than the dc voltage measured at pin 7 of $IC1$. If preferred, the zener may be omitted and the 2500-ohm potentiometer replaced with a 25,000-ohm type; but, according to Allen, this modification will result in less decisive action.

Although neither parts placement nor the wiring arrangement are critical, good wiring practice should be followed when duplicating the circuit. If the SCA adapter is being assembled from "scratch," Wood's original circuit board design could be modified to include the muting feature. On the other hand, the circuit could be added to an existing instrument as an outboard accessory simply by assembling it on a small board and connecting it to the main SCA circuit board using short, direct leads. After installation, the potentiometer is adjusted for optimum performance.

Manufacturer's Circuit. With potential

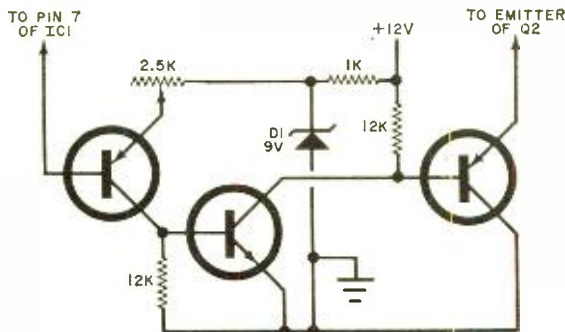

Fig. 2. Squelch circuit was designed to work with PLL SCA adapter described in the December, 1970 issue. It will remove the background hiss that is present between the groups of music selections.

applications in volume expanders, signal compressors, analog computers, recorders, radiotelephone transmitters, receivers, PA systems, background music distribution equipment and test instruments, the linear agc amplifier circuit illustrated in Fig. 3 is one of several application circuits described in the 14-page specifications brochure for Motorola's type MC1594L/1494L four-quadrant multiplier IC. Squaring, multiplication, division, square root, modulation and phase detection circuits also are included in the comprehensive booklet. Copies of the complete specifications brochure are available through Motorola Semiconductor representatives and franchised distributors or on direct request from Motorola Semiconductor Products, Inc., Box 20912, Phoenix, AZ 85036.

A four-quadrant multiplier arrangement offers several advantages over more familiar agc systems. First, the agc is *truly linear*, for the output signal amplitude is directly proportional to the dc control voltage. Second, its agc dynamic range is theoretically infinite, in that a zero dc control voltage will reduce the output to zero regardless of the input signal. Of course, in practice the circuit's actual dynamic range is limited to some extent by the control ability of the input offset potentiometers. Third, unlike older circuits, changes in the agc control voltage have no effect on its signal handling capability, nor do they alter its input impedance. Finally, the multiplier's output voltage swing capability and output impedance both remain unchanged despite variations in the agc dc voltage.

According to Motorola, the circuit shown in Fig. 3 is capable of handling input signals

of up to 1 volt rms while providing a maximum gain of approximately 20 dB. In operation, however, its gain can be controlled through a 60-dB dynamic range by the application of agc voltage from 0 to 1 volt dc. Since the basic IC's effective frequency response is determined by the value of its output load and distributed circuit capacitances, an emitter follower stage (*Q1*) is used as a buffer amplifier to provide an over-all bandwidth of better than 1 MHz.

Assembled in a 16-lead dual-in-line ceramic package, the MC1594L used as the heart of the agc amplifier is a monolithic silicon integrated circuit. Essentially a variable transconductance multiplier with an output voltage which is the linear product of its two input voltages, the device has internal level-shift circuitry, permitting its input and output offsets and scale factor to be adjusted by means of external potentiometers. A pair of built-in complementary voltage regulators serve both to simplify the offset adjustments and improve power supply rejection. Designed for operation on a dual 15-volt dc source, the basic device has a 3-dB frequency response to 1 MHz. The MC1494L is essentially similar to the MC1594L except for linearity tolerances and offset voltage and current characteristics.

Aside from the MC1594L, relatively few components are needed for project assembly. Motorola recommends that cermet multi-turn potentiometers be used for offset controls *R6* and *R7* to permit precise adjustments, but all other resistors are conventional half-watt types. Needed to insure adequate input bias, input load resistor *R1*'s size is not critical, and values up to 100,000 ohms may be used, depending on the im-

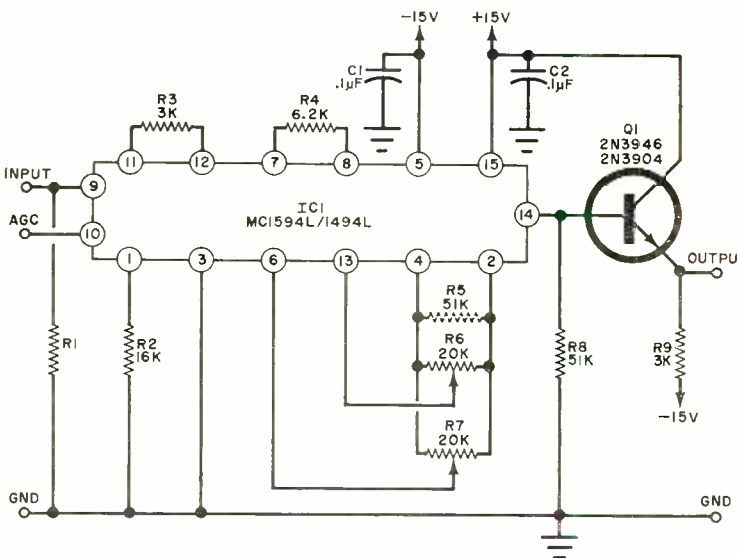

Fig. 3. One of the many uses for the four-quadrant multiplier is this exceptionally linear agc system having a 60-dB range via application of a 0-1-volt signal on pin 10. Bandwidth is 1 MHz.

pedance of the signal drive source. As a general rule, however, $R1$'s value should be as low as practicable for minimum noise and optimum temperature performance.

Circuit layout and lead dress are fairly critical and, therefore, care must be taken to keep signal carrying leads short and direct and, for maximum frequency response, distributed wiring capacities at a minimum. As long as these precautions are observed, the age amplifier may be assembled either bread-board fashion or on a suitable etched circuit board. At the builder's option, the circuit could be used either in a self-contained age instrument amplifier (with suitable power supply, of course) or incorporated into more complex equipment as a functional sub-system.

Pulsar—Phase II. The all IC solid-state digital readout wristwatch discussed in our September 1970 column (*Watch That Watch!*) has moved a giant step closer to commercial availability with the announcement that Electro Data, Inc. of Garland, Texas, has placed a million dollar order with RCA's Solid State Division (Somerville, N. J.) for the integrated circuits to be used in production versions of the watch. Electro/Data developed the original prototype in cooperation with the Hamilton Watch Co. (Lancaster, Pa.), which is marketing the instrument under the trade name "Pulsar."

Booklets and Other Tidbits. The Semiconductors Corporation (265 Canal St., New York, NY 10013) has published a new and revised edition of its popular "Semiconductor Replacement and Interchangeability Guide." Carrying a nominal 25 cent price tag, the 40-page booklet lists thousands of domestic and foreign semiconductor devices by their original type numbers, together with recommended Semitron replacement types.

All major IR semiconductor devices are presented in an easy reference format in a new 20-page, full color, illustrated "Short Form" *Semiconductor Device Digest* released recently by International Rectifier's Semiconductor Division (233 Kansas St., El Segundo, CA 90245). Accurate dimensional case drawings and terminal connections are given, with each category of semiconductor devices presented in compact tables and charts giving ratings, parameters, and other important specifications. Among the items covered are such devices as—SCR's, power logic triacs, high power silicon rectifiers, selenium rectifiers, zeners, low power silicon rectifiers, silicon assemblies, light sensitive devices, and heat exchangers.

Unisem (P.O. Box 11569, Philadelphia, PA 19116) is now offering a unique r-f power transistor guide. A three-fold chart printed

April, 1971

These long playing cartridges will outperform any long playing records



1000ZETA "Measurement Standard"—
Tracks as low as 0.1 grams in laboratory playback arms. List Price—\$99.95.

999VE/X "Professional"—Recommended tracking force 1/4 to 1 1/4 grams. List Price—\$79.95.

Free copy of "Guide to Sound Design for 1971"; Empire Scientific Corp., 1055 Stewart Ave., Garden City, N.Y. 11530

EMPIRE



CIRCLE NO. 13 ON READER SERVICE PAGE

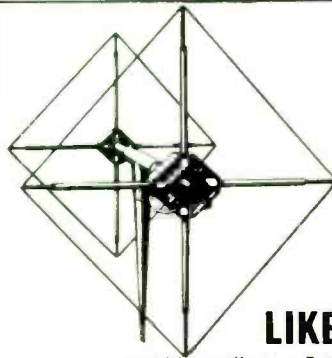

THE P.D.L. LOOKS LIKE A QUAD

... but it's really two 5 element beams.

This is the one that started a CB revolution. Patented polar diversity feature gives rifle-like signal directivity within 11 db gain (over isotropic) on either horizontal or vertical polarity. Superior signal strength is the result of a unique 5 sub-element feature in each polarity mode. Provides a stronger signal than stacked 3-element yagies. Dual polarity switchbox included.

ONLY \$79.95 at your CB dealer.

Write for Catalog

U.S. Patent #3475756

avanti

Avanti Research & Development, Inc.

33-35 WEST FULLERTON AVENUE

ADDISON, ILLINOIS 60101

CIRCLE NO. 1 ON READER SERVICE PAGE

on heavy card stock, the guide has been designed so that it can be used either as an insert in a loose-leaf binder or as a handy wall chart. High-frequency power transistor package outlines and condensed electrical characteristics are presented in the guide, together with a useful applications table. One of the most interesting features, in our opinion, is a unique graph-like chart correlating transistor types with power ratings and frequency capabilities, thus permitting a designer to choose a suitable device almost at a glance, given the power level needed and operating frequency.

New Developments. GE's Research and Development Center (Schenectady, N. Y.) has announced the invention of a new solid-state circuit element which has been dubbed a *surface-charge transistor*. Based on a unique concept involving the transfer of electrical charges between insulated electrodes, the new device has a potential information storage capability of a million bits per square inch.

The basic surface-charge transistor is a sandwich-like device consisting of a silicon substrate, a thin insulating film, two metallic electrodes separated by a narrow gap, a second insulating film, and a third metallic electrode positioned so that it overlaps the thin slit between the other two electrodes. The first two electrodes are identified as the *source* and *receiver*, the third as the *transfer gate*.

In operation, an electrical charge applied to the transfer gate serves to control the transfer (or movement) of a much larger charge through the gap between the source and receiver electrodes, referenced to the

semiconductor substrate, thereby providing a substantial signal gain.

Still in the experimental stage, the surface-charge transistor might well be the first in a whole new class of semiconductor.

Motorola's recently introduced line of low-cost Functional Circuits now totals twenty devices, including flip-flops, voltage regulators, general purpose and audio amplifiers and an electronic attenuator. Unit prices range from a low 92 cents for the type MFC-4040 Single Toggle Flip-Flop to only \$3.81 for the type MFC9000, a 4-watt audio amplifier complete with an integral preamplifier. Simpler than complex integrated circuits, the devices provide common circuit functions at less cost than designs using discrete components. The relatively low prices are achieved by the use of high-volume TO-92 stripline production facilities.

RCA Electronic Components (415 South Fifth St., Harrison, NJ 07029) has expanded its popular line of IC project kits to include four interesting units that will convert any standard AM broadcast band receiver into a VHF receiver by simply placing a loop of wire around the radio. The four new kits, shown below are the KC 4007 Aircraft IC Converter Kit, tuning 118-136 MHz; the KC 4008 Ham, Government and Space Research IC Converter Kit, tuning 134-150 MHz; the KC 4009 Marine, Mobile, Fire and Police IC Converter Kit, with an expanded range from 148 to 164 MHz; and the KC 4010 Police and Fire IC Converter Kit, covering the 160-174-MHz band. All four kits are priced at \$10.95 each and are available through RCA franchised outlets.

That's our Solid State story, for now—happy April Showers, everyone! —Lou.



If you want to snoop around various VHF bands at reasonable cost, RCA is now offering four kits covering 118-136-MHz; 134-150-MHz; 148-164-MHz; and 160-174-MHz. Output is inductively coupled to an ordinary AM receiver unit.

CHEMICALS

(Continued from page 28)

Recorder heads accumulate the oxidized coatings of tapes and if they are not cleaned periodically, the heads will wear excessively and eventually ruin the tapes themselves. Some technicians still use alcohol to clean tape heads, but this is not a good idea. Alcohol is flammable, is not a particularly good cleaner, and has an adverse effect on some plastics. Even today, some commercial tape head cleaners are based on the use of isopropyl alcohol, but the better products use blends of fluorocarbons (Freons).

Cleaner chemical manufacturers are at odds as to whether or not a tape head cleaner should include a lubricant. At least one manufacturer has a cleaner containing a minor amount of silicone. The claim is made that this product leaves a thin coating which permits the tape to slide freely across the head, but other manufacturers, while acknowledging this good effect, say that lubricants tend to accumulate excessive oxide coating particles. Oddly enough, tape equipment manu-

facturers appear to have no firm views on the subject saying that any good effect may result from a lessening of wear from excessive tape tension (a mechanical defect).

Tape head cleaners are available both bottled and in aerosol cans. It is generally preferable to use a bottled compound and to apply it with a clean cotton swab and then wipe the tape head clean. Where space is not available (in compact cassette recorders, for example) a high pressure aerosol cleaner will do a fairly good job of flushing away oxide without leaving residue.

As above, choose your tape head cleaner by the smell and feel. Reject anything that feels abrasive or smells like alcohol.

Chemicals for Cleaning R-F Circuits.

Many hams and SWL's tolerate erratic band-switches when these defects could be readily cured through the application of a TV tuner spray cleanser. Generally speaking, although these products are advertised for TV tuners, they will obviously have the same beneficial effect in a receiver, transceiver, or transmitter.

Tuner sprays usually fall into one of four relatively distinct categories:

1. Pure cleaners. Sometimes referred to as

Mind your own business with the Cobra '6'

The new Cobra 6 ...
definitely a sound
business venture.

**STRIKE CLEAR
THROUGH WITH
COBRA POWER**

Your business will run more efficiently when you can keep in constant touch with your shop or office. Keep track of your service calls. Or check on production deadlines. Maybe you're needed for a quick decision. There are hundreds of reasons why you'll want to keep in touch, and the new Cobra 6 Transceiver is perfect for the job.

The Cobra 6 features six CB channels*, quick push button channel selectors, and slide controls for volume and squelch. And an exclusive 'S' meter, so you can tell incoming signal strength at a glance. The Cobra 6 is compact and can fit under almost any dashboard. Yet, it's powerful. Your message cuts through crisp and sharp, thanks to a full 5-Watt unit. All solid-state circuitry and switching, too.

 **Cobra**
Product of
DYNASCAN CORPORATION
1801 W. Belle Plaine
Chicago, Illinois 60613



*Channel 11 crystals furnished.

CIRCLE NO. 10 ON READER SERVICE PAGE

McGEE RADIO Co.

**WORLD'S BEST SELECTIONS
AND LOWEST PRICES**

SPEAKERS

**ALMOST EVERY SIZE FROM 1½ TO 18 INCH
WOOFERS—TWEETERS—CROSSOVERS**

MANY HIGH FIDELITY KITS

**McGEE'S 176 PAGE 1971 CATALOG
SENT FREE ON REQUEST**

NORELCO HI-FI SPEAKERS

**McGEE HAS ADDED A FULL LINE OF NORELCO
HI-FI SPEAKERS FOR THE SYSTEM BUILDER.**

McGee ships orders all over the U.S. When requesting our catalog please give name, address and zip code. Our 41st year in Kansas City. Catalog offers everything for Hi-Fidelity audio P.A. systems. All kinds of microphones. Names such as Shure, Bogen, Electro-Voice, University, Altec, Ampex, G.E. Tubes and Transistors. All kinds of parts. Everything for Educational and Industrial electronics. Write for your catalog today.

McGEE RADIO CO.—1901—PE

McGee St., Kansas City, Mo. 64108

CIRCLE NO. 19 ON READER SERVICE PAGE

Express Yourself
in creative electronics

FREE!

32-page
25th Anniversary
Catalog.

KITS & WIRED

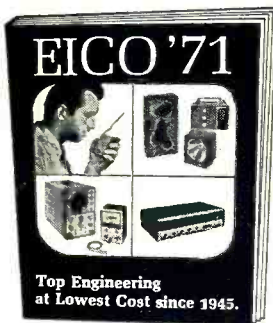

Build all-professional Eico Kits and save 50%. The more you know about electronics, the more you appreciate Eico. Over 2500 local Eico dealers offer you all the top brands, personal technical counsel, fast off-the-shelf service.

- **SOUND N' COLOR**® high fidelity color organs, translators, strobes.
- **TEST EQUIPMENT:** new solid state instruments guaranteed 5 years.
- **CORTINA**® solid state stereo receivers, amplifiers, tuners.
- **EICOCRAFT**® solid state jiffy project electronic kits.

Write for **FREE** catalog to: EICO Electronic Instrument Co., Inc., 283 Malta Street, Brooklyn, N.Y. 11207.

CIRCLE NO. 11 ON READER SERVICE PAGE

“wash” cleaners, these products are generally based on a blend of Freons and may be sprayed on TV tuner contacts or band switches with the assurance that they will leave no residue. These cleaners are especially recommended where foreign matter of any kind might unbalance a critical r-f circuit.

2. Cleaners with light lubricants. It's probably safe to say that these are the traditional TV tuner spray cleaners. These products work reasonably well, but may need to be reapplied to the same switching or contact area within a year.

3. Cleaners with heavy lubricants. This type of spray cleaner is becoming increasingly popular. They may usually be distinguished by the “foaming” action. Many technicians believe these products to be preferable, since they tend to keep tuners and band-switches in good operating condition for longer periods of time.

4. Cleaners with heavy lubricants and polishing agents. This is a relatively new category and may well eventually replace those cleaners mentioned above in category 3.

Any cleaner should be applied to a tuner or a bandswitch with care and the degree of care should follow the numerical order indicated above with category 4 being applied only to switching contact surfaces. Virtually any bandswitch or tuner cleaner will temporarily detune an r-f circuit, but if the cleaner is a good one, the chemical preparation will evaporate in about three minutes and unless the cleaner has been misapplied, no touching up or slug tuning adjustments should ever be necessary.

A follow-up article will describe the use of highly specialized chemicals for electronics—including insulating compounds, coolers, etc. with emphasis on troubleshooting techniques.

-30-

ANNUNCIATOR

(Continued from page 52)

of cardboard over *LDR2*; now *K1* should immediately be energized.

Alternately exposing and covering *LDR2* should cause *K1* to open and close. Leaving *LDR2* covered, illuminate *LDR1*; *K1* should remain energized. Removing the cover from *LDR2* should cause *K1* to deenergize.

The reverse of this procedure to test *K2* is as follows: cover *LDR2* (*K1* and *K2* open);

POPULAR ELECTRONICS

cover *LDR1* (*K2* closes); illuminate *LDR2* (*K2* remains energized); illuminate *LDR1* (*K1* and *K2* open). While the system is operating properly, it should be impossible for both relays to energize simultaneously.

Although the system employs two LDR sensors, it is not necessary, in most cases, to use two light sources. A single light source and a flashlight reflector can be used to illuminate both LDR's satisfactorily if the distances are reasonable. Of course, if the distance between light source and Annunciator is excessive, a two-light source system would be required.

When you get ready to set up your system, orient it so that the minimum amount of ambient light reaches the LDR sensors. Avoid pointing the LDR's toward windows or bright room lighting, and do not set up the system so that an opening door will trigger it. Finally, when counting people passing by, it is a good idea to locate light sources and sensors about 54" from the floor so that swinging arms will not produce multiple counts.

Now, turn on the system and orient the set-up for maximum illumination of the LDR's. If necessary, you can use mirrors to bend the light beam around corners so that more than one area can be surveyed.

Adjusting *R5* and *R6* is simple. Rotate both

controls fully counterclockwise (viewed from the front of the case). Temporarily mask *LDR1* from the light source and rotate *R6* until *K1* pulls in; then back off until *K1* just opens. Interrupt the beam to *LDR2* once or twice with your hand to check that *K1* opens and closes properly.

Remove the mask from *LDR1* and place it in front of *LDR2*. Rotate *R5* until *K2* energizes; then back off until the relay just de-energizes. The controls are now set for maximum sensitivity.

The relay contacts can be used to activate a variety of alarms or counters. In simple one-way systems, use the normally open contacts of the appropriate relay to turn on the system. A slightly more elaborate system, using both relays and a dual door chime is shown in the wiring diagram in Fig. 3. People passing in one direction will cause the chime to sound once; people passing in the opposite direction will cause the chime to sound twice. This same basic arrangement can be used as a secure area monitor by substituting two counters. Anyone entering the area will be registered on one counter, while those leaving the area will be registered on the other counter. In this way, you can tell if someone has gone into the area and has not come out. —30—



MAKING "WAVES"

CADENCE—the musical instrument speakers

Making better, clearer, amplified sound waves is the THING Cadence does . . . better than anything else in the industry. Cadence Speakers are built to withstand heat from sustained notes at a high power level and the vibrations and stresses which are continually placed upon them. Cadence is guaranteed one full year at the power level specified. This proven speaker family has been selected by the manufacturers of most of the world's fine amplified music instruments.

If making beautiful, clear sound waves is your thing, ask for CADENCE SPEAKERS. For complete information and the name of your Cadence Dealer, write:



UTAH ELECTRONICS DIVISION
Utah-American Corporation
1124 East Franklin Street
Huntington, Indiana 46750



NEW HOLLOW SHAFT

nutdriver set

with Locknut/Screw adjusting feature

Speeds, simplifies setting of combination lock-nut/slotted screw adjustments on rheostats and similar controls used in a wide variety of electrical and electronic equipment.

Handle is drilled so you can run an 8" screwdriver blade right through its center and down through the hollow nut-driver shaft.

Ideal for all-round production, maintenance, and service work, this new HSC-1 Set contains eight interchangeable hollow nutdriver shafts in the most popular hex opening sizes from $\frac{3}{16}$ " thru $\frac{1}{4}$ "

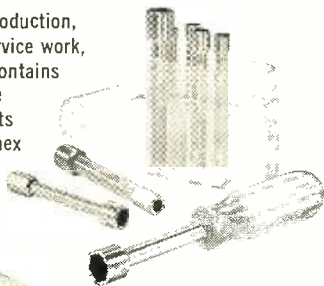

Really compact! Set is small enough, light enough to carry in your hip pocket. Sturdy, see-thru, plastic carrying case doubles as a bench stand.

XCELITE

XCELITE, INC. • 20 BANK ST., ORCHARD PARK, N. Y. 14127
Send Bulletin N867 with information on HSC-1 Hollow Shaft Nutdriver Sets.

name _____

address _____

city _____ state & zone _____

CIRCLE NO. 28 ON READER SERVICE PAGE

LIBRARY

(Continued from page 16)

There are close to 500 diagrams, dozens of tables, over 200,000 words of explanation, a virtual absence of mathematics, and a modest index.

More than likely, the author has little to do with the choice of the book title—since it is a definite misnomer. True, the major emphasis is on amateur radio circuits and construction, but the ideas cut across all lines of the art of electronics communications. Certainly no one working with transmitters and receivers can afford to be without a personal copy of this refreshing and stimulating tome.

Published by Radio Society of Great Britain, 35 Doughty St., London, WC1, England. Soft cover. 208 pages \$3.75.

RECENT ARRIVALS

BASIC ELECTRONICS PROBLEMS SOLVED

by Donald A. Smith

Unlike many books that move too fast through the basics, this handbook starts from scratch and gives a detailed explanation of every step. Not only is a detailed explanation of each point given, but each is backed up by actual examples on how to work out the problems.

Published by TAB Books, Blue Ridge Summit, PA 17214. 192 pages. \$7.95 hard cover; \$4.95 soft cover.

INTRODUCTION TO SIGNAL TRANSMISSION

by William R. Bennett

Demonstrated in this book is how the knowledge of the response of a transmission system to sine waves reveals the performance of any kind of signal. Another book in the Electrical and Electronic Engineering Series, the text is written for the advanced undergraduate or first-year graduate student.

Published by McGraw-Hill Book Co., 330 West 42 St., New York, NY 10036. Hard cover. 266 pages. \$12.50.

LABORATORY MANUAL FOR INTEGRATED COMPUTER CIRCUITS

by Robert F. Coughlin

One of a series of Laboratory Manuals prepared by the Wentworth Institute under a grant from the National Science Foundation. Provides useful guidelines for laboratory study of digital (logic) and operational amplifier (linear) circuits. The text format is on the technician level.

Published by Prentice-Hall, Inc., Englewood Cliffs, NJ 07632. Soft cover. 152 pages. \$5.95.

Popular Electronics

READER SERVICE PAGE

free information service:

Here's an easy and convenient way for you to get additional information about products advertised or mentioned editorially (if it has a "Reader Service Number") in this issue. Just follow the directions below... and the material will be sent to you promptly and free of charge.

1. On coupon below, circle the number(s) that corresponds to the key number(s) at the bottom or next to the advertisement or editorial mention that is of interest to you. (Key numbers for advertised products also appear in the Advertisers' Index.) Print or type your name and address on the lines indicated.

2. Cut out the coupon and mail it to: POPULAR ELECTRONICS, P.O. Box 8391, Philadelphia, PA 19101.

note: If you want to write to the editors of POPULAR ELECTRONICS about an article on any subject that does not have a key number, write to POPULAR ELECTRONICS, One Park Avenue, New York, N.Y. 10016. Inquiries concerning circulation and subscriptions should be sent to POPULAR ELECTRONICS, P.O. Box 1096, Flushing, N.Y. 11352.

4/71-2

Void after May 31, 1971

Popular Electronics

P.O. BOX 8391
PHILADELPHIA, PA. 19101

1 2 3 4 5 6 7 8 9 10 11 12 13 14 15 16 17 18 19 20
21 22 23 24 25 26 27 28 29 30 31 32 33 34 35 36 37 38 39 40
41 42 43 44 45 46 47 48 49 50 51 52 53 54 55 56 57 58 59 60
61 62 63 64 65 66 67 68 69 70 71 72 73 74 75 76 77 78 79 80
81 82 83 84 85 86 87 88 89 90 91 92 93 94 95 96 97 98 99 100

NAME (Print clearly) _____

ADDRESS _____

CITY _____ STATE _____ ZIP CODE _____

STEREO HEADPHONES

(Continued from page 47)

loudspeakers sound relatively natural. Using headphones, the two stereo channels are kept apart, right up to your ears. The positioning "cues" fed your hearing system from the spread-mike recordings are not like those of normal listening.

Several years ago Jensen manufactured a corrective device (called the CC-1) that restored loudspeaker perspective to headphone listening through a complex cross-channel feed and frequency alteration. However, this problem seems to have been corrected by many disc manufacturers and the Jensen CC-1 is no longer marketed. It seems reasonable to assume that microphone recording techniques have swung more and more to the multi-microphone, studio-remix situation that is not aiming for a realism in concert hall sound. This does create some "strange" effects where instruments pop in and out of the "space" according to what the recording director decides is the most exciting scenario.

Pop and rock category music (broadly defined) has moved almost wholly into the domain of the recording director. Nevertheless, with typical pop music, headphones can produce exciting effects and in many instances much more effective than those heard through speakers—in the view of the younger listeners.

Using Headphones. Amplifier manufacturers have acknowledged the headphone boom by putting one or two phone jacks on the front panel of nearly every amplifier and stereo receiver marketed in the past two years. Such headphone jacks make listening dead easy—you simply plug in the head-

phones, put them on your head and listen. If all of this appears a little too easy, you are right. Headphone users soon realize that to obtain full bass note response with some headphones, they must be fitted to the listener's head to make a relatively tight seal around each ear. Any air leakage around the headphone rims will cut down the low frequency response. A few headphones may not require a perfectly tight seal and the response curve of these few headphones has been altered to increase the normal bass response output by the order of 6-10 dB. Obviously, an alternative to a snug headphone fit is turning up the bass control on your amplifier.

Most stereo amplifiers and receivers provide one or two headphone jack outputs. If two headphones are to be used, it is considered preferable to be sure that they are of equal sensitivity—hence, from the same manufacturer and of the same type. Stereo headphones can usually be paralleled without adversely affecting the stereo amplifier receiver. There are also several outlet boxes for multiple headphone listening and these are described in the 1971 Stereo Hi-Fi Directory.

If you are one of the few people with an amplifier or receiver that has no phone jack output, you can wire your own headphones to the speaker terminals (through a four pole, double throw switch) being sure to insert a 100-ohm 2-to-5-watt resistor in series with each "hot" leg of the headset. Using these two resistors ensures that the headset cannot be overloaded and simultaneously because it is a "loss" arrangement, the hum and noise level that might be passed along to the headset is virtually eliminated. Should you hook up the headphones without the series resistors you are taking your life—and your amplifier—in your hands and could well be blasted into kingdom come.

-30-



DIRECT FREQUENCY DIALING

International Short-Wave Broadcast RECEIVER



No more guesswork in identifying stations. Set dial at a station's frequency and if conditions permit you'll hear it everytime . . .

- Ultra-precision tuning dial accuracy, SW and standard AM Broadcast
- Crystal lattice filter for adjacent station rejection and good AF response
- Dual conversion • Solid state AF output • S-meter • Preselector gives superior sensitivity by peaking antenna and RF stages • Crystal-controlled H. F. Oscillator stability • Amplified AVC constant AF output • Price \$299.00

Write for free Brochure

R. L. DRAKE COMPANY • Miamisburg, Ohio 45342

CIRCLE NO. 9 ON READER SERVICE PAGE

CHARGE NOW

(Continued from page 64)

hours. Cells should have been discharged to 1.1 volts before recharging. To recharge nickel-cadmium multicell batteries, run leads to *J1* and *J2* and observe the correct polarities of the leads and battery terminals.

Recharge Mallory SA-15AA, SA-14C, and SA-13D cells in the VLTC mode using *S3* set for the appropriate cell size. For a single cell, use either the B1 or B2 battery holder and charge for 12 to 14 hours. The built-in voltage limiter permits each cell to take what it needs at the maximum rate. Therefore, the cells need not be discharged nor in the same state of charge before placing them on charge. The meter indicates the total current to the VLTC circuit and cell and not the cell current alone. A quick way to check the charging progress is to connect a voltmeter across the cell with *S1* off. If the voltage is above 1.65, the cell is fairly well charged. As cells age, the final voltage drops to below 1.7.

Although only three VLTC charge rates are provided, other cells may be recharged by using the nearest lower rate to that actually required and increasing the charging time accordingly.

Drifting. Due to the base-emitter characteristics of *Q3* there is a certain amount of drift during warmup. For instance, with a load of 1 ampere (output terminals shorted), there may be a drift of 7% for the first 20 minutes. At 1/2 ampere, drift is about 4%, essentially finished in 10 minutes. At 100 mA, drift is about 1%, with stabilization in about 5 minutes. Although drifts of these magnitudes are of no consequence in battery charging, the current may have to be reset after a short warmup period.

Charger "backleak," or cell discharge back into the circuit when *S1* is off, is less than one microampere, which permits storage of the cells in the charger. Nickel-cadmium cells may be placed on continuous trickle charge, but only as specified by the manufacturer.

Constant-Current Use. The Charge Now may be used as a constant-current source for values up to one ampere. The current is taken from *J1* and *J2* with *S3* in the CC position. Tests may then be made on various types of semiconductors and other circuits. -30-

April, 1971

CONTROLLED
QUALITY
CRYSTALS by



CRYTEK



The "On-Channel" Crystals
FOR

CITIZEN BAND

23 Channels and "Mars"

HAM OPERATORS

Commercial 2-Way

Marine-Monitor

See your Distributor for Speedy
"Zip Certificates"



CRYTEK

formerly Texas Crystals
Div. of Whitehall Electronics Corp.

1000 Crystal Drive 4117 W. Jefferson Blvd.
Fort Myers, Florida 33901 Los Angeles, California 90016

CIRCLE NO. 8 ON READER SERVICE PAGE



FREE!

Lafayette's 1971 Golden Jubilee Catalog



Your 1st Guide To
Everything in Electronics

• Stereo/Hi-Fi Components • Musical Instruments and Amplifiers • Photography Equipment • Ham and CB Gear • Public Address Systems • Tools and Test Equipment • Educational and Optical Equipment • Black and White/Color Televisions • Police and Fire Monitor Receivers • Books and Parts
Plus Thousands of Additional Items

Lafayette Radio Electronics Dept. 35041
P. O. Box 10, Syosset, L. I., N. Y. 11791

Send Me the Free Lafayette Golden Jubilee 1971 Catalog 710 35041

Name
Address
City
State Zip

(Please include your zip code)

CIRCLE NO. 17 ON READER SERVICE PAGE

POPULAR ELECTRONICS SUBSCRIBER SERVICE

Please include an address label when writing about your subscription to help us serve you promptly.

Write to: P.O. Box 1096, Flushing, N.Y. 11352

CHANGE OF ADDRESS: Please let us know you are moving at least six to eight weeks in advance. Affix magazine address label in space below and print new address in space provided. If you have a question about your subscription, attach address label to your letter.

If you have no label handy, print OLD address here.

| | | | |
|---------|--|--------------|--|
| name | | please print | |
| address | | | |
| city | | | |
| state | | zip-code | |

TO SUBSCRIBE: Check these boxes: — New — Renewal

5 years \$21 3 years \$15 1 year \$6

SPECIFY: Payment enclosed—You get 1 extra issue per year as a BONUS! Bill me later.

0481

name please print

address

city state zip

Add'l postage: \$1 per year outside U.S., its possessions & Canada.

ABOUT YOUR SUBSCRIPTION

Your subscription to POPULAR ELECTRONICS is maintained on one of the world's most modern, efficient computer systems, and if you're like 99% of our subscribers, you'll never have any reason to complain about your subscription service.

We have found that when complaints do arise, the majority of them occur because people have written their names or addresses differently at different times. For example, if your subscription were listed under "William Jones, Cedar Lane, Middletown, Arizona," and you were to renew it as "Bill Jones, Cedar Lane, Middletown, Arizona," our computer would think that two separate subscriptions were involved, and it would start sending you two copies of POPULAR ELECTRONICS each month. Other examples of combinations of names that would confuse the computer would include: John Henry Smith and Henry Smith; and Mrs. Joseph Jones and Mary Jones. Minor differences in addresses can also lead to difficulties. For example, to the computer, 100 Second St. is not the same as 100 2nd St.

So, please, when you write us about your subscription, be sure to enclose the mailing label from the cover of the magazine—or else copy your name and address exactly as they appear on the mailing label. This will greatly reduce any chance of error, and we will be able to service your request much more quickly.

VR12 REGULATOR

(Continued from page 70)

setting of $R10$. The lamp may also glow slightly with heavy electrical loads at low engine speeds. Neither of these should be considered to be malfunctions.

Installation. Mount the regulator as close to the battery as convenient for good temperature tracking. Wire it into the system (in place of the old regulator) using the appropriate circuit in Fig. 3. Note that the S and R terminals of the alternator are not used with this voltage regulator. An additional lead may have to be added to accommodate the "IGN" terminal on the regulator. Any convenient point that is "hot" when the ignition is on is acceptable—except the coil-ballast connection point.

For generator systems, the $D1$ heat sink assembly is required. This may be mounted at any convenient location close to the voltage regulator. The heat sink must be insulated from ground and sprayed with a moisture resistant before installation. All interconnections must be made with oil-resistant, flame-retardant wire not smaller than #14 AWG for the IGN, LAMP, FLD, and GND connections; #10 AWG for BATT, ARM, and $D1$ connections.

After installation, recheck the lamp circuit (if used) so that the lamp is lit when the engine is not running and out when the engine is charging the battery.

Incidentals. The VR12 is a switching regulator which operates very rapidly. In ammeter installations, some hunting of the meter needle may occur. This is due to the long time constant of the alternator field. The hunting is preferable to high power dissipation in an analog series regulator.

The current drain of the VR12 when the ignition is off is about 15 mA—a reasonable value if the car is not left in long-term storage. If desired, the current drain can be reduced by increasing the value of $R1$ and $R2$ by a factor of 2 and of $R3$, $R4$, and $R5$ by a factor of 10.

—50—

GIANT BRAINS

(Continued from page 33)

Now the time had come to decide which design was best—the Mark I, the Model V, or the ENIAC. The direction computer design was to take lay in the balance. Debate was based on arguments of component reliability, problem set-up time, error-free operation, self-checking ability, and maintenance costs. The builders of ENIAC based their stand on the fundamental advantage of speed, which really meant decreased cost of computing—and this attribute far outweighed ENIAC's disadvantages.

The deciding argument was given by Dr. Mauchly when he said that the life of a computing device should not be based on time alone but on the number of operations it can be expected to perform before failure.⁹ A good relay may average 100,000,000 operations before failure. A vacuum tube may be expected to operate reliably at a pulse rate of one operation per microsecond for 5,000 to 10,000 hours. Thus the tube may perform more than 10^{12} operations compared to 10^8 for the relay.

Not only did great speed mean cheaper computing, it also offered hope of fulfillment of the cybernetist's dream of real-time control of complicated events. The ENIAC could calculate the trajectory of an artillery shell in half the time of the shell's flight.

The strength of ENIAC's success can be seen in changes made by other builders of digital computers. Harvard followed the electromechanical Mark I with a relay Mark II. A twelve-fold increase in speed was achieved. Since this was still no serious challenge to the ENIAC, there followed the Mark III, which got on the electronic bandwagon. The interest of Bell Labs in computer manufacturing was too heavily tied to the use of telephone equipment to convert to electronics. Their contribution to computer technology was to be with the invention of the transistor, not by the direct manufacture of computers.

The Eckert-Mauchly team went commercial and designed the Binae and their small company was absorbed to form the basis of Univac. And what of IBM, the builder of Harvard's Mark I? Suffice it to say that they too recognized the potential of electronic digital computers.

-30-

April, 1971

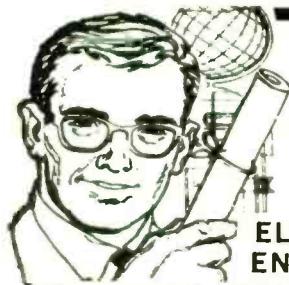

Earn Your Degree

ELECTRONICS ENGINEERING

through HOME STUDY

HIGHLY EFFECTIVE HOME STUDY COURSES IN:
• ELECTRONICS ENGINEERING TECHNOLOGY
• ELECTRONICS ENGINEERING MATHEMATICS

Earn your Associate in Science Degree in Electronics Engineering and upgrade your status and pay to the engineering level. Complete college level courses in Electronics Engineering. We're a forward looking school. Outstanding lesson material—thorough and easy to understand. Engineering taught on the basis of application and understanding rather than on the basis of memorization. Up to date in every respect. Acquire the knowledge and ability that means the difference between a low paying technician job and a high paying engineering position. Low tuition cost with low monthly payments. Free engineering placement service for our graduates. Write for free descriptive literature. Ask for bulletin p, no salesman will call on you.

COOK'S INSTITUTE of Electronics Engineering



Forest Hill Road
P. O. Box 10634
Jackson, Miss. 39209
Established 1945

Formerly Cook's School of Electronics

CIRCLE NO. 7 ON READER SERVICE PAGE

OUR STORE
AT YOUR DOOR

Olson

ELECTRONICS

FREE
Catalog

Fill in coupon for a FREE One Year Subscription to OLSON ELECTRONICS' Fantastic Value Packed Catalog — Unheard of LOW, LOW PRICES on Brand Name Speakers, Changers, Tubes, Tools, Stereo Amps, Tuners, CB, and other Values. Credit plan available.

NAME _____

ADDRESS _____

CITY _____ STATE _____

GIVE ZIP CODE _____

If you have a friend interested in electronics send his name and address for a FREE subscription also.

OLSON ELECTRONICS

Dept. 1P 260 S. Forge Street Akron, Ohio 44308

CIRCLE NO. 20 ON READER SERVICE PAGE

ELECTRONICS MARKET PLACE

NON-DISPLAY CLASSIFIED: COMMERCIAL RATE: For firms or individuals offering commercial products or services, \$1.25 per word (including name and address). Minimum order \$12.50. Payment must accompany copy except when ads are placed by accredited advertising agencies. Frequency discount: 5% for 6 months; 10% for 12 months paid in advance. **READER RATE:** For individuals with a personal item to buy or sell. 80¢ per word (including name and address). No Minimum! Payment must accompany copy.

DISPLAY CLASSIFIED: 1" by 1 column (2 3/8" wide), \$110.00. 2" by 1 column, \$215.00. 3" by 1 column, \$320.00. Advertiser to supply cuts.

GENERAL INFORMATION: First word in all ads set in bold caps at no extra charge. All copy subject to publisher's approval. Closing Date: 1st of the 2nd month preceding cover date (for example, March issue closes January 1st). Send order and remittance to: Hal Cymes, **POPULAR ELECTRONICS**, One Park Avenue, New York, New York 10016.

FOR SALE

FREE! Giant bargain catalog on fiber optics, transistors, diodes, photo cells, rectifiers, SCR's, zeners, parts. Poly Paks, P.O. Box 942, Lynnfield, Mass. 09140.

GOVERNMENT Surplus Receivers, Transmitters, Snooper scopes, Radios, Parts, Picture Catalog 25¢. Meshna, Nahant, Mass. 01908.

ROCKETS: Ideal for miniature transmitter tests. New illustrated catalog. 25¢. Single and multistage kits, cones, engines, launchers, trackers, rocket aerial cameras, technical information. Fast service. Estes Industries, Dept. 18-D, Penrose, Colorado 81240.

LOWEST Prices Electronic Parts. Confidential Catalog Free. **KNAPP**, 3174 8th Ave. S.W., Largo, Fla. 33540.

WE SELL CONSTRUCTION PLANS. TELEPHONE: Answering Machine, Speakerphone, Carphone, Phonevision, Legal Connector, Auto Dialer, Central Dial System. **TELEVISION:** \$35.00 Color Converter, Tape Recorder, 3DTV, \$25.00 Camera. **HOBBYIST:** Electron Microscope, 96 Hour Tape Music System, Ultrasonic Dishwasher, Radar-Oven, Electronic Tranquilizer. Plans \$4.95 each. **COURSES:** Telephone Engineering \$39.50, Detective Electronics \$22.50, Anti-Detective Electronics \$27.50. **NEW SUPER HOBBY CATALOG AIRMAILED \$1.00.** Don Britton Enterprises, 6200 Wilshire Blvd., Los Angeles, Calif. 90048.

WEBBER LAB's. Police & Fire Converters. Catalog 25¢. 72 Cottage Street, Lynn, Mass. 01905.

INVESTIGATORS, LATEST ELECTRONICS AIDS. FREE LITERATURE. CLIFTON, 11500-L NW 7th Ave., MIAMI, FLORIDA 33168.

ELECTRONIC PARTS, semiconductors, kits. **FREE FLYER.** Large catalog \$1.00 deposit. **BIGELOW ELECTRONICS**, Bluffton, Ohio 45817.

RADIO—T.V. Tubes—36¢ each. Send for free catalog. Cornell, 4213 University, San Diego, Calif. 92105.

PSYCHEDELIC catalog. Posters, lighting, etc. Send 50¢ for handling to Hole In The Wall, 6055PE Lankershim, North Hollywood, Calif. 91606.

CLEARANCE SALE rectifiers, transistors, 1000's other items. Catalog 15¢. General Sales Company, 254 Main, Clute, Texas 77531.

MECHANICAL, ELECTRONIC devices catalog 10¢. Greatest Values—Lowest Prices. Fertik's, 5249 'D', Philadelphia, Pa. 19120.

SPACE-AGE TV CAMERA KIT! Terrific for Experimenters, Industry, Education. Solid-state. Only \$116.95! Starter kits: \$18.95 up. Plans 25¢ up. Catalog **FREE.** Phone: 402-987-3771. Write: **ATV RESEARCH**, 1301 Broadway, Dakota City, Nebr. 68731.

BURGLAR ALARM SYSTEMS and accessories. Controls, bells, sirens, hardware, etc. **OMNI-GUARD** radar intruder detection system, kit form or assembled. Write for free catalog. Microtech Associates, Inc., Box 10147, St. Petersburg, Florida 33733.

SENCORE, B&K TEST EQUIPMENT UNBELIEVABLE PRICES. FREE CATALOG AND PRICE SHEET. **FORDHAM RADIO**, 265 EAST 149TH STREET, BRONX, N.Y. 10451.

ELECTRONIC COMPONENTS—Distributor prices, Free catalog. Box 2581, El Cajon, California 92021.

JAPAN & HONG KONG DIRECTORY. Electronics, all merchandise. World trade information. \$1.00 today. Ippano Kaisha Ltd., Box 6266, Spokane, Washington 99207.

FREE Kit Catalog: Shortproof Powersupply \$39.50. Ultrasonic Alarm \$37.25. SWTPC, Box B32040, San Antonio, Tex. 78216.

POLICE-FIRE RADIO DISPATCHER CALLBOOKS! EXCLUSIVE, OFFICIAL LISTINGS: CALLSIGNS, FREQUENCIES! LATEST REVISIONS, NATIONWIDE. CATALOG, SEND STAMP. **COMMUNICATIONS, BOX 56-PE, COMMACK, N.Y. 11725.**

AMATEUR SCIENTISTS, Electronics Hobbyists, Experimenters, Students . . . Construction Plans—all complete, including drawings, schematics, parts lists with prices and sources . . . Radar—Build your own ultrasonic doppler radar. Detect motion of people, automobiles, even falling rain drops. Transistorized, uses 9 volt transistor battery—\$4.50 . . . Long-Range "Sound Telescope"—This amazing device can enable you to hear conversations, birds and animals, other sounds hundreds of feet away. Very directional. Transistorized. Uses 9V battery—\$3.50 . . . Robot Man—Moves hands and arms—\$3.50 . . . Or send 25¢ coin (no stamps) for complete catalog. Other items include Psychedelic strobes, light shows, lasers . . . 46 different projects. Technical Writers Group, Box 5994, State College Station, Raleigh, N.C. 27607.

DIAGRAMS—Radios \$1.50, Television \$3.00. Give make and model. Diagram Service, Box 1151PE, Manchester, Conn. 06042.

ELECTRONIC Ignition. Various Types. Information 10¢. Anderson Engineering, Epsom, N.H. 03239.

NEW! PHONE PATCH with automatic switch. Now you can record those important conversations automatically. **ONLY \$19.95.** Chelco Electronics, 11835 Wilshire Blvd., Los Angeles, Calif. 90025.

BACKGROUND MUSIC, continuous commercial-free. Solid-state **MUSICON SCA ADAPTER** plugs into any FM Tuner, Receiver. Line powered. 5 year guarantee! Only \$39. postpaid. K-Lab, Box 572Z, South Norwalk, Conn. 06856.

NEW SEMICONDUCTOR LIGHT EMITTING DIODES—bright red lights replace light bulbs. Typical life 100 years. Operate at 1.65 volts, 50 milliamps. Order 2 for \$2.98 **NOW.** Data sheet and instructions included. Monsanto Company, Hobby Section, 10131 Bubb Road, Cupertino, California 95014.

CONVERT any television to sensitive, big-screen oscilloscope. Only minor changes required. No electronic experience necessary. Illustrated plans, \$2.00. Relco-A33, Box 10563, Houston, Texas 77018.

FREE catalog, parts, circuit boards for POPULAR ELECTRONICS projects. **PAIA ELECTRONICS**, Box 14359, Oklahoma City, OK 73114.

MATRIX ARRAY COMPONENT UNITS: needed in experimenter laboratory and repair shop, catalog 10¢. **CUHINCO**, 2404 Stratton Drive, Rockville, Maryland 20854.

CITIZENS Band-Shortwave Listener-Ham equipment from Amrad Supply, Inc. Free Flyer, 1025 Harrison St., Oakland, Calif. 94607.

COLOR converter for B&W television. Electronic Patented system. Free Brochure. Bele Electronics Corp., 111 Northeast Second Avenue, Miami, Florida 33132.

PSYCHEDELIC Strobe Kit: Complete with 110w/sec. tube, reflector, chassis and cabinet \$17.50 plus postage and insurance, 2 lbs. (Extra tubes \$3.50) **SWTPC**, Box E32040, San Antonio, Texas 78216.

CONSTRUCTION PLANS: Laser . . . \$2.00. 2-FM microphone transmitters . . . \$1.00. FM telephone transmitter . . . \$2.00. Sound telescope . . . \$2.00. Space monitor-missile tracker . . . \$2.00. Equipment and kits available. Howard, 20174 Ward, Detroit, Michigan 48235.

REPAIR that set! Individual instructions, sketches, \$5. Money-back guarantee. Charles Brown, 321 Price, Philadelphia, Penn. 19144.

TV TUNER REPAIRS—Complete Course Details, 12 Repair Tricks, Many Plans, Two Lessons, all for \$1. Refundable. Frank Bocek, Box 833, Redding, Calif. 96001.

FREE Kit Catalog: Color Organs \$11.00 Psychedelic Strobes \$17.50 Professional quality—lowest prices. **SWTPC**, Box F32040, San Antonio, Texas 78216.

ANTI-GRAVITY, experiment and theory; Rushed—\$2.00. U.S. Inquiries. Intertech 7A6, Box 5373, Station-F, Ottawa, Canada.

EXCITING LISTENING! Police—Fire—Emergency calls on your broadcast radio, \$19.95 up. Also crystals, receivers, scanners, dualband. Saich Company, Woodsboro 48, Texas 78393.

LEARN the facts of electronics and your privacy. Send for the Tron-X Manual, P.O. Box 38155, Hollywood, CA 90038. \$5.95.

HOBBYISTS—Electronic components at huge savings. Transistors 6/25¢, resistors 5¢, capacitors 10¢. Thousands of items. Catalogue free. SASCO Electronics, 1009 King Street, Alexandria, Va. 22314.

PRINTED Circuit Boards, solder plated for magazine projects. Send magazine page or drawing of circuit pattern. 20¢ square inch. Min. \$1.75 per board. Send remittance: General Printed Circuits, Box 4013, Downey, Calif. 90241.

SHORTWAVE—Drake SW4A receiver. Save 25%. Only \$225. Sochor, Box 552, Arlington Heights, Illinois 60006.

duo-band • auto search Monitor Receiver



pei 8-channel scanning monitor HL-44 locks on active channel,

then resumes search when channel goes quiet. Program scanning speed, any number of high or low band channels by plugging in crystals. **NO WIRING CHANGES.** Use it on your desk or in your car.

pei Write for free literature.
PETERSEN ELECTRONICS, INC.
1000 South Main— Council Bluffs, Iowa 51501

ALUMINUM, Brass, Copper, Plastic. Rods, sheets, tubing. Send for free list. J. W. Fowler, 1605 Quill Street, Indianapolis, Ind. 46203. IC's, Accessories. Free price list. Tri-Tek, P.O. Box 14206, Phoenix, Arizona 85031.

BRAINWAVE Feedback Electroencephalophone. Send 10¢, J. & J. Enterprises, 8102E, Bainbridge, Wash. 98110.

PULSE GENERATORS, oscillators, logic modules, booklets, and plans. **FREE LITERATURE.** Scientific Measurements, 2945 Central, Wilmette, Illinois 60091.

WOULD YOU SPEND 25¢ to save \$25.00 or more? Citizens Band, AM and SSB 2-way radios, USA and export models. Send 25¢ for catalog to: **BAGGY'S RADIO**, 6391 Westminster Avenue, Westminster, CA 92683. Dealer Inquiries Invited.

SEMICONDUCTORS: Buy from single source. Serving experimenters, hobbyists. No minimums. SN 7400N, \$1.90; MC724P, \$1.10, Etc. RLabs, Box 253, Burlington, Ma. 01803.

FIND COINS-GOLD-RELICS-TREASURE metal locators by JETCO!

- Lightweight
- Easy to Use
- Comes Complete
- Made in USA
- 5 yr. Guarantee
- Immediate Delivery!
- Write for FREE Catalog.

priced from

\$39.95



Jetco ELECTRONIC INDUSTRIES, INC.

P. O. BOX 132, PE HUNTSVILLE, TEXAS 77340
PHONE ORDER TO: 713/295-5422

NOW! . . . Visible and Infrared Light Emitting Diodes, Matching Receiving Photodiodes, Comprehensive Plans . . . You can build inexpensive secret communications, alarm, control devices! Catalog including \$1.00 discount certificate, 25¢. Lundart, University Station 4008-E6, Tucson, Arizona 85717.

CRYSTAL Calibrator, Integrated Circuit Design. Send For Free Literature. C.O. Associates, P.O. Box 187, Rutherford, N.J. 07070.

FIFTY assorted precision resistors for \$4.50. P.O. Box 203, New Hartford, New York 13413.

FREE Electronics Catalog. Tremendous bargains. Edu-Kits, Department C-695 D, Hewlett, New York 11557.

WOULD YOU SPEND 25¢

to save \$25.00 or more? Citizens Band, AM and SSB 2-way Radios, USA and Export Models. Send 25¢ for catalog to:

BAGGY'S RADIO

P. O. Box 778, 6391 Westminster Avenue
Westminster, CA 92683
Dealer Inquiries Invited

PLANS AND KITS

FREE Kit Catalog: Digital Microlab \$29.95. Also Segmented and Nixie Readouts, Timebases, Scalers, Electronic Digital Clocks (all featured in **Popular Electronics**) SWTPC, Box C32040, San Antonio, Tex. 78216.

PSYCHEDELIC LIGHTING MANUAL! Make strobes, kaleidoscopes, organs, etc. Send \$2.95. Lightrays, 1315-D Weaver, Philadelphia, Pa. 19150.

BUILD your own electronic **COMPUTER**. New book explains theory, practical details. \$2.25 postpaid. Cinnamon Press, Box 8453-A, Minneapolis, Minnesota 55408.

FREE kit Catalog: Amazing new Universal Digital Instruments with plugins as featured in **Popular Electronics**. Unbeatable prices. SWTPC, Box D32040, San Antonio, Tex. 78216.

COLOR CONVERTER FOR BLACK AND WHITE TELEVISION

New electronic patented system. A do-it-yourself kit for hobbyists and experimenters. Plans and instructions available. Write for free brochure.

BELE ELECTRONICS CORP.

111 Northeast Second Avenue, Miami, Florida 33132

FREE Kit Catalog. Why does every major College, University, Technical School, Research & Development Center buy from us? Because we have the highest quality and lowest prices. Free catalog. SWTPC, Box H32040, San Antonio, Tex. 78216.

KITS, Electronics Instruction: featuring semiconductor/integrated circuits. Including test, measurement, amplification, power, control, computer logic, optoelectronics, ultrasonics, electroenvironmental and electroautomotive applications. Kits/Parts Catalog 50¢ Deposit. Electronics Laboratories; Box 738; College Park, Maryland 20740.

SCR (electronic switch) Hobbyist Kit. SCR's, many plans, circuit theory. \$4.95. Catalog free. John Huntley, 909 Wisconsin, San Francisco, CA. 94107.

PRINTED Circuit kits and supplies to make any P.C. Board in this magazine. Send \$5.00 ppd. for Experimenters Kit, catalog and instructions. Techniques, Inc., Englewood, New Jersey 07631.

KIT. Three channel audio-controlled Color Organ. \$8.95. Includes all parts, instructions, and postage. Kustom House Electronics, 8530 Westminster Avenue, Westminster, CA, 92683.

TELEVISION Training Kits, Parts, Plans. \$2.99. Free Flyer. Aline, 434 West 4th Street, West Islip, New York 11795.

AMPLIFIER 500 WATTS RMS STEREO, 250 RMS per board designed for guitar and bass amplifiers, PA systems and stereo. Highest quality possible. Built in protection circuit. Newest semiconductor design, circuit guaranteed, construction cost under \$60.00. Easily constructed. Also includes preamp driver. Specify for guitar, bass, PA or stereo. Complete 8 page brochure of complete assembly plans and applications \$9.95 check or M.O. Amplifier Design Corp., P.O. 4, Rossford, Ohio 43460.

EASILY Built Novel Construction Board Tremendous Aid to Electronic Construction Projects. Plans \$2.00. R & R Enterprises, Box 1317E, Running Springs, Calif. 92382.

COLOR ORGAN Kits \$7.50. IC's 25¢. Catalog. Murphy, 204 Roslyn Ave. Carle Place, N.Y. 11514.

OSCILLOSCOPE Dual Trace Attachment: 10-600,000 Hertz; input impedance 75 kOhms. \$15.47, kit. Turgpob, 9632 Brunett, Silver Spring, Maryland 20901.

INTEGRATED CIRCUIT KITS: COMPUTER, STROBELITE, AUDIO. Catalog free. KAYE ENGINEERING, Box 3932-A, Long Beach, California 90803.

HIGH FIDELITY

TAPE RECORDERS. Hi-Fi. components. Sleep Learning Equipment. tapes. Unusual Values. Free Catalog. Dressner, 1523R, Jericho Turnpike, New Hyde Park. N.Y. 11040.

DIAMOND NEEDLES AND STEREO CARTRIDGES at low, low prices for Shure, Pickering, Stanton, Empire, Grado and ADC. Send for free catalog and price sheet. We will be happy to quote on any cartridge—Magnetic, Ceramic or Crystal. All merchandise brand new. **LYLE CARTRIDGES**, Dept. P, 365 Dahill Road, Brooklyn, N.Y. 11218.

LOW, Low quotes: all components and recorders, HiFi, Roslyn, Penna. 19001.

FREE Kit Catalog. Amplifiers: Lil Tiger \$11.10, Universal Tiger \$30.00. Preamp \$44.50 (Featured in Popular Electronics) SCA Adaptors \$14.55. SWTPC, Box A32040, San Antonio, Tex. 78216.

WANTED

CASH PAID! Unused tubes, electronic equipment. Barry, 512 Broadway, NYC 10012.

QUICKSILVER, Platinum, Silver, Gold, Ores Analyzed. Free Circular. Mercury Terminal, Norwood, Mass. 02062.

WANTED: Radiotelephone study guides—set: \$25.00. Mintz, 1915 Maple, Evanston, Illinois 60201.

TUBES

TUBES "Oldies", latest. Lists free. Steinmetz, 7519 Maplewood, Hammond, Indiana 46324.

RECEIVING & INDUSTRIAL TUBES, TRANSISTORS. All Brands—Biggest Discounts. Technicians, Hobbyists, Experimenters—Request **FREE Giant Catalog and SAVE! ZALYTRON**, 469 Jericho Turnpike, Mineola, N.Y. 11501.

THOUSANDS and thousands of types of electronic parts, tubes, transistors, instruments, etc. Send for Free Catalog. Arcturus Electronics Corp., MPE, 502-22nd St., Union City, N.J. 07087.

RADIO & T.V. Tubes—36¢ each. Send for free catalog. Cornell, 4213 University, San Diego, Calif. 92105.

TUBE Headquarters of World! Send 10¢ for Catalog (tubes, electronic equipment) Barry, 512 Broadway, N.Y.C. 10012.

TUBES—Lowest prices. Foreign-American. Obsolete, receiving, special purpose, transmitting tubes. Send for tube, parts catalog. United Radio Company, 56-P Ferry St., Newark, N.J. 07105.

TAPE AND RECORDERS

OLD radio programs on tape. 6 hours for \$8.00. Catalog 50¢. Don Maris. 1926 Cherokee. Norman, Okla. 73069.

STEREO TAPE RENTAL for particular people. Free catalog. Gold Coast Tape Library, Box 2262, Palm Village Station, Hialeah, Fla. 33012.

RENT 4-Track open reel tapes—all major labels—3,000 different—free brochure. Stereo-Parti, 55 St. James Drive, Santa Rosa, Ca. 95401.

BARGAIN MUSIC, Tape, Equipment Catalog, 25¢. Saxitone, 1776 Columbia Road, Washington, D.C. 20005.

PERSONALS

MAKE FRIENDS WORLDWIDE through international correspondence. Illustrated brochure free. Hermes, Berlin 11, Germany.

INVESTIGATORS, LATEST ELECTRONIC AIDS. FREE LITERATURE. CLIFTON, 11500-K NW 7th AVE., MIAMI, FLORIDA 33168.

INSTRUCTION

LEARN ELECTRONIC ORGAN SERVICING at home all makes including transistor. Experimental kit—trouble-shooting. Accredited NHSC. Free Booklet. **NILES BRYANT SCHOOL**, 3631 Stockton, Dept. A, Sacramento, Calif. 95820.

LEARN WHILE ASLEEP, Hypnotize! Strange catalog free. Auto-suggestion, Box 24-ZD, Olympia, Washington 98501.

DEGREE in Electronics Engineering earned mostly by correspondence. Free brochure. Dept. G-9, Grantham School of Engineering, 1505 N. Western Ave., Hollywood, California 90027.

WANT AN F.C.C. 1st CLASS LICENSE? WANT TO BECOME A DISC-JOCKEY? REI has a school near you VA approved. Call toll free: 1-800-237-2251 or write REI, 1336 Main St., Sarasota, Florida 33577, Florida Residents call: 813-955-6922.

CLASSIFIED ADVERTISING ORDER FORM

Please refer to heading on first page of this section for complete data concerning terms, frequency discounts, closing dates, etc.

| | | | | |
|----|----|----|----|----|
| 1 | 2 | 3 | 4 | 5 |
| 6 | 7 | 8 | 9 | 10 |
| 11 | 12 | 13 | 14 | 15 |
| 16 | 17 | 18 | 19 | 20 |
| 21 | 22 | 23 | 24 | 25 |
| 26 | 27 | 28 | 29 | 30 |
| 31 | 32 | 33 | 34 | 35 |

_____ Words { @ 80¢ (Reader Rate) } = \$ _____
 { @ \$1.25 (Commercial Rate) }
 Insert _____ time(s) Total Enclosed \$ _____

NAME _____

ADDRESS _____

CITY _____ STATE _____ ZIP _____

Signature _____

WORD COUNT: Include name and address. Name of city (Des Moines) or of state (New York) counts as one word each. Zip Code numbers not counted. (Publisher reserves right to omit Zip Code if space does not permit.) Count each abbreviation, initial, single figure or group of figures or letters as a word. Symbols such as 35mm, COD, PO, AC, etc., count as one word. Hyphenated words count as two words.

PE471

HIGHLY effective home study courses in Electronics Engineering Technology and Electronics Engineering Mathematics. Earn your Degree. Write for Free Descriptive Literature. Cook's Institute of Electronics Engineering, (Dept. 15), P.O. Box 10634, Jackson, Miss. 39209. (Established 1945)

FREE brochure self-improvement books. Eldon McBrayer, 412 Arthur Street, Huntsville, Ala. 35805.

MEMORIZE, STUDY: "1971 TESTS-ANSWERS" FOR FCC FIRST AND SECOND CLASS LICENSE—plus—"Self-Study Ability Test." Proven! \$9.95. Satisfaction guaranteed. Command, Box 26348-P, San Francisco 94126.

FCC LICENSE through tape recorded lessons. Radio License Training, 1060D Duncan, Manhattan Beach, Calif. 90266.

Be your own music teacher

Learn guitar, piano, etc.,
this low-cost way



Teach yourself at home in spare time with our lessons-by-mail. Cost is just pennies a day. Learn to read notes, play sheet music. Over 1,300,000 students since 1898. For free booklet, mail this ad with your name, address & zip to U.S. School of Music, Studio A-3734, Port Washington, N.Y. 11050.

HARD TO LEARN THE CODE? Thousands of our customers don't think so. The CODEMASTER system has taught code to people all over the world. Two-hour beginner's tape or cassette (specify) brings you to at least 7 WPM. \$6.95 postpaid USA. More advanced tapes available. Satisfaction guaranteed. Pickering Radio Company, Professional Plaza, Portsmouth, RI 02871.

INVENTIONS WANTED

INVENTIONS wanted. Patented; unpatented. Global Marketing Service, 2420-P 77th, Oakland, Calif. 94605.

PATENT Searches including Maximum speed, full airmail report and closest patent copies, \$6.00. Quality searches expertly administered. Complete secrecy guaranteed. Free Invention Protection forms and "Patent Information." Write Dept. 9, Washington Patent Office Search Bureau, 711 14th Street, N.W., Washington, D.C. 20005.

INVENTORS! Don't sell your invention, patented or unpatented, until you receive our offer. Eagle Development Company, Dept. 9, 79 Wall Street, N.Y., N.Y. 10005.

FREE "Directory of 500 Corporations Seeking New Products." For information regarding development, sale, licensing of your patented/unpatented invention. Write: Raymond Lee Organization, 230-GR Park Avenue, New York City 10017.

PATENT SEARCHES, including copies of related United States Patents. Inventors, attorneys, manufacturers use our "World-Wide" Airmail service Free: "Invention Record" form and "Information Every Inventor Needs", Hayward Company, 1029HR Vermont, Washington, D.C. 20005.

INVENTORS: Protect your ideas! Free "Recommended Procedure". Washington Inventors Service, 422T Washington Building, Washington, D.C. 20005.

FREE PAMPHLET: "Tips on Safeguarding Your Invention." Write: United States Inventors Service Company, 501-H Thirteenth Street N.W., Washington, D.C. 20004.

GOVERNMENT SURPLUS

JEeps Typically From \$53.90 . . . Trucks From \$78.40 . . . Boats, Typewriters, Airplanes, Multimeters, Oscilloscopes, Transceivers, Electronics Equipment. Wide Variety, Condition. 100,000 Bid Bargains Direct From Government Nationwide Complete Sales Directory and Surplus Catalog \$1.00. (Deductible First \$10.00 Order). Surplus Service, Box 820-J, Holland, Michigan 49423.

GOVERNMENT Surplus. How and Where to Buy in Your Area. Send \$1.00. Surplus Information, Headquarters Bldg.-PE, Washington, DC 20036.

GOVERNMENT Surplus. Complete Sales Directory And Buying Guide \$1.00. Surplus Publications, Box 26062-F, Los Angeles, Calif. 90026.

REPAIRS AND SERVICES

TV Tuners rebuilt and aligned per manufacturers specification. Only \$9.50. Any make UHF or VHF Ninety day written guarantee. Ship complete with tubes or write for free mailing kit and dealer brochure. JW Electronics, Box 51C, Bloomington, Indiana 47401.

MIDWEST'S only AR/DYNA independent repair station. We serve over 20 states from Oregon to Tennessee with a factory-trained staff and the largest parts stock in the Midwest. Write: HAYNES MICROELECTRONICS, P.O. Box 457, Lawrence, Kansas 66044.

BOOKS

FREE catalog aviation/electronic/space books. Aero Publishers, 329PE Aviation Road, Fallbrook, California 92028.

FREE book prophet Elijah coming before Christ. Wonderful bible evidence. Megiddo Mission, Dept. 64, 481 Thurston Rd., Rochester, N.Y. 14619.

MAGAZINES

JAPAN PUBLICATIONS GUIDE Business, pleasure, education. \$5.00. INTERCONTINENTAL, CPO 1717, Tokyo 100-91.

OVER 2,000,000 backdate magazines! Specify needs. Midtown, Box 917-PE, Maywood, New Jersey 07607.

HYPNOTISM

"MALE-FEMALE HYPNOTISM" EXPOSED, EXPLAINED! "SECRET METHOD"—THEY NEVER KNOW! \$2, RUSHED. GUARANTEED! ISABELLA HALL, SILVER SPRINGS, FLORIDA 32688.

SLEEP Learning. Hypnotic method. 92% effective. Details free. ASR Foundation, Box 7021PE HC Station, Lexington, Ky. 40502.

HYPNOTIZE ELECTRONICALLY . . . or money-back! Television repairman's accidental discovery. Uses television set. \$2. Elton's, Box 12167-PE, St. Petersburg, Florida 33733.

PHOTOGRAPHY—FILM, EQUIPMENT, SERVICES

SCIENCE Bargains Request Free Giant Catalog "CJ"—148 pages—Astronomical Telescopes, Microscopes, Lenses, Binoculars, Kits, Parts. War surplus bargains. Edmund Scientific Co., 300 Edscorp Bldg., Barrington, New Jersey 08007.

RECORDS

POPULAR organ albums factory direct. Concert Recording, Lynwood, Calif. 90262.

SPECIAL interest records available, produced by the editors of the world's leading special interest magazines. Send for free catalog. Record Catalog-PE, Ziff-Davis Publishing Company, One Park Avenue, New York, N.Y. 10016.

PRINTING

SOMETHING different, 1,000 personalized name address labels with zipcode, imprinted CB/HAM call letters, or phone number, \$1.00. Bargain catalog FREE. D. Electronics, 4725 45th NE, Seattle, Wash. 98105.

SAVE TIME! 1000 Gummed Address labels with dispenser—\$1.00. Rubber stamp with pad 3 lines—\$1.50. Worldwide, Box 339, Hicksville, New York 11802.

EMPLOYMENT INFORMATION

FOREIGN and **USA** job opportunities available now. Construction, all trades. Earnings to \$3,000.00 monthly. Paid overtime, travel bonuses. Write: Universal Employment, Woodbridge, Conn. 06525.

JOBS ON SHIPS! Good Pay! Europe, Asia, Worldwide! Who to see and Where—\$1.00. Seaways, PE, Box 121, Ellicott City, Maryland 21043.

BUSINESS OPPORTUNITIES

I MADE \$40,000.00 Year by Mailorder! Helped others make money! Start with \$10.00—Free Proof. Torrey, Box 318-N, Ypsilanti, Michigan 48197.

FREE BOOK '999 Successful Little Known Businesses' Work home, Plymouth 445-A, Brooklyn, N.Y. 11216.

\$200.00 DAILY In Your Mailbox! Your opportunity to do what mail-order experts do. Free details. Associates, Box 136-J, Holland, Michigan 49423.

MAKE BIG MONEY raising chinchillas, rabbits, guinea pigs for us. Catalog—25¢. Keeney Brothers, New Freedom, Pa. 17349.

HOW to make \$1,000,000 in only ten years! Start with \$10! Details Free! International Service, (PE), Box 11796, Atlanta, Georgia. 30305.

FREE CATALOGS. Repair air conditioning, refrigeration. Tools, supplies, full instructions. Doolin, 2016 Canton, Dallas, Texas 75201.

SELL! Home-Auto, Fire-Burglar Alarms, Extinguishers. Watchdog Alarms, Williamsburg, Ohio 45176.

MAILORDER! Make big money working home. Free report reveals millionaire's trade secrets! Executive (1K4), 333 North Michigan, Chicago 60601.

PIANO TUNING learned quickly at home. Tremendous field! Musical knowledge unnecessary. GI Approved. Information Free. Empire School, Box 327, Miami, Florida 33145.

SELL New Service to wealthy. Info \$3. PSI, P.O. Box 126. Montgomery, Illinois 60538.

MAILORDER. Home Business. Wonderful Method guarantees success. Valuable lists, concrete information, detailed steps. Free Details, Pictures. Prudential, Box 327-PE1, Boston 02199.

BIG EARNINGS selling Hertel Bibles. New 3-dimension cover, finest reference edition sells fast. Demonstrator furnished. Big commissions. International Book, Dept. PE, Box 118, Wichita, Kansas 67201.

I MADE \$2,000.00 Monthly by Mailorder—Evenings only. You can too! Free Proof! Kingman, Box 723ZB, Montclair, New Jersey 07042.

SHORTWAVE LISTENING

SPY, Clandestine, Spacecraft Frequencies—Schedules \$1.00: Monitor, P. O. B. 673, Warner Robins, GA 31093.

TREASURE FINDERS

FREE TREASURE GUIDE! Fact-filled collectors edition; send 50¢ for postage. Also request free literature on ultrasensitive, professional Fisher Detectors. FISHER RESEARCH, Dept. PE-4, Palo Alto, California 94303.

GOLD, Silver, Relics! Located with powerful Detectron Metal Detectors. Free Information, Terms, Detectron, Dept. PE4, Box 243, San Gabriel, California 91778.

TREASURE FINDER locates buried gold, silver, coins, treasures. 5 powerful models. \$19.95 up. Free catalog. Relco-A33, Box 10839, Houston, Texas 77018.

FREE: Jetco Electronics Free 24 page Treasure Finder catalog. Find metals, minerals, gold, silver, coins and relics, Jetco, Box 132 PE, Huntsville, Texas 77340.

MUSICAL INSTRUMENTS

30% **DISCOUNT** name brand musical instruments. Free catalog. Freeport Music, 127-N Sunrise Highway, Freeport, N.Y. 11520.

RUBBER STAMPS

RUBBER ADDRESS STAMPS \$2.00. **SIGNATURE** \$3.50. **FREE CATALOG.** JACKSON'S, BOX 443-G, FRANKLIN PARK, ILLINOIS 60131.

YOUR Call Included! (Pocket.) \$3.00. Brown's, 321 Price, Philadelphia, PA 19144.

REAL ESTATE

FREE . . . BIG 1971 CATALOG! Describes and pictures hundreds of farms, ranches, town and country homes, businesses coast to coast! Specify type property and location preferred. Zip Code, please. **UNITED FARM AGENCY,** 612-EP West 47th St., Kansas City, Mo. 64112.

AUTHORS' SERVICES

PUBLISH your book! Join our successful authors: publicity, advertising, promotion, beautiful books. All subjects invited. Send for free appraisal and detailed booklet. Carlton Press, Dept. ZDP, 84 Fifth Avenue, New York 10011.

MISCELLANEOUS

WINEMAKERS: Free illustrated catalog of yeasts, equipment. Semplex, Box 12276, Minneapolis, Minn. 55412.

STOP BURGLARS THE EASY WAY! Affix authentic "Protected by Electronic Sentry Alarm" decals to auto windows, doors and windows of home, retail stores, vending machines, etc. Whether you have an alarm or not—thieves stay away! Only \$1.00 for each set of two. J. Ross, 80-34 Kent St., Jamaica, N.Y. 11432, Dept. PE.

LIGHT bulbs, thousands sizes, specify—Jetronics, Box 67015ZD, Century City, Calif. 90067.

CLASSIFIED ADVERTISING IN POPULAR ELECTRONICS—Your best bet for outstanding mail order sales! These pages are read thoroughly by electronic hobbyists seeking products and services found only in the **ELECTRONICS MARKET PLACE.** **POPULAR ELECTRONICS** readers respond readily—they rely on the advertisers appearing in the pages of their favorite magazine. Your low cost ad here will result in increased sales responses for you! Send copy and payment to: Hal Cymes, Classified Advertising Manager, **POPULAR ELECTRONICS,** 1 Park Avenue, New York, N. Y. 10016.

DISPLAY CLASSIFIED ADVERTISING NOW!

available in
POPULAR ELECTRONICS

For advertisers who want to achieve maximum exposure at minimum expense, this is the opportunity of a lifetime for you!

The special low rates are:

1" by 1 column (2 $\frac{5}{8}$ " wide)....\$110.00
2" by 1 column (2 $\frac{5}{8}$ " wide)....\$215.00
3" by 1 column (2 $\frac{5}{8}$ " wide)....\$320.00

(Ads larger than 3 column inches not accepted for the **ELECTRONICS MARKET PLACE**—Please ask for regular advertising rates.)

Of course, regular non-display Classified Ads continue at \$1.25 per word (minimum \$12.50).

For immediate action in getting your Display (or non-Display) Classifieds into the very next available issue, call or write:

Hal Cymes, Classified Advertising Manager
POPULAR ELECTRONICS
One Park Avenue, New York, N. Y. 10016
(212) 679-7200

POPULAR ELECTRONICS

APRIL 1971

ADVERTISERS INDEX

| READER SERVICE NO. | ADVERTISER | PAGE NO. |
|--------------------|---|----------------|
| 1 | Avanti Research & Development Co. | 89 |
| 2 | BSR | 8 |
| | CREI, Home Study Div., McGraw-Hill Book Co. | 36, 37, 38 |
| 5 | Chemtronics | 6 |
| 6 | Cleveland Institute of Electronics | 18, 19, 20, 21 |
| 7 | Cook's Institute of Electronics Engineering | 99 |
| 8 | Crystek | 97 |
| 9 | Drake Company, R.L. | 96 |
| 10 | Communications Div., DYNASCAN CORP. | 91 |
| 11 | EICO Electronic Instrument Co., Inc. | 92 |
| 12 | Edmund Scientific Co. | 105 |
| 4 | Electro-Voice, Inc. | FOURTH COVER |
| 13 | Empire Scientific Co. | 89 |
| 14 | Grantham School of Engineering | 5 |
| 15 | Heath Company | 12, 13 |
| 16 | KLH Research & Development Corp. | 17 |
| 17 | Lafayette Radio Electronics | 97 |
| 18 | Logiconcepts | 9 |
| 19 | McGee Radio National Radio Institute | 92 |
| | SECOND COVER, 1, 2, 3 | |
| | National Technical Schools | 72, 73, 74, 75 |
| 20 | Olson Electronics | 99 |
| 21 | Progressive "Edu-Kits" | 106 |
| 22 | RCA Electronic Components & Devices | 24 |
| | RCA Institutes, Inc. | 54, 55, 56, 57 |
| 23 | Regency Electronics, Inc. | 14 |
| 3 | Sams, Howard W. & Co., Inc. | THIRD COVER |
| 24 | TDK Electronics Corp. | 16 |
| 25 | Turner Co., The | 10 |
| 26 | Ungar, Div. of Eldon Industries | 11 |
| 27 | Utah Electronics | 93 |
| 28 | Xcelite, Inc. | 94 |
| | CLASSIFIED ADVERTISING, 100, 101, 102, 103, 104 | |

1000'S OF UNUSUAL SCIENTIFIC BARGAINS including... SPECIAL UNIQUE PSYCHEDELIC LIGHTING for Fun, Profit, & Effects.

SPECIAL VISUAL EFFECTS PROJECTOR SET

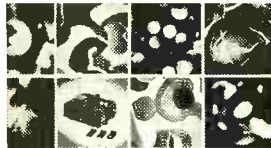

Dazzling, avant-garde visual effects. Fantastic variety. Incredibly beautiful. Special package offer contains all necessary apparatus. Create floating, exploding, fiery bursts of color like "Symphony of Spheres", "Chromatic Starbursts", "Crystal Starbursts". Features 35mmmm 500 W. fan cooled projector—produces big image at short distance. Accepts two 8" diam. wheels (Dry Kaleidoscope & Hexidoscope), 2 cylindrical accessories w/ Colored Cloud & 5" Hexidoscope w/ six photographic mirrors. Perfect for entertaining parties. \$79.50 Ppd. Stock No. 71.212AV Deluxe Model \$99.50 Ppd.

3-CHANNEL COLOR ORGAN BARGAIN!

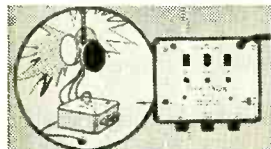

Create tremendous variety of unusual & beautiful lighting effects with this low-cost top-quality 1500-Watt unit (500 W. per channel). Compare with others selling for twice the price. Has pilot light, plus individual sensitivity controls and channel individual lights. Can operate ten 150 W. "spots" or 200 Christmas lights. Uses reg. house current—attaches to standard source w/ RCA-type phone plug, 5/4" x 8 1/4" x 2 1/2". 2 1/2 lbs. Thermal protection. Complete instructions. \$44.50 Ppd. Stock No. 71.223AV

setting plastic case, 6-ft. cord. Including complete instructions. \$44.50 Ppd. Stock No. 71.223AV

1st LOW-COST XENON STROBE!

Price breakthrough in bright, reliable electronic strobes. 50W/Second xenon tube. Variable flash rate—60 to 600 per minute. Long life—more than 1,000,000 flashes. Printed circuit board design. Safe, durable Bakelite case. Externally mounted bulb, plastic shield, 6 1/2" x 8 1/2" x 1 1/2" oz. Perfect for psychedelic, stop-action lighting effects for home light shows, parties, displays. #71.342AV \$24.95 Ppd. #71.343AV



BUILD-IT-YOURSELF STROBE KIT #71.343AV \$19.95 Ppd.

BLACK-LIGHT MIGHTY MITES

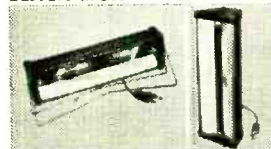

Relatively small (12") fixtures give surprisingly bright black-light. Mirror-finished reflector makes instant starting. Small, high-intensity bulb look like 40-watt. Up to 5,000 hours of safe, long-wave (3600Å) black-light to really turn on parties, light & theatrical shows, psychedelic decors, holiday decorations. Shockproof end-caps remove for safe, easy replacement of bulb and starter. Stands upright or horizontal. Aluminum case.

Stock No. 71.274AV \$14.95 Ppd. DELUXE OUTDOOR/INDOOR MODEL #71.299AV \$19.95 Ppd.

PSYCHEDELIC LIGHTING HANDBOOK



100 information packed pages! Fully explains latest in psychedelic lighting equipment, techniques, developments. Covers all facets of psychedelic light-show production including: strobes, black lights, projectors, crystals, organic slides, mirrors, color organs, polarized color, light beams, HueVibe, etc. Shows how to "psychedelize" parties, musical groups, shows or how to set an "electronic trips" for private gatherings. 8 1/2" x 11" looseleaf paper for 8 rings.

Stock No. 9100AV \$3.00 Ppd.

LONG-WAVE BLACKLIGHT FIXTURE



Extremely versatile, compactly designed, long wave (3200-4000 angstroms) black light (ultraviolet) fixture. Has 6-watt, 110-v lamp with built-in filter—eliminates harmful shorter wave ultraviolet rays. Use to identify minerals, fungi, bacteria—check for surface flaws, oil and gasket leakage—perfect for displays with fluorescent paper, paints, chalk, crayons, trace powder, incl. adjustable aluminum reflector. Mount vert., horiz., or on corner. 10" L., 1 1/2" W., 1 1/4" H.

Stock No. 70.364AV \$12.50 Ppd. Stock No. 60.12AV REPLACEMENT BULB \$7.75 Ppd.

Order by Stock No.—Check or M.O.—Money-Back Guarantee
EDMUND SCIENTIFIC CO., 300 EDSCORP BLDG., BARRINGTON, N.J. 08007

WRITE FOR GIANT FREE CATALOG "AV"



Completely new edition. New items, categories, illustrations. 148 easy-to-read pages packed with 4000 unusual items. Dozens of electrical and electromechanical parts, accessories. Enormous selection of Astronomical Telescopes, Microscopes, Binoculars, Magnifiers, Magnets, Lenses, Lasers, Prisms. Many war surplus items! For hobbyists, experimenters, workshops, factory. Write for catalog "AV."

EDMUND SCIENTIFIC CO. 300 EDSCORP BLDG., BARRINGTON, NEW JERSEY 08007
ORDER BY STOCK NUMBER • SEND CHECK OR MONEY ORDER • MONEY-BACK GUARANTEE

CIRCLE NO. 12 ON READER SERVICE PAGE

BIG RADIO

and Electronics Circuits

PROGRESSIVE HOME RADIO-TV COURSE

Now Includes

- ★ 12 RECEIVERS
- ★ 3 TRANSMITTERS
- ★ SQ. WAVE GENERATOR
- ★ SIGNAL TRACER
- ★ AMPLIFIER
- ★ SIGNAL INJECTOR
- ★ CODE OSCILLATOR

- ★ No Knowledge of Radio Necessary
- ★ No Additional Parts or Tools Needed
- ★ EXCELLENT BACKGROUND FOR TV
- ★ SCHOOL INQUIRIES INVITED
- ★ Sold in 79 Countries



Reg. U.S. Pat. Off.

Training Electronics Technicians Since 1946

YOU DON'T HAVE TO SPEND HUNDREDS OF DOLLARS FOR A RADIO COURSE

The "Edu-Kit" offers you an outstanding PRACTICAL HOME RADIO COURSE at a rock-bottom price. Our Kit is designed to train Radio & Electronics Technicians, making use of the most modern methods of home training. You will learn radio theory, construction practice and servicing. THIS IS A COMPLETE RADIO COURSE IN EVERY DETAIL. You will learn how to build radios, using regular schematics; how to wire and solder in a professional manner; how to service radios. You will work the standard type of punched metal chassis as well as the latest development of Printed Circuit chassis. You will learn the basic principles of radio. You will construct, study and work with RF and AF amplifiers and oscillators, detectors, rectifiers, test equipment. You will learn and practice code, using the Progressive Code Oscillator. You will learn and practice trouble-shooting, using the Progressive Signal Tracer, Progressive Signal Injector, Progressive Dynamic Radio & Electronics Tester, Square Wave Generator and the accompanying instruction manual.

You will receive training for the Novice, Technician and General Classes of F.C.C. Radio Amateur Licenses. You will build Receiver, Transmitter, Square Wave Generator, Code Oscillator, Signal Tracer and Signal Injector circuits, and learn how to operate them. You will receive an excellent background for television, Hi-Fi and Electronics. Absolutely no previous knowledge of radio or science is required. The "Edu-Kit" is the product of years of teaching and engineering experience. The "Edu-Kit" will provide you with a basic education in Electronics and Radio, worth many times the low price you pay. The Signal Tracer alone is worth more than the price of the kit.

THE KIT FOR EVERYONE

You do not need the slightest background in radio or science. Whether you are interested in Radio & Electronics because you want an interesting hobby, a well paying business or a job with a future, you will find the "Edu-Kit" a worth-while investment. Many thousands of individuals of all ages and backgrounds have successfully used the "Edu-Kit" in more than 79 countries of the world. The "Edu-Kit" has been carefully designed, step by step, so that you cannot make a mistake. The "Edu-Kit" allows you to teach yourself at your own rate. No instructor is necessary.

PROGRESSIVE TEACHING METHOD

The Progressive Radio "Edu-Kit" is the foremost educational radio kit in the world, and is universally accepted as the standard in the field of electronics training. The "Edu-Kit" uses the modern educational principle of "Learn by Doing." Therefore you construct, learn schematics, study theory, practice trouble shooting—all in a closely integrated program designed to provide an easily-learned, thorough and interesting background in radio. You begin by examining the various radio parts of the "Edu-Kit." You then learn the function, theory and wiring of these parts. Then you build a simple radio. With this first set you will enjoy listening to regular broadcast stations, learn theory, practice testing and trouble-shooting. Then you build a more advanced radio, learn more advanced theory and techniques. Gradually, in a progressive manner, and at your own rate, you will find yourself constructing more advanced multi-tube radio circuits, and doing work like a professional Radio Technician.

Included in the "Edu-Kit" course are Receiver, Transmitter, Code Oscillator, Signal Tracer, Square Wave Generator and Signal Injector Circuits. These are not unprofessional "breadboard" experiments, but genuine radio circuits, constructed by means of professional wiring and soldering on metal chassis, plus the new method of radio construction known as "Printed Circuitry." These circuits operate on your regular AC or DC house current.

THE "EDU-KIT" IS COMPLETE

You will receive all parts and instructions necessary to build twenty different radio and electronics circuits, each guaranteed to operate. Our Kits contain tubes, tube sockets, variable, electrolytic, micro ceramic and paper dielectric condensers, resistors, tie strips, hardware, tubing, punched metal chassis, Instruction Manuals, hook-up wire, solder, selenium rectifiers, coils, volume controls and switches, etc.

In addition, you receive Printed Circuit materials, including Printed Circuit chassis, special tube sockets, hardware and instructions. You also receive a useful set of tools, a professional signal soldering iron, and a self-powered Dynamic Radio and Electronics Tester. The "Edu-Kit" also includes Code Instructions and the Progressive Code Oscillator, in addition to F.C.C. Radio Amateur License training. You will also receive lessons for servicing with the Progressive Signal Tracer and the Signal Injector, a High Fidelity Guide and a Quiz Book. You receive Membership in Radio-TV Club. Free Consultation Service. Certificate of Merit and Discount Privileges. You receive all parts, tools, Instructions, etc. Everything is yours to keep. Write to Progressive "Edu-Kits" Inc., 1189 Broadway, Dept. 696D, Hewlett, N. Y. 11557.

UNCONDITIONAL MONEY-BACK GUARANTEE

Please rush my Progressive Radio "Edu-Kit" to me, as indicated below:

- Check one box to indicate choice of model
- Deluxe Model \$31.95.
 - New Expanded Model \$34.95 (Same as Deluxe Model plus Television Servicing Course).

- Check one box to indicate manner of payment
- I enclose full payment. Ship "Edu-Kit" post paid.
 - I enclose \$5 deposit. Ship "Edu-Kit" C.O.D. for balance plus postage.
 - Send me FREE additional information describing "Edu-Kit."

Name
Address

PROGRESSIVE "EDU-KITS" INC.
1189 Broadway, Dept. 696D, Hewlett, N. Y. 11557

FREE EXTRAS

SET OF TOOLS

- SOLDERING IRON
- ELECTRONICS TESTER
- PLIERS-CUTTERS
- VALUABLE DISCOUNT CARD
- CERTIFICATE OF MERIT
- TESTER INSTRUCTIONS MANUAL
- HIGH FIDELITY GUIDE & QUIZZES
- TELEVISION BOOK & RADIO TROUBLE-SHOOTING BOOK
- MEMBERSHIP IN RADIO-TV CLUB: CONSULTATION SERVICE & FCC AMATEUR LICENSE TRAINING
- PRINTED CIRCUITRY

SERVICING LESSONS

You will learn trouble-shooting and servicing in a progressive manner. You will practice repairs on the sets that you construct. You will learn symptoms and causes of trouble in home, portable and car radios. You will learn how to use the professional Signal Tracer, the unique Signal Injector and the dynamic Radio & Electronics Tester. While you are learning in this practical way, you will be able to do many a repair job for your friends and neighbors, and charge fees which will far exceed the price of the "Edu-Kit." Our Consultation Service will help you with any technical problems you may have.

FROM OUR MAIL BAG

J. Stataitis, of 25 Poplar Pl., Waterbury, Conn., writes: "I have repaired several sets for my friends, and made money. The "Edu-Kit" paid for itself. I was ready to spend \$240 for a course, but I found you, and sent for your Kit."

Sen Valerio, P. O. Box 21, Magna, Utah: "The Edu-Kits are wonderful. Here I am sending you the questions and also the answers for them. I have been in Radio for the last seven years, but like to work with Radio Kits, and like to build Radio Testing Equipment. I enjoyed every minute I worked with the different kits; the Signal Tracer works fine. Also like to let you know that I feel proud of becoming a member of your Radio-TV Club."

Robert L. Shuff, 4534 Monroe Ave., Huntington, W. Va.: "Thought I would drop you a few lines to say that I received my Edu-Kit, and was really amazed that such a bargain can be had at such a low price. I have already started repairing radios and phonographs. My friends were really surprised to see me get into the swing of it so quickly. The trouble-shooting tests that come with the kit is really swell, and finds the trouble, if there is any to be found."

PRINTED CIRCUITRY

At no increase in price, the "Edu-Kit" now includes Printed Circuitry. You build a Printed Circuit Signal Injector, a unique servicing instrument that can detect many Radio and TV troubles. This revolutionary new technique of radio construction is now becoming popular in commercial radio and TV sets.

A Printed Circuit is a special insulated chassis on which has been deposited a conducting material which takes the place of wiring. The various parts are merely plugged in and soldered to terminals.

Printed Circuitry is the basis of modern Automation Electronics. Knowledge of this subject is a necessity today for anyone interested in Electronics.

CIRCLE NO. 21 ON READER SERVICE PAGE
Printed in U.S.A.

Important New SAMS Books



TV Servicing Made Easy, 2nd Ed.

by WAYNE LEMONS. Fully updated to cover the latest advances in TV circuitry, including the new transistor and integrated circuits; also provides new data on tube-type sets, both black-and-white and color. Includes an entire new chapter on unusual color TV-circuits. Through the use of basic equipment and simple test procedures, this book shows how in-circuit checking helps diagnose and solve troubles quickly in tube-type or transistor-type TV receivers, either monochrome or color. Order 20811, only \$5.25

ABC's of Short-Wave Listening, 3rd Ed.

by LEN BUCKWALTER. Completely updated to provide an introduction to the exciting world of short-wave listening, which includes international broadcasts, amateur voice and code operations, police and emergency transmissions, commercial aircraft and marine communications, and, now, signals from orbiting spacecraft. Describes the programs available; provides practical advice on receivers and antennas; explains how to get the most out of short-wave listening. Order 20797, only \$2.95

Tube Substitution Handbook, 14th Ed.

The most complete, up-to-date guide available to DIRECT tube substitutions. Lists more than 12,000 direct substitutions in the following categories: American receiving tubes; picture tubes; miniature types; industrial types; communications and special-purpose tubes; foreign tubes. Instructions accompanying each section tell how to make proper substitutions. Includes valuable cross-reference between sections showing additional substitutes. An indispensable reference for everyone in electronics. Order 20829 only \$1.75

99 Electronic Projects

by HERBERT FRIEDMAN. The projects presented in this book provide both enjoyment and personal satisfaction for any electronics hobbyist. All of the circuits employ solid-state components of the hobby type, which are readily available at modest cost. The projects included are intended for practical use in the following fields: audio; automotive; home protection; CB, ham, and swl; musical instrumentation; and more. Each project offers practical application and a rewarding building experience. Order 20818, only \$3.50

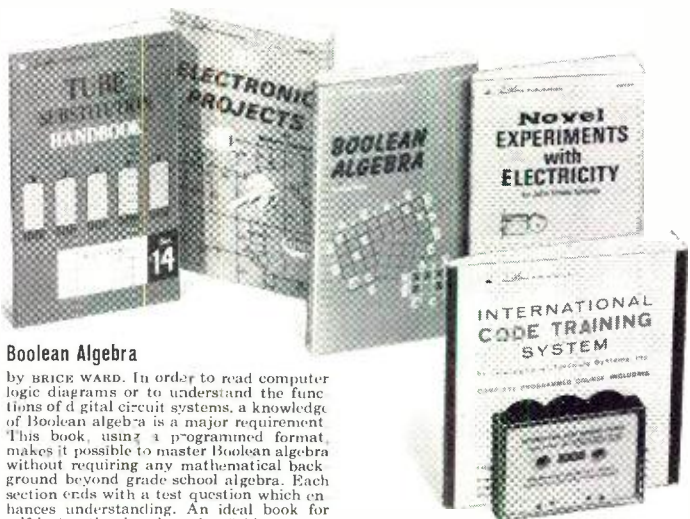

Boolean Algebra

by BRICE WARD. In order to read computer logic diagrams or to understand the functions of digital circuit systems, a knowledge of Boolean algebra is a major requirement. This book, using a programmed format, makes it possible to master Boolean algebra without requiring any mathematical background beyond grade school algebra. Each section ends with a test question which enhances understanding. An ideal book for self-instruction in a booming field. Order 20817, only \$5.50

Novel Experiments With Electricity

by JOHN POTTER SHIELDS. This book clearly explains the fundamentals of electricity and magnetism, and introduces the reader to their fascinating properties through a series of novel experiments. These range from a ground telephone and electric arc to a miniature lightning generator and synchronous motor. The applications range from entertainment to security. Each experiment is easy to perform; parts costs are minimal. This is truly a rewarding book for the experimenter. Order 20794, only \$3.50

International Code Training System

by INTERNATIONAL TEACHING SYSTEMS, INC. Unique text and records or tape teach code faster, and with greater speed and accuracy, than any other method known. Special programmed charts make it unnecessary to memorize code characters the old-fashioned way. Practical exercises help develop sending and receiving speed up to 22 wpm!

With three 33 $\frac{1}{3}$ rpm records. Order 20138, only \$7.50
With pre-recorded tape cassette. Order 20812, only \$10.95



Outboard Motor Service Manuals, 5th Ed.

Step-by-step repair and maintenance information for specific models in the most popular U. S. and foreign makes. Covers everything from tune-ups to complete overhauls. Each volume includes a special section on design fundamentals and operating principles. Profusely illustrated.

Vol. 1. Motors under 30 H. P. Order 20791, only \$5.95
Vol. 2. Motors over 30 H. P. Order 20792, only \$5.95
2-Volume Set. Order 20793, only \$10.50



Snowmobile Service Manual, 4th Ed.

Completely updated to include virtually all 1969 and a number of 1970 models, as well as older machines in operation today. Covers specific models in 34 popular makes. Provides detailed instructions for tune-ups, and for every phase of repair and maintenance. Includes comprehensive section on snowmobile engine design and operating principles. Order 20825, only \$5.95

HOWARD W. SAMS & CO., INC.

Order from your Electronic Parts Distributor, or mail to Howard W. Sams & Co., Inc., Dept. PE-041 4300 W. 62nd St., Indianapolis, Ind. 46268

Send books checked at right, \$_____ enclosed (please include sales tax where applicable).

Send FREE 1971 Sams Book Catalog

Name _____

Address _____

City _____ State _____ Zip _____

- | | |
|--------------------------------|--------------------------------|
| <input type="checkbox"/> 20811 | <input type="checkbox"/> 20138 |
| <input type="checkbox"/> 20797 | <input type="checkbox"/> 20812 |
| <input type="checkbox"/> 20829 | <input type="checkbox"/> 20791 |
| <input type="checkbox"/> 20818 | <input type="checkbox"/> 20792 |
| <input type="checkbox"/> 20817 | <input type="checkbox"/> 20793 |
| <input type="checkbox"/> 20794 | <input type="checkbox"/> 20825 |

Inside the
new E-V
Model 626
and 627A
we've put
one good
idea after
another.



Strong protective grille screen.

Acoustifoam® filter to stop "pops" and wind noise, bar dust and dirt.

Metal screen against magnetic particles.

Element locked positively in place. Helmholtz resonator extends high end.

Stainless steel side grilles.

Virtually indestructible Acoustalloy® diaphragm that shrugs off heat, humidity, mechanical shock.

Sophisticated dynamic cardioid Single-D element for smooth control of feedback plus added bass and extra-high level when working close.

It all
adds up.

To more bass, higher output, and better feedback control when working close, than any other Single-D microphones at any price.

Fawn beige Micomatte™ non-reflecting finish.

Shock absorbing internal "nesting" construction that soaks up abuse and noise.

High efficiency magnetic structure for full volume from any modern amp.

Integral rear cavity maintains "like new" bass response for years, eliminates tiny air leaks.

Reliable, easy to use On-Off switch.

Modern "black chrome" satin finish plating.

Threaded steel insert for long connector life.

Sturdy cable strain relief.



Model 626 \$49.00



Model 627A \$60.00

Nationally Advertised Price

ELECTRO-VOICE, INC., Dept. 412P, 630 Cecil Street, Buchanan, Michigan 49107

Electro-Voice
a GULTON subsidiary

CIRCLE NO. 4 ON READER SERVICE PAGE

www.americanradiohistory.com