

CABLE FM FOR BETTER STEREO FM

# Popular Electronics

FIFTY CENTS / JANUARY 1971

## Crystal- Controlled Time Base Generator

(see page 33)

DIGITAL CLOCK  
READS TO 6 FIGURES  
ELECTRICITY & PHYSIOLOGY  
NEW ELECTRONICALLY  
ACTIVATED LOCK  
ELECTRONIC  
CLINICAL THERMOMETER  
VOLTMETER FOR  
SOLID-STATE TESTING





# firsts

make learning  
**Electronics at home**  
**fast and fascinating—**  
**give you priceless**  
**confidence.**

Some NRI **firsts** in training equipment

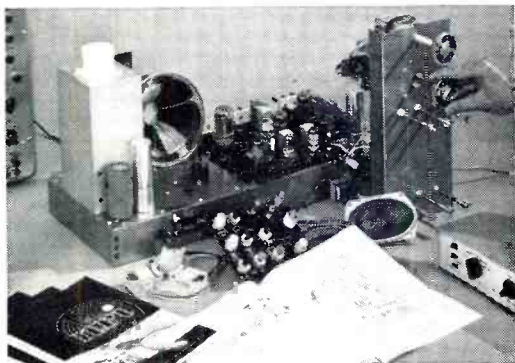

**first** to give you Color Television training equipment engineered specifically for education — built to fit NRI instructional material, *not* a do-it-yourself hobby kit. The end product is a superb Color TV receiver that will give you and your family years of pleasure. You “open up and explore” the functions of each color circuit as you build.

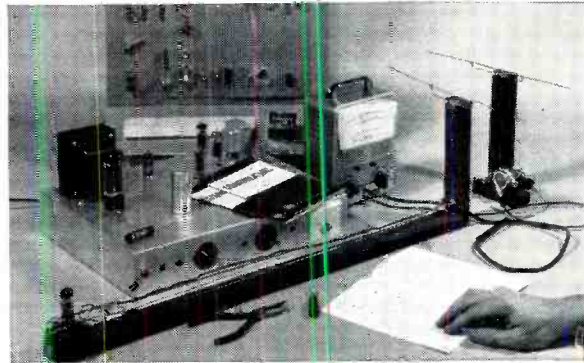

**first** to give you transmission lines and antenna systems that include experiments not otherwise attempted outside of college physics laboratories. The experience gained with this kind of Communications training equipment is matched only by months — sometimes years — of on-the-job experience.



## NRI's "discovery" method is the result of over half a century of leadership simplifying and dramatizing training at home

The FIRSTS described below are typical of NRI's half century of leadership in Electronics home training. When you enroll as an NRI student, you can be sure of gaining the in-demand technical knowledge and the priceless confidence of "hands-on" experience sought by employers in Communications, Television-Radio Servicing and Industrial and Military Electronics. Everything about NRI training is designed for your education . . . from the much-copied, educator-acclaimed Achievement Kit sent the day you enroll, to "bite-size" well-illustrated, easy to read texts programmed with designed-for-learning training equipment.

### YOU GET YOUR FCC LICENSE OR YOUR MONEY BACK

There is no end of opportunity for the trained man in Electronics. You can earn \$6 or more an hour in spare time, have a business of your own or qualify quickly for career positions in business, industry, government. And if you enroll for any of five NRI courses in Communications, NRI prepares you for your FCC License exams. *You must pass* or NRI refunds your tuition in full. No school offers a more liberal money-back agreement. The full story about NRI leadership in Electronics training is in the new NRI Catalog. Mail postage-free card today. No salesman is going to call.  
NATIONAL RADIO INSTITUTE, Washington, D.C. 20016

**APPROVED UNDER NEW GI BILL.** If you have served since January 31, 1955, or are in service, check GI line on postage-free card.

## designed from chassis up for your education



**first** to give you true-to-life experiences as a communications technician. Every fascinating step you take in NRI Communications training, including circuit analysis of your own 25-watt, phone/cw transmitter, is engineered to help you prove theory and later apply it on the job. Studio equipment operation and troubleshooting become a matter of easily remembered logic.



**first** to give you completely specialized training kits engineered for business, industrial and military Electronics. Shown above is your own training center in solid state motor control and analog computer servo-mechanisms. Telemetering circuits, solid-state multi-vibrators, and problem-solving digital computer circuits are also included in your course.

# Popular Electronics

WORLD'S LARGEST-SELLING ELECTRONICS MAGAZINE

## FEATURE ARTICLES

- ELECTRICITY & PHYSIOLOGY 27** Webb Garrison  
*New theories on electrons in your body*
- WHAT DO YOU KNOW ABOUT CAPACITORS? 32** Robert P. Balin
- BUILD A TIME BASE CALIBRATOR 33** Richard J. Valentine  
*Square wave generator of many uses*
- BUILD A CRYPTOLOCK 42** James G. Busse  
*Burglar-proof electronic security*
- MILLIVOLTMETER FOR FET CIRCUITS 45** Frank H. Tooker  
*Hos 100-megohm input*
- A BONUS FOR CATV SUBSCRIBERS: CABLE FM 60** Edward A. Lacy
- TIME-PERIOD MODULE 63** Daniel Meyer  
*For the Digital Measurements Lab*
- STEREO SCENE 68** J. Gordon Holt  
*Is it music or sound?*
- SIX-DIGIT POPULAR ELECTRONICS DIGI-VISTA 71** Charles G. Kay and Daniel Meyer  
*All-electronic clock*
- BUILD AN ELECTRONIC CLINICAL THERMOMETER 75** J. R. Laughlin  
*Fast, easy-to-read, and accurate*
- COMMUNICATIONS 79**  
*Reducing spark plug RFI*
- OPPORTUNITY AWARENESS 81** David L. Heiserman  
*Home study in medical electronics*
- SOLID STATE 83** Lou Garner  
*What to look for in 1971*
- THE PRODUCT GALLERY 86**  
*Heathkit GR-370 Color TV*

## DEPARTMENTS

- DIRECT & CURRENT 7** Oliver P. Ferrell
- INTERFACE 8**
- NEW LITERATURE 14**
- READER SERVICE PAGES 15, 95**
- ELECTRONICS LIBRARY 16**
- NEW PRODUCTS 22**

POPULAR ELECTRONICS is Indexed  
in the Readers' Guide  
to Periodical Literature

Copyright © 1970 by ZIFF-DAVIS PUBLISHING COMPANY. All rights reserved.

This month's cover photo by  
Conrad Studios

POPULAR ELECTRONICS, January 1971, Volume 34, Number 1. Published monthly at One Park Ave., New York, N.Y. 10016. One year subscription rate for U.S., U.S. Possessions and Canada, \$6.00; all other countries, \$7.00. Second class postage paid at New York, N.Y., and at additional mailing offices. Authorized as second class mail by the Post Office Department, Ottawa, Canada and for payment of postage in cash. Subscription service and forms 3479, P.O. Box 1096, Flushing, N.Y. 11352. Editorial offices for manuscript contributions, reader inquiries, etc.: One Park Ave., New York, N.Y. 10016.



# You can make sergeant in just 28 weeks.

The Army has a way to make it happen.

It's called the Non-Commissioned Officer Candidate Program and it's open to high school graduates.

First you receive the standard 16 weeks of basic and advanced individual training that every new soldier goes through.

Then, unlike other new soldiers, you're promoted to corporal, and you begin a 12-week academic and leadership course.

When you complete this program successfully, you'll be promoted to sergeant. Just 28 weeks after you started.

You will have learned how to lead men. To make decisions. To accept responsibility.

See an Army Recruiter about the NCO Candidate Program. Use the coupon or write to Army Opportunities, Department 200A, Hampton, Virginia 23369.

If you want to get ahead, we can make it happen.

Your future, your decision.  
Choose ARMY.



Army Opportunities Date \_\_\_\_\_  
Dept. 200, Hampton, Va. 23369

I want to get ahead fast. Tell me how I can become a sergeant in 28 weeks.

Name \_\_\_\_\_ Date of Birth \_\_\_\_\_

Address \_\_\_\_\_

City \_\_\_\_\_ County \_\_\_\_\_

State \_\_\_\_\_ Zip \_\_\_\_\_ Phone \_\_\_\_\_

Education \_\_\_\_\_

2PE 1-71

*They laughed when  
I started hooking up my own  
public address system.*



*But oh, when it started to play!*

"And ouch, when they heard how much money I saved installing it myself. With just pliers and screwdriver."

"University Sound supplied everything — all pre-matched and pre-engineered. Speakers, amplifier, cables, wires, microphone, turntable — all I did was hook 'em up. And it all worked perfectly the first time."

"It's called 'TCS'. Totally Coordinated Sound. University makes it available for thousands of applications, from churches to restaurants, office buildings to lumberyards."

Just walk in to your University dealer, tell him what you need it for, and walk out with the world's finest public address system.

Only University Sound — the world's largest manufacturer of public address equipment — could do it. They've got a system for every situation, including yours. If you need a public address system, or you know someone who does, write for our free booklet: "How to Install Your Own Public Address System with Pliers and Screwdriver".



**UNIVERSITY SOUND**

A quality company of LTV Ling Aitec Inc  
P O Box 26105 • Oklahoma City, Oklahoma 73126

**CIRCLE NO. 21 ON READER SERVICE PAGE**

# Popular Electronics

**LAWRENCE SPORN**

*Publisher*

**OLIVER P. FERRELL**

*Editor*

**LESLIE SOLOMON**

*Technical Editor*

**JOHN R. RIGGS**

*Managing Editor*

**EDWARD I. BUXBAUM**

*Art Director*

**ALEXANDER W. BURAWA**

*Associate Editor*

**ANDRE DUZANT**

*Technical Illustrator*

**PATTI MORGAN**

*Assistant Editor*

**JUDITH L. HOGAN**

*Editorial Assistant*

**J. GORDON HOLT**

*E. GARNER JR.*

**DAVID L. HEISERMAN**

*Contributing Editors*

**J. ROYCE RICHARD**

*Assistant Publisher*

**RICHARD J. HALPERN**

*Advertising Manager*

**ROBERT UR**

*Marketing Manager*

**MARGARET DANIELLO**

*Advertising Service Manager*

**FURMAN H. HEBB**

*Group Vice President*

*Electronics and Photography*

**ZIFF-DAVIS PUBLISHING COMPANY**

*Editorial and Executive Offices*

One Park Avenue, New York, New York 10016  
212 679-7200

*Midwestern Office*

The Patis Group, 4761 West Touhy Ave.,  
Lincolnwood, Illinois 60466 | 312 679-1100  
GERALD E. WOLFE, DICK POWELL

*Western Office*

9025 Wilshire Boulevard, Beverly Hills, California 90211  
213 CRestview 4-0265; BRadshaw 2-1161  
Western Advertising Manager, BUD DEAN

*Japan: James Yagi*

Ishikawa Mansion #4, Sakuragaoka  
Shibuya-ku, Tokyo, 462-2911-3

*Circulation Office*

P.O. Box 1096, Flushing, N.Y. 11352

William Ziff, President

W. Bradford Briggs, Executive Vice President

Hershel B. Sarbin, Senior Vice President

Stanley R. Greenfield, Senior Vice President

Philip Sine, Financial Vice President

Walter S. Mills, Jr., Vice President, Circulation

Phillip T. Heffernan, Vice President, Marketing

Frank Pomerantz, Vice President, Creative Services

Arthur W. Butzow, Vice President, Production

Edward D. Muhlfeld, Vice President, Aviation Division

Irwin Robinson, Vice President, Travel Division

George Morrissey, Vice President

Sydney H. Rogers, Vice President

Ziff-Davis also publishes Airline Management and Marketing including American Aviation, Boating, Business & Commercial Aviation, Car and Driver, Cycle, Electronics World, Flying, Modern Bride, Popular Photography, Skiing, Skiing Area News, Skiing Trade News, Stereo Review, and Travel Weekly.

Forms 3579 and all subscriptions correspondence should be addressed to POPULAR ELECTRONICS, Circulation Department, P.O. Box 1096, Flushing, N.Y. 11352. Please allow at least six weeks for change of address. Include your old address, as well as new-enclosing if possible an address label from a recent issue.

EDITORIAL CONTRIBUTIONS must be accompanied by return postage and will be handled with reasonable care; however, publisher assumes no responsibility for return or safety of art work, photographs or manuscripts.



Member Audit Bureau  
of Circulations



Fifth in a Monthly Series by Oliver P. Ferrell, Editor

## UNDER ANOTHER GUISE

To my amazement a number of long-time readers of this magazine have asked why I permitted a minor electronics hobby publication to steal my thunder about a "Communicator's License" (see "The CB Dilemma—A Solution," November 1964, p. 78). These faithful readers refer to a petition before the FCC known as RM-1633 that would set aside a major portion of the 220-225-MHz radio amateur band for use by electronics hobbyists and radio communicators. Dozens of other interested POPULAR ELECTRONICS readers (unaware of my 1964 statements) have asked for my opinion in regard to the proposals offered in RM-1633.

My opinions about C3 are well-known (see this page, October 1970 issue) and I feel that there is still a need for a portion of the radio spectrum to be allocated to private citizens for radio communications. I do not feel that it is in the best interest of those most concerned to have a magazine publisher/editor petition the FCC for another citizen's band. Such a petition is tainted and suspect since it has the appearance of commercialism riding roughshod over the public good.

Between 1964 and 1971, the Citizens Band became unmanageable and I see no reason to believe that expropriation of a radio amateur band by CB'ers would solve any problem other than channel congestion. It may be a stimulus to certain radio equipment manufacturers, but as RM-1633 reads, it is simply a method of diverting off the 27-MHz band the flood of illegal CB operators mentioned in my October editorial.

The FCC will give due consideration to RM-1633 and the matter may go before a public hearing. However, there can be no justification for Rule Making in favor of this petition. Too strong a case can be made against RM-1633 by every radio service—especially the hams who have the most to lose. In 1964, I thought otherwise, but a small group of CB manufacturers that pander "linears" and a vocal group of idiots with CB equipment (not even licensed CB'ers) have managed to cast a pall over an otherwise worthwhile radio system.

Although its timing is debatable, I cannot help but wonder if CB might not be salvageable if: (1) more channels were made available to CB'ers around 27 MHz; (2) the FCC undertook a massive enforcement campaign; and (3) a new Part 95 Rule were put into effect to "register" all CB transceivers.



# Suddenly we're a household word.



## New Cobra 25 CB Base Station

As if we weren't famous enough already. Now we're a household word.

Why? Because we've come up with everything you've been asking for in a CB radio designed for the home (or for that matter, any place a base station is used).

It's called the Cobra 25. You have to see it to believe it. Hear it and you'll be convinced.

Ultramodern new solid state circuit design gives you the biggest talk power in the industry—full 5 watts input, maximum legal output up to 4 watts.

And exclusive Dynaboost speech compression puts your message through crisp and sharp, even when others are garbled and unclear.

The word is spreading fast about the new big talking Cobra 25. Shouldn't you have one for your household or communications center?

See your dealer or write us for complete details.

Cobra 25 \$228.00



Product of  
**DYNASCAN  
CORPORATION**  
1801 W. Belle Plaine  
Chicago, Illinois 60613

The Biggest Voice in CB Radio

CIRCLE NO. 5 ON READER SERVICE PAGE

## INTERFACE

### ABOUT READER MAIL

I suggest that reader inquiries that must be answered be submitted with a nominal fee (possibly \$1.00). This would probably reduce the volume and keep inquiries on a meaningful basis—while defraying costs.

N.W. SCHAAF  
Livermore, CA

P.S. Consider this my bill for \$1.00 as it is being mailed in response to a publisher's inquiry.

I'll handle all answerable inquiries at \$1.00 a head—no fee if no answer.

L.J. CASSELMAN  
Stockton, CA

If the authors don't feel morally obligated to answer all letters addressed to them or do not have enough interest to do so, then I feel that their articles shouldn't be published.

A.G. BARRY  
Auburn, AL

Why not a volunteer reader inquiry column with names and addresses and areas of expertise. Let the readers write to these volunteers when they need help.

G. LA BELLE, WB6YZZ  
San Francisco, CA

Turn your mail over to book publishers if the query is covered in a book. Use rubber stamps that say, "NO FREE SUBSCRIPTIONS" and "EDITORIAL FORMAT CHANGE". Don't answer any mail with a typewritten letter—scrawl an answer in red ink at the bottom of the inquiry—most people would rather have a quick answer than none at all.

P. DWORSKY  
Scarsdale, NY

P.S. How about a free subscription?

Thanks to the dozens of readers who submitted suggestions in response to the "Direct & Current" editorial in the November issue. Several are being given consideration as potential solutions to an aggravating problem.

### CB—THE BAD, BEAUTIFUL AND UGLY

You are approaching the CB problem ("Direct & Current", October issue) as many

POPULAR ELECTRONICS

# Important New SAMS Books



## Color-TV Field-Service Guides

These invaluable guides have been compiled to enable the technician to service color-TV more efficiently in the customer's home. Charts provide chassis layouts showing type, function, and location of all tubes and/or transistors used in a particular chassis, ratings and locations of fuses and circuit breakers, location of service controls and adjustments, etc. Specific field-adjustment procedures are shown on page opposite chassis layout. Index provides instant reference to the proper chart for any particular TV chassis. Each volume contains 80 diagrams covering over 3,000 chassis.

Volume 1. Order 20796, only... \$4.95  
Volume 2. Order 20807, only... \$4.95

## Questions and Answers

### About Medical Electronics

by EDWARD J. BUKSTEIN Anyone familiar with basic electronic circuits will find this a fascinating and readily understandable book emphasizing the applications of electronic equipment in clinical and research medicine, general principles of equipment operation, special features of the equipment, and the related medical terminology.

Order 20816, only... \$2.95

### ABC's of Integrated Circuits

by RUFUS P. TURNER. This basic introduction to the integrated circuit (IC) will be welcomed by hobbyists, experimenters, and students who have some familiarity with semiconductors. Describes the fundamentals of the IC, and its applications in amplifiers, oscillators, control circuits, communications, test equipment, and computers.

Order 20823, only... \$2.95

### Transistor Specifications Manual. 4th Ed.

by THE HOWARD W. SAMS ENGINEERING STAFF. Lists the electrical and physical parameters (along with the manufacturers) of virtually all of the transistor types now in use. Also includes frequency, gain, and leakage parameters, as well as a special section on rf power transistors. Comb-bound.

Order 20788, only... \$4.50

### ABC's of FET's

by RUFUS P. TURNER. Clearly explains the theory and describes the operating principles of FET's (field-effect transistors), special semiconductor devices with unique qualities. Describes FET circuit design and typical applications in a number of practical circuits.

Order 20789, only... \$2.95

## Computer Data Handling Circuits

by ALFRED CORBIN. This book offers the beginner a valuable introductory course in practical digital data circuit analysis. Makes understandable the semiconductors and circuitry used in digital equipment. Explains digital data logic and the associated mathematics. Analyzes the basic logic circuits and their functional blocks, as well as digital display devices. Invaluable for anyone desiring to be conversant in the operational theory of data handling circuits.

Order 20808, only... \$4.50

## Color-TV Case Histories

by JACK DARR. Case histories not only provide the TV technician with solutions to troubles he is likely to encounter, but enable him to compare his troubleshooting methods with those of others. Each of these case histories of troubles actually happened. The symptoms are given for each trouble, along with the method used to locate it.

Order 20809, only... \$3.50

## Radio Spectrum Handbook

by JAMES M. MOORE. This book fills the "information gap" about the many types of radiocommunication which exist apart from radio and TV. Each chapter covers a given frequency-allocation range; a table provides an overall summary of the uses of all frequencies in that range, followed by text describing the individual radio services available. Includes information on receivers available for the various frequency bands described. Hardbound.

Order 20772, only... \$7.95

## First-Class Radiotelephone License Handbook. Third Edition

by EDWARD M. NOLL. Completely updated to cover all the new material included in the recently revised FCC Study Guide. Book sections include: Theory and discussion of all phases of broadcasting; all the questions (and the answers) included in the FCC Study Guide; three simulated FCC examinations; appendices containing the most relevant FCC Rules and Regulations. This book will not only help you acquire your license, but will also serve as a textbook for broadcast engineering training. Order 20804, only... \$6.50

## Short-Wave Listener's Guide. 4th Ed.

by H. CHARLES WOODRUFF. Completely revised and enlarged to include the most recent changes in SW broadcasting schedules. Lists world-wide short-wave stations by country, city, call letters, frequency, power, and transmission time. Includes Voice of America and Radio Free Europe stations, and stations operating behind the Iron Curtain. With conversion chart and handy log.

Order 20798, only... \$2.95

## ABC's of Tape Recording. 3rd Ed.

by NORMAN CROWHURST. Newly revised and updated edition of this popular handbook. Explains how tape recorders work (transport mechanisms, heads, controls, etc.), how to choose the best recorder for your needs, and how to use it most effectively for both entertainment and practical purposes. Includes tips on recording quality and recorder care. Order 20805, only... \$2.95

## HOWARD W. SAMS & CO., INC.

Order from your Electronic Parts Distributor, or mail to Howard W. Sams & Co., Inc., Dept. PE-011  
4300 W. 62nd St., Indianapolis, Ind. 46268

Send books checked at right. \$\_\_\_\_\_ enclosed  
 Send FREE 1971 Sams Book Catalog

Name \_\_\_\_\_  
PLEASE PRINT  
Address \_\_\_\_\_  
City \_\_\_\_\_ State \_\_\_\_\_ Zip \_\_\_\_\_

- |                                |                                |
|--------------------------------|--------------------------------|
| <input type="checkbox"/> 20796 | <input type="checkbox"/> 20808 |
| <input type="checkbox"/> 20807 | <input type="checkbox"/> 20809 |
| <input type="checkbox"/> 20772 | <input type="checkbox"/> 20789 |
| <input type="checkbox"/> 20816 | <input type="checkbox"/> 20804 |
| <input type="checkbox"/> 20823 | <input type="checkbox"/> 20798 |
| <input type="checkbox"/> 20788 | <input type="checkbox"/> 20805 |

CIRCLE NO. 16 ON READER SERVICE PAGE

# Every record you buy is one more reason to own a Dual.

If you think of your total investment in records — which may be hundreds or even thousands of dollars — we think you'll agree that those records should be handled with the utmost care.

Which brings us to the turntable, the component that handles those precious records. Spinning them on a platter and tracking their fragile grooves with a diamond stylus, the hardest substance known to man.

For many years, serious music lovers have entrusted their records to one make of automatic turntable — Dual. In fact, most professionals (who have access to any equipment) use a Dual in their own stereo component systems. And not always the highest priced mode.

So the question for you to consider isn't which Dual is good enough, but how much more than "good" your turntable has to be.

This question can be answered in our literature, which includes complete reprints of independent test reports. Or at any of our franchised dealers.

**United Audio Products, Inc.,**  
120 So. Columbus Ave., Mt. Vernon,  
New York 10553. 

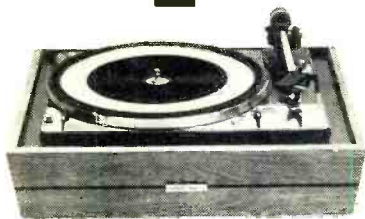

Dual 1209, \$129.50.  
Other models from \$99.50 to \$175.00.

**CIRCLE NO. 20 ON READER SERVICE PAGE**

## INTERFACE

(Continued from page 8)

people do—research has failed to give you any insight.

The FCC should crack down right now. To allow CB'ers to expand into other frequencies and add more channels to this junkyard of the airwaves is unrealistic. The FCC is not in a cul-de-sac; CB is—let it stay right there.

D.C. FALL, WB6OLJ  
Fullerton, CA

It's encouraging to see a magazine offer an intelligent, concise and realistic description of the problems facing the CB service.

DAVID THOMPSON, PRES.  
Linear Systems, Inc.  
Watsonville, CA

### A WORKING READER

Congratulations on your new magazine format and outlook. I find it quite refreshing in the light of other experimenter magazines that flourish on the newsstands.

At present I am constructing the "Super Tiger" amplifier and "Two-by-Two" stereo preamplifier and all seems to be proceeding well. I especially like the construction project evaluations and the operational theory presentations. Since I rarely have the funds to build the more sophisticated circuits, I find that because of the presentation, I can rip them apart and experiment with them mentally!

P. NEWLEY  
Niagara Falls  
Ontario

*What else can we ask? A reader who examines, studies, and experiments.*

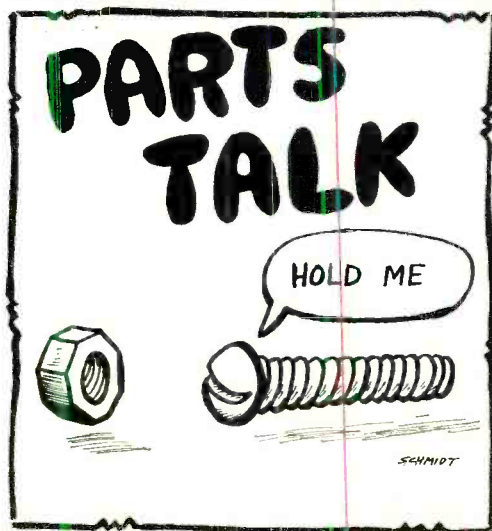



You get

1971 **ELECTRONIC EXPERIMENTER'S HANDBOOK**

Detailed Assembly Plans

- STIMULATING COLOR ORGAN
- VERSATILE Stereo PREAMP
- HOT-ROD DWELL EXTENDER
- SIMPLIFIED RECEIVER
- HI-GAIN TV ANTENNA
- SWL FREQUENCY CHECK
- CAPACITANCE METER
- BATTERY CHARGER
- AUDIO GENERATOR
- DIGITAL CHECKOUT
- DANCING LIGHTS
- STUDIO/MAIL FINDER
- TRAC TRANSFORMER



**THE "ORB"**  
Look Out! It's Alive!

**Bring Your Reference Library Up To Date**

If you've missed any of these current and previously published handbooks, a wide selection is still available. Just circle the corresponding numbers on the coupon below.

**ELECTRONIC EXPERIMENTER'S HANDBOOK.** 148 pages of the most fascinating and challenging construction projects for electronics hobbyists. 1970 winter #97; 1970 spring #14; 1969 spring #88; 1969 winter #85; 1968 spring #84; 1966 spring #36; 1966 fall #39.

**TAPE RECORDER ANNUAL.** Covers every aspect of tape recording . . . plus complete buyer's guide. 1970 #99; 1969 #81.

**STEREO/HI-FI DIRECTORY.** Giant buyer's guide complete with photos, specs, prices. 1970 #98; 1969 #82.

**ELECTRONICS INSTALLATION AND SERVICING HANDBOOK.** Covers all 8 areas of consumer electronics servicing—for the serviceman and hobbyist. 1970 #4; 1969 #83; 1968 #58.

**COMMUNICATIONS HANDBOOK.** Fact-packed pages for the CB, SWL, or Ham! . . . plus equipment buyer's guide. 1970 #10; 1969 #36; 1968 #53.

**GET THE DELUXE LEATHERFLEX-BOUND EDITION FOR JUST \$3.50 POSTPAID!**

The Winter 1971 **ELECTRONIC EXPERIMENTER'S HANDBOOK** is also available in a splendid deluxe edition. Rugged Leatherflex cover provides lasting protection yet is softly textured and gold-embossed for the look of elegance. A collector's item—a superb addition to your electronics bookshelf. And it's yours, for just \$3.50 postpaid, when you check the appropriate box on the order form.

**26 EXCITING ELECTRONICS CONSTRUCTION PROJECTS**

**IN THE ALL-NEW WINTER 1971 EDITION OF ELECTRONIC EXPERIMENTER'S HANDBOOK**

All laboratory-tested by the editors, complete with parts list, easy "how-to-do-it, how-it-works" instructions and many with actual size PC foil patterns!

**BUILD THESE CHALLENGING PROJECTS!**

- The Orb
- MusicVision Light System
- Simplicity + Dwell Meter
- IC Frequency Standard
- The Dorm Special
- Pola Testers
- Encapsulate Your Circuits
- Mini Light Trouble
- "Pyramidal" TV/FM Antenna
- PPFL
- The Picnicker's Friend
- The Homesteader
- Dwell Extender
- Mini-Six Add-On
- Capacitance Meter
- Solid-State Variable Transformer
- Carpenter's Mate
- Squaring with an IC
- All Electric Thermometer
- The Tie Bookshelf Speaker
- AA-C-D Battery Charger
- Speaker Boxes That Are Something Else
- Psychedelia I
- Tigers That Roar
- Why Play Edison Roulette?
- ULD Sine Wave Generator

*Only \$1.50! Order Your Copy Now!*

**ZIFF-DAVIS SERVICE DIV., Dept. EEH-W • 595 Broadway, N.Y., N.Y. 10012**  
Please send me the 1971 **ELECTRONIC EXPERIMENTER'S HANDBOOK**. I want the:

- Regular Edition—\$1.50 plus 35¢ for shipping and handling. (\$2.50 postpaid, for orders outside the U.S.A.)
- Deluxe Edition—\$3.50 postpaid. (\$4.50 postpaid, for orders outside the U.S.A.) Allow three additional weeks for delivery.

I've circled the numbers of the additional annuals I wish to receive.

**\$1.25 each** 36 39 84 53      **\$1.35 each** 81 83 86 99      **\$1.50 each** 14  
53 82 85 88      97 98 4 10

I am enclosing a total of \$\_\_\_\_\_ for the annuals ordered above. I've added an additional 35¢ per copy for shipping and handling. (For orders outside the U.S.A. all regular editions are \$2.50 per copy, postpaid. Deluxe editions are \$4.50 per copy, postpaid.)

PE-1-71

print name \_\_\_\_\_  
address \_\_\_\_\_  
city \_\_\_\_\_  
state \_\_\_\_\_ zip \_\_\_\_\_

**PAYMENT MUST BE ENCLOSED WITH ORDER**

# New Heathkit® Solid-State

## Design and performance features add up to one-of-a-kind superiority.

Over five years were spent in research and development to achieve the notably superior performance, improved convenience features, and ease of service now embodied in the new GR-270 and GR-370. They are premium quality receivers in the truest sense, and, we believe, the finest color TV's on today's market. Here's why...



### Compare these features:

- Modular plug-in circuit board construction.
- MOSFET VHF tuner and 3-stage IF.
- Adjustable video peaking.
- Sound instantly, picture in seconds.
- Built-in Automatic Fine Tuning.
- Pushbutton channel advance.
- Tilt-out convergence and secondary controls.
- Hi-fi sound outputs — for amplifier.
- Virtually total self-service capability with built-in volt-ohm meter, dot generator, and comprehensive manual.
- Premium quality bonded-face etched glass picture tubes.
- Choice of 295" or 227" picture tube sizes.



**Exclusive solid-state circuitry design**...total of 45 transistors, 55 diodes, 2 silicon controlled rectifiers; 4 advanced Integrated Circuits containing another 46 transistors and 21 diodes; plus 2 tubes (picture and high voltage rectifier) combine to deliver performance and reliability unmatched by conventional tube sets.



**Exclusive design solid-state VHF tuner** uses an MOS Field Effect Transistor for greater sensitivity, lower noise, and lower cross-modulation... gives you sharply superior color reception, especially under marginal conditions. Gold/Niobium contacts give better electrical connections and longer wear. Memory fine tuning,

standard. Solid-state UHF tuner uses hot-carrier diode design for increased sensitivity.



**3-stage solid-state IF** has higher gain for better overall picture quality. Emitter-follower output prevents spurious signal radiation, and the entire factory-aligned assembly is completely shielded to prevent external interference.

**Automatic Fine Tuning** — standard on both sets. Just push a button and the assembled and aligned AFT module tunes in perfect picture and sound automatically... eliminates manual fine-tuning. Automatic between-channel defeat switch prevents tuner from locking in on stray signals between channels. AFT can be disabled for manual tuning.

**VHF power tuning**...scan through all VHF and one preselected UHF channel at the push of a button.

**Built-in automatic degaussing** keeps colors pure. Manual degaussing coil can be left plugged into the chassis and turned on from the front panel... especially useful for degaussing after the set is moved some distance.

**Automatic chroma control** eliminates color variations under different signal conditions.

**Adjustable noise limiting and gated AGC** keeps pulse-type interference to a minimum, maintains signal strength at constant level.

**High resolution circuitry** improves picture clarity and new adjustable video peaking lets you select the degree of sharpness and apparent resolution you desire.

**"Instant-On"**. A push of the power switch on the front panel brings your new solid-state set to life in seconds. Picture tube filaments are kept heated for instant operation, and extended tube life. "Instant-On" circuit can be defeated for normal on-off operation.

**Premium quality color picture tubes.** Both the 227 sq. in. GR-270 and 295 sq. in. GR-370 use the new brighter bonded-face, etched glass picture tubes for crisper, sharper, more natural color. And the new RCA HiLite Matrix tube is a low cost option for the GR-370. See below.

**Adjustable tone control** lets you choose the sound you prefer... from deep, rich bass to clean, pronounced highs.



**Hi-fi output** permits playing the audio from the set through your stereo or hi-fi for truly lifelike reproduction. Another Heath exclusive.

**Designed to be owner serviced.** The new Heath solid-state color TV's are the only sets on the market that can be serviced by the owner. You actually can diagnose, trouble-shoot and maintain your own set.

**Built-in dot generator and tilt-out convergence panel** let you do the periodic dynamic convergence adjustments required of all color TV's for peak performance. Virtually eliminate technician service calls.



**Snap-out glass epoxy circuit boards** with transistor sockets add strength and durability and permit fast, easy troubleshooting and transistor replacement. Makes each circuit a module.



**Built-in Volt-Ohm Meter** and comprehensive manual let you check circuits for proper operation and make necessary adjustments. The manual guides you every step in using this built-in capability. Absolutely no knowledge of electronics is required.

**Easy, enjoyable assembly**... the Heathkit way. The seven-section manual breaks every assembly down into simple step-by-step instructions. With Heath's famous fold-out pictorials and simple, straightforward design of the sets themselves, anyone can successfully complete the assembly.

**Heathkit Solid-State Modular Color TV** represents a significant step into the future... with color receiver design and performance features unmatched by any commercially available set at any price! Compare the specifications. Then order yours today.

**Kit GR-270**, all parts including chassis, 227" picture tube, face mask, UHF & VHF tuners, AFT & 6x9" speaker, 114 lbs. \$489.95\*

**Kit GR-370**, all parts including chassis, 295" picture tube, face mask, UHF & VHF tuners, AFT & 6x9" speaker, 127 lbs. \$559.95\*

**Kit GR-370MX**, complete GR-370 with RCA matrix picture tube, 127 lbs. \$569.95\*

**GR-270 AND GR-370 SPECIFICATIONS — PICTURE TUBE SIZE: GR-370** Approximate Viewing Area: 295 Sq. In. GR-270 Approximate Viewing Area: 227 Sq. In. **DEFLECTION:** Magnetic, 90 degrees. **FOCUS:** Electrostatic. **CONVERGENCE:** Magnetic. **ANTENNA INPUT IMPEDANCE:** VHF 300 ohm balanced or 75 ohm unbalanced. UHF: 300 ohm balanced. **TUNING RANGE:** VHF TV channels 2 through 13. UHF TV channels 14 through 83. **PICTURE IF CARRIER:** 45.75 MHz. **SOUND IF CARRIER:** 41.25 MHz. **COLOR IF SUBCARRIER:** 42.17 MHz. **SOUND IF FREQUENCY:** 4.5 MHz. **VIDEO IF BANDWIDTH:** 3.58 MHz. **HI-FI OUTPUT:** Output impedance — 1 k ohm. Frequency response — ±1 dB 30 Hz to 10 kHz. Harmonic distortion — less than 1% at 1 kHz. Output voltage — 0.3 V rms nominal. **AUDIO OUTPUT:** Output impedance — 4 ohm or 8 ohm. Output power — 2 watts. **POWER REQUIREMENTS:** 110 to 130 volts AC, 60 Hz, 240 watts. **NET WEIGHT:** GR-370, 114 lbs.; GR-270, 101 lbs.



# Modular Color Television!

Exclusive Modular Design... Circuit Boards snap in and out in seconds for easy assembly, simple servicing

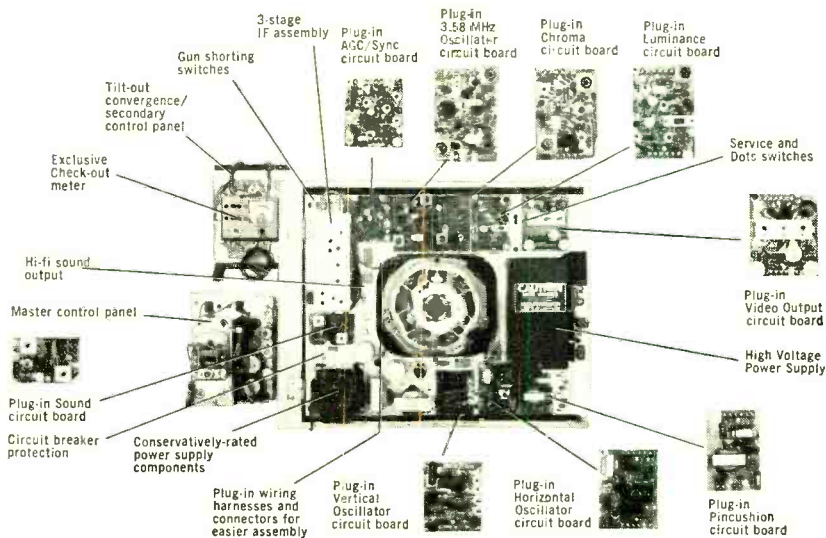

**New Expedited 48-Hour No-Charge Warranty Service Plan for Solid-State TV Modules!** Special service facilities have been established at the factory and all Heathkit Electronic Centers to expedite service and return of Solid-State TV circuit modules within two working days. During the 90-day warranty period, TV modules will be serviced or replaced with no charge for labor or parts. After the initial 90-day warranty period expires, TV modules will be serviced or replaced at a fixed charge of \$5.00 per module for labor and parts for a period of two years from date of original kit purchase.



Add extra convenience and versatility to your new GR-270 or GR-370 Solid-State Color TV with this new ultrasonic remote control kit. Lets you turn the set on and off, adjust volume, change VHF channels and adjust color and tint from the comfort of your chair. Assembles and installs complete in just a few hours and the built-in meter on the receiver makes final adjustment a matter of minutes.  
Kit GRA-70-6, 6 lbs. .... \$64.95\*

## Choose One Of These Handsome, Factory Assembled Cabinets

3 models in 295 sq. in.

**Luxurious Mediterranean Cabinet**... factory assembled of fine furniture grade hardwoods and finished in a flawless Mediterranean pecan. Statuary bronze trim handle. 30-1/32" H x 47" W x 17 3/4" D. Assembled GRA-304-23, 85 lbs. .... \$129.95\*



**Deluxe Early American Cabinet**... factory assembled of a special combination of hardwoods & veneers and finished in classic Salem Maple. 29-21/32" H x 37 1/4" W x 19 3/4" D. Assembled GRA-303-23, 67 lbs. .... \$114.95\*

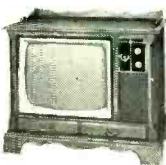

**Contemporary Walnut Cabinet**... factory assembled of fine veneers & solids with an oil-rubbed walnut finish. 29-17/32" H x 35-13/16" W x 19 7/8" D. Assembled GRA-301-23, 56 lbs. .... \$74.95\*



3 models in 227 sq. in.

**Exciting Mediterranean Cabinet**... assembled using fine furniture techniques and finished in stylish Mediterranean pecan. Accented with statuary bronze handle. 27-31/32" H x 41 7/8" W x 19-9/16" D. Assembled GRA-202-20, 70 lbs. .... \$114.95\*



**Contemporary Walnut Cabinet and Base Combination.** Handsome walnut finished cabinet sits on a matching walnut base. Cabinet dimensions 20-31/32" H x 31-7/16" W x 18 5/8" D. Base dimensions 7 3/4" H x 27 3/4" W x 18 5/8" D. Assembled GRA-203-20 Cabinet, 45 lbs. \$49.95\* GRS-203-6 above cab. w/ matching base, 58 lbs. .... \$59.95\*



**Handy Roll-Around Cart and Cabinet Combination.** Features the GRA-203-20 walnut cabinet plus a walnut-trimmed wheeled cart with storage shelf. Assembled GRA-203-20 Cabinet, 45 lbs. .... \$49.95\* GRA-204-20 Roll-Around Cart, 18 lbs. .... \$19.95\* GRS-203-5 Cart & Cabinet Combo, 58 lbs. \$59.95\*

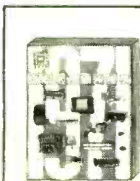
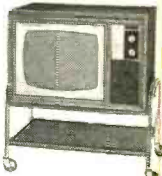

### NEW FREE 1971 CATALOG!

Now with more kits, more color. Fully describes these along with over 300 kits for stereo/hi-fi, color TV, electronic organs, guitar amplifiers, amateur radio, marine, educational, CB, home & hobby. Mail coupon or write Heath Company, Benton Harbor, Michigan 49022.

HEATH COMPANY\*, Dept. 10-1  
Benton Harbor, Michigan 49022



Enclosed is \$\_\_\_\_\_ plus shipping.

Please send model (s)

Please send FREE Heathkit Catalog.  Please send Credit Application.

Name \_\_\_\_\_

Address \_\_\_\_\_

City \_\_\_\_\_ State \_\_\_\_\_ Zip \_\_\_\_\_

\*Mail order prices; F.O.B. factory. Prices & specifications subject to change without notice. CL-392R





# FREE!

## Lafayette's 1971 Golden Jubilee Catalog



Your 1st Guide To  
Everything in Electronics

- Stereo/Hi-Fi Components • Musical Instruments and Amplifiers • Photography Equipment • Ham and CB Gear • Public Address Systems • Tools and Test Equipment • Educational and Optical Equipment • Black and White/Color Televisions • Police and Fire Monitor Receivers • Books and Parts

Plus Thousands of Additional Items

Lafayette Radio Electronics Dept. 35011  
P. O. Box 10, Syosset, L. I., N. Y. 11791

Send Me the Free Lafayette Golden Jubilee 1971 Catalog 710 35011

Name .....

Address .....

City .....

State ..... Zip .....

(Please include your zip code)

CIRCLE NO. 8 ON READER SERVICE PAGE

# TAPE CARTRIDGE TRANSPORTS



Broadcast quality transports for all NAB type endless loop tape cartridges. Three models — manual, semi automatic or automatic for broadcast, industrial or commercial applications. Available in various monaural or stereo head configurations, single or dual speed. From \$86.00. Tape cartridges, associated record/playback electronics available. Made in U.S.

PRODUCTS OF SOUND RESEARCH

## TELEX®

COMMUNICATIONS DIVISION

9600 Aldrich Avenue South  
Minneapolis, Minnesota 55420

CIRCLE NO. 19 ON READER SERVICE PAGE



To obtain a copy of any of the catalogs or leaflets described below, fill in and mail the Reader Service blank on page 15 or 95.

A colorful brochure presenting product information on their complete CB line is being offered by *Midland International Corp.* The selection of CB equipment includes 25 transceivers ranging from low-cost walkie-talkies to sophisticated hand-held and base/mobile transceivers. Three compatible SSB models are shown, including a 3-channel hand-held, 23-channel mobile, and 23-channel base model. The brochure also gives information on such CB accessories as power supplies, microphones, speakers, antennas, and crystals.

Circle No. 75 on Reader Service Page 15 or 95

A completely new, redesigned line of the famous "Concert Series" loudspeakers is described in Catalog 1090-E available from *Jensen Sound Products.* Speakers described range in size from 3" to 15" round types and from 2" x 6" to 6" x 9" oval configurations. All speakers are full-range types, including the dual-cone models. Included are the Jensen special application speakers for aircraft, automobiles, communications, intercoms, etc. A complete line of loudspeakers for electronic musical instruments is also featured.

Circle No. 76 on Reader Service Page 15 or 95

An impressive line of instrument amplifiers, audio systems, and accessories for the artist and concert producer is described in a new catalog available from *Ovation Instruments.* The catalog listing covers preamplifiers, self-contained amplifiers, speaker systems, voice and music systems, sound projectors and emphasizeers, and an extensive line of audio accessories. Illustrations, specifications, and application information are included.

Circle No. 77 on Reader Service Page 15 or 95

A four-page, two-color catalog that describes the complete line of CRX "Portamon" monitor receivers for use on the Public Service, business and commercial, 10-meter ham, and CB bands is being offered by *The Hallcrafters Co.* The receivers are designed to operate in the VHF portion of the AM and FM bands. Both hand-held and table model receivers are described.

Circle No. 78 on Reader Service Page 15 or 95

# Popular Electronics

## READER SERVICE PAGE

### free information service:

Here's an easy and convenient way for you to get additional information about products advertised or mentioned editorially (if it has a "Reader Service Number") in this issue. Just follow the directions below... and the material will be sent to you promptly and free of charge.

**1.** On coupon below, circle the number(s) that corresponds to the key number(s) at the bottom or next to the advertisement or editorial mention that is of interest to you. (Key numbers for advertised products also appear in the Advertisers' Index.) Print or type your name and address on the lines indicated.

**2.** Cut out the coupon and mail it to: POPULAR ELECTRONICS, P.O. Box 8391, Philadelphia, PA 19101.

**note:** If you want to write to the editors of POPULAR ELECTRONICS about an article on any subject that does not have a key number, write to POPULAR ELECTRONICS, One Park Avenue, New York, N.Y. 10016. Inquiries concerning circulation and subscriptions should be sent to POPULAR ELECTRONICS, P.O. Box 1096, Flushing, N.Y. 11352.

1/71-3

Void after February 28, 1971

# Popular Electronics

P.O. BOX 8391  
PHILADELPHIA, PA. 19101

1 2 3 4 5 6 7 8 9 10 11 12 13 14 15 16 17 18 19 20  
21 22 23 24 25 26 27 28 29 30 31 32 33 34 35 36 37 38 39 40  
41 42 43 44 45 46 47 48 49 50 51 52 53 54 55 56 57 58 59 60  
61 62 63 64 65 66 67 68 69 70 71 72 73 74 75 76 77 78 79 80  
81 82 83 84 85 86 87 88 89 90 91 92 93 94 95 96 97 98 99 100

NAME (Print clearly) \_\_\_\_\_

ADDRESS \_\_\_\_\_

CITY \_\_\_\_\_ STATE \_\_\_\_\_ ZIP CODE \_\_\_\_\_

# B&K TEST EQUIPMENT

PRODUCT OF  
DYNASCAN



## FREE CATALOG

TV ANALYSTS  
NEW FET TESTER  
VOMs—VTVMs  
TUBE TESTERS  
COLOR GENERATORS  
CRT CHECKERS  
OSCILLOSCOPE  
TRANSISTOR ANALYSTS  
RF SIGNAL GENERATOR  
SINE/SQ. WAVE GENERATOR  
PROBES—ACCESSORIES



SEND COUPON FOR FREE CATALOG TO:  
DYNASCAN CORPORATION  
1803 WEST BELLE PLAINE AVENUE  
CHICAGO, ILLINOIS 60613

NAME \_\_\_\_\_  
OCCUPATION \_\_\_\_\_  
ADDRESS \_\_\_\_\_  
CITY \_\_\_\_\_  
STATE \_\_\_\_\_ ZIP \_\_\_\_\_

CIRCLE NO. 22 ON READER SERVICE PAGE

## NEW Short-Wave Listening VERTICAL ANTENNA Model SWV-7

For 11,13,16,19,25,31 and 49 meter bands Cramped quarters keeping you from installing an SWL antenna? Your problem is solved! Model SWV-7 mounts easily on the roof or on the ground and stands just 13 ft., 3-5/8 in. tall.

Extensive field testing confirms that this antenna measures up to Mosley's high standards of performance. Construction is of the finest material to bring you years of trouble free listening pleasure. Complete with installation instructions.

Get the facts from your Mosley dealer, or write factory direct, for detailed brochure.

**Mosley Electronics, Inc.**  
Dept. 202

4610 N. LINDBERGH BLVD., BRIDGETON, MO. 63044

CIRCLE NO. 10 ON READER SERVICE PAGE



## USE OF THE OSCILLOSCOPE A Programmed Text

by Charles H. Roth, Jr.

The format of this book is arranged so that it breaks down the process of operating an oscilloscope into a series of logical steps. Understanding the operation of the scope, rather than mere control manipulation, is stressed at each step. The book is divided into four parts. Part I introduces the scope. In Part II, the relations between triggering signals, triggering controls, the sweep waveform, and the waveform displayed on the scope's CRT are discussed. Proper use of the scope and probe to avoid measuring errors is emphasized in Part III, while Part IV deals with phase measurement by the triggered sweep and ellipse methods. Each part is divided into preparation, which presents the basic theory, and lab exercises. The exercises require prediction of scope settings and waveforms followed by experimental verification.

Published by Prentice-Hall, Inc., Englewood Cliffs, NJ 07362. 222 pages. \$8.95 hard cover; \$5.95 soft cover.

## HANDBOOK OF MAGNETIC RECORDING

by Finn Jorgensen

The latest information on magnetic recording covering applications from home audio to weather surveillance data recording is given in this book. Beginning with the basics of magnetic recording, the text explores the differences between recorder types, transport designs for specifications, magnetic head design, how to judge tape quality, how tape is made, and the best type of tape to use for a given purpose. Some of the topics covered include: amplifiers and equalization, tape recorder care and maintenance, specialized taping techniques, and tape recorder measurements and standards.

Published by Tab Books, Blue Ridge Summit, PA 17214. 192 pages. \$7.95 soft cover; \$4.95 hard cover.

## INTRODUCTION TO ELECTRIC CIRCUITS, Third Edition

by Herbert W. Jackson

While the principles of electric circuit theory do not change much from year to year, methods of teaching them do. The author dedicated the Second Edition of this book to students in electrical and electronics technology. In its Third Edition, this book is  
(Continued on page 97)

POPULAR ELECTRONICS





# NEW exciting home training to be a **COMPUTER TECHNICIAN**

NRI program includes a complete, operating computer, with memory, to make you thoroughly familiar with computer organization, design, operation, construction, programming, trouble shooting and maintenance.

You build your own digital computer step-by-step, circuit-by-circuit. You really get involved as you learn computer organization, operation and programming with this remarkable new training aid. It performs the same functions as bigger commercial computers—and it's yours to keep and use.

What better way to learn all about computers than to actually build and use one? That's exactly what you do in NRI's new Complete Computer Electronics home training program.

What you see illustrated may very well be the most unique educational aid ever developed for home training. This is not simply a "logic trainer." It is literally a complete, general purpose, programmable digital computer that contains a memory and is fully automatic. It's a small-scale model of larger, expensive commercial computers. Once you build it and it is operational, you can define and flow-chart a problem, code your program, store your program and data in the memory bank. Press the "start" button and, before you can remove your finger, the computer solves your problem and displays the results.

NRI is offering this new course because this is only the beginning of the "Computer Age." The computer industry continues to leap ahead. Qualified men are urgently needed, not only as digital technicians and field service representatives, but also to work on data acquisition systems in such fascinating fields as telemetry, meteorology and pollution control. Office equipment and test instruments also demand the skills of the digital technician. This exciting NRI program can give you the priceless confidence you seek to walk into a technician's job and know just what to do and how to do it.

*You learn with your hands as well as your head* Planned from the beginning to include training equipment in the pioneering NRI tradition this exceptional new course combines kits with educator-acclaimed NRI "bite-size" texts in an easy-to-understand package. But, unlike other home training, this is not a general electronics course. Lessons have been specifically written to stress computer repair. You perform a hundred experiments,

build hundreds of circuits, use professional test equipment. You build and use your own solid-state, transistorized voltmeter and your own oscilloscope in addition to your digital computer. Because you work with your hands as well as your head, your training is as much fun as it is education.

### *Train at home with the leader*

There is so much to tell you about this latest NRI "first" in home training, you must fill out and mail the coupon today. Get the full story of Complete Computer Electronics and the amazing digital computer you build and use as you learn. The free NRI Catalog you receive also tells you about other NRI training plans in Color TV Servicing, Communications, Electronics Technology. There is no obligation. No salesman will call on you. NATIONAL RADIO INSTITUTE, Washington, D.C. 20016.

### MAIL NOW FOR FREE CATALOG



**NATIONAL RADIO INSTITUTE**  
Washington, D.C. 20016

Please send me your FREE CATALOG with details about new Complete Computer Electronics training. (No salesman will call)

91-011

Name \_\_\_\_\_ Age \_\_\_\_\_

Address \_\_\_\_\_

City \_\_\_\_\_ State \_\_\_\_\_ Zip \_\_\_\_\_

ACCREDITED MEMBER NATIONAL HOME STUDY COUNCIL

# Join "THE TROUBLESHOOTERS"

They get paid top salaries  
for keeping today's  
electronic world running

Suddenly the whole world is going electronic! And behind the microwave towers, push-button phones, computers, mobile radio, television equipment, guided missiles, etc., stand

**THE TROUBLESHOOTERS**  
—the men needed to inspect, install, and service these modern miracles. They enjoy their work, and get well paid for it. Here's how you can join their privileged ranks—without having to quit your job or go to college in order to get the necessary training.





**J**UST THINK HOW MUCH in demand you would be if you could prevent a TV station from going off the air by repairing a transmitter...keep a whole assembly line moving by fixing automated production controls...prevent a bank, an airline, or your government from making serious mistakes by repairing a computer.

Today, whole industries depend on electronics. When breakdowns or emergencies occur, someone has got to move in, take over, and keep things running. That calls for one of a new breed of technicians—The Troubleshooters.

Because they prevent expensive mistakes or delays, they get top pay—and a title to match. At Xerox and Philco, they're called Technical Representatives. At IBM they're Customer Engineers. In radio or TV, they're the Broadcast Engineers.

What do you need to break into the ranks of The Troubleshooters? You might think you need a college diploma, but you don't. What you need is know-how—the kind a good TV service technician has—only lots more.

### Think With Your Head, Not Your Hands

The service technician, you see, "thinks with his hands." He learns his trade by taking apart and putting together, and often can only fix things he's already familiar with.

But as one of The Troubleshooters, you may be called upon to service complicated equipment that you've never seen before or *can't* take apart. This means you have to be able to take things apart "in your head." You have to know enough electronics to understand the engineering specs, read the wiring diagrams, and calculate how a circuit should test at any given point.

Now learning all this can be much simpler than you think. In fact, you can master it without setting foot in a classroom and without giving up your job!

### AUTO-PROGRAMMED™ Lessons Show You How

For over 30 years, the Cleveland Institute of Electronics has specialized in teaching electronics at home. We've developed special techniques that make learning easy, even if you've had trouble studying before.

For one thing, our AUTO-PROGRAMMED™ lessons build your knowledge as you'd build a brick wall—one brick at a time. Each piece rests securely on the one that came before it.

### ENROLL UNDER NEW G.I. BILL

All CIE courses are available under the new G.I. Bill. If you served on active duty since January 31, 1955, or are in service now, check box on reply card for G.I. Bill information.

In addition, our instruction is personal. When your teacher goes over your assignment, no one else competes for his attention. You are the only person in his class. He not only grades your work, he analyzes it to make sure you are thinking correctly. And he returns it the day it's received so that you can read his comments and corrections while everything is fresh in your mind.

### Always Up-To-Date

To keep up with the latest developments, our courses are constantly being revised. This year CIE students are getting new lessons in Laser Theory and Application, Microminiaturization, Single Side-band Techniques, Pulse Theory and Application, and Boolean Algebra.

In addition, there is complete material on the latest troubleshooting techniques including Tandem System, Localizing through Bracketing, Equal Likelihood and Half-Split Division, and In-circuit Transistor Checking. There are special lessons on servicing two-way mobile equipment, a lucrative field in which many of our students have set up their own businesses.

### Your FCC License—or Your Money Back!

Two-way mobile work and many other types of troubleshooting call for a Government FCC License, and our training is designed to get it for you. But even if your work doesn't require a license, it's a good idea to get one. Your FCC License will be accepted anywhere as proof of good electronics training.

And no wonder. The licensing exam is so tough that two out of three non-CIE men who take it fail. But CIE training is so effective that 9 out of 10 of our graduates pass. That's why we can offer this warranty with confidence: *if you complete one of our license preparation courses, you'll get your license—or your money back.*

### Mail Card for 2 Free Books

Want to know more? Mail the postage-paid reply card bound here. We'll send our 40-page catalog describing our courses and the latest opportunities in Electronics. We'll also send a special book on how to get a Commercial FCC License. Both are free. If the card is missing, just send us your name and address.



# CIE

**Cleveland Institute of Electronics**

1776 E. 17th St., Dept. PE-101, Cleveland, Ohio 44114

Accredited Member National Home Study Council  
A Leader in Electronics Training... Since 1934



CIRCLE NO. 2 ON READER SERVICE PAGE



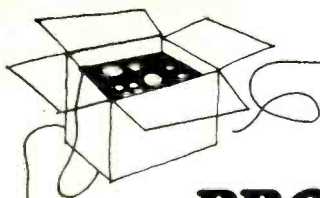

## NEW PRODUCTS

Additional information on products described in this section is available from the manufacturers. Each new product is identified by a corresponding number on the Reader Service Page. To obtain additional information on any of them, circle the number on the Reader Service Page, fill in your name and address, and mail it in accordance with the instructions.

**LAMBDA POWER SUPPLY KITS**—The engineer or experimenter working on a breadboard, pre-production or production model can now build his own ac-dc power supply to avoid hidden flaws, burned-out rectifiers and capacitors, transistors that go into second breakdown, etc. Over 200 pre-designed circuits of commonly required voltage and current combinations are offered "off-the-shelf" by *Lambda Electronics Corp.* Voltage ranges are from 5 to 48 dc, current ranges from 0.25 to 50 A, and regulations from 20% to 0.01%. Circuits range from simple capacitor-choke input filters to IC regulated supplies.

Circle No. 79 on Reader Service Page 15 or 95

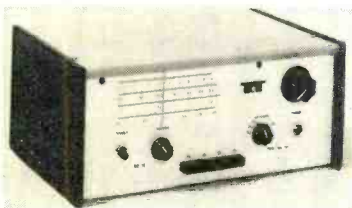

**TEN-TEC COMMUNICATIONS RECEIVER**—Designed primarily for beginners, the *Ten-Tec Inc.* RX10 communications receiver is also priced to make it attractive. The RX10 covers the 80-40-20-15-meter amateur radio bands and employs a "Synchrodyne" circuit for direct conversion which eliminates images and "birdies" usually found in low-priced receivers. Performance is said to meet the requirements of today's crowded band conditions. A built-in oscillator can be used for code practice as well as a side-tone monitor.

Circle No. 80 on Reader Service Page 15 or 95

**KNIGHT-KIT DELUXE RHYTHM CONSOLE**—Now you can add ten perfect rhythms to your band's sound, or provide a precise percussive accompaniment for backing a soloist with the KG-393 Deluxe Rhythm Console made by *Knight-Kit*. The console is an electronic device that creates the sound of bass drum, snare drum, claves, cowbell, maracas, and high and low bongos with amazing realism through a microphone or instrument amp. At the touch of a button, you can select rhythms for swing, twist, slow rock, rhumbas, mambo, beguine, cha-cha, bossanova, tango, or waltz. You can also control the level and tempo of the beats, and the sound of cymbals can be added.

Circle No. 81 on Reader Service Page 15 or 95

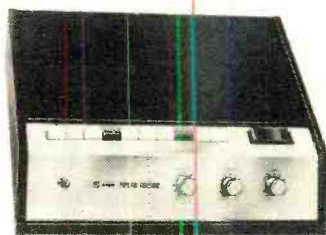

**METROLOGIC OPTICS EDUCATION KIT**—A low-cost optics education kit, complete with instructions for conducting more than 20 classroom experiments using the unique features of laser light to study physical and geometrical optics has been developed by *Metrologic Instruments, Inc.* What the buyer gets for his investment is an optics workbench, precision adjustable laser mount, ultra-sensitive wide-range photometer, a hologram, diffraction slides, lenses, prisms, and other equipment for setting up experiments. Materials are even provided for Michel-



**The sensibly priced tape cassette  
...from MALLORY.**

Just what you've been waiting for. The new Mallory DURATAPE® Cassette.

You get the quality and performance of expensive tape cassettes at a nice, lots-less price. But not the poor performance or the problems of the special-discount cheapies.

And since they're from Mallory — a company long known for quality electronic products—you can expect high fidelity, smooth operation, and long reliability. And get it . . . every time!

They'll fit any cassette recorder, player, cassette-radio. Even the new cassette changers. And you pick the recording time: 30, 60, 90, 120 minutes.

Our DURATAPE® Cassettes are tough but we put them in unbreakable, easy-to-stack containers just for extra protection. Like in the rain or through the mail.

And we make a head cleaner that's perfect for Cassette Recorders, too.

You'll find this great new thing in sound wherever Mallory products are sold.

**MALLORY**

**MALLORY DISTRIBUTOR PRODUCTS COMPANY**

a division of P. R. MALLORY & CO. INC.  
Box 1658, Indianapolis, Indiana 46208; Telephone: 317-636-6363

Batteries • Capacitors **Cassette Tapes** Controls • Resistors • Semiconductors • Sonalert® • Switches • Timers • Vibrators  
**CIRCLE NO. 9 ON READER SERVICE PAGE**

January, 1971

23

## NEW PRODUCTS CONTINUED FROM PAGE 22

son interferometer experiments. Also included in the kit is a loose-leaf manual that outlines the teacher-written experiments. Lasers are not supplied with the kit but are available as separate options.

Circle No. 82 on Reader Service Page 15 or 95

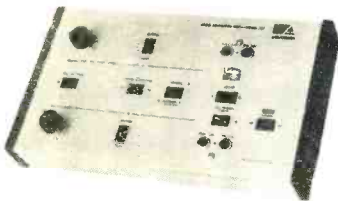

**ADVOCATE NOISE REDUCTION UNIT**—A tape recording control center employing the patented Dolby Audio Noise Reduction System is being marketed by *Advocate Products* as their Model 101 Noise Reduction Unit. When connected to a good-quality home tape recorder, the 101 dramatically reduces the hiss inherent in the tape recording process—without in any way changing the musical integrity of the signal being recorded. The Noise Reduction Unit accomplishes the same noise reduction regardless of the brand or type of tape deck and tape with which it is used, and it can be used on all good tape decks except those with non-defeatable automatic record level controls. When used with a good tape recorder, the Model 101 reduces high-frequency noise by 10 dB, or 90 percent.

Circle No. 83 on Reader Service Page 15 or 95

**CONCORD COMBINATION TAPE RECORDER**—Containing its own built-in amplifier and stereo speakers, the *Concord Electronics Corp.* Mark 8 is a versatile reel-to-reel and eight-track cartridge record/playback system by itself. The unique feature of the system is the ease with which it makes possible the duplication of eight-track cartridges from original or prerecorded 7" open-reel recordings; no external connections are required. The whole process is accomplished simply by pushing a single button. The Mark 8 is said to contain all the features of a professional tape recorder, and in the eight-track cartridge section is an automatic stop with an indicator light.

Circle No. 84 on Reader Service Page 15 or 95



**JERROLD ALL-CHANNEL SIGNAL SPLITTER**—For the more-than-one-receiver family, *Jerrold Electronics Corp.* has a Model FS-1314-FM color-rated VHF/UHF/FM 300-ohm signal splitter that allows you to use a single antenna to feed two color or monochrome TV, two mono or stereo FM, or one of each receiver. The splitter, when connected to the lead-in from any all-channel antenna, produces separate, non-interacting output signals without mismatching the system.

Circle No. 85 on Reader Service Page 15 or 95



**KENWOOD INTEGRATED STEREO AMPLIFIER**—True-blue audiophiles who feel that each component should stand on its own merit will be attracted to the *Kenwood Electronics, Inc.*, KA-4002 solid-state integrated amplifier. This amplifier has the "look" of expensive equipment with its attractive controls and push button function switches, but it sells for a price in the modest well-under-\$150 range. All silicon transistor circuit design provides the KA-4002 with a 95-watt output and a frequency response of 20-40,000 Hz  $\pm 1.5$  dB. Power bandwidth is 18-30,000 Hz (IHF) and harmonic and IM distortion are less than 0.5%.

Circle No. 86 on Reader Service Page 15 or 95

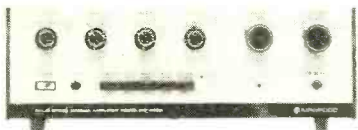



**E. F. JOHNSON "ANTENNA MATE"**—A combination antenna tuner and SWR meter which contains everything needed to measure and correct antenna line mismatches is *E. F. Johnson Company's* newest CB accessory. Called the "Antenna Mate," it can correct antenna line SWR's of up to 5:1 to less than 1.1:1. A built-in meter indicates the standing wave ratio from 1:1 to 10:1 as well as relative power output from a CB rig. By correcting antenna mismatches the Antenna Mate is said to improve receiver performance as well as provide maximum transmitted signal to the antenna.

Circle No. 87 on Reader Service Page 15 or 95

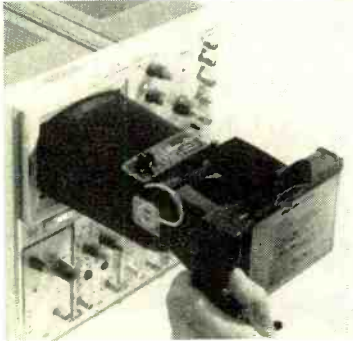
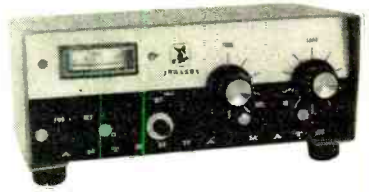

**INTEGRATED CONTROLS SCOPE CAMERA SET**—Capable of fitting 3"-5" round or rectangular oscilloscope CRT faces, the *Integrated Controls, Inc.*, low-cost Model SCO1 "Scope-Mate" camera set can capture and record one-shot or recurring trace pattern data on film. The set utilizes a standard Polaroid Colorpack II or III camera in conjunction with the Scope-Mate hood to give high-quality, high-contrast monochrome waveform photos in just 15 seconds. The object-to-image ratio is 1:1.

Circle No. 88 on Reader Service Page 15 or 95

**ALPHA TONE-CODED SQUELCH FOR CB**—The AM Citizen's Band user can now enjoy the same quiet operation in his system as does the commercial FM user by employing a new tone-coded squelch device available from *Alpha Electronic Services Inc.* Called the TEN-10 "Silencer," the squelch device is an all-solid-state subaudible continuous tone generating system that automatically selects mobile or base stations only in your own system or group, while eliminating noisy interference from all other rigs using your channel. The TEN-10 can be quickly deactivated for full-channel monitoring with the flip of a switch.

Circle No. 89 on Reader Service Page 15 or 95

**MARANTZ STEREO FM RECEIVER**—Billed as the "finest piece of stereo equipment in the world," and tagged with a \$1000 list price, the *Marantz Co., Inc.*, Model 19 receiver is obviously designed to appeal to the no-price-too-great audiophile. Familiar items to look for on the Model 19 are a gyro-touch control and a built-in oscilloscope which work together to provide extremely accurate tuning capability. An exceptionally sophisticated multiplex circuit in the receiver is said to provide an unprecedented stereo separation in excess of 45 dB at 1000 Hz and in excess of 30 dB at 15,000 Hz. Butterworth filters in the i-f section reduce distortion and maintain better high-frequency stereo separation.

Circle No. 90 on Reader Service Page 15 or 95

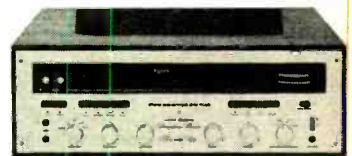

**INGENUICS ENVIRON MICROPHONE**—A new microphone "Environ," made by *Ingenuics, Inc.*, has a pair of dynamic cartridges coupled through a distance discriminating network in the housing. Controlled by a switch on the microphone, it will pick up either near and far sounds or only those originating a few inches away while noise more than 3 feet away is rejected. Frequency response is from 40 Hz to 15 kHz and output impedance is either 250 or 50,000 ohms.

Circle No. 91 on Reader Service Page 15 or 95

# Now it costs less to own the best VOM you need.



The New RCA WV-510A Solid-State Master VoltOhmyst®

I.Q.\*

\*Inexpensive Quality  
†Optional Distributor  
Resale Price

**RCA**

The best you need is the new solid-state RCA WV-510A Master VoltOhmyst®. The most functional VOM we've ever produced, the 510A has all the features you'll ever need no matter what your requirements may be.

And we've added some extra features you won't find in any competitive VOM, at any price... features designed to make your work easier, help you get the job done faster.

For example: RCA WV-510A operates from batteries or AC. Remove the detachable AC line cord while you're taking a measurement and the batteries take over immediately without a flicker of the pointer. And you'll get maximum life from the batteries because they're always on trickle charge during AC operation. Stability? Switch from range to range and watch a whole series of measurements without constantly zero-adjusting the meter.

Some statistics:

Current:  
0.01 milliampere to 1.5 amperes in 8 ranges.

Resistance:  
0.02 ohm to 1000 megohms in 7 ranges.

DC Volts:  
0.01 volt to 500 volts in 8 ranges.

AC Volts:  
0.2 to 1500 rms AC volts in 7 ranges plus peak-to-peak voltages of complex waveforms.  
21 megohm resistance on all DC ranges.

And it's only \$128,† complete with DC/AC ohms probe and flexible shielded input cable with BNC connector, and removable AC line cord.

Some statistics! For complete details, contact your local RCA Distributor.

RCA Electronic Components, Harrison, N. J. 07029

CIRCLE NO. 15 ON READER SERVICE PAGE

BY WEBB GARRISON

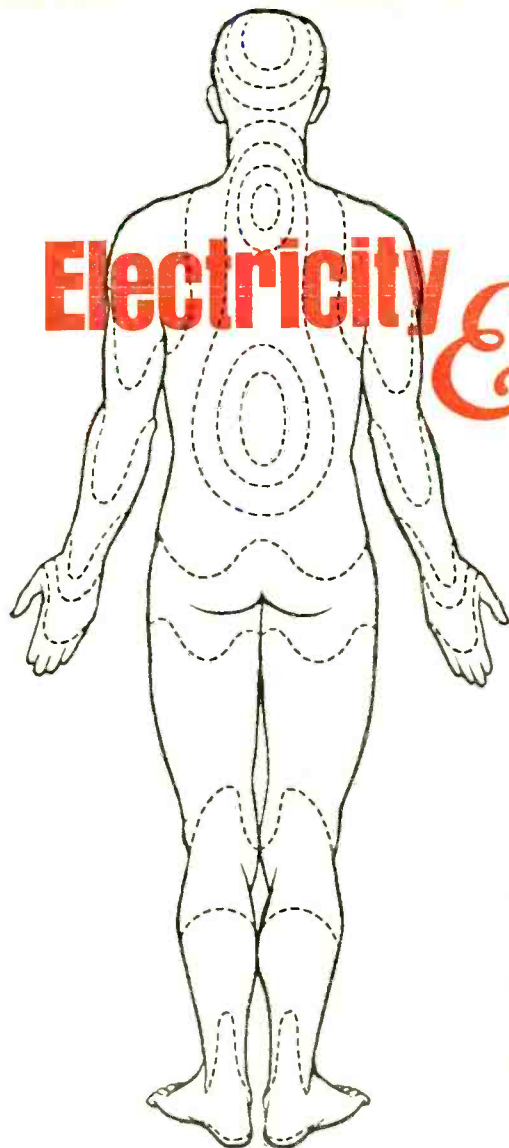

# Electricity & Physiology

*From  
Quackery  
to  
Speculation  
to  
Programmed People*

**This is a state-of-the-art report on the progress being made to unravel the relationships of all the electrical systems in the human body. Some aspects of this research—such as the so-called brain waves—are highly developed, but other areas are just being investigated—for the first time—by reputable scientists. This is the first of a new series on electricity as viewed in 1971 to be published in POPULAR ELECTRONICS.**

**T**HIRTY OR FORTY years ago, few scientists who valued their reputations dabbled with far-out uses of electricity. Before the scientific viewpoint (which requires results that can be repeated) took hold, dabblers in physics and chemistry and medicine had all sorts of odd-ball notions about electricity.

So many different kinds of electrical treatments and cures were tried by eager amateurs and outright quacks that for 125 years after the death of Franz Mesmer in 1815, all ideas about electricity in the human body were suspect.

Within the past few months, Dr. Robert O. Becker, Chief of Staff for Research at the Veterans Administration Hospital, Syracuse, New York has predicted that within 20-30 years it will be possible to grow new parts of the human body to replace those lost as a result of injury or surgery by means of electricity! (The diagram of the body above, developed by Dr. Becker, shows what are known as the slow de systems in the body.)

Animal studies already under way have produced startling results. By stimulating



cells with minute electrical charges, Dr. Becker and his colleagues have caused these cells to produce masses of blastocytes—the initial building blocks of the human body.

Controlled growth of human tissue and bone, including limb regeneration, might prove far more fruitful than transplantation of organs.

Hints that electricity could be the force behind regeneration of bodily parts was first noticed in the mid-1940's. That's when repeated trauma brought about regeneration of a limb in an adult frog. A localized electrical field—produced by trauma—acted on target cells in such a fashion that the cells were stimulated to form blastocytes which developed into a new limb.

Some creatures—notably salamanders—naturally regenerate lost parts. All known mammals do not. Dr. Becker thinks that the

evolutionary processes have concentrated electrical activity in the brain and central nervous system and that mammals now lack the ability to produce electricity vital to the regeneration of bodily parts. All the necessary cells are there, but the required energy is not.

Although some fellow scientists scoff at Dr. Becker's ideas, there is a surge of fresh interest in bioelectricity and biomagnetism.

**Basic To Life.** Wherever there is life, you will find electricity. The electrical effects are as pervasive and essential as chemical reactions once thought to hold all answers to all riddles about the organization and operation of living things.

The minute bones of your inner ear respond to every change of position with respect to gravity and send tiny pulses of electrical current to somehow inform the brain about every



Dr. James Zimmerman adjusts his Superconducting Quantum Interference Device (SQUID) a transducer he invented to monitor electrical activity in the body. It permits external monitoring by means of the measurable fields. (NBS photograph.)

change in your orientation. Your eyes not only require electricity; they are so incredibly sensitive that hardly anything was known about electrical currents in the eyes until sophisticated electronic measuring devices were developed in the past decade.

As your eyes trace this line of type, you trigger reactions that can be measured in terms of the evoked potentials at your scalp. A brain wave monitor—already operational—can feed these electrical signals into a computer that has been programmed to determine what color you are seeing at the moment.

The electroencephalogram (EEG), or tracing of brain waves, has been in use since the 1930's. Measuring devices for EEG are still in the process of refinement, primarily because we are dealing with very low frequencies (0.5-50 Hz) and minute voltages (0.401-0.402 volts).

Today, measurement of brain waves is just a start towards full-scale electrical analysis of what goes on inside your head and body. Electrocardiographic (EKG) tracings reveal some of the things happening in the heart. Skin galvanometers record changes in potential at the surface of your body. Other instruments provide a record of eye movements—including duration and intensity of dreams. Electromyograms depict velocity and intensity of muscular contractions.

**Varied Processes.** Your body is a beehive of electrical activity and has built-in generators, transmission systems, receptors, and even biological rheo-stats. There is growing evidence that the body has a reasonably well defined de system for transmission of "large" amounts of current. However, most electrical activity takes place at the level of the individual cell.

At the Institute for Enzyme Research of the University of Wisconsin, Dr. David E. Green has been studying the mechanism by which charged particles, or ions, are transported across cell membranes by donut-shaped carriers, or ionophores. These potassium or sodium ions are retained by an electro-chemical potential gradient; when the membranes are de-energized, the ions are released. Viewed under the electron microscope, physical changes in the membranes are clearly visible.

Enzymes serve as catalytic agents to speed up chemical reactions without themselves being affected. No one knows for sure how many different enzymes your body includes, but an educated guess places the number at about



The German "Dormed" electro-therapeutic sleep inducer is not available in the USA. It generates 12- to 200-Hz square waves (15 V at 3 mA) which are applied to the patient's temples and forehead. (Photo courtesy the Robert Bosch Corporation.)

10,000. Until 1970, no one knew why enzymes function, but at the University of California in Berkeley, Dr. Daniel E. Koshland, Jr. has shown that enzyme activity is electrical.

It now appears that every enzyme in your body is a mini-micro electronic pilot. At the atomic level it maneuvers "orbital steering" of components and hastens their combination. This catalytic process of nature may be as much as 1,000,000 times as fast as catalytic processes employed in industry. Each enzyme is specific for a particular set of atoms.

Deprive your body of enzymes that guide the atoms together, of cell membranes that are self-adjusting to permit two-way flow of charge particles, or the electrical pulses that keep your heart working and you'd be like an elaborate machine with the power switches pulled open.

**To Cure and to Kill.** Luigi Galvani discovered that electric current can cause the muscles of a dead frog to twitch. This pioneer finding, made in 1791, established a rough relationship between electricity and magnetism and self-styled healers had a field day using magnets to "draw illness from the body." Quacks devised a variety of instruments guaranteed to cure anything from gout to consumption. This movement reached a peak in the era when Mesmer developed the art first called mesmerism and later hypnosis.

Because so many phronics and rogues dabbled with electricity and magnetism in futile

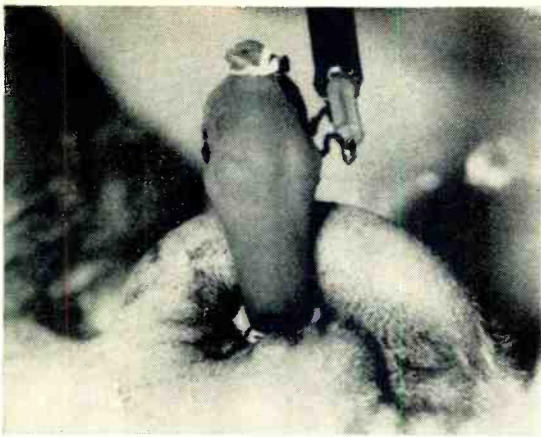

To achieve an "electrical" coupling, Dr. S. R. Topaz perfected a skin tunnel transformer that eliminates chance of irritation and infection. The coaxial cable (note size) feeds in energy and it also permits data to be readout.

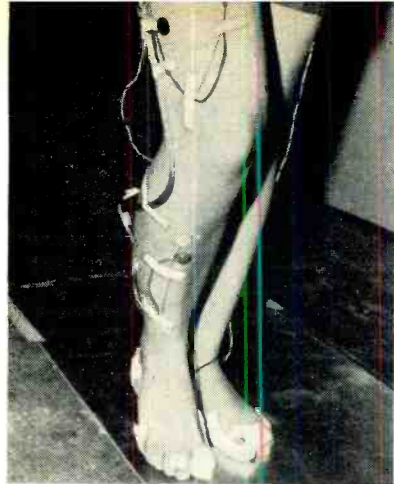

The National Research Council of Canada is investigating the electrical impulses that activate the leg musculature when walking. Data is computer programmed.

efforts to work miraculous cures, reputable scientists turned their backs on all attempts to use these forces in healing.\*

**Rival of Drugs.** Properly applied, electricity will do some things better than any known drug or chemical. This fast growing rival is at the interface where biology, chemistry and electronics intermingle.

Electroconvulsive shock (ECS) has been used in the treatment of psychiatric disorders. ECS works with many patients—but not with all. The amnesia-producing effects of ECS are difficult to produce in some patients. Just why ECS works at all is not wholly understood, but most theories suggest that taking just the right amount of current and applying it in the proper fashion at the right time interferes with the consolidation of "memory traces."

European psychiatrists and others have been experimenting with electrosleep therapy and reporting good results. In the United States the medical profession apparently believes that investigation into possible side ef-

fects on nerve centers, pituitary glands, and enzymatic systems through the introduction of an electrical current into the brain has not gone far enough.

At the University of Texas Medical School, Dr. Saul H. Rosenthal and colleagues have announced some astonishing results from low-intensity electrostimulation of the brain. Tested on a group of insomnia sufferers, there appear to be no side effects; and although sleep was not induced, the patients relaxed and then slept better at night.

Individual treatments usually last for half an hour. The equipment used by Dr. Rosenthal produces a squarewave of one millisecond's duration at a rate of 100 Hz. The current yield is less than 1.2 mA. The report indicates that after as few as two or three treatments, some habitual users of sleeping drugs have found themselves able to go to sleep without barbituates.

It is now considered possible that electroanesthesia may become an important adjunct to the battery of chemical compounds now used in operating rooms to shield patients from the pain of the surgeon's scalpel. Tests made by anesthesiologists from the Indian Army suggest that sine waves between 1200-1500 Hz help maintain a surgically satisfactory state of anesthesia for operations ranging from simple tonsillectomies to complicated internal surgery. But here too, many U.S. physicians brush away reports of electroanesthesia as pure unadulterated nonsense.

**Electrical Stimulation.** Although electrosleep and electroanesthesia are frowned upon in the U.S., it is an entirely different

\*Strangely enough, the electricity applied to the human body found its first significant triumph in the taking of a life. William Kemmler, convicted of murder, was sentenced to death by means of electrocution. Publicity about the impending execution attracted rival bids for the job of making the first "electric" chair. In the competition, a plan involving use of ac won out over Thomas Edison's dc system. Edison had insisted that ac was too dangerous for use in the ordinary American household. But when Kemmler was hit by 1700 volts on August 6, 1890, he began to revive a few moments after having been pronounced dead. After two more lengthy shocks—while one reporter fainted—the killer succumbed. When the public got over its indignation at so barbaric a manner of execution, opinion swung toward the use of ac for home use!



ball game in the case of electrical stimulation of both muscles and brain cells.

Implanted peripheral nerve stimulators have already proved highly effective. Using these devices, therapists seek to put into the body electricity needed for particular functions and usually provided for biologically under normal circumstances.

Most persons who have received peripheral implants are victims of strokes, cerebral palsy, or similar disabilities. A few have even suffered spinal cord injuries. Electricity fed into the body is used to stimulate peripheral nerves so that muscles will contract at appropriate times.

The complexity of "normal activities" is incredible as indicated by work in progress at various Canadian research centers. One such program is attempting to analyze precisely the characteristics and timing of the human gait. It is hoped that a computer-programmed input system will eventually enable paralyzed persons to walk by synchronized stimulation of the nerves involved.

Experiments involving electrical stimulation of the brain (ESB) have been in progress for several decades. Use of miniaturized

radio receivers have given patients complete mobility. In addition, Dr. Steven R. Topaz and colleagues have developed a "skin tunnel" transformer that permits efficient coupling, but eliminates the problem of irritation and infection. Once a skin tunnel transformer has been implanted, it can be used to transmit energy into the body and simultaneously permit readout of telemetry data regarding the electrical processes within the patient's body.

Respiratory rate, heartbeat, gastric secretions, and many other bodily functions can be absolutely controlled by ESB.

**Electronic Vision.** A crude, but functional method of electronic vision for the blind is the most ambitious and elaborate project presently involving the use of electricity applied to the body from the outside.

At the University of London, a self-taught expert in electronics has constructed an elaborate implant consisting of 80 individual radio receivers wrapped in silicone and placed under the scalp of a blind nurse. Radio signals activate the implanted receivers—singly or in groups—causing corresponding electrode stimulators to feed minute voltages to the surface of the nurse's brain. It has been demonstrated by Dr. Giles S. Brindley that this system creates the impression of perceived light. Eventually, Dr. Brindley hopes to give patients an elementary electronic vision, in which all of the optical systems used in normal vision are bypassed.

Polish researchers have taken a different path. Sight is replaced by touch, a usually highly sensitive effect in blind people. Developed by Dr. Witold Starkiewicz and Wiktor Kuprianowicz the device uses a camera, photocells and a system of 60 tiny stimulators. Objects seen through the camera are scanned and displayed on the patient's skin.

All researchers working in the area of electronic vision report that the blind will "see" within two decades. In all probability, one or more of several highly sophisticated systems will give functional sight to most blind people.

From the cardiac pacemaker to nerve stimulators, electricity is the key to much of tomorrow's medicine. However, is it not also possible that, by the use of implanted electrodes, some future super-dictator will make electronic slaves of the human race? Instrumentation for such a system is practically within our grasp. Only time will tell whether the wonders of electricity will be used to liberate man from his handicaps or to create nightmares of the future.

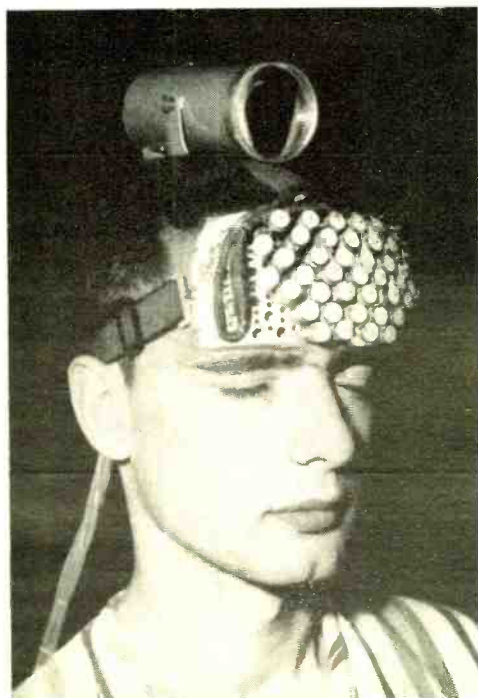

Sight is replaced by touch in the "Elektroftalm" recently developed in Poland. Image is scanned by photoelectric camera atop blind patient's head and "displayed" on forehead. Vision is rudimentary.

# What Do You Know About Capacitors?

BY ROBERT P. BALIN

For the designer or builder of electronic circuits, capacitors can sometimes be the most baffling part of the project since they come in various shapes and sizes and

perform many different functions. Test your "capacitance" by filling in the blanks below.

(Answers are on page 96)

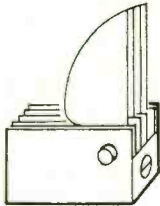

1. When a tuning capacitor in a receiver is wide open, is the receiver tuned to the low \_\_\_ or high \_\_\_ end of the band?

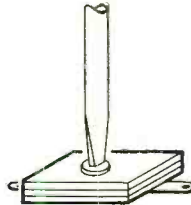

2. Does tightening the adjusting screw on a compression-type capacitor increase \_\_\_ or decrease \_\_\_ its capacitance?

What is the function of the capacitor, C, in each of the circuits shown below?

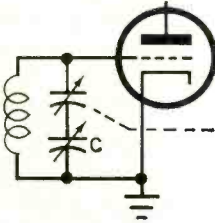

3. \_\_\_\_\_

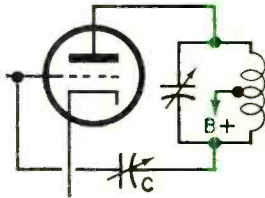

4. \_\_\_\_\_

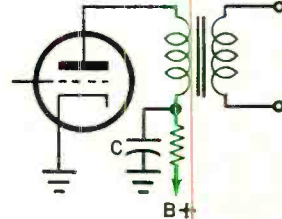

5. \_\_\_\_\_

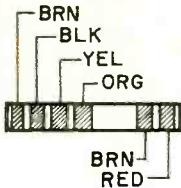

6. What does the color code on this molded tubular paper capacitor indicate about its value \_\_\_\_, tolerance \_\_\_\_, and voltage rating \_\_\_\_?

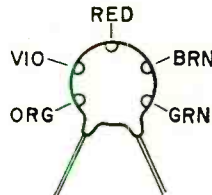

7. What are the value \_\_\_\_, tolerance \_\_\_\_, and temperature coefficient \_\_\_\_ of this ceramic disc capacitor as indicated by the color coding?

What is the total equivalent capacitance for each of the circuits shown here if all capacitors are identical and rated at 6 pF?

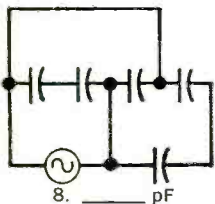

8. \_\_\_\_\_ pF

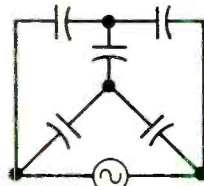

9. \_\_\_\_\_ pF

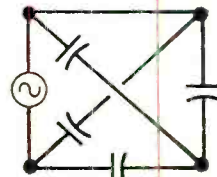

10. \_\_\_\_\_ pF



# BUILD A TIME BASE CALIBRATOR

CLEAN SQUARE WAVES FROM 1 HZ TO 1 MHZ

**This is a laboratory-style electronic construction project that would have been impossible to build without integrated circuits. With IC's, it becomes relatively simple and easy to duplicate. Uses for this project are deceptively varied and range from research to short-wave listening.**

**A** SQUARE WAVE of known frequency is one of the most useful waveforms that the serious electronics experimenter, audiophile, or engineer can have in his workshop. It can be used to check out audio systems, align probes and check attenuators of oscilloscopes. When it is differentiated, a square wave can be used to generate accurate time markers on a scope trace for making precise measurements. It can also be used to keep tabs on the accuracy of a triggered sweep scope. In experimenting with logic circuits, a square wave makes an ideal trigger.

The time base, square-wave generator or calibrator described here is crystal controlled and can deliver any of 13 selected timing

periods from 1 microsecond to 1 second. Other specifications are given in the Table.

**Theory of Circuit Design.** The circuit of the calibrator is shown in Fig. 1. Field-effect transistor *Q1*, with *XTAL1* and other components, forms a 1000-kHz oscillator. The signal generated at the junction of *L1* and *H2* feeds a shaper (*Q2*) which is biased to operate in the saturation region. The shaper provides the necessary square-edged signal for driving the DTL (diode-transistor logic) frequency divider chain.

The divider chain, consisting of 12 dual-JK flip-flops, is arranged to divide in a series of 2 and 5. The basic logic circuit for such division is shown in Fig. 2, which is similar to the actual division using the IC's.

The output of each divider is fed to one position of a 13-position rotary switch (*S1*). The selected signal from the switch is coupled to an output buffer (*Q3*), which also operates in the saturation region. The output is split by *R5* and *R6* to provide an output termination of 50 ohms.

**Construction.** Because of the high fre-

COVER STORY BY RICHARD J. VALENTINE



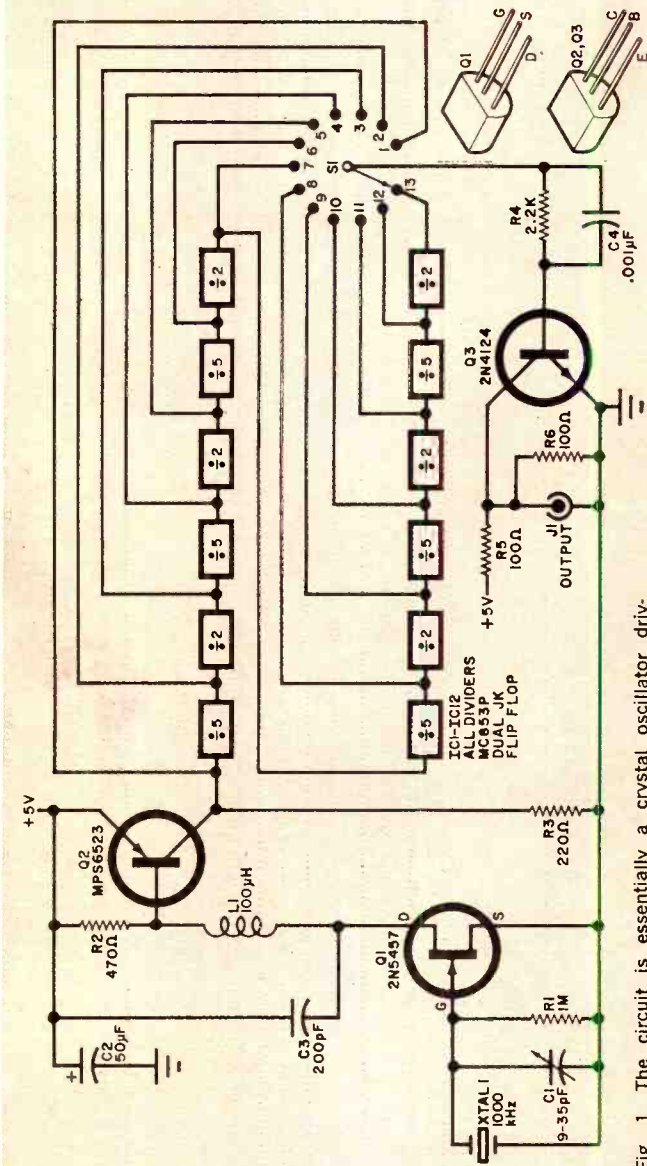

Fig. 1. The circuit is essentially a crystal oscillator driving a shaper circuit, fed to a string of digital dividers. If desired, other frequencies can be obtained either by changing the crystal frequency, the divider chain arrangement, or both.

### S1 POSITIONS

- 1— $1\ \mu\text{S}$ , 1 MHz
- 2— $5\ \mu\text{S}$ , 200 kHz
- 3— $10\ \mu\text{S}$ , 100 kHz
- 4— $50\ \mu\text{S}$ , 20 kHz
- 5— $100\ \mu\text{S}$ , 10 kHz
- 6— $500\ \mu\text{S}$ , 2 kHz
- 7—1 mS, 1 kHz
- 8—5 mS, 200 Hz
- 9—10 mS, 100 Hz
- 10—50 mS, 20 Hz
- 11—1 S, 10 Hz
- 12—5 S, 2 Hz
- 13—1 S, 1 Hz

### PARTS LIST

- C1—9.35- $\mu\text{F}$  miniature trimmer capacitor
- C2—50- $\mu\text{F}$ , 6-volt electrolytic capacitor
- C3—200-pF disc capacitor
- C4—0.001- $\mu\text{F}$  disc capacitor
- IC1-IC12—Dual JK flip-flop (Motorola MC853P)
- J1—BNC jack and mating plug
- L1—100- $\mu\text{H}$  molded choke
- Q1—2N5457 transistor

- Q2—MPS6523 or HEP57 transistor
- Q3—2N4124 or HEP53 transistor
- R1—1-megohm
- R2—470-ohm
- R3—220-ohm
- R4—2200-ohm
- R5, R6—100-ohm
- S1—13-pole rotary switch
- XTAL1—1000-kHz crystal
- Misc.—Suitable chassis, knob, stand-offs, wire, solder, etc.

quencies involved, the use of a printed circuit board is recommended. An actual size foil pattern and component installation diagram are shown in Fig. 3.

The power requirements are 5 volts dc at about 220 mA, which can be obtained either from a power supply such as that shown in

Fig. 4 or, for a portable unit, from three D cells connected in series. If you build the ac supply, use a 2 sq. in. heat sink for Q1.

The completed PC board and power supply can be mounted in any type of metal chassis, with the power switch, frequency selector switch and output jack on the front panel.

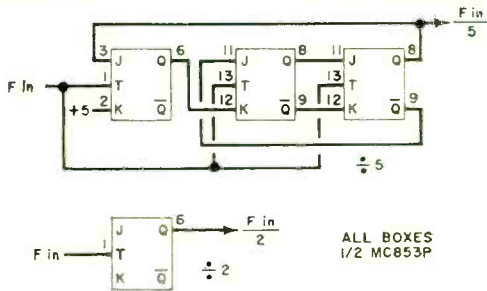
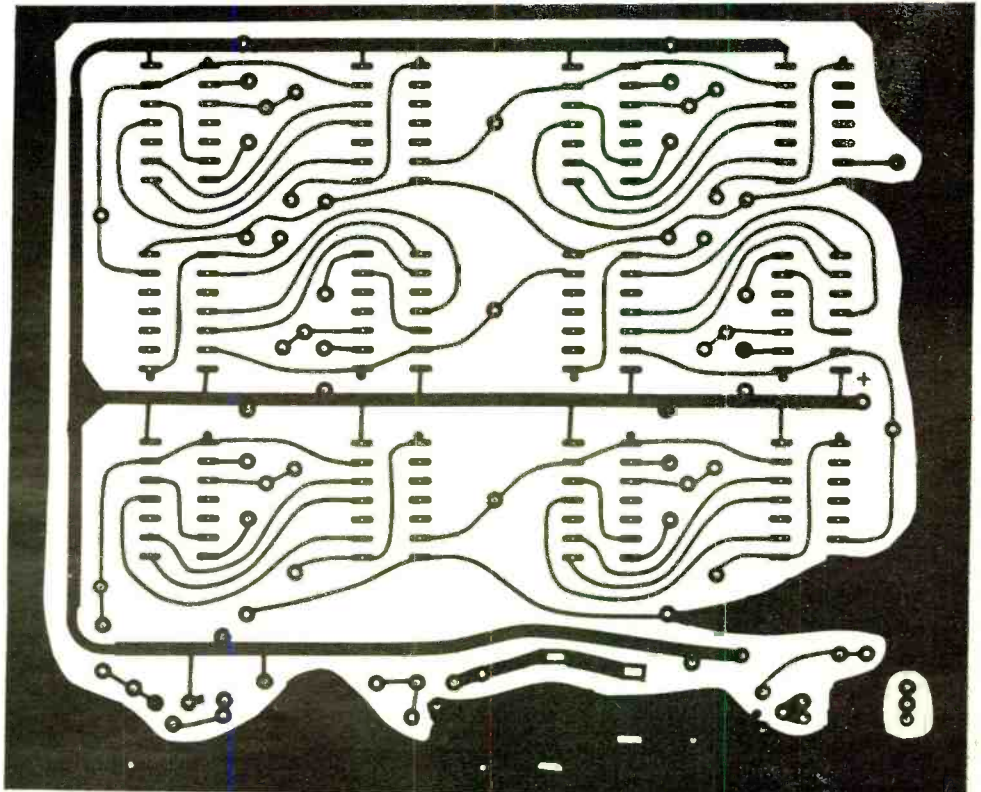
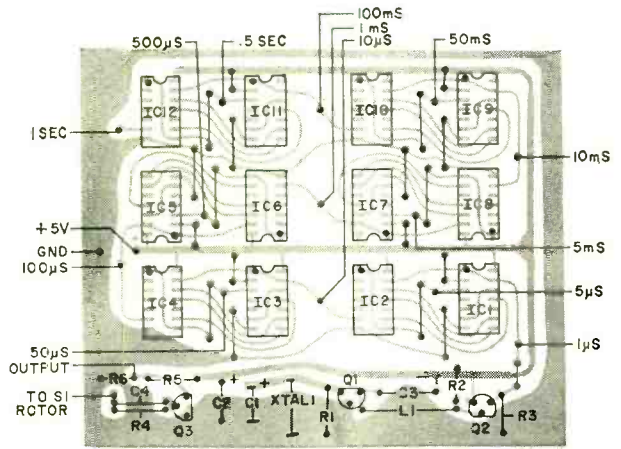
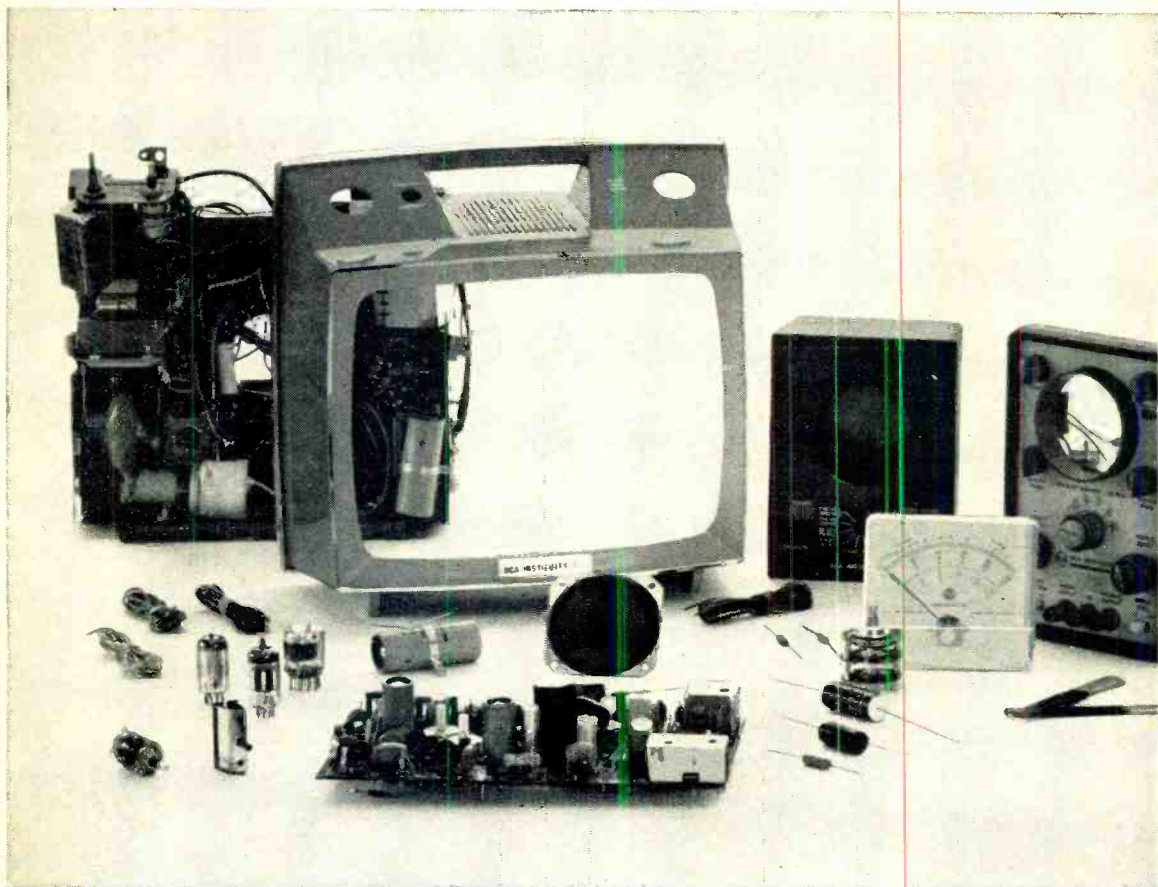

Fig. 2. Minimum hardware divide-by-5 and divide-by-2 circuits used in the calibrator. Because each IC contains a pair of JK flip-flops, a pair of IC's contains the two divide circuits shown at the left.

Fig. 3. The actual size PC board foil pattern shown below simplifies the wiring of the calibrator. Once fabricated, the components are installed as shown at the right. Observe the coding of all components, and make sure that all jumpers are placed properly. Due to the delicacy of this PC pattern all of the drill holes for installing the IC's may not show in this reproduction. Drill holes in each of the 14 contact points for all 12 IC's.





**Look! You get 25 kits...  
more than ever before at no extra  
cost...for your practical "hands-  
on" learning of electronics and  
TV with RCA Institutes Home  
Training! Send postcard today!**



# RCA

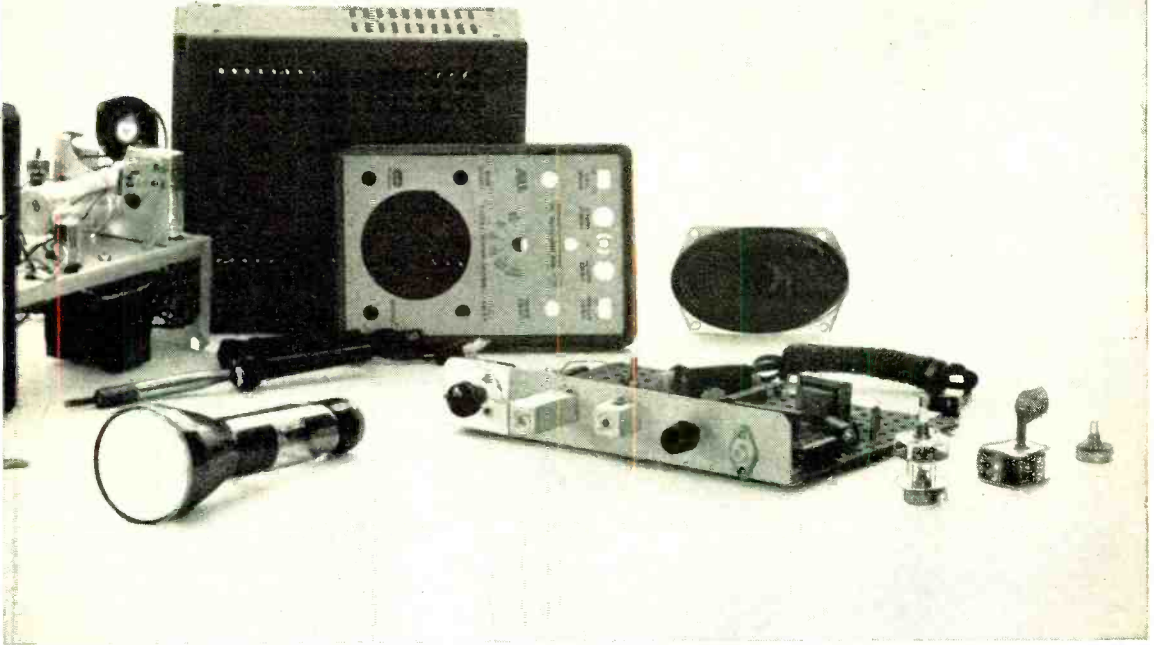

Now, RCA supplies 25 kits in its home-study career program—at no extra cost! Be sure to compare this with other home-study electronics programs. And note, you never have to take apart one kit to build another piece of equipment because there are literally thousands of parts making up the kits. Information on them is included in the catalogue which you'll get when you mail in the reply postcard or the coupon.

Absolutely practical, your kits are used to build such permanent, professional and useful equipment as an oscilloscope, a signal generator, a multimeter, and a fully transistorized breadboard superheterodyne AM receiver. They will give you years of valuable service.

In addition, an easy way to learn—the career programs are all based on the easy, step-by-step AUTOTEXT method. AUTOTEXT is unique and exclusive with RCA Institutes. Math and circuitry problems simply melt away! So check the wide range of electronics and TV career programs.

**Eleven Career Programs:** Television Servicing (including color TV and

CATV) • FCC License Preparation • Automation Electronics • Automatic Controls • Industrial Electronics • Nuclear Instrumentation • Electronics Drafting • including these four all-new: Semiconductor Electronics • Digital Electronics • Solid State Technology • Communications Electronics.

Also check the new Computer Programming course—trains you to work on today's largest data processing systems including IBM/360 and RCA Spectra 70, the Third Generation Computers.

**Easy payment plan:**

Take advantage of easy monthly payments.

No interest charge!

**Classroom training also available—**day and evening coeducational classes start four times a year. No previous training required—you can take preparatory courses if you haven't completed high school.

**Placement service, too—**with RCA Institutes classroom training, you get the full benefits of the RCA Job Placement Service. RCA Institutes grad-

uates are now with companies that include Bell Telephone, GE, Honeywell, IBM, RCA, Westinghouse, Xerox, and major radio/TV networks. This placement service is also available to Home Study Graduates.

**Veterans: enroll now — all courses are approved under the GI bill**

Accredited Member National Home Study Council.

If reply postcard has been removed, mail this coupon.

.....  
• RCA INSTITUTES, INC.  
• Home Study Dept. 694-Q11-1  
• 320 West 31 Street, New York, N.Y. 10001  
• Please send me free illustrated career catalog.  
• Age \_\_\_\_\_  
• Name \_\_\_\_\_  
• (please print)  
• Address \_\_\_\_\_  
• City \_\_\_\_\_  
• State \_\_\_\_\_ Zip \_\_\_\_\_  
• For GI information, check here   
.....

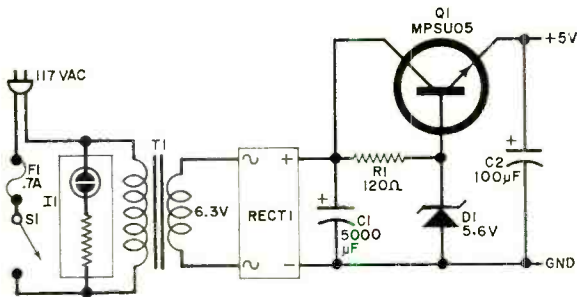

Fig. 4. This regulated power supply can easily handle the calibrator. If you want portability, use three 1½-volt D cells in series for the power supply. The slightly reduced voltage will not affect operation.

### PARTS LIST POWER SUPPLY

*C1*—5000- $\mu$ F, 10-volt electrolytic capacitor  
*C2*—100- $\mu$ F, 6-volt electrolytic capacitor  
*D1*—1N5232 diode  
*F1*—0.7A fuse and holder  
*I1*—120-volt neon lamp indicator assembly  
*Q1*—MPSU05 transistor

*R1*—120-ohm, ½-watt resistor  
*RECT1*—MDA920-1 or HEP175 25-volt, 1A bridge  
*S1*—Spst switch  
*T1*—Filament transformer, secondary 6.3 volts at 600 mA  
*Misc.*—optional power-on indicator, heat sink, terminal strip, mounting hardware, line cord, grommet, etc.

**Operation.** To calibrate the generator accurately, put *S1* in the 1 MHz position and connect a short length of wire to the output jack. With the wire and the calibrator near a shortwave receiver tuned to WWV (5, 10, or 15 MHz), adjust capacitor *C1* to obtain a zerobeat between the generator and WWV. If you have a frequency meter, adjust *C1* to obtain an exact 1-MHz indication on the meter. However, if you have neither a WWV receiver nor a frequency meter, the inherent accuracy of the 1-MHz crystal will be sufficient for most purposes.

In using the calibrator, the output connection should be made through a 50-ohm coaxial cable terminated in a 50-ohm load.

**Spiker.** If you need a sharp spike signal of known frequency, use the circuit shown in Fig. 5 to develop the required signal. The input impedance is 50 ohms; the output is 1000 ohms. The switch is used to select the proper capacitor for each group of frequencies.

**Applications.** Although primarily designed for the calibration of oscilloscopes with triggered sweeps, this square-wave generator and spiker combination has a number of other important laboratory and experimental applications.

First, the generator makes an excellent frequency calibrator for use with general purpose shortwave receivers. For this application,

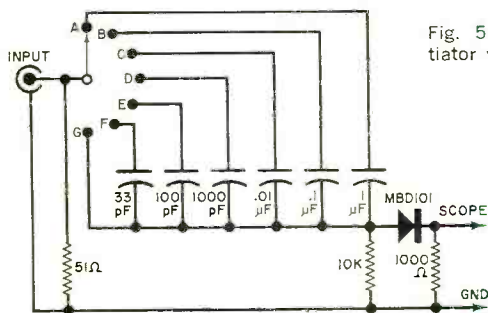

Fig. 5. The spiker is essentially a differentiator whose series capacitor can be selected.

### SWITCH POSITIONS

A—1 S.50 mS  
 B—10 mS.5 mS  
 C—1 mS.500  $\mu$ S  
 D—100  $\mu$ S.50  $\mu$ S  
 E—10  $\mu$ S.5  $\mu$ S  
 F—1  $\mu$ S  
 G—direct

## TECHNICAL SPECIFICATIONS

**Rise and fall times:** 25 nanoseconds  
**Time period:** 13 selectable times in 1 and 5 steps from 1  $\mu$ s to 1 second  
**Accuracy:** 0.005%  
**Amplitude (output):** 1 volt into 50 ohms  
**DC offset:** less than 0.3 volt  
**Noise and ripple:** 20 mV  
**Power required:** 5 volts at 220 mA

connect the spiker to the generator and attach a short antenna to the spiker output. Set the front panel switch to 1 MHz (1  $\mu$ S). This will produce a train of "birdies," 1 MHz apart. With the receiver tuned to WWV on 5, 10, or 15 MHz, the crystal oscillator in the generator can be trimmed to the exact frequency. Use other dial positions and the calibrator will generate the frequencies shown in Fig. 1. Suitable selection of frequencies will permit a very accurate determination of the frequency of an incoming signal.

Due to the fact that the square waves generated have very rapid rise and fall times, they can be used as a source of pulses for triggering many types of IC logic, especially RTL, where steep edges are required. Having complete control of the output frequency means that the logic can be triggered at almost any desired rate.

The square waves are also ideal for testing amplifiers—from conventional audio to broad-bandwidth video. High- and low-frequency

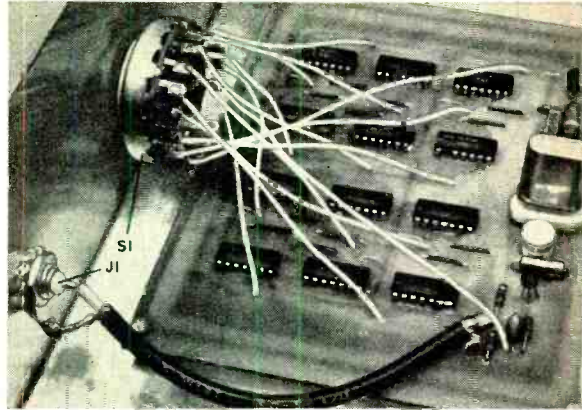

The connections from the PC board to the selector switch should be made as short as possible. A short length of coaxial cable serves as the output lead.

response, as well as ringing, can be detected when using the square-wave generator in conjunction with a wideband scope. Simply driving the amplifier under test with a square wave of suitable frequency and observing the changes (if any) that the amplifier produces on the square wave will show the characteristics of the amplifier. For example, to provide a clean square-wave output, the amplifier response must be from about 1/10 to 10 times the fundamental frequency of the square wave. Thus, if an amplifier can cleanly reproduce a 10-kHz waveform, then its response is good from about 1 kHz (usually much lower) to about 100 kHz.

-50-

Use a 2-square-inch piece of scrap aluminum as the heat sink for Q1. Isolate the heat sink from the chassis using an insulated spacer.

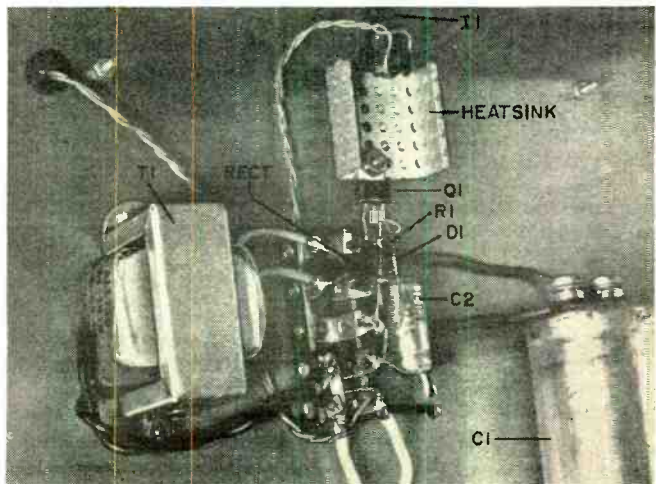



# BUILD A CRYPTO -LOCK

ELECTRONIC SECURITY: SMALL IN SIZE AND BURGLAR PROOF

**This unusual electronically activated lock is the simplest—yet one of the most difficult to “break”—circuits examined by the Editors in the past few months. Its simplicity is deceptive and we urge anyone having a use for such a device to peruse this article carefully.**

**T**HERE ARE almost as many varieties of electronic combination locks as there are combinations to operate them. Most are complex pieces of solid-state wizardry—often employing dozens of costly components in elaborate circuits to provide burglar-proof “one-chance-in-1,774,385” combinations.

By contrast, the “Cryptolock” is a simple device, that is inexpensive, easy to build, and small enough to give you electronic lock protection on such things as medicine cabinets, power tool chests, gun racks, desks, and even strong boxes. Or you can use it to safeguard the doors of your home and garage as safely as the best mechanical lock.

The Cryptolock’s three-digit combination is deceptive. Numerical grouping, two timing circuits and a penalty feature make “cracking” it a difficult task. Yet, when one knows the combination, it can be opened in less

than two seconds. The Cryptolock can be powered by batteries or by a low-voltage dc power supply. Thus it is suitable for both fixed and portable installations.

On the “key” panel for the Cryptolock are six miniature, momentary-contact, push-button switches—each identified by number. The switches are connected to the electronic circuit, which is housed in a small, molded-plastic box mounted inside the area to be protected.

The combination of the unit shown in Fig. 1 is 1/5-4. This means that, to open the lock, switches 1 and 5 must be pressed simultaneously, followed immediately by the pressing of switch 4. Most people find that it is quite easy to press the two initial switches at the same time with their index and middle fingers. Since these two switches are wired in series, they must be closed at the same time for a fraction of a second in order to enter the first part of the combination. Then when the 4 switch is pressed, the solenoid on the lock is energized.

That seems pretty simple, but there is a catch. After the first two numbers are pressed, you have only about one and one-half seconds to press the third. After that time,

---

BY JAMES G. BUSSE  
POPULAR ELECTRONICS

nothing happens when the third number is pressed. It is then necessary to start over with the first two numbers. This two-digit/one-digit combination is enough to confuse most would-be "safe-crackers" who expect to try no end of one-number-at-a-time combinations. That's not the end of the thief's problems, however. If, at any time after he has chanced to press 1 and 5 simultaneously, he chances to press 2, 3, or 6, the lock is automatically deactivated for about 25 seconds. Until the circuit comes to life again, even the correct combination won't open it. What's more, if 2, 3, or 6 is pressed again during this period, the waiting time is extended to the full 25 seconds. The fact that there is no way to tell when he has deactivated the circuit by pressing the wrong number is enough to discourage even the most persistent burglar.

Of course, the combination of the Cryptolock can be changed to any two-digit/one-digit code in a matter of minutes with a soldering iron. It can also be made more complicated by adding four or more switches in parallel with the penalty switches (2, 3, and 6). The combination—while sufficiently complex to foil most attempts to open it illegally—is still simple enough for a child to remember and use.

**Construction.** Using the circuit shown in Fig. 1, the prototype was built in a  $2\frac{1}{8}'' \times 3\frac{1}{4}'' \times 1\frac{1}{8}''$  molded plastic box. This makes the unit as small as possible for use in a limited space. However, a larger enclosure can be used. The circuit can be located some distance away from the key panel and the solenoid latching mechanism. The components were mounted on perf-

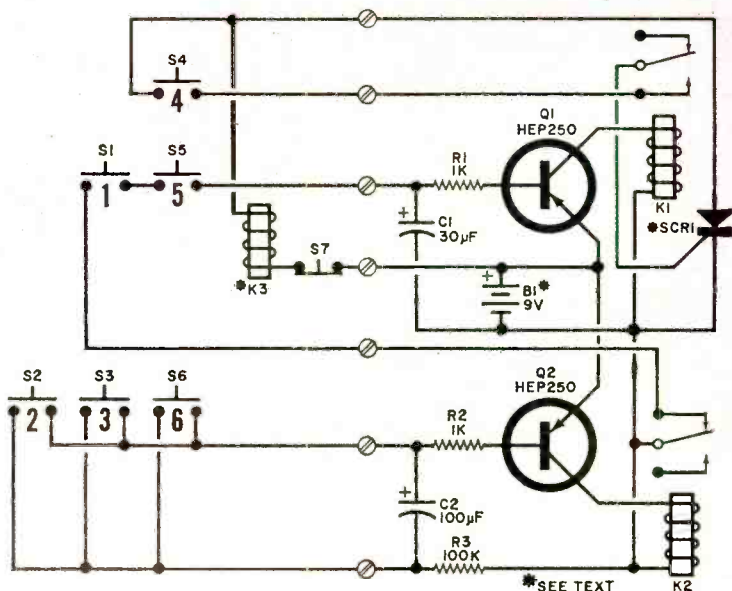

Fig. 1. If desired, circuit can be extended by adding more switches in parallel with S2, S3, and S6; in series with S1 and S5; or in series with S4. To change combinations, rearrange the switch positions on door or plate.

### PARTS LIST

B1—9-volt dc source  
 C1—30- $\mu$ F, 15-volt electrolytic capacitor  
 C2—100- $\mu$ F, 15-volt electrolytic capacitor  
 K1, K2—5000-ohm miniature dc relay (Lafayette Little Jewel 99E60915 or similar)  
 K3—6-to-9-volt dc solenoid or relay (see text)  
 Q1, Q2—SK3004 or HEP250 transistor

R1, R2—1000-ohm,  $\frac{1}{2}$ -watt resistor  
 R3—100,000-ohm,  $\frac{1}{2}$ -watt resistor  
 SCR1—Silicon controlled rectifier (GE-X1 or similar, see text)  
 S1-S7—Spst normally open miniature push-button switch (Switchcraft 961 or similar)  
 Misc.—Test lamp (6-to-9-volt), perf board, plastic case, power relay (optional), interconnecting multi-lead cable.

board. Parts placement is not critical, as long as each component is isolated from the others and free movement of the relay armature is assured. Point-to-point wiring is acceptable if leads are kept short and neat. Use a needle-nose pliers or a clip-type heat sink to protect *Q1* and *Q2* when soldering. The *SCR* is bolted to the perf board by its threaded

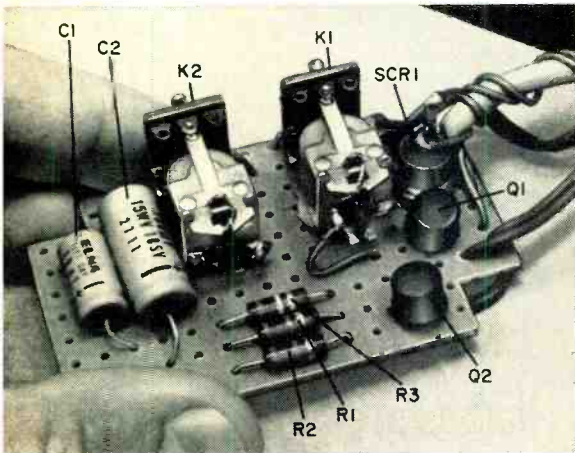

If you build the lock on perf board, you can follow layouts used by the author on prototype model.

anode. Bolt or cement the two miniature relays to the perf board. They should be mounted so that they are upright and relatively level. Their performance will be affected if they are mounted on their sides or inverted.

The components chosen for *SCR1*, *K3* and the power source must be properly related. Start with the selection of solenoid *K3*.

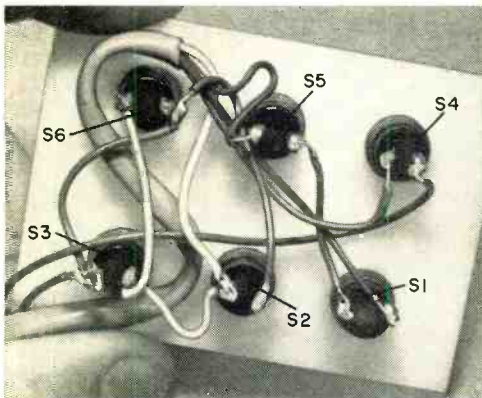

In finished version, the six pushbuttons would be mounted directly on the door being protected.

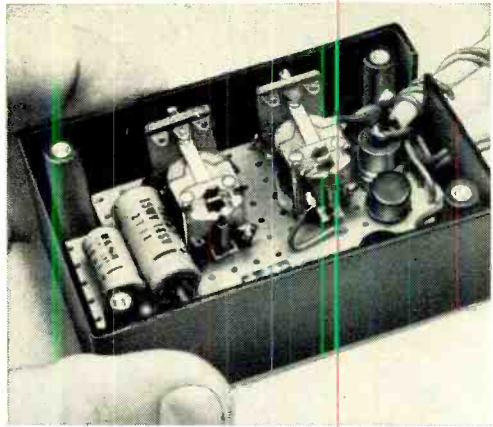

To protect the relays, in the prototype, the unit was mounted in a conventional plastic enclosure.

There are many low-current de solenoids on the market, so select a 6- or 9-volt type that is spring-loaded to remain locked unless the coil is energized. Then choose an SCR that can carry the coil current and a power source that can handle this load. As another option, a 6-to-9-volt relay (with contacts rated to carry the load) can be used instead of *K3* if you wish to activate some form of alarm. With de applied to the SCR, once it is fired, it will remain on unless the supply

*(Continued on page 94)*

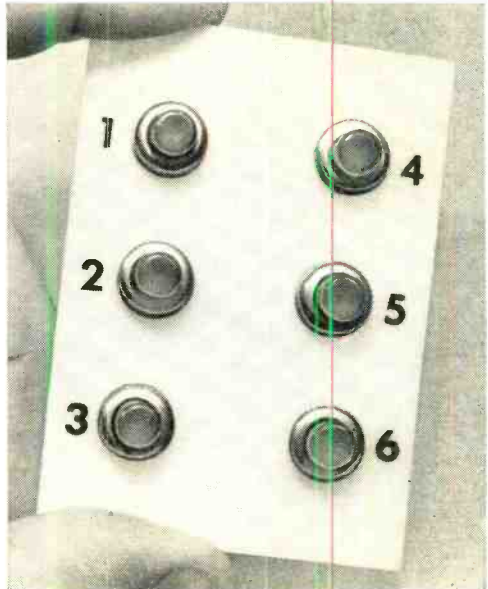

The six pushbuttons can be marked in any fashion with numbers, letters, symbols, or left just plain.



BY FRANK H. TOOKER

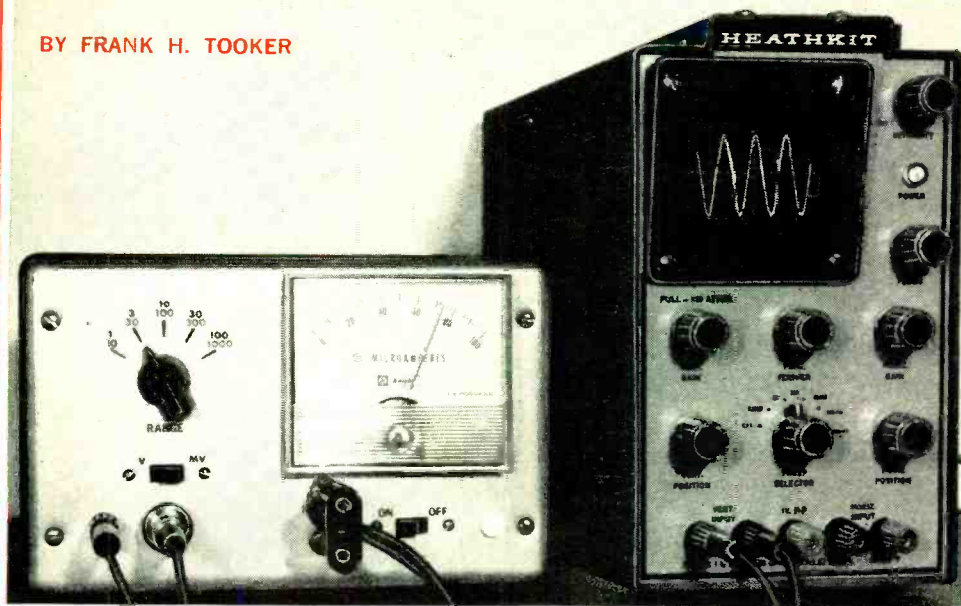

## MILLIVOLTMETER FOR FET CIRCUITS

ULTRA-HIGH VALUE DRAIN RESISTORS REQUIRE  
MINIMUM-LOADING 100-MEGOHM INPUT mV METER

**It may appear to be a vicious circle, but as FET's, MOSFET's, and IGFET's become more common in experimental circuits, the test equipment necessary to check performance must be dramatically improved. This millivoltmeter was designed to measure FET circuits without loading. The input resistance is 100 megohms with a capacitance of 12-15 pF. Complete instructions for assembly are included in this article.**

**A**S ELECTRONICS TECHNOLOGY advances, so must the characteristics of our measuring instruments improve in order to keep pace. Consider how firmly entrenched the FET is in amplifier circuitry and how rapidly behind it are the MOSFET or

IGFET. The output impedances of any of these new devices is so high that for many practical applications it is practical to build amplifier stages with drain resistors having values in the Megohm range.

The question now arises: Just how does one go about checking with any guarantee of accuracy the signal-voltage gain and the waveform or distortion level at the output of such an amplifier stage? Conventional test instruments do not provide this guarantee since, in most cases, they disturb the operating conditions of the circuit under test.

One cannot connect a 1-megohm ac millivoltmeter to the drain circuit of any type of FET circuit and ask for accuracy. Such a connection drops the amplifier's drain resistor to one-half its original value. Worse, accuracy will suffer by 50 percent. Even a 10-Megohm millivoltmeter connected across a

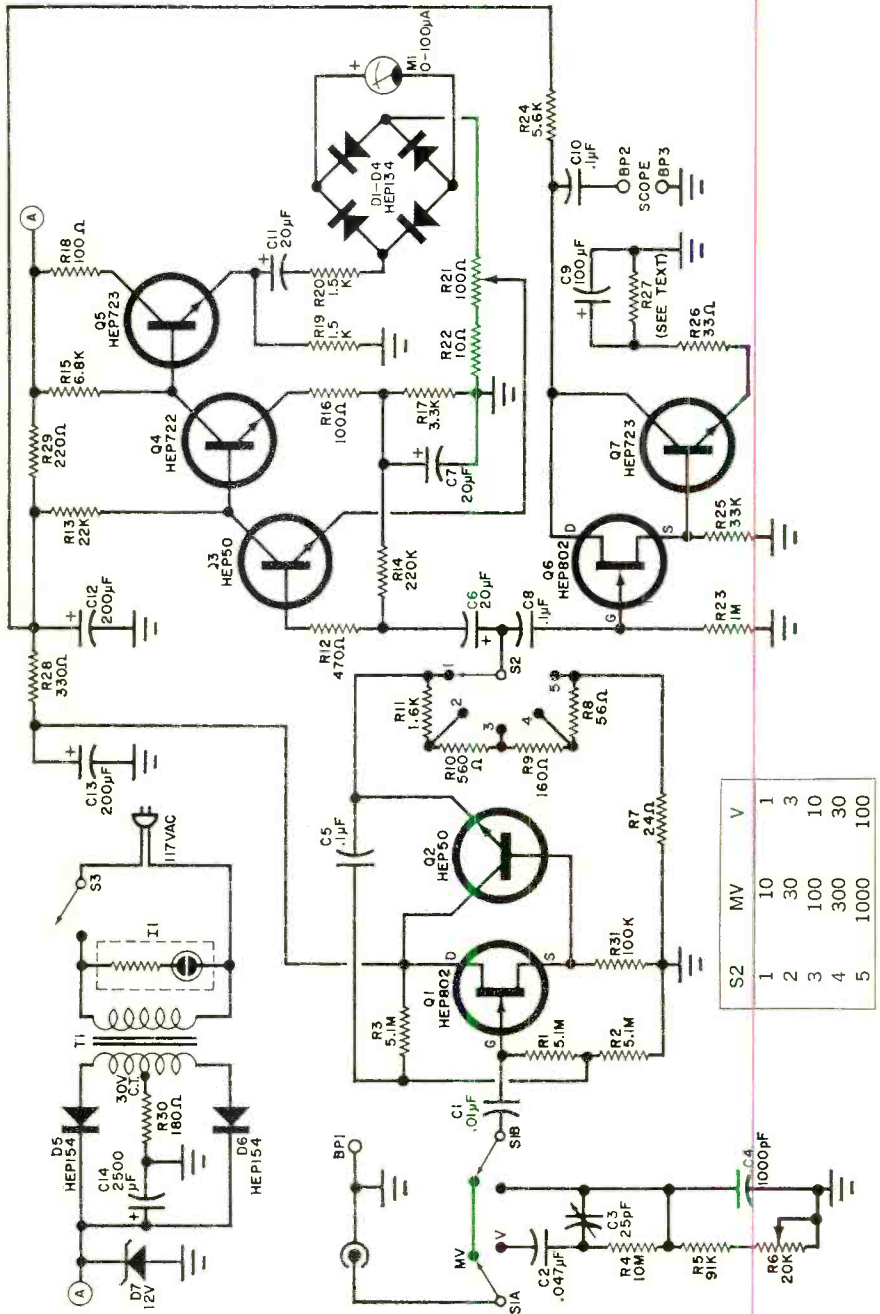

Fig. 1. Function switch S1 allows user to measure 0-1000 mV or 0-1000 volts rms in alternate positions. Range selection is accomplished with switch S2.

## PARTS LIST

- BP1-BP3—Five-way binding post (one red, two black)  
 C1—0.01- $\mu$ F, 100-volt Mylar-paper capacitor (Sprague Type 225P)  
 C2—0.047- $\mu$ F, 100-volt Mylar-paper capacitor (Sprague Type 225P)  
 C3—25-pF, zero-temperature coefficient, ceramic trimmer capacitor (Centralab No. 822-AZ)  
 C4—1000-pF, 100-volt, 5% tolerance,  $\pm 0.05\%$  capacitance-drift silver-mica capacitor (Elmenco No. DM-15-102J)  
 C5, C8, C10—0.1- $\mu$ F, 100-volt Mylar-paper capacitor (Sprague Type 225P)  
 C6, C7, C11—20- $\mu$ F, 12-volt electrolytic capacitor (Sprague No. TE-1130)  
 C9—100- $\mu$ F, 3-volt electrolytic capacitor (Sprague No. TE-1059.5)  
 C12, C13—200- $\mu$ F, 15-volt electrolytic capacitor (Sprague No. TE-1164)  
 C14—2500- $\mu$ F, 15-volt, low-series-resistance electrolytic capacitor (Sprague No. 39D-258G015CP1)—Do not substitute  
 D1, D11—HEP134 germanium diode (Motorola)  
 D5, D6—HEP154 silicon rectifier (Motorola)  
 D7—12-volt, 5% tolerance, 1-watt zener diode ( $I_z = 21$  mA)  
 H—Miniature neon pilot lamp (Leecraft No. 36N-2313 or similar)  
 M1—0-100- $\mu$ A dc shielded meter movement (Allied Radio Shack No. 52A7202)  
 Q1, Q6—HEP302 field-effect transistor (Motorola)  
 Q2, Q3—HEP50 bipolar transistor (Motorola)  
 Q4—HEP722 bipolar transistor (Motorola)  
 Q5, Q7—HEP723 bipolar transistor (Motorola)

- R1-R3—5.1-megohm  
 R4—10-megohm  
 R5—91,000-ohm  
 R12—470-ohm  
 R13—22,000-ohm  
 R14—220,000-ohm  
 R15—6800-ohm  
 R16, R18—100-ohm  
 R17—3300-ohm  
 R19, R20—1500-ohm  
 R22—10-ohm  
 R23—1-megohm  
 R24—5600-ohm  
 R25—33,000-ohm  
 R26—33-ohm  
 R28—330-ohm  
 R29—220-ohm  
 R30—180-ohm  
 R31—100,000-ohm  
 R27—See text

- R7—24-ohm  
 R8—56-ohm  
 R9—160-ohm  
 R10—560-ohm  
 R11—1600-ohm

All resistors  $\frac{1}{2}$ -watt, 5% tolerance

All precision resistors 1% tolerance (IRC Type AS-2)

1-megohm circuit will give accuracy of no better than 90 percent, not counting the inaccuracies inherent in the measuring instrument itself. In the latter case, the total inaccuracies can add up to as much as 14 percent.

Obviously, our 10-megohm ac mV meter can no longer be justifiably called a "negligible loading" device when used on any circuit we might have occasion to test. If we are going to make measurements across resistances on the order of 1 Megohm, without having to take into consideration the loading effect, the time has come to make another ten-fold increase in the input impedance of our measuring equipment.

This is the principle behind the "High-Input-Resistance AC Millivoltmeter" described in the following pages. The schematic diagram of the mV Meter is shown in Fig. 1. It has a 100-megohm input resistance for minimum loading effect. It is capable of measuring ac voltages from as low as 0.2 mV to as high as 1000 mV (1 volt) rms. In the mV range, the input resistance of the mV Meter is 100 megohms, while in the V range, input resistance is a standard 10 megohms.

One more feature of the mV Meter—and one that can be used independently if desired—is the inclusion in the instrument of an oscilloscope preamplifier. This circuit is used in conjunction with the voltage measuring circuit to provide the all-important visual indication of the waveform being measured.

R6—20,000-ohm,  $\frac{1}{2}$ -watt, 15-turn potentiometer (Bourns Type 3068-S)

R21—100-ohm,  $\frac{1}{2}$ -watt, 15-turn, wire-wound potentiometer (Bourns Type 3067-S)

S1—Dpdt slide switch

S2—Single-pole, five-position shorting-type miniature rotary switch

S3—Spst slide or toggle switch

T1—117-volt primary/30-volt at 150 mA, center-tapped, secondary power transformer

1—Bud No. CU-585 utility cabinet

Misc.—Panel-type microphone connector (Amphenol No. 75-PCM); microphone cable-type connector (Amphenol No. 75-MCIF); 3-ft. length of low-capacitance coaxial microphone cable; 2 $\frac{1}{4}$ " crocodile clip (Mueller No. 85); control knob; power cord and strain relief; aluminum-alloy sheet for shields; epoxy-glass circuit boards (see text);  $\frac{1}{16}$ "-diameter buss bar wire; terminal strips;  $\frac{1}{4}$ " cable clamp; heat-shrinkable tubing (optional); #4 and #6 machine hardware; rubber grommets (4); No. 20 solid hookup wire; solder; etc.



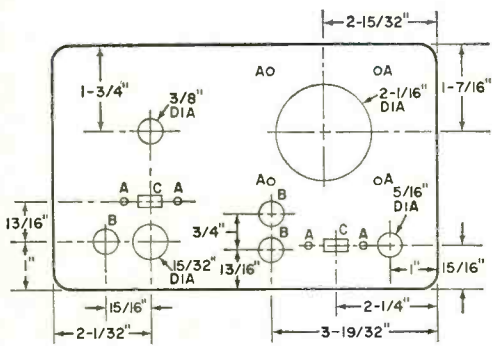

- A = NO. 32 DRILL (8)
- B = 2 1/64" DIA (3)
- C = 1/4" X 1/2" (2)

Fig. 2. Before machining front panel, carefully and accurately locate all hole centers as shown.

**Construction.** This is an advanced construction project and, unless you have successfully assembled and calibrated other sensitive test instruments in the past, it is recommended that you do *not* attempt to build the mV Meter. Any number of problems can beset the beginner. In assembling the mV Meter you must not only be aware of what you are doing, but *why* you are doing it every step of the way. Also, do not substitute for any of the components specified in the Parts List unless you are fully cognizant of the extent to which such substitutions can affect the accuracy and stability of the instrument.

The mV Meter should be assembled in a Bud No. CU-585 steel contour utility cabinet exactly as described in this article. Referring to Fig. 2, first machine the front panel as shown. Then, using the drawings in Fig. 3, fabricate the center shield, input circuit shield, power supply shield, and the shield support bracket from sheet aluminum. It is on these shields and the front panel of the cabinet that all parts and assemblies are to be mounted. So, be careful when machining the parts. Assemble the shields and check them for fit on the front panel via the meter's

The above features, combined with the technical specifications given on page 51, show that this is an advanced instrument for the serious user, whether he be an experimenter or professional engineer.

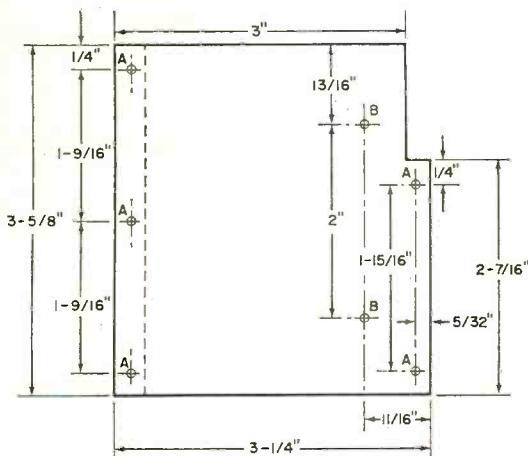

- A = NO. 32 DRILL (5)
- B = NO. 28 DRILL (2)

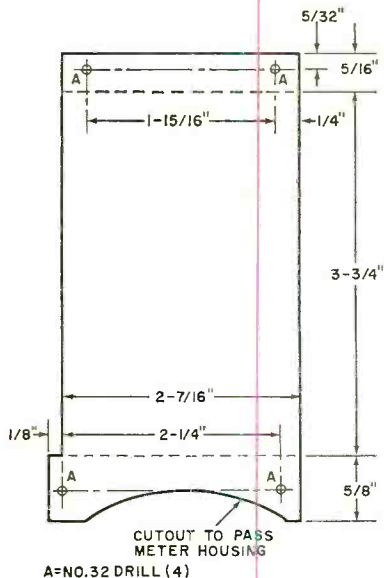

- A = NO. 32 DRILL (4)

Fig. 3. Identified from left to right across both pages are power supply shield, shield support bracket, center shield, and input circuit shield. All shields should be fabricated

mounting hardware and the shield mounting bracket.

You will notice in the drawings that the hole locations for the mounting hardware for the circuit boards are not given. These holes are best located by marking through the appropriate board holes (before the components are mounted on them). Holes for the rubber grommets can be reasonably positioned, since their exact locations are not critical. However, the objective here is to keep the leads which pass through the grommets as short as possible. Also, when assembling the instrument keep the input and output leads of each assembly well separated from each other.

Most of the small components that make up the mV Meter assemble on four small printed circuit boards, the etching guides for which are given in Fig. 4.

Each of the first three circuit board assemblies mounts on a pair of 4-40 × 1" machine screws with three nuts to each screw. One nut anchors the screw to the shield, while the remaining nuts serve as the spacers and board anchors. The meter rectifier assembly mounts directly on the meter terminals, foil side facing the meter housing.

Mount the input circuit assembly on the in-

put circuit shield, foil side facing the shield. Then mount the meter amplifier and scope preamp assemblies on the meter side of the center shield. When mounting these circuit boards orient them so that the foil side on the scope preamp is toward the shield and the foil side on the meter amp faces away from the shield.

Power supply components *C14*, *D5-D7*, *R30*, and *T1* mount on the power supply shield located at the right rear corner of the instrument assembly. The leads between power switch *S3* and the power supply proper should be lengths of plastic-insulated lamp cord.

The lead lengths on pilot lamp assembly *I1* require only slight shortening. Twist these leads together, and with the leads to *S3*, pass them through a 1/4" cable clamp. Then secure the cable clamp to the shield support bracket. Caution: keep these leads as far as possible from the meter amp and scope preamp assemblies.

The power supply filter assembly (*C12*, *C13*, *I:28*, and *I:29*) mounts on a terminal strip secured to the left rear of the center shield. Note that separate leads from the filter must be routed to each circuit board assem-

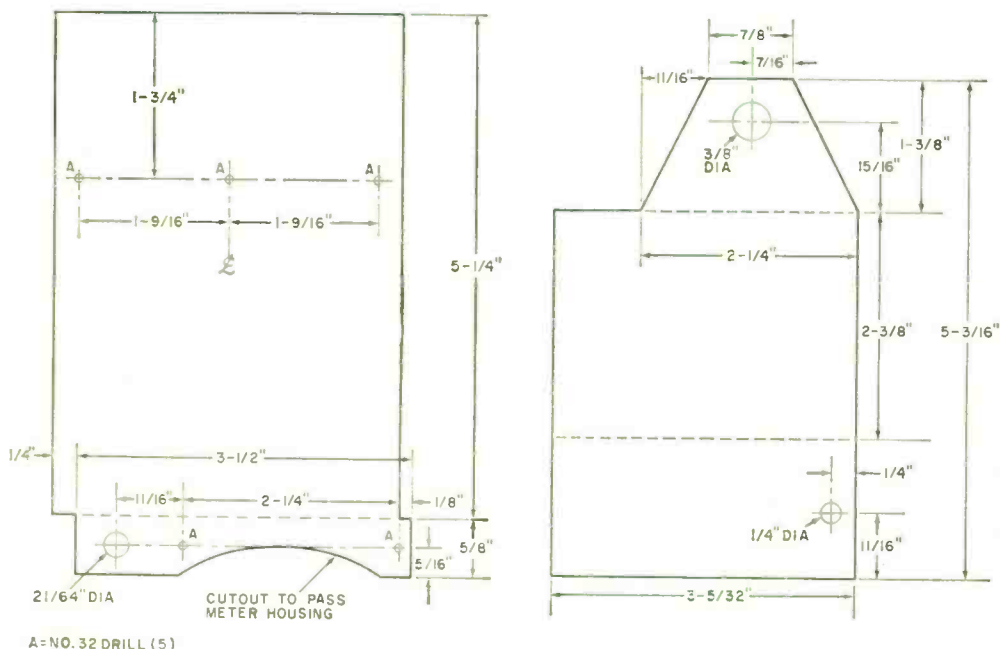

A=NO. 32 DRILL (5)

from 0.050"-thick sheet aluminum alloy to exact dimensions indicated in diagrams. Once fabricated, metal pieces should be bent along dashed lines; far right piece into Z shape.

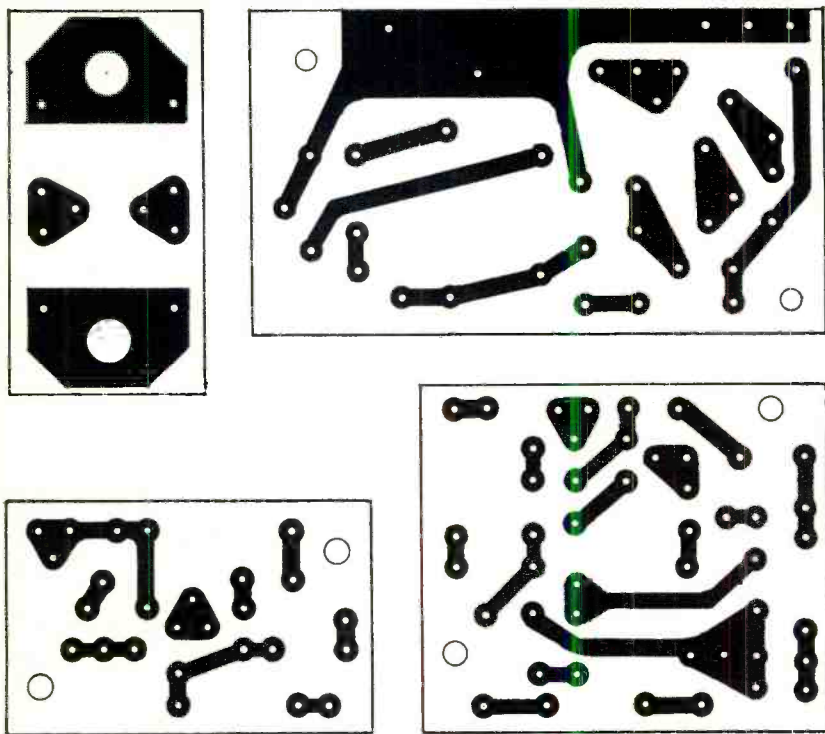

Fig. 4. When reproducing printed circuit boards, using actual size etching guides shown here, best results are obtained if an epoxy-fiberglass base material is used.

bly (except the meter rectifier board). This is necessary to avoid common-lead coupling between the amplifiers.

Now, mount the components in their respective locations on the four circuit boards according to the diagrams provided in Fig. 5. When assembling board (1), mount  $R4$  on the foil side of the board, across the terminals of  $C3$ . Then, for board (2), solder  $R17$  across  $C7$ , close to the body of the capacitor and use the resistor leads to make the solder connections to the foil on the board.

On board (3), temporarily leave  $C9$  out of the circuit. Preset a 5000-ohm potentiometer to the midpoint of its rotation, and lightly tack the pot into the  $R27$  location. Connect the board to an 11-volt dc power supply and use a 20,000-ohms/volt VOM or a VTVM to check the potential between the collector of  $Q7$  and the common ground foil conductor on the circuit board. Adjust the pot until the meter indicates a 5.5-volt level. Remove the meter, disconnect the power supply, and, without disturbing the final setting of the pot, remove the pot from the circuit. Now, use an ohmmeter to check the resistance value of the

pot setting (it should be in the neighborhood of 1000 ohms). Select a 5 percent tolerance,  $\frac{1}{2}$ -watt fixed resistor as close as possible to the value obtained from the pot, and solder this resistor in the  $R27$  location, first connecting it across  $C9$  as described for  $R17$  and  $C7$  above.

A properly designed grounding scheme is of the utmost importance in any sensitive measuring instrument, and the mV Meter makes no exception to this rule. Improper grounding can result in greater than normal hum and noise level, regeneration or instability in the amplifier circuits, and meter indication nonlinearities.

The mV Meter employs a wired ground, and the following procedure is recommended. Run a  $\frac{1}{16}$ "-diameter copper bus bar wire from one ground-level binding post to the other ( $BP1$  to  $BP3$ ), routing it through the grommets as shown in the photos. Then run another bus from the first to the lower ground terminal lug in the filter assembly. (This should be the lug to which the negative end of  $C12$  is connected.)

The remainder of the wiring in the Meter



is accomplished with solid #20, plastic-insulated hookup wire. Use only high-quality, brightly-tinned hookup wire in all instances.

Run a wire from R30 to the lug to which the negative end of C14 is connected. Run another wire to this point and the ground lug of the terminal strip, and still another wire from the same point through a grommet in the center shield to the ground lug of the filter network to which the bus wire is soldered. Then run a final wire from this lug to the ground lug at the upper end of the filter assembly. *These two ground lugs, plus the ground lug on the filter network terminal strip, are the only direct electrical connections to be made between the circuits and the instrument case and shields.*

Insulate the body of the microphone connector from the front panel with the insulating washers supplied with the connector. Run a wire from the ground lug of the connector to BP1. Then connect another wire between BP1 and the ground foil conductor on the input circuit assembly board.

### TECHNICAL SPECIFICATIONS

**Ranges:** 0-10, 30, 100, 300, 1000 mV rms full-scale; 0-1, 3, 10, 30, 100 volts rms full-scale

**Input Resistance:** 100 megohms on mV ranges; 10 megohms on volt ranges

**Frequency Response:** within 0.5 dB from 10 Hz to beyond 100 kHz on both ranges

**Accuracy:** within 3% of full-scale

**Stability:** drift from cold start through one hour continuous operation is negligible; drift due to temperature variations between 50° and 90° F is negligible; drift due to line-voltage variations between 90 and 130 volts is negligible

**Spurious Signals:** internal leakage from ac power line to millivoltmeter open-circuit input is 40 dB below 10 mV

**Scope Preamplifier:** signal voltage gain is 50; frequency response is within 1 dB from 40 Hz to beyond 100 kHz, down 5 dB at 10 Hz; total harmonic distortion, including hum and noise, is 0.1% at 400 Hz

**Power Consumption:** 5 VA or less at 117 VAC

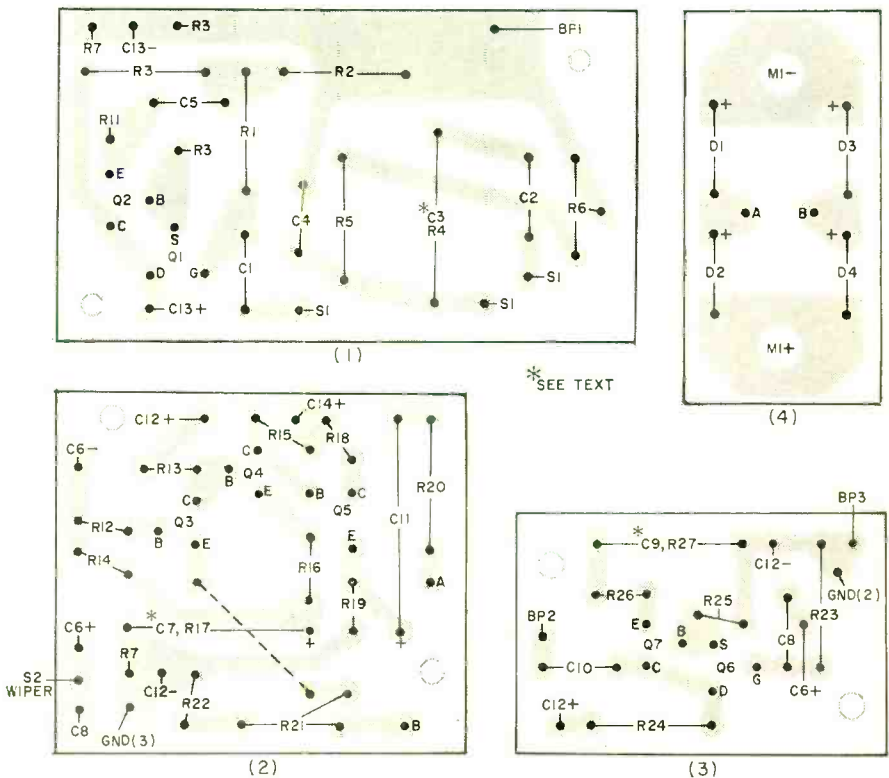

Fig. 5. Circuit board assemblies are identified as follows: (1) input circuit and 100:1 attenuator network; (2) meter amplifier; (3) scope preamplifier; and (4) meter rectifier.

Twist together a pair of wires. Connect one end to the ground conductor (black wire) and the emitter of  $Q2$  (any other color). Connect and solder the other ends of the wires to the appropriate lugs on range switch  $S2$  (to which the ends of precision resistors  $R7$  and  $R11$  are first connected), passing the free ends through a grommet in the top of the input circuit shield.

Again using the color coding scheme, twist together another pair of wires and run it from the same lug to which  $R7$  is connected and the rotor lug on  $S2$  close to the shields and through a grommet in the center shield to the input and ground conductor of the meter amplifier board. Then connect a short twisted pair from the input and ground conductor of this board to the input and ground conductor of the scope preamp board. Connect one more wire between the ground conductor on the scope preamp board and  $BP3$  to complete the signal circuit ground wiring.

Power supply ground leads going to boards (1)-(3) should all be twisted together with their respective positive leads and then dressed against the center shield. Connect the ground leads from boards (2) and (3) to the lower ground lug of the filter network terminal strip and the ground lead from board (1) to the upper ground lug (to which the negative lead of  $C13$  is also connected).

Make absolutely certain that all connections are cleanly and thoroughly soldered. If any connection appears to be "grainy" or otherwise doubtful, resolder it. Also, make certain that there exists a solid electrical connection between the shields and front panel of the cabinet. To insure good contact, you might try placing an internal lock-washer between the metal members at each hardware location. This done, slip the circuit assembly into the cabinet and bolt it in place.

Finally, prepare a shielded test lead as follows. From one end of a 3-ft length of low-capacitance coaxial microphone cable, strip away  $\frac{3}{4}$ " of insulation to expose the braided shield. Trim away  $\frac{3}{8}$ " of the braid and only  $\frac{3}{16}$ " of the plastic insulation from the center conductor. Loosen the set screw on the microphone connector. Then slip the prepared end of the cable into the spring end of the connector and seat it so that the center conductor protrudes through the connector's center contact. Solder the conductor to the contact and tighten the setscrew.

From the other end of the cable, strip away 1" of insulation, all of the exposed wire braid, and  $\frac{5}{8}$ " of insulation from the center conductor. Slip onto the cable a 1" length of heat-shrinkable tubing (optional). Pass the center conductor through the opening in the rear of the crocodile clip until the insulation sits

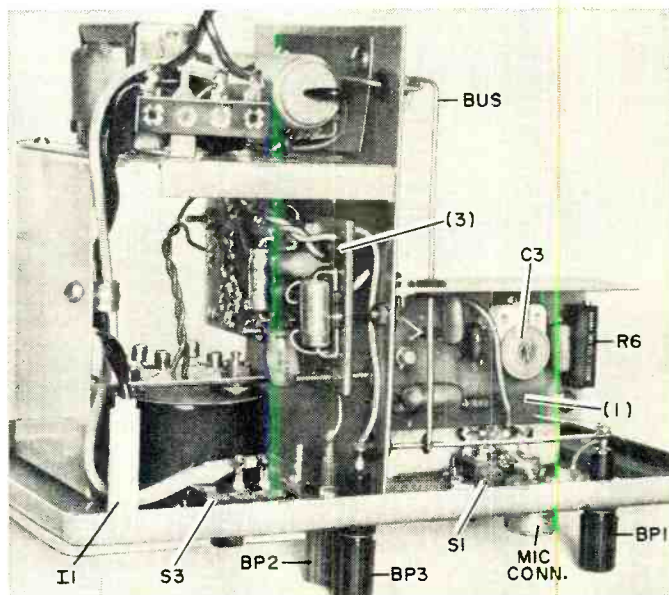

Bus-type wired ground routes through metal parts via rubber grommets. Rectifier assembly mounts directly on terminals of meter movement.

squarily in the opening. Wrap the center conductor around the clip's contact screw and, if possible, crimp the clip around the insulation. Slide over the rear of the clip the tubing and heat shrink it. For details, see Fig. 6.

**Calibration.** When all assembly and wiring steps have been completed and double checked for errors, set *R16* and *R21* to their mid-positions, *S1* to MV, and *S2* to 1000. Connect a precision audio generator with a

## THEORY OF CIRCUIT DESIGN

Although basically a millivoltmeter with a 100-megohm input impedance, the mV Meter is by no means restricted to use only in the millivolt range. As can be seen in Fig. 1, the Meter is capable of measuring ac potentials, in five ranges, up to 100 volts rms with an input impedance of 10 megohms.

Mode switch *S1* permits selection of either the volt (V) or millivolt (MV) ranges. A 100:1 RC attenuator network made up of *C2-C4* and *R4-R6* accurately drops the input signal level when the volt ranges are being used. Components in both the capacitive and resistive elements of the attenuator are adjustable so that the 100 division ratio can be set precisely.

A bootstrapped field-effect transistor Darlington circuit (*Q1/Q2*) is used to obtain the 100-megohm input impedance with actual resistor values no greater than 5.1 megohms. And the range attenuator, made up of precision resistors *R7-R11* and range switch *S2*, is located in the output side of the Darlington pair, rather than at the input where electrical and mechanical design and assembly might prove difficult. The input to the Darlington circuit is dc biased to locate the operating point where a high order of linearity is obtained so that negligible distortion of the ac signals takes place in this amplifier, even at a peak-to-peak signal level of 2.8 volts, and dc stability of the operating point is rigidly maintained. (For a detailed explanation of how the Darlington amplifier circuit is capable of a 100-megohm input impedance when small value resistors are used, refer to the sidebar on page 58.)

The output of the range attenuator is never allowed to exceed 10 mV rms, regardless of the signal level at the input of the mV Meter (this 10-mV signal represents full-scale pointer deflection of *M1*). The signal voltage and power amplification required to drive *M1* is developed by meter amplifier circuit *Q3-Q5* and associated components. The output from the meter amplifier, at the emitter to *Q5*, is fed through *C11* and *R20* to meter rectifier bridge *D1-D4*.

The prime requisites of the meter amplifier are a high order of signal-gain stability, high stability in the dc operating point, and near-perfect cancellation of the nonlinearities inherent in *D1-D4*. Particularly careful design of the meter amplifier gives the instrument a stability and bandwidth consistent with a high order of accuracy through the use of both ac and dc negative feedback techniques.

Transistors *Q3* and *Q4* operate as a two-stage cascaded, direct-coupled amplifier, while

*Q5* is used to develop the power required to drive *M1*. The dc bias for *Q3* is obtained through *R14* from the emitter of *Q4*. This is a dc negative feedback arrangement which provides a high order of stability in the dc operating point of *Q3* and *Q4*. Capacitor *C7* bypasses the dc biasing circuit to ground to prevent ac negative feedback—which would tend to decrease the signal input resistance of *Q3*—via this route. The input resistance to *Q3* is maintained fairly high to prevent any significant loading of the range attenuator. The dc operating point of *Q5* is stabilized by virtue of its emitter-follower configuration which provides very nearly 100 percent negative voltage feedback.

Negative ac feedback is obtained from the meter circuit through potentiometer *R21* and applied to the emitter of *Q3*. This feedback circuit not only gives the meter amplifier a high order of gain stability, but because *D1-D4* are included in the feedback loop, it also provides near-perfect compensation for the nonlinearities in the meter rectifiers. Without this compensation, the linearity of the meter pointer deflection could be adversely affected.

Resistor *R12* is part of the negative feedback loop. It provides a more constant load into which the ac negative-feedback signal works as *S2* is operated through its positions. Without *R12* in the circuit, the negative feedback factor would tend to vary as the setting of the range switch is varied.

Since it is impractical to connect a conventional general-purpose oscilloscope across a circuit that requires the use of a measuring instrument with a 100-megohm input impedance, and since waveform observation is important to the accuracy of the meter reading, a sample of the mV Meter's input signal waveform is obtained at the output of the Darlington circuit. This sample signal is coupled through *C8* into the *Q6/Q7* scope pre-amplifier circuit.

The requisites of the scope preamp are a signal voltage gain of 50 and a low total harmonic distortion level, the latter being far more important than the former. The gain derived from the preamp need be only enough to produce a trace of convenient height on the oscilloscope screen with the minimum of distortion.

The output at the collector of *Q7* is coupled through *C10* to binding post *BP2*, where the sample signal is available for the scope input. Negligible power output from the circuit is required since the input impedance of a good oscilloscope is on the order of at least 1 megohm.





## The best way to get electronics into your head

No book ever written can give you the "feel" of electronics.

This is why every NTS course in Electronics includes the most modern, professional training equipment in kit form.

Putting equipment together, kit by kit, can teach you more about electronics than a whole library of bone-dry theory.

Each kit contains illustrated instructions.

You look at the pictures, then you apply what you see as you assemble or service your equipment.

What could be simpler? Or more fun? You'll enjoy every profitable minute.

Here's just some of the equipment you get to build and what you will learn.

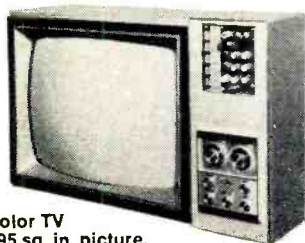

**Color TV**  
295 sq. in. picture.

### NTS COLOR AND B&W TV SERVICING

You receive a big screen color TV with many unique features, including self-servicing equipment so you can make all normal test operations. You also get an AM-SW radio, solid-state radio, field-effect transistor, Volt-Ohmmeter and electronic tube tester. You learn about electronic principles, trouble-shooting, hi-fi, multiplex systems, stereo and color TV servicing.

**Solid-state B&W TV**  
74 sq. in. picture  
(cabinet included)

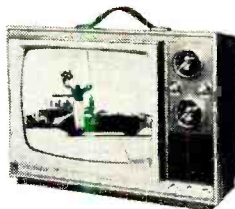

The B&W TV receiver features the latest in *solid-state circuitry*, making your TV training the most modern, most advanced available.

### NTS COMPUTER ELECTRONICS

One of the 10 important kits included is this remarkable Compu-Trainer<sup>®</sup> — an NTS exclusive. It's a fully operational computer logic trainer — loaded with integrated circuits. It introduces you quickly to the how, what, when, and why of computers. This unit is capable of 50,000 operations per second.

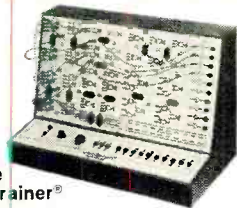

**Exclusive Compu-Trainer<sup>®</sup>**

### NTS ELECTRONICS COMMUNICATIONS

Two exciting courses in the big-paying fields of transmitting and receiving equipment. Either one qualifies you for your FCC First Class Radio-

POPULAR ELECTRONICS

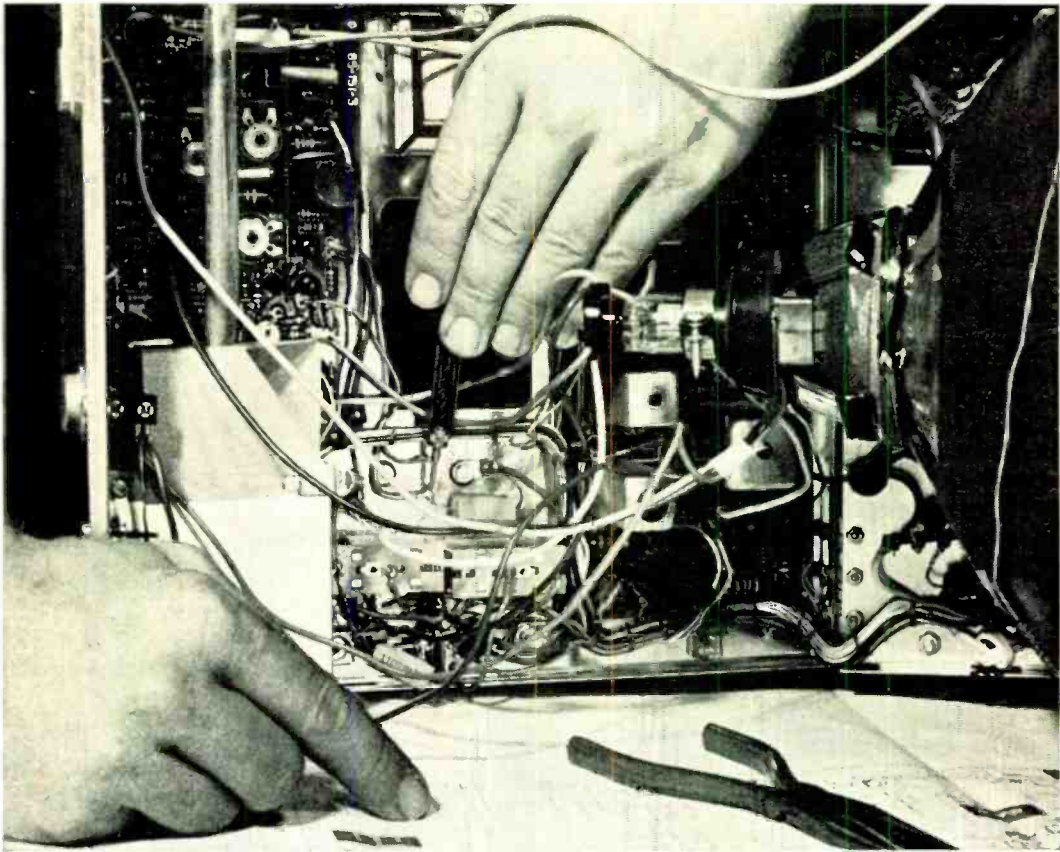

## is to have the actual equipment in your hands.

Telephone License. *NTS assures you will pass this FCC exam within 6 months after successfully completing your course — or your tuition is refunded.* You receive 14 kits to build an amateur phone 6 meter VHF transceiver plus NTS' exclusive 6 transistor solid-state radio and a fully transistorized volt-ohmmeter.

5 watt AM transmitter/receiver.



### NTS AUTOMATION/ INDUSTRIAL ELECTRONICS

Let NTS put you into the age of electronic controls. Systems automation is rapidly becoming the emphasis of modern industry. NTS training includes equipment like a 5" wide band oscilloscope. You also get the new, exclusive NTS Electro-Lab — a

complete workshop that lets you build five industrial controls to regulate motor speed, temperatures, pressure, liquid level, smoke, and much more.

5" Oscilloscope



Mail card today for free, full-color catalog that details what each training program offers. (Or if card is missing, send coupon.) No obligation. No salesman will call.

Remember, the best way to get electronics into your head is to have the actual equipment in your hands. The sooner you mail the card, the sooner you'll get your hands on the finest, most advanced electronics home training ever offered.

#### CLASSROOM TRAINING

**AT LOS ANGELES** You can take classroom training at Los Angeles in sunny California. NTS occupies a city block with over a million dollars in facilities devoted exclusively to technical training. Check box in coupon.

#### APPROVED FOR VETERANS

Accredited Member: National Association of Trade and Technical Schools; National Home Study Council.

## NATIONAL TECHNICAL SCHOOLS

WORLD-WIDE TRAINING SINCE 1905

4000 S. Figueroa St., Los Angeles, Calif. 90037

If card is missing check Coupon and mail for free color catalog and sample lesson. Now.

Please rush Free Color Catalog and Sample Lesson, plus information on course checked below. No obligation. No salesman will call.



#### National Technical Schools

4000 S. Figueroa St., Los Angeles, Calif. 90037

- Master Course in Color TV Servicing
- Color TV Servicing
- Master Course in TV & Radio Servicing
- Practical TV & Radio Servicing
- Master Course in Electronic Comm.
- FCC License Course
- Master Course in Electronics Tech.
- Industrial and Automation Electronics
- Computer Electronics
- Basic Electronics

Dept. 205-011

Name  Age

Address

City  State  Zip

Check if interested in Veteran Training under new G.I. Bill.

Check if interested only in Classroom Training at Los Angeles.



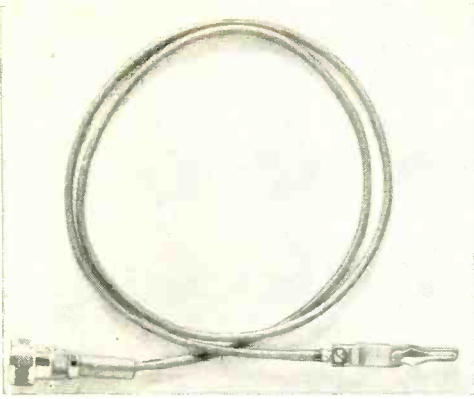

Fig. 6. Signal cable is made from crocodile clip, low-capacitance microphone cable, and mike connector. Use ordinary test lead for the ground cable.

600-ohm output impedance and an accurately calibrated voltage level meter to the input of the mV Meter and an oscilloscope to BP2 and BP3.

When the mV Meter is connected to any circuit for measurements, always make the ground-to-ground connection first (use any cable with a banana jack at one end and an alligator clip at the other for this, connecting it via BP1), then the "high-side" connection—never the other way around. Also, always set S1 to V before making or breaking any connections with the mV Meter turned on. Because the Meter has negligible drift, it is feasible and a great deal safer in most cases to switch it off when changing input connections.

## HOW BOOTSTRAPPING WORKS

The following explanation is provided for the benefit of those who do not know how the bootstrapped Darlington circuit operates to increase its own effective input resistance. Consider first the biasing arrangement used for the gate of Q1 in Fig. 1. For dc, R1 is in series with the gate of Q1, and R2 and R3 form a voltage divider across the power supply. The ac input signal is applied to the gate of Q1 through C1.

Now, without C5 in the circuit, the signal being measured would "see" a resistance nearly equal to  $R1 + [(R2R3)/(R2 + R3)]$ , or about 7.5 megohms for the values specified. During normal operation of the Q1/Q2 amplifier, the signal voltage at the emitter of Q2 is very nearly equal to the amplitude of the input signal applied to the gate of Q1. In the bootstrap circuit, with C5 connected as shown, the signal from the emitter of Q1 is fed back to the junction of R1, R2, and R3 in phase with the input signal voltage through C5. Hence, the signal voltage at the junction is equal to the signal at the emitter of Q2. The amplitude of the feedback signal can easily be as great as 95 percent of the input signal level.

Resistor R1 now has the input signal applied to it at its upper end, while a signal of the same phase and 95 percent its amplitude is applied to its lower end. The signal voltage drop across resistor R1 is, therefore, only a small percentage of the input signal level, making R1 appear to have a value very much higher than its actual value. In fact, R1 appears to have a value equal to  $R1/(1 - 0.95)$ , or very close to 100 Megohms!

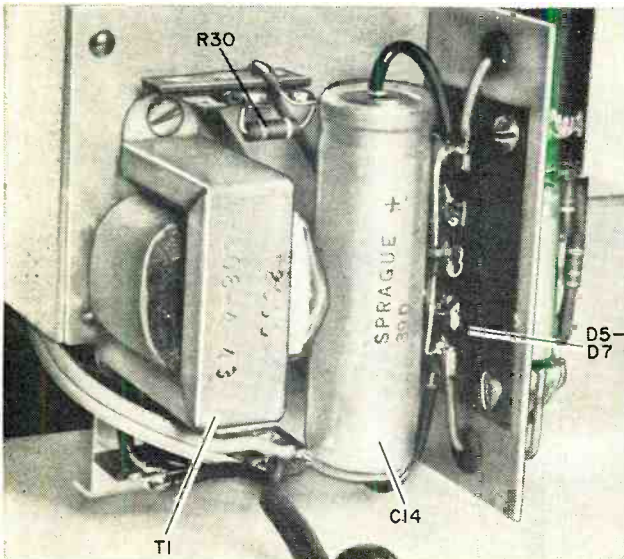

Point-to-point wiring is employed in power supply subsection. Note use of insulating material between terminal strip on which are mounted D5-D7 and C14 and shield (near left). Line cord connects to terminal strip at bottom.



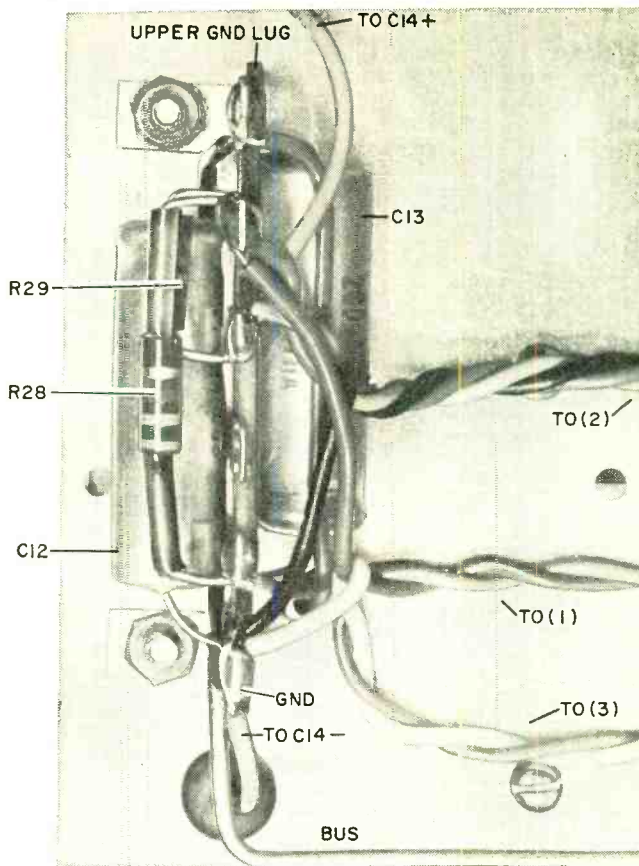

Closeup shows details of terminal strip partially visible in photo at bottom of opposite page. Most connections from power supply to various circuit assemblies are made from this terminal strip, using twisted-together hookup wires.

Once the connections outlined have been made, switch on the mV Meter. The meter pointer should swing to or near its full-scale position a couple of times as the internal electrolytic capacitors charge. Then it should settle back to its zero position. The pointer should come to rest precisely at zero with the instrument connected to the 600-ohm output of the signal generator if the circuit is properly wired and the meter movement's mechanical zero is properly set.

Set the signal generator to 400 Hz and turn its output level control up to where the mV Meter's pointer sits center-scale. Touch your fingertip to the screw-down ferrule of the microphone connector on the instrument; there should be absolutely no deflection of the meter pointer when you do this. Should any deflection occur, switch off the meter and go over your wiring again. The amplifiers in the Meter are stable; so, if you have assembled the instrument properly, there should be little

difficulty in tracing down any trouble.

With the signal generator still set at 400 Hz, turn its output level up to precisely 1 volt rms (on the voltage level meter) and adjust *R21* in the mV Meter for an exact full-scale pointer deflection. Tune the generator for a 40-Hz signal and adjust it for precisely a 1-volt rms output level. Now, adjust *R6* for an exact full-scale deflection. Finally, with *S2* still at the 1-volt position (1000), tune the generator for a 20-kHz, precisely 1-volt rms output and very carefully adjust *C3* with a non-metallic screwdriver until the meter pointer again rests at exactly full scale.

Throughout all of these calibration steps, the waveform displayed on the oscilloscope's CRT screen should be a clean sine wave (if the generator's output signal is clean, that is). If not, the calibration is inaccurate. Or, putting it another way, the calibration is accurate for that one particular waveform and no other.

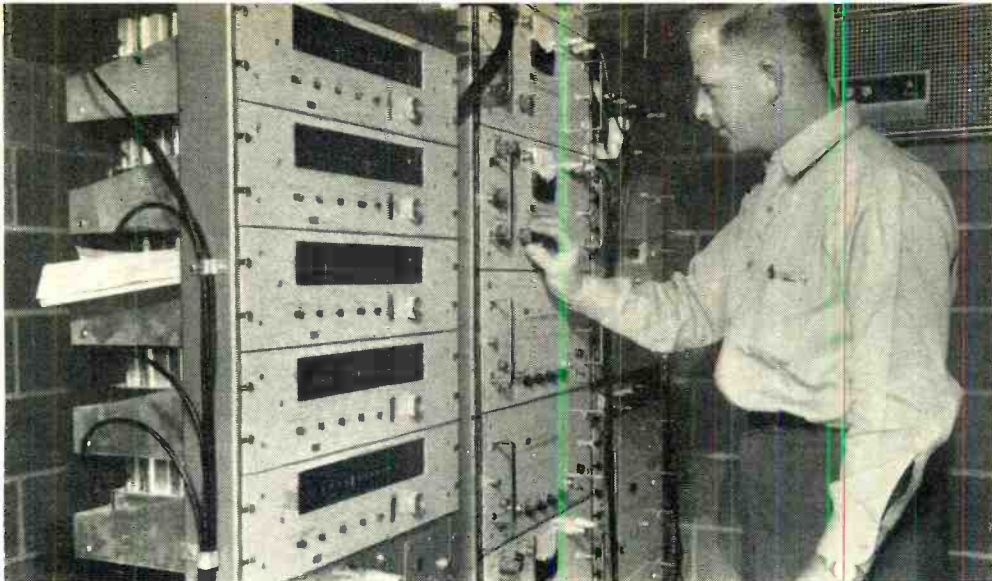

A BONUS FOR CATV SUBSCRIBERS:

## ★ CABLE FM ★

IF YOU HAVE IT, IT MAY PROVIDE BETTER STEREO

**I**N HUNDREDS of communities across the country, music lovers are discovering that cable TV has a surprise bonus for them: FM radio, which is piped into their homes on the TV cable but played through their FM sets, completely independent of their TV.

It's FM radio with a difference, however, for cable FM promises listeners the same benefits that cable TV gives its viewers: a choice of several stations, a minimum of multipath distortion, and a comfortable signal-to-noise level for each station.

"As a result of our strategic receiving locations and the use of highly directive and sensitive antennas," reports one leading CATV operator, "our FM signals are far superior to those received by the average FM listener. Even with all the signal processing that occurs on our cables, the FM bandwidth is not altered. The signals are inserted into the system with the same bandwidth, including guardbands, that the broadcaster transmits."

Be forewarned, however, that all CAFM (cable FM) systems are not working this perfectly—at least not right now. Some of them are carrying inferior signals, some do not have stereo signals (because of cross talk

problems), and several systems actually cut down on the number of stations you can receive (as compared to a good outside antenna).

The reason for this sad situation is simple: an unintentional neglect by the CATV operators who carry CAFM as a piggyback service. Reasonably enough, CATV system operators feel that they have a lot more important problems than CAFM. To name just a few: new FCC rulings that allow CATV systems to originate their own TV programs, possibilities of a synchronous communications satellite for national networking of cable TV, two-way transmission on the cable, etc.

Robert E. Cowley, manager of Flagstaff [Arizona] TV & Cable Company, expresses the industry's attitude: "We give FM as a bonus, when the TV cable is put in, as an added selling point. Our advertisements do not sell FM, only cable TV."

Despite the lack of promotion, CATV customers do hear about CAFM, ask for it, and then like what they get. As a result, CAFM is one of the fastest growing businesses in commercial broadcasting, reports Harry E. Maynard, in *Stereo Quarterly*.

Most 12-channel CATV systems have the

---

BY EDWARD A. LACY

POPULAR ELECTRONICS

necessary band-width for carrying FM signals as well as TV signals. If they are not now carrying CAFM, it's probably because of disinterest, rather than some major technical problem.

A quick count of the 2400 or so CATV systems listed in *Television Factbook* shows 58% of them carrying FM. Of these 1413 systems, 236 did not state how many stations they were carrying, but 587 had between 1 and 10, 138 between 10 and 20, 59 more than 20, and 383 were carrying "all band."

**Imported FM.** For some systems, in areas where there are few if any local FM stations, it's necessary to "import" out-of-town stations. Flagstaff Television & Cable, for example, carries five stations, all of which are imported by microwave. Obviously, importing FM signals gives a listener several more choices than are possible through his own antenna, even if the antenna is highly directional and has a rotor.

On the other hand, most local FM broadcasters consider imported signals to be unfair competition. With half of the FM stations now losing money, it's no wonder they are touchy. What particularly worries them is that some CAFM stations carry imports but do not carry the locals. Nation-wide, the FM industry has not yet agreed if importing is good or bad, and so the National Association of FM Broadcasters has not taken a position, one way or the other.

The National Association of Broadcasters, however, is quite concerned. In a filing with the FCC, they stated:

"Many CATV operators bypass local FM stations to bring in multiple FM signals from outside the area, usually from large metropolitan areas some distance from the CATV community.

"The deleterious effects of such leap-frogging have begun to be evidenced in communities where CATV has made significant penetration. In addition to badly fragmentizing local FM audiences, this practice actually denies local FM stations the opportunity to compete for cable listeners."

What does the FCC say about importing FM? Well, back in 1965 they asked for comments on the problem, but apparently never acted, probably because they have been so tied up with other problems concerned with CATV.

Other government agencies, it should be noted, have almost openly encouraged im-

porting. For instance, the President's Task Force on Communications Policy, reported in 1968 that "The history of broadcasting indicates that complete reliance cannot be placed on a system of local over-the-air stations to achieve our goals. The regulation of radio on the basis of the local station concept limits the program choices available to the listener."

And, they noted, ". . . national policy has carefully sought . . . to develop a legal and economic framework for a communications policy which allows many voices to compete in the market place of ideas and of taste."

Whether they import or not, CAFM probably will eventually be forced to carry all local stations, just as CATV.

**Taped FM.** Rather than get involved with the trouble and expense of importing, some CAFM stations have taped their own music for use where there are few or no FM stations.

In Riverton, Wyoming, about 100 miles from the nearest FM station, a young college instructor, Richard L. Doering, has started what is probably the nation's first CAFM station, simply because he missed the good FM stereo music he enjoyed back east.

Doering's station, "Radio 95," is carried to Riverton cable TV customers by Community Television of Wyoming, Inc., which houses the playback tape transport, stereo generator, and rf exciter. Doering tapes his programs and then sends the tapes to the cable company.

Since November 1968, Doering has been broadcasting in stereo 7 days a week, 8 a.m. to 11 p.m., with classical, popular, jazz, and country-and-western music rotating in half-hour segments. Fourteen minutes of uninterrupted music is provided for each 15 minutes of broadcast time, and advertising time is limited to 2 minutes per hour. Incidentally, advertising is the sole support of Radio 95.

Doering points out that cable FM is the perfect answer for communities too small to support an on-the-air station of their own.

**Signal Processing.** With the exception of locally generated signals such as Doering's, how many stations you will receive on CAFM depends not only on availability, but also on which signal processing technique the CAFM system uses: either all-band or discrete signals.

One metropolitan CATV system told us



this about their experience with all-band processing: "Our original system for FM used an omni-directional antenna on top of a 350-ft building. All the signals received on this antenna were dumped into the FM band on the cable. But the results were unsatisfactory: too many channels with too great a variation in levels.

"We are now installing 20 discrete signal processors to include all of the city's FM broadcast transmitters and those closest to the city limits. Signals from directional antennas will be processed individually and controlled so that all channels are carried on the cable at the same level."

For discrete signal systems, FM stations are equally spaced across the dial with separations of 500 to 800 kHz. Each station is rebroadcast at a CAFM frequency different from that of the off-the-air frequency; this creates a minor nuisance when tuning, but it's necessary to cut out interference between the cable signal and possible leakage from the off-the-air signal. How many signals are processed depends on availability as well as the CAFM operator's budget.

Theoretically, there should be no noticeable degradation of the signals.

The "delivered" signal strength can vary from 200 to 1800 microvolts across 300 ohms, depending on the system. Unfortunately, there is no industry or FCC standard for signal strength. The Canadians have specified a minimum signal level of 200 microvolts and a maximum of approximately 300 microvolts for carriers between 88 and 90 MHz and a maximum of 1000 microvolts for signals with carriers 90 MHz and higher.

The lower FM band signals are limited to prevent interference to channel 6 TV stations. The overall FM band signal limitation is designed to cut down on the background noise on the TV channels.

While CAFM signals are considerably better than those received with an indoor folded dipole at many urban locations, it must be admitted that such reception is not nearly as good as reception with say a 6-element FM antenna at a nearby suburban location.

**CAFM—Where To From Here?** With some prodding of the CAFM systems, CAFM

#### **COST**

Typical charges for cable FM are \$7.50 to \$10.00 for installation and a monthly charge ranging from free to \$1.

#### **FM's FUTURE**

The Chase Manhattan Bank predicts that FM-equipped receivers will replace AM-only sets as the dominant type of radio sold by the early 1970's and that four out of every five sets sold in 1975 will be capable of FM reception.

manufacturers, and the FCC, audio enthusiasts may be able to get the minimum signal level set much higher. Since the FCC has not yet established technical standards for cable FM, now is the time for action by CAFM subscribers.

On July 1, 1970 the FCC issued a Notice of Proposed Rule Making on the establishment of technical standards for CATV. In the notice they said, "We are not at this time proposing standards applicable to the carriage of FM broadcast signals on CATV systems. We may find it necessary to do so in the future . . . We welcome comment on these points."

Considering the present and the expected improvements in FM reception brought about by CAFM, you might expect that an FM set could incorporate a few compromises in order to cut costs. Unfortunately, it can't be done.

Daniel R. von Recklinghausen, technical director for H. H. Scott, Inc., says: "For high-quality listening, a 60-dB signal-to-noise ratio is definitely desirable and this is the reason for using a high-quality tuner, even on a CAFM system. If you did not have a high-quality tuner, other performance characteristics most likely would be degraded and perhaps the expected signal-to-noise ratio would not be as great. For this reason I do not see any reason for connecting a 'cheap' FM tuner to a CATV or a CAFM system."

What type of tuner you do connect may be limited only by the imagination of the audio engineers. For example, with almost unlimited bandwidth available for CAFM, new techniques such as 4-channel stereo should be a breeze.

"Several organizations are working on special audio systems for cable FM," says one prominent CATV consultant. "Some will be in the FM band, but others are expected to use special tuners OUTSIDE the present FM band to give additional channels and special features."

(Lead photo courtesy Jerrod Electronics Corp.)

# Time-Period Module for the Digital

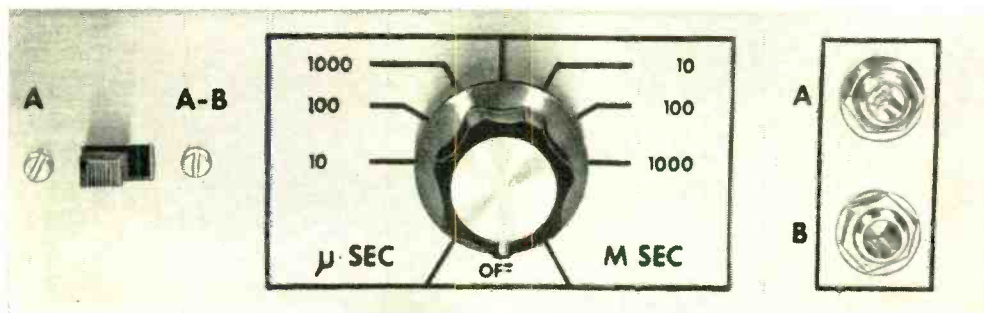

## Measurements Lab

ELAPSED TIME MEASURED DOWN TO 0.01 SECOND

**This is the second plug-in module designed to be used with the Digital Measurements Lab described in our November 1970 issue. Easy to assemble, it has many applications in sporting events, photography, and electronics experiments. A 1.00-MHz crystal-controlled oscillator provides the timing base.**

**I**N NOVEMBER, we began a series of articles on the construction of a group of test instruments to be used with a common main frame. This issue's contribution to the Digital Measurements Lab is a Time-Period module. As with the readout assembly and Frequency Counter plug-in presented earlier, the Time-Period module takes advantage of TTL integrated circuits.

The Time-Period module is similar to the Frequency Counter in some ways. However,

its function is the inverse of the counter in that it is designed to measure accurately the duration, rather than the frequency, of an event. The function is  $1/F$  and it is often used to measure very-low-frequency signals which would have to be counted for an excessive length of time to obtain an accurate readout with a frequency counter.

The Time-Period module can be used as a timer, for velocity measurements, and any other related start/stop function. The wide range of the module makes it possible to time events occurring within a range of 0.01-15 seconds with a 0.1 percent accuracy.

The practical uses for the Time-Period module include measurements of bullet velocities, slot car lap times, and camera shutter speeds. In fact, the Time-Period function can measure the duration of any event that can be converted into an electrical signal. This is done by switching the counter input into one of the six sealed outputs that are generated

BY DANIEL MEYER

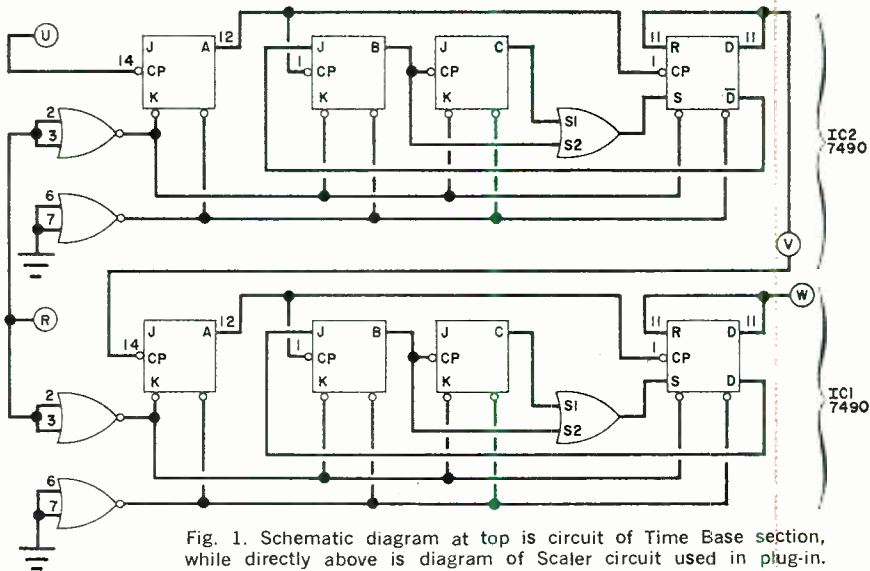
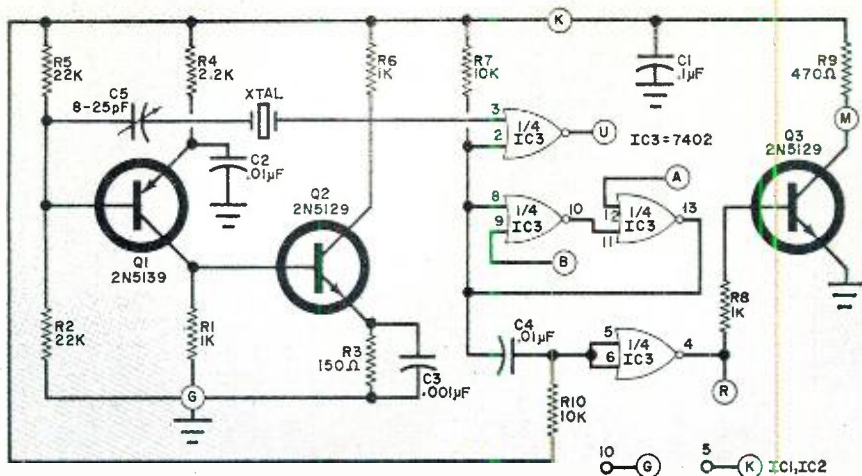

Fig. 1. Schematic diagram at top is circuit of Time Base section, while directly above is diagram of Scaler circuit used in plug-in.

### PARTS LIST

- C1—0.1- $\mu$ F disc capacitor
- C2, C4—0.01- $\mu$ F capacitor
- C3—0.001- $\mu$ F disc capacitor
- C5—8-25-pF trimmer capacitor
- IC1, IC2—7490 integrated circuit
- IC3—7402 integrated circuit
- J1, J2—Two-circuit phone jack (insulated)
- Q1—2N5139 transistor
- Q2, Q3—2N5129 transistor
- R1, R6, R8—1000-ohm
- R2, R5—22,000-ohm
- R3—150-ohm
- R4—2200-ohm
- R7, R10—10,000-ohm
- R9, R11, R12—470-ohm
- R13—33,000-ohm
- S1—Two-pole, 10-position rotary switch with spst attachment (S1 in main frame power supply)

All resistors  
1/2-watt, 10%  
tolerance

XTAL—Crystal (1.00 MHz or 100.00 kHz as desired—see text)

I—Scaler kit

Misc.—15-contact connector; control knob; printed circuit boards for time period and scaler circuits; chassis; spacers; solid and stranded hookup wire; #4 machine hardware; solder; etc.

Note—The following items are available from Southwest Technical Products Corp., Box 16297, San Antonio, TX 78216: Time Period board No. RPTb for \$2.35; all Time Period circuit parts including 1.00-MHz crystal but minus Scaler, chassis, switch, etc. for \$21.50; Scaler circuit board No. SC-10-4b for \$1.90; circuit board and parts for Scaler for \$14.55; complete kit of parts for Time Period plug-in module includes all above parts plus switch, chassis, etc. for \$38.75 plus postage on 3 lb. and insurance.



by a 1.00-MHz crystal-controlled oscillator. Thus, the frequencies that can be counted (in terms of time) range from 100 kHz to 1.0 Hz. The circuit has an automatic reset which properly sets up the system every time a new count or measurement is made. Operation can be from a mechanical switch, microphone, photocell, or break wire.

**Theory of Circuit Design.** The basic timing circuit consists of a 1.00-MHz crystal-controlled oscillator made up of *Q1* and *Q2* in Fig. 1. The frequency can be set precisely with trimmer capacitor *C5* with the aid of an accurate 1-MHz signal source or by zero-beating with WWV.

The output of the oscillator goes to one input of a dual-input gate (part of *IC3*). However, the oscillator's signal cannot pass through the gate until the second input on this gate goes to ground or logic "0." The gate is controlled by a latching circuit consisting of two more of the gates in *IC3*. This latch, or set-reset, circuit is, in turn, controlled by the input signal or signals.

A positive signal at input *A* in the form of a logic "1" opens the gate and allows the oscillator pulses to pass into the scaler chain, continuing to do so until a positive-going signal is applied to the *B* input to close the gate again. If a positive signal is permanently applied to input *B*, the *A* input becomes a duration gate. This input will open the gate and allow oscillator pulses to pass into the scalers as long as the *A* input is at logic 1. When the input is removed from gate input *A*, however, the gate again closes.

The remaining gate in *IC3* and *Q3* are used to reset the circuit and the counter at the beginning of each cycle. When the output of the latch circuit goes to a logic 0 to open the gate, capacitor *C1* causes the reset gate to generate a pulse which resets *IC1* and *IC2*, two divide-by-ten circuits. This pulse is connected to the scaler circuit at point *R*.

The counter is reset by an inverted pulse at the output of transistor *Q3*. This is necessary if the counter is made up of individual flip-flop and gate packages as in the "Utilogie" decade counting system in the main frame. If,

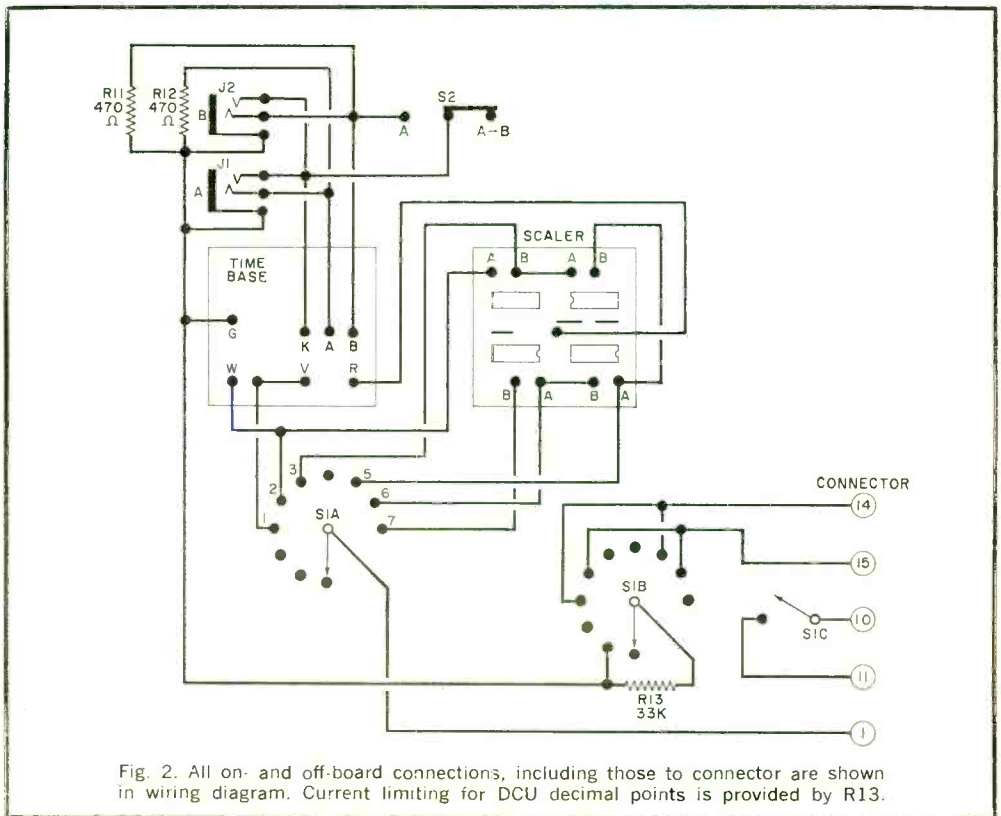

Fig. 2. All on- and off-board connections, including those to connector are shown in wiring diagram. Current limiting for DCU decimal points is provided by R13.

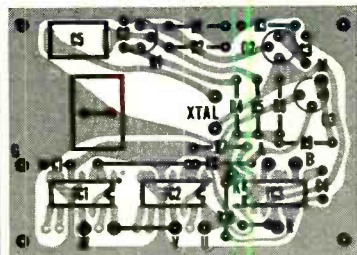
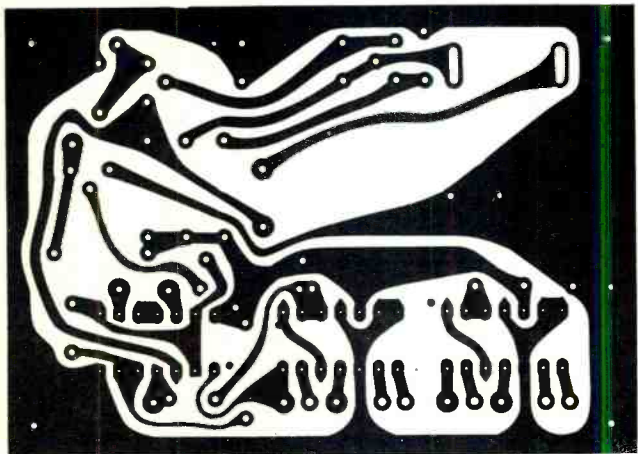

Fig. 3. Actual size etching guide (left) and components placement and orientation diagram (above) are for the Time-Period assembly.

however, the readout system uses medium-scale IC's of the 7490 type, then the reset would be taken directly from point **R** (these decade counters require a positive reset pulse).

Rotary switch *S1* (see Fig. 2) selects the pulse frequency to be fed into the counter and also switches the decimal point to the proper position. Resistor *R13* is the ground return for the decimal point and limits the current to the proper level for this part of the readout.

**Construction.** Most of the assembly work involved in the Time-Period plug-in is performed by wiring the Time-Period and Scaler circuit boards. An actual-size etching guide and a components placement and orientation diagram for the Time-Period assembly are given in Fig. 3. (See Frequency Counter Module in last month's issue for Scaler information.) When mounting the IC's, transistors, and electrolytic capacitors on the circuit boards, make sure that they are properly oriented.

Once the boards are assembled, turn them foil side toward you and compare their foil patterns against the etching guides for solder bridges. If you are satisfied that all is in order, interconnect the boards via rotary switch *S1* and the 15-contact connector as shown in Fig 2. If possible, use #22 stranded hookup wire for the connector cable assembly.

Next, mount the boards to the floor of the chassis with eight sets of #4 machine hardware and eight 1/4"-3/8"-long spacers. Then mount the switches and jacks to the front panel and complete the wiring. Neatly bundle the wiring together and lace it.

Now, connect the Time-Period module to the main frame via the connector assembly and turn on the system by rotating the range switch in the plug-in one or more positions to the right. Use a high-impedance voltmeter to check the potential at point **K** on the Time Period board and the +5-volt point on the Scaler board. In both cases, you should obtain readings of exactly +5 volts dc; if not, adjust the setting of the appropriate control in the power supply. Then adjust trimmer capacitor *C5* so that the oscillator is operating at exactly 1.00 MHz. Use an accurate signal source (WWV, for example) to beat against the oscillator signal. This done, seal the adjustment of *C5*.

Set the range switch on the Time-Period plug-in to the 1000 M SEC position and the mode switch to position **A**. Insert a phone plug in jack **A** and connect the input to the +5-volt power supply source. The counter should begin to count at a rate of one count per second for as long as the +5 volts is applied to the input. Moving the range switch to any other position with the input still connected to the 5-volt source, the counting rate should increase until the numbers in the readout tubes are just blurs.

Set the mode switch to the **A-B** position and the range switch to the 1000 M SEC position. Start the counter by connecting the **A** input to the +5-volt source. The counter should begin counting and stop **only** when the +5-volt source is connected to the **B** input. If everything checks out, the Time-Period module is ready to use.

**Applications and Use.** To test the speed

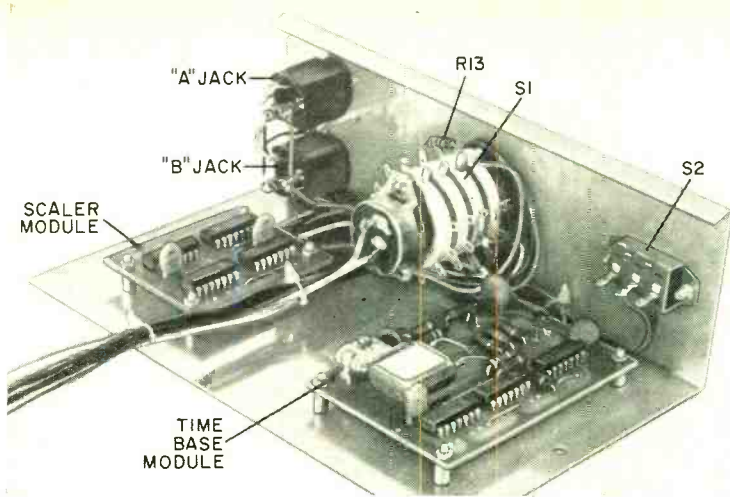

Controls and input jacks mount on front panel and circuit boards fasten to floor of chassis with 4-40 hardware and spacers.

of a camera shutter with the Time-Period instrument, a high-speed photo pick-off of the type shown in Fig. 4 is required. Note that the pickup device is a photo Darlington because of its rapid response to stimulus. Do not attempt to substitute a cadmium-sulfide cell in place of the photo-Darlington pickup since such devices respond far too slowly.

The pickup should be mounted in an opaque tube to exclude as much ambient light as possible. When the circuit is assembled, connect the negative output of the pickoff circuit to the A input of the Time-Period module. Open the camera's shutter and direct the beam of a flashlight through the lens into the photo pick-up. With the mode switch in position A, the counter should begin to run when the light is focused onto the photo-transistor. If it does not, adjust the potentiometer until operation does begin. (The proper setting of the sensitivity control is just slightly beyond the

threshold point at which the ambient light causes the counter to operate.)

Most shutter speeds can be checked by the use of the 100- $\mu$ SEC range position of S1 in the module. The reading obtained can be converted to seconds by multiplying the display count by the switch position. For example, if the switch is in the 100- $\mu$ SEC position and a reading of 200 is obtained, simply multiply  $200 \times 0.0001$  for a result of 0.02 second ( $\frac{1}{50}$  second). A reading of 200 on the 10- $\mu$ SEC range would yield a figure of 0.002 second ( $\frac{1}{500}$  second).

The same pickoff circuit in Fig. 4 can also be used as an input for start-stop applications, such as timing a lap in a race. In this case, the inputs of the Time-Period module would be connected to the positive output of the pickoff circuit. The light beam would be adjusted to keep the counter turned off until

*(Continued on page 93)*

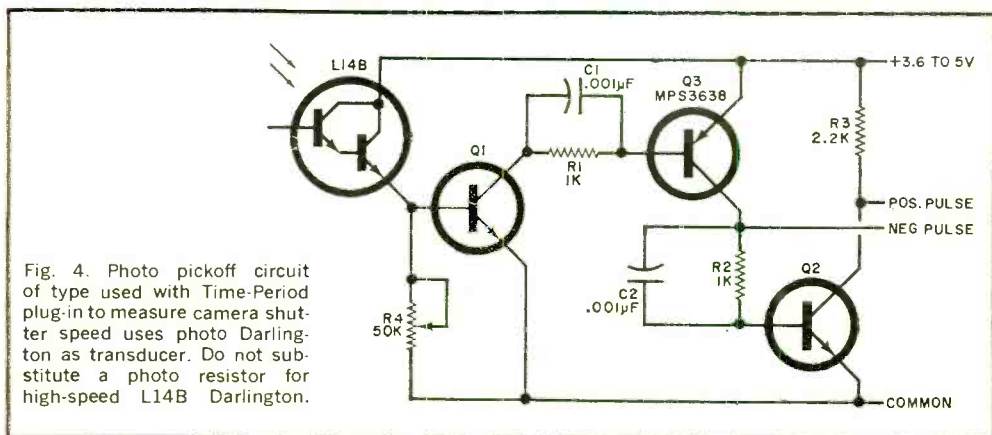

Fig. 4. Photo pickoff circuit of type used with Time-Period plug-in to measure camera shutter speed uses photo Darlington as transducer. Do not substitute a photo resistor for high-speed L14B Darlington.





Fifth in a Monthly Series by J. Gordon Holt

If you can read the writing on the wall, most of the record companies in North America have had it up to here with classical recording. Some months ago a weekly news magazine published a report on the sorry plight of the classical recording business. Classical record sales aren't paying their way and it looks like the big three (Columbia Records, RCA Records, and Capitol Records) will be out of this end of the business within the next few years.

If you follow such things, you are probably aware that the Los Angeles and Chicago Orchestras are working for London Records. The Boston Symphony has left RCA Records (after 52 years of what appeared to be a happy association) and is now recording for Deutsche-Grammophon. The Philadelphia Orchestra is the only major that is still being recorded on a reasonably regular basis (by RCA), but if rumors circulated by RCA executives are any indication, this situation may not continue beyond the expiration of the present contract.

The famous orchestras located in Minneapolis, San Francisco, Pittsburgh, and Cleveland that shared catalog listings with Boston and Philadelphia just a few years ago are rarely recorded. Most American symphonic recording activities have centered around the less glamorous orchestras like the Utah, Hartford, and Rochester. These orchestras work for the smaller companies (Vanguard, Mercury, etc.) which presumably don't expect a Schubert symphony to outsell the latest hot platter from the Hallucinogens. The American classical recording scene is sick—and it brought it on itself.

I don't think it's any secret, but ever since

the public fell in love with the idea of hi-fi, the record manufacturers have been selling sound rather than music. If you happen to think that live music sounds pretty good, you can be reasonably assured that you will not particularly like the sound you hear from disc recordings. I think it is safe to assume that when you shell out good money for a stereo system, you do so on the assumption that the better the reproducer, the more realistically will it produce music. Well, you're wrong! A good reproducing system reproduces exactly what is on the recording—and only when that recording is high fidelity will the ultimate reproduced sound be hi-fi.

**Rolled-off Bass.** Do you pride yourself on the performance of your woofers? Are they flat down to 30 Hz—or even 20 Hz? If so, bully for you! But what does this gain you? Do you realize that practically every American disc recording has a built-in roll-off below 50 Hz—or even higher—and that that roll-off is there by intent rather than accident? A spokesman for one of the major tape recorder manufacturers writing in the respected *Journal of the Audio Engineering Society* stated, "Although we might have difficulty in finding any one who would admit it, it is not uncommon practice in (cutting) disc masters to use a 70-Hz high pass (bass cutoff) filter, except for organ recordings. It is generally found that the elimination of these very low frequencies gives an improvement in overall sound quality, since the low frequency noises (in and about the studio) are eliminated, and no significant musical content is removed."

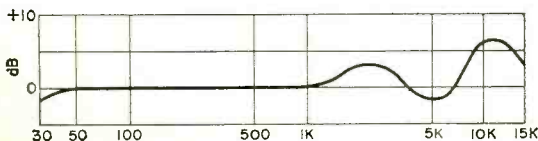

Manufacturer's published frequency response curve for a capacitor microphone that is widely used in making professional recordings.

Personally, I feel that a composer's scoring for double-bass and bass drum constitutes "significant" musical content—but then, that's my own opinion. My opinion, however, has no bearing on two recordings I own from a major manufacturer in which the 70-Hz filter was quite evidently used on pipe organ selections.

Happily, the blithe admission of low-fi practices mentioned above was originally published in 1962 and things have improved—most bass filtering is now limited to the range below about 45 Hz. It may not be what we think of as hi-fi, but it's at least a step in the right direction and, since the filtering is usually gradual, some 35-40 Hz stuff occasionally trickles through to the super woofer.

An amazing variety of disc recording gear have resonant peaks between 12,000 and 14,000 Hz. Microphones, cutter-heads, pick-ups, and tone arms have such peaks, and, since the peaks are additive, it is no wonder so many recordings sound rough at the top. Of course, high-end peaks in these components can be excused because they don't get there intentionally. The low-end roll-off on recordings does, because recording engineers like to listen to loudspeakers with under damped low-end resonance and then condemn full-range recordings because they sound muddy.

**Columbia Went the Other Way.** By an odd quirk, Columbia Records is noted for having too much bass in its recordings. A visit to most Columbia Records recording studios will reveal a proliferation of Altec A-7 "Voice-of-the-Theatre" speaker systems. Although these are fine speaker systems, they are not noted for an outstanding deep-bass response. Some environmental response curves that I have seen show the A-7 systems being virtually dead below 45-50 Hz. Thus, during playback, the Columbia engineers discovered a thin sounding bottom and evidently decided to whoop up the low-end response until things sounded "right." It is hardly surprising that many Columbia records have too much bass when reproduced through speaker systems that really plumb the lower depths. This, of course, is the risk that any recording company runs when it tailors sounds by ear. The tailoring corrects imperfections in the playback monitoring speaker systems as well as in the recording itself. Since different speaker systems have different imperfections, the tailoring just doesn't suit most other speakers.

Many Columbia records are characterized by audible gimmicking. Somewhere along the line—possibly as a result of one of those marketing surveys that purport to find out what the public really needs—a few recording directors must have the idea that the average classical record listener is a person of acutely limited perception. Since

the listener is incapable of observing anything for himself, the omniscient recording director with his multi-mikes therefore shows the listener what instruments need to be highlighted. So, the woodwinds stay unobtrusively tucked away in the background until they have an "important statement"—introducing the second theme, for instance—at which time a flick of the mixer controls spotlights the woodwinds so they will not be overlooked. After their little act, the woodwinds are pulled back while the violas have their go.

Of course, it's only fair to point out that practically no one records an orchestra with two or three microphones hung in strategic spots. The musicians' union has forced hourly pay scales so high that experimental recording sessions to find out the optimum microphone recording locations have become uneconomical. It is now deemed better to use a technique that allows maximum flexibility after the recording session. Thus, orchestral recordings are made with one microphone for each instrumental section, plus a few extra mikes for hall-reverb pick-up and soloist spotlighting. Each microphone has its own mixer and often its own equalization. The tape master is multitrack that allows much of the final mixing to be done when the pay-scale pressure is off. The resulting mix then becomes the prerogative of the recording director and while multi-miking can yield musically realistic-sounding recordings if the director has a good ear and judgement (Deutsche-Grammophon does quite well) it can also yield sonic monstrosities, particularly when the recording

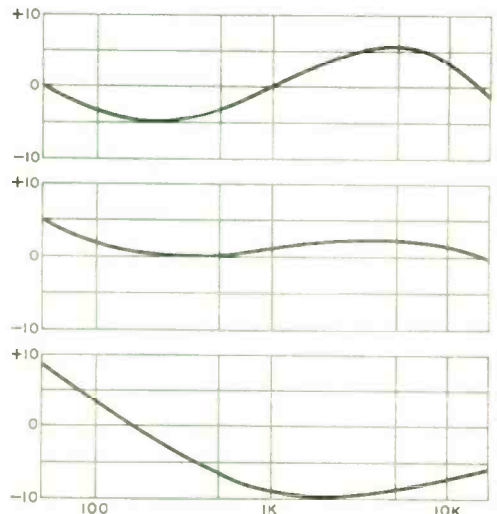

Dynagroove's continuously variable "loudness compensation" at high volume (top), medium volume, and low volume. We defy anyone to try to correct for these variations with ordinary tone controls.

director gets it into his head to out-conduct the orchestral conductor.

Most recording companies do some of this gimmicking and it frequently escapes the listener's attention because it is done subtly. One wonders if someone at Columbia Records forgot the meaning of subtle. They have produced some of the most shocking recordings I have heard with instrumental groups zooming back and forth like the slides of a trombone ensemble.

**RCA Tells All.** Columbia Records did have the discretion not to publicly admit audible gimmicking, but RCA Records was somewhat less discreet. In fact, RCA publicized gimmickry in their massive advertising campaign to introduce the "Dynagroove" system.

As I interpret Dr. Harry Olson's description of the Dynagroove system, it involves "modifying" the original sound so as to compensate for deficiencies in the average home hi-fi reproducing system—as well as the deficiencies of the average listener! These modifications include compression of musical dynamics and a continuously variable loudness compensation system predicated on the contention that the human ear's frequency response curve varies with the volume level of the sound being heard. Thus it becomes necessary for the Dynagroove system to correct for these deficiencies every time the orchestra plays more loudly or softly. It is undeniable that the ear's response changes as sound level changes, but like it or not, this is *the way* human beings hear sounds. The changing response of the ear contributes to the sound we think of as the "real thing," and any attempt to make the ear more efficient by adding corrections simply falsifies the original sonic content. Not too happily for RCA, Dynagroove was not a smashing commercial success—possibly because so many of the early releases sounded ghastly!

You don't need market researchers to show that while hi-fi stereo may be on every tongue, it isn't in every ear. Listeners with Magnavoxes, Philcos and Zeniths vastly outnumber listeners with Dyna-Kits, Sherwoods, Scotts, etc., and the cheap portable stereo is scarcely extinct. When record manufacturers sell sound, they sell ultimate sound and if this means turning up the treble to overcome the mellowness of the average home reproducer, then so be it. Of course, that extra treble boost is added to the boost required to complement the RIAA equalization curve, which is one reason why so many 1960-70 disc recordings are impossible to track cleanly. The high frequency groove modulations become so sharp and emphasized that the grooves get narrower than the playback stylus tip, which rattles across

the tops of the modulations. I scarcely consider this high fidelity.

This columnist cannot help but note with amusement the ploy of record critics who, seeking to dull the edge of a daval about a disc recording's miserable frequency response, will add the statement, "Of course, judicious use of tone controls can remedy the problem." I say—hogwash! Tone controls will never straighten out a fouled-up disc recording any more than a pair of yellow-tinted sunglasses can turn a cloudy day into sunshine.

### What Your Tone Controls Can't Do.

Every audio enthusiast must initially realize that tone controls are not the equivalent of a professional recording studio equalizer. The recording engineer can, if he wishes, add a sharp peak at 3000 Hz for the sake of "presence," a 10 dB-per-octave boost from 8 to 10 kHz (for "overtones"), and a sharp cutoff above to keep the stylus from jumping out of the groove. The engineer can also

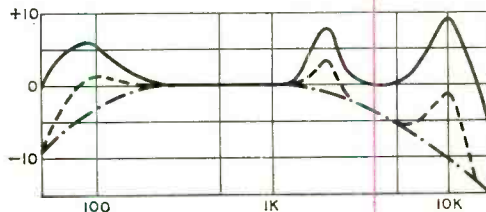

What a recording engineer can do with his equalizers (solid line) versus what you can do with ordinary tone controls (dashed line). The resulting frequency response is shown by the dotted line.

add a broad bump at 80 Hz so that the listener imagines that he's hearing bass notes and the hi-fi enthusiast won't be too aware of the roll-off below 60 Hz. An engineer can add this sort of equalization on any selective basis to any one or more of the 18 channels he might be mixing. And once he has prepared his master and you have it on two-channel stereo disc or tape, the equalized and unequalized channels are irrevocably and inextricably combined. The listener can't "de-equalize" the violin section without adding unwanted equalization to the woodwinds.

Realizing the built-in deficiencies of tone controls, we are seeing the introduction of multiband equalizers such as the Advent Frequency Balance Control, Citation 11 and Infinity preamps. These equalizers can make the average mixed-down recording somewhat more listenable. But nothing can overcome the continuously-varying "loudness compensation," of a Dynagroove recording.

How does the listener get realistic sound from recordings? Well, with electronically-

*(Continued on page 96)*





# Assemble the **SIX-DIGIT** **Popular Electronics** **DIGI-VISTA**

ELECTRONIC READOUT TO THE TENTH OF A SECOND

**T**RUE ELECTRONIC digital clocks are hard to find these days—most digital clocks work electrically with some type of mechanical readout. In the December 1970 **POPULAR ELECTRONICS**, we introduced the “Digi-Vista” clock, a completely electronic unit using transistor-transistor logic and Nixie® readout tubes. Described in detail in that article was a four-digit clock, which indicates hours and minutes and has a blinker to indicate every other second.

This month, we will describe the six-digit Digi-Vista. Since some of the details of theory and construction will not be repeated here, we suggest you consult the December article before assembling the six-digit clock.

The six-digit clock indicates hours, minutes, and seconds. The logic-flow diagram of the

clock is shown in Fig. 1. The circuit is essentially the same as the four-digit version, except for the addition of a seconds decade counter and a tens-of-seconds modulo-6 counter. These two counters are the same as those previously described for the minutes and tens-of-minutes counters. And since the six-digit version actually counts the seconds rather than indicating them by a flashing lamp, only two IC's (*IC2* and *IC4*) are used on the sealer module. The one-pulse-per-second output of *IC4* drives the seconds decade counter.

The circuits of the pushbutton controls have been changed slightly and a new HOLD pushbutton has been added. When the latter is depressed, counting is stopped and does not start again until the button is released. This permits the user to set the clock to some pre-

---

BY CHARLES G. KAY AND DANIEL MEYER

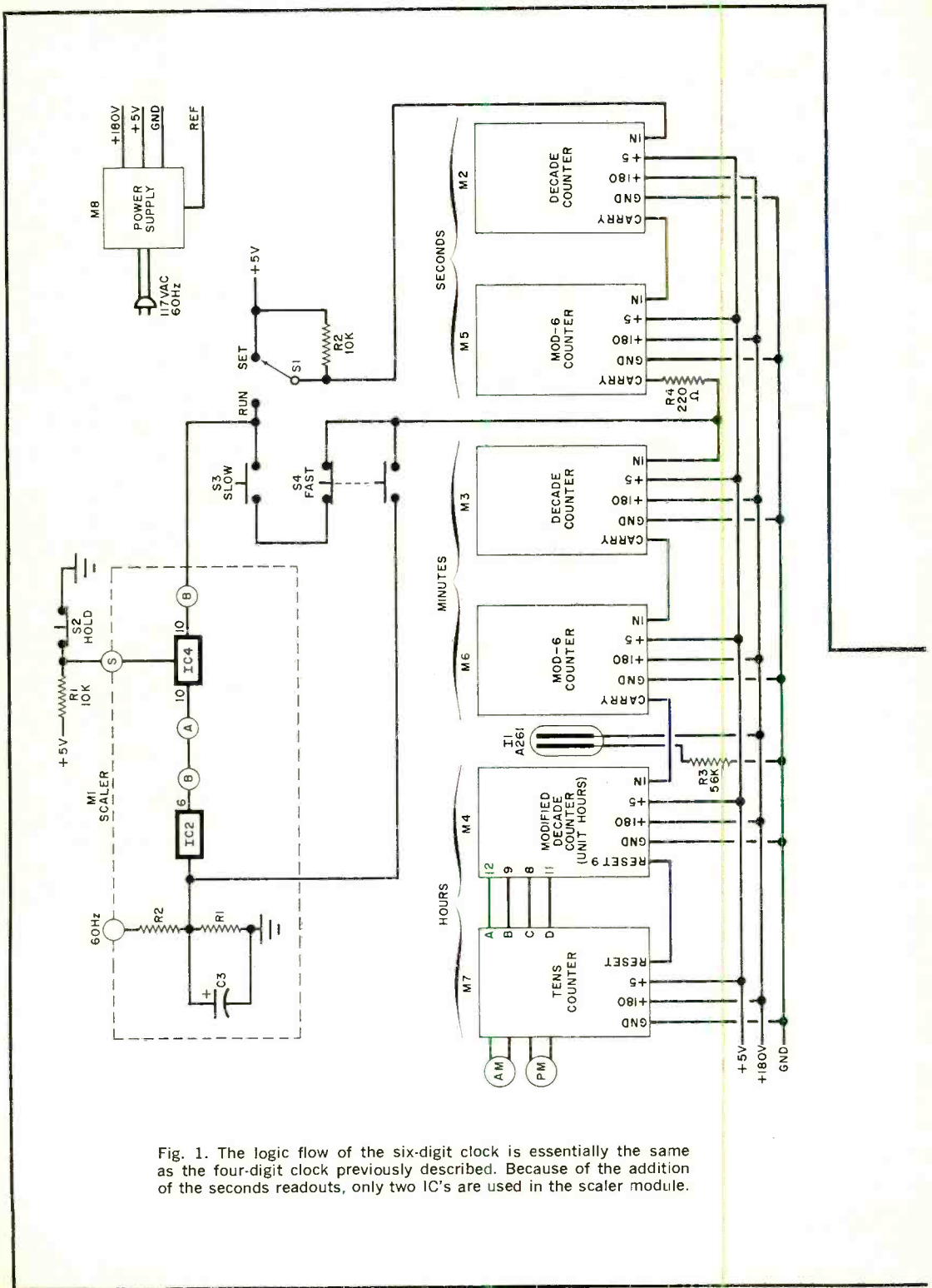
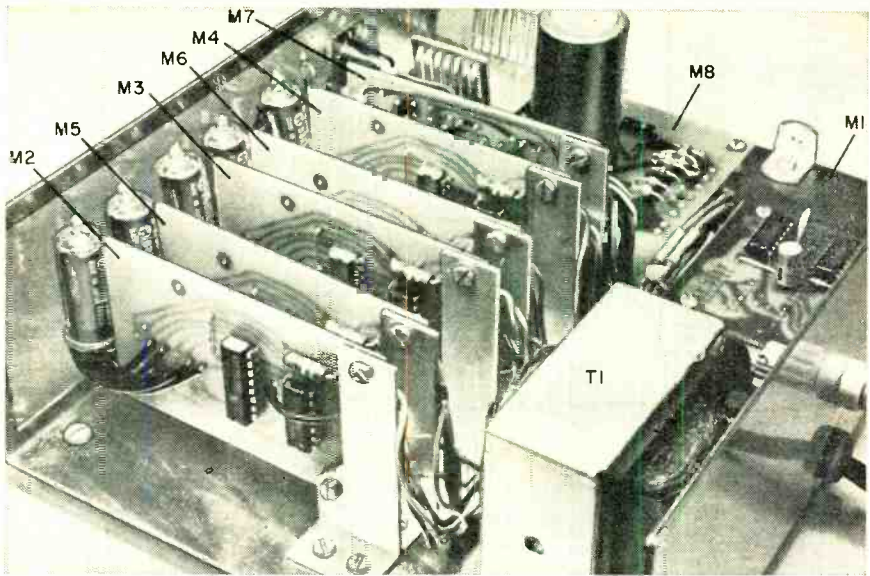

Fig. 1. The logic flow of the six-digit clock is essentially the same as the four-digit clock previously described. Because of the addition of the seconds readouts, only two IC's are used in the scaler module.



Although the prototype was built into a metal cabinet with the arrangement shown here, it could be mounted within any type of cabinet deep enough to accept the modules. The power supply and scaler can be above or below the readouts, and the operating controls hidden away.

### PARTS LIST

M1—Neon lamp (optional) (Signalite A261 or similar)

M2-M4—Decade counter module

M5,M6—Modulo-6 counter module

M7—Tens counter module

M8—Power supply module

R1,R2—10,000-ohm, 1/2-watt resistor

R3—56,000-ohm, 1/2-watt resistor

R4—220-ohm, 1/2-watt resistor

S1—Spdt slide or toggle switch

S2—Spst normally closed pushbutton switch

S3—Spst normally open pushbutton switch

S4—Dpdt no/nc pushbutton switch

Misc.—Suitable chassis, polarized plastic glare shield, spacers, mounting brackets, hook-up wire, etc.

Note—The following are available from Southwest Technical Products Corp., 219 W. Rhapsody, San Antonio, TX 78216: decade counter module NX-10 at \$15, postpaid; modulo-6 counter module NX-6 at \$15, postpaid; tens counter module CL-1 at \$8.50, postpaid (specify neon or incandescent lamp); scaler module SC-6 at \$8.75, postpaid; power supply module 169 at \$11.55, plus postage for 4 lb; polaroid plastic at 25¢/sq in. (specify size required).

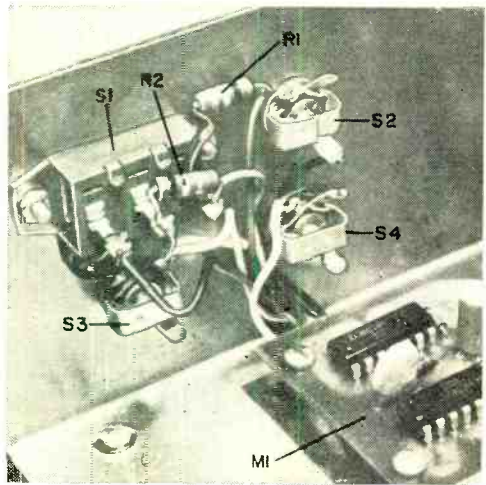

The operating controls can be mounted anywhere desired. Once the clock is set, the controls are not used, so they can be hidden from sight on the rear apron, or concealed in chassis.



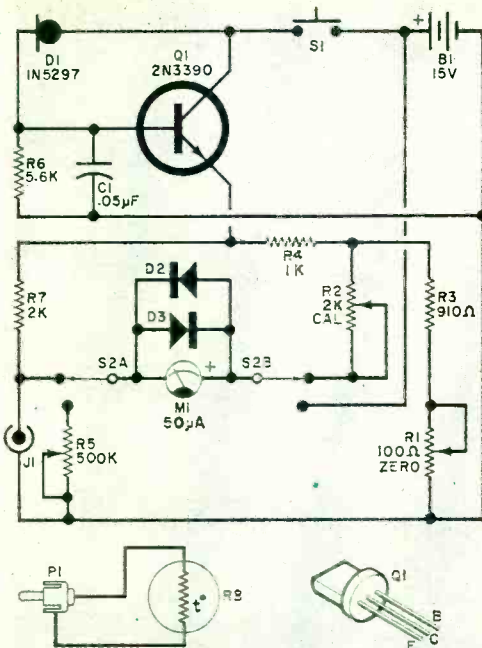

Fig. 1. The thermometer is essentially a Wheatstone bridge powered by a regulated battery power supply. Potentiometer R5 is used to set the meter to full scale with a new battery.

### PARTS LIST

- B1—15-volt battery (Everready 411 or similar)
- C1—0.05- $\mu$ F, 20-volt ceramic capacitor
- D1—Constant-current diode (Motorola 1N5297)
- D2, D3—Silicon rectifier diode (1N4001 or similar)
- J1—Phono jack
- M1—50- $\mu$ A meter (Calectro D1-910 or similar)
- P1—Plug to mate with J1
- Q1—2N3390 transistor
- R1—100-ohm, PC-type trimming potentiometer (Spectrol 84-3-8 or similar)
- R2—2000-ohm, PC-type trimming potentiometer (Spectrol 84-3-8 or similar)
- R3—910-ohm, 5% resistor
- R4—1000-ohm, 5% resistor
- R5—500,000-ohm potentiometer
- R6—5600-ohm, 5% resistor
- R7—2000-ohm, 5% resistor
- R8—300-ohm at 25°C, 1% thermistor (Yellow Springs Instrument 44005 or similar)
- S1—Spst normally open pushbutton switch (Switchcraft 903 or similar)
- S2—Dpdt pushbutton switch (Switchcraft FF-1006 or similar)
- Misc.—Plastic case (4" x 3" x 1½", Calectro JA-725 or similar), length of two-conductor cable (RG-174U, Belden 8216, or similar), press-on type, heat shrinkable tubing, spaghetti tubing, battery clip, wire, etc.

conventional glass clinical thermometer and is thus less uncomfortable for the patient. The probe is difficult to damage by accidentally biting. Its small size also allows it to respond rapidly to temperature changes and the low thermal mass of the housing does not affect the environment of the surround-

ings when temperature is being taken.

Thermistors generally have better long-term stability than thermocouples, and they tend to become more stable with age. In one test, thermistors varied in temperature indication by only 0.03°C per year, over a 12-year period. The resistance value, at any

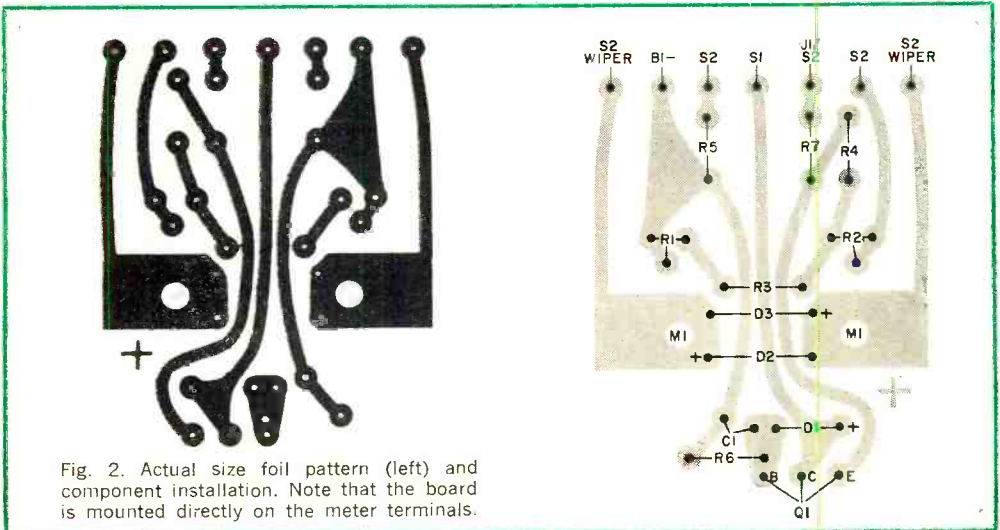
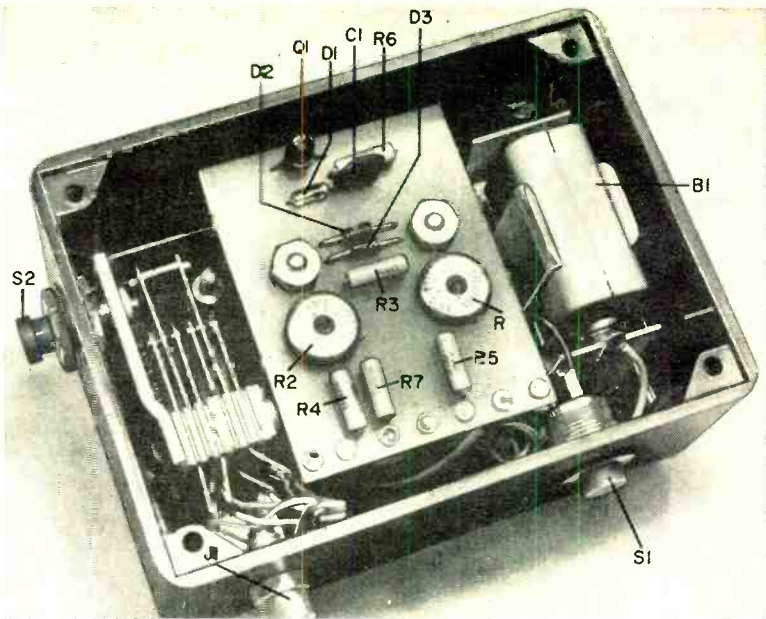

Fig. 2. Actual size foil pattern (left) and component installation. Note that the board is mounted directly on the meter terminals.



Completed thermometer fits in a small plastic case, including battery. Observe that meter is mounted in the "bottom" of case so that removing the cover allows access.

given temperature, for the thermistor used in the thermometer is accurate to less than 1%. This tolerance represents less than  $0.18^{\circ}\text{F}$  variation in temperature indication, which permits the use of any number of probes interchangeably.

**Construction.** A schematic of the thermometer circuit is shown in Fig. 1. It can be constructed on a small PC board (see Fig. 2) and mounted directly on the meter terminals. The two large holes shown in the foil pattern should be drilled just to fit the meter terminals without sliding around.

Very carefully remove the cover of the meter to expose the scale. Place the meter movement in a dust-free enclosure while modifying the scale. Using a light eraser, remove the numerals and the small division markers, leaving only the six large division markers. Using india ink and ruling equipment, add five matching division markers exactly between the six original markers. This results in ten equal divisions across the scale, each indicating one degree Fahrenheit. Using some form of press-on type, mark the left-hand marker 96. Number every other mark as shown in the photograph. Place a small dot over the 100 mark to indicate the battery cutoff voltage and draw a red line at 98.6 to indicate "normal" temperature. A "TEMP

$^{\circ}\text{F}$ " notation can be added below the scale if desired. Reassemble the scale and meter, taking care that the zero screw engages the proper slot in the movement.

The thermometer can be assembled in a small plastic instrument case measuring  $4" \times 3" \times 1\frac{1}{2}"$  with the meter mounted on the bottom of the case so that the rest of the assembly can be reached by removing the cover. You can dress up the unit by removing the feet on the bottom of the case and covering it with contact paper. Once the meter is secured, fit the PC board in place and locate the holes for the two switches and probe jack. They must not interfere with the circuit board. Also locate a suitable spot for the battery clip and mount it.

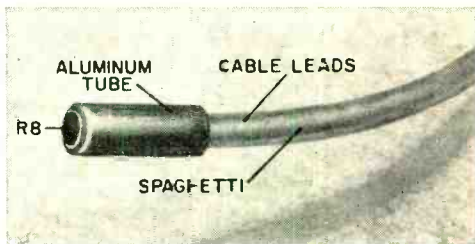

Great care must be used when making up the probe. Use a non-toxic glue to mount the thermistor in the aluminum tube. Observe the Caution on page 78.

To make the probe, obtain approximately two feet of light, flexible two-conductor cable (RG-174U or similar) and terminate one end with a plug that matches the jack on

### HOW IT WORKS

The circuit is essentially a Wheatstone Bridge powered by a well-regulated supply. The resistance values for the two legs of the bridge were selected to produce a linear output of desired amplitude for the temperature range covered.

Resistor *R7* is connected in series with the thermistor (*R8*) to form a voltage divider which is one arm of the bridge. The voltage at the junction of these two components is a function of the resistance value of the thermistor, which varies with the temperature. This voltage is applied to the negative terminal of the meter. The other arm of the bridge consists of resistors *R1*, *R3*, and *R4*, with the voltage at the junction of *R3* and *R4* capable of being set to equal exactly the voltage at the meter negative terminal when the thermistor probe is at 96°F. In this condition, no current flows through the meter and it indicates at the left end of the scale.

As the thermistor temperature increases, the voltage at the meter negative terminal goes down with respect to that at the positive terminal which is fixed by the resistor network. A probe temperature of 106°F produces a voltage difference sufficient to deflect the meter full scale. Precise adjustment is made with *R2*.

A well-regulated supply is mandatory for accuracy even though the battery voltage drops with use. The regulator circuit used is superior to a zener regulator in two respects: regulation is better (especially as the battery voltage approaches the cutoff point) and it does not require a minimum current to function with a low dynamic resistance.

Operation of the regulator is based on the constant-current diode. The latter is actually a FET transistor with the gate connected internally to the source. It is carefully selected to obtain the most desirable characteristics. The constant-current diode functions in a manner just the opposite of the zener diode. Instead of maintaining a constant voltage drop, it maintains a constant current for a wide range of impressed voltages. A resistor connected in series with the diode (*R6*) then has a constant voltage across it. In the thermometer, this voltage is 5.6 volts, which is applied to *Q1*. The latter is connected as an emitter follower to supply power to the circuit. The circuit not only provides excellent regulation, but draws only about 1 milliampere. Capacitor *C1* insures that the transistor will not oscillate, which may be a problem with high-gain transistors.

Diodes *D2* and *D3* protect the meter from excessive voltages when the unit is operated without the probe or with a shorted probe. Voltage across the meter is limited to 0.6 volt.

Resistor *R5* is used to test the battery by causing a full-scale indication for 20 volts. The battery should be replaced when it falls to 8 volts.

the case. Cut a piece of slender aluminum tubing just large enough in diameter to allow the thermistor and connections to be inserted. The edges of the tube should be slightly rounded at each end. If you are using RG-174U cable, trim back the outer plastic cover and the braid for about two inches. The insulated center lead of the cable is connected to one thermistor lead (cut very short and insulated) while the other thermistor lead is brought down the outside and connected to the braid. Slide a length of spaghetti tubing down this pair until it contacts the braid. Use a small piece of heat-shrinkable tubing to secure the spaghetti in place. Insert the thermistor and connections into the aluminum tubing with the aluminum just touching or slightly covering the spaghetti. Flow epoxy into the space between the thermistor and tubing and allow to harden. Use an abrasive paper to make the completed probe smooth.

**Calibration.** To calibrate the electronic thermometer, you will need an accurate bulb-type thermometer. Adjust the meter zero screw until the needle is directly on the 96 mark. Fill a large pot with water and heat to a temperature slightly over 96°F. Remove the heat, place the probe and bulb thermometer in the water, in close proximity, and stir the water continuously. When the water cools to exactly 96°F as indicated by the bulb thermometer, adjust *R1* so that the meter indicates exactly 96. Heat the water to slightly above 106°F, keep stirring and turn off the heat. When the water cools down to exactly 106, adjust *R2* to obtain this indication on the meter. As the water continues to cool, check the mid-scale marks.

### CAUTION

Great care must be exercised in fabricating the thermistor probe. A non-toxic epoxy must be used to keep the thermistor in place (particularly at the lead end of the thermistor); and the user must be cautioned not to bite or break the tube while it is in the mouth. Excessive strain should not be placed on the thermistor leads. Some people are allergic to the epoxy that covers the thermistor and can develop a rash when this chemical comes in contact with the sensitive areas within the mouth.

Cleanliness is as important in the use of this thermometer as it is with any other clinical instrument. Always sterilize the probe (with alcohol) before each use.





## RESEARCH

**What Are They Up To?**—The mysterious time signal station on 13.56 MHz has been identified as KC2XIO. Licensed for tests by the Department of Commerce, it appears that this station may be the forerunner of the WWV to come. Users of the WWV signals will recall being surveyed in 1969. Unofficial results indicated that two changes were most requested: more voice announcements (including ionospheric information) and getting rid of the binary coded transmissions. Rumors persist that the 440- and 600-Hz tones will also go and that time ticks with voice announcements every minute will be made.

## CITIZENS RADIO (CB)

**The "Too Much" Base Station**—*A manufacturer of CB equipment has a base station console design on the drawing board that will probably sell for \$2000! Custom-built, the CB console will include every operating convenience imaginable—phone patch, tape recording, multiple antenna switching, selective calling, etc. Plans call for 100 consoles to be partially assembled against delivery in late 1971. Get your order in early!*

## MILITARY

**Almost Unbelievable**—At the 1970 convention of the Antique Wireless Association, Continental Electronics revealed some of the startling statistics about its work in building the super-power low-frequency (17.8-kHz) transmitter and antenna at Cutler, Maine. Actually, two identical antennas have been erected so that one is always in use when the other is de-iced. The r-f amperage going into the antenna is about 2500 and the voltage nodes exceed 250,000! To radiate efficiently at this low frequency, an enormous ground screen was buried and the antenna Q was raised to such a value that, to transmit frequency shift keying (FSK) RTTY, the whole antenna system must be slightly detuned (with saturable reactors)—the shift is plus or minus 25 Hz.

## SHORTWAVE LISTENING

**Illegal Taping**—*Strictly interpreted, Section 325(b) of the 1934 Communications Act makes it unlawful to tape record program material if there is any possibility that the recording might be radio transmitted back to or heard in the U. S. Waiver of this requirement may be obtained from the FCC, but enforcement since World War II has been almost non-existent. Some SWL's are obviously breaking the law, but since they are non-professionals, no effort is made to enforce the letter of the law. The appropriate Section reads "No person shall be permitted to locate, use or maintain a radio broadcast studio, or other place or apparatus from which or whereby sound waves are converted into electrical energy, or mechanical or physical reproduction of sound waves produced, and caused to be transmitted or delivered to a radio station in a foreign country for the purpose of being broadcast . . ." (Submitted by the Short Wave News Service)*

*(Continued on next page)*

electronics courses from a reputable resident or home study school right after graduation from high school. Although your high school may prepare you for a job in the electronics industry, high school graduates taking post-high school electronics courses generally get better jobs and higher starting salaries than those who rely only upon their high school diplomas.

There are several reasons why you can expect a better job and higher pay if you're taking electronics courses after graduation from high school:

1. Post-high school electronics courses give you a chance to review the material you have been taught, and they can lead you into more specialized training. Employers recognize this fact and are willing to reward you for your efforts.

2. By taking post-high school electronics courses, you will be associating and competing with men who are older and have some electronics job experience. Dealing with these people in an enthusiastic and professional manner in the classroom or through the mail shows your prospective employer that you will be able to get along with the many different kinds of men and women working in the electronics industry.

3. Pressures from society, teachers, and parents encourage most students to complete their high school training. These pressures, however, aren't so great for students taking post-high school courses. Keeping up with your post-high school studies and showing a sincere interest in completing them will prove you are the kind of man who takes his career seriously.

You should begin looking for an electronics school before graduating from high school. You can get a free list of nationally accredited home study schools by writing for "A Directory of Accredited Private Home Study Schools." The address is:

National Home Study Council  
1601 Eighteenth Street, N.W.  
Washington, D.C. 20009

If you are interested in attending classes at a local resident school, be sure to check the school's programs and business methods. Do these things:

1. Visit the school while classes are in session to see how the instructors and students conduct themselves.

2. Get the names and addresses of recent graduates living in your community, and ask them how they feel about the school and the training they received.

3. Write to your State Department of Education, and ask about the school's academic standing.

4. Contact your local Better Business Bureau to see if they have any complaints on file about the school.

## College Courses by Home Study

*I have heard that some colleges and universities offer home study courses in college-level subjects. Where can I get a list of these schools and the courses they offer?*

● For the benefit of readers who haven't heard of these programs, many well-known American colleges and universities do, indeed, offer college-level home study courses. It is possible for a home study student to get full college credit for successfully completing some of these courses. Most of the credit courses are on the freshman and sophomore levels, however, so it isn't possible to get a college degree strictly through home study. Many students begin their college careers with these home study courses, though, and complete their requirements for a degree by attending classes at a later time.

These colleges and universities also offer full-credit high school home study courses as well as non-credit vocational, technical, and general interest courses.

For a listing of the schools and the home study courses they offer, send fifty cents and a request for the "Guide to Correspondence Study" to:

National University Extension  
Association  
900 Silver Spring Avenue  
Silver Spring, Maryland 20910

(This information comes from the "National Home Study Council News", November 1969 Supplement.)





One Hundred Seventy-Sixth in a Monthly Series by Lou Garner

**J**ANUARY—named after the two-faced Roman god, *Janus*, who looked forwards and backwards at the same time—a new month and the beginning of a new year. As Janus, we, too, must look in two directions . . . back to our January, 1970 column, in which we made predictions of solid-state developments for 1970, and ahead to our forecasts for 1971.

First, a look at the past twelve months. One year ago we predicted:

*Light-emitter diodes (LED's) at prices comparable to those of long-life incandescent lamps.* Home run! Monsanto Electronic Special Products (10131 Bubb Road, Cupertino, CA 95014), Motorola Semiconductor Products (Box 20912, Phoenix, AZ 85036), and Hewlett-Packard (1501 Page Mill Road, Palo Alto, CA 94304) all have introduced inexpensive LED's. Monsanto's type H-1 is offered to experimenters at two for \$2.98, or less than \$1.50 each.

*Linear IC's with built-in special in-pu devices, such as sensors or pick-ups.* Home run! RCA's (Harrison, NJ 07029) type TA5371B (now type CA-3062), reported in our June column, is a linear IC amplifier with an integral light sensor.

*Moderate power (5 to 10 watts, or more) IC amplifiers at prices competitive with discrete component designs.* Home run! Several firms are now producing moderately priced multi-watt IC amplifiers. GE's (Electronics Park, Syracuse, NY 13201) PA246 is a typical device. Capable of delivering 5 watts rms (10 watts peak) to a 16-ohm load, the PA246 is an 8-transistor, 5-diode IC which nets for only \$5.00 each in unit quantities. Try matching that at the same price with a discrete component assembly!

*A virtually complete switch-over to solid-state circuitry in consumer products.* Home run! Although vacuum tubes are still used in some TV sets, virtually all other consumer (electronic) products use solid-state circuitry exclusively, including variable-speed blenders, power tools, cassette players, receivers, CB gear, burglar alarms, dictation equipment, etc. One firm has even introduced a solid-state controlled soldering iron!

*The introduction of rf IC's with integral,*

*rather than external, inductance elements.* Home run! Many commercial UHF/VHF IC's now feature built-in inductors, and at least one company (Epitek Electronics, Ltd., 19 Grenfell Cres., Ottawa 12, Ontario, Canada) offers a standard line of chip type inductance devices for use by hybrid IC manufacturers.

Actually, the conventional inductor may soon become obsolete as far as IC's are concerned. A number of special purpose circuits and devices have been developed which can serve as substitutes for bulky inductance coils, including unique monolithic quartz crystals, the capacitor-loaded gyrator, various active filters, and the versatile phase-locked loop.

*The formation of a new corporation offering a broad range of specialized semiconductor-operated products at the consumer level.* Home run! Several such firms started operations during the year. One, North American Electronics (Rockford, IL 61108), offers a wide line of consumer-oriented electronic products and components, including semiconductor-operated standard and wireless intercoms, telephone amplifiers, door answering communicators, battery chargers, and amplifier modules.

*The use of lasers as production tools in the manufacture of solid-state devices.* Home run! Serving as standard production equipment, medium-to high-power lasers are now being used by major manufacturers for such tasks as scribing semiconductor wafers, trimming IC resistors to value, and welding microminiature contact leads.

*The introduction of an unusual new solid-state device—perhaps an IC opto-coupler or monolithic microwave circuit.* Home run! Not one, but several unusual new solid-state devices were announced during 1970. On the West Coast, engineers at the Boeing Company in Seattle developed a unique monolithic silicon gyrator—a circuit capable of simulating the operation of a sizeable inductor. Down South, TI engineers developed a pair of monolithic silicon microwave circuits—an experimental 100-watt Ku-band phase shifter and a single-ended X-band mixer.



And in the East, RCA announced their new adaptive ferroelectric devices, as reported in our April column.

The production of "all-IC" consumer items with few, if any, discrete components, except for electro-mechanical devices, such as loudspeakers and controls, or physically large units, such as transformers. While we could legitimately score a "homer" for this prediction, we feel that a "double" is more realistic—a "homer" only through error. True, several "all-IC" products were introduced during the year, including receivers, phonographs, hearing aids, and various specialized controls, but, quite frankly, we had anticipated a much broader use of IC's in consumer products in making our original forecast. Reluctantly, then, but honestly, just a double.

The development of a new solid-state memory system suitable either for a computer or, possibly, an "electronic" camera. Home run—with the bases loaded! Although, truthfully, we had considered this the "wildest" of our forecasts for 1970, we were able to score late in the game with an assist from the scientists at the Bell Telephone Laboratories. As discussed in our October column, BTL scientists and engineers were successful in developing a completely new type of memory—a solid-state device called a *ferpic* which can store picture images until electronically erased or changed.

Final score for our 1970 predictions, then, 9 home runs, 1 double in ten times at bat.

**Things to Come.** Each year at this time, we feel inclined to discontinue our annual predictions. After all, why spoil a good record? But, trembling and with apprehension, we suggest you expect the following during 1971:

*The production of relatively inexpensive*

*solid-state computers suitable for student use in public schools. . . the introduction of a solid-state oscilloscope in the \$100 to \$150 price range, perhaps as a kit. . . LED's priced at less than one dollar in unit quantities. . . medium- to high-power (10 to 50 watts, or more) IC audio amplifier devices in the "under \$10" price range. . . an expanded use of linear IC subsystems by both engineers and hobbyists, as well as the introduction of new subsystem devices comparable to gyrators and PLL's. . . a unique solid-state microwave device based on a technological breakthrough. . . the development of a new semiconductor manufacturing technique. . . despite inflation and increased labor costs, a continuing drop in the prices of both IC's and discrete solid-state devices. . . an interesting new semiconductor sensor. . . a significant increase in the use of solid-state electronic equipment in bio-medical research and medical applications.*

**Reader's Circuit.** Designed to switch off a conventional tape recorder/player automatically at the end of a reel, the control circuit illustrated in Fig. 1 was submitted by Richard F. Serge, ETR-2, aboard the USS Columbus (CG-12). Although intended for a specific purpose, the basic circuit is reasonably versatile and, with a little ingenuity, could be modified for more general applications.

Referring to the schematic diagram, common-emitter amplifier  $Q1$  normally is held in a conducting state by the base bias established by voltage-divider  $R4$ - $R5$ , thus energizing  $K1$  (4- to 30-mA pull-in current) and permitting equipment operation. At the same time, base diode  $D1$  is held in a high resistance (non-conducting) state by a reverse bias obtained from a voltage-divider

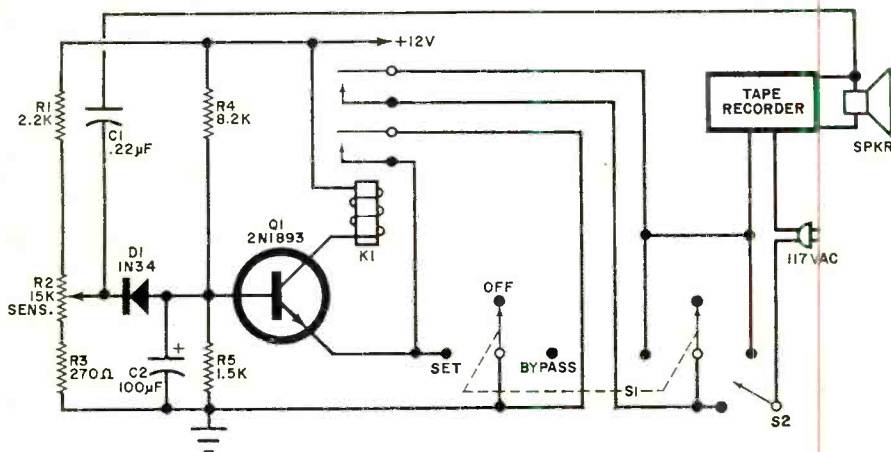

Fig. 1. The control circuit can be used with a battery-operated recorder with the same effect.

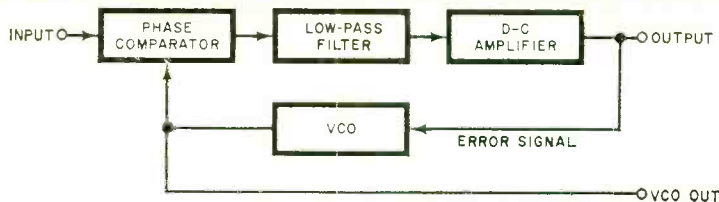

Fig. 2. "Innards" of a phase-locked loop (above) show how the voltage-controlled oscillator is kept in step with varying frequency input signal.

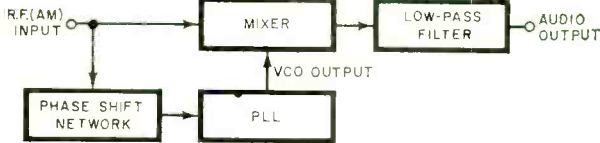

Fig. 3. The simple circuit shown at the left illustrates the use of the PLL as a synchronous AM demodulator.

made up of  $R1$ ,  $R3$  and sensitivity control  $R2$ . If the tape player's output signal, coupled back through  $C1$ , rises to sufficient amplitude to overcome  $D1$ 's reverse bias, however, the diode will conduct, reducing  $Q1$ 's base bias and allowing  $K1$  to drop out, thereby switching off both the control circuit and the tape player. In practical operation, "switch off" action is initiated by a pre-recorded high level signal at the end of the tape.

Neither layout nor lead dress are critical, and the control device can be assembled on an etched circuit board, small chassis, or perf board. If space is available, the unit may be mounted within the tape player's cabinet—if not, in a small metal or plastic case as an outboard accessory.

A nominal 12-volt dc supply is required for circuit operation. In his installation, Richard utilized an existing 35-volt source within the tape recorder, relying on a voltage-dropping regulator circuit to reduce this to approximately 12 volts. Naturally, an independent power supply can be used, if preferred.

For optimum circuit performance, the tapes used with the recorder/player must have a pre-recorded control signal at the end of the program material, with this signal of greater amplitude than the maximum level of the regular program. Richard suggests that a 12-kHz. high-level tone be recorded at the beginning of each tape and repeated at the end of the reel for approximately a half-second. Initially, this tone is used for adjusting the unit's sensitivity control, serving, later, to trigger "switch off" operation.

The unit's set-up is straightforward. Switch  $S2$  is closed and  $S1$  turned to its "set" position. Next, sensitivity control  $R2$  is adjusted so that  $K1$  remains energized on program material, but drops out on the high-level control signal. Finally, with the tape playing,  $S1$  is turned to its "off" position. Thereafter, operation is automatic, with the equipment turning itself off when the control signal is played at the end of the reel.

### The Phabulous Phase-Lock Loop.

Would you believe a system *without tuned circuits* which can: (a) detect AM signals, (b) demodulate FM signals, (c) isolate tones, (d) reconstitute signals, (e) track unstable signals, (f) synthesize precise frequencies, and serve as a frequency selective (g) multiplier or (h) divider? Moreover, a circuit with superb noise immunity and exceptional selectivity.

Would it be a design engineer's pipe dream? An experimenter's fantasy?

Neither! Just such a circuit concept—the phase-locked loop, or PLL—has been around since the early 1930's and has been widely used in a number of special applications. Unfortunately, the basic system is quite complex and, therefore, costly to reproduce with discrete components. As a result, the PLL's past applications have been justifiably limited to expensive precision equipment requiring exceptional noise immunity and very high selectivity.

Today, however, two major semiconductor manufacturers—Motorola Semiconductor Products (P.O. Box 20912, Phoenix, AZ 85036) and the Signetics Corporation (811 East Arques Ave., Sunnyvale, CA 94086)—are offering PLL IC's at comparatively low prices, thus providing a new and exciting field for both the equipment designer and the advanced experimenter.

A simplified block diagram of the basic phase-locked loop is given in Fig. 2. In operation, an external (input) signal and a locally generated signal obtained from a voltage-controlled oscillator (VCO) are applied to a phase comparator which, in turn, develops an output error voltage proportional to the phase difference between the two signals. This error signal, after filtering and amplification, is coupled back to the VCO as a control signal, thus establishing a feedback loop. The error signal acts to shift the VCO's frequency in such a way as to reduce the phase difference between it and the input signal. If the VCO's "natural" free-running

(Continued on page 90)

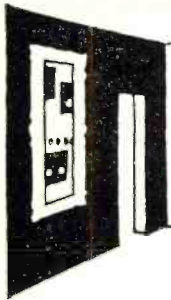

## THE PRODUCT GALLERY

Fifth in a Monthly Series by "The Reviewer"

**W**ELL, kiddies, it's color TV kit building time!

How time flies and how the color TV kit building art has progressed since the first kit was introduced in 1963. Five color TV kits later, the Heath Company is now offering its first solid-state modular color TV receiver kit. I am going to let the Heath Company advertising tell you about most of the refinements and conveniences in this new kit while I concentrate below on the essential differences between the solid-state concept and the, say for example, GR-681, the comparable Heathkit color TV with all vacuum tubes.

**Heathkit GR-370.** The Heath Company has introduced three solid-state color TV kits. All three share some of the same features, but this report concentrates on the GR-370 (295 sq in. picture) available with the new matrix tube for \$569.95, or the regular 23VARP22 picture tube for \$10 less.

Besides the modular construction so well described in the Heath Company advertising, I was particularly attracted to the "instant-on" philosophy which means that the three filaments in the picture tube are kept warm at all times. This should prolong picture tube life since most tube failure is confined to turn-on surges. The GR-370 also contains an adjustable pulse noise limiting circuit, gated agc, and an adjustable peaking control in the circuits between the i-f strip and the luminance PC module.

Servicing, one of the primary reasons for investing in a kit is simplified through the use of the solid-state modules\* and the inclusion of a simple VOM as part of the GR-370 kit.

The weighty assembly manual—such as that accompanying the GR-681—has been dissected and expanded so that the builder receives 6 or 7 separate manuals—depending on whether or not he has remote controls. Most of the manuals may be filed away after use and only Book 5 retained for ser-

vic-ing and maintenance information.

**Book 1—Introduction and Circuit Boards.** The heart of the GR-370 comprises 9 plug-in printed circuit boards that are assembled according to the detailed wiring plans in this book. In order of construction the boards contain the circuits for the following systems: sound (1 IC and 1 transistor), luminance (6 transistors including 1 Darlington pair), video-output (1 IC and 4 transistors), chroma (6 transistors), 3.58-MHz oscillator (1 IC and 2 transistors), agc-sync (8 transistors), vertical oscillator (4 transistors), horizontal oscillator (2 transistors), and the pincushion and convergence boards (no solid-state components required).

Soldering in the components on these 9 boards is far from a difficult task. It is time consuming, but scarcely what this reviewer would call tedious since each board becomes an integral unit and your work may be safely interrupted between boards. Sockets are used for all IC's and transistors and there is little opportunity for heat damage to these components. My only suggestion in the assembly process is to feel free to reverse the order of installation—install capacitors before resistors (rather than vice versa) if you find it convenient. Also, use heat sinks on all diodes when soldering—just in case.

My work total for Book 1 was 12 hours and 35 minutes which I feel is about average. I did use a soldering iron with variable heat (Heathkit GH-17A) and was particularly careful about solder bridges between foil patterns. In fact, it is a good idea to go over each foil pattern after the soldering operation has been completed and examine it with a magnifying glass. Check for cold solder connections and solder bridges.

**Book 2—Chassis Assembly.** By and large, all of the mechanical assembly and wiring steps detailed in this book go smoothly. I think that a very fast kit builder could tear through this book in 8 hours—possibly a little less. However, I would expect the amorphous "average" builder to spend at least 9 hours.

You will be delighted to find that the

\*Within the 90-day warranty period, the GR-370 builder may have the modules serviced or replaced at no charge for parts or labor. After the warranty expires, modules will be serviced or replaced at \$5 per module for parts and labor for a two-year period from the date of purchase.



## HEATHKIT SOLID-STATE COLOR TV GR-370

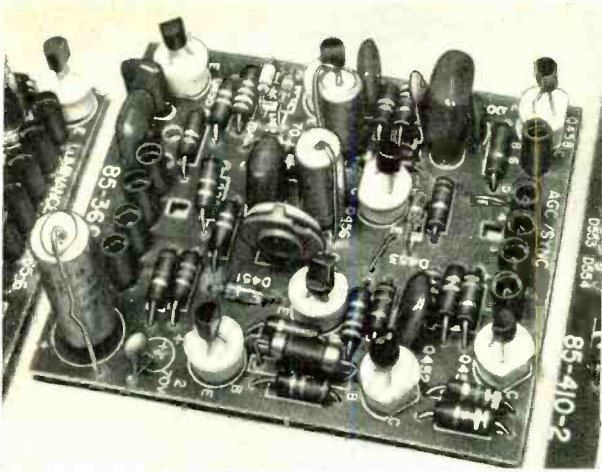

**EASIER CONSTRUCTION/SERVICING.** Major assets of the GR-370 are convenience of modular construction and ease of troubleshooting. Builder assembles 9 modules similar to that above containing agc and sync circuits. Note use of sockets for transistors and clear identification of leads.

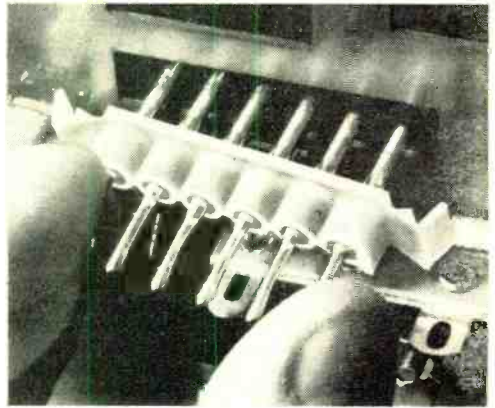

**SNAP INTO PLACE.** Each printed circuit board or module is suspended between two 6-contact circuit board connectors. Each connector is snapped into place in the pre-punched chassis. Modules are easily removed for checks and servicing. This view is from the inside of chassis looking out.

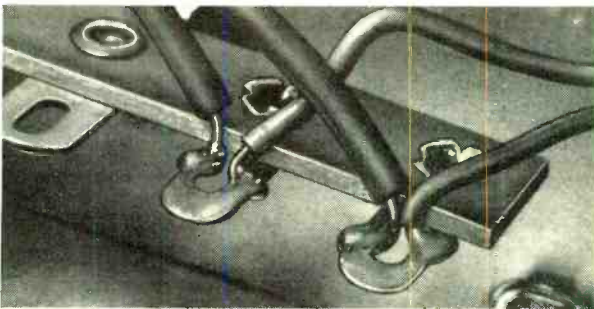

**SOLDER TACKING HELPS.** Your reviewer feels that each connection (whenever possible) should be tack-soldered when made. If the connections are lightly touched with solder when made, they cannot spring loose and a well-soldered "final" connection is assured—regardless of number of wires to be soldered.

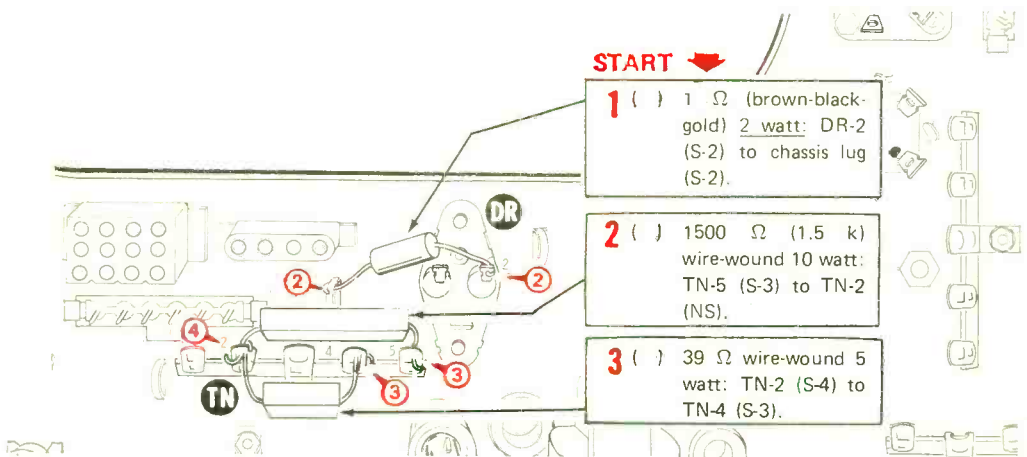

**NEW WIRING PROCEDURE.** This reduced example of the two-color assembly diagrams in Book 2 illustrates the "flow" of instructions (sequential and boxed) as well as the finished soldered terminations (the circled numerals). Use of this type of system virtually eliminates chances of making wiring errors.

4-transistor i-f assembly is delivered pre-assembled and prealigned. It is simply fastened into place and phono cable connections made to the sound circuit and luminance boards. The automatic fine tuning (aft) assembly with its two IC's is also preassembled and has been partially aligned.

This book introduces the Heathkit builder to the two-color wiring diagram with the new expanded—but, single page—wiring diagram. Be careful of page 2-13—it is a SAMPLE page—not an actual wiring diagram. Step-by-step wiring instructions are made a part of each pictorial and the red numerals tell how many wires are finally soldered into place at a particular terminal.

**Book 3—Front Panel Assembly.** The “guide word” for following instructions in this part of the GR-370 assembly process is—look before you leap. Particularly note that this book is in two distinctly separate sections and that they are nonconsecutive. Both parts of this book deal with the front panel: one section about the panel assembly WITHOUT remote controls and the second section WITH remote controls. Don't go pell-mell into the assembly unless you're at the right starting page; which is page 3-3 if you have NO remote and page 3-25 if you HAVE remote controls.

The front panel is that part of the GR-370 where you mount two tuners, motors on the color and tint controls (if used), and all of the usual viewers' controls: color, tint, volume, brightness, contrast, etc. Wiring is straightforward and there are very few rough spots. There is a lot of cabling (supplied) to be connected and I think that 4 hours total assembly time is just about the minimum you might expect.

**Book ??—Picture Tube and Shield Assembly.** I guess the numbering of this instruction manual was lost in the shuffle, although it obviously belongs between Books 3 and 4. As the title indicates, this is the procedure for mounting the picture tube to the face mask, assembling the shield, placing the automatic de-gaussing coil into position around the neck of the tube and finally hanging the chassis (it is hinged) and making the 9 different cable assembly interconnections. Be careful to do step number 9 on page 14 (Pictorial 1-11) since it is “hidden” in the lower lefthand corner and I missed it first time around.

This is the most laborious part of the GR-370 kit and also the one requiring the most muscle. I would normally allocate over 4 hours—although an experienced builder (someone who has built a 1968-70 color TV kit) might run through everything in under 3 hours and 30 minutes.

#### **Book 4—Adjustments and Operation.**

Before starting on the steps detailed on the charts in the first part of this Book, you should assemble the little Heathkit “Trouble-shooter.” This is a 20,000-ohms-per-volt VOM with two voltage measuring ranges (0-50 and 0-500 volts) and two resistance ranges (RX1k and RX10k). I suspect that many builders with previous kit experience may skip this part of the project; but if they do it may well be to their grief. Putting the simplified VOM together is a matter of about 50 minutes and the checkout tests take just under another 30 minutes. This is not bad for the feeling of competence a successful run-through will impart when all of the resistance tests match the predicted results shown in the charts.

Should any resistance measurement not be up to snuff, the charts indicate what steps to take to isolate the trouble—which most frequently at this stage would be a solder bridge on one of the PC boards or a wrong value resistor inserted in error on one of the boards. If absolutely nothing else, these tests tell you in advance that the GR-370 is not going to go up in smoke the first time it is turned on.

Also in Book 4 are short sections on Normal Operating Characteristics (a very good idea if you worry about strange buzzing and crackling noises), De-Gaussing, Final Assembly (pole pieces, speaker and Trim Panel), and Tests and Adjustments. The latter includes setting vertical size, making static and dynamic convergence, purity, pincushioning, etc. adjustments.

**Remote Control Assembly—**For an extra \$64.95 you can obtain from Heathkit a “Wireless” (ultrasonic in the spectrum 34-44 kHz) remote control that greatly enhances the armchair viewing pleasure of color TV. Although the remote control facilities may be added to the GR-370 at any time, I think everyone will find it easier to make the initial investment when buying the GR-370 and build the control units (transmitter, receiver, and motor drives) before starting on Book 3.

The remote control (kit GRA-70-6) can be assembled in 3½-4 hours and presents no difficult problems—just use a modest amount of care in soldering the transistors to the PC board (no sockets used here).

To reach this point I had spent 34 hours building the GR-370 with remote control facilities. Still to go were all of the steps incidental to convergence and final mounting of the receiver in its cabinet. A good full raster has been obtained at first turn-on and my comments on TV picture quality and operating conveniences will appear in next month's column.

Circle No. 92 on Reader Service Page 15 or 95



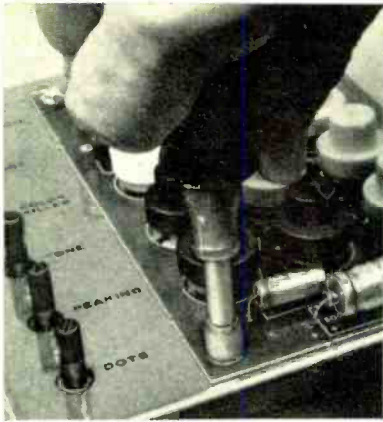

**TOOLS WHEN YOU NEED THEM.** The Heath Company has supplied solder with its kits and your reviewer observes that a number of important tools are now packaged. In the GR-370 kit there are two nut drivers and a miniature end wrench. This is the PC board of the convergence assembly being attached to the metallic bracket with some sheet metal screws.

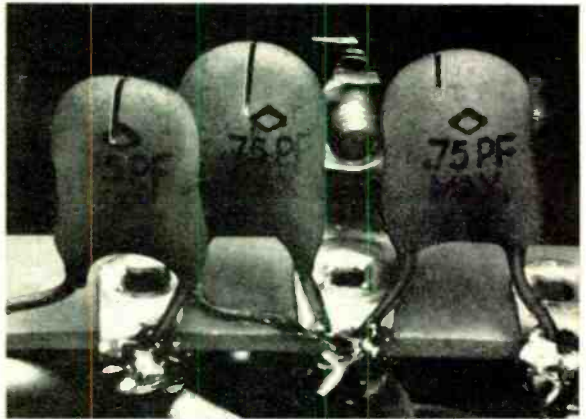

**SPARK GAP CAPACITORS.** Nine special high-voltage capacitors are wired into the GR-370 around the picture tube. Although ceramic, they are distinguished by an elongation that has what appears to be a cut in the edge away from the leads.

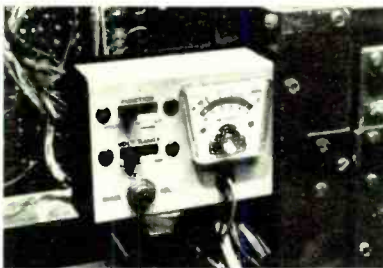

**EVEN A VOM**—As part of the overall GR-370 kit package, the builder receives the plans and parts for a small VOM. This instrument is used to check the receiver before first turn-on and may be used to service the set in case of difficulty. The meter scale is imprecise and the readings are very approximate.

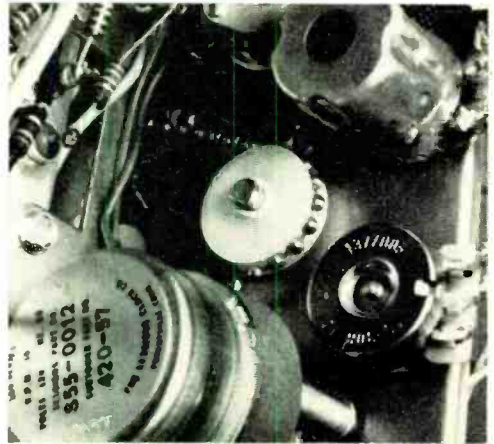

**YOU WOULDN'T EXPECT TO FIND**—The concentric fine tuning knob on the VHF tuner has disappeared from the GR-370 and has been replaced by a separate knob and chain drive. The object in the left foreground is motor for the color potentiometer.



**NO CHANGE HERE**—The ultrasonic remote control receiver is still the very sturdy and practical GRA-70-6. A six-channel system, it is slug-tuned between 34 and 44 kHz. Enclosed relays (the six rectangular objects) activate color and tint motors or pull in the stepping relay (which is the right-hand wafer switch visible).

## HEATHKIT SOLID-STATE COLOR TV GR-370

January, 1971

89



# SYDMUR

The Last Word in "CD" Ignition Systems



**SAVE MONEY**  
on GAS! COILS!  
SPARK PLUGS!  
TUNE-UPS!

NEW heavy duty solid state "CD" ignition systems available. Take advantage of the latest technology . . . get the most out of your car's engine.

- Increased mileage
- Greatly extended spark plug life
- Fast cold weather starting
- Fewer tune ups

Well built, conservatively rated components. Every Syd mur part is pre-tested and guaranteed. The easy to install Syd mur is fully adaptable; 6 or 12 volt systems, positive or negative ground.

Fly-away assembled	.....	\$60.00	prepaid
Fly-away kit	.....	44.50	prepaid
Compac assembled	.....	\$34.75	plus \$1.00 handling
Compac kit	.....	24.95	plus \$1.00 handling

Or Build Your Own—Free Instructions!!  
Power Transformer plus detailed instructions  
SPC-4 (6 and 12 volt) ..... \$14.95

As described in June 1965 Popular Electronics (New York State residents add sales tax)  
Recommended by many of the world's leading automotive manufacturers. Send check or money order today.

For free literature and parts list write:

**SYDMUR ELECTRONIC SPECIALTIES**

1268 East 12th Street Brooklyn, NY 11230

**CIRCLE NO. 18 ON READER SERVICE PAGE**

OUR STORE  
AT YOUR DOOR

**Olson**

ELECTRONICS

**FREE**  
Catalog

Fill in coupon for a FREE One Year Subscription to OLSON ELECTRONICS' Fantastic Value Packed Catalog — Unheard of LOW, LOW PRICES on Brand Name Speakers, Changers, Tubes, Tools, Stereo Amps, Tuners, CB, and other Values. Credit plan available.

NAME \_\_\_\_\_  
 ADDRESS \_\_\_\_\_  
 CITY \_\_\_\_\_ STATE \_\_\_\_\_  
 GIVE ZIP CODE \_\_\_\_\_

If you have a friend interested in electronics send his name and address for a FREE subscription also.

**OLSON ELECTRONICS**

Dept. IA 260 S. Forge Street Akron, Ohio 44308

**CIRCLE NO. 13 ON READER SERVICE PAGE**

## SOLID STATE

(Continued from page 85)

frequency is close to that of the external signal, it will "lock" with the input and follow it over small frequency variations.

Once the PLL is "locked-in" (or synchronized) with the external signal, it acts as a type of signal-tracking filter, precisely duplicating the frequency of the input signal and developing a low frequency signal voltage representing the instantaneous phase (or frequency) difference between the input and VCO signals. These are the essential features of the circuit's operation which account for its great versatility.

The PLL may be used as an *FM demodulator*, for example, simply by abstracting the amplified error voltage (OUTPUT, Fig. 2), for this represents the detected FM signal.

On the other hand, if an output signal is obtained from the VCO, the PLL becomes a *frequency-selective signal conditioner*, since the VCO's output duplicates the input signal frequency at a higher power level and with a far superior signal/noise ratio.

Furthermore, since the PLL can—and will—lock-in on multiples (or submultiples) of the input signal, the circuit can be used as an accurate tuned *frequency divider* or *multiplier*.

The addition of a mixer and a phase-shifting network will permit the PLL to be used as a synchronous *AM detector*, as illustrated in Fig. 3. Here, the PLL "block" represents the complete circuit given in Fig. 2. In operation, the PLL locks on the r-f carrier, developing a reference signal at the same frequency, but without modulation. When combined with the AM r-f input signal in the mixer, a difference signal is developed representing the modulation (audio) components. This detected signal is then abstracted through a conventional low-pass filter network.

A practical application for a commercial PLL IC is shown schematically in Fig. 4. Many, but not all, FM stations broadcast uninterrupted (SCA) background music for business outlets, using a 67-kHz frequency modulated subcarrier. This circuit, obtained from a technical bulletin for the Signetics type SE/NE565 phase-locked loop IC, permits the subcarrier to be abstracted and demodulated, thus furnishing a commercial-free source of background music. The SCA decoder can be duplicated quite easily in the home workshop and used as an accessory with a conventional FM broadcast band receiver. (Another such circuit was described in "Build an SCA Adapter for FM Reception," POPULAR ELECTRONICS, Dec. 1970, p 53.)

Referring to the circuit diagram, the de-

modulated signal obtained from the FM receiver is coupled to the PLL through a dual high-pass filter consisting of  $C1$ ,  $R1$ ,  $C2$  and  $R4$ . Voltage-divider  $R2$ - $R3$  establishes input bias, while variable resistor  $R7$  serves as the internal VCO's fine tuning control. The detected output signal is obtained through a triple-stage low-pass L-type filter network,  $R8$ ,  $C5$ ,  $R9$ ,  $C6$ ,  $R10$  and  $C7$ , which provides de-emphasis and, incidentally, serves to attenuate the high-frequency noise which sometimes accompanies SCA broadcasts.

Except for potentiometer  $R7$ , all resistors are half-watt types, while the capacitors are small mica, ceramic, or high quality tubular paper units. A 10- to 24-volt dc power supply is required. With an input signal of 80 to 300 mV, from a 10,000-ohm source, the PLL SCA decoder will deliver an output signal of approximately 50 mV with a frequency response to about 7 kHz.

In addition to the applications outlined above, phase-locked loops may be used for frequency shift keying, motor speed control, time base generation, frequency synthesis, tone decoding, and data locking. If you'd like to explore the PLL in greater depth, detailed application notes and technical specification bulletins for commercial PLL IC's are available from both Motorola and Signetics.

**Device News.** A number of new products have been introduced recently by Motorola Semiconductor Products, Inc., including several new complementary MOS IC's, five new series of complementary Darlington power transistors, and two new npn silicon r-f power transistors.

Featuring quiescent power consumption in the nanowatt range, Motorola's new MOS IC's are monolithic digital logic devices. The

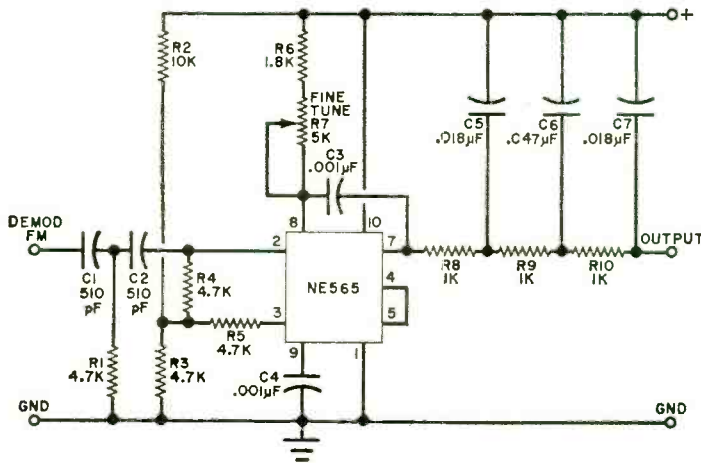

Fig. 4. Note that this 67-kHz SCA adapter has no LC circuits as tuning is adjusted by  $R7$ . To change the center frequency, capacitor  $C4$  and total resistance of  $R6$  and  $R7$  will have to be changed. Bandpass is 7 kHz.

## FREE McIntosh CATALOG and FM DIRECTORY

Get all the newest and latest information on the new McIntosh Solid State equipment in the McIntosh catalog. In addition you will receive an FM station directory that covers all of North America.



MX 114

FM/FM STEREO TUNER  
and STEREO PREAMPLIFIER

### SEND TODAY!

McIntosh Laboratory Inc.  
2 Chambers St., Dept. PT-171  
Binghamton, N.Y. 13903

NAME \_\_\_\_\_

ADDRESS \_\_\_\_\_

CITY \_\_\_\_\_ STATE \_\_\_\_\_ ZIP \_\_\_\_\_

CIRCLE NO. 12 ON READER SERVICE PAGE

**STATEMENT OF OWNERSHIP, MANAGEMENT AND CIRCULATION** (Act of October 23, 1962; Section 4369, Title 39, United States Code).

1. Date of filing: October 1, 1970.
2. Title of publication: Popular Electronics.
3. Frequency of issue: Monthly.
4. Location of known office of publication: One Park Avenue, New York, New York 10016.
5. Location of the headquarters or general business offices of the publishers: One Park Avenue, New York, New York 10016.

6. Names and addresses of publisher, editor, and managing editor: Publisher, Lawrence Sporn, One Park Avenue, New York, New York 10016; Editor, Oliver P. Ferrell, One Park Avenue, New York, New York 10016; Managing Editor, John R. Riggs, One Park Avenue, New York, New York 10016.

7. Owner: (If owned by a corporation, its name and address must be stated and also immediately thereunder the names and addresses of stockholders owning or holding 1 percent or more of total amount of stock. If not owned by a corporation, the names and addresses of the individual owners must be given. If owned by a partnership or other unincorporated firm, its name and address, as well as that of each individual must be given.) 1. William Ziff, Jr., One Park Avenue, New York, New York 10016. 2. Barbara Ziff, Charles Houtsman and Jules I. Whitman, Trustees F/B/O Dirk Ziff, Et Al, One Park Avenue, New York, New York 10016.

8. Known bondholders, mortgagees, and other security holders owning or holding 1 percent or more of total amount of bonds, mortgages or other securities: None.

10. Extent and nature of circulation:

	Average No. Copies Each Issue During Preceding 12 Months	Actual Number of Copies of Single Issue Published Nearest to Filing Date
A. Total No. Copies printed (Net Press Run) .....	476,247	472,136
B. Paid circulation		
1. Sales through dealers and carriers, street vendors and counter sales .....	67,583	63,000
2. Mail subscriptions .....	309,445	308,300
C. Total paid circulation .....	377,028	371,300
D. Free distribution (including samples) by mail, carrier or other means .....	5,882	5,883
E. Total distribution (Sum of C and D) .....	382,910	377,183
F. Office use, left-over, unaccounted, spoiled after printing .....	93,337	94,953
G. Total (Sum of E and F— should equal net press run shown in A) .....	476,247	472,136

I certify that the statements made by me above are correct and complete.

WILLIAM L. PHILLIPS, Assistant Treasurer

series includes the MC2501L Quad 2-Input NOR Gate, the MC2502L Dual 4-Input NOR Gate, and the MC2503L Dual type Flip-Flop, all in 14-pin dual in-line ceramic packages, as well as the MC2597G Dual 2-Input NAND Gate and the MC2598G "D" Flip-Flop, both in 10-pin metal cans. Typical quiescent power dissipations range from 10 nW for the gates to 50 nW for the flip-flops.

Providing gains of up to 2500 and with current ratings of from 4 to 16 amperes, Motorola's new complementary Darlingtons are available in both 60- and 80-volt  $BV_{CEO}$  versions, except for the 16 ampere series, which also includes a 100-volt type. The devices incorporate both driver and output transistors, plus any necessary resistors, in a single monolithic structure. Requiring drives in the milliamperage range, the full line includes the 16-ampere MJ4030/4033 series, the 10-ampere MJ2500/3000 series, the 5-ampere MJE1090/1100 series, the 5-ampere MJ900/1000 series, and the 4-ampere MJ4000/4010 series. Except for the MJE1090/1100 series, which are supplied in 70-watt plastic thermopad-type packages, all the devices are assembled in standard TO-3 cases.

Utilizing balanced-emitter construction, Motorola's new npn silicon r-f power transistors are intended for use as high-power class C amplifiers in the 100-175-MHz VHF range. Identified as types MM1552, a 65-volt device, and MM1553, a 100-volt unit, the transistors are assembled in strip-line packages. The MM1552 is rated at 90 watts peak power output for 18 W input at 150 MHz, with a 27-volt dc source, permitting close to 100-percent modulation with a 25 W carrier at  $V_{CC}$  of 13.5 volts dc. In FM or CW service, both devices are capable of continuous 75 W output at 150 MHz.

Fairchild Semiconductor (313 Fairchild Drive, Mountain View, CA 94040) has announced a new line of low-cost power transistors assembled in distinctive plastic TO-66 packages. The new transistor family consists of true npn and pnp complements. All the devices operate at collector currents of up to 4 amperes maximum and have power ratings of 36 watts at case temperatures of 25°C. Voltage capabilities range from 40 to 80 volts. Type numbers are 2N5293 through 2N5298 for the npn's and 2N6021 through 2N6026 for their pnp complements, plus seven complementary pairs identified by single type numbers with special "SD" prefixes.

Also from Fairchild comes news of substantial price reductions on some seventy dual transistors as well as on its entire line of MSI 9300 TTL integrated circuits.

That completes our solid-state story for January ... but, if it isn't too late—**HAPPY NEW YEAR!**

—Lou.



# TIME-PERIOD

(Continued from page 67)

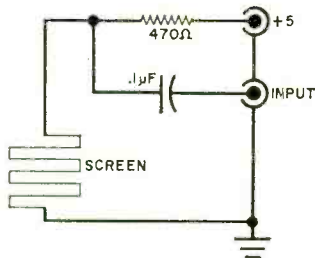

Fig. 5. Transducer circuit used for determining bullet velocity employs a continuous-conductor break screen.

the beam is blocked or interrupted. A simple mechanical switch or a break-wire arrangement can also be used in timing applications.

A system for measuring the velocity of a bullet is shown in Fig. 5. When the bullet breaks the wire at the start screen, a positive pulse is generated by the charging action of the capacitor. Similarly, a positive pulse is generated at the stop terminal (where a duplicate circuit is employed) when the stop

screen is broken by the bullet. The bullet's velocity is then equal to (screen spacing in feet × 1000)/(counter range × readout value) in feet/sec.

For example, if the screens were 4 ft apart and a reading of 200 were obtained with the selector switch in the 10 M SEC position, velocity would be equal to (4 × 1000)/(0.01 × 200), or 2000 ft/sec. Since the counter is accurate to within 0.1%, the screen spacing must be quite accurate to prevent this from affecting the accuracy of the reading obtained. At a 4-ft spacing, the screens must be placed within 1/32 in. of the correct distance.

The Time-Period circuit board assembly can also be combined with a readout system to produce a "Sports Timer" (POPULAR ELECTRONICS, Oct. 1968). Changing the crystal to a 100.00-kHz type will produce pulses at 1/1000 second intervals at the output of the second scaler. This output can be applied directly to a 4 1/2-digit readout to give readings up to 10 minutes with an accuracy of ±0.001 second.

The circuit could also be used as a portable time base for electronic digital clocks that would normally be driven by the 60-Hz ac line. In this case, both the Time-Period and Scaler circuits would be needed to produce pulses at exact 1-second intervals.

-30-

## If you can't come to the world's newest, largest and most exciting electronics department store, we'll mail the store to you!

**Exclusive!**  
Knight-Kit and Science-Fair Kits.

**Exclusive!**  
Realistic Lifetime Tubes.

**Exclusive!**  
Battery-A-Month Club.

World's finest selection of famous brands—in one book!



**New! 1971 Allied Radio Shack Catalog**  
460 pages—thousands of electronic values!



**Big Choice of Audio Items . . . Factory-Direct Savings!**  
Allied TD-1099, 3-Head Stereo Tape Deck. Walnut-grain case. \$179.95



**Realistic STA-120.** Wideband AM, FET-FM Stereo Receiver. 140 Watts. With case. \$269.95

**MAIL COUPON . . . or bring to Allied Radio Shack store.**

ALLIED RADIO SHACK, 100 N. Western Avenue, 616 Chicago, Illinois 60680

Yes! I want your big new 1971 Catalog. I enclose \$1 for mailing and handling (refundable with my first purchase of \$1 or more).

NAME \_\_\_\_\_  
First Middle Last

ADDRESS \_\_\_\_\_  
Street or Route and Box No.

CITY \_\_\_\_\_ STATE \_\_\_\_\_ ZIP \_\_\_\_\_

I enclose  check  money order  cash.

**WORLD'S LARGEST! OVER 800 STORES IN 48 STATES. SEE YOUR PHONE BOOK.**

# POPULAR ELECTRONICS SUBSCRIBER SERVICE

Please include an address label when writing about your subscription to help us serve you promptly. Write to: P.O. Box 1096, Flushing, N.Y. 11352  
**CHANGE OF ADDRESS:** Please let us know you are moving at least four to six weeks in advance. Affix magazine address label in space to the right and print new address below. If you have a question about your subscription, attach address label to your letter.

**TO SUBSCRIBE:** Check below.  
 5 yrs. \$21     3 yrs. \$12  
 1 yr. \$6     New     Renewal  
**Specify:**  Payment enclosed  
 You get 1 extra issue per year as a **BONUS!**  
 Bill me later.

If you have no label handy, print OLD address here.

name    please print

address

city

state

zip code

AFFIX LABEL 0452

print name \_\_\_\_\_

address \_\_\_\_\_

city \_\_\_\_\_

state \_\_\_\_\_ zip code \_\_\_\_\_

Add'l postage: \$1 per year outside U. S., its possessions & Canada.

## McGEE RADIO Co. WORLD'S BEST SELECTIONS AND LOWEST PRICES

# SPEAKERS

ALMOST EVERY SIZE FROM 1½ TO 18 INCH  
 WOOFERS—TWEETERS—CROSSOVERS  
 MANY HIGH FIDELITY KITS  
 McGEE'S 176 PAGE 1971 CATALOG  
 SENT FREE ON REQUEST

### NORELCO HI-FI SPEAKERS

McGEE HAS ADDED A FULL LINE OF NORELCO  
 HI-FI SPEAKERS FOR THE SYSTEM BUILDER.

McGee ships orders all over the U.S. When requesting our catalog please give name, address and zip code. Our 41st year in Kansas City. Catalog offers everything for Hi-Fidelity audio P.A. systems. All kinds of microphones. Names such as Shure, Bogen, Electro-Voice, University, Altec, Ampex, G.E. Tubes and Transistors. All kinds of parts. Everything for Educational and Industrial electronics. Write for your catalog today.

**McGEE RADIO CO.—1901—PE**  
 McGee St., Kansas City, Mo. 64108

CIRCLE NO. 11 ON READER SERVICE PAGE

## CRYPTOLOCK

(Continued from page 44)

is interrupted. This is the purpose of the normally closed pushbutton *S7*. When *S7* is depressed, the SCR is cut off.

**Checkout.** When all components have been secured in place and wired in accordance with Fig. 1, substitute a 6-to-9-volt lamp for *K3*. Depress pushbutton switches 1 and 5 and note that relay *K1* closes. If it does not, recheck all wiring, including the connections to the pushbuttons on the key panel. It's easy to wire them incorrectly since you are working from behind and they are in reverse order. Once assured that the wiring is correct, press 1 and 5 again, followed quickly by 4. The test lamp should light, indicating that SCR has been triggered and the lock is open. If not, use needle-nose pliers to bend the metal tab (carefully) to which the armature spring of *K1* is attached. Bend it upward to decrease the tension on the spring. Try the combination again. An additional adjustment of *K1*'s spring may be necessary. Switch *S7* is used to de-activate the system.

Now press 2, 3, or 6 on the key panel. Relay *K2* should close and remain closed for 20 to 30 seconds. During this time, it is impossible to activate *K1*. If *K2* doesn't close, repeat the adjustment procedure specified for *K1*. Generally speaking, you won't have to adjust *K2* because it closes with much more force than *K1*. There are a number of types of miniature, 5000-ohm de relays on the market and their response times vary considerably so be prepared to switch relays if necessary. Once *K1* and *K2* are adjusted, no further adjustments should be necessary. Just be sure they remain in an upright position while the Cryptolock is being activated.

In the typical home or garage installation, it's a good idea to provide a key switch backup to the electronic locking system. Simply wire a spst key switch so that it bypasses the electronic lock and (when closed with a mechanical key) applies power directly to the solenoid latch to open the door. The key switch can be located some distance from the electronic key panel and concealed. This will enable you to open the door in the event the key panel is damaged as a result of an attempted burglary. Also remember to keep pushbutton *S7* within the protected area. —30—

# Popular Electronics

## READER SERVICE PAGE

### free information service:

Here's an easy and convenient way for you to get additional information about products advertised or mentioned editorially (if it has a "Reader Service Number") in this issue. Just follow the directions below... and the material will be sent to you promptly and free of charge.

**1.** On coupon below, circle the number(s) that corresponds to the key number(s) at the bottom or next to the advertisement or editorial mention that is of interest to you. (Key numbers for advertised products also appear in the Advertisers' Index.) Print or type your name and address on the lines indicated.

**2.** Cut out the coupon and mail it to: POPULAR ELECTRONICS, P.O. Box 8391, Philadelphia, PA 19101.

**note:** If you want to write to the editors of POPULAR ELECTRONICS about an article on any subject that does not have a key number, write to POPULAR ELECTRONICS, One Park Avenue, New York, N.Y. 10016. Inquiries concerning circulation and subscriptions should be sent to POPULAR ELECTRONICS, P.O. Box 1096, Flushing, N.Y. 11352.

1/71-4

Void after February 28, 1971

## Popular Electronics

P.O. BOX 8391  
PHILADELPHIA, PA. 19101

1 2 3 4 5 6 7 8 9 10 11 12 13 14 15 16 17 18 19 20  
21 22 23 24 25 26 27 28 29 30 31 32 33 34 35 36 37 38 39 40  
41 42 43 44 45 46 47 48 49 50 51 52 53 54 55 56 57 58 59 60  
61 62 63 64 65 66 67 68 69 70 71 72 73 74 75 76 77 78 79 80  
81 82 83 84 85 86 87 88 89 90 91 92 93 94 95 96 97 98 99 100

NAME (Print clearly) \_\_\_\_\_

ADDRESS \_\_\_\_\_

CITY \_\_\_\_\_ STATE \_\_\_\_\_ ZIP CODE \_\_\_\_\_



## LONG DISTANCE CB MOBILE ANTENNAS

Our fiberglass "Racers 4 & 6" have tunable tips so you can tune your SWR to 1.1:1 and get the most distance out of your mobile transceiver. Extra strong, non-fraying military grade fiberglass . . . fits all standard  $\frac{1}{8}$ "-24 thread mounts. The prices are right, too.

Racer 6 . . . . . 6' length . . . . . \$11.95  
Racer 4 . . . . . 4' length . . . . . \$11.25  
Racer Mounts . . . . . \$ 4.95

See your local CB dealer.

TUNABLE TIP  
FOR LOWEST  
POSSIBLE SWR

# avanti

Avanti Research & Development, Inc  
Addison, Illinois 60101

CIRCLE NO. 1 ON READER SERVICE PAGE

## ABOUT YOUR SUBSCRIPTION

Your subscription to POPULAR ELECTRONICS is maintained on one of the world's most modern, efficient computer systems, and if you're like 99% of our subscribers, you'll never have any reason to complain about your subscription service.

We have found that when complaints do arise, the majority of them occur because people have written their names or addresses differently at different times. For example, if your subscription were listed under "William Jones, Cedar Lane, Middletown, Arizona," and you were to renew it as "Bill Jones, Cedar Lane, Middletown, Arizona," our computer would think that two separate subscriptions were involved, and it would start sending you two copies of POPULAR ELECTRONICS each month. Other examples of combinations of names that would confuse the computer would include: John Henry Smith and Henry Smith; and Mrs. Joseph Jones and Mary Jones. Minor differences in addresses can also lead to difficulties. For example, to the computer, 100 Second St. is not the same as 100 2nd St.

So, please, when you write us about your subscription, be sure to enclose the mailing label from the cover of the magazine—or else copy your name and address exactly as they appear on the mailing label. This will greatly reduce any chance of error, and we will be able to service your request much more quickly.

## STEREO SCENE

(Continued from page 70)

made or electronically-augmented music, you play games with your tone controls until it sounds reasonably "good." That's about all you can do for there was no reality here to start with. When playing classical and orchestral music, there is substantial reality and you can work it over until the result is reasonably realistic, or better still, look around for the better grade of European-made disc recordings—many of which are made to sell music rather than sound.

Possibly, if you write letters to RCA and Columbia Records and Capitol Records, you might convince them to let classical recordings suffer from benign neglect. Isn't it worthwhile to suggest that these record manufacturers could save all the money that they spend on equalizers and compressors, recording directors that are frustrated conductors and simply produce the best average simulation of a live concert hall sound? Perhaps if American record manufacturers could get back to basics and simply record music and not supersonics, they could recover the prestige and dignity they so rightfully deserved in the mid-1950's. —30—

## CAPACITOR QUIZ ANSWERS

(Quiz is on page 32)

1. High end
2. Increase
3. Padder
4. Neutralizing
5. Decoupling
6.  $0.1 \mu\text{F}$   
 $\pm 3$  percent  
1200 volts
7.  $720 \text{ pF}$   
 $\pm 5$  percent  
 $-150 \text{ PPM}/^\circ\text{C}$
8.  $12 \text{ pF}$
9.  $6 \text{ pF}$
10.  $10 \text{ pF}$

# LIBRARY

(Continued from page 16)

dedicated to the instructors. Basically, this book covers technician-level fundamentals; the content is indistinguishable from most others of the same genre. The big difference is in the easy-to-follow format and the contrasting graphics used for the illustrations.

Published by Prentice-Hall, Inc., Englewood Cliffs, NJ 07632. Hard cover. 720 pages. \$13.50.

## 125 ONE-TRANSISTOR PROJECTS

by Rufus P. Turner

Here is a book that will interest just about any hobbyist or experimenter in electronics, but especially the neophyte. This collection of useful, practical one-transistor circuits covers a wide range of projects, from audio amplifiers to radio receivers and transmitters. Each of the circuits provided is accompanied by a thorough description and a complete schematic diagram, and each is designed to take advantage of only easy-to-obtain components. All of the circuits listed are designed to serve a practical application. And for more sophistication, several can be combined.

Published by Tab Books, Blue Ridge Summit, PA 17214. 192 pages. \$6.95 hard cover, \$3.95 soft cover.

## DISCIPLINES IN COMBINATIONAL AND SEQUENTIAL CIRCUIT DESIGN

by R. M. M. Oberman

The aim is to provide graduate students with a textbook on the design of combinational and sequential circuits as they are used in all kinds of automatic equipment. The book first develops the mathematical concepts of switching theory (Boolean algebra) and uses them in the design of combinational circuits with different types of components as contacts and semiconductor devices. The same

mathematical concepts are used in the theory of memory elements and applications in counting, shifting, ordinary mathematical operations, transmission of BCD information, and the design of sequential circuits. This massive work is well worth the investment.

Published by McGraw-Hill Book Co., 330 West 42 St., New York, NY 10036. Hard Cover. 754 pages. \$19.50.

## LINEAR INTEGRATED CIRCUITS, IC-42

The latest linear IC manual from RCA has been extensively revised and expanded to cover innovations in IC technology and provide broader, more detailed general information on modern IC's. Circuit descriptions and application information are provided for a broad family of RCA integrated circuits for use in a variety of general- and special-purpose linear applications. Also, the manual has a new application guide which indicates circuit types recommended for specific uses and technical data and outlines sections provide ratings, characteristics, and package details for RCA linear integrated circuits.

Published by RCA Solid State Division, Somerville, NJ 08876. Soft cover. 416 pages. \$2.50.

## INTRODUCTION TO COMPUTER ENGINEERING

by B. S. Walker

Although primarily intended for use by undergraduate engineers and technologists, this book will also appeal to the scientific-minded individual who is curious about computers. The text carefully dissects the fundamental principles and philosophies underlying the concept of computers and their applications to make the logic of technical advances easier to follow. A non-mathematical approach is used to explain what the computer is, what it does, and how it performs its various operations. The only math you can expect to find is in Chapter 4, headed "Arithmetic," in which basic computer language is discussed.

Published by Hart Publishing Co., Inc., 510 Sixth Ave., New York, NY 10011. Hard cover. 385 pages. \$12.

ADDED MOBILE POWER WHEN YOU NEED ADDITIONAL COVERAGE FOR CLEAR COMMUNICATIONS



170 WATT INPUT

Complete with remote power switch and indicator control panel plus mounting brackets.

FCC TYPE ACCEPTED Parts 89, 91, 93

\$129.95  
12 VDC

## SMALL PACKAGED MOBILE POWER LINEAR R.F. POWER AMPLIFIER

Covers greater distances with increased transmit power. Can be used with SONAR BR20, FM40 or any similar FCC approved equipment with 1-15 watt output. Designed with top performance and dependable service when you need it. Automatic standby/transmit switching • Covers 25-50MHz range • transistorized power supply — negative ground • Used on amateur 28MHz for FM-AM-SSB. Small, compact, rugged design. Size: 2"H x 6"W x 8"D. Wt. 3 lbs. 12 VDC

SONAR RADIO CORP., 73 Wortman Avenue, Bklyn, N.Y. 11207 | Please send information on Model BR 2906 Linear Amplifier. |

Name \_\_\_\_\_ Dept. 232  
Address \_\_\_\_\_  
City \_\_\_\_\_ State \_\_\_\_\_ Zip \_\_\_\_\_

# ELECTRONICS MARKET PLACE

**NON-DISPLAY CLASSIFIED: COMMERCIAL RATE:** For firms or individuals offering commercial products or services, \$1.25 per word (including name and address). Minimum order \$12.50. Payment must accompany copy except when ads are placed by accredited advertising agencies. Frequency discount: 5% for 6 months; 10% for 12 months paid in advance. **READER RATE:** For individuals with a personal item to buy or sell, 80¢ per word (including name and address). No Minimum! Payment must accompany copy.

**DISPLAY CLASSIFIED:** 1" by 1 column (2 1/2" wide), \$110.00. 2" by 1 column, \$215.00. 3" by 1 column, \$320.00. Advertiser to supply cuts.

**GENERAL INFORMATION:** First word in all ads set in bold caps at no extra charge. All copy subject to publisher's approval. Closing Date: 1st of the 2nd month preceding cover date (for example, March issue closes January 1st). Send order and remittance to: Hal Cymes, **POPULAR ELECTRONICS**, One Park Avenue, New York, New York 10016.

## FOR SALE

**FREE!** Giant bargain catalog on transistors, diodes, rectifiers, SCR's, zeners, parts. Poly Paks, P.O. Box 942, Lynnfield, Mass. 09140.

**GOVERNMENT** Surplus Receivers, Transmitters, Snooperscopes, Radios, Parts, Picture Catalog 25¢. Meshna, Nahant, Mass. 01908.

**ROCKETS:** Ideal for miniature transmitter tests. New illustrated catalog. 25¢. Single and multistage kits, cones, engines, launchers, trackers, rocket aerial cameras, technical information. Fast service. Estes Industries, Dept. 18-A, Penrose, Colorado 81240.

**LOWEST** Prices Electronic Parts. Confidential Catalog Free. **KNAPP**, 3174 8th Ave. S.W., Largo, Fla. 33540.

**EUROPEAN** and Japanese bargains catalogs. \$1 each. Dee, 10639E Riverside, North Hollywood, Calif. 91602.

**WE SELL CONSTRUCTION PLANS. TELEPHONE:** Answering Machine, Speakerphone, Carphone, Phonevision, Legal Connector, Auto Dialer, Central Dial System. **TELEVISION:** \$35.00 Color Converter, Tape Recorder, 3DTV. \$25.00 Camera. **HOBBYIST:** Electron Microscope, 96 Hour Tape Music System, Ultrasonic Dishwasher, Radar-Oven, Electronic Tranquilizer. Plans \$4.95 each. **COURSES:** Telephone Engineering \$39.50, Detective Electronics \$22.50, Anti-Detective Electronics \$27.50. **NEW SUPER HOBBY CATALOG AIRMAILED \$1.00.** Don Britton Enterprises, 6200 Wilshire Blvd., Los Angeles, Calif. 90048.

**WEBBER LAB'S.** Police & Fire Converters. Catalog 25¢. 72 Cottage Street, Lynn, Mass. 01905.

**INVESTIGATORS, LATEST ELECTRONICS AIDS. FREE LITERATURE.** CLIFTON, 11500-L NW 7th AVE., MIAMI, FLORIDA 33168.

**LINEAR AMPLIFIERS:** 10 meters. "Hawk"—25 watts output—\$59.95; "Hornet"—50 watts—\$98.50; "Raider"—100 watts—\$139.95; "Maverick-250"—250 watts—\$244.95; AM/SSB. "Scorpion" 50 watt 12 volt mobile—\$99.95; "Bandit III" 100 watt mobile—\$169.95. 20-35 megacycles. (Illegal Class D 11 meters.) Dealer inquiries invited. D & A Manufacturing Co., 1217 Avenue C, Scottsbluff, Nebraska 69361.

**ELECTRONIC PARTS,** semiconductors, kits. **FREE FLYER.** Large catalog \$1.00 deposit. **BIGELOW ELECTRONICS**, Bluffton, Ohio 45817.

**RADIO—T.V. Tubes—**36¢ each. Send for free catalog. Cornell, 4213 University, San Diego, Calif. 92105.

**PSYCHEDELIC** catalog. Posters, lighting, etc. Send 50¢ for handling to Hole In The Wall, 6055PE Lankershim, North Hollywood, Calif. 91606.

**CLEARANCE SALE** rectifiers, transistors, 1000's other items. Catalog 15¢. General Sales Company, 254 Main, Clute, Texas 77531.

**MECHANICAL, ELECTRONIC** devices catalog 10¢. Greatest Values—Lowest Prices. Fertik's, 5249 "D", Philadelphia, Pa. 19120.

**SPACE-AGE TV CAMERA KIT!** Terrific for Experimenters, Industry, Education. Solid-state. Only \$116.95! Starter kits: \$18.95 up. Plans 25¢ up. Catalog **FREE.** Phone: 402-987-3771. Write: **ATV RESEARCH**, 1301 Broadway, Dakota City, Nebr. 68731.

**BURGALAR ALARM SYSTEMS** and accessories. Controls, bells, sirens, hardware, etc. **OMNI-GUARD** radar intruder detection system, kit form or assembled. Write for free catalog. Microtech Associates, Inc., Box 10147, St. Petersburg, Florida 33733.

**SENCORE, B&K TEST EQUIPMENT UNBELIEVABLE PRICES. FREE CATALOG AND PRICE SHEET.** FORDHAM RADIO, 265 EAST 149TH STREET, BRONX, N.Y. 10451.

**AMATEUR SCIENTISTS,** Electronics Hobbyists, Experimenters, Students . . . Construction Plans—all complete, including drawings, schematics, parts lists with prices and sources . . . Radar—Build your own ultrasonic doppler radar. Detect motion of people, automobiles, even falling rain drops. Transistorized, uses 9 volt transistor battery—\$4.50 . . . Long-Range "Sound Telescope"—This amazing device can enable you to hear conversations, birds and animals, other sounds hundreds of feet away. Very directional. Transistorized. Uses 9V battery—\$3.50 . . . Robot Man—Moves hands and arms—\$3.50 . . . Or send 25¢ coin (no stamps) for complete catalog. Other items include Psychedelic strobes, light shows, lasers . . . 46 different projects. Technical Writers Group, Box 5994, State College Station, Raleigh, N.C. 27607.

**ELECTRONIC COMPONENTS—**Distributor prices, Free catalog. Box 2581, El Cajon, California 92021.

**JAPAN & HONG KONG DIRECTORY.** Electronics, all merchandise. World trade information. \$1.00 today. Ippano Kaisha Ltd., Box 6266, Spokane, Washington 99207.

**PLANS-PARTS-KITS** A wide range of the unusual for the experimenter, hobbyist and amateur scientist. Many psychedelic items; **STROBES**, color organs. **ELECTRIC CANDLES**, Touch Switches, **LIGHTNING GENERATORS.** Complete line of **COMPONENTS.** Air Mail Catalog 50¢. Teletronics, Box 1266, South Lake Tahoe, Calif. 95705.

**CITIZEN BAND** Radios, SSB, AM, Swan CB, Amateur. Accessories, Free Catalogue. Dealers send letterhead for factory prices. Call 714-894-7555, "Baggy's" Radio, 6391 Westminster Avenue, Westminster, Calif. 92683.

**DIAGRAMS—**Radios \$1.50, Television \$3.00. Give make and model. Diagram Service, Box 1151PE, Manchester, Conn. 06042.

**ELECTRONIC** Ignition. Various Types. Information 10¢. Anderson Engineering, Epsom, N.H. 03239.

**NEW! PHONE PATCH** with automatic switch. Now you can record those important conversations automatically. **ONLY \$19.95.** Cheico Electronics, 11835 Wilshire Blvd., Los Angeles, Calif. 90025.

**BACKGROUND MUSIC,** continuous commercial-free. Solid-state **MUSICON SCA ADAPTER** plugs into any FM Tuner, Receiver. Line powered. 5 year guarantee! Only \$39. postpaid. K-Lab, Box 572Z, South Norwalk, Conn. 06856.

**PACEMATE** CB 2-way radio 2 watts 3 channel \$39.95. Regularly \$99.95. Request information. American Comset, 1638 W. 135th Street, Gardena, Calif. 90249.

**NEW SEMICONDUCTOR LIGHT EMITTING DIODES—**bright red lights replace light bulbs. Typical life 100 years. Operate at 1.65 volts, 50 milliamps. Order 2 for \$2.98 **NOW.** Data sheet and instructions included. Monsanto Company, Hobby Section, 10131 Bubb Road, Cupertino, California 95014.

**CONVERT** any television to sensitive, big-screen oscilloscope. Only minor changes required. No electronic experience necessary. Illustrated plans, \$2.00. Relco-A33, Box 10563, Houston, Texas 77018.

**FREE** catalog, parts, circuit boards for **POPULAR ELECTRONICS** projects. **PALA ELECTRONICS**, Box 14359, Oklahoma City, OK 73114.

**MATRIX ARRAY COMPONENT UNITS;** needed in experimenter laboratory and repair shop, catalog 10¢. **CUHINCO**, 2404 Stratton Drive, Rockville, Maryland 20854.

**ELECTRICIANS:** Basic A.C. Control Diagrams for Motor Starting Using 440-220 Volts 3 Ph. Includes Wiring Tables. Pocket Size. \$2.50. Paul R. Himes, 164 Westgate, R.D.1, Newton Falls, Ohio.

**CIRCUIT BOARDS:** Complete Job Shop Operation. Jetca, Inc., Box 418, Monon, Indiana 47959.



**FREE** catalog on construction plans—silver recovery unit! X-Ray fluorescence machine, scintillator, geiger counter, portable black or ultraviolet light unit, radar oven, ozone air-freshener and ultra sensitive metal detector, plans \$5.00 each—Apogee Corporation, 2408 Ludelle, Fort Worth, Texas 76105.

**CB's** top performance beam for under \$10. Send \$1.25, Promack, 1917 W. 67th, Chicago, Ill. 60636.

**GRAB** bag! Electronic Components. Values over \$1.00 plus free catalogue. Send \$1.00. Martronics, Box 98771, Des Moines, Washington 98188.

**MOBILE** linear with 40 watts output and compact size of 3H-5W-7D for \$74.95 factory wired; kit available for \$64.90. (Illegal class D 11 meters), 50 watt base unit factory wired \$72.95, kit \$59.90. Star Communication, Rt. 8, Paducah, Ky. 42001.

**TV TUNER REPAIRS**—Complete Course Details, 12 Repair Tricks, Many Plans, Two Lessons, all for \$1. Refundable. Frank Boeck, Box 833, Relling, Calif. 96001.

**NEW** expanded catalogue featuring relays, test equipment, and components at reasonable prices. Send 10¢ to Gust & Company, Box 24081, Edina, Minnesota 55424.

**BURGLAR** and **FIRE ALARM SYSTEMS** and supplies. **INSTALLATION MANUAL** and catalog \$1.00. Refunded first order. Electronic Sentry Systems, P.O. Box 8023A, Sacramento, California 95818.

**FREE** Electronics Catalog. Tremendous bargains. Edu-Kits, Department C-689 D, Hewlett, New York 11557.

**SUPERIOR COLOR ORGAN, ACCURATE TEMPERATURE CONTROLLER, BETTER HALL EFFECT KIT, OUTSTANDING FET VOLTMETER, OTHER ITEMS, GUARANTEED, LITERATURE, TRI-TEK LABS, BOX 629, DELAWARE, OHIO 43015.**

**DISCOVER HIDDEN TREASURE**  
WITH A JETCO ELECTRONIC METAL DETECTOR

A powerfully sensitive instrument — detects gold, silver, coins, relics, etc. Fully tested — transistorized — guaranteed.

Send for Free Catalog  
JETCO, P.O. Box 132 PEM, Huntsville, Texas 77340

**\$29.95**  
up

**POLICE/FIRE MONITOR** (Scanner) Receiver. Automatically "scans" eight channels. Regular \$139.95—Sale \$119.50. Each crystal \$5.00. Electronic Distributors, 1960 Peck, Muskegon, Michigan 49441.

**ELECTRONIC** Circuits. FET VOM, power supplies, amplifiers, logic. Catalog 50¢. Electronics Laboratories, Box 738, College Park, Maryland 20740.

## PLANS AND KITS

**BUILD** your own electronic **COMPUTER**. New book explains theory, practical details. \$2.25 postpaid. Cinnamon Press, Box 8453-A, Minneapolis, Minnesota 55408.

**KITS** \$2.99. Buy two, one free. Free information. Aline, 434 West 4th Street, West Islip, New York 11795.

**BURGLAR** alarm. Plans for reliable alarm systems for home or automobile \$3.00 each. Both for \$5.00. Plans, Box 54, Bronxville, N.Y. 10708.

**CB's** Build your own 250 watt linear. Instructions \$2.00. Electronic catalog 25¢. Roberts, Box 403, Whiting, Indiana 46394.

**INTEGRATED CIRCUIT KITS: COMPUTER, OPTOELECTRONICS, AUDIO.** Catalog free. KAYE ENGINEERING, Box 3932-A, Long Beach, California 90803.

**NOW** available all new solid state and integrated circuit kits, plans and equipment. Oscilloscope improvement kits, logic laboratory, logic system modules and laboratory test equipment. Designed for the experimenter, educational institutions and industry. Scope calibrator, vertical attenuators, triggered sweep, dual trace, DC vertical amplifier, regulated high voltage and more. Prices start under \$3.00. Send 25¢ for money saving catalog. Product Development, 55 Broadfield Road, Hempstead, New York 11550.

**COLOR** converter for black and white television. New patented system. Plans and instructions only \$6.50. Write for free brochure. Bele Electronics Corp Service Department 1717, 111 Northeast Second Avenue, Miami, Florida 33132.

**PSYCHEDELIC LIGHTING MANUAL!** Make strobes, kaleidoscopes, organs, etc. Send \$2.95. Lightrays, 1315 D Weaver, Philadelphia, Pa. 19150.

## HIGH FIDELITY

**LOW**, Low quotes: all components and recorders, HiFi, Roslyn, Penna. 19001.

**TAPE RECORDERS**, Hi-Fi, components. Sleep Learning Equipment, tapes. Unusual Values. Free Catalog. Dressner, 1523R, Jericho Turnpike, New Hyde Park, N.Y. 11040.

**DIAMOND NEEDLES AND STEREO CARTRIDGES** at low, low prices for Shure, Pickering, Stanton, Empire, Grado and ADC. Send for free catalog and price sheet. We will be happy to quote on any cartridge—Magnetic, Ceramic or Crystal. All merchandise brand new and shipped **PREPAID**. **LYLE CARTRIDGES**, Dept. P, 265 East 149 Street, Bronx, New York 10451.

## WANTED

**CASH PAID!** Unused tubes, electronic equipment. Barry, 512 Broadway, NYC 10012.

**QUICKSILVER**, Platinum, Silver, Gold, Ores Analyzed. Free Circular. Mercury Terminal, Norwood, Mass. 02062.

## TUBES

**TUBES "Oldies"**, latest. Lists free. Steinmetz, 7519 Maplewood, Hammond, Indiana 46324.

**RECEIVING & INDUSTRIAL TUBES, TRANSISTORS**. All Brands—Biggest Discounts. Technicians, Hobbyists, Experimenters—Request **FREE** Giant Catalog and **SAVE!** **ZALYTRON**, 469 Jericho Turnpike, Mineola, N.Y. 11501.

**THOUSANDS** and thousands of types of electronic parts, tubes, transistors, instruments, etc. Send for Free Catalog. Arcturus Electronics Corp., MPE, 502-22nd St., Union City, N.J. 07087.

**RADIO & T.V. Tubes**—36¢ each. Send for free catalog. Cornell, 4213 University, San Diego, Calif. 92105.

**TUBES**—Lowest prices. Foreign-American. Obsolete, receiving, special purpose, transmitting tubes. Send for tube, parts catalog. United Radio Company, 56-P Ferry St., Newark, N.J. 07105.

**TUBE** Headquarters of World! Send 10c for Catalog (tubes, electronic equipment) Barry, 512 Broadway, N.Y.C. 10012.

## TAPE AND RECORDERS

**BEFORE** Renting Stereo Tapes try us. Postpaid both ways—no deposit—immediate delivery. Quality—Dependability—Service—Satisfaction—prevail here. If you've been dissatisfied in the past, your initial order will prove this is no idle boast. Free Catalog. Gold Coast Tape Library, Box 2262, Palm Village Station, Hialeah, Fla. 33012.

**OLD** radio programs on tape. 6 hours for \$8.00. Catalog 50¢. Don Maris, 1926 Cherokee, Norman, Okla. 73069.

**TAPE RECORDERS, TAPE**—blank, pre-recorded. Catalog 25¢. Tower, Lafayette Hill, Pa. 19444.

## INSTRUCTION

**LEARN ELECTRONIC ORGAN SERVICING** at home a!l makes including transistor. Experimental kit—trouble-shooting. Accredited NHSC, Free Booklet. **NILES BRYANT SCHOOL**, 3631 Stockton, Dept. A, Sacramento, Calif. 95820.

**LEARN WHILE ASLEEP**, Hypnotize! Strange catalog free. Auto-suggestion, Box 24-ZD, Olympia, Washington 98501.

**DEGREE** in Electronics Engineering earned mostly by correspondence. Free brochure. Dept. G-9, Grantham School of Engineering, 1505 N. Western Ave., Hollywood, California 90027.

**F.C.C. FIRST CLASS LICENSE** in three to four weeks. Write American Institute of Radio, 2622 Old Lebanon Road, Nashville, Tennessee 37214 or 3986 Beach Boulevard, Box 16652, Jacksonville, Florida.

**HIGHLY** effective home study courses in Electronics Engineering Technology and Electronics Engineering Mathematics. Earn your Degree. Write for Free Descriptive Literature. Cook's Institute of Electronics Engineering, (Dept. 15), P.O. Box 10634, Jackson, Miss. 39209. (Established 1945).

**FCC FIRST CLASS LICENSE THROUGH TAPE RECORDED LESSONS.** Also **RADAR ENDORSEMENT.** Radio License Training, 1060D Duncan, Manhattan Beach, Calif. 90266.

**WANT AN F.C.C. 1st CLASS LICENSE? WANT TO BECOME A DISC-JOCKEY?** REI has a school near you VA approved. Call toll free: 1-800-237-2251 or write REI, 1336 Main St., Sarasota, Florida 33577, Florida Residents call: 813-955-6922.

**MEMORIZE, STUDY: "1971 TESTS-ANSWERS" FOR FCC FIRST AND SECOND CLASS LICENSE.**—plus—"Self-Study Ability Test." Proven! \$9.95. Satisfaction guaranteed. Command, Box 26348-P, San Francisco 94126.

**AMATEUR RADIO.** Correspondence Sight-and-Sound no-textbook courses for **GENERAL, ADVANCED AND EXTRA CLASS** licenses—complete Code and Theory. These are not memory courses. Amateur Radio License School, 12217 Santa Monica Blvd., Los Angeles, Calif. 90025.

## INVENTIONS WANTED

**INVENTIONS** wanted. Patented; unpatented. Global Marketing Service, 2420-P 77th. Oakland, Calif. 94605.

**PATENT** Searches including Maximum speed, full airmail report and closest patent copies, \$6.00. Quality searches expertly administered. Complete secrecy guaranteed. Free Invention Protection forms and "Patent Information." Write Dept. 9, Washington Patent Office Search Bureau, 711 14th Street, N.W., Washington, D.C. 20005.

**INVENTORS!** Don't sell your invention, patented or unpatented, until you receive our offer. Eagle Development Company, Dept. 9, 79 Wall Street, N.Y., N.Y. 10005.

**FREE** "Directory of 500 Corporations Seeking New Products." For information regarding development, sale, licensing of your patented/unpatented invention. Write: Raymond Lee Organization, 230-GR Park Avenue, New York City 10017.

**PATENT SEARCHES,** including copies of related United States Patents. Inventors, attorneys, manufacturers use our "World-Wide" Airmail service Free: "Invention Record" form and "Information Every Inventor Needs", Hayward Company, 1029HR Vermont, Washington, D.C. 20005.

**INVENTORS:** Protect your ideas! Free "Recommended Procedure". Washington Inventors Service, 422T Washington Building, Washington, D.C. 20005.

**FREE PAMPHLET:** "Tips on Safeguarding Your Invention." Write: United States Inventors Service Company, 501-H Thirteenth Street N.W., Washington, D.C. 20004.

## GOVERNMENT SURPLUS

**GOVERNMENT** Surplus. How and Where to Buy in Your Area. Send \$1.00 to: Surplus Information Headquarters, Box 8225 PE, Washington, DC 20024.

**JEeps** Typically From \$53.90 . . . Trucks From \$78.40 . . . Boats, Typewriters, Airplanes, Multimeters, Oscilloscopes, Transceivers, Electronics Equipment. Wide Variety, Condition. 100,000 Bid Bargains Direct From Government Nationwide Complete Sales Directory and Surplus Catalog \$1.00. (Deductible First \$10.00 Order). Surplus Service, Box 820-J, Holland, Michigan 49423.

## BOOKS

**FREE** catalog aviation/electronic/space books. Aero Publishers, 329PE Aviation Road, Fallbrook, California 92028.

**FREE** book prophet Elijah coming before Christ. Wonderful bible evidence. Megiddo Mission, Dept. 64, 481 Thurston Rd., Rochester, N.Y. 14619.

**PLAYBOY** magazines buying and selling all dates, Jerald Daily, 2901 Oak, Evansville, Ind. 47714.

## PHOTOGRAPHY—FILM, EQUIPMENT, SERVICES

**SCIENCE** Bargains Request Free Giant Catalog "CJ"—148 pages—Astronomical Telescopes, Microscopes, Lenses, Binoculars, Kits, Parts. War surplus bargains. Edmund Scientific Co., 300 Edscorp Bldg., Barrington, New Jersey 08007.

## AUTHORS' SERVICES

**AUTHORS!** Learn how to have your book published, promoted, distributed. **FREE** booklet "ZD," Vantage, 120 West 31 St., New York 10001.

# CLASSIFIED ADVERTISING ORDER FORM

Please refer to heading on first page of this section for complete data concerning terms, frequency discounts, closing dates, etc.

1	2	3	4	5
6	7	8	9	10
11	12	13	14	15
16	17	18	19	20
21	22	23	24	25
26	27	28	29	30
31	32	33	34	35

Words { @ 80¢ (Reader Rate) } = \$ \_\_\_\_\_  
 { @ \$1.25 (Commercial Rate) }

Insert \_\_\_\_\_ time(s) Total Enclosed \$ \_\_\_\_\_

NAME \_\_\_\_\_

ADDRESS \_\_\_\_\_

CITY \_\_\_\_\_ STATE \_\_\_\_\_ ZIP \_\_\_\_\_

Signature \_\_\_\_\_

**WORD COUNT:** Include name and address. Name of city (Des Moines) or of state (New York) counts as one word each. Zip Code numbers not counted. (Publisher reserves right to omit Zip Code if space does not permit.) Count each abbreviation, initial, single figure or group of figures or letters as a word. Symbols such as 35mm, COD, PO, AC, etc., count as one word. Hyphenated words count as two words.

PE171

## MAGAZINES

**JAPAN PUBLICATIONS GUIDE** Business, pleasure, education. \$5.00. INTERCONTINENTAL, CPO 1717, Tokyo 100-91.

**OVER 2,000,000** backdate magazines! Specify needs. Midtown, Box 917-PE, Maywood, New Jersey 07607.

## HYPNOTISM

**"MALE-FEMALE HYPNOTISM" EXPOSED, EXPLAINED! "SECRET METHOD"—THEY NEVER KNOW! \$2, RUSHED. GUARANTEED! ISABELLA HALL, SILVER SPRINGS, FLORIDA 32688.**

**SLEEP** Learning. Hypnotic method. 92% effective. Details free. ASR Foundation, Box 702leg HC Station, Lexington, Ky. 40502.

**HYPNOTIZE PERFECT STRANGERS—EITHER SEX—SUCCESSFULLY!** Secret Methods—they never know! Illustrated Course and 10 inch Hypnodisk \$2.00. **RESULTS ABSOLUTELY GUARANTEED!** Dr. H. Arthur Fowler, Box 4399, Woodbury, New Jersey 08096.

## MAGNETS

**MAGNETISM** (100) page script newly discovered magnetic principles (\$3.00). Jesse Costa, Box 26, Waquoit, Mass. 02536.

## REPAIRS AND SERVICES

**TV Tuners** rebuilt and aligned per manufacturers specification. Only \$9.50. Any make UHF or VHF Ninety day written guarantee. Ship complete with tubes or write for free mailing kit and dealer brochure. JW Electronics, Box 51C, Bloomington, Indiana 47401.

**TELEVISION** tuners, any make VHF or UHF, cleaned, repaired and realigned per manufacturer's specifications \$9.50. One year guarantee. Quality Tuner Repair, 526 West Busby Street, Lebanon, Indiana 46052.

## PERSONALS

**MAKE FRIENDS WORLDWIDE** through international correspondence. Illustrated brochure free. Hermes, Berlin 11, Germany.

**INVESTIGATORS, LATEST ELECTRONIC AIDS. FREE LITERATURE. CLIFTON, 11500-K NW 7th AVE., MIAMI, FLORIDA 33168.**

## RECORDS

**POPULAR** organ albums factory direct. Concert Recording, Lynwood, Calif. 90262.

**SPECIAL** interest records available, produced by the editors of the world's leading special interest magazines. Send for free catalog. Record Catalog-PE, Ziff-Davis Publishing Company, One Park Avenue, New York, N.Y. 10016.

## PRINTING

**SOMETHING** different, 1,000 personalized name address labels with zipcode, imprinted CB/HAM call letters, or phone number. \$1.00. Bargain catalog FREE. D. Electronics, 4725 45th NE, Seattle, Wash. 98105.

**SIMULATED** Engraved Business cards, one color \$6.00, Two colors \$7.00. Free sample book. Stewart Printing Service, P.O. Box 19284, Dallas, Texas 75219.

**QSL'S** Ham-SWL-CB Samples 25¢. C & C Printers, Gladwin, Michigan 48624.

**OFFSET** Printing. Free catalog. Speedy Print, 1906 Swede, Norristown, Pa. 19401.

## EMPLOYMENT INFORMATION

**FOREIGN** and **USA** job opportunities available now. Construction, all trades. Earnings to \$3,000.00 monthly. Paid overtime, travel bonuses. Write: Universal Employment, Woodbridge, Conn. 06525.

**JOBS ON SHIPS!** Good Pay! Europe, Asia, Worldwide! Who to see and Where—\$1.00. Seaways, PE, Box 121, Elliott City, Maryland 21043.

**EXCITING OVERSEAS JOBS.** Directory \$1.00. Research Associates, Box 942-E, Belmont, California 94002.

## BUSINESS OPPORTUNITIES

**I MADE \$40,000.00** Year by Mailorder! Helped others make money! Start with \$10.00—Free Proof. Torrey, Box 318-N, Ypsilanti, Michigan 48197.

**FREE BOOK** "999 Successful Little Known Businesses" Work home, Plymouth 445-R, Brooklyn, N.Y. 11216.

**\$200.00 DAILY** In Your Mailbox! Your opportunity to do what mail-order experts do. Free details. Associates, Box 136-J, Holland, Michigan 49423.

**MAKE BIG MONEY** raising chinchillas, rabbits, guinea pigs for us. Catalog—25¢. Keeney Brothers, New Freedom, Pa. 17349.

**FREE CATALOGS.** Repair air conditioning, refrigeration. Tools, supplies, full instructions. Doolin, 2016 Canton, Dallas, Texas 75201.

**MAILORDER!** Make big money working home. Free report reveals millionaire's trade secrets! Executive (1K1), 233 North Michigan, Chicago 60601.

**\$2000.00 MONTHLY** possible. Details. Ropchan, Box 5341 X, Shermanoaks, California 91413.

**SELL HERTEL BIBLES**—Part Time. Finest reference Bible available. Demonstrator and supplies furnished. Excellent commissions. Write International Book, Dept. PE, Box 118, Wichita, Kansas 67201.

**EASY** to make plastic fishing worms. Costs 3¢. Sell for up to \$1.00. Big profits. Details and formula \$2.00. Poco Plantation, Dept. 150A, Box 5046, Augusta, Georgia 30906.

**CAPITAL CONTACTS.** Before you submit your deal to Underwriters, Investment Co's, write for helpful information to Confidential Consultant, 817 51st St., Brooklyn, N.Y. 11220.

**PIANO TUNING** learned quickly at home. Tremendous field! Musical knowledge unnecessary. GI Approved. Information Free. Empire School, Box 327, Miami, Florida 33145.

**HOW** to make \$1,000,000 in only ten years! Start with \$10! Details Free! International Service, (PE), Box 11796, Atlanta, Georgia. 30305.

**FREE** Millionaire Book. Get 996 \$partime, Odd, Little-Known Businesses. Work home, National-22, Kerrville, Texas 78028.

## TREASURE FINDERS

**FREE TREASURE GUIDE!** Fact-filled collectors edition; send 50¢ for postage. Also request free literature on ultrasensitive, professional Fisher Detectors. FISHER RESEARCH, Dept. PE-1, Palo Alto, California 94303.

**GOLD, Silver, Relics!** Located with powerful Detectron Metal Detectors. Free Information. Terms, Detectron, Dept. PE1, Box 243, San Gabriel, California 91778.

**TREASURE FINDER** locates buried gold, silver, coins, treasures. 5 powerful models. \$19.95 up. Free catalog. Relco-A33, Box 10839, Houston, Texas 77018.

## MUSICAL INSTRUMENTS

**30% DISCOUNT** name brand musical instruments. Free catalog. Freeport Music, 127-N Sunrise Highway, Freeport, N.Y. 11520.

## REAL ESTATE

**FREE . . . NEW SPRING 1971 CATALOG!** Describes and pictures hundreds of farms, ranches, town and country homes, businesses coast to coast! Specify type property and location preferred. Zip Code, please. **UNITED FARM AGENCY**, 612-EP West 47th St., Kansas City, Mo. 64112.

## RUBBER STAMPS

**RUBBER ADDRESS STAMPS \$2.00. SIGNATURE \$3.50. FREE CATALOG. JACKSON'S, BOX 443-G, FRANKLIN PARK, ILLINOIS 60131.**



## ACTION SPORTS FILMS

**SPEND** Your Christmas Money on Films! Complete Catalog, Super 8/8mm . . . Color . . . Black and White. SPORTLITE-PE, 20 North Wacker Drive, Chicago 60606.

## STAMPS

**WOW! 110 ALL DIFFERENT GERMANY 10¢** Commemoratives, Air-mails, High Values, Big catalog, bargain lists. Also, fine stamps from our approval service, which you may return without purchases and cancel service at any time. Jamestown Stamp, Dept. A11EG, Jamestown, N.Y. 14701.

## MISCELLANEOUS

**WINEMAKERS:** Free illustrated catalog of yeasts, equipment. Semplex, Box 12276, Minneapolis, Minn. 55412.

**DRIVER'S** License, Birth Certificate, H.S. & College Diploma, Marriage & Divorce Certificates—Blank Forms. Fill them in yourself. Highest quality you can buy! Confidential 3 day service! \$2.00 each; any four—\$5.00, post-paid. Formco, Box 834-ED, Warren, Mich. 48090.

**HYPNOTIZE ELECTRONICALLY . . . or money back!** Television repairman's accidental discovery. Uses television set. \$2. ELTON'S, Box 12167-PE, St. Petersburg, Florida. 33733.

**CLASSIFIED ADVERTISING IN POPULAR ELECTRONICS**—Your best bet for outstanding mail order sales! These pages are read thoroughly by electronic hobbyists seeking products and services found only in the **ELECTRONICS MARKET PLACE. POPULAR ELECTRONICS** readers respond readily—they rely on the advertisers appearing in the pages of their favorite magazine. Your low cost ad here will result in increased sales responses for you! Send copy and payment to: Hal Cymes, Classified Advertising Manager, **POPULAR ELECTRONICS**, 1 Park Avenue, New York, N. Y. 10016.

# NOW!

## DISPLAY CLASSIFIED ADVERTISING available in POPULAR ELECTRONICS

Effective with this issue, Display Classified Ads are being accepted in these columns.

For those advertisers who want to achieve maximum exposure at minimum expense, this is the opportunity of a lifetime for you!

The special low rates are:

1" by 1 column (2 $\frac{5}{8}$ " wide)....\$110.00

2" by 1 column (2 $\frac{5}{8}$ " wide)....\$215.00

3" by 1 column (2 $\frac{5}{8}$ " wide)....\$320.00

(Ads larger than 3 column inches not accepted for the **ELECTRONICS MARKET PLACE**—Please ask for regular advertising rates.)

Of course, regular non-display Classified Ads continue at \$1.25 per word (minimum \$12.50).

For immediate action in getting your Display (or non-Display) Classifieds into the very next available issue, call or write:

Hal Cymes, Classified Advertising Manager  
**POPULAR ELECTRONICS**  
One Park Avenue, New York, N. Y. 10016  
(212) 679-7200

## POPULAR ELECTRONICS

JANUARY 1971

## ADVERTISERS INDEX

### READER

SERVICE NO.	ADVERTISER	PAGE NO.
	Allied Radio Shack . . . . .	93
3	Antenna Specialists Co., The . . . . .	THIRD COVER
1	Avanti Research & Development Co. . . . .	96
	CREI, Home Study Div., McGraw-Hill Book Co. . . . .	105, 106
2	Cleveland Institute of Electronics . . . . .	18, 19, 20, 21
5	Communications Div., DYNASCAN CORP. . . . .	8
22	Communications Div. DYNASCAN CORP. . . . .	16
4	EICO Electronic Instrument Co. . . . .	FOURTH COVER
6	Edmund Scientific Co. . . . .	103
7	Heath Company . . . . .	12, 13
8	Lafayette Radio Electronics . . . . .	14
9	P.R. Mallory & Co. . . . .	23
10	Mosley Electronics, Inc. . . . .	16
11	McGee Radio . . . . .	94
12	McIntosh Labs . . . . .	91
	National Radio Institute . . . . .	SECOND COVER, 1, 2, 3, 17
	National Technical Schools . . . . .	54, 55, 56, 57
13	Olson Electronics . . . . .	90
14	Progressive "Edu-Kits", Inc. . . . .	104
15	RCA Electronic Components & Devices . . . . .	26
	RCA Institutes, Inc. . . . .	36, 37, 38, 39
16	Sams, Howard W. & Co., Inc. . . . .	9
17	Sonar Radio Corp. . . . .	97
18	Sydmur Electronics . . . . .	90
19	Telex Communications Division . . . . .	14
	U.S. Army . . . . .	5
20	United Audio Products (DUAL) . . . . .	10
21	University Sound . . . . .	6

CLASSIFIED ADVERTISING 98, 99, 100, 101, 102





# BUILD YOUR OWN RADIO

## and Electronics Circuits

### PROGRESSIVE HOME RADIO-TV COURSE

#### Now Includes

- ★ 12 RECEIVERS
- ★ 3 TRANSMITTERS
- ★ SQ. WAVE GENERATOR
- ★ SIGNAL TRACER
- ★ AMPLIFIER
- ★ SIGNAL INJECTOR
- ★ CODE OSCILLATOR

- ★ No Knowledge of Radio Necessary
- ★ No Additional Parts or Tools Needed
- ★ EXCELLENT BACKGROUND FOR TV
- ★ SCHOOL INQUIRIES INVITED
- ★ Sold in 79 Countries



Reg. U.S. Pat. Off.

Training Electronics Technicians Since 1946

### YOU DON'T HAVE TO SPEND HUNDREDS OF DOLLARS FOR A RADIO COURSE

The "Edu-Kit" offers you an outstanding PRACTICAL HOME RADIO COURSE at a rock-bottom price. Our Kit is designed to train Radio & Electronics Technicians, making use of the most modern methods of home training. You will learn radio theory, construction practice and servicing. THIS IS A COMPLETE RADIO COURSE IN EVERY DETAIL.

You will learn how to build radios, using regular schematics; how to wire and solder in a professional manner; how to service radios. You will work the standard type of punched metal chassis as well as the latest development of Printed Circuit chassis.

You will learn the basic principles of radio. You will construct, study and work with RF and AF amplifiers and oscillators, detectors, rectifiers, test equipment. You will learn and practice code, using the Progressive Code Oscillator. You will learn and practice trouble-shooting, using the Progressive Signal Tracer, Progressive Signal Injector, Progressive Dynamic Radio & Electronics Tester, Square Wave Generator and the accompanying instructional material.

You will receive training for the Novice, Technician and General Classes of F.C.C. Radio Amateur Licenses. You will build Receiver, Transmitter, Square Wave Generator, Code Oscillator, Signal Tracer and Signal Injector Circuits and learn how to operate them. You will receive an excellent background for television, Hi-Fi and Electronics.

Absolutely no previous knowledge of radio or science is required. The "Edu-Kit" is the product of many years of teaching and engineering experience. The "Edu-Kit" will provide you with a basic education in Electronics and Radio, worth many times the low price you pay. The Signal Tracer alone is worth more than the price of the kit.

### THE KIT FOR EVERYONE

You do not need the slightest background in radio or science. Whether you are interested in Radio & Electronics because you want an interesting hobby, a well paying business or a job with a future, you will find the "Edu-Kit" a worth-while investment. Many thousands of individuals of all

ages and backgrounds have successfully used the "Edu-Kit" in more than 79 countries of the world. The "Edu-Kit" has been carefully designed, step by step, so that you cannot make a mistake. The "Edu-Kit" allows you to teach yourself at your own rate. No instructor is necessary.

### PROGRESSIVE TEACHING METHOD

The Progressive Radio "Edu-Kit" is the foremost educational radio kit in the world, and is universally accepted as the standard in the field of electronics training. The "Edu-Kit" uses the modern educational principle of "Learn by Doing." Therefore you construct, learn schematics, study theory, practice trouble shooting—all in a closely integrated program designed to provide an easily-learned, thorough and interesting background in radio. You begin by examining the various radio parts of the "Edu-Kit." You then learn the function, theory and wiring of these parts. Then you build a simple radio. With this first set you will enjoy listening to regular broadcast stations, learn theory, practice testing and trouble-shooting. Then you build a more advanced radio, learn more advanced theory and techniques. Gradually, in a progressive manner and at your own rate, you will find yourself constructing more advanced multi-tube radio circuits, and doing work like a professional Radio Technician.

Included in each "Edu-Kit" course are Receiver, Transmitter, Code Oscillator, Signal Tracer, Square Wave Generator and Signal Injector Circuits. These are not unprofessional "breadboard" experiments, but genuine radio circuits, constructed by means of professional wiring and soldering on metal chassis, plus the new method of radio construction known as "Printed Circuitry." These circuits operate on your regular AC or DC house current.

### THE "EDU-KIT" IS COMPLETE

You will receive all parts and instructions necessary to build twenty different radio and electronics circuits, each guaranteed to operate. Our Kits contain tubes, tube sockets, variable, electrolytic, mica, ceramic and paper dielectric condensers, resistors, tie strips, hardware, tubing, punched metal chassis, Instruction Manuals, hook-up wire, solder, selenium rectifiers, coils, volume controls and switches, etc.

In addition you receive Printed Circuit materials, including Printed Circuit chassis, special tube sockets, hardware and instructions. You also receive a useful set of tools, a professional electric soldering iron, and a self-powered Dynamic Radio and Electronics Tester. The "Edu-Kit" also includes Code Instructions and the Progressive Code Oscillator, in addition to F.C.C. Radio Amateur License training. You will also receive lessons for servicing with the Progressive Signal Tracer and the Progressive Signal Injector, a High Fidelity Guide Book. You receive Membership in Radio-TV Club, Free Consultation Service, Certificate of Merit and Discount Privileges. You receive all parts, tools, instructions, etc. Everything is yours to keep. 1189 Broadway, Dept. 690D, Hewlett, N. Y. 11557.

### UNCONDITIONAL MONEY-BACK GUARANTEE

- Please rush my Progressive Radio "Edu-Kit" to me, as indicated below:
- Check one box to indicate choice of model
- Deluxe Model \$31.95.
  - New Expanded Model \$34.95 (Same as Deluxe Model plus Television Servicing Course).
- Check one box to indicate manner of payment
- I enclose full payment. Ship "Edu-Kit" post paid.
  - I enclose \$5 deposit. Ship "Edu-Kit" C.O.D. for balance plus postage.
  - Send me FREE additional information describing "Edu-Kit."

Name \_\_\_\_\_  
Address \_\_\_\_\_

### PROGRESSIVE "EDU-KITS" INC.

1189 Broadway, Dept. 690D, Hewlett, N. Y. 11557

### FREE EXTRAS

- SET OF TOOLS
- SOLDERING IRON
- ELECTRONICS TESTER
- PLIERS-CUTTERS
- VALUABLE DISCOUNT CARD
- CERTIFICATE OF MERIT
- TESTER INSTRUCTIONS MANUAL
- HIGH FIDELITY GUIDE & QUIZZES
- TELEVISION BOOK & RADIO
- DOUBLE SHOOTING BOOK
- MEMBERSHIP IN RADIO-TV CLUB
- CONSULTATION SERVICE, F.C.C.
- AMATEUR LICENSE TRAINING
- PRINTED CIRCUITRY

### SERVICING LESSONS

You will learn trouble-shooting and servicing in a progressive manner. You will practice repairs on the sets that you construct. You will learn symptoms and causes of trouble in home, portable and car radios. You will learn how to use the professional Signal Tracer, the unique Signal Injector and the dynamic Radio & Electronics Tester. While you are learning in this practical way, you will be able to do many a repair job for your friends and neighbors, and charge fees which will far exceed the price of the "Edu-Kit." Our Consultation Service will help you with any technical problems you may have.

### FROM OUR MAIL BAG

J. Statistis, of 25 Poplar Pl., Waterbury Conn., writes: "I have repaired several sets for my friends, and made money. The "Edu-Kit" paid for itself. I was ready to spend \$240 for a course, but I found your ad and sent for your Kit."

Ben Valerio, P. O. Box 21, Magna, Utah: "The Edu-Kits are wonderful. Here I am sending you the questions and also the answers for them. I have been in Radio for the last seven years, but like to work with Radio Kits, and like to build Radio Testing Equipment. I enjoyed every minute I worked with the different kits; the Signal Tracer works fine. Also like to let you know that I feel proud of becoming a member of your Radio-TV Club."

Robert L. Shuff, 1534 Monroe Ave., Huntington, W. Va.: "Thought I would drop you a few lines to say that I received my Edu-Kit, and was really amazed that such a bargain can be had at such a low price. I have already started repairing radios and phonographs. My friends were really surprised to see me get into the swing of it so quickly. The Trouble-shooting Tester that comes with the Kit is really swell, and finds the trouble, if there is any to be found."

### PRINTED CIRCUITRY

At no increase in price, the "Edu-Kit" now includes Printed Circuitry. You build a Printed Circuit Signal Injector, a unique servicing instrument that can detect many Radio and TV troubles. This revolutionary new technique of radio construction is now becoming popular in commercial radio and TV sets.

A Printed Circuit is a special insulated chassis on which has been deposited a conducting material which takes the place of wiring. The various parts are merely plugged in and soldered to terminals.

Printed Circuitry is the basis of modern Automation Electronics knowledge. This subject is a necessity today for anyone interested in Electronics.

CIRCLE NO. 14 ON READER SERVICE PAGE

Printed in U.S.A.



# "I'll always have a job for a man who really knows advanced electronics."

Opportunities are poor today for men who lack sound technical qualifications. But men who combine experience with up-to-date knowledge of advanced electronics are always in demand.

Make yourself a valuable specialist. Get the additional education you need to enjoy challenging work, high pay and security for yourself and your family.

Going back to school isn't easy for a man with a full-time job and family obligations. But CREI Home Study Programs make it possible for you to get the additional education you need without attending classes. You study at home, at your own pace, on your own schedule. You study with the assurance that what you learn can be applied to the job almost immediately.

You're eligible for a CREI Program if you work in electronics and have a high school education. Free book gives complete information. Mail postpaid card for your copy today.

**In-depth coverage of solid state electronics . . . including integrated circuits!**

**Free book tells all about CREI programs. For your copy, tear out and mail postpaid card or write:**

CREI Dept. E1201B, 3224 16th St., N.W.  
Washington, D.C. 20010



E1201B

Please mail me FREE book describing CREI Home Study Programs. I am employed in electronics and have a high school education.

I am interested in:

- Electronic Engineering Technology
- Space Electronics
- Computers
- Nuclear Engineering Technology
- Industrial Electronics
- NEW! Electronics Systems Engineering
- NEW! Non-technical Course in Computer Programming



Name \_\_\_\_\_

Age \_\_\_\_\_

Address \_\_\_\_\_

City \_\_\_\_\_

State \_\_\_\_\_

Zip \_\_\_\_\_

Employed by \_\_\_\_\_

Type of Present Work \_\_\_\_\_

G.I. Bill

APPROVED FOR TRAINING UNDER NEW G.I. BILL

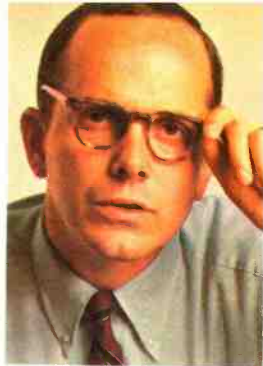

**"I'll always have a job for a man who really knows advanced electronics."**

# Protect your future in electronics. Make yourself a specialist in one of these key areas:

- Electronic Engineering Technology
- Aeronautical & Navigational
- Television
- Communications
- Nuclear Instrumentation & Control
- Missile & Spacecraft Guidance
- Radar & Sonar
- Nuclear Engineering Technology
- Automatic Control
- Industrial Electronics
- Computers
- Digital Communications
- Electronics Systems Engineering

**In-depth coverage of solid state electronics . . . including integrated circuits!**

Take the advice of men who know the electronics industry. Make yourself a specialist in one of the key areas of electronics. Then stop worrying about how cutbacks, layoffs and contract terminations will affect you and your family. If you have up-to-date specialized knowledge of electronics, you can look forward to security and excellent earnings when men with ordinary qualifications are let go.

But to become a specialist, you must supplement your experience in electronics with more technical education. CREI Home Study Programs offer you an opportunity to get that additional education without going back to school.

You're eligible for a CREI Program if you work in electronics and have a high school education. Free book gives complete information. Mail postpaid card for your copy today.

APPROVED FOR TRAINING UNDER NEW G.I. BILL

FIRST CLASS  
Permit No. 288-R  
Washington, D.C.

**BUSINESS REPLY MAIL**

No Postage Necessary If Mailed In The United States

Founded 1927



Accredited Member of the National Home Study Council

**CREI, Continuing Education Division**

McGraw-Hill, Inc.

3224 Sixteenth Street, N.W.

Washington, D.C. 20010

**Free book tells all about CREI programs. For your copy, tear out and mail postpaid card or write:**

CREI, Dept. E1201B,  
3224 16th St., N.W.  
Washington, D.C. 20010





# the Super Scanner

It took us two years  
to make the  
CB Scanner scan 360°  
automatically

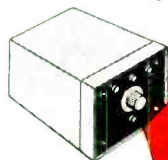

NEW  
OMNI-LOCATOR  
POSITION

It takes the  
MR119 Super Scanner  
1/3 of a second to do it!

- **Beam Mode:** positive electronic "beaming" in choice of sectors—no mechanical rotator needed!
- **Omni Mode:** Special position for omnidirectional "searching"—just switch to use!
- **Tremendous 7.75 dB forward gain** in beam mode; 2.5 dB gain in omni mode!
- **Front-to-back 23 dB**—cuts backside noise drastically, increases effective forward range.
- **Compact design**—beats all beams for size and weight (just 17 lbs.) yet ruggedly constructed to take 100 MPH winds!

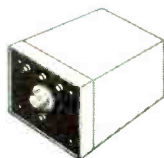

**Soup up your Scanner!** Turn your present Scanner into a Super Scanner with Model M-219 conversion kit.

Make it a match... with famous Maggie Mobile—world's biggest-selling mobile communications antennas!

**the antenna  
specialists co.**

Division of Allen Electric and Equipment Co.  
12435 Euclid Ave., Cleveland, Ohio 44106  
Export offices: 2200 Shames Dr.,  
Westbury, N.Y. 11590



"Stripes of Quality"

CIRCLE NO. 3 ON READER SERVICE PAGE



# Be creative—and thrifty too!

Save up to 50% with EICO Kits and Wired Equipment.

## NEW "TREASURE HUNTER" KIT

Finds metals, pipes several inches underground. EICO TH-30 Solid State Treasure Hunter locates iron, steel, tin, gold, silver, copper etc. Beep pitch increases as you near object.

Battery operated. \$29.95.



## NEW "BULLHORN" KIT

Carries your voice up to 400 feet. EICO BH-16 Solid State Bullhorn. 2½ lbs. light, is perfect for all outdoors, camping, sports. Battery-operated. \$15.95.



## NEW EICOCRAFT

The electronic science project kits for beginners, sophisticates, educators. 42 kits to date.



FM Wireless Mike \$9.95.

## 8 NEW EICOCRAFT KITS

Automotive "LIGHTGUARD" • "VARIVOLT" DC Power Supply • "MOODLITE" Light Dimmer Control • "VARASPEED" Motor Speed Control • "LIGHTSHOW" Sound/Lite Translator • "ELECTRIC FIESTA" Audio Color Organ • "SUPER MOODLITE" Remote Control Light Dimmer • "ELECTROPLATER" From \$2.50 to \$14.95.

## NEW "FLEXI-CAB"

Build your own custom designed cabinet in minutes! Give your EICOCRAFT and other projects that finished professional look with decor-styled FLEXI-CAB vinyl clad steel cabinets. Fast, easy, push-together assembly. 3-sizes from \$3.49.

## COLOR IMAGES

Electronic Art in Motion.

### "CHROMA-CUBE"

Classic white 18" Cube features a fantastic audio-responsive light display.

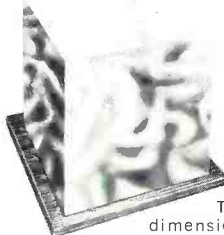

### "CELESTIAL LITES"

Constantly flowing color images move in rhythm to music. 24" x 24" x 6".



### "LIGHT FANTASTIC"

Translucent dome provides 3-dimensional world of ever changing light patterns in response to music. 38" high.

## NEW Cortina2 STEREO KITS

The lowest-priced component quality high fidelity!



EICO 3780 50-Watt Silicon Solid State FET AM-FM Stereo Receiver. Kit \$109.95, Wired \$169.95



EICO 3080 50-Watt Silicon Solid State Stereo Amplifier. Kit \$69.95, Wired \$109.95



EICO 3300 Silicon Solid State FET AM-FM Stereo Tuner. Kit \$69.95, Wired \$109.95

## NEW SOLID STATE TEST INSTRUMENTS

The first and only solid-state test equipment guaranteed for 5 years!



EICO 240 Solid State FET-TVM. Kit \$59.95, Wired \$79.95.

EICO 379 Solid State Sine/Square Wave Generator. Kit \$69.95, Wired \$99.95

EICO 242 Solid State FET-TVOM. Kit \$69.95, Wired \$94.50.

EICO 150 Solid State Signal Tracer. Kit \$49.95, Wired \$69.95.

EICO 330 Solid State RF Signal Generator. Kit \$59.95, Wired \$89.95

NOW YOU CAN SEE THE MUSIC YOU HEAR.

## Sound n' Color

Color Organs, Translators, Strobes



### COLOR ORGANS

The new dimension to music pleasure.

EICO all electronic solid-state Audio Color Organs transform sound waves into moving synchronized color images.

MODEL 3450 Giant (30" x 12" x 10") 4-Channels. Kit \$79.95, Wired \$109.95.

MODEL 3445 (24" x 12" x 10") 4-Channels. Kit \$64.95, Wired \$99.95.

MODEL 3440 (10" x 15" x 16") 3-Channels. Kit \$49.95. Wired \$79.95. Other models to choose, from \$19.95 and up.

### TRANSLATORS

The electronics you need to create audio-stimulated light displays.



MODEL 3460 1 Channel. Kit \$24.95, Wired \$39.95.

MODEL 3465 3 Channel. Kit \$39.95, Wired \$69.95.

### STROBE LITES

Burst of white light flash in cadence of each beat of audio.

Model 3470 Adjustable Rate. Kit \$29.95, Wired \$39.95.

Model 3475 Audio Actuated. Kit \$39.95, Wired \$59.95.



### AUTOMOTIVE

EICO 889 Solid State Capacitive Ignition System.

Boost gas mileage up to 25% life of points, plugs to 100,000 miles. Kit \$29.95, Wired \$39.95.



EICO 888 Solid State Universal Engine Analyzer. Tunes and troubleshoots your car/boat engine, totally professional work. Kit \$54.95. Wired \$79.95



## FREE 1971 EICO CATALOG PE-1

Send me FREE catalog, describing the full EICO line of 200 best buys, and name of nearest dealer.

Name \_\_\_\_\_

Address \_\_\_\_\_

City \_\_\_\_\_ State \_\_\_\_\_ Zip \_\_\_\_\_

EICO Electronic Instrument Co., Inc.  
283 Malta Street, Brooklyn, N.Y. 11207



www.americanradiohistory.com