

PHASE-LOCKED LOOP SCA ADAPTER

# Popular Electronics

FIFTY CENTS / DECEMBER 1970

## Build a Digital Clock

PINK NOISE GENERATOR  
Helps You Concentrate

PROGRAMMED SELF-STUDY

UPGRADE HEATHKIT IG-72

INDUCTION RECEIVER  
For Home or Lab Use

## Time-signal Receiver



# NRI "hands-on" training in TV-Radio, Electronics can give you as much as 2 years of on-the-job experience.

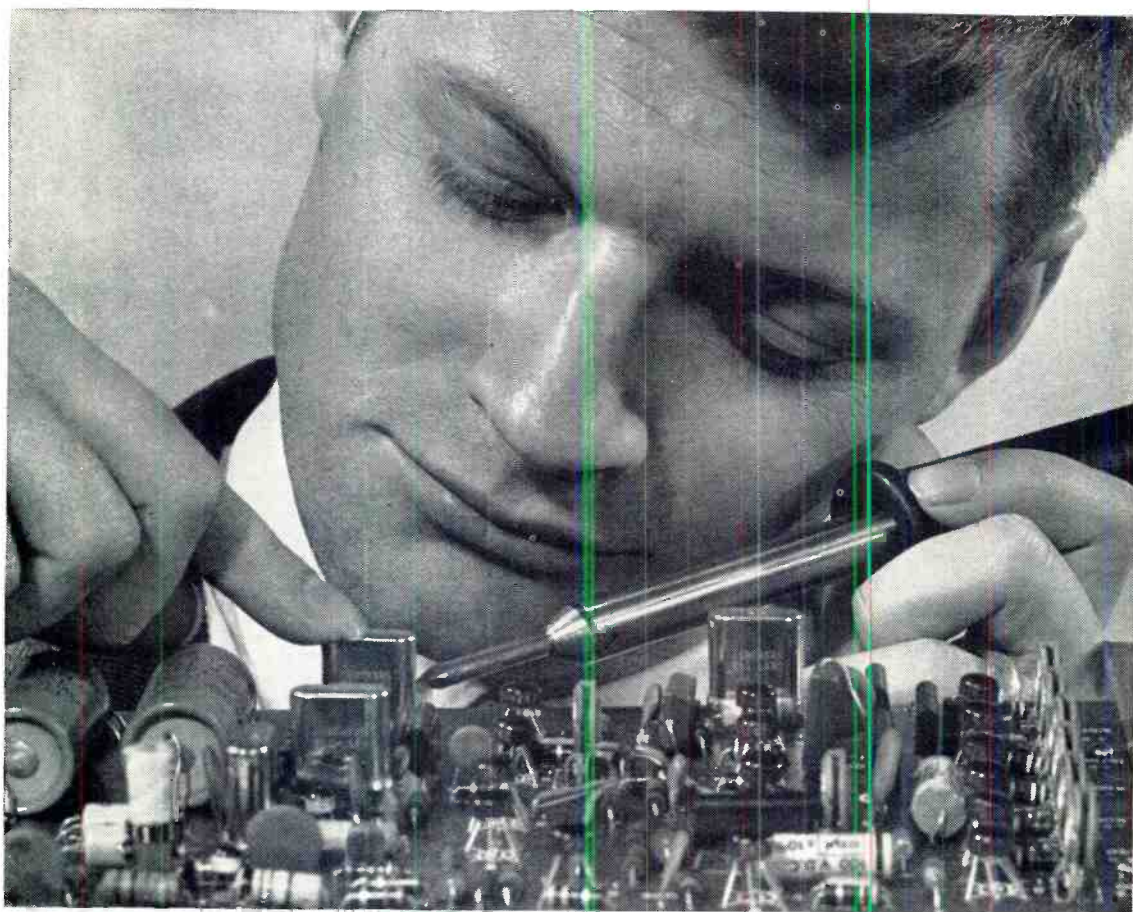

## EARN YOUR FCC LICENSE – OR YOUR MONEY BACK

NRI Communications training programs will qualify you for a First Class Commercial Radiotelephone License issued by the FCC. If you fail to pass the FCC examinations for this license after successfully completing an NRI Communications course we will, on request, refund in full the tuition you have paid. This agreement is valid for the period of your active student membership and for six months after completion of your training. NRI School offers a more liberal FCC License agreement.



# Experience is still your best teacher



**NRI Achievement Kit** is educator-acclaimed and the original "starter" kit in home study training. Imitated but never duplicated, this kit is designed and personalized for you and your training objective. It has one purpose — to get you started quickly and easily.



**"Bite-Size" Texts** average an easily-digested 40 pages of well-illustrated, scientifically prepared subject matter in the course of your choice. Questions in each book are carefully hand-graded and returned to you with helpful instructional notes. You get unlimited personal help from the day you enroll.



## Designed-For-Learning Equipment

Like this phone-cw transmitter (Kit #7 in the Communications course) is engineered from chassis up to demonstrate principles you must know. NRI does not use modified hobby kits for training, but the finest parts money can buy, professionally and educationally applied.

*...here's how you get it with unique NRI training at home*

Ask any teacher, job counselor, engineer, technician or prospective employer about the need for practical application of theory in Electronics. He'll tell you Electronics is as much a "hands-on" profession as dentistry or chemistry. That's how you learn at home with NRI. You prove the theory you read in "bite-size" texts, by actual experimentation with the type of solid-state, transistor and tube circuits you'll find on the job today — *not* hardware or hobby kits. You introduce circuit defects, analyze results, discover quickly the kind of trouble-shooting and design techniques that will make you employable in Electronics.

## Train with the leader—NRI

NRI lab equipment is designed from chassis up for effective, fascinating training — not for entertainment. The fact that end results are usable, quality products is a bonus. In Communications, for example, you build and analyze, stage by stage, your own 25-watt phone/cw transmitter. It's suitable for use on the 80-meter amateur band, if you have an interest in ham radio. In TV-Radio Servicing your practical training gives you your choice of monochrome or color TV sets. All training equipment is included in the low tuition — you pay nothing extra. Discover for yourself the ease, excitement and *value* of NRI training. Mail postage-free card today for new NRI Catalog . . . or use the coupon below. No obligation. No salesman will call on you. NATIONAL RADIO INSTITUTE, Washington, D.C. 20016.

### APPROVED UNDER NEW GI BILL

If you have served since January 31, 1955, or are in service now, check GI line on postage-free card or in coupon.

MAIL THIS COUPON IF CARD IS GONE



### NATIONAL RADIO INSTITUTE

Washington, D.C. 20016

1-120

Please send me your new NRI Catalog. I understand no salesman will call and there is no obligation.

Name \_\_\_\_\_ Age \_\_\_\_\_

Address \_\_\_\_\_

City \_\_\_\_\_ State \_\_\_\_\_ Zip \_\_\_\_\_

Check for facts on new GI Bill

ACCREDITED MEMBER NATIONAL HOME STUDY COUNCIL

# Popular Electronics

WORLD'S LARGEST-SELLING ELECTRONICS MAGAZINE

## FEATURE ARTICLES

- |   |           |                                    |
|---|-----------|------------------------------------|
| <b>ASSEMBLE THE POPULAR ELECTRONICS DIGI-VISTA</b><br><i>A true electronic digital clock</i>  | <b>25</b> | Charles G. Kay<br>and Daniel Meyer |
| <b>BUILD A THREE-CHANNEL TIME RECEIVER</b><br><i>Get signals from WWV or CHU</i>  | <b>33</b> | Charles Caringella                 |
| <b>QUIZ ON AC CIRCUIT THEORY</b>  | <b>44</b> | Robert P. Balin                    |
| <b>ELECTRONICS SELF-STUDY COURSE</b><br><i>Inexpensive way to get a start</i>   | <b>45</b> | Kenneth J. Englert                 |
| <b>BUILD THE LIBERATOR</b><br><i>Get free of receiver-tending</i>   | <b>49</b> | C. P. Troemel                      |
| <b>BUILD AN SCA ADAPTER FOR FM RECEPTION</b><br><i>Music without commercials</i>  | <b>53</b> | Vincent Wood                       |
| <b>BUILD A PINK NOISE GENERATOR</b><br><i>Eliminate annoying racket</i>   | <b>61</b> | John S. Simonton, Jr.              |
| <b>AN EASY WAY TO DETERMINE<br/>REFLEX ENCLOSURE DIMENSIONS</b>   | <b>64</b> | E. G. Lescault                     |
| <b>SECOND GUESSING THE HEATHKIT IG-72</b><br><i>How to get a zerobeat</i>   | <b>65</b> | D. W. Palomaki                     |
| <b>SINGLE FILAMENT TAIL LIGHT CONVERTER</b>   | <b>66</b> | Marvin Beier                       |
| <b>THE PRODUCT GALLERY</b><br><i>Heathkit Vectorscope IO-101</i><br><i>Johnson Smith Co. Intrusion Alarm</i><br><i>Ungar IC Desoldering Tools</i> | <b>67</b> |                                    |
| <b>STEREO SCENE</b><br><i>Keeping economy in mind</i>   | <b>71</b> | J. Gordon Holt                     |
| <b>COMMUNICATIONS</b><br><i>Photo story on ETLF</i>   | <b>78</b> |                                    |
| <b>SOLID STATE</b><br><i>Microwave components coming on fast</i>  | <b>81</b> | Leu Garner                         |

## DEPARTMENTS

- |  |               |                   |
|--|---------------|-------------------|
| <b>DIRECT &amp; CURRENT</b>                | <b>7</b>      | Oliver P. Ferrell |
| <b>INTERFACE</b>                           | <b>8</b>      |                   |
| <b>NEW LITERATURE</b>                      | <b>14</b>     |                   |
| <b>READER SERVICE PAGES</b>                | <b>15, 95</b> |                   |
| <b>ELECTRONICS LIBRARY</b>                 | <b>16</b>     |                   |
| <b>NEW PRODUCTS</b>                        | <b>22</b>     |                   |
| <b>INDEX TO VOLUME 33 (JUNE-DEC. 1970)</b> | <b>100</b>    |                   |

POPULAR ELECTRONICS is indexed  
in the Readers' Guide  
to Periodical Literature

This month's cover photo by  
Justin Kerr

Copyright © 1970 by ZIFF-DAVIS PUBLISHING COMPANY. All rights reserved.

POPULAR ELECTRONICS, December 1970, Volume 33, Number 6, Published monthly at One Park Ave., New York, N.Y. 10016. One year subscription rate for U.S., U.S. Possessions and Canada, \$6.00; all other countries, \$7.00. Second class postage paid at New York, N.Y. and at additional mailing offices. Authorized as second class mail by the Post office Department, Ottawa, Canada and for payment of postage in cash. Subscription service and Forms 3579: P.O. Box 1996, Flushing, N.Y. 11352. Editorial offices for manuscript contributions, reader inquiries, etc.: One Park Ave., New York, N.Y. 10016.



# If you can't come to the world's newest, largest and most exciting electronics department store, we'll mail the store to you!

**Exclusive!** Knight-Kit and Science-Fair Kits. Exciting build-your-own kits made to our own exacting standards. Stereo, CB, automotive, ham radio, science, hobby, test equipment, photography and more!

**Exclusive!** Realistic Life-time Tubes. Never worry about buying another tube. We guarantee ours will last as long as your set—or we replace it FREE!

**Exclusive!** Battery-A-Month Club. Join the Allied Radio Shack Club and receive a powerful battery every month for a full year—FREE!



## New Allied Radio Shack Catalog!

Thousands of electronic values!

Allied Radio and Radio Shack have joined forces to form the largest electronics distributing company in the world! This new 1971 460-page catalog offers you the best of both companies: famous-name brands, exclusive new products you'll find nowhere else (including some items you didn't even think were invented yet), and special money-saving prices that only the combined buying power of these two great companies could offer!

**World's Largest Electronic Department Stores. Over 800 stores in 48 states. See your phone book for store nearest you.**

**Exclusive!** Quality Audio Products at Factory-Direct Savings

Allied TD-1099 Head Stereo Tape Deck. New one-piece head makes tape threading a snap. With case. Spectacular value! \$175.95

Realistic STA-120 Wideband AM, FE-FM Stereo Receiver. 140 Watts. With case. \$269.95



Mail Coupon To Address Below ... or bring to Allied Radio Shack store for new catalog!



ALLIED RADIO SHACK 100 N. Western Avenue Chicago, Illinois 60680 615

Yes! I want your big new 1971 catalog. I enclose \$1 for mailing and handling (refundable with my first purchase of \$1 or more).

NAME \_\_\_\_\_  
 First Middle Last

ADDRESS \_\_\_\_\_  
 Street or Route and Box No.

CITY \_\_\_\_\_ STATE \_\_\_\_\_ ZIP \_\_\_\_\_

I enclose  check  money order  cash

CB gets a first ever from Turner

# FULL MODULATION GUARANTEED

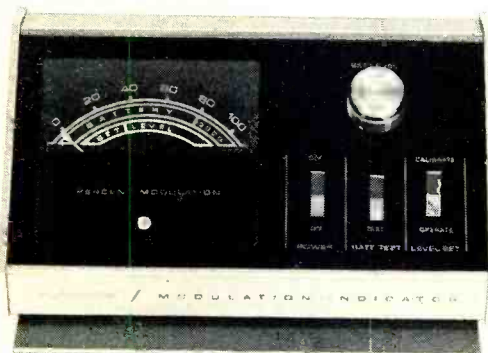

Get the most out of your base rig. Put something new into it. Buy a Turner Modulation Indicator and be sure of full modulation every time. There's no other way to keep a steady eye on your signal. And nothing could be easier to operate. Just work the volume control on your Turner +2 or +3 microphone until the indicator shows 100%. You'll get a clearer signal. You'll send it a lot farther. Buy now. Be among the first to own this handsome instrument with a black-lucite and brushed-aluminum finish. Works with all CB sets, comes with complete operating instructions. Features solid state construction, plug-in installation, self-contained standard 9-volt battery operation. CB users net price \$39.50. Manufactured in the United States by the Turner Company, A Subsidiary of Conrac Corporation, 909 17th Street N.E., Cedar Rapids, Iowa 52402.

## The Turner Company

CIRCLE NO. 27 ON READER SERVICE PAGE

# Popular Electronics

**LAWRENCE SPORN**  
*Publisher*

**OLIVER P. FERRELL**  
*Editor*

**LESLIE SOLOMON**  
*Technical Editor*

**JOHN R. RIGGS**  
*Managing Editor*

**EDWARD J. BUXBAUM**  
*Art Director*

**ALEXANDER W. BURAWA**  
*Associate Editor*

**ANDRE DUZANT**  
*Technical Illustrator*

**PATTI MORGAN**  
*Assistant Editor*

**JUDITH L. HOGAN**  
*Editorial Assistant*

**J. GORDON HOLT**  
**L. E. GARNER, JR.**  
**DAVID L. HEISERMAN**  
*Contributing Editors*

**J. ROYCE RICHARD**  
*Assistant Publisher*

**RICHARD J. HALPERN**  
*Advertising Manager*

**ROBERT UR**  
*Marketing Manager*

**MARGARET DANIELLO**  
*Advertising Service Manager*

**FURMAN H. HEBB**  
*Group Vice President*  
*Electronics and Photography*

**ZIFF-DAVIS PUBLISHING COMPANY**  
Editorial and Executive Offices  
One Park Avenue, New York, New York 10016  
212 679-7200

Midwestern Office

The Pattis Group, 4761 West Touhy Ave.,  
Lincolnwood, Illinois 60646, 312 679-1100  
GERALD E. WOLFE, DICK POWELL

Western Office

9025 Wilshire Boulevard, Beverly Hills, California 90211  
213 CRestview 4-0265; BRadshaw 2-1161  
Western Advertising Manager: **BUD DEAN**

Japan: James Yagi

Ishikawa Mansion #4, Sakuragaoka  
Shibuya-ku, Tokyo, 462-2911-3

Circulation Office

P.O. Box 1096, Flushing, N.Y. 11352

William Ziff, President

W. Bradford Briggs, Executive Vice President

Hershel B. Sarbin, Senior Vice President

Stanley R. Greenfield, Senior Vice President

Philip Sine, Financial Vice President

Walter S. Mills, Jr., Vice President, Circulation

Phillip T. Heffernan, Vice President, Marketing

Frank Pamerantz, Vice President, Creative Services

Arthur W. Butzow, Vice President, Production

Edward D. Muhlfeld, Vice President, Aviation Division

Irwin Robinson, Vice President, Travel Division

George Morrissey, Vice President

Sydney H. Rogers, Vice President

Ziff-Davis also publishes *Airline Management and Marketing*, *Including American Aviation*, *Boating*, *Business & Commercial Aviation*, *Car and Driver*, *Cycle*, *Electronics World*, *Fishing*, *Modern Bride*, *Popular Photography*, *Skating*, *SKIING*, *Yaca News*, *SKIING*, *Trade News*, *Stereo Review*, and *Travel Weekly*.

Forms 3579 and all subscriptions correspondence should be addressed to **POPULAR ELECTRONICS**, Circulation Department, P.O. Box 1896, Flushing, N.Y. 11352. Please allow at least six weeks for change of address. Include your old address, as well as new—enclosing if possible an address label from a recent issue.

**EDITORIAL CONTRIBUTIONS** must be accompanied by return postage and will be handled with reasonable care; however, publisher assumes no responsibility for return or safety of art work, photographs or manuscripts.



Member Audit Bureau  
of Circulations

POPULAR ELECTRONICS



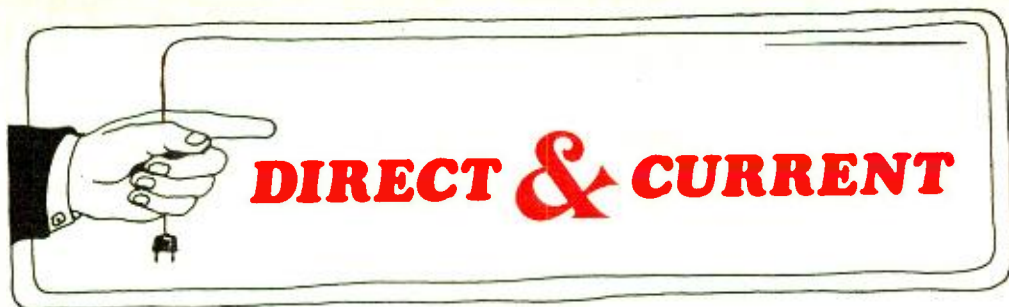

Fourth in a Monthly Series by Oliver P. Ferrell, Editor

## IT TAKES ALL KINDS!

After the introduction of this monthly editorial, I was besieged by readers requesting "action" on an assortment of pet gripes. Many readers felt that this page was an auspicious location to publicize some dubious business practices. After some investigation, I must agree that a couple of things have happened in the past few months that are fairly reprehensible.

Topping my list is a cute trick that at least one mail order supplier has instituted—probably without the knowledge of the ownership and top management. It is penny ante stuff, but sufficiently irritating to POPULAR ELECTRONICS readers to have been brought to my attention on several occasions. The scheme works like this: a buyer orders a two-channel walkie-talkie (for example) and, when the unit arrives, it is discovered to be a single-channel model. The buyer complains and instead of getting the proper product, he gets a discount refund of a couple of dollars. It sounds innocent enough, but the buyer could have bought the single-channel model initially for less than his out-of-pocket investment (original price of the two-channel model less the discount)! Apparently, if the buyer continues to complain to the supplier, the whole deal is rectified, but by that time the majority of buyers are either disgusted or willing to forget the whole thing.

The second "trick" is difficult to pin-point—so I am going to go along with several readers who spotted the same thing. They say that they have been buying IC's from distress or surplus dealers, but the IC's are impossible to solder to a printed circuit board. Upon inspection they find that the thin gold plating on the leads has been removed—probably by a gold reclaimer—and the raw metal that is exposed is either unsolderable or requires so much heat in soldering that the interior of the IC is permanently damaged. The obvious solution is to use IC sockets, but the seller doesn't say anything about that in his advertisements for IC's at very attractive prices.

Personally, I haven't been able to prove or disprove this missing gold business and it may be localized to a dealer or two on the West Coast. The distress IC's available here on the East Coast seem to be perfectly legit.

All of this goes again to verify the adage that it's best to know the supplier you are dealing with. Certainly 99% of the mail order suppliers are OK, but don't be too surprised when you run into an occasional rotten apple.

Earn Your

# B. S. E. E. DEGREE

Grantham School of Engineering in Los Angeles, California offers an evening program in Electronics Engineering, designed for working technicians, and leading to a degree in engineering. Classes meet three evenings per week for a total of 100 meetings per school-year. In four school-years of this evening program, you earn the Degree of Associate in Science in Electronics Engineering (the ASEE). Then, by attending an additional school-year of evening classes and transferring certain non-technical credits from other colleges to Grantham, you earn the Degree of Bachelor of Science in Electronics Engineering (the BSEE).

Grantham School of Engineering—Eve. Div.—12-70  
1505 N. Western Ave., Hollywood, Calif. 90027

Gentlemen: I have been in electronics for \_\_\_ years. Please mail me your free Evening-School Bulletin.

Name \_\_\_\_\_  
Address \_\_\_\_\_  
City \_\_\_\_\_ State \_\_\_\_\_ Zip \_\_\_\_\_

Earn Your

# A. S. E. E.

(Associate in Science in Electronics Engineering)

Mostly by **HOME STUDY** Instruction

Grantham School of Engineering—"the college that comes to you"—offers to electronics technicians a home-study educational program for the Degree of Associate in Science in Electronics Engineering (the ASEE), accredited by the Accrediting Commission of the National Home Study Council and approved under the G.I. Bill.

This complete degree program except for the final ten lessons is presented entirely by correspondence. However, these last ten lessons are part of a two-week "Graduation Seminar" held at the School. Thus, you may do all of your ASEE Degree work by correspondence except for the final two weeks.

Grantham School of Engineering PE-12-70  
1505 N. Western Ave., Hollywood, Calif. 90027

Gentlemen: I have been in electronics for \_\_\_ years. Please mail me your free Home-Study School Bulletin.

Name \_\_\_\_\_  
Address \_\_\_\_\_  
City \_\_\_\_\_ State \_\_\_\_\_ Zip \_\_\_\_\_

CIRCLE NO. 13 ON READER SERVICE PAGE

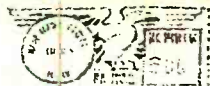

## INTERFACE

### "MEGGER"—A TRADEMARK

Our attention has been drawn to the article in *POPULAR ELECTRONICS*, August, 1970, p 50, titled, "Make Your VTVM a Megger Too." We would inform you that the word "Megger" is a registered trademark belonging to this company and is registered in all major countries of the world including the United States.

DR. G. F. TAGG  
Evershed & Vignoles Ltd.  
Acton Lane Works, Chiswick  
London, W4, England

### IT'S THAT TIME OF YEAR

One of the first signs that the fall months are approaching is the release of the 1971 catalogs from the various mail order suppliers. Itemizing hundreds of new products and components (all at higher prices) I think that these catalogs should be labeled: Warning! May be hazardous to your wealth!

M. OLENSKI  
Milford, Conn.

### ANY VOLUNTEERS?

In February I am planning a visit to New York City and would like to start a correspondence with fellow electronics kit builders in the New York City area—with the objective in mind that my correspondent might be able to show me around the city. I may be reached at P.O. Box 151, San Nicolas, Aruba, Netherlands Antilles.

ERIC F. TCHONG  
West Indies

### NO FI LIKE HI-FI

The story, "Experiment That Saved Hi-Fi," (September issue) echos the thesis of a noted writer and acoustic engineer who espoused that true hi-fi was the sound that pleased the ears of the customer. A graphic illustration of this occurred in 1952 when I returned from a trip to New York City and had been able to procure from the Cortlandt St. "radio row" a paper cone for a collector's item RCA 1924 console. This straight TRF was used by an old lady who wept from pure joy when she heard the clear tones so familiar to her when the speaker to that 35-year-old radio had been fixed!

Sometime later I had the amusement of solving a complaint from a young, but tone deaf, hi-fi enthusiast who had invested in a  
(Continued on page 97)

POPULAR ELECTRONICS





## The talk of the town

### New Cobra PF-1 AM/FM Police/Fire Monitor

Now you can hear about all the exciting events in your town as they happen. Traffic jams, robberies, dangerous criminals at large. Exact details of the latest fire. Hazardous storm warnings . . . before it's too late.

It's amazing! The new Cobra PF-1 monitors government VHF channels and lots more. Does it better than any other radio of its kind. All at a price you can afford.

Unlike other monitors, you receive both AM and FM high and low bands without an extra set of crystals. And in addition to manual tuning, you get crystal control option for a high and low pre-selected frequency—a feature usually available only in the most expensive radios.

So why settle for less? Exclusive noise limiting circuits reduce ignition interference and insure quiet operation. And the ultimate in new solid state circuit design gives you top reach and selectivity.

You even get a modern decorator-styled exterior suitable for any decor or auto interior.

Ask your dealer about the exciting new Cobra PF-1. Or write us for complete details. And you'll know all the talk of the town!

**Cobra PF-1 \$119.95**

All solid state with IC. 2 tunable VHF bands (30MHz to 50MHz & 152MHz to 174MHz), independent tuning knobs for each band, dial scale calibration, crystal control option for high and low band preselected frequency (your choice of crystals, \$5 each), reverse polarity protection for DC operation, exclusive dual noise limiting circuits, antenna and mounting bracket for mobile use included. 117 volt AC or 12 volt DC. Unique circuit permits application of AC and DC simultaneously. If AC fails, DC power source takes over.



**CIRCLE NO. 10 ON READER SERVICE PAGE**

# New from Heath...in time

## New Heathkit® solid-state modular color TV

The result of over five years in research and development, these sets represent one of today's greatest color TV values. Here's why: a total of 45 transistors, 55 diodes, 2 silicon controlled rectifiers, 4 IC's containing another 46 transistors and 21 diodes plus 2 tubes (picture and high voltage rectifier) combine to deliver performance and reliability unequalled by any conventional tube set. Other features include: MOSFET VHF tuner; high-gain 3-stage solid-state IF; emitter-follower output; automatic fine tuning; VHF power tuning; built-in degaussing plus manual degaussing coil; automatic chroma control; adjustable noise limiting and gated AGC; "instant-on" . . . sound instantly, picture in seconds; bonded-face, etched glass picture tubes; adjustable tone control; exclusive hi-fi outputs; and 48-hour factory service facility for modules. The sets are designed to be owner-serviced . . . the only sets on the market with this exclusive feature. A built-in dot generator, volt-ohm meter, and modular snap-out epoxy circuit boards make routine adjustments and service a snap . . . virtually eliminating service calls and offering significant savings over the life of the set. It all adds up to the color TV buy of a lifetime in the GR-270 and GR-370 . . . ready now for Christmas giving!

Kit **GR-270**, 227" 20V tube, 114 lbs. . . . . \$489.95\*  
 Kit **GR-370**, 295" 23V tube, 127 lbs. . . . . \$559.95\*  
 Kit **GR-370MX**, **GR-370** with RCA matrix tube, 127 lbs. . . . . \$569.95\*

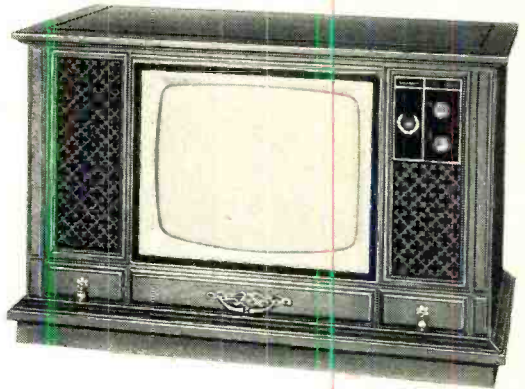

- Modular plug-in circuit board construction
- MOSFET VHF tuner and 3-stage IF
- Pushbutton channel advance
- Hi-fi sound outputs — for amplifier
- Designed for owner-servicing

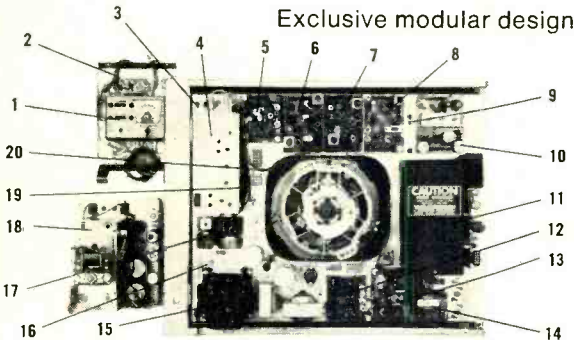

- Exclusive modular design**
- 1 Exclusive check-out meter
  - 2 Tilt-out convergence/secondary control panel
  - 3 Gun shorting switches
  - 4 3-stage IF assembly
  - 5 Plug-in AGC/Sync circuit board
  - 6 Plug-in 3.58 MHz oscillator circuit board
  - 7 Plug-in Chroma circuit board
  - 8 Plug-in Luminance circuit board
  - 9 Service and Dots switches
  - 10 Plug-in Video Output circuit board
  - 11 High voltage power supply
  - 12 Plug-in Vertical Oscillator circuit board
  - 13 Plug-in Horizontal Oscillator circuit board
  - 14 Plug-in Pincushion circuit board
  - 15 Conservatively-rated power supply components
  - 16 Circuit breaker protection
  - 17 Plug-in Sound circuit board
  - 18 Master control panel
  - 19 Hi-fi sound output
  - 20 Plug-in wiring harnesses and connectors for faster assembly

### Choice of factory-assembled cabinets

3 models in 295 sq. in.

**Luxurious Mediterranean Cabinet**...factory assembled of fine furniture grade hardwoods and finished in a flawless Mediterranean pecan. Stately bronze trim handle. 30<sup>1</sup>/<sub>2</sub>" H x 47" W x 17<sup>3</sup>/<sub>4</sub>" D. Assembled **GRA-304-23**, 78 lbs. . . . . \$129.95\*

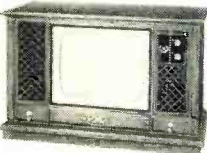

**Deluxe Early American Cabinet**...factory assembled of hardwoods & veneers and finished in classic Salem Maple. 29<sup>1</sup>/<sub>2</sub>" H x 37<sup>1</sup>/<sub>4</sub>" W x 19<sup>3</sup>/<sub>4</sub>" D. Assembled **GRA-303-23**, 73 lbs. . . . . \$114.95\*



**Contemporary Walnut Cabinet**...factory assembled of fine veneers & solids with an oil-rubbed walnut finish. 29<sup>1</sup>/<sub>2</sub>" H x 35<sup>1</sup>/<sub>2</sub>" W x 19<sup>3</sup>/<sub>4</sub>" D. Assembled **GRA-301-23**, 60 lbs. . . . . \$74.95\*



3 models in 227 sq. in.

**Exciting Mediterranean Cabinet**...assembled using fine furniture techniques and finished in stylish Mediterranean pecan. Accented with stately bronze handle. 27<sup>1</sup>/<sub>2</sub>" H x 41<sup>7</sup>/<sub>8</sub>" W x 19<sup>1</sup>/<sub>2</sub>" D. Assembled **GRA-202-20**, 85 lbs. . . . . \$114.95\*

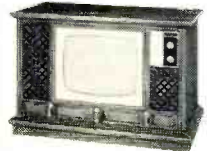

**Contemporary Walnut Cabinet and Base Combination**. Handsome walnut finished cabinet sits on a matching walnut base. Cabinet dimensions 20<sup>3</sup>/<sub>4</sub>" H x 31<sup>3</sup>/<sub>4</sub>" W x 18<sup>3</sup>/<sub>4</sub>" D. Base dimensions 7<sup>3</sup>/<sub>4</sub>" H x 27<sup>3</sup>/<sub>4</sub>" W x 18<sup>3</sup>/<sub>4</sub>" D. Assembled **GRA-203-20** Cabinet, 46 lbs. \$49.95\* **GRS-203-6** above cab. w/matching base. 59 lbs. . . . . \$59.95\*

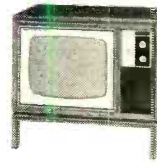

**Handy Roll-Around Cart and Cabinet Combination**. Features the **GRA-203-20** walnut cabinet plus a walnut-trimmed wheeled cart with storage shelf. Assembled **GRA-203-20** Cabinet, 46 lbs. \$49.95\* **GRA-204-20** Roll-Around Cart, 19 lbs. \$19.95\* **GRS-203-5** Cart & Cabinet Combo, 65 lbs. . . . . \$59.95\*

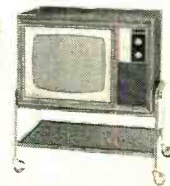



# for Christmas giving

## New Heathkit Electronic Oven

...only \$399.95\*

Now, through the miracle of microwave energy, a cooking revolution that frees you from conventional kitchen drudgery forever!

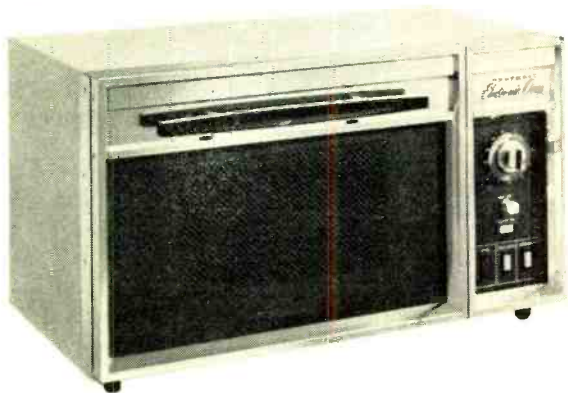

Imagine a baked potato in 4 minutes, baked beans in a little over 6 minutes, a five-pound roast in 45 minutes. This is the miracle of microwave cooking. And now Heath brings you this modern miracle for the first time in money-saving, easy-to-assemble kit form. For busy families on the go, meal preparation is a matter of minutes. You can cook on china, glass, or even paper dishes since only the food becomes hot. Your cooking dish can be your serving dish. Frozen foods can be defrosted in minutes for quick spur-of-the-moment frozen meals cooked right in their own containers. And there is not the slightest cause for concern about the safety of your Heathkit electronic oven. Exclusive door design prevents microwave leakage from the oven cavity. And with a SAFETY INTERLOCK SYSTEM UNIQUE IN THE INDUSTRY, not only does the oven stop cooking if the door is opened, but the door can't be opened unless the interlock is operating properly. A second independent door interlock is also provided for maximum protection. And all interlock mechanisms are tamperproof. Assembled in accordance with the

manual, the GD-29 meets all the new federal standards for safety and radio interference. No special precautions are required when operating. The Heathkit electronic oven is as safe as your conventional oven! Quality components are used throughout: magnetron tube by Litton, the uncontested leader in the field; avalanche diode circuitry for longer tube life; simplified wiring harness with push-on quick-connectors for reliability and ease of assembly. GD-29 prototypes endured grueling "life-tests" equivalent to over 60 years of continuous service...further assurance of uncompromised reliability. Another feature is portability: the Heathkit electronic oven operates on regular household current. Plug it in anywhere...on a countertop, a wheeled cart, in the kitchen, on the patio, at the cottage...anyplace a grounded 120V AC power outlet is available. Make this a Christmas to remember by putting a Heathkit electronic oven under the tree. It's a gift your wife will thrill to...and a present the whole family will enjoy...meal after meal after meal.

Kit GD-29, 80 lbs. .... \$399.95\*

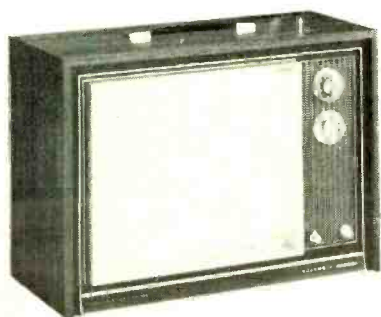

## New Heathkit portable solid-state color TV

- Big set performance, portable convenience
- MOSFET VHF tuner & 3-stage IF
- Modular, self-service design
- 102", 14 V picture tube



What do you do for an encore after you've created the solid-state GR-270 and GR-370 big-screen sets? Simple. Make them portable. That's virtually what's been done in the new Heathkit GR-169 solid-state portable color TV. Heath engineers took the same cool-running solid-state circuitry from the large screen chassis and packaged it in an easy-to-assemble compact chassis...with the same nine plug-in glass epoxy circuit board modules used in the big sets. In fact the only difference is the smaller preassembled horizontal deflection and high voltage power supply. The same MOSFET tuner and high gain 3-stage IF found in the big sets offer superlative color performance. And, as in the larger sets, complete owner-service features are provided by inclusion of built-in dot

generator and degaussing along with an exclusive volt-ohm check-out meter. 48-hour factory service facilities for modules are also provided with the GR-169. Other features include: built-in antennas and connections for external antennas; instant picture and sound; complete secondary controls available behind the hinged door on the front panel; high resolution circuitry for sharp, crisp pictures; adjustable noise limiting to keep external interference to a minimum. If you're looking for big set color fidelity and performance with portable convenience...put the new Heathkit GR-169 on your Christmas shopping list now!

Kit GR-169, 48 lbs. .... \$349.95\*

# New Heath-gift ideas... for



## New Heathkit® AJ-29 AM-FM-FM stereo tuner

This is the feature-packed tuner section of the famous Heathkit AR-29 stereo receiver... now available as a stereo "separate." The pre-assembled, factory-aligned FM tuner boasts 1.8 uV sensitivity for whopping station pulling power using FET design for superior overload characteristics. Three IC's in the IF section offer superior AM rejection, hard limiting, temperature stability, and outstanding reliability. Other features include a computer-designed 9-pole L-C filter for greater than 70 dB selectivity; new "blend" and "mute" functions; and a built-in AM rod antenna that swivels for best reception.

Kit **AJ-29**, 19 lbs., less cabinet ..... **\$169.95\***  
Assembled **AE-19**, oiled pecan cab., 9 lbs. .... **\$19.95\***

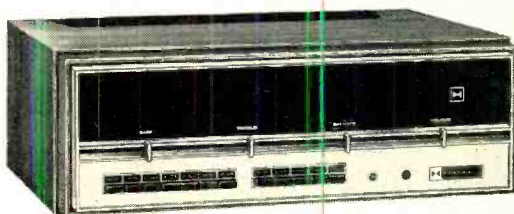

## New Heathkit® AA-29 100-watt stereo amplifier

Power-packed amplifier section of the Heathkit AR-29, the AA-29 stereo "separate" marks another milestone in superior Heathkit amplifier design. Its 70-watts of continuous power is more than enough to drive even the most inefficient speaker systems. A massive, fully-regulated and filtered power supply, 4 conservatively heat sunked output transistors and the best IM and harmonic distortion specifications in the industry add up to sound fidelity you never expected to hear outside the theater. Modular plug-in circuit boards make assembly easier... snap out in seconds for future servicing.

Kit **AA-29**, 27 lbs., less cabinet ..... **\$149.95\***  
Assembled **AE-19**, oiled pecan cab., 9 lbs. .... **\$19.95\***

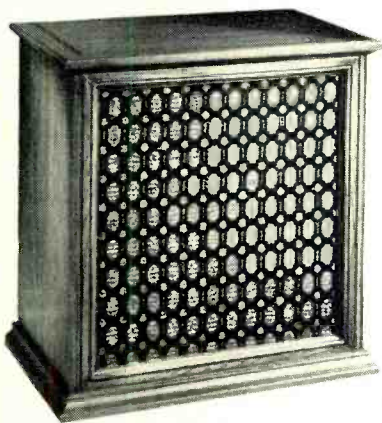

## New Heathkit® floor model speaker systems

In the new Heathkit AS-101 and AS-102 speaker systems, Heath engineers have combined the best of both worlds of sound and beauty. The AS-101 Heath/Altec-Lansing 2-way system features a 15" woofer and sectoral horn delivering from 35 to 22,000 Hz with uncompromising accuracy. The AS-102 Heath/Bozak 3-way system uses a 12" woofer, 6" mid-range, and two 2 1/2" tweeters in an infinite baffle design to produce clean natural reproduction from 40 to 20,000 Hz. Both systems are housed in assembled Mediterranean pecan cabinets. 29 3/8" H x 27 3/4" W x 19 7/8" D.

Kit **AS-101**, 53 lbs. .... **\$259.95\***  
Kit **AS-102**, 39 lbs. .... **\$259.95\***

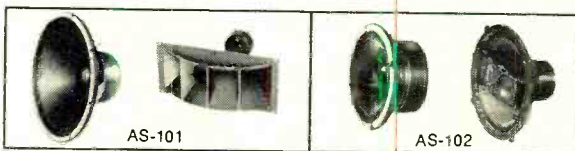

## New Heath stereo equipment credenza

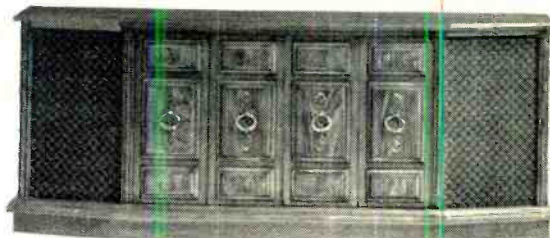

Romantic Mediterranean styling in wife-pleasing one-piece console design... yet with plenty of room for your favorite separate stereo components. Six-and-a-half feet of solid craftsmanship executed in North American Hickory veneers and solid oak trim, finished in oiled pecan. Completely assembled and finished, ready for installation of Heath or other components. Speaker enclosures

are ducted port reflex design, pre-cut for 12" speakers. An adjustable shelf has room for stereo receiver, cartridge or cassette tape player or separate tuner and amplifier. Below the shelf is room for your turntable and record storage. Accessory matching drawers on ball bearing slides are available for turntable and tape player.

Model **AE-101**, 90 lbs. .... **\$189.95\***

# home, shop and ham shack

## New Heathkit® IC 15 MHz frequency counter...199.95\*

A highly accurate, low cost frequency meter for anyone requiring accurate frequency measurements. Compare these features to counters selling for over twice this low price: accurate counting, 1 Hz to over 15 MHz; integrated circuitry; automatic trigger level for wide range input without adjustment; five digit readout with Hz/kHz ranges and overrange indicators for eight digit capability; high input impedance; storage circuitry for non-blinking, no-count-up readout; computer-type circuitry, no divider chain adjustment; temperature-compensated crystal time base oscillator; BNC input with cable; double-sided, plated-thru circuit board with sockets; three-wire, removable line cord; heavy-duty aluminum case handle/tilt stand and die cast zinc front panel; no special instruments required for accurate calibration.

Kit **IB-101**, 7 lbs. .... \$199.95\*



**IB-101 SPECIFICATIONS:** Frequency Range: 1 Hz to greater than 15 MHz. Accuracy:  $\pm 1$  count = time base stability. Gate Times: 1 millisecond or 1 second with automatic reset. Input Characteristics: Sensitivity: 1 Hz to 1 MHz, less than 100 mV rms; 1 MHz to 15 MHz, less than 250 mV rms. After 30 minutes warmup. Trigger Level: Automatic. Impedance: 1 Meg ohm shunted by less than 20 pF. Maximum Input: 200 V rms, DC-1 kHz. Derate at 48 V per frequency decade. TIME BASE: Frequency: 1 MHz, crystal controlled. Aging Rate: Less than 1 PPM/month after 30 days. Temperature: Less than  $\pm 2$  parts in  $10^7$ /degree C. 20 to 35 degrees C after 30 minutes warmup.  $\pm 0.02\%$  from 0 to 50 degrees C. GENERAL: Readout: 5 digits plus overrange. Temperature Range: Storage: -55 to 80 degrees C. Operating: 0 to 50 degrees C. Power Requirements: 105-125 or 210-250 VAC, 50/60 Hz, 8 watts. Cabinet Dimensions: 3 3/4" W x 3 3/4" H x 9" D not including handle. Net Weight: 4 1/2 lbs.

See these and 300 other  
Heath-gift suggestions at one of the  
following Heathkit Electronic Centers:

**Anaheim, Calif. 92805**  
330 E. Ball Road

**Boston Area**  
Wellesley, Mass. 02181  
165 Worcester St.

**Chicago, Illinois 60645**  
3462-66 W. Devon Ave.

**Chicago Area**  
Downers Grove, Ill. 60515  
224 Ogden Avenue

**Cleveland, Ohio 44129**  
5444 Pearl Road

**Dallas, Texas 75201**  
2715 Ross Avenue

**Denver, Colorado 80212**  
5940 W. 38th Ave.

**Detroit, Michigan 48219**  
18645 W. 8 Mile Road

**Fair Lawn, N. J. 07410**  
35-07 Broadway (Rt. 4)

**Houston, Texas 77027**  
3705 Westheimer

**Los Angeles, Calif. 90007**  
2309 S. Flower St.

**Milwaukee, Wisc. 53216**  
5215 W. Fond du Lac

**Minneapolis Area**  
Hopkins, Minn. 55343  
101 Shady Oak Road

**New York, N.Y. 10036**  
35 W. 45th Street

**Philadelphia, Pa. 19149**  
6318 Roosevelt Blvd.

**Pittsburgh, Pa. 15235**  
3482 William Penn Highway

**St. Louis, Mo. 63123**  
9296 Gravois Ave.

**San Diego Area**  
LaMesa, Calif. 92041  
8363 Center Drive

**San Francisco Area**  
Redwood City, Calif. 94063  
2001 Middlefield Road

**Seattle, Wash. 98121**  
2221 Third Avenue

**Washington, D. C. Area**  
Rockville, Md. 20852  
5542 Nicholson Lane

**Los Angeles Area**  
Woodland Hills, California  
Atlanta, Georgia

Prices listed are factory mail order.  
Retail prices are slightly higher.

During 1971, consult Heathkit Catalog Supplements and local newspapers for announcements of new Heathkit Electronic Centers opening in these places:

**Long Island Area**  
Westbury, New York  
Miami, Florida

**San Francisco Area**  
El Cerrito, California  
Cincinnati, Ohio

... or send for your FREE  
factory mail order catalog

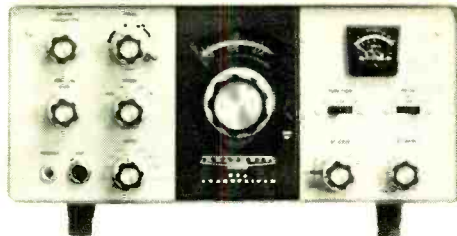

## New Heathkit® HW-101 SSB transceiver

The Hams at Heath have done it again... with an updated version of the Heathkit HW-100, one of the most popular pieces of ham gear on the market! The HW-101 features improved receiver circuitry resulting in better than 0.35 uV sensitivity for 10 dB S+N/N. Image and IF rejection are better than 50 dB. Other improvements are a new 36-to-1 ball-bearing dial drive; new selectable SSB or CW filters and attractive new front-panel styling.

Kit **HW-101**, 23 lbs. .... \$249.95\*

## New Heathkit wattmeter/SWR bridge

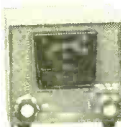

Two switch-selected ranges allow measurement of RF output from 10-200 W and 100-2000 W. Built-in calibrator permits 10% accuracy throughout the 80-10 M ham bands.

Kit **HM-102**, 3 lbs. .... \$29.95\*

HEATH COMPANY, Dept. 10-12  
Benton Harbor, Michigan 49022  
a Schlumberger Company

Enclosed is \$ \_\_\_\_\_, plus shipping.

Please send model (s) \_\_\_\_\_

Please send FREE Heathkit Catalog.     Please send Credit Application.

Name \_\_\_\_\_

Address \_\_\_\_\_

City \_\_\_\_\_ State \_\_\_\_\_ Zip \_\_\_\_\_

\*Mail order Prices: F.O.B. factory.  
Prices & specifications subject to change without notice. CL-394R

CIRCLE NO. 14 ON READER SERVICE PAGE



**Telex writes  
tough  
new specs**



**on sensitivity and  
ruggedness in  
headphones.**

### Communications Series 1320

**HIGH SENSITIVITY AND LOW OPERATING POWER.** Communications Series 1320 headphones are designed around a dramatic new driver that requires only minimal operating power. This added efficiency makes the 1320 Series the most sensitive and versatile headphones available today.

**RUGGED, CONSISTENT PERFORMANCE.** The 1320's rugged new cone provides peak performance without being affected by temperature or humidity. You get consistent, high quality performance, day in and day out, under the most demanding communications conditions. Contact your nearest Telex dealer or write.



PRODUCTS OF SOUND RESEARCH  
**TELEX**<sup>®</sup>  
COMMUNICATIONS DIVISION  
9600 Aldrich Avenue South  
Minneapolis, Minnesota 55420

**CIRCLE NO. 26 ON READER SERVICE PAGE**



To obtain a copy of any of the catalogs or leaflets described below, fill in and mail the Reader Service blank on page 15 or 95.

Available on request to Canadians from *Gladstone Electronic Supply Co.*, 1736 Avenue Rd., Toronto 12, Canada, is a 112-page electronic parts and equipment catalog. In addition to an extensive listing of basic electronic components (capacitors, resistors, etc.), Catalog No. 6 also features such consumer items as hi-fi systems, tape recorders and players, TV receivers, shortwave receivers, and electronic test equipment. Among the brand-name items represented are Garrard, Kenwood, EICO, Electro-Voice, BSR, McDonald, Shure, and Mallory. Technical descriptions and prices are given for all items listed.

Circle No. 74 on Reader Service Page 15 or 95

Described and illustrated in a 16-page, four-color brochure (No. P/N 11-1247) obtainable from *Koss Electronics, Inc.*, is the company's entire line of dynamic and electrostatic headphones. The brochure devotes a section to explaining the sound of headphone listening and how it is achieved, including cutaway illustrations and line drawings to support the text explanations. Another section lists and describes such accessories as a connector box, connector plate, adapter cables, extension cord, and chairside and remote listening stations that add versatility to the stereophones.

Circle No. 75 on Reader Service Page 15 or 95

*Alco Electronic Products, Inc.*, has just released three catalogs that describe the company's line of "Elfin" neon display devices and associated hybrid decoder/drivers; Alco-Display incandescent readouts; and Alco-Lite miniature indicator lamps and assemblies. The cold-cathode indicators in the Elfin line are described in detail with specifications, ratings, and physical dimensions given. The incandescent readouts include five families of miniature single-plane numeric and symbol indicators. Decoder/drivers with memory or counter are described for each family. The "Brite Glo" panel lamps listed range from lamps with 10" leads to lamps with metal bases. There are also miniature transistorized neon lights that operate from a low-voltage supply source.

Circle No. 76 on Reader Service Page 15 or 95

# Popular Electronics

## READER SERVICE PAGE

### free information service:

Here's an easy and convenient way for you to get additional information about products advertised or mentioned editorially (if it has a "Reader Service Number") in this issue. Just follow the directions below... and the material will be sent to you promptly and free of charge.

**1.** On coupon below, circle the number(s) that corresponds to the key number(s) at the bottom or next to the advertisement or editorial mention that is of interest to you. (Key numbers for advertised products also appear in the Advertisers' Index.) Print or type your name and address on the lines indicated.

**2.** Cut out the coupon and mail it to: POPULAR ELECTRONICS, P.O. Box 8391, Philadelphia, PA 19101.

**note:** If you want to write to the editors of POPULAR ELECTRONICS about an article on any subject that does not have a key number, write to POPULAR ELECTRONICS, One Park Avenue, New York, N.Y. 10016. Inquiries concerning circulation and subscriptions should be sent to POPULAR ELECTRONICS, P.O. Box 1096, Flushing, N.Y. 11352.

Void after January 31, 1971

# Popular Electronics

P.C. BOX 8391  
PHILADELPHIA, PA. 19101

1 2 3 4 5 6 7 8 9 10 11 12 13 14 15 16 17 18 19 20  
21 22 23 24 25 26 27 28 29 30 31 32 33 34 35 36 37 38 39 40  
41 42 43 44 45 46 47 48 49 50 51 52 53 54 55 56 57 58 59 60  
61 62 63 64 65 66 67 68 69 70 71 72 73 74 75 76 77 78 79 80  
81 82 83 84 85 86 87 88 89 90 91 92 93 94 95 96 97 98 99 100

NAME (Print clearly) \_\_\_\_\_

ADDRESS \_\_\_\_\_

CITY \_\_\_\_\_ STATE \_\_\_\_\_ ZIP CODE \_\_\_\_\_

12 Na

# Every record you buy is one more reason to own a Dual.

If you think of your total investment in records — which may be hundreds or even thousands of dollars — we think you'll agree that those records should be handled with the utmost care.

Which brings us to the turntable, the component that handles those precious records. Spinning them on a platter and tracking their fragile grooves with a diamond stylus, the hardest substance known to man.

For many years, serious music lovers have entrusted their records to one make of automatic turntable — Dual. In fact, most professionals (who have access to any equipment) use a Dual in their own stereo component systems. And not always the highest priced mode.

So the question for you to consider isn't which Dual is good enough, but how much more than "good" your turntable has to be.

This question can be answered in our literature, which includes complete reprints of independent test reports. Or at any of our franchised dealers.

United Audio Products, Inc.,  
120 So. Columbus Ave., Mt. Vernon,  
New York 10553. 



Dual 1209, \$129.50.  
Other models from \$99.50 to \$175.00.

CIRCLE NO. 28 ON READER SERVICE PAGE



## THE VERSATILE OP AMP

by Michael Kahn

This practical textbook covers the fundamentals and significant applications of the operational amplifier. Explanations are fully detailed and accompanied by numerous worked-out problems. The first half of the book discusses the fundamentals of amplification and deals with the amplifier on a "black box" or module basis. The basic concepts pertinent to amplifiers are all covered, but here they are applied specifically to an amplifier which is manufactured in a single package. Review questions are given at the end of each chapter, and an answer key for odd-numbered questions is provided in the rear of the book.

Published by Holt, Rinehart and Winston, Inc., 383 Madison Ave., New York, NY 10017. Hard cover. 227 pages. \$10.

## HANDBOOK OF ELECTRONIC CHARTS, GRAPHS AND TABLES

by John D. Lenk

Here is a convenient and comprehensive guide to quick, accurate answers to the most important calculations employed in modern electronics. Many valuable graphs link the theoretical and practical aspects of electronics; and instant answers to the most frequently encountered problems are given. Most notable are the graphs that handily convert rectangular to polar coordinates for impedance and related calculations, Smith charts for microwave calculations, and many others used in circuit design and parametric determinations.

Published by Prentice-Hall, Inc., Englewood Cliffs, NJ 07632. Hard cover. 224 pages. \$10.95.

## INTRODUCTION TO SWITCHING CIRCUIT THEORY

by Donald D. Givone

In this book, the author attempts to find a medium between the extremes of considering switching circuit theory as a set of logic design procedures and that of considering it as a purely mathematical study. To attain this goal, the two extremes are integrated. The fundamental math principles for switching circuit theory are given first; then the mechanics of logic design are presented as a direct consequence of theory. Since this book is designed to be used in a first course

(Continued on page 99)

POPULAR ELECTRONICS



Join the listening majorities—give Regency

# 7 out of 8 Channel Santas Recommend

  
*Regency*

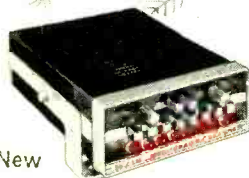

New



**TMR-8H/L—Monitoradio/Scanner**  
Two bands in one gift box  
Automatically receives any combination of  
8 hi or lo channels \$169.00

**TMR-8—Monitoradio/Scanner**  
Automatic 8 channel VHF listener with  
push button program cont ol  
148-174 MHz or 30-50 MHz \$139.00



**TMR-8U—Monitoradio/Scanner**  
Push button controlled  
Listening for the intricate UHF Band  
450-470 MHz \$159.00



**TMR-1—Single Channel Monitoradio**  
for your choice of bands  
148-174 MHz or 30-50 MHz \$99.75-  
450-470 MHz \$119.00



New

New

**TMR-8A—Monitoradio/Scanner**  
Automatic monitoradio of 8 Aircraft  
radio channels—from jumbo jet to  
tiny cub \$149.00

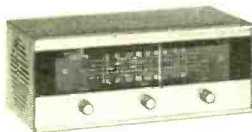

**MR-10—The VHF/FM receiver that**  
made emergency broadcast signal  
listening famous \$84.95

New

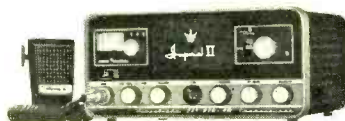

**Imperial II—The Citizens Radio Ultimate**  
Your choice of Sideband or AM in our  
do-it-all package \$359.00

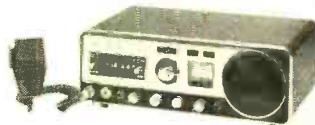

**Formula 23—your formula for better**  
less experience base citizen's radio on  
all 23 channels—only \$189.00

  
*Regency* **ELECTRONICS, INC.**  
7900 Pendleton Pike Indianapolis, Indiana 46226

December, 1970

**CIRCLE NO. 23 ON READER SERVICE PAGE**

17

**“Get more  
education  
or  
get out of  
electronics  
...that’s my advice.”**



**IN-DEPTH  
COVERAGE OF  
SOLID STATE  
ELECTRONICS  
...including  
integrated circuits!**



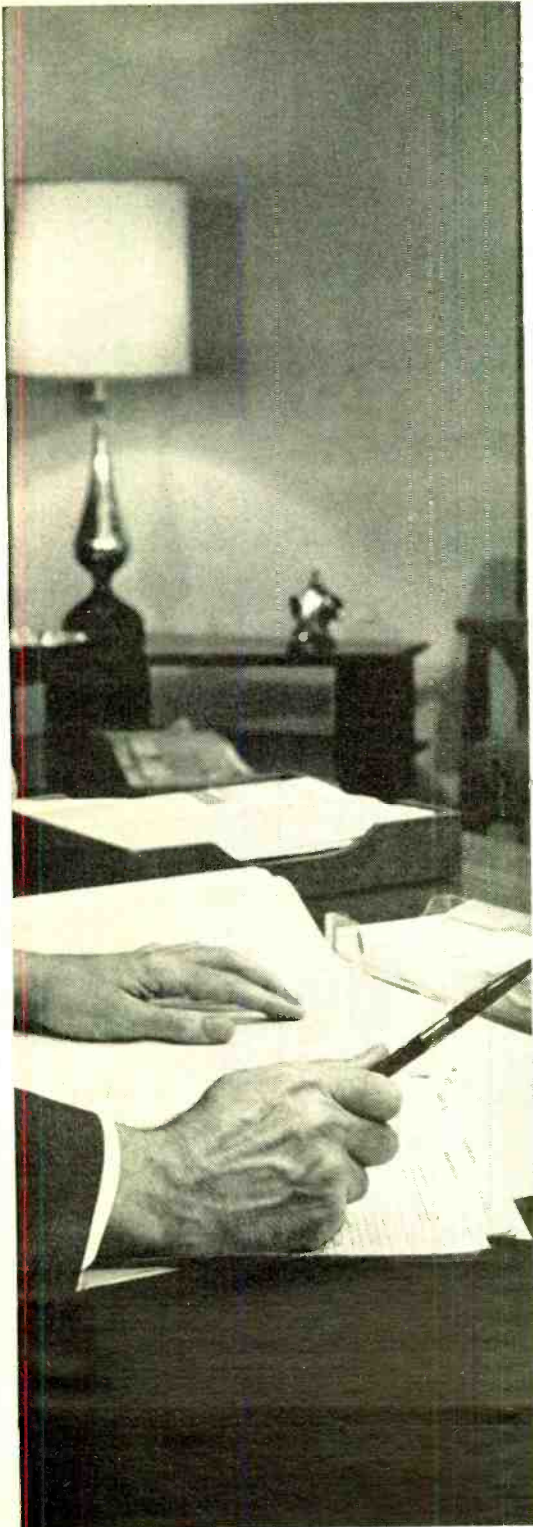

**Ask any man who really knows the electronics industry.**

Opportunities are few for men without advanced technical education. If you stay on that level, you'll never make much money. And you'll be among the first to go in a layoff.

But, if you supplement your experience with more education in electronics, you can become a specialist. You'll enjoy good income and excellent security. You won't have to worry about automation or advances in technology putting you out of a job.

How can you get the additional education you must have to protect your future—and the future of those who depend on you? Going back to school isn't easy for a man with a job and family obligations.

CREI Home Study Programs offer you a practical way to get more education without going back to school. You study at home, at your own pace, on your own schedule. And you study with the assurance that what you learn can be applied on the job immediately to make you worth more money to your employer.

You're eligible for a CREI Program if you work in electronics and have a high school education. Our FREE book gives complete information. Mail postpaid card for your copy. If card is detached, use coupon below or write: CREI, Dept. 1212A, 3224 Sixteenth Street, N.W., Washington, D.C. 20010.

Founded 1927



Accredited Member of the National Home Study Council



**CREI, Home Study Division  
McGraw-Hill Book Company  
Dept. 1212A, 3224 Sixteenth Street, N.W.  
Washington, D.C. 20010**

Please mail me FREE book describing CREI Programs. I am employed in electronics and have a high school education.

NAME \_\_\_\_\_ AGE \_\_\_\_\_

ADDRESS \_\_\_\_\_

CITY \_\_\_\_\_ STATE \_\_\_\_\_ ZIP CODE \_\_\_\_\_

EMPLOYED BY \_\_\_\_\_

TYPE OF PRESENT WORK \_\_\_\_\_  G.I. BILL

I am interested in

Electronic Engineering Technology  Computers

Space Electronics  Nuclear Engineering Technology

Industrial Automation  NEW! Electronics Systems Engineering

**APPROVED FOR TRAINING UNDER NEW G.I. BILL**



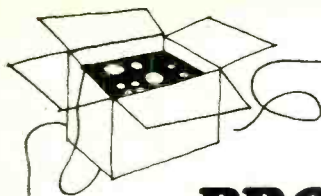

# NEW PRODUCTS

Additional information on products described in this section is available from the manufacturers. Each new product is identified by a corresponding number on the Reader Service Page. To obtain additional information on any of them, circle the number on the Reader Service Page, fill in your name and address, and mail it in accordance with the instructions.

**GENERAL RADIO STROBOSCOPE**—Trouble-shooting your car's or boat's engine is made easier and cheaper with a new low-cost 1542 Strobomite electronic stroboscope from *General Radio Co.* The 1542 provides bright white-light xenon flashes from 180 to 3780 flashes per minute in a single range with constant image illumination at any flash rate. Flash duration can be as short as five millionths of a second and beam angle is  $40^\circ$  at the half-intensity points. Setting the flash rate to coincide with the machine motion provides a "stopped" image while the equipment is working; a slight variation in strobe flash rate permits slow-motion analysis of the machine.

Circle No. 77 on Reader Service Page 15 or 95

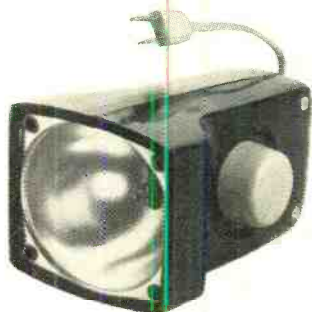

**KNIGHT-KIT STEREO RECEIVER**—Factory-built features are now available in a kit. It's *Allied Radio Shack's* Knight-Kit Model KG-996, 240-watt stereo FM-AM receiver. With a FET front end providing 2 microvolts sensitivity and integrated circuits in the i-f stage, the receiver has a rated response of 20-30,000 Hz  $\pm 1$  dB. Stereo separation is over 30 dB and signal-to-noise ratio is 50 dB. Assembly is simplified by modular construction and critical adjustments have been made at factory.

Circle No. 78 on Reader Service Page 15 or 95

**ELECTRA AIRCRAFT SCANNER**—Bearcat Model BCA, made by *Electra Corp.*, covers both ground and air communications in the 118-136-MHz range. The scanner stops for any communication and then continues the signal search when the transmission ends. Rated sensitivity of one microvolt is achieved over any 10-MHz spread within the range. Channel switches permit selection of only those frequencies of greatest interest.

Circle No. 79 on Reader Service Page 15 or 95



**MARANTZ STEREO AMPLIFIER**—A new entry for *Marantz Co.* in the stereo field is an integrated amplifier/pre-amplifier Model 30. The amplifier delivers 120 watts rms at 8 ohms with both channels driven at, or below, rated distortion of 0.15% at any audible frequency. A "variable overlap drive circuit" eliminates crossover notch distortion frequency found in solid-state amplifiers. A time-delay circuit eliminates turn-on and turn-off noise.

Circle No. 80 on Reader Service Page 15 or 95

**SONIC FREQUENCY COMPENSATOR**—The SONEX 100, made by *Sonic Research Co., Inc.*, compensates (in play-

back systems) for the frequencies reduced during re-cording and reproduction. Lows and highs are boosted while midrange frequencies are unaffected. Frequency response with controls set flat is 20 Hz to 30 kHz  $\pm$  1 dB. Four frequency controls are continuously variable. As an example, the high treble boost is a maximum of 13 dB at 20 kHz. Total hum and noise is better than 75 dB below rated output of 2 volts.

Circle No. 81 on Reader Service Page 15 or 95



**BOMAN FM CONVERTER**—Conversion of an automobile radio from AM to FM is made simpler with the *Boman Astrosonix* Model AT-6000 which is small enough to fit under most any dashboard. The 4" x 1 1/8" x 5 7/8" unit uses eight transistors and requires a 12-volt negative ground supply. It has an illuminated dial and comes complete with mounting hardware.

Circle No. 82 on Reader Service Page 15 or 95

**REGENCY 2-METER TRANSCEIVER**—Growing interest in the amateur band of 144-148 MHz for personal and civil defense applications has prompted the introduction by *Regency Electronics, Inc.*, of a mobile 10-watt FM transceiver for the band. Operation can be on any of 6 transmit and receive channels in the band, while a simple modification permits operation on any of 12 duplex combinations. Receiver is double-conversion with ceramic filter for operation on wide- and narrow-band signals.

Circle No. 83 on Reader Service Page 15 or 95



**SONAR LOW-BAND TRANSCEIVER**—Two-way communications in the business band of 32-50 MHz will get a boost from the new *Sonar Radio Co.* Model 2303A transceiver. For police and fire departments and other public services, the all solid-state unit has an output power of 1.6 watts, separate transmit and receiver channels, squelch, and external connections for antenna, earphone, and battery charger. It is supplied with crystals for either the 32-41-MHz or 42-50-MHz band.

Circle No. 84 on Reader Service Page 15 or 95

**ALTEC WIDE-RANGE AUTOMOBILE SPEAKER**—Motorists who aren't happy with the sound they get from FM radios or cassettes in their cars because of poor speaker sound will welcome the *Altec Lansing* Model 405A Dia-Cone speaker. The 4-in., 8-ohm unit has a frequency range of 60 to 15,000 Hz and will handle 10 watts. The cone is water resistant and the thin profile allows for shallow mounting.

Circle No. 85 on Reader Service Page 15 or 95

**LAFAYETTE 8-TRACK STEREO TAPE DECK**—The Model RK-890 stereo 8-track cartridge recorder/player tape deck from *Lafayette Radio Electronics Corp.* is all solid-state with 13 transistors and 12 diodes and built-in pre-amplifiers. An exclusive automatic cartridge ejector operates when unit is turned off to protect tape heads and cartridge rollers. Frequency range is from 30 Hz to 12 kHz with wow and flutter less than 0.3% and channel separation more than 40 dB.

Circle No. 86 on Reader Service Page 15 or 95



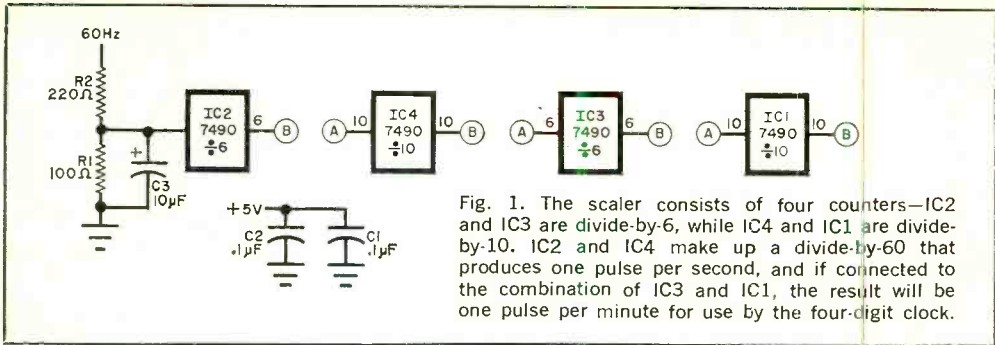

Fig. 1. The scaler consists of four counters—IC2 and IC3 are divide-by-6, while IC4 and IC1 are divide-by-10. IC2 and IC4 make up a divide-by-60 that produces one pulse per second, and if connected to the combination of IC3 and IC1, the result will be one pulse per minute for use by the four-digit clock.

The use of small printed circuit boards in the Digi-Vista keeps the size to a minimum and permits the builder to use almost any type of enclosure for the finished clock.

The basic circuit for the clocks contains a scaler to generate the required timing information; a power supply; a combination of conventional Nixie® decade counters (see "All-Purpose Nixie Readout," POPULAR ELECTRONICS, November 1968); a modulo-6 Nixie counter to indicate to 5 and then reset; and a "ten's" board to supply the "1" for the hours from 10:00 to 12:59. The latter board also includes the a.m./p.m. indicator.

As shown in the block diagram in Fig. 1, the scaler uses the 60-Hz reference to drive a divide-by-6 counter (IC2). The other three IC's in the scaler can be interconnected to divide-by-60 (divide-by-6 in series with a divide-by-10) to generate only one pulse per second for the six-digit clock or to divide-by-3600 (divide-by-60 in series with a divide-by-60) to produce one pulse per minute for the four-digit clock. As an example of how this works, if the B6 output of IC2 is coupled to the A10 input of IC4, then the B10 output of IC4 is one pulse per second. If the B10 output of IC4 is coupled to the A6 input of IC3 and the B6 output of IC3 to the A10 input of IC1, then the B10 output of IC1 is one pulse per minute.

In either case, the same foil pattern (Fig. 2) is used for the scaler board. Figure 2 also shows the component and jumper installation on the top of the board. The three capacitors, two resistors, and jumper are used in both versions. If you are assembling the four-digit clock, install only IC2 and IC4, taking care to observe the notch and dot code on the IC's. If you are making the six-digit version, install all four IC's. Use fine solder and a low-power soldering iron. After construction, inspect the board for clean soldering and make sure there are no solder bridges between foil sections.

**Power Supply.** The power supply, whose schematic is shown in Fig. 3, can be built on a piece of perf board (except for the transformer which is mounted on the chassis) or you can fabricate a PC board. A heat sink should be used for Q2.

**Readouts.** Two types of Nixie readouts are used in the clock: a modulo-10 that indicates from 0 to 9 and then resets to 0, and a modulo-6 that indicates from 0 to 5 and then resets to 0. The two types are required to dis-

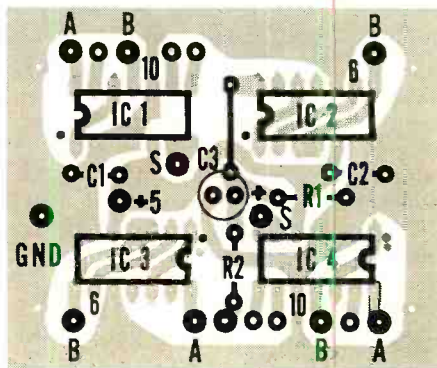
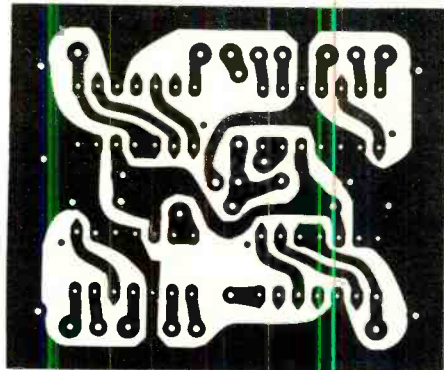

Fig. 2. Actual size foil pattern is shown above and component installation for the scaler below.



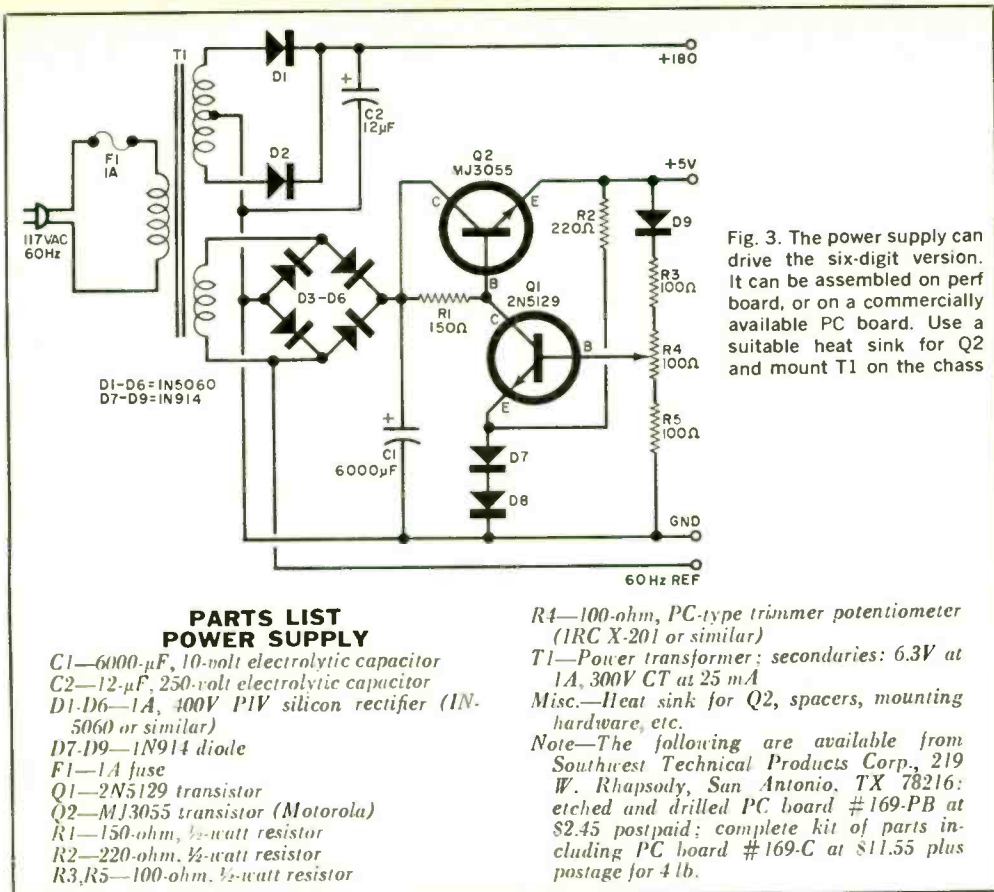

Fig. 3. The power supply can drive the six-digit version. It can be assembled on perf board, or on a commercially available PC board. Use a suitable heat sink for Q2 and mount T1 on the chassis

play such values as 59 seconds or minutes. The modulo-10 readout is identical to that described in the November 1968 **POPULAR ELECTRONICS**, referred to above. The modulo-6 is the same except for some minor circuit changes which are shown in the foil pattern in Fig. 4.

For the unit hours readout, the indicator must progress from 0 to 9, through 0.1, and 2 and then back to 1 to pick up the count. In this way, the indicators can display 9:00,

10:00, 11:00, 12:00, and 1:00. To achieve this effect, you have to alter the wiring of the Nixie tube to the unit hour board so that the tube indicates ahead two digits. That is, the Nixie "2" should be connected to the "0" terminal of the board, with "3" on the "1", "4" on the "2", and so forth up the decade. When the unit hours board is so modified and properly connected to the tens counter board, the clock will indicate 12:59; and at the next pulse, 1:00.

Fig. 4. Foil pattern for the modulo-6 stage. Component and jumper installation are the same as those shown for the decade counter in the November, 1968 issue.

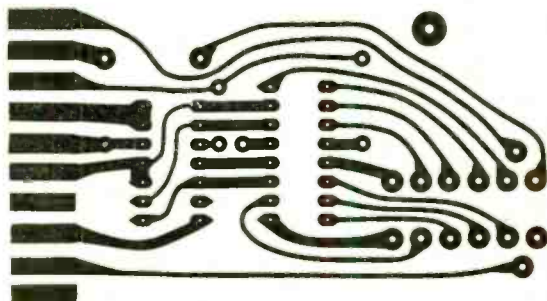

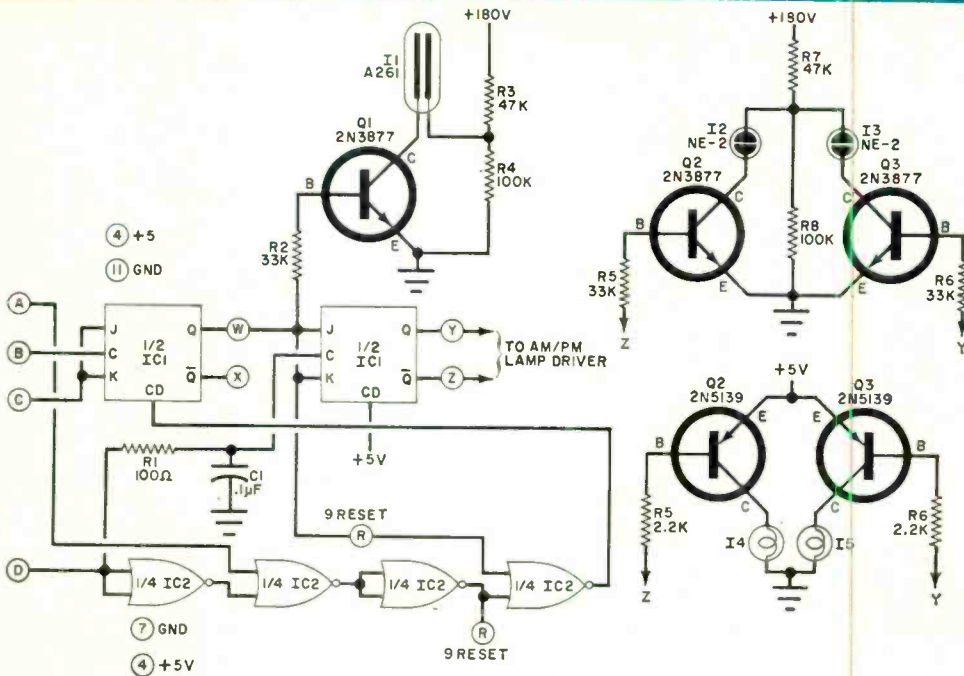

### PARTS LIST TENS COUNTER

*C1*—0.1- $\mu$ F, 12-volt disc capacitor  
*I1*—Neon lamp (Signalite A-261 or similar)  
*IC1*—7473 dual flip-flop  
*IC2*—7400 quad two-input gate  
*Q1*—2N3877 transistor  
*R1*—100-ohm,  $\frac{1}{2}$ -watt resistor  
*R2*—33,000-ohm,  $\frac{1}{2}$ -watt resistor  
*R3*—47,000-ohm,  $\frac{1}{2}$ -watt resistor  
*R4*—100,000-ohm,  $\frac{1}{2}$ -watt resistor

### For neon a.m./p.m. indicators

*I2, I3*—NE-2 neon lamp  
*Q2, Q3*—2N3877 transistor  
*R5, R6*—33,000-ohm,  $\frac{1}{2}$ -watt resistor  
*R7*—47,000-ohm,  $\frac{1}{2}$ -watt resistor  
*R8*—100,000-ohm,  $\frac{1}{2}$ -watt resistor

### For incandescent a.m./p.m. indicators

*I4, I5*—6-volt, 50-mA miniature incandescent lamp  
*Q2, Q3*—2N5139 transistor  
*R5, R6*—2200-ohm,  $\frac{1}{2}$ -watt resistor  
 Misc.—Plastic covers for two lamps, mounting hardware, etc.

Fig. 5. The ten's counter accepts inputs from the unit hours board, and turns on the "1" neon lamp (I1) at the correct pulse. It also generates the correct reset pulse for the unit hours board. The constructor is given the option of using neon or incandescent lamps for the a.m./p.m. indicators.

The circuit for the tens-of-hours lamp and the a.m./p.m. indicator is shown in Fig. 5. Note that either of two types of indicator can be used for the a.m./p.m. function—neon lamps or conventional incandescent lamps. The foil pattern for this board, shown in Fig. 6, has provisions for the options. For neon indicators, omit the jumper at *J1* and install jumpers at *I4* and *I5*. For incandescent indicators, install jumpers at *J1*, *I2*, and *I3*.

**Assembly.** The overall schematic of the four-digit clock is shown in Fig. 7.

The prototype shown in the photographs was constructed in a conventional two-piece metal chassis with cutouts for the readouts.

The cutout is covered with a piece of polarized plastic to reduce the glare and improve legibility. The a.m./p.m. indicator lamps are mounted in snugly fitting plastic holders with the letters marked or press-typed on the front window.

The power transformer and fuseholder are mounted on the bottom of the chassis with the PC boards mounted on spacers. In the prototype, the sealer and power supply were mounted horizontally, readouts vertically.

Each PC board should have its ground return and +5-volt supply connections made with individual leads to the power supply. Do not use the chassis as a common ground return.

Fig. 6. Foil pattern and component installation for ten's counter board. Note that provisions are made for either neon or incandescent lamp indicators. Text explains where to connect required jumpers.

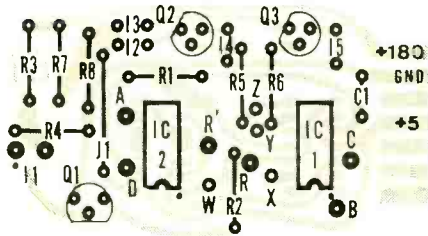
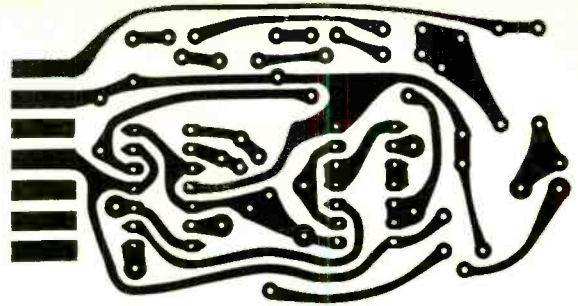

Note that the usual carry-to-input series circuit is used between the DCU's except for the connections between the unit hours board and the tens of hours board. In this case, the A, B, C, and D logic line of IC1 (decade counter SN7490) of the unit hours DCU (pins 12, 9, 8, and 11 respectively) are connected to the A, B, C, and D inputs of the tens of hours board.

The +180-volt line to the Nixie tubes should be very carefully installed as this voltage can damage components if wrong connections or shorts occur.

**Operation.** Plug the power line into a 117-volt 60-Hz outlet and note that the Nixies come on and either the a.m. or p.m. lamp is glowing. Adjust *R1* of the power supply so that the 5-volt supply is correct. Place the SET-RUN switch on SET and depress the FAST button. The minutes readouts in either clock will start to cycle and at 11:59, the a.m. and p.m. indicators will switch over. Cycle the clock through a 24-hour period to clear all of the counter units. With the SET-RUN switch on RUN, use the FAST button to bring the clock to within a few seconds of the actual time,

The original clock was built in a conventional metal chassis having a cutout for the readouts, and the operating controls on front panel. Any other type of mounting may be used, and controls hidden; once set, they are not needed for clock.

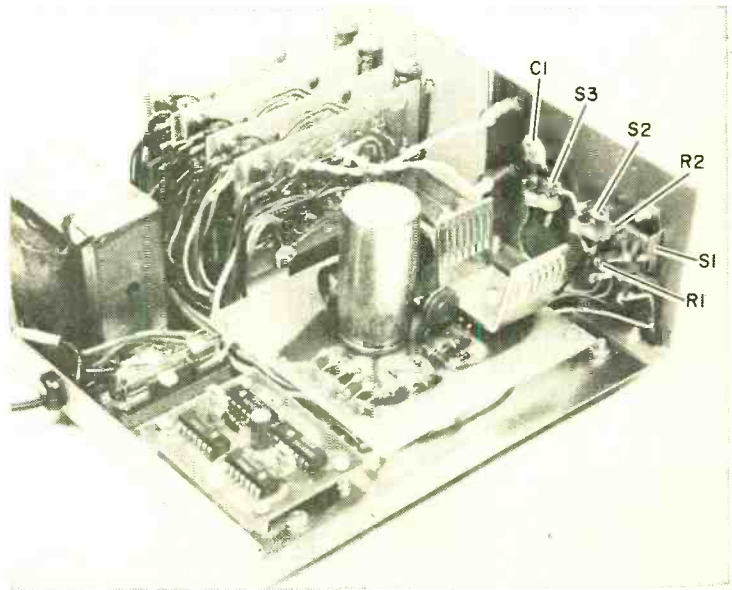



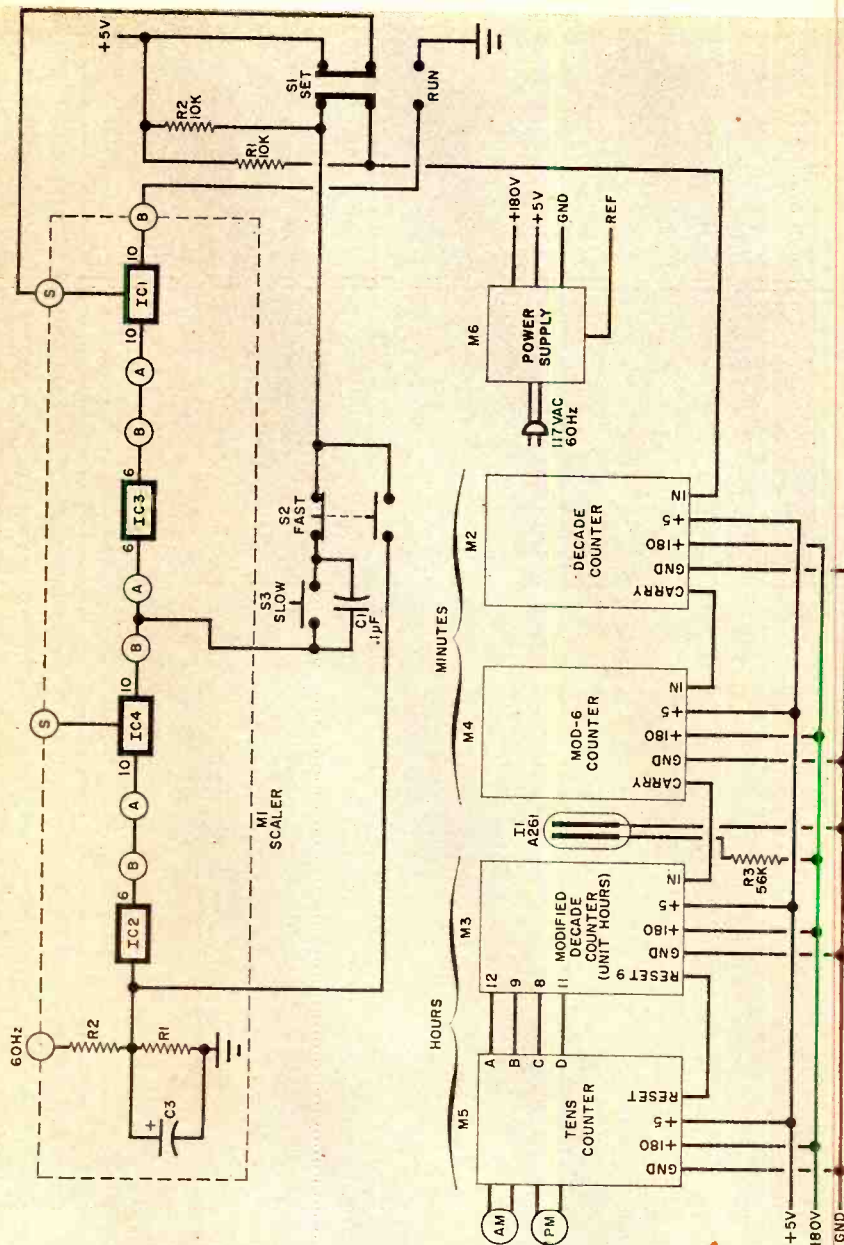

### PARTS LIST FOUR-DIGIT CLOCK

- C1—0.1- $\mu$ F capacitor
  - I1—Neon lamp (optional) (Signalite A-261 or similar)
  - M1—Scaler module
  - M2, M3—Decade counter module
  - M4—Modulo-6 counter module
  - M5—Tens counter module
  - M6—Power supply module
  - Misc.—Suitable chassis, polarized plastic glare shield, spacers, mounting brackets, hookup wire, etc.
- Note—The following are available from

Southwest Technical Products Corp., 219 W. Rhapsody, San Antonio, TX 78216: decade counter module NX-10 at \$15, postpaid; modulo-6 counter module NX-6 at \$15, postpaid; tens counter module CL-1 at \$8.50, postpaid (specify neon or incandescent lamp); scaler module SC-10-4 at \$14.75, postpaid; power supply module 169 at \$11.55, plus postage for 4 lb; polaroid plastic at 25¢/sq in. (specify size required).

Fig. 7. Overall wiring of the four-digit clock. Lamp I1 is used to make a colon between the minutes and hours indications, and a narrow black band around the center of the lamp breaks up the neon glow into two glowing dots. In the slow set position, the clock is driven from the one-pulse-per-second point, while in the fast set, the drive is from the 60-Hz line. When the time shown is correct, place S1 to run.

Fig. 8. This optional electronic "tic-toc" is connected to the output of scaler IC4 and blinks on and off to indicate that the clock is operating.

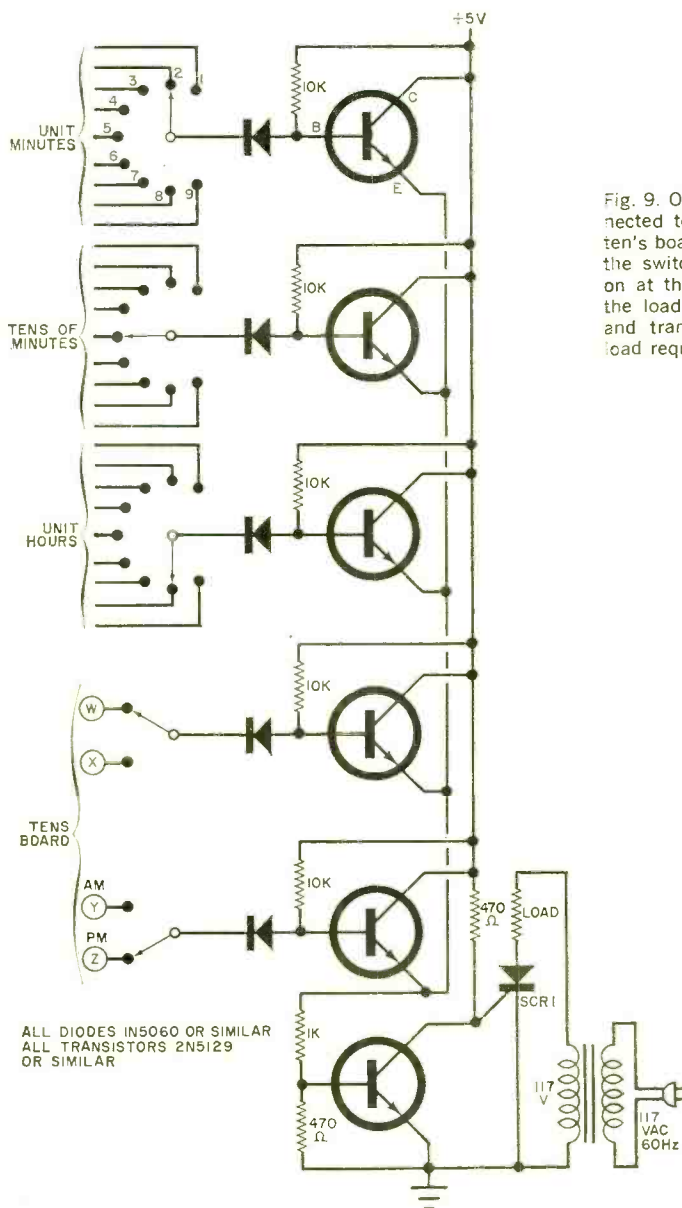
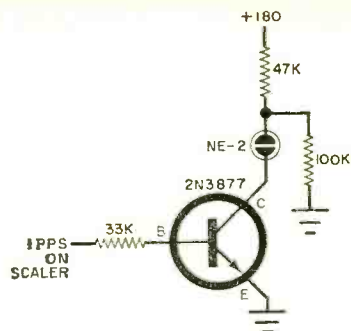

Fig. 9. Optional alarm system can be connected to the three readouts and to the ten's board as shown here. By positioning the switches properly, the SCR will turn on at the selected time, thus energizing the load (bell or other alarm). The SCR and transformer are selected to match load requirements of voltage and current.

## THEORY OF CIRCUIT DESIGN

The unit hours board is modified so that the Nixie-tube indicates ahead by two digits. This results in a "2" being shown when the counter would normally show a "0". This is done to simplify the logic needed to count to 12:59 and reset to 1:00. The operating cycle is as follows.

The counter is reset to "9" through the nine-reset input on the board. This results in a "1" being displayed. The count then proceeds up normally. After the count of "9", we must reset the counter to "0" and turn on the "1" lamp to indicate a "10". The "1" lamp is operated by the C and B lines coming into the tens counter board. When the displayed numeral on the unit hours board goes to "0", C and B both go to a logical zero state, and IC1 of the tens counter changes state. This turns on Q1 and ignites the "1" neon lamp. This then forms the number "10". The count then proceeds through 11 and 12. When the counter reaches 11:59, the next pulse causes the D line to go to a logical zero. This causes the second half of IC1 to change states and switch the AM and PM lights.

When the counter reaches 12:59, the system must be reset to 1:00. This requires a reset pulse to the "9" reset terminals of the unit hours counter, and to the first flip-flop of the tens counter, to reset the circuit and turn the "1" neon lamp off. This reset pulse is generated at the proper time by decoding the output of the first flip-flop of the tens counter which controls the "1" lamp, and lines A and D on the unit hours counter. When the output of this flip-flop is at logical 1, and A and D occur at the same time, a reset pulse is generated to reset the counter and the flip-flop.

then use the SLOW button to set the time exactly. Place the SET-RUN switch on RUN.

**Options.** In building the four-digit clock, the optional seconds blinker circuit shown in Fig. 8 may be used. The circuit can be built on a terminal strip with the neon lamp lying horizontally below the actual time indicators. The input to this circuit comes from the B10 output of IC4 on the scaler board. Operation is such that the neon lamp glows for one second and is off for one second. Although it is an accurate time marker, this indicator only serves to show that the clock is working and is the optical version of a "tie-toe."

The optional alarm circuit shown in Fig. 9 can be used to turn on an external alarm at any desired time of the day or night. Any type of switch may be used, though the prototype used conventional rotary switches. The bottom two switches are ordinary dpst types. The alarm circuit is a NOR logic system and all inputs must be at a logic zero before the alarm will work. At this time, all the transistors will have low voltages on their emitters and the gate switching transistor will have no base current drive. This transistor then turns off and the SCR (or triac) conducts to supply power to the external circuit. The transformer secondary voltage should match the required drive for the external circuit. The diodes in series with the transistor bases block the voltages from the Nixies when they go above 5 volts. This prevents destruction of the NOR transistors.

-50-

Arrangement used in the prototype may be duplicated or any other layout may be used. The optional neon lamp seconds blinker is mounted horizontally under the four indicators so that it is clearly visible when viewing the clock from the front.

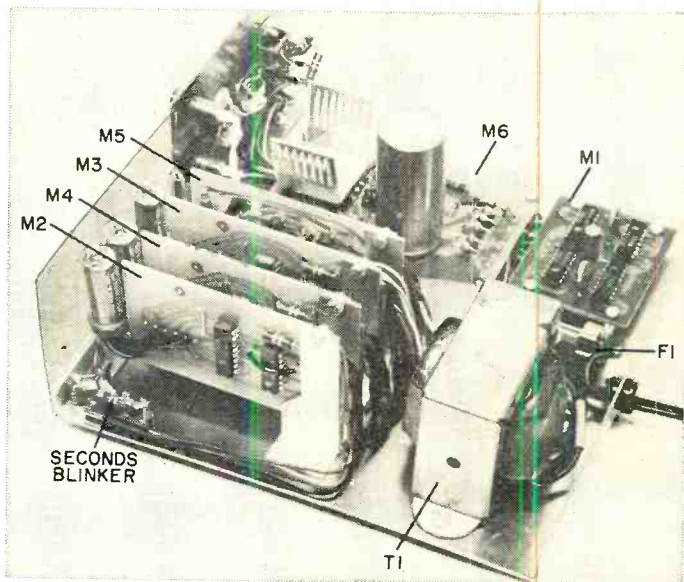



# Build A Three-Channel Time Receiver



## ACCURATE TIME SIGNALS FROM WWV OR CHU

Using dual-gate MOSFET's, this receiver has a sensitivity of 0.25 microvolts for a 10-dB (S + N)/N ratio. Self-contained (except for power) it offers the selection of one of three possible crystal-controlled receive channels. The version illustrated is set up for WWV, but the builder can adapt the circuit for a "mix" of WWV and CHU frequencies.

**W**HAT DO amateur astronomers, jewelers, boat owners, and radio and TV stations have in common? The need for accurate time. How about radio amateurs, 2-way radio service shops, and electronics labs? Many of them must also make accurate frequency measurements. If your requirements are for accurate time or frequency, build this super-sensitive receiver and tune in on the standard time/frequency broadcasts of WWV or CHU

(in Eastern Canada and along the East Coast). A choice of three crystal-controlled frequencies assures uninterrupted reception, day or night. You can build this sophisticated 10-transistor superhet receiver in just a few hours and you don't need any test equipment.

The National Bureau of Standards transmits standard time and frequency information continuously on several frequencies via stations WWV in the continental United States and on identical frequencies from WWVH in Hawaii. In Canada, the Dominion Observatory station, CHU, transmits standard time continuously. The program format of WWV varies from that of CHU. While WWV transmits a "tick" each second and a digital and voice time announcement every five minutes (along with meteorological information), CHU broadcasts a tone-type "beep" each second and a voice time announce-

COVER STORY BY CHARLES CARINGELLA

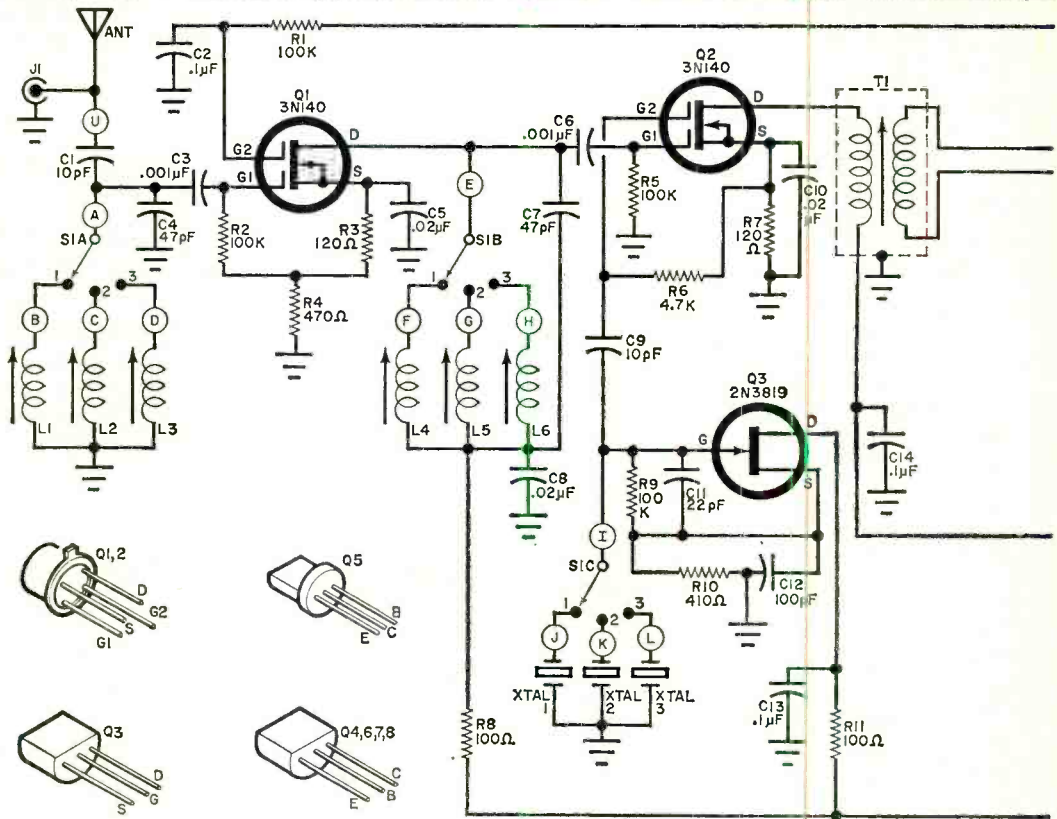

### PARTS LIST

- C1,C9—10-pF, dipped silvered mica capacitor  
 C2,C13-C17—0.1- $\mu$ F miniature disc capacitor  
 C3,C6—0.001- $\mu$ F ceramic disc capacitor  
 C4,C7—47-pF dipped silvered mica capacitor  
 C5,C8,C10,C20—0.02- $\mu$ F miniature disc capacitor  
 C11—22-pF dipped silvered mica capacitor  
 C12,C19—100-pF dipped silvered mica capacitor  
 C18,C21—100- $\mu$ F, 15-volt miniature PC electrolytic capacitor  
 C22,C23—1000- $\mu$ F, 15-volt miniature PC electrolytic capacitor  
 D1—6-volt, 500-mW zener diode (Motorola 1N5233 or similar)  
 D2,D3—1N914 silicon diode  
 J1—Phono jack  
 J2—Miniature phone jack  
 L1,L4—For 5.0-MHz WWV, 10.0-18.7- $\mu$ H adjustable PC r-f coil (J.W. Miller 23A155-RPC); for 7.335-MHz CHU, 5.6-10- $\mu$ H adjustable PC r-f coil (J.W. Miller 23A826-RPC)  
 L2,L5—For 10.0-MHz WWV, 2.4-4.1- $\mu$ H adjustable PC r-f coil (J.W. Miller 23A336-RPC)  
 L3,L6—For 15.0-MHz WWV, 1.65-2.75- $\mu$ H

adjustable PC r-f coil (J.W. Miller 23A226-RPC); for 14.670-MHz CHU, 1.65-2.75- $\mu$ H adjustable PC r-f coil (J.W. Miller 23A226-RPC)

- M1—1-F amplifier module (J.W. Miller 8902-B)  
 Q1-Q2—Dual-gate MOSFET (Motorola 3N140 or similar)  
 Q3—N-channel FET (Texas Instruments 2N3819)  
 Q4,Q6—Transistor (Motorola MPS6517)  
 Q5—Transistor (GE 2N2925)  
 Q7—Transistor (Motorola MPS6560)  
 Q8—Transistor (Motorola MPS6562)  
 R1,R2,R5,R9,R21—100,000-ohm  
 R3,R7—120-ohm  
 R4,R10,R13,R17—470-ohm  
 R6,R24—4700-ohm  
 R8,R11,R15—100-ohm  
 R12—3300-ohm  
 R14—1500-ohm  
 R16,R22—10,000-ohm  
 R19—220,000-ohm  
 R20—330,000-ohm  
 R23—22-ohm  
 R25,R26—2.7-ohm  
 R27,R29—47-ohm  
 R28—2700-ohm

All resistors  
 1/2-watt  
 10% tolerance

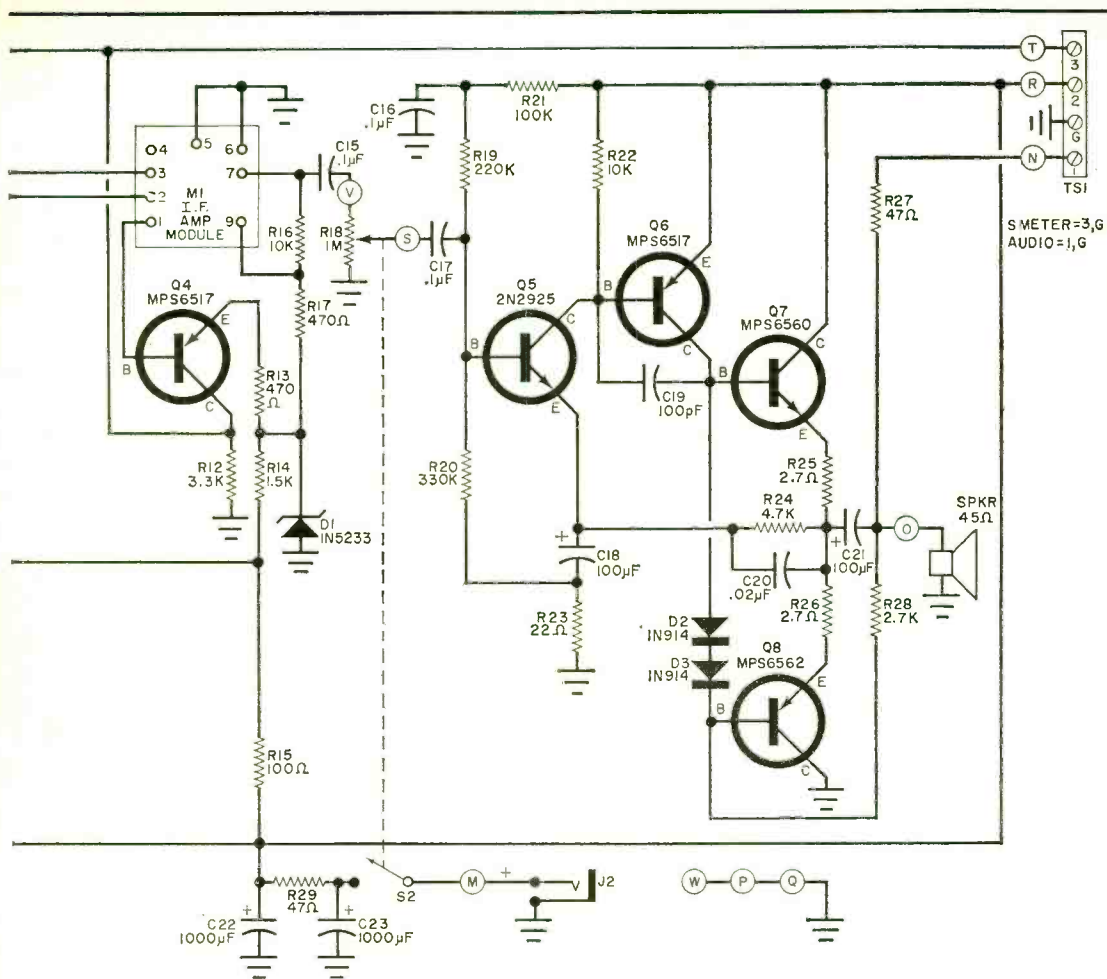

R18—1-megohm potentiometer with spst switch (S2)

S1—Special 2-section rotary switch with shield between sections; 3-pole, 3-position switch, first section 1 pole, second section 2 poles

S2—Spst switch, part of R18

SPKR—3" PM speaker, 45-ohm coil (Quam 3A07Z45 or similar)

T1—1-f transformer (J.W. Miller 8901-B)

XTL1—For 5.0-MHz WWV, 5.455-MHz  $\pm 0.01\%$  crystal, HC/6U holder; for 7.335-MHz CHU, 7.790-MHz  $0.01\%$  crystal, HC/6U holder

XTL2—For 10.0-MHz WWV, 9.545-MHz  $0.01\%$  crystal, HC/6U holder

XTL3—For 15.0-MHz WWV, 14.545-MHz  $0.01\%$  crystal, HC/6U holder; for 14.670-MHz CHU, 14.215-MHz  $0.01\%$  crystal, HC/6U holder

Misc.—Crystal sockets, telescoping antenna, knobs, angle brackets,  $\frac{1}{8}$ " spacers, terminal strip, chassis, solder tuz, insulating washers, rubber feet, hardware, solder, etc.

Note—The following are available from Carinella Electronics, Inc., P.O. Box 327, Upland, CA 91786: special 2-section rotary switch at \$3.95; etched and drilled printed circuit board at \$6.95; assembled power supply at \$5.95; complete kit of parts for S-meter, including matching cabinet, at \$11.95; complete kit of all parts for receiver less power supply and S-meter, including PC board, chassis, and one set of coils and crystal for 10.0-MHz WWV at \$54.95. Add \$7.95 for each additional set of coils and crystal (specify frequency). All prices post-paid. California residents add 5% sales tax.

Fig. 1. The receiver uses dual-gate MOSFET's for minimum noise, highest gain, and lowest cross modulation. All of this contributes to extremely good sensitivity and selectivity of the receiver. Crystal-controlled local oscillator (Q3) eliminates tuning problems.



**Hunting for a better job?**

**Here's the  
license  
you need  
to go after  
the big ones**

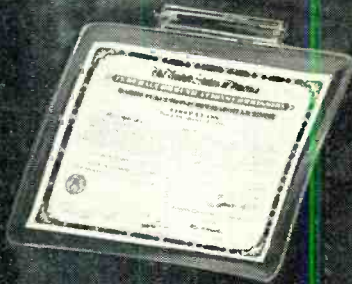



**A Government FCC License can help you bring home up to \$10,000, \$12,000, and more a year. Read how you can prepare for the license exam at home in your spare time—with a passing grade assured or your money back.**

**I**F YOU'RE OUT TO BAG A BETTER JOB in Electronics, you'd better have a Government FCC License. For you'll need it to track down the choicest, best-paying jobs that this booming field has to offer.

Right now there are 80,000 new openings every year for electronics specialists—jobs paying up to \$5, \$6, even \$7 an hour... \$200, \$225, \$250, a week... \$10,000, \$12,000, and up a year! You don't need a college education to make this kind of money in Electronics, or even a high school diploma.

But you *do* need knowledge, knowledge of electronics fundamentals. And there is only one nationally accepted method of measuring this knowledge... the licensing program of the FCC (Federal Communications Commission).

**Why a license is important**

An FCC License is a legal requirement if you want to become a Broadcast Engineer, or get into servicing any other kind of transmitting equipment—two-way mobile radios, microwave relay links, radar, etc. And even when it's not legally required, a license proves to the world that you understand the principles involved in *any* electronic device. Thus, an FCC "ticket" can open the doors to thousands of exciting, high-paying jobs in communications, radio and broadcasting, the aerospace program, industrial automation, and many other areas.

So why doesn't everyone who wants a good job in Electronics get an FCC License and start cleaning up?

The answer: it's not that simple. The government's licensing exam is tough. In fact, an average of two out of every three men who take the FCC exam fail.

There is one way, however, of being pretty certain that you will pass the FCC exam. And that is to take one of the FCC home study courses offered by Cleveland Institute of Electronics.

CIE courses are so effective that better than 9 out of 10 CIE graduates who take the exam pass it. That's why we can back our courses with this iron-clad Warranty: Upon completing one of our FCC courses, you must be able to pass the FCC exam and get your license—or you'll get your money back!

**They got their licenses and went on to better jobs**

The value of CIE training has been demonstrated time and again by the achievements of our thousands of successful students and graduates.

**2 NEW CIE CAREER COURSES**

**1. BROADCAST (Radio and TV) ENGINEERING...** now includes Video Systems, Monitors, FM Stereo Multiplex, Color Transmitter Operation.

**2. ELECTRONICS ENGINEERING...** covers steady-state and transient network theory, solid state physics and circuitry, pulse techniques, computer logic and mathematics through calculus. A college-level course for men already working in Electronics.

Ed Dulaney, Scottsbluff, Nebraska, for example, passed his 1st Class FCC License exam soon after completing his CIE training... and today is the proud owner of his own mobile radio sales and service business. "Now I manufacture my own two-way equipment," he writes, "with dealers who sell it in seven different states, and have seven full-time employees on my payroll."

Daniel J. Smithwick started his CIE training while in the service, and passed his 2nd Class exam soon after his discharge. Four months later, he reports, "I was promoted to manager of Bell Telephone at La Moure, N.D. This was a very fast promotion and a great deal of the credit goes to CIE."

Eugene Frost, Columbus, Ohio, was stuck in low-paying TV repair work before enrolling with CIE and earning his FCC License. Today, he's an inspector of major electronics systems for North American Aviation. "I'm working 8 hours a week less," says Mr. Frost, "and earning \$228 a month more."

**Send for FREE book**

If you'd like to succeed like these men, send for our FREE 24-page book "How To Get A Commercial FCC License." It tells you all about the FCC License... requirements for getting one... types of licenses available... how the exams are organized and what kinds of questions are asked... where and when the exams are held, and more.

With it you will also receive a second FREE book, "How To Succeed In Electronics." To get both books without cost or obligation, just mail the attached postpaid card. Or, if the card is missing, just mail the coupon below.

**ENROLL UNDER NEW G.I. BILL.** All CIE courses are available under the new G.I. Bill. If you served on active duty since Jan. 31, 1955, or are in service now, check box on reply card for complete details.

**CIE Cleveland Institute of Electronics**

1776 E.17th St., Cleveland, Ohio 44114

Accredited Member National Home Study Council  
A Leader in Electronics Training... Since 1934



**Cleveland Institute of Electronics**  
1776 East 17th Street, Cleveland, Ohio 44114

Please send me without cost or obligation:

Your 44-page book "How to Succeed in Electronics" describing job opportunities in Electronics today, and how your courses can prepare me for them.

Your book on "How To Get A Commercial FCC License."

I am especially interested in:

- Electronics Technology     Electronic Communications
- Broadcast Engineering     Industrial Electronics
- First Class FCC License     Electronics Engineering

Name \_\_\_\_\_ (PLEASE PRINT)

Address \_\_\_\_\_

City \_\_\_\_\_

State \_\_\_\_\_ Zip \_\_\_\_\_ Age \_\_\_\_\_

Check here for G.I. Bill information **PE-11**

**CIRCLE NO. 7 ON READER SERVICE PAGE**

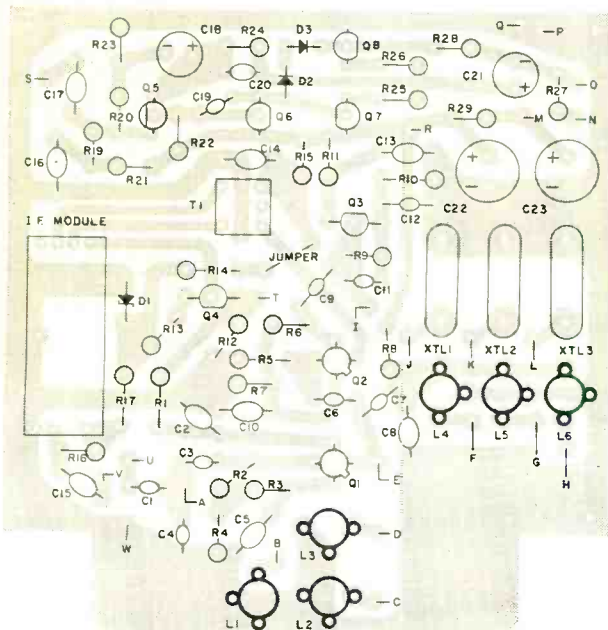
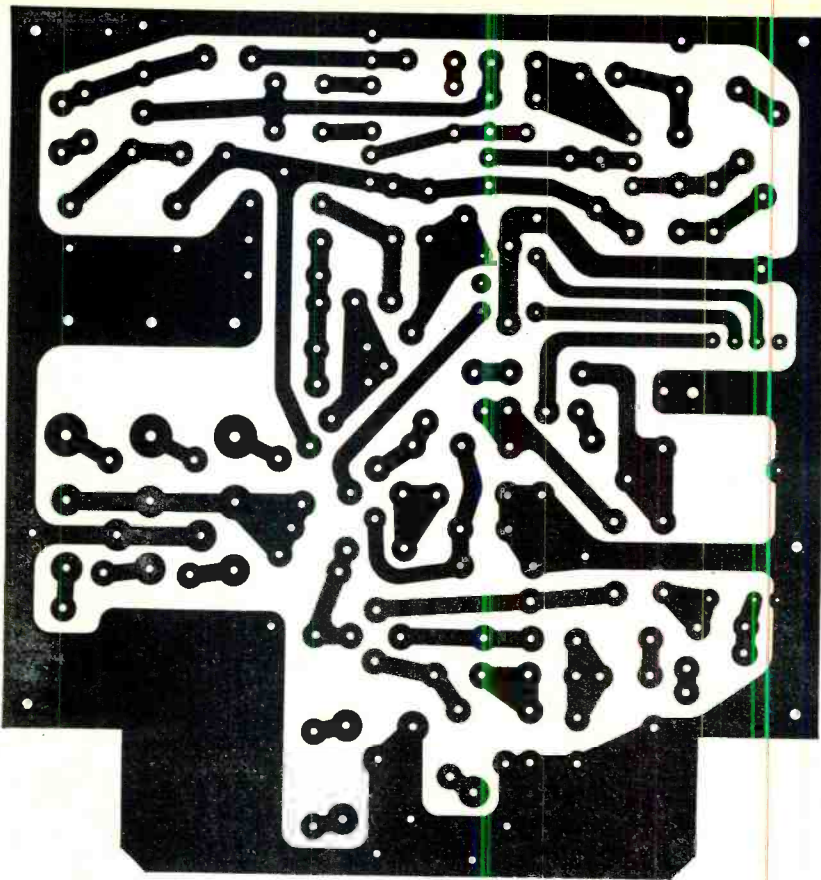

Fig. 2. Actual-size foil pattern and component installation for the receiver. Note that many components are mounted "on end" with the other lead bent over to the appropriate hole in the board. Observe the polarities of electrolytics and diodes and re-read the precautions before wiring the MOSFET's into the circuit (see text).



ment every minute in both English and French.

The complete Standard-Time Receiver can be built for about \$75, with power supply, crystals, telescoping antenna, and built-in speaker. The circuit (see Fig. 1) consists of an r-f amplifier, mixer, crystal-controlled oscillator, pre-assembled i-f amplifier with built-in detector, and push-pull complementary-symmetry audio amplifier.

The receiver operates from any 12-volt dc source and, therefore, can be used in an automobile, boat or airplane. It will also operate on 12 volts from flashlight batteries, making it completely portable. Power consumption is 70 mA. For ac operation on the workbench all that is required is a conventional 12-volt filament transformer and four silicon rectifiers in a full-wave bridge configuration. Filtering is provided within the receiver.

A sensitivity of 0.25 microvolt for 10-dB (S+N)/N ratio makes this unit one of the hottest receivers around. A 2' telescoping antenna is all that is needed in most locations. A jack on the back panel can be used for an external antenna should one be required for mobile operation. Provision has also been made for an external S-meter circuit.

**Construction.** The receiver is constructed on a printed circuit board as shown in Fig. 2. You can make your own board or purchase it as mentioned in the Parts List. Start by cutting off pin 8 on the preassembled i-f module; this pin is not used. Mount the i-f module and i-f transformer *T1* on the circuit board. To avoid damaging the MOSFET's, use a low-power (50 watts or less) soldering iron—not a gun.

Next, install the coils, crystal sockets, and the jumper wire. Mount all resistors at right angles to the board with one end of the resistor in contact with the board and the lead on the other end folded down to the other hole. After all resistors have been installed, start on the capacitors, being careful to observe the polarities on the electrolytics. Diodes *D1*, *D2*, and *D3* are also mounted vertically with a heat sink to protect them during the soldering operation. Using care, install transistors *Q3* through *Q8*, again with a heat sink on the leads during soldering. Transistors *Q1* and *Q2* require special handling. Note that they are supplied with a shorting ring on the four leads. Substitute a wire loop for the shorting ring, and remove the loop after the transistor has been soldered in the board.

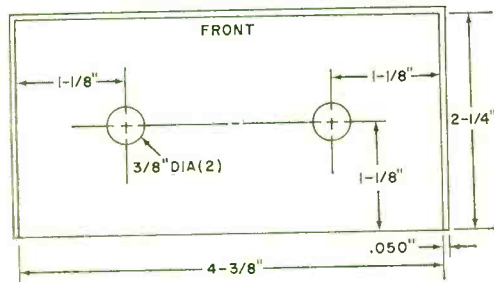
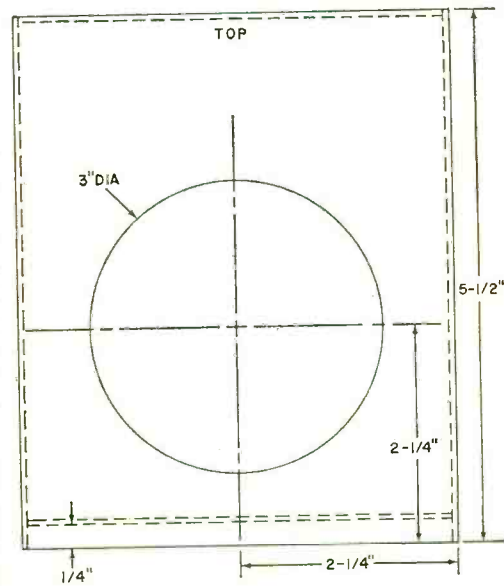
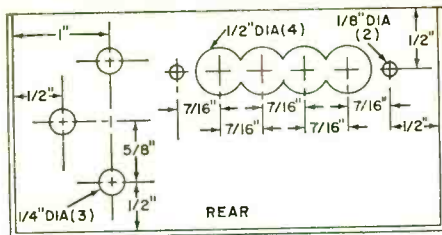
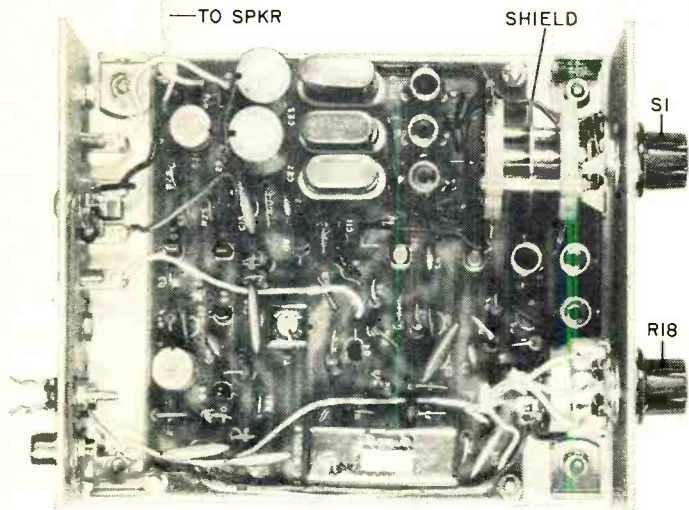

Fig. 3. If you want to duplicate the author's prototype, a metal chassis can be created using the construction information shown above. Thin sheet aluminum was used for the original two-piece chassis, which was formed in two U-shaped sections.

Handling or soldering MOSFET's with the leads unshorted can cause permanent damage.

The prototype receiver shown in the photos was fabricated from 0.050" sheet aluminum formed into two U-shaped pieces. The front panel, rear apron, and top are



It is recommended that a shield be located between the two segments of S1 to avoid coupling. The collapsible antenna is attached to a pair of insulated fuse clips mounted on the rear apron. The speaker is fixed to the upper part of the chassis, while the four angle brackets secure the two chassis sections.

dimensioned and machined as shown in Fig. 3. Small threaded angle brackets in each corner hold the two parts of the chassis together. The speaker, on the top, is protected by a piece of perforated metal. Other components are mounted as shown in the photos. The antenna mounting clips can be made from a fuse holder, insulated from the metal chassis. No matter what type of

### TECHNICAL SPECIFICATIONS

- Sensitivity:** 0.25 microvolt for 10-dB S + N/N
- Frequency:** 5.0 MHz WWV or 7.335 MHz CHU  
10.0 MHz WWV  
15.0 MHz or 14.670 MHz CHU
- Audio Power:** Approximately 1/3 watt into built-in 45-ohm speaker
- Selectivity:** 5 kHz at 6 dB
- I-F Frequency:** 455 kHz
- Power Requirement:** 12 volts dc at 70 mA

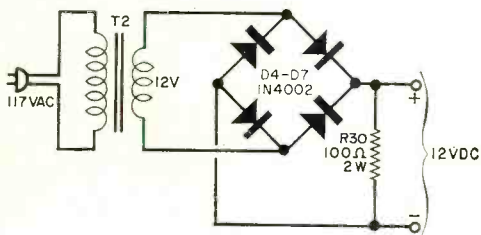

Fig. 4. This simple power supply can be used to power the receiver. No filter is shown as this is provided by components mounted on the PC board.

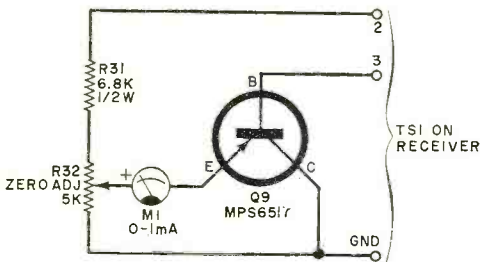

Fig. 5. This simple S-meter circuit is used when aligning an external oscillator with selected WWV.

chassis is used, make the distance between the board and selector switch S1 as short as possible to keep the leads to a minimum.

Connect the various leads to the PC board as shown in Fig. 1. And mount the board on 1/8" spacers on the bottom of the chassis. Recheck all wiring and then plug in the crystals making sure that XTAL1 operates with L1 and L4, XTAL2 with L2 and L5, and XTAL3 with L3 and L6.

**CHU Conversion.** The 5-MHz WWV channel can be converted to receive CHU on 7.335 MHz by replacing XTAL1 with a 7.790-MHz crystal and L1 and L4 with 5.6-10-μH printed circuit adjustable r-f coils (see Parts List). The 15-MHz WWV channel can be converted to receive CHU on 14.670 MHz by replacing XTAL3 with a 14.215-MHz crystal and realigning L3 and L6.

Although the author used a conventional phone jack for connecting to the external power supply, almost any type of two-terminal connector may be used. The terminal strip may be omitted if you have no need for either the external audio or optional S-meter.

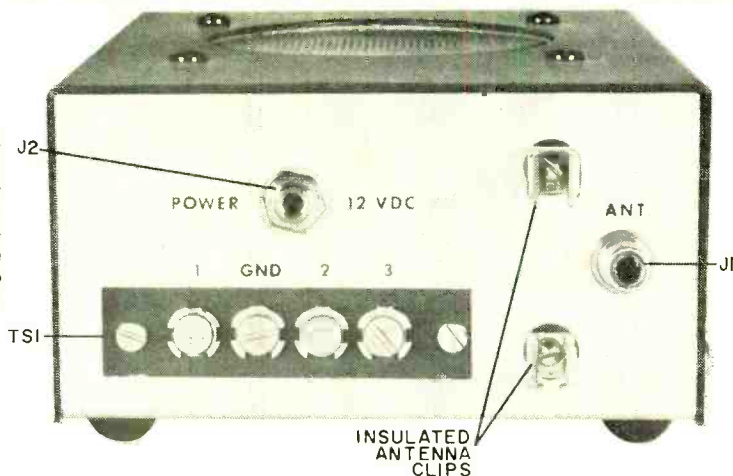

**Power Supply and S-Meter.** Any type of 12-volt dc power supply may be used with the receiver. One suitable circuit is shown in Fig. 4. Note that no filtering is shown since there are filters on the receiver PC board.

An optional S-meter attachment is shown in Fig. 5. This meter circuit provides a visual aid to obtain precise zero beat when calibrating external oscillators to the extremely accurate WWV signals. The connections shown in Fig. 5 mate with those of TSI in Fig. 1.

**Alignment and Operation.** Attach the telescoping antenna to the clips on the rear of the receiver and connect the power source. The receiver can be aligned directly from "on the air" signals as the local oscillator is crystal-controlled. Tune each pair of coils for maximum signal or background noise if the signal is not present. There are also tuning adjustments on the tops of the i-f module and the i-f transformer. They should be touched up to get maximum volume.

Signal strength will depend on the propagation conditions at the time. If the 2' telescoping antenna does not provide satisfactory reception, attach a longer antenna to J1. Reception of WWV on 5, 10, and 15 MHz should be reasonably good throughout most of the U.S.A., and at least one of these frequencies should be audible day or night. Reception of CHU on 7.335 MHz is confined primarily to the East Coast of North America, while reception of CHU

### THEORY OF CIRCUIT DESIGN

The pair of dual-gate MOSFET's (*Q1*, *Q2*) used in the front end offer high gain with low noise, as well as lower cross modulation and greater dynamic range than either conventional bipolars or single-gate FET's. MOSFET *Q1* serves as the r-f amplifier with the incoming signal applied to gate 1 and the agc voltage applied to gate 2. The crystal-controlled local oscillator (*Q3*) consists of a conventional n-channel FET used as an untuned crystal-controlled oscillator.

Switch *S1* selects the desired tuned circuits and the crystal for the selected channel. This switch should have a shield between the switch sections to isolate the input tuned circuit from the output circuit in the r-f amplifier. Otherwise, the r-f amplifier could become extremely unstable and might possibly oscillate due to the high gain within the stage.

After the i-f transformer (*T1*), the signal is amplified by a commercial miniature pre-assembled and pre-aligned module that contains two transistors, three i-f transformers, and a diode detector. Transistor *Q4* serves as the agc amplifier for the r-f stage as well as provided the driving voltage for an optional, external S-meter circuit.

The recovered audio signal is developed across volume control *R18* and fed to a four-transistor audio amplifier that can deliver about 1/2 watt to the speaker. The audio is also available at a rear apron terminal strip for headphones.

The external 12-volt dc source need not be filtered since *C22*, *C23* and *R29* perform this function.

on 14.670 MHz extends into the Midwest during daylight hours and into the Far West in the evening.



# QUIZ ON AC CIRCUIT THEORY

BY ROBERT P. BALIN

Voltage measurements made in a series ac circuit seldom add up as simply as they do in a dc circuit. You may even find the voltage across a coil or capacitor to be greater than the supply voltage! Nevertheless, Ohm's Law and Kirchhoff's Law do apply, and careful measurements will show that the supply voltage and the various voltage drops around a series ac circuit are related in an unusual way: the square of the supply voltage is equal to the square of the difference between the voltage on the coil and the voltage on the capacitor, plus the square of the voltage on the resistor.

This relationship,  $(VT)^2 = (VL-VC)^2 + (VR)^2$ , can be used to find any unknown voltage if all others are known.

In parallel ac circuits, the currents add up the same way as voltages do in a series ac circuit. Brush up on your ac theory and see if you can solve the missing voltage or current in the circuits below. Where necessary, the voltages and currents are related by the 3:4:5 ratio to provide easy, whole number answers. Only simple algebra is required. Vectors, phasors, and quadratic equations are not necessary to find the solutions.

(Answers are on page 98)

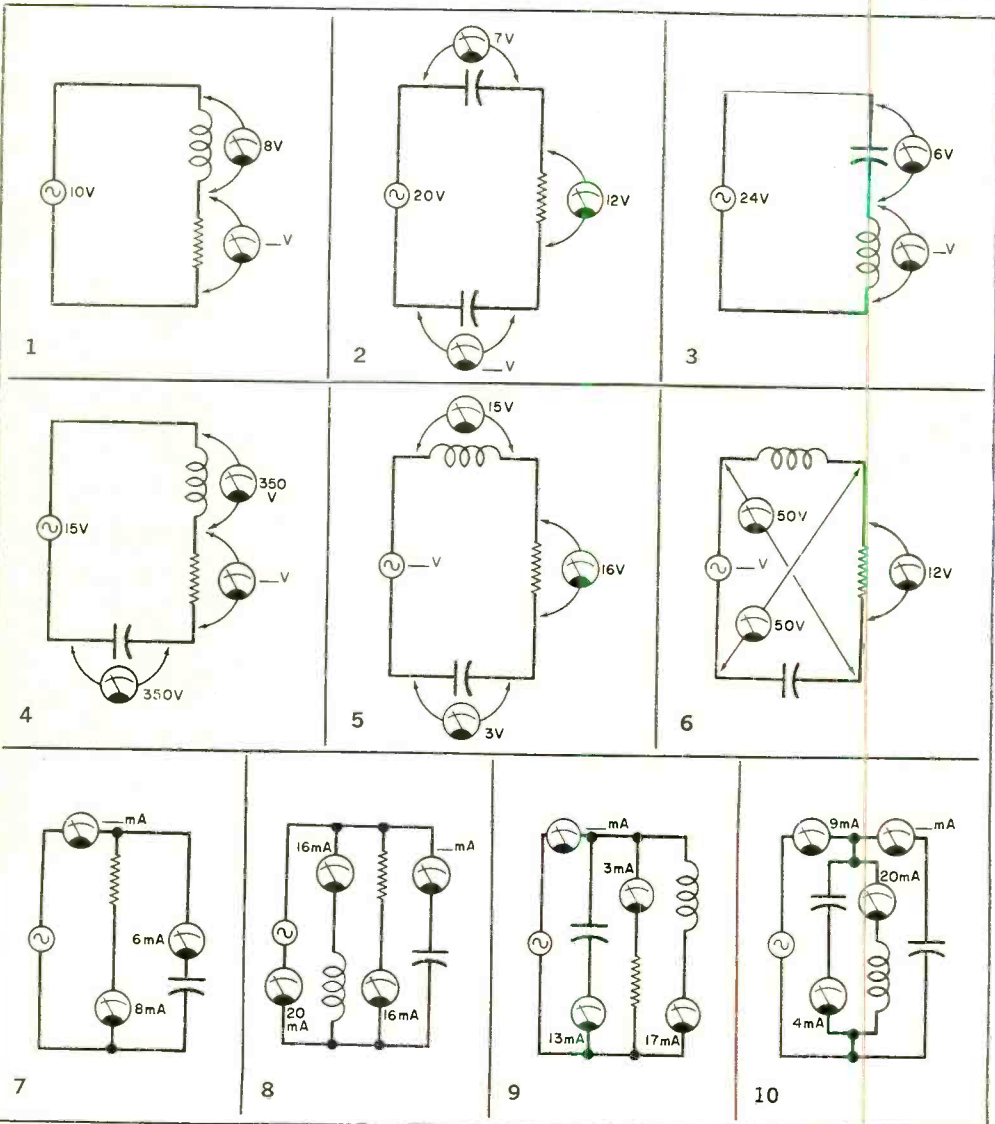

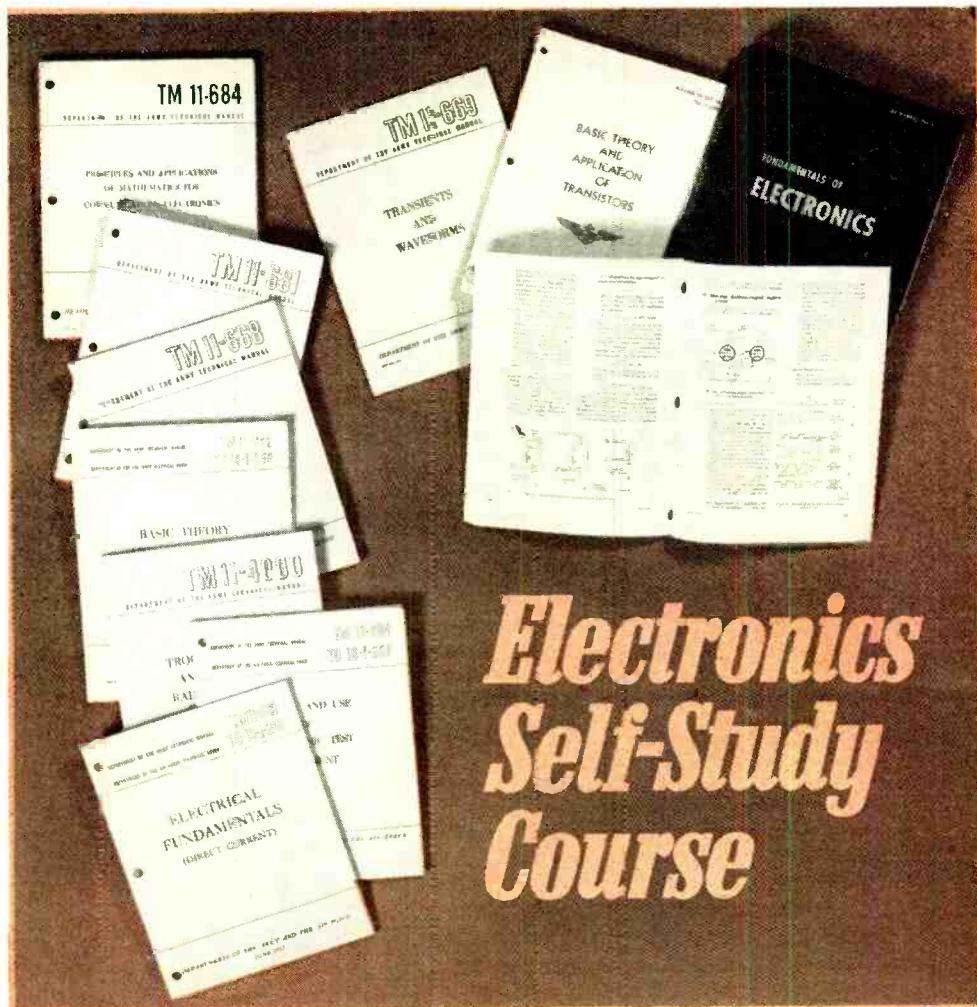

# Electronics Self-Study Course

## SETTING UP A TRIAL HOME-STUDY PROGRAM COURTESY OF THE GOVERNMENT PRINTING OFFICE

IT'S AN ESTABLISHED FACT that money spent on an electronics education is a wise investment. Of course the most common—and most highly recommended—avenues of obtaining an electronics education are through resident and formal home study courses. There are, however, several reasons why you might not wish to commit yourself to a “formal” educational program.

A hobby interest in electronics, for example, might not justify the cost of the training. Or, you might lack sufficient exposure to electronics and its career opportunities to have a

firm incentive. You might even be in a disadvantaged situation where technical training is simply a luxury.

Whatever your reason, the main objection is likely to be the rather large monetary commitment for something that might not pan out. However, there is one more avenue you might give thought to trying: informal, or “go-it-alone,” home study. Self-study is fraught with built-in disadvantages, admittedly. But with proper guidance and a wise choice of study materials, you *can* gain a firm understanding of the theories employed in electron-

BY KENNETH J. ENGLERT

ies, using this knowledge as a stepping stone to bigger and better things. If electronics, on the other hand, is not your cup of tea, you will find this out, too—without losing much more than pocket money.

The one major advantage to self-study is that the monetary investment is minimal. All you really have to pay for are the materials used for studying—in this case a generous supply of textbooks. Beyond this, your only investment will be the time you use to apply yourself to studying. There are no consultation or guidance fees to add to your “tuition.”

**A Realistic Program.** Just grabbing a book off a shelf and reading it is no guarantee that you will learn anything or that you will learn enough of anything to give you a broad enough scope. Going one step further, an indiscriminate selection of study materials can do you more harm than good. The texts in most electronics books presuppose either prior electronics training or that the reader will have available some form of guidance. Few books, other than those written in a “programmed” format, are truly tailored to the needs of self-study programs.

The immediate aim, then, is to select the best possible study materials that can be obtained on a very limited budget. Fortunately, military training manuals (available from the U.S. Government Printing Office) admirably meet both demands. Listed in the Study Ma-

terials Table (see below) are twelve training manuals that, when taken together, can provide a complete course in modern electronics technology. Yet, the cost of the entire package of books comes to only \$18.55, including postage and handling.

The twelve military training manuals selected to make up a self-study course cover not only the basics that are common to all areas of electronics, but they also cover such advanced topics as pulse and switching circuits, transients and waveforms, oscilloscope and other test equipment circuitry, wideband amplifiers, microwaves and radar, etc. In fact, the material presented in these manuals covers every area of the technology.

The training manuals contain a great deal more than just “dry theory.” They are well organized and profusely illustrated for easy understanding. And, although they were originally intended for use in a classroom environment, the Department of Defense has successfully used them in many thousands of non-classroom situations. This is due primarily to the fact that the material is presented in an easily understood language so that it can be quickly absorbed by the average military trainee. Even if you are still a high school student, you should experience little difficulty in understanding the material.

Once you have the training manuals (you need not buy them all at once since the first three manuals listed in the Table will see you

### STUDY MATERIALS TABLE

MANUAL NO.	MANUAL TITLE	GPO CAT. NO.	PRICE*
AF-101-8	Fundamentals Of Electronics	D301.7:101-8	\$4.00
TM-11-661	Electrical Fundamentals (D.C.)	D101.11:11-661	\$1.00
TM-11-662	Basic Theory And Application Of Electron Tubes	D101.11:11-662	\$1.25
TM-11-664	Theory And Use of Electronic Test Equipment	D101.11:11-664	\$ .75
TM-11-6668	F Transmitters And Receivers	D101.11:11-668	\$1.50
TM-11-669	Transients And Waveforms	D101.11:11-669	\$ .50
TM-11-671	Cathode Ray Tubes And Their Associated Circuits	D101.11:11-671	\$1.25
TM-11-672	Pulse Techniques	D101.11:11-672	\$ .55
TM-11-681	Electrical Fundamentals (A.C.)	D101.11:11-681	\$2.25
TM-11-684	Principles And Applications Of Mathematics For Communications-Electronics	D101.11:11-684	\$1.25
TM-11-690	Basic Theory And Application Of Transistors	D101.11:11-690	\$2.25
TM-11-4000	Troubleshooting And Repair Of Radio Equipment	D101.11:11-4000	\$2.00

\*Send check or money order in full with order to Superintendent of Documents, U.S. Government Printing Office, Division of Public Documents, Washington, D.C. 20402.



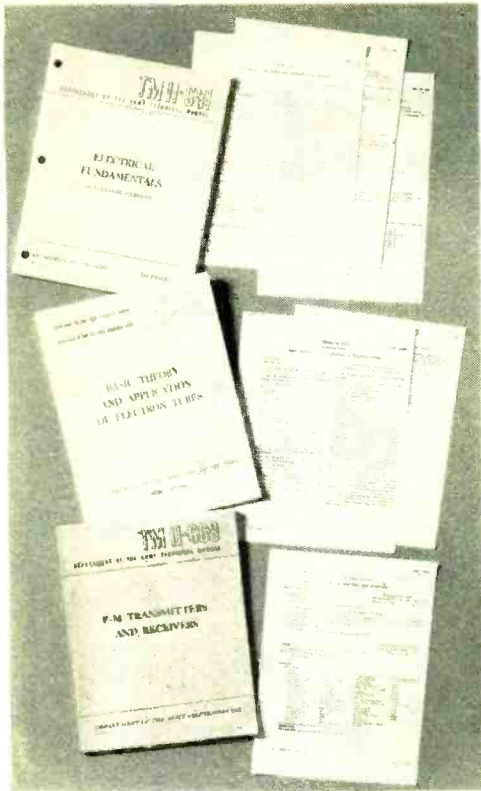

Manuals are updated as required. Superseding material and directions for use are supplied with appropriate manuals in the form of addenda sheets.

through quite a few study sessions), leaf through them and examine their tables of contents. You will note that there is a wide diversity of topics and that each topic is treated to an in-depth discussion.

The reason for selecting twelve books in preference to a single all-encompassing volume is that the repetition of the material covered is an important facet of the learning process. Furthermore, since most subjects are discussed more than once and from slightly different points of view, any questions that might arise will usually be anticipated so that your progress will not be impeded.

A program of study using the twelve manuals listed should be based on a logical selection and order of topics. If you wish, you can send 25¢ to this magazine (to cover postage and handling) for a 167-lesson program, an excerpt of which is shown on page 48, that will let you make full use of your materials. This program is simply too lengthy to publish in the pages of this magazine; so it is offered separately. Bear in mind that the pro-

gram is designed *only* for the manuals and not electronics books in general.

**About the Manual Program.** While the program for the self-study course is planned for those people who have no experience or previous background in electronics, the student with some knowledge or experience must judge for himself what material he thoroughly understands and can skip. Most of the manuals have review questions at the end of each chapter that can serve as a guide. If you can unhesitatingly answer these questions, you can safely bypass the material of the subject the questions refer to. Also, the same applies to your study efforts; if after studying a chapter you can answer the review questions with certainty, you can go on to the next chapter.

The importance of a solid understanding of the basics cannot be overemphasized. You must resist the temptation to skim over this very vital part of your studies. It is not until these fundamental concepts are fully understood that you can hope to master the more complex theory and circuitry that you will encounter as you progress in your studies. Even if you are more advanced, you should take advantage of the excellent lessons on basic electronics theory.

As mentioned earlier, the manuals that make up this course are profusely illustrated, including several large fold-out schematic and block diagrams that help to clarify the text material.

Electronics is a branch of the physical sciences and as such is best explained and understood through mathematics. But don't let the word "mathematics" scare you off. A little of it is necessary for the comprehension of some of the more advanced topics. The manual chosen to teach you math, TM 11-684, is one of the finest tutorial math books available today. It presupposes that the student has had only small exposure to mathematics and starts off with percentages, ratios and proportions, and powers and roots. Then, step by step, it explains in detail algebra, geometry, and trigonometry. All this is done in such a way that your absorption of mathematics will be practically painless.

Besides the many clear example problems presented in each chapter of TM 11-684, exercise problems are provided for you to work out on your own. Answers for the exercise problems are given in the rear of the book so that you can check your progress as you go along. Lessons on how to use the slide rule and

## SAMPLE OF COURSE OUTLINE\*

Lesson No.	TM or AF No.	Chapter	Chapter Title
59	101-8	17	Parallel AC Circuits
60	11-684	11	Radians
61	101-8	18	Resonance
62	11-684	12	Vectors
63	11-681	4	AC Circuits With Inductance, Capacitance and Resistance
109	11-664	9	Signal Generators And Oscillators
110	11-668	2	Principles of FM
111	11-690	5	Bias Stabilization
112	11-664	10	Frequency Measurement
113	11-668	3	Methods Of Producing FM
137	11-669	1	Analysis Of Non-Sinusoidal Waveforms
138	101-8	23	Cathode Ray Tubes
139	11-669	2	Transient Response
140	101-8	33	Basic Radar Principles
141	11-669	3	Response Of R-L Circuits
142	101-8	34	Microwave Oscillators

\* See text for availability of complete course outline.

the binary number system, which is the basic language of computers, are also included.

**Course Limitations.** It would be unfair to tell you that this is the "ultimate" course of study for obtaining an electronics education. In spite of the extremely low cost of the self-study course, it should be pointed out that it is no substitute for a good resident course or home study training through an accredited school.

One of the more serious limitations of the course is its lack of practical training. The Department of Defense backs up the training manuals with solid laboratory and on-the-job training experience. As a private individual, you will have no such facilities available to you and must look elsewhere for practical experience.

Secondly, there is no "feedback" from instructors or teachers in the form of exams for you to gauge your rate of progress. If you get stuck on a particular topic or idea propounded in the manuals, there are no consultation services for you to appeal to. Your only recourse here would be for you to find someone who might be able to help; say, someone from a local radio club.

Another disadvantage is that the low monetary commitment and lack of formal guidance might induce you to slacken your incentive as you go along. (This is not an uncommon ailment even with formal study programs, but you will probably be more prone to it since you will lose very little if you decide to discontinue your studies.) The only answer to this problem is to practice self-discipline. Set up a study schedule and allow nothing to interfere with it. Do not allow a day to pass without applying a certain predetermined minimum of time on your studies. Slacken once and you are almost certainly going to back slide.

One final disadvantage of any self-study course is that no diploma or certificate of completion is forthcoming when all of the work is behind you. However, you can obtain a side benefit which will attest for your proficiency in electronics. You can apply your knowledge toward obtaining a Federal Communications Commission Radiotelephone License. This document, especially if it is a First Class "ticket," is a formidable document when you apply for a job. And once you have that job (be fair and tell your employer that your knowledge of electronics is limited only to the theory; you will gain practical experience on the job) you can enroll in a formal course that will yield you a diploma.

Self-study is a means of obtaining an education in electronics. But it is up to you to decide whether or not you are satisfied to sit back and marvel at the wonders of electronics without getting involved. Only you can make up your mind to become an active participant.

-50-

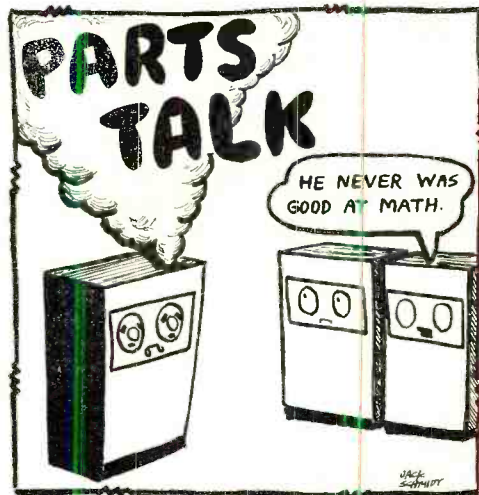

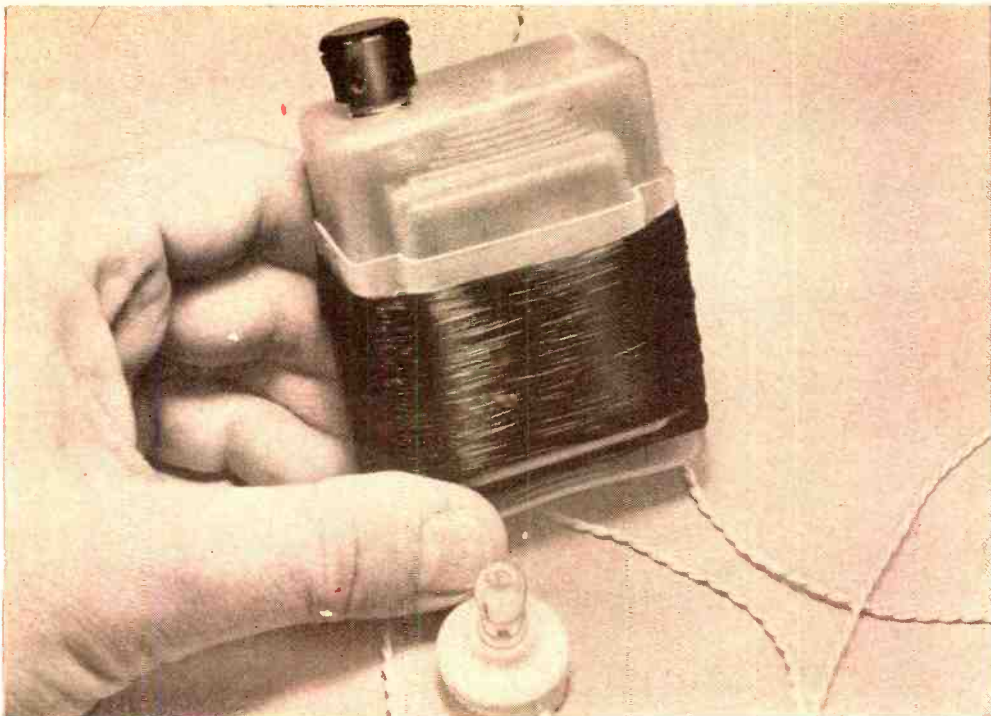

## BUILD THE LIBERATOR



KEEPS YOU IN TOUCH WHILE ON THE GO

**Built inexpensively and easily in a plastic cigarette case, this handy project "liberates" you from the necessity of sticking by your receiver when calls are few and far between. An integrated circuit and printed circuit board make construction foolproof.**

**T**HERE ARE TIMES when it becomes an impossible task to remain glued to a communications receiver if you are a ham, CB'er or SWL. Having to sit waiting for an identification to be made or a call to come through can be quite boring. The "Liberator," a shirt-pocket-size induction (not r-f) receiver, permits you to move about the house, office, or even a large area away from the receiver and

still hear everything that is going on at the receiver.

The Liberator can also be used for private, individual listening to conventional radios or audio systems. This is a particular advantage if one person in a group likes to hear loud music and the others don't.

**Theory of Circuit Design.** The complete system can be considered to be a form of audio transformer. The receiver or amplifier drives current through an ordinary wire transmission loop that is strung around the area of interest and produces a magnetic field that varies at the audio rate. This forms the primary of the transformer.

The receiver (see Fig. 1) has an "antenna" which forms the secondary of the transformer and detects the varying magnetic field. This

---

---

BY C. P. TROEMEL



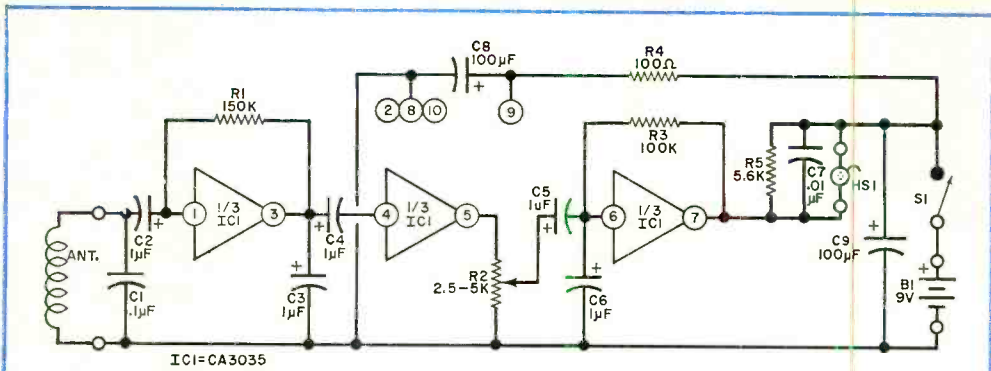

### PARTS LIST

- B1—9-volt battery
- C1—0.1-0.47- $\mu$ F capacitor (see text)
- C2-C6—1- $\mu$ F, 10-volt electrolytic capacitor
- C7—0.01- $\mu$ F capacitor
- C8, C9—100- $\mu$ F, 10-volt electrolytic capacitor
- HS1—Crystal earphone (Lafayette 99E25512 or similar)
- IC1—Integrated circuit (RCA CA3035)
- R1—150,000-ohm, 1/2-watt resistor

- R2—2500-5000-ohm miniature replacement potentiometer with switch (Lafayette 99E60-196 or similar)
- R3—100,000-ohm, 1/2-watt resistor
- R4—100-ohm, 1/2-watt resistor
- R5—5600-ohm, 1/2-watt resistor
- Misc.—Battery clip, plastic cigarette case, #24 or #26 enameled wire, knob, wire for loop, switch for loop.

Fig. 1. The circuit is basically a high-gain IC amplifier whose input is a loop "antenna", which forms the secondary of the induction system. With the transmitting loop wound around the main floor, excellent reception was obtained from basement to attic of a typical three-story brick structure.

signal is then amplified by an integrated circuit (IC1) to drive an earphone. The antenna and C1 resonate within the audio range to reduce the effect of interference from nearby r-f transmitters. The frequency response is limited to reduce noise from both 60-Hz power lines and emissions from TV receiver sweep circuits. A crystal earphone is used to prevent feedback between it and the receiving antenna. The IC contains three independent amplifiers and has an overall gain of approximately 100,000 (100 dB). Resistors R1 and R3 bias the first and last amplifiers for linear operation.

**Transmitter.** The transmitting loop consists of a length of insulated wire surrounding the area to be covered. Inside a building, the loop may be concealed in the wall moldings, under a large rug, or taped to the walls or ceiling. For outside use, the wire can be supported on insulators on posts or just simply strung (off the ground) around the area. The actual configuration depends on the location. Keep the coil off the ground and make sure it is insulated from metal surfaces. If the loop is to be located some distance from the amplifier, connect the two with ordinary two-conductor lamp cord or TV twin lead.

Usually, one turn of wire around the area

should be enough. However, two things should be kept in mind: the current in the loop and the number of turns determining the strength of the field; and do not overload or short circuit the transmitting amplifier by connecting a loop having too low a resistance.

Survey the area to be covered by the loop and calculate how long the wire will have to be to make the loop. Then determine the output impedance of the amplifier used (usually specified on the amplifier or in the instruction manual). The loop resistance can then be made approximately equal to the amplifier output impedance by choosing the correct wire size. Resistances of the more common wire sizes are given in the Table. Pick the wire whose resistance for the length required comes

RESISTANCE (OHMS) OF WIRE				
Wire Length	Wire Size			
feet	#20	#22	#24	#26
25	0.26	0.40	0.64	1.0
50	0.51	0.80	1.3	2.0
100	1.0	1.6	2.6	4.1
150	1.5	2.4	3.9	6.1
200	2.0	3.2	5.1	8.2
300	3.0	4.8	7.7	12.2
400	4.1	6.4	10.2	16.3
500	5.1	8.0	12.9	20.4

closest to the output impedance of the amplifier. If the finished loop has less resistance than that required, a small fixed resistor can be added in series with the loop to make up the difference. However, since signal will be lost in this resistor, consider using a double loop around the area, with a larger-diameter wire.

To power the transmitting loop, simply switch the normal output leads that go to the speaker to the loop (see Fig. 2).

**Receiver.** The circuit of the receiver is shown in Fig. 1. It can be constructed on a printed circuit board using the foil pattern shown in Fig. 3. Once the board has been made, install the components, taking care to observe the polarity of the electrolytic capacitors and the orientation of the IC.

The prototype was built in a common plastic cigarette case with the board supported by the mounting hardware of potentiometer *R2*. A small hole, just large enough to accommodate the twisted-lead cable from the earphone, is made on the same side as the *R2* mounting.

Before installing the board in the case, the receiving antenna must be made. Drill two small holes at the end of the larger of the two plastic halves and feed about six inches of the end of  $\pm 24$  or  $\pm 26$  enamelled wire through one hole. Wind 150 to 200 turns of the wire around the plastic case and feed the other end of the wire in through the second hole. Leave about six inches on this end also. Coat the winding with cement or tape to hold it in place.

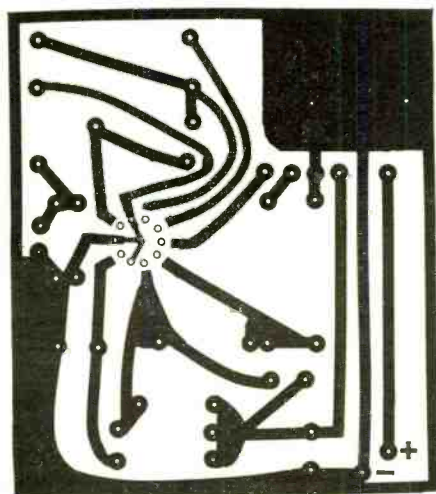

Fig. 3. Actual size foil pattern and component installation. Observe the placement of IC1 and the polarity of the electrolytic capacitors.

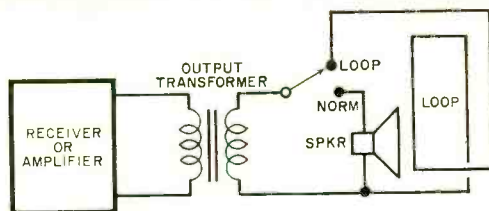
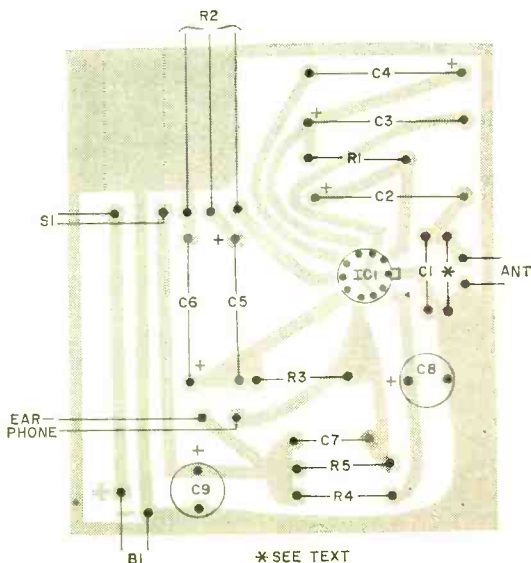

Fig. 2. If you wish simultaneous loop and speaker operation, hook a low-impedance speaker in series with the loop, so that the total load is the same as normally used with the particular transformer.

After connecting the earphone and battery leads and the two antenna wires to their proper holes on the PC board, slide the board into the plastic case. Locate the position of the shaft of *R2* and drill a suitable hole for it. Insert the board and secure it in place with the mounting hardware of *R2*. Put a knob on the potentiometer and turn the switch off. The battery is stored in the antenna half of the case.

**Operation.** With the earphone in your ear, turn on the Liberator. You should hear some hum, which can be made a maximum by orienting the antenna in different directions. The hum will be loudest when the Liberator is held near a fluorescent lamp.

Apply power to the transmitting loop by having some program material properly set up on the transmitter amplifier. Turn the amplifier gain up slightly. Switch its output to the loop position. If the Liberator is turned



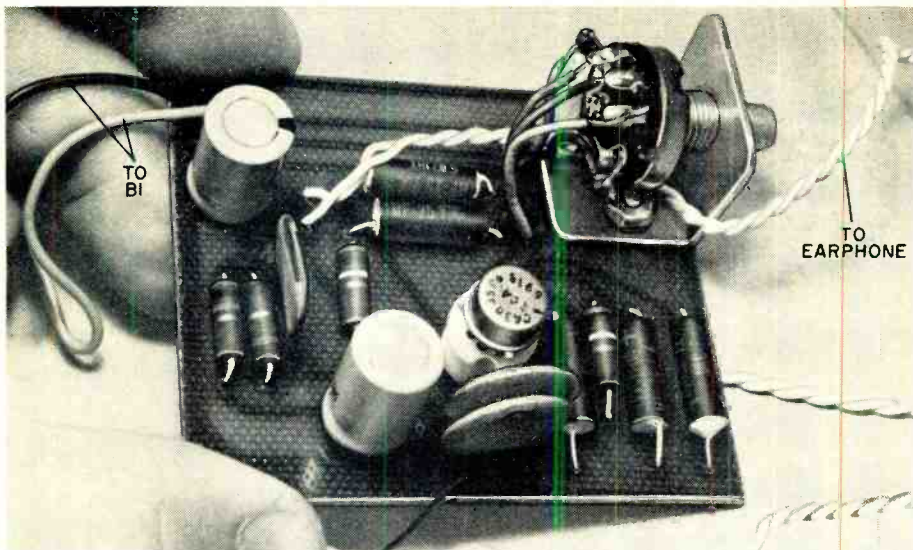

Although presently as small as a cigarette pack, the receiver can be made smaller by tightening up on the foil pattern, eliminating the IC socket, and using smaller physical sizes for C8, C9 and R2. A hearing-aid battery can be substituted for the 9-volt transistor radio battery, and a ferrite loopstick can be tried in place of the coil. Any number of receivers can be used on one loop.

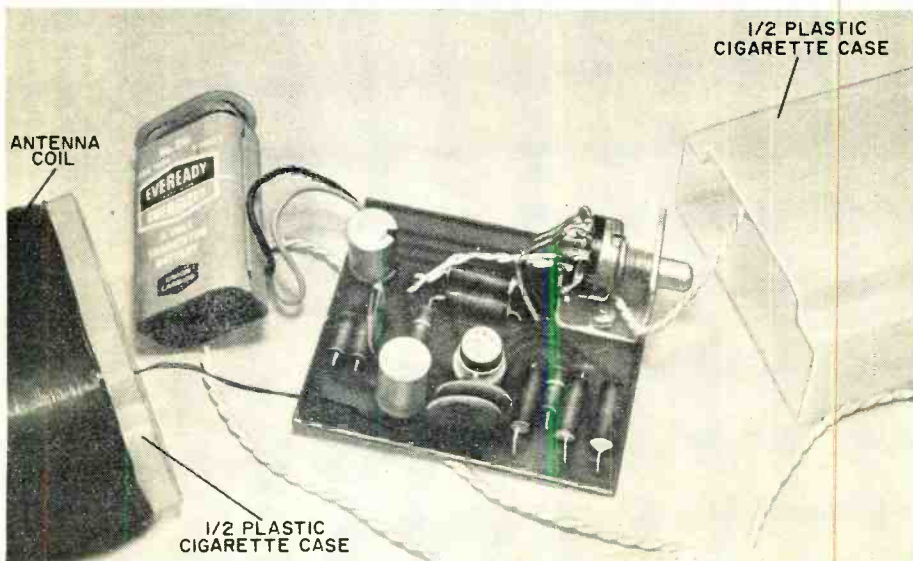

on, you should hear the program on the ear-  
phone. You will get the best reception when  
the plane of the Liberator antenna coincides  
with the plane of the transmitting loop, and  
you are within the loop. Adjust the trans-  
mitting amplifier's volume for minimum dis-  
tortion; gain can be adjusted on the Liberator.  
If you are using battery powered gear for the  
transmitter, keep its volume control down to  
conserve power.

**Modifications.** To improve low-frequency  
response, the values of coupling capacitors  
C2, C4, and C5 can be increased. However,  
the pickup of unwanted 60-Hz noise will be  
increased. Shunting capacitors C3, C6, and C7  
control the high-frequency gain and amplifier  
noise. Smaller values here will improve the  
high-frequency response, but will also increase  
the noise.

*(Continued on page 98)*



# BUILD AN SCA ADAPTER FOR FM RECEPTION

*Phase-Locked Loop Technique*

*Simplifies Design*

One of the inherent advantages of integrated circuits is the manufacturer's ability to design a complex circuit that would otherwise necessitate scores of discrete components on a single chip. This circuit is built around the Signetics NE-565 IC in a phase-locked loop configuration. This is the first hobby use of this IC to appear in a national electronic experimentation magazine.

**M**ANY FM STATIONS broadcast special educational material and music (without commercials) on the SCA subcarrier. This programming material is used (on a subscription basis) by commercial institutions for background music. The normal home receiver cannot pick up the SCA program without a special adapter. It is illegal to use such an adapter in a commercial establishment; but you can do so for your own personal pleasure at home.

The SCA subcarrier frequency is 67 kHz—which is high enough not to interfere with either the main carrier or the stereo subcarrier sidebands. A suitable filter and detector may be used to extract the SCA subcarrier, but

because the modulated frequency deviation of the SCA subcarrier is such a large percentage of the subcarrier center frequency, it is difficult to make an FM detector using tuned circuits. In most cases, the very low Q that would be required to get linear demodulation using this method would result in a very low detected output. Also, the exacting alignment of the filter and detector requires special equipment and critical adjustments. All of these problems can be alleviated by using a "phase-locked loop" (PLL) detector to demodulate the SCA subcarrier. Using such a concept and taking advantage of a new integrated circuit to simplify the design and construction, it is possible to construct a modern SCA adapter that has no critical adjustments and is easily coupled to any good FM receiver.

**Theory of Circuit Design.** A phase-locked loop such as that shown at Fig 1A consists of three elements: a phase comparator or detector, a low-pass filter, and a voltage controlled oscillator. The phase detector compares the phase of the incoming signal with the phase of the signal from the voltage-

BY VINCENT WOOD

Second in a series...

# Can you solve these problems in electronics?

They're a cinch after you've taken RCA Institutes' new communications electronics program.

It includes new preparation for the FCC license plus the assurance of your money back if you fail to get it.

This one is quite elementary.

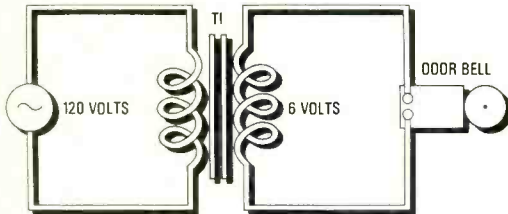

In this door bell circuit, which kind of transformer is T<sub>1</sub> — step-up or step-down?

Note: if you had completed only the first lesson of any of the RCA Institutes Home Study programs, you'd easily solve this problem.

This one is more advanced.

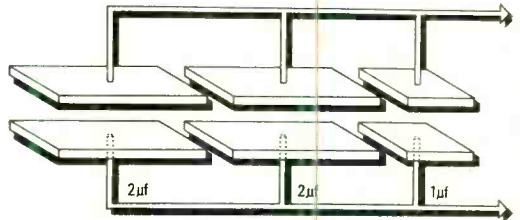

What is the total capacitance in the above circuit?

Note: you'd know the solution to the problem if you'd taken only the first two lessons in RCA's new Communications Electronics Program.

These are the lessons that prepare you step-by-step for an FCC License.

This license is a requirement for servicing all types of transmitting equipment and can help open doors to jobs commanding high income in communications, radio and broadcasting, aerospace, industrial automation and many others.

For a rewarding career with good pay, take that first step now. Send for complete information—mail the attached card.

Answers: Step-down, 5 μf

# RCA Institutes Autotext learning method makes problem-solving easier... gets you started faster towards a good-paying career in electronics

Are you just a beginner with an interest in electronics? Or, are you already making a living in electronics, and want to brush-up or expand your knowledge? In either case, RCA has the training you need. And Autotext, RCA Institutes' own method of Home Training will help you learn more quickly and with less effort.

## Wide Range of Courses

Select from a wide range of courses. Pick the one that suits you best and check it off on the attached card. Courses are available for beginners and advanced technicians.

- Electronics Fundamentals
- Black & White Television Servicing (Transistorized TV Kit Available)
- Color Television Servicing (Color TV Kit Available)
- FCC License Preparation
- Automatic Controls
- Automation Electronics
- Industrial Electronics
- Nuclear Instrumentation
- Electronics Drafting
- Computer Programming



Build and keep this valuable oscilloscope.

## Plus these new up-to-the-minute courses

- Semiconductor Electronics
- Digital Electronics
- Solid State Electronics
- Communications Electronics

## Prepare for good paying positions in fields like these

- Television Servicing
- Telecommunications
- Mobile Communications
- CATV
- Broadcasting
- Marine Communications
- Nuclear Instrumentation
- Industrial Electronics
- Automation
- Computer Programming
- Solid State
- Electronics Drafting



In the new program on Solid State Electronics you will study the effects of temperature and leakage characteristics of transistors.



## Variety of Kits—Yours to Keep

A variety of RCA Institutes engineered kits are included in your program of study. Each kit is yours to keep when you've completed the course. Among the kits you construct and keep is a working signal generator, a multimeter, a fully transistorized breadboard superheterodyne AM receiver, and the all-important oscilloscope. These 4 kits are at no extra cost. Compare this selection with other home study schools.

## Two Convenient Payment Plans

Pay for lessons as you order them. No contract obligating you to continue the course. Or, you can take advantage of RCA's convenient monthly payment plan. No interest charges!

## Classroom Training Also Available

RCA Institutes operates one of the largest technical schools of its kind. Day and evening classes. No previous training is required. Preparatory courses are available. Classes start four times a year.

## Job Placement Service, Too!

Companies like Bell Telephone Labs, GE, Honeywell, IBM, RCA, Westinghouse, Xerox, and major radio and TV networks have regularly employed graduates through RCA Institutes' own placement service.

**All RCA Institutes courses and programs are approved for veterans under the new G.I. Bill.**

**Send Attached Postage Paid Card Today. Check Home Study or Classroom Training.**

Accredited Member National Home Study Council.

IF REPLY CARD IS DETACHED, SEND THIS COUPON

### RCA Institutes Inc.

Home Study Dept. 694-012-0  
320 West 31 Street  
New York, N. Y. 10001

Please send me FREE illustrated career catalog.

Name \_\_\_\_\_ Age \_\_\_\_\_  
(please print)

Address \_\_\_\_\_

City \_\_\_\_\_ State \_\_\_\_\_ Zip \_\_\_\_\_



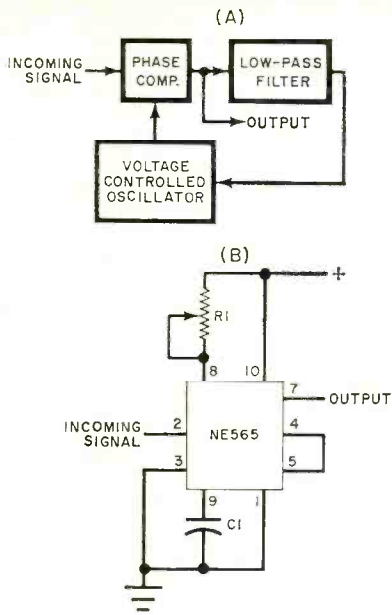

Fig. 1. The VCO tries to lock to the frequency of the incoming signal because of error voltage coming from the phase comparator. The filter removes the audio leaving the dc component. Error voltage varies with the SCA signal and becomes the audio.

controlled oscillator and generates an output voltage that is proportional to the phase difference between the two. This voltage is filtered and applied to the oscillator so that it always tries to reduce the phase difference between the two signals. The loop is "locked" when the control voltage causes the oscillator

frequency to equal the average frequency of the input signal.

Most television receivers use a similar phase-locked loop in the horizontal sync section. The phase detector in the TV set compares the frequency of the horizontal oscillator with a large number of horizontal sync pulses and adjusts the horizontal oscillator frequency so that the average phase difference is very small. The effect of any noise that may be present is greatly reduced by the phase-locked loop since it is an averaging process.

Note that the oscillator frequency tries to track the incoming frequency if the latter should change for any reason. Since the input to the PLL SCA system is a signal with some noise and the output of the VCO is clean, noise coming in is rejected.

The integrated circuit used in this project contains all of the elements necessary for the phase-locked loop and can provide highly linear FM demodulation over a range of 60% of the center frequency. Linearity is typically within 0.5% and the IC can be used to 300 kHz.

The VCO portion is set to oscillate at approximately the frequency we desire to demodulate by changing the values of  $R1$  and  $C1$  as shown in the simplified circuit in Fig 1B. When a frequency-modulated input is applied to pin 2, the output at pin 7 consists of the error signal generated by the phase difference between the VCO and the incoming signal. This error signal is exactly the same as the frequency modulation of the incoming signal, less noise; and, after proper de-

The SCA adapter is small enough to be mounted within the FM receiver being used, with a small bracket for support. The low power requirements enable this unit to be directly connected to the 9-to-18 volts usually used in solid-state receivers. The text explains a simple circuit to be installed if you use a vacuum-tube unit.

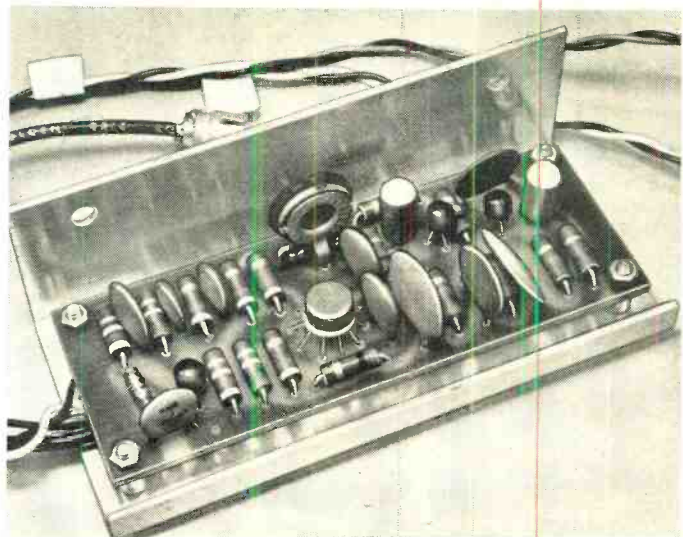

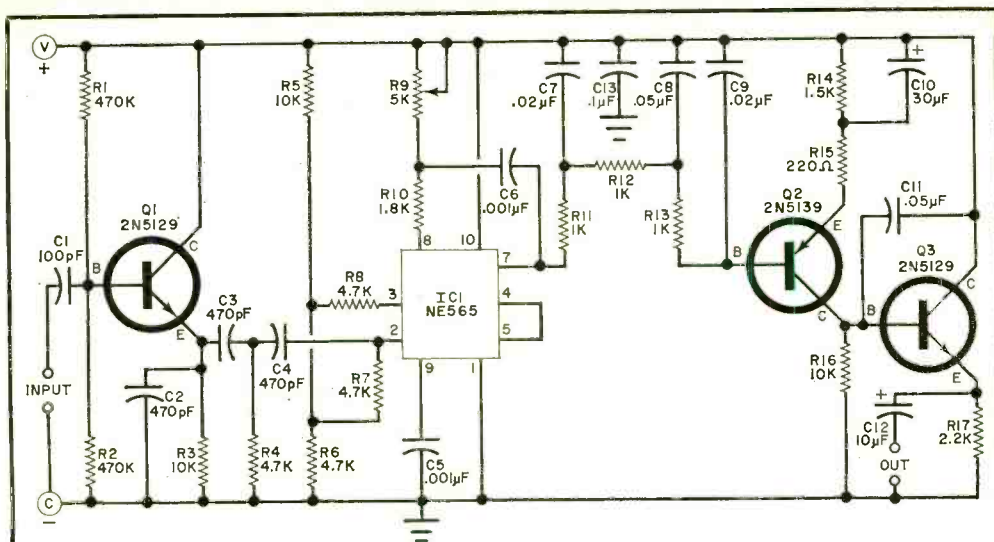

### PARTS LIST

C1—100-pF polystyrene capacitor  
 C2-C4—470-pF ceramic disc capacitor  
 C5, C6—0.001- $\mu$ F ceramic disc capacitor  
 C7, C9—0.02  $\mu$ F ceramic disc capacitor  
 C8, C11—0.05- $\mu$ F ceramic disc capacitor  
 C10—30- $\mu$ F, 6-volt electrolytic capacitor  
 C12—10- $\mu$ F, 15-volt electrolytic capacitor  
 C13—0.1- $\mu$ F ceramic disc capacitor  
 IC1—NE565 integrated circuit (Signetics)  
 Q1, Q3—2N5129 transistor  
 Q2—2N5139 transistor  
 R1, R2—470,000-ohm  
 R3, R5, R16—10,000-ohm  
 R4, R6-R8—1700-ohm

R10—1800-ohm  
 R11-R13—1000-ohm  
 R14—1500-ohm  
 R15—220-ohm  
 R17—2200-ohm  
 R9—5000-ohm trimmer potentiometer (IRC  
 X-201 or similar)

Note—The following are available from South-  
 west Technical Products Corp., 219 W.  
 Rhapsody, San Antonio, TX 78216: etched  
 and drilled printed circuit board #179 at  
 \$2.15, postpaid; complete kit of parts  
 #179C including PC board at \$14.55 plus  
 postage and insurance for 8 oz.

Fig. 2. Phase-locked loop IC is connected through an emitter follower (Q1) to remove any loading  
 on the FM detector. Once R9 is properly adjusted, there are no further adjustments to be made.

emphasis, it can be used to drive an audio  
 amplifier.

Transistor Q1 is a high-input-impedance  
 emitter follower which prevents loading on  
 the tuner output. The signal is filtered by  
 R3, R4, C3, and C4 to remove as much signal  
 below 50 kHz as possible. This makes it much  
 easier for the PLL system to lock on and re-  
 tain the SCA subcarrier at 67 kHz.

The demodulated output at pin 7 is passed  
 through another filter to remove any high-  
 frequency noise and provide de-emphasis, be-  
 fore voltage amplification (to 1 volt) by Q2.  
 Transistor Q3 is a conventional emitter fol-  
 lower used to drive the outboard audio system.  
 The top of the frequency range of the entire  
 system is approximately 7 kHz, which is suf-  
 ficient for the type of programming usually  
 carried on the SCA subcarrier.

**Construction.** The schematic of the adapt-  
 er is shown in Fig. 2. The entire circuit is  
 assembled on a printed circuit board as shown  
 in Fig. 3. All parts, with the exception of the  
 transistors and the IC, should be pulled down  
 firmly against the board with their leads bent  
 over and soldered to the foil. Leave about 1/8"  
 of lead exposed on each transistor and be  
 sure pin arrangement is correct before solder-  
 ing them in place. The leads of the IC must be  
 separated and bent to form a "spider" ar-  
 rangement. Again be sure the leads are prop-  
 erly oriented before soldering it in place. The  
 "T" on the foil pattern indicates where the  
 tab should be. Use a low-power soldering iron  
 and fine solder (resin flux).

The adapter circuit board can be mounted  
 on a support within the existing tuner or re-  
 ceiver or it can be mounted separately on a

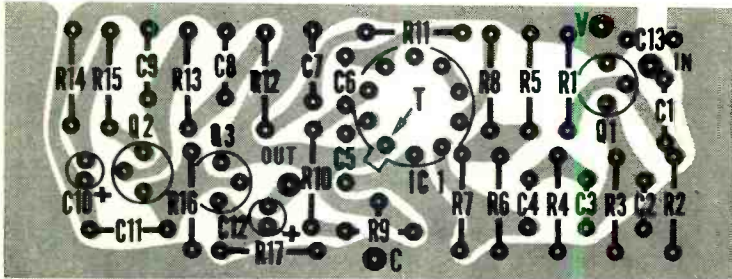
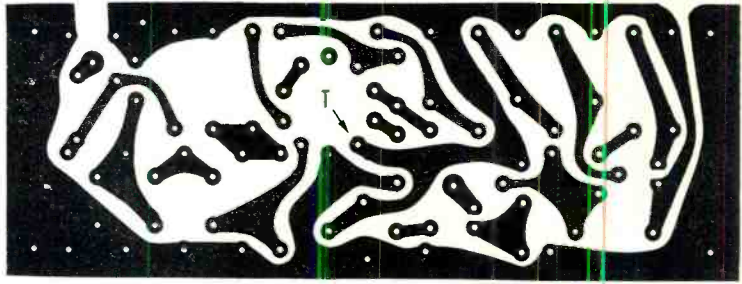

Fig. 3. When installing the components on the board, make sure the IC is oriented properly by noting exactly where the tab is located. Also observe the polarity of the electrolytics and the transistors.

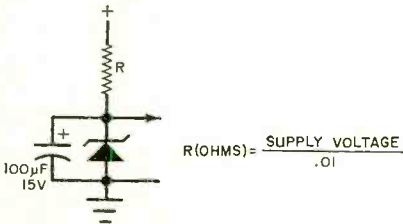

Fig. 4. This circuit is used if you happen to have a vacuum-tube receiver with its high dc voltage. After selecting a 9-to-18-volt zener, and allowing about 10 mA for it, calculate the resistor value.

small metal support. It requires 9 to 18 volts dc at 5 mA, which can be obtained from almost any solid-state tuner or receiver. If you have an older tube-type receiver, a voltage-dropping network such as that shown in Fig. 4 will be necessary. The resistor should be selected to supply approximately 10 mA to the zener diode with the available voltage supply. The zener can be any type within the 9-to-18-volt range.

**Operation.** The adapter is connected to the FM tuner at the output of the FM detector, before the internal de-emphasis network. It will not work on either stereo output jack. If the tuner or receiver contains a stereo multiplex circuit, the adapter can be connected to the same point where the multiplex circuit is connected.

The output of the adapter is connected to one of the high-level inputs of the audio amplifier. Tune in a station known to have SCA and adjust *R9* until the sound is clear. Once the center of lock range is found, the control may be left alone for all other stations. If you hear some feedthrough during pauses in the SCA transmission, the cause is probably insufficient bandwidth, improper alignment of the tuner i-f strip, or FM detector nonlinearity. In some areas, stations often turn off their SCA subcarrier when not in use. When this happens, the adapter will produce typical interstation noise.

-30-

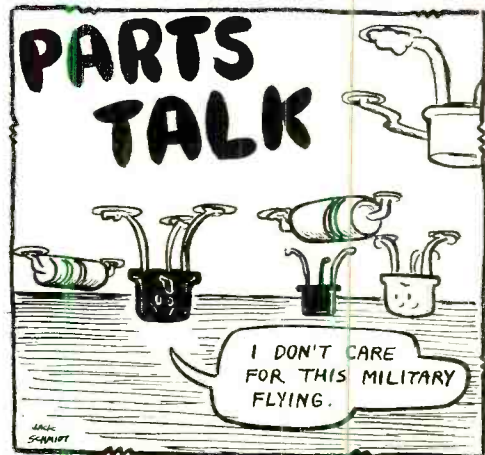



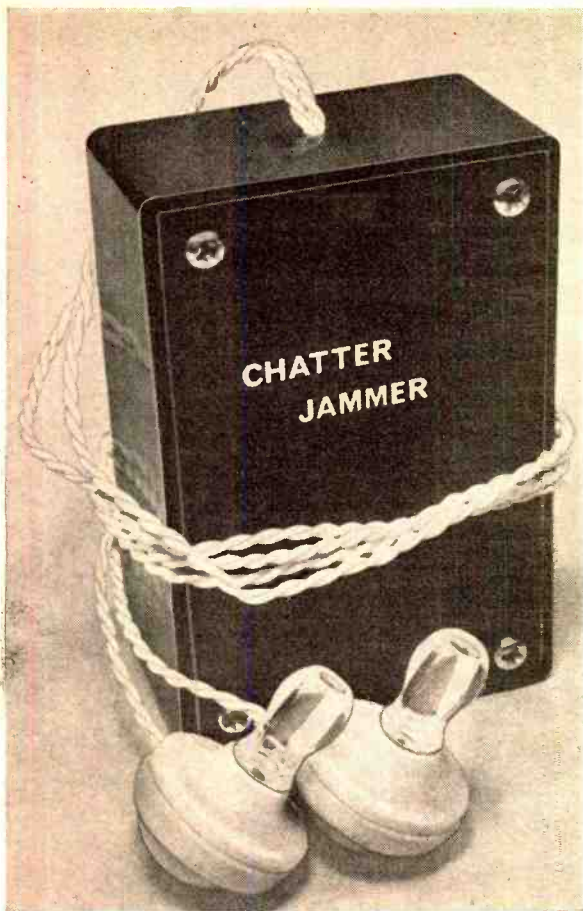

# BUILD A PINK NOISE GENERATOR

CUT OUT NOISE POLLUTION AND KEEP YOUR COOL

This article is about a unique device that masks disturbing noises by substituting the gentle "rushing" sound of pink noise. Self-contained, the pink noise generator can be assembled in less than an hour. Its masking effect should not be underestimated.

**E**VERY FAN of spy movies knows that the best way to keep hidden mikes from picking up top-secret information is to repeat the information only while you've got a shower running. Why? Because the sound of the shower covers up the conversation. Probably any sound, such as jack hammers or rock and roll music would do, but a real pro spy will settle only for a shower because it simulates a thing called pink noise.

Pink noise is a special case of a large general class of signal called white noise. Whereas white noise is a Gaussian (equal probability) distribution of all possible frequencies, pink noise is a distribution which is weighted toward the audio spectrum.

Besides being able to mask outside sounds, white noise has some other interesting properties. For instance, many people find a rain storm relaxing; and, while other effects such as the high concentration of ionized air may have some effect, at least part of the general feeling of well-being can be traced to the sound of the falling raindrops—a type of pink noise. The same is true of the sound of the ocean.

Some years ago a group of dentists experimented with the use of pink noise in the place

---

---

BY JOHN S. SIMONTON, JR.

## PARTS LIST

- B1*—Two 9-volt transistor batteries connected in series  
*C1*—0.1- $\mu\text{F}$  disc capacitor  
*C2*—0.005- $\mu\text{F}$  disc capacitor  
*C3*—0.01- $\mu\text{F}$  disc capacitor  
*Q1, Q2*—2N2712 transistor (see text)  
*R1, R2*—1-megohm, 1/2-watt, 10% tolerance resistor  
*R3*—100,000-ohm, 1/2-watt, 10% tolerance resistor  
*R4*—100-ohm, 1/2-watt, 10% tolerance resistor  
*Misc.*—Crystal earphones (2); printed circuit board (optional); plastic or Bakelite case; hookup wire; solder; etc.
- Note*—The following items are available from PAIA Electronics, Inc., P.O. Box 14359, Oklahoma City, OK 73114: etched and drilled printed circuit board for \$1.00; complete kit of parts, including PC board but not including batteries for \$4.75.

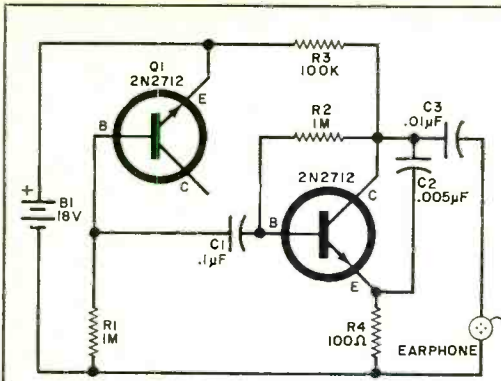

Fig. 1. Operated in avalanche, *Q1* serves as pink noise source. To preserve constant-level signal characteristic of pink noise, *C2* shunts appropriate levels of high frequencies away from earphone.

of local anesthetics. The results were questionable but in some patients the noise seemed to create a definite reaction on the nervous system so that pain sensations were blocked. Finally, several rock and roll groups mix a little pink noise in with their recordings to add body to the sound—which may be why so many of them are unintelligible.

The point of all this is that, if you must work in a noisy environment and sometimes have trouble concentrating or if you're just "up tight," you might want to try the "Chatter Jammer," a cheap, shirt-pocket-size gen-

erator of pink noise that not only keeps the noise out but will probably soothe your nerves as well.

**Theory of Circuit Design.** As can be seen from the schematic diagram in Fig. 1, the circuit of the Chatter Jammer is very simple. Transistor *Q1* is a silicon type that has a low emitter-to-base breakdown voltage rating. The base-emitter junction is reverse biased by the two series-connected 9-volt batteries that make up *B1*. In this setup, the base-emitter junction is operated in an avalanche condition.

Resistor *R1* in the base circuit of *Q1* limits the current flow through the junction and also serves as the load resistor for the shot noise which results from the avalanche process. The random ac voltage fluctuations produced by the avalanche effect are coupled into a single common-emitter amplifier stage, *Q2*, through capacitor *C1*. Once the signal is amplified, it is coupled through *C3* to the crystal earphones where it can be heard as a "rushing" sound similar to the sound you would hear if you held a seashell to your ear.

Capacitor *C2* shunts some of the high-frequency signal amplitude away from the earphone. As a result, all sound frequencies reaching the earphone are at one signal voltage level, giving the sound its "pink" characteristic.

**Construction.** There are only a dozen parts that make up the circuit of the Chatter

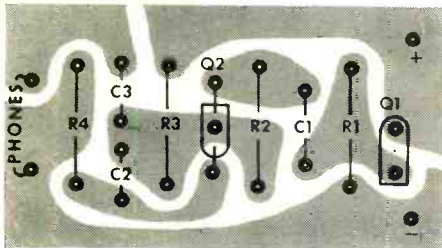
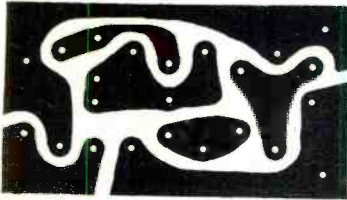

Fig. 2. PC board etching and drilling guide at top is shown full size. Directly above is components placement and orientation diagram.

Jammer, including the earphones and battery pack. Add to this the fact that there are no high frequencies involved that could cause assembly problems, and you can readily see that just about any method of construction can be used. A printed circuit board, however, makes the project more compact and rugged. So, if you make your own circuit board, use the etching and drilling guide and components placement diagram in Fig. 2.

During construction, there is one point that you should be aware of. There is the remote possibility that the first transistor you try for Q1 might not be a good noise source. Some transistors may not avalanche at all, while others may produce a very "grainy" sound. About 95 percent of all 2N2712 transistors will give the proper results; so, if you buy two for the project, at least one and probably both will work fine.

A power switch is not used on the Chatter Jammer for a very good reason. The current drain of the project's circuit is in the low-microampere region which means you will obtain essentially shelf life from the batteries even if the project is left on at all times.

Since the life of most 9-volt transistor batteries is so long, there is no reason why you should not simply solder leads from the batteries into the circuit instead of using battery clips that add to the project's cost. If you use stiff wire for the power leads, the leads can also support the circuit board.

The whole circuit, including board and batteries, fit neatly into a  $3\frac{1}{4}'' \times 2\frac{1}{4}'' \times 1\frac{1}{8}''$  plastic or Bakelite box (see photos). First

drill a small exit hole for the earphone leads in one end of the box. Pass the leads of two crystal earphones through the hole and tie a knot about 2'' from the free ends of the leads. Solder the leads to the appropriate points on the circuit board. (Note: Two earphones are used with the Chatter Jammer to increase the project's effectiveness. The addition of the second earphone will not affect the life of the battery supply.) A thin piece of Styrofoam can be cut to fit inside the case to keep the battery pack from working loose.

**How To Use.** Once the Chatter Jammer is operating properly, the only operation involved is to plug the earphones into your ears. You should immediately hear a rushing sound. Don't be surprised if it takes a minute or so to get used to the sound and feel of the earphones. After a short time, you will not be conscious of the rushing sound, nor will you be disturbed by extraneous sounds.

Musicians can try using the Chatter Jammer as a noise source by leaving the earphones off and connecting the output of the project to an unused high-impedance input of their instrument amplifiers. For a really strange effect, try passing the pink noise through a variable passband amplifier such as the "Waa-Waa" (POPULAR ELECTRONICS, Jan. 1970).

After you have used the Chatter Jammer for a while, you will be resorting to it whenever conditions prevent concentration or relaxation. It's sort of like having your own soothing rain sounds wherever and whenever you seem on edge.

-50-

To keep batteries in place and prevent circuit board from rattling, place piece of rigid foamed plastic, cut to size, under circuit board as shown.





# Reflex Enclosure Dimensions

BY E. G. LESCAULT

**D**ESIGNING your own reflex speaker enclosure is really very simple (see "Rally Round The Reflex," November 1969) if you don't have to juggle numbers. The nomograph on this page lets you determine the optimum enclosure dimensions—without mathematics—for a given enclosure volume in cubic feet. The scale calibration marks are set up to provide direct readout of length, width, and depth in inches for a given volume, all

the while preserving the optimum 1:1.44:2.08 dimension ratio.

To use the nomograph, simply lay a straight edge down so that it intercepts the appropriate cubic-foot figure in the Volume column and the other three columns for the most convenient dimensions. For example, the line drawn across the nomograph indicates a length of 30", width of 19", and depth of 12" for a 7 cu ft enclosure volume. —30—

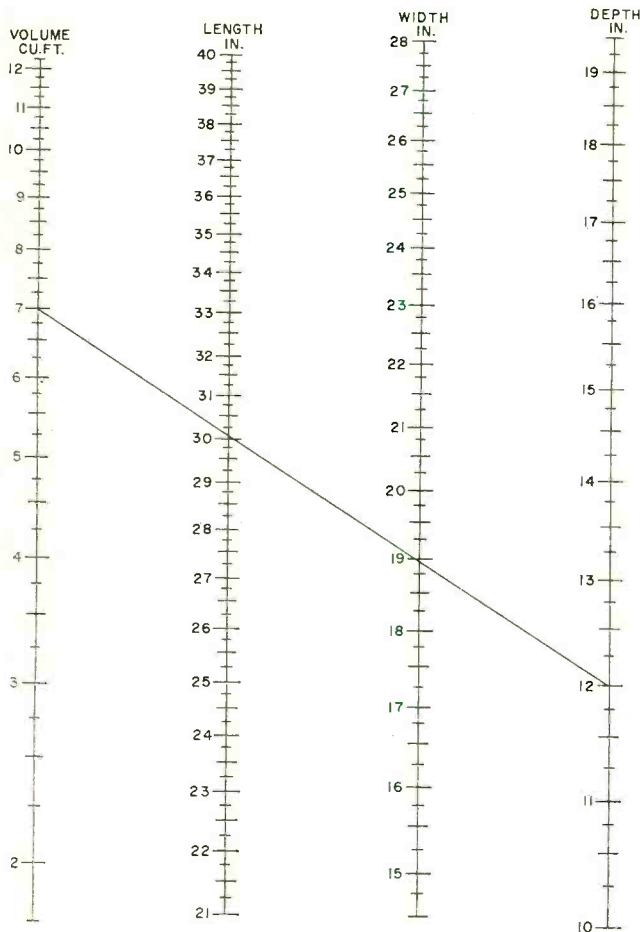

# Second Guessing The Heathkit IG-72

## HOW TO GET A ZEROBEAT

BY D. W. PALOMAKI

**I**F YOU OWN a Heathkit Model IG-72 audio generator, you already have an excellent piece of equipment. But you might not be able to zerobeat the IG-72 with a signal from another source. This is because the IG-72 has a switch-selectable discrete frequency output. However, for less than \$5, you can modify your IG-72 to provide zerobeat capability with continuously variable or the original discrete-frequency output. The modification is easy to perform and requires very little time. (The Heath Company engineers agree with the modification described in this article and point out that this idea is an integral part of their updated Model IG-18 and IG-18W solid-state sine-square-wave audio generator.)

The output frequency of the IG-72 is determined by a bridge-T network in a feed-

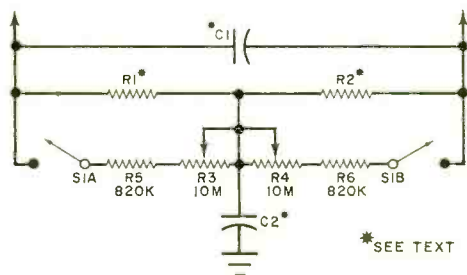

Fig. 1. Modification components to be added to IG-72 circuit are S1 and R3 through R6.

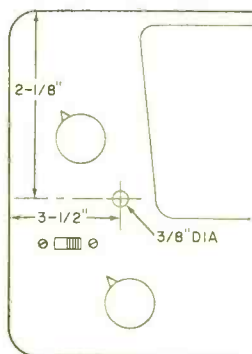

Fig. 2. Before drilling R3/R4 mounting hole, check for adequate behind-panel clearance.

back circuit as shown in Fig. 1. The multiplier (1, 10, 100 and 1000) is determined by the values of capacitors  $C1$  and  $C2$ . The significant figures are selected by the "cycles" switches on the front panel of the instrument. These switches change the resistances of  $R1$  and  $R2$ . For the "tens" range, the values of  $R1$  and  $R2$  are determined by parallel-connected resistors, effectively 100,000 ohms per step. The "units" range values are set by 1-megohm parallel-connected resistors, each of which is selected in discrete increments. Hence, a 4700-Hz signal setting would be the equivalent of four 100,000-ohm and seven 1-megohm resistors in parallel, with a multiplier setting of 100.

Now, the modification in the IG-72 allows you to obtain a continuously variable frequency output by adding a variable resistance in parallel with the resistance selected by the "cycles" switches. With the values given in Fig. 1, a range of 10.82 megohms to 820,000 ohms is available. This has the effect of providing a variable third significant figure that is continuously adjustable between 4709 and 4920 Hz.

The overlap of ranges is required for two reasons: First, it allows for the variation in tolerances of component values to insure full coverage. The second reason is due to the nature of available potentiometers; the ideal would be a pot with values that range continuously from infinity to 1 megohm, but 10 megohms is the best that can be had for the high end. This prevents attainment of zero with the third significant figure unless the switch is thrown to remove the added resistors from the circuit.

To increase the overlap range, the values of  $R5$  and  $R6$  can be reduced. Using 680,000-ohm values provides the variable function over a range of 0.094 to 1.45. The use of 500,000-ohm values extends the high end to 2.0 for an overlap of one full step in the units range.

The details for making the modification installment in your IG-72 are shown in Fig. 2. Switch section  $S1$  and pot sections  $R3$  and

*R4* must be wired to provide a dpst-switched 10-megohm dual-pot arrangement. (This is a single part consisting of a dual-pot with an add-on dpst switch attachment.) The dual-pot is then mounted through a  $\frac{3}{8}$ "-diameter hole previously drilled in the front panel at the location shown. (Note: Be sure to check for proper clearance behind the panel before you drill this hole.)

When installing the modification components, bear in mind that *C1*, *C2*, *R1* and *R2* represent a simplified version of the original bridge-T network in the IG-72 generator. You will be adding the modification components to the circuit without breaking any of the original circuit's lines. Hence, only three short lengths of hookup wire from the new circuit will complete wiring.

**To operate the new circuit**, just turn the control knob clockwise past the click, varying the setting as required to obtain zero-beat. Turning the control knob counter-clockwise past the click restores the circuit to normal operation.

The rated frequency accuracy of the IG-72 is 5%, although most generators operate within tighter tolerances. This means that if you select a 2500-Hz output, it could be as low as 2375 Hz or as high as 2625 Hz and still meet the rated specification. So you can see that calibration of the newly installed control would serve no useful purpose since, by calibrating it, you might know that you have added, say, 0.6 times the third significant figure in Hertz without knowing the absolute frequency of the output signal. —30—

## Single-Filament Tail Light Converter

BY MARVIN BEIER

**M**UST YOU RESTRICT your trailer hauling to daylight hours because you don't have the safety lights required by law for night hauling? If so, a simple converter circuit, installed in your trailer lamp circuit, can allow any single-filament trailer light to operate as tail and brake lights, four-way safety flashers, and individual turn signal indicators.

The converter circuit, shown in the schematic diagram, consists of two 10-watt resistors and two 25-volt, 5-ampere silicon diodes. These few components can be housed in a 4" × 2" × 2" metal utility box, which can then be bolted in any convenient location near the trailer lights. Connections to and from the converter circuit should be through a screw-type barrier block.

The cables from your car brake and tail lights and to the trailer lights should

be #16 or heavier wire. Use spade lugs on the ends of the wires that connect to the barrier block.

Once installed between the car and trailer lights, the converter operates as follows: with the car lights turned on, current flows through the tail light lead and both pairs of resistors and diodes to the trailer lights. The brilliance of the trailer lights is somewhat subdued as a result of the voltage drops across the resistors.

Now, when the car brake is operated, current flow bypasses the resistors and diodes, going directly to the trailer lights via the left and right brake-light leads. Here, full current is delivered, and the trailer lights operate at full brilliance. The diodes are in reverse bias, preventing current from circulating through the diode/resistor circuit.

When the directional signal or four-way safety lights are operated, the trailer lights again glow at full brilliance. Each lamp can operate singly since the diodes again restrict the current flow in one direction.

You will notice from the schematic diagram that only one connection is shown to each of the trailer lights from the car. The diagram assumes that the trailer and car grounds are coupled together to complete the circuit. —30—

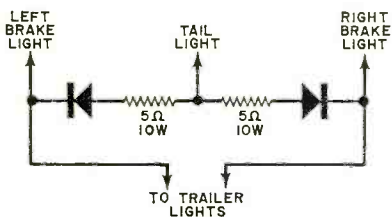

Only "hot" lead hookups are shown; circuit must be completed by connecting a cable between trailer and car chassis.



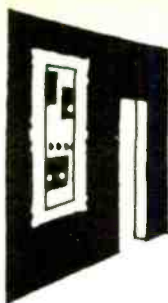

## THE PRODUCT GALLERY

Third in a Monthly Series by "The Reviewer"

EVERY NOW AND THEN, after visiting a friend's house, I come away mumbling to myself that color TV should have never been foisted on the American public. Not only wasn't the public ready for it, but they are asked to contend with so many variables in terms of tints and color tones that anything seen in most homes resembling "good" color TV is strictly accidental.

To some extent, the problem of obtaining "good" color presupposes that the broadcasting station is transmitting optimum color values in the first place. Possibly half of the stations transmit a good color signal, but the other half have a "Captain Video" whose eye is the colorimeter that sets skin tones and color values. Of course, all of this ignores the fact that live programming, tape and film each have color values of their own. The demise of Captain Video is within the foreseeable future, however, and with the introduction of the Heathkit Vectorscope Model IO-101, any color TV receiver can be optimized; putting the burden of good color back where it belongs—at the doorstep of the transmitting station.

### Heathkit Model IO-101 Vectorscope.

This is a specialized oscilloscope designed to display a petal-shaped pattern that is a representation of the burst phase angle and the phase angles and magnitudes of the color signals in a TV receiver. The Vectorscope itself is used in conjunction with a color bar generator so a bar generator similar to the IG-28 has been built in. With this integrated instrument, the user can quickly and accurately align or tune every circuit in the chroma sections of the receiver. The Vectorscope process requires only a logical interpretation of the petal display and it is easier to use and generally agreed to be more accurate than other color alignment methods.

About a year ago, this department spoke very highly of the Heathkit Model IG-28, noting particularly the applications of digital IC logic design, full pattern capability (including Heath's exclusive 3×3 and 9×9 dis-

play functions), crystal control, operator conveniences, and last, but far from least, low cost. The color bar/dot generator in the IO-101 bears a strong resemblance to the IG-28 and offers all of the same flexibility and stability.

The Vectorscope sub-section of the IO-101 is designed to provide a visual display of the 10 color bars generated in the instruments, amplified and demodulated by the color TV receiver under test. Thus, the Vectorscope comes into operation only when the function switch is in the "Color Bars" position.

**Assembly.** The IO-101 kit can be assembled in about 16 hours. There are no difficult construction problems although some builders may find wiring the front panel a little tricky since tight spaces are involved.

There is one change immediately apparent on the divider circuit board. In the IO-101, IC sockets have been replaced by ingenious discrete IC pin clips. The innovation has its advantages, not the least of which is that it helps eliminate the problem of the IC's working loose.

You will be surprised to find that the IO-101 Vectorscope weighs less than 10 lb. This is an obvious attraction for the color TV technician and when the price tag of \$125.00 is considered by the electronics hobbyist, it is not hard to imagine that this instrument will be found in many workshops where color TV alignment (and repair) is a sometime thing.

**Connections and Use.** The user connects the Vectorscope to a color TV receiver through a gun-shorting cable assembly. Alligator clips on the ends of the cable assembly are connected to the picture tube socket assembly and either the cathode or grid CRT feed (depending on the receiver).

When the interconnections are made, the display pattern is an exact presentation of the phase angles and intensities of the chroma signals being fed to the guns of the

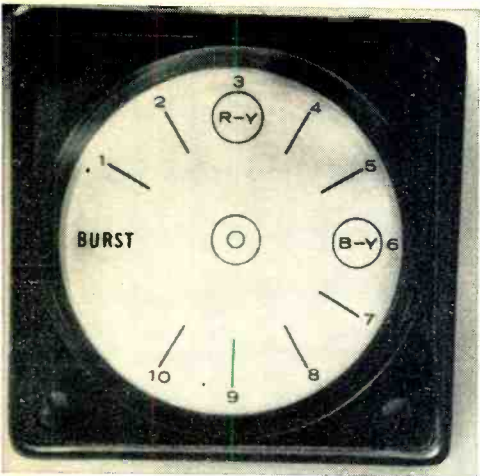

Vectorscope face numerals correspond to 10 bars from built-in generator. In 3x3 pattern the petals indicate deficiencies in display of red, green and blue bars.



The Heathkit 10-101 Vectorscope is a lightweight self-contained test instrument for setting up convergence, purity, and gray scale of any color TV receiver. Much of the wiring (to left) is on a printed circuit board and relatively easy to handle. Rear of the instrument has hooks for retaining necessary interconnecting cables to color TV receiver. Note "chroma" switch which permits use of Vectorscope with any picture tube feed circuit arrangement.

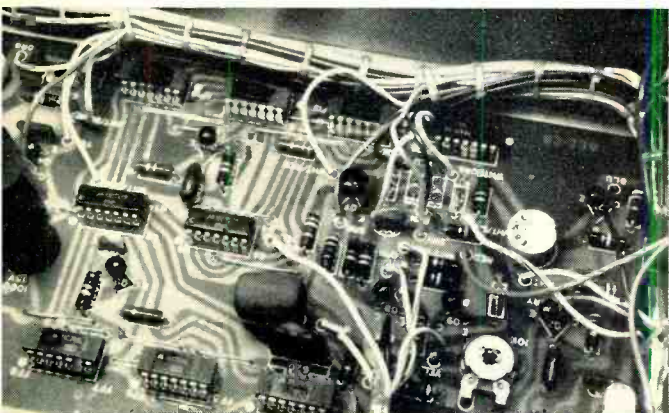

Controls shown below pertain to functions of the built-in Vectorscope color bar generator.





CRT. The instruction manual with the Vectorscope kit goes into extensive detail on how to interpret the petal display pattern and how the pattern is used to diagnose troubles and the alignment of chroma circuits. From the size, shape, and angle of the petals displayed, you can determine if a color is missing or weak. For alignment purposes you can adjust the burst and phase transformers, reactance coil, etc., precisely and accurately by simply observing the petal display.

I cannot help but be enthusiastic about the Vectorscope. Here at last, is a test instrument that will permit the knowledgeable electronics enthusiast with a color TV receiver to establish his own shading and skin tones as theory indicates they should be.

**Ungar IC De-Soldering Tools.** Printed circuit boards are a mixed blessing to the manufacturer and the serious electronics experimenter. I say "mixed" because some of the advantages go down the drain when defective components must be replaced. The multi-lead IC has aggravated the removal-replacement problem.

Evidently, the boys at Ungar (Div. of Eldon Industries, Inc.) were not only aware of the problem, but able to come up with a brand new line of desoldering tools that simplifies the life of everyone working with a PC board. What Ungar has done is take one of their low-wattage heating elements and make some new screw-in tips. One tip has a rimmed rectangular shape that can simultaneously de-solder all the pins of a dual in-line IC. A second type is a rimmed circular tip that fits around the clipped ends of conventional transistor pin arrangements. Then there is a slightly larger circular tip that can be used to de-solder circular pin configurations of some IC's (0.6" diameter).

The new tips represent a partial solution to the removal problem but Ungar was able to turn some attention to IC and transistor extraction also—not everyone is born with a third hand. Ungar has solved the removal problem with a pair of spring-loaded extractors—one for in-line IC's and the other for various TO's. To remove an IC or transistor you simply attach the extractor to the component and heat up the connections

on the foil side of the PC board. As soon as enough heat gets to the pins to "unstuck" the solder, out pops the transistor or IC.

If you have some of the Ungar handles or low-wattage irons, all you need to convert them to de-soldering tools is the #1235 drilled and tapped heating unit—which screws into the #776 soldering iron handle. Then, depending on the type of work you are doing, select the necessary extractors and de-soldering tips from the manufacturer's Princess line.

**Not Strictly as Advertised Department.** Last July, the editor dropped on my desk a press release concerning a "New Electronic Intrusion Alarm." It said, in part, that any movement within its 20' detection range immediately sets off the alarm. That it could be hidden anywhere, even in the dark and that an adjustable electronic sensor cell circuit gives continuous protection. It was \$19.95 postpaid from Johnson Smith Co., 16535 E. Warren, Detroit, MI 48224.

A peek at the photograph accompanying this release revealed that it was our old friend the "Sentray" from AMF-Paragon. For those who may not have followed the in's and out's of burglar alarm development, the Sentray is a photocell device that operates from three size C flashlight cells. The circuit is on a PC board with a single transistor controlling the gate of a C106Q1 SCR which triggers a not-too-loud buzzer. To operate the Sentray, you aim the end that has the photocell (which peeks through a 3/8" hole) at a light source—which really means that the room to be protected must be illuminated since the circuit operates when a shadow falls on the photocell.

Although the promotional copy distributed by Johnson Smith is not a "distortion," neither is it written to protect the gullible. Getting the Sentray to work at a 20' range takes some fancy doing. It requires a very strong light and quite obviously the light source must be shining on the photocell.

The "operating instructions" from AMF-Paragon are well-written, clear and concise. In fact, they give all possible malfunctions and no effort is made (once the unit has been purchased) to hide any potential deficiencies—something this reviewer can't say for the promotional copy. -30-

*(Photos Overleaf)*

**FOR MORE INFORMATION**

Vectorscope—Circle No. 87 on Reader Service Page 15 or 95.

Ungar—Circle No. 88 on Reader Service Page 15 or 95.

Sentray—Circle No. 89 on Reader Service Page 15 or 95.





Ungar's "Princess" line of de-soldering tools are in blister packages and they fit easily into the basic Ungar handle. Two photos below show how the in-line de-soldering tip is applied to the foil side of board to heat the connections to the IC, while the spring-loaded removal clip is attached to the IC itself. It's a 1-2 operation, requires no third hand, and won't damage rest of board.

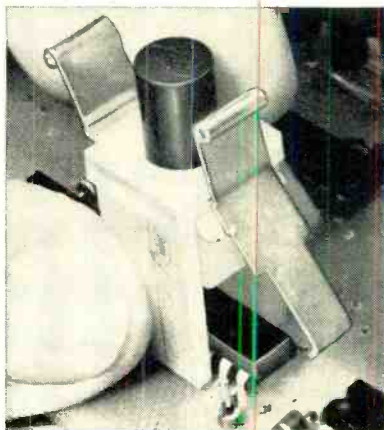
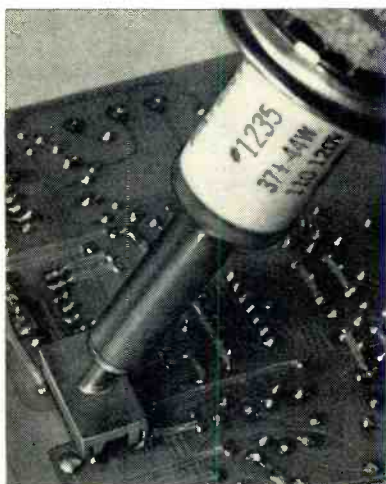

Johnson Smith & Co. electronic intrusion alarm is Sentry system manufactured by Paragon Electric. A CdS photocell at the other end of the plastic case must be illuminated. Slide switch breaks SCR circuit to silence buzzer during setup. Our purchased test unit arrived with buzzer held in place by one and one-half plastic pins and one push-on speednut (below). Two speednuts and another plastic pin were rattling around inside the alarm's plastic case.

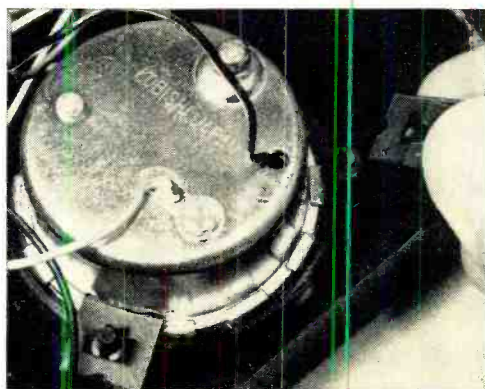



Fourth in a Monthly Series by J. Gordon Holt

**O**NE OF THE LETTERS I received in response to my first column here (September 1970) was from a young man who said "It's all very well to be idealistic about super-fidelity and patronizing about mass-market components, but what about those of us who can't afford a \$1000 system, let alone a \$2000 speaker?"

If my column gave the impression that I scorn anything that is less than super-fi, let me set the record straight. I practically *love* super-fi, and I feel vaguely unfulfilled when listening to anything less, but that doesn't mean I'm an audio snob. Like most people, I can't afford to be. My exposure to top-of-the-line equipment is a result of the cooperation of manufacturers who loan me things for testing. I am able to keep them just long enough to appreciate how good they really are, and then—sadder but wiser—return them.

Most of the components I do call my own are what would be considered upper-level moderate-cost equipment, which is very enjoyable to listen to once I've recovered from the trauma of parting with a \$2000 loudspeaker system. I also own an antique Granco FM radio and it may shock some readers to learn that I enjoy listening to that, too, when my mood is more for good music than supersonics.

I find that my own reaction to reproduced sound has a great deal to do with the *pretensions* of the reproducer. When listening to an \$800 system, I *expect* it to have a rather wide range and respectably clean and uncolored sound. If it doesn't it annoys me much more than do the same deficiencies in a system that doesn't pretend to be hi-fi. Much of what I enjoy in music is very nearly as audible from a small system as from a super-rig, so the former suffices when it is inconvenient to listen to the latter.

What does this digression have to do with the equipment buyer? Simply this: since all components fall short of perfection in differ-

ent ways, your own personal reaction to any component will depend more on the things *you* are most critical of than on the actual objective quality of the unit.

Loudspeakers have wide variations in "character," and even the top-of-the-pile speakers are so different in sound that any expert who names one speaker as the "best" is climbing out on a rotten limb. What he means is either "this measures the best" or "this sounds the best to me." Neither tells you what you need to know: will it sound "best" to you?

In the middle- and low-price ranges, where deviations from perfection are much more pronounced, there are almost as many expert opinions as there are experts. For this reason—and several others that I won't go into now—tabular listings of recommended systems in various price ranges should be viewed as opinions and nothing more.

**Self-Analysis.** There are a few questions you should ask yourself before you start to think in terms of brands and model numbers. Determine what kind of a system would best suit your needs. Do you plan to use music

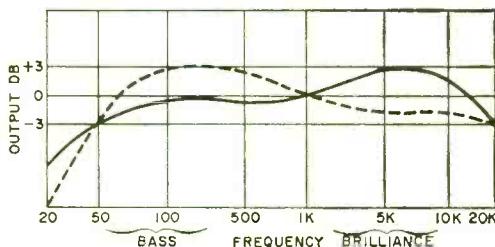

Averaged frequency response curves of two hypothetical loudspeakers, both of which have "identical" measured response of  $\pm 3$  dB from 50 Hz to 20 kHz. Quite obviously, they will not sound even remotely alike, and only you can determine which you will prefer when you hear them side-by-side.



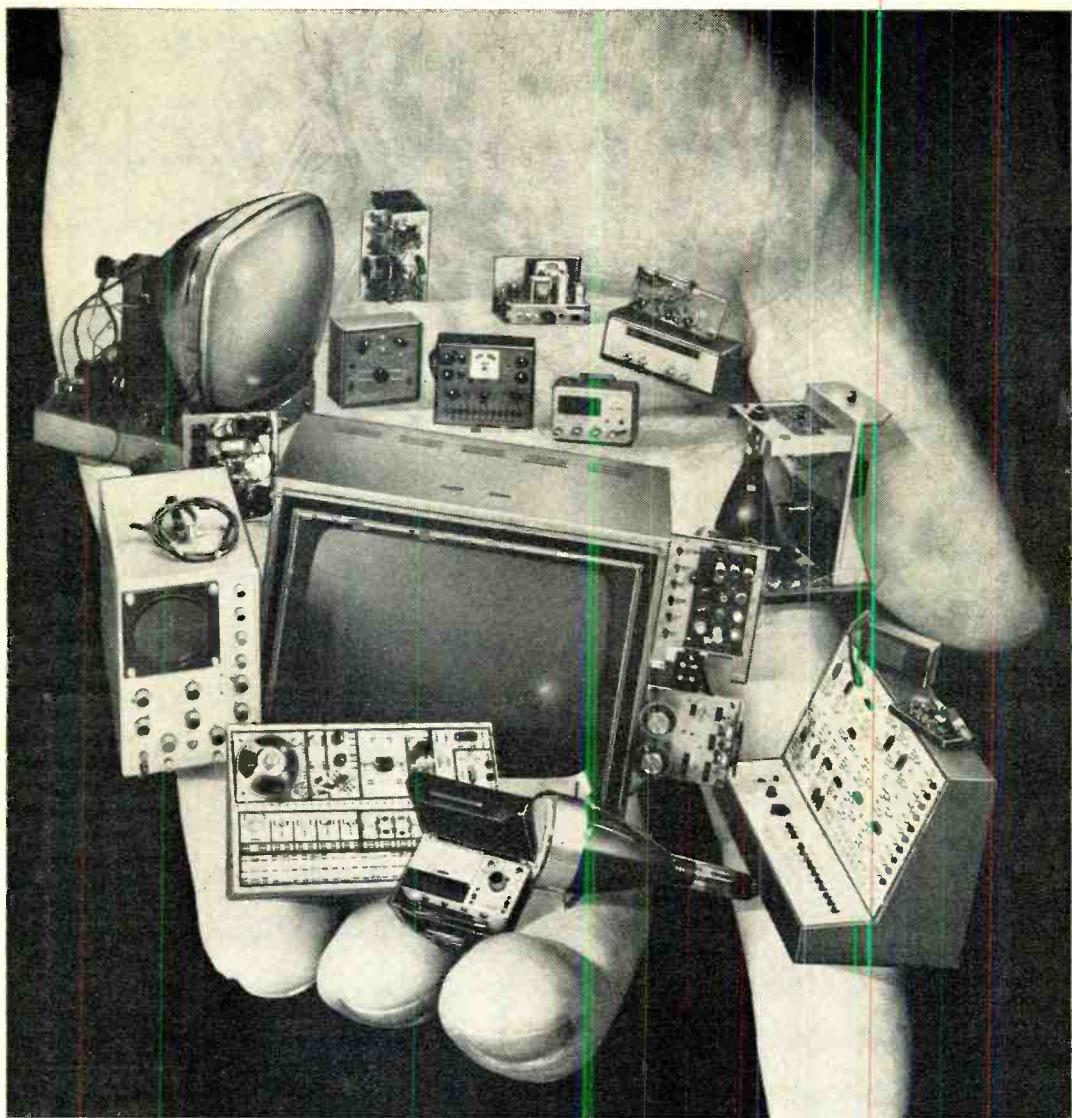

## NTS puts a whole new world at your fingertips.

NTS home training can put a whole new way of life in the palm of your hand. A new, exciting job, a much bigger income is now easily within your reach.

NTS training is something special. We provide all the kits you need for the most effective training. National Technical Schools sends kits with every course, and teaches you to build and test a

wide range of professional equipment — the same kind of equipment you'll actually use on the job. That's the NTS "Project Method" — training that's practical and in-depth. You learn everything from fundamentals to the latest innovations. From beginning to end, NTS makes it fascinating and fun to learn this way. And all you need is a little

spare time and an interest in electronics.

Each year, men are moving into important new jobs, or their own businesses, straight out of NTS electronics training. NTS is what's happening to men everywhere. Check the coupon. Take hold of the career you want most. Do it now. No obligation. No salesman will call.



# We pack your electronics course with kits to make your training fast. You'll enjoy every minute of it.

## NTS COLOR TV SERVICING

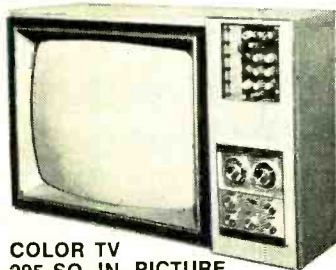

**COLOR TV**  
295 SQ. IN. PICTURE

NTS training provides an easy way to become a professional home-entertainment service technician. You receive a big screen Color TV with many unique features. The unit even includes self servicing equipment that permits you to make all normal test operations. No additional test equipment is needed for adjusting your set. In addition you get an AM-SW radio, Solid-State radio, Field-Effect Transistor Volt-Ohmmeter, and Electronic Tube Tester. You learn about Electronic principles and trouble shooting, hi-fi, multiplex systems, stereo, and color TV servicing.

## NTS COMPUTER ELECTRONICS

This is the future. And it's happening now. The number of computers will increase many times in the next few years.

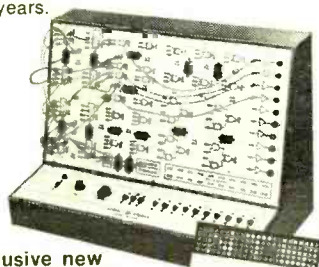

Exclusive new **Compu-Trainer®**

If card is missing check coupon and mail for free color catalog and sample lesson. Now.

### National Technical Schools

4000 S. Figueroa St., Los Angeles, Calif. 90037  
Please rush Free Color Catalog and Sample Lesson, plus information on course checked below. No obligation. No salesman will call.



NTS offers a solid grounding in computer operation, wiring, data processing and programming. One of the 10 important kits included is our exclusive Compu-Trainer®. It's a fully operational computer logic trainer — loaded with integrated circuits — the first ever offered in home study. It introduces you quickly to how, what, when and why of computers . . . from theory to practical servicing techniques. This unit is capable of performing 50,000 operations per second.

## NTS ELECTRONICS COMMUNICATIONS

Choose from two exciting courses to get into the big-paying fields of transmitting and receiving equipment: (1) The FCC License Course. (2) The Master Course in Electronic Communications (more comprehensive, with Citizens' Band Two-Way-Radio). Either Communications program qualifies you for your FCC First Class Commercial Radio-Telephone License — NTS assures you will pass this FCC exam within six months after successfully completing your course or your tuition is refunded. Kits include an Amateur-Phone 6 Meter VHF Transceiver — NTS exclusive, 6 transistor Solid-State Radio, Volt-Ohmmeter (fully transistorized).



5 Watt AM Transmitter/Receiver

## NTS AUTOMATION/ INDUSTRIAL ELECTRONICS

Let NTS put you into the age of electronic controls. Systems Automation is rapidly becoming the emphasis of modern industry. Your NTS training in automation electronics includes equipment like a 5" wide band Oscilloscope. You also get the new NTS Electronics Lab. It's an exclusive NTS experimental laboratory — a complete workshop that simplifies learning about solid-state, miniature and integrated circuits.

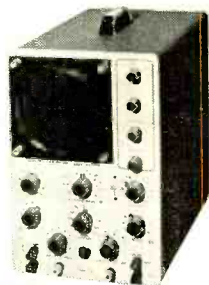

5" Oscilloscope

## CLASSROOM TRAINING AT LOS ANGELES

You can take classroom training at Los Angeles in sunny Southern California. NTS occupies a city block with over a million dollars in facilities devoted exclusively to technical training. Check box in coupon.

## NATIONAL TECHNICAL SCHOOLS

WORLD-WIDE TRAINING SINCE 1905

4000 South Figueroa Street  
Los Angeles, Calif. 90037, U.S.A.

## APPROVED FOR VETERANS

Accredited Member: National Association of Trade and Technical Schools; National Home Study Council.

- Master Course in Color TV Servicing
- Color TV Servicing
- Master Course in TV & Radio Servicing
- Practical TV & Radio Servicing
- Master Course in Electronic Comm.
- FCC License Course
- Master Course in Electronics Tech.
- Industrial and Automation Electronics
- Computer Electronics
- Basic Electronics

Name \_\_\_\_\_ Age \_\_\_\_\_

Address \_\_\_\_\_

City \_\_\_\_\_ State \_\_\_\_\_ Zip \_\_\_\_\_

- Check if interested in Veteran Training under new G.I. Bill
- Check if interested only in Classroom Training at Los Angeles

Dept. 205-120

merely as a background for other activities (audible wallpaper) or will there be times when you expect to listen to it intently? One way you can tell this in advance is by your reaction to an offer of free tickets to a live musical concert. If you choose to attend instead of doing something else, you'll probably want to listen to music (instead of just at it) in your home, and this means you should consider things like amplifier power and loudspeaker smoothness. For background listening, practically any reproducing system will suffice.

If you *are* the attentive-listener type—what kinds of music will you be listening to? And how loud? Do you like classical music heard from a front row seat? If so, you'll want a high-powered amplifier (50 to 100 watts per channel) and a moderately efficient and "forward-sounding" speaker. If you prefer a first-balcony seat, you'll need moderate amplifier power (35 to 70 watts) and a more neutral- or distant-sounding speaker.

For chamber music heard from a reasonable distance, a moderate-powered amp and a neutral speaker are indicated, while in-the-room re-creation of non-electronic instruments or high-intensity rock will call for highly efficient speakers and as high-powered an amplifier as the speakers can handle with safety. Remember, though, that overly loud music can be just as damaging to your ears as moonlighting in a boiler factory. On the other hand, the proximity of unappreciative neighbors may frustrate your desire for traumatic deafness unless you resort to headphone listening.

Generally, folk music or folk rock is best reproduced at a level just loud enough to allow spoken conversation at a distance of 2 to 3 feet. Amplifier power requirements are fairly low (20 to 40 watts) and the speakers should be neutral or a shade close-sounding. You can of course make a lot of noise with a 10-watt amplifier driving fairly efficient speakers, but it probably won't sound too good. This isn't because the amp lacks power—indeed, you can produce concert-hall levels from high-efficiency speakers with a mere 5-watt amplifier—but because low-powered amplifiers are not usually designed for the very low distortion of high-power units. In fact, the more powerful the amplifier, the better it usually sounds, even at listening levels well below the lesser amplifier's overload point. So it pays to aim high, if only for your in-the-future "dream system."

It's easy to say "I don't need that kind of fidelity; my hearing isn't all that acute," until you've cut your teeth (ears?) on a good component rig. If you're a listener who really listens, it's a good idea to view your

budget system as only a first step toward perfection, and plan accordingly.

For example, whether you opt for discs or one of the tape media, I strongly suggest that you *not* skimp on the purchase of your playback unit. The rest of the budget system can be junk for the time being, but a good phono cartridge or tape machine will help to ensure that your music collection will still be in good condition by the time you graduate to a system that is capable of reproducing every nuance of music—and distortion.

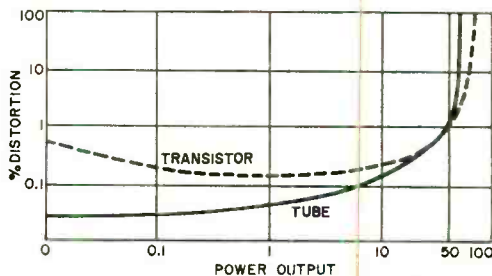

Typical distortion-vs-output curves of a good tube-type amplifier and an early solid-state amp, both of which are rated "identically" at 1% distortion for 50 watts output. Statistically, most signals occur below 1 watt, where the amplifiers have quite different distortion characteristics.

Even if you have been buying discs and tapes, your first decision before embarking on a serious system purchase should be "disc or tape, or both?" Open-reel 4-track tapes look like a dead issue as far as 1971 commercial releases are concerned—even if 4-channel does give it a brief shot in the arm. Cassettes and cartridges are comparable as to convenience, but you can't rewind a cartridge, whereas you can't let a cassette run all day nonstop *without* rewinding it—although automatic rewind of cassettes narrows the distinction. Cassettes are shaping up as the tape medium for the attentive listener, whereas cartridges are being promoted for the people who want background or incidental music. Discs are easily damaged by casual handling or by playing on mediocre equipment, but they allow easy "spotting" of individual selections, and you can be reasonably assured that every recording issued for some years to come will be issued on disc. If you can't decide, you can always go for all three media and buy a player for each—but don't speak to me about budgets.

**The Components.** The phono turntable or player need not be any great shakes, as long as its rumble and speed variation are low enough so as not to drive you up the wall. Some otherwise excellent phono car-

tridges are sensitive to inductive hum interference, though, so check this aspect of compatibility. The phono pickup cartridge itself should be of top quality, for the better its tracking ability (at a given contact pressure), the easier it will be on records. And since there is evidence that elliptical styli are harder on records than sphericals, I'd advise flying in the face of fashion and buying a spherical.

The tone arm (if you go to a turntable instead of a player) need not be of the very best, at least not to start with. You may end up with a Rabco SL8E eventually, but in a budget system, the most important thing is freedom from pivot friction. You can check the pivots by taping enough coins to the empty head shell to allow the arm to be balanced to zero grams, and then blowing gently on it from above and from the side. It should swing smoothly and easily in all directions (although slowly, if viscous-damped). Any hesitation indicates pivot problems.

Get into the habit of caring for discs properly. You've been told that dust is destructive to discs, but you have to hear what a scratched, dirty record sounds like on a good system before you can appreciate what your pristine new discs will sound like one year hence if you don't take care of them. Of course, dust particles can be removed at any time, but you can never remove the gouges and pot-holes caused by the stylus grinding the particles into the groove walls. You should keep your fingers off the playing surfaces, and either clean each side *carefully* before playing or, preferably, use a perpetual cleaner like the "Dust Bug." Do *not* use a dry brush or pad, nor any of the silicone-impregnated cloths sold in most record stores. The best record cleaners I know of are the Cecil Watts devices marketed by ELPA Industries.

If you're going the tape route, your player should be able to handle the longer-playing cassettes or cartridges with adequate gentleness and, in the case of cassettes, it should have some form of protection against end-of-rewind tape pulloff or recorder damage due to motor-stalling.

In a modest system, the amplifier should be the next-best component after the player unit. A good, low-distortion amplifier will sound pretty good through a rather lousy loudspeaker, but a good loudspeaker reveals things about a poor amplifier that are best left unheard. This is why the speaker should usually be the *last* thing to be upgraded from one "quality level" to another.

Since you can expect to pay a relatively substantial amount of money for the amplifier, it is wise to try and get one that will have some trade-in value. Although this is impossible to predict with certainty for any

particular model, you can generally trade in those amps from manufacturers who don't obsolete their models every year or so. A component that has been in production for several years is a fairly good bet for relatively low depreciation in future, particularly if you elect to sell it while it is still in the manufacturer's catalog.

I do not recommend buying a stereo receiver for a budget system because, apart from the initial cost (which must be borne in one fell swoop), you won't be able to upgrade your tuner, preamp or amplifier individually until you can afford an even bigger outlay to replace the whole receiver. And although there are fine receivers available, you can get *better sound for the money* from a well-chosen trio of individual components. Magazine equipment reports are your best source of information about what is good in each component category, even if you are sometimes obliged to "read between the lines" in order to divine what the reviewer *really* thinks. Watch for the case of two different publications agreeing about a certain component. Three or more agreements are the next best thing to a guarantee of quality.

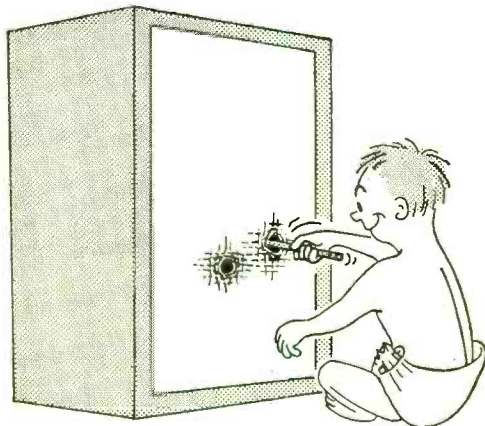

In used speakers, holes in the grille cloth may indicate that the cone itself has been damaged.

**What to Buy?** Many dealers have some sort of "audio comparator" gadget that allows them to switch from one component to another so you may make listening comparisons. This reveals gross differences, but not much more. And if you are not thoroughly familiar with the sound of live music, you will invariably choose from an A-B-C comparison that system which is either the loudest or which best meets your peculiar concept of how hi-fi should sound. How, then, can you be reasonably assured of starting out with a passably good system?

(Continued on page 94)





# COMMUNICATIONS

## CITIZENS RADIO (CB)

**CeeBRON Gets Under Way**—A new CB organization claiming that “representation” is its prime goal is making a charter membership drive. Calling itself Citizens Band Radio Operators National (pronounced CeeBRON) the new group is based in Washington, D. C. President of CeeBRON is John Gonella, a legislative consultant and recently assistant for Congressional liaison to President Johnson. General Counsel of CeeBRON is Robert M. Lowe, attorney and consultant on communications policies. CeeBRON is to publish a newsletter containing a variety of items of interest to CB'ers. For further information write CeeBRON, 2135 Wisconsin Ave., Suite 100, Washington, DC 20007.

## SHORTWAVE LISTENING

**WPE Becomes WDX**—*Final plans for the transition of WPE monitor identifiers to the new WDX prefix have been announced by Hank Bennett. All WPE certificate holders will have until December 31, 1972 to apply for and receive a new WDX certificate bearing the original area coding suffix and identifier. A nominal handling charge is being made and full details are available from Monitor & DX Headquarters, P.O. Box 333, Cherry Hill, NJ 08034.*

## AMATEUR RADIO

**Clearing 40-Meter QRM**—As of October 9th the FCC has added Resolution 10 of the Geneva 1959 meeting of the International Telecommunications Union convention to the amateur radio Rules & Regulations (Part 97). The Resolution acknowledges that the range 7000-7100 kHz is for the exclusive use (world-wide) of radio amateurs and that 7100-7300 kHz is authorized for hams in the Americas. The latter spectrum is however assigned to the broadcasting services in the remainder of the world; thereby creating a monumental interference problem because many stations beam transmissions to the Americas contrary to international agreement. The FCC hopes that by making the Resolution “official” it will discourage broadcasting and commercial incursions into the 40-meter ham band. (Submitted by Herb Brier, W9EGQ)

## SHORTWAVE LISTENING

**New Relay in South Pacific?**—A well-known international shortwave broadcaster is quietly making inquiries about setting up several relay transmitters on Nauru Island. Unknown—except for their phosphate deposits—Nauru Islanders recently began to assert their independence under their President Chief Hammer Derouburt. Aware that the phosphate may run out by the year 2000, Chief Hammer is said to be receptive to any long-range source of revenue that will simultaneously “glamorize” Nauru. Practically unknown on shortwaves (a few radio ham expeditions have been made), Nauru is 500 miles northeast of the Solomons.

*(Continued on page 80)*

# ETLF, Addis Ababa, Ethiopia

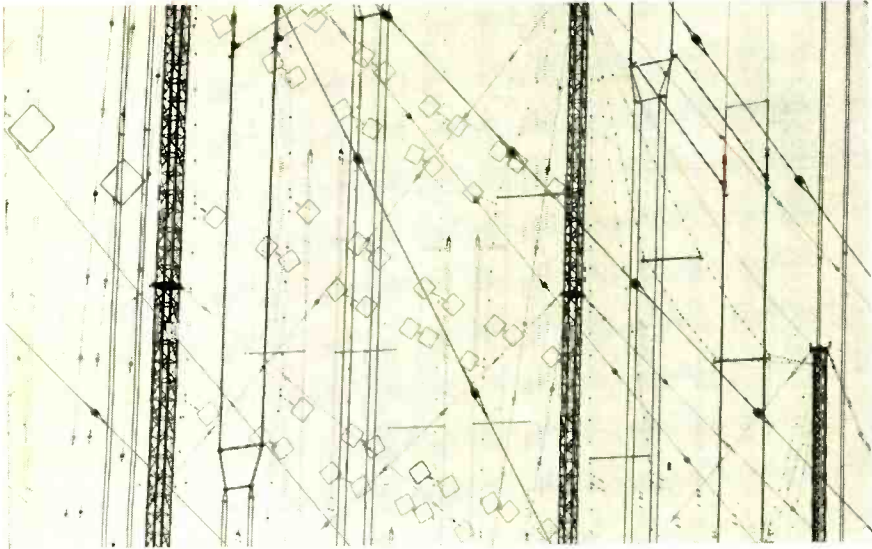

The attractive designs above are formed by the curtain antennas of ETLF, beamed to India, Ceylon, the Far and Middle East, eastern Africa, and Madagascar. The "floating" squares are spreaders in the transmission lines. The station has two 100,000-watt transmitters (see below).

Broadcasters from other parts of Africa come to Addis Ababa to prepare programs. The Nigerian announcer, Rev. Udo Etuk, is seen here working with Ethiopian production technician Befekadu Desta.



ETLF broadcasts on the following frequencies: 6065, 9680, 9695, 11850, 11910, 15265, 15270, 15310, 15400, 15425, 17775 kHz.



ETLF, Radio Voice of the Gospel, is largely operated by trained African electronics technicians. Vittorio Bonfanti and Yemane G/Egzeabher—both Ethiopians—get ready to switch over to a different curtain array. Sign says "Check Antenna Crew FIRST!"

**SHORTWAVE LISTENING**

**1971 Communications Handbook**—The ninth edition of the annual COMMUNICATIONS HANDBOOK, assembled by the Editors of POPULAR ELECTRONICS, has just been published and is now on the newsstands. Feature shortwave listening and mediumwave material was written by Dr. Richard E. Wood. A special catalog of receivers ranging in price from \$60 to \$4500 has been added to the new edition. A detailed listing of SWL clubs and associations is also included.

**CITIZENS RADIO (CB)**

**Raising Antenna Heights**—*CB'ers are cheering the surprise petition entered before the FCC by the Electronics Industries Association to void the 20' antenna height restriction. Present CB Rules prohibit erecting an antenna that extends more than 20 feet above an existing structure. Although this Rule is obviously violated by thousands of CB'ers, the EIA has spoken out in favor of making the Rules more realistic. In the petition, the EIA points out that TV receiving antennas are often 100 feet above ground level and recommends a new limit of 60'.*

**SHORTWAVE LISTENING**

**ISWC Station Popularity Poll**—The International Short Wave Club (England) is conducting its 1971 Station Popularity Poll. Held every third year, the poll is considered a barometer of the esteem in which international broadcasters are held by serious SWL's. Listeners are asked to send a list of their 5 most popular shortwave stations (in order of popularity) to ISWC, 100 Adams Gardens Estate, London, S.E. 16, with a note (not more than 30 words) telling why they chose No. 1. Votes for pirate broadcasters are not allowed or counted. Deadline is December 31. Winners will be announced in February.

**VHF MONITORING**

**Weather Bureau Goes Tone Alert**—*The nationwide network of 162.55- or 163.275-MHz weather radio broadcasting stations is being equipped with "tone-alert" devices. A distinctive 3-to-5-second audio tone will be added to the routine broadcasts to assure positive notice of severe weather changes—such as hurricanes, tornados, thunderstorms, etc. In early September, weather bureau stations equipped with tone alert were located at Boston, New London, Atlantic City, Washington, Norfolk, Charleston, Jacksonville, Miami, Tampa, New Orleans, Galveston, Cleveland, Akron, Los Angeles, San Francisco, and Honolulu. The New York City station (KW0-35) was to have tone alert installed by early December. New weather bureau stations—with tone alert—are being installed at Brownsville, Tex., Seattle, Wash., and Portland, Wash. All of the weather bureau stations transmit narrow-band FM with a power rating averaging 300 watts and vertical antenna polarization.*

**SHORTWAVE LISTENING**

**BBC Uses New Interval Signal**—About half of the shortwave broadcasters (and nearly all international broadcasters) transmit an interval signal 5 to 15 minutes before a scheduled program. This interval signal serves the dual purpose of permitting the listener to find and tune in the signal before the program commences and also serves notice to other broadcasters that that particular frequency or channel is occupied. SWL's soon learn to identify 20-30 different interval signals and thus are able to pin-point a DX station with considerable ease. Interval signals may be a few bars of music, bells, chimes, bird calls, etc. For years the BBC World Service has used "Bow Bells", but in September switched to a few bars of "The Bells of St. Clements". A nice distinctive tune, but somehow not as "British".





# SOLID STATE

One Hundred Seventy-Fifth in a Monthly Series by Lou Garner

**A**LTHOUGH TWT's, klystrons, BWO's, and magnetrons are still being used extensively by equipment designers, and the exotic UHF/microwave vacuum-tube market is far from "dead," the popularity of these devices is under increasingly heavy pressure from the solid-state industry. While it is unlikely that microwave vacuum tubes will disappear from the technical scene within the foreseeable future, there is a good chance that—within a few years—an overwhelming majority of new microwave equipment

designs will feature solid-state devices in part, if not exclusively.

Two major trends are responsible for the economic-technical pressure on the microwave tube market. One is the substantial, and continuing, improvement in the state-of-the-art relating to the design, fabrication, production, and application of discrete semiconductor components. The second is the development of efficient, lightweight, compact, and reliable microwave integrated circuits (often identified as "MIC's").

Two new hybrid microwave IC's developed by RCA are shown at right. UHF power amplifier is at top, while below it is combiner/divider. Shown uncovered, these IC's are fraction of the sizes of discrete versions, hundreds of times smaller than vacuum tube circuit versions.

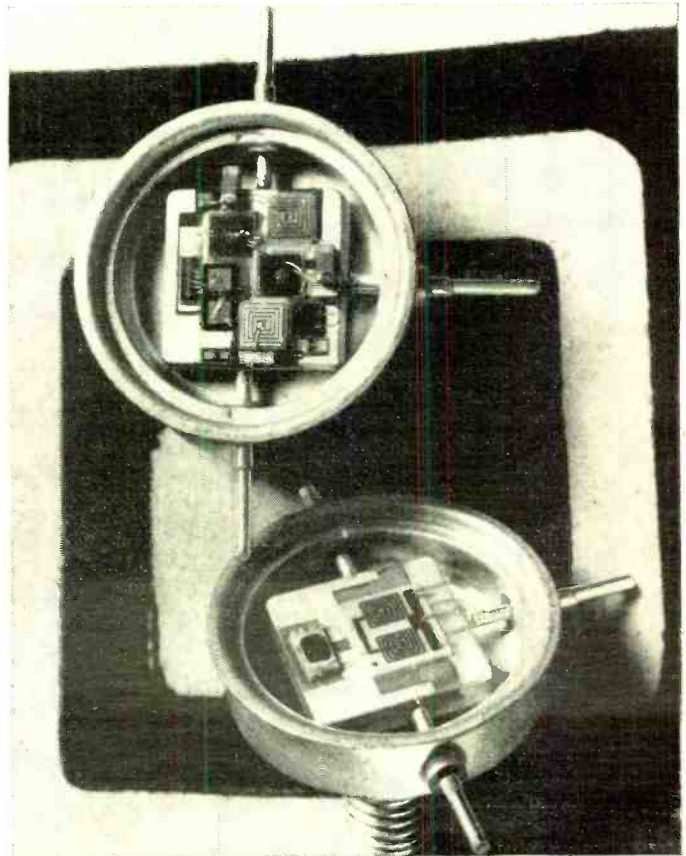

Today, the design engineer or advanced experimenter can choose off-the-shelf solid-state devices operating well into the gigahertz range and supplying power outputs up to the multiwatt level.

As far as transistors are concerned, Hewlett-Packard's (1501 Page Mill Road, Palo Alto, CA 94304) type HP35806E probably is typical of the upper-range, small-signal devices now available. Selling for less than fifty dollars in single quantities, this unit has a gain-bandwidth product of 7.0 GHz and can deliver 50 mW output with a 9.5 dB gain at 2 GHz. Where relatively high power is needed, the designer might select a TRW (TRW Semiconductor Division, 14520 Aviation Boulevard, Lawndale, CA 90260) type PT8610, which can provide 10 watts output at 2 GHz, or the MSC (Microwave Semiconductor Corp., 100 School House Road, Somerset, N.J. 08873) type MSC 1100, a device with a 35-watt power dissipation rating and capable of delivering peak powers of 100 watts at 1.09 GHz in pulsed applications.

Gunn-effect diodes, varactors, LSA (Limited Space-Charge Accumulation) devices, Schottky-barrier diodes, and various avalanche devices, in general, can be used at even higher frequencies than available transistors. Experimental LSA units, for example, have delivered as much as 20 mW CW at 88 GHz and have a projected upper frequency limit of, perhaps, 500 GHz.

At least one firm is now offering *complete* solid-state microwave oscillator assemblies at prices considerably lower than those of the more exotic vacuum tubes. If you're a manufacturer developing a new commercial microwave product intended for mass-production, for example, Fairchild's Microwave and Optoelectronics Division (2513 Charleston Road, Mountain View, CA 94040) can sell you Gunn diode X-band (8-12 GHz) 50 mW signal sources for about *five dollars* each in lots of 100,000 units. Even the single

unit price is less than that of a good dinner with cocktails and wine at a better restaurant.

MIC's are offered by a number of manufacturers, including Avantek, Inc. (2981 Copper Road, Santa Clara, CA 95051), American Electronic Laboratories, Inc. (P.O. Box 552, Lansdale, PA 19446), and RCA (Electronic Components, 415 South Fifth St., Harrison NJ 07029).

For the most part, currently available MIC's are hybrid devices using chip transistors, diodes and capacitors and thin-film inductance and resistance elements, although some work has been done with monolithic designs. Physically, the typical MIC is assembled in a package about the size of a multiwatt power transistor or high-power SCR.

A pair of typical MIC's is RCA's recently introduced TA7702/7703 UHF power amplifier and TA7747/7748 three-port hybrid power combiner/divider. The TA7702/7703 is a thin-film lumped-element design featuring a silicon *npn* "over-layer" power transistor and integral input and output networks designed to match a 50-ohm source and load. Intended for operation in the 225-400 MHz range, the device(s) can furnish a nominal output of 16 watts at 350 MHz with a 6-dB gain, using a 28-volt dc power source. With an efficiency between 50% and 75%, the amplifier features a gain variation of less than 1 dB for output powers from 4 to 16 watts. It can be used in AM applications with greater than 85% modulation and less than 10% distortion by the use of a feedback modulation system and low-pass r-f filter.

An extremely interesting device, the TA-7747/7748 is a unique integrated circuit capable of combining or dividing the power of UHF signals in the 225-400-MHz range. It is equipped with three "ports" (terminals), each having an impedance of 50 ohms. As the power amplifier, the device is fabri-

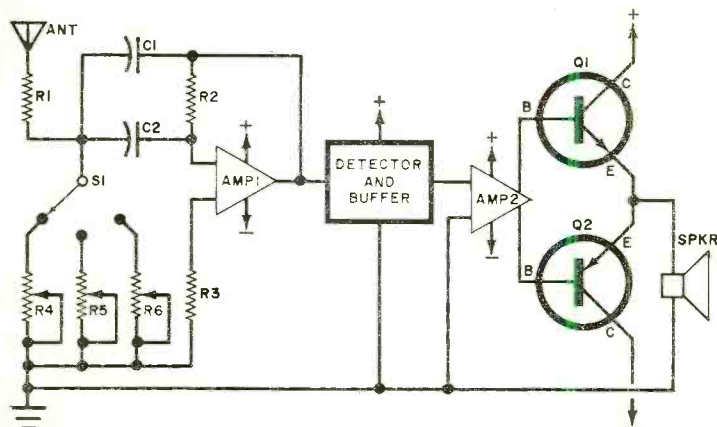

Fig. 1. Reader's proposed radio receiver circuit design uses Amp 1 as active filter/amplifier; Amp 2 as straight amplifier. Amps are integrated circuits.

cated using a lumped-element hybrid design.

In operation, UHF power applied to one port is divided into two equal signals and supplied through the other two ports. On the other hand, if two signals with the same frequency, phase and amplitude are injected into the nominal "output" ports, their power will be accurately combined and furnished at the "input" port.

Capable of handling up to 40 watts input (or output), the TA7747/7748 may be used to divide a UHF signal for, say, driving different elements of a directional antenna array or, conversely, for combining the outputs of two amplifiers to achieve higher power levels. Typically, the device might be used to combine the outputs of two TA7702/7703 amplifiers to deliver 32 watts.

An exciting and interesting field, microwave experimentation can offer substantial intellectual rewards to the advanced hobbyist willing to acquire the special knowledge and skills needed to work at UHF and GHz frequencies. Among other things, he'll learn that some aspects of extremely high frequency phenomena are at variance with his experiences at lower frequencies.

For example, one normally can assume that a high frequency transistor will provide improved performance, higher gain, and greater power output when used at lower frequencies. A 5-MHz transistor, for example, may be more efficient when used at audio values. This assumption is *not valid* at GHz frequencies, however. As a general rule, a typical advanced GHz power transistor can operate at higher power levels at or near its specified design frequency than at much lower values.

**Reader's Circuit.** Reviewing the specifications of commercially available linear IC amplifiers, SP4 Mark Mondt (478-69-4366, HHT 3d Sqdn, 7th Cavalry, APO New York 09033), discovered that many of these devices have frequency responses extending well into the MHz ranges. RCA's CA3020, for example, can be used to frequencies as high as 8 MHz with a resistive load, while their CA3023 is useful to 16 MHz. Realizing this and knowing that an amplifier can be used as an active filter with a suitable feedback network, Mark has theorized that an R-C tuned receiver might be a feasible project. He submitted the tentative circuit given in Fig. 1 to illustrate his thoughts, suggesting that other readers might like to experiment with this approach to receiver design.

An R-C tuned feedback network consisting of  $C1$ ,  $C2$ ,  $R2$  and a switch-selected trimmer resistor ( $R4$ ,  $R5$ , or  $R6$ ) are used to operate IC AMP 1 as an active filter/amplifier. Different frequencies (stations) are pre-tuned by trimmer resistor adjustment and

selected by  $S1$ . AMP 1's output is applied to a detector and buffer amplifier (DET/BUFF), and the resulting audio signal is a second IC amplifier section, AMP 2, which provides audio gain. Finally, a complementary push-pull power amplifier,  $Q1-Q2$ , is used to drive the loudspeaker.

Although Mark's idea has merit, several modifications in his suggested circuit may be necessary to achieve satisfactory performance in a practical receiver.

First, we suspect that a different type of feedback network would be required to achieve optimum filter operation. Most of the active filter designs we've seen and used successfully employ parallel-T networks. Naturally, the R-C values would have to be chosen to provide a peak response at the desired r-f (station) values.

Second, Mark may find that the receiver's overall selectivity leaves a bit to be desired as far as the crowded AM broadcast band is concerned. Q's of 10 or more can be achieved without too much difficulty with currently available IC operational amplifiers used as active filters, but we feel it may be necessary to cascade several R-C tuned stages to obtain reasonable selectivity.

Third, there may be some problem with cross-modulation where strong and weak stations are on nearby frequencies. The basic design does not lend itself to an effective agc arrangement and, therefore, optimum bias for maximum gain to receive weak signals may lead to overload, distortion, and cross-modulation when strong signals are present.

But with all factors considered, Mark's suggested approach should prove to be an educational project for those experimenters who enjoy trying "off-beat" designs. Before tackling actual circuit design and construction, however, we recommend that interested readers first obtain and study Fairchild's excellent Application Brief No. 132, *Active Filters with Gain* (contact Fairchild Semiconductor, 313 Fairchild Drive, Mountain View, CA 94040).

**Manufacturer's Circuit.** Featuring monolithic Darlington silicon devices, the audio amplifier circuit illustrated in Fig. 2 was abstracted from Application Note AN-483-A, published by Motorola Semiconductor Products, Inc. (P.O. Box 20912, Phoenix, Arizona 85036). Entitled "15 to 60 Watt Audio Amplifiers Using Complementary Darlington Output Transistors," the eight-page publication was prepared by Motorola applications engineer Richard G. Ruehs. In addition to the circuit shown, the paper describes a number of other practical designs, including a 15-to-20-watt 4-transistor amplifier, a 15-to-60-watt circuit with ac coupled output, and a reliable overload protection circuit.





across the device to prevent high-frequency parasitic oscillation. The output stages are forward-biased by  $Q_4$  to eliminate crossover distortion, while constant current source  $Q_5$  precludes the need for boot-strapping  $Q_7$ 's base, thus insuring minimum distortion at low frequencies. Dc stability is assured by providing 100% dc feedback through  $R_6$  to  $Q_2$ 's base and using a 10-volt zener diode ( $D1$ ) in conjunction with emitter resistor  $R_3$  to establish the input bias. A handwound series output choke is included to prevent high-frequency oscillation with capacitive loading.

According to Motorola's Application Note, the basic amplifier has a typical idling current of 20 mA and an input impedance of 10,000-ohms. It requires an input signal of 1.0 volt, rms, for rated power output, and its frequency response is flat within 1 dB from 10 Hz to 50 kHz. The amplifier's harmonic and intermodulation distortion figures are 0.15% and 0.1%, respectively.

Final component values, supply voltage, and device types depend on the amplifier's desired maximum output power level and load impedance. For 60-watt operation with an 8-ohm load, a dual 36-volt, well-filtered dc power supply is required. Under these conditions,  $R_4$  would be 8200 ohms,  $R_5$  430 ohms, and  $R_7$  33,000 ohms. The dual transistor used as a pre-driver would be type MD-8002,  $Q_3$  type MPS-A56,  $Q_4$  type MJE-520,  $Q_5$  type MPS-A06,  $Q_6$  type MJ-3001, and, finally,  $Q_7$  type MJ-2501.

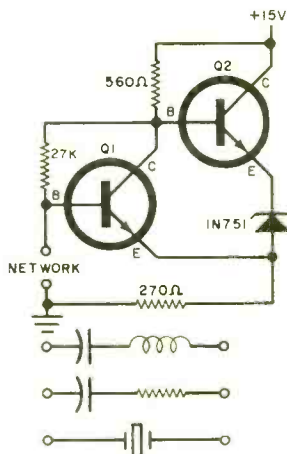

Fig. 3. Ultimate oscillator can generate square, sawtooth, or sine waves over wide frequency range.

**Ultimate Oscillator?** Submitted by Mrs. Dorothy L. Zachary, of Richardson, Texas, the oscillator circuit shown in Fig. 3 can generate square, sawtooth, or sine wave-



**FREE!**

**Lafayette's  
1971 Golden  
Jubilee  
Catalog**

Your 1st Guide To  
Everything in Electronics

- Stereo/Hi-Fi Components
- Musical Instruments and Amplifiers
- Photography Equipment
- Ham and CB Gear
- Public Address Systems
- Tools and Test Equipment
- Educational and Optical Equipment
- Black and White/Color Televisions
- Police and Fire Monitor Receivers
- Books and Parts
- Plus Thousands of Additional Items

Lafayette Radio Electronics Dept. 35110  
P. O. Box 10, Syosset, L. I., N. Y. 11791

Send Me the Free Lafayette Golden Jubilee 1971 Catalog 710 35120

Name

Address

City

State  Zip

(Please include your zip code)

**CIRCLE NO. 17 ON READER SERVICE PAGE**

the original "wedge-type" screwdriver

**QUICK-WEDGE**

SCREW-HOLDING SCREWDRIVER

**Just ONE  
Screwdriver  
does all the job!**

**HOLDS STARTS  
DRIVES AND SETS**

**THE SCREW  
to normal lightness!**

**Unconditionally  
Guaranteed  
Finest Quality  
Workmanship  
& Materials**

**17 SIZES  
GET A SET TODAY!  
At Your Dealers or Write**

**KEDMAN COMPANY**

P. O. Box 267 - Salt Lake City, Utah 84110

**CIRCLE NO. 16 ON READER SERVICE PAGE**



© 1969 by Kedman Company





another great  
new idea

# reversible ratchet handles

for Xcelite "99" tools



These two unique plastic (UL) handles extend the usefulness of all Xcelite Series "99" tools, make welcome additions to any "99" set.

Both regular (99-1R) and Tee (99-4R) types accept more than 60 individually available nut-driver, screwdriver, and special purpose snap-in blades to speed and simplify assembly and service work.

Fully enclosed ratchet mechanism is built to highest socket wrench quality standards. Recessed reversing shift operates at the flick of a thumb. Patented spring chuck holds blades firmly.

*nationwide availability through local distributors*

REQUEST BULLETIN N670

Made in U.S.A.

# XCELITE

XCELITE INC. • 20 BANK ST., ORCHARD PARK, N. Y. 14127  
Send Bulletin N670 on Series "99" Reversible Ratchet Handles.

name \_\_\_\_\_

address \_\_\_\_\_

city \_\_\_\_\_

state & zone \_\_\_\_\_

**CIRCLE NO. 30 ON READER SERVICE PAGE**

forms over the range from a fraction of a Hz to MHz. The active portion of the oscillator does not contain any frequency-dependent components, with the exception of parasitic elements. The two transistors are npn planar epitaxial types—2N918 or similar. The power supply used should be of the low-impedance type since it also acts as the ac ground return.

Either RC, LC or a piezoelectric network can be used to create the oscillations. Functionally, the oscillator goes into operation when the base of  $Q1$  is "grounded" by the selected series-tuned network. The voltage variations at the collector of  $Q1$  are coupled to its emitter by the emitter-follower action of  $Q2$ . Since the circuit has a closed-loop voltage gain greater than one under these conditions, it begins to regenerate. The waveform depends, to a great extent, on the  $Q$  of the network used. A very high  $Q$  will result in a square wave, a low  $Q$  produces a sinusoidal wave.

This circuit has performed as a crystal-controlled oscillator from 18 kHz to 15 MHz, a pulse generator operating from 0.001 to 0.5 Hz, and a general-purpose test oscillator from the low audio range to 40 MHz. The output can be taken from either the collector, emitter, or base of  $Q1$ , preferably through some form of isolation circuit.

**Low-cost Logic Lab.** Would you believe a practical basic course in computer logic complete with an operating solid-state computer circuit lab for a mere \$39.00, postpaid? Such a course and lab are available from

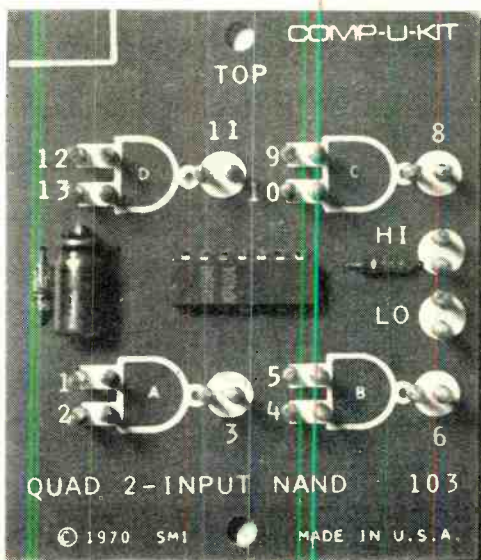

Fig. 4. Photo shows one of modules that make up Comp-U-Kit Logic Lab Model 103. Shown is preassembled quad two-input NAND gate module setup.



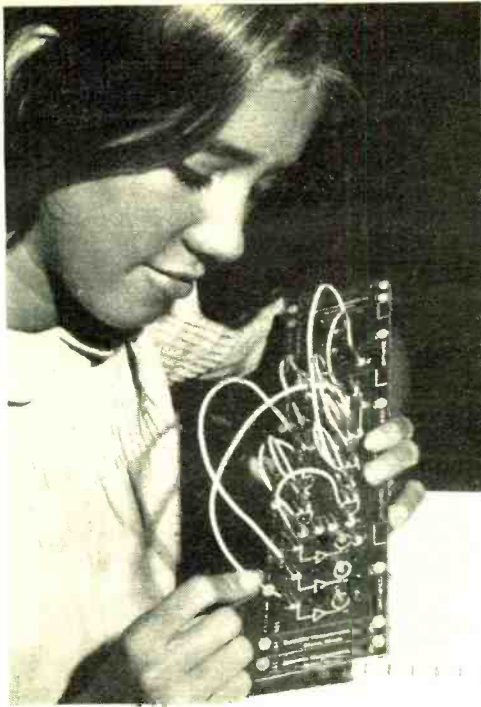

Fig. 5. Comp-U-Kit modules assemble on support rails which double as power supply buses. Circuit interconnections are made via flexible jumpers.

Scientific Measurements, Inc., 9701 N. Kenton Ave., Skokie, IL 60076, as their Comp-U-Kit Logic Lab I, Model 10.

Actually an instruction manual entitled "An Introduction to Computer Logic," the "course" covers both basic theory and practical experiments. Starting with fundamental definitions and discussions of such topics as analog and digital computers, digital devices, and binary systems, the book then describes the "Logic Lab" in detail, outlines power supply requirements, and gives step-by-step assembly instructions. Later chapters describe a number of practical experiments for demonstrating switch, inverter, gate, clock, flip-flop, scalar, storage element, shift register, display, and ring counter operation. Other chapters and experiments cover the logic equation, Boolean algebra, truth tables, and binary arithmetic. Several "fun" projects are described, including an electronic coin flipper and a game-like reaction timer.

The "Lab" itself consists of a number of individual circuit modules assembled on PC boards similar to the quad 2-input NAND gate illustrated in Fig. 4. Up-to-date TTL circuitry is employed, with some modules featuring commercial IC devices, others discrete component construction.

The complete kit includes a clock-switch

THE SOUND OF  
**Trouble**  
 ON ITS WAY... ARE  
 YOU READY FOR IT?  
**DELTALERT IS!**

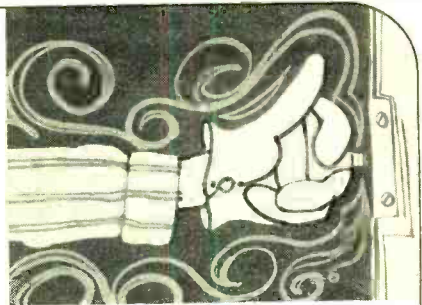

A door knob rattling in the night... footsteps on the front porch... the shattering of window glass. In that moment you, your family and your property are in danger.

Enjoy new peace of mind with a reliable DeltAlert detection and alarm system. DeltAlert detects motion in 150 to 300 sq. ft. of critical space with a silent ultrasonic blanket... turning on lights automatically to drive away prowlers.

When the separate DeltaHorn is plugged into the DeltAlert unit, the intruder faces the additional obstacle of loud, ear-shattering noise. A built-in 20-second delay switch allows authorized persons to turn off the horn when entering the monitored area. The sturdy units, finished in handsome walnut veneer, are maintenance-free, economical and need no installation.

At home or work, proven economical security begins with DeltAlert alarm and detection protection.

DELTAHCRN  
 3 1/4" w x 3 1/4" h x 3 1/4" d  
 \$24.95 ppd

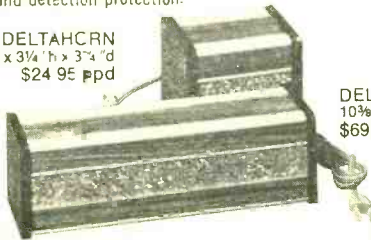

DELTALERT  
 10 3/8" x 3 1/4" h x 3 1/4" d  
 \$69.95 ppd

Made in U.S.A.

Order your DeltAlert Security System today!



**DELTA PRODUCTS, INC.**

P.O. Box 1147 PE/Grand Junction, Colo. 81501  
 (303) 242-9000

- Please send me literature immediately:
- Enclosed is \$\_\_\_\_\_  Ship ppd.  Ship C.O.D.
- Please send \_\_\_\_\_ DeltAlert(s) @ \$69.95 ppd.
- Please send \_\_\_\_\_ DeltaHorn(s) @ 29.95 ppd.

• Name \_\_\_\_\_

• Address \_\_\_\_\_

• City/State \_\_\_\_\_ Zip \_\_\_\_\_

CIRCLE NO. 9 ON READER SERVICE PAGE

## Fast easy soldering is a gift from

# Weller®

Give a Weller soldering tool for Christmas and you give a man the ability to make secure soldered connections quickly and easily. And because no other soldering tools match Weller for features and dependability, you know you're giving the best.



### 8-Piece Dual Heat Soldering Gun Kit

Gun tip heats instantly when trigger is pulled. Two trigger positions for instant switching to high 140 watt or low 100 watt heat. Built-in spotlight. Included: 3 soldering tips, tip wrench, flux brush, soldering aid, solder, plastic case. Model 8200PK. **\$1095** list



### New TEMPATIC® Temperature Controlled Soldering Tool

Combines all the advantages of a fast heating soldering gun, a lightweight pencil iron and tip temperature control. Gives maximum component protection in the most delicate work situations. Yet it does heavy jobs like chassis soldering. Weighs only 7 ounces. Powerhead contains Weller's temperature control system. Model GT-7A has 700°F. 3/16" chisel point Powerhead. Model GT-6B has 600°F. conical 1/2" point Powerhead. Each tool—**\$1298** list

### Weller MARKSMAN Soldering Iron Kit

Lightweight 25-watt iron outperforms all other irons of its size and price. Has replaceable tip, stainless steel barrel, cool handle. Included: 2 extra tips, soldering aid, solder. Model SP-23K. **\$479** list



**WELLER**

Division of Cooper Industries, Inc.  
Easton, Pennsylvania 18042

CIRCLE NO. 29 ON READER SERVICE PAGE

module, flip-flops, NAND gates, and a 3-bit lamp display using built-in transistor driver amplifiers. These modules are assembled on support rails which also serve as power supply busses, with circuit interconnections made by using plug-in jumpers, as shown in Fig. 5. All the modules are designed for 6-volt dc operation, thus permitting the use of a lantern battery or inexpensive line-operated dc supply as the power source.

**Laser Breakthrough.** Scientists at the Bell Telephone Laboratories (BTL), Murray Hill, N. J., have devised a new solid-state laser, smaller than a grain of sand, that can be powered by ordinary dry cell batteries. It emits a beam of near-visible infrared light.

Designed by BTL scientists Izuo Hayashi and Morton Panish with the aid of co-workers P. W. Foy and S. Sumski, the new semiconductor laser can operate continuously at normal room temperatures (75-80°F). With a current level of approximately 3000 amperes per cm<sup>2</sup>, the device delivers approximately 20 mW, and has a power efficiency of about 1.5 to 2%.

In the past, the heat generated by semiconductor lasers was too great to permit operation at room temperatures for more than a minute fraction of a second. The heat results from passing the large currents needed for lasing operation through a very small area. Even when mounted on heat sinks, room temperature operation was limited to about one ten-thousandth of a second. As a result, semiconductor lasers have been used only in pulsed applications and continuous operation was virtually impossible.

BTL's new device is a double hetero-structure diode comprised of four layers of gallium aluminum arsenide alternating with gallium arsenide and doped with tin, silicon, zinc and germanium. Two of the layers, each about 60 millionths of an inch thick, confine laser light to a thin central layer of the structure. This "active region" layer is about 20 millionths of an inch thick.

Measuring about 15 thousandths of an inch long by about 3 thousandths of an inch wide, the new laser diode is actually smaller than the smile on Lincoln's profile on a U.S. common cent. Still experimental, the new laser diode may one day find widespread commercial application in high-capacity optical communications and data transmission.

**Device News.** RCA Electronic Components (Harrison, N.J. 07029) has launched a new standard line of microwave solid-state power sources. Known as transferred-electron oscillators (or TEO's) the new line consists of four families of microwave devices: C-Band (4 to 8 GHz) CW, C-Band pulse, X-Band (8 to 12 GHz) CW, and X-Band pulse.



Employing bulk-effect epitaxial gallium-arsenide diodes, the new TEO's can be operated from single-voltage, low-level power supplies. Power outputs of up to 120 mW CW or 10 watts pulsed are possible.

Potential applications for the new devices include handheld radars, fuzes, police radars, intrusion alarms, auto collision avoidance equipment, IFF systems, altimeters, signal generators, marine radars, missile guidance gear, weather radars, remote television pick-ups, industrial telemetry, weapon location beacons, commercial transponders, phased array antennas, municipal vehicle control, short range and mobile communications, downed pilot locators, pollution detectors, blind guidance, auto toll systems and other products.

In addition to the new TEO's, RCA recently has introduced a number of new discrete semiconductor devices, including a pair of UHF/VHF high-power transistors, two new dual insulated-gate MOS/FET's, and a series of sensitive-gate silicon triacs.

Featuring emitter-ballasted overlay construction utilizing refractory metallic connections, RCA's new UHF/VHF transistors, types TA7706 and TA7707, can deliver a minimum power output of 30 watts at 400 MHz with a minimum gain of 5 dB. Similar except for packaging, both units are silicon npn planar devices.

Designated types 3N187 and 3N200, the new MOS field-effect transistors are n-channel silicon depletion types with insulated gates and integrated back-to-back diodes for gate protection. With superior cross-modulation performance and greater dynamic range than comparable bipolars or junction-gate FET's, the two units are designed for rf amplifier applications at up to 300 MHz (type 3N187) and 500 MHz (type 3N200).

Intended for low-power phase control and load switching applications, RCA's new series of 2.5-ampere sensitive-gate triacs includes types 40766 and 40767 for low voltage circuits, 40691 and 40761 for 120-volt line operation, and 40692 and 40762 for 240-volt power designs. The devices are offered in both modified TO-5 and heat-radiator packages suitable for printed circuit boards.

TRW's Semiconductor Division (14520 Aviation Blvd., Lawnsdale, CA 90260) has announced the addition of a new hybrid power amplifier to their microelectronic product line. Identified as the HMD 2000, this versatile new device can be operated in either a linear or switching mode with capabilities of delivering 3 amps peak current from dual power supplies of up to 25 volts. Assembled in a TO-3 package, the unit is intended for such applications as switching, class B servos, hi-fi audio amplifiers and motor drivers.

—Lou

- Increases point and plug life—practically eliminates tune-ups.
- All weather starts—improves performance—easy to install.
- Waterproof construction makes Thor-Go ideal for marine use.



**NOW!**

# A Quality C. D. I. Unit At A Reasonable Price. . .

Satisfaction guaranteed - 5-year service warranty.

Send me \_\_\_\_\_ Thor-Go's—enclosed find my check or M.O.  
—Thor-Go will pay the postage!

Send me \_\_\_\_\_ Thor-Go's C.O.D.—I will pay the postage!

NAME \_\_\_\_\_

ADDRESS \_\_\_\_\_

CITY \_\_\_\_\_ STATE \_\_\_\_\_ ZIP \_\_\_\_\_

**\$34.50**

Never before priced this low.

**THOR-GO**

Reviewed by Popular Electronics  
on page 72 of the August, 1970, issue.  
Ask your Dealer-Or mail coupon today!

Thor-Go - P.O. Box 1164 - Norman, Oklahoma 73069

CIRCLE NO. 31 ON READER SERVICE PAGE



# \$ \_\_\_\_\_,000

## Tell Bell & Howell what kind of money you'd like to make. We'll show you how to get it in Electronics.

Today, young men who are just starting in Electronics, are making \$600, \$700, even \$800 a month!

But that's just the beginning. You'll find ads *right now* in technical magazines, newspapers and The Wall St. Journal, offering salaries of \$8,000, \$12,000 and considerably higher for many Electronics specialists with... "some experience". How come?

### Every computer and automation system needs an electronics expert

Men who really know their stuff are truly indispensable in the design and operation—not only of computers and automation systems—but in broadcasting, TV manufacturing (and repair), air and space craft, inter-com systems and electronic telephone switching—to name just a few.

Naturally, the law of supply and demand means salaries go up when there aren't enough experienced men in *any* field. And in Electronics, *there simply aren't enough good men to go around!*

### Men from all walks of life are making it in electronics

How difficult is it to understand and

work in Electronics? Not very, really. Men of all ages, men with a high school education or *less*—men with a wide variety of previous job experience have little or no difficulty with the basics.

If you like working with your hands, and don't mind using your head a little—you, like they, can carve out a good income and secure future in the mushrooming field of Electronics.

### Where do you get the training you need to get into electronics?

That depends a little on what area of Electronics you're interested in. And what your income and career objectives are.

We can tell you this: when you are ready to talk employment, it is a tremendous advantage to have gotten your training with Bell & Howell. Because you get what business and industry recognize as the most up-to-date, practical and thorough-going preparation that is available anywhere.

And that makes quite a difference in the kind of money you can get as well as how far you can expect to go!

### Many programs to choose from

Bell & Howell offers you a number of different programs designed to fit your individual situation and interests. Our Electro-Lab-at-Home Plans now include a new program on Computer Control as well as the fundamentals of Electronics.

There is a newly expanded Plan that covers the entire home entertainment area—Home Entertainment Electronic Systems. It features the *first solid-state Color TV Kit* for home training . . . a big, 25" screen set you assemble and adjust yourself. When you see the vivid color you get you'll be proud you put it together.

### Bell & Howell's proven programs turn out better-salaried men

There is a very real dollars-and-cents reason for this. As one major TV-Radio manufacturer put it: "*The men you have sent us show that Bell & Howell Schools have consistently kept up in the field of Electronics.*"

### \$100,000 yearly—just to keep up!

Bell & Howell invests well over \$100,000 annually to keep our programs in step with constant changes in the world of Electronics. As a result, Bell & Howell's Electro-Lab-at-Home Plans are based on

valuable experience gained in our own nationwide technical colleges—information that is available nowhere else.

These plans enable you to obtain the *latest* theory and the most modern and usable application of that theory. In short, when you have completed your program, you'll know *exactly* what you are doing!

**Student loans now available.** If you are a non-veteran, and need financial assistance, Bell & Howell can arrange for a Student Loan. This may enable you to *learn now and pay later*. All Plans are approved for Veterans' Benefits.

### Free-for-life—national employment service

When you've finished all phases of your Bell & Howell Electro-Lab-at-Home Plan, we will help you locate a well-paid position in the area that fits in with your experience and interest. This service is available without charge throughout your Electronics career.

Mail the card today for Bell & Howell's new FREE BOOKLET and complete information about planning and choosing a profitable career in Electronics. There's no obligation of any kind.

MAIL CARD  
NOW FOR

FREE  
BOOKLET

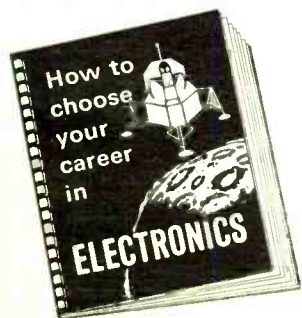

## BELL & HOWELL SCHOOLS

APPROVED FOR VETERANS' TRAINING  
(Benefits just increased 35%)

If card is detached, mail this coupon for your Free Booklet and complete information on career opportunities in Electronics to:

BELL & HOWELL SCHOOLS  
4141 Belmont, Chicago, Illinois 60641

Name \_\_\_\_\_ (please print) \_\_\_\_\_ Age \_\_\_\_\_

Address \_\_\_\_\_ Phone \_\_\_\_\_

City \_\_\_\_\_ State \_\_\_\_\_ Zip Code \_\_\_\_\_

Check here for latest information on GI Bill  Student Loans

319

M-7041

NEW **jensen**



**GENERAL  
PURPOSE  
SPEAKER  
CATALOG**

The newest, largest selection of General Purpose, Musical Instrument and Special Application speakers. Anywhere!

Send for your **FREE** copy today!

Send also  Hi-Fi Catalog  
 Commercial Sound Catalog

Jensen Manufacturing Division, The Muter Company  
5655 West 73rd Street • Chicago, Illinois 60638

Name \_\_\_\_\_

Address \_\_\_\_\_

City \_\_\_\_\_ State \_\_\_\_\_ Zip \_\_\_\_\_

**CIRCLE NO. 15 ON READER SERVICE PAGE**

**McGEE RADIO Co.**

**WORLD'S BEST SELECTIONS  
AND LOWEST PRICES**

**SPEAKERS**

**ALMOST EVERY SIZE FROM 1 1/2 TO 18 INCH  
WOOFERS—TWEETERS—CROSSOVERS  
MANY HIGH FIDELITY KITS  
McGEE'S 176 PAGE 1971 CATALOG  
SENT FREE ON REQUEST**

**NORELCO HI-FI SPEAKERS**

**McGEE HAS ADDED A FULL LINE OF NORELCO  
HI-FI SPEAKERS FOR THE SYSTEM BUILDER.**

McGee ships orders all over the U.S. When requesting our catalog please give name, address and zip code. Our 41st year in Kansas City. Catalog offers everything for Hi-Fidelity audio P.A. systems. All kinds of microphones. Names such as Shure, Bogen, Electro-Voice, University, Altec, Ampex, G.E. Tubes and Transistors. All kinds of parts. Everything for Educational and Industrial electronics. Write for your catalog today.

**McGEE RADIO CO.—1901—PE**

McGee St., Kansas City, Mo. 64108

**CIRCLE NO. 19 ON READER SERVICE PAGE**

**STEREO SCENE**

*(Continued from page 77)*

One good way of choosing speakers is to listen to a couple of the most expensive models in the store (adjusting volume so that all are equally loud), and then A-B'ing some of the systems you can afford (also at the same volume) until you find one that sounds to your ear the most like the top-priced speakers. Arrange to take your chosen speakers home on approval, and listen to them for a week or so at your leisure. If nothing about their sound is starting to annoy you at the end of this approval period, then buy them. Don't worry at this point about the possibility that there might be others you'd prefer. This may be the case, but you will be far better qualified to know what you *do* prefer after you've lived with your first choice.

If you're interested in literal fidelity as well as what sounds "good" to you, get out and hear live music as often as you can, and see whether it sounds like what you hear at home. If you can't hear the difference to begin with, you will eventually, and once you do, you'll be well on the way to equipping yourself with a really good system, whatever price ceiling you've decided to set.

That's the time to face the question "How good a system do I really need?" Nobody else can answer this for you, and you can't really answer it yourself until some exposure to a component system in your own home reveals your listening habits and preferences.

One way to acquire a good system at minimal cost is to buy used equipment. This offers a bonus in that you can get a generally better grade of components than you could otherwise afford.

Used loudspeakers are as good as brand-new speakers, unless obviously defective. And speaker defects are rarely subtle! Check the tweeter level controls, though, to make sure they aren't scratchy-sounding or intermittent; this is the commonest "hidden" problem with elderly speakers. Also, if the grille cloth looks ratty, hold a flashlight against it and peek at the cone, to make sure nobody has poked holes through it with a pencil.

Used tone arms, too, are generally a safe buy, but check the pivots as described previously. A sudden interruption of swing suggests dirty pivots, which you may or may not feel qualified to repair yourself, but should certainly give you a price-bargaining lever if you choose to try.

Never buy a used cartridge unless you can replace the stylus. The elastic suspension

POPULAR ELECTRONICS



# Popular Electronics

## READER SERVICE PAGE

### free information service:

Here's an easy and convenient way for you to get additional information about products advertised or mentioned editorially (if it has a "Reader Service Number") in this issue. Just follow the directions below... and the material will be sent to you promptly and free of charge.

**1.** On coupon below, circle the number(s) that corresponds to the key number(s) at the bottom or next to the advertisement or editorial mention that is of interest to you. (Key numbers for advertised products also appear in the Advertisers' Index.) Print or type your name and address on the lines indicated.

**2.** Cut out the coupon and mail it to: POPULAR ELECTRONICS,  
P.O. Box 8391, Philadelphia, PA 19101.

**note:** If you want to write to the editors of POPULAR ELECTRONICS about an article on any subject that does not have a key number, write to POPULAR ELECTRONICS, One Park Avenue, New York, N.Y. 10016. Inquiries concerning circulation and subscriptions should be sent to POPULAR ELECTRONICS, P.O. Box 1096, Flushing, N.Y. 11352.

Void after January 31, 1971

## Popular Electronics

P.O. BOX 8391  
PHILADELPHIA, PA. 19101

1 2 3 4 5 6 7 8 9 10 11 12 13 14 15 16 17 18 19 20  
21 22 23 24 25 26 27 28 29 30 31 32 33 34 35 36 37 38 39 40  
41 42 43 44 45 46 47 48 49 50 51 52 53 54 55 56 57 58 59 60  
61 62 63 64 65 66 67 68 69 70 71 72 73 74 75 76 77 78 79 80  
81 82 83 84 85 86 87 88 89 90 91 92 93 94 95 96 97 98 99 100

NAME (Print clearly) \_\_\_\_\_

ADDRESS \_\_\_\_\_

CITY \_\_\_\_\_ STATE \_\_\_\_\_ ZIP CODE \_\_\_\_\_

12Nb

# BUILD YOUR OWN LASER.

Ride into the future on a beam of coherent light! Our HeNe gas laser kits are lab-quality, easy to put together, and use in holography, interferometry, laser optics, communication, many others.

Metrologic Instrument, Inc.  
143 Harding Avenue, Bellmawr, N.J. 08030



Dear laser-makers:  
The whole idea of a light that turns me on is fascinating. And I'd like to get started on building my own. Please send me the things I've checked below.

#### Basic Laser-Building Equipment

- Complete laser kit contains laser tube, power supply and housing \$79.50
- 60-203 Transceiver Kit.\* Use your laser for communications. Transmit-receive \$74.25
- 60-708 Laser Optics Experiment Kit.\* Lenses, prisms, mirrors, diffraction gratings, polarizers, beam splitters, interferometer, lab manual \$40.00
- 60-625 Laser Holograph Kit.\* Contains all critical optics, film, and chemicals \$34.75  
\*Laser not included.
- Information only. Complete catalog and prices.
- Please enclose check or money order for the total amount.

Name \_\_\_\_\_  
Address \_\_\_\_\_  
City \_\_\_\_\_ State \_\_\_\_\_ Zip \_\_\_\_\_

CIRCLE NO. 18 ON READER SERVICE PAGE

in most styli stiffens with age and there is no guarantee that the pickup will function satisfactorily unless that particular model wasn't on the market a year ago.

Mechanical devices like used tape recorders and used disc players may be poor risks because with typical owner neglect they go steadily downhill during their working life, and may be costly to repair. An experienced audiophile, with a "feel" for properly functioning players and recorders can often choose a good used item, but it's risky, and even a used professional tape recorder of outstanding durability may require appreciable servicing.

**The Other Side of the Coin.** A buyer of used preamps, amplifiers and tuners is faced with the obverse side of the depreciation coin—the lower the unit's depreciation rate, the more you'll pay for it. Most early solid-state amplifiers should be shunned, even if the price looks good. They may be in new condition, but the highly touted "transistor sound" of the early solid-state stuff was due mainly to excessive distortion, as witness the fact that today's best transistor amps sound very much like the best of the vacuum-tube amps.

If you spot a used solid-state component that has received consistently good reports in magazines within the past three years, buy it if the price is right. Otherwise, I'd advise a tube-type unit. Since the buying public has been brainwashed into believing that transistors are inherently better than tubes, you can often get a used tubed component for less money than you'd pay for an inherently inferior solid-state one. It may need some new tubes, and possibly some bias adjustments, but these minor ministrations will usually restore it to new condition.

Don't fret over the unanswerable question, "Why did the original owner sell this?" He may have sold it because he didn't like its appearance, or because he was about to be drafted or jailed for malicious empathy. The reason is of no concern to you, because your tastes in sound are not his. No dealer will guarantee that you will like a used-component purchase, but any reputable dealer should at least guarantee that what you buy is not downright defective, and be willing to service it free or take it back for a full refund if it is. The whole point of buying inexpensive equipment is that, since you're likely to make some mistakes the first few times around, it's better to make them on modest purchases than on costly ones.

Of course, if you have the means at your disposal, you can always pay an expert to come in and equip you with a \$5000 custom installation. But try and get a written guarantee that the resulting sound will suit your personal taste. Just try!

-30-

POPULAR ELECTRONICS

CONTROLLED  
QUALITY  
CRYSTALS by



**CRYSTEK**



The "On-Channel" Crystals  
FOR  
**CITIZEN BAND**  
23 Channels and "Mars"

**HAM OPERATORS**  
Commercial 2-Way

**Marine-Monitor**

See your Distributor for Speedy  
"Zip Certificates"



**CRYSTEK**

formerly Texas Crystals  
Div. of Whitehall Electronics Corp.  
1000 Crystal Drive 4117 W. Jefferson Blvd.  
Fort Myers, Florida 33901 Los Angeles, California 90016

CIRCLE NO. 8 ON READER SERVICE PAGE

## INTERFACE

(Continued from page 8)

new speaker that he insisted was cutting off sharply at 16,000 Hz. Laboratory measurements proved that the speaker was flat (as claimed by the manufacturer) out to 20,000 Hz, but the listener was deaf to everything above 9,000 Hz.

HOWARD ADAMS  
Norman, Oklahoma

### EDISON, AMONG OTHERS

I read Fred Shunaman's article, "A Question of Semantics" (October issue) with great interest. However, may I draw to your attention that I feel the Indian scientist and Professor Jagdishchandra Basu warrants consideration as the inventor of wireless. Professor Basu never cared to patent his inventions and discoveries or cash in on them in terms of monetary rewards.

ROHIT ZAVERI  
Pittsburgh, Pa.

*A search of biographical material and the various published histories on wireless and radio reveal no mention of Prof. Basu. POPULAR ELECTRONICS would welcome the opportunity to learn more about Prof. Basu's activities—especially since it is reported that he may have had contact with Marconi (in England) prior to the first long distance demonstration of radio communications.*

### MORE ON THE "NEW LOOK"

I want to commend you on your "New Look" and the material organization in the October issue. I particularly like your new tests—complete with graphs—on the construction projects.

D. WAGNER  
Chattanooga, Tenn.

I have been a reader since 1954 and I must say that the "New Look" is the most fantastic thing that has happened in all these years. Keep up the good work.

R. N. WILLIS  
Camp Lejeune, N.C.

Far better than many previous issues. I found nearly every article in the September issue of interest instead of the usual one or two.

E. MORRIS  
Dearborn Heights, Mich.

Your "New Look" may very well be outstanding in the experimentation field, but I think the "Communications" section is a dud!

J. GONZALEZ  
San Antonio, Texas

# SWITCH ON



### Musi-cube the "switched on" speaker

Musi-Cube has revolutionized the idea of what a speaker should be. Four "switched on" color designs make them fun—even when they're quiet. And because Musi-Cubes measure just 7 $\frac{3}{8}$ " on a side, you can put them almost anywhere. 50 to 16,000 Hz response and full 12-watt music power rating produces a sound so big, you have to hear it to believe it. Write for free full color literature.

## Argos<sup>®</sup>

PRODUCTS COMPANY

600 So. Sycamore, Genoa, Ill. 60135

CIRCLE NO. 1 ON READER SERVICE PAGE

# Olson ELECTRONICS

# FREE Catalog

Fill in coupon for a FREE One Year Subscription to OLSON ELECTRONICS' Fantastic Value Packed Catalog — Unheard of LOW, LOW PRICES on Brand Name Speakers, Changers, Tubes, Tools, Stereo Amps, Tuners, CB, and other Values. Credit plan available.

NAME \_\_\_\_\_  
ADDRESS \_\_\_\_\_  
CITY \_\_\_\_\_ STATE \_\_\_\_\_  
GIVE ZIP CODE \_\_\_\_\_

If you have a friend interested in electronics send his name and address for a FREE subscription also.

## OLSON ELECTRONICS

DEPT. IL, 260 S. FORGE STREET, AKRON, OHIO 44308

CIRCLE NO. 20 ON READER SERVICE PAGE



## Cut out high speaker costs!

Mail coupon and pay less for latest high-compliance cone-edge speakers for hi-fi stereo. Factory-to-you from CTS, pioneers of air-suspension speakers. Also available—rugged speakers for bass and lead guitar and other musical instrument amps.



CTS of Paducah, Inc.  
1565 North 8th Street  
Paducah, Ky. 42001

Please send Catalog of CTS speakers at factory-to-me prices. Specify:

- Hi-Fi Stereo Speaker Catalog  
 Musical Instrument Amplifier Speaker Catalog

Name \_\_\_\_\_

Address \_\_\_\_\_

City \_\_\_\_\_ State \_\_\_\_\_ Zip \_\_\_\_\_

CIRCLE NO. 6 ON READER SERVICE PAGE

## BAGGY'S RADIO

AM AND SSB CB RADIOS, AMATEUR RADIOS  
AND ACCESSORIES

SEND FOR FREE BIG BONUS CATALOG

P.O. Box 778, 6391 Westminster Ave.

Westminster, California 92683

714-894-7555



BAGGY

**USE FOR:**  
**HOME**  
**BOAT**  
**BUSINESS**  
**CAMPER**  
**CAR**  
**TRUCK**

**STINGER ANTENNAS**  
**SWAN HAM RIGS**  
**MAJOR BRANDS**  
**CB RADIOS &**  
**ACCESSORIES.**  
**MONITORS**  
**POLICE**  
**FIRE**  
**WEATHER**  
**METAL DETECTORS**  
**HV + 2 QUAD®**  
**ADAPT-A-MOUNTS®**  
**VFO 11 METER**  
**SLIDER SCANNER®**  
**AND MUCH MORE!**

**DEALERS SEND LETTERHEAD**  
**FOR**

**FACTORY DIRECT PRICES**

"BAGGY'S" RADIO ASSOCIATE STORES NOW AVAILABLE

SEND FOR FULL INFORMATION

CIRCLE NO. 5 ON READER SERVICE PAGE

## LIBERATOR

(Continued from page 52)

Do not substitute a magnetic earphone for the crystal unit. If you do, oscillations may set up and possible damage to the IC can result.

If 60-Hz pickup is a serious problem, wrap the antenna with aluminum foil, leaving a small gap somewhere so that the antenna is not completely shielded, and connect the foil to the circuit ground. To optimize signal pickup, the antenna may have to be tuned. Experiment with various capacitors in parallel with  $C1$  (provisions for this are made on the PC board) to get best results with the antenna on the package. If you want to remove the 200-turn antenna from the outside of the plastic case, try a common ferrite loopstick in its place, experimenting with various values of  $C1$  to get maximum signal.

How much power do you need to cover an area? The author used a conventional transistor pocket radio to power a 30' by 50' loop. The 100-mW audio output from the radio was more than sufficient to do the job and a good magnetic field was found 25' above the loop. (It might have been higher but the house wasn't.)

If you want speaker and loop operation at the same time, select a speaker with a lower impedance than normally used and couple it in series with the loop so that the total resistance is approximately the same as the output impedance of the amplifier. -30-

## CIRCUIT QUIZ ANSWERS

(Quiz appears on page 44)

1.  $(10)^2 = (8)^2 + (VR)^2$ ;  $VR = 6V$
2.  $(20)^2 = (7+VC)^2 + (12)^2$ ;  $VC = 9V$
3.  $(24)^2 = (VL-6)^2$ ;  $VL = 30V$
4.  $(15)^2 = (350-350)^2 + (VR)^2$ ;  $VR = 15V$
5.  $(VT)^2 = (15-3)^2 + (16)^2$ ;  $VT = 20V$
6.  $(50)^2 = (VL)^2 + (12)^2 = (VC)^2 + (12)^2$ ;  $VL = VC$   
 $(VT)^2 = (VL-VC)^2 + (12)^2$ ;  $VT = 12V$
7.  $(IT)^2 = (6)^2 + (8)^2$ ;  $IT = 10mA$
8.  $(20)^2 = (16-IC)^2 + (16)^2$ ;  $IC = 4mA$
9.  $(IT)^2 = (17-13)^2 + (3)^2$ ;  $IT = 5mA$
10.  $(9)^2 = (20-4-IC)^2$ ;  $IC = 7mA$

## LIBRARY

(Continued from page 16)

in switching circuit theory on the undergraduate level, the math is developed in full detail. An entire chapter is devoted to the universal NAND and NOR logic operators. And fundamental mode and pulse mode sequential circuits are studied concurrently to emphasize their similarities and differences.

Published by McGraw-Hill Book Co., 330 West 42 St., New York, NY 10036. Hard cover. 494 pages. \$14.50.

### 20 SOLID STATE HOME AND HOBBY PROJECTS

by R. M. Marston

The circuits described in this book cover a wide range of interesting applications. In addition to the almost mandatory baby alarm and light-operated switch, such circuits as a metal detector, motor speed control, and photographic timer are presented. Each circuit diagram is accompanied by a detailed parts list, a circuit description, and construction details. A very interesting feature of the book is that, where applicable, printed circuit board etching guides are given. The choice of semiconductor devices around which each project is built includes Triacs, SCR's, IC's, UJT's and FET's, as well as the more familiar silicon planar bipolar transistor. The book is well illustrated and even has photos of some finished projects.

Published by Hayden Book Co., Inc., 116 West 14 St., New York, NY 10011. Soft cover. 112 pages. \$3.75.

### RADIO HANDBOOK, 18th Edition

by William I. Orr, W6SAI

It has been three years since publication of the 17th edition of "the other" Handbook; and as might be expected, the changes in ham radio equipment design are reflected in this new edition. If you skip through the first 300 pages (practically all theory), you will start spotting numerous brand-new construction projects—each photographed and

diagrammed for ease of duplication. Printed circuit boards have made their appearance and considerably more emphasis is placed on solid-state equipment than in the 1967 edition. Bill has new ideas for SSB linears and VHF gear that should attract many hams.

Published by Editors & Engineers, Ltd., c/o Howard W. Sams & Co., Inc., 4300 West 62St., Indianapolis, Ind. 46268. Hard cover. 896 pages. \$13.50.

### DIGITAL COMPUTERS MADE SIMPLE

by Saul Heller

Computers, already in widespread use, are now profoundly affecting our lives and will continue to do so in the future. Obviously, some knowledge of them is desirable. Although many books have already been written on the subject, few if any are tailored to suit the layman with no knowledge of computers. This book attempts to rectify that oversight. Only one chapter (the last one that deals with basic computer circuits) is technical in nature. The remainder describes computer numbering systems; computer language; computer systems in brief; input and output devices; computer memory; and computer programming.

Published by Ameco Publishing Corp., 314 Hillside Ave., Williston Park, L.I., NY 11596. Soft cover. 128 pages. \$1.75.

### WORKSHOP IN SOLID STATE

by Harold E. Ennes

Providing a rapid, effective, and practical method of making the transition from vacuum-tube to solid-state circuitry, this book presupposes that the reader has already received training in basic electronics principles. The text approach is about midway between the simplified "serviceman" and the sophisticated mathematical and equivalent-circuit approaches. Hence, the transition is fairly broad-based. The text is written to provide a learning pace that is consistent with a practical study of circuit analysis and fundamental design.

Published by Howard W. Sams & Co., Inc., 4300 West 62 St., Indianapolis, IN 46268. Hard cover. 382 pages. \$9.95.



Switches select desired channels

SIZE 9"W x 4"H x 7"D



PAT. APPLIED FOR

BEARCAT MODELS

BCH 150-174 MHz.....\$139.95  
 BCL 30-50 MHz.....\$139.95  
 BCU 450-470 MHz.....\$149.95  
 BCA 118-136 MHz.....\$149.95  
 (AERONAUTICAL BAND)  
 PLUS CRYSTALS @ \$5.00 ea.

CIRCLE NO. 12 ON READER SERVICE PAGE

## Hear the news as it happens!

with the **Electra BEARCAT**  
 FIRST AND FINEST  
 Scanning FM Monitor Receiver

Automatically scans 1 to 8 FM frequencies you select—Police, Sheriff, Fire, Civil Defense, Marine, Weather, Utilities, Business, etc. Stops for any transmission, then continues signal search. Monitors base, mobile, relay and repeater stations. AM aircraft band model also available. Transistorized integrated circuitry with plug-in crystals. U.S. made. Front-mounted speaker makes it ideal for table, desk, bedside, car or boat. Get the original . . . at better dealers everywhere.

ELECTRA CORPORATION • CUMBERLAND, IND. 46229

# INDEX

## TO VOLUME 33

### JUNE-DEC. 1970

#### AMATEUR RADIO

1-2-3-4 On A Mast (Alexander).....	27 Aug.
Amateur Radio (Brier)	
The Flight Of Oscar-5.....	88 July
Cleopatra Was An Amateur.....	83 Aug.
Amateur Radio Equipment 1970-1971 (Brier).....	51 Aug.
Calibrator, Build A Gated 100-kHZ (Tooker).....	53 Sept.
Coaxial Connectors, Care and Handling of (Orr).....	47 Aug.
Communications	
85 Sept., 87 Oct., 80 Nov., 78 Dec.	
Liberator, Build the (Troemel).....	49 Dec.
Lightning Protection, Automatic (Phillips).....	61 July
The Ham & The Lady Psychologist (Ebel).....	60 Sept.
Three-Channel Time Receiver, Build a (Caringella).....	33 Dec.

#### AUTOMOTIVE ELECTRONICS

Four-Way Flasher, An Improved (Hicke).....	80 Aug.
Ignition Lock, Electronic Combination (Beiswenger).....	40 July
Single Filament Tail Light Converter (Beier).....	66 Dec.

#### CITIZENS BAND RADIO

Annual Catalog of 5-Watt CB Equipment (Staff).....	32 Aug.
Coaxial Connectors, Care and Handling of (Orr).....	47 Aug.
Communications	
85 Sept., 87 Oct., 80 Nov., 78 Dec.	
Liberator, Build the (Troemel).....	49 Dec.
Three-Channel Time Receiver, Build a (Caringella).....	33 Dec.

#### CONSTRUCTION

1-2-3-4 On A Mast (Alexander).....	27 Aug.
Audio Multicaupler, Build An (Wherry).....	31 July
Bug Shoo, Build The (Greenlee).....	27 July
Calibrator, Build A Gated 100-kHZ (Tooker).....	53 Sept.
Camera Shutter Release, Remote (Mangieri).....	65 July
Camera Shutter Speed Meter, Assembling A (Coomes).....	73 Sept.
Digital Measurements Lab, Assemble A (Meyer).....	51 Nov.
Digi-Vista, Assemble the POPULAR ELECTRONICS (Kay and Meyer).....	25 Dec.
Diode Tester, Build Dynamic (Andrew).....	53 July
Drain-Dip Oscillator, VHF-UHF (McGee).....	69 Oct.
Four-Way Flasher, An Improved (Hicke).....	80 Aug.
Electrolytic Restorer, Build an (Plamondon).....	46 Oct.
Expanded Scale Milliohmmer, a Practical (Corbin).....	77 Oct.
Frequency Counter Module, 20-MHz (Meyer).....	51 Nov.
Frequency Equalizer, Assemble a (Meyerle).....	51 Oct.
Ignition Lock, Electronic Combination (Beiswenger).....	40 July
Instrument Sensitivity Booster, Build the X10/X100 (Bongiorno).....	43 July
LED Communicator—The Opticam, Assemble an (Mims).....	45 Nov.

Liberator, Build the (Troemel).....	49 Dec.
Lightning Protection, Automatic (Phillips).....	61 July
Mini-DVM, Assembling the POPULAR ELECTRONICS (Lancaster).....	35 Sept.
Pink Noise Generator, Build a (Simonton).....	61 Dec.
Printing Exposure Lightmeter, Build a (Mangieri).....	60 Oct.
RIAA/NAB Preampfier, Build a (Huffnagle).....	61 Aug.
SCA Adapter for FM Reception, Build an (Wood).....	53 Dec.
Seven-Segment Readout, Make Your Own (Klaop).....	68 Aug.
Stage Lighting Control System (Thuraw).....	65 Aug.
Super Substitution Box (Tenny).....	79 July
Three-Channel Time Receiver, Build a (Caringella).....	33 Dec.
Universal Tiger, Assembling a (Meyer).....	31 Oct.
VTVM a Megger Too, Make Your (Childs, Eskridge).....	50 Aug.
Winding Your Own Output Transformers (Francis).....	78 Sept.
Woofer Guard, Build a (Arthur).....	49 July

#### DEPARTMENTS

Direct & Current (Ferrell)	
The "New Look".....	7 Sept.
CBI For Better? Or Worse?.....	7 Oct.
About Reader Mail.....	7 Nov.
It Takes All Kinds.....	7 Dec.
Electronics Library	
12 July, 14 Aug., 16 Sept., 12 Oct., 14 Nov., 14 Dec.	
Interface (Letters From Our Readers)	
8 July, 8 Aug., 10 Sept., 113 Oct., 8 Nov., 8 Dec.	
New Literature	
16 July, 100 Aug., 14 Sept., 8 Oct., 12 Nov., 12 Dec.	
New Products	
22 July, 22 Aug., 22 Sept., 22 Oct., 22 Nov., 22 Dec.	
Operation Assist.....	96 Aug.
Out Of Tune	
Modify Your Electronic Guitar Sound (June 1970, p. 53).....	97 Aug.
Build A Signal Injector (June 1970, p. 43).....	116 Sept.
Build A Low-Cost Time Delay Relay (June 1970, p. 71).....	116 Sept.
Build A RIAA/NAB Preampfier (Aug. 1970, p. 61).....	111 Oct.
Build Dynamic Diode Tester (July 1970, p. 53).....	111 Oct.
An Improved Four-Way Flasher (Aug. 1970, p. 80).....	102 Nov.

#### EDUCATION

Electronics Self-Study Course (Englert).....	45 Dec.
Opportunity Awareness (Heiserman)	
All About Medical Electronics.....	60 July
Sound Engineering Opportunities.....	83 Sept.
Thoughtful Reflections On Your Future.....	98 Oct.
The Sacred Club of Engineers.....	44 Nov.

#### FEATURE ARTICLES

Bug-Shoo, Build the (Greenlee).....	27 July
Coaxial Connectors, Care and Handling of (Orr).....	47 Aug.
Drain-Dip Oscillator, VHF-UHF (McGee).....	69 Oct.
Electrolytic Restorer, Build an (Plamondon).....	46 Oct.
Electronics Goes Cat Catching (Garrison).....	29 Nov.
Electronics Self-Study Course (Englert).....	45 Dec.
Experiment That Saved Hi-Fi, The (Weems).....	29 Sept.



The Ham & The Lady Psychologist (Ebel).....	60 Sept.
Hobnobbing With Harbaugh (Harbaugh).....	48 July
JK Flip-Flop, Getting to Know the (Tooker).....	67 Sept.
LED Communicator—The Opticom, Assemble an (Mims).....	45 Nov.
Light Emitting Diodes (Mims).....	35 Nov.
Lightning Protection, Automatic (Phillips).....	61 July
Numbers Game, The (Weems).....	64 Nov.
Question Of Sematics, A (Shunaman).....	27 Oct.
Quiz on AC Circuit Theory (Balin).....	44 Dec.
Stage Lighting Control System (Thuraw).....	65 Aug.
Super Substitution Box (Tenny).....	79 July
Universal Tiger, Assembling a (Meyer).....	31 Oct.
Winding Your Own Output Transformers (Francis)....	78 Sept.
Wire Music (Steiner).....	35 July

### HI-FI/STEREO AND AUDIO

Audio Multicaupler, Build an (Wherry).....	31 July
Experiment That Saved Hi-Fi, The (Weems).....	29 Sept.
Frequency Equalizer, Assemble a (Meyerle).....	51 Oct.
Numbers Game, The (Weems).....	64 Nov.
Reflex Enclosure Dimensions, An Easy Way to Determine (Lescault).....	64 Dec.
RIAA/NAB Preampfier, Build a (Huffnagle).....	61 Aug.
SCA Adapter for FM Reception, Build an (Wood)....	53 Dec.
Stereo Scene (Holt) What It's All About.....	97 Sept.
Those Crazy Speakers.....	94 Oct.
Four Channels From Two On Discs.....	69 Nov.
Keeping Economy in Mind.....	71 Dec.
Universal Tiger, Assembling a (Meyer).....	31 Oct.
Woofer Guard, Build a (Arthur).....	49 July

### OPTOELECTRONICS

LED Communicator—The Opticom, Assemble an (Mims).....	45 Nov.
Light-Emitting Diodes (Mims).....	35 Nov.

### PHOTOGRAPHY

Camera Shutter Release, Remote (Mangieri).....	65 July
Camera Shutter Speed Meter, Assembling a (Coomes)	73 Sept.
Printing Exposure Lightmeter, Build a (Mangieri)....	60 Oct.

### PRODUCT GALLERY

Dual Automatic Turntable.....	69 July
Curtis Electronic Fist.....	69 July
Realistic Sound Level Meter.....	69 July
Healthkit Fish Spotter.....	69 July
Hallicrafters SX-133 Receiver.....	71 Aug.
Thor-Go Ignition System.....	71 Aug.
Radio Shack DX-150A Receiver.....	71 Aug.
Triplet Model 602 Volt-Ohmmeter.....	93 Sept.
Ten-Tec Enclosures.....	93 Sept.
GC Electronics "B Neg" Patterns.....	93 Sept.
Knight-Kit R-195 Receiver.....	81 Oct.
Eico 150 Signal Tracer.....	81 Oct.
Electro-Voice Landmark 100 Stereo System.....	81 Oct.
Avanti Astro-Plane Antenna.....	76 Nov.
B & K Cobra Transceiver.....	76 Nov.
Healthkit Vectorscope IO-101.....	67 Dec.
Jahnsen Smith Co. Intrusion Alarm.....	67 Dec.
Ungar IC Desoldering Tools.....	67 Dec.

### SCIENCE FAIR PROJECTS

LED Communicator—The Opticom, Assemble an (Mims).....	45 Nov.
Pink Noise Generator, Build a (Simonton).....	61 Dec.

### SHORTWAVE LISTENING

Coaxial Connectors, Care and Handling of (Orr)....	47 Aug.
Communications 85 Sept., 87 Oct., 80 Nov., 78 Dec.	
English-Language News Broadcasts To North America (Legge) 84 July, 84 Aug.	
Liberator, Build the (Troemel).....	49 Dec.
Shortwave Listening (Bennett) KVBR To Test For DX'ers.....	83 July
SWL Through The Years.....	85 Aug.

### SOLID-STATE CIRCUITS

Audio Multicaupler, Build an (Wherry).....	31 July
Calibrator, Build a Gated 100-kHz (Tooker).....	53 Sept.
Digital Measurements Lab, Assemble a (Meyer).....	51 Nov.
Digi-Vista, Assemble the POPULAR ELECTRONICS (Kay and Meyer).....	25 Dec.
Diode Tester, Build Dynamic (Andrew).....	53 July
Frequency Counter Module, 20-MHz (Meyer).....	51 Nov.
Frequency Equalizer, Assemble a (Meyerle).....	51 Oct.
Instrument Sensitivity Booster, Build the X10/X100 (Bongiarno).....	43 July
JK Flip-Flop, Getting to Know the (Tooker).....	67 Sept.
LED Communicator—The Opticom, Assemble an (Mims).....	45 Nov.
Light-Emitting Diodes (Mims).....	35 Nov.
Mini-DVM, Assembling The POPULAR ELECTRONICS (Lancaster).....	35 Sept.
RIAA/NAB Preampfier, Build a (Huffnagle).....	61 Aug.
Solid State (Garner) 85 July, 81 Aug., 100 Sept., 100 Oct., 82 Nov.,	81 Dec.
Stage Lighting Control System (Thuraw).....	65 Aug.
Universal Tiger, Assembling a (Meyer).....	31 Oct.

### TEST EQUIPMENT

Calibrator, Build a Gated 100-kHz (Tooker).....	53 Sept.
Camera Shutter Speed Meter, Assembling a (Coomes).....	73 Sept.
Digital Measurements Lab, Assemble a (Meyer).....	51 Nov.
Diode Tester, Build Dynamic (Andrew).....	53 July
Drain-Dip Oscillator, VHF-UHF (McGee).....	69 Oct.
Electrolytic Restorer, Build an (Plamondon).....	46 Oct.
Expanded Scale Milliohmmeter, A Practical (Corbin).....	77 Oct.
Frequency Counter Module, 20-MHz (Meyer).....	51 Nov.
Instrument Sensitivity Booster, Build the X10/X100 (Bongiarno).....	43 July
Mini-DVM, Assembling The POPULAR ELECTRONICS (Lancaster).....	35 Sept.
Printing Exposure Lightmeter, Build a (Mangieri)....	60 Oct.
Second Guessing the Healthkit IG-72 (Palomaki).....	54 Dec.
Seven-Segment Readout, Make Your Own (Kroop)....	68 Aug.
Super Substitution Box (Tenny).....	79 July
VTVM A Megger Too, Make Your (Childs, Eskridge) ..	50 Aug.

# ELECTRONICS MARKET PLACE

**COMMERCIAL RATE:** For firms or individuals offering commercial products or services. \$1.25 per word (including name and address). Minimum order \$12.50. Payment must accompany copy except when ads are placed by accredited advertising agencies. Frequency discount: 5% for 6 months; 10% for 12 months paid in advance. **READER RATE:** For individuals with a personal item to buy or sell. 80c per word (including name and address). No Minimum! Payment must accompany copy.

**GENERAL INFORMATION:** First word in all ads set in bold caps at no extra charge. All copy subject to publisher's approval. Closing Date: 1st of the 2nd month preceding cover date (for example, March issue closes January 1st). Send order and remittance to: Hal Cymes, POPULAR ELECTRONICS, One Park Avenue, New York, New York 10016.

## FOR SALE

**FREE!** Giant bargain catalog on transistors, diodes, rectifiers, SCR's, zeners, parts. Poly Paks, P.O. Box 942, Lynnfield, Mass. 09140.

**GOVERNMENT Surplus Receivers, Transmitters, Snooperscopes, Radios, Parts, Picture Catalog 25¢.** Meshna, Nahant, Mass. 01908.

**ROCKETS:** Ideal for miniature transmitter tests. New illustrated catalog. 25¢. Single and multistage kits, cones, engines, launchers, trackers, rocket aerial cameras, technical information. Fast service. Estes Industries, Dept. 18-M, Penrose, Colorado 81240.

**LOWEST Prices Electronic Parts.** Confidential Catalog Free. **KNAPP**, 3174 8th Ave. S.W., Largo, Fla. 33540.

**EUROPEAN and Japanese bargains catalogs.** \$1 each. Dee, 10639E Riverside, North Hollywood, Calif. 91602.

**WE SELL CONSTRUCTION PLANS. TELEPHONE:** Answering Machine, Speakerphone, Carphone, Phonevision, Legal Connector, Auto Dialer, Central Dial System. **TELEVISION:** \$35.00 Color Converter, Tape Recorder, 3DTV. \$25.00 Camera. **DETECTIVE:** Infinity Transmitter, Tail Transmitter, Police Radar Detector. **HOBBYIST:** Electron Microscope, 96 Hour Tape Music System, Ultrasonic Dishwasher, Radar-Oven, Electronic Tranquilizer. Plans \$4.95 each. **COURSES:** Telephone Engineering \$39.50, Detective Electronics \$22.50, Anti-Detective Electronics \$27.50. **NEW SUPER HOBBY CATALOG AIRMAILED \$1.00.** Don Britton Enterprises, 6200 Wilshire Blvd., Los Angeles, Calif. 90048.

**WEBBER LAB's.** Police & Fire Converters. Catalog 25¢. 72 Cottage Street, Lynn, Mass. 01905.

**INVESTIGATORS, LATEST ELECTRONICS AIDS. FREE LITERATURE.** CLIFTON, 11500-L NW 7th AVE., MIAMI, FLORIDA 33168.

**LINEAR AMPLIFIERS:** 10 meters. "Hawk"—25 watts output—\$59.95; "Hornet"—50 watts—\$98.50; "Raider"—100 watts—\$139.95; "Maverick-250"—250 watts—\$244.95; AM/SSB. "Scorpion" 50 watt 12 volt mobile—\$99.95; "Bandit II" 100 watt mobile—\$169.95. 20-35 megacycles. (Illegal Class D 11 meters.) Dealer inquiries invited. D & A Manufacturing Co., 1217 Avenue C, Scottsbluff, Nebraska 69361.

**ELECTRONIC PARTS, semiconductors, kits. FREE FLYER.** Large catalog \$1.00 deposit. **BIGELOW ELECTRONICS**, Bluffton, Ohio 45817.

**RADIO—T.V. Tubes—36¢ each.** Send for free catalog. Cornell, 4213 University, San Diego, Calif. 92105.

**ULTRA-SENSITIVE AND POWERFUL METAL DETECTORS—**join the many who are finding buried coins, minerals, relics and artifacts. Don't buy till you see our **FREE** catalog of new models. Write Jetco, Box 132-PE, Huntsville, Texas 77340.

**LASER parts catalog 60¢.** Moynihan, 107 North Brighton, Atlantic City, New Jersey 08401.

**PSYCHEDELIC catalog.** Posters, lighting, etc. Send 50¢ for handling to Hole In The Wall, 6055PE Lankershim, North Hollywood, Calif. 91606.

**THE ART OF DE-BUGGING—\$5.95.** TRON-X PUBLICATIONS, P.O. BOX 38155, HOLLYWOOD, CALIFORNIA 90038.

**CLEARANCE SALE** rectifiers, transistors, 1000's other items. Catalog 15¢. General Sales Company, 254 Main, Clute, Texas 77531.

**SEMI-CONDUCTORS and parts catalogue** free over 100 pages. J. & J. Electronics, Box 1437, Winnipeg, Manitoba, Canada, U.S. Trade directed.

**MECHANICAL, ELECTRONIC devices catalog 10¢.** Greatest Values—Lowest Prices. Fertik's, 5249 "D", Philadelphia, Pa. 19120.

**MUSIC LOVERS, CONTINUOUS, UNINTERRUPTED BACKGROUND MUSIC FROM YOUR FM RADIO, USING NEW INEXPENSIVE ADAPTOR. FREE LITERATURE. ELECTRONICS, 1500-Z NW 7th AVE., MIAMI, FLORIDA 33168.**

**SPACE-AGE TV CAMERA KIT!** Terrific for Experimenters, Industry, Education. Solid-state. Only \$116.95! Starter kits: \$18.95 up. Plans 25¢ up. Catalog **FREE.** Phone: 402-987-3771. Write: **ATV RESEARCH**, 1301 Broadway, Dakota City, Nebr. 68731.

**BURGLAR ALARM SYSTEMS and accessories.** Controls, bells, sirens, hardware, etc. **OMNI-GUARD** radar intruder detection system, kit form or assembled. Write for free catalog. Microtech Associates, Inc., Box 10147, St. Petersburg, Florida 33733.

**PRINTED CIRCUITS.** Magazine projects and experimental. Free listing. Vico, Box 1590, Los Angeles, Calif. 90053.

**SENCORE, B&K TEST EQUIPMENT UNBELIEVABLE PRICES. FREE CATALOG AND PRICE SHEET. FORDHAM RADIO, 265 EAST 149TH STREET, BRONX, N.Y. 10451.**

**AMATEUR SCIENTISTS, Electronics Hobbyists, Experimenters, Students . . .** Construction Plans—all complete, including drawings, schematics, parts lists with prices and sources . . . Radar—Build your own ultrasonic doppler radar. Detect motion of people, automobiles, even falling rain drops. Transistorized, uses 9 volt transistor battery—\$4.50 . . . Long-Range "Sound Telescope"—This amazing device can enable you to hear conversations, birds and animals, other sounds hundreds of feet away. Very directional. Transistorized. Uses 9V battery—\$3.70 . . . Robot Man—Moves hands and arms—\$3.50 . . . Or send 25¢ coin (no stamps) for complete catalog. Other items include Psychedelic strobes, light shows, lasers . . . 46 different projects. Technical Writers Group, Box 599A, State College Station, Raleigh, N.C. 27607.

**ANTIGRAVITY, EXPERIMENT AND THEORY;** rushed—\$1.00. U.S. Inquiries. Intertech-7A4, Box 5373, Station-F, Ottawa, Canada.

**ELECTRONIC COMPONENTS—**Distributor prices, Free catalog. Box 2581, El Cajon, California 92021.

**JAPAN & HONG KONG DIRECTORY.** Electronics, all merchandise. World trade information. \$1.00 today. Ippano Kaisha Ltd., Box 6266, Spokane, Washington 99207.

**PLANS-PARTS-KITS** A wide range of the unusual for the experimenter, hobbyist and amateur scientist. Many psychedelic items; **STROBES**, color organs. **ELECTRIC CANDLES**, Touch Switches, **LIGHTNING GENERATORS.** Complete line of **COMPONENTS.** Air Mail Catalog 50¢. Teletronics, Box 1266, South Lake Tahoe, Calif. 95705.

**CITIZEN BAND Radios, SSB, AM, Swan CB, Amateur. Accessories.** Free Catalogue. Dealers send letterhead for factory prices. Call 714-894-7555, "Baggy's" Radio, 6391 Westminister Avenue, Westminister, Calif. 92683.

**ELECTRONIC CD Ignitions, RPM Limiters, Precision Timers.** Send \$ .50 for complete Christmas catalog. ARPe, P.O.B. 9562, San Jose, California 95117.

**DIAGRAMS—**Radios \$1.50, Television \$3.00. Give make and model. Diagram Service, Box 1151PE, Manchester, Conn. 06042.

**ELECTRONIC Ignition.** Various Types. Information 10¢. Anderson Engineering, Epsom, N.H. 03239.

**BURGLAR and FIRE ALARM SYSTEMS and supplies. INSTALLATION MANUAL and catalog \$1.00.** Refunded first order. Electronic Sentry Systems, P.O. Box 8023A, Sacramento, California 95818.

**NEW! PHONE PATCH** with automatic switch. Now you can record those important conversations automatically. **ONLY \$19.95.** Chico Electronics, 11835 Wilshire Blvd., Los Angeles, Calif. 90025.



**BACKGROUND MUSIC**, continuous commercial-free. Solid state **MUSICON SCA ADAPTER** plugs into any FM Tuner, Receiver. Line powered. 5 year guarantee! Only \$39. postpaid. K-Lab, Box 572Z, South Norwalk, Conn. 06856.

**PACEMATE CB** 2-way radio 2 watts 3 channel \$39.95. Regularly \$99.95. Request information. American Comset, 1638 W. 135th Street, Gardena, Calif. 90249.

**NEW SEMICONDUCTOR LIGHT EMITTING DIODES**—bright red lights replace light bulbs. Typical life 100 years. Operate at 1.65 volts. 50 milliamps. Order 2 for \$2.98 NOW. Data sheet and instructions included. Monsanto Company, Hobby Section, 10131 Bubb Road, Cupertino, California 95014.

**CONVERT** any television to sensitive, big-screen oscilloscope. Only minor changes required. No electronic experience necessary. Illustrated plans, \$2.00. Relco-A33, Box 10563, Houston, Texas 77018.

**POLICE-FIRE RADIO DISPATCHER CALLBOOKS!** EXCLUSIVE, OFFICIAL LISTINGS: CALLSIGNS, FREQUENCIES! LATEST REVISIONS, NATIONWIDE. CATALOG, SEND STAMP. COMMUNICATIONS, BOX 56-PE, COMMACK, N.Y. 11725.

**DIFFERENT?** You bet. Industrial and Government Electronic Surplus. Get our latest list now. Startronics, Box 17127, Portland, Oregon 97217.

**COLOR ORGANS**, three channel, 1000 watt, \$12.50. Strobes. Soundlights. J&J Enterprises, 8102, Bainbridge, Wash. 98110.

**BRAINWAVE FEEDBACK**. Integrated circuit electroencephalophone. J&J Enterprises, 8102, Bainbridge, Wash. 98110.

**ELECTRONIC Components**. Lowest Wholesale Prices. Catalog 25¢. Hazelton Scientific, Hazel Park, Michigan 48030.

**DEALER PRICES, FREE Catalog**. Newell Electronics, Box 4334, Meridian, Miss. 39301.

**GEIGER COUNTERS**, strobe lights, alarms. Catalog 35¢. Taurus, 706 Franklin, Worcester, Massachusetts 01604.

**X-RAY fluoroscope machine**. See through all kinds of objects! Complete high quality plans and instructions, \$5.00. Apogee Corporation, P. O. Box 8400, Ft. Worth, Texas 76112.

**ELECTRONICS AND NOVELTIES**. Catalog Free. WLT Enterprises, Box 1067, Lillington, N. C. 27546.

**FREE catalog, parts, circuit boards for POPULAR ELECTRONICS projects**. PALA ELECTRONICS, Box 14359, Oklahoma City, OK 73114.

**TV TUNER REPAIRS**—Complete Course Details, 12 Repair Tricks, Many Plans, Two Lessons, all for \$1. Refundable. Frank Bocek, Box 833, Redding, Calif. 96001.

**MATRIX ARRAY COMPONENT UNITS**; needed in experimenter laboratory and repair shop, catalog 10¢. CUHINCO, 2404 Stratton Drive, Rockville, Maryland 20854.

**NEW expanded catalogue** featuring relays, test equipment, and components at reasonable prices. Send 10¢ to Gust & Company, Box 24081, Edina, Minnesota 55424.

**2N3055 \$1.50. IN4007 28¢. Capacitors** all new 1500 MFD 25 volt 50¢, 1000 MFD 50 Volt 50¢. 100 MFD 15 volt 20¢. All ppd stamp for list. Weinschenker, Box 353, Irwin, Pa. 15642.

**CIRCUIT BOARDS**: Complete Job Shop Operation. Jetca, Inc., Box 418, Monon, Indiana 47959.

## HOME MOVIES

**MONEY SAVING GIFT FILM CATALOG**—Action 8mm/Super 8 color. SPORTLITE-PE, 20 North Wacker, Chicago 60606.

## PLANS AND KITS

**BUILD your own electronic COMPUTER**. New book explains theory, practical details. \$2.25 postpaid. Cinnamon Press, Box 8453-A, Minneapolis, Minnesota 55408.

**KITS \$2.99**. Buy two, one free. Free information. Aline, 434 West 4th Street, West Islip, New York 11795.

**COLOR converter** for black and white television. New patented system. Do-it-yourself electronic kit, for hobbyists and experimenters. Write for free brochure. Bele Electronics Corp., 111 Northeast Second Avenue, Miami, Fla. 33132.

**BURGLAR alarm**. Plans for reliable system for home or business. \$3.00. Plans, Box 54, Bronxville, N. Y. 10708.

**"ONE TUBE DXER"** Handbook—50¢. "Coil Winding"—50¢. Catalog. Laboratories, 2612-L Butano, Sacramento, Calif. 95821.

December, 1970

## 1400-PC. GLASS FIBER OPTIC KIT

It's FUN!

It's Educational!

It's Gifty!



\$5.50

- ★ Make light "pipes"
- ★ Dazzling displays
- ★ Triggers photo & infra-red cells

**OPTICAL SCIENTIFIC BREAKTHRU!** Allows "hair thin" glass fibers (2-ft. long) to transmit & receive cold light energy of any color, by internal reflection. Bundled, jacketed, it guides, announces, pipes light around corners, walls, even in circles, triggering such devices as light sensitive transistors, diodes, aers. It CUTS, BLENDS, ACTS like wire. Only one's imagination controls its 100% of uses. PRICE: 12-pee. accessory kit, with "how-to-do booklet".

- \$25 SURPRISE PAK: transistors, rect. diodes, etc. .. \$1
- 50 GERMANIUM GLASS DIODES, 1N34, 1N48 no test \$1
- 40 TOP HAT SILICON RECTIFIERS, no test/asst values \$1
- 25 EPOXY RECTIFIERS, silicon asst, no test .. \$1
- 40 PRECISION RESISTORS, 1/2-2W, 1% asst values .. \$1
- 30 TRANSISTORS, rf, if, audio, osc, no test .. \$1
- 60 TUBULAR CONDENSERS, to .5mf to 1KV, asst .... \$1
- 50 DISC CONDENSERS, to .05mf npo, temp coef, asst \$1
- 30 POWER RESISTORS, to 25 watts, to 24K ohms .... \$1
- 10 VOLUME CONTROLS, to 1 meg, switch too! .... \$1
- 10 ELECTROLYTICS, to 100mf, tubulars too, asst .... \$1
- 50 RADIO & TV KNOBS, asstd colors & styles .. \$1
- 10 TRANS'OR ELECTROLYTICS to 100mf, asst values \$1
- 50 COILS and CHOKES, if, rf, ant, osc, peaking, etc \$1
- 65 HALF WATERS, to 1 meg, 5% popular values too \$1
- 2 FIELD EFFECT TRANSISTORS, n channel, hobby ... \$1
- 10 PANEL SWITCHES, toggle, slide, micro, rotary ... \$1
- 3 "SUN" BATTERIES, for 100's of lite sens proj's ... \$1
- 5 "IBM" COMPUTER BOARDS, many trans, diodes \$1
- 40 "MICRO" CONDENSERS, for transistor circuitry \$1
- 50 TERMINAL STRIPS, 1 to 8 lug types .. \$1
- 4 PHOTO ELECTRIC CELLS, hi. imp., schematic .... \$1
- 40 "TINY" RESISTORS, 1/10W, 5% too! to 1 mek. \$1

ADD POSTAGE, avg. wt: 1/2 lb.  CATALOG 10¢

## POLY PAKS

P.O. BOX 942E  
LYNNFIELD, MASS.  
01940

CIRCLE NO. 21 ON READER SERVICE PAGE

## POPULAR ELECTRONICS SUBSCRIBER SERVICE

Please include an address label when writing about your subscription to help us serve you promptly. Write to: P.O. Box 1096, Flushing, N.Y. 11352

**CHANGE OF ADDRESS:** Please let us know you are moving at least four to six weeks in advance. Affix magazine address label in space to the right and print new address below. If you have a question about your subscription, attach address label to your letter.

**TO SUBSCRIBE:** Check below.  
 5 yrs. \$21     3 yrs. \$15  
 1 yr. \$6     New     Renewal

Specify:  Payment enclosed  
 You get 1 extra issue per year as a BONUS!  
 Bill me later.

If you have no label handy, print OLD address here.

name \_\_\_\_\_

address \_\_\_\_\_

city \_\_\_\_\_

state \_\_\_\_\_

zip code \_\_\_\_\_

AFFIX LABEL

print name \_\_\_\_\_ 0449

address \_\_\_\_\_

city \_\_\_\_\_

state \_\_\_\_\_ zip code \_\_\_\_\_

Add'l postage: \$1 per year outside U.S., its possessions & Canada.



**AMAZING** Speakerchair. Perfect realism within luxurious chair. Multi-speaker model, \$70. Plans \$5.00. Audiovox Speakerchair, 8 Poplar Road, Wellesley, Mass. 02181.

**LSD-type** exploding multicolors with eyes shut. 100 unusual speakers. 50 black lights, strobes. Sound-modulated cigarettes, posters, flames, massage. Sound lamp (peace-, nude-, flower-shaped glowing electrodes). Head-shop hottest zero-investment business. \$500. lights more spectacular than \$1,000,000. show. Catalog, plans, \$2.00 each. Complete Library (much more) \$19.95. Mel, 9634 16th SW, Seattle, Washington 98106.

**EXPERIMENTERS**—Use any transistor radio for simple Radio Control Experiments. Complete Plans \$2. Creative Electronics, Box 4943A, Austin, Texas 78751.

**AMAZING** Electronic Hypnotizer—Easy to make. Complete Plans \$2. Creative Electronics, Box 4943, Austin, Texas 78751.

**INTEGRATED CIRCUIT KITS: COMPUTER, OPTOELECTRONICS, AUDIO.** Catalog free. **KAYE ENGINEERING**, Box 3932-A, Long Beach, California 90803.

**ELECTRONIC IGNITION** plans \$1.00 equals \$45.00 units. **KIT** \$29.95. **MEDLEY ENTERPRISES**, Box 12393, El Paso, Texas 79912.

**COLOR Organ Kits** \$7.50. Power Supplies \$2.75. Catalog. Murphy, 204 Roslyn Ave., Carle Place, N. Y. 11514.

## HIGH FIDELITY

**LOW**, Low quotes: all components and recorders, HiFi, Roslyn, Penna. 19001.

**TAPE RECORDERS**, Hi-Fi, components, Sleep Learning Equipment, tapes. Unusual Values. Free Catalog. Dressner, 1523R, Jericho Turnpike, New Hyde Park, N.Y. 11040.

**DIAMOND NEEDLES AND STEREO CARTRIDGES** at low, low prices for Shure, Pickering, Stanton, Empire, Grado and ADC. Send for free catalog and price sheet. We will be happy to quote on any cartridge—Magnetic, Ceramic or Crystal. All merchandise brand new and shipped **PREPAID**. **LYLE CARTRIDGES**, Dept. P, 265 East 149 Street, Bronx, New York 10451.

## WANTED

**CASH PAID!** Unused tubes, electronic equipment. Barry, 512 Broadway, NYC 10012.

**QUICKSILVER**, Platinum, Silver, Gold, Ores Analyzed. Free Circular. Mercury Terminal, Norwood, Mass. 02062.

## TUBES

**TUBES** "Oldies", latest. Lists free. Steinmetz, 7519 Maplewood, Hammond, Indiana 46324.

**RECEIVING & INDUSTRIAL TUBES, TRANSISTORS.** All Brands—Biggest Discounts. Technicians, Hobbyists, Experimenters—Request **FREE** Giant Catalog and **SAVE!** **ZALYTRON**, 469 Jericho Turnpike, Mineola, N.Y. 11501.

**THOUSANDS** and thousands of types of electronic parts, tubes, transistors, instruments, etc. Send for Free Catalog. Arcturus Electronics Corp., MPE, 502-22nd St., Union City, N.J. 07087.

**RADIO & T.V. Tubes**—36¢ each. Send for free list. Cornell, 4213 University, San Diego, Calif. 92105.

**TUBES**—Lowest prices. Foreign-American. Obsolete, receiving, special purpose, transmitting tubes. Send for tube, parts catalog. United Radio Company, 56-P Ferry St., Newark, N.J. 07105.

**TUBE** Headquarters of World! Send 10¢ for Catalog (tubes, electronic equipment) Barry, 512 Broadway, N.Y.C. 10012.

## TAPE AND RECORDERS

**BEFORE** Renting Stereo Tapes try us. Postpaid both ways—no deposit—immediate delivery. Quality—Dependability—Service—Satisfaction—prevail here. If you've been dissatisfied in the past, your initial order will prove this is no idle boast. Free Catalog. Gold Coast Tape Library, Box 2262, Palm Village Station, Hialeah, Fla. 33012.

**STEREO TAPES**, save 20,30% and more, postpaid anywhere U.S.A. We discount batteries, recorders, tape/cassettes, 80-page catalog 25¢. **SAXITONE TAPES**, 1776 Columbia Road, N.W., Washington, D.C. 20009.

**OLD** radio programs on tape, 6 hours for \$8.00. Catalog 50¢. Don Maris, 1926 Cherokee, Norman, Okla. 73069.

**CASSETTES**—Cash in on a tremendous All-year round market. Send for lowest pricing and details. Include \$1.00 for 2 cassette samples. **DICTATION PRODUCTS**, PO Box 87 DPM, Hallandale, Florida 33009.

**TAPE RECORDERS, TAPE**—blank, pre-recorded. Catalog 25¢. Tower, Lafayette Hill, Pa. 19444.

**8-TRACK** Blank Recording Tapes custom made to your order. Sizes 30 to 50 minutes, \$1.95. 51 to 80 minutes, \$2.25. Royal Assembly, PO Box 267, Franklin Square, New York 11010.

**EXCITING** Apollo 11 moon landing tapes. 30 minutes. Guaranteed. Specify speed. \$4.00. Box 2373, Van Nuys, Calif. 91401.

**HEAR** them again—old radio programs. Catalog 50¢. Radio, Box 62, Struthers, Ohio 44471.

## REPAIRS AND SERVICES

**TV** Tuners rebuilt and aligned per manufacturers specification. Only \$9.50. Any make UHF or VHF Ninety day written guarantee. Ship complete with tubes or write for free mailing kit and dealer brochure. **JW Electronics**, Box 51C, Bloomington, Indiana 47401.

**TELEVISION** tuners, any make VHF or UHF, cleaned, repaired and realigned per manufacturer's specifications \$9.50. One year guarantee. Quality Tuner Repair, 526 West Busby Street, Lebanon, Indiana 46052.

## PERSONALS

**MAKE FRIENDS WORLDWIDE** through international correspondence. Illustrated brochure free. Hermes, Berlin 11, Germany.

**INVESTIGATORS, LATEST ELECTRONIC AIDS. FREE LITERATURE.** CLIFTON, 11500-K NW 7th AVE., MIAMI, FLORIDA 33168.

## INSTRUCTION

**LEARN ELECTRONIC ORGAN SERVICING** at home all makes including transistor. Experimental kit—trouble-shooting. Accredited NHSC. Free Booklet. **NILES BRYANT SCHOOL**, 3631 Stockton, Dept. A, Sacramento, Calif. 95820.

**LEARN WHILE ASLEEP**, Hypnotize! Strange catalog free. Auto-suggestion, Box 24-ZD, Olympia, Washington 98501.

**DEGREE** in Electronics Engineering earned mostly by correspondence. Free brochure. Dept. G-9, Grantham School of Engineering, 1505 N. Western Ave., Hollywood, California 90027.

**HIGHLY** effective home study courses in Electronics Engineering Technology and Electronics Engineering Mathematics. Earn your Degree. Write for Free Descriptive Literature. Cook's Institute of Electronics Engineering, (Dept. 15), P.O. Box 10634, Jackson, Miss. 39209. (Established 1945).

**F.C.C. FIRST CLASS LICENSE** in three to four weeks. Write American Institute of Radio, 2622 Old Lebanon Road, Nashville, Tennessee 37214 or 3986 Beach Boulevard, Box 16652, Jacksonville, Florida.

**FCC FIRST CLASS LICENSE THROUGH TAPE RECORDED LESSONS.** Also **RADAR ENDORSEMENT.** Radio License Training, 1060D Duncan, Manhattan Beach, Calif. 90266.

**MORE** sales through proper training. Pacific Institute of Programmed Instruction, P.O. Box 1326, Seattle, Washington 98102.

**LEAP! LEAP! LEAP!** Into Big Money! 150,000 Computer Programmers needed in 5 years. Diploma Home Study Course, Price Breakthrough: only \$9.95. Act Now. Money Back Guarantee. U.S. Inquiries, Intertech-764, Box 5373, Station-F, Ottawa, Canada.

**WANT AN F.C.C. 1st CLASS LICENSE? WANT TO BECOME A DISC-JOCKEY?** REI has a school near you VA approved. Call toll free: 1-800-237-2251 or write REI, 1336 Main St., Sarasota, Florida 33577, Florida Residents call: 813-955-6922.

**SCIENCE TEACHERS**—Experimenters—Save Money—Use an adjustable regulated DC Power Supply instead of batteries. Free Brochure. Advance Instrument Corp., Box 179, Belmar, N. J. 07719.

## INVENTIONS WANTED

**INVENTIONS** wanted. Patented; unpatented. Global Marketing Service, 2420-P 77th, Oakland, Calif. 94605.

**PATENT** Searches including Maximum speed, full airmail report and closest patent copies, \$6.00. Quality searches expertly administered. Complete secrecy guaranteed. Free Invention Protection forms and "Patent Information." Write Dept. 9, Washington Patent Office Search Bureau, 711 14th Street, N.W., Washington, D.C. 20005.

**INVENTORS!** Don't sell your invention, patented or unpatented, until you receive our offer. Eagle Development Company, Dept. 9, 79 Wall Street, N.Y., N.Y. 10005.

**FREE** "Directory of 500 Corporations Seeking New Products." For information regarding development, sale, licensing of your patented/unpatented invention. Write: Raymond Lee Organization, 230-GR Park Avenue, New York City 10017.

**INVENTORS:** Protect your ideas! Free "Recommended Procedure". Washington Inventors Service, 422T Washington Building, Washington, D.C. 20005.

**PATENT SEARCHES**, including copies of related United States Patents. Inventors, attorneys, manufacturers use our "World-Wide" Airmail service Free: "Invention Record" form and "Information Every Inventor Needs", Hayward Company, 1029HR Vermont, Washington, D.C. 20005.

**FREE PAMPHLET:** "Tips on Safeguarding Your Invention." Write: United States Inventors Service Company, 501-H Thirteenth Street N.W., Washington, D.C. 20004.

## GOVERNMENT SURPLUS

**GOVERNMENT** Surplus. How and Where to Buy in Your Area. Send \$1.00 to: Surplus Information Headquarters, Box 8225 PE, Washington, DC 20024.

**JEEPS** Typically From \$53.90 . . . Trucks From \$78.40 . . . Boats, Typewriters, Airplanes, Multimeters, Oscilloscopes, Transceivers, Electronics Equipment. Wide Variety. Condition: 100,000 Bid Bargains Direct From Government Nationwide Complete Sales Directory and Surplus Catalog \$1.00. (Deductible First \$10.00 Order). Surplus Service, Box 820-J, Holland, Michigan 49423.

## BOOKS

**FREE** catalog aviation/electronic/space books. Aero Publishers, 329PE Aviation Road, Fallbrook, California 92028.

**"UNUSUAL"** Books! Catalog Free! International, Box 7798 (PE), Atlanta, Georgia 30309.

**FREE** book prophet Elijah coming before Christ. Wonderful bible evidence. Megiddo Mission, Dept. 64, 481 Thurston Rd., Rochester, N.Y. 14619.

**INFORMATION.** Amazing Book. Swimsuits, jewelry. Write: LYN, Box 1573, Waco, Texas 76710.

## MAGAZINES

**JAPAN PUBLICATIONS GUIDE** Business, pleasure, education. \$5.00. **INTERCONTINENTAL.** CPO 1717, Tokyo 100-91.

**OVER 2,000,000** backdate magazines! Specify needs. Midtown, Box 917-PE, Maywood, New Jersey 07607.

## HYPNOTISM

**"MALE-FEMALE HYPNOTISM" EXPOSED, EXPLAINED! "SECRET METHOD"—THEY NEVER KNOW! \$2, RUSHED. GUARANTEED! ISABELLA HALL, SILVER SPRINGS, FLORIDA 32688.**

**SLEEP** Learning. Hypnotic method. 92% effective. Details free. ASR Foundation, Box 702leg HC Station, Lexington, Ky. 40502.

**HYPNOTIZE PERFECT STRANGERS—EITHER SEX—SUCCESSFULLY!** Secret Methods—they never know! Illustrated Course and 10 inch Hypnodisk \$2.00. **RESULTS ABSOLUTELY GUARANTEED!** Dr. H. Arthur Fowler, Box 4399, Woodbury, New Jersey 08096.

## RECORDS

**POPULAR** organ albums factory direct. Concert Recording, Lynwood, Calif. 90262.

**SPECIAL** interest records available, produced by the editors of the world's leading special interest magazines. Send for free catalog. Record Catalog-PE. Ziff-Davis Publishing Company, One Park Avenue, New York, N.Y. 10016.

## MAGNETS

**MAGNETISM** (100) page script newly discovered magnetic principles: (\$3.00). Jesse Costa, Box 26, Waquoit, Mass. 02536.

## PHOTOGRAPHY—FILM, EQUIPMENT, SERVICES

**SCIENCE** Bargains Request Free Giant Catalog "CJ"—148 pages—Astronomical Telescopes, Microscopes, Lenses, Binoculars, Kits, Parts. War surplus bargains. Edmund Scientific Co., 300 Edscorp Bldg., Barrington, New Jersey 08007.

## PRINTING

**OFFSET** Printing. Free catalog. Speedy Print, 1906 Swede, Norristown, Pa. 19401.

## EMPLOYMENT INFORMATION

**FOREIGN** and **USA** job opportunities available now. Construction, all trades. Earnings to \$3,000.00 monthly. Paid overtime, travel bonuses. Write: Universal Employment, Woodbridge, Conn. 06525.

**EXCITING OVERSEAS JOBS.** Directory \$1.00. Research Associates, Box 942-E, Belmont, California 94002.

## BUSINESS OPPORTUNITIES

**I MADE \$40,000.00** Year by Mailorder! Helped others make money! Start with \$10.00—Free Proof. Torrey, Box 318-N, Ypsilanti, Michigan 48197.

**FREE BOOK** "999 Successful Little Known Businesses" Work home, Plymouth 445-P, Brooklyn, N.Y. 11216.

**\$200.00 DAILY** In Your Mailbox! Your opportunity to do what mail-order experts do. Free details. Associates, Box 136-J, Holland, Michigan 49423.

**MAKE BIG MONEY** raising chinchillas, rabbits, guinea pigs for us. Catalog—25c. Keerey Brothers, New Freedom, Pa. 17349.

**FREE CATALOGS.** Repair air conditioning, refrigeration. Tools, supplies, full instructions. Doolin, 2016 Canton, Dallas, Texas 75201.

**PRODUCE** Household Products. Your trade name—our formulas. Details 50c. Thinker/Tinker, Box 205PE, Riverside, Conn. 06878.

**MAILORDER!** Make big money working home. Free report reveals millionaire's trade secrets! Executive (1K12), 333 North Michigan, Chicago 60601.

**\$2000.00 MONTHLY** possible. Details. Ropchan, Box 5341 X, Shermanoaks, California 91413.

**BIG EARNINGS** selling Hertel Bibles. New 3-dimension cover, finest reference edition sells fast. Demonstrator furnished. Big commissions. International Book, Dept. PE, Box 118, Wichita, Kansas 67201.

**BOOK** Sent "996 Millionaire Plans, Odd, Unusual, little-known Businesses" on request. No cost. National-22, Kerrville, Texas 78028.

**MAKE MONEY** thru capital gains. 10 rules for success, \$2.00. Money back if dissatisfied. Thomas, Box 339, Concord, N. H.

**HOW TO FINANCE YOUR OWN BUSINESS.** Get \$1,000. to \$200,000. Free trial offer. Capital-48, Kerrville, Texas 78028.

**PIANO TUNING** learned quickly at home. Tremendous free! Musical knowledge unnecessary. GI Approved. Information Free. Empire School, Box 327, Miami, Florida 33145.

## TREASURE FINDERS

**GOLD, SILVER, RELICS!** Located with powerful Detectors Metal Detectors. Free information. Terms. Detector, Dept. PE-12, Box 243, San Gabriel, California 91778.

**TREASURE FINDER** locates buried gold, silver, coins, treasures. 5 powerful models. \$19.95 up. Free catalog. Relco-A33, Box 10839, Houston, Texas 77018.

**FREE TREASURE GUIDE!** Fact-filled collectors edition; send 50¢ for postage. Also request free literature on ultrasensitive, professional Fisher Detectors. **FISHER RESEARCH**, Dept. PE-12, Palo Alto, California 94303.

# Build this magnificent Schober Theatre Organ



for only  
\* \$1730!

\*Includes finished walnut console. Amplifier, speaker system, optional accessories extra. Only \$1256 if you build your own console.

You couldn't touch an organ like this in a store for less than \$3500—and there hasn't been a musical instrument with this vast variety of genuine Theatre Organ voices since the days of the silent movies! If you've dreamed of the grandeur of authentic big-organ sound in your own home, you won't find a more satisfying instrument anywhere—kit or no kit.

You can learn to play it. And you can build it, from Schober Kits, world famous for ease of assembly without the slightest knowledge of electronics or music, for design and parts quality from the ground up, and—above all—for the highest praise from musicians everywhere.

Send right now for your copy of the full-color Schober catalog, containing specifications of the five Schober Organ models, beginning at \$499.50. No charge, no obligation—but lots of food for a healthy musical appetite!

The *Schober* Organ Corp., Dept. PE-36  
43 West 61st Street, New York, N.Y. 10023

- Please send me Schober Organ Catalog and free 7-inch "sample" record.  
 Enclosed please find \$1.00 for 12-inch L.P. record of Schober Organ music.

NAME \_\_\_\_\_

ADDRESS \_\_\_\_\_

CITY \_\_\_\_\_ STATE \_\_\_\_\_ ZIP \_\_\_\_\_

CIRCLE NO. 24 ON READER SERVICE PAGE



**DISCOVER HIDDEN TREASURE**  
WITH A JETCO ELECTRONIC METAL DETECTOR

A powerfully sensitive instrument—detects gold, silver, coins, relics, etc. Fully tested—transistorized—guaranteed.

**\$29.95**  
UP

Send for Free Catalog  
JETCO, P.O. Box 132 PEM, Huntsville, Texas 77340

## MUSICAL INSTRUMENTS

30% DISCOUNT name brand musical instruments. Free catalog. Freeport Music, 127-N Sunrise Highway, Freeport, N.Y. 11520.

## RUBBER STAMPS

RUBBER ADDRESS STAMPS \$2.00. SIGNATURE \$3.50. FREE CATALOG. JACKSON'S, BOX 443-G, FRANKLIN PARK, ILLINOIS 60131.

## REAL ESTATE

FREE . . . 232-PAGE CATALOG! Describes and pictures hundreds of farms, ranches, town and country homes, businesses coast to coast! Specify type property and location preferred. Zip Code, please. UNITED FARM AGENCY, 612-EP West 47th St., Kansas City, Mo. 64112.

## MISCELLANEOUS

WINEMAKERS: Free illustrated catalog of yeasts, equipment. Semplex, Box 12276, Minneapolis, Minn. 55412.

DRIVER'S License, Birth Certificate, H.S. & College Diploma, Marriage & Divorce Certificates—Blank Forms. Fill them in yourself. Highest quality you can buy! Confidential! 3 day service! \$2.00 each; any four—\$5.00, post-paid. Formco, Box 834-EC, Warren, Mich. 48090.

HEAR TV SOUND Without Disturbing Others. Easily clips to television, radio. Fits ear for private listening. \$3.95. Tannenbaum, 6 Fiesta Court, Hewlett, N. Y. 11557.

STOP BURGLARS THE EASY WAY! Affix authentic "Protected by Electronic Sentry Alarm" decals to auto windows, doors and windows of home, retail stores, vending machines, etc. Whether you have an alarm or not—thieves stay away! Only \$1.00 for each set of two. J. Ross, 80-34 Kent St., Jamaica, N.Y. 11432, Dept PE.

# NOW!

## DISPLAY CLASSIFIED ADVERTISING available in POPULAR ELECTRONICS

Effective with the January, 1971 issue, Display Classified Ads are being accepted in these columns.

For those advertisers who want to achieve maximum exposure at minimum expense, this is the opportunity of a lifetime for you!

The special low rates are:

- 1" by 1 column (2<sup>5</sup>/<sub>8</sub>" wide)....\$110.00
- 2" by 1 column (2<sup>5</sup>/<sub>8</sub>" wide)....\$215.00
- 3" by 1 column (2<sup>5</sup>/<sub>8</sub>" wide)....\$320.00

(Ads larger than 3 column inches not accepted for the ELECTRONICS MARKET PLACE—Please ask for regular advertising rates.)

Of course, regular non-display Classified Ads continue at \$1.25 per word (minimum \$12.50).

For immediate action in getting your Display (or non-Display) Classifieds into the very next available issue, call or write:

Hal Cymes, Classified Advertising Manager  
POPULAR ELECTRONICS  
One Park Avenue, New York, N. Y. 10016  
(212) 679-7200

**PARTS! CORNELL TUBES!**

Send For FREE CORNELL'S New Color Catalog 40 Pgs. New Items

33¢

per tube

36¢

per tube

ORDER FREE IF NOT SHIPPED IN 24 HOURS!

4219 UNIVERSITY AVE. SAN DIEGO, CALIF. 92105



# POPULAR ELECTRONICS

DECEMBER 1970

## ADVERTISERS INDEX

### READER

SERVICE NO.	ADVERTISER	PAGE NO.
	Allied Radio Shack	5
1	Alpha Lunco	89
3	Avanti Research & Development	THIRD COVER
5	Baggy's Radio	98
	Bell & Howell Schools (DeVry Institute of Technology)	90, 91, 92, 93
	CREI, Home Study Div., McGraw-Hill Book Co.	18, 19, 20, 21
6	CTS of Paducah, Inc.	98
7	Cleveland Institute of Electronics	36, 37, 38, 39
	Cornell Electronics	106
8	Crystek	96
9	Delta Products, Inc.	87
10	Communications Div., DYNASCAN CORP.	9
11	Edmund Scientific Co.	107
12	Electra Products	99
4	Electro-Voice, Inc.	FOURTH COVER
13	Grantham School of Engineering	8
14	Heath Company	10, 11, 12, 13
15	Jensen Mfg. Div., The Muter Co.	94
	Jetco	106
16	Kedman Electronics	85
17	Lafayette Radio Electronics	85
18	Metrologic Instruments	96
19	McGee Radio	94
	National Radio Institute..SECOND COVER, 1, 2, 3	
	National Technical Schools	72, 73, 74, 75
20	Olson Electronics	97
21	Poly Paks	103
22	Progressive "Edu-Kits"	108
33	RCA Electronics Components & Devices	24
	RCA Institutes	54, 55, 56, 57
23	Regency Electronics	17
24	Schober Organ Corp.	106
25	Sonar Radio Corp.	84
26	Telex Communications Division	14
32	Ten-Tec, Inc.	84
27	Turner Microphone Co.	6
28	United Audio Products (DUAL)	16
	Weller Electric Co.	88
	Xcelite, Inc.	86

CLASSIFIED ADVERTISING 102, 103, 104, 105, 106

## 1000'S OF UNUSUAL SCIENTIFIC BARGAINS including... SPECIAL UNIQUE PSYCHEDELIC LIGHTING for Fun, Profit, Exports!

### 3" ASTRONOMICAL TELESCOPE



See moon shots, orbits-stars, phases of Venus, planets close up, 60 to 180X. New improved aluminum & overcoated 3" diameter f30 primary mirror, ventilated cell, Equatorial mount w/locks on both axes. Six eyepiece, mounted Barlow, 3x finder telescope, hardwood tripod, Incl. PRICE: "SPECIAL CLAR": 272-P. "HANDBOOK": Inst.

No. 85,050AV ..... \$29.95 Ppd.  
No. 85,105AV (4 1/4") ..... \$94.50 F.O.B.  
No. 85,086AV ..... (6") ..... \$239.50 F.O.B.

### CHROMATIC "MACHINE-GUN" STROBE



Red, Green, Blue & White light barrage the eyeballs every 6 seconds with this low cost mechanical strobe that can run continuously without fear of burning up. Devastating effects over 500 sq. area. Created by rotating color wheel in front of 100W, 120v reflector floodlamp (incl.) - elements seem to flash on & off as colors fluctuate. Turns store windows, posters, parties into flashing pulsating productions. Convection cooled. Walnut cabinet. Brass handle. Reg. house current.

Stock No. 71,271AV ..... (9x10x6 1/4") ..... \$28.50 Ppd.

### PSYCHEDELIC LIGHTING HANDBOOK



100 Information packed pages! Fully explains latest in psychedelic lighting equipment, techniques, developments. Covers all facets of psychedelic light-show production including strobes, black lights, projectors, crystals, organic slides, mirrors, color organs, polarized color light boxes, MusicVision, etc. Shows how to "psychedelize" parties, musical groups, shows or how to set up "electric trips" for private gatherings. 8 1/2" x 11" looseleaf paper for 3 rings.

Stock No. 9100AV ..... \$3.00 Ppd.

### LONG-WAVE BLACKLIGHT FIXTURE

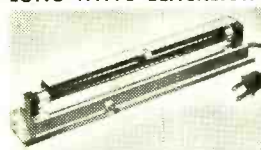

Extremely versatile, compactly designed, long wave (3200-4000 angstroms) black light (ultraviolet) fixture. Has 6-watt, 110-V lamp with built-in filter—eliminates harmful shorter wave ultraviolet rays. Use to identify minerals, fungi, bacteria—check for surface flaws, oil and gas leakage—perfect for displays with fluorescent paper, paints, chalk, crayons, trace powder. Incl. adjustable aluminum reflector. Mount vert., horrr. or on corner. 10" L, 1 1/2" W, 1 1/2" H.

Stock No. 70,364AV ..... \$12.50 Ppd.  
Stock No. 60,124AV ..... REPLACEMENT BULB ..... \$4.75 Ppd.

### 4 GIANT 180' DAY GLOW TAPES!



4 bands of fluorescent pink, green, red, yellow. Brilliant in normal light—wild and exciting "hot" glow under blacklight. Self adhesive. Easily removed. All kinds of uses—decorate clubs, dances, parties; highlight posters, costumes; design "top pictures," wall decorations; ideal for safety markers, shelf strips. Medium strength tape, paper backing, 720 feet in all.

Stock No. P-71,303AV \$9.50 Ppd.

### BLACK-LIGHT MIGHTY MITES

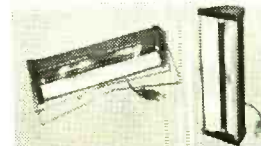

Relatively small (12") fixtures give surprisingly bright blacklight. Mirror-finished reflector makes instant starting 8-watt, high-intensity bulb look like 40-watter. Up to 3,000 hours of safe, long-wave (3600A) blacklight to really turn on parties, light & theatrical shows, psychedelic decors, holiday decorations. Shockproof end-caps remove for safe, easy replacement of bulb and starter. Stands

upright or horizontal. Aluminum case.

Stock No. 71,274AV ..... \$14.95 Ppd.

DELUXE OUTDOOR INEOR MODEL  
Stock No. 71,299AV ..... \$19.95 Ppd.

Order by Stock No.—Check or M.O.—Money-Back Guarantee

EDMUND SCIENTIFIC CO., 300 EDSCORP BLDG., BARRINGTON, N.J. 08007

### WRITE FOR GIANT FREE CATALOG "AV"



Completely new edition. New items, categories. Illustrations, 138 easy-to-read pages packed with 4000 unusual items. Dozens of electrical and electromagnetic parts, accessories. Spacious selection of Astronomical Telescopes, Microscopes, Binoculars, Mammals, Minerals, Lenses, Lasers, Prisms. Many war surplus items; for hobbyists, experimenters, workshops, factory. Write for catalog "AV".

EDMUND SCIENTIFIC CO. 300 EDSCORP BLDG. BARRINGTON, NEW JERSEY 08007  
ORDER BY STOCK NUMBER - SEND CHECK OR MONEY ORDER - MONEY-BACK GUARANTEE

CIRCLE NO. 11 ON READER SERVICE PAGE

# BUILD YOUR OWN RADIO and Electronics Circuits



Training Electronics Technicians Since 1946

## PROGRESSIVE "Edu-Kit"® HOME RADIO COURSE

### Now Includes

- ★ 12 RECEIVERS
- ★ 3 TRANSMITTERS
- ★ SQ. WAVE GENERATOR
- ★ SIGNAL TRACER
- ★ AMPLIFIER
- ★ SIGNAL INJECTOR
- ★ CODE OSCILLATOR

- ★ No Knowledge of Radio Necessary
- ★ No Additional Parts or Tools Needed
- ★ EXCELLENT BACKGROUND FOR TV
- ★ SCHOOL INQUIRIES INVITED
- ★ Sold in 79 Countries

### YOU DON'T HAVE TO SPEND HUNDREDS OF DOLLARS FOR A RADIO COURSE

The "Edu-Kit" offers you an outstanding PRACTICAL HOME RADIO COURSE at a rock-bottom price. Our Kit is designed to train Radio & Electronics Technicians, making use of the most modern methods of home training. You will learn radio theory, construction practice and servicing. THIS IS A COMPLETE RADIO COURSE IN EVERY DETAIL. You will learn how to build radios, using regular schematics; how to wire and solder in a professional manner; how to service radios. You will work the standard type of punched metal chassis as well as the latest development of Printed Circuit chassis. You will learn the basic principles of radio. You will construct, study and work with trouble-shooting, using the Progressive Code Oscillator. You will learn and practice progressive Dynamic Radio & Electronic Tester, Square Wave Generator and the accompanying instructional material.

You will receive training for the Novice, Technician and General Classes of F.C.C. Radio Amateur Licenses. You will build Receiver, Transmitter, Square Wave Generator, Oscillator, Signal Tracer and Signal Injector circuits, and learn how to operate them. You will receive an excellent background for television, Hi-Fi and Electronics.

Absolutely no previous knowledge of radio or science is required. The "Edu-Kit" is the product of many years of teaching and engineering experience. The "Edu-Kit" will provide you with a basic education in Electronics and Radio, worth many times the low price you pay. The Signal Tracer alone is worth more than the price of the kit.

### THE KIT FOR EVERYONE

You do not need the slightest background in radio or science. Whether you are interested in Radio & Electronics because you want an interesting hobby, a well paying business or a job with a future, you will find the "Edu-Kit" a worth-while investment.

Many thousands of individuals of all

ages and backgrounds have successfully used the "Edu-Kit" in more than 79 countries of the world. The "Edu-Kit" has been carefully designed, step by step, so that you cannot make a mistake. The "Edu-Kit" allows you to teach yourself at your own rate. No instructor is necessary.

### PROGRESSIVE TEACHING METHOD

The Progressive Radio "Edu-Kit" is the foremost educational radio kit in the world, and is universally accepted as the standard in the field of electronics training. The "Edu-Kit" uses the modern educational principle of "Learn by Doing." Therefore you construct, learn schematics, study theory, practice trouble shooting—all in a closely integrated program designed to provide an easily-learned, thorough and interesting background in radio. You begin by examining the various radio parts of the "Edu-Kit." You then learn the function, theory and wiring of these parts. Then you build a simple radio. With this first set you will enjoy listening to regular broadcast stations, learn theory, practice testing and trouble-shooting. Then you build a more advanced radio, learn more advanced theory and techniques. Gradually, in a progressive manner, and at your own rate, you will find yourself constructing more advanced multi-tube radio circuits, and doing work like a professional Radio Technician.

Included in the "Edu-Kit" course are Receiver, Transmitter, Code Oscillator, Signal Tracer, Square Wave Generator and Signal Injector Circuits. These are not unprofessional "breadboard" experiments, but genuine radio circuits, constructed by means of professional wiring and soldering on metal chassis, plus the new method of radio construction known as "Printed Circuitry." These circuits operate on your regular AC or DC house current.

### THE "EDU-KIT" IS COMPLETE

You will receive all parts and instructions necessary to build twenty different radio and electronics circuits, each guaranteed to operate. Our Kits contain tubes, tube sockets, variable, electrolytic, mica, ceramic and paper dielectric condensers, resistors, tie strips, hardware, tubing, punched metal chassis, instruction manuals, hook-up wire, solder, selenium rectifiers, coils, volume controls and switches, etc.

In addition, you receive Printed Circuit materials, including Printed Circuit chassis, special tube sockets, hardware and instructions. You also receive a useful set of tools, a professional electric soldering iron, and a self-powered Dynamic Radio and Electronic Tester. The "Edu-Kit" also includes Code Instructions and the Progressive Code Oscillator. In addition to F.C.C. Radio Amateur License training, you will also receive Lessons for Fidelity Guide and a Quiz Book. You receive Membership in Radio-TV Club. Free Consultation Service, including of merit and Discount Privileges. You receive all parts, tools, instructions, etc. Everything is yours to keep.

Progressive "Edu-Kits" Inc., 1189 Broadway, Dept. 688D, Hewlett, N. Y. 11557.

### UNCONDITIONAL MONEY-BACK GUARANTEE

Please rush my Progressive Radio "Edu-Kit" to me, as indicated below:

Check one box to indicate choice of model

- Deluxe Model \$31.95.
- New Expanded Model \$34.95 (Same as Deluxe Model plus Television Servicing Course).

Check one box to indicate manner of payment

- I enclose full payment. Ship "Edu-Kit" post paid.
- I enclose \$5 deposit. Ship "Edu-Kit" C.O.D. for balance plus postage.
- Send me FREE additional information describing "Edu-Kit."

Name

Address

### PROGRESSIVE "EDU-KITS" INC.

1189 Broadway, Dept. 688D, Hewlett, N. Y. 11557

### FREE EXTRAS

#### • SET OF TOOLS

- SOLDERING IRON
- ELECTRONICS TESTER
- PLIERS-CUTTERS
- VALUABLE DISCOUNT CARD
- CERTIFICATE OF MERIT
- TESTER INSTRUCTIONS MANUAL
- HIGH FIDELITY GUIDE • QUIZZES
- TELEVISION BOOK • RADIO
- TROUBLE-SHOOTING AND
- MEMBERSHIP IN RADIO-TV CLUB:
- CONSULTATION SERVICE • FCC
- AMATEUR LICENSE TRAINING
- PRINTED CIRCUITRY

### SERVICING LESSONS

You will learn trouble-shooting and servicing in a progressive manner. You will practice repairs on the sets that you construct. You will learn symptoms and causes of trouble in home, portable and car radios. You will learn how to use the professional Signal Tracer, the unique Signal Injector and the dynamic Radio & Electronics Tester. While you are learning in this practical way, you will be able to do many a repair job for your friends and neighbors, and charge fees which will far exceed the price of the "Edu-Kit." Our Consultation Service will help you with any technical problems you may have.

### FROM OUR MAIL BAG

J. Stataitis, of 25 Poplar Pl., Waterbury Conn., writes: "I have received several sets for my friends, and made money. The "Edu-Kit" I paid for myself. I was ready to spend \$240 for a Course, but I found your ad and sent for your Kit."

Ben Valerio, P. O. Box 21, Magna, Utah: "The Edu-Kits are wonderful. Here I am sending you the questions and also the answers for them. I have been in Radio for the last seven years, but like to work with Radio Kits, and like to build Radio Testing Equipment. I enjoyed every minute I worked with the different kits; the Signal Tracer works fine. Also like to let you know that I feel proud of becoming a member of your Radio-TV Club."

Robert L. Shuff, 1534 Monroe Ave., Huntington, W. Va.: "Thought I would drop you a few lines to say that I received my Edu-Kit, and was really amazed that such a bargain can be had at such a low price. I have already started repairing radios and phonographs. My friends were really surprised to see me get into the swing of it so quickly. The trouble-shooting Tester that comes with the Kit is really swell, and finds the trouble, if there is any to be found."

### PRINTED CIRCUITRY

At no increase in price, the "Edu-Kit" now includes Printed Circuitry. You build a Printed Circuit Signal Injector, a unique servicing instrument that can detect many Radio and TV troubles. This revolutionary new technique of radio construction is becoming popular in commercial radio TV sets.

A Printed Circuit is a special insulating chassis on which has been deposited a ducting material which takes the plating. The various parts are merely placed in and soldered to terminals.

Printed Circuitry is the basis of modern Automation Electronics. A knowledge of this subject is a necessity today for anyone interested in Electronics.

CIRCLE NO. 22 ON READER SERVICE PAGE

Printed in U.S.A.

# HALF PRICE

on an introductory subscription to  
**POPULAR ELECTRONICS**

**12 months for only \$3<sup>00</sup>**

(Regular Subscription Rate \$6 per year)

**SUBSCRIBE NOW AND SAVE**

**12 months \$3.00 (SAVE \$3.00!)**

**Payment enclosed.**

Please bill me.

name \_\_\_\_\_ (please print)

address \_\_\_\_\_ 4180

city \_\_\_\_\_

state \_\_\_\_\_ zip code \_\_\_\_\_

**NO POSTAGE NECESSARY IF MAILED IN U.S.A.**



**BUSINESS REPLY MAIL**  
NO POSTAGE NECESSARY IF MAILED IN THE UNITED STATES

POSTAGE WILL BE PAID BY—

**POPULAR ELECTRONICS**

**P.O. Box 1096**

**Flushing, N.Y. 11352**

FIRST CLASS  
Permit No. 9330  
Flushing, N.Y.

**AT  
LAST!**

***A sensible antenna for  
long distance mobile  
communications***

**NEW AVANTI GATORWHIP** is designed for long distance mobile communications with low noise and reliable performance. GATORWHIP combines the

best features of a fiberglass whip with the best features of a stainless steel whip for the ultimate in performance for a tunable CB mobile antenna.



*only*  
**\$15.95**  
ea.

Full 9' length. The bottom 5' is specially developed Gatorglass... designed for military use on tanks and jeeps. It is super strong... won't lay back or take a set, stays erect for better radiation. Gatorglass won't split, run or peel like ordinary fiberglass. It will stand up under corrosive atmospheres and retain its smooth white finish. We have set a highly conductive copper strip right into the fiberglass for high power handling. A new bonding technique permanently sets the whip into the mounting base. The 4' stainless steel top slides into the Gatorglass section and is secured with all stainless steel and chrome fittings making it instantly tunable. This stainless steel whip stops fraying and breakage in case you should hit an overhead obstacle.

**TECHNICAL ADVANTAGES:** Tunable to 1.1: 1 VSWR, getting maximum power out of your set into the air... Can be tuned from 25 to 40 HMZ for business use... Will take 200 watts of power... Standard 3/8"-24 thread fits all popular body and bumper mounts... Full one year warranty against defects in materials or workmanship.

Boost performance 25%. Co-phasing 2 GATORWHIPS with an Avanti AV-504 harness will give 25% more performance without becoming directional (if properly spaced less than 6' apart as per instructions).



**avanti**

**AVANTI RESEARCH & DEVELOPMENT, INC.**  
**THE PACESETTER IN HIGH PERFORMANCE ANTENNAS**

33-35 WEST FULLERTON AVENUE,  
ADDISON, ILLINOIS 60101

# LOUD MOUTH!

## The new E-V Eliminator.

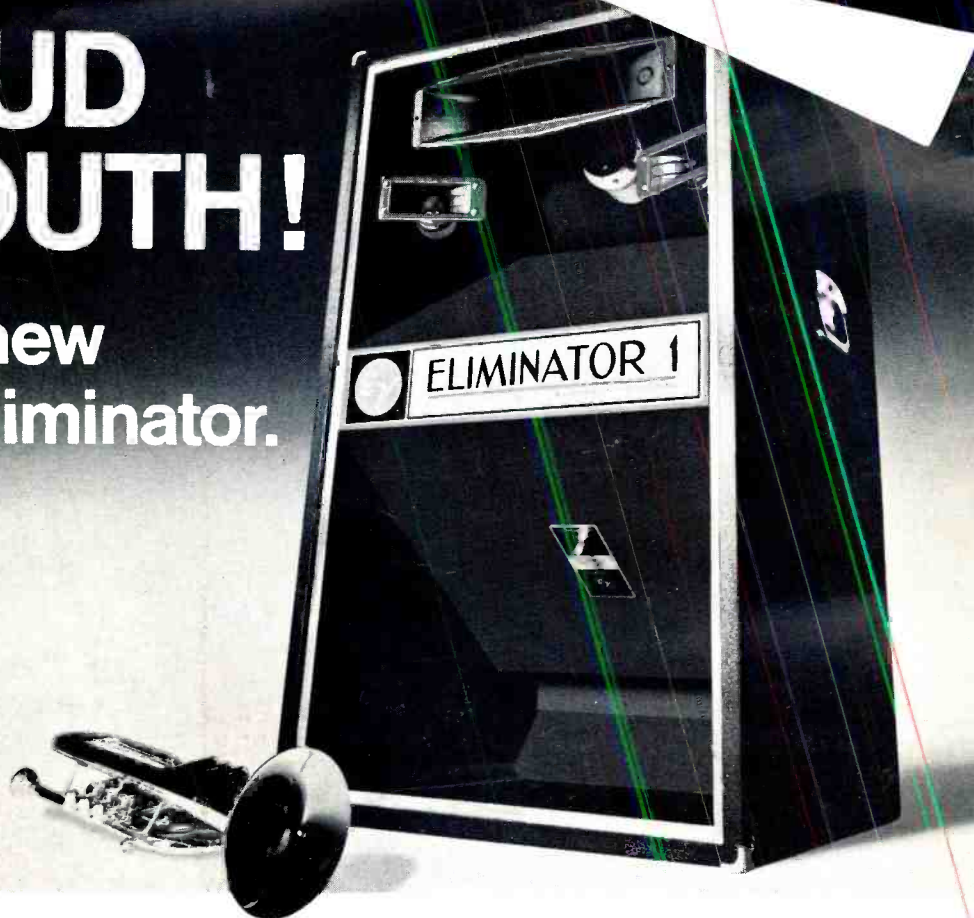

**E-V** The first Eliminator was built to prove a point. Because young musicians, in a search for more volume, were literally driving the guts out of some very good speakers mounted in some very poor enclosures.

It started an intensive investigation into the failure of speakers (ours and the competition) used by guitars and organs. The testing was very rugged. For instance, we took miles of high-speed motion pictures while test speakers destroyed themselves with sound.

We found out a lot about how to improve our speakers. But we also learned that by simply putting our SRO/15 speaker in a folded horn enclosure we created a combination that was unbeatable for efficiency, high power handling capacity, low distortion, and extended bass. It was an important first step.

Of course, this now meant we needed a solid high end. So we added the time-tested 1829 treble driver and 8HD horn, or (optionally) a T25A treble driver plus a pair of T35 super tweeters. These combinations were a revelation to musicians. They got more sound power per watt than they thought possible. And they could use the Eliminator for both vocals or instruments.

But we weren't satisfied. If the Eliminator was good for popular music, what would it do with other kinds of program material? So we tested it in good rooms and bad rooms. With test instruments and with live

audiences. And we decided that the Eliminator was too good to sell only to the young.

For example, in one test installation in a difficult domed building, four E-V Eliminator I speakers far outperformed an elaborate multicell installation in naturalness of sound for voice and music, in uniform sound pressure level throughout the listening area, and in the ability to reproduce the extremes of loudness of a big, driving jazz band with ease.

Granted, the E-V Eliminators have a flash of chrome. But don't be misled. They perform to beat the band. And they solve problems. Get turned on to the great sound of the E-V Eliminators today.

**ELIMINATOR I** 3-way system: Response 55-15,000 Hz; Power Handling Capacity 100 watts RMS (white noise shaped to stringent lead guitar frequency spectrum); Dispersion 100°; Sound Pressure Level 122 db at 4' with full power input; Suggested Resale \$465.00.

**ELIMINATOR II** 2-way system: Response 55 to 10,000 Hz; Power Handling Capacity 100 watts RMS (shaped to stringent lead guitar frequency spectrum); Dispersion 100°; Sound Pressure Level 123 db at 4' with full power input; Suggested Resale \$370.00.

**ELECTRO-VOICE, INC.**, Dept. 1206P  
630 Cecil Street, Buchanan, Michigan 49107



**Electro-Voice**<sup>®</sup>

a GULTON subsidiary

CIRCLE NO. 4 ON READER SERVICE PAGE

[www.americanradiohistory.com](http://www.americanradiohistory.com)



# AT LAST!

## *A sensible antenna for long distance mobile communications*

**NEW AVANTI GATORWHIP** is designed for long distance mobile communications with low noise and reliable performance. GATORWHIP combines the

best features of a fiberglass whip with the best features of a stainless steel whip for the ultimate in performance for a tunable CB mobile antenna.



*only*  
**\$15.95**

ea.

Full 9' length. The bottom 5' is specially developed Gatorglass... designed for military use on tanks and jeeps. It is super strong... won't lay back or take a set, stays erect for better radiation. Gatorglass won't split, run or peel like ordinary fiberglass. It will stand up under corrosive atmospheres and retain its smooth white finish. We have set a highly conductive copper strip right into the fiberglass for high power handling. A new bonding technique permanently sets the whip into the mounting base. The 4' stainless steel top slides into the Gatorglass section and is secured with all stainless steel and chrome fittings making it instantly tunable. This stainless steel whip stops fraying and breakage in case you should hit an overhead obstacle.

**TECHNICAL ADVANTAGES:** Tunable to 1.1: 1 VSWR, getting maximum power out of your set into the air... Can be tuned from 25 to 40 HMz for business use... Will take 200 watts of power... Standard  $\frac{3}{8}$ -24 thread fits all popular body and bumper mounts... Full one year warranty against defects in materials or workmanship.

Boost performance 25%. Co-phasing 2 GATORWHIPS with an Avanti AV-504 harness will give 25% more performance without becoming directional (if properly spaced less than 6' apart as per instructions).



**avanti**

AVANTI RESEARCH & DEVELOPMENT, INC.

THE PACESETTER IN HIGH PERFORMANCE ANTENNAS

33-35 WEST FULLERTON AVENUE,  
ADDISON, ILLINOIS 60101

CIRCLE NO. 3 ON READER SERVICE PAGE

[www.americanradiohistory.com](http://www.americanradiohistory.com)

# LOUD MOUTH!

## The new E-V Eliminator.



**EY** The first Eliminator was built to prove a point. Because young musicians, in a search for more volume, were literally driving the guts out of some very good speakers mounted in some very poor enclosures.

It started an intensive investigation into the failure of speakers (ours and the competition) used by guitars and organs. The testing was very rugged. For instance, we took miles of high-speed motion pictures while test speakers destroyed themselves with sound.

We found out a lot about how to improve our speakers. But we also learned that by simply putting our SRO/15 speaker in a folded horn enclosure we created a combination that was unbeatable for efficiency, high power handling capacity, low distortion, and extended bass. It was an important first step.

Of course, this now meant we needed a solid high end. So we added the time-tested 1829 treble driver and 8HD horn, or (optionally) a T25A treble driver plus a pair of T35 super tweeters. These combinations were a revelation to musicians. They got more sound power per watt than they thought possible. And they could use the Eliminator for both vocals or instruments.

But we weren't satisfied. If the Eliminator was good for popular music, what would it do with other kinds of program material? So we tested it in good rooms and bad rooms. With test instruments and with live

audiences. And we decided that the Eliminator was too good to sell only to the young.

For example, in one test installation in a difficult domed building, four E-V Eliminator I speakers far out performed an elaborate multicell installation in naturalness of sound for voice and music, in uniform sound pressure level throughout the listening area, and in the ability to reproduce the extremes of loudness of a big, driving jazz band with ease.

Granted, the E-V Eliminators have a flash of chrome. But don't be misled. They perform to beat the band. And they solve problems. Get turned on to the great sound of the E-V Eliminators today.

**ELIMINATOR I** 3-way system: Response 55-15,000 Hz; Power Handling Capacity 100 watts RMS (white noise shaped to stringent lead guitar frequency spectrum); Dispersion 100°; Sound Pressure Level 122 db at 4' with full power input; Suggested Resale \$465.00.

**ELIMINATOR II** 2-way system: Response 55 to 10,000 Hz; Power Handling Capacity 100 watts RMS (shaped to stringent lead guitar frequency spectrum); Dispersion 100°; Sound Pressure Level 123 db at 4' with full power input; Suggested Resale \$370.00.

**ELECTRO-VOICE, INC.**, Dept. 1206P  
630 Cecil Street, Buchanan, Michigan 49107



**Electro-Voice**

• GULTON subsidiary

CIRCLE NO. 4 ON READER SERVICE PAGE

[www.americanradiohistory.com](http://www.americanradiohistory.com)