

NEW LOOK — NEW STORIES — NEW DEPARTMENTS

Popular Electronics

FIFTY CENTS / SEPTEMBER 1970

**High-quality,
Low-cost
Miniature
Digital
Volt ohmmeter**

EXPERIMENT THAT
SAVED HI-FI
CAMERA SHUTTER
SPEED METER
GATED 100-kHz
CALIBRATOR
WINDING OUTPUT
TRANSFORMERS
GETTING TO KNOW
THE J-K FLIP-FLOP
HAM & THE LADY
PSYCHOLOGIST

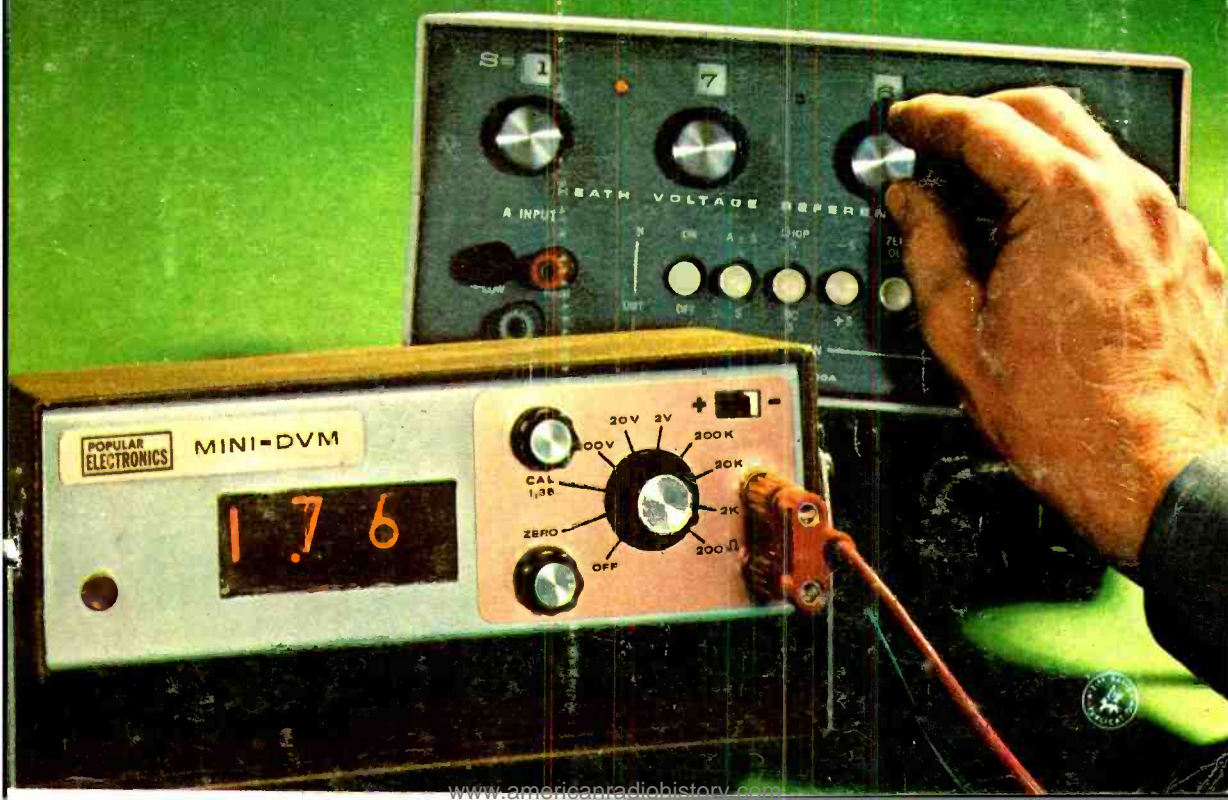

Discover the ease
and excitement of NRI's

3 DIMENSIONAL METHOD

of Electronics, Communications, TV-Radio Training

12 HOME STUDY PLANS TO CHOOSE FROM

Practically all vocational and engineering schools require students to conduct carefully planned laboratory demonstrations to prove theory presented in textbooks. So does NRI. Why? Because the only way to really learn at home . . . to recognize and understand circuits . . . is to get your hands on actual equipment, including transistors, printed circuits and today's other solid-state devices. NRI's unique, 3-Dimensional training method puts theory you learn into actual practice. You learn with your hands as well as your head. You learn by unique "discovery" methods the WHY of Electronics, Communications, TV-Radio . . . WHY circuits do the things they do. NRI training starts with carefully, condensed "bite-size," interesting books programmed with ab-

sorbing, revealing experiments using the finest parts money can buy. You get the kind of technical training that gives you experience equal to many, many months of performance on the job.

Whatever your interest, whatever your education, the NRI 3-Dimensional training method can fill your needs. Learning becomes as close to being *fun* as any school can make it. Tens of thousands of men have learned the NRI way. Pick the field of your choice and mail the postage-free card today for your FREE NRI Color Catalog. NATIONAL RADIO INSTITUTE, Electronics Division, Washington, D.C. 20016.

**BEGIN NOW AN ABSORBING
ADVENTURE—LEARN ELECTRONICS
THE NRI WAY—MAIL CARD TODAY**

OVER 50 YEARS OF LEADERSHIP



IN ELECTRONICS TRAINING

1 Start Fast with NRI's Educator-Acclaimed Achievement Kit

The day you enroll with NRI this remarkable starter kit is on its way to you—regardless of the course you choose. It is specifically designed for *you* and your training objective. It has one purpose—to get you started quickly and easily. It is an outstanding way of introducing you to NRI training methods . . . an unparalleled "first dimension" that opens the way to new discoveries, new knowledge, new opportunities. The Achievement Kit is worth many times the small payment required to start your training. Find out more about it. Mail the postage-free card now.



2 NRI "Bite-Size" Lesson Texts Program Your Training

Reading is a necessary part of any training program, but it takes a great deal of stamina to wade through a 300-page technical textbook. Every NRI course is condensed into "bite-size" texts that are simple, direct, well-illustrated, averaging an easily-digested 40 pages. These are "programmed" with NRI training equipment you build, experiments you perform, to bring to life the fundamental laws of electronics, the theory, the training of your choice. You are always kept well supplied with these books, NRI does not require you to "pay as you go."

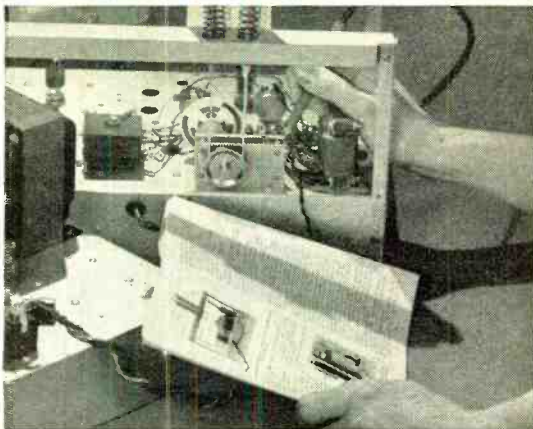

3 You Get Practical Experience With Actual Electronic Equipment

NRI does not leave the practical side of Electronics to your imagination. Electronics becomes a clear, understandable force under *your* control as you build, experiment, explore, discover. NRI pioneered the concept of home-lab training equipment to give you 3-Dimensional knowledge and experience. Every kit is designed by NRI to demonstrate principles you must know and understand. Kits contain the most modern parts, including solid state devices. NRI invites comparison with equipment offered by any other school, at any price. Prove to yourself what nearly a million NRI students could tell you . . . that you get more for your money from NRI. Mail postage-free card for your NRI Color Catalog. No obligation. No salesman will call.

APPROVED UNDER GI BILL if you served since January 31, 1955, or are in service, check GI line in postage-free card.

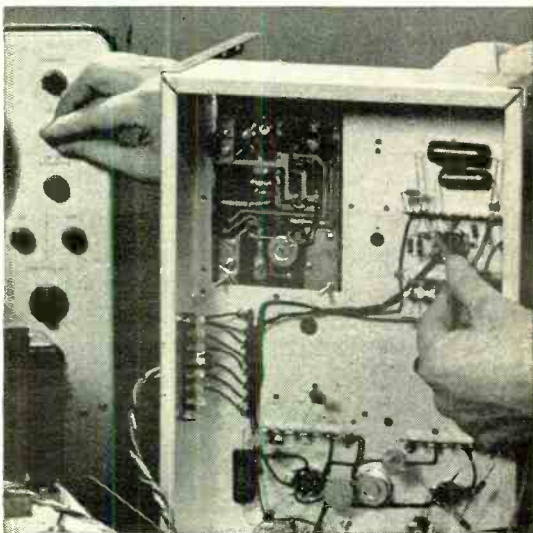

Popular Electronics

WORLD'S LARGEST-SELLING ELECTRONICS MAGAZINE

FEATURE ARTICLES

- THE EXPERIMENT THAT SAVED HI-FI** 29 *David B. Weems*
Live music and an acoustical filter
- ASSEMBLING THE POPULAR ELECTRONICS MINI-DVM** 35 *Don Lancaster*
High quality, low cost
- BUILD A GATED 100-KHZ CALIBRATOR** 53 *Frank H. Tooker*
Deluxe signal reference generator
- THE HAM & THE LADY PSYCHOLOGIST** 60 *Fred Ebel*
Analysis turns sour
- GETTING TO KNOW THE JK FLIP-FLOP** 67 *Frank H. Tooker*
Theory and use of an important circuit
- ASSEMBLING A CAMERA SHUTTER SPEED METER** 73 *William Coomes*
Check your camera's operation
- WINDING YOUR OWN OUTPUT TRANSFORMERS** 78 *Ed Francis*
For improved matching and power handling
- OPPORTUNITY AWARENESS** 83 *David L. Heiserman*
Sound engineering opportunities
- COMMUNICATIONS** 85
SWL—CB—Ham—Research—BCB
- THE PRODUCT GALLERY** 93
Triplet Model 602 Volt-ohmmeter
Ten-Tec Enclosures
GC Electronics "B Neg" Patterns
- STEREO SCENE** 97 *J. Gordon Holt*
What it's all about
- SOLID STATE** 100 *Lou Garner*

DEPARTMENTS

- DIRECT & CURRENT** 7 *Oliver P. Ferrell*
- INTERFACE** 10
- NEW LITERATURE** 14
- READER SERVICE PAGES** 15, 115
- ELECTRONICS LIBRARY** 16
- NEW PRODUCTS** 22
- OUT OF TUNE** 116

Build a Signal Injector
Build a Low-Cost Time Delay Relay

POPULAR ELECTRONICS is indexed
 in the Readers' Guide
 to Periodical Literature

This month's cover photo by
 Bruce Pendleton

Copyright © 1970 by ZIFF-DAVIS PUBLISHING COMPANY. All rights reserved.

POPULAR ELECTRONICS, September 1970, Volume 33, Number 3. Published monthly at One Park Ave., New York, N.Y. 10016. One year subscription rate for U.S., P.S. Possessions and Canada, \$6.00; all other countries, \$7.00. Second class postage paid at New York, N.Y. and at additional mailing offices. Authorized as second class mail by the Post Office Department, Ottawa, Canada and for payment of postage in cash. Subscription service and Forms 3579, P.O. Box 1096, Flushing, N.Y. 11352. Editorial offices for manuscript contributions, reader inquiries, etc.: One Park Ave., New York, N.Y. 10016.

Big mouth



Sure it's got a big mouth. We designed it that way. With FETs for better selectivity and ICs that give more sensitivity and trouble free performance.

You get a full 3.5 watts output, instead of the usual 3. And exclusive Dyna-Boost speech compression and a noise cancelling microphone put your message through crisp and sharp, even when others are garbled and unclear.

The all solid-state Cobra 24 has big ears, too. A selective dual-conversion super-heterodyne receiver with ceramic filter gives you outstanding sensitivity and gain.

It even has a handsome face—a striking, no-nonsense case compact enough to fit under and dash.

And that's not all. You get crystal controlled transmit and receive on all 23 channels. Plus positive or negative ground operation without internal wiring changes.

There's also a PA/CB switch with adjustable volume. And an illuminated channel selector and 'S' meter that make night transmission easy. It even comes with its own mounting bracket. And an AC adapter is available.

So why settle for less? The Cobra 24 has all these important features plus the biggest power output in its class.

Cobra 24 \$169.95

STRIKE CLEAR THROUGH WITH COBRA POWER



Cobra

Product of DYNASCAN CORPORATION
1801 W. Belle Plaine
Chicago, Illinois 60613



CAM 88 \$219.95

You don't have to pay a lot of money to get a great CB transceiver. Though similar to the Cobra 98, the CAM-88 costs slightly less and has the same striking power that has made Cobra famous. You get full 5 watts input, 3.5 watts output, exclusive Dyna-Boost speech compression, and lots more.



Cobra V \$99.95

The Cobra V is designed for business. Its five-channel operation is ideal for most commercial CB applications, and its low price is a real money saver. It's all solid-state circuitry and switching, too. Which means it's compact enough to hide under even the smallest dashboards.

CIRCLE NO. 10 ON READER SERVICE PAGE

Every record you buy is one more reason to own a Dual.

If you think of your total investment in records — which may be hundreds or even thousands of dollars — we think you'll agree that those records should be handled with the utmost care.

Which brings us to the turntable, the component that handles those precious records. Spinning them on a platter and tracking their fragile grooves with a diamond stylus, the hardest substance known to man.

For many years, serious music lovers have entrusted their records to one make of automatic turntable — Dual. In fact, most professionals (who have access to any equipment) use a Dual in their own stereo component systems. And not always the highest priced mode.

So the question for you to consider isn't which Dual is good enough, but how much more than "good" your turntable has to be.

This question can be answered in our literature, which includes complete reprints of independent test reports. Or at any of our franchised dealers.

United Audio Products, Inc.,
120 So. Columbus Ave., Mt. Vernon,
New York 10553. 



Dual 1209, \$129.50.

Other models from \$99.50 to \$175.00.

CIRCLE NO. 23 ON READER SERVICE PAGE

Popular Electronics

LAWRENCE SPORN

Publisher

OLIVER P. FERRELL

Editor

LESLIE SOLOMON

Technical Editor

JOHN R. RIGGS

Managing Editor

EDWARD I. BUXBAUM

Art Director

ALEXANDER W. BURAWA

Associate Editor

ANDRE DUZANT

Technical Illustrator

PATTI MORGAN

Assistant Editor

JUDITH L. HOGAN

Editorial Assistant

H. BENNETT, W2PNA

H. S. BRIER, W9EQG

L. E. GARNER, JR.

DAVID L. HEISERMAN

Contributing Editors

J. ROYCE RICHARD

Assistant Publisher

RICHARD J. HALPERN

Advertising Manager

ROBERT UR

Marketing Manager

MARGARET DANIELLO

Advertising Service Manager

FURMAN H. HEBB

Group Vice President

Electronics and Photographic

ZIFF-DAVIS PUBLISHING COMPANY

Editorial and Executive Offices

One Park Avenue, New York, New York 10016

212 679-7200

Midwestern Office

The Patis Group, 4761 West Touhy Ave.,

Lincolnwood, Illinois 60466, 312 679-1100

GERALD E. WOLFE, DICK POWELL

Western Office

9025 Wilshire Boulevard, Beverly Hills, California 90211

213 Crestview 4-0265; Bradshaw 2-1161

Western Advertising Manager, BUD DEAN

Japan: James Yagi

Ishikawa Mansion #4, Sakuragokoku

Shibuya-ku, Tokyo, 462-2911-3

Circulation Office

P.O. Box 1096, Flushing, N.Y. 11352

William Ziff, President

W. Bradford Briggs, Executive Vice President

Hershel B. Sorbin, Senior Vice President

Stanley R. Greenfield, Senior Vice President

Philip Sine, Financial Vice President

Walter S. Mills, Jr., Vice President, Circulation

Phillip T. Heffernan, Vice President, Marketing

Frank Pomerantz, Vice President, Creative Services

Arthur W. Butzow, Vice President, Production

Edward D. Muhlfeld, Vice President, Aviation Division

Irwin Robinson, Vice President, Travel Division

George Morrissey, Vice President

Sydney H. Rogers, Vice President

Ziff-Davis also publishes Airline Management and Marketing including American Aviation, Boating, Business & Commercial Aviation, Car and Driver, Cycle, Electronics World, Flying, Modern Bride, Popular Photography, Skiing, Skiing Area News, Skiing Trade News, Stereo Review, and Travel Weekly.

Forms 3579 and all subscriptions correspondence should be addressed to POPULAR ELECTRONICS, Circulation Department, P.O. Box 1096, Flushing, N.Y. 11352. Please allow at least six weeks for change of address. Include your old address, as well as new-enclosing if possible an address label from a recent issue.

EDITORIAL CONTRIBUTIONS must be accompanied by return postage and will be handled with reasonable care; however, publisher assumes no responsibility for return or safety of art work, photographs or manuscripts.



Member Audit Bureau
of Circulations

POPULAR ELECTRONICS



First in a Monthly Series by Oliver P. Ferrell, Editor

THE "NEW LOOK" 7

Regular readers of POPULAR ELECTRONICS can scarcely fail to notice that many important changes have been made in this issue. Not only do we have a new logo design, there will be more technical content, more news, more state-of-the-art reporting, more new product mentions, improved typography and layout, plus many other minor editorial additions and changes. The purpose of our "new look" in this magazine has been to aim its editorial content toward the electronics experimenter whose hobby interests are serious, challenging, and extraordinarily motivated. While reading the new POPULAR ELECTRONICS, we expect you to be stimulated into more active participation in hobby electronics—either building our unusual projects, studying our test reports, arguing with our columnists, investigating our product dissertations, or even looking for what's new among our advertisers.

POPULAR ELECTRONICS has observed that within the past few years a new "community" of electronics experimenters has reached maturity. These people are primarily interested in more technical, somewhat more complex, and more useful types of construction projects—analogue to our stories on lasers, holography, decimal counting units, digital voltmeters, stereo power amplifiers, etc. We believe that an extension of our new editorial policy will result in more far-reaching and earnest electronics experimentation.

From now on, all of the construction projects published in POPULAR ELECTRONICS will be unique,
(Continued overleaf)

NEW Short-Wave Listening VERTICAL ANTENNA Model SWV-7

For 11,13,16,19,25,31 and 49 meter bands Cramped quarters keeping you from installing an SWL antenna? Your problem is solved! Model SWV-7 mounts easily on the roof or on the ground and stands just 13 ft., 3-5/8 in. tall.

Extensive field testing confirms that this antenna measures up to Mosley's high standards of performance. Construction is of the finest material to bring you years of trouble free listening pleasure. Complete with installation instructions.

Get the facts from your Mosley dealer, or write factory direct, for detailed brochure.

Mosley Electronics, Inc.
Dept. 202

4610 N. LINDBERGH BLVD., BRIDGETON, MO. 63044
CIRCLE NO. 16 ON READER SERVICE PAGE



DIRECT & CURRENT CONTINUED

relatively sophisticated, and submitted to a whole battery of tests and examinations prior to publication. "The Product Gallery" is an unusual method of reporting on new items appearing in the electronics marketplace. Our monthly department, "Opportunity Awareness," will continue to provide valuable guidance to the reader seeking career and job information. The "Stereo Scene" department has been assigned to a writer of outstanding ability with strong opinions about what is right—and not-so-right—with the stereo/hi-fi component equipment field. This department we feel will fill the need for an objective overview that has been sadly lacking in the audio field.

Our new "Communications" section replaces four departments that have regularly appeared in POPULAR ELECTRONICS for the past decade. Through the means of this department, we will bring you more pertinent information on what is taking place in communications in a more understandable and usable fashion. The "Solid State" department has been upgraded to include extra experimental applications involving the use of transistors and integrated circuits.

Many exciting things are ahead for POPULAR ELECTRONICS. They will embrace a number of areas of experimental electronics—including test equipment, audio and stereo gear, communications accessories, computer terminals, advanced electronic games, etc. Electronics is an ever-changing technology and the avocation of hobby electronics should advance consonant with the technology—and, as in the past, you will find POPULAR ELECTRONICS in the forefront.



It's yours
FREE



**GIANT 260 PAGE
1971
RADIO-TV
ELECTRONICS
CATALOG**

**RESERVE
YOUR COPY**

Write to:

**BURSTEIN-APPLEBEE CO.,
DEPT. PE-9 3199 MERCIER ST.,
KANSAS CITY, MO. 64111**

Name _____
Address _____
City _____
State _____ Zip Code _____

CIRCLE NO. 8 ON READER SERVICE PAGE

Newest SAMS Books

Hi-Fi Stereo Servicing Guide

by ROBERT G. MIDDLETON. A complete guide to effective hi-fi and stereo servicing. Provides the basis for a full understanding of hi-fi tuner and amplifier circuitry and procedures for servicing this type of equipment. The proper use of audio test and measurement equipment and the basic principles of acoustics are also given. Covers all hi-fi components (except record players and tape recorders). Order 20785, only . . . \$3.95

ABC's of Avionics

by LEX PARRISH. Provides a basic understanding of avionics—the electronic equipment used to insure the safety of crew and passengers. The type of equipment and the techniques employed in private aircraft operations are featured. Discusses requirements for basic communications, navigation aids, instrument flight aids, weather guidance, and flight control safety devices. Order 20764, only . . . \$3.50

Mobile-Radio Systems Plannig

by LEO G. SANDS. Here is practical, basic information about various types of mobile-radio systems, how they work, their capabilities and limitations, system requirements, licenses, channels, band and frequency selection, transmitter-receiver selection, antenna systems, and accessories. Includes an invaluable system-requirements form for planning a mobile-radio system. Order 20780, only . . . \$4.50

Transistor-TV Servicing Made Easy

by JACK DARR. This practical guide will help you become skilled in the special techniques of transistor-TV servicing. Covers tools and equipment required; transistors and transistor-servicing techniques; power supplies; horizontal and vertical sweep circuits; video if and output circuits; age and sync-separator problems; tuners; audio circuits; and selecting replacement transistors. Order 20776, only . . . \$4.95

Security Electronics

by JOHN E. CUNNINGHAM. Explains the operating principles of modern electronic devices and systems used to provide security against crime. Describes intrusion alarms and intrusion-detection devices. Includes chapters on the detection of hidden metal objects, announcement of detected intrusions, bugging, debugging, and speech-scrambling systems, and future developments. Order 20767, only . . . \$4.50

How to Hear, Police, Fire, and Aircraft Radio

by LEN BUCKWALTER. After World War II, police, fire, and aircraft radio moved to the less crowded vhf bands, and the "police band", which was found in many older radios, was silenced. Few listeners had receivers capable of covering the vhf band, because they were relatively expensive. With the advent of solid-state circuitry, a wide variety of relatively low-cost monitoring equipment is available. This book is a guide to the selection and use of vhf radio. Order 20781, only . . . \$3.50

101 Questions and Answers About Transistor Circuits

by LEO G. SANDS. Answers the most commonly asked questions about transistor circuitry. Explains transistor nomenclature, biasing, the three basic circuit configurations, input and output impedances, current and voltage gain, and other basic considerations. Covers power supplies and circuits; af circuits; rf circuits, and oscillators. Order 20782, only . . . \$3.50

1-2-3-4 Servicing Automobile Stereo

by FOREST H. BELT. This book first applies the ingenious "1-2-3-4" repair method to both mechanical and electrical equipment. It then proceeds to cover the electronic and mechanical principles of automobile stereo, fm multiplex and tape cartridge systems. Finally, the book shows how to apply the method to auto stereo systems. Order 20737, only . . . \$3.95

North American Radio-TV Station Guide, 6th Edition

by VANE A. JONES. Lists all radio and TV stations in the U.S., Canada, Mexico, and the West Indies. Includes operating a-m, fm, and television stations, as well as those that are about to start operating, or are temporarily off the air. Separate listings arranged by geographical location, frequency (or channel), and call letters make this guide the most useful one available. Order 20779, only . . . \$2.95



Aviation Electronics, 2nd Edition

by KEITH W. ROSE. This practical handbook for aircraft owners, pilots, technicians, and engineers explains the design, operation, and maintenance of aviation electronics equipment. Covers automatic direction finders, distance-measuring equipment, omnirange, ATC transponders and weather radar, communications and instrument-landing systems, and related devices and systems used in aviation today. Order 20743, only . . . \$9.95

Questions & Answers on Short-Wave Listening

by H. CHARLES WOODRUFF. A helpful guide to the interesting world of listening afforded by short-wave receivers. Questions and answers cover international short-wave broadcasting, frequencies, and services; how short-wave is transmitted; how short-wave is received; and how short-wave receivers are constructed and operated. Order 20783, only . . . \$3.50

1-2-3-4 Servicing Transistor Color TV

by FOREST H. BELT. The "1-2-3-4 Method" is a simple, logical, step-by-step process that helps do the service job the right way and the easy way. In this book, the fundamentals of transistor color TV are covered, followed by a detailed explanation of how to apply the method for quick troubleshooting and easy repairs. Order 20777, only . . . \$4.95

HOWARD W. SAMS & CO., INC.

Order from your Electronic Parts Distributor, or mail to Howard W. Sams & Co., Inc., Dept. PE-090
4300 W. 62nd St., Indianapolis, Ind. 46268

Send books checked at right. \$ _____ enclosed
Send FREE 1970 Sams Book Catalog

Name _____
Address _____
City _____ State _____ Zip _____

- | | |
|--------------------------------|--------------------------------|
| <input type="checkbox"/> 20785 | <input type="checkbox"/> 20777 |
| <input type="checkbox"/> 20764 | <input type="checkbox"/> 20767 |
| <input type="checkbox"/> 20780 | <input type="checkbox"/> 20781 |
| <input type="checkbox"/> 20776 | <input type="checkbox"/> 20782 |
| <input type="checkbox"/> 20743 | <input type="checkbox"/> 20737 |
| <input type="checkbox"/> 20783 | <input type="checkbox"/> 20779 |

CIRCLE NO. 20 ON READER SERVICE PAGE



INTERFACE

BUG-SHOO REPORT

Used your Bug-Shoo (p 27, July 1970) for two days while camping and got only one mosquito bite—on my ankle! Frequency was set at 2050 Hz. Thanks for a great idea.

J. M. TEICH, WB2JAE
Edison, N. J.

HI-FI SYSTEM EQUALIZER

Having built quite a few of your hi-fi/stereo projects, I hope you will publish plans for a loudspeaker equalizer. It need not be super-complex.

RION DUDLEY
Seattle, Wash.

See our up-coming October issue for a low-distortion frequency equalizer using slide potentiometers. It is designed for insertion between a stereo preamp and power amplifier.

SLEEP LEARNING—REAL OR HOAX

The conclusions drawn on page 70 of your June issue ("Sleep Learning—Real or Hoax?") are rather hastily and scantily presented.

Much work has been done on hypnopaedia in the Soviet Union. Researcher A. M. Svyadoshch reports that in one experiment of 20 test subjects, 16 of the subjects were able to reproduce 89% of the material presented to them while asleep. The other four subjects reproduced 18% of the material.

The subject of hypnopaedia is a controversial one and certain authors do deny the ability to learn, memorize, and retain subject matter while asleep. This is a scientific phenomenon and the application of sleep learning determines its success. I would encourage those who are interested to read the book, *Current Research In Hypnopaedia*, edited by F. Rubin, and published by MacDonald & Co., London, 1968.

ROBERT B. WICKS
State College, Pa.

SCA INTERCONNECTIONS

An alternate method of connecting your SCA Adapter (page 49, June 1970) is to feed it to the Tape Monitor input. The user must surrender tape monitoring, but he is also as-

(Continued on page 116)



The does-it-all turntable at a do-it-yourself price.

It's the BSR McDonald 310/X, and it's the best buy in automatic turntables. Anywhere.

This is no "little brother" turntable, either. It's got a full-size platter, cue and pause control, low mass tone arm system and a visible stylus pressure indicator.

And because it's a famous BSR Total Turntable, it comes complete with a tinted dust cover, custom molded base and a Shure M-75 magnetic cartridge—all factory-installed and balanced and included in the low price.

The BSR McDonald 310/X. It's perfect for people who want the best, no matter how little it costs.

Send for free full color catalog on all our automatic turntables. BSR (USA) Ltd., Blauvelt, N.Y. 10913

BSR McDONALD

CIRCLE NO. 7 ON READER SERVICE PAGE

Try these installations with any other five watt unit!

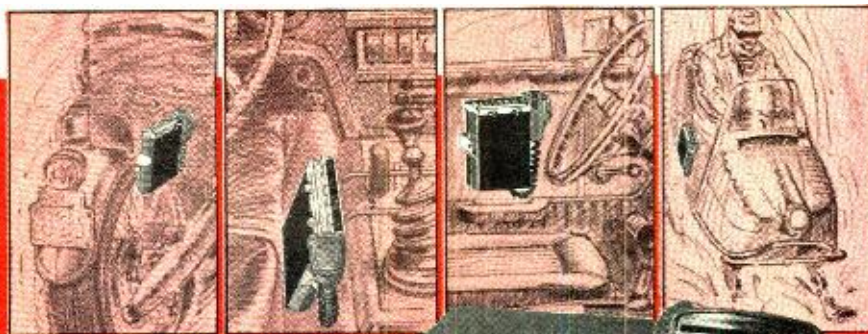

*At \$99⁹⁵ the Messenger 125 fits anywhere
...including your budget.*

Best of all, even with its mini-size and price, the Messenger 125 is *big* on performance. Its 5-watt transmitter, with high level class B modulation and speech compression, gives it all the "talk power" you'd expect from a full-size radio. Half-a-microvolt receiver sensitivity pulls in the weak ones. Automatic threshold noise limiting, IF clipping, and special AGC circuitry means less noise—better quieting. Full 2-watt audio lets you hear even in noisy vehicles. And the Messenger 125 looks great, too. Not a single knob—push-buttons select up to 5 channels, slide-levers adjust squelch and volume. Installs between bucket seats, in door pockets, on trail bikes—or over your shoulder with its optional rechargeable battery pack.



Dimensions: 1 $\frac{1}{16}$ " High x 4 $\frac{1}{2}$ " Wide x 7" Deep • 4-watts output at 13.8 VDC • FCC type accepted, DOC approved • All solid state—draws just 0.2 amperes on squelched stand-by • Optional portable pack available with rechargeable battery, charger, antenna, and leather carrying case



E. F. JOHNSON CO.
WASECA, MINN. 56093

CIRCLE NO. 13 ON READER SERVICE PAGE

New Heathkit® Solid-State

Design and performance features add up to one-of-a-kind superiority.

Over five years were spent in research and development to achieve the notably superior performance, improved convenience features, and ease of service now embodied in the new GR-270 and GR-370. They are premium quality receivers in the truest sense, and, we believe, the finest color TV's on today's market. Here's why...



Compare these features:

- Modular plug-in circuit board construction.
- MOSFET VHF tuner and 3-stage IF.
- Adjustable video peaking.
- Sound instantly, picture in seconds.
- Built-in Automatic Fine Tuning.
- Pushbutton channel advance.
- Tilt-out convergence and secondary controls.
- Hi-fi sound outputs — for amplifier.
- Virtually total self-service capability with built-in volt-ohm meter, dot generator, and comprehensive manual.
- Premium quality bonded-face etched glass picture tubes.
- Choice of 295" or 227" picture tube sizes.



Exclusive solid-state circuitry design... total of 45 transistors, 55 diodes, 2 silicon controlled rectifiers; 4 advanced Integrated Circuits containing another 46 transistors and 21 diodes; plus 2 tubes (picture and high voltage rectifier) combine to deliver performance and reliability unmatched by conventional tube sets.



Exclusive design solid-state VHF tuner uses an MOS Field Effect Transistor for greater sensitivity, lower noise, and lower cross-modulation... gives you sharply superior color reception, especially under marginal conditions. Gold/Niobium contacts give better electrical connections and longer wear. Memory fine tuning, standard. Solid-state UHF tuner uses hot-carrier diode design for increased sensitivity.



3-stage solid-state IF has higher gain for better overall picture quality. Emitter-follower output prevents spurious signal radiation, and the entire factory-aligned assembly is completely shielded to prevent external interference.

Automatic Fine Tuning — standard on both sets. Just push a button and the assembled and aligned AFT module tunes in perfect picture and sound automatically... eliminates manual fine-tuning. Automatic between-channel defeat switch prevents tuner from locking in on stray signals between channels. AFT can be disabled for manual tuning.

VHF power tuning... scan through all VHF and one preselected UHF channel at the push of a button.

Built-in automatic degaussing keeps colors pure. Manual degaussing coil can be left plugged into the chassis and turned on from the front panel... especially useful for degaussing after the set is moved some distance.

Automatic chroma control eliminates color variations under different signal conditions.

Adjustable noise limiting and gated AGC keeps pulse-type interference to a minimum, maintains signal strength at constant level.

High resolution circuitry improves picture clarity and new adjustable video peaking lets you select the degree of sharpness and apparent resolution you desire.

"Instant-On". A push of the power switch on the front panel brings your new solid-state set to life in seconds. Picture tube filaments are kept heated for instant operation, and extended tube life. "Instant-On" circuit can be defeated for normal on-off operation.

Premium quality color picture tubes. Both the 227 sq. in. GR-270 and 295 sq. in. GR-370 use the new brighter bonded-face, etched glass picture tubes for crisper, sharper, more natural color. And the new RCA HiLite Matrix tube is a low cost option for the GR-370. See below.

Adjustable tone control lets you choose the sound you prefer... from deep, rich bass to clean, pronounced highs.



Hi-fi output permits playing the audio from the set through your stereo or hi-fi for truly lifelike reproduction. Another Heath exclusive.

Designed to be owner serviced. The new Heath solid-state color TV's are the only sets on the market that can be serviced by the owner. You actually can diagnose, trouble-shoot and maintain your own set.

Built-in dot generator and tilt-out convergence panel let you do the periodic dynamic convergence adjustments required of all color TV's for peak performance. Virtually eliminate technician service calls.



Snap-out glass epoxy circuit boards with transistor sockets add strength and durability and permit fast, easy troubleshooting and transistor replacement. Makes each circuit a module.



Built-in Volt-Dhm Meter and comprehensive manual let you check circuits for proper operation and make necessary adjustments. The manual guides you every step in using this built-in capability. Absolutely no knowledge of electronics is required.

Easy, enjoyable assembly... the Heathkit way. The seven-section manual breaks every assembly down into simple step-by-step instructions. With Heath's famous fold-out pictorials and simple, straightforward design of the sets themselves, anyone can successfully complete the assembly.

Heathkit Solid-State Modular Color TV represents a significant step into the future... with color receiver design and performance features unmatched by any commercially available set at any price! Compare the specifications. Then order yours today.

Kit GR-270, all parts including chassis, 227" picture tube, face mask, UHF & VHF tuners, AFT & 6x9" speaker, 114 lbs. \$489.95*

Kit GR-370, all parts including chassis, 295" picture tube, face mask, UHF & VHF tuners, AFT & 6x9" speaker, 127 lbs. \$559.95*

Kit GR-370MX, complete GR-370 with RCA matrix picture tube, 127 lbs. \$569.75*

GR-270 AND GR-370 SPECIFICATIONS — PICTURE TUBE SIZE: GR-270
 Approximate Viewing Area: 295 Sq. In. GR-270 Approximate Viewing Area: 227 Sq. In. DEFLECTION: Magnetic, 90 degrees. FOCUS: Electrostatic. CONVERGENCE: Magnetic. ANTENNA INPUT IMPEDANCE: VHF 300 ohm balanced or 75 ohm unbalanced. UHF: 300 ohm balanced. TUNING RANGE: VHF TV channels 2 through 13. UHF TV channels 14 through 83. PICTURE IF CARRIER: 45.75 MHz. SOUND IF CARRIER: 41.25 MHz. COLOR IF SUBCARRIER: 42.17 MHz. SOUND IF FREQUENCY: 4.5 MHz. VIDEO IF BANDWIDTH: 3.58 MHz. HI-FI OUTPUT: Output impedance — 1 k ohm. Frequency response — ±1 dB 30 Hz to 10 kHz. Harmonic distortion — less than 1% at 1 kHz. Output voltage — 0.3 V rms nominal. AUDIO OUTPUT: Output impedance — 4 ohm or 8 ohm. Output power — 2 watts. POWER REQUIREMENTS: 110 to 130 volts AC, 60 Hz, 240 watts. NET WEIGHT: GR-370, 114 lbs.; GR-270, 101 lbs.

Modular Color Television!

Exclusive Modular Design... Circuit Boards snap in and out in seconds for easy assembly, simple servicing

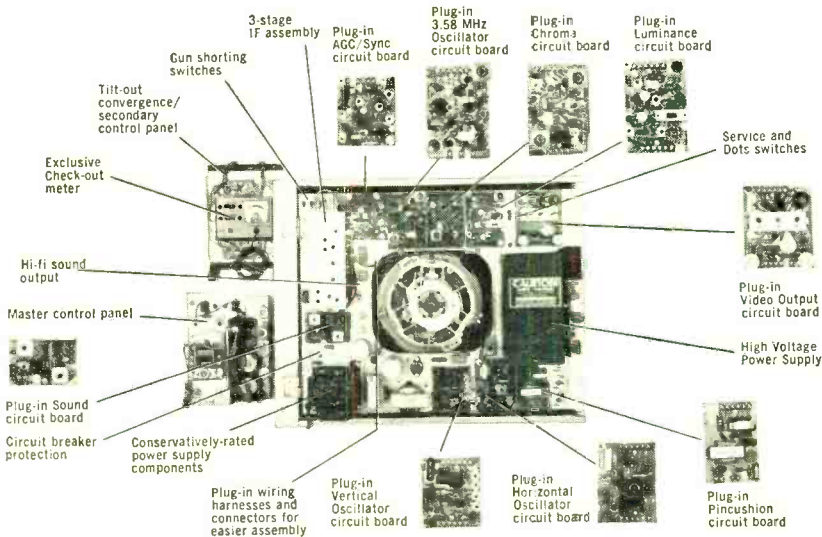

New Expedited 48-Hour No-Charge Warranty Service Plan for Solid-State TV Modules! Special service facilities have been established at the factory and all Heathkit Electronic Centers to expedite service and return of Solid-State TV circuit modules within two working days. During the 90-day warranty period, TV modules will be serviced or replaced with no charge for labor or parts. After the initial 90-day warranty period expires, TV modules will be serviced or replaced at a fixed charge of \$5.00 per module for labor and parts for a period of two years from date of original kit purchase.



Add extra convenience and versatility to your new GR-270 or GR-370 Solid-State Color TV with this new ultrasonic remote control kit. Lets you turn the set on and off, adjust volume, change VHF channels and adjust color and tint from the comfort of your chair. Assembles and installs complete in just a few hours and the built-in meter on the receiver makes final adjustment a matter of minutes.
Kit GRA-70-6, 6 lbs. \$64.95*

Choose One Of These Handsome, Factory Assembled Cabinets

3 models in 295 sq. in.

Luxurious Mediterranean Cabinet... factory assembled of fine furniture grade hardwoods and finished in a flawless Mediterranean peccan. Stately bronze trim handle. 30-1/32" H x 47" W x 17 3/4" D. Assembled GRA-304-23, 85 lbs. \$129.95*

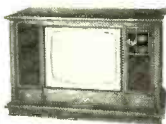

Deluxe Early American Cabinet... factory assembled of a special combination of hardwoods & veneers and finished in classic Salem Maple. 29-21/32" H x 37 1/4" W x 19 3/4" D. Assembled GRA-303-23, 67 lbs. \$114.95*



Contemporary Walnut Cabinet... factory assembled of fine veneers & solids with an oil-rubbed walnut finish. 29-17/32" H x 35-13/16" W x 19 7/8" D. Assembled GRA-301-23, 56 lbs. \$74.95*

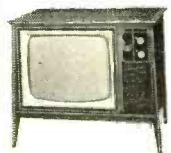

3 models in 227 sq. in.

Exciting Mediterranean Cabinet... assembled using fine furniture techniques and finished in stylish Mediterranean peccan. Accented with stately bronze handle. 27-31/32" H x 41 7/8" W x 19-9/16" D. Assembled GRA-202-20, 70 lbs. \$114.95*

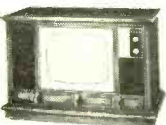

Contemporary Walnut Cabinet and Base Combination. Handsome walnut finished cabinet sits on a matching walnut base. Cabinet dimensions 20-31/32" H x 31-7/16" W x 18 3/8" D. Base dimensions 7 3/8" H x 27 3/4" W x 18 5/8" D. Assembled GRA-203-20 Cabinet, 45 lbs. \$49.95* GRS-203-6 above cab. w/ matching base, 58 lbs. \$59.95*



Handy Roll-Around Cart and Cabinet Combination. Features the GRA-203-20 walnut cabinet plus a walnut-trimmed wheeled cart with storage shelf. Assembled GRA-203-20 Cabinet, 45 lbs. \$49.95* GRA-204-20 Roll-Around Cart, 18 lbs. \$19.95* GRS-203-5 Cart & Cabinet Combo, 58 lbs. \$59.95*

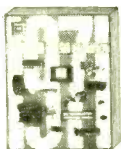

NEW FREE 1971 CATALOG! Now with more kits, more color. Fully describes these along with over 300 kits for stereo/hi-fi, color TV, electronic organs, guitar amplifiers, amateur radio, marine, educational, CB, home & hobby. Mail coupon or write Heath Company, Benton Harbor, Michigan 49022.

HEATH COMPANY, Dept. 10-9
Benton Harbor, Michigan 49022

Enclosed is \$ _____, plus shipping.

Please send model (s) _____

Please send FREE Heathkit Catalog.

Please send Credit Application.

Name _____

Address _____

City _____

State _____

Zip _____

*Mail order prices; F.O.B. factory. Prices & specifications subject to change without notice. CL-387R

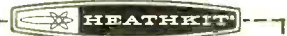

Olson ELECTRONICS FREE Catalog

Fill in coupon for a FREE One Year Subscription to **OLSON ELECTRONICS' Fantastic Value Packed Catalog** — Unheard of **LOW, LOW PRICES** on Brand Name Speakers, Changers, Tubes, Tools, Stereo Amps, Tuners, CB, and other Values. Credit plan available.

NAME _____
ADDRESS _____
CITY _____ STATE _____
GIVE ZIP CODE _____

If you have a friend interested in electronics send his name and address for a FREE subscription also.

OLSON ELECTRONICS
DEPT. 11, 260 S. FORGE STREET, AKRON, OHIO 44308

CIRCLE NO. 18 ON READER SERVICE PAGE

how to use

BARGAIN TRANSISTORS



New book shows simple ways to test and identify thousands of cheap, surplus transistors now widely available. Includes plans for an amazing, inexpensive tester that reveals the inside of unknown, unmarked transistors.

Also describes over 100 projects you can build with bargain transistors; receivers, transmitters, amplifiers and control gadgets. Build them on a handy "breadboard" fully described. Plus a valuable rating section on 3000 transistors.

No risk! Satisfaction guaranteed or money back. For your postpaid copy, send only \$3 to:

Capstone Electronics Corp.
9 Danbury Road, Wilton, Conn. 06897

INVENTORS IDEAS

Have an idea? Could you use one or several? Quad-i Inc., through its nation-wide network of consultants, locates and works with inventors and their ideas. Quad-i evaluates, classifies, offers developmental and marketing services and then exposes marketable ideas to industry and investors through computer systems. Call or write **Quad-i, Inc., 277 Park Avenue, Chalfont, Penna. 18194. 215-822-0181.**

FIND BURIED TREASURE

Powerful electronic detector finds buried gold, silver, coins, etc. 5 new models. Write for free catalog.



RELCO, Dept. D-220 **19⁹⁵**
BOX 10839, HOUSTON, TEX. 77018



To obtain a copy of any of the catalogs or leaflets described below, fill in and mail the Reader Service blank on page 15 or 115.

The "Semiconductor Replacement And Interchangeability Guide," available from *Semiconductors Corp.* (265 Canal St., New York, NY 10013) and authorized distributors for 25¢ is a handy item to have around if you do a lot of electronics servicing. The guide lists EIA-type transistors, foreign substitutes, silicon and selenium rectifiers, germanium and silicon diodes, and zener diodes. In addition, there are a guide to all Semiconductors devices with complete technical specifications and a replacement list for color TV rectifiers and crystals.

Currently being offered by *Vaco Products Co.* is Catalog No. SD-170 describing the company's comprehensive line of hand tools. Each tool listed in the 140-page, four-color catalog is fully illustrated, described, and keyed to an applications guide for correct selection and use. Included is a variety of "unique" tools specifically designed to solve usage problems faster and, more importantly, safer.

Circle No. 92 on Reader Service Page 15 or 115

Information on enclosed pushbutton and rotary switches and high-quality termination hardware is at your finger tips with *Grayhill's* No. G-306-A catalog. Its 88 pages contain descriptions of decorative pushbutton, environmentally sealed pushbutton, key-operated pushbutton, build-your-own rotary (kit), smallest available 24-position rotary, and other types of switches. The engineering data section lists switch parameters and their importance when choosing switches.

Circle No. 93 on Reader Service Page 15 or 115

The newest edition of the *Edmund Scientific Co.* catalog, No. 705, is once again jam-packed with interesting listings. Basically a science and optics catalog, its 148 pages include listings of unique lighting effects equipment, scientific educational toys for everyone from toddlers to adults, tools and measuring devices, and HeNe lasers and holography kits.

Circle No. 94 on Reader Service Page 15 or 115

POPULAR ELECTRONICS READER SERVICE PAGE

free information service:

Here's an easy and convenient way for you to get additional information about products advertised or mentioned editorially (if it has a "Reader Service Number") in this issue. Just follow the directions below... and the material will be sent to you promptly and free of charge.

1. On coupon below, circle the number(s) that corresponds to the key number(s) at the bottom or next to the advertisement or editorial mention that is of interest to you. (Key numbers for advertised products also appear in the Advertisers' Index.) Print or type your name and address on the lines indicated.

2. Cut out the coupon and mail it to: POPULAR ELECTRONICS,
P.O. Box 8391, Philadelphia, PA 19101.

note: If you want to write to the editors of POPULAR ELECTRONICS about an article on any subject that does not have a key number, write to POPULAR ELECTRONICS, One Park Avenue, New York, N.Y. 10016. Inquiries concerning circulation and subscriptions should be sent to POPULAR ELECTRONICS, P.O. Box 1096, Flushing, N.Y. 11352.

**POPULAR
ELECTRONICS**

P.O. BOX 8391
PHILADELPHIA, PA. 19101

Void After October 31, 1970

1 2 3 4 5 6 7 8 9 10 11 12 13 14 15 16 17 18 19 20
21 22 23 24 25 26 27 28 29 30 31 32 33 34 35 36 37 38 39 40
41 42 43 44 45 46 47 48 49 50 51 52 53 54 55 56 57 58 59 60
61 62 63 64 65 66 67 68 69 70 71 72 73 74 75 76 77 78 79 80
81 82 83 84 85 86 87 88 89 90 91 92 93 94 95 96 97 98 99 100

NAME (Print clearly) _____

ADDRESS _____

CITY _____ STATE _____ ZIP CODE _____

9 N a



ACTIVE FILTERS

edited by L. P. Huelsman

Composed of contributions by experts in the fields of active filters, integrated circuit filters, parametric amplifiers, and gyrator filters. The purpose of this book is to summarize and discuss a wide variety of available approaches and techniques applicable to the general problem of processing signal information. This approach enables the engineer to make a selection as to which particular method is most appropriate for any one given filtering problem. *Hard cover. 372 pages. \$16.50.*

RADAR HANDBOOK

edited by Merrill I. Skolnik

In a single volume, is provided a comprehensive survey of the major aspects of radar. Broad in its coverage, with each chapter written by an expert describing his particular specialty, the book is intended for those involved with the design, development, or procurement of radar systems or with research in radar technology. Some of the chapters present detailed design information, while others are descriptive. Almost every topic of significance in modern radar is included. *Hard cover. 1536 pages. \$39.50.*

HANDBOOK OF SEMICONDUCTOR ELECTRONICS, Third Edition

edited by Lloyd P. Hunter

This Third Edition of a now-famous handbook in the field of solid-state electronics gives the practicing engineer the methods and techniques for designing whatever semiconductor circuit he may need. It also gives valuable background material on device physics and device and circuit fabricating techniques so that the engineer can understand the built-in limitations of the devices with which he works. New information on integrated circuits, including the physics, fabrication, and design of these devices is included. Seventeen leading experts pooled their abilities to provide the modern engineer with this book. *Hard cover. \$27.50.*

INTRODUCTION TO SIGNAL TRANSMISSION

by William R. Bennett

Drawing upon years of research experience, the author demonstrates how the knowledge of the response of a transmission system to sine waves reveals the performance of any

kind of signal in the system. The essential core of communications engineering is imparted to the reader in a straightforward manner. The important cases of voice, data, and television transmission are explained in detail. *Hard cover. 266 pages. \$12.50.*

Above four titles published by McGraw-Hill Book Co., 330 West 42 St., New York, NY 10036.

ELECTRONIC ORGANS, Volume 2

by Norman H. Crowhurst

The author presents models of electronic organs produced by eight well-known manufacturers. The first chapter discusses general considerations. Thereafter, each chapter deals with individual manufacturers, discussing important features of one or more of their organ models. Items covered in the individual models are selection stops and voices offered, tone-generation methods, keying methods, pedal generators, special sound effects, etc. Many schematic diagrams are included throughout the book. The final chapter deals with tuning methods and commercial tuning aids.

Published by Howard W. Sams & Co., Inc., 4300 West 62 St., Indianapolis, IN 46268. *Soft cover. 199 pages. \$5.50.*

RCA HIGH-SPEED, HIGH-VOLTAGE, HIGH-CURRENT POWER TRANSISTORS (PM-80)

This 96-page manual is designed to provide a basic understanding of the theory and application of the RCA line of medium-frequency power transistors. It covers physical theory, structures, geometries, packaging, critical application-limiting factors, and the operation and requirements of power transistors in amplifier, switching, and control applications. Typical circuits illustrate the use of transistors in series voltage regulators, linear amplifiers, switching regulators, and inverters and converters, as well as the application of complementary transistor pairs.

Published by RCA Solid State Division, Somerville, NJ 08876. *Soft cover. 96 pages. \$2.*

RCA RECEIVING TUBE MANUAL, RC-27

Revised to include up-to-date tube types and technology, this data-packed manual provides information on the complete RCA line of home-entertainment-type receiving tubes, monochrome and color picture tubes, and voltage-regulator and voltage-reference tubes. The manual includes material on electron tube types, characteristics, installation, and testing. The circuits section illustrates 36 practical tube applications and includes detailed descriptive text explaining the operation and function of individual circuits and stages. In all, this is an indispensable tool for the use and understanding of receiving tubes.

Published by RCA Electronics Components, Harrison, NJ 07029. *Soft cover. 672 pages. \$2.00.*

The modern Army goes to school, and there's a place in class for you.

In fact, high school graduates have more than 300 job training courses to choose from.

And if you qualify for the Army's enlistment program, we guarantee your course selection *before* you step forward and raise your hand.

There's still another plus. The training is great. A leading American university credits the Armed Forces with one of the most advanced and comprehensive educational programs in the world.

Job training in the Army could be the opportunity you need to acquire a vital and rewarding skill. At the same time, you fulfill your military obligation.

We can give you more than 300 good reasons for joining the Army.

But all you need to choose is one.

Your future, your decision... choose **ARMY**.

Army Opportunities
Dept. 200
Hampton, Va. 23369

2 PE 9-70

Please send me your free 40-page booklet.
I understand there's no obligation
attached to this request.

Name _____ Age _____

Address _____

City _____ County _____

State _____ Zip _____

Phone _____ Education _____

Enroll in the Army.



How to become a “Non-Degree Engineer”



In today's electronics boom the demand for men with technical education is far greater than the supply of graduate engineers. Thousands of real engineering jobs are being filled by men without engineering degrees—provided they are thoroughly trained in basic electronic theory and modern application. The pay is good, the future is bright . . . and the training can now be acquired at home—on your own time.

THE ELECTRONICS boom has created a new breed of professional man—the non-degree engineer. Depending on the branch of electronics he's in, he may "ride herd" over a flock of computers, run a powerful TV transmitter, supervise a service or maintenance department, or work side by side with distinguished scientists on a new discovery.

But you do need to know more than soldering connections, testing circuits and replacing components. You need to really know the fundamentals of electronics.

How can you pick up this necessary knowledge? Many of today's non-degree engineers learned their electronics at home. In fact, some authorities feel that a home study course is the *best* way. *Popular Electronics* said:

"By its very nature, home study develops your ability to analyze and extract information as well as to strengthen your sense of responsibility and initiative."

Cleveland Method Makes It Easy

If you do decide to advance your career through home study, it's best to pick a school that *specializes* in the home study method. Electronics is complicated enough without trying to learn it from texts and lessons that were designed for the classroom instead of the home.

Cleveland Institute of Electronics concentrates on home study exclusively. Over the last 30 years it has developed tech-



niques that make learning at home easy, even if you once had trouble studying. Your instructor gives the lessons and questions you send in his undivided personal attention—it's like being the only student in his "class." He not only grades your work, he analyzes it. And he mails back his corrections and comments the same day he gets your lessons, so you read his notations while everything is still fresh in your mind.

Students who have taken other courses often comment on how much more they learn from CIE. Says Mark E. Newland of Santa Maria, Calif.:

"Of 11 different correspondence courses I've taken, CIE's was the best prepared, most interesting, and easiest to understand. I passed my 1st Class FCC exam after completing my course, and have increased my earnings by \$120 a month."

Always Up-to-Date

Because of rapid developments in electronics, CIE courses are constantly being revised. This year's courses include up-to-the-minute lessons in Microminiaturization, Laser Theory and Application, Suppressed Carrier Modulation, Single Sideband Techniques, Logical Troubleshooting, Boolean Algebra, Pulse Theory, Timebase Generators...and many more.

CIE Assures You an FCC License

The Cleveland method of training is so successful that better than 9 out of 10 CIE

graduates who take the FCC exam pass it. This is despite the fact that, among non-CIE men, 2 out of every 3 who take the exam fail! That's why CIE can promise in writing to refund your tuition in full if you complete one of its FCC courses and fail to pass the licensing exam.

This Book Can Help You

Thousands who are advancing their electronics careers started by reading our famous book, "How To Succeed in Electronics." It tells of many non-degree engineering jobs and other electronics careers open to men with the proper training. And it tells which courses of study best prepare you for the work you want.

If you would like to cash in on the electronics boom, let us send you this 44-page book free.

Just fill out and mail the attached postpaid card. Or, if the card is missing, mail the coupon at right.

NEW COLLEGE-LEVEL CAREER COURSE FOR MEN WITH PRIOR EXPERIENCE IN ELECTRONICS

ELECTRONICS ENGINEERING... covers steady-state and transient network theory, solid state physics and circuitry, pulse techniques, computer logic and mathematics through calculus. A college-level course for men already working in Electronics.

CIE Cleveland Institute of Electronics

1776 East 17th Street
Cleveland, Ohio 44114

Please send me without cost or obligation:

Your 44-page book "How To Succeed in Electronics" describing the job opportunities in Electronics today, and how your courses can prepare me for them.

Your book on "How To Get A Commercial FCC License."

I am especially interested in:

- Electronics Technology
- Broadcast Engineering
- First Class FCC License
- Electronic Communications
- Industrial Electronics
- Electronics Engineering

Name _____ (PLEASE PRINT)

City _____

Address _____

State _____

Zip _____ Age _____

ENROLL UNDER NEW G.I. BILL. All CIE courses are available under the new G.I. Bill. If you served on active duty since January 31, 1955, or are in service now, check box on card or in this coupon for G. I. bill information.

PE-06

CIRCLE NO. 9 ON READER SERVICE PAGE

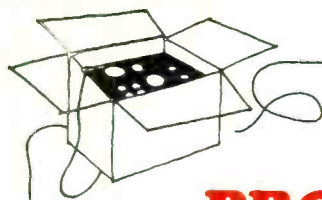

NEW PRODUCTS

Additional information on products described in this section is available from the manufacturers. Each new product is identified by a corresponding number on the Reader Service Page. To obtain additional information on any of them, circle the number on the Reader Service Page, fill in your name and address, and mail it in accordance with the instructions.

SENCORE HI-LO MULTIMETER—Here's something really new in a VOM for checking solid-state equipment. *Sencore, Inc.* has just introduced a VOM with an ohmmeter powered by either 1.5 or 0.08 volts! The latter voltage is so low that resistors can be measured in circuits without the readings being falsified by conduction in the surrounding solid-state components. The 1.5-volt battery is only used when conduction is required such as when reading diode front-to-back ratios. Sencore claims that the Model FE21 Hi-Lo VOM was developed to check integrated circuits where it is obviously impossible to disassemble individual transistors. The Model FE21 has plenty of general servicing uses and will read from 0.1 volt to 3000 volts full scale. There are 9 ranges for measuring direct current flow from 100 microamperes to 1.0 A and 7 resistance ranges from 100 ohms to 1000 megohms.

Circle No. 77 on Reader Service Page 15 or 115

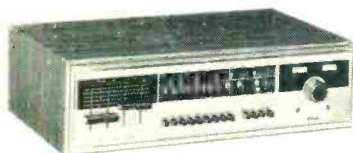

OLSON AM/FM/STEREO FM RECEIVER—Slide potentiometers and pushbutton controls are "in" according to the *Olson Electronics RA-300* stereo receiver. Measuring only 5 inches in height, the RA-300 is a nicely styled, 250-watt (total), all solid-state unit featuring ceramic fixed-tuned i-f's, four IC's, and a FET FM front end. Slide potentiometers are used for the right/left volume and tone controls. Pushbuttons control the programming, speaker switching, filters, tape monitoring, loudness, muting, etc. The manufacturer claims a frequency range of 15 to 25,000 Hz, capture ratio of 2.5 dB, and an FM separation of 35 dB.

Circle No. 78 on Reader Service Page 15 or 115

TOMPKINS WIRELESS BROADCASTER—A new version of an old trick is being marketed by *Herbert Salch & Co.* It's a "wireless broadcaster" operating within the realm of Part 15 of the FCC Rules & Regulations. Available in either of two models (65 and 76), it takes its input from the speaker leads of a hi-fi system, TV receiver, CB transceiver, etc., and radiates a limited-range AM signal between either 640-660 kHz or 750-770 kHz. The units are solid-state and may be battery operated or powered by an optional extra-cost rectified ac supply. A unique feature is the avc circuit that prevents over-modulation of the AM carrier from the speaker connection. Range with the antenna supplied is about 100 ft.

Circle No. 79 on Reader Service Page 15 or 115

FISHER 4-CHANNEL STEREO RECEIVER—Expressing the firm conviction that 4-channel is the hi-fi of the future, *Fisher Radio* has introduced its 701, a 4-channel, 250-watt (total) music power stereo receiver. Solid-state with 14 IC's, the 701 can be used either as a conventional 2-channel stereo receiver or as a 4-channel tuner/amplifier for tapes, records, and broadcasts with a rating of 40 watts rms/channel. The user has numerous programming options with the 701, including: remote control speakers for all four channels, AutoScan FM electronic tuning (using varactor diodes), simulated concert hall acoustic conditions using all four speakers on 2-channel material, high filtering of front and rear speakers, etc. There are the usual provisions for loudness compensation, tape monitoring, headphones, AM broadcast band reception, channel reversing, muting, etc.

Circle No. 80 on Reader Service Page 15 or 115

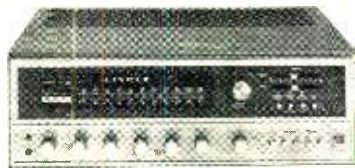

TECHNI-TOOL DESOLDERING PUMP—One-hand operation is the major claim for the imported *Techni-Tool Inc.* T-2 Desoldering Pump. Built in an aluminum housing, the T-2 can be primed using your thumb and released by your index finger. There is no external plunger so this hazard is removed from the lab bench. Teflon replaceable tips are available from the distributor. Cleaning of the T-2 is easy since it is easily disassembled into 3 separate parts.

Circle No. 81 on Reader Service Page 15 or 115



VICTOREEN RADIATION METER—With so many of the populace worrying about color TV receiver radiation it's nice to know if you're being zapped or not. To detect both X-ray and gamma radiation, *Victoreen Instrument Division of VLN* has announced its Model 499 VIC-CHEK with a range up to 1000 counts per minute. Radiation is admitted through an aluminized Mylar window to a Geiger-Mueller counter tube with organic quenching. The counting circuit is battery operated and the small (1 lb) handheld instrument has meter readout.

Circle No. 82 on Reader Service Page 15 or 115

PANASONIC PROFESSIONAL TAPE DECK—Some fairly flamboyant claims are made for *Panasonic's* RS-736 Professional Tape Deck. However, this much seems to be obvious: the RS-736 is a 3-speed deck (15, 7½, 3½ in./sec) with slide potentiometer recording and output level controls. Both sound-on-sound and sound-with-sound recording is possible due to the variety of intermixing and special effect controls. The user can also select the proper oscillator bias for optimum signal-to-noise ratio at each recording speed. It also has a 4-digit counter, pause control, walnut wood-style enclosure, and the Panasonic "hot pressed ferrite" tape heads.

Circle No. 83 on Reader Service Page 15 or 115

HOULE FAST-ETCHING KIT—If you want to speed up your small PC board etching, investigate the new process offered by *Houle Manufacturing Co.* A trial kit is available containing ammonium persulfate, 25 square inches



NEW PRODUCTS

CONTINUED FROM PAGE 23

of one-sided copper board, a role of black tape and strips of donuts and teardrops, plus a special bottle of catalyst. The latter is said to speed up the etching process so that a board is ready to be rinsed in 3 to 5 minutes.

Circle No. 84 on Reader Service Page 15 or 115



LITTELFUSE REPLACEMENT COILS—In an attempt to broaden its marketing base, *Littelfuse, Inc.* has entered the peg-board replacement r-f. coil and i-f transformer business. See-thru packages are being distributed to stores to provide a variety of coils and transformers. Each coil is packaged with a wiring diagram and i-f transformers are packaged with pin connection diagrams and a plastic hex alignment tool. The manufacturer claims that these coils and transformers will be "universal" as replacements and can often be used by the hobbyist and experimenter requiring pre-determined inductances and tuning ranges.

Circle No. 85 on Reader Service Page 15 or 115

MOSLEY 80-METER KIT—Any ham using, or contemplating installing, the *Mosley Electronics, Inc.* Model RV-4C vertical should know that a 75/80-meter conversion kit is available to make this popular antenna tune all 5 shortwave ham bands. The kit is designated RV-8C and consists of a loading coil, capacitor tube and a trombone matching section. The builder must also install a suitable length radial (not supplied) to enable the antenna to work efficiently against ground. The power rating on 80 meters is 750 watts AM and CW, or 2 kW PEP SSB input to the final amplifier.

Circle No. 86 on Reader Service Page 15 or 115

MARANTZ STEREO POWER AMPLIFIER—If you want plenty of stereo power at practically no distortion, you will probably be satisfied with the *Marantz Co., Inc.* Model 32. With a frequency response in the audio spectrum of plus or minus 0.25 dB, the solid-state amplifier has a continuous rms power output rating (both channels driven) of 120 watts into either 4 or 8 ohms and 60 watts into 16 ohms. This is equal to an IHF tested rating of 180 watts into 8 ohms or a music power rating of plus or minus 1.0 dB of 240 watts into 8 ohms. The Model 32 is loaded with protective features for turn-on stabilization and current limitation. A walnut cover is available as an option. There is a 3-year warranty.

Circle No. 87 on Reader Service Page 15 or 115



ADVENT UTILITY LOUDSPEAKER—If you want to save \$20 on a stereo installation, you can now obtain a utility version of the *Advent Corp.* two-way speaker system. The saving is in the enclosure exterior which, in the utility version, is walnut-finish vinyl with a neutral colored grille cloth. The Advent speakers inside remain

(continued on page 26)



New Mallory ultrasonic Crime Alert®... Nobody can get around it.

Our new ultrasonic Crime Alert® alarm.

It catches intruders flatfooted. With invisible, silent, unavoidable ultrasonic waves.

Just plug it in . . . no complicated installation. Any movement within its range triggers its piercing scream . . . accessory outlet lets you plug in lights, siren, or other device.

It's the first really sophisticated electronic warning device available to consumers in its price range. And no wires, lightbeams, or anything else to see and get around.

It's the perfect, low-cost (only \$89.95) intruder warning for homes, stores, industry, plants . . . anything you want to keep safe.

MALLORY

MALLORY DISTRIBUTOR PRODUCTS COMPANY

a division of P. R. MALLORY & CO. INC.

Box 1658, Indianapolis, Indiana 46208; Telephone: 317-636-5353

Batteries • Capacitors • DURATAPE® • Controls **CRIME ALERT®** Resistors • Semiconductors • Sonalert® • Switches • Timers • Vibrators

CIRCLE NO. 15 ON READER SERVICE PAGE

NEW PRODUCTS

CONTINUED FROM PAGE 24

the same—a particularly unusual woofer with an effective cone diameter of about 7½" and a direct radiator tweeter. The enclosure measures 14¼" x 25½" x 11½". The manufacturer recommends a minimum amplifier rating of 20 watts rms per channel for good performance. The Advent speaker has been getting rave reviews in the stereo press. The system was designed by Henry E. Kloss, co-founder of AR and later of KLH.

Circle No. 88 on Reader Service Page 15 or 115



DIALALARM SECURITY SYSTEM—If you worry about burglaries, power failures, or personal safety, it would be worth your while to investigate the Mark X system offered by *Dialalarm, Inc.* Principal ingredient in the new system is a tape cassette player that has been programmed to transmit a recorded message over the telephone lines. The self-contained system dials the number and then repeats the message several times to insure correct interpretation. The cassette player is activated by any of the usual fire, water, or theft sensors employed in business and home protection systems.

Circle No. 89 on Reader Service Page 15 or 115

PIONEER ELECTRONIC CROSSOVER—Electronic crossovers, popular hi-fi items in the late '50's, are coming back in style. Usable only between separate component stereo systems (preamp separate from power amplifier) *Pioneer Electronics U.S.A. Corp.* has just announced its Model SF-700 crossover. This unit divides the audio spectrum into three discrete bands with volume level adjustments from the front panel. The crossover frequencies may be selected by the user. The lower to mid-range crossover can be at 125, 250, 500, 700, or 1000 Hz; midrange to upper at 1000, 2000, 4000, 6000, or 8000 Hz. Transition between ranges can be set at 6, 12, or 18 dB per octave. A center channel woofer output is also available. Insertion loss and distortion are reported by the manufacturer to be extremely low.

Circle No. 90 on Reader Service Page 15 or 115



VECTOR BREADBOARD IC SOCKET—Anyone working in experimental logic circuitry will probably appreciate the new 570F *Vector Electronic Co., Inc.* breadboard IC socket. Designed for 12-pin TO-5 IC's, the breadboard socket has spring-loaded pins (6 to a side) that permit up to 4 connecting leads to be temporarily attached to the IC. The 570F also has two pins mounted on the bottom of the socket plate that can be press-fitted into an "AA" pattern Vectorboard with 3/32" holes. The spring pins are numbered to correspond to the TO-5 lead numbering.

Circle No. 91 on Reader Service Page 15 or 115



**White hot...
antenna specialists'
great new line of
fiber glass CB
mobile antennas!**



the antenna specialists co.

Division of Allen Electric and Equipment Co.
12435 Euclid Avenue, Cleveland, Ohio 44106

EXPORT: 2200 Shames Drive, Westbury, L. I., New York 11690
CANADA: A. C. Simmonds & Sons, Ltd.

If you need a fishing rod look elsewhere.

Antennas are our only business. These communications antennas, the first and only complete fiber glass line designed from the manufacturing equipment on up with one idea in mind—the rugged, varied environment and special requirements of mobile two-way radio.

Nobody makes anything like them. Nobody even makes the machines they're made on. We designed our own.

Why A/S fiber glass?

Antenna Specialists fiber glass has all the advantages, none of the failings of conventional fiber glass materials:

- Perfect elasticity—bend one and it will return to its exact vertical position.
- Super strength—stronger than brass, aluminum, even most steels.
- Impervious to corrosion—and positively will not fade or deteriorate under most intense sunlight, even ultraviolet.
- Will not split or run — Exclusive "Armorweave" material contains much more fiber glass, woven in both directions to resist blows.

White-hot new designs, features!

Entirely new, contemporary styling and features make this the most beautiful and versatile line you've ever seen. Like the slim and elegant new tapered spring that seems to flow right into the slender tapered whip... the quick-disconnect joints that make full length whips practical... like the ingenious new tuneable whip-tip that allows instant VSWR adjustment with a twist.

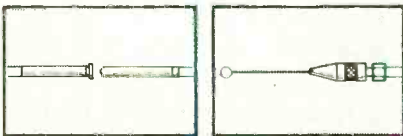

® Stripes of Quality

R-960-1

Now it costs less to own the best VOM you need.



The New RCA WV-510A Solid-State Master VoltOhmyst®

I.Q.*

*Inexpensive Quality
†Optional Distributor
Resale Price

RCA

The best you need is the new solid-state RCA WV-510A Master VoltOhmyst®. The most functional VOM we've ever produced, the 510A has all the features you'll ever need no matter what your requirements may be.

And we've added some extra features you won't find in any competitive VOM, at any price... features designed to make your work easier, help you get the job done faster.

For example: RCA WV-510A operates from batteries or AC. Remove the detachable AC line cord while you're taking a measurement and the batteries take over immediately without a flicker of the pointer. And you'll get maximum life from the batteries because they're always on trickle charge during AC operation. Stability? Switch from range to range and watch a whole series of measurements without constantly zero-adjusting the meter.

Some statistics:

Current:

0.01 milliampere to 1.5 amperes in 8 ranges.

Resistance:

0.02 ohm to 1000 megohms in 7 ranges.

DC Volts:

0.01 volt to 500 volts in 8 ranges.

AC Volts:

0.2 to 1500 rms AC volts in 7 ranges plus peak-to-peak voltages of complex waveforms.

21 megohm resistance on all DC ranges.

And it's only \$128,† complete with DC/AC ohms probe and flexible shielded input cable with BNC connector, and removable AC line cord.

Some statistics! For complete details, contact your local RCA Distributor.

RCA|Electronic Components|Harrison, N. J. 07029

CIRCLE NO. 19 ON READER SERVICE PAGE

The Experiment That Saved Hi-Fi

They said cutting off highs and lows would make everyone happy

BY DAVID B. WEEMS

BY THE TIME World War II ended in 1945, the wartime shortage of home radio and phonograph products had become acute. Even radio experimenters were hampered by the shortage of parts, but that didn't stop some of them from tinkering with a concept they called "high fidelity." What could have stopped them cold didn't happen until a month after the war ended.

That was a report¹ by Chinn and Eisenberg in the *Proceedings of the IRE*, describing the results of a study to investigate the tonal spectrum preference of radio listeners. An audience had been given a choice of three frequency ranges to choose from: narrow (150-3500 Hz), medium (100-5000 Hz), and wide (50-10,000 Hz). Surprisingly, most of the listeners chose the narrowest band. In fact, they continued to choose narrow-range sound even after they were told that it was "low fidelity."

Professional musicians listening to classical music picked the low-fi sound by an even

greater margin than the average listener. Among the musicians, 73% chose narrow range, while only 5% liked the wide range and 22% were undecided.

For hi-fi fans, that report was a double whammy. The study purported to fix the "ideal" frequency range for the recording and broadcasting industries. What good was it to build wide-range hi-fi amplifiers and speaker systems if the frequency response of records and radio broadcasts were to be restricted?

However, there wasn't much to be criticized in the experiment. The qualifications of the investigators were impeccable. One, a consultant to the Office of Scientific Research and Development, with extensive experience in broadcasting, had been associated with M.I.T. and Harvard. His colleague was a professor of psychology. Their audio equipment was the best available—flat from 40 to 10,000 Hz with "supposedly" low measurable distortion. The speaker system used was coaxial with a multi-cellular horn for highs; folded horn for lows.

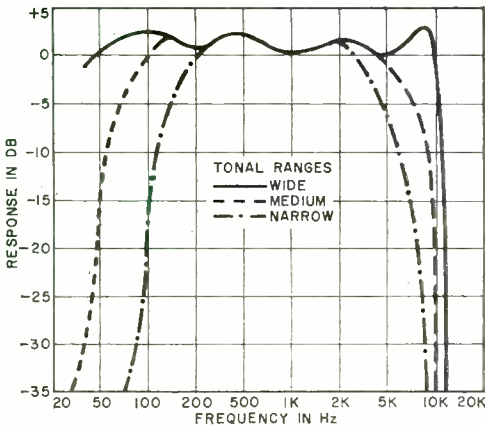

Frequency responses used in the Chinn and Eisenberg tests. Most people preferred the narrow band which rolled off at 3500 Hz. (See reference 1.)

The investigators had kept record noise to a negligible level by using original master recordings and playing each only one time. To double check the results with records, a live network broadcast of a 29-piece orchestra with a 14-voice female chorus was monitored in the listening room for some of the tests. Again, the frequency range for the medium and narrow bands was altered by an electronic (single-section band-pass) filter inserted in the system. And the listeners liked the filter.

Highs Are for the Birds. If the study threw a wet blanket over hi-fi, it wasn't the first one. In 1944, O. J. Hanson, chief engineer for one of the major broadcasting networks questioned the desirability of high fidelity.² He suggested that frequencies above 10,000 Hz were good only for sound effects: non-musical noises such as key jingling, hand-clapping, and resin squeaks. Anyway, he said, the jokes of a favorite comedian were just as funny when heard on a radio with a 200-to-3000-Hz range as on a wide-range system.

Those who argued against a wide response on the grounds that it was impractical had many reasons to cite. They said that a listener would have to sit directly in front of his speaker because if he were 45° off the axis, the response would be inadequate at frequencies as low as 3000 Hz. Critics also noted that background noise increased along with bandwidth and that the extension of high-frequency response beyond 5000 Hz on AM radios would only result in "monkey chatter" due to the 10-kHz spacing of radio stations.

Such were the views of the "establishment."

It was hardly surprising, then, that many of the first post-WWII radio receivers were built on the same chassis layouts as the last prewar models. The economic climate of wartime price fixing and high demand was also partly to blame. But a scientific study which showed a one-sided preference for low-fi music discouraged all but the most adventurous manufacturers.

Low-Fi Reigns Supreme. And so the console AM radio was still king of the mountain, or at least of the American living room. Eighteen million had been manufactured; the latest of them being superhets with a pair of push-pull pentodes in the output stage. The power output may have been listed in the tube manual at 8 to 10 watts; but it was usually considerably less than that, depending on how much distortion one would tolerate. A small output transformer coupled the output tubes to a 10- or 12-inch electromagnetic stiffened speaker, mounted in the lower section of the open-back cabinet. That arrangement produced a booming resonance in the 200-Hz region that almost masked the absence of fundamental bass response under about 100 Hz. The almost total lack of either electrical or mechanical damping on the speaker permitted the cone to vibrate after a signal had ended and added the word "hangover" to our audio vocabulary.

Sometimes the radio amplifier was fed by a 78-r/min record player whose massive tone arm carried a crystal pick-up. At the end of the cartridge was a "chuck" or set screw that held the stylus, which was called a needle but looked like a brad nail. People who were fussy about record wear could substitute a cactus needle, which killed what little high-frequency response might have escaped the other equipment.

Those were the "components" of a home music system: commercial sound systems were not much better. An investigation by Eagleson and Eagleson in 1946³ showed that, when listeners tried to identify musical instruments heard over a p.a. system, the results were wild guesses. In a test involving 35 listeners, 22 of them musicians, the one who got the best score identified the instrument correctly less than 40% of the time. And he wasn't one of the musicians. In fact, he'd had no musical training at all.

The Chinn-Eisenberg study clearly backed up the engineers who had argued for a "sensible" frequency range, and against hi-fi. But when the paper was read carefully, some odd

comparisons emerged. For example, when the professional musicians listened to male speech, they showed a preference for widerange reproduction. Another curiosity: Why did listeners prefer a higher sound intensity for speech than for music? This was a suspicious reversal of the normal difference in sound intensity for live speech and live music.

Fortunately for the future of hi-fi, some readers were skeptical of the results. One of these was Harry F. Olson. Born in Mt. Pleasant, Iowa, Olson had received his Ph. D at the University of Iowa in 1928 and had gone to work for RCA that year. Six years later he was placed in charge of acoustical research for RCA.

As Olson analyzed the conclusions of the controversial paper, he decided that there could be three possible explanations for the results. The first two were:

People were so conditioned to a narrow frequency range from listening to the radio that they accepted it as natural.

Musical instruments are improperly designed. They should be redesigned to eliminate the undesirable overtones.

Olson was offering these suggestions to

cover all the possibilities. He knew that the professional musicians should have had no difficulty choosing what was the most natural sound. And as for recognizing musical instruments, stripping the overtones would rob each instrument of its individuality. A violin, for example, would lose its gutty string tone and sound somewhat like a flute. One might as well write music for a battery of sine-wave generators!

The third possibility? Olson said, "the distortions and deviations from true reproduction of the original sound are less objectionable with a restricted frequency range."

But how could he prove his suspicion? If distortion were the demon, his problem was to design an experiment that would eliminate distortion. His solution was simple.

If distortion in amplifiers and speakers could not be eliminated, he would bypass 1945 electronics and use live music. This time "live music" would mean exactly that—no microphone, no amplifiers, and no speaker system.

A Real Acoustical Filter. Olson's background in acoustics served him and the cause

Now retired, Dr. Harry F. Olson had a long, distinguished career with RCA. Holder of numerous patents, Dr. Olson spent many years developing a phonetic typewriter. Here he is speaking into the microphone connected to an early model of his typewriter. Capacity of this model was limited to 100 speech elements; it was developed before the advent of solid-state components which eventually reduced the physical size and increased the speech memory capacity. Research work on the speech typewriter is still taking place although there are reportedly many unsolved problems.



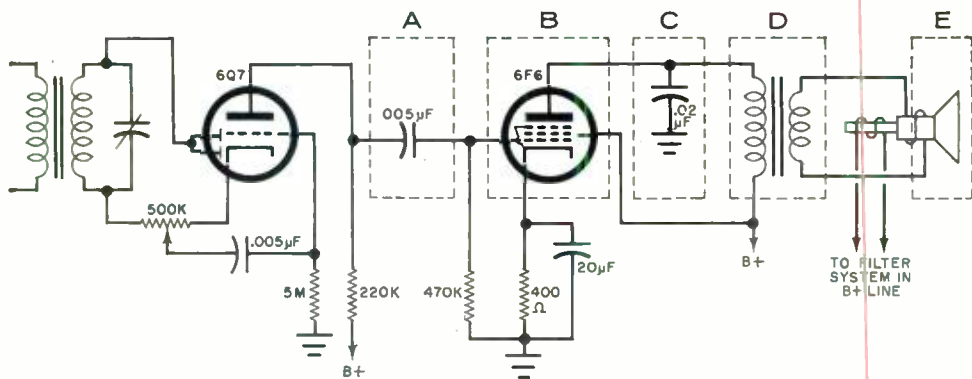

Audio section of a typical pre-hi-fi radio. Lettered sections indicate points where frequency response was restricted: A—small coupling capacitor reduced hum by rolling off bass. B—pentode output without feedback produced distortion and inadequate speaker damping. C—plate capacitor served purpose of maintaining proper load on output tube but knocked down high-frequency response. D—small transformer limited low-frequency response; its leakage inductance cut highs. E—electro-magnetic speaker had limited response; stiff cone and poor baffling cut lows; large, straight cone gave poor high-frequency and polar response.

Behind the filter, a small orchestra—piano, trumpet, violin, clarinet, contrabass, drums, and traps—was assembled. A sound-transparent curtain prevented the audience from seeing the position of the filter. Then Olson assembled his listeners: chemists and gardeners, doctors and farmers, secretaries and electricians—anyone who was available as worker or visitor at RCA Laboratories. The orchestra played and A-B tests were made, the filter changed every 15 seconds during each number. For different tests, the letters A and B were reversed to prevent the results from being skewed by letter preference. The listeners made their choice, and added comments if they desired.

The results of the experiment produced a reversal of all previous studies. It was a striking victory for the concept of high fi-

delity. A strong majority, 69% of the listeners, preferred full-frequency-range hi-fi, compared to 31% who voted for the low-fi music.

But there was a suspicion that even some of the minority who didn't like the full-frequency range may have been reacting to something other than sound quality. Because of the small room, Olson could not supply classical music devotees with a full symphony orchestra. Some of them added negative remarks about popular music to their votes for narrow-range sound.

Olson also disproved another belief held by the broadcasting industry: that the product of the upper and lower limits of the reproduced frequency range should always equal about 500,000 in order to insure proper balance between highs and lows. He found that his listeners did not approve when he cut off the bass at 100 Hz to balance the high-frequency cut-off at 5000 Hz.

Tests on speech produced comments that the restricted frequency range produced "muffled" speech that was not as intelligible as the full-range speech.

Olson's experiment showed that previous workers who had attempted to find the "ideal" frequency range for music reproduction had been working in the dark. Evidently his third suggestion, that distortion was less objectionable with a narrow frequency range, was correct.

Get the Distortion Out. "Distortion was inherent in the phonographs and radio receivers of that day," Dr. Olson said recently.

(Continued on page 117)

References

- Howard A. Chinn and Philip Eisenberg, *Proceedings of the I.R.E.*, Vol 33, Sept. 1945, p 571, "Tonal Range and Sound Intensity Preferences of Broadcast Listeners."
- O. J. Hanson, *Electronics*, Vol 17, Aug. 1944, p 130, "Comments on High Fidelity."
- Hanson V. Eagleson and Oran N. Eagleson, *Journal of the Acoustical Society of America*, Mar. 1947, "Identification of Musical Instruments When Heard Directly Over a Public Address System."
- Harry F. Olson, *Journal of the Acoustical Society of America*, July 1947, p 41, "Frequency Range Preference for Speech and Music."

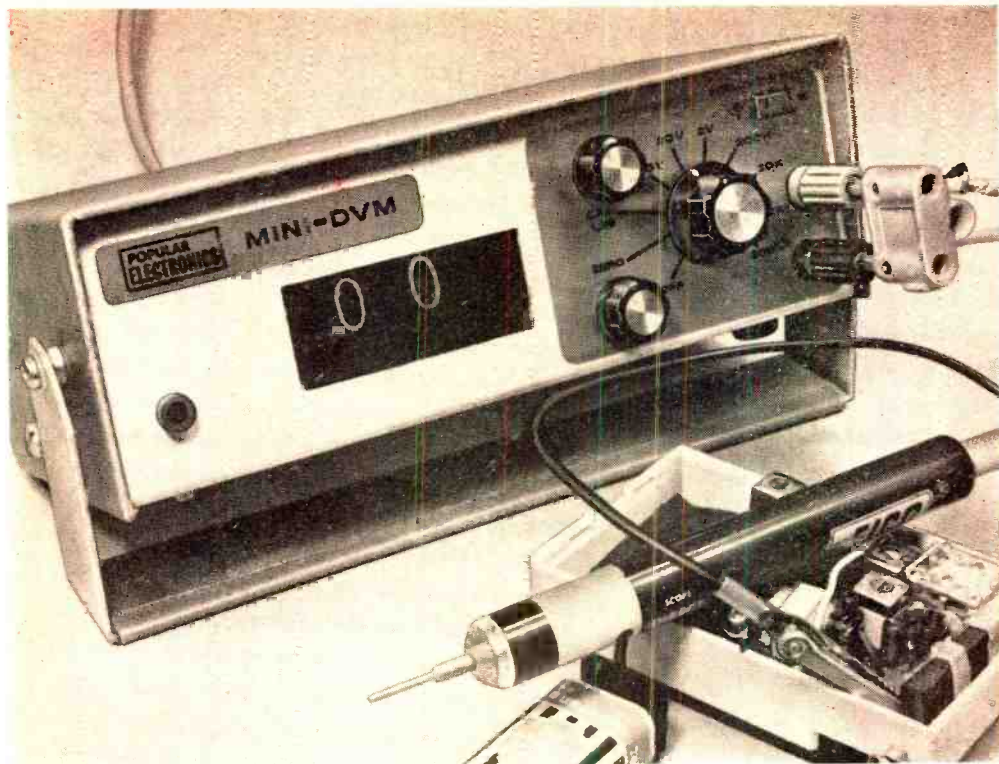

**ASSEMBLING THE
POPULAR ELECTRONICS**

MINI-DVM

HIGH-QUALITY, LOW-COST

MINIATURE DIGITAL VOLTOHMMETER

This is an up-graded version of the original Popular Electronics "Low-Cost Digital Volttohmmeter" that appeared in our December 1968 issue. Assembly has been eased, accuracy and stability improved, and the instrument may be constructed for a dollar outlay of less than the 1968 prototype. Detailed specifications appear on page 45. Full assembly details are published in this issue.

IT ISN'T OFTEN that you see a small, compact digital voltohmmeter with Nixie® tube readout that doesn't cost at least several hundred dollars. The "Mini-DVM" described here is a seven-range, high-impedance digital

volttohmmeter with 1% accuracy that can be built for about the cost of a better-grade analog multimeter. It uses 2½-decade Nixie-tube numeric display to indicate—brightly and unambiguously—any d.c. voltage from 10 millivolts to 200 volts or any resistance value from 1 to 200,000 ohms. It has internal self-calibration and zeroing.

The Mini-DVM can be assembled in its own case or the internal electronics can be used as a 0-199 digital counter or panel meter to indicate digitally any quantity that can be converted into a 0-2-volt d.c. signal driving a 1-megohm load. Complete technical specifications are given in the Table. The instrument consists of a counter module, a power module, and some case-mounted controls and components.

COVER STORY BY DON LANCASTER

10 Reasons why RCA Home Training is your best investment for a rewarding career in electronics:

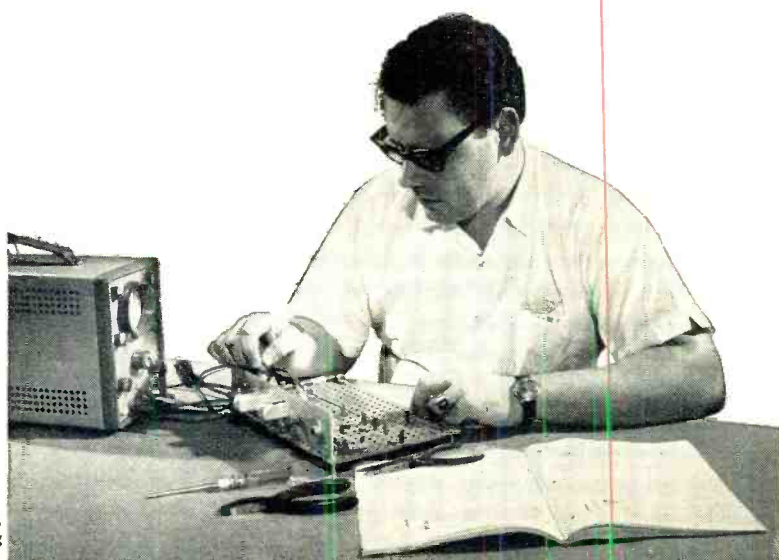

Performing transistor experiments on programmed breadboard — using oscilloscope

1 LEADER IN ELECTRONICS TRAINING

When you think of electronics, you immediately think of RCA...a name that stands for dependability, integrity and pioneering scientific advances. For over a half century, RCA Institutes, Inc., a service of Radio Corporation of America, has been a leader in technical training.

2 RCA AUTOTEXT TEACHES ELECTRONICS FASTER, EASIER, ALMOST AUTOMATICALLY

Beginner or refresher, AUTOTEXT, RCA Institutes' own method of programmed Home Training will help you learn electronics more quickly and with less effort, even if you've had trouble with conventional learning methods in the past.

3 THOUSANDS OF WELL PAID JOBS ARE NOW OPEN TO MEN SKILLED IN ELECTRONICS

RCA Institutes is doing something positive to help men with an interest in electronics to qualify for rewarding jobs in this fascinating field. Every year, literally thousands of high paying jobs in electronics go unfilled just because not enough men take the opportunity to train themselves for these openings.

4 WIDE CHOICE OF CAREER PROGRAMS

Start today on the electronics career of your choice. On the attached card is a list of "Career Programs", each of which starts with the amazing AUTOTEXT method of programmed instruction. Look the list over, pick the one best suited to you and check it off on the card.

5 SPECIALIZED ADVANCED TRAINING

For those already working in electronics or with previous training, RCA Institutes offers advanced courses. You can start on a higher level without wasting time on work you already know.

6 PERSONAL SUPERVISION THROUGHOUT

All during your program of home study, your training is supervised by RCA Institutes experts who become personally involved in your efforts and help you over any "rough spots" that may develop.

7 VARIETY OF KITS YOURS TO KEEP

To give practical application to your studies, a variety of valuable RCA Institutes engineered kits are included in your program. Each kit is complete in itself. You never have to take apart one piece to build another. At no extra cost, they're yours to keep and use on the job.

8 FROM RCA INSTITUTES ONLY - TRANSISTORIZED TV KIT, VALUABLE OSCILLOSCOPE

Those enrolled in RCA's television course or program receive complete transistorized TV Kit. All students receive a valuable oscilloscope—both at no extra cost and only from RCA Institutes.

9 CONVENIENT PAYMENT PLANS

RCA Institutes offers a unique tuition plan that lets you progress at your own pace. You only pay for lessons as you order them. You don't sign a contract obligating you to continue the course. There's no large down-payment to lose if you decide

not to continue. However, if you desire, RCA Institutes also offers a convenient monthly payment plan.

10 RCA INSTITUTES GRADUATES GET TOP RECOGNITION

Thousands of graduates of RCA Institutes are now working for leaders in the electronics field; many others have their own profitable businesses. This record is proof of the high quality of RCA Institutes' training.

CLASSROOM TRAINING ALSO AVAILABLE

If you prefer, you can attend classes at RCA Institutes Resident School, one of the largest of its kind in New York City. Coeducational classroom and laboratory training, day and evening sessions, start four times a year. Simply check "Classroom Training" on the attached card for full information.

JOB PLACEMENT SERVICE, TOO!

Companies like IBM, Bell Telephone Labs, GE, RCA, Xerox, Honeywell, Grumman, Westinghouse, and major Radio and TV Networks have regularly employed graduates through RCA Institutes' own placement service.

SEND ATTACHED POSTAGE PAID CARD TODAY! FREE DESCRIPTIVE BOOK YOURS WITHOUT OBLIGATION! NO SALESMAN WILL CALL!

All RCA Institutes courses and programs are approved for veterans under the New G.I. Bill.

RCA INSTITUTES, DEPT. 694-009-0
320 West 31st Street,
New York, N.Y. 10001

Accredited Member National Home Study Council

RCA

Construction of Multimeter.

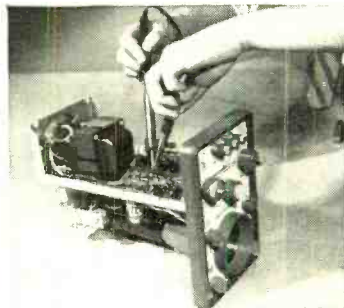

Construction of Oscilloscope.

Temperature experiment with transistors.

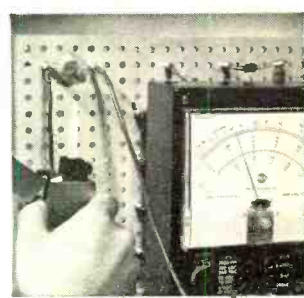

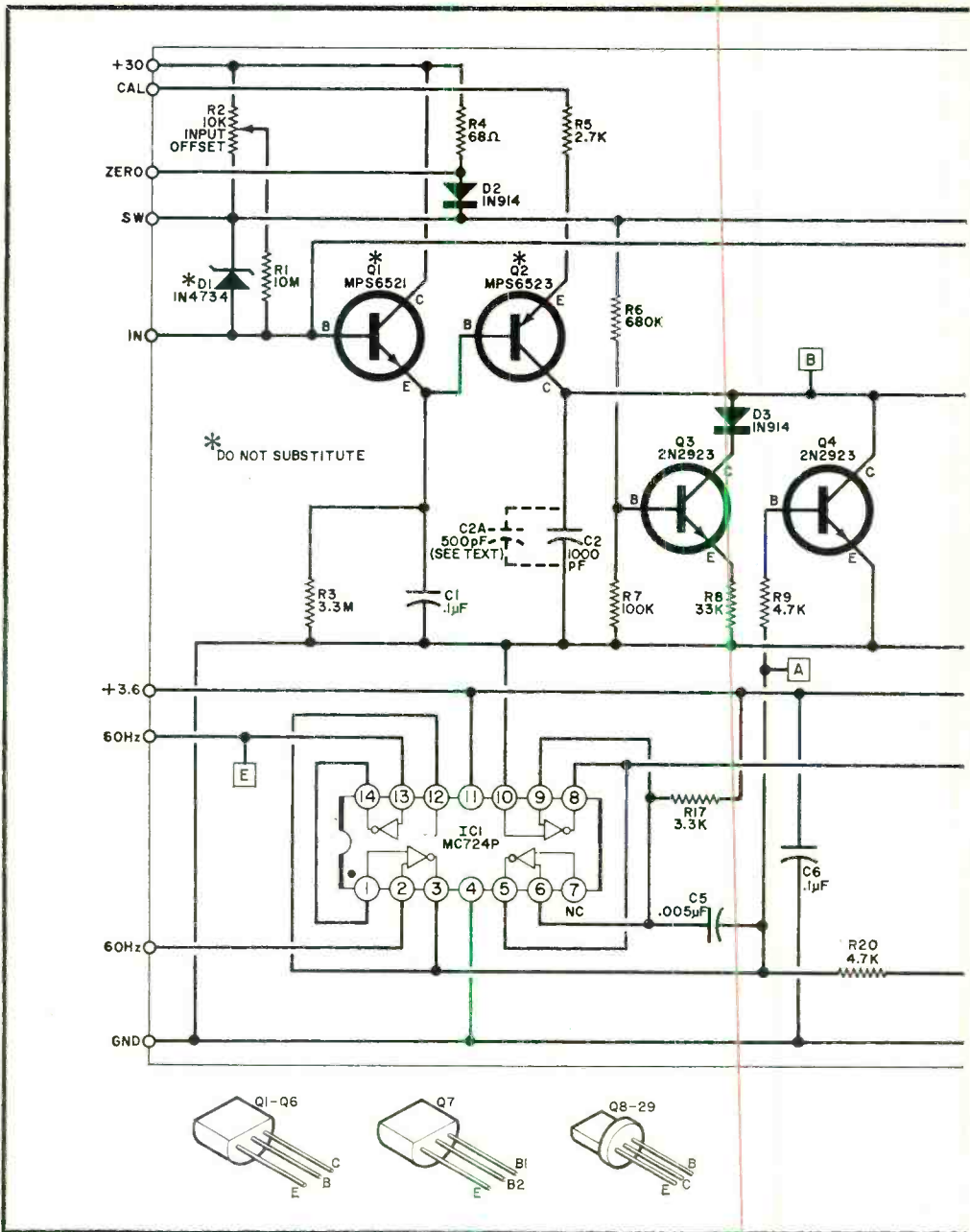

Counter Module Construction. The schematic of the counter module is shown in Fig. 1. A printed circuit board is essential for this module. You can purchase one as mentioned in the Parts List or you can make your own using the etching guide shown in Fig. 2 and the drilling instructions in Fig. 3.

In laying out the components as shown in Fig. 4, make sure that the jumpers (#24

wires) are positioned exactly as shown and that insulated sleeving is used where it is needed.

Note particularly the orientation of the semiconductors, diodes, IC's, etc. There are three different kinds of basing involved on the transistors "point" the same way, except for Q6. The IC's are identified by a dot and notch. Note that IC5

PARTS LIST COUNTER MODULE

- C1*—0.1- μ F, 50-volt Mylar capacitor
C2—1000-pF polystyrene or mica capacitor
C2A—0.800-pF polystyrene or mica capacitor as needed (see text)
C3—100- μ F, 50-volt electrolytic capacitor
C4—1- μ F, 10-volt electrolytic capacitor
C5—0.005- μ F disc ceramic capacitor
C6—0.1- μ F, 10-volt disc ceramic capacitor
D1, D6—1N4734 5.6-volt zener diode (do not substitute *D1*)
D2, D3, D5—Silicon computer diode (1N914 or similar)
D4—27-volt, 1-watt zener (1N4750 or similar)
IC1—Quad two-input gate (Motorola MC724P)
IC2, IC3—Decade counter (Motorola MC780P)
IC4—Dual JK Flip-flop (Motorola MC791P)
IC5, IC6—Low-level 1/10 decoder (Motorola MC770P)
Q1—Transistor (Motorola MPS6521, do not substitute)
Q2—Transistor (Motorola MPS6523, do not substitute)
Q3-Q6—Transistor (Motorola MPS2923 or 2N2923)
Q7—Transistor (Texas Instruments TIS43, do not substitute)
Q8-Q29—Transistor (Sprague 2N3877, do not substitute)
R1—10-megohm
R3—3.3-megohm
R4—68-ohm
R5—2700-ohm
R6—680,000-ohm
R7—100,000-ohm
R8, R23, R24, R27—33,000-ohm
R9, R20—4700-ohm
R10, R21, R22—6800-ohm
R11—330-ohm
R17—3300-ohm
R18, R28, R29—1000-ohm
R19—12-ohm
R25, R26—68,000-ohm
R2—10,000-ohm, PC-mount linear potentiometer
R12—565,000-ohm, 1% precision resistor
R13—60,100-ohm, 1% precision resistor
R14—5900-ohm, 1% precision resistor
R15—590-ohm, 1% precision resistor
R16—250-ohm, PC-mount linear potentiometer
V1, V2—Nixie tube (Burroughs B-5750)
V3—Neon bulb (Signalite A-261)

All resistors
1/4-watt

Misc—Printed circuit terminals (21, optional); #24 solid wire for jumpers; insulated sleeving; snap-in mounting spacers (8); solder; etc.
Note—The following is available from Southwest Technical Products, Box 16297, San Antonio, TX 78216: etched and drilled PC board, \$6.75, postpaid, insurance extra.

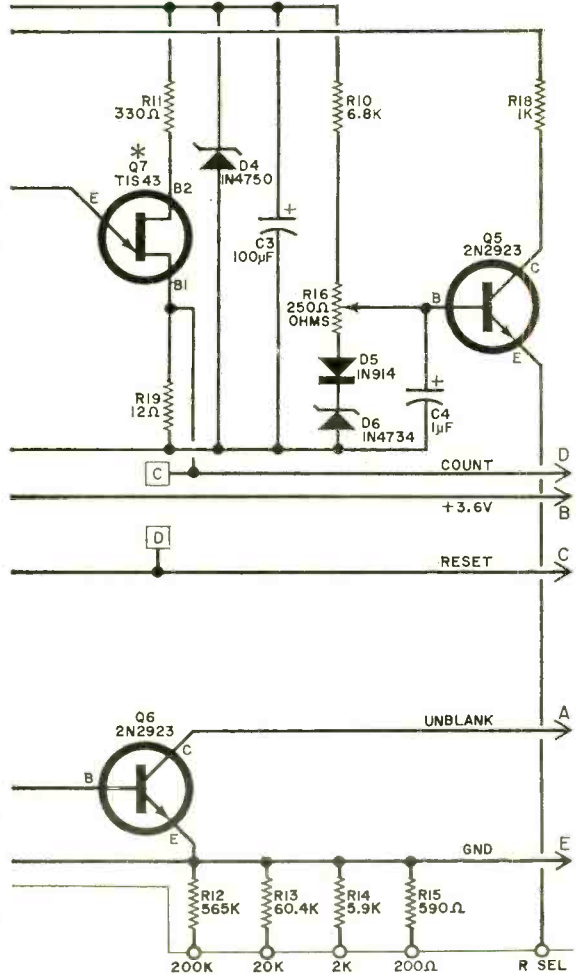

and *IC6* go in "upside down" with respect to *IC1-IC5*. Also, be careful not to mix up the two calibration potentiometers, *R2* and *R16*. The warning, "Do Not Substitute," on some parts in the Parts List should be observed since subtle changes in performance may result from apparently reasonable alternatives. Use a low-wattage soldering iron and fine solder to install all components.

Fig. 1. The schematic has been broken into two parts. This section contains the voltage-to-frequency converter, the reset and unblinking circuit, and the ohms constant-current source. Circuit continued overleaf.

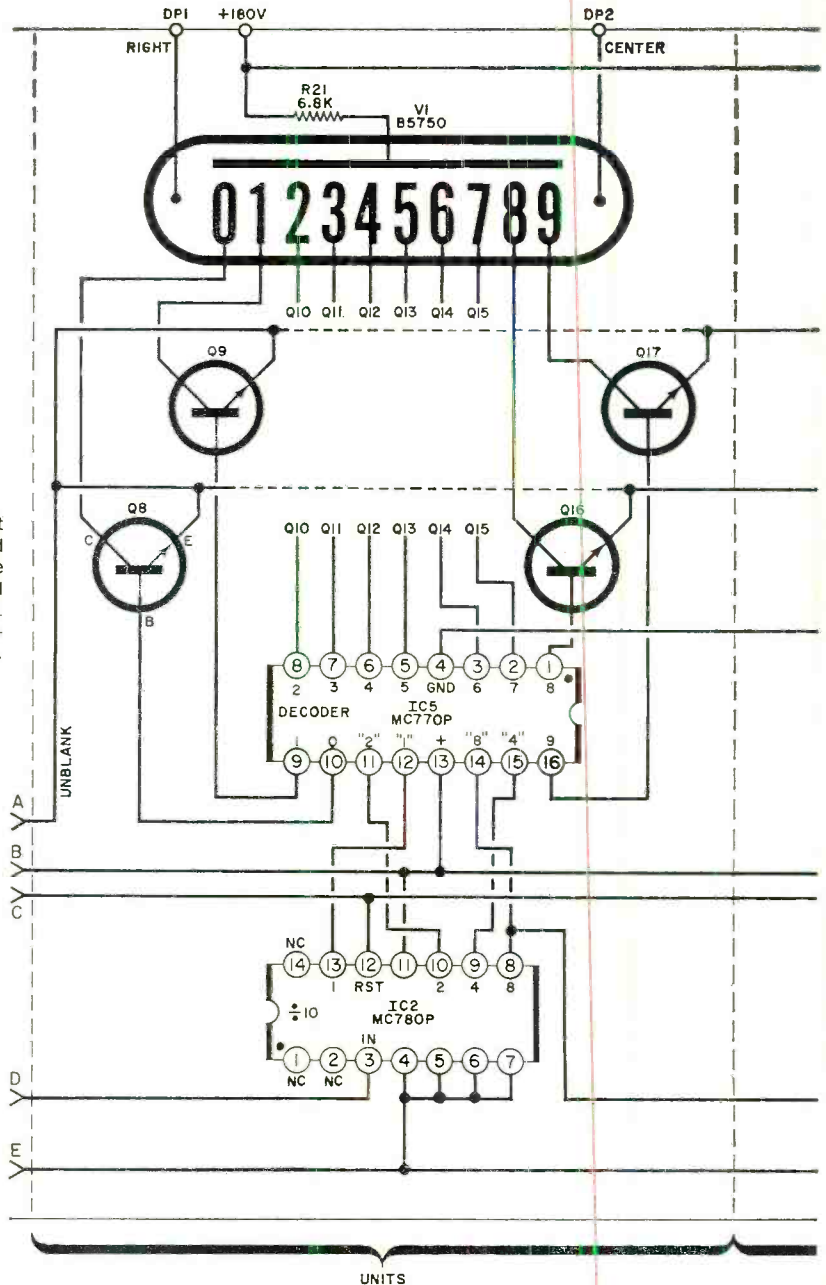

The second half of the circuit contains the units, tens, 1, and overrange indicators. Only the units decade is shown in detail as the tens decade is similar. The overrange indicator is connected to terminal marked "X".

The Nixie indicators may be mounted either using the plastic basing guide as an insertion aid; or the leads may be cut diagonally so that progressively shorter leads can be inserted two at a time until the tube is seated. Be careful to have both Nixie tubes vertical when you finally solder them in place. Also be

sure that the tube leads are pulled all the way through the PC board; a bent or shorting lead inside the plastic insertion guide can be very difficult to fix after the tube is soldered in place.

Power Module Construction. The coun-

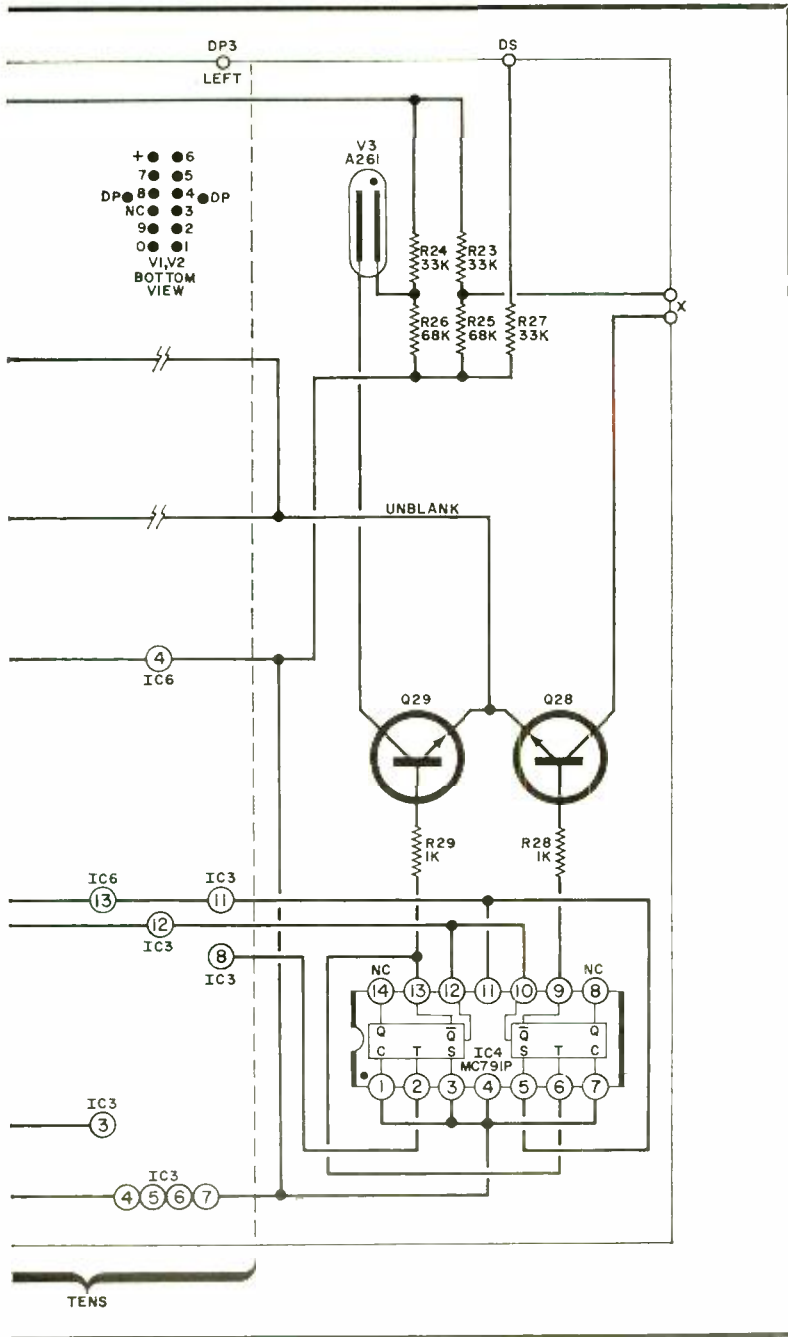

ter module requires 3.6 volts at 400 mA, 180 volts at 5 mA and 30 volts at 35 mA for power. These are provided by the power module which is driven by a power transformer. The power module (see Fig. 5) has a full-wave center-tapped rectifier for the high voltage and a similar one for the low voltage,

with 30 volts derived through a dropping resistor. Watch the diode polarity; and, if different breakdown voltage ratings are used for the low-voltage diodes, be sure not to interchange them.

While a printed circuit board is not essential for the power module, it is convenient.

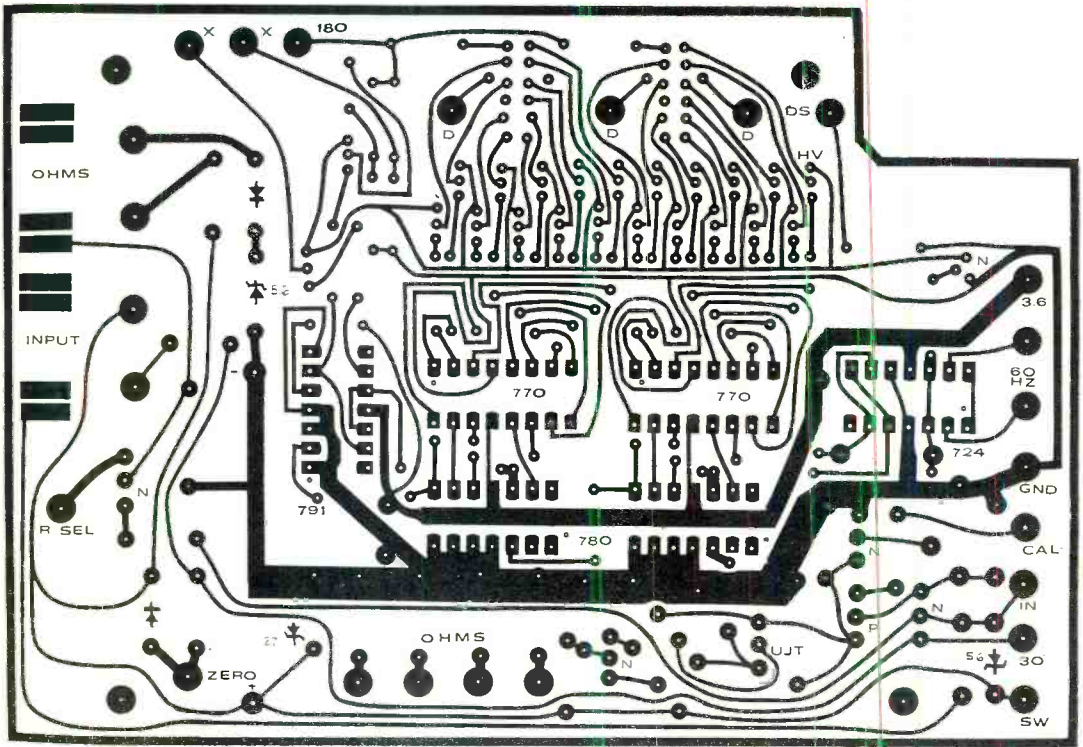

Fig. 2. Actual size foil pattern can be duplicated if you are very careful or use photography. If you don't feel up to it, a commercially made, pre-drilled board is available.

An etching guide and drilling instructions are shown in Figs. 6 and 7 respectively. Components are mounted as shown in Fig. 8. Watch the polarities on the diodes and the electrolytic capacitors. Be certain that *R1* is spaced well away from the electrolytics since

actual contact can shorten the capacitor's life.

Assembly. Four plastic spacers are used to mount the power supply module over the counter module (see Fig. 9). The spacers

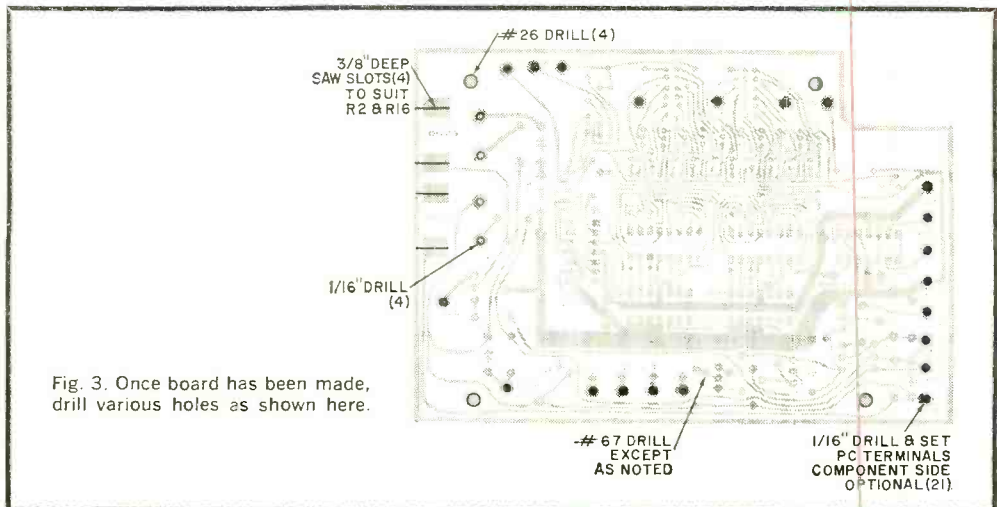

Fig. 3. Once board has been made, drill various holes as shown here.

TECHNICAL SPECIFICATIONS MINI-DVM

Ranges	D.c. volts: 0.2, 20, 200 Ohms: 0.200, 2000, 20,000, 200,000 Range extendable to anything that can be represented by a variable 0.2-volt d.c. signal.
Input Impedance (voltmeter)	0.2 volts: 1 megohm 0.20 volts: 1 megohm 0.200 volts: 10 megohms
Input Current (ohmmeter)	0.200 ohms: 10 mA maximum 0.2000 ohms: 1 mA maximum 0.20,000 ohms: 100 μ A maximum 0.200,000 ohms: 10 μ A maximum

Resolution	One part in 200, any range ± 5 mV, 0.2-volt range
Accuracy	± 0.5 chms, 0.200-ohm range Better than $\pm 1\%$ over most portions of most ranges Internal calibration with 1.35-volt diode standard
Stability	Less than 1 count drift per 20 minutes after 15-minute warmup
Noise Rejection	Dual input filter plus fixed phase measurement with respect to power line hum and noise
Update Time	60 measurements per second. Instrument integrates input for 8.33 milliseconds and displays for 8.33 milliseconds.

should have shoulders on both ends and suitable holes may be drilled in both PC boards.

The over-all wiring of the Mini-DVM is shown in Fig. 10. While the photographs show the prototype mounted in an 8" \times 2 $\frac{3}{4}$ " \times 4 $\frac{1}{4}$ " two-piece metal enclosure, any other

type of housing may be used, as long as a 2 $\frac{1}{2}$ " \times 1" opening for the readout is provided.

Five-way binding posts, spaced $\frac{3}{4}$ " apart should also be provided on the front panel for input terminals *J1* and *J2*. In addition, holes

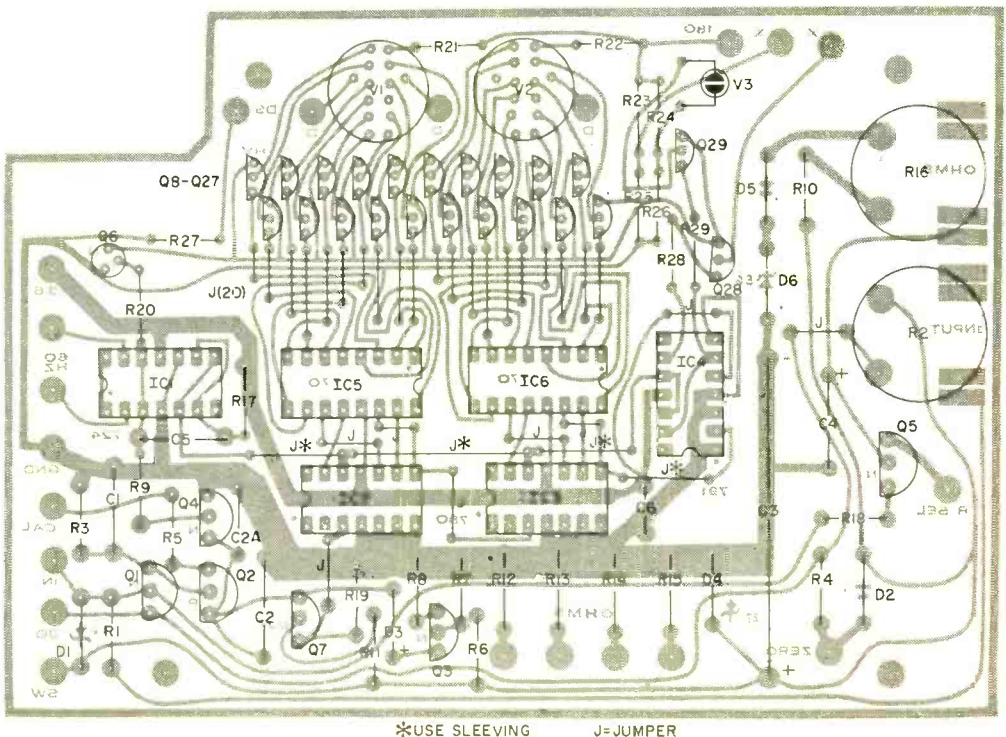

Fig. 4. Take your time when installing the components to make sure you insert the IC's and transistors properly. Certain jumpers are insulated to remove the possibility of shorts when all components are installed.

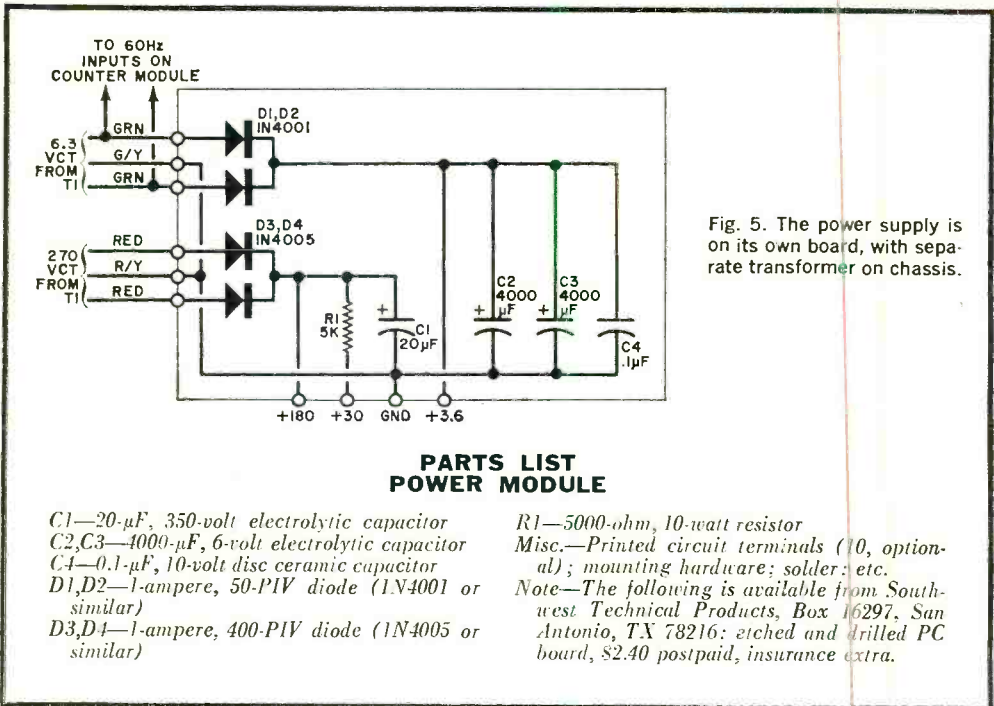

Fig. 5. The power supply is on its own board, with separate transformer on chassis.

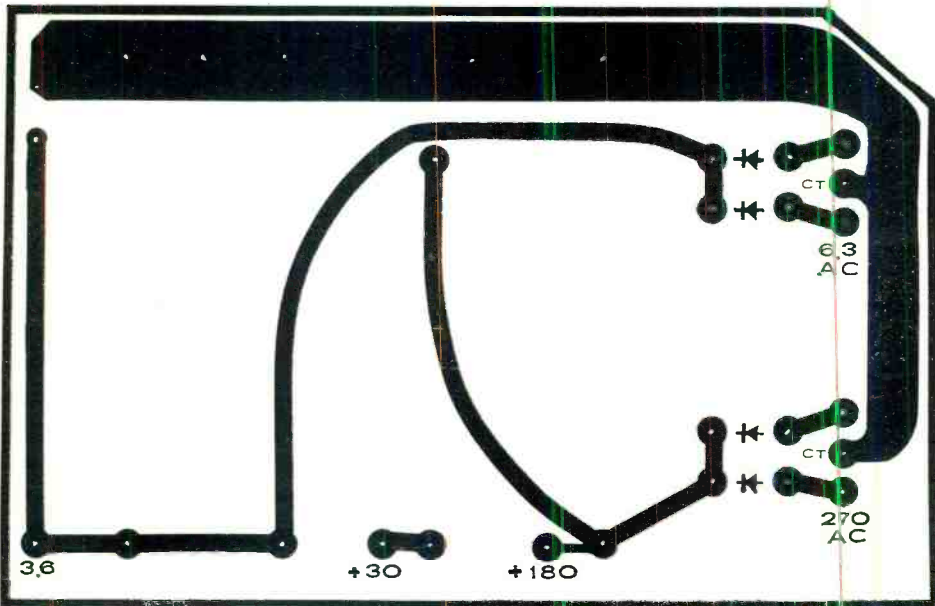

Fig. 6. Actual size foil pattern for the power supply.

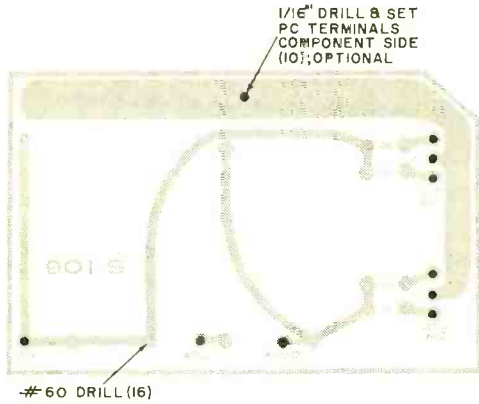

Fig. 7. Drill the power supply board as shown here. Use of PC terminals makes connections easier.

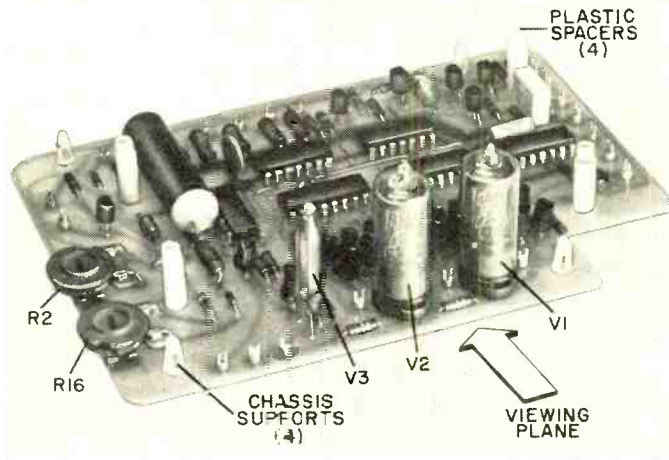

Fig. 9. Two sets of spacers are used. One set mounts the board to the chassis while the other supports power supply PC board.

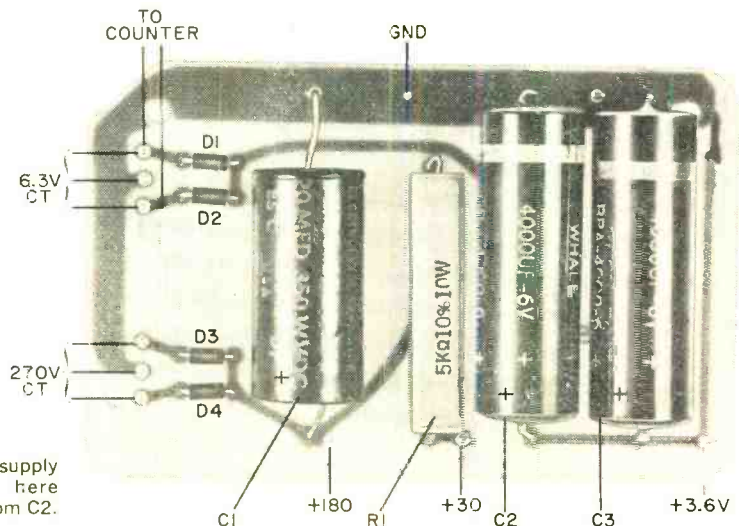

Fig. 8. Install the power supply components as shown here making sure R1 is away from C2.

must be made for 12-position rotary switch *S1*, polarity reversal switch *S2*, calibration and zero potentiometers *R2* and *R1*, and the plastic lens for overrange neon lamp *11*.

The switch specified for *S1* has five decks: the first (*S1A*) determines the position of the decimal point; *S1B* controls the ohmmeter current source; *S1C* and *S1D* provide input sealing and selection. With *S1* in the ZERO position, the SW terminal on the counter module is connected directly to the IN terminal. In the CAL position, the SW reference is connected through a 1.35-volt reference diode (*D1*) and the ohmmeter current source is switched to provide the 10 mA required by the reference diode. In the various voltage ranges, fixed resistors are used to provide the required attenuation of the input signal before it is applied to the counter module.

HOW IT WORKS

The Mini-DVM consists of two elements: a counter module and a power supply module. The operation of the power supply is straightforward and will not be discussed here. On the counter module there are two principal circuits: the counter and the 2½-decade display. In the following discussion, reference should be made to Fig. 1 as well as the diagrams shown here.

The counter circuit is made up of a timing gate generator (*IC1*), a display unblanker (*Q6*), a voltage-to-current converter (*Q1*, *Q2*, *Q3*), a gated oscillator (*Q4*, *Q7*), an ohmmeter current source (*Q5*), and a 1.35-volt calibration reference source.

The timing gate generator takes a split-phase 60-Hz reference from the power line via *T1* (waveform E) and uses it to drive a set-reset flip-flop in *IC1*. This produces a sharp-rise square wave that is initially grounded for 8.33 milliseconds and then is positive for 8.33 milliseconds (waveform A).

At the beginning of each measure cycle, the square wave suddenly drops to zero, producing a reset output pulse that "erases" any number that was in the counter and readout, thus resetting the counter to 000. At the same time, drive is removed from the unblanking transistor (*Q6*), which turns the display off. Simultaneously, drive is removed from the gating transistor (*Q4*), allowing the oscillator to operate.

Thus, for the first half cycle, the gated oscillator is allowed to run and the initially reset counter accumulates the desired 0-199 counts in proportion to the input voltage. On the second half of the cycle, the V/F converter is stopped and the display is unblanked, or turned on. The counter "keeps" the total count presented to it on the first half cycle and the display in turn presents it as a visual output.

The time that the gated oscillator is allowed to run is a constant 8.33 milliseconds. The frequency is determined by the input current to the gated oscillator, which in turn is proportional to the input signal voltage. By suitable scaling, the total number of counts per measurement interval is made to relate to the input voltage. As a result, for example, an input of 1.35 volts produces 135 counts.

The input voltage is applied to impedance matcher *Q1* and voltage-to-current converter *Q2*. The input signal is protected by *D1* and an input offset compensation is provided by *R1* and *R2*. Transistor *Q3* is a current sink that constantly removes 100 microamperes of *Q2*'s collector current to make the conversion process very linear. The zero input current is determined by the front-panel ZERO potentiometer, while the scaling or gain is controlled by the CAL potentiometer and *R5*.

The gated oscillator performs the current-to-frequency conversion. The output of uni-junction transistor *Q7* consists of pulses appearing across *R19* (waveform C). Transistor *Q4* provides the gating that determines whether *Q7* is allowed to oscillate. Waveform B can be measured only with a 10-megohm scope probe.

The display circuit is an improved version of the circuit used in the "Numeric Glow Tube DCU" described in POPULAR ELECTRONICS, February 1970.

The first two decades are identical to each other. They start with a decimal counter (*IC2* or *IC3*) driving a 1-of-10 low-level decoder (*IC5* or *IC6*). The decoder drives ten high-voltage transistors (*Q8-Q17* or *Q18-Q27*) which, in turn, drive the Nixie tube.

The overflow counter uses a single dual flip-flop to serve both as a 100-up counter and a 200-up overflow latch. Each half drives a neon lamp—the first one aligned with the Nixies to produce a "1" and the second mounted on the front panel behind a red "overrange" lens.

The ohmmeter current source is *Q5*, whose base voltage is fixed by *D6* (adjusted slightly by *R16*) and temperature-compensated by *D5*.

Emitter resistors are selected to get the four values of ohmmeter current needed (0.01, 0.1, 1, and 10 mA), as well as the 10 mA for the 1.35-volt calibrate diode. The emitter is left unconnected to disable the current source for the input voltage ranges. A resistance measurement is made by delivering the selected amount of current to the resistor under test and then using the Mini-DVM to measure the resultant voltage drop. This method provides a great convenience over the normally cramped and highly nonlinear ohmmeter scales common to most analog multimeters.

With *S1* in any of the ohms positions, the input is connected directly to the counter module and the ohmmeter current source is switched to provide the proper current.

The fifth deck of *S1* is a snap-action power switch (*S1E*) which turns the power input to the meter on and off.

Power transformer *T1* mounts on the bottom of the chassis, behind the selector switch, while the fuseholder fits on the rear wall of the chassis. After all mechanical parts are mounted, wire the Mini-DVM together as

shown in Fig. 10. The two modules are attached to the bottom of the chassis using four plastic supports.

Put four non-skid rubber feet on the bottom of the chassis, making sure that the back ones are directly along the rear wall. This permits standing the case on the swivel handle. The handle is fabricated as shown in the photographs and should be attached to the chassis so that it can swing and be used either as a carrying handle or a support.

A polarized orange filter should be glued

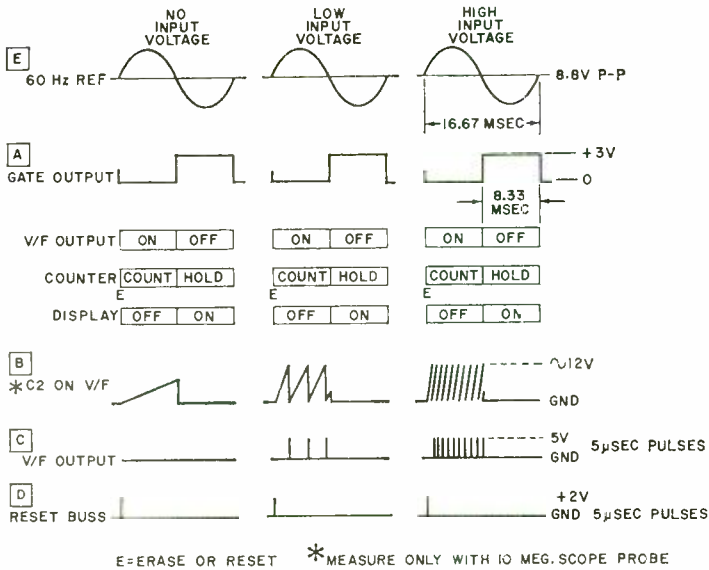
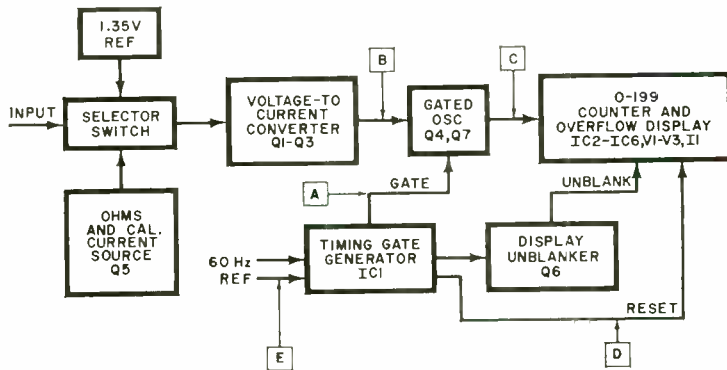

with epoxy to the back of the display opening. The filter orientation is critical and the filter should be installed to provide the darkest possible interior when the interior is illuminated and viewed from the outside.

Checkout and Calibration. With the selector switch off, plug the Mini-DVM into a 117-volt, 60-Hz power source. Now place the selector switch on ZERO and note that the two Nixie tubes glow with some number. If the instrument has been properly wired, varying

the ZERO control should cause the display to vary from 0.00 to about 0.40 with the 0.01 indication at about the middle of the range control. The proper setting for the ZERO control is just before the numeral one is lit on the right-hand side.

Put the selector switch on CAL and note that the Nixies and the neon 1 indicator are all lit. With the selector switch in this position, adjusting the CAL control can vary the reading by about 60 counts, depending on the particular unit. If the operation seems nor-

mal, add up to 800 pF of capacitance as needed across $C2$ (on the counter PC board) until 1.35 can be obtained at about the midpoint of the rotation of the CAL potentiometer. (Be sure that the zero adjustment has been properly set previously.)

The input offset potentiometer ($R2$) on the counter module is set next. Put the selector switch on ZERO and adjust the front-panel ZERO control to obtain an indication of 0.01 on the display. Place the selector switch on 2V and short the input jacks together. The display should not change from the 0.01 indication. Remove the short, and, if necessary, adjust the input offset potentiometer ($R2$) to regain the 0.01 indication. Place the selector switch on ZERO and reset the ZERO control to get a 0.00 display.

Obtain a 1% precision resistor with a value

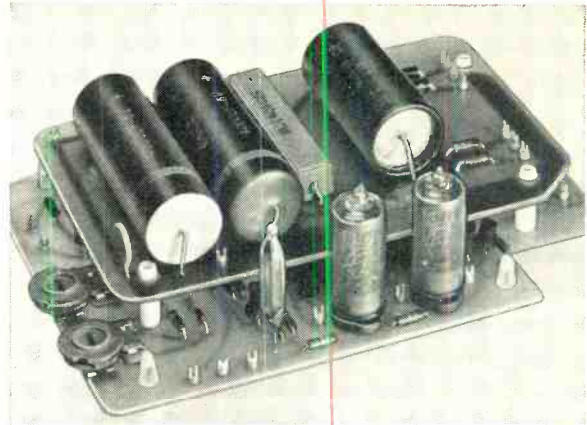

Power supply is joined to counter board via plastic spacers. Make sure both Nixies and the "1" neon lamp are vertical. Photograph is into viewing plane.

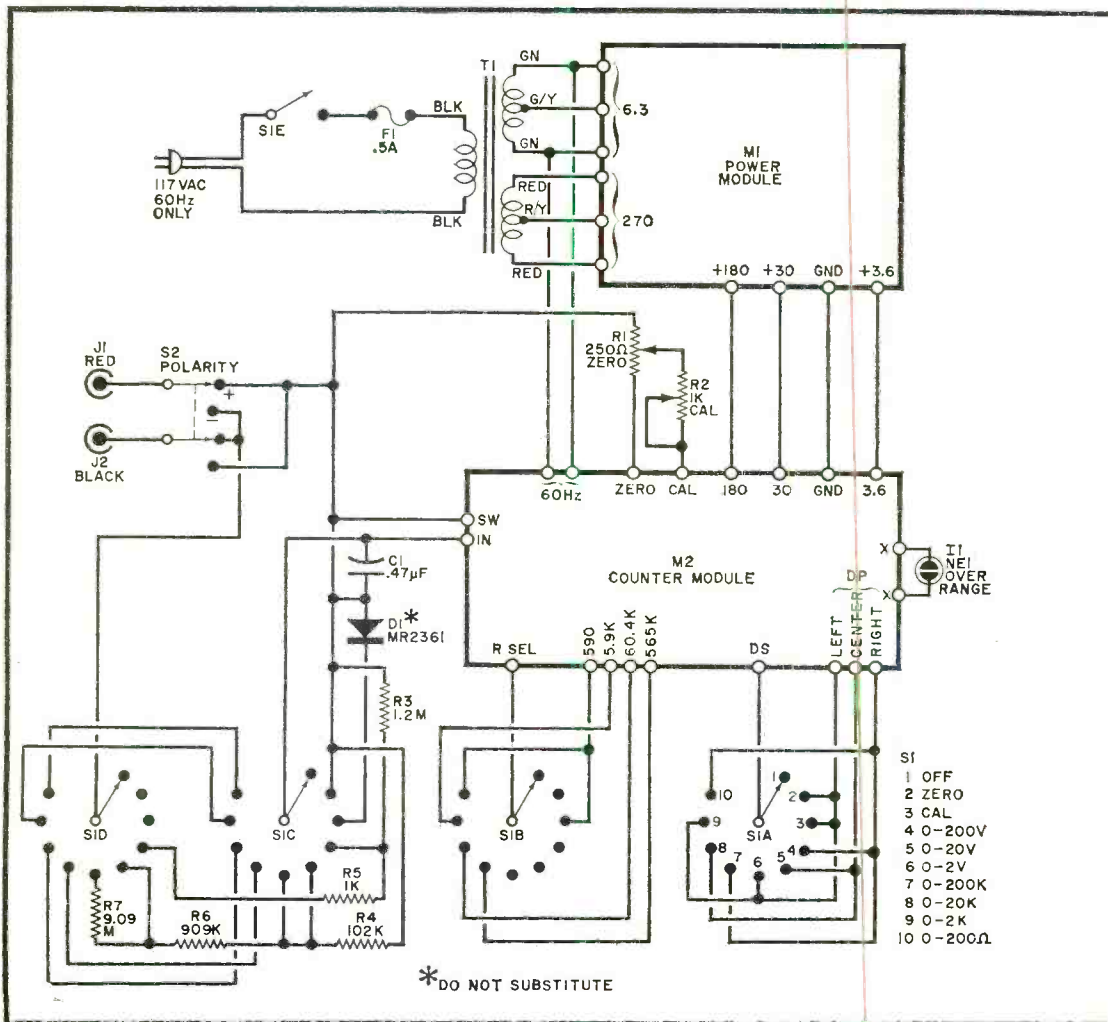

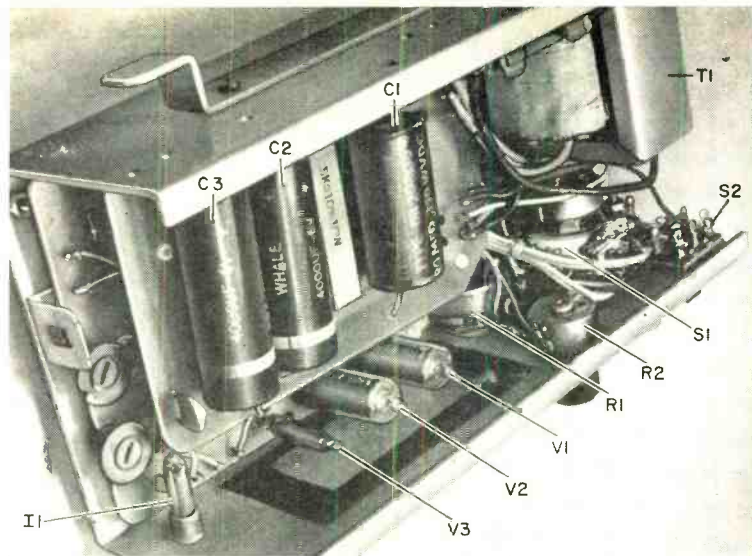

PARTS LIST COMPLETE MINI-DVM

C1—0.47- μ F, 50-volt Mylar capacitor (do not substitute an electrolytic)

D1—1.35-V, 10-mA reference diode (Motorola MR2361)

F1—0.5-ampere fuse and fuseholder

I1—Neon lamp and overrange lens (A261 or NE-2)

J1, J2—Banana jack or 5-way binding post (one red, one black)

M1—Power module

M2—Counter module

R1—250-ohm linear potentiometer

R2—1000-ohm linear potentiometer

R3—1.2-megohm, $\frac{1}{2}$ -watt resistor

R4—102,000-ohm, 1% precision resistor

R5—1000-ohm, $\frac{1}{2}$ -watt resistor

R6—909,000-ohm, 1% precision resistor

R7—9.09-megohm, 1% precision resistor

S1—Four-pole, ten-position, non-shorting rotary switch with s.p.s.t. snap switch attached to make on positions 2-10.

S2—D.p.d.t. slide switch

T1—Transformer; primary, 117 V; secondary #1, 6.3 VCT at 500 mA; secondary #2, 270 VCT at 40 mA

Misc.—Case with three-way handle; line cord with strain relief; $\frac{5}{8}$ " knobs (2); 1" knob; circularly polarized orange viewing filter; rubber feet (4); mounting and stand-off hardware; solder; sleeving; wire; etc.

Note—The following is available from Southwest Technical Products, Box 16297, San Antonio, TX 78216: complete kit of all above parts, #MDVM-K, \$69.95; postpaid, insurance extra. Any and all individual parts also available.

Fig. 10. The overall DVM showing module interconnections. This system is to be used on 60-Hz power only as the counting circuit will have to be changed for other power-line frequencies.

The two photos above and below show how the DVM is assembled within its low-profile case. The viewing window should be large enough to show the readouts clearly and covered with optical filter as explained in text. The small bracket visible at the rear of the chassis is used to wind up the power line. The overrange indicator is isolated from the display so as to be very eye catching when it comes on.

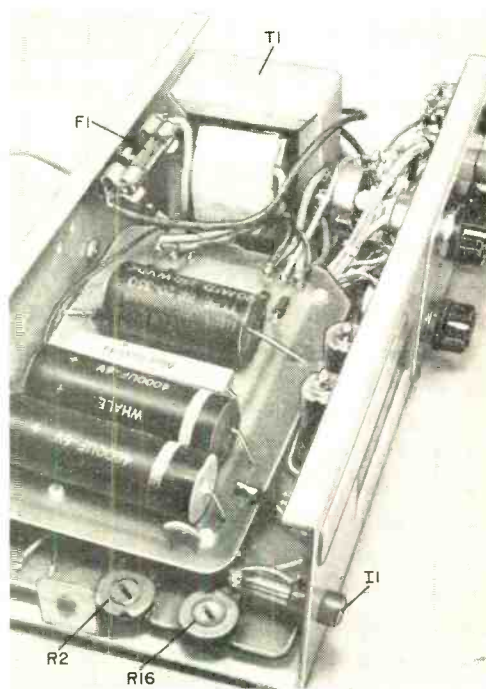

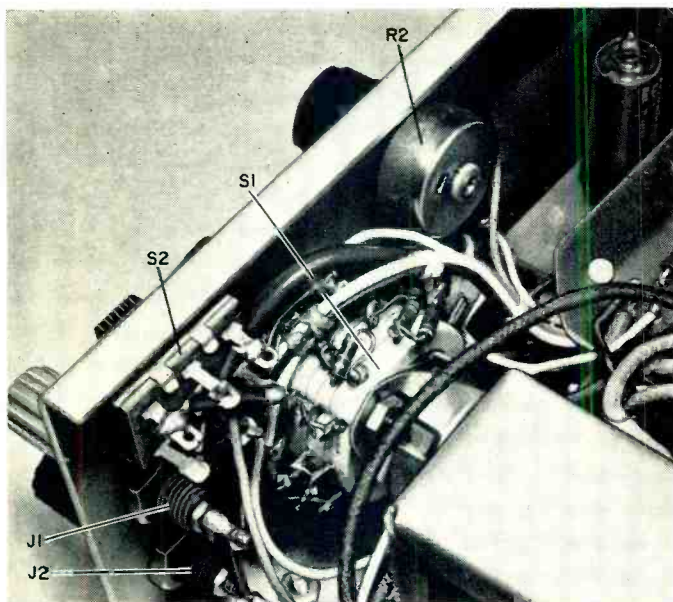

The various front-end resistors are wired point-to-point directly on the switch. This can be done before the switch is mounted, but be sure to double check the assembly before installation. Keep all wiring short and make sure no part shorts against the metal chassis.

between 1200 and 1400 ohms. Using test leads, connect this resistor to the input jacks. After zeroing and calibrating, place the selector switch in the 2K position. Adjust the Ohms potentiometer (*R6*) on the counter module until the display indicates the exact resistance value (in kilohms). Potentiometers *R2* and *R6* will rarely, if ever, need re-adjustment.

In using the Mini-DVM, allow a minute or

two for warmup before making any measurements. Then check both the ZERO and CAL positions of the selector switch and make any necessary front-panel adjustments. There is a slight interaction between these two controls so double check their operation. Calibration of the Mini-DVM can always be checked by switching back to the ZERO and CAL positions of the selector switch.

-30-

The handle is optional if the DVM is mounted on a shelf. Otherwise, the handle also serves as a tilting support to make the viewing easy.

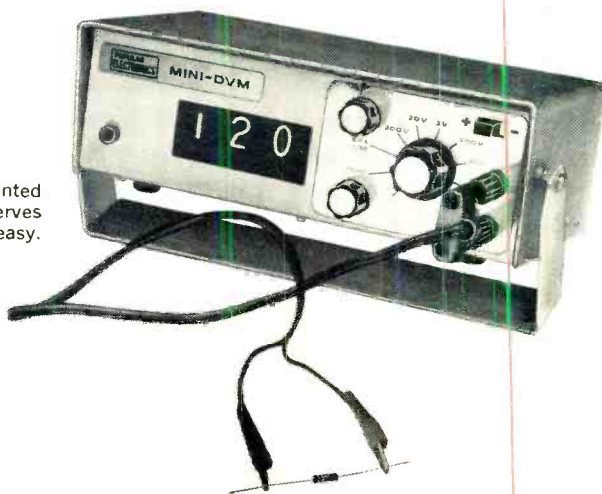



BUILD A GATED 100-kHz CALIBRATOR

*Deluxe reference
signal generator
is keyed for
easy identification*

This 100-kHz calibrator has a rich harmonic output. For easy identification, the calibrator signal is pulsed on and off 0.5 sec., alternately. Maximum stability is insured by sturdy construction. Two IC's are used in the oscillator/modulator. A single transistor output amplifier permits critical adjustment of the harmonic intensity through the use of an attenuator potentiometer in the emitter circuit. Zero-beating to WWV is controlled by a coarse and fine tuning adjustment. Construction cost (less metal working) is under \$25.

NUMEROUS FREQUENCY standard or calibrator circuits have appeared in print—some relatively simple, others quite elaborate. The majority of such circuits generate the required harmonics satisfactorily, but few have been really practical in use.

In addition to generating vigorous harmonics out to 30 MHz, a really good calibrator should have several important features. First, it should have an attenuator capable of varying the output signal from maximum down to a very low level, and it should work

as satisfactorily at 30 MHz as it does at 100 kHz. Second, it should have available a means of modulation that can be easily identified (a sine wave is not always easy to recognize on the crowded bands). Third, it should be provided with coarse *and* fine frequency adjustments so that very close calibration against WWV can be obtained easily. Finally, it should be so efficiently and properly shielded that the output signal is inaudible when the attenuator is on maximum and no connection is made to the "high" output, even if the calibrator is on top of the receiver. In a very practical sense, this means that leakage must be down at least 60 dB.

The "Reference Signal Generator" described in this article meets all of the above requirements. However, this is not a project for the neophyte; while the instrument is not especially complex, skill in forming and drilling sheet metal parts accurately and a knowledge of r.f. circuit layout and wiring are essential to assembly.

About The Circuit. A schematic and a

BY FRANK H. TOOKER

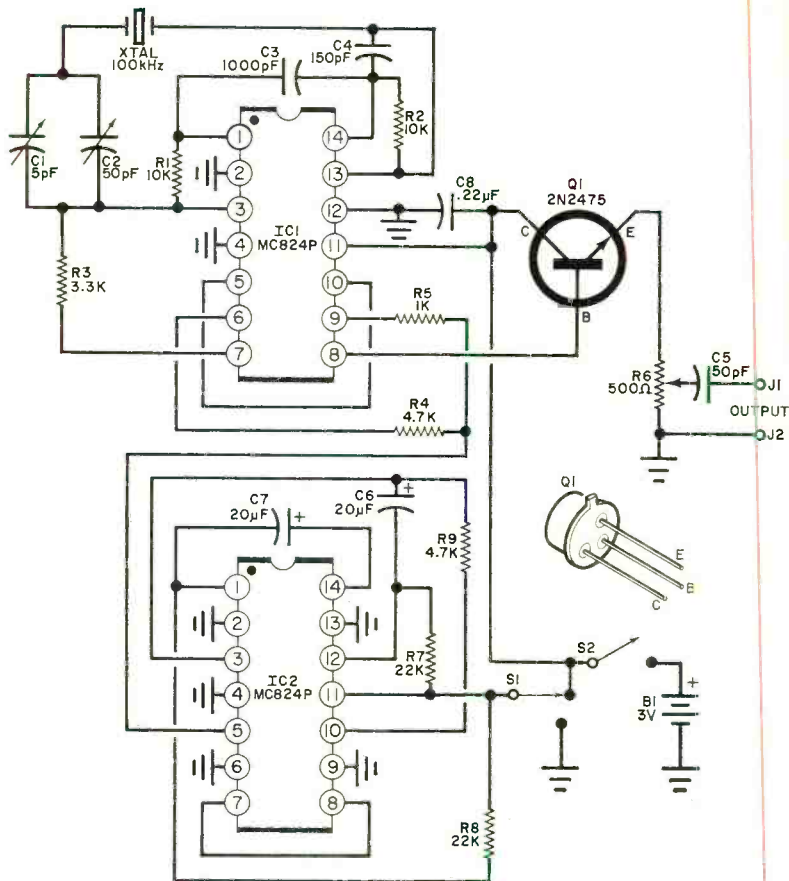

Fig. 1. Crystal and IC logic circuitry assure precise frequency control. The Q1 amplifier stage boosts output signal to usable level.

PARTS LIST

- B1—Two 1.5-volt D cells connected in series
 C1—5-pF variable capacitor with ceramic insulation (Hammarlund Type APC with 1/4" shaft or similar)
 C2—50-pF variable capacitor with ceramic insulation (Hammarlund Type APC with screwdriver adjustment or similar)
 C3—1000-pF polystyrene capacitor
 C4—150-pF silver-mica capacitor
 C5—50-pF silver-mica capacitor
 C6, C7—20- μ F, 6-volt miniature electrolytic capacitor
 C8—0.22- μ F, 100-volt Mylar capacitor
 IC1, IC2—Quad, two-input gate integrated circuit (Motorola MC824P or HEP570)
 J1, J2—Banana jack, one red and one black (or use color-coded five-way binding post)
 Q1—2N2475 or HEP56 transistor
 R6—500-ohm linear-taper potentiometer (Ohmite Type AB, No. CU5011—DO NOT

SUBSTITUTE)

- R1, R2—10,000-ohm
 R3—3300-ohm
 R4, R9—4700-ohm
 R5—1000-ohm
 R7, R8—22,000-ohm
 S1—S.p.d.t. slide or toggle switch
 S2—S.p.s.t. slide or toggle switch
 XTAL—100,000-kHz frequency standard crystal (James Knight No. H17T)
 1—5" x 4" x 3" aluminum utility box
 Misc.—5" x 3" x 1/8" hardboard; 2-cell battery holder; aluminum alloy sheet (22 gauge) for subchassis and brackets; small flexible coupling with ceramic insulation; printed circuit board or perforated phenolic board and push-in terminals; two control knobs; four rubber feet; panel bearing; four metal posts; rubber grommet; epoxy cement; paint; #6 hardware; hookup wire; solder; etc.

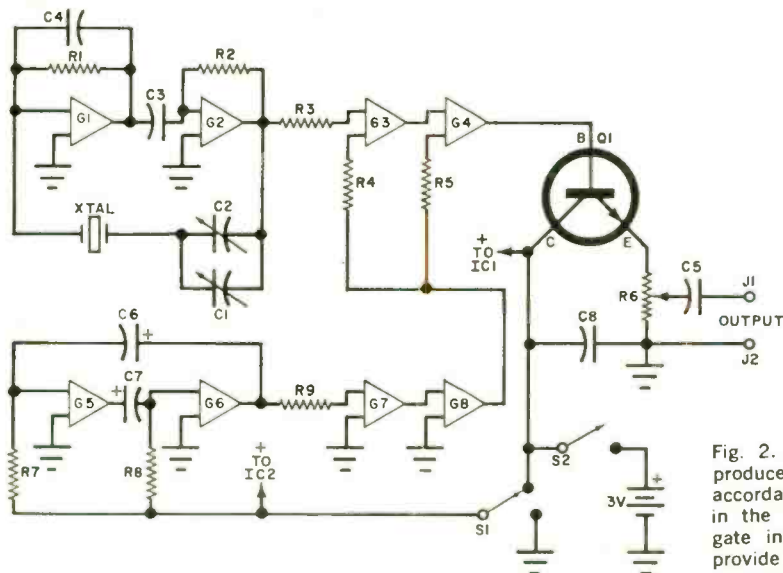

Fig. 2. Each gate is used to produce the output signal in accordance with the flow shown in the logic diagram. Unused gate inputs are grounded to provide good circuit stability.

block diagram of the circuit are given in Figs. 1 and 2, respectively. In Fig. 1, IC1 and IC2 are quad two-input gates, while in Fig. 2, each gate is represented as a triangle. The outputs are taken from the apices of the triangles, while the connections to the bases are the two inputs. Nonfunctional inputs in the circuit are grounded.

In Fig. 2, gates G1-G4 make up IC1 and gates G5-G8 make up IC2. Gates G1 and G2 are part of the crystal oscillator. Feedback

occurs through the crystal, which is in series with calibration capacitors C1 and C2. Resistors R1 and R2 supply gate input bias, capacitor C1 is a parasitic suppressor, and capacitor C3 couples the two gates.

Gates G3 and G4 operate as a buffer and a driver stage, respectively, for the crystal oscillator. Resistor R3 keeps oscillator loading at a low level. The output of the buffer is coupled directly to the input of the driver.

Modulation is applied to the second input of both the driver and buffer stages. The modulating signal is a square wave which keys the calibrator's output on and off at a rate of one pulse/second. Since the waveform of the modulation is symmetrical, output from the calibrator is on for 0.5 second and off for 0.5 second. This rate is sufficiently rapid not to be passed easily during careful tuning, yet it is not so fast that it might be mistaken for a CW signal. (The only signal resembling it is the modulation on the carrier of Canadian station CHU.)

Keying is clean and sharp. The output of the calibrator is at a very low level during the "key up" intervals, even though the crystal oscillator operates continuously while the instrument is powered. Keying clicks are audible when the attenuator is set for maximum output; and no attempt is made to suppress them since they help to identify the calibrator's signal in the presence of QRM, at which time the output from the calibrator is set at or near maximum.

The one-pulse/second signal is generated in IC2. Gates G5 and G6 are connected as a

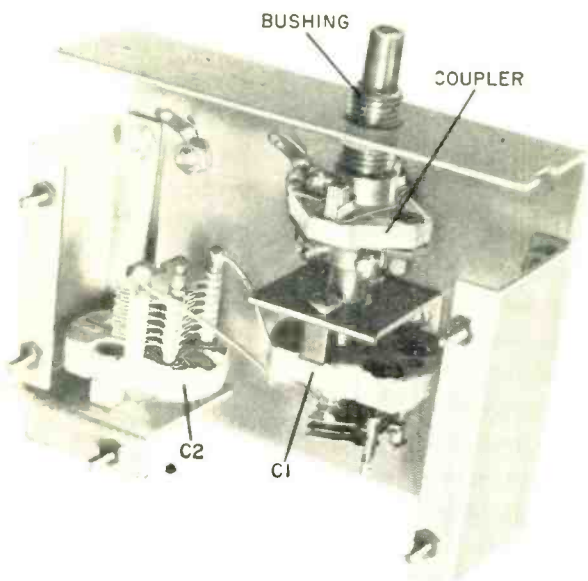
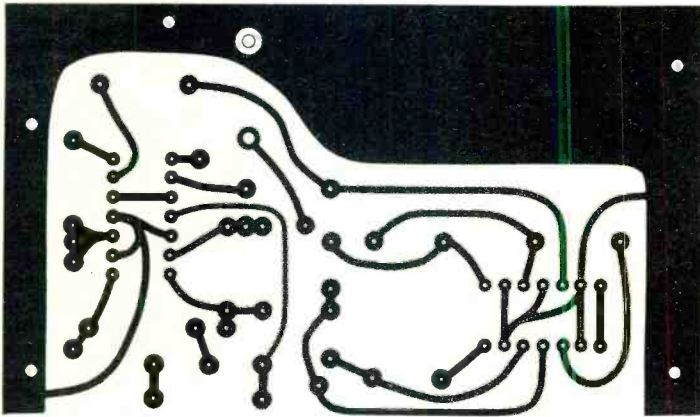
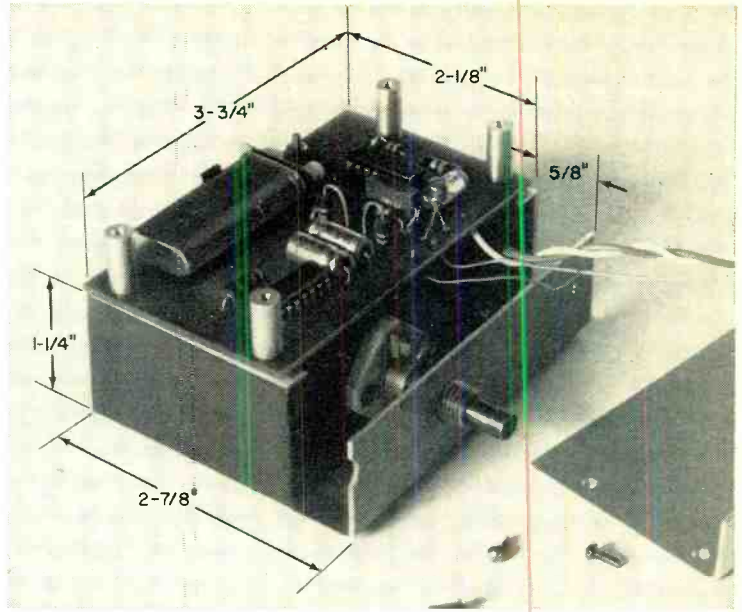
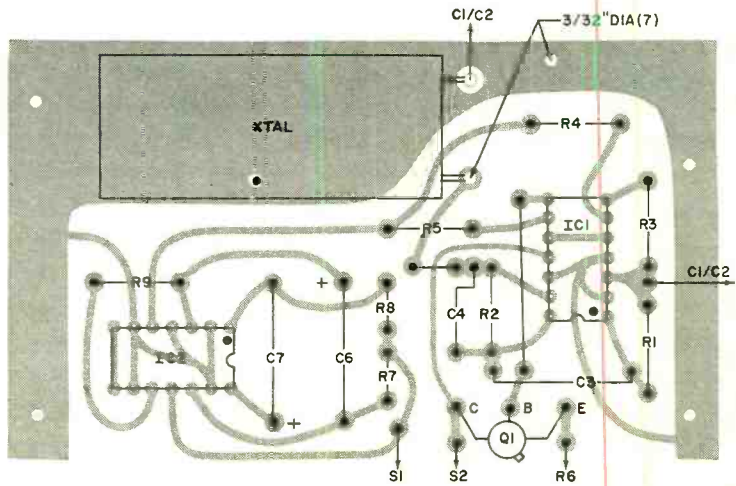

Fig. 3. Capacitors C1 and C2 mount on three-piece subchassis; note facilities for board mounting.

Fig. 4. Four tapped metal spacers affix circuit board on top of subchassis. Shield at far right is 3 3/4" long by 2 1/8" wide and has a 3/8"-wide skirt.



Actual size printed circuit board etching guide is shown above, while at right is component placement/orientation guide.



symmetrical cross-coupled astable multivibrator, using electrolytic capacitors *C6* and *C7*. Resistors *R7* and *R8* supply gate input bias. The output from *G6* is fed to *G7* through *R9*. The output of *G7* is directly coupled to output stage *G8*, the signal from which is fed to the buffer and driver in *IC1* through *R1* and *R5*. Resistor *R9* decouples the multivibrator, thereby helping to maintain the symmetry of the modulating signal.

High-speed computer transistor *Q1* operates as an output amplifier, connected in an emitter-follower configuration with the output of *IC1* direct-coupled to the base. Output attenuator potentiometer *R6* is located in the emitter circuit, while the wiper lead couples the signal through *C5* to "high" output jack *J1*.

"Gate" switch *S1* turns on and off modulator *IC2*, while *S2* is the power switch. The instrument is powered by 3-volt supply *B1* but satisfactory operation can be obtained down to a terminal potential of about one volt. The maximum overall swing of the calibrator's output signal is approximately equal to the supply potential. Hence, the output signal level decreases as the supply potential level deteriorates.

Construction. The calibrator is best built in a 5" × 4" × 3" aluminum utility box, to one side of which has been epoxy cemented a 5" × 3" × 1/8" piece of hardboard to improve appearances. Before cementing the hardboard in place, degrease the flange of the box with lighter fluid, and when the surface is thoroughly dry, cement the hardboard in place—do *not* use a clamp as, unlike other cements, epoxy holds best when it is fairly thick. Allow the epoxy to set for at least 24 hours. Then sand all surfaces.

Machine the holes through the front panel of the utility box, and spray paint the box in the color desired. Most of the components mount on a small L-shaped bracket which is shown as the basic part of the assembly in Fig. 3. Capacitor *C1*, which is the front-panel frequency control, mounts on another L bracket and is coupled to the knob shaft with a small flexible coupling. The capacitor shaft, the insulated coupling, and the panel bushing must be aligned accurately.

Coarse frequency control capacitor *C2* mounts on a bracket which also supports one end of the circuit board. The other end of the board fastens to a U bracket of equal height at the opposite end of the chassis. Capacitors *C1* and *C2* must be insulated from the chassis

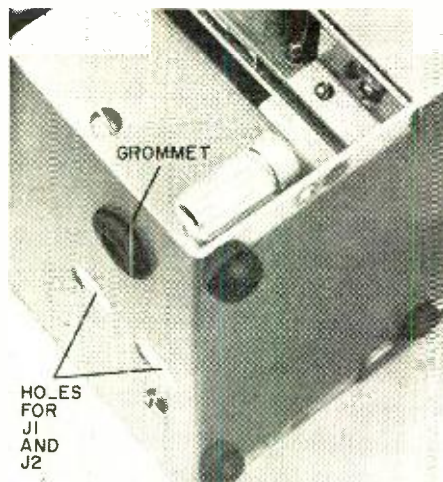

Exit holes for *J1* and *J2* and access to *C2* tuning screw must be drilled through rear of utility box. Access hole for *C2* must be rubber-grommet-lined.

since neither the rotor nor the stator can be grounded. (A "postage-stamp" type capacitor is not recommended for *C2*. The APC type shown in Fig. 3 and specified in the Parts List is much more stable.) When high-quality components are used for *C1* and *C2*, the latter ordinarily requires only occasional resetting.

All of the small components, except *C5* and *C8* mount on a 35/16" × 21/8" glass-epoxy printed circuit board or on perforated board with push-in solder clips. Layout is not especially critical.

Solder *C5* directly to *J1* and *C8* across *S1*. Then solder leads of appropriate lengths (for connections to *C1*, *C2*, *S1*, *S2*, and *R6*) to the circuit board before mounting the board on the subchassis with four tapped metal posts as shown in Fig. 4. Then mount the subchassis, securing it to the front panel with the panel bearing at the top and a single 2-56 steel machine screw at the lower end.

Solder the leads from the circuit board to *C1*, *C2*, *S1*, *S2*, and *R6*. Note that the leads between *R6* and the circuit board should be a *twisted* pair and should be positioned singly against the front panel. Note also that the crystal holder should be a printed-circuit type which grips and grounds the crystal's metal case.

An L-shaped aluminum shield, mounted on the threaded posts secures the circuit board to the brackets on the subchassis. The largest dimensions of the shield should be equal to the longest dimensions of the circuit board, and the flange part, which goes toward the front of the chassis, extends in the direction of the circuit board for a distance equal to the

length of the posts. An L bracket, to support the output jacks, can then be secured to the shield before it is mounted in the utility box.

Run a twisted pair from *R6* to *J1*, via *C5*, and *J2*. Press these leads up against the circuit board shield as shown in Fig. 5.

Mount battery holders for the C cells on a bracket secured to the rear wall of the box. Two holes (see p 57), to provide exits for *J1* and *J2*, and a third hole, rubber-grommet-lined, to allow access for adjusting *C2* must now be drilled. Finally, assemble the box.

Adjustment and Use. If the calibrator is located at a distance from the receiver, connect a wire from the instrument's ground post and the ground terminal on the receiver. However, if the calibrator is to stand on top of the metal cabinet of the receiver, a ground connection between the two units will not usually be needed.

Connect a composition resistor with a value equal to the nominal input impedance of the receiver between the calibrator's "high" output jack (*J1*) and the receiver's antenna terminal. If you do not know the receiver's input impedance, chances are that it is about 400 ohms. In any event, it is not critical; so a 470-ohm composition resistor will probably be satisfactory.

Switch on the receiver and tune it to any of the WWV broadcast frequencies. Set the instrument's calibration and level controls to their midpositions, and switch on the calibrator. Gate switch *S1* should be in the off position. When the WWV carrier is unmodulated (except for ticks), adjust *C2* with an insulated screwdriver (through the access hole in the rear of the cabinet) until the beat with WWV is within a few cycles. Then bring the calibrator to zero beat by adjusting the front panel control.

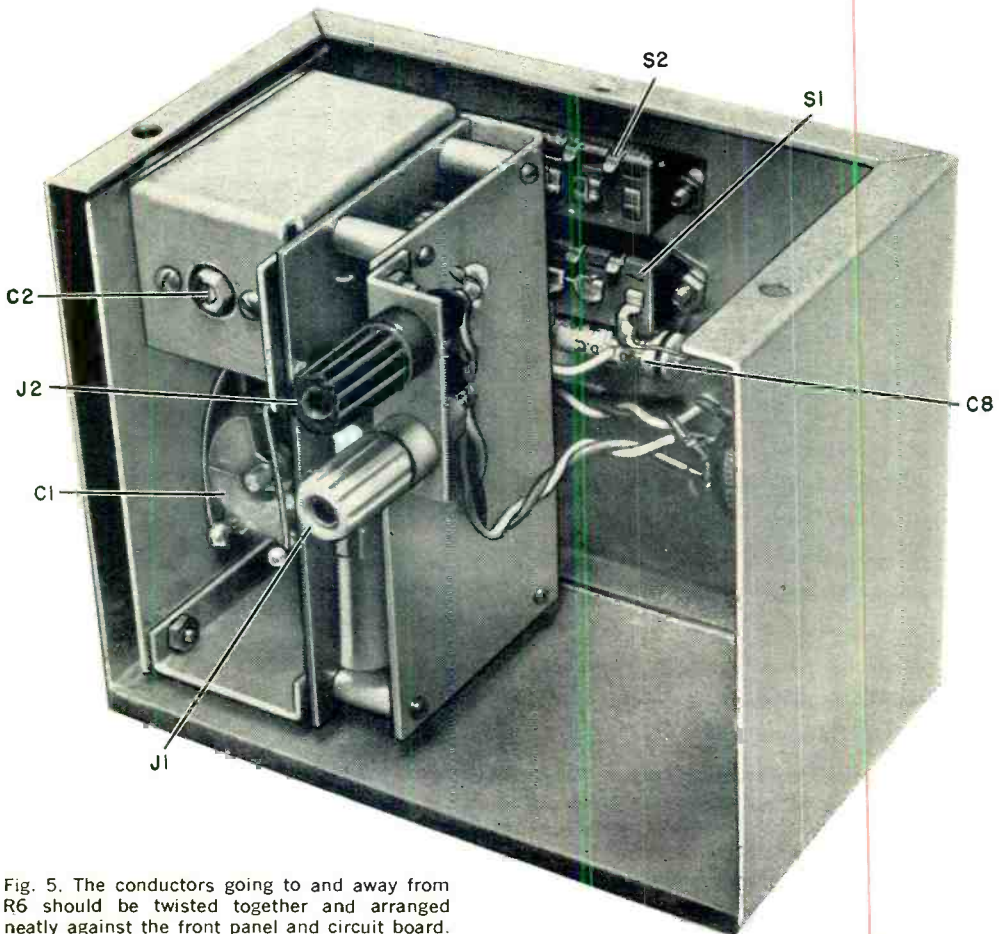
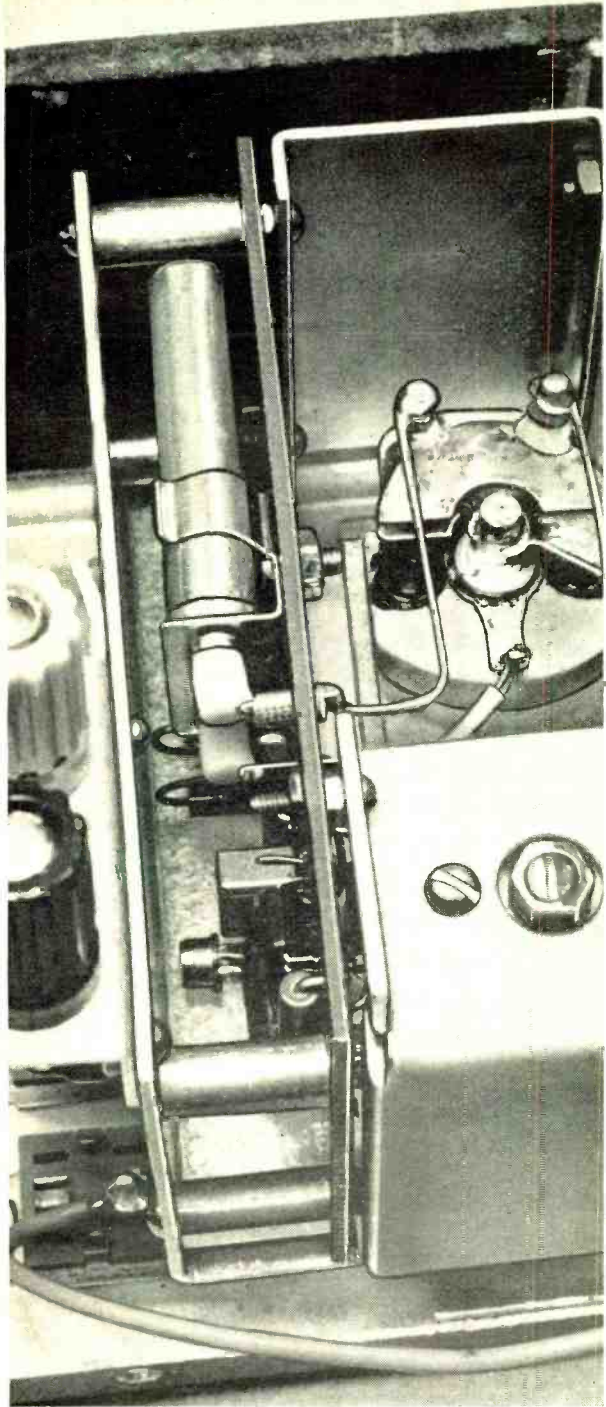

Fig. 5. The conductors going to and away from *R6* should be twisted together and arranged neatly against the front panel and circuit board.



If care is exercised during the fabrication of the metal parts that make up the subchassis, the project will have a neat, professional appearance.

September, 1970

Near zero beat with WWV is best observed as the "breathing" or very slow rise and fall in background noise as the two signals alternately add and subtract at the receiver's input. This effect is maximum when the signals are of equal strength. Simply rotate the level control until the beat is the loudest. It is often advantageous to switch off the receiver's a.v.c. and use the manual r.f. gain control for this step.

The calibrator produces accurate marker signals at 100-kHz intervals to 30 MHz and beyond. To locate markers, it is generally best to switch off the a.v.c. and switch on the b.f.o. Set the manual r.f. gain control at about mid-position initially. Switch on the calibrator and the gate switch to key the calibrator's output. Keep the Level control turned up high during initial trials with the calibrator. Optimum settings of the receiver's r.f. gain and the calibrator's Level controls can be determined when you have become well acquainted with the operation of the calibrator. Too high a setting of the Level control, however, might cause the receiver to block. Pinpoint the exact location of the marker signal with the Gate switch set to the off position.

Alternate markers are at noticeably different levels. This is quite normal and is, in fact, the normal characteristic of harmonics contained in a square wave.

If the value of the series resistor between the calibrator and the receiver has been properly selected, it will not be necessary to disconnect the calibrator when it is not in use. Its presence should produce little or no attenuation of incoming signals from the antenna to the receiver.

-30-

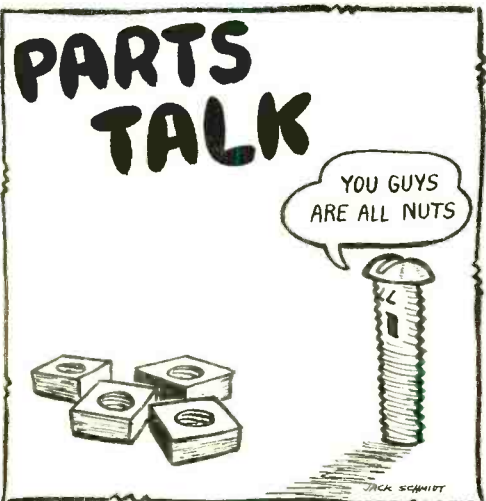

PSYCHOLOGIST

THE HAM & THE LADY

SOME NOT-SO-PRODUCTIVE RESEARCH

by Fred Ebel

THE FORWARD GAIN of the stacked blonde at the door made neon lights out of my eyes. After a series of gulps, I stammered an invitation to come in.

"Are you the radio ham?" she asked in dulcet tones.

"Yes-s-s," I said guardedly, ready to give my lecture on why hams are unjustly accused of TVI. "Why don't we go into the ham shack," I added, sounding more like an old roué than the conservative individual that I am.

"I suppose you're wondering why I'm here," as she looked into my eyes and pinned my biological S-meter.

"I'm Dr. Susan Sweetie from *Tell It Like It Is* magazine. We deal in the psychology of human behavior and the editors thought it would be interesting to interview a radio ham on just why he is a ham. The local amateur radio club suggested you, and here I am."

"Well, Sweetie—I mean Dr. Sweetie—go right ahead and ask me anything."

She started her cassette tape recorder and said, "Now what started you in ham radio?"

"Fascination," I said, looking into her warm brown eyes. "I was absolutely fascinated by the idea that I could talk through the air without wires."

"So, you were motivated by the aura of mystery?"

"Yeah! I guess so."

"Any other reasons for being a ham?"

"Yes. Pride. Radio amateurs are respected." I straightened my shoulders. "It takes ability to pass an FCC code and theory examination."

"Hmmm. Gratification of the ego with overtones of narcissism."

I frowned.

She looked at me as one does at a slow-thinking individual. "Don't be alarmed. The real reasons behind one's actions are often disguised. Now, please continue."

"Well, I think another big reason I'm a ham is because I like to fish."

"A piscatorial complex. How interesting!"

Now she had me with a complex. What next? "It's like this," I said. "Your lure is a CQ call which you cast out from the rod which is the beam antenna. Now, you never know what kind of 'fish' will strike at your bait. It could be a small bass, a muskie, or a tarpon on the other side of the world. That's what makes it interesting—you never know whether you're going to hook someone a hundred miles away or eight thousand miles away."

She leaned forward, eyes aglow. "Would you say that you're hooked by this facet of ham radio?"

I laughed. "Yeah! I sure am."

She squealed with delight. "This is simply wonderful. I can hardly wait to report this to the psychology society. I'll call it the Waltonian syndrome."

I looked sideways at her. "Syndrome? That sounds like I'm sick."

She apparently didn't hear me. "Here," she said, pointing to the couch, "why don't you lie down. You'll have better free association."

I jumped up. "What is this—a psychoanalysis?"

"Come," she said, leading me to the couch, "you'll be able to think much more clearly."

The glow was still in her eyes and I thought it was best to humor her.

"There, there," she said like a mother to a small son. "Now tell me about your hostilities."

"My hostilities!" I raised my head but she pushed me down.

"Yes. Let's regress to your childhood. Tell me about your father. Did you hate him?"

"I don't think so. He was a nice guy. One funny thing, though."

"Yes!" The eyes were even more ecstatic.

"He got a bad electric shock once and didn't want me to fool around with any electrical stuff. You know, bells, lights, and—"

"That's it! That's it!" She screamed. "You took up ham radio because your father repressed your normal desire for things electrical."

I inched away from her. The attraction I initially felt was disappearing as she bent over me like a vampire.

"Hatred of father resulting in a compulsion neurosis or obsession for ham radio," she said into the microphone of the tape recorder. Then, speaking to me "oh, this is the happiest day of my life. Neuroses, complexes, obsessions, hostilities. You're just filled with them!"



"That's it! You took up ham radio because your father repressed . . ."

"You got it all wrong," I said, "I like ham radio. It's fun. What other hobby brings the world into your home? Here," I waved my log book under her eyes, "look at all the different people I've talked to in the last few days. A doctor, a missionary, a salesman, an Antarctic scientist, a businessman in his airplane, mobiles, ships, even a submarine!"

She grabbed the recorder microphone tighter, spoke excitedly. "Patient evidences sublimation, receives gratification in ham radio without physical association."

I jumped off the couch. "No physical association? I've met many of these hams. I stayed a week with a ham's family in England, a month with a ham in Australia. And I intend to marry a girl ham!"

She didn't hear. Instead she uttered terms I didn't understand into the

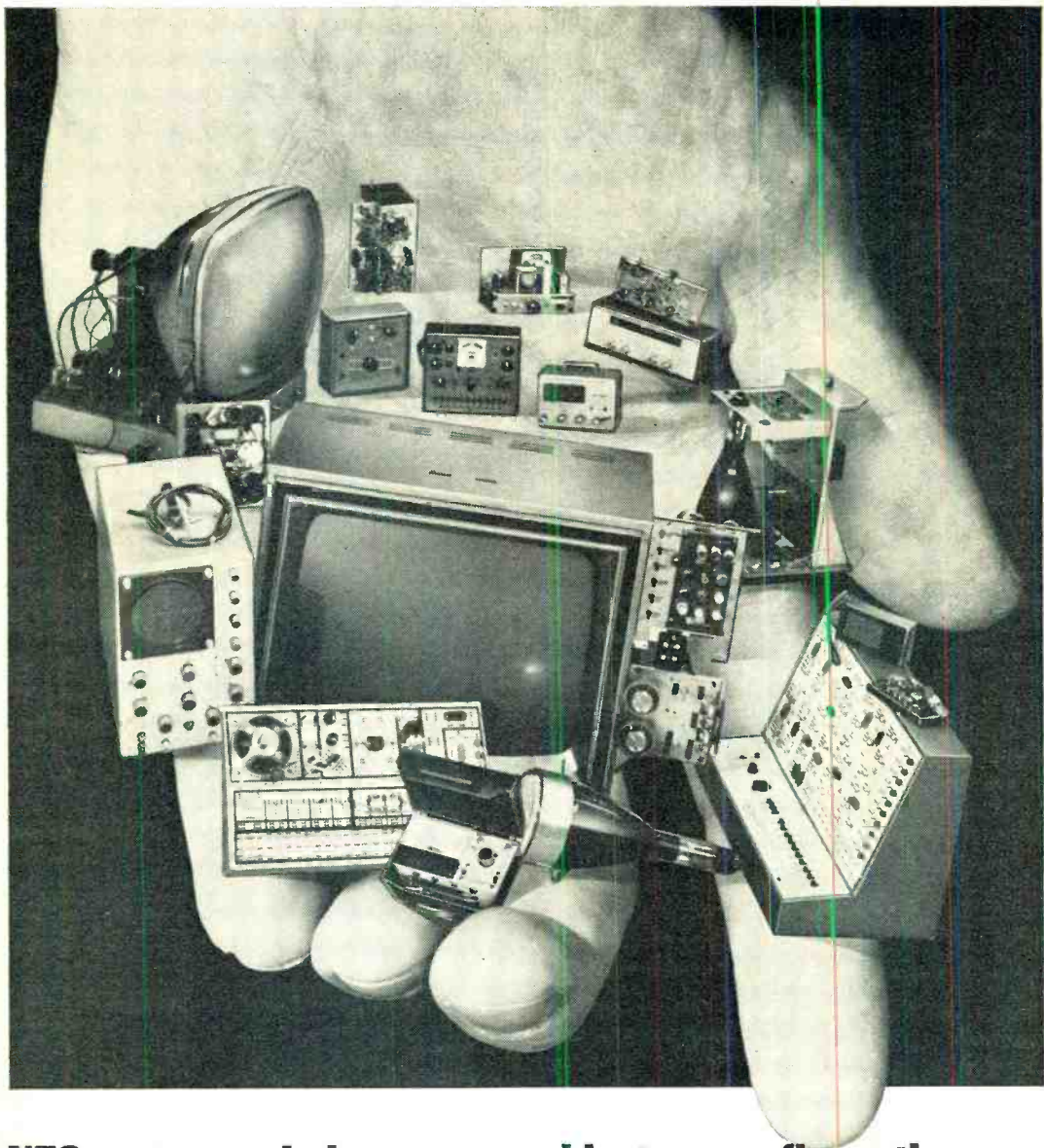

NTS puts a whole new world at your fingertips.

NTS home training can put a whole new way of life in the palm of your hand. A new, exciting job, a much bigger income is now easily within your reach.

NTS training is something special. We provide all the kits you need for the most effective training. National Technical Schools sends kits with every course, and teaches you to build and test a

wide range of professional equipment — the same kind of equipment you'll actually use on the job. That's the NTS "Project Method" — training that's practical and in-depth. You learn everything from fundamentals to the latest innovations. From beginning to end, NTS makes it fascinating and fun to learn this way. And all you need is a little

spare time and an interest in electronics.

Each year, men are moving into important new jobs, or their own businesses, straight out of NTS electronics training. NTS is what's happening to men everywhere. Check the coupon. Take hold of the career you want most. Do it now. No obligation. No salesman will call.

We pack your electronics course with kits to make your training fast. You'll enjoy every minute of it.

NTS COLOR TV SERVICING

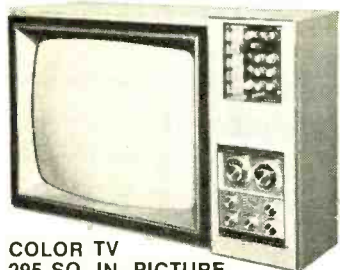

COLOR TV
295 SQ. IN. PICTURE

NTS training provides an easy way to become a professional home-entertainment service technician. You receive a big screen Color TV with many unique features. The unit even includes self servicing equipment that permits you to make all normal test operations. No additional test equipment is needed for adjusting your set. In addition you get an AM-SW radio, Solid-State radio, Field-Effect Transistor Volt-Ohmmeter, and Electronic Tube Tester. You learn about Electronic principles and trouble shooting, hi-fi, multiplex systems, stereo, and color TV servicing.

NTS COMPUTER ELECTRONICS

This is the future. And it's happening now. The number of computers will increase many times in the next few years.

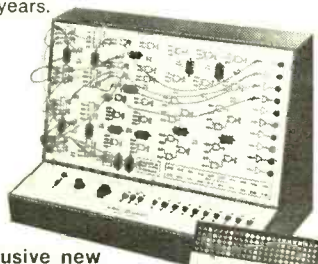

Exclusive new
Compu-Trainer®

If card is missing check coupon and mail for free color catalog and sample lesson. Now.



National Technical Schools

4000 S. Figueroa St., Los Angeles, Calif. 90037

Please rush Free Color Catalog and Sample Lesson, plus information on course checked below. No obligation. No salesman will call.

NTS offers a solid grounding in computer operation, wiring, data processing and programming. One of the 10 important kits included is our exclusive Compu-Trainer®. It's a fully operational computer logic trainer — loaded with integrated circuits — the first ever offered in home study. It introduces you quickly to how, what, when and why of computers . . . from theory to practical servicing techniques. This unit is capable of performing 50,000 operations per second.

NTS ELECTRONICS COMMUNICATIONS

Choose from two exciting courses to get into the big-paying fields of transmitting and receiving equipment: (1) The FCC License Course. (2) The Master Course in Electronic Communications (more comprehensive, with Citizens' Band Two-Way-Radio). Either Communications program qualifies you for your FCC First Class Commercial Radio-Telephone License — *NTS assures you will pass this FCC exam within six months after successfully completing your course or your tuition is refunded.* Kits include an Amateur-Phone 6 Meter VHF Transceiver — NTS exclusive, 6 transistor Solid-State Radio, Volt-Ohmmeter (fully transistorized).



5 Watt AM Transmitter/
Receiver

NTS AUTOMATION/ INDUSTRIAL ELECTRONICS

Let NTS put you into the age of electronic controls. Systems Automation is rapidly becoming the emphasis of modern industry. Your NTS training in automation electronics includes equipment like a 5" wide band Oscilloscope. You also get the new NTS Electronics Lab. It's an exclusive NTS experimental laboratory — a complete workshop that simplifies learning about solid-state, miniature and integrated circuits.



5" Oscilloscope

CLASSROOM TRAINING AT LOS ANGELES

You can take classroom training at Los Angeles in sunny Southern California. NTS occupies a city block with over a million dollars in facilities devoted exclusively to technical training. Check box in coupon.

NATIONAL TECHNICAL SCHOOLS

WORLD-WIDE TRAINING SINCE 1905

4000 South Figueroa Street
Los Angeles, Calif. 90037, U.S.A.

APPROVED FOR VETERANS

Accredited Member: National Association of Trade and Technical Schools, National Home Study Council.

- Master Course in Color TV Servicing
- Color TV Servicing
- Master Course in TV & Radio Servicing
- Practical TV & Radio Servicing
- Master Course in Electronic Comm.
- FCC License Course
- Master Course in Electronics Tech.
- Industrial and Automation Electronics
- Computer Electronics
- Basic Electronics

Name _____ Age _____

Address _____

City _____ State _____ Zip _____

- Check if interested in Veteran Training under new G.I. Bill
- Check if interested **only** in Classroom Training at Los Angeles

Dept. 205-090

microphone. It was obvious I had become a patient instead of an interviewee. "Please," she said, "lie down again. You were having such wonderful free associations."

"No! I want to tell you more about the wonders of ham radio. Can you name a hobby where friendships are made so quickly? Where with the exchange of 'handles' you are friends on a first-name basis. Why a twelve-year-old youngster can call a senator or a company president by his first name! Here, let me demonstrate."

I turned on the rig. The 20-meter band was jumping and I soon worked a ham in London. We exchanged reports and handles. "You see," I said, "we've talked only two minutes and already I'm Bill and he's Byron."

Dr. Sweetie seemed impressed; but there was a glint in her eye that suggested she was working on some new theory.

I decided to show her another facet of ham radio. "Most ham QSO's or conversations are nothing more than an exchange of reports. But look what happens when we mention our work."

It was my turn to transmit. "Thanks for the fine report, Byron. By the way, I'm in electronics. What do you do?"

He came back with the wish that he knew more about electronics. And then he dropped a bomb. "About the work here, old man—I'm a psychoanalyst."

Dr. Sweetie's big eyes became even bigger. Here was my chance to capitalize on coincidence and at the same time demonstrate one of the most unusual features of ham radio. "I have a surprise for you," I came back. "I've got a Dr. Susan Sweetie, a beautiful girl psychologist, in the shack."



"What a QSO . . . !"

Before I could open my mouth, she was gone. Too bad. I wanted to tell her about the hams that meet YL's on the air and get married. —30—

"Wonderful!" he said.
"Maybe she would like to discuss my latest research project—dream interpretation."

I gave her the mike and that was the last time I had it until I signed one hour later. What a QSO those two had! The terminology made my head spin—unconscious fantasies, Oedipus complex, punishment fantasies, symbolism, Nirvana principle—to name a few that I remember.

When I finally signed, I looked around. Dr. Sweetie was rushing toward the door. "Wait!" I yelled. "I want to tell you about one of the greatest things in ham radio."

"Can't," she said, her face aglow. "Byron wants me to visit him as soon as I finish this report. He needs an assistant."

GETTING
TO
KNOW
THE

JK FLIP-FLOP

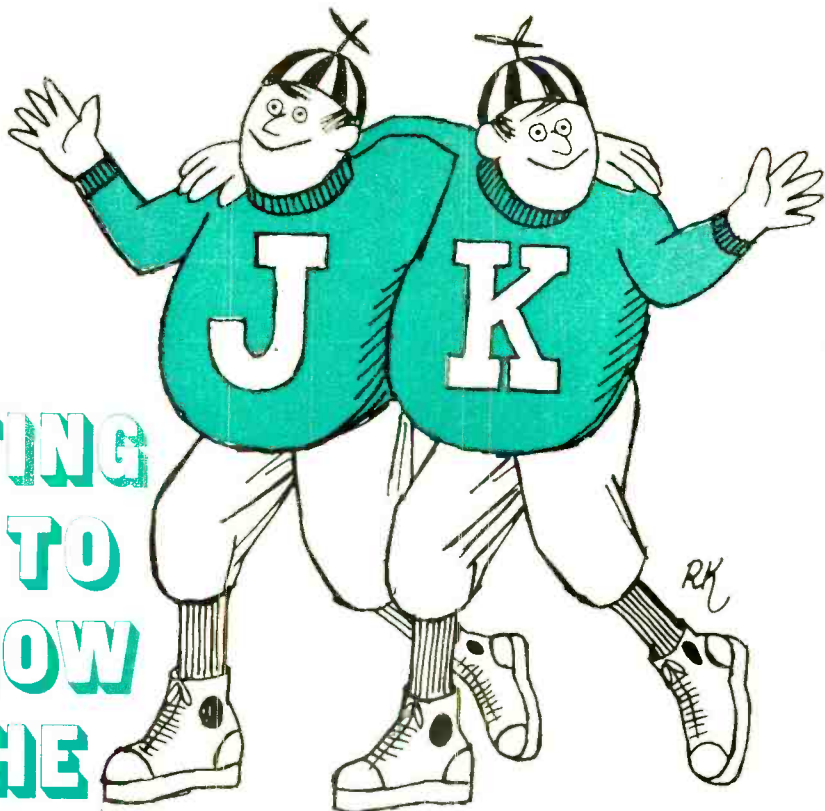

BETTER UNDERSTANDING OF A MISUNDERSTOOD CIRCUIT

JUST BECAUSE the JK flip-flop is one of the basic devices on which today's complex and sophisticated computers are based is no reason for you to jump to the conclusion that it is too complicated for you to understand and use. Much of the mystery can be dispelled if you view the JK flip-flop for what it is: nothing more nor less than a very clever and extremely versatile switch.

On this and the following pages, we will trace the evolution of the JK flip-flop to its present integrated circuit form and explain how it operates. Then we will describe a few basic circuits which employ JK flip-flops as dividers.

Bistable Multivibrators. The JK flip-flop is a sophisticated and highly versatile

form of the bistable multivibrator. As shown in Fig. 1, a bistable multivibrator is simply a pair of amplifier stages whose inputs and outputs are cross-coupled to each other.

When power is applied to the circuit in Fig. 1, a state in which one transistor conducts heavily and the other transistor is held at cutoff is forced upon the circuit. A heavily conducting transistor has a collector-to-emitter resistance that is very low (on the order of between 10 and 20 ohms). If the collector load resistance is about 40 times this value (typically 640 ohms in an IC package), virtually the entire supply voltage is dropped across the load resistor, and the collector is essentially at ground potential. When a transistor is cut off, its collector-to-emitter resistance is so high that it can be considered as an

BY FRANK H. TOOKER

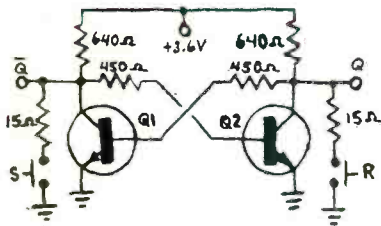

Fig. 1. A bistable multivibrator consists of a pair of amplifier stages whose inputs and outputs are cross-coupled to each other.

open circuit. The transistor's no-load collector potential will then approach the amplitude of the supply voltage.

For the purposes of positive computer logic, when a transistor's collector is very close to ground, its output (taken between collector and ground) is said to be a logical "0." Conversely, when the collector is at some potential significantly higher than zero volts, the transistor's output is said to be a logical "1."

With $Q2$ conducting heavily, the circuit's output is $Q = 0$; and $Q1$, held at cutoff, produces an output of $\bar{Q} = 1$. (The vinculum or bar over the Q , as in \bar{Q} , means "not." Hence,

Q means "not Q ." Whenever the vinculum appears, it is an indication that the logic level at that symbol is the opposite or complement of the logic where the symbol is unaccompanied by the vinculum.) This can be defined as the reset or preset state of the circuit and, unless the circuit is deliberately made to change, it will maintain this state indefinitely for as long as power is applied.

To change the state, "set" pushbutton switch S must be momentarily pressed. This lowers the collector potential of $Q1$ to near ground level, depriving $Q2$ of base bias. Transistor $Q2$ ceases conducting, its collector rises to the supply voltage value, and provides base bias to $Q1$. Therefore, $Q1$ turns on and remains conducting while $Q2$ is cut off until "reset" switch R is momentarily pressed to make the circuit change state again.

The 15-ohm resistors connected in series with switches S and R simply simulate the approximate collector-to-emitter resistances of heavily conducting transistors. If it is desired to trigger the bistable multivibrator into changing state electrically with a pulse (instead of mechanically with a switch), a transistor is used in place of each switch and 15-ohm resistor (see Fig. 2).

In Fig. 2, making the input of $Q3$ positive ($S = 1$) has the same effect as pressing switch S in Fig. 1. Similarly, making the input of $Q4$

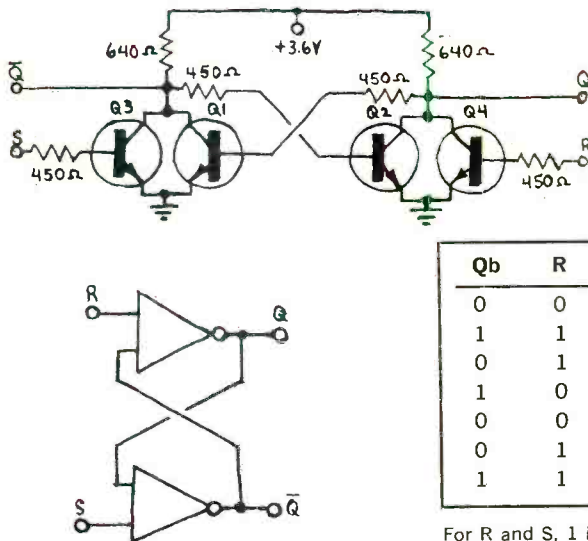

Fig. 2. Schematic and logic diagrams of SR flip-flop are shown above. All possible circuit states are indicated in truth table.

Qb	R	S	Qa
0	0	0	0
1	1	0	0
0	1	0	0
1	0	1	1
0	0	1	1
0	1	1	*
1	1	1	*

For R and S , 1 indicates a positive pulse.

Qb and Qa indicate state of Q before and after pulse, respectively.

*Doubtful state (see text).

Fig. 3. Positive pulses at toggle (T) input go through inverter Q3 and are steered to proper flip-flop stage through diode gates. Note absence of doubtful states in table.

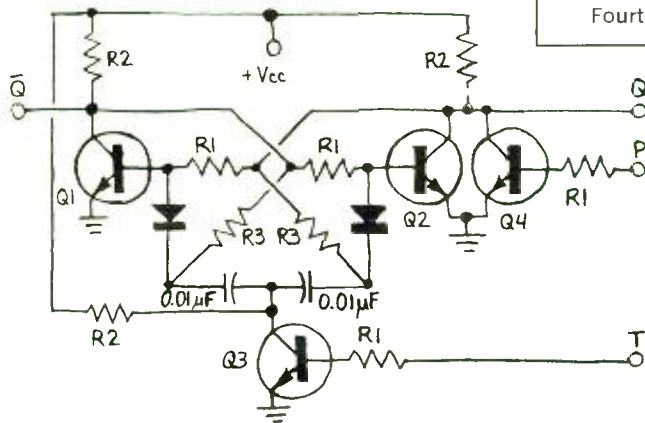

Input Pulse Sequence	Q	\bar{Q}
Preset	0	1
First	1	0
Second	0	1
Third	1	0
Fourth	0	1

positive ($R = 1$) has the same effect as pressing switch R . The circuit in Fig. 2 is known as an RS (for reset-set) flip-flop or a latch, the latter term derived from its operational resemblance to a latching relay.

Also shown in Fig. 2 are a "truth table" and a "logic diagram" for the schematic. The truth table lists all possible inputs and the outputs resulting from these inputs. Two states not previously described are those on the bottom two lines of the table. With inputs S and R both pulsed positive, the resulting output state of the flip-flop can be either 0 or 1, depending primarily on which of the two inputs is the last to occur. Because the output is doubtful, S and R inputs are never pulsed simultaneously in practical applications.

The logic diagram is a symbolic representation of the flow of logic through the circuit. The triangles are amplifier symbols. Here they are shown with two inputs, while the small circles at the apexes indicate that the outputs are inverted versions of the inputs. So, if the input is a logical 1, the output will be a logical 0. If no circle is shown, the output is non-inverted.

The RS flip-flop is not as versatile as the JK flip-flop, nor is it used as often. It does, however, find use as a start/stop switch in such instruments as digital voltmeters, fre-

quency meters, and as a bounceless contact for the toggle input of a JK flip-flop.

The Toggled Flip-Flop. There are certain advantages to having a flip-flop that can be made to toggle or shift from state to state with the application of a pulse to a single input point and without having any doubtful states. The circuits in Fig. 1 and 2 cannot accomplish this. What is needed is a circuit like that shown in Fig. 3, in which diode gates are used to "steer" the input pulse to the side of the circuit where it will be effective. (The diodes in this circuit are biased according to the conductive states of their respective transistors. This means that one of the diodes will be biased in such a way that it cannot pass the pulse, while the other diode, more appropriately biased, can at any given instant.)

Toggle pulses are applied to the circuit at the junction between the two $0.01\text{-}\mu\text{F}$ capacitors. Because the pulses must be negative-going, transistor $Q3$ is included in the circuit to demonstrate the principle of negation or inversion and to make the circuit responsive to positive-going pulses applied to toggle input T .

The Truth Table for Fig. 3 shows that, for successive pulses, the Q output is alternately toggled between 0 and 1; the \bar{Q} output is the Q output complement (or as Q goes from 0 to

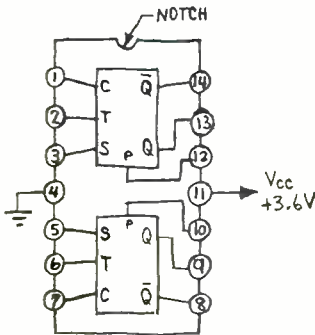
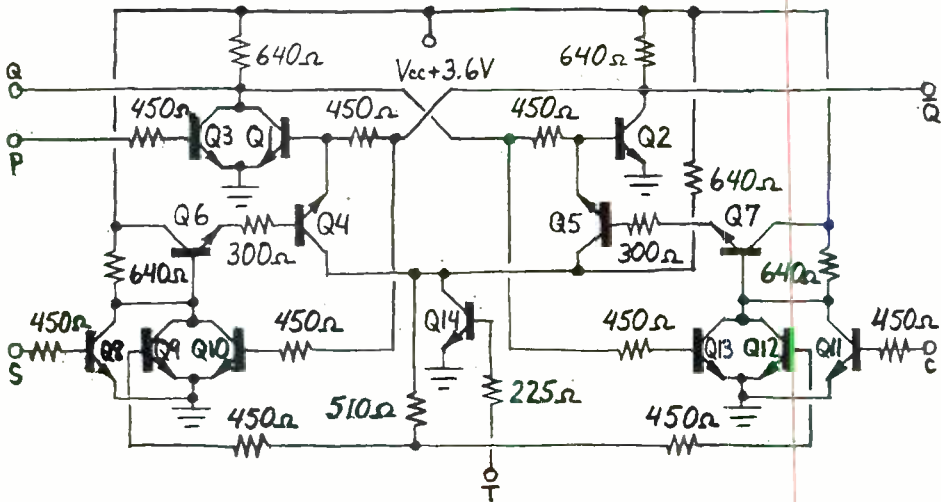

If Q Is:	And Prior to CP S Is:	After CP C Is:	Q Will Be:
0	0	0	1
1	0	0	0
0	0	1	0
1	0	1	0
0	1	0	1
1	1	0	1
0	1	1	0
1	1	1	1

Fig. 4. Half of a Motorola MC790P or HEP572 dual JK flip-flop is shown schematically at top, while directly above is top view IC pin identification diagram. Truth table is given above right, and logic terminology for output states is at right.

State	Level	Positive Logic
0	Low	False
1	High	True

1. \bar{Q} goes from 1 to 0). A T input at the base of Q_3 becomes a T at its collector; when a T input goes to 1, the output at the collector goes to 0 at the instant of toggling.

A study of the truth table shows that the circuit in Fig. 3 divides by two. So, for the four input pulses listed, there will be two output pulses in each of the Q and \bar{Q} columns.

Transistor Q_4 , with its input terminal P, is used for presetting the toggled flip-flop to $Q = 0$. Hence, input terminal P in Fig. 3 is used for exactly the same purpose and in the same manner as terminal R in Fig. 2.

The JK Flip-Flop.

A typical JK flip-

flop circuit (see Fig. 4, which is a schematic diagram of one section of a Motorola HEP-572 IC) seems a far cry from the simple circuits thus far described, but they have much in common with each other. Familiar circuits can be found in Fig. 4. And the JK flip-flop has much the same features—toggling and pre-setting—plus a couple of others that are essential but have not yet been described, such as set and clear (S and C) inputs.

Transistors Q_1 and Q_2 make up the bistable multivibrator proper, while Q_3 performs the preset function, exactly as in the preceding circuits. Transistors Q_4 and Q_5 take the place of the capacitors shown in Fig. 3. The charges

FLIP-FLOP SYMBOLOGY

Because many electronic notations are extremely repetitive, an easily identifiable symbology, or shorthand, for these notations has evolved. For example, vacuum (and even gas) tubes are identified by the letter V, transistors by Q, integrated circuits by IC, etc. Symbols have also been applied to IC logic devices—sometimes with seeming abandon. However, since the symbology has become standardized throughout the industry, you should be familiar with the letter symbols used. Here is how they are derived:

- RS—Reset/Set
- J and K—Arbitrarily chosen designations
- T—Toggle input
- S—Set input
- C—Clear input
- P—Preactor input
- Q—Arbitrarily chosen output designation
- \bar{Q} —Complement of Q

stored in the base-to-collector junctions of these transistors toggle the flip-flop when the toggle input is sufficiently fast. (The charge capacity of a transistor's base-to-collector junction is small, so toggle transit must be rapid.)

The toggle input is applied to terminal T and enters the circuit via transistor Q11. The pulse must be negative-going (the "fall" of a square wave, known as "trailing edge triggering," is a typical T input) and fall time must be within the range of 10-100 nanoseconds. Any T input that meets these requisites is called a "clock" or "toggle" pulse.

Inputs to terminals S and C are valuable features of the JK flip-flop. They determine whether or not the flip-flop will change state and, if so, in which direction in response to a clock pulse. In divider applications, they are essential to obtaining division ratios other than 2, 4, 8, etc., which are strictly binary.

When inputs at Q8-Q10 are 0, a CP (clock pulse) at T sends the Q output to 0. Similarly, when inputs at Q11-Q13 are 0, a CP at T produces a Q output of 1. Thus, steering is obtained by connecting the input of Q10 to the output of Q2, and the input of Q13 to the output of Q1. The states mentioned, in which S = 0 and C = 0, are shown on the first two lines of the truth table in Fig 4.

On the third and fourth lines, note that if S = 0 and C = 1 at the time a CP arrives at T, the Q output will go to or remain at 0. Similarly, on the fifth and sixth lines, if S = 1 and C = 0 when a CP arrives at T, the Q output will go to 1 or remain at 1 if it is already there. If S = 1 and C = 1, the flip-

flop does not change state in response to a CP, as demonstrated on the last two lines of the table.

A 1 input to S or C cannot independently cause the JK flip-flop to change state. It simply prepares the JK flip-flop so that operations described in the statements in the truth table can occur coincidentally with a CP input. Unlike inputs at S and C, a 1 input at P sends the Q output to 0 independently.

Inputs at S and C must be applied sufficiently before a CP arrives (setup time) to assure that they are well established at the time toggling takes place. A definite release time is also required. Minimum intervals equal to about twice the propagation delay, or 60 nanoseconds, should be sufficient for the average medium-power JK flip-flop.

FAN-IN AND FAN-OUT

The terms "fan-in" and "fan-out" refer to the input load and output drive factors, respectively, of digital-logic devices. Fan-in is associated with the required power to the input terminals, while fan-out is related to the maximum power available at the output terminals. These two terms apply to any digital logic device and must be taken into consideration whenever you are interconnecting digital devices.

When a JK flip-flop is connected to one or more additional JK F/F's and/or other devices, the sum of the load factors must not exceed the drive factor. For example, a Fairchild 9923 single JK flip-flop, or each of the two JK flip-flops in the Motorola MC790P or HEP572, has a fan-out of 10. (The fan-in and fan-out of other digital devices can be found by examining their specification sheets.) The T input and the P input of each JK F/F has a fan-in of 5, while the S input and C input each has a fan-in of 3. Thus, the Q or \bar{Q} output of one JK flip-flop can drive two T inputs (5 + 5), or three S and/or C inputs (3 + 3 + 3) with a little to spare.

The HEP571 is an inverting dual-buffer. In medium-power service. It has a fan-in of 6 and a fan-out of 80, or about 8 times the fan-out of a typical medium-power JK flip-flop (such as one section of the HEP572). A buffer is actually a current amplifier. It can be an emitter-follower; in this case, it is noninverting, but its voltage output is lower by the amount of the base-emitter drop in the transistor involved. Each section of the HEP571 involves three transistors, and the circuit more nearly resembles a power amplifier. The output is inverted.

JK flip-flops are sensitive to capacitive loads. Where such loads are unavoidable, a buffer should be used, with the JK flip-flop driving the buffer's input and the buffer's output driving the load. Some JK F/F's have buffers built-in as part of the IC.

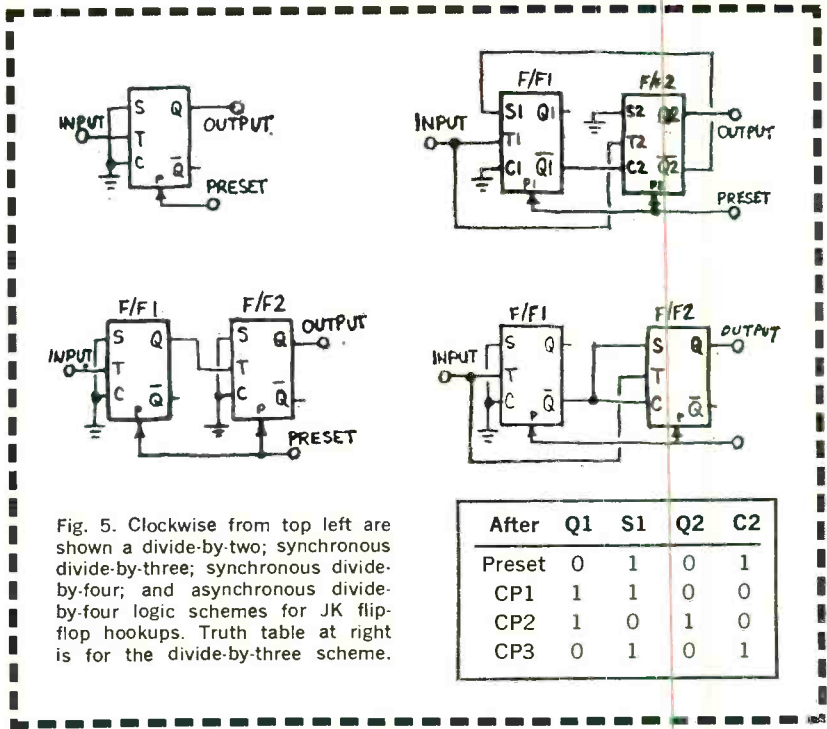

The JK flip-flop is not responsive to positive-going pulses or to steady-state signals of either polarity at the T input.

While the S, C, and P inputs of a JK flip-flop are not particularly sensitive to rate or multiple pulsings, the input at T is very much so. At the T input, a CP must be fast, singular, negative-going, and have at least a 1.5-volt peak amplitude. Ordinary mechanical contacts bounce on closure, producing a ragged signal that will toggle a JK flip-flop an indefinite and random number of times instead of just once at each closing. For accurate performance, a JK flip-flop must be toggled electronically, preferably with an RS flip-flop, a Schmitt trigger, or a monostable multivibrator. Sine waves must be clipped severely to convert them into essentially square waves with fast fall times to make them suitable for clock pulses. (Suitable "bounceless contact" circuits were given in "Build Numeric Glow Tube DCU," POPULAR ELECTRONICS, Feb. 1970, Fig. 8.)

Simple Divider Circuits. Now that the evolution and theory concerning the JK flip-flop are out of the way, let us go to a few examples of practical circuits. The JK flip-flops thus far described are used with resistor-transistor logic, or in engineering shorthand, RTL.

A single JK flip-flop divides only by two, which means that for each output pulse there must be two input or trigger pulses.

Greater division ratios can be obtained by connecting the output (Q or \bar{Q}) of one JK flip-flop to the toggle input of another JK flip-flop in a chain of as many JK F/F's as desired. This connection is often called a "ripple divider," because the toggling of each flip-flop (except the first) is produced by an output pulse provided by the preceding flip-flop. The maximum division ratio of a string of JK flip-flops connected in this manner is equal to 2^n , where n is the number of JK F/F's in the chain. In simpler terms this means that two JK flip-flops divide by four, three divide by eight, and so on.

A divider made up of JK flip-flops connected in this manner is called an asynchronous divider because all JK flip-flops in the chain are not clocked at their T inputs simultaneously. Each JK flip-flop exhibits a certain delay between the arrival of a CP and the appearance of a pulse at the output.

For a medium-power JK flip-flop, like each section of a HEP572, this amounts to a delay of about 36 nanoseconds per JK flip-flop. Called propagation delay time, it accumulates in a chain of asynchronous connected JK flip-

(Continued on page 117)

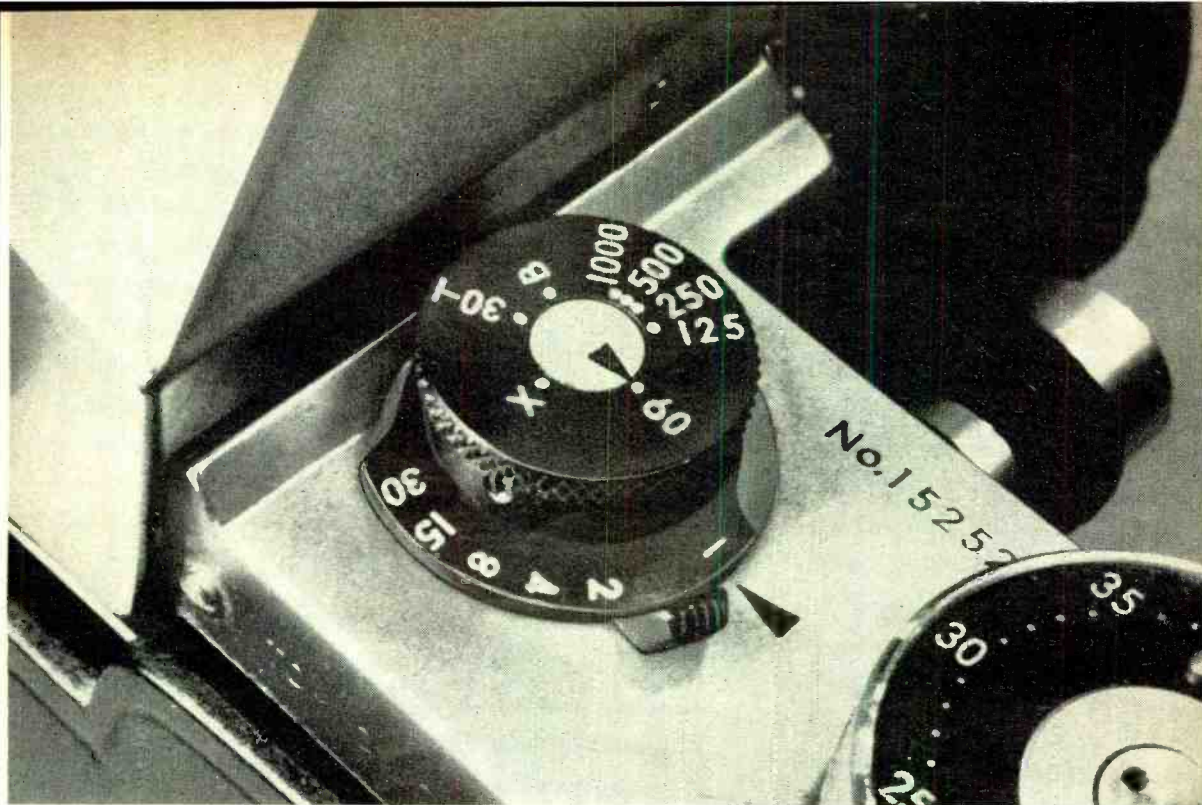

Assembling a **CAMERA SHUTTER SPEED METER**

ONE TO ONE-THOUSANDTH MEASUREMENTS
WITH REASONABLE ACCURACY

A peak-reading voltmeter activated by a phototransistor is calibrated for the range between 1.0- and 0.001-second shutter speeds. The voltmeter circuit uses a high-quality capacitor and a MOSFET. The builder can make his own meter coincide with the scale illustrated through manipulation of the various internal calibration controls.

HOW OFTEN have you wondered whether the shutter speeds marked on your camera are correct? Have you ever missed an important, unrepeatable shot because of over- or under-exposure and considered whether your camera's shutter was at fault?

If you have, you probably took your cam-

era to the repair shop to have it checked. For little more than it cost for that one check-up you can build your own Shutter Speed Meter so that you can check your camera anytime you have a suspicion that it is not performing properly. You can also use this device to check your camera for cold-weather operation.

Shutter speed ranges are 1 to 1/10 sec, 1/10 to 1/100 sec, and 1/100 to 1/1000 sec. In measuring shutter speed, the camera is placed on the pickup unit with a light source over the camera. Then the RESET button is pushed and the shutter is released; shutter speed is read directly from the single-scale meter. Any camera may be checked, whether it has a focal-plane or between-the-lens shutter. The meter

BY WILLIAM COOMES

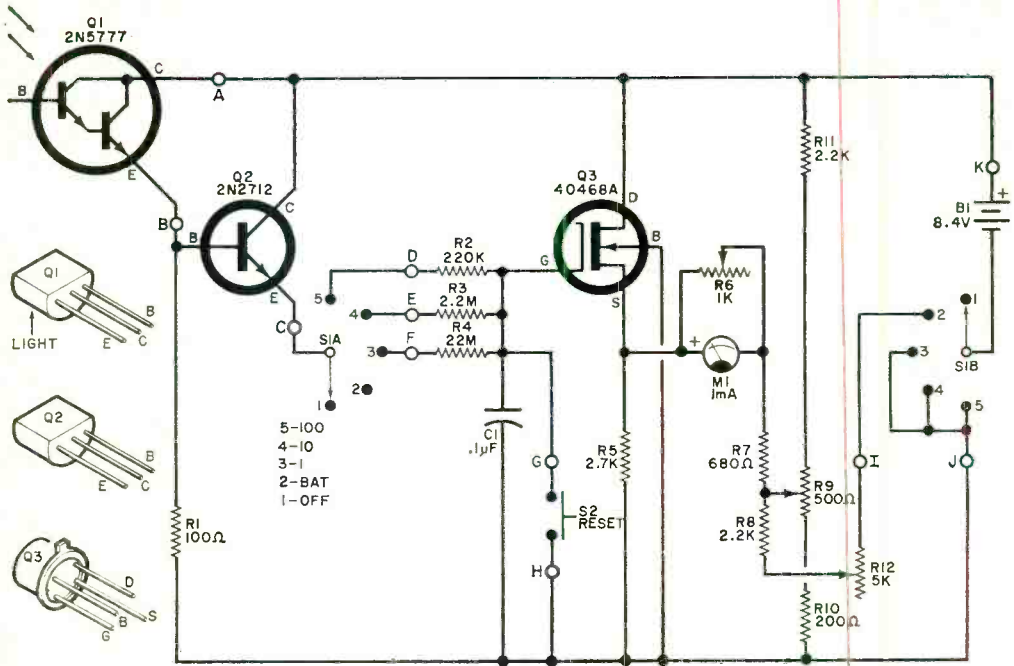

Fig. 1. The circuit is essentially a very high input resistance d.c. voltmeter with a MOSFET. It measures charge on capacitor C1, which is a function of how long light is applied to Q1.

retains a reading for several minutes, depending on the quality of the components used.

Construction. The Shutter Speed Meter consists of two physically separate sections: a light-sensitive transistor in its own case and an electronics package on which the meter readout is mounted.

The schematic of the circuit is shown in Fig. 1. A foil pattern for a printed circuit board and component mounting layout are shown in Fig. 2. The printed circuit board was designed to mount directly on the meter terminals. If you do not want to use the PC board, assemble the circuit on perforated board following the same layout. Note that 5% resistors are used for R2, R3, and R4 to obtain nominal accuracy. For greater accuracy use 1% resistors. It is also important that capacitor C1 be hermetically sealed (glass or ceramic with metal) and of high quality. If you use the foil pattern, the potentiometers specified in the Parts List cannot be substituted.

A silicon transistor with low leakage must be used for Q2. Transistor Q3 is a MOSFET and must be carefully handled. The MOSFET is shipped with a shorting ring around its four leads to prevent the possibility of elec-

PARTS LIST

- B1—8.4-volt mercury battery
- C1—0.1- μ F, hermetically sealed capacitor (Sprague 96P-10491 or similar)
- M1—0.1-mA, d.c. meter (Calectro D1-912 or similar)
- Q1—Phototransistor (G.E. 2N5777)
- Q2—2N2712 transistor
- Q3—MOSFET (RCA 40468A)
- R1—100-ohm
- R2—220,000-ohm, 5%
- R3—2.2-megohm, 5%
- R4—22-megohm, 5%
- R5—2700-ohm
- R7—680-ohm
- R8, R11—2200-ohm
- R10—200-ohm
- R6—1000-ohm potentiometer (Clarostat U39 or similar if PC board is not used)
- R9—500-ohm potentiometer (Clarostat U39 or similar if PC board is not used)
- R12—5000-ohm potentiometer (Clarostat U39 or similar if PC board is not used)
- S1—2-pole, 5-position rotary switch (Calectro E2-163 or similar)
- S2—Momentary pushbutton switch
- Misc.—Plastic cases (Lafayette 99E62721 and 99E80722 or similar), printed circuit board, battery holder, transistor socket, felt, wire, solder, etc.

All resistors
1/2-watt

trostatic charges accumulated on the fingers from damaging the transistor's gate. *Do not remove* this shorting ring until after the device has been installed in the circuit. If a shorting rivet is supplied, wind a single turn of copper wire around the four leads, remove the rivet, and leave the wire in place until construction is complete. When soldering *Q3* into the circuit, use a heat sink on the leads and a small soldering iron rather than a soldering gun since it is possible for the magnetic field created by a soldering gun to damage the MOSFET. For further safety, ground the metal frame of the soldering iron. If, after construction is complete, you have to make any wiring changes, install a shorting wire around the MOSFET leads.

To remake the meter face, gently remove the front of the meter, taking care not to bend the needle, and carefully remove the meter scale. Cut out or copy the scale shown in Fig. 3 and put it on the meter face. Carefully reassemble the meter, making sure that the mechanical zeroing adjustment is properly aligned.

The printed circuit board and other components, including the meter, are mounted in a 6" × 3¼" × 2" plastic box with a metal cover as shown in the photographs. Drill the required mounting holes for the meter so that the top of the meter is about ½" from the top of the panel. Drill the mounting hole for rotary switch *S1* below the meter, on the panel centerline. RESET switch *S2* can be located in any convenient place on the front panel. In the prototype, a miniature earphone jack was used to connect the phototransistor box to the meter box but the wires can be passed through a small hole in the box just as well.

Mount the printed circuit board on the meter terminals and tighten the nuts. This automatically makes the required electrical connections between the meter and the circuit. Mount the battery in a holder secured to the case. Use mercury batteries for stability. Wire up the circuit as shown in Fig. 1, but do not assemble the meter on the box until after calibration.

The box holding phototransistor *Q1* must be large enough to support the camera to be

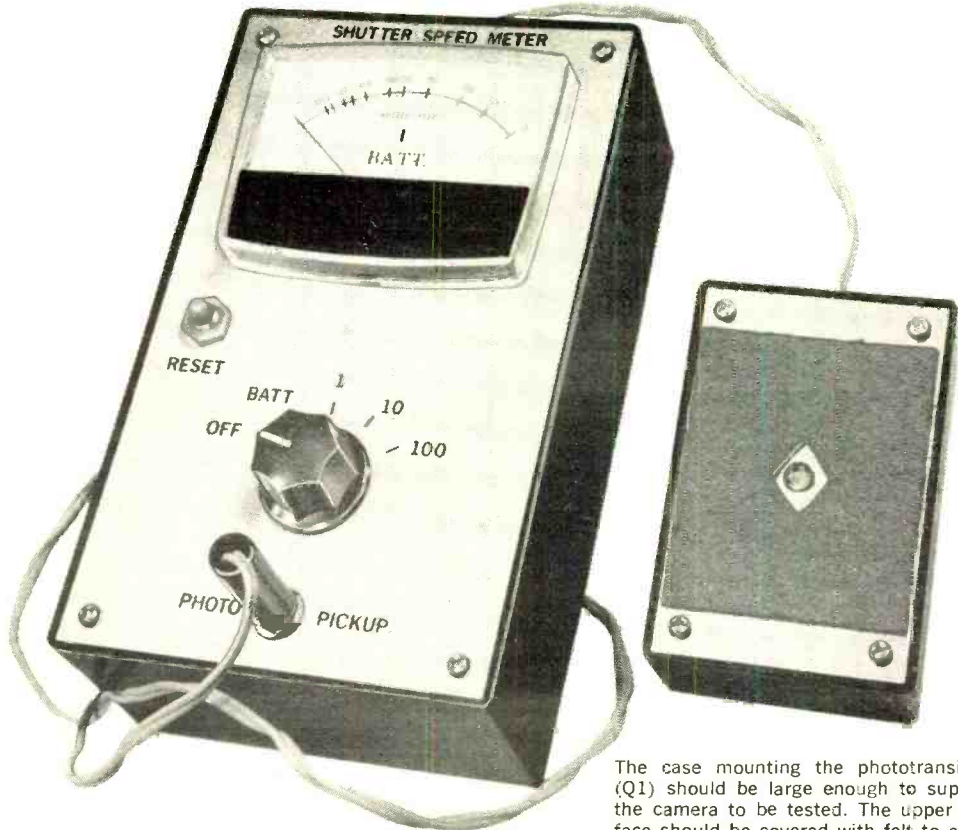

The case mounting the phototransistor (*Q1*) should be large enough to support the camera to be tested. The upper surface should be covered with felt to avoid scratching the face of the tested camera.

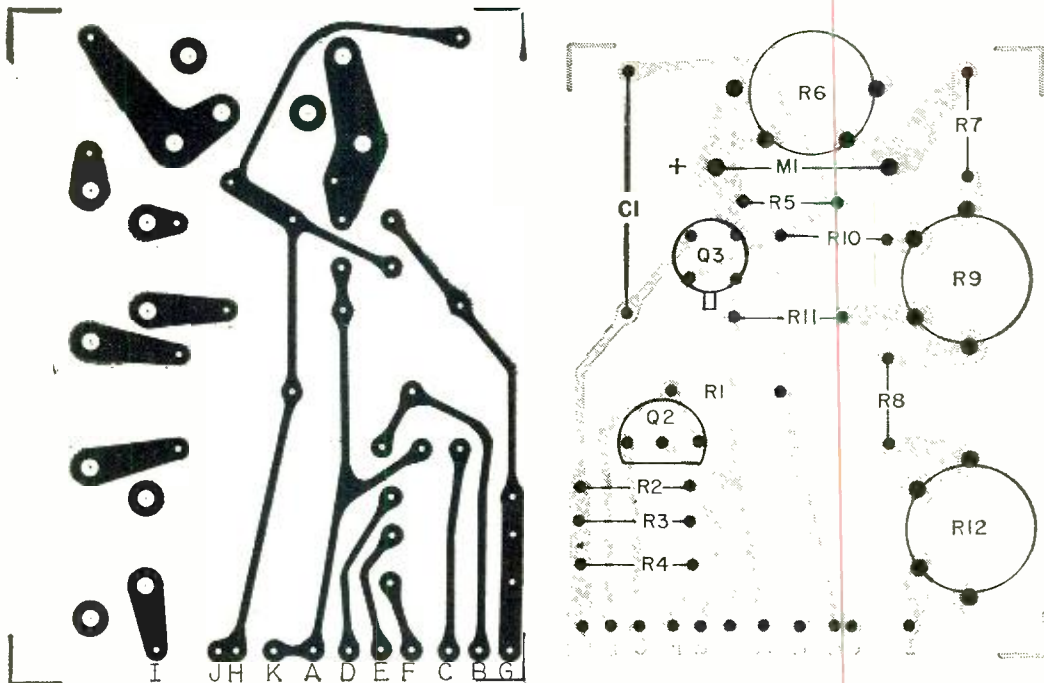

Fig. 2. Make printed circuit board using the actual size foil pattern at left. Install components as shown at right. Board is supported directly on meter terminals and should be drilled accordingly. Alter layout if potentiometers in Parts List are not used.

tested. Drill a hole slightly smaller than the sensitive face (the rounded part) of the phototransistor at the center of the upper panel. Cement the phototransistor to the panel so that the light-sensitive surface is visible through the drilled hole. Attach a piece of felt to the upper surface of the case, cutting out a hole to match the phototransistor hole, to protect the camera finish. In the prototype a transistor socket was used for the *Q1* leads with the cable to the meter box attached to the socket.

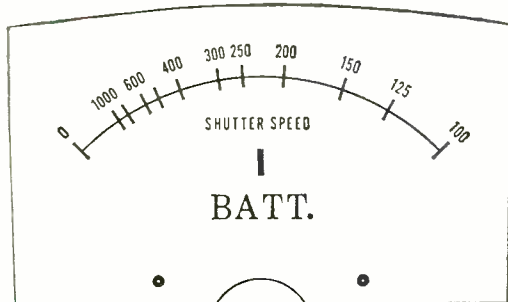
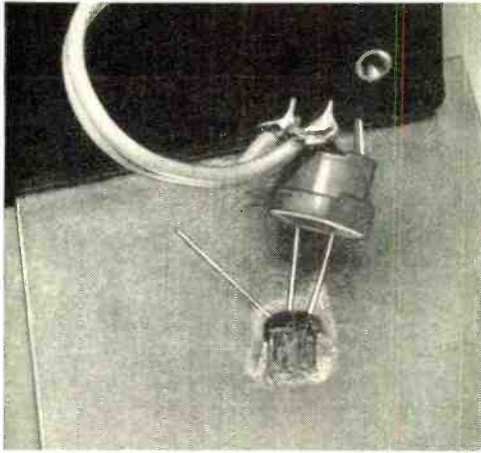

Fig. 3. Cut out or copy this meter scale and substitute it for the original 0.1-mA meter scale.

Checkout and Calibration. If at any time during the following tests, the meter deflects hard below zero, check out the instrument before installing it in the case. Place switch *S1* to OFF and install the battery. Note that the meter needle rests on the left-hand zero mark. If it does not, gently adjust the mechanical zero setting until it does. Place *S1* in the BATT position and note that the meter deflects to the BATT position on the scale. Adjust *R12* if it does not. A new battery may indicate slightly above the mark.

Connect the phototransistor to the circuit and place it near a bright light. Switch *S1* can be in any position (1, 10 or 100). Note that the meter starts to indicate upscale. Remove the light source and note that the meter indication does not change. With the meter indicating upscale, depress *S2*, the RESET switch. The meter should drop to zero immediately. Adjust *R9* to make the zero exact. Repeat this procedure a couple of times, making sure that the meter drops to zero whenever *S2* is depressed.

The next step is calibration. If you have access to a time-interval counter, all you have to do is measure the length of time that charging voltage is present across *C1* when a shut-



Phototransistor is cemented with epoxy to metal lid using a socket to make necessary connections.

To use meter, camera back is removed and camera is placed on the phototransistor mount. Very bright light source is used to activate the phototransistor when the camera shutter is operated. Be sure the light source is bright to insure the complete saturation of the phototransistor.

ter is tested and adjust *R6* so that the meter indication matches the counter reading. If you don't have a digital counter, you can use a camera having a 1-sec shutter that is known to be accurate and, using it as a model, adjust *R6* to get a 1-sec reading on the meter. Depress the RESET button after each test. Another means of calibration is to disconnect *Q1* temporarily and apply 1.6 volts (a fresh flashlight cell will do) across *C1*. Then adjust *R6* until the meter indicates exactly full scale.



Operation. Before using the Shutter Speed Tester, always check the battery condition and then depress *S2* to zero the meter. Make sure the camera lens is wide open. To test the camera shutter speed, remove or open
(Continued on page 116)

The board mounts directly on the meter terminals and is wired to the front panel components. Be sure to observe the special precautions before handling *Q3*.

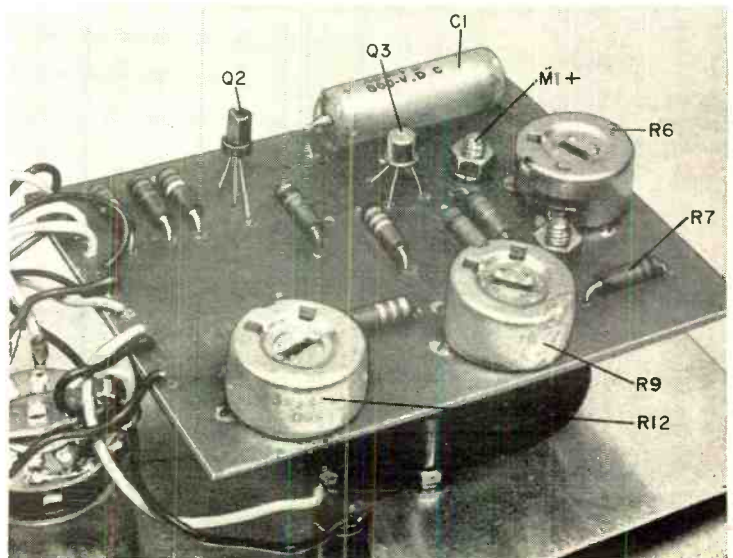

by Ed Francis



Winding Your Own Output Transformers

For Improved Matching and Power Handling

Circuits involving solid-state components frequently require "non-standard" audio output transformers. This article describes simplified methods of calculating the primary/secondary ratios, wire sizes, and numbers of turns for low-impedance matching transformers wound on "salvaged" cores.

PROJECT BUILDERS and experimenters occasionally need a small impedance matching audio transformer with an uncommon impedance ratio. When such a transformer is specially wound, its cost is usually prohibitively high compared to the total cost of the project in which it is to be used. However, with a few calculations and a little work on your part, you can duplicate many unusual transformers or any special audio coupling or matching transformer to suit your needs. The techniques prescribed in this article are limited to transformers of average

size and low-to-medium impedance. It is impractical to duplicate subminiature transformers that normally cost only \$1 or less and high-impedance transformers that require many turns of very fine wire.

Throughout this article, you will find the term "volt amperes" (VA) used in the same manner that "watts" is used for power. This usage involves an assumption which is not quite true. However, for this type of work, if you accept the assumption that the two are equal, the results will be acceptable.

Calculations involved in designing an audio transformer are covered by the nine steps outlined in the box on page 81. To see how these steps work, let's design a typical transformer.

Assume that a transistor output transformer with a 130-ohm primary and a 4/8/16-ohm secondary is needed to match the output of an RCA CA3020 IC to a loudspeaker. By referring to the mail-order catalogs, we find that the full output of the IC is 0.5 watt. The nearest thing you can find in the catalog

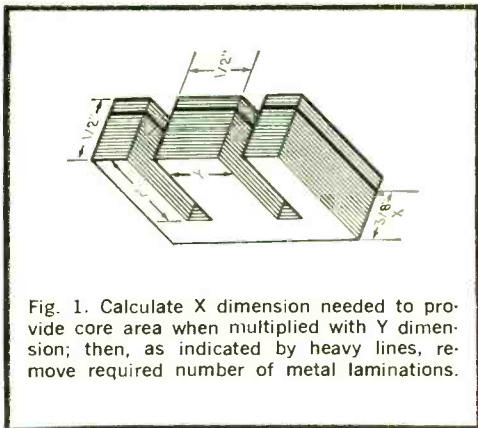

is a 125-ohm center-tapped transformer rated at 300 mW. This transformer could be used, but you can make one that will be just as good and design it for a full watt if space and weight requirements permit.

First calculate the core area required. Note, however, that the core area applies only to the cross-sectional area of the core's center leg as shown in Fig. 1. Referring to Fig. 2, we find that the graph shows an approximate core area of 0.18 sq in. will suit our requirements. (We can use an approximation since the actual core area is not too critical.)

Determine the turns ratio from the impedance ratio. Since we know the primary and lowest secondary impedances to be used, plug 130 and 4 into the equation: Ratio = the square root of (130/4) : 1 = 5.7 : 1. Hence, the actual turns ratio required shows 5.7 turns in the primary winding for every turn in the secondary winding.

Next, determine the d.e. voltage to be applied to the transformer's primary. In this case, we desire 9-volt operation. The CA3020 employs a push-pull output. So, bear in mind that an 18-volt figure must be used in all primary calculations.

Calculate the wire size needed for the primary winding. Since we have decided to design the transformer to handle 1 watt of power, let us first determine how much current will be handled by the primary: $I = (VA/V_{ec}) = 1/9 = 0.111$ A. Now, because of the push-pull division of the current, we divide the primary current by two for determining the wire size; this gives us 55 mA in each half of the primary winding. If 700 circular mils/ampere is desired, refer to the Wire Table (column four) on page 80, and locate the current at or greater than 55 mA. Column one shows that #34 wire will safely handle 57

mA, the nearest figure to 55 mA. This size is quite small and difficult to work with, so choose #28 wire for ease of winding.

We will have to make some assumptions now in determining the number of primary turns to be used. For this calculation, we will use 2V_{ec}, or 18 volts, and an area of 0.18 sq in. for our 1-watt transformer. The frequency we will arbitrarily settle on as being 100 Hz. For flux density BM in gauss/sq in., any figure between 40,000 and 90,000 can be used; we'll settle on 70,000 to be conservative:

$$\text{Primary Turns} = \frac{2V_{ec} \times 10^8}{4.44 \times A \times f \times BM}$$

$$= \frac{18 \times 10^8}{4.44(0.18)(100)(70,000)} = 321$$

so, 320 turns will be close enough.

Having calculated the number of primary turns, we use the turns ratio formula to calculate the number of secondary turns needed. This is a step-down-type transformer, so we divide the number of primary turns by the turns ratio: Secondary Turns = Primary Turns/Turns Ratio = 320/5.7 = 56 turns.

Secondary wire size is determined by the current ratio method. Secondary current is equal to the primary current multiplied by the turns ratio: $0.111 \times 5.7 = 0.64$ A. The secondary wire size is determined by the same

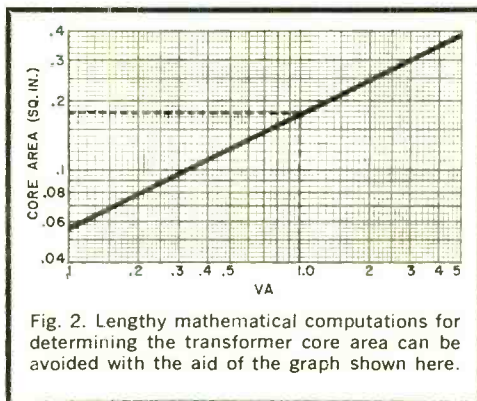

method as used for the primary. At 700 circular mils/ampere, the Wire Table indicates a 577-mA current capacity for #24 and 728 mA for #23 wire. Since 640 mA is about midway between the two sizes, we will settle on #23 wire.

Finally, the 8- and 16-ohm taps must be calculated. Again, refer to the turns ratio formula, and determine the turns ratio for 8 and 16 ohms separately. Then use these ratios with the primary turns to determine the

exact number of turns required for each impedance: 16-ohm ratio = the square root of (130/16) :1 = 2.86:1; 8-ohm ratio = the square root of (130/8) :1 = 4.04:1. Secondary turns = $320/2.86 = 112$ turns for the 16-ohm ratio; Secondary turns = $320/4.04 = 79$ turns for the 8-ohm ratio. Hence, the composite secondary will consist of 112 turns of wire with taps at the 56th and 79th turns.

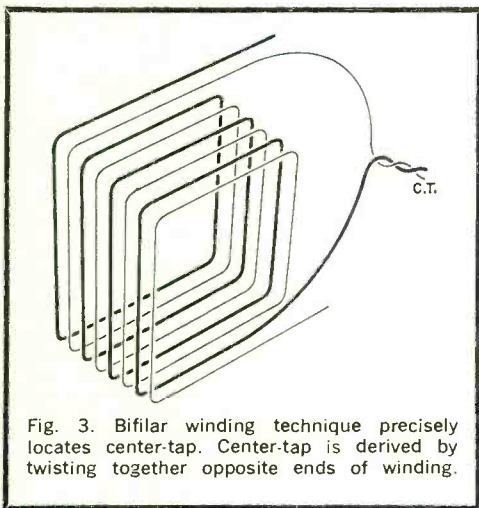

Fig. 3. Bifilar winding technique precisely locates center-tap. Center-tap is derived by twisting together opposite ends of winding.

Now that we have all of the design parameters, we can proceed to assembling our special-purpose transformer.

Assembling the transformer from the design parameters derived from the above procedure is easy. We know that the core area must be about 0.18 sq in. The simplest and least expensive way of obtaining a suitable core is to salvage an old audio output transformer. Many such transformers have a core area of 0.25 sq in. If about a quarter of the laminations are removed, approximately the correct dimensions will be obtained (about 0.185 sq in.).

Disassemble the salvaged transformer, and remove and discard the windings, but reserve the plastic winding bobbin if it has one. If no bobbin is available, you can make one from an index card or heavy waxed (butcher's) paper. This bobbin should easily slide over the core leg and be a little shorter than the center leg of the laminations.

Slide the bobbin onto a length of wood to serve as a winding handle. Then begin winding the primary turns onto the bobbin, starting and ending along the $\frac{1}{2}$ " side of the bobbin to avoid having the ends exit from the

WIRE TABLE

AWG B&S	Area (circular mils)	Current capacity at 600 c.m. per ampere	Current capacity at 700 c.m. per ampere	Current capacity at 800 c.m. per ampere	Turns/ linear inch, enamel insulation
14	4107	6.85	5.87	5.14	15.0
15	3257	5.43	4.65	4.07	16.8
16	2583	4.31	3.69	3.24	18.9
17	2048	3.42	2.93	2.56	21.2
18	1624	2.71	2.32	2.03	23.6
19	1288	2.14	1.84	1.61	26.4
20	1022	1.71	1.46	1.28	29.4
21	810	1.35	1.16	1.02	33.1
22	642	1.07	.918	.804	37.0
23	509	.848	.728	.636	41.3
24	404	.674	.577	.505	46.3
25	320	.534	.458	.400	51
26	254	.424	.363	.318	58
27	201	.336	.288	.252	64
28	160	.265	.228	.199	72
29	126	.210	.181	.158	81
30	100	.167	.144	.125	90
31	79	.133	.114	.096	101
32	63	.105	.090	.079	113
33	50	.083	.072	.063	127
34	39	.065	.057	.049	143
35	31	.053	.045	.039	158
36	25	.042	.036	.031	175
37	20	.033	.028	.025	198
38	15	.025	.022	.019	224
39	12	.020	.018	.015	248
40	10	.017	.014	.012	282

core "windows" when the bobbin is in place. Ordinary "scatter" winding is acceptable in most cases; but if space is limited, you might have to close-wind the turns. Our hypothetical transformer has a further complication: The primary winding is center-tapped. It must be wound so that both sides of the wind-

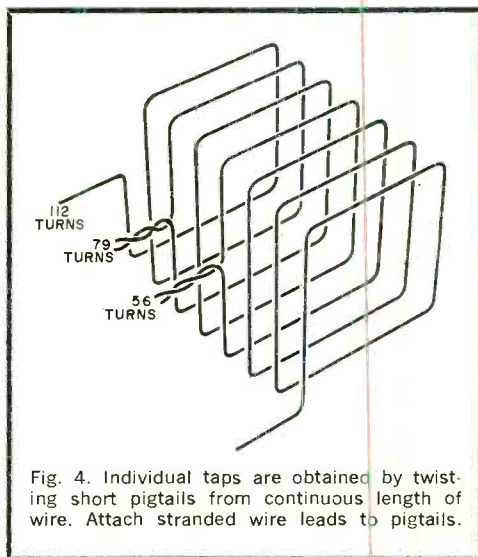

Fig. 4. Individual taps are obtained by twisting short pigtailed wires from continuous length of wire. Attach stranded wire leads to pigtailed.

NINE-STEP AUDIO TRANSFORMER DESIGN

In approaching something like the design of your own special-purpose audio matching or output transformer, you should use a practical, realistic procedure. The nine steps outlined here are set up so that you will not overlook time and work-saving steps and will lead you from start to finish without a lot of messy mathematical calculations.

Step (1). Refer to the catalogs for all available data (such as primary and secondary impedances and power and voltage ratings) concerning the transformer needed.

Step (2). Determine the transformer core area; from the transformer power rating (VA), area is equal to the square root of VA divided by 5.58. A quicker method is to refer to the graph in Fig. 2. Read up from the selected volt-amperes figure to the diagonal line, project to the left and read the core area in square inches.

Step (3). Calculate the turns ratio. From the impedance ratio, the turns ratio is equal to the square root of (Z_1/Z_2), where Z_1 is the larger and Z_2 the smaller impedances.

Step (4). Determine the voltage for which the transformer primary is to be used. For single-ended operation, use supply voltage Vcc; for push-pull operation use 2Vcc.

Step (5). Compute the size of the wire needed for the primary turns. Using the transformer power rating and the d.c. operating voltage (Vcc), primary current equals VA/Vcc. For audio service, a minimum of 600 circular mils/ampere is recommended; winding space permitting, it would be better to figure on using 700-1000 circular mils/ampere. A center-

tapped primary would have only half of the total current flowing through each half of the winding at any one time, so the metric area can be reduced by half.

Step (6). Calculate the number of primary turns needed:

$$\text{Primary Turns} = \frac{V_{cc} \times 10^8}{4.44 (A) (f) (BM)}$$

where Vcc is supply voltage; A is core area in square inches; f is the lowest frequency to be passed without loss; and BM is flux density in gauss/square inch).

Step (7). Determine the number of secondary turns required. If the transformer is to be an impedance-step up type, multiply the turns ratio by the number of primary turns calculated; if step-down, divide the primary turns by the turns ratio.

Step (8). Calculate the secondary wire size by the turns ratio method. Current transfer is inversely proportional to the turns ratio. Hence, if the transformer is a 10:1 step-down type, the secondary should be capable of handling ten times as much current as the primary. Once the current capacity is determined, you can refer to the Wire Table to find the smallest diameter wire that will suit your needs. It is, however, advisable to use the largest practical size wire to obviate a large d.c. voltage drop in the windings.

Step (9). If the center tap is required, use the "bifilar" method of winding (see text). For multi-impedance outputs, recalculate the turns ratios, secondary currents, etc., for each output impedance.

ing are balanced. To do this we will use the "bifilar" winding method shown in Fig. 3.

For our 320-turn primary winding, we wind two wires onto the bobbin simultaneously, side by side, until there are 160 double turns on the bobbin. Then to complete the bifilar winding, we connect one end of one wire to the *opposite* end of the other wire and solder on a 5" length of stranded hookup wire to make the center tap. Two more stranded wires soldered to the free ends of the primary windings complete the primary assembly.

Color code the wires so that the center tap is easily identifiable. Make sure that each soldered connection is well insulated from the others; then wrap a layer or two of plastic tape over the windings.

Now wind the secondary turns onto the bobbin. Count the turns as you go, and make a pig-tail tap leads at the 56th and 79th turns for the 4- and 8-ohm taps (see Fig. 4). Use color coded stranded hookup wires for the winding ends and taps so that each can be easily identifiable. Again, make sure that the

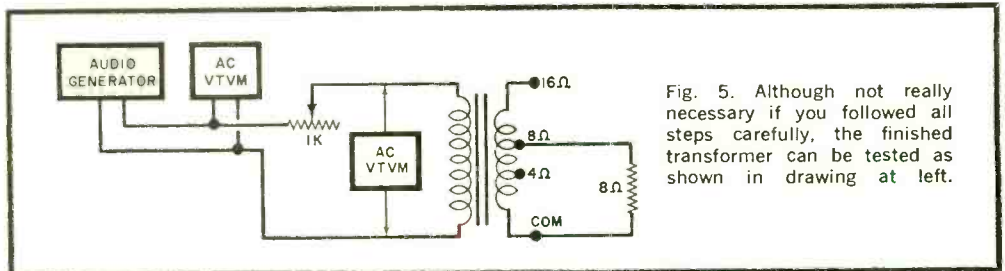
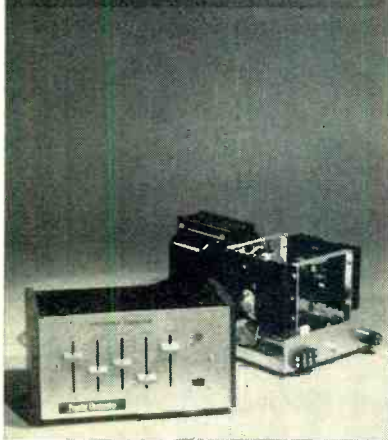

Fig. 5. Although not really necessary if you followed all steps carefully, the finished transformer can be tested as shown in drawing at left.

Popular Electronics

FIFTY-CENTS / OCTOBER 1970



On Sale September 17

FEATURING:

- Virtually indestructible hi-fi 70 watts/channel power amplifier. Tested by Hirsch-Houck Laboratories with verified performance at half power of 0.02% distortion from 20 Hz to 20 kHz. Full construction details in the October issue.
- A Graphic Frequency Equalizer with remarkably low distortion (2 volts output) for insertion between preamp and power amplifier. Tone control range of plus or minus 12 dB at 60, 250, 1000, 3500, and 10,000 Hz. Complete details for construction.
- How Thomas Alva Edison lost out on the discovery of "wireless" because of a simple question of semantics.
- How to assemble: an electrolytic reformer usable over a wide range of voltages; an enlarger lightmeter for your darkroom; and a VHF-UHF Drain-Dip Oscillator covering the range between 140 and 550 MHz.

solder connections are well insulated from each other, and wrap a layer or two of electrical tape over the assembly to prevent the windings from unraveling.

Slip the bobbin assembly off the winding handle. Orient the primary leads to one side and the secondary leads to the other side of the bobbin. Then slip the bobbin onto the center leg of the transformer core laminations. Assemble the transformer.

Testing the completed transformer is not really necessary if you exercised care during assembly and followed each step exactly as described. However, if you want to be on the safe side, you can test the transformer with the aid of an audio signal generator, two ac VTVM's or FET VOM's, an 8-ohm load resistor, and a 1000-ohm potentiometer as shown in Fig. 5. Set the generator's amplitude control for an output of several volts at 1000 Hz. Adjust the potentiometer for minimum resistance so that both meters have an identical reading.

Now, increase the resistance of the potentiometer until meter #2 indicates exactly one half its original indication while making sure that meter #1 remains at the original voltage setting. Since changing the resistance of the potentiometer decreases the load on the audio generator, meter #1 will indicate an increase in voltage. Simply reduce the generator's output level to return meter #1 to the original voltage setting.

After jockeying back and forth between the generator's amplitude control and the potentiometer a few times, you should be able to arrive at settings where meter #1 indicates the original voltage and meter #2 indicates exactly half of its original voltage. When this occurs, remove the potentiometer from the circuit without upsetting its final setting and measure its resistance. This resistance should be equal (or as near as possible) to the transformer's input impedance, or 130 ohms. However, if the transformer is loaded with an incorrect impedance (say, the 8-ohm load resistor connected across the 4- or 16-ohm output leads), it will reflect an incorrect impedance into the primary. As a matter of fact, if you use a 3.2-ohm speaker on the 4-ohm transformer output, a primary impedance somewhat lower than that for which the transformer was designed will be reflected. But if you plan to use such a speaker with the transformer, you could easily have plugged into the equations the 3.2-ohm figure for the 4-ohm figure.

-50-



OPPORTUNITY AWARENESS

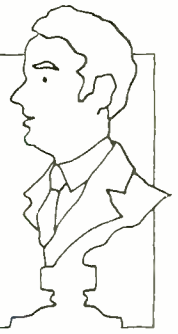

Thoughtful Reflections On Your Future

Sixth in a Monthly Series by David L. Heiserman

Sound Engineering Opportunities

I would like to become a sound recording engineer, but I find it almost impossible to get any information on the training and career opportunities.

● After discussing your problem with several engineers at recording studios and radio stations, I can see why there is so little available information. Every company that works with sound recording equipment seems to have a different idea of what a sound engineer is supposed to be, and how he gets the job.

The term, "engineer," is misleading because it doesn't necessarily mean that a sound recording specialist has a college degree. Some sound "engineers" do nothing but set up and monitor sound recording equipment, while other "engineers" design, maintain and troubleshoot the recording equipment.

As a would-be sound "engineer," you have two different career opportunities. Most sound recording engineers work in the radio or TV broadcasting industry. A second group of sound engineers works in recording or motion picture studios.

To get into radio or TV broadcasting, you must have a First-Class FCC license. This license tells the chief broadcasting engineer, your prospective boss, that you are fully qualified to operate and maintain all of his transmitting equipment. Even though your main responsibility might be sound equipment, you must have the knowhow of the First-Class license to get through the front door of a radio or TV engineering department.

Two schools accredited by the National Home Study Council offer courses in "broadcast engineering," a catch-all phrase for engineering jobs in broadcasting. They are: Cleveland Institute of Electronics (1776 East 17th St., Cleveland, Ohio 44114) and Grant-ham School of Engineering (1505 N. West-

ern Avenue, Hollywood, California 90027). Dozens of other home study schools offer special courses in FCC license preparation. Most courses are somewhat short on material about sound equipment engineering, but they at least pave the way for getting a sound engineering job in the broadcasting industry.

Electronics technicians who work as sound "engineers" at recording or motion picture studios don't have to worry about radio or TV broadcasting problems, so they don't need the FCC license. However, just as in the broadcasting business, it helps to have a good background in basic electronics so that you can learn to trouble shoot your own gear. You'll stand a much better chance of getting a job in these studios after you have completed a home study course in electronics technology and get some experience with sound equipment.

Starting Your Own Business

I work as an electronics engineering technician at a major aviation company. In the evenings, I manufacture a circuit that automatically turns on the house lighting when the sun goes down. Most of my customers like to use this gadget when they go on vacation. The gadget is selling so well I am thinking about quitting my regular job and putting all my time into this business. Do you think it is safe and worthwhile?

● Presumably, you are doing your manufacturing in your own laboratory or basement and there may be local zoning laws to stop you from operating such a manufacturing operation from your home. You had better check with your city zoning commission to find out how the laws read for your particular neighborhood. You may be able to get a waiver if you can prove that your business won't upset the "residential flavor" of your neighborhood. Be careful in this area and stay on good terms with your neighbors,

because one complaint is enough to cancel the waiver.

Although your "moonlighting" manufacturing operation sounds promising, I wonder if you have as great a market as you imagine. Unless you advertise and market this gadget outside of your own city, you'll soon saturate the market and run yourself out of business. I would suggest that you study some of the publications available from the Small Business Administration government offices. Their address is: Small Business Administration, Washington, D.C. 20416. Ask them for a copy of a free booklet titled, "Small Business Administration—What it is and What it Does."

From the description of your product, it sounds like something that is commonly available and appears in most of the mail-order catalogs. Unless you have several other products, I wouldn't recommend going into business with only one thing to sell.

Qualifications Questioned

In your May 1970 column, your comment concerning electronics teaching opportunities in high school and technical colleges is misleading. You imply that a degree is required to teach vocational electronics at the technician level. This is not so. Although a college degree would not hurt, it is definitely not a necessity. The desired qualifications for an electronics teacher at the high school and technical school level are simply a strong theoretical training in the field at the level to be taught and a reasonable depth of practical experience.

● The reader who asked about the preparation for a career in electronics teaching was a 16-year-old lad in high school. If the questioner had been a mature, experienced and highly skilled electronics technician, the question would have been answered in the manner you suggest.

Experienced electronics technicians who do not have a college degree can find teaching jobs at just about any kind of non-accredited school. Some states even offer a waiver that lets a technician without a degree teach in regular high schools and technical colleges.

Note that a mature, experienced electronics technician isn't betting his whole future on a school that happens to hire such people at the present time. He can always leave teaching and get his technician's job again. However, the growing popularity of electronics in high schools is bound to change the scope, quality, and methods of teaching this subject.

Until some guidelines are spelled out as to what will be demanded of tomorrow's electronics teacher, the only responsible recom-

mendation for a 16-year-old is for him to get a college degree, special electronics training, and, ideally, practical experience. I could not in all honesty tell a 16-year-old he can expect a successful lifetime career in electronics teaching without a degree.

Technical Writing

Although I am working as an electronics technician, I would like to try my hand at technical writing. My employer's publications department has given me some suggestions, but I'd like to know where I can learn more about technical writing.

● Let's draw a distinction between people who are technical writers and those who write about technical subjects. A technical writer generally works for a manufacturer that must generate a lot of instruction manuals concerning the equipment he has developed. The technical writer studies the equipment and works with the engineers and technicians who designed the equipment. He then prepares the necessary instruction manual telling what the equipment will do, how to install it, how to keep it in operation, and how to troubleshoot when necessary.

People writing about technical subjects are really book or magazine authors and are not necessarily technical writers. In electronics, many people writing on technical subjects are free-lance authors and are moonlighting since this is not a field that will support too many technical authors. It is difficult to break into the field of writing technical articles for publication in nationally circulated magazines or hard or soft cover books. However, there continue to be a number of good openings in the technical writing field for commercial (including military) equipment. To obtain more information on this subject, write to the Society of Technical Writers and Publishers, 1010 Vermont Ave., N.W., Washington, DC 10005.

You can also obtain information from the following home study schools offering courses in technical writing. All of these schools have been approved by the National Home Study Council.

Brittanica Schools, Inc.
425 N. Michigan Ave.
Chicago, IL 60611

Famous Writers School
Westport, CT 06881

Grantham School of Engineering
1505 N. Western Ave.
Hollywood, CA 90027

Newspaper Institute of America
2 Park Ave.
New York, NY 10016

Palmer Writers School
500 S. Fourth St.
Minneapolis, MN 55415



COMMUNICATIONS

BROADCASTING

It Started with Caroline—Pirate broadcasting is becoming a chess game played in the European North Sea. It all started nearly a decade ago with a pirate AM broadcaster called "Radio Caroline" aboard a vessel anchored outside England's territorial waters. The programming was 100% commercial with the then upcoming Beatles and Rolling Stones songs being played over and over. Soon a half-dozen similar pirates were on the air—openly defying the British Broadcasting Corporation's ban on commercials and rock music. The pirates were check-mated by a British law that changed the outer limits of the territorial waters. Since then, pirates have moved to waters off the shore of the Netherlands—the latest being "Radio Nordsee International" which has been driven off the air by jamming supposedly originating from secret transmitters operated by the British Post Office! Last spring "RNI" operated on 1610 kHz outside the high end of the broadcast band. A shortwave outlet on 6210 kHz is active.



See! It's not uncomfortable at all. The 25-lb elk collar is weatherproof and it is lined. Cross-dipole antenna is on top.

RESEARCH

The Space-Age Elk—A female elk, undoubtedly wondering what mankind will think of next is wandering around the Jackson Hole, Wyoming, elk refuge wearing a 25-pound collar. The subject of this indignity is communicating her travels to an orbiting weather satellite, Nimbus III. Each time the satellite passes overhead, it radios (on 401.5 MHz) a query to the elk as to where she is and how she's feeling. The collar responds on 466.0 MHz in an FM binary code. Animals are taking an unwilling part in an experiment related to the IRLS (Interrogation, Recording, and Locations System) built by Radiation, Inc. The collar has been designed to transmit for 6 months (April through October 1970) and, besides being protected from severe shock, it has a bank of solar cells to recharge the battery pack, an altitude sensor, skin temperature sensor, and a 32-MHz ground tracking transmitter. If the experiment works, more elks will be "collared."

INTERNATIONAL

Mao's Thoughts Go VHF-TV—It is reported that channel 7 TV viewers in Kuala Lumpur, Malaysia, are being treated to an unannounced show around 2:30 a.m. Probably due to some freak reception, viewers have been seeing weak TV pictures that are obviously Mao Communist inspired. Whether the TV transmitter is actually in Peking, or even in Yunnan, is unknown; but rumors have been flooding Malaysia that Mao's "thoughts" are so powerful that they propagate themselves via 625 lines and 60 frames. Even the Russians are unable to duplicate a comparable TV system.

(More "Communications" overleaf)

COMMUNICATIONS

CONTINUED

RADIO CONTROL

For Other Than R/C Aircraft—Aircraft modelers unhappy with the proposed sharing of frequencies in the 72-76-MHz band with R/C'ers working boats and cars have been mollified by the FCC. In early June the FCC announced a new plan permitting aircraft modelers exclusive use of 72.08, 72.24 and 75.64 MHz. There will be shared use of 72.40 and 72.96 MHz, while models other than aircraft will use 72.16 and 72.32 MHz. The FCC's proposals concerning use of the 72-76 MHz band have been hanging fire since November 1969. Final date for comments on the original proposal and the expansion mentioned above is August 31.



Radio Hauraki's second vessel, Tiri II, suffered many mishaps, but always was refitted and returned to the air. During a severe storm, she failed to reach shelter and drifted 60 miles before running aground on Uretiti Beach, North Auckland.

BROADCASTING

1111 Days At Sea—It took 3 years, but the New Zealand pirate radio station "Radio Hauraki" broke the monopoly of the Government's broadcasting corporation and this month opens up as a duly-licensed, land-based AM broadcaster. Radio Hauraki made its first appearance on Nov. 20, 1966 and its history was dotted with storms, mishaps and frustrations. Using 2 kW on 1480 kHz, Radio Hauraki operated from the Tiri I outside the New Zealand territorial waters. An almost immediate commercial success, Tiri I went aground on Great Barrier Island while trying to assist in the rescue of a man who fell from a passing ship. The public—by now listening to Radio Hauraki by the thousands—raised an outcry and forced the government to establish a "broadcasting authority" that finally saw the light and granted a commercial license for a land-based transmitter. Radio Hauraki shut down on June 1 from the Tiri II and is expected to open its new 5000-watt transmitter from Auckland in late September. (Submitted by Arthur Cushen, MBE.)

CITIZENS RADIO (CB)

Can CB'ers Be All Wrong?—Washington lobbyists may soon be vying for the privilege of representing 875,000 licensed CB'ers. One CB club has already established a Washington office to work with the FCC. Rumors in the capital city have it that CB has caught the eye of an ex-White House staffer and several Texas Congressmen. A nationwide CB organization is said to be in the offing. Doubtlessly, CB does need a Washington voice, but several previous attempts to organize CB'ers have been disasters. With the proper political connections and good financing, a CB lobby could become a potent force in reorienting FCC thinking about the value of CB, which would be good for everyone.

AMATEUR RADIO

John Gore Memorial Scholarship—A licensed amateur who has completed one year in an accredited college or university may apply before October 31 for the John Gore \$500 scholarship.

Supervised by the Foundation for Amateur Radio, Inc., Suite 72, 1150 Connecticut Ave., N.W., Washington, DC 20036, the scholarship honors John W. Gore, who was president of F.A.R. until his untimely death in 1960. Applicants must be enrolled in a course of study leading to a degree. All things being substantially equal, preference will be shown to applicants in the Washington area.

INTERNATIONAL

WWVH Moves to Kauai—Within the next 9 months, the National Bureau of Standards' time and frequency station now located on Maui Island in Hawaii will be set up on a 35-acre site on another island—Kauai. The new location was chosen over Guam, Wake Island, and the American Samoas. Virtually free of electromagnetic interference, WWVH will erect antennas favoring all of the Orient, from Alaska to New Zealand. In addition to a power increase from 2 kW to 10 kW, a 20.0-MHz transmitter will be added to existing services on 2.5, 5.0, 10.0 and 15.0 MHz. WWVH will be phase-locked to the VLF atomic clock signal originating from National Bureau of Standards' Boulder Labs., Fort Collins, Colorado.

RESEARCH

Noise-Free Mercury Lamp—Japanese scientists claim to have produced a mercury lamp free of the static discharge that plagues shortwave and VHF reception. Contributing to the research were Toshiba and Nippon Hoso Kyokai (NHK), the Japanese national broadcasting service. Toshiba is said to have perfected a noiseless fluorescent lamp in 1965 and has been devoting the past 5 years to the reduction of radio interference from mercury lamps. Price, production schedules and exporting information on the new lamps were not available at press time.



Hughes Aircraft ADAR receiving array consists of a microwave optical system with individual 2°-beamwidth horn feeds. Computer selects beam to track many targets.

RESEARCH

Faster Than A Speeding Bullet—A scaled-down version of a new radar system called ADAR (Advanced Design Array Radar) is being tested by the Hughes Aircraft Company. Funded by the USAF Rome (N.Y.) Air Development Center, ADAR comprises two antennas, a specialized transmitter/receiver site and a computer center. The transmitting antenna is a phased-array billboard with electronic beam steering. The receiving array selects the desired beams and feeds them to receivers. ADAR will be the most powerful radar yet built in terms of radiated peak power. Targets are automatically acquired and tracked. Resolution is now being checked and ADAR is expected to track a target with a true air speed exceeding that of a rifle bullet. Although more complex than conventional radar equipments, the phase-array concept is expected to replace all ICBM intercept radar in the next 5 years and all FAA radar within 10-12 years.

BROADCASTING

Marconi Company Half Century—A little over 50 years ago, Dame Nellie Melba sang into a microphone at the Marconi Works

**“He’s a good worker.
I’d promote him
right now if he had
more education
in electronics.”**

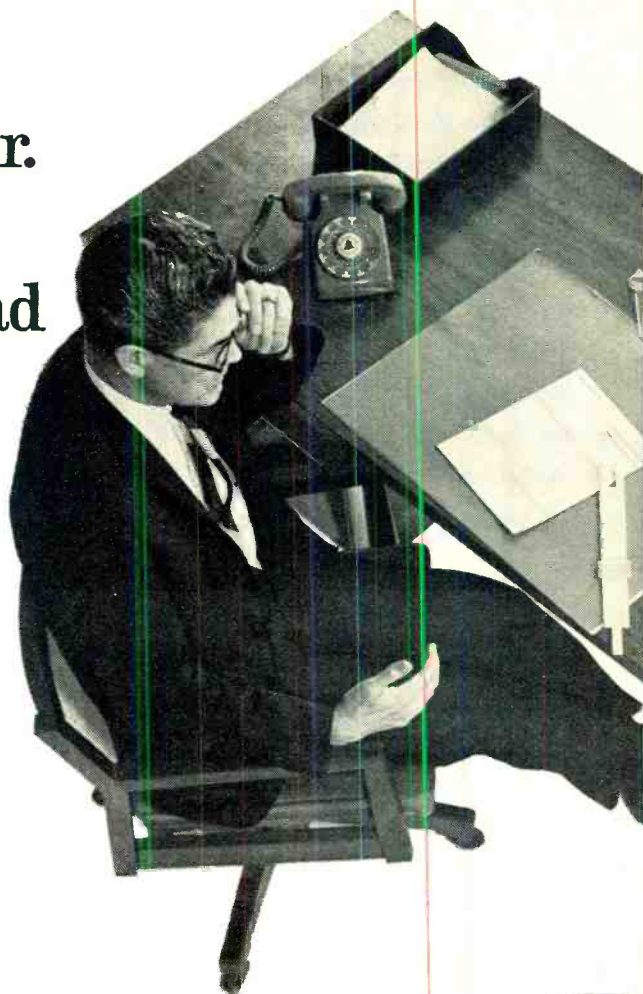

Could they be talking about you?

You'll miss a lot of opportunities if you try to get along in the electronics industry without an advanced education. Many doors will be closed to you, and no amount of hard work will open them.

But you can build a rewarding career if you supplement your experience with specialized knowledge of one of the key areas of electronics. As a specialist, you will enjoy security, excellent pay, and the kind of future you want for yourself and your family.

Going back to school isn't easy for a man with a

full-time job and family obligations. But CREI Home Study Programs make it possible for you to get the additional education you need without attending classes. You study at home, at your own pace, on your own schedule. You study with the assurance that what you learn can be applied to the job immediately.

CREI Programs cover all important areas of electronics including communications, radar and sonar, even missile and spacecraft guidance. You're sure to find a program that fits your career objectives.



**IN-DEPTH
 COVERAGE OF
 SOLID STATE
 ELECTRONICS**
 ...including
 integrated circuits!

You're eligible for a CREI Program if you work in electronics and have a high school education. Our FREE book gives complete information. Mail postpaid card for your copy. If card is detached, use coupon at right or write: CREI, Dept. 1209A, 3224 16th St., N.W., Washington, D.C. 20010.



CREI, Home Study Division
McGraw-Hill Book Company
Dept. 1209A, 3224 Sixteenth Street, N.W.
Washington, D.C. 20010

Please mail me FREE book describing CREI Programs. I am employed in electronics and have a high school education.

NAME _____ AGE _____
 ADDRESS _____
 CITY _____ STATE _____ ZIP CODE _____
 EMPLOYED BY _____
 TYPE OF PRESENT WORK _____ G.I. BILL

I am interested in

Electronic Engineering Technology Computers
 Space Electronics Nuclear Engineering Technology
 Industrial Automation NEW! Electronics Systems Engineering

APPROVED FOR TRAINING UNDER NEW G.I. BILL

COMMUNICATIONS

CONTINUED

in Chelmsford, England and made broadcasting history. The British claim that this was one of the first truly "advertised" radio broadcasts. Melba's broadcast to about 400 radio amateurs was on 110 kHz using a 15,000-watt transmitter. Subsequent to the June 1920 broadcast, Marconi Works inaugurated regular transmissions from 2MT and from the famous 2LO, which became the keystone of the BBC. Today, the spot where Melba sang "Home Sweet Home" is part of the Marconi High Power Test Dept., where equipment for overseas broadcasting studios is tested.

RESEARCH

Shad Tagging—In an effort to ascertain how shad fish cope with river pollution, the Pennsylvania Fish Commission will "sonic tag" about 50 shad and follow them up the Delaware River. Miniature transmitters were forced down the throats of female shad by commercial netters and then returned to the water in lower Delaware Bay. Biologist Dick Marshall will follow the shad to see what happens when they reach the pollution block between the Benjamin Franklin Bridge and Marcus Hook. He wants to find out if the fish die, turn around and go back downstream, or find a way around the pollution block. (Submitted by Leo Mooney.)

SHORTWAVE LISTENING

To ALL WPE Registrants—The world-renowned WPE SWL Registration Program will be continued by Hank Bennett. To avoid future conflicts, all WPE callsigns will be re-issued with the prefix WDX. All old and new registrants should send a self-addressed stamped envelope to Hank Bennett, WDX Program, Box 333, Cherry Hill, NJ 08034, for details on obtaining a new certificate. During the 10-year life of the WPE Program, nearly 40,000 SWL's were registered and assigned identifying WPE callsigns.

FCC NEWS

License Fees—August 1 was the effective date selected by the FCC to implement its multi-million-dollar license fee program. The schedule of fees covers all radio communications services and even affects CATV. Of interest to POPULAR ELECTRONICS readers is the increase in the fee for a class D Citizens Radio (CB) license from \$8 to \$20. Amateur radio licenses were not given comparable boosts, but now are \$9 (instead of \$4) for a license other than Novice (still free), \$4 for a change of address (instead of \$2) and \$25 (instead of \$20) when applying for a special callsign or license.

SHORTWAVE LISTENING

Deutsche Welle Opens in Portugal—The Iberian peninsula is the home of another major international shortwave relay broadcaster. Following the example of Radio Liberty (Spain) and Radio Free Europe (Portugal), Deutsche Welle, the radio voice of the German Federal Republic has opened a new relay site at Sines, Portugal. Operating in June on 5595, 6075, 7275, 9545 and 11795 kHz, the relay is beamed to eastern Europe and is being heard with a strong signal—so far without jamming. Special over-printed QSL cards are being issued.

(Continued on page 112)

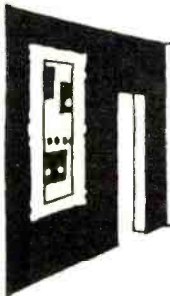

THE PRODUCT GALLERY

First in a New Series by "The Reviewer"

Having reviewed a dozen or so items for The Product Gallery it is not too surprising that I feel a proprietary interest in this department. In line with the revised editorial outlook of POPULAR ELECTRONICS, inaugurated in this issue, The Product Gallery is undergoing a facelifting. The stuffiness of product reviewing will hopefully be eliminated in future columns and along with it the too-glowing summary write-ups. This is not to say that, if I see something particularly noteworthy about a new product, it won't be described in favorable terms. However, I don't intend to make mountains out of insignificant molehills.

Nor, do I intend to blast or fault products (à la consumer reporting services) simply because I want everyone to know how smart I am. I will chide and I will recommend (usually in private to the manufacturer) certain modifications or adjustments that my experience tells me might prove valuable. Furthermore, I intend to use that experience to seek and report on actual product usages and not depend on manufacturer-originated write-ups or handout press releases.

I think the ground rules for product reviews are quite simple. Don't exalt trivia or go overboard for a marginal product. Provide the POPULAR ELECTRONICS reader with an accurate, objective appraisal of electronic products to enable him to make a sound buying decision. Look, test and report on products as actually used, not as I suspect they might be employed.

I intend to keep The Product Gallery as informal as possible. This department is a service to the POPULAR ELECTRONICS reader and I will attempt to answer your mail about products that have been discussed in print. I will not be able to make comparisons between similar products of different manufacturers and please don't ask me what to buy—there are just too many unknowns and variables for me to make an objective judgment in your behalf.

Tools of Our Hobby—Through the years I have concurred with the tenet of buying the best tools you can afford. Good tools are

nothing less than long-term investments. While most of us think this applies particularly to hand and power tools, it should be given equal weight in buying essential electronic test equipment—a VOM, a tube/transistor tester, a scope, etc.

Several years ago I started using two VOM's on my lab bench—a 20,000-ohm-per-volt Triplett 630-L and a solid-state Triplett 600. Both VOM's have their uses and have performed as well as I expected when they came into my possession. Thus, it was with interest that I learned of the new Triplett solid-state Model 602 which has features not built into the 600.

The Triplett Model 602, Type 1 is a 2½-pound FET-VOM with eight ac and dc voltage ranges, six ohmmeter ranges, and four ac or dc current ranges. The input resistance is 11.12 megohms on all voltage measuring ranges. The manufacturer emphasizes the introduction of "Auto Polarity"—a circuit that makes the meter read upscale regardless of the polarity being measured. This eliminates the need for continually switching the two test leads.

There are distinct differences between the older Model 600 and the new Model 602. These can best be summarized as follows:

1. A current measuring provision has been added to the 602.
2. The same switch positions are now used for measuring ac or dc volts—not different switch positions as in the older 600.
3. The top resistance range is now X1 meg versus X100K as in the older 600.
4. The OHMS ADJ and ZERO NULL knobs have been reversed from side to side and the labelling is now visible since it is above the knob.
5. A special BATT CHECK position on the selector switch enables the user to check the condition of the two 9-volt batteries.
6. The voltage scales have been changed so that the full scale readings on the Model 602 are now: 0.3; 1.0; 3.0; 10.0; 30.0; 100.0; 300.0; and 1000.0. On the older Model 600 the ranges were: 0.4; 0.8; 1.6; 4.0; 8.0; 16.0; 40.0; 160.0; 400.0; and 1600.0.

Wringing out the 602 —The “Mini-DVM” featured in this issue and the Heath (Mainstadt-Enke) EU-80A voltage reference source were still available in the POPULAR ELECTRONICS laboratory so these were used to verify the low-voltage accuracy of the 602. On the 1-volt scale an input of exactly 0.5 volt read out on the 602 as 0.49 V. On the 3-volt scale, 1.5 volt was read as 1.6 V by several observers. And, on the 10-volt scale, 5.0 V was read as 4.7 V. All of these readings are under the manufacturer’s stated accuracy.

From my precision resistor box, I selected some random values to check the X1, X10, X100, X1K and X10K scales. It went like this: 10.0 ohms at 1% was read as 9.9 ohms; 250 ohms at 1% as 250 ohms; 2778 ohms at 1% as 2800 ohms; 14,400 ohms at 1% as 14,600 ohms; and 825,000 ohms at 1% as 810,000 ohms. Again, all of these readings are well under the manufacturer’s accuracy claims.

Rather than bore you with further details, it should suffice to say that the 602 was checked on the current ranges and the ac ranges to further demonstrate that the unit under test had an accuracy of something usually better than 3%.

So far I am quite pleased by the operation of the 602. It is slightly different than the older Model 600 especially in the handling of the ZERO NULL adjustment. You must learn to rock this control back and forth around zero to obtain an absolute minimum reading to achieve maximum accuracy. The AUTO POLARITY is a remarkably handy feature that you really don’t appreciate until you have used it for several weeks. In fact, it is difficult to break the habit of interchanging leads for polarity reversal measurements. Frankly, the 602 is starting to be a

“spoiler” (as the TV commercial goes).

As far as I am concerned there is still a major problem unsolved regarding FET VOM’s—automatic turnoff. On a few occasions I left the older Model 600 “on” for several days exhausting the batteries. The 602 hasn’t solved this headache, although it is now possible to double-check battery condition. I’ve always thought that the old Amphenol “Millivolt Commander” with the switch in the lid was a great idea for insuring turnoff—until I got sick and tired of unscrewing the test probe from the instrument itself to be able to shut the lid. Okay Triplet, go to work.

A Better Instrument Enclosure —Seven months ago The Product Gallery observed that very few modestly priced instrument enclosures that didn’t look like a plain square box were available to the experimenter. The exception noted was an LMB Model CO-3—a low profile sturdy enclosure with a spot-welded integral chassis. A few months after that item appeared in print, Al Kahn, president of a new electronics manufacturing company brought to my attention some of his equally new Ten-Tec Inc. enclosures. I couldn’t help but be impressed if only from the view that here was another nicely styled enclosure—different than the LMB—that would make almost any home-made project look like it was built by a professional.

Al, a ham with the two-letter call, K4FW, founder and ex-president of Electro-Voice, retired to go into the business of manufacturing specialized gear for hams and experimenters. The new enclosures follow the introduction of a variety of unusual low power ham transmitters. There are two basic enclosure styles and six sizes within each style. There are also two finishes available—the

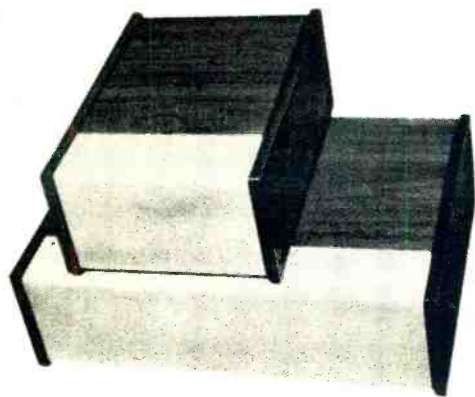

NEW AND FANCY: Decorator series of enclosures has egg-shell white fronts, wood-grain tops and sides.

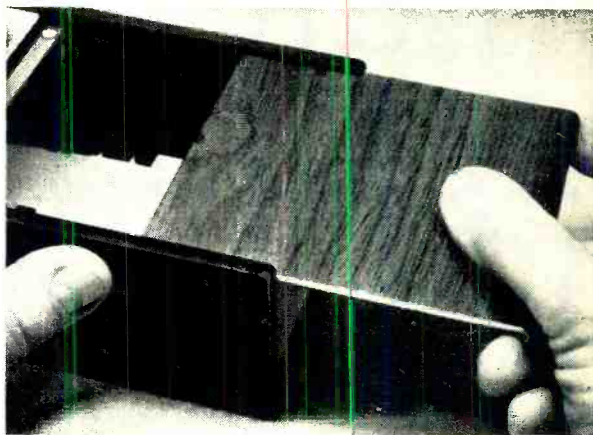

ACCESSIBILITY: Top of the enclosure slides off after removal of two sheet-metal retaining screws.

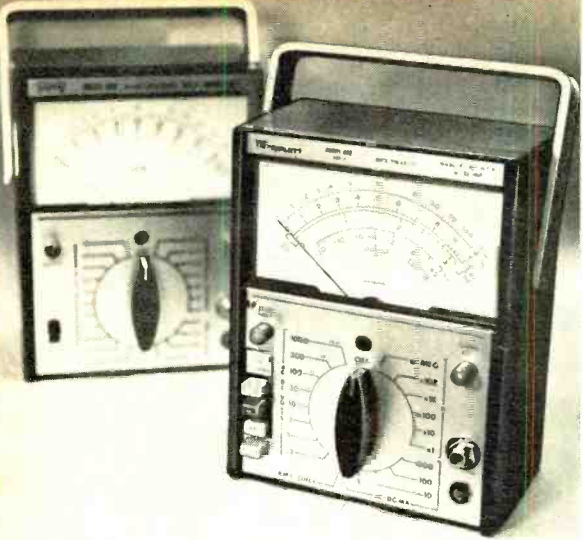

LOOK ALIKES: The Triplet Models 600 (rear) and 602 (front) appear identical, but are different.



PROBES—NEW and OLD: Triplet made two minor and one major change on the test probe. There is a bigger slide switch button, brighter and bigger lettering and a needle point vs the old tip pin of the 602 probe. Alligator clips are supplied.

BATTERY CHECK: New on the 602 is a battery check switch position to monitor the 9-volt batteries.

PUSH BUTTONS: Four push buttons (below) on Model 602 select polarity options of the test probe. If button AP is depressed, the needle reads upscale in the automatic polarity seeking mode. Positions for plus and minus also reverse the ohms battery polarity for ease in making solid-state tests.

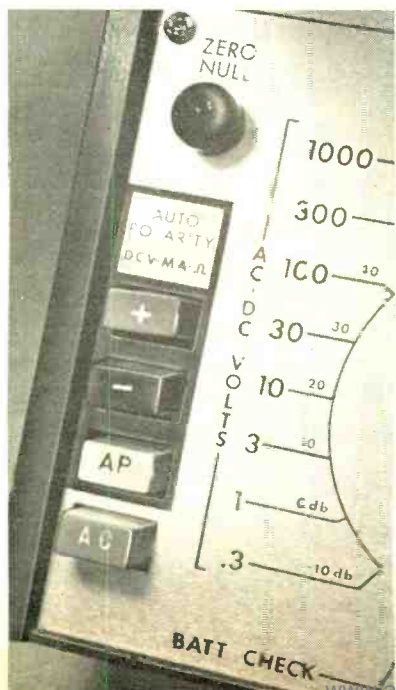
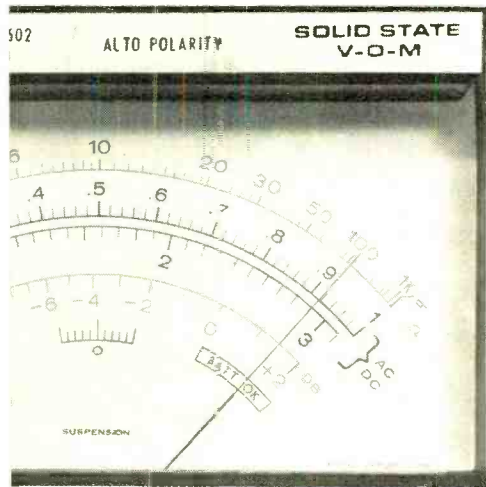

PRECISION LOW VOLTAGE TEST: The 602 passed all tests with flying colors. Using the Heath EU-80-A (see cover photo) and the Lancaster "Mini-DVM", the 602 was well within any possible meter needle parallax error between values of 0.1 and 9.9 volts.

"Professional" with grey and black and the "Decorator" in egg-shell white with wood-grain top and side panels. A matching chassis for each size and style is available.

I haven't built anything too fancy into the Ten-Tec enclosures that are in my workshop. I say this not to indicate that this review may be premature, but to illustrate the quandary I face in putting the right project in an instrument enclosure you almost hate to deface.

B Negative Patterns—Most electronics experimenters are familiar with two easy ways of making their own printed circuit boards. The first—direct masking—is used to make a single board. In this method, the circuit is created on the copper surface using pressure-sensitive tape or some type of liquid resist. Once the circuit is laid out, the board is etched.

The second method—photo mask cut and peel—is used when tracing a foil pattern. Here, a two-layer mask (one dark film and the other clear) is used and the circuit outline is cut out with a sharp knife. The dark layer is removed to expose the circuit. The board is prepared with light-sensitive resist and allowed to dry. The film is then placed over the prepared board and exposed to light. After exposure, the film mask is removed and the board is treated and etched.

To produce a board with good, clean lines, both methods depend on a steady hand and a sharp knife. This becomes even more difficult when you are working with transistors and IC's.

Recently, I started using the GC Electronics "B Neg" Drafting Aids to make an actual size master that is equal to the best photographic product. The B Neg stick-on's eliminate the need for photography and are speedy and easy to use. I simply determine the circuit pattern and place the negatives for the terminals in their proper positions on clear acetate. The remaining area is filled in with adhesive-backed black background. The interconnecting lines are carefully drawn with a sharp white charcoal pencil and then cut out using a sharp knife and metal guide. If a mistake is made or the circuit must be redone, the necessary portion of the black background can be easily removed and replaced.

After using the B Negs to make several relatively complex PC boards, I found that I could turn out really professional looking boards. Although designed for the small electronics manufacturer, the B Neg approach is excellent for the serious experimenter who takes pride in his work.

Incidentally, GC Electronics distributors also have an excellent manual called "Printed Circuit Handbook" costing 50¢. This well-written and illustrated manual details

all the methods used to make a PC board, giving each step. This is a must if you make your own boards, or would like to.

Work in Progress—Due to a few editorial disruptions this first installment of the new "TPG" is unfortunately brief. However, next month, it will be enlarged and will include discussions on the Electro-Voice "Landmark 100" stereo system, Avanti "Astro-Plane" CB antenna, Eico Model 150 signal tracer and Knight-Kit R-195 communications receiver.

In the months to come, The Product Gallery will take a look at two new Heathkit items, the IO-101 Vectorscope/Color Generator and the solid-state GR-370 color TV receiver. Test equipment, shortwave receivers, ham radio gear and various CB transceivers will be laboratory and field tested. If you would like a report published on a particular item, drop me a letter or postcard. —30—

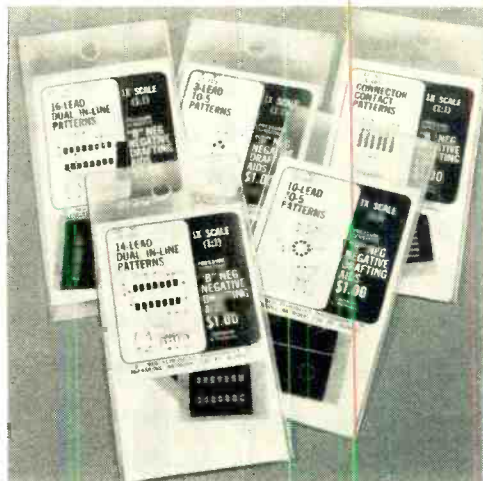

SIMPLICITY PLUS: Use of "B Negs" results in PC boards with accuracy equal to photo-made patterns.

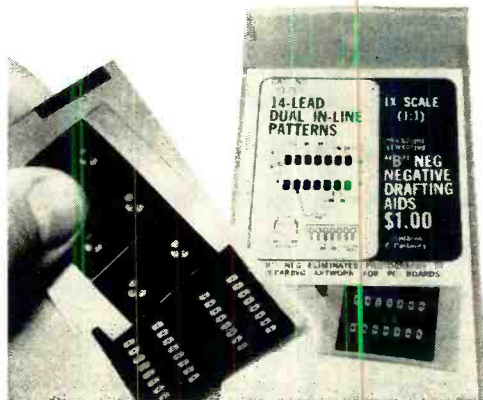

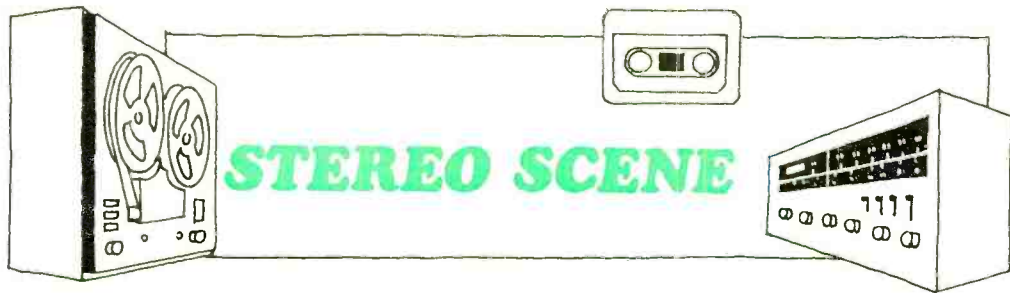

First in a Monthly Series by J. Gordon Holt

MY INITIAL REACTION when asked to do a monthly column on audio for this magazine was, "Phooey!" Not that I have anything against POPULAR ELECTRONICS specifically—it just happens to be an advertiser-supported, hobby-oriented, consumer-type magazine; and my experience writing for such magazines had been that I could say anything I wanted so long as I did not criticize, embarrass or otherwise cause discomfiture to the advertisers, some of whose products I was supposed to discuss for the edification of the reader. However, I was assured that this time I could do my own thing so I agreed to take a crack at it. It seemed too good to be true, but a writer with opinions can't resist a soap box.

Let me make it clear at the outset that, though I try to be fair, I *am* opinionated. I say this in the hope of forestalling letters from those readers who are offended by some of my opinions. I have definite ideas about the aims and objectives of high-fidelity sound reproduction and about the people who make the equipment and those who buy it in the stores. I am, in fact, what is sometimes called a "purist." Which is to say that I believe that high fidelity is, by definition, the pursuit of *realistic* sound reproduction—not pretty, or spectacular, or effective sound reproduction, but realistic! I feel that it should be the aim of every component manufacturer, recording studio, and audio hobbyist to reproduce the best possible semblance of a live musical performance, as heard from a good seat in the auditorium or wherever the music might be performed. I do not abide with the fiction concerning sound as heard from the "best seat in the house," because it was that fanciful idea that gave birth to the theory that a recording should be a "work of art unto itself," devoid of any relationship to a live-performance experience. That *may* be art, and it may provide an outlet for the frustrated musical creativity of recording directors, but it ain't fidelity.

Without the concept of the "original sound," there can be no appreciation of

fidelity in reproduced sound. By definition, a high-fidelity reproduction is a highly accurate reproduction, and without the original by which to judge the copy, there can be no meaningful measure of fidelity. An original abstract painting has no fidelity. Only a reproduction of it can be judged in terms of fidelity of color, texture, and so on. Similarly, the sound of live music has no fidelity; only the reproduction of it can be judged on that basis. You may prefer more brilliant coloring or more spectacular sound in the reproduction of the painting or the music, and that's your privilege. But if you do, don't kid yourself by thinking that you are a high-fidelity enthusiast. You're a color enthusiast or a sound enthusiast, and you will probably disagree with much of what I'll have to say in this and future columns. That's your privilege, also.

So You're Way Out. Those of you who are addicted to rock and roll will no doubt be screaming that my view of high fidelity excludes your particular type of music because there is no original performance. The far-out sounds of the Beatles' "Sergeant Pepper" and the Blood, Sweat and Tears records don't exist in a "live" form. They are created on tape, and are never heard until the tape is played through a reproducing system, which in this case is actually the "producing" system. It's true—I *don't* consider this to lie within the realm of fidelity, unless we think in terms of fidelity's being the original intent of the people who made the tape. Nevertheless, an audio system that can faithfully reproduce a recording of orchestral music will do equal justice to rock—at least at moderate volume levels.

Speaking of reproducing rock music, it is obvious from the epidemic of burned-out loudspeakers and smoldering amplifiers that the listening levels for rock music are far beyond the bounds of what is adequate for reproducing "serious" music. So fidelity aside, it would seem that the new music, with its mystique of the traumatized ear,

has created the need for a new breed of audio systems. But we'll discuss that at length at a later time.

I will go on record now as being a confirmed audio snob. I have no interest in and no personal commitment to the so-called mass-hi-fi field. High fidelity sound reproduction is really for people who *listen*; and there aren't very many who can do this for more than a few minutes at a time without talking, reading, or filling their stomachs. Most so-called "listeners" would be just as happy with a cheap portable stereo; but if they're willing to pay for something more in the name of status, I can't criticize them or the industry which caters to them. I'm just not that concerned about either one.

What I am concerned about is that segment of the audio industry which seems willing to corrupt the entire audio field by bowing to the imagined "preferences" of those people who don't pay enough attention to what they're listening to to have any preferences. By far the worst offenders are the recording companies, who can give you a long list of reasons—backed up by market surveys—why they can't sell a recording that is as high in fidelity as the current state of the art permits it to be. Dynamic range must be compressed, individual instruments must be spotlighted and the lows must be rolled off below 70 Hz.

Then the highs must be given an extra dose of presence because the "average buyer" listens at low volume in a small living room with drapes and overstuffed furniture to a phonograph with lousy trackability and a treble control that is turned down. Certainly, there's nothing the matter with doing this kind of thing to background music and similar forms of aural chewing gum, but why must it also be done to recordings of grand opera, pipe organ, and that segment of the orchestral repertoire that isn't included in the "twenty great masterpieces that every music lover must have in his library?"

All Is Not Lost. If I have given the impression that I am a sourpuss who disapproves of everything, that is not really the case. I can see *some* things to be happy about. I am still not convinced that four-channel (quadrasonic) stereo is one of them, but I am immensely happy with a few new components that have recently made their appearances and am encouraged by the announcements of some others.

The Crown DC-300 stereo power amplifier, for example, is something to do cartwheels over, not only because of the way it is built, but also because of the way it sounds. Whether the superb transparency and detail of this costly hunk of hardware are due to its extremely low distortion, its high available power, or its rock-solid stability is a matter

for conjecture. The fact is that it does sound better than anything else I've listened to, even at low volume levels; and my reaction to those critics who've reported that they couldn't hear the difference is that they either didn't really listen to it or they need to do some more ear-training exercises.

The current popularity of the DC-300 is encouraging to me in another way. It was only a few years ago that "established" high-fidelity equipment manufacturers were telling me that they had no intention of supplementing their mass-market line with top-priced, no-holds-barred components because "there's no demand for top-flight equipment." I wonder how they are feeling about the consumer reaction to the DC-300 and some of the other astronomically priced new components like the SAE preamplifier and the Infinity Servo-Statik I speaker system that bears a pricetag in the \$2000 range and then calls for *two* power amplifiers to drive it (one of which should, according to Infinity, be a Crown DC-300). I don't expect to see components like this cornering the high-fidelity market, but I find it encouraging that some manufacturers are at least interested in advancing the art instead of trying to make cheaper mass-market items that are "almost as good as" last year's.

Europeans to the Rescue. Another thing that I find encouraging on the current audio scene is the increasing number of disc recordings that are being imported from Europe. Until fairly recently, most U.S. releases of European discs were "mastered" here from imported tapes and were "equalized" according to the prevailing philosophy of

J. GORDON HOLT

A graduate of Lehigh University, with a journalism major, Gordon got his primary and secondary education in Melbourne, Australia. He joined the staffs of *High Fidelity* and *Audiocraft* magazines in the mid-50's, and moved to Weathers Industries to write instruction manuals and service bulletins in 1960. Resuming free lance writing, he contributed to various magazines, including our sister publication *Stereo Review*. Seeking further freedom, Gordon started his own magazine, *The Stereophile*, in 1962 to report extensively on hi-fi/stereo components.

Always interested in obtaining the highest fidelity, he has been involved since 1948 in the live recording of choral and orchestral groups, including folk singer Richard Dyer-Bennet on discs bearing the latter's own label. Gordon designs and does consulting work for various equipment manufacturers and stereo enthusiasts planning ambitious reproducer installations.

U.S. recording tastes. Western Europe, however, has tended to view serious music as primarily of interest to the discriminating so there has been less inclination to compromise their discs to please a mass market. Previously, the quality obtainable from Europe was available only to a few dedicated hobbyists who had learned to order their discs from overseas. Now, Argo, Odeon, and Oiseau-Lyre (and others) discs are coming into the U.S. as pressings, cut in Europe to European standards. And some U.S. shops are importing—probably illegally—English recordings that would normally be processed and released by licensed American companies.

I am pleased to note the growing popularity of the so-called "compact" tape media—the cassettes and cartridges—but for an unusual reason. Sonically, they are not, and probably never will be, as good as the better discs or open-reel tapes; but they serve a purpose that can only be considered beneficial to the quality audio field: they are siphoning off that large segment of the music-buying market whose existence has been the principal excuse for the compromising of all recordings.

The portability, convenience, and relative ruggedness of the instant-load, easy-carry compacts have great appeal to the mass music consumer (using consumer in the sense of one who buys, uses, and discards). These compacts will very probably be The Medium of the Future for the casual music listener. This means that most of the firms currently making discs will eventually abandon that medium in favor of the compact tapes, leaving the recording of music with less mass appeal to smaller companies who believe strongly enough in the artistic value of what they record to be content with selling it to a relatively small but appreciative market. This has happened before. Westminster Records started as the latter type of company, as did the now defunct Unicorn Records.

It is even possible that some of the major U.S. recording firms will acknowledge the existence of that small band of record buyers who have been resisting the kind of domestic recording practices that reached their zenith with RCA Victor's much-heralded but (to audiophiles) disappointing Dynagroove recordings. Columbia Records has been reissuing "discontinued" definitive recordings that have little if any mass appeal, so it is not unlikely that they might start doing the same thing for fidelity-conscious buyers, for the same ostensibly altruistic reasons.

In other words, there are, even now, forces for good at work on the domestic high-fidelity scene. I do recognize their existence. So please keep this in mind when, in future col-

umns, I harp on all the things I do not like about recordings, components, dealers and musicians. (Yes, musicians are partly to blame for the sorry state of most domestic orchestral recordings, simply because their union rules have raised the price of experimental recording to the point where it is better to play it safe than to try new techniques.)

It's fine to give due credit for things that are done right, and I am happy to do this from time to time. But there are other audio publications whose devotion to positive thinking should yield all the praise the industry deserves. What is needed, I feel, is some constructive criticism; and I hope this column will contribute something interesting and informative along those lines.

Early Beginnings. I became hooked on both music and high fidelity as the result of a music appreciation course in Junior High School. The school was the proud possessor of one of the first genuine high-fidelity phonographs—a two-piece ensemble consisting of a variable-speed 78-r/min turntable with a 5-oz crystal pickup, a vacuum-tube amplifier with real bass and treble controls, and a separate speaker system about the size of a large steamer trunk.

My exposure to music at home had been through such ditties as "Falling Leaves" and "Today I Feel So Happy," played on a vintage wind-up portable Victrola (whose wooden case now carries my microphone cables for remote recording jobs). Since music-appreciation courses are predicated on the notion that the most important thing about music is how it developed, I was subjected to a succession of Gregorian chants, descants, polyphony, Baroque pieces, and Italian opera. Then there was Wagner—and a recording of the Prelude to Act III of "Lohengrin"—and I was hooked.

I bought the record, probably expecting it to sound just as hair-raising on my little Victrola. That was when I realized that some sound reproducers were better than others and started trying to improve my own. I'm still trying.

Today, I find that there are other musical works that impress me as much as my first "revelation" did, but my tastes still aren't particularly catholic. I like most orchestral music; but I consider John Cage a practical joker, the vast bulk of rock and roll unmitigated trash, and live music better than canned music. I like the transparency of electrostatic speakers; I prefer a row-A seat in the first balcony at live performances; and, accordingly, I play reproduced music somewhat but not terribly loud. And I am—in no uncertain terms—a nut about high fidelity.



One Hundred Seventy-Second in a Monthly Series by Lou Garner

WITH ALL the recent interest in digital display devices, it is no wonder that a 7-segment readout that measures only $\frac{3}{4}$ " \times $\frac{1}{2}$ " \times $\frac{1}{8}$ " would create an exceptional stir. Such has been the case with the announcement by Monsanto Electronics Special Products of the availability of their H-4 light-emitting diode display. Because of their small size and compatible power requirements (3.6 volts d.c. at 20 mA per segment), the H-4's have been tried in the designs of several devices requiring digital readout.

In fact, while the article on the Mini-DVM which is featured in this issue of POPULAR ELECTRONICS, was being prepared, the editors tried using the Monsanto H-4's as readouts for the DVM. The instrument's circuit was duplicated except for the Nixies and the "1" and overrange lamps. Instead two H-4's and small filament lamps for the "1" and overrange were used. Two printed circuit boards were made—one for the driving and decoding integrated circuits, the other for the readouts. The two narrow PC boards were installed in an aluminum tube 1" in diameter and 5" long, with a cutout for viewing the readouts. A cap was molded for the front of the tube and a probe tip was installed in it to make the input for the DVM.

The remainder of the electronic circuit for the DVM was mounted in a separate chassis and a 3' narrow-diameter, multi-lead cable was used to connect the readout package to the chassis.

The result was a new look in DVM's. Having the complete readout within the probe enabled the user to bend over the equipment being tested and still see the measured quantity with great ease. The probe handled easily and was small enough to fit the hand comfortably.

You might want to give the Monsanto readouts a try—either in the DVM or in a digital clock. They cost \$11 each from Monsanto Electronics Special Products, 10131 Bubb Road, Cupertino, CA 95014. Decade counters and driver circuits are available from Southwest Technical Products Corp.,

219 W. Rhapsody, San Antonio, TX 78216. If there is sufficient interest, POPULAR ELECTRONICS may put together a set of construction plans for either the DVM or the clock.

Laser Communicator. An efficient commercial laser communications and data transmission system was among the interesting products displayed at the annual convention of the Armed Forces Communications Electronics Association (AFCEA) held recently in Washington. Although similar in principle to the laser communication system described in the May issue of this magazine, the commercial system uses an all-solid-state circuit. Developed and manufactured by the University Instruments Corporation (2585 Arapahoe St., Boulder, CO 80302), the system is intended for commercial, industrial and military applications and can transmit digital data at a high speed over appreciable distances.

Designed specifically for integrated-circuit applications, the breadboard module shown in Fig. 1, was exhibited at the Western Electronics Conference (WESCON) in

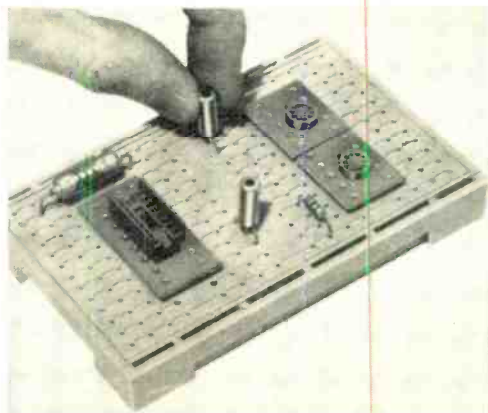

Fig. 1. Breadboarding module was designed specifically for setting up experimental and pre-production IC prototype layouts using plug-in technique.

If you can't come to the world's newest, largest and most exciting electronics department store, we'll mail the store to you!

Exclusive! Knight-Kit and Science-Fair Kits. Exciting build-your-own kits made to our own exacting standards. Stereo, CB, automotive, ham radio, science, hobby, test equipment, photography and more!

Exclusive! Realistic Life-time Tubes. Never worry about buying another tube. We guarantee ours will last as long as your set—or we replace it FREE!

Exclusive! Battery-A-Month Club. Join the Allied Radio Shack Club and receive a powerful battery every month for a full year—FREE!



New Allied Radio Shack Catalog! Thousands of electronic values!

Allied Radio and Radio Shack have joined forces to form the largest electronics distributing company in the world! This new 1971 460-page catalog offers you the best of both companies: famous-name brands, exclusive new products you'll find nowhere else (including some items you didn't even think were invented yet), and special money-saving prices that only the combined buying power of these two great companies could offer!

World's Largest Electronic Department Stores. Over 800 stores in 48 states. See your phone book for store nearest you.

Exclusive! Quality Audio Products at Factory-Direct Savings

Allied TD-1093 3-Head Stereo Tape Deck. New one-piece head makes tape threading a snap. With case. Spectacular value! \$179.95

Realistic STA-120 Wideband AM, FET-FM Stereo Receiver. 140 Watts. With case. \$269.95



Mail Coupon To Address Below

...or bring to
Allied Radio
Shack store for
new catalog!



ALLIED RADIO SHACK 100 N. Western Avenue
Chicago, Illinois 60680 612

Yes! I want your big new 1971 catalog. I enclose \$1 for mailing and handling (refundable with my first purchase of \$1 or more).

NAME _____
First Middle Last

ADDRESS _____
Street or Route and Box No.

CITY _____ STATE _____ ZIP _____

I enclose check money order cash

Los Angeles in August. This is a product of S.D.C. Electronics, Ltd., one of the twenty-eight British firms participating in the conference. An improved and modified version of the general purpose S-DeC breadboard described in our Product Gallery in July 1969, the IC board is distributed in the U.S. by Intratec (399 Jefferson Davis Highway, Arlington, VA 22202).

Although there were many interesting displays at the National Electronic Packaging and Production Conference (NEPCON East) held at the New York Coliseum, the major emphasis, naturally, was on production equipment, and comparatively few new components and instruments were introduced. There was, however, one item which could be of real interest to serious experimenters and advanced hobbyists. Presented by Bishop Graphics, Inc. (7300 Radford Ave., North Hollywood, CA 91605) and called Circuit Zaps®, the new circuit board elements are copper components patterns, mounting pads, and conductor paths etched on thin semi-flexible glass-epoxy base material backed with a special pressure-sensitive adhesive. A number of individual patterns are offered, including various TO-type, DIP, and flat-pack IC terminal configurations; connector pads; terminal strips; and conductor lines. A comprehensive introductory assortment, the Circuit Zap "Speedkit" is available for \$59.50.

In practice, a functional prototype circuit board can be made by selecting the needed component terminal patterns and applying them directly to any suitable insulating substrate, much as one would apply a pre-

gummed label to a package. Ceramic plates, phenolic sheets, glass-epoxy laminates, or similar substrates may be used. The component and active-device terminal patterns are interconnected using either pressure-sensitive conductor strips or short lengths of hook-up wire to complete the circuit. Parts are mounted and soldered as with conventional etched boards.

Reader's Circuit. Designed primarily for automotive applications, the solid-state lamp flasher circuit shown in Fig. 2 was submitted by reader Paul Schultz (6208 Templeton Dr., Carmichael, CA 95608), who also contributed the sequential lamp control circuit featured in our August column. Suitable for use in conjunction with the earlier circuit, the flasher can be used as a replacement for conventional electro-mechanical flashers, offering higher efficiency coupled with a fully adjustable flashing rate.

Unijunction transistor *Q1* is used as a conventional *RC* relaxation oscillator to furnish control pulses to switching devices *SCR1* and *SCR2*. The oscillator's repetition rate is determined by the time constant of the circuit made up of *R1*, *R2*, and *C1*. Capacitor *C5* provides commutation between the two *SCR*'s, which, in turn, furnish a drive signal to the cascaded output circuit, *Q2* and *Q3*. Voltage regulation is provided by *R8* in conjunction with zener diode *D2* to insure stable operation.

Coupling diode *D1* is type 1N2615, although any silicon diode with a PIV rating of at least 200 volts and a maximum current rating of at least 500 mA can be used. Ca-

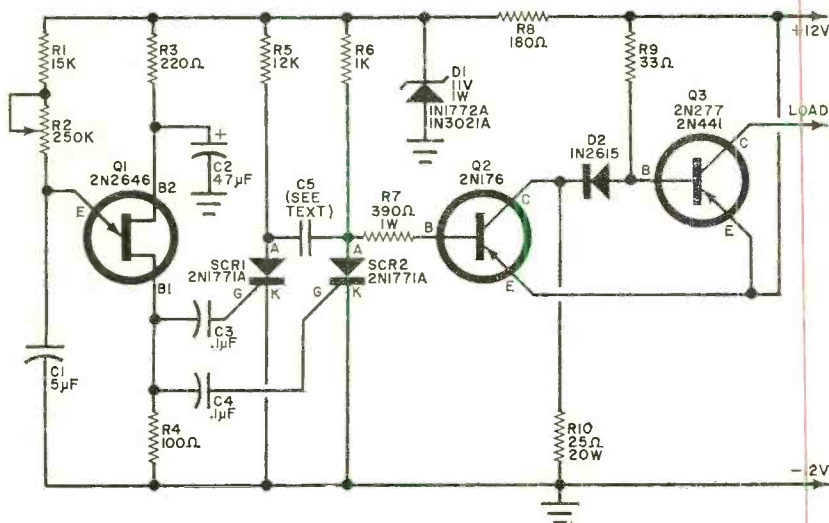

Fig. 2. Solid-state lamp flasher circuit can replace conventional electro-mechanical flashers, offering greater efficiency and fully adjustable flash rate control.



Shortstop.

Our exclusive posted-filament design stops shorts in high-voltage rectifiers.

And you know what shorts cause . . . catastrophic failure, or weakened tubes and components.

The result: unprofitable callbacks.

Our 3CU3A, 3BM2A, 3BL2A, and 3DC3 high-voltage rectifiers all use the fail-safe posted-filament design.

Put our shortstops on your team. You'll find that callbacks won't even get to first base.

Sylvania Electronic Components,
Electronic Tube Division, West Third
St., Emporium, Pa. 15834.

SYLVANIA
GENERAL TELEPHONE & ELECTRONICS

capacitor $C5$ is a $2\text{-}\mu\text{F}$, 100-volt non-polarized unit which may be made up by connecting two $4\text{-}\mu\text{F}$, 100-volt electrolytics back-to-back.

The circuit can be assembled using any construction method; layout and lead dress are not critical. All dc polarities must be carefully observed; and if desired, insulated heatsinks may be provided for the SCR's and output transistors.

If the circuit is to be used *only* for standard turn signal applications, rather than in conjunction with the sequential control described last month, components $C2$, $D2$, and $R8$ may be omitted, with $C1$'s value reduced to $2\ \mu\text{F}$.

Intended for use in autos with conventional 12-volt negative-ground electrical systems, the assembled circuit is normally mounted under the dashboard as a direct replacement for the standard electro-mechanical flasher. After installation and check-out, rate control $R2$ should be adjusted for the desired flashing rate.

TV Set on a Chip? Not quite, but give the industry a little time and it may occur. For example, consider RCA's new TA5914 integrated circuit. This 18-lead plastic package contains an 85-dB video i-f amplifier, video detector, video amplifier, sound channel amplifier and detector, 4.5-MHz amplifier, keyed agc-noise immunity circuit, tuner agc delay amplifier, and zener diode voltage regulator. A block diagram of the circuits in the device is shown in Fig. 3.

If you decide you want color, you can also use the TA5625 chroma control system which has a gain-controlled chroma amplifier, band-pass amplifier, injection-locked oscillator, automatic color correction detector-amplifier, killer detector-amplifier, dc chroma gain control, and a zener voltage

regulator. The TA5625 comes in a 16-lead plastic package.

Also in the color section is the TA5752 chroma demodulator that contains a synchronous detector with color-difference matrix, complete dc phase-shift (tint) control, oscillator injection limiter, output amplifiers for the R-Y, G-Y, and B-Y signals, and a zener diode voltage regulator. Again this is in a 16-lead package. All we need now is an IC tuner, IC sweep circuits, a micro-color tube, and we are ready for color TV in the shirt pocket.

Watch That Watch! If you were watching NBC-TV's "Today" show a few months ago, you saw one of the first public demonstrations of an amazing new all-electronic, solid-state wristwatch. If you missed the show, you probably saw a write up on the watch in the newspaper. In any case, you are probably wondering how it works.

Actually it is still in the prototype stage, but the watch is scheduled for production and sale in 1971. It is a joint development of Electro/Data, Inc. (Garland, Texas) and the Hamilton Watch Co. (Lancaster, Pa.). The watch is essentially a battery-powered microminiature electronic digital computer with a fixed precision signal source and a

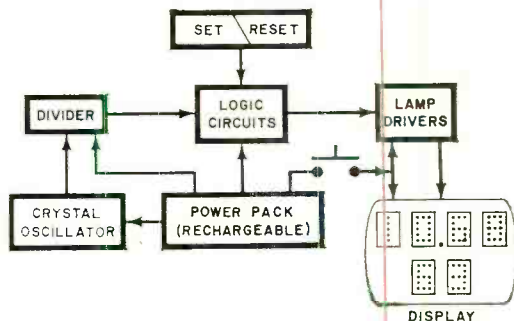

Fig. 4. Block diagram shows circuit breakdown of total electronic watch. Precision oscillator drives divider and logic circuits to provide numeric readout via light-emitting diodes. Readouts are passive until switch is closed to conserve battery power.

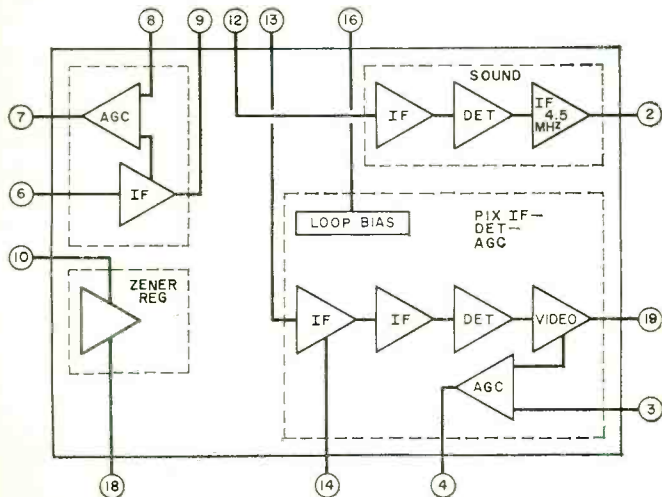

Fig. 3. Just add a front end, power supply, horizontal and vertical drive circuits, a picture tube, and maybe a volume control to RCA's TA5914 IC (diagram at left), and you have a complete monochrome TV receiver.

FREE!

1971
CATALOG
NO. 710

**JUST OFF THE PRESS!!
SEND FOR YOUR EXCITING COPY NOW!**



**YOUR 1st GUIDE TO
EVERYTHING IN
ELECTRONICS**

- ★ CITIZENS BAND 2-WAY RADIO
- ★ STEREO/HI-FI COMPONENTS
- ★ MUSICAL INSTRUMENTS AND AMPLIFIERS
- ★ PUBLIC ADDRESS
- ★ AMATEUR RADIO
- ★ TEST EQUIPMENT
- ★ PARTS
- ★ PORTABLE AND TABLE RADIOS
- ★ PHOTO EQUIPMENT
- ★ TOOLS-BOOKS
- ★ AUTO ACCESSORIES
- ★ EDUCATIONAL AND OPTICAL
- ★ TV AND ANTENNAS

Your Complete Buying Guide to Everything in Electronics

LAFAYETTE Radio ELECTRONICS
Dept. 35090, P.O. Box 10
Syosset, L.I., N.Y. 11791

Send me the FREE 1971 LAFAYETTE Catalog 710 35090

Name

Address

City State

Zip
(please include your Zip Code No.)

**Mail the Coupon Today
for your FREE 1971 Lafayette
Catalog 710**

CIRCLE NO. 14 ON READER SERVICE PAGE

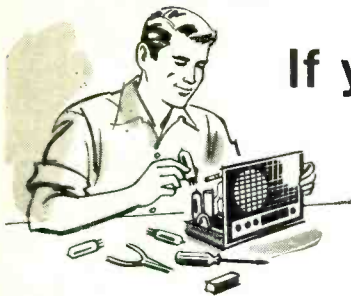

If you're a natural "Mr. Fix-it"...

why not see your knack by sending for this on your future in

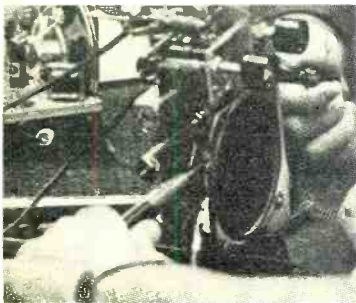
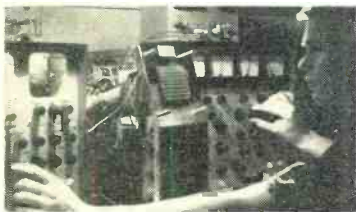

If you've been using your mechanical ability only on weekend projects while you spend the rest of the week in a dull, low-paying job—you just don't know how much your ability could be worth!

Consider this: according to the National Science Foundation, four million trained technicians will be needed within the next five years; yet projections show that *less than one million* will be available. Already, big and small companies are competing desperately for technicians...spending hundreds of millions of dollars in newspaper advertising to woo them with excellent salaries and mouth-watering fringe benefits!

Today there's almost no field that doesn't depend on electronic equipment and the technicians who can make it work...from life-saving medical electronics to computer technology to the exotic new field of *astrionics*—the application of electronics to space flight!

How can you learn to become a technician? Our free booklet will explain how United Technical Institute can actually train you to be ready for your first position in just a matter of months—thanks to our practical learn-by-doing approach.

Whether you attend classes or take our home-study course, you'll find yourself thinking and acting like a professional technician from the very first day...facing the same challenges you would face on the job...simple at first, then more complex in a series of natural, easy-to-digest steps. All along the way, you'll be guided by expert UTI instructors. Even if you found ordinary schooling dull, you'll find UTI training fascinating!

There couldn't be a better time for you to put your technical ability to work on the most important project of all...earning you more money at work you really enjoy doing! Send for UTI's free booklet today by mailing the card or coupon.

how much is worth— free booklet electronics!



ADVANTAGES ONLY THE FINEST SCHOOLS OFFER:

- ★ Nationwide placement assistance at no extra cost!
- ★ Accredited Member of the National Association of Trade and Technical Schools.
- ★ Eligible institution under the Federally Insured Student Loan Program.
- ★ Resident Schools approved for veteran training.
- ★ Your choice of home study or classroom training in major cities from coast to coast.

UTI TRAINING WORKS!

"Patrick is making good use of his UTI education now at the Westinghouse Defense and Space Center. In September, they're going to send him through Johns Hopkins University. Thanks to UTI from us and from Patrick."
—Mr. & Mrs. Eugene Beattie

"I'm classified as an Advanced Graduate because of my schooling at UTI!"
—Gerald A. Modjeski

"Finally settled here in sunny Southern California. Will be getting a raise in October and a higher cost of living allowance too. I must thank UTI!"
—Kirby Wanden

"Joined a young company... outstanding opportunity to grow and be within a stone's throw from one of the best fishing areas in the country. Wish to again thank UTI for the education I received!"
—William F. Secraw

"We will always be glad that our son Bob, attended UTI and would like you to know that he is doing very well in his chosen vocation!"
—Mrs. V. M. Irwin

"I'm very glad I attended UTI. I don't know where I would have been without your help. Thank you!"
—James Wukoman

FOR FREE BOOKLET
MAIL COUPON BELOW TODAY!

CAREER ACADEMY

United Technical Institute Division
611 E. Wells Street, Dept. 07N087221
Milwaukee, Wisconsin 53201

Please send me the FREE booklet describing the exciting future waiting for me in electronics!

Name _____ Age _____
(please print)

Address _____

City _____

State/Province _____ Zip _____

Year of high school graduation _____ Phone _____
(Home, Business, or Neighbor)

Interested in Classroom Study Home Study
Check here if eligible for Veteran's Benefits

CIRCLE NO. 24 ON READER SERVICE PAGE

POPULAR ELECTRONICS SUBSCRIBER SERVICE

Please include an address label when writing about your subscription to help us serve you promptly. Write to: P.O. Box 1096, Flushing, N.Y. 11352

CHANGE OF ADDRESS: Please let us know you are moving at least four to six weeks in advance. Affix magazine address label in space to the right and print new address below. If you have a question about your subscription, attach address label to your letter.

TO SUBSCRIBE: Check below.

5 yrs. \$21 3 yrs. \$15
 1 yr. \$6 New Renewal

Specify: Payment enclosed
 You get 1 extra issue per year as a BONUS!
 Bill me later.

If you have no label handy, print OLD address here.

Please print

name _____

address _____

city _____

state _____ zip code _____

AFFIX LABEL →

0406

print name _____

address _____

city _____

state _____ zip code _____

Add'l postage: \$1 per year outside U.S., its possessions & Canada.

ABOUT YOUR SUBSCRIPTION

Your subscription to POPULAR ELECTRONICS is maintained on one of the world's most modern, efficient computer systems, and if you're like 99% of our subscribers, you'll never have any reason to complain about your subscription service.

We have found that when complaints do arise, the majority of them occur because people have written their names or addresses differently at different times. For example, if your subscription were listed under "William Jones, Cedar Lane, Middletown, Arizona," and you were to renew it as "Bill Jones, Cedar Lane, Middletown, Arizona," our computer would think that two separate subscriptions were involved, and it would start sending you two copies of POPULAR ELECTRONICS each month. Other examples of combinations of names that would confuse the computer would include: John Henry Smith and Henry Smith; and Mrs. Joseph Jones and Mary Jones. Minor differences in addresses can also lead to difficulties. For example, to the computer, 100 Second St. is not the same as 100 2nd St.

So, please, when you write us about your subscription, be sure to enclose the mailing label from the cover of the magazine—or else copy your name and address exactly as they appear on the mailing label. This will greatly reduce any chance of error, and we will be able to service your request much more quickly.

SOLID STATE

(Continued from page 104)

numeric readout. A block diagram of the watch is shown in Fig. 4.

A crystal-controlled oscillator operating at 32.768 kHz provides the instrument's time base. The oscillator's output is coupled to a multi-stage binary counter which serves as a frequency divider, reducing the signal to 1-Hz pulses. Logic and counter circuits establish the pulse forms needed to provide a running memory of second, minute, and hour time intervals. These signals are coupled to appropriate drive amplifiers which, in turn, actuate a dot-matrix gallium arsenide phosphide LED readout on the face of the watch. Micropower subminiature LSI circuitry is used throughout, while dc operating power is furnished by a tiny 3-cell, 4.5-volt rechargeable silver zinc battery.

Special circuits are provided for setting the watch, while a light sensor automatically adjusts the LED readout brightness to compensate for varying ambient light.

Although the oscillator, divider and logic circuit operate continuously, the LED readout is energized only on demand to conserve battery power. When the control switch is closed momentarily, the hour and minute display is activated for 1.25 sec. If switch closure is maintained, the hour/minute display darkens and a continuously counting seconds display appears.

With a maintained accuracy of better than 3 seconds per month, the new watch, called the "Pulsar," is expected to retail for approximately \$1,500.00.

ESD or Super Capacitor. A new solid-state capacitor-like device developed by Gould Ionics, Inc. (P.O. Box 1377, Canoga Park, CA 91304) was described last May in a technical paper presented by H. I. Rudman and J. E. Oxley at the 20th Electronic Components Conference in Washington, D.C. It has almost unbelievable characteristics. It can have an effective capacitance of up to 50 farads (no that's not a typographical error—it's 50 F) in less than $\frac{1}{3}$ cu in. and will retain better than 97% of its charge for an indefinite period. (Tests, thus far, have been extended to only 9 months, but extrapolation and theoretical considerations indicate a multi-year charge retention.)

So unique that it is called an Energy Storage Device (ESD) rather than a capacitor, and identified by a special schematic symbol, the new component has virtually unlimited potential in control, timing, memory, time delay, filter, and power supply applications.

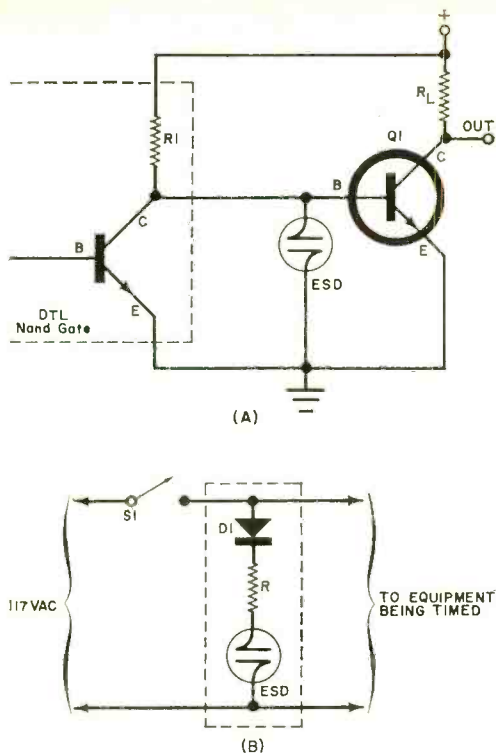

Fig. 5. Energy Storage Device (ESD) can have effective capacitance of up to 50 F! So new, special schematic symbol had to be evolved. In (A) is a time control circuit; (B), running time integrator.

Except for its extremely high capacitance, its electrical characteristics are roughly analogous to those of an electrolytic capacitor. It has an internal series resistance of a little less than 1 ohm with a very high shunt (leakage) resistance and it is dc polarized. A single ESD cell has a breakdown rating of approximately 0.66 volts; 0.5 volt is considered its nominal working voltage. Series and series-parallel cell connections may be used,

however, if they are needed to increase the capacitance and/or working voltage.

Externally, a typical ESD cell somewhat resembles a flat nickel-cadmium or mercury battery, although thick-film versions of the device have been assembled for test purposes. The standard cell consists of two electrode wafers separated by an electrolyte, with suitable electrode terminals attached and the entire unit encapsulated in a small metal can. Its extremely high capacitance (which can reach 300 farads per cu in, is a result of a maximization of the electrode-electrolyte interface area and the development of a blend of finely divided carbon and a high-ionically conducting solid electrolyte.

Two typical circuit applications for the ESD are shown in Fig. 5. Note the special symbol. The long time control circuit shown in Fig. 5A uses an ESD as a shunt element between logic circuits and a control amplifier (Q1). Depending on R1 and the ESD's values, such a circuit could provide delays of several hours to many weeks.

A running time integrator arrangement is shown in Fig. 5B. Requiring only a diode (D1), a dropping resistor (R), and the ESD, this circuit can be used to determine the total running time of a piece of electrical or electronic equipment. In operation, the ESD is charged during each positive half cycle and slightly discharged by the diode's leakage during each negative half cycle. As a result, the ESD's charge will increase linearly with operating time, permitting a measurement to be made simply by checking the ESD's voltage with a VTVM and correlating to a standard charge curve. With a suitable resistor, a low reverse leakage diode, and a 50-F ESD, over a century of continuous operation can be obtained.

Not yet in full production as stock items, currently available ESD's command relatively high prices as prototypes. All types, from the Model 1050C-1 50-F unit to the Model 5.5U-1 0.5-F, are \$30.00.

So, Happy Farads, Everybody. —Lou

FREE McIntosh CATALOG and FM DIRECTORY

Get all the newest and latest information on the new McIntosh Solid State equipment in the McIntosh catalog. In addition you will receive an FM station directory that covers all of North America.



MX 114

FM/FM STEREO TUNER
and STEREO PREAMPLIFIER

SEND TODAY!

McIntosh Laboratory Inc.
2 Chambers St., Dept. PT-97
Binghamton, N.Y. 13903

NAME _____

ADDRESS _____

CITY _____ STATE _____ ZIP _____

CIRCLE NO. 17 ON READER SERVICE PAGE



not by a long shot it isn't !!

There's certainly nothing top secret about Popular Electronics' classified pages. They're wide open to every buyer in the market for the product or service he knows can be found in Electronics Market Place.

More than 375,000 buyers of Popular Electronics, largest readership of any electronics magazine in the world, guarantee that your ad is being read by people constantly looking for and buying electronics products. It is these people to whom you MUST direct YOUR advertising as do the many key advertisers appearing in this issue and in each issue throughout the year.

No doubt about it—there's a vast market of buyers searching the classified advertising pages of Popular Electronics and it's important that your ad be exposed to them. Prove to yourself that the leading electronics magazine MUST ALSO be the leader in sales responses to the many classified ads presently enhancing its pages—it makes a great deal of sense—give it a try.

See classified section for rate information or write to HAL CYMES, *Classified Advertising Manager* ZIFF-DAVIS PUBLISHING COMPANY One Park Avenue, New York, N. Y. 10016



DISCOVER HIDDEN TREASURE

WITH A JETCO ELECTRONIC METAL DETECTOR

A powerfully sensitive instrument — detects gold, silver, coins, relics, etc. Fully tested — transistorized — guaranteed.



\$29.95 up

Send for Free Catalog

JETCO, P.O. Box 132 PEM, Huntsville, Texas 77340

**COOPERATE WITH
THE ZIP CODE
PROGRAM
OF THE POST OFFICE
DEPARTMENT.
USE ZIP CODE
IN ALL ADDRESSES**

COMMUNICATIONS

(Continued from page 92)

SHORTWAVE LISTENING

Interview with Keith Glover—The "Voice of Australia" to millions of listeners everywhere is Radio Australia's popular "Overseas Mailbag" man, Keith Glover. Over the last two decades, Keith has broadcast personal calls to over 10,000 listeners during his North American show. POPULAR ELECTRONICS met Keith during his first U.S. visit, and the following conversation ensued:

POPULAR ELECTRONICS: Welcome to North America, Keith. Tell us about your North American Mailbag show.

KEITH GLOVER: Thank you. I'm delighted to be here in the U.S. and Canada for the first time, meeting some of my listeners and radio friends. The North American Mailbag goes out twice every Sunday. In the morning at 7:45 EST, on 9580 and 11,710 kHz, and in the evening at 8:10 EST on 15,320, 17,840 and 21,740 kHz. During DST in America, we shift the morning transmission.

PE: Is the North American Mailbag your only show on Radio Australia?

KG: No, it's just one of my three Mailbag sessions: the European and British Isles Mailbag is broadcast once every Sunday, and the Asian and Pacific edition (which also covers Africa, and has some South American listeners) goes out seven times.

PE: Does this mean that Radio Australia stresses broadcasts to Asia?

KG: Yes, we see Asia as our main sphere of influence, and we beam the majority of our transmissions there. For instance, our 250-kw booster station at Darwin is beamed to Asia exclusively. And we broadcast in 6 Asian languages, besides English (24 hours a day) and French.

PE: Now that Darwin is operational, what other plans does Radio Australia have?

KG: We will keep on stressing our Asian beams; we would like to add an Indian language—Hindi or Tamil—soon. But the other areas will not be forgotten. Our Perth transmitters are now used for the service to Africa, where we have a sizable audience. And we are considering Spanish broadcasts.

PE: Some Western countries such as Denmark have made cuts in their international broadcast services. Even the Voice of America recently dropped its Japanese service and made other cuts. How do you see this trend?

KG: We are going to do our best to keep our place in the international bands. Our Japanese service is very popular with its

The New 1970 Improved Model 257 **A REVOLUTIONARY NEW TUBE TESTING OUTFIT**

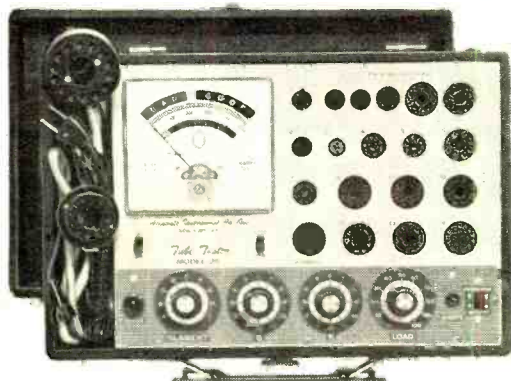

COMPLETE WITH ALL ADAPTERS AND ACCESSORIES, NO "EXTRAS"

STANDARD TUBES:

- ✓ Tests the new Novars, Nuvistors, 10 Pins, Magnovals, Compactrons and Decals.
- ✓ More than 2,500 tube listings.
- ✓ Tests each section of multi-section tubes individually for shorts, leakage and Cathode emission.
- ✓ Ultra sensitive circuit will indicate leakage up to 5 Megohms.
- ✓ Employs new improved 4½" dual scale meter with a unique sealed damping chamber to assure accurate, vibration-less readings.
- ✓ Complete set of tube straighteners mounted on front panel.

The Model 257 is housed in a handsome, sturdy, portable case. Comes complete with all adapters and accessories, ready to plug in and use. No "extras" to buy. Only

BLACK AND WHITE PICTURE TUBES:

- ✓ Single cable used for testing all Black and White Picture Tubes with deflection angles 50 to 114 degrees.
- ✓ The Model 257 tests all Black and White Picture Tubes for emission, inter-element shorts and leakage.

COLOR PICTURE TUBES:

- ✓ The Red, Green and Blue Color guns are tested individually for cathode emission quality, and each gun is tested separately for shorts or leakage between control grid, cathode and heater. Employment of a newly perfected dual socket cable enables accomplishments of all tests in the shortest possible time.

\$52⁵⁰

NOTICE

We have been producing radio, TV and electronic test equipment since 1935, which means we were making Tube Testers at a time when there were relatively few tubes on the market, way before the advent of TV. The model 257 employs every design improvement and every technique we have learned over an uninterrupted production period of 34 years.

Accurate Instrument Co., Inc.

SEND NO MONEY WITH ORDER PAY POSTMAN NOTHING ON DELIVERY

Pay Cash or in EASY MONTHLY PAYMENTS AFTER 15 Day Trial!

Try it for 15 days before you buy. If completely satisfied remit \$52.50 plus postage and handling charge. (If you prefer you may PAY MONTHLY ON OUR EASY PAYMENT PLAN.) If not completely satisfied, return to us, no explanation necessary.

ACCURATE INSTRUMENT CO., INC. Dept. 753
2435 White Plains Road, Bronx, N. Y. 10467
Please rush me one Model 257. If satisfactory I agree to pay at the terms specified at left. If not satisfactory, I may return for cancellation of account.

Name _____
Address _____
City _____ State _____ Zip _____

Save Money! Check here and enclose \$52.50 with coupon and we will pay all shipping and handling charges. You still retain privilege of returning after 15 day trial for full refund.

CIRCLE NO. 1 ON READER SERVICE PAGE

listeners; and, in fact, we have been beaming transmissions to Expo '70 in Osaka. Of course, Australian taxpayers pay for our operations, but we keep them informed.

PE: You work for the domestic services too, then?

KG: Yes, I spend about 25% of my time on the ABC's domestic networks, as a sportscaster and outside broadcast coordinator. On Radio Australia; I also read the news and do musical programs.

PE: Getting back to the Mailbag, how many letters do you receive a year?

KG: For the North American edition, about 750 or 800 a year. I try to read ten each Sunday—7 from the U.S. and 3 from Canada. Judging from the reports, by the way, most North American listeners, especially on the East Coast, tune in our morning program at 7:45 EST; the bands are quiet then and reception is good. In the evening, we run into big interference from other stations—especially European ones—beaming to America at the same time. Talking about mail, last year Radio Australia got no less than 289,000 letters from overseas listeners.

PE: so the audience is growing as Radio Australia grows. Thank you, Keith. We look forward to many more years of Mailbag programs. (Interviewed by Richard E. Wood.)

MARINE LISTENING

Nation's Boat Owners "Discover" SSB—With a Report & Order released June 16, 1970, the FCC has completed major changes in the 2-3-MHz and the 156-162-MHz VHF/FM marine communications bands. Transition to single-sideband (SSB) in the 2-3-MHz band begins January 1, 1972, when there'll be no more new installation of AM marinephones (now used) and January 1, 1977, when all use of AM will be banned. Any AM equipment installed before January 1, 1972, can stay on the air until January 1, 1977. New installations of SSB marinephones (mandatory on 2-3 MHz after January 1, 1972) won't be permitted unless the boat already has VHF/FM. Even then, the FCC won't allow use of SSB "when within VHF range" which is regarded unofficially by the Coast Guard as 20 miles ship-to-shore. This transition to SSB in the most-used marine band—termed "precipitous" by some—was dictated by America's unique recreational boat population explosion which made it impossible for the FCC to go along with the international framework of January 1, 1973 and January 1, 1982 as the respective dates for "no more installation" and "no more use" of AM in the 2-3-MHz band. (Submitted by Richard Humphrey.)



1970—WINTER \$1.35 ELECTRONIC EXPERIMENTER'S HANDBOOK

148 pages of the most fascinating and challenging construction projects for the electronics hobbyists. All with complete schematics, illustrations, parts list, and easy-to-follow instructions that guarantee you perfect finished products.

1970—SPRING \$1.50 ELECTRONIC EXPERIMENTER'S HANDBOOK

Another big package containing the most challenging, fun-to-build electronics projects ever! Be sure to order this one today!

1970 STEREO/HI-FI DIRECTORY \$1.35
Giant 180 page buyer's guide listing more than 1,600 individual Stereo/Hi-Fi components by 176 manufacturers. Nine individual sections complete with specs, photos, prices—the works!

6 Vital Components

*For Knowledge...
For Profit... For Sheer
Electronics Enjoyment!*



1970 TAPE RECORDER ANNUAL \$1.35
Over 130 pages covering every aspect of tape recording. Complete buyer's guide to the brands and models on the market. Expert tips on equipment—making better tapes—editing—copying—everything you want and need to know about tape recording.

1970 COMMUNICATIONS HANDBOOK \$1.35
148 fact packed pages for the CB, SWL or HAM. Equipment buyer's guide—photos—tables—charts—getting a license—everything to make this the world's most complete guide to communications.

1970 ELECTRONICS INSTALLATION & SERVICING HANDBOOK \$1.35
Covers all 8 areas of consumer electronics servicing—all the tricks of the trade in one complete guide. The industry's "how-to" book for installing and servicing consumer electronics equipment.

ZIFF-DAVIS SERVICE DIVISION • Dept. W
595 Broadway, New York, N.Y. 10012

Please send me the annuals I've checked below:

- 1970 Electronic Experimenter's Handbook—Winter
- 1970 Electronic Experimenter's Handbook—Spring
- 1970 Stereo/Hi-Fi Directory
- 1970 Tape Recorder Annual
- 1970 Communications Handbook
- 1970 Electronics Installation & Servicing Handbook

I am enclosing \$..... My remittance includes an additional 25¢ per copy for shipping and handling (Outside U.S.A. all magazines are \$2.00 per copy, postpaid.)

PE-9-70

print name _____

address _____

city _____

state _____

zip _____

PAYMENT MUST BE ENCLOSED WITH ORDER

POPULAR ELECTRONICS READER SERVICE PAGE

free information service:

Here's an easy and convenient way for you to get additional information about products advertised or mentioned editorially (if it has a "Reader Service Number") in this issue. Just follow the directions below... and the material will be sent to you promptly and free of charge.

1. On coupon below, circle the number(s) that corresponds to the key number(s) at the bottom or next to the advertisement or editorial mention that is of interest to you. (Key numbers for advertised products also appear in the Advertisers' Index.) Print or type your name and address on the lines indicated.

2. Cut out the coupon and mail it to: POPULAR ELECTRONICS, P.O. Box 8391, Philadelphia, PA 19101.

note: If you want to write to the editors of POPULAR ELECTRONICS about an article on any subject that does not have a key number, write to POPULAR ELECTRONICS, One Park Avenue, New York, N.Y. 10016. Inquiries concerning circulation and subscriptions should be sent to POPULAR ELECTRONICS, P.O. Box 1096, Flushing, N.Y. 11352.

POPULAR ELECTRONICS

P.O. BOX 8391
PHILADELPHIA, PA. 19101

VOID AFTER OCTOBER 31, 1970

1 2 3 4 5 6 7 8 9 10 11 12 13 14 15 16 17 18 19 20
21 22 23 24 25 26 27 28 29 30 31 32 33 34 35 36 37 38 39 40
41 42 43 44 45 46 47 48 49 50 51 52 53 54 55 56 57 58 59 60
61 62 63 64 65 66 67 68 69 70 71 72 73 74 75 76 77 78 79 80
81 82 83 84 85 86 87 88 89 90 91 92 93 94 95 96 97 98 99 100

NAME (Print clearly) _____

ADDRESS _____

CITY _____ STATE _____ ZIP CODE _____

9 N b

SHUTTER SPEED METER

(Continued from page 77)

the camera back and place the camera on top of the phototransistor unit. Make sure that Q1 is directly under the center of the space occupied by the film.

Place a strong light source (such as a high-intensity lamp) over the camera not more than a couple of inches away from the lens. A camera with a between-the-lens shutter may be placed with the lens up or down, while types with focal-plane shutters are placed with the back down.

To read the shutter speed, turn on the lamp, select the shutter speed and cock the shutter. Momentarily depress the RESET button and note that the meter indicates zero. Then operate the shutter release. The meter pointer will rise to the correct shutter speed and remain steady. Over a period of several minutes, the meter pointer will slowly drift up-scale.

Besides checking the shutter for accuracy, you can also check its consistency. Take several readings at each shutter speed and note how closely the readings agree. A slight variation is normal; but if one or more readings differ greatly, the shutter's mechanical operation should be checked.

If you make photographs in cold weather, you can get some useful information by running a series of temperature tests. Place the camera in a refrigerator (or outside if it is cold) for a couple of hours to allow all moving parts to get cold. Then make a series of shutter-speed tests before the camera has had time to warm up. You may have to remove the lens so that moisture condensation will not block the light—or you can use a stronger light

source. You will probably find that the shutter slows down somewhat at low temperatures; but if it becomes inoperative, special low-temperature lubrication must be used.

If, at any time, you find that your shutter is not operating properly, do not attempt to repair it yourself unless you are expert at the job. Take it to a professional and save time and money. —30—

INTERFACE

(Continued from page 10)

sure that the power to the tuner part of his stereo receiver is not cut off when he wants to listen to SCA. The only disadvantage that I am aware of is that on some cheaper stereo receivers this connection may reduce the maximum power output—but who wants to listen to loud SCA?

Experimenters may find that attempting to rewire stereo receivers that are still under the manufacturer's warranty is likely to void the warranty. This is a situation that should be considered if the builder is not too familiar with modern stereo receiver circuits.

JOSEPH FENG
Kenilworth, Ill.

OUT OF TUNE

"Build a Signal Injector" (June 1970). In Fig. 3, page 45, change callout J3 to read J2.

"Build a Low-Cost Time Delay Relay" (June 1970). The third line from the bottom in the left column on page 71 should read: "... thermal relay K2 (NOT K3) and the a.c. outlet."

NEW/CB TRANSCEIVER SOLID STATE PRE-AMP



- Improves CB Base Station Performance
- Works on tube or transistor equipment
- No Modification to CB unit
- On-the-air sign automatically lights when transmitting

Model PCB with built-in power supply, transfer relay, connecting cables, wired and tested.....\$59.95

Write for free literature



AMECO / DIVISION OF AEROTRON, INCORPORATED
P. O. BOX 6527 • RALEIGH, NORTH CAROLINA 27608

CIRCLE NO. 2 ON READER SERVICE PAGE

EXPERIMENT THAT SAVED HI-FI

(Continued from page 34)

"The engineers cut back the frequency range until the performance was satisfactory."

But the fact that listeners preferred full-range sound, if undistorted, had now been proved. It gave a solid foundation for hi-fi development work that had once been conducted on faith alone. The hi-fi or stereo fan of today owes much to Dr. Olson and to the men who kept building better amplifiers and speaker systems when no one else seemed to care enough to listen.

If you ever find that your ears and your test equipment disagree, trust your ears until they are proven to be wrong. The listeners who chose the narrow range for reproduced music were reacting to the high-order distortion in the wide-range equipment of the 1940's. In that respect their low-fi choice was the correct one and explains why the professional musicians objected more than the average listener to the distortion. And it was the ears of Dr. Olson's listeners that proved the desirability of a full-frequency range.

Perhaps there should be a minority report from the people who chose the narrow band with live music. One such reaction came from a lady in Texas when the local radio-TV shop returned a repaired console radio to her. "Oh good," she said. "I'll be glad to listen to a radio with a good tone again. And the records you get today just don't sound like the old ones."

Maybe she read that 1945 report. Too bad she didn't catch Dr. Olson's experiment. —30—

KNOW THE JK FLIP-FLOP

(Continued from page 72)

flops. In complex circuits, it can limit the maximum operating speed. In contrast, in a synchronous divider, all JK flip-flops are clocked simultaneously. So, the total propagation delay is equal to that of a single JK flip-flop.

A few simple divider circuits that make use of the JK flip-flop are given in Fig. 5. Note how the S and C inputs are used to return the circuits to the same state as preset at the occurrence of the desired count.

The "divide-by-three" circuit, for example, is a synchronous divider; so both T inputs are pulsed simultaneously with each CP. After preset, Q1 of F/F1 is at 0, and Q2 of F/F2 is also at 0; S1 is at 1 (Q2 output) and C2 is at 1 (Q1 output). Thus, F/F1 can change state when it receives a CP, but F/F2 cannot.

After the first CP, Q1 is at 1 and Q2 remains at 0. With Q1 = 1 and S1 = 1, and Q2 = 0 and C2 = 0, F/F1 cannot change state upon receipt of a CP, but F/F2 can. Thus, after the second CP, Q2 = 1 and Q1 remains at 1. With S1 = 0 and C2 = 0, both JK F/F's can change state upon receipt of a CP. After the third CP, Q1 is at 0 and Q2 is at 0. This is the same as the preset state, so the cycle is completed at the count of 3. A concise resume of these events is given in the truth table in Fig. 5.

Pin connections and numbers for the Motorola MC790P and HEP572 RTL dual-JK flip-flop integrated circuits are also provided in Fig. 5. —30—

ADDED MOBILE POWER WHEN YOU NEED ADDITIONAL COVERAGE FOR CLEAR COMMUNICATIONS

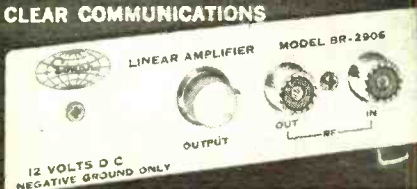

170 WATT INPUT

Complete with remote power switch and indicator control panel plus mounting brackets.

FCC TYPE ACCEPTED
Parts 89, 91, 93

\$129⁹⁵
12 VDC

SMALL PACKAGED MOBILE POWER

LINEAR R.F. POWER AMPLIFIER

Covers greater distances with increased transmit power. Can be used with SONAR BR20, FM40 or any similar FCC approved equipment with 1-15 watt output. Designed with top performance and dependable service when you need it. Automatic standby/transmit switching • Covers 25-50MHz range • transistorized power supply — negative ground • Used on amateur 28MHz for FM-AM-SSB. Small, compact, rugged design. Size: 2"H x 6"W x 8"D. Wt. 3 lbs 12 VDC

SONAR RADIO CORP., 73 Wortman Avenue, Bklyn, N.Y. 11207
Please send information on Model BR 2906 Linear Amplifier. Dept. 200

Name _____

Address _____

City _____ State _____ Zip _____

CIRCLE NO. 22 ON READER SERVICE PAGE

ELECTRONICS MARKET PLACE

COMMERCIAL RATE: For firms or individuals offering commercial products or services. \$1.15 per word (including name and address). Minimum order \$11.50. Payment must accompany copy except when ads are placed by accredited advertising agencies. Frequency discount: 5% for 6 months; 10% for 12 months paid in advance. **READER RATE:** For individuals with a personal item to buy or sell. 70¢ per word (including name and address). No Minimum! Payment must accompany copy.

GENERAL INFORMATION: First word in all ads set in bold caps at no extra charge. All copy subject to publisher's approval. Closing Date: 1st of the 2nd month preceding cover date (for example, March issue closes January 1st). Send order and remittance to: Hal Cymes, POPULAR ELECTRONICS, One Park Avenue, New York, New York 10016.

FOR SALE

FREE! Giant bargain catalog on transistors, diodes, rectifiers, SCR's, zeners, parts. Poly Paks, P.O. Box 942, Lynnfield, Mass. 09140.

GOVERNMENT Surplus Receivers, Transmitters, Snooperscopes, Radios, Parts, Picture Catalog 25¢. Meshna, Nahant, Mass. 01908.

ROCKETS: Ideal for miniature transmitter tests. New illustrated catalog. 25¢. Single and multistage kits, cones, engines, launchers, trackers, rocket aerial cameras, technical information. Fast service. Estes Industries, Dept. 18-J, Penrose, Colorado 81240.

LOWEST Prices Electronic Parts. Confidential Catalog Free. **KNAPP**, 3174 8th Ave. S.W., Largo, Fla. 33540.

EUROPEAN and Japanese bargains catalogs. \$1 each. Dee, 10639E Riverside, North Hollywood, Calif. 91602.

WE SELL CONSTRUCTION PLANS. TELEPHONE: Answering Machine, Speakerphone, Carphone, Phonevision, Legal Connector, Auto Dialer, Central Dial System. **TELEVISION:** \$35.00 Color Converter, Tape Recorder, 3DTV. \$25.00 Camera. **DETECTIVE:** Infinity Transmitter, Tail Transmitter, Police Radar Detector. **HOBBYIST:** Electron Microscope, 96 Hour Tape Music System, Ultrasonic Dishwasher, Radar-Oven, Electronic Tranquilizer. Plans \$4.95 each. **COURSES:** Telephone Engineering \$39.50, Detective Electronics \$22.50, Anti-Detective Electronics \$27.50. **NEW SUPER HOBBY CATALOG AIRMAILED \$1.00.** Don Britton Enterprises, 7906 Santa Monica Blvd., Hollywood, Calif. 90046.

WEBBER LAB'S, Police & Fire Converters. Catalog 25¢. 72 Cottage Street, Lynn, Mass. 01905.

INVESTIGATORS, LATEST ELECTRONICS AIDS. FREE LITERATURE. CLIFTON, 11500-L NW 7th AVE., MIAMI, FLORIDA 33168.

LINEAR AMPLIFIERS: "Hawk"—25 watts output—\$59.95; "Hornet"—50 watts—\$98.50; "Raider"—100 watts—\$139.95; "Maverick 250"—250 watts—\$244.95; AM/SSB. "Scorpion" 50 watt 12 volt mobile—\$99.95; "Bandit II" 100 watt mobile—\$169.95. 20-35 megacycles. (Illegal Class D 11 Meters.) Dealer inquiries invited. D & A Manufacturing Co., 1217 Avenue C, Scottsbluff, Nebraska 69361.

ELECTRONIC PARTS, semiconductors, kits. **FREE FLYER.** Large catalog \$1.00 deposit. **BIGELOW ELECTRONICS**, Bluffton, Ohio 45817.

RADIO—T.V. Tubes—33¢ each. Send for free catalog. Cornell, 4213 University, San Diego, Calif. 92105.

ULTRA-SENSITIVE AND POWERFUL METAL DETECTORS—join the many who are finding buried coins, minerals, relics and artifacts. Don't buy till you see our **FREE** catalog of new models. Write Jetco, Box 132-PE, Huntsville, Texas 77340.

LASER parts catalog 60¢. Moynihan, 107 North Brighton, Atlantic City, New Jersey 08401.

PSYCHEDELIC catalog. Posters, lighting, etc. Send 50¢ for handling to Hole In The Wall, 6055PE Lankershim, North Hollywood, Calif. 91606.

THE ART OF DE-BUGGING—\$5.95. TRON-X PUBLICATIONS, P.O. BOX 38155, HOLLYWOOD, CALIFORNIA 90038.

CONSTRUCTION PLANS: LASER . . . \$2.00. Listening Devices—two F.M. Mike Transmitters . . . \$1.00. Tail Transmitter . . . \$1.00. Sound Telescope . . . \$2.00. Infinity Transmitter . . . \$2.00. Equipment and kits available. Howard, 20174 Ward, Detroit, Michigan 48235.

COMPONENTS? Kits? Hardware? Free catalog! Truvue Paks, Box 275, Chelsea, Mass. 02150.

ELECTRONIC ignition, various types. Free literature. Anderson Engineering, Epsom, N.H. 03239.

SENCORE, B&K TEST EQUIPMENT UNBELIEVABLE PRICES. FREE CATALOG AND PRICE SHEET. FORDHAM RADIO, 265 EAST 149TH STREET, BRONX, N.Y. 10451.

AMATEUR SCIENTISTS, Electronics Hobbyists, Experimenters, Students . . . Construction Plans—all complete, including drawings, schematics, parts lists with prices and sources . . . **Laser**—Build your own coherent-light optical laser. Operates in pulsed mode, visible light range—\$6.00 . . . **Radar**—Build your own ultrasonic doppler radar. Detect motion of people, automobiles, even falling rain drops. Transistorized, uses standard small 9-volt battery—\$4.00 . . . **Long-Range "Sound Telescope"**—This amazing device can enable you to hear conversations, birds and animals, other sounds hundreds of feet away. Very directional. Transistorized. Uses 9V battery—\$3.00 . . . Or send 25¢ coin (no stamps) for complete catalog. Other items include Psychedelic strobes, light shows, robots . . . 38 different projects. Technical Writers Group, Box 5994, State College Station, Raleigh, N.C. 27607.

MECHANICAL, ELECTRONIC devices catalog 10¢. Greatest Values—Lowest Prices. Fertik's, 5249 "D", Philadelphia, Pa. 19120.

CLEARANCE SALE rectifiers, transistors, 1000's other items. Catalog 15¢. General Sales Company, 254 Main, Glute, Texas 77531.

SEMICONDUCTORS and parts catalogue free over 100 pages. J. & J. Electronics, Box 1437, Winnipeg, Manitoba, Canada. U.S. Trade directed.

MUSIC LOVERS, CONTINUOUS, UNINTERRUPTED BACKGROUND MUSIC FROM YOUR FM RADIO, USING NEW INEXPENSIVE ADAPTOR. FREE LITERATURE. ELECTRONICS, 11500-Z NW 7th AVE., MIAMI, FLORIDA 33168.

SPACE-AGE TV CAMERA KIT! Terrific for Experimenters, Industry, Education. Solid-state. Only \$116.95! Starter kits: \$18.95 up. Plans 25¢ up. Catalog **FREE.** Phone: 402-987-3771. Write: **ATV RESEARCH**, 1301 Broadway, Dakota City, Nebr. 68731.

CONVERT any television to sensitive, big-screen oscilloscope. Only minor changes required. No electronic experience necessary. Illustrated plans, \$2.00. Relco-A33, Box 10563, Houston, Texas 77018.

BURGLAR ALARM SYSTEMS and accessories. Controls, bells, sirens, hardware, etc. **OMNI-GUARD** radar intruder detection system, kit form or assembled. Write for free catalog. Microtech Associates, Inc., Box 10147, St. Petersburg, Florida 33733.

PRINTED CIRCUITS. Magazine projects and experimental. Free listing. Vico, Box 1590, Los Angeles, Calif. 90053.

ELENCO LR-6 Bi-Lateral linear amplifier 150 watts output, variable receive boost, \$149.95. (Illegal for Class D CB use.) Elenco, Dept. A, Wabash, Ind. 46992.

MC790P \$2.00. MC724P, MC789P \$1.05. Write for catalog. Hal Devices, Box 3652, Urbana, Illinois 61801.

ELECTRONIC COMPONENTS—Distributor prices, Free catalog. Box 2581, El Cajon, California 92021.

C.B. SALE CATALOG. Send today. Hirsch's, 219 California Drive, Williamsville, New York 14211.

PRINTED CIRCUITS WITHOUT THE MESS!! Design your own Circuits on circuit cards that are removable. Kit includes Pre-Funched card 4.5" x 6.5" with 35 etched contacts, matching panel mount receptacle, and 50 push-in terminals for component mounting. Complete Kit \$12.95, extra cards \$6.50 each, Card Holders \$5.50 each, Package of 50 terminals \$2.50 each. Cash, check, money order. Ky. Residents Add 5% Tax. Federated Electronics, Inc., 3004 Preston Highway, Louisville, Kentucky 40217.

SLOW FLASHING TURNLIGHTS ARE DANGEROUS. WINKER-KIT **DOUBLES FLASHING RATE. \$3.00 FOR ALL CARS. GUARANTEED.** ACE, 11500 N.W. 7TH AVENUE, MIAMI, FLORIDA 33168.

STROBES, Xenon, save over 50%. \$14.95 assembled! Guaranteed. Plans, \$1.00. Box 233P, Mablevale, AR 72103.

PRINTED CIRCUITS for projects. Popular Electronics or others. Send page or black-white drawing of circuit pattern, 25¢ square inch. Min. order \$1.75. Send remittance: General Printed Circuits, Box 4013, Downey, California 90241.

CIRCUIT BOARDS—Complete Job Shop Operation. Jetca, Inc., Box 418, Monon, Indiana 47959.

BURGLAR and FIRE ALARM SYSTEMS and supplies. **INSTALLATION MANUAL** and catalog \$1.00. Refused first order. Electronic Sentry Systems, P.O. Box 8023A, Sacramento, California 95818.

ANTI GRAVITY, EXPERIMENT AND THEORY; rushed—\$1.00. U.S. Inquiries, Intertech 7A1, Box 5373, Station-F, Ottawa, Canada.

POODLE RADIO—Transistor \$9.95. Details, Universal Distribution, Box 156, Brooklyn, New York 11226.

SWL'S, Ham's, CB'ers—Rotary QSL File CB-8. MB Sales, 1917 Lowell, Chicago, Illinois 60639.

INFRARED light beam audio communicator. Private, clear transmission to one mile. Unique solid state, optoelectronic portable system. No license required. Brochure, 30¢. Comprehensive construction manual, \$6.00. Parts sources provided. Lundart, University Station, 4008-E2, Tucson, Arizona 85717.

RESISTORS-PRECISION, assorted values, 100 \$10.00 postpaid. Check, Money Order. Utah Electronics Co., 956 W. 2nd S. Salt Lake City, Utah 84104.

SWLS—DRAKE SW4A receiver, brand new, factory sealed/warrantied, \$230 (save \$70). SOCHOR, 419 South Euclid, Oak Park, Illinois 60302.

COMP-U-KIT, Computer micro-circuits, a unique inter-connection method, and a book which tells all about computer logic. Free illustrated literature. Scientific Measurements, C131, 9701 Kenton, Skokie, Illinois 60076.

TV TUNER REPAIRS—Complete Course Details, 12 Repair Tricks, Many Plans, Two Lessons, all for \$1. Refundable. Frank Bocek, Box 833, Redding, California 96001.

RADIO CHASSIS'S NEW. Postpaid with **SCHEMATIC**. AM/FM 10 TRANSISTOR \$5.20 each. AM 6 Transistor \$2.65 each. Information 15¢. Union Supply, Box 32; Niles, Illinois 60648.

INSIDE THE FAREAST ELECTRONICS INDUSTRY. Told like it is. We traveled throughout the Orient, hiring interpreters, visiting factories, Chambers of Commerce, Banks, government offices, trade centers and shows. Now offering a comprehensive directory of products in every area of electronics, manufacturers, traders, information on customs, trade agreements, finance, pitfalls, political trends, much more. \$5.00 complete. TPI, 2833 Paradise Park Road, Pebble Beach, California 93953.

INFRARED light beam audio communicator. Private, clear transmission to one mile. Unique solid state, optoelectronic portable system. No license required. Brochure, 30¢. Comprehensive construction manual, \$6.00. Parts sources provided. Lundart, University Station 4008-E2, Tucson, Arizona 85717.

BARGAIN sheets listing relays, steppers, & other electronics parts for experimenters. Send name, address and a dime to: Gust & Company, Box 24081, Edina, Minnesota 55424.

50 NEW PRECISION RESISTORS 1/2w-1w 1% and better with **50 NEW MICA CAPACITORS**. Tremendous assortment of values. \$3.95. General Instrumentation Services, Box 34721, Los Angeles, California 90034.

STROBES, color organs, the incredible Strobot, Electric Candles, Remote Switch, Touch Switch. All in **KIT** and **ASSEMBLED** forms. Send 25¢ for complete catalog. Teletronics, Box 1266, South Lake Tahoe, California 95705.

SOUND EFFECTS. Every sound conceivable. From professional master tapes. Theatrical or home use. Reichert, 125 East 23, New York City 10010. (212) 533-0180.

CHEMICAL FORMULAS and preparation instructions when possible. Send self-addressed stamped envelope and \$3.50 to Chemtronics, Box 1266, South Lake Tahoe, California 95705.

JAPAN & HONG KONG DIRECTORY. Electronics, all merchandise. World trade information. \$1.00 today. Ippano Kaisha Ltd., Box 6266, Spokane, Washington 99207.

SINGERS—Sing like the professionals do in a matter of minutes. New scientific device changes tonality, volume, articulation. Device also used as a great aid to stop stuttering, stammering, lisping. Send \$10.00. Money back guarantee. Micro Wave Corp., 433 Durnan St., Rochester, N.Y. 14621.

PLANS AND KITS

ROCKET Plans Proven. Catalog 10¢. Rockets, P.O. Box 7274, Long Beach, California 90807.

CIRCUITS for 32 electronic projects, R.F., audio and gadgetry complete plans \$1.00. P.M. Electronics, Inc., Box 46204, Seattle, Wash. 98146. Dealer inquiries invited.

B&W TELEVISION CONVERTED TO COLOR. Patented System. Do it yourself kit. Free brochure. Bele Electronics Corp. 111 N.E. Second Avenue, Miami, Florida 33132.

FIBRE OP-KITS, using the "magical optical fibers" that transmit light energy. **FREE CATALOG**. Scientific Devices, 211E Albion, Wakefield, Mass. 01880.

METAL DETECTOR Plans, beat frequency type—\$3.25. New, operational amplifier discriminator type—\$6.00. Magneto-Hydro-Dynamics, Box 114, Plaza Station, Merrick, New York 11566.

BUILD amazing new device. Automatically indicates when oil in your auto's crankcase becomes 1 quart low. Inexpensive, easy to build. 12 volt neg. gnd. Plans \$3.00. J. R. Boykin, 40 Doncaster, Rome, Georgia 30161.

HOBBYISTS—PLANS INCLUDING PC BOARDS FOR DWELL METER—\$1.50, 3 CHANNEL COLOR ORGAN—\$3.00, METAL DETECTOR—\$2.50, STROBE LIGHT—\$2.00, SCA CONVERTER—\$2.50. DYNAMAX, P.O. BOX 11495, PHOENIX, ARIZONA 85017.

COMP-U-KIT. Unique modules and kits and fascinating booklets and plans. Free illustrated literature. Scientific Measurements, C132, 9701 Kenton, Skokie, Illinois 60076.

300% More CB POWER with new antenna. Plans, \$1.00 and stamped self-addressed envelope. Roddenbery, Bainbridge Road, Cairo, Georgia 31728.

INTEGRATED CIRCUIT KITS: COMPUTER, OPTOELECTRONICS, AUDIO. Catalog free. **KAYE ENGINEERING**, Box 3932-A, Long Beach, California 90803.

BUILD your own electronic **COMPUTER**. New book explains theory, practical details. \$2.25 postpaid. Cinnamon Press, Box 8453-A, Minneapolis, Minnesota 55408.

RADIO Control any device, using **SIMPLE** Transistor Circuit. Complete Plans \$2. Creative Electronics, Box 4943A, Austin, Texas 78751.

PSYCHEDELIC ELECTRONICS HANDBOOK, \$8.95. Medical Electronics, Box 46156, Seattle 98146.

FORTY Transistor Projects, \$1.00. Sirens, treasure finders, more! EDI, 1918B, 49th Street East, Palmetto, Florida 33561.

COLOR ORGAN KITS, Home/Auto \$7.50. Power supplies \$2.75. Catalog, Murphy, 204 Roslyn Avenue, Carle Place, N.Y. 11514.

SURVEILLANCE DEVICES IN KIT FORM: Telephone Transmitter, FM Spy Transmitter, Telephone-Recorder Actuator, Tail Transmitter, Bug Detector. Complete Kits Send \$15.00 each. **ELECTRONIC SECURITY SYSTEMS**, 1101 West Rosecrans Avenue, Gardena, California 90247.

TUBES

TUBES "Oldies", latest. Lists free. Steinmetz, 7519 Maplewood, Hammond, Indiana 46324.

RECEIVING & INDUSTRIAL TUBES, TRANSISTORS. All Brands—Biggest Discounts. Technicians, Hobbyists, Experimenters—Request **FREE** Giant Catalog and **SAVE! ZALYTRON**, 469 Jericho Turnpike, Mineola, N.Y. 11501.

TUBE Headquarters of World! Send 10¢ for Catalog (tubes, electronic equipment) Barry, 512 Broadway, N.Y.C. 10012.

THOUSANDS and thousands of types of electronic parts, tubes, transistors, instruments, etc. Send for Free Catalog. Arcturus Electronics Corp., MPE, 502-22nd St., Union City, N.J. 07087.

RADIO & T.V. Tubes—33¢ each. Send for free list. Cornell, 4213 University, San Diego, Calif. 92105.

TUBES—Lowest prices. Foreign-American. Obsolete, receiving, special purpose, transmitting tubes. Send for tube, parts catalog. United Radio Company, 56-P Ferry St., Newark, N.J. 07105.

TUBES SPECIAL LABORATORY MONTREAL—Buying—Selling—Testing. U.S. Inquiries. Zdravko Nikolovski, 400 Sherbrooke Street, Room 200, Montreal 129, Canada.

TAPE AND RECORDERS

BEFORE Renting Stereo Tapes try us. Postpaid both ways—no deposit—immediate delivery. Quality—Dependability—Service—Satisfaction—prevail here. If you've been dissatisfied in the past, your initial order will prove this is no idle boast. Free Catalog, Gold Coast Tape Library, Box 2262, Palm Village Station, Hialeah, Fla. 33012.

RENT 4-Track open reel tapes—all major labels—3,000 different—free brochure. Stereo-Parli, 55 St. James Drive, Santa Rosa, Ca. 95401.

AMAZING DISCOUNTS on famous brand high fidelity stereo components. No small wonder that we have set new sales records each year since 1959. Write: Arkay Electronics, 1028-03 Commonwealth, Boston, Mass. 02215.

STEREO TAPES, save 20,30% and more, postpaid anywhere U.S.A. We discount batteries, recorders, tape/cassettes, 80-page catalog 25¢. **SAXITONE TAPES**, 1776 Columbia Road, N.W., Washington, D.C. 20009.

OLD radio programs on tape. 6 hours for \$8.00. Catalog 50¢. Don Maris, 1926 Cherokee, Norman, Okla. 73069.

CASSETTES, Pre-recorded Spoken word—over 100 titles—educational, including language. Cassette and 8-track Blanks plus many accessories. Send 10¢ in stamps or coin for latest literature. Cassettes Unlimited, P.O. Box 13119P, Pittsburgh, Pennsylvania 15243.

TAPE RECORDERS, TAPE—blank, pre-recorded. Catalog 25¢. Tower, Lafayette Hill, Pa. 19444.

REPAIRS AND SERVICES

TV Tuners rebuilt and aligned per manufacturers specification. Only \$9.50. Any make UHF or VHF Ninety day written guarantee. Ship complete with tubes or write for free mailing kit and dealer brochure. JW Electronics, Box 51C, Bloomington, Indiana 47401.

24 HOURS Plastic Laminating Service for Diagrams, Drawings, Charts, Licenses. 3¢ per square inch. Check with order. V.M.F. Company, Box 278E, Chuluota, Florida 32766.

ELECTRONIC assembling. Receive, assemble and return. Small to medium sized devices wanted. Satisfaction guaranteed. Electronics, Box 384, Everett, Wash. 98201.

PRINTED CIRCUITS made for experimenters. Send 10¢ for prices, brochure. U.S. Inquiries. **SATELLITE CIRCUITS**, Box 488, Hespeler, Ontario, Canada.

PERSONALS

MAKE FRIENDS WORLDWIDE through international correspondence. Illustrated brochure free. Hermes, Berlin 11, Germany.

INVESTIGATORS, LATEST ELECTRONIC AIDS, FREE LITERATURE. CLIFTON, 11500-K NW 7th AVE., MIAMI, FLORIDA 33168.

INSTRUCTION

LEARN ELECTRONIC ORGAN SERVICING at home all makes including transistor. Experimental kit—trouble-shooting. Accredited NHSC. Free Booklet. **NILES BRYANT SCHOOL**, 3631 Stockton, Dept. A, Sacramento, Calif. 95820.

FCC First Class License in six weeks—approved for Veterans Training. Write Elkins Institute, 2603B Inwood Road, Dallas, Texas 75235.

R.E.I.'s famous (5) week course for the First Class Radio Telephone License is the shortest, most effective course in the nation. Over 98% of R.E.I. graduates pass F.C.C. exams for 1st class license. Total tuition \$395.00. Job placement free. Write for brochure. Radio Engineering Incorporated Schools, 1336 Main Street, Sarasota, Florida 33577—or 3123 Gillham Road, Kansas City, Missouri 64109—or 809 Caroline Street, Fredericksburg, Virginia 22401—or 625 E. Colorado Street, Glendale, California 91205.

LEARN WHILE ASLEEP, Hypnotize! Strange catalog free. Auto-suggestion, Box 24-ZD, Olympia, Washington 98501.

DEGREE in Electronics Engineering earned mostly by correspondence. Free brochure. Dept. G-9, Grantham School of Engineering, 1505 N. Western Ave., Hollywood, California 90027.

PLAY ORGAN EASILY! AMAZING METHOD! FREE INFORMATION. KEGLEY, 1016-PE KELLY, JOLIET, ILLINOIS 60435.

HIGHLY effective home study courses in Electronics Engineering Technology and Electronics Engineering Mathematics. Earn your Degree. Write for Free Descriptive Literature. Cook's Institute of Electronics Engineering, (Dept. 15), P.O. Box 10634, Jackson, Miss. 39209. (Established 1945).

F.C.C. FIRST CLASS LICENSE in three to four weeks. Write American Institute of Radio, 2622 Old Lebanon Road, Nashville, Tennessee 37214 or 3986 Beach Boulevard, Box 16652, Jacksonville, Florida.

TAPE recorded lessons for **FCC RADIOTELEGRAPH LICENSE** requirements for **SHIP RADIO OFFICER** positions or **FIRST CLASS RADIO-TELEPHONE LICENSE**. Our nineteenth year teaching FCC license courses. Radio License Training, 1060D Duncan, Manhattan Beach, Calif. 90266.

LEAP! LEAP! LEAP! Into BIG Money; 150,000 Computer Programmers needed in 5 years. Diploma Home Study Course, Price Breakthrough: only \$9.95. Act Now. Money Back Guarantee. U.S. Inquires, Intertech-7G1, Box 5373, Station-F, Ottawa, Canada.

LEARN code from tireless teacher. Wilkinson programmed course and LP player stays with beginners to license speed. \$9.45 postpaid. Florida residents \$9.83. Details free. Wilkinson Laboratories, Box 14196, Gainesville, Fla. 32601.

AMATEUR RADIO. Correspondence Sight-and-Sound no textbook courses for **GENERAL, ADVANCED** and **EXTRA CLASS** licenses—complete Code Theory. These are **NOT** memory courses. **AMATEUR RADIO LICENSE SCHOOL**, 12217 Santa Monica Blvd., Los Angeles, California 90025.

MEMORIZE: "1970 TESTS—ANSWERS" for **FCC FIRST AND SECOND CLASS LICENSE**. Plus "Self-Study Ability Test." **PROVEN**. \$5.00. Command, Box 26348-P, San Francisco 94126.

HIGH FIDELITY

FREE! Send for money saving stereo catalog # P9E, lowest quotations on your individual component, tape recorder, or system requirements. Electronic Values, Inc., 200 W. 20th St., New York, N.Y. 10011.

LOW, Low quotes: all components and recorders, HiFi, Roslyn, Penna. 19001.

HI-FI components. Tape Recorders, at guaranteed "We Will Not Be Undersold" prices. 15-day money-back guarantee. Two-year warranty. No Catalog. Quotations Free. Hi-Fidelity Center, 239 (P) East 149th Street, New York 10451.

TAPE RECORDERS, Hi-Fi, components, Sleep Learning Equipment, tapes. Unusual Values. Free Catalog. Dressner, 1523R, Jericho Turnpike, New Hyde Park, N.Y. 11040.

DIAMOND NEEDLES AND STEREO CARTRIDGES at low, low prices for Shure, Pickering, Stanton, Empire, Grado and ADC. Send for free catalog and price sheet. We will be happy to quote on any cartridge—Magnetic, Ceramic or Crystals. All merchandise brand new and shipped **PREPAID**. **LYLE CARTRIDGES**, Dept. P, 265 East 149 Street, Bronx, New York 10451.

WANTED

CASH PAID! Unused tubes, electronic equipment. Barry, 512 Broadway, NYC 10012.

QUICKSILVER, Platinum, Silver, Gold, Ores Analyzed. Free Circular. Mercury Terminal, Norwood, Mass. 02062.

INVENTIONS WANTED

INVENTIONS wanted. Patented; unpatented. Global Marketing Service, 2420-P 77th, Oakland, Calif. 94605.

PATENT Searches including Maximum speed, full airmail report and closest patent copies, \$6.00. Quality searches expertly administered. Complete secrecy guaranteed. Free Invention Protection forms and "Patent Information," Write Dept. 9, Washington Patent Office Search Bureau, 711 14th Street, N.W., Washington, D.C. 20005.

INVENTORS! Don't sell your invention, patented or unpatented, until you receive our offer. Eagle Development Company, Dept. P, 79, Wall Street, N.Y., N.Y. 10005.

GOVERNMENT SURPLUS

GOVERNMENT Surplus How and Where to Buy in Your Area. Send \$1.00 to: Surplus Information PE, Headquarters Building, Washington, D.C. 20036.

JEPS Typically From \$53.90 . . . Trucks From \$78.40 . . . Boats, Typewriters, Airplanes, Multimeters, Oscilloscopes, Transceivers, Electronics Equipment. Wide Variety, Condition. 100,000 Bid Bargains Direct From Government Nationwide Complete Sales Directory and Surplus Catalog \$1.00. (Deductible First \$10.00 Order). Surplus Service, Box 820-J, Holland, Michigan 49423.

SPORTS ACTION FILMS

BEST VALUE YET—25¢ for catalog saves 50¢ on purchase. **SPORT-LITE FILMS**, Dept. PE, Box 500, Speedway, Indiana 46224.

SHORTWAVE LISTENING

CONFIDENTIAL frequencies revealed! Over 450—spies, space, military. \$2.00. EDI, 1918B 49th Street East, Palmetto, Florida 33561.
DX REPORT FORMS. SWL \$3.00 per hundred. BCB \$3.00 per hundred. DX Log Forms \$3.00 per hundred. Special DX information packet 50¢. Minimum order \$3.00 plus 25¢ handling. NY orders include Sales Tax. O'Connell's, 329P Water Street, Binghamton, New York 13901.

BOOKS

FREE catalog aviation/electronic/space books. Aero Publishers, 329PE Aviation Road, Fallbrook, California 92028.

"UNUSUAL" Books! Catalog Free! International, Box 7798 (PE), Atlanta, Georgia 30309.

FREE book prophet Elijah coming before Christ. Wonderful bible evidence. Megiddo Mission, Dept. 64, 481 Thurston Rd., Rochester, N.Y. 14619.

PSYCHEDELIC LIGHTING MANUAL! Make light-machines, strobes, organs, Kaleidoscopes, etc. Send \$2.00, Lightrays, 713D Pine, Philadelphia, Pa. 19106.

INFORMATION. Amazing Book. Swimsuits, jewelry. Write: LYN, Box 1573, Waco, Texas 76710.

MAGAZINES

BACK DATE MAGAZINES! Send needs. Midtown, Box 917-PE, Maywood, N.J. 07607.

HYPNOTISM

FREE Hypnotism. Self-Hypnosis. Sleep Learning Catalog! Drawer H400, Ruidoso, New Mexico 88345.

"MALE-FEMALE HYPNOTISM" EXPOSED, EXPLAINED! "SECRET METHOD"—THEY NEVER KNOW! \$2, RUSHED. GUARANTEED! ISABELLA HALL, SILVER SPRINGS, FLORIDA 32688.

HYPNOTIZE PERFECT STRANGERS—EITHER SEX—SUCCESSFULLY! Secret Methods—they never know! Illustrated Course and 10 inch Hypnodisk \$2.00. **RESULTS ABSOLUTELY GUARANTEED!** Dr. H. Arthur Fowler, Box 4399, Woodbury, New Jersey 08096.

MAGNETS

MAGNETISM (100) page script newly discovered magnetic principles (\$3.00). Jesse Costa, Box 26, Waquoit, Mass. 02536.

MAGNETS. All types. Special—20 disc magnets, or 2 stick magnets, or 10 small bar magnets, or 8 assorted magnets, \$1.00 Maryland Magnet Company, 5412-H Gist, Baltimore, Maryland 21215.

PHOTOGRAPHY—FILM, EQUIPMENT, SERVICES

SCIENCE Bargains Request Free Giant Catalog "CJ"—148 pages—Astronomical Telescopes, Microscopes, Lenses, Binoculars, Kits, Parts. War surplus bargains. Edmund Scientific Co., 300 Edscorp Bldg., Barrington, New Jersey 08007.

RECORDS

POPULAR organ albums factory direct. Concert Recording, Lynwood, Calif. 90262.

September, 1970

SPECIAL interest records available, produced by the editors of the world's leading special interest magazines. Send for free catalog. Record Catalog-PE, Ziff-Davis Publishing Company, One Park Avenue, New York, N.Y. 10016.

EMPLOYMENT INFORMATION

FOREIGN and **USA** job opportunities available now. Construction, all trades. Earnings to \$3,000.00 monthly. Paid overtime, travel bonuses. Write: Universal Employment, Woodbridge, Conn. 06525.

EXCITING OVERSEAS JOBS. Directory \$1.00. Research Associates, Box 942-E, Belmont, California 94002.

BUSINESS OPPORTUNITIES

ELECTROPLATING Equipment and supplies. All types for home workshops and industrial. Send \$2.00 (refundable) for equipment guide formulas, operating data, catalog. HBS Equipment Division 90, 3543 East 16th, Los Angeles, California 90023.

I MADE \$40,000.00 Year by Mailorder! Helped others make money! Start with \$10.00—Free Proof. Torrey, Box 318-N, Ypsilanti, Michigan 48197.

FREE BOOK "999 Successful Little Known Businesses" Work home, Plymouth 445-J, Brooklyn, N.Y. 11216.

\$200.00 DAILY In Your Mailbox! Your opportunity to do what mail-order experts do. Free details. Associates, Box 136-J, Holland, Michigan 49423.

MAKE BIG MONEY raising chinchillas, rabbits, guinea pigs for us. Catalog—25¢. Keeney Brothers, New Freedom, Pa. 17349.

FREE CATALOGS. Repair air conditioning, refrigeration. Tools, supplies, full instructions. Doolin, 2016 Canton, Dallas, Texas 75201.

BECOME CITIZEN BAND DEALER. Write RJS Communications, Brockton, Massachusetts 02403.

MAKE extra \$25 to \$75 spare time! Take orders for double air cushion Bronson Shoes, Men's, women's line for dress, work, play. Highest commissions. Shoes for yourself. Outfit FREE. Bronson, Dept. 299, Minneapolis, Minnesota 55408.

PIANO TUNING learned quickly at home. Tremendous field! Musical knowledge unnecessary. GI Approved. Information Free. Empire School, Box 327, Miami, Florida 33145.

MAILORDER! Make big money working home. Free report reveals millionaire's trade secrets! Executive (1K9), 333 North Michigan, Chicago 60601.

SELL HERTEL BIBLES—Part Time. Finest reference Bible available. Demonstrator and supplies furnished. Excellent commissions. Write International Book, Dept. PE, Box 118, Wichita, Kansas 67201.

SPARE TIME CASH—Sell advertising Book Matches—every business a prospect—no investment—no experience needed—build steady repeat business. Power house selling kit with new complete catalog FREE. Quick sales and big cash commissions. Dept. T-970, Superior Match, 7530 S. Greenwood, Chicago 60619.

MAKE MONEY in spare time. Information write, Capitol, Box 9363, Austin, Texas 78757.

\$2,000.00 MONTHLY Possible. Details, Ropchan, Box 5341 X, Sherman Oaks, California 91413.

TREASURE FINDERS

GOLD, SILVER, RELICS! Located with powerful Detectron Metal Detectors. Free information. Terms. Detectron, Dept. PE-9, Box 243, San Gabriel, California 91778.

TREASURE FINDER locates buried gold, silver, coins, treasures. 5 powerful models. \$19.95 up. Free catalog. Relco-A33, Box 10839, Houston, Texas 77018.

FIND BURIED TREASURE! New book shows how, maps exact locations. Details Free. Kankowski, 6 Alan Okell Pl., Cranford, N.J. 07016.

FREE TREASURE GUIDE! Fact-filled collectors edition; send 50¢ for postage. Also request free literature on ultrasensitive, professional Fisher Detectors. **FISHER RESEARCH**, Dept. PE-9, Palo Alto, California 94303.

AUTHORS' SERVICES

AUTHORS! Learn how to have your book published, promoted, distributed. **FREE** booklet "ZZ," Vantage, 120 West 31 St., New York 10001.

REAL ESTATE

FREE . . . NEW FALL-WINTER CATALOG! Describes and pictures hundreds of farms, ranches, town and country homes, businesses coast to coast! Specify type property and location preferred. Zip Code, please. **UNITED FARM AGENCY**, 612-EP West 47th St., Kansas City, Mo. 64112.

RUBBER STAMPS

RUBBER ADDRESS STAMPS \$2.00. SIGNATURE \$3.50. FREE CATALOG. JACKSON'S BOX 443-G, FRANKLIN PARK, ILL. 60131.

QUALITY Rubber Address Stamps \$2.00, Denton's, Box 3594, Albuquerque, New Mexico 87110.

STAMPS

WOW! 110 ALL DIFFERENT GERMANY 10¢. Commemoratives, Air-mails, High Values, Big catalog, bargain lists. Also, fine stamps from our approval service, which you may return without purchases and cancel service at any time. **Jamestown Stamp, Dept. A80EG, Jamestown, New York 14701.**

FREE! BIG BARGAIN CATALOG—NEW EDITION listing thousands of bargains including U.S. & B.N.A. stamps, packets, albums, accessories and supplies. Also, fine stamps from our approval service which you may return without purchases and cancel service at any time. **Jamestown Stamp, Dept. E80EG, Jamestown, N.Y. 14701.**

MUSICAL INSTRUMENTS

30% DISCOUNT any name brand musical instrument. Free catalog. **Freeport Music, 127-N Sunrise Highway, Freeport, N.Y. 11520.**

PRINTING

OFFSET Printing. Free catalog. **Speedy Print, 1906 Swede, Norristown, Pa. 19401.**

QUALITY PRINTING—Both Letterpress and Offset. Economically priced. Speedy service. Free samples on request. **Charles McCallister, 1222 W. Sevier St., Clarksville, Arkansas 72830.**

MISCELLANEOUS

WINEMAKERS: Free illustrated catalog of yeasts, equipment. **Semplex, Box 12276, Minneapolis, Minn. 55412.**

JAPAN'S PUBLICATIONS GUIDE Business, pleasure, education. \$5.00. **INTERCONTINENTAL, CPO 1717, Tokyo 100-91.**

SCARE BURGLARS away. Warning alarm sticker—Protects Car, Home—Anything—\$1.00 for three. Refundable. **Staydri, Whitestone, New York 11357.**

CLASSIFIED ADVERTISING IN POPULAR ELECTRONICS

Your best bet for outstanding mail order sales. These pages are read thoroughly by electronics hobbyists seeking products and services found only in **ELECTRONICS MARKET PLACE. POPULAR ELECTRONICS** readers respond readily—they rely on the advertisers appearing in the pages of their favorite magazine. Your low cost ad will result in increased sales responses for you! Send copy and payment to:

Hal Cymes, Classified Advertising Manager

POPULAR ELECTRONICS

1 Park Avenue

New York, N.Y. 10016

CLASSIFIED ADVERTISING ORDER FORM

Please refer to heading on first page of this section for complete data concerning terms, frequency discounts, closing dates, etc.

1	2	3	4	5
6	7	8	9	10
11	12	13	14	15
16	17	18	19	20
21	22	23	24	25
26	27	28	29	30
31	32	33	34	35

Words { @ 70¢ (Reader Rate) }
 { @ \$1.15 (Commercial Rate) }

Insert _____ time(s)

Total Enclosed

= \$ _____
\$ _____

NAME _____

ADDRESS _____

CITY _____

STATE _____

ZIP _____

Signature _____

WORD COUNT: Include name and address. Name of city (Des Moines) or of state (New York) counts as one word each. Zip Code numbers not counted. (Publisher reserves right to omit Zip Code if space does not permit.) Count each abbreviation, initial, single figure or group of figures or letters as a word. Symbols such as 35mm, COD, PO, AC, etc., count as one word. Hyphenated words count as two words.

PE-970

POPULAR ELECTRONICS
SEPTEMBER 1970
ADVERTISERS INDEX

READER SERVICE NO.	ADVERTISER	PAGE NO.
1	Accurate Instrument Co.	113
2	AMECO, Div. of Aerotron, Inc.	116
	Allied Radio Shack	101
6	Antenna Specialists Co., The	27
3	Avanti Research & Development, Inc. THIRD COVER	
7	BSR	10
8	Burstein-Applebee Co.	8
	CREI, Home Study Div., McGraw-Hill Book Co.	88, 89, 90, 91
	Capstone Electronics Corp.	14
9	Cleveland Institute of Electronics ...	18, 19, 20, 21
10	Communications Div., DYNASCAN CORP.	5
11	Edmund Scientific Co.	124
4	GC Electronics (CALECTRO)	FOURTH COVER
12	Heath Company	12, 13
	Jetco	112
13	Johnson Company, E.F.	11
14	Lafayette Radio Electronics	105
15	Mallory & Co., Inc., P.R.	25
16	Musley Electronics, Inc.	8
17	McIntush Labs	111
	National Radio Institute, SECOND COVER, 1, 2, 3	
	National Technical Schools	62, 63, 64, 65
18	Olson Electronics, Inc.	14
	Quad-I, Inc.	14
19	RCA Electronic Components & Devices	28
	RCA Institutes, Inc.	36, 37, 38, 39
	Relco	14
20	Sams, Howard W. & Co., Inc.	9
21	Scientific Devices	123
22	Sonar Radio Corp.	117
	Sylvania Electric	103
23	United Audio Products (DUAL)	6
	U.S. Army	17
24	United Technical Institute, Div. of Career Academy	106, 107, 108, 109

CLASSIFIED ADVERTISING 118, 119, 120, 121, 122

FIBRE OP-KITS SPACE AGE BREAKTHRU
MAGIC FIBERS EMITTING
"COLD" LITE! BRAND NEW



A SPACE AGE MIRACLE! Optical science called FIBER OPTICS. Imagine! Light transmits or receives in glass and plastic fibers by internal reflection, triggering 1000's of lite sensitive projects using photo cells and infra red. The magical fibers, pipes light up walls, around corners, bends, cuts, acts like wire, but **NO ELECTRICITY!** Safe, fun, educational, hypnotic. A kit for all ages, all seasons, for science fairs, science classes. Makes dazzling displays, light pipes, games, for H-O railroad. Illuminates panels in home, hi-fi, electronics, and hot rodders. Literally **OBSOLETES PANEL LIGHTS!** FIBRE OP-KITS feature: **RE-DO** process (make 1000's of projects using same fibers), "BLINKY" the variable color control winks-blinks-twinks-strobes in instant color. With accessories, many booklets.

- FIBRE OP-KIT #1** — "EXPERIMENTERS" makes light pipes, displays, scanners. Kit: 1400 glass fibers 2-ft. long, vinyl jackets, accessories, adhesive, self-powered light source, "Blinky" booklets **\$5.49**
- FIBRE OP-KIT #2** — "CELESTIAL LIGHTS" an 18" 3-level optical display. Kit: same as #1, except fibers 12" long **\$4.95**
- FIBRE OP-KIT #3** — "MAGIC WAND OR PSYCHEDELIC STROBE". Kit: same as #1, fibers 8" long **\$3.50**
- FIBRE OP-KIT #4** — "CROFON® PLASTIC", 100-feet of solid 10-mil "micro" lite wire on handy reel, 11 times more light than glass. Accessories, booklet **\$2.50**
- FIBRE OP-KIT #5** — "HOBBY", 1000 glass fibers, hobby type, with assortment of plastic micro lites, accessories, booklet **\$1.95**
- FIBRE OP-KIT #6** — "IMAGE STIK", 4" coherent light pipe, transmits images with magnifier **\$1.49**
- FIBRE OP-KIT #7** — "LIGHT PIPES", 200 glass fibers, 24" long, with jacket, booklet 3 feet for **\$1.00**

SCIENTIFIC DEVICES 211E ALBION ST.
WAKEFIELD, MASS. 01880 — (617) 245-3829

CIRCLE NO. 21 ON READER SERVICE PAGE

Deluxe POPULAR ELECTRONICS
MAGAZINE CASES
DESIGNED TO HOLD A FULL YEAR'S COPIES

These decorative cases are just what you've been looking for to keep your copies of Popular Electronics Magazine in easy-to-find order.

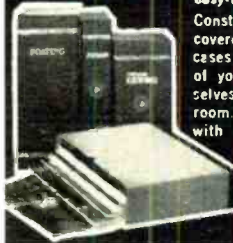

Constructed of reinforced fibreboard and covered in rich leatherette, these durable cases guard against soiling and tearing of your magazines while lending themselves handsomely to the decor of any room. The magazine cases are available with embossed gold lettering in either all black or attractive maroon back with black sides.

\$3.50 ea., 3 for \$10, 6 for \$19

FULLY GUARANTEED!

Ziff-Davis Publishing Co., Dept. SD

1 Park Ave., N.Y., N.Y. 10016

Please send me _____ Popular Electronics Magazine

Files as checked below:

- All black, gold embossed
- Maroon back, gold embossed/black sides

NAME _____

ADDRESS _____

PE-9-70

CITY _____

STATE _____

ZIP _____

Enclosed is \$_____ at \$3.50 per case, 3 for \$10, 6 for \$19 (Quantity prices apply for combination orders of more than one title). Orders outside U.S.A. \$4.50 ea., 3 for \$13, 6 for \$25.

Payment must accompany order

1000's OF UNUSUAL SCIENTIFIC BARGAINS including... SPECIAL UNIQUE PSYCHEDELIC LIGHTING for Fun, Profit, Effects!

CHROMATIC "MACHINE-GUN" STROBE

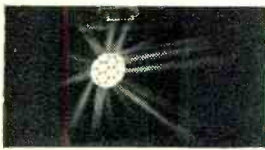

Red, Green, Blue & White light barrage the eyeballs every 6 seconds with this low-cost mechanical strobe that can run continuously without fear of burning up. Dazzling effects over 600 ft. sq. area. Created by rotating color wheel in front of 100W, 120v reflector flood lamp (incl.)—elements seem to flash on & off as colors fluctuate. Turns store windows, posters, parties into flashing, pulsating productions. Convection cooled. Walnut cabinet. Brass handle. Reg. house current.

Stock No. 71.271AV (9x10x6 1/4") \$28.50 Ppd.

PSYCHEDELIC LIGHTING HANDBOOK



Information packed pages! Fully explains latest in psychedelic lighting equipment, techniques, developments. Covers all facets of psychedelic light-show production including strobes, black lights, projectors, crystals, organic slides, mirrors color organs polarized color light boxes, MusicVision, etc. Shows how to "psychedelize" parties, musical groups, shows or how to set up "electric trips" for private gatherings. 8 1/2" x 11" illustrated paper for 3 rings.

Stock No. 9100AV \$3.00 Ppd.

LONG-WAVE BLACKLIGHT FIXTURE

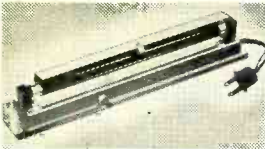

Extremely versatile, compactly designed, long wave (3200-4000 angstroms) black light (ultraviolet) fixture. Has 6-watt, 110-V lamp with built-in filter—eliminates harmful shorter wave ultraviolet rays. Use to identify minerals, fungi, bacteria—check for surface flaws, oil and gas leakage—perfect for displays with fluorescent paper, paints, chalk, crayons, trace powder, incl. adjustable aluminum reflector. Mount vertically on corner. 10" L., 1 1/2" W., 1 1/4" H.

Stock No. 70.364AV \$12.50 Ppd.
Stock No. 60.124AV REPLACEMENT BULB \$4.50 Ppd.

NEW! STATIC ELECTRICITY GENERATOR



Sturdy, Improved Model
See a thrilling spark display as you set off a miniature bolt of lightning. Sturdily made—stands 14" high. Two 9" plastic discs rotate in opposite directions. Metal collector brushes pick up the static electricity, store it in the Leyden jar type condenser until discharged by the jumping spark. 24 page illustrated booklet included.

Stock No. 70.070AV \$19.50 Ppd.

3-CHANNEL COLOR ORGAN BARGAIN!

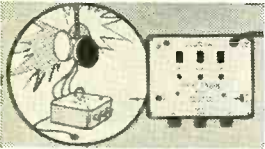

Create tremendous variety of unusual & beautiful lighting effects with this low-cost, top quality 1500-watt unit (500 W. per channel). Compare with others selling for twice the price! Has pilot light, plus individual sensitivity controls and channel indicator lights. Can operate ten 100 W. "spots" or 200 Christmas lights. Uses reg. house current—attaches to audio source w/RCA-type phone plug. 5 1/2" x 6 3/4" x 2 1/4" 2 1/2 lbs. Thermal protection. Complete instructions included. \$34.95 Ppd.

setting plastic case. 6-ft. cord. Stock No. 71.223AV \$34.95 Ppd.

GREAT INTERNATIONAL PAPER PLANE BOOK!



Official fly them yourself book of paper airplanes from SCIENTIFIC AMERICAN'S "1st International Competition." Includes plans of all winning entries, time-of-flight records, photos, technical data commentaries. Has 20 unusual designs on perforated pages for easy tear out. You won't believe how some of them fly! Amusing, entertaining. 128 pages. 9" x 11 3/4".

Stock No. 9391AV \$2.95 Ppd.

Order by Stock No.—Check or M.O.—Money-Back Guarantee
EDMUND SCIENTIFIC CO., 300 EDSCORP BLDG., BARRINGTON, N.J. 0800

WRITE FOR GIANT FREE CATALOG "AV"



Completely new edition. New items, categories. Illustrations. 118 easy-to-read pages packed with 4000 unusual items. Dozens of electrical and electronic parts, accessories. Enormous selection of astronomical telescopes, microscopes, Binoculars, Magnifiers, Magnets, Lenses, Lasers, Prisms! Many new surplus items; for hobbyists, experimenters, workshops, factory. Write for catalog "AV." Includes Zip Code.

Stock No. 71.223AV \$2.95 Ppd.

TERRIFIC BUY! TOP QUALITY!

PRICE BREAKTHROUGH IN LARGE SIZE

OPAQUE PROJECTOR

"Best Opaque of its Kind Under \$200"



Projects brilliant, sharp 4 1/2 ft. square image from 8 feet away using up to 5"x5" color, b&w illustrations. Retains all original colors and proportions. Enlarges drawings, blueprints, watercolors. Pictures, stamps, coins, other objects. Features high speed, 200mm anastigmatic projection lens (f3.5, 8" F.L.); powerful peanut-size quartz halogen lamp (50 hr. life); unique internal reflecting system. Gives maximum brightness, entire field focus. Flat stage and removable magnetic platen enable use upside down. Turbo-blower cooled. Tough plastic case. 5 1/2" ft. cord.
Stock No. 71.272AV (8 3/4" x 6" x 12 1/2" — 11 1/2 lbs.) \$89.75 Ppd.

4 GIANT 180' DAY GLOW TAPES!

1" bands of fluorescent pink, green, red, yellow. Brilliant in normal light—wild and exciting "hoo" glow under blacklight. Self adhesive. Easily removed. All kinds of uses—decorate clubs, dances, parties; highlight posters, costumes; design "top" pictures, wall decorations; ideal for safety markers, shelf strips. Medium strength tape. Paper flatback. 750 feet in all.
Stock No. P-71.303AV \$9.50 Ppd.



Stock No. 70.364AV \$12.50 Ppd.
Stock No. 60.124AV REPLACEMENT BULB \$4.50 Ppd.

BLACK-LIGHT MIGHTY MITES

Relatively small (12") fixtures give surprisingly bright black-light. Mirror-finished reflector makes instant starting 8-watt, high-intensity bulb look like 40-watt. Up to 5,000 hours of safe, long-wave (3600A) black-light to really turn on parties, light & theatrical shows, psychedelic decors, holiday decorations. Shockproof end-caps remove for safe, easy replacement of bulb and starter. Stands upright or horizontal. Aluminum case.
Stock No. 71.274AV \$14.95 Ppd.
DELUXE OUTDOOR/INDOOR MODEL
Stock No. 71.299AV \$19.95 Ppd.



3-CHANNEL COLOR ORGAN BARGAIN!

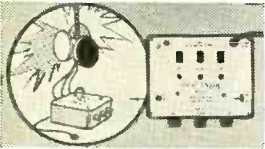

Create tremendous variety of unusual & beautiful lighting effects with this low-cost, top quality 1500-watt unit (500 W. per channel). Compare with others selling for twice the price! Has pilot light, plus individual sensitivity controls and channel indicator lights. Can operate ten 100 W. "spots" or 200 Christmas lights. Uses reg. house current—attaches to audio source w/RCA-type phone plug. 5 1/2" x 6 3/4" x 2 1/4" 2 1/2 lbs. Thermal protection. Complete instructions included. \$34.95 Ppd.

setting plastic case. 6-ft. cord. Stock No. 71.223AV \$34.95 Ppd.

MIRRORED BALLS BOUNCE LIGHT

Yesteryear's ballrooms echo in mirrored lights that ricochet to the beat of today's discotheque. Up to 1,000 lustrous, clear, handmade glass mirrors on each ball create fantastic lighting effects. Motorized—they cast reflections that blow the mind! Ideal for light shows, displays, restaurants, hotels, and modern gigs.
Stock No. 71.066AV (12" Diam.) \$30.00 Ppd.
Stock No. 85.180AV (16" Diam.) \$75.00 FOB
Stock No. 71.065AV (8" Diam.) \$17.50 Ppd.



GREAT INTERNATIONAL PAPER PLANE BOOK!



Official fly them yourself book of paper airplanes from SCIENTIFIC AMERICAN'S "1st International Competition." Includes plans of all winning entries, time-of-flight records, photos, technical data commentaries. Has 20 unusual designs on perforated pages for easy tear out. You won't believe how some of them fly! Amusing, entertaining. 128 pages. 9" x 11 3/4".

Stock No. 9391AV \$2.95 Ppd.

Order by Stock No.—Check or M.O.—Money-Back Guarantee
EDMUND SCIENTIFIC CO., 300 EDSCORP BLDG., BARRINGTON, N.J. 0800

WRITE FOR GIANT FREE CATALOG "AV"



Completely new edition. New items, categories. Illustrations. 118 easy-to-read pages packed with 4000 unusual items. Dozens of electrical and electronic parts, accessories. Enormous selection of astronomical telescopes, microscopes, Binoculars, Magnifiers, Magnets, Lenses, Lasers, Prisms! Many new surplus items; for hobbyists, experimenters, workshops, factory. Write for catalog "AV." Includes Zip Code.

Stock No. 71.223AV \$2.95 Ppd.

81 "WILD" 35MM SLIDES

Created by Hollywood's premier special lighting effects man—Bob Beck. Produce fantastic backgrounds, light-shows, psychedelic slide shows, etc. 81 bromprinted slides especially selected for impact, vividness and/or intriguing scene. Range from "way-out" group of eves to kaleidoscopic images, critical illusions, etc. Low-cost, unduplicated sets fill popular Kodak Carotone film! Ideal for modern professional—Loads of fun for amateurs.
Stock No. P-60.749AV—(Set A) \$22.50 Ppd.
Stock No. P-60.750AV—(Set B) \$22.50 Ppd.



ASTRONOMICAL TELESCOPE KITS

Grind your own mirror for powerful telescopes. Kits contain fine annealed pyrex mirror, blank, tool abrasives, diagonal mirror, and eyepiece lenses. Instruments you build range in value from \$75 to hundreds of dollars.
4" DIAMETER—3 1/2" Thick
Stock No. 70.003AV \$10.75 Ppd.
6" DIAMETER—3 1/2" Thick
Stock No. 70.004AV \$13.95 Ppd.
8" DIAMETER—1 3/8" Thick
Stock No. 70.005AV \$21.50 Ppd.
10" DIAMETER—3 1/2" Thick
Stock No. 70.006AV \$52.50 FOB



EDMUND SCIENTIFIC CO.
ORDER BY STOCK NUMBER - OPEN ACCOUNT TO MEMBERS - MONEY-BACK GUARANTEE
300 EDSCORP BLDG. BARRINGTON, NEW JERSEY 08007

CIRCLE NO. 11 ON READER SERVICE PAGE

Printed in U.S.A.

www.americanradiohistory.com

6 good reasons why the revolutionary Avanti Astro Plane is the best omni-directional C.B. antenna you can buy.

1. It has top radiation which means that your signal gets out from the highest part of your antenna. This is especially important where antenna height is limited because your signal radiates about 15 feet higher than other antennas which radiate near the bottom. This 15 feet means you get increased range and fewer dead spots.
2. The ASTRO PLANE has a lower angle of radiation which makes more efficient use of the radiated signal by allowing it to hug the curvature of the earth instead of shooting your power up into the sky. This also gives you greater distance than an ordinary omni-directional antenna, one thing the professional users really look for.
3. The ASTRO PLANE has 4.46 db gain (over an isotropic source) which gives you a stronger signal and better, clearer reception.
4. You'll get long lasting, trouble free performance because it is compact in design—without long drooping radials, without coils to burn or short out, and with direct ground construction to dissipate static charges and lightning.
5. You'll find it easy to install because of its lightweight construction (less than 5 lbs.) and only 12 feet of total height and 30 inches in diameter.
6. All of these features need not cost you more money. Part of good engineering is how to make a better product for less money—by eliminating the coils for example we not only make the Astro Plane more reliable, but cheaper. Just like a radio back in the 30's cost \$100.00, today they're even better for \$20.00 or \$30.00! So you can buy this advanced antenna for only \$29.95 and it is guaranteed for one full year against mechanical or electrical defects.

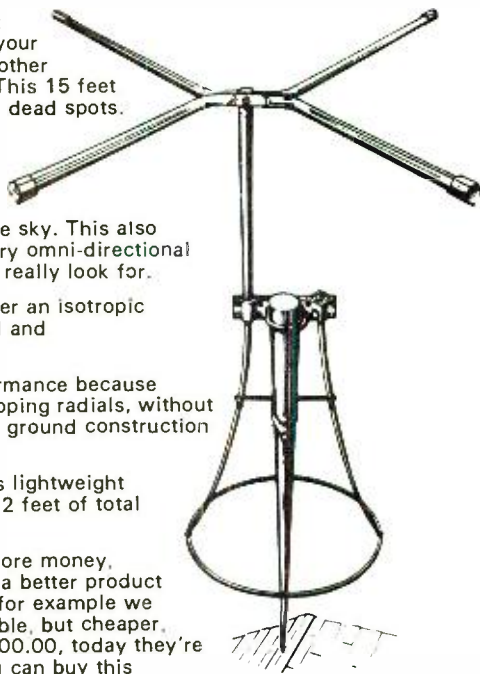

If your local C.B. Dealer does not have an ASTRO PLANE in stock, have him order you one or write direct to AVANTI.



avanti

33-35 WEST FULLERTON AVENUE.
ADDISON, ILLINOIS 60101

AVANTI RESEARCH & DEVELOPMENT, INC.

THE PACESETTER IN HIGH PERFORMANCE ANTENNAS

CIRCLE NO. 3 ON READER SERVICE PAGE

THE CALECTRO SUPERMARKET



EVERYTHING IN ELECTRONICS!



VARIABLE BALANCE STEREO HEAD PHONE

Unique "Sound Level" control on each earpiece permits adjustment. Frequency range: 20 to 20,000 + cps. $1\frac{1}{2}$ ' cord with stereo plug. Impedance 4 to 16 ohms.
Cat. No. Q4-132 \$17.95 Net

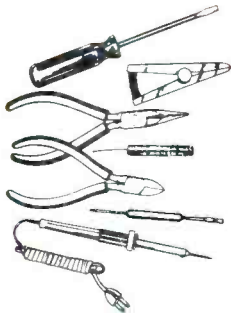

HOBBYIST'S SOLDERING AND TOOL KIT

Diagonals, long nose pliers, soldering iron and solder, solder aid tool, heat-sink, and screwdriver. An ideal gift item.
Cat. No. H3-378 \$7.95 Net.



TAPE RECORDER MICROPHONE

Outstanding performance on music and speech for the price. Low impedance matches late model solid state recorders. Removable desk stand; $4\frac{1}{2}$ ' cord with dual plugs that fit most models. Freq. Response: 100-8k Hz. Output: — 77 dB. Impedance: 200 ohms
Cat. No. Q4-146 \$4.95 Net

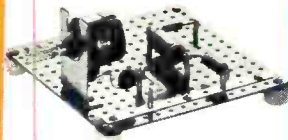

EXPERIMENTER'S CIRCUIT BOARD KIT

Contains a $3\frac{3}{4}$ x 4" perforated board, 15 terminals (No. J4-636) and 4 mounting feet w/screws. Build small circuits, hobby and science projects, etc.
Cat. No. J4-660 \$9.98 Net



AUDIO ADAPTORS

"Y" Audio Adaptor has a phono pin jack on one end and dual phono pin plugs on the other.
Cat. No. Q4-288 \$9.99 Net



TWO STATION WIRELESS INTERCOM

Just plug into any electrical outlet. Completely portable. Expand system anytime with additional units. Two unit system complete in display pack.
Cat. No. N4-110 \$34.95 Net



MINIATURE LAMPS

Type PR2 • 2.5 volt • 0.50 amp • Cat. No. E2-430 • Pkg. of 2 \$2.29 Net
Type PR3 • 3.6 volt • 0.50 amp • Cat. No. E2-431 • Pkg. of 2 \$2.29 Net

RESISTORS

Attractively packaged 2 per pack, showing values, color codes and formulas.

STANDARD 1000 VOLT CAPACITOR

High quality, compact and reliable.



THE "GC CALECTRO HOBBYIST HANDBOOK"

The "GC Calectro Hobbyist Handbook" is available at your nearest Calectro Electronic Supermarket. One is located near you. WRITE TODAY and we'll rush you the name and address of your nearest Calectro Supermarket.



CALECTRO

G-C ELECTRONICS
A DIVISION OF
HYDROMETALS, INC.



400 SO. WYMAN ST. ROCKFORD, ILLINOIS 61101
CIRCLE NO. 4 ON READER SERVICE PAGE