

BUILD COMBINATION IGNITION LOCK

POPULAR ELECTRONICS

JULY
1970

50
CENTS



AUDIO MULTICOUPLER
INSTRUMENT SENSITIVITY BOOSTER
DYNAMIC DIODE TESTER
AUTOMATIC LIGHTNING PROTECTION
PROTECTING WOOFER SPEAKERS

**ELECTRONIC
MOSQUITO REPELLENT**

(see page 27)



firsts

**make learning
Electronics at home
fast and fascinating —
give you priceless
confidence.**

Some NRI **firsts** in training equipment



first to give you Color Television training equipment engineered specifically for education — built to fit NRI instructional material, *not* a do-it-yourself hobby kit. The end product is a superb Color TV receiver that will give you and your family years of pleasure. You “open up and explore” the functions of each color circuit as you build.

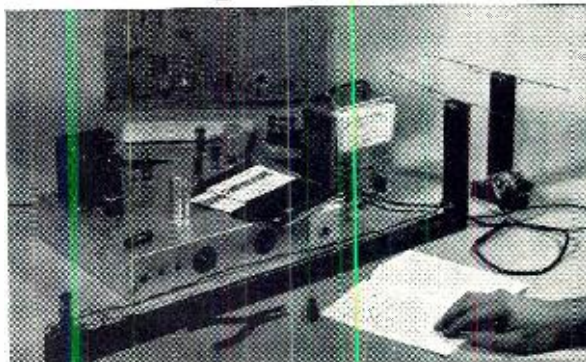

first to give you transmission lines and antenna systems that include experiments not otherwise attempted outside of college physics laboratories. The experience gained with this kind of Communications training equipment is matched only by months — sometimes years — of on-the-job experience.

NRI's "discovery" method is the result of over half a century of leadership simplifying and dramatizing training at home

The FIRSTS described below are typical of NRI's half century of leadership in Electronics home training. When you enroll as an NRI student, you can be sure of gaining the in-demand technical knowledge and the priceless confidence of "hands-on" experience sought by employers in Communications, Television-Radio Servicing and Industrial and Military Electronics. Everything about NRI training is designed for your education . . . from the much-copied, educator-acclaimed Achievement Kit sent the day you enroll, to "bite-size" well-illustrated, easy to read texts programmed with designed-for-learning training equipment.

YOU GET YOUR FCC LICENSE OR YOUR MONEY BACK

There is no end of opportunity for the trained man in Electronics. You can earn \$6 or more an hour in spare time, have a business of your own or qualify quickly for career positions in business, industry, government. And if you enroll for any of five NRI courses in Communications, NRI prepares you for your FCC License exams. *You must pass* or NRI refunds your tuition in full. No school offers a more liberal money-back agreement. The full story about NRI leadership in Electronics training is in the new NRI Catalog. Mail postage-free card today. No salesman is going to call.

NATIONAL RADIO INSTITUTE, Washington, D.C. 20016

APPROVED UNDER NEW GI BILL If you have served since January 31, 1955, or are in service, check GI line on postage-free card.

designed from chassis up for your education

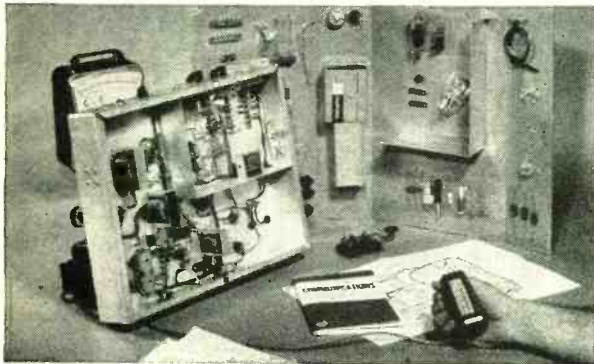

first to give you true-to-life experiences as a communications technician. Every fascinating step you take in NRI Communications training, including circuit analysis of your own 25-watt, phone/cw transmitter, is engineered to help you prove theory and later apply it on the job. Studio equipment operation and troubleshooting become a matter of easily remembered logic.

first to give you completely specialized training kits engineered for business, industrial and military Electronics. Shown above is your own training center in solid state motor control and analog computer servo-mechanisms. Telemetering circuits, solid-state multi-vibrators, and problem-solving digital computer circuits are also included in your course.

POPULAR ELECTRONICS

VOLUME 33 NUMBER 1

JULY 1970

WORLD'S
LARGEST-SELLING
ELECTRONICS
MAGAZINE

FEATURE ARTICLES

- BUILD THE BUG SHOO** 27 *Lyman E. Greenlee*
Fight mosquitoes the electronic way
- BUILD AN AUDIO MULTICOUPLER** 31 *Don M. Wherry*
For recording more than one tape
- WIRE MUSIC** 35 *Nyle A. Steiner*
Latest thing on the music scene
- ELECTRONIC COMBINATION IGNITION LOCK** 40 *John Beiswenger*
Protect your boat
- BUILD THE X10/X100 INSTRUMENT SENSITIVITY BOOSTER** 43 *James Bongiorno*
Extended range on scope or VTVM
- HOBNOBBING WITH HARBAUGH** 48
- BUILD A WOOFER GUARD** 49 *Phil Arthur*
Safety first for speaker cones
- BUILD DYNAMIC DIODE TESTER** 53 *Charles L. Andrew*
Identifies semiconductor diodes
- OPPORTUNITY MIRROR** 60 *David L. Heiserman*
All about medical electronics
- AUTOMATIC LIGHTNING PROTECTION** 61 *Howard Phillips*
Ground your antenna
- REMOTE CAMERA SHUTTER RELEASE** 65 *A. A. Mangieri*
Variable solenoid control circuit
- THE PRODUCT GALLERY** 69
Dual Automatic Turntable
Curtis Electronic Fist
Realistic Sound Level Meter
Heathkit Fish Spotter
- SUPER SUBSTITUTION BOX** 79 *Ralph Tenny*
- CHANNEL 9 RESERVED FOR EMERGENCIES** 81
- SHORT-WAVE LISTENING** 83 *Hank Bennett, W2PNA*
- ENGLISH LANGUAGE NEWS BROADCASTS TO N.A.** 84 *Roger Legge*
- SOLID STATE** 85 *Lou Garner*
- AMATEUR RADIO** 88 *Herb S. Brier, W9EGQ*

DEPARTMENTS

- LETTERS FROM OUR READERS** 8
- ELECTRONICS LIBRARY** 12
- READER SERVICE PAGES** 15, 93
- NEW LITERATURE** 16
- NEW PRODUCTS** 22

POPULAR ELECTRONICS is Indexed
in the Readers' Guide
to Periodical Literature

This month's cover photo by
Justin Kerr

Copyright © 1970 by ZIFF-DAVIS PUBLISHING COMPANY. All rights reserved.

POPULAR ELECTRONICS, July 1970, Volume 33, Number 1, Published monthly at One Park Ave., New York, N.Y. 10016. One year subscription rate for U.S., U.S. Possessions and Canada, \$6.00; all other countries, \$7.00. Second class postage paid at New York, N.Y. and at additional mailing offices. Authorized as second class mail by the Post Office Department, Ottawa, Canada and for payment of postage in east. Subscription service and forms J379; P.O. Box 1096, Flushing, N.Y. 11352. Editorial offices for manuscript contributions, reader inquiries, etc.: One Park Ave., New York, N.Y. 10016.

4 reasons we're so big in CB

More power, more features, more transceiver for the money. That's why you buy Midland. These four units, all leaders in their fields, give you that Midland extra. Solid state circuitry, finest crystal-controlled superheterodyne receivers, optional power sources for batteries, AC, or rechargeable nickel-cadmium pack. All have rugged metal cabinets for extra years of reliable use.

Integrated Circuit 5-Watt 6-Channel
Maximum solid state efficiency plus isolated chassis, Call Signal® long-range alert, battery/power/signal strength meter. Hi-lo battery saver switch; battery charger jack. Tuned RF and AGC, fully variable squelch. Channel 7 crystals, earphone, leather case. Model 13-770 \$89.95

MIDLAND
INTERNATIONAL®

For free brochure, write Dept. 1407,
P.O. Box 1903, Kansas City, Mo. 64141

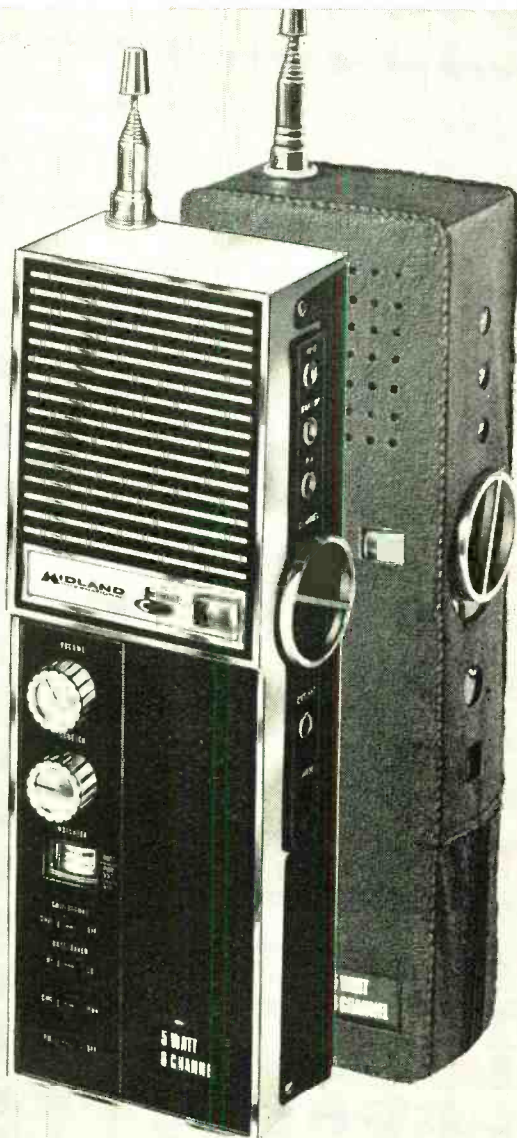

**Solid State
100 MW
Transceiver**
with carrying
case, high-
performance
features.
Model 13-113B
\$23.50



**2-Channel
1-Watt
Transceiver**
with Call
Signal®
carrying
strap.
Model 13-700
\$36.95



**3-Channel
2-Watt, I.C.**
Separate
speaker and
 mike, Call
Signal®
leather case.
Model 13-724
\$52.95

Prices shown are suggested retail, each unit.

**FIRST
TIME
EVER!**

Build your own

LASER COMMUNICATOR



AS FEATURED IN POPULAR ELECTRONICS
Get in on the excitement of this challenging new area of communications. The Metrologic Communicator Kit is designed expressly for voice transmission, and adaptable for other types of communication . . . over several hundred feet without lens system. With Telescope Accessory Kit and Telescope, system operates for many miles, depending on atmospheric stability.

LASER COMMUNICATOR KIT 60-203
Includes chassis, transmitter section, receiver section and low voltage power supply. (Laser tube and high voltage power supply not included.) **\$74.25**

CONVERSION KIT 60-204
Converts 60-203 for use with most astronomical telescopes. **\$24.50**

4 1/4" TELESCOPE with stand; 60-205 \$94.50*
Without stand; 60-206 \$67.50*

*Shipping charges collect

metrologic
INSTRUMENTS, INC.



Metrologic Instruments, Inc.,
143 Harding Ave.,
Bellmawr, N.J. 08030

- Send FREE catalog of lasers and kits
- Please ship following items:

Model #	Item	Price

Check M.O. enclosed for \$_____

Name _____
Address _____
City _____ State _____ Zip _____

CIRCLE NO. 11 ON READER SERVICE PAGE

POPULAR ELECTRONICS

LAWRENCE SPORN
Publisher

OLIVER P. FERRELL
Editor

LESLIE SOLOMON
Technical Editor

JOHN R. RIGGS
Managing Editor

EDWARD I. BUXBAUM
Art Director

ALEXANDER W. BURAWA
Associate Editor

ANDRE DUZANT
Technical Illustrator

PATTI MORGAN
Assistant Editor

JUDITH L. HOGAN
Editorial Assistant

H. BENNETT, W2PNA
H. S. BRIER, W9EQG
L. E. GARNER, JR.
DAVID L. HEISERMAN
Contributing Editors

J. ROYCE RICHARD
Assistant Publisher

RICHARD J. HALPERN
Advertising Manager

ROBERT UR
Marketing Manager

MARGARET DANIEL O
Advertising Service Manager

FURMAN H. HEBB
Group Vice President
Electronics and Photography

ZIFF-DAVIS PUBLISHING COMPANY
Editorial and Executive Offices
One Park Avenue, New York, New York 10016
212 679-7200

Midwestern Office
The Paltis Group, 4761 West Touhy Ave.,
Lincolnwood, Illinois 60466, 312 679-1100
GERALD E. WOLFE, DICK POWELL

Western Office
9025 Wilshire Boulevard, Beverly Hills, California 90211
213 CRestview 4-0265; BRadshaw 2-1161
Western Advertising Manager, BUD DEAN

Japan: James Yagi
Ishikawa Mansion #4, Sakuragaoka
Shibuya-ku, Tokyo, 462-2911-3

Circulation Office
P.O. Box 1096, Flushing, N.Y. 11352

- William Ziff, President
- W. Bradford Briggs, Executive Vice President
- Hershel B. Sarbin, Senior Vice President
- Stanley R. Greenfield, Senior Vice President
- Philip Sine, Financial Vice President
- Walter S. Mills, Jr., Vice President, Circulation
- Phillip T. Heffernan, Vice President, Marketing
- Frank Pomerantz, Vice President, Creative Services
- Arthur W. Butzow, Vice President, Production
- Edward D. Muhlfeld, Vice President, Aviation Division
- Irwin Robinson, Vice President, Travel Division
- George Morrissey, Vice President
- Sydney H. Rogers, Vice President

Ziff-Davis also publishes Airline Management and Marketing, including American Aviation, Boating, Business & Commercial Aviation, Car and Driver, Cycle, Electronics World, Flying, Modern Bride, Popular Photography, Skiing, Skiing Area News, Skiing Trade News, Stereo Review, and Travel Weekly.

Forms 3579 and all subscriptions correspondence should be addressed to POPULAR ELECTRONICS, Circulation Department, P.O. Box 1096, Flushing, N.Y. 11352. Please allow at least six weeks for change of address. Include your old address, as well as new—enclosing if possible an address label from a recent issue.

EDITORIAL CONTRIBUTIONS must be accompanied by return postage and will be handled with reasonable care; however, publisher assumes no responsibility for return or safety of art work, photograph- or manuscripts.



Member Audit Bureau of Circulations

POPULAR ELECTRONICS

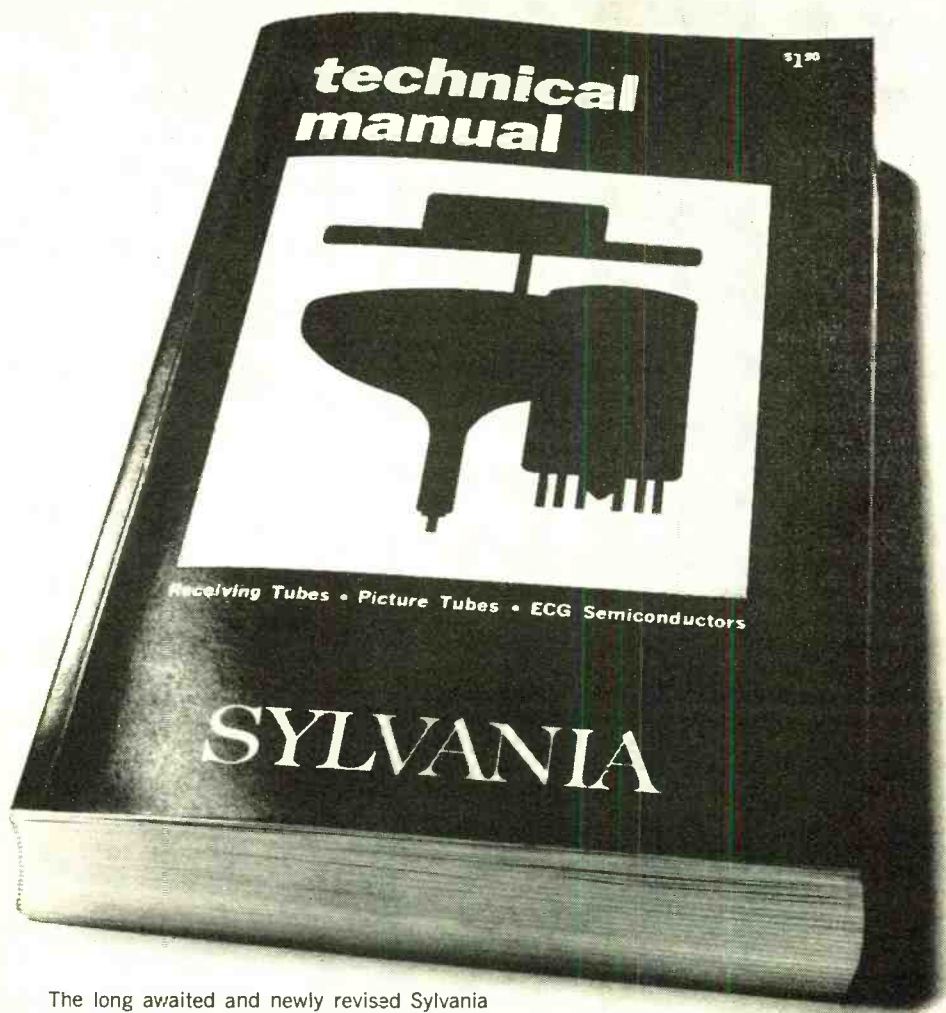

The long awaited and newly revised Sylvania Technical Manual is out. Complete and unexpurgated. The fantasy of every Independent Service Technician. Written anonymously by an agile team of Sylvania engineers. 32,000 components described in breathtaking detail. Including thousands of unretouched diagrams and illustrations. Discover the unspeakable thrill of new color TV Tubes, listed as never before. The ecstasy of 28,000 ECG Semiconductors.

From exotic Deflection Oscillators to a lurid account of Transistors and Rectifiers.

This book has what you want. Components for the man who knows what to do with them.

The 14th Edition of the Sylvania Technical Manual is not available in any bookstore. Your Sylvania Distributor is discreet. Speak to him.

SYLVANIA
GENERAL TELEPHONE & ELECTRONICS

“Electrifying”

learn electronics at home in spare time



you'll be turning that spare time into extra money very soon!

Learn the skills of electronics and help fill the critical shortage of trained electronics personnel. You can keep your present job and still turn spare time into extra money. The home study program of United Technical Institute has been drawn from a resident course taught in our Milwaukee, Boston, and Los Angeles schools; a course that has produced graduates now earning good pay in the electronics industry from coast to coast. UTI is a division of Career Academy, the world's largest private schooling organization. *Mail coupon today for colorful, free booklet with all the details.*

United Technical Institute

division of Career Academy

135 West Wells St. • Milwaukee, Wis. 53203
Dept. N087222



Please rush me your exciting free booklet with all the details of how I can train in the field of electronics.

Name _____ Age _____

Address _____ Phone _____

City/State/Zip _____

I am interested in Home Study Resident

CIRCLE NO. 22 ON READER SERVICE PAGE

letters

FROM OUR READERS

VEHICLE ALARM NOTATION

Motorists installing the Meyerle "Vehicle Burglar Alarm" (April 1970, p 59) should be advised that certain General Motors cars (Pontiac '69, for example) have color-coded wires going to the left-hand (driver's side) door switch. One of these wires (usually the black one) sounds the ignition key "buzzer" when grounded. This wire should NOT be used to activate the alarm system. The other wire (usually white) should be connected instead. Only the white wire goes to the right-hand door switch.

A "bonus" from this alarm is that, when door switches are added to a GM four-door car, the inside dome light will now operate (through the connection in the alarm) on all doors (and even the hood).

E. SMITH
Park Ridge, N.J.

ONE DIGITAL READOUT CLOCK

In regard to the letter from Mr. J. Wright (April 1970, p 10), I suggest that he read the publication called "Bulletin of the National Association of Watch and Clock Collectors, Inc." The August 1969 issue contains an article on digital clocks written by Paul Horowitz. Unfortunately, I have not been able to obtain specifics in regard to his clocks and ideas on how they are to be duplicated. Nevertheless, he does indicate that building a digital clock at a price of \$100 or less is quite possible.

AL OLTMANNS
Wisner, Neb.

ANOTHER DIGITAL READOUT CLOCK

Having gotten impatient soon after reading your article on the original DCU, I decided a digital (Nixie®, no less) clock was for me. The photograph shows the results of my efforts. The clock is in two separate units—one the power supply and logic chassis, the other a neat, formal display unit, which looks very much at home on top of my stereo cabinet.

My reasons for housing the clock in this manner were two: I wanted a compact display unit, too small to house even the power supply, let alone the logic circuits; and the separate chassis also provides power and logic for an auxiliary timer/control system which will soon provide automatic (timed) control for my stereo system.

The clock is fairly simple, consisting of a

CIRCLE NO. 7 ON READER SERVICE PAGE →

THE CALECTRO SUPERMARKET



EVERYTHING IN ELECTRONICS!



VARIABLE BALANCE STEREO HEAD PHONE

Unique "Sound Level" control on each earpiece permits adjustment. Frequency range: 20 to 20,000 + cps. 6 1/2' cord with stereo plug. Impedance 4 to 16 ohms.
Cat. No. Q4-132 \$17.95 Net

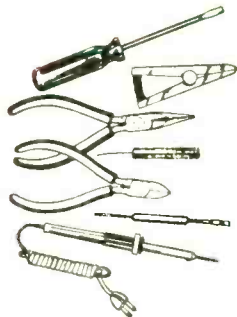

HOBBYIST'S SOLDERING AND TOOL KIT

Diagonals, long nose pliers, soldering iron and solder, solder aid tool, heat-sink, and screwdriver. An ideal gift item.
Cat. No. H3-378 \$7.95 Net.



TAPE RECORDER MICROPHONE

Outstanding performance on music and speech for the price. Low impedance matches late model solid state recorders. Removable desk stand; 4 1/2' cord with dual plugs that fit most models. Freq. Response: 100-8k Hz. Output: -77 dB. Impedance: 200 ohms.
Cat. No. Q4-146 \$4.95 Net



EXPERIMENTER'S CIRCUIT BOARD KIT

Contains a 3 3/4" x 4" perforated board, 15 terminals (No. J4-636) and 4 mounting feet w/screws. Build small circuits, hobby and science projects, etc.
Cat. No. J4-660 \$.98 Net



AUDIO ADAPTORS

"Y" Audio Adaptor has a phono pin jack on one end and dual phono pin plugs on the other.
Cat. No. Q4-288 \$.99 Net



TWO STATION WIRELESS INTERCOM

Just plug into any electrical outlet. Completely portable. Expand system anytime with additional units. Two unit system complete in display pack.
Cat. No. N4-110 \$34.95 Net

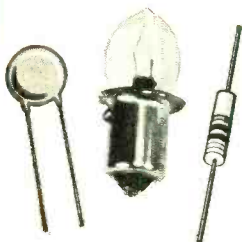

MINIATURE LAMPS

Type PR2 - 2.5 volt • 0.50 amp • Cat. No. E2-430 • Pkg. of 2 \$2.29 Net
Type PR3 - 3.6 volt • 0.50 amp • Cat. No. E2-431 • Pkg. of 2 \$2.29 Net

RESISTORS

Attractively packaged 2 per pack, showing values, color codes and formulas.

STANDARD 1000 VOLT CAPACITOR

High quality, compact and reliable.



THE "GC CALECTRO HOBBYIST HANDBOOK"

The "GC Calectro Hobbyist Handbook" is available at your nearest Calectro Electronic Supermarket. One is located near you. WRITE TODAY and we'll rush you the name and address of your nearest Calectro Supermarket.



CALECTRO

G-C ELECTRONICS
A DIVISION OF
HYDROMETALS, INC.



400 SO. WYMAN ST. ROCKFORD, ILLINOIS 61101

NEW Short-Wave Listening VERTICAL ANTENNA Model SWV-7

For 11,13,16,19,25,31 and 49 meter bands Cramped quarters keeping you from installing an SWL antenna? Your problem is solved! Model SWV-7 mounts easily on the roof or on the ground and stands just 13 ft., 3-5/8 in. tall.

Extensive field testing confirms that this antenna measures up to Mosley's high standards of performance. Construction is of the finest material to bring you years of trouble free listening pleasure. Complete with installation instructions.

Get the facts from your Mosley dealer, or write factory direct, for detailed brochure.

Mosley Electronics Inc.
Dupl. 202

4610 N. LINDBERGH BLVD., BRIDGETON, MO. 63044

CIRCLE NO. 13 ON READER SERVICE PAGE

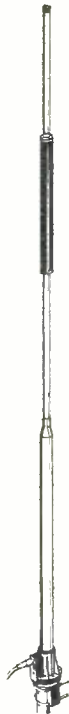

LETTERS (Continued from page 8)



counter chain which uses the 60-Hz line as a reference with decimal and divide-by-six counters feeding BCD-to-decimal decoders. If I were to build another one right now, I could do it for a little under \$90.

PAUL A. TURVILL
Des Moines, Wash.

Congratulations! It is indeed a fine looking clock. The one we plan to present shortly will be somewhat similar, except that it will probably use RCA Numitrons instead of the Burroughs Nixie tubes.

WHERE DO THEY GO?

I find your magazine quite enjoyable and I must particularly commend you for publishing the "Digital Logic Microlab" (April 1970).

I have been wondering what happens to the products that are evaluated and discussed in The Product Gallery?

L. B. GELLER
Bronx, N. Y.

Almost all of the major items evaluated in The Product Gallery are returned to the manufacturer. The sole exception pertains to the kits which become the property of the builder. Also, a few of the minor items eventually find their way into the POPULAR ELECTRONICS laboratory.

SECURITY 1 NOT FOR PARTY LINES

One caution to the builders of "Security 1" telephone speech scrambler (March 1970, p 27). It is required by New York state law—and, I believe, by other states as well—that a party-line telephone be yielded immediately to another party in event of an emergency.

I doubt if the plain speech of a party attempting to get the line would be detectable through the scrambler. Worse, the party needing the police, fire, etc. for emergency might assume the phone was out of order upon hearing the SSB-type noise on the line.

LAURENCE F. BLAISING
Utica, N.Y.



It's yours
FREE



**GIANT 260 PAGE
1971
RADIO-TV
ELECTRONICS
CATALOG**

**RESERVE YOUR COPY
NOW FOR DELIVERY
IN LATE AUGUST**

Write to:

**BURSTEIN-APPLEBEE CO.,
DEPT. PE-7 3199 MERCIER ST.,
KANSAS CITY, MO. 64111**

Name _____

Address _____

City _____

State _____ Zip Code _____

CIRCLE NO. 2 ON READER SERVICE PAGE

Enjoy your favorite hobby—
and save \$\$\$—with the new

ELECTRONIC EXPERIMENTER'S HANDBOOK SPRING 1970 EDITION

Build these challenging electronic projects at home
—and make your hobby hours pay off! Each article
contains complete schematics, illustrations, parts
lists and easy-to-follow instructions that guarantee
perfect results.

Order your Spring 1970 Electronic Experimenter's
Handbook today. Only \$1.50!

EXCITING PROJECTS TO BUILD!

- Psych-Analyzer • Third-Generation DCU •
- 200-Watt Dual Flasher • Thrifty 3-Way • "Op-
Tach" • Sound-with-Sound Mixer • Simplest
Antenna Bridge • Constant Current Ohmmeter
- Build a Happy Hybrid • LC Telltale • Touch
Control • A Home for Ohms • The K Table •
- Electronic Shutter Control • Low-Cost A. C.
Ammeter • A "Bigger-than-Life" Speaker Sys-
tem • Slot-Car Win Detector • Transistor Sorter
- Compression Sustainer for your Guitar •
- Power Inverter • Darkroom Timer • and more
absorbing projects!

**GET THE DELUXE
LEATHERFLEX-BOUND EDITION
for just \$3.50 POSTPAID!**

The Spring 1970 ELECTRONIC
EXPERIMENTER'S HANDBOOK is
also available in a handsome de-
luxe edition. Rugged Leatherflex
cover provides lasting protection
—yet is softly textured and gold-
embossed for the look of elegance.
A collector's item—a luxurious
addition to your electronic book-
shelf. And it's yours for just \$3.50
postpaid, when you check the ap-
propriate box on the order form.

ZIFF-DAVIS SERVICE DIV., Dept. EEH-W • 595 Broadway, New York, N.Y. 10012

Please send me the Spring 1970 ELECTRONIC EXPERIMENTER'S HANDBOOK. I want the

Regular Edition—\$1.50 plus 25c for shipping and handling. (\$2 postpaid for orders
outside the U.S.A.)

Deluxe Edition—\$3.50, postpaid. (\$4.50 postpaid, for orders outside the U.S.A.)
Allow three additional weeks for delivery.

I've circled the numbers of additional annuals I wish to receive: PE-7-70

\$1.25 36 39 53 58
each 82 84 85 88

\$1.35 4 10 81 83
each 86 97 98 99

I am enclosing a total of \$_____ for the annuals ordered above. I've added an
additional 25c per copy for shipping and handling. (For orders outside the U.S.A., all
regular editions are \$2.00 per copy, postpaid. Deluxe editions are \$4.50 per copy postpaid.)

print name _____

address _____

city _____

state _____

zip _____

PAYMENT MUST BE ENCLOSED WITH ORDER

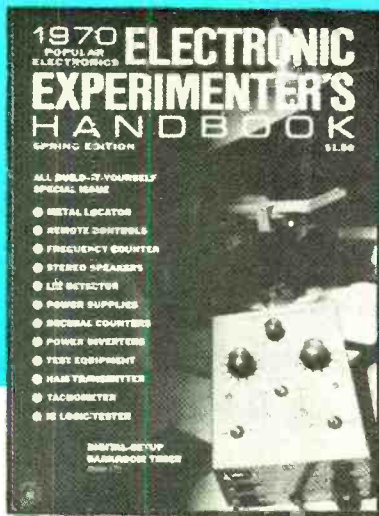

BRING YOUR REFERENCE LIBRARY UP TO DATE!

If you've missed any of these current and
previously published handbooks, a wide
selection is still available. Just circle the
corresponding numbers on the coupon.

Electronic Experimenter's Handbook—148
pages of the most fascinating and challeng-
ing construction projects for electronic
hobbyists. Winter 1970 #97; Spring 1969
#88; Winter 1969 #85; Spring 1968 #84;
Spring 1966 #36; Fall 1966 #39.

Tape Recorder Annual—Covers every aspect
of tape recording... plus complete buyer's
guide. 1970 #99; 1969 #81.

Stereo/Hi-Fi Directory—Giant buyer's guide
complete with photos, specs, prices. 1970
#98; 1969 #82.

**Electronics Installation & Servicing Hand-
book**—Covers all 8 areas of consumer elec-
tronics servicing—for the serviceman and
hobbyist. 1970 #4; 1969 #83; 1968 #58.

Communications Handbook—Fact-packed
pages for the CB, SWL or Ham... plus
equipment buyer's guide. 1970 #10; 1969
#86; 1968 #53.

Get the last word every time.



Get Turner's "+2" series:

+2 base station mike (List Price: \$55.00) and M+2/U mobile mike (List Price: \$39.50). Up to 50 times the modulation of other mikes. No more fade outs. No more static. (Even at great distances). Both "+2" series microphones use a

two - transistor pre-amp and work with all transistor and tube sets. See them at your CB dealer or distributor soon. And get the last word.



TURNER

919-17th Street N.E.,
Cedar Rapids, Iowa 52402
In Canada: Tri-Tel Associates, Ltd.

CIRCLE NO. 55 ON READER SERVICE CARD

ELECTRONICS library

QUIET

BASICS OF DIGITAL COMPUTERS Revised Second Edition (Three Volumes)

by John S. Murphy

With progress in computer technology moving ahead by leaps and bounds, there is an urgent need for people with a broad-based knowledge of electronic data processing. This illustrated three-volume set was designed to provide a framework from which the reader can go on to the study of specific computer systems. The text does not focus on any particular system; rather, it is relevant to all systems. An excellent introduction to the computer world, the set does not require a technical background of the reader. Volume 1 discusses the evolution of today's sophisticated computers. In Volume 2, the discussion is on how the computer is made up of logic elements. A comprehensive explanation of the computer as an integrated system of units performing together is the subject of Volume 3.

Published by Hayden Book Co., Inc., 116 West 14 St., New York, NY 10011. 390 pages in three-volume set. Volumes 1-3, soft cover, \$3.75 each, \$11.25 set. Three volumes in one book, hard cover, \$9.95.

THEORY OF NONLINEAR CONTROL SYSTEMS

by Nicolai Minorsky

This is a post-graduate textbook bringing together all of the important theoretical work being developed in both the Soviet Union and the United States. The author is considered to be one of the world's leading authorities on the subject and is probably best known for his "USS New Mexico" stability experiments.

Published by McGraw-Hill Book Co., 330 West 42 St., New York, NY 10036. Hard cover. 331 pages. \$16.50.

1970 POPULAR TUBE/TRANSISTOR SUBSTITUTION GUIDE

This is probably the most valuable service book around. Brand new and updated to include listings of the newest popular tube and transistor types, the new edition contains 40% more material than last year's edition. There are eight sections, four of which are devoted to tube and four to transistor listings. The listings cover American-to-American and American-to-foreign substitutions as well as

(Continued on page 14)

POPULAR ELECTRONICS

this FREE catalog

shows 300 electronic kits—
world's largest selection

A Kit For Every Interest ... All Described and Illustrated
• Color Television • Stereo/Hi-Fi • Electronic Organs •
Guitar Amplifiers • Shortwave Radio • Portable Radios •
Phonographs • Intercoms • Garage Door Openers • Amateur
Radio • Model Radio Control • Radio Control Cars • Test
Equipment • Trail Bikes • Marine Electronics • Automotive
Electronics • Photographic Aids • Scientific Equipment

this FREE booklet

shows how easy
it is to build kits

Learn how to choose your first kit ... see examples of the easy Heathkit assembly instructions ... see what tools are needed ... learn how to identify parts ... how to solder ... read answers to typical questions. This FREE booklet will convince you that you, too, can build Heathkit electronics ... that no special skills or knowledge are necessary to enjoy this exciting hobby.

HEATHKIT
1970
22nd year of kit leadership

Heathkit Organ
Color Television

HEATHKIT electronics—the space age hobby. Over 300 different kits—world's largest selection.

welcome to the world
of **HEATHKIT**
do-it-yourself electronics

a guide for first-time kit builders

FACTORY MAIL ORDER
CATALOG 818-388
HEATH COMPANY
a Schlumberger company

ask for both...

learn how you can get better
equipment at up to 50% sav-
ings. It's easy ... it's fun.

Mail today for Complete
FREE information.



HEATH COMPANY, Dept. 10-7
Benton Harbor, Michigan 49022

a Schlumberger company

Please send FREE 1970 Heathkit Catalog and
Guide for First-Time Kitbuilders.

Name _____

Address _____

City _____ State _____ Zip _____

CL-380

CIRCLE NO. 8 ON READER SERVICE PAGE

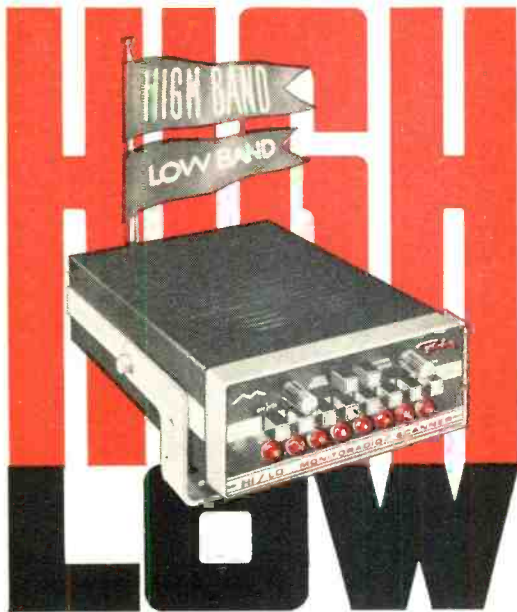

Automatic Cross Band Monitoring

only in the fantastic **HI/LO**

MONITORADIO / Scanner

A computer patch board matrix, coupled with push button program control, allows automatic scanning of any combination of High or Low Band frequencies.

You can use any mixture of 30-50 or 144-174 MHz crystals . . . it makes no matter to our busy little radio. It details the signal search with fascinating read-out lights. Upon a signal detection, in either band, our radio stops to bring the entire transmission . . . then resumes its search.

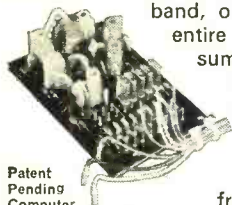

Patent Pending Computer Patch board matrix

Push button control enables you to program for both sides of complex base/mobile networks. Each channel has a push button for placing the frequency in or out of service.

Push button, too, for manual or automatic operation.

It's compact! It performs base or mobile. And it has a built in 4" speaker and detachable, telescope antenna.

The Hi/Lo Scanner is a bargain at \$169.00 plus crystals at \$4.95 each. See it to believe it . . . at your favorite Regency retailer.



REGENCY ELECTRONICS, INC.
7900 Pendleton Pike
Indianapolis, Indiana 46226

CIRCLE NO. 19 ON READER SERVICE PAGE

LIBRARY (Continued from page 12)

basing diagrams. Only readily available and comparably priced substitutes are listed, eliminating the need to search through listings of tube and transistor numbers that are rarely seen in use. The result is a substitution guide that lists 99% of the tube and transistor types that ever need replacement.

Published by **TAB Books, Blue Ridge Summit, PA 17214**. 224 pages. \$4.95 leatherette binding, \$2.95 soft cover.

VHF-UHF MANUAL

by **G. R. Jessop, G6JP**

The Radio Society of Great Britain has recently undertaken the publication of several handbooks that are so exhaustive in detail that your reviewer feels they must have been under preparation for several years. A superb case in point is this recently published manual or handbook on VHF-UHF equipment and practices. As any ham, or experimenter, using or building equipment for frequencies above 100 MHz is well aware, most low frequency wiring practices can be thrown out the window. Generally speaking, the builder must be as good a mechanic and machinist as he is an electronics technician. The "VHF-UHF Manual" is an amazingly comprehensive book and a veritable treasure load of ideas on the construction of receivers, transmitters, antennas, and test equipment. It is doubtful that anyone interested in the VHF-UHF region could not find something of immense value in this book.

Published by the **Radio Society of Great Britain, 35 Doughty St., London W.C.1, England**. Available in North America from **Comtec, Box 592, Amherst, NH 03031**. Soft cover. 248 pages. \$3.95.

ENGINEER'S RELAY HANDBOOK Revised Second Edition

In a new printing, this valuable working guide has been brought up to date and expanded to reflect recent advances in the technology. The book's scope has been enlarged to include new sections on reed and mercury-wetted relays and solid-state devices. Hence, more than ever, the Handbook meets the practical needs of all those who use, buy, specify, inspect, or troubleshoot relays. The Handbook presents coverage of relays, inspection and life tests, military specification requirements, and standardized definitions. Particularly valuable features are the complete discussions of magnet wire and the unique description of hybrid combinations of relays and solid-state devices.

Published by **Hayden Book Co., Inc., 116 West 14 St., New York, NY 10011**. Hard cover. 355 pages. \$13.95.

POPULAR ELECTRONICS READER SERVICE PAGE

free information service:

Here's an easy and convenient way for you to get additional information about products advertised or mentioned editorially (if it has a "Reader Service Number") in this issue. Just follow the directions below... and the material will be sent to you promptly and free of charge.

1. On coupon below, circle the number(s) that corresponds to the key number(s) at the bottom or next to the advertisement or editorial mention that is of interest to you. (Key numbers for advertised products also appear in the Advertisers' Index.) Print or type your name and address on the lines indicated.

2. Cut out the coupon and mail it to: POPULAR ELECTRONICS, P.O. Box 8391, Philadelphia, PA 19101.

note: If you want to write to the editors of POPULAR ELECTRONICS about an article on any subject that does not have a key number, write to POPULAR ELECTRONICS, One Park Avenue, New York, N.Y. 10016. Inquiries concerning circulation and subscriptions should be sent to POPULAR ELECTRONICS, P.O. Box 1096, Flushing, N.Y. 11352.

POPULAR ELECTRONICS

P.O. BOX 8391
PHILADELPHIA, PA. 19101

Void After August 31, 1970

1 2 3 4 5 6 7 8 9 10 11 12 13 14 15 16 17 18 19 20
 21 22 23 24 25 26 27 28 29 30 31 32 33 34 35 36 37 38 39 40
 41 42 43 44 45 46 47 48 49 50 51 52 53 54 55 56 57 58 59 60
 61 62 63 64 65 66 67 68 69 70 71 72 73 74 75 76 77 78 79 80
 81 82 83 84 85 86 87 88 89 90 91 92 93 94 95 96 97 98 99 100

NAME (Print clearly) _____

ADDRESS _____

CITY _____ STATE _____ ZIP CODE _____

7 N a

B&K TEST EQUIPMENT

PRODUCT OF
DYNASCAN

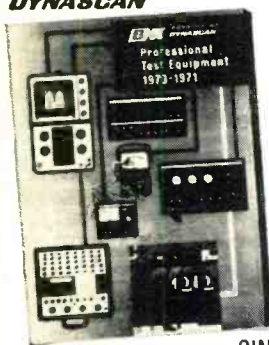

FREE CATALOG

TV ANALYSTS
NEW FET TESTER
VOMs—VTVMs
TUBE TESTERS
COLOR GENERATORS
CRT CHECKERS
OSCILLOSCOPE
TRANSISTOR ANALYSTS
RF SIGNAL GENERATOR
SINE/SQ. WAVE GENERATOR
PROBES—ACCESSORIES

TAKE ONE



new literature

To obtain a copy of any of the catalogs or leaflets described below, simply fill in and mail the coupon on page 15 or 93.

Sharpe Audio Division of Scintex, Inc., has available their new Audio Visual Catalog. Among the items listed are high-quality headphones, headset microphones, induction-type cordless headsets, wireless r.f. headsets, and audio station and sound centers. There is also an extensive coverage of impedances and radio frequencies.

Circle No. 75 on Reader Service Page 15 or 93

A new Condensed Semiconductors and Components Catalog is available from Texas Instruments. The 60-page booklet, No. CC300, provides information on new TI products as well as a listing of the company's semiconductor product lines. A ten-page section highlights recently introduced products, including TTL/MSI integrated circuits, silicon transistors, optoelectronic devices, etc. Electrical parameters, mechanical data, features, application information, and circuit diagrams are included in the listings. Seven pages are devoted to case outlines, while for military device selection a list cross-references military specification requirements with appropriate transistors, diodes, and resistors.

Circle No. 76 on Reader Service Page 15 or 93

In addition to their recently released 20-page CB antenna catalog, *New-Tronics Corp.* has announced the availability of two additional catalogs. The 1970 *Hustler Ham* catalog details new and improved antenna models for fixed-station and mobile HF, VHF, and UHF amateur band coverage; mobile antenna accessories; and SWR bridges. Then, to include every requirement, product coverage has been doubled in the *Newport Auto Antenna* catalog to illustrate a complete line of auto replacement AM/FM antennas for domestic and foreign cars, "Signal Probe," and "Hot-Rod" models, and universal and exact replacement masts and multi-length extension leads.

Circle No. 77 on Reader Service Page 15 or 93

POPULAR ELECTRONICS



SEND COUPON FOR FREE CATALOG TO:
DYNASCAN CORPORATION
1803 WEST BELLE PLAINE AVENUE
CHICAGO, ILLINOIS 60613

NAME _____
OCCUPATION _____
ADDRESS _____
CITY _____
STATE _____ ZIP _____

CIRCLE NO. 5 ON READER SERVICE PAGE

Citizens Band for Everyone



the
MICRO-12 Only **79⁹⁵**
Stock No.
89-31957WX

Can you get desperately needed help on the highway for your flat-tire, mechanical breakdown, or sudden illness?

Over two million calls for assistance were handled by CB radio last year. And with a Micro-12 as a traveling companion you can keep in touch on any of 12 CB Channels . . . you can get help when and where you need it most!

Uses 12 volts DC, (optional AC power supply and portable battery pack available). Meets FCC and Canadian D.O.C. requirements. Complete with push-to-talk dynamic mike, mobile mounting bracket, channel 10 crystals, DC power lead, and FCC form 505. Size: 1 3/4 Hx5 Wx1 1/2" D.

See your dealer or write us for full details. And write for our FREE 1971 Catalog 710 available in late summer.

LAFAYETTE Radio Electronics

P. O. Box 10, Dept 35070
Syosset, L. I., New York 11791

CIRCLE NO. 9 ON READER SERVICE PAGE

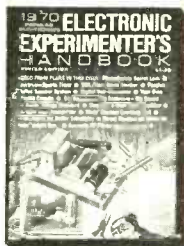

1970 WINTER ELECTRONIC EXPERIMENTER'S HANDBOOK

148 pages of the most fascinating and challenging construction projects for the electronics hobbyists. All with complete schematics, illustrations, parts list, and easy-to-follow instructions that guarantee you perfect finished products.

\$1.35

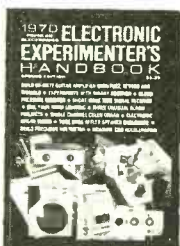

1970 SPRING ELECTRONIC EXPERIMENTER'S HANDBOOK

Another big package containing the most challenging, fun-to-build electronics projects ever! Be sure to order this one today!

\$1.50



1970 STEREO HI-FI DIRECTORY

Giant 180 page buyer's guide listing more than 1,600 individual Stereo/Hi-Fi components by 176 manufacturers. Nine individual sections complete with specs, photos, prices—the works!

\$1.35

SIX VITAL COMPONENTS
*For Knowledge...
 For Profit... For Sheer
 Electronics Enjoyment!*



1970 TAPE RECORDER ANNUAL

Over 130 pages covering every aspect of tape recording. Complete buyer's guide to the brands and models on the market. Expert tips on equipment—making better tapes—editing—copying—everything you want and need to know about tape recording.

\$1.35



1970 COMMUNICATIONS HANDBOOK

148 fact packed pages for the CB, SWL or HAM. Equipment buyer's guide—photos—tables—charts—getting a license—everything to make this the world's most complete guide to communications.

\$1.35

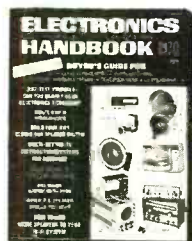

1970 ELECTRONICS INSTALLATION & SERVICING HANDBOOK

For the serviceman who is also a businessman—the hobbyist who is also a perfectionist! Covers all 8 areas of consumer electronics servicing—all the tricks of the trade—in one complete, up-to-date guide. This is the industry's "how-to" book for installing and servicing consumer electronics equipment.

\$1.35

GET THE DELUXE LEATHERFLEX BOUND EDITIONS FOR JUST \$3.50—POSTPAID!

These valuable annuals are also available in handsome DELUXE EDITIONS. Each volume is bound in superb leatherflex—a softly textured, gold-embossed cover which also provides rugged, lasting protection. They are truly collector's items... prized additions to your electronics bookshelf. And they're yours, for just \$3.50 each, postpaid. Please allow three additional weeks for delivery.

USE THIS COUPON TO ORDER YOUR COPIES TODAY!

ZIFF-DAVIS SERVICE DIVISION • Dept. W • 595 Broadway, New York, N.Y. 10012

Please send me the annuals I've checked below:

- Winter 1970 Electronic Experimenter's Handbook, \$1.35 1970 Stereo Hi-Fi Directory, \$1.35
- Deluxe Edition, \$3.50 Deluxe Edition, \$3.50
- Spring 1970 Electronic Experimenter's Handbook, \$1.50 1970 Tape Recorder Annual, \$1.35
- Deluxe Edition, \$3.50 Deluxe Edition, \$3.50
- 1970 Electronics Installation & Servicing Handbook, \$1.35 1970 Communications Handbook, \$1.35
- Deluxe Edition, \$3.50 Deluxe Edition, \$3.50

In U.S.A., add 25¢ for shipping and handling for each Regular Edition; Deluxe Editions are postpaid. Outside U.S.A., Regular Editions are \$2.00 each. Deluxe Editions are \$4.50 each, postpaid.

print name _____ ENCLOSED \$ _____

address _____

city _____ state _____ zip _____

PAYMENT MUST BE ENCLOSED WITH ORDER

PE-7-70

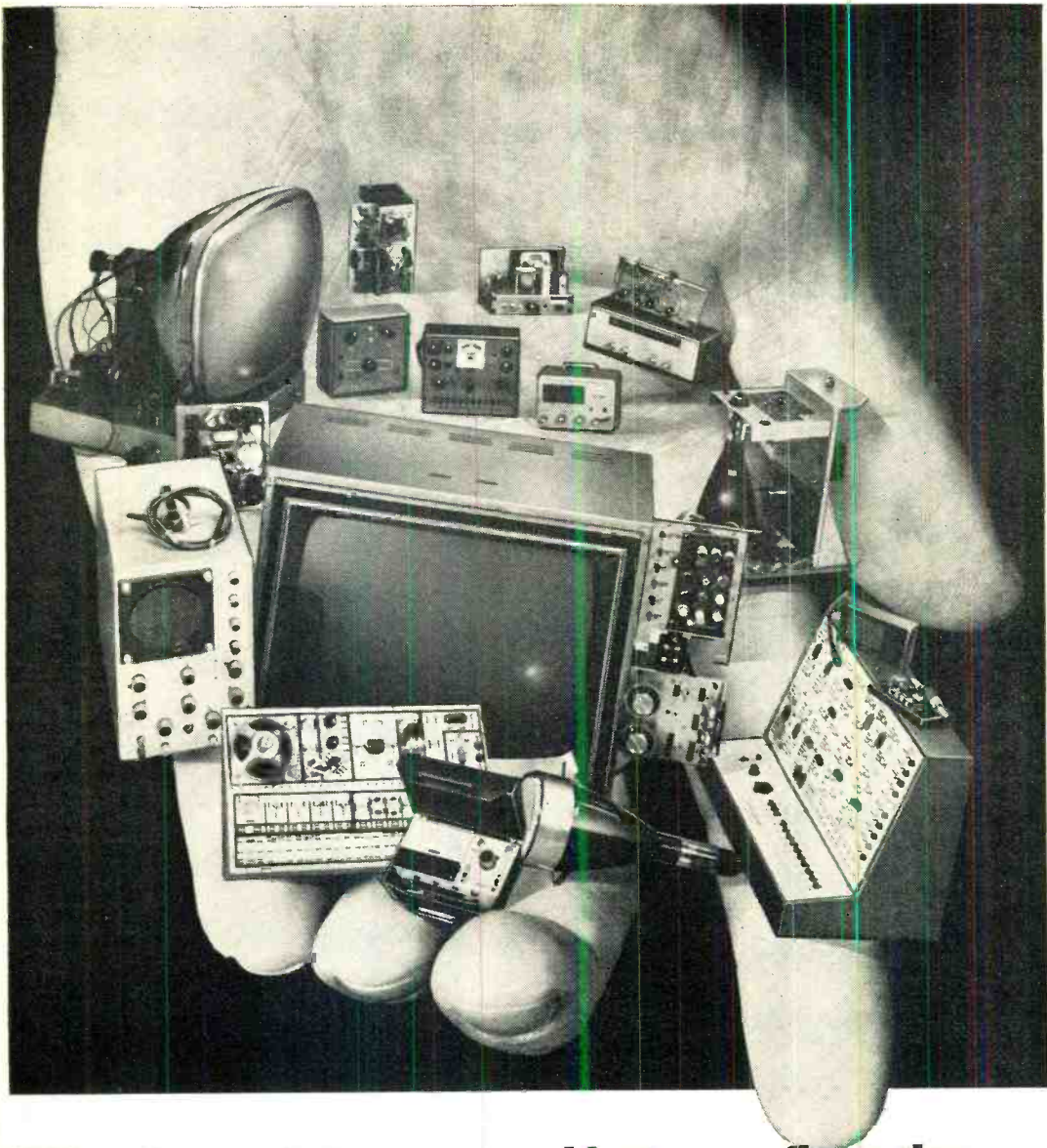

NTS puts a whole new world at your fingertips.

NTS home training can put a whole new way of life in the palm of your hand. A new, exciting job, a much bigger income is now easily within your reach.

NTS training is something special. We provide all the kits you need for the most effective training. National Technical Schools sends kits with every course, and teaches you to build and test a

wide range of professional equipment — the same kind of equipment you'll actually use on the job. That's the NTS "Project Method" — training that's practical and in-depth. You learn everything from fundamentals to the latest innovations. From beginning to end, NTS makes it fascinating and fun to learn this way. And all you need is a little

spare time and an interest in electronics.

Each year, men are moving into important new jobs, or their own businesses, straight out of NTS electronics training. NTS is what's happening to men everywhere. Check the coupon. Take hold of the career you want most. Do it now. No obligation. No salesman will call.

We pack your electronics course with kits to make your training fast. You'll enjoy every minute of it.

NTS COLOR TV SERVICING

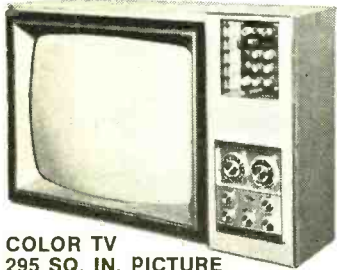

**COLOR TV
295 SQ. IN. PICTURE**

NTS training provides an easy way to become a professional home-entertainment service technician. You receive a big screen Color TV with many unique features. The unit even includes self servicing equipment that permits you to make all normal test operations. No additional test equipment is needed for adjusting your set. In addition you get an AM-SW radio, Solid-State radio, Field-Effect Transistor Volt-Ohmmeter, and Electronic Tube Tester. You learn about Electronic principles and trouble shooting, hi-fi, multiplex systems, stereo, and color TV servicing.

NTS COMPUTER ELECTRONICS

This is the future. And it's happening now. The number of computers will increase many times in the next few years.

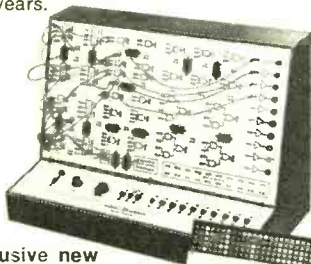

**Exclusive new
Compu-Trainer®**

If card is missing check coupon and mail for free color catalog and sample lesson. Now.



National Technical Schools

4000 S. Figueroa St., Los Angeles, Calif. 90037

Please rush Free Color Catalog and Sample Lesson, plus information on course checked below. No obligation. No salesman will call.

NTS offers a solid grounding in computer operation, wiring, data processing and programming. One of the 10 important kits included is our exclusive Compu-Trainer®. It's a fully operational computer logic trainer — loaded with integrated circuits — the first ever offered in home study. It introduces you quickly to how, what, when and why of computers . . . from theory to practical servicing techniques. This unit is capable of performing 50,000 operations per second.

NTS ELECTRONICS COMMUNICATIONS

Choose from two exciting courses to get into the big-paying fields of transmitting and receiving equipment: (1) The FCC License Course. (2) The Master Course in Electronic Communications (more comprehensive, with Citizens' Band Two-Way-Radio). Either Communications program qualifies you for your FCC First Class Commercial Radio-Telephone License — *NTS assures you will pass this FCC exam within six months after successfully completing your course or your tuition is refunded.* Kits include an Amateur-Phone 6 Meter VHF Transceiver — NTS exclusive, 6 transistor Solid-State Radio, Volt-Ohmmeter (fully transistorized).



**5 Watt AM Transmitter/
Receiver**

NTS AUTOMATION/ INDUSTRIAL ELECTRONICS

Let NTS put you into the age of electronic controls. Systems Automation is rapidly becoming the emphasis of modern industry. Your NTS training in automation electronics includes equipment like a 5" wide band Oscilloscope. You also get the new NTS Electronics Lab. It's an exclusive NTS experimental laboratory — a complete workshop that simplifies learning about solid-state, miniature and integrated circuits.

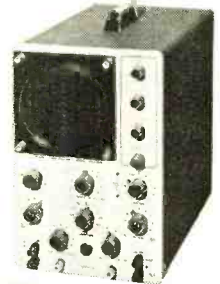

5" Oscilloscope

CLASSROOM TRAINING AT LOS ANGELES

You can take classroom training at Los Angeles in sunny Southern California. NTS occupies a city block with over a million dollars in facilities devoted exclusively to technical training. Check box in coupon.

NATIONAL TECHNICAL SCHOOLS

WORLD-WIDE TRAINING SINCE 1905

4000 South Figueroa Street
Los Angeles, Calif. 90037, U.S.A.

APPROVED FOR VETERANS

Accredited Member: National Association of Trade and Technical Schools; National Home Study Council.

- Master Course in Color TV Servicing
- Color TV Servicing
- Master Course in TV & Radio Servicing
- Practical TV & Radio Servicing
- Master Course in Electronic Comm.
- FCC License Course
- Master Course in Electronics Tech.
- Industrial and Automation Electronics
- Computer Electronics
- Basic Electronics

Name _____ Age _____

Address _____

City _____ State _____ Zip _____

- Check if interested in Veteran Training under new G.I. Bill
- Check if interested only in Classroom Training at Los Angeles

Dept. 205-070



NEW PRODUCTS

Additional information on products covered in this section is available from the manufacturers. Each new product is identified by a code number. To obtain further details on any of them, simply fill in and mail the coupon on page 15 or 93.

STEREO PROGRAM MONITOR

The capability to monitor any portion of a two-, three-, or four-channel stereo system is provided for the first time in consumer



equipment by the *Hegeman Labs Inc.* Model HL-320 Volume Level Indicator and Dual Patch Panel.

The user can monitor the level of input or output signals anywhere in the system, change the configuration of the system by patching, and add auxiliary equipment for evaluation or temporary use. The HL-320 actually consists of two separate units: the HL-D3 volume level indicator containing two VU meters with associated isolation amplifiers and step-type attenuators, and two HL-B1 16-jack patch panels. The HL-D3's attenuators are calibrated to produce 0 VU on the meters at levels from -14 to +8 VU, with an additional switch adding 20-VU capability.

Circle No. 78 on Reader Service Page 15 or 93

CAPACITIVE DISCHARGE IGNITION

Automotive Research Electronics has announced the latest addition to its assortment of quality high-performance automotive products



with the introduction of the "Ramfire" capacitive discharge ignition system. Said to be the ultimate in high performance systems, the Model CD-21 Ramfire

operates with a stock coil and breaker point distributor, increasing plug and point life many times over and delivering a hotter spark across a larger gap to racing speeds well in excess of 10,000 r/min. Its ultra-fast primary voltage rise time (less than 1 μ sec) enables the Ramfire to fire even oil-fouled spark plugs. Silicon semiconductors are used exclusively in construction to assure reliable operation under extreme conditions. Also, Ramfire is said to offer the only true anti-point bounce and secondary arcing protection, as well as added horsepower.

Circle No. 79 on Reader Service Page 15 or 93

SOLID-STATE LABORATORY VOM

The Model 801 solid-state portable laboratory VOM available from *Triplet Corp.* features a "low-power-ohms" circuit for testing IC's, 5-



mV sensitivity, and 11 megohms input resistance. The 801 has a one-ohm center scale reference; large 8" mirrored meter movement with simplified layout, having only two arcs for a.c. and d.c. volts; and a single compact test probe for all

functions. Technical specifications—d.c. voltage ranges: 0-0.05, 0.5, 1.5, 5, 15, 50, 150, 500, 1500 with 2% of full-scale accuracy; a.c. voltage ranges: same as for d.c. plus 0-0.005 and 0.015 with 3% accuracy and frequency range of 50-50,000 Hz; current ranges: 5 μ A-1500 mA full scale in 12 ranges with 3% d.c. and 4% a.c. accuracy; resistance ranges X1, X10, X100, X1K, X10K, X100K, and X1MEG at 1.5 volts (low power ohms: X.1-X1MEG at 35 mV) with 3° of arc accuracy on all ranges; d.c. input resistance: 11 megohms; a.c. input impedance: 10 megohms; dB range: -70 to +66 dB.

Circle No. 80 on Reader Service Page 15 or 93

"NATURAL SOUND" MICROPHONE

A new omnidirectional dynamic microphone that meets the requirements of fine quality PA systems, as well as recording studio radio-TV applications, is being marketed by

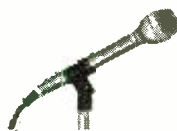

Shure Brothers, Inc. Called the "Vocal Sphere" Model 579SB, the microphone is a low-impedance unit that delivers peak-free, linear, wide-range response for life-like natural sound. Its

uniform pickup pattern minimizes unnatural voice coloration that often occurs when the speaker moves from side to side. Effective built-in wind and "pop" filters make the Vocal Sphere ideal for close-up situations, while handling and mechanical noises are sharply reduced by the mike's shock-mounted isolated cartridge. The mike features a built-in on/off switch and comes with a 20' detachable cable with a trouble-free Cannon connector on the mike end.

Circle No. 81 on Reader Service Page 15 or 93

R/C MODEL RACING CAR KIT

Heath Company announces its entry into radio controlled model car racing with the introduction of the Heathkit Model GD-101 "Spectre" race car kit. The Spectre is completely equipped, needing



no modification to accept any proper size R/C engine or proportional R/C electronic system. The car's $\frac{1}{8}$ scale body, made of a

single piece of high-impact plastic with GT-Sports styling, measures 19 $\frac{3}{4}$ " long. Designed to reach scale speeds of up to 200 mi/hr, the Spectre features independent front-wheel coil



**New Mallory ultrasonic Crime Alert®...
Nobody can
get around it.**

Our new ultrasonic Crime Alert® alarm.

It catches intruders flatfooted. With invisible, silent, unavoidable ultrasonic waves.

Just plug it in . . . no complicated installation. Any movement within its range triggers its piercing scream . . . accessory outlet lets you plug in lights, siren, or other device.

It's the first really sophisticated electronic warning device available to consumers in its price range. And no wires, lightbeams, or anything else to see and get around.

It's the perfect, low-cost (only \$89.95) intruder warning for homes, stores, industry, plants . . . anything you want to keep safe.



MALLORY DISTRIBUTOR PRODUCTS COMPANY

a division of P. R. MALLORY & CO. INC.
Box 1558, Indianapolis, Indiana 46206; Telephone: 317-636-5353

Batteries • Capacitors • DURATAPE® • Controls **CRIME ALERT®** Resistors • Semiconductors • Sonalert® • Switches • Timers • Vibrators
CIRCLE NO. 10 ON READER SERVICE PAGE

PRODUCTS (Continued from page 22)

spring suspension with adjustable toe-in and caster, live rear axle, chrome-plated chassis, and special tires that fit onto nylon "mag"-type wheels. The car's "sidewinder" R/C engine mount accommodates any 0.15-0.23 cu in. R/C engine. Also featured are an adjustable centrifugal clutch, 5.5:1 ratio gear train, automatic brake, and exclusive molded plastic radio equipment case to keep the electronics clean.

Circle No. 82 on Reader Service Page 15 or 93

TIME-SIGNAL-ONLY RECEIVER

A unique, fixed-frequency, portable WWV receiver, called the Simex Time Standard, which provides extremely accurate voice time signals on a continuous basis is available from *Coast Navigation School*. With the Time



Standard, anyone, anywhere, who needs extremely accurate time can receive an immediate voice time signal of astronomically accurate Greenwich Mean Time 24 hours a day. Where absolute time is required

on a regular basis, a Time Zone Chart can be used for conversion. The receiver operates on fixed frequencies of 2.5, 5, 10, 15, and 20 MHz to receive signals broadcast from the National Bureau of Standards, Fort Collins, Colorado and WWVH in Hawaii. A special additional frequency at 7.335 MHz provides for signal reception from the Dominion Conservatory in Ottawa, Canada. Also, the receiver will pick up standard time signals from Tokyo, Moscow, Johannesburg, etc.

Circle No. 83 on Reader Service Page 15 or 93

CARDIOID CONDENSER MICROPHONE

Sony's Model ECM-22 compact electret cardioid condenser microphone, available from *Superscope*, has professional quality but is



designed for home-recording and semiprofessional user. The mike is equipped with a swivel-mount stand adapter, wind screen and vinyl case. Other accessories include a 20' cadmium-bronze, two-conductor shielded cable. A three-position switch turns the ECM-22 on and off and selects either flat frequency response or a response

that "rolls off" below 200 Hz. The microphone employs a permanently polarized electret capsule, eliminating the need of a polarized voltage source, the major source of noise in condenser microphones. Technical specifications: 40-20,000 Hz ± 3 dB frontal frequency response; balanced 50-, 250-, and 600-ohm output impedance at 1000 Hz; 0.44-dB output level; cardioid directional characteristics.

Circle No. 84 on Reader Service Page 15 or 93

VHF FM MONITOR RECEIVERS

Regency Electronics, Inc., is marketing two FM monitoring receivers for operation in the 30-50-MHz band and two in the 144-MHz



band. Four models are available: TM II-H1 has single-channel, narrow-band reception capability in the 144-172-MHz band; TM II-L1 is the same for operation in the 30-50-MHz band;

TM II-H2 and TM II-L2 feature six-channel reception capability in the respective bands. All receivers have a complete assortment of optional equipment, including sequential tone alarm decoding. Sensitivity of all models is $0.5 \mu\text{V}$; selectivity is 50 dB at ± 15 kHz; and audio output power is 5 watts maximum. Each of the receivers can operate on 117-volt a.c. line power with accessories or on 12 volts d.c. (or internal nickel-cadmium batteries).

Circle No. 85 on Reader Service Page 15 or 93

AM/STEREO FM TUNER

The new *Marantz Co., Inc.*, Model 23 AM/stereo FM tuner includes many advanced engineering concepts in an economy priced package. The features include signal-strength



and center-channel/multipath meters which enable the user to tune in broadcasts with absolute accuracy. The center-channel meter can also be switched to

indicate the degree of multipath and thus allow the user to correct multipath distortion by reorienting his antenna. Other features include the Marantz patented "Gyro-Touch Tuning" mechanism; inter-station muting; integrated circuits; and black-out dial panel. Gyro-Touch Tuning renders smooth, effortless station-to-station changes with the absolute minimum wear and friction. Inter-station muting is controlled by rear panel adjustment but can be defeated by a front panel switch.

Circle No. 86 on Reader Service Page 15 or 93

MARINE DEPTH METER

Now electronics comes to the aid of the angler—an electronic depth meter, *Knight-Kit's* Model KG-711, tells him just where and how deep the fish are. The ultrasonic Depth Meter and Fish Finder kit is a useful navigational aid, too, indicating how deep the water is so that you can cruise safely, without fear of running your boat aground. An electronic transducer easily attaches to the transom, side, or bottom of your boat. In operation, return echoes of



the ultrasonic signal show up as flashes of

(Continued on page 82)



THE 2 MOST IMPORTANT RECORDS IN YOUR ENTIRE COLLECTION!



New Standard in Stereo Testing! The All-New Model SR12 STEREO TEST RECORD
The most complete . . . most sophisticated . . . most versatile Test Disc available today!

The Most Spectacular Sound Exhibition of STEREO FIDELITY Ever Available on one Disc.

Whether you're an avid audiophile who'll settle for nothing but peak performance from his stereo components . . . a casual listener who'd like more insight into the challenging world of stereo reproduction . . . or a professional technician who needs precise standards for lab testing . . . the new MODEL SR12 will be the most important disc in your entire collection. SR12 has been produced by Stereo Review Magazine for music lovers who want immediate answers to questions about the performance of their stereo systems and how to get the best possible sound reproduction. SR12 is the most complete test record of its kind—containing the widest range of checks ever included on one test disc.

MAKE THESE IMPORTANT STEREO CHECKS BY EAR . . . (NO INSTRUMENTS OF ANY KIND REQUIRED)

FREQUENCY RESPONSE — a direct warble-tone check of nineteen sections of the frequency spectrum, from 20 to 20,840 Hz • **SEPARATION** — indicates whether you have adequate separation for good stereo • **CARTRIDGE TRACKING** — devised for checking the performance of your cartridge, stylus and tone arm • **CHANNEL BALANCE** — two broad-band, random-noise signals which permit you to eliminate any imbalances originating in cartridge, amplifier, speakers or room acoustics • **HUM AND RUMBLE** — foolproof tests that help you evaluate the actual audible levels of rumble and hum in your system • **FLUTTER** — a sensitive "musical" test to check whether your turntable's flutter is low, moderate, or high • **PLUS: Cartridge and Speaker Phasing • Anti-Skating Adjustment • "Gun Shot Test" for Stereo Spread • Multi-purpose Musician's "A" • Equal-tempered Chromatic Octave • Guitar-tuning Tones.**

FOR THE ULTIMATE IN STEREO TESTING, 7 CRITICAL TEST EQUIPMENT CHECKS . . .

Attention professionals: Model SR12 is also designed to be used as a highly efficient design and measurement tool. In the following tests, recorded levels, frequencies, etc. have been controlled to laboratory tolerances—affording accurate numerical evaluation when used with oscilloscope, chart recorder, output meter, intermodulation-distortion meter and flutter meter.

- 1,000-Hz square waves to test transient and high-frequency response of phono pickups.
- 500 to 20,000 Hz frequency-response sweep.
- Sine-wave tone-bursts to test transient response of pickup.
- Intermodulation test using simultaneous 400-Hz and 4,000-Hz signals.
- Intermodulation sweep to show distortion caused by excessive resonances in tone arm and cartridge.
- 1,000-Hz reference tones to determine groove velocity.
- 3,000-Hz tone for flutter and speed tests.
- **Sample waveforms** — illustrating both accurate and faulty responses are provided in the Instruction Manual for comparison with the patterns appearing on your own oscilloscope screen.

This record is the result of two years of intensive research in the sound libraries of Deutsche Grammophon Gesellschaft, Connoisseur Society, Westminster Recording Company and Cambridge Records Incorporated. The Editors of Stereo Review have selected and edited those excerpts that best demonstrate each of the many aspects of the stereo reproduction of music. **The record offers you a greater variety of sound than has ever before been included on a single disc.** It is a series of independent demonstrations, each designed to show off one or more aspects of musical sound and its reproduction. Entirely music the Record has been edited to provide self-sufficient capsule presentations of an enormous variety of music arranged in a contrasting and pleasing order. It includes all the basic musical and acoustical sounds that you hear when you listen to records, isolated and pointed up to give you a basis for future critical listening.

WIDE RANGE OF DEMONSTRATIONS

- Techniques of Separation & Multiple Sound Sources
- Acoustic Depth
- Ambiance of Concert Hall
- Sharp Contrasts of Dynamics
- Crescendo & Diminuendo
- Very High & Very Low Pitched Musical Sounds
- Polyphony (2 or more melodies at once) With Both Similar & Contrasting Instruments
- Tonal Qualities of Wind, String & Percussion Instruments
- Sounds of Ancient Instruments
- Sounds of Oriental Instruments
- Sound of Singing Voice, Both Classically Trained and Untrained
- Plus a Large Sampling of Finger Snapping, Hand Clapping, Foot Stamping & Other Musical & Percussive Sounds.

13 SUPERB SELECTIONS

- STRAUSS:** Festive Prelude, Op. 61 (excerpt) DGG.
- DEBUSSY:** Feux d'artifice (excerpt). Connoisseur Society.
- BEETHOVEN:** Wellington's Victory (Battle Symphony) (excerpt from the first movement) Westminster Records.
- MASSAINO:** Canzona XXXV à 16 (complete) DGG Archive.
- CORRETTE:** Concerto Comique Op. 8, No. 6, "Le Plaisir des Dames" (third movement) Connoisseur Society.
- KHAN:** Raga Chandranandan (excerpt) Connoisseur Society.
- RODRIGO:** Concert—Serenade for Harp and Orchestra (excerpt from the first movement) DGG.
- MANITAS DE PLATA:** Gypsy Rhumba (complete) Conn. Soc.
- MARCELLO:** (arr. King): Psalm XVII "The Heavens are Telling" (complete) Connoisseur Society.
- PRAETORIUS:** Terpsichore: La Bourrée XXXII (complete) DGG Archive.
- BERG:** Wozzeck (excerpt from Act III) DGG.
- BARTÓK:** Sonata for two pianos and Percussion (excerpt from the first movement) Cambridge Records.
- BEETHOVEN:** Wellington's Victory (Battle Victory) (excerpt from the last movement) Westminster.

FREE 8 Page Instruction Manual includes detailed instructions, charts, tables and diagrams.

Only \$4.98 each

Descriptive Booklet Enclosed includes discussion of the selections on the record, plus a complete description of each selection and the purpose behind its demonstration.

FREE

NOTE — THE STEREO DEMONSTRATION RECORD ONLY IS AVAILABLE IN YOUR CHOICE OF 33½ RPM OR 45 RPM

Both the Model SR12 Stereo Test Record and Stereo Demonstration Record are processed and pressed on a newly developed, improved vinyl. It is permanently anti-static, repels dust and dirt and promotes longer stylus wear. The use of this material is conducive to low surface noise and contributes to the production of full dynamics and frequency range. The record continually looks new, sounds new and wears longer.

RECORDS • Ziff-Davis Service Division
 595 Broadway • New York, N.Y. 10012

PE-7-70

My check (or money order) for \$_____ is enclosed.
 Please send:

_____ Stereo Review Stereo Demonstration Records at \$4.98 each, postpaid.

Check one: 33½ RPM 45 RPM

_____ Model SR12 Stereo Test Records at \$4.98 each, postpaid.

(Outside U.S.A.—please send \$7.00 per record ordered.) New York State residents please add local sales tax.

Print Name _____
 Address _____
 City _____
 State _____ Zip _____

PAYMENT MUST BE ENCLOSED WITH ORDER

Now it costs less to own the best oscilloscope you need.



The New RCA WO-505A Solid-State Oscilloscope

I.Q.*

*Inexpensive Quality
†Optional Distributor.
Resale Price

RCA

The best you need is the new 5-inch RCA WO-505A, all solid-state oscilloscope. It makes yesterday's general-purpose 'scopes look old-fashioned.

At just \$298.50† the WO-505A offers an unmatched list of features usually found only in more expensive, laboratory-type instruments. For example there's the all solid-state circuitry... an illuminated graph screen calibrated directly in volts, and a deep-lip bezel for exceptional clarity. The regulated power supply minimizes trace bounce and provides excellent stability. And the camera mounting studs offer still more evidence of the functional value built into the new WO-505A.

But you've got to see this new RCA 'scope in operation — see the sharp, clean trace it provides — to appreciate it.

Some statistics:

- High-frequency response, usable to 8 MHz.
- High Sensitivity (.05 V p-p range).
- DC vertical amplifier; DC/AC input.
- Return trace blanking... Trace polarity reversal switch... Phase control.
- High-frequency horizontal sweep; solid lock-in on 5 MHz.
- Preset TV "V" and "H" frequencies for instant lock-in.
- Built-in square-wave signal for calibrating P-P voltage measurements.
- Provision for connection to vertical deflection plates of CRT.

Some statistics! For complete details, contact your RCA Distributor.

RCA | Electronic Components | Harrison, N. J. 07029

CIRCLE NO. 18 ON READER SERVICE PAGE

Build the Bug Shoo

*Greaseless,
odorless
mosquito
repellent*

COVER STORY
BY LYMAN E. GREENLEE

THROUGH OBSERVATION and scientific study of the habits of mosquitoes, certain facts have been compiled leading to the design of an electronic repellent for the little beasties. It has been determined that the male mosquito is attracted by a humming noise at a frequency of about 2000 Hz. But the male mosquito does not sting; it is the female of the species that creates all the discomfort.

The female mosquito is said to be repelled by the same sound that attracts the male. And since it is the female mosquito you want to ward off, having a device that will "repel" her is mighty handy. The trick is to ward off the female without attracting too many male mosquitoes, and the "Bug-Shoo," a simple cigarette-package-size device, has proven itself to be quite effective since female mosquitoes usually avoid the male "humming" area.



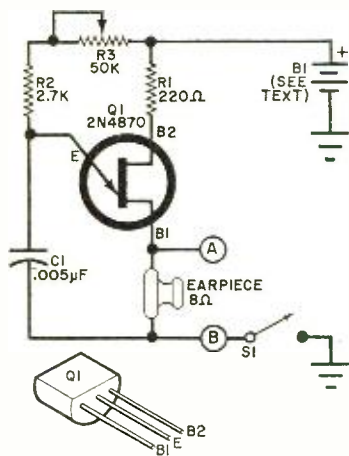

Fig. 1. Simple UJT relaxation oscillator makes up repeller; output is from earpiece.

PARTS LIST

- B1—9-volt transistor or 22.5-volt miniature battery (see text)
 C1—0.005- μ F disc capacitor
 Q1—Transistor (Motorola 2N4870 or IIEP 310)
 R1—220-ohm, $\frac{1}{2}$ -watt resistor
 R2—2700-ohm, $\frac{1}{2}$ -watt resistor
 R3—50,000-ohm miniature P.C. potentiometer
 S1—S.p.s.t. slide or miniature toggle switch
 1—8-ohm miniature earpiece (from transistor radio)
 1— $3\frac{1}{4}$ " x $2\frac{1}{8}$ " x $1\frac{1}{8}$ " aluminum utility box
 Misc.—Brass shim stock; 22-gauge aluminum (or old money clip) for pocket clip; 2-56 machine hardware; 1"-square piece of fiber paper insulator; perforated phenolic or Bakelite board; hookup wire; solder; etc.

About The Circuit. A simple UJT relaxation oscillator (see Fig. 1) is the heart of the Bug-Shoo. Unijunction transistor Q1 is the active element in the circuit, while capacitor C1 and the combined resistances of R2 and potentiometer R3 form the frequency-determining RC network. Potentiometer R3 provides control over a wide frequency range.

Resistor R1 is the B2 load for Q1. The output transducer for the Bug-Shoo is an inexpensive miniature earpiece with an impedance of 8 ohms. Power for the circuit is not critical and can be anywhere between 9 and 22 volts, using a small transistor radio battery.

Construction. Due to the simplicity of the circuit, assembly is best performed

as shown in Fig. 2 on a piece of Bakelite or perforated phenolic board. The board should measure no more than $1\frac{3}{4}$ " x $1\frac{1}{2}$ " if you wish the entire project to fit inside a $3\frac{1}{4}$ " x $2\frac{1}{8}$ " x $1\frac{1}{4}$ " metal utility box. You can assemble the circuit on the board by drilling holes for and routing cross-connecting wiring under the undersides of the board. Control R3 also mounts to the

underside of the board. Next, machine the top half of the utility box so that the opening of the earpiece and control slot for R3 are accessible from the outside. Then mount the circuit board with 2-56 machine hardware and $\frac{1}{4}$ "-long spacers. Switch S1 mounts near the board with 6-32 screws.

If you are using a miniature 22.5-volt battery for B1, you can mount it in place as follows. Make an indentation (centered $\frac{5}{8}$ " in from one end of the bottom half of the utility box) to accommodate the negative contact of the battery. Then cement a 1"-square piece of black fiber paper on the opposite wall of the half section (see Fig. 3). Solder the free end of the positive hookup wire to a $\frac{1}{2}$ "-square piece of brass shim stock and wedge the shim between the positive contact of the battery and fiber paper. (If

AN EXPERIMENTAL DEVICE

The Bug-Shoo is an experimental device. As such, it makes an excellent research project. The fact that sounds attract or repel mosquitoes has been proved in laboratory experiments. Recordings have been made of the mating calls of mosquitoes, and playbacks of these recordings have proved effective in luring mosquitoes into traps where they could be conveniently destroyed.

Just because you are wearing the Bug-Shoo, there is no absolute guarantee that you will not be attacked and stung by mosquitoes. But then the application of greasy or odorous "repellents" or powders is no guarantee against stings either. One method works about as well as the other, but the Bug-Shoo is not gooey, greasy, or smelly.

I would be pleased to hear from anyone who builds and uses the Bug-Shoo and will be eager to compare notes—and sizes of sting marks. Do some experimenting on your own and let me know what you found the effective range of the Bug-Shoo to be and the best frequency to use. Here is where your own research will pay off. Just what is the best frequency to use? Only extensive field checking can provide the answer.

—Lyman E. Greenlee

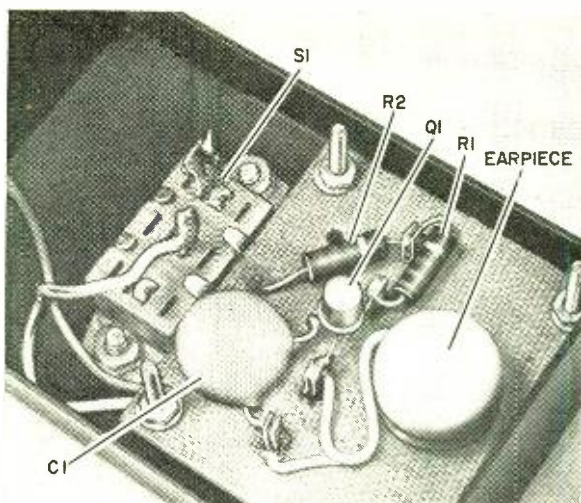

Fig. 2. All components except switch and battery are on circuit board. Interconnecting wiring is routed on bottom of board; earpiece is cemented in place.

you use a 9-volt battery, there is no need to dimple the side or use fiber paper; the usual snap-on connector will serve as a wedge.) The battery can then be held in place with a small L bracket and 2-56 machine hardware.

Finally, bolt to the outside surface of the bottom of the utility box a pocket clip. The clip can be made from an old money clip or from 22-gauge aluminum stock. Assemble the box.

Use. You can "tune" the Bug-Shoo oscillator by ear or by comparison with the output signal heard from a loudspeaker from an audio generator. A frequency between 2000 and 2500 Hz seems to work best as a repellent. However, it is inter-

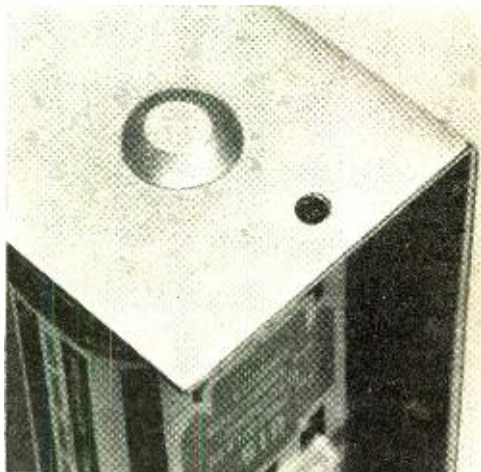
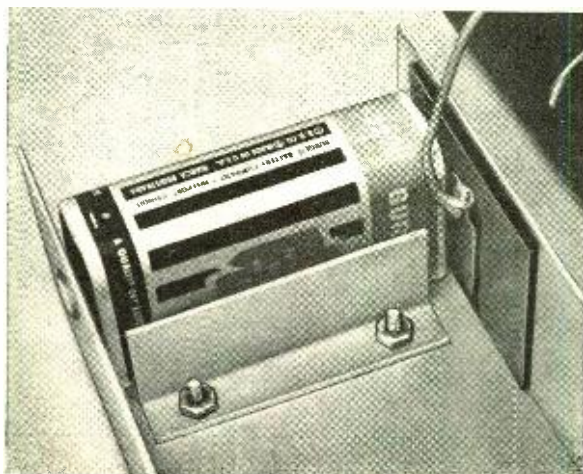

Fig. 3. For installation of 22.5-volt battery, one side of chassis box must be dimpled to accept negative contact (above). Positive pole connection consists of brass shim (left), insulated from box with fiber paper. Small L-bracket holds battery in upright position. Note the wire connected to shim.



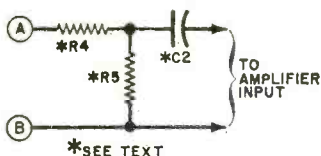

Fig. 4. Optional add-on allows Bug-Shoo to be used with amplifier for larger area coverage. Points A and B connect to respective points in main schematic diagram.

esting to note that *all* mosquitoes seem to be repelled by a high frequency, above 10,000 Hz. If you set $R3$ so that the oscillator produces the highest pitched squeal you can hear, and then turn it just slightly into the ultrasonic range, the sound will be unnoticeable to you but will be detected by mosquitoes. But your dog might hate you!

The Bug-Shoo's observed effective range is 3' or more. Hence, it is not recommended for beach use where most of your epidermis (that's skin in case you don't know what epidermis is) is exposed as a succulent meal for a passing female mosquito. You should use the Bug-Shoo when you are fully clothed from the waist down and want to protect your upper body.

If you want greater coverage from the Bug-Shoo, you can connect it to an audio amplifier. In this case you will need an add-on circuit as shown in Fig. 4; points A and B indicate the connections to be made to the basic oscillator circuit in Fig. 1. In the add-on circuit, capacitor $C2$ can have any value between 0.05 and 0.1 μF . Resistors $R4$ and $R5$ serve as a volume reducing pad for the input signal to the amplifier. For a 10:1 reduction in signal amplitude, try using 10 ohms for $R4$ and 100 ohms for $R5$.

By using an amplifier with your Bug-Shoo, it is possible to increase greatly the area of coverage against mosquito attacks. But there is a practical limit to the coverage area—especially if there are a lot of dogs in the vicinity. -30-



For carrying convenience, you can fashion pocket clip from 22-gauge aluminum stock and bolt it to rear of chassis box. An old money clip can also be used if available.

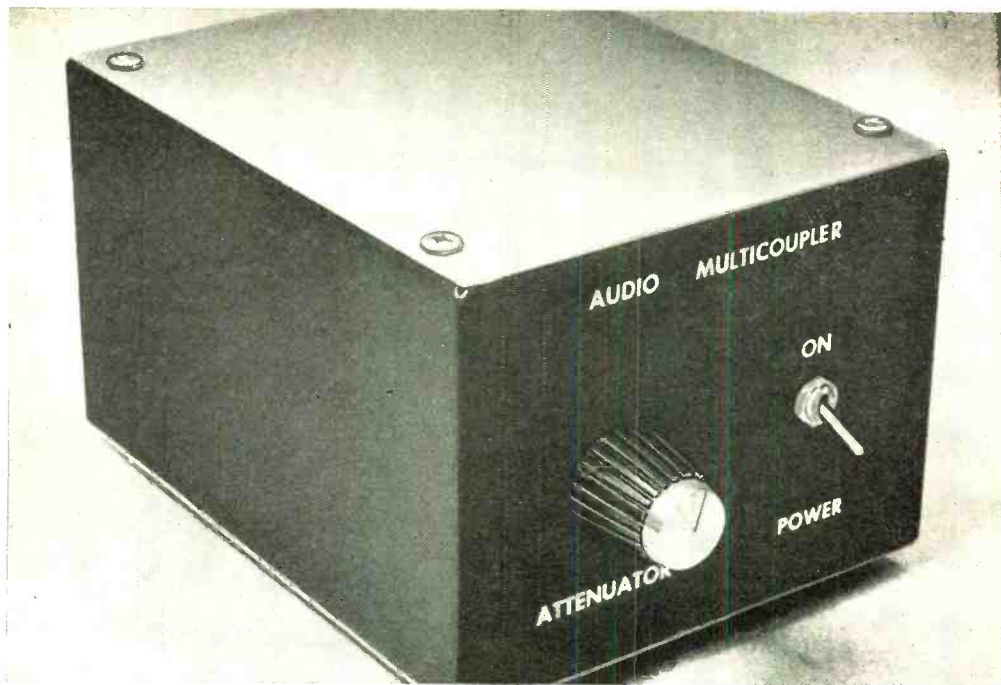

Build an AUDIO MULTICOUPLER

ISOLATE TAPE RECORDER INPUTS AND MINIMIZE LOADING

BY DON M. WHERRY

WHEN YOU record "live" or "off-the-air" on magnetic tape, situations are sometimes encountered which require equipment that is not commonly available. This can occur when more than one tape recorder is being fed from a single pickup. The usual approach here is simply to parallel the recorders somewhere in the pickup line, and forget it.

However, this arrangement has two definite drawbacks.: If the input to one of the recorders becomes open-circuited, the input signal levels to the remaining

recorders increase. On the other hand (and more disastrously), if one of the recorder inputs becomes short-circuited, the result is a zero or near-zero input level to the remaining recorders. In any parallel-fed, direct-from-the-pickup system, either or both of these problems is likely to develop with annoying regularity.

To prevent such occurrences, it is necessary to isolate each recorder input line from the other input lines in the system. This can be accomplished with the simple

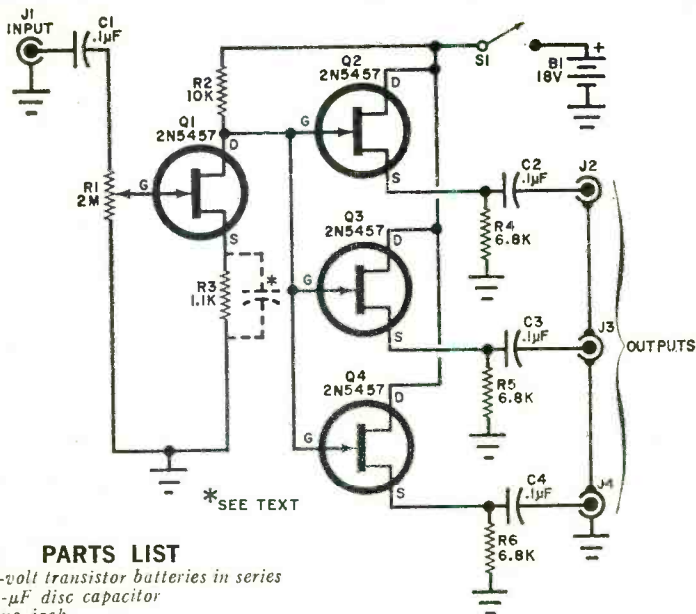

PARTS LIST

- B1*—Two 9-volt transistor batteries in series
C1-C4—0.1- μ F disc capacitor
J1-J4—Phono jack
Q1-Q4—2N5457 field effect transistor
R1—2-megohm audio-taper potentiometer
R2—10,000-ohm, $\frac{1}{2}$ -watt resistor
R3—1100-ohm, $\frac{1}{2}$ -watt resistor
R4-R6—6800-ohm, $\frac{1}{2}$ -watt resistor
S1—S.p.s.t. slide or toggle switch
Misc.—Electrolytic capacitor, 50- μ F, 15-volt (optional, see text); aluminum utility box 5" x 4" x 3"; printed circuit board or perforated phenolic board and flea clips; #6 hardware; U-bracket for batteries; hookup wire; solder; etc.

Fig. 1. Multicoupler circuit is designed to independently feed signals from single source to several tape recorders. Failure of any one stage has no effect on others.

and inexpensive "Audio Multicoupler" described in this article. In addition to satisfying the isolation requirement, the Multicoupler provides 8-10 dB of gain, depending on the tape recorder load, and operates flat 12-100,000 Hz ± 1 dB. The noise figure is good, too—more than 70 dB below the rated output when a battery supply is used. And all of this comes in a 5" x 4" x 3" package.

About The Circuit. As shown in Fig. 1, the Audio Multicoupler consists of a single FET input stage and three (or more) discrete FET output stages, the latter operated in a source-follower configuration. Hence, not only is each output line isolated from the others, the input and outputs are also isolated from each other.

The program source, connected to the Multicoupler via *J1*, can be a microphone,

tuner, turntable, or tape recorder. The signal developed by the program source undergoes amplification in the *Q1* stage, and is then passed through source-follower stages *Q2*, *Q3*, and *Q4* and out to the individual recorders.

Each of the output channel stages is driven by the same amount of signal current, and each is "live" whenever a signal is applied to the input. Potentiometer *R1* controls the output signal level in all channels simultaneously. This control is adjusted for the least sensitive recorder in the system; then the recording level controls on the other recorders are used to adjust for undistorted recordings.

With a high-impedance load, the Multicoupler has a gain of more than 10 dB, which drops as the load approaches 3300 ohms. Lower impedance loads should be avoided, since distortion increases as the

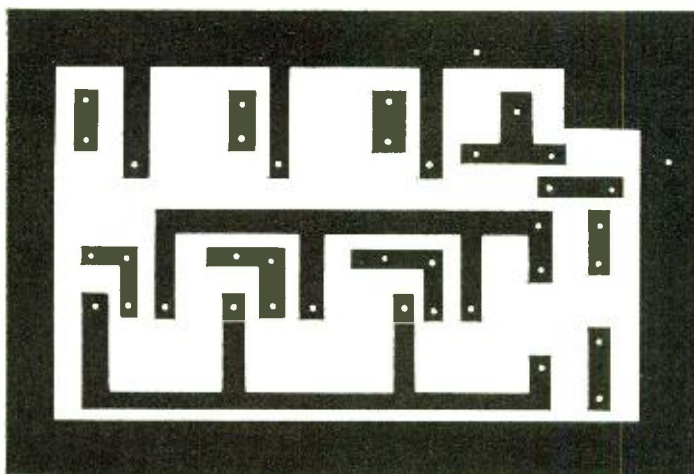
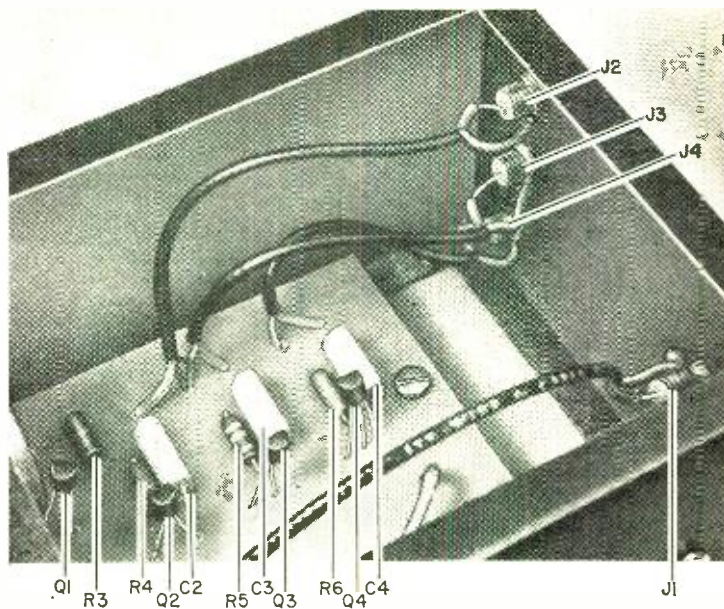

Fig. 2. Actual-size printed circuit board etching guide is shown directly above. At top, components are shown mounted to board and on side of box.

load is reduced below 3300 ohms. However, you can obtain a lower impedance output by dividing R_4 , R_5 , and R_6 and taking your output from the lower tap. While this procedure will reduce gain, adding a 50- μ F, 15-volt electrolytic capacitor across R_3 will restore the lost gain.

If you wish more than three output channels, simply add the required number of stages ($Q_2/R_4/C_2$) as shown.

However, limit the total number of stages to six for practical purposes.

Construction. The Audio Multicoupler is best assembled on a printed circuit board, the full-size etching guide and components placement diagram for which are shown in Fig. 2. If you wish, however, the circuit can also be assembled on a piece of perforated phenolic board with the aid of flea clips for parts mounting.

HIRSCH-HOUCK LABORATORIES Project Evaluation

The "Audio Multicoupler" has every bit of the frequency response claimed by the author, but the response seems to fall off a bit at 100 kHz. However, in the audio range, the frequency response is flat. The

results of tests performed on the Audio Multicoupler are as follows: gain is 8.7 dB at 1000 Hz; maximum output is 4.65 volts; and output impedance is 1200 ohms. Referenced at 1000 Hz, outputs of 0.1, 0.3, 1.0, 2.0, 3.0, and 4.0 volts produced total harmonic distortions (THD's) of 0.082%, 0.19%, 0.58%, 1.22%, 1.8%, and 2.5%, respectively.

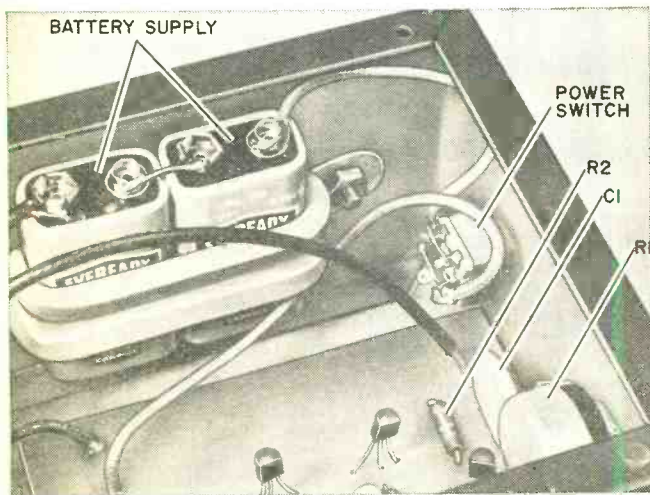
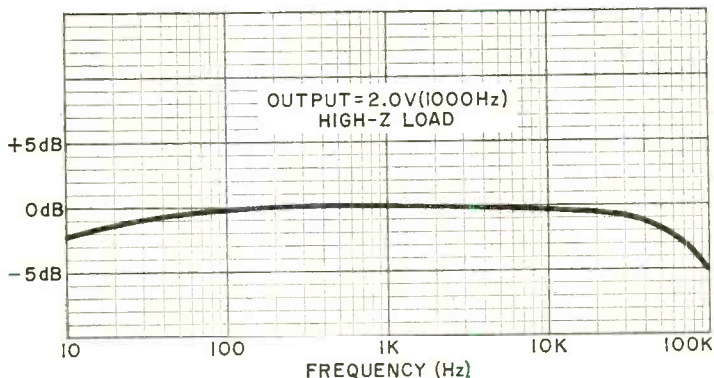

Fig. 3. Two 9-volt transistor batteries, connected in series, can be mounted to box with U brackets or small drawer pull.

Whichever method of assembly you choose, mount the completed circuit board inside a 5" × 4" × 3" aluminum utility box (see Fig. 3). Mount the in- and output phono jacks on the back panel, and if a battery supply is used, mount the two 9-volt batteries to one side of the circuit board. Then mount the switch

and potentiometer on the box front.

Interconnect the outboard components with the appropriate points on the circuit board, using shielded cable between the input and output jacks and their board connections. Then assemble the utility box, and you are ready to make multiple magnetic recordings. —30—



BY NYLE A. STEINER

WIRE MUSIC

LATEST THING

ON THE MUSIC SCENE

WIRE MUSIC! What is it? Well, the sound is like nothing you ever heard before; and the way it's produced is like nothing you ever saw before. Yet, Wire Music is a fascinating way of adding zest and "newness" to your music scene.

Wire Music is the amplified sound picked up from a long (about 30 ft) piece of taut steel wire which is set in vibration in one of a number of ways—plucking, stroking, etc. It may sound crazy but the whole thing is easy and inexpensive to set up; and the result provides a whole new musical experience—one you won't want to miss, even if you're just curious.

The first step in setting up a Wire Music instrument is to wind your own magnetic pickup. Use a small permanent magnet and #30 to 36 enameled copper wire. Fashion a bobbin from two cardboard discs, using the magnet as the crosspiece and gluing the cardboard in place (see drawings). Then wind the bobbin nearly full with the enameled wire.

Scrape away about $\frac{1}{2}$ " of the enamel on the free ends of the wire, and solder to these wires the conductors of a length of shielded audio cable. Tape insulate the exposed wires and connections, and securely tape the shielded cable to the winding body to provide a strain relief. At the other end of the shielded cable, connect a plug that is compatible with the microphone input jack to your tape recorder or amplifier.

The wire which is used to produce the musical sounds should be about #30 steel. (It can be heavier or lighter, depending on the pitch of the sound you
(Continued on page 42)

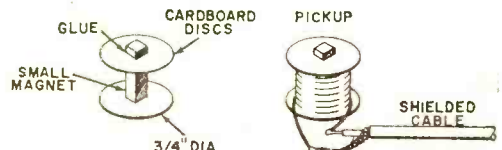

Bond cardboard discs to magnet with epoxy cement. Tape cable to pickup coil winding.

**“He’s a good worker.
I’d promote him
right now if he had
more education
in electronics.”**



Could they be talking about you?

You'll miss a lot of opportunities if you try to get along in the electronics industry without an advanced education. Many doors will be closed to you, and no amount of hard work will open them.

But you can build a rewarding career if you supplement your experience with specialized knowledge of one of the key areas of electronics. As a specialist, you will enjoy security, excellent pay, and the kind of future you want for yourself and your family.

Going back to school isn't easy for a man with a

full-time job and family obligations. But CREI Home Study Programs make it possible for you to get the additional education you need without attending classes. You study at home, at your own pace, on your own schedule. You study with the assurance that what you learn can be applied to the job immediately.

CREI Programs cover all important areas of electronics including communications, radar and sonar, even missile and spacecraft guidance. You're sure to find a program that fits your career objectives.



**IN-DEPTH
 COVERAGE OF
 SOLID STATE
 ELECTRONICS**
 ...including
 integrated circuits!

You're eligible for a CREI Program if you work in electronics and have a high school education. Our FREE book gives complete information. Mail postpaid card for your copy. If card is detached, use coupon at right or write: CREI, Dept. 1207A, 3224 16th St., N.W., Washington, D.C. 20010.



**CREI, Home Study Division
 McGraw-Hill Book Company
 Dept. 1207A, 3224 Sixteenth Street, N.W.
 Washington, D.C. 20010**

Please mail me FREE book describing CREI Programs. I am employed in electronics and have a high school education.

NAME _____ AGE _____

ADDRESS _____

CITY _____ STATE _____ ZIP CODE _____

EMPLOYED BY _____

TYPE OF PRESENT WORK _____ G.I. BILL

- I am interested in
- Electronic Engineering Technology Computers
 - Space Electronics Nuclear Engineering Technology
 - Industrial Automation NEW! Electronics Systems Engineering

APPROVED FOR TRAINING UNDER NEW G.I. BILL

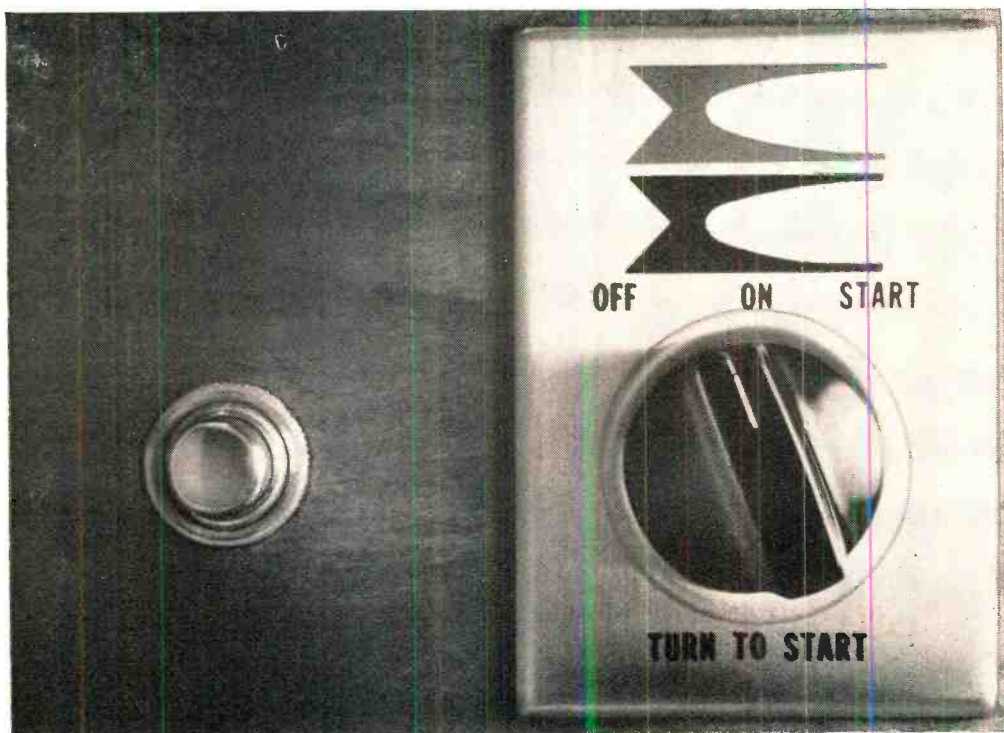

ELECTRONIC COMBINATION IGNITION LOCK

SURE-FIRE PROTECTION FOR YOUR BOAT

BY JOHN BEISWENGER

DURING THE PAST FEW YEARS, there have appeared in print a wealth of anti-theft/anti-intruder lock projects for the home and automobile. But as one boat owner so aptly put it: "Doesn't anyone know or care that boats get stolen, too?" Well someone does know and has done something about curtailing boat thefts by designing an "Electronic Combination Ignition Switch" just for marine engines.

Aside from providing theft protection, the electronic combination switch saves a lot of frustration if you have a knack for forgetting rarely used boat keys or drop your keys into the drink. The reason is that there just aren't any keys to remember or guard. The lock works essentially like a mechanical combination lock.

Inexpensive and easy to build, the lock is designed to operate with any manual or electric start outboard motor that includes, as an accessory, the conventional off/on or off/on/start switch characteristic of most such systems. The lock is also designed to operate positive ignition engines, such as the inboard and inboard/outboard types.

About The Circuit. The Electronic Combination Ignition Lock is, as mentioned above, very similar in operation to its mechanical counterparts. Numbers must be "dialed in" in a set sequence to "open" the lock. (The lock does not actually open; instead, it actuates a battery of relay contacts.)

In the schematic diagram (Fig. 1), the combination for the prototype lock

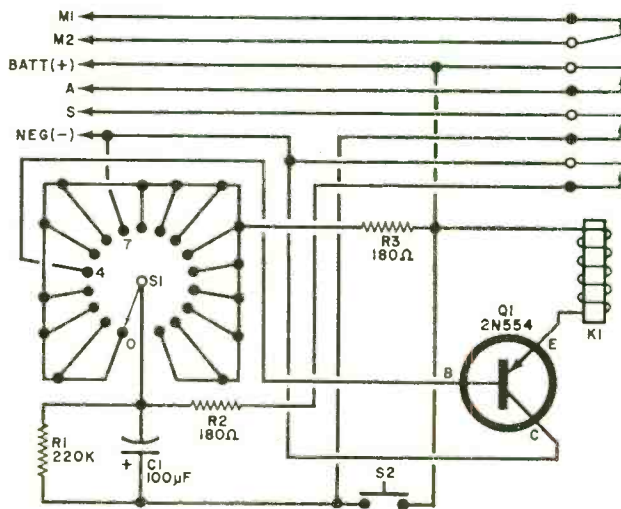

Fig. 1. Combination sequence is 7-4. Simple rewiring of S1 allows selection of any other two-digit combination desired.

PARTS LIST

C1—100- μ F, 15-volt electrolytic capacitor
 K1—4p.d.t. 12-volt d.c. relay with 5-ampere contacts (Potter & Brumfield No. GA17D or similar)
 Q1—2N554 or IEP-230 transistor (Motorola)
 R1—220,000-ohm, $\frac{1}{2}$ -watt resistor

R2, R3—180-ohm, $\frac{1}{2}$ -watt resistor
 S1—17-position non-shorting rotary switch (Malloy No. 311171 or similar)
 S2—S.p.s.t. momentary-action pushbutton switch 1-2 $\frac{1}{4}$ " x 2 $\frac{1}{4}$ " x 4" aluminum utility box
 Misc.—Hardware, switch knob, hookup wire, solder, etc.

is 7-4, in that order. Any attempt to open the lock by feeding in a 4-7 combination will meet with frustration. Switch S1 is the combination dial; with it, the operator enters his combination. After each number, in its proper sequence, is dialed, momentary-action pushbutton switch S2 must be depressed to "program" the actuating circuit consisting of transistor Q1 and relay K1.

When 7 is dialed into the lock and S2 is momentarily closed, capacitor C1 is charged up to approximately the supply voltage level. Then, when S1 is dialed to position 4 and S2 is again depressed, the charge on C1 is applied to the base of Q1, triggering into conduction the transistor, which energizes relay K1.

The operator has approximately ten seconds in which to dial in the second

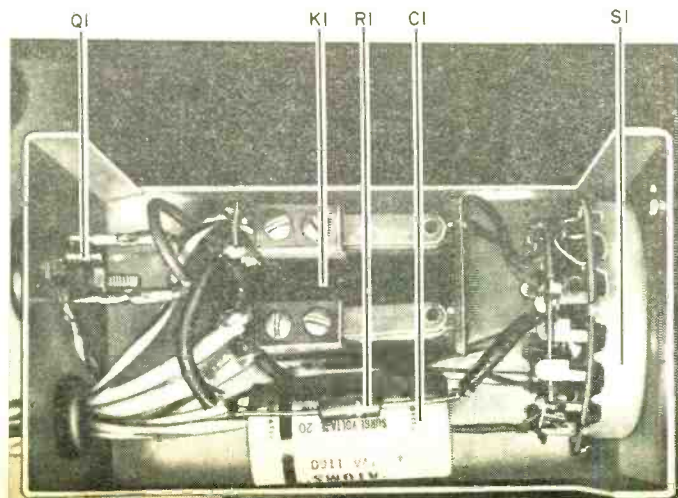

Fig. 2. After mounting components in small utility box or under dashboard, try to waterproof circuit to prevent relay and switch contact corrosion.

number after actuating the first to have the lock open. Any longer delay, including the depressing of *S2*, will allow the charge across *C1* to bleed off through *R1*, resulting in an insufficient potential to trigger on *Q1*.

As *Q1* conducts heavily and *K1* energizes, the top relay contacts open; the second, third, and fourth, in descending order, close to complete various functions. The lowest contacts supply a negative bias to the base of *Q1* via position 4 of *S1* continuously. The next set of contacts puts *S2* directly into the start solenoid circuit. The remaining set of closed contacts supplies power to the boat's accessories. The top contacts simply open the grounding circuit of the boat's motor magnets. (Note: If the boat motor is an inboard or inboard/outboard type, eliminate the top contacts and let the second set of contacts supply power to the ignition and accessories.)

Now, to "close" the lock, all you need

do is switch *S1* out of position 4. This will remove the bias from *Q1* and allow *K1* to deenergize immediately, shutting down all systems.

How To Install. Since the project is so simple, the only construction information necessary is shown in Fig. 2. This is only a suggested layout; if you wish, you can use your own ingenuity to house and mount the circuit. One thing, however, is worth pointing out: Do not put numerals at the knob pointer locations for *S1*'s positions. Plan to count the clicks instead. This will preserve the security of your lock combination if someone is watching you open it.

Now, referring to Fig. 1, connect the ground lead of your boat's magneto ground wire to the uppermost contacts of *K1* (if used). The remaining system wires connect to the other contacts on *K1* as indicated by the original key switch terminal markings. -50-

WIRE MUSIC *(Continued from page 35)*

wish.) This wire must be magnetic (ferrous) if it is to drive the magnetic pickup effectively. The thin steel wire used in hobby crafts to string Indian beads is an excellent choice.

String this wire between two points that are about 28'-30' apart. Almost any solid supports will do. For example, one end of the wire can be anchored to a wall-mounted conduit and the other end weighted and hung over the back of a weighted chair. If the wire is hung or wrapped around a metal object, however, be sure to insulate the object with electrical tape to eliminate a sound of static whenever the wire is touched.

Mount the magnetic pickup at the weighted end of the strung wire. Make sure that the magnet core of the pickup is within $1\frac{1}{8}$ "- $\frac{3}{16}$ " of the wire.

The tension weight on the wire can be any object weighing several pounds (a single-jack hammer, a power transformer, or even a pail of lead sinkers).

The tension of the wire should be adjusted until it gives a crisp and lively echoing sound when it is plucked. If the tension is too loose, the sound will be "muddy;" if too tight, you run the risk of breaking the wire.

The instrument can produce an astonishing range of sounds, depending on the methods used to play it. The sounds generated range from a compelling, penetrating throb to those of a very subtle nature full of pleasant harmonics.

It would be futile to attempt to enumerate all of the methods of play possible. This is because, like all musical instruments, much depends on the taste and artistry of the performer. However, among the basic approaches you can try are plucking with your fingers to obtain a bright, pulsating echo and using a violin bow to stroke the wire near the pickup to produce a great variety of sounds.

A three cornered file produces a recognizable musical note when one of its corners is struck against the wire. The pitch of the note here will depend on the length of the wire between where it is struck and the pickup. Hence, definite pitches and melodies can be played if the wire is marked at the proper intervals with paint. The file can also be slid up and down the length of the wire for glissando effects. Or it can be rubbed violently across the wire in the same manner as a violin bow to produce a very powerful, penetrating sound. -50-

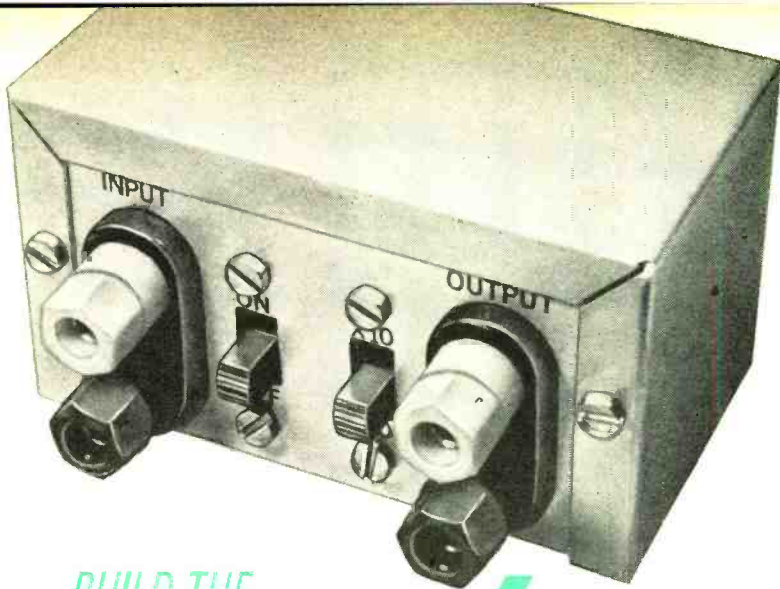

BUILD THE
X10 / X100
INSTRUMENT SENSITIVITY BOOSTER

EXTEND THE RANGE OF YOUR SCOPE OR VTVM

BY JAMES BONGIORNO

MOST low- and medium-priced oscilloscopes have input sensitivities between 10 and 15 millivolts per scale division. This means that, if you are probing for very low-level signals (such as 100 to 200 microvolts of noise in a preamp), even a wide-open gain control on the scope may not help.

Of course, you can always build a one-transistor preamplifier which simply boosts the scope's input sensitivity, but you may run into more problems than you solve. The bandpass of an amplifier for this purpose must be at least as good as that of the scope. The amplifier should not introduce any noise of its own; it must not clip the signal; and it should have good rise and fall times, very low harmonic distortion, and a high enough

input impedance to avoid loading the circuit under test. Obtaining these qualifications in a better preamplifier is not impossible. What you need is the X10/X100 Instrument Sensitivity Booster.

The specifications in the Table show just how good the Booster is; and a glance at the circuit in Fig. 1 will prove that this is not just an everyday preamp but a carefully designed, highly useful instrument "add on."

The Booster can also be used to extend the range of old VTVM's that do not have the very low voltage scales required for semiconductor voltage measurements.

Construction. It is best to build the Booster on a printed circuit board, using the foil pattern and component layout

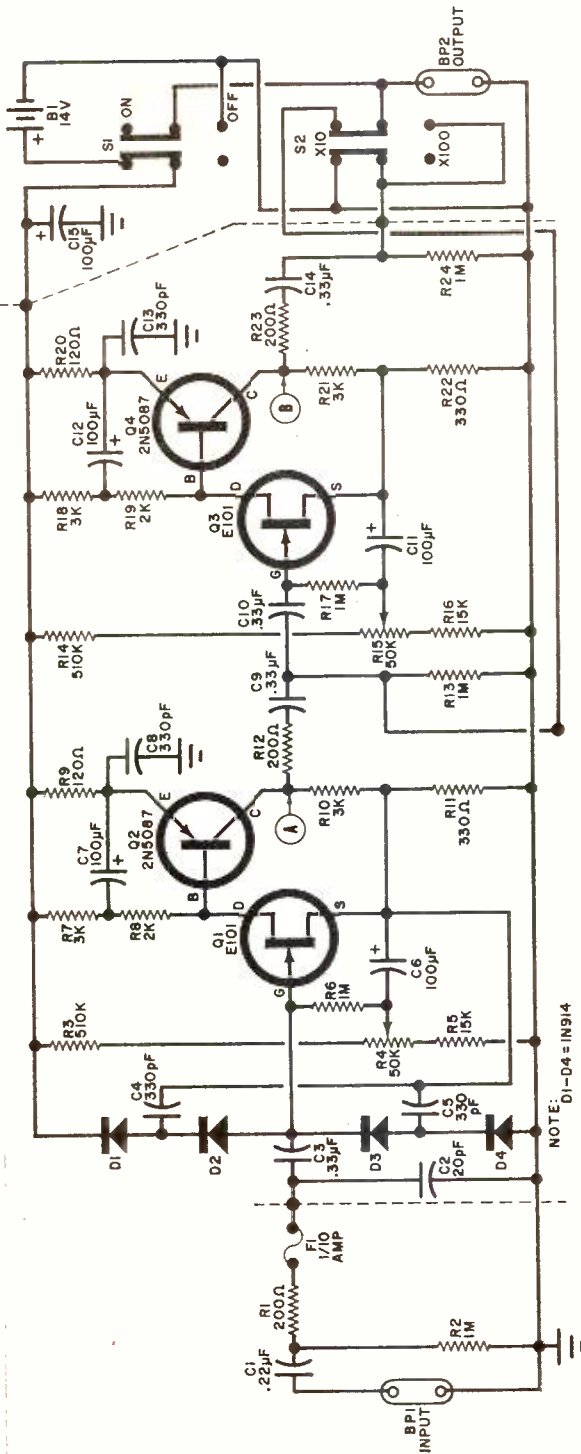

Fig. 1. Besides being an instrument pre-amplifier, either, or both stages can be used wherever a high input impedance, low-noise, broadband amplifier is required.

PARTS LIST

- B1—Two 7-volt mercury batteries in series (Mallory TR-135 or similar)
- BP1, BP2—Dual binding-post assembly (H.I. Smith 269RB or similar)
- C1—0.22-µF, 600-volt capacitor
- C2—20-pF, 50-volt polystyrene capacitor

- C3, C9, C10, C14—0.33-µF, 50-volt Mylar capacitor
- C4, C5, C8, C13—330-pF, 50-volt polystyrene capacitor
- C6, C7, C11, C12—100-µF, 3-volt, electrolytic capacitor
- C15—100-µF, 15-volt electrolytic capacitor
- D1-D4—1N914 diode
- F1—100-mA, fast-acting instrument fuse (SAG)
- Q1, Q3—Field-effect transistor (Siliconix E101, do not substitute)
- Q2, Q4—Transistor (Motorola 2N5087, do not substitute)
- R1—200-ohm, 10-watt, non-inductive resistor
- R2, R6, R13, R17, R24—1-megohm, 1/2-watt, 5% resistor
- R3, R14—510,000-ohm, 1/2-watt, 5% resistor
- R4, R15—50,000-ohm trimmer potentiometer

- (Mallory MTC 5-111 or similar)
- R5, R16—15,000-ohm, 1/2-watt, 5% resistor
- R7, R18—3,000-ohm, 1/2-watt, 5% resistor
- R8, R19—2,000-ohm, 1/2-watt, 5% resistor
- R9, R20—120-ohm, 1/2-watt, 5% resistor
- R10, R21—3,000-ohm, 1/2-watt, 1% resistor
- R11, R22—330-ohm, 1/2-watt, 1% resistor
- R12, R23—200-ohm, 1/2-watt, 5% resistor
- S1, S2—D.p.d.t. slide switch
- Misc.—Battery holders (2, Keystone #21135), misc. holder, aluminum chassis (Bud CU-30034, or similar), one-bag terminal strip, mounting hardware, press type, etc.

Note: The following are available from Lambert Laboratories, 48 Washington St., Westfield, NY 14787 (all prices postpaid): G-10 glass epoxy PC board, \$5; E101 FET, \$1.95 each; complete kit of parts for Booster, \$29.95.

shown in Fig. 2. Since the board is small and spacing is close, take care not to make solder bridges between adjacent foil lines. Also note that, if you duplicate the prototype shown here, R4 and R15 are mounted on the foil side of the board. They can be mounted on the component side if you prefer another mechanical arrangement.

A 4" x 2 1/4" x 2 1/4" aluminum two-piece chassis can be used to hold the PC board plus the batteries, switches, and input-output connectors. As shown in the photographs, the battery clips are mounted on the bottom of the U-shaped chassis with 2-inch PC board mounting screws between the clips and 3 1/4" apart. The dual binding posts, one for the input

and the other for the output, and the two switches are mounted on one long side.

After securing the two PC board mounting screws, place a nut on the screw nearest the input jacks and about 1" above the chassis bottom. Place a one-lug terminal strip (ungrounded) on the screw, and secure it in place with a lockwasher and nut. With the batteries in place in their clips, place C1 in position on top of the batteries and solder one end to the "hot" input connection (BPI) and the other end to the one-lug terminal strip along with one end each of R1 and R2. The other end of R2 is soldered to the ground battery clip connector along with the negative end of C15.

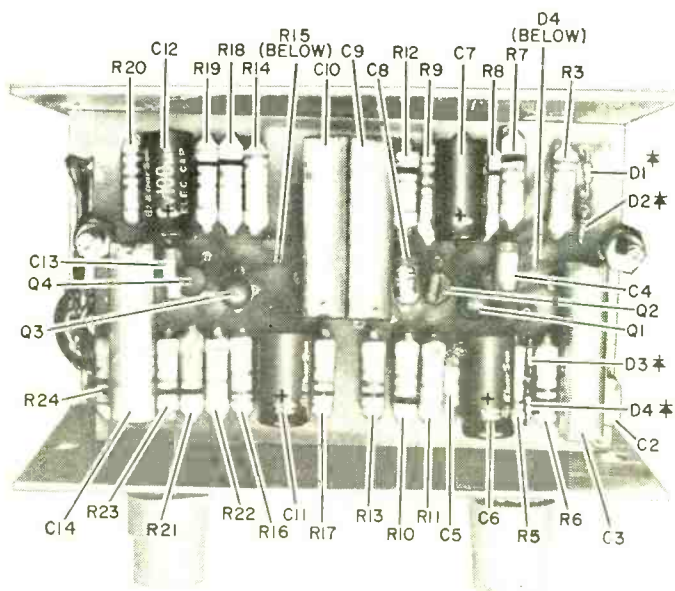
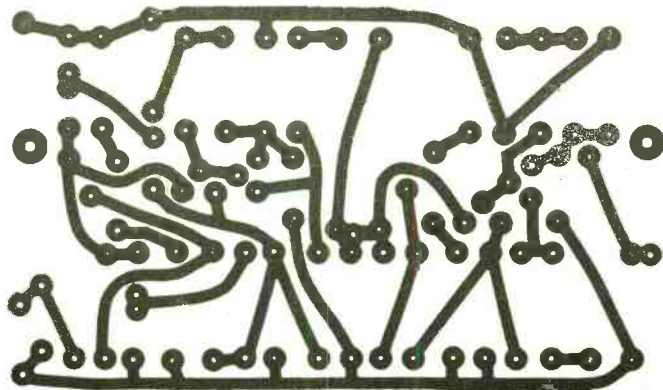
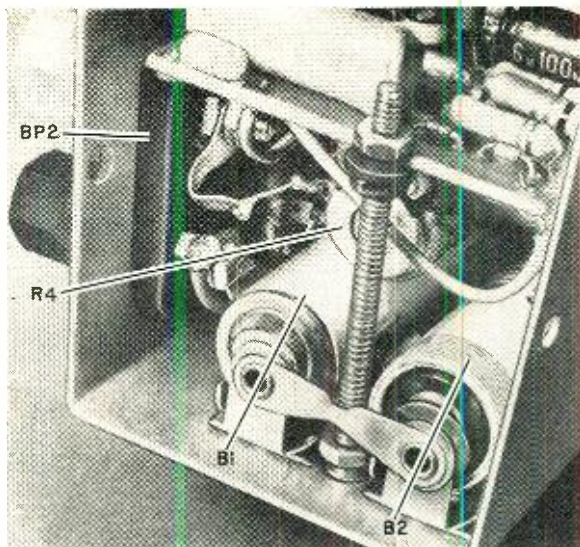

Fig. 2. The actual size printed-circuit foil pattern (right) can be used to make a compact arrangement. Components are installed as shown above. Booster may be installed in the actual instrument if a suitable power source can be made available.



The circuit board is mounted on a pair of long screws using nuts and washers to keep the board in place. The batteries mount in clips secured to the base of the chassis. Note that in the original prototype, both potentiometers are located on the under (foil) side of board.



The other end of $R1$ is connected, through fuse $F1$, to the input terminal of the PC board.

Before permanently securing the board in place, temporarily short capacitor $C2$ and resistor $R13$ to ground. Connect the battery power, and wait a few seconds for the voltage to stabilize. Connect a d.c. voltmeter between test point A and

ground (see Fig. 1) and adjust $R4$ until the meter indicates exactly 7.2 volts. Do the same at test point B using $R15$ to make the voltage adjustment. Remove the two temporary shorts.

Wire the complete circuit as shown in Fig. 1. Then mount the PC board on the two long screws, using a nut below and above the board to secure it in place. All

The off-board components forming the input to the circuit are supported by a terminal strip affixed to a supporting screw. Use one point as common ground.

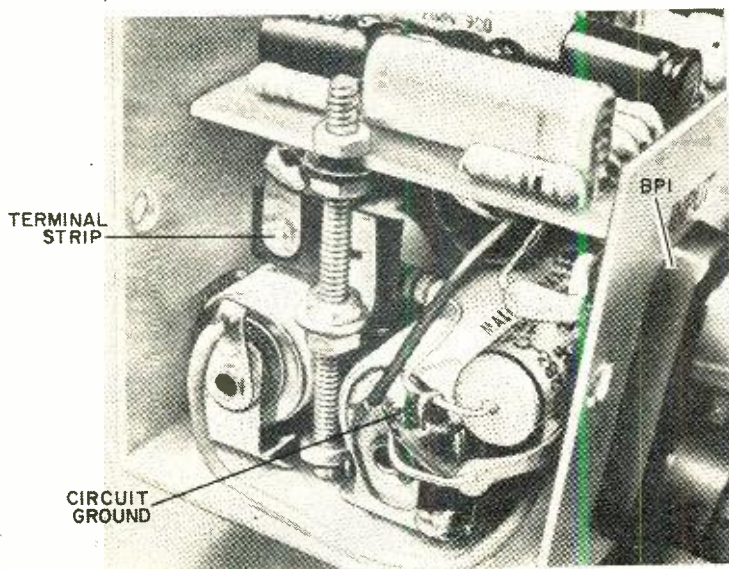

grounds should be made to the same grounded battery clip where the negative end of *C15* is connected.

Although 1% resistors are specified for the gain-determining elements (*R10*, *R11*, *R21*, and *R22*), they may be trimmed if desired to obtain more exact multiplication ratios. Do not substitute for *Q1* and *Q3* as this particular FET has exactly the characteristics required for best operation of the circuit.

Operation. Since the overall noise at the input is less than 7 microvolts, the Booster can be used to trace very low-level signals; and it can be used at frequencies up to 10 MHz. If you use a scope having an input capacitance of less than 10 pF, measurements to 10.7 MHz (FM i.f.) may be obtained by using a suitable probe. Sensitivity is high enough in the X100 range to view a signal as low as 70 microvolts with a 20-dB noise margin.

Since the rise time is fast (50 nanoseconds or less), the Booster can be used with all types of electronic systems. However, remember that it is an un-

HOW IT WORKS

The Booster contains two similar stages of amplification, each having a gain of 10 (20 dB). Two stages were used to get the high gain as well as extend the frequency response. If only one stage were used, there would be less feedback and the frequency range would be to only 700 kHz rather than 7 MHz.

The inputs to both stages use a FET with naturally high input impedance and are connected in the bootstrap mode to further increase the input impedance. The FET also has a lower noise level than a bipolar transistor, especially when the source impedance is high. The actual frequency response is determined by the two bipolar transistors in the circuit.

Resistor *R1*, fuse *F1*, diodes *D1-D4*, and capacitors *C4*, *C5*, and *C15* form the a.c. input protection circuit. Any positive input voltage that exceeds the 14-volt battery level causes *D1* and *D2* to be forward biased. As the voltage increases so does the voltage drop across *R1* (current also increases). Capacitor *C15* bypasses this a.c. current to ground to protect the battery. When the current reaches about 200 mA (depending on the amount of overvoltage and the time constant), the fuse blows.

On the negative excursions, any voltage more negative than about 2 volts, forward biases *D3* and *D4*, shunting the signal to ground. Capacitors *C4* and *C5* bootstrap the protection diodes at high frequencies so that their capacitance does not shunt the input impedance.

TECHNICAL SPECIFICATIONS

Gain: X10 or X100, optional switching
Frequency response: 3.5 Hz to 7 MHz (-3 dB)
Maximum output level (before clipping): 3.5 volts r.m.s.
Input impedance: 1 megohm in parallel with less than 10 pF
Equivalent wideband input noise: less than 7 microvolts, input shorted
Rise time (unloaded): 50 nanoseconds or less
Fall time (unloaded): 70 nanoseconds or less
Harmonic distortion up to 20 kHz (X10 position):
less than 0.5% at 3 volts r.m.s. output;
less than 0.15% at 1 volt r.m.s. output;
less than 0.05% at 0.3 volt r.m.s. output
Maximum d.c. input: 600 volts
Maximum input level: total d.c. and peak a.c. should not exceed 600 volts.

terminated preamplifier and should be used with a high-input-impedance scope.

The connections to the input and output of the preamplifier must be made carefully to avoid degradation of the signal. The best method is to use short pieces of wire to make all connections to the scope. Do not use coaxial cables as the preamp will not drive coax properly at high frequencies.

D.c. input protection is provided by *C1* which should have a rating of 600 volts d.c. or more. Remember, however, that the total input voltage should not exceed 600 volts—the d.c. level plus the peak a.c. signal. —[30]



Hobnobbing
with
Harbaugh



"... That's what you wanted,
the best equipped CB station on wheels ..."



"May Day!, ... May Day! ..."



"... You wanna talk to some guy from the FCC?,
... I think he wants a contribution ..."

"... Why can't she buy a nice cheap 50 dollar
dress like other teenagers? ..."

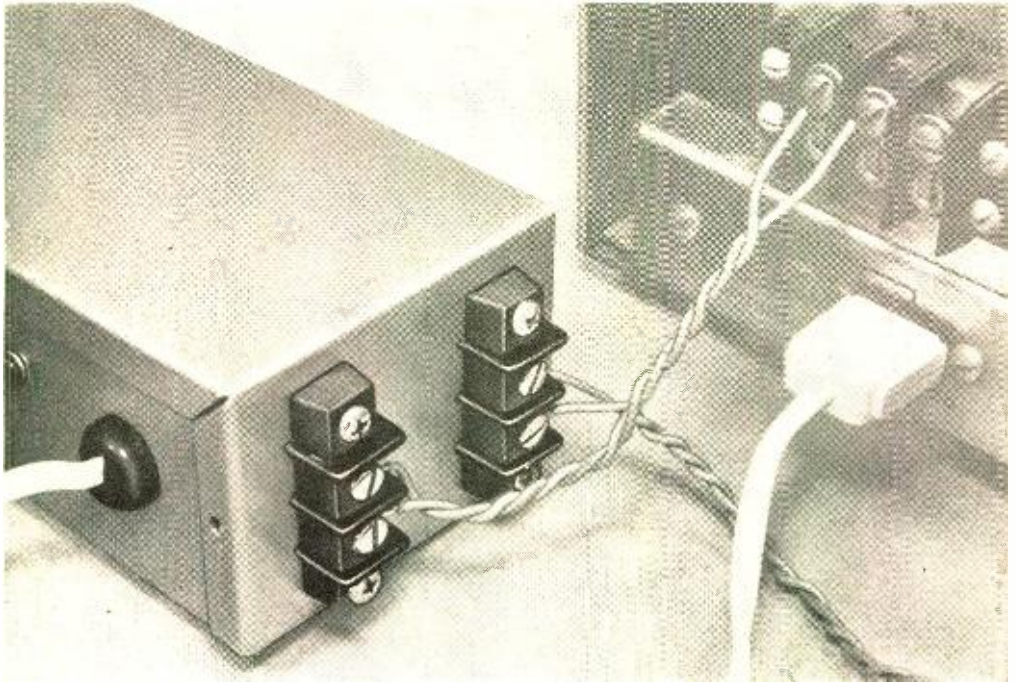

Build a WOOFER GUARD

SAFETY FIRST FOR SPEAKER CONES

BY PHIL ARTHUR

MANY DIRECT-COUPLED solid-state output amplifiers produce a loud "thump" every time you turn them on or off. Worse still, if their output circuits fail, the full supply voltage (on the order of 37.5-42 volts d.c.) could be delivered to your speaker systems, causing serious damage if not detected in time.

The turn-on/turn-off thump is a result of the supply voltage's being suddenly applied or removed from the output stages of the amplifier. If of sufficient amplitude, these voltage transients can "pop" speaker cones, irreparably damaging your speaker systems. The way to eliminate the thump is to delay the output signal (and, consequently, the transient) until the output voltage is at a safe level for the speakers—especially the woofers which are most prone to damage by the low frequency of the transient.

The other big hazard connected with direct-coupled outputs—short-circuit failures that deliver full supply voltage to the speakers—can be dealt with by the

same delay circuit. Since such a delay circuit is voltage sensitive, it would actuate long before the voltage available at the output could attain a damaging level.

The "Woofers Guard" was designed to allow hi-fi buffs to operate their systems with complete safety. Placed between the output terminals of any direct-coupled power amplifier and the speaker systems, it quite literally "guards" the speakers from damage.

About The Circuit. The Woofers Guard is composed of two circuits: a timer which prevents turn-on and turn-off transients from reaching the speakers, and a voltage sensing circuit that "samples" the output voltage of the amplifier to determine whether or not to complete the circuit to the speakers. Resistor *R8*, potentiometer *R9*, and capacitor *C2* in Fig. 1 form an *RC* timing circuit.

Resistor *R8* and potentiometer *R9* allow capacitor *C2* to charge up to about 1.2 volts when voltage is applied to the

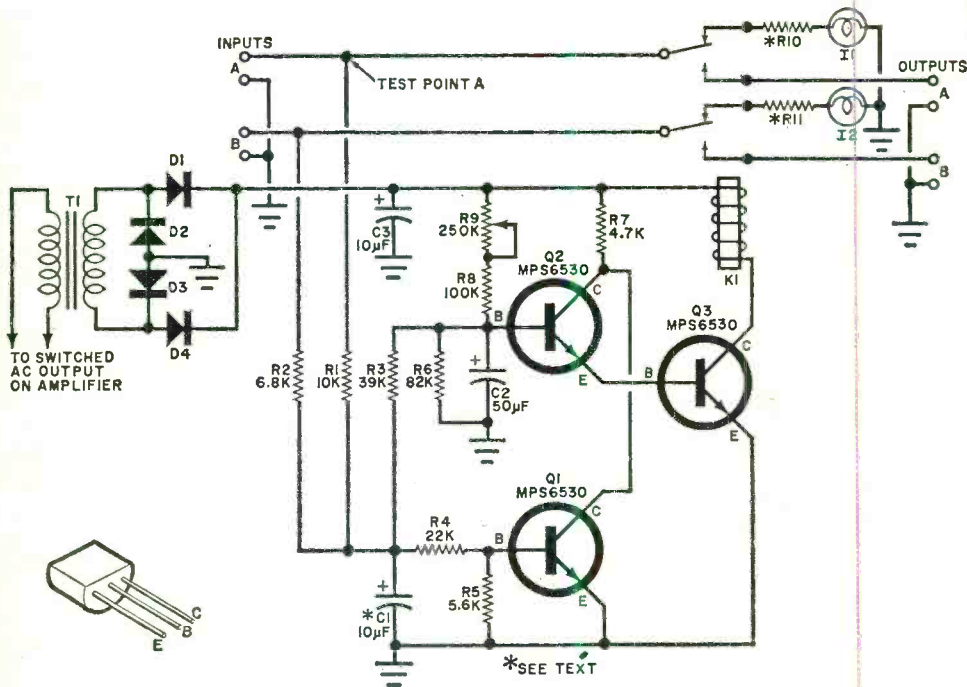

Fig. 1. Any high-level audio signal or constant d.c. voltage detected by amplifier circuit Q1-Q3 causes relay K1 to be deenergized.

PARTS LIST

- C1—10- μ F, 50-volt electrolytic capacitor (see text)
 C2—50- μ F, 15-volt electrolytic capacitor
 C3—10- μ F, 50-volt electrolytic capacitor
 D1-D4—100-volt, 0.5-ampere diode
 I1, I2—Optional indicator lamp (see text)
 K1—D.p.d.t. 24-volt, 600-ohm relay (Allied Electronics No. 41D4659 or similar)
 Q1-Q3—Bipolar transistors (Motorola MPS6530, IIEP 721, or similar)

- R1—10,000-ohm
 R2—6800-ohm
 R3—39,000-ohm
 R4—22,000-ohm
 R5—5600-ohm
 R6—82,000-ohm
 R7—4700-ohm
 R8—100,000-ohm
 R9—250,000-ohm, linear-taper potentiometer
 R10, R11—Optional dropping resistors for I1 and I2 (see text)

All resistors
 1/2-watt

- T1—24-volt, 0.5-ampere filament transformer
 Misc.—Aluminum utility box; rubber grommets for I1 and I2; a.c. line cord with plug; screw-type barrier blocks; hookup wire, solder; hardware; etc.

circuit. Since transistors Q2 and Q3 are arranged in a Darlington-pair configuration, the transistors are cut off until the charge across C2 exceeds the sum of Q2's and Q3's emitter-to-base junction voltage (approximately 0.6 for each transistor, or a total of about 1.2 volts). As soon as 1.2 volts is exceeded, Q2 and Q3 will immediately go into conduction and cause K1, the relay, to be energized which completes the circuit between the amplifier and speaker systems. Now, if a component in the amplifier fails and the amplifier applies a positive or negative voltage, with respect to ground, to the output, the sensing circuit goes into ac-

tion and reverses the process just outlined, disconnecting the speakers from the amplifier output circuits.

Resistors R1 and R2 serve to isolate the Woofer Guard, preventing it from interfering with the normal operation of the amplifier. Capacitor C1 prevents the sensing circuit from going into action on loud music (high-voltage) passages.

If a positive voltage with a sufficient time duration appears at the output of the amplifier, a portion of this voltage will bias Q1 into conduction and cause the collector voltage of Q2 to decrease. This decrease, in turn, cuts off Q3 and

causes *K1* to deenergize and disable the circuits between amplifier and speaker systems.

If a negative voltage is applied to the input of the Speaker Guard circuit, a portion of this voltage would be fed, through *R3*, to the base of *Q2*, biasing both *Q2* and *Q3* into cutoff. Again, with these two transistors cut off, *K1* will be deenergized.

The power supply for the Speaker Guard consists of a simple bridge rectifier and a small-value filter capacitor (*D1-D4* and *C3*). Capacitor *C3* prevents *K1* from "chattering" prior to being fully energized.

The *I1/R10* and *I2/R11* circuits are optional features that provide a visual indication of which output circuit is defective in the event of an amplifier failure. The operation of these circuits is as follows: If channel A malfunctions and supplies the full supply (42 volts) to the Woofer Guard, the voltage-sensing circuit deenergizes *K1* as described above, disconnecting the speaker systems. The relay contacts are now in the positions shown, applying the supply voltage to *I1* through *R10*, indicating that Channel A is malfunctioning.

The values of resistors *R10* and *R11* must be calculated for your given amplifier. Since power supply voltages differ from amplifier to amplifier, you will have to use Ohm's Law to compute the values: $R = E/I$, where *E* is the amplifier's supply voltage minus the voltage rating of

the lamp, and *I* is the current rating of the lamp.

To show how the values of *R10* and *R11* are computed, assume that *E* is 42 volts and the lamp is rated at 6 volts at 40 mA. Plugging these figures into the Ohm's Law equation, we get: $R = E/I = (42 - 6)/0.04 = 900$ ohms. Then, to obtain the power rating of the resistor, use the power formula: $P = E^2/R = 36^2/900 = 1.44$ watts. Hence, we would use a 900-ohm, 2-watt resistor for the lamp voltage dropper in each channel.

Construction. Due to the simplicity of the circuit, all components (except *T1* and *K1*) can be easily mounted on a small piece of perforated phenolic board as shown in Fig. 2. The board is held in place with #6 hardware and 1/2" spacers.

Notice that input and output connections are made to separate screw-type barrier blocks. Make sure that, when wiring the blocks up, you do the job correctly. (Note: If your amplifier has one channel that can be switched to reverse the phase, check to make sure that the grounds in each channel are common to each other. If they are not, run separate ground wires for each channel through the Woofer Guard, and do NOT GROUND either of these wires to the chassis of the Woofer Guard or operating the phase reversal switch can damage your amplifier.)

When soldering to the diodes and transistors, exercise caution to prevent heat

Fig. 2. Except for relay, jacks, and transformer, all components mount on small piece of perforated phenolic board; use small L brackets for board mounting.

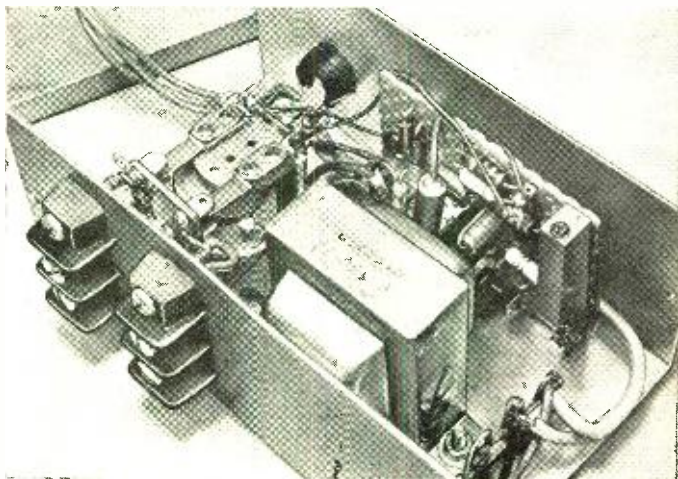

damage to these components. Use a low-wattage soldering iron, and apply the heat only long enough to get the solder to flow, while protecting the component lead with a heat sink. Also, make sure that electrolytic capacitors, diodes, and transistors are installed in the proper lead orientation.

Test and Adjustment. Without the speakers and amplifier connected to the Woofer Guard, plug in the guard's line

cord and adjust the setting of *R9* to obtain approximately a 2-second delay before the relay contacts close. Time the delay from the instant the power cord is connected until the contacts close.

To test the voltage-sensing circuit, momentarily touch the positive contact of a 9-volt transistor battery to test point A in the Woofer Guard circuit; the negative contact goes to the COMMON input terminal. The relay should immediately deenergize. Then, by momentarily touching the battery contacts to the same points in the Woofer Guard circuit in the opposite direction, the relay should again almost immediately deenergize.

HIRSCH-HOUCK LABORATORIES

Project Evaluation

Tested on the laboratory workbench, it was found that the relay in the Woofer Guard dropped out with as low as ± 3 volts d.c. applied to the inputs. It seemed a little sluggish at this low voltage (perhaps 0.5-second operating time), but at 5 volts or more, it operates in about 0.1 second. The release time after dropping out is on the order of 2 seconds.

Low-frequency audio signals were tried to determine what would trip the Woofer Guard. A sine wave of 10 volts r.m.s. at 5-6 Hz was capable of tripping the circuit, but a 9-volt peak-to-peak square wave of any frequency up to 50 kHz would also trip it. This is consistent with the static operation (d.c.) of the device, since it operates on both polarities; the square wave appears to the Woofer Guard as a d.c. input of about 4.5 volts.

The Woofer Guard was then connected between an Acoustic Research receiver and a pair of 8-ohm speakers. It trips on the muting "thump" if the volume setting on the amplifier is somewhat above the normal listening level, or if any great amount of bass boost is used. The only way the Woofer Guard was made to trip when fed with program material was to play the amplifier at very high levels, preferably with bass boost.

The Woofer Guard protects only the woofer in a speaker system, but the tweeter in many cases is more vulnerable. Even though few amplifiers have direct-coupled outputs, there is always the chance that the blocking capacitor will break down and place half of the supply voltage in the amplifier across the speaker system. The Woofer Guard should take care of such a situation nicely.

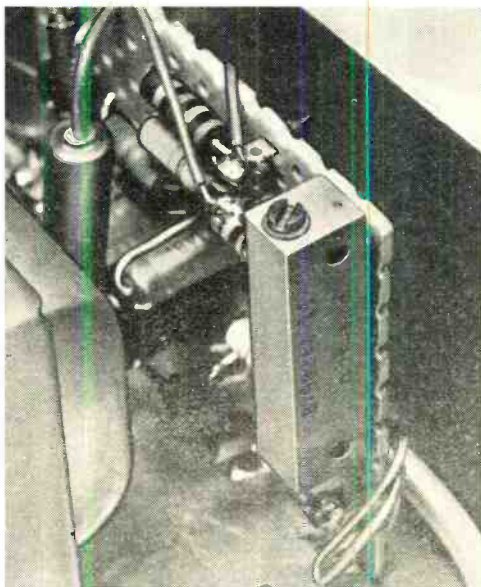

Long block shown in foreground is special trimmer potentiometer. You can substitute commonly available printed circuit type pot of appropriate value.

Now, assemble the Woofer Guard's case and connect it to your amplifier outputs and speaker systems. In use, you might notice that the Woofer Guard disconnects your speaker systems on high-level, low-frequency notes (about 70 watts r.m.s./channel below 20 Hz). If you find this annoying, you can replace *C1* with a 20- μ F capacitor.

-30-



BUILD Dynamic Diode Tester

SORTING OUT THOSE UNIDENTIFIED DIODES

BY CHARLES L. ANDREW

TAKE A QUICK LOOK in your electronics storage cabinet. Got some diodes there that you can't readily identify? Are they signal diodes, rectifiers, or zeners? Silicon or germanium? Which end is which? Many of these questions can be answered by the "Dynamic Diode Tester." The Tester is easily built and works in conjunction with an oscilloscope to identify clearly all your diodes as well as many other types of semiconductors. It will even test capacitors and light-sensitive devices for certain characteristics.

As the schematic in Fig. 1 shows, the Tester is very simple. To use it, all you have to do is attach it to your scope, plug a diode into the test terminals, manipulate a knob and a pushbutton, and the diode characteristics are clearly displayed on the CRT screen.

About the Circuit. The a.c. voltage applied to the device to be tested is deter-

mined by potentiometer *R1*, while resistor *R2* limits the applied current to a safe value. Resistor *R3* acts as a shunt to provide the vertical input to the scope. Thus the voltage across the device is applied to the horizontal terminals and the current to the vertical terminals; and the VI characteristic is displayed on the screen.

For best results, a d.c. scope should be used. With an a.c. scope, the display is usable, but it may shift as *R1* is adjusted.

Diode *D1* is used to determine whether or not the test diode is properly connected to the test terminals. It is normally shorted out by pushbutton *S2*.

Construction. The prototype Tester was built in a 5" × 2½" × 1½" plastic box with a metal cover as shown in the photos. All components were mounted on the metal cover, with *R2* and *R3* wired point-to-point to the proper locations. Any

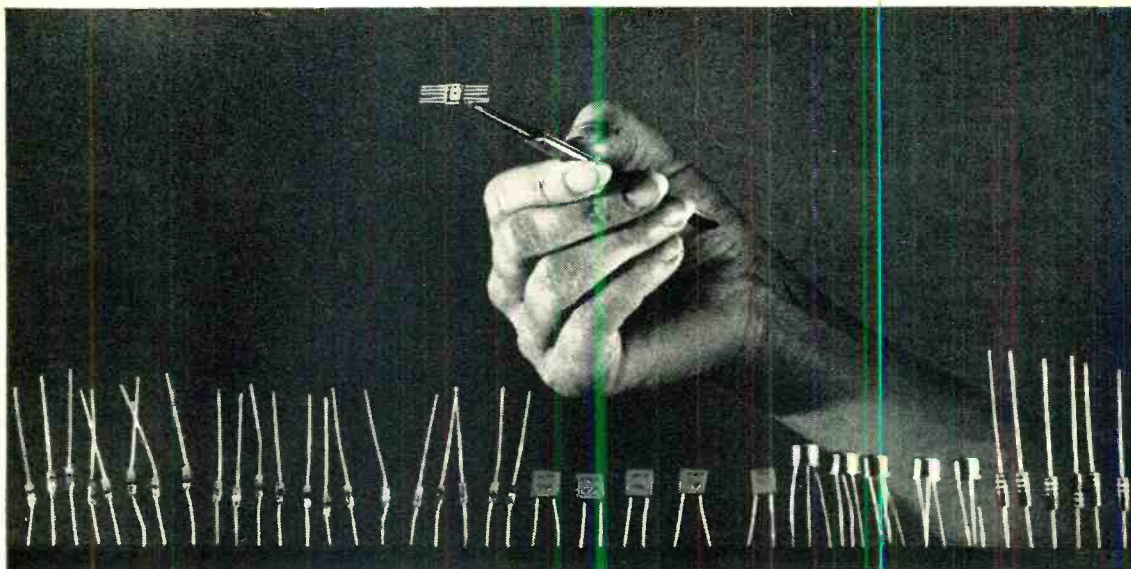

50 functions in a single chip. *The functions of 50 separate transistors, diodes, resistors and capacitors can now be performed by the tiny dot in the center of the integrated circuit held by the tweezers.*

The "Chip"

...will it make or break your job future?

TINY ELECTRONIC "CHIPS," each no bigger than the head of a pin, are bringing about a fantastic new Industrial Revolution. The time is near at hand when "chips" may save your life, balance your checkbook, and land a man on the moon.

Chips may also put you out of a job...or into a better one.

"One thing is certain," said *The New York Times* recently. Chips "will unalterably change our lives and the lives of our children probably far beyond recognition."

A single chip or miniature integrated circuit can perform the function of 20 transistors, 18 resistors, and 2 capacitors. Yet it is so small that a thimbleful can hold enough circuitry for a dozen computers or a thousand radios.

Miniature Miracles of Today and Tomorrow

Already, as a result, a two-way radio can now be fitted inside a signet ring. A complete hearing aid can be worn entirely inside the ear. There is a new desk-top computer, no bigger than a typewriter yet capable of 166,000 operations per second. And it is almost possible to put the entire circuitry of a color television set inside a man's wristwatch case.

And this is only the beginning!

Soon kitchen computers may keep the housewife's refrigerator stocked, her menus planned, and her calories counted.

Money may become obsolete. Instead you will

simply carry an electronic charge account card. Your employer will credit your account after each week's work and merchants will charge each of your purchases against it.

Doctors will be able to examine you internally by watching a TV screen while a pill-size camera passes through your digestive tract.

New Opportunities for Trained Men

What does all this mean to someone working in Electronics who never went beyond high school? It means the opportunity of a lifetime—if you take advantage of it.

It's true that the "chip" may make a lot of manual skills no longer necessary.

But at the same time the booming sales of articles and equipment using integrated circuitry has created a tremendous demand for trained electronics personnel to help design, manufacture, test, operate, and service all these marvels.

There simply aren't enough college-trained engineers to go around. So men with a high school education who have mastered the fundamentals of electronics theory are being begged to accept really interesting, high-pay jobs as engineering aides, junior engineers, and field engineers.

How To Get the Training You Need

You can get the up-to-date training in electronics fundamentals that you need through a carefully

chosen home study course. In fact, some authorities feel that a home study course is the best way. "By its very nature," stated one electronics publication recently, "home study develops your ability to analyze and extract information as well as to strengthen your sense of responsibility and initiative." These are qualities every employer is always looking for.

If you do decide to advance your career through spare-time study at home, it makes sense to pick an electronics school like the Cleveland Institute of Electronics. We teach only Electronics—no other subjects. And our courses are designed especially for home study. We have spent over 30 years perfecting techniques that make learning Electronics at home easy, even for those who previously had trouble studying.

Your instructor gives your assignments his undivided personal attention. He grades your work, analyzes it, and he mails back his comments the same day he gets your lessons, while everything is still fresh in your mind.

Always Up-to-Date

Because of rapid developments in Electronics, CIE courses are constantly being revised. This year, for example, CIE students are receiving exclusive up-to-the-minute lessons in Microminiaturization, Logical Troubleshooting, Laser Theory and Application, Single Sideband Techniques, Pulse Theory and Application, and Boolean Algebra. For this reason CIE courses are invaluable not only to newcomers in Electronics but also for "old timers" who need a refresher course in current developments.

Get FCC License or Money Back

No matter what kind of job you want in Electronics, you ought to have your Government FCC License. It's accepted everywhere as proof of your education in Electronics. And no wonder—the Government licensing exam is tough. So tough, in fact, that without CIE training, two out of every three men who

Tiny TV camera
for space and military use is one of the miracles of integrated circuitry. This one weighs 27 ounces, uses a one-inch vidicon camera tube, and requires only four watts of power.

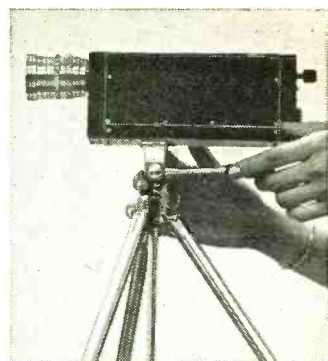

take the exam fail. But better than 9 out of every 10 CIE graduates who take the exam pass it.

This has made it possible to back our FCC License courses with this famous Warranty: you *must* pass your FCC exam upon completion of the course or your tuition is refunded in full.

Mail Card for Two Free Books

Want to know more? The postpaid reply card bound in here will bring you a free copy of our school catalog describing today's opportunities in Electronics, our teaching methods, and our courses, together with our special booklet on how to get a commercial FCC License. If card is missing, use the coupon below.

ENROLL UNDER NEW G.I. BILL

All CIE courses are available under the new G.I. Bill. If you served on active duty since January 31, 1955, or are in service now, check box on reply card for G.I. Bill information.

CIE Cleveland Institute of Electronics

1776 East 17th Street, Cleveland, Ohio 44114

NEW COLLEGE-LEVEL COURSE IN ELECTRONICS ENGINEERING

for men with prior experience in Electronics. Covers steady-state and transient network theory, solid state physics and circuitry, pulse techniques, computer logic and mathematics through calculus. A college-level course for men already working in Electronics.

Cleveland Institute of Electronics
1776 East 17th Street, Cleveland, Ohio 44114

Please send me without cost or obligation:

1. Your 44-page book "How To Succeed In Electronics" describing the job opportunities in Electronics today, and how your courses can prepare me for them.
2. Your book on "How To Get A Commercial FCC License."

I am especially interested in:

- | | | |
|--|---|--|
| <input type="checkbox"/> Electronics Technology | <input type="checkbox"/> Broadcast Engineering | <input type="checkbox"/> First Class FCC License |
| <input type="checkbox"/> Electronic Communications | <input type="checkbox"/> Industrial Electronics | <input type="checkbox"/> Electronics Engineering |

Name _____ Age _____

Address _____

City _____ State _____ Zip _____

Check here for G.I. Bill information.

PE-04

Accredited Member National Home Study Council • A Leader in Electronics Training... Since 1934

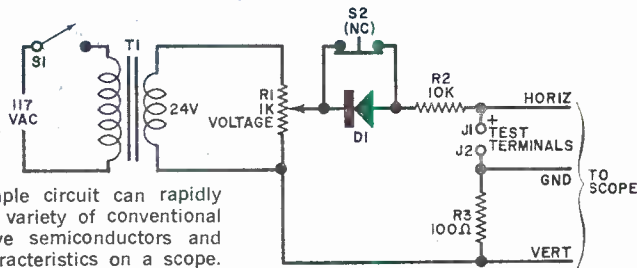

Fig. 1. This simple circuit can rapidly sort out a great variety of conventional and light-sensitive semiconductors and display their characteristics on a scope.

PARTS LIST

- D1—50-volt PIV silicon rectifier (1N4001 or similar)
- J1, J2—Five-way binding post
- R1—100-ohm, 2-watt linear potentiometer with switch (S1)
- R2—10,000-ohm, 1/2-watt resistor
- R3—100-ohm, 1/2-watt resistor

- S1—S.p.s.t. switch (on R1)
- S2—Normally closed pushbutton switch
- T1—Filament transformer, secondary 24 volts (Lajayette 99T6266 or similar)
- Misc.—Box with cover, a.c. line cord, color-coded three-lead cable, pair of alligator clips attached to banana jacks.

other type of construction may be used. A short length of color-coded, three-wire cable is used to make connections to the scope terminals.

Operation. Connect the three leads from the tester to the proper terminals on the scope. Then set the scope horizontal input to the "external input" position. With $R1$ at a minimum, center the dot on the CRT screen.

In all cases, an open circuit between

the test terminals is indicated by a horizontal line on the scope, while a short circuit shows up as a vertical line. In either case, the length of the line is determined by the setting of $R1$.

Connect a rectifier diode that is known to be good to the Tester terminals without regard for the polarity. Observe the scope as $R1$ is slowly adjusted to give a higher applied voltage. The dot should slowly extend into a short horizontal line (adjust the scope horizontal gain if nec-

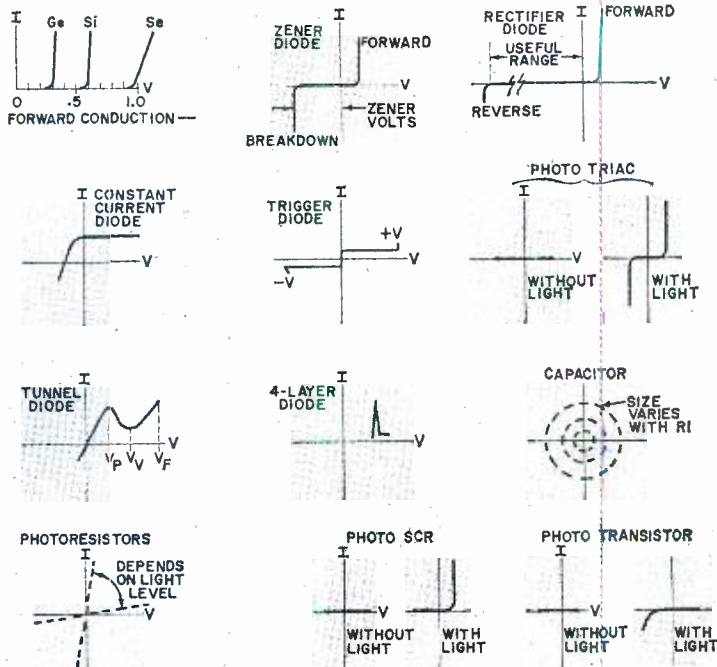

Fig. 2. Typical curves as seen on the scope. For other semiconductors, consult the applicable manual. For exact values, you must use a calibrated d.c. scope.

essary); and then the trace should suddenly take a sharp 90° vertical turn. This is the forward conduction curve and it should be on the upper right-hand side of the display. If it is, the diode lead connected to the positive terminal on the tester is the cathode. If the vertical portion is on the lower left portion of the trace, going down, reverse the diode. To check that you are observing the forward conduction curve, depress *S2* and note that the vertical trace remains while the horizontal trace disappears. If the diode is connected backwards, the horizontal trace remains and the short vertical trace disappears.

Advance voltage control *R1* and note the reverse conduction, if any. In case of a zener diode, for example, as *R1* is advanced, there will be a sudden drop in the trace at the zener voltage point, creating a step-like curve. In the case of most power rectifiers, the tester may not have enough voltage to produce the reverse breakdown.

Calibration. The Tester was designed primarily as a simple means of identification. To obtain rating information, you must have a d.c.-coupled scope and calibrate its horizontal axis by applying known voltages to the horizontal input and adjusting the gain control of the Tester to obtain a specific number of volts per division. Once this has been done, do not reset the gain control or calibration will be destroyed. Since most forward conduction values will not exceed about one volt, it is best to set the scope dot to the right side of the screen.

Since the Tester provides only 24 volts r.m.s., the reverse breakdown voltage of most rectifiers is not reached. If you

The complete tester is assembled on the metal cover of the plastic cabinet. Point-to-point wiring is used and a three-conductor cable connects to scope.

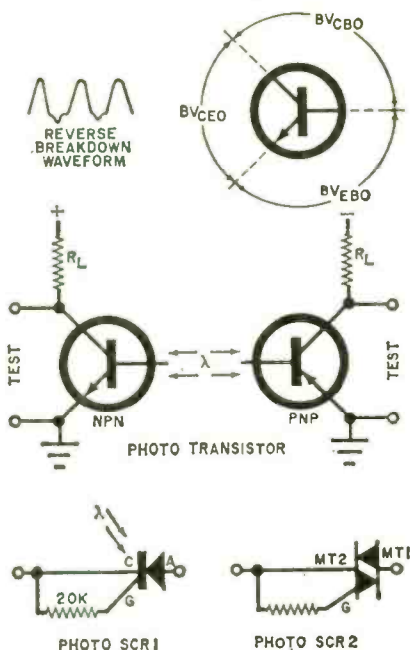
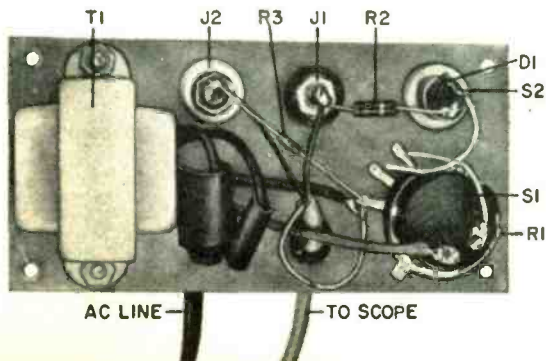

Fig. 3. Reverse breakdown of transistors can be determined, as well as the operation of several types of light-sensitive semiconductors. The two circuits at the bottom show how to wire these semiconductors.

want to know the exact value of reverse breakdown, the secondary voltage value of *T1* must be increased.

Some typical curves for common semiconductors are shown in Fig. 2. No current or voltage values are given except for those that are used to identify the semiconductor itself. Note that capacitors can be tested for condition—not for value—by obtaining a circle on the scope. The size of the circle is determined by the setting of *R1*. Voltage-current curves for other devices may be obtained from various handbooks.

Breakdown voltages of transistors may be determined as shown in Fig. 3. Set the scope sweep so that it displays two or three 60-Hz sine waves (when such a signal is applied to the vertical input). With the transistor properly connected, increasing *R1* will produce a half sine wave. A further increase in *R1* produces a small negative bump, indicating reverse breakdown. (The transistor is not damaged by this test.) The a.c. voltage (peak) is then measured to determine the breakdown value. Remember that the maximum voltage is 24 volts r.m.s. so some transistors will not show the reverse breakdown.



OPPORTUNITY MIRROR



Thoughtful Reflections On Your Future

Fifth in a Monthly Series by David L. Heiserman

Medical Electronics

I have heard that there will be thousands of job openings for medical electronics technicians within the next 18-24 months. It is reported that salaries are good; but if all this is true, why can't I find a home study or resident school that will train me for a career in medical electronics?

● The occupation outlook for medical electronics technicians over the coming decade is exciting. Although it is difficult to estimate accurately the manpower needs of medical electronics (occupational guides and references still refer to medical electronics careers as traditional electronics technicians), we have been able to make some projections for the next two years.

Kind of organization	Present starting salary range	Additional technicians by 1972
Hospitals and other health services	\$4500-\$6500	less than 1000
Medical research institutions, including universities	\$5000-\$8000	1000
Medical electronics manufacturing, sales and service company	\$6000-\$15,000	2500

The above figures are the result of interviews with officials at the Mt. Carmel School of Medical Technology, the American Hospital Supply Corporation, and "Medical Electronics News" magazine.

Scientific Products, a division of the American Hospital Supply Corporation, is an example of a large manufacturing, sales and service organization that is actively searching for medical electronics technicians. Job opportunities here range from electronics assembly to field service and design engineering. This company trains its own tech-

nicians to work with medical electronic equipment. Men (and women, too) with some training in electronics can get more information about job opportunities by writing to: Personnel Department, Scientific Products, American Hospital Supply Corp., 1740 Ridge Ave., Evanston, IL 60201.

You are apparently correct in your estimate that there is no formal education in medical electronics in either home study or resident programs. However, both types of schools do offer courses in electronics instrumentation—which in itself is a step in the right direction.

According to Joseph A. Risse, Director of Electronics Creative Services for International Correspondence Schools (ICS), they would be willing to add new courses, "... if there were evidence that a substantial market and interest existed in this subject area."

We feel that it's just a matter of time before the major electronics home study schools realize that a substantial market and interest in medical electronics is coming over the horizon.

The Green of Thule, Greenland

I understand that the Ballistic Missile Early Warning site at Thule, Greenland pays a very high salary to its electronics technicians. Is this so? Who has the maintenance contract and what are the job qualifications?

● A capable electronics technician at a BMEWS site can expect a starting salary of about \$200 per week, including bonus—roughly double the amount he might make in the States. If he stays at the Thule site over 18 months, the money earned is tax free! And, of course, the room and board are free!

There is a catch. Since the winters are long and lonely and married men can't take their families, the BMEWS jobs are best

(Continued on page 90)



AUTOMATIC LIGHTNING PROTECTION

DON'T *zap* YOUR ANTENNA SYSTEM

BY HOWARD PHILLIPS

MOST HAMS FORGET, on occasion, to ground their antennas—or never even bother to provide a grounding facility—when they are not operating their rigs. These oversights or lack of foresight can have grave consequences before or during an electrical storm, causing a lot of good equipment to go up in smoke. There is no substitute for connecting an antenna to the earth ground common to the communications equipment for good protection against lightning damage.

Regardless of the quality of your present antenna grounding system, the automatic lightning protection system described here can reduce the possibility of your equipment's sustaining serious damage from lightning or static charge

buildup. The operation of the system is automatic in the sense that turning on and off your transceiver is all that is required. So, you cannot forget to ground your antenna, since you are not likely to forget to turn off your transceiver when you are finished using it.

Lightning Effects. There are three basic effects of electrical storm activity that can cause damage to communications equipment.

First is static charge buildup on the antenna. This is not caused by a direct lightning "hit" on the antenna but by the same conditions which produce lightning. Static charge buildup occurs when an ungrounded antenna accumulates a large d.c. charge as a result of its coming

About The Circuit. Shown in Fig. 1 is the schematic diagram of the automatic lightning protection system. Notice that there is a facility (switch *SI*) to switch into the circuit either of two antennas. Jacks *J1* and *J2* should be r.f. coaxial type connectors.

Radio frequency chokes *RFC1* and *RFC2* provide protection against damage from static charge buildup on either antenna. Relay *K1* shorts both antennas directly to ground when the transceiver, connected to a.c. receptacle *SO1*, is turned off or when a power failure occurs.

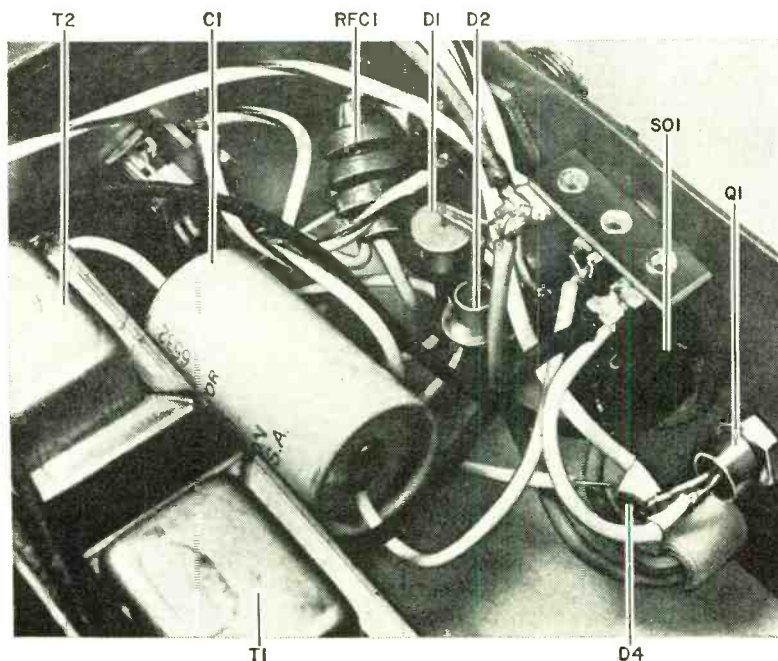
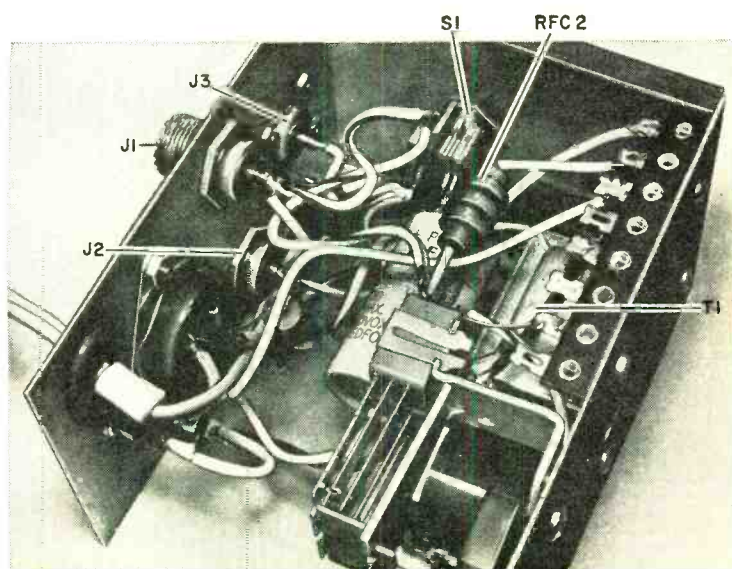

Fig. 2. Component mounting is best accomplished if ends of chassis are bent slightly outward during machining and chassis wiring.



The current threshold detector circuit made up of *D1*, *D2*, and *T1* controls the power delivered to the solenoid of *K1*. The voltage drop across monitoring diodes *D1* and *D2* is on the order of 1.5 volts peak-to-peak and is independent of the power required by the transceiver. The square-wave voltage drop across the diode pair is coupled through transformer *T1* to silicon controlled rectifier *SCR1*.

Resistors *R1* and *R2* form a voltage divider which determines the amplitude of the triggering signal delivered to the gate of *SCR1*. The value of *R2* depends on the sensitivity of *SCR1* and the power required by the transceiver when turned off (some transceivers contain a heating element which operates continuously).

When the transceiver is turned on and the voltage applied to the gate of *SCR1* is sufficient, the SCR turns on and voltage is applied to the coil of *K1* through rectifier diode *D4*. Diode *D3* insures that excessive reverse bias is never applied to the gate of *SCR1*. The transformer phase relationships, indicated by the dots in the schematic diagram, are required to provide d.c. power to *K1*'s solenoid.

The voltage applied to *K1* is half-wave rectified d.c. with some ripple content (*C1* provides filtering). Because of voltage drops across *D4* and *SCR1*, the relay voltage is typically between 5 and 20 volts, depending on the d.c. resistance of the relay coil. Hence, a 9- or 12-volt relay will work well. An a.c. or a d.c. coil can be used, since the ripple content of the voltage is low enough to prevent relay "chatter."

Construction. Component placement in the metal utility box is shown in Fig. 2. To facilitate machining and project assembly, it is suggested that you bend outward the ends of the utility box. Then parts mounting and connection can be quickly accomplished.

Leads carrying r.f. power should be kept as short as possible so that the transmission line standing wave ratio (SWR) will not be adversely affected. Also, the relay should not be mounted too close to the transformers unless the transformers have reasonably good magnetic shielding.

The phasing of the transformers need not be known during assembly since no component damage will result from a

wiring error. If the assembled project will not unground the antennas when transceiver power is turned on, the leads from any pair of the four transformer lead pairs can be reversed to provide proper phasing.

The anode (mounting stud) of *SCR1* is at ground potential in this project to obviate the need for special insulating hardware. A fused power plug is recommended because it provides more protection from damage due to over-voltage which can be caused by a hit by lightning on the power line.

A special note is in order here. The circuit shown schematically in Fig. 1 should first be wired without *R2*. When the turned-off transceiver is plugged into *SO1*, *K1* should not unground the antennas. If it does, a potentiometer can be connected across the secondary of *T1* to determine the value of *R2* required to cause *K1* to trip only when the transceiver is turned on.

Checkout and Use. If both an amplifier and a transceiver are to be used, the amplifier output should be connected to the lightning protector via *J3*. Standing wave ratio measurements should be made with the project in and out of the antenna system to insure that the quality of construction is adequate. There should be no detectable difference between your SWR readings.

The antenna-switching capability of the lightning protector is more than adequate to handle any 1-kW transmitter. With proper construction techniques, the antenna switch can be used to switch any transmitting antenna operating in the frequency range between 3.5 and 30 MHz.

The project provides more than adequate protection against damage from static charge buildup on the antennas, even when the transceiver is switched on. When the transceiver is off, full protection against voltage transients on the antennas is automatically provided and the antennas are automatically grounded via the relay contacts. So some protection—although not complete—against damage caused by direct lightning hits is also provided.

Antenna ungrounding requires 117-volt a.c. line power to trip *K1*. Consequently, a power failure insures that the antenna will automatically be grounded. -30-

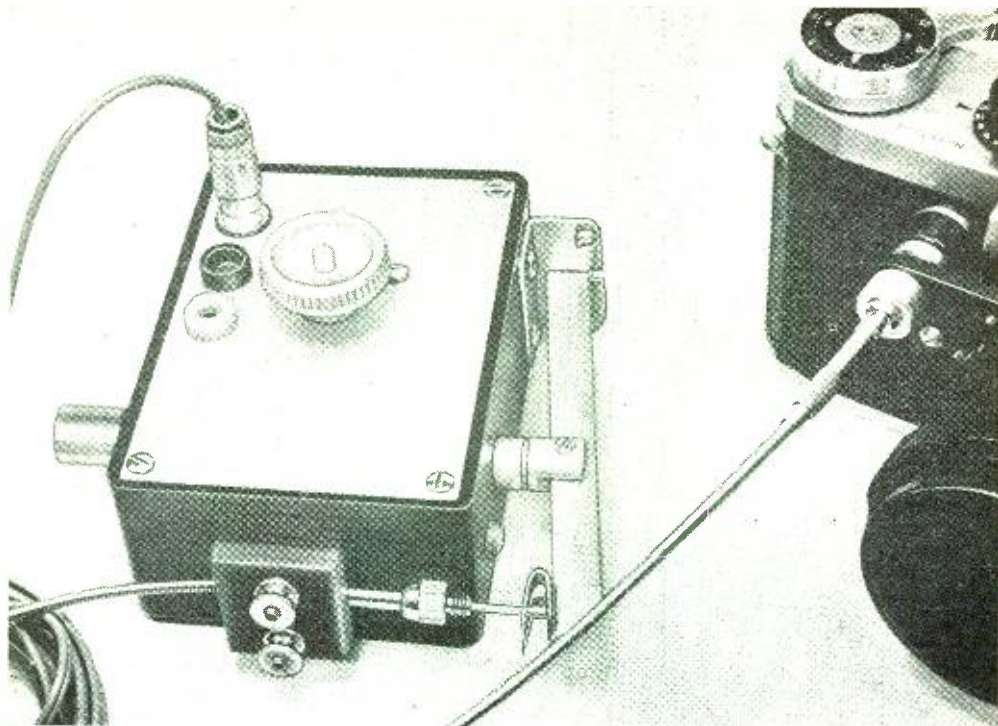

REMOTE CAMERA SHUTTER RELEASE

VARIABLE SOLENOID CONTROL CIRCUIT
TRIGGERS HUNDREDS OF FEET AWAY

BY A. A. MANGIERI

IF HE IS planning wildlife or surveillance shots—or just some tricky setups in his studio—the serious camera buff knows that he has to have a remote shutter release system. Such a system need not be elaborate or expensive. In fact, the electrically operated shutter release described here is compact, easily constructed using ordinary tools, and contains a minimum of components. The system includes stroke and trip-force adjustments to match the requirements of most cameras.

Either of two control circuits can be used. One provides for more or less direct electrical operation from distances up to 50 feet. The second uses a transistor amplifier for truly remote control from hundreds of feet away.

About the Circuit. Both shutter release circuits are shown in Fig. 1. One is a simple series loop including a battery, *B1*, solenoid force control, *R1*, and solenoid, *K1*. Battery polarity in the circuit is important only when an external battery charger is used (through jacks *J1* and *J2*).

Since up to 2.5 amperes of current flows through the circuit, it is necessary that the trip cable between *PL1* and trip switch *S1* be two-conductor lamp cord. This cable actually forms part of the series loop, connecting *R1* to *K1*, and carries the full tripping current.

The power booster circuit (Fig. 1B) employs a single transistor to amplify the signal delivered to solenoid *K1*. It is inadvisable to try to trip the solenoid

PARTS LIST

B1—Four 1.5-volt, 500-mA-hr nickel-cadmium cells in series (Eveready No. BH500)
J1, J2—Banana jack (one red, one black)
J3—Phono jack
K1—6-volt d.c., 1.6-ohm solenoid (Dormeyer No. B24-755-A-1; Allied Electronics No. 41D7941)
PL1—Phono plug
Q1—30-watt, 60-volt, 3-ampere npn silicon power transistor (Motorola HEP245)
R1—3-ohm, 5-watt midget potentiometer
R2—200-ohm, 5-watt miniature potentiometer
R3—4.7-ohm, 1-watt resistor
S1—S.p.s.t. normally open, momentary-action pushbutton switch
 1—4" x 2 $\frac{3}{8}$ " x 1 $\frac{1}{16}$ " plastic or Bakelite case with aluminum cover
 Misc.—1" x 1" x $\frac{1}{4}$ " Bakelite (2); Amphenol No. 3-12 shell and No. 78-B blank insert; sheet aluminum; #24 two conductor juke box cable (or lamp cord—see text); D cell holder (see text); 4 $\frac{1}{4}$ " x $\frac{3}{8}$ " x $\frac{3}{32}$ " steel strip for shutter actuator arm; control knob; #6 machine hardware; hookup wire; solder; etc.

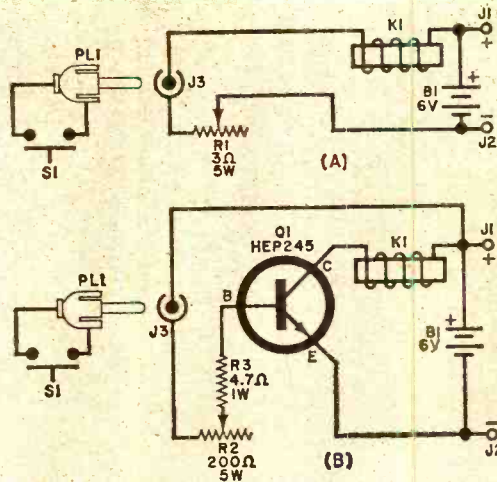

Fig. 1. Circuit in (A) is used for short runs where line voltage drop is minimal; (B) circuit provides current gain through *Q1* for long runs.

from a distance of more than 50 feet through a simple series loop. The cable resistance would probably reduce the current flow enough to prevent energization of *K1*. Hence, in the booster circuit, only biasing current for transistor *Q1* is routed through the trip switch/cable assembly. This allows the use of inexpensive and less cumbersome juke box cable.

Both circuits have provision for varying the solenoid actuating force. Potentiometer *R2* accomplishes this by varying the bias on the base of *Q1*. Polarity of the battery in this circuit is critical. Not only must it match the coding of the charger jacks, it must also conform to the requirements of the transistor.

Construction. Referring to Fig. 2, lo-

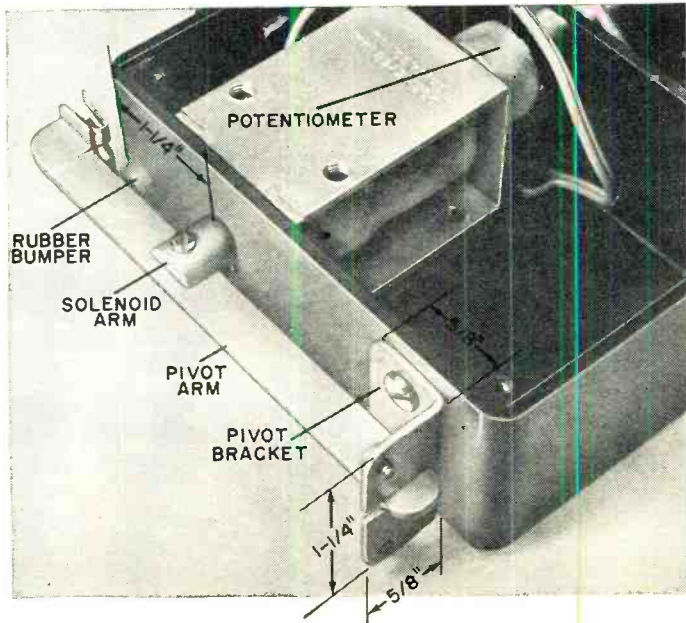
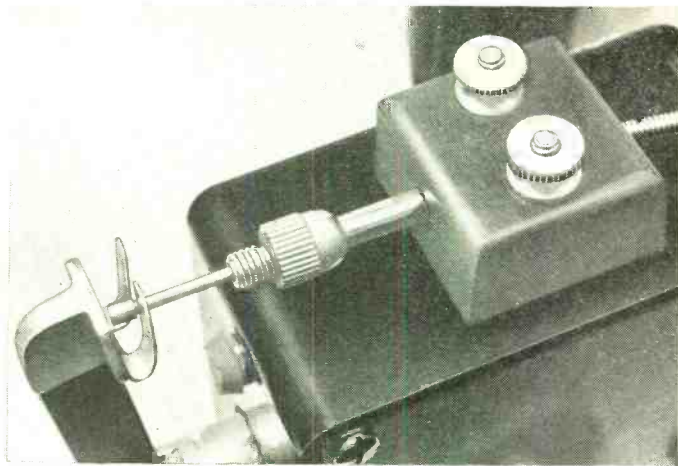

Fig. 2. Mechanical linkage between solenoid and pivot arm requires fabrication of several small metal parts. Note location of potentiometer *R2* under housing of solenoid coil.

Fig. 3. Plunger consists of two blocks of Bakelite, machined to provide friction fit. Plunger retainer (far left in photo) can be soldered or brazed to pivot arm; if aluminum is used for pivot arm, use machine screw, washer, and nut.



cate and drill the exit hole for the arm of the solenoid, centering it between the two sides of the box. Then drill the mounting holes for the solenoid and actuating arm pivot bracket, and for the potentiometer (located directly opposite the exit hole for the solenoid).

Now, mount the potentiometer and solenoid in their respective locations. Use washers between the solenoid frame and wall of the box to align the solenoid arm with the exit hole. Attach a small rubber bumper (or a spot of silicone rubber compound) about $\frac{1}{2}$ " in from the end of the box and centered as shown. Then mount the pivot bracket in place with $\#6$ machine hardware.

Drill and tap two 6-32 holes through the upright leg of the pivot bracket, start two $\#6$ screws into the holes, and notch the bracket. Now, set the pivot arm into the notches in the solenoid arm and pivot bracket. Secure it to the solenoid arm with hardware, and test the movement to make sure that the pivot arm does not bind in either notch. Then place a piece of steel wire across the pivot point, route the ends of the wire under the previously started screws, and tighten down the screws. This wire is not a spring; it merely retains the arm in the pivot. Hence, it should not bind the arm.

Firmly clamp the two Bakelite blocks so that they align exactly with each other. Then, at the interface and exactly centered, carefully drill a hole large enough to accommodate (with slight binding pressure) the barrel at the plunger end of your shutter release cable.

Remove the Bakelite blocks from the clamp and, holding them mated together, drill two $\#8$ holes through the blocks. Then drill two holes through the wall of the box in line with the holes in the blocks. (Locate the holes as close as possible to the push pad on the pivot arm with the plunger fully in but without depressing the cable release button. Loosely bolt down the block/cable assembly with $\#8$ hardware. This allows for later stroke adjustments. If the cable release has a very short barrel, position the blocks to provide the required stroke for your particular camera.) Details for attaching the block/cable assembly to the box are shown in Fig. 3.

Now, referring to Fig. 4, fashion an L bracket out of 22-gauge aluminum. Cut up a D-cell holder to make the NiCad

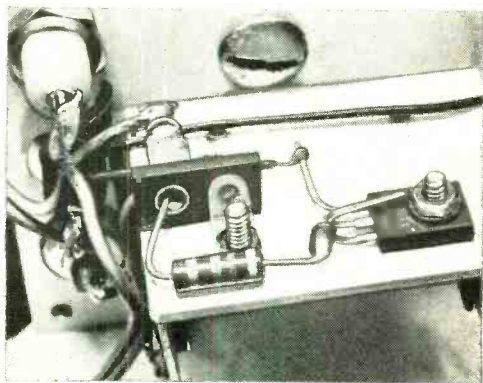

Fig. 4. Electronic components are wired together on L bracket secured to front plate of the box.

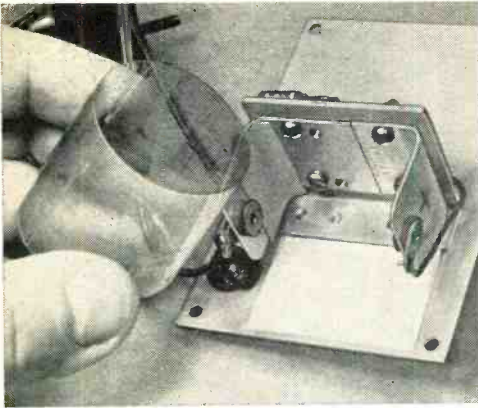

Fig. 5. Cut-down D cell holder, bolted to L bracket, and sheet plastic or card stock provide convenient method of connecting batteries to circuit.

battery holder (see Fig. 5). Mount the holder to the L bracket. Then, as shown in Fig. 4, mount the components on the opposite side of the bracket. The transistor mounts with a 4-40 screw, which also secures one point of the battery holder. Place the copper pad (collector) of the transistor against the metal bracket and tighten the screw gently.

Install charging jacks *J1* and *J2* and phono plug *PL1* on the front panel. Use shoulder fiber washers to insure that the jacks and plugs are insulated from each other. Then assemble the box.

Make the trip switch assembly from an Amphenol No. 3-12 shell and No. 78-B blank insert. Depending on which of the two circuits you plan to use, route the lamp cord or juke box cable through the side of the shell (see Fig. 6), lining the entry hole with a small rubber grommet to prevent the metal from cutting through the cable insulation. The momentary-action pushbutton switch mounts in the top hole in the shell. Connect and solder the conductors of the cable to the switch lugs, and press-fit the blank insert onto the shell. Then, at the other end of the trip switch cable, solder on a phono jack.

How To Use. With the shutter release mounted firmly next to your camera, and before loading the camera, make trial adjustments of the stroke length by moving the cable release in the clamp blocks and depressing the plunger by hand. Use

just enough stroke movement to trip the camera with the plunger fully in.

Set the force control potentiometer for maximum resistance (minimum force) and plug in the trip switch cable. Advance the force control in small steps,

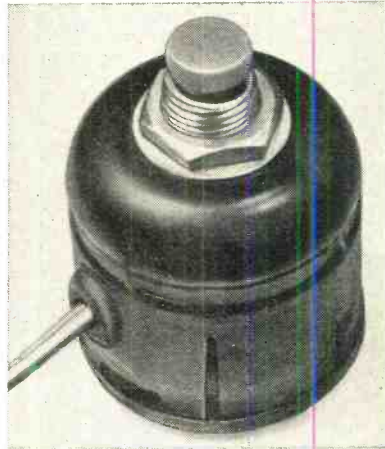

Fig. 6. Amphenol shell accommodates remote actuating switch. Cable should be routed through a grommet-lined hole.

depressing the trip switch momentarily each time, until the shutter trips. Do not hold down on the pushbutton more than a moment as this only wastes battery power.

-30-



the product gallery

REVIEWS AND COMMENTARY ON ELECTRONIC GEAR AND COMPONENTS



**PROFESSIONAL
AUTOMATIC TURNTABLE
(Dual Model 1219)**

THERE IS a big difference between claiming that an automatic record changer can be operated in the manual mode with the same quality as a professional turntable and proving that it does. The Dual 1219 Automatic Turntable, marketed by *United Audio Products, Inc.*, in your reviewer's opinion, provides the proof. This player will change the purist's opinion that the single-play, manually operated turntable is the only means of listening to music.

The 1219 is basically a record changer. Its features, however, put it in a class by itself. The tonearm, for example, is the longest on any available automatic, insuring minimum tracking distortion. The tonearm is mounted in a ring-in-ring gimbal, with four low-friction bearings, for smooth up-and-down and tracking movement.

The cueing control of the 1219 is unique. Operating it, whether slowly and smoothly or quickly, lifts and lowers the tonearm slowly and precisely. Vertical movement is damped in both directions to allow very precise control over the cueing. In addition to the normal speed selector (33 $\frac{1}{3}$, 45, and 78 r/min), there is also a built-in pitch control that allows the user to "trim" the selected speed within a semi-tone. A Mode Selector lever shifts the tonearm base down for manual play; up for "stack" play. In the single-play setting, the tone arm is positioned for perfect 15° tracking of a single record on the platter. Since conical and elliptical styli skate differently, separately calibrated scales for each are provided on the anti-skate control.

Rounding out the features, you will find that the tonearm counterweight clicks for



Special features of Dual 1219 include disc diameter selector and damped up/down cueing levers (far left foreground) and antiskate and tonearm leveler controls (near left foreground). Cast platter is a full 12" in diameter and comes with molded neoprene ribbed disc mat.

every 0.01 gram change, while a calibrated stylus pressure gauge allows the user to set up the pressure quickly and precisely for prevailing conditions. There is a separate switch that must be used for the different record sizes. This function comes preset to start each size record in the lead-in grooves, but if it ever becomes necessary, an easy-access control is provided to allow adjustment.

Taken together, the 1219's features add up to a precision and professionalism never be-

fore found in an automatic record changer. But the proof, in this case, is in the using. We found the 1219 to be a superior changer and an excellent manual-play turntable, well worth the rather high investment (\$175 for the basic turntable, including manual and automatic 33 $\frac{1}{3}$ r/min spindles and 45 r/min disc, but minus cartridge and optional walnut base). You could easily pay much more and get a lot less in features and quality.

Circle No. 93 on Reader Service Page 15 or 93

ELECTRONIC FIST KIT (Curtis Model EK-38)



LISTENING in on the CW portions of the ham bands, we have come to the conclusion that there are quite a few active hams who could use some help with their code transmitting techniques. More often than not, whole letters and words get lost in a train of sounds that are neither dots nor dashes and indistinguishable from each other. For these people, we have one suggestion: get your hands on Curtis Electro Devices' Model EK-38 Electronic Fist! With the Fist, actually an advanced electronic keyer, you'll send snappy, well-defined code.

The EK-38 uses digital integrated circuitry to form the code characters. Though it is available for \$73.95 in kit form, we found it to be a "semi-kit." Except for minimal point-

to-point wiring and hardware mounting, there is little for the kit builder to do. The printed circuit card, for example, is supplied with all parts mounted and soldered into place. There are even two resistors, selected at the factory to assure reasonable calibration of the speed scale for the printed circuit card supplied, mounted and soldered to the SPEED control.

Among the features you will find in the Fist are: improved dot memory; a calibrated speed range of 8-50 words/min; instant starting and self-completing dots and dashes; jam-proof spacing; silicon solid-state or optional relay output; built-in sidetone; momentary and locked TUNE modes; provision for manual stand-by key; and operation with either paddle or squeeze key.



Rear apron of Curtis EK-38 electronic keyer accommodates all external cable connectors, a relay/transistor output selector switch, and power fuse. Mating connectors and cables (shown in foreground) are supplied with kit.

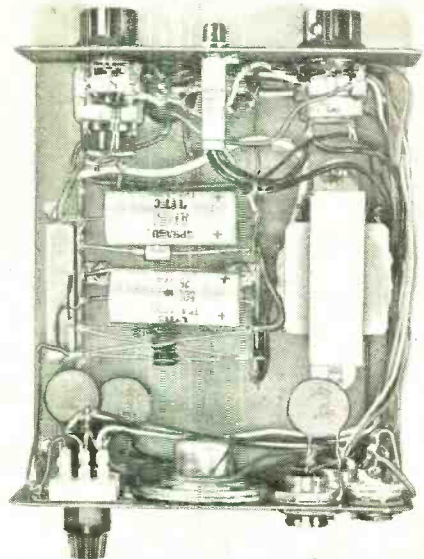
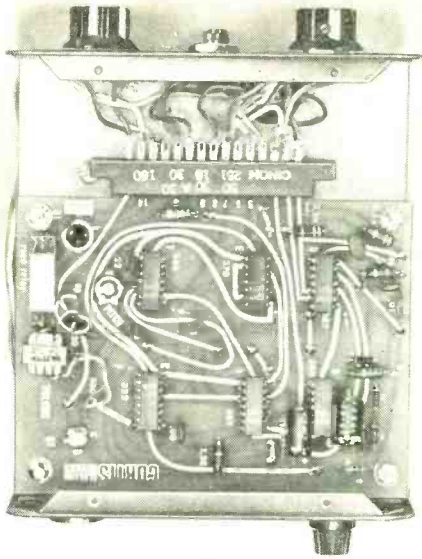

Bottom of keyer chassis has compartment for mounting prewired logic circuit board and edge connector (above left). Note uncluttered layout of power supply, controls, connectors, etc., in upper compartment of chassis (above right).

When we first opened the shipping carton we were immediately impressed by the quality of the components. All components and connectors are brand-name items. The assembled printed circuit card, with patterns on both sides and made of military-quality epoxy-glass, is designed to plug into an edge connector. A close inspection of the components on the board shows that only the very best quality components are used here, too.

Assembly goes quickly and easily. Our kit went together without a hitch and was ready to go on the air in less than four hours. It was a real pleasure listening to the train of well-defined, well-spaced dots and dashes we were able to produce with our "lead" Fist. Hence, we can heartily recommend the EK-38 Electronic Fist for any ham, rank amateur

or Extra Class, who feels the need for a code-sending aid. With a little practice, the keyer will undoubtedly improve sending speed, especially if it is used properly with one of the paddle or squeeze keys recommended.

Curtis seems to have thought of everything. Not only is the kit well made, it is made to blend with the most popular ham equipment in use. It comes with a light blue cover and dark green panels to complement the Heath SB series, a light gray cover and dark gray panels similar to the Collins look, or textured black cover and dark gray panels to complement the styling used by Swan, Drake, and Galaxy. Top performance, quality components, and good looks make an excellent combination in any ham shack.

Circle No. 94 on Reader Service Page 15 or 93

REALISTIC SOUND LEVEL METER (Radio Shack No. 33-1028)

Modern design techniques and large-volume production are making considerable advances toward bringing specialized devices to the consumer at low costs. A good example is the recently introduced Realistic Sound Level Meter sold by the Radio Shack for just \$39.95. This is a surprisingly small investment for a device that formerly sold in commercial form for \$250 and up. And, the Sound Level Meter has many applications—including use by audiophiles.

The Sound Level Meter is a functionally



10 Reasons why RCA Home Training is your best investment for a rewarding career in electronics:



Performing transistor experiments
on programmed breadboard—using
oscilloscope

1 LEADER IN ELECTRONICS TRAINING

When you think of electronics, you immediately think of RCA... a name that stands for dependability, integrity and pioneering scientific advances. For over a half century, RCA Institutes, Inc., a service of Radio Corporation of America, has been a leader in technical training.

2 RCA AUTOTEXT TEACHES ELECTRONICS FASTER, EASIER, ALMOST AUTOMATICALLY

Beginner or refresher, AUTOTEXT, RCA Institutes' own method of programmed Home Training will help you learn electronics more quickly and with less effort, even if you've had trouble with conventional learning methods in the past.

3 THOUSANDS OF WELL PAID JOBS ARE NOW OPEN TO MEN SKILLED IN ELECTRONICS

RCA Institutes is doing something positive to help men with an interest in electronics to qualify for rewarding jobs in this fascinating field. Every year, literally thousands of high paying jobs in electronics go unfilled just because not enough men take the opportunity to train themselves for these openings.

4 WIDE CHOICE OF CAREER PROGRAMS

Start today on the electronics career of your choice. On the attached card is a list of "Career Programs", each of which starts with the amazing AUTOTEXT method of programmed instruction. Look the list over, pick the one best suited to you and check it off on the card.

5 SPECIALIZED ADVANCED TRAINING

For those already working in electronics or with previous training, RCA Institutes offers advanced courses. You can start on a higher level without wasting time on work you already know.

6 PERSONAL SUPERVISION THROUGHOUT

All during your program of home study, your training is supervised by RCA Institutes experts who become personally involved in your efforts and help you over any "rough spots" that may develop.

7 VARIETY OF KITS YOURS TO KEEP

To give practical application to your studies, a variety of valuable RCA Institutes engineered kits are included in your program. Each kit is complete in itself. You never have to take apart one piece to build another. At no extra cost, they're yours to keep and use on the job.

8 FROM RCA INSTITUTES TRANSISTORIZED TV KIT, VALUABLE OSCILLOSCOPE

Those enrolled in RCA's television course or program receive complete transistorized TV Kit. All students receive a valuable oscilloscope—both at no extra cost and only from RCA Institutes.

9 CONVENIENT PAYMENT PLANS

RCA Institutes offers a unique tuition plan that lets you progress at your own pace. You only pay for lessons as you order them. You don't sign a contract obligating you to continue the course. There's no large down-payment to lose if you decide not

to continue. However, if you desire, RCA Institutes also offers a convenient monthly payment plan.

10 RCA INSTITUTES GRADUATES GET TOP RECOGNITION

Thousands of graduates of RCA Institutes are now working for leaders in the electronics field; many others have their own profitable businesses. This record is proof of the high quality of RCA Institutes' training.

CLASSROOM TRAINING ALSO AVAILABLE

If you prefer, you can attend classes at RCA Institutes Resident School, one of the largest of its kind in New York City. Coeducational classroom and laboratory training, day and evening sessions, start four times a year. Simply check "Classroom Training" on the attached card for full information.

JOB PLACEMENT SERVICE, TOO!

Companies like IBM, Bell Telephone Labs, GE, RCA, Xerox, Honeywell, Grumman, Westinghouse, and major Radio and TV Networks have regularly employed graduates through RCA Institutes' own placement service.

SEND ATTACHED POSTAGE PAID CARD TODAY! FREE DESCRIPTIVE BOOK YOURS WITHOUT OBLIGATION! NO SALESMAN WILL CALL!

All RCA Institutes courses and programs are approved for veterans under the New G.I. Bill.

RCA INSTITUTES, DEPT. 694-007-0
320 West 31st Street,
New York, N.Y. 10001

Accredited Member National Home Study Council

RCA

Construction of Multimeter.

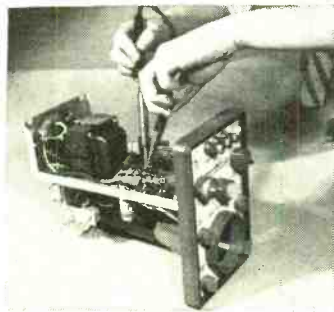
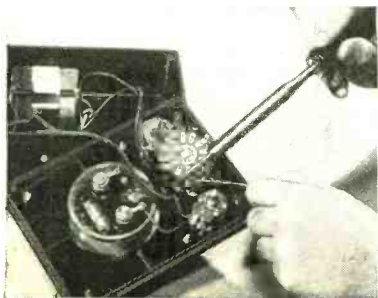

Construction of Oscilloscope.

Temperature experiment with transistors.

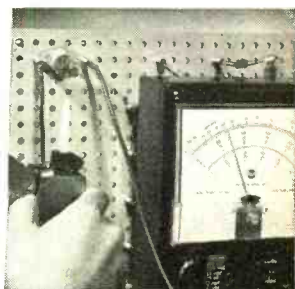

HIRSCH-HOUCK LABORATORIES

Product Evaluation

This is a most intriguing and useful instrument. Its calibration and frequency response were checked side-by-side with our calibrated Altec Model 21BR150 microphone, with the microphone units of each instrument about 18" apart and both facing a speaker some 24" away.

If the absolute calibration of our microphone is assumed to be correct, the Realistic Sound Level Meter reads low by about 3 dB at a 70-dB reading and by about 5 dB at readings of 90 and 100 dB. However, there is a screwdriver adjustment on the side of the Realistic unit which allows the calibration to be set accurately. We have no way of knowing if it had been disturbed since its initial setting. Incrementally, both on the meter scale and from range to range, the Realistic unit seems to be quite accurate, within 1 dB by our estimate.

Compared to our Altec mike, the Realistic Sound Level Meter's frequency response is within ± 4 dB from 50 to 8500 Hz, which is considered quite adequate for a sound level meter, even if it does not meet the rated 40-14,000 Hz response.

We made tape recordings with the Realistic instrument as a microphone, comparing them to recordings made with an inexpensive dynamic mike supplied with an Ampex Model 1455A tape recorder. The sound quality from the Realistic recording is adequate but not quite as clean as with the Ampex mike. The output signal level from the Realistic instrument is very high, and it cannot be fed to the mike input of the recorder without causing overloading. Into the line input, the gain was so high that we had to operate the unit at 110 dB sensitivity (minimum gain) for use within a few feet. At maximum sensitivity, the Realistic mike picked up sounds from points 20' to 30' away, with perfect clarity.

This is a fine dual-purpose instrument. As a mike, it offers very high sensitivity, far beyond anything obtainable with unaided microphones and tape recorder amplifiers. And as a Sound Level Meter, it can be useful in setting up audio systems, judging power requirements for amplifiers, etc. Even with observed errors, which may not be typical, it is acceptably accurate for amateur use.

REALISTIC SOUND LEVEL METER

At one end of Sound Level Meter is located microphone pickup; bottom compartment houses battery; side wall contains small access hole to calibrate control and output jack.

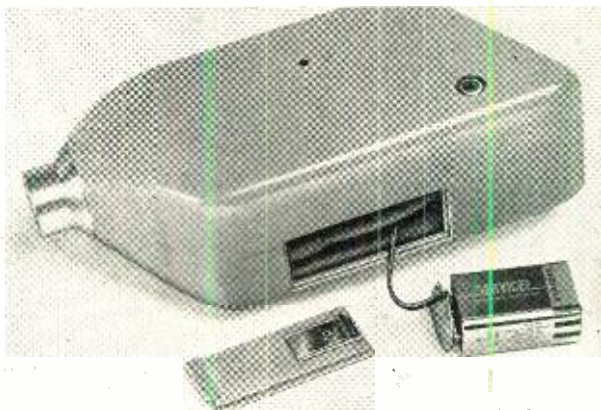

REALISTIC SOUND LEVEL METER TECHNICAL SPECIFICATIONS

Range: 65-80, 75-90, 85-100, 95-110 dB
Accuracy: ± 2 dB at 74 dB sound pressure
Output: 1 volt at 1000 Hz

Response: 40-14,000 Hz ± 2 dB (0 dB at 1000 Hz)
Output impedance: 10,000 ohms minimum
Output gain: 72 ± 3 dB at 1000 Hz
Distortion: less than 2% at 1000 Hz, 0.5-volt output

designed hand-held instrument. A microphone is mounted on one end; while, at the other end, facing the user for easy monitoring is a meter movement. On one side is an output jack; on the other, a range selector switch and an on/off, mode-selector switch.

Using the instrument in various locations, we found it to be a no-nonsense device. Once the controls are set, the user simply aims the pickup end at the source of sound and monitors the meter movement. That's all there is to it. He doesn't have to be an audio engineer to interpret the meter indications.

The Sound Level Meter is a rugged, solid-state device. It provides a usable range for measuring sound intensities from about 65 db to 100 db in four overlapping ranges—which covers sound intensities from average conversation to a turbojet whine.

The mode control switch provides power to the meter whenever it is in either the

FAST or SLOW position. In the former, the meter movement reacts almost instantaneously to the sound level. This position is somewhat like a "music power" setting since the meter movement responds at the rate used for indicating most amplifier music power specifications (in agreement with ASA standards and equivalent to the way the human ear responds). In the SLOW position, the meter movement is damped so that it indicates an "average" value and is not responsive to music peaks of extremely short duration.

The output jack provided allows the Sound Level Meter to be used as a microphone. Electrical equalizers maintain the frequency response between about 40 Hz and 8500 Hz ± 2 dB. High-impedance headphones can also be connected to the output jack as can an oscilloscope or a distortion analyzer.

Circle No. 95 on Reader Service Page 15 or 93



FISH SPOTTER
(Heathkit Model MI-29)

THIS REVIEWER, like a good many of our readers, is a real fishing nut. Living close to the Atlantic Ocean, it doesn't take much of an excuse for us to grab the rod and go prowling around in our mighty (50-hp) 17-footer. Like most fishermen, however, luck plays an important role in whether or not we catch any fish. Luck also plays a hand sometimes in keeping us out of the mud or

away from an unseen bank. Consequently, we have always envied the larger boats with their bottom-measuring, fish-finding fathometers. Because of the cost and installation problems involved, we could merely think about it and wish.

Now things are looking up. The Heath Co. has come to the rescue with their really portable, easy-to-install Model MI-29 Fish

Spotter, for \$84.95. This small, honest-to-gosh sonar system can be assembled in 6 to 8 hours and, in a box only 6" x 7" x 10", weighs 7 pounds. Operating from a pair of internal lantern batteries, battery life is estimated to be about 80 operating hours. When the case is open, the top forms a sun shield for the spinning indicator wheel and neon lamp read-out. The barium titanate transducer fits within a compartment in the box and is connected to the circuit through a length of waterproof cable. Range is from zero to 200 feet (on a hard bottom). For someone who has never used a sonar system before, a small waterproof operating manual also fits within the box.

A clamp to hold the transducer is mounted on a waterproof wooden board which is attached to the hull of the boat (at the waterline) by a pair of large suction cups. A nylon

safety line is used to make sure you don't lose the board if it should come loose.

There are only two controls: on/off-sensitivity and noise-rejection, the latter being used to minimize false echoes produced by a noisy ignition system.

The Fish Spotter was tested on a commercial fishing boat which had a large, expensive fathometer. Over a wide range of depths and types of bottoms (from mud to very hard), the indications of the two instruments agreed quite closely. Both picked up schools of fish (striped bass) at a depth of 35 feet and both were used to guide the boat confidently into relatively shallow water.

Since the Fish Spotter is easily portable, you can take it home with you and not have to leave it on the boat subject to possible thievery.

Circle No. 96 on Reader Service Page 15 or 93

HEATHKIT MI-29 FISH SPOTTER

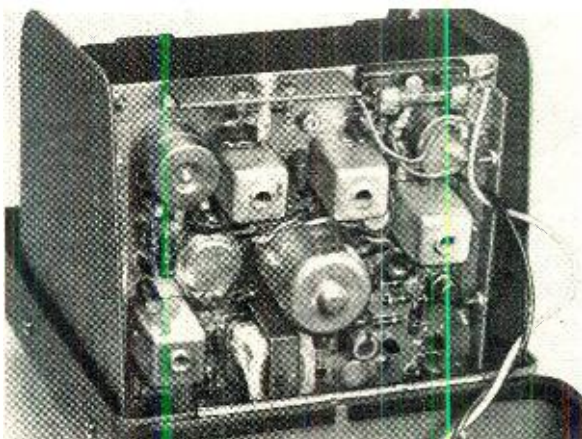

Except for the transducer, indicator assembly, and battery supply, all electronic parts mount on large printed circuit board, which is bolted to flip-up water-tight metal cover.

Transducer slides into strong, board-mounted retainer. Large suction cups on board permit attachment to non-porous hull of boat, while nylon safety line prevents assembly from tearing away in event suction cups work loose.

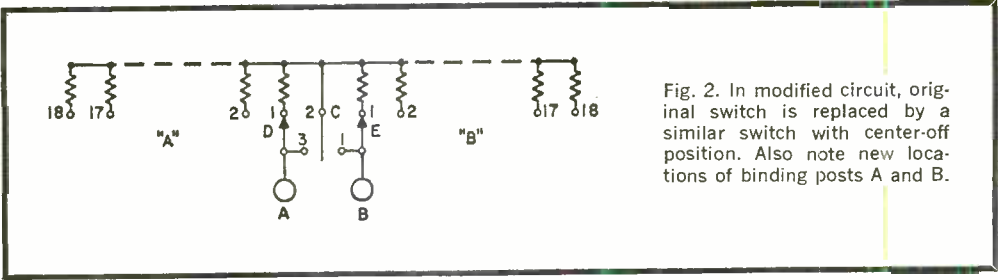

Fig. 2. In modified circuit, original switch is replaced by a similar switch with center-off position. Also note new locations of binding posts A and B.

the new switch to have a center-off position: Connect binding post A to lug 3 on the switch and binding post B to lug 1. Finally, connect lug 2 on the switch to the common buss where binding post A was originally connected.

This change now permits a selection of 360 resistance values, but only about 120 of these are significantly different in value from the others. These values are selected as follows: The standard 36 values are selected in the manner outlined in the Heath manual. Slide the newly installed switch to the center-OFF position. Then dial the extra values. For example, set the selector switches to 15 and 15K, respectively. Move the LOW selector from 15 to 10K, and you are set up to select any one of 18 values between 15K and 28K.

This process can be repeated for any resistor on the HIGH selector, but 1 megohm is about the upper limit for practical use. After all, 1 megohm plus 10,000 ohms is only a 1% change! The lines drawn in Fig. 3 further illustrate possible combinations of switch settings between 15,000 ohms and 1 megohm.

A second modification can be performed on the IN-37 to allow you to select more than 240 useful values between 1000 ohms and 1 megohm in addition to the usual ones. To make the modification, first perform the changes already outlined with reference to the slide switch. Then eliminate the 68-ohm, 680-ohm, 6.8-k, 68-k, 680-k, 6.8-megohm, and 10-megohm resistors in the original instrument. Substitute 10-ohm, 56-ohm, 560-ohm, 5.6-k, 56-k, 560-k, and 5.6-megohm resistors, respectively, for the resistors eliminated.

Mount the resistors on the selector switches in the order shown in Fig. 4. When you are finished with the wiring, each switch should contain half of the

resistors less than 10,000 ohms and half above 10,000 ohms.

The center-OFF, or A + B mode, is especially versatile. It now lets you select many small values of resistance around a single value.

One final modification finishes the project. You must redo the front panel of the substitution box so that the switches indicate the proper values selected. To do this, first mask off both ends of the panel and the center area around the switches with 3-M "Magic Mending" tape. Trim the tape around the position locator dots near the switches, permitting the dots to show after the panel is repainted.

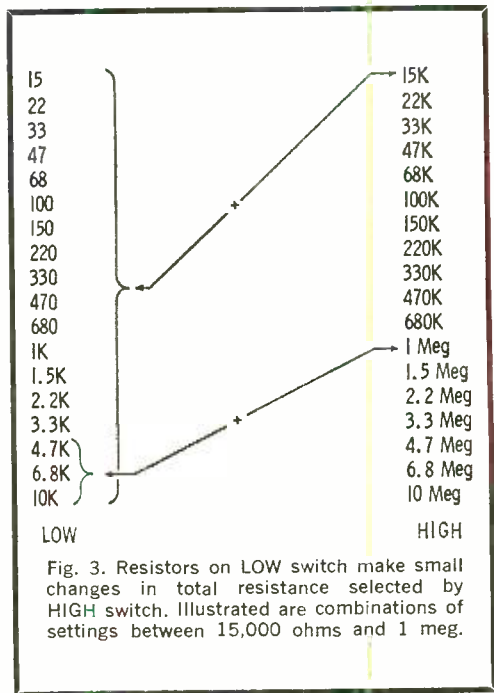

Fig. 3. Resistors on LOW switch make small changes in total resistance selected by HIGH switch. Illustrated are combinations of settings between 15,000 ohms and 1 meg.

NEW PRODUCTS

(Continued from page 24)

CB BASE BEAM FOR ANTENNA EXPERTS

Antenna Specialists Co. has announced a new CB base station antenna, called the "Boss 404," heralded as the antenna for antenna experts. It employs a true yagi beam design with tapered elements to focus the signal into an extremely narrow beam, only 52° at the half-power points. Operating in both the horizontal and vertical modes, the antenna produces a signal with an effective rated power of 100 watts from a 5-watt CB rig. The absence of gimmick wires, which distort radiation patterns, permit the antenna to achieve optimum spacing with a 17' boom. The optimum spaced elements produce maximum front-to-back and front-to-side ratios, greatly reducing interference. Precision horizontal and vertical gamma-match feeds, identical to those used on ham antennas, produce a VSWR of less than 1.5:1, and 1:1 if the user fine tunes. Heat-treated boom and elements allow the Boss 404 to withstand 90 mi/hr winds.

Circle No. 90 on Reader Service Page 15 or 93

AUTO REAR DECK SPEAKERS

In response to consumer demand for improved quality in rear deck speakers, *Eastern Specialties Corp.* has produced the "Stereo Magic" Model DES-500DW deluxe wedge speaker. In addition to being attractively styled, these speakers easily install on any flat surface merely by bolting them down with the hardware provided. Cable for the installation is also provided. The molded plastic housing contains a 5½" round ceramic-magnet loudspeaker, rated at 8 ohms impedance and 5 watts power handling capacity. You can buy the speakers in pairs for stereo.

Circle No. 91 on Reader Service Page 15 or 93

BUDGET-PRICED THREE-WAY SPEAKER SYSTEM

When the people at *Empire Scientific Corp.* say "We've done it!" they mean that they have finally produced a three-way, high-power omnidirectional speaker system with downward facing woofer selling for less than \$100. Called the Empire Model 6000 Grenadier, the new speaker system contains three drivers: an ultrasonic domed tweeter, a powerful midrange radiator for full presence, and a heavy 10" woofer. The styling of the enclosure is along the earlier Grenadier lines, a free-standing octagonal column with polished walnut finish or optional marble top. Technical specifications: 30-20,000 Hz frequency range; 75-watt power handling capacity; three-way speaker system with downward facing woofer and wide-angle lens; 8-ohm impedance; 18" diameter x 24¾"-high.

Circle No. 92 on Reader Service Page 15 or 93

light on the depth meter dial. A firm, level bottom shows up as a thin flash, while a wider flash indicates that the bottom slopes, is soft, or is uneven. Fish schools are indicated by a series of thin flashes between the zero and bottom indications. Soundings to 200' on hard bottoms or 100' on soft bottoms are possible.

Circle No. 87 on Reader Service Page 15 or 93

AUTOMATIC TURNTABLE

The Models PE2038 and PE2040 available from *Elpa Marketing Industries* are billed as the world's gentlest automatic turntables. Both models feature such items as "Dial-A-Matic" vertical tracking

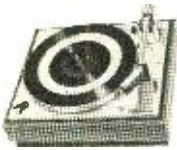

angle adjustment for every record in an eight-record stack; independent ultragentle fingertip cueing control for single and multiple play; fail safe stylus protector; automatic record scanner; and a single lever

control for all operations. The turntables boast an exclusive continuous record repeat function that allows any record in the stack to be repeated by a simple turn of the automatic spindle. And newly designed platters act as noise mufflers to aid in quiet reproduction. Technical specifications: three speeds; 4-pole induction motor; speed pitch control; 0-6 grams stylus pressure control; 7.1-lb for PE2040, 4.4-lb for PE2038, platter weight.

Circle No. 88 on Reader Service Page 15 or 93

LOW-COST SIREN/PA SYSTEM KIT

The Heathkit Model GD-18, available from *Heath Company*, offers professional performance at half the price of other such siren/PA systems. Although this kit can be used



only by those authorized to have a siren in their vehicles, its low price offers attractive savings when used in municipal and volunteer emergency vehicles. The GD-18 provides both

"wail" and "yelp" warnings (pitch of the siren is adjustable), depending on the position of the function switch. The siren can be momentarily interrupted for PA operation. Siren power output is 55 watts, and PA output is 20 watts. A radio-call-alert feature amplifies incoming radio calls and routes them through an external speaker. An exclusive radio input level control sets the top limit of the volume control so that full radio call alert volume is always at a predictable level. The GD-18 can be operated from any mobile 12-volt system.

Circle No. 89 on Reader Service Page 15 or 93



SHORT-WAVE LISTENING

By **HANK BENNETT**, WZPNA/WPE2FT
Short-Wave Editor

KVBR TO TEST FOR DX'ERS

READERS who like to tune the standard AM broadcast band will be interested in test broadcasts being made by KVBR, Brainerd, Minnesota. This information came in too late for us to publicize the May tests but if you receive your copy in time you'll still be able to catch the June tests. KVBR will be operating on 1340 kHz on June 19 and 20 at 0530, 0600, 0630, 0700, 0730, 0800, and 0830 GMT, with each transmission being ten minutes in length. Correct reports will be verified but you must enclose a self-addressed stamped envelope; further, you must address your carefully detailed reception report specifically to Mr. Mark W. Persons, Chief Engineer, KVBR, 1340 Ransford Building, Brainerd, Minnesota 56401.

Trans World Radio has reportedly begun a special DX show that will be aired each Saturday from the station in Monte Carlo, Monaco, and rebroadcast from the Bonaire relay. Monte Carlo will broadcast it at 1645 on 9585 kHz to Europe and South Africa and at 1745 on 11,755 kHz to India, the Far East, and South Pacific. Bonaire will transmit it at 1205 on 11,820 kHz and at 0335 on 11,755 kHz, both to North America. Reports

go to *Trans World Radio*, P.O. Box 141, Monte Carlo, Monaco.

The Association of North American Radio Clubs (ANARC) is taking a census of DX'ers. If you wish to be listed, send your name, address, occupation, education level, and preference in DX'ing; also list any clubs in which you hold membership, whether you do or do not hold a Citizens Band license, your receiver and antenna, your preference in electronics magazines and articles contained therein, and, finally, whether you build and/or repair any of your own equipment. Please send all of this to ANARC Census, 152 Third Street, Leominster, MA 01453.

The Dominican Republic Law of Telecommunications has reportedly forbidden short-wave stations in that country to operate below 60 meters (approximately 5060 kHz). Thus, HISSD, Santo Domingo, is no longer operating on 6090 kHz. The only exception to this appears to be HISSD's 9505-kHz outlet which, through special agreement, is being leased to a New York religious group, *Radio Libertad, Broadcasting*
(Continued on page 95)

This is the well-equipped DX listening post of Jim Boos, WPE9JXL, Milwaukee, Wisc. A Hallicrafters S-108 is used for SW reception and Jim has heard about 30 countries with 22 verified. Also visible in this photo are a tape recorder, Olson RA-48, outboard VS WR meter and antenna relay.



ENGLISH LANGUAGE NEWS BROADCASTS FOR THE MONTH OF JULY

Prepared by **ROGER LEGGE**

TO EASTERN AND CENTRAL NORTH AMERICA		TO WESTERN NORTH AMERICA	
TIME-EDT	STATION AND LOCATION	TIME-PDT	STATION AND LOCATION
	FREQUENCIES (MHz)		FREQUENCIES (MHz)
7:00 a.m.	Stockholm, Sweden	8:00 a.m.	Tokyo, Japan
7:30 a.m.	Melbourne, Australia	6:30 p.m.	Melbourne, Australia
8:00 a.m.	Peking, China		Tokyo, Japan
8:15 a.m.	Montreal, Canada	7:00 p.m.	Oslo, Norway (Sun.)
12 Noon	London, England	7:30 p.m.	Johannesburg, South Africa
5:30 p.m.	Hilversum, Holland	8:00 p.m.	Madrid, Spain
6:00 p.m.	Ankara, Turkey		Moscow, U.S.S.R.
7:00 p.m.	Helsinki, Finland		Peking, China
	Montreal, Canada		Prague, Czechoslovakia
7:45 p.m.	Tokyo, Japan		Seoul, Korea
8:00 p.m.	London, England	8:30 p.m.	Tokyo, Japan
	Moscow, U.S.S.R.		Berlin, Germany
	Sofia, Bulgaria		Stockholm, Sweden
8:30 p.m.	Johannesburg, South Africa		Tirana, Albania
	Stockholm, Sweden	9:00 p.m.	Budapest, Hungary
8:50 p.m.	Brussels, Belgium		Havana, Cuba
	Vatican City		Lisbon, Portugal
9:00 p.m.	Berlin, Germany		London, England
	Budapest, Hungary		Moscow, USSR (via Khabarovsk)
	Havana, Cuba		Sofia, Bulgaria
	Madrid, Spain		Tokyo, Japan
	Peking, China		Kiev, USSR (Mon., Thu., Sat.)
	Prague, Czechoslovakia	9:30 p.m.	Berne, Switzerland
	Rome, Italy	9:45 p.m.	Cologne, Germany
9:30 p.m.	Berne, Switzerland		Havana, Cuba
	Cologne, Germany	10:00 p.m.	Hilversum, Holland (via Bonaire)
	Melbourne, Australia	11:00 p.m.	Moscow, USSR (via Khabarovsk)
	Tirana, Albania		Tokyo, Japan
10:00 p.m.	Cairo, U.A.R.	11:30 p.m.	Havana, Cuba
	Hilversum, Holland (via Bonaire)		
	Lisbon, Portugal		
	London, England		
	Moscow, U.S.S.R.		

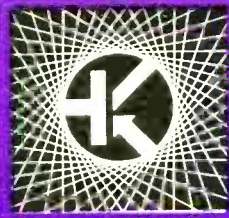

SOLID STATE

By LOU GARNER, Semiconductor Editor

CAMERA TUBE CAN SEE IN DARK

USING SOLID-STATE technology in conjunction with vacuum-tube techniques, RCA has developed a revolutionary TV camera tube that is sensitive enough to "see" in almost total darkness—yet rugged enough to withstand bright sunlight without damage. In fact, useful pictures can be picked up from a scene illuminated with a light level equivalent to that supplied by a 100-watt lamp two miles away!

The new device, a Silicon Intensifier Tube (SIT), incorporates a special electronic light amplifier and a silicon integrated circuit target as its "retina." It is expected that it will find use in classrooms, as a night military or police observer, or to originate telecasts from the surface of the moon.

The SIT consists of a vidicon-type scanning electron gun and image intensifier section separated by the IC target. The latter provides the gain which results in the tube's ultrasensitive performance at low light levels and is a two-dimensional array of more than 600,000 junction diodes formed in an *n*-type silicon wafer. The diodes are positioned with their *p* regions facing the electron scanning beam. Insulation covers the exposed *n* regions to keep the scanning beam from reaching the substrate.

In operation, light striking the photocathode in the front of the tube causes the emission of photoelectrons. These are accelerated through approximately 10 kV by the image intensifier and electron-optically imaged on the IC target.

The diodes making up the target are re-

verse biased, with the *n*-type substrate held at a positive potential and the scanned side maintained near cathode (ground) potential. Each diode element, then, constitutes a minute storage capacitor due to the insulating properties of the depletion layer formed by its reverse bias, as shown in Fig. 1. The *n* region serves as a signal plate and the individual depletion regions form the dielectrics of the elemental storage capacitors.

Interacting with the silicon, the energetic photoelectrons create a large number of hole-electron pairs for each primary electron. The holes diffuse to the depletion layer and, transverseing this region, discharge the diode capacitors, forming a stored charge pattern. The output signal is generated by the capacitive displacement current when the elemental capacitors are recharged by the scanning electron beam. This signal is amplified using conventional techniques.

The SIT should be extremely useful in crime prevention, industrial surveillance, oceanography, aerospace research, and navigation. Relatively expensive, the present device is aimed primarily at specialized industrial and governmental applications. Later, when broadcast types are introduced, reduced studio lighting should be possible, saving considerable sums on electricity and air conditioning costs. Improved telecasting of outdoor events under poor light conditions should also be possible.

Reader's Circuit. Suitable for use as a Science Fair project, in supplying unusual

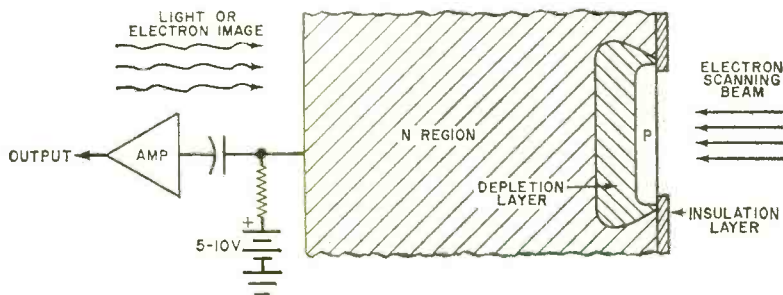

Fig. 1. Silicon Intensifier Tube (shown in blocked portion of diagram) incorporates special light amplifier and a silicon integrated circuit as its retina.

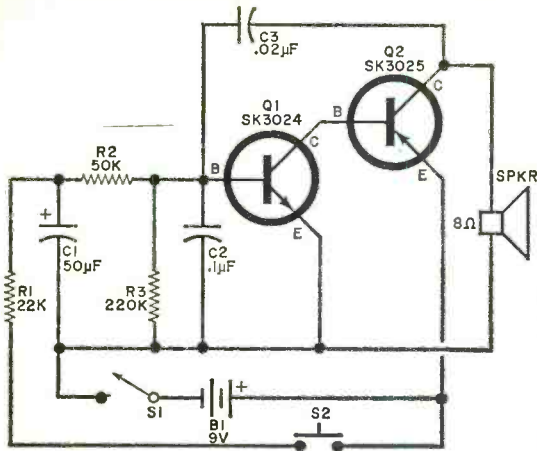
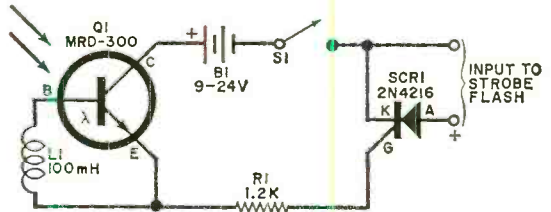

Fig. 2. Electronic siren circuit at left produces short, high-pitched scream when S2 is depressed, followed by the falling wail typical of sounds heard from police sirens.

Fig. 3. The remote photoflash slave adapter circuit shown below uses only two active devices, phototransistor Q1 and SCR1, and a minimum of fixed components for simplicity.



sound effects for amateur theatrical productions, and in signalling applications, the electronic "siren" shown in Fig. 2 was submitted by Tom Dilger (622 Moray Place, Corpus Christi, TX 78411). He writes that the circuit produces a short, high-pitched scream when its control button is depressed, followed by the falling wail typical of a police siren.

Referring to the schematic diagram, Tom has used *nnp* (Q1) and *npn* (Q2) transistors in a two-stage, direct-coupled complementary relaxation oscillator. A loud-speaker voice coil serves as Q2's collector load, while capacitive voltage-divider C2-C3 provides the feedback needed to initiate oscillation.

Normally, the circuit remains inactive since Q1 has no steady base bias. When control switch S2 is closed momentarily, C1 is charged rapidly through current-limiting resistor R1 and, until discharged, supplies Q1's base bias through voltage divider R2-R3, initiating oscillation at a frequency determined by the circuit's RC time constants. Since Q1's effective base-emitter impedance is an important part of the RC feedback network, its value controls the frequency of oscillation. This impedance varies with Q1's bias current and therefore changes as C1 is discharged, causing a corresponding change in output frequency and developing the characteristic siren wail.

Manufacturer's Circuit. While an expensive, complex, regulated multi-stage circuit might accomplish a desired objective and impress (or confuse) one's associates and friends, the really clever engineer accomplishes the same results with an inexpensive one- or two-stage design. We think the Motorola engineer who developed the remote photoflash slave adapter circuit

shown in Fig. 3 had this principle in mind. Abstracted from Applications Note AN-508, *Applications of Phototransistors in Electro-optic Systems*, prepared by John Bliss and published by Motorola Semiconductor Products (Box 20912, Phoenix, AZ 85036), this circuit uses only two active devices and a minimum of fixed components. The 24-page Application Note also reviews phototransistor theory, characteristics and terminology, discusses the design of electro-optic systems, and describes a number of other practical circuits.

In operation, phototransistor Q1 normally is cut off due to the relatively low d.c. resistance of base-emitter r.f. choke L1, even under high ambient light conditions. When a sudden, sharp pulse of light from the main strobe flash strikes Q1's photosensitive base region, L1 acts as a very high impedance, permitting Q1 to be biased into conduction and supplying a signal pulse to SCR1's gate through current limiting resistor R1. Triggered into conduction, SCR1 serves as a solid-state relay to actuate the secondary flash assembly.

Neither layout nor lead dress is critical and the project can be built in any standard configuration. Generally it would be assembled in a small plastic or metal case, with a simple tubular light shield provided for the phototransistor. You might prefer, however, to assemble a self-contained slave flash by combining this basic control circuit with a standard strobe flash design in a single cabinet.

In tests at Motorola, the circuit was unaffected by ambient light conditions, yet could be fired at distances of up to 20 feet from commercial strobe flash units using only the integral phototransistor lens for light pickup. A supplementary external lens should result in even higher sensitivity.

Device Developments. Almost every transistor or linear IC is basically an amplifier whose actual operation is determined by the circuit in which it is used. Recently, an IC has been developed that goes quite a bit further than just straight amplification. Announced by Motorola Semiconductor Products, the device, the MC1595L monolithic multiplier, opens new areas of design to the engineer and, in fact, puts a low-cost desk calculator within the reach of the serious electronics experimenter.

Unlike conventional amplifiers, this device operates in all four quadrants as shown in Fig. 4 and, depending on the types of inputs (X and Y), provides a product of the correct sign for all four combinations of positive and negative voltage values at the inputs.

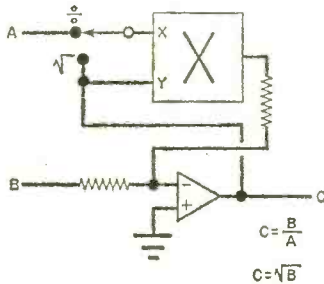

Fig. 4. Motorola IC operates in all four quadrants; puts low-cost calculator in reach of experimenter.

What can you do with it? The most obvious application is as an analog device to determine the product of two quantities expressed as voltages. The circuit that can do this can also be used for the special case where X equals Y to provide the square of the input. The configuration shown in Fig. 4 illustrates both division and square-root extraction. When switch S1 is placed in the divide position, output voltage equals voltage B divided by voltage A. When S1 is in the square root position, the output is the square root of input B.

Other circuit configurations permit the

multiplication of A and B or enable the device to be used as a balanced modulator or demodulator for single sideband techniques. You will probably see a lot of the MC1595 in future issues of POPULAR ELECTRONICS.

Transitips. A ground is a ground is a ground—or is it? Where high frequencies, high gains, or high powers are involved, a ground may not be a ground. Instead it may be a coupling loop which can introduce hum, noise, instability, oscillation, and a number of other problems.

Consider the diagrams in Fig. 5. A signal source (such as a tuner or signal generator) is coupled to an amplifier by a shielded two-conductor cable. Both the source and its amplifier load are independently connected to earth grounds for safety.

With the connections shown in Fig. 5A, circulating currents may be set up between the earth grounds and the shielded cable. These currents may include hum, noise, or other undesired signals which can be coupled to the cable's internal conductors through inductive fields or internal capacitances. The result is trouble.

A better coupling technique is shown in Fig. 5B. Here, only one side of the shield is grounded—in this case, the source. Circulating currents are reduced and trouble is minimized.

In practice, troublesome ground loops can occur between stages within a single piece of equipment as well as between separate system components.

Unfortunately, there is no absolutely infallible rule that can be followed in eliminating ground loops and their associated problems. However, trouble can be minimized by: making all ground connections to a single point within a stage, and using a single ground connection between separate circuits or pieces of equipment.

—Lou

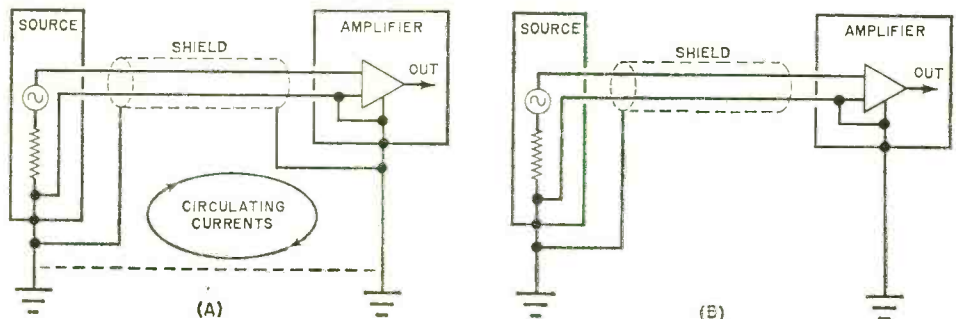

1970 ARMED FORCES DAY
 16 MAY 70
 To all to whom these presents
 that Amateur Radio Station

HAS BEEN IN QSO WITH
WA9DZL
 VOICE OF THE WISCONSIN AIR NATIONAL GUARD
128th Air Refueling Group
 General Mitchell Field, Milwaukee, Wisconsin



WINNER OF THE U.S. AIR FORCE OUTSTANDING UNIT AWARD

One of the few reserve units in the nation to win this award without being mobilized to active duty status. The 128th Air Refueling Group is one of a few select units presented this honor for continuing superior participation in mid-air refueling of regular Air Force aircraft over northern Europe since 1967.

FREQUENCY _____ TIME _____ GMT _____
 SSB _____ R _____ S _____
 TRANSCEIVER KWM-2A
 ANTENNA Dipole
 OPERATOR _____

Thomas F. Bailey, Col. Wis ANG
 Commander, 128th Air Refueling Group

Paul B. Dowd, Lt. Col., Wis ANG
 Deputy Commander of Operations

This attractive certificate was awarded by the Wisconsin Air National Guard to radio amateurs who worked WA9DZL of the 128th Air Refueling Group during 1970 May 16th Armed Forces Day.



Ray Reedy, WA9BCB, Columbus, Ind., operates with a Knight-Kit T-60 transmitter and Heathkit HR10B.

indicated d.c. power input. Thus, the maximum permissible SSB transmitter power input remains 1000 watts, but the new language apparently circumvents the trick circuit devised by some sharp operators that causes the plate meter of a transmitter r.f. amplifier to indicate an apparent power input that is less than its true input.

Section 97.67 currently specifies that when transmitter power input exceeds 900 watts, accurate means to measure the actual power input must be employed. Under the rewritten regulation, the rule applies whenever power input exceeds 90 per cent of the applicable power limit. Therefore, a Novice using a transmitter power in excess of 67.5 watts

(90 per cent of the 75-watt Novice power limit) must measure his transmitter power input accurately.

Manufacturers of new Novice transmitting equipment in the 75-watt power class can comply with the new rule simply by indicating on the output stage d.c. milliammeter the point that represents 75 watts input under conditions of maximum line voltage. But some popular Novice transmitters on the used-equipment market capable of over 75 watts input are tuned for maximum output without regard to the precise power input. Such transmitters will have to be modified slightly to comply with the letter of the new regulation. One possible modification would be to install meters to monitor the actual plate voltage and current. Another would be to decrease the amplifier tube screen voltage so that the transmitter power input cannot exceed 67.5 watts under any conditions of adjustment. Incidentally, dropping transmitter power from 75 to 67.5 watts will decrease your transmitted signal strength a negligible amount—less than a tenth of an "S" unit.

Docket 18803's requirement that the call letters of repeater stations must be transmitted automatically in code at a speed no greater than 20 WPM at least once every three minutes brings to mind that British regulations specify that British amateurs must transmit their call letters at a slow speed for the convenience of the GPO monitoring stations. In the past, 12 WPM (the required British amateur code speed) satisfied the definition of "slow speed," but recently speeds up to 20 WPM have been

(Continued on page 90)

OPPORTUNITY MIRROR

(Continued from page 60)

suiting for bachelors. Some married men go there, though, to get money to pay for a home or clean up some debts.

The ITT Arctic Services, Inc. has the maintenance contract for BMEWS. Recruiters are looking for new technicians to service the high performance radar, microwave and computer equipment. To qualify for a job, you must have an excellent background in electronics. ITT Arctic Services takes no chances and if you have the right kind of background, the next hurdle is to pass their electronics exam which covers basic electronics, radar and communications theory.

Once you're on their payroll, you are sent to a school in Streator, Illinois. You will be paid at the stateside rate. When you finish the school, you will be sent off to Thule where the big money starts. The usual tour of duty at Thule is 18 months, although many technicians return for additional tours. You can always work your way up to a higher position and higher pay.

To get more information write to Mr. James Zito, Employment Supervisor, ITT Arctic Services, Inc., 633 Industrial Avenue, Paramus, New Jersey 07652.

Jim Zito is also interviewing for technicians on the DEWLine which has sites scattered along the Arctic Circle from Alaska to Greenland.

AMATEUR RADIO

(Continued from page 90)

accepted. Of course, the British amateurs can conduct their contacts at any desired speed.

Speaking of Great Britain, *Radio Communications*, London, recently reported that in the first nine months or so of 1969, the GPO successfully prosecuted 71 individuals for transmitting without a license. Sentences ranged up to 100 pound fines and confiscation of the equipment. Forty-eight others escaped with severe warnings.

Five-Band WAS Certificate. After cutting your teeth on a Worked-all-States certificate—probably still the most popular of all

U.S. amateur operating awards—you might like to try for the new American Radio Relay League 5-Band WAS award. To earn it, you must work each of the 50 states on five different amateur bands since January 1, 1970. Sound tough? W1AX (formerly W1JYH) made the required 250 contacts, presented the 250 written confirmations to ARRL, and received the first 5-BWAS trophy awarded, all before the end of January! As amateur awards go, the 5-BWAS is a fairly expensive proposition. Entries are accepted only in the official record book; it costs \$10.00, but the amount prepays the cost of the attractive 5-BWAS trophy when it is earned. Only ARRL members are eligible for the trophy, by the way. Full rules are available upon request from ARRL, Inc., 225 Main St., Newington, CN 06111.

W1AX was also one of the first to make the required 500 contacts in the 5-BDXCC competition, but he was number seven in submitting written proof of the feat. Bob, W4QCW, was "number one" for this one.

Another Florida Suit. Ada, WN4MPU, and Frank, WB4LWA, Klarmen, North Redington Beach, Fla., were recently denied a permit for their antenna installation. Frank's story is that he was assured that, legally, he did not need a permit, but they filed for one anyway when the mayor told him that the permit would be granted. But it wasn't; as a result, the Klarmans brought suit to force the village to issue the permit. We are not attempting to judge the merits of the case, but it is interesting that the judge who presided at the preliminary hearing was the lawyer, who, as village attorney, had refused to issue the tower permit in the first place! The Klarmans forced him to withdraw from the case. From *Florida Skip*.

NEWS AND VIEWS

Peter Neveling, ZS6PD, 14 Thames Rd., Fernglen, Port Elizabeth, South Africa, was first licensed in 1954 and received his present call letters in 1968. Since the latter date, Peter has confirmations from 170 of the 220 countries worked, all on SSB phone. His equipment consists of a Swan 500C, SSB/AM/CW transceiver feeding a Mosley TA-33 triband beam on a 60-foot tower. Look for ZS6PD daily on 14-MHz SSB between 0700-0800 and 1700-1900, GMT. Peter is active on 144 MHz, but we doubt if many U.S. amateurs are going to hear him on that frequency . . . It took **Ken Johnson, WN0YTJ**, 3723 Wyoming, St. Louis, MO 63116, five months after getting his license to get on the air. But then he moved rapidly; he worked 29 states in six weeks on 40 meters. Ken receives on a Heathkit HR-10B and transmits on a Heathkit DX-60B. A new vertical for 80 meters and a 15-meter dipole were about to join the 40-meter dipole on the WN0YTJ antenna farm when Ken wrote . . . **Mike Mattes, WN6QND**, 5411 Wortser Ave., Van Nuys, CA 91401, believes in starting out small. He started with a homebrew, 2-watt, transistor transmitter, and his states-worked total was exactly half of his power in watts. Next, a friend lent him his old Novice

transmitter; with it, Mike worked 20 states and Japan ten times in five days on 21 MHz. Mike's antenna is a Hustler 4-BTV vertical, and his receiver is a Heathkit SB-301. If all went according to plan, he got the SB-401 transmitter on the line about the same time that he passed his General test—that was the plan, anyway.

Joe Hendrzak, WA3NGQ, Cornwells Heights, PA 19020 announces that he has doubled his states-worked total and earned his Advanced class ticket since his first letter, published in April "News and Views." He hopes we get his call letter right this time. It is WA3NGQ, not WA3NGO.

Daniel Laurier, WN2KZM, R.D. 1, Walton, NY 13856, operates on 80 and 40 meters and has worked 40 states and three Canadian provinces. His receiver is a war-surplus BC-348Q, his transmitter is a Heathkit DX-60B, and his antennas are 80- and 40-meter dipoles, with a 150-foot wire for receiving.

Don Cheatem, WA0TYL, 1335 W. Arlington, St. Paul, MN 55108, has spent his first two years of amateur radio operating in a horizontal position. But he will be up and going again soon. Don has a 2-element Quad for 10, 15, and 20 meters, and a dipole for 75 meters. He divides his time about equally between the four bands on SSB and CW, rag chewing, chasing DX, and message handling using a Heathkit HW-100 SSB/CW transceiver. Don has earned Worked All States (WAS), Worked All Continents (WAC) and 20-WPM code-proficiency certificates and has worked 97 countries. His next goal is passing the Advanced class examination.

Mike Fuller, WN3MWS, 841 Pheasant Road, Harrisburg, PA 17112, shares a Globe Champion-300 transmitter and a home-built receiver with his Dad, WN3MWT. Using a 132-foot antenna, Mike has worked 38 states—all on 80 meters.

Greg Carter, WN4OPG, 101 Hycliff Road, Rome, GA 30161, likes DX chasing, rag chewing and contests equally well. His Heathkit TX-1 transmitter running 75 watts to a Hy-Gain 18-AVQ vertical antenna, and Drake 2A receiver have worked 47 states and 15 countries. Most of the countries worked have been in Europe, and Greg rates UA3FU, Moscow, as his best "catch." Greg also uses an Ameeco AC-1T transmitter running 15 watts for low-power work on 80 and 40 meters.

Ronald Fox, WN4ONW, P.O. Box 6516, North Augusta, SC 29841, worked 38 states and three countries his first three months on the air. His tools are a Globe Chief 90-A transmitter, a National NC-188 receiver, 80- and 40-meter folded-dipole antennas, and an antique semi-automatic "bug" key. Greg is an ex-Navy Radioman, and his code



Bill Draher, WA4HNQ, 1448 N.W. Terr., Miami, FL 33125, operates on 2- and 6-meter phone and RTTY and is active in MARS. His latest interest is in Radar Astronomy. He is also a TV cameraman.

July, 1970

POPULAR ELECTRONICS SUBSCRIBER SERVICE

Please include an address label when writing about your subscription to help us serve you promptly. Write to: P.O. Box 1096, Flushing, N.Y. 11352

CHANGE OF ADDRESS: Please let us know you are moving at least four to six weeks in advance. Affix magazine address label in space to the right and print new address below. If you have a question about your subscription, attach address label to your letter.

TO SUBSCRIBE: Check below.
 5 yrs. \$21 3 yrs. \$15
 1 yr. \$6 New Renewal

Specify: Payment enclosed
 You get 1 extra issue per year as a BONUS!
 Bill me later.

If you have no label handy, print OLD address here.

name _____ please print
 address _____
 city _____
 state _____ zip code _____

AFFIX LABEL

print name _____ 0403
 address _____
 city _____
 state _____ zip code _____
 Add'l postage: \$1 per year outside U. S., its possessions & Canada.

It costs only



New Easy Dispenser Pak 60/40 18 S.W.G.*

1/100 of 1¢ more



Latest PC (Printed Circuit) Pak
 60/40 Extra Thin 22 S.W.G.—.028**

per solder joint to know you are using the world's finest cored solder

* Each only 59¢ per package at your dealer.



MULTICORE SALES CORP., WESTBURY, N.Y. 11590

CIRCLE NO. 14 ON READER SERVICE PAGE



During his 2-year illness, Don Cheatham, WAØTYL, St. Paul, Minn., found amateur radio a good way to pass the time. He's worked over 97 countries.

speed is approximately 18 WPM; so he expects little difficulty in passing the General class exam . . . In June, 1969, we published an item about G2UV—one of the first amateurs to send QSL cards over 40 years ago. **Charlie Jenkins, W2VX**, 129 Oak Ave., Westville, NJ 08093, does better than that. He sent us one of his 3VX QSL cards printed in 1925. This was before the use of call-letter prefixes to identify the country, and part of New Jersey was then in the third call area. Charlie first got on the air on "spark" back in 1913 and is still going strong. His latest activity was introducing 124 school children to amateur radio . . . Speaking of the long ago, **Cal, WA3HPS/9**, displays a QSL card from PD3WKI, Holland, confirming a contact in the IdZerda Memorial Contest in September, 1969, which celebrated the 50th anniversary of the first scheduled radio broadcast service in the world by PCGG.

We will be looking for you here next month. Thank you for continuing to send your "News and Views," pictures, and club papers. The address remains: Herb S. Brier, W9EGQ, Amateur Radio Editor, POPULAR ELECTRONICS, P.O. Box 678, Gary, IN. 46401.

73, Herb, W9EGQ

WHERE TO TAKE YOUR NOVICE OR TECHNICIAN EXAMINATION

Novice and Technician class amateur licenses are normally issued by mail through the cooperation of amateurs 21 years or older who hold General, Advanced or Extra class licenses. These volunteer examiners administer the examinations as agents of the Federal Communications Commission. To assist prospective Novices and Technicians in locating volunteer examiners near them, we publish here a list of such volunteers. When you think you are ready for the examination, contact the nearest examiner to make the necessary arrangements.

Where a club is listed, the individual whose name is given may not be the one who will actually give the examination; most of the clubs have a number of examiners available. Some of the clubs also conduct regularly scheduled amateur classes.

California. William Welsh, W6DDB, LERC Amateur Radio Club, Lockheed Employees Recreation Club, 2814 Empire Ave., Burbank, CA 91504. Tel: 213-842-1863.

Colorado. Allen Auten, WØECN, Denver Amateur Radio Club, Inc., 2575 S. Dahlia St., Denver, CO 80222. Tel: 303-756-1211.

Connecticut (and nationally). Membership Services Dept., American Radio Relay League, Inc., 225 Main St., Newington, CT 06111. (If other sources fail, they may be able to put you in touch with a local ARRL affiliated amateur radio club which can help you.)

District of Columbia. Beale E. Riddle, WA3-MGA, 1808 Connecticut Ave., Washington, DC 20009.

Florida. J. A. Tews, WA4ANZ, 1307 N. Alabama Ave., Deland, FL 32720.

Florida. H. G. Parker, W4YNM, Sec.-Treas.,

Columbia Amateur Radio Society, Inc., 1005 Pennsylvania Ave., Lake City, FL 32055.

Illinois. Wilson Thomas, W9WKA, Chicago Suburban Amateur Radio Association, 4017 Vernon Ave., Brookfield, IL 60513. Tel: 312-485-0541. (Has volunteer examiners in Berwyn, La Grange, Maywood, etc.)

Illinois. Steven E. Margison, WA9DRE, AREC Emergency Coordinator, DuPage County, 4428 Elm St., Downers Grove, IL 60515. Tel: 312-964-8428.

Indiana. Calvin J. Cooley, WA3HPS/9, 2437 Waverly Dr., Gary, IN 46404. Tel: 219-949-9051.

Indiana. Paul W. Deppert, WA9BNX, Lafayette Amateur Radio Club, Inc., 2303 Iroquois Trail, Lafayette, IN 47905.

Kentucky. Gary Tarus, WB4LIV, P.O. Box 18187, Louisville, KY 40218. Tel: 502-451-6775.

Michigan. Homer E. McLucas, WB8BOT, Sect., Genesee County Radio Club, P.O. Box 3275, Flint, MI 48501. Tel: 313-743-3092.

Missouri. Richard R. Moist, Jr., KØLJJ, Pres., Southwest Missouri Amateur Radio Club, Inc. (WØBE), 2860 S. Barnes Ave., Springfield, MO 65804. Tel: 417-883-2395.

Maryland. Walter Page Pyne, WA3EOP, 717 Oak Hill Ave., Hagerstown, MD 21740.

New York. Hy Davidowitz, W2MBU, Flatbush Radio Club (W2RAK), 911 E 15th St., Brooklyn, NY 11215. Tel: 212-258-3119.

New York. Robert G. Farricy, WB2YEE, 1017 Westmoreland Ave., Syracuse, NY 13210.

Washington. Marvin G. Cowles, K7ZEF, Auburn High School Amateur Radio Society (WA7-HRY), 800 4th Ave., N.E., Auburn, WA 98002. Tel: 206-833-6383.

Wisconsin. Walter Glisch, W9YYW, Sect., Milwaukee Radio Amateur Club, 1221 N. 72nd., Wauwautosa, WI 53213.

POPULAR ELECTRONICS READER SERVICE PAGE

free information service:

Here's an easy and convenient way for you to get additional information about products advertised or mentioned editorially (if it has a "Reader Service Number") in this issue. Just follow the directions below... and the material will be sent to you promptly and free of charge.

1. On coupon below, circle the number(s) that corresponds to the key number(s) at the bottom or next to the advertisement or editorial mention that is of interest to you. (Key numbers for advertised products also appear in the Advertisers' Index.) Print or type your name and address on the lines indicated.

2. Cut out the coupon and mail it to: POPULAR ELECTRONICS, P.O. Box 8391, Philadelphia, PA 19101.

note: If you want to write to the editors of POPULAR ELECTRONICS about an article on any subject that does not have a key number, write to POPULAR ELECTRONICS, One Park Avenue, New York, N.Y. 10016. Inquiries concerning circulation and subscriptions should be sent to POPULAR ELECTRONICS, P.O. Box 1096, Flushing, N.Y. 11352.

POPULAR ELECTRONICS

P.O. BOX 8391
PHILADELPHIA, PA. 19101

VOID AFTER AUGUST 31, 1970

1 2 3 4 5 6 7 8 9 10 11 12 13 14 15 16 17 18 19 20
21 22 23 24 25 26 27 28 29 30 31 32 33 34 35 36 37 38 39 40
41 42 43 44 45 46 47 48 49 50 51 52 53 54 55 56 57 58 59 60
61 62 63 64 65 66 67 68 69 70 71 72 73 74 75 76 77 78 79 80
81 82 83 84 85 86 87 88 89 90 91 92 93 94 95 96 97 98 99 100

NAME (Print clearly) _____

ADDRESS _____

CITY _____ STATE _____ ZIP CODE _____

7 N b

DX STATES AWARDS PRESENTED

To be eligible for one of the DX States Awards designed for WPE Monitor Certificate holders, you must have verified stations (any frequency or service) in 20, 30, 40, or 50 different states in the U. S. The following DX'ers have qualified for and received their state awards.

20 STATES VERIFIED

Eric Hansen (WPE6HBT), Selma, Calif.
Edward Sue (WPE1HMA), Brookline, Mass.
Jeff Guernsey (WPE0FJE), Salina, Kansas
Richard Rauscher (WPE9JFF), Milwaukee, Wisc.
Paul Tvrdy (WPE9JOJ), Palatine, Ill.
Brook Howard (WPE1HQY), Amherst, Mass.
Robert Olszewski (WPE8KFW), Toledo, Ohio
Charles Loftis (WPE4KEF), Landrum, S. C.
Peter Vegter (VE5PE6G), Regina, Sask.
Everett Slosman (WPE2QZB), Endicott, N. Y.
Steve Smith (WPE5FAU), El Dorado, Ark.
Fred Parkinson (WPE2QTV), Hewlett, N. Y.
Ken Asmus (VE4PE7W), Winnipeg, Man.
Daniel Laurier (WPE2QHP), Walton, N. Y.
Doug Rittinger (VE5PE6N), Swift Current, Sask.
Everett McLeod, III (WPE1HTG), Gloucester, Mass.
Martin Paterson (WPE7CWR), Tucson, Ariz.
Jerry Smith (WPE5FCX), Beeville, Texas
John Petrykowski (WPE9JKP), Milwaukee, Wisc.
Kurt Ullman (WPE9JPO), Bluffton, Ind.
Nicolas Chinn (WPE6HKH), San Leandro, Calif.
Anthony Toscani (WPE3HVN), Philadelphia, Pa.
Bill Tchr (VE3PE20P), Sault Ste. Marie, Ont.
Charles Smith (VE5PE6R), Saskatoon, Sask.
George Hudak, Jr. (WPE9JOK), Cedar Lake, Ind.
Jack Dashper (WPE4KJ), Camden, Tenn.
Richard Lewinski, (WPE8KAS), Wyandotte, Mich.
James Ziegler (WPE9JOW), Milwaukee, Wisc.
Gary Munn (WPE2QZL), Kinnelon, N. J.
Jeff Steinkamp (WPE0FNF), Kansas City, Mo.
Kent Kirkland (WPE3HXL), Wilmington, Del.
Jim Townsend (WPE8KJT), Painesville, Ohio
Steve Hansberry (WPE0FPN), Webster Groves, Mo.
Robert Kimak (WPE4KFM), Orlando, Fla.
Brian Heller (WPE2QVP), Lawrenceville, N. J.
David Irby (WPE4KFV), Memphis, Tenn.
Ernest Baird (VE2PE1KI), Pointe Claire, Que.
Howard O'Connell (WPE8KCH), E. Cleveland, Ohio
Charles Costa, Jr. (WPE6HNF), Lodi, Calif.
James Sanders (WPE4KCH), Savannah, Ga.
Bruce Mitchell (VE3PE20L), Ottawa, Ont.
James Hurst (WPE3HWP), Vienna, Md.
Tom Purnell, Jr. (WPE5EUB), Dallas, Texas
Dave Olinyk (VE4PE7Y), Transcona, Man.
Bob Morgan (WPE0FKO), Bainbridge Island, Wash.
Dave Christensen (WPE7CXC), Seattle, Wash.
R. D. Gee (VE7PE1EG), Victoria, B. C.
George Danko (WPE8JUR), Toledo, Ohio
Joey Nonnast (WPE5FAP), Kingsville, Texas
David Larrabee (WPE1HRB), Bucksport, Maine
Lance Kimmel (WPE2QQY), Forest Hills, N. Y.
Ronald Boestfleisch (WPE2NRJ), College Point, N. Y.
Ken Brookner (WPE5EWM), Memphis, Tenn.
Thomas Phillips (WPE1HQE), Rutland, Vt.
Donald Gross (WPE7CQX), Roseburg, Ore.
Robert Friedrich (WPE2RCB), Whitestone, N. Y.
Mike Daniels (WPE0FMX), Webster Groves, Mo.
Gary Marks (WPE2QZK), Tonawanda, N. Y.
T. K. Viswanathan. (VU2PE1K), Shillong, India
Joseph Molon (WPE1HSC), Torrington, Conn.
Noel Mann (WPE5ERN), Indianola, Miss.
David Lubar (WPE9JFD), Elmwood, Ill.
Tom Bergh (WPE8KGS), Flushing, Mich.
Reid Wheeler (WPE7CUD), Aberdeen, Wash.
Jeff Falconer (VE3PE2PG), Clinton, Ont.
Michael Garrett (WPE9JOG), Donaldson, Ind.
James Fonte (WPE9JVU), New Carlisle, Ind.
Scott Lieberman (WPE2RCX), Huntington, N. Y.
Bill Lauterbach (WPE8KKW), Albion, Mich.
Roger Horie (WPE7COV), Mountain Home Air Force Base, Idaho
Frank Swanberg (WPE9JVD), Dolton, Ill.
John Lango (WPE2QST), Williamsville, N. Y.
Robert Gerardi (WPE9JUG), Benton, Ill.
Ronald Hatton (WPE4JXR), Camp Lejeune, N. C.
Joel Bahl (WPE9JFY), Worth, Ill.

30 STATES VERIFIED

Jim Corcoran (WPE8JNT), Cincinnati, Ohio
Mike Witkowski (WPE9JFT), Stevens Point, Wisc.
Jeff Wilson (VE3PE2NL), Sarina, Ont.
Tim Ohrman (WPE3HHA), Monroeville, Pa.
Bob Estand (WPE5FAV), El Paso, Texas
Chris Kriebel (WPE8IVB), Wooster, Ohio
David Allaway (WPE2QOB), Port Washington, N. Y.
Robert Asbury (WPE2PYT), Williston Park, N. Y.
Rev. Jack Peiza (WPE6HCP), Ojai, Calif.
Mitchell Stern (WPE2QIA), Brooklyn, N. Y.
Richard Davis (WPE0AKR), Denver, Colo.
Richard Hayes (WPE6HEH), Los Angeles, Calif.
Robert Spear (WPE3HEI), Baltimore, Md.
James Bochantin (WPE9JDA), Du Bois, Ill.
David Peters (WPE6HDM), Modesto, Calif.
James Pogue (WPE9HJL), Farmland, Ind.
Martin Miron (WPE8JTN), Warren, Mich.
Loren Davis (WPE6HMA), Hayward, Calif.
Richard Thompson (WPE3HQW), Washington, D. C.
Stanley Garfield (WPE2QIO), Tenafly, N. J.
John Swart (ZS1PE2A), Epping, Cape Town, South Africa
James Ziegler (WPE9JOW), Milwaukee, Wisc.
Gary Kromer (WPE2PIH), Auburn, N. Y.
Dennis Driscoll (WPE4KDI), Asheboro, N. C.
Steve Smith (WPE5FAU), El Dorado, Ark.
Frederick Webster (WPE2PRD), Secaucus, N. J.
Dave Olinyk (VE4PE7Y), Transcona, Man.
Charles Loftis (WPE4KEF), Landrum, S. C.
Terry Jarvis (WPE0FMR), Kirksville, Mo.
Noel Mann (WPE5ERN), Indianola, Miss.
Michael Gray (WPE0FFV), O'Fallon, Mo.
Robert Neal, Jr. (WPE6HFY), Forbestown, Calif.
Richard Eddie (WPE0FFT), St. Louis, Mo.
Jack Dashper (WPE4KJ), Camden, Tenn.
Don Gross (WPE7CQX), Roseburg, Ore.
Anthony Baleno (WPE3HWY), Verona, Pa.
Brian Hajder (WPE0FFI), Crystal, Minn.
Everett Mac Leod, II (WPE1HTG), Gloucester, Mass.
Gregory Martin (WPE8KFL), Wyoming, Mich.
Mike Hardester (WPE6HIM), Modesto, Calif.

40 STATES VERIFIED

Robert Miller (WPE9JHL), Berwyn, Ill.
Ron Budziack (WPE9JHK), Cicero, Ill.
Joseph Williams (WPE9JKD), Milwaukee, Wisc.
Thomas Lamphere (WPE2QDB), Johnson City, N. Y.
Michael Wheeler (WPE7CSY), Portland, Ore.
Michael Northam (WPE7CME), Beaverton, Ore.
Jack Bacon, Jr. (WPE0FDJ), Bloomington, Minn.
Marion Lienthal (VE3PE2DO), Waterloo, Ont.
Ronald Richmond (WPE9JIH), Alexandria, Ind.
Ken Chinn (WPE6HKH), San Leandro, Calif.
Loren Davis (WPE6HMA), Hayward, Calif.
Jack Graham (WPE2QNT), New Milford, N. J.
Robin Chase (VE3PE2NS), Gananoque, Ont.
Steve Smith (WPE5FAU), Ruston, La.
Allen Jones (VE3PE2AM), Islington, Ont.
Robert Scott (WPE4HHX), Kingsport, Tenn.
Montie Fisher (WPE5ESZ), Oklahoma City, Okla.
Tim Ohrman (WPE3HHA), Monroeville, Pa.
Kurt Leonhardt (WPE9FLI), Blue Island, Ill.
Charles Loftis (WPE4KEF), Landrum, S. C.
Herbert Rørow (WPE1HBN), Moodus, Conn.
Byron Hurder, Jr. (WPE3HYH), Fort Meade, Md.

50 STATES VERIFIED

Benjamin Botvenek (WPE2QQX), Jackson Heights, N. Y.
Leo Baca (WPE5CLR), E. Bernard, Texas
D. J. Brillon (WPE7CIR), Bremerton, Wash.
Alan Carpenter (WPE8JXS), Fairmont, W. Va.
Robert Shumaker (WPE8KBE), Southfield, Mich.
John White (WPE4JPC), Jacksonville, Fla.
Richard Roll (WPE3HYE), Malvern, Pa.

(Continued from page 83)

Tropical and Radio TV Dominicana are now broadcasting (excluding the 9505-kHz outlet) on the medium waves. Most of the others are operating above 60 meters.

Several DX'ers have asked us to identify a Spanish-speaking station operating on 760 kHz with a format of all news, a time check each minute, and continuous time ticks in the background. Your Editor has often heard it, too, but never with satisfactory enough reception to obtain a definite identification. Try for it evenings (your own local time) and let us know if you can identify it.

SPECIAL REPORT ON BOLIVIA

Your Editor asked one of our veteran DX'ers to run a special survey on the Bolivian stations in an attempt to obtain an accurate and up-to-date listing of the stations that are currently on the air. The following is his survey; please correct your logs accordingly. The listing is by frequency.

- 4755 CP62 *Radiodifusora Boliva*, Oruro—opened in 1966 on 4760 kHz, later moved to 4755 kHz. S/off varies 0400-0500. It's QSL policy was good but has deteriorated in recent years.
- 4775 CP84 *Radio Los Andes*, Tarija—s/off varies 0400-0500. It'll likely take more than just one report to get an answer out of them.
- 4785 CP74 *Radiolndoamerica*, Potosi—opened in 1961 on 6202 kHz and moved to 60-meter band in 1962; it is weak and closes at 0200 or earlier. Nine reports have gone unanswered.
- 4795 CP73 *Radio Nueva America*, La Paz—This one is widely reported; their s/off is after 0300; QSL policy is fair.
- 4824 CP70 *Radio Grigota*, Santa Cruz—for years on 4831 kHz, it now operates here. S/off varies 0300-0500 and it is another poor verifier.

- 4845 CP12 *Radio Fides*, La Paz—here for three years, it was formerly on 6164 kHz. S/off is 0400; tough to verify.
- 4850 CP66 *Radio Centenario*, Santa Cruz—previously on 3395 kHz; s/off time is 0400 and it's almost impossible to get a QSL out of them. Radioteletype QRM is usually present on this channel.
- 4871 CP110 *Radio Norte*, Montero—began on short-wave in 1967 and was once on 4940 kHz. S/off is between 0300-0400; it is unverified after eleven reports.
- 4885 CP77 *R. Sararenda*, Camiri—up from previous 4882 kHz, this one is usually QRM'ed to 0100 s/off. In the past it has always verified quickly.
- 4900 CP88 *R. Amboro*, Santa Cruz—may vary from 4898 to 4912 kHz. S/off is 0400 but schedule is irregular and it's another poor verifier.
- 4958 CP105 *R. Ibare*, Trinidad—this opened in 1966 when it announced 4885 kHz. S/off is 0200; a fair verifier.
- 4975 CP90 *R. Juan XXIII*, San Inacio de Velasco—this opened in 1967 and previously was on 4951 kHz. Other L.A. stations provide much QRM. S/off 0200 and they verify poorly.
- 5017 CP48 *R. Universo*, La Paz—began testing in 1964 on 5013 kHz. S/off time is 0300 or shortly thereafter; QSL policy is not too good.
- 5025 CP75 *Radio la Cruz del Sur*, La Paz—a recent move from 4985 kHz, this one has some English programming. S/off time around 0300 and QSL policy is good.
- 5045 CP38 *R. Altiplano*, La Paz—this opened in 1963 on 9505 kHz and moved to 5045 kHz in the same year. S/off is irregular and may operate around the clock at times. Veri policy is unpredictable but eventually you may hit it lucky.
- 5055 CP87 *Radio San Rafael*, Cochabamba—another 1967 opener, this goes to 0200-0230 and is rough to verify.
- 5460 CP85 *R. Universidad*, Tarija—has used this channel for six years. S/off time is irregular but seldom after 2300. Verification policy is fair.

For DX'ers interested in the Bolivian stations, it may be of worth to note that the many

FREE McIntosh CATALOG and FM DIRECTORY

Get all the newest and latest information on the new McIntosh Solid State equipment in the McIntosh catalog. In addition you will receive an FM station directory that covers all of North America.



MX 114

FM/FM STEREO TUNER
and STEREO PREAMPLIFIER

CIRCLE NO. 15 ON READER SERVICE PAGE

SEND TODAY!

McIntosh Laboratory Inc.
2 Chambers St., Dept. PT7
Binghamton, N.Y. 13903

NAME _____

ADDRESS _____

CITY _____ STATE _____ ZIP _____

Olson ELECTRONICS FREE Catalog

Fill in coupon for a FREE One Year Subscription to OLSON ELECTRONICS' Fantastic Value Packed Catalog — Unheard of LOW, LOW PRICES on Brand Name Speakers, Changers, Tubes, Tools, Stereo Amps, Tuners, CB, and other Values. Credit plan available.

NAME _____
ADDRESS _____
CITY _____ STATE _____
GIVE ZIP CODE _____

If you have a friend interested in electronics send his name and address for a FREE subscription also.

OLSON ELECTRONICS

DEPT. 1G, 260 S. FORGE STREET, AKRON, OHIO 44308

CIRCLE NO. 16 ON READER SERVICE PAGE



KITS FEATURED IN

POPULAR ELECTRONICS

AND FROM OTHER SOURCES

Psychedelic Strobe Light	\$17.50
LII Tiger Amplifier (40w)	\$37.50
Tiger Amplifier (80w)	\$50.00
Super Tiger Amplifier (100w)	\$75.00
FET Preamp (less power supply)	\$42.50

Prices plus postage and insurance

Also:

Psychedella I Color Organ, Sonolite,
Nixie Readouts, Frequency Counters,
Sports Timers, Ultrasonic Alarm, etc.

WRITE FOR FREE CATALOG

Southwest Technical Products

219 (PE) W. Rhapsody
San Antonio, Texas 78216

CIRCLE NO. 21 ON READER SERVICE PAGE

Union-operated stations that were on the air in the past are now silent and have been since 1966-67. It seems unlikely that any of them will return to the airwaves in the near future. This is primarily due to the profound political changes in the country.

CURRENT STATION REPORTS

The following is a resume of current reports. At time of compilation all reports were as accurate as possible, but stations may change frequency and/or schedule with little or no advance notice. All times shown are Greenwich Mean Time (GMT) and the 24-hour system is used.

Albania—China has delivered a considerable amount of broadcasting equipment to this country. New short-wave xmt's may go on the air within a few months. *Radio Tirana* expects to greatly increase broadcasts to both western and eastern Europe.

Andorra—Medium-wave DX'ers will agree that reception of overseas stations on 818 kHz is often impossible due to a number of high-powered stations operating there. To add to the fun, *Sud-Radio* will, according to an overseas source, increase power to 600 kHz in early 1971.

Angola—CR6RB, R. *Ecclesia*, Luanda, 4984 kHz, is now operating past 0400, apparently on an extended schedule with modern pop tunes and anmt's in Portuguese. *A Voz do Angola*, Luanda, s/on at 0501 after flute and drums IS; the ID is given numerous times (on one occasion it was given 15 times!); anmt's and music are given to 0512, then pop music non-stop to 0600. This is all in Portuguese, and the frequency is 5960 kHz.

Austria—Vienna carries "Report From Austria" in English at 0030-0045 on 9770 kHz on Tuesday and Sunday. Vienna's 15,145-kHz outlet has English at 0030-0045, then Spanish to 0100, beamed to the Caribbean and Central America. *Schulungssender des Osterreichischer Bundesheeres* of the Austrian army operates in German, seemingly with educational broadcasts, on 6255 kHz at 1100-1230 and 1630-1900 and on 6855 kHz at 1830-1900.

Bolivia—CP89, R. *Santa Ana*, 3400 kHz, is VFO controlled according to the station and may operate anywhere between 3390 and 3400 kHz with 250 watts and a s/off time of 0100.

Brazil—ZYF23, *Radiodifusora do Maranhao*, Sao Luis, off the air for some time, is back and on 4757 kHz; ZYY3, R. *Brazil*, Campinas, is on 4755 kHz at the same time and both stations are in Portuguese; a definite ID from either may be difficult!

Burma—XZK42, Rangoon, 5040 kHz, has Burmese at 1200 while XZK2 on 4725 kHz has Burmese at 1210 but the two stations are not in dual. The 5040 kHz outlet also has English at 1450.

China—Provincial Chinese stations as heard by a DX'er in Japan include *Kiangsi Provincial Radio*, Nanchang, 5020 kHz in Chinese around 1100; *Kirin Provincial Radio*, Changchun, irregularly on 6070 kHz in Chinese at 0900 and in Korean at 0930-1000; *Fukien Provincial Radio*, Foochow, 5040 kHz, in Chinese at 0945 s/off; *Kansu Provincial Radio*, Lanchow, 4865 and 7323 kHz in Chinese from 0945; *Heilungkiang Provincial Radio*, Harbin, 5950 kHz in Korean at 0900 s/on and in Chinese at 1000; and *Tibet Provincial Radio*, Lhasa, on 5935 and 9490 kHz at 1000 s/on.

Colombia—HJAG, R. *Atlantico*, Barranquilla, last heard in 1962, is back on 4905 kHz and audible at times after 0400 in Spanish. R. *Catatumbo* (new; location unknown) on 4767 kHz is weak from 0238-0308 with music.

Dominican Republic—A new station is *Emissora Cultural, La Voz de las Fuerzas Armadas*, Santo Domingo, is on 4825 kHz and heard well daily except Sundays from 2330 to s/off around 0120; programming is all Spanish and reports are requested but no address has been given.

Ecuador—Recently active *R. Vision*, Cuenca, 6141 kHz. has an English ID at times indicating dual channels on 650 kHz and 90.9 FM and stating "... all of the equipment was designed and built in Ecuador".

Egypt—Cairo has English news at 2210 on 9605 kHz. This is another new frequency.

Ethiopia—*R. Ethiopia*, Addis Ababa, 6185 kHz, is

often good at 0335-0400 with native singing; from 0400 with news in Somali and, at 0412, more singing.

Finland—Helsinki, 15.185 kHz. has a DX show on Monday in English to Europe at 1800-1830. The N.A. xmsn at 2300-2330 in English and to 0000 in Finnish is generally good but with some QRM at times.

DX ALL-CANADA AWARDS PRESENTED

To be eligible for one of the DX All-Canada Awards designed for WPE Monitor Certificate holders, you must have verified stations in 6, 8, 10, or 12 different Canadian areas. The following qualified for and have received awards.

6 CANADIAN AREAS VERIFIED

Henry Gac (WPE8JST), Detroit, Mich.
 Jim Kowalski (WPE9GZB), Two Rivers, Wisc.
 Mike Mickes (WPE7CVF), Gooding, Idaho
 Bruce Kirkpatrick (WPE0DZY), Topeka, Kansas
 Douglas Goodman (WPE9JJI), Lombard, Ill.
 David Allaway (WPE2QOB), Port Washington, N. Y.

Jack Osborne (WPE8BXV), Milton, W. Va.
 Harry Smith (WPE8IHZ), Springfield, Ohio
 Donald Appling (WPE7CNG), Spokane, Wash.
 Todd Pollock (VE3PE2NJ), Oshawa, Ont.
 Clarke Thacher (WPE9IXP), Mishawaka, Ind.
 Rev. Jack Pejza (WPE6HCP), Ojai, Calif.
 Ron Budziack (WPE9JHK), Cicero, Ill.
 Arthur Martin (WPE0EJY), St. Paul, Minn.
 Eugen Floda (WPE20FH), Bronx, N. Y.
 Steve Swift (WPE7CVH), Olympia, Wash.
 Marvin Robbins (WPE0MW), Omaha, Nebr.
 Gabriel Houle (VE2PE7C), Montreal, Que.
 Charles Mohr, Jr. (WPE2MKI), White Plains, N. Y.
 Gary McNelly (WPE9IRG), Cahokia, Ill.
 James Conrad (WPE0ENQ), Texarkana, Ark.
 Martin Miron (WPE8JTN), Warren, Mich.
 Rick Abshier (WPE9IQX), Lisle, Ill.
 Mrs. Mildred Marshall (WPE0FIR), Devils Lake, N. D.

Ronald Richmond (WPE9JIH), Alexandria, Ind.
 James Ziegler (WPE9JOW), Milwaukee, Wisc.
 Mike Witkowski (WPE9JFT), Indianapolis, Ind.
 Gary Kromer (WPE2PIH), Auburn, N. Y.
 Mark Koukol (WPE9JKV), Naperville, Ill.
 Steve Smith (WPE5FAU), El Dorado, Ark.
 Loren Davis (WPE6HMA), Hayward, Calif.
 Charles Brooks (WPE0EXW), Mitchell, S. D.
 Dan Broadbooks (WPE9IYK), Cottage Hills, Ill.
 John White (WPE4JPC), Jacksonville, Fla.
 Joseph Williams (WPE9JKD), Milwaukee, Wisc.
 Scott Brockway (WPE2QJP), Rome, N. Y.
 Kurt Leonhardt (WPE9FLI), Blue Island, Ill.
 Thomas Langley (WPE7CXY), Portland, Ore.
 G. W. Fisher (WPE7CXZ), Longview, Wash.
 Robert Shumaker (WPE8KBE), Southfield, Mich.
 Don Moman (VE6PE8C), Clive, Alta.
 Roy Haynes (WPE6HEI), San Jose, Calif.

James Murray (WPE2RFR), Troy, N. Y.
 Donald Asp (WPE6HGY), Tustin, Calif.
 Robert Scott (WPE4HHX), Kingsport, Tenn.

8 CANADIAN AREAS VERIFIED

Ian Davidson (VE3PE2ND), Sarnia, Ont.
 Richard Pistek (WPE9HOA), Chicago, Ill.
 Walter Miscichowski (WPE2BEH), Buffalo, N. Y.
 Kevin Kruger (WPE9JDI), W. Allis, Wisc.
 Francis Wheeler (WPE6HLK), Sacramento, Calif.
 Jack Bacon, Jr. (WPE0FDJ), Bloomington, Minn.
 Joseph Hueter (WPE3EP), Philadelphia, Pa.
 Charles Smith (VE5PE6R), Saskatoon, Sask.
 Dennis Driscoll (WPE4KDI), Ashboro, N. C.
 Ron Budziack (WPE9JHK), Cicero, Ill.
 Steve Smith (WPE5FAU), El Dorado, Ark.
 Allan Jones (VE3PE2AM), Islington, Ont.
 Charles Mohr, Jr. (WPE2MKI), White Plains, N.Y.
 John White (WPE4JPC), Jacksonville, Fla.
 Marvin Robbins (WPE0MW), Omaha, Nebr.
 Kurt Leorhardt (WPE9FLI), Blue Island, Ill.

10 CANADIAN AREAS VERIFIED

Robert Asbury (WPE2PYT), Williston Park, N. Y.
 Brian Begg (WPE2JPR), New Brunswick, N. J.
 Everett MacLeod, II (WPE1HTG), Gloucester, Mass.
 Robin Chase (VE3PE2NS), Gananoque, Ont.
 John Swart (ZS1PE2A), Epping, Cape Town, South Africa
 Ron Budziack (WPE9JHK), Cicero, Ill.
 Robert Byers (VE3PE2XP), Gananoque, Ont.
 Vincent Geraci (WPE1HMP), Shelton, Conn.
 Tim Ohrman (WPE3HHA), Monroeville, Pa.
 Richard Roll (WPE3HYE), Malvern, Pa.

12 CANADIAN AREAS VERIFIED

Joel Resnick (WPE2LMZ), New York, N.Y.
 Mark Connelly (WPE1HGJ), Arlington, Mass.
 Dave Glow (WPE1FKZ), Pepperell, Mass.
 Everett MacLeod, II (WPE1HTG), Gloucester, Mass.
 Thomas Creery (WPE2PHZ), Conklin, N. Y.

ADDED MOBILE POWER WHEN YOU NEED ADDITIONAL COVERAGE FOR CLEAR COMMUNICATIONS



170 WATT INPUT

Complete with remote power switch and indicator control panel plus mounting brackets.

FCC TYPE ACCEPTED
 Parts 89, 91, 93

\$129⁹⁵
 12 VDC

SMALL PACKAGED MOBILE POWER LINEAR R.F. POWER AMPLIFIER

Covers greater distances with increased transmit power. Can be used with SONAR BR20, FM40 or any similar FCC approved equipment with 1-15 watt output. Designed with top performance and dependable service when you need it. Automatic standby/transmit switching • Covers 25-50MHz range • transistorized power supply - negative ground • Used on amateur 28MHz for FM-AM-SSB. Small, compact, rugged design. Size: 2" H x 6" W x 8" D. Wt. 3 lbs. 12 VDC

SONAR RADIO CORP., 73 Wortman Avenue, Bklyn, N.Y. 11207
 Please send information on Model BR 2906 Linear Amplifier. Dept. 890

Name

Address

City State Zip

CIRCLE NO. 20 ON READER SERVICE PAGE

France—The long-wave station at Allouis on 164 kHz continues to be heard on the N.A. East Coast from 0500-0600 with French music, features and news.

Ghana—Accra broadcasts to N.A. daily in English at 2000-2100 with news and native music. Also heard: 3366 kHz at 2240-2302 s/off in English religious programs, and on 4915 kHz with English news at 0600 and to 0640 in African language and music.

India—All India Radio is setting up two new 100-kW short-wave xmr's in Aligarh, Upper India, to cover Europe; test broadcasts may now be in progress; in addition two 1000 kW medium-wave xmr's are anticipated. No specific frequencies were given. Delhi is heard daily at 1500-1600 on 10,355 kHz with news at 1515 in Hindi and at 1530 in English. Bombay, 15,080 kHz, has English news at 1800.

Iran—R. Iran can be heard in English to Europe from 2000-2029 on 12,040 kHz (a move from 9020

SHORT-WAVE CONTRIBUTORS

Bill Jarvis (WPE1GFP), Wakefield, Mass.
 Michael Collins (WPE1GFG), Stratford, Conn.
 John Duane (WPE1HBC), Hingham, Mass.
 Stephen Ruggles (WPE1HCH), Lunenburg, Mass.
 D. L. Mahler, M. D. (WPE1HOK), Newton Centre, Mass.
 Paul Kinnaly (WPE1HRI), Dedham, Mass.
 Michael Nedeau (WPE1HUA), Cheshire, Conn.
 Ron Paul (WPE1HVV), Hamden, Conn.
 Riley Sundstrom (WPE2AJ), Willingboro, N. J.
 Bill Feidt (WPE2AM), Lanham, Md.
 Bob Arnold (WPE2QPR), Canastota, N. Y.
 Nicholas Zelinsky (WPE2QTB), Mantua, N. J.
 Mark Chinsky (WPE2QTI), Flushing, N. Y.
 Everett Slosman (WPE2QZB), Endicott, N. Y.
 Lloyd Blueweiss (WPE2RBH), Valley Stream, N. Y.
 Steve McGregor (WPE2RBK), Edison, N. J.
 Leo Alster (WPE2RBN), Rahway, N. J.
 Sam Alcorn (WPE2RDL), Millville, N. J.
 Rod Behrend (WPE2RDL), Syosset, N. Y.
 Lawrence Markham (WPE2REK), Albany, N. Y.
 John Brandt (WPE2REL), Brooklyn, N. Y.
 Henry Seidner (WPE2REP), Pearl River, N. Y.
 George Cuccia (WPE2REX), Millville, N. J.
 Steve Zimmerman (WPE2RFK), Scarsdale, N. Y.
 Charles Maier (WPE3FXJ), Baltimore, Md.
 Gary Blau (WPE3HWT), Rockville, Md.
 Charles Harlich (WPE3HXA), Pittsburgh, Pa.
 Leonard Modzelesky (WPE3HXW), Scranton, Pa.
 Grady Ferguson (WPE4BC), Charlotte, N. C.
 Dan Henderson (WPE4GW), Laurel, Md.
 Scott Wilds (WPE4JNC), Memphis, Tenn.
 Steven Handler (WPE4JK), Evanston, Ill.
 Carroll Patterson (WPE4KHM), Decatur, Ga.
 Bill Peck (WPE4KKY), Roanoke, Va.
 Eddie Gilman (WPE4KLO), North Miami Beach, Fla.
 Richard Fortson (WPE5EHW), Edinburg, Texas.
 David Larson (WPE5FED), Harlingen, Texas.
 John Wheeler (WPE5FES), San Angelo, Texas.
 Charles Bennett (WPE5HW), Sumrall, Miss.
 John Boessenecker (WPE6GPN), Mill Valley, Cal.
 Dennis Monticelli (WPE6GZO), Burlingame, Cal.
 John Clark-on (WPE6HIL), Burlingame, Cal.
 Steven Hirsch (WPE6HKP), Los Angeles, Cal.
 Michael Caditz (WPE6HOA), Los Angeles, Cal.
 Robert Zaug (WPE7CWL), Tacoma, Wash.
 Dave Williams (WPE7CWW), Astoria, Ore.
 Roy Neese (WPE7CWX), Kent, Wash.
 Joseph Hutchens (WPE8EUM), Biloxi, Miss.

Pete Bonk (WPE8JOF), Dearborn Height, Mich.
 David Cornell (WPE8KFA), Brockport, N. Y.
 George Smith (WPE8KJJ), Grand Rapids, Mich.
 Bruce Call (WPE8KKR), Akron, Ohio
 Bob Smith (WPE8KKY), Grand Rapids, Mich.
 Ben Mancine (WPE8KAN), South Euclid, Ohio
 Joseph Margevidius, Jr. (WPE8KVO), Cleveland Ohio
 Jeffery Hollis (WPE8KVT), Martinsburg, W. Va.
 Gerry Dexter (WPE8HDB), Lake Geneva, Wis.
 Richard Pi-stek (WPE9HOA), Chicago, Ill.
 Kris Lemna (WPE9JKN), Muncie, Ind.
 Bruce McCoy (WPE9JMY), La Porte, Ind.
 John Patterson (WPE9JOL), Oswego, Ill.
 Roger Gerardi (WPE9JUG), Benton, Ill.
 Robert Pelz (WPE9JVP), Elkhorn, Wis.
 Dave Way (WPE9JWO), Des Plaines, Ill.
 Bob Mackey (WPE9JXS), Rockford, Ill.
 Arthur Nelson (WPE9JYG), Rockford, Ill.
 A. R. Niblack (WPE9JYM), Vincennes, Ind.
 John Beaver (WPE9JAE), Pueblo, Colo.
 Lowell Samples (WPE9JRT), Quincy, Mo.
 Keith Brandt (CA8PE1B), FPO (Kenrita, Morocco)
 Jack Perolo (PE2PE1C), Sao Paulo, Brazil
 Erwin Feuchter (VE2PE1A), Kitchener, Ont.
 Paul Moeller (VE3PE2NQ), Harrow, Ont.
 Paul Cau (VE3PE2OZ), St. Catharines, Ont.
 Leo Cellini (VE3PE2SK), Hamilton, Ont.
 Kenneth MacLennan (VE3PE2SS), Dundas, Ont.
 Charles Anzman, Merrick, N. Y.
 Lloyd Berman, Van Nuys, Cal.
 Kim Bodker, Detroit, Mich.
 John Boegehold, Orchard Lake, Mich.
 William Crews, Rochester, N.Y.
 Sam Dolan, Indianapolis, Ind.
 Kalyan Dutta, Stanford, Cal.
 Robert Gearing, Maplewood, N. J.
 Eric Johnson, East Paterson, N. J.
 Dave Kaiser, Fort Lauderdale, Fla.
 Ed King, Columbia, Mo.
 Julian Kratter, New York, N. Y.
 Edmund Lai, Boulder, Colo.
 Bill Lauterbach, Albion, Mich.
 William Likens, Columbus, Ohio
 Joel Minamide, Encinitas, Cal.
 James Poterba, Plainview, N. Y.
 Rudy Precourt, Ottawa, Ont.
 Alan Simpson, Salem, Ind.
 Thaug Win, Santa Monica, Cal.
 Sweden Calling DX'ers Bulletin, Stockholm, Sweden

NEW/CB TRANSCEIVER SOLID STATE PRE-AMP



Write for free literature



AMECO / DIVISION OF AEROTRON, INCORPORATED
 P. O. BOX 6527 • RALEIGH, NORTH CAROLINA 27608

- Improves CB Base Station Performance
- Works on tube or transistor equipment
- No Modification to CB unit
- On-the-air sign automatically lights when transmitting

Model PCB with built-in power supply, transfer relay, connecting cables, wired and tested.....\$59.95

CIRCLE NO. 1 ON READER SERVICE PAGE

POPULAR ELECTRONICS

kHz); the 9020-kHz channel now has Farsi xmsn's. Reports are wanted.

Japan—Tokyo is now verifying with a special full color QSL showing the Tower of the Sun at the 1970 ExPO. Also included were five mint commemorative Japanese stamps, a map of ExPO and a calendar.

Luxembourg—R. Luxembourg, Villa Louvigny, 6090 kHz, noted at 0645-0717 in French and English and with rock music; also at 2230 in English with pop music.

Malta—Deutsche Welle (Germany) is to set up a relay base here for services directed to Africa; xmsn's will be mainly in Arabic.

Nigeria—An English program called "Morning Melodies" is aired by Voice of Nigeria at 0600-0730 on 7275 kHz. The 15,370 kHz outlet is good to the United Kingdom at 1900 with news and to 1928 s/off with concert music.

Pakistan—R. Pakistan has English on 17,945 kHz at 1345-1400 and 1415-1420; native language at 1400-1415. Dacca on 15,520 kHz was noted s/on under Peking at 0058 with news in Pushto at 0100.

Peru—OAX7Z, R. Juliaca, 5082 kHz, is announcing as being on 5015 kHz; in Spanish, it closes at 0400. R. El Sol, Lima, is good on 5970 kHz in all Spanish with L.A. music, many ads and clear ID's, time pips (at 0158) and news.

Portugal—Lisbon, 11,935 kHz, is in Portuguese to East Coast N.A. at 0000-0100 with news and Portuguese music; English is also noted at 0200-0245. On medium-wave, both 755 and 1061 kHz are fair to good at 2245-2330 with "Voice of the West" and at 0715-0730 with "Holiday in Portugal".

Reunion—"Ici Reunion, Office de Radiotelevision Francaise" was the ID given at 0231 s/on after a beautiful solo guitar IS and "La Marseillaise"; a like signal but a rapid fade-out by 0244. This was on 2446 kHz.

Saudi Arabia—Djeddah was noted on 11,745 kHz in Arabic at 0130.

Seychelles—Radio FEBA, 15,185 kHz, was logged at 0340 with light pop music and request for reports, and from 0415 with music, ID's, and all English. Some sources claim this station is operating on 15,440 kHz; this is incorrect; Manila is on 15,440 kHz.

South Africa—Commercial Service of R. South Africa was heard well at 2230-2300 with rousing commercials and lively music in both English and Afrikaans, on 6195 kHz.

Tanzania—Dar-es-Salaam, 5050 kHz, was found at 0304-0321 with chanting and choral music in a Swahili xmsn.

Togo—Lome on 5047 kHz was noted from 2235 with soft instrumentals non-stop to 2257; then an ID in French and a time check for 2257; then four descending notes on an unknown instrument and into a news summary. Closing anmt's said the station would reopen at 0530 on 5047 and 1394 kHz.

Tunisia—Tunis is now on 9595 kHz in Arabic from 0630 at strong level but under Radio Free Europe on the same frequency.

USSR—R. Moscow is operating in the 60 meter band for broadcasts abroad. The frequency used is 4825 kHz and programs in various European languages are given at 1600-2200. Both 60 and 90 meter bands are intended for local and regional broadcasting in the equatorial countries and are therefore referred to as the tropical bands. R. Moscow is the first station to use one of these bands for international broadcasting.

Vatican City—Vatican Radio has Spanish to L.A. and southern N.A. on 11,850 kHz at 2328-2345. Another new frequency is 11,725 kHz, noted at 0028-0104 to N.A. with Spanish to 0045, then English. This is dual with 9615 and 15,285 kHz. The station has also been heard on 9720 kHz in Spanish at 0050.

Venezuela—Station announcing for Radio Rumbos at 2230-2330 with ads, boleros and native music was found on 9660 kHz. They also had ID for R. Cadena Nacional. Possibly this is a relay or a net. R. Rumbos has been on 4970 kHz for years.

WHOLESALE TO ALL

Breadboard Kits—"RF" Kits—"PC" Kits—Perf. Phenolic Board Copper Clad Board—Cowl Type Electronic Cabinets—Heat Sinks Solid State Hobby Kits—Solderless Connectors—Hardware Kits Transistor Sockets and many more items. Send for free catalog from: H. M. C. Sales, P. O. Box 276—Santa Susana, California 93063.

HAVE YOUR OWN RADIO STATION

Learn AMATEUR RADIO

A fascinating hobby. Join the international network of "ham" operators. NRI trains you quickly at home. You get equipment to build your own shortwave station, Morse Code long-playing records, preparation for FCC license. Write National Radio Institute, Dept. 58-070, Washington, D.C. 20016 and say, "Send me your Amateur Radio catalog." No salesman will call. An accredited NHSC school,



DISCOVER HIDDEN TREASURE
WITH A JETCO ELECTRONIC METAL DETECTOR

A powerfully sensitive instrument — detects gold, silver, coins, relics, etc. Fully tested — transistorized — guaranteed.

Send for Free Catalog
JETCO, P.O. Box 132 PEM, Huntsville, Texas 77340

\$29.95 up

GET INTO ELECTRONICS

V.E.T. training leads to success as technicians, field engineers, specialists in communications, guided missiles, computers, radar, automation. Basic & advanced courses. Electronic Engineering Technology and Electronic Technology curricula both available. Associate degree in 20 months, B.S. obtainable. G.I. approved. Start September, February, Dornis, campus. High school graduate or equivalent. Catalog

VALPARAISO TECHNICAL INSTITUTE
DEPARTMENT PE, VALPARAISO, INDIANA 46383



TUBES! CORNELL TUBES!

FREE Send For FREE
CORNELL'S
New 1970
CATALOG
Many New Items

30¢ per tube

33¢ per tube

WE SELL PICTURE TUBES

4221 UNIVERSITY AVE., SAN DIEGO, CALIF. 92105

**COOPERATE WITH
THE ZIP CODE
PROGRAM
OF THE POST OFFICE
DEPARTMENT.
USE ZIP CODE
IN ALL ADDRESSES**

ELECTRONICS MARKET PLACE

COMMERCIAL RATE: For firms or individuals offering commercial products or services. \$1.15 per word (including name and address). Minimum order \$11.50. Payment must accompany copy except when ads are placed by accredited advertising agencies. Frequency discount: 5% for 6 months; 10% for 12 months paid in advance. **READER RATE:** For individuals with a personal item to buy or sell. 70c per word (including name and address). No Minimum! Payment must accompany copy.

FOR SALE

FREE! Giant bargain catalog on transistors, diodes, rectifiers, SCR's, zeners, parts. Poly Paks, P.O. Box 942, Lynnfield, Mass. 09140.

GOVERNMENT Surplus Receivers, Transmitters, Sniperscopes, Radios, Parts, Picture Catalog 25¢. Meshna, Nahant, Mass. 01908.

ROCKETS: Ideal for miniature transmitter tests. New illustrated catalog. 25¢. Single and multistage kits, cones, engines, launchers, trackers, rocket aerial cameras, technical information. Fast service. Estes Industries, Dept. 18, Penrose, Colorado 81240.

LOWEST Prices Electronic Parts. Confidential Catalog Free. **KNAPP**, 3174 8th Ave. S.W., Largo, Fla. 33540.

EUROPEAN and Japanese bargains catalogs. \$1 each. Dee, 10639E Riverside, North Hollywood, Calif. 91602.

WE SELL CONSTRUCTION PLANS. TELEPHONE: Answering Machine, Speakerphone, Carphone, Phonevision, Legal Connector, Auto Dialer, Central Dial System. **TELEVISION:** \$35.00 Color Converter, Tape Recorder, 3DTV. \$25.00 Camera. **DETECTIVE:** Infinity Transmitter, Tail Transmitter, Police Radar Detector. **HOBBYIST:** Electron Microscope, 96 Hour Tape Music System, Ultrasonic Dishwasher, Radar-Oven, Electronic Tranquilizer. Plans \$4.95 each. **COURSES:** Telephone Engineering \$39.50, Detective Electronics \$22.50, Anti-Detective Electronics \$27.50. **NEW SUPER HOBBY CATALOG AIRMAILED \$1.00.** Don Britton Enterprises, 7906 Santa Monica Blvd., Hollywood, Calif. 90046.

WEBBER LAB's. Police & Fire Converters. Catalog 25¢. 72 Cottage Street, Lynn, Mass. 01905.

INVESTIGATORS, LATEST ELECTRONICS AIDS. FREE LITERATURE. CLIFTON, 11500-L NW 7th AVE., MIAMI, FLORIDA 33168.

LINEAR AMPLIFIERS: "Hawk"—25 watts output—\$59.95; "Hornet"—50 watts—\$98.50; "Raider"—100 watts—\$139.95; "Maverick-250"—250 watts—\$244.95; AM/SSB. "Scorpion" 50 watt 12 volt mobile—\$99.95; "Bandit II" 100 watt mobile—\$169.95. 20-35 megacycles. (Illegal Class D 11 Meters.) Dealer inquiries invited. D & A Manufacturing Co., 1217 Avenue C, Scottsbluff, Nebraska 69361.

ELECTRONIC PARTS, semiconductors, kits. **FREE FLYER.** Large catalog \$1.00 deposit. **BIGELOW ELECTRONICS,** Bluffton, Ohio 45817.

RADIO—T.V. Tubes—33¢ each. Send for free catalog. Cornell, 4213 University, San Diego, Calif. 92105.

ULTRA-SENSITIVE AND POWERFUL METAL DETECTORS—join the many who are finding buried coins, minerals, relics and artifacts. Don't buy till you see our **FREE** catalog of new models. Write Jetco, Box 132-PE, Huntsville, Texas 77340.

LASER parts catalog 60¢. Moynihan, 107 North Brighton, Atlantic City, New Jersey 08401.

PSYCHEDELIC catalog. Posters, lighting, etc. Send 25¢ for handling to Hole In The Wall, 6055PE Lankershim, North Hollywood, Calif. 91606.

THE ART OF DE-BUGGING—\$5.95. TRON-X PUBLICATIONS, P.O. BOX 38155, HOLLYWOOD, CALIFORNIA 90038.

CONSTRUCTION PLANS: **LASER** . . . \$2.00. Listening Devices—two F.M. Mike Transmitters . . . \$1.00. Tail Transmitter . . . \$1.00. Sound Telescope . . . \$2.00. Infinity Transmitter . . . \$2.00. Equipment and kits available. Howard, 20174 Ward, Detroit, Michigan 48235.

COMPONENTS? Kits? Hardware? Free catalog! Truvue Paks, Box 275, Chelsea, Mass. 02150.

GENERAL INFORMATION: First word in all ads set in bold caps at no extra charge. All copy subject to publisher's approval. Closing Date: 1st of the 2nd month preceding cover date (for example, March issue closes January 1st). Send order and remittance to: Hal Cymes, **POPULAR ELECTRONICS**, One Park Avenue, New York, New York 10016.

SENCORE, B&K TEST EQUIPMENT UNBELIEVABLE PRICES. FREE CATALOG AND PRICE SHEET. FORDHAM RADIO, 265 EAST 149TH STREET, BRONX, N.Y. 10451.

ELECTRONIC ignition, various types. Free literature. Anderson Engineering, Epsom, N.H. 03239.

AMATEUR SCIENTISTS, Electronics Hobbyists, Experimenters, Students . . . Construction Plans—all complete, including drawings, schematics, parts lists with prices and sources . . . Laser—Build your own coherent-light optical laser. Operates in pulsed mode, visible light range—\$6.00 . . . Radar—Build your own ultrasonic doppler radar. Detect motion of people, automobiles, even falling rain drops. Transistorized, uses standard small 9-volt battery—\$4.00 . . . Long-Range "Sound Telescope"—This amazing device can enable you to hear conversations, birds and animals, other sounds hundreds of feet away. Very directional. Transistorized. Uses 9V battery—\$3.00 . . . Or send 25¢ coin (no stamps) for complete catalog. Other items include Psychedelic strobes, light shows, robots . . . 38 different projects. Technical Writers Group, Box 5994, State College Station, Raleigh, N.C. 27607.

MECHANICAL, ELECTRONIC devices catalog 10¢. Greatest Values—Lowest Prices. Fertik's, 5249 "D", Philadelphia, Pa. 19120.

CLEARANCE SALE rectifiers, transistors, 1000's other items. Catalog 15¢. General Sales Company, 254 Main, Clute, Texas 77531.

DIAGRAMS—Radios \$1.50, Television \$3.00. Give make and model. Diagram Service, Box 1151PE, Manchester, Conn. 06042.

SEMICONDUCTORS and parts catalogue free over 100 pages. J. & J. Electronics, Box 1437, Winnipeg, Manitoba, Canada. U.S. Trade directed.

SPACE-AGE TV CAMERA KIT! Terrific for Experimenters, Industry, Education. Solid-state. Only \$116.95! Starter kits: \$18.95 up. Plans 25¢ up. Catalog **FREE.** Phone: 402-987-3771. Write: **ATV RESEARCH**, 1301 Broadway, Dakota City, Nebr. 68731.

CONVERT any television to sensitive, big-screen oscilloscope. Only minor changes required. No electronic experience necessary. Illustrated plans, \$2.00. Relco-A33, Box 10563, Houston, Texas 77018.

BURGLAR ALARM SYSTEMS and accessories. Controls, bells, sirens, hardware, etc. **OMNI-GUARD** radar intruder detection system, kit form or assembled. Write for free catalog. Microtech Associates, Inc., Box 10147, St. Petersburg, Florida 33733.

PRINTED CIRCUITS. Magazine projects and experimental. Free listing. Vico, Box 1590, Los Angeles, Calif. 90053.

ELENCO LR-6 Bi-Lateral linear amplifier 150 watts output, variable receive boost, \$149.95. (Illegal for Class D CB use.) Elenco, Dept. A, Wabash, Ind. 46992.

MC790P \$2.00. MC724P, MC789P \$1.05. Write for catalog. Hal Devices, Box 365Z, Urbana, Illinois 61801.

ELECTRONIC COMPONENTS—Distributor prices, Free catalog. Box 2581, El Cajon, California 92021.

C.B. SALE CATALOG. Send today. Hirsch's, 219 California Drive, Williamsville, New York 14221.

AM TRANSISTOR RADIO CHASSIS 6 transistors—1 diode **CHECKED-OUT GOOD.** \$1.75 each 2/\$3.00 postpaid. **FREE CATALOG.** R.W. Electronics, 4005 West Belmont, Chicago, Illinois 60641.

DIGITAL linear IC's. Largest selection, lowest prices in U.S. Counters and readout kits. Free application notes. Send 24¢ stamps for giant catalog. Environmental, 220 South, West Lafayette, Ind. 47906.

STROBES, color organs, the incredible Strobot. New! Heavy-Duty CD Ignition. Electric candles for flameless candle-light. Remote (wireless) switch for anti-prowl system. Touch switch for space-age lamps, lights. Assembled and Kits. Send 25¢, specify interest. Teletronics. Box 1266 A, South Lake Tahoe, California 95705.

"EASY Ways to Improve TV Reception" \$1.00 (no stamps), GJM Electronics, Dept. P, Box 218, Goleta, California 93017.

PRINTED Circuits, make your own, fast cheap. Complete instructions \$1.00. Logue, Box 82, Bayville, New York 11709.

MUSIC LOVERS, CONTINUOUS, UNINTERRUPTED BACKGROUND MUSIC FROM YOUR FM RADIO, USING NEW INEXPENSIVE ADAPTOR. FREE LITERATURE. ELECTRONICS, 11500-Z NW 7th AVE., MIAMI, FLORIDA 33168.

THE SOLID STATE SWITCH FROM MONSANTO. Single pole-single throw dry circuit switching of low level voltages. Up to 10 volts at 10 milliamps with 900 volts isolation between emitter and detector. The H-6 is ideal for your design project. Order one now for \$5.00. Data sheet and instructions included. Monsanto Company, Hobby Section, 10131 Bubb Road, Cupertino, California 95014.

IMPROVE your speaking voice. Increase your popularity. 124 page book reveals how. Only \$1.00. Suburban Variety, 440 Mountain View Road, Englewood, New Jersey 07631.

UNIQUE COLOR ORGANS. 200 WATTS, \$14.95. Kits. \$19.95 Assembled, postpaid. **MONEY-BACK GUARANTEE.** CYBULSKI, Box 31174, Washington, D.C. 20031.

CCTV equipment. Will sell demonstration models at factory cost. Complete Panasonic line. Also background music systems, Melody Masters, 235 N. Main, Danielson, Conn. 06239.

SOUND EFFECTS. Every sound conceivable stereo or mono. Really. Reichert, 125 East 23, New York City 10010. 212 533-0180.

COLOR ORGANS. Light Displays, Posters. Dealers welcome. KAS, Box 384Z, Beltsville, MD. 30705.

67KC SCA ADAPTER, manufacturer's closeout on this model. The missing link between FM tuner and audio amplifier if you want commercial free music. Solid state demodular board wired and tested. Operates on 9 to 30 volts. Variable gain input and adjustable mute. Easily switched in and out. Packed with instructions and station lists. All orders shipped postpaid same date as received, anywhere USA \$17.50 each. Marvin Industries, Box 551, Hudson, Ohio 44236.

SINGERS—Sing like the professionals do in a matter of minutes. New scientific device changes tonality, volume, articulation. Device also used as a great aid to stop stuttering, stammering, lisping. Send \$10.00. Money back guarantee. Micro Wave Corp., 433 Durnan St., Rochester, N.Y. 14621.

COMPUTER LOGIC LAB of your own for only \$39 postpaid. **COMP-U-KIT** has clock, display lamps, microcircuits, patchcords, and our outstanding Logic Handbook. Free literature. Scientific Measurements, C112, 9701 Kenton, Skokie, Ill. 60076.

LEARN TO REPAIR T.V. TUNERS—How I Earn \$10 per hour. Introduction, Contents, Details of Complete Course, Twelve **REPAIR TRICKS, PLANS** for Special Probes and Power Supplies. Two complete Sample Lessons. All for \$1. Refundable. Frank Bocek, Box 833, Redding, California 96001.

FREE—Digital IC, op-amp, transistor, diode, decade counter, read-out tube, MSI-giant 40 page catalog and application notes. DVM, digital counters, digital clock kits. EPD, Box 326, Lafayette, Ind. 47906.

BARGAIN Sheets listing relays, steppers, & other electronics parts for experimenters. Send name, address, and stamp to: Gust & Company, Box 42081, Edina, Minnesota 55424.

YOU CAN GET MORE OUT OF ELECTRONICS! You can do the everyday math that gives you the edge! Multiply, divide, do percentages, proportions, conversions, calculate angles, powers, etc., in seconds, the easy way. Order amazing **MATHQUICK** circular slide rule today! Simple to use. Only \$6.95 postpaid, with instructions. Send name and address and check or money order to: Technical Equipment, P.O. Box 391, Upland, California 91786.

STROBELIGHT KITS, highest intensity helical flashtube. Complete \$29.50. J&J Enterprises, Box 8102E, Bainbridge, Wash. 98110.

LOCKSMITHS: New!!! Integrated Circuit electronic aid for safe lock manipulation. Free brochure, SLF Enterprises, Box 36, Demarest, New Jersey 07627.

COMP-U-KIT ELECTRONIC MODULES. Signal Generators, Square Wave oscillators, Photocell Amplifiers, Logic units, Many others. Outstanding values. Write for **FREE** illustrated literature. Scientific Measurements, C114, 9701 Kenton, Skokie, Ill. 60076.

PROTECT your hearing! Soundoscope will indicate normal, loud and dangerous sound level of your Hi-Fi, flashing decibel calibrated color lights. Solid state battery operated portable precision instrument—\$34.95. Omicron Instruments, Dept. PE, 1710 Nineteenth St., Santa Monica, California 90404.

CUSTOM LIGHTING EQUIPMENT! 1.8KW Color Organ \$150! Plexiglas Dancefloors! Spirit Electronics, Rt. 6, Fayetteville, Arkansas 72701.

BURGLAR and Fire Alarm Systems and supplies. Installation Manual and catalog \$1.00. Refunded first order. Electronic Sentry Systems, P.O. Box 8023A, Sacramento, California 95818.

PLANS AND KITS

SURVEILLANCE DEVICES IN KIT FORM: Telephone Transmitter, FM Spy Transmitter, Telephone-Recorder Actuator, Tail Transmitter, Bug Detector. Complete Kits Send \$15.00 each. **ELECTRONIC SECURITY SYSTEMS**, 1101 West Rosecrans Avenue, Gardena, California 90247.

OSCILLOSCOPE IMPROVEMENT KITS. High speed Triggersweep eliminates sync problems. Dual-trace FET switch displays two waveforms together. **SOLID-STATE SERVICES**, P.O. Box 901, Cupertino, California 95014.

CIRCUITS for 32 electronic projects, R.F., audio and gadgetry complete plans \$1.00. P.M. Electronics, Inc., Box 46204, Seattle, Wash. 98146. Dealer inquiries invited.

ALLWAVE Radio Kit, Tube, Transistor included \$5.00. Headset \$2.50. Ekeradio, Box 131, Temple City, California 91780.

TRANSISTOR Projects: Simple, high-performance circuits for all applications. Free catalog: EDI 1918B 49 Street East, Palmetto, Florida 33561.

BUILD Psychedelic Xenon Strobe under \$10.00! Plans \$1.00. Box 233P, Mablevale, Arkansas 72103.

"DISTANCE CRYSTAL SET CONSTRUCTION" Handbook—50¢. "Coil Winding"—50¢. Catalog. Laboratories, 2612-L Butano, Sacramento, California 95821.

BURGLAR-FIRE alarms and kits. Build for profit. Brochure, 25¢. The Securtronics Co., Box 371, Frankfort, Indiana 46041.

POWER your bicycle electrically using storage battery. Complete illustrated plans \$3.00. A.E.E., P.O. Box 292, Minneapolis, Minnesota 55440.

MYSTERY BOX 12 random flashing neon lamps operates six months to a year on one battery. Complete plans and parts list \$2.00. Pre-wired neon lamps \$1.25 ea. Complete Mystery Box Kit. \$19.95. SWOP, P.O. Box 26545, New Orleans, La. 70126.

INTEGRATED CIRCUIT KITS: COMPUTER, OPTOELECTRONICS, AUDIO. Catalog free. **KAYE ENGINEERING**, Box 3932-A, Long Beach, California 90803.

PARTS ASSORTMENT \$1.00 and \$5.00 New. No Junk. Guaranteed 5 times cost. Resistor and condenser kits, Jacks, boxes, many other parts below cost. Send 50¢ for complete list refundable to SWOP, Box 26545, New Orleans, La. 70126.

BUILD: "Circuitester"—audible, transistorized, safe for components continuity tester. Plans \$2.50. "Output Power Meter"—measures maximum 100W RMS or Peak output of Hi-Fi amplifier. Plans \$3.50. Omicron Instruments, Dept. PE, 1710 Nineteenth St., Santa Monica, California 90404.

COLOR ORGAN KITS \$3.25 to \$7.50, Power Supplies \$2.75. Catalog. Murphy, 204 Roslyn Ave., Carle Place, N.Y. 11514.

B&W TELEVISION CONVERTED TO COLOR. Patented System. Do it yourself kit. Free brochure. Bele Electronics Corp. 111 N.E. Second Avenue, Miami, Florida 33132.

ROCKET Plans Proven. Catalog 10¢. Rockets, P.O. Box 7274, Long Beach, California 90807.

TELSA COIL—40" SPARKS! Plans \$5.00 Information 50¢. Huntington Electronics, Box 9-P, Huntington, Conn. 06484.

HIGH FIDELITY

FREE! Send for money saving stereo catalog # P7E, lowest quotations on your individual component, tape recorder, or system requirements. Electronic Values, Inc., 200 W. 20th St., New York, N.Y. 10011.

LOW, Low quotes: all components and recorders, HiFi, Roslyn, Penna. 19001.

HI-FI components. Tape Recorders, at guaranteed "We Will Not Be Undersold" prices. 15-day money-back guarantee. Two-year warranty. No Catalog. Quotations Free. Hi-Fidelity Center, 239 (P) East 149th Street, New York 10451.

TAPE RECORDERS. Hi-Fi, components, Sleep Learning Equipment, tapes. Unusual Values. Free Catalog. Dressner, 1523R, Jericho Turnpike, New Hyde Park, N.Y. 11040.

STEREO COMPONENTS at low discount prices. Send for our low quotes today and our cartridge trade-in specials (Shure, ADC, Pickering, Empire, etc.). Send \$1.00 for our discount catalog. **DEFA ELECTRONICS**, 2207 Broadway, New York, N.Y. 10024.

DIAMOND NEEDLES AND STEREO CARTRIDGES at low, low prices for Shure, Pickering, Stanton, Empire, Grado and ADC. Send for free catalog and price sheet. We will be happy to quote on any cartridge—Magnetic, Ceramic or Crystal. All merchandise brand new and shipped **PREPAID**. **LYLE CARTRIDGES**, Dept. P, 265 East 149 Street, Bronx, New York 10451.

WANTED

CASH PAID! Unused tubes, electronic equipment. Barry, 512 Broadway, NYC 10012.

QUICKSILVER, Platinum, Silver, Gold, Ores Analyzed. Free Circular. Mercury Terminal, Norwood, Mass. 02062.

TUBES

TUBES "Oldies", latest. Lists free. Steinmetz, 7519 Maplewood, Hammond, Indiana 46324.

RECEIVING & INDUSTRIAL TUBES, TRANSISTORS. All Brands—Biggest Discounts. Technicians, Hobbyists, Experimenters—Request **FREE** Giant Catalog and **SAVE!** **ZALYTRON**, 469 Jericho Turnpike, Mineola, N.Y. 11501.

TUBE Headquarters of World! Send 10c for Catalog (tubes, electronic equipment) Barry, 512 Broadway, N.Y.C. 10012.

THOUSANDS and thousands of types of electronic parts, tubes, transistors, instruments, etc. Send for Free Catalog. **Arcturus Electronics Corp.**, MPE, 502-22nd St., Union City, N.J. 07087.

RADIO & T.V. Tubes—33¢ each. Send for free list. Cornell, 4213 University, San Diego, Calif. 92105.

TUBES—Lowest prices. Foreign-American. Obsolete, receiving, special purpose, transmitting tubes. Send for tube, parts catalog. **United Radio Company**, 56-P Ferry St., Newark, N.J. 07105.

TAPE AND RECORDERS

BEFORE Renting Stereo Tapes try us. Postpaid both ways—no deposit—immediate delivery. Quality—Dependability—Service—Satisfaction—prevail here. If you've been dissatisfied in the past, your initial order will prove this is no idle boast. Free Catalog. **Gold Coast Tape Library**, Box 2262, Palm Village Station, Hialeah, Fla. 33012.

RENT 4-Track open reel tapes—all major labels—3,000 different—free brochure. **Stereo-Parti**, 55 St. James Drive, Santa Rosa, Ca. 95401.

AMAZING DISCOUNTS on famous brand high fidelity stereo components. No small wonder that we have set new sales records each year since 1959. Write. **Arkay Electronics**, 1028-03 Commonwealth, Boston, Mass. 02215.

STEREO TAPES, save 20,30% and more, postpaid anywhere U.S.A. We discount batteries, recorders, tape/cassettes, 80-page catalog 25¢. **SAXITONE TAPES**, 1776 Columbia Road, N.W., Washington, D.C. 20009.

OLD radio programs on tape. 6 hours for \$8.00. Catalog 50¢. **Don Maris**, 1926 Cherokee, Norman, Okla. 73069.

CASSETTES, Pre-recorded Spoken word—over 100 titles—educational, including language. Cassette and 8-track Blanks plus many accessories. Send 10¢ in stamps or coin for latest literature. **Cassettes Unlimited**, P.O. Box 13119P, Pittsburgh, Pennsylvania 15243.

PERSONALS

MAKE FRIENDS WORLDWIDE through international correspondence. Illustrated brochure free. **Hermes**, Berlin 11, Germany.

INVESTIGATORS, LATEST ELECTRONIC AIDS. FREE LITERATURE. CLIFTON, 11500-K NW 7th Ave., MIAMI, FLORIDA 33168.

ASTROLOGY birthcharts, horoscopes, future profiles, U.S. Inquiries. **Matrix Services**, Box 113, station Q, Toronto, 7, Canada.

SPORTS ACTION FILMS

SUMMER SPECIAL—Send 50¢ . . . Catalog Super 8/8mm, Color/ B&W. Receive \$1.00 credit on purchase. **SPORTLITE FILMS**, Dept. PE, 20 North Wacker Drive, Chicago, Illinois 60606.

REPAIRS AND SERVICES

TV Tuners rebuilt and aligned per manufacturers specification. Only \$9.50. Any make UHF or VHF Ninety day written guarantee. Ship complete with tubes or write for free mailing kit and dealer brochure. **JW Electronics**, Box 51C, Bloomington, Indiana 47401.

KITS assembled 5% original cost. Work guaranteed and accomplished by qualified electrical engineer. For more information write **Karwatzki & Co.**, 3333 Wilton, Long Beach, California 90804.

INSTRUCTION

LEARN ELECTRONIC ORGAN SERVICING at home all makes including transistor. Experimental kit—trouble-shooting. Accredited **NHSC**, Free Booklet. **NILES BRYANT SCHOOL**, 3631 Stockton, Dept. A, Sacramento, Calif. 95820.

FCC First Class License in six weeks—approved for Veterans Training. Write **Elkins Institute**, 2603B Inwood Road, Dallas, Texas 75235.

R.E.I.'s famous (5) week course for the **First Class Radio Telephone License** is the shortest, most effective course in the nation. Over 98% of R.E.I. graduates pass F.C.C. exams for 1st class license. Total tuition \$395.00. Job placement free. Write for brochure. **Radio Engineering Incorporated Schools**, 1336 Main Street, Sarasota, Florida 33577—or 3123 Gillham Road, Kansas City, Missouri 64109 —or 809 Caroline Street, Fredericksburg, Virginia 22401—or 625 E. Colorado Street, Glendale, California 91205.

DEGREE in Electronics Engineering earned mostly by correspondence. Free brochure. Dept. G-9, **Graham School of Engineering**, 1505 N. Western Ave., Hollywood, California 90027.

LEARN WHILE ASLEEP, Hypnotize! Strange catalog free. Auto-suggestion, Box 24-ZD, Olympia, Washington 98501.

PLAY ORGAN OR GUITAR EASILY! AMAZING METHOD! FREE INFORMATION. **KEGLEY**, 1016-PE KELLY, JOLIET, ILLINOIS 60435.

HIGHLY effective home study courses in Electronics Engineering Technology and Electronics Engineering Mathematics. Earn your Degree. Write for Free Descriptive Literature. **Cook's Institute of Electronics Engineering**, (Dept. 15), P.O. Box 10634, Jackson, Miss. 39209. (Established 1945).

EARN College degree at home. Many subjects. **Florida State Christian College**, Post Office Box 1674, Fort Lauderdale, Florida 33309.

TAPE recorded lessons for **FCC RADIOTELEGRAPH LICENSE** requirement for **SHIP RADIO OFFICER** positions or **FIRST CLASS RADIO-TELEPHONE LICENSE**. Our nineteenth year teaching **FCC license** courses. **Radio License Training**, 1060D Duncan, Manhattan Beach, Calif. 90266.

OWN your own business! New course teaches proven methods to start, operate your own manufacturing company—no previous experience needed. Highest income and security. No obligation; send today for free course outline to **NIMS**, Dept. PEG, Box 1273, Alameda, CA 94501.

AMATEUR RADIO. Correspondence Sight-and-Sound no-textbook courses for **GENERAL, ADVANCED** and **EXTRA CLASS** licenses—complete code and theory. These are **NOT** memory courses. **AMATEUR RADIO LICENSE SCHOOL**, 12217 Santa Monica Blvd., Los Angeles, Calif. 90025.

F.C.C. FIRST CLASS LICENSE in three to four weeks. Write **American Institute of Radio**, 2622 Old Lebanon Road, Nashville, Tennessee 37214 or 3986 Beach Boulevard, Box 16652, Jacksonville, Florida.

MEMORIZE: "1970 TESTS—ANSWERS" for FCC FIRST AND SECOND CLASS LICENSE. Plus "Self-Study Ability Test." **PROVEN.** \$5.00. Command, Box 26348-P, San Francisco 94126.

INVENTIONS WANTED

INVENTIONS wanted. Patented; unpatented. Global Marketing Service, 2420-P 77th, Oakland, Calif. 94605.

FREE "Directory of 500 Corporations Seeking New Products." For information regarding development, sale, licensing of your patented/unpatented invention. Write: Raymond Lee Organization, 230-GR Park Avenue, New York City 10017.

INVENTORS: Protect your ideas! Free "Recommended Procedure". Washington Inventors Service, 422T Washington Building, Washington, D.C. 20005.

PATENT SEARCHES, including copies of related United States Patents. Inventors, attorneys, manufacturers use our "World-Wide" Airmail Service Free: "Invention Record" form and "Information Every Inventor Needs", Hayward Company, 1029HR Vermont, Washington, D.C. 20005.

PATENT Searches including Maximum speed, full airmail report and closest patent copies, \$6.00. Quality searches expertly administered. Complete secrecy guaranteed. Free Invention Protection forms and "Patent Information." Write Dept. 9, Washington Patent Office Search Bureau, 711 14th Street, N.W., Washington, D.C. 20005.

FREE PAMPHLET: "Tips on Safeguarding Your Invention." Write: United States Inventors Service Company, 501-H Thirteenth Street N.W., Washington, D.C. 20004.

INVENTORS! Don't sell your invention, patented or unpatented, until you receive our offer. Eagle Development Company, Dept. P, 79, Wall Street, N.Y., N.Y. 10005.

GOVERNMENT SURPLUS

JEEPS Typically From \$53.90 . . . Trucks From \$78.40 . . . Boats, Typewriters, Airplanes, Multimeters, Oscilloscopes, Transceivers, Electronics Equipment. Wide Variety, Condition. 100,000 Bid Bargains Direct From Government Nationwide Complete Sales Directory and Surplus Catalog \$1.00. (Deductible First \$10.00 Order). Surplus Service, Box 820-J, Holland, Michigan 49423.

GOVERNMENT Surplus How and Where to Buy in Your Area. Send \$1.00 to: Surplus Information PE, Headquarters Building, Washington, D.C. 20036.

BOOKS

FREE catalog aviation/electronic/space books. Aero Publishers, 329PE Aviation Road, Fallbrook, California 92028.

"UNUSUAL" Books! Catalog Free! International, Box 7798 (PE), Atlanta, Georgia 30309.

FREE book prophet Elijah coming before Christ. Wonderful bible evidence. Megiddo Mission, Dept. 64, 481 Thurston Rd., Rochester, N.Y. 14619.

BOOKS for every interest! Free details. Reed Company, West Kingston, Rhode Island 02892.

PSYCHEDELIC LIGHTING MANUAL! Make light-machines, strobes, organs, Kaleidoscopes, etc. Send \$2.00, Lightrays, 713D Pine, Philadelphia, Pa. 19106.

MAGAZINES

BACK DATE MAGAZINES! Send needs. Midtown, Box 917-PE, Maywood, N.J. 07607.

POPULAR ELECTRONICS Volume 1, #1 to Volume XX :: 6, complete set from October '54 to June '64. Best Offer. C. Bradley, 1430 Orangethorpe, Fullerton, California 92631.

EMPLOYMENT INFORMATION

FOREIGN and **USA** job opportunities available now. Construction, all trades. Earnings to \$3,000.00 monthly. Paid overtime, travel bonuses. Write: Universal Employment, Woodbridge, Conn. 06525.

EXCITING OVERSEAS JOBS. Directory \$1.00. Research Associates, Box 942-E, Belmont, California 94002.

PRINTING

"FREE Circular!" Personalized Stationery, Labels, Envelopes. Longwood D-2870, Fort Johnson, New York 12070.

HYPNOTISM

FREE Hypnotism, Self-Hypnosis, Sleep Learning Catalog! Drawer H400, Ruidoso, New Mexico 88345.

"MALE-FEMALE HYPNOTISM" EXPOSED, EXPLAINED! "SECRET METHOD"—THEY NEVER KNOW! \$2. RUSHED. GUARANTEED! ISABELLA HALL, SILVER SPRINGS, FLORIDA 32688.

HYPNOTIZE PERFECT STRANGERS—EITHER SEX—SUCCESSFULLY! Secret Methods—they never know! Illustrated Course and 10 inch Hypnodisk \$2.00. **RESULTS ABSOLUTELY GUARANTEED!** Dr. H. Arthur Fowler, Box 4399, Woodbury, New Jersey 08096.

MAGNETS

MAGNETISM (100) page script newly discovered magnetic principles (\$3.00). Jesse Costa, Box 26, Waquoit, Mass. 02536.

MAGNETS. All types. Special—20 disc magnets, or 2 stick magnets, or 10 small bar magnets, or 8 assorted magnets, \$1.00 Maryland Magnet Company, 5412-H Gist, Baltimore, Maryland 21215.

PHOTOGRAPHY—FILM, EQUIPMENT, SERVICES

SCIENCE Bargains Request Free Giant Catalog "CJ"—148 pages—Astronomical Telescopes, Microscopes, Lenses, Binoculars, Kits, Parts. War surplus bargains. Edmund Scientific Co., 300 Edscomp Bldg., Barrington, New Jersey 08007.

SUPER-8 Titles—Deluxe Sample. \$1.00. Vega, Box 14172, Las Vegas, Nevada 89114.

RECORDS

POPULAR organ albums factory direct. Concert Recording, Lynwood, Calif. 90262.

DIDDIES—45RPM original hits. Over 4000 available. Catalog 50¢. C & S Record Sales, Box 197, Wampsville, N.Y. 13163.

SPECIAL interest records available, produced by the editors of the world's leading special interest magazines. Send for free catalog. Record Catalog-PE, Ziff-Davis Publishing Company, One Park Avenue, New York, N.Y. 10016.

RUBBER STAMPS

RUBBER ADDRESS STAMP \$2.00. SIGNATURE \$3.50. FREE CATALOG. JACKSON'S BOX 443-G, FRANKLIN PARK, ILL. 60131.

BUSINESS OPPORTUNITIES

PIANO TUNING learned quickly at home. Tremendous field! Musical knowledge unnecessary. GI Approved. Free Information. Empire School, Box 327, Miami, Florida 33145.

ELECTROPLATING Equipment and supplies. All types for home workshops and industrial. Send \$2.00 (refundable) for equipment guide formulas, operating data, catalog. HBS Equipment Division 90, 3543 East 16th, Los Angeles, California 90023.

I MADE \$40,000.00 Year by Mailorder! Helped others make money! Start with \$10.00—Free Proof. Torrey, Box 318-N, Ypsilanti, Michigan 48197.

FREE BOOK "999 Successful Little Known Businesses" Work home, Plymouth 445-G, Brooklyn, N.Y. 11216.

\$200.00 DAILY In Your Mailbox! Your opportunity to do what mail-order experts do. Free details. Associates, Box 136-J, Holland, Michigan 49423.

MAKE BIG MONEY raising chinchillas, rabbits, guinea pigs for us. Catalog—25¢. Keeney Brothers, New Freedom, Pa. 17349.

SPARE Time Cash—Sell Advertising Book Matches—every business a prospect—no investment—no experience needed to build steady repeat business. Daily Cash commission in advance. Write today. We'll send your sure-fire selling kit by return mail. Dept. T-770 Superior Match Co., 7530 S. Greenwood, Chicago, Illinois 60619.

FREE CATALOGS. Repair air conditioning, refrigeration. Tools, supplies, full instructions. Doolin, 2016 Canton, Dallas, Texas 75201.

SELL HERTEL BIBLES—Part Time. Finest reference Bible available. Demonstrator and supplies furnished. Excellent commissions. Write International Book, Dept. PE, Box 118, Wichita, Kansas 67201.

\$700-\$1000 MONTHLY to men with electronics knowledge. Quality Control needs you. Information \$1. Quality Services, P.O. Box 162, Sycamore, Ill. 60178.

279 FAST, EASY ways to make money! Free! Rush name, address, zip. Perry, 13263P Ventura Boulevard, Studio City, Cal. 91604.

REAL ESTATE

FREE . . . 224-page **SUMMER CATALOG!** Describes and pictures hundreds of farms, ranches, town and country homes, businesses coast to coast! Specify type property and location preferred. **UNITED FARM AGENCY**, 612-EP West 47 St., Kansas City, Mo. 64112.

TREASURE FINDERS

GOLD, SILVER, RELICS! Located with powerful Detectron Metal Detectors. Free information. Terms. Detectron, Dept. PE-7, Box 243, San Gabriel, California 91778.

TREASURE FINDER locates buried gold, silver, coins, treasures. 5 powerful models. \$19.95 up. Free catalog. Relco-A33, Box 10839, Houston, Texas 77018.

TREASUREPROBES—Patented transistorized detector signals "dig" by earphone "beeping". 5" search head. PC board, two coilpit oscillators improve stability. Kit \$15.95, assembled \$18.88, with speaker \$24.88. 60 day guarantee. Send for Free Bibliography, "Treasure Maps and Books of U.S." Treasurehouse, PE-70, Tennant, N.J. 07763.

FREE TREASURE GUIDE! Fact-filled collectors edition; send 50¢ for postage. Also request free literature on ultrasensitive, professional Fisher Detectors. **FISHER RESEARCH**, Dept. PE-7, Palo Alto, California 94303.

TREASURETRON high-performance metal locators. Free catalog. EDI, 1918B 49th St. East, Palmetto, Florida 33561.

FIND BURIED TREASURE! New book shows how, maps exact locations. Details free. Kankowski, 6 Alan Okell Pl., Cranford, N.J. 07016.

MUSICAL INSTRUMENTS

30% DISCOUNT any name brand musical instrument. Free catalog. Freeport Music, 127-N Sunrise Highway, Freeport, N.Y. 11520.

USED Electronic and Pipe Organs, Consoles, Kits and Accessories. Write for Brochure; Newport Organs, 1593 Monrovia, Newport Beach, California 92660.

MUSIC

FREE Song selling information. Peerless Publications, Box 193-F, Bloomfield, Conn. 06002.

AUTHORS' SERVICES

AUTHORS! Learn how to have your book published, promoted, distributed. **FREE booklet "ZD,"** Vantage, 120 West 31 St., New York 10001.

SHORTWAVE LISTENING

TOP-SECRET! Classified frequencies: spies, NASA, military, many more—\$1.00. EDI, 1918B 49th Street E., Palmetto, Florida 33561.

SWL RECORD SHEETS. Samples sase. 50 for \$2.10. **TRAUBTRONICS**, Box 231, Farmland, Ind. 47340.

SPY, CLANDESTINE, SPACECRAFT FREQUENCIES, SCHEDULES. \$2.00. Monalert, P.O.B. 673, Warner Robins, Ga. 31093.

MISCELLANEOUS

WINEMAKERS: Free illustrated catalog of yeasts, equipment. Semplex, Box 12276, Minneapolis, Minn. 55412.

JAPAN'S PUBLICATIONS GUIDE Business, pleasure, education. \$5.00. **INTERCONTINENTAL**, CPO 1717, Tokyo 100-91.

CLASSIFIED ADVERTISING IN POPULAR ELECTRONICS

Your best bet for outstanding mail order sales. These pages are read thoroughly by electronic hobbyists seeking products and services found only in **ELECTRONICS MARKET PLACE. POPULAR ELECTRONICS** readers respond readily—they rely on the advertisers appearing in the pages of their favorite magazine. Your low cost ad will result in increased sales responses for you! Send copy and payment to:

Hal Cymes, Classified Advertising Manager

POPULAR ELECTRONICS
1 Park Avenue
New York, N.Y. 10016

CLASSIFIED ADVERTISING ORDER FORM

Please refer to heading on first page of this section for complete data concerning terms, frequency discounts, closing dates, etc.

1	2	3	4	5
6	7	8	9	10
11	12	13	14	15
16	17	18	19	20
21	22	23	24	25
26	27	28	29	30
31	32	33	34	35

_____ Words { @ 70¢ (Reader Rate) } = \$ _____
 { @ \$1.15 (Commercial Rate) }

Insert _____ time(s) Total Enclosed \$ _____

NAME _____

ADDRESS _____

CITY _____ STATE _____ ZIP _____

Signature _____

WORD COUNT: Include name and address. Name of city (Des Moines) or of state (New York) counts as one word each. Zip Code numbers not counted. (Publisher reserves right to omit Zip Code if space does not permit.) Count each abbreviation, initial, single figure or group of figures or letters as a word. Symbols such as 35mm, CDD, PO, AC, etc., count as one word. Hyphenated words count as two words.

PE-770

POPULAR ELECTRONICS

JULY 1970

ADVERTISERS INDEX

READER SERVICE NO.	ADVERTISER	PAGE NO.
1	AMECO, Div. of Aerotron, Inc.	98
2	Burstein-Applebee Co.	10
	CREI, Home Study Div., McGraw-Hill Book Co.	36, 37, 38, 39
3	Cleveland Institute of Electronics	54, 55, 56, 57
5	Communications Div., DYNASCAN CORP.	16
	Cornell Electronics	99
4	EICO Electronic Instrument Co., Inc.	FOURTH COVER
6	Edmund Scientific Co.	105
7	GC Electronics (CALECTRO)	9
8	Heath Company	13
	Houle Mfg. Co.	99
	Jetco	99
9	Lafayette Radio Electronics	16
10	P.R. Mallory & Co.	23
15	McIntosh Labs	95
11	Metrologic Instruments, Inc.	6
12	Midland International	5
13	Mosley Electronics, Inc.	10
14	Multicore Sales Corp.	91
	National Radio Institute SECOND COVER, 1, 2, 3	99
	National Technical Schools	18, 19, 20, 21
16	Olson Electronics	96
17	Progressive "Edu-Kits", Inc.	106
	RCA Electronic Components & Devices THIRD COVER	
18	RCA Electronic Components & Devices	26
	RCA Institutes, Inc.	72, 73, 74, 75
19	Regency Electronics, Inc.	14
20	Sonar Radio Corp.	97
21	Southwest Technical Products	96
	Sylvania Electric	7
55	Turner Microphone Co.	12
22	United Technical Institute	8
	Valparaiso Technical Institute	99

CLASSIFIED ADVERTISING 100, 101, 102, 103, 104

KEEP PACE WITH SPACE AGE! SEE SPACE FLIGHTS, LANDINGS CLOSE UP!
AMAZING SCIENCE BUYS
for FUN, STUDY or PROFIT

PSYCHEDELIC LIGHTING HANDBOOK



100 Information packed pages! Fully explains latest in psychedelic lighting equipment techniques, developments. Covers all facets of psychedelic light-show production including strobes, black light projectors, crystals, organic slides, mirrors, color organs, polarized color light boxes, MusicVision, etc. Shows how to "psychedelize" parties, musical groups, shows or how to set up "electro trips" for private gatherings. 8 1/2" x 11" looseleaf paper for 3 rings.

Stock No. 9100AV

\$3.00 Ppd.

LONG-WAVE BLACKLIGHT FIXTURE

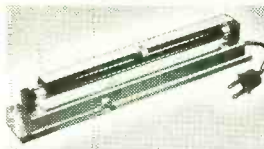

Extremely versatile, compactly designed, long wave (3200-4000 angstroms) black light (ultraviolet) fixture. Has 6-watt, 110-v lamp with built-in filter-eliminates harmful shorter wave ultraviolet rays. Use to identify minerals, fungi, bacteria-check for surface flaws, oil and gas leakage-perfect for displays with fluorescent paper, paints, chalk, crayons, trace powder, incl. adjustable aluminum reflector. Mount vert. hor. or on corner-10" L, 1 1/2" W, 1 1/4" H.

Stock No. 70,364AV

\$12.50 Ppd.

Stock No. 60,124AV

REPLACEMENT BULB \$4.50 Ppd.

NEW \$99.50 HELIUM-NEON LASER!



Completely assembled, instant-starting w/three times power output of comparable models. Steady, ripple-free light of moderate (safe) power. Particularly useful for studies, experiments in holography, interferometry, diffraction, optical alignment. Simple and safe to use. The 4 1/2" H. unit receives 5% power in 3 sec.; full power, typically 0.5 milliwatt (0.3 mW minimum) in 3 mins. Beam divergence only 2 milliradians; 2 cms at 40 feet.

Stock No. 79,004AV

\$99.50 Ppd.

3-CHANNEL COLOR ORGAN BARGAIN!



Create tremendous variety of unusual & beautiful lighting effects with this low-cost top-quality 1500-Watt unit (500 W per channel). Compare with others selling for twice the price. Has pilot light, plus individual sensitivity controls and channel indicator lights. Can operate ten 150 W 40-A type phone plug, 2 1/2" x 6 3/4" x 2 1/2", 2 1/2 lbs. Thermal

setting plastic case. 6-ft. cord. Including complete instructions.

Stock No. 71,223AV \$34.95 Ppd.

PLUG-IN ULTRASONIC ALARM/LIGHTER



Silent, economical, easy to install. No special attachments or electrical needed. Just plug in socket then plug lights and/or alarm into it. Activates when it "hears" someone. Resets automatically. Ultra-sensitive up to 30 ft. Sensitivity control can adjust out pet noise. Convenient for night lighting, fire alarm or injury in darkness. Ideal for apartment, home, office, plant. Walnut finish with built-in timer, on-off switch. 35KHZ frequency; 110-130v, 60 Hz AC.

Stock No. 71,283AV

(103 1/2" x 3 1/2" x 3 1/4") \$59.95 Ppd.

SPECIAL VISUAL EFFECTS PROJECTOR SET

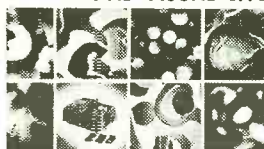

Dazzling, avant-garde visual effects. Fantastic variety. Incredibly beautiful. Special package offer contains all necessary apparatus. Create floating, exploding, fiery bursts of color like "Symphony of Spheres", "Chromatic Starbursts", "Crystal Starburst". Features 35mm 50 W, fan cooled projector—produces big image at short distance. Accepts two 8" diam. wheels (Dry Kaleidoscope), 2 cylinders, 2 cylindrical accessories (Color Cloud & Hevidoscope w/six internal mirrors). Perfect for entertaining, parties, photography.

Stock No. 71,212AV

Complete instructions. \$79.50 Ppd.

Order by Stock No.—Check or M.O.—Money-Back Guarantee
EDMUND SCIENTIFIC CO., 300 EDSCORP BLDG., BARRINGTON, N.J. 08007

WRITE FOR GIANT FREE CATALOG "AV"



Completely new edition. New items, categories, illustrations. 148 easy-to-read pages packed with 4000 unusual items. Dozens of electrical and electronic kits, parts, accessories. Enormous selection of Astronomical Telescopes, Microscopes, Binoculars, Magnifiers, Magnets, Lenses, Lasers, Prisms. Many war surplus items for hobbyists, experimenters, workshops, factory. Write for catalog "AV." Include Zip.

ORDER BY STOCK NUMBER • SEND CHECK OR MONEY ORDER • MONEY-BACK GUARANTEE
EDMUND SCIENTIFIC CO. 300 EDSCORP BUILDING
BARRINGTON, NEW JERSEY 08007

CIRCLE NO. 6 ON READER SERVICE PAGE

BUILD YOUR OWN RADIO

and Electronics Circuits

Reg. U.S.
Pat. Off.



Training Electronics Technicians Since 1946

PROGRESSIVE "Edu-Kit"[®]

HOME RADIO COURSE

- Now Includes**
- ★ 12 RECEIVERS
 - ★ 3 TRANSMITTERS
 - ★ SQ. WAVE GENERATOR
 - ★ SIGNAL TRACER
 - ★ AMPLIFIER
 - ★ SIGNAL INJECTOR
 - ★ CODE OSCILLATOR
- ★ No Knowledge of Radio Necessary
 - ★ No Additional Parts or Tools Needed
 - ★ EXCELLENT BACKGROUND FOR TV
 - ★ SCHOOL INQUIRIES INVITED
 - ★ Sold in 79 Countries

YOU DON'T HAVE TO SPEND HUNDREDS OF DOLLARS FOR A RADIO COURSE

The "Edu-Kit" offers you an outstanding PRACTICAL HOME RADIO COURSE at a rock-bottom price. Our Kit is designed to train Radio & Electronics Technicians, making use of the most modern methods of home training. You will learn radio theory, construction practice and servicing. THIS IS A COMPLETE RADIO COURSE IN EVERY DETAIL. You will learn how to build radios, using regular schematics; how to wire and solder in a professional manner; how to service radios. You will work the standard type of punched metal chassis as well as the latest development of Printed Circuit chassis.

You will learn the basic principles of radio. You will construct, study and work with RF and AF amplifiers and oscillators, detectors, rectifiers, test equipment. You will learn and practice code using the Progressive Code Oscillator. You will learn and practice trouble-shooting, using the Progressive Signal Tracer, Progressive Signal Injector, Progressive Dynamic Radio & Electronics Tester, Square Wave Generator and the accompanying instruction manual.

You will receive training for the Novice, Technician and General Classes of F.C.C. Radio Amateur Licenses. You will build Receiver, Transmitter, Square Wave Generator, Code Oscillator, Signal Tracer and Signal Injector, and learn how to operate them. You will receive an excellent background for television, Hi-Fi and Electronics.

Absolutely no previous knowledge of radio or science is required. The "Edu-Kit" is the product of years of teaching and engineering experience. The "Edu-Kit" will provide you with a basic education in Electronics and Radio, worth many times the low price you pay. The Signal Tracer alone is worth more than the price of the kit.

THE KIT FOR EVERYONE

You do not need the slightest background in radio or science. Whether you are interested in Radio & Electronics because you want an interesting hobby, a well paying business or a job with a future, you will find the "Edu-Kit" a worth-while investment. Many thousands of individuals of all ages and backgrounds have successfully used the "Edu-Kit" in more than 79 countries of the world. The "Edu-Kit" has been carefully designed, step by step, so that you cannot make a mistake. The "Edu-Kit" allows you to teach yourself at your own rate. No instructor is necessary.

PROGRESSIVE TEACHING METHOD

The Progressive Radio "Edu-Kit" is the foremost educational radio kit in the world, and is universally accepted as the standard in the field of electronics training. The "Edu-Kit" uses the modern educational principle of "Learn by Doing." Therefore you construct, learn schematics, study theory, practice trouble shooting—all in a closely integrated program designed to provide an easily-learned, thorough and interesting background in radio.

You begin by examining the various radio parts of the "Edu-Kit." You then learn the function, theory and wiring of these parts, then you build a simple radio. With this first set you will enjoy listening to regular broadcast stations, learn theory, practice testing and trouble-shooting. Then you build a more advanced radio, learn more advanced theory and techniques. Gradually, in a progressive manner and at your own rate, you will find yourself constructing more advanced multi-tube radio circuits, and doing work like a professional Radio Technician.

Included in the "Edu-Kit" course are Receiver, Transmitter, Code Oscillator, Signal Tracer, Square Wave Generator and Signal Injector Circuits. These are not unprofessional "breadboard" experiments, but genuine radio circuits, constructed by means of professional wiring and soldering on metal chassis, plus the new method of radio construction known as "Printed Circuitry." These circuits operate on your regular AC or DC house current.

THE "EDU-KIT" IS COMPLETE

You will receive all parts and instructions necessary to build twenty different radio and electronics circuits, each guaranteed to operate. Our Kits contain tubes, tube sockets, variable, electrolytic, mica, ceramic and paper dielectric condensers, resistors, tie strips, hardware, tubing, punched metal chassis, Instruction Manuals, hook-up wire, solder, selenium rectifiers, coils, volume controls and switches, etc.

In addition you receive Printed Circuit materials, including Printed Circuit chassis, special tube sockets, hardware and instructions. You also receive a useful set of tools, a professional electric soldering iron, and a Self-powered Dynamic Radio and Electronics Tester. The "Edu-Kit" also includes Code Instructions and the Progressive Code Oscillator, in addition to F.C.C. Radio Amateur License training. You will also receive lessons for servicing with the Progressive Signal Tracer and the Progressive Signal Injector, and the Fidelity Quiz Book. You become Membership in Radio-TV Club, Free Consultation Service, Certificate of Merit and Discount Privileges. You receive all parts, tools, Instructions, etc. Everything is yours to keep.

Progressive "Edu-Kits" Inc., 1189 Broadway, Dept. 686D, Hewlett, N. Y. 11557.

UNCONDITIONAL MONEY-BACK GUARANTEE

Please rush my Progressive Radio "Edu-Kit" to me, as indicated below:

Check one box to indicate choice of model

Deluxe Model \$31.95.

New Expanded Model \$34.95 (Same as Deluxe Model plus Television Servicing Course).

Check one box to indicate manner of payment

I enclose full payment. Ship "Edu-Kit" post paid.

I enclose \$5 deposit. Ship "Edu-Kit" C.O.D. for balance plus postage.

Send me FREE additional information describing "Edu-Kit."

Name _____

Address _____

PROGRESSIVE "EDU-KITS" INC.
1189 Broadway, Dept. 686D, Hewlett, N. Y. 11557

FREE EXTRAS SET OF TOOLS

- SOLDERING IRON
- ELECTRONICS TESTER
- PLIERS-CUTTERS
- VALUABLE DISCOUNT CARD
- CERTIFICATE OF MERIT
- TESTER-INSPECTORS MANUAL
- HIGH FIDELITY GUIDE • QUIZZES
- TELEVISION BOOK • RADIO
- TROUBLE-SHOOTING BOOK
- MEMBERSHIP IN RADIO-TV CLUB:
- CONSULTATION SERVICE • FCC
- AMATEUR LICENSE TRAINING
- PRINTED CIRCUITRY

SERVICING LESSONS

You will learn trouble-shooting and servicing in a progressive manner. You will practice repairs on the sets that you construct. You will learn symptoms and causes of trouble in home, portable and car radios. You will learn how to use the professional standard Tracer, the unique Signal Injector and the dynamic Radio & Electronics Tester. While you are learning in this practical way, you will be able to do many a repair job for your friends and neighbors, and charge fees which will far exceed the price of the "Edu-Kit." our Consultation Service will help you with any technical problems you may have.

FROM OUR MAIL BAG

J. Statistis, of 25 Poplar Pl., Waterbury, Conn., writes: "I have repaired several sets for my friends, and made money. The "Edu-Kit" paid for itself. I was ready to spend \$240 for a course, but I found your ad and sent for your Kit."

Ben Valerio, P. O. Box 21, Magna, Utah: "The Edu-Kits are wonderful. Here I am sending you the questions and also the answers for them. I have been in Radio for the last seven years, but like to work with Radio Kits, and like to build Radio Testing Equipment. I enjoyed every minute I worked with the different kits; the Signal Tracer works fine. Also like to let you know that I feel proud of becoming a member of your Radio-TV Club."

Robert L. Shuff, 1534 Monroe Ave., Huntington, W. Va.: "Thought I would drop you a few lines to say that I received my Edu-Kit, and was really amazed that such a bargain can be had at such a low price. I have already started repairing radios and phonographs. My friends were really surprised to see me get into the swing of it so quickly. The Trouble-shooting Tester that comes with the Kit is really swell, and finds the trouble, if there is any to be found."

PRINTED CIRCUITRY

At no increase in price, the "Edu-Kit" now includes Printed Circuitry. You build a Printed Circuit Signal Injector, a unique servicing instrument that can detect many Radio and TV troubles. This revolutionary new technique of radio construction is now becoming popular in commercial radio and TV sets.

A Printed Circuit is a special insulated chassis on which has been deposited a conducting material which takes the place of wiring. The various parts are merely plugged in and soldered to terminals.

Printed Circuitry is the basis of modern Automation Electronics. A knowledge of this subject is necessary today for anyone interested in Electronics.

Put your money (only \$2.00)* where your profits are.



**New and bigger than ever!
The RC-27**

Solid-state design is the big thing in electronics today, but your profit margin is—and will be for years—directly related to your tube business.

That's why we keep on expanding and up-dating the RCA Receiving Tube Manual—the "bible"—to help you continue to save time (and make more money) in the servicing of tube-designed equipment.

Now 672 pages, the manual includes comprehensive technical data and curves for all active RCA receiving tubes . . . a useful circuits section . . . handy Applications Guide . . . tabulated data on color and black-and-white picture tubes, voltage-reference and VR tubes . . . plus a Replacement Guide.

Get a copy today from your RCA Distributor. It's almost as indispensable as your tube-tester and V-O-M!

RCA | Electronic Components | Harrison, N. J. 07029

*Optional Price

RCA

Dazzle your friends with lightworks.



Sound n' Color®

The new dimension to music pleasure. EICO All Electronic Solid-State Audio-Color Organs transform sound waves into moving synchronized color images. Connect easily to speaker leads of hi-fi or radio. From \$29.95.



Translators

The electronics you need to create audio-stimulated light displays to your own imagination. Actuates: Light Display Units, Strobe Lites, any lamp configuration (Xmas trees, patio lights, etc.). From \$24.95 kit, \$39.95 wired.



Strobe Lites

High-intensity bursts of white light from Xenon tube flash in cadence with each beat of audio. From \$24.95 kit, \$39.95 wired.

Build the Stereo Kits praised by experts.

All amplifier power ratings according to IHF standards. Cortina® designed and manufactured in U.S.A. and guaranteed by EICO.



70-Watt AM/FM Stereo Receiver including cabinet. Cortina 3770, \$189.95 kit, \$279.95 wired.

70-Watt FM Stereo Receiver including cabinet. Cortina 3570, \$169.95 kit, \$259.95 wired.



150-Watt Silicon Solid-State Stereo Amplifier, including cabinet. For the audio perfectionist. Cortina 3150, \$149.95 kit, \$225 wired.

70-Watt Silicon Solid-State Stereo Amplifier, including cabinet. Cortina 3070, \$99.95 kit, \$139.95 wired.



FM Stereo Tuner including cabinet. Cortina 3200, \$99.95 kit, \$139.95 wired.



EC-1100
FM WIRELESS MIKE \$9.95

Build for fun and use with Eicocraft jiffy project kits.

The newest excitement in kits. 100% solid-state and professional. Expandable, interconnectable. Excellent as introductions to electronics. No technical experience needed. Finest parts, pre-drilled etched printed circuit boards, step-by-step instructions. 36 kits to select from, \$2.50 to \$9.95. Just released: EC-2600 "Super Snoop" \$8.95; EC-2700 Police & Fire Converter



(lo band) \$7.95; EC-2600 Aircraft Converter \$7.95; EC-2900 Police & Fire Converter (hi band) \$7.95; EC-3100 2-Station Intercom (with cases) \$10.95; EC-3200 "Do-It-Yourself" PC Etching Kit \$4.95; EC-2300 Audio Pre-amplifier \$8.95; EC-2400 Bullhorn \$8.95; EC-2500 Fuzzbox \$8.95.



EC-1900 TREASURE FINDER \$9.95

Shape up your own car/boat with EICO Engine Analyzer

For all 6V/12V systems; 4, 6, 8-cyl. engines. Now you can keep your car or boat engine in tip-top shape with this solid-state, portable, self-powered universal engine analyzer.

Completely tests your total ignition/electrical system. Complete with comprehensive Tune-up & Trouble-shooting Manual. EICO 888, \$49.95 kit, \$69.95 wired.



The first and only solid state test equipment GUARANTEED FOR 5 YEARS

Only EICO brings you laboratory precision and long life at lowest cost.



EICO 240 Solid-State FET-TVOM \$59.95 kit, \$79.95 wired



EICO 379 Solid-State Sine/Square Wave Generator \$69.95 kit, \$94.50 wired



EICO 242 Solid-State Deluxe FET-TVOM \$69.95 kit, \$94.50 wired



EICO 150 Solid-State Signal Tracer \$49.95 kit, \$69.95 wired



EICO 330 Solid-State RF Signal Generator \$59.95 kit, \$84.50 wired

You save up to 50% with EICO Kits. Since 1945, Best Buys in Electronics. Over 3 Million EICO Instruments Now in Use.

FREE 1970 CATALOG

Send me FREE catalog describing the full EICO line of 200 best buys, and name of nearest dealer.



EICO Electronic Instrument Co., Inc.
283 Malta Street, Brooklyn, N.Y. 11201
EICO Canada Ltd.
20 Millwick Drive, Weston, Ontario

Name _____
Address _____
City _____ State _____ Zip _____

CIRCLE NO. 4 ON READER SERVICE CARD

www.americanradiohistory.com