

BUILD LASER BEAM COMMUNICATION SYSTEM

POPULAR ELECTRONICS

MAY
1970

50
CENTS



SUPER-FLASH BLINKER LIGHT

BUILD DIGITAL SHIFT REGISTER

MAKING PERFECT SQUARE WAVES

BUILD 500/50kHz FREQUENCY STANDARD

PRODUCT GALLERY REPORTS:

- **Mosley SWV-7 SWL Antenna**
- **DeltAlert Ultrasonic Alarm System**
- **Metal/Mineral Locator**

One of two versions
of our Laser
Communicator
uses low-cost
astronomical
reflector
telescope
(page 27)



Electronics comes alive with NRI Training Kits

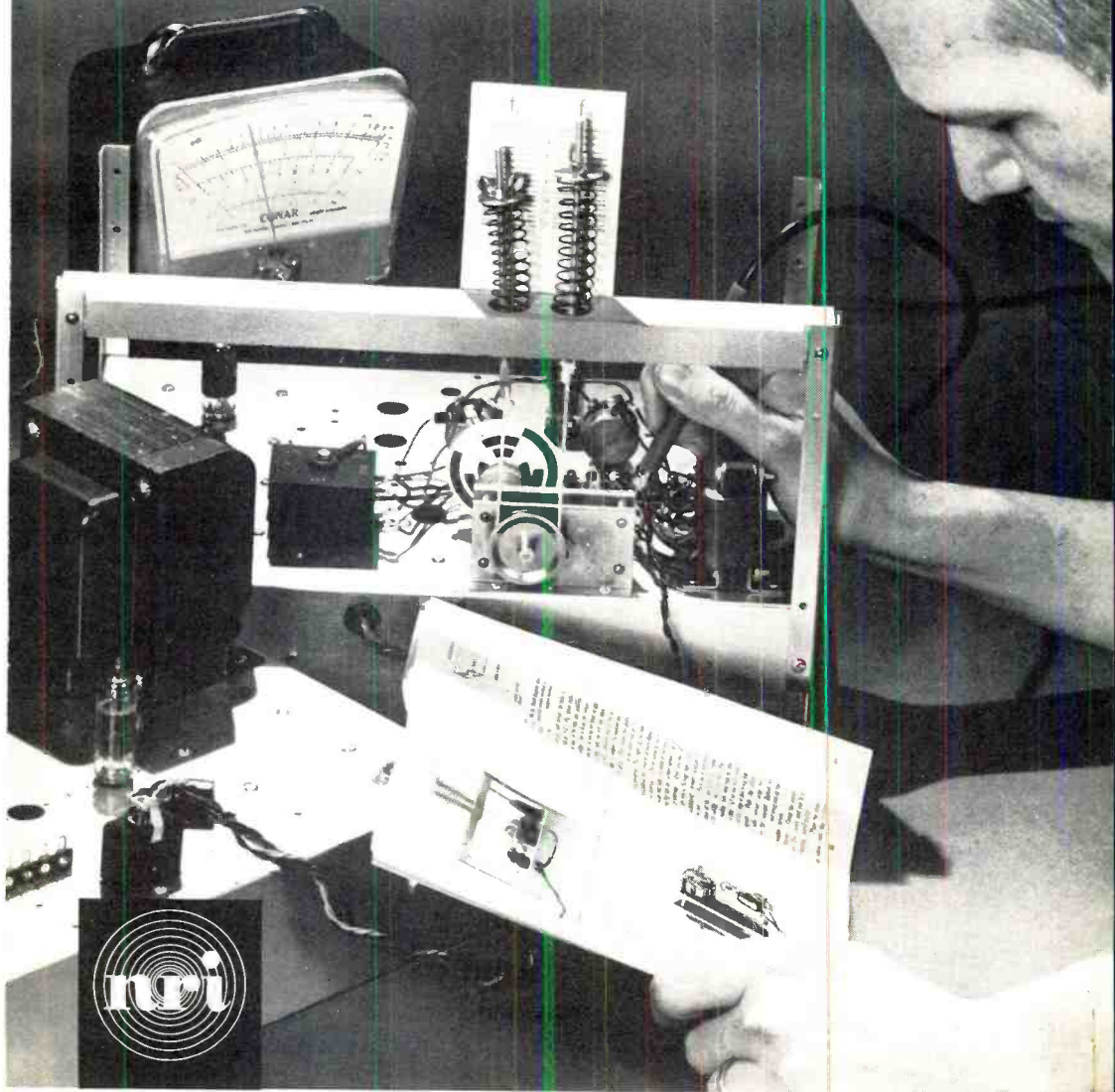

DISCOVER THE EASE AND EXCITEMENT OF TRAINING AT HOME THE NRI WAY

New Achievement Kit—Custom Training Kits—"Bite Size" Texts

Only NRI offers you this pioneering method of simplified "3 Dimensional" home-study training in Electronics, TV/Radio and Broadcasting/Communications. It's a remarkable teaching idea unlike anything you have ever encountered, the result of more than half a century of simplifying, organizing and dramatizing learning-at-home techniques. If you are an ambitious man—regardless of your education—you can effectively learn the Electronics field of your choice the NRI way.

NRI has *simplified* Electronics by producing "bite size" lesson texts averaging only 40 pages each. Dozens of illustrations open wide a picture window through which you'll see and understand practical uses of Electronics. You start out with NRI's exclusive Achievement Kit, containing everything you need to get started fast. (Illustrated at right.)

NRI has *organized* Electronics training to take you step-by-step from the first stages into more intriguing areas. Once you know the fundamentals thoroughly, it's easy to grasp more advanced theory and techniques. You move with confidence and enthusiasm into a new adventure filled with the excitement of discovery.

NRI has *dramatized* Electronics through the careful development of special training equipment that is *programmed* into your training systematically... beginning with your first group of lessons. Things you read about come alive in your hands as you build, experiment, purposely cause "problems" in circuits—and solve them. You learn to use test equipment, to build radios and TV sets, transmitter, or computer circuits. It's the priceless "third dimension" in NRI training... practical experience.



YOU GET MORE FOR YOUR MONEY FROM NRI

Mail postage-free card now for your free NRI catalog. Then, compare. You'll find—as have thousands of others—NRI training can't be beat. Read about the new Achievement Kit sent the day you enroll; about "bite-size," texts and custom designed training equipment. See why NRI gives you more value. Whatever your reason for wanting more knowledge of Electronics, NRI has an instruction plan for you. Choose from major programs in TV/Radio Servicing, Industrial Electronics and Complete Communications. Or select from special courses to meet specific needs. Check the course of interest to you on postage-free card and mail today for free NRI catalog. No salesman will call. NATIONAL RADIO INSTITUTE, Electronics Div., Washington, D.C. 20016.

Available Under NEW GI BILL

If you served since January 31, 1955, or are in service, check GI line in postage-free card.

More than 50 years of leadership
in Electronics Training



Career? Part-Time Earnings? Hobby? Choose From 12 Training Plans

1. TELEVISION-RADIO SERVICING — Learn to fix all TV sets, including Color. Includes your choice of NRI Color Kit or 19" black-white TV Kit. Also covers radios, stereo hi-fi, etc. Profitable field spare or full-time.

2. INDUSTRIAL-MILITARY ELECTRONICS — Basics to computers. Starts with fundamentals, covers servos, telemetry, multiplexing, phase circuitry, other subjects.

3. COMPLETE COMMUNICATIONS* — Operation, service, maintenance of AM, FM and TV broadcasting stations. Also covers marine, aviation, mobile radio, facsimile, radar, microwave.

4. FCC LICENSE* — Prepares you for 1st Class FCC License exams. Begin with fundamentals, advance to required subjects in equipment and procedures.

5. MATH FOR ELECTRONICS — Brief course for engineers, technicians seeking quick review of essential math: basic arithmetic, short-cut formulas, digital systems, etc.

6. BASIC ELECTRONICS — For anyone wanting a basic understanding of Radio-TV Electronics terminology and components, and a better understanding of the field.

7. ELECTRONICS FOR AUTOMATION — Not for beginners. Covers process control, ultrasonics, telemetering and remote control, electromechanical measurements, other subjects.

8. AVIATION COMMUNICATIONS* — Prepares you to install, maintain, service aircraft in-flight and landing systems. Earn your FCC License with Radar Endorsement.

9. MARINE COMMUNICATIONS* — Covers electronic equipment used on commercial ships, pleasure boats. Prepares for FCC License with Radar Endorsement.

10. MOBILE COMMUNICATIONS* — Learn to install, maintain mobile transmitters and receivers. Prepares for FCC License exams.

11. ELECTRICAL APPLIANCE REPAIR — Learn to repair all appliances, including air conditioning, refrigeration, small gas engines. Leads to profitable part or full-time business.

12. ELECTRONICS FOR PRINTERS — Operation and maintenance of Electronic equipment used in graphic arts industry. From basics to computer circuits. Approved by major manufacturers.

*You must pass your FCC License exams (any Communications course) or NRI refunds in full the tuition you have paid.

POPULAR ELECTRONICS

VOLUME 32 NUMBER 5

MAY 1970

WORLD'S
LARGEST-SELLING
ELECTRONICS
MAGAZINE

SPECIAL FEATURE

- LASER BEAM COMMUNICATOR** 27 C. Harry Knowles
Audio modulate POPULAR ELECTRONICS laser

FEATURE ARTICLES

- BUILD A SHIFT REGISTER** 43 Don Lancaster
Check digital functions and logic
- SUPER FLASH** 48 Thomas Couch
Brightest incandescent lamp flasher
- BUILD THE ADD-ON SQUARER** 51 James Bongiorno
Top-quality a.f. square waves
- DESIGN YOUR OWN PRINTED CIRCUITS** 59 Alexander W. Burawa
It's much simpler than you think
- 500/50-kHz FREQUENCY STANDARD** 63 Neil Johnson, W2OLU
Accurate calibration for your receiver
- BUILD A PHOTOGRAPHIC WASH TESTER** 65 Andre Brosnac
For better developing and printing
- THE PRODUCT GALLERY** 67
Mosley SWV-7 Antenna
Delta Ultrasonic Alarm
Caringella Metal/Mineral Locator
- BURNING OUT YOUR CIRCUITS** 71 Errol J. Queen
Without really trying
- ENGLISH LANGUAGE NEWS BROADCASTS TO N.A.** 76 Roger Legge
- OPPORTUNITY MIRROR** 77 David L. Heiserman
Preparing a resume
- SOLID STATE** 79 Lou Garner
- AMATEUR RADIO** 81 Herb S. Brier, W9EGQ
- SHORT-WAVE LISTENING** 83 Hank Bennett, W2PNA

DEPARTMENTS

- LETTERS FROM OUR READERS** 8
- NEW LITERATURE** 14
- READER SERVICE PAGES** 15, 97
- ELECTRONICS LIBRARY** 16
- NEW PRODUCTS** 22
- OPERATION ASSIST** 87
- OUT OF TUNE** 88
- The Touch-A-Tone (March 1970)*
- Numitron Readout (March 1970)*
- One-Step Motion Detector (March 1970)*
- Build Security 1 (March 1970)*

POPULAR ELECTRONICS is indexed
in the Readers' Guide
to Periodical Literature

This month's cover photo by
Justin Kerr

Copyright © 1970 by ZIFF-DAVIS PUBLISHING COMPANY. All rights reserved.

POPULAR ELECTRONICS, May 1970, Volume 32, Number 5, Published monthly at One Park Ave., New York, N.Y. 10016. One year subscription rate for U.S., U.S. Possessions and Canada, \$6.00; all other countries, \$7.00. Second class postage paid at New York, N.Y. and at additional mailing offices. Authorized as second class mail by the Post Office Department, Ottawa, Canada and for payment of postage in cash. Subscription service and forms 3579, P.O. Box 1096, Flushing, N.Y. 11352. Editorial offices for manuscript contributions, reader inquiries, etc.: One Park Ave., New York, N.Y. 10016.

We thought the Cobra 98 was the best CB yet.



Cobra 98—
Five-watt power
input, 23-channel
crystal-controlled CB
transceiver. Complete with all
crystals for immediate operation.
Transistorized universal AC-DC
power supply. Jack for earphones or
P.A. system. Plug-in microphone
included. Net: \$239.95.

You proved it.

A lot of people have bought the Cobra 98 transceiver since its introduction. And now most of them agree that it's the best—even though they could have paid more for something else.

Why? Because the Cobra 98 really works. And it has a combination of features that nobody else has quite been able to put together.

Features like the exclusive Dyna-Boost circuit that controls voice modulation to give you maximum talking power. A pre-amplifier that increases the strength of incoming voice signals. And a receiver that selects those signals from adjacent channel and image interference.

You even get an illuminated 3-in-1

master meter: An accurate SWR scale for determining impedance match to your antenna. An 'S' scale for received signal strength. Plus a third scale for power output.

Add it all up and you can see why the Cobra 98 may be the best CB you can buy. Prove it to yourself, as so many others have.

Ask your distributor for the "snake," or write us for complete information.



Product of
DYNASCAN CORPORATION
1801 W. Belle Plaine
Chicago, Illinois 60613

We're offering two booklets about turntables. We didn't write either one.

One tells you more than you need to know.

Our first free booklet tells you what makes one turntable or changer play better than the next. Thanks to Stereo Review (largest of the music magazines) we were able to reprint one of their in-depth studies. Without mentioning specific products, this article takes a look at turntables, changers, and tone arms from the inside out. With detailed information that lets you detect the gimmicks from the significant features.

One tells you all you need to know.

Our second free booklet tells you why the Dual 1219 plays better than any turntable you've ever heard. But don't just take our word for it. Take the word of four independent experts. We've collected and reprinted verbatim the results of many extensive tests of the Dual 1219 by four different test labs. (Which will make you just as happy as it made us.)



Once you've read both booklets, we know you'll want to see and hear a Dual for yourself. Once you've heard a Dual 1219 at your United Audio dealer, you'll know why it's the highest priced turntable today. \$175. You'll also know why most audio experts keep putting Duals in their own stereo systems.

United Audio Products, Inc. 
120 So. Columbus Ave., Mt. Vernon, N.Y. 10553
Please send your free literature on turntables.

Name _____
Address _____
City _____ State _____ Zip _____

CIRCLE NO. 30 ON READER SERVICE PAGE

POPULAR ELECTRONICS

LAWRENCE SPORN
Publisher

OLIVER P. FERRELL
Editor

LESLIE SOLOMON
Technical Editor

JOHN R. RIGGS
Managing Editor

EDWARD I. BUXBAUM
Art Director

ALEXANDER W. BURAWA
Associate Editor

ANDRE DUZANT
Technical Illustrator

PATTI MORGAN
Assistant Editor

JUDITH L. HOGAN
Editorial Assistant

H. BENNETT, W2PNA
H. S. BRIER, W9EGQ

L. E. GARNER, JR.
DAVID L. HEISERMAN
Contributing Editors

RICHARD J. HALPERN
Advertising Manager

ROBERT UR
Marketing Manager

MARGARET DANIELLO
Advertising Service Manager

FURMAN H. HEBB
*Group Vice President
Electronics and Photographic*

ZIFF-DAVIS PUBLISHING COMPANY
Editorial and Executive Offices
One Park Avenue, New York, New York 10016
212 679-7200

Midwestern Office
307 North Michigan Avenue, Chicago, Illinois 60601
312 726-0892
Midwestern Advertising Manager, JAMES WEAKLEY

Western Office
9025 Wilshire Boulevard, Beverly Hills, California 90211
213 CRestview 4-0265; BRadshow 2-1161
Western Advertising Manager, BUD DEAN

Japan: James Yagi
Ishikawa Mansion, 2-4, Sakuragaoka
Shibuya-ku, Tokyo, 462-2911-3

Circulation Office
P.O. Box 1096, Flushing, N.Y. 11352

William Ziff, President
W. Bradford Briggs, Executive Vice President
Hershel B. Sorbin, Senior Vice President
Stanley R. Greenfield, Senior Vice President
Philip Sine, Financial Vice President
Walter S. Mills, Jr., Vice President, Circulation
Phillip T. Heffernan, Vice President, Marketing
Frank Pomerantz, Vice President, Creative Services
Arthur W. Butzow, Vice President, Production
Edward D. Muhlfeld, Vice President, Aviation Division
Irwin Robinson, Vice President, Travel Division
George Morrissey, Vice President
Sydney H. Rogers, Vice President

Ziff-Davis also publishes Airline Management and Marketing, Including American Aviation, Boating, Business & Commercial Aviation, Car and Driver, Cycle, Electronics World, Flying, Modern Bride, Popular Photography, Skiing, Skiing Area News, Skiing Trade News, Stereo Review, and Travel Weekly.

Forms 3579 and all subscription correspondence should be addressed to POPULAR ELECTRONICS, Circulation Department, P.O. Box 1096, Flushing, N.Y. 11352. Please allow at least six weeks for change of address. Include your old address, as well as new—enclosing if possible an address label from a recent issue.

EDITORIAL CONTRIBUTIONS must be accompanied by return postage and will be handled with reasonable care; however, publisher assumes no responsibility for return or safety of art work, photographs or manuscripts.



Member Audit Bureau
of Circulations

CIRCLE NO. 12 ON READER SERVICE PAGE →

THE CALECTRO SUPERMARKET

EVERYTHING IN ELECTRONICS!



VARIABLE BALANCE STEREO HEADPHONE
 Unique "Sound Level" control on each earpiece permits adjustment. Frequency range, 20 to 20,000 + cps. 6' cord with stereo plug. Impedance 4 to 16 ohms.
Cat. No. Q4-132 \$17.95 Net

MINIATURE LAMPS



Type PR2 - 2.5 volt - 0.50 amp -
Cat. No. E2-430 - Pkg. of 2 \$2.29 Met
 Type PR3 - 3.6 volt - 0.50 amp -
Cat. No. E2-431 - Pkg. of 2 \$2.29 Met



TAPE RECORDER MICROPHONE
 Outstanding performance on music and speech for the price. Low impedance matches late model solid state recorders. Removable desk stand; 4 1/2' cord with dual plugs that fit most models. Freq. Response: 100-8k Hz. Output: -77 dB. Impedance: 200 ohms
Cat. No. Q4-146 \$4.95 Net

AUDIO ADAPTORS

"Y" Audio Adaptor has a phono pin jack on one end and dual phono pin plugs on the other.
Cat. No. Q4-288 \$.99 Net

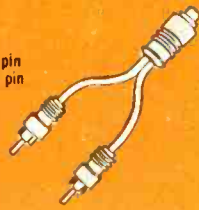

RESISTORS

Attractively packaged 2 per pack, showing values, color codes and formulas.

Type	Rating	Available Sizes	Price	Unit
Carbon	1/2 Watt	10 Ohm	.19	Ea.
		10 Meg		
Carbon	1 Watt	10 Ohm	.25	Ea.
		1 Meg		
Carbon	2 Watt	10 Ohm	.36	Ea.
		100K		
Wire Wound	10 Watt	10 Ohm	.36	Ea.
		15K		



STANDARD 1000 VOLT CAPACITOR

High quality, compact and reliable. Minimum capacity change with varying temperature. Rating: 1000 volts; tolerance: 20%.

Cat. No.	Description	Met	Unit
A1-060	220pF	\$.25	Pkg. of 2
A1-061	330pF	.25	Pkg. of 2
A1-062	470pF	.25	Pkg. of 2
A1-063	680pF	.25	Pkg. of 2
A1-064	0.001uF	.19	Ea.
A1-065	0.005uF	.19	Ea.
A1-066	0.01uF	.19	Ea.

HOBBYIST'S SOLDERING AND TOOL KIT

Diagonals, long nose pliers, soldering iron and solder, solder aid tool, heat-sink, and screwdriver. An ideal gift item.
Cat. No. H3-378 \$7.95 Net.



EXPERIMETER'S CIRCUIT BOARD KIT

Contains a 3 1/4" x 4" perforated board, 15 terminals (No. J4-636) and 4 mounting feet w/screws. Build small circuits, hobby and science projects, etc.
Cat. No. J4-660 \$.98 Net



The "GC Calectro Hobbyist Handbook" is available at your nearest Calectro Electronic Supermarket. One is located near you. **WRITE TODAY** and we'll rush you the name and address of your nearest Calectro Supermarket.



TWO STATION WIRELESS INTERCOM
 Just plug into any electrical outlet. Completely portable. Expand system anytime with additional units. Two unit system complete in display pack.
Cat. No. M4-110 \$34.95 Net

CALECTRO

G-C ELECTRONICS

400 SO. WYMAN ST. ROCKFORD, ILLINOIS 61101



A DIVISION OF HYDROMETALS, INC.

letters

FROM OUR READERS

READER TAKES EXCEPTION

I would like to take exception to a few of your comments in the article "Engineering-Level Opportunities for You" (February 1970). My main objection is your reference to "gimmicky training kits or home-built TV receivers . . . costly kits and training aids . . ." This is an obvious rap at technical instruction and their advertising efforts.

I am a student at one of the schools which uses training aids and kits in their course of instruction, and I object to paying for a magazine which belittles my technical proficiency and the manner in which I spend my money. When I became interested in

electronics about a year ago, I had no background in either the technical fields or in mathematics. I enrolled in a home study course and have been delighted with the methods used to instruct me.

I trust that in the future you will practice some discretion.

EDWARD J. FREEMAN
New Haven, Conn.

The phrases you have extracted from the article were meant to apply only to engineering-level—not technician-level—home study courses. Admittedly, training aids and kits are a necessary tool in teaching the practical aspects of elementary electronics. However, in engineering-level training, where previous experience in electronics and with its associated equipment is required, any kits or training aids would have to be "gimmicky" if the cost of the program is to remain within reason. As an example, suppose you took a course in computer design: would you expect or want to pay an extra \$150 a month for a computer terminal in your home as part of the course? Of course not! And any school that offered such an item as part of its course would find very few applicants indeed.

Rest assured, there was no intent to "belittle" home study courses—on any level.

(Continued on page 10)



**MODEL
SPR-4
\$379.00
NET**

COMMUNICATIONS RECEIVER

A general purpose receiver, the SPR-4 may be programmed to suit any interest: SWL, Amateur, Laboratory, Broadcast, Marine Radio, etc. Frequency Coverage: 150-500 KHz plus any (23) 500 KHz ranges, .500 to 30 MHz.

FEATURES: • Linear dial with 1 KHz readout • 4-pole crystal filter in first IF • 4-pole LC filter in second IF • Three bandwidths: 0.4 KHz, 2.4 KHz, and 4.8 KHz for: CW, SSB, AM • Superior cross-modulation and overload performance • Power: 120 VAC, 220 VAC, and 12 VDC • Crystals supplied for LW, BC and seven SW bands • Built-in speaker • Notch Filter.

ACCESSORIES: 100 KHz calibrator, noise blander, transceiver adapter (T-4XB), DC power cord, loop antenna, crystals for other ranges.

- Direct Frequency Dialing • All Solid State
- Programmable Coverage • FET Circuitry

For more details write: **R. L. DRAKE COMPANY**, 540 Richard St., Miamisburg, Ohio 45342

CIRCLE NO. 9 ON READER SERVICE PAGE



DIRECT FREQUENCY DIALING International Short-Wave Broadcast RECEIVER

No more guesswork in identifying stations. Set dial at a station's frequency and if conditions permit you'll hear it everytime . . .

- Ultra-precision tuning dial accuracy, SW and standard AM Broadcast
- Crystal lattice filter for adjacent station rejection and good AF response
- Dual conversion • Solid state AF output • S-meter • Preselector gives superior sensitivity by peaking antenna and RF stages • Crystal-controlled H. F. Oscillator stability • Amplified AVC constant AF output • Price \$299.00

Write for free Brochure

R. L. DRAKE COMPANY • Miamisburg, Ohio 45342

CIRCLE NO. 34 ON READER SERVICE PAGE

Here's how you can order this \$13.65 home-study course . . .

TRANSISTORS: A SELF-INSTRUCTIONAL PROGRAMED MANUAL for only \$2.49

And receive a FREE, no-risk Charter Membership in the ELECTRONICS BOOK SERVICE

(No obligation to buy ANY minimum number of books)

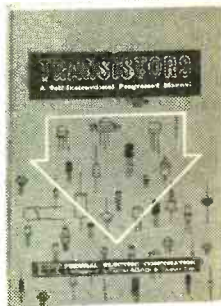

ACT NOW—take advantage of this amazingly generous demonstration offer, and get your copy of *Transistors: A Self-Instructional Programed Manual*. Regularly priced at \$13.65, it's yours for only \$2.49. In addition, you will be enrolled as a Charter Member in the new Electronics Book Service, on a *free trial basis*, with no cost or obligation. See for yourself how membership can help make your work easier, put you in line for a promotion or raise, or make your hobby more fun.

As your first selection under this charter membership, we will send you—for only \$2.49—this remarkable home-study course, *TRANSISTORS: A SELF-INSTRUCTIONAL PROGRAMED MANUAL*.

No experience needed

You need no previous experience with transistors to teach yourself—quickly, easily—all the major principles and applications of transistor circuitry. This amazing ITT-FED home-study course makes it easy to learn valuable new skills you can use to advance your career, earn extra money on the side, or build your own electronic home entertainment center. Acquire the expert knowledge of transistors to troubleshoot and service radio, audio and TV equipment. *At your own pace, in your own spare time.* Go as fast or slowly as you like—you can review any information whenever you need it, as often as you require.

Money-making, practical knowledge

The course gives you a *solid* working knowledge of transistors, their design, construction and operation. It covers semiconductor physics, transistor symbols, transistor applications, and characteristics of circuits commonly used in electronics today. And features a special treatment of *computer* circuits using transistors and diodes.

The manual is completely self-contained. You'll need no extra reference material. As you proceed step-by-step you will be acquiring a strong foundation for logic and switching circuits—the basis of all digital computers.

This book will be a boon to you whether you're a novice or a veteran in electronics. If there is some phase of transistors about which you're not sure, or never learned, or about which you'd like to refresh your memory, *TRANSISTORS'* unique presentation is made to order for you.

Learn the subjects you're most interested in

Start at any point you choose—with transistor structure (metals, crystals, bonding), rectification and amplification, oscillation, modulation, or pulse and switching circuits. You can use any part of the manual, any time you have a few minutes. You simply read one of the questions, give what you think is the answer, then uncover the hidden answer to see if you're right. This extraordinary programed format has brought *excellent results* to *hundreds* of electronics technicians working for International Telephone and Telegraph alone.

No-risk trial membership

As a Charter Member in the Electronics Book Service—on a free trial basis—the \$2.49 is your only financial commitment. You have *no further cost or obligation*. You need purchase no other books. However, if you decide to buy any book you're especially interested in, you are entitled to the special 15% to 30% Charter Member discount.

Even if you never buy another book you'll still be informed bi-monthly of books that can be yours at generous savings—books written by some of the most knowledgeable men in the field, on phases of electronics such as the following:

AC Circuits & Measurements/Electronic Troubleshooting/Elements of TV Servicing/DC Circuits & Measurements/Feedback Control Systems/Color TV Servicing/Electron Devices & Circuits/Radio Servicing

Preparation for FCC Radio Operators License Exam Capacitors, Magnetic Circuits and Transformers, Electronics and Nuclear Engineering Terms . . . plus many other guides to circuitry, radio, TV and electronic equipment, the math and physics of electronics, and all related areas.

Save more than 80% now

Just mail the coupon below to receive all Charter Member benefits on a FREE trial basis and get your copy of *"TRANSISTORS: A SELF-INSTRUCTIONAL PROGRAMED MANUAL"* for only \$2.49 (reg. price \$13.65). As a Charter Member of Electronics Book Service, you need purchase no other Service selections—but those you do wish to own will be offered to you at substantially reduced prices. Don't wait another day for this valuable, money-making knowledge. *Send the coupon right now!*

THE PRIVILEGES OF MEMBERSHIP YOU WILL ENJOY WITHOUT CHARGE

1. You will be under no obligation to buy any specific number of member selections.
2. You will be kept informed, free of charge, of the good new electronics books being published.
3. You will be entitled to buy—at the members' special discount price—any of the selections that appeal to you.
4. You receive the first selection "*TRANSISTORS: A SELF-INSTRUCTIONAL PROGRAMED MANUAL*" (reg. price \$13.65) for only \$2.49 under this special demonstration offer.

Electronics Book Service, Dept. 6651-G1(5)

Englewood Cliffs, New Jersey 07632

Please enroll me in Electronics Book Service on a free-trial basis. I am to receive all announcements, free of charge, and will be entitled to full-privileges as a Charter Member without obligation to buy any specific number of club selections. As my first selection under this trial membership, send me "*TRANSISTORS: A SELF-INSTRUCTIONAL PROGRAMED MANUAL*" (reg. price \$13.65) for only \$2.49.

Name

Address

City State Zip

CIRCLE NO. 26 ON READER SERVICE PAGE



simple - safe -
inexpensive

lasers

for education & experimentation

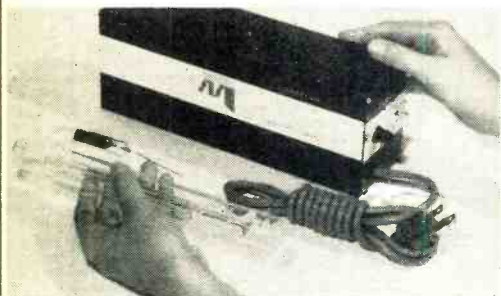

Now Metrologic Instruments offers a wide assortment of low-cost lasers and laser kits, designed especially for educational use and for experimenters and hobbyists. Based on the He-Ne laser, operating at 6328Å, all Metrologic lasers are extremely simple and safe to operate. Complete instructions are included. Choose from a broad line, including:

- Instructional lasers (for high school and college science departments)
- Lasers for industrial research laboratories
- Lasers for hobbyists and experimenters
- Do-it-yourself laser kits
- Holography kits
- Complete laser/optics bench
- Laser communications kit

TYPICAL PRICES

- Complete laser instruments from \$99.50
- Laser tubes from \$49.50
- Laser power supplies \$18.50
- Holography kits from \$34.75

Send for your
FREE Catalog
of lasers and
laser kits to

Metrologic Instruments, Inc.,
143 Harding Ave.,
Bellmawr, N.J. 08030



CIRCLE NO. 18 ON READER SERVICE PAGE

LETTERS (Continued from page 8)

SAFETY, AND OTHER COMMENTS

While you don't believe in lasers that have an output greater than 3 milliwatts, many of your construction projects are potentially dangerous (in terms of voltage) and/or capable of jamming legitimate communications.

Also, why not an author's biography with each article?

S. S. COLES
Tacoma, Wash.

The dangers involved in dealing with electrical voltages are well-known and, in the opinion of the editors, recognized and accepted by all readers. (Even so, we do often caution the reader when unusual circumstances exist.) The laser to most people is a new device and we feel our self-imposed restrictions are necessary. In addition, the hazards involved with the laser are important not only to the user or the reader who builds the project, but may also affect an unknowing bystander. That's another reason we are being "extravagant" with our warnings.

On the biographies, we have printed a few in the past, and will be publishing more in the future.

HI-FI, OF A SORT

Robert MacDonald ("Stereo Scene," March 1970) may have the right idea, but I suggest a new twist: use a heavy-duty musical instrument speaker for the woofer. I have a Utah 75-watt rated MI speaker (bought on sale from Allied Radio) coupled in with an inexpensive tweeter (also Allied) to a Heath-kit AA-14. It sounds great and at full volume will entertain the whole block!

R. M. BLACKLOCK
Merritt, E. C., Canada

PE ON TAPE

We are quite pleased, and hope that you will be glad to know, that several persons have responded to your printing of our letter regarding the availability of excerpts from POPULAR ELECTRONICS on tape for the blind and physically handicapped.

We have recently completed a survey of our present readership and it proves that those who receive our tapes are very grateful for them, as they are for everything else which helps them lead a more "normal" life.

MRS. L. FULLER
Science for the Blind

POPULAR ELECTRONICS is available to the blind and physically handicapped on magnetic tape from SCIENCE FOR THE BLIND, 221 Rock Hill Road, Bala Cynwyd, Pa. 19004. The magazine is read onto tape by volunteer readers with the publisher's permission and is intended solely for the use of the blind and the physically handicapped. If you know someone who could use this service, please pass the word.

POPULAR ELECTRONICS

The New 1970 Improved Model 257 **A REVOLUTIONARY NEW TUBE TESTING OUTFIT**

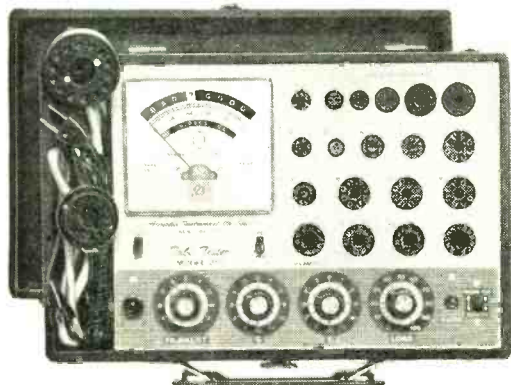

COMPLETE WITH ALL ADAPTERS AND ACCESSORIES, NO "EXTRAS"

STANDARD TUBES:

- ✓ Tests the new Novars, Nuvisitors, 10 Pins, Magnovals, Compactrons and Decals.
- ✓ More than 2,500 tube listings.
- ✓ Tests each section of multi-section tubes individually for shorts, leakage and Cathode emission.
- ✓ Ultra sensitive circuit will indicate leakage up to 5 Megohms.
- ✓ Employs new improved 4½" dual scale meter with a unique sealed damping chamber to assure accurate, vibration-less readings.
- ✓ Complete set of tube straighteners mounted on front panel.

The Model 257 is housed in a handsome, sturdy, portable case. Comes complete with all adapters and accessories, ready to plug in and use. No "extras" to buy. Only

BLACK AND WHITE PICTURE TUBES:

- ✓ Single cable used for testing all Black and White Picture Tubes with deflection angles 50 to 114 degrees.
- ✓ The Model 257 tests all Black and White Picture Tubes for emission, inter-element shorts and leakage.

COLOR PICTURE TUBES:

- ✓ The Red, Green and Blue Color guns are tested individually for cathode emission quality, and each gun is tested separately for shorts or leakage between control grid, cathode and heater. Employment of a newly perfected dual socket cable enables accomplishments of all tests in the shortest possible time.

\$52⁵⁰

NOTICE

We have been producing radio, TV and electronic test equipment since 1935, which means we were making Tube Testers at a time when there were relatively few tubes on the market, way before the advent of TV. The model 257 employs every design improvement and every technique we have learned over an uninterrupted production period of 34 years. Accurate Instrument Co., Inc.

SEND NO MONEY WITH ORDER PAY POSTMAN NOTHING ON DELIVERY

Pay Cash or in EASY MONTHLY PAYMENTS AFTER 15 Day Trial!

Try it for 15 days before you buy. If completely satisfied remit \$52.50 plus postage and handling charge. (If you prefer you may **PAY MONTHLY ON OUR EASY PAYMENT PLAN.**) If not completely satisfied, return to us, no explanation necessary.

ACCURATE INSTRUMENT CO., INC. Dept. 742
 2435 White Plains Road, Bronx, N. Y. 10467
 Please rush me one Model 257. If satisfactory I agree to pay at the terms specified at left. If not satisfactory, I may return for cancellation of account.
 Name _____
 Address _____
 City _____ State _____ Zip _____
 Save Money! Check here and enclose \$52.50 with coupon and we will pay all shipping and handling charges. You still retain privilege of returning after 15 day trial for full refund.

CIRCLE NO. 1 ON READER SERVICE PAGE

8 New Action-Packed Kits From Heath —



Heathkit GD-101
\$49.95*



NEW Heathkit "Spectre" 1/4 Scale R/C Car Join The Most Exciting New Hobby In America . . .

building and racing radio-controlled Grand Prix cars up to scale speeds of 200 mph. The Heathkit "Spectre" R/C car reaches that speed and has already proven itself a winner. And no wonder; its design is unique. It has a chrome plated steel chassis, adjustable caster and toe-in, specially formulated rubber tires that lock onto the cast nylon wheels, independent front suspension for excellent cornering and a 5.5:1 gear ratio for maximum torque at all speeds. The snap on, 1/4 scale car body (length: 19 3/4") is of high impact plastic — almost indestructible. Suspension is by real coil springs. The radio equipment compartment is dirt and oil proof. The Heathkit "Spectre" is the only complete car kit available. You get the body, chassis, wheels & tires, 4 oz. fuel tank & tubing, equipment case & protective foam, centrifugal clutch & gears, axles, servo linkages & mounting tape, all hardware, decals, numbers and a comprehensive manual. The "Spectre" accepts any .15 to .23 cubic inch R/C engine and any proportional R/C electronics system. It requires only two servos to operate the steering, brake and throttle. Get in on all the thrills of R/C car racing at the lowest possible price . . . order a Heathkit "Spectre".

Kit GD-101, R/C car only, 8 lbs. \$49.95*
Assembled GDA-101-1, Veco .19 R/C engine, 1 lb. \$19.95*

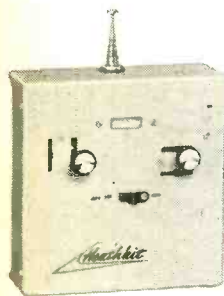

Heathkit GD-57
\$129.95*

NEW Heathkit 3-Channel Digital Proportional R/C System For Planes, Gliders, Cars And Boats

Ideal for use with the new Heathkit "Spectre" R/C car to give you total control . . . ease of handling. Here's what the Heathkit GD-57 R/C system includes: Transmitter with assembled, factory aligned RF circuitry; new 2 oz. miniature receiver that needs no IF alignment, in a tough nylon case; you also get two servos; all plugs; connectors; cables; charging cord; new flat-pack rechargeable nickel-cadmium transmitter and receiver batteries . . . and a special soldering iron. You can have your choice of five operating frequencies in each of three bands . . . 27, 53 or 72 MHz. This is the most value ever offered in a 3-channel rig.

Kit GD-57, transmitter, receiver, 2 servos, batteries, charging cord, switches and soldering iron, (specify freq. desired), 11 lbs. \$129.95*

Kit GDA-57-1, transmitter, battery, charging cord, (specify freq. desired), 5 lbs. \$54.95*

Kit GDA-57-2, receiver only, (specify freq.), 1 lb. \$34.95*



Battery Pack

Receiver

Servos

Heathkit Siren & Speaker
\$99.95*

NEW Heathkit Siren/PA For Licensed Emergency Vehicle Only

Hey Chief! Save up to 60% on a new electronic siren/PA system by ordering the low cost Heathkit GD-18. The siren gives both "wail" and "yelp" warnings at 55 watts output power, and you can adjust the pitch. As a public address it will amplify your voice with a full 20 watts of power, and it's practically immune to acoustical feedback. (Either PA or siren can be interrupted to use the other.) Incoming radio calls can be channeled through the GD-18 so you can hear them when away from your vehicle. Use it on any 12-volt auto electrical system with either positive or negative frame ground. It will operate from -20° to 150° F conditions. Control panel is lighted. Comes with gimbal bracket mounting. Take your choice of speakers . . . concealed or exposed.

Kit GD-18, Siren/PA Amplifier, 7 lbs. \$54.95*

Assembled GDA-18-1, Exterior Horn, 9 lbs. \$49.95*

Assembled GDA-18-2, Concealed Horn, 4 1/2 x 4 1/2 x 13", 9 lbs. \$49.95*

System GD-18A, (includes GD-18 plus exterior horn), 16 lbs. \$99.95*

System GD-18B, (includes GD-18 plus concealed horn), 16 lbs. \$99.95*



Amplifier
& Controls



Exterior Horn



Concealed Horn

Heathkit MI-29
\$84.95*



NEW Heathkit Solid-State Portable Fish Spotter

Costs half as much as comparable performers. Probes to 200 ft. Doubles as depth sounder. Transducer mounts anywhere on suction cup bracket. Adjustable Sensitivity Control. Exclusive Noise-Rejection Control stops ignition noise. Runs for 80 hrs. on two 6 VDC lantern batteries (not included). Manual explains typical dial readings. Get set for next season; order your Heathkit MI-29 today.

Kit MI-29, 9 lbs. \$84.95*

The Value Leader



NEW Heathkit 5-Band SSB Amateur Transceiver

The new Heathkit SB-102... proud successor to the famous "100" & "101". You can expect top performance and value from this rig... and you get it. An all solid-state Linear Master Oscillator delivers faster warmup, greater stability and better tracking... new receiver circuitry gives better than 0.35 uV sensitivity for real performance under bad band conditions. Plus all the features that made the SB-101 the world's most famous, most popular transceiver... 180 watts PEP SSB input... 170 watts CW input... 80 through 10 meter coverage... USB, LSB or CW modes... built-in VOX or PTI operation... built-in CW sidetone... built-in 100 kHz crystal calibrator... Triple Action Level Control for reduced clipping & distortion... fast, easy bandswitching and tune-up... rugged, inexpensive 6146 finals... separate headphone level control & front panel jack... simple assembly with circuit board-wiring harness construction... sharp Heathkit SB-Series styling plus many more features. Order yours now.

Kit SB-102, 23 lbs.....\$380.00*
Kit SBA-100-1, mobile mt., 6 lbs.....\$14.95*

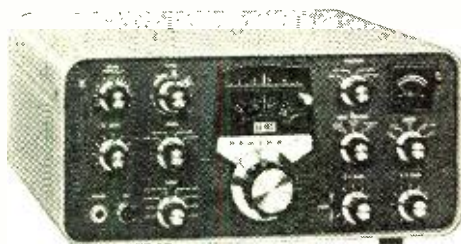

Heathkit SB-102
\$380⁰⁰*

NEW Heathkit 60-Watt AM-FM-FM Stereo Receiver

Superb stereo performance at budget price, that's the new Heathkit AR-19. A giant, electronically regulated power supply provides 60 watts IHF music power (ideal for all modular and high efficiency speaker systems)... frequency response is -1 dB from 6 Hz to 35,000 Hz... and Harmonic & IM distortion are less than 0.25% at any output. This advanced performance assures you of crisp, clean highs without ringing or breakup... solid, clean-cut lows without distortion — just pure, uncolored sound reproduction at all frequencies and power levels. The FM Stereo circuitry is unequalled by any receiver in this price class... a factory assembled & aligned FET FM tuners... superior overload characteristics & 2.0 uV sensitivity... a factory assembled & aligned FM IF circuit board with 4 IC's for superior AM rejection, hard limiting, greater stability and 35 dB selectivity... a precision ball-bearing inertia flywheel for smooth, precise tuning... two front panel tuning meters for exact station selection. Other features include modular snap-out circuit boards, built-in self-servicing capability, hi-fi AM reception and much more. Make the AR-19 the heart of your stereo system now.

Kit AR-19, 29 lbs.....\$225.00*
Assembled AE-19, oiled pecan cabinet, 10 lbs.....\$19.95*

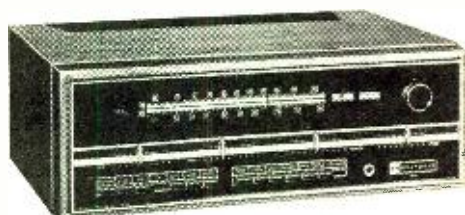

Heathkit AR-19
\$225⁰⁰*

Heathkit Solid-State Metal Locator

Here's versatile, professional performance in a metal locator at lowest cost. The all solid-state GD-48 uses a unique induction balance detection system that doesn't produce a tone until metal enters the search field... eliminates having to listen for a change in tone. The built-in Sensitivity control allows adjustment to detect varying size objects down to 6 feet. A built-in speaker audibly signals presence of metal... for higher sensitivity use the accurate front-panel meter. And the front-panel headphone jack lets you use headphones to screen out annoying background noise. Look no further for an excellent metal locator... order the GD-48 now.

Kit GD-48, 4 lbs.....\$59.95*
GDA-48-1, 9 V battery, 1 lb.....\$1.30*

Heathkit GD-48
\$59⁹⁵*

Heathkit Screw-Drive Radio-Controlled Garage Door Opener Now Costs Less

Like having a personal doorman. The powerful yet gentle screw-drive door mechanism gives you ease & convenience you want with the reliability & safety you need. Just a touch of a button and the factory assembled & aligned UHF electronics open your garage door from up to 150 ft. away and turns on a light too. Once inside, another push of the button closes the door safely behind you, yet the light remains on long enough for you to enter your home. Fast, easy one-night assembly... all wires pre-cut with connectors installed... no soldering. Fits any 7 1/2' overhead, jamb or pivot single or double size residential doors. Automatic instant reverse feature prevents injury to kids, pets, etc. Send for yours now.

GD-209A, mechanism, receiver & transmitter, 66 lbs.....\$139.95*
GD-209B, mechanism, receiver & 2 transmitters, 66 lbs.....\$149.95*

New Lower Price
Kit GD-209A
\$139⁹⁵*



NEW

FREE 1970 CATALOG!

Now with more kits, more color. Fully describes these along with over 300 kits for stereo/hi-fi, color TV, electronic organs, guitar amplifiers, amateur radio, marine, educational, CB, home & hobby. Mail coupon or write Heath Company, Benton Harbor, Michigan 49022.

HEATH COMPANY, Dept. 10-5
Benton Harbor, Michigan 49022

Enclosed is \$ _____, plus shipping.

Please send model (s) _____
 Please send FREE Heathkit Catalog. Please send Credit Application.

Name _____

Address _____

City _____ State _____ Zip _____

*Mail order prices; F.O.B. factory. Prices & specifications subject to change without notice. CL-386

*They laughed when
I started hooking up my own
public address system.*



But oh, when it started to play!

"And ouch, when they heard how much money I saved installing it myself. With just pliers and screwdriver."

"University Sound supplied everything — all pre-matched and pre-engineered. Speakers, amplifier, cables, wires, microphone, turntable — all I did was hook 'em up. And it all worked perfectly the first time."

"It's called 'TCS'. Totally Coordinated Sound. University makes it available for thousands of applications, from churches to restaurants, office buildings to lumberyards."

Just walk in to your University dealer, tell him what you need it for, and walk out with the world's finest public address system.

Only University Sound — the world's largest manufacturer of public address equipment — could do it. They've got a system for every situation, including yours. If you need a public address system, or you know someone who does, write for our free booklet: "How to Install Your Own Public Address System with Pliers and Screwdriver".



UNIVERSITY SOUND

A quality company of LTV Ling Altec, Inc.
P.O. Box 26105 • Oklahoma City, Oklahoma 73126

CIRCLE NO. 31 ON READER SERVICE PAGE



To obtain a copy of any of the catalogs or leaflets described below, simply fill in and mail the coupon on page 15 or 97.

A 20-page booklet, Form AT-622, featuring tips on how to improve TV reception and a do-it-yourself approach to installing MATV systems is available from *Mosley Electronics, Inc.* Titled "How To Improve Your TV Picture," the booklet outlines how you can have a TV receiver in every room in your house operating from a single roof-top antenna, using accessory equipment. Divided into two parts, the booklet focuses on reception requirements and conditions in the first part, while the second deals with a listing of the various accessories that can be used to improve reception and operate receivers from a single antenna.

Circle No. 75 on Reader Service Page 15 or 97

A 12-page catalog describing the company's complete line of advanced electronic test equipment for service and industry is available from *Sencore, Inc.* The Form No. 517 catalog features five new instruments, two color signal generators, a FET tester, and a seven-in-one bias supply. Other instruments listed include FET VOM's, a sweep and marker generator, sweep circuit analyzer, combination oscilloscope/vectorscope, combination transistor/FET testers, CRT tester, and special-purpose instruments. All listings have complete performance data listings and prices.

Circle No. 76 on Reader Service Page 15 or 97

TDK Electronics Corp. has just released an eight-page, full-color technical bulletin on its "Super Dynamic" cassette tape. The comprehensive bulletin describes the features of Super Dynamic cassette tape plus its characteristics and specifications. Included are photomicrographs of magnetic particles and tape surfaces. Graphic comparisons between conventional and SD tape are given, showing bias current curve, dynamic range, and harmonic distortion. The brochure concludes with a section on how to handle and store cassette tapes.

Circle No. 77 on Reader Service Page 15 or 97

POPULAR ELECTRONICS READER SERVICE PAGE

free information service:

Here's an easy and convenient way for you to get additional information about products advertised or mentioned editorially (if it has a "Reader Service Number") in this issue. Just follow the directions below... and the material will be sent to you promptly and free of charge.

1. On coupon below, circle the number(s) that corresponds to the key number(s) at the bottom or next to the advertisement or editorial mention that is of interest to you. (Key numbers for advertised products also appear in the Advertisers' Index.) Print or type your name and address on the lines indicated.

2. Cut out the coupon and mail it to: POPULAR ELECTRONICS, P.O. Box 8391, Philadelphia, PA 19101.

note: If you want to write to the editors of POPULAR ELECTRONICS about an article on any subject that does not have a key number, write to POPULAR ELECTRONICS, One Park Avenue, New York, N.Y. 10016. Inquiries concerning circulation and subscriptions should be sent to POPULAR ELECTRONICS, P.O. Box 1096, Flushing, N.Y. 11352.

POPULAR ELECTRONICS

P.O. BOX 8391
PHILADELPHIA, PA. 19101

Void After June 30, 1970

1 2 3 4 5 6 7 8 9 10 11 12 13 14 15 16 17 18 19 20
21 22 23 24 25 26 27 28 29 30 31 32 33 34 35 36 37 38 39 40
41 42 43 44 45 46 47 48 49 50 51 52 53 54 55 56 57 58 59 60
61 62 63 64 65 66 67 68 69 70 71 72 73 74 75 76 77 78 79 80
81 82 83 84 85 86 87 88 89 90 91 92 93 94 95 96 97 98 99 100

NAME (Print clearly) _____

ADDRESS _____

CITY _____ STATE _____ ZIP CODE _____

5 Na

ELECTRONICS library

QUIET

FUNDAMENTALS OF DIGITAL COMPUTERS

by Donald D. Spencer

This book is an excellent introductory text to general electronic computing. It begins with a discussion of various types of computer applications, surveys the history and evolution of computers, and covers the fundamental facts about computers and their operation. The text details the functional organization of a computer system, individual components of a system data preparation, storage devices, input and output devices, conversion units, and the central processor. The text is neither technical nor academic; rather, it is extremely readable, and the format is down to earth. This is a good book for anyone interested in the non-technical aspects of computers.

Published by Howard W. Sams & Co., Inc., 4300 West 62 St., Indianapolis, IN 46268. Hard cover. 304 pages. \$6.95.

BASIC ELECTRIC CIRCUITS

by Donald P. Leach

For the electrical/electronics technician, this book provides the background necessary to study advanced subjects in fields such as power, commercial and industrial electronics, and communications. No previous background in physics or electronics is assumed; so the book is eminently suited for go-it-alone study. However, a course in college algebra should be taken currently or prior to the study of the material in this book. The text can be divided into two main categories: the first ten chapters deal with the fundamentals of electricity and steady d.c. circuits; the remaining chapters focus on circuits in which the currents and voltages vary with time. There are more than 300 example problems, each of which is worked out in detail, and more than 400 review questions.

Published by John Wiley & Sons, Inc., 605 Third Ave., New York, NY 10016. Hard cover. 665 pages. \$9.95.

INFORMATION TRANSMITTAL AND COMMUNICATING SYSTEMS

by John P. Froehlich

The field of communications has developed rapidly in the past few years, and the trend is toward more sophisticated electronic systems capable of handling enormous amounts of information simultaneously. Most books on the subject of modulation focus on the cir-

(Continued on page 100)

Turner Improves On Turner



**Turner +2
The Old Best**

There never was a better base station microphone than the transistorized Turner +2. Until now. Now there is a new best. The +3 from Turner. A superior microphone with modern styling and several important features. Transistorized electronics. A volume control for greater range and signal strength. ModuGard™, the compression amplifier which prevents over modulation and ensures a loud, clear signal. Frequency range 300-3000 Hz. Output -23 db. Push-to-talk bar. Lock lever. List price \$75.00. At your dealer. The Turner Company. 909 17th Street N.E., Cedar Rapids, Iowa 52402.



**Turner +3
The New Best**

CIRCLE NO. 29 ON READER SERVICE PAGE

New SAMS Books for every electronics interest

New 18th Edition of the famous E & E RADIO HANDBOOK

by WILLIAM I. ORR, W6SAI. Completely updated edition of the famous communications handbook which is the electronics industry standard for engineers, technicians and advanced amateurs. Explains in authoritative detail how to design and build all types of radiocommunications equipment. Includes SSB design and equipment, RITTY circuits, latest semiconductor circuits and IC's, as well as special-purpose and computer circuitry. Order 24020, only...\$13.50

New 13th Edition of the famous TUBE SUBSTITUTION HANDBOOK

Lists over 12,000 direct substitutions. A complete guide to substitutions for receiving, picture tube, miniature, industrial, and communications types; includes foreign tubes. Tells how and when to substitute. Order 20769, Twin-Pak (regular size for bench use; pocket-size for caddy) both for only...\$2.25

Order 20768, shop edition, only...\$1.75

Color-TV Waveform Analysis

This book provides both the theoretical and the practical knowledge of waveform analysis essential for profitable and efficient color TV servicing. It begins with the rf and i-f sections, and proceeds through the video-amplifier, bandpass-amplifier, color-sync, color-demodulator, and matrix circuits. Order 20763, only...\$3.50

101 Q & A About Hi-Fi and Stereo

A practical and useful reference book explaining the essential facts about hi-fi and stereo, with important help on troubleshooting and maintenance. The six sections of the book cover: high-fidelity systems; amplifiers; tuners; record and tape players; maintenance and troubleshooting procedures. Order 20753, only...\$3.50

SWL Antenna Construction Projects

Provides detailed information on how to construct 35 different antennas for improved short-wave reception. Explains basic antenna principles and then presents the construction projects which fall into six basic classes of design. Order 20766, only...\$2.95

Color-TV Trouble Clues, Vol. 3

by HOWARD W. SAMS EDITORIAL STAFF. Helps speed diagnosis of color-TV troubles. Tells how to get right to the heart of the problem, how to make positive checks, how to use meaningful clues for quick troubleshooting. Order 20762, only...\$3.50

Record Changer Servicing Guide

Provides a complete understanding of record changers, how they operate, and the various systems employed. With detailed instructions on how to track down troubles encountered in record changers and how to repair them in the fastest and most effective way. Order 20730, only...\$3.95

Electronic Organs—Vol. 2

Explains the fundamental principles of electronic organs, including theory, development, features and operation. Shows in block diagram and schematic illustrations what is inside an organ. Order 20754, only...\$5.50

Auto Radio Servicing Made Easy

2nd Ed. Explains the circuitry of both new and old auto radios, covering each of the tube and transistor stages. Provides step-by-step troubleshooting and repair details; explains how to eliminate noise and interference, and how to make proper adjustments. Order 20719, only...\$3.95

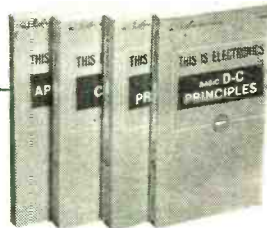
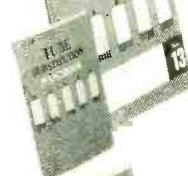
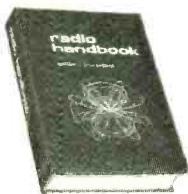

THIS IS ELECTRONICS Series

by ITT EDUCATIONAL SERVICES, INC. These books provide a remarkable introduction to electronics, imparting to any reader a clear understanding of the basics of this vital technology. All topics are completely covered and readily mastered.

Vol. 1. Basic D-C Principles

Covers electronics—past and present; electronic components and symbols; matter and electricity; current, voltage, and resistance; series and parallel circuits; conductors, semiconductors, and insulators; resistors; and sources of d-c power. Order 20657, only...\$5.95

Vol. 2. Basic A-C Principles

Covers alternating voltage and current; capacitors and capacitive reactance; magnetism and electromagnetism; electrical measuring instruments; and inductors and inductive reactance. Order 20727, only...\$6.95

Vol. 3. Circuits

A-c and d-c principles and components are used to illustrate how vacuum tubes and semiconductors operate. Various amplifier and oscillator circuits of both tube and transistor types are fully described. Order 20759, only...\$6.95

Vol. 4. Applications

This volume explains how amplifier and oscillator circuits are used in actual applications. Explains principles of modulation, broadcast receiver fundamentals, a-m and f-m receiver circuits, etc. Order 20760, only...\$5.95
4-Vol Set. Order 20761, only...\$23.50

Amateur Radio Incentive Licensing Study Guide

Fully explains the new incentive licensing which affects both newcomers and old-timers. Covers all the new FCC Regulations and band allocations. Includes sample exams for Novice, Technician, Conditional, and General-Advanced- and Extra-Class licensing. Order 24004, only...\$2.75

HOWARD W. SAMS & CO., INC.

Order from any Electronic Parts Distributor or mail to Howard W. Sams & Co., Inc., Dept. PE-5
4300 W. 62nd St., Indianapolis, Ind. 46268

Send the following books: Nos. _____

_____ \$ _____ enclosed

Send FREE 1970 Sams Book Catalog

Name _____
PLEASE PRINT

Address _____

City _____ State _____ Zip _____

CIRCLE NO. 33 ON READER SERVICE PAGE

One of our students wrote this ad!

Harry Remmert decided he needed more electronics training to get ahead. He carefully "shopped around" for the best training he could find. His detailed report on why he chose CIE and how it worked out makes a better "ad" than anything we could tell you. Here's his story, as he wrote it to us in his own words.

By Harry Remmert

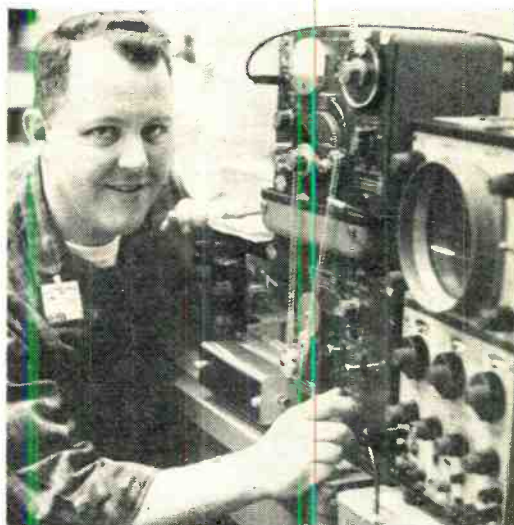

Harry Remmert on the job. An Electronics Technician with a promising future, he tells his own story on these pages.

AFTER SEVEN YEARS in my present position, I was made painfully aware of the fact that I had gotten just about all the on-the-job training available. When I asked my supervisor for an increase in pay, he said, "In what way are you a more valuable employee now than when you received your last raise?" Fortunately, I did receive the raise that time, but I realized that my pay was approaching the maximum for a person with my limited training.

Education was the obvious answer, but I had enrolled in three different night school courses over the years and had not completed any of them. I'd be tired, or want to do something else on class night, and would miss so many classes that I'd fall behind, lose interest, and drop out.

The Advantages of Home Study

Therefore, it was easy to decide that home study was the answer for someone like me, who doesn't want to be tied down. With home study there is no schedule. I am the boss, and I set the pace. There is no cramming for exams because I decide when I am ready, and only then do I take the exam. I never miss a point in the lecture because

it is right there in print for as many re-readings as I find necessary. If I feel tired, stay late at work, or just feel lazy, I can skip school for a night or two and never fall behind. The total absence of all pressure helps me to learn more than I'd be able to grasp if I were just cramming it in to meet an exam deadline schedule. For me, these points give home study courses an overwhelming advantage over scheduled classroom instruction.

Having decided on home study, why did I choose CIE? I had catalogs from six different schools offering home study courses. The CIE catalog arrived in less than one week (four days before I received any of the other catalogs). This indicated (correctly) that from CIE I could expect fast service on grades, questions, etc. I eliminated those schools which were slow in sending catalogs.

FCC License Warranty Important

The First Class FCC Warranty* was also an attractive point. I had seen "Q" and "A" manuals for the FCC exams,

*CIE backs its FCC License-preparation courses with this famous Warranty: graduates must be able to pass the applicable FCC License exam or their tuition will be refunded in full.

and the material had always seemed just a little beyond my grasp. Score another point for CIE.

Another thing is that CIE offered a complete package: FCC License and technical school diploma. Completion time was reasonably short, and I could attain something definite without dragging it out over an interminable number of years. Here I eliminated those schools which gave college credits instead of graduation diplomas. I work in the R and D department of a large company and it's been my observation that technical school graduates generally hold better positions than men with a few college credits. A college degree is one thing, but I'm 32 years old, and 10 or 15 years of part-time college just isn't for me. No, I wanted to *graduate* in a year or two, not just *start*.

If a school offers both resident and correspondence training, it's my feeling that the correspondence men are sort of on the outside of things. Because I wanted to be a full-fledged student instead of just a tagalong, CIE's exclusively home study program naturally attracted me.

Then, too, it's the men who know their theory who are moving ahead where I work. They can read schematics and understand circuit operation. I want to be a good theory man.

From the foregoing, you can see I did not select CIE in any haphazard fashion. I knew what I was looking for, and only CIE had all the things I wanted.

Two Pay Raises in Less Than a Year

Only eleven months after I enrolled with CIE, I passed the FCC exams for First Class Radiotelephone License with Radar Endorsement. I had a pay increase even before I got my license and *another* only ten months later. I'm getting to be known as a theory man around work, instead of one of the screwdriver mechanics.

These are the tangible results. But just as important are the things I've learned. I am smarter now than I had ever thought I would be. It feels good to know that I know what I know now. Schematics that used to confuse me completely are now easy for me to read and interpret. Yes, it is nice to be smarter, and that's probably the most satisfying result of my CIE experience.

Praise for Student Service

In closing, I'd like to get in a compliment for Mr. Chet Martin, who has faithfully seen to it that my supervisor knows I'm studying. I think Mr. Martin's monthly reports to my supervisor and generally flattering commentary have been in large part responsible for my pay increases. Mr. Martin has given me much more student service than "the contract calls for," and I certainly owe him a sincere debt of gratitude.

And finally, there is Mr. Tom Duffy, my instructor. I don't believe I've ever had the individual attention in any classroom that I've received from Mr. Duffy. He is clear, authoritative, and spared no time or effort to answer my every question. In Mr. Duffy, I've received everything I could have expected from a full-time private tutor.

I'm very, very satisfied with the whole CIE experience.

ENROLL UNDER NEW G.I. BILL

All CIE courses are available under the new G.I. Bill. If you served on active duty since January 31, 1955, or are in service now, check box on reply card or coupon for G.I. Bill information.

Every penny I spent for my course was returned many times over, both in increased wages and in personal satisfaction.

Perhaps you too, like Harry Remmert, have realized that to get ahead in Electronics today, you need to know much more than the "screwdriver mechanics." They're limited to "thinking with their hands"... learning by taking things apart and putting them back together... soldering connections, testing circuits, and replacing components. Understandably, their pay is limited—and their future, too.

But for men like Harry Remmert, who have gotten the training they need in the fundamentals of Electronics, there are no such limitations. As "theory men," they think with their heads, not their hands. For trained technicians like this, the future is bright. Thousands of men are urgently needed in virtually every field of Electronics, from two-way mobile radio to computer testing and troubleshooting. And with this demand, salaries have skyrocketed. Many technicians earn \$8,000, \$10,000, \$12,000 or more a year.

Send for Complete Information—FREE

Many men who are advancing their Electronics career started by reading our famous book, "How To Succeed In Electronics." It tells of the many electronics careers open to men with the proper training. And it tells which courses of study best prepare you for the work you want.

If you're "shopping around" for the training you need to move up in Electronics, this 44-page book may have the answers you want. We'll send it to you FREE. With it, we'll also include our other helpful book, "How To Get A Commercial FCC License."

To get both FREE books, just fill out and mail the bound-in postpaid card. If the card is missing, send the coupon below.

CIE Cleveland Institute of Electronics

1776 East 17th Street, Cleveland, Ohio 44114

Accredited Member National Home Study Council • A Leader in Electronics Training Since 1934



NEW COLLEGE-LEVEL COURSE IN ELECTRONICS ENGINEERING

for men with prior experience in Electronics. Covers steady-state and transient network theory, solid state physics and circuitry pulse techniques, computer logic and mathematics through calculus. A college-level course for men already working in Electronics.

Cleveland Institute of Electronics
1776 East 17th Street, Cleveland, Ohio 44114

Please send me without cost or obligation:

1. Your 44-page book "How To Succeed In Electronics" describing the job opportunities in Electronics today, and how your courses can prepare me for them.
2. Your book on "How To Get A Commercial FCC License."

I am especially interested in:

- | | |
|--|--|
| <input type="checkbox"/> Electronics Technology | <input type="checkbox"/> Electronic Communications |
| <input type="checkbox"/> Broadcast Engineering | <input type="checkbox"/> Industrial Electronics and Automation |
| <input type="checkbox"/> First-Class FCC License | <input type="checkbox"/> Electronics Engineering |

Name _____

(PLEASE PRINT)

Address _____

City _____

State _____ Zip _____ Age _____

Check here for G.I. Bill information. PE '98

CIRCLE NO. 8 ON READER SERVICE PAGE

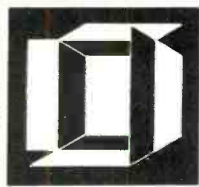

NEW PRODUCTS

Additional information on products covered in this section is available from the manufacturers. Each new product is identified by a code number. To obtain further details on any of them, simply fill in and mail the coupon on page 15 or 97.

60-WATT AM/STEREO FM RECEIVER KIT

The Model AR-19 deluxe medium-power stereo receiver made by the *Heath Company* features advanced FET and IC design to provide the ultimate in hi-fi listening. Contained in its five IC's are a total of 57 transistors and 35 diodes to provide a frequency response of 6-35,000 Hz with less than 0.25% harmonic and i.m. distortion at any power level. There are also breakthroughs for the kit builder—like snap-in/out circuit board construction and a built-in test circuit that eliminates the need for test equipment. The factory-assembled and aligned FM tuner has a 2- μ V sensitivity; and for AM reception, there is a built-in antenna that swivels in two planes. The audio output of the AR-19 receiver is rated at 60 watts music power into 8 ohms.



Circle No. 78 on Reader Service Page 15 or 97

PORTABLE ELECTRONIC TUNING FORK

Schober Organ Corp. recently made available the Schober Electronic Tuning Fork that provides 12 steady tones from middle C through B above middle C for tuning keyboard and other musical instruments. The pitch accuracy is said to be within 5 cents (5% of a semitone). A special knob on the instrument sets the scale at A = 440 Hz, but it permits resetting between 435 and 445 Hz. The tone harmonics allow easier zero-beating so that the user can tune instruments in higher and lower octaves. The Electronic Tuning Fork operates from two 9-volt transistor batteries and has a voltage regulator that maintains pitch accuracy during the entire life of the batteries. The circuitry is entirely solid-state, and a built-in loudspeaker is featured.



Circle No. 79 on Reader Service Page 15 or 97

CUTTING DEVICE FOR PLASTICS

Designers, engineers, scientists, model makers, artists, architects, sign makers, and all types of craftsmen will find a great many

uses for the "Model Machine" for cutting plastic foam made by *Technical Devices*. The Model Machine cuts plastic foam, such as Dow Chemical's Styrofoam, up to 6" thick with ease and accuracy. The cutting wire does not vibrate, "saw," or move—it works by melting a fine cut through the plastic material.

Circle No. 80 on Reader Service Page 15 or 97

PSYCHEDELIC COLOR ORGAN KIT

Now you can enjoy a psychedelic light show at home with the new *Knight-Kit* Model KG-338 color organ kit. This fascinating music system accessory provides a brilliant display of flashing lights and colors, perfectly synchronized to the music being played. The lights flash in time with the music, varying in color and intensity according to the amplitude and frequency of the music being used to drive them. All-solid-state, three-channel circuitry separates the high, mid-range, and low frequencies into blue, green, and red lights, respectively, that provide a three-dimensional display through a prismatic screen. The KG-338 connects in moments to the speaker terminals of any receiver, amplifier, or console system, yet does not affect the sound quality of the system in any way.

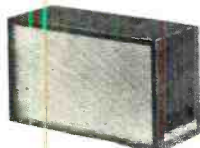

Circle No. 81 on Reader Service Page 15 or 97

SINGLE-CHANNEL VHF MONITORADIO

Regency Electronics, Inc., is marketing its compact Model TMR-1, a new base or mobile VHF receiver. The TMR-1 is capable of operating in either the 30-50- or 148-174-MHz bands. The receiver is provided complete with a.c. and d.c. power cords, mobile mounting bracket, detachable telescoping antenna, and a built-in 4" speaker. External speaker terminals and a standard auto antenna jack are available on the rear apron of the TMR-1. The chrome-trimmed front panel is equipped with an on/off-volume and a variable-squelch controls. Five watts of audio output power is complemented by a 0.5- μ V sensitivity and 50-dB selectivity at \pm 15 kHz. The TMR-1 measures 2 $\frac{1}{4}$ " x 5 $\frac{1}{2}$ " x 7 $\frac{1}{2}$ ".



Circle No. 82 on Reader Service Page 15 or 97

CASSETTE STEREO RECORD/PLAY SYSTEM

Novelco's Model 2400 is a versatile self-contained stereo cassette recorder and playback system with its own sealed satellite speakers. Solid-state circuitry, pushbutton controls, illuminated VU meter, digital counter, automatic end-of-tape stop, and monitoring facilities are featured. With a frequency range of 60-10,000 Hz, the 2400 is ideal for home recording through its own dynamic

Need an 80-db blast?

Actual size



You'll get it from our 1¼-ounce Sonalert® electronic audible signal.

With as little as 6 VDC and 3 ma., Sonalert produces a piercing sound that's hard to ignore. Yet it weighs only a couple of ounces because it's all solid state. Even the transducer is a crystal. This makes Sonalert reliable, efficient and long lasting. And because it's solid state, there's no danger of arcing, no RFI or EMI noise.

Standard units vibrate at a fixed frequency of 2900 ± 500 Hz or 4500 ± 500 Hz depending

* Registered trademark, P. F. Mallory & Co., Inc.

MALLORY

MALLORY DISTRIBUTOR PRODUCTS COMPANY

A DIVISION OF P. F. MALLORY & CO., INC.
Box 1258, Indianapolis, Indiana 46206. Tel. (317) 434-5700

on model. Pulsing, warbling and AC models are also available. The penetrating sound covers a wider area than alarm lights and demands instant action. Examples: electrical overload, computer error, automobile door ajar, headlights-on warning, shipboard, communications alarms, etc.

For an informative 48-page booklet of projects and circuit ideas, write for folder No. 9-406. Address Mallory Distributor Products Company, a division of P. F. Mallory & Co., Inc., Indianapolis, Indiana 46206.

Batteries • Capacitors • Cassette Tapes • Controls • Resistors • Semiconductors • Sonalert® • Switches • Timers • Vibrators • ICs

CIRCLE NO. 17 ON READER SERVICE PAGE

PRODUCTS (Continued from page 22)



stereo microphone. Also included are patch cords for recording from radio receivers, phonographs, or another tape recorder. Controls provided include volume, balance, treble, bass, and recording.

Circle No. 83 on Reader Service Page 15 or 97

SOLID-STATE VOLT/OHMMEETER

A portable all-solid-state Master VoltOhmyst, Model WV-510A, especially designed for service, industrial, and laboratory applications was announced by *RCA Electronic Components* recently. The new solid-state meter can be operated from either internal batteries or a 117-volt a.c. power line. The WV-510A measures d.c. voltage from 0.01 to 1500 volts; direct current from 0.01 mA to 1.5 amperes; a.c. voltage from 0.2 to 1500 volts; a.c. peak-to-peak voltages of complex waveforms from 0.5 to 4200 volts; and resistance from 0.2 ohm to 1000 megohms. Seven overlapping ranges are provided for a.c., resistance, and current measurements, and eight ranges for d.c. voltage measurements. Accuracy for all voltage and current functions is 3% of full-scale. The d.c. input resistance of the WV-105A is 21 megohms.

Circle No. 84 on Reader Service Page 15 or 97

HIDDEN-MICROPHONE RECORDER

For those people who are "mike shy," *Superscope* has introduced the Sony Model 110 Cassette-Corder featuring a hidden built-in electret condenser microphone that is no bigger than a quarter but has exceptionally good pick-up characteristics. The Model 110 has the exclusive Sony-matic Recording Control which automatically adjusts varying sound levels



to a constant level during recording. An end-of-tape alarm gives an audible signal when the tape has reached the end. The recorder has piano-key pushbutton controls.

Circle No. 85 on Reader Service Page 15 or 97

MINI-MOBILE CB TRANSCEIVER

The Micro-12 miniature CB transceiver now available from *Lafayette Radio Electronics* combines a powerful three-stage 5-watt transmitter and a sensitive, highly selective receiver into a package that measures only 7½" x 5" x 1¾". Its crystal-controlled transmit and receive positions can be used to select any 12 of the 23 available CB channels. The receiver section utilizes an r.f. amplifier stage for 1-μV sensitivity at 10 dB signal-to-noise ratio. An automatic noise limiter, mechanical filter, and variable squelch permit convenient quiet operation. Other features include a TVI trap, illuminated channel indicator, ear-phone/speaker jack and Range Boost audio circuitry.



Circle No. 86 on Reader Service Page 15 or 97

C-D IGNITION SYSTEM

A radical new design that utilizes only recently developed silicon semiconductors instead of germanium types is featured in the Mach II capacitive-discharge ignition system made by *C-D Systems*. The design permits reliable operation under the most severe driving conditions; and, since only silicon components are used, the Mach II will operate even when under-the-hood temperatures reach 300° F. A silicon controlled rectifier is used to discharge a 450-volt pulse into the stock coil, generating a voltage at the spark plugs in excess of 60,000 volts. Current drain is less than one ampere at idle, 7 amperes at 12,000 r/min. Maximum current through the points is 0.25 ampere, extending point life to 100,000 miles or more. The Mach II is designed to work with stock ignition parts, requires no rewiring, and can be used in any 12-volt, negative ground system. It comes with a three-year guarantee.



Circle No. 87 on Reader Service Page 15 or 97

BREAKTHROUGH IN AUDIO RECORDING

Bell & Howell has entered the magnetic tape market with the introduction of its Ultra High Density (UHD) and High Density (HD) audio tapes with exclusive gamma-oriented coating process. The UHD tapes are said to give appreciably higher fidelity at all speeds, regardless of factory bias settings, than magnetic tapes currently on the market. The HD tapes have the characteristics most needed for voice and music recording on modern

(Continued on page 99)

Now is a great time to
move up to JOHNSON
quality and performance...



SAVE
up to
\$40⁰⁰
on your next
CB SET

**FACTORY
AUTHORIZED
SALE!**

... at your Johnson distributor
HURRY—Offer expires June 30th!



E. F. JOHNSON COMPANY
WASECA, MINNESOTA 56093

CIRCLE NO. 14 ON READER SERVICE PAGE

Now it costs less to own the best oscilloscope you need.



The New RCA WO-505A Solid-State Oscilloscope

*Inexpensive Quality
†Optional Distributor
Resale Price

RCA

The best you need is the new 5-inch RCA WO-505A, all solid-state oscilloscope. It makes yesterday's general-purpose 'scopes look old-fashioned.

At just \$298.50† the WO-505A offers an unmatched list of features usually found only in more expensive, laboratory-type instruments. For example there's the all solid-state circuitry... an illuminated graph screen calibrated directly in volts, and a deep-lip bezel for exceptional clarity. The regulated power supply minimizes trace bounce and provides excellent stability. And the camera mounting studs offer still more evidence of the functional value built into the new WO-505A.

But you've got to see this new RCA 'scope in operation — see the sharp, clean trace it provides — to appreciate it.

Some statistics:

- High-frequency response, usable to 8 MHz.
- High Sensitivity (.05 V p-p range).
- DC vertical amplifier; DC/AC input.
- Return trace blanking... Trace polarity reversal switch... Phase control.
- High-frequency horizontal sweep; solid lock-in on 5 MHz.
- Preset TV "V" and "H" frequencies for instant lock-in.
- Built-in square-wave signal for calibrating P-P voltage measurements.
- Provision for connection to vertical deflection plates of CRT.

Some statistics! For complete details, contact your RCA Distributor.

RCA | Electronic Components | Harrison, N. J. 07029

CIRCLE NO. 27 ON READER SERVICE PAGE

POPULAR ELECTRONICS EXCLUSIVE DEVELOPMENTAL PROJECT

LASER BEAM COMMUNICATOR

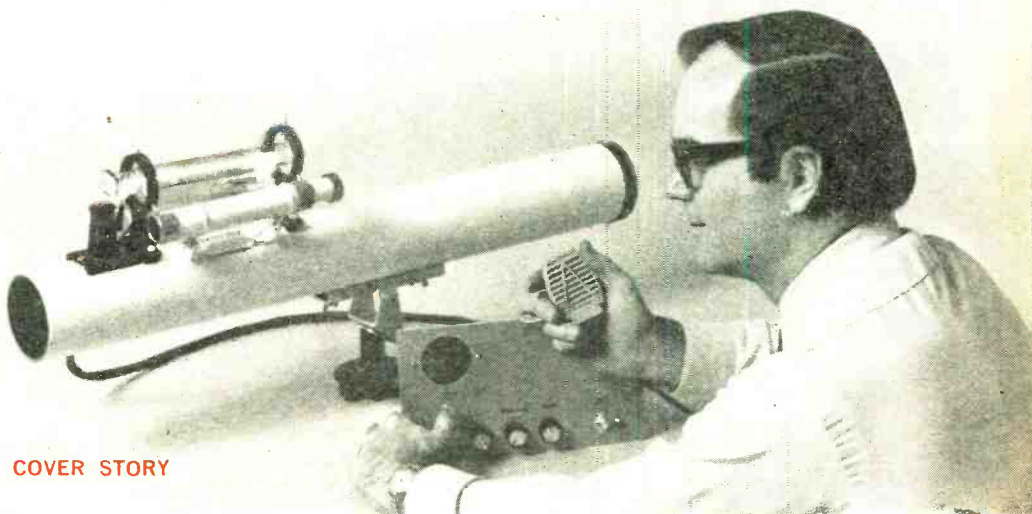

COVER STORY

AUDIO MODULATE OUR LOW-COST LASER

BY C. HARRY KNOWLES

COMMUNICATING by means of a laser beam is as fresh and new as the tomatoes picked from your garden tomorrow morning. The mere idea of being able to transmit information on a beam of coherent laser light suggests all sorts of possibilities for secret, non-jammable, interference-free communications. And it is possible today!

Communications by laser beam offers several advantages over conventional radio links. Neither atmospheric lightning nor airborne electrical noise affects laser communications though they can completely ruin radio communications. On the debit side, however, laser performance is degraded, over any reasonable distance, by heavy fog, rain, snow, or terrestrial heat.

Unlike radio, in which the signal is "sprayed" out over a wide area, a laser beam communications system operates on a line-of-sight basis and the beam is

tight enough to provide excellent privacy. Of course, obstructions cannot be permitted to interrupt the beam but conventional optical mirrors can be used to bend the light beam around obstructions if necessary.

Two approaches to laser communications are described in this article. The

PE AT SMITHSONIAN

A pair of POPULAR ELECTRONICS laser communicators, similar to the one described in this article, is scheduled to be shown in operation at the Laser-10 exhibit at the Smithsonian Institution's National Museum of History and Technology in Washington, D. C. this spring and summer. Readers living in the area or visiting Washington will want to see this excellent exhibit, which features a wide variety of lasers in many unique applications. The POPULAR ELECTRONICS laser communicators will be set up to carry two-way conversations.

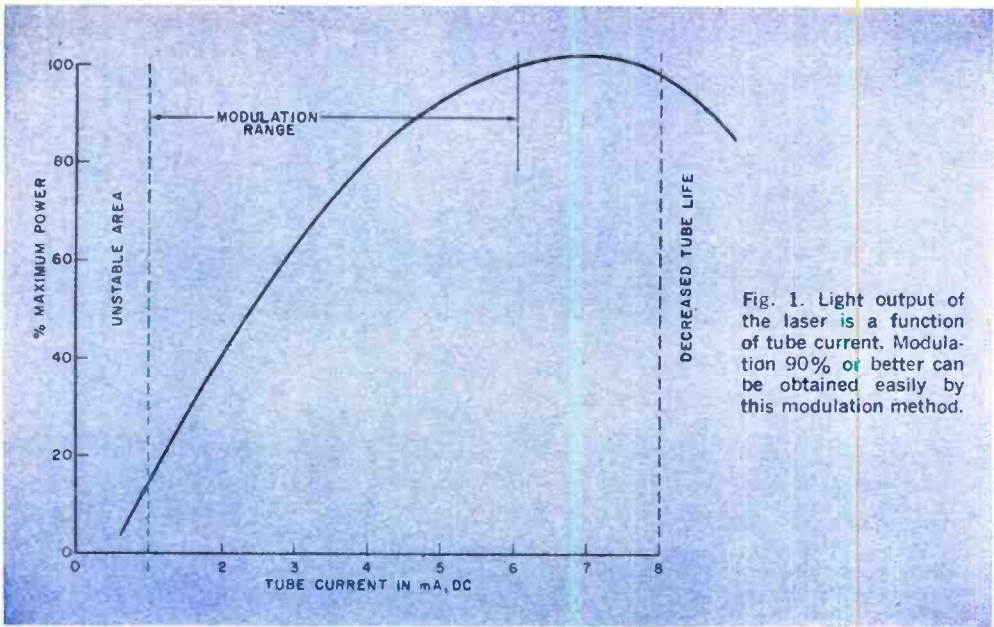

Fig. 1. Light output of the laser is a function of tube current. Modulation 90% or better can be obtained easily by this modulation method.

first involves only a simple addition to the basic laser described in **POPULAR ELECTRONICS** in December 1969. This system has a range of about 100 ft, and can be used for experimenting within a room and provides a "breadboard" for use in understanding modulated laser action. It also makes an excellent science fair project.

The second approach uses a modulation and receiving scheme similar to the

first but it operates through conventional low-cost telescopes to achieve a range of several miles (depending on atmospheric conditions).

Laser Modulation. The light output of a gas laser such as the 0.5-mw helium-neon type described in our previous article is a function of the current flowing through the laser tube (see Fig. 1). At very low currents, the laser becomes unstable and

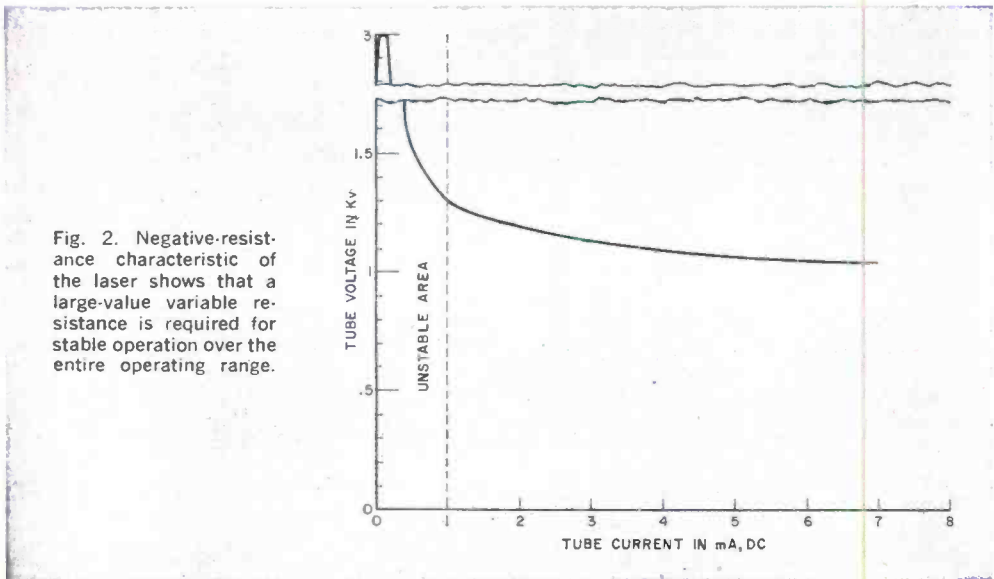

Fig. 2. Negative-resistance characteristic of the laser shows that a large-value variable resistance is required for stable operation over the entire operating range.

tends to turn itself off. The light output increases reasonably linear with tube current up to approximately 5 mA. Above that, the light output drops drastically and tube life is decreased. If the current is centered on the middle of the linear portion of the curve and varied about that point, the light output can be made to swing in a linear fashion and very high modulation levels can be obtained.

The voltage-current curve in Fig. 2 shows that the laser tube has a negative resistance characteristic (voltage decreases as current increases). Stable, linear operation thus depends on the use of a ballast resistor. When the tube is operating at 5 mA, approximately 1100 volts are required. At this point, the negative dynamic resistance is about 30,000 ohms. As the current is decreased the required voltage rises until, at about 1 mA, it is approximately 1300 volts. Here the negative resistance is 80,000 ohms. Therefore, the ballast resistor must have an effective value well above 80,000 ohms to keep the tube operating.

A basic modulator circuit, using a pentode with a large dynamic resistance, is shown in Fig. 3. The pentode is in series with the laser tube and forms a simple amplitude modulator. The dynamic resistance of the pentode is a function of the applied audio signal on its control grid. A potentiometer in the cathode circuit of the pentode determines the basic operating resistance of the tube and, hence, the operating point of the laser. Once the latter point (located on

the curve in Fig. 1) has been set by the bias potentiometer, an audio input to the pentode causes the laser current to fluctuate about the operating point and the emitted light is amplitude modulated.

Almost any type of audio driver can be used to generate the input audio signal to the pentode.

Basic Modulator. The circuit for converting the original laser project into a light-beam transceiver is shown in Fig. 4. A photograph of the finished project is shown in Fig. 5. A complete vacuum-tube system is used simply because a high resistance device is required and the tube that will do the job is inexpensive and readily available. In addition, the +175 and 6.3-volt sources required by the pentode can be used elsewhere in the circuit.

The modulator circuit can be divided into two portions. The transmitter (V1) consists of the pentode modulator driven by the triode half of the tube acting as a microphone preamplifier. Potentiometer *R4* provides modulation level control. The three gas tubes in series (I1-I3) are 200-volt breakdown lamps which chop off the high-voltage spikes that trigger the laser. Although the operating plate voltage of the tube is below its maximum rating, a much higher voltage spike is used to trigger the laser. The three gas lamps limit this spike to 600 volts. Unlike semiconductors, a vacuum tube can withstand an overvoltage for a short time. The trigger spike here lasts only about one millisecond so no damage can be done to the tube. If you can't locate the gas tubes called for in the Parts List, use any combination of conventional neon lamps that add up to approximately 600 volts.

The receiving portion of the modulator consists of a three-stage conventional audio amplifier driven from the output of the solar cell. Unlike a conventional light-dependent resistor, a solar cell generates a voltage that is a function of the amount of light striking the photosensitive surface.

Construction. If you built the original laser project, the same metal chassis may be used. Drill or punch holes for two 9-pin and one 7-pin tube sockets. These may be located on the top of the chassis,

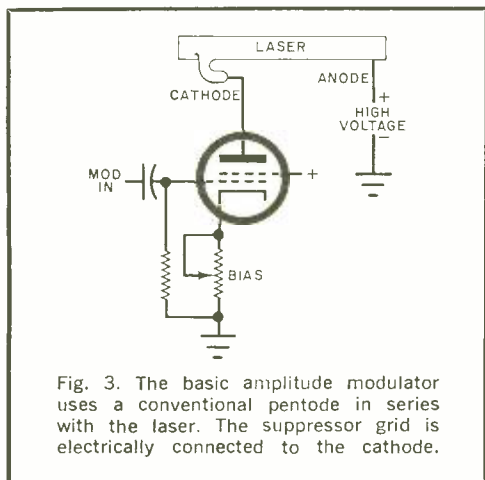

Fig. 3. The basic amplitude modulator uses a conventional pentode in series with the laser. The suppressor grid is electrically connected to the cathode.

next to the laser tube. (Be sure to remove the laser tube when doing mechanical work on the chassis.) On the wall opposite the high-voltage laser power supply, mount the three potentiometers ($R6$, bias; $R4$, modulation level; and $R12$, receiver volume), the microphone

input jack ($J1$), and the photocell input jack ($J2$) (see Fig. 5). Mount power transformer $T2$ on the outside of the chassis using the same mounting hardware as were used for the original 600-volt transformer. (It was $T1$; now it is $T3$.)

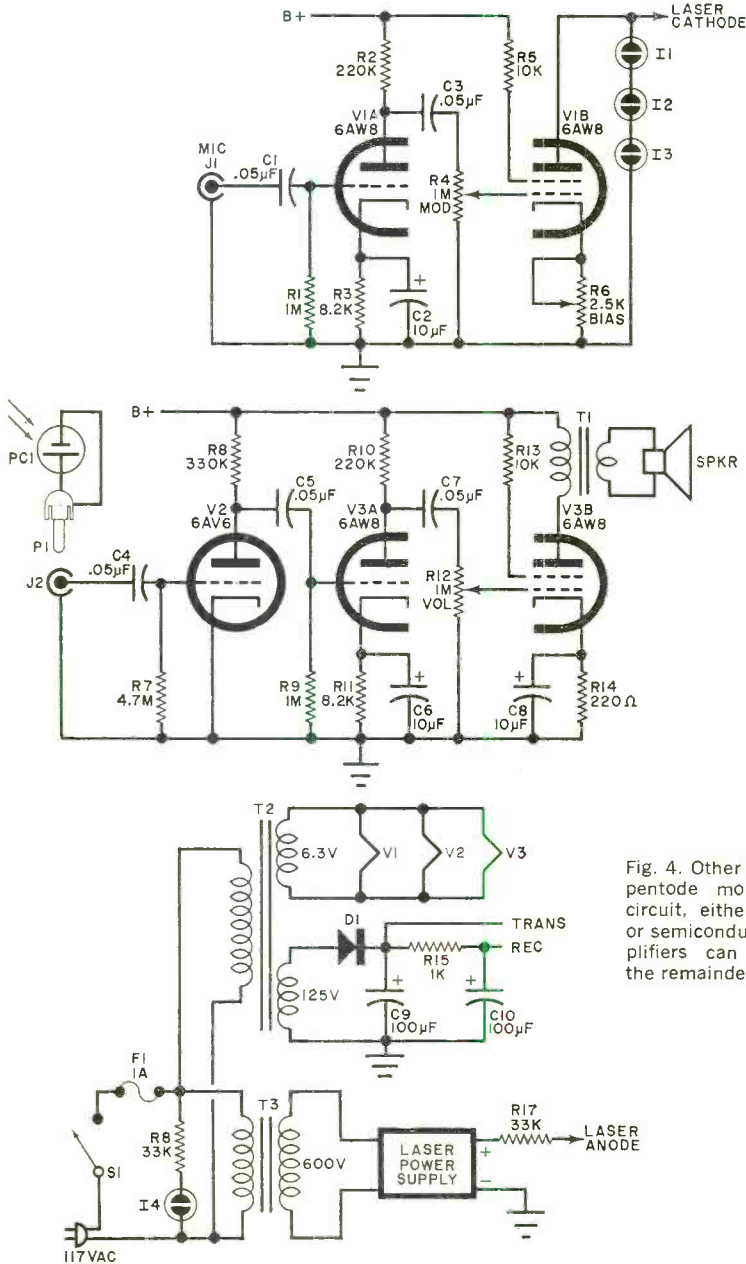

Fig. 4. Other than the basic pentode modulator (V1B) circuit, either vacuum-tube or semiconductor audio amplifiers can be used for the remainder of the circuit.

Once all the components are installed, wire up the circuit point-to-point (using terminal strips as required) following the circuit shown in Fig. 4. Of course, it is not necessary to use vacuum tubes for the microphone amplifier. You can use the 6AU6 pentode for the laser driver and, for the amplifier, any one of several commercially available transistor amplifiers. The author used one of the new RCA IC kits—the KC4000 microphone pre-amplifier—in one model and found that it worked fine. The solid-state receiver consisted of a KC4000 microphone preamplifier for the photocell pre-

amplifier and a KC4003 1/2-watt audio amplifier to drive the speaker.

The receiving photocell in this simple light communicator is mounted at one end of a dark plastic tube. (A cleaned out container of Polaroid print coater works very well.) If you use a cardboard tube, paint the interior a dull black before installing the cell. For testing and experimentation, make up a microphone cable with a phono connector at one end. Use a phone jack to make the connection to the earphone output of a conventional transistor radio. The radio is silent when the earphone jack is plugged in and produces a non-tiring audio signal for testing.

PARTS LIST ONE-WAY COMMUNICATOR

- C1,C3,C5,C7—0.05- μ F capacitor
 C2,C6,C8—10- μ F, 15-volt electrolytic capacitor
 C9,C10—100- μ F, 250-volt electrolytic capacitor
 D1—Silicon rectified diode (1N4001 or similar)
 F1—1-ampere fuse and holder
 H1—15—200-volt breakdown lamp (Signallite A-250 or similar)
 L4—NE-2 neon lamp
 J1,J2—Phono jack
 P1—Phono plug
 PC1—Solar cell (Allied Electronics 60D7569)
 R1,R9—1-megohm
 R2,R10—220,000-ohm
 R3,R11—8200-ohm
 R5,R13—10,000-ohm
 R7—4.7-megohm
 R8—330,000-ohm
 R14—220-ohm
 R15—1000-ohm
 R16—33,000-ohm
 R4,R12—1-megohm potentiometer
 R6—2500-ohm potentiometer
 S1—S.p.s.t. switch
 Spkr—3.2-ohm speaker
 T1—5000-to-3.2-ohm output transformer
 T2—Power transformer; secondaries, 6.3 volts at 2 amperes and 125 volts at 50 mA (CTC PA8421 or similar)
 T3—Power transformer; secondary 620-650 volts at 50 mA
 V1,V3—6AV8A
 V2—6AV6
 Misc.—Laser power supply, laser, nine-pin socket (2), seven-pin socket, multi-lug terminal strip, mounting hardware, insulated wire, microphone, speaker, etc.
- Note—The following are available from Metrologic Instruments Inc., 143 Harding Ave., Bellmawr, NJ 08030: laser model 205, 0.3 to 0.7 mW power output, 2.0 milliradians beam divergence, multimode, \$50.50, postpaid; or laser model 215, 0.5 to 1.0 mW output, 0.8 milliradians divergence, single mode, \$70.50, postpaid; model 60-141 power supply kit complete with PC board, all components and transformer, \$18.50, postpaid; model 60-203 complete one-way communicator (except laser and its power supply) including chassis, PC boards, microphone, solid-state 1-KHz oscillator, amplifiers, speech compressor, power supply, solar cell, speaker, and instruction book, \$74.25, postpaid (this kit is convertible for telescope transmission and reception).

All resistors
1/2-watt

Testing. Place the volume, modulation, and bias potentiometers in their minimum resistance positions. Connect up the speaker, photocell, and radio and turn on the power. The laser tube will start to blink at a low level until the modulation pentode warms up. Once the tube is hot, the laser will operate at its full brightness. A slight increase in the resistance of R6 should cause the laser beam to dim slightly. This shows that the bias control is operating properly. Now set the control for full brightness. Increasing the volume control should produce some hum in the speaker. If conventional room light is allowed to fall on the sensitive face of the solar cell, it will produce a distinctive hum. This is the reason the solar cell should be mounted in a dark tube.

Separate the laser and the solar cell by a few feet and aim the beam at the receiver. Alternatively, aim the laser beam at a mirror so that it is reflected back to the cell. (The beam must be aimed straight down the cell tube and not at the interior wall.)

With the laser beam shining on the solar cell at full brightness, turn on the radio, tune to a station, and plug in the earphone jack. On the laser chassis, turn up the receiver volume control and note that, as the hand is passed through the laser beam, a thump is heard in the speaker.

Slightly reduce the bias control to dim the laser a little, and turn up the modulation control slightly. These two controls interact somewhat so you will have to "juggle" them for best modulation.

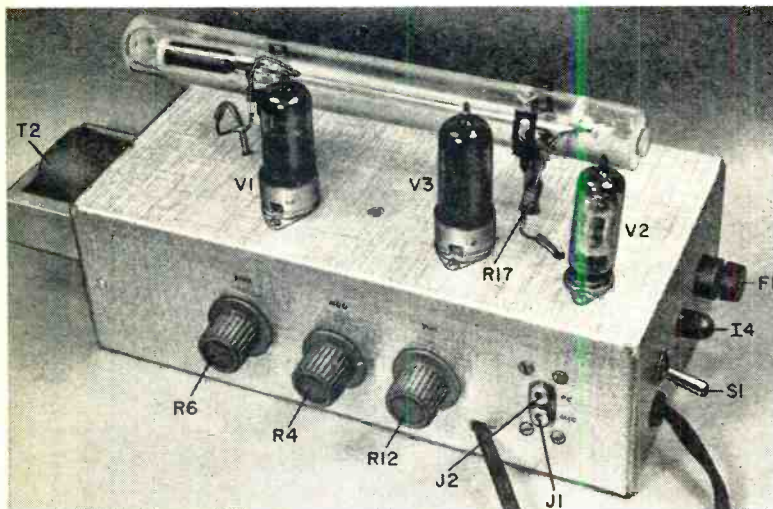

Fig. 5. The prototype was built on the original laser chassis (December 1969 issue). Any other layout will do as long as the pentode modulator is as close as possible to the laser.

Make sure that the radio volume is turned up sufficiently.

Once the communicator is working, you can experiment with the controls and the circuit (always retaining the pentode as the laser modulator) to increase your understanding of laser communications.

Optical Systems. Depending on how you want to use it, the laser communicator can be set up with any one of three optical systems. The simplest, which can be used for point-to-point communications around a room (to a total of 100 ft round trip), is as described above, without any lenses. To improve the reception somewhat, a simple lens can be placed in the beam path at the receiver end to reduce the size of the diverged beam.

The second type of optical system, requires the use of a set of binoculars, one eyepiece for the transmitter and the other for the receiver. Simple toy telescopes may also be used. The range for this type of system is a few hundred feet.

For communicating over greater distances, a reasonably high-power telescope is necessary. Such a telescope, attached to the laser communicator, acts like a high-gain antenna on a conventional radio system. In both cases the transmitted and received signals get a boost from the "antenna." And in both cases, the telescope or antenna is used for both transmitting and receiving through a simple mechanical switching process.

How far can you transmit using a telescope? It depends on a number of factors, the most important being beam divergence and atmospheric conditions. As the beam travels along its path, it tends to enlarge (diverge). This means that, although the beam leaving the laser is quite small (1 millimeter in the POPULAR ELECTRONICS laser), it does enlarge considerably—though not as much as a comparable beam of conventional light. Using a telescope improves this condition considerably.

Atmospheric disturbances of the laser beam cause it to wander.

As the beam of light is projected over a long distance, it may encounter various forms of air turbulence, such as localized temperature changes. In each of these turbulences, the density of the air changes and each change in density acts as a prism as the beam passes through it, changing the beam's direction slightly. The amount of wander can be as much as several feet per mile. In the still, relatively even temperature of morning, before the sun has had a chance to warm up the air, beam wander may be as little as a few inches per mile.

In using a reflector telescope such as that described later in this article, the beam should be collimated as closely as possible to the distant receiver, allowing for thermal refractive variations for the time of day and the atmospheric conditions. If the air is still and of an even temperature, the beam will wander only a few inches per mile. In this case, also,

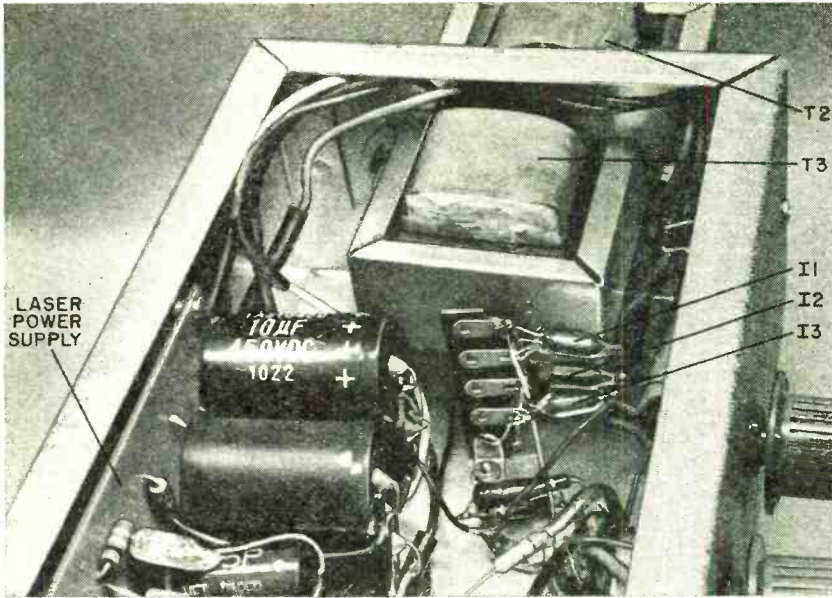

Internal layout of the prototype transceiver (above) showing the laser power supply mounted on one wall with the rest of the components occupying the remaining space. The internal arrangement of the telescope electronics (shown below) shows the modulator tube and its associated components arranged within its smaller metal enclosure.

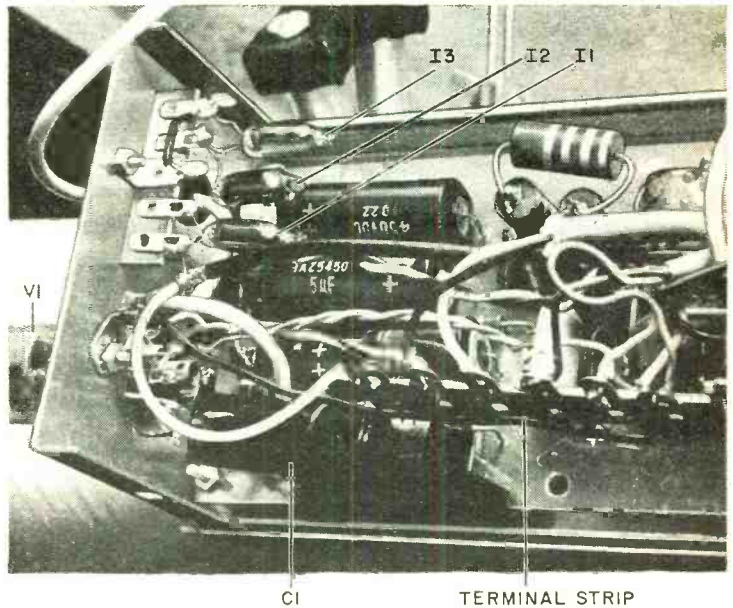

the beam may be focussed so that at the receiver, the beam diameter has diverged only about one foot per mile. If the atmosphere is clear, there is little absorption by airborne particulants (smoke, dust, etc.); and the overall result is that

about 3 to 5% of the transmitted beam power is obtained at the receiver. This extremely high efficiency is one of the many attractive features of laser communications that will help make it the system of the future.

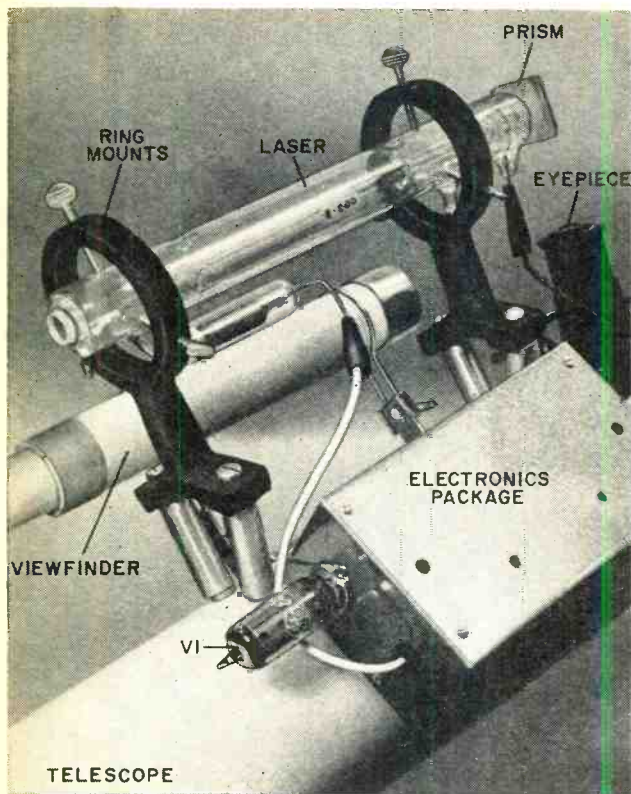

The complete telescope system can communicate as far as a 12-inch target can be clearly seen via the telescope. At night, this target will have to be illuminated. In good visibility, range can be very great but is dependent on certain conditions (see text). To assist distant communications, an optional 1-kHz audio oscillator is used to modulate the transmitter, and both ends must be "juggled" until the received audio tone is at a maximum. To get around opaque objects, a large-size front-surface mirror (not a ladies compact mirror) may be used to reflect the laser beam.

Reflector Telescope Construction. A telescopic system is shown in Fig. 6. The laser tube is supported by a pair of viewfinder ring mounts attached to the telescope tube. The laser is positioned within the mounts so that the light-emitting end is almost directly over the telescope eyepiece. (Check your laser tube to make sure whether the light beam comes out of the anode or the cathode. Some models are one way; some the other.)

Make up an L-shaped length of heavy bus bar with the long side about 2½" — the other about 1" long. Cement (with epoxy) the short end of the bus bar to the relay armature so that it swings back and forth as the relay is energized and de-energized. Position the relay about 90° from the telescope eyepiece so that when the long end of the bus bar is placed through a slot cut in the telescope tube and with the relay energized (talk position) the end of the bus bar is out of the beam path. With the relay de-energized (listen position) the wire should be in the beam path. Remove the telescope eyepiece to watch this.

Fig. 6. Complete telescope communicator showing the use of semiconductor audio amplifiers. Any neon lamps may be used for I1, I2, or I3 if their breakdown totals up to about 600 volts.

PARTS LIST TELESCOPE COMMUNICATOR

- C1—0.1- μ F capacitor
- C2—10- μ F, 250-volt electrolytic capacitor
- C3, C4—100- μ F, 25-volt electrolytic capacitor
- D1-D5—Silicon rectifier diode (1N4003 or similar)
- F1—1-ampere fuse and holder
- I1-I3—200-volt breakdown lamp (Signallite A259 or similar)
- I4—NE-2 neon lamp
- J1—Phono jack
- K1—117-volt relay
- P1—Octal plug
- P2—Phono plug
- P3—2-lead plug
- R1—33,000-ohm, 2-watt resistor
- R2—470,000-ohm, ½-watt resistor
- R3—10,000-ohm, ½-watt resistor
- R4—2500-ohm potentiometer
- R5, R6—1-megohm potentiometer
- R7—1000-ohm, ½-watt resistor
- R8—33,000-ohm, ½-watt resistor
- S1—Normally open s.p.s.t. pushbutton switch
- SO1—Octal socket
- SO2—2-lead socket
- T1—Power transformer; secondaries, 6.3 volts at 2 amperes, 125 volts at 50 mA (CTC PA8421 or similar)

**Someone
should develop
an easy way
to learn
electronics at
home**

**RCA Institutes
did!**

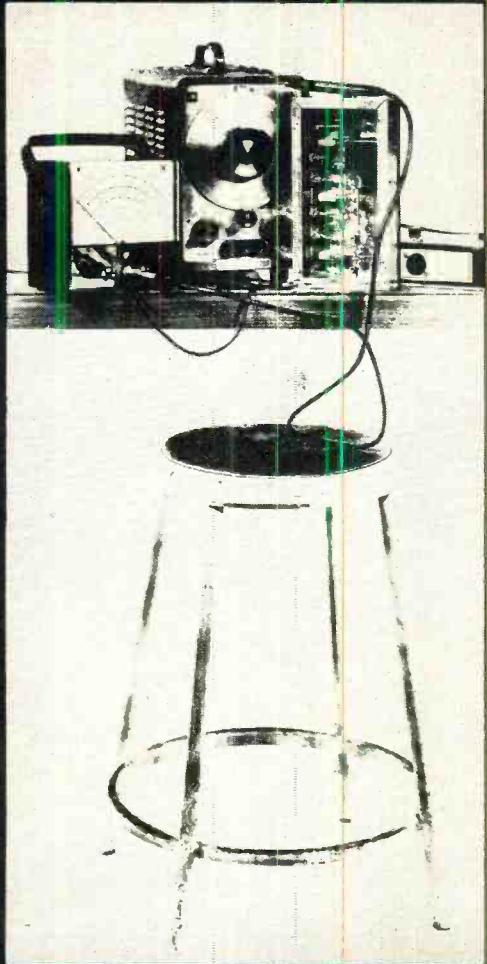

Here is a modern approach to learning electronics at home! RCA Institutes, one of the nation's largest schools devoted to electronics, has developed a faster, easier way for you to gain the skills and the knowledge you need for the career of your choice. Here for the first time is a student-proved, scientifically designed way to learn. If you have had any doubts in the past about home training in electronics—if you have hesitated because you thought you might not be able to keep up—or that electronics was too complicated to learn—here is your answer! Read how RCA Institutes has revolutionized its home training ideas!

**NEW courses
in Solid State Technology
and Communications
Electronics.**

**Mail card today
for full information.**

ALL CAREER PROGRAMS BEGIN WITH "AUTOTEXT" INSTRUCTION METHOD!

Prepare for the field of your choice immediately!
No previous training or experience in electronics needed!

With this new revolutionized method of home training you pick the career of your choice—and RCA Institutes trains you for it. RCA's Career Programs assure you that everything you learn will help you go directly to the field that you have chosen! No wasted time learning things you'll never use on the job! The Career Program you choose is especially designed to get you into that career in the fastest, easiest possible way!

And each Career Program starts with the amazing "AUTOTEXT" Programmed Instruction Method—the new, faster way to learn that's almost automatic! "AUTOTEXT" helps even those who have had trouble with conventional home training methods in the past. This is the "Space Age" way to learn everything you need to know with the least amount of time and effort.

CHOOSE A CAREER PROGRAM NOW
Your next stop may be the job of your choice. Each one of these RCA Institutes Career Programs is a complete unit. It contains the know-how you need to step into a profitable career. Here are the names of the programs and the kinds of jobs they train you for. Which one is for you?

Television Servicing. Prepares you for a career as a TV Technician/Serviceman; Master Antenna Systems Technician; TV Laboratory Technician; Educational TV Technician; CATV Technician.

FCC License Preparation. For those who want to become TV Station Engineers, Communications Laboratory Technicians, or Field Engineers.

Automation Electronics. Gets you ready to be an Automation Electronics Technician; Manufacturer's Representative; Industrial Electronics Technician.

Automatic Controls. Prepares you to be an Automatic Controls Electronics Technician; Industrial Laboratory

Technician; Maintenance Technician; Field Engineer.

Digital Techniques. For a career as a Digital Techniques Electronics Technician; Industrial Electronics Technician; Industrial Laboratory Technician.

Telecommunications. For a job as TV Station Engineer, Mobile Communications Technician, Marine Radio Technician.

Industrial Electronics. For jobs as Industrial Electronics Technicians; Field Engineers; Maintenance Technicians; Industrial Laboratory Technicians.

Nuclear Instrumentation. For those who want careers as Nuclear Instrumentation Electronics Technicians; Industrial Laboratory Technicians.

Solid State Electronics. Become a specialist in the Semiconductor Field.

Electronics Drafting. Junior Draftsman, Junior Technical Illustrator; Parts Inspector; Design Draftsman Trainee Chartist.

SEPARATE COURSES

In addition, in order to meet specific needs, RCA Institutes offers a wide variety of separate courses which may be taken independently of the Career Programs, on all subjects from Electronics Fundamentals to Computer Programming.

TWO CONVENIENT PAYMENT PLANS

Pay for lessons as you order them. No contract obligating you to continue the course. Or, you can take advantage of RCA's convenient monthly payment plan. No interest charges!

VARIETY OF KITS

You receive valuable kits which provide practical application to your studies—yours to keep and use on the job.

Programmed Electronics

Breadboard. You now will receive a scientifically programmed electronic breadboard with your study material. This breadboard provides limitless experimentation with basic electrical and electronic circuits involving vacuum tubes and transistors and includes the construction of a working signal generator and superheterodyne AM Receiver.

Bonus From RCA—Multimeter and Oscilloscope Kits. At no additional cost, you will receive with almost every RCA Institutes Career Program the instruments and kit material you need to build a multimeter and oscilloscope. The inclusion of both these kits is an RCA extra.

CLASSROOM TRAINING ALSO AVAILABLE

RCA Institutes maintains one of the largest schools of its kind in New York City where classroom and laboratory training is available in day or evening sessions. You may be admitted without any previous technical training; preparatory courses are available if you haven't completed high school. Coeducational classes start four times a year.

JOB PLACEMENT SERVICE, TOO!

Companies like IBM, Bell Telephone Labs, GE, RCA, Xerox, Honeywell, Grumman, Westinghouse, and major Radio and TV Networks have regularly employed graduates through RCA Institutes' own placement service.

SEND ATTACHED POSTAGE PAID CARD FOR COMPLETE INFORMATION, NO OBLIGATION.

All RCA Institutes courses and programs are approved for veterans under the new G.I. Bill.

Accredited Member
National Home Study Council

IF REPLY CARD IS DETACHED—SEND THIS COUPON TODAY

RCA INSTITUTES, Inc., Dept. 694-005-D
320 West 31st Street, N.Y., N.Y. 10001

Please rush me FREE illustrated catalog. I understand that I am under no obligation.

Name _____ Age _____
(please print)
Address _____
City _____
State _____ Zip _____

RCA



The main chassis for the telescope communicator mounts the relatively heavy power supplies (except for the laser), all controls, and is connected to the telescope electronics via a multi-lead flexible cable. Microphone plugs into the rear.

On the solar cell called for in the Parts List of Fig. 4, the black side is the sensitive area. Cement the shiny side of the cell to the bus bar and then slide the cell and relay assembly into position. Make sure that the cell switches cleanly in and out of the beam path as the relay is operated. The two leads from the solar cell are taken out of the same slit and terminated on a two-lug terminal strip mounted near the relay.

Mount the empty half of the two-piece electronic chassis on the telescope tube, just below the two laser mounting rings, drilling mating holes in both chassis and telescope tube. Use short mounting hardware so as not to interfere with the beam path. Recheck all mechanical work and tighten the telescope tripod screws.

To keep weight to a minimum, only the modulator pentode and the laser power supply are mounted in the chassis on the telescope. This is necessary to reduce the possibility of oscillation in the circuits.

Mount the power supply on the inside of the chassis, using an insulated spacer (about $\frac{1}{4}$ ") at each corner. Be sure that the high-voltage end is far enough from the metal to avoid arcing. The seven-pin tube socket for the pentode is mounted at one end, while a multi-lug terminal strip supports the ends of the wiring. A $\frac{1}{2}$ " grommetted hole should be provided for the incoming cable.

The circuit for the scope-mounted electronics is shown in Fig. 7. Only the relay, solar cell, and laser are external to the chassis. The circuit above *SO1* is mounted at the scope. The lower portion is built in a larger conventional chassis.

Once again, either vacuum-tube or semiconductor amplifiers may be used. The latter save quite a bit of work. Connections between the two chassis are made with multi-lead cable, with the exception of a small coaxial cable for the solar cell leads. Make the connections long enough to allow plenty of space between the telescope and the other chassis. The cables may be taped at intervals to keep them from separating.

When all electronic work is finished, attach the second half of the chassis to the one on the telescope. The cable should be placed where it will not interfere with scope operation.

Fully open the ring mount thumb-screws and slide the laser into position as described above. Tighten the thumb-screws gently to avoid damaging the tube. Attach the plus side of the high-voltage supply to the laser anode and the negative side to the cathode.

Make up a phono connector to connect the solar cell leads to *J1*. Connect the two leads to the relay.

Setup. Connect the far end of the multi-

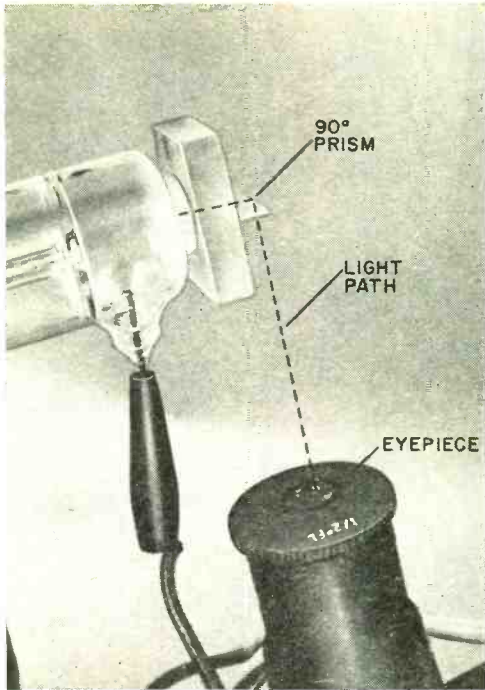

A small 90° prism is cemented to a plastic block to aim the laser light at the telescope eyepiece. The plastic block is press fit to the laser end.

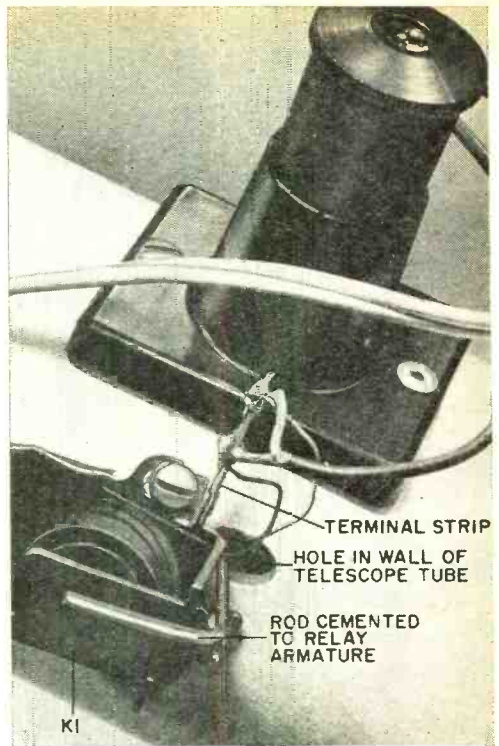

The transmit-receive relay is mounted to the telescope tube with the solar cell and rod passed inside through a hole cut in the telescope tube wall.

lead cable to the main chassis, along with the solar cell and microphone connectors. (You can substitute a radio for the microphone for testing.) The push-to-

talk button may be temporarily shorted to keep the solar cell out of the beam path during the following optical alignment.

Three commercial IC audio kits were used for all stages except the pentode modulator. Power supplies are mounted under the chassis. Telescope cable termination is on rear apron.

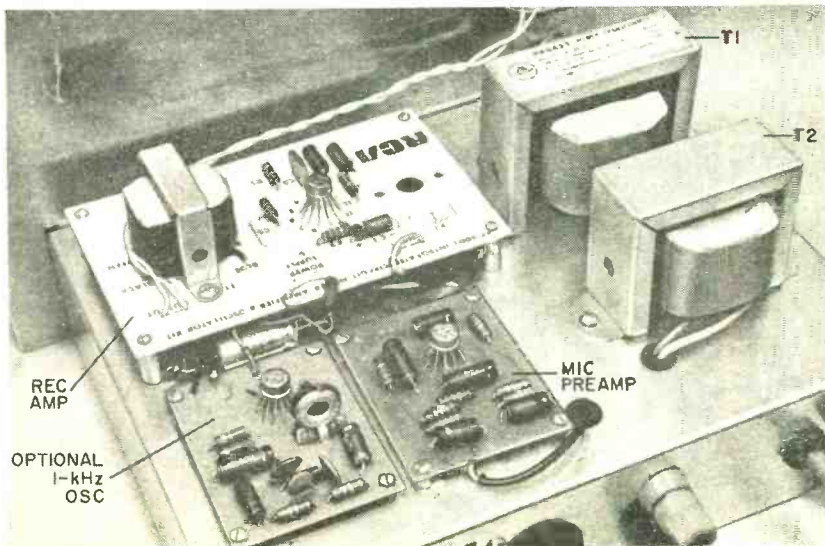

View looking into end of telescope shows how the solar cell, in transmit condition, is out of beam path from laser to diagonal. In the receive mode, the cell enters the beam path between diagonal and eyepiece. Make sure that sensitive side of solar cell faces the diagonal.

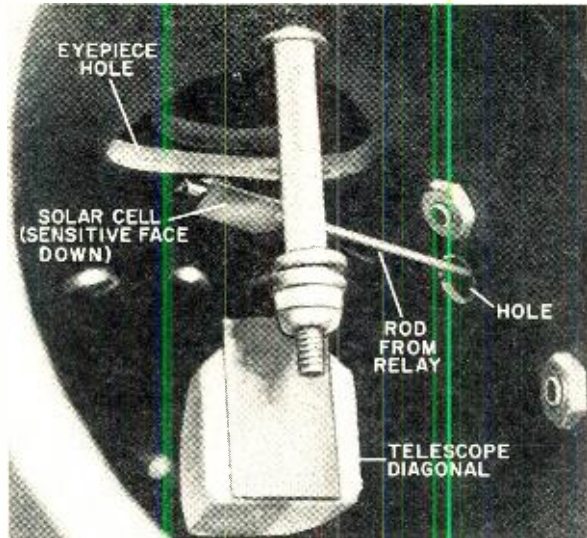

In the simple transceiver, the solar cell is mounted within a tube having a dark interior—in this case, it's a clean Polaroid print coater. Cell is affected by ambient light so that it must be shielded during use. Any method of mechanical mounting may be used to position the cell correctly.

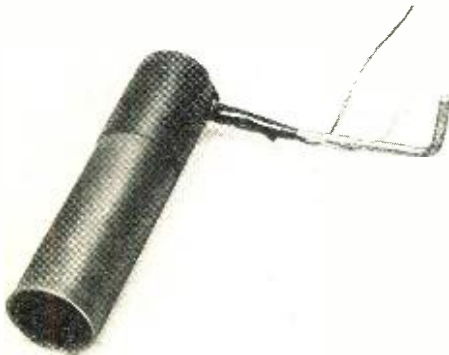

It is assumed that the telescope optics have been set up as described in the telescope operating manual.

On the main chassis, set bias control R_4 , volume control R_5 , and modulation control R_6 to minimum resistance. Plug in the 117-volt line cord and turn on the power. The laser tube will blink a few times until $V1$ warms up. After the laser starts to glow at full power, allow the entire system to stabilize for a few moments. Adjusting the bias control should cause the laser glow to diminish a little. Set this control for maximum laser brilliance.

Place the 90° plastic prism over the protuberance at the laser exit hole and adjust the prism so that the laser beam is reflected down the telescope eyepiece. Aim the telescope at a wall and keep adjusting the prism—and if necessary the position of the laser—until a red circle.

with the diagonal mirror shadow centered in it, is clearly visible on the wall. At this point, the laser has been properly set up and should not be moved.

If you have to keep looking at the laser beam, a pair of blue sunglasses may be worn to reduce the red glare.

To test the system, aim the telescope at a distant mirror and reflect the beam back to a duplicate solar cell that has been connected to the main chassis. You can also use the second telescope of the communications system if you have built it at this time.

With the light beam shining on the solar cell, make sure that the radio is playing at a reasonable volume and turn up the laser volume control R_5 . If artificial light falls on the solar cell, a hum will be heard; so for best reception keep the ambient light dim. Slowly adjust the bias control (R_4) until the laser dims a little. Then bring up slightly the modulation control (R_6) until music is heard from the main chassis speaker. Since R_4 and R_6 are interlocking in their action, you will have to adjust them together to get the desired results. If R_4 is set for too low a beam level and R_6 is set too high, modulation peaks may extinguish the laser. The automatic power supply will retrigger the laser, but the controls should be adjusted to prevent the drop-out. Once clean modulation has been obtained, the radio can be replaced by the microphone and R_6 adjusted for this type of input.

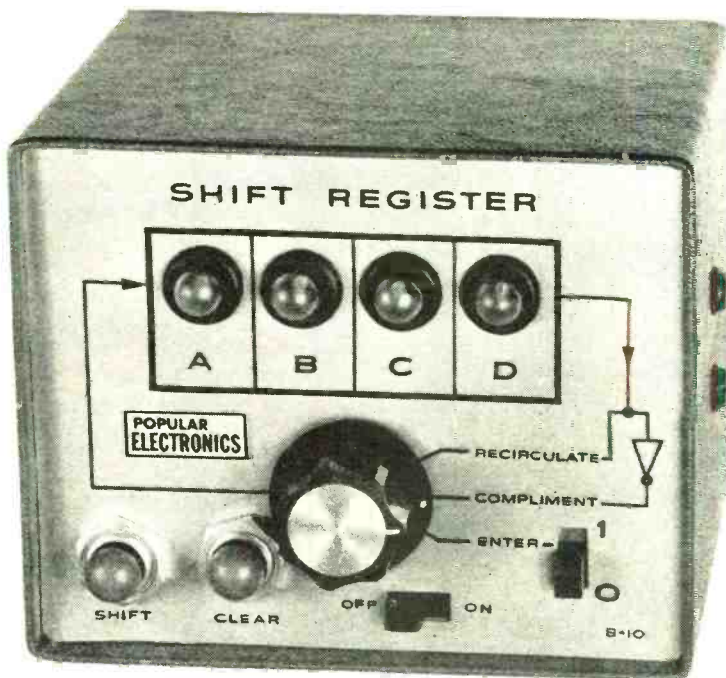

Build a SHIFT REGISTER

*Storage for digital computers,
computer logic*

BY DON LANCASTER

HAVE YOU EVER wondered how computers and electronic calculators perform arithmetic operations, or how they move data and numbers about? A unique circuit known as a "shift register" is responsible for these operations. The shift register is an electronic device that stores numbers, commands, words or locations when programmed to do so. Later, it "plays back" the stored information,

either all at once or bit by bit until the register is empty or is back where it started from.

If you would like to experiment with the shift register, you can make one of your own at very little cost, using the instructions provided here. Your project can then be used as an entry in a science fair, a teaching aid, or simply as an interesting device for studying digital integrated circuits and computer logic.

This shift register employs three IC's and four transistors, arranged to form a "four-bit, serial-in/serial-out parallel-read" system. The functions provided are *enter*, *recirculate*, *compliment*, *shift*, and *clear*. The same project also demonstrates "walking ring counters" and "disallowed subroutines."

Shift Registers in General. Almost all digital computers and computer circuits

IC
EXPERIMENTER'S
CORNER

NO. 4 of 5

May, 1970

43

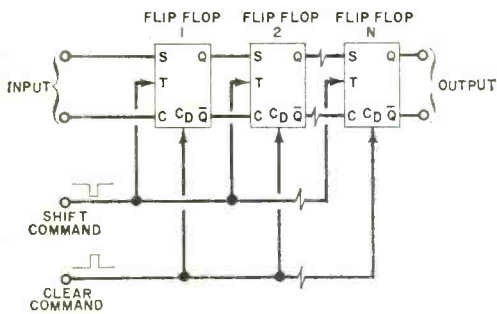

Fig. 1. Shift register is basically string of JK flip-flops connected in cascade. Any number of JK flip-flops can be connected in the manner shown.

are made up of simple elements that can have only two states: *on* and *off*, voltage and no voltage, or, most commonly, 1 and 0. The 1 or 0 represented at any time in a single element is called a *bit* (for binary digit). A string of related bits is a *word* (sometimes referred to as a *byte*). A word can represent a number (in binary, octal, binary coded decimal, decimal, or any other coding system), an address (a specific location or element in the machine), or an instruction (such as a "multiply" command).

A computer or calculator gets its words from a program on tape, cards, discs, drums, or a programmer (the person operating the computer). It then stores all the words it needs and later manipulates them as instructed.

The length of a word is simply the number of bits required to make up the word. The longer the word, the more accurate it can be. For example, for six-place accuracy using binary coded decimal (BCD) numbering, 25 bits are needed in each word.

The words are often stored in shift registers. A shift register comprises a number of stages, each of which can store one bit; 25 stages are needed to store a 25-bit word, and so on. There are several ways to get information into and out of a shift register, and there are several types of shift registers. For those of interest here, information is put in and taken out one bit at a time. This type is known as a "serial-in/serial-out" register.

The *shift* operation takes place when it is desired to move the stored word. On a

shift command, every bit moves one—and only one—element to the right as the first element accepts a new bit from outside. (The sidebar on page 47 summarizes how this operation takes place.) The input can be an outside *enter* command, or the output *recirculated*, or the opposite of the output known as the *complement* for special counter circuits.

Some shift registers, including this one, also have provision for a *clear* instruction that automatically puts all 0's in the register.

A shift register can be built with a train of conventional JK clocked flip-flops as shown in Fig. 1. Assuming that a *clear* command is first fed into the circuit, all stages are reset to a 0 condition. Upon receipt of a *shift* command, each stage passes its 0 one stage to the right, and the first stage accepts a new input.

Shift registers are then a means of accepting, storing, and later providing digital words when given the proper commands. In the *recirculate* mode, a shift register can march its word around bit by bit, produce one bit at a time as an output, and end up with the word right back where it started, ready for another use.

PARTS LIST

- C1—0.1- μ F disc capacitor
 - C2—100- μ F, 6-volt electrolytic capacitor
 - 11-14—X1490 panel lamp
 - IC1—Dual two-input gate integrated circuit (Fairchild μ L914)
 - IC2, IC3—Dual JK flip-flop integrated circuit (Motorola MC790P)
 - Q1-Q4—2N4400 transistor (or Motorola MPS6554)
 - R1-R6—470-ohm, $\frac{1}{4}$ -watt resistor
 - S1—S.p.s.t. slide switch
 - S2—S.p.s.t. normally-open snap-action pushbutton switch
 - S3—Dual s.p.s.t. snap-action pushbutton switch; one pair of normally closed, other pair of normally open contacts
 - S4—Two-pole, three-position non-shorting rotary switch (Mallory No. 3223J)
 - S5—D.p.t. slide switch
 - Misc.—Printed circuit board (see text); dialplate; $3\frac{1}{2}$ " x 4" x 5" case; $\frac{3}{16}$ " metal or fiber spacers (3); $\frac{3}{8}$ "-inner diameter rubber grommets for mounting lamps on front panel (4); #24 insulated wire for circuit board jumpers; control knob; #6 hardware; hookup wire; solder; etc.
- Note—A metalphoto aluminum dial plate is available for \$3 postpaid in U.S. from Reill's Photo Finishing, 4627 N. 11 St., Phoenix, AZ 85014. The following items are available from Southwest Technical Products Corp., 219 W. Rhapsody, San Antonio, TX 78216: Etched and drilled printed circuit board, #1726, \$1.90; complete kit of parts including prepunched vinyl-clad case and dialplate, #172c, \$9.75 postpaid in U.S.

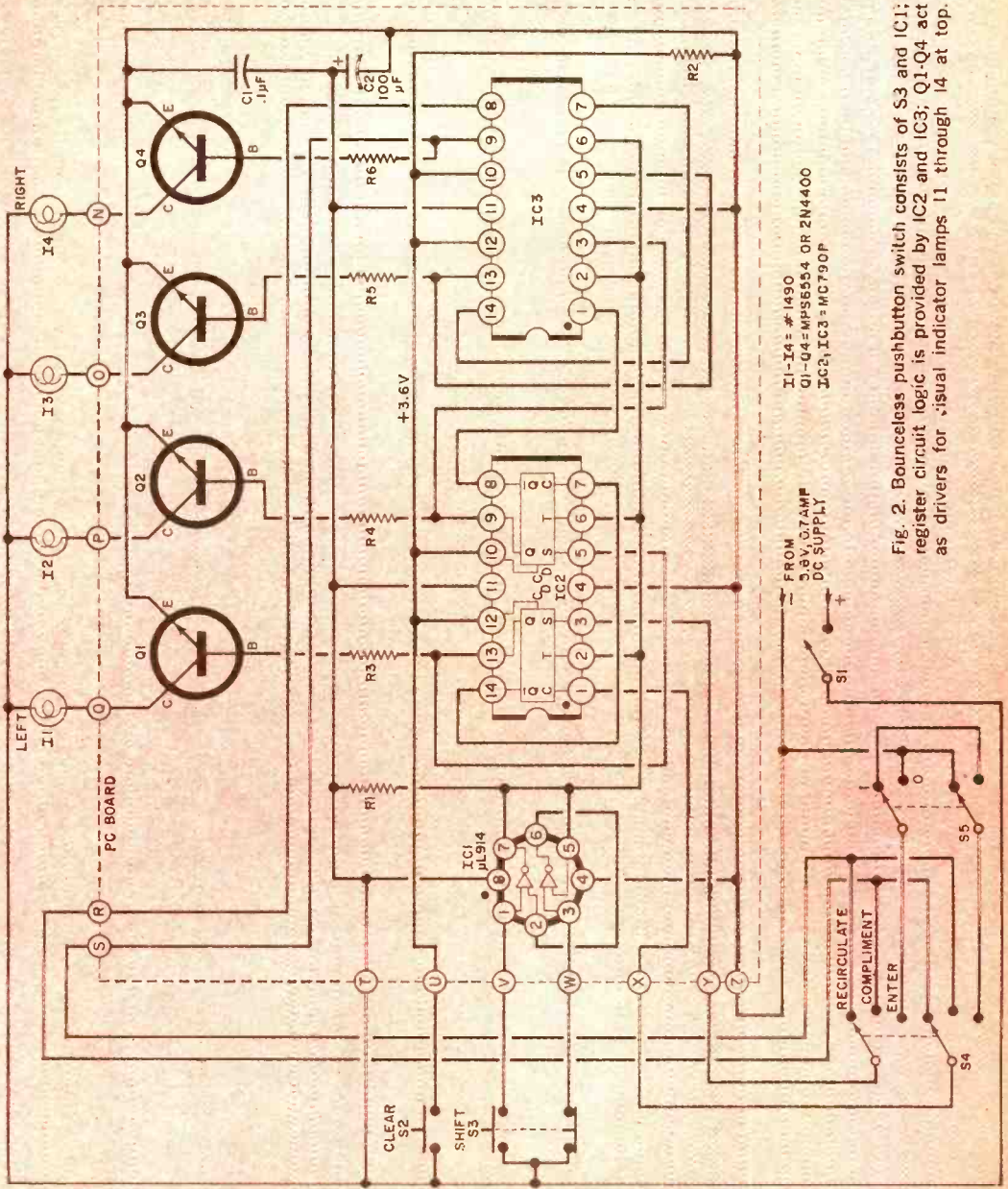

I1-I4 = # 1490
 Q1-Q4 = MP5554 OR 2N4400
 IC1, IC2 = MC790P

Fig. 2. Bounceless pushbutton switch consists of S3 and IC1; register circuit logic is provided by IC2 and IC3; Q1-Q4 act as drivers for visual indicator lamps I1 through I4 at top.

How It Works. Four JK flip-flops, IC2 and IC3 in Fig. 2, are used as the storage elements. These flip-flops are cascaded, with the first stage being driven from a source selected by switch S4. The source of the input data can be from switch S5 (enter), the output (recirculate), or the

opposite of the output (compliment).

A shift command is delivered to the toggle, or T, input of each stage from the bounceless pushbutton circuit made up of IC1 and S3, which moves each bit one stage to the right for each shift command received. The clear operation is accom-

plished when S2 delivers a positive voltage to the CD input of each stage, forcing the register into the 0000 condition.

The condition or state of each stage is indicated by lamps I1-I4. A lighted lamp indicates a "1" state, while an extinguished lamp indicates a "0" state.

Construction. A printed circuit board is a must for this project. The PC board can be purchased etched and drilled (see Parts List), or you can make your own by following the actual size etching guide provided in Fig. 3.

Component placement on the circuit

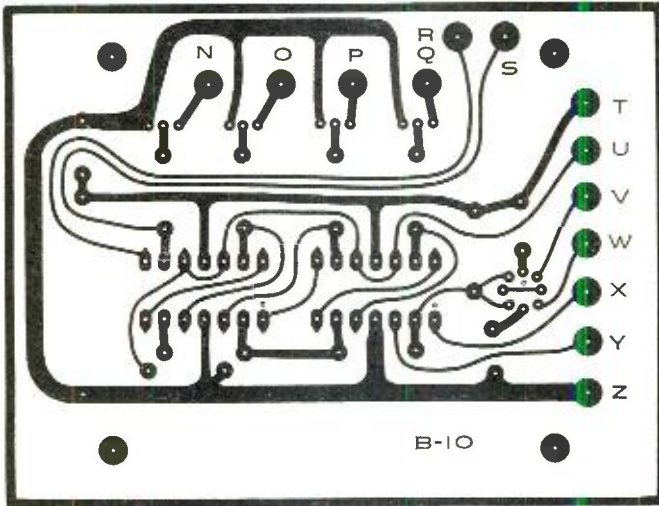

Fig. 3. In actual size printed circuit board etching guide, lettered contacts indicate off-the-board component connections.

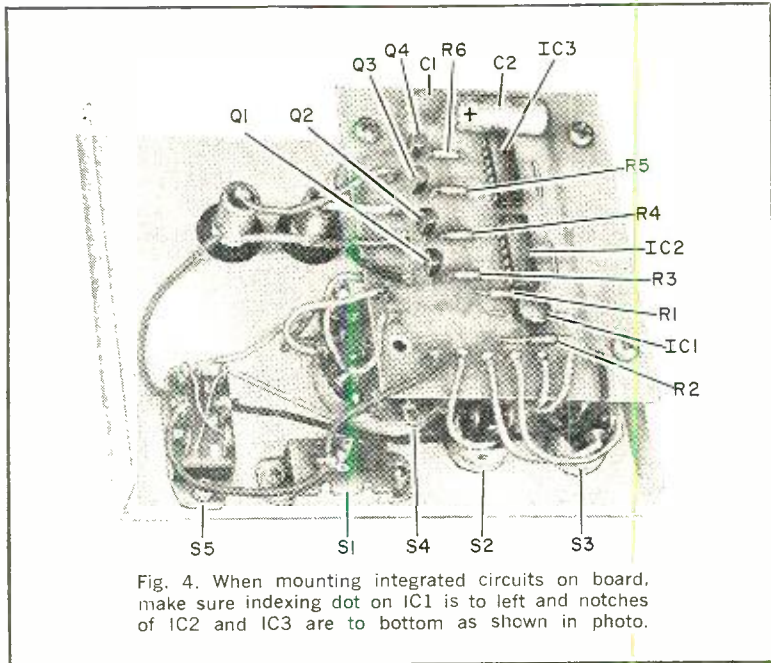

Fig. 4. When mounting integrated circuits on board, make sure indexing dot on IC1 is to left and notches of IC2 and IC3 are to bottom as shown in photo.

HOW THE SHIFT REGISTER WORKS

CLEAR: With the clear command fed in, the register automatically resets to indicate 0000, regardless of the previous states. This operation empties the register, preparing it for its next use.

ENTER: The register places a selected 1 or 0 into the first stage on a shift command. All other 1's and 0's in the register then move one stage to the right. This is how a register is "filled" or "loaded."

Start with 0000
Enter a 1 1000
Enter a 1 1100
Enter a 0 0110
Enter a 0 0011

With each digit entry, a shift command must be initiated.

RECIRCULATE: The register shifts the word one stage to the right with each command received, with the last stage passing its 0 or 1 back to the first stage. This condition "marches" out a word bit by bit for outside use. When finished, the word ends up in its initial position if you shift exactly the number of stages in the register. This is how a word can be used but still retained.

Start with 0011
Shift to get 1001
Shift to get 1100
Shift to get 0110
Shift to get 0011

The binary word has gone "once around," one bit at a time appearing at the farthest right stage for outside use.

COMPLIMENT: This is a "trick" that is sometimes used to change a register into a counter. To compliment a register, the opposite of what is in the last stage gets passed back to the first stage, with all other stages passing their 0 or 1 one position to the right as usual. Eight shift commands are required to get the register back to where it started in a four-stage register.

Start with 0011
Shift for 0001
Shift for 0000
Shift for 1000
Shift for 1100
Shift for 1110
Shift for 1111
Shift for 0111
Shift for 0011

At this point, the register is back to where it started, taking eight shift commands to get it there. Hence, a divide-by-eight counter, called a "walking ring counter," is obtained.

board is shown in Fig. 4. When mounting components on the board, notice that *IC1* is identified by a flat and color dot near lead 8, while *IC2* and *IC3* are identified by a dot-and-code notch. Also take careful note of the lead orientations of transistors *Q1-Q4*. Use fine-grade solder and a small pencil soldering iron.

The lamps mount on the dialplate by press fitting them into "X" rubber grommets as shown in Fig. 4. The hookup wires are soldered directly to the contacts on the lamps, saving the price of individual lamp sockets. Next, the circuit board mounts on the front panel with the aid of three spacers. (Note: bend the lugs of *S4* so that they do not interfere with or touch the circuit board.

Once the components are mounted on the front panel and the circuit board is in place, interconnect with hookup wire, referring back to Fig. 2 as needed. Then mount the assembly in the vinyl-clad metal box provided with the kit of parts, or mount it in an aluminum utility box with dimensions at least 5" x 4" x 3½", and construction is complete.

When using the shift register, bear in mind that the circuit requires 3.6 volts at 700 mA, with less than 700 mV of ripple peak-to-peak. Any good bench supply will do.

-30-

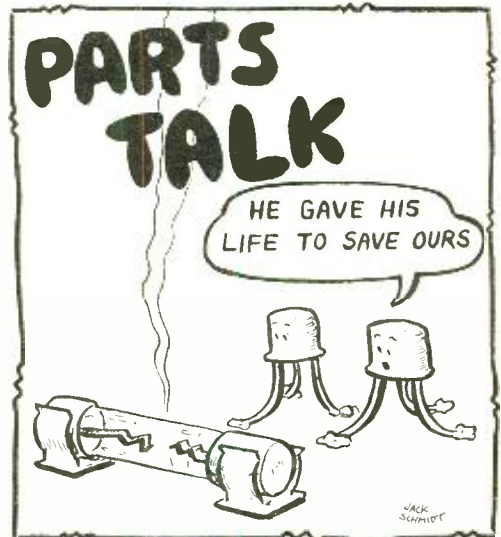

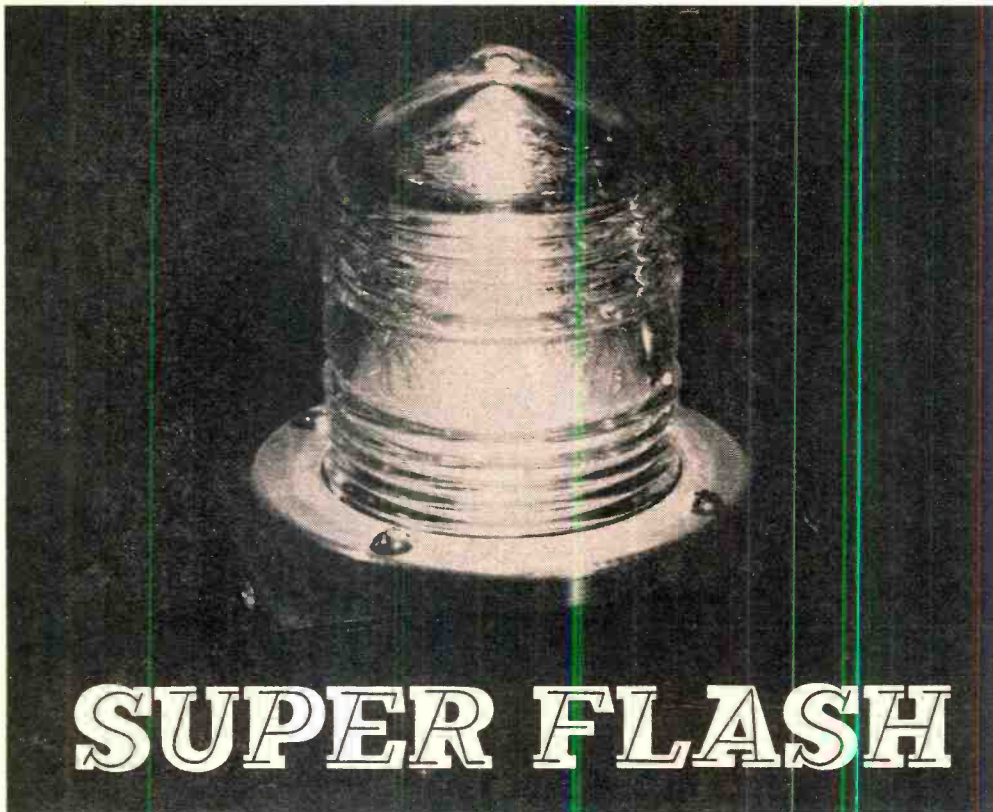

SUPER FLASH

WORLD'S BRIGHTEST INCANDESCENT LAMP FLASHER

BY THOMAS COUCH

FLASHING LIGHT systems are one of the most popular types of projects found in electronics experimenters' publications. But wait a minute! No matter how many flashers you may have seen or built, you are in for a surprise when you build the "Super Flash". It uses only a 117-volt, 6-watt lamp, but the amount of light emitted is practically blinding! In fact, an ordinary D26 Christmas-tree lamp was found to deliver slightly more than 500 foot candles in one flash. Because of this extreme brightness, it is recommended that the Super Flash *not* be used indoors where a person might stare at it at close range.

Although this new approach to flashers was designed for use with a disabled vehicle on a dark roadway, it can also be used as a boat light, a pier or dock indicator, or a sure-to-be-seen obstruction light.

Construction. The circuit for the Super Flash is shown in Fig. 1. The prototype was built in a 5" x 4" x 3" metal enclosure, though any type of construction can be used. If you use the metal enclosure, drill a hole in one end large enough to accommodate the two-pin bayonet socket. If you are going to use the Fresnel lens, also drill the four holes required to mount the lens retainer ring.

The two power resistors are mounted in sockets, each socket supported by a pair of insulated standoffs. The two sockets and the transformer are mounted on one long wall as shown in the photograph. Arrange the sockets so that the terminals are facing you and are accessible.

The dual potentiometers, along with a two-lug terminal strip (non-grounded) are mounted on the other half of the chassis. Arrange these parts so that,

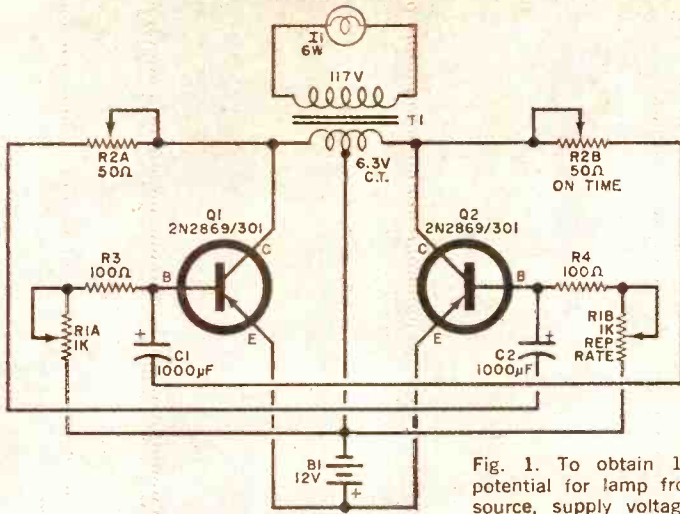
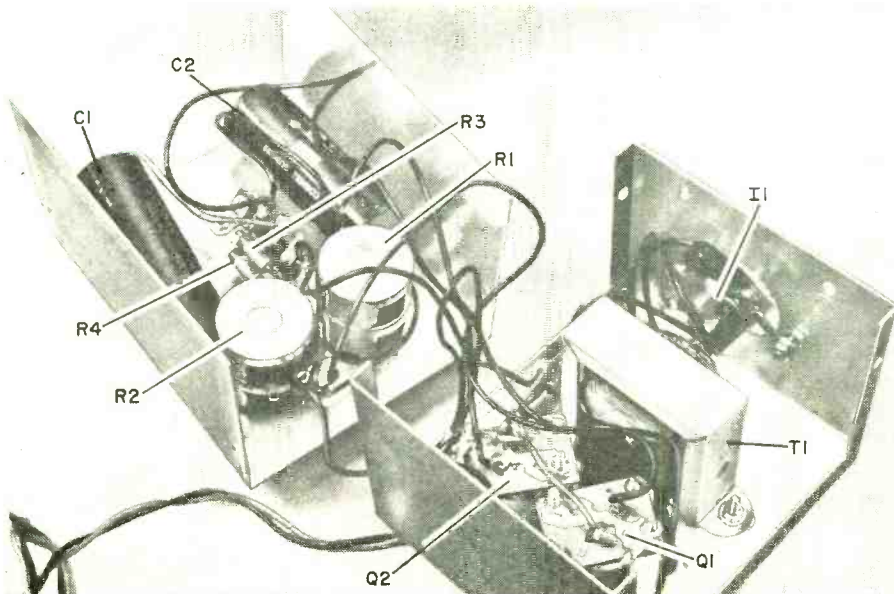

Fig. 1. To obtain 117-volt driving potential for lamp from 12-volt d.c. source, supply voltage is converted to a.c. via oscillator and stepped up.

PARTS LIST

- C1,C2—1000- μ F, 50-volt electrolytic capacitor
 I1—117-volt, 6-watt incandescent lamp, Chicago Miniature 6S6, or similar
 Q1,Q2—2N2869/301 power transistor
 R1—1000-ohm, linear-taper, dual potentiometer
 R2—50-ohm, linear-taper, dual potentiometer
 R3,R4—100-ohm, 1-watt resistor
 T1—Filament transformer, 117-volt primary, 6.3-volt, 6-amp CT secondary (Chicago Stancor P-3064 or similar)

- Misc.—5" x 4" x 3" metal enclosure, 2-pin bayonet socket, power transistor socket (2), insulated standoff with mounting hardware (4), terminal strip, length of twin-conductor lead with cigarette-lighter attachment, Fresnel lens (optional).
 Note—A clear Fresnel lens, with gasket and retaining ring, is available at #2826 for \$5.00 from Gordon S. Anderson, Mfg. Co., Mabbittsville County Rd., RD #1, Millbrook, NY 12545.



Due to simplicity of circuit, point-to-point wiring, using stranded hookup wire, is best for assembling project. Mount controls on front, lamp and lens assembly to top of chassis box.

With aid of standard phenolic sockets and insulated spacers, mount transistors to rear of chassis below transformer T1 as shown.

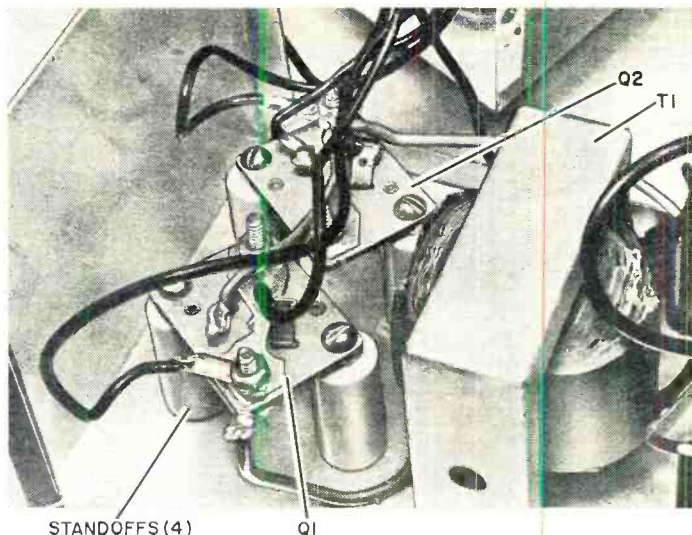

The Fresnel lens assembly bolts to the top of the chassis box with four sets of #6 machine hardware.

when the two halves of the metal enclosure are fitted together, the potentiometer metal shells do not contact the transistor socket terminals.

Once these parts have been assembled, wire the circuit in accordance with Fig. 1. Note that T1 is wired "backwards." That is, the center-tapped low-voltage winding is used as the primary, while the 117-volt winding is used as the secondary. To avoid component damage, make sure that no part of the electrical circuit is connected to the metal chassis.

Power for the Super Flash is obtained from an external 12-volt vehicle battery capable of delivering 2 amperes. A length of two-conductor cable is terminated in a conventional cigarette-lighter plug. Be sure that the proper connections are made to the plug. On a negative-ground vehicle system, the center pole of the cigarette lighter is positive.

If you want to test the flasher on your workbench, use a low-impedance 12-volt d.c. power supply capable of delivering 2 amperes.

Insert the 6-watt lamp in the socket and mount the Fresnel lens. Do not use a lamp with a power rating any higher than 6 or 7 watts as the load may keep the circuit from oscillating.

With the lamp installed, connect up the power. Do not stare at the lamp when it is operating as a very bright flash of light
(Continued on page 86)

BUILD THE

ADD-ON

SQUARER

NO OVERSHOOT AND 70-NANOSECOND RISE/FALL TIME

BY JAMES BONGIORNO

WITH THE QUALITY of audio equipment and the "know-how" of the serious audio experimenter constantly improving, better test gear (usually meaning ultra-low distortion) is a must. One of the primary tools in this area is the audio sine-wave generator. Although most audio generators have characteristics that greatly exceed those of even a few years ago—many enthusiasts have built the "Ultra-Low-Distortion Sine-Wave Generator" (POPULAR ELECTRONICS, October 1969)—there is one aspect in which there is room for improvement. This is in the generation of good clean square waves, which are essential for proper audio testing.

Of course there are all types of squaring circuits that can be permanently coupled to the output of sine-wave generators, permitting a choice in the type of output. The big drawback to this approach, however, is that some form of regenerative Schmitt trigger is used to create square waves from sine waves. Unfortunately, although the square waves are good, large switching transients are produced back in the sine-wave generator so that the sine waves have disturbances that appear as spikes or notches when that type of output is being used.

The "Add-On Squarer" described here is a new approach to squaring circuits in that no disturbances are reflected into the sine-wave source. In addition, the

circuit has essentially no overshoot, ringing, or transistor storage time; and the symmetry remains constant up to about 1 MHz. Rise and fall times have also been improved and are approximately 70 nanoseconds each. If desired, rise and fall times can be improved further by the use of faster transistors and a minor resistance change. As is, the circuit will satisfy the most critical of audio experimenters, and the same circuit can be used to trigger most logic circuits as well.

The output of the Add-On is short-circuit proof and has no triggering offset or hysteresis. It triggers as the input sine wave goes through zero.

About the Circuit. The Add-On is basically a d.c. operational amplifier (see Fig. 1) having positive rather than negative feedback. There are, however, two distinct differences between this circuit and other regenerative feedback systems. First, none of the stages will saturate under any condition. This insures an absolute minimum of overshoot and ringing. Second, there is no storage time so that rise and fall times of 70 nanoseconds can be achieved. Incidentally, you will need a top-quality laboratory scope to measure such fast rise times.

Since the output stage is non-saturating, loading does not have any effect on the quality of the output square waves—only on the amplitude. The Add-On will

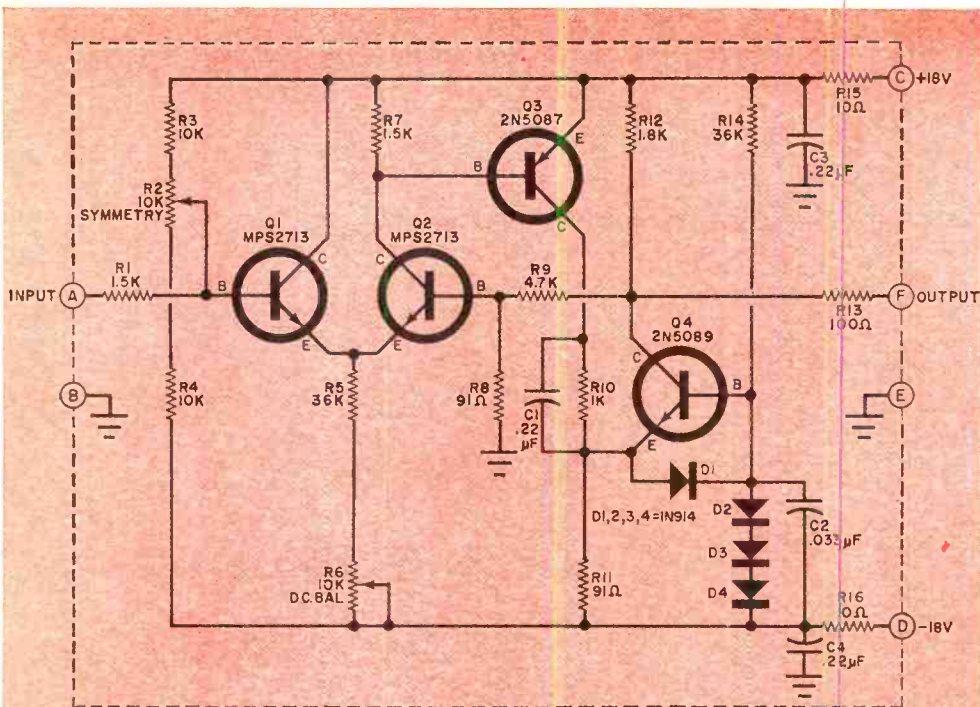

PARTS LIST

- C1, C3, C4—0.22- μ F Mylar capacitor
 C2—0.033- μ F Mylar capacitor
 D1-D4—1N914 or similar diode
 Q1, Q2—Transistor (Motorola MPS2713)
 Q3—Transistor (Motorola 2N5087 or 2N3906)
 Q4—Transistor (Motorola 2N5089)
 R1, R7—1500-ohm
 R3, R4—10,000-ohm
 R5, R14—36,000-ohm
 R8, R11—91-ohm
 R9—4700-ohm
 R10—1000-ohm
 R12—1800-ohm
 R13—100-ohm
 R2, R6—10,000-ohm PC-type trimmer potentiometer
 R15, R16—10-ohm, $\frac{1}{2}$ -watt, 10% resistor
- All resistors
 $\frac{1}{2}$ -watt, 5%*

Fig. 1. Basically a d.c. operational amplifier, the circuit can change states in less than 70 nanoseconds—much faster than most scopes can display. Besides high-quality audio testing, the pulses can be used with many digital circuits.

*Misc.—Small heat sinks for Q3 and Q4.
 Note—An etched and drilled G-10 glass epoxy circuit board is available for \$4.25 postpaid from Lambert Laboratories Ltd., 13 Washington St., Westfield, N.Y. 14787. Residents of New York state add sales tax.*

deliver 15 volts peak-to-peak into an essential open load and will trigger with any input signal of a half a volt or more.

The circuit will trigger and deliver a symmetrical output waveform up to approximately 1 MHz.

Construction. A foil pattern for a printed circuit board for the Add-On is shown in Fig. 2. If you do not use a PC board, make sure that you follow the physical placement of the components as shown in Fig. 3 as closely as possible to insure clean, fast waveforms. Wire the circuit as shown in Fig. 1.

If you want to further reduce the rise and fall times, use a faster switching transistor for Q3 and Q4 and raise the value of R8 to about 200 ohms. The only critical transistor in the circuit is Q3, and you must use the one specified (or a faster one). Small heat sinks may be used on Q3 and Q4.

If you suspect that you have fluctuating line voltage and you want to insure the quality of the square-wave output, remove R5 and R6, and substitute the circuit shown in Fig. 4.

Calibration. After applying power to

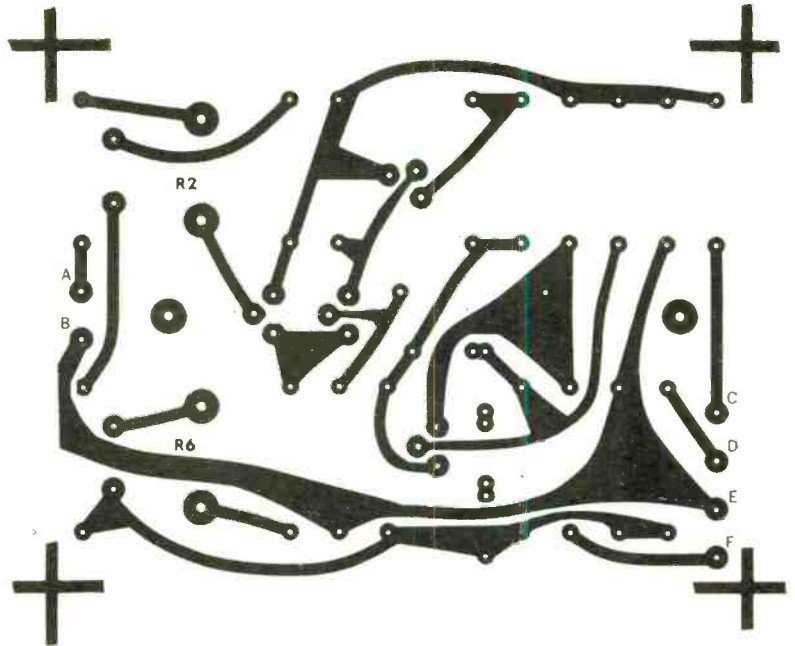

Fig. 2. Actual size printed circuit foil pattern. The marks at the corners are for board dimensions. The two mounting holes are shown along the center line.

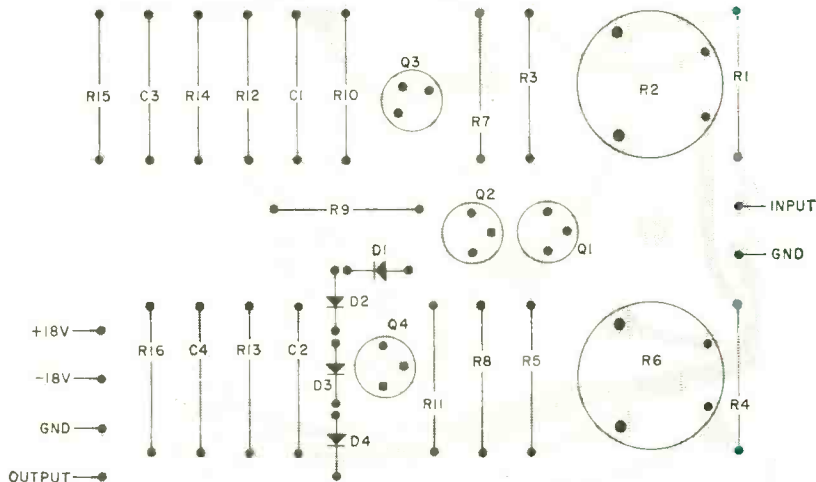
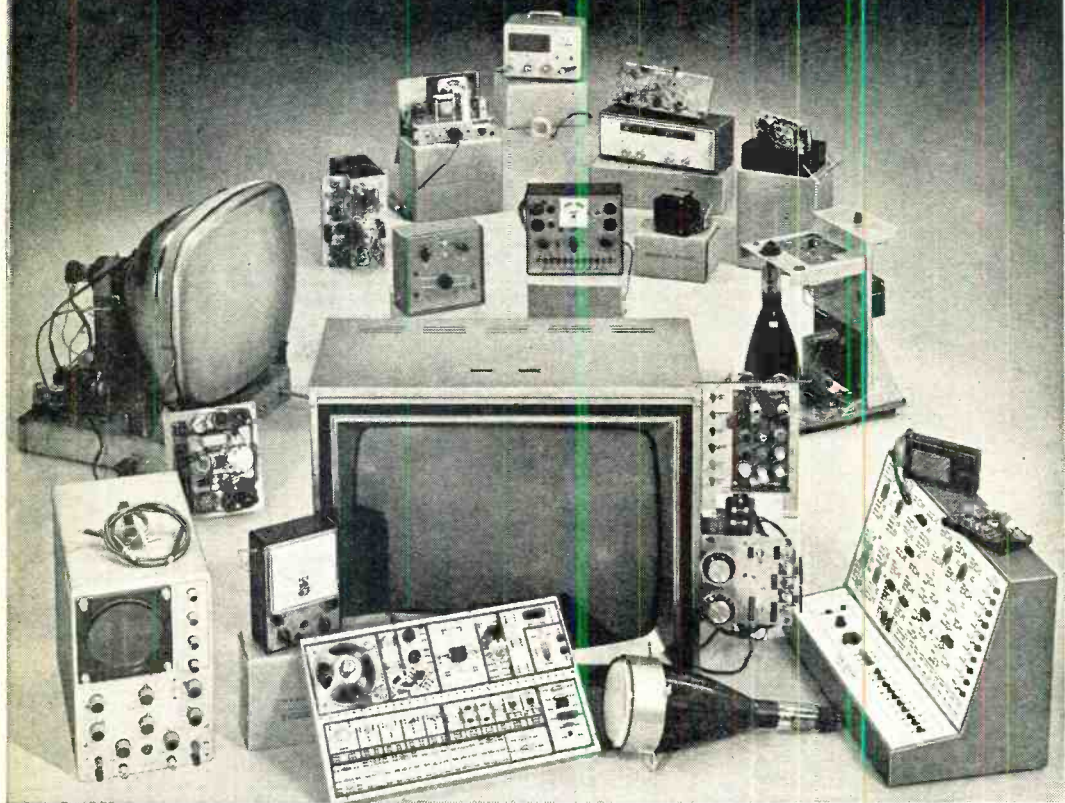

Fig. 3. When installing the components, make sure that the semiconductors are properly installed. This figure also shows external connections to be made.

We pack your electronics course with kits to make your training fast. You'll enjoy every minute of it.



Your NTS success package

Choose a career in electronics: Computers. Color TV Servicing. Automation. Communications. Whatever the field, NTS has a complete home-study package to get you to the top *faster*. 10 thorough training courses. Each includes *everything* to give you the *working* knowledge required of successful technicians.

NTS Project-Method Training is the practical way to learn elec-

tronics. It's a proven combination of lessons and the best professional kit equipment available. NTS provides the *biggest selection of kits ever offered in home-study . . . all at no extra cost*. You'll construct these exciting kits to fully understand electronic circuits, components, and concepts. Our Project-Method lets you build skills by putting theory into practice . . . by working with your hands, as well as your head.

The NTS "learn and practice" approach makes training at home really easy. All it takes is a few hours a week . . . whether you're starting from scratch or in advanced courses. This is the all-inclusive success package that put thousands of men into the best paying jobs . . . or into their own business. If "just a living" isn't good enough for you, now is the time to get something better going for you!

NTS COMPUTER ELECTRONICS

This is the future. And it's happening now. The number of computers will *increase many times* in the next few years.

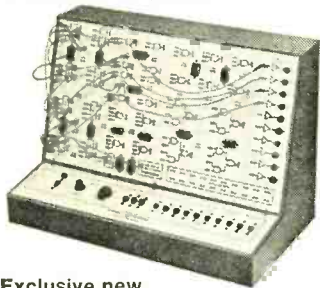

Exclusive new Compu-Trainer®

NTS offers a solid grounding in computer operation, wiring, data processing and programming. One of the 10 important kits included is our exclusive Compu-Trainer®. It's a fully operational computer logic trainer — loaded with integrated circuits — the first ever offered in home study. It introduces you quickly to how, what, when and why of computers . . . from theory to practical servicing techniques. This unit is capable of performing 50,000 operations per second. And it's sent at no extra cost.

NTS COLOR TV SERVICING

This is a broad, easily understood

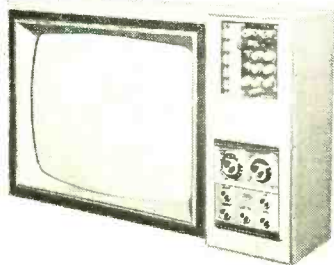

COLOR TV 295 SQ. IN. PICTURE

program designed to make you a complete home-entertainment service technician. Included, at no extra cost, is a color TV that has more features than any

set on the market. You also learn all about stereo, hi-fi, multiplex systems, and become a specialist in Color TV Servicing. Kits also include AM-SW radio, solid-state radio, field-effect transistor volt-ohmmeter, electronic tube tester.

NTS AUTOMATION/ INDUSTRIAL ELECTRONICS

You're trained in the "push-button" electronics that keep industry going and growing . . . from relay type controls to highly advanced systems essential to production. You receive 16 kits including a 5" wide band oscilloscope, and the new NTS electronics lab: a fascinating NTS exclusive experimental laboratory. A complete workshop which makes you familiar with solid-state, miniature, and integrated circuits.

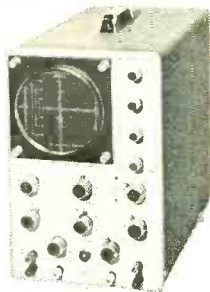

5" Oscilloscope

NTS ELECTRONIC COMMUNICATIONS

The use of 2-way radio systems in private and commercial applications is skyrocketing. NTS prepares you for the big-money opportunities in the field of transmitting and receiving equipment. *Your tuition will be refunded in full if you cannot pass the FCC exam for a 1st Class Commercial Radio-Telephone License within*

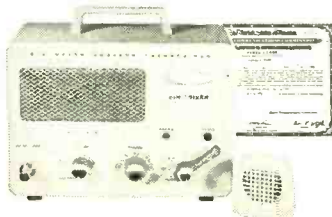

5 Watt AM Transmitter & Receiver

six months after successfully completing this course. You build valuable kits including Amateur-Phone 6 Meter VHF Transceiver, solid-state Radio, and a field-effect transistor volt-ohmmeter.

CLASSROOM TRAINING AT LOS ANGELES

You can take classroom training at Los Angeles in sunny Southern California. NTS occupies a city block with over a million dollars in facilities devoted exclusively to technical training. Check box in coupon.

NATIONAL TECHNICAL SCHOOLS

World-Wide Training Since 1905
4000 South Figueroa Street
Los Angeles, Calif. 90037, U.S.A.

APPROVED FOR VETERANS

Accredited Member: National Association of Trade and Technical Schools, National Home Study Council.

TODAY, MAIL
COUPON
FOR FREE
COLOR
CATALOG
AND SAMPLE
LESSON.



NATIONAL TECHNICAL SCHOOLS
4000 S. Figueroa St., Los Angeles, Calif. 90037

Please rush Free Color Catalog and Sample Lesson, plus information on field checked below. No obligation. No salesman will call.

- MASTER COURSE IN COLOR TV SERVICING
- COLOR TV SERVICING
- MASTER COURSE IN TV & RADIO SERVICING
- PRACTICAL TV & RADIO SERVICING
- MASTER COURSE IN ELECTRONIC COMMUNICATIONS
- FCC LICENSE COURSE
- MASTER COURSE IN ELECTRONICS TECHNOLOGY
- INDUSTRIAL AND AUTOMATION ELECTRONICS
- COMPUTER ELECTRONICS
- BASIC ELECTRONICS

Name _____ Age _____

Address _____

City _____ State _____ Zip _____

- Check if interested in Veteran Training under new G.I. Bill.
- Check if interested ONLY in Classroom Training at Los Angeles. Dept. 205-050

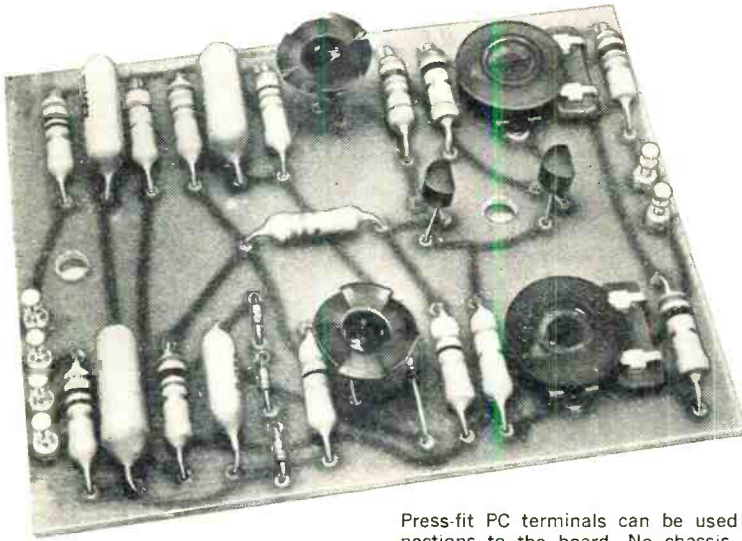

Press-fit PC terminals can be used to make connections to the board. No chassis is shown here because board is designed to be mounted in an existing single-wave generator and get its d.c. power either from the generator supply or a built-in source of +18 and -18 volts. The squarer can be switched in through a switch on the front panel.

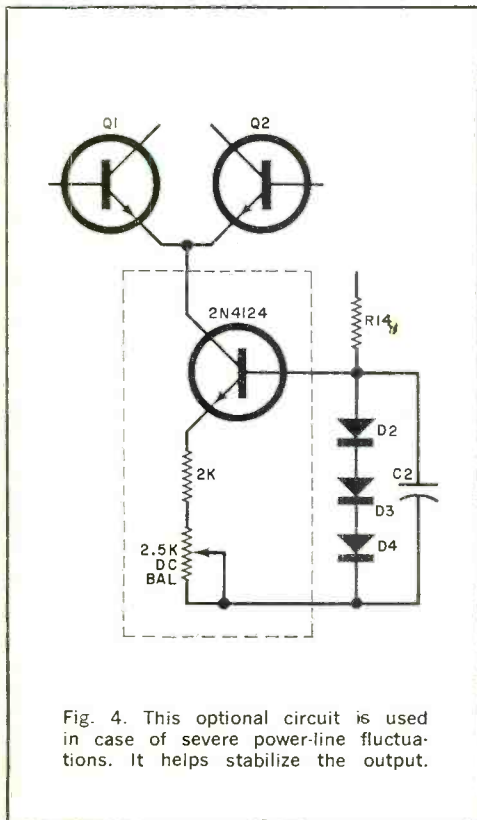

Fig. 4. This optional circuit is used in case of severe power-line fluctuations. It helps stabilize the output.

the circuit, wait at least one minute to allow charges to build up on the capacitors. The d.c. balance control, $R6$, is the key to making the unit work properly. Once $R6$ is adjusted, it should not have to be reset unless you have a badly fluctuating line voltage.

After the unit has been on for a couple of minutes, apply a 10-kHz sine wave to the input and mechanically center $R2$. Connect an oscilloscope to the output and adjust $R6$ until a swing of 15 volts peak-to-peak is obtained. If you can't get 15 volts, slightly lower the value of $R5$. Having made this initial adjustment, let the unit sit for about 5 or 10 minutes to allow all voltages to settle. If the bottom of the visible square wave starts to show some slight tilt, adjust $R6$ to make it square. The unit is now calibrated and should remain stable.

When using the Add-On to test systems where rise and fall times are important, use an absolute minimum of connecting cable since cable capacitance has a distinct effect on these sharp transients.

The Add-On Squarer makes an ideal companion to the Sine-Wave Generator mentioned above. It can be built within the same cabinet and can use the same +18- and -18-volt power supply. -50-

DESIGN YOUR OWN PRINTED CIRCUITS

FROM DIAGRAM TO BOARD IS SIMPLER THAN YOU THINK

BY ALEXANDER W. BURAWA
Associate Editor

THE PRINTED CIRCUIT board undoubtedly ranks among the most important developments in the history of electronics. The PC method of construction, compared to point-to-point wiring, has many advantages and they become more apparent with increasing circuit complexity. The PC board reduces construction and assembly time (and generally costs), virtually eliminates wiring errors, is easy to trace and troubleshoot, and provides neater, more compact, lighter weight modular assemblies.

Unfortunately, many experimenters and hobbyists avoid using the PC board for a misguided reason—they think that designing their own is beyond their capabilities. The fact is, however, that designing a printed circuit board is a great deal easier than designing a circuit. All you have to do is master a few simple techniques. With a little practice, the techniques outlined here will allow you to design PC boards that are every bit as professional as those produced commercially.

Discussion in this article is purposely limited to the techniques that can be employed by *anyone* interested in electronics. The materials required are basic dime-store items: tracing and opaque paper, a straight-edge rule with sixteenth-inch divisions, pencils, a compass, and a protractor. Three optional items

that really save time and paper are graph paper with ten divisions/inch, a large sheet of heavy-duty clear acetate, and a grease pencil.

Preliminary Layout. Many electronic components are manufactured in standard sizes. So, it is to your advantage to make up a template that shows mounting hole locations and minimum area required for these components. If you wish to make such a template, you can copy the drawing shown in Fig. 1. Put it on heavy clear acetate and carefully perforate the acetate at the hole locations.

Now, assume that the circuit you want to mount on a PC board is the one shown in Fig. 2. First, decide which of the components will *not* be mounted on the board. Break the connecting lines to these components, and insert a letter or numeral designation at the breaks. Examples of components that should not be mounted on a PC board are primary controls and switches (because of their frequency of use), power relays and heavy transformers (because of their weight), and high-power or high-current semiconductors (which generate excessive heat). These components should be mounted on a strong accompanying chassis that is capable of quickly conducting away excessive heat.

Next, redraw the schematic diagram

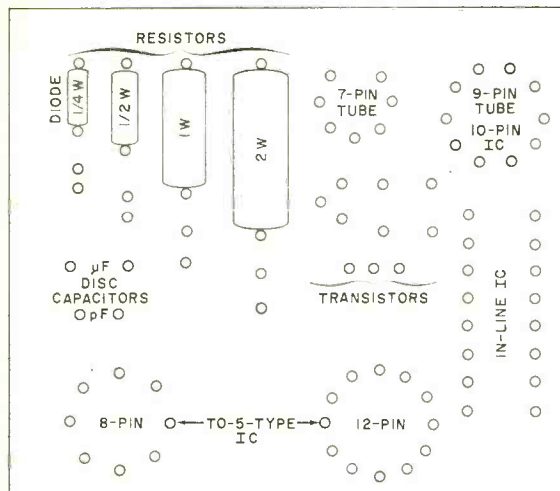

Fig. 1. Template guide, shown actual size, gives minimum hole spacing for most commonly used components. Most signal and low-current diodes fit into $\frac{1}{4}$ -watt resistor slot; other silicon diodes fit into $\frac{1}{2}$ - or 1-watt resistor slots. Eliminate one dot in upper right drawing for nine-pin tubes.

so that only the conductor pattern, as viewed from the *underside* of the board, remains (see Fig. 3). If possible, keep the input-to-output flow from right to left, and route the ground or signal reference conductor so that it encircles the circuit. Make sure you include a dot or circle for *each* connection to be made to the pattern (including the connections for the off-the-board components). *Never* have more than one component lead connected to a given point in the conductor diagram. Then letter in the schematic part number between the connection points, preferably on a tracing paper overlay to avoid confusion. Identify polarities of electrolytic capacitors and diodes, lead orientation for transistors and the indexing tabs or dots and pin numbers of IC's.

Bear in mind that, to avoid the need for jumper wires to complete a circuit, you can route conductors between connection points of resistors, large capacitors, and most diodes. *Never* route conductors between transistor leads. And try to limit the number of conductors inside the pin outlines of IC's to a maximum of three side-by-side, and then only for the conductors specifically related to the IC. If a jumper is unavoidable, plan it so that it does not bridge a component; route it around components as necessary, or even on the underside of the board.

Once you are satisfied that your conductor pattern layout is correct, a good idea is to "breadboard" your circuit exactly as laid out to determine whether or

not you will have to deal with feedback, crosstalk, hum and noise, etc. If the design is troublesome, now is the time to find out; otherwise what you do from here on will be fruitless.

If you experience any of the problems enumerated above, you have two choices: you can start fresh with an alternate conductor pattern design; or, you can try the less drastic step of shielding sensitive components or assemblies with metal barriers, or isolating troublesome circuits on separate circuit boards. In very extreme cases, a combination of the two methods might be called for, such as in the two channels of a stereo pre-amplifier that are first mounted side-by-side on a single PC board. If metal shields are used, when they are mounted in place with either hardware or solder they must touch only the common ground or signal reference conductors. They must *not* touch conductors that are not common to each other.

Once you are satisfied that the circuit will operate as designed, you can proceed to make the full-size drawing of the etching guide you will use to make the PC board.

Making the Etching Guide. Tape down on your work surface a clean sheet of graph paper. Then over this, tape a sheet of good quality tracing paper. Vellum is best—it is expensive but well worth it since it does not crack or tear easily and readily takes a pencil line.

Now, make sure you have several pen-

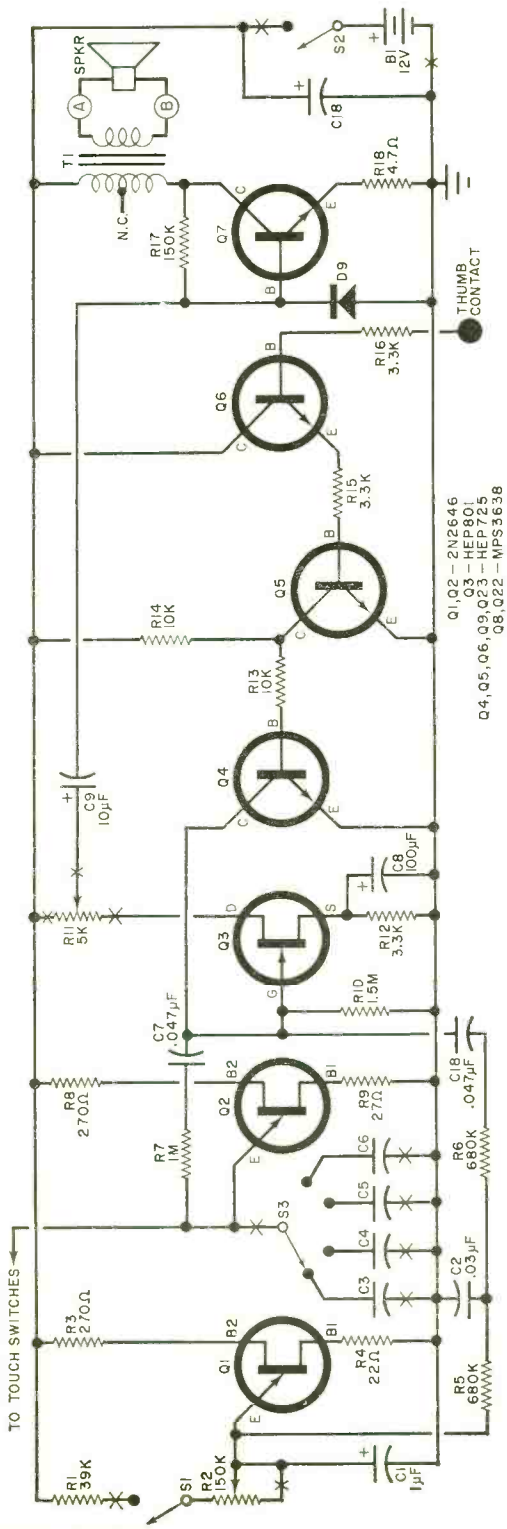

Fig. 2. Shown at left is sample circuit. Off-the-board components are shown by small X marks; you can break lines at these points and insert letters.

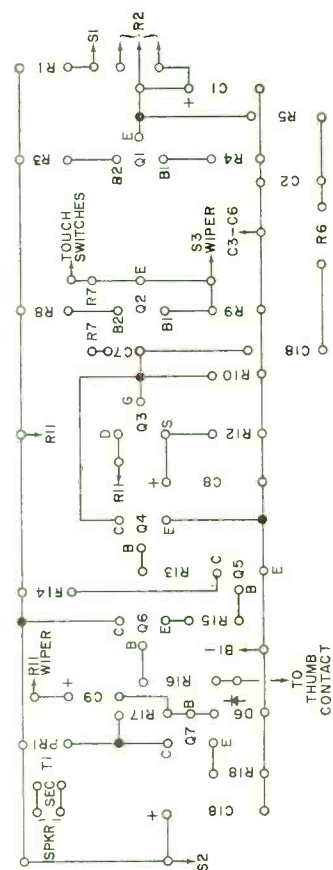

Fig. 3. Drawing above is conductor pattern diagram of sample circuit shown at left.

cils, your rule, component sizing template, and protractor handy. By consolidating your materials close at hand, you will work faster and more efficiently and make fewer errors.

Begin your etching guide layout by striking the top and right border lines perpendicular to each other and about 6" long. If you have succeeded in routing the ground or signal reference conductor around all other conductors, strike two more lines, each spaced 1/4"-3/8" in from and parallel to the border lines. If not, make these new lines at least 3/8" in from the border lines to allow for circuit board mounting without the hardware touching the foil.

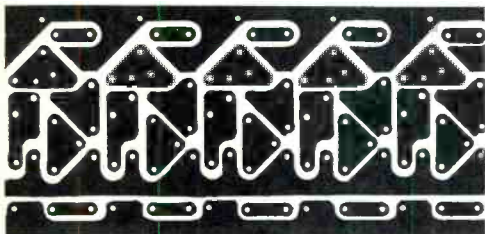
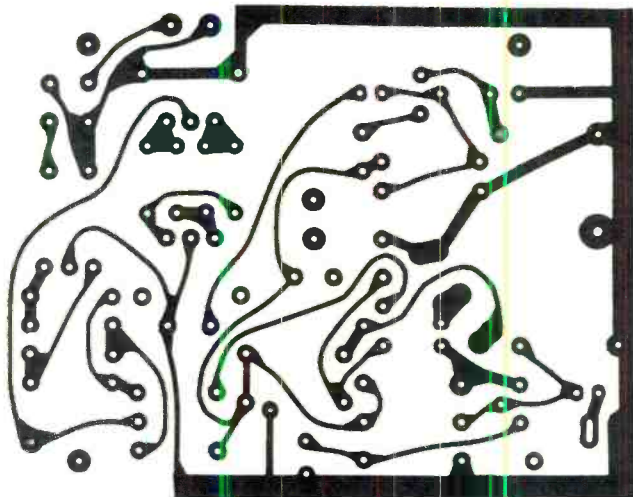

Fig. 4. Examples of both minimum-width conductor (above) and "area etch" (left) etching guides are shown. Note differences in amount of copper (blackened-in portions) in guides.

Now, using your template and/or rule, start filling in hole locations and foil patterns in the same sequence as in your conductor pattern diagram. Condense the areas on which the components are to be mounted for maximum space utilization. However, do not be afraid to assign a component more space than it requires if you want to preserve symmetry of the layout or to prevent thermal problems.

The foil pattern can be any thickness from $\frac{3}{32}$ " to as wide as you want, within the limits of the circuit board size required. Another basic rule to remember is to space conductors no closer together than $\frac{1}{16}$ " (except for inline IC's, where spacing can be as small as $\frac{1}{32}$ " between the two rows of pins). If the conductors are to be less than $\frac{1}{8}$ " wide, plan to have solder pads that are a
(Continued on page 98)

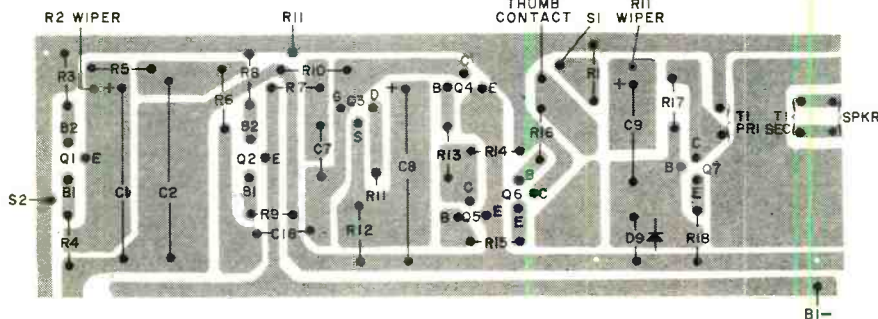

Fig. 5. Viewed from conductor side of board, foil pattern is in grey. Area etch technique was used here, but minimum-width conductor would have served just as well.

500/50-kHz FREQUENCY STANDARD

ACCURATE CALIBRATION FOR YOUR RECEIVER

BY NEIL JOHNSON

THE CRYSTAL CALIBRATOR is the most versatile test instrument available to hams and SWL's for accurately checking the calibration of their receivers. Most available crystal calibrators operate on a fundamental frequency of 100 kHz with multiple markers obtained from the 100-kHz spaced harmonics of the fundamental.

The main problem here is that the markers are inflexibly placed at predetermined intervals. So if you have to set your receiver dial in the HF range between 20 and 30 MHz where the markers are close together, it is often difficult to determine whether your receiver is set to 20.1 or 20.2 MHz. Conversely, on the low end of the spectrum, the markers may be too far apart for adequate coverage. Therefore, if you could obtain a frequency standard capable of delivering markers at both 50- and 500-kHz intervals, you might have a more useful instrument. The secondary "Frequency Standard" described here is designed with that philosophy in mind.

About the Circuit. The "Frequency Standard" is basically a conventional

crystal calibrator with one major advantage—it can split the fundamental frequency as desired. The crystal oscillator stage (*V1* in schematic diagram) employs a tetrode vacuum tube in an electron-coupled configuration. This type of design provides good frequency stability so that changes in output loading have little effect on the input circuit.

There are no reactive elements in either the plate or screen-grid circuits. As a result of eliminating any trace of a resonant load, the fundamental frequency and its harmonics are free to appear at the output of the stage.

Stages *V2A* and *V2B* serve a dual purpose. With *S1* open, they act as a straight amplifier. By closing *S2*, a feedback loop from the screen grid of *V2B* to the grid of *V2A*, through *C7* and *S1*, connects the two stages in a multivibrator configuration. Again, the use of a tetrode for *V2B* allows either high- or low-impedance loads to be connected to the frequency standard with no ill effects on the circuit.

The typical multivibrator, being basically an unstable circuit, is excited with a crystal-stabilized signal from *V1*. With

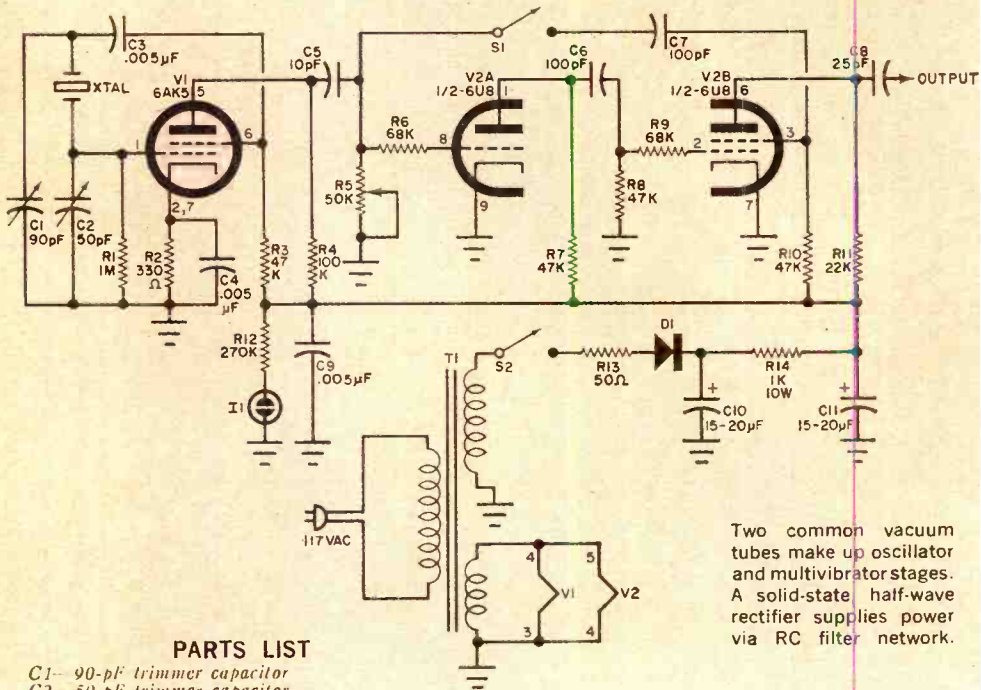

PARTS LIST

- C1—90-pF trimmer capacitor
- C2—50-pF trimmer capacitor
- C3, C4, C9—0.005- μ F ceramic capacitor
- C5—10-pF ceramic capacitor
- C6, C7—100-pF ceramic capacitor
- C8—25-pF ceramic capacitor
- C10, C11—15-20- μ F, 250-volt electrolytic capacitor
- D1—1N3105 diode
- R1—1-megohm
- R2—330-ohm
- R3, R7, R8, R10—47,000-ohm
- R4—100,000-ohm
- R6, R9—68,000-ohm
- R11—22,000-ohm
- R12—270,000-ohm

All resistors
1/2 watt

- R5—50,000-ohm, linear-taper potentiometer
- R13—50-ohm, 5-watt resistor
- R14—1000-ohm, 10-watt resistor
- S1, S2—S.p.s.t. slide or toggle switch
- T1—125-volt, 100-mA power transformer with 6.3-volt filament winding
- V1—6AK5 vacuum tube
- V2—6U8 vacuum tube
- XTAL—500-kHz crystal with matching socket (see text)
- Misc.—Metal utility box; 7-pin and 9-pin tube sockets; hookup wire; solder; hardware; etc.

Two common vacuum tubes make up oscillator and multivibrator stages. A solid-state half-wave rectifier supplies power via RC filter network.

R5 set at approximately mid-range, an uncontrolled oscillation of about 50 kHz is obtained. However, by injecting the 500-kHz signal from V1 into the multivibrator, a very stable 50-kHz signal appears at the output.

The frequency standard also features an instant-on type of design. Switch S2 in the power supply controls only the B+ to the three stages. Heater power is applied at all times when the line cord is plugged into an a.c. outlet.

Construction. Because of the relative simplicity of the circuit, almost any method of assembling and mounting it inside an appropriate size cabinet will do. The cabinet, however, should be

metal and vent holes should be drilled in it at the rear and top to provide adequate convection cooling for the tubes.

Switches S1 and S2 should be easily accessible and clearly marked to show which positions they are set to and the functions they perform. For S2, you have the added convenience of indicator lamp I1 to indicate when the B+ is applied to the plates of V1 and V2.

When selecting the crystal, try to obtain one that is right on 500 kHz. If you buy from surplus parts suppliers, it is worth noting that the FT-241 variety are generally too far off frequency—especially on the harmonics—for your purpose. A better choice would be the HC-6U
(Continued on page 98)

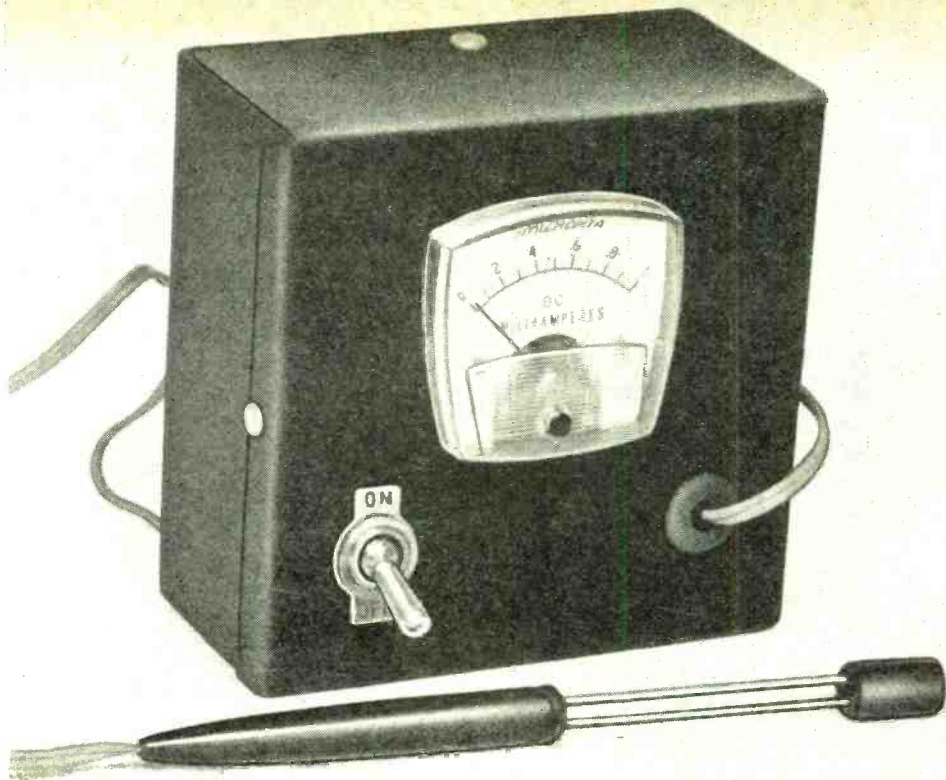

BUILD A PHOTOGRAPHIC WASH TESTER

FOR BETTER DEVELOPING AND PRINTING

BY ANDRE BROSNAK

AFTER a hypo bath, photographic film and paper require a thorough wash in running water to remove any residual sodium thiosulfate (the hypo chemical). There are several ways of checking the wash water to make sure that the cleansing process is complete. Some of these are complicated and some are too expensive; but now you can build your own photographic wash tester which gives good indication of the amount of hypo left in the wash water, at a cost of only \$8 or less.

The principle of the wash tester's operation is simple and is based on the fact that the electrical conductance of the wash water increases with increasing strength of hypo in the wash. A comparison of meter readings for the wash water and for plain tap water enables the photography buff to determine exactly when the wash is complete.

The circuit (see Fig. 1) of the photo-

graphic wash tester is very simple, consisting of a series circuit loop. It is self-powered by battery *B1*. Power is applied and removed by switch *S1*. Meter *M1* is the visual indicator, and resistor *R1* is used to limit the flow of current around the loop to a safe value.

When the probe is immersed in the wash and *S1* is closed, *M1*'s pointer will deflect upscale by an amount proportional to the amount of hypo solution in the bath. If the hypo concentration is high, the pointer deflects to a high upscale position. As the solution becomes less and less concentrated, the meter pointer will move downscale until it reaches the preset reference.

The first step in assembling the wash tester is to machine the chassis box. Then mount the meter movement, power switch, terminal strip, battery holder, and rubber grommet as shown in Fig. 2.

Referring to Fig. 1, wire together the

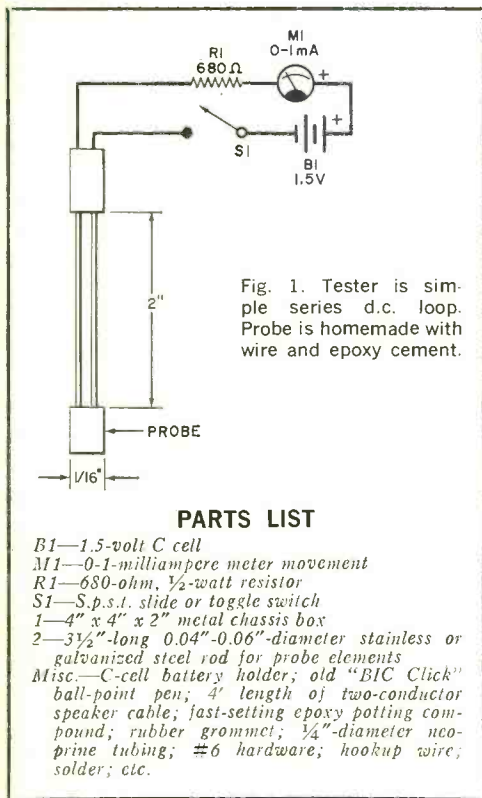

PARTS LIST

- B1—1.5-volt C cell
- M1—0-1-milliamper meter movement
- R1—680-ohm, $\frac{1}{2}$ -watt resistor
- S1—S.p.s.t. slide or toggle switch
- 1—4" x 4" x 2" metal chassis box
- 2—3 $\frac{1}{2}$ "-long 0.04"-0.06"-diameter stainless or galvanized steel rod for probe elements
- Misc.—C-cell battery holder; old "BIC Click" ball-point pen; 4' length of two-conductor speaker cable; fast-setting epoxy potting compound; rubber grommet; $\frac{1}{4}$ "-diameter neoprene tubing; #6 hardware; hookup wire; solder; etc.

chassis mounted components. Make sure that no component interferes with the others and that the meter movement is connected with the proper polarity.

Next, assemble the sensor probe as follows. Cut a $\frac{1}{2}$ " length of $\frac{1}{4}$ "-inner-diameter neoprene tubing to size. Seal one end with masking tape. Then insert

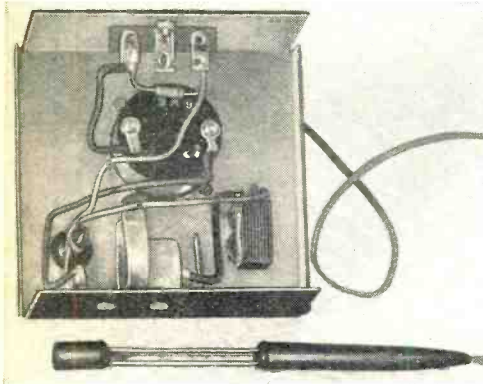
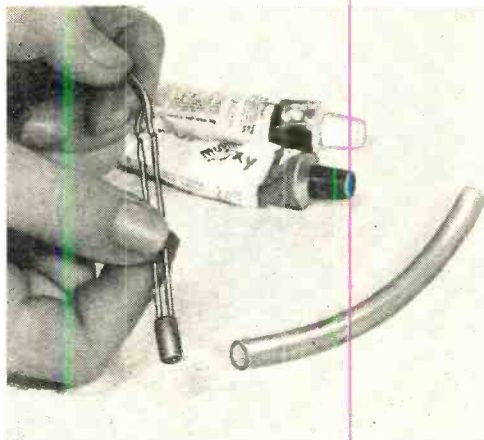

Fig. 2. Neat, open layout is facilitated by simplicity of circuit. Batteries are at bottom of case.



Taped-end neoprene tubing serves as the form when assembling the probe elements with hard-set epoxy.

the 3 $\frac{1}{2}$ "-long sensor rods (see Parts List) into the tubing, keeping them spaced $\frac{1}{16}$ " apart. Pour epoxy potting compound into the tubing and allow sufficient time for the compound to set. Then peel off the neoprene tubing.

Solder one end of a two-conductor cable to the free ends of the sensor rods. Seal this end of the sensor assembly with epoxy potting compound as described above.

Remove and discard the ink cartridge, return spring, operating button, and bottom half of an old ballpoint pen. Feed the free end of the two-conductor cable through the top half of the pen shell, and epoxy cement the sensor probe element assembly to the shell.

Finally, connect the free ends of the sensor cable to the appropriate points in the circuit. Assemble the chassis box, and the tester is ready to use.

To use the wash tester, first immerse the sensor probe in plain tap water. Set power switch S1 to the ON position. Wait about 45 seconds, and mark the position on the meter face where the pointer comes to rest. The mark represents the reference point for your tests.

Now, as you use the tester to monitor your wash, continue to wash the film or paper with the probe immersed in the wash water until the meter pointer deflects to your mark. At this point, the wash will be complete, and you can proceed to the next step in your processing.

the product gallery

REVIEWS AND COMMENTARY ON ELECTRONIC GEAR AND COMPONENTS

VERTICAL SWL ANTENNA (Mosley SWV-7)

ABOUT A YEAR AGO, the Editor of POPULAR ELECTRONICS (who considers himself to be an active SWL) asked Mosley Electronics about the possibility of their re-designing a vertical ham-band antenna to cover the international shortwave broadcasting bands—one that would be a counterpart to the excellent Mosley SWL-7 horizontal antenna. The response was encouraging and it eventually resulted in Mosley's developing an entirely new SWL antenna—the SWV-7 (\$33.71).

This new antenna is a center-loaded vertical with an overall height of 13 feet above the supporting base insulator. It tunes (resonates automatically) to the center of the 11-, 13-, 16-, 19-, 25-, 31-, and 49-meter broadcasting bands. It is designed to be used either at ground level (if the soil conductivity is right) or on a rooftop in conjunction with seven radials of different lengths.

The SWV-7 makes use of the very sturdy Mosley base insulator and is sold with a length of pipe that may be used to support the antenna at ground level or on a roof. Assembly of the vertical section is very simple and, from all appearances (we have had it installed for the month of February), it will withstand considerable weathering without ill effects. In fact, a conductive paste is supplied to insure good electrical contact between the vertical rod sections.

We have not had the opportunity—nor the properly cleared area—to mount the SWV-7 at ground level. In the rooftop installation, a triangular 5-foot high TV antenna tower was used as a support. Unfortunately, in a case such as this, the user must supply his own radials (7 of them) varying in length (from 9 to 38 feet) and position them around the base insulator. The radials are necessary to make the SWV-7 resonate in the proper bands. You can tune without them, but a bad mismatch is set up and the signals are degraded by 5 to 9 S-units.

Installing the radials is not the world's easiest job; but with patience, and by placing the supporting tower at the proper spot on the roof, you can run the radials to the eaves (using egg insulators where necessary) without too much trouble. Coaxial feedline

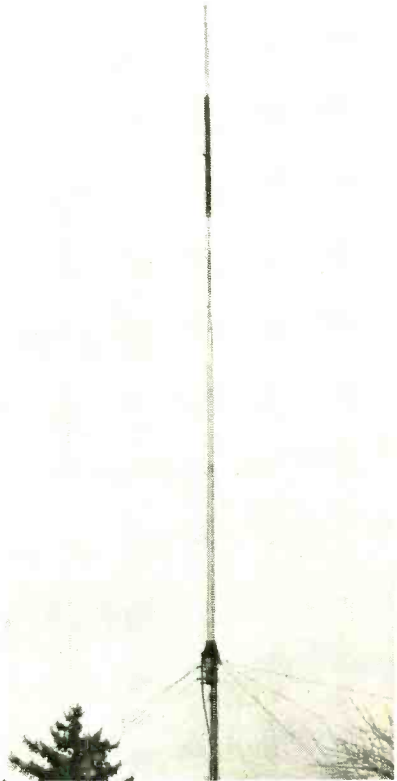

Only thirteen feet tall, the new Mosley SWV-7, antenna is center-loaded with coils tuned to the 11-, 13-, 16-, 19-, 25-, 31-, and 49-meter bands. In our tests, the SWV-7 was centered on the peak of roof supported by a triangular TV tower and 5 ft steel tube. The 7 wire radials are seen here spreading out over the rooftop toward the eaves. The SWV-7 out-performed all other SWL antennas.

must also be supplied by the installer/user and should be a good grade of RG-59/U (75-ohm) cable.

The results obtained by tuning the bands with the vertical SWV-7, when compared with those using the horizontal SWL-7, were quite amazing and firmly reinforced our frequently stated recommendation that every SWL should use two different types of receiving antennas. This is particularly necessary because of the ever-changing angles at which incoming signals arrive—sometimes high, sometimes very low. No one antenna

RECEPTION REPORTS

Station	SWL-7	SWV-7
11,710 (R. Australia)	S8	S9+6 dB
11,725 (RFE, Lisbon)	S7	S9+10 dB
11,760 (Havana)	S6	S9+10 dB
15,060 (R. Peking)	S3	S4
15,070 (BBC, London)	S7	S8
15,110 (Moscow)	S6	S9+4 dB
15,205 (VOA, Wooferton)	S6	S8
17,710 (Moscow)	S7	S8
17,820 (R. Canada)	S8	S6
17,919 (Cairo)	S3	S2
21,490 (Moscow)	S6	S8
21,645 (Paris)	S9+4 dB	S9+10 dB
25,730 (Norway)	S4	S5
25,750 (BBC, London)	S5	S8

can really suffice for adequate SWL DX'ing.

Some sample reports showing the differences in reception with the two antennas are given in the Table. Results on the 31- and 49-meter bands were equally impressive. In some directions and on most signals, the vertical outperforms the horizontal by an average of 4 S-units!

However, the vertical does have some peculiar characteristics—particularly in that the lobe pattern (directivity) of the antenna favors the azimuth of the matching radial for that band. Of course, with a vertical, the listener shouldn't expect directivity; but it is there, nevertheless. Also, the SWV-7 operates much more efficiently as a broadband antenna than the SWL-7 and is usable without a balun on 41, 60, 90, and 120 meters

where it tunes as if it were two unequal random lengths of wire.

All-in-all, we are happy with the SWV-7, but we would caution the installer/user about the problems involved in putting up the radials and the extra money required (about \$12.00).

Circle No. 91 on Reader Service Page 15 or 97

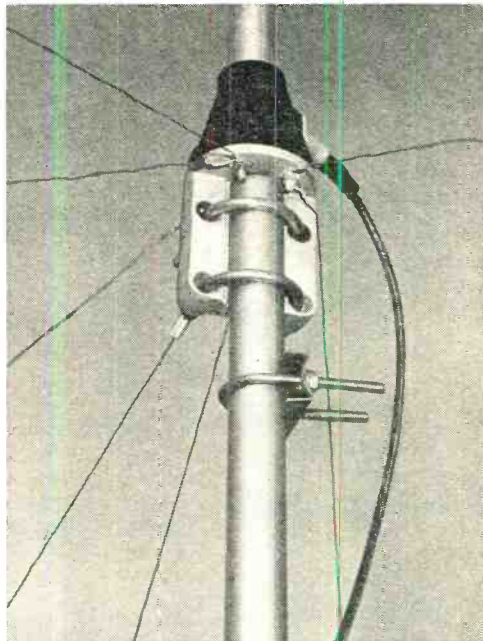

The SWV-7 antenna uses the "proven-in-practice" sturdy Mosley insulated mounting. Seven radial wires are attached to the bolts holding the insulator to the metallic support that is clamped to the steel mast. A 75-ohm coax feedline is attached to the opposite side of the insulator via a special connector. The "extra" clamp below the insulator doesn't belong to this setup—it was a leftover from another antenna mounting experiment.

ULTRASONIC ALARM (Delta Products DeltAlert)

THE USEFULNESS of an ultrasonic alarm system to protect a fixed-volume area should not be underestimated. If you are unfamiliar with the operation of such alarms, we suggest that you write Delta Products (use the Reader Service Number on page 69) for a colorful brochure that carefully explains the operation and application of ultrasonic alarms.

Recently, a member of the staff of **POPULAR ELECTRONICS** had the opportunity of

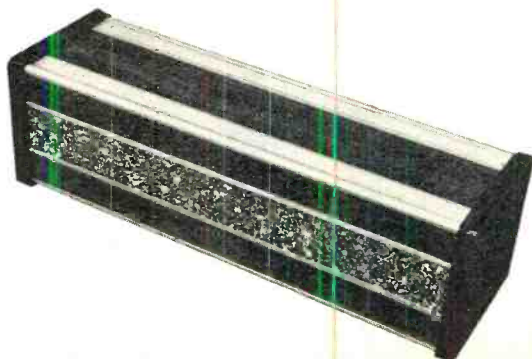

conducting an extensive test of the DeltAlert over a period of several weeks while valuable equipment was being stored in a two-car garage. In the area and volume of the garage, the DeltAlert worked to perfection. Sitting unobstructively on a steel storage shelf, the DeltAlert "flooded" the garage with ultrasonic sound and any motion such as entering from the house or opening the overhead swinging doors immediately set off the alarm (a Thomas Industries Audibell).

The DeltAlert is sold complete (except for alarm) for \$59.95 and is ready to be installed. It has a 10-second delay after it is turned on to permit the operator to leave the protected area. Should any motion disturb the ultrasonic "flooded" area, the alarm is sounded and the period that the alarm is activated may be preset to last from 15 seconds to less than 2 minutes. After the preset interval, the DeltAlert re-cycles and either remains quiescent or re-sounds the alarm for an additional period.

The workmanship on the DeltAlert is top

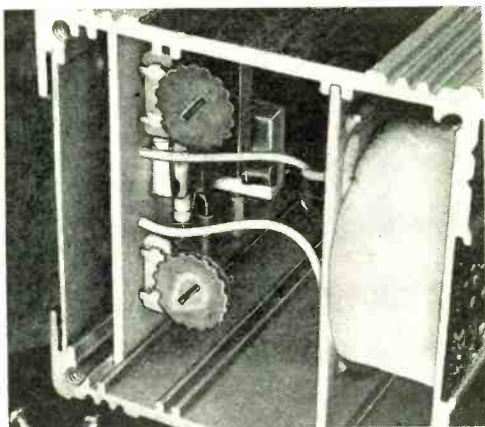

Two controls, for sensitivity (top) and time interval, are conveniently located just inside one end of the chassis. Sensitivity is easily set by connecting a lamp to the normal alarm outlet and walking back and forth through ultrasonic field. Time interval depends on the type of alarm used.

quality and there is no doubt that this alarm will operate efficiently for many months without an adjustment of the sensitivity (or range of detection) control. In an enclosed area, where there should be no abnormal motion (or forcible entry), we highly recommend the ultrasonic alarm.

Circle No. 92 on Reader Service Page 15 or 97



Unobtrusively set on a storeroom shelf, DeltAlert ultrasonic alarm fans 35-kHz energy out at a horizontal angle of about 100° and vertical angle of 40-45°. Used in this storeroom (a 2-car garage), it immediately sensed any "foreign" movement and energized a loud alarm bell for thirty seconds.

METAL/MINERAL LOCATOR (Caringella TRL-1)

THE BOYS who carried mine detectors during World War II won't believe the evolution that has transpired in such devices when they see the Caringella TRL-1. Compared to those old heavyweights, the TRL-1 weighs only 1 lb 9 oz (including the one-piece earphone). In kit form (\$29.95), it is easy and foolproof to build in just about two hours. It can safely be recommended to an electronics

novice as a very first project—it's just about impossible for it not to work, as long as the builder follows the wiring instructions.

The TRL-1 is a FET-circuit, beat-frequency type of metal-mineral locator. The presence of metal or mineral in sand or common earth changes the pitch of the low-frequency beat note heard in the earphone. The unit operates from a single 9-volt battery and the audio beat note has sufficient volume to override the ambient noise picked up by the uncovered ear.

We started this review by mentioning the WW II mine detector for the simple reason that the TRL-1 is not the most sensitive metal/mineral locator we have tested. It will not respond to very small metallic objects, but will note the presence of something the size of a land mine that might be 6 to 9 inches under the ground. Objects smaller than the size of a coffee can lid can only be detected if they are near ground level (maybe 1 or 1½ inches under) and the soil is very dry. Without trying it, we suspect that the TRL-1 would be great fun on a dry sandy beach.

Circle No. 93 on Reader Service Page 15 or 97

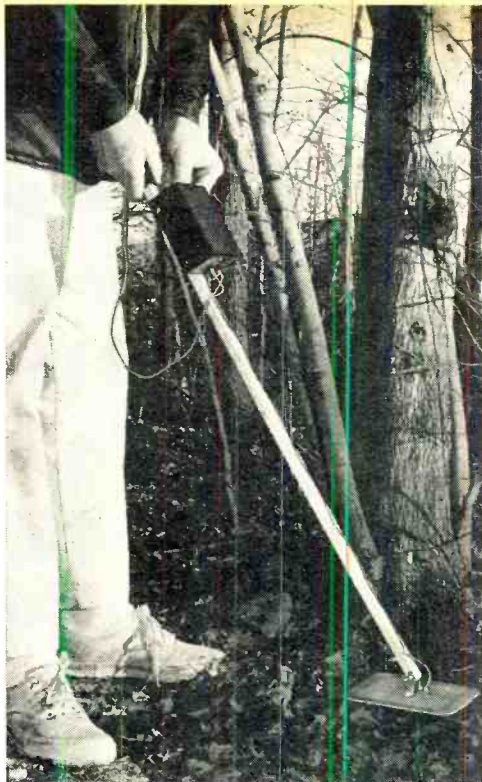

The metal/mineral locator is very light in weight and easy to use. Angle of search coil plane may be changed to suit convenience of user. Support pole is in two pieces and can be folded up into a relatively small package to fit in car trunk.

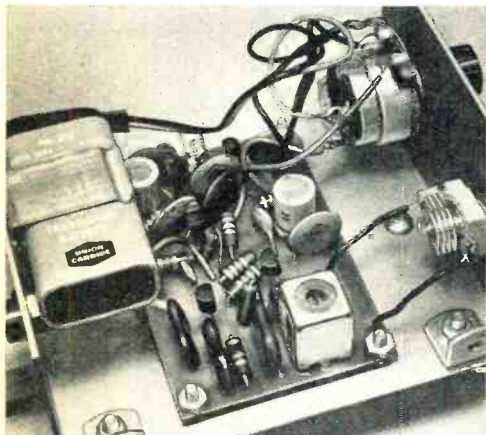

Most of electronics package is on a PC board. Use care in soldering in the 5 transistors (3 FET's). Assembly of board took your reviewer about 1½ hr.

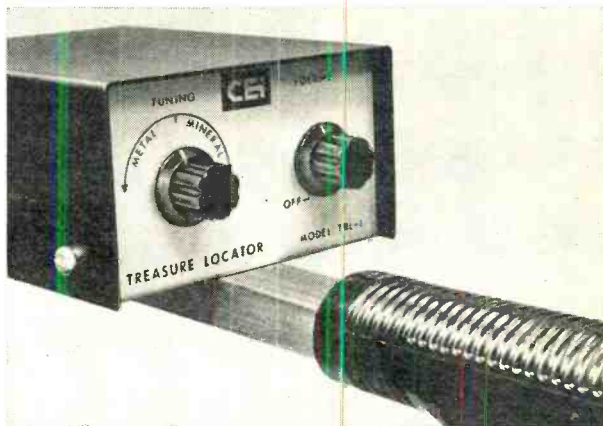

Knob at left (above) controls beat note frequency and offers some indication of "type" of detected substance. Other knob controls volume and on/off switch. Earpiece connection is on back of the box.



Search coil (left) is a double-sided piece of copper-clad fiberglass PC board. Top side has a coil etched out of the copper. On the bottom is a continuous band of copper connected to coax shield.

BURNING OUT YOUR CIRCUITS WITHOUT REALLY TRYING

BY ERROL J. QUEEN

THE AGE OF SEMICONDUCTORS brought with it the many advantages of subminiaturization, cool operation, and improved performance in everything from sophisticated FM tuners to electronic light dimmers. Diodes and transistors are not without problems, however; as I recently discovered.

I am an audio-visual enthusiast and take great pains to put on semi-professional slide shows for friends and relatives who visit us frequently. A Kodak Carousel projector is connected through a Sound Synchronizer to a transistorized tape deck and amplifier. The Synchronizer unit receives trip signals from one track of the stereo tape, in turn changing the slides in coordination with pre-recorded commentary and music. Colored lamps light the projection screen prior to the show's beginning; and by means of a light dimmer, the room lights and colored spots are slowly dimmed as the first slide comes on.

Recently, in redecorating our family room, I made the mistake of having acrylic wall-to-wall carpeting put in. I was unaware of its highly electrostatic nature, particularly on cool winter evenings. Sparks can play havoc with apparatus containing semiconductors.

When my wife or I walked across the room and then touched any metal surface, an intense spark was created. While not dangerous because of the infinitesimally low current, the voltage was probably near 100,000 volts with sparks as long as an inch and a half. We even found that we were able to locate metal surfaces behind the wall plaster (such as plumbing and conduits) by walking about and probing with a finger until a spark jumped into the wall. My wife insisted that perhaps there were treasures buried beneath the floor and asked that I crawl along the carpeting as a human treasure locator!

In all seriousness, the electrostatic nature of acrylic was such that within a

week I saw sparks fly into my FM tuner, lamp dimmer, and FM-AM clock radio. Each in turn suffered semiconductor damage, which was costly and emotionally disconcerting. At that point, I felt I would have to make a serious decision—sell the carpeting at a tremendous loss, or sell the semiconductor equipment at a loss of dollars and pleasure. I searched the catalogs and concluded that tube-type tuners and clock radios were rapidly becoming a thing of the past—what with their problems of size, heat dissipation, and lack of demand.

My problems were finally resolved when I called in the firm which sold the carpeting. They recommended one of several available sprays, which, when applied, reduce the charge buildup on such fibers. Powders are also available for the same purpose. They can be brushed into the rug, with the excess vacuumed up immediately.

If you own or plan to buy transistorized radios, amplifiers, tuners, tape decks, light dimmers, or other appliances, make sure your carpeting is static-free.

-30-



I made an excellent human treasure locator!

**“He’s a good worker.
I’d promote him
right now if he had
more education
in electronics.”**



Could they be talking about you?

You'll miss a lot of opportunities if you try to get along in the electronics industry without an advanced education. Many doors will be closed to you, and no amount of hard work will open them.

But you can build a rewarding career if you supplement your experience with specialized knowledge of one of the key areas of electronics. As a specialist, you will enjoy security, excellent pay, and the kind of future you want for yourself and your family.

Going back to school isn't easy for a man with a

full-time job and family obligations. But CREI Home Study Programs make it possible for you to get the additional education you need without attending classes. You study at home, at your own pace, on your own schedule. You study with the assurance that what you learn can be applied to the job immediately.

CREI Programs cover all important areas of electronics including communications, radar and sonar, even missile and spacecraft guidance. You're sure to find a program that fits your career objectives.



**IN-DEPTH
 COVERAGE OF
 SOLID STATE
 ELECTRONICS**
 ...including
 integrated circuits!

You're eligible for a CREI Program if you work in electronics and have a high school education. Our FREE book gives complete information. Mail postpaid card for your copy. If card is detached, use coupon at right or write: CREI, Dept. 1205A, 3224 16th St., N.W., Washington, D.C. 20010.

CREI, Home Study Division
McGraw-Hill Book Company
 Dept. 1205A, 3224 Sixteenth Street, N.W.
 Washington, D.C. 20010

Please mail me FREE book describing CREI Programs. I am employed in electronics and have a high school education.

NAME _____ AGE _____
 ADDRESS _____
 CITY _____ STATE _____ ZIP CODE _____
 EMPLOYED BY _____
 TYPE OF PRESENT WORK _____ G. I. BILL

- I am interested in
- Electronic Engineering Technology Computers
 - Space Electronics Nuclear Engineering Technology
 - Industrial Automation NEW! Electronics Systems Engineering

APPROVED FOR TRAINING UNDER NEW G.I. BILL



ENGLISH LANGUAGE NEWS BROADCASTS FOR THE MONTH OF MAY

Prepared by **ROGER LEGGE**

TO EASTERN AND CENTRAL NORTH AMERICA		TO WESTERN NORTH AMERICA	
TIME-EDT	STATION AND LOCATION	TIME-PDT	STATION AND LOCATION
	FREQUENCIES (MHz)		FREQUENCIES (MHz)
7:00 a.m.	Stockholm, Sweden	8:00 a.m.	Tokyo, Japan
7:30 a.m.	Melbourne, Australia	9:00 a.m.	Stockholm, Sweden
8:00 a.m.	Peking, China	6:30 p.m.	Melbourne, Australia
8:15 a.m.	Montreal, Canada		Tokyo, Japan
12 Noon	London, England	7:30 p.m.	Johannesburg, South Africa
5:30 p.m.	Hilversum, Holland	8:00 p.m.	Madrid, Spain
7:00 p.m.	Montreal, Canada		Moscow, U.S.S.R.
7:45 p.m.	Tokyo, Japan		Peking, China
8:00 p.m.	London, England		Prague, Czechoslovakia
	Moscow, U.S.S.R.		Seoul, Korea
	Sofia, Bulgaria		Tokyo, Japan
	Tirana, Albania	8:30 p.m.	Berlin, Germany
8:30 p.m.	Johannesburg, South Africa		Stockholm, Sweden
	Stockholm, Sweden		Tirana, Albania
8:50 p.m.	Brussels, Belgium	9:00 p.m.	Budapest, Hungary
	Vatican City		Havana, Cuba
9:00 p.m.	Berlin, Germany		Lisbon, Portugal
	Budapest, Hungary		London, England
	Havana, Cuba		Moscow, USSR (via Khabarovsk)
	Madrid, Spain		Sofia, Bulgaria
	Peking, China		Tokyo, Japan
	Prague, Czechoslovakia	9:30 p.m.	Kiev, U.S.S.R. (Mon., Thu., Sat.)
	Rome, Italy	9:45 p.m.	Berne, Switzerland
9:30 p.m.	Berne, Switzerland		Cologne, Germany
	Cologne, Germany	10:00 p.m.	Havana, Cuba
	Melbourne, Australia		Hilversum, Holland (via Bonaire)
10:00 p.m.	Cairo, Egypt	11:00 p.m.	Moscow, USSR (via Khabarovsk)
	Hilversum, Holland (via Bonaire)	11:30 p.m.	Tokyo, Japan
	Lisbon, Portugal		Havana, Cuba
	London, England		
	Moscow, U.S.S.R.		
	Oslo, Norway (Sunday)		
10:30 p.m.	Beirut, Lebanon		



OPPORTUNITY MIRROR



Thoughtful Reflections On Your Future

Third in a Monthly Series, BY DAVID L. HEISERMAN

Preparing a Resume

I notice that most "help wanted" ads request a resume from the applicant. I have never prepared one. What information should I include in a resume?

● Your resume should be as brief and factual as possible, but do not leave out any important or interesting information about yourself that might help you get the job. The following items must be included in your resume:

1. Full legal name.
2. Home address and telephone number.
3. Personal information. (Date of birth, marital status, and number of dependents.)
4. Educational background. (Name and location of your high school and any college, technical school or military school you have attended and the amount of time spent at each. Describe the major courses you studied and indicate any certificates, diplomas, degrees, or honors you have received. Detail any home study courses you have completed and name the schools and describe the courses.)
5. Work experience. (List your last employer first and then the names and addresses of all previous employers showing the date you started working and the date you left each employer. Also include the name of the immediate supervisor at your last place of employment. Describe the kinds of work you performed for each employer and the titles of the positions held. Name any special equipment you have worked on—military or civilian. Lastly, give an honest reason for your leaving each job.)
6. Military and draft status, including any military experience. (Show dates, duties and rank.)
7. Special interests. (Detail your hobbies and favorite pastimes.)

Don't be afraid to prepare one master resume and to send copies (Xerox or other) of your resume to different prospective em-

ployers. However, be sure to attach a personal note to each prospective employer telling who you are and why you are submitting the resume.

Sams Photofacts

I work in a TV service shop and we have a complete file of Sams Photofacts. I use at least three different folders of schematics and maintenance data every day. In the years that I've worked at the service shop I've never discovered how Sams develops these valuable folders. Is it true that errors are occasionally put in the schematics to circumvent the equipment manufacturers' copyrights?

● Since 1948, Howard W. Sams & Company has been publishing complete circuit schematics, parts lists, troubleshooting hints, and maintenance tips on just about every TV, radio, and phonograph made in the United States. These folder packets of information are available at a modest price from most of the large electronics retailers and are considered the bibles of the TV and radio service industry.

It is not true that errors are intentionally introduced. In fact, Sams is very careful to avoid errors of any kind. According to Les Nelson, Director of the Photofact division of Howard W. Sams, all of the schematics are original and not copies of the circuits distributed by the manufacturer.

It seems hard to believe, but Sams develops the schematics the hard way—by tracing the circuit on working models of the equipment. Sams has a staff of about 60 technicians who trace out the schematics, take voltage readings, photograph oscilloscope waveforms, and develop maintenance and alignment techniques. Sams also has an expensive staff of draftsmen, photographers, and artists to put together the Photofact folders.

Most manufacturers are so pleased with

the services provided by Sams that new working models of home entertainment electronic equipment are loaned to the Sams laboratory as soon as the first models are off the production line.

Electronics technicians and draftsmen interested in more information about job opportunities with Howard W. Sams should write to: Mr. Frank Wallace, Personnel Department, Howard W. Sams & Company Inc., 4300 West 62nd Street, Indianapolis, IN 46206.

Frank Wallace tells us that he is especially interested in hearing from people who have completed training at a two-year technical school, and have had several years experience in home entertainment manufacturing or servicing.

Teaching Electronics

I am a senior in high school and have always had a great interest in electronics. I also have a ham radio license. I would like to teach electronics, but my school counsellor hasn't been able to find any material on how to prepare for a career in this particular field. He has information about science and the industrial arts, but nothing on electronics. Is there anything different about the kind of training an electronics teacher must have?

● I assume that you do not want, or intend, to teach electronics in high school. Very few high schools offer any courses in electronics. Those few schools that do use their regular science teachers, or hire a part-time electronics teacher. Generally speaking, electronics in high school is usually at a hobby level.

In order to teach electronics full time, you should be shooting for a teaching job in a vocational school or a two-year technical college.

Teachers at accredited vocational schools and technical colleges must have college degrees in the subjects they teach. Since you want to teach electronics, your counsellor should find you a good university where you can study electrical/electronic engineering.

If you don't want to teach at the vocational level, you must get a college degree in education and according to the rules of the various educational colleges, a prospective teacher must "minor" in a secondary subject that he can also teach. Unfortunately, electronics is not one of the minors offered by any of the usual education colleges. If you want to teach electronics in high school, you will probably find it necessary to have a minor in science.

Even with a degree in education and a minor in science, you should have formal electronics training. Let your counsellor help

you select a home study course in electronics technology.

Electronic Organ Repair

Here is a case where the tail may be wagging the dog! I have been working as a digital circuit design technician for six years. Last Christmas I bought my family the large Heathkit electronic organ. I became so entranced by organ circuits that I am seriously considering getting into the electronic organ repair business. However, is there such a thing?

● The electronic organ manufacturers that we have talked to all tell us that they hire organ repairmen and technicians who can meet two principal qualifications: a good solid background in electronics, and at least a one-finger ability to play the instrument.

However, the electronic organ repair business is very specialized and it is doubtful that you can make it a going business just by yourself. Each organ is a different design and it would appear to us that your best bet would be to try part-time electronic organ servicing in behalf of a large music store or organ dealer's service shop.

If the shop thinks you are qualified, they may have you tag along with an experienced technician. Then, they'll probably ask you to go to a full-time factory school for a week or so—with pay, of course.

At these factory schools the instructors will tell you about the circuits used in their organs and how to cure the most common bugs and defects.

From that point on, you will be a specialist in that particular brand of electronic organ. And, you can expect to spend at least a week each year back at the factory brushing up on new circuits and maintenance tricks. If you happen to get a job with one of the larger companies you'll also be spending several days a year at regional seminars.

The career opportunities in electronic organ repair appear to be very good at the present time. Organ sales are rising steadily and there is a demand for top-notch repair technicians. At the same time we cannot disguise the fact that the complexity of organ electronics is increasing at an alarming rate. Organ dealers are paying top wages to attract and keep electronics technicians who feel at home with modern solid-state computer-type circuits.

If you don't want to get too involved, you might contact the Niles Bryant School, 3631 Stockton Boulevard, Sacramento, California 95820 concerning a home study course on electronic organ repair.

OPTOELECTRONICS—A GROWING FIELD

OPTOELECTRONICS is rapidly emerging as a full-fledge technology which, one day, may rank with microwaves, telemetry, instrumentation, etc. in terms of applications and numbers of individual specialists. An interdisciplinary field involving both optical and electronic techniques, it offers rich rewards to the serious experimenter.

With light as the common denominator, optoelectronics employs devices in four principal classes: sources, directors, modifiers, and detectors (or sensors). The former include units as simple as the common incandescent bulb and as exotic as high-power lasers. Light directors include lenses, prisms, and reflectors, while typical modifiers are filters, polarizers, and modulators. The detector category covers specialized units ranging from photodiodes to light multipliers, photo-FET's, and high-gain photo-transistor Darlington amplifiers. Although some of these devices have been available for years, the field's rapid expansion lately has been due, in large part, to the development of a variety of new semiconductor optoelectronic components, principally light sources and sensors.

Two major manufacturers have recently introduced low-cost plastic encapsulated light-emitting diodes (LED's) suitable for hobbyist applications. Motorola's MLED600 and Monsanto's MV50 are basically similar in that both are gallium arsenide-phosphide diodes and they emit visible red light at about 700-750 foot-lamberts, require approximately 40 mA for maximum output, operate on low voltages (up to 2.0 volts) and have response times on the order of a nanosecond. With extremely long service lives (perhaps as much as 100 years), the two devices are more expensive than standard pilot bulbs but they are competitive with special long-life incandescent lamps.

The experimenter or circuit designer may choose from a number of commercial semiconductor light sensors, including photovoltaic (solar) cells, photodiodes, and even multi-stage units such as photosensitive IC amplifiers. While most devices are available with a broad range of optical and electrical specifications, no single unit may have char-

acteristics that are ideal for a specific application.

Light communications systems, switching or logic circuits, and pulsed laser beam detectors require sensors with ultra fast response times. A good choice for these applications would be one of Motorola's newly introduced *pin* photodiodes, types MRD500 or MRD510. These devices have a typical response time of only 1 nanosecond. Both units are similar except for packaging. The MRD500 has a convex lens which provides a narrow field of view and a typical radiation sensitivity of $1.8 \mu\text{A}/\text{mW}/\text{cm}^2$, while the MRD510, equipped with a flat-glass window for a wide field of view, has a sensitivity of $0.4 \mu\text{A}/\text{mW}/\text{cm}^2$.

If overall sensitivity, rather than response time, is the critical parameter in a specific project, the experimenter/designer might select from GE's 2N5777-80 series of light sensors. Suitable for alarms and control circuits, these devices are low-cost *npn* planar silicon photo-sensitive Darlington amplifiers packaged in a clear epoxy. Depending on type, sensitivities range from $0.25 \text{ mA}/\text{mW}/\text{cm}^2$ to $1.0 \text{ mA}/\text{mW}/\text{cm}^2$.

Solid-state light emitters and matching detectors are combined in some optoelectronic devices. Illustrated schematically in Fig. 1, Monsanto's MCT 1 is typical, consisting of a gallium arsenide LED and an *npn* silicon phototransistor closely coupled

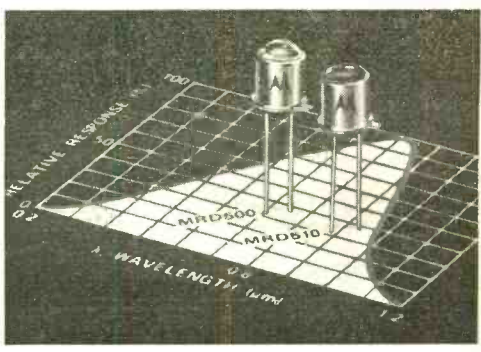

Motorola photodiodes have response times of only 1 nsec and are sensors for switching circuits.

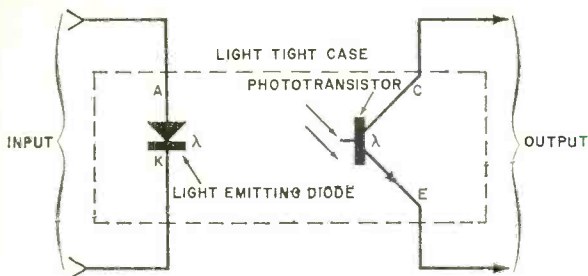

Fig. 1. Light emitting diode and phototransistor are combined in a TO-5 case. For use as high-speed switch, device has an input-output isolation resistance of about 100,000 megohms.

in a package no larger than a TO-5 transistor case. Used principally as high-speed, solid-state switches and signal couplers, these devices have input-output isolation resistances on the order of 100,000 megohms! In operation, input signal currents are converted into light radiation by the LED which is directly coupled to the photosensitive detector and, in turn, controls the unit's output current. With light as the only coupling medium, there is no electrical connection between the input and output circuits.

Readers' Circuit. Useful as a tuning indicator as well as for measuring relative signal strength, an S-meter can be a valuable accessory on any receiver used by the ham, SWL, or communications buff. Wishing to add such an instrument to his inexpensive short-wave set, reader W.J. Kreamer, WA2ZLR (10 Manning Ave., Troy, N.Y. 12100) devised the circuit shown in Fig. 2. Suitable for virtually all tube-type receivers, the project can be assembled in a few hours.

Emitter follower *Q1*, in conjunction with isolation resistor *R1*, provides a high input impedance to minimize receiver a.v.c. circuit loading. Resistor *R2* serves as *Q1*'s emitter load and *R3* as a current-limiting interstage coupling resistor. Transistor *Q2*

and its emitter resistor *R5* form one of the lower arms of a bridge circuit, with *R8* serving as the matching lower arm and *R4* and *R7* forming the upper arms. Meter *M1*, shunted by sensitivity control *R6*, is used to measure bridge unbalance.

In operation, a change in the receiver's a.v.c. voltage resulting from changing r.f. signal strength, is amplified by *Q1* and applied to *Q2*, causing a corresponding change in bridge balance and hence in *M1*'s reading. The higher the a.v.c. voltage, the greater the meter (current) indication, and vice versa.

All components needed for the project are available through regular distributor outlets. The transistors are general purpose *pnp* types, and, except for linear potentiometers *R5* and *R6*, all resistors are 1/2-watt types.

Any construction technique may be used for assembling the S-Meter, for neither parts placement nor the wiring arrangement should be critical. The circuit can be wired on a small piece of perf board mounted directly on the meter, using the terminal studs for support.

The S-meter is installed by connecting its input terminals to the receiver's negative a.v.c. bus and circuit ground, as indicated in the diagram. If space is available, the instrument can be mounted directly in the receiver.

(Continued on page 95)

Fig. 2. Easy-to-build homemade S-meter is a valuable accessory on any receiver used by ham or SWL.

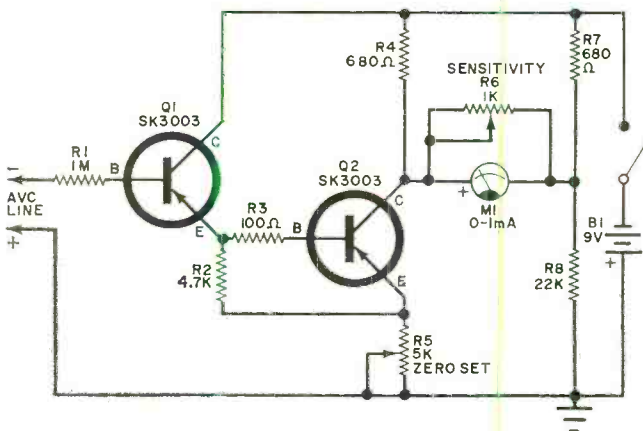

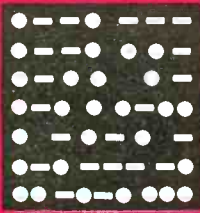

AMATEUR RADIO

By **HERB S. BRIER**, W9EGQ
Amateur Radio Editor

NEW USE FOR SMOG!

AS EXPERIENCED VHF operators know, when an atmospheric temperature inversion occurs—that is, when a layer of warm, damp air flows over cool air close to the ground—VHF radio signals are diffracted or bent back to the earth many miles beyond their normal, “line-of-sight” range. The same atmospheric condition compounds the air-pollution-smog problems in our cities, because the dense upper layer of air prevents the air pollutants spewed out by our cars, chimneys and factories from floating away into space. So the next time your city is under a smog alert, rejoice! Get on the 50-MHz and higher frequency amateur bands and work stations you have never worked before. The other operators will be tolerant of your cough. Isn’t progress wonderful?

But cheer up. All is not lost, even if you do not have smog. Each year around the

first of May, as regular as spring, the VHF spectrum suddenly erupts into a raging cacophony of strong signals from distances of 600 to 2400 miles. The phenomenon (“sporadic E”) may last only a few minutes or for hours on end and will repeat itself many times before the summer is over.

Sporadic E propagation (“short skip”) results from unpredictable, intense radiations from the sun that ionize small patches within the ionosphere. These patches reflect back to the earth signals that leak through the normal ionosphere into space.

Short skip is especially exciting to 50-MHz operators, because it permits many of them to work 20 or 30 states and a neighboring country or two during the summer months. Sporadic E propagation affects all frequencies from 3.0 to 100 MHz and higher. Thus, short skip openings are frequent summer occurrences on the 14-, 21-, and 28-MHz



AMATEUR
STATION
OF THE
MONTH

Mike Flenz, WB9ANR, 805 Maple St., Neenah, WI 54956, divides his time between 40- and 15-meter AM phone and CW with a Heathkit DX-60B transmitter and HR-10B receiver in conjunction with either a 40-meter horizontal dipole or an inverted-V dipole. We are sending WB9ANR a 1-year subscription to POPULAR ELECTRONICS for winning this month's Amateur Station Photo Contest. You can enter by sending a clear (black and white) photo of yourself at the controls of your station along with some details about your amateur career, to Amateur Photo Contest, c/o Herb S. Brier, W9EGQ, POPULAR ELECTRONICS, P.O. Box 678, Gary, IN 46401.

HAMS ON FILM

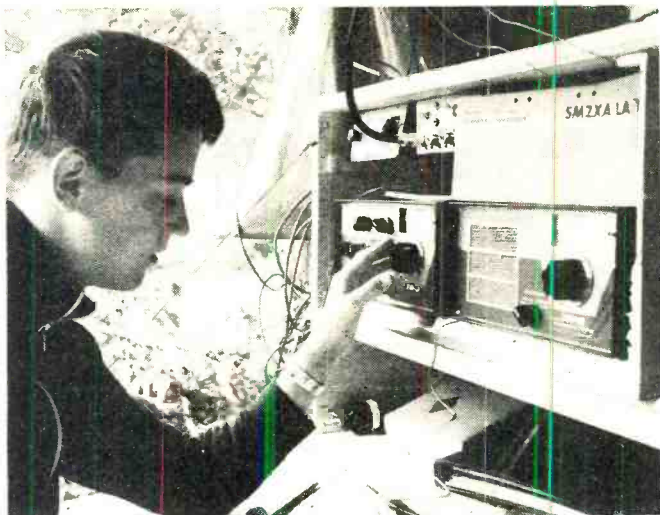

The ARRL has recently produced a 27-minute color film telling the story of amateur radio today. Covering the activities of some typical hams (including some novices and a pretty female ham), field days, and emergency operation, the film includes some shots of the fantastic station used by Barry Goldwater to illustrate phone patch conversations between servicemen overseas and their families. There are also some interesting sequences showing ham TV in operation.

The film is narrated by Arthur Godfrey (K4LIB), Barry Goldwater (K7UGA) and Bill Leonard (W2SKE), and is recommended for active hams, would-be hams and anyone else interested in amateur radio. Watch your local TV station listings to see when it is to be broadcast, or contact a ham club for details.



amateur bands, as they scramble the commercial, point-to-point services operating between 30 and 50 MHz and substitute strange TV signals for the regular stations on many receivers tuned to TV channels 2 through 6.

Sporadic E in Europe. In England and Europe, the 70-MHz (4-meter) band replaces the 50-MHz amateur band. In spite of the fact that many U.S. 50-54-MHz amateurs believe that they must stick as close as possible to 50 MHz to take advantage of "short skip," there are many inter-European 70-MHz, sporadic E contacts. Gibraltar to England (1000 miles), England to Iceland (1200 miles), and contacts with Spain, Hungary, Poland, Russia, Sweden, etc., are reported regularly in England's "Radio Communications" and "Short-Wave Magazine." In fact, last May, HG5AIR, Hungary, worked a couple of English stations via 144-MHz sporadic E propagation. Denmark and

Swedish amateurs were hearing Italian and
(Continued on page 92)



Bruce Oliver, WA6CAA, Modesto, Calif., has worked all states and 23 countries with an ancient Harvey-Wells TBS-50 transmitter and Gonset G-63 receiver plus a Gotham 3-band Quad and a dipole.



SHORT-WAVE LISTENING

By **HANK BENNETT**, W2PNA/WPE2FT
Short-Wave Editor

SCATTERED NOTES FROM OUR DESK

THE 1970 COMMUNICATIONS HANDBOOK contained a couple of errors in the listings of radio clubs. On page 145, the Newark News Radio Club is listed as having a yearly dues fee of "(about) \$10.00". The North American Shortwave Association (NASWA) listing shows its yearly dues to be \$1.00. In reality the dues of both organizations are \$5.00 per year and in each case this entitles members to 12 bulletins per year, third-class mail. Both clubs will mail their bulletins first class (for faster service) but the fee for this is higher. Finally, the address for NNRC should be 215 (not 25) Market St., Newark, N. J. 07101.

Over the years we have mailed out over 6000 copies of leaflet K (Time and Standard Frequency Stations). One of the various versions of this leaflet has a listing for JAQ56, Tokyo, Japan. If you have this particular leaflet, delete this station from the listing since it has closed all operations according to the Midwest DX Club, to whom we send our thanks. (For information on this club please write directly to David Alpert, 6636 Davis St., Morton Grove., Ill. 60053).

Again referring to leaflet K, we have an updating on some of the other material as supplied by Bill Orr, W6SAI, Menlo Park, Calif. The Chinese station, BPV, Shanghai, is now listed as using 9351 kHz. Under USSR listings, add RTA, Novosibirsk, on 4996, 9996 and 14,996 kHz. Also add RKM and RID, Irkutsk, both of whom use the same transmitter, on 0554, 10,004 and 15,004 kHz. Bill mentions that the transmissions are sporadic and not on at all hours; but, he adds, all of these stations have been heard recently in the U. S. Meanwhile we're endeavoring to learn if the station that we have listed, RWM, is still in operation. The last schedule that we had shows 5000 kHz in service at 0500-0800 and 1700-0600; 10,000 kHz at 1300-1600; and 15,000 kHz at 0100-0400 and 0830-1306.

Congratulations are in order for Jim Young, WPE6ENA, of Wrightwood, California. Jim not only retains his position of first place on our DX Honor Roll, he does

so in a most impressive manner. He is the first DX'er on our rolls to achieve the distinction of having obtained QSL's from over 300 countries (305 to be exact). The proud holder of a 300 Country Letter of Certification, the first one that we've issued, Jim also has DX Awards for all 50 states, the 12 Canadian areas, and all 40 world radio



Powerful HCJB, Quito, Ecuador, is offering four different—and all colorful—QSL cards this year. This one, two boys on a donkey on a banana plantation, is available through June. Send 3 IRC's or equivalent U.S. stamps or money, with your report, which must be as complete as possible, especially with regard to frequency—within 5 kHz.

zones, for a total score of 402. This places him well ahead of his nearest contender. The four runners-up as we go to press are Chuck Edwards, WPE4BNK, Fort Lauderdale, Fla., with a total of 292, Mark Connelly, WPEIHGI, Arlington, Mass., with 252, Charles Mattered, WPE6DGA, San Leandro, Calif., with 242, and Paul Kilroy, WPE3FOB, Washington, D. C., with 232.



Using an Allied A-2515 receiver with a total of 140 feet of antenna wire, Michael Skinner, Columbus, Ohio, WPE8JVR, has now verified 47 countries.

CURRENT STATION REPORTS

The following is a resume of current reports. At time of compilation all reports were as accurate as possible, but stations may change frequency and/or schedule with little or no advance notice. All times shown are Greenwich Mean Time (GMT) and the 24-hour system is used. Reports should be sent to Short-Wave Listening, P. O. Box 333, Cherry Hill, N. J. 08034, in time to reach us by the fifth of each month. Be sure to include your WPE identification and the make and model number of your receiver.

Albania—*R. Tirana* has two new channels in use: 6165 kHz at 0300 s/on with "Govorit Tirana" ID, and on 7060 kHz at 0000-0028, dual to 9780 kHz, in English to N.A. This latter xmsn is scheduled for one half-hour later but is being heard now at this earlier time. The foreign service outlet on 1394 kHz is being heard from 1630-1830 in four 25-minute xmsn's in various languages, but no English; s/on is with Tirana's two-trumpet IS; s/off is with the *Chinese* ("The East is Red") anthem.

Australia—*R. Australia*, Melbourne, is on 11,930 kHz at 1800-1820 in English to Africa and Pacific, on 11,840 and 9540 kHz to the Pacific in English at 1800, and on 6155 kHz, beam not yet determined, at 1940-2000 with pop music. VLI6, Sydney, is also heard on 6090 kHz around 1000-1200 with music and news and around 1445 with horse racing announcements.

Austria—*R. Austria*, Vienna, was noted on 21.670 kHz at 0700-0755 with no ID but the IS of "The Blue Danube" was given often. The station can also be easily recognized on 7245 kHz at 0345-0400 with the same IS.

Bolivia—CP70. *R. Grigota*, Santa Cruz de la Sierra, is on 4824 kHz and heard in Spanish after 2200 but badly QRM'ed by stations on 4823 and 4825 kHz. . . CP84, *R. Los Andes*, Tarija, 4775 kHz, was logged at 0337-0406 with continuous music and time checks.

Botswana—*R. Gaborones* has been heard on 4844

and 3356 kHz at 0358 with a cowbell IS, anthem at 0400 and to past 0430 with light music, including some U.S. pop tunes, and possibly a newscast around 0425. The languages are English and vernaculars.

Cape Verde Islands—*R. Clube de Cabo Verde* has moved from 3960 kHz to 3883 kHz and is scheduled at 2100-2300. Reports go to C.P. Box 26, Praia, Ilha de Santiago, Cape Verde Islands.

China—Chinese stations logged lately include Kweiyang, 3260 kHz, in Chinese at 1343-1444, and Chengtu, 3245 kHz, in Chinese at 1434 to past 1500 with music to 1459 and a time check on the hour.

Denmark—The latest schedule that we have from Copenhagen shows Danish xmsn's ONLY as 0945-0950, 1130-1155, 1330-1345 and 1730-1815 to Greenland, 1200-1245 and 0100-0145 to N.A., 1400-1445 to S. Asia, 1830-1915 to Africa and 2100-2145 to South America. All xmsn's are on 15,165 kHz except for the 0100-0145 xmsn to N.A. on 9520 kHz. Another 15,165 kHz is listed at 0730-0815 to "Fjernøsten." No reports will be answered unless written in Danish. A "DX-Window" memory card with a photo of the "DX-Window Gang" can be obtained by sending one IRC to Danish Short-Wave Club, DK-2670 Greve Strand, Denmark.

Ecuador—*R. Pastaza*, Puyo, 3315 kHz, was heard at 0301-0308 in Spanish with L.A. music. . . HC4FA, *La Voz de Manabi*, Portoviejo, 5990 kHz, is noted at 1158-1215 with continuous Spanish talking. . . HCOS4, *La Voz del Rio Carrizal*, Calceta, 3570 kHz, has listener's requests after 0100. . . HCDY4, *R. Iris Esmeraldas*, has moved up to 3381 kHz. Only a 2000 watt unit, it is heard fairly often.

England—London was logged with a sideband xmsn (possibly a feed to Cyprus) on 9318 kHz at 1845 in Arabic, 2015 in Eastern European languages, 2145 with World Service, 0030 in Indian languages, and at 0315 in Persian.



John Wheeler, WPE5FFS, San Angelo, Texas, has a Hallicrafters Sky Champion and a U.S. Navy RCH-2. The small box between receivers is a homemade antenna switching unit. And it's all very compact.

Ethiopia—ETLF, Addis Ababa, is fair on a new frequency of 11.910 kHz at 1930 with multi-lingual announcements, including English.

France—We have a report from Georgia listing reception of *France Inter*, Allouis, on 164 kHz (long-wave) at 0045. This on a Zenith Transoceanic 3000-1 receiver. Long-wave listeners might do well to check this band from time to time.

Ghana—*R. Ghana*, Accra, is on 21.645 kHz as logged at 1510 with dance music and in English in their External Service.

(Continued on page 90)



The all new PE-2040 PErfection in PErformance

Your inevitable choice among automatic turntables. Sooner or later other automatic turntables will incorporate the exclusive features *now* available on the new PE-2040: Dial-a-Matic vertical tracking angle adjustment for all records . . . Independent, ultra-gentle, fingertip cueing control . . . Fail safe stylus protector . . . Automatic record scanner . . . Single lever control for all modes of operation . . . Continuous record repeat. These are just some of the exclusive features. Stop by at your PE dealer for the complete story and a demonstration of PErfection in PErformance. PE-2040—\$145.00; PE-2038—\$115.00.

Elpa Marketing Industries, Inc., New Hyde Park, N.Y. 11040
CIRCLE NO. 35 ON READER SERVICE PAGE



PErfection in PErformance



SUPER FLASH

(Continued from page 50)

is developed. Since the ability of the human eye to see a signalling device such as this is directly proportional to the amount of time that the lamp remains on, the on time can be set by adjusting dual potentiometer R2. Dual potentiometer R1 is adjusted to determine the flashing rate.

Almost any type of 6- or 7-watt, 117-volt lamp can be used with the Super Flash. However, don't use a Christmas-tree lamp that has its own built-in thermal flasher since it has a mind of its own about when it will go on and off. The best type of lamp (such as a 6S6) to use is that normally used on appliances where quite a bit of mechanical vibration is normally expected.

You may wonder why the lamp doesn't burn out rapidly. At each flash, the lamp is subjected to a considerable overvoltage and would indeed burn out if the duration of the power were for an appreciable length of time. The flashes are

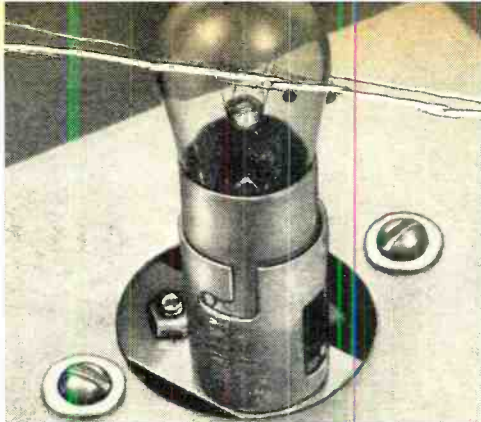

Ferrule of bayonet socket protrudes through a hole in top of box and is fastened with machine screws.

so short, however, that the lamp has a chance to cool down between them. The brightness of the flash is due to the fact that a lamp rated at 117 volts delivers an increase in light of approximately 30% for every additional volt above its rating. The current consumption of the Super Flash is low because the circuit draws no current when the lamp is not flashing.

-50-

ABOUT YOUR SUBSCRIPTION

Your subscription to POPULAR ELECTRONICS is maintained on one of the world's most modern, efficient computer systems, and if you're like 99% of our subscribers, you'll never have any reason to complain about your subscription service.

We have found that when complaints do arise, the majority of them occur because people have written their names or addresses differently at different times. For example, if your subscription were listed under "William Jones, Cedar Lane, Middletown, Arizona," and you were to renew it as "Bill Jones, Cedar Lane, Middletown, Arizona," our computer would think that two separate subscriptions were involved, and it would start sending you two copies of POPULAR ELECTRONICS each month. Other examples of combinations of names that would confuse the computer would include: John Henry Smith and Henry Smith; and Mrs. Joseph Jones and Mary Jones. Minor differences in addresses can also lead to difficulties. For example, to the computer, 100 Second St. is not the same as 100 2nd St.

So, please, when you write us about your subscription, be sure to enclose the mailing label from the cover of the magazine—or else copy your name and address exactly as they appear on the mailing label. This will greatly reduce any chance of error, and we will be able to service your request much more quickly.

FREE McIntosh CATALOG and FM DIRECTORY

Get all the newest and latest information on the new McIntosh Solid State equipment in the McIntosh catalog. In addition you will receive an FM station directory that covers all of North America.



MX 114

FM/FM STEREO TUNER
and STEREO PREAMPLIFIER

CIRCLE NO. 21 ON READER SERVICE CARD

SEND TODAY!

McIntosh Laboratory Inc.
2 Chambers St., Dept. PT5
Binghamton, N.Y. 13903

NAME _____

ADDRESS _____

CITY _____ STATE _____ ZIP _____

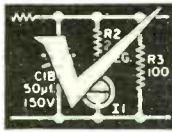

OPERATION ASSIST

Through this column we try to make it possible for readers needing information on outdated, obscure, and unusual radio-electronics gear to get help from other P.E. readers. Here's how it works: Check the list below. If you can help anyone with a schematic or other information, write him directly—he'll appreciate it. If you need help, send a postcard to Operation Assist, POPULAR ELECTRONICS, One Park Avenue, New York, N.Y. 10016. Give maker's name and model number of the unit. If you don't know both the maker's name and the model number, give year of manufacture, bands covered, tubes used, etc. State specifically what you want, i.e., schematic, source for parts, etc. Be sure to print or type everything legibly, including your name and address. Do not send an individual postcard for each request; list all requests on one postcard. Because we get so many inquiries, none of them can be acknowledged. POPULAR ELECTRONICS reserves the right to publish only those items not available from normal sources.

Hickok Model 530 tube tester. Instruction manual and last available roll chart needed. (Marion H. Traylor, P. O. Box 432, Norris TN 37825)

Heathkit Model FM-2 tuner. Assembly manual needed. (Bill Swafford, 119 Stallville Rd., Summerville, SC 29183)

Admiral Model T1S07-N TV. Schematic needed. (Tim Behal, 508 7th Ave., Durant, IA 52747)

Atwater-Kent Model 35 radio. Schematic and operating instructions needed. (Phil Knobel, 16 Apple Tree Ln., Walpole, MA 02081)

Euophon Model ES 59 Italian made six tube AM-FM-SW. Manufacturer's name and address needed. (Thomas J. Miller, 103 E. Poplar St., Wenonah, NJ 08090)

Precision Apparatus Series 920 Electronic Tube and Set Tester. Operating instructions and schematic needed. (James Gwathmey, 950 Aster Ave., El Cajon, CA 92020)

Heathkit Model A-9C Amp. Operating manual and schematic needed. (Jamie Cass, 173 Dufferin Ave., Belleville, Ont., Canada)

Atwater Kent Model 70 BC receiver. Eight tubes, UY-227, UY-224A, UX-280, UX-245. Need schematic, source of parts and tubes. (C. A. Bugbee, 155 Jobin Dr., Manchester, NH 03103)

Heathkit Model 0-7 oscilloscope. Construction and operating manuals needed. (Jeff Bonar, 7850 Whitsett Ave., N. Hollywood, CA 91605)

Dumont Model OBL-I oscillograph. Instruction manual and schematics needed. (Lete Connelly, 7350 Graham Rd., Hazelwood, MO 63042)

Arvin Model 741T radio chassis RE 352. Schematic and tuning information needed. (Justin De Vault, 610 Foxx St., Johnson City, TN 37601)

Hallicrafters SX 24. Schematic and manual needed. (Paul Emickerbocker, 7750 Highgate Ln., La Mesa, CA 92041)

Hammarlund HQ-140X. Schematic needed. (K. Youngblood, 2801 NW 151 St., Opa-Locka, FL 33054)

Hallicrafters Model S120. Schematic needed. (Robert Henry, Box 238, Toronto, OH 43964)

If you can solve this "problem" you could become a computer programmer!



INSTRUCTIONS FOR COMPLETING THE LOGIC SERIES TEST

- (1) The problem shows a series of 4 figures and a blank answer box.
- (2) Note VERY CAREFULLY exactly HOW the figure changes from box to box.
- (3) In the blank answer box, draw the figure which you logically believe would be next in the series.

Do you enjoy unscrambling problems? Like the one illustrated above? Then it's likely you have a logical mind—which is really what it takes to become a successful computer programmer.

Programmers are in Demand—Even though 300,000 men and women work as computer programmers, thousands more are still needed. Now, through a remarkable home-study course, you could qualify for a high paying job as a Computer Programmer.

No Math Required—You'll use IBM's official course material. Learn by methods which actually enable you to

progress at your own pace. You don't need math. You don't have to know how to operate a computer (that's another field). All you really need is a logical mind.

Without interfering with your present job, you can prepare yourself for a fascinating, rewarding future.

Academy Guarantee! Computer Programming Academy™ guarantees that if after successful completion of your home study course, you have been unable to secure employment in this field and have furnished documented proof of a sincere effort to do so, Computer Programming Academy will at its option either refund to you the full tuition paid or permit you to repeat the course at no additional cost.

Free Brochure: An Exciting Age—Mail coupon for a FREE Copy of "An Exciting Age." Plus full details on your course of study and an aptitude exam. There's no obligation.

COMPUTER PROGRAMMING ACADEMY, Box #PE-5
640 Palisades Ave.
Englewood Cliffs, N.J. 07632

Please mail to me the free illustrated booklet "An Exciting Age."

Name _____ Age _____

Address _____

City _____ State _____ Zip _____

Occupation _____

CIRCLE NO. 22 ON READER SERVICE PAGE

OUT OF TUNE

"One-Step Motion Detector" (March 1970). The following information on testing the unit was inadvertently omitted from the article: The slugs in *L1* and *L2* should be flush with the top of the cans. Coil *L3* slug is set about $\frac{1}{8}$ " in from the top. Temporarily connect a 1000-ohm resistor between point A and the center of the transmitter phono plug. Connect an a.c. voltmeter (or scope) between the transducer side of this resistor and ground. Adjust *L3* slug with a non-metallic tuning tool until a dip is noticed on the readout. Remove the resistor and reconnect the lead. Coils *L1* and *L2* are used as r.f. chokes.

"Build Security 1" (March 1970). In the Parts List on page 29, *R6* should be a 5000-ohm potentiometer, not 500 ohms. The schematic diagram is correct.

"The Touch-A-Tone" (March 1970). The electrolytic capacitor shown in Fig. 1 near *S2* is *C19*, not *C18*. Also, in Fig. 2, the capacitor labeled *C17* at lower left should be *C19*.

"Numitron Readout" (March 1970). The foil pattern on page 75 is incorrect. Use the one below.

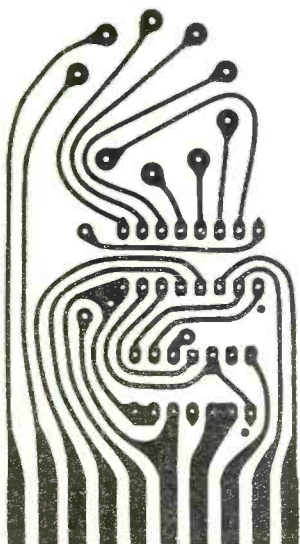

DELUXE RECORD AND TAPE CASES

plus *Free* cataloging forms

- DUST PROOF
- PADDED BACK • GOLD EMBOSSED



These decorative, yet sturdily constructed cases are just what you've been looking for

to keep your records and tapes from getting tossed about and damaged, disappearing when you want them most and just generally getting the "worst of it" from constant handling. They're ideal too for those valuable old '78's that always seem to get thrown about with no place to go.

Constructed of reinforced fiberboard and covered in rich leatherette in your choice of five decorator colors, the STEREO REVIEW Record and Tape Cases lend themselves handsomely to the decor of any room, whether it be your library, study, den, music room or pine-paneled garage. The leatherette back (in your color choice) is gold tooled in an exclusive design available only on STEREO REVIEW Record and Tape Cases. The sides are in standard black leatherette to keep them looking new after constant use.

With each Record and Tape Case you order you will receive, **FREE OF CHARGE**, a specially designed record and tape cataloging form with pressure-sensitive backing for affixing to the side of each case. It enables you to list the record names and artists and will prove an invaluable aid in helping you locate your albums. The catalog form can be removed from the side of the case at any time without damaging the leatherette.

Record Cases are available in three sizes: for 7", 10" and 12" records. Each case, with a center divider that separates your records for easy accessibility, holds an average of 20 records in their original jackets. The Recording Tape Case holds 6 tapes in their original boxes.

- The Tape Cases and the 7" Record Cases (with catalog forms) are only \$4 each; 3 for \$11; 6 for \$21.
- The 10" and 12" Record Cases (with catalog forms) are \$4.25 each; 3 for \$12; 6 for \$22.

Add an additional \$1.00 per order (regardless of number of cases ordered) for shipping and handling.

Ziff-Davis Publishing Company, Dept. PE 5-70
One Park Avenue, New York, N.Y. 10016

My remittance in the amount of \$ _____
Is enclosed for the Cases indicated below.

Quantity

_____ Tape Case at \$4 ea., 3 for \$11, 6 for \$21.

_____ 7" Record Case at \$4 ea., 3 for \$11, 6 for \$21.

_____ 10" Record Case at \$4.25 ea., 3 for \$12, 6 for \$22.

_____ 12" Record Case at \$4.25 ea., 3 for \$12, 6 for \$22.

ADD \$1.00 PER ORDER FOR SHIPPING AND HANDLING.
Check color choice for back of case (sides in black only):

- Midnight Blue
- Pine Green
- Red
- Black
- Spice Brown

Name _____

Address _____

City _____

State _____

Zip _____

PAYMENT MUST BE ENCLOSED WITH ORDER

Pump up your mobile installation performance with this

Professional "SPRING" TUNE-UP!

Here's the professional touch to dress up and power up your mobile rig! Famous high-performance, low-noise A/S base loaded design . . . 17-7PH stainless steel whip (bend it in a full circle, snaps back to perfect vertical) . . . fine-tuning adjustment built-in. Functional stainless steel shock spring adds a handsome, professional touch. Famous "Quick-Grip"® trunk mount—no holes to drill, cable completely hidden, permanent installation yet removable!

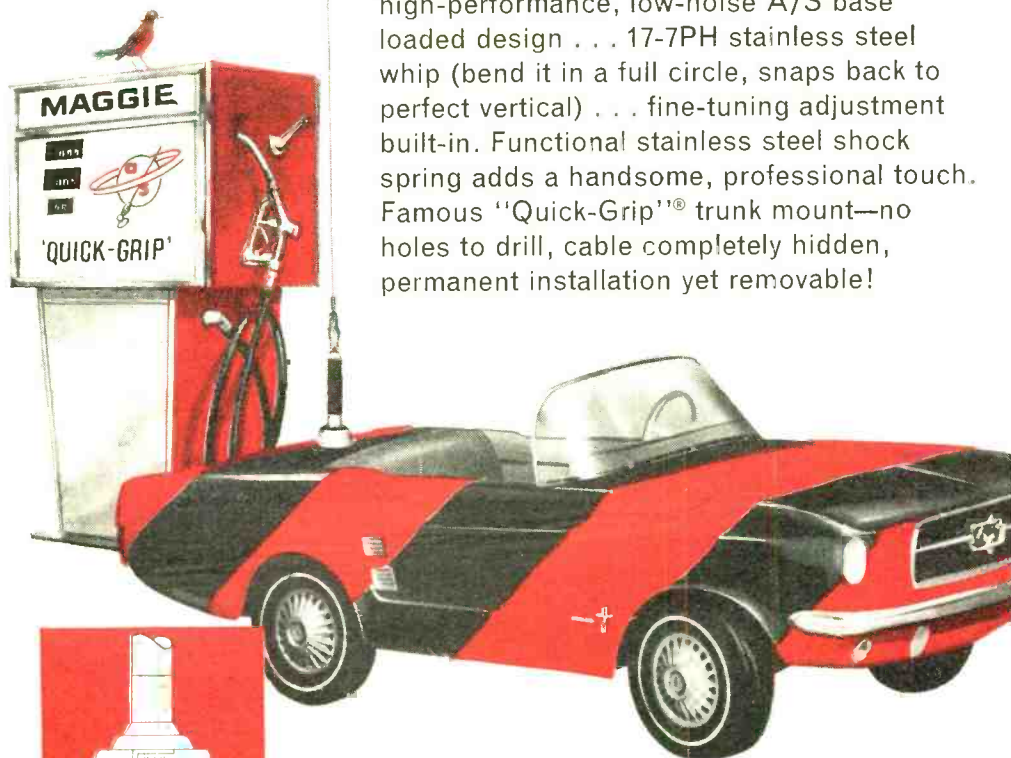

MODEL M-176 "MAGGIE MOBILE"

CB antenna. Suggested resale: \$21.95

the antenna specialists co.

Div. of Allen Electric and Equipment Co.
12435 Euclid Ave., Cleveland, Ohio 44106

Famous Quick Grip® mount — clamps on trunk lip . . . no holes to drill . . . no soldering . . . cable completely hidden!



"Stripes of Quality"®

SHORT-WAVE LISTENING

(Continued from page 84)

Guatemala—TGNA. Guatemala City, has English at 0300-0430 (0100-0430 Sundays) on 5955 kHz. This is dual to medium-wave TGN on 720 or 730 kHz, depending of whether you read their QSL card or their schedule. Does anyone know for sure which frequency they use?

Honduras—HRVC. *La Voz Evangelica de Honduras*, Tegucigalpa, operates on 4820 and 1380 kHz at 1100-0400 in Spanish, 1500-1600 and 0300-0400 in English. Reports go to Apartado 270. . . HRN. *La Voz de Honduras*, Tegucigalpa, has been running substantially later than its normal s/off time, usually to about 0300 with L.A. music, news, and long strings of commercials. Because of its unusual frequency (5875 kHz) it is one of the easiest stations to hear from this country.

Indonesia—Indonesian stations noted on the West Coast recently: R. *Samarinda*, YDY, 3294 kHz, at 1420-1432 with South Sea music. . . R. *Pontianak*, 3346 kHz, at 1209-1435 with light music and some South Sea music. . . R. *Djakarta*, YDD, 3277 kHz, at 1200-1248 with local news and native music; language used on all three was Indonesian.

Ireland—Anyone needing this country should look for *Shannon Aeradio* on 5559 kHz with aero weather for Ireland and European airports at 0430, 0500 and 0530. Tune just before the times shown and you may hear Gander Radio in Newfoundland.

Malawi—The current schedule for Malawi Broadcasting Corp. is 0345-0605 (Sunday from 0335) on 3380 kHz, 0620-1445 on 5995 kHz, and 1500-2105 (Saturday to 2305) on 3380 kHz. All reports go to P. O. Box 453, Blantyre. Programming is mostly in native language but they do have some English commercials.

Mauretania—R. *Nouakchott* is on 7245 kHz at 0805-0907 and later, dual to 9610 kHz, with Arabic chanting and announcements and some guitar music, and a French ID at 0900.

Morocco—Rabat is fair to good on 6170 kHz in all-Arabic from 2215 with chanting.

Mozambique—Lourenco Marques opens at 0300 off 3265 kHz with usual format of time checks, lively pop music and commercials. It may not be heard daily due to propagation conditions.

New Zealand—R. *New Zealand*, Wellington, is good at 0600-0845 in English to the Pacific Islands on 11,780 and 9540 kHz, and at 0900-1045 to Australia on 11,830 and 9520 kHz.

Niger—R. *Niamey* was heard on 3260 kHz at 0529 with an anthem, s/on anmt's and an ID in French; to 0631 s/off with African music and anmt's in several African languages.

Papua and New Guinea—VL8BM. Port Moresby, is on the air on 11,880 kHz with 10 kW on Monday to Friday at 0100-0200 and 0430-0530. This station has been heard with a special news broadcast to regional stations during the 0500-0530 xmsn. . . VL9CG. R. *Goroka*, 2410 kHz, is heard at times in Pidgin with U.S. pop music; best listening time has been 1030-1100.

Peru—OBX70. *Onda Imperial*, Cuzco, is on 5058 kHz, slightly above its listed frequency, where it is noted with Andean music and many anmt's in Spanish from 0100.

Philippines—Voice of the Philippines, Manila, was noted briefly on 9580 kHz at 0900-0945 in English but they were soon QRM'ed out.

Rwanda—Deutsche Welle, Kigali, has African news and a program preview in English at 1725-1730 s/off on 11,965 kHz.

Seychelles—R. *Seychelles*, Victoria, opens at 2325 on 15,440 kHz with news from Manila at 2330. We

SHORT-WAVE CONTRIBUTORS

Anthony Palmieri (WPE1HDG), Providence, R. I.
Jordan Leff (WPE1HSR), Woburn, Mass.
Mark Bonadies (WPE1HWD), Wethersfield, Conn.
R. G. Williams (WPE2QCI), Syracuse, N. Y.
Bill Nasso (WPE2QIC), Lackawanna, N. Y.
James Farrell (WPE2QIJ), Ridgefield Park, N. J.
Bob Arnold (WPE2QPR), Canastota, N. Y.
Rev. Michael Mayer (WPE2QVV), New York, N. Y.
Ivan Waule (WPE2QVD), St. Johnsville, N. Y.
Richard Hankison (WPE2QWU), Waldwick, N. J.
Marcus Berman (WPE2QXO), Montclair, N. J.
Bill Potorti (WPE2QYH), Ithaca, N. Y.
Rick Weibezahl (WPE2QYV), Washington, N. J.
Lt. Paul Steen (WPE2RBA), FPO (Guam)
Steve Grayson (WPE2RDS), Poughquag, N. Y.
Henry Seidner (WPE2REP), Pearl River, N. Y.
Larry Gilboy (WPE3HVL), Pittston, Pa.
James Hurst (WPE3HVP), Vienna, Md.
Jesse Finklestein (WPE3IBR), Dover, Del.
Grady Ferguson (WPE4BC), Charlotte, N. C.
Joey Leonard (WPE4KA), Winston-Salem, N. C.
John Limbach (WPE4KCV), Fayetteville, N. C.
Jule Bowles (WPE4KFW), Moultrie, Ga.
Robert Haase (WPE4KHT), Brunswick, Ga.
Carroll Patterson (WPE4KHW), Decatur, Ga.
C. Vernon Hyson (WPE4KLQ), Charlotte, N. C.
Woodrow Ferris (WPE5DYG), Anadarko, Okla.
Richard Fortson (WPE5EIV), Edinburg, Texas
Richard Murphy (WPE5EZR), El Paso, Texas
James Krempel (WPE5FEH), San Antonio, Texas
James Young (WPE6ENA), Wrightwood, Calif.
Trevor Clegg (WPE6FAF), Fresno, Calif.
John Boessenecker (WPE6GPN), Mill Valley, Calif.
Dale Ott (WPE6HEC), Norfolk, Va.
Douglas Smith (WPE6HGG), Concord, Calif.
Fred Schulz (WPE6HNV), La Mesa, Calif.
Jim Weber (WPE6HPO), Beaumont, Calif.
Mike Rohde (WPE6HRE), Cypress, Calif.
Ron Snider (WPE7CUM), Spokane, Wash.
Chuck Albertson (WPE7CWI), Bellevue, Wash.
David Williams (WPE7CWW), Astoria, Ore.
Mark McCann (WPE8KJH), Flint, Mich.
Bill Jenkins (WPE8KAW), Willowick, Ohio

also have a report that they are operating daily except Saturday from 1400 s/on in English, and from 1430-1530 s/off in French.

South Africa—The All-Night Service from Johannesburg in English and Afrikaans can be heard on 7150 kHz at 2300-0100 with variety music, public service anmt's and commercials. This same channel is also logged in a non-commercial service at 0300-0400 with light music and anmt's in English and Afrikaans. . . R. RSA has replaced 11,875 kHz with 15,250 kHz, dual to 21,480 kHz, at 1800 to Europe. . . *Springbok Radio* is excellent on 7190 kHz at 0430 with news on the hour and half hour. It is scheduled from 0300-2200 and, from the standpoint of commercials, they are completely sold out of time.

Spain—Radio Nacional Espana, Madrid, has been found on 11,705 kHz, an unlisted frequency, dual to 11,800 kHz at 0210-0225. They list their English schedule as being 0100-0345 daily except Sunday on 6140 kHz (100 kW) and 9760 kHz (20 kW).

Tanzania—R. *Tanzania*, Zanzibar, considered to be an excellent DX catch, is on 3339 kHz from 0330 s/on. The IS, before s/on, seems to be a group of musical chords, possibly on a percussion instrument. Programming is mostly Moslem or Arabic chants; there may be a newscast in Swahili around 0400. Reports indicate a rapid fade-out on this with the signal rarely being heard after 0400-0410.

Togo—Lome, 5047 kHz, is good and consistent on the West Coast at 0530 s/on with African and western pop music, news, and native language programming.

Thomas Gualtieri (WPE8KDJ), S. Euclid, Ohio
 George Smith, Jr. (WPE8KJJ), Grand Rapids, Mich.
 Bob Smith (WPE8KKT), Grand Rapids, Mich.
 Gerry Dexter (WPE9HDB), Lake Geneva, Wis.
 Richard Pistek (WPE9HOA), Chicago, Ill.
 E. O. Cole (WPE9JZ), Rolling Meadow, Ill.
 David Lubar (WPE9JFD), Elmwood, Ill.
 Kris Lemma (WPE9JKN), Muncie, Ind.
 Steve Phelps (WPE9JSM), Pittsburgh, Pa.
 Dave Newkirk (WPE9JSW), Norridge, Ill.
 Robert Gerardi (WPE9JUG), Benton, Ill.
 B. L. Cummins (WPE9JUI), Columbus, Ind.
 Mark Andrew (WPE9JUZ), Lincolnwood, Ill.
 Daniel Wlodek (WPE9JVV), Chicago, Ill.
 A. R. Niblack (WPE9KMI), Vincennes, Ind.
 John Beaver (WPE9AEF), Pueblo, Colo.
 Roger Chambers (WPE9FKK), Salina, Kans.
 Mike Carrick (WPE9FLX), Omaha, Nebr.
 Arthur Burke (WPE9FOJ), Topeka, Kan.
 John Stap (WPE9FQA), Colorado Springs, Colo.
 Mark Schwing (WPE9FRB), Aurora, Colo.
 David Szafranski (WPE9FRQ), Colorado Springs, Colo.
 Marvin Robbins (WPE9MIV), Omaha, Nebr.
 Jack Perolo (PY2PEIC), Sao Paulo, Brazil
 D. L. Thomas (VE3PE2IR), Burlington, Ont.
 Doug Stark (VE3PE2OY), London, Ont.
 Edward Swynar (VE3PE2RT), Oshawa, Ont.
 Anthony D'Agostino (VE3PE2SD), Hamilton, Ont.
 Les Hughes (VE7PE1EH), S. Burnaby, B. C.
 Charles Richardson (VK3PE1P), Horsham, Victoria, Australia
 Lloyd Berman, Van Nuys, Calif.
 Rick Cosby, Chicago, Ill.
 Dana Friend, Medfield, Mass.
 Mark Hogarth, Bronx, N. Y.
 Harold Honnold, Modesto, Calif.
 Jerry Kapenzynski, Fountainville, Pa.
 Bud Kelly, Champaign, Ill.
 Patrick Marineau, Marinette, Wis.
 Carla Mills, St. Paul, Minn.
 Tommy Najman, Montreal, Que.
 Bob Roeder, El Cerrito, Calif.
 Michael Stasiak, Baltimore, Md.
 Jon Weiner, Beachwood, Ohio
 Sweden Calling DX'ers Bulletin, Stockholm, Sweden

Vatican City—We can always depend on reports of new frequencies being placed in service by *Vatican Radio*: 6175 kHz at 0100 in English, and 11.845 kHz at 2328-2346 s/off in Spanish to the Americas. Programming is Church news and a brief period of Mexican folk music.

Venezuela—YVMO, R. Lara, Barquisimeto, is now on 4800 kHz and noted at 2330-0000 in Spanish with L.A. music, commercial anmt's and much musical fanfare. . . YVKD, R. Cultura, Caracas, is up to 5060 kHz (from 5050 kHz) and heard after 2300 in Spanish. From this it would seem that reports of a R. *Litoral* on this frequency may be in error. . . R. Barquisimeto, 9510 kHz, has a time check, then news in Spanish at 1115-1200.

SHORT-WAVE ABBREVIATIONS

anmt—Announcement
 GMT—Greenwich Mean Time
 ID—Identification
 IRC—International Reply Coupon
 IS—Interval Signal
 kHz—Kilohertz
 kW—Kilowatts
 L.A.—Latin America
 N.A.—North America
 QRM—Station interference
 R—Radio
 s/off—Sign-off
 s/on—Sign-on
 xmsn—Transmission

POPULAR ELECTRONICS SUBSCRIBER SERVICE

Please include an address label when writing about your subscription to help us serve you promptly. Write to: P.O. Box 1096, Flushing, N.Y. 11352

CHANGE OF ADDRESS: Please let us know you are moving at least four to six weeks in advance. Affix magazine address label in space to the right and print new address below. If you have a question about your subscription, attach address label to your letter.

TO SUBSCRIBE: Check below.
 5 yrs. \$21 3 yrs. \$15
 1 yr. \$6 New Renewal

Specify: Payment enclosed
 You get 1 extra issue per year as a BONUS!
 Bill me later.

If you have no label handy, print OLD address here.

name _____
 address _____
 city _____
 state _____ zip code _____

AFFIX LABEL

print name _____ 0395
 address _____
 city _____
 state _____ zip code _____
 Add'l postage: \$1 per year outside U. S., its possessions & Canada.

Hey! Hams, Engineers, Hobbyists MARK LIKE MAGIC



Any surface * can be marked with **DATAK'S DRY TRANSFER** titles and symbols. The results are professional, it looks like the finest printing!

Write for your FREE **SAMPLE** and Catalog, listing hundreds of letter sheets and symbol sets.

Order from your distributor or directly from:



* From #K-64 1/4" letters and numerals... \$1.50
 Also available #9581 professional title set for electronic equipment... \$5.95

85 Highland Ave. / Passaic, New Jersey 07055

CIRCLE NO. 10 ON READER SERVICE PAGE

KITS FEATURED IN

POPULAR ELECTRONICS

AND FROM OTHER SOURCES

Psychedelic Strobe Light	\$17.50 + Postage
Lil Tiger Amplifier (40w)	
Stereo Complete	\$37.50 + Postage
Tiger Amplifier (80w)	
Stereo Complete	\$50.00 + Postage
Super Tiger Amplifier (100w)	
Stereo Complete	\$75.00 + Postage
FET Preamp Complete	\$42.50 + Postage
(less power supply)	

Also:
 PSYCHEDELIA I COLOR ORGAN
 SONOLITE
 NIXIE READOUTS
 FREQUENCY COUNTERS
 SPORTS TIMERS
 ULTRASONIC ALARM
 ETC.



WRITE FOR FREE CATALOG

SOUTHWEST TECHNICAL PRODUCTS CORPORATION
 219 (PE) W. RHAPSODY
 SAN ANTONIO, TEXAS 78216

CIRCLE NO. 32 ON READER SERVICE PAGE

NEW Short-Wave Listening VERTICAL ANTENNA Model SWV-7

For 11,13,16,19,25,31 and 49 meter bands Cramped quarters keeping you from installing an SWL antenna? Your problem is solved! Model SWV-7 mounts easily on the roof or on the ground and stands just 13 ft., 3-5/8 in. tall.

Extensive field testing confirms that this antenna measures up to Mosley's high standards of performance. Construction is of the finest material to bring you years of trouble free listening pleasure. Complete with installation instructions.

Get the facts from your Mosley dealer, or write factory direct, for detailed brochure.

Mosley Electronics, Inc.
Dept. 202

4610 N. LINDBERGH BLVD., BRIDGETON, MO. 63044

CIRCLE NO. 19 ON READER SERVICE PAGE



AMATEUR RADIO

(Continued from page 82)

Spanish 144-MHz amateurs at the same time.

FCC and Related News. Effective in March, the Federal Communications Commission shifted the 2-meter exclusive CW (code) assignment from the 147.9-148-MHz range to 144-144.1 MHz. The latter frequencies are used for almost all 2-meter CW "moon-bounce" and other international CW experiments.

At the same time, the FCC shifted the 10-meter F1 (RTTY) teleprinter assignment out of the phone segment of the band to the 28-to-28.5-MHz CW segment. Now on the FCC docket are two proposals to permit Technicians to operate on 10 meters and one by W9HTF to reserve portions of the 7- and 14-MHz phone bands, exclusively for Extra class licensees, possibly with a 50-kHz increase in the width of the 14-MHz phone band.

Coincident with the FCC's final implementation of the Incentive Licensing program last November, a group of Southwestern amateurs began campaigning on 75-meter phone to force the Commission to rescind the program—especially the portion limiting the phone frequencies available to Conditional and General class licensees. They appointed Senator Barry Goldwater (Arizona), K7UGA/K3UIG, to be their Washington spokesman. But they neglected to check first with Barry. When the Senator learned of this unilateral action, he ordered them to cease associating him with their activities. In addition, Barry informed the

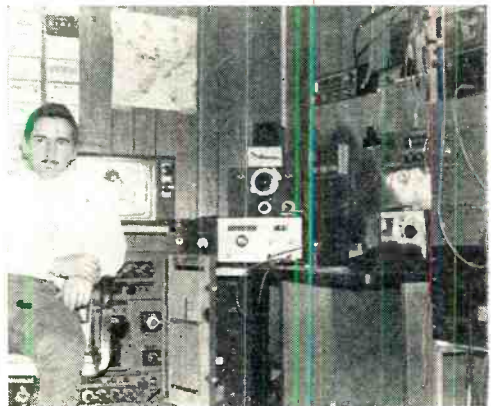

Using a homebuilt 500 milliwatt, Tom Varnecky, WA3CPH, Johnstown, Pa., transmits television on 432 MHz. He's worked 27 states on 50 and 144 MHz.

group that he approved of the Incentive Licensing Program.

By the way, Barry took a slow-scan television camera with him on his last trip to Southeast Asia and used it to transmit TV pictures from Vietnam across the Pacific to the United States via MARS (Military Affiliate Radio System) stations. Feeding the output of a slow-scan television camera unit into its microphone jack converts any phone transmitter into a TV transmitter. The received signals may be seen on a conventional receiver fitted with an SSTV receiving unit or recorded on a standard tape recorder for later viewing.



Joe K. Winner, W8BAST, Beckley, W.Va. operates with an Eico 50 watter plus Mosley CM-1 receiver.

NEWS AND VIEWS

Chuck Elquist, W6JIF/6, Grass Valley, Ca., has a "gopher": at least he did while he was operating KR6FB, Okinawa, last year. KR6FB, operated by off-duty military personnel, is used mostly to keep phone-patch skeds back to the States. According to Chuck's buddy, Dick Eymar—not a ham—he was the station "Gopher"—go for coffee, go for this, and go for that. Operating seven days a week, KR6FB averages about 40 "patches" a day, and after 4000 of them, is still going strong. But Chuck and Dick are now back in the states, running phone patches with Okinawa from the opposite end of the circuit. W6JIF uses a Swan 500-C transceiver and a Mosley TA-33 beam atop a 60-foot tower. Try Rte #1, Box 569, Grass Valley, Ca. 95945, if you want to reach Chuck by mail.

A. Edw. Terpening, W4VCY, M.E., 838 Darlington Rd., Tarpon Springs, Fla., 33589, Public Relations Director of the Gold Coast Amateur Radio Club, is another who believes that the way to encourage new amateurs is to help prepare them for their examinations. He conducts free amateur classes at his home each Saturday morning and afternoon.

As a result of Dave, WA0QYS's "doubt" that Vermont existed in January "News and Views," Arthur Greenleaf, W1TEQI, RFD #2, Montpelier, Vermont 05602, President of the Central Vermont Amateur Radio Club, W1BD, offers to arrange skeds with CVARC members for anyone needing Vermont for a new state or other reasons. Art reports that the club has many members, both male and female, active on all bands and modes; consequently, there should be no difficulty in meeting any reasonable request. We suggest including a

May, 1970

Live Better Electronically With

LAFAYETTE RADIO ELECTRONICS

1970 Catalog 700 **FREE!**

Now OFF PRESS
BETTER THAN EVER
496 Pages

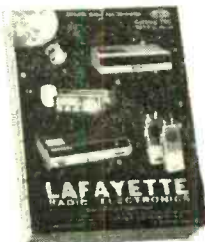

Stereo Hi-Fi • Citizens Band • Ham Gear • Tape Recorders • Test Equipment • TV and Radio Tubes and Parts • Cameras • Auto Accessories • Musical Instruments • Tools • Books

Featuring Everything in Electronics for
• HOME • INDUSTRY • LABORATORY
from the "World's Hi-Fi & Electronics Center"

LAFAYETTE Radio ELECTRONICS
Dept. 35050 P.O. Box 10
Syosset, L.I., N.Y. 11791

Please Send the FREE 1970 CATALOG 700 35050

Name _____
Address _____
City _____
State _____ Zip _____

CIRCLE NO. 15 ON READER SERVICE PAGE

IMPROVED

ULD Sine Wave Oscillator

Now with Square Wave Output

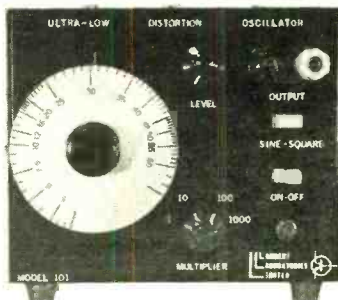

As Appeared
in Oct. 1969
POPULAR
ELECTRONICS

Frequency Range—5HZ to 60KHZ in Four Ranges.
Distortion—.02% or less at 5 volts out.
Output Range—.65 volts R.M.S. open load.
Square Wave Rise & Fall Times—70 N. Sec. or less.
CHASSIS PUNCHED & SILK SCREENED
Price—Kit LL101K2 Wt. 4 lbs. \$64.95
Wired & Tested \$89.50

IMMEDIATE DELIVERY

Also Available—R-1 Pulse Generator
(As appeared in Feb. '70 Radio Electronics)
Freq. Range—100HZ to 1MHz, variable delay & with
Double pulse mode 5V into 50 Ohm, 10V open
Rise & Fall Times—26 N. Sec. or less
Separate level controls for Pos. & Neg. outputs.
MANY MORE FEATURES
Price—Kit LL103K1—Wt. 10 lbs. \$150.00
Wired & Tested \$215.00
N.Y.S. Residents Add 6% Tax.
Please include Postage

**LAMBERT
LABORATORIES
LIMITED**

48 WASHINGTON ST., WESTFIELD, N.Y. 14787
716-326-2833

CIRCLE NO. 16 ON READER SERVICE PAGE



**LOOKING FOR
QUALITY
FAST DELIVERY
LOW PRICES ON
SEMI-CONDUCTORS**

?

NEW JERSEY SEMI CONDUCTOR

U.S. Highway 22, Blue Star Mall
Watchung, N.J. 07060 Tel. (201) 322-9200

TESTING FACILITIES AVAILABLE

CIRCLE NO. 23 ON READER SERVICE PAGE

It's yours
free

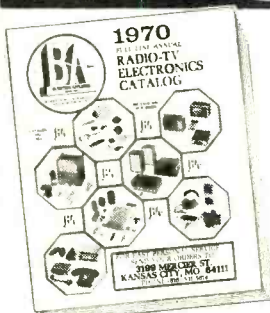

**GIANT 274 PAGE
1970
RADIO-TV
ELECTRONICS
CATALOG**

Write to:

**BURSTEIN-APPLEBEE CO.,
DEPT. PE-5 3199 MERCIER ST.,
KANSAS CITY, MO. 64111**

Name _____

Address _____

City _____

State _____ Zip Code _____

CIRCLE NO. 7 ON READER SERVICE PAGE

stamped reply envelope with your note to WA1EQI.

Jeff Crawford, WA0ZRT, P.O. Box 197, Sidney, Iowa 51652, started his amateur career with a General class ticket; and four months later, qualified for an Advanced class license. He usually works 10 and 15 meter phone or 20 meter CW in the daytime and 75 meter phone at night. He transmits and receives on a Galaxy GT-550 CW/SSB transceiver via a Mosley TA-33, tri-band beam and presumably a 75-meter dipole. Jeff has worked all states but still lacks QSL cards from four of them; he also has worked 76 countries. Probably his most thrilling contact was working Senator Barry Goldwater using his K3UIG call letters in Washington, D.C. . . . **Murray Cutler, W9EHQ**, 338 South Geneva Ave., Bellwood, Illinois 60104, has spent 99% of his 9-year amateur career on 50-MHz AM until very recently. On 50 MHz, he uses a modified Knight-Kit T-150 transmitter and a Knight-Kit R-100 receiver aided by a Tecraft 6-meter converter. The antenna is two, stacked Cushcraft, 5-element beams mounted on a 10-foot tripod tower on the roof of his house, putting the antenna 50 feet above the ground. This equipment has worked 25 states. Murray operates 6-meter mobile with a Lafayette HA-460 transceiver. The latest addition at W9EHQ is 2-meter FM mobile with a Varitronics FDFM-2S transceiver. Murray is also a recording buff with a sound-proof studio, nine turntables and recorders, six amplifiers, all tied together in elaborate remote-control and mixing networks . . . **Bob Pie-**

Guz Guzanski, WB2EZX, 585 Chapman Parkway, Hamburg, N.Y. 14075, got started in amateur radio "rather late in life" 22 months ago. Guz pretty well proves his contention that you do not need high power by posting a record of 195 countries worked with the Heathkit SB-400 SSB/CW transmitter and SB-301 receiver. His antenna farm sprouts a 3-element, tri-band beam (brand unknown), 30 feet high, and dipoles for 80 and 40 meters. WB2EZX recommends that prospective amateurs join the local amateur radio club . . . **Susi Christen, HE9AOE**, is a long way from her home in Switzerland. She is a pretty coed at Jackson State University, International House, J.S.U., Jacksonville, Ala. 36265. (The half-tone picture she sent isn't sharp enough to reproduce.) Susi operates 144 MHz with a 500-milliwatt, homebuilt transmitter feeding an 11-element beam. Receiving gear includes a National HRO, a surplus BC-946, and a homebuilt converter.

73, *Herb, W9EGQ.*



Charles Cash, W9LNC, Cayuga, Ind., is a Civil Defense Radio Officer and ARRL Emergency Coordinator. He works 80-meter CW with a Knight-Kit T-150 and National HRO and 2 meters with a Clegg 99'er as well as with a Heathkit Two-er transceiver.

POPULAR ELECTRONICS

SOLID STATE

(Continued from page 80)

ceiver's cabinet, but an "outboard" mounting can be used if necessary or preferred. Here, a small sloping front meter cabinet or other small chassis can be used for housing the unit, with circuit connections made through a short length of shielded microphone cable. After installation, $R5$ is adjusted for a "0" meter reading with zero input signal (receiver antenna terminals shorted) and $R6$ for a full-scale reading on the strongest station that can be received.

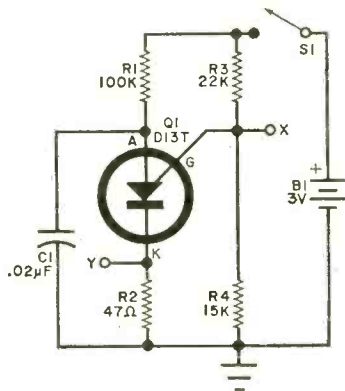

Fig. 3. Low-voltage oscillator circuit using programmable unijunction transistors has many uses.

Manufacturer's Circuit. Abstracted from GE's application notes on its type D13T programmable unijunction transistor, the low-voltage oscillator circuit shown in Fig. 3 may be used in a number of projects. Typically, it can be incorporated in digital "clocks," timers, sweep circuits, signal injectors, test equipment, electronic musical

instruments and industrial controls. Extremely simple, it can be breadboarded for experimental tests in less than an hour.

Essentially a relaxation oscillator, the design features a familiar RC timing circuit. In operation, $Q1$ is initially in a non-conducting state. Capacitor $C1$ is charged slowly through $R1$ until its voltage reaches $Q1$'s anode-cathode breakdown voltage, as pre-established by the device's gate potential, determined by voltage-divider $R3$ - $R4$. At this point, $Q1$ "fires" (i.e., switches to a conducting state), discharging $C1$ through $R2$, and developing a narrow positive-going pulse across this resistor (point Y). At the same time, a negative-going pulse appears across $R4$ (point X). With $C1$ discharged, $Q1$ switches back to its non-conducting state and the action repeats. Operating power is furnished by $B1$, controlled by switch $S1$.

With neither layout nor lead dress critical, the oscillator may be assembled on a small chassis, or perf board, or on a suitable etched circuit board, as preferred. Its basic operating frequency (or repetition rate) is approximately 1 kHz with the parts specified in Fig. 3. Within moderate limits, however, this frequency may be lowered by using a larger-valued capacitor for $C1$ and raised by using a smaller value.

Device Developments. TRW Semiconductors Incorporated (14520 Aviation Blvd., Lawndale, CA 90260) has announced a new series of 3-GHz transistors designed for operation on a 28-volt d.c. source. The series includes four devices with output power ratings ranging from 300 mW for type PT6669 to 5 watts for type PT6636. Featuring a stripline package design, the new units can furnish from 3 to 6 dB gain, depending on type.

At a lower frequency level, and perhaps of more immediate interest to advanced amateurs, Motorola Semiconductor Prod-

ADDED MOBILE POWER WHEN YOU NEED ADDITIONAL COVERAGE FOR CLEAR COMMUNICATIONS



170 WATT INPUT

Complete with remote power switch and indicator control panel plus mounting brackets.

FCC TYPE ACCEPTED
Parts 89, 91, 93

\$129.95
12 VDC

SMALL PACKAGED MOBILE POWER LINEAR R.F. POWER AMPLIFIER

Covers greater distances with increased transmit power. Can be used with SONAR BR20, FM40 or any similar FCC approved equipment with 1.15 watt output. Designed with top performance and dependable service when you need it. Automatic standby/transmit switching • Covers 25-50MHz range • transistorized power supply — negative ground • Used on amateur 28MHz for FM-AM-SSB. Small, compact, rugged design. Size: 2"H x 6"W x 8"D. Wt. 3 lbs. 12 VDC

SONAR RADIO CORP., 73 Wortman Avenue, Bklyn, N.Y. 11207
Please send information on Model BR 2906 Linear Amplifier.

Dept. 827

Name _____

Address _____

City _____ State _____ Zip _____

CIRCLE NO. 28 ON READER SERVICE PAGE

Olson ELECTRONICS FREE Catalog

Fill in coupon for a FREE One Year Subscription to OLSON ELECTRONICS' Fantastic Value Packed Catalog — Unheard of LOW, LOW PRICES on Brand Name Speakers, Changers, Tubes, Tools, Stereo Amps, Tuners, CB, and other Values. Credit plan available.

NAME _____
ADDRESS _____
CITY _____ STATE _____
GIVE ZIP CODE _____

If you have a friend interested in electronics send his name and address for a FREE subscription also.

OLSON ELECTRONICS

DEPT. 1E 260 S. FORGE STREET, AKRON, OHIO 44308

CIRCLE NO. 24 ON READER SERVICE PAGE



New **Patio**
outdoor speaker
in timeless redwood
\$15.95 Audiofile net

- Silicone-treated speaker.
- 10-watt, full-range, 8-ohms.
- Handy, built-in volume control.
- Weather-resistant cane grille.
- 14" x 10 1/2" x 3 1/2" fits in any sheltered space.

Write for
FREE

Argos

CATALOG PRODUCTS COMPANY
CIRCLE NO. 5 ON READER SERVICE PAGE

ucts, Inc. (Box 20924, Phoenix, AZ 85036) has introduced a group of *npn* silicon r.f. power transistors capable of providing up to 12 watts output in the 450-to-470-MHz band. While intended for use as power amplifiers in the UHF FM bands used primarily for police, taxicab and industrial communications, the new transistors, types 2N5644 through 2N5646, are suitable for applications in equipment operating up to 520 MHz. The three new devices are supplied in 3/8" ceramic stripline opposed-emitter packages with wide, low-inductance leads. Designed for operation on 12.5-volt d.c. power supplies, the entire family features a balanced-emitter construction which is very resistant to damage from mismatched loads or detuning.

Motorola has also announced the development of a new monolithic IC tuning indicator circuit designed for use in color-TV and FM receivers. Requiring only the addition of a miniature lamp bulb, the device is used to compare input voltages furnished by the receiver's ratio detector. If these voltages are equal, the lamp is turned on, if unequal, indicating the need for retuning, the lamp is switched off. Identified as type MC1335, the new IC is encased in an eight-lead dual in-line plastic package and requires a 20-volt d.c. power supply.

An experimental field-effect transistor capable of handling up to 40 watts has been developed by research scientists at Japan's Semiconductor Research Institute. This power capability was achieved by departing from customary FET construction and developing an entirely new internal configuration. Several techniques were used. First, breakdown voltage was raised by using a thick *n*-type intrinsic semiconductor layer between the source and drain electrodes. Second, current flow was spread over the entire wafer area by using a lattice-shaped *p*-type gate region, with the gate channel length reduced to minimize internal voltage drops and depletion layer spreading. Although the initial units have only a 200-volt, 200-mA capacity, theoretical studies reveal that kilovolt, multiamp units are feasible if fabrication techniques can be refined and improved. With further work, then, *kilowatt FET's* may be within reach.

Two new low-cost bridge rectifiers have been announced by the Amperex Electronic Corporation (Semiconductor Division, Slattersville, RI 02876). These units, types BY164 and BY179, are plastic-encapsulated assemblies made up of four silicon double-diffused diodes. The BY164 provides 1.2 amperes output at 54 volts, while the BY179 is specified at 1.0 ampere output at 255 volts.

—Lou

POPULAR ELECTRONICS READER SERVICE PAGE

free information service:

Here's an easy and convenient way for you to get additional information about products advertised or mentioned editorially (if it has a "Reader Service Number") in this issue. Just follow the directions below... and the material will be sent to you promptly and free of charge.

1. On coupon below, circle the number(s) that corresponds to the key number(s) at the bottom or next to the advertisement or editorial mention that is of interest to you. (Key numbers for advertised products also appear in the Advertisers' Index.) Print or type your name and address on the lines indicated.

2. Cut out the coupon and mail it to: POPULAR ELECTRONICS, P.O. Box 8391, Philadelphia, PA 19101.

note: If you want to write to the editors of POPULAR ELECTRONICS about an article on any subject that does not have a key number, write to POPULAR ELECTRONICS, One Park Avenue, New York, N.Y. 10016. Inquiries concerning circulation and subscriptions should be sent to POPULAR ELECTRONICS, P.O. Box 1095, Flushing, N.Y. 11352.

VOID AFTER JUNE 30, 1970

POPULAR ELECTRONICS

P.O. BOX 8391
PHILADELPHIA, PA. 19101

1 2 3 4 5 6 7 8 9 10 11 12 13 14 15 16 17 18 19 20
21 22 23 24 25 26 27 28 29 30 31 32 33 34 35 36 37 38 39 40
41 42 43 44 45 46 47 48 49 50 51 52 53 54 55 56 57 58 59 60
61 62 63 64 65 66 67 68 69 70 71 72 73 74 75 76 77 78 79 80
81 82 83 84 85 86 87 88 89 90 91 92 93 94 95 96 97 98 99 100

NAME (Print clearly) _____

ADDRESS _____

CITY _____ STATE _____ ZIP CODE _____

ENb

PRINTED CIRCUITS

(Continued from page 62)

minimum of $\frac{1}{8}$ " in diameter wherever a hole is to be drilled to avoid breaking the foil during drilling.

There are two methods of making an etching guide. The first employs a minimum-width conductor pattern that leaves large areas of the board etched (without copper foil). The second method, known as "area etch," provides for a minimum amount of copper foil to be removed from the board: in some cases, the foil left on the board is not connected to a current-carrying conductor. Examples of both methods are shown in Fig. 4.

When you have finished laying out your etching guide, black-in the conductor pattern, leaving small white dots where holes for component leads, hook-up wire, and hardware are to pass through the circuit board. Make these holes *small* since their only purpose is to serve as guide markers for drilling.

Your completed etching guide should look like the one shown in Fig. 5. Note that the guide employs the "area etch" technique. The minimum-width technique could just as easily have been employed.

From your etching guide, you can now determine exactly how large a copper-clad board is needed for your project. A good idea is to add about $\frac{1}{8}$ " to the length and width dimensions for safety. After all, it is better to have a slightly oversize board that can be trimmed than an undersize board that will not fill your requirements. —30—

FREQUENCY STANDARD

(Continued from page 64)

crystal mounting with matching socket.

You might have to experiment with grid resistors $R6$ and $R9$ to find the optimum values for proper operation of the multivibrator circuits. But the values shown in the schematic diagram and specified in the Parts List will be adequate in most cases. If not, start with the values specified and work from there.

How To Use. With both switches set to the off position, plug the line cord into an a.c. outlet. The heaters of both tubes should begin to glow. Now close $S2$, leaving $S1$ open, and tune your receiver to WWV on 2.5, 5, 10, or 15 MHz. Loosely couple the output of the frequency standard to your receiver's antenna and adjust $C1$ to approximately midrange. Vary $C2$ until the output of the frequency standard zero beats with the WWV signal. If necessary, touch up $C1$ to obtain zero beat.

Remove the antenna lead from your receiver, and connect the output lead of the frequency standard in its place. Tune your receiver across the 3.5-4.0-MHz band: you should hear two markers, one at each end of the band. Now close $S1$ and again tune across the 3.5-4.0-MHz band, listening for markers. If you do not hear eleven markers (one at 3.5 MHz and every 50 kHz apart as you go up the band), adjust $R5$ until you do. Since the setting is somewhat broad, adjust $R5$ midway between its upper and lower drop-off settings. —30—

PROFESSIONAL TYPE MOBILE MONITOR RECEIVER

Solid State FM / Crystal Controlled / 6 Channels \$99⁹⁵
LESS CRYSTALS



SEND FOR FREE LITERATURE



This expertly engineered, all solid-state, crystal controlled FM receiver provides instant monitoring of the VHF frequencies between 39 and 46 mcs or 153 to 157 mcs. Outdating all of the bulky tube-type monitors which take up needed space under dashboards, the compact Ameco Model MRT-6 high band or MRT-7 low band unit measures only 2-1/8" high by 5-5/16" wide by 7-7/8" deep. It's a professional type receiver with latest double conversion superheterodyne circuitry providing 3/4 microvolt sensitivity for 20 db quieting. Has built-in speaker and mobile mounting bracket. Optional AC power supply available.

DIVISION OF AEROTRON/BOX 6527/RALEIGH, N. C. 27608

CIRCLE NO. 2 ON READER SERVICE PAGE

NEW PRODUCTS

(Continued from page 24)

equipment. The UHD delivers high output, extended frequency response, broader dynamic range, and a signal-to-noise ratio impossible to achieve with conventional tapes. The HD has a consistent output, broad frequency response, wide dynamic range, and a better signal-to-noise ratio than tapes comparatively priced. Both tape types are available in cassette and 5" and 7" open-reel configurations.

Circle No. 88 on Reader Service Page 15 or 97

NEW TAPE RECORDER LINE

The first in a new series of *Tundberg of America, Inc.*, tape recorders is the three-speed solid-state Model 6000X stereo deck. With the 6000X, it is possible to obtain professional quality recordings even at the lower speeds. The compact deck features four precision-gapped mumetal screened heads with Crossfield design for superior record frequency response, signal-to-noise ratio, and dynamic range. Available in quarter- and half-track models, the 6000X has peak-reading VU meters for record and playback levels; automatic overload protection; independent microphone line record level controls for each channel; pushbutton control for electrical functions; single-lever tape transport control; hysteresis synchronous motor; stereo mixing, cueing, and special effects.



Circle No. 89 on Reader Service Page 15 or 97

THEFT-PROOF YOUR CAR

A system that can virtually eliminate auto theft and can be adapted to any lock has been introduced by *HR Enterprises Inc.* The heart of the system is "Kode-Kee," a patented device that replaces the standard ignition locking mechanism with a combination of electrical impulses. A toggle or proximity switch, located on the dash board, takes the place of a key. Only the right combination of impulses, right and left, will permit the car to start. Because of the infinite variety of combinations, no two systems are alike, eliminating the fear of a master key being used. A built-in alarm hookup automatically sounds the car's horn if an attempt is made to bypass the Kode-Kee by short circuiting the starter. Two optional items—a gasoline shut-off system and an anti-towing device—complete the system.

Circle No. 90 on Reader Service Page 15 or 97



It costs only



New Easy Dispenser Pak 60/40 18 S.W.G.*

1/100 of 1¢ more



Latest PC (Printed Circuit) Pak
60/40 Extra Thin 22 S.W.G.—.028**

per solder joint to know you are using the world's finest cored solder

* Each only 59¢ per package at your dealer.



MULTICORE SALES CORP., WESTBURY, N.Y. 11590

CIRCLE NO. 20 ON READER SERVICE PAGE

GET INTO ELECTRONICS

V.T.I. training leads to success as technicians, field engineers, specialists in communications, guided missiles, computers, radar, automation, basic & advanced courses. Electronic Engineering Technology and Electronic Technology curricula both available. Associate degree in 29 months. B.S. obtainable. G.I. approved. Start September, February. Degrees, campus. High school graduate or equivalent. Catalog.

VALPARAISO TECHNICAL INSTITUTE
DEPARTMENT PE, VALPARAISO, INDIANA 46383



HAVE YOUR OWN RADIO STATION

Learn AMATEUR RADIO

A fascinating hobby. Join the international network of "ham" operators. NRI trains you quickly at home. You get equipment to build your own shortwave station, Morse Code long-playing records, preparation for FCC license. Write National Radio Institute, Dept. 58-050, Washington, D.C. 20016 and say, "Send me your Amateur Radio catalog." No salesman will call. An accredited NHSC school.



STEREO TAPE TRANSPORT

7" reel—2 speeds—pause control made for famous manufacturer—50 to 15,000 Hz—with rec/play and erase heads, without case. Send m.o. or check for \$19.50 to:

STEREO CENTER
218 Columbia St., Utica, N.Y. 13502
\$2.50 for prepaid shipping and insurance.

LIBRARY

(Continued from page 16)

cuts and mechanisms used to achieve modulation, without providing much theory on why this modulation is necessary. This book attempts to rectify the oversight. The text is broken up into five sections: Communication; Signal Transmission in Electrical Networks; Amplitude Modulation; Angle Modulation; and Pulse Modulation. A working knowledge of calculus is required for understanding this book.

Published by Holt, Rinehart and Winston, Inc., 383 Madison Ave., New York, NY 10017. Soft cover. 274 pages. \$3.95.

PRACTICAL SEMICONDUCTOR DATA BOOK FOR ELECTRONIC ENGINEERS AND TECHNICIANS

by John D. Lenk

If you really want to know how to design and use solid-state components, this is the book you need. It is the first one-volume key to the critical data most frequently used in working with solid-state components. This book is a simple yet highly detailed guide to the operating characteristics, circuit design procedures and applications, and theory of the dozen or so basic different types of transistors. The volume bridges the gap between fundamentals of semiconductor theory and the practical world of the working professional. It clarifies each equation and procedure with step-by-step explanations, detailed test procedures, and itemized coverage of data sheet specifications. It is a "must have" book.

Published by Prentice-Hall, Inc., Englewood Cliffs, NJ 07632. Hard cover. 260 pages. \$10.95.

TV TROUBLESHOOTER'S HANDBOOK Second Edition

This book is a completely updated quick-reference source for scores of tried-and-tested solutions to "tough-dog" TV receiver problems. It is a detailed compilation of

practical help; a well-organized file of proven troubles and cures, field factory changes, new and unusual circuit descriptions and how they work, etc. This new edition represents the only known up-to-date digest of specific troubles and cures for both color and monochrome receivers (every major brand name is included), up to and including the 1969 models.

Published by Tab Books, Blue Ridge Summit, PA 17214. 288 pages. \$7.95 hard cover, \$2.95 soft cover.

PRACTICAL ELECTRICITY

by Robert G. Middleton

One of the most complete and practical handbooks on electricity available, this book may very likely open the way to success for countless electrical workers and apprentices. Containing more than 1300 illustrations and electrical diagrams, it presents in clear, concise language the fundamentals of electricity. The book contains 15 chapters, starting with magnetism and electricity and continuing right up to generating stations and substations. Each chapter concludes with a short summary of the material covered and a series of test questions.

Published by Howard W. Sams & Co., Inc., 4300 West 62 St., Indianapolis, IN 46268. Hard cover. 486 pages. \$5.95.

TELEVISION SERVICE MANUAL

by Edwin P. Anderson

Fully revised and updated by Robert G. Middleton, this book covers the entire scope of television transmission and reception. Both circuit operation and theory are detailed for color and monochrome television. The revised portions of the text include considerable coverage of the recent innovations in transistorized TV receivers. Additionally, a complete section is devoted to the coverage of test equipment. Considerable use of photos, schematic diagrams, and drawings has been made in this Audel book to explain and clarify points made in the text.

Published by Howard W. Sams & Co., Inc., 4300 West 62 St., Indianapolis, IN 46268. Hard cover. 544 pages. \$5.95.

New Products from THE PHASE CORPORATION



FOUR TRACE PRE-AMP

Convert any single trace scope to display four separate signals at the same time without any internal modifications.



\$34.95

All Solid State
FET Input
Center & Gain
Controls for each
Channel
1 Megahertz/
channel
bandwidth

Kit with Custom cabinet (Model A1KC) \$34.95; wired & tested (Model A1W) \$54.95

Send Check, Money Order, or ask us to bill your BankAmericard or Master Charge. We pay all postage. Dealer inquiries invited.

TEST OSCILLATOR

Generates all three functions.

SAW: 0.1HZ
—100KHZ
SQUARE: 0.05HZ
—50KHZ
PULSE: 0.1HZ
—100KHZ



\$34.95

All Solid State
FET & Unijunction
Circuitry
Calibrated ranges
Portable &
Compact

Kit with Custom Cabinet (Model O1K) \$34.95; wired & tested (Model O1W) \$54.95

THE PHASE CORPORATION, ELECTRONICS DIVISION, MEDFORD, MASS. 02155

CIRCLE NO. 25 ON READER SERVICE PAGE

ELECTRONICS MARKET PLACE

COMMERCIAL RATE: For firms or individuals offering commercial products or services. \$1.15 per word (including name and address). Minimum order \$11.50. Payment must accompany copy except when ads are placed by accredited advertising agencies. Frequency discount: 5% for 6 months; 10% for 12 months paid in advance.
READER RATE: For individuals with a personal item to buy or sell. 70c per word (including name and address). No Minimum! Payment must accompany copy.

FOR SALE

FREE! Giant bargain catalog on transistors, diodes, rectifiers, SCR's, zeners, parts. Poly Paks, P.O. Box 942, Lynnfield, Mass. 09140.

GOVERNMENT Surplus Receivers, Transmitters, Snooperscopes. Radios, Parts, Picture Catalog 25¢. Meshna, Nahant, Mass. 01908.

ROCKETS: Ideal for miniature transmitter tests. New illustrated catalog. 25¢. Single and multistage kits, cones, engines, launchers, trackers, rocket aerial cameras, technical information. Fast service. Estes Industries, Dept. 18, Penrose, Colorado 81240.

LOWEST Prices Electronic Parts. Confidential Catalog Free. **KNAPP**, 3174 8th Ave. S.W., Largo, Fla. 33540.

EUROPEAN and Japanese bargains catalogs. \$1 each. Dee, 10639E Riverside, North Hollywood, Calif. 91602.

MUSIC LOVERS, CONTINUOUS, UNINTERRUPTED BACKGROUND MUSIC FROM YOUR FM RADIO, USING NEW INEXPENSIVE ADAPTOR. FREE LITERATURE. ELECTRONICS, 11500-Z NW 7th AVE., MIAMI, FLORIDA 33168.

WE SELL CONSTRUCTION PLANS. TELEPHONE: Answering Machine, Speakerphone, Carphone, Phonevision, Legal Connector, Auto Dialer, Central Dial System. **TELEVISION:** \$35.00 Color Converter, Tape Recorder, 3DTV. \$25.00 Camera. **DETECTIVE:** Infinity Transmitter, Tail Transmitter, Police Radar Detector. **HOBBYIST:** Electron Microscope, 96 Hour Tape Music System, Ultrasonic Dishwasher, Radar-Oven, Electronic Tranquilizer. Plans \$4.95 each. **COURSES:** Telephone Engineering \$39.50, Detective Electronics \$22.50, Anti-Detective Electronics \$27.50. **NEW SUPER HOBBY CATALOG AIRMAILED \$1.00** Don Britton Enterprises, 7906 Santa Monica Blvd., Hollywood, Calif. 90046.

WEBBER LAB'S. Police & Fire Converters. Catalog 25¢. 72 Cottage Street, Lynn, Mass. 01905.

RADIO-T.V. Tubes—33¢ each. Send for free catalog. Cornell, 4213 University, San Diego, Calif. 92105.

INVESTIGATORS, LATEST ELECTRONICS AIDS. FREE LITERATURE. CLIFTON, 11500-L NW 7th AVE., MIAMI, FLORIDA 33168.

FREE ELECTRONICS PARTS FLYER. Large catalog \$1.00 deposit. **BIGELOW ELECTRONICS, BLUFFTON, OHIO 45817.**

JAPAN & HONG KONG DIRECTORY. Electronics, all merchandise. World trade information. \$1.00 today. Ippano Kaisha Ltd., Box 6266, Spokane, Washington 99207.

ULTRA-SENSITIVE AND POWERFUL METAL DETECTORS—join the many who are finding buried coins, minerals, relics and artifacts. Don't buy till you see our **FREE** catalog of new models. Write Jetco, Box 132-PE, Huntsville, Texas 77340.

LASER parts catalog 60¢. Moynihan, 107 North Brighton, Atlantic City, New Jersey 08401.

PSYCHEDELIC catalog. Posters, lighting, etc. Send 25¢ for handling to **Hotel In The Wall, 6055PE Lankershim, North Hollywood, Calif. 91606.**

THE ART OF DE-BUGGING—\$5.95. TRON-X PUBLICATIONS, P.O. BOX 38155, HOLLYWOOD, CALIFORNIA 90038.

CONSTRUCTION PLANS: LASER . . . \$2.00. Listening Devices—two F.M. MIC Transmitters . . . \$1.00. Tail Transmitter . . . \$1.00. Sound Telescope . . . \$2.00. Infinity Transmitter . . . \$2.00. Equipment and kits available. Howard, 20174 Ward, Detroit, Michigan 48235.

COMPONENTS? Kits? Hardware? Free catalog! Truvue Paks, Box 275, Chelsea, Mass. 02150.

SENCORE TEST EQUIPMENT UNBELIEVABLE PRICES. FREE CATALOG AND PRICE SHEET. FORDHAM RADIO, 265 EAST 149TH STREET, BRONX, N.Y. 10451.

GENERAL INFORMATION: First word in all ads set in bold caps at no extra charge. All copy subject to publisher's approval. Closing Date: 1st of the 2nd month preceding cover date (for example, March issue closes January 1st). Send order and remittance to: Hal Cymes, **POPULAR ELECTRONICS**, One Park Avenue, New York, New York 10016.

ELECTRONIC ignition, various types. Free literature. Anderson Engineering, Epsom, N.H. 03239.

AMATEUR SCIENTISTS, Electronics Hobbyists, Experimenters, Students . . . Construction Plans—all complete, including drawings, schematics, parts lists with prices and sources . . . **Laser**—Build your own coherent-light optical laser. Operates in pulsed mode, visible light range—\$6.00 . . . **Radar**—Build your own ultrasonic doppler radar. Detect motion of people, automobiles, even falling rain drops. Transistorized, uses standard small 9-volt battery—\$4.00 . . . **Long-Range "Sound Telescope"**—This amazing device can enable you to hear conversations, birds and animals, other sounds hundreds of feet away. Very directional. Transistorized. Uses 9V battery—\$3.00 . . . Or send 25¢ coin (no stamps) for complete catalog. Other items include Psychedelic strobes, light shows, robots . . . 38 different projects. Technical Writers Group, Box 5994, State College Station, Raleigh, N.C. 27607.

MECHANICAL, ELECTRONIC devices catalog 10¢. Greatest Values—Lowest Prices. Fertik's, 5249 "D", Philadelphia, Pa. 19120.

CLEARANCE SALE rectifiers, transistors, 1000's other items. Catalog 15¢. General Sales Company, 254 Main, Clute, Texas 77531.

DIAGRAMS—Radios \$1.50, Television \$3.00. Give make and model. Diagram Service, Box 1151PE, Manchester, Conn. 06042.

LINEAR AMPLIFIERS: "Hornet" 50 watts output—\$98.50; "Raider" 100 watts—\$139.50; "Maverick-250" 250 watts—\$244.95. AM and SSB. "Scorpion" 50 watt 12 V. Mobile Amplifier—\$99.95; "Bandit II" 12 V. Mobile Amplifier—\$169.95. Mobile amplifiers positive or negative ground. Frequency range 20-35 megacycles (illegal for class D 11 meters.) Dealer inquiries invited. D & A Manufacturing Co., 1217 Avenue C, Scottsbluff, Nebraska 69361.

SEMICONDUCTORS and parts catalogue free over 100 pages. J. & J. Electronics, Box 1437, Winnipeg, Manitoba, Canada. U.S. Trade directed.

SPACE-AGE TV CAMERA KIT! Terrific for Experimenters, Industry, Education. Solid-state. Only \$116.95! Starter kits: \$18.95 up. Plans 25¢ up. Catalog FREE. Phone: 402-987-3771. Write: **ATV RESEARCH, 1301 Broadway, Dakota City, Nebr. 68731.**

EXCITING LISTENING! POLICE—FIRE—AIRCRAFT—SHORTWAVE calls on your broadcast radio! Free catalog. Salch Company, Woodboro 24, Texas 78393.

CONVERT any television to sensitive, big-screen oscilloscope. Only minor changes required. No electronic experience necessary. Illustrated plans, \$2.00. Relco-A33, Box 10563, Houston, Texas 77018.

PSYCHEDELIC Lighting Manual: Make light-machines, strobes, organs, slides, etc. Send \$2.00. Lightrays, 713D Pine, Philadelphia, Pa. 19106.

BURGLAR ALARM SYSTEMS and accessories. Controls, bells, sirens, hardware, etc. **OMNI-GUARD** radar intruder detection system, kit form or assembled. Write for free catalog. Microtech Associates, Inc., Box 10147, St. Petersburg, Florida 33733.

PRINTED CIRCUITS. Magazine projects and experimental. Free listing. Vico, Box 1590, Los Angeles, Calif. 90053.

POLICE-FIRE RADIO DISPATCHER CALLBOOKS! EXCLUSIVE, OFFICIAL LISTINGS: CALLSIGNS, FREQUENCIES! LATEST REVISIONS, NATIONWIDE. CATALOG, SEND STAMP. COMMUNICATIONS, BOX 56-PE, COMMACK, N.Y. 11725.

SUBMINIATURE MICROPHONE extremely sensitive \$2.95, **MINIATURE SPEAKER** \$1.80, 6"x10" **ONE WAY MIRROR** \$1.00. All items guaranteed, postage prepaid. **MICRO-M**, Box 251, Dept. A22, Hatfield, Pennsylvania 19440.

DECADE COUNTER-DECODER/DRIVER-SEVEN SEGMENT READDUT TUBE all for \$14.95. PC layout included. Environmental Products, Box 326, Lafayette, Ind. 47902.

\$PACE Monitor-Missile Tracker. Transistorized. Both Plans . . . \$2.00. Micord, 20278 Westbrock, Detroit, Michigan 48219.

LEARN TO REPAIR T.V. TUNERS: High Earnings. Introduction, Contents, Two Sample Lessons, Details of Complete Course, Many Plans, Twelve "Tricks", all for \$1. Refundable. Frank Bocek, Box 833, Redding, Calif. 96001.

AVIATION TECHNICAL TAPES and MANUAL by expert Flight Instructor tells and shows what you should know about Aircraft. Introduction to Flight explains airfoils, controls, instruments, navigation, radios, engines, props, and much more. Standard tapes or cassettes—state which. **INTRODUCTORY PRICE \$10.** Tech Tapes, Box 10900, Pittsburgh, Pa. 15236.

POLICE, FIRE AND WEATHER CONVERTERS—No connections necessary, simply place near regular AM radio. 145-175 & 450-470 MHz. models. Specify frequency. Only \$17.95. Free literature. Dealer inquiries invited. Ultra Electronics, 3434 McCalla, Knoxville, Tennessee 37914.

POPULAR ELECTRONICS' DYNADIM automatic light dimmer. Kit or assembled. Free reprints. PCS, Box 1281, San Luis Obispo, Calif. 93401.

DIRECTORY of Japanese Electronics Companies \$2.00, now. Jago PE5, 120 South First Avenue, Highland Park, New Jersey 08904.

BEAT HEAT WITH COOLANT-GEL SOLDER AID: Prevents remelt of nearby solder joints and protects delicate electronic components. Performance guaranteed. \$2.95 lb. postpaid. **DYNATEK INDUSTRIES**, Box 24268, Cleveland, Ohio 44124.

FREE—Bargain flyer listing relays, steppers, and other electronics parts. Send a large stamped self-addressed envelope to: Gust & Company, Box 24081, Edina, Minnesota 55424.

PSYCHEDELICALLY NEW!!! COMPLETELY ENCASED IN BREAK, SHOCK PROOF PLASTIC MODULES, COLOR ORGAN CIRCUITS. 1" x 2" x 1 1/2" UNIT CAN EASILY BE BUILT INTO AMPLIFIERS, STEREOs, RECORDERS. BUY TWO FOR STEREO! 200 WATT UNIT—\$5.00, 500 WATT UNIT—\$7.50, 1,000 WATT UNIT—\$10.00 POSTPAID! COMPLETE WITH APPLICATION SHEET. ECONOMY SINGLE CHANNEL LIGHT BOX WITH LENTICULAR SCREEN—\$11.00 POSTPAID. CUSTOM MADE MODULES AVAILABLE. ELECTRONIC HÖHNER HARMONICAS—\$10.00. CATALOGUE 50¢. MAT RESTIVO PSYCHEDELIC LIGHTING, 3547 TUSCALA STREET, SEAFORD, NEW YORK 11783.

PARTS: ALL AMERICAN MADE. Priced below "Bargain Imports." Free catalog. K. & J. B. Electronics, 120 Brookside, Darien, Conn. 06820.

POPULAR ELECTRONICS, complete set, make offer. Britting, 13 Plochmann, Woodstock, N.Y. 12498.

COMPREHENSIVE design of IC circuits, schematically illustrated article covering every aspect of IC circuit design, send \$3.00. Solid State Tekneex, Rt 1, Doniphan, Mo. 63935.

BURGLAR AND FIRE ALARM SYSTEMS and supplies. **INSTALLATION MANUAL** and catalog \$1.00. Refunded on first order. Electronic Sentry Systems, P.O. Box 8023A, Sacramento, California 95818.

QUALITY LINEAR AMPLIFIERS: 200 Watts, 20-35 mc, base, \$125 (illegal class D, 11 meters); other units mobile and base; Amateur, CB, & Experimenter's products, free catalog, quality and low prices. K. & J. B. Electronics, 120 Brookside, Darien, Conn. 06820.

NEW!! Elenco LR-5 Bi-Lateral linear amplifier 150 watts output, variable receive boost, \$149.95. (Illegal for Class D CB use.) Elenco, Dept. A, Wabash, Ind. 56992.

PLANS AND KITS

SURVEILLANCE DEVICES IN KIT FORM: Telephone Transmitter, FM Spy Transmitter, Telephone-Recorder Actuator, Tail Transmitter, Bug Detector. Complete Kits Send \$15.00 each. **ELECTRONIC SECURITY SYSTEMS**, 1101 West Rosecrans Avenue, Gardena, California 90247.

BUILD color organs, computers, stereos, alarms, slide-synchronizers. Catalog. Workshop, 33E Cain, Plainview, New York 11803.

KITS, SUPER SNOOPER \$5.95. Metal Detector \$5.95. FM Wireless Transmitter \$4.95, others. Lextronix, Box 42, Madison Heights, Michigan 48071.

FAMOUS Quad Antenna Kit for FM \$9.95, Postpaid U.S.A. Rose Electronics, Box 3245, Vero Beach, Florida 32960.

COLOR Organ Kit \$7.50. Power Supplies \$3.98. Catalog. Murphy, 204 Roslyn Ave., Carle Place, N.Y. 11514.

CIRCUITS for 32 electronic projects, R.F., audio and gadgetry complete plans \$1.00. P.M. Electronics, Inc., Box 46204, Seattle, Wash. 98146. Dealer inquiries invited.

BURGLAR-proof your automobile ignition (or any device) electronically! Illustrated plans including PC, \$5. Information, 25¢. Logan, 403 Lakewood Circle, Virginia Beach, Virginia 23451.

OSCILLOSCOPE IMPROVEMENT KITS. High speed Triggersweep eliminates sync problems. Dual-trace FET switch displays two waveforms together. **SOLID-STATE SERVICES**, P.O. Box 901, Cupertino, California 95014.

MUSIC ADAPTER FOR COMMERCIAL-FREE FM BACKGROUND MUSIC. Connects easily to any FM tuner. 6-transistor circuit uses standard components. Plans and 3x4 1/2" etched circuit board \$4.50. Wallace Enterprise, Inc., 83-15 98th Street, Woodhaven, N.Y. 11421.

INTEGRATED CIRCUIT KITS: COMPUTER, OPTOELECTRONICS, AUDIO. Catalog free. **KAYE ENGINEERING**, Box 3932-A, Long Beach, California 90803.

TRADE CONSTRUCTION PLANS. FREE. Wegner, P.O. Box 262, Glendale, Calif. 91209.

"ONE TUBE DXER" Handbook—50¢. "Coil Winding"—50¢ Catalog. Laboratories, 2612-L Butano, Sacramento, Calif. 95821.

BURGLAR ALARM, complete instructions, blueprint, send \$2.00. Petron, Box 8505, Fountain Valley, Calif. 92708.

MATRIX ARRAY COMPONENT UNIT KITS; versatile, programmed, substitution networks experimenters need. 25¢ catalog includes 75¢ first order coupon. **CUHINCO**, 2404 Stratton Drive, Rockville, Maryland 20854.

HIGH FIDELITY

FREE! Send for money saving stereo catalog # P5E, lowest quotations on your individual component, tape recorder, or system requirements. Electronic Values, Inc., 200 W. 20th St., New York, N.Y. 10011.

HI-FI components. Tape Recorders, at guaranteed "We Will Not Be Undersold" prices. 15-day money-back guarantee. Two-year warranty. No Catalog. Quotations Free. Hi-Fidelity Center, 239 (P) East 149th Street, New York 10451.

LOW, Low quotes: all components and recorders, HiFi, Roslyn, Penna. 19001.

BACKGROUND MUSIC—SOLID-STATE SCA DECODER DELIVERS SUBCARRIER COMMERCIAL-FREE MUSIC PIGGYBACKED ON MANY FM STATIONS. LINE-POWERED ADAPTER SIMPLY PLUGS INTO ANY FM TUNER. NO ADJUSTMENTS OR TUNING. NEW DESIGN BREAK-THRU GUARANTEES OPTIMUM PERFORMANCE, LOWEST PRICE EVER! \$35 POSTPAID. K-LAB, BOX 572, S. NORWALK, CONN. 06856.

TAPE RECORDERS. Hi-Fi. components, Sleep Learning Equipment. tapes. Unusual Values. Free Catalog. Dressner, 1523R, Jericho Turnpike, New Hyde Park, N.Y. 11040.

STEREO COMPONENTS at low discount prices. Send for our low quotes today and our cartridge trade-in specials (Shure, ADC, Pickering, Empire, etc.). Send \$1.00 for our discount catalog. **DEFA ELECTRONICS**, 2207 Broadway, New York, N.Y. 10024.

DIAMOND NEEDLES AND STEREO CARTRIDGES at low, low prices for Shure, Pickering, Stanton, Empire, Grado and ADC. Send for free catalog and price sheet. We will be happy to quote on any cartridge—Magnetic, Ceramic or Crystal. All merchandise brand new and shipped **PREPAID.** **LYLE CARTRIDGES**, Dept. P, 265 East 149 Street, Bronx, New York 10451.

WANTED

CASH PAID! Unused tubes, electronic equipment. Barry, 512 Broadway, NYC 10012.

QUICKSILVER, Platinum, Silver, Gold, Ores Analyzed. Free Circular. Mercury Terminal, Norwood, Mass. 02062.

TUBES

TUBES "Oldies", latest. Lists free. Steinmetz, 7519 Maplewood, Hammond, Indiana 46324.

RECEIVING & INDUSTRIAL TUBES, TRANSISTORS. All Brands—Biggest Discounts. Technicians, Hobbyists, Experimenters—Request **FREE** Giant Catalog and **SAVE!** ZALYTRON, 469 Jericho Turnpike, Mineola, N.Y. 11501.

TUBE Headquarters of World! Send 10c for Catalog (tubes, electronic equipment) Barry, 512 Broadway, N.Y.C. 10012.

RADIO & T.V. Tubes—33¢ each. Send for free list. Cornell, 4213 University, San Diego, Calif. 92105.

THOUSANDS and thousands of types of electronic parts, tubes, transistors, instruments, etc. Send for Free Catalog, Arcturus Electronics Corp., MPE, 502-22nd St., Union City, N.J. 07087.

TUBES—Lowest world prices. Foreign-American. Obsolete, current. Receiving, special purpose, transmitting tubes. Send for tube and parts catalog. United Radio Company, 56-P Ferry St., Newark, N.J. 07105.

TAPE AND RECORDERS

BEFORE Renting Stereo Tapes try us. Postpaid both ways—no deposit—immediate delivery. Quality—Dependability—Service—Satisfaction—prevail here. If you've been dissatisfied in the past, your initial order will prove this is no idle boast. Free Catalog. Gold Coast Tape Library, Box 2262, Palm Village Station, Hialeah, Fla. 33012.

RENT 4-Track open reel tapes—all major labels—3,000 different—free brochure. Stereo-Parti, 55 St. James Drive, Santa Rosa, Ca. 95401.

TAPEMATES makes available to you **ALL 4-TRACK STEREO TAPES—ALL LABELS**—postpaid to your door—at tremendous savings. For free brochure write: **TAPEMATES**, 5727 W. Jefferson Blvd., Los Angeles, California 90016.

AMAZING DISCOUNTS on famous brand high fidelity stereo components. No small wonder that we have set new sales records each year since 1959. Write: Arkay Electronics, 1028-03 Commonwealth, Boston, Mass. 02215.

STEREO TAPES, save 20.30% and more, postpaid anywhere U.S.A. We discount batteries, recorders, tape/cassettes. 80-page catalog 25¢. **SAXITONE TAPES**, 1776 Columbia Road, N.W., Washington, D.C. 20009.

CASSETTE and 8 track blanks, language tapes, dozens of accessories and recorders. Literature 25¢. **CASSETTES UNLIMITED**, P.O. Box 13119-P, Pittsburgh, Pa. 15243.

OLD radio programs on tape. 6 hours for \$8.00. Catalog 50¢. Don Maris, 1926 Cherokee, Norman, Okla. 73069.

USED Mylar Tapes 1800'. Ten for \$9.00. Fremerman, 4041 Central, Kansas City, Mo. 64111.

VIDEO Tape Recorders. New Norelco Only \$585.00. **DENSON ELECTRONICS CORP.**, ROCKVILLE, CONN. 06066.

REPAIRS AND SERVICES

TV Tuners rebuilt and aligned per manufacturers specification. Only \$9.50. Any make UHF or VHF Ninety day written guarantee. Ship complete with tubes or write for free mailing kit and dealer brochure. JW Electronics, Box 51C, Bloomington, Indiana 47401.

PERSONALS

MAKE FRIENDS WORLDWIDE through international correspondence. Illustrated brochure free. Hermes, Berlin 11, Germany.

INVESTIGATORS. LATEST ELECTRONIC AIDS. FREE LITERATURE. CLIFTON, 11500-K NW 7th AVE., MIAMI, FLORIDA 33168.

INSTRUCTION

LEARN ELECTRONIC ORGAN SERVICING at home all makes including transistor. Experimental kit—trouble-shooting. Accredited NHSC. Free Booklet. **NILES BRYANT SCHOOL**, 3631 Stockton, Dept. A, Sacramento, Calif. 95820.

FCC First Class License in six weeks—approved for Veterans Training. Write Elkins Institute, 2603B Inwood Road, Dallas, Texas 75235.

R.E.I.'s famous (5) week course for the First Class Radio Telephone License is the shortest, most effective course in the nation. Over 98% of R.E.I. graduates pass F.C.C. exams for 1st class license. Total tuition \$360.00. Job placement free. Write for brochure. Radio Engineering Incorporated Schools, 1336 Main Street, Sarasota, Florida 33577—or 3123 Gillham Road, Kansas City, Missouri 64109—or 809 Caroline Street, Fredericksburg, Virginia 22401—or 625 E. Colorado Street, Glendale, California 91205.

DEGREE in Electronics Engineering earned mostly by correspondence. Free brochure. Dept. G-9, Grantham School of Engineering, 1505 N. Western Ave., Hollywood, California 90027.

LEARN WHILE ASLEEP, Hypnotize! Strange catalog free. Auto-suggestion, Box 24 ZD, Olympia, Washington 98501.

F.C.C. License training by correspondence. G.I. Bill approved. Money-Back Warranty. Free brochure. Write: Dept. Z-9, Pathfinder School of Electronics, 1505 N. Western Ave., Hollywood, Calif. 90027.

PLAY ORGAN OR GUITAR EASILY! AMAZING METHOD! FREE INFORMATION. KEGLEY, 1016-PE KELLY, JOLIET, ILLINOIS 60435.

FCC FIRST CLASS LICENSE THROUGH TAPE RECORDED LESSONS at home plus one week personal instruction in Detroit, Washington, San Francisco, Seattle or Los Angeles. Our nineteenth year teaching FCC license courses, Radio License Training, 1060D Duncan, Manhattan Beach, Calif. 90266.

MATHEMATICS. ELECTRONICS. Satisfaction guaranteed. Free brochure, Indiana Home Study, Dept. PE, Box 1189, Panama City, Florida 32401.

HIGHLY effective home study courses in Electronics Engineering Technology and Electronics Engineering Mathematics. Earn your Degree. Write for Free Descriptive Literature, Cook's Institute of Electronics Engineering, (Dept. 15), P.O. Box 10634, Jackson, Miss. 39209. (Established 1945).

MEMORIZE: "1970 TESTS—ANSWERS" for FCC FIRST AND SECOND CLASS LICENSE. Plus "Self-Study Ability Test." **PROVEN.** \$5.00. Commard, Box 26348-P, San Francisco 94126.

GUITAR INSTRUCTION BOOK \$1.25. Jack L. Lamb, Rt. #4, Box 3018, Lakeland, Florida 33803.

INVENTIONS WANTED

INVENTIONS wanted. Patented; unpatented. Global Marketing Service, 2420-P 77th Oakland, Calif. 94605.

FREE "Directory of 500 Corporations Seeking New Products." For information regarding development, sale, licensing of your patented/unpatented invention. Write: Raymond Lee Organization, 230-GR Park Avenue, New York City 10017.

INVENTORS: Protect your ideas! Free "Recommended Procedure". Washington Inventors Service, 422T Washington Building, Washington, D.C. 20005.

PATENT SEARCHES, including copies of related United States Patents. Inventors, attorneys, manufacturers use our "World-Wide" Airmail service Free: "Invention Record" form and "Information Every Inventor Needs". Hayward Company, 1029HR Vermont, Washington, D.C. 20005.

PATENT Searches including Maximum speed, full airmail report and closest patent copies, \$6.00. Quality searches expertly administered. Complete secrecy guaranteed. Free Invention Protection forms and "Patent Information," Write Dept. 9, Washington Patent Office Search Bureau, 711 14th Street, N.W., Washington, D.C. 20005.

FREE PAMPHLET: "Tips on Safeguarding Your Invention." Write: United States Inventors Service Company, 501-H Thirteenth Street N.W., Washington, D.C. 20004.

INVENTORS! Don't sell your invention, patented or unpatented, until you receive our offer. Eagle Development Company, Dept. P, 79, Wall Street, N.Y., N.Y. 10005.

GOVERNMENT SURPLUS

JEEPS Typically From \$53.90 . . . Trucks From \$78.40 . . . Boats, Typewriters, Airplanes, Multimeters, Oscilloscopes, Transceivers, Electronics Equipment. Wide Variety. Condition. 100,000 Bid Bargains Direct From Government Nationwide Complete Sales Directory and Surplus Catalog \$1.00. (Deductible First \$10.00 Order). Surplus Service, Box 820-J, Holland, Michigan 49423.

GOVERNMENT Surplus How and Where to Buy in Your Area. Send \$1.00 to: Surplus Information PE, Headquarters Building, Washington, D.C. 20036.

BOOKS

FREE catalog aviation/electronic/space books. Aero Publishers, 329PE Aviation Road, Fallbrook, California 92028.

"UNUSUAL" Books! Catalog 10¢! International, PE, Box 7798, Atlanta, Georgia 30309.

FREE book prophet Elijah coming before Christ. Wonderful bible evidence. Megiddo Mission, Dept. 64, 481 Thurston Rd., Rochester, N.Y. 14619.

BOOKS for every interest! Free details. Reed Company, West Kingston, Rhode Island 02892.

COINS

BUYING? SELLING? MONTHLY MAILORDER COIN AUCTIONS. \$1.00. Traders, 322 N. 13th, San Jose, Calif. 95112.

MAGAZINES

BACK DATE MAGAZINES! Send needs. Midtown, Box 917-PE, Maywood, N.J. 07607.

POPULAR ELECTRONICS, Vol. 1—No. 1 to December 1969. For best offer: T. R. Walker, 1568 Lodge St., Alcoa, Tenn. 37701.

AUTHORS' SERVICES

AUTHORS! Learn how to have your book published, promoted, distributed. FREE booklet "ZD," Vantage, 120 West 31 St., New York 10001.

HYPNOTISM

FREE Hypnotism, Self-Hypnosis, Sleep Learning Catalog! Drawer H400, Ruidoso, New Mexico 88345.

"MALE-FEMALE HYPNOTISM" EXPOSED, EXPLAINED! "SECRET METHOD"—THEY NEVER KNOW! \$2, RUSHED. GUARANTEED! ISABELLA HALL, SILVER SPRINGS, FLORIDA 32688.

AMAZING self-hypnosis record releases fantastic mental power. Instant results! Facts free. Write: Forum (AA5), 333 North Michigan Avenue, Chicago 60601.

HYPNOTIZE PERFECT STRANGERS—EITHER SEX—SUCCESSFULLY! Secret Methods—they never know! Illustrated Course and 10 inch Hypnodisk \$2.00. RESULTS ABSOLUTELY GUARANTEED! Dr. H. Arthur Fowler, Box 4399, Woodbury, New Jersey 08096.

MAGNETS

MAGNETISM (100) page script newly discovered magnetic principles (\$3.00). Jesse Costa, Box 26, Waquoit, Mass. 02536.

MAGNETS. All types. Special—20 disc magnets, or 2 stick magnets, or 10 small bar magnets, or 8 assorted magnets, \$1.00 Maryland Magnet Company, 5412-H Gist, Baltimore, Maryland 21215.

MAGNETS, 24 disc or bars, \$1.00; both \$1.75. Magnetics, Box 2279, Sunnyvale, Calif. 94087.

PHOTOGRAPHY—FILM, EQUIPMENT, SERVICES

SCIENCE Bargains Request Free Giant Catalog "CJ"—148 pages—Astronomical Telescopes, Microscopes, Lenses, Binoculars, Kits, Parts. War surplus bargains. Edmund Scientific Co., 300 Edscorp Bldg., Barrington, New Jersey 08007.

RECORDS

POPULAR organ albums factory direct. Concert Recording, Lynwood, Calif. 90262.

OLDIES—45RPM original hits. Over 4000 available. Catalog 25¢. C & S Record Sales, Box 197, Wampsville, N.Y. 13163.

SPECIAL interest records available, produced by the editors of the world's leading special interest magazines. Send for free catalog. Record Catalog-PE, Ziff-Davis Publishing Company, One Park Avenue, New York, N.Y. 10016.

REAL ESTATE

FREE . . . NEW SUMMER CATALOG! Describes and pictures hundreds of farms, ranches, town and country homes, businesses coast to coast! Specify type property and location preferred. Zip code, please. UNITED FARM AGENCY, 612-EP West 47th St., Kansas City, Mo. 64112.

CLASSIFIED ADVERTISING ORDER FORM

Please refer to heading on first page of this section for complete data concerning terms, frequency discounts, closing dates, etc.

1	2	3	4	5
6	7	8	9	10
11	12	13	14	15
16	17	18	19	20
21	22	23	24	25
26	27	28	29	30
31	32	33	34	35

Words { @ 70¢ (Reader Rate) }
 { @ \$1.15 (Commercial Rate) }

Insert _____ time(s)

Total Enclosed

\$ _____

\$ _____

NAME _____

ADDRESS _____

CITY _____

STATE _____

ZIP _____

Signature _____

WORD COUNT: Include name and address. Name of city (Des Moines) or of state (New York) counts as one word each. Zip Code numbers not counted. (Publisher reserves right to omit Zip Code if space does not permit.) Count each abbreviation, initial, single figure or group of figures or letters as a word. Symbols such as 35mm, COD, PO, AC, etc., count as one word. Hyphenated words count as two words.

PE-570

PRINTING

FREE LITERATURE: Address labels, business cards, printing, Rubber Stamps. **JORDAN'S**, 552 West O'Connor, Lima, Ohio 45801.

EMPLOYMENT INFORMATION

FOREIGN and USA job opportunities available now. Construction, all trades. Earnings to \$3,000.00 monthly. Paid overtime, travel bonuses. Write: Universal Employment, Woodbridge, Conn. 06525.

BUSINESS OPPORTUNITIES

RAISE Rabbits for us on \$500 month plan. Free details. White's Rabbitry, Mt. Vernon, Ohio 43050.

PIANO TUNING learned quickly at home. Tremendous field! Musical knowledge unnecessary. GI Approved. Free Information. Empire School, Box 327, Miami, Florida 33145.

FREE BOOK "999 Successful Little Known Businesses" Work home, Plymouth 445-Y, Brooklyn, N.Y. 11216.

ELECTROPLATING Equipment and supplies. All types for home workshops and industrial. Send \$2.00 (refundable) for equipment guide formulas, operating data, catalog. HBS Equipment Division 90, 3543 East 16th, Los Angeles, California 90023.

I MADE \$40,000.00 Year by Mailorder! Helped others make money! Start with \$10.00—Free Proof. Torrey, Box 318-N, Ypsilanti, Michigan 48197.

\$200.00 DAILY In Your Mailbox! Your opportunity to do what mail-order experts do. Free details. Associates, Box 136-J, Holland, Michigan 49423.

MAKE BIG MONEY raising chinchillas, rabbits, guinea pigs for us. Catalog—25¢. Keeney Brothers, New Freedom, Pa. 17349.

SELL inexpensive fire-burglar alarms. Foolproof! Write: **WATCHDOG, PROFITS BROCHURE**, Williamsburg, Ohio 45176.

FREE CATALOGS. Repair air conditioning, refrigeration. Tools, supplies, full instructions. Doolin, 2016 Canton, Dallas, Texas 75201.

\$20,000—\$50,000 year. Ohio Bonding School, 7101 Lake, Elyria, Ohio 44035.

ADDRESSERS (Commission Mailers) wanted. Everything Supplied. Details, 25¢. Smyre's, Box 953-ZD, Newark, N.J. 07101.

SELL HERTEL BIBLES—Part Time. Finest reference Bible available. Demonstrator and supplies furnished. Excellent commissions. Write International Book, Dept. PE, Box 118, Wichita, Kansas 67201.

OLDIES But Goodies—45 rpm's available at .05. No disc jockeys. Records are factory fresh. Excellent assortment—top labels such as Atlantic, Buddah, ABC, Tamla-Motown and many others. House of Sounds, Inc., Dept. D, 10 No. 9 St., Darby, Pennsylvania 19023.

MANAGER FOR LOCAL CONSUMER ELECTRONICS STORE—WILL TRAIN. Nationally known company offering brand-name home electronics items requires manager/part owner for new stores to be located Midwest. Selected man will become officer and general manager of corporation, with excellent salary plus 49% of profits. Minimum equity investment of \$12,000 required. Write for full details, indicating interest in full franchise or managing partner plan. Write Box 201, **POPULAR ELECTRONICS**, Classified, One Park Avenue, New York, N.Y. 10016.

MAKE money in mailorder, join "THE ASSOCIATION". Details 10¢. Satterfield, 3882 Via Cristobal, Campbell, California 95008.

SPARE Time Cash—Sell Advertising Book Matches—every business a prospect—no investment—no experience needed to build steady repeat business. Daily Cash commission in advance. Write today. We'll send your sure-fire selling kit by return mail. Dept. T-570 Superior Match Co., 7530 S. Greenwood, Chicago, Illinois 60619.

ELECTRONIC moneymaking projects. Knowledge, investment unnecessary. 25¢. Barta PEA, Box 15083, San Francisco, California 94115.

RUBBER STAMPS

RUBBER ADDRESS STAMP \$2.00. SIGNATURE \$3.50. FREE CATALOG. JACKSON, BOX 443-G, FRANKLIN PARK, ILL. 60131.

SPORTS ACTION FILMS

BONUS CATALOG—More than 100 exciting titles. Super 8/8 mm. **SPORTLITE FILMS**, Dept. PE, Box 500, Speedway, Indiana 46224.

STAMPS

STAMP approvals—state preferences. Hicks, Box 9050, College Station, Texas 77840.

MUSICAL INSTRUMENTS

30% DISCOUNT any name brand musical instrument. Free catalog. Freeport Music, 127-G West Sunrise, Freeport, N.Y. 11520.

TREASURE FINDERS

GOLD, SILVER, RELICS! Located with powerful Detectron Metal Detectors. Free information. Terms. Detectron, Dept. PE-5, Box 243, San Gabriel, California 91778.

TREASURE FINDER locates buried gold, silver, coins, treasures. 5 powerful models. \$19.95 up. Free catalog. Relco-A33, Box 10839, Houston, Texas 77018.

TREASUREPROBES—Patented transistorized detector signals "dig" by earphone "beeping". 5" search head. PC board, two colpitt oscillators improve stability. Kit \$13.95, assembled \$18.88, with speaker \$24.88. 60 day guarantee. Send for Free Bibliography, "Treasure Maps and Books of U.S." Treasurehouse, PE-50, Tennant, N.J. 07763.

FREE TREASURE GUIDE! Fact-filled collectors edition; send 50¢ for postage. Also request free literature on ultrasensitive, professional Fisher Detectors. **FISHER RESEARCH**, Dept. PE-5, Palo Alto, California 94303.

MISCELLANEOUS

WINEMAKERS: Free illustrated catalog of yeasts, equipment. Semplex, Box 12276, Minneapolis, Minn. 55412.

BILLS paid without borrowing—Nobody refused up to \$10,000.00. Bad credit no problem, not a Loan Company. Write for free application. **INTERNATIONAL ACCEPTANCE**, Dept. 50-A, 3003 N. Central Ave., Phoenix, Arizona 85012; 1000 N. Madison Avenue, Greenwood, Ind. 46142; 507 Carondelet St., New Orleans, La. 70130; 1825 Conn. Ave. N.W., Room 428, Washington, D.C. 20009.

BALLOON WINE—Make inexpensive wine with toy balloon and gallon jug. Illustrated \$1.00. EMS Co., P.O. Box 3965, St. Louis, Mo. 63136.

CLASSIFIED ADVERTISING IN POPULAR ELECTRONICS

Your best bet for outstanding mail order sales. These pages are read thoroughly by electronic hobbyists seeking products and services found only in **ELECTRONICS MARKET PLACE**. **POPULAR ELECTRONICS** readers respond readily—they rely on the advertisers appearing in the pages of their favorite magazine. Your low cost ad will result in increased sales responses for you! Send copy and payment to:

Hal Cymes, Classified Advertising Manager

POPULAR ELECTRONICS

1 Park Avenue

New York, N.Y. 10016

KEEP PACE WITH SPACE AGE! SEE MOON SHOTS—LANDINGS, SPACE FLIGHTS, CLOSE-UP!
AMAZING SCIENCE BUYS
 for FUN, STUDY or PROFIT

NEW \$99.50 HELIUM-NEON LASER!



Stock No. 79,004 AV

Completely assembled, instant-starting w/three times power output of comparable models. Steady, ripple-free light of monochromatic (safe) power. Particularly useful for studies, experiments in holography, interferometry, diffraction, optical alignment. Simple and safe to use. The 4 1/2 lb. unit reaches 7.5% power in 2 secs.; full power, typically 0.3 milliwatt (0.3 mW minimum) in 3 mins. Beam divergence only 3 milliradians; 2 cms at 40 feet. **\$99.50 Ppd.**

FIND BURIED METAL TREASURE!



all, adj. 11" diam. loop. includes 9 Volt (150 hr.) battery. Stock No. 80,119AV

Detect individual coins, rings as deep as 12"; bags of coins, tools to 6 feet! Best fully transistorized, induction-balance loop detector at moderate price. Rugged, lightweight (3 1/2 lbs.) battery powered. Perfect for treasure hunters, collectors, explorers, beachcombers. Has visual and audible indicators, adjustable soil conductivity knob, on-off switch control. "Humistaled" solid state circuitry. 3" over-voiced. **\$147.50 Ppd.**

STEREO MICROSCOPE—TERRIFIC BUY!



Stock No. 85,056 AV

American made. High powered. Direct measurement. Up to 3" working distance—wide 3-Dimensional field. Used in production, research, hobby, for inspections, counting, checking, assembling. 2 sets of objectives on rotating turret. Standard pair of wide field 10X Keilner Eye-pieces give 23" power and 10" power clear, sharp, erect image. Helical rack and pinion focusing. Interparallax distance adjustable. 10-day free trial. **\$99.50 FOB.**

SPECIAL VISUAL EFFECTS PROJECTOR SET

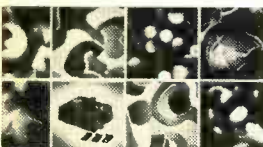

Stock No. 71,212AV

Dazzling, avant-garde visual effects. Fantastic variety, incredibly beautiful. Special package offer contains all necessary apparatus. Create floating, exploding, fiery bursts of color like "Symphony of Spheres" "Chromatic Starbursts", "Crestal Starburst". Features 5mm 500 W. fan cooled projector, produces big image at short distance. Accepts 35mm diaphragms (Kaleidoscope & Hexidoscope). 2 cylindrical accessories (6" Colored Cloud & 3" Hexix internal mirrored walls). Perfect for entertaining, parties, photography. Complete instructions. **\$79.50 Ppd.**

PSYCHEDELIC LIGHTING HANDBOOK



Stock No. 9100AV

100 Information packed pages! Fully explains latest in psychedelic lighting equipment, techniques, developments. Covers all facets of psychedelic light-show production including strobes, black lights, projectors, crystals, organic slides, mirrors, color organs, polarized color, light boxes, MusicVision, etc. Shows how to "psychedelize" parties, musical groups, shows or how to set an "electric trips" for private catering. 8 1/2" x 11" looseleaf paper for 3 rings. **\$3.00 Ppd.**

LONG-WAVE BLACKLIGHT FIXTURE

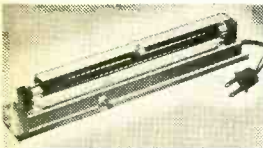

Stock No. 70,364AV
 Stock No. 60,124AV

Extremely versatile, compactly designed, long wave (2000-4000 angstroms) black light (ultraviolet) fixture. Has 6-watt, 110-V lamp with built-in filter—eliminates harmful shorter wave ultraviolet rays. Use to identify minerals, fungi, bacteria—check for surface flaws, oil and gas leakage—perfect for displays with fluorescent paper, paints, chalk, crayons, trace powder. Incl. adjustable aluminum reflector. Mount vert., hor. or on corner. 10" L. 1 1/2" W. 1 1/4" H. **\$12.50 Ppd.**

REPLACEMENT BULB . . . \$4.50 Ppd.

Order by Stock No.—Check or M.O.—Money-Back Guarantee
 EDMUND SCIENTIFIC CO., 300 EDCORP BLDG, BARRINGTON, N.J. 08007

WRITE FOR GIANT FREE CATALOG "AV"



Completely new edition. New items, categories. Illustrations. 148 easy-to-read pages packed with 4000 unusual items. Dozens of electrical and electromagnetic parts, accessories. Enormous selection of Astronomical Telescopes, Microscopes, Binoculars, scopes, Magnifiers, Magnets, Lenses, Lasers, Prisms. Many war surplus items for hobbyists, experimenters, workshops factory. Write for catalog "AV." Include 20¢.

ORDER BY STOCK NUMBER • SEND CHECK OR MONEY ORDER • MONEY-BACK GUARANTEE
EDMUND SCIENTIFIC CO., 300 EDCORP BUILDING
 BARRINGTON, NEW JERSEY 08007
 CIRCLE NO. 11 ON READER SERVICE PAGE

POPULAR ELECTRONICS

MAY 1970

ADVERTISERS INDEX

READER SERVICE NO.	ADVERTISER	PAGE NO.
1	Accurate Instrument Co.	11
2	AMECO, Div. of Aerotron, Inc.	98
3	Antenna Specialists Co., The	89
5	Argos Products Co.	96
7	Burstein-Applebee Co.	94
	CREI, Home Study Div., McGraw-Hill Book Co.	72, 73, 74, 75
8	Cleveland Institute of Electronics ...	18, 19, 20, 21
6	Communications Div., DYNASCAN CORP.	5
10	Datak Corp.	91
9	Drake Company, R.L.	8
34	Drake Company, R.L.	8
4	EICO Electronic Instrument Co., Inc.	FOURTH COVER
11	Edmund Scientific Co.	106
35	Elpa Marketing Industries, Inc.	85
12	GC Electronics (CALECTRO)	7
13	Heath Company	12, 13
14	Johnson Company, E.F.	25
15	Lafayette Radio Electronics	93
16	Lambert Laboratories Limited	93
17	Mallory & Co., Inc., P.R.	23
18	Metrologic Institute, Inc.	10
19	Mosley Electronics, Inc.	92
20	Multicore Sales Corp.	99
21	McIntosh Labs	86
22	National Academy of Computer Programming ..	89
	National Radio Institute	SECOND COVER, 1, 2, 3, 99
	National Technical Schools	54, 55, 56, 57
23	New Jersey Semi-Conductor Products	94
24	Olson Electronics	96
25	Phase Corp.	100
26	Prentice-Hall (Electronics Book Service)	9
27	RCA Electronic Components & Devices	26
	RCA Electronic Components & Devices	THIRD COVER
	RCA Institutes, Inc.	36, 37, 38, 39
33	Sams, Howard W. & Co., Inc.	17
28	Sonar Radio Corp.	95
32	Southwest Technical Products	92
	Stereo Center	99
29	Turner Microphone Co., The	76
30	United Audio Products (DUAL)	6
31	University Sound	14
	Valparaiso Technical Institute	99

CLASSIFIED ADVERTISING 101, 102, 103, 104, 105

Printed in U.S.A.
 POPULAR ELECTRONICS

When you don't have time to
take it back to the bench...

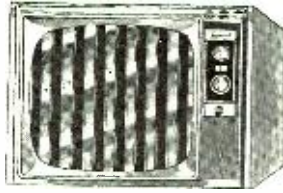

take this book to the home.

Volume 3

Field-Service Guide
for RCA Color-TV Receivers
1969-1970
CTC - 22 through CTC - 4C



Tells all, shows all, for in-the-home
circuit adjustments on latest RCA color TV's

Here's Volume 3 of the renowned Field Service Guide—the most complete TV service reference of its kind! Add this new edition to Volumes 1 and 2 and you're ready for every RCA color TV dating back to 1955. Seven sections in easy-to-understand form, schematics, plus waveforms and illustrated adjustment procedures:

1. **General Field Service Adjustments.** Step-by-step procedures and illustrations for adjusting purity, black-and-white setup, static and dynamic convergence, and AFPC.
2. **RCA Receiving Tubes for Color TV.** Lists all the type numbers used in RCA color receivers.
3. **Chassis Section.** Specific procedures for adjustment of each chassis series, top-and-rear views, tube removal directions, etc.
4. **Parts List.** Includes major components and their replacement part numbers.
5. **Tuner Section.** Schematics, transistor and electrical control parts lists.
6. **Remote Tuner Section.** Schematics of transmitters and receivers in tuners used in Chassis Series CTC-22 to CTC-4C.
7. **Index.** Cross-references for all receivers by model numbers, set names and chassis numbers.

ONLY \$1.90*

*Optional Price

See your RCA Tube Distributor for details on how you can get this valuable Guide.
RCA Electronic Components Harrison, N.J.

RCA

Dazzle your friends with lightworks.



Sound n' Color®

The new dimension to music pleasure. EICO All Electronic Solid-State Audio-Color Organs transform sound waves into moving synchronized color images. Connect easily to speaker leads of hi-fi or radio. From \$29.95.



Translators

The electronics you need to create audio-stimulated light displays to your own imagination. Actuates: Light Display Units, Strobe Lites, any lamp configuration (Xmas trees, patio lights, etc.). From \$24.95 Kit, \$39.95 wired.



Strobe Lites

High-intensity bursts of white light from Xenon tube flash in cadence with each beat of audio. From \$24.95 kit, \$39.95 wired.

Build the Stereo Kits praised by experts.

All amplifier power ratings according to IHF standards. Cortina® designed and manufactured in U.S.A. and guaranteed by EICO.

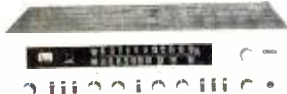

70-Watt AM/FM Stereo Receiver including cabinet. Cortina 3770, \$189.95 kit, \$279.95 wired.

70-Watt FM Stereo Receiver including cabinet. Cortina 3570, \$169.95 kit, \$259.95 wired.



150-Watt Silicon Solid-State Stereo Amplifier, including cabinet. For the audio perfectionist. Cortina 3150, \$149.95 kit, \$225 wired.

70-Watt Silicon Solid-State Stereo Amplifier, including cabinet. Cortina 3070, \$99.95 kit, \$139.95 wired.



FM Stereo Tuner including cabinet. Cortina 3200, \$99.95 kit, \$139.95 wired.



EC-1100 FM WIRELESS MIKE \$9.95

Build for fun and use with Eicocraft® jiffy project kits.

The newest excitement in kits. 100% solid-state and professional. Expandable, interconnectable. Excellent as introductions to electronics. No technical experience needed. Finest parts, pre-drilled etched printed circuit boards, step-by-step instructions. 36 kits to select from, \$2.50 to \$9.95. Just released: EC-2600 "Super Snooper" \$8.95; EC-2700 Police & Fire Converter



(lo band) \$7.95; EC-2800 Aircraft Converter \$7.95; EC-2900 Police & Fire Converter (hi band) \$7.95; EC-3100 2-Station Intercom (with cases) \$10.95; EC-3200 "Do-It-Yourself" PC Etching Kit \$4.95; EC-2300 Audio Preamplifier \$8.95; EC-2400 Bullhorn \$8.95; EC-2500 Fuzzbox \$8.95.



EC-1900 TREASURE FINDER \$9.95

Shape up your own car/boat with EICO Engine Analyzer

For all 6V/12V systems; 4, 6, 8-cyl. engines. Now you can keep your car or boat engine in tip-top shape with this solid-state, portable, self-powered universal engine analyzer.

Completely tests your total ignition/electrical system. Complete with comprehensive Tune-up & Trouble-shooting Manual. EICO 888, \$49.95 kit, \$69.95 wired.



The first and only solid state test equipment GUARANTEED FOR 5 YEARS

Only EICO brings you laboratory precision and long life at lowest cost.



EICO 240 Solid-State FET-TVOM \$59.95 kit, \$79.95 wired



EICO 379 Solid-State Sine/Square Wave Generator \$69.95 kit, \$94.50 wired



EICO 242 Solid-State Deluxe FET-TVOM \$69.95 kit, \$94.50 wired



EICO 150 Solid-State Signal Tracer \$49.95 kit, \$69.95 wired



EICO 330 Solid-State RF Signal Generator \$59.95 kit, \$84.50 wired

You save up to 50% with EICO Kits. Since 1945, Best Buys in Electronics. Over 3 Million EICO Instruments Now in Use.

FREE 1970 CATALOG

Send me FREE catalog describing the full EICO line of 200 best buys and name of nearest dealer



EICO Electronic Instrument Co., Inc.
283 Malta Street, Brooklyn N.Y. 11207
EICO Canada Ltd.
20 Millwick Drive, Weston, Ontario

Name _____

Address _____

City _____

State _____

Zip _____

PE-5

CIRCLE NO. 4 ON READER SERVICE CARD

www.americanradiohistory.com