

BUILD FULLY AUTOMATIC AUTO THEFT ALARM

POPULAR ELECTRONICS

APRIL
1970

50
CENTS



NEW TOUCH ON/OFF CONTROL CIRCUIT

BETTER BASS RESPONSE WITH "FRISKY" SPEAKERS

SIMPLIFIED AM RECEIVER ALIGNMENT TOOL

GETTING TO KNOW THE UNIJUNCTION

PRODUCT GALLERY REPORTS:

- RCA IC Kits ● New De-soldering Tool
- Heathkit AR-29 ● Eico Curve Tracer
- Phase Corp. Pre-amp

BUILD DIGITAL LOGIC DEMONSTRATOR / MICROLAB

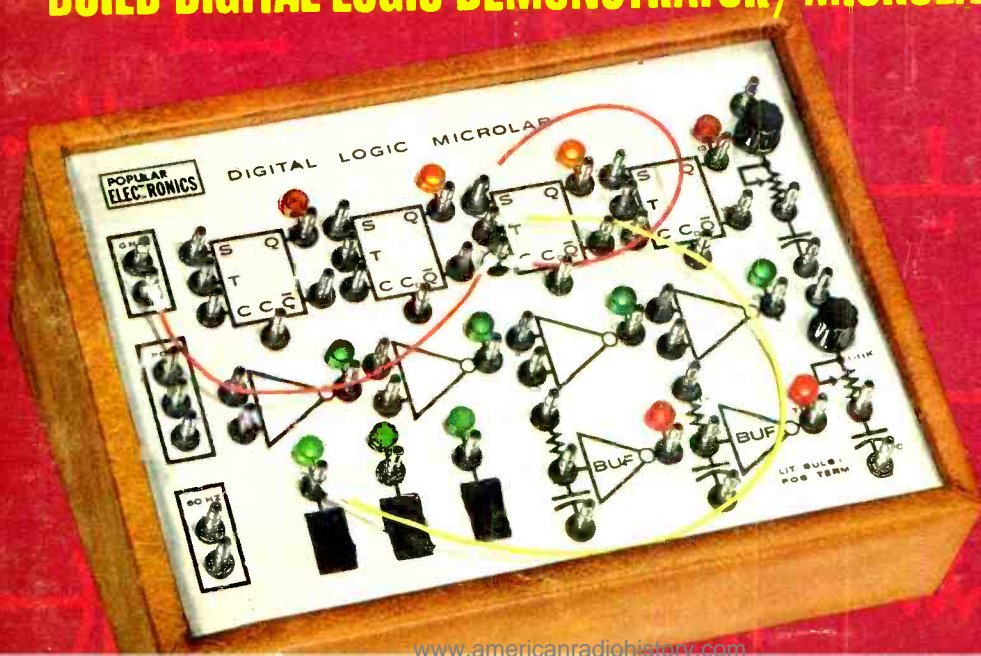

NRI "hands-on" training in TV-Radio, Electronics can give you as much as 2 years of on-the-job experience.

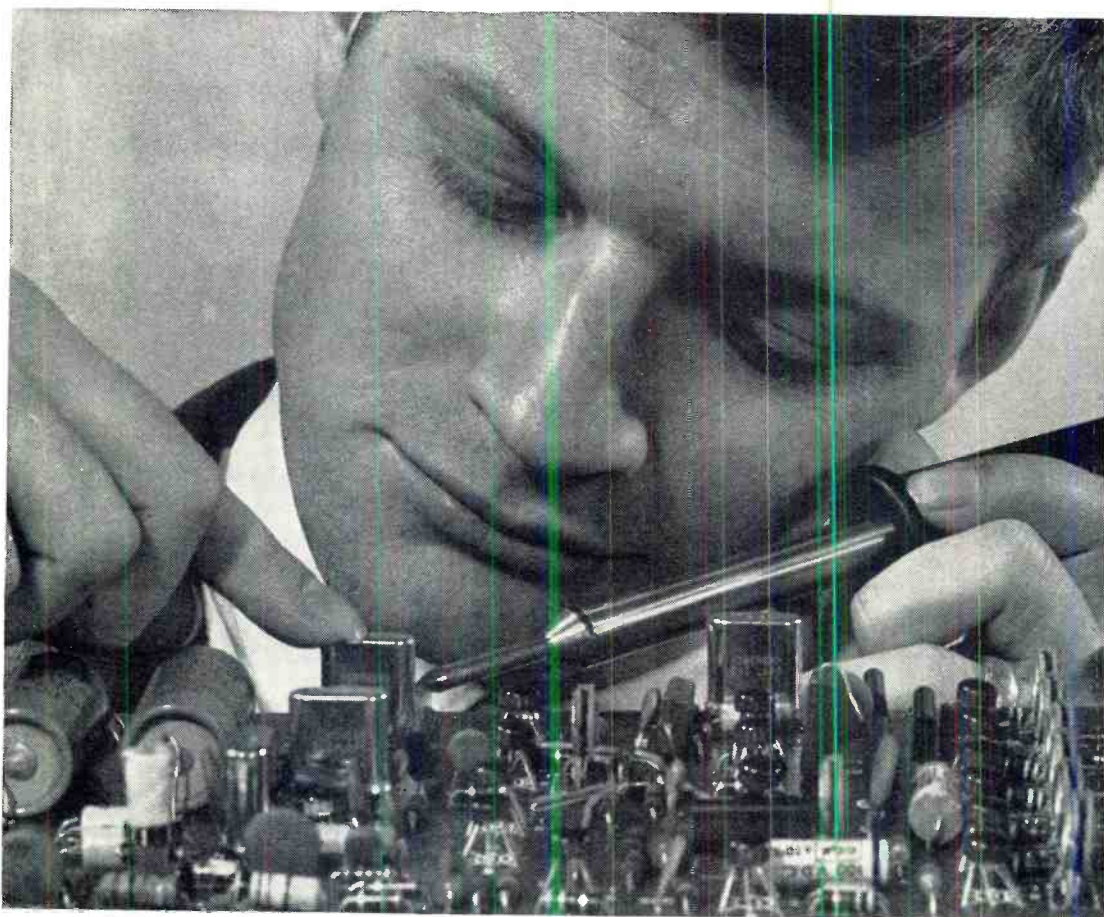

EARN YOUR FCC LICENSE – OR YOUR MONEY BACK

NRI Communications training programs will qualify you for a First Class Commercial Radiotelephone License issued by the FCC. If you fail to pass the FCC examinations for this license after successfully completing an NRI Communications course we will, on request, refund in full the tuition you have paid. This agreement is valid for the period of your active student membership and for six months after completion of your training. No school offers a more liberal FCC License agreement.

Experience is still your best teacher

*...here's how you get it with
unique NRI training at home*

Ask any teacher, job counselor, engineer, technician or prospective employer about the need for practical application of theory in Electronics. He'll tell you Electronics is as much a "hands-on" profession as dentistry or chemistry. That's how you learn at home with NRI. You prove the theory you read in "bite-size" texts, by actual experimentation with the type of solid-state, transistor and tube circuits you'll find on the job today — *not* hardware or hobby kits. You introduce circuit defects, analyze results, discover quickly the kind of trouble-shooting and design techniques that will make you employable in Electronics.

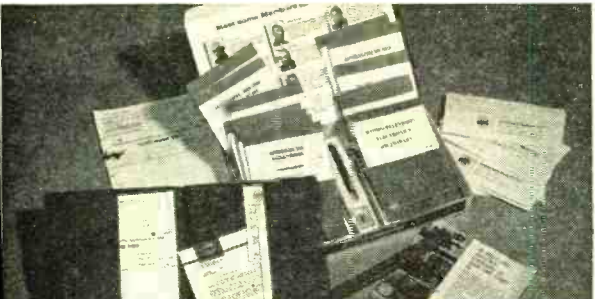

NRI Achievement Kit is educator-acclaimed and the original "starter" kit in home study training. Imitated but never duplicated, this kit is designed and personalized for you and your training objective. It has one purpose — to get you started quickly and easily.

Train with the leader — NRI

NRI lab equipment is designed from chassis up for effective, fascinating training — not for entertainment. The fact that end results are usable, quality products is a bonus. In Communications, for example, you build and analyze, stage by stage, your own 25-watt phone/cw transmitter. It's suitable for use on the 80-meter amateur band, if you have an interest in ham radio. In TV-Radio Servicing your practical training gives you your choice of monochrome or color TV sets. All training equipment is included in the low tuition — you pay nothing extra. Discover for yourself the ease, excitement and *value* of NRI training. Mail postage-free card today for new NRI Catalog . . . or use the coupon below. No obligation. No salesman will call on you. NATIONAL RADIO INSTITUTE, Washington, D.C. 20016.



"Bite-Size" Texts average an easily-digested 40 pages of well-illustrated, scientifically prepared subject matter in the course of your choice. Questions in each book are carefully hand-graded and returned to you with helpful instructional notes. You get unlimited personal help from the day you enroll.



Designed-For-Learning Equipment

Like this phone-cw transmitter (Kit #7 in the Communications course) is engineered from chassis up to demonstrate principles you must know. NRI does not use modified hobby kits for training, but the finest parts money can buy, professionally and educationally applied.

APPROVED UNDER NEW GI BILL

If you have served since January 31, 1955, or are in service now, check GI line on postage-free card or in coupon.

MAIL THIS COUPON IF CARD IS GONE



NATIONAL RADIO INSTITUTE

Washington, D.C. 20016

1-040

Please send me your new NRI Catalog. I understand no salesman will call and there is no obligation.

Name _____ Age _____

Address _____

City _____ State _____ Zip _____

Check for facts on new GI Bill

ACCREDITED MEMBER NATIONAL HOME STUDY COUNCIL

POPULAR ELECTRONICS

VOLUME 32 NUMBER 4

APRIL 1970

WORLD'S
LARGEST-SELLING
ELECTRONICS
MAGAZINE

FEATURE ARTICLES

- | | | |
|--|-----------|----------------------|
| BUILD THE DIGITAL LOGIC MICROLAB
<i>A super breadboard for learning logic</i> | 27 | Don Lancaster |
| ELECTRONICS GEOGRAPHY QUIZ | 42 | Thomas Haskett |
| THE FRISKY FOUR SPEAKER SYSTEM
<i>Small speakers give top response</i> | 43 | David B. Weems |
| MICRO'LIGN GENERATOR
<i>Low-cost signal source</i> | 48 | Michael S. Robbins |
| TC SWITCH—FOR REMOTE CONTROL
<i>One touch does it</i> | 52 | Jack Bechtold |
| BUILD THE 100-kHz STANDARD
<i>Stable source of square waves</i> | 56 | Don Lancaster |
| AUTOMATIC VEHICLE BURGLAR ALARM
<i>Works when others don't</i> | 59 | George Meyerle |
| GETTING TO KNOW THE UJT
<i>Explains the unijunction transistor</i> | 69 | Frank H. Tooker |
| TIPS & TECHNIQUES | 74 | |
| DEHUMMING SMALL RECEIVERS | 75 | Ronald L. Ives |
| THE PRODUCT GALLERY
<i>Eico Semiconductor Curve Tracer</i>
<i>Heathkit AR-29 Stereo Receiver</i>
<i>Phase Corp. Four-Trace Pre-Amp</i>
<i>RCA Integrated Circuit Kits</i>
<i>Continental De-Soldering Tool</i> | 77 | |
| OPPORTUNITY MIRROR | 83 | David L. Heiserman |
| SOLID STATE | 86 | Lou Garner |
| TWO-WAY REACTIONS | 93 | G. H. Reese, KCN6990 |
| ENGLISH LANGUAGE NEWS BROADCASTS TO N.A. | 94 | Roger Legge |
| AMATEUR RADIO | 95 | Herb S. Brier, W9EGQ |
| SHORT-WAVE LISTENING | 97 | Hank Bennett, W2PNA |

DEPARTMENTS

- | | |
|---------------------------------|----------------|
| LETTERS FROM OUR READERS | 8 |
| ELECTRONICS LIBRARY | 14 |
| READER SERVICE PAGES | 15, 115 |
| NEW LITERATURE | 16 |
| NEW PRODUCTS | 22 |
| OPERATION ASSIST | 104 |
| OUT OF TUNE | 105 |
- Two-Tone "Waverly" Alarm (February 1970)*

POPULAR ELECTRONICS is indexed
in the Readers' Guide
to Periodical Literature

This month's cover photo by
Conrad Studios

Copyright © 1970 by ZIFF-DAVIS PUBLISHING COMPANY. All rights reserved.

POPULAR ELECTRONICS, April 1970, Volume 32, Number 4. Published monthly at One Park Ave., New York, N.Y. 10016. One year subscription rate for U.S., U.S. Possessions and Canada, \$6.00; all other countries, \$7.00. Second class postage paid at New York, N.Y. and at additional mailing offices. Authorized as second class mail by the Post Office Department, Ottawa, Canada and for payment of postage in cash. Subscription service and Forms 3579: P.O. Box 1096, Flushing, N.Y. 11352. Editorial offices for manuscript contributions, reader inquiries, etc.: One Park Ave., New York, N.Y. 10016.

Every minute is longer up there.

You can save as many as 20 or 30 of those long minutes when you put up one of our larger antennas, because they're pre-assembled. Our snap-joints take only seconds to lock in place.

Sylvania antennas are equipped with a double boom (for strength and rigidity).

All have strong, seamless, half-inch tubular elements (not rolled-over strips of aluminum).

All aluminum parts are gold-alodized inside and out (not sprayed, but dipped).

Even more care goes into the electronics.

We've peaked our antennas for flat response over the entire 6 MHz bandwidth of each TV channel. Flat response is absolutely necessary for good color reception. Otherwise, color ren-

dition may be lost.

You also need high gain—that's obvious. But coupled with high directivity to knock out interference. Polar patterns from our antennas show almost complete rejection of signals from the rear and sides.

We designed our antennas so you wouldn't have to (1) climb back up there or (2) fiddle around up there.

We know that the fiddler on the roof is just fiddling his own money away.

For more information on our line of antennas see your Sylvania distributor.

SYLVANIA
GENERAL TELEPHONE & ELECTRONICS

**Here's where we
can save you time.**



letters

FROM OUR READERS

TAPE RECORDING, LITERATURE ON

I am in the process of building my own recording studio with the intention of going into this business (eventually) on a professional basis. However, I am appalled by the lack of books or literature on professional tape recording. Certainly, there must have been something published on this subject. Where is it hidden?

R. STODDARD
Kansas City, Mo.

Reader Stoddard has a good point. To our knowledge, the last definitive book published about magnetic tape recording is now 6 years old. However, there is some information in a later book by Alec Nisbett entitled "The Technique of the Sound Studio" (Sagamore Publishing Co., 980 Old Country Rd., Plainview, NY 11803, \$10.50).

KUDOS

As a guitarist, I appreciate the fun and savings that result from such projects as the "Treble Boost" (December 1969) and "Waa-Waa" (February 1970).

Keep up the good work.

A. P. TETON
Wilmette, Ill.

Just finished the "Capacitance Meter" (October 1969) and am very pleased with its performance. I used a 4½" meter and calibrated the unit with 2% capacitors. It is now almost twice as good as my friend's capacitance bridge that cost him twice the money to build.

ROBERT LEBMAN
Flushing, N. Y.

LOW-FREQUENCY STATIONS

A friend tells me that there are radio stations operating on frequencies below 20 kilohertz. I find this hard to believe, since down at those frequencies you would start hearing radio directly through your own hearing.

B. R. HALL
Clearwater, Florida

You are confusing radio waves and sound waves. Radio waves travel at the speed of light. Sound waves do not and although the frequencies seem to be similar, there are two different things involved. There are ra-

The Turner 360.



See it at your dealer's showroom.

The 360. A lightweight sporty compact from Turner. Reduced in size and weight (12 oz.), this custom styled mike is made to order for mobile units. Standard equipment on the 360 almost sounds optional: dash mounting knob and hardware, five foot extended coiled cord, beautiful black cyclolac finish. Get in the driver's seat with a 360. It's got the smoothest transmission on wheels. □ The TURNER Co., Inc., A subsidiary of Conrac Corporation, 909 17th Street N.E., Cedar Rapids, Iowa. 52402, (319) 365-0421.

CIRCLE NO. 27 ON READER SERVICE PAGE

**“You’ll never get rich
by digging a ditch,
you’re in the Army now.”**

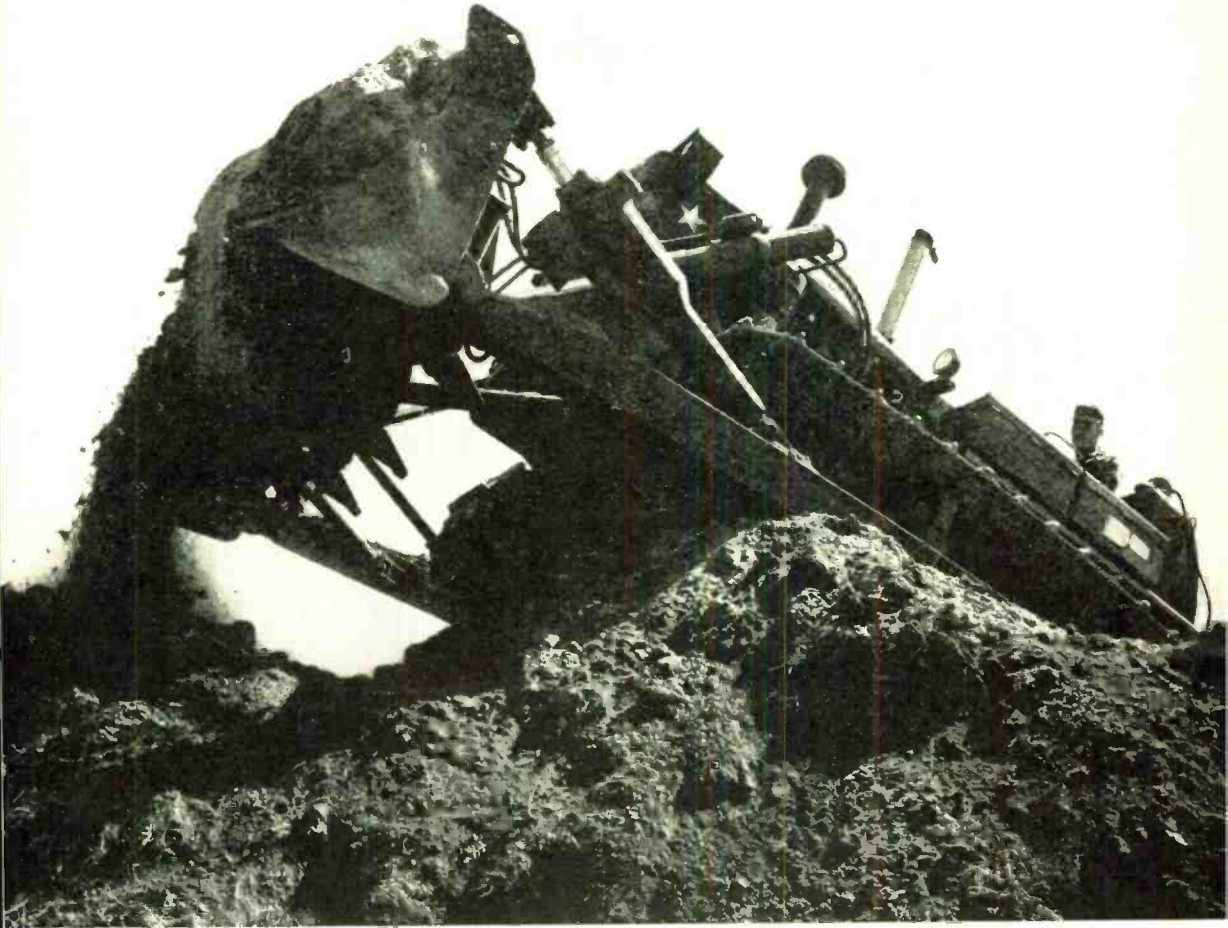

That’s an old song. Don’t you believe it. The Army has hundreds of job training courses you can choose from before you enlist. If you do find yourself digging a ditch, you’ll probably be doing it at the controls of a brute like the one in the picture. That’s just one of the skills we teach.

Okay, how about getting rich? If yours is an important skill, the Army will pay you a handsome bonus to keep you on the team at the end of your first hitch. \$2000. \$3000. \$5000. up to \$10,000 for the most critical specialties. Add your regular pay, promotions and fringe benefits, and a certain old song begins to lose its meaning.

Songs change. So do armies. See your Army Recruiter. He’s got a whole new set of lyrics.

Your future, your decision . . . choose ARMY.

Use coupon or write: Army Opportunities
Dept. 200A, Hampton, Va. 23369.

Army Opportunities Date _____
Dept. 200
Hampton, Va. 23369

Please send me full information on Army training opportunities with a future.

Name _____

Date of Birth: _____

Address _____

City _____ County _____

State _____ Zip _____ Phone _____

Education _____

2PE 4-70



For use at home, on hobby bench, or in classroom

RCA

Every one of these new Integrated Circuit experimenter kits has all the parts you need to assemble them easily, quickly, completely. All the active and passive components plus the pre-drilled printed-circuit boards—and full, clear instructions. A soldering iron is all you need to build them.

KC4000: Microphone Preamplicator IC Kit—a high-gain, low-noise, wideband preamplicator that accommodates both low- and high-impedance microphones.

KC4001: 2-Channel Mixer IC Kit—combines any two audio inputs, such as microphone, radio, phono, or oscillator, into a single output.

KC4002: Audio Oscillator IC Kit—for testing audio, hi-fi equipment, and amateur radio transmitters—also for code practice.

KC4003: IC Amplifier/Oscillator Kit—a 500 mW audio amplifier or a variable tone audio oscillator.

KC4500: IC Kit Enclosure and Hardware Pack—optional for KC4000, KC4001 and KC4002—a handsome, sturdy, prepunched case with input and output jacks, switch, and other hardware.

Also look for—KD2105 SCR Experimenter's Kit containing the active components for building numerous useful electronic control circuits, and KD2117 IC Variety Pack containing five IC's plus instructions for building twelve circuits useful on the hobby bench and around the home.

Buy these kits from your RCA Distributor. For information write: RCA Electronic Components, Commercial Engineering, Section D133SD, Harrison, N. J. 07029.

4 NEW IC KITS FROM RCA

(STARTING AT UNDER \$5.00*)

*Optional distributor resale price

Want your new IC Kits right away? The following Distributors have stocked them.

ALABAMA
Mobile
Specialty Distributing Co.
1276 Bellline Highway, South

ALASKA
Team Electronics

ARKANSAS
Ft. Smith
Wise Radio & TV
1001 Towson Avenue
Little Rock
David White Electronics, Inc.
1222 Main Street
Texarkana
Lavender Electronics
522 East 4th Street

CALIFORNIA
Canoga Park
Sandy's Electronic Supply
21305 Satcoy St.
Hollywood
Pacific Radio Exchange, Inc.
1351 Cahuenga Blvd.
Yale Radio Electronic Co.
6616 Sunset Blvd.

San Francisco
Hauer Electronic Supply
281 Ninth St.
South Gate
Mac's Electronics
3351 Tweedy Blvd.
Temple City
G&M Wholesale Electronics
5651 N. Rosemead Blvd.

Thousand Oaks
Sandy's Electronic Supply
369 Hampshire Rd.
COLORADO
Team Electronics
Denver
Burstein-Applebee of Colorado
800 Lincoln St.

CONNECTICUT
Hartford
Sceli Electronics, Inc.
78 Maple Avenue
GEORGIA
Albany
Specialty Distributing Co.
428 Roosevelt Avenue
Athens
Specialty Distributing Co.
731 Edps Bridge Road
Atlanta
Specialty Distributing Co.
763 Juniper Street, Northeast
Augusta
Specialty Distributing Co.
1541 Fifteenth Street

BRUNSWICK
Specialty Distributing Co.
2812 Carrie Street
COLUMBUS
Specialty Distributing Co.
1112 Brookhaven Blvd.
MACON
Specialty Distributing Co.
539 Arch Street
MARIETTA
Specialty Distributing Co.
355 White Avenue, S. E.
SAVANNAH
Specialty Distributing Co.
612 East Broad Street
VALDOSTA
Specialty Distributing Co.
916 Marion Street

ILLINOIS
Team Electronics
Chicago
Allied Radio Corp.
100 North Western Ave.
Howard Electronics Sales, Inc.
4573 Archer Avenue
North Central Electronic
Supply Co.
3412 W. Bryn Mawr Avenue
Crest Hill
Mainline Supply Co., Inc.
804 Theodore Street
Peoria
Klaus Radio & Electric Co.
8400 N. Pioneer Parkway
Waukegan
Badger Electronics, Inc.
1105 Washington Street

INDIANA
Anderson
Electronic Supply of Anderson
23rd & Columbus Avenue
Bloomington
H. A. Williams Co.
204 South Roger's
Columbus
H. A. Williams Co.
1003 Washington St.
Evansville
Ohio Valley Sound, Inc.
20 E. Sycamore St.
Ft. Wayne
Ft. Wayne Electronic Supply, Inc.
3606 East Maume Ave.

Indianapolis
Graham Electronic-Glendale, Inc.
6101 North Keystone Ave.

Graham Electronic Supply, Inc.
133 S. Pennsylvania St.
Jeffersonville
Moakler Electronics
500 E. Chestnut
Lafayette
Lafayette Radio Supply, Inc.
408 East North St.
Muncie
Muncie Electronic Supply, Inc.
222 North Madison St.
Richmond
H. A. Williams Co.
1114 S. "F" St.
Vincennes
Ohio Valley Sound, Inc.
902 Main Street

IOWA
Team Electronics
Burlington
Union Supply Company
231 S. Third St.
KANSAS
Team Electronics
Topeka
Acme Radio Inc.
135 Kansas Avenue
Wichita
Radio Supply Company, Inc.
115 Laura

KENTUCKY
Louisville
The Collins Company
829 S. Floyd Street
Owensboro
Ohio Valley Sound, Inc.
600 W. 3rd Street
Peeries Elec. Equip. Co.
1815 S. 7th St.

LOUISIANA
Alexandria
Raiph's of Lafayette, Inc.
601 N. 3rd St.
Baton Rouge
Raiph's Radio Electronic Supply
1732 Plank Road
Lafayette
Raiph's of Lafayette, Inc.
3004 Cameron St.
Metairie
Pelican Supplies, Inc.
3321 Division St.
Shreveport
Industrial Electronic Supply, Inc.
2422 Southern Ave.
Interstate Electric Co.
1419 Culepper St.

MAINE
Portland
Commercial Distributors
8 Somerset Street
MARYLAND
Hagerstown
Allegheny Electronics, Inc.
1301 Potomac Avenue
Mt. Rainier/Hyattsville
Lafayette Radio Electronics
3191 Queens Chapel Road
MASSACHUSETTS
Boston
A. W. Mayer Co., Inc.
895 Boylston Street
DeMambo Radio Supply
1095 Commonwealth Avenue
Lynn
Land Electronics Supply Co.
9 Franklin Street
New Bedford
C. E. Beckman Co.
11-35 Commercial Street
MICHIGAN
Adrian
Wedemeyer Electronic Supply Co.
2982 Treat Rd.
Ann Arbor
Wedemeyer Electronic Supply Co.
213-217 North 4th Ave.
Detroit
Radio Specialties Co., Inc.
12775 Lyndon Ave.
Radio Supply & Engineering Co.
10001 Chalmers Ave
Radio Supply & Engineering Co.
90 Selden Ave.
Radio Supply & Engineering Co.
15200 Wyoming Ave.
Rissi Electronic Supply Co.
14405 Wyoming Ave.
Ferndale
Midway Electronics Supply
990 W. Eight Mile Road
Flint
Shand Electronics, Inc.
2401 S. Dort Hwy.
Jackson
Fulton Radio Supply Co.
1208 Greenwood Ave.
Wedemeyer Electronic Supply Co.
1617 East Michigan Ave.
Lansing
Wedemeyer Electronic Supply Co.
800 Merrill Ave.
Muskegon
Electronic Distributors, Inc.
1960 Peck Street

Pontiac
Electronic Supply Co. of
Pontiac, Inc.
248 E. Pike St.
Saginaw
Morley Brothers Inc.
4375 Holland Rd.
Taylor
RCA Distributing Corp.
27000 Troy Drive
MINNESOTA
Team Electronics
MISSOURI
Kansas City
Burstein-Applebee Co.
3199 Mercier St.
Electronic Supply Company, Inc.
4100 Main St.
Rolla
Show-Me Electronics, Inc.
Highway 72 East
St. Joseph
St. Joseph Radio & Supply Co.
720 S. Ninth Street
St. Louis
Radchons Electronics
2171 Big Bend
Springfield
Reed Radio and Supply, Inc.
805-808 Boonville Ave.

MONTANA
Team Electronics
NEBRASKA
Team Electronics
NEW HAMPSHIRE
Concord
Evans Radio, Inc.
Route 3A-Bow Junction
NEW JERSEY
Camden
General Radio Supply Co.
600 Penn St.
Cape May
Mytron Electronics Corp.
1400 Texas Avenue
Paramus
Lafayette Radio Electronics
182 Route 17
Totowa
Lafayette Radio Electronics
410 Route 46
NEW YORK
Albany
RTA Distributors, Inc.
991 Broadway
New York
Dale Electronics Corp.
244 West 14th St.
Lafayette Radio Electronics
71 West 45th Street
Scarsdale
Lafayette Radio Electronics.
691 Central Avenue
Syosset, L. E.
Lafayette Radio Electronics
111 Jericho Turnpike
Westbury, L. I.
Adelphi Electronics, Inc.
30 Jericho Turnpike
NORTH CAROLINA
Asheville
Freck Radio & Supply Co., Inc.
38 Biltmore Ave.
NORTH DAKOTA
Team Electronics
OHIO
Akron
Fox Radio Parts Co.
300 Akron Sq. Shopping Ctr.
1615 So. Arlington Street
Canton
The Electronic Center, Inc.
1300 North Cherry Ave.
Cincinnati
United Radio, Inc.
Summit Road & Reinhold Drive
Cleveland
Fox Audio Center
3736 Rocky River Drive
Fox Radio Parts Co.
4314 Lee Road
Dayton
The Stotts-Friedman Co.
108 North Jefferson St.
Elyria
El-A-Co.
235 Lodi Street
Lima
Hutch & Son
Roberts at Lenore
Mansfield
Fox Radio Parts Co.
1225 Park Avenue, West
Toledo
Hillebrand Electronic Supply
4665 West Bancroft
Main Line Distributors, Inc.
380 South Erie St.
Zanesville
Thompson Radio Supplies
110 South Sixth St.
OKLAHOMA
Oklahoma City
Dulaney's
100 N.W. 44th St.

Radio Supply, Inc.
724 N. Hudson Ave.
OREGON

Pendleton
Round-Up Electronics
2927 Riverside Avenue
PENNSYLVANIA

Allentown
RESCO of L V
425 Hanover Ave.
Drexel Hill
Kass Electronics Distributors
2502 Township Line Rd.
Easton
RESCO of L V
1700 Northampton St.
Erie
Mace Electronics
2631 W. 8th St.
Pottsville
Moyer Electronic Supply Co.
330 East Norwegian St.
Reading
Barbey Electronics
333 W. 4th St.
Wilkes-Barre
Sheiborne Electronics
169 N. Pennsylvania Ave.
SOUTH DAKOTA
Team Electronics

TENNESSEE
Chattanooga
Specialty Distributing Co.
1313 Central Avenue
Knoxville
McClung Appliances
5915 Casey Drive
Memphis
Bluff City Distributing
Co., Inc.
234 East Street
Teague Electronics, Inc.
2122 Madison Avenue
TEXAS
Austin
Hargis-Austin, Inc.
410 Baylor Street
Dallas
Adieta Electronics Co.
1914 Cedar Springs
Southwest Radio Supply Co.
1820 North Harwood Street
El Paso
Midland Specialty Co.
2225 Wyoming Avenue
Ft. Worth
Adieta Electronics Co.
100 S. Freeway at Vickery
Houston
Electro
2300 Richmond Avenue
Lubbock
Nunn Electric Supply Co.
7817 Fourth Street
R & R Electronics Co.
1607 Avenue G
Tyler
Lavender Electronics
5035 East Oakwood Street
Waco

UTAH
Team Electronics
ODGEN
Ballard Supply Corporation
3109 Washington Blvd.
VIRGINIA
Arlington
Arlington Electronic
Wholesalers, Inc.
3636 Lee Highway
Falls Church
Lafayette Radio
Electronics
Plaza 7 Shopping Center
Richmond
Avec Electronics Corp.
2002 Staples Mill Road
Roanoke
H. C. Baker Sales Co.
19 Franklin Rd.
WASHINGTON
Everett
Pringle Electronic Supply
2101 Colby Avenue
Wenatchee
Mid-State Electronics
611A N. Wenatchee Avenue
WISCONSIN
Team Electronics
Madison
Satterfield Electronics, Inc.
1900 S. Park Street
Milwaukee
Taylor Electric Co.
2131 W. Forest Home Avenue
Taylor Electric Co.
5600 W. North Avenue
Portage
Satterfield Electronics, Inc.
201 DeWitt
Wisconsin Rapids
Satterfield Electronics, Inc.
1900 8th Street South



Automatically and continually scan your choice of frequencies. Regency push-button programming allows you to hear complex base/mobile networks. Choose from 4 or 8 channel, high or low band models.

Our busy little radios do not miss a trick or transmission.

A fascinating, lighted display details the progress of a search for all transmissions on any combination of channels in the area of police, fire, civil defense, marine, radio telephone and weather FM radio—148-174 MHz or 30-50 MHz.

Push button control enables you to completely monitor complex simulcast or duplex base/mobile networks. Each of the crystal controlled channels on all models has a push button for placing the channel quickly in or out of service. Push buttons, too, for manual or automatic operation.

Our compact (2 1/4" x 5 1/2" x 7 1/2") solid state receivers perform base or mobile. All models come complete with AC and DC power cords, built in 4" speaker, detachable telescope antenna and mobile mounting bracket.

Sensitivity? You bet! 1/2 microvolt. Audio output? A big 5 watts at 1 KC. Price? A bargain! Crystals: \$4.95 each.

More information? Why not get a demonstration at your favorite Regency Distributor. You'll love them at first look and listen!

American Made
One Year Warranty
Patent Pending

Regency ELECTRONICS, INC.

7900 Pendleton Pike • Indianapolis, Indiana 46226
CIRCLE NO. 22 ON READER SERVICE PAGE

ELECTRONICS library

QUIET

101 TV TROUBLES FROM SYMPTOM TO REPAIR

by Art Margolis

This invaluable "cause-and-cure" guide to the solution for virtually any color and monochrome TV receiver trouble is a handy reference that will lead the reader right to the cause of the trouble in a matter of minutes. All the reader needs to do is analyze what he sees and hears, look up the symptoms in the book, and follow the clear and simple steps to a speedy trouble cure. Troubles are broken down into five basic categories in the text: brightness, contrast, sweep, color, and sound. Each category lists specific troubles relating to the symptom.

Published by Tab Books, Blue Ridge Summit, PA 17214. 223 pages. \$7.95 hard cover, \$4.95 soft cover.

RADAR DESIGN PRINCIPLES

by Fred E. Nathanson

Written for the engineer or senior technician engaged in all phases of modern radar engineering, this book is a comprehensive survey of all types of current radars and ancillary equipment. It covers all the latest techniques. The book's 14 detail-packed chapters provide a wealth of information covering the relationship between radar and its environment, performance, computations, detection processes, target details, effects of weather and artificial interference, etc. The text is complete, containing mathematical analyses, the most applicable curves and graphs, and includes a detailed bibliography and reference sections for readers who require more detail than is given in the discussions.

Published by McGraw-Hill Book Co., 330 West 42 St., New York, NY 10036. Hard cover. 626 pages. \$22.50.

INTRODUCTION TO NONLINEAR NETWORK THEORY

by Leon O. Chua

This is the first undergraduate book to cover both the theory and techniques for the analysis and synthesis of practical large-scale, or nonlinear, circuits regardless of the component used. Emphasis in the text is on the methods used—not the single individual component. Hence, students can adapt any newly developed electronic component by analyzing (Continued on page 114)

POPULAR ELECTRONICS READER SERVICE PAGE

free information service:

Here's an easy and convenient way for you to get additional information about products advertised or mentioned editorially (if it has a "Reader Service Number") in this issue. Just follow the directions below... and the material will be sent to you promptly and free of charge.

1. On coupon below, circle the number(s) that corresponds to the key number(s) at the bottom or next to the advertisement or editorial mention that is of interest to you. (Key numbers for advertised products also appear in the Advertisers' Index.) Print or type your name and address on the lines indicated.

2. Cut out the coupon and mail it to: POPULAR ELECTRONICS, P.O. Box 8391, Philadelphia, PA 19101.

note: If you want to write to the editors of POPULAR ELECTRONICS about an article on any subject that does not have a key number, write to POPULAR ELECTRONICS, One Park Avenue, New York, N.Y. 10016. Inquiries concerning circulation and subscriptions should be sent to POPULAR ELECTRONICS, P.O. Box 1096, Flushing, N.Y. 11352.

POPULAR ELECTRONICS

P.O. BOX 8391
PHILADELPHIA, PA. 19101

Void After May 31, 1970

1 2 3 4 5 6 7 8 9 10 11 12 13 14 15 16 17 18 19 20
21 22 23 24 25 26 27 28 29 30 31 32 33 34 35 36 37 38 39 40
41 42 43 44 45 46 47 48 49 50 51 52 53 54 55 56 57 58 59 60
61 62 63 64 65 66 67 68 69 70 71 72 73 74 75 76 77 78 79 80
81 82 83 84 85 86 87 88 89 90 91 92 93 94 95 96 97 98 99 100

NAME (Print clearly) _____

ADDRESS _____

CITY _____ STATE _____ ZIP CODE _____

4Na

TAKE ONE



new literature

To obtain a copy of any of the catalogs or leaflets described below, simply fill in and mail the coupon on page 15 or 115.

Just recently made available by *New-Tronics Corp.* is the company's twenty-page 1970 "Hustler" CB catalog, No. NT-1470. Printed in three colors, the catalog contains the company's full line of CB antenna and accessory equipment. More than 80 models are detailed for complete coverage of every antenna requirement ranging from 25" center-loaded short antennas to power-gain base station arrays.

Circle No. 75 on Reader Service Page 15 or 115

Two full-color booklets describing the automatic turntables in the two separate Garrard lines for 1970 have been issued by *British Industries Co.* The first, titled "Component Series," lists eight turntables, describing the

features of each in full detail. The other booklet, "Module Series," focuses the accent on the "mod." The four automatic turntables listed and described in the second booklet are ready to plug into other components for immediate use; they are pictured in typical set-ups.

Circle No. 76 on Reader Service Page 15 or 115

The 1970 edition of *Tab Books'* catalog describes more than 125 current and forthcoming books on electronics. The 16-page illustrated catalog's listing covers such subject areas as schematic/servicing manuals; broadcasting; basic electronics technology; CATV; electric motors; electronics engineering; television; etc. Among the new and forthcoming titles in the catalog is the newly revised 1970 edition of "Popular Tube/Transistor Substitution Guide." Prices are given for each book listed.

Circle No. 77 on Reader Service Page 15 or 115

Whether you use a microphone for tape recording, professional and amateur performing, or for PA applications, you will want a copy of *RCA's* new "Starmaker Microphones for the Art of Performing" catalog. Listed in the four-color, 12-page catalog are microphones for every need—including communications. Each microphone is fully described, and its list price is given.

Circle No. 78 on Reader Service Page 15 or 115

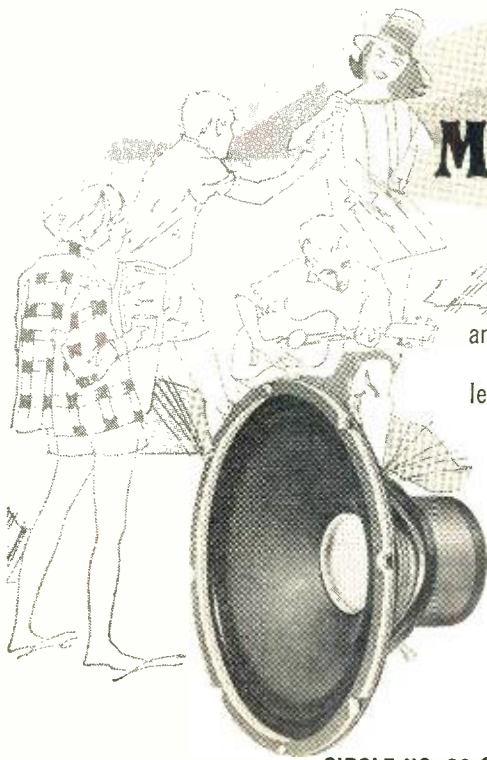

MAKING "WAVES"

CADENCE—the musical instrument speakers

Making better, clearer, amplified sound waves is the THING Cadence does... better than anything else in the industry. Cadence Speakers are built to withstand heat from sustained notes at a high power level and the vibrations and stresses which are continually placed upon them. Cadence is guaranteed **one full year** at the power level specified. This proven speaker family has been selected by the manufacturers of most of the world's fine amplified music instruments.

If making beautiful, clear sound waves is your thing, ask for CADENCE SPEAKERS. For complete information and the name of your Cadence Dealer, write:



UTAH ELECTRONICS DIVISION
Utah-American Corporation
1124 East Franklin Street
Huntington, Indiana 46750

CIRCLE NO. 29 ON READER SERVICE PAGE

New SAMS Books for every electronics interest

New 18th Edition of the famous E & E RADIO HANDBOOK

by WILLIAM I. ORR, W6SAI. Completely updated edition of the famous communications handbook which is the electronics industry standard for engineers, technicians and advanced amateurs. Explains in authoritative detail how to design and build all types of radiocommunications equipment. Includes SSB design and equipment, RTTY circuits, latest semiconductor circuits and IC's, as well as special-purpose and computer circuitry. Order 24020, only... \$13.50

New 13th Edition of the famous TUBE SUBSTITUTION HANDBOOK

Lists over 12,000 direct substitutions. A complete guide to substitutions for receiving, picture tube, miniature, industrial, and communications types; includes foreign tubes. Tells how and when to substitute. Order 20769, Twin-Pak (regular size for bench use; pocket-size for caddy) both for only... \$2.25
Order 20768, shop edition, only... \$1.75

Color-TV Waveform Analysis

This book provides both the theoretical and the practical knowledge of waveform analysis essential for profitable and efficient color TV servicing. It begins with the rf and i-f sections, and proceeds through the video-amplifier, bandpass-amplifier, color-sync, color-demodulator, and matrix circuits. Order 20763, only... \$3.50

101 Q & A About Hi-Fi and Stereo

A practical and useful reference book explaining the essential facts about hi-fi and stereo, with important help on troubleshooting and maintenance. The six sections of the book cover: high-fidelity systems; amplifiers; tuners; record and tape players; maintenance and troubleshooting procedures. Order 20753, only... \$3.50

SWL Antenna Construction Projects

Provides detailed information on how to construct 35 different antennas for improved short-wave reception. Explains basic antenna principles and then presents the construction projects which fall into six basic classes of design. Order 20766, only... \$2.95

Color-TV Trouble Clues, Vol. 3

by HOWARD W. SAMS EDITORIAL STAFF. Helps speed diagnosis of color-TV troubles. Tells how to get right to the heart of the problem, how to make positive checks, how to use meaningful clues for quick troubleshooting. Order 20762, only... \$3.50

Record Changer Servicing Guide

Provides a complete understanding of record changers, how they operate, and the various systems employed. With detailed instructions on how to track down troubles encountered in record changers and how to repair them in the fastest and most effective way. Order 20730, only... \$3.95

Electronic Organs—Vol. 2

Explains the fundamental principles of electronic organs, including theory, development, features and operation. Shows in block diagram and schematic illustrations what is inside an organ. Order 20754, only... \$5.50

Auto Radio Servicing Made Easy

2nd Ed. Explains the circuitry of both new and old auto radios, covering each of the tube and transistor stages. Provides step-by-step troubleshooting and repair details; explains how to eliminate noise and interference, and how to make proper adjustments. Order 20719, only... \$3.95



THIS IS ELECTRONICS Series

by ITT EDUCATIONAL SERVICES, INC. These books provide a remarkable introduction to electronics, imparting to any reader a clear understanding of the basics of this vital technology. All topics are completely covered and readily mastered.

Vol. 1. Basic D-C Principles

Covers electronics—past and present; electronic components and symbols; matter and electricity; current, voltage, and resistance; series and parallel circuits; conductors, semiconductors, and insulators; resistors; and sources of d-c power. Order 20657, only... \$5.95

Vol. 2. Basic A-C Principles

Covers alternating voltage and current; capacitors and capacitive reactance; magnetism and electromagnetism; electrical measuring instruments; and inductors and inductive reactance. Order 20727, only... \$6.95

Vol. 3. Circuits

A-c and d-c principles and components are used to illustrate how vacuum tubes and semiconductors operate. Various amplifier and oscillator circuits of both tube and transistor types are fully described. Order 20759, only... \$6.95

Vol. 4. Applications

This volume explains how amplifier and oscillator circuits are used in actual applications. Explains principles of modulation, broadcast receiver fundamentals, a-m and f-m receiver circuits, etc. Order 20760, only... \$5.95
4-Vol Set. Order 20761, only... \$23.50

Amateur Radio Incentive Licensing Study Guide

Fully explains the new incentive licensing which affects both newcomers and old-timers. Covers all the new FCC Regulations and band allocations. Includes sample exams for Novice, Technician, Conditional, and General-Advanced-and Extra-Class licensing. Order 24004, only... \$2.75

HOWARD W. SAMS & CO., INC.

Order from any Electronic Parts Distributor, or mail to Howard W. Sams & Co., Inc., Dept. PE-4
4300 W. 62nd St., Indianapolis, Ind. 46268

Send the following books: Nos. _____

_____ \$_____ enclosed

Send FREE 1970 Sams Book Catalog

Name _____

PLEASE PRINT

Address _____

City _____ State _____ Zip _____

CIRCLE NO. 23 ON READER SERVICE PAGE

**“Get more
education
or
get out of
electronics
...that’s my advice.”**



**IN-DEPTH
COVERAGE OF
SOLID STATE
ELECTRONICS
...including
integrated circuits!**



Ask any man who really knows the electronics industry.

Opportunities are few for men without advanced technical education. If you stay on that level, you'll never make much money. And you'll be among the first to go in a layoff.

But, if you supplement your experience with more education in electronics, you can become a specialist. You'll enjoy good income and excellent security. You won't have to worry about automation or advances in technology putting you out of a job.

How can you get the additional education you must have to protect your future—and the future of those who depend on you? Going back to school isn't easy for a man with a job and family obligations.

CREI Home Study Programs offer you a practical way to get more education without going back to school. You study at home, at your own pace, on your own schedule. And you study with the assurance that what you learn can be applied on the job immediately to make you worth more money to your employer.

You're eligible for a CREI Program if you work in electronics and have a high school education. Our FREE book gives complete information. Mail postpaid card for your copy. If card is detached, use coupon below or write: CREI, Dept. 1204A, 3224 Sixteenth Street, N.W., Washington, D.C. 20010.

Founded 1927



Accredited Member of the National Home Study Council



**CREI, Home Study Division
McGraw-Hill Book Company
Dept. 1204A, 3224 Sixteenth Street, N.W.
Washington, D.C. 20010**

Please mail me FREE book describing CREI Programs. I am employed in electronics and have a high school education.

NAME _____ AGE _____

ADDRESS _____

CITY _____ STATE _____ ZIP CODE _____

EMPLOYED BY _____

TYPE OF PRESENT WORK _____ G. I. BILL

I am interested in

- Electronic Engineering Technology Computers
- Space Electronics Nuclear Engineering Technology
- Industrial Automation NEW! Electronics Systems Engineering

APPROVED FOR TRAINING UNDER NEW G.I. BILL



NEW PRODUCTS

Additional information on products covered in this section is available from the manufacturers. Each new product is identified by a code number. To obtain further details on any of them, simply fill in and mail the coupon on page 15 or 115.

LOW-COST VHF-FM RADIOTELEPHONE

The first low-cost VHF-FM marine radiotelephone to be made available to the average boating public is being marketed by *Simpson Electronics, Inc.*, as the Model T. The 6-watt Model T comes as a complete pretuned package, including antenna, mount, and crystals for four channels to meet minimum boat-equipment budgets.



Featured are a push-button channel selector, quality carbon microphone with coil cord, internal speaker, and epoxy-glass printed circuit board. The Model T operates from 12-volt d.c. supplies with negligible current drain. Overall dimensions of the radiotelephone are 8½" wide x 10¾" deep x 2¾" high.

Circle No. 79 on Reader Service Page 15 or 115

HI/LO BAND VHF FM MONITOR RECEIVER

Fanon Electronics' new Hi/Lo Band FM-VHF Monitor Model APO-50HL receiver zooms the listener right into the moment of action. The listener can monitor fire and police calls, accident reports and emergency broadcasts, hear official business communications, and keep abreast of the latest weather developments. The monitor has a built-in 117-volt a.c. power supply, but it can also be used in a 12-volt d.c. mobile setup. Six high-band frequencies from 150-175 MHz and six low-band frequencies between 25 and 50 MHz are provided with all channels crystal controlled. The solid-state design incorporates IC's. Featured are an exclusive r.f. peaking coil for maximum receiver sensitivity, and adjustable squelch, and a tone control that allows the user to emphasize the highs or lows.



Circle No. 80 on Reader Service Page 15 or 115

PORTABLE PA SYSTEM

Capable of being heard up to 600 yards away over crowd ambient noise, *The VP Company's* Model VP280 public address system is just the

thing for bazaars, rallies, club meetings, guided tours, etc. The portable PA system is completely self-contained. It is line-independent, operating from batteries; weather proof; and lightweight. The circuit design of the VP280 is all solid state, including the use of integrated circuits designed to provide a long trouble-free life. Output power is 5 to 9 watts r.m.s. Two speakers are built in, one or both of which can be switched into operation by a switch on the microphone. A power on/off switch is also located on the microphone housing, while a volume control is located on the side of the amplifier's housing.

Circle No. 81 on Reader Service Page 15 or 115



AMATEUR LINEAR AMPLIFIER

A pair of Eimac 3-500Z's as a grounded-grid final are used in the new Model SB-220 linear amplifier available from *Heath Company* to provide 2000 watts PEP input on SSB and 1000 watts on CW and RTTY. The SB-220 requires only 100 watts of driving power for full output. A pretuned broadband pi-input delivers maximum efficiency and low distortion throughout the 80-10 meter amateur bands. Features of the SB-220 include a built-in solid-state 120/240-volt a.c. power supply and circuit breaker protection. A zener diode regulates operating bias and reduces zero signal plate current for cooler operation and longer tube life. Double shielding provides maximum TVI protection, and an open layout permits the fan in the PA compartment to move large volumes of air for really cool operation. The kit can be assembled in about 20 hours.

Circle No. 82 on Reader Service Page 15 or 115



ADVANCED INTEGRATED MUSIC SYSTEM

The company's first integrated or "compact" system, the Landmark 100, is now available from *Electro-Voice, Inc.* A complete music

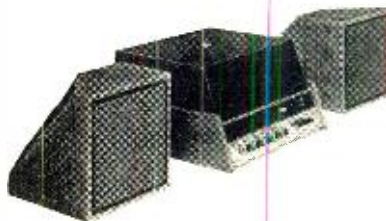

system, including an AM/stereo FM tuner and record changer, the Landmark 100 incorporates "Acoust-Array" speaker systems and a "Servo-Linear" motional feedback circuit in the amplifier. Each speaker system has three full-range loudspeakers and a tweeter

IF YOU WANT TO GET MAXIMUM PERFORMANCE FROM YOUR CB RADIO, MAIL IN THIS COUPON.

Pearce-Simpson

A Division of **GLADDING** Corporation
 P.O. Box 800, Biscayne Annex
 Miami, Florida 33152 Dept. PE-4

Send me complete information on your full line of base and mobile antennas, from 18 to 105 inches, in fiberglass or stainless steel. *I want to get more out of my CB Radio.*

I am looking for a new radio and want the right antenna.

Name

Address

City

State.....Zip.....

You bought a real "talk" radio. You paid anything from about \$50 to \$500 for it. You expected great range. Clear reception.

But you're just not getting the results you thought you would. So you blame your radio. Don't.

Your radio's probably fine. But what about the antenna? You might think all antennas are the same. They're not.

Pearce-Simpson offers a complete line of Talking Antennas. From 18 to 105 inches. In fiberglass or stainless steel. Base station and mobile. And every one is backed by the Gladding Corporation, first in outdoor recreation since 1816.

There's one that will give your radio the talk power it's missing.

Every Pearce-Simpson antenna is designed with the lowest possible Standing Wave Ratio in its class—which means all the power you put into it goes where it's supposed to—to the man who is listening—not right back into your set.

How do we know so much about antennas? Because we build radios. And because we build better radios than anyone else, we know that a bad antenna can hurt the performance of even the best radio. So we designed antennas just as good as our radios.

If you want to find out what antenna is best suited to your radio, fill in the coupon. Get our catalogue of Pearce-Simpson Talking Antennas.

And make your good radio a great radio.



The Talking Antennas by Pearce-Simpson



Pearce-Simpson, a Division of Gladding Corporation. First in outdoor recreation since 1816. **GLADDING**

CIRCLE NO. 20 ON READER SERVICE PAGE

PRODUCTS (Continued from page 22)

in a relatively small truncated cube enclosure, to achieve multi-directional sound and balanced stereo throughout the listening room. The tuner features a FET front end with four IC's in the i.f. and multiplex sections. The Servo-Linear feature corrects for any distortion produced in the loudspeakers by sampling the actual movement of the cones and comparing the motions with the input signal. It then corrects the difference by applying negative feedback.

Circle No. 83 on Reader Service Page 15 or 115

PAGING RECEIVER

A versatile paging receiver that can be used in the home, office, or small industry is currently being marketed by *Radio Shack* as the Model MTA-20. A monaural FM receiver, 15-watt audio amplifier, and a microphone input circuit make up the receiver. The paging receiver's front panel carries receiver tuning, tone and volume, and standard hi-fi FM/phono/tape switch controls, plus an electrically silent spring-return paging switch and microphone jack. Located on the rear panel are a paging volume control, switched power outlet, connections for four loudspeakers, and auxiliary and magnetic phono inputs. The audio frequency range of the receiver is 20-20,000 Hz.



Circle No. 84 on Reader Service Page 15 or 115

CASSETTE "CIRCULATOR"

The *Norelco* Model CC6 cassette "circulator" is a snap-on device that gives to cassette tape players the features of an automatic record changer—plus a little more. A simple but ingenious device with no moving parts, the CC6 makes possible 12 hours of non-stop, no-repeat playback and then recycles. It can be loaded with four to six cassettes, automatically flips

over each for second-side play, and restacks the cassettes for replay. Functionally styled in tinted plastic and standing only 5" high, the CC6 is simply snapped into place for instant use. The CC6 is compatible with *Norelco* cassette player Models 2401, 2401A, and 2502; *Bell & Howell* Models 332 and 337; and *Ampex Micro* Models 90 and 95.

Circle No. 85 on Reader Service Page 15 or 115

VHF MARINE RADIOTELEPHONE

The new *COMCO Communications Co.* Model 610 VHF marine radiotelephone features a unique dual front-end receiver which provides full sensitivity on both simplex and duplex



channels and optimum selectivity and inter-modulation rejection at sea and in big city harbors. Designed for operation in the uncrowded

VHF portion of the marine band, the 610 has an output of 25 watts for dependable ship-to-ship communications up to 30 miles and ship-to-shore up to 50 miles. Twelve channels permit full-range operation. The use of transistor and IC circuitry assures maximum reliability and minimizes heat, space, and battery drain requirements. Special circuitry prevents damage if battery polarity is reversed or the transmitter is keyed with a shorted antenna or no antenna at all.

Circle No. 86 on Reader Service Page 15 or 115

ADVANCED AM/STEREO FM RECEIVER

Contained in the *Pioneer Electronics U.S.A. Corp.* Model SX-990 AM/stereo FM receiver are features of interest to sophisticated hi-fi buffs. The receiver's push-pull output can supply 100 watts (IHF) of clear audio power across an 8-ohm load. Bass and treble controls are provided, but the user has the option of a completely flat response. Two pushbutton filters are featured: low-pass provides an 8-dB cut at 50 Hz and high-pass 7.5 dB at 10 kHz. A switchable loudness contour provides 12 dB of boost at 50 Hz and 9 dB at 10 kHz, with the volume control set at -40 dB. Harmonic distortion is maintained at less than 0.5% at 1000 Hz for rated output. Frequency response is ± 3 dB 10-100,000 Hz. The FM tuner has a usable sensitivity of $1.7 \mu\text{V}$ and a 62-dB signal-to-noise ratio. In the multiplex section, a time-switching demodulator, with automatic stereo selection, is used to provide left-right channel separation of 42 dB at 1000 Hz.



Circle No. 87 on Reader Service Page 15 or 115

AUTO-SCAN FM MONITOR RECEIVER

A choice of low- or high-band monitoring facilities on the emergency and public service bands, an automatic scanning feature, and a dual-purpose power supply are available with the *Sonar Radio Corp.*'s "Auto-Scanner" FM



monitor receiver series. Available are the Model FR-2514 (25-50 MHz) and Model FR-2515 (150-175 MHz). The receivers automatically

scan and lock onto any of eight programmed channels. A priority channel signal will lock to the exclusion of all other signals. A carrier delay allows the operator to hear mobile callbacks to eliminate lost information. Also, manual selection is accomplished by a slow-scan facility. The receivers have dual limiter Foster Seeley discriminators, quadruple

(Continued on page 116)

CIRCLE NO. 8 ON READER SERVICE PAGE

**What a Beauty,
What a Build
And Boy!!!!
What Performance!**



**The 176 is the up-top CB
base antenna for on-top
people . . . from**

S Shakespeare

C/P Corporation Division, The Shakespeare Co., P. O. Box 5207, Columbia, S. C. 29205

Clip the coupons!

Present one or more to your participating RCA Test Equipment Distributor for big discounts on these four instruments during RCA's big Spring Coupon Carnival. (Only one coupon will be accepted per instrument.) Do it today. Offer good only between February 15th and April 30th, 1970.

\$7.50 Toward Purchase of RCA WT-501A Transistor Tester



Mr. Distributor, please refer to RCA 1970 Carnival announcement. Void where prohibited, taxed, or restricted. Cash value 1/20¢. Offer expires April 30, 1970.

\$10.00 Toward Purchase of RCA WT-509A Picture Tube Tester



Mr. Distributor, please refer to RCA 1970 Carnival announcement. Void where prohibited, taxed, or restricted. Cash value 1/20¢. Offer expires April 30, 1970.

\$7.50 Toward Purchase of RCA WV-98C Senior VoltOhmyst



Mr. Distributor, please refer to RCA 1970 Carnival announcement. Void where prohibited, taxed, or restricted. Cash value 1/20¢. Offer expires April 30, 1970.

\$20.00 Toward Purchase of RCA WR-99A Crystal Calibrated Marker Generator



Mr. Distributor, please refer to RCA 1970 Carnival announcement. Void where prohibited, taxed, or restricted. Cash value 1/20¢. Offer expires April 30, 1970.

RCA Electronic Components, Harrison, N. J. 07029
CIRCLE NO. 33 ON READER SERVICE PAGE

RCA

POPULAR ELECTRONICS

Fig. 1. Complete schematic diagram of Microlab is shown here in two parts; points A, B, C, and D in each half connect to their respective letters. Logic, schematic, and post designations on the front panel—not circuit board—are shown in bold lines. These lines refer to functions inside the IC's and onboard connections.

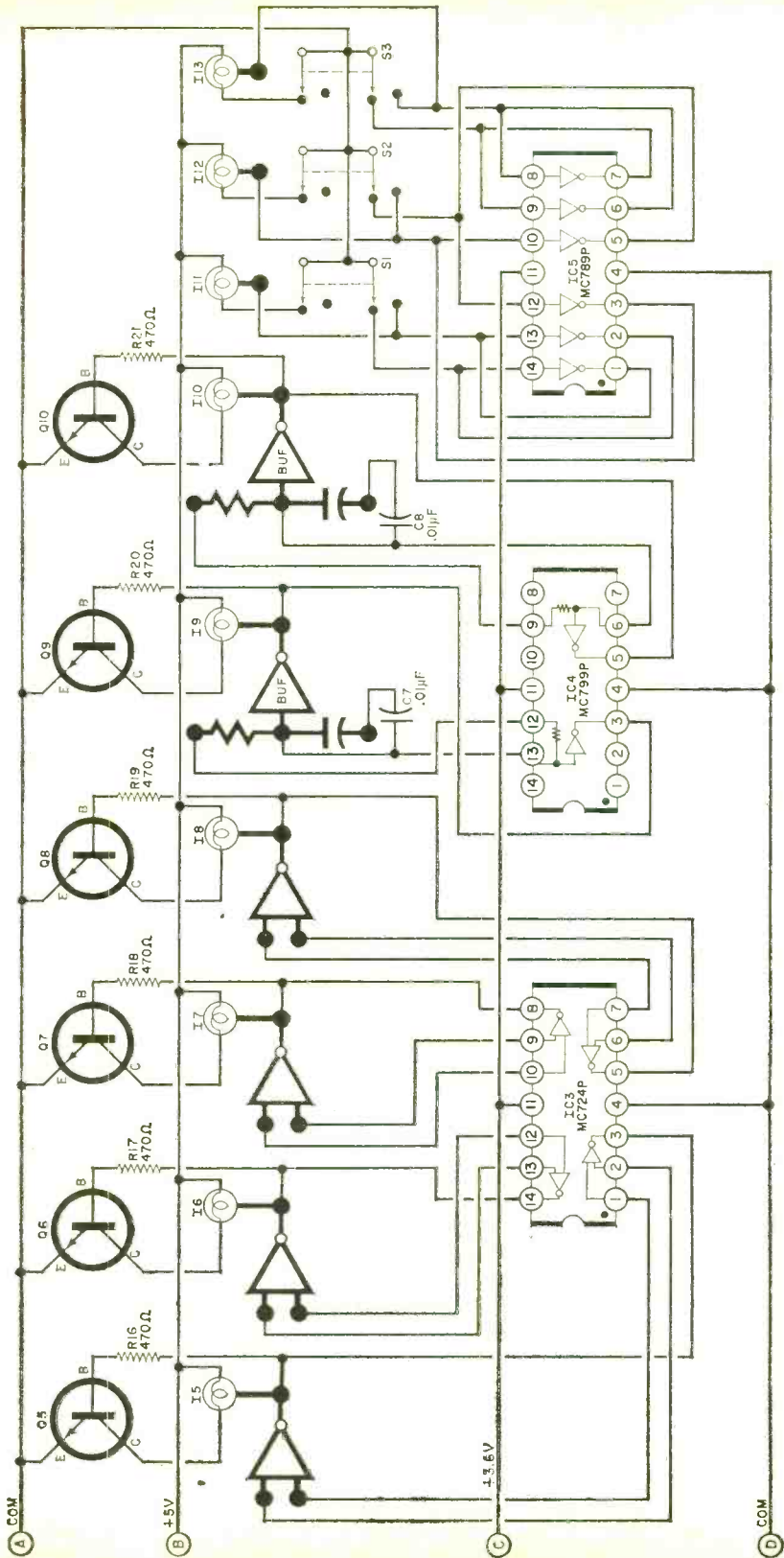

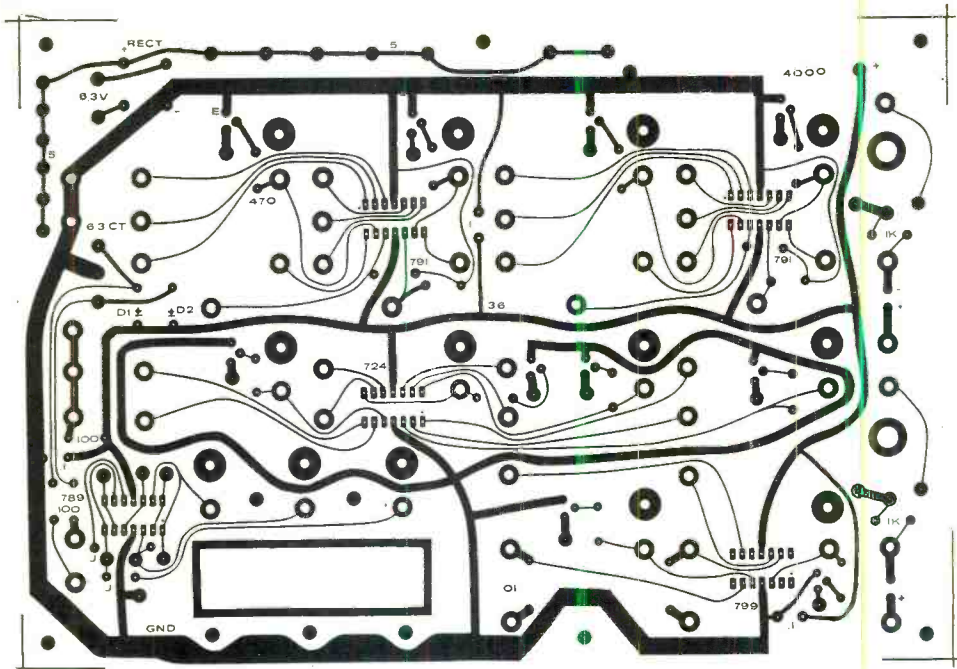

Fig. 2. Foil pattern etching guide is shown here half-size. The best method of obtaining a full-size guide is to use photographic blow-up. However, board is available from the source specified in Parts List if you prefer not to make your own.

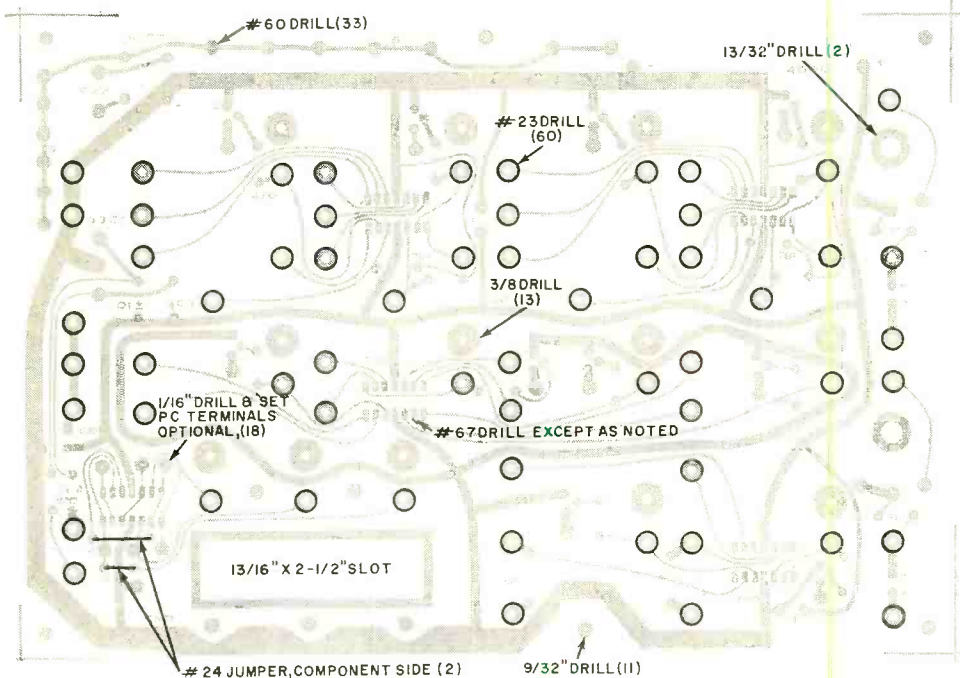

Fig. 3. Circles around solder pads indicate locations of terminal posts. Slot at bottom is to provide clearance for switches. Note jumpers at lower left of illustration.

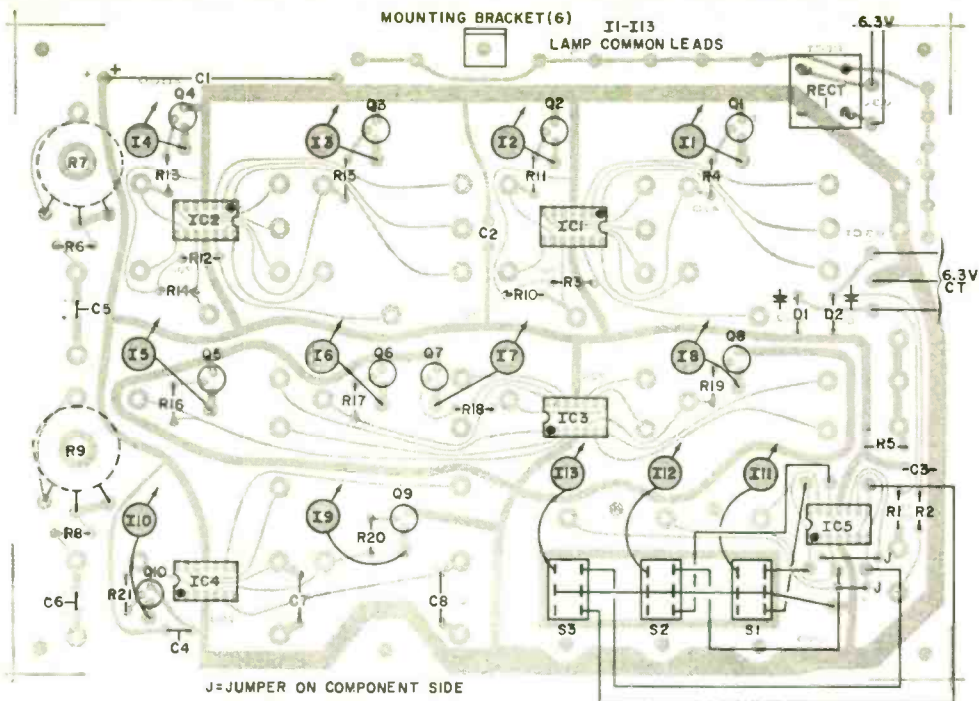

Fig. 4. Be extremely careful when mounting components on circuit board to observe proper lead orientations. Terminal ends of S1-S3 pass through slot in board (lower right) and terminals connect to appropriate points in circuit via wire.

each block are permanently installed and properly bypassed. In using the Micro-lab, all you do is make the logic connections using simple "zip" leads that require no soldering and are easy to attach and remove.

Three types of input signals are available on the front panel: a constant-value positive voltage, the 60-Hz power line that can be properly conditioned for driving the logic blocks, and three conditioning actuators that may be used as either

PARTS LIST

- C1—4000- μ F, 6-volt electrolytic capacitor
- C2-C4—0.1- μ F, 10-volt disc ceramic capacitor
- C5, C6—220- μ F, 6-volt electrolytic capacitor
- C7, C8—0.01- μ F, 50-volt Mylar capacitor
- D1, D2—1-ampere, 25-volt silicon power diode 1N4001 or similar)
- I1-I13—5-volt, 50-mA pilot lamp and color-coded lens (3 green, 4 blue, 2 red, 4 orange)
- IC1, IC2—Dual JK flip-flop (Motorola MC791P)
- IC3—Quad two-input gate (Motorola MC724P)
- IC4—Dual buffer (Motorola MC799P)
- IC5—Hex inverter (Motorola MC780P)
- Q1-Q10—Transistor (National or Fairchild 2N-5129, available from New Jersey Semiconductor, 20 Commerce St., Springfield, NJ 07081)
- R1, R2, R4, R11, R13, R15-R21—470-ohm, $\frac{1}{4}$ -watt resistor
- R3, R10, R12, R14—2200-ohm, $\frac{1}{4}$ -watt resistor
- R5—100-ohm, $\frac{1}{4}$ -watt resistor
- R6, R8—1000-ohm, $\frac{1}{4}$ -watt resistor
- R7, R9—10,000-ohm linear potentiometer
- RECT1—1-ampere, 25-volt diode bridge assembly

S1-S3—D.p.d.t. rocker switch

T1—Filament transformer, secondaries: 6.3 volts at 0.5 amperes, 6.3 volts center-tapped at 0.5 amperes; or two separate transformers.

Misc.—Match-drilled dialplate; 5-ferrule terminal posts (Southwest Technical \approx TP-7563-3GD or similar, 60 required); vinyl grommets (60); vinyl-clad wood case; heat-shrinkable tubing (2 ft); red lead wire (15 ft); yellow lead wire (9 ft); plated hair pin cutters (Southwest Technical P11PC-43, 80 required); $\frac{1}{8}$ -inch knobs (2); line cord; wire nuts (2); mounting brackets with hardware (6); switch bracket and hardware; epoxy cement; \approx 24 solid wire; sleeving; $\frac{1}{4}$ " nylon nuts or other insulated spacers (7); PC terminals (18, optional); solder, etc.

Note—The following are available from Southwest Technical Products, Box 16297, San Antonio, TX 78216; etched and drilled printed circuit board \approx 907, \$10.50; complete kit of all parts including front panel and vinyl-clad case \approx 907-K, \$26.75; 240-page experimenter laboratory manual \approx B-1, \$5.25; all prices postpaid. All individual parts are also available.

Fig. 5. Photo shows how to layout and label the front panel.

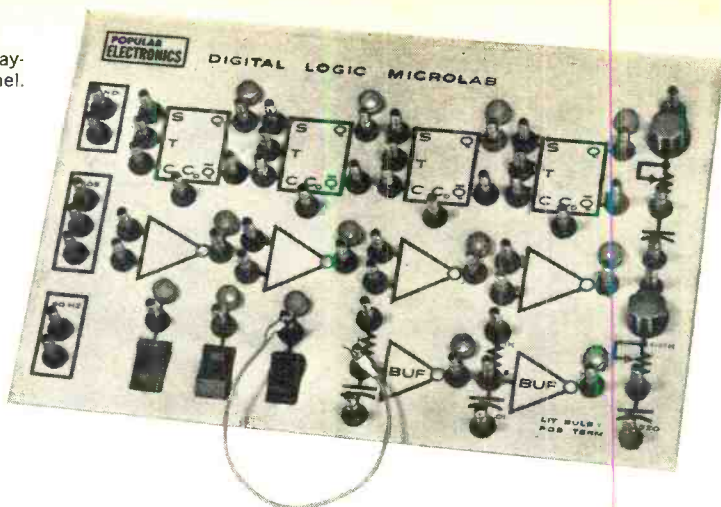

pushbuttons or slide switches. The latter are bounceless and can drive all logic blocks. If desired, certain blocks may be interconnected to form oscillators for driving or test purposes.

Another important feature of the Microlab is that, if you are going to use it as a teaching aide, the entire instrument is "student proof" in that no possible combination of panel connections, however wrong, can damage the circuits.

You can build the Microlab for \$20 to \$30 using the printed circuit boards and complete kits mentioned in the Parts List for Fig. 1. A 240-page experimenter's manual is also available.

What Do the Logic Blocks Do? In general logic blocks perform "yes-no" decisions based upon the presence or absence of "yesses" and "nos" at their inputs. Each block follows a predetermined set of rules and always does the same thing in response to a particular set of input conditions.

There are four types of logic blocks in the Microlab: *two-input gates*, *buffers*, *counting flip-flops* (called JK flip-flops by the computer people), and *inverters*, the latter being inside the unit. The principal components in the blocks are RTL integrated circuits. The outputs of each block are either grounded or at some positive potential (between 1.5 and 3.6 volts), depending on the presence or absence of similar positive or grounded conditions on the inputs.

Two-Input Gate. The logic rule for the

two-input gate states that, if both inputs are grounded, the output is positive; and if either one or both of the inputs is made positive, the output is grounded. If you call ground a "yes" and positive a "no", the two-input gate is a NAND gate. On the other hand, if you call positive a "yes" and ground a "no", you have a NOR gate. The choice is up to you. By combining these gates, all the remaining logic functions can be generated. Two-input gates may also be used to form flip-flops and perform decoding and decision logic.

Buffer. A buffer is an inverting high-power one-input gate and is used where lots of output drive is needed. Its logic rule is simple: if the input is positive, the output is grounded; and vice versa.

A capacitor and resistor are also connected to the buffer's input. If you connect the buffer normally, you simply leave both these components floating. If you connect the resistor to positive and the input to the capacitor, a sudden positive-to-ground transition on the input will produce a brief positive output pulse lasting only several microseconds. This type of pulse is used to reset counting chains or to recognize the beginning, but not the duration, of some event.

Although such an arrangement is seldom used, the resistor can be grounded and a sudden ground-to-positive transition applied to the capacitor. In this case the buffer's output is normally positive and goes to ground briefly for a few microseconds.

Buffers are used as amplifiers to increase drive capability and as reset pulse generators for counters; or, when used in pairs, they may be cross-coupled to form an oscillator or latch.

Counting Flip-Flop. This is the most complex of the logic blocks in the Microlab. Each flip-flop has two outputs, called Q and \bar{Q} , and four inputs, S , T , C , and C_D . The Q and \bar{Q} outputs are complementary. This simply means that, if one is positive, the other is grounded, and vice versa. The inputs are used to make the flip-flop's outputs either change states or stay the way they are.

The C_D input is called a direct input. It is normally left grounded or unconnected. If it is made positive, the flip-flop will immediately go to the state where Q is grounded and \bar{Q} is positive. This is used to initially set the states on a number of flip-flops or to reset a flip-flop. After such a resetting, the C_D input must be returned to ground to allow the other inputs to function.

Inputs S , T , and C are normally used together and are called *clocked* inputs. No matter what happens to the S and C inputs, nothing happens to the outputs until the T input suddenly changes from positive to ground. The rules are as follows:

1. If both S and C are grounded, the output changes state when the T input suddenly goes from positive to ground.
2. If S is grounded and C is positive, and the T input suddenly goes from positive to ground, the outputs are ground at Q and positive at \bar{Q} .
3. If S is positive and C is grounded, and the T input suddenly goes from positive to ground, the outputs are positive at Q and ground at \bar{Q} .
4. If both S and C are positive, nothing happens when the T input goes from positive to ground.

The clocked nature of the JK inputs permits us to set up what the flip-flop is going to do before it actually does it. This is the key to the operation of counters, registers, sequencers, synchronizers, and many other circuits which use clocked flip-flops.

Inverter. The inverter—there are six inside the Microlab—is a low-power buffer. A positive input produces a ground at the output and vice versa. The six inverters are used to make the three con-

ditioning switches bounceless so that they properly drive the T inputs of the flip-flops. Conditioning is accomplished by cascading two inverters to form a set-reset latch whose output is a fast-rise square wave, independent of any contact bounce and noise.

Construction. The Microlab is built in three major parts: a large printed circuit board on which are mounted all of the parts except the power transformer, a front panel that displays the logic symbols and makes available the required connections, and a sloping-front vinyl-clad cabinet.

The schematic is shown in Fig. 1. Since the PC board is so large, a *half-*

HOW IT WORKS

The Microlab contains five IC's, a dual power supply, and some discrete components. One power supply provides +5.6 volts of filtered, bypassed d.c. for the logic circuits; a current-limited positive voltage reference for the front panel; and a split-phase, current-limited 60-Hz reference. The other supply provides 5 volts of full-wave rectified but unfiltered d.c. to drive the state-indicating pilot lights. Either a single tapped transformer or two filament transformers may be used.

The logic circuits in each IC are brought out to the front panel. For instance, IC1 and IC2 are dual JK (counting) flip-flops. Each of the four independent flip-flops is brought out to its own symbolic terminal grouping on the front panel. Resistors are added to the C_D inputs so that they may be safely left unconnected.

Each logic block has its state indicated by a pilot light driven by an *npn* silicon transistor having a base-current limiting resistor. When the output terminal is positive, the lamp lights.

The four two-input gates in IC3 are also brought out to symbolic terminals on the front panel; as are the two buffers in IC4. The 1000-ohm resistors shown in the inputs are internal to the IC, while two capacitors are added as shown. These are useful for pulse and reset generation and for cross-coupling of two buffers to build a high-frequency oscillator.

Hex inverter IC5 is used to form three bounceless actuators in conjunction with S1, S2, and S3. This permits direct driving of the T inputs of the flip-flops without erratic triggering. An extra contact on each switch directly controls a pilot light when the post output is positive, saving three driver transistors and three resistors.

Two networks on the right side of the front panel complete the circuit. Each of these consists of a potentiometer, a fixed resistor, and an electrolytic capacitor. They are used with the two-input gates to form either a monostable multivibrator (one network) or an astable low-frequency oscillator (two networks) adjustable over a 10:1 range from several cycles per second to a cycle every second or so. The values have been selected for optimum visual demonstration of logic and count sequences.

size foil pattern is shown in Fig. 2. If you make your own board, match drill it to the front panel so that all 60 terminal posts are correctly registered—within the play of the rubber grommets that insulate the board from the panel if the latter is metal.

Using Fig. 3. as a guide, press fit each terminal post into place on the foil side of the board, making sure that each post is vertical to the board. Press the posts down so that the first ferrule is in contact with the board. Solder them in place. After soldering, turn the board over and either stake or cement (with epoxy) each post in place. Mount the other components in accordance with Fig. 4, using a low-power iron and fine solder. Note that not all of the IC's are mounted the same way. Follow the notch and dot code on each IC body to position it correctly.

The three switches are mounted $\frac{1}{4}$ " below the component side of the board on a suitable standoff bracket. L-brackets are then attached to the component side of the board as shown. These brackets will be used to support the PC board assembly on the case.

Prepare the front panel as shown in Fig. 5. Be sure that the holes in the panel align with the appropriate components—terminal posts, switches, and potentiometers. Drill holes for and mount the 13 pilot light lenses. In the prototype, orange lenses were used for the four IC displays, blue for the two-input gates, red for the two buffers, and green for the three switch indicators. These lenses press fit into place and can be glued for extra security. The holes for the terminal posts should have enough leeway to permit the installation of $\frac{1}{4}$ " grommets. (As noted in the Parts List, a front panel can be purchased.)

Before attaching the PC board to the front panel, wire up the pilot lights. Check that you have enough lead length on each lamp so that it can be fitted into place before mating the board with the front panel. Place a couple of $\frac{1}{4}$ " insulating spacers (nylon nuts are fine) over a few of the terminal posts to keep the board from contacting the metal front panel.

Ease the front panel and PC board together slowly, starting by aligning each grommet on its post and applying only enough pressure to register against the

grommets. As you ease the two components together, apply pressure to each grommet every time around. After several "rounds" of pressure, the board and front panel can be seated together perfectly. The operation is simple; but, if you hurry, a grommet may pop out. If you ever want to separate the board from the panel, simply reverse the procedure (see Fig. 6).

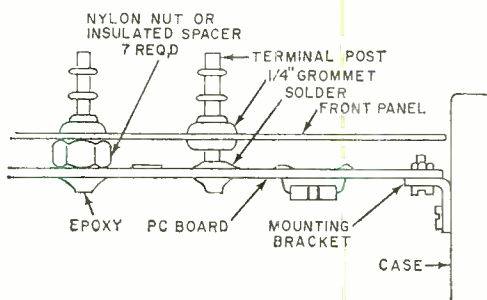

Fig. 6. Nylon spacers prevent circuit board from shorting against metal front panel. Rubber grommets keep terminal posts from contacting panel.

The supporting case is made from wood or particle board and may be covered with vinyl if desired. The PC board and front panel assembly is fitted into the case and secured with wood screws through the L-brackets. The power transformer is then attached to the cabinet interior as desired and wired to the board. Though they are not really necessary, an optional on-off switch and fuse may be added at this time.

Making the Zip Leads. The wires used to make connections on the front panel are called "zip" leads. Each is made of a length of insulated wire (size is not critical but #22 is good), two $\frac{3}{8}$ "-long pieces of heat-shrinkable tubing, and two $\frac{5}{32}$ "-diameter plated hair pin cotters. Unplated hair pin cotters, such as GC Electronics #7378, may be used if they are cleaned carefully before soldering.

For general experimenting, about 40 leads (perhaps 30 red ones 6" long and 10 yellow ones 10" long) will be required. To make a zip lead, cut the wire to the proper length and strip $\frac{1}{4}$ " of insulation from each end. Slip a piece of heat-shrinkable tubing over each end and solder a hair pin cotter to each end. Then

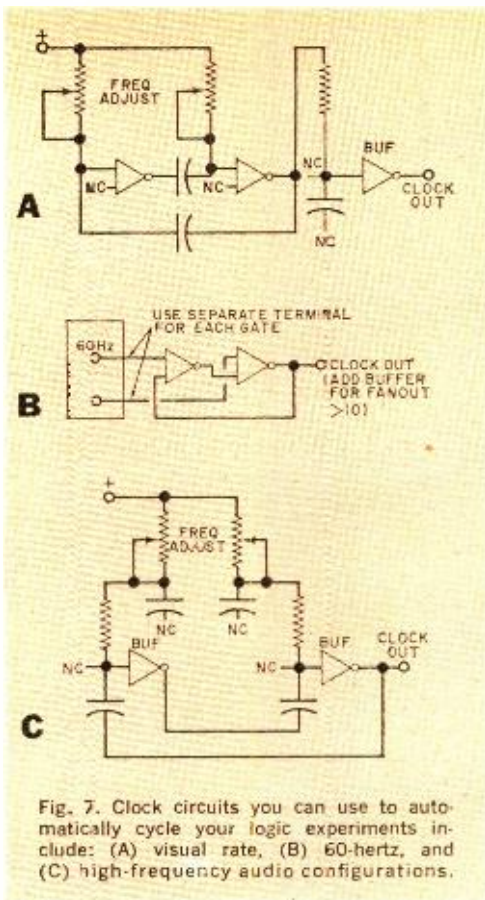
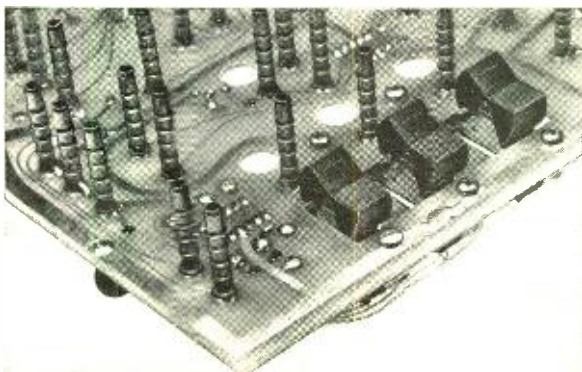

Fig. 7. Clock circuits you can use to automatically cycle your logic experiments include: (A) visual rate, (B) 60-hertz, and (C) high-frequency audio configurations.

slip the tubing over the joint and heat it to shrink it in place. You can do a very neat shrinking job by holding the tubing lightly against the ceramic portion of a screw-in-element soldering iron and rotating slowly.



April, 1970

OVER A HUNDRED CIRCUITS YOU CAN BUILD WITH THE MICROLAB

GATES AND BUFFERS:

Buffer amplifier, positive pulser, negative pulser, high- or low-frequency astable; logic demonstrators—2-input OR, NOR, AND, NAND, EXOR, EXNOR, positive or negative logic, 3-input OR, NOR, AND, NAND, positive or negative logic, 4-through-8-input OR, NOR, positive and AND/NAND negative logic; binary encoder and decoder; inverter demonstrator.

TYPES OF MULTIVIBRATORS:

RS flip-flop; set-reset latch; edge trimmer latch; monostable multi-, high-, or low-frequency, buffered or load-isolated; half monostable; reset pulse generator; astables, including load isolated, sure start, symmetric, VCO, and negative recovery types; frequency doublers and quadruplers; risetime improvers; squaring circuits; linear amplifier modification.

COUNTERS, REGISTERS, AND SCALERS:

Binary up or down counters, modulo 2,4,8, and 16; synchronous binary 2,4, and 8; shift registers, 1,2,3, and 4 bit; shift register counter, modulo 3,7, and 15; walking ring counters, 2,4,6, and 8, including protected 6 and 8; odd length walking ring counters, 3,5, and 7; factored counters, 2,4,6,8,9,10,12,14, and 16; halfway addition counters, 3,5,6,7,9,10,11,12, 13,14,15; pseudo-random counter sequencers 7 and 15; even-odd reduction modulo 3, 5, and 9; bucket brigade counters, open ended or closed, modulo 1,2,3, and 4; decoded counters, 2,3,4, and 5.

OTHER CLOCKED FLIP-FLOP CIRCUITS:

Sequential pass-ons, 1,2,3, and 4; divide-by-two synchronizer; gated divider; straight synchronizer; one-and-only-one; sequencer; demonstrators, JK, T, D, and RS; type D registers, rings, binary dividers, and sequential pass-ons; disallowed state 2/6 and 2/8 demonstrators.

DECIMAL COUNTERS:

Modulo 10 minimum; inverted M-10-Min; 1-2-4-8; 1-2-4-5; excess 3; 1-2-2'-4; 1-1'-2-5 binary ring; quibinary ring; halfway addition modulo 10.

DIGITAL TEST INSTRUMENTS, ETC:

Bounceless pushbuttons; 60-Hz power line clock; visual rate clocks; audio high-frequency clock; state indicators; 0.1-second time base; synchronized 0.1-second time base; power line zero-crossing detector; synchronizers; buffer interface; contact conditioner; heads/tails machine; electronic die; pseudo and random number generators; gated oscillator; counter prescaler; reset pulse generator; signal injector; audio oscillator; electronic siren, doorbell, or panic alarm.

Terminal posts insert through foil side of board, soldered to foil, and expoxied to component side.

Hunting for a better job?

**Here's the
license
you need
to go after
the big ones**



A Government FCC License can help you bring home up to \$10,000, \$12,000, and more a year. Read how you can prepare for the license exam at home in your spare time—with a passing grade assured or your money back.

IF YOU'RE OUT TO BAG A BETTER JOB in Electronics, you'd better have a Government FCC License. For you'll need it to track down the choicest, best-paying jobs that this booming field has to offer.

Right now there are 80,000 new openings every year for electronics specialists—jobs paying up to \$5, \$6, even \$7 an hour... \$200, \$225, \$250, a week... \$10,000, \$12,000, and up a year! You don't need a college education to make this kind of money in Electronics, or even a high school diploma.

But you *do* need knowledge, knowledge of electronics fundamentals. And there is only one nationally accepted method of measuring this knowledge... the licensing program of the FCC (Federal Communications Commission).

Why a license is important

An FCC License is a legal requirement if you want to become a Broadcast Engineer, or get into servicing any other kind of transmitting equipment—two-way mobile radios, microwave relay links, radar, etc. And even when it's not legally required, a license proves to the world that you understand the principles involved in *any* electronic device. Thus, an FCC "ticket" can open the doors to thousands of exciting, high-paying jobs in communications, radio and broadcasting, the aerospace program, industrial automation, and many other areas.

So why doesn't everyone who wants a good job in Electronics get an FCC License and start cleaning up?

The answer: it's not that simple. The government's licensing exam is tough. In fact, an average of two out of every three men who take the FCC exam fail.

There is one way, however, of being pretty certain that you will pass the FCC exam. And that is to take one of the FCC home study courses offered by Cleveland Institute of Electronics.

CIE courses are so effective that better than 9 out of 10 CIE graduates who take the exam pass it. That's why we can back our courses with this iron-clad Warranty: Upon completing one of our FCC courses, you must be able to pass the FCC exam and get your license—or you'll get your money back!

They got their licenses and went on to better jobs

The value of CIE training has been demonstrated time and again by the achievements of our thousands of successful students and graduates.

2 NEW CIE CAREER COURSES

1. BROADCAST (Radio and TV) ENGINEERING... now includes Video Systems, Monitors, FM Stereo Multiplex, Color Transmitter Operation and CATV.

2. ELECTRONICS ENGINEERING... covers steady-state and transient network theory, solid state physics and circuitry, pulse techniques, computer logic and mathematics through calculus. A college-level course for men already working in Electronics.

CIRCLE NO. 9 ON READER SERVICE PAGE

Ed Dulaney, Scottsbluff, Nebraska, for example, passed his 1st Class FCC License exam soon after completing his CIE training... and today is the proud owner of his own mobile radio sales and service business. "Now I manufacture my own two-way equipment," he writes, "with dealers who sell it in seven different states, and have seven full-time employees on my payroll."

Daniel J. Smithwick started his CIE training while in the service, and passed his 2nd Class exam soon after his discharge. Four months later, he reports, "I was promoted to manager of Bell Telephone at La Moure, N.D. This was a very fast promotion and a great deal of the credit goes to CIE."

Eugene Frost, Columbus, Ohio, was stuck in low-paying TV repair work before enrolling with CIE and earning his FCC License. Today, he's an inspector of major electronics systems for North American Aviation. "I'm working 8 hours a week less," says Mr. Frost, "and earning \$228 a month more."

Send for FREE book

If you'd like to succeed like these men, send for our FREE 24-page book "How To Get A Commercial FCC License." It tells you all about the FCC License... requirements for getting one... types of licenses available... how the exams are organized and what kinds of questions are asked... where and when the exams are held, and more.

With it you will also receive a second FREE book, "How To Succeed In Electronics." To get both books without cost or obligation, just mail the attached postpaid card. Or, if the card is missing, just mail the coupon below.

ENROLL UNDER NEW G.I. BILL. All CIE courses are available under the new G.I. Bill. If you served on active duty since Jan. 31, 1955, or are in service now, check box on reply card for complete details.

CIE Cleveland Institute of Electronics

1776 E. 17th St., Cleveland, Ohio 44114

Accredited Member National Home Study Council
A Leader in Electronics Training... Since 1934



Cleveland Institute of Electronics
1776 East 17th Street, Cleveland, Ohio 44114

Please send me without cost or obligation:
Your 44-page book "How to Succeed In Electronics" describing job opportunities in Electronics today, and how your courses can prepare me for them.

Your book on "How To Get A Commercial FCC License."

I am especially interested in:

<input type="checkbox"/> Electronics Technology	<input type="checkbox"/> Electronic Communications
<input type="checkbox"/> Broadcast Engineering	<input type="checkbox"/> Industrial Electronics
<input type="checkbox"/> First Class FCC License	<input type="checkbox"/> Electronics Engineering

Name _____ (PLEASE PRINT)
Address _____
City _____
State _____ Zip _____ Age _____

Check here for G.I. Bill information **PE-95**

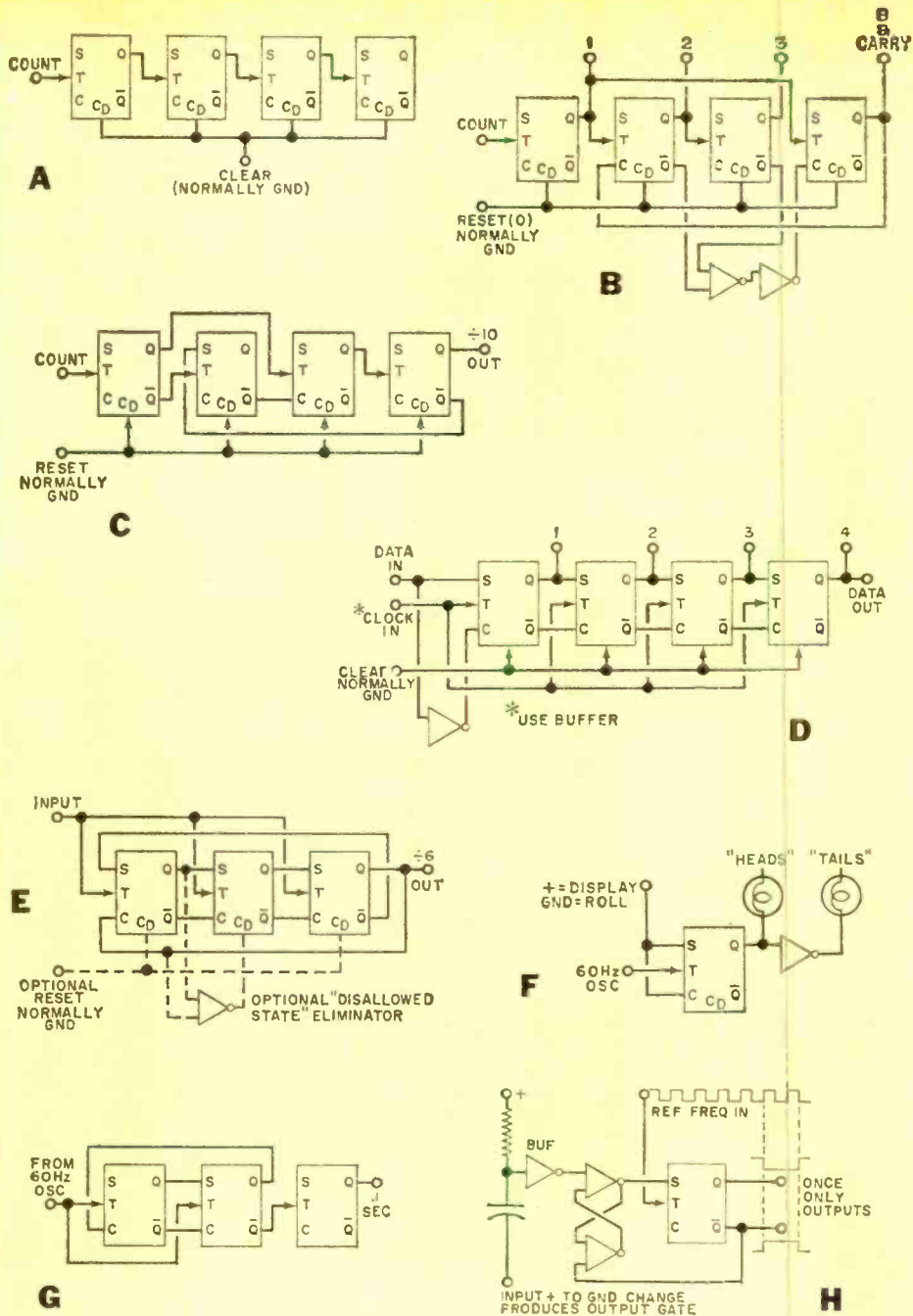

Fig. 9. Some popular digital logic demonstration circuits you can set up are: (A) divide-by-16 binary ripple counter; (B) "1-2-4-8" BCD divide-by-ten counter; (C) "modulo-10 minimum" divide-by-ten scaler; (D) four-stage shift register; (E) divide by six walking ring counter; (F) heads-or-tails "honest odds" coin flipper; (G) 0.1-sec time base (square-wave generator); and (H) "one-and-only-one" synchronizer.

How to Use. The manual prescribed in the Parts List gives many of the experiments you can perform with the Micro-lab. Many of the drawings are in logic block form and ready for instant bread-boarding. Generally, you set up an experiment using a logic diagram and the zip leads and then put the circuit through all its possible states in one of several ways.

For instance, you can use the positive and ground reference posts and, by changing zip leads, cycle the circuit. Or you can use the actuators, either as slide switches or by rocking them with two fingers, as pushbuttons.

For automatic experimenting, you can drive the circuit from one of the "clocks" shown in Fig. 7. Figure 7A shows how to use the two RC networks to build a variable low-frequency oscillator that can cycle an experiment at an easy-to-watch, adjustable rate. Figure 7B shows how to build a 60-Hz power-line driven oscillator, which is useful for time bases, heads-tails and random-number circuits, and other cases where you want to cycle the logic faster. Finally, Fig. 7C shows how to create a high-frequency oscillator by cross-coupling the two buffers. This high-speed cycling circuit is most useful when you have an oscilloscope to observe the resulting waveforms or are cycling or testing an external digital instrument.

Several small numbers appear next to terminals on the front panel. These tell you either how much drive is available if the terminal is an output or how much drive is needed if the terminal is an input. For instance, the two-input gate has 13 units of drive available at its output and needs 3 units of drive at either of its inputs. With this gate, you can drive, say, two T inputs (5 units each) and an S input (3 units); but three T inputs (totalling 15) would be too much. Any time you run out of drive capability, run the output through a buffer. Either buffer output is powerful enough (77 units) to drive every input on the board simultaneously. Each of the three switches can put out 13 units of drive power. Use a buffer if you simultaneously (synchronously) drive all four T inputs.

Figure 8 shows some of the more popular digital demonstration circuits. Figure 8A is a binary ripple counter that counts to 16 and then repeats; B is a 1-2-4-8 decimal or divide-by-10 counter;

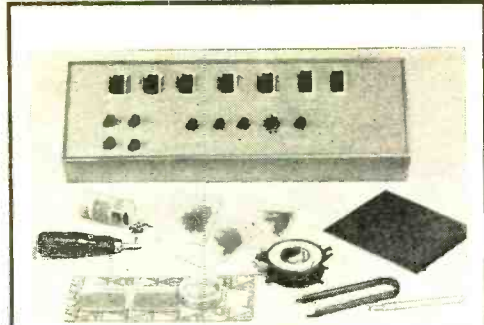

A DIGITAL LOGIC BREADBOARD

Sometimes, the digital logic experimenter would like to put together a circuit consisting of a mixture of 14- or 16-pin in-line IC's, round IC's, some transistors, etc. Obviously, he wants to avoid the constant soldering and unsoldering of IC or transistor leads, since this usually results in component damage.

To help this experimenter, the Vector Electronic Corp. (12460 Gladstone Ave., Sylmar, CA 91342) has a number of logic experimentation kits available. For example, the Model 29X (\$59.75) consists of a 4½" x 14" perforated board supported on all sides by a 2" aluminum extrusion. The sockets provided include ten for 14-pin in-line IC's, two four 16-pin in-line IC's, four for TO-5 transistors (four-lead type), four for 8-lead and two for 10-lead round IC's, and ten 12-hole mounting pads to adapt round IC's to a square hole.

Although primary connections are made through vinyl covered clip leads (50 provided), the kit also includes a mixture of other types of wire connectors used to make up your own test leads. In addition, there are an IC extractor tool, 200 small clip terminals for external component mounting, all required hardware, a couple of small perforated boards, and extra copper wire including 20 feet of the solder-through type. The board can be made without a single solder joint. Once a circuit has been confirmed, the board can be "cleaned off" to await the next project.

C is a modulo-ten minimum-hardware decimal counter; D is a four-stage shift register; E is a walking-ring divide-by-six counter useful in digital clocks and as an electronic die; F is an honest-odds, heads-or-tails coin flipper; G is a 0.1-second time base and square-wave oscillator; H is a one-and-only-one synchronizer that can be used with the time base to get one precise 0.1-second gate under random command every time you flip the switch; I is a divide-by-3 counter; J is a divide-by-five counter; and K is a 15-state pseudo random-sequence generator.

-30-

Electronics Geography Quiz

BY THOMAS HASKETT

ANYONE who works, studies, or experiments in the field of electronics will sooner or later associate certain cities with well-known electronics manufacturing facilities. For instance, what electronics manufacturer do you think of when Harrison, N.J. is mentioned? RCA Electronic Devices, of course. While there may be other smaller companies there, chances are you thought of the one most well-known.

This little quiz is divided into three parts: Easy, Difficult, and Very Difficult.

Even a duffer should be able to get 9 or 10 of the Easy ones. If you do that well on the Difficult, you're pretty well-informed about locations; and if you get 10 or more in the third category, you're an expert on Electronics Geography. See how well you can do—and no fair peeking at the advertisement in this magazine. Match the cities on the left with the companies on the right. Note that for some cities, a group of manufacturers is listed.

(Answers on page 104)

PART I: EASY

- | | |
|--------------------------------------|-----------------------|
| 1 <u> G </u> Harrison, N.J. | A. R.L. Drake |
| 2 <u> </u> Benton Harbor, Mich. | B. Edmund Scientific |
| 3 <u> </u> Brooklyn, N.Y. | C. Bogen |
| 4 <u> </u> Skokie, Ill. | D. Ohmite |
| 5 <u> </u> Indianapolis, Ind. | E. Sencore |
| 6 <u> </u> Orchard Park, N.Y. | F. Allied Radio |
| 7 <u> </u> North Adams, Mass. | Belden |
| 8 <u> </u> Owensboro, Ky. | B & K Mfg. |
| 9 <u> </u> Paramus, N.J. | Switchcraft |
| 10 <u> </u> Chicago, Ill. | G. RCA Electron. Div. |
| 11 <u> </u> Addison, Ill. | H. Heath Co. |
| 12 <u> </u> Bluffton, Ohio | I. Xcelite |
| 13 <u> </u> Buchanan, Mich. | J. Eico |
| 14 <u> </u> Barrington, N.J. | K. Sonar |
| 15 <u> </u> Miamisburg, Ohio | K. Sprague |
| | L. Howard W. Sams |
| | P.R. Mallory |
| | M. Triplett |
| | N. Electro-Voice |
| | O. G.E. Tube Div. |

PART II: DIFFICULT

- | | |
|----------------------------------|----------------------|
| 1 <u> </u> Waseca, Minn. | A. H.H. Scott |
| 2 <u> </u> Newark, N.J. | B. ITT Semiconductor |
| 3 <u> </u> Hicksville, N.Y. | C. Amperex |
| 4 <u> </u> Evanston, Ill. | D. Astatic |
| 5 <u> </u> Malden, Mass. | E. 3M Co. |
| 6 <u> </u> Conneaut, Ohio | F. Delco Radio |

- | | |
|--------------------------------------|-----------------------|
| 7 <u> </u> Rockford, Ill. | G. E.F. Johnson |
| 8 <u> </u> Redwood City, Calif. | H. Shure |
| 9 <u> </u> W. Palm Beach, Fla. | I. Ampex |
| 10 <u> </u> Kokomo, Ind. | J. Accoustic Research |
| 11 <u> </u> Peoria, Ill. | K. Winegard |
| 12 <u> </u> Maynard, Mass. | L. GC Electronics |
| 13 <u> </u> Burlington, Iowa | M. Blender-Tongue |
| 14 <u> </u> Cambridge, Mass. | N. James Millen |
| 15 <u> </u> St. Paul, Minn. | O. Rohn Towers |

PART III: VERY DIFFICULT

- | | |
|--------------------------------------|---------------------------|
| 1 <u> </u> Cleveland, Ohio | A. Hewlett-Packard |
| 2 <u> </u> Quincy, Ill. | B. Tektronix |
| 3 <u> </u> Cedar Rapids, Iowa | C. Grommes |
| 4 <u> </u> Beaverton, Ore. | D. New-Tronics |
| 5 <u> </u> Liberty Corner, N.J. | E. Energy Conv. Dev. |
| 6 <u> </u> Palo Alto, Calif. | F. Pearce-Simpson |
| 7 <u> </u> El Segundo, Calif. | G. Jackson Instru. |
| 8 <u> </u> Troy, Mich. | H. Measurements
inc. |
| 9 <u> </u> Santa Ana, Calif. | Ballantine Labs. |
| 10 <u> </u> Boonton, N.J. | I. International Rect. |
| 11 <u> </u> Miami, Fla. | J. Squires-Sanders |
| 12 <u> </u> Spartanburg, S.C. | K. Langevin |
| 13 <u> </u> Franklin Park, Ill. | L. Gates Radio |
| 14 <u> </u> Dayton, Ohio | M. Turner Micro-
phone |
| 15 <u> </u> Garden City, N.Y. | Collins Radio |
| | N. Reeves Instrument |
| | O. Quietrole |

The FRISKY FOUR SPEAKER SYSTEM



*Small
speakers
give
top
response*

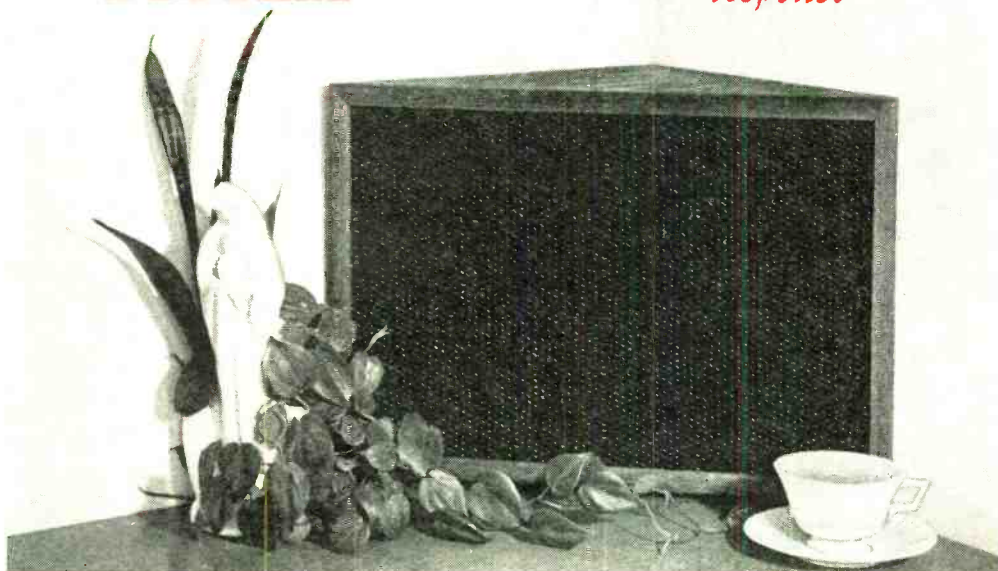

BY DAVID B. WEEMS

THE IDEA OF USING several small loudspeakers in a single enclosure to obtain full-range sound was popularized by the "Sweet Sixteen" system described in *POPULAR ELECTRONICS* in January 1961. That system consisted of 16 inexpensive replacement-type speakers and utilized close coupling to achieve a fair bass range response.

In the years since the Sweet Sixteen appeared, there has been a revolution in small speaker design. Now some small speakers have a free air resonance that is from one to four octaves below that of the common replacement-type speakers of the same diameter. When a single low

resonance speaker can surpass the bass response range of several replacement types, there is little advantage in using a large number of speakers for good bass response, unless you have some special application in mind.

For conventional direct radiator systems, it is probably easier and less expensive to obtain full bass response with a single woofer. Hence, the number of small speakers used in a system should be limited to a figure which will keep the total cost less than the combined price of a large woofer, mid-range speaker, and tweeter.

The "Frisky Four" speaker system

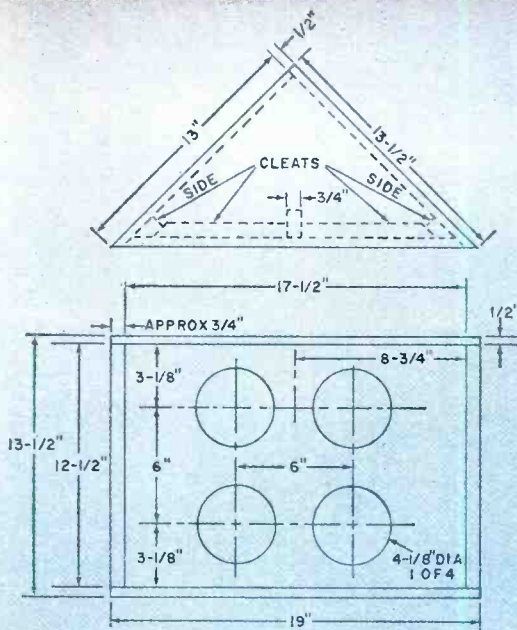

Fig. 1. Due to small size and triangular configuration, enclosure can be almost entirely assembled with nails only.

BILL OF MATERIALS

- 4—Loudspeakers (No. XS-510, \$3.50 each from McGee Radio Co., 1901 McGee St., Kansas City, Mo. 64108)
- 1—17 1/2" x 12 1/2" piece of 1/2" plywood for speaker mounting board
- 1—13 1/2" x 12 1/2" piece of 1/2" plywood for side
- 1—13" x 12 1/2" piece of 1/2" plywood for side
- 1—13 5/8" x 13 5/8" piece of 1/2" plywood, cut diagonally from corner to corner to make top and bottom plates
- 1—38" length of 1" x 2" pine for side cleats and brace

- 1—30" length of 3/4"-square pine for top and bottom cleats
- 1—72" length of 3/4" molding for trim
- 1—Two-lug screw-type terminal strip
- 14—#8 x 1" flathead wood screws
- 3—Plastic furniture glides or rubber bumper tacks
- 13—#8 x 1 1/4" flathead wood screws
- 16—#8 x 1/2" pan-head sheet metal screws
- Misc.—Finishing nails (see text); wire brads; glue; gasket material (see text); grille cloth; sound-absorbent material; speaker cable; solder; etc.

described here employs four \$3.50 speakers. The price tag makes sense, especially for speakers with rolled-edge suspensions and large (10-oz) magnet assemblies. And four speakers can be housed in a small enclosure that saves space as well as money. Frisky Four somewhat describes the transient response of the speaker system's nimble little cones.

About the System. The enclosure (see Fig. 1), designed to use a room corner for better air loading on the cones, aids the bass response. Another advantage to the triangular enclosure configuration is the absence of parallel walls; internal reflections are reduced and structural rigidity is improved, permitting simplified construction.

Working together, the speakers and

enclosure produce good sound. The system is particularly good for use with low-power amplifiers because its efficiency at low volume levels conserves audio power.

A typical location for the system in your listening room is on a corner table. If such is not available, there are many other possibilities, such as the upper corner of the room. The enclosure can be hung on the wall like a framed picture or even supported by a pole lamp. However, the junction of two walls and the ceiling is an ideal location for maximum bass response. One enclosure in each of two adjacent ceiling corners will give very good stereo coverage. An alternate possibility is a floor corner, but make sure the sound path is not blocked by furniture.

Construction. Assembly of the enclosure is quick and easy due to the use of finishing nails and glue on the sides, top, and bottom. Such construction techniques, though not suitable for a large enclosure, are quite adequate for a small box enclosure.

Referring to Fig. 1, cut the sides, top, and bottom plates, and the speaker mounting board to the dimensions given. Notice also that you will have to make several 45° miter cuts, one at the front edge of each side, one at each end of the speaker board, and one for each of the side cleats. To save time, the angled edges of the side cleats can be made with one pass of the saw. Simply set your saw at 45° and rip the length of a 1" × 2" pine stud into two strips of equal thickness. The lengths can be trimmed to the proper dimensions later.

Strike a line on the inside surfaces of the top and bottom plates, spaced ½" in from the front edges, to show the location of the inside surface of the speaker board. Then begin assembling the enclosure by joining the sides at the rear corner. Make sure that the longer wall overlaps the shorter one. Put glue on the surfaces being joined. Then set the short-

er side in a vise, or have someone hold it upright on a solid surface, while you drive in the six-penny finishing nails. Wipe off excess glue after nailing.

Now, glue and nail the top and bottom plates to the walls as shown in Fig. 2. Cut the side cleats to the proper lengths. Glue and nail or screw the cleats in place as in Fig. 3. Three-penny finishing nails are adequate for anchoring these cleats in place if C-clamps are used to apply pressure while the glue sets. Otherwise, you will have to substitute 1" flathead wood screws.

The positions of the side cleats are defined by the lines on the inside surfaces of the top and bottom plates. Seat the cleats behind the lines, leaving space between each cleat and the line to allow for the compressed thickness of the gasket material you plan to use.

Cut a length of 1" × 2" pine to exact length for the center brace. Locate the brace behind the lines the same distance as the side cleats. Then glue and nail it in place by driving two six-penny nails through the top and bottom plates and into the butt ends of the brace.

Trim four ¾"-square lengths of pine to the exact lengths to fit between the



Fig. 2. Liberal bead of white glue between joined members helps to rigidize enclosure and provides air seal. Finishing nails anchor members together.



Fig. 3. Side cleats are miter cut at 45° angles; then glued and nailed to sides, 1/2" in from front.

brace and side cleats, cutting one end of each to 45° as shown in Fig. 4. Glue and nail or screw the cleats to the top and bottom plates. Then sand and stain the enclosure shell.

Assuming that you have already made

the speaker cutouts as shown in Fig. 1, now you must drill about thirteen 1/64" guide holes for mounting the speaker board. Locate a vertical row of three holes about 1 1/4" in from each mitered outside edge of the speaker board, and a vertical row of three holes down the center of the board. Then drill one hole between each vertical row, top and bottom. Mark each guide hole location. Then set the speaker board temporarily in place to check for possible positioning errors. When you are satisfied, remove the speaker board, and apply a coat or two of flat black paint to its front surface and the insides of the cutouts.

Remove sawdust and other debris from your work surface. Set the speaker board face down, and mount the speakers with #8 x 3/4" pan-head screws as shown in Fig. 5. Then, referring to Fig. 6, wire together the speakers. (Note: When wiring the speakers, set the enclosure shell nearby so that you can route the cable that connects the parallel wired pairs *behind* the center brace.)

Now, check the speaker polarity by momentarily touching the contacts of a D cell to the free ends of the wiring. All speaker cones in the system should move in the same direction at contact. Any that move in the opposite direction should be desoldered and the leads transposed and resoldered. Connect the bat-

Fig. 4. Front cleats are mounted on top and bottom plates between center brace and sides.

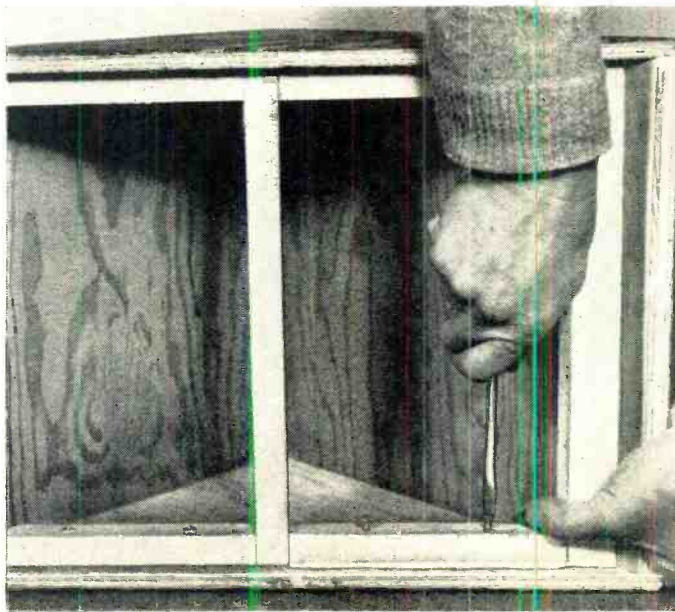

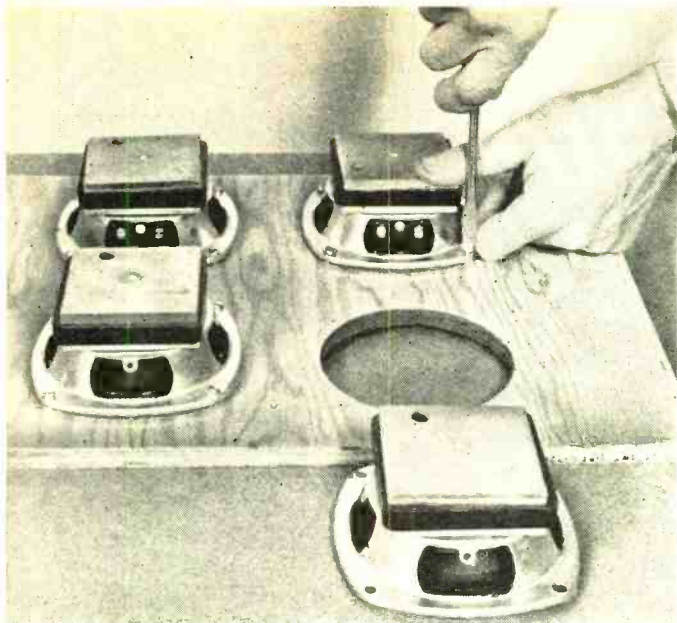

Fig. 5. Fasten loudspeakers to speaker mounting board with #8 x 1/2" pan-head sheet metal screws.

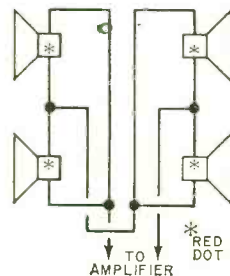

Fig. 6. Parallel-series speaker hookup is required to preserve uniformity and standard impedance. Note carefully red dot orientations. When properly wired, system connects to 8-ohm output.

tery again so that the cones move *outward*; code the wire touching the positive terminal of the battery.

Due to the angled fitting and large area of the speaker mounting board as compared to the small volume of the enclosure, air leaks might present a problem. To obviate any such problems, a gasket should be used. It can be adhesive-backed foam rubber, thin cork, or felt. Or you can run a bead of silicone rubber caulking compound along the outer surfaces of the cleats; this method provides a positive seal even for loose-fitting parts, but it makes access to the speakers difficult—if not impossible.

Another point to seal is the exit hole for the speaker cable. One method is to use a two-lug screw-type terminal strip, located at the center of the bottom plate of the enclosure. Mark and drill two 1/4" holes to accept the solder lugs. Then use the drill bit to ream out one side of the holes so they are large enough to accept both solder lug and screw end. Pass the speaker cable through the holes and solder them to the lugs. Code the screw terminal connected to the wire previously coded. Then glue and screw the terminal strip down, and attach three plastic furniture glides or rubber bumper tacks about 2" from each corner of the bottom plate.

Stuff the enclosure with fiberglass or other sound absorbent material. Begin by lining the top, bottom and sides. Then loosely fill the empty space in the middle with glass wool or cut-up pieces of fiberglass wool.

Attach the speaker board with about four evenly spaced screws and give the system a test run at normal listening volume. You can experiment at this stage by removing or adding stuffing until the sound reproduction meets with your approval. Then install the speaker board with #8 x 1 1/4" flat-head wood screws.

Tack or staple a 12 1/2" x 18" piece of grille cloth over the front of the enclosure. Then select a decorative molding to cover the raw edges of the wood and staples or tacks. Cut the molding to size, stain and finish it to match the enclosure shell, and use small wire brads to affix it in place.

If you are an apartment dweller, limited to low volume levels, you will like the Frisky Four. Some systems, particularly those with large speakers, must be driven at high levels in a large room for maximum enjoyment. This is not a matter of efficiency but of final sound intensity. The Frisky Four, however, sounds good at a low level in a small room like those in apartments. Try one and see for yourself.

Low-cost
signal
source
for
a.f./i.f./r.f.

MICRO'LIGN GENERATOR

A PROBLEM often encountered upon completion of a kit- or magazine project-built radio receiver for AM broadcast reception is getting it properly aligned. Sure, you can tune the receiver by ear, but to get it to track properly, the intermediate frequency (i.f.) should be as close to 455 kHz as possible. For the casual hobbyist, a signal generator is usually a luxury. However, the "Micro'Lign" generator, an inexpensive, easy-to-build, accurate a.f./i.f./r.f. signal source, fills the need nicely.

The Micro'Lign is "on frequency" as soon as it is assembled so there is no need for test or calibration equipment to make it work properly. The output of the generator is a 500-Hz audio tone and a 455-kHz i.f. signal, both rich in harmonics. (The i.f. harmonics are usable to beyond 30 MHz.) The 455-kHz output, modulated at 500 Hz is used in AM broadcast-band work for i.f. alignment,

and modulated signals at 910 kHz and 1365 kHz are for r.f. alignment. The 500-Hz signal is also useful for troubleshooting the audio stages of a receiver or other audio circuits.

How It Works. The r.f. oscillator ($Q3$ circuit in Fig. 1) is a variation of the Hartley or Colpitts circuit, but it uses a Clevite Transfilter, $XTAL$, in place of the usual coils and capacitors. The Transfilter is a piezoelectric device consisting of a plated ceramic disc. The disc has natural mechanical vibration modes which can be induced by applying a voltage to the plated terminals.

Transistor $Q3$ amplifies the signal produced by the vibrating disc in $XTAL$ and feeds it back in the proper phase to sustain oscillations. Initial oscillations are caused by the sudden application of voltage to the circuit when power switch $S1$ is closed. The Transfilter oscillator

then produces the 455-kHz "r.f." signal and its harmonics.

Audio for amplitude modulation is produced by the astable multivibrator circuit consisting of transistors $Q1$ and $Q2$. A voltage divider made up of resistors $R1$ and $R2$ is used to supply audio and the oscillator voltage from $B1$ to $Q3$. The use of the divider insures that $Q3$ will oscillate even on the audio half-cycles when $Q1$ is cut off.

Construction. To keep construction simple, it is suggested that you use a printed circuit board for parts mounting. You can make your own board from the full-size etching guide provided in Fig. 2, or you can buy one already etched and drilled from the source given in the Parts List.

In assembling the circuit, notice that all components, with the exception of the Transfilter, mount on the top of the

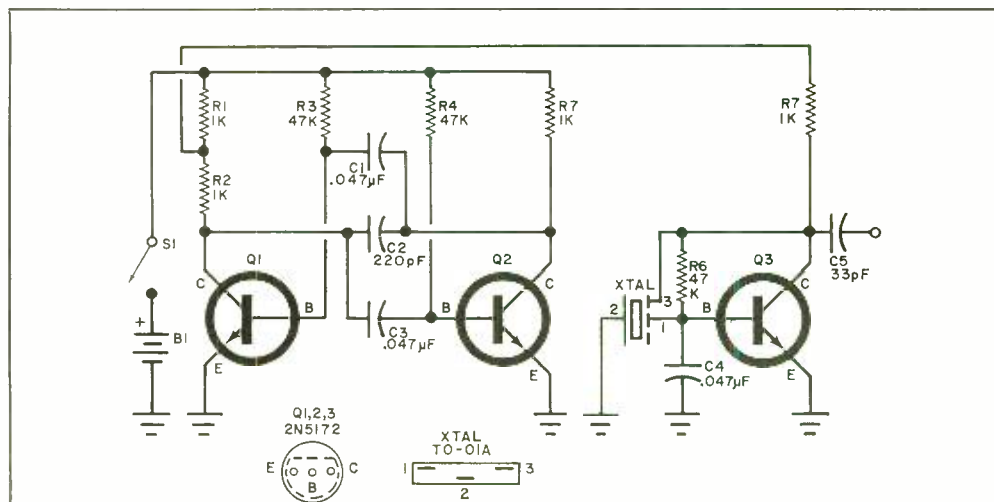

Fig. 1. Generator consists of crystal-controlled r.f. oscillator $Q3$ and $Q1/Q2$ multivibrator which provides amplitude modulating signal.

PARTS LIST

$B1$ —9-volt transistor battery
 $C1, C3, C4$ —0.047- μ F, 10-volt disc capacitor
 $C2$ —220-pF disc capacitor
 $C5$ —33-pF disc capacitor
 $R1, R2, R5, R7$ —1000-ohm, $\frac{1}{4}$ -watt resistor
 $R3, R4, R6$ —47,000-ohm, $\frac{1}{4}$ -watt resistor
 $S1$ —S.p.s.t. printed-circuit-type slide switch
 $XTAL$ —Transfilter (Clevite Corp. No. TO-01A)
 I —2 $\frac{1}{4}$ " x 1 $\frac{1}{2}$ " x 1 $\frac{3}{8}$ " chassis box (LMB No. M00, available from Newark Electronics—No. 91F1105—or similar)

Misc.—Printed circuit board; battery connector; miniature alligator clips (2); hardware; hook-up wire; solder; etc.

Note—A complete kit of parts (including Transfilter, battery, printed circuit board, chassis box, and all components) is available for \$7.95, postpaid, from Kits Industries, Inc., 16774 Schoenborn St., Sepulveda, CA 91345. Clevite Transfilter is available from Semiconductor Specialists, Inc., P.O. Box 66125, Chicago, IL 60666, or from Kits Industries for \$1.75. Printed circuit board is available separately from Kits Industries for \$2.

circuit board (see parts placement photo in Fig. 2). The transfilter mounts on the foil side of the board. It must be mounted as close as possible to the board and carefully soldered with a miniature soldering iron.

The ground connection can be made to the chassis by soldering it to a #6 solder lug mounted between the switch tab and chassis.

The slide switch holds the small circuit board in place inside the chassis box by bolting the switch to the front of the box after bringing out the signal and

ground leads from the board as shown in the photo on the first page of this article. This allows you to mount the battery directly behind the circuit board. Then place a piece of sponge rubber or other insulating material between the battery and bottom of the circuit board. Finally, solder alligator clips onto the output leads, and assemble the box.

How To Use. Connect the output lead clips of the Micro'Lign together to form a loop, and place the loop near the ferrite rod antenna of an AM broadcast receiv-

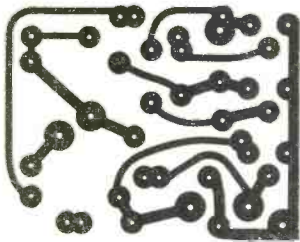
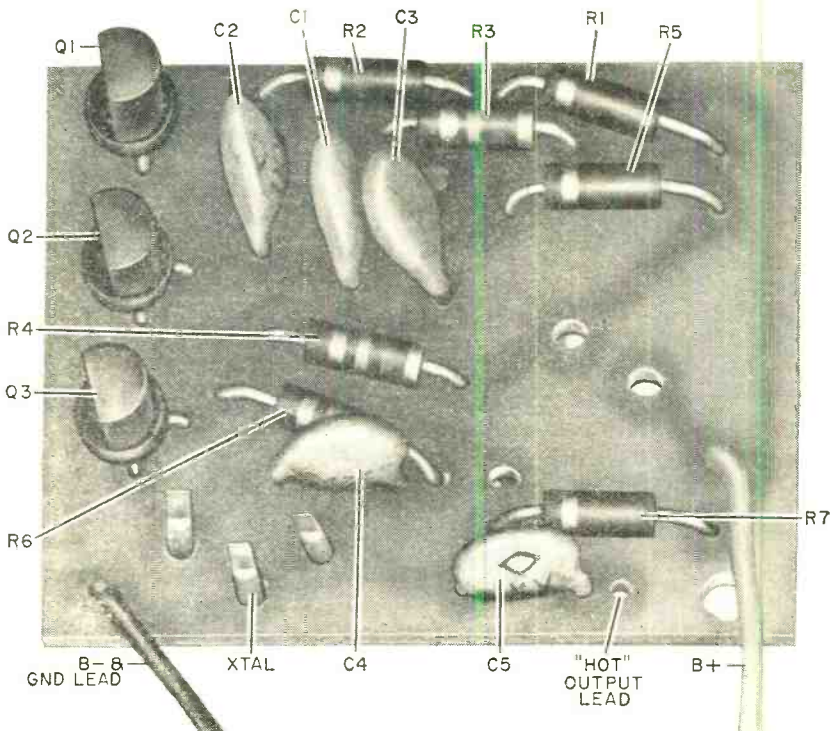
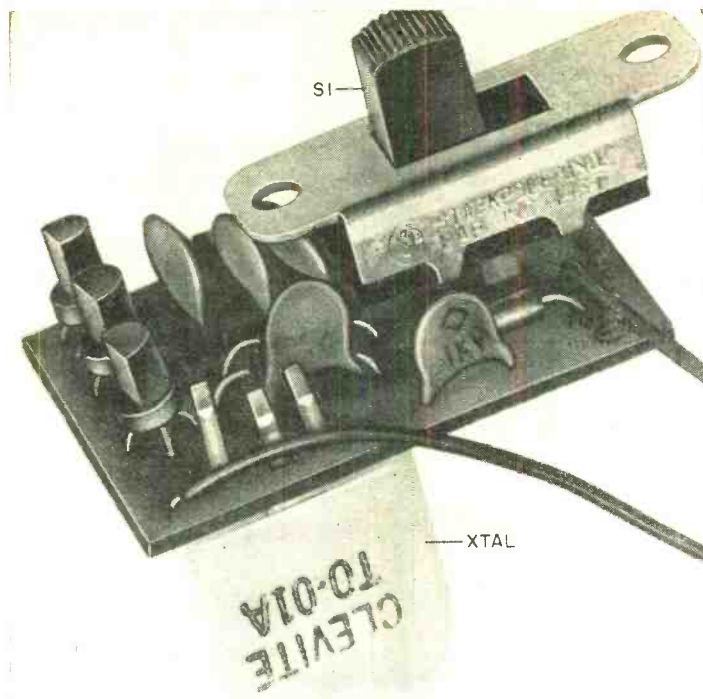

Fig. 2. Actual size printed circuit etching guide is shown at left. Photo below shows component placement (except S1) on board.





Special Clevite Transfilter must be seated on circuit board from foil side; switch S1 mounts on top (component side) of board.

er. Tune the receiver to its lowest frequency (535-540 kHz, if the dial markings go that low). Turn on the receiver.

With the receiver volume turned up, you should hear the 500-Hz tone coming from its speaker. However, if you do not hear the tone, or the tone is too low in volume, move the Micro'Lign's loop closer to the antenna; if too loud, move the loop farther away. Now, adjust the i.f. transformer slugs to obtain the loudest note. Move the Micro'Lign away from the receiver until the note volume diminishes, and adjust the slugs again for maximum volume. Do this until you hear no perceptible change in the level of the note.

After peaking the i.f. transformers, turn off the Micro'Lign. Tune in a station at the low end of the receiver dial and adjust the oscillator coil slug and the setting of the station selector until

you hear the broadcast on the correct dial setting. Now, tune in a station at the top end of the receiver dial, and adjust the oscillator trimmer capacitor and the setting of the station dial until the station comes in at the proper dial setting. Repeat this procedure at the low and high ends of the dial until no further change is noted.

Again, turn on the Micro'Lign. Tune in the generator's signal at 910 kHz on the receiver dial. Move the Micro'Lign away from the receiver until you can barely hear the signal. Adjust the antenna trimmer capacitor for maximum volume level.

The Micro'Lign can also be used as a signal injector for troubleshooting the audio and i.f. stages in both tube and transistor type receivers. It can even be used to trace troubles in high quality amplifiers.

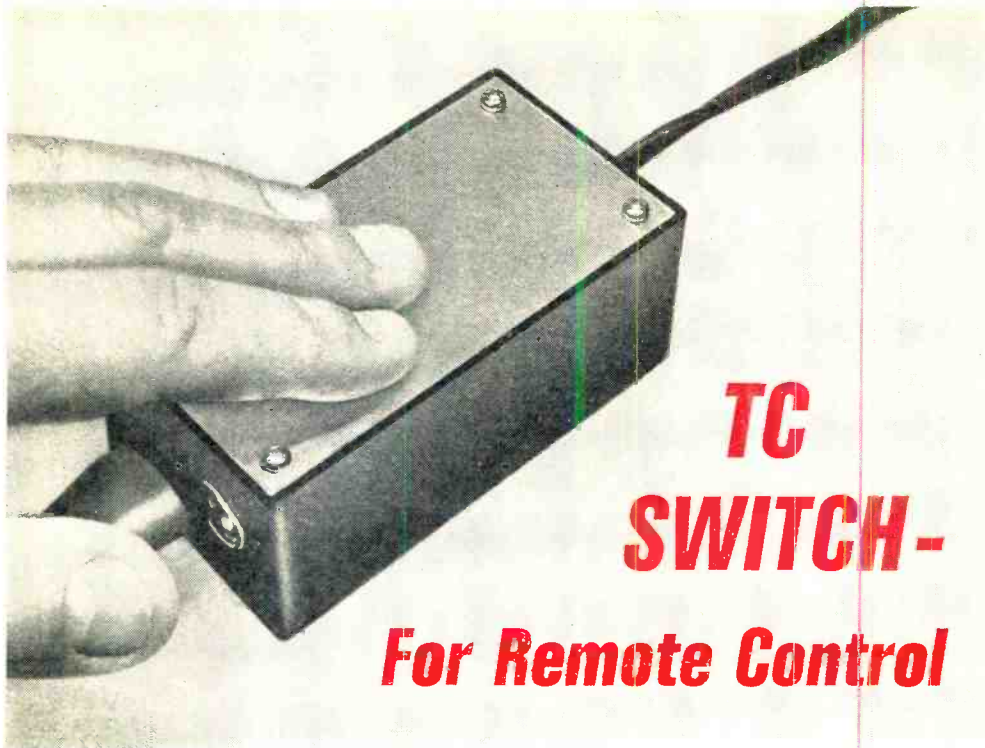

ONE TOUCH, IT'S ON—ANOTHER, IT'S OFF

BY JACK BECHTOLD

WHEN YOUR "lazy streak" gets the upper hand and convenience is the most important thing in the world, that's when you want a "Touch Control Switch." With this handy device you can turn off the television without getting out of bed; you can start the coffee to perking without moving from the dining table; and you can turn on the lights when you come in the house with your arms full of packages.

The Touch Control Switch can be located any place where a wall outlet is available. The appliance or light to be controlled is then plugged into the TC Switch and can be turned on or off with a simple touch of the finger, wrist, elbow, etc. The touch plate can be located remote from the TC Switch itself to make control even more convenient and versatile.

About the Circuit. The circuit of the TC Switch is composed of five main

sections—detector, pulse shaper, switch memory, switch, and power supply. Alternate touches of a metal plate toggle on and off a triac, gated by a flip-flop circuit. The system operates around a multifunction integrated circuit (IC1 in Fig. 1) which consists of an inverter, two inverter/buffer stages, and a J-K flip-flop.

Referring to the schematic diagram, when the user touches the touch plate, he creates the equivalent of small capacitance C_b which forms a series circuit with C_3 to provide a voltage divider across the a.c. line. As soon as the potential across C_3 exceeds the firing voltage of I_1 , SCR1 triggers into conduction (the SCR is very sensitive, requiring only a few microamperes to trigger it). As long as contact is made with the touch plate, SCR1 remains conducting on the positive alternations of the a.c. line, producing a low-voltage, half-wave rectified train of pulses across R_4 .

The pulse shaper section generates a

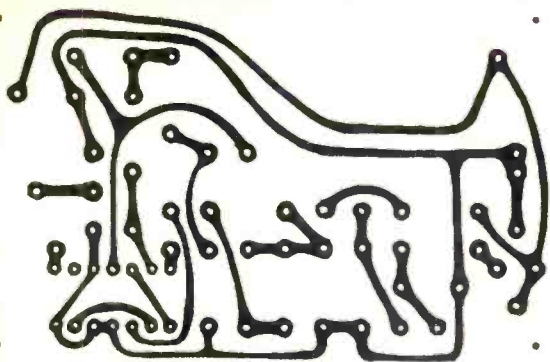
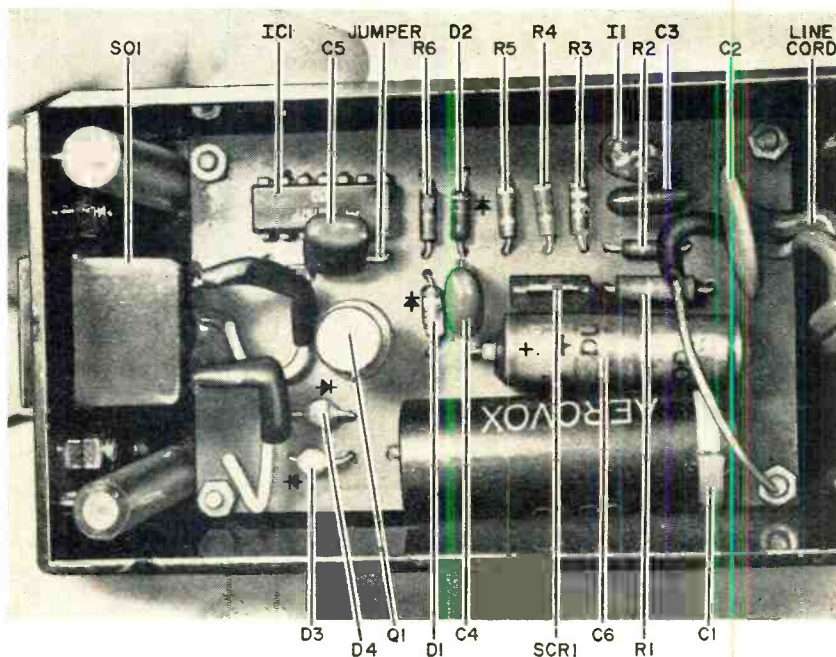

Fig. 2. Full-size etching guide is shown at left. Photo below shows component locations on circuit board and box ends.



circuit board (see Fig. 2 for etching guide and part location photograph) and mounted inside a plastic case that is equipped with an aluminum cover. The metal cover will then serve as a convenient touch plate.

Be very careful when soldering into place the solid-state components to prevent heat damage. Use a low-power soldering iron (not more than 40 watts) and a clip-on heat sink. Also, before mounting *Q1* slip on the finned heat sink specified in the Parts List.

After assembling the circuit, make the rectangular cutout and drill a $\frac{1}{4}$ " hole at opposite ends of the plastic case for the a.c. receptacle and line cord entry, respectively (see Fig. 3). Now feed the free

end of the line cord through the hole, tie a strain relief knot in it, and solder the conductors to the appropriate points on the circuit board. Then solder 2" lengths of hookup wire to the appropriate circuit board holes for the a.c. receptacle. Use $\frac{3}{8}$ "-long spacers and 4-40 hardware to mount the circuit board on the bottom of the case.

Next, mount the a.c. receptacle in place. Cut the leads coming from the circuit board to the appropriate lengths, strip the ends, and solder them to the lugs on the receptacle.

There should be an uninsulated lead still left to connect. This lead goes to the touch plate via one of the hold-down screws used to secure the aluminum cov-

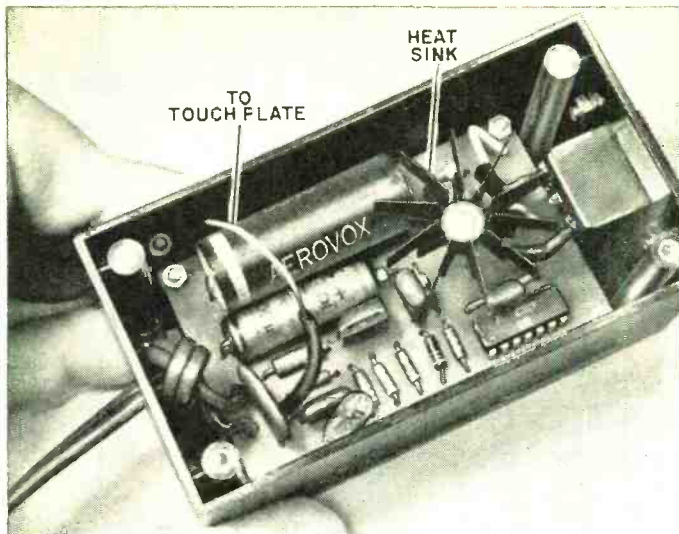

Fig. 3. Heat sink slips onto Q1's case; bare wire end goes to cabinet's metal cover plate.

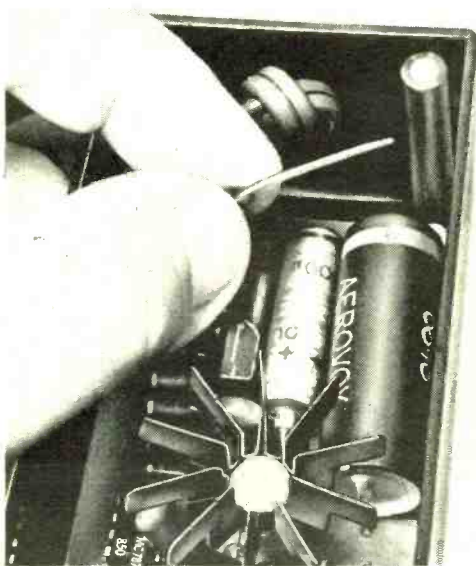

Fig. 4. Bare wire can be either wrapped around cover holddown screw or clamped in screw receptacle.

er. Cut this lead to a length of 3" and route the wire to the nearest screw hole, making sure it does not touch any other component or lead (see Fig. 4). Slip on the case cover, and secure it with the screws supplied.

How To Use. Before using the TC Switch, it is a good idea to keep in mind that full line voltage is present at various points in the circuit. For this reason, it is recommended that you not operate

the circuit with the cover of the case removed; if you must, exercise extreme caution. You can obviate any possibility of shock hazard if you epoxy encapsulate the entire circuit board before mounting and slipping heat-shrinkable tubing over the lugs of the a.c. receptacle.

Connect the lamp or appliance you wish to control to the TC Switch via the a.c. receptacle. turn on the appliance, and plug in the line cord of the touch switch. If the appliance immediately goes on, touch the metal plate on the touch switch; the appliance should go off. In the event that the lamp or appliance does not turn on immediately as the line cord is plugged in, touch the touch plate to turn it on. If nothing happens, reverse the line cord at the wall outlet.

For proper operation of the TC Switch, alternate touches of the metal plate should turn the appliance on and off.

The TC Switch, with the parts specified, will handle a maximum load of 150 watts. If you want to control an appliance with a greater drain, you can substitute a higher power triac for Q1, The RCA 40485, for instance, safely handles loads up to 720 watts (be sure to use the appropriate heat sink).

Instead of using the aluminum cover of the case as a touch plate, a remote touch plate can be used. This permits you to use a wall plate, mounted on a commercial wall box. However, make the distance between the project and remote touch plate as short as possible. -30-

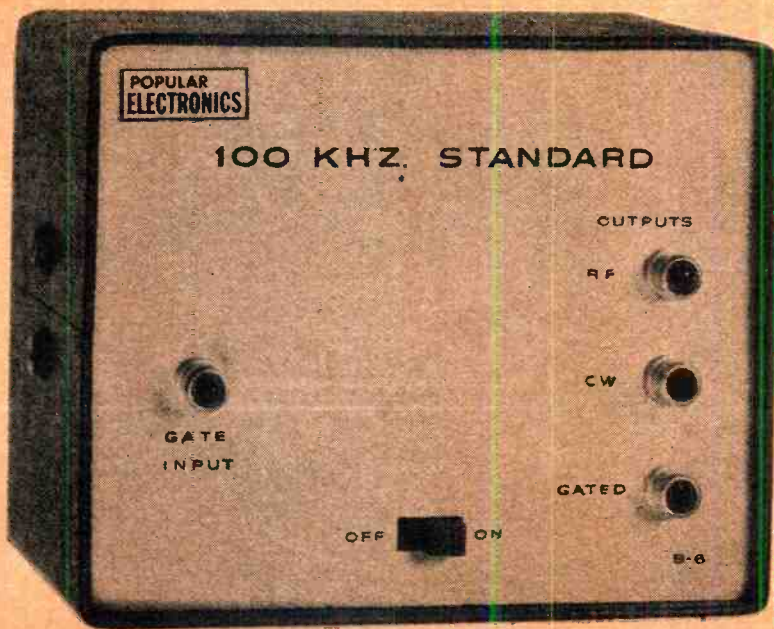

Build The 100-kHz Standard

STABLE, ACCURATE SOURCE OF REFERENCE SQUARE WAVES

BY DON LANCASTER

A STABLE, accurate source of 100-kHz reference square waves has many applications—most of which are adequately filled by the “100-kHz Standard” described here. For the ham or SWL, it is a must for receiver calibration, providing a “birdie” every 100 kHz and, if desired, it can be adjusted to zero beat against WWV for optimum accuracy.

For general experimental and laboratory work, the Standard can be used as a top-notch calibrator for oscilloscopes

and r.f. generators, since it has a very accurate frequency and excellent rise time (about 12 nanoseconds) for probe compensation.

In work involving digital IC's, the unit is a handy high-frequency clock source. For example the frequency can be divided to obtain ultra-precise time gates for an electronic counter. Or, the gate input can be used to start and stop the gate output making available a train of 10- μ sec pulses that can be fed to the counter to measure the velocity of a bullet and perform other experiments in the laboratory.

About the Circuit. The 100-kHz standard employs a crystal and a single integrated circuit (XTAL and IC1 in Fig. 1) in a very simple circuit. Three outputs are provided: CW (J3) for 100-kHz square waves all of the time; RF (J2) for wide-spectrum narrow (10- μ sec) period spikes for receiver calibra-

IC
EXPERIMENTER'S
CORNER

tion; and GATED (*J4*) for the 100-kHz square waves only when a separate GATE INPUT (*J1*) is grounded. Application of +1.4 volts d.c. to the GATE INPUT removes the output signal.

In addition, an internal trimmer capacitor, *C5*, is provided to allow shifting the frequency approximately 100 Hz on either side of the crystal frequency to provide compensation for crystal tolerance, variations in supply voltage and temperature, and zero beating with WWV. A buffer stage between the oscillator and the outputs insures minimum constant loading.

Integrated circuit *IC1* consists of four

two-input gates, two of which are biased into the class A region to act as linear amplifiers with resistors *R1* and *R2*. These amplifiers are cross-connected to each other through capacitors *C3* and *C4* and the crystal to form a feedback loop.

A third gate and *R3* provide an isolating buffer stage. The output of this gate goes to *J3* directly, and to *J2* through capacitor *C6* to provide only the sharp leading and trailing edges for the calibrator output.

The fourth gate is the only one in which the second input is used. This stage is used for gating the CW output

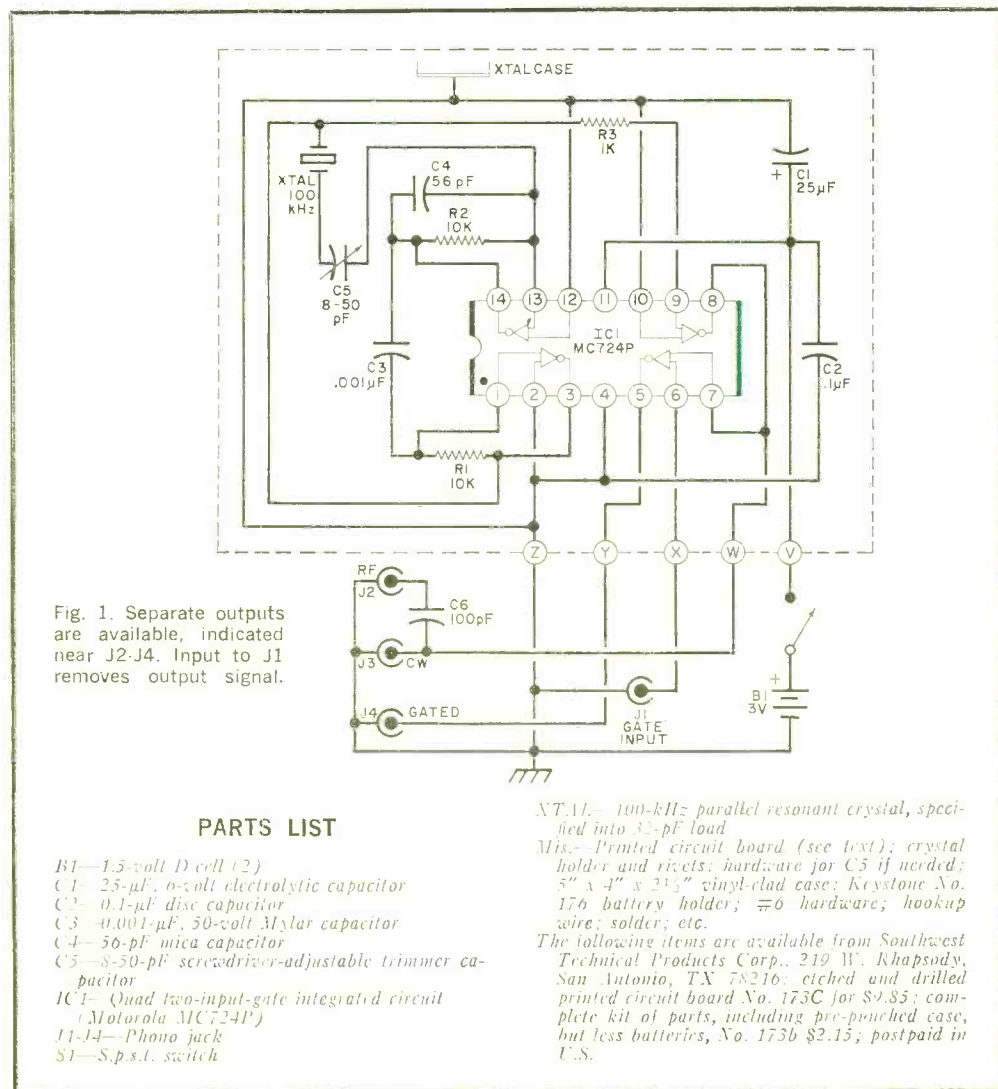

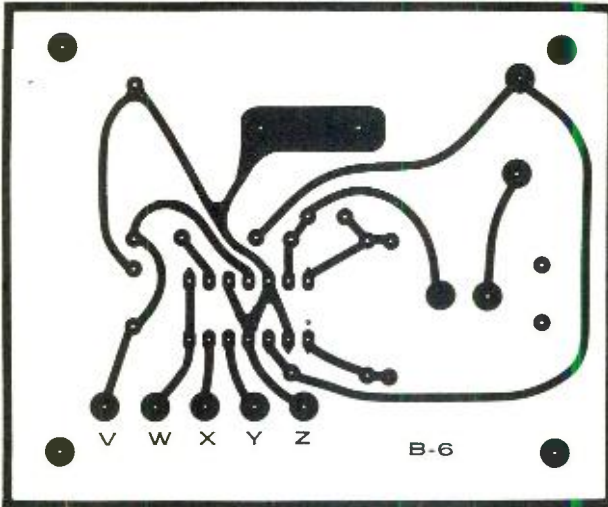

Fig. 2. Full-size printed circuit etching guide at left should be copied exactly as shown. Exercise caution to avoid short circuits between close proximity IC pin solder pads.

and, in turn, provide a gated output signal.

The crystal specified is a 100-kHz parallel-resonant type into a 32-pF load. When $C5$ is set to 32 pF, the operating frequency will be the same as the characteristic frequency of the crystal. Increasing the capacity of $C5$ decreases the crystal's operating frequency, and vice versa. This feature allows the user to "pull" the oscillator frequency to exactly 100 kHz.

Construction. A printed circuit board is recommended for this project. You can buy one already etched and drilled (see Parts List), or you can make your own by carefully following the etching guide provided in Fig. 2.

The first step in assembling the circuit is to rivet the crystal clip to the component side of the PC board in the appropriate location. Then mount the components on the board as shown in Fig. 3. Use a low-power, small tip soldering iron to solder the leads of $IC1$ to the foil pattern, and apply heat just long enough to get the solder to flow.

Next, mount the circuit board to the front panel with #6 hardware and four $\frac{1}{2}$ "-long spacers. Interconnect the jacks, switch, and circuit board.

For a housing, you can use either the pre-punched vinyl-clad one specified in the Parts List or a 5" \times 4" \times 3" metal

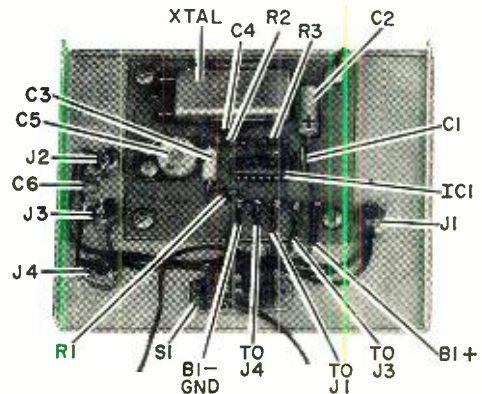
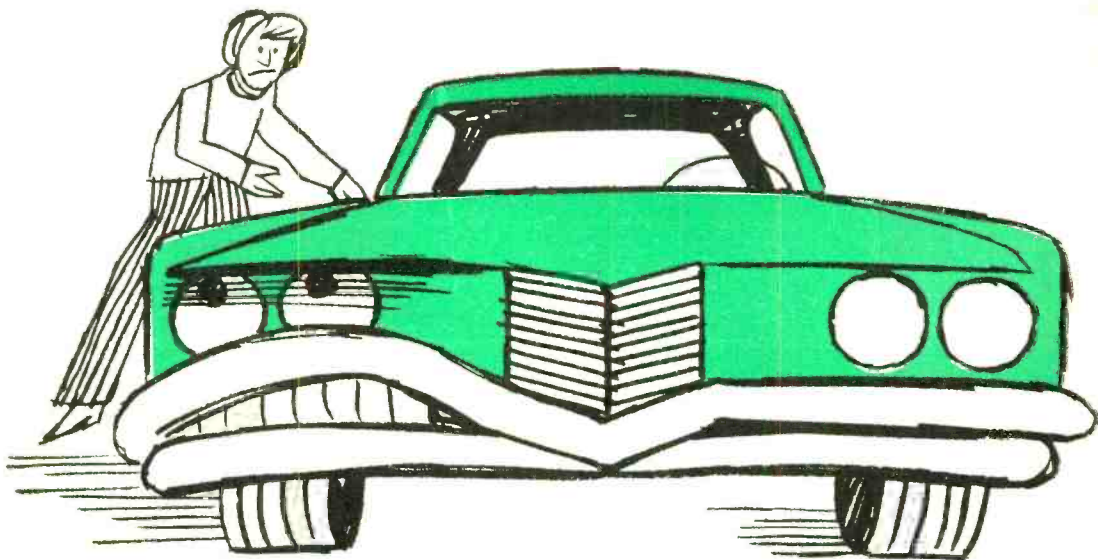

Fig. 3. Photo shows component locations on circuit board and front panel. Notch on $IC1$ is to left.

utility box. In either case, the batteries should be mounted to the rear of the case, and an access hole to $C5$ should be drilled. (Note that both sides of $C5$ must be "floating," precluding the use of a conventional panel-mounting variable capacitor; so do not attempt to substitute this component.)

How To Use. Calibration of the 100-kHz Standard is needed only for very exacting applications since the normal operating frequency of the standard will usually be well within a 99.9-100.1-kHz range. To calibrate, use either an electronic counter or a communications receiver tuned to a high-frequency WWV transmission. Adjust $C5$ with an insulat-

(Continued on page 105)



Automatic
**VEHICLE
BURGLAR
ALARM**

OVERALL PROTECTION—
WITHOUT AN
EXTERNAL
KEY
SWITCH

IF YOUR CAR is stolen, there are automobile rental agencies which will give you special rates until the insurance pays off. That's some comfort; but these days most people should prefer a burglar alarm system to prevent theft in the first place. Most of these alarm systems require an external lock in a hole drilled somewhere in the car frame—and that leads to trouble due to dirt and ice in the lock or the fact that you lose or forget the key.

With an automatic Vehicle Burglar Alarm that is entirely electronic you can



BY GEORGE MEYERLE

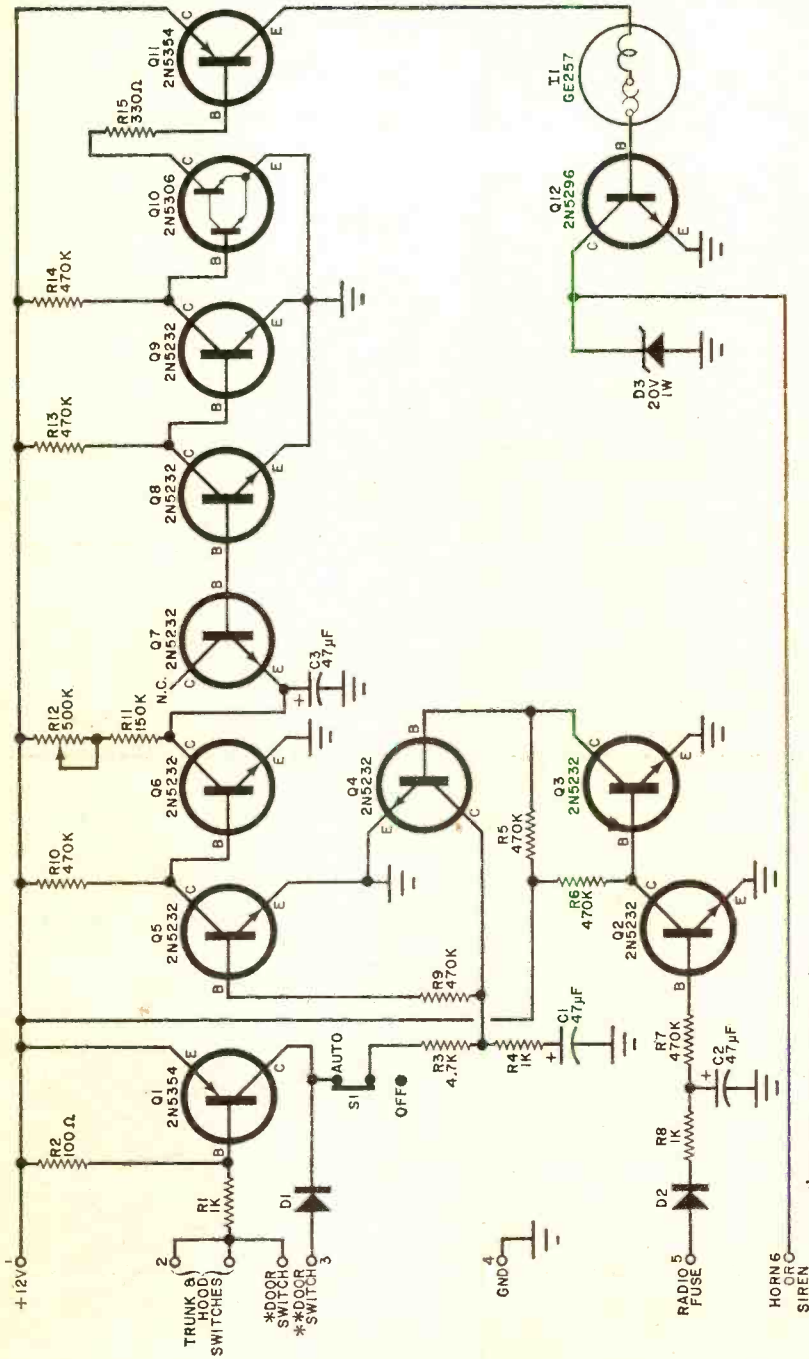

Fig. 1. The circuit appears complicated because there are three timing circuits as well as a multi-transistor power-driver for the vehicle horn. If you desire siren operation, substitute a 220-ohm, 1-watt resistor for R11 and use the output line to operate a suitable relay, that in turn operates the siren.

*EXCEPT FORD PRODUCTS
 **1965 TO PRESENT FORD

protect your car easily and completely without the use of an extra key. Once it is installed, you can forget about it and rest assured that the car, plus the contents of the hood and trunk, are protected by a loud, persistent alarm system.

Hidden in the glove compartment, the alarm arms itself two minutes after the ignition key is turned off. This gives you sufficient time to get out of the car and close all the doors. When you return and open the doors, you have 10 to 45 seconds (depending on how you set the controls) to put the key in the ignition switch and turn it either to the ignition or accessories position before the alarm circuit is activated. Wired directly to the courtesy light circuit, the system operates when the car doors are opened. Other, optional switches are mounted under the hood and trunk covers to protect those areas.

If the alarm should sound before you get the key in the ignition, it will shut off as soon as the key is inserted. For the alarm, you can use either the vehicle horn or an optional siren. With the horn the alarm does not operate continuously, but "beeps" about once per second.

PARTS LIST

- C1-C3—47- μ F, 15-volt tantalum electrolytic capacitor (Sprague 150D or similar)
 D1, D2—50-volt, 1-ampere silicon diode
 D3—20-volt, 1-watt zener diode
 I1—Thermal flash lamp (GE257 or similar)
 (I1, Q11)—2N5354 (GE)
 (Q2, Q9)—2N5232 (GE)
 (O10)—2N5306 (GE)
 (O12)—2N5296 (RCA)
 R1, R4, R8—1000-ohm
 R2—100-ohm
 R3—4700-ohm
 R5—R7, R9, R10, R13
 R14—470,000-ohm
 R11—150,000-ohm
 R12—500,000-ohm, printed circuit potentiometer
 R15—330-ohm, $\frac{1}{2}$ -watt resistor
 S1—S.p.s.t. slide or toggle switch
 Misc. Metal cabinet, insulated color-coded leads, barrier strip (three lug), solderless splice connectors (2), fuse connectors (2), normally closed spring-loaded switch (2, optional), horn relay for Ford products, siren (optional), mounting hardware.

Note—The following are available from Metro-tee Industries, 1405 Northern Blvd., Roslyn, N.Y. 11576: printed circuit board, \$1.75; PC board and all electronic components, \$12.95; complete kit including all hardware, fuse connectors, solderless splices, decal, two remote switches, and metal cabinet, \$17.50; wired and tested unit with 2-year guarantee, \$29.95; trunk and hood switches, 50¢ each; horn relay for Ford products after 1965, \$1.50; heavy duty siren, \$17.95. New York state residents, add 5% sales tax.

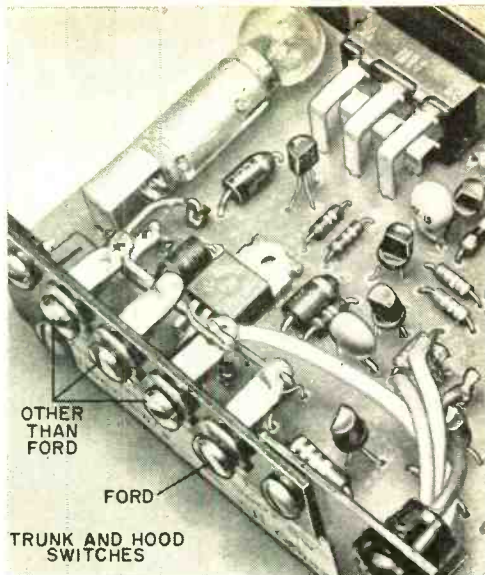

Fig. 2. The prototype was arranged for both Ford and non-Ford products. If you build your own, use only the terminals required and leave the others off. Three other-than-Ford lugs are in parallel.

The alarm sounds for about two minutes and then automatically stops. If the trouble has not been corrected—door, trunk or hood closed—the alarm starts again. If the condition has been corrected, the alarm remains off and rearms itself for further protection. This feature prevents needless public annoyance and battery drain and may also prevent a passerby from cutting a wire to make it stop. All he has to do is close the open door, hood, or trunk.

The circuit is designed so that, if you don't use the hood protection switch and a thief uses a jumper on the ignition circuit, the alarm will sound when he opens the door and tries to drive the car. The alarm will also sound, after the slight delay, even if a protected area is opened for a fraction of a second and then closed immediately.

A switch on the alarm chassis can be used to disable the system but it will not shut off the alarm once it has been set off by an intruder. The alarm system is designed to operate with any 12-volt negative-ground system. It is not temperature sensitive and standby current is only 250 microamperes.

Construction. The circuit of the automatic burglar alarm is shown in Fig. 1.

Second in a series...

Can you solve these problems in electronics?

They're a cinch after you've taken RCA Institutes' new communications electronics program.

It includes new preparation for the FCC license plus the assurance of your money back if you fail to get it.

This one is quite elementary.

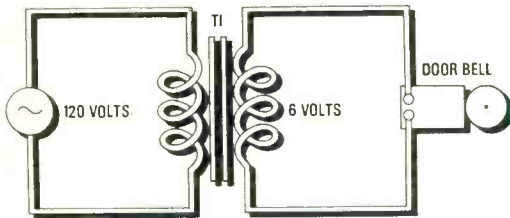

In this door bell circuit, which kind of transformer is T_1 — step-up or step-down?

Note: if you had completed only the first lesson of any of the RCA Institutes Home Study programs, you'd easily solve this problem.

This one is more advanced.

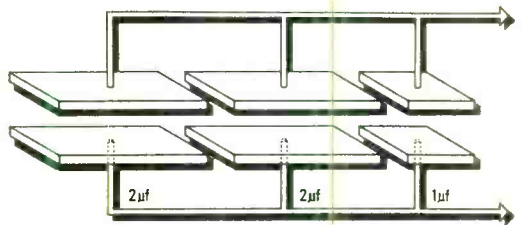

What is the total capacitance in the above circuit?

Note: you'd know the solution to the problem if you'd taken only the first two lessons in RCA's new Communications Electronics Program.

These are the lessons that prepare you step-by-step for an FCC License.

This license is a requirement for servicing all types of transmitting equipment and can help open doors to jobs commanding high income in communications, radio and broadcasting, aerospace, industrial automation and many others.

For a rewarding career with good pay, take that first step now. Send for complete information—mail the attached card.

Answers: Step-down.
5 µf

RCA Institutes Autotext learning method makes problem-solving easier... gets you started faster towards a good-paying career in electronics

Are you just a beginner with an interest in electronics? Or, are you already making a living in electronics, and want to brush-up or expand your knowledge? In either case, RCA has the training you need. And Autotext, RCA Institutes' own method of Home Training will help you learn more quickly and with less effort.

Wide Range of Courses

Select from a wide range of courses. Pick the one that suits you best and check it off on the attached card. Courses are available for beginners and advanced technicians.

Electronics Fundamentals
Black & White Television Servicing
(Transistorized TV Kit Available)
Color Television Servicing (Color TV Kit Available)
FCC License Preparation
Automatic Controls
Automation Electronics
Industrial Electronics
Nuclear Instrumentation
Electronics Drafting
Computer Programming

Plus these new up-to-the-minute courses

Semiconductor Electronics
Digital Electronics
Solid State Electronics
Communications Electronics

Prepare for good paying positions in fields like these

Television Servicing
Telecommunications
Mobile Communications
CATV
Broadcasting
Marine Communications
Nuclear Instrumentation
Industrial Electronics
Automation
Computer Programming
Solid State
Electronics Drafting



Build and keep this valuable oscilloscope.

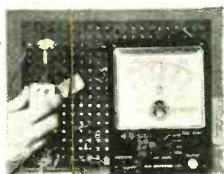

In the new program on Solid State Electronics you will study the effects of temperature and leakage characteristics of transistors.

RCA

Variety of Kits—Yours to Keep

A variety of RCA Institutes engineered kits are included in your program of study. Each kit is yours to keep when you've completed the course. Among the kits you construct and keep is a working signal generator, a multimeter, a fully transistorized breadboard superheterodyne AM receiver, and the all-important oscilloscope. These 4 kits are at no extra cost. Compare this selection with other home study schools.

Two Convenient Payment Plans

Pay for lessons as you order them. No contract obligating you to continue the course. Or, you can take advantage of RCA's convenient monthly payment plan. No interest charges!

Classroom Training Also Available

RCA Institutes operates one of the largest technical schools of its kind. Day and evening classes. No previous training is required. Preparatory courses are available. Classes start four times a year.

Job Placement Service, Too!

Companies like Bell Telephone Labs, GE, Honeywell, IBM, RCA, Westinghouse, Xerox, and major radio and TV networks have regularly employed graduates through RCA Institutes' own placement service.

All RCA Institutes courses and programs are approved for veterans under the new G.I. Bill.

**Send Attached Postage Paid Card Today.
Check Home Study or Classroom Training.**

Accredited Member National Home Study Council.

IF REPLY CARD IS DETACHED, SEND THIS COUPON

RCA Institutes Inc.

Home Study Dept. 694-004-0
320 West 31 Street
New York, N. Y. 10001

Please send me FREE illustrated career catalog.

Name _____ Age _____
(please print)

Address _____

City _____ State _____ Zip _____

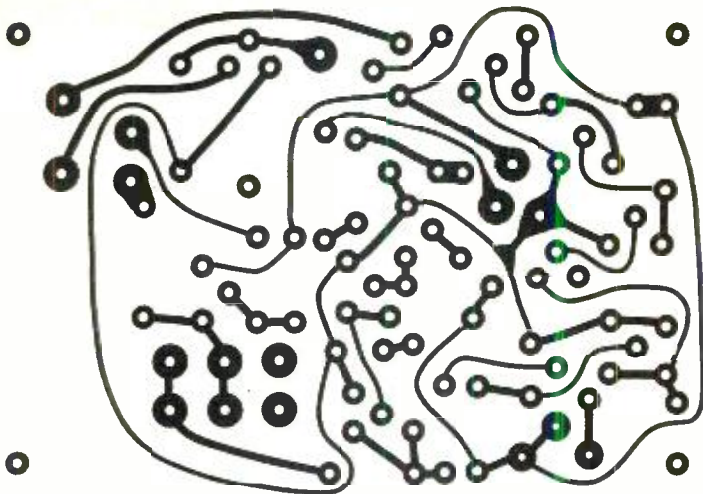
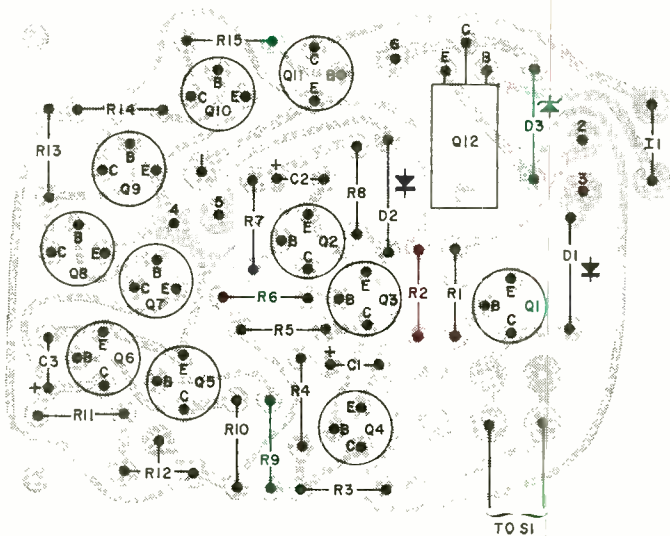

Fig. 2. Actual size foil pattern for the alarm. It can be easily duplicated with some reasonable care.

Fig. 3. Install the components as shown here. Be sure the semiconductors and the electrolytics are correctly installed and watch for solder bridges.



A printed circuit board (Fig. 2) should be used in the construction. (See Parts List if you want to buy one already etched and punched.) Mount the components on the board as shown in Fig. 3.

Install the board in a suitable metal enclosure with switch *S1* on the front panel. Drill a hole for screwdriver adjustment of potentiometer *R12*. Also drill a hole and put a grommet in it for the wires to the car's electrical system. These wires should be color-coded and about 5 feet long. Wires are connected to terminals 1, 4, 5, and 6 on the board. Also connect a wire to terminal 3 if your car is a Ford product. If it is not, mount a three-

lug barrier strip on the back of the alarm chassis and connect the three lugs in parallel to terminal 2 on the circuit board. (See Fig. 4, A and B)

Installation. The alarm may be placed in the glove compartment with a small hole in the bottom or rear of the compartment for the leads. Connect the lead from terminal 1 to any point that is always at 12 volts, whether or not the ignition is on. This can be on the clock, cigarette lighter, turn indicator, dome light, battery, etc. The lead from terminal 4 is secured to any point that is in electrical contact with the vehicle chassis

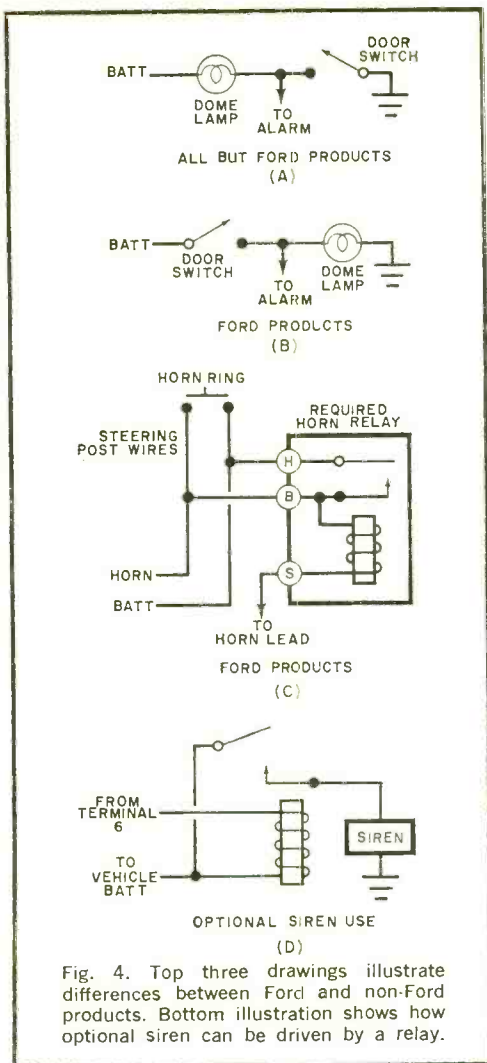

Fig. 4. Top three drawings illustrate differences between Ford and non-Ford products. Bottom illustration shows how optional siren can be driven by a relay.

(ground). Connect the lead from terminal 5 to either side of the fuse that supplies the radio (or any other accessory that is powered only when the ignition key is in either the ignition or accessory position).

Connect terminal 6 to the horn. If the car is not a Ford product, the horn sounds only when this wire is grounded. You can use a length of test lead with one end connected to the chassis and the other end terminated in a pin or needle to find the wire that will make the horn sound. If you have a Ford product, an additional horn relay must be used, wired as shown in Fig. 4C.

If the car is not a Ford product, connect one lug of the barrier strip (terminal 2 of the board) to the lead coming from the dome or courtesy lights. The other two lugs on the barrier strip are used to make connections to the switches on the hood and trunk. These switches should be installed so that they close when the hood or trunk lid is opened. To install the switches, locate a spot where the lid comes close to the metal chassis when the lid is closed. Use good-quality insulated wire to connect these switches to the barrier strip on the alarm. Secure the wires so that they do not interfere with other vehicle wiring and operation. Do not hook up the dome light or remote switches to the barrier strip at this time.

In Ford products, the door switches are not grounded on one side. Therefore connect these switches to terminal 3 on the board and ignore the barrier strip. If you want hood and trunk protection in Ford

Although designed for automobiles, the burglar alarm can be fitted to a boat by installing hood or trunk switches on various access doors. Anyone entering such a protected area causes the boat's horn to blast an alarm signal.



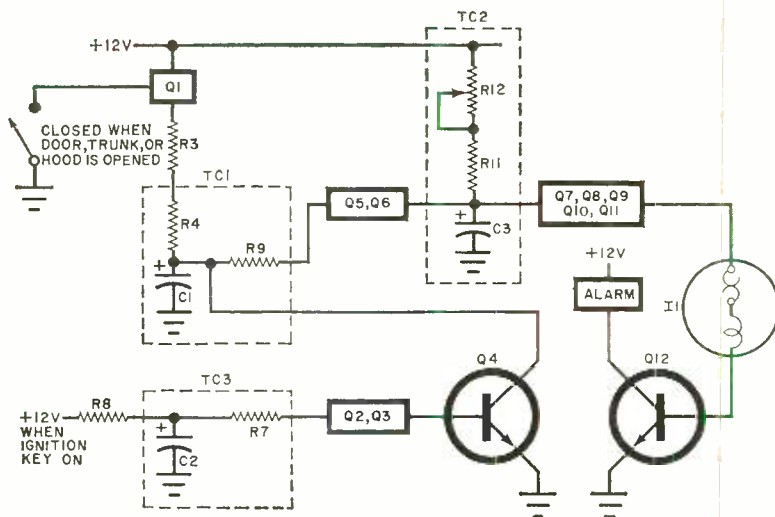

HOW IT WORKS

All of the protected-area switches are open when the doors, trunk and hood are closed. When any one of these areas is opened, the associated switch closes. The base of transistor *Q1* is automatically grounded and the transistor is turned on. The time constant of timing circuit *TC1* is about 2 minutes. While *TC1* is discharging, *Q5* and *Q6* are turned on and timing circuit *TC2* is energized. Its time constant is made variable from about 10 to 45 seconds. As soon as this shorter time constant is reached, alarm drivers *Q7* through *Q11* supply base current to power transistor *Q12* through thermal flash lamp *I1*.

As long as base current is flowing in *Q12*, the alarm sounds. The flash lamp has a built-in thermal circuit breaker that opens the filament circuit after the filament has reached a predetermined temperature. When the breaker opens, the current to the lamp and *Q12* is interrupted

and the alarm stops. After a very short time—about one second—the filament cools off and the breaker closes to remake the circuit. This cycle repeats producing a “beeping” of the horn or alarm.

After about 2 minutes when the time constant of *TC1* has been reached, if the protected area has not been closed and all switches returned to open, the alarm system continues to operate. If the protected area has been closed in the meantime, *TC1* stops charging and the system is reset, ready to operate again if any switch is closed.

When the operator gets into the vehicle, he has the time determined by the setting of *R12* (10 to 45 seconds) to insert the ignition key. When this is done, timing circuit *TC3* charges up and transistors *Q2*, *Q3* and *Q4* are turned on. This drains the charge off of *TC1*. When the ignition key is removed, *TC3* starts its discharge of about two minutes. After that, *TC1* is ready to be charged up again.

products, wire these switches to the barrier strip (terminal 2) connectors.

When all wiring is complete, recheck everything to make sure it is correct. Close the trunk and hood lids and use an ohmmeter to make sure that the normally open switches are open when the lids are closed and closed when the lids are open.

With all doors closed, connect the door, hood, and trunk switches to the alarm. Insert the key in the ignition and momentarily turn on the accessories. Turn the ignition off and wait at least two minutes.

The alarm is now armed as it would be in normal use. If any protected area is opened now, even for a fraction of a second, the alarm should sound after 10 to 45 seconds. To stop the alarm, turn the ignition on momentarily. Using a small screwdriver, adjust potentiometer *R12* to get the desired off time between triggering and sounding of the alarm.

If you require an unlimited amount of time with the doors, trunk or hood open, place the key in the ignition and turn it
(Continued on page 73)

GETTING TO KNOW THE UJT

AN ALL-ROUND SIGNAL GENERATOR:
SAW-TOOTH, SQUARE-WAVE, SINE-WAVE

BY FRANK H. TOOKER

ALMOST EVERYONE who has an interest in electronics is aware of the existence of a device called the unijunction transistor, or UJT. (If he remembers it from its very beginning, he might recall that it was originally referred to as a "double-base diode.") The UJT is used most often in circuits requiring a positive-going spike pulse and, occasionally, as a generator of sawtooth waveforms.

However, the UJT is actually much more versatile than these two uses would imply. It can also be used to generate square waves and, believe it or not, sine waves having quite pure waveforms. It behooves the serious electronics experimenter to learn more about all of these uses—and to do so, he will need to know more about the UJT itself.

How the UJT Works. The UJT can be represented by a circuit approximation consisting of two resistances in series, with a diode connected at their junction as in Fig. 1. (Also shown in the figure is the accepted schematic symbol and base diagram for the UJT. Note that in

both cases the leads are identified as E, B1, and B2 for emitter, base-1, and base-2.) The resistance approximation is a *passive* representation of the UJT. In simple terms, this means that a pair of resistors and a diode connected as shown will *not* operate as a unijunction transistor. The approximation is simply a means by which operation of the UJT can be explained.

In the majority of applications, the

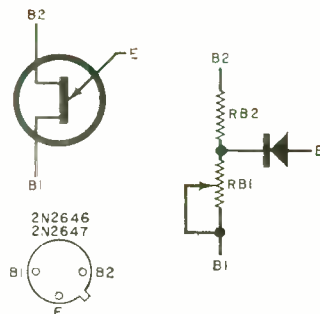

FIGURE 1

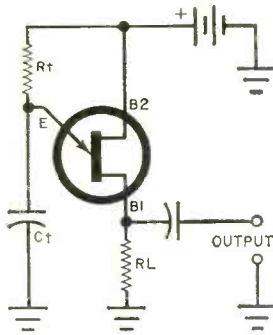

FIGURE 2

emitter is the control electrode of the UJT. The magnitude and polarity of a potential applied to the emitter determine whether or not the UJT will fire. With the emitter circuit open (diode non-conducting), resistance $RB1$ is maximum, and the sum of $RB1$ and $RB2$, called interbase resistance, is between 5000 and 10,000 ohms for the 2N2646 and 2N2647 (two typical, useful UJT's).

Resistance $RB1$ is shown variable because current flow in the emitter circuit causes a decrease in the ohmic value of this resistance. The greater the current flow, the lower the resistance. Hence, a UJT exhibits negative resistance, a characteristic that can be thought of as amplification. What actually happens inside the UJT is that current flowing into the E-to-B1 circuit "pulls" current carriers from the B2 area, increasing the circuit's conductance.

The supply voltage, usually applied through a series resistor, is connected across the interbase resistance, B1 to B2, with B2 positive with respect to B1. To fire the UJT, a positive potential (called the peak-point voltage) is applied to the emitter.

The ratio of $RB1$ to the interbase resistance is called η (Greek eta), or the intrinsic standoff ratio. The peak-point voltage is this ratio times the supply voltage plus the potential hill of the diode (about 0.5 volt). Thus, the voltage required for firing the UJT varies as the supply voltage is varied, and in the same direction.

UJT Relaxation Oscillators. The schematic diagram in Fig. 2, or some varia-

tion of it, is probably familiar to most experimenters. It is the one most commonly used circuits for relaxation oscillators by circuit designers.

Referring to the diagram, capacitor Ct charges up through resistor Rt at a rate determined by the RC time constant of these two components. The larger these values, the slower the charging rate. During the charging interval, the emitter junction is reverse biased, and the only current flowing in the emitter circuit is due to leakage (similar to the I_{co} of a bipolar transistor). Emitter leakage for the 2N2646 is a maximum of 2 μA , and for the 2N2647, only 0.2 μA .

When the potential across Ct reaches the value of peak-point voltage for the particular UJT being used in the circuit, the emitter junction goes suddenly into conduction. Using the UJT approximation shown in Fig. 1, $RB1$ promptly drops to a much lower value and Ct in Fig. 2 discharges abruptly through load resistor RL , producing a spike pulse of voltage across the output terminals.

Capacitor Ct does not discharge to zero potential. Rather, it is discharged to a value determined by the series resistance between the emitter and ground and the magnitude of the discharge current. The actual value to which Ct discharges is termed the "valley voltage." When Ct discharges to this value, the emitter junction of the UJT becomes reverse biased again; then Ct begins to recharge, and the cycle repeats. The charge-discharge action of Ct produces a sawtooth waveform signal.

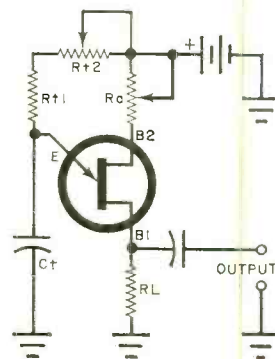

FIGURE 3

When It Doesn't Work. The operation of a UJT relaxation oscillator involves more than just raising the potential across timing capacitor Ct to the firing level. A certain value of current, called the "peak-point emitter current," is required to fire the unijunction transistor. This current must be supplied through timing resistor Rt (see Fig. 2). If the current through Rt is too low, capacitor Ct will charge to a value that is below the peak-point voltage, and operation will cease. The UJT will not fire. This need for sufficient emitter current becomes important when Rt must have a large value to operate the UJT at a very low repetition rate.

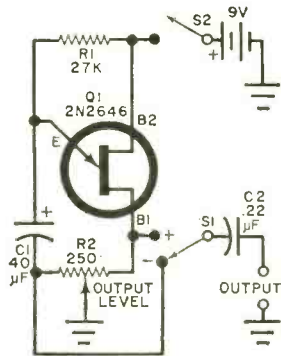

FIGURE 4

The peak-point emitter current for the 2N2646 is about $5 \mu\text{A}$; for the 2N2647 it is only $2 \mu\text{A}$. It is important to bear in mind that even though the 2N2647 is 2.5 times better than the 2N2646, if an electrolytic capacitor is used in the circuit, the leakage current of the capacitor has the same effect as an identical increase in the peak-point emitter current of the UJT. Consequently, care must be exercised in choosing a capacitor with the lowest leakage or the value of the 2N2647 might be lost.

Characteristics vary from one UJT to another, even for those with the same type number. Thus, if the relaxation oscillator is to have a definite repetition rate, the value of timing resistor Rt should be made adjustable to allow you to "trim" the circuit to the desired frequency or repetition rate.

The circuit shown in Fig. 3 has trimming facilities. Varying the resistance of either Ra or $Rt2$ varies the interbase voltage, thereby altering the peak-point voltage and, thus, the repetition rate. The value of potentiometer Ra in such a circuit should be limited to a maximum of 5000 ohms.

Negative-Pulse Generator. Pulses obtained at the B1 terminal of a UJT are positive-going. Negative-going pulses can be obtained from the B2 terminal when a resistor is connected between B2 and ground. Negative pulses can also be obtained from a resistor connected in series with the lower end of the timing capacitor.

The circuit shown in Fig. 4 provides a choice of either positive or negative pulses, depending on the setting of $S1$. Adjusting the setting of level control potentiometer $R2$ adds resistance to one of the two circuits, while it subtracts an equal amount of resistance from the other circuit. So, when $R2$ is set for maximum amplitude of a negative output pulse, resistance in the positive side of the circuit is zero, and vice versa. This gives the circuit maximum efficiency, providing maximum pulse amplitude in either direction.

The repetition rate of the circuit with the component values shown is about one pulse in every two seconds. This rate was selected to provide a useful instrument for checking experimental hookups

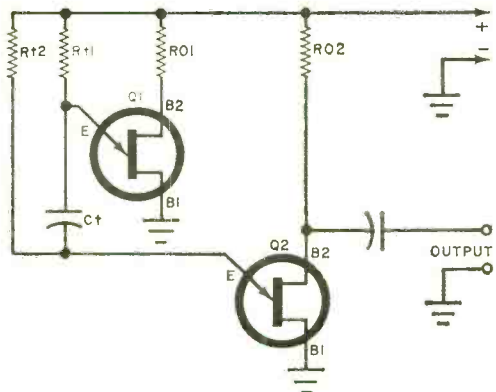

FIGURE 5

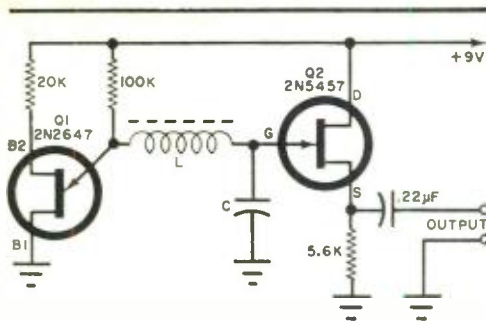

FIGURE 6

of JK flip-flops, SCR's, SCS's, and other pulse-operated devices.

Square-Wave Generator. The circuit of a square-wave generator (actually a dual-UJT multivibrator) is shown in Fig. 5. This circuit generates excellent square waves within the frequency range of efficient operation of the unijunction transistors.

When the power is applied to the dual-UJT circuit, both emitters are made positive with respect to ground through resistors $Rt1$ and $Rt2$. One UJT fires promptly, bringing both ends of the timing capacitor, Ct , to a value well below the peak-point voltage. This UJT remains conducting while Ct charges through the timing resistor of the other UJT circuit.

As soon as the second UJT's emitter becomes sufficiently positive with respect to ground, it suddenly conducts, driving the first UJT negative and causing it to stop conducting. With the second UJT conducting and the first cut off, Ct starts charging in the opposite direction, through the timing resistor of the first UJT. Now, when the emitter of the first UJT becomes sufficiently positive, it fires, and the second UJT cuts off. The alternate-stage fire/cutoff cycle is self repeating whenever power is applied to the circuit, and the output of the system is a train of rectangular pulses.

Sine-Wave Generator. Sine waves are produced by allowing a UJT circuit to charge and discharge a capacitor through an inductance. When the charge-discharge period is equal to the resonant

frequency of the LC circuit, sine waves are generated across the capacitor. A schematic diagram of a UJT sine-wave generator is shown in Fig. 6.

The tuned circuit of the generator is made up of inductor L and capacitor C . Field effect transistor $Q2$ operates as a source follower to prevent loading down the tuned circuit; this stage is not otherwise essential to the operation of the oscillator as a sine-wave generator. The circuit shown has operated well up to 50,000 Hz.

The output of the sine-wave generator is obtained across $Q1$'s source resistor. The waveform here is cleanest when the ratio of inductance to capacitance is high.

Modulate a Relaxation Oscillator. A UJT relaxation oscillator can be frequency modulated by applying the modulating signal across a resistor in the B2 circuit as shown in Fig. 7. The waveform of the modulating signal can be sine, sawtooth, square, triangular, or irregular.

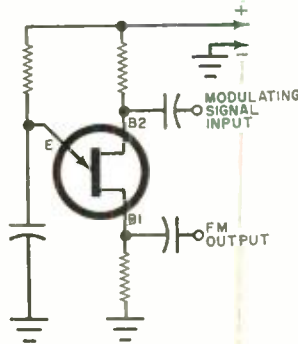

FIGURE 7

A practical example of a modulated UJT oscillator is shown in Fig. 8. This circuit is known as a "bell-tone" oscillator. In operation, $Q2$ and its associated components make up a relaxation oscillator which, when unmodulated, has an operating frequency of about 700 Hz. Unijunction transistor $Q1$ and its associated components make up a low-frequency astable multivibrator. The wave-form of the $Q1$ setup is not as good as that of the circuit in Fig. 6, but it

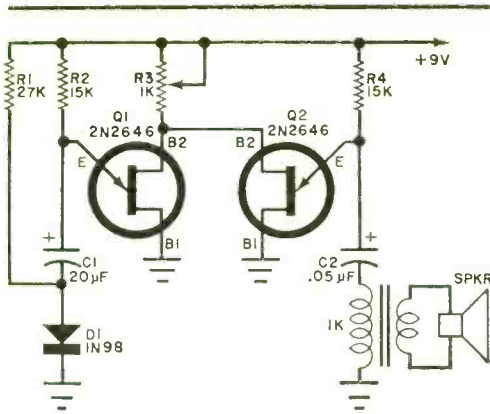

FIGURE 8

serves the purposes of the bell-tone oscillator well.

In the multivibrator, *C1* charges through *R2*, while diode *D1* is maintained in a forward conducting state by

the charging current and the current through *R1*. When *Q1* fires, reverse bias is applied to *D1*, and the diode appears as an open circuit. Transistor *Q1* remains conducting while capacitor *C1* discharges through resistor *R1*. At the end of this interval, *D1* begins conducting again, *Q1* cuts off, and the cycle repeats. The result is a rectangular signal across *R3*.

Since the B2's of *Q1* and *Q2* are tied together, each time *Q1* fires, its B2 signal decreases the interbase voltage of *Q2* and causes an increase in *Q2*'s operating frequency. As *Q2* conducts and cuts off, the pitch of the sound heard from the loudspeaker rises and falls sharply, giving the sound a distinct bell-like quality. The speaker is preferably a small one, such as a 3" replacement type, to provide "tinny" reproduction. When working with the circuit, adjust potentiometer *R3* to obtain the most pleasing sound.

-30-

AUTOMATIC VEHICLE BURGLAR ALARM/CONT. FROM P. 68

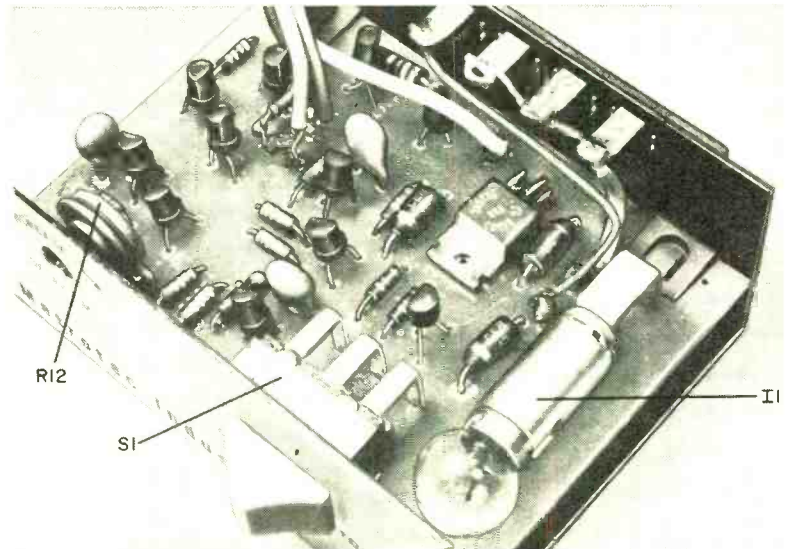

When mounting the PC board in the metal chassis, make sure that you can gain screwdriver access to *R12* so that delay time can be externally adjusted as desired. If you have no need to vary this time, the chassis hole can be eliminated.

on. Then turn *S1* to the off position. Return the switch to the automatic position to re-actuate the alarm.

To use a siren or optional horn, replace *I1* with a 220-ohm 1-watt resistor and wire the circuit as shown in Fig. 4D.

-30-

tips & techniques

PERMANENT MARKING PEN RENEWS WORN OUT DIAL MARKINGS

After years of service, the dial markings and numerals on some radio receivers and other electronic gear become worn out and faded, and the enamel cracks and falls out of the marking grooves. It is a messy and sometimes impossible job to clean some cabinets—notably plastic types—without causing further damage to the markings. However, in the case of white and ivory cabinets on which black enameled markings need refurbishing, it is a simple matter to restore them with a black permanent marking pen (such as the Sanford "Sharpie" shown in the photo). The points of such pens are just the right size to fit the grooves, and the ink is permanent and waterproof. Before using the marking pen, make sure the dial is clean and free of oil and grease.



—Art Trauffer

MINIATURE KNOBS FOR STANDARD SIZE POTENTIOMETERS

Most miniature potentiometers are available only with a linear taper; so it is often necessary to substitute a standard size pot when a log taper is required. If you are designing your project with the mini look, that standard pot will stick out like a sore thumb—unless you use a Harry Davis Co. Type 1450 miniature knob (available from Allied Radio Corp., catalog No. 47A4134). And if you need a position locator dot on the knob, you can apply a professional-looking one in just three steps. First, use the tip of a heated nail to mark the desired location of the dot. Next, enlarge the dot mark with the tip of a 3/32" drill (make it shallow). Finally, use a toothpick to deposit one drop of white model airplane dope in the hole. When the dope dries, put the knob on the shaft.

—Donald R. Hicke

CLASSIFY SOLID-STATE COMPONENTS WITH IDENTIFICATION "PLATES"

Once you have identified and tested unmarked transistors, diodes, and IC's, the next step is to record the data directly on the device. Unfortunately, grease pencil and graphite pencil markings rub off too easily,

and paper tags tied or taped to the devices often clutter up a spare parts box or become dislodged in the shuffle. The easy way out of your dilemma is to paint one of the surfaces of the device with liquid typing error cover-ups, such as "Sno-pake" or "Liquid Paper," and record the data on the coating with India ink or a ballpoint pen. These coatings apply quickly and dry almost instantly. They are particularly useful as identification "plates" for recording n and p types and betas for transistors, peak-inverse-voltage ratings for diodes, and IC functions. And, the coatings actually improve the heat radiating properties of the solid-state devices.

—John Brosemer

MAKE NUT STARTER TOOLS FROM HEAT-SHRINKABLE PVC TUBING

Anyone who has ever built an electronic kit or has had to fasten machine hardware in an almost inaccessible area of a chassis knows how handy and useful a nut starter can be. Unfortunately, nut starters are available only in the most common sizes— $\#4$, $\#6$, and $\#8$. Consequently, for miniature hardware, you are still faced with the problem of fumbling with hardware in blind places. But with a length of scrap irradiated polyvinyl chloride ("heat-shrinkable" PVC) tubing, you can fashion your own nut starters for virtually any size hardware. All you need do is select a size tubing that just fits the hardware. Insert the nut at one end of the tubing, flush with the tubing's edge. Apply heat until the tubing shrinks snugly around the nut. —Stephen E. Maziarz



SAFELY ENLARGE HOLES IN THIN SHEET METAL

It is practically impossible to use a twist drill to enlarge a hole in sheet metal without tearing the metal or producing an eccentric hole. To do the job safely and neatly, the most satisfactory small hole enlarger available is the taper pin reamer (obtainable from most machine tool dealers and some well-stocked hardware stores).

These reamers can be obtained in a variety of sizes, but the most useful for the electronic equipment builder are the $\#1/0$, $\#2/0$, and $\#1$ sizes. With just these three sizes, you will have a continuous range from 0.0869" to 0.198", which permits enlarging holes in tube socket saddles, solder lugs, etc., to clear $\#4$, $\#6$, and $\#8$ machine screws. Reaming is best done by hand with a pin drill or screw-tap check; do not use an electric drill.

—Robert F. Lewis, K7YBF/W8MQU



DEHUMMING SMALL RECEIVERS

PERK UP YOUR SHORT-WAVE LISTENING

BY RONALD L. IVES

DO YOU LISTEN to the short-wave bands through a veil of a.c. hum? Such hum troubles are commonly generated in the d.c. power supply. Though a comparative rarity, hum can also originate in the filament circuit. Efficient d.c. filtering and a simple redesign can drastically reduce this a.c. hum to a very low level.

Most power supplies in modestly-priced or inexpensive shortwave receivers use a half-wave rectifier and a "brute-force" filtering circuit. A few receivers do use a full-wave rectifier, but on occasion even these receivers are subject to certain a.c. hum problems.

Troubles in a.c. hum can also be caused by a cold solder connection and before delving into the circuit of the receiver itself, it is always best to check the tubes for heater-to-cathode leakage.

And, while you have the receiver open, carefully inspect underneath the chassis for any evidence of corrosion or leakage around the filter capacitors.

Reducing Rectifier Hum. Hum that can be traced back to the rectifier can be reduced by two expedients. If the receiver is small and inexpensive, the most effective method of reducing the hum is to

replace the half-wave rectifier with a packaged bridge rectifier. The typical half-wave rectifier seen in many low-cost

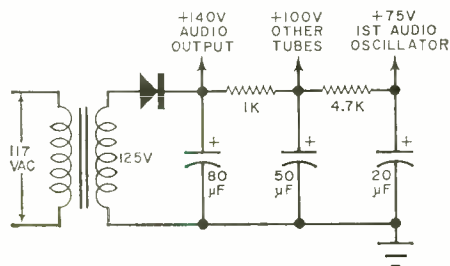

Half-wave rectification and RC filtering are hallmarks of most inexpensive receiver power supplies.

receivers is shown in Fig. 1. The circuit for a modified full-wave bridge rectifier is shown in Fig. 2. Choose the specific rectifier to have a rated input voltage (rms) slightly higher than the nominal output voltage of the power transformer.

This substitution will change the a.c. hum ripple frequency from 60 Hz to 120 Hz and will thereby double the effectiveness of each filter component. Check the results after the substitution and, if the

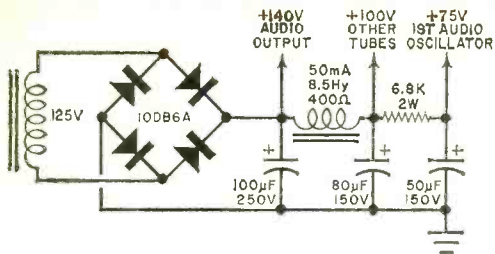

Full-wave bridge rectification and LC filtering remove most of the a.c. ripple from the d.c. output.

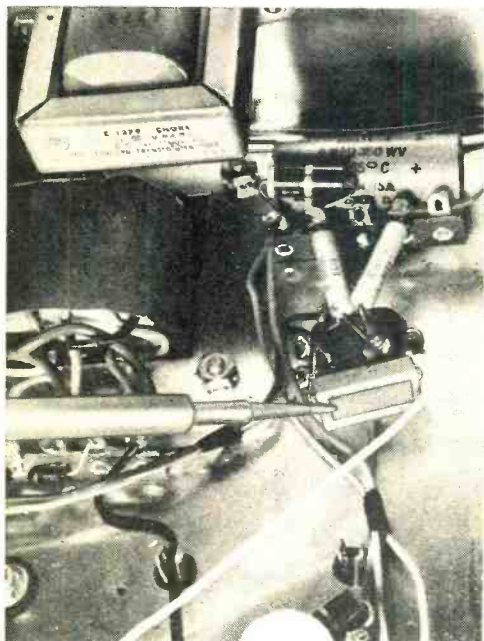

Pointer shows filter resistor to be removed and replaced with filter choke mounted to side of chassis.

hum level is now tolerable, the job is done.

Further hum reduction might be obtained by increasing the capacitance of one or all of the active filter elements. Try shunting the electrolytic filter capacitors, one at a time, with other capacitors of equivalent value. Note the results and if the tests indicate that larger value filter capacitors are called for, they should be installed up to the point of space limitations.

Oddly enough, many short-wave receivers use a resistive element in the filter in preference to an inductance whose higher reactance would vastly increase the effectiveness of filtering. A 1-henry filter choke has a reactance at 120 Hz of about 750 ohms. A tremendous reduction in a.c. hum is possible through the substitution of a choke having an inductance in excess of 7.5 henrys for the resistor. For most small receivers, a Stancor C-2318 (12 H at 30 mA) or C-1515 (30 H at 50 mA) or the equivalent of other manufacturers will be more than adequate.

Replacement of the resistive filter element by an inductive element (choke) has another advantage. Audible hum consists not only of the fundamental ripple frequency, but also of its harmonics, of which those at 240 and 360 Hz are possibly more important. Obviously, a resistive filter element has the same reactance at all frequencies. An inductive filter element, however, has a reactance proportional to the frequency and a 1-H choke which has a reactance of 750 ohms at 120 Hz has a reactance of about 1500 ohms at 240 Hz and 22,500 ohms at 360 Hz.

-30-

MODERNIZED "TYPE A" L/C/F CALCULATOR

The American Radio Relay League recently released a modernized "Type A" Calculator, a slice-rule-like device used for solving inductance, capacitance, and frequency problems. The calculator can be used for frequency-to-wavelength conversions; determining inductance and capacitance; finding resonant frequency; and calculating coil size for a particular inductor (and its number of turns/in. for a given length and diameter). Inductance scales range from 0.1 to 1500 μ H, capacitance from 3 to 10,000 pF, and frequency from 300 kHz to 100 MHz. Priced at \$2, the Type A Calculator can be obtained from ARRL, 225 Main St., Newington, CT 06111.



the product gallery

REVIEWS AND COMMENTARY ON ELECTRONIC GEAR AND COMPONENTS

SEMICONDUCTOR CURVE TRACER (EICO Model 443)

Until fairly recently, the only semiconductor curve tracers available on the market were for the transistor industry. The average solid-state circuit experimenter had to make do with his ohmmeter and/or transistor tester. Now, however, there is available a curve tracer adapter or add-on that converts virtually any existing oscilloscope into a semiconductor curve tracer. And, considering the versatility of the curve tracer, it behooves the experimenter who buy transistors on the surplus market (usually without knowing types, power-handling capabilities, or gain) to have such an instrument handy.

The EICO Electronic Instrument Co., Inc., (283 Malta St., Brooklyn, NY 11207) Model 443 Solid-State Semiconductor Curve Tracer sells in kit form for \$79.95 and factory wired for \$119.95. It has the ability to convert most scopes into versatile instruments that can trace a family of curves for any transistor, whether its characteristics are known or not, display PIV and forward voltages of diodes, test for d.c. gain and linearity, and test for current leakage.

We built the kit version of the 443, and like most test instrument kits in which the

functions are tied together through inter-related multi-deck rotary switches, assembly time was long—about 20 hours from start to finish—but well worth the effort. The assembly manual provided with the kit is well-written with separate assembly charts for each strip.

There are several features of the 443 worth mentioning. An epoxy-glass printed circuit board is used in the electronic portion of the instrument. All of the parts and components are of excellent quality. The power cord is a three-conductor "safe" type; a feature which is good to see on any type of electronic equipment, particularly test equipment. We particularly like the low silhouette design of the cabinet and the sloping front panel that gives easy access to all controls. The instrument can be set up with two transistors, allowing the user to select and compare the two with the flip of a switch—which comes in handy when you want to find two transistors with identical characteristics.

Supplied with the 443 are a pair of banana-plug clips that allow rectifiers to be tested safely without bending leads, and a calibrated graticule for 5" oscilloscopes. An operating manual, also included, outlines all calibration and testing procedures that can be performed with the 443 curve tester adapter.

Circle No. 95 on Reader Service Page 15 or 115

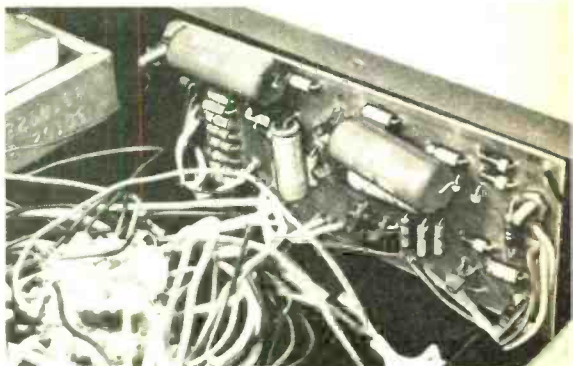
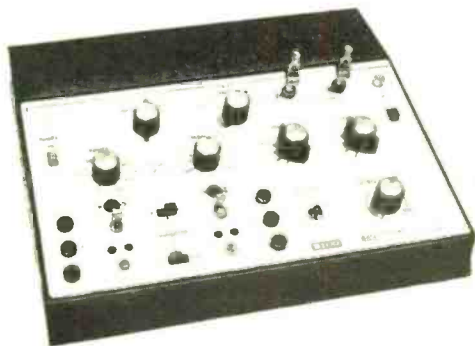

All functions in the curve tracer are tied together through a fairly complicated switching arrangement. Inside, the finished kit (photo at left) appears to be nothing but wiring and more wiring. The electronic portion of tracer is mounted on a printed circuit board which is held in place by the vertical and horizontal binding posts (above).

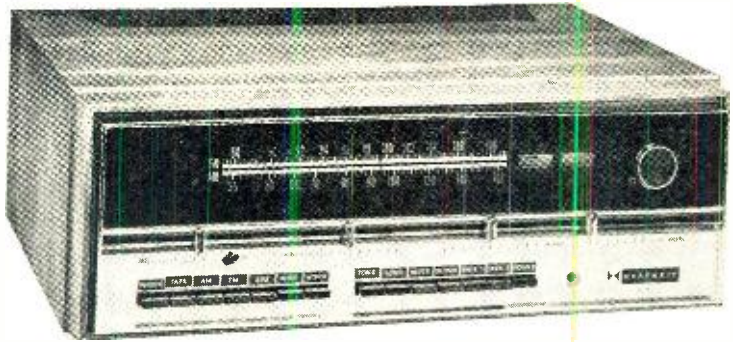

MEDIUM-POWER STEREO RECEIVER (Heathkit Model AR-29)

HOW DOES a company that is reputed by the experts and hi-fi purists to be the maker of the world's finest top-of-the-line stereo receiver (AR-15) outdo itself? Simple (or so it seems)! It proceeds to make the world's finest medium-power, medium-price stereo receiver. This is exactly what the Heath Company (Benton Harbor, MI 49022) has done with its Model AR-29 receiver. For features and styling, the AR-29 is, in our opinion, a triumph of modern technology. It sells in kit form for only \$285, plus \$19.95 for an oiled pecan (?) cabinet.

It is difficult to focus on any one feature that makes the AR-29 the best receiver in its class. For example, there are such innovations as a built-in test circuit (a hallmark of Heath); IC's and mechanical filtering in the FM i.f. section; plus plug-in circuit boards that save a lot of wiring time and reduce the chance of wiring errors.

High-Q toroids, a Heath exclusive, give better performance than transformer-type, multi-stage i.f. designs or crystal filters. A new "blend" function in the AR-29 attenuates any on-station FM hiss and high-frequency noise, while a "mute" function eliminates between-station noise on FM without affecting tuner sensitivity.

Some other features worth mentioning include a switching arrangement that allows the user to select either left and right stereo channels, or left, right, and center stereo outputs. A built-in rod-type AM antenna, housed in a unique plastic swivel assembly, can be positioned for the best AM reception. The output stages of the amplifier section are short-circuit proof. And input level controls are provided for each channel and source, allowing the user to preset levels with respect to each other so that, when switching inputs, the level remains constant.

The front-panel controls are functionally realistic. Sources, outputs, and modes of

operation are easily switched in and out as desired, facilitated by two banks of push-button switches. The power control is also a pushbutton switch. Four slide controls provide bass, treble, balance, and volume settings, and a single control knob lets the user tune either AM or FM stations.

The dial window features a "Black Magic" panel that presents a toned-down black face when the receiver is turned off. Turned on, the front panel springs into life with a cool green tint. The AR-29 has a quiet distinction that will fit into any decor, especially when housed in its handsome cabinet set off by the chrome, black, and white of the front panel.

We built the kit, and your reviewer can honestly state that it was a pleasurable hobby activity. Assembly time will be contingent upon your experience in kit building, but it is safe to say that you should allow between 15 and 25 hours for the job depending on your kit building experience.

The kit is laid out in an orderly fashion. The builder tackles first the seven printed circuit boards, each of which refers to a different numbered box (the only exception is the output amplifier box; both boards and their components are packed in the same box). Assembling the circuit boards takes up the lion's share of construction time. But if you pace your work and allow for frequent rests, the job can be made reasonably easy.

Chassis construction, due to the plug-in feature of the boards and the use of wiring harnesses, is minimal. This portion takes place at the very end of assembly, and when you get to it, you know you are just about finished.

Once the kit is assembled, and before the circuit boards are plugged in, resistance checks must be made. Then each board is plugged into place individually and in a given sequence, and voltage checks are made. Both tests are performed with the AR-29's built-in test circuit.

Finally, hum injection tests, FM adjustments, and multiplex adjustments are performed—all without the aid of or need for special tools or equipment.

The assembly/operating manual that comes with the kit bears the usual Heath mark of excellence. The manual's thickness is deceptively formidable, but a large part of it is devoted to testing and troubleshooting procedures, theory of operation, etc. All construction procedures, testing information, and adjustment techniques are clearly outlined.

You don't have to live with the AR-29 to

know you have a good receiver. Turn it on and tune along the dial and listen to how stations drop in and stay solidly in place in both FM and AM. Listen to your best tapes and records and you will find that the reproduction is crisp and natural—even the deepest bass tones. You will know right away that the Heathkit AR-29 is the best medium power receiver you have ever heard or are likely to hear.

Circle No. 96 on Reader Service Page 15 or 115

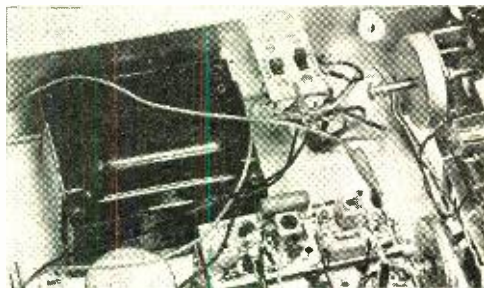
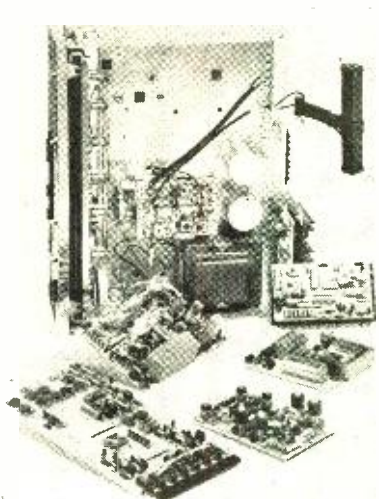

Special test circuit (switch bracket shown at top center and meter on front panel) is built in to eliminate the need for outboard test equipment. Assembly/operating manual details test procedures.

Unique plug-in circuit boards greatly reduce assembly time. Clockwise from bottom left are input preamplifier, FM i.f., audio output, power supply, and multiplex circuit boards. Control pre-amp circuit board is mounted behind front panel, and at center of chassis, AM r.f. board and AM/FM tuner.

TECHNICAL SPECIFICATIONS (Heathkit Model AR-29)

FM Section:

88-108 MHz tuning range
10.7 MHz i.f.
20-15,000 Hz ± 1 dB frequency response
1.5 μ V typical sensitivity
Greater than 70 dB selectivity
90 dB image and i.f. rejection
50 dB AM suppression
1.5 dB capture ratio
0.5% or less harmonic distortion
0.4% or less i.m. distortion
Greater than 60 dB hum and noise
Greater than 90 dB spurious rejection
40 dB minimum at 1000 Hz channel separation
55 dB or greater 19 kHz and 38 kHz suppression
55 dB typical SCA suppression

AM Section:

535-1620 kHz tuning range
455 kHz i.f.
20 μ V at 1400 kHz with external antenna; 300 μ V at 1400 kHz with built-in rod antenna sensitivity

Greater than 40 dB (alternate channel) selectivity
60 dB at 600 kHz, 45 dB at 1400 kHz image rejection
50 dB i.f. rejection
Less than 2% harmonic distortion
35 dB hum and noise

Amplifier Section:

50 watts into 8-ohm load dynamic power output/channel (65 watts into 4 ohms; 30 watts into 16 ohms)
35 watts into 8-ohm load continuous output power/channel (35 watts into 4 ohms; 25 watts into 16 ohms)
Less than 5 Hz to greater than 30 kHz power bandwidth for constant 0.25% THD
Greater than 50 damping factor
2.2-mV phono; 180-mV tape, auxiliary, and tape monitor input sensitivities
155 mV phono; greater than 10 volts tape, auxiliary, and tape monitor input overload
-65 dB minimum hum and noise
50 dB minimum channel separation
4-16 ohms output impedance
50 ohms tape output impedance
49,000 ohms, RIAA equalized, phono; 100,000 ohms auxiliary, tape, and tape monitor input impedances

FOUR-TRACE PRE-AMP KIT (Phase Corporation)

OSCILLOSCOPES are wonderful tools to have around when one is trying to follow a waveform around a complex circuit. However, with a conventional single-trace scope, you can only look at one waveform at a time. In most multi-stage circuits, there is a definite relationship between the waveforms within each stage; and this you just can't see with a single-trace scope. This is particularly true of digital circuits where accurate time-related waveforms are an essential.

With the need for a multiple display on a single-trace scope in mind, the Phase Corporation has introduced its Model A1KC Four Trace Pre-Amp (\$34.95 for the basic kit). Powered by its own 9-volt battery, the device accepts up to four independent inputs, passes them through a four-stage FET-transistor switch, and delivers a composite signal to the single-trace scope where it appears as four independent traces. Each input

has its own gain control and can be positioned as desired on the scope CRT through independent centering controls. A sync signal for the scope sweep is derived from the signal appearing at the input to channel 1.

The actual switching is performed by a pair of multivibrators that gate each stage sequentially. If you find that the display "breaks up" due to the input signal being harmonically related to the switching frequency, a built-in slide switch is provided to change the gating frequency. This approach also makes the Pre-Amp applicable for conventional audio work as well as for discrete pulses.

Each channel of the Pre-Amp has an input impedance of 1 megohm and a bandwidth of 1 MHz, while the composite output is 0.5 volt, peak-to-peak. The circuit contains 4 FET's (high-impedance input stages), 9 transistors, and 2 diodes, all mounted on a single PC board. The kit goes together easily and is simple to adjust and get to working properly. An assembled and tested unit in a custom cabinet is available for \$54.95.

After using the Four Trace Pre-Amp with a conventional single-trace scope, this reviewer can say that it is an extremely handy piece of test equipment that can save a lot of time and effort when building or troubleshooting almost any multistage circuit.

Circle No. 97 on Reader Service Page 15 or 115

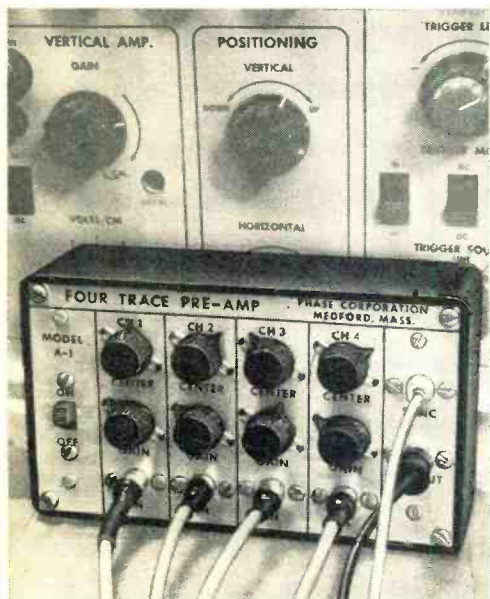

Four coaxial cables terminated in alligator clips are used to connect channels to multiple inputs. One output cable goes directly to vertical input on single-trace scope, while the other provides the scope with sync from the signal at channel 1.



The Four-Trace Pre-Amp is constructed on a PC board, with controls and jacks mounted on metal front panel. Complete pre-amp, with battery, fits compactly within plastic case that is provided.

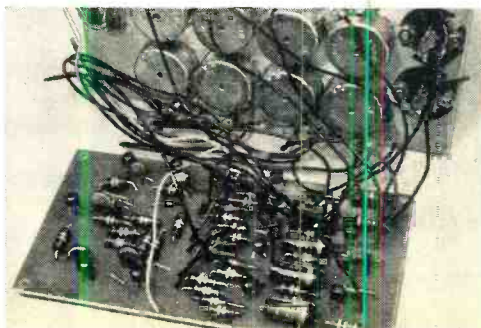

RCA INTEGRATED CIRCUIT KITS

ONCE SEMICONDUCTORS became an important part of electronics, several companies started to market various types of transistors in blister-type packages for the electronics experimenter. Some went even further and included a printed circuit board and all other components required to make a complete project. Such packages are now quite common and can be found at just about all parts distributors.

Now that we are in the age of integrated circuits, several companies are following the same procedure with low-cost integrated circuits. Thus IC's are available on a fairly wide basis, either singly or in combinations.

RCA (Harrison, N.J.) has now taken one more step, packaging complete IC projects. Four basic projects are now available: Mike Preamplifier (KC4000, \$5.95); Two-Channel Mixer (KC4001, \$6.50); Audio Oscillator (KC4002, \$4.95); and 500-mW Oscillator-Amplifier (KC4003, \$8.95). With other circuits to be announced in the future, each project is complete with IC, printed circuit board, and all components—including solder—to build the project. The only things not supplied are batteries and a soldering iron and, in the case of the amplifier, the loud-speaker.

A detailed brochure, packed with each project, explains exactly what the project is and how to use it, illustrates the circuit, includes a parts list, and discusses soldering techniques (especially those for IC's) and methods of construction. A photograph of the completed project, calling out all components, is also included.

We assembled the four projects and found that they went together very easily and worked the first time around. Laboratory checks showed that each project performed excellently and exceeded most requirements for high-quality sound reproduction. In fact, the 500-mW audio amplifier and mike pre-amplifier are now part of our test bench for checking those projects that require audio amplification. This enables us to check a project before finishing the audio portion.

If you spend a lot of time outdoors, several of these handy IC projects can be combined to make a portable, yet high-quality, audio system that can be driven from a mike or pair of mikes, from a portable phono system, from the earphone output of a conventional transistor radio, or from the output of an electronic instrument. The half-watt of power available from the KC4003 delivers a surprising amount of sound. The units are small enough to be packed in a single small cabinet; and all you need is the input, batteries, and a speaker.

In addition to the project kits, RCA has available a Kit Enclosure and Hardware Pack (KC4500, \$4.75), which includes a sturdy plastic case and cover, input and output jacks, on-off switch, and all required mounting hardware. The kit is designed to hold the KC4000, KC4001, and KC4002 projects and also is suitable for some of the upcoming projects.

Incidentally, the transparent plastic containers that the kits come in make excellent holders for small parts and hardware. The hinged lids have strong snap latches that will not separate during normal handling.

Circle No. 98 on Reader Service Page 15 or 115

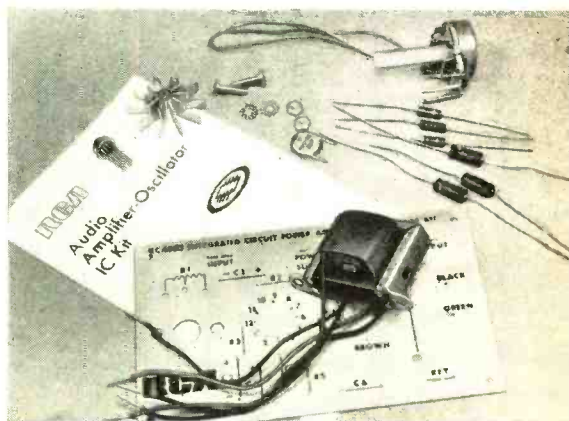

Each kit is complete with drilled PC board and all components, including solder. All you need are soldering iron, battery, and input/output device. Construction details, suggested uses, and IC techniques are provided in enclosed brochure.

DE-SOLDERING TOOL (Continental Products)

ELECTRONICS technicians in Europe have, for several years, used a somewhat different type of de-soldering tool. In the States, the usual de-soldering tool consists of a separate special soldering iron with a rubber, bulb-activated suction pump. The unwanted solder is first heated by the iron and then sucked up into the barrel of the de-soldering tool and expelled by shaking the iron or pumping it out through additional bulb action.

Europeans use a solder "remover" (sold under the trade name of Oryx) which is a plastic barrel with a spring-loaded suction pump and Teflon tip. Rather than heat the work to be de-soldered with a special tool, you simply use your regular soldering instrument, cock the "remover" and, when the solder is molten, release the trigger so that the solder is sucked up into the barrel.

The so-called Oryx remover is distributed in this country by Continental Products Co. (P.O. Box 129, Bronxville, N.Y.) and sells for about \$18. Its obvious advantage is that there is no waiting for a special tool to heat up. Your reviewer used one for several weeks and was very satisfied with its performance. Our only admonition is to be careful of the plunger release—it has tremendous force and the plunger shoots upward like a bolt of lightning.

Circle No. 99 on Reader Service Page 15 or 115



The Continental Products de-soldering tool is operated by depressing the plunger (knob shown at top) to create sucking-pump action. The release for the plunger is the button at top of the barrel and, in this reviewer's opinion, was not in a particularly "handy" location. A redesign to put the release button at bottom of shaft would help.

Imported de-soldering tool has tremendous sucking action. Molten solder is drawn into Teflon tip and expelled by releasing plunger. Note that de-soldering tool does not require a separate soldering iron with attachments—as in some other of the products distributed in U.S.A.

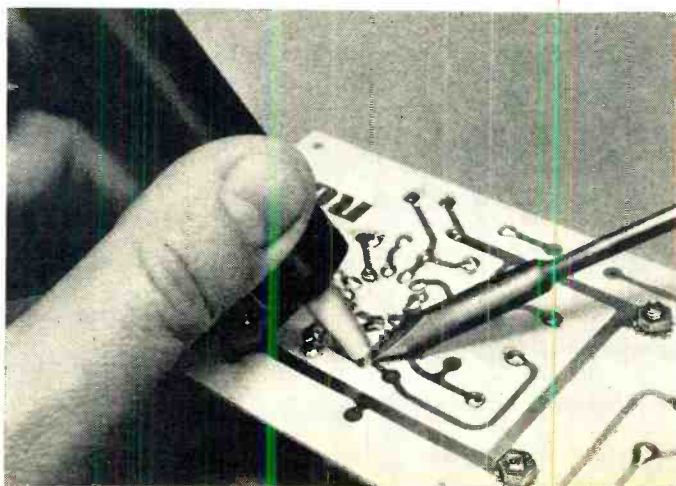



OPPORTUNITY MIRROR



Thoughtful Reflections On Your Future

BY DAVID L. HEISERMAN

Technicians in Scientific Electronics

Because I have a ham radio license and have expressed an interest in following electronics as a career, my high school counselor suggests "scientific electronics" as the opportunity of the future. I don't have the credits for an engineering college, but could certainly make a top-notch technician. What do you think?

THIS IS AN important question and, as a result, I am devoting this entire column to answering this high school senior.

Before the end of the '70's, one out of four electronics technicians will be working in the exciting branch of modern technology called scientific electronics. For the past twenty-five years, electronics technicians have worked in either commercial or industrial electronics. Now, however, the explosive growth of science and technology is creating new career opportunities, and a third major branch of electronics.

The need for specialists in scientific electronics is developing the same way the need for industrial electronics technicians devel-

oped after World War II. Before WWII, everyone who worked in electronics dealt with commercial electronics—the electronics of home entertainment and communications. The war brought on major developments in electronic control systems and gave birth to industrial electronics. Today's relentless pressure to develop new scientific ideas and techniques is the catalyst which is creating scientific electronics.

Scientific electronics concerns itself with the endless variety of the latest electronic test instruments and specialized circuitry that fill modern science research laboratories. Scientific electronics technicians deal with problems quite different from their commercial and industrial counterparts. Solving these problems demands an especially rigorous understanding of electronics and science, combined with a well-developed sense of personal initiative and creativity.

What Do Scientific Electronics Technicians Do?

Today's scientists have a lot of electronic

The skills of electronics technicians made it possible for Battelle Memorial Institute, a major private research lab, to develop a life-sustaining bacteria for long space missions. (Photos are courtesy of BMI.)

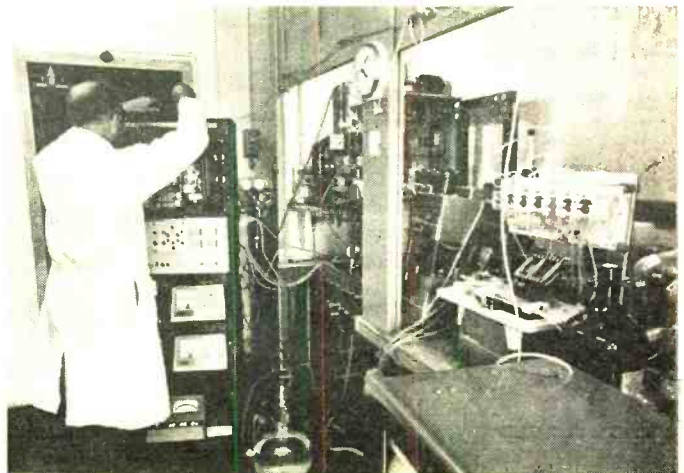

equipment that is considered "standard"—high-gain, high-impedance preamplifiers, signal-averaging oscilloscopes, analog recorders, etc. In fact, there is enough off-the-shelf research electronics equipment in physics and biology labs to keep thousands of technicians busy with routine operation, maintenance, and repair.

The really unique feature of scientific electronics, however, is not the "standard" laboratory electronic equipment. Research labs need an almost endless variety of one-of-a-kind electronic circuits, instruments, and systems. The whole point of scientific research is to push knowledge and techniques to new frontiers; and this calls for equally new and unusual electronic circuits and devices. One of the most attractive features of a job in scientific electronics is the lack of routine.

Most scientists have a rough idea of what electronics can do for their research projects. They rely on their engineering technicians, however, to show them exactly how to go about it, and to put the ideas into practice. The design work scientific electronics technicians do today falls into three main categories: (1) designing special kinds of transducers and the circuits to match them to standard scientific instruments; (2) designing special instruments and measuring devices; (3) designing ways to interconnect standard scientific electronic test and measuring equipment to do non-standard tasks.

What Labs Need Technicians Now?

Physics labs were among the first to recognize the importance of electronic instrumentation. Bio-medical labs got off to a late start but they now spend more money for electronic equipment than for all other kinds of materials and equipment combined. Electronics also finds its way into some of the most unlikely sciences—such as anthropology, psychology, and zoology.

Electroscience laboratories seem to use more scientific electronics technicians than any other kind of research lab. "Electroscience" is a relatively new term that describes scientific and technical research in all phases of electronics. The most active areas of electroscience research are in solid-state electronics, advanced control systems research, and communications.

A scientific electronics technician can find a position in electroscience labs that are either privately owned or sponsored by the U.S. Government. Bell Labs, G.E., RCA, and IBM—to name only a few—are private firms that sponsor extensive electroscience research programs. Many government contracts for electroscience research go to colleges and universities. Ohio State University, for instance, has one of the world's largest electroscience labs. It employs nearly

100 technicians and engineering assistants, and specializes in space communications research.

Physics labs use nearly as many scientific electronics technicians as electroscience labs. Present-day physics research can be divided into atomic and high-energy research, solid-state physics, laser research and development, low-temperature physics, and plasma physics. Most physics research is carried out in university labs, though some government-sponsored research goes on at private laboratories.

Biological research runs second to physics in the number of electronics technicians employed. If we include medical technology as part of biological research, however, the number of scientific electronics technicians employed surpasses that of physics. Most bio-medical research is carried out at large universities.

A technician with more than a passing interest in the biological sciences stands a good chance of getting into some kind of biological research lab, and one interested in the physical sciences should try for a spot in a physics or electroscience lab. The career opportunities in scientific electronics, however, have not yet stabilized to a point where a technician interested in cell research, for example, can be sure he will find a job in a cell research lab; but that point may be reached before too long.

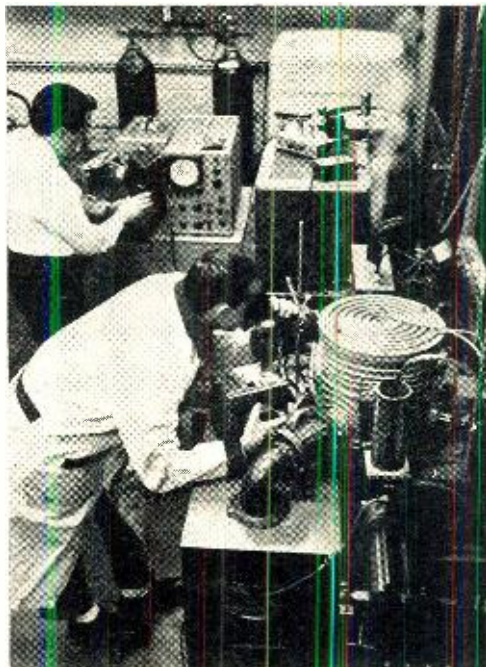

These electronics technicians at BMI are using a pulsed laser and electronic measuring instruments in carrying out a delicate thermal physics study.

Salaries and Benefits

As in any other situation, the salary a scientific electronics technician makes depends largely on his experience, talent, capabilities, and the amount of responsibility he can handle. The lowest salary is around \$5000 per year for a technician who operates equipment or does routine maintenance and minor repair work. Engineering technicians who do a lot of design work, take an active part in the research programs or supervise a staff of technicians can earn an annual salary of \$12,000 or more. A typical salary for a technician in scientific electronics is around \$7500 per year.

Unlike commercial and industrial electronics, however, salaries for scientific electronics technicians are often sensitive to the amount of laboratory funding. In a small university lab, for instance, one technician may have the responsibilities of a graduate engineer and do the work of two technicians. His salary, however, might be very small if the scientist in charge can't find enough money to support the research.

Once noted for their low-paying technical jobs, university labs now realize the need for sound technical talent. So, with the help of some fringe benefits, they are trying to offer opportunities that will attract good electronics technicians from industry.

Jobs in scientific electronics offer unique fringe benefits. University scientists are usually anxious to help technicians further their education, either in electronics or in some specific area of science. Scientific electronics technicians can attend part-time classes on the campus, and eventually earn a college degree.

Technicians who take an active part in the actual research work and make creative contributions to its success often see their names on scientific papers. Top-notch technicians sometimes publish their own papers in important electronics and scientific journals. This gives a scientific electronics technician recognition not only as a technician but also as an active scientist.

Preparing for a Job

The Vice President of Education for the DeVry Institute of Technology, J. J. Gershon, says, "The scientific electronics technician is not a special type of person. A qualified electronics engineering technician with a good, strong background in mathematics through at least calculus and differential equations as well as a rigorous course in physics on the engineering level has the prime requisites for a scientific electronics technician." Mr. Gershon also believes that the scientific electronics technician should undertake a few specialized science courses.

The main educational requirements—electronics, mathematics, and physics—are rela-

TECHNICAL COURSES FOR SCIENTIFIC ELECTRONICS TECHNICIANS

Parenthetical numbers indicate:

- (1) Readily available from most technical and home study schools.
- (2) Presently offered by a few schools.
- (3) Presently offered by very few, if any, schools.

Parenthetical letters indicate:

- (S) For all scientific electronics technicians.
- (P) For technicians in physics labs.
- (B) For technicians in biological labs.

Electronics

Introductory electronics (1-S)

Intermediate electronics (1-S)

Solid-state electronic circuit analysis and design (1-S)

Digital electronics (1-S)

Mathematics

Algebra (1-S)

Trigonometry (1-S)

Calculus and analytic geometry (1-S)

Differential equations (1-S)

Physics

Mechanics (1-S)

Heat and light (1-S)

Electricity and magnetism (1-S)

Atomic energy (2-S)

Modern physical theories (3-P)

Technical writing (1-S)

Chemistry

Inorganic chemistry (2-S)

Organic chemistry (3-B)

Biology and physiology (3-B)

tively easy to fulfill because most home study and resident technical schools already offer these courses. Schools that offer the specialized science courses, however, are difficult to find. It is nearly impossible to find a technical electronics school that offers any kind of course in the biological sciences, so an eager technician who wants to work in a biology research lab must learn the biology on his own.

The employers in scientific electronics are generally professional scientists. These men recognize the fact that most new technicians will know little, if anything, about the scientific work they have to do. To compensate for this lack, scientists look for men who have the ability to learn quickly and a knack for scientific thinking. According to Dr. E. L. Jossem, Chairman of the Ohio State University physics department, "We look for men with initiative and creativity. When we find these technicians, learning the science takes care of itself."

In time, scientific electronics will be recognized as an important part of modern technology. Now is the time for creative, ambitious technicians to get in on the ground floor and shape the image of a new and exciting kind of career opportunity.



SOLID STATE

By LOU GARNER, Semiconductor Editor

NEWEST CONTROL DEVICE IS CERAMIC

RECENTLY developed by RCA is a new solid-state device that may lead to the development of many new remote control systems. According to Dr. William M. Webster, Vice President of RCA's Princeton (N.J.) Laboratories, the device is a tiny ceramic element whose electrical properties can be adjusted electronically so that it turns on, turns off, or smoothly varies current flow in any circuit in which it is installed.

Completely solid state, the device offers long life and high reliability. Made of relatively common materials, its fabrication is inexpensive, and the associated circuitry can be quite simple. In addition, the device will "remember" its last setting indefinitely, even if power to the circuit is shut off completely.

With the unit installed as a part of standard circuits in the home, many electrical appliances could be controlled from a remote location. For example: a light in the hall or bathroom could be controlled from a bedside table. Kitchen appliances, could be turned off or on and even adjusted from elsewhere in the house. The furnace thermostat could be adjusted from anywhere in the home. A more sophisticated version of such a remote-control thermostat could be used to turn on the heater or air-conditioner in an unoccupied vacation cottage by means of a telephone call from the owner. In other applications, the new RCA device could be used to provide an infinite variety of speeds in household equipment such as blenders, grinders, mixers and fans or, similarly, as a smooth speed control for common power tools.

According to Dr. Stuart S. Perlman and Joseph H. McCusker, co-developers of the new component, its unique control action derives from the interplay of two electrical phenomena—piezoelectricity and ferroelectricity—which are inherent in the device. A piezoelectric material, of course, can transform mechanical motion into an electrical signal, and vice versa, while a ferroelectric material can remain in a state of electric polarization indefinitely, much as a permanent magnet retains its magnetic characteristics. When a material contains both properties, a change in its ferroelectric polarization changes the efficiency of its piezoelectric effect.

The interaction of these two effects was utilized by designing a sandwich consisting of two ceramic wafers bonded together on a common electrode with epoxy cement, as illustrated in Fig. 1. Each wafer has both ferroelectric and piezoelectric properties. Physically, the complete device is comparable, in overall size to standard transistors.

In operation, an a.c. signal applied to one wafer causes it to vibrate due to its piezoelectric properties. These vibrations are transmitted to the second wafer which converts them back to an electric output signal. The amplitude of the output signal can be raised or lowered by subjecting either wafer to an electronic control pulse, thus changing its ferroelectric polarization and its piezoelectric efficiency. Since the wafers are made of a stable material, the output signal changes only when the polarization is changed.

Two versions have been developed. One, an adaptive resonant filter, responds only

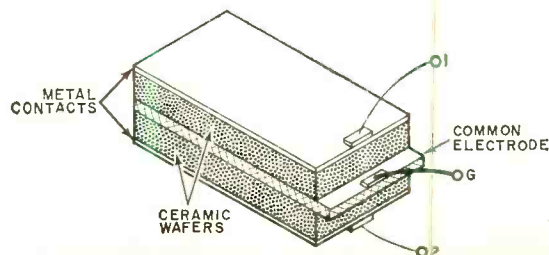

Fig. 1. Drawing shows sandwich construction of new RCA solid-state device that has many new remote control possibilities. The elements are bonded together with epoxy cement.

to input signals in a narrow frequency range. The other, designated an adaptive ferroelectric transformer, responds to input signals covering a broad frequency spectrum.

Both versions of the device use wafers made of ceramic lead zirconate/lead titanate material, commonly used in ordinary phonograph pickups. The wafer's polarization can be altered in any desired magnitude by applying voltage pulses that produce an electric field intensity, typically, of from 10 to 45 volts per mil of wafer thickness. In this way, the output signal of the device can be changed over a dynamic range of approximately 60 dB in as little as ten-thousandths of a second or as slow as 1000 seconds by high and low field pulses, respectively.

In more sophisticated versions, the input wafer can be mechanically coupled to several smaller output wafers. Each output wafer can be pulsed and its output regulated independently, thus making it possible for one device to control several functions of an electronic device as, for example, the tint, color and audio volume of a TV set.

Still experimental, it is unlikely that production versions of this exciting new device will be available until late this year.



The new RCA control element is the tiny rectangular "tab" projecting from the transistor header.

several years to accomplish the same action. Part Two, then, was the publication of his circuit in our December 1968 column—a unijunction oscillator driving an SCR served as an electronic switch across the regular wiper control.

Now for Part Three of the story. Reader Charles A. Huber found neither of the earlier circuits satisfactory for use in his truck and, remembering another article featuring a four-layer diode, worked up the design

Fig. 2. Very simple "slow-kick" circuit for electric windshield wiper motors is adaptable to any 12-volt electrical system, regardless to the ground polarity.

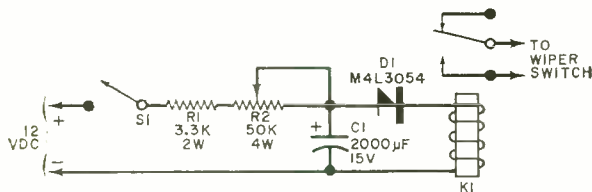

Reader's Circuit. Quite often, any of a variety of circuits may be used to achieve a specific goal. A good example of this can be found in the stirring "Saga of the Slow-Kick Windshield Wiper." The slow-kick operation is to provide slow wiper movement for use under such marginal driving conditions as mist or drizzle, where there is inadequate moisture to lubricate the wiper blades in continuous action, yet enough to require occasional cleaning.

Part One of this exciting drama took place in our March 1968 issue with the publication of Donald K. Belcher's original article "Slow Kick your Windshield Wipers." Belcher devised an interesting circuit using a unijunction relaxation oscillator driving a two-stage transistor amplifier which, in turn, controlled an electromagnetic relay to operate the wiper switch.

Belcher's article struck a responsive chord with reader Jonathan J. Albers, who had been using a somewhat different circuit for

illustrated in Fig. 2. It is by far the simplest of the three designs and should be suitable for all vehicles with electric wiper motors and 12-volt systems, regardless of ground polarity.

Referring to the schematic diagram, Charles has used 4-layer diode *D1* in a simple relaxation oscillator to drive an electromagnetic relay (*K1*) which, in turn, controls the wiper switch. In operation, closing switch *S1* permits *C1* to be slowly charged from the d.c. power source through current-limiting resistor *R1* and rate control *R2*. When *C1*'s voltage reaches *D1*'s breakdown voltage, the diode switches to a conducting state, discharging *C1* through the relay's coil and actuating this device. As *D1*'s current drops below 1 mA, it switches back to a non-conducting (high-resistance) state, the relay drops out, and the cycle starts to repeat, continuing at a rate determined by *R2*'s setting as long as *S1* is closed.

Conventional components are used in the

We pack your electronics course with kits to make your training fast. You'll enjoy every minute of it.

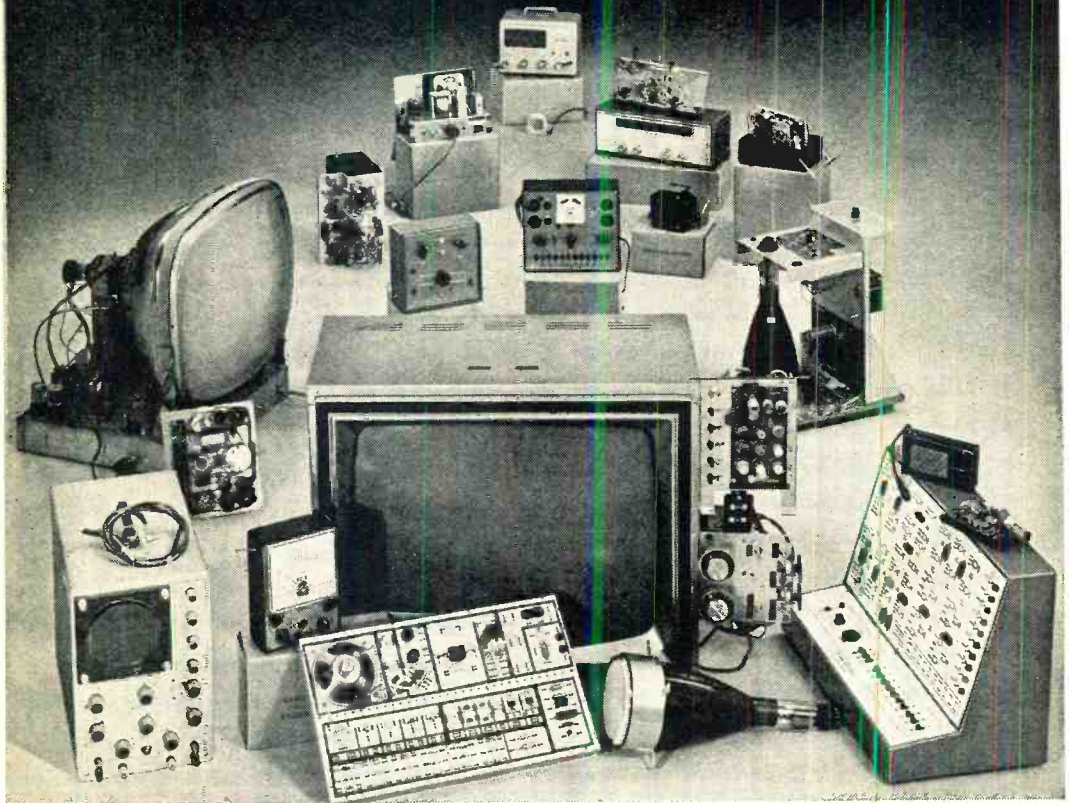

Your NTS success package

Choose a career in electronics: Computers. Color TV Servicing. Automation. Communications. Whatever the field, NTS has a complete home-study package to get you to the top *faster*. 10 thorough training courses. Each includes *everything* to give you the *working* knowledge required of successful technicians.

NTS Project-Method Training is the practical way to learn elec-

tronics. It's a proven combination of lessons and the best professional kit equipment available. NTS provides the *biggest selection of kits ever offered in home-study . . . all at no extra cost*. You'll construct these exciting kits to fully understand electronic circuits, components, and concepts. Our Project-Method lets you build skills by putting theory into practice . . . by working with your hands, as well as your head.

The NTS "learn and practice" approach makes training at home really easy. All it takes is a few hours a week . . . whether you're starting from scratch or in advanced courses. This is the all-inclusive success package that put thousands of men into the best paying jobs . . . or into their own business. If "just a living" isn't good enough for you, now is the time to get something better going for you!

NTS COMPUTER ELECTRONICS

This is the future. And it's happening now. The number of computers will *increase many times* in the next few years.



Exclusive new Compu-Trainer®

NTS offers a solid grounding in computer operation, wiring, data processing and programming. One of the 10 important kits included is our exclusive Compu-Trainer®. It's a fully operational computer logic trainer — loaded with integrated circuits — the first ever offered in home study. It introduces you quickly to how, what, when and why of computers . . . from theory to practical servicing techniques. This unit is capable of performing 50,000 operations per second. And it's sent at no extra cost.

NTS COLOR TV SERVICING

This is a broad, easily understood

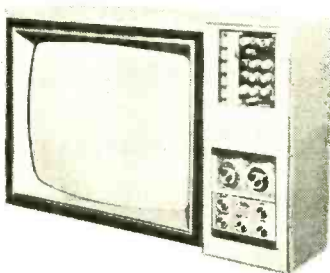

**COLOR TV
295 SQ. IN. PICTURE**

program designed to make you a complete home-entertainment service technician. Included, at no extra cost, is a color TV that has more features than any

set on the market. You also learn all about stereo, hi-fi, multiplex systems, and become a specialist in Color TV Servicing. Kits also include AM-SW radio, solid-state radio, field-effect transistor volt-ohmmeter, electronic tube tester.

NTS AUTOMATION/ INDUSTRIAL ELECTRONICS

You're trained in the "push-button" electronics that keep industry going and growing . . . from relay type controls to highly advanced systems essential to production. You receive 16 kits including a 5" wide band oscilloscope, and the new NTS electronics lab: a fascinating NTS exclusive experimental laboratory. A complete workshop which makes you familiar with solid-state, miniature, and integrated circuits.



5"
Oscilloscope

NTS ELECTRONIC COMMUNICATIONS

The use of 2-way radio systems in private and commercial applications is skyrocketing. NTS prepares you for the big-money opportunities in the field of transmitting and receiving equipment. *Your tuition will be refunded in full if you cannot pass the FCC exam for a 1st Class Commercial Radio-Telephone License within*

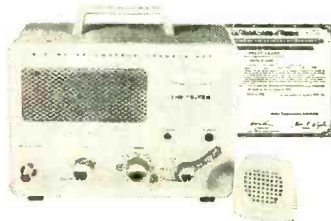

5 Watt AM Transmitter & Receiver

six months after successfully completing this course. You build valuable kits including Amateur-Phone 6 Meter VHF Transceiver, solid-state Radio, and a field-effect transistor volt-ohmmeter.

CLASSROOM TRAINING AT LOS ANGELES

You can take classroom training at Los Angeles in sunny Southern California. NTS occupies a city block with over a million dollars in facilities devoted exclusively to technical training. Check box in coupon.

NATIONAL TECHNICAL SCHOOLS

World-Wide Training Since 1905
4000 South Figueroa Street
Los Angeles, Calif. 90037, U.S.A.

APPROVED FOR VETERANS

Accredited Member: National Association of Trade and Technical Schools, National Home Study Council.

**TODAY, MAIL
COUPON
FOR FREE
COLOR
CATALOG
AND SAMPLE
LESSON.**



NATIONAL TECHNICAL SCHOOLS
4000 S. Figueroa St., Los Angeles, Calif. 90037

Please rush Free Color Catalog and Sample Lesson, plus information on field checked below. No obligation. No salesman will call.

- MASTER COURSE IN COLOR TV SERVICING
- COLOR TV SERVICING
- MASTER COURSE IN TV & RADIO SERVICING
- PRACTICAL TV & RADIO SERVICING
- MASTER COURSE IN ELECTRONIC COMMUNICATIONS
- FCC LICENSE COURSE
- MASTER COURSE IN ELECTRONICS TECHNOLOGY
- INDUSTRIAL AND AUTOMATION ELECTRONICS
- COMPUTER ELECTRONICS
- BASIC ELECTRONICS

Name _____ Age _____

Address _____

City _____ State _____ Zip _____

- Check if interested in Veteran Training under new G.I. Bill.
- Check if interested ONLY in Classroom Training at Los Angeles. Dept. 205-040

design. A Motorola type M4L3054 diode is used for *D1*, while relay *K1* is a s.p.d.t. type having a 12-volt d.c. coil (typically, P & B type KA5DY).

Neither parts placement nor wiring arrangement should be critical and, therefore, the circuit can be assembled using any standard construction technique. A small case (probably aluminum) can be used for housing the project. The completed assembly, after test, normally would be installed below the vehicle's dash at a position within easy reach of the driver.

Manufacturer's Circuit. The relatively simple electronic photoflash circuit shown in Fig. 3 is one of three schematics featured in *Thyristor Application Report 901*, published by the Transistron Electronic Corp. (168 Albion St., Wakefield, Mass. 01881). The circuits were all chosen to highlight the manufacturer's versatile RTJ series of low-cost plastic-encapsulated SCR's.

Not far different from popular commercial designs, circuit action is straightforward and easily followed. Components *R5*, *D1* and *C1* form a conventional line-operated d.c. power supply, shunted by bleeder resistor *R1*. In operation, *C2* is charged slowly to source voltage through *R4*, with *SCR* remaining in an "open" (non-conducting) state during this period. When normally open shutter switch *S1* is closed, a gate signal, established by voltage divider *R2-R3*, is applied to the SCR, switching this device to a conducting state and discharging *C2* through trigger transformer *T1*'s primary winding. The resulting secondary voltage is applied to the flash-tube's control winding, firing this device and discharging *C1*. With both *D1* and *C2* discharged, the SCR switches back to an open state. Afterwards, *C1* and *C2* recharge slowly, resetting the circuit.

Easily assembled in one or two evenings, the project requires relatively few components. Rectifier *D1* is a 400-volt line rec-

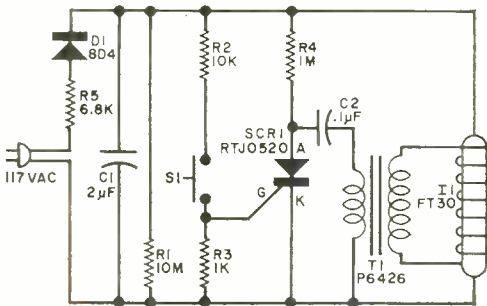

Fig. 3. Relatively simple electronic photoflash circuit uses low-cost plastic-encapsulated SCR.

tifier (typically, International Rectifier type 8D4), while *SCR1* is a Transistron type RTJ0520. Except for *R5*, a 2-watt unit, all resistors are half-watt; *C1* and *C2* are 400-volt plastic or paper tubular capacitors, trigger transformer *T1* is Stancor type P6426 and flash-tube *I1* is a type FT-30.

Although neither layout nor lead dress are overly critical, good wiring practice should be followed when assembling the unit, with special care taken to insure adequate insulation in *T1*'s secondary circuit, due to the high voltages developed by this component. In addition, for safety's sake the entire circuit should be isolated from chassis ground and the unit's housing, with a plastic case preferred to a metal cabinet. Naturally, a suitable reflector assembly should be provided for the flashtube.

Power!!! High power, as happiness, means different things to different people and, moreover, its meaning is likely to change as time passes. During the transistor's first half-decade, a one- or two-watt device was considered a "high-power" type. A little later, this designation was reserved for 5- to 10-watt units. Today, a device must have at least a 20- to 25-watt rating to warrant a high-power classification, and the day is not far distant when any device with less than a 100-watt rating will be considered a medium- to low-power type.

TRW's Semiconductors Division (14520 Aviation Blvd., Lawndale, Calif. 90260), for example, has recently announced a new hybrid microcircuit capable of handling a 500-watt power output. The device, designated type DPS-1000, is a dual power Darlington switch mounted in a TO-3 package, with each switch capable of delivering currents of 5 amperes average, 10 amperes peak, from power supplies up to 50 volts.

If high voltages are to be handled, then Delco Radio (Kokomo, Indiana) can offer a real contender with its type DTS-702 triple diffused silicon power transistor. An *npn* unit designed for use in television deflection circuits, the DTS-702 has a 1200-volt collector-to-emitter rating and a maximum collector current rating of 3 amperes. Its power dissipation rating is 50 watts.

Where substantial power is needed at relatively high frequencies, one can turn to the Electronic Components Division of the United Aircraft Corporation (Trevose, Pa. 19047) and their type 2N5643. An *npn* silicon transistor with a 60-watt dissipation rating, the 2N5643 can deliver 40 watts at 175 MHz when powered by a 28-volt d.c. source.

On the other hand, if one requires sheer power, the Transistron Electronic Corp. (Continued on page 103)

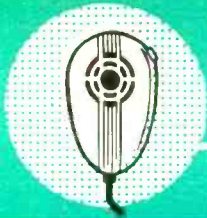

TWO WAY REACTIONS

BY G.H. REESE, KC6990

CHANNEL 9: USE OR ABUSE?

AS THIS WAS being written in late January, we were still awaiting final FCC action on the proposed rule limiting CB on channel 9 to communications for emergencies.

This pending action is of great significance to the future of the Citizens Radio Service. It will provide a new, more serious, positive communications function that should attract many users. While the final action has not been taken, we have every reason to hope that it will become effective in the spring of this year. In addition to the support of many individual REACT teams and CB clubs, REACT National Headquarters and many individuals; such organizations as the Citizens Radio Section of the Electronic Industries Association, the American Automobile Association (AAA), and the Automobile Manufacturers Association have officially supported the rule change. A number of official governmental agencies including state police and Civil Defense authorities have also endorsed the action.

A few objections to this proposal have been received—the chief one being the problem of simultaneous monitoring for emergency calls and personal communications. Some monitors now use channel 9 to receive personal communications as well as emergency calls. Under the proposed rule, non-emergency communications would not be permitted on channel 9. Thus, the dual-purpose monitoring cannot be accomplished with a single transceiver.

We recognize this as a problem that will perhaps reduce the number of people who monitor channel 9 in some areas. However, the advantages of the emergency channel far outweigh the disadvantages. If use of the emergency channel is strictly observed, many official agencies such as police, fire, Coast Guard, Civil Defense and others will be encouraged to monitor channel 9. In addition, many dedicated REACT team members and individuals are sure to enlarge their monitoring of the channel. Monitors who are interested in maintaining their own personal communications as they monitor channel 9 can utilize a secondary receiver unit for that purpose. It is anticipated that special low-cost

equipment for this purpose will be made available.

Many REACT teams now use a secondary “work” channel for communications between team members. This removes traffic from channel 9 to permit emergency messages to get through. Often they maintain a supplementary receiver to handle the two-channel communications. This can be a used piece of equipment purchased at low cost.

Once channel 9 becomes an official emergency channel, all CB radio users will be challenged.
(Continued on page 102)



Members of Prescott (Ariz.) Emergency Radio Association (REACT) line up on a fire lookout tower operated by the U.S. Forest Service. In cooperation with the Forest Rangers, they have installed a base station in the tower on 7700-ft. Spruce Mt.

ENGLISH LANGUAGE NEWS BROADCASTS FOR THE MONTH OF APRIL

Prepared by **ROGER LEGGE**

TO EASTERN AND CENTRAL NORTH AMERICA			TO WESTERN NORTH AMERICA		
TIME-EST	STATION AND LOCATION	FREQUENCIES (MHz)	TIME-PST	STATION AND LOCATION	FREQUENCIES (MHz)
7:00 a.m.	Peking, China	11.685, 15.095	7:00 a.m.	Tokyo, Japan	9.505
7:15 a.m.	Montreal, Canada	9.625, 11.72	8:00 a.m.	Stockholm, Sweden	15.315
7:30 a.m.	Melbourne, Australia	9.58, 11.71	5:30 p.m.	Melbourne, Australia	15.17, 17.775, 21.74
9:00 a.m.	Stockholm, Sweden	15.315		Tokyo, Japan	15.235, 17.825, 21.64
12 Noon	London, England	21.61	6:30 p.m.	Johannesburg, South Africa	9.715, 11.875, 15.22
4:30 p.m.	Hilversum, Holland	11.73, 15.425	7:00 p.m.	Madrid, Spain	6.14, 9.76
6:00 p.m.	Montreal, Canada	9.625, 11.945, 15.19		Moscow, U.S.S.R.	9.685, 9.70, 11.90
6:45 p.m.	Tokyo, Japan	15.445, 17.825		Peking, China	15.095, 17.673, 21.735
7:00 p.m.	London, England	6.11, 9.58, 11.78		Prague, Czechoslovakia	5.93, 7.345, 9.54, 11.99
	Moscow, U.S.S.R.	9.685, 11.87, 11.90		Seoul, Korea	15.43
	Sofia, Bulgaria	9.70		Tokyo, Japan	15.105
	Tirana, Albania	7.30, 9.78	7:30 p.m.	Berlin, Germany	9.65, 9.73, 11.84
7:30 p.m.	Johannesburg, South Africa	9.705, 11.875, 15.22		Stockholm, Sweden	9.725
	Stockholm, Sweden	11.915		Tirana, Albania	6.20, 7.30
7:50 p.m.	Brussels, Belgium	6.125	8:00 p.m.	Budapest, Hungary	9.833, 11.91
	Vatican City	9.615, 11.725, 15.285		Havana, Cuba	9.525, 11.76
8:00 p.m.	Berlin, Germany	9.56, 9.73		Lisbon, Portugal	6.025, 11.935, 15.125
	Budapest, Hungary	9.833, 11.91		London, England	6.11, 9.58, 11.78
	Havana, Cuba	9.525		Moscow, USSR (via Khabarovsk)	11.87, 15.18, 17.775
	Madrid, Spain	6.14, 9.76		Sofia, Bulgaria	9.70
	Peking, China	15.06, 17.715		Tokyo, Japan	15.105
	Prague, Czechoslovakia	5.93, 7.345, 9.54, 11.99	8:30 p.m.	Kiev, U.S.S.R. (Mon., Thu., Sat.)	9.685, 11.90
	Rome, Italy	9.575, 11.81	8:45 p.m.	Berne, Switzerland	9.72, 11.715
	Berne, Switzerland	6.12, 9.535, 11.715		Cologne, Germany	6.145, 9.545
8:30 p.m.	Cologne, Germany	6.075, 9.735	9:00 p.m.	Havana, Cuba	11.76
	Melbourne, Australia	15.17, 17.775		Hilversum, Holland (via Bonaire)	9.715, 11.73
9:00 p.m.	Hilversum, Holland (via Bonaire)	11.73	10:00 p.m.	Moscow, USSR (via Khabarovsk)	11.87, 15.18, 17.775
	Lisbon, Portugal	6.025, 11.935, 15.125		Tokyo, Japan	9.505
	London, England	6.11, 9.58, 11.78	10:30 p.m.	Havana, Cuba	11.93
	Moscow, U.S.S.R.	9.685, 9.70, 11.87			
	Oslo, Norway (Sunday)	11.85			
9:30 p.m.	Beirut, Lebanon	11.82			

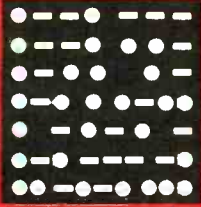

AMATEUR RADIO

By **HERB S. BRIER**, W9EGQ
Amateur Radio Editor

VISITING HAMS

Some years ago, R. L. Gunther, VK7RG, Tasmania, Australia (then a W6) organized the "International Ham Hop Club," in which U. S. and overseas amateurs exchanged visiting and housing in each other's countries. The club was quite successful as long as Mr. Gunther coordinated its activities, but "Ham Hop" faded away when he was no longer available to do so.

In late 1968, Fred Thode, DL8VQ/W2, revived the idea under the name "Ham Exchange." Fred wrote articles for a Sunday edition of a Syracuse, N.Y. newspaper and the German amateur radio magazine *DL-QTC*, and gave talks at radio clubs. The

idea of "Ham Exchange" is for participating amateurs in different countries to supply a home base—food and room only—for guests, including the entire family. Beyond these basics, the details are left to the individuals involved.

Through the efforts of Fred in the United States and of Uwe, DL8QP, in Germany, lists of interested amateurs were prepared in the two countries. In 1969, a number of amateurs and their families from each country visited the other country under the auspices of "Ham Exchange." Byron Jay, K8WGJ, who supplied much of the information used here through the Amateur Radio

AMATEUR STATION OF THE MONTH



Joe Zolik, WB2SAF, 153 Lincoln Ave., East Paterson, N.J. 07407, operates a Collins kilowatt "S-line" station into a Mosley TA-33 beam on a 66-ft motorized Tri-Ex tower. He has worked all states and over 100 countries and runs phone patches for men on U.S. ships. He's now building a TV station. We are sending WB2SAF a one-year subscription for winning this month's Amateur Station Photo Contest. You can enter by sending us a clear picture of yourself at the controls of your station with some details about your amateur radio career. Send them to Amateur Radio Photo Contest, Herb S. Brier, POPULAR ELECTRONICS, P.O. Box 678, Gary, IN 46401

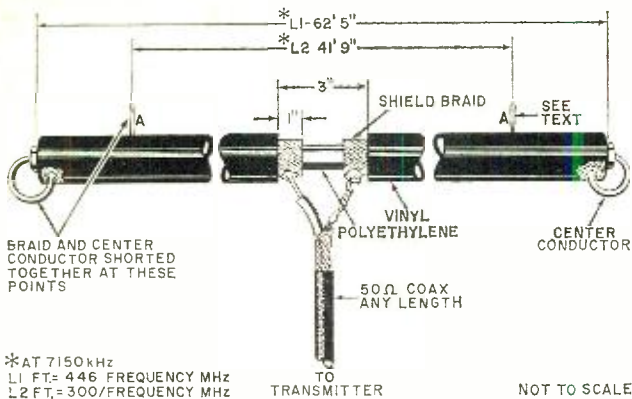

Homebrew dipole made of coax has a standing wave ratio very close to 1:1 over the entire 40-meter band. Large effective diameter helps to broaden the antenna's frequency response.

News Service *Bulletin*, was one of the satisfied participants in last year's program and is an enthusiastic booster of the idea of amateurs being ambassadors of good will and hosts in the program. For more information, write to Ham Exchange, c/o Fred Thode, DL8VQ/W2, 225 Candee Ave., Syracuse, N. Y. 13224.

The Coaxial Dipole Antenna. Bill Caldwell, W9ALM, Kokomo, Ind., extols the virtues of a new idea in a coaxial dipole antenna. Bill (and others) claim that it has a wider frequency loading capability than a conventional dipole, radiates just as well, and produces a close match to a 50-ohm transmission line. Bill says, for example, that the standing wave ratio (SWR) of the coaxial dipole sketched in Fig. 1 is very close to 1:1 over the entire 40-meter band.

If you would like to try this antenna, cut a piece of RG-8/U coaxial cable to the overall length shown. Remove about three inches of the vinyl covering at the center of the cable. Cut out an inch of the exposed outer braid at the exact center. Connect the inner conductor of the 50-ohm coaxial feedline to one side of the split braid, and connect the shield of the feedline to the other side. Wrap the connections firmly with plastic tape to waterproof the assembly and keep the weight of the feedline off of the connections. (Note that the center conductor of the radiator is not broken or connected to the feedline.) However, connect the inner conductor and the shield braid together at each end of the radiator. Tape these connections for weatherproofing.

For broadest frequency coverage, short the outer braid and the inner conductor of the radiator together at the "A" points in the sketch; however, the antenna will work well over a slightly reduced frequency range without these shorts. Alternatively, the coaxial cable can be cut to the shorter length and extended to the required length with

number 12 wire at each end. This coaxial dipole is a variation of the folded dipole. By varying the ratio of the diameters of its conductors, the center impedance of a folded dipole can be varied over a wide range. It happens that the ratio between the inner and outer conductors of conventional, polyethylene insulated, 50-ohm coaxial-cable folded dipole effects a good match to a 50-ohm transmission line. Also, the large effective diameter of the antenna (actually the braid) helps to broaden its frequency response. The large diameter also decreases the physical length of the antenna.

Developing New Amateurs. As evidence of our long-held belief that help and encouragement are the main ingredients in producing new amateurs, we offer the record of Richard Hardt, WA9SBR, 242 Marimar Court, Crown Point, IN 46307. In one year, he taught code and theory to seven Novices.

(Continued on page 111)

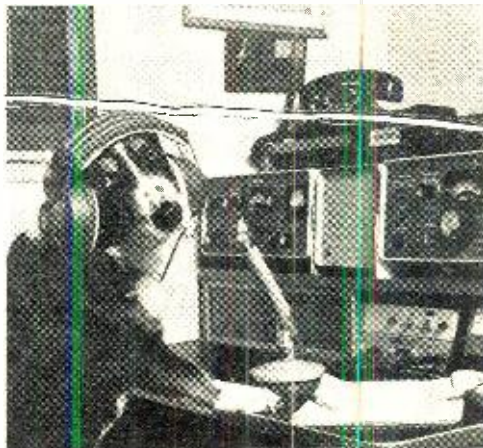

At WA6THG, Goleta, Calif., everybody gets into the act using Collins 75S-3 and 32S-B, even K9 Sam.



SHORT-WAVE LISTENING

By **HANK BENNETT**, W2PNA/WPE2FT
Short-Wave Editor

DX ON THE BROADCAST BAND

THE OTHER DAY at the post office, one of my buddies, who knew vaguely that I have something to do with radio (which thereby qualified me, in his opinion, as an expert), asked me how come he can hear WHAS, 840 kHz, Louisville, Ky. at 2 o'clock a.m. (EST) but not in the daytime. It seems he wakes up every morning at 2 a.m. (he didn't explain why) and likes to tune in to Louisville. But tuning the same frequency during daylight hours proves to be fruitless.

In order to get my friend to understand why he can't hear WHAS in the daytime, it was necessary to give him a dissertation on radio theory, including a discussion on the ionospheric layers, sunspots, skip effect, daytime stations, and the whole bit. This took about 10 minutes. My friend shook his head resignedly, said he understood fully, and probably felt that I was more of a kook than he had first surmised. But he still wasn't satisfied; he wanted to hear WHAS at 2 p.m. as well as at 2 a.m. Realizing that I was a complete failure at explaining the workings of the AM broadcast band, I made it a point to come straight home and prove out some of my pet theories. But much to my amazement the AM band was wide open.

WHAS was coming in like a local—at 5:15 p.m. Other 50-kW stations around the eastern states were heard, too, along with a number with lower power. Conditions were extraordinary and it's just as well that my friend hadn't tuned in that afternoon.

Having read in various club bulletins of the tricks involved in hearing real DX on the AM broadcast band, we tried to put some of these practices to use. For instance, the appearance of heterodyne whistle may signify that a station is coming in on a split frequency. (Europeans and some Latin Americans operate on channels between our normal 10-kHz separations.) The first one that we found was Rome on 845 kHz. When we snapped on the crystal selectivity switch and rotated the phasing knob a bit, Rome came through in the clear and was almost perfectly readable. At 7 p.m. we heard an unmistakable

ID from "Radiotelevisione Italiana." Other stations tuned within a couple of hours included Lille, France, on 1376 kHz; Surinam on 725 kHz; *R. Titania*, San Jose, Costa Rica, on 825 kHz; Miramar, Portugal, on 782 kHz; an unidentified station on 1394 kHz (which was probably Albania); and one on 818 kHz which we think was Andorra although Cairo is the station usually reported on this frequency. We have no clue about what we heard on 566 kHz.

Dyed-in-the-wool AM broadcast band DX'ers will quickly realize that what I've listed here are stations that have been heard for months and years. But for the newcomer to the hobby it can be a genuine thrill to be able to tune in a trans-Atlantic AM station.



Ben Messersmith, WPE7CLQ, Ogden, Utah has 35 QSL's from 100 states and countries logged. His receivers include a Hallicrafters S-118, Realistic DX-150, and PRO-2 for VHF work. As you can see, he has a lot of CB (Civil Defense) and test equipment.

And careful tuning like this can make you feel like a real expert; at least you've accomplished something that you can talk about.

So, folks, the AM broadcast band does have DX. It's up to you to pull it through. Have fun trying and let us know of your results.

Arthur Cushen Now M.B.E. Although we're positive our photo feature on Arthur Cushen (February, page 74) had nothing to do with it, we were delighted to learn that he was on Queen Elizabeth's New Year Honours List. Arthur was given the M.B.E. for his work in many community services involving radio broadcasting, journalism, and work with the blind—Arthur is blind himself.

Our heartiest congratulations for a well-deserved honor to this New Zealand SWL.

World Time Wheel Available. The Hallcrafters Co. (600 Hicks Road, Rolling Meadows, IL 60008) is offering a small "World Time Dial and Radio Frequency Chart" for \$1. The face of the rotary slide rule is marked to show the time in various major cities. On the reverse side are listings of frequencies used for broadcasting, time signals, hams, aircraft, etc., etc.

CURRENT STATION REPORTS

The following is a resume of current reports. At time of compilation all reports were as accurate as possible, but stations may change frequency and/or schedule with little or no advance notice. All times shown are Greenwich Mean Time (GMT) and the 24-hour system is used. Reports should be sent to Short-Wave Listening, P. O. Box 333, Cherry Hill, N. J. 08034, in time to reach us by the fifth of each month. Be sure to include your WPE identification and the make and model number of your receiver.

Albania—*R. Tirana* is heard well on 7065 kHz at 2358-0028 in English to N.A. with news, music, talks, and in dual to 9750 kHz. Other outlets heard include 9510 kHz at 0145-0157 s/off and 6200 kHz at 0230-0300, both in English. Albania is also heard on 1394 kHz (*R. Tirana's* medium-wave foreign service outlet) around 2200 in language.

Angola—*R. Luanda*, 9535 kHz, has a wood-like drum IS at 0457-0501; s/on in Portuguese follows. News is given to 0506 and into African music until past 0514; this is parallel to 7245 kHz.

Argentina—Seemingly new, a Buenos Aires outlet, *R. El Mundo*, is noted on 11,754 kHz around 0130-0300 closing with native music and a two-gong tone at breaks. From announcements given, it belongs to "Emisora Comerciales de Argentina" network.

Austria—*Osterreichischer Versuchsende-Verband* is operating over OE3XNB on Saturday at 1300-1330 on 3678 kHz and on Sunday at 1000-1030 on 7040 kHz. Programs include DX news. Reports are welcome and IRC's will be appreciated. Reports go to the station at A-2380 Perchtoldsdorf, Hugo-Wolf-Gasse 31, Austria . . . Vienna is heard well on 9770 kHz at 0015 to N. A. and on 7245 kHz to Europe from 0700 s/on.

Brazil—A station on 5035 kHz is believed to be ZYW22. *R. Anhaquera*, Goiania, heard from 0230 to abrupt s/off at 0330 with "Taps"; it featured Portuguese talks and music. Another, rarely heard well, is ZYX2, *R. Brasil Central*, Goiania, 4995 kHz. Check for it during the silent period of WWV at

2345; it features US pop music and Portuguese talks.

Cape Verde Islands—*R. Clube Cabo Verde* is fair in Portuguese with semi-classical music from 2230-2300 s/off on 3883 kHz but you may expect QRM from US amateur stations.

China—Reports from west and southwest areas include: Peking on 17,700 kHz at 0130 in English, 6155 kHz at 1425 in Japanese, 7490 kHz at 1450 in Chinese, 7420 kHz at 1435 in Chinese, 7025 kHz at 0225-0337 with English talks and Chinese music, 4200 and 3830 kHz at 1517-1525, both in Chinese, 3660 kHz at 1508 in English, and 3290 kHz at 1458 in Chinese; Foochow on 2340 kHz at 1445 in Chinese and on 2200 kHz at 1145 with Chinese music; and Fukien on 3535 kHz at 1505 in Chinese, 2430 kHz at 1454 in Chinese, and at 1107 on the same frequency with Chinese and high-pitched music, but very weak.

Colombia—All Spanish heard on *R. Colosal*, 4945 kHz, at 0530-0545; *R. Santa Fe*, 4965 kHz, at 0100-0130 and 0430-0445; *La Voz de Caqueta*, Florencia, 5035 kHz, at 0315; *R. Sutatenza*, 5060 kHz, at 0515-0532 s/off, and *La Voz del Llano*, Villavicencio, 6065 kHz, at 2357. Back on the air is HJLW, *Ecos del Combeima*, Ibaque, on 4790 kHz, as noted at 0200 in Spanish.

Costa Rica—*R. Reloj*, San Jose, is wandering as noted recently on frequencies from 4650 kHz to 4750 kHz at 0215-0300 in Spanish with many ID's.

Ecuador—After its return of a few months ago, HCCR1, *R. Casa de la Cultura*, Quito, has settled down on 4930 kHz where it is heard from 0100 to past 0300 in usual Spanish programming.

Egypt—Cairo is good on 11,630 kHz at 0045 with Arabic news after a clock strike, and on 9475 kHz at 0240 in English requesting letters from listeners.

Ethiopia—A new frequency for ETLF, Addis Ababa, is 11,855 kHz, heard at 0250 with light music and multi-lingual announcements.

Greece—The current schedule for *R. Athens* reads: 0700-0815, 0900-1000, 1030-1300, 1930-2100, 2200-2230 and 2300-2330 on 9605 and 11,720 kHz; 1330-1515, 1630-1700 and 1830-1900 on 7295 and 9605 kHz; and at 1730-1800 on 11,720 and 15,425 kHz.

Guatemala—TGNB, *R. Cultural*, Guatemala City, may be back on the air by the time you read this, probably on 9670 kHz. All equipment is ready and only the slowness of the government in issuing the license is keeping the station off the air. Wayne Berger, Chief Engineer, writes that he will answer all reception reports but please be patient since he is also in charge of YNOL and YSHQ, in Nicaragua and El Salvador respectively.

Guyana—*Action Radio*, Georgetown, is on the



With a variety of antennas covering virtually any frequency. Bruce McCoy, LaPorte, Ind., has DX awards for 25 countries and 10 zones. WPE9JMY uses a Realistic DX-150, EV20CL tap-deck amplifier.

DX ALL-ZONE AWARDS PRESENTED

To be eligible for one of the new DX All-Zone Awards designed for WPE Monitor Certificate holders, you must have verified stations in 10, 20, 30, or 40 of the radio zones of the world. The following recently qualified for and have received awards.

10 ZONES VERIFIED

Rick Abshier (WPE9IQX), Lisle, Ill.
 Alain Miville-de Chene (VE2PE1NK), Hauteville, Que.
 Ron Budziack (WPE9JHK), Cicero, Ill.
 Mike Martin (WPE0BTP), Manassas, Va.
 David Reichert (WPE4JWU), Mary Esther, Fla.
 Tom Felton (VE7PE1EA), Vancouver, B. C.
 Roger Matus (WPE2OBQ), Lido Beach, N. Y.
 Terry Moorby (VE3PE2OI), Ottawa, Ont.
 Ken Piper (WPE5GVB), Stockton, Calif.
 John Stevenson (WPE9GNU), Delavan, Wisc.
 Ernest Baird (VE2PE1KI), Pointe Claire, Que.
 Marvin Robbins (WPE0MW), Omaha, Nebr.
 Harold Hollabaugh (WPE8AHX), Toledo, Ohio
 Robert Sygiel (WPE2QBD), Clifton, N. J.
 Gordon Collister (WPE0EZK), Lawrence, Kansas
 Thomas Blossom (WPE9FHQ), Lancaster, Pa.
 Peter Rudolph (WPE6GOR), Sylmar, Calif.
 Paul Curran (WPE1HNV), E. Boston, Mass.
 Gary Nuthals (WPE9JNA), Green Bay, Wisc.
 Bruce McCoy (WPE9JMY), La Porte, Ind.
 Charles Mohr, Jr. (WPE2MKI), White Plains, N. Y.
 Joseph Havrilla (WPE3HMN), Trescow, Pa.
 David Arndt (WPE8KAT), Ann Arbor, Mich.
 John Ehrmann (WPE9JJO), Chicago, Ill.
 Kevin Boutwell (WPE2QSA), Latham, N. Y.
 David Perry (WPE2QFK), Pleasant Valley, N. Y.
 Stanley Starks (WPE8KDR), Midland, Mich.
 Dennis Davenport (WPE9JLT), Edwardsville, Ill.
 Paul Dougherty (WPE4JSN), Birmingham, Ala.
 Gary Hawkins (WPE7CWG), Phoenix, Ariz.
 Michael Dopson (WPE4KCF), Enterprise, Ala.
 Jeff Guernsey (WPE0FJE), Salina, Kansas
 David Weinberger (WPE3HVV), Philadelphia, Pa.
 E. Lloyd (VE7PE1ED), N. Vancouver, B. C.
 W. Striplong (WPE5FCL), Fort Worth, Texas
 T. Wieber (WPE2QVT), Summit, N. J.
 Richard Moore (VE3PE2NZ), London, Ont.
 Michael Nickel (WPE0FML), St. Louis, Mo.
 Barry Levine (WPE2QMM), Elmira, N. Y.
 Mark Waldman (WPE5FBD), Kilgore, Texas
 Thomas Phillips (WPE1HQE), Rutland, Vt.
 Wade Smith (WPE3FGX), Wayne, Pa.
 James Bochantin (WPE9JDA), Du Bois, Ill.
 R. D. Gee (VE7PE1EG), Victoria, B. C.
 Warren Flack (WPE4KEL), Atlanta, Ga.

Alan Macnaughton (VE3PE2PP), Kitchener, Ont.
 John Cazahous (WPE6FCR), San Francisco, Calif.
 Charles Leftis (WPE4KEF), Landrum, S. C.
 Steven d'Adolf (KX6PE1B), APO, San Francisco, Calif.
 Gary De Bock (WPE7CUX), FPO, Seattle, Wash.
 John Burda, Jr. (WPE8KAO), Willard, Ohio
 John Kiernan (WPE2EMN), New York, N. Y.
 Fred Parkinson (WPE2QTW), Hewlett, N. Y.
 Joseph Cooper (WPE9JRT), Milwaukee, Wisc.
 Donald Williams (WPE7CVW), Salem, Ore.
 Jim Brenner (WPE2QUL), Nutley, N. J.
 Anthony Arndt (WPE6HII), Los Angeles, Calif.
 Milton Nichols (WPE1HGE), Holden, Mass.
 Everett Slosman (WPE2QZB), Endicott, N. Y.
 Gregory Martin (WPE8KFL), Wyoming, Mich.
 Bruce Towle (WPE9JQQ), Thornton, Ill.
 Laurie Coghlin (VE4PE7N), Winnipeg, Man.
 Walter Miscichowski (WPE2BEH), Buffalo, N. Y.
 Steven Solomon (WPE2QTM), Saddle Brook, N. J.
 Bob Raymond (WPE1HOE), Bradford, Mass.
 Rex Wilson (VE3PE2OV), Kitchener, Ont.
 J. L. Smith (WPE5FCX), Beeville, Texas
 Nick Chinn (WPE6HKB), San Leandro, Calif.
 Willie Martin (WPE5FBJ), Blytheville Air Force Base, Ark.
 Mike Hardester (WPE6HIM), Modesto, Calif.
 Dan De Carlo (WPE0FJL), Joplin, Mo.
 Mike Mc Clelland (KL7PE4C), Anchorage, Alaska
 Robert Reynolds (WPE9JAF), Elmwood Park, Ill.
 John Mraz, Jr. (WPE3HIT), Phoenixville, Pa.
 Bob Barr (WPE3HNC), Willow Grove, Pa.
 Charles Smith (VE5PE6R), Saskatoon, Sask.
 Andre Lavigne (VE2PE1NO), La Salle, Que.
 Glen Wilson (WPE4KDK), Arlington, Va.
 Mitchell Bademan (WPE6HAB), Long Beach, Calif.
 Ronald Richmond (WPE9JII), Alexandria, Ind.
 James Ziegler (WPE9JOW), Milwaukee, Wisc.
 Robert Bass (WPE5FDE), New Orleans, La.
 Frank Priore (WPE2MYB), Bayside, N. Y.
 Peter Heindel (WPE6GLR), Waukegan, Ill.
 Jack Dashper (WPE4KCJ), Camden, Tenn.
 Kim Stenson (WPE1HPU), Wilmington, Vt.
 Kent Kirkland (WPE3HXL), Wilmington, Del.
 George Butela (WPE3HAZ), Glenshaw, Pa.
 Homer Ingler (WPE4JYY), Durant, Fla.
 Terry Luttrell (WPE4KXB), Columbia, Tenn.

air on 560 kHz (20 kW), 705 kHz (2 kW), and on 3290 and 5950 kHz, both with 10 kW.

Honduras—HRN, *La Voz de Honduras*, Tegucigalpa, was heard on 5875 kHz relaying HRVF. R. *Esitos*, 5955 kHz, with a special program at 0430.

Iran—R. *Iran* is on a new frequency of 7044 kHz as noted at 0315-0400 in Home Service with Balkan music, language news and pop music.

Japan—Far East Network, Tokyo, 15,260 kHz, is good at 0200 with pop music and some news.

Kuwait—R. *Kuwait* is now using 15,185 kHz in English to India and Pakistan starting at 0400 with mostly pop music to 0500; a weathercast is given at 0500.

Mexico—R. *Mexico* is good on 6055 kHz at 0123-0137 with Spanish amnt's and L.A. music, XEUDS, R. *Universidad de Sonora*, is strong on 6115 kHz at 1700-0300 with Spanish programming and mostly Mexican music.

Nepal—R. *Nepal*, Kathmandu, was heard on 11,696 kHz at 0120 s/on in Nepali with IS and bells; then into local music and talks. It fades by 0300.

Pakistan—R. *Pakistan*, 21,730 kHz, has English news at 1500. Other outlets heard: 11,705 kHz at 0130 s/on in Urdu with chanting but QRM'ed out by 0153, and on 7135 kHz with Urdu chanting at

0136, a newscast from 0141-0159, a time signal on the hour, and into Indian language.

Papua and New Guinea, Territory of—A recent program schedule shows a new station, VH9RA, on 5985 kHz with xmsn time of 1430-2130. No xmtv power or station location was given.

Peru—OAZAR, R. *San Juan*, Tarma, was noted on 4891 kHz with lengthy listener request music and Andean music, with Spanish amnt's after 0200.

Poland—R. *Warsaw* is scheduled to Europe at 0800-0830 on 7125 and 6035 kHz, 1200-1225 on 7115 and 9675 kHz, 1930-2000 and 2130-2155 on 6135 and 7145 kHz, 2030-2057 on 6035 and 7125 kHz, and 2330-0000 on 5995, 7285, 9540, and 11,955 kHz. Numerous reports list English at 0315-0345 on 9675 kHz but we have no information on this xmsn. Does anyone know the target area?

Puerto Rico—DX'ers who need this country for DX Awards might try for WPR, Mayaguez, 990 kHz, at 0900 s/on in Spanish and English.

Senegal—Dakar can be heard daily on 4890 kHz at 0530-0800 in French with news, sports and music. Also good is 4950 kHz at 0630 with jazz and amnt's in French, and 7120 kHz at 0725-0758 with a variety of music.

(Continued on page 110)

Exciting New Kit Ideas from Heath

New Heathkit 100-Watt AM/FM/FM-Stereo Receiver

World's finest medium power stereo receiver . . . designed in the tradition of the famous Heathkit AR-15. All Solid-State . . . 65 transistors, 42 diodes plus 4 integrated circuits containing another 56 transistors and 24 diodes. 100 watts music power output at 8 ohms — 7 to 60,000 Hz response. Less than 0.25% distortion at full output. Direct coupled outputs protected by dissipation-limiting circuitry. Massive power supply. Four individually heat sinked output transistors. Linear motion bass, treble, balances and volume controls. Push-button selected inputs. Outputs for 2 separate stereo speaker systems. Center speaker capability. Stereo headphone jack. Assembled, aligned FET FM tuner has 1.8 uV sensitivity. Two tuning meters. Computer designed 9-pole L-C filter plus 3 IC's in IF gives ideally shaped bandpass with greater than 70 dB selectivity and eliminates alignment. IC multiplex section. Three FET's in AM tuner. AM rod antenna swivels for best pickup. Kit Exclusive: Modular Plug-In Circuit Boards . . . easy to build & service. Kit Exclusive: Built-In Test Circuitry lets you assemble, test and service your AR-29 without external test equipment. The AR-29 will please even the most discriminating stereo listener.

Kit AR-29, (less cabinet), 33 lbs. \$285.00*
 AE-19, Assembled oiled pecan cabinet, 10 lbs. \$19.95*

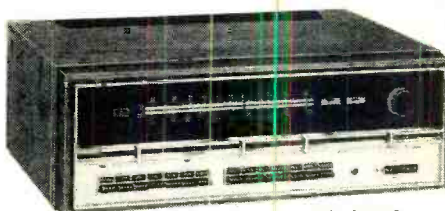

Kit AR-29
\$285.00*

New Heathkit 60-Watt AM/FM/FM Stereo Receiver

The AR-19 circuitry reflects many of the advanced concepts of the AR-29. It uses 108 transistors and 45 diodes including those in 5 integrated circuits. It delivers 60 watts music power at 8 ohms. At any power level, Harmonic and IM Distortion is less than 0.25%. Frequency response ranges from 6 to 35,000 Hz. Direct coupled outputs are protected by dissipation-limiting circuitry. A massive power supply includes a section of electronically regulated power. The assembled, aligned FET FM tuner has 2.0 uV sensitivity.

A preassembled and factory aligned FM IF circuit board gives 35 dB selectivity. The multiplex IC circuit provides inherent SCA rejection. It features two switched noise muting circuits; linear motion controls for bass, treble, volume and balance; input level controls; outputs for 2 separate stereo speaker systems; center speaker capability; two tuning meters; stereo indicator light; front panel stereo headphone jack. The Modular Plug-in Circuit Board design speeds assembly. Built-in Test Circuitry aids assembly, simplifies servicing. "Black Magic" panel lighting, black lower panel, chrome accents. Compare it with any model in its price range . . . the AR-19 will prove itself the better buy.

Kit AR-19, (less cabinet), 29 lbs. \$225.00*
 Assembled AE-19, cabinet, 10 lbs. \$19.95*

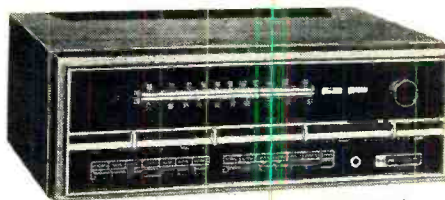

Kit AR-19
\$225.00*

New Heathkit Deluxe 18-Watt Solid-State Stereo Phono

Looks and sounds like it should cost much more. Here's why: 16-transistor, 8-diode circuit delivers 9 watts music power per channel to each 4 1/2" high-compliance speaker. Speaker cabinets swing out or lift off . . . can be placed up to 10' apart for better stereo. Has Maestro's best automatic, 4-speed changer — 16, 33-1/3, 45 & 78 rpm. It plays 6 records, shuts off automatically. Ceramic stereo cartridge with diamond/sapphire stylus. Has volume, balance & tone controls. Changer, cabinet & speaker enclosures come factory built . . . you build just one circuit board . . . one evening project. Wood cabinet has yellow-gold & brown durable plastic coated covering. This is a portable stereo you can take pride in.

Kit GD-109, 38 lbs. \$74.95*

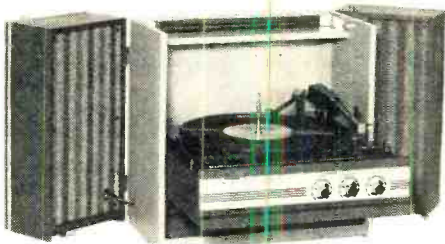

Kit GD-109
\$74.95*

New Heathkit 80-10 Meter 2 KW Linear Amplifier

Incomparable performance and value. The new SB-220 has 2000 watts PEP input on SSB & 1000 watts on CW and RTTY. Uses a pair of Eimac 3-500Z's. Pretuned broad band pi input coils. Requires only 100 watts PEP drive. Solid-state power supply operates from 120 or 240 VAC. Circuit breaker protected. Safety interlocked cover. Zener diode regulated operating bias. Double shielded for max. TVI protection. Quiet fan — fast, high volume air flow. Also includes ALC to prevent over-driving. Two meters: one monitors plate current; the other is switched for relative power, plate voltage and grid current. Styled to match Heath SB series. Assembles in about 15 hours.

Kit SB-220, 55 lbs. \$349.95*

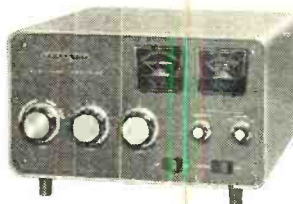

Kit SB-220
\$349.95*

New Heathkit Portable Fish-Spotter

Costs half as much as comparable performers. Probes to 200 ft. Spots individual fish and schools . . . can also be used as depth sounder. Manual explains typical dial readings. Transducer mounts anywhere on suction cup bracket. Adjustable Sensitivity Control. Exclusive Heath Noise-Reject Control stops motor ignition noise. Runs for 80 hrs. on two 6 VDC lantern batteries (not included). Stop guessing — fish electronically.

Kit MI-29, 9 lbs. \$84.95*



Kit MI-29
\$84.95*

NEW IMPROVED 1970 HEATHKIT COLOR TV

New Lower-Than-Ever Prices



Here's How The Color TV That Thousands Call Best Became Even Better and Lower In Price

Since the very first model was introduced, thousands of owners, electronic experts, and testing labs have praised the superior color picture quality and extra features of Heathkit Color TV. Now Heath has made improvements that make the 1970 models even better.

ADVANCED PERFORMANCE.

BY HEATHKIT DESIGN

Sharper, More Detailed Pictures. Latest design improvement in the circuitry of Heathkit Color TV video amplifiers has increased their bandpass capabilities. The result is an increase in the number of lines of resolution . . . greater than in any other brand of color TV we have tested. This improvement means you get sharper, more detailed pictures as shown by test pattern measurements. You not only get the superior color pictures Heathkit Color TV has always been noted for, but you also get sharper pictures.

New Brighter Tube. Now all Heathkit Color TV models include the new brighter picture tube you've read so much about. These new tubes produce noticeably brighter pictures with more life-like, natural colors and better contrast. (We also offer the RCA Hi-Lite Matrix tube as an extra-cost option for the Heath GR-681 and GR-295 kits.)

New Safety Features. As an added safety precaution, AC interlocks have been added to all Heathkit Color TV cabinets.

Now The Best Costs Less. How can Heath make improvements in its Color TV Models and still reduce the prices? We have passed on to you the savings which have accrued due to reduced picture tube prices. The result is your 1970 Heathkit Color TV will cost you \$20 to \$55 less depending upon which model you choose . . . proof that Heathkit Color TV is a better buy than ever.

All Heathkit Color TV's Have These Superior Features

- New brighter American brand rectangular color tube with bonded-face, etched anti-glare safety glass
- Exclusive built-in self-servicing aids so you can adjust and maintain the set for best performance always
- Automatic degaussing plus mobile degaussing coil
- New broader video bandwidth for better resolution
- 3-stage video IF
- Improved retrace blanking
- Gated automatic gain control for steady pictures
- Automatic color control
- Exclusive Magna-Shield surrounds picture tube for better color purity
- Deluxe VHF tuner with "memory" fine tuning and precious metal contacts (models with automatic fine tuning are available in all 3 picture tube sizes)
- 2-speed UHF solid-state tuner
- Completely shielded hi-voltage supply
- Extra B+ boost for better definition
- 2 hi-fi sound outputs for built-in speaker or your hi-fi system
- 300 ohm & 75 ohm antenna inputs
- Circuit breaker protection
- Optional wireless remote control can be added anytime
- Factory assembled and adjusted tuners, IF section, and hi-voltage supply
- Exclusive 3-way installation capability — in a wall, custom cabinet or Heath cabinets

Choose Your Heathkit Color TV Now . . .

It's Better Than Ever in Performance . . . and A Better Buy Than Ever



NEW FREE 1970 CATALOG!

Now with more kits, more color. Fully describes these along with over 300 kits for stereo/hi-fi, color TV, electronic organs, guitar amplifiers, amateur radio, marine, educational, CB, home & hobby. Mail coupon or write Heath Company, Benton Harbor, Michigan 49022.

New Lower-Than-Ever Prices On All Models

Heathkit GR-681 (295" AFT) save \$30
Now only \$46995*



Heathkit GR-681MX (with Matrix tube) save \$55
Now only \$47995*



Heathkit GR-295 (295" AFT) save \$30
Now only \$41995*



Heathkit GR-295MX (with Matrix tube) save \$55
Now only \$42995*

cabinets from \$65*

Heathkit GR-581 (227" AFT) save \$20
Now only \$39995*



Heathkit GR-227 (227" AFT) save \$20
Now only \$35995*



cabinets from \$39.95*

Heathkit GR-481 (180" AFT) save \$30
Now only \$32995*

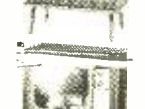

Heathkit GR-180 (180" AFT) save \$30
Now only \$29950*



cabinets from \$27.50*

HEATH COMPANY, Dept. 10-4
Benton Harbor, Michigan 49022



a Schlumberger company

Enclosed is \$ _____ plus shipping.

Please send model(s)

Please send FREE Heathkit Catalog. Please send Credit Application.

Name _____

Address _____

City _____

State _____

Zip _____

*Mail order prices; F.O.B. factory. Prices & specifications subject to change without notice. CL-377R

CIRCLE NO. 14 ON READER SERVICE PAGE

POPULAR ELECTRONICS SUBSCRIBER SERVICE

Please include an address label when writing about your subscription to help us serve you promptly. Write to: P.O. Box 1096, Flushing, N.Y. 11352

CHANGE OF ADDRESS:

Please let us know you are moving at least four to six weeks in advance. Affix magazine address label in space to the right and print new address below. If you have a question about your subscription, attach address label to your letter.

TO SUBSCRIBE: Check below.

5 yrs. \$21 3 yrs. \$15
 1 yr. \$6 New Renewal

Specify: Payment enclosed
You get 1 extra issue per year as a BONUS!
 Bill me later.

If you have no label handy, print OLD address here.

name _____ please print

address _____

city _____

state _____ zip code _____

AFFIX LABEL

print name _____ 0394

address _____

city _____

state _____ zip code _____

Add'l postage: \$1 per year outside U. S., its possessions & Canada.

the
LANCER

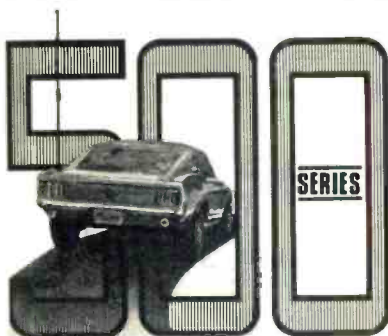

THREE NEW CB MOBILE ANTENNAS With 500 Watt Coil

NOW AT POPULAR PRICES. Each model loaded with a SOLID-STATE high "Q" coil field tested to take up to 500 watts. Maximum legal power is assured!

Mosley innovated guying device, introduced in this series, keeps antenna upright at top highway speeds.

- Model 500A. . . With 500 watt solid-state high "Q" coil
- Model 500B. . . With 500 watt solid-state coil, and capacity adapters
- Model 500C. . . With 500 watt solid-state coil, capacity adapter and breaker (hinge) feature

For details see your Mosley dealer or write Factory direct, Dept 200.

Mosley Electronics Inc.

4610 N. LINDBERGH BLVD., BRIDGETON MD. 63044
CIRCLE NO. 16 ON READER SERVICE PAGE

TWO-WAY REACTIONS

(Continued from page 93)

lenged to demonstrate good citizenship and pride in their use of equipment. We know that a few outlaws on the air will make it difficult for all of us to get the maximum benefit from our CB equipment. The FCC action making channel 9 an official emergency channel however gives a new level of recognition to the entire CB community. It elevates the Citizens Radio Service to a point where the FCC recognizes that CB can be used for a serious and worthwhile purpose.

We hope that everyone who is on the air will acknowledge this coming of age for CB radio. With a new maturity, goes a new and higher level of responsibility. Let us all observe the channel 9 ruling as strictly as possible. It may very well be that the future of the Citizens Radio Service depends on how well users observe the ruling on channel 9. If compliance is universal, then we can expect CB radio to develop into a bigger, more significant service. However, if the ruling is extensively violated, then it is very possible that the Citizens Radio Service may be seriously curtailed.

REACT National Director, Henry B. Kreer, presented a paper before the Automotive Engineering Conference of the Society of Automotive Engineers in Detroit in January, entitled, "Safety and Service Applications of Citizens Two-Way Radio." It brought the knowledge of CB radio to this important group of people who are the technical backbone of the automotive industry.

CURRENT EVENTS

Fruita, Colo. . . . Mayor Roe F. Saunders and Chief of Police Richard S. Walker recently commended the All American Citizens Band Radio Club of Grand Junction for their assistance during the power failure in Fruita. Donna Cosby, KGC1383, acted as monitor and dispatcher for the town police department. Other members of this REACT team cooperated to assist in patrolling the town for fire and vandalism.

Dodge City, Kan. . . . Citizens Two-Way Radio was used in a Civil Air Patrol search and rescue operation with the cooperation of Civil Defense authorities here recently. Primary communications between air and ground were on the local sheriff's frequency. Ground vehicles communicated with each other on CB channel 11. Air-to-air communications were on the CAP frequency.

Mexico, N.Y. . . . Oswego County REACT's snowmobiles saw a lot of action last winter in search and rescue operations. The members assist the sheriff and state police in rescuing people in the rugged Adirondack Mountains.

Rockford, Ill. . . . Rock River Valley CB Club Jamboree will be held May 30 and 31 at the Winnebago Co. Fair Exhibit Bldg., Pecatanica, Ill. Contact, H. E. Keirn, Box 4002, Rockford, Ill. 61110.

SOLID STATE

(Continued from page 92)

(Wakefield, Mass. 01880) can supply their ST14030-32 and ST40002-04 series. Both series are silicon planar devices with 60-ampere current and 300-watt power dissipation rating. They are assembled in TO-63 stud-mounted packages. The ST14030-32 are *npn* units with voltage ratings from 125 to 170 volts, while the ST40002-04 are *pnp* complements with ratings from 80 to 120 volts.

Transitips. Our discussion of the basic blocking oscillator and its possible applications in January brought an unusually rapid response from readers. While most of the letters were complimentary, a few complained about our failure to detail component values.

Actually, parts values were omitted deliberately since the design is so basic that, quite literally, any of hundreds of transistors and scores of transformers could be used. The optimum component values in any specific case depend on the type of transistor used, on the supply voltage, and, to some extent, even on the transformer's characteristics.

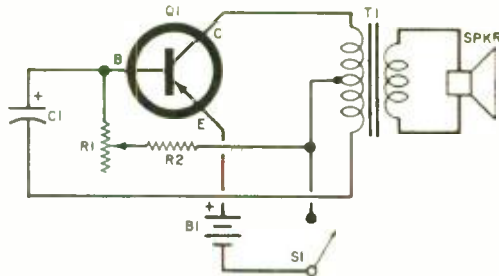

Fig. 4. Component values depend on the transistor type, supply voltage, and transformer windings.

In view of reader interest, however, we can offer a few guidelines for the serious experimenter. The original circuit is reproduced in Fig. 4 for reference. Capacitor *C1*'s d.c. polarity is indicated in the event an electrolytic capacitor is used, while all d.c. polarities are for a *pnp* transistor. If an *npn* type is used, of course, these polarities would be reversed.

If *Q1* is a small-signal transistor with characteristics similar, say, to the 2N107 or 2N109, then a conventional 9-volt power supply (*B1*) can be used, while *T1* should have a primary impedance of from 500 to 1500 ohms (Argonne types AR-137 or AR-138 are good choices). A 500,000- or

If you're switched on to CB, switch up to Courier



New Traveller II

Sleek and sassy, it's the world's smallest 23 channel CB radio. Instant warm-up, solid-state dependability, 100% modulation. All chrome cabinet and diecast face. One year warranty. **\$139⁹⁵**

New Classic II

A legend in its own time, it's a sleek mobile rig with equally good base station capabilities. Built-in AC power supply and P.A. function. 23 channels with 100% modulation. Illuminated S meter, slide controls, ANL delta tuning. One year warranty. **\$199⁹⁵**

New Base Station Mike BMT-1

Improve the performance of your CB, AM, FM or SSB transceiver with our base station mike with built-in pre-amp. Only **\$29⁹⁵**



New Ranger 23

Great performance, great value. Features cascade front end for greater sensitivity, nuvistor mixer for improved S/N ratio and full-time range expand. S-RF meter. Complete with all crystals for 23 channel operation. **\$199⁹⁵**

Special Offer!
17" x 22" CB
Psychedelic Posters
In Full Color



Courier Communications.
100 Hoffman Place, Hillside, New Jersey 07205

Please send me more information on:

- Traveller II* Classic II*
 Ranger 23 Plus BTM-1 Mike

* Enclose \$1 each and we'll send you a 17" x 22" full color psychedelic CB poster featuring the sensational new Classic II Traveller II (check one or both)

Name

Address

City State Zip

Dept. PE-04

CIRCLE NO. 11 ON READER SERVICE PAGE

1-megohm potentiometer can be used for R_1 , while R_2 should be a half-watt resistor of 10,000 to 16,000 ohms. Feedback capacitor C_1 can have values ranging from 0.02 μF for a CPO to as high as 20 μF for a metronome.

On the other hand, if a medium-power transistor such as the 2N301 is used for Q_1 , T_1 should have a 40- to 50-ohm primary, with the Argonne AR-503 a suitable choice. A 6-volt lantern battery (or four series-connected flashlight cells) should be used for B_1 . Potentiometer R_1 , in this case, should be about 5000 ohms and R_2 a half-watt type with a value of from 500 ohms to, say, 1000 ohms. Here, C_1 can range in value from 0.1 μF for a CPO to as high as 100 μF for a metronome.

These suggested values are not necessarily optimum for all modes of operation, but can serve as "starting values" for experimental tests. A higher gain transistor will require larger bias resistors (R_1 and R_2) and a smaller feedback capacitor for a given application, while a moderately high-power transistor could require relatively small bias resistors and a fairly large feedback capacitor.

—Lou.



OPERATION ASSIST

Through this column we try to make it possible for readers needing information on outdated, obscure, and unusual radio-electronics gear to get help from other P.E. readers. Here's how it works: Check the list below. If you can help anyone with a schematic or other information, write him directly—he'll appreciate it. If you need help, send a postcard to Operation Assist, POPULAR ELECTRONICS, One Park Avenue, New York, N.Y. 10016. Give maker's name and model number of the unit. If you don't know both the maker's name and the model number, give year of manufacture, bands covered, tubes used, etc. State specifically what you want, i.e., schematic, source for parts, etc. Be sure to print or type everything legibly, including your name and address. Do not send an individual postcard for each request; list all requests on one postcard. Because we get so many inquiries, none of them can be acknowledged. POPULAR ELECTRONICS reserves the right to publish only those items not available from normal sources.

ELECTRONICS GEOGRAPHY QUIZ ANSWERS

(Quiz appears on page 42)

Part I	Part II	Part III
1-G	1-G	1-D
2-H	2-M	2-L
3-J	3-C	3-M
4-D	4-H	4-B
5-L	5-N	5-J
6-I	6-D	6-A
7-K	7-L	7-I
8-O	8-I	8-E
9-C	9-B	9-K
10-F	10-F	10-H
11-E	11-O	11-F
12-M	12-A	12-O
13-N	13-K	13-C
14-B	14-J	14-G
15-A	15-E	15-N

Philco AM/FM phono TV console chassis No. 30227. Circa 1948. Schematic and operating instructions needed.
RCA color TV chassis No. 643L1, serial No. B5124970. Circa 1959. Schematic needed. (Joseph Slacca, 855 Alden Rd., Paramus, NJ 07652)

Autovox S.P.A. Noma transmobile radio (made in Italy). Volume control, tuning knobs and additional info needed. (Alfred Brown, RR #2, Matheson, Ontario, Canada)

Challenger Model CH30 PA amp. Schematic and info needed. (Cornel Buboi, 3329 W. 8 Mile Rd., Detroit, MI 48221)

Precision Model 201 signal tracer. Operation manual and schematic needed. (Arvin Richardson, Box 389, Ashley, OH 43003)

Western Auto Supply Co. Model 557 receiver. Schematic needed. (Rick Bowersox, 7415 Canton Dr., Lemon Grove, CA 92045)

New Products from THE PHASE CORPORATION

FOUR TRACE PRE-AMP

Convert any single trace scope to display four separate signals at the same time without any internal modifications.



\$34.95

All Solid State
FET Input
Center & Gain
Controls for each
Channel
1 Megahertz/
channel
bandwidth

Kit with Custom cabinet (Model A1K) \$34.95; wired & tested (Model A1W) \$54.95

Send Check, Money Order, or ask us to bill your BankAmericard or Master Charge. We pay all postage. Dealer inquiries invited.

TEST OSCILLATOR

Generates all three functions.

SAW: 0.1HZ
—100KHZ
SQUARE: 0.05HZ
—50KHZ
PULSE: 0.1HZ
—100KHZ



\$34.95

All Solid State
FET & Unijunction
Circuitry
Calibrated ranges
Portable &
Compact

Kit with Custom Cabinet (Model O1K) \$34.95; wired & tested (Model O1W) \$54.95

THE PHASE CORPORATION, ELECTRONICS DIVISION, MEDFORD, MASS. 02155

CIRCLE NO. 21 ON READER SERVICE PAGE

100-kHz STANDARD

(Continued from page 58)

ed alignment tool to obtain either a 100 kHz reading on the counter or a quiet "chuffing" zero-beat note from the receiver speaker.

The circuit should operate properly with all good-quality 100-kHz parallel-resonant crystals. However, older surplus or odd cut crystals might require a shift in the values of capacitor C_4 and, rarely, C_3 for proper starting and clean operation. If you are using non-standard crystals, you might have to experiment to get the best results. Also, crystals with other frequencies can be used for special applications, up to 8 MHz or so.

For powering the standard, you can use batteries or any power supply capable of delivering 1.5-6 volts of relatively clean d.c. Supply voltage has a slight effect on the operating temperature; so, be sure to calibrate your 100-kHz Standard at the voltage you will be using. —30—

OUT OF TUNE

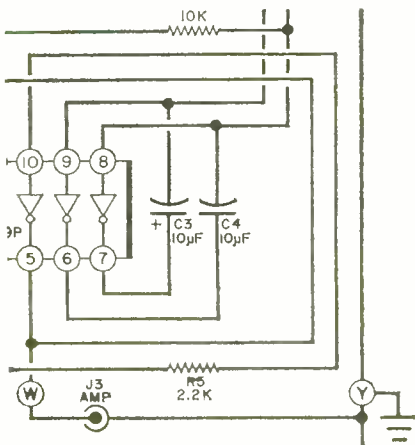

"Build the Two-Tone 'Waverly' Alarm" (February 1970). The schematic diagram, Fig. 1 on page 30, shows R_6 and R_7 connected to the incorrect pins on IC_1 . In the partial diagram above the correct connections are shown.

April, 1970

It costs only



New Easy Dispenser Pak 60/40 18 S.W.G.*

1/100 of 1¢ more



Latest PC (Printed Circuit) Pak
60/40 Extra Thin 22 S.W.G.—.028"*

per solder joint to know you are using the world's finest cored solder

* Each only 59¢ per package at your dealer.



MULTICORE SALES CORP., WESTBURY, N.Y. 11590

CIRCLE NO. 17 ON READER SERVICE PAGE

This is the BOOK that ALL... tells about TV antennas & home TV systems! (And it's free!)



Write today for your free copy of the giant 1970 Winegard Catalog offering the world's finest selection of TV and FM Antennas, Mounts, Amplifiers, Wire — plus everything you need for a home TV outlet system. Professional or do-it-yourselfer, you'll learn more about the new Winegard products that can bring you sharper, clearer TV and FM reception. Mail coupon now for your free copy.



Winegard

® ANTENNA SYSTEMS

3022-4 Kirkwood Street • Burlington, Iowa 52601

Please send your free catalog to:

NAME _____

ADDRESS _____

CITY _____

STATE _____ ZIP _____

I'm a Dealer

Do-It-Yourselfer

CIRCLE NO. 30 ON READER SERVICE PAGE

Every one of these men was a "Doubting Thomas" about the opportunities in Electronics



Read what they say now:

"My salary increases have totaled \$3,800 and I'm now number two in a four man department. Much of my progress and growth in Electronics is due to the practical preparation I gained from Bell & Howell programs." Tom Cason, Billerica, Massachusetts

"My income has gone up 40% after I moved into the field of Electronics. This has been the most significant change in my life and I feel I owe a lot to the excellent training I got from Bell & Howell." Leslie R. Unger, Panorama City, California

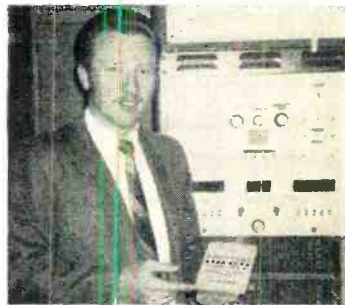

"It's wonderful to really enjoy your work, a feeling I certainly have today. My thanks to Bell & Howell's valuable background and training in Electronics. It gave me the career opportunity I've always wanted." Don W. Helms, Birmingham, Michigan

"I've opened a new \$10,000 building and now have two people working for me. My diploma—displayed as proof of my technical preparation—has been a big factor in the growth of my TV repair business." Charles R. Wagoner, Keithsburg, Illinois

"Electronics opened up a new life for me in geophysical prospecting. Your thoroughly practical instruction has placed me in a position to become entirely independent." G. D. Richardson, Spokane, Washington

Recent developments create new opportunities for you

You, as a reader of Electronics magazines, are probably better informed than the average person about the opportunities in this growing field. Yet you may not be fully aware of two recent developments which promise to increase the de-

mand for Electronics specialists in the next few years. For example:

- **Medical electronics.** Devices for physiological monitoring and the heart pacemaker are among several new, and highly sophisticated

pieces of equipment requiring expert Electronics personnel.

• **Electronic switching systems.** A major manufacturer of telephone equipment has already invested \$175 million in ESS. Estimates indicate a \$20 BILLION investment in the next 30 years!

The meaning is clear: The man who is fully and properly prepared to take advantage of opportunities like these in Electronics today, *will have no worries about the future!*

Where do you get the *right* kind of preparation? We think you will find it a tremendous advantage to have acquired your Electronics training with Bell & Howell Schools.

Why us? Because you'll get what executives in business and industry generally recognize as the most up-to-date, practical and thoroughgoing preparation available today. And these men are prepared to bid higher for men with this kind of background in Electronics.

Why Bell & Howell's proven programs turn out better-salaried men

For the past several years, we've invested more than \$100,000 each year—just to keep our programs in step with the constant changes in the world of Electronics.

As a result, you'll find our Lab-at-Home Plans are based on valuable experience gained from our own nation-wide technical colleges. (Information not available anywhere else.)

It means you get the latest theory, reinforced by the most modern and useful applications of that theory. And you'll receive personal guidance from exceptionally well qualified instructors—men with considerable practical electronics

experience and the ability to "get-it-across".

16 films make understanding easier. Some things in Electronics *are* complicated, yet quite basic. We simplify these things for you by picturing what happens a step at a time. We also lend you a projector so you can run each film as often as you need to.

Our exclusive Electro-Lab® includes a remarkably instructive, self-contained circuit design console. It enables you to rapidly "breadboard" a great variety of circuits—like those you'll encounter in today's real world of Electronics.

You'll also receive 16 big shipments of components—including everything you need to build your own portable, 5-inch band oscilloscope and a fully transistorized volt meter. You'll have two of the best precision instruments available—professional quality gear you'll want to keep and use throughout your career.

Free-for-life national employment service. Whatever your interest and experience are, we will help you locate the better-paying positions in Electronics—completely without cost. And this service is available to you at *any* time—now or in the future.

Whether you know a little, or a lot about Electronics, we urge you to *do something about your interest—NOW!*

Mail the postage-free card for Bell & Howell's new **FREE BOOKLET** and complete information about planning and choosing a profitable career in Electronics. There is absolutely no obligation of any kind.

MAIL CARD NOW FOR **FREE BOOKLET**

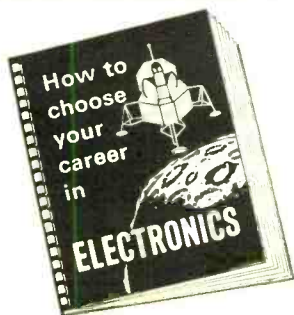

APPROVED FOR VETERANS' TRAINING

If card is detached, mail this coupon for your Free Booklet and complete information on career opportunities in Electronics to:

BELL & HOWELL SCHOOLS
4141 Belmont, Chicago, Illinois 60641

Name _____ (please print) _____ Age _____

Address _____

City _____ State _____ Zip Code _____

Check here for latest GI Bill information.

309

M-7012

SHORT-WAVE LISTENING

(Continued from page 99)

Spain—Madrid is on 6140 kHz (up from its former 6130 kHz spot), dual with 9760 kHz in all Spanish at 2300-0000 beamed to the Canary Islands and mid-Atlantic areas.

Upper Volta—Ouagadougou, 4815 kHz, was logged with a French talk after 2045; this seemed to be some sort of interview.

USA—AAC55 is an experimental Civil Defense station operating on long-wave at 179 kHz with tone modulation and word recognition tests and, on the hour, a short amnt that gives callsign, frequency, power (5 kW) and location (. . . a few miles south of Hagerstown, Maryland . . .). One of our long-wave listeners has heard it at times from 1900 to 0600.

USSR—Another long-wave station is one on 388 kHz with about 50 kW operating from Moscow for non-stop music for public and working clubs,

schools, villages, and probably also for city street networks in smaller towns. There are no amnt's but after each third tune there is the Morse signal for the letter U . . . Novosibirsk, Siberia, a Zone 18 area, is in an Oriental language at 0254 to past 0346 on 11.815 kHz. Baku can be heard on 11,920 kHz at 0319 with classical music and amnt's to 0330, a Moscow ID plus another—probably a local station ID—and more music and amnt's. Baku is also being reported on 4785 kHz at 0315 to past 0400 with talks and music in Russian.

Vatican City—Two more new frequencies are in use by *Vatican Radio*: 6175 kHz, heard closing English at 0104 and opening in French until 0125, and on 21.700 kHz with an English religious program to Southeast Asia with s/off at 1138.

Venezuela—*Ecos del Torbes*, 4980 kHz, has a special news bulletin for Venezuelans abroad at 0200, 0500 and 0900 on Monday and Friday; this is in Spanish and English. Reports go to P. O. Box 152, San Cristobal . . . YVMS, *R. Universo*, Barquisimeto, 4880 kHz, is heard after 2315 with L.A. pop tunes and Spanish amnt's. . . . YVPE, *R. Central*, Maracay, 3345 kHz, is heard well in the West at 0015-0100 in all Spanish with L.A. music, frequent amnt's and ID's. . . . YVLR, *R. Rumbos*, Caracas,

SHORT-WAVE CONTRIBUTORS

John Duane (WPE1HBC), Hingham, Mass.
Duane Randall (WPE1HUB), New Bedford, Mass.
Aimand Pelland (WPE111), S. Bellingham, Mass.
Brian Heiler (WPE2Q1P), San Jose, Calif.
Everett Slosman (WPE2QZB), Endicott, N. Y.
Robert Halprin (WPE2QZZ), Fair Lawn, N. J.
Steven Fix (WPE2RAS), Rochester, N. Y.
Lt. Paul Steen (WPE2RBA), FPO, San Francisco, Calif.
Lawrence Gould (WPE2RDC), Tenafly, N. J.
William Matthews (WPE3GIW), Columbus, Ohio
Gary Blau (WPE3HWV), Rockville, Md.
Dan Ferguson (WPE4AUL), Coral Gables, Fla.
James Phillips (WPE4EDV), Waverly, Va.
Bruce Roberts (WPE4KAH), Waynesboro, Pa.
David Weronka (WPE4KBE), Durham, N. C.
John Limbach (WPE4KCV), Fayetteville, N. C.
Frank O'Neil (WPE4KDI), Birmingham, Ala.
Roger Boyd (WPE4KEK), Valdosta, Ga.
Jack Simpson (WPE4KGI), Camp Lejeune, N. C.
David Greene (WPE4KIP), Memphis, Tenn.
Richard Fortson (WPE5FHX), Edinburg, Texas
James Krempel (WPE5FEH), San Antonio, Texas
Charles Bennett (WPE5SW), Sumrall, Miss.
Jim Young (WPE6ENA), Wrightwood, Calif.
Wallace Glavich (WPE6EPX), Eureka, Calif.
Trevor Clegg (WPE6FAF), Fresno, Calif.
John Boessenecker (WPE6GXP), Mill Valley, Calif.
Jim Lacko (WPE6HCX), Arleta, Calif.
Glenn Edens (WPE6HIP), Ontario, Calif.
Nick Chinn (WPE6HKB), San Leandro, Calif.
Loren Davis (WPE6HMA), Hayward, Calif.
David Williams (WPE7CIW), Astoria, Ore.

Roy Neese (WPE7CWZ), Kent, Wash.
Gary Steele (WPE8KEO), Benton Harbor, Mich.
Tom Palmer (WPE8KII), Detroit, Mich.
Gene Moser (WPE8KIG), Coloma, Mich.
George Smith (WPE8KIJ), Grand Rapids, Mich.
Bob Smith (WPE8KKI), Grand Rapids, Mich.
James Pogue (WPE9HLL), Farmland, Iowa
Tom Williams (WPE9IEL), Crown Point, Ind.
Mark Koukol (WPE9IKV), Naperville, Ill.
Bruce McCoy (WPE9IMY), La Porte, Ind.
Joseph Gannon (WPE9JOC), Chicago, Ill.
James Tracz (WPE9JRD), Morton Grove, Ill.
Mark Andrew (WPE9JUZ), Lincolnwood, Ill.
Frank Swanberg (WPE9JVD), Dolton, Ill.
A. R. Niblack (WPE9KII), Vincennes, Ind.
John Beaver (WPE9AE), Pueblo, Colo.
Mike Carrick (WPE9FLX), Omaha, Neb.
Jack Perolo (PY2PEIC), Sao Paulo, Brazil
David Gladstone (VE2PELV), Chomede, Ont.
F. R. Cook (VE3PEJWX), Willowdale, Ont.
Paul Cau (VE3PE2OZ), St. Catherine, Ont.
John Hudak (VE3PE2RC), Oakville, Ont.
Steve Zieffe (VE6PEM), Calgary, Alta.
A. L. Hughes (VE7PEIH), S. Burnaby, B. C.
John Brandt, Brooklyn, N. Y.
Victor Burgess, Roanoke, Va.
Ronald Fribush, Silver Spring, Md.
Mike Hance, Richardson, Texas
Bob Mackay, Rockford, Ill.
Bill Morell, Ontario, Calif.
Donald Roberts, Windsor, N. Y.
Jim Reeder, El Cerrito, Calif.
William Scheider, Jersey City, N. J.
David Szafranski, Colorado Springs, Colo.
L. K. Wheeler, Midwest City, Okla.
Sweden Calling DX'ers Bulletin, Stockholm, Sweden

PROFESSIONAL TYPE MOBILE MONITOR RECEIVER

Solid State FM / Crystal Controlled / 6 Channels \$99⁹⁵

LESS CRYSTALS



SEND FOR FREE LITERATURE



This expertly engineered, all solid-state, crystal controlled FM receiver provides instant monitoring of the VHF frequencies between 39 and 46 mcs or 153 to 157 mcs. Outdating all of the bulky tube-type monitors which take up needed space under dashboards, the compact Ameco Model MRT-6 high band or MRT-7 low band unit measures only 2-1/8" high by 5-5/16" wide by 7-7/8" deep. It's a professional type receiver with latest double conversion super-heterodyne circuitry providing 3/4 microvolt sensitivity for 20 db quieting. Has built-in speaker and mobile mounting bracket. Optional AC power supply available.

DIVISION OF AEROTRON/BOX 6527/RALEIGH, N. C. 27608

CIRCLE NO. 1 ON READER SERVICE PAGE

is often very good on the West Coast at 0930-1000 with lively L.A. music, many ID's and time checks and network news at 1000. This is on 4970 kHz.

Windward Islands—*W. I. Broadcasting Service*, Grenada, has two new channels in service: 15.115 kHz at 2115 to Great Britain in English, and 15.140 kHz at 2325 with pop music and time checks. Two other channels, well heard, include 5015 kHz at 2200-2250 with news at 2200 and 2245, and 11,970 kHz at 0123-0209 with L.A. music on "Juke Box Saturday Night".

Zambia—*R. Lusaka*, 6165 kHz, has religious music with singing at 0810 and anmt's, possibly in French, to 0816, then more music and piano tunes.

Clandestine—*Radio Peyk-e Iran* is heard on 11.695 kHz at 1530 in Kurdish or Persian with some music, and at 1725 on both 11.395 and 11.695 kHz . . . *R. Euzkadi* is being heard at 2030, 2130, and 2330 with xmsns usually 30 minutes long. Frequencies are 13,250 and 15,080 kHz. Opening ID's are in Basque, English, French, and Spanish. Preceding this (but not always) is an eight-chime IS. The mailing address given is P. O. Box 59, Paris-16, France . . . What is believed to be the *Voice of the Patriotic Militiamen's Front* is being heard on 7216 kHz at 1500-1515 with a male Vietnamese announcer and some type of military music.

AMATEUR RADIO

(Continued from page 96)

In September 1969, he organized a radio club at the school where he teaches. It has 22 members; by Christmas vacation, one member had his Novice license, and two members had passed the code test and were waiting for their written tests. Another 15 members were waiting to take code tests. Rich was confident that these members would all obtain their licenses, and he had hopes for the rest. The club has applied for its own station license and will use a donated transmitter, receiver and vertical antenna.

Of course, there is more to helping prospective Novices than just the desire to do so, as several clubs have discovered when their inadequately prepared amateur courses have turned out to be mediocre successes. Anyone interested in organizing an amateur study course should send a 10" x 12" return envelope with \$2.00 in stamps attached and \$2.00 to cover printing costs for a sample set of the LERC Amateur Radio Club's license course examinations and handouts. Address your request to: William Welsh, W6DDB, LERC Amateur Radio Club, 2814 Empire Ave., Burbank, CA 91505. Bill has probably taught more people to become amateurs than anyone else in the country.

Sixth Annual Florida QSO Party, 1500-2000, GMT, Sunday, April 5. Florida stations exchange the names of their counties

April, 1970

Live Better Electronically With

LAFAYETTE RADIO ELECTRONICS

1970 Catalog 700 **FREE!**

**Now OFF PRESS
BETTER THAN EVER
496 Pages**



Stereo Hi-Fi • Citizens Band • Ham Gear • Tape Recorders • Test Equipment • TV and Radio Tubes and Parts • Cameras • Auto Accessories • Musical Instruments • Tools • Books

Featuring Everything in Electronics for
• HOME • INDUSTRY • LABORATORY
from the "World's Hi-Fi & Electronics Center"

LAFAYETTE Radio ELECTRONICS
Dept. 35040 P.O. Box 10
Syosset, L.I., N.Y. 11791

Please Send the FREE 1970 CATALOG 700 35040

Name
Address
City
State Zip

CIRCLE NO. 15 ON READER SERVICE PAGE

CONTROLLED
QUALITY
CRYSTALS by



CRYSTEK



The "On-Channel" Crystals

"MARS" TOO!

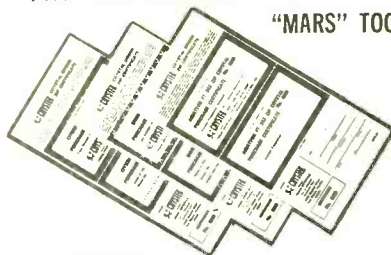

NOW **ZIP-ORDER** CRYSTALS

Your dealer has new, fast, direct-factory ZIP Order Purchase Certificates to enable you to get CRYSTEK CB, Monitor Amateur, and Mars freq. Crystals mailed direct to you promptly. Ask about them.

CRYSTEK formerly *Texas Crystals*
Div. of Whitehall Electronics Corp.

1000 Crystal Drive
Fort Myers, Florida 33991

4117 W. Jefferson Blvd.
Los Angeles, California 90016

CIRCLE NO. 12 ON READER SERVICE PAGE

News and Views

for the names of the states, provinces or countries (if not U.S. or Canada) of the stations worked. Vice versa for stations outside of Florida. Phone and CW contests are separate, and the same station can be worked once per band. Suggested frequencies: CW: 1807, 3570, 7070, 14,070, 21,070, and 28,070 kHz. Phone: 1817, 3870, 7270, 14,270, 21,370, and 28,570 kHz. General class licensee's might also try 3970 and 14,330 kHz. Florida stations multiply their QSO points by the number of states, provinces and foreign countries (up to 11) worked. Other QSO's count for points but not as a multiplier. Stations outside of Florida multiply QSO points by the number of Florida counties worked (67 maximum). Mail full log information to: *Florida Skip*, Contest Chairman, P.O. Box 501, Miami Springs, Fla. 33166. Include a 6-cent stamp to receive a tabulation of contest results when compiled.

Steve Barrymore, WA5YBX, 4760 N.W. 24. Apt. 124, Oklahoma City, OK 73127, enjoys helping prospective Novices as much as anything he does in amateur radio. Steve's landlord objects to antennas on the roof, but Steve has an indoor 10-meter dipole, and he snakes in a coaxial feedline from the mobile whip on his car for the other bands. The whip is a Webster "Bandspanner" and is fed by a Galaxy 550. The combination has worked 45 states, but Steve is another radio amateur who is convinced that certain states do not really exist. His nominee is Delaware. . . **Paul Hitchcock, WN2JBE**, State Street, Port Byron, NY 13140, credits the Port Byron Amateur Radio Club for getting his license. He works the 80-, 40- and 15-meter Novice bands with a Heathkit DX-60 transmitter and a Hallicrafters S-85 receiver. Also on his operating bench are a homebuilt, ten-watt transmitter, homebuilt transmit/receive switch, and a tape recorder (which RCA claims to have made). Paul uses the recorder to record "prime" contacts, like new states and countries. . . To keep the record straight, **Dr. Shailer Peterson, W5PJ**, whose Memphis station was pictured in our January column, is Associate Dean of the University of Texas Dental School. He was recently Dean at the University of Tennessee.

Joe Hendrzak, WA3NGO, 3104 Richlieu Road, Cornwells Heights, PA 19020, works 15 meters mostly with an occasional visit to 10 meters for local ragchews. He uses a Swan 270 Cygnet Deluxe on SSB and CW. His record of 20 states and six countries more or less verifies Joe's preference to ragchew than to chase DX. He is waiting for his Rag Chewer's Club certificate to arrive and hopes to have an Advanced ticket by the time this is printed.

Dan Vanderplough, WA9ZRA, 824 Earl Road, Michigan City, IN 46360, is doing his modest bit to decrease the Citizen Band population. He became an amateur via the CE route and has so far made Novices of two more CE'ers. Dan splits his air time mostly between 80 and 20 meters on phone and CW using an EICO 753 transceiver to drive separate 80- and 20-meter dipoles. Even though he is not pushing hard for a Worked All States certificate, he has 30 states confirmed. We have to guess his DX record; nevertheless, he does chase DX, usually on 20-meter CW. . . **Bill Kresl, WN9BBC**, 1109 Sherman, Janesville, WI 53545, started out with a borrowed homebrew 15 wattier then graduated to AMECO AC-1—about the same power. A Heathkit GR-64 did the receiving and a "long wire" the radiating on 40 meters. A converted "surplus" BC-453 receiver and a 40-meter converter then took over the receiving chores, and a much-modified 50-watt transmitter materialized. But, while trying to "soup up" its power to 75 watts, something burned out in the latter; so Bill put



Having built his own console, Mark Garrett, WN3KXV Baltimore, Md., worked 28 states and six countries using his Elmac AF-67 with a Hallicrafters S-20.

ADDED MOBILE POWER WHEN YOU NEED ADDITIONAL COVERAGE FOR CLEAR COMMUNICATIONS



170 WATT INPUT

Complete with remote power switch and indicator control panel plus mounting brackets.

FCC TYPE ACCEPTED
Parts 89, 91, 93

\$129⁹⁵
12 VDC

SMALL PACKAGED MOBILE POWER LINEAR R.F. POWER AMPLIFIER

Covers greater distances with increased transmit power. Can be used with SONAR BR20, FM40 or any similar FCC approved equipment with 1-15 watt output. Designed with top performance and dependable service when you need it. Automatic standby/transmit switching • Covers 25-50MHz range • transistorized power supply—negative ground • Used on amateur 28MHz for FM-AM-SSB. Small, compact, rugged design. Size: 2" H x 6" W x 8" D. Wt. 3 lbs. 12 VDC

SONAR RADIO CORP., 73 Wortman Avenue, Bklyn, N.Y. 11207

Please send information on Model BR 2906 Linear Amplifier.

Dept. 804

Name

Address

City State Zip

CIRCLE NO. 24 ON READER SERVICE PAGE



Jaime A. Coloma, OA4EK, Lima, Peru, works DX and U.S. with Johnson Viking on 40, 20, and 15 meters.

the AC-1 back on the line, and he is getting out better than ever! Bill has 24 states confirmed, and his twin brother, Bob, WN9BJX, has 32. If all went well during Christmas vacation, Bill is now sporting a General ticket.

Eric Strassler, writing for the **Passaic, N. J. High School Radio Club, WA2YXQ**, reports that code and theory lessons, talks by members of the club, and operating the club station are regular features of their club meetings. A Heathkit DX-100 transmitter; Hallicrafters SX-99 receiver; Clegg 66'er, 6-meter transceiver; a 10-, 15-, 20-meter beam; and a 6-meter Saturn Halo antenna comprise the equipment. Four of the members are licensed and teach the code and theory to other members. . .

Jerome Olson, WB0AAC, 2927 Hillsboro, New Hope, MN 55427, reports that he is "delighted" that his station takes up half of the bedroom closet in a small apartment. The station consists of a Heathkit DX-60B transmitter and HG-10B VFO; Allied Radio 2515A receiver; SWR bridge, crystal calibrator; and audio amplifier/compressor. Jerry's antenna, a Hy-Gain 18-V vertical, is fastened to a balcony railing. He works 80- and 15-meter CW and 10-meter, AM phone, where he has worked 10 states. Adding his CW totals gives him 22 states and two Canadian provinces in the log. . . **Jaime A. Coloma, OA4EK**, P.O. Box 538, Lima, Peru, transmits on a Johnson Viking transmitter via a Hy-Gain 152-TG-3 on 20 and 15 meters and a vertical on 40 meters. He receives on either a Hammarlund Super Pro or an Italian-made Geloso 209. He has worked 36 countries and 30 U.S. states and is QRV (ready) for your call.

Ambrose Barry, W4GHV, reports that **WB4ICJ**, of the Kennedy Space Center (Florida) Amateur Radio Society, worked 1650 stations in 50 countries during the first 17 hours of operation following the launching of Apollo 11. At least that many more stations were still calling when the "Special Event" ended. **WB4ICJ** gets on the air during each space shot from Cape Kennedy and sends attractive certificates to each amateur worked who includes a couple of stamps with his QSL card. Watch for **WB4IBJ** on 80, 40, 20, 15, and 10 meters, phone and CW when the next Apollo space shot is scheduled.

As always, we remind you that the first step toward seeing your "News and Views" and picture in *your* column is for you to write that letter you keep planning to send. We continue to thank all clubs and individuals who see that we receive copies of their club publications. If we are not on your club's mailing list, we would appreciate being added to it. The address is: Herb S. Brier, W9EGQ, Amateur Radio Editor, Popular Electronics, P. O. Box 678, Gary, IN 46401.

73, Herb, W9EGQ.

April, 1970

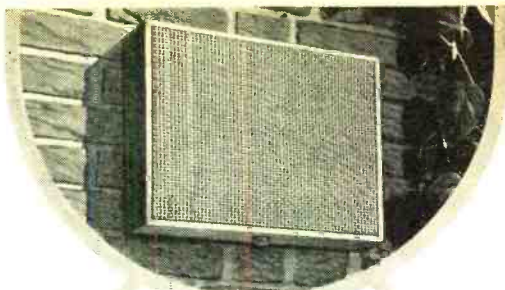

New **Patio**
outdoor speaker
in timeless redwood
\$15.95 Audiofile net

- Silicone-treated speaker.
- 10-watt, full-range, 8-ohms.
- Handy, built-in volume control.
- Weather-resistant cane grille.
- 14" x 10½" x 3½" fits in any sheltered space.

Write for
FREE **Argos**
CATALOG PRODUCTS COMPANY
CIRCLE NO. 5 ON READER SERVICE PAGE

It's yours
free

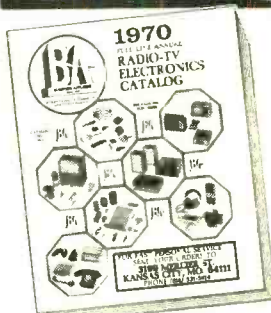

GIANT 274 PAGE
1970
RADIO-TV
ELECTRONICS
CATALOG

Write to:
BURSTEIN-APPLEBEE CO.,
DEPT. PE-4 3199 MERCIER ST.,
KANSAS CITY, MO. 64111

Name _____
Address _____
City _____
State _____ Zip Code _____

CIRCLE NO. 7 ON READER SERVICE PAGE

KITS FEATURED IN

POPULAR ELECTRONICS

AND FROM OTHER SOURCES

Psychedelic Strobe Light	\$17.50 + Postage
Lil Tiger Amplifier (40w)	
Stereo Complete	\$37.50 + Postage
Tiger Amplifier (80w)	
Stereo Complete	\$50.00 + Postage
Super Tiger Amplifier (100w)	
Stereo Complete	\$75.00 + Postage
FET Preamp Complete	
(less power supply)	\$42.50 + Postage

Also:

PSYCHEDELIA I COLOR ORGAN

SONOLITE

NIXIE READOUTS

FREQUENCY COUNTERS

SPORTS TIMERS

ULTRASONIC ALARM

ETC.



WRITE FOR FREE CATALOG

SOUTHWEST TECHNICAL PRODUCTS CORPORATION
219 (PE) W. RHAPSODY
SAN ANTONIO, TEXAS 78216

CIRCLE NO. 25 ON READER SERVICE PAGE

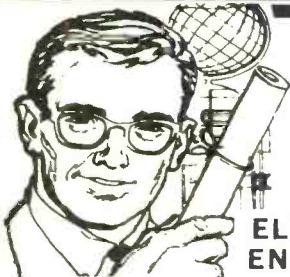

Earn Your Degree

ELECTRONICS ENGINEERING

through HOME STUDY

HIGHLY EFFECTIVE HOME STUDY COURSES IN:

- ELECTRONICS ENGINEERING TECHNOLOGY
- ELECTRONICS ENGINEERING MATHEMATICS

Earn your Associate in Science Degree in Electronics Engineering and upgrade your status and pay to the engineering level. Complete college level courses in Electronics Engineering. We're a forward looking school. Outstanding lesson material—thorough and easy to understand. Engineering taught on the basis of application and understanding rather than on the basis of memorization. Up to date in every respect. Acquire the knowledge and ability that means the difference between a low paying technician job and a high paying engineering position. Low tuition cost with low monthly payments. Free engineering placement service for our graduates. Write for free descriptive literature. Ask for bulletin K, no salesman will call on you.

COOK'S INSTITUTE of Electronics Engineering



Southwest Regional Office
Sharpstown Center, P.O. Box 36185
Houston, Texas 77036
Established 1945

Formerly Cook's School of Electronics

CIRCLE NO. 10 ON READER SERVICE PAGE

LIBRARY

(Continued from page 14)

and designing circuits. By means of the "black box" approach, the student applies general techniques to a large class of problems. His insight is developed through graphical methods, and he is encouraged to implement the techniques learned—by digital computer wherever possible. The book is not limited to college use; anyone with a firm grasp of electronics fundamentals and familiarity with calculus will find it interesting and rewarding.

Published by McGraw-Hill Book Co., 330 West 42 St., New York, NY 10036. Hard cover. 1014 pages. \$22.50.

ELECTRONIC INSTRUMENTATION AND MEASUREMENT TECHNIQUES

by William David Cooper

In the past, test instruments were mainly used to measure values of such physical quantities as current, resistance, and voltage. Transducers now allow the measurement of many other physical parameters. Hence, it behooves the technician and technologist to know how to use intelligently the test equipment available to him. He must also have a good knowledge of the component, circuit, or system under test and understand the capabilities and limitations of his test instruments. This book, therefore, was written to familiarize the reader with the properties of the circuit and component under test and the instruments to be used. It is a storehouse of information, covering both basic and sophisticated test gear.

Published by Prentice-Hall, Inc., Englewood Cliffs, NJ 07632. Hard cover. 495 pages. \$12.95.

TRANSMISSION LINES AND ANTENNAS

by Stephen Roman

Most books written about transmission lines and antennas are directed at the graduate or advanced undergraduate engineering student. This book, however, attempts to fill a genuine need for this subject matter discussed at a level that most engineering students can comprehend. It also tempers the strictly intuitive approach with some of the mathematical statements necessary for a firm understanding of the subject. The book is decidedly not for the beginner; a working knowledge of both differential and integral calculus and vector algebra is required. Notwithstanding, this is decidedly an excellent tutorial book for anyone seriously interested in antennas and transmission lines.

Published by Holt, Rinehart and Winston, Inc., 383 Madison Ave., New York, NY 10017. Soft cover. 146 pages. \$3.95.

POPULAR ELECTRONICS READER SERVICE PAGE

free information service:

Here's an easy and convenient way for you to get additional information about products advertised or mentioned editorially (if it has a "Reader Service Number") in this issue. Just follow the directions below... and the material will be sent to you promptly and free of charge.

1. On coupon below, circle the number(s) that corresponds to the key number(s) at the bottom or next to the advertisement or editorial mention that is of interest to you. (Key numbers for advertised products also appear in the Advertisers' Index.) Print or type your name and address on the lines indicated.

2. Cut out the coupon and mail it to: POPULAR ELECTRONICS, P.O. Box 8391, Philadelphia, PA 19101.

note: If you want to write to the editors of POPULAR ELECTRONICS about an article on any subject that does not have a key number, write to POPULAR ELECTRONICS, One Park Avenue, New York, N.Y. 10016. Inquiries concerning circulation and subscriptions should be sent to POPULAR ELECTRONICS, P.O. Box 1096, Flushing, N.Y. 11352.

VOID AFTER MAY 31, 1970

POPULAR ELECTRONICS

P.O. BOX 8391
PHILADELPHIA, PA. 19101

1 2 3 4 5 6 7 8 9 10 11 12 13 14 15 16 17 18 19 20
21 22 23 24 25 26 27 28 29 30 31 32 33 34 35 36 37 38 39 40
41 42 43 44 45 46 47 48 49 50 51 52 53 54 55 56 57 58 59 60
61 62 63 64 65 66 67 68 69 70 71 72 73 74 75 76 77 78 79 80
81 82 83 84 85 86 87 88 89 90 91 92 93 94 95 96 97 98 99 100

NAME (Print clearly) _____

ADDRESS _____

CITY _____ STATE _____ ZIP CODE _____

4Nb



Be an Architectural DRAFTSMAN

1000s big pay jobs open to trained Draftsmen (see "help wanted" ads in city papers). U. S. Labor Dept. says "42% more Draftsmen needed in next 10 years." Easy step-by-step spare time home-study plan has helped 100s beginners toward \$\$\$\$\$, security, prestige! Why not you? Send for "DRAFTING CAREER KIT" & new 5-Way Drafting Instrument—**ALL FREE!** No salesman will call. G. I. approved. Write & state age.

NORTH AMERICAN SCHOOL OF DRAFTING
4500 Campus Dr., Dept. 01346, Newport, California 92640

FREE 1970 CATALOG.

1001 Bargains—Speakers—Parts—Tubes—High Fidelity Components—Record Changers—Tape Recorders—Kits—Everything in Electronics. Write: **McGEE RADIO COMPANY**
PE, 1901 McGee Street,
Kansas City, Missouri 64108.

GET INTO ELECTRONICS

V.I.I. training leads to success as technicians, field engineers, specialists in communications, guided missiles, computers, radar, automation, basic & advanced courses, Electronic Engineering Technology and Electronic Technology curricula both available. Associate degree in 29 months. B.S. obtainable. G.I. approved. Start September, February. Dorms, campus. High school graduate or equivalent. Catalog.

VALPARAISO TECHNICAL INSTITUTE
DEPARTMENT PE, VALPARAISO, INDIANA 46383



\$12.95 BLACK DIAL TELEPHONES

Complete add \$2.00 for color
Factory rebuilt Western Electric in white, beige, ivory, pink, green or blue. If 4 prong plug is required add \$2.00. Fully guaranteed. Designs may vary.
Write for free list. All shipments F.O.B.
SURPLUS SAVING CENTER
DEPT. PE-70, WAYMART, PENNA. 18472



HAVE YOUR OWN RADIO STATION

Learn AMATEUR RADIO

A fascinating hobby. Join the international network of "ham" operators. NRI trains you quickly at home. You get equipment to build your own shortwave station, Morse Code long-playing records, preparation for FCC license. Write National Radio Institute, Dept. 58-040, Washington, D.C. 20016 and say, "Send me your Amateur Radio catalog." No salesman will call. An accredited NHSC school.



**COOPERATE WITH
THE ZIP CODE
PROGRAM
OF THE POST OFFICE
DEPARTMENT.
USE ZIP CODE
IN ALL ADDRESSES**

NEW PRODUCTS

(Continued from page 24)

tuned r.f. stages for greater image rejection, temperature-compensated noise-free squelch, plug-in channel crystals, and military-quality glass-epoxy circuit boards.

Circle No. 88 on Reader Service Page 15 or 115

1.5-KW COLOR LIGHT ORGAN

The new Model LO-104 light organ made by *Science Workshop* translates electronic signals into patterns of throbbing, flashing lights that are precisely synchronized to the electronic signal. High-power outputs (500 watts/channel) provide power sufficient to transform a large room into a total light/sound environment. The light organ employs three

solid-state frequency-selective filters to divide the audio range into the low, medium, and high frequencies. Each amplifier has an intensity control to enable the user to adjust relationships between channels. The amplifiers, in turn, drive high-power solid-state switching devices which control the amount of power available at the three receptacles mounted on the top panel of the instrument.

Circle No. 89 on Reader Service Page 15 or 115



STEREO HEADSET

As a solution to the ever-present problem of musical privacy, *Pioneer Electronics U.S.A. Corp.*, has announced the availability of their new Model SE-20A headset. The headphones reproduce the sound of the original music with a fidelity not possible with any but the most expensive speaker systems. Each ear-piece contains a cone-type high-fidelity speaker with a frequency range of 20-18,000 Hz. The response is practically distortion-free, with a deep, rich bass, smooth midrange, and outstanding clarity of the highs. Each ear-piece element is rated at 8 ohms and a maximum allowable input of 0.5 watt.



Circle No. 90 on Reader Service Page 15 or 115

OUTDOOR VERTICAL SWL ANTENNA

The shortwave listener who has looked enviously at ham-band vertical antennas now has a vertical receiving antenna of his own. The *Mosley Electronics, Inc.*, Model SWV-7 vertical antenna was designed at the behest of the **POPULAR ELECTRONICS** staff. It stands a little over 13' tall and is "loaded" to tune to the 11-, 13-, 16-, 19-, 25-, 31-, and 49-meter international broadcast bands. Inside the heavy-duty center section are six weather-proofed loading coils that "automatically" tune the antenna to these bands. The SWV-7

can be mounted near ground level or atop a roof when used with a group of home-made copper wire radials. Ground-level mounting requires only a 3' length of pipe—no concrete footing.

Circle No. 91 on Reader Service Page 15 or 115

AM/STEREO FM RECEIVER

The Model RA-193 AM/stereo FM solid-state receiver is the most recent addition to *Olson Electronics'* high-fidelity equipment line. It



has 2 IC's, 23 transistors, and 15 diodes. The walnut cabinet has a black-out dial glass; precision tuning meter; stereo station indicator;

and flip-tab switches for tape monitor, high and low filters, loudness, mono-stereo mode selection, and a.f.c. Technical specifications: circuit breaker overload protection; stereo headphone and tape output jacks; magnetic and crystal phono, tape, and auxiliary inputs; 2- μ V FM sensitivity; 25-dB multiplex separation; 20-20,000-Hz frequency range.

Circle No. 92 on Reader Service Page 15 or 115

THREE-CHANNEL VHF MONITOR RECEIVERS

Two new VHF monitor receivers, the Model COP-30L for 25-50 MHz and Model COP-20H for 150-175 MHz coverage, are being marketed by *Courier Communications*. The



three crystal-controlled channels provided in these receivers pick up broadcasts on the VHF police and fire bands, as well as weather reports. Also included are facilities for receiving the AM broadcast band. Both receiver models feature a variable squelch control, built-in battery indicator, earphone and carrying strap, built-in antenna, and jack for an optional a.c. adapter. (The optional a.c. adapter is available as the Model PEC-1.)

Circle No. 93 on Reader Service Page 15 or 115

AUDIO CONTROL CENTERS

Designed for home and professional sound installations, the *ALCO Electronic Products, Inc.*, control centers allow up to four or six stereo speaker systems to be selected for simultaneous operation. Unique push-on/



push-release switches allow the user to select only the speaker systems of his choice and he has easy-access rear panel connectors to suit

his particular system. No external power is required for operation, nor are there any internal resistors to affect impedance matches. The centers are usable in both low- and high-impedance systems. There are two major models from which to choose, and each is available with phono, miniature phone, or standard phone jacks. The basic models available are the CC4 and CC6.

Circle No. 94 on Reader Service Page 15 or 115

April, 1970

FIX IT FAST WITH MICROFLAME



Perfect Gift. Ideal for workshop or lab. Perfect for electrical, electronic repair and wiring. The do-it-yourselfer's dream!



A must for every home workshop. Microflame is designed to handle most light-weight welding jobs. It's a

proven, professional miniature welding torch. Completely self-contained, this patented torch produces 5000° F pin-point accurate flame. Operates on miniature oxygen and LP Gas cylinders. No wires or connections needed. Make your workshop complete! Microflame is the ideal gift for birthdays, Xmas, every special occasion. Only \$19.95 (with oxygen and LP Gas) Deluxe Kit \$29.95 (with oxygen, LP Gas and accessories).

• FREE BROCHURE



MICROFLAME, INC.

300 Computer Avenue, Dept. _____
Minneapolis, Minnesota 55424
Area 612 927-8681

CIRCLE NO. 32 ON READER SERVICE PAGE

Olson ELECTRONICS

FREE Catalog

Fill in coupon for a FREE One Year Subscription to OLSON ELECTRONICS' Fantastic Value Packed Catalog — Unheard of LOW, LOW PRICES on Brand Name Speakers, Changers, Tubes, Tools, Stereo Amps, Tuners, CB, and other Values. Credit plan available.

NAME _____
ADDRESS _____
CITY _____ STATE _____
GIVE ZIP CODE _____

If you have a friend interested in electronics send his name and address for a FREE subscription also.

OLSON ELECTRONICS
DEPT. 1D 260 S. FORGE STREET, AKRON, OHIO 44308

CIRCLE NO. 19 ON READER SERVICE PAGE

ELECTRONICS MARKET PLACE

COMMERCIAL RATE: For firms or individuals offering commercial products or services. \$1.15 per word (including name and address). Minimum order \$11.50. Payment must accompany copy except when ads are placed by accredited advertising agencies. Frequency discount: 5% for 6 months; 10% for 12 months paid in advance. **READER RATE:** For individuals with a personal item to buy or sell. 70c per word (including name and address). No Minimum! Payment must accompany copy.

FOR SALE

FREE! Giant bargain catalog on transistors, diodes, rectifiers, SCR's, zeners, parts. Poly Paks, P.O. Box 942, Lynnfield, Mass. 09140.

GOVERNMENT Surplus Receivers, Transmitters, Snooperscopes, Radios, Parts, Picture Catalog 25¢. Meshna, Nahant, Mass. 09108.

ROCKETS: Ideal for miniature transmitter tests. New illustrated catalog. 25¢. Single and multistage kits, cones, engines, launchers, trackers, rocket aerial cameras, technical information. Fast service. Estes Industries, Dept. 18, Penrose, Colorado 81240.

LOWEST Prices Electronic Parts. Confidential Catalog Free. **KNAPP**, 3174 8th Ave. S.W., Largo, Fla. 33540.

EUROPEAN and Japanese bargains catalogs. \$1 each. Dee, 10639E Riverside, North Hollywood, Calif. 91602.

MUSIC LOVERS, CONTINUOUS, UNINTERRUPTED BACKGROUND MUSIC FROM YOUR FM RADIO, USING NEW INEXPENSIVE ADAPTOR. FREE LITERATURE. ELECTRONICS, 11500-Z NW 7th AVE., MIAMI, FLORIDA 33168.

WE SELL CONSTRUCTION PLANS. TELEPHONE: Answering Machine, Speakerphone, Carphone, Phonevision, Legal Connector, Auto Dialer, Central Dial System. **TELEVISION:** \$35.00 Color Converter, Tape Recorder, 3DTV. \$25.00 Camera. **DETECTIVE:** Infinity Transmitter, Tail Transmitter, Police Radar Detector. **HOBBYIST:** Electron Microscope, 96 Hour Tape Music System, Ultrasonic Dishwasher, Radar-Oven, Electronic Tranquilizer. Plans \$4.95 each. **COURSES:** Telephone Engineering \$39.50, Detective Electronics \$22.50, Anti-Detective Electronics \$27.50. **SUPER HOBBY CATALOG** 25¢. Don Britton Enterprises, 7906 Santa Monica Blvd., Hollywood, Calif. 90046.

WEBBER LAB's. Police & Fire Converters. Catalog 25¢. 72 Cottage Street, Lynn, Mass. 01905.

RADIO—T.V. Tubes—33¢ each. Send for free catalog. Cornell, 4213 University, San Diego, Calif. 92105.

INVESTIGATORS, LATEST ELECTRONICS AIDS. FREE LITERATURE. CLIFTON, 11500-L NW 7th AVE., MIAMI, FLORIDA 33168.

FREE ELECTRONICS PARTS FLYER. Large catalog \$1.00 deposit. BIGELOW ELECTRONICS, BLUFFTON, OHIO 45817.

JAPAN & HONG KONG DIRECTORY. Electronics, all merchandise. World trade information. \$1.00 today. Ippano Kaisha Ltd., Box 6266, Spokane, Washington 99207.

FREE Catalog low priced, high performance subminiature listening devices direct from manufacturer. Emery LT-104, 156 Fifth Avenue, New York, N. Y., 10010.

ULTRA-SENSITIVE AND POWERFUL METAL DETECTORS—join the many who are finding buried coins, minerals, relics and artifacts. Don't buy till you see our **FREE** catalog of new models. Write Jetco, Box 132-PE, Huntsville, Texas 77340.

LASER parts catalog 60¢. Moynihan, 107 North Brighton, Atlantic City, New Jersey 08401.

PSYCHEDELIC catalog. Posters, lighting, etc. Send 25¢ for handling to Hole In The Wall, 6055PE Lankershim, North Hollywood, Calif. 91606.

THE ART OF DE-BUGGING—\$5.95. TRON-X PUBLICATIONS, P.O. BOX 38155, HOLLYWOOD, CALIFORNIA 90038.

CONSTRUCTION PLANS: LASER . . . \$2.00. Listening Devices—two F.M. MIC Transmitters . . . \$1.00. Tail Transmitter . . . \$1.00. Telephone Transmitter . . . \$1.00. Infinite Transmitter . . . \$2.00. Equipment and kits available. Howard, 20174 Ward, Detroit, Michigan 48235.

COMPONENTS? Kits? Hardware? Free catalog! Truvee Paks, Box 275, Chelsea, Mass. 02150.

GENERAL INFORMATION: First word in all ads set in bold caps at no extra charge. All copy subject to publisher's approval. Closing Date: 1st of the 2nd month preceding cover date (for example, March issue closes January 1st). Send order and remittance to: Hal Cymes, POPULAR ELECTRONICS, One Park Avenue, New York, New York 10016.

SENCORE TEST EQUIPMENT UNBELIEVABLE PRICES. FREE CATALOG AND PRICE SHEET. FORDHAM RADIO, 265 EAST 149TH STREET, BRONX, N.Y. 10451.

ELECTRONIC ignition, various types. Free literature. Anderson Engineering, Epsom, N.H. 03239.

AMATEUR SCIENTISTS. Electronics Hobbyists, Experimenters, Students . . . Construction Plans—all complete, including drawings, schematics, parts lists with prices and sources . . . Laser-Build your own coherent-light optical laser. Operates in pulsed mode. visible light range—\$6.00 . . . Radar—Build your own ultrasonic doppler radar. Detect motion of people, automobiles, even falling rain drops. Transistorized, uses standard small 9-volt battery—\$4.00 . . . Long-Range "Sound Telescope"—This amazing device can enable you to hear conversations, birds and animals, other sounds hundreds of feet away. Very directional. Transistorized. Uses 9V battery—\$3.00 . . . Or send 25¢ coin (no stamps) for complete catalog. Other items include Psychedelic strobes, light shows, robots . . . 38 different projects. Technical Writers Group, Box 5994, State College Station, Raleigh, N.C. 27607.

MECHANICAL, ELECTRONIC devices catalog 10¢. Greatest Values—Lowest Prices. Fertik's, 5249 "D", Philadelphia, Pa. 19120.

CLEARANCE SALE rectifiers, transistors, 1000's other items. Catalog 15¢. General Sales Company, 254 Main, Clute, Texas 77531.

DIAGRAMS—Radios \$1.50, Television \$3.00. Give make and model. Diagram Service, Box 1151PE, Manchester, Conn. 06042.

HEARING AIDS below wholesale. Smallest, most powerful. Free home trial. No salesman will call. Free details. Write Prestige-C-42, Box 10880, Houston, Texas 77018.

LINEAR AMPLIFIERS: "Hornet" 50 watts output—\$98.50; "Raider" 100 watts—\$139.50; "Maverick-250" 250 watts—\$244.95. AM and SSB. "Scorpion" 50 watt 12 V. Mobile Amplifier—\$99.95; "Bandit II" 12 V. Mobile Amplifier—\$169.95. Mobile amplifiers positive or negative ground. Frequency range 20-35 megacycles (illegal for class D 11 meters.) Dealer inquiries invited. D & A Manufacturing Co., 1217 Avenue C, Scottsbluff, Nebraska 69361.

SEMICONDUCTORS and parts catalogue free over 100 pages. J. & J. Electronics, Box 1437, Winnipeg, Manitoba, Canada. U.S. Trade directed.

SPACE-AGE TV CAMERA KIT! Terrific for Experimenters, Industry, Education. Solid-state. Only \$116.95! Starter kits: \$18.95 up. Plans 25¢ up. Catalog **FREE.** Phone: 402-987-3771. Write: **ATV RESEARCH**, 1301 Broadway, Dakota City, Nebr. 68731.

EXCITING LISTENING! POLICE—FIRE—AIRCRAFT—SHORTWAVE calls on your broadcast radio! Free catalog. Salch Company, Woodboro 24, Texas 78393.

CONVERT any television to sensitive, big-screen oscilloscope. Only minor changes required. No electronic experience necessary. Illustrated plans, \$2.00. Relco-A33, Box 10563, Houston, Texas 77018.

PSYCHEDELIC Lighting Manual: Make light-machines, strobes, organs, slides, etc. Send \$2.00. Lightrays, 713D Pine, Philadelphia, Pa. 19106.

FREE CATALOG surplus bargains: Fans, Bodine reduction motors, switches, relays, steppers, PC Boards, Many others. IEM Inc., Box 4280, Irvine, California 92664.

DIRECTORY of Japanese Electronics Companies. \$2.00 now. Jago, PE-4, 120 South First Avenue, Highland Park, N.J. 08904.

RESISTORS 1/2 watt 10% 7¢ each. One dollar minimum order. Specify values. Capitol House, Park Plaza Station, Box 1013, Lincoln Park, Michigan 48146.

BURGLAR ALARM SYSTEMS and accessories. Controls, bells, sirens, hardware, etc. **OMNI-GUARD** radar intruder detection system, kit form or assembled. Write for free catalog. Microtech Associates, Inc., Box 10147, St. Petersburg, Florida 33733.

ROUTER bits, 1/4" shank, Hi-speed, used, excellent condition, \$2.50 dozen, postpaid. Lillian's, Box 17165PE, Chicago, Illinois 60617.

AM TRANSISTOR RADIO CHASSIS 6 transistors—1 diode. **CHECKED-OUT GOOD**. \$1.75 each 2/\$3.00 postpaid. **FREE CATALOG**. R.W. Electronics. 4005 West Belmont, Chicago, Illinois 60641.

VISUAL AID DISKS—TURNING REVEALS ELECTRICAL EFFECTS, EXPLANATIONS OF ELECTRICAL COMPONENTS, CAPACITOR, INDUCTOR, ETC. S-UNIT, BOX 7127, RINCON ANNEX, SAN FRANCISCO, CALIF. 94119.

ANTENNAS INC. stocks more than 30 lines of amateur, CB and SWL antennas, cable, towers, hardware, etc. Our 100 plus page catalog \$1.00 refundable first order. Antennas, Inc., 300 Shawnee, Leavenworth, Kansas 66048.

FREE TV TUNER REPAIR TRICKS, Plans, Details, complete courses. Frank Bocek, Box 833, Redding, Calif. 96001.

DESIGN with transistors 25 page article. Anyone can design successful projects. Send \$1.00. Solid State Tekneex, Route 1, Doniphan, Mo. 63935.

"CRIME BUSTER" the first professional burglar alarm with do-it-yourself instructions. Free brochure. Silmar, 3476-E NW 7th Street, Miami, Florida 33125.

PSYCHEDELIC LIGHTING. STROBES, COLOR ORGANS, LIGHT-BOXES, FILMS, SLIDES, BLACKLIGHTS, PROJECTORS, COMPONENTS, CABINETS, MORE! Send \$4.25 for a psychedelic **MIRRORED BALL** (pp.) and 1970 **PSYCHEDELIC LIGHTING CATALOGUE**. Dealer inquiries welcome. **CUSTOM DESIGNING AVAILABLE**, send complete needs for estimate. **COLOR ORGAN KIT** (3 channel, freq selective. 200 watts @ channel) only \$16.99 postpaid. Send orders to: **MAT RESTIVO PSYCHEDELIC LIGHTING, 3547 TUSCALA STREET, SEAFORD, NEW YORK 11783.**

RADIO, WORLD'S SMALLEST, wear behind either ear, quarter hides it! Superb tone, to 15 stations. \$24.95; extra powerful model \$34.95. Personal Radio Company, Box 2279, Sunnyvale, Calif. 94087.

STROBES, color organs, the incredible Strobot. **NEW!** Heavy-Duty CD ignition. **ELECTRIC CANDLES** for flameless candlelight. **REMOTE (WIRELESS) SWITCH** for anti-prowl system. **TOUCH SWITCH** for space-age lamps, lights. **ASSEMBLED and KITS**. Send 25c. specify interest. Teletronics, Box 1266A, South Lake Tahoe, Calif. 95705.

UFO's—notes on Detection using your TV. Photoelectric detector circuits, all for \$1.40. Radar & Electronic Publications, "Highlands", Needham Market, Suffolk, England.

FREE—Bargain sheets listing relays, steppers and other electronics parts for experimenters. Send your name, address, and a stamp to: Gust & Company, Box 24081, Edina, Minnesota 55424.

COLOR ORGANS, 2000 WATTS, \$24.00 postpaid. GUARANTEED. CYBULSKI, Box 31174, Washington, D.C. 20031.

BURGLAR and FIRE ALARM SYSTEMS and supplies. INSTALLATION MANUAL and catalog \$1.00. Refunded on first order. Electronic Sentry Systems, P.O. Box 8023A, Sacramento, California 95818

PRINTED CIRCUITS. Magazine projects and experimental. Free listing. Vico, Box 1581, Los Angeles, Calif. 90053.

NEW SEMICONDUCTOR LIGHT EMITTING DIODES—bright red lights replace light bulbs. Typical life 100 years. Operate at 1.65 volts, 50 millamps. Order 2 for \$2.98 NOW. Data sheet and instructions included. Monsanto Company, Hobby Section, 10131 Bubb Road, Cupertino, California 95014.

HOBBYISTS, experimenters; black and white television converted to color by means of a new patented color converter adaptor circuit. Installation all do it yourself. Write for free brochure Bele Electronics Corp., 111 N.E. Second Ave., Miami, Florida 33132.

PLANS AND KITS

COLOR Organ Kit \$7.50. Power Supplies \$3.98. Catalog. Murphy, 204 Roslyn Ave., Carle Place, N.Y. 11514.

SURVEILLANCE DEVICES IN KIT FORM: Telephone Transmitter. FM Spy Transmitter, Telephone-Recorder Actuator, Tail Transmitter, Bug Detector. Complete Kits Send \$15.00 each. **ELECTRONIC SECURITY SYSTEMS**, 1101 West Rosecrans Avenue, Gardena, California 90247.

BUILD color organs, computers, stereos, alarms, slide-synchronizers. Catalog. Workshop, 33E Cain, Plainview, New York 11803.

KITS, SUPER SNOOPER \$5.95. Metal Detector \$5.95. FM Wireless Transmitter \$4.95, others. Lextronix, Box 42, Madison Heights, Michigan 48071.

HE/NE GAS LASER completed tube with internal mirrors and power supply schematic. 0.5 MW with 1 MW typical red power output—only \$49.95. Cash, check or money order. Order from C. W. Radiation, P.O. Box 1299, Mtn. View, Calif. 94040.

LASER POWER METER measures up to 5 MW laser output power at 6328A \$49.95 complete or kit \$34.95. Plans \$5.00. Rush money order to C.W. Radiation, P.O. Box 1299, Mtn. View, Calif. 94040.

"ONE TUBE DXER" Handbook 50¢. "Coil Winding" 50¢. Catalog. Laboratories, 2612-L Butano. Sacramento, Calif. 95821.

CURVES, obtain characteristic curves for any transistor, fast simple hook up, complete plans \$2.00. V. P. Dahmen, 285 Division Avenue, Carlstadt, N.J. 07072.

STEREO Amplifier, 200 watts RMS. simple to build! Plans. \$3.50. Bill Carlquist, 9336 Fostoria St., Downey, CA. 90241.

BUILD powerful crystal radio. Easy to build. Complete plans. Send \$4.95 cash, check, money order. Radio, 2139 Eaton Road, Charlotte, N.C. 28205.

FAMOUS Quad Antenna Kit for FM \$9.95. Postpaid U.S.A. Rose Electronics, Box 3245, Vero Beach, Florida 32960.

METAL DETECTOR PLAN \$2.00 complete instructions, parts list, schematic. Magneto-Hydro-Dynamics, Box 114, Plaza Station, Merrick, New York 11566.

SOLID STATE DIMMER-MOTOR CONTROL. Complete kit and Instructions for Triac power control. Includes UL listed printed circuit board \$4.50; with chassis and cover \$5.50. R & R Electronics, Box 19, Abington, Penna. 19001.

ULTRASONIC high voltage oscillator from salvaged television. Easy plans \$5. Blackstone. P.O. Box 34, Franklin Square, New York 11010.

INTEGRATED CIRCUIT KITS: COMPUTER, OPTOELECTRONICS, AUDIO, Catalog free. **KAYE ENGINEERING**, Box 3932-A, Long Beach, California 90803.

CHECKERMATE Computer, checker player's low cost logic aid. Plans \$2.00. N. Adamenko, 2809 Via Segovia, Palos Verdes, Calif. 90274.

TRANSISTOR Scr, Triac, Fet, Unijunction. TESTER—Unique, Fool-proof. Portable—Designed for Novice and Technicians. Plans \$5.00—WITH ORDER—Solid State Mini-Tracer Plans FREE. J. Weir, 5558 Dorothy Drive, San Diego, Calif. 92115.

SHORTWAVE LISTENING

DXVISION Art of catching sneaky skip openings WTFDA fees \$4.50 Worldwide TV FM-DX Association. Box 5001P, Milwaukee, Wis 53204.

SWL GUIDE NEWSLETTER, Quarterly. \$1.00 per year, credited towards purchase of Selected Items for SWLs. 414 Newcastle, Syracuse, N.Y. 13219.

HIGH FIDELITY

FREE! Send for money saving stereo catalog # P4E, lowest quotations on your individual component, tape recorder, or system requirements. Electronic Values, Inc., 200 W. 20th St., New York, N.Y. 10011.

Hi-Fi components. Tape Recorders, at guaranteed "We Will Not Be Undersold" prices. 15 day money-back guarantee. Two-year warranty. No Catalog. Quotations Free. Hi-Fidelity Center, 239 (P) East 49th Street, New York 10451.

LOW, Low quotes: all components and recorders. HiFi, Roslyn, Penna. 19001.

BACKGROUND MUSIC—SOLID-STATE SCA DECODER DELIVERS SUBCARRIER COMMERCIAL-FREE MUSIC PIGGYBACKED ON MANY FM STATIONS. LINE-POWERED ADAPTER SIMPLY PLUGS INTO ANY FM TUNER. NO ADJUSTMENTS OR TUNING. NEW DESIGN BREAK-THRU GUARANTEES OPTIMUM PERFORMANCE, LOWEST PRICE EVER! \$35 POSTPAID. K-LAB, BOX 572, S. NORWALK, CONN. 06856.

TAPE RECORDERS, Hi-Fi, components, Sleep Learning Equipment, tapes. Unusual Values. Free Catalog. Dressner, 1523R, Jericho Turnpike, New Hyde Park, N.Y. 11040.

STEREO COMPONENTS at low discount prices. Send for our low quotes today and our cartridge trade-in specials (Shure, ADC, Pickering, Empire, etc.). Send \$1.00 for our discount catalog. **DEFA ELECTRONICS**, 2207 Broadway, New York, N.Y. 10024.

TAPE PLAYERS, car radios, home stereos—below wholesale! Catalog 25¢. Total-Sound, 134 State, Newtown, Pa. 18940.

SOUND TO LITE TRANSLATOR. Create audio stimulated light displays. Activates any lamp, strobe, etc. \$9.95 kit \$14.95 wired. Thorr Electronics, Box 531, Malaga, N.J. 08328.

DIAMOND NEEDLES AND STEREO CARTRIDGES at low, low prices for Shure, Pickering, Stanton, Empire, Grado and ADC. Send for free catalog and price sheet. We will be happy to quote on any cartridge—Magnetic, Ceramic or Crystal. All merchandise brand new and shipped **PREPAID**. **LYLE CARTRIDGES**, Dept. P, 265 East 149 Street, Bronx, New York 10451.

WANTED

CASH PAID! Unused tubes, electronic equipment. Barry, 512 Broadway, NYC 10012.

QUICKSILVER, Platinum, Silver, Gold, Ores Analyzed. Free Circular. Mercury Terminal, Norwood, Mass. 02062.

CASH PAID for all tubes. **DAMESCO**, 308 Hickory, Arlington, N.J. 07032.

ALL "Don Britton" CONSTRUCTION PLANS, COURSES. Wegner, P.O. Box 262, Glendale, California 91209.

TUBES

TUBES "Oldies", latest. Lists free. Steinmetz, 7519 Maplewood, Hammond, Indiana 46324.

RECEIVING & INDUSTRIAL TUBES, TRANSISTORS. All Brands—Biggest Discounts. Technicians, Hobbyists, Experimenters—Request **FREE** Giant Catalog and **SAVE!** **ZALYTRON**, 469 Jericho Turnpike, Mineola, N.Y. 11501.

TUBE Headquarters of World! Send 10c for Catalog (tubes, electronic equipment) Barry, 512 Broadway, N.Y.C. 10012.

RADIO & T.V. Tubes—33¢ each. Send for free list. Cornell, 4213 University, San Diego, Calif. 92105.

THOUSANDS and thousands of types of electronic parts, tubes, transistors, instruments, etc. Send for Free Catalog. Arcturus Electronics Corp., MPE, 502-22nd St., Union City, N.J. 07087.

TUBES—Lowest world prices. Foreign-American. Obsolete, current. Receiving, special purpose, transmitting tubes. Send for tube and parts catalog. United Radio Company, 56-P Ferry St., Newark, N.J. 07105.

TAPE AND RECORDERS

TAPES . . . blank recording . . . pre-recorded music. Catalog 10¢. Tower, Lafayette Hill, Pa. 19444.

BEFORE Renting Stereo Tapes try us. Postpaid both ways—no deposit—immediate delivery. Quality—Dependability—Service—Satisfaction—prevail here. If you've been dissatisfied in the past, your initial order will prove this is no idle boast. Free Catalog. Gold Coast Tape Library, Box 2262, Palm Village Station, Hialeah, Fla. 33012.

RENT 4-Track open reel tapes—all major labels—3,000 different—free brochure. Stereo-Parti, 55 St. James Drive, Santa Rosa, Ca. 95401.

TAPEMATES makes available to you **ALL 4-TRACK STEREO TAPES—ALL LABELS**—postpaid to your door—at tremendous savings. For free brochure write: **TAPEMATES**, 5727 W. Jefferson Blvd., Los Angeles, California 90016.

AMAZING DISCOUNTS on famous brand high fidelity stereo components. No small wonder that we have set new sales records each year since 1959. Write. Arkay Electronics, 1028-03 Commonwealth, Boston, Mass. 02215.

STEREO TAPES, save 20,30% and more, postpaid anywhere U.S.A. We discount batteries, recorders, tape/cassettes, 80-page catalog 25¢. **SAXITONE TAPES**, 1776 Columbia Road, N.W., Washington, D.C. 20009.

CASSETTE and 8-track blanks, language tapes, dozens of accessories and recorders. Literature 25¢. **CASSETTES UNLIMITED**, P.O. Box 13119-P, Pittsburgh, Pa. 15243.

OLD radio programs on tape. 6 hours for \$8.00. Catalog 50¢. Don Maris, 824 Owl, Norman, Okla. 73069.

TRY RECORDING monaural music from your car radio with your 4 or 8 track player. For plans of an easy to build \$10.00 converter send \$2.00 to **TAB**, P.O. Box 1212, Brenham, Texas 77833.

REPAIRS AND SERVICES

TV Tuners rebuilt and aligned per manufacturers specification. Only \$9.50. Any make UHF or VHF Ninety day written guarantee. Ship complete with tubes or write for free mailing kit and dealer brochure. **JW Electronics**, Box 51C, Bloomington, Indiana 47401.

PERSONALS

MAKE FRIENDS WORLDWIDE through international correspondence. Illustrated brochure free. Hermes, Berlin 11, Germany.

INVESTIGATORS, LATEST ELECTRONIC AIDS. FREE LITERATURE. **CLIFTON**, 11500-K NW 7th AVE., MIAMI, FLORIDA 33168.

SECRET LOANS BY MAIL. Borrow \$100 to \$1500 for any good reason in absolute privacy. No interviews, no endorsers, no co-signers. Fast service. Write **Dial Finance Co.**, Dept. D-593, 410 Kilpatrick Bldg., Omaha, Nebraska 68102.

INSTRUCTION

LEARN ELECTRONIC ORGAN SERVICING at home all makes including transistor. Experimental kit—trouble-shooting. Accredited NHSC. Free Booklet. **NILES BRYANT SCHOOL**, 3631 Stockton, Dept. A, Sacramento, Calif. 95820.

FCC First Class License in six weeks—approved for Veterans Training. Write **Elkins Institute**, 2603B Inwood Road, Dallas, Texas 75235.

R.E.I.'s famous (5) week course for the First Class Radio Telephone License is the shortest, most effective course in the nation. Over 98% of R.E.I. graduates pass F.C.C. exams for 1st class license. Total tuition \$360.00. Job placement free. Write for brochure. Radio Engineering Incorporated Schools, 1336 Main Street, Sarasota, Florida 33577—or 3123 Gillham Road, Kansas City, Missouri 64109—or 809 Caroline Street, Fredericksburg, Virginia 22401—or 625 E. Colorado Street, Glendale, California 91205.

DEGREE in Electronics Engineering earned mostly by correspondence. Free brochure. Dept. G-9, **Grantham School of Engineering**, 1505 N. Western Ave., Hollywood, California 90027.

LEARN WHILE ASLEEP, Hypnotize! Strange catalog free. Auto-suggestion, Box 24-ZD, Olympia, Washington 98501.

F.C.C. License training by correspondence. G.I. Bill approved. Money-Back Warranty. Free brochure. Write: Dept. Z-9, **Pathfinder School of Electronics**, 1505 N. Western Ave., Hollywood, Calif. 90027.

PREPARE NOW for Rewarding Career as "ELECTRONICS TROUBLE-SHOOTING & REPAIR SPECIALIST." Highly Effective Home Study Training. Earn your **MASTER DIPLOMA**. Graduates in Great Demand. High Pay. Nationally Accredited. Write for Free Descriptive Literature. No salesman will call. **COOK'S INSTITUTE OF ELECTRONICS**, Dept. 21, P.O. Box 10634, Jackson, Miss. 39209. (Established 1945).

PLAY ORGAN OR GUITAR EASILY! AMAZING METHOD! FREE INFORMATION. **KEGLEY**, 1016-PE KELLY, JOLIET, ILLINOIS 60435.

SLEEP SUGGESTION—YOGA—HYPNOTISM! Unique catalog free! **Friendlyco**, Box 669-ZD, Haynesville, Louisiana 71038.

TAXIDERM Success Training sure, easy way into Taxidermy. Complete training, no skipping, all steps illustrated. Request information and free samples. Box 5815, Bossier City, Louisiana 71010.

MEMORIZE: "1970 TESTS-ANSWERS" for FCC FIRST AND SECOND CLASS LICENSE. Plus "Self-Study Ability Test." **PROVEN.** \$5.00. Command, Box 26348-P, San Francisco 94126.

FCC FIRST CLASS LICENSE THROUGH TAPE RECORDED LESSONS at home plus one week personal instruction in Detroit, Washington, San Francisco, Seattle or Los Angeles. Our nineteenth year teaching FCC license courses. Radio License Training, 1060D Duncan, Manhattan Beach, Calif. 90266.

MATHEMATICS. ELECTRONICS. Satisfaction guaranteed. Free brochure, Indiana Home Study, Dept. PE, Box 1189, Panama City, Florida 32401.

ELECTRONICS Home Study Course by programmed tape-(Lecture-Tape) developed by instructor who trained Apollo satellite tracking equipment technicians. Brochure on request. Write: Findlay Technical College, 1041 N. Main, Findlay, Ohio 45840.

MAGIC easily learned with home study course. Inexpensive. Magic-Masters, P.O. Box 774E, Bowie, Maryland 20715.

INVENTIONS WANTED

INVENTIONS wanted. Patented; unpatented. Global Marketing Service, 2420-P 77th, Oakland, Calif. 94605.

FREE "Directory of 500 Corporations Seeking New Products." For information regarding development, sale, licensing of your patented/unpatented invention. Write: Raymond Lee Organization, 230-GR Park Avenue, New York City 10017.

INVENTORS: Protect your ideas! Free "Recommended Procedure". Washington Inventors Service, 422T Washington Building, Washington, D.C. 20005.

PATENT SEARCHES, including copies of related United States Patents. Inventors, attorneys, manufacturers use our "World-Wide" Airmail service Free: "Invention Record" form and "Information Every Inventor Needs". Hayward Company, 1029HR Vermont, Washington, D.C. 20005.

PATENT Searches including Maximum speed, full airmail report and closest patent copies. \$6.00. Quality searches expertly administered. Complete secrecy guaranteed. Free Invention Protection forms and "Patent Information." Write Dept. 9, Washington Patent Office Search Bureau, 711 14th Street, N.W., Washington, D.C. 20005.

FREE PAMPHLET: "Tips on Safeguarding Your Invention." Write: United States Inventors Service Company, 501 H Thirteenth Street N.W., Washington, D.C. 20004

SPORTS ACTION FILMS

50¢ CATALOG SAVES YOU \$1.00 on first purchase. Super 8/8mm Live Color. **SPORTLITE FILMS,** Dept. PE, 20 North Wacker Drive, Chicago, Illinois 60606.

GOVERNMENT SURPLUS

JEEPS Typically From \$53.90 . . . Trucks From \$78.40 . . . Boats, Typewriters, Airplanes, Multimeters, Oscilloscopes, Transceivers, Electronics Equipment. Wide Variety, Condition. 100,000 Bid Bargains Direct From Government Nationwide Complete Sales Directory and Surplus Catalog \$1.00. (Deductible First \$10.00 Order). Surplus Service, Box 820-J, Holland, Michigan 49423.

GOVERNMENT Surplus How and Where to Buy in Your Area. Send \$1.00 to: Surplus Information PE, Headquarters Building, Washington, D.C. 20036.

BOOKS

FREE catalog aviation/electronic/space books. Aero Publishers, 329PE Aviation Road, Fallbrook, California 92028.

UNUSUAL Books! Catalog free! International, Box 7798 (PE), Atlanta, Georgia 30309.

FREE book prophet Elijah coming before Christ. Wonderful bible evidence. Megiddo Mission, Dept. 64, 481 Thurston Rd., Rochester, N.Y. 14619.

BOOKS for every interest! Free details. Reed Company, West Kingston, Rhode Island 02892.

PUBLISH your book! Join our successful authors: publicity advertising promotion, beautiful books. All subjects invited. Send for free appraisal and detailed booklet. Carlton Press, Dept. ZDD, 84 Fifth Avenue, New York 10011.

MAGAZINES

BACK DATE MAGAZINES! Send needs. Midtown, Box 917-PE, Maywood, N.J. 07607.

CLASSIFIED ADVERTISING ORDER FORM

Please refer to heading on first page of this section for complete data concerning terms, frequency discounts, closing dates, etc.

1	2	3	4	5
6	7	8	9	10
11	12	13	14	15
16	17	18	19	20
21	22	23	24	25
26	27	28	29	30
31	32	33	34	35

_____ Words } @ 70¢ (Reader Rate) } = \$ _____
 } @ \$1.15 (Commercial Rate) }

Insert _____ time(s) Total Enclosed \$ _____

NAME _____

ADDRESS _____

CITY _____ STATE _____ ZIP _____

Signature _____

WORD COUNT: Include name and address. Name of city (Des Moines) or of state (New York) counts as one word each. Zip Code numbers not counted. (Publisher reserves right to omit Zip Code if space does not permit.) Count each abbreviation, initial, single figure or group of figures or letters as a word. Symbols such as 35mm, COD, PO, AC, etc., count as one word. Hyphenated words count as two words.

PE-470

HYPNOTISM

FREE Hypnotism, Self-Hypnosis, Sleep Learning Catalog! Drawer H400, Ruidoso, New Mexico 88345.

"MALE-FEMALE HYPNOTISM" EXPOSED, EXPLAINED! "SECRET METHOD"—THEY NEVER KNOW! \$2, RUSHED. GUARANTEED! ISABELLA HALL, SILVER SPRINGS, FLORIDA 32688.

HYPNOTIZE PERFECT STRANGERS—EITHER SEX—SUCCESSFULLY! Secret Methods—they never know! Illustrated Course and 10 inch Hypnodisk \$2.00. **RESULTS ABSOLUTELY GUARANTEED!** Dr. H. Arthur Fowler, Box 4399, Woodbury, New Jersey 08096.

AMAZING self-hypnosis record releases fantastic mental power. Instant results! Facts free. Write: Forum (AA3), 333 North Michigan Avenue, Chicago 60601.

MAGNETS

MAGNETISM (100) page script newly discovered magnetic principles (\$3.00). Jesse Costa, Box 26, Waquoit, Mass. 02536.

MAGNETS, 24 disc or bars, \$1.00; both \$1.75. Magnetics, Box 2279, Sunnyvale, Calif. 94087.

PHOTOGRAPHY—FILM, EQUIPMENT, SERVICES

SCIENCE Bargains Request Free Giant Catalog "CJ"—148 pages—Astronomical Telescopes, Microphones, Lenses, Binoculars. Kits, Parts. War surplus bargains. Edmund Scientific Co., 300 Edscorp Bldg., Barrington, New Jersey 08007.

RECORDS

POPULAR organ albums factory direct. Concert Recording, Lynwood, Calif. 90262.

OLDIES—45RPM original hits. Over 4000 available. Catalog 25¢. C & S Record Sales, Box 197, Wampsville, N.Y. 13163.

PRINTING

FREE LITERATURE: Address labels, business cards, printing. Rubber Stamps. JORDAN'S, 552 West O'Connor, Lima, Ohio 45801.

FREE Giant Discount Printing Catalog. Gables, 405C Clifton, Glenshaw, Pa. 15116.

EMPLOYMENT INFORMATION

FOREIGN and **USA** job opportunities available now. Construction, all trades. Earnings to \$3,000.00 monthly. Paid overtime, travel bonuses. Write: Universal Employment, Woodbridge, Conn. 06525.

EARN big money. Computer programing job guide, \$1.00. Couto, Box 615, Eatontown, N.J. 07724.

BUSINESS OPPORTUNITIES

RAISE Rabbits for us on \$500 month plan. Free details. White's Rabbitry, Mt. Vernon, Ohio 43050.

PIANO TUNING learned quickly at home. Tremendous field! Musical knowledge unnecessary. GI Approved. Free Information. Empire School, Box 327, Miami, Florida 33145.

FREE BOOK "999 Successful Little Known Businesses" Work home, Plymouth 445-A, Brooklyn, N.Y. 11216.

ELECTROPLATING Equipment and supplies. All types for home workshops and industrial. Send \$2.00 (refundable) for equipment guide formulas, operating data, catalog. HBS Equipment Division 90, 3543 East 16th, Los Angeles, California 90023.

I MADE \$40,000.00 Year by Mailorder! Helped others make money! Start with \$10.00—Free Proof. Torrey, Box 318-N, Ypsilanti, Michigan 48197.

\$200.00 DAILY In Your Mailbox! Your opportunity to do what mail-order experts do. Free details. Associates, Box 136-J, Holland, Michigan 49423.

FREE Selling Outfit. Office supplies, furniture & equipment. Oseco, 15-PE North Jefferson, Chicago 60606.

MAKE BIG MONEY raising chinchillas, rabbits, guinea pigs for us. Catalog—25¢. Keeney Brothers, New Freedom, Pa. 17349.

SELL inexpensive fire-burglar alarms. Foolproof! Write: **WATCHDOG, PROFITS BROCHURE**, Williamsburg, Ohio 45176.

FREE CATALOGS. Repair air conditioning, refrigeration. Tools, supplies, full instructions. Doolin, 2016 Canton, Dallas, Texas 75201. \$20,000—\$50,000 year. Ohio Bonding School, 7101 Lake, Elyria, Ohio 44035.

BIG EARNINGS selling Herte! Bibles. New 3-dimension cover, finest reference edition sells fast. Demonstrator furnished. Big commissions. International Book, Dept. PE, Box 118, Wichita, Kansas 67201.

HOW AND WHERE TO GET FINANCE CAPITAL. Get \$500 to \$2 million. Free trial offer. Counselor-48, Kerrville, Texas 78028.

ADDRESSERS (Commission Mailers) wanted. Everything Supplied. Details, 25¢. Smyre's, Box 953-ZD, Newark, N.J. 07101.

SELL your photos. Report tells how, where. \$1.00. D.J. Russell Company, 2 DiDonato Terrace, Dudley, Mass. 01570.

REAL ESTATE

FREE SPRING 1970 CATALOG! Describes and pictures hundreds of farms, ranches, town and country homes, businesses in 33 states coast to coast! Specify type property and location preferred. Zip code, please. **UNITED FARM AGENCY**, 612-EP West 47th Street, Kansas City, Mo. 64112.

MUSICAL INSTRUMENTS

30% DISCOUNT any name brand musical instrument. Free catalog. Freeport Music, 127 West Sunrise, Freeport, N.Y. 11520.

RUBBER STAMPS

RUBBER ADDRESS STAMP \$2.00. SIGNATURE \$3.50. FREE CATALOG. JACKSON, BOX 443-G, FRANKLIN PARK, ILL. 60131.

TREASURE FINDERS

GOLD, SILVER, RELICS! Located with powerful Detectron Metal Detectors. Free information. Terms. Detectron, Dept. PE-4, Box 243, San Gabriel, California 91778.

TREASURE FINDER locates buried gold, silver, coins, treasures. 5 powerful models. \$19.95 up. Free catalog. Relco-A33, Box 10839, Houston, Texas 77018.

TREASUREPROBES—Patented transistorized detector signals "dig" by earphone "beeping". 5" search head. PC board, two colpitt oscillators improve stability. Kit \$13.95, assembled \$18.88, with speaker \$24.88. 60 day guarantee. Send for Free Bibliography, "Treasure Maps and Books of U.S." Treasurehouse, PE-40, Tenant, N.J. 07763.

FREE TREASURE GUIDE! Fast-filled collectors edition; send 50¢ for postage. Also request free literature on ultrasensitive. professional Fisher Detectors. **FISHER RESEARCH**, Dept. PE4, Palo Alto, California 94303.

SUMMER CAMPS

CAMP SKYCREST. 25th year. 90 boys, 6-16. Pocono Mountains. Learn Astronomy, Auto Mechanics, Biology, Chemistry, Photography, Metal, Woodworking. Get ham license. All sports, karting. Heated pool. Friendly staff. Nurse. Modern Dorms. Write: Dr. F. E. Brown, 17 Doney Drive, Glen Cove, New York 11542. 516-676-2190.

MISCELLANEOUS

WINEMAKERS: Free illustrated catalog of yeasts, equipment. Semplex, Box 12276, Minneapolis, Minn. 55412.

BILLS paid without borrowing—Nobody refused up to \$10,000.00. Bad credit no problem, not a Loan Company. Write for free application. **INTERNATIONAL ACCEPTANCE**, Dept. 50-A, 3003 N. Central Ave., Phoenix, Arizona 85012; 1000 N. Madison Avenue, Greenwood, Ind. 46142; 507 Carondelet St., New Orleans, La. 70130; 1825 Conn. Ave. N.W., Room 428, Washington, D.C. 20009.

FREE Taxidermy Supply Catalog—World's largest selection forms. Taxidermy Supply, Route 1, Bossier City, Louisiana 71010.

POPULAR ELECTRONICS

APRIL 1970

ADVERTISERS INDEX

READER SERVICE NO.	ADVERTISER	PAGE NO.
1	AMECO, Div. of Aerotron, Inc.	110
2	Antenna Specialists Co., The	11
5	Argos Products Co.	113
	Bell & Howell Schools	106, 107, 108, 109
7	Burstein-Applebee Company	113
8	C/P Corp.	25
	CREI, Home Study Div., McGraw-Hill Book Co.	18, 19, 20, 21
9	Cleveland Institute of Electronics	36, 37, 38, 39
6	Communications Div., DYNASCAN CORP.	7
10	Cook's Institute of Electronic Engineering	114
11	Courier Communications, Inc.	103
12	Crystek	111
13	Edmund Scientific Co.	124
4	Electro-Voice, Inc.	FOURTH COVER
14	Heath Co.	100, 101
3	Johnson Company, E.F.	THIRD COVER
15	Lafayette Radio Electronics	111
32	Microflame, Inc.	117
16	Mosley Electronics, Inc.	102
17	Multicore Sales Corp.	105
	McGee Radio	116
	National Radio Institute	SECOND COVER, 1, 2, 3, 116
	National Technical Schools	88, 89, 90, 91
	North American School of Drafting	116
19	Olson Electronics	117
20	Pearce-Simpson	23
21	Phase Corp.	104
	RCA Electronic Components & Devices	12, 13
33	RCA Electronic Components & Devices	26
	RCA Institutes, Inc.	62, 63, 64, 65
22	Regency Electronics, Inc.	14
23	Sams, Howard W. & Co., Inc.	17
24	Sonar Radio Corp.	112
25	Southwest Technical Products	114
	Surplus Saving Center	116
	Sylvania Electric	5
26	Telex Communications Division	10
27	Turner Microphone Co., The	8
	U.S. Army	9
28	United Technical Institute	6
29	Utah Electronics	16
	Valparaiso Technical Institute	116
30	Winegard Antenna Systems	105
31	Xcelite, Inc.	123

CLASSIFIED ADVERTISING 118, 119, 120, 121, 122

how often could
you have used...

a Seizer?

Two-position snap-lock

Handy as an extra hand or helper. Clamps lightly or tightly... for moments or minutes.

A remarkably versatile tool with unusual holding qualities. Clamps tightly. Holds wires for soldering, acts as a heat sink, retrieves small parts from hard-to-reach places. Two-position snap-lock. Box joint construction. Precision machined from perfectly tempered stainless steel.

4 MODELS: 6" (serrated jaws) Nos. 42H straight and 43H curved nose; 5" Jr. (smooth, slim jaws) Nos. 32H straight and 33H curved nose.

XCELITE

XCELITE, INC., 20 Bank St., Orchard Park, N. Y. 14127
Send Bulletin N564 on Seizers.

name _____
address _____
city _____ state & zip _____

In Canada contact Charles W. Ponton, Ltd.

CIRCLE NO. 31 ON READER SERVICE PAGE

KEEP PACE WITH SPACE AGE! SEE MOON SHOTS—LANDINGS, SPACE FLIGHTS, CLOSE-UP!

AMAZING SCIENCE BUYS

for FUN, STUDY or PROFIT



FIND BURIED METAL TREASURE!



Detect individual coins, rings as deep as 12" boxes of coins, tools to 3'; metal chests, safes to 6 feet! Best fully transistorized, induction-balance loop detector at moderate price. Rugged, lightweight (3 1/2 lbs.) battery powered. Perfect for treasure hunters, collectors, explorers, beachcombers. Has visual and audible indicators, adjustable soil conductivity knob, on-off switch control. "Humisealed" solid state circuitry. 9" overall solid state circuitry. 9 Volt (150 hr.) battery.

all, ad., 1" diam. loop. Includes Stock No. 80.119AV \$147.50 Ppd.

TAPE-SLIDE SYNCHRONIZER



Automatically coordinates tape recordings with a series of slides. Just hook up stereo tape recorder and slide carousel with the TSS—then record what you wish for each slide. On playback, the TSS will AUTOMATICALLY change slide in conjunction with that slide's recording. Makes 1-man show into NO-MAN show. Your presentation "gives itself." Perfect for presentation, sales meetings, lectures. Make "talking album" of child's growth, add new dimension to vacations, slides, pictures from zoo, party, anywhere.

Stock No. 41.222AV \$19.95 Ppd.

GET YOUR OWN 4 7" "SLAVE"!



Really spectacular 55" light columns translate every note, beat, vibration of sound into dazzling, throbbing, criss-cross patterns of vibrant color. Super-sensitive 4-channel color organ in "master" column features individual color controls, master sensitivity knob, 1200V cap.—600 ea. for "Master" & "Slave." Listed below. Easily attached to stereo amplifier. Uses 110-120V AC, 55" x 19" x 10" D.

Stock No. 85.188AV (57 lb. Shpg. Wt.) \$249.50 F.O.B. "SLAVE UNIT"—Works only in tandem w./Master Stock No. 85.189AV (55 lb. Shpg. Wt.) \$149.50 F.O.B.

SPECIAL VISUAL EFFECTS PROJECTOR SET

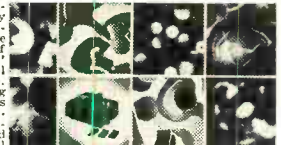

Dazzling, avant-garde visual effects. Fantastic variety. Incredibly beautiful. Special package offer contains all necessary apparatus. Create floating, exploding, fiery bursts of color like "Symphony of Spheres," "Chromatic Starbursts," "Crystal Starburst". Features 35mm 300 W fan cooled projector. Produces big image at short distance. Accepts two 9" diam wheels (Dry, Kaleidoscope & Hexidoscope), cylindrical accessories (6" Colored Cloud & 5" Hexidoscope w/six internal nitrocellulose entertaining parties, photography, Instr.

Stock No. 71.212AV \$79.50 Ppd.

PSYCHEDELIC LIGHTING HANDBOOK



100 information packed pages! Fully explains latest in psychedelic lighting equipment, techniques, developments. All facets of psychedelic light-show production including strobes, black lights, projectors, crystal, organic slides, mirrors, color organs, polarized color, light boxes, Music/lesion, etc. Shows how to organize parties, musical groups, shows or how to set up "electric trips" for private groups. 8 1/2" x 11" looseleaf paper for 3 rings.

Stock No. 9100AV \$3.00 Ppd.

50-150-300 POWER MICROSCOPE



Amazing Value—3 Achromatic Objective Lenses on Revolving Turret Imported! The color-corrected, cemented achromatic lenses in the objectives give you far superior results to the single lenses found in the microscopes selling in this range. Results are worth the reference! Fine rack and pinion focusing.

Stock No. 70.008AV \$19.50 Ppd. Mounted 500 Power Objective: Threaded achromatic lenses, 3mm F.L. Stock No. 30.197AV \$ 5.00 Ppd.

LONG-WAVE BLACK LIGHT FIXTURE

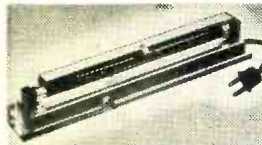

Extremely versatile, compactly designed, long wave (3200-4000 angstroms) black light (ultraviolet) fixture. Has 6-watt, 110-V lamp with built-in filter—eliminates harmful shorter wave ultraviolet rays. Use to identify minerals, fungi, bacteria—check for surface flaws, oil and gas leakage—perfect for displays with fluorescent paper, paints, chalk, crayons, trace powder. Use adjustable aluminum reflector. Mount vertically, 9" on corner. 10" L., 1 1/2" W., 1 1/2" H.

Stock No. 70.364AV \$12.50 Ppd. Stock No. 60.124AV REPLACEMENT BULB \$4.50 Ppd.

ASTRONOMICAL TELESCOPE KITS



Grind your own mirror for powerful telescopes. Kits contain fine annealed pyrex mirror blank, tool, abrasives, diagonal mirror, and eyepiece lenses. Instruments you build range in value from \$75 to hundreds of dollars.

4 1/4" DIAMETER—3 1/2" Thick Stock No. 70.003AV \$ 9.75 Ppd. 6" DIAMETER—1 1/2" Thick Stock No. 70.004AV \$13.95 Ppd. 8" DIAMETER—1 3/4" Thick Stock No. 70.005AV \$21.00 Ppd. 10" DIAMETER—1 1/2" Thick Stock No. 70.006AV \$34.25 F.O.B.

GREAT INT'L PAPER PLANE BOOK!



Official fly-them-yourself book of paper airplanes from SCIENTIFIC AMERICAN's 1st International Competition! Includes plans of all winners, time-also records, photos, technical data, commentaries. Has 20 unusual designs on perforated pages for easy tear-out. You won't believe how some of them fly! Amusing, entertaining. 128 pages. 9" x 11 3/4".

Stock No. 9391AV \$2.95 Ppd.

AMAZING "TRICK" PHOTOGRAPHY KIT



Now any amateur can produce all kinds of weird, wild, wacky photo effects. No special knowledge or equipment required. Unique kit enables you to turn friends into monsters, show house with warts to 2nd floor, make psychedelic slides, kaleidoscope photos, impressionistic photo-art—unlimited possibilities. Complete instructions reveal the secrets—includes all accessories needed.

Stock No. 71.229AV \$10.50 Ppd.

NEW! PROJECTION KALEIDOSCOPE



Infinite variety of brilliant color patterns which do not repeat. Specially designed interchangeable 3" diam. liquid wheel, 3" proj. lens and Edmund Projector make in all possible. Easily operated. Large screen image at short projection distance perfect for backgrounds, light shows, parties, dances, etc. Front or rear projection.

Stock No. 71.121AV \$94.50 Postpaid

NEW \$99.50 HELIUM-NEON LASER!



Completely assembled. Instant-starting w/ three times power output of comparable models. Steady, ripple-free light of moderate (safe) power. Excellent collimation. Simple and safe to use—laser tube reaches 75% power in 2 secs.; full power, typically, 0.5 milliwatts (0.5 mW minimum) in 40 mts. Beam divergence only 2 milliradians; beam only 2 cm x 40 cm.

Stock No. 79.064AV \$99.50 Ppd.

Order by Stock No.—Check or M.O.—Money-Back Guarantee EDMUND SCIENTIFIC CO., 300 EDSCORP BLDG., BARRINGTON, N.J. 08007

WRITE FOR GIANT FREE CATALOG "AV"



Completely new 1970 edition. New items, categories, illustrations. 148 easy-to-read pages packed with 4000 unusual items. Dozens of electrical and electromagnetic parts, accessories. Enormous selection of Astronomical Telescopes, Microscopes, Binoculars, Magnifiers, Magnets, Lenses, Triangles. Many war surplus items for hobbyists, experimenters, workshops, factory. Write for catalog AV. Include ZIP.

"FISH" WITH A MAGNET



Go treasure hunting on the bottom! Fascinating fun & sometimes profitable! Tie a line to our 3-lb. Magnet—drop it overboard in bay, river, lake or ocean. Trawl it along bottom—your "treasure" haul can be outboard motors, anchors, other metal valuables. 3-lb. Magnet is war surplus—Alnico Type Gov't cost \$50. Lifts over 150 lbs. on land—much greater weights under water.

Stock No. 70.570AV \$ 5 lbs. \$14.00 Ppd. Stock No. 70.570AV \$ 3 1/2 lbs. \$ 8.75 Ppd. Stock No. 70.572AV \$ 7 1/2 lbs. \$18.75 Ppd. Stock No. 75.152AV \$ 13 1/2 lbs. \$33.60 F.O.B.

ORDER BY STOCK NUMBER • SEND CHECK OR MONEY ORDER • MONEY-BACK GUARANTEE

EDMUND SCIENTIFIC CO. 300 EDSCORP BUILDING BARRINGTON, NEW JERSEY 08007

CIRCLE NO. 13 ON READER SERVICE PAGE

*It took more than skill
to design the world's
smallest complete mobile
5-watt CB
transceiver*



Johnson Messenger 125

\$99⁹⁵

Only the famous Johnson "talk-power" is big as ever on Johnson's radically new Messenger 125! Virtually every vehicle on the road, including the 1969 and 1970 models, can easily accommodate this versatile new radio. Its far-ahead features make operation extremely simple and enjoyable. Best of all, we sliced the most out of the price!

Features

- 5 push button channels—no knobs
- slide-lever vol. and squelch
- World's smallest panel configuration— $1\frac{1}{8}$ " by $4\frac{1}{32}$ ", just 7" deep
- 4 watts output at 13.8 VDC
- Accessories for portable use

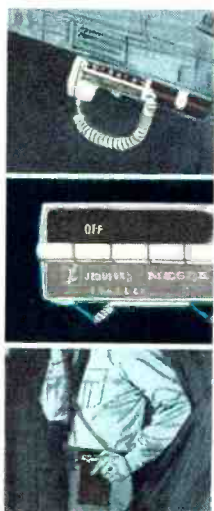

E. F. JOHNSON CO.

WASECA, MINNESOTA 56093

CIRCLE NO. 3 ON READER SERVICE CARD

Inside the
 new **E-V**
Model 626
 and **627A**
 we've put
 one good
 idea after
 another.



**It all
 adds up.**

To more bass,
 higher output, and
 better feedback control
 when working close,
 than any other Single-D
 microphones at any price.



Nationally Advertised List Prices

ELECTRO-VOICE, INC., Dept. 404P, 630 Cecil Street, Buchanan, Michigan 49107

CIRCLE NO. 4 ON READER SERVICE PAGE

www.americanradiohistory.com

Electro-Voice

A SUBSIDIARY OF GULTON INDUSTRIES, INC.