

IONS—HOW THEY CONTROL YOUR FEELINGS

POPULAR ELECTRONICS

NOVEMBER
1969

50
CENTS



MICROWAVE EXPERIMENTS

SIMPLE EQUIPMENT ON 2400 MHz

DARKROOM TIMER

STABLE, 5 TO 60 SECONDS

RALLY ROUND THE REFLEX

SPEAKER ENCLOSURE THEORY

PUBLIC ADDRESS AMPLIFIER

TEN WATTS WITH IC DRIVER

PULSE GENERATOR

MUST FOR DIGITAL TESTS

Construction Project

page 20

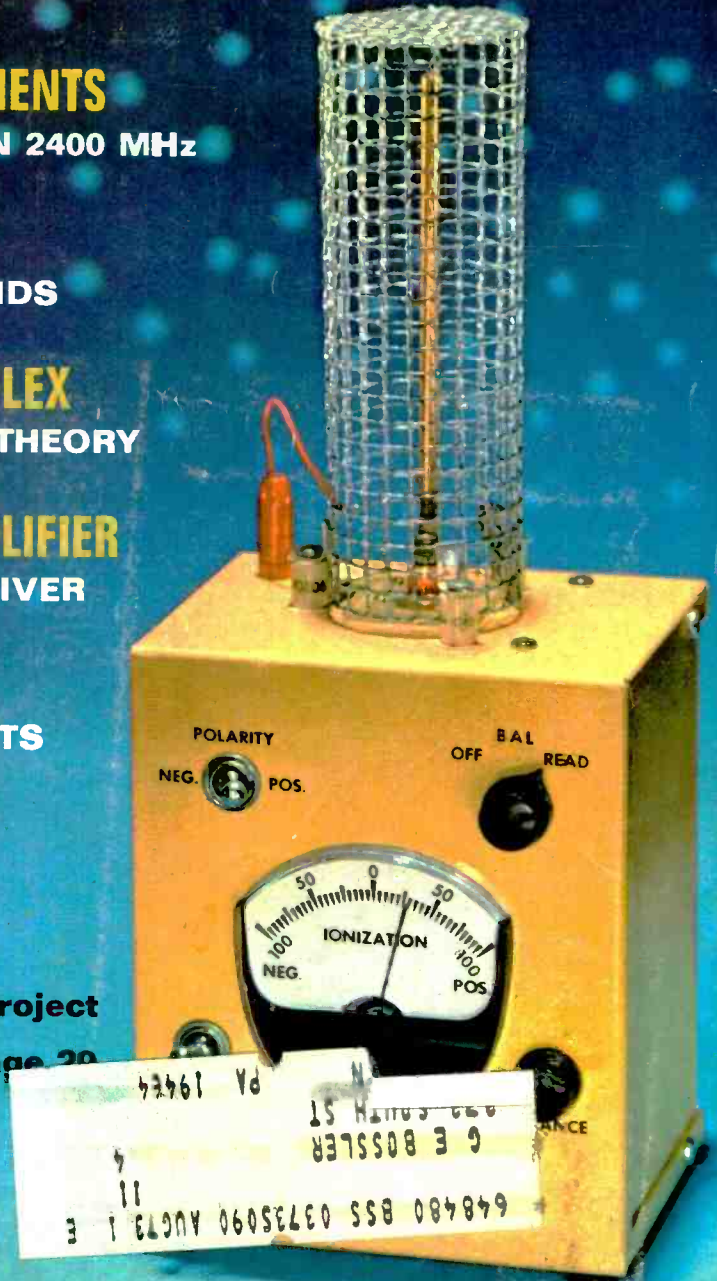



firsts

make learning

Electronics at home

fast and fascinating—

give you priceless

confidence.

Some NRI **firsts** in training equipment



first to give you Color Television training equipment engineered specifically for education — built to fit NRI instructional material, *not* a do-it-yourself hobby kit. The end product is a superb Color TV receiver that will give you and your family years of pleasure. You "open up and explore" the functions of each color circuit as you build.

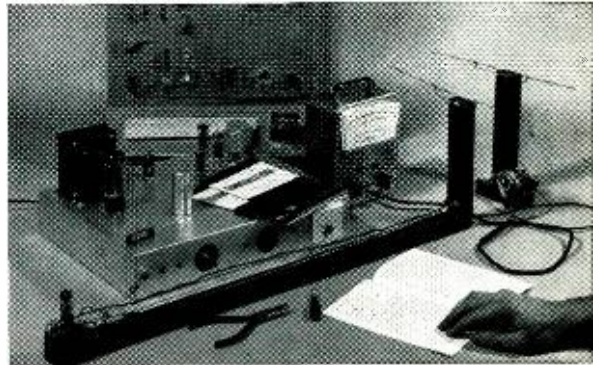

first to give you transmission lines and antenna systems that include experiments not otherwise attempted outside of college physics laboratories. The experience gained with this kind of Communications training equipment is matched only by months — sometimes years — of on-the-job experience.

NRI's "discovery" method is the result of over half a century of leadership simplifying and dramatizing training at home

The FIRSTS described below are typical of NRI's half century of leadership in Electronics home training. When you enroll as an NRI student, you can be sure of gaining the in-demand technical knowledge and the priceless confidence of "hands-on" experience sought by employers in Communications, Television-Radio Servicing and Industrial and Military Electronics. Everything about NRI training is designed for your education . . . from the much-copied, educator-acclaimed Achievement Kit sent the day you enroll, to "bite-size" well-illustrated, easy to read texts programmed with designed-for-learning training equipment.

YOU GET YOUR FCC LICENSE OR YOUR MONEY BACK

There is no end of opportunity for the trained man in Electronics. You can earn \$6 or more an hour in spare time, have a business of your own or qualify quickly for career positions in business, industry, government. And if you enroll for any of five NRI courses in Communications, NRI prepares you for your FCC License exams. *You must pass* or NRI refunds your tuition in full. No school offers a more liberal money-back agreement. The full story about NRI leadership in Electronics training is in the new NRI Catalog. Mail postage-free card today. No salesman is going to call.
NATIONAL RADIO INSTITUTE, Washington, D.C. 20016

APPROVED UNDER NEW GI BILL If you have served since January 31, 1955, or are in service, check GI line on postage-free card.

designed from chassis up for your education



first to give you true-to-life experiences as a communications technician. Every fascinating step you take in NRI Communications training, including circuit analysis of your own 25-watt, phone/cw transmitter, is engineered to help you prove theory and later apply it on the job. Studio equipment operation and troubleshooting become a matter of easily remembered logic.

first to give you completely specialized training kits engineered for business, industrial and military Electronics. Shown above is your own training center in solid state motor control and analog computer servo-mechanisms. Telemetering circuits, solid-state multi-vibrators, and problem-solving digital computer circuits are also included in your course.

POPULAR ELECTRONICS

VOLUME 31 NUMBER 5

NOVEMBER, 1969

WORLD'S
LARGEST-SELLING
ELECTRONICS
MAGAZINE

SPECIAL FEATURES

- STRANGE POWER OF AIR IONS** 29 *Howard Burgess*
How do they affect our health?
- MAKE YOUR OWN ION CHAMBER** 31 *Howard Burgess*
Detect and measure air ionization

FEATURE ARTICLES

- MICROWAVES FOR THE BEGINNER** 40 *William F. Hoisington, K1CLL*
Experiments with a 2400-MHz system
- RALLY ROUND THE REFLEX** 47 *David B. Weems*
Learn how to tune a speaker enclosure
- BUILD THE SCS DARKROOM TIMER** 52 *Frank H. Tooker*
Wide range, high accuracy
- TEN WATT PA AMPLIFIER** 55 *Ed Francis*
- PORTABLE PULSE GENERATOR** 61 *Philip Harms*
Trigger source for digital circuits
- THE STEREO SCENE** 69 *Charles Lincoln*
Design innovations in new stereo system
- FIELD EFFECT TRANSISTOR PROJECT KIT** 72
- THE PRODUCT GALLERY** 73
Megart Globe Pletter
Drake Programmable Receiver
- ENGLISH-LANGUAGE NEWS BROADCASTS TO N.A.** 76 *Roger Legge*
- SOLID STATE** 77 *Iou Garner*
Lasers in thin films
- TWO-WAY REACTIONS** 79 *G. H. Reese, KC6990*
- SHORT-WAVE LISTENING** 81 *Hank Bennett, W2PNA*
- AMATEUR RADIO** 84 *Herb S. Brier, W9EQG*

DEPARTMENTS

- LETTERS FROM OUR READERS** 8
- OUT OF TUNE** 12
Simplicity+ Dwell Meter (August 1969)
- NEW LITERATURE** 14
- READER SERVICE PAGE** 15
- ELECTRONICS LIBRARY** 16
- NEW PRODUCTS** 22

POPULAR ELECTRONICS is indexed
in the Readers' Guide
to Periodical Literature

This month's cover photo by
Conrad Studio

Copyright © 1969 by ZIFF-DAVIS PUBLISHING COMPANY. All rights reserved.

POPULAR ELECTRONICS, November 1969, Volume 31, Number 5, Published monthly at One Park Ave., New York, N.Y. 10016. One year subscription rate for U.S., U.S. Possessions and Canada, \$6.00; all other countries, \$7.00. Second class postage paid at New York, N.Y., and at additional mailing offices. Authorized as second class mail by the Post Office Department, Ottawa, Canada and for payment of postage in cash. Subscription service and forms: 3579; Postpaid direct subscriber, Colorado 80302. Editorial offers for manuscript contributions, reader inquiries, etc.: One Park Ave., New York, N.Y. 10016.

Special \$5 Offer

Learn TV repair...10 day trial!

Don't take *our* word for it—prove it to yourself! If you don't agree with every word we say about ICS's new TV Servicing/Repair course—we lose the bet and *you lose nothing*.

Send Just \$5

Simply send us \$5 for the first text of the course. Read through it. See how simple and easy-to-understand the instruction is. And how thorough. Then decide for yourself. While this first text will not, by any means, give you a complete training—it *will* convince you how easy it is to learn—the ICS way.

And, if by chance you're not convinced—simply return the text within the 10 day trial period and receive a full refund.

Worth Much More

As a part of the complete course, this text is worth much more than \$5. This special trial is simply our way of showing you how completely confident we are that the ICS TV Servicing/Repair course can stand up to *any* TV Repair training you can get *anywhere*, at *any price*—yet the full cost is only \$99.

In just a few months you can be trouble-shooting on color sets. Just the first two texts combined will enable you to repair 70 percent of *all* TV troubles. Instruction is simple, very easy to grasp. Photos show you what a TV screen looks like when everything is normal, and what it looks like when trouble fouls it up. The texts tell you how to remedy the problem and why that remedy is best. What's more, quizzes are spotted throughout the course so you can check your progress.

Course is Short . . . Complete

All in all, the course consists of 6 texts . . . 936 pages of concise, easy-to-follow instruction . . . plus 329 detailed illustrations . . . a dictionary of TV terms geared directly to course material—which will be invaluable during the course and later.

At the end, you get the coveted ICS diploma,

plus membership in the ICS TV Servicing Academy. And by that time you will be able to handle tough, multiple TV problems on color sets as well as black and white—100% of all TV malfunctions! This could mean a tremendous future for you. Full-time, part-time, your own business.

The National Electronic Associations found this ICS course so thorough, so helpful, easy to grasp that they approved it (first home study course ever to receive such an honor) for use in their own apprenticeship training program.

Act Now

You have nothing to lose. Send coupon today or write ICS, Scranton, Pa. 18515. Then examine the first text. See for yourself. If, during the 10 day trial period, you're not convinced—just return the text. And we'll refund quickly.

ICS International Correspondence Schools Division of Intext

ICS, Scranton, Pa. 18515

66748K

Here's my \$5.00. Send me the first text of the ICS TV Servicing/Repair Course. If I'm not convinced within 10 days that this is the most thorough and easy to understand way to learn TV repair, you'll refund my money and that's that.

Name _____
(please print)

Address _____

City _____ State _____ Zip# _____

Send the full course. I've included \$99—plus state tax. (And I'll still have the 10 day trial refund privilege.)

Return This Coupon Today For 10 Day Trial.

**The people
most likely to
appreciate the new
Dual 1209
are the least likely
to need one.**



If you already own an earlier Dual automatic turntable, you can really appreciate the new Dual 1209.

Because the 1209, just like your present Dual, offers flawless tracking and smooth, quiet performance that will be yours for years to come.

All Duals are made that way. And all recent ones have such exclusive features as pitch control that lets you "tune" your records by a semitone. No wonder so many hi-fi professionals use Duals in their personal stereo component systems.

But the 1209 has some new refinements of more than passing interest. A motor with high starting torque plus synchronous speed constancy. Anti-skating separately calibrated for elliptical and conical styli. A tonearm counterbalance with 0.01 gram click-stop adjustments.

These refinements aren't intended to seduce you away from your present Dual. But if you don't already own a Dual, perhaps it's time you talked with someone who does.

United Audio Products, Inc.,
120 So. Columbus Ave., Mt. Vernon,
New York 10553. 

CIRCLE NO. 41 ON READER SERVICE PAGE

POPULAR ELECTRONICS

PHILLIP T. HEFFERNAN
Publisher

OLIVER P. FERRELL
Editor

LESLIE SOLOMON
Technical Editor

JOHN R. RIGGS
Managing Editor

EDWARD I. BUXBAUM
Art Director

ALEXANDER W. BURAWA
Associate Editor

ANDRE DUZANT
Technical Illustrator

PATTI MORGAN
Assistant Editor

H. BENNETT, W2PNA

H. S. BRIER, W9EGQ

L. E. GARNER, JR.

G. H. REESE, KC6990
Contributing Editors

RICHARD J. HALPERN
Advertising Manager

ARDYS C. MORAN
Advertising Service Manager

LAWRENCE SPORN
Associate Publisher

ZIFF-DAVIS PUBLISHING COMPANY
Editorial and Executive Offices

One Park Avenue, New York, New York 10016
212 679-7200

Midwestern Office
307 North Michigan Avenue, Chicago, Illinois 60601
312 726-0892

Midwestern Advertising Manager, JAMES WEAKLEY

Western Office
9025 Wilshire Boulevard, Beverly Hills, California 90211
213 CRestview 4-0265; BRadshaw 2-1161
Western Advertising Manager, BUD DEAN

Japan: James Yagi
Ishikawa Mansion, #4, Sakuragaoka
Shibuya-ku, Tokyo, 462-2911-3

Circulation Office
Portland Place, Boulder, Colorado 80302

William Ziff, President
W. Bradford Briggs, Executive Vice President
Hershel B. Sarbin, Senior Vice President
Philip Sine, Financial Vice President
Walter S. Mills, Jr., Vice President, Circulation
Stanley R. Greenfield, Vice President, Marketing
Phillip T. Heffernan, Vice President, Electronics Division
Frank Pomerantz, Vice President, Creative Services
Arthur W. Butzow, Vice President, Production
Edward D. Muhlfeld, Vice President, Aviation Division
Irwin Robinson, Vice President, Travel Division
Furman Hebb, Administrative Vice President
George Morrissey, Vice President
Sydney H. Rogers, Vice President

Ziff-Davis also publishes *Airline Management and Marketing*, *Boating*, *Business & Commercial Aviation*, *Car and Driver*, *Cycle*, *Electronics World*, *Flying*, *Modern Bride*, *Popular Photography*, *Skiing*, *Skiing Area News*, *Skiing Trade News*, *Stereo Review*, and *Travel Weekly*.

Forms 3579 and all subscription correspondence should be addressed to POPULAR ELECTRONICS, Circulation Department, Portland Place, Boulder, Colorado 80302. Please allow at least six weeks for change of address. Include your old address, as well as new—enclosing if possible an address label from a recent issue.

EDITORIAL CONTRIBUTIONS must be accompanied by return postage and will be handled with reasonable care; however, publisher assumes no responsibility for return or safety of art work, photographs or manuscripts.



Member Audit Bureau
of Circulations

POPULAR ELECTRONICS



Motorola IC Kit HEK-1

One J-K Flip-Flop
 One Dual Buffer
 One 4-Input Gate
 Two Dual 2-Input Gates
 5 RTL IC's that will function in many digital
 as well as linear applications.
 "Tips on Using I.C.'s" Brochure
 Including an Integrated Circuit Cross
 Reference Guide and 8 I.C. Project Circuits.

Motorola FET Kit HEK-2

- One Audio J-FET
- One RF J-FET
- One NPN Silicon Transistor
- One PNP Silicon Transistor
- "Tips on Using FET's" Brochure

Including detailed theory of Field Effect
 Transistors, tips on FET applications, a
 glossary of terms, FET Cross Reference
 Guide, and 9 FET Project Circuits.



Check with your HEP supplier for either or both of these great kits.
 If you can't find a HEP distributor near you, just drop us a line. We'll
 send you a list of HEP suppliers in your area.

MOTOROLA HEP SEMICONDUCTORS

P. O. Box 20924 / Phoenix, Arizona 85034

CIRCLE NO. 28 ON READER SERVICE PAGE

Electronics Technicians

COMSAT

LABORATORIES



COMMUNICATIONS SATELLITE CORPORATION—the unique commercial communications company authorized by Congress to establish a global communications satellite system—has immediate needs for electronic technicians to work in its rapidly expanding laboratories.

Presently located in downtown Washington, D. C., the laboratories will move next year to its new facility now under construction in nearby Maryland.

Immediate openings are now available for candidates experienced in construction and testing:

- **SATELLITE COMMAND AND TELEMETRY SYSTEMS**
- **HIGH SPEED DIGITAL SUBSYSTEMS AND CIRCUITS**
- **RF RECEIVERS AND TRANSMITTERS**
- **MODULATOR AND DEMODULATORS**
- **MICROWAVE COMPONENTS, ANTENNAS AND FILTERS**
- **SPACE BORN MICROWAVE AMPLIFIERS AND OSCILLATORS**

COMSAT Laboratories offers excellent salaries, outstanding education, insurance, retirement and hospitalization benefits.

RELOCATION TO THE WASHINGTON AREA WILL BE PAID

If you are interested please direct your resume and salary requirements to J. K. Milligan.

COMSAT

COMMUNICATIONS SATELLITE CORPORATION

Box 115—D1969 Clarksburg, Maryland 20734

An Equal Opportunity Employer

CIRCLE NO. 12 ON READER SERVICE PAGE

letters

FROM OUR READERS

ANGRY VOICE ANGERS READERS

I am surprised that POPULAR ELECTRONICS would publish "Angry Voice from Red Lion" (September 1969, p 73) which suggested that short-wave broadcaster WINB be taken off the air. It displays the usual intolerance of liberals who despise anything critical of communism, however true.

H. E. FOSS
Coulee Dam, Wash.

I did not like the article and I'm glad my subscription ran out.

CARL MILLER
Greensboro, N.C.

The slander of "Lifeline" and "The Manion Forum," which are simple and relatively pure expressions of traditional Americanism, clearly indicates the evil motivations of the author.

V. L. CHAPPELL
Los Angeles, Calif.

I'm sure that there are many anti-communist listeners in foreign countries who are not at all confused, but greatly encouraged by the true American culture reflected over WINB.

MARGARET E. LANGRIDGE
Geneseo, Ill.

POPULAR ELECTRONICS is not a magazine for airing personal political opinions.

Y. SAWERDA
San Diego, Cal.



POPULAR ELECTRONICS

At least Dr. Carl McIntyre isn't trying to get the World Council of Churches, or others, thrown off the air, because he believes in freedom with responsibility, not irresponsible freedom.

K. VEVEKKE
Central City, Iowa

The story is an excellent communist promotion of the limitation of freedom by right-wing conservatives.

Name Withheld

I would welcome the opportunity of WINB to respond to your editorial.

Name Withheld

Reader comments regarding the "Red Lion" story were numerous and easily placed in two categories: POPULAR ELECTRONICS should be a non-political magazine; and the story was a communist "plant." Neither opinion deserves editorial recognition or rebuttal. No letter has been received supporting the FCC viewpoint that radio programs for "domestic" consumption should not be aired on shortwaves.

CB! YUK!

I monitored CB from a hill near the Bernhiem Forest in Kentucky and every station heard was outside of Kentucky with the closest being in Nashville—about 150 miles distant. One station in Fairfield, Alabama was "in contact" with a fellow in Findlay, Ohio. Fourteen more were in a roundtable on one channel and at this distance none of them could have been operating with legal power. None signed legitimate callsigns, but used fictitious identification such as "Grand Ole Pappy," "Mississippi John Henry," etc.

Obviously, CB'ers do as they please—the FCC notwithstanding. I say let's close CB down or make every licensee show a useful cause for his having a CB rig.

W.R. YEARY, K1AEL/K5HZG
Louisville, Ky.

There is no argument from POPULAR ELECTRONICS that a minor percentage of CB'ers is making this whole communication medium look ridiculous. Obviously, there are many healthy and helpful aspects, but the legitimate CB'ers cannot clean house without the support of the FCC—which appears to let "things slide."

ENCAPSULATION

I have been using the plastic resin casting technique ("Encapsulate Your Circuit," August 1969, p 82) for a year. But be careful of hardening the casting with a hair dryer. I found that encapsulating the "PPFL" project, shown in the same issue, created some problems when the resistors upped their values alarmingly.

JACK KOLTON
Reading, Pa.

(Continued on page 10)

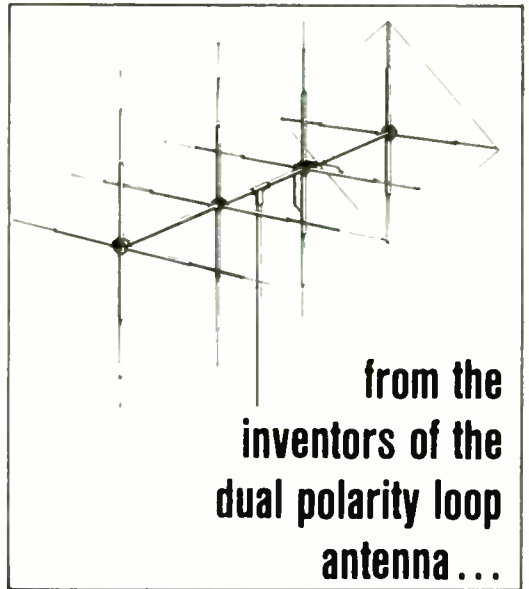

from the
inventors of the
dual polarity loop
antenna...

*THE MOONRAKER!

Designed along the lines of antennas used to pinpoint signals on "moon bounce."

Uses only a 15' boom to eliminate efficiency loss inherent in multiple in-line quad designs, thus better signal excitation is achieved to provide greater true gain.

Combines 1/2 wave cross dipole elements with the famous Avanti PDL™ design reflector. Switch box (included) permits operation on the horizontal or vertical mode.

Aircraft quality seamless aluminum construction ... extrusions and castings used in hubs and mounts ... no stampings. 1 year guarantee.

SPECIFICATIONS

Gain:	14.5 db
SWR:	1.20:1
Impedance:	50 ohms
Power Handling:	1000 watts
Front to Back	
Separation:	38 db
Vertical to Horizontal	
Separation:	25 db
Wind Survival:	90 mph
Weight:	24 lbs.

\$129.95

*Patent Pending

Made in America



avanti
33-35 WEST FULLERTON AVENUE
ADDISON, ILLINOIS 60101
AVANTI RESEARCH & DEVELOPMENT, INC.
THE PACESETTER IN HIGH PERFORMANCE ANTENNAS

CIRCLE NO. 6 ON READER SERVICE PAGE

THE CALECTRO

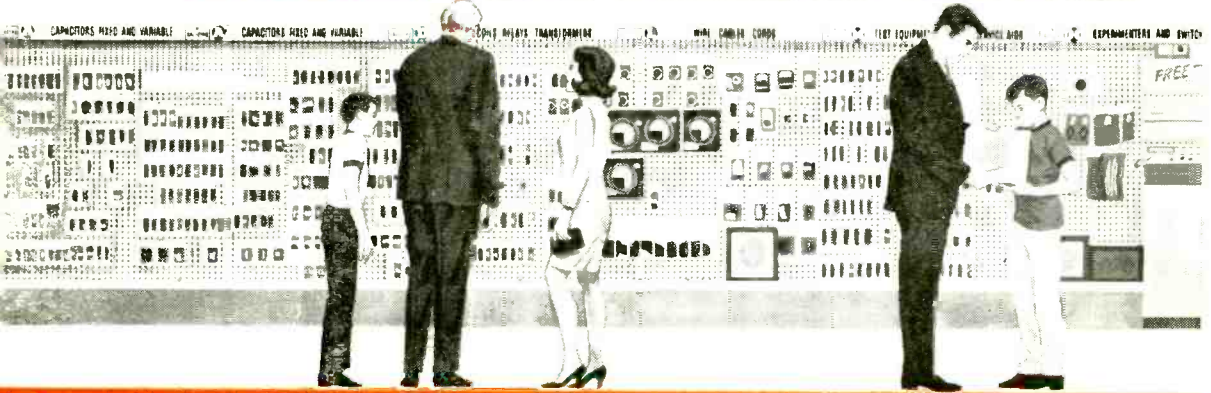

EVERYTHING IN ELECTRONICS!

Over 800 popular, new Calectro products for every household use!
Now at each location, hundreds and hundreds of items for everyone
hobbyist, enthusiast, amateur, executive, homeowner, do-it-yourselfer.
See the SELF-SERVICE G.C. Calectro display
at your Calectro SUPERMARKET TODAY.

VARIABLE BALANCE STEREO PHONE
Slide "Sound Level" control on each
speaker permits adjustment
frequency range: 20 to 20,000 cps
6' cord with stereo plug, impedance
4 to 16 ohms.
Cat. No. 04-132 \$17.95 Net



"C" (FLASHLIGHT) TYPE CELL HOLDER
Holds 4 "C" cells; connects
with wire.
Cat. No. 73-064 \$6.25 Net

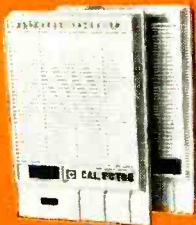

TWO STATION WIRELESS INTERCOM
Just plug into any electrical outlet.
Completely portable. Expand system
with up to 10 additional units. Two
unit system complete in display pack.
Cat. No. 04-110 \$34.95 Net

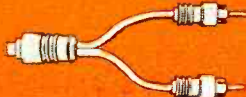

AUDIO ADAPTERS
"Y" Audio Adapter has a phone, two
talk on one end and dual phone pins
on the other.
Cat. No. 04-280 \$9.99 Net



EXPERIMENTER'S CIRCUIT BOARD KIT
Contains a 3 1/2" x 4" perforated
board, 15 terminals (No. 14-636) and
8 mounting feet w/screws. Board
small enough for hobby and science
projects, etc.
Cat. No. 14-660 \$9.98 Net



2 CONDUCTOR PHONE PLUG
Plug has black and red plastic handle
w/solder lug and clamp.
Cat. No. 02-435 (black) \$4.43 Net
Cat. No. 02-437 (red) \$4.43 Net

MINIATURE LAMPS



Type P10 - 2 1/2 volts - 0.50 amp -
Cat. No. 02-430 - Pkg. of 2 \$3.29 Net
Type P5 - 1 1/2 volts - 0.50 amp -
Cat. No. 02-431 - Pkg. of 2 \$3.29 Net



Type 17 - 6.3 volts - 0.15 amp -
Cat. No. 02-435 - \$3.39 ea. Net



Type 40 - 6.3 volt - 0.15 amp -
Cat. No. 02-437 - Pkg. of 2 \$3.29 Net
Type 46 - 6.3 volt - 0.25 amp -
Cat. No. 02-441 - Pkg. of 2 \$3.29 Net



1" WIRE STANDOFF HOLDERS

Round screw type, 2 1/2" long. Insulator
has "flat line" base and can be cable.
Cat. No. 32-050 Pkg. of 4 \$4.47 Net
Some as above, but 7/8" long.
Cat. No. 32-054 Pkg. of 3 \$3.71 Net
Snap-on type. Fits on 1/4" nuts.
Universal insulation for all types of
cable.
Cat. No. 32-062 Pkg. of 2 \$3.58 Net

RESISTORS

Attractively packaged 2 per pack, showing
values, color codes and formulas.

Type	Rating	Series Available	Price	Dist.
Carbon	1/2 Watt	10 Ohm - 10 Meg	\$19	Pkg. of 2
Carbon	1 Watt	10 Ohm - 1 Meg	19	Ea.
Carbon	2 Watt	10 Ohm - 100K	25	Ea.
Wire	10 Watt	10 Ohm - 15K	36	Ea.



STANDARD 1000 P.O.L. CAPACITOR

High quality, compact and reliable.
Minimum capacity change with
varying temperature. Rating: 1000
volts, tolerance: 20%.

Cat. No.	Description	Net	Unit
060	220pF	\$2.25	Pkg. of 2
061	330pF	25	Pkg. of 2
062	470pF	25	Pkg. of 2
063	680pF	25	Pkg. of 2
064	0.001uF	19	Ea.
065	0.005uF	19	Ea.
066	0.01uF	19	Ea.



SUPERMARKET

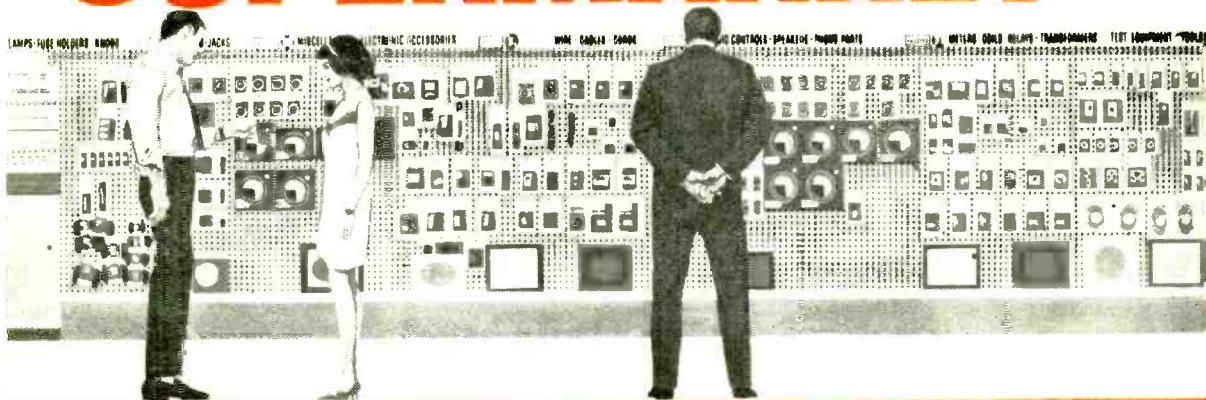

"HOBBY PACK" SE RECONDUCTORS



TUPN GAIN PUMPS: Audio/RT Silicon Transistor - 18 case - typ. gain-60 - max. operat. -100-1 - freq. to 2MHz
Cat. No. 84-5013P... of 3 \$3.99 Net



PNP HI POWER Germanium Transistor: TO 3 case - typ. gain-50 - max. operat. -100-15 - max. freq. -15m
Cat. No. 84-529 \$1.99 Ea.



TV PICTURE TUBE BRIGHTENERS
Restore brightness and eliminate cathode-ray emission problems or internal shorts... Just plugs in in parallel across circuits.

Cat. No.	Description	Net
74-025	For 10" B/W Tubes	\$1.95
74-036	For 12" B/W Tubes	2.95
74-037	For Round Color Tubes	2.95
74-038	For Rect. Color Tubes	2.95



CIGARETTE LIGHTER PLUG
Warning: CP Sets, warning lights, ballast resistors, etc. to auto dash wiper/bleed
Cat. No. 84-829 \$1.75 Net



HOBBYIST'S SOLDERING AND TOOL KIT

Do yourself, long nose pliers, soldering iron and solder, solder aid tool, heat sink, and screwdriver.
A wonderful gift item
Cat. No. 83-378 \$7.95 Net



TAPE RECORDER MICROPHONE

Outstanding performance on music and speech for the price. Low impedance matches late model solid state recorders. Removable desk stand, 4W cord with dual plugs that fit most models. Free. Response, 100 Hz Output - 77 db. Impedance, 200 ohms
Cat. No. Q4 146 \$4.95 Net

PHONE JACK

Chassis mount jack for open or closed circuit.
Cat. No. F2-842 \$1.29 Net



PRECISION PANEL METERS

Economical, high quality, dependable meters give 2% accuracy. Hard calibrated - Linear dial scales - D Rotational movement with sorted bearings. Clear cover. DC Current Types. DC Volt Types. AC Volt Types also available in VUMeter and "S" Meter.

See Calectro Handbook page 38 for prices and specifications.

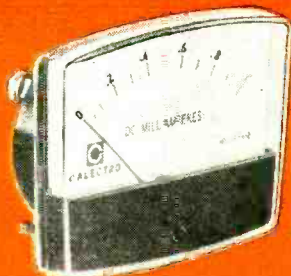

The "GC Calectro Hobbyist Handbook" is available at your nearest Calectro Electronic Supermarket. One is located near you. WRITE TODAY and we'll rush you the name and address of your nearest Calectro Supermarket.

700 locations all over the country and Canada. See your electronic parts distributor and SAVE.

CALECTRO

G-C ELECTRONICS

400 SO. WYMAN ST. ROCKFORD, ILLINOIS 61101



A DIVISION OF HYDROMETALS, INC.

CIRCLE NO. 18 ON READER SERVICE PAGE

THE TRUTH
about the complete line of
Electro-Voice[®]
HIGH FIDELITY
loudspeakers and electronics.

Over 50 different high fidelity products, including tuners, amplifiers, receivers, speaker systems, and component loudspeakers. Write today.



ELECTRO-VOICE, INC., Dept. 1194P
630 Cecil Street, Buchanan, Michigan 49107

Send my **FREE** product folder on the complete line of Electro-Voice high fidelity components.

Name _____

Address _____

City _____ State _____ Zip _____

CIRCLE NO. 15 ON READER SERVICE PAGE

THE TRUTH
about the
complete line of
Electro-Voice[®]
MICROPHONES

Capsule listings of over 85 microphones for recording, communications, sound reinforcement and radio-TV broadcasting. Send today for this helpful product folder.



ELECTRO-VOICE, INC., Dept. 1192P
630 Cecil Street, Buchanan, Michigan 49107

Send my free product folder on the complete line of Electro-Voice microphones.

Name _____

Address _____

City _____ State _____ Zip _____

CIRCLE NO. 16 ON READER SERVICE PAGE

LETTERS (Continued from page 9)

WHY EDISON ROULETTE AT ALL?

I commend you and the author of "Why Play Edison Roulette?" (August 1969, p 71) for one more warning that every home can be a death house.

However, aren't we treating the wrong thing? Shouldn't we look at the real criminal

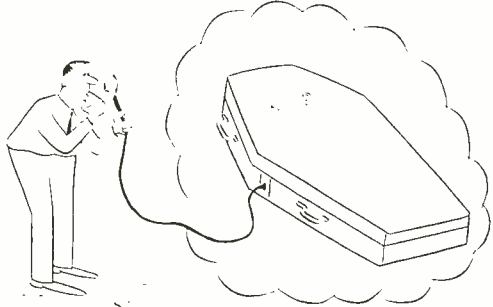

—the improperly manufactured electrical appliance?

The public should be told that the conventional twin-wire power cord is a do-it-yourself death tool. The public must be made aware that a three-wire power cable is the only route to life assurance.

C.O. TAYLOR
San Diego, Cal.

SERVICE FOR THE BLIND

Our contact with the blind community indicates to us that many blind persons are unaware of the fact that **POPULAR ELECTRONICS** is available to them on tape from **Science for the Blind**. This is true in spite of the fact that we have tried to notify the community through notices in braille periodicals and through direct mail to our own mailing list.

Perhaps you and your readers can help.

Mrs. L. FULLER
Science for the Blind

POPULAR ELECTRONICS is available to the blind and physically handicapped on magnetic tape from SCIENCE FOR THE BLIND, 221 Rock Hill Road, Bala Cynwyd, Pa. 19004. The magazine is read onto tape by volunteer readers with the publisher's permission and is intended solely for the use of the blind and the physically handicapped. If you know someone who could use this service, please pass the word.

OUT OF TUNE

"Simplicity + Dwell Meter" (August 1969). In the Parts List, the current-regulator diode should be listed as 1N5299 not 1N5899. The schematic diagram is correct.

smooth

RCA WP-700A, 702A, 703A and 704A constant voltage dc power supplies are all solid-state. A negative feedback circuit maintains constant output voltage with low ripple—regardless of varying line. In fact, at rated load, these supplies are so smooth that “they hardly cause a ripple.”

They are versatile bench-type units—ideally suited for use in circuit design, servicing, industrial, and educational applications.

Output voltage of the WP-700A and WP-702A is continuously adjustable from 0 to 20 volts at current levels up to 200 mA.

Output voltage of the WP-703A is continuously adjustable from 0 to 20 volts at current levels up to 500 mA.

Output voltage of the WP-704A is continuously adjustable from 0 to 40 volts at current levels up to 250 mA.

All four power supplies have built-in electronic short-circuit protection — and a front panel overload-indicator that signals approach to maximum rated current level.

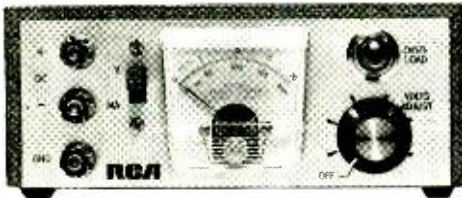

WP-700A: \$40.00* (five or more) \$48.00* (less than five)

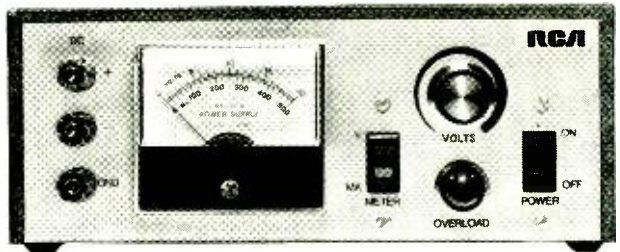

WP-703A: \$49.00* (five or more) \$58.00* (less than five)

WP-704A: \$49.00* (five or more) \$58.00* (less than five)

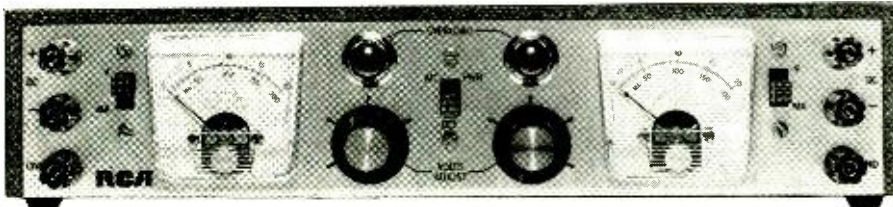

WP-702A: Siamese Twins of WP-700A, but electrically isolated \$73.00* (five or more) \$87.00* (less than five)

*Optional Distributor Resale Price.

For further information write: RCA Electronic Components, Commercial Engineering, Department K-133W, Harrison, N. J. 07029.

Look to RCA for instruments to test/measure/view/monitor/generate



CIRCLE NO. 34 ON READER SERVICE PAGE

November, 1969

13

TAKE ONE



new literature

To obtain a copy of any of the catalogs or leaflets described below, simply fill in and mail the coupon on page 15.

The 1970 edition of the Heathkit Catalog, featuring the world's largest selection of electronic kits, is now available from the *Heath Company*. The catalog lists more than 300 kits for every budget and area of interest within its 116 pages, 66 pages of which are in full color. Among the items listed in the catalog are hi-fi/stereo components; ham radio equipment; marine gear; test, service, and laboratory equipment; CB radio; and other special interest items. Items of general interest include color and monochrome TV receivers, electronic organs, clock radios, intercoms, and automotive kits.

Circle No. 75 on Reader Service Page 15

Microphones and their accessories are the theme of Catalog No. 2520 now available from the *Turner Company, Inc.* Listed and described in the new catalog are some 25 or more microphone models—stand-mount, hand-held, lavaliers—for every application from mobile and fixed communications, to hi-fi, general-purpose and paging. The accessories listed include microphone stands, uprights and flexible arms, replacement cables, line transformers, remote amplifiers, wind-screens, and replacement cartridges for microphones. In addition, the catalog tells how to choose a microphone, describes the different types of microphones (cardioid and dynamic), and explains the meaning of frequency performance and output levels.

Circle No. 76 on Reader Service Page 15

Allied Radio Corp. is making available, free on request, their 552-page catalog, No. 290, for 1970. The catalog lists and describes with detailed specifications general-interest and specialty items. Among the general-interest items listed are hi-fi gear, including a large selection of tape recorders; color and monochrome TV receivers; electronics and associated hobby kits; and auto receivers and tape players. Other items include ham and CB equipment; short-wave receivers for the SWL; public address systems; and test instruments. There is also an extensive listing of electronic parts and books.

Circle No. 77 on Reader Service Page 15

MAKING "WAVES"

CADENCE—the musical instrument speakers

Making better, clearer, amplified sound waves is the THING Cadence does... better than anything else in the industry. Cadence Speakers are built to withstand heat from sustained notes at a high power level and the vibrations and stresses which are continually placed upon them. Cadence is guaranteed **one full year** at the power level specified. This proven speaker family has been selected by the manufacturers of most of the world's fine amplified music instruments.

If making beautiful, clear sound waves is your thing, ask for **CADENCE SPEAKERS**.

For complete information and the name of your Cadence Dealer, write:

utah  **UTAH ELECTRONICS DIVISION**
Utah-American Corporation
1124 East Franklin Street
Huntington, Indiana 46750

CIRCLE NO. 43 ON READER SERVICE PAGE

POPULAR ELECTRONICS READER SERVICE PAGE

free information service:

Here's an easy and convenient way for you to get additional information about products advertised or mentioned editorially (if it has a "Reader Service Number") in this issue. Just follow the directions below... and the material will be sent to you promptly and free of charge.

1. On coupon below, circle the number(s) that corresponds to the key number(s) at the bottom or next to the advertisement or editorial mention that is of interest to you. (Key numbers for advertised products also appear in the Advertisers' Index.) Print or type your name and address on the lines indicated.

2. Cut out the coupon and mail it to: POPULAR ELECTRONICS, P.O. Box 8391, Philadelphia, PA 19101.

note: If you want to write to the editors of POPULAR ELECTRONICS about an article on any subject that does not have a key number, write to POPULAR ELECTRONICS, One Park Avenue, New York, N.Y. 10016. Inquiries concerning circulation and subscriptions should be sent to POPULAR ELECTRONICS, Portland Place, Boulder, Colo. 80302.

POPULAR ELECTRONICS

P.O. BOX 8391
PHILADELPHIA, PA. 19101

VOID AFTER DECEMBER 31, 1969

1 2 3 4 5 6 7 8 9 10 11 12 13 14 15 16 17 18 19 20
21 22 23 24 25 26 27 28 29 30 31 32 33 34 35 36 37 38 39 40
41 42 43 44 45 46 47 48 49 50 51 52 53 54 55 56 57 58 59 60
61 62 63 64 65 66 67 68 69 70 71 72 73 74 75 76 77 78 79 80
81 82 83 84 85 86 87 88 89 90 91 92 93 94 95 96 97 98 99 100

NAME (Print clearly) _____

ADDRESS _____

CITY _____ STATE _____ ZIP CODE _____

11 a

Weller
simplifies soldering



**New
TEMPMATIC®
Temperature
Controlled Soldering Tool**

Combines all the advantages of a pencil iron, a fast heating soldering gun, and tip temperature control. Exclusive removable Powerhead contains Weller's temperature control system. Protects components even in the most delicate work situations. Tool weighs 7 oz. Use it for light or heavy duty soldering. Model GT-7A has 700°F. $\frac{3}{16}$ " chisel point Powerhead. Model GT-6B has 600°F. $\frac{1}{8}$ " conical point Powerhead.



**The original
Dual Heat Guns**

Fast heating. Long-life tips. Exclusive trigger-controlled dual heat. High soldering efficiency. Spotlight. 3 models from 100/140 watts to 240/325 watts.



Dependable MARKSMAN Irons

They outperform other irons of their size and weight. Long-reach stainless steel barrels. Replaceable tips. 5 models from 25 watts to 175 watts.



Weller 25-watt Iron for intricate work

Industrial rated. Weighs $1\frac{3}{4}$ oz. Delivers tip temperatures to 860°F. Cool, impact-resistant handle. Model W-PS with $\frac{1}{16}$ " tip.

Weller

WELLER ELECTRIC CORP., Easton, Pa.
WORLD LEADER IN SOLDERING TOOLS

CIRCLE NO. 44 ON READER SERVICE PAGE

**ELECTRONICS
library**

QUIET

**HANDBOOK OF ELECTRONIC METERS:
THEORY AND APPLICATION**

by John D. Lenk

Manufacturers of meters provide instructions on the operation and circuit theory of their particular instruments, but rarely do these instruction manuals give any applications data describing the many uses of meters. This book attempts to rectify the oversight. The opening chapters give a simplified presentation of the principles and characteristics of meters, as well as a brief description of meter accessories. Beyond the first three chapters, the book becomes a guide for experienced technicians and engineers. In detailing the greatest number of meter applications available, it covers a full range of practical solid-state and IC data.

Published by Prentice-Hall, Inc., Englewood Cliffs, N.J. 07632. Hard cover. 130 pages. \$10.95.

FELL'S GUIDE TO OPERATING SHORTWAVE RADIO

by Charles J. Vlahos

This is a book written to fill that gap between the position of knowing absolutely nothing about shortwave and the decision to become a ham, or SWL, or even a CB'er. In other words, this is an "introduction" to shortwave radio and to a small extent is similar to the COMMUNICATIONS HANDBOOK published annually by the Editors of this magazine. The author's enthusiasm is contagious and we can recommend his book as a safe guide in making those first steps into shortwave.

Published by Frederick Fell, Inc., 386 Park Avenue South, New York, N.Y. 10016. Hard cover. 180 pages. \$4.95.

**UNDERSTANDING AND USING
UNIUNCTION TRANSISTORS**

by Stu Hoberman

This book explains in detail the construction, operation, and characteristics of the unijunction transistor (UJT). It describes the various applications of UJT's, and typical circuits in which they are used. Separate chapters are devoted to the use of the UJT in oscillator circuits, voltage control devices, time delay and flasher applications, and in sensing circuits.

Published by Howard W. Sams & Co., Inc., 4300 West 62 St., Indianapolis, Ind. 46268. Soft cover. 96 pages. \$2.50.

Earn Your DEGREE in Electronics!

Grantham School of Engineering offers an educational program leading to the Degree of Associate in Science in Electronics Engineering — the ASEE. *Beginners in electronics* must take resident classes in Hollywood, Calif., or in Washington, D.C. However, *experienced electronics technicians* may complete the entire degree program by home study, except for the final two weeks which must be taken in Hollywood. There are three different ways the program is offered, referred to as *Daytime-Residence*, *Supplemented-Correspondence*, and *Home Study*. Each method is discussed below.

Daytime-Residence

The Daytime-Resident program is designed for *beginners*. You may enroll in Hollywood or Washington. Classes meet five days per week, and each semester is 16 weeks long. Three semesters are offered each year. Upon satisfactory completion of the five semester program (about 20 months), you are awarded a Diploma in Electronics Engineering Technology. Then, to complete the requirements for the ASEE Degree, you must attend the associate-degree seminar—a two-week period of review, consultation, and evaluation.

This seminar is held, for Hollywood and Washington students, at the main School in Hollywood. For Washington students the School pays the round-trip (to and from Hollywood) airline transportation charges, so that all the graduating students in both schools may participate in each seminar together.

For those who wish to continue their engineering studies beyond the ASEE Degree level, Grantham offers a BSEE Degree program in Hollywood. The Grantham ASEE Degree or other equivalent background is prerequisite to enrollment in the BSEE Degree program.

Supplemented-Correspondence

The Supplemented-Correspondence program is designed for *beginners*. You take the correspondence lessons from the main school in Hollywood, but the supplementary resident classroom and laboratory sessions, one evening per week, may be taken in either Hollywood or Washington. The main part of the program is divided into five semesters, each semester being slightly less than six months long, so that you normally complete the five semesters in 2½ years. Upon completion of this five-semester program, you are awarded a Diploma in Electronics Engineering Technology. Then, to complete the requirements for the ASEE Degree, you must attend the associate-degree seminar—a two-week period of review, consultation, and evaluation—in Hollywood, the same as is explained under "Daytime-Residence" above. Seminar round-trip airline transportation for Washington students is paid by the School.

Home Study

In the ASEE Degree program offered to *experienced electronics technicians*, the entire educational program leading to the Diploma in Electronics Engineering Technology is conducted by home study. It consists of 370 home study lessons, divided into five "correspondence semesters". The prerequisite for enrollment is high school graduation (or equivalent) and at least one year of fulltime experience as an electronics technician.

Upon completion of the 370 home-study lesson (five semester) and receipt of your EET Diploma, you are then eligible to attend the associate-degree seminar—a two-week period of review, consultation, and examination—in Hollywood, as the final requirement for your ASEE Degree.

This *accredited* ASEE Degree program offered to experienced technicians, begins with a review of electrical and electronic principles and systems, and then continues with applied engineering mathematics (including algebra, trigonometry, analytic geometry, and calculus), classical and modern physics, technician writing, computer systems, electrical network design, and semiconductor circuit design.

Accreditation, and G.I. Bill Approved

Grantham School of Engineering was established in Hollywood, California in 1951, and the Eastern Extension Division of the School was opened in Washington, D.C. in 1955.

The School is *approved* in California by the California State Department of Education, is *approved* in the District of Columbia by the D.C. Board of Education, is *approved* under the "Cold War G.I. Bill" to offer resident courses in Hollywood and Washington and correspondence courses from Hollywood, is *accredited* by the Accrediting Commission of the National Home Study Council, and is *authorized* under the laws of the State of California to grant academic degrees.

Grantham School of Engineering

Specializing in Electronics since 1951

1505 N. Western Ave. 818 18th Street, N.W.
Hollywood, Calif. 90027 or Washington, D.C. 20006

Telephone:
(213) 469-7878

Telephone:
(202) 298-7460

Grantham School of Engineering

PE-11-69

1505 N. Western Ave., Hollywood, Calif. 90027

Please mail your free Bulletin, which explains how the Grantham educational program can prepare me for my Associate in Science Degree in Electronics Engineering.

Name _____ Age _____

Address _____

City _____ State _____ Zip _____

I am interested in: Daytime-Residence
 Supplemented-Correspondence. Home-Study

We pack your electronics course with kits to make your training fast. You'll enjoy every minute of it.

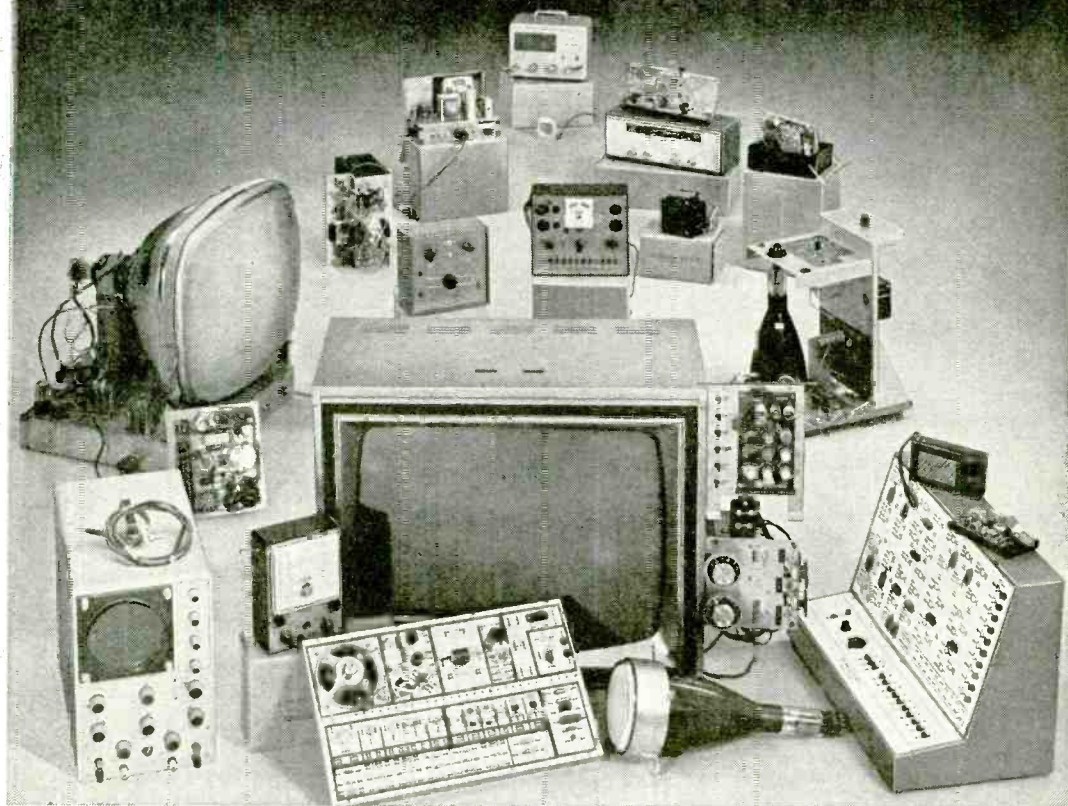

Your NTS success package

Choose a career in electronics: Computers. Color TV Servicing. Automation. Communications. Whatever the field, NTS has a complete home-study package to get you to the top *faster*. 10 thorough training courses. Each includes *everything* to give you the *working* knowledge required of successful technicians.

NTS Project-Method Training is the *practical* way to learn elec-

tronics. It's a proven combination of lessons and the best professional kit equipment available. NTS provides the *biggest selection of kits ever offered in home-study . . . all at no extra cost*. You'll construct these exciting kits to fully understand electronic circuits, components, and concepts. Our Project-Method lets you build skills by putting theory into practice . . . by working with your hands, as well as your head.

The NTS "learn and practice" approach makes training at home really easy. All it takes is a few hours a week . . . whether you're starting from scratch or in advanced courses. This is the all-inclusive success package that put thousands of men into the best paying jobs . . . or into their own business. If "just a living" isn't good enough for you, now is the time to get something better going for you!

NTS COMPUTER ELECTRONICS

This is the future. And it's happening now. The number of computers will *increase many times* in the next few years.



Exclusive new Compu-Trainer®

NTS offers a solid grounding in computer operation, wiring, data processing and programming. One of the 10 important kits included is our exclusive Compu-Trainer®. It's a fully operational computer logic trainer — loaded with integrated circuits — the first ever offered in home study. It introduces you quickly to how, what, when and why of computers . . . from theory to practical servicing techniques. This unit is capable of performing 50,000 operations per second. And it's sent at no extra cost.

NTS COLOR TV SERVICING

This is a broad, easily understood

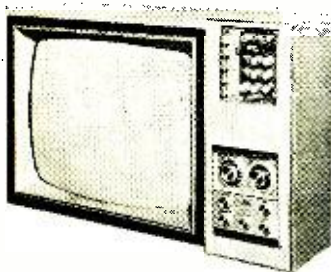

COLOR TV 295 SQ. IN. PICTURE

program designed to make you a complete home-entertainment service technician. Included, at no extra cost, is a color TV that has more features than any

set on the market. You also learn all about stereo, hi-fi, multiplex systems, and become a specialist in Color TV Servicing. Kits also include AM-SW radio, solid-state radio, field-effect transistor volt-ohmmeter, electronic tube tester.

NTS AUTOMATION/ INDUSTRIAL ELECTRONICS

You're trained in the "push-button" electronics that keep industry going and growing . . . from relay type controls to highly advanced systems essential to production. You receive 16 kits including a 5" wide band oscilloscope, and the new NTS electronics lab: a fascinating NTS exclusive experimental laboratory. A complete workshop which makes you familiar with solid-state, miniature, and integrated circuits.

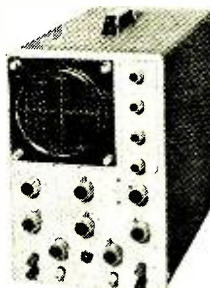

5"
Oscilloscope

NTS ELECTRONIC COMMUNICATIONS

The use of 2-way radio systems in private and commercial applications is skyrocketing. NTS prepares you for the big-money opportunities in the field of transmitting and receiving equipment. *Your tuition will be refunded in full if you cannot pass the FCC exam for a 1st Class Commercial Radio-Telephone License within*

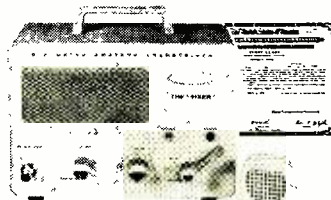

5 Watt AM Transmitter & Receiver

six months after successfully completing this course. You build valuable kits including Amateur-Phone 6 Meter VHF Transceiver, solid-state Radio, and a field-effect transistor volt-ohmmeter.

CLASSROOM TRAINING AT LOS ANGELES

You can take classroom training at Los Angeles in sunny Southern California. NTS occupies a city block with over a million dollars in facilities devoted exclusively to technical training. Check box in coupon.

NATIONAL TECHNICAL SCHOOLS

World-Wide Training Since 1905
4000 South Figueroa Street
Los Angeles, Calif. 90037, U.S.A.

APPROVED FOR VETERANS

Accredited Member: National Association of Trade and Technical Schools, National Home Study Council.

**TODAY, MAIL
COUPON
FOR FREE
COLOR
CATALOG
AND SAMPLE
LESSON.**

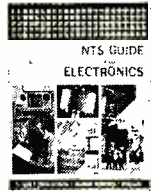

NATIONAL TECHNICAL SCHOOLS
4000 S. Figueroa St., Los Angeles, Calif. 90037

Please rush Free Color Catalog and Sample Lesson, plus information on field checked below. No obligation. No salesman will call.

- MASTER COURSE IN COLOR TV SERVICING
- COLOR TV SERVICING
- MASTER COURSE IN TV & RADIO SERVICING
- PRACTICAL TV & RADIO SERVICING
- MASTER COURSE IN ELECTRONIC COMMUNICATIONS
- FCC LICENSE COURSE
- MASTER COURSE IN ELECTRONICS TECHNOLOGY
- INDUSTRIAL AND AUTOMATION ELECTRONICS
- COMPUTER ELECTRONICS
- BASIC ELECTRONICS

Name _____ Age _____

Address _____

City _____ State _____ Zip _____

- Check if interested in Veteran Training under new G.I. BILL.
- Check if interested ONLY in Classroom Training at Los Angeles. Dept. 205-119



NEW PRODUCTS

Additional information on products covered in this section is available from the manufacturers. Each new product is identified by a code number. To obtain further details on any of them, simply fill in and mail the coupon on page 15.

CURVE-TRACER INSTRUMENT FOR SCOPES

The new *EICO* Model 443 transistor-diode curve tracer makes possible direct readout of semiconductor characteristics on a general-purpose oscilloscope. Diodes, rectifiers, and power signal transistors are tested with this versatile instrument. Diode and rectifier characteristics that can be displayed include forward voltage, forward current, reverse current, and peak inverse voltage. Transistor tests include those most commonly available with lab-type instruments of this nature. A special matching switch allows comparison and matching of sets of transistors. The Model 443 has solid-state, printed-circuit board construction; dual transformers for isolation and safety; flashing light that indicates when high voltage is on the diode test terminals; built-in oscilloscope voltage calibrators; and terminals for connecting external test sockets.



Circle No. 78 on Reader Service Page 15

DUAL-PURPOSE TAPE ERASER

The *Audiotex* Model 30-140 is a dual-purpose magnetic tape eraser designed for hand-held and table-top use. It accommodates both open reel and cassette tapes. As a table model, the 30-140 is the only tape eraser available with a reel post. Hand-held, it is passed over the tape reel in a circular motion. A momentary-action switch and cord are included.



Circle No. 79 on Reader Service Page 15

ULTRASONIC CLEANER

An ultrasonic cleaner with a 5"-square by 3" deep tank is currently being offered by *Esterline Angus* as the Model EA 12. The tank size is ideal for cleaning inking components for pen recorders, precision parts, electronic components, optical equipment, lab glassware, surgical and dental instruments, jewelry, and other items. The cleaner can be

operated with common household detergents or with solvent cleaners such as Dow Chemical chlorothene nu or Dupont Freon T-WD. Cleaning power is 50 watts.

Circle No. 80 on Reader Service Page 15

SOLID-STATE AM/FM STEREO RECEIVER

Professional features not often found in economy-priced receivers are standard with the *Kenwood* KR-77 solid-state AM/stereo FM receiver. The KR-77's FM tuner, for example, incorporates two FET's, a four-gang tuning capacitor, and two IC FM i.f. stages which combine to offer a 1.9- μ V sensitivity, 45-dB selectivity (alternate channel), and a capture ratio of 2.5 dB. The KR-77 permits full amplifier flexibility, with left and right channel preamplifier outputs and corresponding power amplifier inputs to permit separate operation of any amplifier and to make possible simple connection of a multi-channel system. The most often used receiver functions—interstation muting, low and high filter circuits, and loudness control—are available via handy center-panel keyboard switches. Front panel jacks provide easy access for dubbing/tape record and stereo headphones.



Circle No. 81 on Reader Service Page 15

UHF/FM MONITOR RECEIVER

The "Reporter" six-channel monitor receiver made by *Unimetrics, Inc.*, is now available in a UHF/FM ultra-high-band model. Called the "UHF/FM Reporter," its frequency ranges include any six crystal-controlled FM channels in the ranges 450-455 MHz, 455-460 MHz, 460-465 MHz, and 465-470 MHz. The 20-transistor/8-diode circuit is designed for extremely low battery drain and miniature size (only 8" x 6" x 2" for the overall receiver). The dual-conversion receiver is ruggedly built to permit heavy-duty use in truck, car, home, boat, or office. Optional accessories include a 117-volt a.c. power supply, external speaker jack provision, and "UNITONE" encoders and decoders.



Circle No. 82 on Reader Service Page 15

AUTOMATIC TURNTABLE

The first new Dual record changer to be introduced in four years by *United Audio Products, Inc.*, is the Model 1219. The Dual 1219 features a 12" platter and 8 $\frac{3}{4}$ " tone arm, and a number of design and operating features unique to automatic turntables. A mode selector shifts the tone arm base down for playing one record and shifts it up for playing a stack (the tone arm is parallel to the record in single play, shifted to parallel the center of the stack in multi-play). A four-point gyro-



Which of these comparably priced, top quality speakers offer you Electronic Suspension?

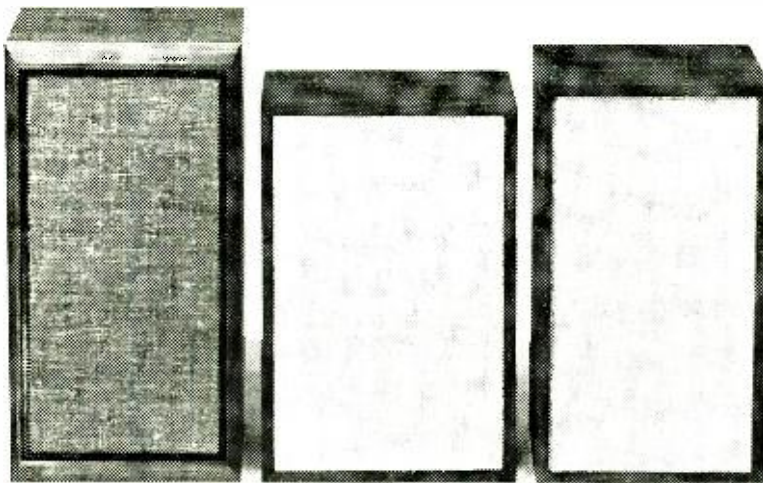

KLH FIVE
in oiled walnut

LWE III
in oiled walnut

AR 5
in oiled walnut

Only LWE.

LWE introduces a whole new era in speaker design. No longer must a speaker depend on porting, or reflex, or resonance, or baffles, or sand, or weighted cones, or cabinet size, shape or design. LWE's newly patented (March 1969) Electronic Suspension speakers actively eliminate reproduction distortion by electrical commands to the amplifier. The result is remarkable and unrivaled fidelity. □ LWE research has uniquely applied the principle of inverse — or negative — feedback to control the speaker cone electronically at all times. This produces greatly improved transient response, virtual elimination of speaker distortion, and extension of low frequency response. In short, LWE out-performs any conventional speaker on the market today — regardless of size or price. Hear LWE for yourself. And for more detailed information write for our Sound of Excellence brochure. Our prices range from \$60 to \$469. LWE Electronic Suspension has arrived, and you've never heard it so good.



The Sound of Excellence

LWE is a division of

ACOUSTRON CORPORATION

2418 Bartlett / Houston, Texas 77006 / (713) 524-7407

CIRCLE NO. 17 ON READER SERVICE PAGE

PRODUCTS (Continued from page 22)

scopic ring-in-ring gimbal suspension, a new motor designed for high starting torque, a synchronous element that locks running speed into line frequency, and a pitch control which allows each speed to be varied up to 6% are standard items. Also, an extra degree of precision has been incorporated into the anti-skate system, and separate scales for each stylus type are provided.

Circle No. 83 on Reader Service Page 15

3" FIELD SERVICE OSCILLOSCOPE

The Model LBO-31M oscilloscope has been designed by *Leader Instruments Corp.* for field use in addition to multi-channel monitoring applications in the laboratory. The chassis is narrow, measuring only 4" in width, to allow many scopes to be placed side by side for maximum density and to occupy minimum space on the home work bench. The bandwidth of 1 MHz makes the LBO-31M suitable for use in the video-frequency region. Technical specifications—vertical axis: 80 mV peak-to-peak/cm at 1 kHz sensitivity and -3 dB, 3



Hz to 1 MHz frequency response; horizontal axis—2.5 volts peak-to-peak/cm sensitivity, 10 Hz to 400 kHz sweep frequency, and -3 dB, 3 Hz to 400 kHz frequency response. The scope requires a 105-125-volt a.c., 50-60-Hz power input and consumes only 40 VA of power. Overall dimensions and weight are 12" X 7" X 4" and 11 lbs.

Circle No. 84 on Reader Service Page 15

CASSETTE TAPE DECK

"Techno-Built" precision tape heads, a hysteresis synchronous drive motor, and an illuminated dual-level indicator are features of the *TEAC Corp. of America* Model A-20U stereo cassette deck. The A-20 also has easy pushbutton loading and unloading, separate input and output controls for each channel, and a unidirectional microphone. Standard deck items include an editing control, headphone monitoring jack, and three-digit reset counter. Technical specifications—Wow and flutter: 0.2% or less; signal-to-noise ratio: 45 dB or better; frequency range: 60-10,000 Hz; 0.3-mV for 500-ohm microphone and 0.5-volt for 120,000-ohm line inputs; 0.5-volt for 50,000-ohm line and 0.1-mW for 8-ohm headphone outputs.



Circle No. 85 on Reader Service Page 15

ANTENNA TRIPODS

Three new gold tripods to facilitate home antenna installation are available from *GC Elec-*

tronics in 2', 3', and 5' sizes. Each of the tripods has an attractive gold baked-enamel finish and is supplied with six lag screws and three tar patches for sealing and mounting holes. The 3' and 5' towers have heavy-duty 1¼"-diameter legs and a tilt-up feature to facilitate antenna installation.

Circle No. 86 on Reader Service Page 15

HIGH-POWER AM/STEREO FM RECEIVER

Instant-acting electronic protection circuits and an electronically regulated power supply are two of the many features available in the new *H.H. Scott, Inc.*, Model 386 AM/stereo FM receiver. The i.f. section employs a crystal



lattice filter that eliminates the need for periodic alignment. An IC in the AM front end features pre-tuned multipole filter for optimum AM fidelity, while another IC in the multiplex section provides greater reliability and a 40-dB stereo separation. Technical specifications—continuous output power: 42 watts/channel at 4 ohms, 35 watts/channel at 8 ohms; selectivity: 40 dB; frequency response: 20-20,000 Hz, ± 1 dB, hum and noise: -65 dB; crossmodulation rejection: 80 dB; usable sensitivity: 1.9 μ V; tuner stereo separation: 40 dB; capture ratio: 2.5 dB; signal-to-noise ratio: 65 dB; phono sensitivity: 3.6 mV.

Circle No. 87 on Reader Service Page 15

SUPER-POWER INSTRUMENT LOUDSPEAKER

There is no truth stretching when *Jensen Sound Products* claims that their new Model SMI-285 Lifetime Guaranteed Electronic Musical Instrument Loudspeaker is "Super" high power. Rated at 250 watts, the new 18" speaker features a massive 12½-lb. magnetic structure, using a highly efficient 3¼-lb. DP-Alnico-5 magnet to provide all that power. A precision-wound 4" voice coil is fabricated on a special high-power bobbin. A large aluminum dome provides perfect balance and crisp, clean highs. Solid brass notes are achieved with a laminated, reinforced, flexible edge suspension, and the rugged cast construction of the housing maintains precision line-up and protects against damage from rough handling.



Circle No. 88 on Reader Service Page 15

NEW CONCEPT COMMUNICATIONS RECEIVER

The Mark '6' Scan-O-Matic made by *Sonic Industries, Inc.*, represents the newest concept in communications receivers today. The Mark 6 is much like any other well-designed basic receiver capable of monitoring police, fire, and other public service transmissions. It can monitor up to six crystal-controlled channels. But "Scan-O-Matic" is what sets the Mark 6 off from all other receivers. This special fea-

(Continued on page 118)

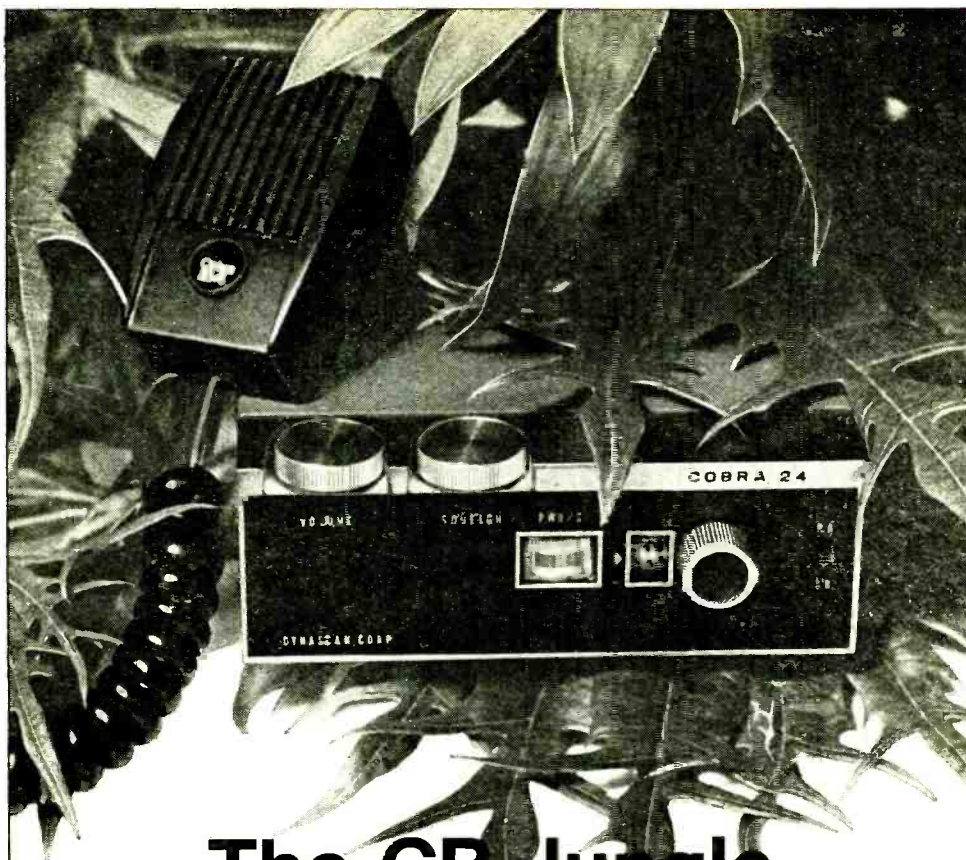

The CB Jungle is suddenly still...

There's a new Cobra Lurking!

The new Cobra 24: with more power, intelligence, and beauty than any of the others in its class!

The Cobra 24 preys on the others' weaknesses. With *more talk power*—a full, legal-limit 5-watt input and exclusive Dynascan DYNA-BOOST Speech Compression. And a selective dual-conversion superhet receiver with ceramic filter to give outstanding selectivity and gain.

And *more intelligence*—it always gets the message through crisp and sharp, even when others are garbled and unclear. Crystal-controlled transmit and receive on all 23 channels. (No extra crystals to buy!)

And *more beauty*—a striking, no-nonsense exterior. Designed for attack...with a push-to-talk mike, automatic noise limiter,

and positive or negative ground operation without internal wiring changes, featuring reverse polarity protection. There's a PA/CB switch with adjustable volume. And the illuminated channel selector and "S" meter makes even night transmission easy. Beautiful, with all silicon transistor, F.E.T. and integrated circuit. It uses 12 volt DC; AC adapter available. Meets FCC requirements. It even comes with its own mounting bracket.

See your dealer or write us for full details.



Cobra 24 Net \$169.95.

Product of DYNASCAN CORPORATION
1801 W. Belle Plaine, Chicago, Illinois 60613

CIRCLE NO. 7 ON READER SERVICE PAGE

IF YOU WANT A CAREER IN ELECTRONICS, DO IT THE RIGHT WAY. GO TECHNIPAC.TM

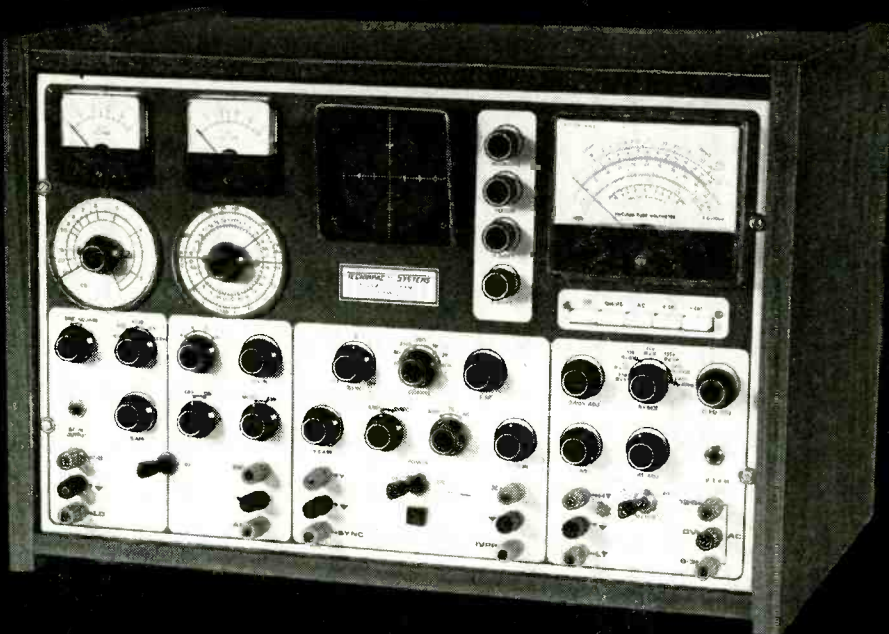

With the TECHNIPACTM System, you conduct over 400 experiments and build the TECMARK IITM which contains a power supply, an oscilloscope, a vacuum tube voltmeter, an audio generator and an R.F. generator. This instrument console will be of constant use to you throughout your career as an electronics technician.

Here's a truly unique electronics training program. It combines the theory and practical application of Electronics in a simple, logical and effective manner. We call it the TECHNIPAC System.

The TECHNIPAC System is new to you, but it's the result of 30 years experience training people in technical fields. And, it isn't all study, either. It also includes more than 400 actual experiments and the assembly of a first-class testing console, the TECMARK II™ shown here.

It doesn't matter whether you're a beginner or have some electronics experience, we've designed the TECHNIPAC System to meet your individual needs. There's no contract for you to sign, either, for each of 26 separate TECHNIPACS is sent to you only when you're ready for it.

Write for the free brochure, "ELECTRONICS, TECHNIPAC AND YOU" today.

(TTI™ is approved by the Accrediting Commission of the National Home Study Council)

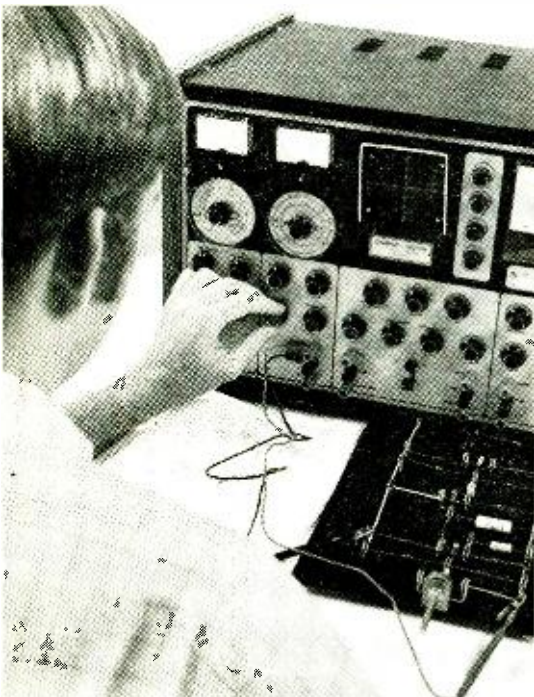

Technical Training International™

203 Lincoln Broadway Building
1475 North Broadway
Walnut Creek, California 94596

Please send me the free brochure,
"ELECTRONICS, TECHNIPAC™ and you."

Name: _____ Age: _____

Street: _____

City: _____

State: _____ Zip: _____

104

CIRCLE NO. 38 ON READER SERVICE PAGE

Heavyweight solder guns were hot news 30 years ago.

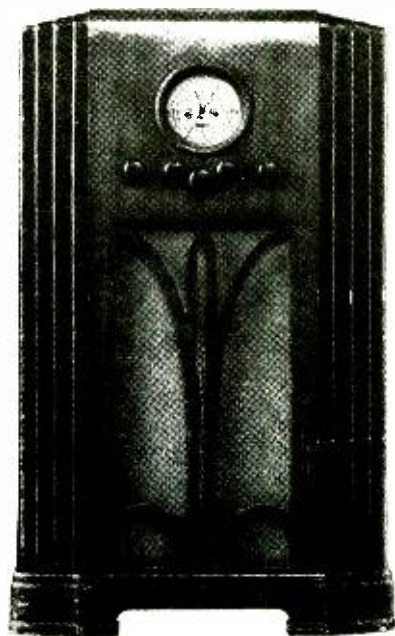

Now for a look at today's lighter news...

a featherlight solder gun for the delicate, dense micro-circuitry of the '70's. The new Ungar Solid State Solder Gun. Under five ounces. No dead-weight transformer.

To assure you damage-free soldering of IC's and FET's, the tip is "electrically-isolated"—no current leakage.

And, three different interchangeable micro-tips are included. You simply thread them on and off—no need to remove or replace heat cartridge. At a flip of the dual-heat selector switch, you have your choice of a safe 500° or 900°F tip temperature range.

So drop the heavy artillery. Ungar's got the solder gun (#6760) for the solid state age. Fast. Safe. Economical. Under 5 oz.

Call your nearest Ungar distributor or dealer now.

Or write directly for information.



WEIGHS LESS THAN 5 OZ.



Division of Eldon Industries, Inc., Dept. C2-1
Compton, California 90220

IN THE AGE OF SOLID STATE, UNGAR OUTGUNS THE HEAVYWEIGHTS.
CIRCLE NO. 40 ON READER SERVICE PAGE

Strange Power of AIR IONS

THE NEGATIVE IONS ARE THE GOOD GUYS—
POSITIVE IONS THE BAD

BY HOWARD F. BURGESS

IN THE 1700's the naive and superstitious believed that "air electricity" could influence both mind and body. A crime committed when a strong dry wind was blowing was believed to be caused by the wind, and some judges in Europe were more lenient during these windy seasons.

Yesterday's fantasy is today's scientific fact. The most exciting research programs develop when an old superstition is found to have some scientific truth. Many, such as the riddle of "air electricity," are being put together one bit at a time. Like a jig-saw picture puzzle some pieces fall into place. Others which can be recognized as part of the picture must wait on a piece that is still missing.

Although there are still some important bits to find, the picture of "air electricity" is becoming clear. We now know beyond a doubt that it can do much to control the mind and body of man. It may be the secret of controlling disease.

In 1921 Frederick Dessauer, of Germany, recognized enough pieces of the puzzle to make a start and by 1931 a picture was beginning to take shape from the data he had been able to collect. He was convinced that "air electricity" was charged air particles which surround us at all times. He had also found that if the negative particles exceed the positive particles, a condition was created which was beneficial to both mind and body. Harmful effects were

found when the positive particles exceeded the negative.

Since the early work of Dessauer, many men and many laboratories have added bits to the picture. Researchers have found that air electricity is really air ionization and the results depend upon whether the majority of the ions are positive or negative in polarity. The negative ions are the good guys and the positive ions seem to be the bad guys.

What is an ion? "Ion" is a short name for a very small piece of matter. Ions are usually measured in millimicrons which are one thousandth of one millionth of a meter. Although small, the physics involved is quite complicated. However, for present purposes the explanation can be quite simple.

An ion is a molecule or group of molecules that has become electrically charged as a result of gaining or losing an electron. A "negative ion" is one which has gained an electron. A "positive ion" is one which has lost an electron. Ions are created in many ways. Any force which can dislodge an electron from an uncharged molecule will create two ions. The molecule which loses the electron becomes a positive ion and the molecule which picks up the wandering electron becomes a negative ion. When ions of opposite polarity collide, another exchange takes place and they are neutralized.

Nature is an endless source of ions. Energy from outer space such as X-rays, ultraviolet, and cosmic rays create ions. Radioactive material in the soil also contributes to the supply. Other natural events such as thunder storms, rain and snow add their effect. Even the wind and the moon have their part in the story.

Air is composed of several gases including oxygen, nitrogen, carbon dioxide and others in lesser amounts. Air also carries varying amounts of pollution in the form of microscopic particles of anything that man can dump into the atmosphere. Water vapor also has a major part in air ionization.

Air ions seldom consist of just one gas molecule. An ion generally consists of a cluster of gas molecules which are sometimes grouped around a water particle or air pollution material. These clusters are classified according to size. Small ions may consist of 3 to 8 molecules and are capable of rapid movement. They are somewhat important for their effect on man. The intermediate sized ions may have several hundred molecules. They move slower than the small ions, and have the greatest effect on living things. Ions classed as large may contain several thousand molecules. They move very slowly and are generally related to air pollution.

For research work ions of the small and intermediate size are desired. These can be generated artificially in several ways. Radioactive sources are very good ion generators but are difficult for the ordinary experimenter to obtain. Ions can also be generated by use of a high voltage applied between special electrodes. Another source is a simple electric heating element at higher than normal temperature. Generators usually require some type of electric filter to remove ions of the unwanted polarity.

Ions are disappointingly short-lived. After generation they will travel only a short distance before being neutralized by another particle.

Ion Effects. Many events generally accepted without an explanation are the results of natural ions. The oppressive feeling before a thunder storm that is felt by both men and animals is due to the predominance of positive ions ahead of

a storm. The oppression may take the form of headaches, rheumatism or respiratory attacks. The fresh, wonderful feeling that follows a storm comes from the high level of negative ions that follows a storm front. A misty rain of small droplets usually raises the positive level while a shower of large drops brings up the negative count.

The strong dry winds which occur in some areas will bring up the positive count and may have a marked effect on the temperament of both man and beast. Tests have shown that in areas that have long been noted as health resorts, the ion count many times runs predominantly negative.

In a recent news broadcast from *Radio Moscow*, Doctor G. Tsitsishvili of the Sanitary and Hygienic Institute stated that it has been determined that the higher you live (above sea level), the longer you live. Although no mention was made of ions, the findings of the doctor are interesting. American researchers have found that the number of negative ions increases with altitude.

As in other things, man alters the level and polarity of ions. Ions produced by nature are generally of the small or intermediate size and are found in clean air. But, air pollution is a factor in generating large ions. Large ions are found in urban areas or where there is air contamination. They are slow in movement. Because they are large and slow, they absorb the smaller but faster ions that collide with them and so reduce any possibility of negative ionization.

Research in air conditioning has shown that ions in an unoccupied room with open windows will be very similar to that outside. If the windows are closed, ion level of both polarities will decrease somewhat. As people begin to occupy the room the number of large ions increases and small and intermediate ions will continue to decrease. The comfort factor will decrease as the number of large ions increase. Forced ventilation through duct work will decrease the ion density but will increase the unbalance in favor of the positive ions. It has been shown that air in close quarters can be kept at the correct temperature and humidity but the occupants will still be quite uncomfortable and distressed if the number of

(Continued on page 114)

MAKE YOUR OWN ION CHAMBER

*Detect and Measure
Air Ionization Polarity*

BY HOWARD BURGESS

USEFUL and interesting information can be gained about the effects of air ionization by making measurements under various conditions. A commercial instrument capable of doing this is expensive and delicate but a simple unit can be built which will indicate the polarity and relative amount of ionization present where larger changes are involved.

A home-built ion chamber is used to detect the ions of the polarity which we wish to count. The collected charges are then routed to the grid of an electrometer tube. This tube is a vacuum tube capable of sensing currents far smaller than those which can be detected by an ordinary tube. Currents in this type of instrument can be less than one millionth of a microampere.

The tube was chosen in preference to a field effect transistor because it can take more abuse from the high voltages which may be encountered in this type or work. Luckily the electrometer tube requires only a modest plate voltage. The output of the tube is quite low and requires amplification (transistors *Q1* and *Q2*) to operate the meter, *M1*.

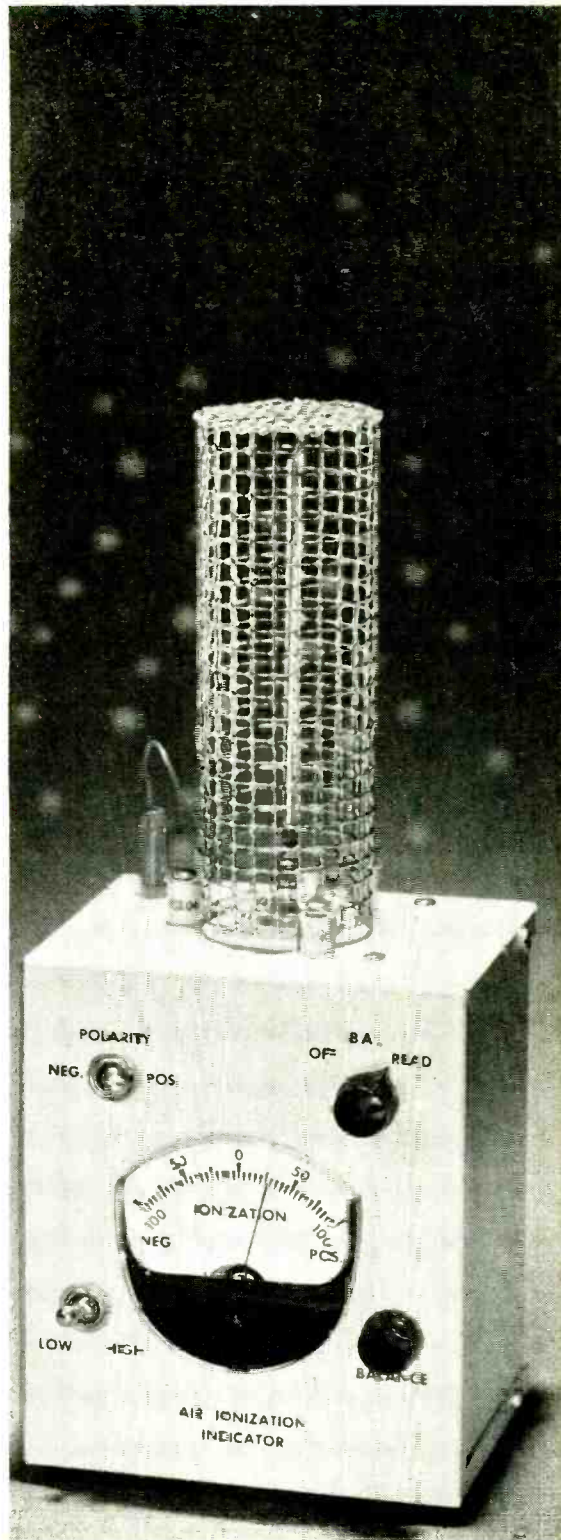

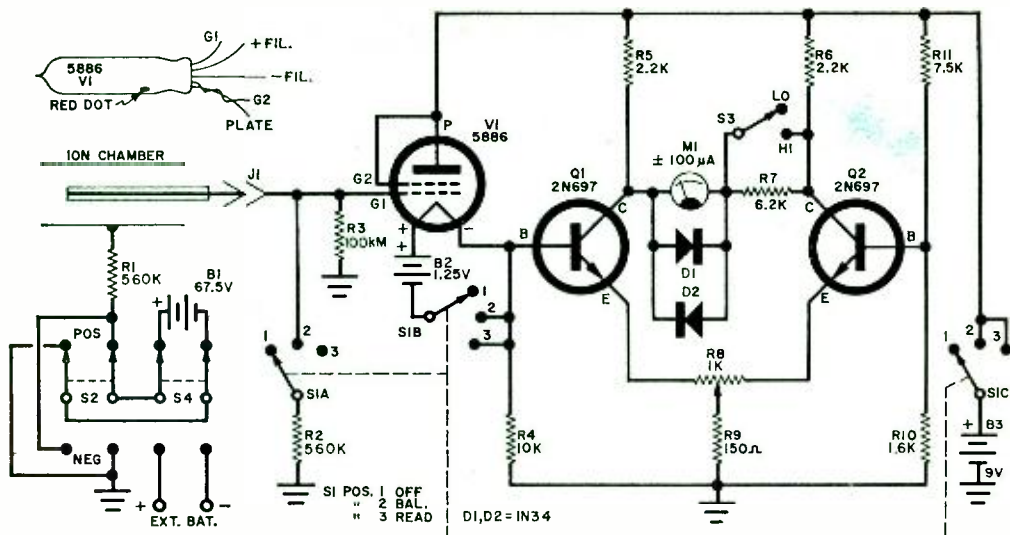

Ions detected by the ion chamber develop a small voltage drop across the very high resistance of R3. This voltage is amplified and operates a transistorized bridge. Sensitivity depends on the value of R3 which must be extremely high to make the circuit effective.

PARTS LIST

- B1—67½-volt B battery
- B2—1.25-volt mercury cell (Mallory RM12R)
- B3—9-volt transistor battery
- D1, D2—1N34 diode
- M1—100-0-100-microampere meter
- Q1, Q2—2N697 transistor
- R1, R2—560,000-ohm
- R3—100,000-ohm
- R4—10,000-ohm
- R5, R6—2200-ohm
- R7—6200-ohm
- R8—150-ohm
- R9—1600-ohm
- R10—7500-ohm
- R11—7500-ohm

} all resistors
½-watt

- R3—100,000-megohm resistor* (see text)
- R8—1000-ohm, wirewound potentiometer
- S1—3-pole, 3-position ceramic switch
- S3—S.p.s.t. toggle switch
- S2, S4—D.p.d.t. toggle switch
- V1—5886 electrometer tube (Allied No. 5886 50P2)

Misc.—Phone tip packs (4), standoff insulator (3), 1" x 3" terminal strip, battery holders, 4" x 5" x 6" utility box, knobs, hardware, etc.
*Victoreen Instrument Div., 10101 Woodland Ave., Cleveland, Ohio 44104.

Construction. The unit is housed in a 4" x 5" x 6" aluminum box and construction is quite simple. The small parts are mounted on a 1" x 3" terminal board as in the photo. Switch S1 must be of high quality ceramic. The variable resistor R8 can be a standard wirewound potentiometer; however a vernier or 10-turn potentiometer makes for easier adjustment if you are lucky enough to have one. The only unusual items are the 5886 electrometer tube (V1) and its grid resistor (R3) which has a value of 100,000 megohms. Both items are made by the Victoreen Company and are available from sources shown in the Parts List.

The tube must be covered to protect it from light while it is in operation or the photoelectric effect of light falling on the elements can upset the operation of the sensitive circuit. Only the best of in-

HOW IT WORKS

The ion chamber consists of an outer electrode which is in the form of a screen cage through which air can flow. The inner electrode is a rod in the center of the cage. If a polarizing voltage is connected with the negative to the cage and the positive to the rod, negative ions are attracted to the rod. This produces a voltage across resistor R3. The value of the voltage depends on the number of ions present. This voltage is sensed by the electrometer tube V1 which activates the meter drive circuit. The meter is driven by transistors Q1 and Q2 in a balanced bridge circuit. The zero-center meter will read to right or left depending on whether the charge is positive or negative.

If the polarizing voltage is reversed to the screen cage the center rod will collect positive ions and the meter will read to the right to indicate the level of positive ionization.

The sensitivity of the meter can be reduced by S3 when high field strengths are encountered. The number of ions collected depends somewhat upon the value of polarizing voltage applied to the chamber. For personnel safety reasons the voltage should be kept below 250 volts.

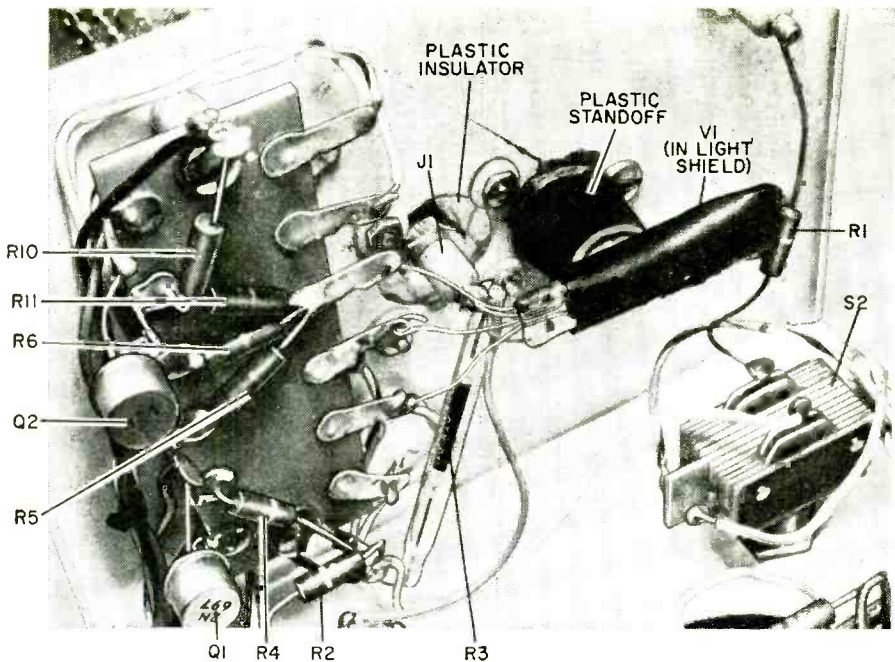

Component installation. Because the presence of light greatly reduces the electrometer tube sensitivity, it must be enclosed in an opaque tape housing. It mounts on a standoff.

Insulation should be used in the grid circuit of the 5886 if full sensitivity is to be obtained. After assembly, all insulation in the grid circuit should be cleaned with alcohol to remove any oils or moisture left by the fingers.

The ion chamber, which is mounted on top of the case, consists of an outer electrode which resembles a small cage 6"

high and 2" in diameter. It is constructed of 1/4" wire netting as shown in the photos. The bottom is open and is insulated from the metal case by three ceramic insulators. The polarizing voltage of 67½ volts supplied by the battery mounted in the case will be sufficient for most work. For experimental work where higher voltage is required, provision has

Switch S2 reverses the polarity of the ion chamber voltage. Resistor R1 is a safety resistor to reduce current flow in case of accidental short between cage and case.

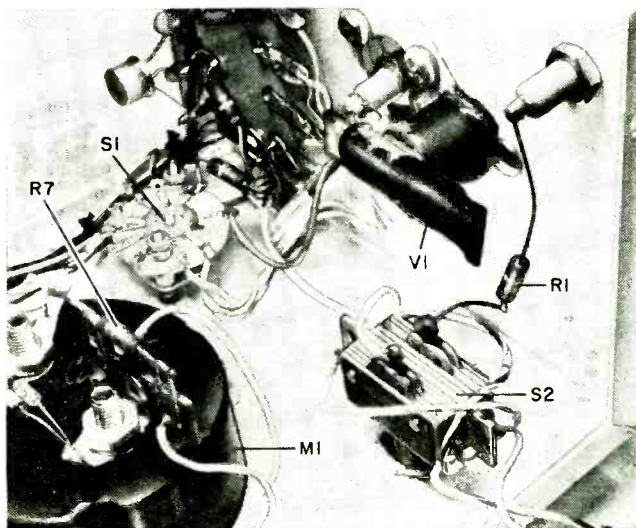

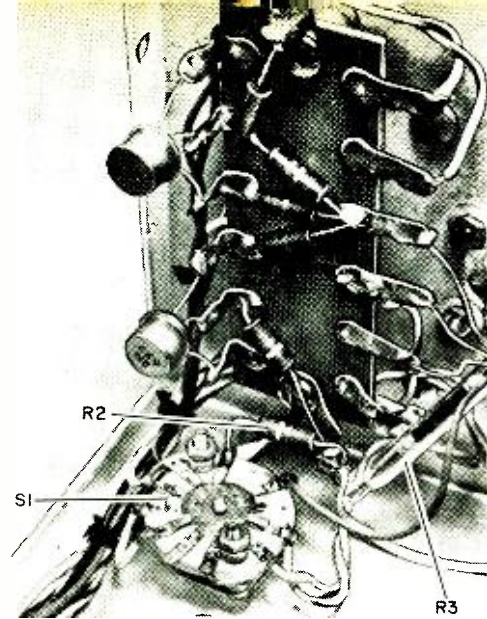

Function switch S1 is located near the electronics board. Use a high-quality ceramic switch to prevent leakage around the very high value of resistor R3.

been made to switch to an outside source which can be connected to terminals on the rear of the case.

The cage is electrically above ground by the amount of the polarizing voltage. Resistor R1 has been placed in the circuit to prevent serious shock in case the cage is touched. Voltage to the cage can be removed by the switch in the rear.

The inner conductor of the chamber is a rod or wire $\frac{1}{16}$ " in diameter and five inches long. A phone tip is mounted on one end of the rod and plugs into a tip jack. This makes for easy removal for experiments with other types of chambers. The tip jack should be mounted on insulating material of the best quality with a long leakage path. Do not depend on the insulation supplied on the tip jack; cut out a square of quality plastic as shown.

The 10,000-megohm resistor R3 is expensive. To make a substitute, use a ceramic-body r.f. choke, about $1\frac{1}{2}$ " to 2" long, with a pigtail at each end. Remove the coil and clean the form thoroughly. Draw a line of Higgins india ink about $\frac{3}{16}$ " wide between the pigtails. Allow the ink to dry completely and never handle the form so as to touch the ink line or otherwise introduce body oils that might reduce the resistance. You may also use a narrow piece of PC board by drilling

a small hole close to each end. Then wrap copper wires through each hole, leaving short lengths to make connections. Solder the wire wraps and draw an india ink line between the two solder joints.

Adjustment and Operation. When the construction is finished and checked, place S1 in the OFF position and S3 in the LOW position and install the batteries. When S1 is moved to the BAL position, the unit becomes operational but with greatly reduced sensitivity. The meter should now be adjusted to center zero. If the meter does not adjust to zero with R8 near the center of its range, the value of R10 should be changed to balance the currents of the two transistors. The value of R10 can be raised or lowered a small amount as required.

When the meter zeroes near the mid-range of R8 and all appears well, put S1 in the READ position and close S3 by placing it on HIGH. Several seconds may be required for the meter to stabilize. If S2 is in the POS position, the meter will read to the right for any positive charge. Now place S1 in BAL and reverse S2. Return S1 to READ and read the negative charge. Under normal conditions the readings will be small and nearly equal.

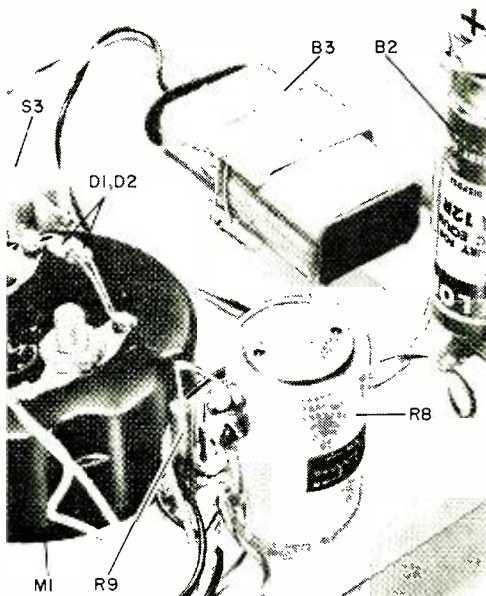

Standard potentiometer may be used for R8 instead of 10-turn unit. Diodes mount on meter terminals.

The cage is mounted on three ceramic spacers around the perimeter and is connected via an insulated lead to resistor R1.

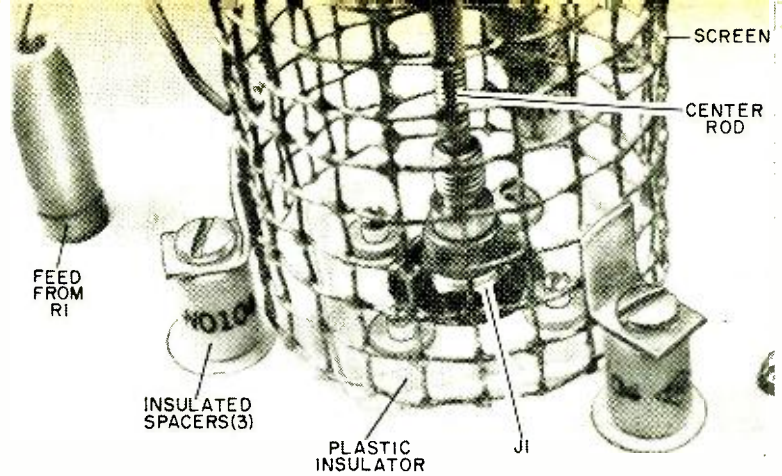

Never change S2 except when S1 is in the BAL position.

If a lighted match is brought close to the chamber the results of ionization will be seen. Tobacco smoke blown into the chamber will also indicate ionized particles. If an ultraviolet lamp is available, turn it on the chamber and observe the results.

A small slow-moving fan is useful to force air through the chamber. A fan which stirs the air too violently or which has arcing brushes can generate ions of its own which can make measurements meaningless.

An interesting test can be made on electric heaters. Many heaters generate positive ions and the side effects that go with them. One electric hair dryer tested was capable of pushing the meter off scale from as far away as six feet. The use of such heaters will probably not cause any violent side effects but they have been known to cause drowsiness, fatigue and headaches. Long periods of continued use could be damaging to the general health. Heaters which are rich in ions usually have heating elements which glow brightly.

It has been found that metal duct work in some air conditioning systems creates a positive ion condition by attracting negative ions to the duct walls and leaving an excess of positive ions. The result can be minor respiratory troubles.

If the meter is placed near an automobile exhaust in a position which will allow the gases to reach the ion chamber large values can be read. In this case both positive and negative ions will

be indicated. These will re-combine in a short time under normal conditions.

Radioactive material will also register on the meter. As an auxiliary use the meter can be used to measure or monitor radioactive conditions or fallout. Other types of chambers may be constructed for use in this field.

If the instrument is operating properly it will be sensitive enough to register movements of your body several feet away. This is a static charge on the body and not ionization. This effect can be reduced somewhat by connecting the meter case to a good ground.

Although this little meter is not as versatile as the sophisticated laboratory models, it will make many interesting measurements and it will introduce you to the fundamentals of what may prove to be one of the secrets of life itself. -30-

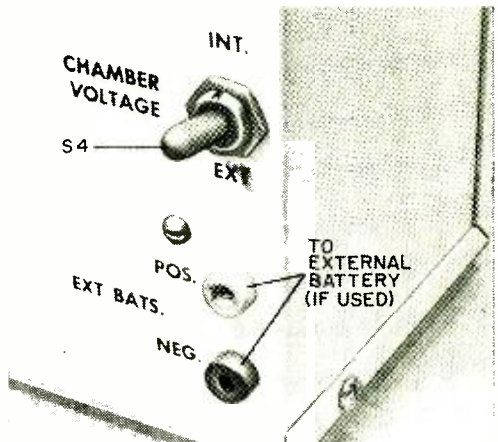

Switch S4 is used if it is desired to use a higher voltage for the ion chamber for more sensitivity.

**“Get more
education
or
get out of
electronics
...that’s my advice.”**

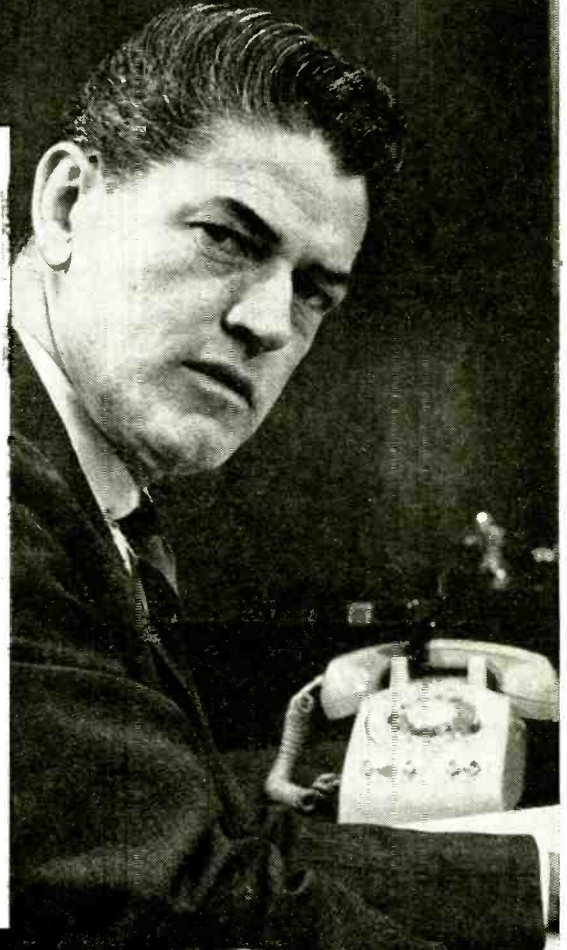

NEW!

Expanded
coverage of
solid state
electronics
including
integrated
circuits!



Ask any man who really knows the electronics industry.

Opportunities are few for men without advanced technical education. If you stay on that level, you'll never make much money. And you'll be among the first to go in a layoff.

But, if you supplement your experience with more education in electronics, you can become a specialist. You'll enjoy good income and excellent security. You won't have to worry about automation or advances in technology putting you out of a job.

How can you get the additional education you must have to protect your future—and the future of those who depend on you? Going back to school isn't easy for a man with a job and family obligations.

CREI Home Study Programs offer you a practical way to get more education without going back to school. You study at home, at your own pace, on your own schedule. And you study with the assurance that what you learn can be applied on the job immediately to make you worth more money to your employer.

You're eligible for a CREI Program if you work in electronics and have a high school education. Our FREE book gives complete information. Mail postpaid card for your copy. If card is detached, use coupon below or write: CREI, Dept. 1211H, 3224 Sixteenth Street, N.W., Washington, D.C. 20010.

Founded 1927



Accredited Member of the National Home Study Council



**CREI, Home Study Division
McGraw-Hill Book Company
Dept. 1211H, 3224 Sixteenth Street, N.W.
Washington, D.C. 20010**

Please send me FREE book describing CREI Programs. I am employed in electronics and have a high school education.

NAME _____ AGE _____

ADDRESS _____

CITY _____ STATE _____ ZIP CODE _____

EMPLOYED BY _____

TYPE OF PRESENT WORK _____ G.I. BILL

I am interested in

- Electronic Engineering Technology Computers
- Space Electronics Nuclear Engineering Technology
- NEW!** Digital Communications **NEW!** Industrial Automation

APPROVED FOR TRAINING UNDER NEW G.I. BILL

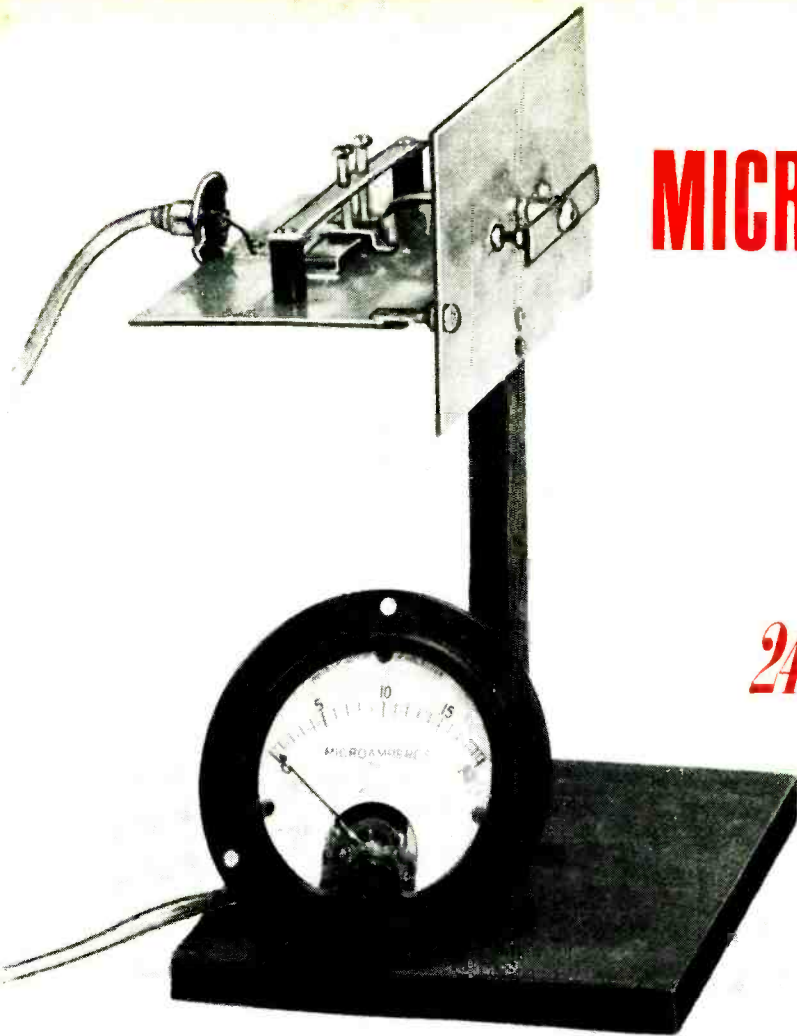

MICROWAVES FOR

Experiments with a 2400-MHz System

AS AN ELECTRONICS hobbyist or ham operator, you have probably built or experimented with receivers and transmitters in all of the usual frequency ranges—up to the top of the 450-MHz ham band. Isn't it about time you tried microwaves? In the past, this has been difficult—special vacuum tubes or solid-state devices that operate in the microwave region were expensive and some of the metal-working (plumbing) required was difficult.

The microwave system described here—including transmitter, antenna, and receiver—can be built at a moderate cost, with a small amount of hardware work. It operates in the S band from 2300 to

2450 MHz; and although the transmitting power and range are very low, building and experimenting with this system will give you a good insight into how microwaves are generated, propagated, and detected. In principle, the system behaves just like its big brothers in telephone and TV distribution.

In most microwave work, it is customary to use a technique known as "stripline" in constructing the tuned circuit. Stripline consists of a lamination of a copper ground plane, a layer of insulation, and then a thin strip of copper to conduct the r.f. energy. Unfortunately, making stripline requires a precision layout and chemical etching, and it is

THE BEGINNER))))))

BY WILLIAM F. HOISINGTON, K1CLL

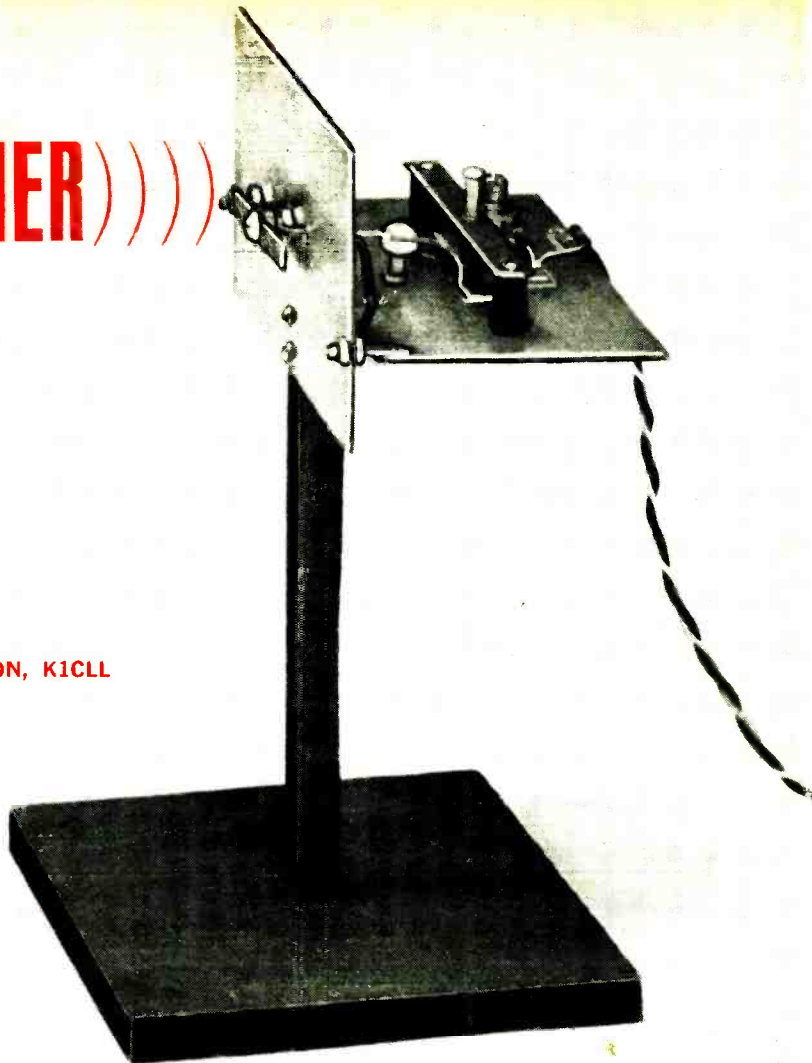

not easy to tune. The construction technique used in this project results in a tuned circuit that is electrically the same as stripline but it is easier to build and tune. In this case, we use a ground plane, air and nylon for insulation, and ordinary thin copper strips for the r.f. conductors.

Transmitter. The schematic of the transmitter is shown in Fig. 1, while Figs. 2, 3, and 4 show the method of construction. The ground plane is a piece of conventional copper-clad PC board measuring about $4\frac{1}{2}'' \times 3''$.

The tuned circuit, *L1*, is made from a piece of thin (about 0.024") copper

$\frac{7}{16}''$ wide $\times 1\frac{1}{16}''$ long. Bend a $\frac{1}{8}''$ lip at each end, then make another bend $\frac{5}{32}''$ from each lip. The $\frac{1}{8}''$ lips are used to solder the inductor to the ground plane, so that the inductor is $1\frac{1}{16}''$ long and stands $\frac{5}{32}''$ from the ground plane. Apply heat to the lips and coat the bottoms with solder. Center the inductor on the copper foil of the ground plane and tin the area under each lip. Then solder the inductor to the copper foil. Pick one side of the ground plane to be the front and the other side the rear.

Make up bypass capacitor *C1* using a thin sheet of copper or brass $\frac{1}{2}''$ square. Deburr the edges, and drill a small hole in the center to accommodate a small

PARTS LIST TRANSMITTER

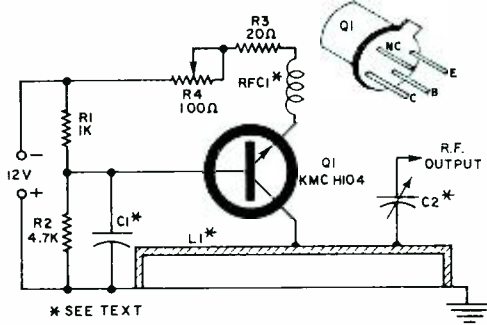

Fig. 1. The transmitter uses a special microwave transistor as a very low-power oscillator.

C1, C2—See text

L1—See text

*Q1—KMC H104 high-frequency transistor**

R1—1000-ohm, ½-watt resistor

R2—4700-ohm, ½-watt resistor

R3—20-ohm, ½-watt resistor

R4—100-ohm potentiometer

RFC1—Five turns of #30 DSC wire, on ¼" diameter

Misc.—4½" x 3" conventional copper-clad PC board (2), thin brass sheet for C1 and C2, nylon screws and nuts (available at hobby shops), thin copper strip for L1 and antenna, metal hardware, solder, etc.

**An H104 transistor is available from Rayville Associates, Mr. S. Nelson, Parker Rd., RD 2, Long Valley, N.J. 07853, for \$5.*

screw—either metal or nylon. Drill a similar hole through the ground plane at approximately the center of *L1* and about ⅓ of the way from the edge of *L1* to the rear edge of the ground plane. If you use a metal mounting screw, scrape away a small area of copper around the ground plane hole so that the screw will not make electrical contact with the ground plane.

Cut a piece of mica (a power transistor mounting insulator will do) or a small piece of 3-mil fiberglass slightly larger than the plate of *C1*. Mount the capacitor on the insulator and secure it in place with one edge of *C1* parallel to the length of *L1*. If you use metal mounting hardware, use an ohmmeter to make sure the capacitor plate is not making contact with the ground plane.

Using Fig. 2 as a guide, drill a hole at the rear corner of the ground plane large enough to accommodate the shaft of potentiometer *R4*. Scrape out an island in the foil near the *R4* shaft to form a terminal for the 12-volt connection, one end of *R1*, and a lead to *R4*.

To make antenna coupling capacitor *C2*, cut a piece of thin brass so that it is about 1 inch long and very narrow except for a ¼" square tab at one end. This is the capacitor plate. Glue a mica or fiberglass insulator sheet, slightly larger than the capacitor plate, to the top of *L1*, centered about ¼" from the end of *L1* (see Fig. 3). Drill a hole in the ground plane about half way between *L1* and the front of the ground plane large enough to accommodate a nylon screw. Then following Fig. 3, affix the thin end

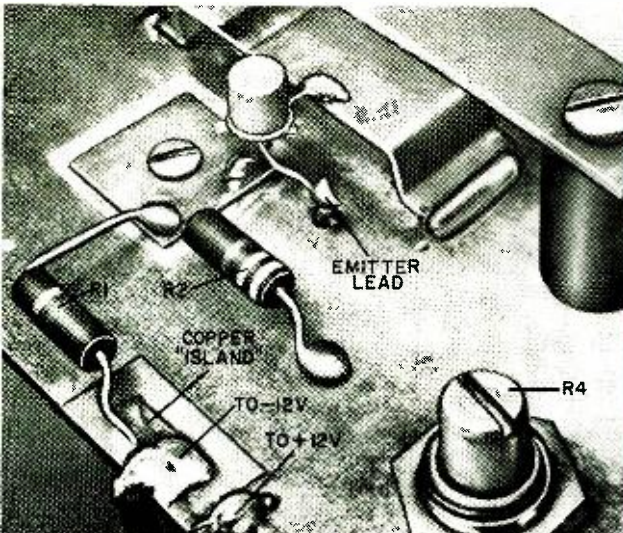

Fig. 2. The emitter of *Q1* couples to *RFC1* via an insulated wire fed through a hole in the PC board. Use a sharp blade to create an insulated "island" for the -12-volt feed. Don't forget the mica insulator underneath bypass capacitor *C1*.

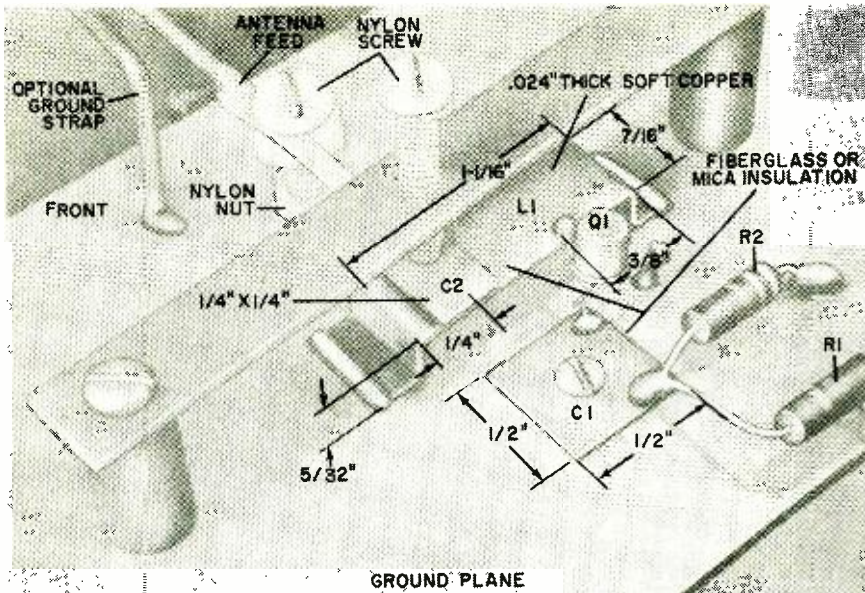

Fig. 3. Mechanical construction of the transmitter. Antenna coupling capacitor $C2$ has its thin lead wedged between the nylon support screw head and a nylon nut. Use a piece of scrap PC board to make the tuning screw support bridge, using a metal screw to tap the $C2$ hole.

of the capacitor lead to this screw using a nylon nut and making sure that the plate end of the capacitor fits directly over the insulator on $L1$.

Using a piece of scrap plastic and standoff insulators, make a "bridge" over $L1$ as shown in Fig. 3. Mark off a point directly over the plate of $C2$ and drill a small hole in the bridge. Use a metal screw to tap the hole and insert a nylon screw (having the same pitch) in the bridge so that it touches the capacitor plate and can be used to adjust the spacing between the capacitor and $L1$.

Note where the collector of transistor $Q1$ is to be soldered to $L1$ as described in the next paragraph. Directly under where the emitter lead will be, drill a small hole to accommodate a length of insulated wire.

Using a heat sink on the transistor lead to protect the device from heat, solder the collector lead to a point $3/8$ " from the end of $L1$ and the base lead to the metal bypass capacitor $C1$. Bend the emitter lead toward the hole drilled in the preceding paragraph. The fourth lead on the transistor is not used and can be cut off short. Connect $R1$ and $R2$ into the circuit.

On the underside of the ground plane

(see Fig. 4), connect one end of $R4$ to the -12 -volt terminal. Connect $R3$ to the other end and the rotor of $R4$. Choke $RFC1$ is made by winding five turns of number 30 DSC wire around any $1/16$ " form. You can impregnate it with coil dope or wax to make it retain its shape. One end of $RFC1$ is fed through the hole in the ground plane and soldered to the transistor emitter lead. The other end is soldered to $R3$.

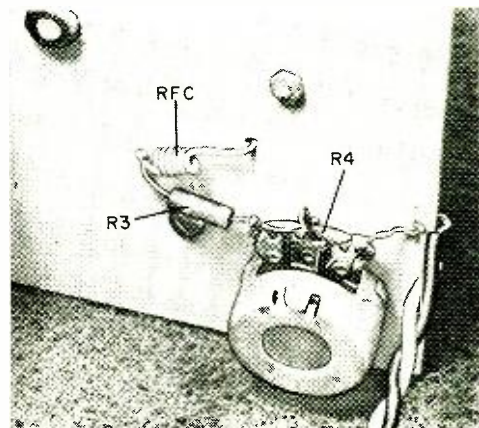

Fig. 4. Underside view of the transmitter showing the location of the RFC and $R3$. One end of the RFC feeds through a hole and contacts $Q1$ emitter.

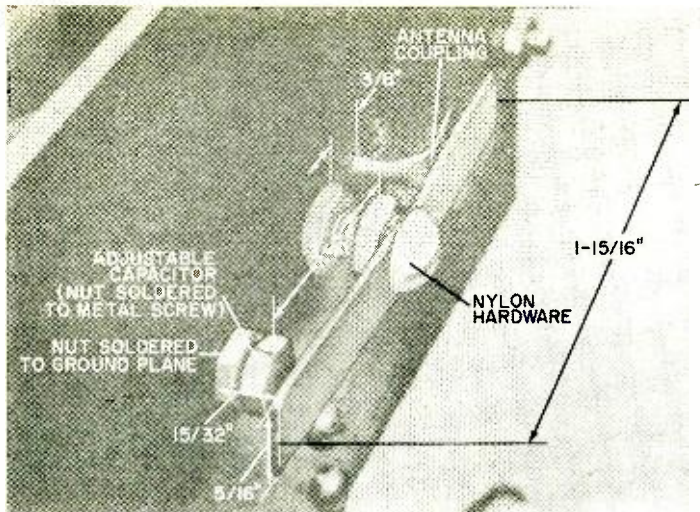

Fig. 5. The antenna coupling (from C2 on the transmitter) is made by creating a flat on one end of a piece of soft-copper bus bar. To install it, rotate the antenna by 90-degrees. After installation, the antenna coupling should be close, but not touching the antenna proper.

Antenna. The ground plane for the antenna is the same physical size as that used for the transmitter. To make the actual antenna (see Fig. 5) cut a piece of thin copper sheet $1\frac{1}{16}'' \times \frac{5}{16}''$. Drill a hole in the center of the copper and in the center of the ground plane so that the antenna can be mounted using nylon hardware.

The antenna is tuned by a small nut soldered to the end of a conventional 6-32 metal screw. Drill a hole in the ground plane $\frac{3}{4}''$ from the antenna mounting screw hole and on the same center line. Solder a 6-32 nut to the copper foil of the ground plane so that it is centered on the hole just drilled. Thread a 6-32 metal screw an inch or so long into the nut from the back so that it protrudes to a maximum on the antenna side. Put a metal nut on the screw so that the nut is flush with the end of the screw. Solder the nut to the screw and file the end surface flat. This screw is now a variable capacitor, with the flat end of the nut-screw combination capable of being adjusted with respect to the antenna (when it is installed). On the other side of the antenna mounting hole, about $\frac{3}{8}''$ away and still on the antenna center line, drill a hole large enough for a piece of round copper bus bar. Trim the copper foil away from the perimeter of the hole to avoid accidental grounding when the antenna feed is installed.

Take a piece of soft-copper, round bus bar and, using a hammer, make a $\frac{1}{4}'' \times$

$\frac{1}{4}''$ flat on one end. This will be the antenna feed.

Solder a small L-bracket at each corner of the front of the transmitter ground plane. Hold the antenna ground plane at right angles to the transmitter and adjust the height so that the antenna feed hole is in line with the slim metal lead on the antenna coupling capacitor (C2) secured in the nylon screw.

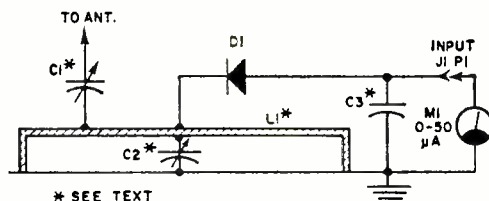

Fig. 6. Because of the very high frequencies used, a special microwave diode is used in the receiver. The diode can be inserted with either polarity to L1, as long as it matches the polarity of meter M1.

PARTS LIST RECEIVER

- C1, C2, C3—See text
 D1—PD0820 diode*
 J1—Phono jack
 L1—See text
 P1—Coaxial phono plug
 Misc.— $4\frac{1}{2}'' \times 3''$ conventional copper-clad PC board (2), thin brass sheet for C1, C2, and C3, nylon screws and nuts (available at hobby shops), thin copper strip for L1 and antenna, metal hardware, solder, etc.
 *A PD0820 Schottky barrier diode is available from Parametric Industries, Inc., 742 Main St., Winchester, Mass., 01890 for \$2.75.

Attach the antenna ground plane to the L-bracket so that a continuous ground is made from the transmitter ground plane to the antenna ground plane.

Once the two ground planes are fastened, pass the antenna-feed bus bar through its hole in the antenna ground plane so that the tab is approximately $1\frac{5}{32}$ " from the ground plane and bent out toward the end of the antenna. Be sure the feed line does not touch the ground plane. Cut the other end of the bus bar so that it can be soldered to the end of $C2$ in the transmitter. Rotate the antenna tuning capacitor (on the antenna ground plane) so that the soldered-on nut is touching the nut on the ground plane.

Slide, or thread, the actual antenna onto an inch-long nylon screw until it touches the head of the screw and secure the antenna in place with a nylon nut. Place another nylon nut on the screw and place the screw into its hole so that the antenna is $1\frac{5}{32}$ " off the ground plane (about $\frac{1}{5}$ of a wave-length). Secure the antenna in place with a metal (or nylon) nut at the rear of the board. Position the antenna feed so that it is close to but not touching the antenna.

The antenna-transmitter combination can be mounted on a wood base. Connect a wire to the -12-volt terminal "island"

and another wire for the +12-volt connection to the main foil of the transmitter ground plane.

Receiver. The schematic of the receiver is shown in Fig. 6. Inductor $L1$ and bypass capacitor $C3$ are fabricated just as they are for the transmitter and are shown in Fig. 7. The receiver has a tuning capacitor ($C2$) made up of a piece of thin brass sheet, $\frac{1}{4}$ " wide, bent so that a small lip can be soldered to the ground plane at the center of $L1$. Another lip on the top straddles $L1$ but is separated from it by an insulator. The antenna coupling capacitor $C1$ is similar to that in the transmitter. Nylon screws for adjusting $C1$ and $C2$ are supported in the plastic bridge over $L1$.

Diode $D1$ is soldered to the center of $L1$ (either polarity) and to the bypass capacitor. A phono jack with the shield pin soldered to the ground plane and the center pin connected to the bypass capacitor serves as a meter connector. The antenna for the receiver is constructed in the same manner as that for the transmitter.

A 50-microampere meter is used to measure the signal level of the rectified signal output from $D1$. The meter can be connected through a length of twin-conductor cable and a suitable plug and placed for easy viewing.

Fig. 7. Construction details of receiver. Strapline $L1$ is the same as used in the transmitter. Be sure to install mica insulators under capacitors $C1$, $C2$, and $C3$. Receiver uses the same antenna construction as that used with the transmitter.

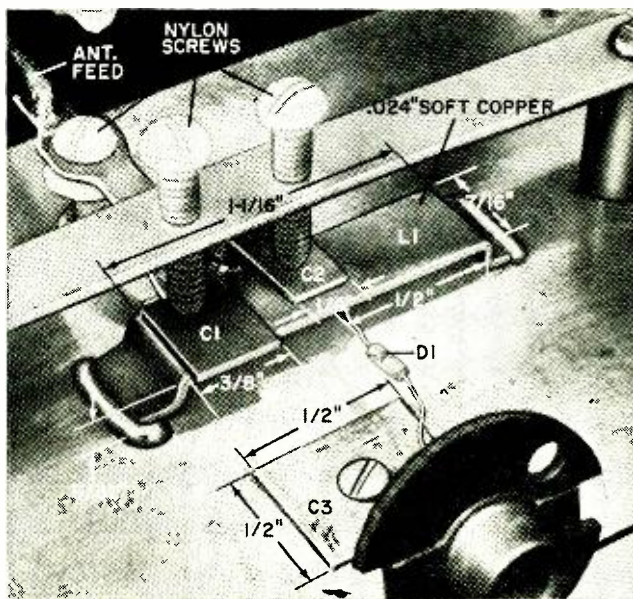

HOW IT WORKS TRANSMITTER

In the tuned circuit, the r.f. is bypassed by capacitor *C1* and bias is determined by the network of *R1* and *R2*. The base of *Q1* is 180° out of phase with the oscillator collector r.f. voltage. This is the necessary condition for oscillation. The emitter of *Q1* is r.f. decoupled from the power supply by *RFC1* and the transistor current is determined by the setting of potentiometer *R4*. There is an internal in-phase feedback from collector to emitter.

The tuned circuit, *L1*, is a half-wave line grounded at both ends. At one instant, the center of *L1* (collector connection) goes r.f. positive, while the base and the ground plane are negative. One half-cycle later, the polarities of both points are reversed. If the *Q* (figure of merit of *L1* and the circuit as a whole is sufficiently high, the circuit will oscillate at a frequency determined by the physical dimensions and distance from the ground plane of *L1*.

The amateur band of 2300 to 2450 MHz has been picked for this experimental microwave oscillator because that region is approved for experimental amateur purposes. Changing the dimensions of *L1* and its proximity to the ground plane permits tuning the transmitter to any frequency within the band.

Increasing the emitter current by varying *R4* increases the transmitter output power. Resistor *R3* is a safety resistor which prevents *Q1* from burning up from too much current. Trimmer capacitor *C2* couples the r.f. output to the antenna.

Operation. To tune the receiver to the transmitter, place the two units a short distance apart on the workbench, with the antennas facing each other. Supply power to the transmitter from a 12-volt d.c. source being careful to observe the correct polarity. Set *R4* between half and $\frac{3}{4}$ resistance. The receiver meter may or may not show an indication of output. Gently adjust *C2* on the receiver, looking for a meter indication. Tuning may be sharp, so be careful. If the two units are close together in frequency, the meter should show a signal somewhere in the course of tuning *C2*.

Once a signal is detected, adjust the transmitter antenna coupling capacitor *C2*, the transmitter antenna tuning capacitor and potentiometer *R4* for maximum signal. With the transmitter rough tuned, adjust the receiver antenna coupling capacitor *C1* and the receiver antenna tuning capacitor for maximum signal. Once these have all been adjusted for a maximum signal, trim the transmitter and receiver coupling tabs for maximum signal and recheck all variable adjustments. As the received signal strength increases, it may be necessary

to separate the two devices by a couple of feet more.

Frequency Measurement. Once the microwave system is operating, a frequency check must be made to make sure that it is operating within the 2300-2450-MHz band. The approach (see Fig. 8) is called "interferometry" and was first used over a century ago to measure the frequency of light waves. (Heinrich Hertz used it in 1887 to measure the first electromagnetic waves ever generated.)

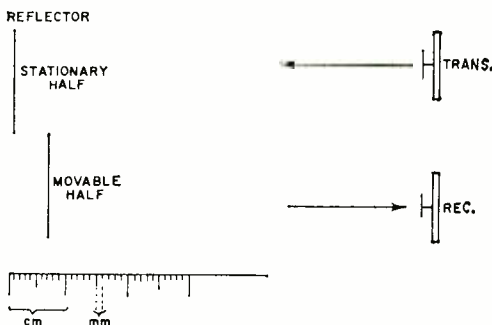

Fig. 8. Basic interferometer is used to measure frequency. As the movable half of the reflector is brought closer to the antennas, a series of "nulls" will be seen on the receiver meter. You measure the distance between nulls to determine frequency.

Place the transmitter and receiver side by side so that their antennas are facing in the same direction. Place a ruler calibrated either in inches or centimeters at 90 degrees to the plane of the antennas and about 2 feet in front of them.

Make two flat metal reflectors (several inches on a side) and place them in front of the two antennas at the zero mark of the ruler. The butting edges of the two reflectors should be approximately cen-

(Continued on page 112)

HOW IT WORKS RECEIVER

The tuned circuit of the receiver is similar to that of the transmitter. Trimmer capacitor *C1* couples the antenna to the tuned circuit. The rest of the circuit is a conventional crystal detector with a microammeter as the readout. Because of the very high frequencies involved, a Schottky-barrier diode must be used. Unlike conventional diodes, this device is especially made to operate efficiently at microwave frequencies. Capacitor *C3* is an r.f. bypass for the meter.

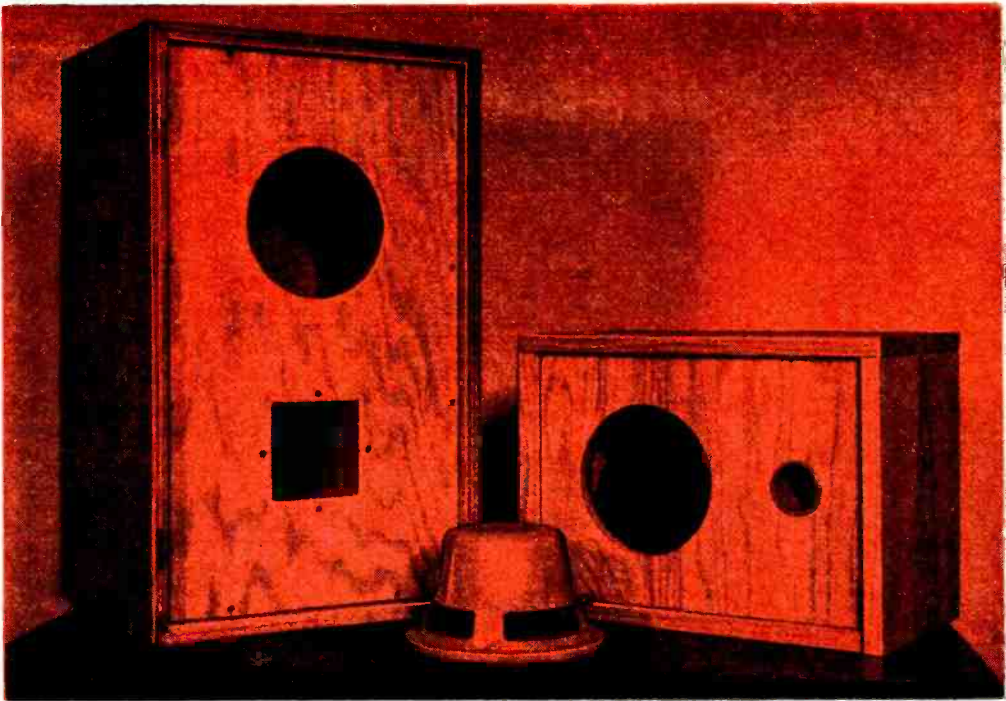

Rally Round the Reflex

BY DAVID B. WEEMS

*Proper enclosure
tuning
gives maximum
enjoyment*

MAN YOUR sabre saws, reflex partisans, and look to your ports; the much maligned bass reflex is again under attack! Let's start a campaign to take the boom out of the boom box and preserve it from extinction. The hi-fi system you save may be your own!

Few people will argue that the idealized bass reflex enclosure is efficient and that you can readily obtain ear-shattering sound from only a few watts of audio power. The "boominess" of the homemade bass reflex results from either the lack of know-how or the inability to tune the enclosure properly.¹ Any solution to the boominess and size problems will depend upon whether you want to

emphasize transient response or clean low-frequency reproduction and bass efficiency.

All enclosure designers must make a compromise at some point or another in building a bass reflex. Presumably each manufacturer makes the decision which best complements his loudspeakers, but he may have been influenced by what he believes most customers want. If you prefer the satisfaction of doing the job yourself or just want "something differ-

1. The author attempted to answer these questions in his article, "Tune Up Your Bass Reflex," POPULAR ELECTRONICS, July 1968, page 47. Unfortunately, while answering one question he emphasized the puzzling problem of how big to make the enclosure. (Editor)

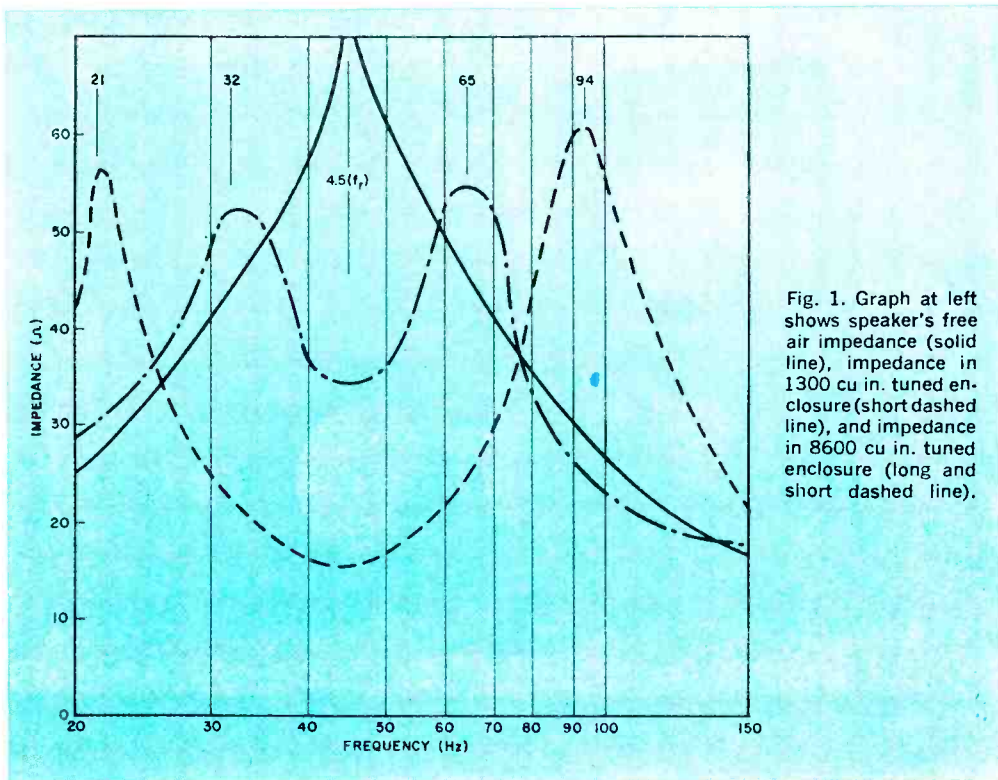

Fig. 1. Graph at left shows speaker's free air impedance (solid line), impedance in 1300 cu in. tuned enclosure (short dashed line), and impedance in 8600 cu in. tuned enclosure (long and short dashed line).

ent." here are some guides to help you. Anyone can use the chart design method, but those with test equipment will want to apply the impedance checks. For easy tuning we shall stick to enclosures with ordinary ports which can readily be adjusted after completion.

Reflex Working Principles. In order to consider enclosure size and other questions, let's take a quick look at how the ported enclosure works. A speaker in a closed box acts like a piston, compressing the air in the box as the cone moves in, lessening the pressure in the box as the cone moves out. Add a port to the box so the pressure can be relieved and you have an adaptation of a Helmholtz resonator. The term "resonator" indicates that the air in the box is resonant at a certain natural frequency. The frequency of the resonance is determined by the enclosed volume of air and the size of the port.

You might think of the air in the box as a large spring, compressing and expanding, with a piston at each end. One piston is the air in the port, and the oth-

er piston is, of course, your speaker. At resonance, both pistons act to compress the spring at once, another way of saying that the two pistons are in phase.

What effect does this have on the speaker? A speaker cone in free air, or in a closed box, vibrates at increasing amplitude as the signal goes down in frequency (below 200 Hz) with the exception of the resonant point where there is a peak in amplitude. Because of this, speakers used in small sealed enclosures are designed with long-throw voice coils so that the voice coil can move over a comparatively large distance and still remain in the region of uniform magnetic field. Such speakers are relatively inefficient.

Speakers designed for large ported enclosures are high in efficiency. When one of these speakers is mounted in a ported box, and the system is working at resonance, the air in the enclosure (being under compression when the speaker moves in and at a partial vacuum while the speaker cone is moving out) acts on the cone in opposition to its movement. This damping reduces cone

travel at resonance, resulting in significantly lower distortion at low frequencies. And the sound output is augmented by the supplementary "piston"—the air in the port. In a properly designed system, port radiation is at a maximum in the frequency range where it is most needed to compensate for natural bass loss.

Enclosure Size. Your choice between moderate, large, or colossal enclosure size may depend on whether you want to emphasize low frequency reproduction, transient response, or peace in the family. The design chart, Table I, shows that the volume determines the tuning frequency for a given size port. Or stated differently, the larger the enclosure, the larger the port for a given frequency. And the larger the port, the greater the radiation from the port—up to a certain point. Beyond that, as the port becomes larger, the enclosure is changed from a box with a hole in it to a box with one side missing and the air behind the speaker ceases to act on the speaker. A useful rule of thumb is to set the upper limit of port size equal to the effective cone area of the speaker. In other words, the box should be no larger than that which allows you to tune the enclosure at the desired frequency with such a port.

Even this may be too large for optimum performance, particularly if you like "tight" bass. The goal then is to choose an enclosure volume that is large enough to yield a port area that is sufficient to be effective without ringing or sounding "mushy."

At the other end of the size range, a ported enclosure that is too small has several undesirable characteristics. Small enclosures demand small ports, and a tiny port may produce more whistling noises than bass notes. Similarly, avoid a slit port unless you are using several of them as an acoustical resistance. If you find that the correct port area for a given situation is only a few square inches, use a duct instead of a simple port.

Another disadvantage of the too small box is the greater tendency to boom. And the low bass notes are cut off. Even ducts can't alleviate these faults satisfactorily.

If you have no audio test equipment, you must resort to design charts. One rule of thumb is to look at the chart and choose an enclosure volume that will require a port area from 30 to 100% of the effective cone area of your speaker for proper tuning (more about this later). The range in square inches is:

Rated Speaker Diameter (in.)	Port Area (sq. in.)
8	9 to 28
10	15 to 50
12	24 to 78
15	40 to 133

You can choose your enclosure volume within the limits determined by the port areas given above in relation to the space you have available.

Here is an example. You have an 8-inch speaker that requires an enclosure tuned to 45 Hz. From Table I you see that the largest recommended enclosure volume is 6 cu. ft., requiring a port area of 28 sq. in. The smallest recommended volume is 3.5 cu. ft. with a port of 11

**TABLE I—DESIGN CHART
FOR ENCLOSURES WITH SIMPLE PORTS**

VOLUME (cu ft)	PORT AREA (sq in.)				
	PORT FREQUENCY (Hz)				
	35	40	45	50	60
12	38	52	90	130	**
11	34	48	84	120	**
10	30	40	64	90	**
9	26	36	56	80	**
8	24	30	50	74	145
7	18	24	36	50	110
6	12	18	28	36	75
5	9	14	20	30	50
4	*	10	15	20	36
3½	*	*	11	16	28
3	*	*	8	12	22
2½	*	*	*	8	16

The figures given are approximately correct for simple square or circular ports. For rectangular ports (length:width ratio = 4:1) the port should be reduced in area to about 75% of that shown here.

*Use ducts.
**Close port.

sq. in. Note that these values are given for simple ports; ducts must be used for smaller enclosures.

To choose the best enclosure volume for your speaker system, you should use every aid available, including all the information supplied by the manufacturer. With test equipment you can also run an impedance curve for the speaker.

Use of Impedance Curves. The impedance of a speaker is usually rated at 4, 8, or 16 ohms at X Hz. Because the impedance of a voice coil is made up of its d.c. resistance plus both capacitive and inductive reactances, which change with frequency, it varies widely over the audible spectrum.

Figure 1 is a typical graph of impedance vs frequency to show something of the effects of an enclosure on a speaker. A speaker operating in free air has a single low-frequency peak in its impedance curve. The peak occurs at the fundamental resonance point. Put the speaker in a closed box and the peak is still there, but now it's higher in frequency. Port the box and there will be two peaks with the valley between them located at the frequency to which the system is tuned, usually at the free air resonance of the speaker.

Don't try to equate impedance curves with frequency response. As James F. Novak, Senior Design Engineer for Jensen, says, "Any amplifier of reasonably high quality has a damping factor good enough to make it a constant voltage source. With this type of amplifier, the speaker/enclosure response is independent of the impedance variations. If the amplifier were constant current, the response would follow the impedance curve."

Nevertheless, the impedance curve does provide useful information. As mentioned earlier, it tells you to what frequency your system is tuned. And it tells you the frequency of the upper peak, the greatest danger zone for boom in ported enclosures. If this peak occurs above 100 Hz, into the male voice range, announcers and some singers may sound as if their microphones were located in the bottom of a barrel.

The impedance curves shown in Fig. 1 demonstrate the effect of enclosure size on impedance. These curves are for a good quality 8-inch speaker in two enclosures (the smallest and largest recommended sizes), each tuned to 45 Hz, the free-air resonance of the speaker.

It is evident that the small enclosure has the greater effect on the impedance of the speaker. Stated differently, the smaller enclosure is more closely "coupled" to the speaker. The speaker impedance is much lower at resonance in

the small enclosure than in the larger enclosure. This indicates that the smaller enclosure is doing more effectively what a tuned enclosure should do—control the cone movement at resonance. But it is impossible to say, just looking at the impedance curves at resonance, what enclosure volume is optimum.

However, you can get some idea of the frequency response range of the two enclosures. The bass output from ported enclosures cuts off at some point below the frequency of the upper impedance peak. Looking again at the curves, you will see that the small enclosure will cut off somewhere below 94 Hz. But the larger enclosure will cut off somewhere below 65 Hz. This difference would be noticeable, particularly in the reproduction of musical tones of large instruments.

Another difference in the impedance curves produced by the large and small enclosures is the frequency span between the impedance peaks. Note that the twin peaks of the large enclosure are much closer together in frequency than the peaks of the smaller enclosure. A useful term of reference in measuring this span is to divide the frequency of the upper peak by the frequency of the lower peak. The quotient is then simply the ratio of the upper frequency peak to the lower frequency peak, a convenient small number. For the enclosures referred to in Fig. 1, the ratio is 2 (65/32) for the larger enclosure and 4 (94/21) for the smaller enclosure. The larger the enclosure, the closer together will be the twin peaks and the lower the ratio.

The ratio should fall within certain limits for enclosures of proper volume. For conventional loudspeakers of the 1950's, the limits were between 1.5 and 2.4.² These low values would result in extremely large enclosures by today's standards. One reason for larger enclosures in those days was that many high-fidelity loudspeakers then had a resonant frequency of about 60 to 70 Hz. It was necessary to use a large enclosure so that the upper peak would be below 100 Hz. For today's low-resonance speakers a more reasonable range might be from about 2 to 3.

2. F. Langford Smith, *Radiotron Designer's Handbook*, 4th ed.; Radio Corp. of America, 1953, p. 847.

James F. Novak has suggested the precise ratio of 3.13 which he says produces optimum transient response. It yields rather compact enclosures except in the case of very-high-compliance, low-resonance speakers. For the latter, simple rules of thumb do not apply, and some reduction of interior volume will give excellent results with ducted ports even when the peak:peak ratio is somewhat greater than 3.13.

You can use this ratio as a rough guide to estimate whether your enclosure is at the large or small end of the scale for your particular speaker. Listening tests conducted with three enclosures of various sizes with peak:peak ratios ranging from 4 to about 2 indicated that the average listener preferred a ratio of 2 (the largest enclosure) by a wide margin. Several listeners greeted the sound from the box with the peak:peak ratio of 4 with sarcastic comments.

Unfortunately, it is difficult to predict in advance what the ratio will be for a particular speaker/box combination. Novak has described a useful method of estimating the preferred values for his optimum volume enclosures (with a peak:peak ratio of 3.13) by measuring the free-air resonance of a speaker and then measuring its resonance in a "standard" box.³

If you test your present enclosure and find that it is too small or too large by these standards, there are possible cures without major surgery. For the small box, a collar of damping material, such as fiberglass, over the speaker will often help. And for the rare large system that has too much port output, a cloth stretched tightly across the port will usually be sufficient.

If you are designing an enclosure, you should consider its shape as well as its volume because the shape will have some effect on frequency response and impedance. Try to avoid extreme shapes, such as a cube or a pipe. A good general rule is to make each inside dimension slightly different, but limit the longest inside measurement to less than 3 times as great as the shortest. Some manufacturers select precise ratios for these

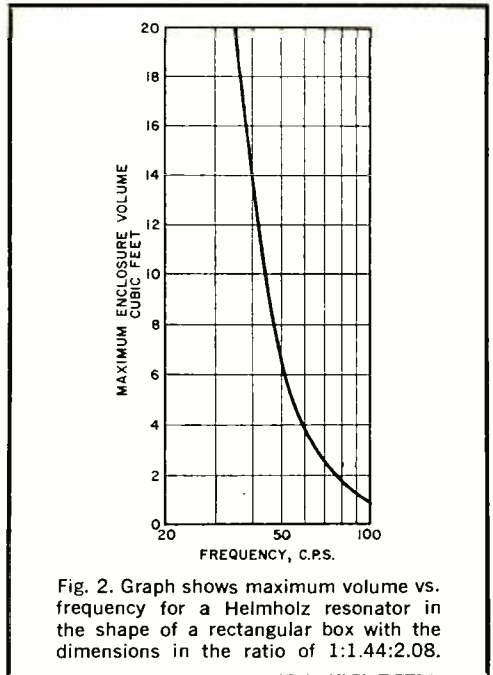

Fig. 2. Graph shows maximum volume vs. frequency for a Helmholtz resonator in the shape of a rectangular box with the dimensions in the ratio of 1:1.44:2.08.

dimensions. For example, John Gilliom at Electro-Voice states that the optimum dimension ratio is 1: 1.44: 2.08 (see Fig. 2). In other words, a typical bookshelf enclosure might have an inside depth of 1 ft., an inside height of 1.44 ft. (about 17¼"), and a length of 2.08 ft. (about 25"). Or the 5 cu ft "universal" enclosure shown in Fig. 3 would have approximate inside dimensions as follows: A 30"; B 21"; C 14½".

Tuning the Ported Enclosure. Tuning an enclosure to a specific frequency is not very difficult (see POPULAR ELECTRONICS, July 1968, for an easy method), but choosing the frequency may not be so simple. The traditional goal, almost universal in articles and books about ported enclosures, is to tune the box to the free-air resonant frequency of the loudspeaker. Theoretically, the tendency of the speaker cone to undergo excessive movement at resonance would be controlled by the resistive action of the air in the box as described earlier. Although the practice is still followed by some companies, there are certain situations in which poor bass is the result.

(This article will conclude next month with more about tuning the enclosure and instructions for running an impedance curve.)

3. James F. Novak, "Designing a Ducted Port Bass Reflex Enclosure," *Electronics World*, January 1966.

Build the SCS Darkroom Timer



REPEAT ACCURACY IN A PROJECT FOR THE PHOTO BUFFS

BY FRANK H. TOOKER

AN ESSENTIAL for making clean, crisp photographic enlargements is a dependable means of accurately controlling exposure time. The specially designed instrument described here is continuously variable over the range from 5 to 60 seconds. Its function switch has a FOCUS position for quick and easy setup of the enlarger as desired, or required, for each negative. Its accuracy is better than that of many previous electronic timers because the semiconductor used does not load the RC circuit which determines the timing interval.

The majority of darkroom practitioners are aware that most enlargements are made in the range of 10 to 40 seconds printing time. Intervals of less than 10 seconds make control (manipulation) measures difficult, while those longer than 40 seconds increase the possibility of blurring. Only when considerable manipulation is required is the full 60-second interval actually needed. However, it should be included in every darkroom timer.

The timer's circuit is somewhat susceptible to ambient temperature variations, but far less so than the photographic processes themselves. (Since optimum darkroom temperature is around 68° to 70° F, calibration at that temperature is desirable.) The timer's response to line-voltage transients is negligible. If the test-strip method of determining exposure is used, repeat accuracy is more important than absolute accuracy and the repeat accuracy of this timer has been found to be 3% or better.

Construction. The circuit of the timer is shown in Fig. 1. It is assembled in a 5" × 4" × 3" aluminum cabinet using the front-panel layout shown in Fig. 2. Figures 3 and 4 show the internal arrangement. Power transformer *T1* and relay *K1* occupy the bottom of the cabinet while the power supply is built on a perforated (or etched) board supported by the transformer mounting hardware. Most of the other electronic components

are assembled on a printed circuit board as shown in Fig. 3. A foil pattern for this board is shown in Fig. 5. Use a glass-epoxy board to avoid leakage and possible mistiming due to moisture. This board is mounted on the top of the cabinet using appropriate spacers.

Depending on the relay used, its frame may be connected to the moving contact and therefore "hot" so the relay should be well insulated from the metal cabinet. Once all components have been assembled, wire the timer point-to-point in accordance with Fig. 1. Use dry-transfer lettering to mark the controls on the front panel.

Adjustment. When assembly and wiring are complete and checked, plug a table lamp using a 50- to 100-watt bulb into receptacle *SO1*. Turn on the lamp switch. Set *S1* to FOCUS and *S2* to ON. The lamp should light. Set *S1* to RESET and the lamp should go off.

Now set potentiometer *R1* to its maximum resistance position (should be maximum clockwise). Put *S1* on TIME and observe that the lamp goes on. Using a stop watch or an electric clock with a sweep second hand, check the interval during which the lamp stays on. It

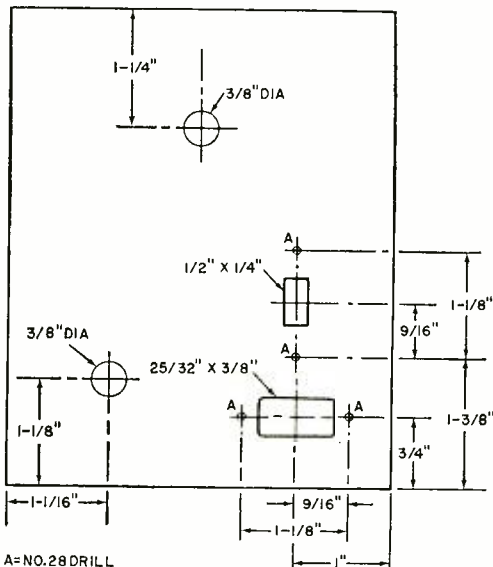

Fig. 2. To duplicate the front panel layout as used on the prototype, you can follow this guide.

should be somewhere between 65 and 70 seconds. If it is less than 65 seconds, unplug the timer and slightly decrease the value of *R5*. Then make the test again. Repeat the process if necessary.
(Continued on page 117)

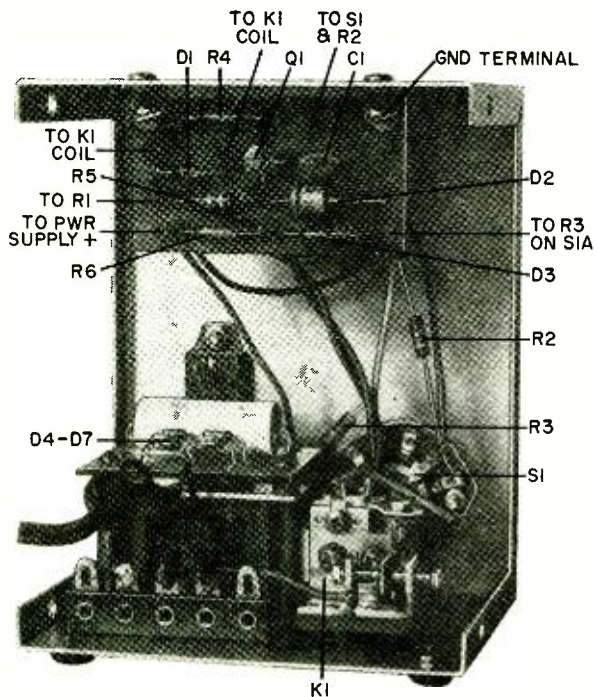
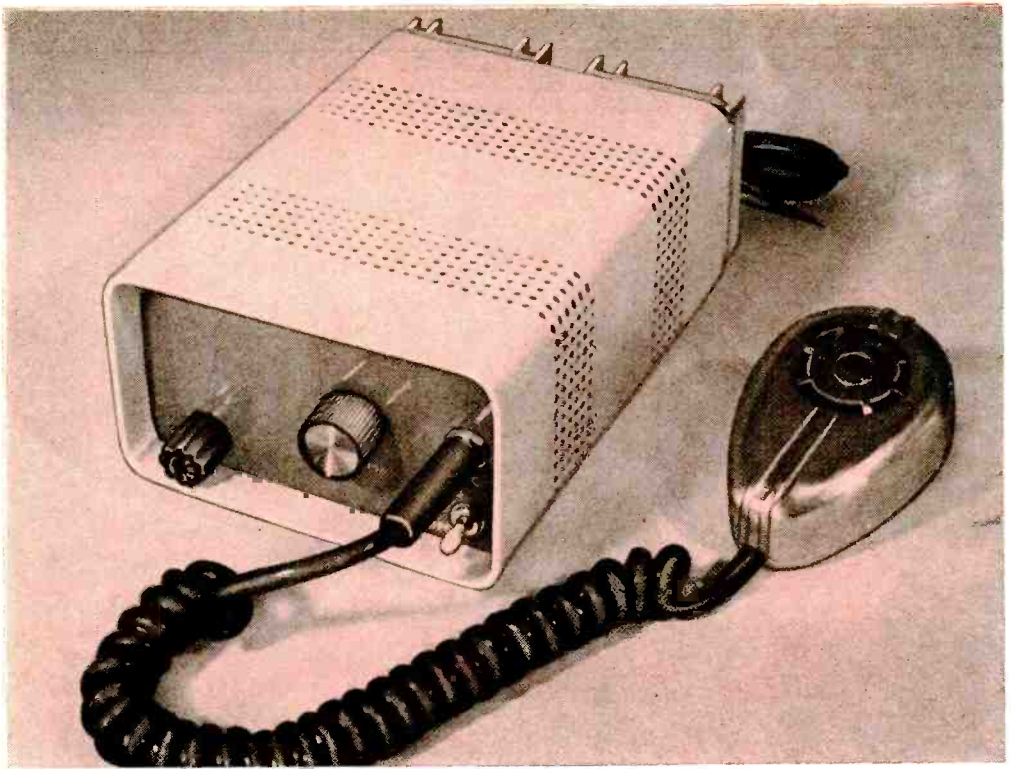

Fig. 3. The PC board containing the timing circuit is mounted on brackets to the top of the chassis. The power supply is mounted on its own board fastened to the top of the power transformer. Note that the relay frame is insulated from the metal chassis by a small piece of plastic sheet. In many relays, the armature is connected to the main frame.



TEN-WATT PA AMPLIFIER

INTEGRATED CIRCUIT SIMPLIFIES CONSTRUCTION

BY ED FRANCIS

WHEN A NEW electronic component is put on the market for experimenters, it is usually only after the commercial users have exploited it to the full. This is not so of the RCA CA3020 integrated-circuit audio power amplifier. From the moment of its introduction, the CA3020 was available to both commercial users and experimenters. It has been used in scores of applications.

The CA3020's success is due to a blend of small size, low cost, high reliability, ease of use, and a respectable $\frac{1}{2}$ -watt output. Even so, it is not powerful enough for public address audio amplifier applications. But, capitalizing on the IC's push-pull output configuration, it is possible to produce a PA system that develops a 10-watt output with the addition of a handful of components.

For maximum appeal, the PA system described here was designed for mobile/home use. All you need do after the project is assembled is connect it to a suitable d.c. power source, plug in mike and speakers, and you're in business.

About The Circuit. The CA3020 IC amplifier has an output stage consisting of two *npn* transistors in a push-pull configuration, requiring a 130-ohm center-tapped load. Since the outputs (taken at pins 4 and 7 of *IC1* in Fig. 1) are 180° out of phase with each other, they are complementary-symmetry coupled to the bases of *pnp* power transistors *Q1* and *Q2* which are also connected in push-pull.

The input impedance of the 2N2869/2N301 transistors specified for *Q1* and

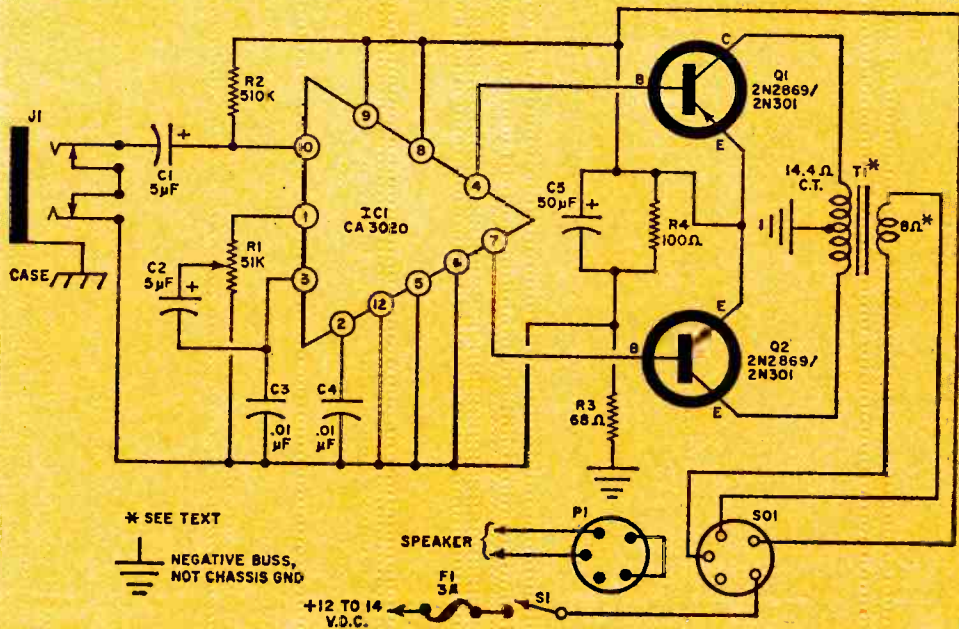

Fig. 1. Because IC1 cannot tolerate more than 9 volts d.c., connections to negative side of power source are actually 4-5 volts positive with respect to negative buss. Only connection made to the chassis is the J1 mounting bushing.

PARTS LIST

C1, C2—5- μ F, 12-volt electrolytic capacitor
 C3, C4—0.01- μ F disc capacitor
 C5—50- μ F, 15-volt electrolytic capacitor
 F1—Standard 3-ampere fuse (NOT slow blow)
 IC1—RCA CA3020 1-watt audio integrated circuit; amplifier
 J1—Two-circuit control-transfer phone jack
 P1—Five-pin molded plug (Amphenol 78-PCG5)
 Q1, Q2—2N2869/2N301 power transistor
 R1—5000-ohm audio taper potentiometer (IRC 60 137 6507)
 R2—510,000-ohm, 5% resistor
 R3—68-ohm resistor
 R4—100-ohm resistor

All resistors
 1/2-watt

S1—S.p.s.t. switch (can be part of R1 or a separate slide or toggle switch)
 SO1—Five-pin socket (Amphenol 91-MPM5L)
 T1—Output transformer (see text)
 1—LMB Type CO-3 metal cabinet (Newark Electronics Corp. 91F1196)
 2—Heat sinks (Olson Electronics X-951)
 Misc.—Transistor sockets, hardware, mica insulators (2 each) for T0-3 case configuration; high-impedance (50,000-ohm) dynamic microphone with two circuit phone plug attached as described in text; 35 $\frac{1}{2}$ " \times 13 $\frac{1}{4}$ " primed circuit board; loudspeaker (see text); fuse holder; control knob; three-lug terminal strip; rubber grommets; 1" metal spacers (6); 1 $\frac{1}{2}$ " 6-32 machine screws and matching nuts and lock-washers; coded power cable; hookup wire; solder, etc.

Q2 serves as the necessary center-tapped load for IC1 and eliminates the need for a driver transformer. Transistors Q1 and Q2 feed output transformer T1. Since a complementary-symmetry configuration is also used here, no bias arrangement is needed for the power output stage.

The output stages operate on between 12 and 14 volts d.c., but IC1 cannot tolerate more than 9 volts d.c. Consequently, the voltage divider chain formed by R3 and R4 is incorporated into the circuit to provide a safe operating voltage for IC1. Because of this arrangement,

the common (usually grounded) pins of the IC are actually 4-5 volts above the negative buss reference; so it is necessary to use a two-circuit phone jack for J1 to prevent shorting R3. (Note that with this setup, chassis or case ground is not used as the ground reference for the input signal.)

Protection for the output transistors is built-in and the loudspeaker load must be plugged into the amplifier through the P1/SO1 connectors before d.c. power can be applied. When P1 is unplugged, the positive input voltage line is broken.

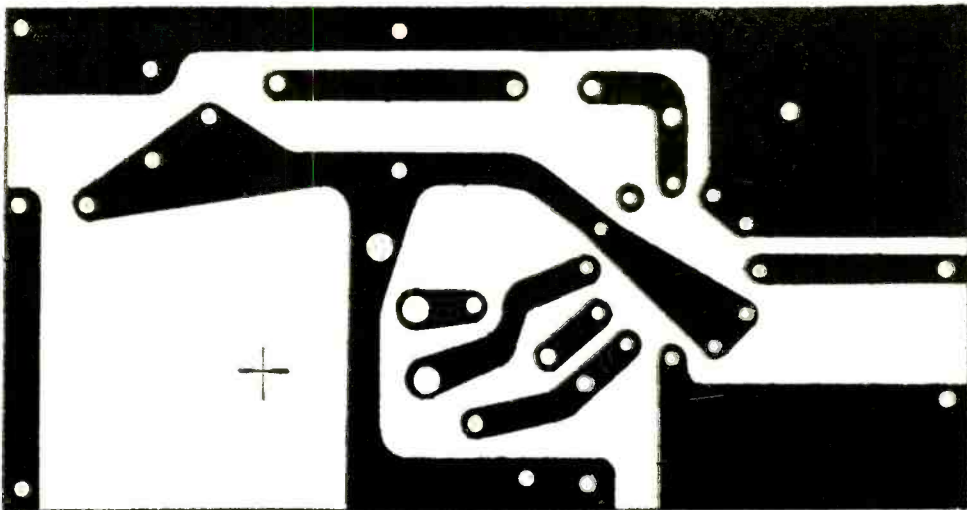
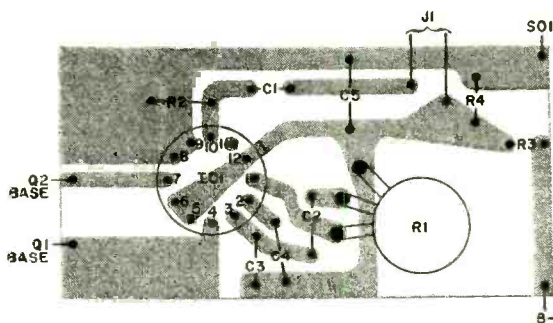

Fig. 2. When making printed circuit board, copy actual-size etching guide exactly as shown above. Then mount components on top of board (see drawing at left), making sure indexing tab of IC1 is located as shown.



No electrical connections are made to the amplifier cabinet, so the system can be used in either positive- or negative-ground mobile electrical systems.

Construction. Apart from the fact that this is one project for which you will have to make your own printed circuit board (if you choose this method of assembly), construction is very easy. Except for the output transistors and transformer, the fuse holder, and the microphone and speaker/power connectors, all parts mount directly on the circuit board. If you prefer, you can assemble the circuit on a piece of perforated phenolic board, but a printed circuit board is recommended (see Fig. 2 for actual-size foil pattern guide and component layout).

Mount the components on the board in the following order: first the resistors, then the capacitors and volume control *R1*, and finally the integrated circuit *IC1*.

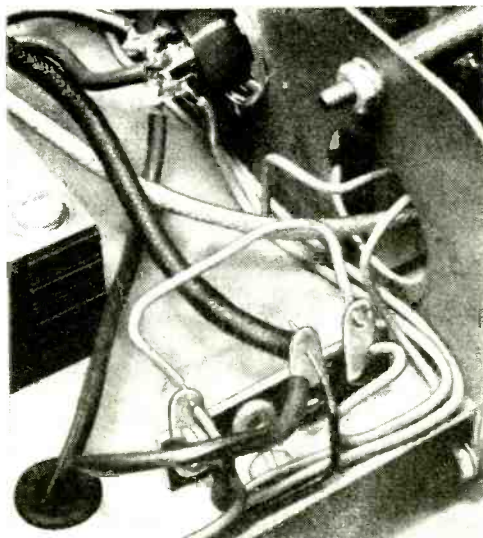

Terminal strip, mounted right rear of chassis, simplifies interconnections between power cable, output transformer *T1*, output transistors *Q1* and *Q2*.

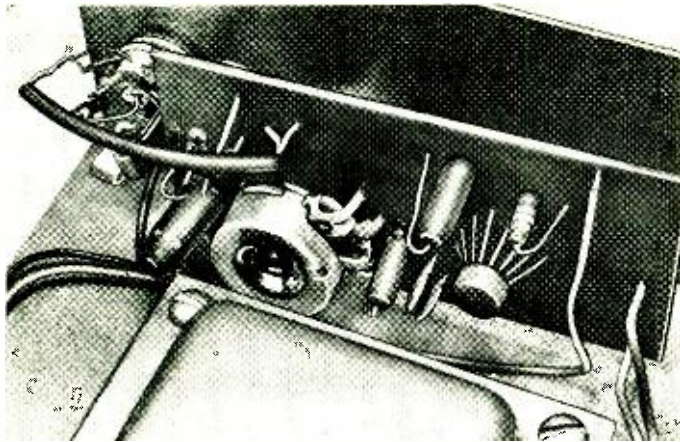

Fig. 3. Circuit board mounts to front of case via long threaded shaft of volume control. Use shielded cable to connect input jack to circuit board as shown.

When mounting *IC1*, leave the leads full length, carefully inserting them into the proper holes in the board. Then, heat sink each lead as you solder it to the foil. Temporarily set the circuit board assembly aside.

The next step is to homebrew an output transformer with specifications to match the circuit. To make this transformer, refer to the instructions provided in the sidebar on page 67. Then, mount the transformer inside the amplifier case in a position where it will not interfere with the circuit board or output transistor wiring.

Now mount the power switch (if it is not part of *R1*), fuse holder, and circuit board on the front of the case as shown in Fig. 3. Use two hex nuts and a control lockwasher to secure the extra-long threaded bushing of the potentiometer in place so that it protrudes from the front

no more than $\frac{3}{16}$ " , including the thickness of the hex nuts.

The heat sinks, as you get them, will not fit directly onto the rear apron of the case. Hence it is necessary to cut them down to size and file or grind the corners to fit the curvature of the case corners as shown in Fig. 4.

If the heat sinks are not pre-drilled to accommodate the TO-3 transistor and socket, machine them so that they do. Bear in mind, however, that care must be exercised in this operation to insure that, when mounted, the transistor leads or case do not short to the heat sinks. When you are satisfied, mount the transistors and their sockets on their respective heat sinks, placing a mica or teflon insulator and silicone paste between the transistor cases and heat sinks.

Space on the rear panel of the amplifier case is at a premium. Therefore,

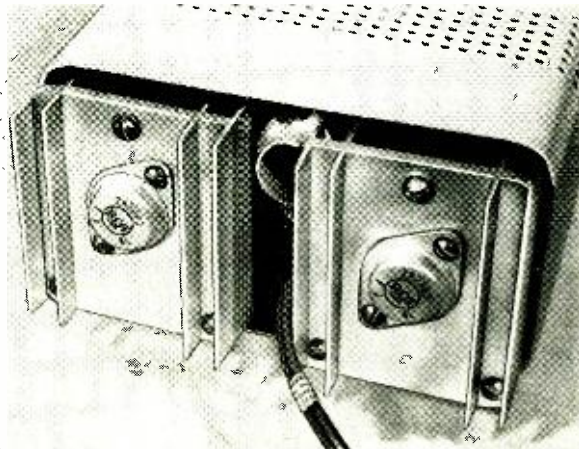
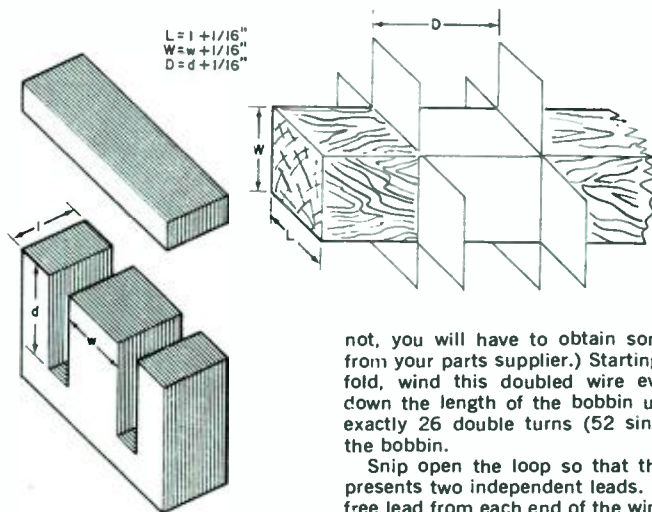

Fig. 4. Heat sinks for output transistors are slightly over size and must be machined to fit within chassis cowling; note rounded edges. They can be mounted to rear of case with spacers and hardware.

carefully select the location for SO1. Drill the hole for and mount this five-contact socket. Then solder 6" lengths of heavy-duty stranded hookup wire to the contacts of each transistor socket, and mount the transistor/heat-sink assemblies on the rear of the case. Use

1"-long metal spacers and 1 1/4"-long 6-32 hardware.

Now, referring back to Fig. 1, interconnect the circuit board, switch, fuse, power transformers and power transistors. For some of these connections, the job will be easier if you use a terminal



TRANSFORMER CONSTRUCTION

Since the output transformer needed for the PA amplifier is not a standard item, it must be homemade from a transformer that has been salvaged from an old radio or TV receiver. The only requirement is that the salvaged transformer have a core cross-sectional area ($l \times w$ in upper left drawing) of approximately 0.7 sq in.

Disassemble the salvaged transformer as follows. First, remove the hardware securing the laminations together at the corners. Next, score through the weatherproofing shellac and remove one set of E and I laminations at a time, taking care not to bend them out of shape. If any of the laminations show signs of rust, clean them with steel wool or very fine emery cloth.

Now, referring to the drawing at the upper right, prepare a bobbin and winding handle. The winding handle can be a piece of scrap wood, while the bobbin material can be lightweight card stock (an index card, for example) or heavy-duty waxed paper, such as the type used for wrapping industrial tools or freezer wrap. Slide the bobbin onto the winding handle.

To insure that the center tap of the primary winding is exactly centered, fold a 10' length of #16 enameled wire exactly in half. (Check the original windings on the transformer. If the wire is the correct size, you can use it; if

not, you will have to obtain some #16 wire from your parts supplier.) Starting 4" from the fold, wind this doubled wire evenly up and down the length of the bobbin until there are exactly 26 double turns (52 single turns) on the bobbin.

Snip open the loop so that the folded end presents two independent leads. Now take one free lead from each end of the winding, and cut them so that they are just long enough to form a 1/2" pigtail when twisted together at the center of the bobbin. Scrape away the insulating enamel from each lead. Then twist together the two leads and one end of a 6" length of #16 or #14 stranded hookup wire, and solder the connection.

Cut the two remaining leads of the primary winding to the same length, scrape away 1/2" of the insulating enamel from each, and solder 6" lengths of #14 or #16 stranded hookup wire to each. These two leads should have a different color code from the center-tap lead to permit easy identification. Flatten all connections against the windings (do not allow the exposed connections to touch each other) and wrap a layer of electrical tape around the entire assembly.

Next, neatly wind the appropriate number of secondary turns (27 for 4-ohm output; 39 for 8-ohm output; 54 for 16-ohm output) over the tape-wrapped primary winding. Solder 6"-long #16 or #16-stranded hookup wire to the ends of these windings. Then tape the assembly as described above.

To assemble the transformer, slide the entire winding assembly off the winding handle and insert the crossbar of each E lamination into the windings core. Interleave these E laminations; do not insert them all in one direction. This done, slip an I lamination into place at the open ends of the E laminations. Replace the corner hardware. Then apply a coat of shellac to all exposed surfaces of the core laminations to provide a weather seal.

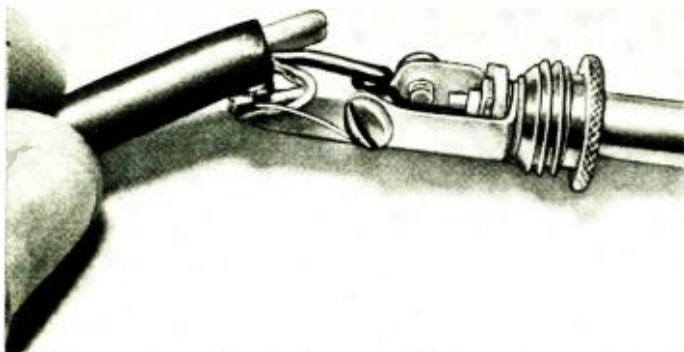

Fig. 5. When connecting plug to microphone cable, use only two shorter contacts. Do NOT allow cables to touch long one.

strip. Now wire *SO1*, and use a length of shielded cable to connect *J1* to the circuit board. Then drill holes through the lower center of the rear panel and inner mounting base of the cabinet, insert a rubber grommet into each hole, and route the power cable through the holes, connecting it to the appropriate points in the circuit. (Note: the power cable should be coded so that the positive lead is clearly identifiable.) Assemble the amplifier case.

Disassemble the two-circuit phono plug that will be connected to the microphone cable. So that you do not make a mistake when connecting the cable, remove and discard the screw on the longest contact lug (there will be no connection made to this lug), and connect the conductors from the microphone cable to the two remaining lugs as shown in Fig. 5: This might appear to be an unconventional hookup, considering that the usual "common" contact is not being used. But this connection must be made exactly as described to prevent damaging the IC when power is applied and a microphone is plugged into *J1*.

Finally, wire the jumper across the appropriate contacts and the proper impedance speaker to its respective contacts of *P1*. Then slide the circuit assembly into the wrap-around case, and bolt the two pieces together.

How To Use. The input impedance of the CA3020 integrated circuit is 50,000 ohms. Although this is a fairly high impedance, the wiring of *J1* described above precludes any possibility that hum will be introduced into the amplifier when the microphone is unplugged. With the

microphone plug withdrawn, the input of the amplifier is short circuited.

Now to use the amplifier, simply plug *P1* into *SO1* and the microphone into *J1*. Being careful to observe the proper polarity, connect the 12-14-volt d.c. source to the power cable. Switch on *S1* and, while talking into the microphone, slowly bring up the volume (rotate *R1* clockwise) until the output sound level is perfect. Make sure, however, that the speaker is facing away from the microphone pickup or you will run into a feedback problem.

Only one precaution remains to be pointed out. The output transistors dissipate considerable heat, so it is necessary that you locate the PA amplifier where air will be allowed free circulation around the rear of the cabinet. If mounting space under the dashboard of your car, for example, is shallow, avoid mounting the PA amplifier there. -50-

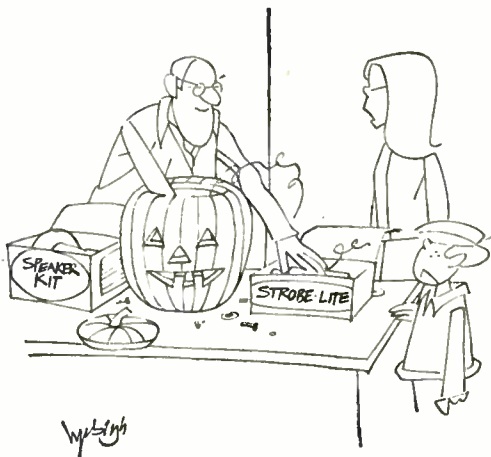

What's wrong with just a candle?

BY PHILIP HARMS

Portable Pulse Generator

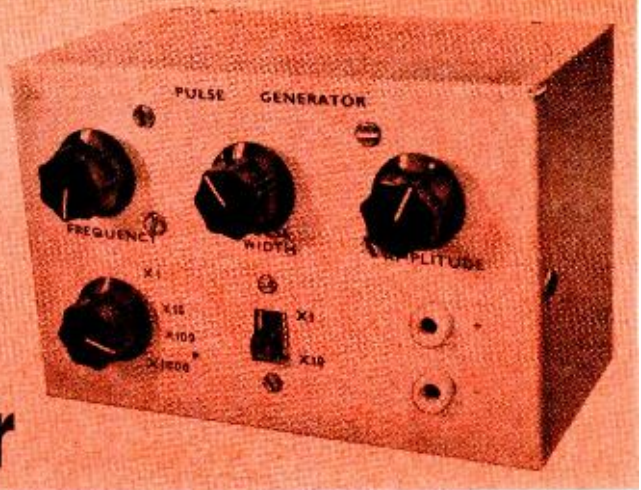

PERFECT TRIGGER SOURCE FOR THOSE DIGITAL PROJECTS

IT'S ELEMENTARY! If you have built or are planning to build one of those digital instruments (timers, voltmeters, counters, etc.) that have become so popular since integrated circuits for digital applications were introduced, you'll need a pulse generator to check it out.

Pulse generators of many varieties are available—to be purchased or built—but most of them are too fancy and/or expensive for the needs of the ordinary experimenter. Here's one you can build for about \$12 (less, if your junk box is well stocked) and it meets all the usual requirements. It is compatible with both IC and discrete transistor circuits and it is adjustable in the three major parameters: pulse width, amplitude, and frequency. Specifications for the generator are given in the Table.

As a frequency source, this pulse generator uses a unijunction transistor, which operates over wide voltage ranges and oscillates from very low audio frequencies up to several hundred kilohertz. Its output trigger is easily adapted to conventional pulse design, and frequency is controlled by varying the applicable timing resistor or capacitor.

The pulse generator is portable, using a 9-volt transistor battery with a current drain of 9 milliamperes, no load.

Construction. The pulse generator, whose schematic is shown in Fig. 1, can

be built in an aluminum box about 6" × 4" × 3". The battery is secured to the rear panel by a metal clip or elastic band.

Assemble the electronic components on a 3" × 1½" piece of perf board as shown in Fig. 2. (The transistor sockets are optional.) The controls and the output jacks are mounted on the front panel as shown in Figs. 2 and 3 and the front-panel photo. The perf board is mounted on stand-off spacers directly over the controls. The capacitors associated with S1 and S2 are mounted directly on the switches. Although component placement is not critical, lead lengths should be kept to a minimum.

The front panel can be lettered using any type of dry-transfer process, following the nomenclature shown in the photograph.

Operation. Although the Table of Specifications for the generator lists a maximum pulse width of 100 microseconds, the generator has a maximum duty cycle of about 75%. This means that, above a pulse width of 75 microseconds, the instrument "cheats" slightly and makes the width of every other pulse slightly narrower than it should be according to the setting of the controls. You will notice this discrepancy if you apply the generator output to an oscilloscope. It does not mean that the generator is not operating properly. If an attempt is made

Exciting New Home & Hobby Kits

New Heathkit® "Component Credenza"



• Combines all solid-state FM stereo receiver, 4-speed automatic turntable with diamond stylus and two full-range, two-way speaker systems into a luxurious Mediterranean cabinet • 15 watts per channel music power output • Full range tone controls • Very low Harmonic & IM Distortion • Excellent channel separation • Transformerless output circuit for minimum phase shift, wide response • Electronically filtered power supply • Stereo headphone jack • Auxiliary input • Filtered tape output • Excellent FM tuner selectivity & sensitivity • 4-stage IF • AFC • Stereo indicator light • SCA filter • High quality BSR McDonald 500A Automatic Turntable with low mass counterbalanced aluminum tone arm plays up to 6 records • Comes with Shure diamond stylus magnetic cartridge • Vernier stylus pressure adjustment • Anti-Skate control • Cue/Pause control • Two ducted-port reflex 2-way speaker systems for performance comparable to fine component-type separate speaker systems • Each system contains 10" high compliance woofer & 3½" ring-damped tweeter for 60-16,000 Hz response • Complete system housed in a magnificent factory assembled Mediterranean cabinet of beautiful oak veneers with solid oak trim • Easy assembly with the famous Heathkit Manual . . . build only the receiver & install the components • The finest value anywhere in quality stereo consoles

Mediterranean Styling . . .
30-Watt FM-Stereo Receiver
. . . 4-Speed Automatic
Turntable . . . Full-Range
Speaker Systems

Real Stereo Performance Demands Real Stereo Components . . . the kind used for custom-designed systems. The new "Component Credenza", as the name implies, integrates separate components into a single functional unit. Here are those components . . .

Component-Quality FM Stereo Receiver. The heart of the new AD-19 is the famous Heathkit AR-14 FM-FM-Stereo Receiver circuitry. The amplifier produces a solid 30 watts IHF music power. The FM Stereo tuner features 5 uV sensitivity, excellent separation and flywheel tuning. The AR-14 has been rated as the best value obtainable in a medium power receiver.

Component-Quality 4-Speed Automatic Turntable with such professional features as Cue/Pause control, Anti-Skate control, adjustable stylus pressure and famous Shure diamond stylus magnetic cartridge.

Component-Quality Speaker Systems. Two independent, ported speaker systems, each with a 10" woofer and 3 x 3½" tweeter deliver 60-16,000 Hz response for remarkable fidelity.

Elegant Mediterranean Oak Cabinet . . . a fine example of cabinet-making, flawlessly executed in oak veneer with solid oak trim. Rigidly constructed using fine-furniture techniques.

The New Heathkit AD-19 "Component Credenza". . . A Masterpiece in sight and sound. Put it in your home now.

Kit AD-19, 158 lbs. \$299.95*



NEW
Kit GR-78
\$129.95*

NEW
Kit GD-209A
\$149.95*

NEW Heathkit GR-78 Solid-State General Coverage Receiver . . . Tunes 190 kHz To 30 MHz In Six Bands

The new GR-78 combines wide coverage, superior performance and portability with sharp styling to provide a remarkable value in general coverage receivers. Tunes AM, CW & SSB signals from 190 kHz to 30 MHz in six switch-selected bands. The all solid-state circuit employs modern FET's in the RF section and 4 ceramic filters in the IF to deliver maximum sensitivity and sharp selectivity. Bandspread Tuning is built-in, and can be calibrated for either Shortwave Broadcast or Amateur Bands. Completely portable . . . comes with a nickel-cadmium rechargeable battery pack and built-in charger that operates from 120 or 240 VAC and 12 VDC. Many built-in features . . . 500 kHz crystal calibrator . . . switchable Automatic Noise Limiter . . . switchable Automatic Volume Control . . . Receiver Muting . . . Headphone Jack and many more. Order yours today. 14 lbs.

NEW Heathkit Deluxe Radio-Controlled Screw-Drive Garage Door Opener Semi-Kit

The next best thing to a personal doorman. The "wireless" factory assembled transmitter operates up to 150 feet away. Just push the button and your garage door opens and the light turns on . . . and stays on until you're safely inside your home. The giant 7 ft. screw mechanism coupled with the ½ HP motor mean real power and reliability and the adjustable spring-tension clutch automatically reverses the door when it meets any obstruction . . . extra safety for kids, pets, bikes, even car tops. Assembles completely without soldering in just one evening. Easy, fast installation on any 7' overhead track (and jamb & pivot doors with accessory adapter). Order yours now. 66 lbs.

Adapter arm for jamb & pivot doors, Model GDA-209-2, \$7.95*

Nov. P. Elec.—No. 3

From The Leader



NEW Heathkit Ultra-Deluxe "681" Color TV With AFT . . . Power Channel Selection & Opt. RCA Hi-Lite Matrix Tube

The new Heathkit GR-681 is the world's most advanced Color TV with more built-in features than any other set on the market. Automatic Fine Tuning on all 83 channels . . . power push button VHF channel selection, built-in cable-type remote control . . . or you can add the optional GRA-681-6 Wireless Remote Control any time . . . plus the built-in self-servicing aids that are standard on all Heathkit color TV's. Other features include high & low AC taps to insure that the picture transmitted exactly fits the "681" screen, automatic degaussing, 2-speed transistor UHF tuner, hi-fi sound output, two VHF antenna inputs, top quality American brand color tube with 2-year warranty. With optional new RCA Matrix picture tube that doubles the brightness, Model GR-681MX only \$535.00.

GRA-295-4, Mediterranean Cabinet shown . . . \$124.95*

Heathkit "295" Color TV

With Optional RCA Matrix Tube . . . with the same high performance features and built-in servicing facilities as GR-681 above . . . less AFT, VHF power tuning and built-in cable-type remote control. You can add the optional GRA-295-6 Wireless Remote Control at any time. New optional RCA Matrix tube doubles the brightness, Model GR-295MX, \$485.00.

GRA-295-1, Contemporary Walnut Cabinet shown . . . \$64.95*

Both the GR-681 and GR-295 fit into the same Heath factory assembled cabinets; not shown Early American style at \$109.95*

NEW Deluxe Heathkit "581" Color TV With AFT

The new Heathkit GR-581 will add a new dimension to your TV viewing. Brings you color pictures so beautiful, so natural, so real . . . puts professional motion picture quality right into your living room. Has the same high performance features and exclusive self-servicing facilities as the GR-681, except with 227 sq. inch viewing area, and without power VHF tuning or built-in cable-type remote control. The optional GRA-227-6 Wireless Remote Control can be added any time you wish. And like all Heathkit Color TV's you have a choice of different installations . . . mount it in a wall, your own custom cabinet, your favorite B&W TV cabinet, or any one of the Heath factory assembled cabinets. **GRA-227-2, Mediterranean Oak Cabinet shown . . . \$109.95***

Heathkit "227" Color TV

Same as the GR-581 above, but without Automatic Fine Tuning . . . same superlative performance, same remarkable color picture quality, same built-in servicing aids. Like all Heathkit Color TV's you can add optional Wireless Remote Control at any time (GRA-227-6). And the new Table Model TV Cabinet and roll around Cart is an economical way to house your "227" . . . just roll it anywhere, its rich appearance will enhance any room decor.

GRS-227-5, New Cart and Cabinet combo shown . . . \$54.95*

Both the GR-581 and GR-227 fit into the same Heath factory assembled cabinets; not shown, Contemporary cabinet \$64.95*

NEW Heathkit Deluxe "481" Color TV With AFT

The new Heathkit GR-481 has all the same high performance features and exclusive self-servicing aids as the new GR-581, but with a smaller tube size . . . 180 sq. inches. And like all Heathkit Color TV's it's easy to assemble . . . no experience needed. The famous Heathkit Color TV Manual guides you every step of the way with simple to understand instructions, giant fold-out pictorials . . . even lets you do your own servicing for savings of over \$200 throughout the life of your set. If you want a deluxe color TV at a budget price the new Heathkit GR-481 is for you.

GRA-180-1, Contemporary Walnut Cabinet shown . . . \$49.95*

Heathkit "180" Color TV

Feature for feature the Heathkit "180" is your best buy in color TV viewing . . . has all the superlative performance characteristics of the GR-481, but less Automatic Fine Tuning. For extra savings, extra beauty and convenience, add the table model cabinet and mobile cart. Get the value-packed GR-180 today.

GRS-180-5, Table Model Cabinet & Cart combo . . . \$42.50*

Both the GR-481 and GR-180 fit the same Heath factory assembled cabinets; GRA-180-2, Early American Cabinet \$94.95*

Add the Comfort And Convenience Of Full Color Wireless Remote Control To Any Rectangular Tube Heathkit Color TV . . . New Or Old!

Kit GRA-681-6, for Heathkit GR-681 Color TV's . . . \$64.95*

Kit GRA-295-6, for Heathkit GR-295 & GR-25 TV's . . . \$69.95*

Kit GRA-227-6, for Heathkit GR-581, GR-481 & GR-180 Color TV's . . . \$69.95*

Now There Are 6 Heathkit® Color TV's To Choose From

2 Models In 295 Sq. Inch Size

NEW

Kit GR-681
With AFT

\$499.95*

(less cabinet)



Kit GR-295

\$449.95*

(less cabinet)

2 Models In 227 Sq. Inch Size

NEW

Kit GR-581
with AFT

\$419.95*

(less cabinet)



Kit GR-227
NOW ONLY

\$379.95*

(less cabinet
& cart)

2 Models In 180 Sq. Inch Size

NEW

Kit GR-481
with AFT

\$359.95*

(less cabinet)



Kit GR-180
NOW ONLY

\$329.95*

(less cabinet & cart)

Reception Is Simulated
On All Sets Shown



a Schlumberger subsidiary



NEW

FREE 1970 CATALOG!

Now with more kits, more color. Fully describes these along with over 300 kits for stereo/hi-fi, color TV, electronic organs, electric guitar & amplifier, amateur radio, marine, educational, CB, home & hobby. Mail coupon or write Heath Company, Benton Harbor, Michigan 49022.

HEATH COMPANY, Dept. 10-68
Benton Harbor, Michigan 49022

Enclosed is \$ _____ plus shipping.

Please send model (s)

Please send FREE Heathkit Catalog. Please send Credit Application.

Name _____

Address _____

City _____

State _____

Zip _____

*Mail order prices; F.O.B. factory. Prices & specifications subject to change without notice.

CL-367

CIRCLE NO. 20 ON READER SERVICE PAGE

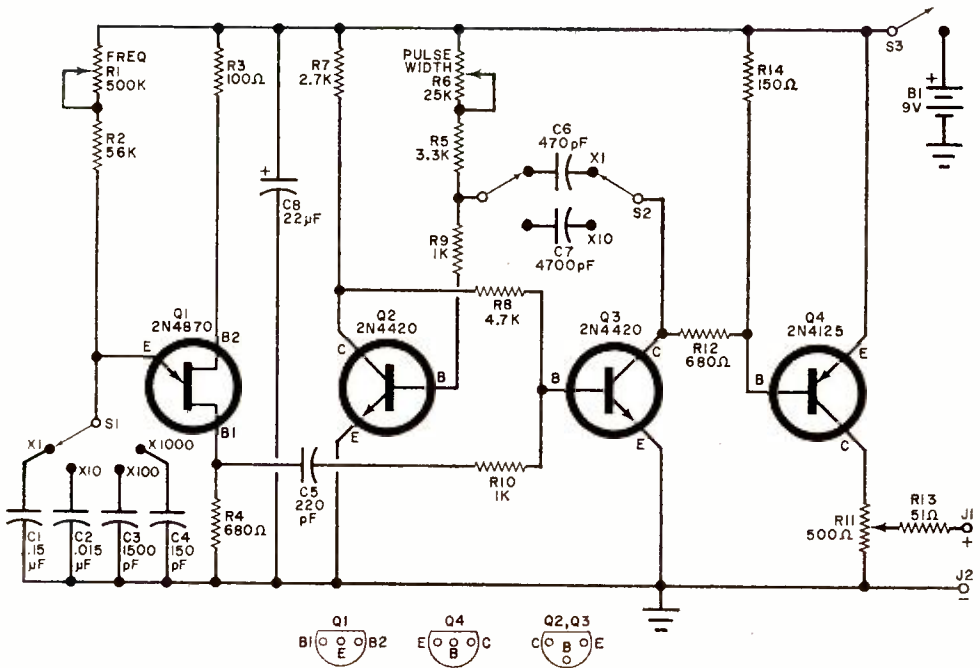

Fig. 1. The circuit consists of a variable-speed UJT oscillator driving a time-adjustable one-shot multivibrator. In this way, the narrow spikes from the UJT are converted into one of two selected output pulse widths.

PARTS LIST

- B1—9-volt battery
- C1—0.15- μ F capacitor
- C2—0.015- μ F capacitor
- C3—1500-pF capacitor
- C4—150-pF capacitor
- C5—220-pF capacitor
- C6—470-pF capacitor
- C7—4700-pF capacitor
- C8—22- μ F, 15-volt electrolytic capacitor
- J1, J2—Banana tip jack
- Q1—2N4870 unijunction transistor
- Q2, Q3—2N4420 transistor
- Q4—2N4125 transistor
- R1—500,000-ohm potentiometer
- R2—56,000-ohm

- R3—100-ohm
 - R4, R12—680-ohm
 - R5—3300-ohm
 - R7—2700-ohm
 - R8—4700-ohm
 - R9, R10—1000-ohm
 - R13—51-ohm
 - R14—150-ohm
 - R6—25,000-ohm linear taper potentiometer
 - R11—500-ohm potentiometer
 - S1—Single-pole, 4-position rotary switch
 - S2—D.p.d.t. slide switch
 - S3—S.p.s.t. switch on R1
 - Misc.—4" x 6" x 3" chassis, knobs (4), battery support, dry-transfer lettering, spaces (4), perf board, transistor sockets (4, optional), wire, solder, etc.
- } All resistors
1/2-watt

to increase the pulse width to more than 100 microseconds, the generator may start to divide the frequency. To insure stable operation, it is good practice to start with a narrow pulse width and then increase it as necessary.

Some times it is necessary to terminate the output in a low impedance. In this case, current drain will increase in proportion to the duty cycle, so it is a good idea to keep the pulse width as low as possible.

A 9-volt battery should give about 48

PULSE GENERATOR TECHNICAL SPECIFICATIONS

- Frequency range: 10 Hz to 100 kHz
- Pulse width: 1 to 100 microseconds
- Amplitude: 0 to 8 volts
- Rise time: 10 nanoseconds at output terminals
20 nanoseconds with 3" coax lead
- Fall time: 35 nanoseconds at output terminals
60 nanoseconds with 3" coax lead
- Output series resistance: 51 ohms
- Power supply: 9 V at 9 mA, no load
- Maximum pulse duty cycle: approximately 75%

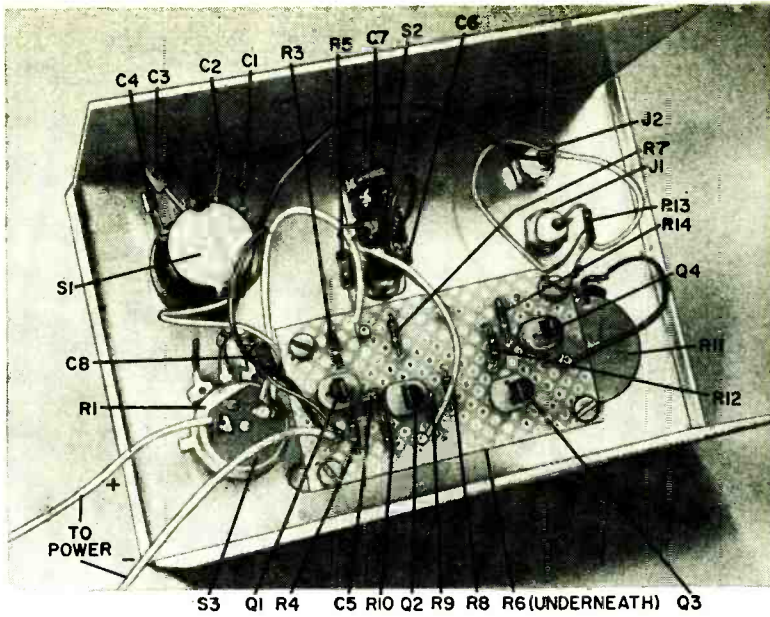

Fig. 2. Underside of chassis shows placement of board components and front-panel mounted controls and terminals.

hours continuous operation in this pulse generator before performance is impaired. If you need more life, use six D cells. Needless to say, the generator should be turned off when not in use.

In checking the rise time of your pulse generator, remember that the rise time you measure can be no better than the

rise time of the oscilloscope you are using. Also remember that, if too long a coaxial lead is used on the output, some degradation of the rise time may result due to capacitance in the cable.

If you want a negative going pulse, simply reverse the output lead. To obtain a negative going pulse which is

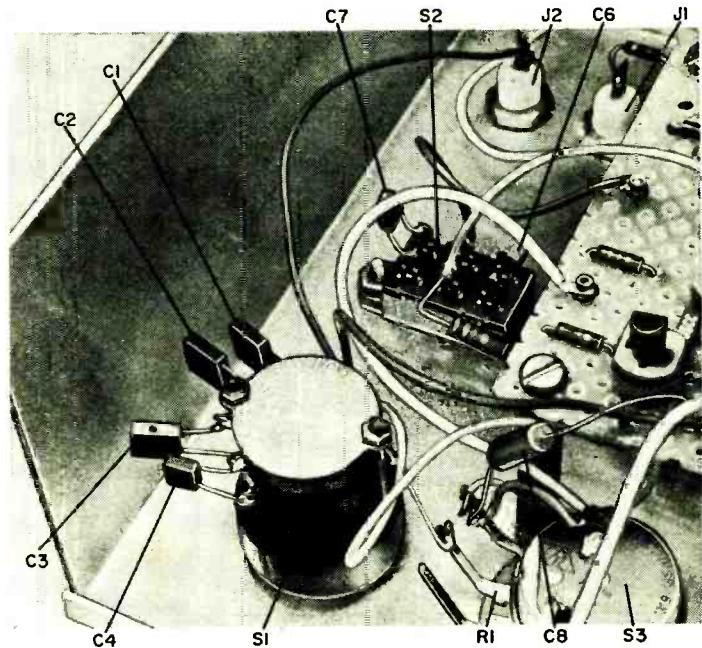
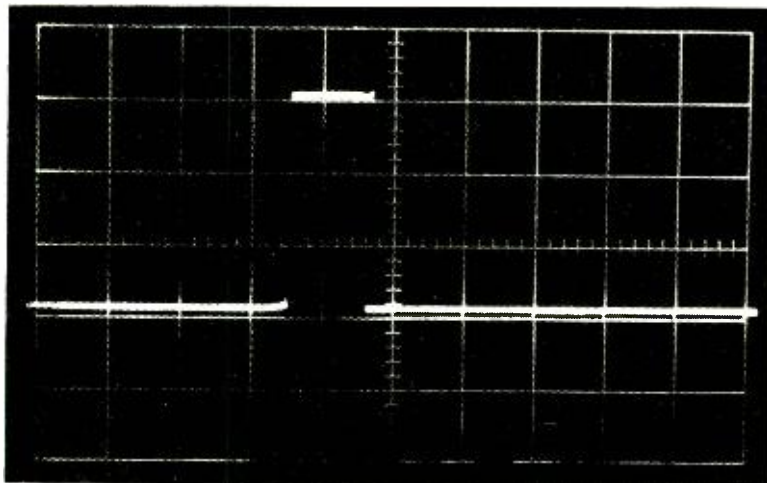

Fig. 3. Close-up view shows oscillator timing capacitors mounted on S1 and multivibrator capacitors mounted on S2. Perf board mounts on spacers.



Typical output pulse shows the extremely rapid rise and fall times on this pulse generator. The width of the pulse can be adjusted by the setting of switch S2.

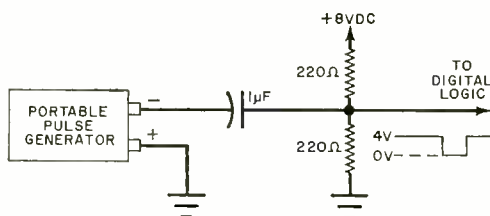

Fig. 4. If you want to drive 4- or 5-volt IC's with pulse generator, this external circuit is needed.

HOW IT WORKS

The basic pulse frequency is generated in the relaxation oscillator circuit containing uni-junction transistor *Q1*. Potentiometer *R1* provides the fine frequency adjustment while selector switch *S1* chooses the applicable multiplier capacitor (*C1* through *C4*). The selected capacitor charges up at a rate determined by *R1* and *R2*. When the capacitor charges up to about two-thirds of the supply voltage, the emitter of *Q1* is forward biased and the capacitor discharges rapidly through the base-emitter junction and *R4*. The resulting pulse is differentiated (narrowed) by *C5* and applied to the base of (*Q3* through *R10*).

Transistors *Q2* and *Q3* form a monostable (one-shot) multivibrator. This circuit is in a stable state with *Q2* saturated (collector voltage near ground) and *Q3* cut off (collector voltage at supply voltage) until triggered by a pulse at the base of *Q3*. This causes *Q3* to turn on, which forces the base of *Q2* negative and turns it off. The selected timing capacitor (*C6* or *C7*) then charges up at a rate depending on the total resistance of *R5* and *R6*. Once the capacitor is charged up, the circuit reverts to its original condition, until the next pulse arrives from *Q1*. The result is a pulse at the collector of *Q3* whose width is independent of the width of the trigger from *Q1* but with a maximum width that must be slightly less than the time between input pulses. Also, the width cannot be reduced to less than that of the input trigger.

The negative (with respect to the supply voltage) pulse at the collector of *Q3* saturates *Q4* and its collector voltage rises, generating an output pulse across *R11*. The latter can be adjusted to give any desired amplitude. Resistor *R13* minimizes overshoot of the output pulse and prevents damage to *Q4* if the output is shorted.

referenced to 4 volts, reverse the leads and use the setup shown in Fig. 4. Since most integrated circuits operate on a 5-volt pulse and can be damaged if too high a pulse is applied to them, it is a good idea to mark the generator's dial at the 5-volt point.

The pulse generator is designed to drive all types of integrated circuits; however some forms require current-drive capability while others supply current back to the generator. The generator will drive several RTL circuits because they draw current from the generator. On the other hand DTL and TTL types use the generator as a current sink and supply current to it. This means that the output resistance to ground must be kept low. Thus if several DTL or TTL circuits are to be driven and long coax cables are used, a buffer IC should be tied into the input of the IC circuit.

-30-

The Stereo Scene

by Charles Lincoln

INNOVATION IS THE NAME OF THE GAME

THAT NEW STEREO receiver with the low, low distortion, the extraordinary FM sensitivity, and all the rest—the one that brought you into the audio shop—how did it get there? What did it take to design and produce such a beautiful, complicated device?

To get the answer, Stereo Scene took a long look inside the process of creation and production of a representative first-grade American stereo unit, the Scott 342C stereo receiver. At the H. H. Scott plant in Maynard, Mass. we got a story that should prove to the audio buyer's satisfaction that the stereo receiver is one of the most remarkable consumer products turned out by any industry. Even a color television receiver, the only comparable domestic device, doesn't meet the exacting standards of performance we expect of a good stereo receiver.

Stereo Scene is dividing this story into two installments. The first, published here, covers the conception and design of the unit. The second, coming next month, tells how the performance abilities of the 342C are safe-guarded in quantity production, a demanding and fascinating process.

For a product to run strong on today's very competitive high-fidelity market, it must embody at least one really good new idea, an idea involving a technical advance that will benefit the user materially. Of course; the idea must be practical and realizable within the cost framework prevailing in the industry. It is worth noting that the intense competitiveness of the American high-fidelity industry has provided many benefits for the audio buyer. He gets *far* more performance for his money than he did 6, 8, and 10 years ago. Consider, for instance, that a stereo receiver like the 342C, which sells for around \$300, includes an FM stereo tuner and two complete hi-fi amplifiers. A high-grade mono amplifier alone cost about the same amount 10 years ago, with no tuner! And today's unit will perform rings around the older one—the difference is almost ludicrous.

The Key—New Ideas. The conception of the 342C included several important new ideas. It was aimed, as we noted before, at the \$300 price bracket. That fact roughly established the power level and general configu-



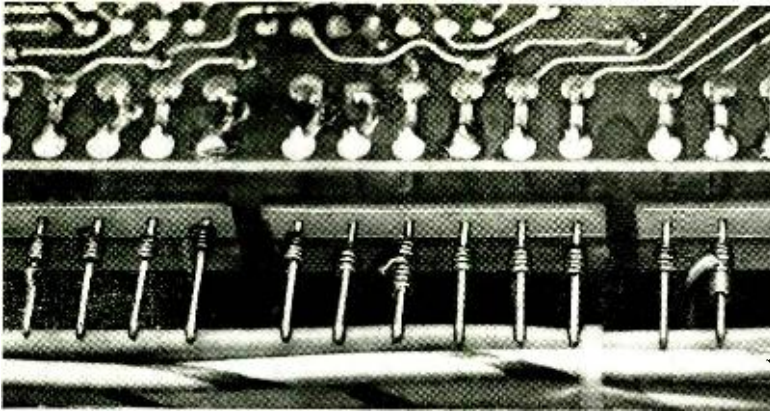

Scott will probably be the first hi-fi manufacturer to use the wire-wrap technique. A special tool tightly wraps the wire around a square metal post. Perfect electrical contact is achieved and the connection is superior to ordinary soldering.

ration of the final stereo system design.

The first of the new ideas was "modularization," the concentration of several vital sections of the receiver on standardized printed circuit units that plug into sockets on the main chassis. Using plug-ins was in large part a response by the engineering department to the growing severity of the servicing dilemma. The dilemma is that technical personnel capable of servicing complex high-fidelity units are getting scarcer all the time, while the units themselves, with dozens or scores of semiconductor devices tucked away in corners, get harder to service.

Now, if a 342C develops a rare fault, servicing is a breeze with plug-in modules. By simple test methods, he can isolate the trouble to one of the modules, and "fix" it simply by plugging in a new one. In a sense this takes us back to the "leap-frogging" method, when the radio-TV serviceman simply put a new tube into one socket after another until the trouble cleared.

The modularization idea made the most sense, the Scott engineers decided, if they could develop a set of standard modules that would be usable in a variety of stereo units. (The name "modules" implies this.) The functions finally chosen for modularization were the i.f. strip, the FM multiplex decoding section, the tone control section, the audio preamplifier, and the audio driver (two of the last for a stereo unit). Thus the design of the 342C was firmed up around those five standard units. The modules themselves, having been designed and tried out successfully in the 342C, are likely to turn up in other Scott stereo units.

The module story tells us quite a bit about the kind of engineering a hi-fi manufacturer needs in order to develop quality products—the engineering that goes into any

receiver in the audio shop worth your unqualified admiration. The manufacturer must have a competent engineering team to originate both radio and audio design that will do a better job, at a practical cost. That demands a high level of creativity and long experience in turning creativity into practicality.

Integrated Circuits Make the Scene. Another important step in the conception of the 342C was the introduction of integrated



This is where it all ends—on the "burn-in" rack. These are model 342C's being individually tested before packaging. Details on the exhaustive test procedures will appear in the next "Scene" column.

circuits (IC's). As electronics enthusiasts know, these tiny, complex semiconductor devices contain whole sections of i.f. and audio amplifier circuits, the equivalent of scores of resistors, transistors, capacitors, etc. in one small unit. There will be wider use of IC's in stereo circuits, because, compared to circuits assembled from separate parts, IC's save space, eliminate dozens of soldered connections, speed production, and are potentially much more reliable.

Scott units already used IC's in the i.f. section. Now their use was extended to the preamplifier and FM multiplex sections. Since there were no available IC's of the right types for these circuits, Scott engineers worked closely with a semiconductor manufacturer to develop the necessary devices. As an example of what they came up with, the IC for the multiplex section is the equivalent of 40 transistors and 27 resistors!

Also aimed at reliability and easier, faster manufacture was a decision to use the wire-wrap technique for many of the connections on the chassis outside the printed circuit modules. The Bell Telephone Company perfected the wire-wrap system to reduce the trouble they had with the millions of soldered connections in telephone central offices and exchange equipment. In the wire-wrap system, a powered hand tool wraps several turns of the wire around a square connection post so tightly that the corners of the post bite into the wire and hold it permanently in place. You can't have a bad connection that looks good, as you can with a "cold" solder joint. The wire is either on the post for good or it doesn't stay at all. It's faster than soldering and takes less human operator skill; the skill is in the tool.

Another design decision was to use crystal i.f. filters to couple one stage to the next, instead of the tunable transformers that had always been used. Crystal filter coupling is coming into hi-fi receivers from satellite and space electronics. It has been used in one or two stereo receivers of a considerably higher price than the 342C. Crystal filters sharply reduce one of the most troublesome servicing problems: keeping the FM tuner in alignment (crystal filters never need retuning). They also have better pass-band characteristics, with broad, flat "tops" that pass the whole FM signal and a sharp cut-off for high selectivity.

Direct Output Coupling. The audio output circuit is representative of the type of amplifier design that was not possible before vacuum tubes were replaced by semiconductors. The output transistors are direct coupled to the speaker voice coil in each channel to eliminate the usual large-value

coupling capacitor—a source of much trouble. Careful balancing of the circuit keeps d.c. out of the speaker. The output amplifier is also free of distortion at low-power output levels that used to occur in many transistor amplifiers.

Something of a gimmick, but one that really helps, is "Perfectune," a circuit that turns on a special panel light when you are exactly tuned to the center channel of an FM station—a prerequisite for low distortion and noise. For many years, of course, tuning meters and electric eyes have told us where we were tuned on FM. But a circuit like Perfectune is more precise than the human eye focussed on a moving meter needle, in finding the exact center-channel point. Scott's engineers believe that, as ste-

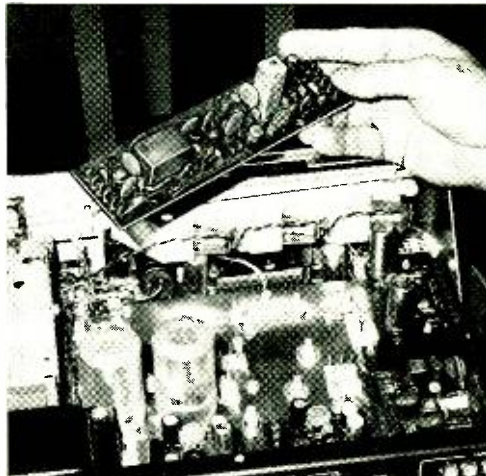

Another innovation being introduced by Scott will be the modularization of certain circuits. The obvious advantage will be to pass along to the customer monetary savings in ease of replacement.

ereo equipment becomes more complex, there will have to be more automation of control functions similar to the Perfectune. They see this as an important future trend in stereo design.

What we've described above are obviously just a few of the design decisions that are made in developing an advanced stereo receiver. But these items illustrate the kind of creative thinking that went into the stereo receiver on the audio shop shelf.

Model-Building Time. After the thinking, and the paper work that goes with it, there are four more long steps before a new receiver actually goes into production. First comes "breadboarding," with what look like jumbles of resistors, capacitors, IC's and transistors twisted together on the lab bench and connected to signal generators, os-

cilloscopes, and meters. Each circuit can be tried out this way with maximum ability to change things around. If a resistor, for example, turns out to be the wrong value, another can be connected in a few seconds.

Once the circuits have been proved out in this disciplined helter-skelter, an "engineering model" is built. This is the complete receiver with everything in its approximate place on a chassis of the desired size and shape. The model is put through extensive laboratory measurements and listening tests in a special reverberant room—as well as in rooms designed to be representative of actual use surroundings. The stylist studies the "model" carefully to develop a cabinet and front-panel layout.

When everybody is satisfied with the electrical and physical design, 25 or 30 "pilot models" are built of the final design. Scott considers this pilot model stage extremely important. Pilots are given to executives of the company, neighbors, and work-

ers in the plant for home trials of several days to a week. Does the user like the way the unit operates? Any problems? Each trial user makes a full, carefully detailed, subjective report.

Since early in the design process, the manufacturing division has been working up a complete plan for producing the unit in quantity. This is an entirely separate problem from designing the unit, and an extremely complex one that takes a different set of specialized skills. By the time the pilot models have passed the shake-down, manufacturing is ready to go. That part of the 342C story will be told in next month's Stereo Scene.

Are you beginning to get an idea of what it took to put that stereo receiver, bright and shiny, on your audio dealer's shelf? Such products are innovative in the extreme, combining the knowledge and experience of a wide variety of engineers and designers in a very demanding field.

-30-

FIELD EFFECT TRANSISTOR PROJECT KIT

Although the field-effect transistor (FET) was developed long before the bipolar transistor, the FET has not been widely used until the last few years. In general terms, the FET exhibits many of the desirable characteristics of a triode vacuum tube in that it has a very high input impedance—up to 100,000 megohms in some cases, while still retaining some characteristics of the more common bipolar transistor (low operating voltage for example).

The FET differs from the more conventional bipolar transistor in the method of operation. Whereas a bipolar acts like a pair of back-to-back diodes, the FET is more like a high-speed, electrically variable resistor, whose instantaneous resistance is controlled by an electric field.

What held the FET back? Besides price, (it was high due to lack of demand), the big obstacle was a high noise factor. However, intensive research, improved materials, and advanced manufacturing techniques have led to a semiconductor product that holds great promise of becoming one of the stalwarts of the semi-conductor realm.

Things have gotten to the point where the ordinary electronics experimenter can now afford to play around with FET's. In line with this, Motorola is now introducing its HEK-2 HEP Field Effect Transistor Experimenter Kit (at most electronics suppliers for \$3.95). The package contains a pair of FET's—one for

d.c. to medium r.f. frequencies, the other for much higher frequencies—and a pair of conventional bipolar transistors to be used with the FET's. With the kit is a brochure entitled "Tips on Using FET's," which not only covers the theory of operation of the various types of FET's, discusses their various parameters, and tells how to test them, but also includes nine practical projects using the devices in the kit.

The projects include a three-semiconductor relay which consists of a basic circuit that can have one of three functions: timing from 5 to 50 seconds; detecting moisture (one drop of rain); or detecting the presence of light on a photo device. Other projects: a touch switch that operates a relay when a metal plate is contacted by a fingertip; a sound-activated relay controlled by any sharp sound such as the clap of the hands; a d.c. amplifier for extending the range of a scope, VTVM, etc.; a microphone or phono preamplifier; and a simple audio preamplifier with a high input impedance. For those interested in r.f. work: a broadband r.f. preamplifier with a range of 1 to 40 MHz and gain up to 100. And for the ham: a 14-dB gain, low-noise, 2-meter (150 MHz) preamplifier.

The HEK-2 kit is a good companion to the Motorola booklet "Field Effect Transistor Projects," priced at \$1.00.

the product gallery

REVIEWS AND COMMENTARY ON ELECTRONIC GEAR AND COMPONENTS

GLOBE PLOTTER (Megart Company)

THIS REVIEWER is always fascinated by new products that demonstrate originality—particularly if the simplicity of the product resolves a long-standing problem. This is the case with the Megart "Globe Plotter" (\$17.95). For years, hams and SWL's have tried all sorts of tricks to "visualize" the great circle route of a DX signal. Probably the most common solution is to hang a great circle map on the wall. This works, but you'll find it impossible to buy a map less than three feet square and none that is suitable for just about any QTH. Also, the flat map leaves something to be desired—it doesn't "feel" quite right.

Megart is offering this cute globe that you arrange on a moveable pedestal to suit your own requirements. The globe measures 6" in diameter and is up-to-date. The printing is clear and there are ample country, city, and island identifications to suit almost any DX'er.

You'll find on unboxing the Plotter that the globe is free of its pedestal. You then

move the north pole around toward the guide wire facing the mirror and spot your QTH right under the aiming circle at the top of the frame work. Rotate the degree circle (holding the globe) so that it lines up with the north pole and, once you are satisfied that everything is in place, put 3 spots of glue on the pedestal uprights.

Now, as you rotate the degree circle, the world rotates around your QTH and the front wire guide tells the aiming azimuth toward a DX signal. Or, conversely, putting a DX station under the guide shows the path a signal follows to get to your QTH.

The value of the Plotter to hams with rotatable beams is obvious; perhaps not so obvious, however, is its value to SWL'ers. After using the Plotter for several weeks we realized that, when switching back and forth between two receiving antennas we were plotting the antenna lobe patterns. One antenna was great on 19 meters to Europe, but another antenna was better only 20° further east of north for stations in the Azores. Now as DX signals are heard and identified, we know which antenna to use and what countries "next door" to look for.

Circle No. 92 on Reader Service Page 15



World globe is positioned with your locations directly under the aiming circle at the top junction of the wire grids. North pole is set at 360° and globe glued in place. As degree dial rotates, the world revolves around your ham shack or SWL listening post.

Mirror is used to see locations below earth's curvature. Aiming location is 80° east of north from New York which is azimuth to Madagascar and Ft. Lamy, Chad Republic.

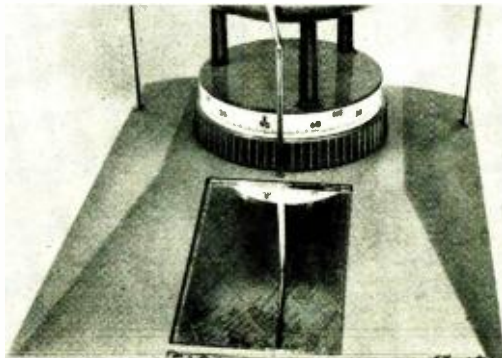

PROGRAMMABLE RECEIVER

(R. L. Drake Co. SPR-4)

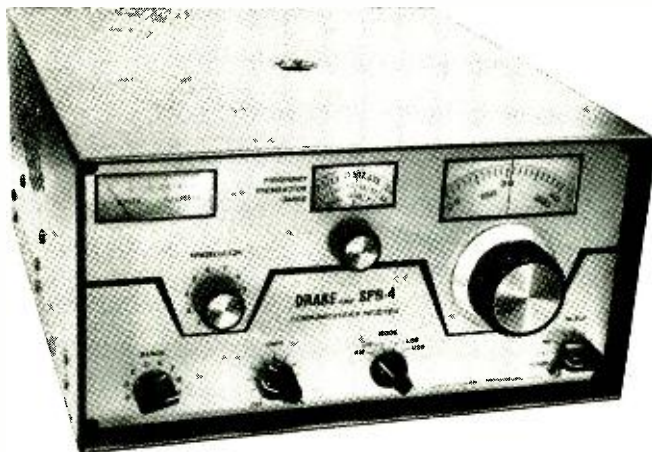

IF, AS CERTAIN advertisements say, you have a friend at such-and-such a bank, the shortwave listener is equally fortunate since he has an enthusiastic friend at R.L. Drake Co. The SWL got an inkling of this in 1966 when Drake introduced the SW-4 (now SW-4A) receiver. This was a product that tuned only the long-wave, medium-wave and short-wave broadcasting bands. The crystal-controlled front end permitted excellent linear dial calibration and the SWL could read out a frequency to better than one kilohertz.

The next logical step after the success of the SW-4 series was to go from tubes to solid-state, add more tuning ranges, add an internal speaker and tape recorder output, improve the selectivity, add optional noise limiting and crystal calibration, etc. It sounds like a big order, but Drake has fulfilled it in the brand new SPR (Solid-state Programmable Receiver)-4.

POPULAR ELECTRONICS had the opportunity to field-test one of the half dozen prototypes of the SPR-4. Matched against the SW-4A, there were some pretty outstanding differences. First, the dial mechanism has been simplified and made a little smoother (SW-4A and R-4B users, please note) and second, the selectivity is really meaningful. In fact, the SPR-4 has 3 selectivity positions that are automatically switched into the circuit as you move from straight AM (4.8 kHz at 6 dB down), to SSB (2.4 kHz), to CW (0.4 kHz). The skirts are much steeper and signals are easier to separate. As opposed to the 16-kHz-wide selectivity of the SW-4A (at 60 dB down), the SPR-4 is rated at 10 kHz

(-60 dB) a really meaningful improvement.

Band selection and r.f. tracking on receivers similar to the SPR-4 have always constituted a problem. However, this has been solved by putting notations on the main Frequency Preselector Range dial using numerals and letters. The SPR-4 also has two thumb lever controls: one for an r.f. gain potentiometer, the other for selecting operation with a Noise Blanker or a Calibrator (both optional at extra cost) in the circuit. It is obvious that considerable thought has gone into making the SPR-4 more functionally useful for SWL's as well as laboratories, hams, etc.

In listening tests with the prototype, sensitivity and signal-to-noise ratio on all the short-wave bands were equal to a receiver costing 3 times as much. Selectivity was better. Medium-wave reception using the

CAPSULE CIRCUIT INFORMATION

R.L. Drake SPR-4: All solid-state (dual-gate FET's) dual-conversion 24-band superhet, tuning 150-500 kHz and any of 23 ranges 500 kHz wide between 0.5 and 30.0 MHz. May be supplied to tune 0.5-1.0, 1.0-1.5, 6.0-6.5, 7.0-7.5, 9.5-10.0, 11.5-12.0, 15.0-15.5, 17.5-18.0, and 21.5-22.0 MHz. Three band-widths determined automatically by reception mode (AM, SSB, or CW). R.f. gain control. Built-in speaker. Built-in provisions for Notch Filter. Noise Blanker, 25-kHz crystal calibrator. Loop antenna input. May be used on d.c. with optional power cord. Manual fine adjustment for dial calibration. \$375.00.

loop proved interesting and locals could be nulled out without difficulty. Reception of SSB and CW was at least comparable to the Model R4-B—clean and easy.

Our only arguments with the prototype (one of which was immediately corrected and won't be discussed here) concerned the S-meter sensitivity (200 microvolts for S9)

and the placement of the headphone jack on the rear skirt (inconvenient to reach). Both of these may be modified before production models are delivered to the public.

All in all, the SPR-4 is a fantastic value and we'd say snap one up before the price goes up.

Circle No. 95 on Reader Service Page 15

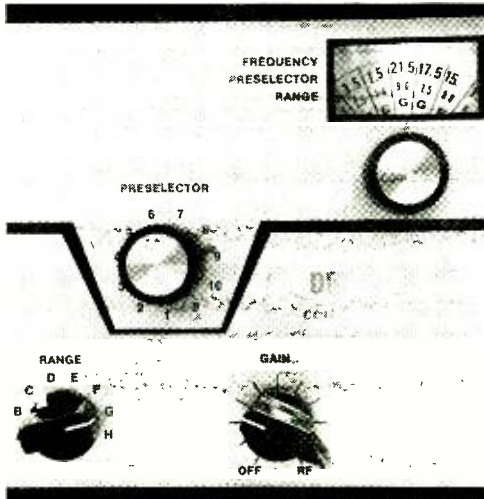

Don't get upset! We "phantomed out" the S-meter to emphasize the tie-in between the Range selector, Preselector and Range controls. Note the illuminated dial shows where each control is to be set.

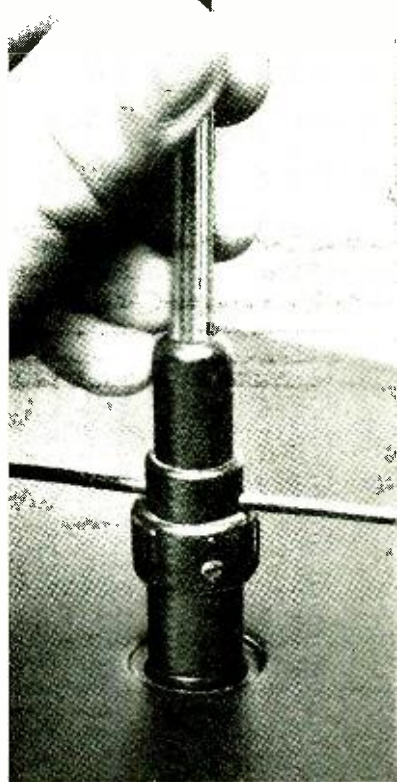
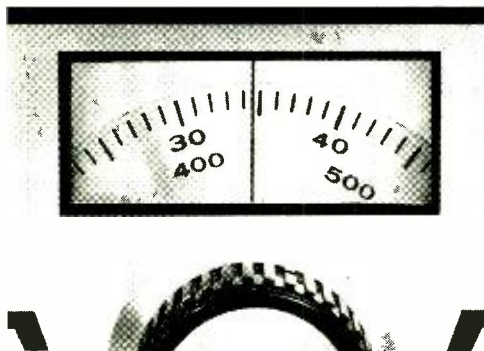

Base of rotatable loop antenna plugs into top of the SPR-4. It is fed to an internal amplifier and is rotated to null out local medium-wave broadcasters. New dial design (left) has two rotating translucent discs—one calibrated in units and the other in hundreds. Add the figures shown to Range position and the frequency is 21.935 MHz.

INS RECEIVER

Two thumb lever controls under the Gain and Notch knobs are for r.f. gain and either noise blanker or 25-kHz crystal calibrator use respectively.

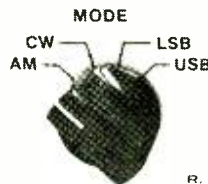

R. L. DRAKE COMPANY, MIAMISBURG, OHIO

ENGLISH LANGUAGE NEWS BROADCASTS FOR THE MONTH OF NOVEMBER

Prepared by **ROGER LEGGE**

TO EASTERN AND CENTRAL NORTH AMERICA		TO WESTERN NORTH AMERICA	
TIME-EST	STATION AND LOCATION	FREQUENCIES (MHz)	STATION AND LOCATION
		FREQUENCIES (MHz)	
7:00 a.m.	Peking, China	11.685, 15.095	Tokyo, Japan
7:15 a.m.	Melbourne, Australia	9.58, 11.71	Stockholm, Sweden
	Montreal, Canada	9.625, 11.72	Tokyo, Japan
7:30 a.m.	Stockholm, Sweden	15.315	Melbourne, Australia
7:45 a.m.	Copenhagen, Denmark	15.165	Bonaire, Neth. Antilles
6:00 p.m.	Montreal, Canada	9.625, 11.945, 15.19	Johannesburg, South Africa
7:00 p.m.	London, England	6.11, 9.58, 11.78	London, England
	Moscow, U.S.S.R.	7.15, 9.685, 11.87	Madrid, Spain
	Peking, China	15.06, 17.673	Peking, China
	Sofia, Bulgaria	9.70	Prague, Czechoslovakia
7:30 p.m.	Johannesburg, South Africa	9.705, 11.875, 15.22	Seoul, Korea
	Kiev, USSR (Mon., Thu., Sat.)	7.28, 9.685	Taipei, Taiwan
	Stockholm, Sweden	5.99	Berlin, Germany
7:50 p.m.	Brussels, Belgium	6.125	Stockholm, Sweden
	Vatican City	6.145, 9.615, 11.785	Tirana, Albania
8:00 p.m.	Berlin, Germany	9.50, 9.73	Budapest, Hungary
	Budapest, Hungary	6.234, 9.833, 11.91	Havana, Cuba
	Havana, Cuba	9.525	Lisbon, Portugal
	Madrid, Spain	6.14, 9.76	Moscow, USSR (via Khabarovsk)
	Prague, Czechoslovakia	5.93, 7.345, 9.54, 9.63	Peking, China
	Rome, Italy	6.01, 9.575	Sofia, Bulgaria
8:30 p.m.	Berne, Switzerland	6.12, 9.535, 11.715	Kiev, USSR (Mon., Thu., Sat.)
	Bucharest, Rumania	9.57, 11.94	Berne, Switzerland
	Cologne, Germany	6.075, 9.735	Cologne, Germany
	Tirana, Albania	6.20, 7.30, 9.50	Havana, Cuba
9:00 p.m.	Hilversum, Holland (via Bonaire)	11.73	Hilversum, Holland (via Bonaire)
	Lisbon, Portugal	6.025, 9.68, 11.935	Quito, Ecuador
	London, England	6.11, 9.51, 9.58	Tokyo, Japan
	Moscow, U.S.S.R.	7.15, 9.695, 11.87	Moscow, USSR (via Khabarovsk)
	Peking, China	15.06, 17.673	Havana, Cuba
			9.735, 11.85, 15.18
			11.93



SOLID STATE

By LOU GARNER, Semiconductor Editor

LASER IN THIN FILM

BY USING a prism to couple a laser beam into a thin semiconductor film, scientists at the Bell Telephone Laboratories (BTL) have taken a promising step toward the integration of lasers and thin-film solid-state circuits. In the future, this technique could lead to the development of miniature laser amplifiers, light modulators, harmonic generators, and parametric oscillators, all of which would be useful in laser communication systems. In such miniature laser circuits, light beams would flow through thin transparent crystal layers, much as electricity flows in the copper wires of conventional circuits.

The basic idea of combining solid-state and laser technologies is not new; but before effective techniques could be developed, it was necessary to devise an efficient and practical means of putting laser beams into thin films.

Previous attempts concentrated on directing the beam through the film's edge. However, the ragged edges of semiconducting films tended to scatter the beam. In addition such films generally are much thinner than laser beams, often thousands of times thinner. Even if a beam could be focused down to the size of the film, the required precise alignment of the beam and film made this approach impractical.

In the BTL arrangement, the base of a

rutile prism is placed parallel to the film, but at a precisely controlled distance from it, to form a *coupling gap*, as illustrated diagrammatically in Fig. 1. The laser beam, entering the prism through its longest side, reflects from the base, according to the laws of optics. Contrary to convention, however, not all the laser energy is reflected.

Instead, a portion of the light waves "tunnels" out of the prism base, generating electric and magnetic fields which travel along the coupling gap at a speed set by the angle of incidence and the frequency of the laser beam. Under proper conditions, these fields transfer the laser energy into the film. Initial experiments have shown that over 50 per cent of the incident laser energy can be transferred into the film, while theoretical calculations predict a transfer efficiency as high as 80 per cent.

The light waves developed in the semiconductor film travel through it very much as do electromagnetic waves in waveguides . . . that is, in predictable and distinct patterns of vibration, or modes. Acting somewhat as a dielectric waveguide, then, the film can support a number of different modes, each with its own characteristic speed of propagation. The different modes do not interfere with each other.

One major advantage of the prism-film coupler is that it can excite any selected one

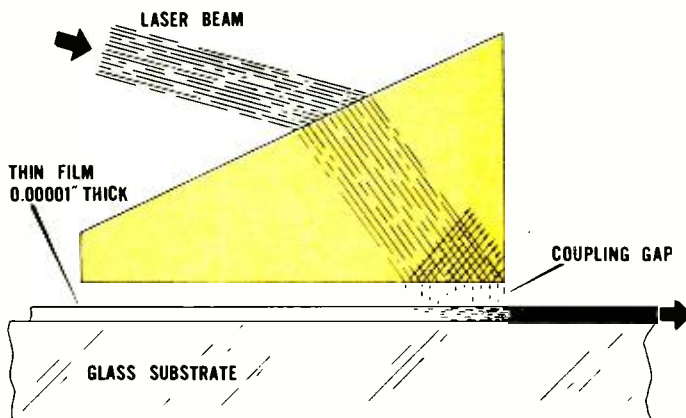

Fig. 1. Using a rutile prism placed parallel to thin film, laser beam can be made to enter film and travel through it like regular electromagnetic waves in standard waveguides.

of the possible modes simply by directing the laser beam at a proper angle, relative to the film.

The new technique is expected to be useful in a number of applications. Typically, it might be used to split light beams into different wavelengths to form separate channels of a laser communication system. Within the film, the beams could be modulated or amplified. Then the beams would leave the thin film via another prism-film coupler and travel to the destination point, probably along an underground "pipe line." At the destination, these beams again could be coupled into thin film circuits for signal processing.

Reader's Circuit. Intended for use in equipment employing electromechanical devices (motors or solenoids) as well as electronic circuitry, the dual-output power supply whose schematic is shown in Fig. 2 was submitted by reader Albert H. Reichel, Jr. (Rd. 2, Box 419, Monongahela, Pa. 15063). It can be used in control units, tape recorders or record players. Featuring a noncritical design and standard components, the project can be assembled in two or three evenings or on a weekend. The unit can supply up to 12 volts at 1 ampere through a single output stage, somewhat less if both outputs are used simultaneously.

All the items required for project assembly are readily available. Diodes *D1* through *D4* are 100-PIV, 1-ampere rectifiers similar to GE type A14A. Transistors *Q1*, *Q2*, and *Q3* are general purpose *pnp* power units, type 2N554 or equivalent, while *D5* is a 1-watt zener diode, with its voltage rating selected to meet individual circuit needs. Motorola types HEP-104 (9.1 volts) or HEP-105 (12 volts) are suitable. Capacitors *C1*, *C2* and *C3* are 15-volt electrolytics, while all resistors are half-watt types. A 12.6-volt, 1- to 2-ampere filament transform-

er serves as *T1* (typically, Stancor type P-8130 or Triad type F-25X).

In common with most power supply circuits, neither parts placement nor wiring arrangement is critical, and virtually any construction technique may be used for assembly: perf board, chassis, breadboard, or etched wiring, as preferred. All d.c. polarities must be observed, of course, and the power transistors (*Q1*, *Q2* and *Q3*) should be mounted on suitable insulated heat sinks. The completed unit can be installed in a metal enclosure or a commercial instrument cabinet, with either binding posts or plug-type jacks used as output connectors.

Generally speaking, regulated output "A" (Fig. 2) is used to power electronic circuitry, while output "B" is used to operate auxiliary motors or electromechanical devices (a turntable motor in a record player, for example). If only a single power source is needed, as in a radio receiver or audio amplifier, the isolated auxiliary output stage (*Q3*, *R5*, *R6*) may be omitted.

Manufacturer's Circuit. The touch-switch circuit illustrated in Fig. 3 was abstracted from "Tips On Using FET's," Bulletin No. HMA-33, published by Motorola Semiconductor Products, Inc. (Box 20924, Phoenix, Arizona 85034). Other projects in the publication include d.c., audio, r.f. and i.f. amplifiers, a sound-activated relay, and a general-purpose circuit which may be used as a timer, moisture detector, or light controlled relay. All the projects use low-cost components and are suitable for home assembly.

The touch switch is essentially a three-stage, direct-coupled amplifier. A FET, *Q1*, is used in the first stage to achieve an extremely high input impedance. In operation, the small control signal picked up on the metal touch plate changes *Q1*'s instantaneous gate bias, supplying a d.c. signal to
(Continued on page 105)

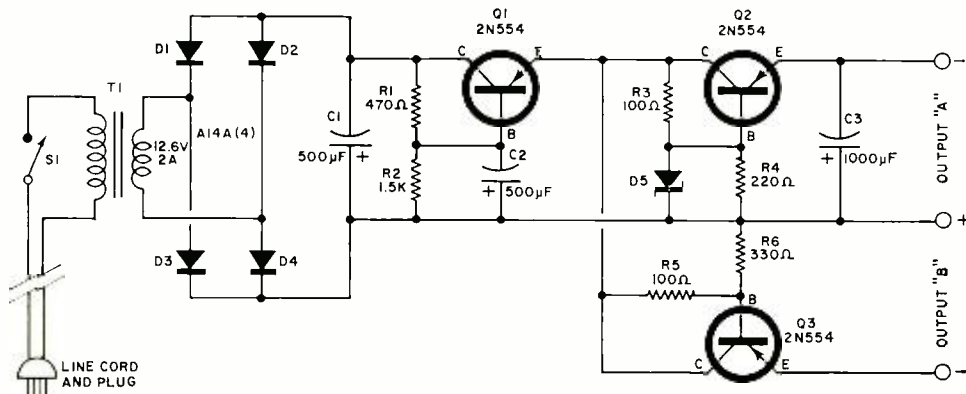

Fig. 2. Power supply to control electromechanical devices has two outputs of 12 volts at 1 ampere.



TWO WAY REACTIONS

BY G. H. REESE, KCN6990

NEW PROGRAM IN NEBRASKA

NEBRASKA CB radio operators are being asked to serve as volunteer reporters in a new experimental program. This program will be known as PROJECT 20/20 and will research means to improve the handling of emergency and disaster messages. Also under study will be the prompt detection of such emergencies.

One of the significant weaknesses in emergency reporting systems—especially critical in rural areas—is the time lapse between the occurrence of an emergency or accident and the subsequent detection and notification of proper authorities. The usual information sources (state police patrols, county sheriffs, local police, the casual passersby, etc.) fail to insure rapid detection of even the most ordinary emergency or accident.

PROJECT 20/20 will coordinate a wide variety of reporters/travellers into a Volunteer Highway Surveillance System, known as NERS (Nebraska Emergency Reporting System).

Incorporated into NERS will be the reporting capabilities of several information sources:

NEBRASKA COUNTIES IN NERS

Adams	Howard	Otoe
Cass	Jefferson	Pawnee
Clay	Johnson	Richardson
Fillmore	Lancaster	Saline
Gage	Merrick	Sherman
Greeley	Nance	Thayer
Hall	Nemaha	Valley
Hamilton	Nuckolls	Webster

1. State and county two-way radio-equipped vehicles which are on the road a major portion of the time—Departmental Roads, Agricultural Extension Agents, etc.
2. Vehicles that operate in rural areas on a regular schedule—RFD mailmen, milk tank trucks, bakery trucks, etc.
3. Citizens Radio volunteer groups.

The state of Nebraska has been divided into 8 Civil Defense emergency areas, and the 24 counties listed in the table are within two of these areas being utilized for PROJECT 20/20. Each CB area will eventually have a centrally located Emergency Operating Center (EOC) equipped to communicate on designated emergency frequencies in each of the public service, industrial, business, military, governmental, and citizen's radio bands.

When notification of an emergency is received the location of the incident is plotted on a grid map, and the type of assistance required is determined. Selection of the assistance (police, fire, ambulance, doctor, etc.) nearest to the scene and best equipped to handle the emergency is made by a computer. The memory banks of the computer contain a central information source listing all of the services available within the Emergency Operating Sector. The computer readout is in the EOC, whose operator then telephones for the service required.

While some phases of this experimental system are not in full operation, the system will eventually be statewide and may serve as a model for national expansion.

Recently, Henry B. Kreeer, REACT National Director, and Arthur Underwood



Citizens Radio operators who are part of Nebraska Emergency Reporting System will display this symbol.

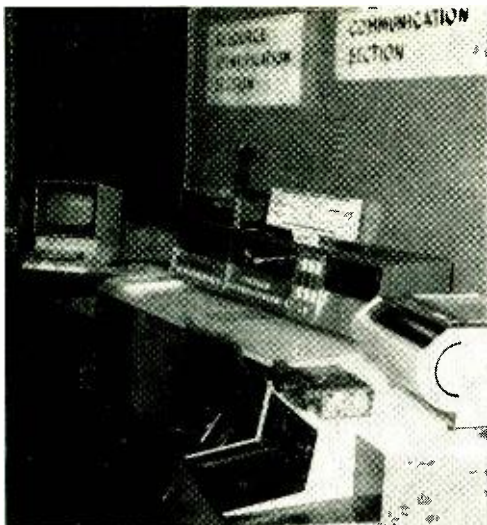

Communications Center for Project 20/20 is a model of its type. Computer display provides information as to proper agency to notify in emergencies.

Manager of General Motors Research Laboratories, visited PROJECT 20/20 headquarters at Lincoln, Nebraska for a first-hand look at the test facility. They returned with a glowing report of the fine work being accomplished under the direction of Brig. General D. G. Pentermann, Deputy Adjutant General of the State of Nebraska.

Citizens Radio users in the 24 Nebraska counties tied into the system are invited to enlist as NERS volunteers. This may be done as an individual, as an entire CB club, and as a REACT team. For information on how to become a NERS monitor, write to: Mr. John P. Nelson, Staff Assistant, PROJECT 20/20, 1300 Military Road, Lincoln, Nebraska 68508.

Travelers with citizen's two-way radio equipment will be able to call NERS monitors on channel 9 for assistance.

FCC Action. The FCC has requested comments on a proposed rule-making action that would amend the current Part 95 rules to exempt the use of CB radio to relay traffic information to licensed broadcast stations. This action is a result of a petition filed by National Capital REACT, Inc., Washington, D.C.

The change was requested after the FCC indicated that a proposed CB system of reporting traffic conditions to the AAA for subsequent broadcast was ruled in violation of the rule against transmitting messages for third parties. The FCC has now indicated that it intends to permit CB radio to be used for relaying traffic information for broadcast by licensed radio stations—and only that purpose! The public service aspects are apparently going to be recognized in this case and official approval may have been granted by the time you read this.

REACT National Headquarters has submitted its endorsement of the proposal along with the other leading CB organizations.

CB From A Wheelchair. Some of the most active Citizens Radio users are physically handicapped. Many find that CB radio opens a whole world that would otherwise be lost to them. For example, Ed Powell, Jr., KPK2106, of Chicago, Illinois, may be confined to a wheelchair, but his CB activity has given him the ability to reach out into the Chicago area and "meet" people while helping them.

Ed says that an interest in electronics led him into CB. After being licensed for 3 months, he joined a local REACT team and spent many hours monitoring Channel 9. During the record Chicago snow storm of 1967, he maintained contact with a number of local radio and TV stations, providing them with information about the emergency conditions as reported to him via CB radio.

Ed says, "When a young person is con-
(Continued on page 102)

Ottawa Valley (Ontario, Canada) REACT team uses this trailer unit as a field base station.





SHORT-WAVE LISTENING

By **HANK BENNETT**, W2PNA/WPE2FT
Short-Wave Editor

MORE ON THOSE OLD QSL CARDS

FAR MORE than just casual interest has been shown in our discussion of old-time QSL cards (see April and July 1969 issues). Mr. Albert J. Sauerbier, WPE2NDA, of Washington, N. J., officer of the Newark News Radio Club, writes that he prizes as his oldest QSL's those from WSB, "The Voice of the South," Atlanta, Ga., dated August 13, 1923; WJAZ, Edgewater Beach Hotel, Chicago, Ill., dated two days earlier; WBAP, Fort Worth, Texas, from December 17, 1924,

and WOAI, San Antonio, Texas, with a date of January 15, 1926. On short-waves, Mr Sauerbier has a QSL from Berlin, Germany dated September 20, 1933; the League of Nations, Geneva, Switzerland, dated January 15, 1934, and one from EAQ, Madrid, Spain, dated March 18, 1934. Mr. Sauerbier says that the once-popular EKKO stamps came along at a later date and that, as a rule, you had to send a dime with your report in order to obtain a stamp. A person was considered

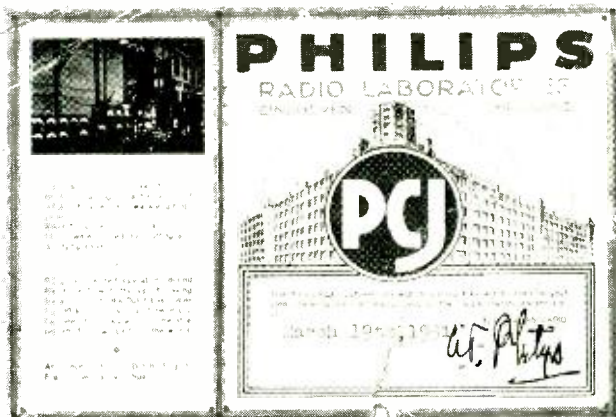

These interesting QSL cards from old-time broadcasters PCJ and LSX are from the collection of James Bruning, K2BZ, North Arlington, New Jersey.

NEW OPERATING SCHEDULES FOR INTERNATIONAL BROADCASTERS

AUSTRIA

Service Area	Time	Frequency	North America (General)	2300-0400	6155
Europe	0400-2305 (Sunday from 0500)	6000	North America (East)	2300-0400	9770
Europe (North)	1800-2000	11,925	Central America	0000-0200	15,145
Europe (East)	1000-1200	9770	South America (East)	2300-0000	9525
Europe (Southeast)	0500-0700	7245		0200-0400	11,875
Europe (South) and North Africa	1300-1500	11,785	East Africa	1800-2100	15,210
Europe (West)	0700-0900	7245	South Africa	2000-2200	15,200
Europe, North Africa, Middle East	0500-1300	6155		0700-1000	17,855
	0900-1300	7245	Middle East	1600-1800	17,880
	1300-1700	9770		0600-1000	15,410
	1500-1700	11,795	Southeast Asia	1700-2000	9610
	1700-2200	6155		0400-0700	17,715
	2000-2200	7245	Australasia	1400-1600	17,780
			East Asia	1000-1200	17,885
				1200-1400	15,385

KOREA (SOUTH)

VOICE OF FREE KOREA

Transmission	Time	Callsign	Frequency	Language
General Service	2100-2130	HLK5	9640	English
	0500-0530	HLK5	9640	English
	1030-1100	HLK5	9640	English
	1100-1130	HLK5	9640	Korean
Japan	0100-0130	HLK5	9640	Korean
	0130-0200	HLK5	9640	Japanese
	0900-1000	HLK5	9640	Japanese
	1300-1400	HLK53	6065	Japanese
		HLK5	9640	Japanese
Vietnam	2230-2300	HLSA	970	Japanese
		HLK5	9640	Korean
	0430-0500	HLK41	15,430	Korean
	1600-1630	HLK41	15,430	Korean
Southeast Asia	0800-0830	HLK5	9640	English
		HLSA	970	English
	0830-0900	HLK53	6065	Chinese
		HLK5	9640	Chinese
	1430-1500	HLK41	15,430	English
	1500-1530	HLK41	15,430	Chinese
	1530-1600	HLK41	15,430	French
Russia	2130-2200	HLK5	9640	Russian
	1430-1500	HLK5	9640	Russian
Latin America	0230-0300	HLK41	15,430	Spanish
North America	0200-0230	HLK41	15,430	Korean
	0300-0400	HLK41	15,430	English
Europe	0600-0700	HLK41	15,155	English
	0700-0730	HLK41	15,155	French
China	2200-2230	HLK5	9640	Chinese
	1400-1430	HLK5	9640	Chinese
	1500-1530	HLK41	15,430	Chinese

KUWAIT

KUWAIT BROADCASTING SERVICE

Frequency	Power	Language	Time	Beamed to
4967.5	10 kW	English	0400-0600	Not specified
9520	50 kW	Arabic	0400-1500	Not specified
15,370	250 kW	English	0400-0600	India, Pakistan
15,405	250 kW	English	1600-1900	Europe
15,430	250 kW	Arabic	0900-1100	Europe
21,685	250 kW	Arabic	1300-1905	North Africa

LIBERIA

ELWA, MONROVIA

Transmission	Sunday	Weekdays	Frequency	Languages
Liberia and West Africa	0645-2245	0615-0815	4770	English, French, African dialects
Liberia	0615-1115	0610-0815	3225	Arabic, Liberian
	1805-2240	1805-2240		
West and Cen- tral Africa	0600-1100	0600-0745	11,950	English, French
	1200-1330	1200-1300	11,975	Hausa, Igala, More, Yoruba, Twi
	1600-2100	1645-2100		
Congo, E. Africa and Madagascar	1715-1900	1715-1900	15,155	French, Congo languages
Middle East	1900-2100	1900-2100	15,170	Arabic
North Africa	2000-2200	2000-2200	15,170	French, Arabic

twice blessed if he was able to get the stamps without the dime charge.

James Bruning, K2BZ, of North Arlington, N. J. listed as his three oldest QSL cards those from VRY, PCJ and LSX. Taking them one at a time, VRY was in Georgetown, British Guiana (now Guyana) and operated on 6840 kHz with 120 watts. They publicized their country as being the "Land of Many Waters and Eternal Summer." This card was dated October 12, 1930.

PCJ was owned by Philips Radio Laboratories in Eindhoven, Holland, and was the forerunner of *Radio Nederland* in Hilversum. Their QSL card listed the frequency as being 9.59×10^6 cycles/sec (9590 kHz). Power on March 19, 1931 (date on the card) was a mere 27 kW. They state on their card that PCJ commenced operations during March, 1927, with the epoch-making transmissions to the Dutch East Indies "12000 kilometers . . ." Announcements in those days were in Dutch, English, French, German, and Spanish.

LSX was operated by Transradio Internacional, Buenos Aires, Argentina, and operated with 20 kW on 10,350 kHz. The date on this card was December 29, 1930. Your Editor may be in error but we believe LSX is now operating in the coastal service rather than as a regular broadcaster.

Mr. Bruning was instrumental in the formation of the Pennsylvania State Police radio system. He designed and constructed WJL, a 500-watt station, that operated first on 1499 meters (about 200 kHz), later on 750 meters (400 kHz) and finally on 203 meters (about 1480 kHz). He has a reception report from a listener who tuned in on WJL on 1499 meters in 1924.

Transmissions from Greensburg, near Pittsburgh, were of unusual interest back in 1925. Harrisburg area headquarters personnel complained that they could not hear morning or afternoon broadcasts from WJL although early evening transmissions came in very well. On the other hand, morning transmissions were being heard hundreds of miles away to the west. Mr. Bruning states that this phenomenon, easily understood by any modern-day SWL, puzzled everyone including broadcast engineers from Westinghouse's KDKA.

Another station designed and built by Mr. Bruning was WBR, another of the police outlets, in Butler, Pa. Its output came from two fifty-watt tubes in parallel (not in push-pull). When first wired up and fired, it developed a nasty habit: first one tube, then the other, would turn brick red. After trying several remedies, none of which worked, a lead pencil wound with about 30 turns of fine wire with the two ends being connected to the two tube grids and the center point to the normal grid lead. The tubes stayed black and normal

power could be used. Modern-day hams would recognize this effect as "parasitic oscillations" with the wired pencil acting as a pair of grid chokes.

Bruning says, "I don't recall the call letters of the other two state police stations. However, my recollection is that Harrisburg Headquarters was WBAK and that their transmitter was donated by KDKA."

(Editor's note: My own recollection of tuning in the late 1930's and early 1940's was that Harrisburg Headquarters was then known as WPSF and that the frequency had been again shifted, possibly to 1674 kHz. Another reader, Ronald Shopinski, WPE3-DKA, Mt. Carmel, Pa., also informed us recently that the Pennsylvania State Police are now operating on 42,620 kHz.)

CURRENT REPORTS

The following is a resume of current reports. At time of compilation all reports were as accurate as possible, but stations change frequency and/or schedule with little or no advance notice. All times shown are Greenwich Mean Time (GMT) and the 24-hour system is used. Reports should be sent to Short-Wave Listening, P. O. Box 333, Cherry Hill, N. J. 08034, in time to reach Your Short-Wave Editor by the fifth of each month; be sure to include your WPE identification and the make and model number of your receiver.

Alaska—DX'ers who need this country should monitor 630 kHz for KYAK, Anchorage. Having obtained permission to operate with 25 kW, KYAK is now the most powerful station in Alaska and is expected to be an all-night station. It should be on the air now.

Andorra—Word has been received that *R. Andorra* has been operating in English since last May 30 on 5995 and 701 kHz at 2300-0300. Your Editor hasn't been able to pull them in; has anyone else?

Angola—CR6RZ, *Emisora Oficial*, Luanda, continues to be well heard on the West Coast from 0500 s/on with native instrument IS, anthem, and Portuguese language on 4820 kHz.

(Continued on page 96)

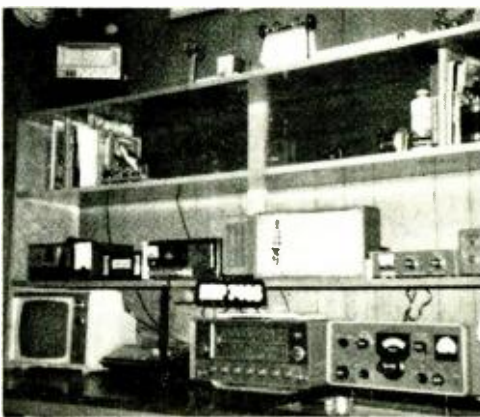

The well-appointed listening post of Daniel Trotto, WPE2QFZ, Little Falls, N.Y. features a Lafayette HA-225 and a Collins 75S-3B receiver. He also has an Allied 2682 receiver, an RCA TV, an RCA tape recorder and various pieces of CB equipment. Daniel now has 16 states and 40 countries verified.

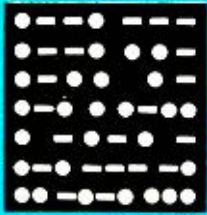

AMATEUR RADIO

By **HERB S. BRIER, W9EGQ**
Amateur Radio Editor

INCENTIVE LICENSING, PHASE TWO

ON NOVEMBER 23, the second step of the Federal Communications Commission's revision of the amateur frequencies available to different classes of licensees goes into effect. Barring last-minute changes, the new frequency breakdown is as shown in the Table.

As the first anniversary of the FCC's Incentive Licensing regulations approaches, we have tried to evaluate its effects on ham radio by examining the FCC's monthly readout of the number of amateur licenses. In summary, the average number of amateur licenses in effect peaked at 259,000 in 1966, dropped to 256,300 in 1967, rose to 258,000 in 1968, and at writing is slightly above 258,000. Similarly, the number of Novices was 13,380 in 1966, dropped to 12,000 in 1967, rose to 13,540 in 1968, and to 15,080 in the first quarter of 1969. Also, the number of General class

licenses increased from 103,205 in September, 1965, to 108,595 at the end of 1968.

On the other hand, Technician, Conditional, and Advanced class licenses decreased 2800, 6165, and 2440, respectively. (It is interesting that, although new Advanced licenses had not been issued since 1952, this class showed less attrition than either Conditional or Technician.) To complete the picture, from the time the Extra class license was first made available in 1952 until the fall of 1967, the number of Extra class licenses increased at a fairly steady rate of approximately 25 a month, reaching a total of 4930 in October, 1967.

After the initial details of the Incentive regulations were released in late 1967, however, the number of Extra class licenses issued a month quickly increased by approximately

AMATEUR STATION OF THE MONTH



Donald Rubin, WA3JRA, 3919 Bancroft Rd., Baltimore, Md. 21215, likes DX chasing, contests, and ragchewing, in that order. He does all three with a Swan 500-C SSB/CW transceiver and a Mosley TA-33, triband beam. Already on his shack wall are Rag Chewers Club, Worked All Continents, and Worked All States certificates; but of the 115 countries worked so far, only 70 have QSL'ed therefore DX Century Club is 30 cards away. We are sending WA3JRA a 1-year Subscription for winning this month's Amateur Station Photo Contest. You can enter the contest by sending a clear photo (black and white preferably) of you at the controls of your station, plus some details about your amateur career to: Amateur Photo Contest, c/o Herb S. Brier, W9EGQ, Amateur Radio Editor, Box 678, Gary, Ind. 46401.

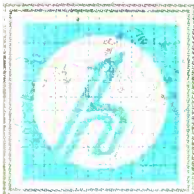

Hear it like it is, When it is, Where it is...

With the All New, Solid-State S-120A "STAR QUEST" Shortwave Radio

Every second, every minute, every day from every corner of the earth, the air is alive with exciting sounds of shortwave adventure . . . Peking Radio . . . Spy Stations . . . Voice of America . . . WWV signals . . . airplanes . . . (SSB) Single Side Band/ Code (CW) . . . Amateurs . . . plus many more. The new "STAR QUEST" Model S-120A fully transistorized takes you there . . . Hallicrafters engineered to provide you with more than 200% greater station receiving sensitivity for CW/SSB/AM. DX'ers can now enjoy incomparable performance on AM broadcast and 75 shortwave services from 1.6 MHz continuous to 30 MHz in four tuning ranges. Professionally engineered to include: BFO for CW and SSB reception • calibrated electrical band spread for precision tuning • large illuminated slide-rule dial, headphone jack, AGC, over 1000 mw of audio power • built-in communications speaker • 2-way antenna system and an exclusive emergency 12 VDC battery power capability for portable use anywhere. Today hear it like it is, when it is, where it is for only \$59.95 (Suggested List Price). At your local Hallicrafters distributor.

■ YOU'RE IN THE GLOBAL COMMUNICATIONS COMMUNITY WITH A HALLCRAFTERS

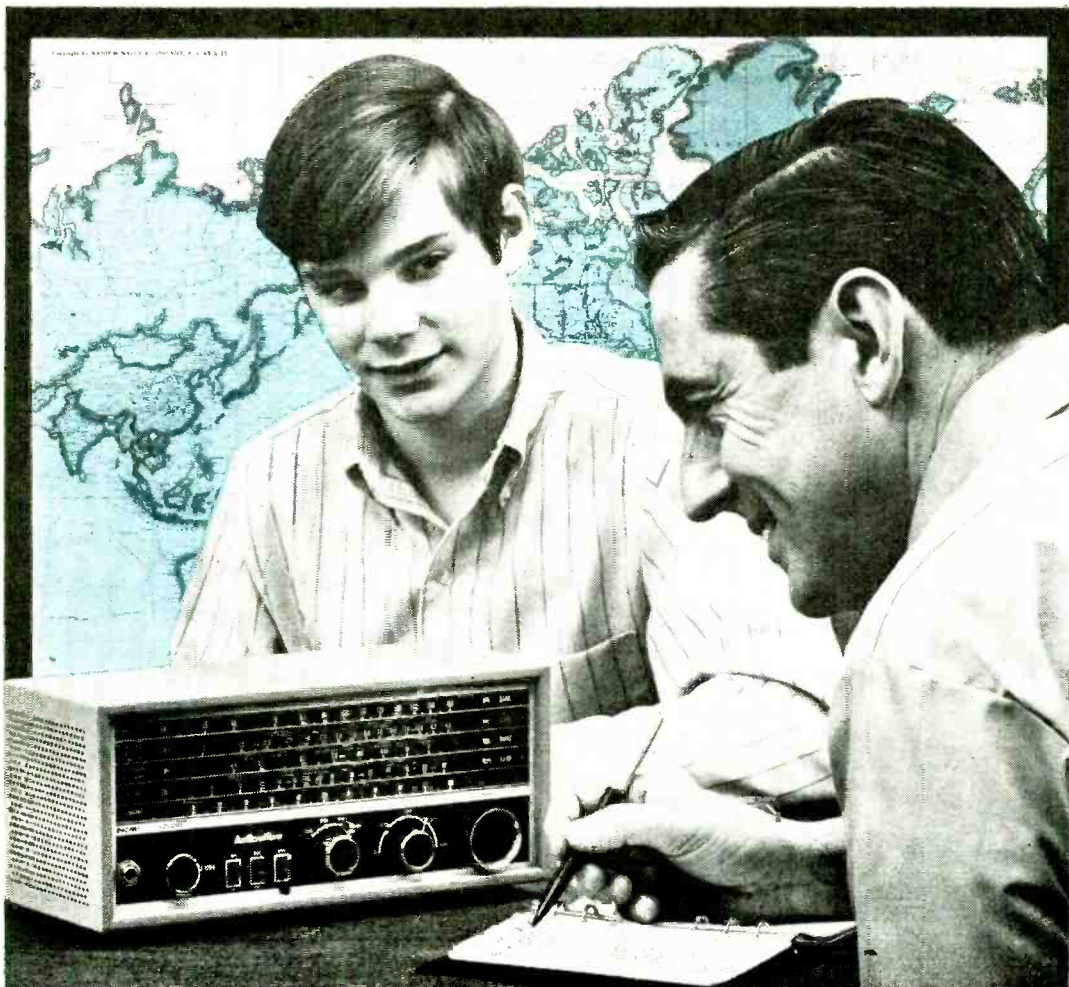

the hallicrafters co.
A Subsidiary of Northrop Corporation



600 HICKS ROAD
ROLLING MEADOWS, ILLINOIS 60008

CIRCLE NO. 19 ON READER SERVICE PAGE

November, 1969

85

700%, reaching a total of 8541 in April, 1969. On the same date, the number of Advanced licenses had risen from its December, 1967, low of 36,691 to 46,215, while the number of General licenses was down to just under 100,000.

Obviously, changing the Extra class license from a status symbol to a valuable possession has increased its popularity. In fact, so far in the Incentive Program, more Extra class than Novice class licenses have been issued! This fact casts doubt on the claims of some "authorities" that only geniuses can pass the Extra class test. At any rate, we hope that the increase in number of Novice, Advanced, and Extra class licenses encourages others to step up the amateur licensing ladder.

Antenna Tragedy. Via Bob Carter, W7INP, the *Arizona Republic*, and the *WCARSentinel* (Reno), we learn that three CB operators were electrocuted and three more were severely injured when the antenna tower they were erecting fell across a 12,000-volt power line. The tragedy emphasizes the importance of extreme care when installing an antenna anywhere near a power line. Even a 120-volt line can be lethal when an antenna mast falls into it. Furthermore, most utility poles carry power lines charged with far over 120 volts these days.

Amateur Radio in New Zealand. According to *Break-In*, journal of the New Zealand Association of Radio Transmitters, there were 4000 licensed amateurs in New Zealand at the end of 1968—an increase of six per cent in the year—and 10 per cent of the total participated in their December (midsummer) Field Day.

AMATEUR FREQUENCIES (November 23, 1969)	
Class of License	Frequencies
Novice	3.7-3.75, 7.15-7.2, 21.1-21.25, and 145-147 MHz (75 watts code only)
Technician	50.25-54, 145-147*, and all amateur frequencies above 220 MHz
General & Conditional	1.8-2**, 3.55-3.8, 3.9-4, 7.05-7.2, 7.25-7.3, 14.05-14.2, 14.275-14.35, 21.05-21.25, 21.35-21.45 MHz, and all higher amateur frequencies except 50-50.25 MHz
Advanced	1.8-2**, 3.55-3.8, 3.825-4, 7.05-7.3, 14.05-14.35, 21.05-21.25, 21.275-21.45 MHz, and all higher amateur frequencies
Extra	All amateur frequencies

*At a later date, the 2-meter Technician assignment may be extended to cover the entire 144-148-MHz band.

**The 1.8-2-MHz band frequency and power assignments differ from state to state. Check with the nearest FCC office for your state.

Contests. The two big amateur contests of the fall operating season are upon us. The World-Wide DX Contest (CQ magazine) is scheduled for 0000 GMT, October 25 to 2400, GMT, October 26 (phone) and 0000 GMT, November 29 to 2400 GMT, November 30 (CW). These times translate to 7:00 p.m., EST, 6:00 p.m., CST, and 4:00 p.m., PST, Friday, until the same hour, Sunday, each weekend. Work as many DX stations as possible on the amateur bands up to 29.7 MHz;

(Continued on page 92)



Donn, W2SNH, Henry, K3POD, Phil, W4TFX, Fritz, W3SQB, and Herman, WA3FVV, at W3FBE, the station of the Cadroerock (Md.) Amateur Radio Club at the Cadroerock Naval Ship Research and Development Center. (Official photo)

LATEST BEST SELLER (for you)

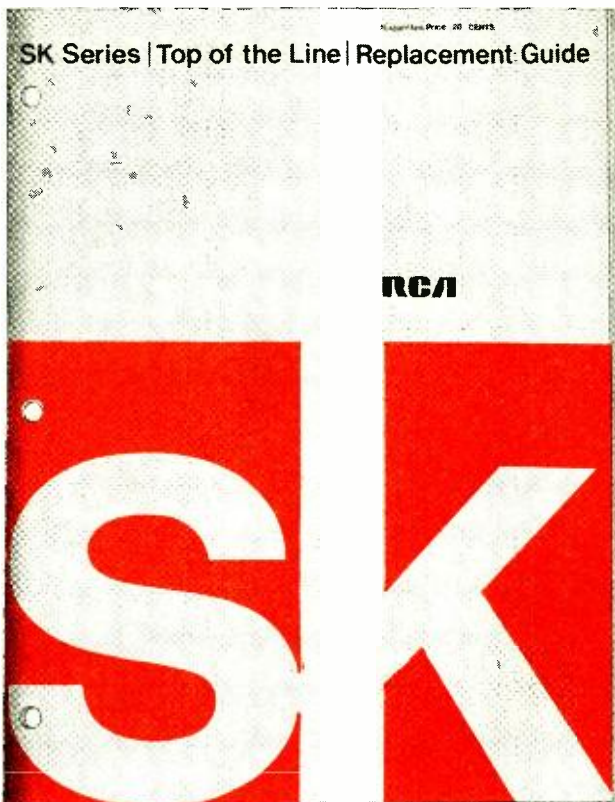

Here it is, strictly non-fiction—in fact, all fact—the indispensable RCA solid-state replacement guide. It works for you by charting the replacements of some 12,200 semiconductors—domestic and foreign. The 39 SK “Top-of-the-Line” transistors, integrated circuits, and rectifiers are designed and manufactured specifically for your kind of servicing problems. All top quality, too—no cast-offs, no factory seconds, no unbranded culls. All with electrical characteristics comparable or superior to originally designed-in devices.

As for range—from small-signal operations to the newest 100-watt audio outputs!

The comprehensive RCA SK Series—and the thousands of types they can replace—are *clearly* cross-referenced in the RCA SK Series Top-of-the-Line Replacement Guide.

Pick up your copy from your local RCA Distributor today.

RCA/Electronic Components/Harrison, N. J. 07029.

RCA

CIRCLE NO. 45 ON READER SERVICE PAGE

Printed in U.S.A.

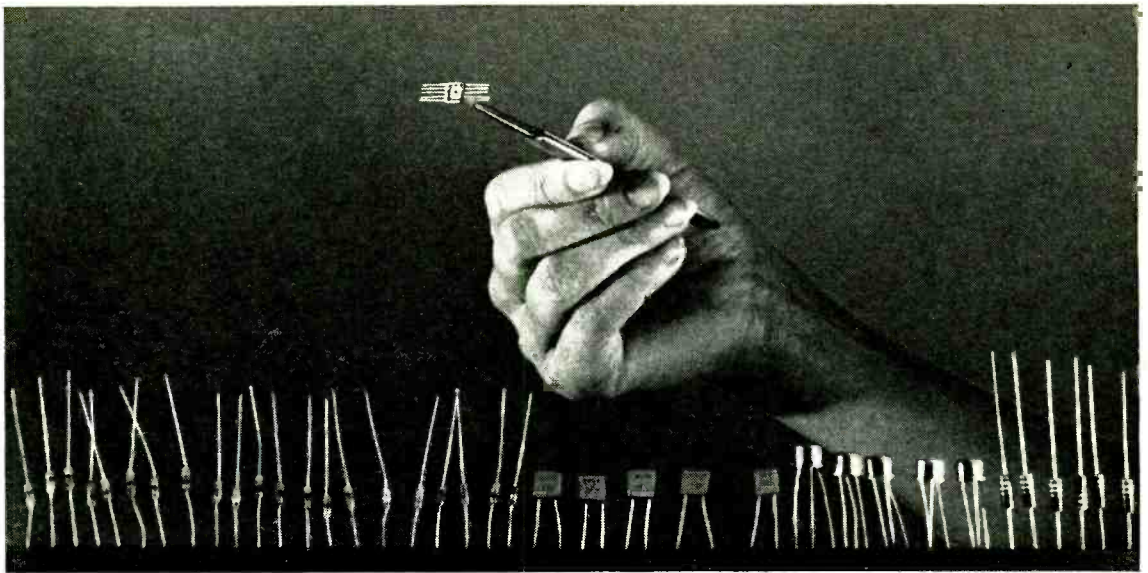

50 functions in a single chip. *The functions of 50 separate transistors, diodes, resistors and capacitors can now be performed by the tiny dot in the center of the integrated circuit held by the tweezers.*

The "Chip"

...will it make or break your job future?

TINY ELECTRONIC "CHIPS," each no bigger than the head of a pin, are bringing about a fantastic new Industrial Revolution. The time is near at hand when "chips" may save your life, balance your checkbook, and land a man on the moon.

Chips may also put you out of a job...or into a better one.

"One thing is certain," said *The New York Times* recently. Chips "will unalterably change our lives and the lives of our children probably far beyond recognition."

A single chip or miniature integrated circuit can perform the function of 20 transistors, 18 resistors, and 2 capacitors. Yet it is so small that a thimbleful can hold enough circuitry for a dozen computers or a thousand radios.

Miniature Miracles of Today and Tomorrow

Already, as a result, a two-way radio can now be fitted inside a signet ring. A complete hearing aid can be worn entirely inside the ear. There is a new desk-top computer, no bigger than a typewriter yet capable of 166,000 operations per second. And it is almost possible to put the entire circuitry of a color television set inside a man's wristwatch case.

And this is only the beginning!

Soon kitchen computers may keep the housewife's refrigerator stocked, her menus planned, and her calories counted.

Money may become obsolete. Instead you will

simply carry an electronic charge account card. Your employer will credit your account after each week's work and merchants will charge each of your purchases against it.

Doctors will be able to examine you internally by watching a TV screen while a pill-size camera passes through your digestive tract.

New Opportunities for Trained Men

What does all this mean to someone working in Electronics who never went beyond high school? It means the opportunity of a lifetime—if you take advantage of it.

It's true that the "chip" may make a lot of manual skills no longer necessary.

But at the same time the booming sales of articles and equipment using integrated circuitry has created a tremendous demand for trained electronics personnel to help design, manufacture, test, operate, and service all these marvels.

There simply aren't enough college-trained engineers to go around. So men with a high school education who have mastered the fundamentals of electronics theory are being begged to accept really interesting, high-pay jobs as engineering aides, junior engineers, and field engineers.

How To Get the Training You Need

You can get the up-to-date training in electronics fundamentals that you need through a carefully

chosen home study course. In fact, some authorities feel that a home study course is the best way. "By its very nature," stated one electronics publication recently, "home study develops your ability to analyze and extract information as well as to strengthen your sense of responsibility and initiative." These are qualities every employer is always looking for.

If you do decide to advance your career through spare-time study at home, it makes sense to pick an electronics school like the Cleveland Institute of Electronics. We teach only Electronics—no other subjects. And our courses are designed especially for home study. We have spent over 30 years perfecting techniques that make learning Electronics at home easy, even for those who previously had trouble studying.

Your instructor gives your assignments his undivided personal attention. He grades your work, analyzes it, and he mails back his comments the same day he gets your lessons, while everything is still fresh in your mind.

Always Up-to-Date

Because of rapid developments in Electronics, CIE courses are constantly being revised. This year, for example, CIE students are receiving exclusive up-to-the-minute lessons in Microminiaturization, Logical Troubleshooting, Laser Theory and Application, Single Sideband Techniques, Pulse Theory and Application, and Boolean Algebra. For this reason CIE courses are invaluable not only to newcomers in Electronics but also for "old timers" who need a refresher course in current developments.

Get FCC License or Money Back

No matter what kind of job you want in Electronics, you ought to have your Government FCC License. It's accepted everywhere as proof of your education in Electronics. And no wonder—the Government licensing exam is tough. So tough, in fact, that without CIE training, two out of every three men who

Tiny TV camera for space and military use is one of the miracles of integrated circuitry. This one weighs 27 ounces, uses a one-inch vidicon camera tube, and requires only four watts of power.



take the exam fail. But better than 9 out of every 10 CIE graduates who take the exam pass it.

This has made it possible to back our FCC License courses with this famous Warranty: you *must* pass your FCC exam upon completion of the course or your tuition is refunded in full.

Mail Card for Two Free Books

Want to know more? The postpaid reply card bound in here will bring you a free copy of our school catalog describing today's opportunities in Electronics, our teaching methods, and our courses, together with our special booklet on how to get a commercial FCC License. If card is missing, use the coupon below.

ENROLL UNDER NEW G.I. BILL

All CIE courses are available under the new G.I. Bill. If you served on active duty since January 31, 1955, or are in service now, check box on reply card for G.I. Bill information.

CIE Cleveland Institute of Electronics

1776 East 17th Street, Cleveland, Ohio 44114

NEW COLLEGE-LEVEL COURSE IN ELECTRONICS ENGINEERING

for men with prior experience in Electronics. Covers steady-state and transient network theory, solid state physics and circuitry, pulse techniques, computer logic and mathematics through calculus. A college-level course for men already working in Electronics.

Cleveland Institute of Electronics
1776 East 17th Street, Cleveland, Ohio 44114

Please send me without cost or obligation:

1. Your 44-page book "How To Succeed In Electronics" describing the job opportunities in Electronics today, and how your courses can prepare me for them.
2. Your book on "How To Get A Commercial FCC License."

I am especially interested in:

- | | | |
|--|---|--|
| <input type="checkbox"/> Electronics Technology | <input type="checkbox"/> Broadcast Engineering | <input type="checkbox"/> First Class FCC License |
| <input type="checkbox"/> Electronic Communications | <input type="checkbox"/> Industrial Electronics | <input type="checkbox"/> Electronics Engineering |

Name _____ Age _____

Address _____

City _____ State _____ Zip _____

Check here for G.I. Bill information.

PE-90

Accredited Member National Home Study Council • A Leader in Electronics Training... Since 1934

CIRCLE NO. 14 ON READER SERVICE PAGE

New EXCLUSIVE CB BEAM

The Saser Beam
Two Mini-Beams on one boom.
Two polarizations: vertical
and horizontal.

Mosley Electronics Incorporated
4610 N. Lindbergh Blvd. Bridgeton Missouri 63042

Please send me FREE of charge and obligation, literature on the SASER BEAM, MODEL MS-3D

Name _____

Address _____

City/State _____

Zip Code No. _____

Mosley Electronics, Inc. #190

4610 N. Lindbergh Blvd. Bridgeton Mo. 63042

CIRCLE NO. 27 ON READER SERVICE PAGE

SYDMUR

The Last Word In Ignition Systems



SAVE MONEY
on GAS! COILS!
SPARK PLUGS!
TUNE-UPS!

The most advanced solid state CD ignitions systems available. Take advantage of the latest technology... get the most out of your car's engine.

- Increased mileage
- Greatly extended spark plug life
- Fast cold weather starting
- Fewer tune ups

Well built, conservatively rated components. Every Sydmur part is pre-tested and guaranteed. The easy to install Sydmur is fully adaptable; 6 or 12 volt systems, positive or negative ground.

Fly-away assembled \$60.00 prepaid

Fly-away kit 44.50 prepaid

Compac assembled \$34.75 plus 75¢ handling

Compac kit 24.95 plus 75¢ handling

Or Build Your Own—Free Instructions!!

Transformer plus detailed instructions \$14.95

SPC4 (6 and 12 volt) \$14.95

As described in June 1965 Popular Electronics (New York State residents add sales tax)

Recommended by many of the world's leading automotive manufacturers. Send check or money order today.

For free literature and parts list write:

SYDMUR ELECTRONIC SPECIALTIES

1268 East 12th Street Brooklyn, NY 11230

CIRCLE NO. 46 ON READER SERVICE PAGE

AMATEUR RADIO

(Continued from page 86)

and exchange signal reports and DX "zone" numbers with each station worked. Check the *Call Book* for your zone number, or send a large return envelope with 18 cents postage to: WW DX Contest, % CQ Magazine, 14 Vanderventer Ave., Port Washington, N.Y. 11050, for a free zone map and other contest information.

The ARRL "SS" (Section Sweepstakes) Contest is possibly the world's most popular amateur contest, based on the number of participants. The 36th Annual Sweepstakes is scheduled for 2100 GMT, November 8 to 0300 GMT, November 9 (phone) and 2100 GMT, November 15 to 0300 GMT, November 16 (CW). Operate any 24 hours of the contest periods and work as many stations as possible in the ARRL "sections." Exchange message "preambles" as prescribed in the official contest rules. Send a stamped envelope to ARRL, 225 Main St., Newington, Conn. 06111, for the SS Contest package.



Jerry Dahl, WB4HUG, Charlotte, N.C., earned his Novice and General tickets through the code and theory classes of the Mecklenburg Amateur Radio Society. His equipment is a Heathkit SB-401 for transmitting and a Lafayette HA-500 for receiving.

News and Views

Landon Chapman, W4VTU, offers a free circular and folder to any would-be amateur in the United States who accompanies his request for information with a stamped, self-addressed number-10 return envelope. The address is *Amateur Radio World*, 204 Sunset St., Bristol, Tenn. 37520. Landon reports that he has helped 15 hams obtain their tickets. He also included an enthusiastic letter from a youngster of 74 who received his ham ticket at the age of 72 years. Unfortunately, neither of them mentioned the "youngster's" call letters...

POPULAR ELECTRONICS

Go on a quality kick

You can afford it

with these Outperformers

You give up nothing — except a high price — when you buy these quality performance Pioneer hi-fi units. Designed for the discriminating budget-minded buyer, they contain advanced engineering features and looks that put them in the class of much more expensive stereo components.

SA-500 INTEGRATED STEREO AMPLIFIER — The perfect starter unit for a stereo system, the all solid state SA-500 produces 44 watts of music power. Even at the highest crescendo, distortion is less than 0.5%. Four inputs plus outputs for speakers, tape recording, loudness contour and a headset jack make it tops in versatility. \$99.95

TX-500 AM-FM TUNER — All solid state, its multiplex circuitry provides wide channel separation with excellent frequency response. An FET front end, combined with years-ahead design, assures high sensitivity and superb image

rejection. Containing advanced features that place it on a par with more expensive units, it is priced at \$99.95.

SR-202 REVERBERATION AMPLIFIER — The most dramatic new component in years! No matter what your system is, the SR-202 adds dimension and greater realism to your stereo sound than you can realize. The SR-202 increases the natural quality of your recordings and tapes. Reverberation can be added to an audio amplifier using one or two tape recorders, a record player, or a tuner. In fact, a total of 15 equipment combinations are possible. \$95.00

These three Pioneer Outperformers are each housed in a handsome cabinet with brushed chrome facing and Brazilian rosewood end pieces. Hear them in action at your local Pioneer dealer.



 **PIONEER**®

PIONEER ELECTRONICS U.S.A. CORPORATION, 140 Smith Street, Farmingdale, N.Y. 11735 • (516) 694-7720
 West Coast: 1335 W. 134th St., Gardena, Calif. 90249 (213) 323-2374 & 321-1076 • Canada: S. H. Parker Co., Prov. Ontario

CIRCLE NO. 32 ON READER SERVICE PAGE



Beale E. Riddle, WA3MGA, 1808 Connecticut Ave., Washington, D.C. 20009, has a good antenna location and a fantastic landlord. His antennas are 200 feet above the ground on top of an apartment building on a hill, and the landlord says, "I don't care what you put on the roof—as long as it doesn't fall in the street." In three months as a Novice, Beale worked 33 states and four countries using a Knightkit T-60 transmitter to drive a base-loaded, 40-meter vertical antenna and a 15-meter dipole. He receives on a Hammarlund HQ-145. Three weeks after passing the General exam, WA3MGA passed the Advanced exam. If you need a volunteer examiner for your Novice or Technician exam or need Washington, Beale is your man . . . **Gary W. Kent, WN0SZY**, R.R. 1, Eddyville, Iowa, feeds

HAMARAMA

Annual Texoma Hamarama, November 14, 15, 16, at Lake Texoma State Lodge, Kingston, Okla. Fun for the entire family. Annual joint meeting with the Quarter Century Wireless Assoc. Plenty of camping and trailer locations. Registration orders to Texoma Hamarama, P.O. Box 246, Kingston, Okla. 73439. Write directly to the Lake Texoma Lodge, Kingston, Okla. 73439, for lodge or cabin accommodations.



This photo is also the clever QSL card of Steve King, WN8CHK, Greenville, Ohio. He has 40 states with Heathkit DX-60B transmitter, HR-10 receiver.

a Hy-Gain 18-AVQ vertical antenna with a Heathkit DX-60B transmitter and receives on a Drake 2B assisted by a Heathkit HD-11 Q-Multiplier. Thirty-four states have been worked and confirmed, and Gary should now have received his General license.

Ronald Del Buono, WN2JUI, 415-41st St., Union City, N.J. 07087, uses a Heathkit DX-20 souped up to 60 watts to drive a 40-meter dipole. He didn't mention the model number, but his receiver is a Hallcrafters, and he worked five states and Canada the first few days he had his ticket. Ron listens to local 6-meter activity on a Heathkit Six'er and has 30 states and 30 countries confirmed as an SWL . . . **Larry Skidmore, WN4LOE**, 2855 Shady Oaks Dr., Titusville, Fla. 32780, seems to have almost two of everything. He transmits on an EICO 723 running 45 watts to either a 15-meter dipole or a Hy-Gain 18-AVQ vertical antenna. He receives on a Hallcrafters SX-99. Larry's first contact was with KP4AOD (Puerto Rico); he also has 32 states, and two foreign countries (Canada, and Cuba) in his log. Larry also set up a second

Patented components . . . a 30-year reputation for innovative design . . . a consistently creative approach to sound reproduction . . . this is where it all comes together, in the creation of extraordinary speakers such as the 312. A glance at its specifications will tell you the 312 is an exceptionally fine reproducer. Unfortunately, they won't begin to show you how extraordinarily pleasing the sound is that flows from it. You must discover that for yourself, by listening. It's not inexpensive. Still, it's only about half what you'd expect to pay. Hear the 312 soon. Find out why we call it: "the speaker your other components will be proud of."

This is where it all comes together

"Listen . . .
University
Sounds
Better."

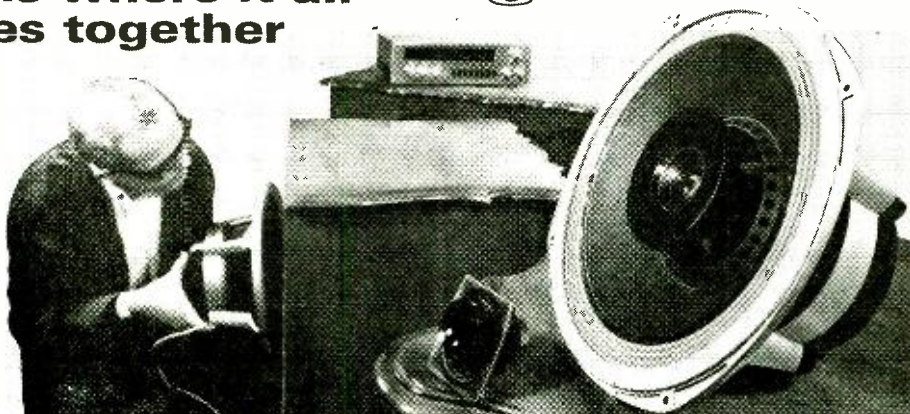

CIRCLE NO. 42 ON READER SERVICE PAGE

station at his school—the Titusville High School—using a Hallicrafters HT-40 transmitter, SX-140 receiver, and a 15-meter dipole, which he keeps active during the school year . . . **Robert Mahoney, WN8CXN**, 26355 Normandy, Roseville, Mich. 48066, says that the biggest problem he faced in becoming an amateur was finding someone to be his volunteer examiner. In five months, Bob has worked 35 states using a Heathkit DX-20 transmitter, Hallicrafters S-76 receiver, and 40- and 15-meter dipoles. Next on his schedule is visiting the FCC for his General ticket . . . Maybe if enough qualified amateurs (over 21 and holding a General class license or higher) will follow Walt, WA3EOP's suggestion in August "News and Views" to indicate their willingness to act as volunteer examiners for prospective Novices and Technicians, we can alleviate the problem for other prospective amateurs.



Peter J. Harvey, WN2FWK, Delmar, N.Y., travelled the road from SWL, to CB, to Novice. He has worked thirty-nine states and 12 countries with an EICO 720 transmitter and a Hammarlund HQ-170 receiver.

David Mizerak, W34???, P.O. Box 724, Burgaw, N.C., 23425, started as a Novice in 1966. He has worked 45 states and 52 countries since then using a Swan 350C, SSB/CW transceiver, Heathkit DX-60B transmitter, and National NC-109 receiver in conjunction with an 80-meter dipole and a Hy-Gain 14-AVQ vertical antenna. Dave is investigating the theoretical properties of semiconductors as a science project in High School . . . Congratulations to **Adah Elliott, W9RTH**, for receiving the Indiana Radio Club Council's 1969-70 Indiana Outstanding Radio Amateur Award; and to **Phillip Haller, W9HPG**, American Radio Relay League Central Division Director, for receiving the 1969 Illinois Amateur of the Year award. The awards were announced at the annual Indiana IRCC picnic in July and the Illinois Hamfesters Club picnic in August . . . Followup on the New England ham who forgot to give his call in the August column. He is **Frank Arciuolo, WN1KLU**, 16 Patten Rd., North Haven, Conn. 06473. Using his dad's (ex-W1NZM) HRO-7 receiver and a Heathkit DX-60B and a Windom antenna, Frank has now worked 26 states and has given his Dad the "itch" to get back on the air!

Will we see your "News and Views" and picture in an upcoming column? The first step is up to you. Thanks to you who have kept us on the mailing list to receive your club bulletins and announcements; if we do not receive your bulletin, we certainly would like to! The address is: Herb S. Erier, W9EGQ, Amateur Radio Editor, POPULAR ELECTRONICS, P. O. Box 678, Gary, Ind. 46401.

73, Herb, W9EGQ.

NEW AND IMPORTANT SAMS BOOKS

New "THIS IS ELECTRONICS" Series

This remarkable new series, written under the direction of the Training Department of ITT Educational Services, Inc., imparts to any reader a sound understanding of the basics of electronics.

Vol. 1. Basic D-C Principles. Covers: Wonderful World of Electronics; Components & Symbols; Matter and Electricity; Circuit, Voltage, & Resistance; Series and Parallel Circuits; Conductors, Semiconductors, & Insulators; Resistors; and Sources of D-C Power.

Order 20657, only \$5.95

Vol. 2. Basic A-C Principles. Covers: Alternating Voltage & Current; Capacitors & Capacitive Reactance; Magnetism & Electromagnetism; Magnetic Induction; Measuring Instruments; Inductors & Inductive Reactance; Transformers & Inductive Circuits; A-C Circuits I; A-C Circuits II; Resonance; and Filters.

Order 20727, only \$6.95

ABC's of Radio-Frequency Heating

Explains the basic principles of heating by means of radio-frequency energy, covering both induction and dielectric heating. Describes power supply sources, microwave range, special applications, and servicing of heating equipment. Includes experimental projects.

Order 20747, only \$2.95

FM From Antenna to Audio

Clearly explains the entire subject of fm, from basic principles through receiving equipment to latest developments in afc and tuning aids. Also includes information on receiver measurements and alignment procedures. Order 20723, only \$3.95

1-2-3-4 Servicing Automobile Stereo

This book is the first to apply the remarkable 1-2-3-4 Method to an easy understanding of the electrical and mechanical principles of automobile stereo, fm multiplex, and tape cartridge systems, and then shows how to apply the Method to the servicing of auto systems. Order 20737, only \$3.95

The Famous AUDIO CYCLOPEDIA. 2nd Ed.

Completely revised—the most comprehensive reference available on audio. Covers every phase of acoustics, recording, and reproduction. Includes all the latest developments right down to the newest solid-state and integrated circuits. A one-volume library on the entire audio art. Order 20675, only \$29.95

RECENT BESTSELLING BOOKS

Fundamentals of Digital Computers. 20714 \$5.50
Learn Electronics Thru Troubleshooting. 20651 7.95
101 Q. & A. About Amateur Radio. 20731 2.95
Record Changer Servicing Guide. 20730 3.95
Auto Radio Servicing Made Easy. 2nd Ed. 20719 3.95
Closed-Circuit Tel. Handbook. 2nd Ed. 20726 5.95
CB Radio Servicing Guide. 2nd Ed. 20722 3.95
Citizens Band Radio Handbook. 3rd Ed. 20569 4.25
How to Build Speaker Enclosures. 20520 3.50
Tape Recorders—How They Work. 2nd Ed. 20445 4.50

— HOWARD W. SAMS & CO., INC. —

Order from any Electronic Parts Distributor, or mail to Howard W. Sams & Co., Inc., Dept. PE-11 4300 W. 62nd St., Indianapolis, Ind. 46268

Send the following books: Nos. _____

_____ \$ _____ enclosed

Send FREE 1970 Sams Book Catalog

Name _____

Address _____

City _____ State _____ Zip _____

CIRCLE NO. 36 ON READER SERVICE PAGE

Telex writes new specs on sensitivity and ruggedness in headphones.



the Communicator Series

HIGH SENSITIVITY AND LOW OPERATING POWER. The new Communicator Series of headphones is designed around a dramatic new driver unit that requires only absolute minimal operating power. This added efficiency allows for a substantial increase in sensitivity without any increase in distortion, making the Communicator Series the most sensitive and versatile headphones available today.

RUGGED. CONSISTENT PERFORMANCE. Unlike the soft aluminum or paper cones in most of today's headphones, the Communicator's rugged new cone is made of special material that will provide peak performance without being affected by temperature or humidity. This means that you get consistent, high quality performance, day in and day out, under the most demanding communications conditions.

For more information on Telex's new Communicator headphones, contact your nearest Telex dealer or write.

PRODUCTS OF SOUND RESEARCH
TELEX
COMMUNICATIONS DIVISION
9600 Aldrich Avenue South
Minneapolis, Minnesota 55420



SHORT-WAVE LISTENING

(Continued from page 83)

Antilles, Netherlands—*Trans-World Radio*. Bonaire, has moved its English xmsn at 0225-0340 from 15.345 kHz to 11.775 kHz. A new, unlisted xmsn in Portuguese to South America has been found on 15.305 kHz at 2300-2330.

Australia—VNG, Lyndhurst, Victoria, a time station on 12.000 kHz, has been consistently strong in the west around 0600; time pips given each second except at the 59th second; ID on the hour.

Austria—Vienna is good on 9770 kHz from 2300 in German. New frequencies include 15.145 kHz from 0000 s/on to Central America and 15.200 kHz from 2120-2150 s/off with light music and multi-lingual amnt's, including English, requesting reception reports.

Belgium—*R. Belge*, Brussels, has increased its xmsn's to N.A. and is now scheduled at 2205 on 11.715, 9615 and 9555 kHz and at 0050 on 11.715, 9615 and 6125 kHz.

Bolivia—CP90, *R. Juan XXIII*, San Inacio de Velasco, has moved from 4951 kHz to 4974 kHz where signals have decreased; it is heard only weakly at 0200 in Spanish talks with infrequent ID's.

Burundi—*La Voix de la Revolution*, Bujumbura, 6140 kHz, is heard at 0420-0450 with news in French, an ID, and a commentary in native language; two IS's are given after the news and commentary.

Canada—CKZU, Vancouver, noted on 6160 kHz relaying CBU at 1307-1344 with music, news, and a Peace River weather bulletin.

Chile—*La Voz de Chile*, Santiago, 9690 kHz, is heard in Spanish at 0100 with music program. It is easy to ID because of the extensive use of "Pomp And Circumstance" as an ID signal.

Colombia—HJZJ, one of the newer outlets of *R. Nacional de Colombia*, 6030 kHz, has been noted lately with apparent test xmsn's until 0500 s/off dual to 4955 and 9635 kHz. English lessons are given at 2250. HJKC, *Emisora Nuevo Mundo*, Bogota, is audible on 4755 kHz after a Bolivian and a Brazilian on the same frequency close down; best listening time is after 0500 but there may be QRM from a Congo station.

Congo Republic—*R. Brazzaville* was noted on 11.710 kHz with a special xmsn in French summarizing recent space events, including the moon-walk and landing of Apollo 11. This was from 2230-2258 s/off.

Costa Rica—TIRICA, *La Voz de la Victor*, San Jose, noted from 2345-0200 and 0430-0510 with pop music and mostly Spanish except for frequent amnt's in English offering free tourist information for prospective visitors. This is on 9615 kHz. TIQ, *R. Casino*, Puerto Limon, continues to transmit its English "East Coast Broadcast" from 0430-0600 s/off on 5954 kHz.

Ecuador—HCJB, Quito, has been heard on 11,880 kHz at 0015 in English and 15,300 kHz, dual to 17,880 kHz, in English to 2000, then into German. HCOS4, *La Voz del Rio Carrizal*, Calceta, 3570 kHz, was logged at 0500 with Spanish and music. HCCR1, *R. Casa de la Cultura*, Quito, last heard on 4930 kHz in 1960 when they stated they would soon have a 10-kW xmitr. is now on 4843 kHz with s/off generally around 0405; programming is mostly classical music.

El Salvador—*R. Nacional*, San Salvador, has moved from 6010 kHz to 5980 kHz where it is heard from 0255-0500 s/off with many speeches in Spanish. The dual channel of 9555 kHz is also heard, but much more weakly, also to 0500 s/off.

(Continued on page 100)

CIRCLE NO. 39 ON READER SERVICE PAGE

the Super Scanner

**MODEL
OF THE
MONTH**

It took us two years
to make the
CB Scanner scan 360°
automatically

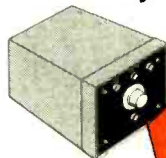

**NEW
OMNI-LOCATOR
POSITION**

It takes the
Super Scanner
1/3 of a second to do it!

- **Beam Mode:** positive electronic beaming in choice of sectors — no mechanical rotator needed!
- **Omni Mode:** Special position for omni-directional "searching"—just switch to use!
- **Tremendous 7.75 dB forward gain** in beam mode; 2.5 dB gain in omni mode!
- **Front-to-back 23 dB**—cuts backside noise drastically, increases effective forward range.
- **Compact design**—beats all beams for size and weight (just 17 lbs.) yet ruggedly constructed to take 100 MPH winds!

the antenna specialists co.

Division of Allen Electric and Equipment Co.
12435 Euclid Ave., Cleveland, Ohio 44106
Export offices: 2200 Shames Dr.,
Westbury, N.Y. 11590



®

"Stripes of Quality"



Join Johnson's BIG CB safety campaign

Johnson wants every citizen to be safe with citizens two-way radio! You can help — and WIN A FLIGHT AROUND THE WORLD . . . A HOT LITTLE MAVERICK . . . OR DOZENS OF OTHER VALUABLE PRIZES!

HERE'S ALL YOU DO:

1. Visit your near-by Johnson Dealer and pick up an official entry blank. Complete the following statement in 25 words or fewer:
 "Every citizen should own citizens two-way radio because . . ."
2. Return entry to your distributor or mail to: E. F. Johnson Co., Waseca, Minn. 56093 before midnight Dec. 31, 1969.
3. Entries will be judged on the basis of aptness of thought and originality. Judges decisions will be final. Material becomes the property of E. F. Johnson Co., and may not be returned.
No Purchase Required. Void where prohibited.

**SPECIAL VALUES
ON JOHNSON
EQUIPMENT**

**during our
celebration
of the**

**500,000th
JOHNSON CB SET!**

**BONUS OPPORTUNITY!
EARN A \$50
GIFT CERTIFICATE!**



Help spread the "Safe Way is Two-Way!" story by persuading your friends to join the Cber ranks. For every five Johnson CB radios your friends purchase, Johnson will award you a Merit Certificate good for \$50 toward the purchase of any Johnson radio or accessory! Details on Official Entry Form, or write to E. F. Johnson Co., Waseca, Minn. Offer ends midnight, January 31st, 1970.

**FREE GIFT... JUST
FOR VISITING YOUR
JOHNSON DEALER!**



equipped with **JOHNSON**
Citizens 2-way radio

CB CHANNEL
9 *"The safe way is two-way!"*

and **WIN**...

GRAND PRIZE!



AIR TRAVEL AROUND THE WORLD FOR TWO!

Free air travel! 50,000 miles worth — enough to take *two persons clear around the world* or any number of shorter trips. Travel may be used at any time . . . fly yourself and your family on vacations, if you prefer!

2nd PRIZE!



THIS HOT LITTLE MAVERICK CAR—WITH MESSENGER 125 INSTALLED!

America's most-wanted, most popular new compact — ready to drive, and ready to *communicate* with Johnson's equally hot little Messenger 125, 5-channel push-button CB rig!

THREE 3rd PRIZES!

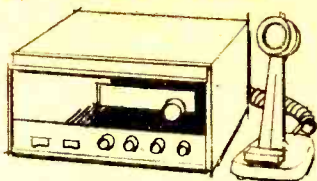

MESSENGER 124 base stations!

Johnson's newest, most sophisticated base station for the operator with a purpose. All solid state, 23-channels, complete with mike.

TWENTY-FIVE 4th PRIZES!



JOHNSON DESK MIKES!

Johnson's top quality desk mike. Tremendously increases your base station performance. Finest available.

Colorful "EQUIPPED WITH TWO-WAY RADIO" bumper sticker available from your Johnson dealer. Identifies you as a responsible citizen able to respond to highway emergencies.

YOU are needed now for a BIG PAY JOB in ELECTRONICS!

Look at the ads in your newspapers! Check the BIG MONEY OPPORTUNITIES that await the man who knows ELECTRONICS!



TRAIN AT HOME SPARE TIME
Keep present job and income and you prepare for best pay jobs in this booming field!

EARN while you LEARN

A few months after enrolling you can be doing spare time Electronics repair jobs paying up to \$25 to \$35 for an evening's work!



PREPARE TO STEP INTO JOBS LIKE THESE:

Industrial Controls Maintenance
• Your Own Electronic Service Shop • Closed Circuit T.V. Installation Service • Electronic Computer Maintenance • Communications • Aerospace Work • Automation Electronics Installation . . . and hundreds more we'll tell you about!

LEARN BY DOING

Build and keep vital electronics test equipment from big kits we supply. All yours to use and keep!



FREE MAIL COUPON FOR BIG FACT BOOK

Get big Free fact pack! See how you learn fast at home; start earning fast! Rush coupon today!



I. T. I. APPROVED FOR TRAINING UNDER NEW G.I. BILL

MAIL COUPON FOR ELECTRONICS MONEY MAKING FACTS

Industrial Training Institute, Dept. 65194
815 Rosecrans, Los Angeles, Calif. 90059

Rush me big FREE BOOK, "Get Into Big Pay Electronics." Show how I can learn Electronics at home spare time

Name _____

Address _____

City _____ State _____ Zip _____

CIRCLE NO. 21 ON READER SERVICE PAGE

SHORT-WAVE LISTENING

(Continued from page 96)

Germany (East)—*R. Berlin International* was heard at 0100 on 11,890 kHz and at 1340 on 21,600 kHz, both with talks in English, and at 2000 with news in Spanish on 11,825 kHz. Another Spanish xmsn, to Europe, is aired on 11,840 kHz at 0220.

Germany (West)—*R. Free Europe* was monitored free of jamming on 11,825 kHz at 2000 in Russian. *RIAS*, 6005 kHz, has uninterrupted classical music at 0230-0315. *Sueddeutscher Rundfunk*, Stuttgart, 6030 kHz, was logged at 0535-0555 with a night-club-comedian type of program in German.

Guatemala—*Radiodifusora Popol Vuh*, 5070 kHz, is noted Friday 2230 to Saturday 0135 with a long talk to 0115, some songs, and an ID at 0130. The *Popol Vuh* (some sources spell it *Buh*) is said to be the sacred book of the Quiche race. Other facts are as yet undetermined but location may be Mazatenango. This is a rough one to copy and the only listening time is found to be as given above.

Guyana—One of our Ohio monitors, vacationing at Cape Breton Island, Canada, found ZFY, *R. Demerara*, Georgetown, with a good signal on 760 kHz at 1235-1305 with English and native language ann't's for American products.

SHORT-WAVE ABBREVIATIONS

annt—Announcement	L.A.—Latin America
GMT—Greenwich Mean Time	N.A.—North America
ID—Identification	QRM—Interference
IS—Interval Signal	R—Radio
kHz—Kilohertz	s/off—Sign-off
kW—Kilowatt	s/on—Sign-on
	xmsn—Transmission

Holland—*R. Nederland*, Hilversum, has returned to 11,730 kHz after a brief stay on 15,220 kHz with English to N.A., dual to 15,425 kHz, at 2125-2250. It's also heard at 2000-2030 in English to Europe.

Honduras—During the national crisis here, HRVC, Tegucigalpa, 4820 kHz, was monitored with its English "Master Control" program signing off at 0300 rather than at the usual s/off time of 0400.

Iran—Teheran's English xmsn at 2000-2030 is often good on 17,735 kHz. Two different IS's seem to be used, one being a stringed instrument, the other a clock ticking. Reports from the West Coast indicate a rapid dropoff in signal strength after s/on of the Russian xmsn which begins at 1730.

Italy—Rome is on 15,410 kHz at 2230-0000 in Italian and at 0100-0120 in English, both to N.A., and dual to 15,340 and 11,810 kHz. The 21,560 kHz outlet has Italian to Africa at 0435 and to Latin America at 1840 with both xmsn's being well heard.

Lebanon—Beirut, 15,285 kHz, has music at 0150, an ID and into Arabic at 0200. English at 0230-0300 to N.A. with news at 0230.

Papua—VLK3, Port Moresby, was heard on 9650 kHz from 0700-0715 s/off with a local interest program and recordings.

Peru—OBX7V, *R. Tawantinsuyu*, Cuzco, has moved back from the 49-meter band to 4910 kHz where it is heard with typical Andean music at 0200. OBX4U, *R. America*, Lima, is noted on 3240 kHz at 0340-0400 with L.A. music and Spanish ann't's.

Ryukyu Islands—*Voice of United Nations Command*, Deragawa, found on 14,460 kHz at 1453 with a male announcer in Korean.

South Africa—Low-frequency stations heard re-

SHORT-WAVE CONTRIBUTORS

John Duane (WPE1HBC), Hingham, Mass.
 Joseph Breton (WPE1HKV), Methuen, Mass.
 Bob Raymond (WPE1HOE), Bradford, Mass.
 Robert Briggs (WPE1HTD), Pittsfield, Mass.
 George Stein (WPE1HTY), Niantic, Conn.
 Peter Macinta (WPE2OKB), Kearny, N. J.
 John Banta (WPE2PHU), Bay Shore, N. Y.
 John Herkimer (WPE2PIL), Caledonia, N. Y.
 David Galletly (WPE2OHG), Sound Beach, N. Y.
 Carter Scholz (WPE2QNL), Tenally, N. J.
 Al Kosinski (WPE2QNH), Latham, N. Y.
 John Mac Donald (WPE2QOI), East Orange, N. J.
 Bob Taylor (WPE2OSK), Waldwick, N. J.
 David Lain (WPE2OSH), Rochester, N. Y.
 Michael Szoke (WPE2QUM), South River, N. J.
 Ivan Waufile (WPE2OVD), St. Johnsville, N. Y.
 Henry Borawski (WPE2OVF), Brooklyn, N. Y.
 Leo Alster (WPE2RRN), Rahway, N. J.
 Ronald Shopinski (WPE3KDA), Mt. Carmel, Pa.
 Gary Blau (WPE3HWV), Rockville, Md.
 Jerry Kapezynski (WPE3HYX), Fountainville, Pa.
 Kevin Conley (WPE3HYZ), Bethesda, Md.
 Dan Ferguson (WPE4AUL), Coral Gables, Fla.
 Grady Ferguson (WPE4ABC), Charlotte, N. C.
 Paul Hill (WPE4JCV), Virginia Beach, Va.
 Bruce Roberts (WPE4KAI), Waynesboro, Va.
 David Weronka (WPE4KBE), Durham, N. C.
 Duke Rumley (WPE4KCD), Mayodan, N. C.
 Frank O'Neil (WPE4KDI), Birmingham, Ala.
 Russell Hummel, Jr. (WPE4KEI), Bon Air, Va.
 Jule Bowles (WPE4KFI), Moultrie, Ga.
 Carlton Blake (WPE4ETX), Fort Smith, Ark.
 Richard Fortson (WPE4ELX), Edinburg, Texas
 F. J. Layman (WPE4FDC), Dallas, Texas
 Wallace Glavich (WPE4EPX), Euroka, Calif.
 Trevor Clegg (WPE4EAF), Fresno, Calif.
 Kevin Slater (WPE4CAF), Salem, Ore.
 Chuck Albertson (WPE4CWI), Spokane, Wash.
 David Williams (WPE4CWH), Astoria, Ore.

Chris Kneibel (WPE4HUB), Wooster, Ohio
 Bill Pelles (WPE4JWU), North Olmsted, Ohio
 Robert Lewinski (WPE4KAS), Wyandotte, Mich.
 David Cornell (WPE4KFA), Brockport, N. Y.
 Wayne Shifflett (WPE4KFI), Harrisonburg, Va.
 George Smith, Jr. (WPE4KJI), Grand Rapids, Mich.
 Marty Himes (WPE4KJS), Chillicothe, Ohio
 Tom Kennedy (WPE4KKE), Battle Creek, Mich.
 Robert Moser (WPE4KSH), Chicago, Ill.
 Richard Pistek (WPE4HOA), Chicago, Ill.
 Barry Aprison (WPE4JCS), Indianapolis, Ind.
 Bruce McCoy (WPE4JMS), La Porte, Ind.
 John Hedstrom (WPE4JITQ), Wheaton, Ill.
 Scot Witt (WPE4JUX), Park Forest, Ill.
 A. R. Niblack (WPE4KMI), Vincennes, Ind.
 John Beaver (WPE4OAE), Pueblo, Colo.
 C. Vernon Hyson (WPE4OCVF), Somerville, N. J.
 Jim Randles (WPE4OCW), Cunningham, Kansas
 Fred Mc Cormack (WPE4ODSU), Des Lacs, N. D.
 Steve Opydyke (WPE4OFW), Salina, Kansas
 Jack Perolo (PE4PEIC), Sao Paulo, Brazil
 Paul Cau (VE4PEZO), St. Catharines, Ont.
 Art Strandquist (VE4PE7G), Winnipeg, Man.
 Bruce Archinal, Dover, Ohio
 Lloyd Berman, Van Nuys, Calif.
 Kim Bodkar, Detroit, Mich.
 Carl Borden, Piedmont, Calif.
 Anthony Coppa, Glenolden, Pa.
 Charles Green, Rialto, Calif.
 William Hecutt, Tuscaloosa, Ala.
 Leslie Kom, Montreal, Que.
 Mark Markham, Martinez, Calif.
 Claudio Moraes, Curitiba, Brazil
 Richard Nathan, Indianapolis, Ind.
 Bob Stone, Los Angeles, Calif.
 Osterreichischer Rundfunk, Vienna, Austria
 Switzerland Calling Bulletin, Berne, Switzerland
 American Shortwave Listeners Club, Huntington Beach, Calif.

cently include *R. RSA*, Johannesburg, 4895 kHz, at 0500 with English news, and *Springbok Radio*, Paradys, on 3952 kHz at 0450 in Afrikaans and on 3997 kHz at 0430-0450 with a morning get-up show with exercises and piano music.

Sweden—*R. Sweden*, Stockholm, is scheduled to eastern N.A., on 11,950 kHz at 0000 and 0130 in Spanish, 0030 and 0200 in English and at 0100 in Swedish, and on 15,315 kHz at 1100 and 1400 in English, 1130 and 1430 in Swedish and at 1500 in French; to western N.A. on 11,705 kHz at 0300 French, 0330 English and 0400 Swedish, and on 15,315 kHz at 1600 English and 1630 Swedish. Also noted well are English xmsn's at 1400-1430 and 1600-1630 on 21,585 kHz.

Turkey—*R. Ankara* is heard well in English at 2200-2230 and 0200-0230 on 15,166 kHz and at 1415-1445 on 17,820 kHz. Programs contain news, comment, music, and weather warnings for Turkish navy boats.

USA—NSS, U. S. Navy station, Annapolis, Md., has time signals from 2255-2300 with an 1D in Morse a few seconds later; other xmsn's are in all Morse. This one, often used by Your Editor for time correction, is on 5870 kHz.

USSR—*R. Kiev* has English to Europe at 1930-2000 on 15,150, 11,700 and 9740 kHz, and to N.A. on Monday, Thursday and Saturday at 0030-0100 on 12,010, 11,960, 11,730 and 9600 kHz and at 0430-0500 on 12,010, 11,730, 11,700 and 9600 kHz. Kiev's 17,900 kHz outlet has also been found in English at 0030 dual to 17,760, 15,260 and 11,700 kHz. Minsk, Byelorussia, 15,150 kHz, has a *R. Moscow* relay to N.A. at 2300 in English. Mrs. Stepanova is reportedly now issuing verification cards marked "via Minsk." *R. Yerevan*, 17,880 kHz, is heard at 0318 with music, at 0324 with news in Armenian and in English at 0328 closedown. USSR Home Service from Irkutsk has an unusual IS at 1200, then into Russian, on 11,905 kHz.

ADDED MOBILE POWER WHEN YOU NEED ADDITIONAL COVERAGE FOR CLEAR COMMUNICATIONS

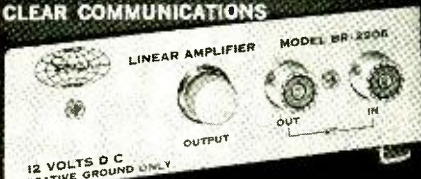

170 WATT INPUT

Complete with remote power switch and indicator control panel plus mounting brackets.

FCC TYPE ACCEPTED
 Parts 89, 91, 93

\$119⁹⁵

12 VDC

SMALL PACKAGED MOBILE POWER

LINEAR R.F. POWER AMPLIFIER

Covers greater distances with increased transmit power. Can be used with SONAR BR20, FM40 or any similar FCC approved equipment with 1-15 watt output. Designed with top performance and dependable service when you need it. Automatic standby/transmit switching • Covers 25-50MHz range • transistorized power supply — negative ground • Used on amateur 28MHz for FM-AM-SSB. Small, compact, rugged design. Size: 2"H x 6"W x 8"D. Wt. 3 lbs. 12 VDC

SONAR RADIO CORP., 73 Wortman Avenue, Bklyn, N.Y. 11207
 Please send information on Model BR 2906 Linear Amplifier

Name Dept. 500
 Address
 City State Zip

CIRCLE NO. 37 ON READER SERVICE PAGE

It's yours free

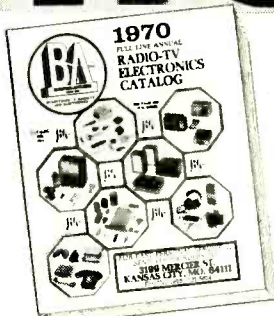

**GIANT 274 PAGE
1970
RADIO-TV
ELECTRONICS
CATALOG**

Write to:

**BURSTEIN-APPLEBEE CO.,
DEPT. PE-K 3199 MERCIER ST.,
KANSAS CITY, MO. 64111**

Name _____

Address _____

City _____

State _____ Zip Code _____

CIRCLE NO. 9 ON READER SERVICE PAGE

**CB'ERS
POLICEMEN
FIREMEN
EMERGENCY
GROUPS
HAMS**

**KEEP IN TOUCH! LISTEN TO NEWS
AS IT HAPPENS! POLICE-FIRE CALLS
ON YOUR BROADCAST RADIO WITH
TUNAVERTER, KING OF CONVERTERS!**

**OUTSTANDING
PERFORMANCE**
with
MORE FEATURES
plus

EASY Installation
and 100% American
made dependability!



The Perfect low cost solution for Noiseless Monitoring on High-Low Police-Fire & Aircraft bands! Installs in seconds! Just plug in auto radio! Use auto antenna!

Crystal & Tunable by the flip of a switch!
Extra Sensitivity & Selectivity with unique 3 gang tuning capacitor! It is signal peaker on crystal control!
Changeable Crystals for Versatility & Usability! Change channels at will! Never obsolete!

SQUELCH Built in for NOISE FREE monitoring!
● 12 volt powered ● 1 year guarantee
● Includes coax, mount ● Size—2 1/2" x 3 1/2" x 4 1/2"

2 WEEK MONEY-BACK GUARANTEE!
Models for AM & FM Tunable & Crystals (less crystal)
HAND MODEL COVERS OUTPUT
Faller, Inc. 2185 30-AM mc 1500 kc
Weather, etc. 1564 150-164 mc 1500 kc
Aircraft. etc. 1828 118-128 mc

ONLY \$44.95

The Most VERSATILE converter for No crystal needed for each band. (Write for price of Crystals models.)

Coupling Loop & Ext. Antenna for use with home and Transistor Radios \$3.95 ppd.
Crystals—State Exact Listening Freq. \$5.10 ppd.
Order from: AIR MAIL add \$.85 ext.

HERBERT SALCH & CO. Marketing Division of Tompkins Radio Products
Woodsboro 15, Texas 78393

CIRCLE NO. 35 ON READER SERVICE PAGE

TWO-WAY REACTIONS

(Continued from page 80)

fined to a wheelchair it is difficult to learn things that he would normally learn through experience. Thus CB is a great educational tool. It can give you many valuable experiences without leaving home. Just listening to the radio is informative because all kinds of people are on the air. You get exposed to people you could meet no other way."



Members of Gateway REACT (Waveland, Miss.) as well as many others, provided emergency communications plus general assistance in the wake of hurricane Camille. They brought much-needed supplies of all types in addition to their 3500-watt generator.

CURRENT NEWS

San Diego, Calif. . . . Southwestern REACT recently participated in a unique communications activity in connection with the annual Powder Puff Derby, a transcontinental air race. Using a callsign assigned by the FCC for the event, they relayed the takeoff of each entrant from San Diego's Lindbergh Field to E. A. Johnston, KMX8506, who is also a member of the West Coast Amateur Radio Association. Mr. Johnston then initiated the first in a series of six relays between San Diego and Washington, D.C., to keep all points advised of times of departure for the 92 women flyers. This is an outstanding example of cooperation between Citizens Radio users and ham radio operators.

Atlanta, Ga. . . . Summertime is usually a quiet period for most organizations—but not CB clubs and REACT teams. For example, Capital City CB Communications, Inc., started out the summer with a retreat and training exercise at Fort Yargo State Park. At 1:00 A.M., on July 3rd, they were called out to search for a missing woman. Then after finding her in the woods when daylight came, they rested up to prepare for 4th of July parade communications. On July 14th, 30 club members enrolled in a 30-hour Red Cross First Aid course. On July 25th, 4 members, supported through CB

POPULAR ELECTRONICS

More Power To You!

MIDLAND
5-WATT
6-CHANNEL **\$79.95**

**ABSOLUTELY LOADED
WITH DELUXE FEATURES!**

- Integrated Circuit, new concept in maximum solid state efficiency.
- Sensitive superheterodyne receiver has tuned RF, active AGC, battery-saver.

Maximum 5-watt power plus 6-channel versatility now combined with hand-held convenience. Extra value features: long-range Call Signal® hi-level push-pull audio modulation, PA switch, hi-lo battery saver switch. 3-way meter indicates battery level, RF output, signal strength. Jacks: battery charger, AC adaptor, external mike, antenna. Includes channel 7 crystals, earphone and leather case. **Model 13-770**

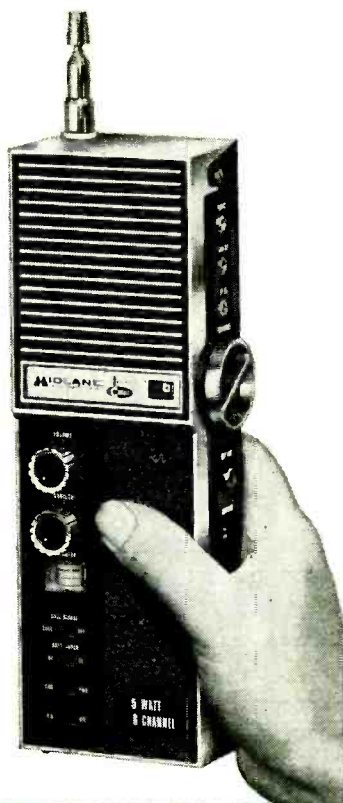

4 more reasons why Midland leads the field in CB...

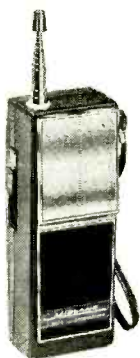

13-700



13-790

1-Watt 2-Channel.
Solid state. High-level class B push-pull audio, active AGC circuit. Jacks for battery charger, AC adaptor. With earphone, channel 11 crystals. Model 13-700 **\$29.95**

23-Channel 5-Watt.
Power and performance of big base-mobile units. Solid state, Integrated Circuit, 23-channel equipped. Has dual conversion receiver with tuned RF, squelch. Model 13-790 **\$149.95**



Deluxe AC/DC 23-Channel Base-Mobile. 4 Integrated Circuits, F.E.T. front end, forward/reverse SWR meter. Built-in clock-timer, delta tune. Model 13-877 **\$199.95**



5-Watt 6-Channel Base-Mobile. Solid state Integrated Circuit. Superhet receiver has tuned RF, 3 IF stages, AGC. With channel 9 crystals. Model 13-855 **\$69.95**

MIDLAND
INTERNATIONAL
CIRCLE NO. 26 ON READER SERVICE PAGE

Prices shown are suggested retail

Free color brochure!
Write: P.O. Box 1903
Kansas City, Mo. 64141

Live Better Electronically With

LAFAYETTE RADIO ELECTRONICS

1970 Catalog 700 **FREE!**



Now OFF PRESS
BETTER THAN EVER
496 Pages

Stereo Hi-Fi • Citizens Band • Ham Gear • Tape Recorders • Test Equipment • TV and Radio Tubes and Parts • Cameras • Auto Accessories • Musical Instruments • Tools • Books

Featuring Everything in Electronics for
• HOME • INDUSTRY • LABORATORY
from the "World's Hi-Fi & Electronics Center"

LAFAYETTE Radio ELECTRONICS

Dept. 35129 P.O. Box 10
Syosset, L.I., N.Y. 11791

Please Send the FREE 1970 CATALOG 700 35119

Name
Address
City
State Zip

CIRCLE NO. 24 ON READER SERVICE PAGE

communications with other members, won the WQXI Great River Raft Race. August 22-28 was the occasion of the National Convention of the American Legion in Atlanta. CB radio was used to coordinate communications for the Legion parade. Lasting over 6 hours, it was the longest ever in Atlanta history. Another retreat was held at Fort Yargo State Park on September 13 and 14. In addition to all this activity, the Capital City Club maintained its REACT monitor 24 hours daily to assist the many additional vacation-bound motorists in the Atlanta area.

An interesting incident took place in the course of this monitoring function last summer. According to CCCBC President, Terry Simonds, a stranded motorist radioed for assistance to "Capital City REACT". The Atlanta monitor answered the call in the customary manner. When the motorist responded with an unfamiliar location, another REACT monitor offered to be of assistance. This was Capital City REACT in Sacramento, California. They were the object of the motorist's call. He was on a freeway in Sacramento, California and the signal "skipped" to Atlanta Georgia.

DON'T FORGET

If your club is interested in becoming a REACT team, write us for information.

Remember? "Two-Way REACTions!"

We are interested in receiving information from everyone involved in Citizens Two-Way Radio. Send us all the news about your activities so that we can include it in this column. Be sure to include photos! Remember, we are also interested in a celebrity list of Citizens Radio users. Send direct to "Two-Way REACTions," c/o REACT National Headquarters, 205 West Wacker Drive, Chicago, Ill. 60606.

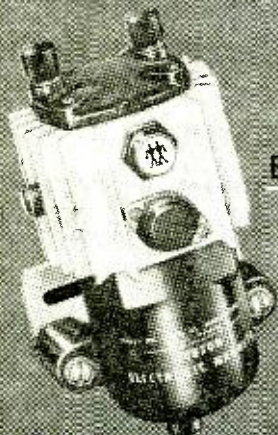

WE DON'T
CLAIM OUR
ELECTRONIC
IGNITION
SYSTEM
IS BEST...

OUR CUSTOMERS DO!

WRITE TODAY FOR FREE LITERATURE

JUDSON

RESEARCH AND MFG. CO.
CONSHOHOCKEN, PA. U.S.A.



CIRCLE NO. 23 ON READER SERVICE PAGE

Among summertime activities are the many jamborees, coffee breaks, barbecues and picnics held by clubs. There are so many of these that we simply cannot list them all. It is sufficient to say that if one wished to drive 100 miles or more in any direction on a summer weekend, he could attend an event sponsored by a citizens radio group. Our publication deadline is so far in advance that it is not too soon to send in information for next summer's jamboree calendar. We actually need four months notice to be sure of publication.

While we give emphasis to the public service aspects of CB activities, we must recognize that there are purely social groups. They use a common interest in two-way radio as a means of drawing people together purely for fellowship. Sometimes these social clubs also participate in civic events, but that is secondary. These CB clubs often do much to encourage the positive use of Citizens Radio among their members. In addition, they are prepared when called upon to serve others with emergency communications. Among the groups of this type who regularly send us their bulletins are: Tri-County Citizens Radio League of Akron, Ohio; Waukesha County CB Club, Inc., Oconomowoc, Wisconsin; Lycoming CB Radio Club, Inc., Montoursville, Pa.; 7-11 CB Radio Club, Spokane, Washington; Sociable 5 Watts, Inc., Enon Valley, Pa.; Holiday Citizens Banders, Baltimore, Maryland; Cereal City Citizens Band Radio Club, Battle Creek, Michigan; Chicago Citizens Radio League, Chicago, Illinois; Citizens Radio Association of Lake County, Waukegan, Ill.; Five-Eleven Radio Club, Inc., Pittsburgh, Pa.; York CB Assistance Club, York, Pa. and Calgary General Radio Club, Calgary, Alberta, Canada.

-50-

SOLID STATE

(Continued from page 78)

$Q2$'s base and causing a corresponding change in its collector current. This, in turn, controls $Q3$'s base bias. Transistors $Q2$ and $Q3$ together form a complementary d.c. amplifier. A conventional electromagnetic relay ($K1$) acts as $Q3$'s collector load, and as the control switch for an external device.

The active devices used in the project were selected from Motorola's popular HEP line. A 15-volt electrolytic capacitor is used for $C1$, while all resistors are half-watt units. The relay should be a moderately sensitive type having a 12-volt coil, such as the Calctro type D1-967. The power source ($B1$) may be either a line-operated d.c. supply, a 12-volt lantern battery, or eight series-connected penlight or flashlight cells.

Well suited to either perf board or etched wiring construction, the touch switch can be assembled in just a few hours time. Although neither layout nor lead dress are overly critical, $Q1$'s gate connection leads should

be kept as short and direct as possible. The touch plate can be any small piece of metal, with neither exact size nor shape important as far as circuit operation is concerned . . . use your imagination!

In practice, the relay serves to actuate an external electrical device whenever the touch plate is touched lightly by the user. The external device, operated by a separate power source, may be a safelight in a darkroom, a solenoid, a small motor, an electric light, or an alarm signal, depending on individual user needs. The relay's contacts are used as a simple switch to turn the external device "on" or "off," as needed.

New Devices. RCA Electronic Components (Harrison, New Jersey 07029) is continuing to expand its line of linear integrated circuits. Among the devices which should be of special interest to experimenters and hobbyists are a series of three high-gain wide-band amplifiers with low current and voltage requirements, making them ideal for battery powered projects. All three are assembled in 12-lead TO-5 packages. The CA3021, with a 2.4-MHz bandwidth, requires only 4 mW, for operation, yet can supply 56-dB gain

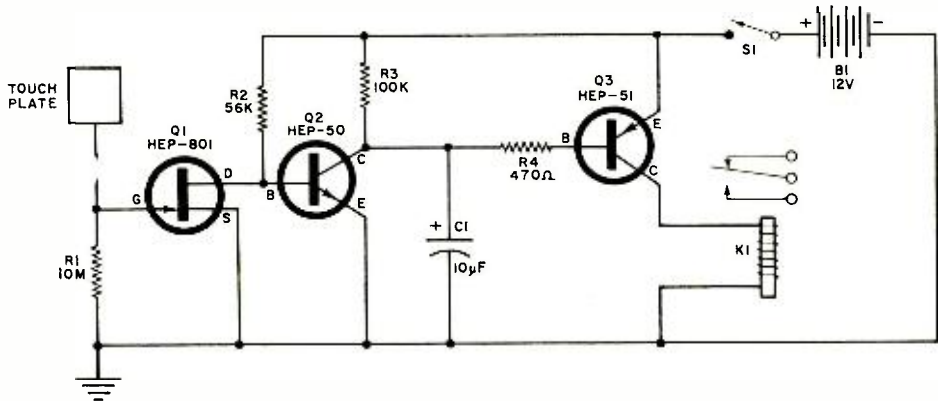

Fig. 3. A FET is used in the first stage of touch switch amplifier to achieve high input impedance.

FOUR TRACE SCOPE PREAMP

ANOTHER ORIGINAL
FROM THE

PHASE CORPORATION

EXPERIMENT WITH A FOUR TRACE OSCILLOSCOPE PREAMP. WORKS WITH ANY OSCILLOSCOPE. SEE FOUR SIGNALS FROM FOUR SEPARATE SOURCES AT THE SAME TIME! COMPARE WAVEFORMS, PULSE TRAINS, ETC. KIT INCLUDES PRINTED CIRCUIT BOARD, PARTS AND INSTRUCTIONS (MINIBOX NOT INCLUDED).

ONLY \$24.95 (PRICE INCLUDES POSTAGE & HANDLING).

DEALERS INQUIRY INVITED

SEND CHECK OR
MONEY ORDER TO:

THE PHASE CORPORATION
315A BOSTON AVE.

MASS. RES. ADD.
3% SALES TAX

MEDFORD, MASS. 02155

CIRCLE NO. 31 ON READER SERVICE PAGE

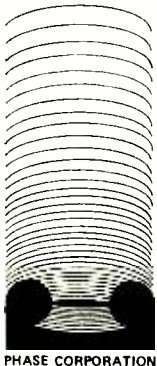

November, 1969

105

**Someone
should develop
an easy way
to learn
electronics at
home**

**RCA Institutes
did!**

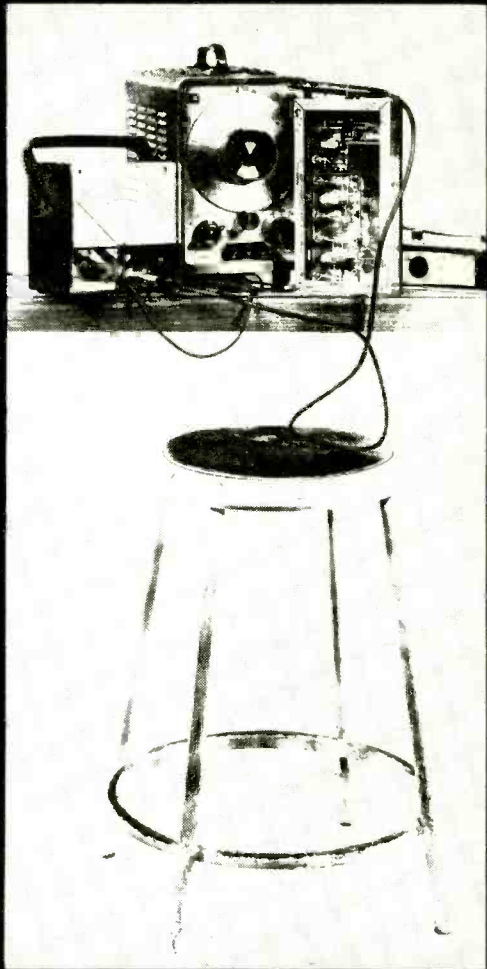

Here is a modern approach to learning electronics at home! RCA Institutes, one of the nation's largest schools devoted to electronics, has developed a faster, easier way for you to gain the skills and the knowledge you need for the career of your choice. Here for the first time is a student-proved, scientifically designed way to learn. If you have had any doubts in the past about home training in electronics—if you have hesitated because you thought you might not be able to keep up—or that electronics was too complicated to learn—here is your answer! Read how RCA Institutes has revolutionized its home training ideas!

**NEW courses
in Solid State Technology
and Communications
Electronics.**

**Mail card today
for full information.**

**ALL CAREER PROGRAMS
BEGIN WITH "AUTOTEXT"
INSTRUCTION METHOD!**

**Prepare for the field of your
choice immediately!
No previous training or
experience in electronics
needed!**

With this new revolutionized method of home training you pick the career of your choice—and *RCA Institutes trains you for it.* RCA's Career Programs assure you that everything you learn will help you go directly to the field that you have chosen! No wasted time learning things you'll never use on the job! The Career Program you choose is especially designed to get you into that career in the fastest, easiest possible way!

And each Career Program starts with the amazing "AUTOTEXT" Programmed Instruction Method—the new, faster way to learn that's almost automatic! "AUTOTEXT" helps even those who have had trouble with conventional home training methods in the past. This is the "Space Age" way to learn everything you need to know with the least amount of time and effort.

CHOOSE A CAREER PROGRAM NOW
Your next stop may be the job of your choice. Each one of these RCA Institutes Career Programs is a complete unit. It contains the know-how you need to step into a profitable career. Here are the names of the programs and the kinds of jobs they train you for. Which one is for you?

Television Servicing. Prepares you for a career as a TV Technician/Serviceman; Master Antenna Systems Technician; TV Laboratory Technician; Educational TV Technician; CATV Technician.

FCC License Preparation. For those who want to become TV Station Engineers, Communications Laboratory Technicians, or Field Engineers.

Automation Electronics. Gets you ready to be an Automation Electronics Technician; Manufacturer's Representative; Industrial Electronics Technician.

Automatic Controls. Prepares you to be an Automatic Controls Electronics Technician; Industrial Laboratory

Technician; Maintenance Technician; Field Engineer.

Digital Techniques. For a career as a Digital Techniques Electronics Technician; Industrial Electronics Technician; Industrial Laboratory Technician.

Telecommunications. For a job as TV Station Engineer, Mobile Communications Technician, Marine Radio Technician.

Industrial Electronics. For jobs as Industrial Electronics Technicians; Field Engineers; Maintenance Technicians; Industrial Laboratory Technicians.

Nuclear Instrumentation. For those who want careers as Nuclear Instrumentation Electronics Technicians; Industrial Laboratory Technicians; Industrial Electronics Technicians.

Solid State Electronics. Become a specialist in the Semiconductor Field.

Electronics Drafting. Junior Draftsman, Junior Technical Illustrator; Parts Inspector; Design Draftsman Trainee Chartist.

SEPARATE COURSES

In addition, in order to meet specific needs, RCA Institutes offers a wide variety of separate courses which may be taken independently of the Career Programs, on all subjects from Electronics Fundamentals to Computer Programming.

**TWO CONVENIENT
PAYMENT PLANS**

Pay for lessons as you order them. No contract obligating you to continue the course. Or, you can take advantage of RCA's convenient monthly payment plan. No interest charges!

VARIETY OF KITS

You receive valuable kits which provide practical application to your studies—yours to keep and use on the job.

Programmed Electronics

Breadboard. You now will receive a scientifically programmed electronic breadboard with your study material. This breadboard provides limitless experimentation with basic electrical and electronic circuits involving vacuum tubes and transistors and includes the construction of a working signal generator and superheterodyne AM Receiver.

Bonus From RCA—Multimeter and Oscilloscope Kits. At no additional cost, you will receive with almost every RCA Institutes Career Program the instruments and kit material you need to build a multimeter and oscilloscope. The inclusion of both these kits is an RCA extra.

**CLASSROOM TRAINING
ALSO AVAILABLE**

RCA Institutes maintains one of the largest schools of its kind in New York City where classroom and laboratory training is available in day or evening sessions. You may be admitted without any previous technical training; preparatory courses are available if you haven't completed high school. Coeducational classes start four times a year.

JOB PLACEMENT SERVICE, TOO!

Companies like IBM, Bell Telephone Labs, GE, RCA, Xerox, Honeywell, Grumman, Westinghouse, and major Radio and TV Networks have regularly employed graduates through RCA Institutes' own placement service.

**SEND ATTACHED POSTAGE PAID CARD
FOR COMPLETE INFORMATION, NO OB-
LIGATION.**

All RCA Institutes courses and programs are approved for veterans under the new G.I. Bill.

Accredited Member
National Home Study Council

IF REPLY CARD IS DETACHED—SEND THIS COUPON TODAY

RCA INSTITUTES, Inc., Dept. PEN-9
320 West 31st Street, N.Y., N.Y. 10001

Please rush me FREE illustrated catalog. I understand that I am under no obligation.

Name _____ Age _____
(please print)
Address _____
City _____
State _____ Zip _____



Olson ELECTRONICS FREE Catalog

Fill in coupon for a FREE One Year Subscription to OLSON ELECTRONICS' Fantastic Value Packed Catalog — Unheard of LOW, LOW PRICES on Brand Name Speakers, Changers, Tubes, Tools, Stereo Amps, Tuners, CB, and other Values. Credit plan available.

NAME _____
ADDRESS _____
CITY _____ STATE _____
GIVE ZIP CODE _____

If you have a friend interested in electronics send his name and address for a FREE subscription also.

OLSON ELECTRONICS

509 S. FORGE STREET, AKRON, OHIO 44308

CIRCLE NO. 30 ON READER SERVICE PAGE

1400-PC. GLASS FIBER OPTIC KIT

It's FUN! It's Educational! It's Gifty!



\$4.88

- ★ Make light "pipes"
- ★ Dazzling displays
- ★ Triggers photo & infra-red cells

OPTICAL SCIENTIFIC BREAKTHRU!
Allows "hair thin" glass fibers (2.5 ft. long) to transmit & reflect Gold light energy of any color by total internal reflection. Bundled, jacketed, 1/2" guide, 500µm, pigtail light around corners, w/te. wire to circles, triggering such devices as light sensitive transistors, diodes, scrs, IC CUTS, BENDS, ACTS like wire. Only one imagination controls its loads of uses. FREE 12pc. accessory kit, with "how-to" d. booklet.

- \$25 SURPRISE PAK, transistors, resist, diodes, etc. \$1
- 50 GERMANIUM GLASS DIODES, 1N34, 1N48 no test \$1
- 40 TOP HAT SILICON RECTIFIERS, no testast values \$1
- 25 EPOXY RECTIFIERS, silicon asst, no test \$1
- 40 PRECISION RESISTORS, 1/2-2W, 1% asst values .. \$1
- 30 TRANSISTORS, rf, if, audio, osc, no test \$1
- 60 TUBULAR CONDENSERS, to .5mf to 1KV, asst \$1
- 50 DISC CONDENSERS, to .05mf npo, temp coef, asst \$1
- 30 POWER RESISTORS, to 2 1/2 watts, to 24K ohms \$1
- 10 VOLUME CONTROLS, to 1 meg, switch too! \$1
- 10 ELECTROLYTICS, to 100mf, tubulars too, asst \$1
- 50 RADIO & TV KNOBS, asstd colors & styles \$1
- 10 TRANS-TOR ELECTROLYTICS, to 100mf, asst values \$1
- 50 COILS AND CHOKES, if, rf, ant, osc, peaking, etc \$1
- 65 HALF WATTERS, to 1 meg, 1/2% popular values too \$1
- 2 FIELD EFFECT TRANSISTORS, n channel, hobby \$1
- 10 PANEL SWITCHES, toggle, slide, micro, rotary \$1
- 3 "SUN" BATTERIES, for 100's of lite sens proj's \$1
- 5 "IBM" COMPUTER BOARDS, many trans, diodes. \$1
- 40 "MICRO" CONDENSERS, for transistor circuitry \$1
- 50 TERMINAL STRIPS, 1 to 8 lug, types \$1
- 4 PHOTO ELECTRIC CELLS, hi. imp., schematic \$1
- 40 "TINY" RESISTORS, 1/10W, 5% tol 1 to 1 meg. \$1

ADD POSTAGE, avg, wt: 1/2 lb. CATALOG 10c

POLY PAKS

P.O. BOX 942E
LYNNFIELD, MASS.
01940

CIRCLE NO. 33 ON READER SERVICE PAGE

using a 6-volt supply. Furnishing up to 57-dB voltage gain, the CA3022 has a 7.5-MHz bandwidth and needs only 12.5 mW, at 6 volts. Maximum bandwidth is supplied by the CA3023, with a 16-MHz rating and a power requirement of but 35 mW, at 6 volts when furnishing 53-dB gain.

A pair of complementary transistors suitable for 100-watt audio amplifiers, a new 90-watt plastic encapsulated unit, and two sets of 50-ampere complementary devices are among the new silicon power transistors recently introduced by Motorola Semiconductor Products, Inc. (P.O. Box 20912, Phoenix, Arizona 85036).

Packaged in modified TO-3 cases, *pnp* type MJ4502 and *npn* type MJ802, can each replace up to three parallel transistors in audio amplifier circuits supplying up to 100-watt output. The units have d.c. current gains of 25 to 100 at collector currents of 7.5 amperes and a power dissipation rating of 200 watts at 25°C.

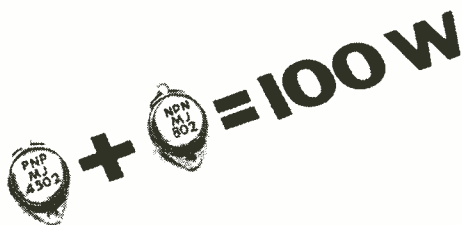

Complementary *pnp* and *npn* transistors have d.c. current gains up to 100 for total output of 100 W.

A new monolithic amplifier-detector silicon integrated circuit designed primarily for control system applications has been introduced by the Sprague Electric Company (115 Northeast Cutoff, Worcester, Mass. 01606). Identified as the ULN-2301M, the new device is a linear differential amplifier with a relatively high input impedance (70,000 ohms), 37-dB gain, and a frequency response of 150 kHz. Assembled in a modified 8-pin dual in-line molded plastic package, the unit features an internal zener diode voltage regulator and is intended as a control amplifier/driver for medium power SCR's.

The Amperex Electronic Corporation (Slatersville, Rhode Island 02876) has announced the development of a complete AM radio receiver IC on a single monolithic silicon chip. Designated the TAD100, the device is offered in a 14-lead, dual-in-line package, and contains all the active components of a complete AM receiver, including the oscillator, mixer, i.f. amplifier, detector, AGC, audio preamp and driver stages. The unit requires external tuning elements and con-

POPULAR ELECTRONICS

trols. The performance of a TAD100 receiver is comparable to that of a similar set made from discrete components. Its AM sensitivity is 50 μ volts/meter for 100 mW, audio output, its a.g.c. range is 65 dB for an audio output change of 10 dB, and its total harmonic distortion is typically 2%.

The TAA300 is another new Amperex IC device. A 1-watt audio amplifier, the unit is packaged in a 10-lead TO-5 case and has a sensitivity of 10 mV for full output, including 20 dB feedback. Its input impedance is over 10,000 ohms, while its total harmonic distortion is only 10% and its noise figure is typically less than 6 dB from 30 Hz to 15 kHz. The device is intended for use in battery-powered portable equipment such as phonograph amplifiers, radio and TV audio systems, walkie-talkie audio and speech amplifiers, tape-cassette systems and miniature hi-fi sets.

Transitips. Increasingly popular among solid-state equipment manufacturers, direct-coupled circuits require servicing techniques which differ somewhat from those used to troubleshoot conventional capacitor- or transformer-coupled designs. With each stage dependent upon all preceding stages for correct biasing, a minor defect near the input can result in a later stage being biased to cut-off or saturation. The familiar signal tracing technique may not isolate the defect, for an (a.c.) signal may appear to be normal until stage biases exceed rather broad tolerances.

One of the most effective test techniques is a stage-by-stage check of d.c. bias levels, starting at the last (output) stage and working back towards the input. Naturally, power supply voltages should be checked for normal levels before individual stages are tested.

If the input (base) bias is normal in a specific stage, but its output d.c. levels are far off, further checks of individual components in the stage generally will isolate the defective part. If all fixed components test "good," suspect the active device.

There are exceptions to this general rule, however. A leaky or shorted input circuit can affect the preceding stage. Here, one must consider the following stage's input circuit as an active part of the stage under test.

Finally, never overlook the possibility of a defect in an early stage causing parts damage in later stages. An initial minor defect in a preamp, for example, may cause a later driver stage to overload, damaging, say, a load resistor by excessive heating. Once a defective component has been located and replaced, then, *recheck* the entire circuit. —Lou

November, 1969

The World's Smallest HIGH FIDELITY AMPLIFIER

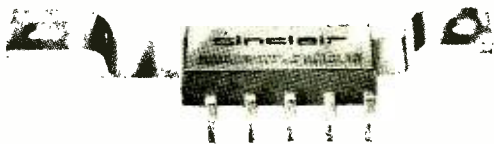

SINCLAIR IC-10

THE SINCLAIR IC-10 produces 10 watts of hi-fi audio. Combined with a gain factor of 110 dB and low distortion, the IC-10 meets requirements for many critical audio applications. Each IC-10 sells for \$12.00 (Cash, check or M.O.) and includes a comprehensive 32 page instruction manual. Write for quantity pricing for more than one IC-10. Please allow two weeks for delivery.

AUDIONICS, INC. stocks the entire experimenter's line by SINCLAIR, England's leading manufacturer of miniaturized high fidelity components. A detailed brochure describing the entire line including speakers is available free from Audionics, Inc.



AUDIONICS, INC.

9701 S.E. Mill

Portland, Ore., 97216

CIRCLE NO. 5 ON READER SERVICE PAGE

SAVE ON EVERYTHING IN ELECTRONICS!



Stereo hi-fi • Tape recorders & tape, electronic & hobby kits. • CB 2-way radios • Radios • Shortwave • Phonographs • Amateur gear • Automotive electronics • Tools & hardware • Tubes, transistors, parts, batteries, books ... and much more!

FREE

ALLIED 1970 ELECTRONICS CATALOG

Huge 552-page book, our biggest ever—right off the press and crammed with values! Mail coupon now for free copy!

ALLIED RADIO Dept. 545
P.O. Box 4398, Chicago, Ill. 60680

Please
Print

NAME First Middle Last

STREET ADDRESS or ROUTE & BOX NO.

CITY

STATE

ZIP

CIRCLE NO. 2 ON READER SERVICE PAGE

MICROWAVES

(Continued from page 46)

tered between the transmitter and receiver antennas. Make one of the antennas fixed; leave the other movable. Turn on the power at the transmitter and observe that the receiver readout indicates upscale. This proves that r.f. energy radiates from the transmitter, hits, and is reflected back from, the metal sheets, and produces a reading on the receiver.

Slowly slide the movable reflector toward the antennas. You will soon reach a point where the received power drops to a null and then rises again. This is the half-wave point where half of the transmitted r.f. is being supplied to the receiver out of phase with the signal from the fixed reflector. Carefully note and record the position of the movable reflector as indicated by the ruler. Keep sliding the movable reflector in toward the antennas, recording the exact points where nulls occur.

Calculate the centimeters or inches difference between each ruler indicated, add them up and divide by the number of nulls measured. This will give the average half wavelength. Double the value to obtain the full wavelength.

For the band being used here, full wavelength for 2300 MHz is 13.04 cm or 5.13 in.; and for 2450 MHz, 12.24 cm or 4.81 in. If your wavelength is not within these limits, bend tuning inductor *L1* to change the frequency. Retune the receiver to the transmitter either with *C2* (if the frequency difference is not too great) or by bending *L1* in the receiver.

Microwave Experiments. Once your microwave system is operating on frequency, you can experiment with various types of antennas and reflectors. For instance, with the transmitter and receiver facing each other a couple of feet apart, note that placing a metal sheet above the transmission path will greatly boost the signal. This is similar to the way the ionosphere reflects low-frequency r.f. signals.

Placing a pair of metal sheets near either antenna so that the antenna is at

NEW/CB TRANSCEIVER SOLID STATE PRE-AMP



- Improves CB Base Station Performance
- Works on tube or transistor equipment
- No Modification to CB unit
- On-the-air sign automatically lights when transmitting

Model PCB with built-in power supply, transfer relay, connecting cables, wired and tested..... **\$59.95**

Write for free literature



AMECO / DIVISION OF AEROTRON, INCORPORATED
P. O. BOX 6527 • RALEIGH, NORTH CAROLINA 27608

CIRCLE NO. 1 ON READER SERVICE PAGE

990 MODEL

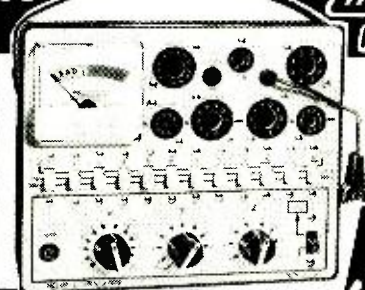

Mercury

NEW COMPACT TUBE TESTER OUTPERFORMS MANY HIGHER PRICED INSTRUMENTS

- Full Conductance Cathode Test • Has All The Latest Sockets
- Tests Over 3000 Tubes • Special, Unique Open-Circuit 12-Button Master Selection Slide-Switch Row Makes Unit Truly Obsolescent Proof • Tests Multiple Element Terminations Quickly, Easily
- Complete With Latest Tube Test Data That Is Permanently Kept Up-To-Date.

All Mercury Test Equipment Guaranteed For One Full Year!

Write for complete catalog of Mercury Test and Repair Equipment, and name of your nearest dealer

MERCURY ELECTRONICS CORPORATION

315 Roslyn Road • Mineola, N.Y. 11501 • (516) 742-5400

CANADA: William Cohen Corp.

Power Req.: 115V, 50/60 Hz 50W

Hi-impact molded case, 6 1/2 x 7 1/2 x 3 1/2 - 4 lbs.

ONLY
21.95
KIT
34.95 WIRED

American Made

CIRCLE NO. 25 ON READER SERVICE PAGE

the apex of a right angle also boosts the signal. This is a basic horn antenna. It can be used at either the transmitter or the receiver, or both. The signal strength can be vastly increased by various antenna configurations, even though the transmitter power remains unchanged.

To demonstrate this further, make a dipole as shown in Fig. 9. Connect the center feed to the thin coaxial cable to the transmitter antenna coupling capacitor *C2* and the shield to the ground plane. Disconnect the regular antenna. Now you can add directors and/or reflectors to the basic dipole to experiment with beam arrays. A couple of things will become apparent as you experiment: First, as gain goes up, directivity increases; second, to double the range (distance), you must have four times the power. The latter can be proved by using the potentiometer on the transmitter to vary the power. A milliammeter can be inserted in the 12-volt line to measure the transistor current.

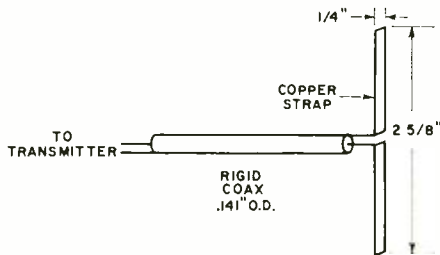
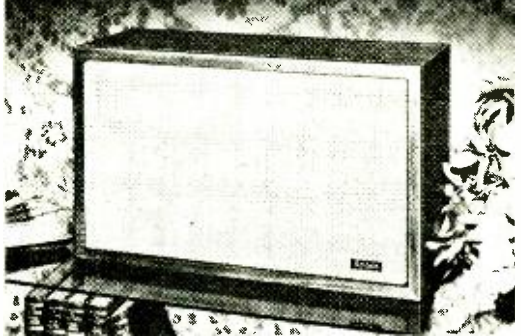

Fig. 9. This simple dipole can be used to perform experiments with various antenna arrays. These can include beams, horns, or parabolic systems. Remove the old antenna and ground plane and install this.

In experimenting with various horns and arrays, remember that, to get about 20 dB of gain, the antenna aperture should be at least six wavelengths square (or 36 square wavelengths) at the aperture.

The transmitter can be audio modulated by conventional techniques and such a system makes a very interesting Science Fair project. Microwave signals can be "bounced" around corners and over other intervening objects, by means of simple metal reflectors. When a hand is placed in the beam path, the signal level changes, showing that the microwave r.f. is actually carrying the signal.

Argos' new speaker technology creates a genuine price breakthrough in two-way system design.



The new Argos TX-200 is a totally new dimension in high fidelity sound reproduction systems—a superb instrument offering fine-furniture construction, big-system performance and compactness for maximum versatility. The TX-200 matches a specially-designed high compliance, low-resonance woofer with a new high-compression horn-loaded driver component to produce distortion-free response from 30 Hz to the inaudibles at 18,000 Hz.

Specifications

Cabinet: Select walnut, Belgian linen

Argos
Products Company

grille. Size: 18 7/8" x 11 1/8" x 7 7/8"

Genoa, Illinois 60135

Price: Audiophile net \$45.00.

CIRCLE NO. 4 ON READER SERVICE PAGE

CONVERT YOUR F.M. TUNER to STEREO!

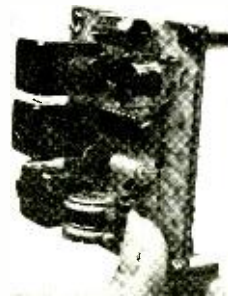

- State-of-the-Art
- Equivalent of 30 transistors and 10 diodes, assures maximum separation, minimum noise and distortion and broad frequency response
- Thoroughly tested and aligned
- Will convert any F.M. radio to receive stereo broadcasts
- Suitable for use on automobile F.M. receivers
- Built in voltage regulator assures stable operation
- Facilities for interstation muting and stereo light
- Operates on 12-15 V.D.C., can be adapted for wide variety of D.C. or A.C. voltages
- Written Guarantee

only **\$34.55**

PLEASE PRINT . . . DEALER INQUIRIES INVITED

BROADCAST SYSTEMS INTERNATIONAL, INC.

P.O. Box 8528—Capitol Heights, Md. 20027

PLEASE RUSH ME _____ MPX 39 @ 34.55

NAME _____

ADDRESS _____

CITY _____ STATE _____ ZIP _____

I AM ENCLOSING _____ IN CASH OR MONEY ORDER
MARYLAND RESIDENTS INCLUDE 4% SALES TAX

CIRCLE NO. 8 ON READER SERVICE PAGE

Get the last word every time.

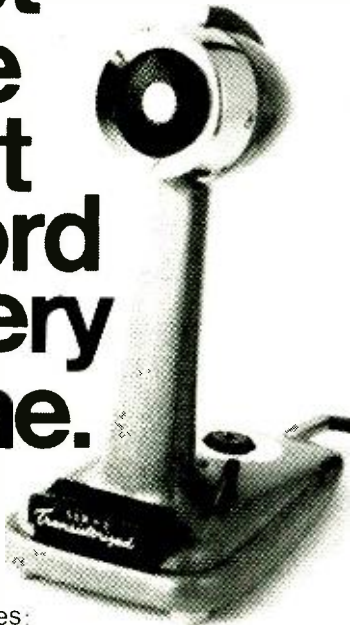

Get

Turner's

"+2" series:

+2 base station mike (List Price: \$55.00) and M+2/U mobile mike (List Price: \$39.50). Up to 50 times the modulation of other mikes. No more fade outs. No more static. (Even at great distances). Both "+2" series microphones use a

two - transistor pre-amp and work with all transistor and tube sets. See them at your CB dealer or distributor soon. And get the last word.



TURNER

919-17th Street N.E.

Cedar Rapids, Iowa 52402

In Canada: Tri-Tel Associates, Ltd.

CIRCLE NO. 55 ON READER SERVICE CARD

AIR IONS

(Continued from page 30)

large ions in the air is not controlled. Work has been done in this field in an attempt to improve conditions in closed quarters (such as submarines).

European scientists were among the first to research the relationship between ions and human health. A great emphasis in clinical work with ions has developed within the past few years. The effects on tissue and cell life of animals and humans are increasingly popular areas of research. The field is attracting the physicist, biologist, climatologist, and medical researcher. In this country additional work has been done by the heating and air conditioning interests in an effort to determine the factors that are involved in human comfort.

The Air We Breathe. One area of research which has received considerable attention is the effect of ionization on hay fever, asthma and other respiratory troubles. Some of the early work in this field was done by Dr. Kornbluh in 1953. As a result of his early experiments he found that symptoms of hay fever and asthma were relieved when patients were exposed to negative air ionization in a closed room. However, the symptoms returned when the patients left the room. In later experiments he established a hay fever clinic at Northeastern Hospital in Philadelphia. Under controlled conditions 63% of the patients received complete or partial relief under negative ionization. The symptoms returned when patients returned to their normal environment. Positive ionization gave no relief and in some cases increased the distress of the patient.

Research has shown that negative ionization has an unusual effect on the bronchial tubes and trachea. These portions of the respiratory system are lined with tiny hairlike filaments called cilia which maintain a wave-like motion. With this motion they keep the air passages free of dust and pollen. When an excess of positive ions was maintained in the intake air, the wave-like motion decreased by several hundred beats per minute.

100% MUSIC POWER



PHOTOGRAPH BY FRANK EYDIO

Words are inherently limited in stimulating the emotions aroused by music. This is especially so in describing how high fidelity components perform.

With cartridges, for example, we speak of flat frequency response, high compliance, low mass, stereo separation. Words like these enlighten the technically minded. But they do little or nothing for those who seek only the sheer pleasure of listening.

We kept both aspects in mind when developing the XV-15 series of cartridges. We made the technical measurements. And we listened.

We listened especially for the ability of these cartridges to reproduce the entire range

of every instrument. With no loss of power. That's what it takes for a cartridge to recreate the most subtle nuances that distinguish one musical instrument from another. An oboe from an English horn. A trumpet from a cornet.

We call this achievement "100% music power."

When you play your records with an XV-15, you won't be concerned with even that simple phrase.

Instead, you'll just feel and enjoy the renewed experience of what high fidelity is really all about.

PICKERING



THE NEW PICKERING XV-15/750E. PREMIER MODEL OF THE XV-15 SERIES. TRACKS AT 1/5 TO 1 GRAM DYNAMIC DOUBLING FACTOR OF 750 FOR USE IN FINEST TONEARMS. \$60.00. OTHER XV-15 CARTRIDGES FROM \$29.95. PICKERING & CO., PLAINVIEW, L.I., N.Y.

CIRCLE NO. 47 ON READER SERVICE PAGE

FREE 1970 CATALOG.

1001 Bargains—Speakers—Parts—Tubes—High Fidelity Components—Record Changers—Tape Recorders—Kits—Everything in Electronics. Write:

McGEE RADIO COMPANY

PE, 1901 McGee Street,
Kansas City, Missouri 64108.

**Guaranteed
10 Years!**

\$1.98



The knife for hunting, fishing, and all around use. Mirror polished, imported stainless steel blade honed to a razor's edge. Rugged. Opens with flick of finger. Locks into position. Blade will not close when in use. Press button in handle to close. Safety finger guard. Sure-grip handle. Balanced for target throwing.

IF BROKEN WITHIN 10 YEARS

WE WILL REPLACE AT NO CHARGE! Use 30 days. Money back if not pleased. Only \$1.98 plus \$.27 postage and handling. ORDER NOW! Midwest Knife Co., 9043 S. Western Ave., Dept. LRC-1, Chicago, Ill. 60620. Established 1936.

**COOPERATE WITH
THE ZIP CODE
PROGRAM OF THE
POST OFFICE
DEPARTMENT.
USE ZIP CODE
IN ALL ADDRESSES**

GET INTO ELECTRONICS

V.T.I. training leads to success as technicians, field engineers, specialists in communications, guided missiles, computers, radar, automation. Basic & advanced courses. Electronic Engineering Technology and Electronic Technology curricula both available. Associate degree in 30 months. B.S. obtainable. G.I. approved. Start September, February. Dorms, campus. High school graduate or equivalent. Catalog.

VALPARAISO TECHNICAL INSTITUTE
DEPARTMENT PE, VALPARAISO, INDIANA 46383



**Stereo
Input
Mixing
Monitoring**

**1st
Time!**

Also Control Center allows your choice of up to 6 stereo speaker systems to be selected simultaneously. *Push-on & push-off* switches enable you to optionally select your choice of speaker pairs. Easy access rear panel connect

Model No.	Prs.	Connector Type	Each
CC4RCA	1	RCA	\$19.95
CC4PHM	1	Phone (Miniature)	21.95
CC4PHS	1	Phone (Standard)	22.95
CC6RCA	6	RCA	26.95
CC6PHM	6	Phone (Miniature)	28.95
CC6PHS	6	Phone (Standard)	29.95

CHOICE
OF 6
MODELS

ALCO

Buy Direct: BOX 1348PE
LAWRENCE, MASS. 01842

Use push-on & push-off switches to select speaker pairs.

When the tissue was exposed to an excess of negative ions the motion was accelerated above normal values. It was also found that under positive ionization the tissues were much more susceptible to bruise or damage.

Other studies have shown that negative ions have been used successfully to treat hypertension, slow-healing wounds, and to reduce the pain in severe burn cases.

The details of the picture puzzle are being filled in piece by piece but several important details are still missing. As one researcher put it, we do not know *why* ionized air has a physiological effect on living things but it does have an effect on all of us.

Another point on which most researchers agree is that negative air ions do not cure anything. During the time that they are being applied they apparently set up a favorable condition or perhaps supply something that is missing in the individual being treated. When the supply of negative ions is removed the condition returns. However, this does not diminish their value. They should be very useful in pointing the way to what is defective or lacking in the patient. Just the relief of symptoms has its value.

One item that should not be overlooked is the fact that most negative ions are formed around an oxygen molecule and most positive ions are formed around carbon dioxide or sometimes nitrogen. The charge may be important only as the nail that holds the package together.

To solve the riddle of the ion and to apply the knowledge gained could be a breakthrough as important as the moon landing, at least to those who will get relief from a serious ailment. The fascinating thought is that some reader may just do it in his back-room laboratory.

-30-

RESERVE YOUR DECEMBER ISSUE!

In the next issue, POPULAR ELECTRONICS will publish the most exciting construction project in its history—a safe, but fully operational LASER!

Subsequent issues will show how to use this laser for secret communications and making holograms.

Don't miss this most important issue of 1969-70.

DARKROOM TIMER

(Continued from page 54)

With the maximum timing interval properly set, turn potentiometer *R1* to its minimum resistance position. Using the stop watch or clock, check the minimum timing interval. It should be somewhere between 4 and 5 seconds. If it is longer, slightly *decrease* the value of *R2* and check the interval again. (Selecting the optimum value for *R2* has no significant effect on the maximum timing interval.)

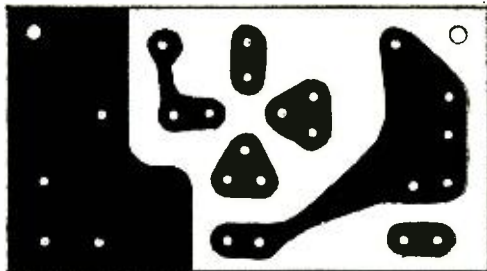
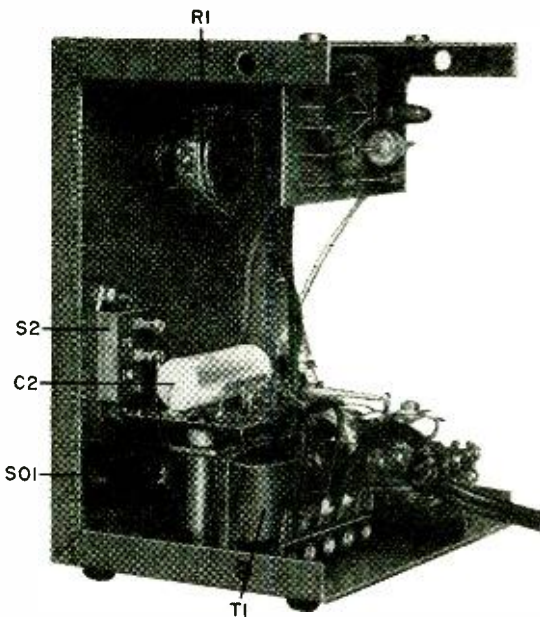

Fig. 5. Actual-size printed circuit foil pattern can be duplicated. Use a glass-epoxy board to reduce moisture absorption and possible mistiming.

Calibration. The timer may be calibrated with the same stop watch or clock used in making the adjustments. Mark the 10-second intervals first. As each position of the pointer knob on *R1* is accurately located, make a tiny prick point on the cabinet front panel. Do the same for the 5-second intervals. Then remove the knob and apply decals or dry transfer at these points. Make certain the knob is replaced in exactly the same position in which it was taken off.

-30-

Fig. 4. This view shows the placement of the outlet socket *S01*, input power control switch *S2*, and timing potentiometer *R1*. Make sure that the cover can be installed without touching any components.

**DELIVERY TIME
PUTTING THE
SQUEEZE
ON YOUR SEMI CONDUCTOR NEED?**

Perhaps we can help. We are offering low prices and "off the shelf" delivery on most Jedec type devices. Here are a few examples!

Type	Price for 1K and up
2N 214.....	25c
2N 404.....	13c
2N 697.....	16c
2N 1305.....	16c
2N 3565.....	12c
2N 3638.....	13c

**WE ALSO
CUSTOM TEST
TO YOUR OWN
SPECIFICATIONS**

**NEW JERSEY
SEMI CONDUCTOR**

U.S. Highway 22, Blue Star Mall
Watchung, N.J. 07060 Tel. (201) 322-9200

CIRCLE NO. 29 ON READER SERVICE PAGE

**Which of these
4 fascinating
Radio-TV
careers**

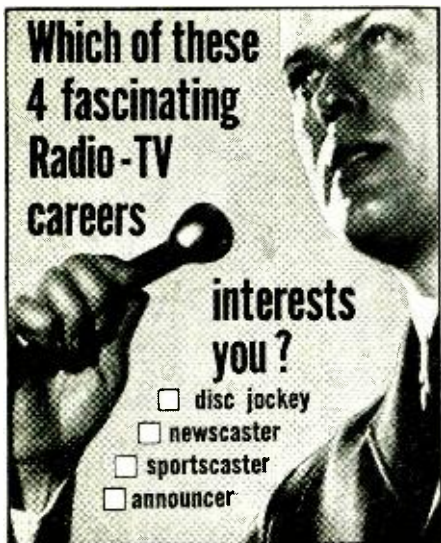

**interests
you?**

disc jockey
 newscaster
 sportscaster
 announcer

**Our Free Voice Analysis Tells You
Whether You Have The Talent To
Become A Broadcast Personality!**

IMMEDIATE DEMAND • Radio-TV stations everywhere need both men and women to take over important good-paying jobs right now. **NATIONWIDE PLACEMENT ASSISTANCE** at No Extra Cost.

TRAIN AT HOME OR IN ONE OF OUR STUDIO SCHOOLS • You can study broadcast techniques at home, in your spare time, or in one of our many studio schools throughout the country under the supervision of our Directing Faculty of 11 Famous Broadcasters. Accredited Member National Home Study Council and National Association of Trade and Technical Schools.

Approved for Veterans' Educational Assistance Benefits ("G.I. Bill")! Check coupon for special information

Send to CAREER ACADEMY's division of famous broadcasters for free booklet, record and voice analysis details!

CAREER ACADEMY

825 North Jefferson Street • Studio 454
Milwaukee, Wisconsin 53202

I want to know if I have broadcasting aptitude worth developing. Please rush more information.

name _____ age _____

address _____ phone _____

city/state / zip _____ 07N087210

I am interested in: Home Study

School Study G. I. Bill



CIRCLE NO. 10 ON READER SERVICE PAGE

PRODUCTS

(Continued from page 24)

ture automatically rotates to each of the receiver's channels every half second. When one channel is active, scanning stops at that channel until the message is complete. Then the scan engages again until stopped by another active channel. The scan circuit, however, can be disengaged if desired simply by flipping a switch located on the front panel. The Mark 6 is also available as an excellent receiver without the "Scan-O-Matic" feature.

Circle No. 89 on Reader Service Page 15

VHF/FM MONITOR RECEIVER KITS

Two new monitor receiver kits are now available from the *Heath Company* for coverage of the 108-136 MHz (Model GR-98) and 154-174 MHz (Model GR-88) bands.

The GR-98 is for aircraft signal monitoring, while the GR-88 is for monitoring VHF marine channels, weather bureau broadcasts, fire and police calls, commercial radio, etc. Both receivers feature six-to-one vernier tuning controls to make it easy to tune closely-spaced stations, and built-in whip antennas. Selectivity and sensitivity in both cases are 40 kHz and 1.5- μ V, respectively. If continuous monitoring of only one station is desired in either model, separate plug-in crystals are available. The receivers have adjustable noise-operated squelch, operate on six C cells, and feature a carrying handle that converts into a tilt stand.



Circle No. 90 on Reader Service Page 15

CONTROL AMPLIFIER

Dynaco's new solid-state Model SCA-80 control amplifier is a single, integrated package combining a high-reliability power amplifier and a versatile preamplifier with all the performance and flexibility of sophisticated independent components. It is rated at 40 watts continuous r.m.s. power/channel across the entire audio spectrum with both channels driven simultaneously into an 8-ohm load. Harmonic distortion is less than 0.5%, and i.m. distortion is less than 0.1% at the rated output, decreasing as power is reduced. The amplifier is said to operate with reliability and stability into such reactive loads as electrostatic speaker systems. The control section has complete facilities, yet is simple to operate with a basic, two-knob control action. A front-panel stereo headphone jack, always live, can be used with speakers either live or off.

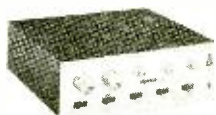

performance and flexibility of sophisticated independent components. It is rated at 40 watts continuous r.m.s. power/channel across the entire audio spectrum with both channels driven simultaneously into an 8-ohm load. Harmonic distortion is less than 0.5%, and i.m. distortion is less than 0.1% at the rated output, decreasing as power is reduced. The amplifier is said to operate with reliability and stability into such reactive loads as electrostatic speaker systems. The control section has complete facilities, yet is simple to operate with a basic, two-knob control action. A front-panel stereo headphone jack, always live, can be used with speakers either live or off.

Circle No. 91 on Reader Service Page 15
POPULAR ELECTRONICS

ELECTRONICS MARKET PLACE

COMMERCIAL RATE: For firms or individuals offering commercial products or services. \$1.15 per word (including name and address). Minimum order \$11.50. Payment must accompany copy except when ads are placed by accredited advertising agencies. Frequency discount: 5% for 6 months; 10% for 12 months paid in advance. **READER RATE:** For individuals with a personal item to buy or sell. 70c per word (including name and address). No Minimum! Payment must accompany copy.

FOR SALE

FREE! Giant bargain catalog on transistors, diodes, rectifiers, SCR's, zeners, parts. Poly Paks, P.O. Box 942, Lynnfield, Mass. 09140.

GOVERNMENT Surplus Receivers, Transmitters, Snooperscopes, Radios, Parts, Picture Catalog 25¢. Meshna, Nahant, Mass. 09108.

ROCKETS: Ideal for miniature transmitter tests. New illustrated catalog. 25¢. Single and multistage kits, cones, engines, launchers, trackers, rocket aerial cameras, technical information. Fast service. Estes Industries, Dept. 18, Penrose, Colorado 81240.

LOWEST Prices Electronic Parts. Confidential Catalog Free. **KNAPP**, 3174 8th Ave. S.W., Largo, Fla. 33540.

EUROPEAN and Japanese bargains catalogs. \$1 each. Dee, 10639E Riverside, North Hollywood, Calif. 91602.

MECHANICAL, ELECTRONIC devices catalog 10¢. Greatest Values—Lowest Prices. Fertik's, 5249 "D", Philadelphia, Pa. 19120.

MUSIC LOVERS, CONTINUOUS, UNINTERRUPTED BACKGROUND MUSIC FROM YOUR FM RADIO, USING NEW INEXPENSIVE ADAPTOR. FREE LITERATURE. ELECTRONICS, 11500-Z NW 7th AVE., MIAMI, FLORIDA 33168.

WE SELL CONSTRUCTION PLANS. TELEPHONE: Answering Machine, Speakerphone, Carphone, Phonovision, Legal Connector, Auto Dialer, Central Dial System. **TELEVISION:** \$35.00 Color Converter, Tape Recorder, 3DTV. \$25.00 Camera. **DETECTIVE:** Infinity Transmitter, Tail Transmitter, Police Radar Detector. **HOBBYIST:** Electron Microscope, 96 Hour Tape Music System, Ultrasonic Dishwasher, Radar-Oven, Electronic Tranquilizer. Plans \$4.95 each. **COURSES:** Telephone Engineering \$39.50. Detective Electronics \$22.50. Anti-Detective Electronics \$27.50. **SUPER HOBBY CATALOG** 25¢. Don Britton Enterprises, 7906 Santa Monica Blvd., Hollywood, Calif. 90046.

WEBBER LAB'S. Police & Fire Converters. Catalog 10¢. 72 Cottage Street, Lynn, Mass. 09105.

RADIO—T.V. Tubes—33¢ each. Send for free catalog. Cornell, 4213 University, San Diego, Calif. 92105.

WHOLESALE COMPONENTS: Manufacturers and distributors only. Request free catalog on business letterhead. **WESCOM**, Box 2536, El Cajon, California 92021.

INVESTIGATORS, LATEST ELECTRONICS AIDS. FREE LITERATURE. CLIFTON, 11500-L NW 7th AVE., MIAMI, FLORIDA 33168.

TV CAMERA PRICE BARRIER BROKEN: Complete solid-state TV camera kit now only \$116.95. Starter kits \$18.95 up. Plans 25¢ up. Easy-educational-economical. Also vidicons, lenses, modules, etc. Catalog **FREE.** **ATV RESEARCH**, 1301 Broadway, Dakota City, Nebr. 68731.

FREE ELECTRONICS PARTS FLYER. Large catalog \$1.00 deposit. **BIGELOW ELECTRONICS, BLUFFTON, OHIO 45817.**

JAPAN & HONG KONG DIRECTORY. Electronics, all merchandise. World trade information. \$1.00 today. Ippano Kaisha Ltd., Box 6266, Spokane, Washington 99207.

CIRCUIT Boards, Parts for "Poptronics" projects. Free catalog. S.W. Technical, Box 16297, San Antonio, Texas 78216.

FREE Catalog low priced, high performance subminiature listening devices direct from manufacturer. Emery LT-11 156 Fifth Avenue, New York, N. Y., 10010.

ULTRA-SENSITIVE AND POWERFUL METAL DETECTORS—join the many who are finding buried coins, minerals, relics and artifacts. Don't buy till you see our **FREE** catalog of new models. Write Jetco, Box 132-PE, Huntsville, Texas 77340.

LASER parts catalog 60¢. Moynihan, 107 North Brighton, Atlantic City, New Jersey 08401.

GENERAL INFORMATION: First word in all ads set in bold caps at no extra charge. Additional words may be set in bold caps at 10c extra per word. All copy subject to publisher's approval. Closing Date: 1st of the 2nd preceding month (for example, March issue closes January 1st). Send order and remittance to: Hal Cymes, **POPULAR ELECTRONICS**, One Park Avenue, New York, New York 10016.

"GIZMOTCHY" CB beams, dealers wanted Box 1820, Huntington Beach, Calif. 92647.

PSYCHEDELIC catalog. Posters, lighting, etc. Send 25¢ for handling to Hole In The Wall, 6055PE Lankershim, North Hollywood, Calif. 91606.

CONSTRUCTION PLANS: LASER . . . \$2.00. Surveillance Devices—two F.M. Bugging Transmitters . . . \$1.00. Tail Transmitter . . . \$1.00. Bug Detector . . . \$1.00. Surveillance equipment and kits available. Howard, 20174 Ward, Detroit, Michigan 48235.

SECURE TEST EQUIPMENT UNBELIEVABLE PRICES. FREE CATALOG AND PRICE SHEET. FORDHAM RADIO, 265 EAST 149TH STREET, BRONX, N.Y. 10451.

FM BACKGROUND MUSIC! Miniaturized adapter connects to any FM Radio Tuner. Brings in hidden commercial free programs. Performance guaranteed. \$29 postpaid. K-Lab, Dept. Z, Box 572, S. Norwalk, Conn. 06856.

RESISTOR PROBLEMS? Too expensive? No longer! 1/2w only 8¢; 10/60¢ assorted. Garrett Industries, 4504 Nunnwood, Lakeland, Florida 33803.

THE ART OF DE-BUGGING—\$5.95. TRON-X PUBLICATIONS, P.O. BOX 38155, HOLLYWOOD, CALIFORNIA 90038.

POLICE—FIRE RADIO-DISPATCHER DIRECTORIES! Exclusive latest **CONFIDENTIAL** listings. Official CALLSIGNS, FREQUENCIES! Catalog for stamp. Communications, Box 56-PE, Commack, N.Y. 11725.

COMPONENTS? Kits? Hardware? Free catalog! Truvue Paks, Box 275, Chelsea, Mass. 02150.

HOW a tube amplifies \$.50. The hybrid coil \$.50. Free catalog. **BECO**, Box 27011, Minneapolis, Minnesota 55427.

ELECTRONIC ignition, various types. Free literature. Anderson Engineering, Epsom, N.H. 03239.

NEW! Low cost aluminum UHF-VHF towers. **COFFELT**, 909 Hayter, Dallas, Oregon 97338.

PROXIMITY switch. Detects nearness of human body. Free information. Claremont Products, 860 Reed, Claremont, Calif. 91711.

NEW! **PHONE PATCH** with automatic switch. Now you can record those important conversations automatically. **ONLY \$12.95.** Chelco Electronics, 11835 Wilshire Blvd., Los Angeles, Calif. 90025.

AMATEUR SCIENTISTS, Electronics Hobbyists, Experimenters, Students . . . Construction Plans—all complete, including drawings, schematics, parts lists with prices and sources . . . Laser—Build your own coherent-light optical laser. Operates in pulsed mode, visible light range—\$6.00 . . . Radar—Build your own ultrasonic doppler radar. Detect motion of people, automobiles, even falling rain drops. Transistorized, uses standard small 9-volt battery—\$4.00 . . . Long-Range "Sound Telescope"—This amazing device can enable you to hear conversations, birds and animals, other sounds hundreds of feet away. Very directional. Transistorized. Uses 9V battery—\$3.00 . . . Or send 25¢ coin (no stamps) for complete catalog. Other items include Psychedelic strobes, light shows, robots . . . 38 different projects. Technical Writers Group, Box 5994, State College Station, Raleigh, N.C. 27607.

DIAGRAMS—Radios \$1.50, Television \$3.00. Give make and model. Diagram Service, Box 1151PE, Manchester, Conn. 06042.

SONAR Monitor Receivers unsurpassed. Fire, police, ambulance, Taxi, highway patrol communications, Free antenna offer. Griffin's, 322 West State, Ithaca, N.Y. 14850.

GENUINE Western Union instruments: key, relay, sounder, \$10.00 each; all three \$25.00 postpaid. Lillian's, Box 17165PE, Chicago, Illinois 60617.

FREE TV TUNER REPAIR TRICKS, Plans, Details Complete Courses. Frank Bocek, Box 833, Redding, Calif. 96001.

COLOR TRANSISTORS, 3-channels, 600 watts, factory assembled, \$24.95 ppd. Dealers inquiries welcome. R & M Enterprises, 2271 Rose Way, Fullerton, Calif. 92632.

SOMETHING DIFFERENT EACH MONTH. SEND STAMPED, ADDRESSED ENVELOPE TO RECEIVE BARGAINS IN GOVERNMENT SURPLUS ELECTRONICS, TEST EQUIPMENT, AMATEUR GEAR, TECH MANUALS, TUBES, COMPONENTS, RECEIVERS, TRANSMITTERS, LORAN, RADAR. HAVE THOUSANDS OF ITEMS COMING MONTHLY. SLEP ELECTRONICS COMPANY, 2412 HIGHWAY 301N. ELLENTON, FLORIDA 33532.

CLEARANCE SALE rectifiers, transistors, 1000's other items. Catalog 15¢. General Sales Company, 254 Main, Clute, Texas 77531.

USED TV repair equipment for sale. Everything needed for complete shop including B & K 1076 analyst, Heathkit 10-14 Oscilloscope, Hickok Cardmatic tube tester, and many other items. Write Doug Strande, Northwood, N.D. 58267. Phone 701-587-6681.

RELAYS, 10 assorted, \$3.00. Small Salvage, Box 9502, Norfolk, Va. 23505.

BURGLAR-Proof your Home, Business. Specify, Schematic instructions 25¢. SILMAR, 3476-E N.W. 7th St., Miami, Florida 33125.

HEARING AIDS below wholesale. Smallest, most powerful. Free home trial. No salesman will call. Free details, Write Prestige-C-42, Box 10880, Houston, Texas 77018.

IGNITION C-D 26.95 Silicon Semiconductors. Free info. Semiconducter Industries, Box 27, Boston 02131.

LINEAR AMPLIFIERS: "Hornet" 50 watts output—\$98.50; "Raider" 100 watts—\$139.50; "Maverick-250" 250 watts—\$244.95, AM and SSB. "Scorpion" 50 watt 12 V. Mobile Amplifier—\$99.95; "Bandit II" 12 V. Mobile Amplifier—\$169.95. Mobile amplifiers positive or negative ground. Frequency range 20-35 megacycles (illegal for class D 11 meters.) Dealer inquiries invited. D & A Manufacturing Co., 1217 Avenue C, Scottsbluff, Nebraska 69361.

CONVERT any television to big-screen oscilloscope. Only minor changes required. No experience necessary. Easy, illustrated step-by-step plans, \$1.95. Secret automatic telephone recorder, Remote telephone Intrusion Alarm. Detailed illustrated plans \$1.00 each. 3 for \$3.00. Relco-A179, Box 10839, Houston, Texas 77018.

SEMICONDUCTORS and parts catalogue free over 100 pages. J. & J. Electronics, Box 1437, Winnipeg, Manitoba, Canada. U.S. Trade directed.

BIG EXTERNAL S METER for ALL CB Radios. 2 wire connection. \$8.95. AREA, Box 8236, Atlanta, Georgia 30306.

PLANS AND KITS

KITS, metal detector \$5.95. Audio Telescope \$5.95. others. Lectronix, Box 42, Madison Heights, Michigan 48071.

SOLAR FLYING SAUCERS. (Brand New Solid State Engine, Fantastic Performance, Flies Miles on Sun's Power. lifts animals, sends messages, parachutes. Build many, easily, inexpensively with everyday materials. Complete plans, descriptions, drawings, plus FREE Space-tronics CATALOG \$1. Single Catalog 25¢. Spacetrronics, Box 31043-PES, San Francisco, California 94131.

RADAR INTRUDER ALARM detects human movement thirty feet away. TRANSISTORIZED. BUILD YOURSELF with complete instructions. Parts, kits and assembled units also available. Plans \$3.00. Microwave Research Co., Box 10147, St. Petersburg, Florida 33733.

KITS GALORE! Free catalog subscription. Alsynco PE-119, 171 South Main, Natick, Mass. 01760.

SURVEILLANCE DEVICES IN KIT FORM: Telephone Transmitter, FM Spy Transmitter, Telephone-Recorder Actuator, Tail Transmitter, Bug Detector. Complete Kits Send \$15.00 each. ELECTRONIC SECURITY SYSTEMS, 1101 West Rosecrans Avenue, Gardena, California 90247.

"COIL WINDING" Handbook 50¢. Experimenter's catalog includes 250 exclusive items 25¢, refundable. Laboratories, 12041-L Sheridan, Garden Grove, Calif. 92640.

SUB-CARRIER MUSIC ADAPTER for commercial-free music. 6- transistor circuit uses standard components. Plans and 3x4½" etched circuit board \$4.50. Wallace Enterprises, Inc., 83-15 98th Street, Woodhaven, N.Y. 11421.

AUDIO your hobby? Details on advanced plans, projects free. Sonic, 307 Dickinson, Swarthmore, Pa. 19081.

KIT BUILDING done by professional radio—television serviceman. Write for price, giving make, model, description of kit. Stephen Mayan, 3rd Region TMA, APD San Francisco 96384.

COLOR Organ Kit \$7.50. Power Supplies \$3.98. Catalog. Murphy, 204 Roslyn Ave., Carle Place, N.Y. 11514.

TESLA COIL—40" SPARKS! Plans \$5.00. Information 50¢. Huntington Electronics, Box 9-P, Huntington, Conn. 06484.

INTEGRATED CIRCUIT KITS: COMPUTER, AUDIO, Others. New catalog free. KAYE ENGINEERING, Box 3932-A, Long Beach, California 90803.

NOVEL electronic lock. Random combination lets others watch—they still can't succeed. Baffle your friends. Unlimited applications. Uses inexpensive I.C.'s \$4.95. Newell Labs, Box 1254, Redondo Beach, Calif. 90278.

COLOR ORGAN, five channel stereo plans \$2.00. Turino, Box 124, El Segundo, Calif. 90245.

PSYCHEDELIC light build one for less than \$10.00. Transforms room into dynamic colorama. Plans \$2.00. Write Chimera, 515 Brisbane Bldg., Buffalo, N.Y. 14203.

C.B.er's increase your range! Send \$2.00 for detailed plans on antenna coupler plus our invaluable antenna facts sheet. Bertani, 5516 Grand Lake, Houston, Texas 77036.

SHORTWAVE LISTENING

INTERESTED IN SHORTWAVE RADIO? Then you'll be interested in the Radio Worldwide Listeners Club! Thousands of members throughout the world now receive a magazine filled with special features dealing with almost every aspect of communications (including SWL) and electronics. Discover the Club. Write for your free sample issue of the Radio Worldwide magazine or join now, dues are just \$2.00 a year for U.S.A. Radio Worldwide Listeners Club, Dept. 177, 485 Madison Avenue, New York 10022.

HIGH FIDELITY

FREE! Send for money saving stereo catalog # P11E, lowest quotations on your individual component, tape recorder, or system requirements. Electronic Values, Inc., 200 W. 20th St., New York, N.Y. 10011.

DON'T THROW YOUR OLD CARTRIDGE AWAY. Send us \$19.95 and any old cartridge. We will ship PREPAID any one of the following top rated elliptical diamond stereo cartridges NEW: Shure M75E, M91E, M92E, M93E, Empire 888E, Pickering V15AME3, XV15 ATE, ADC 660E, 550E. Write for lowest quotations all stereo components. Send \$1.00 for our discount catalog. DEFA ELECTRONICS, 2207 Broadway, New York, N.Y. 10024.

Hi-Fi components. Tape Recorders, at guaranteed "We Will Not Be Undersold" prices. 15-day money-back guarantee. Two-year warranty. No Catalog. Quotations Free. Hi-Fidelity Center, 239 (P) East 149th Street, New York 10451.

LOW, Low quotes: all components and recorders, HiFi, Roslyn, Penna. 19001.

TAPE RECORDERS, Hi-Fi, components, Sleep Learning Equipment, tapes. Unusual Values. Free Catalog. Dressner, 1523R, Jericho Turnpike, New Hyde Park, N.Y. 11040.

DON'T THROW YOUR OLD CARTRIDGE AWAY. Send us \$50.00 and any old used cartridge and we will ship you via air Prepaid anywhere any one of the following Top Stereo Cartridges: Shure V-15 Type II, Empire 999VE, ADC 10EMK 11, Stanton 681EE. Write for lowest quotations all stereo components. Send \$1.00 for our discount catalog. DEFA ELECTRONICS, 2207 Broadway, New York, N.Y. 10024.

WANTED

CASH PAID! Unused tubes, electronic equipment. Barry, 512 Broadway, NYC 10012.

QUICKSILVER, Platinum, Silver, Gold, Ores Analyzed. Free Circular. Mercury Terminal, Norwood, Mass. 02062.

CASH PAID for all tubes. DAMESCO, 308 Hickory, Arlington, N.J. 07032.

PICTURE TUBE No. 20BP4 or any T.V. or station monitor with 20BP4. DUMONT: T.V.'s RA 106-RA-106, Scopes 208-241. Voltage Calibrator 264A. Schwartzman, 107 Ontario, Corning, N.Y.

TUBES

TUBES "Oldies", latest. Lists free. Steinmetz, 7519 Maplewood, Hammond, Indiana 46324.

RECEIVING & INDUSTRIAL TUBES, TRANSISTORS. All Brands—Biggest Discounts. Technicians, Hobbyists, Experimenters—Request **FREE** Giant Catalog and **SAVE!** ZALYTRON, 469 Jericho Turnpike, Mineola, N.Y. 11501.

TUBE Headquarters of World! Send 10c for Catalog (tubes, electronic equipment) Barry, 512 Broadway, N.Y.C. 10012.

RADIO & T.V. Tubes—33¢ each. Send for free list. Cornell, 4213 University, San Diego, Calif. 92105.

THOUSANDS and thousands of types of electronic parts, tubes, transistors, instruments, etc. Send for Free Catalog. Arcturus Electronics Corp., MPE, 502-22nd St., Union City, N.J. 07087.

TUBES—lowest prices in the world. Hard to get British, German, Foreign and American obsolete and present day special purpose transmitting tubes. Send for giant tube and parts catalog. United Radio Co., Dept. Y-56 Ferry Street, Newark, N.J. 07105.

TV TUBES NEW BOXED UP TO 80% OFF LIST. For catalog price sheets send \$1.00. T & T Sales Co., 4802 Ave. K, Brooklyn, N.Y. 11234.

TAPE AND RECORDERS

TAPES . . . blank recording . . . pre-recorded music. Catalog 10¢. Tower, Lafayette Hill, Pa. 19444.

BEFORE Renting Stereo Tapes try us. Postpaid both ways—no deposit—immediate delivery. Quality—Dependability—Service—Satisfaction—prevail here. If you've been dissatisfied in the past, your initial order will prove this is no idle boast. Free Catalog. Gold Coast Tape Library, Box 2262, Palm Village Station, Hialeah, Fla. 33012.

RENT 4-Track open reel tapes—all major labels—3,000 different—free brochure. Stereo-Parti, 55 St. James Drive, Santa Rosa, Ca. 95401.

TAPEMATES makes available to you **ALL 4-TRACK STEREO TAPES—ALL LABELS**—postpaid to your door—at tremendous savings. For free brochure write: **TAPEMATES**, 5727 W. Jefferson Blvd., Los Angeles, California 90016.

STEREO TAPES, CARTRIDGES, CASSETTES, REELS, 33% DISCOUNT. UNAVAILABLE ELSEWHERE. MAIL 20¢—CATALOGS. STAR RECORDINGS-PE, BOX 1055, EL PASO, TEXAS 79946.

CASSETTE blanks, also educational and language, accessories and recorders. Literature—Write **CASSETTES UNLIMITED**, P.O. Box 13119-P, Pittsburgh, Pa. 15243.

AMAZING DISCOUNTS on famous brand high fidelity stereo components. No small wonder that we have set new sales records each year since 1959. Write. Arkay Electronics, 1028-03 Commonwealth, Boston, Mass. 02215.

STEREO TAPES, save 20,30% and more, postpaid anywhere U.S.A. We discount batteries, recorders, tape/cassettes, 80-page catalog 25¢. **SAXITONE TAPES**, 1776 Columbia Road, N.W., Washington, D.C. 20009.

REPAIRS AND SERVICES

TV Tuners rebuilt and aligned per manufacturers specification. Only \$9.50. Any make UHF or VHF Ninety day written guarantee. Ship complete with tubes or write for free mailing kit and dealer brochure. JW Electronics, Box 51C, Bloomington, Indiana 47401.

PRINTED CIRCUITS to specifications. Write requirements. Vico, Box 1581, Los Angeles, California 90053.

NEGATIVES made for printed circuits. Free information. Bigelow Electronics, Bluffton, Ohio 45817.

PERSONALS

MAKE FRIENDS WORLDWIDE through international correspondence. Illustrated brochure free. Hermes, Berlin 11, Germany.

INVESTIGATORS, LATEST ELECTRONIC AIDS. FREE LITERATURE. CLIFTON, 11500-K NW 7th Ave., MIAMI, FLORIDA 33168.

FREE Catalog low priced, high performance subminiature listening devices direct from manufacturer. Dealers welcome. Emery A-11, 156 Fifth Avenue, New York, N.Y. 10010.

SECRET LOANS BY MAIL. Borrow \$100 to \$1500 for any good reason in absolute privacy. No interviews, no endorsers, no co-signers. Fast service. Write Dial Finance Co., Dept. L-593, 410 Kilpatrick Bldg., Omaha, Nebraska 68102.

REMAILING, personal \$1.00 monthly, no limit. Jones, Box 563-P, Silverado Canyon, Calif. 92676.

INSTRUCTION

LEARN ACCIDENT INVESTIGATION. Train at home to earn \$750 to \$1,000 monthly. Car furnished. Expenses paid, no selling. No college needed. Full or spare time. Men urgently needed. Free placement service. Write for **FREE** information. No obligation, Universal Schools CZ-11, 6801 Hillcrest, Dallas, Texas 75205.

LEARN ELECTRONIC ORGAN SERVICING at home all makes including transistor. Experimental kit—trouble-shooting. Accredited NHSC. Free Booklet. **NILES BRYANT SCHOOL**, 3631 Stockton, Dept. A, Sacramento, Calif. 95820.

FCC First Class License in six weeks—nation's highest success rate—approved for Veterans Training. Write Elkins Institute, 2603B Inwood Road, Dallas, Texas 75235.

R.E.I.'s famous (5) week course for the First Class Radio Telephone License in the shortest, most effective course in the nation. Over 98% of R.E.I. graduates pass F.C.C. exams for 1st class license. Total tuition \$360.00. Job placement free. Write for brochure. Radio Engineering Incorporated Schools, 1336 Main Street, Sarasota, Florida 33577—or 3123 Gillham Road, Kansas City, Missouri 64109—or 809 Caroline Street, Fredericksburg, Virginia 22401—or 625 E. Colorado Street, Glendale, California 91205.

FCC FIRST CLASS LICENSE THROUGH TAPE RECORDED LESSONS. Our seventeenth year teaching FCC license courses. Radio License Training, 1060D Duncan, Manhattan Beach, Calif. 90266.

LEARN WHILE ASLEEP. Hypnotize! Strange catalog free. Auto-suggestion, Box 24-ZD, Olympia, Washington 98501.

DEGREE in Electronics Engineering earned mostly by correspondence. Free brochure. Dept. G-9, Grantham School of Engineering, 1505 N. Western Ave., Hollywood, California 90027.

FOLLOW THE LEADER—the nation's original four week F.C.C. 1st Class License Course. Tuition: \$295.00. Results guaranteed. Tennessee Institute of Broadcasting, 2106-A 8th Ave., South, Nashville, Tenn. 37204, or, Technical Institute of Broadcasting, 800 Silver Lane, East Hartford, Conn. 06106.

ART talent? Be your own boss. Earn \$200.00 weekly free-lancing. Free brochure. Famous American Studios, Dept. PE Spring Park, Minn. 55384.

F.C.C. License training by correspondence. G.I. Bill approved. Money-Back Warranty. Free brochure. Write: Dept. Z-9, Pathfinder School of Electronics, 1505 N. Western Ave., Hollywood, Calif. 90027.

NO: TUITION, RENT. Memorize, study—Command's "TEST-ANSWERS" for **FCC FIRST CLASS LICENSE.** Plus Command's "Self-Study Ability Test." **PROVEN.** \$5.00. Command, Box 26348-P, San Francisco 94126.

EARN College degree at home. All subjects, Florida State Christian College, 4307 North Andrews Avenue, Fort Lauderdale, Florida 33309.

AMATEUR RADIO SCHOOL. Correspondence Sight-and-Sound no textbook courses for **GENERAL, ADVANCED** and **EXTRA CLASS** licenses; complete Code and Theory. These are **NOT** memory courses. **REED ELECTRONICS SCHOOL**, 12217 Santa Monica Blvd., Los Angeles, Calif. 90025.

INVENTIONS WANTED

INVENTIONS wanted. Patented; unpatented. Global Marketing Service, 2420-P 77th, Oakland, Calif. 94605.

INVENTORS! OUR FREE EXPERT ANALYSIS of your invention can save valuable time, help you realize full sale value. Strictly confidential. **FREE INVENTION CERTIFICATE.** Write today: Pioneer Invention Service, Dept. 35, 150 Broadway, New York, N.Y. 10038.

FREE "Directory of 500 Corporations Seeking New Products." For information regarding development, sale, licensing of your patented/unpatented invention. Write: Raymond Lee Organization, 230-GR Park Avenue, New York City 10017.

INVENTORS: Protect your ideas! Free "Recommended Procedure". Washington Inventors Service, 422T Washington Building, Washington, D.C. 20005.

PATENT SEARCHES, including copies of related United States Patents. Inventors, attorneys, manufacturers use our "World-Wide" Airmail service Free: "Invention Record" form and "Information Every Inventor Needs", Hayward Company, 1029HR Vermont, Washington, D.C. 20005.

FREE PAMPHLET: "Tips on Safeguarding Your Invention." Write: United States Inventors Service Company, 501-H Thirteenth Street N.W., Washington, D.C. 20004.

INVENTORS! Don't sell your invention, patented or unpatented, until you receive our offer. Eagle Development Company, Dept. P, 79, Wall Street, N.Y., N.Y. 10005.

INVENTIONS WANTED

YOUR IDEA could be worth a fortune. Get the **OFFICIAL GUIDE** to your Patent Protection. \$2.00. SIELCO, Box 141D, Kensington, Maryland 20795.

TREASURE FINDERS

FREE TREASURE GUIDE! Fact-filled collectors edition; send 50¢ for postage. Also request free literature on ultrasensitive, professional Fisher Detectors. FISHER RESEARCH, Dept. PE11, Palo Alto, California 94303.

GOVERNMENT SURPLUS

JEeps Typically From \$53.90 . . . Trucks From \$78.40 . . . Boats, Typewriters, Airplanes, Multimeters, Oscilloscopes, Transceivers, Electronics Equipment. Wide Variety, Condition. 100,000 Bid Bargains Direct From Government Nationwide Complete Sales Directory and Surplus Catalog \$1.00. (Deductible First \$10.00 Order). Surplus Service, Box 820-J, Holland, Michigan 49423.

GOVERNMENT Surplus How and Where to Buy in Your Area. Send \$1.00 to: Surplus Information PE, Headquarters Building, Washington, D.C. 20036.

GRAB-BAG—valuable government surplus electronic parts, wide variety, mostly new. \$3.50 for 3 lb. assortment. Postpaid, no returns. Lazarov Electronics, Box 7176, Memphis, Tennessee 38107.

BOOKS

FREE catalog aviation/electronic/space books. Aero Publishers, 329PE Aviation Road, Fallbrook, California 92028.

UNUSUAL Books! Catalog free! International, Box 7798 (PE), Atlanta, Georgia 30309.

AMAZING self help books. Write Lynn, Box 1573, Waco, Texas 76703.

FREE Book Prophet Elijah Coming Before Christ. Wonderful Bible Evidence. PE Megiddo Mission, Rochester, New York 14619.

PAPERBACK CATALOGUE, 261 pages, 15,000 titles, subject indexed. \$1.00, credited toward order. New York Book, 4AM West 43rd Street, N.Y.C. 10036.

MAGAZINES

BACK DATE MAGAZINES! Send needs. Midtown, Box 917-PE, Maywood, N.J. 07607.

AUTHORS' SERVICES

AUTHORS! Learn how to have your book published, promoted, distributed. **FREE** booklet "ZD," Vantage, 120 West 31 St., New York 10001.

HYPNOTISM

FREE Hypnotism, Self-Hypnosis, Sleep Learning Catalog! Drawer H400, Ruidoso, New Mexico 88345.

"MALE-FEMALE HYPNOTISM" EXPOSED, EXPLAINED! "SECRET METHOD"—THEY NEVER KNOW! \$2. RUSHED. GUARANTEED! ISABELLA HALL, SILVER SPRINGS, FLORIDA 32688.

HYPNOTIC sleep learning recordings produce fabulous results. Details Free. ASR Foundation, Box 7021eg Henry Clay Station, Lexington, Ky. 40502.

HYPNOTIZE PERFECT STRANGERS—EITHER SEX—SUCCESSFULLY! Secret Methods—they never know! Illustrated Course and 10 inch Hypnodisk \$2.00. **RESULTS ABSOLUTELY GUARANTEED!** Dr. H. Arthur Fowler, Box 4399, Woodbury, New Jersey 08096.

EMPLOYMENT INFORMATION

FOREIGN and **USA** job opportunities available now. Construction, all trades. Earnings to \$3,000.00 monthly. Paid overtime, travel bonuses. Write: Universal Employment, Woodbridge, Conn. 06525.

CLASSIFIED ADVERTISING ORDER FORM

Please refer to heading on first page of this section for complete data concerning terms, frequency discounts, closing dates, etc.

1	2	3	4	5
6	7	8	9	10
11	12	13	14	15
16	17	18	19	20
21	22	23	24	25
26	27	28	29	30
31	32	33	34	35

_____ Words { @ 70¢ (Reader Rate) } = \$ _____
 { @ \$1.15 (Commercial Rate) }

Insert _____ time(s) Total Enclosed \$ _____

NAME _____

ADDRESS _____

CITY _____ STATE _____ ZIP _____

Signature _____

WORD COUNT: Include name and address. Name of city (Des Moines) or of state (New York) counts as one word each. Zip Code numbers not counted. (Publisher reserves right to omit Zip Code if space does not permit.) Count each abbreviation, initial, single figure or group of figures or letters as a word. Symbols such as 35mm, COD, PO, AC, etc., count as one word. Hyphenated words count as two words.

PE-1169

MAGNETS

MAGNETISM (100) page script newly discovered magnetic principles (\$3.00). Jesse Costa, Box 26, Waquoit, Mass. 02536.

MAGNETS. All types. Special—20 disc magnets, or 2 stick magnets, or 10 small bar magnets, or 8 assorted magnets, \$1.00 Maryland Magnet Company, 5412-H Gist, Baltimore, Maryland 21215.

PHOTOGRAPHS—FILM, EQUIPMENT, SERVICES

SCIENCE Bargains Request Free Giant Catalog "CJ"—148 pages—Astronomical Telescopes, Microphones, Lenses, Binoculars, Kits, Parts. War surplus bargains. Edmund Scientific Co., 300 Edscorp Bldg., Barrington, New Jersey 08007.

FINE GRAIN PROCESSING 90¢. B&W 8x10's 75¢. 35mm **SPEICALISTS**, P.O.B. #5871, Pasadena, Calif. 91107.

DYNACHROME, ANSCOCHROME film—save by mail, free price list. Hillis Products, Box 1182, Kokomo, Indiana 46901.

RECORDS

SPECIAL INTEREST RECORDS AVAILABLE, PRODUCED BY THE EDITORS OF THE WORLD'S LEADING SPECIAL INTEREST MAGAZINES. SEND FOR FREE CATALOG. RECORD CATALOG-PE, ZIFF-DAVIS PUBLISHING COMPANY, ONE PARK AVENUE, NEW YORK, N.Y. 10016.
POPULAR organ albums factory direct. Concert Recording, Lynwood, Calif. 90262.

OLDIES—45RPM original hits. Over 4000 available. Catalog 25¢. C & S Record Sales, Box 197, Wampsville, N.Y. 13163.

PRINTING

FREE LITERATURE: Address labels, business cards, printing. Rubber Stamps. **JORDAN'S**, 552 West O'Connor, Lima, Ohio 45801.

PRINTING 25% discount, free catalog. Gables, 405D Clifton, Glenshaw, Pa. 15116.

RUBBER STAMPS

RUBBER ADDRESS STAMP \$2.00. Signature \$3.50. Free catalog. Jackson, Box 443-G, Franklin Park, Ill. 60131.

BUSINESS OPPORTUNITIES

RAISE Rabbits for us on \$500 month plan. Free details. White's Rabbitry, Mt. Vernon, Ohio 43050.

FREE CATALOGS. Repair air conditioning, refrigeration. Tools, supplies, full instructions. Doolin, 2016 Canton, Dallas, Texas 75201.

PIANO TUNING learned quickly at home. Tremendous field! Musical knowledge unnecessary. GI Approved. Free Information. Empire School, Miami, Florida 33145.

FREE Book "990 Successful Little Known Businesses" Work home. Plymouth 345K, Brooklyn, N.Y. 11218.

ELECTROPLATING Equipment and supplies. All types for home workshops and industrial. Send \$2.00 (refundable) for equipment guide formulas, operating data, catalog. HBS Equipment Division 90, 3543 East 16th, Los Angeles, California 90023.

I MADE \$40,000.00 Year by Mailorder! Helped others make money! Start with \$10.00—Free Proof. Torrey, Box 318-N, Ypsilanti, Michigan 48197.

\$200.00 DAILY In Your Mailbox! Your opportunity to do what mail-order experts do. Free details. Associates, Box 136-J, Holland, Michigan 49423.

MAILORDER! How to prepare your own catalog for pennies . . . without merchandise investment! Free catalog! Obie, 5711-EN 14th, Brooklyn, New York 11219.

RADIO-TELEVISION Dealers & Repairmen. Want sales increased? Proven copyrighted system. \$5.00. Speaver's, Drawer C, New Sarpy, Louisiana 70078.

FREE Selling Outfit. Office supplies, furniture & equipment. Oseco, 15-PE North Jefferson, Chicago 60606.

MAKE BIG MONEY raising chinchillas, rabbits, guinea pigs for us. Catalog—25¢. Keeney Brothers, New Freedom, Pa. 17349.

SELL HERTEL BIBLES—Part Time. Finest reference Bible available. Demonstrator and supplies furnished. Excellent commissions. Write International Book, Dept. PE, Box 118, Wichita, Kansas 67201.

FREE SECRETS Of How To Finance Your Own Business Start a craft-shop business on no-risk plan. Free details. Capital-48, Kerrville, Texas 78028.

UHF ANTENNAS OPEN FIELD BIG PROFITS. Build 14DB gain antenna at home for less than \$5.00, sell for \$30 or more. For plans and information send \$1.00 to E & A Enterprises, 807 South Weller, Springfield, Mo. 65804.

EXCELLENT CAREER OPPORTUNITY selling and servicing trouble-free USA manufactured Payroll and Job Cost Time Clocks. Exclusive territories. Great sales potential. Non-competitive lines permitted. Write: Acroprint, 800 St. Mary's St., Raleigh, N.C. 27605.

REAL ESTATE

FREE . . . 232 page FALL-WINTER CATALOG! Describes and pictures over 2,200 farms, ranches, town and country homes, businesses in 33 states coast to coast! Specify type property and location preferred. Zip code, please. **UNITED FARM AGENCY**, 612-EP West 47th St., Kansas City, Mo. 64112.

PLASTICS

NEW Liquid Plastic hardens like glass without heat. Clear, Colors. Embed real flowers, photos, coins. Create unusual craft objects for big profits at home. Illustrated. **HOW** Booklet—25¢. Dept. 9/105M, **CASTOLITE**, Woodstock, Ill. 60098.

MAGIC

AMAZING color vanishing card trick, plus catalog. Send \$1.00. Ace Magic, Box 329, Evanston, Illinois 60204.

MUSIC

PLAY ORGAN EASILY, AMAZING METHOD, free information. Kegley, 1016-PE Kelly, Joliet, Illinois 60435.

MISCELLANEOUS

WINEMAKERS: Free illustrated catalog of yeasts, equipment. Semplex, Box 12276, Minneapolis, Minn. 55412.

BILLS paid without borrowing—Nobody refused up to \$10,000.00. Bad credit no problem, not a Loan Company. Write for free application. **INTERNATIONAL ACCEPTANCE**, Dept. 50-A, 5133 N. Central Ave., Phx., Arizona 85012; 2511 E. 46th Street, Indianapolis, Ind., 46205; 711 14th St., N.W., Washington, D.C. 20005; 507 Carondelet St., New Orleans, La. 70130.

32 PAGE big illustrated joke and novelty catalog. 25¢. Joke, Box 7212JJ, Chicago 60680.

UP to \$151 daily track wins with scientific computer. \$2 stakes. Proof supplied. Free details: RH-P11, 5715, Carmel, Calif. 93921.

BEERS, PEACH BRANDY, WINES—Strongest Formulas, \$2.25. (hydrometers list, brew supplies catalog included)—Research Enterprises, 29-D Samoset, Woburn, Mass. 01801.

CLASSIFIED ADVERTISING IN POPULAR ELECTRONICS

Your best bet for outstanding mail order sales. These pages are read thoroughly by electronic hobbyists seeking products and services found only in **ELECTRONICS MARKET PLACE**. **POPULAR ELECTRONICS** readers respond readily—they rely on the advertisers appearing in the pages of their favorite magazine. Your low cost ad will result in increased sales responses for you! Send copy and payment to:

Hay Cymes, Classified Advertising Manager
POPULAR ELECTRONICS
1 Park Avenue
New York, N.Y. 10016

UNUSUAL BARGAINS EXCELLENT XMAS GIFTS!

... MANY U. S. GOV'T SURPLUS

SUPER 6" SPACE CONQUEROR



Share the wonders of space exploration. Features aluminized & overcoated 6" f/8.5 ground and polished pyrex parabolic mirror accurate to 1/4 wave, 18 F.L. 6X achromatic finder scope, 4 eyepieces 48X, 96X, 192X. Barlow to double or triple power—rack & pinion focusing mount. Electric clock drive w/manual slow-motion control. Setting circles. Heavy-duty equatorial mount. Pedestal. Compares to \$295-\$350 models.

Stock No. 85,086AV \$239.50 FOB
 Stock No. 85,105AV 4 1/4" REFLECTOR TELESCOPE \$94.50 FOB
 Stock No. 85,050AV 3" REFLECTOR TELESCOPE \$29.95 Ppd

LONG-WAVE BLACK LIGHT FIXTURE



Extremely versatile, compactly designed, long wave (3200-4000 angstroms) black light (ultraviolet) fixture. Has 6-watt, 110-V lamp with built-in filter—eliminates harmful shorter wave ultraviolet rays. Use to identify minerals, fungi, bacteria—check for surface flaws, oil and gas leakage—perfect for displays with fluorescent paper, paints, chalk, crayons, trace powder. Incl. adjustable aluminum reflector. Mount vert on corner.

Stock No. 70,364AV \$12.50 Ppd.
 Stock No. 60,124AV REPLACEMENT BULB \$4.50 Ppd.

"FISH" WITH A MAGNET



Go treasure hunting on the bottom. Essential for fun & sometimes profitable. Tie a line to our 5-lb. Magnet—drop it overboard in bay, river, lake or ocean. Troll it along bottom—your "treasure" haul can be outboard motors, anchors, other metal valuables. 5-lb. Magnet is war surplus—Alnico V Type—cost \$20. Lifts over 150 lbs. on land—much greater weights under water.

Stock No. 70,571AV \$14.00 Ppd.

NEW LOW-COST ULTRASONIC CLEANER



Top-quality hard pint unit for only \$39.95. Cleans dirt, grime completely, quickly, safely. Small delicate parts, precision electronic items, lab instruments, jewelry, coins, even dentures sparkle like new. American-made—operates on regular house current. Solid state generator w/automatic turn-off. Power regulating knob. No shocks. No radio interference. 6" x 4" x 4" stainless.

Stock No. 71,003AV \$39.95 Ppd.
 QUART SIZE
 Stock No. 71,198AV \$89.95 Ppd

'BRIGHT IDEAS' in UNIQUE LIGHTING



Big, new 100-page handbook packed with facts, loaded with illustrations. All latest developments, applications, equipment. Covers strobes, sources, black light projectors, crystal and organic slides, color organs, mirrors, polarized color, screens, light boxes, MusicVision, etc. Rare find for business, home, hobby. Ideal for display houses, combine, experimenters, hobbyists. 8 1/2" x 11" looseleaf paper punched to fit 3 ring binder.

Stock No. 9100AV \$3.00 Ppd.

ASTRONOMICAL TELESCOPE KITS



Grind your own mirror for powerful telescopes. Kits contain fine annealed pyrex mirror blank, tool, abrasives, diagonal mirror, and eyepiece lenses. Instructions you build are valued up to \$100's.

4 1/4" DIAMETER—\$9.75 Ppd.
 6" DIAMETER—1" THICK No. 70,003AV \$12.95 Ppd.
 8" DIAMETER—1 1/2" THICK No. 70,005AV \$21.00 Ppd.
 10" DIAMETER—1 3/4" THICK No. 70,006AV \$34.25 FOB

Order by Stock No.—Check or M.O.—Money-Back Guarantee
 EDMUND SCIENTIFIC CO., 300 EDCORP BLDG., BARRINGTON, N.J. 08007

WRITE FOR GIANT FREE CATALOG "AV"



Completely new 1970 edition. New items, cut-price illustrations, 118 easy-to-read pages packed with 1000 unusual items, dozens of electrical and electronic parts, accessories. Enormous selection of Astronomical Telescopes, Microscopes, Binoculars, Magnifiers, Magnets, Lenses, Prisms. Many war surplus items; for hobbyists, experimenters, workshops, factory. Write for catalog AV. Include Zip.

ORDER BY STOCK NUMBER • SEND CHECK OR MONEY ORDER • MONEY-BACK GUARANTEE
 EDMUND SCIENTIFIC CO., 300 EDCORP BUILDING
 BARRINGTON, NEW JERSEY 08007

CIRCLE NO. 13 ON READER SERVICE PAGE

POPULAR ELECTRONICS

NOVEMBER 1969

ADVERTISERS INDEX

READER SERVICE NO.	ADVERTISER	PAGE NO.
1	AMECO, Div. of Aerotron, Inc.	112
	Alco Electronic Products	116
2	Allied Radio	111
3	Antenna Specialists Co., The	97
4	Argos Products Company	113
5	Audionics, Inc.	111
6	Avanti Research & Development, Inc.	9
	Bell & Howell Schools	125, 126
8	Broadcast Systems International, Inc.	113
9	Burstein-Applebee Company	102
	CREI, Home Study Division, McGraw-Hill Book Co.	36, 37, 38, 39
10	Career Academy	118
14	Cleveland Institute of Electronics	88, 89, 90, 91
7	Communications Division, Dynascan Corp	25
12	Communications Satellite Corporation	8
13	Edmund Scientific Co.	124
11	EICO Electronic Instrument, Inc. FOURTH COVER	
15	Electro-Voice, Inc.	12
16	Electro-Voice, Inc.	12
17	Erath, L.W.	23
18	GC Electronics	10, 11
	Grantham School of Electronics	17
19	Hallcrafters	85
20	Heath Company	62, 63, 64, 65
	ICS	5
21	Industrial Training Institute	100
22	Johnson Company, E.F.	98, 99
23	Judson Research & Mfg. Co.	104
24	Lafayette Radio	104
25	Mercury Electronics Corp.	112
26	Midland International Corporation	103
27	Mosley Electronics, Inc.	92
28	Motorola HEP Program	7
	McGee Radio Co.	116
	National Radio Institute, SECOND COVER, 1, 2, 3	
	National Technical Schools	18, 19, 20, 21
29	New Jersey Semi-Conductor Products, Inc.	117
30	Olson Electronics	110
31	Phase Corporation	105
47	Pickering & Company	115
32	Pioneer Electronics Co.	93
33	Poly Paks	110
	RCA Electronic Components & Devices	
	THIRD COVER	
34	RCA Electronic Components & Devices	13
45	RCA Electronic Components & Devices	87
	RCA Institutes	106, 107, 108, 109
35	Salch & Co., Herbert	102
36	Sams & Co., Inc., Howard W.	95
37	Sonar Radio Corporation	101
46	Sydmar Electronic Specialties	92
38	Technical Training International	26, 27
39	Telex Communications Division	96
55	Turner Company, Inc.	114
40	UNGAR/Div. of Eldon Industries	28
41	United Audio Products, Inc.	6
	United Binocular Co.	116
42	University Sound	94
43	Utah Electronics/Div. of Utah American Corp. 14	
	Valparaiso Technical Institute	116
44	Weller Electric Corp.	16

CLASSIFIED ADVERTISING 119, 120, 121, 122, 123

Printed in U.S.A.

POPULAR ELECTRONICS

Nov. P. Elec.—No. 6

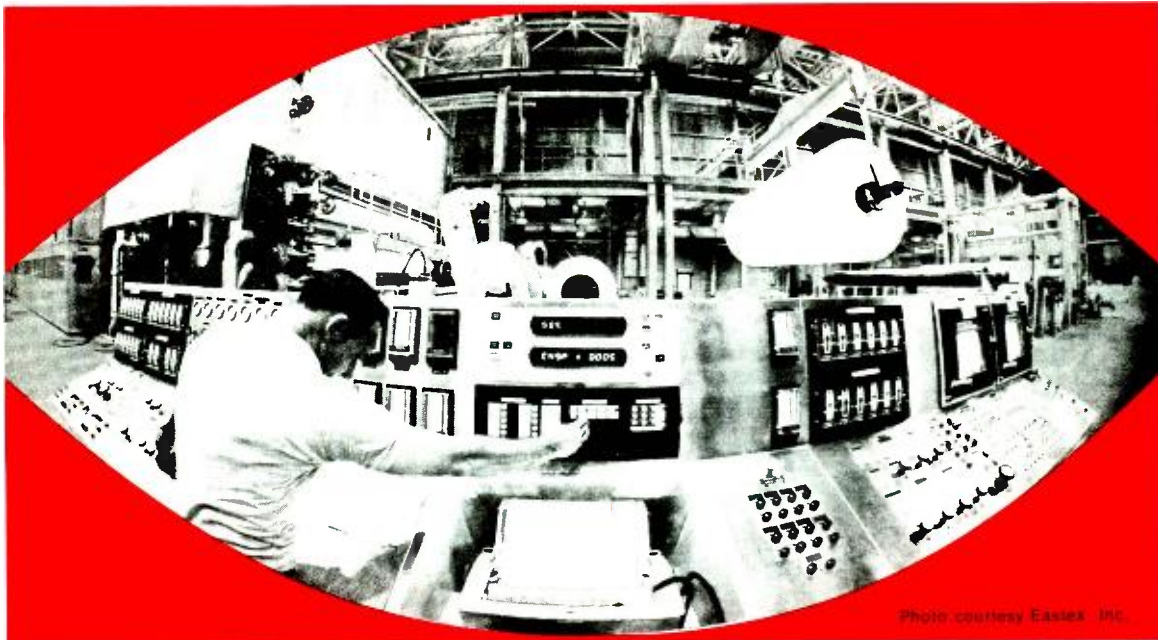

Photo courtesy Eastex, Inc.

BE THE MAN IN CONTROL

The man in control—today—is the technician who has mastered electronic operations. A specialist in the most sophisticated phases of electronic instrumentation and computer controls. The operations-oriented expert who makes automated equipment work. The trouble shooter who keeps it working.

Electronic Operations Technicians are in greater demand than ordinary electronic technicians. They have a higher skill level and they earn more. They understand digital and analog computers. They know computer logic, computer applications and computer technology.

How about you? Are you caught in a dead-end job with a dead-end salary? If you are, it's time to break out. To grow. To get ready for a great future!

You can learn Electronic Operations Technology and Computer Control, even if you have no electronic background. An exclusive new home study program, developed by Bell & Howell Schools, takes you through all the fundamentals . . . integrated circuits, semi-conductors, pulse and digital circuitry, field-effect transistors, and more.

You'll be expert in the latest technological advances, including every phase of computer controls. You'll even have a working knowledge of computer applications and computer programming . . . another Bell & Howell plus!

Other advantages, too! Personalized instruction, counseling service, postgraduate classroom study, a nationwide job placement service, and the exclusive Electro-Lab shown on the following page.

Want to know more? About this or other Bell & Howell Schools home study or resident school programs? Just mail the card attached. We'll see that you receive details plus a free, fact-filled brochure, "Career Horizons in Electronics."

Send me your free brochure, "Career Horizons in Electronics," plus information about the Bell & Howell programs I have checked below:

Home study:

- New! Electronic Operations and Computer Controls
- Communications Electronics
- Radio/TV Electronics, including Color TV

In-School Programs leading to:

- A Bachelor's Degree in Engineering Technology
- An Associate Degree in Engineering Technology
- A diploma as an Electronics Technician

Name _____ Age _____

Address _____

City & State _____ Zip _____

Years of school completed _____ County _____

Check for information about: G.I. Bill Student Loans

DE VRY INSTITUTE OF TECHNOLOGY

4141 WEST BELMONT AVENUE CHICAGO ILLINOIS 60641



ONE OF THE

BELL & HOWELL SCHOOLS

- Accredited Member National Home Study Council
- Eligible Institution under the Federal Insured Student Loan Program

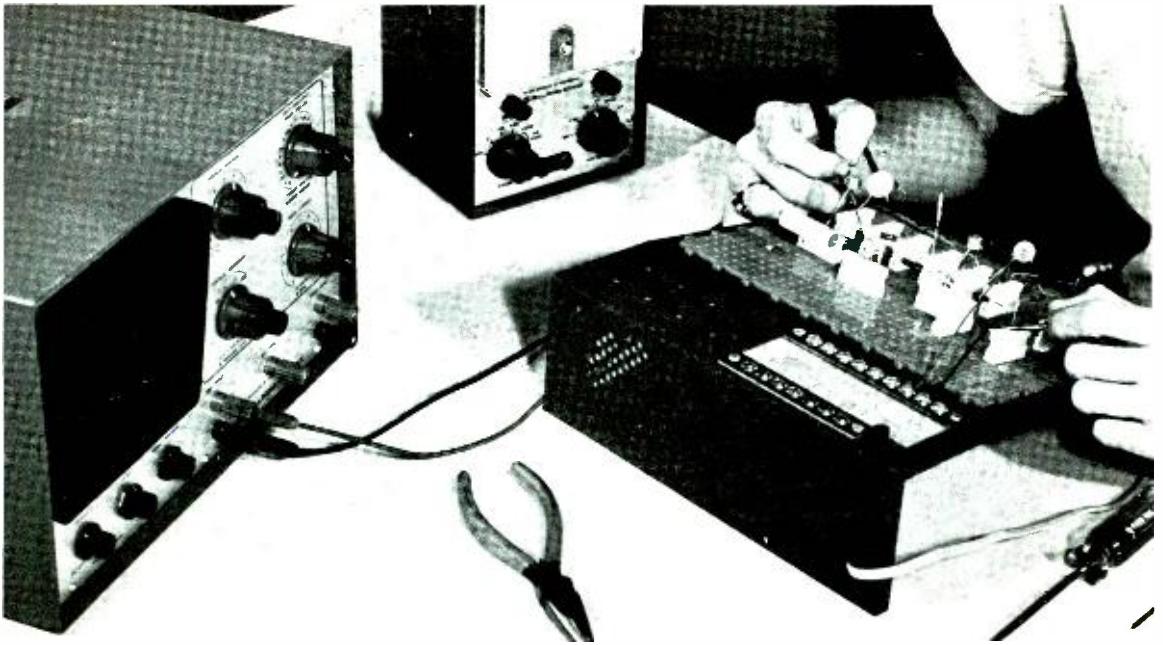

DESIGN, BUILD AND TEST YOUR OWN CIRCUITS

... The Exclusive Bell & Howell Electro-Lab® Makes It Easy

And it makes you an expert. With the Bell & Howell School Design Console and our patented Modular Connectors, just plug in the transistors, diodes, capacitors you need. Circuits go together quickly—in any combination of components—without soldering. Yet this three-dimensional system of breadboarding is only part of the exclusive Electro-Lab you receive with every Bell & Howell Schools home study program in electronics.



You'll have everything you need to set up a complete industrial electronics laboratory in your own home, including a wide-band oscilloscope, a transistorized voltmeter and the unique Design Console. No other home study course matches the Electro-Lab for up-to-date, quality equipment. No other course lets you duplicate actual industrial experiments with such a flexible, easy-to-use system of breadboarding your own test circuits.

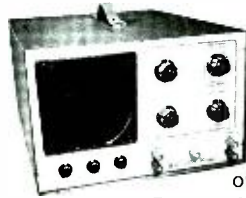

Does this laboratory experience pay off? Judge for yourself:

Rodney Drescher, of Lus Summit, Mo., upped his income and upgraded his job three levels.

Gordon Nelson, of Alamogordo, N. Mexico, doubled his salary.

Tom Cason, of Billerica, Mass., increased his income \$3800 a year.

If you want this kind of results, you need the help a Bell & Howell School career program can give you.

MAIL THIS CARD NOW FOR A 12-PAGE CAREER GUIDE

BUSINESS REPLY MAIL

NO POSTAGE STAMP NECESSARY IF MAILED IN THE UNITED STATES

Postage Will be Paid By:

DE VRY INSTITUTE OF TECHNOLOGY



BELL & HOWELL SCHOOLS

4141 WEST BELMONT AVENUE,
CHICAGO, ILLINOIS 60641

PE-11A

First
Class
Permit
No. 4148,
Chicago,
Illinois



On a color TV Service Call... GO BY THE BOOK!

Speed up your trouble-shooting and routine service adjustments on 15 makes of 1967 and 1968 model color TV sets with this remarkable book. All the data you usually need on a color service call is right here. Just look up the chassis number of the

set you're working on in the Chassis Index and you'll be guided to the proper sections of the Handbook. Chassis layouts...purity and convergence adjustments...and so much more...you'll find it indispensable for servicing color sets of

recent make. The RCA Color TV Service Handbook (1A1759) is available from your local RCA Tube Distributor. RCA Electronic Components, Harrison, N. J.

RCA

Dazzle your friends with lightworks.

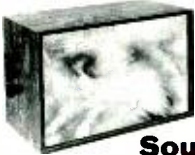

Sound n' Color®

The new dimension to music pleasure. EICO All Electronic Solid-State Audio-Color Organs transform sound waves into moving synchronized color images. Connect easily to speaker leads of hi-fi or radio. From \$29.95.



Translators

The electronics you need to create audio-stimulated light displays to your own imagination. Actuates: Light Display Units, Strobe Lites, any lamp configuration (Xmas trees, patio lights, etc.). From \$24.95 kit, \$39.95 wired.



Strobe Lites

High-intensity bursts of white light from Xenon tube flash in cadence with each beat of audio. From \$24.95 kit, \$39.95 wired.

Build the Stereo Kits praised by experts.

All amplifier power ratings according to IHF standards. Cortina® designed and manufactured in U.S.A. and guaranteed by EICO.



70-Watt AM/FM Stereo Receiver including cabinet. Cortina 3770, \$189.95 kit, \$279.95 wired.

70-Watt FM Stereo Receiver including cabinet. Cortina 3570, \$169.95 kit, \$259.95 wired.



150-Watt Silicon Solid-State Stereo Amplifier, including cabinet. For the audio perfectionist. Cortina 3150, \$149.95 kit, \$225 wired.

70-Watt Silicon Solid-State Stereo Amplifier, including cabinet. Cortina 3070, \$99.95 kit, \$139.95 wired.



FM Stereo Tuner including cabinet. Cortina 3200, \$99.95 kit, \$139.95 wired.



EC-1100
FM WIRELESS MIKE \$9.95

Build for fun and use with Eicocraft jiffy project kits.

The newest excitement in kits. 100% solid-state and professional. Expandable, interconnectable. Excellent as introductions to electronics. No technical experience needed. Finest parts, pre-drilled etched printed circuit boards, step-by-step instructions. 36 kits to select from, \$2.50 to \$9.95. Just released: EC-2600 "Super Snoop" \$8.95; EC-2700 Police & Fire Converter



(lo band) \$7.95; EC-2800 Aircraft Converter \$7.95; EC-2900 Police & Fire Converter (hi band) \$7.95; EC-3100 2-Station Intercom (with cases) \$10.95; EC-3200 "Do-It-Yourself" PC Etching Kit \$4.95; EC-2300 Audio Preamplifier \$8.95; EC-2400 Bullhorn \$8.95; EC-2500 Fuzzbox \$8.95.



EC-1900 TREASURE FINDER \$9.95

Shape up your own car/boat with EICO Engine Analyzer

For all 6V/12V systems; 4, 6, 8-cyl. engines. Now you can keep your car or boat engine in tip-top shape with this solid-state, portable, self-powered universal engine analyzer.

Completely tests your total ignition/electrical system. Complete with comprehensive Tune-up & Trouble-shooting Manual. EICO 888, \$49.95 kit, \$69.95 wired.



The first and only solid state test equipment GUARANTEED FOR 5 YEARS

Only EICO brings you laboratory precision and long life at lowest cost.



EICO 240 Solid-State FET-TVOM \$49.95 kit, \$69.95 wired



EICO 379 Solid-State Sine/Square Wave Generator \$54.95 kit, \$74.95 wired



EICO 242 Solid-State Deluxe FET-TVOM \$59.95 kit, \$79.95 wired



EICO 150 Solid-State Signal Tracer \$49.95 kit, \$69.95 wired



EICO 330 Solid-State RF Signal Generator \$59.95 kit, \$79.95 wired

You save up to 50% with EICO Kits. Since 1945, Best Buys in Electronics. Over 3 Million EICO Instruments Now in Use.

FREE 1970 CATALOG

Send me FREE catalog describing the full EICO line of 200 best buys, and name of nearest dealer.



EICO Electronic Instrument Co., Inc.
283 Malta Street, Brooklyn, N.Y. 11207
EICO Canada Ltd.
20 Millwick Drive, Weston, Ontario

Name _____
Address _____
City _____ State _____ Zip _____

PE-11

CIRCLE NO. 11 ON READER SERVICE PAGE

www.americanradiohistory.com