

Build Electronic Indoor/Outdoor Thermometer

POPULAR ELECTRONICS

OCTOBER
1969

50
CENTS



- DWELL EXTENDER IGNITION SYSTEM ●
- LAB STANDARD AUDIO OSCILLATOR ●
- AUTOMATIC HOME ALARM SYSTEM ●
- AA-C-D BATTERY CHARGER ●
- SPEAKER BOXES THAT ARE SOMETHING ELSE ●
- SOLID-STATE VARIABLE TRANSFORMER ●
- BUILD CAPACITOR CHECKER ●

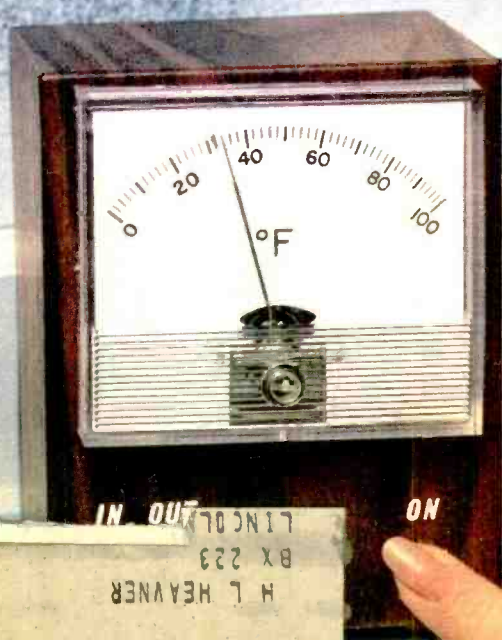

IN OUT
BX 223
H L HEAVNER
531708 MAY 80223H98 SEP70 A 1

Discover the ease and excitement of learning Electronics with programmed equipment NRI sends you

When you train at home with NRI, you train with your hands as well as your head. You learn the WHY of Electronics, Communications, TV-Radio the NRI pioneering "3-Dimensional" way. NRI training is the result of more than half a century of simplifying, organizing, dramatizing subject matter, and providing personal services unique for a home study school. You get the kind of technical training that gives you priceless confidence as you gain experience equal to many, many months of training on the job.

NRI—The 53 Year Leader in Electronics Training



APPROVED UNDER NEW GI BILL

If you served since January 31, 1955, or are in service, check GI line in postage-free card.



*Earn \$5 or more an hour
spare or full time in*

TV-RADIO SERVICING

Color Television has arrived. Sales are soaring, along with the continuing popularity of other home entertainment equipment like portable radios, tape recorders, hi-fi sets, phonographs and auto radios. TV-Radio servicing is one of your best routes to spare-time earnings, a good paying job or a business of your own. NRI not only trains you quickly and expertly, but also shows you how to get started in Servicing soon after you enroll, earning as you learn. NRI trains you in today's methods of installing and repairing all Electronic equipment for the home—including booming Color TV. You even build, experiment with and keep to enjoy your own solid-state radio and your choice of black-and-white or Color TV receiver. Like thousands of others, you can be earning \$5 or more an hour extra in spare time starting soon.

*There's money and
success awaiting you in*

BROADCASTING— COMMUNICATIONS

The experience you gain from intensely practical NRI training in Complete Communications equals as much as two years of training on the job. With NRI, you can train for a choice of careers ranging from mobile, marine and aviation radio to TV broadcasting and space communications. You learn how to install, maintain and operate today's remarkable transmitting and receiving equipment by actually *doing* it. You build and experiment with test equipment, like a VTVM you keep. You build and operate amplifier circuits, transmission line and antenna systems, even build and use a phone-cw transmitter suitable for transmission on the 80-meter amateur band. Whichever of five NRI Communications courses you choose, you prepare for your FCC License exams, and *you must pass your FCC exams or NRI refunds your tuition in full.*

*Move ahead in America's
fast growing industry as*

ELECTRONICS TECHNICIAN

Electronics touches everyone's lives. This vast field of opportunity is open to you with NRI training. Industrial/Military Electronics training—like all NRI courses—prepares you quickly, thoroughly the practical "hands on" way. You build with, and learn to understand the functions of, today's miracle solid-state components like printed circuits, diodes and transistors. You build and experiment with Electronic circuitry used in automation, data processing, ultrasonics, telemetry. Whatever your interest in Electronics, NRI training can fill your needs. Prove to yourself what nearly a million NRI students could tell you . . . that you get more for your money from NRI. Check the postage-free card and mail it today for your FREE NRI Color Catalog. No salesman will call. NATIONAL RADIO INSTITUTE, Electronics Division, Washington, D.C. 20016.

YOU GET MORE FOR YOUR MONEY FROM NRI — Build, test, explore, discover. Everything you see here is included in one NRI course—including Color TV. Other courses equally complete. And you'll be surprised at the low tuition costs. Text for text, kit for kit, dollar for dollar—you get more for your money from NRI.



POPULAR ELECTRONICS

VOLUME 31 NUMBER 4

OCTOBER, 1969

WORLD'S
LARGEST-SELLING
ELECTRONICS
MAGAZINE

SPECIAL FEATURES

- INDOOR/OUTDOOR ALL-ELECTRONIC THERMOMETER** 27 C. P. Troemel
Accurate, easy to build, easy to install

FEATURE ARTICLES

- POPULAR ELECOMICS** 32
- AA-C-D BATTERY CHARGER** 33 A. A. Mangieri
Save money on replacements
- BUILD A SOLID-STATE VARIABLE TRANSFORMER** 42 Robert C. Arp, Jr.
- SPEAKER BOXES THAT ARE SOMETHING ELSE** 45 David B. Weems
- WHAT DOES AN OP AMP DO?** 50 John Seginski
- BUILD A DWELL EXTENDER** 51 George Meyerle
Improve your car's performance
- ULD SINE-WAVE GENERATOR** 55 James Bongiorno
Ultra-low-distortion audio generator
- BUILD A CAPACITANCE METER** 66 Stanley Sula
Check your junk-box capacitors
- BUILD THE HOMESTEADER** 71 Dan Meyer
Professional burglar alarm
- THE STEREO SCENE** 74 Charles Lincoln
What's new this fall
- THE PRODUCT GALLERY** 78
Heathkit Sine-Square Audio Generator
Weller Temperature-Controlled Soldering Tool
- ENGLISH-LANGUAGE NEWS BROADCASTS TO N.A.** 80 Roger Legge
- TWO-WAY REACTIONS** 81 L. H. Reese, KC6990
- SHORT-WAVE LISTENING** 83 Hank Bennett, W2PNA
- AMATEUR RADIO** 85 Herb S. Brier, W9EGQ
- SOLID STATE** 87 Lou Garner

DEPARTMENTS

- LETTERS FROM OUR READERS** 8
- OUT OF TUNE** 12
Build the PPFY (August 1969)
- ELECTRONICS LIBRARY** 14
- READER SERVICE PAGES** 15, 115
- NEW LITERATURE** 16
- NEW PRODUCTS** 22
- TIPS AND TECHNIQUES** 71
- OPERATION ASSIST** 98

POPULAR ELECTRONICS is indexed
in the Readers' Guide
to Periodical Literature

This month's cover photo by
Justin Kerr

Copyright © 1969 by ZIFF-DAVIS PUBLISHING COMPANY. All rights reserved.

POPULAR ELECTRONICS, October 1969, Volume 31, Number 4. Published monthly at 307 North Michigan Avenue, Chicago, Illinois 60601. One year subscription rate for U.S., U.S. Possessions and Canada, \$7.00; all other countries, \$8.00. Second class postage paid at Chicago, Illinois and at additional mailing offices. Authorized as second class mail by the Post Office Department, Ottawa, Canada and for payment of postage in cash. Subscription service and Forms 3579: Portland Place, Boulder, Colorado 80302. Editorial offices for manuscript contributions, reader inquiries, etc.: One Park Ave., New York, N.Y. 10016.

Perfect speed synchronous motor
Ultra low-mass tonearm floating within a gyroscopically gimballed mounting

Viscous damped cueing and pause control

Viscous damped tonearm descent during single and automatic play

Adjustable sliding weight anti-skating control

Safe, gentle two-point record support.

**You will not find all of these important features on
automatic turntables selling for almost twice as much.**

You will find them all – and more – on

Garrard's new SL72B for only \$89.50.



Garrard[®]
World's Finest

There are now twelve new models in the Garrard line, just introduced.
They are priced from \$37.50 to \$129.50 and include four ready to plug in modules.

Write for complementary, full-color Comparator Guide to:

Garrard, Dept. AR149, Westbury, N.Y. 11590

CIRCLE NO. 43 ON READER SERVICE PAGE

FOR MEN WHO NEED WEATHER INFO

RADIO SHACK

*Invents the
World's
1st and Only*
**Instant
Weather
Radio**

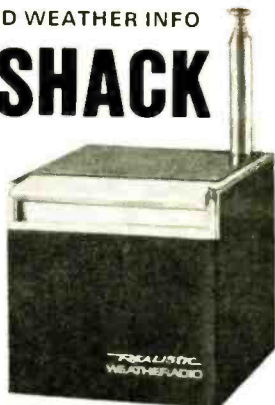

Touch— It's ON

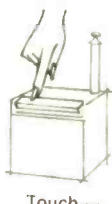

Touch—
It's OFF



Pre-Set
Controls

*Unique 3" Square
"Talking Barometer"* **14⁹⁵** Post Paid

From your desk or deck—monitor the new U.S. Gov't 24-hour VHF weathercasts on 162.55 MHz with a palm-size cube radio that's battery-operated and PRE-SET for instant automatic listening. Invented by 47-year-old Radio Shack for its brilliant "Realistic" line. Volume, fine tuning controls hidden under the set! Just touch the Play Bar to turn on and off! Rosewood details. Solid state circuit. An unusual and inexpensive gift.

**AVAILABLE COAST TO COAST
IN 600 RADIO SHACK STORES***

* See phone book. Or order by mail.



Free Color Catalog

See what's really new in electronics

RADIO SHACK

DIV OF TANDY CORP.

EAST: 730 Comm. Ave., Boston, Mass. 02215

MID: P.O. Box 9027, Ft. Worth, Texas. 76107

WEST: 7340 Lampson, Garden Grove, Calif. 92641

Weatheradios @ 14.95 Postpaid

FREE Radio Shack 1970 Catalog

Dept. ZS

Name (print) _____

Street _____

City _____

State _____

Zip _____

CIRCLE NO. 29 ON READER SERVICE PAGE

POPULAR ELECTRONICS

PHILLIP T. HEFFERNAN
Publisher

OLIVER P. FERRELL
Editor

LESLIE SOLOMON
Technical Editor

JOHN R. RIGGS
Managing Editor

EDWARD I. BUXBAUM
Art Director

ALEXANDER W. BURAWA
Associate Editor

ANDRE DUZANT
Technical Illustrator

PATTI MORGAN
Assistant Editor

SHARON SOTZKY
Editorial Assistant

H. BENNETT, W2PNA

H. S. BRIER, W9EGQ

L. E. GARNER, JR.

G. H. REESE, KC6G990
Contributing Editors

RICHARD J. HALPERN
Advertising Manager

ARDYS C. MORAN
Advertising Service Manager

LAWRENCE SPORN
Associate Publisher

ZIFF-DAVIS PUBLISHING COMPANY

Editorial and Executive Offices

One Park Avenue, New York, New York 10016
212 679-7200

Midwestern Office

307 North Michigan Avenue, Chicago, Illinois 60601
312 726-0892

Midwestern Advertising Manager, JAMES WEAKLEY

Western Office

9025 Wilshire Boulevard, Beverly Hills, California 90211
213 Crestview 4-0265, BRadshaw 2-1161

Western Advertising Manager, BUD DEAN

Japan: James Yagi

Ishikawa Mansion, #4, Sakuragaoka
Shibuya-ku, Tokyo, 462-2911-3

Circulation Office

Portland Place, Boulder, Colorado 80302

William Ziff, President

W. Bradford Briggs, Executive Vice President

Hershel B. Sorbin, Senior Vice President

Philip Sine, Financial Vice President

Walter S. Mills, Jr., Vice President, Circulation

Stanley R. Greenfield, Vice President, Marketing

Phillip T. Heffernan, Vice President, Electronics Division

Frank Pomerantz, Vice President, Creative Services

Arthur W. Butzow, Vice President, Production

Edward D. Muhlfeld, Vice President, Aviation Division

Irwin Robinson, Vice President, Travel Division

Furman Hebb, Administrative Vice President

George Morrissey, Vice President

Sydney H. Rogers, Vice President

Ziff-Davis also publishes *Airline Management and Marketing*, *Boating*, *Business & Commercial Aviation*, *Car and Driver*, *Cycle*, *Electronics World*, *Flying*, *Modern Bride*, *Popular Photography*, *Skating*, *Skating Area News*, *Skating Trade News*, *Stereo Review*, and *Travel Weekly*.

Forms 3579 and all subscription correspondence should be addressed to POPULAR ELECTRONICS, Circulation Department, Portland Place, Boulder, Colorado 80302. Please allow at least six weeks for change of address. Include your old address, as well as new—enclosing if possible an address label from a recent issue.

EDITORIAL CONTRIBUTIONS must be accompanied by return postage and will be handled with reasonable care; however, publisher assumes no responsibility for return or safety of art work, photographs or manuscripts.



Member Audit Bureau
of Circulations

POPULAR ELECTRONICS

IC & FET PROJECT CIRCUITS

FREE

NO strings attached

THAT'S RIGHT...

your Motorola HEP distributor will give you a copy of our latest Integrated Circuit or Field Effect Transistor project brochure at absolutely no charge! All you have to do is go to your Motorola HEP supplier and ask for:

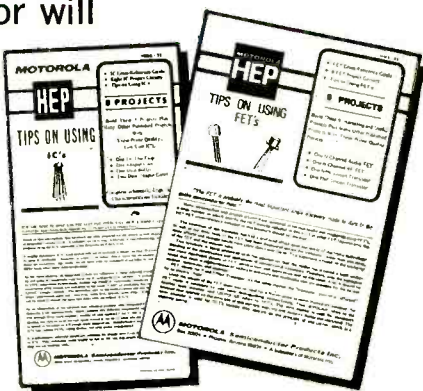

HEP—“**Tips on Using IC's**”—#HMA32. Includes integrated circuit theory, and terminology, IC cross reference guide, and 8 project circuits: precision auto tachometer, electronic siren, etc.

HEP—“**Tips on Using FET's**”—#HMA33. Contains detailed theory of field effect transistors, terminology, FET cross reference guide, and 9 project circuits: sound activated relay, touch switch, moisture detector, etc.

These project circuit brochures are right down your alley if you want to learn more about IC's or FET's and how to use them. Pick up your FREE copies from your Motorola HEP supplier today!



MOTOROLA HEP
Semiconductors

P.O. Box 20924 Phoenix, Arizona 85034



avanti
*ASTRO
PLANE



**MORE THAN
4 db GAIN...
MUCH MORE!**

\$29.95

*Patent Pending

Compact omni-directional design . . . no long drooping radial elements that can break or bend under wind or icing . . . no coils to burn or short out . . . no need to climb tower to straighten or replace radials. Carries Avanti's exclusive 1 year guarantee.

SPECIFICATIONS

Gain: 4.46 db
Weight: 3½ lbs.
Height: 12'
SWR: Less than 1.4:1
Material: Aircraft quality seamless aluminum construction
Maximum Power: 1000 watts
Wind Survival: 120 mph

90% TOP RADIATION

Astro Plane is the only omni-directional antenna that can generate maximum signal strength at the very top of the full legal antenna height limit (see diagram).



Ordinary collinear or ground plane antenna signals are blocked. . . they radiate from the bottom.



Astro Plane gets its signal over obstacles. . . it radiates from the top.

AVANTI RESEARCH & DEVELOPMENT, INC.

33-35 WEST FULLERTON AVENUE

ADDISON, ILLINOIS 60101

THE PACESETTER IN HIGH PERFORMANCE ANTENNAS

CIRCLE NO. 5 ON READER SERVICE PAGE

letters

FROM OUR READERS

OLD MODEL, NEW MODEL NUMBER

In the Bill of Materials for "A Bigger Than Life Speaker System" (May 1969) an Olson Electronics Model S-971 deluxe three-way speaker is specified. The latest Olson catalog lists the Model S-785 as a deluxe three-way speaker. Is this the speaker required for this project?

JAY ALLEN ROSEN
North Hollywood, Calif.

When specifying parts in our articles, we try to provide up-to-the-minute part and model numbers. The Model S-785 speaker was the speaker listed in the Olson catalog at the time of publication of the article. However, Olson is marketing the same speaker as the Model S-971, so that was the one we gave. Presumably you can order the speaker by either model number.

A LOOK BACK INTO RADIO HISTORY

The feature article, "What Ever Happened to Atwater Kent?" (July 1969) caught my attention. I worked for the advertising company in Philadelphia that handled the Kent account in those early days.

The very early Kent products were chiefly parts for homemade sets, though the company must have been making the breadboard sets then as well. My duties brought me into contact with the Kent advertising manager and, just once, with Mr. Kent himself. We rode in one of his innumerable cars, and I recall that Mr. Kent mentioned his belief that we would soon see the end of the four-cylinder car.

In April 1923, the *Literary Digest* and the *Saturday Evening Post* carried ads for Atwater Kent radios. We weren't spending money on professional modeling talent in those days, so Mr. Alexander H. Davisson, Jr., and I modeled for the photo that appeared in the ad. I am also sending a copy of this ad to Mr. Atlee.

GEORGE T. STREET, JR.
Lansdowne, Pa.

RADIO RELICS

Enjoyed the article on Atwater Kent (July 1969, p 33) and have been wondering if there is a group of people, or a club, interested in collecting old radio receivers. I have a small collection (13 receivers) from the 1930's.

DUANE THORNTON
St. Charles, Mo.

POPULAR ELECTRONICS

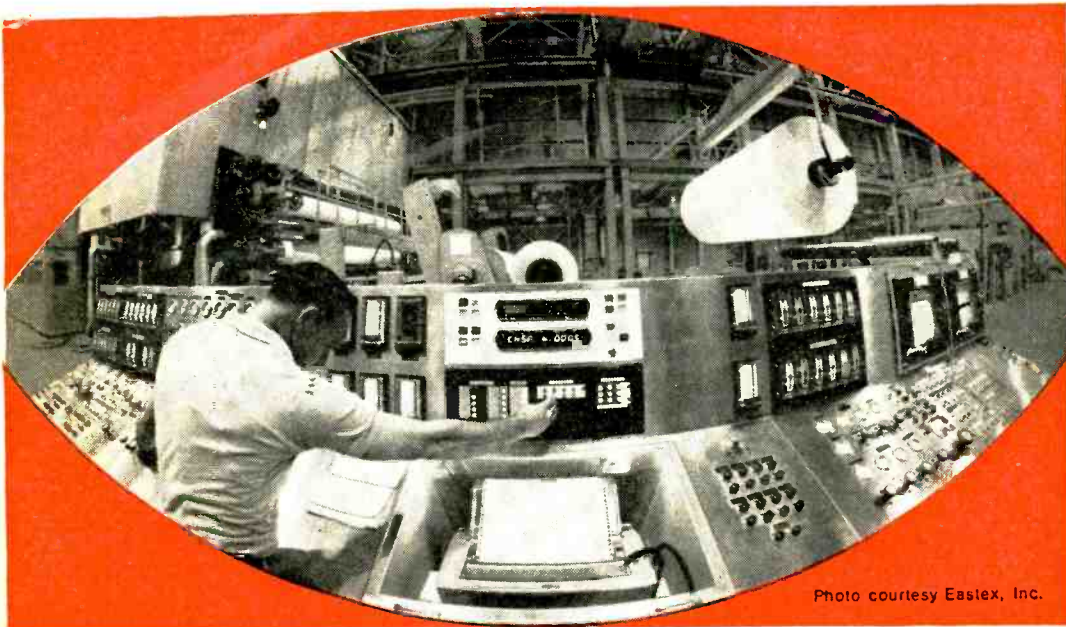

Photo courtesy Eastex, Inc.

BE THE MAN IN CONTROL

The man in control—today—is the technician who has mastered electronic operations. A specialist in the most sophisticated phases of electronic instrumentation and computer controls. The operations-oriented expert who makes automated equipment work. The trouble shooter who keeps it working.

Electronic Operations Technicians are in greater demand than ordinary electronic technicians. They have a higher skill level and they earn more. They understand digital and analog computers. They know computer logic, computer applications and computer technology.

How about you? Are you caught in a dead-end job with a dead-end salary? If you are, it's time to break out. To grow. To get ready for a great future!

You can learn Electronic Operations Technology and Computer Control, even if you have no electronic background. An exclusive new home study program, developed by Bell & Howell Schools,

takes you through all the fundamentals... integrated circuits, semi-conductors, pulse and digital circuitry, field-effect transistors, and more.

You'll be expert in the latest technological advances, including every phase of computer controls. You'll even have a working knowledge of computer applications and computer programming... another Bell & Howell plus!

You'll work with the exclusive Electro-Lab[®], a complete industrial electronics laboratory for your home—all up-to-date equipment any Electronic Operations Technician might use: wide-band oscilloscope, transistorized volt meter, and the patented Bell & Howell Schools' Design Console that makes it easy to build and analyze your own circuits.

Other advantages, too! Personalized instruction, counseling service, postgraduate classroom study, and a nationwide job placement service.

Want to know more? About this or other Bell & Howell Schools home study or resident school programs? Just mail the coupon. We'll see that you receive full details plus a free fact-filled brochure, "Career Horizons in Electronics."

DE VRY INSTITUTE OF TECHNOLOGY
4141 WEST BELMONT AVENUE, CHICAGO, ILLINOIS 60641

ONE OF THE
BELL & HOWELL SCHOOLS

- Accredited Member National Home Study Council
- Eligible Institution Under the Federal Insured Student Loan Program

DE VRY INSTITUTE OF TECHNOLOGY[®]
4141 WEST BELMONT AVENUE, CHICAGO, ILLINOIS 60641

PE-10A

ONE OF THE
BELL & HOWELL SCHOOLS

Send me your free brochure, "Career Horizons in Electronics" plus information about the Bell & Howell programs I have checked below:

Home Study:

- New! Electronic Operations and Computer Controls
- Communications Electronics
- Radio/TV Electronics, including Color TV

In-School Programs leading to:

- A Bachelor's Degree in Engineering Technology
- An Associate Degree in Engineering Technology
- A diploma as an Electronics Technician

Name _____ Age _____

Address _____

City & State _____ Zip _____

Years of school completed _____ County _____

Check for information about: G.I. Bill Student Loans

**The people
most likely to
appreciate the new
Dual 1209
are the least likely
to need one.**



If you already own an earlier Dual automatic turntable, you can really appreciate the new Dual 1209.

Because the 1209, just like your present Dual, offers flawless tracking and smooth, quiet performance that will be yours for years to come.

All Duals are made that way. And all recent ones have such exclusive features as pitch control that lets you "tune" your records by a semitone. No wonder so many hi-fi professionals use Duals in their personal stereo component systems.

But the 1209 has some new refinements of more than passing interest. A motor with high starting torque plus synchronous speed constancy. Anti-skating separately calibrated for elliptical and conical styli. A tonearm counterbalance with 0.01 gram click-stop adjustments.

These refinements aren't intended to seduce you away from your present Dual. But if you don't already own a Dual, perhaps it's time you talked with someone who does.

United Audio Products, Inc.,
120 So. Columbus Ave., Mt. Vernon,
New York 10553. 

CIRCLE NO. 38 ON READER SERVICE PAGE

LETTERS (Continued from page 8)

There's a club for people interested in collecting old radio equipment. Unfortunately, it has a limited membership (500) and only accepts new members as vacancies occur. To get on the "waiting list" (or learn more about the club), send a self-addressed envelope to: Antique Wireless Association, 69 Boulevard Parkway, Rochester, N.Y. 14612. Include information about your collection(s) and interests.

NASA FREQUENCIES

Can the radio messages to and from the various space programs launched by NASA be received in our homes directly?

RICHARD MOSER
Marion, Va.

There are numerous problems here. If you are referring to the Apollo program, the answer is 99.99% "no." The lunar walk communication was on about 235 MHz but apparently was not heard direct (on earth), but was relayed through "Tranquility Base" and converted to a signal in the S band (2000-plus MHz). Various unmanned satellites do transmit on frequencies between 136-137 MHz. These transmissions are not distinguishable according to satellite (no calls) except by frequency and time of orbit. The signals are all weak and cannot be heard without special antennas or extra r.f. (low noise) amplification ahead of a VHF receiver.

LOOKING GLASS

In regard to the D. J. Holford article (August 1969, p 51), the "Looking Glass" network is the 15th Bomber Wing. It is airborne at all times ready for a retaliatory strike in case of attack.

(UNSIGNED)
Vandenberg AFB, Calif.

The National Geographic magazine said in Vol 128 No. 3 (p 291) that "Looking Glass" remains on day and night vigil and could direct nuclear retaliation should SAC headquarters be destroyed.

DANIEL BARTEK, JR.
Binghamton, N.Y.

PYRAMIDAL TV/FM ANTENNA

Thanks go to George Mosner for his article on the TV/FM antenna in your July 1969 issue (p 27). My material cost came to \$9.88 not including the lead-in. I used a wooden mast and eliminated the standoff blocks. A second antenna will be for my daughter's house.

Results? Real good! Locals 6, 8, 10, 12, 15, and 39; plus Los Angeles (80-90 miles away) 2, 3, 4, 5, 7, 9, 11, 13, 24, 28, and 34. Receiver is Sylvania color with Belden 8290 lead-in, no rotor.

HAROLD SECOR, WB6PJK
San Diego, Calif.

Just finished making the TV/FM antenna— it's the fourth in this neighborhood.

R. McWILLIAMS
Park Forest, Ill.

POPULAR ELECTRONICS

Go on a quality kick

You can afford it with these Outperformers

You give up nothing — except a high price — when you buy these quality performance Pioneer hi-fi units. Designed for the discriminating budget-minded buyer, they contain advanced engineering features and looks that put them in the class of much more expensive stereo components.

SA-500 INTEGRATED STEREO AMPLIFIER — The perfect starter unit for a stereo system, the all solid state SA-500 produces 44 watts of music power. Even at the highest crescendo, distortion is less than 0.5%. Two sets of inputs plus outputs for speakers, tape recording, loudness contour and a headset jack make it tops in versatility. \$99.95

TX-500 AM-FM TUNER — All solid state, its multiplex circuitry provides wide channel separation with excellent frequency response. An FET front end, combined with years-ahead design, assures high sensitivity and superb image

rejection. Containing advanced features that place it on a par with more expensive units, it is priced at \$99.95.

SR-202 REVERBERATION AMPLIFIER — The most dramatic new component in years! No matter what your system is, the SR-202 adds dimension and greater realism to your stereo sound than you can realize. The SR-202 increases the natural quality of your recordings and tapes. Reverberation can be added to an audio amplifier using one or two tape recorders, a record player, or a tuner. In fact, a total of 15 equipment combinations are possible. \$95.00

These three Pioneer Outperformers are each housed in a handsome cabinet with brushed chrome facing and Brazilian rosewood end pieces. Hear them in action at your local Pioneer dealer.



 **PIONEER**[®]

PIONEER ELECTRONICS U.S.A. CORPORATION, 140 Smith Street, Farmingdale, N.Y. 11735 • (516) 694-7720
West Coast: 1335 W. 134th St., Gardena, Calif. 90249 (213) 323-2374 & 321-1076 • Canada: S. H. Parker Co., Prov. Ontario
October, 1969

CIRCLE NO. 26 ON READER SERVICE PAGE



In ONE Educational Program Earn BOTH Your

F.C.C. LICENSE

And Your

A. S. E. E.

(Associate in Science in Electronics Engineering)

DEGREE

Grantham School of Engineering

has conferred on

John Doe

the degree of

Associate in Science in Electronics Engineering



With all the rights and privileges thereunto appertaining. No portion thereof shall however
be reproduced hereon without the express written consent of the School Administration upon communication of the
Faculty at the school on this _____ day of _____, 1968.

Ed. Grantham
President
H. D. Young
Dean

The home-study program which accomplishes both of these objectives is the Grantham Associate-Degree Program in Electronics Engineering. This educational program consists of a total of 370 correspondence lessons, followed by a two-week period of review and evaluation at the School. The prerequisite for enrollment is high school graduation (or equivalent) and at least one full year of experience as an electronics technician. Upon completion of the first 160 correspondence lessons, you are prepared for your first class FCC license and radar endorsement. Then, upon completion of the remainder of the program, you are awarded the ASEE Degree.

Grantham School of Engineering is accredited by the Accrediting Commission of the National Home Study Council, is approved under the G.I. Bill, and is authorized under the laws of the State of California to grant academic degrees.

Grantham School of Engineering

• Established in 1951 •

Telephone
(213) 469-7878

1505 N. Western Ave.
Hollywood, Calif. 90027

Grantham School of Engineering PE-10-69
1505 N. Western Ave., Hollywood, Calif. 90027

Please mail me your free Bulletin, which explains how the Grantham home-study educational program can prepare me for my FCC license and Associate Degree. I understand no salesman or counselor will call.

Name _____ Age _____

Address _____

City _____ State _____ Zip _____

LETTERS

(Continued from page 10)

THE TREND TOWARD "LO-FI"

In recent years, the trend toward tape cartridges and cassettes and away from record discs and reel-to-reel prerecorded tapes seems paradoxical. I can understand the logic behind using the new types of music reproduction systems in a car; as of now it seems the only practical way of getting relatively high-fidelity music under mobile conditions. What I can't understand is the logic that suggests that cassettes and cartridge tapes can provide really great sound.

First of all, the playing speeds are too slow to squeeze in the full range of frequencies produced during a live performance—for the cartridge, it's only 3 3/4 in./s, and for the cassette it's only 1 7/8 in./s. And with as many as eight tracks on a very narrow tape width, what must happen to the signal-to-noise ratio? This compounds the problem of tape alignment, which is bad enough with only four tracks on a 1/4" magnetic tape! The Dolby system can probably take the woes of low-speed tape playing, but is the extra expense really worth it?

It doesn't make sense to shell out \$8 on a cassette or cartridge that can't equal the quality and performance of a \$5 record disc. Could it be that the so-called hi-fi industry is attempting to turn us into a bunch of "hi-fi Babbitts?"

MIKE POOLE
Notre Dame, Ind.

We wonder (your last question).

OUT OF TUNE

"Build the PPFL" (August 1969). The silicon controlled rectifier called for in the Parts List is a General Electric Type C106G2. General Electric has discontinued this model. In this project, and in most others where the C106G2 is called for, General Electric's Type C106A2 can be substituted. It is readily available from Allied Radio—and many other suppliers—at a price slightly above \$1.00.

"Build Op Tach" (March 1969). In a letter in our July issue, a fluorescent light method of calibrating the "op tach" was proposed. This will work but the repetition rate is 7200 times/min not 3600. Since 60-Hz power has two maximum peaks the fluorescent fires 120 times/sec.

In the Age of Solid State, Ungar outguns the heavyweights.

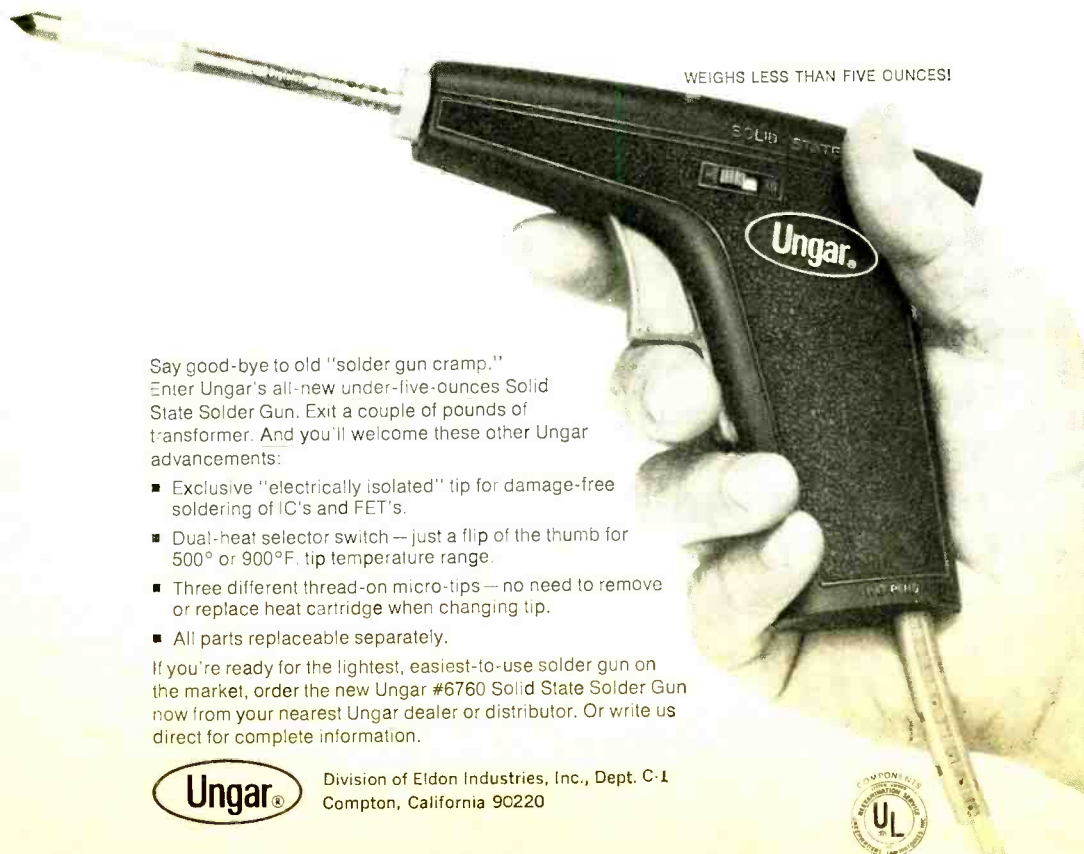

WEIGHS LESS THAN FIVE OUNCES!

Say good-bye to old "solder gun cramp."
Enter Ungar's all-new under-five-ounces Solid
State Solder Gun. Exit a couple of pounds of
transformer. And you'll welcome these other Ungar
advancements:

- Exclusive "electrically isolated" tip for damage-free soldering of IC's and FET's.
- Dual-heat selector switch — just a flip of the thumb for 500° or 900°F. tip temperature range.
- Three different thread-on micro-tips — no need to remove or replace heat cartridge when changing tip.
- All parts replaceable separately.

If you're ready for the lightest, easiest-to-use solder gun on the market, order the new Ungar #6760 Solid State Solder Gun now from your nearest Ungar dealer or distributor. Or write us direct for complete information.



Division of Eldon Industries, Inc., Dept. C-1
Compton, California 90220



CIRCLE NO. 37 ON READER SERVICE PAGE

ELECTRONICS library

QUIET

RTL COOKBOOK

by Don Lancaster

Well known to POPULAR ELECTRONICS readers for his many high-quality projects that have appeared in these pages, Don Lancaster, in his first full-length book, explains the principles and uses of resistor-transistor-logic (RTL) integrated circuits. The text provides the experimenter with an understanding of RTL in IC circuits as they are used in everyday electronics projects (including those projects that have from time to time appeared in this magazine). The technician is shown through step-by-step analysis how these circuits work and how they are maintained. The book also provides the engineer with circuits that can easily be added as building blocks to larger systems. We especially recommend this book to anyone who understands elec-

tronics but wants to update his knowledge with digital principles.

Published by Howard W. Sams & Co., Inc., 4300 West 62 St., Indianapolis, Ind. 46268. Soft cover. 256 pages. \$5.25.

104 SIMPLE ONE-TUBE PROJECTS

by Robert M. Brown

As its title implies, this book is a collection of useful and easy-to-build vacuum tube(!) projects for those people who have a supply of tubes they do not know what to do with. All of the projects presented are inexpensive to build—no more than \$5 each if you have to buy parts—and employ only one tube. The projects include a VLF receiver, DSB converter for CB radios, modulation scope, grid dip meter, SSB detector, and many more. Each project is a section in itself, with a schematic diagram, parts list, and short descriptive text.

Published by Tab Books, Blue Ridge Summit, Pa. 17214. 192 pages. \$6.95 hard cover; \$3.95 soft cover.

RCA TRANSISTOR, THYRISTOR, & DIODE MANUAL, SC-14

This new manual, the successor to the RCA Transistor Manual, contains the latest information on basic technology, operating principles, characteristics and ratings, and testing of RCA semiconductor devices. Twenty per-

(Continued on page 116)

The 1969 Turner 360.

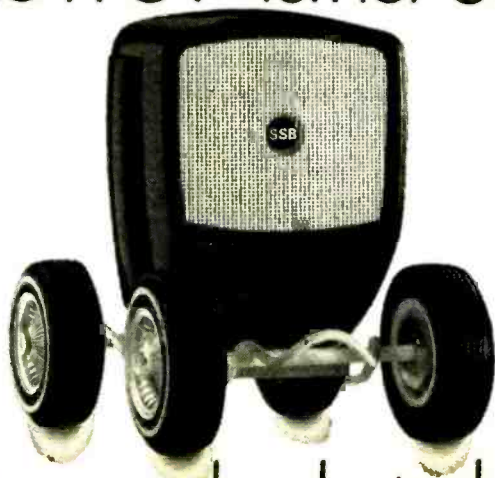

See it at your dealer's showroom.

The 360. A lightweight sporty compact from Turner. Reduced in size and weight (12 oz.), this custom styled mike is made to order for mobile units. Standard equipment on the 360 almost sounds optional: dash mounting knob and hardware, five foot extended coiled cord, beautiful black cyclac finish. Get in the driver's seat with a 360. It's got the smoothest transmission on wheels. □ The TURNER Co., Inc., A subsidiary of Conrac Corporation, 909 17th Street N.E., Cedar Rapids, Iowa. 52402. (319) 365-0421.

CIRCLE NO. 36 ON READER SERVICE PAGE

POPULAR ELECTRONICS READER SERVICE PAGE

free information service:

Here's an easy and convenient way for you to get additional information about products advertised or mentioned editorially (if it has a "Reader Service Number") in this issue. Just follow the directions below... and the material will be sent to you promptly and free of charge.

1. On coupon below, circle the number(s) that corresponds to the key number(s) at the bottom or next to the advertisement or editorial mention that is of interest to you. (Key numbers for advertised products also appear in the Advertisers' Index.) Print or type your name and address on the lines indicated.

2. Cut out the coupon and mail it to: POPULAR ELECTRONICS, P.O. Box 8391, Philadelphia, PA 19101.

note: If you want to write to the editors of POPULAR ELECTRONICS about an article on any subject that does not have a key number, write to POPULAR ELECTRONICS, One Park Avenue, New York, N.Y. 10016. Inquiries concerning circulation and subscriptions should be sent to POPULAR ELECTRONICS, Portland Place, Boulder, Colo. 80302.

POPULAR ELECTRONICS

P.O. BOX 8391
PHILADELPHIA, PA. 19101

VOID AFTER NOVEMBER 30, 1969

1 2 3 4 5 6 7 8 9 10 11 12 13 14 15 16 17 18 19 20
21 22 23 24 25 26 27 28 29 30 31 32 33 34 35 36 37 38 39 40
41 42 43 44 45 46 47 48 49 50 51 52 53 54 55 56 57 58 59 60
61 62 63 64 65 66 67 68 69 70 71 72 73 74 75 76 77 78 79 80
81 82 83 84 85 86 87 88 89 90 91 92 93 94 95 96 97 98 99 100

NAME (Print clearly) _____

ADDRESS _____

CITY _____ STATE _____ ZIP CODE _____

10 a

**The top
C.B. performer**



**New Tram®
CORSAIR
Mobile sideband
plus A. M.**

Get set for the sound of the future! Corsair-Tram's all new solid-state sideband-plus rig for cars, boats, aircraft.

Tram's Corsair works beautifully with any unit; standard A.M., single or double sideband, reduced or suppressed carrier. Corsair is two transceivers in one - with crystal-controlled A.M. capability; greater range; less sensitivity to noise and skip signals. A built-in Collins Mechanical Filter cuts interference and gives maximum selectivity. Corsair's noise blanker and noise limiter reduce ignition interference to a new low.

Get in on the big move to mobile sideband Corsair. Send for details.

Tram Corporation

Dept. E-4, Lower Bay Road, P.O. Box 187,
Winnisquam, New Hampshire 03289 • Phone: (603) 524-0622

CIRCLE NO. 35 ON READER SERVICE PAGE

TAKE ONE



**new
literature**

To obtain a copy of any of the catalogs or leaflets described below, simply fill in and mail the coupon on page 15 or 115.

Arcturus Electronics Corporation has recently acquired 9800 obsolete vacuum tubes (circa 1925-1930) to add to their considerable inventory of hard-to-obtain items. These and thousands of other items are listed with their prices in Arcturus' Mid-1969 Catalog, available on request.

Circle No. 75 on Reader Service Page 15 or 115

Just listed by Xcelite, Inc., is their four-page, full-color Catalog 166 Supplement, describing and listing specifications on all professional hand tools and sets added to the company's line since the publication of the latest general catalog. Included in the listing are fixed-handle screwdrivers for slotted, Phillips, and Allen hex-type screws; fixed-handle, hollow-shaft nutdrivers; a compact interchangeable-blade Allen hex-type set in a pocket-size plastic case; etc. Also listed are metric tools.

Circle No. 76 on Reader Service Page 15 or 115

Crystal Bulletin available from K-W Industries, Inc., contains a list of quartz crystals in the range from 50 kHz to 200 MHz. Complete dimensional data and ordering information for standard and custom crystals are included, along with the completely revised chart listing specifications on military types.

Circle No. 77 on Reader Service Page 15 or 115

A 24-page booklet, titled "Recording Basics," written to help the reader improve sound quality of home tape recordings can be obtained from the 3M Company. The illustrated booklet offers tips on proper selection of magnetic tapes, recording techniques, and recording procedures, all in non-technical language. It also defines various types of tape recorders and illustrates the proper techniques for editing and splicing magnetic tapes.

Circle No. 78 on Reader Service Page 15 or 115

Catalog No. 103L (48 pages) available from International Correspondence Schools describes 17 electrical engineering programs, refresher courses for graduate engineers, and practical electrical courses. The catalog explains the exact makeup of the ICS electrical engineering courses and the scope of the programs and gives synopses of the texts. In addition, articles describe careers in electronics and electrical engineering.

Circle No. 79 on Reader Service Page 15 or 115

The modern Army goes to school, and there's a place in class for you.

In fact, high school graduates have more than 300 job training courses to choose from.

And if you qualify for the Army's enlistment program, we guarantee your course selection *before* you step forward and raise your hand.

There's still another plus. The training is great. A leading American university credits the Armed Forces with one of the most advanced and comprehensive educational programs in the world.

Job training in the Army could be the opportunity you need to acquire a vital and rewarding skill. At the same time, you fulfill your military obligation.

We can give you more than 300 good reasons for joining the Army.

But all you need to choose is one.

Your future, your decision...choose **ARMY**.

Army Opportunities
Dept. 200
Hampton, Va. 23369

2-PE-1069

Please send me your free 40-page booklet.
I understand there's no obligation
attached to this request.

Name _____ Age _____

Address _____

City _____ County _____

State _____ Zip _____

Phone _____ Education _____

Enroll in the Army.



Can you solve these two basic problems in electronics?

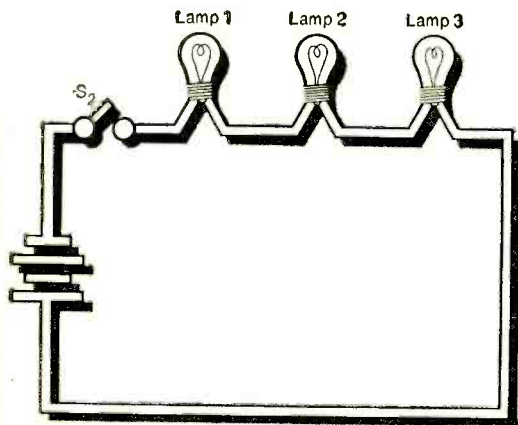

This one is relatively simple:

When Switch S_2 is closed, which lamp bulbs light up?

Note: If you had completed only the first lesson of any of the RCA Institutes Home Study programs, you could have solved this problem.

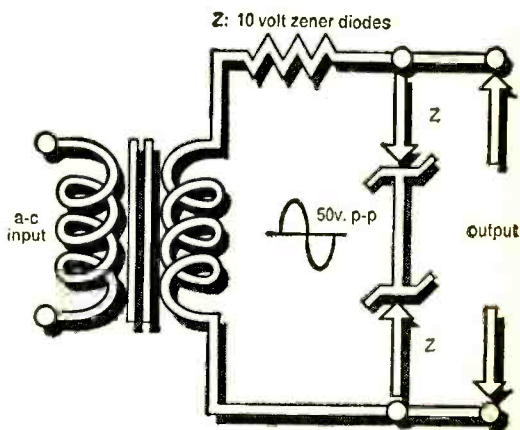

This one's a little more difficult:

What is the output voltage (p-p)?

Note: If you had completed the first lesson in the new courses in Solid State Electronics, you could have easily solved this problem.

These new courses include the latest findings and techniques in this field. *Information you must have if you are to service today's expanding multitude of solid state instruments and devices used in Television, Digital, and Communications Equipment.*

If you had completed an entire RCA Institutes Home Study Course in Semiconductor Electronics, Digital Electronics, or Solid State Electronics, you should now be qualified for a good paying position in the field you choose. Send for complete information. Take that first essential step now by mailing the attached card.

ANSWERS: Problem 1—they all light up
ANSWERS: Problem 2—20 Volts (p-p)

RCA Institutes Autotext learning method makes problem-solving easier... gets you started faster towards a good-paying career in electronics

Are you just a beginner with an interest in electronics? Or, are you already making a living in electronics, and want to brush-up or expand your knowledge? In either case, RCA has the training you need. And Autotext, RCA Institutes' own method of Home Training will help you learn more quickly and with less effort.

Wide Range of Courses

Select from a wide range of courses. Pick the one that suits you best and check it off on the attached card. Courses are available for beginners and advanced technicians.

- Electronics Fundamentals
- Black & White Television Servicing (Transistorized TV Kit Available)
- Color Television Servicing (Color TV Kit Available)
- FCC License Preparation
- Automatic Controls
- Automation Electronics
- Industrial Electronics
- Nuclear Instrumentation
- Electronics Drafting
- Computer Programming

Plus these new up-to-the-minute courses

- Semiconductor Electronics
- Digital Electronics
- Solid State Electronics
- Communications Electronics

Prepare for good paying positions in fields like these

- Television Servicing
- Telecommunications
- Mobile Communications
- CATV
- Broadcasting
- Marine Communications
- Nuclear Instrumentation
- Industrial Electronics
- Automation
- Computer Programming
- Solid State
- Electronics Drafting



Build and keep this valuable oscilloscope.

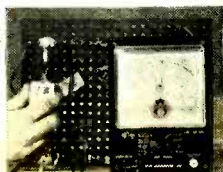

In the new program on Solid State Electronics you will study the effects of temperature and leakage characteristics of transistors.



Valuable Equipment—Yours To Keep

A variety of RCA Institutes engineered kits are included in your program of study. Each kit is yours to keep when you've completed the course. Among the kits you construct and keep is a working signal generator, a multimeter, a fully transistorized breadboard superheterodyne AM receiver, and the all-important oscilloscope. These 4 kits are at no extra cost. Compare this selection with other home study schools.

Convenient Payment Plans

RCA Institutes offers liberal monthly payment plans to suit your budget.

Classroom Training Also Available

RCA Institutes operates one of the largest technical schools of its kind. Day and evening classes. No previous training is required. Preparatory courses are available. Classes start four times a year.

Job Placement Service, Too!

Companies like Bell Telephone Labs, GE, Honeywell, IBM, RCA, Westinghouse, Xerox, and major radio and TV networks have regularly employed graduates through RCA Institutes' own placement service.

All RCA Institutes courses and programs are approved for veterans under the new G.I. Bill.

Send Attached Postage Paid Card Today. Check Home Study or Classroom Training.

Accredited Member National Home Study Council.

IF REPLY CARD IS DETACHED, SEND THIS COUPON

RCA Institutes Inc.

Home Study Dept. PE-09
320 West 31 Street
New York, N.Y. 10001

Please send me FREE illustrated career catalog.

Name _____ Age _____
(please print)

Address _____

City _____ State _____ Zip _____

NEW PRODUCTS

Additional information on products covered in this section is available from the manufacturers. Each new product is identified by a code number. To obtain further details on any of them, simply fill in and mail the coupon on page 15 or 115.

AUTO TUNE-UP METER

Capable of measuring dwell, r/min, and d.c. voltage on any four-cycle, 3-, 4-, 6-, or 8-cylinder engine with standard ignition system, the *Heathkit* Model ID-29 solid-state



Auto Tune-Up Meter is a real steal at less than \$30 for the kit. Both dwell and r/min measurements can be made without having to reconnect the test leads between steps, and the meter can be used interchangeably on both 6- and 12-volt systems. The ID-29 connects directly to the primary

side of the ignition coil for both dwell and tach measurements, receiving both signal and power from the engine under test. For breaker point settings, the dwell angle is read directly from the large 4½" meter. The built-in voltmeter is handy for chasing down faults in the electrical system. The ID-29 can be calibrated using standard a.c. house current. The instrument is housed in a rugged black polypropylene case with carrying handle.

Circle No. 80 on Reader Service Page 15 or 115

FM MONITOR RECEIVERS

Sonar Radio Corp. is marketing a pair of high-quality, ruggedly built FM monitor receivers. The Model FR-104 is designed for the low band between 25 and 50 MHz, while the Model FR-105 is a high-band 150-175-MHz receiver. Both models have dual limiter and Foster-



Seeley discriminator; quadruple-tuned r.f. stage for greater image rejection; temperature-compensated, noise-free squelch; six crystal-controlled frequencies; military epoxy-glass circuit board; and built-in 2" x 6" speaker. Technical specifications—maximum frequency separation: ±1 MHz for FR-104, ±3.5 MHz for FR-105; sensitivity: 0.3 μV for 20-dB quieting; squelch sensitivity: 0.18 μV minimum; selectivity: 6 dB ±6 kHz/60 dB ±30 kHz (FR-104/FR-105); audio output power: 1.5 watts at 4 ohms; power consumption: 4.4 watts at 13.8 volts d.c./17.5 watts at 117 volts a.c.

Circle No. 81 on Reader Service Page 15 or 115

CASSETTE PLAYER RECORDER

Three new portable cassette player/recorders which can be operated on line power, on batteries, or adapted for mobile use are from the *Ampex Corporation* and are now available. The Models include the "Micro 32," which includes an AM/FM receiver; "Micro 24," a deluxe model; and "Micro 14," with plug-in dynamic microphone that can be attached to an extension cord for remote operation. The Micro



32 and Micro 24 have 1-watt power output, 5" speaker, automatic battery charger circuit, remote control facilities, and earphone. The Micro 14 also has a 1-watt power output, bi-directional speaker, extension cord, etc. All three models have pushbutton cassette function controls, manual or automatic recording level control, and recording level/battery condition meter. Technical specifications—frequency range: 100-10,000 Hz; signal-to-noise ratio: 42 dB; rewind/fast forward time: 90 seconds maximum.

Circle No. 82 on Reader Service Page 15 or 115

ELECTRIC GUITAR SYSTEM

Innovex (division of *Hammond Corp.*) has developed a sophisticated electric guitar system consisting of the "Condor SSM" (Sound System Modulator), "Condor SS (Sound System)," and "Condor" electric guitar. The SSM offers a new concept in sound reproduction. It has a room rocker to create a shift in sound color; a phaser that produces tremolo or vibrato loud in one channel, soft in the other channel; a patented reverberation system; echo, volume, treble, and bass controls; and remote control. The SS has two 15" speakers and a horn tweeter; phase inversion cabinetry; special damping materials; remote control a.c. power relay; and short-circuit protection. The guitar features the Condor pickup which provides a microphone for each string.



Circle No. 83 on Reader Service Page 15 or 115

REVERBERATION AMPLIFIER

A solid-state, double-scatter reverb amplifier is being marketed by *Pioneer Electronics U.S.A. Corp.* as the Model SR-202. The feeling of depth provided by the reverb system supplies concert-hall presence without the audible distortions usually associated with equipment of this type. The reverb time can be manually adjusted as desired, and the amount of depth used can be set to fit the particular recording and environmental acoustics. An easy-to-view



POPULAR ELECTRONICS

smooth

RCA WP-700A, 702A, 703A and 704A constant voltage dc power supplies are all solid-state. A negative feedback circuit maintains constant output voltage with low ripple—regardless of varying line. In fact, at rated load, these supplies are so smooth that "they hardly cause a ripple."

They are versatile bench-type units—ideally suited for use in circuit design, servicing, industrial, and educational applications.

Output voltage of the WP-700A and WP-702A is continuously adjustable from 0 to 20 volts at current levels up to 200 mA.

Output voltage of the WP-703A is continuously adjustable from 0 to 20 volts at current levels up to 500 mA.

Output voltage of the WP-704A is continuously adjustable from 0 to 40 volts at current levels up to 250 mA.

All four power supplies have built-in electronic short-circuit protection—and a front panel overload-indicator that signals approach to maximum rated current level.

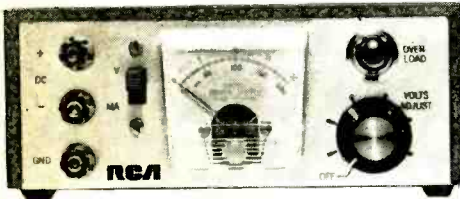

WP-700A: \$40.00* (five or more) \$48.00* (less than five)

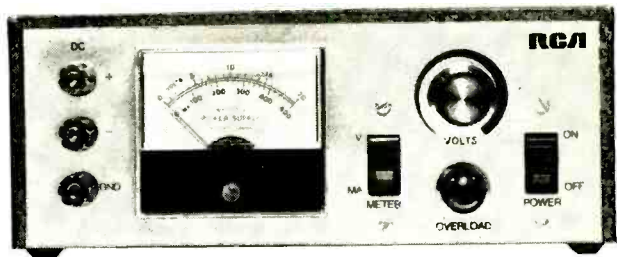

WP-703A: \$49.00* (five or more) \$58.00* (less than five)

WP-704A: \$49.00* (five or more) \$58.00* (less than five)

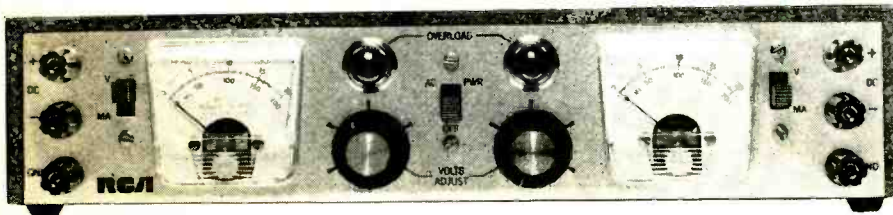

WP-702A: Siamese Twins of WP-700A, but electrically isolated \$73.00* (five or more) \$87.00* (less than five)

*Optional Distributor Resale Price.

For further information write: RCA Electronic Components, Commercial Engineering, Department J-133W, Harrison, N. J. 07029.

Look to RCA for instruments to test/measure/view/monitor/generate

CIRCLE NO. 42 ON READER SERVICE PAGE

PRODUCTS (Continued from page 22)

light panel is coupled to the manually adjustable reverberation control, supplying both aural and visual control of reverberation. Technical specification—input signal: 3 volts maximum at 1 kHz with reverb at minimum; harmonic distortion: less than 0.2% at 1 kHz, with output level at 330 mV and reverb time at minimum; frequency response: +2 dB, 20-35,000 Hz.

Circle No. 84 on Reader Service Page 15 or 115

RHYTHM INSTRUMENT

A complete electronic rhythm section, the "Rockmate" Model X-92, that plays through any guitar or music amplifier is available from *Olson Electronics, Inc.* The instrument allows the user to select from five basic rhythm patterns, then adjust tempo to suit his mood. He can also add a solo drum beat if desired. The rhythm patterns available include fox trot, after beat, jazz, rock, rock beat, fore beat, and rock-a-ballad. The Rockmate operates on self-contained battery, or it can be line-powered with the addition of an optional a.c. power supply.

Circle No. 85 on Reader Service Page 15 or 115

THREE-WAY SPEAKER SYSTEM

A new concept in speaker design, with a resulting midrange that has outstanding transient response and a sharp reduction in distortion, is incorporated in the *Sansui Electronics Corp.* Model SP-1001 speaker system. This new three-way, three-speaker system has several exclusive features, among them pushbutton input connectors and electronic crossover terminals for hookup of bi- or tri-amplification systems. A special step-down attenuator utilizing a 12 dB/octave network makes it possible to change output levels, in 3-dB steps, of the midrange and tweeter independently. Technical specifications—speakers: 10" cone woofer, 6½" cone midrange, 1" domed tweeter; maximum input: 40 watts IHF; impedance: 8 ohms; sound pressure level: 100 dB; frequency range: 35-20,000 Hz; Crossovers; 600 and 5000 Hz.

Circle No. 86 on Reader Service Page 15 or 115

AUDIO-LIGHTING FAMILY

The *EICO Electronic Instrument Co., Inc.*, recently expanded its line of "Sound n' Color" audio-lighting products with the introduction of a complete line of color organs, sound/color translators, and electronic strobe lites. The



color organ line includes: Model 3440 three-channel system; Model 3445 four-channel system; Model 3450 large-size four-channel system; Model 3450 three-channel light display/receiver (less electronics); and Model 3480 combination three-channel color organ and two-way speaker system. The Model 3465 three-channel and Model 3460 one-channel systems make up the sound/color translator line. The high-intensity strobe lite line includes the Model 3475 sound-actuated system and the Model 3470 electronic strobe lite. All sound n' Color products are available in kit or wired form.

Circle No. 87 on Reader Service Page 15 or 115

A.C. LEAKAGE TESTER

Simpson Electric Company recently introduced the Model 229 current leakage tester for 120-volt a.c. appliances and other electrical equipment in accordance with U.S. Standards

Committee proposed specifications. Performance of the tester approximates the normal perception curve within ± 1.0 dB, and the meter measures leakage currents as small as $5 \mu\text{A}$. Operation is simple, and all ranges are protected from damage if accidentally subjected to line voltage. Technical specifications— a.c. current ranges: 0-0.3, 1, 3, 10 mA; a.c. voltage: 0-150 volts; accuracy: $\pm 2\%$ at 60 Hz; resolution: $5 \mu\text{A}$ on 0.3-mA range; accuracy-versus-frequency: approximates Dalziel's "percentile 50 threshold of perception within ± 1 dB;" input impedance: 1500 ohms, shunted by shaping network, on all ranges; input resistance: 500,000 ohms.

Circle No. 88 on Reader Service Page 15 or 115

MULTI-ANTENNA ROOF TOWER

The Model TRM-716 is a new 7½' single-mast, multiple-antenna tri-mount roof tower designed by *South River Metal Products Co., Inc.* Areas where multiple antennas are oriented to different compass points are particularly suited to this new tall tri-mount tower. The mast, integrated into a special triangular base assembly, permits two or three antennas to be mounted quickly and securely. The one-piece base assembly opens like an umbrella and is secured into position with a single wing nut. Both the mast and base assembly are made of heavy-gauge steel tubing, galvanized for long life under changing weather conditions.

Circle No. 89 on Reader Service Page 15 or 115

HI-FI/STEREO HEADPHONE KIT

The *Knight-Kit/Koss* Model KG-802 stereo headphone kit offers wide-response hi-fi/ stereo sound at substantial savings over fac-

(Continued on page 118)

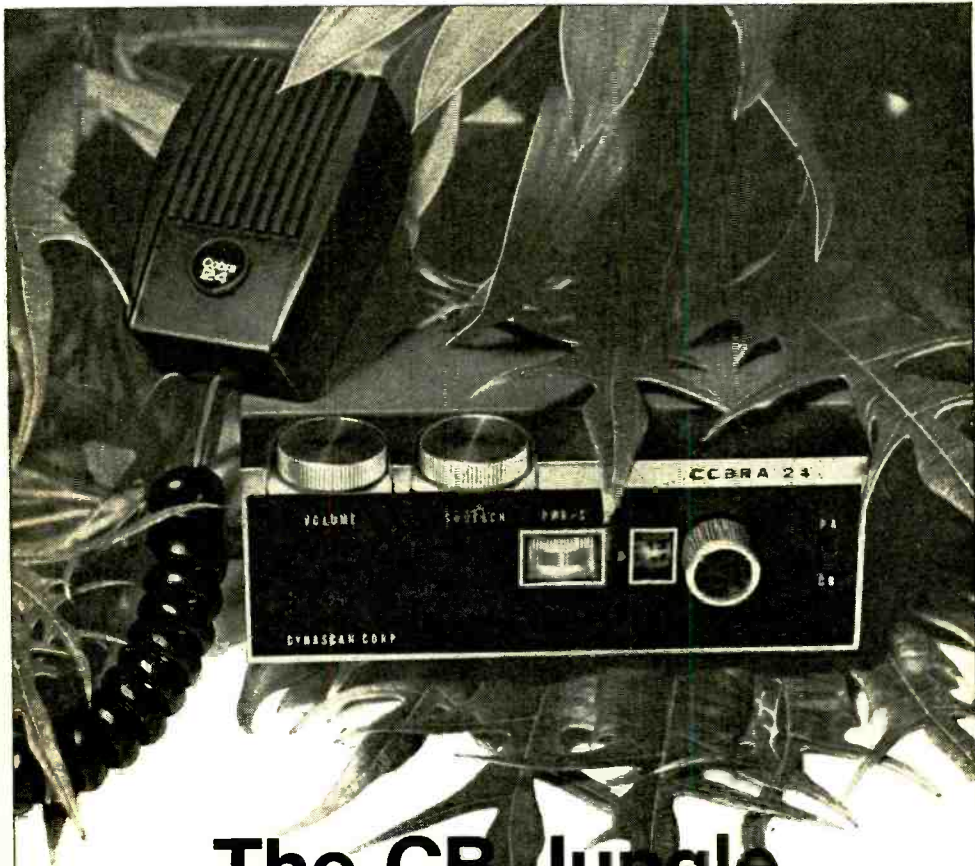

The CB Jungle is suddenly still...

There's a new Cobra Lurking!

The new Cobra 24: with more power, intelligence, and beauty than any of the others in its class!

The Cobra 24 preys on the others' weaknesses. With *more talk power*—a full, legal-limit 5-watt input and exclusive Dynascan DYNA-BOOST Speech Compression. And a selective dual-conversion superhet receiver with ceramic filter to give outstanding selectivity and gain.

And *more intelligence*—it always gets the message through crisp and sharp, even when others are garbled and unclear. Crystal-controlled transmit and receive on all 23 channels. (No extra crystals to buy!)

And *more beauty*—a striking, no-nonsense exterior. Designed for attack...with a push-to-talk mike, automatic noise limiter,

and positive or negative ground operation without internal wiring changes, featuring reverse polarity protection. There's a PA/CB switch with adjustable volume. And the illuminated channel selector and "S" meter makes even night transmission easy. Beautiful, with all silicon transistor, F.E.T. and integrated circuit. It uses 12 volt DC; AC adapter available. Meets FCC requirements. It even comes with its own mounting bracket.

See your dealer or write us for full details.

 **Cobra 24** Net \$169.95.

Product of DYNASCAN CORPORATION
1801 W. Belle Plaine, Chicago, Illinois 60613

CIRCLE NO. 6 ON READER SERVICE PAGE

23 Portable Channels for 149⁹⁵

Plus: 5 Watts—maximum FCC Power. Midland Integrated Circuit for ultimate solid state efficiency. Isolated Chassis for efficient operation in cars and trucks. 3-Way Meter monitors battery, power and signal strength.

Midland once again demonstrates its leadership in the CB field! This hand-held synthesized transceiver has all the power and channel capabilities of deluxe base/mobile units. Dual conversion superhet receiver has tuned RF, 6 IF's. High-level class B push-pull modulation. Jacks for: AC adaptor/battery charger, external antenna, external mike, PA speaker, earphone/external speaker. All crystals supplied for immediate 23-channel operation. With telescoping antenna, leather case.

Model 13-790

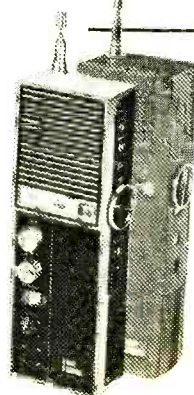
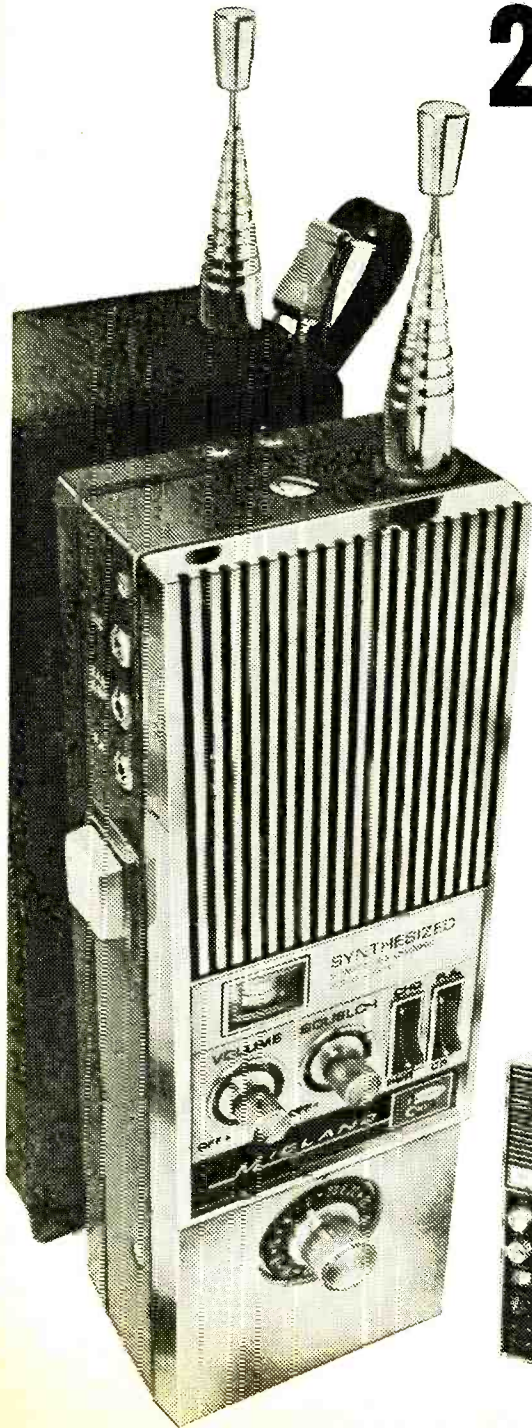

5-Watt,
6-Channel
Transceiver
Model 13-770
\$79.95

Super 5-Watt,
6-Channel with
Integrated
Circuit
Model 13-775B
\$99.95

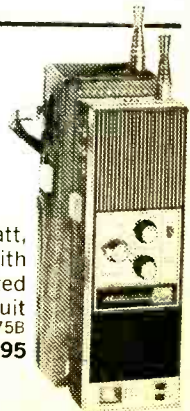

Prices shown are suggested retail, each unit.

MIDLAND[®]

INTERNATIONAL

FOR FREE BROCHURE, write: 1909 Vernon, North Kansas City, Mo. 64116 or 5055 Alcoa, Vernon, Calif. 90058
CIRCLE NO. 21 ON READER SERVICE PAGE

Indoor/Outdoor

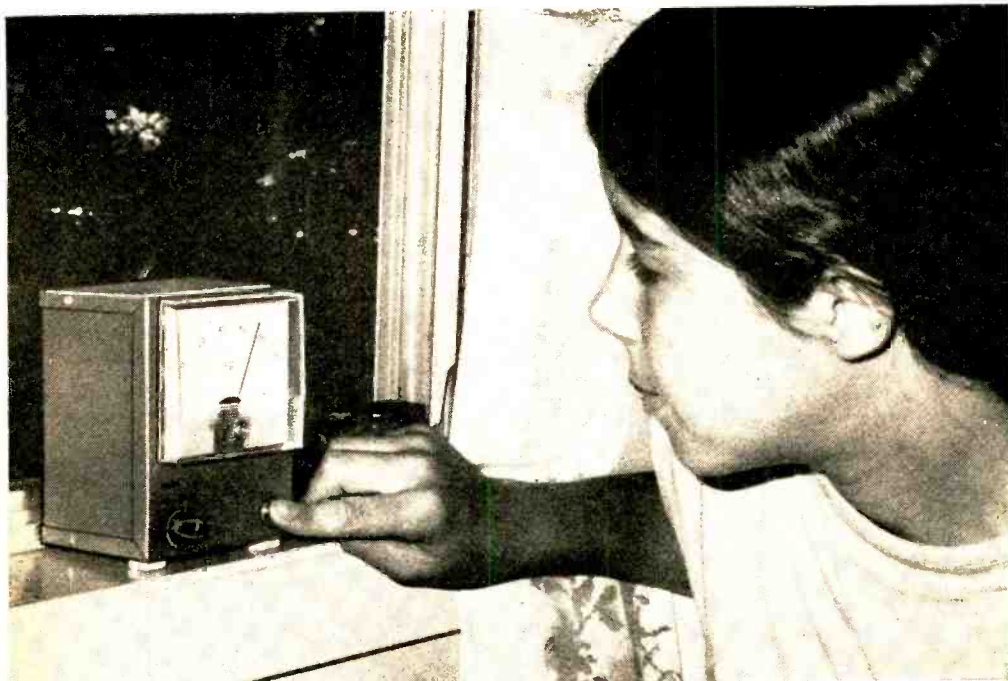

All-Electronic Thermometer

HELP SAVE MERCURY METAL—GO ELECTRONIC!

BY C.P. TROEMEL

UNLESS YOU happen to live “up in Central Park” or “in the Chicago Loop” the temperature reports that come over the radio are not really enough to prepare you for what you will find when you step out your front door. So everyone wants an outdoor thermometer. Unfortunately, just hanging a standard thermometer outside a window is not always the best solution—either you can't see it or it's in a protected spot that doesn't give true indications. Similarly, if you use the conventional outdoor-indoor bulb-type thermometer with remote sensing, you must locate the bulb in the best place you can and then carefully bring a long copper capillary tube into the house through a window frame or wall.

It is possible, however, to have an outdoor-indoor electronic thermometer

that is accurate, easy to build, and easy to install. The sensing element in this thermometer is a resistor (Sensistor®) with a positive temperature coefficient—that is, its resistance increases linearly as the surrounding temperature increases. The connection between the sensor and the temperature readout is made with flexible twin-conductor cable (zip cord, 300-ohm twin-lead, etc.) so that the sensor can be in any location, inside or out.

Construction. The circuit of the thermometer is basically a simple resistance bridge as shown in Fig. 1. Any number of sensing units may be used and you can locate them anywhere you like. Two (one indoors and one outdoors) are shown in Fig. 1. Use a multi-contact selector switch for *SI* to choose the sensor

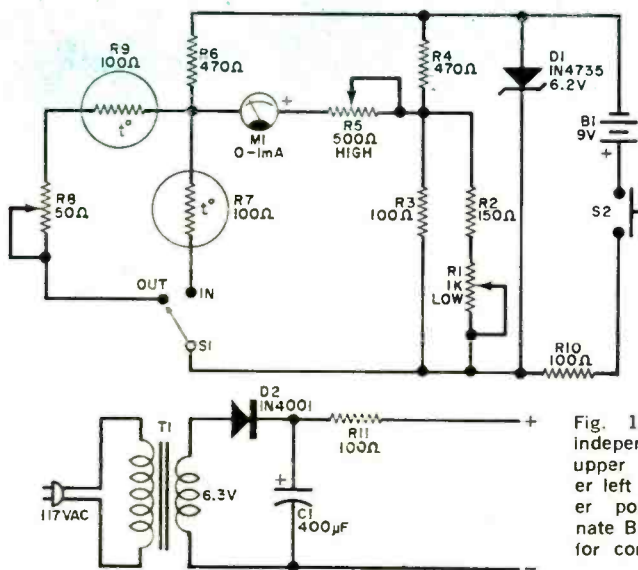

Fig. 1. Entire circuit of line-independent thermometer is shown upper left. Power supply at lower left can be connected in proper polarity across D1 (eliminate B1, R10, and S2) to provide for constant a.c. line operation.

PARTS LIST

B1—9-volt battery
 C1—400- μ F, 15-volt electrolytic capacitor
 D1—1N4735, 6.2-volt, 1-watt zener diode
 D2—1N4001 diode
 M1—0-1-mA meter, 100 ohms maximum resistance. (If a more sensitive meter is used, increase the value of R5.)
 R1—100-ohm potentiometer
 R2—150-ohm, $\frac{1}{2}$ -watt resistor
 R3—100-ohm, $\frac{1}{2}$ -watt resistor
 R4, R6—470-ohm, $\frac{1}{2}$ -watt resistor (must be closely matched)
 R5—500-ohm potentiometer

R7, R9—100-ohm Sensistor (Texas Instruments TM1/4)*

R8—50-ohm miniature potentiometer

R10, R11—100-ohm, $\frac{1}{4}$ -watt resistor

S1—S.p.d.t. switch (see text)

S2—S.p.s.t., normally open pushbutton switch

T1—Filament transformer, 6.3-volt secondary
 Misc.—5" x 4" x 3" metal enclosure, rubber grommet, aluminum for L-bracket, elastic band, knob, terminal strips, lengths of twin-conductor cable, mounting hardware, etc.

*Available from Newark Electronics Corp., 500 N. Pulaski Rd., Chicago, Illinois 60624, Cat. No. 12F055, \$1.

you want to read. If the thermometer is to be located in a fixed position in the house, you can use the line-operated power supply shown in the schematic. If you want a thermometer free of power lines, use the internal battery. In either case, the zener diode, D1, must be in the circuit.

If you use a battery, you will need pushbutton switch S2 to turn on the thermometer to make a reading. If you use the line-operated supply, the meter will indicate temperature at all times. Current drain is only about 20 mA so there is no harm in having it on constantly.

The first step in assembling the thermometer is to modify the meter scale to read degrees Fahrenheit. Gently remove the plastic cover from the meter face. The original 0-1-mA scale division markers can be used. Remove the old numer-

als using a typewriter eraser. Then, using Datak press-on lettering (available at most art stores), renumber the scale divisions as shown in Fig. 2, making the 32°F (freezing) mark red if desired. Replace the face cover.

The thermometer is assembled in a 5" x 4" x 3" metal cabinet. The meter and switches S1 and S2 (if they are used) are mounted on the front panel. After the meter is installed, make sure that the needle rests on the zero mark. If it does not, adjust the meter zero screw at the axis of the meter movement.

The high- and low-range calibration potentiometers (R5 and R1, respectively) are mounted on a small L-bracket on the bottom of the chassis (see Fig. 3). An elastic band is wrapped around the L-bracket to hold the battery behind the potentiometers. If used, remote-sen-

Fig. 2. Use the original scale markings, but renumber scale to indicate between 0 and 100; affix °F marking under scale.

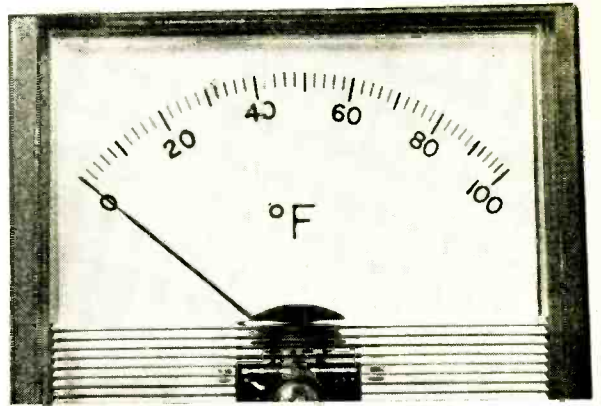

sensor trimming potentiometer *R8* is mounted on a two-lug terminal strip (neither lug grounded) fastened to the front panel under one of the meter mounting nuts. A three- or four-lug terminal strip can be mounted under the other meter mounting screw to serve as a connector for the sensor cables.

Drill a hole in the top of the chassis for the sensor cables. Put a rubber grommet on the hole to protect the cables. Then wire the circuit point-to-point following Fig. 1. Check that *R4* and *R6* are within a few per cent of each other in resistance values. At the same time, measure the resistance of both sensors, being careful not to heat them with your fingers. Use the higher valued sensor for the indoor unit (*R7*).

Since the sensors are encapsulated, they are not affected by rain, snow, etc. A good way to mount the sensors is to put them on small two-lug terminal strips which can be attached to almost any surface. Lengths of conventional twin-conductor cable (such as 300-ohm TV twin lead) can be used to connect the sensors to the thermometer. Be careful not to get more than a few ohms of resistance in the sensor circuit. Assume that most wire has a resistance of about $\frac{1}{2}$ ohm per 100 feet (one wire, one way). Calibration is performed with the sensors actually connected to the necessary lead lengths.

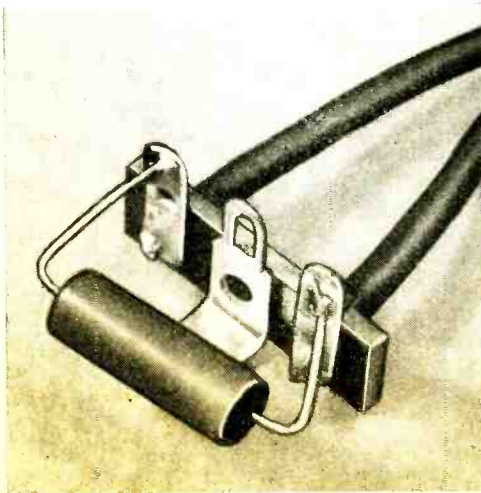

Three-lug terminal strip provides most convenient method of connecting a sensing resistor to cable.

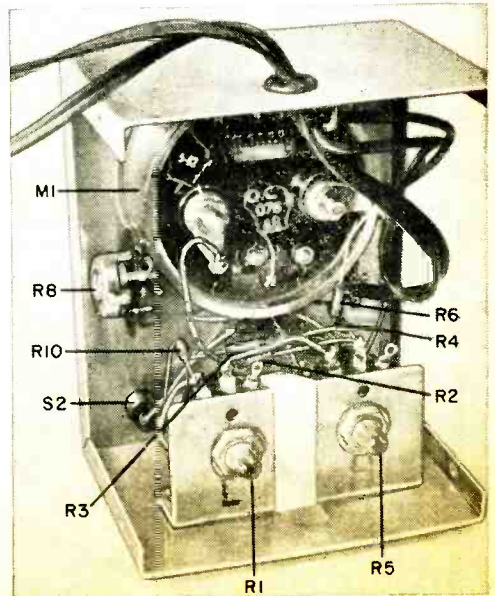
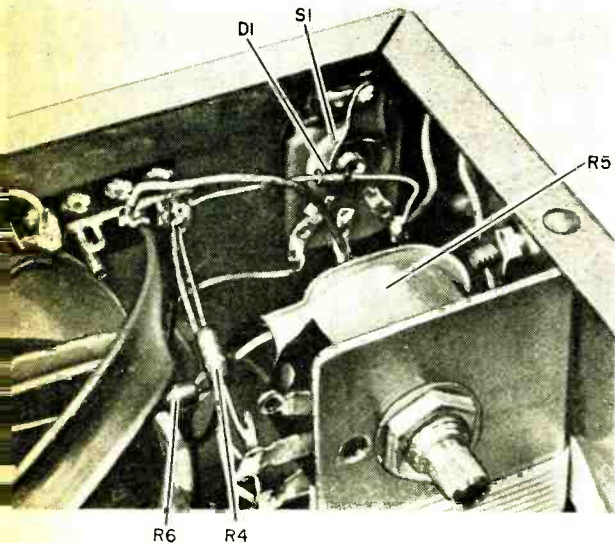

Fig. 3. Wiring is point-to-point. An elastic band secures B1 against the rear surfaces of R1 and R5.



Selector switch S1 (at top) is for two-sensor operation. If more sensors are used, substitute a switch with the appropriate number of positions.

Calibration. To calibrate the thermometer, you will need an accurate bulb thermometer covering the range from 0° to 100°F. With S1 in the indoor position and the indoor sensor connected to the length of cable that will actually be used, wrap a small piece of wire around the sensor and the bulb thermometer to hold them in close thermal contact, making sure you can see the bulb-thermometer scale graduations.

Place the sensor-thermometer combination in a cold environment that is as close to 0°F as possible (refrigerator freezer) and allow the temperature to stabilize for 10 or 15 minutes. Turn on the electronic thermometer and compare its indication with the temperature as indicated by the bulb thermometer. Adjust R1 until the meter agrees with the bulb thermometer. Remove the sensor and thermometer from the cold area and allow them to come up to room temperature.

Now place the sensor-thermometer combination in a hot environment that is as close to 100°F as possible (kitchen oven) and allow the temperature to stabilize again. Adjust R5 until the meter indicates the same temperature as the bulb thermometer. Repeat the low- and high-temperature adjustments until the controls do not have to be touched up. If the low-temperature adjustment is made at exactly 0°F, the high-tempera-

ture adjustment need only be done once. Put a drop of glue on both potentiometer shafts to keep them from being moved accidentally. If you prefer maximum accuracy at some specific temperature, seek an environment that is exact-

HOW IT WORKS

The positive temperature coefficient resistor used as a sensor for the electronic thermometer is actually a semiconductor (silicon) device whose resistance versus temperature curve is extremely linear. Unlike the conventional thermistor, its resistance increases in proportion to an increase in temperature.

As shown in the schematic, the sensor forms one arm of a conventional Wheatstone bridge that is made to balance at 0°F. The resistance of the parallel combination of R3 and R1 plus R2 is made to equal the resistance of R7 at that temperature. In this condition, there is no voltage drop across the bridge so that no current flows and the meter indicates zero.

When the ambient temperature surrounding R7 rises, the resistance of R7 increases in proportion. This unbalances the bridge so that the voltage at the junction of R6 and R7 is higher than at the junction of R4 and R3. Current then flows through the milliammeter, whose meter face has been calibrated in degrees Fahrenheit. If the ambient temperature surrounding R7 decreases, its resistance decreases, less current flows through the meter and the needle drops. The circuit is designed so that zero current through the meter is 0°F—however, as pointed out in the text, any other temperature can be used.

Potentiometer R1 is used to adjust the low (0°F) end of the meter scale, while potentiometer R5 adjusts the high (100°F) end.

The power supply is regulated to prevent input-voltage variations from affecting the thermometer calibration.

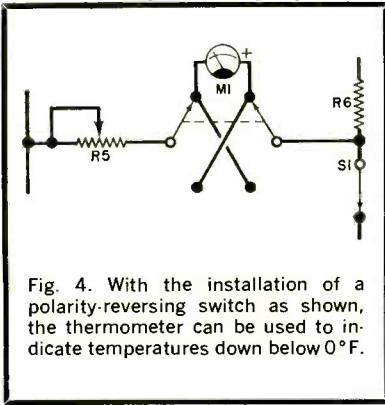
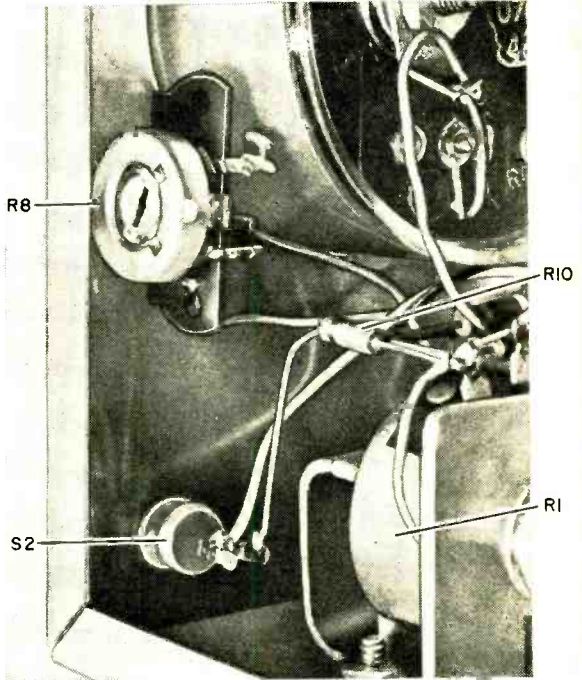
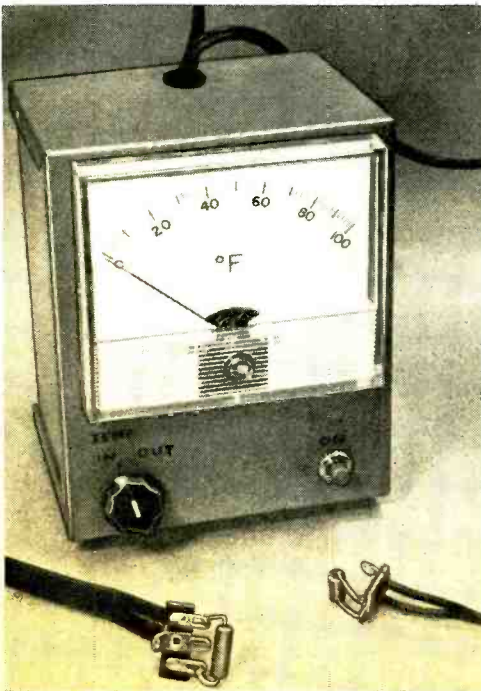

Fig. 4. With the installation of a polarity-reversing switch as shown, the thermometer can be used to indicate temperatures down below 0°F.



Potentiometer R8 should be mounted on a two-lug, ungrounded terminal strip. Terminal strip is held under the meter corner hardware.



Power line (if used) and sensor cables should enter top of the cabinet through grommet-lined hole.

ly the temperature that you want (as indicated on the bulb thermometer) and adjust either the high or low control to get the correct indication on the meter.

Once the thermometer has been calibrated for the indoor sensor, connect the outdoor sensor to its required length of cable and repeat the low-temperature calibration, using R8 to make the necessary adjustment. Calibration of the outdoor sensor for the high end is not possible now but the accuracy will not be greatly affected.

Modifications. If you want to measure below 0°F, build the meter-reversal circuit shown in Fig. 4 and calibrate the thermometer accordingly. To measure above 100°F, change the meter scale markings and calibrate using the desired temperatures. If the meter cannot be brought on scale, increase the value of R5.

To add more sensors, change selector switch S1 accordingly and connect the sensors just as R8 and R9 are in Fig. 1. The added trimmer potentiometers are mounted in the cabinet and adjusted as described above for R8.

Popular EleComics



Boy, was this a good day for television . . .
Everything went wrong!



I guess you weren't ready
for me to plug it in.

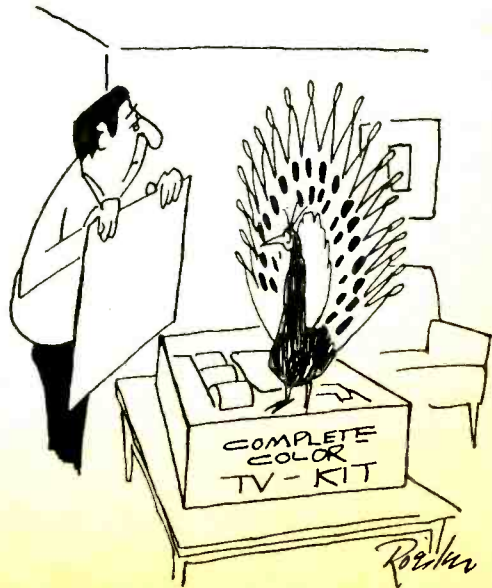

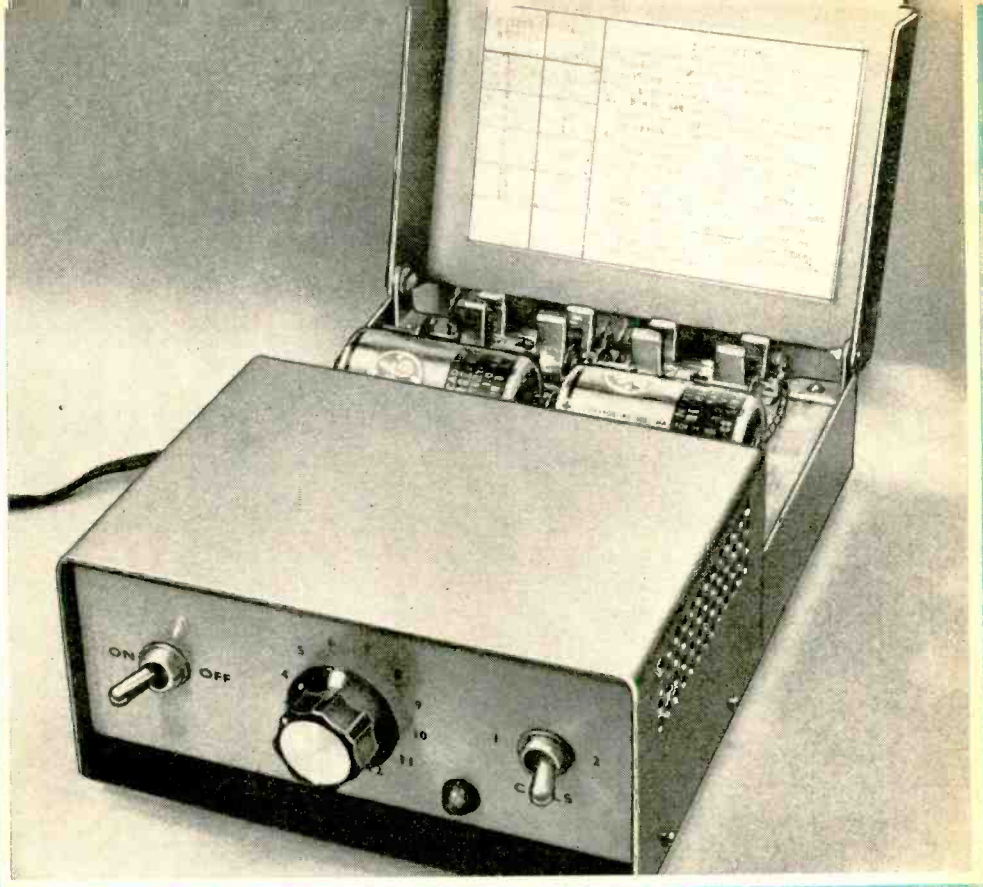

AA-C-D Battery Charger

BUILD A CONSTANT-CURRENT CHARGER FOR
NICKEL-CADMIUM CELLS

BY A. A. MANGIERI

EVERY DAY another new piece of battery powered equipment is introduced on the market. There are radios, tape recorders, instruments, flashlights, toys—you name it—and you probably have several of them in your home. You have also been struck by the amount of money spent on replacing worn-out batteries. Did you ever consider buying rechargeable batteries and doing the “revitalizing” yourself?

Although the purchase price of rechargeable batteries is higher than that of conventional zinc-carbon flashlight batteries, the fact that they can be recharged and used so many times makes their end cost substantially lower.

To recharge a rechargeable battery, you can build the constant-current battery charger described here for a very modest price. It has fixed charge rates, covering nearly all types and ranges of cells—with capacities from 45 to slightly over 500 mA.

This charger has built-in clips for holding AA, C, and D cells or a simple connector and cable arrangement can be used to recharge groups of cells (up to six) without removing them from the equipment in which they are installed. Besides the larger cells, the “button” type found in subminiature equipment can be recharged. Metering and a variable charge-rate control can be included.

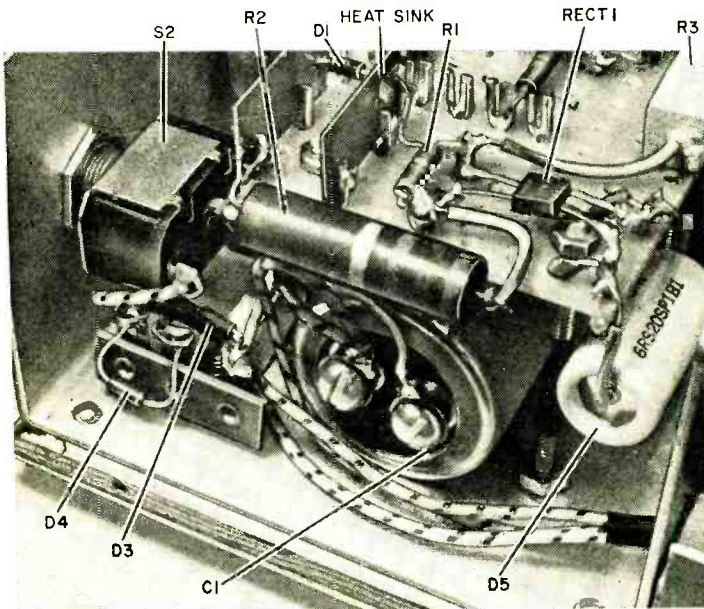

A clamp must be used when mounting C1 to the chassis. When tightening clamp hardware, be careful to avoid puncturing plastic jacket that encloses this capacitor.

Construction. Almost any type of mechanical assembly can be used for the charger. The photos show the commercial looking design built by the author. Although he used a metal chassis, secured to a wood base, the only metal actually required is a few square inches of aluminum and copper for heat sinks. If you use a closed container, make sure that enough ventilating holes are provided to prevent heat damage during prolonged operation.

The schematic of the charger is shown in Fig. 1. Most of the components are mounted on a small piece of perf board using clips to hold them in place. Note that zener diode *D1* is placed between a pair of thin copper plates $\frac{1}{2}'' \times 1''$ to provide a heat sink. Capacitor *C1* has an insulated jacket and should be mounted with a clamp to avoid puncturing the jacket.

Mount the battery holders on a non-metallic surface (preferably wood) so that they do not touch and are sufficiently separated so that batteries can be installed and removed with a minimum of effort. Note that the author used a symmetrical arrangement in mounting the battery holders—with a D, C, and AA holder on each side. When wiring cell selector switch *S2*, be sure that, with the switch to the left, the left row of holders is selected and vice versa.

CHARGING TIMES AND CURRENTS

Manufacturer	Type	Capacity (mA-Hr)	Charge current (mA)	Charge time (Hr)
Burgess	CD6-AA	450	45	14-16
	CD7-D	2500	250	14-16
	CD11-D	3000	300	14-16
	CD10-D	4000	400	14-16
Eveready	CH450-AA	450	45	14
	CH400-AA	500	50	14
	CH1.5-C	1500	150	14
	CH4-D	4000	400	14
General Electric	GC-1-AA	500	50	15
	GC-2-C	1000	100	15
	GC-3-D	1000	100	15
Mallory	SA-15-AA	300	13.5	30-36
	SA-14-C	1000	40	30-36
	SA-13-D	2000	80	30-36

MAGIC FIGURES

Nickel-cadmium batteries are usually sold with a rating clearly printed on the side of the battery. This rating is either in terms of a 10-hour discharge at "X" mA or in a "total" battery charge of "Y" mA-Hr. To recharge, you use the same discharge rate (if the 10-hour figure is given) or divide the mA-Hr by 10 to obtain the idealized recharging rate. To this you add the magic figure of 40%. Thus a 200 mA-Hr nickel-cadmium battery would be recharged at 20 mA for 14 hours (or 15 if specified by the manufacturer as shown in table).

10 New Exciting Kits For Home & Hobby



NEW
Kit ID-29
\$29.95*



NEW
Kit TD-17
\$12.95*

NEW
Kit GR-78
\$129.95*



\$49.95*
each



NEW
Kit GR-88

NEW
Kit GR-98

NEW
Kit GR-38
\$32.95*

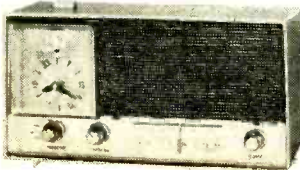

NEW Kit GD-209A
\$149.95*

NEW Heathkit Solid-State Auto Tune-Up Meter . . . Measures Dwell, RPM And DC Voltage

The new Heathkit ID-29 is most versatile . . . really three automotive test instruments in one . . . and its low price makes it even a better value. Measures Dwell on all 4-cycle 3, 4, 6, or 8 cylinder engines . . . measures RPM in two ranges 0-1500 and 0-4500 . . . measures DC voltage from 0 to 15 volts. And no batteries are needed . . . running engine provides both signal and power. Easy to use . . . on both 6 and 12 volt system without changing leads. It's lightweight, easy to carry . . . comes equipped with black polypropylene case that has a built-in lead storage compartment and is resistant to virtually everything. Fast, simple assembly . . . takes just one evening. The perfect accessory for the handyman who wants to do his own car tune-up, emergency road service personnel, or shop mechanics . . . order your ID-29 now. 4 lbs.

NEW Heathkit Electronic Metronome

The new Heathkit TD-17 is a low cost, precise performing electronic Metronome . . . a handy helper for any music student. Battery operated . . . no springs to wind . . . accurate, steady calibration is always maintained . . . from 40 to 210 beats per minute. Instruction label on bottom gives conversion from time signature and tempo to beats per minute. Stylish fruit wood finished cabinet. Easy solid state circuit board construction . . . assembles and calibrates in only 2-3 hours. The new Heathkit TD-17 Electronic Metronome is so low in cost every music student can afford one . . . order yours now. 1 lb.

NEW Heathkit GR-78 Solid-State General Coverage Receiver . . . Tunes 190 kHz To 30 MHz In Six Bands

The new GR-78 combines wide coverage, superior performance and portability with sharp styling to provide a remarkable value in general coverage receivers. Tunes AM, CW & SSB signals from 190 kHz to 30 MHz in six switch-selected bands. The all solid-state circuit employs modern FET's in the RF section and 4 ceramic filters in the IF to deliver maximum sensitivity and sharp selectivity. Bandspread Tuning is built-in, and can be calibrated for either Shortwave Broadcast or Amateur Bands. Completely portable . . . comes with a nickel-cadmium rechargeable battery pack and built-in charger that operates from 120 or 240 VAC and 12 VDC. Many built-in features . . . 500 kHz crystal calibrator . . . switchable Automatic Noise Limiter . . . switchable Automatic Volume Control . . . Receiver Muting . . . Headphone Jack and many more. Order yours today. 14 lbs.

NEW Heathkit GR-88 & GR-98 Solid-State Portable Monitor Receivers For VHF-FM And Aircraft Bands

GR-88 . . . Tunes narrow and wide band signals between 154-174 MHz . . . for police, fire, most any emergency service. Exceptional sensitivity and selectivity. Smart compact styling, portable or fixed station capability with accessory AC power supply, variable tuning plus single channel crystal control, collapsible whip antenna, adjustable squelch control, easy circuit board construction. 5 lbs. GR-98 . . . Tunes 108 through 136 MHz for monitoring commercial and private aircraft broadcasts, airport control towers. Same features as the GR-88 above. 5 lbs. GRA-88-1, Accessory AC Power Supply . . . \$7.95*

NEW Heathkit GR-38 Solid-State AM Clock Radio

Discover An Easier Way To Get Up In The Morning . . . with the new GR-38. Set the front panel switch to "Alarm" to hear both alarm and news & music of AM radio, or use "Auto" position for only the radio. The "Snooze" alarm lets you turn off the alarm for ten minutes but keeps the radio on to wake you up gradually, and cycles continuously until selector switch is reset. The accurate, dependable clock controls the accessory AC socket so you can have coffee perking or lights turned on in the morning. The all solid-state radio really pulls in those stations and runs cool, maintenance-free. AGC keeps stations at a constant volume and a full wave transformer power supply eliminates power line hum. Styled in coral with matching grille. There IS a better way to get up in the morning . . . with the Heathkit GR-38 . . . order yours now. 6 lbs.

NEW Heathkit Deluxe Radio-Controlled Screw-Drive Garage Door Opener Semi-Kit

The next best thing to a personal doorman. The "wireless" factory assembled transmitter operates up to 150 feet away. Just push the button and your garage door opens and the light turns on . . . and stays on until you're safely inside your home. The giant 7 ft. screw mechanism coupled with the 1/4 HP motor mean real power and reliability, and the adjustable spring-tension clutch automatically reverses the door when it meets even the smallest obstruction . . . extra safety for kids, pets, bikes, even car tops. Assembles completely without soldering in just one evening. Easy, fast installation on any 7' overhead track door and jamb & pivot doors with GDA-209-2 Adaptor at \$7.95. Order yours now. 66 lbs.

From The Leader



NEW Heathkit Ultra-Deluxe "681" Color TV With AFT . . . Power Channel Selection & Opt. RCA Hi-Lite Matrix Tube

The new Heathkit GR-681 is the world's most advanced Color TV with more built-in features than any other set on the market. Automatic Fine Tuning on all 83 channels . . . power push button VHF channel selection, built-in cable-type remote control . . . or you can add the optional GRA-681-6 Wireless Remote Control any time . . . plus the built-in self-servicing aids that are standard on all Heathkit color TV's. Other features include high & low AC taps to insure that the picture transmitted exactly fits the "681" screen, automatic degaussing, 2-speed transistor UHF tuner, hi-fi sound output, two VHF antenna inputs, top quality American brand color tube with 2-year warranty. With optional new RCA Matrix picture tube that doubles the brightness, Model GR-681MX only \$535.00.

GRA-295-4, Mediterranean Cabinet shown . . . \$124.95*

Heathkit "295" Color TV

With Optional RCA Matrix Tube . . . with the same high performance features and built-in servicing facilities as GR-681 above . . . less AFT, VHF power tuning and built-in cable-type remote control. You can add the optional GRA-295-6 Wireless Remote Control at any time. New optional RCA Matrix tube doubles the brightness, Model GR-295MX, \$485.00.

GRA-295-1, Contemporary Walnut Cabinet shown . . . \$64.95*

Both the GR-681 and GR-295 fit into the same Heath factory assembled cabinets; not shown Early American style at \$109.95*

NEW Deluxe Heathkit "581" Color TV With AFT

The new Heathkit GR-581 will add a new dimension to your TV viewing. Brings you color pictures so beautiful, so natural, so real . . . puts professional motion picture quality right into your living room. Has the same high performance features and exclusive self-servicing facilities as the GR-681, except with 227 sq. inch viewing area, and without power VHF tuning or built-in cable-type remote control. The optional GRA-227-6 Wireless Remote Control can be added any time you wish. And like all Heathkit Color TV's you have a choice of different installations . . . mount it in a wall, your own custom cabinet, your favorite B&W TV cabinet, or any one of the Heath factory assembled cabinets.

GRA-227-2, Mediterranean Oak Cabinet shown . . . \$109.95*

Heathkit "227" Color TV

Same as the GR-581 above, but without Automatic Fine Tuning . . . same superlative performance, same remarkable color picture quality, same built-in servicing aids. Like all Heathkit Color TV's you can add optional Wireless Remote Control at any time (GRA-227-6). And the new Table Model TV Cabinet and roll around Cart is an economical way to house your "227" . . . just roll it anywhere, its rich appearance will enhance any room decor.

GRS-227-5, New Cart and Cabinet combo shown . . . \$54.95*

Both the GR-581 and GR-227 fit into the same Heath factory assembled cabinets; not shown, Contemporary cabinet \$64.95*

NEW Heathkit Deluxe "481" Color TV With AFT

The new Heathkit GR-481 has all the same high performance features and exclusive self-servicing aids as the new GR-581, but with a smaller tube size . . . 180 sq. inches. And like all Heathkit Color TV's it's easy to assemble . . . no experience needed. The famous Heathkit Color TV Manual guides you every step of the way with simple to understand instructions, giant fold-out pictorials . . . even lets you do your own servicing for savings of over \$200 throughout the life of your set. If you want a deluxe color TV at a budget price the new Heathkit GR-481 is for you.

GRA-180-1, Contemporary Walnut Cabinet shown . . . \$49.95*

Heathkit "180" Color TV

Feature for feature the Heathkit "180" is your best buy in color TV viewing . . . has all the superlative performance characteristics of the GR-481, but less Automatic Fine Tuning. For extra savings, extra beauty and convenience, add the table model cabinet and mobile cart. Get the value-packed GR-180 today.

GRS-180-5, Table Model Cabinet & Cart combo . . . \$42.50*

Both the GR-481 and GR-180 fit the same Heath factory assembled cabinets; GRA-180-2, Early American Cabinet \$94.95*

Add the Comfort And Convenience Of Full Color Wireless Remote Control To Any Rectangular Tube Heathkit Color TV . . . New Or Old!

Kit GRA-681-6, for Heathkit GR-681 Color TV's . . . \$64.95*

Kit GRA-295-6, for Heathkit GR-295 & GR-25 TV's . . . \$69.95*

Kit GRA-227-6, for Heathkit GR-581; GR-481 & GR-180 Color TV's . . . \$69.95*

Now There Are 6 Heathkit® Color TV's To Choose From

2 Models In 295 Sq. Inch Size

NEW
Kit GR-681
With AFT
\$499.95*
(less cabinet)



Kit GR-295
\$449.95*
(less cabinet)

2 Models In 227 Sq. Inch Size

NEW
Kit GR-581
with AFT
\$419.95*
(less cabinet)



Kit GR-227
NOW ONLY
\$379.95*
(less cabinet & cart)

2 Models In 180 Sq. Inch Size

NEW
Kit GR-481
with AFT
\$359.95*
(less cabinet)



Kit GR-180
NOW ONLY
\$329.95*
(less cabinet & cart)

Reception Is Simulated

On All Sets Shown



NEW

FREE 1970 CATALOG!

Now with more kits, more color. Fully describes these along with over 300 kits for stereo, hi-fi, color TV, electronic organs, electric guitar & amplifier, amateur radio, marine, educational, CB, home & hobby. Mail coupon or write Heath Company, Benton Harbor, Michigan 49022.

HEATH COMPANY, Dept. 10-67

Benton Harbor, Michigan 49022

Enclosed is \$ _____, plus shipping.

Please send model(s)
 Please send FREE Heathkit Catalog. Please send Credit Application.

Name _____

Address _____

City _____

State _____

Zip _____

*Mail order prices; F.O.B. factory. Prices & specifications subject to change without notice.

CL-364R

CIRCLE NO. 15 ON READER SERVICE PAGE

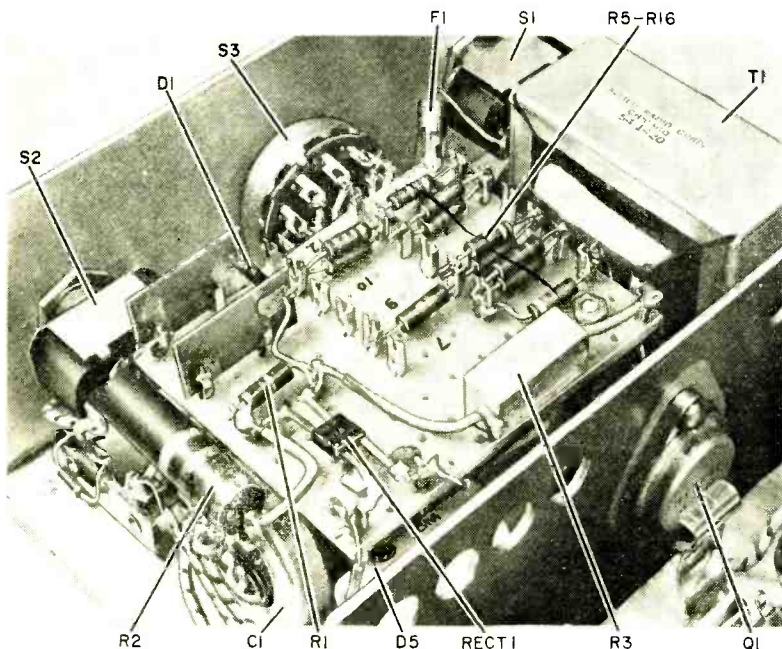

All components not on the chassis can be mounted on a piece of perforated phenolic board. Flea clips facilitate the connections.

The author used a 12-position switch for S3. This provides enough of a variety of charging currents for most applications. Resistors R5 through R16 provide base bias for the transistor and thus determine the charging rates. Their resistances must be chosen to account for variations in the characteristics of the transistor. If desired, you can use only a few rates to suit your immediate needs (or if you are using only one type of battery) and add others as your needs change. The Table gives a number of charging rates for the common AA, C, and D cells. The charging rate and time for a cell are usually marked on its jack-

et. Note that physical size is not an indication of the required charging rate.

To select resistors R5 through R16 (if you are going to use this many intervals) allow the equipment to warm up for about 20 minutes at normal room temperature (75 to 78 degrees F). Insert a fresh carbon-zinc D cell in one of the D-cell holders and clip a milliammeter across the other D-cell holder. When S2 is in the 2 CELL position, the meter and the battery will be in series with the rest of the circuit. First use a 5000- or 10,000-ohm potentiometer for the base bias resistors and set it to its highest resistance. Slowly rotate the potentiometer until the milliammeter indicates the desired charging rate. Turn off the power and remove the potentiometer. Measure the resistance of the potentiometer to determine the fixed resistor to be used for that charging rate. Since you may wind up with non-standard resistance values, it is best to use a resistor with a slightly larger value and put a second resistor of higher value in parallel to get the required value. You should be able to set the desired charging current to within five percent of the target value.

If you use the optional meter circuit, then potentiometer R17 is the base bias resistor and the charging current is read

RECHARGING ZINC-CARBON BATTERIES

A fully discharged zinc-carbon battery will be unable to accept a recharge. To put anything back into a zinc-carbon battery you must interrupt its service life before it has dropped below the level of 1.0 volt. This is tricky since the battery may not have displayed any indication that its useful life was ending.

Recharge zinc-carbon batteries immediately after removal from service. The rate of recharging should be about 120% the average rate of discharge and the charge period should be 12 to 16 hours. Put recharged batteries back into service immediately and don't expect to recharge zinc-carbon batteries more than 4 times—if that.

HOW IT WORKS

The battery charger is basically a d.c. power supply (*T1*, *RECT1*, and *C1*) which is placed in series with the battery to be charged. A power transistor (*Q1*) maintains the series current flow at a predetermined level. The transistor chosen for this application has little change in collector current for moderately large changes in both collector voltage and load current, once its base bias has been set. This bias (and hence the collector current) is set by the relatively stable d.c. voltage determined by zener diode *D1* and the series base resistors.

Switch *S2* selects either one bank of cell holders or both banks in series. Charge indicator *I1* and diodes *D3* and *D4* provide visual indication of charge over the range of 45 to 500 mA. Diode *D2* prevents slow discharge of cells left in the charger for storage. Thyrector diode *D5* suppresses any voltage transients that might enter the circuit from the power line.

Two optional components may be added to the charger. A 0-500-mA meter can be inserted at point X in Fig. 1 to measure current flow, and a 10,000-ohm potentiometer can be inserted as shown by the dotted lines for variable control of recharging current.

appropriate battery holder. To charge two *identical* cells, set *S2* to the 2 CELL position and insert both cells in their holders, one on each side. Do not attempt to charge cells in parallel. It will damage the charger.

The charger can handle up to six identical cells connected in series. For this, make up a charging jack and cable to go between the charger and the batteries.

Recharge cells as soon as they appear to be weak in service. This avoids excessive discharging which tends to reduce the cycle life of the cell. Normally, a cell should be recharged when its voltage drops to about 1.1 volts at a load current equal to one-tenth the cell's rated mA-hour capacity at the normal 10-hour discharge rate.

Rechargeable alkaline cells may be recharged (at the recommended rate) with

Three time-saving ideas are shown in the photo at right: Battery holders are arranged symmetrically; large black arrows indicate directions of positive poles; and chart gives directions for use of charger.

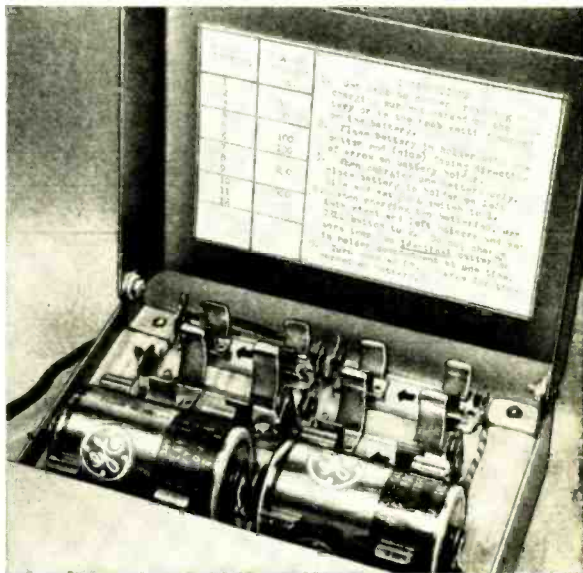

directly off the meter for each application. In this case, increase the value of R_4 to limit the highest charging current to 650 mA.

Applications. Make up a chart showing the correct setting of *S3* for each type of rechargeable cell you have, including the recommended charging time. This information is usually indicated on the package or the battery itself. Paste this chart on the charger so that you can refer to it when necessary. To charge one cell, set *S2* in the 1 CELL position and use the

a few precautions: Be sure to turn off the charger at the end of the charge period to avoid cell damage. Recharge cells when cell voltage drops to 1.1 volts. Never discharge a cell below 0.9 volt or cell damage will result.

Alkaline cells are supplied fully charged. If it is necessary to recharge a partially discharged cell, clip a voltmeter across the cell and recharge it until the voltage reaches 1.65 to 1.75 volts. Or, discharge the cell to 1.1 volts and recharge for the full recommended time.

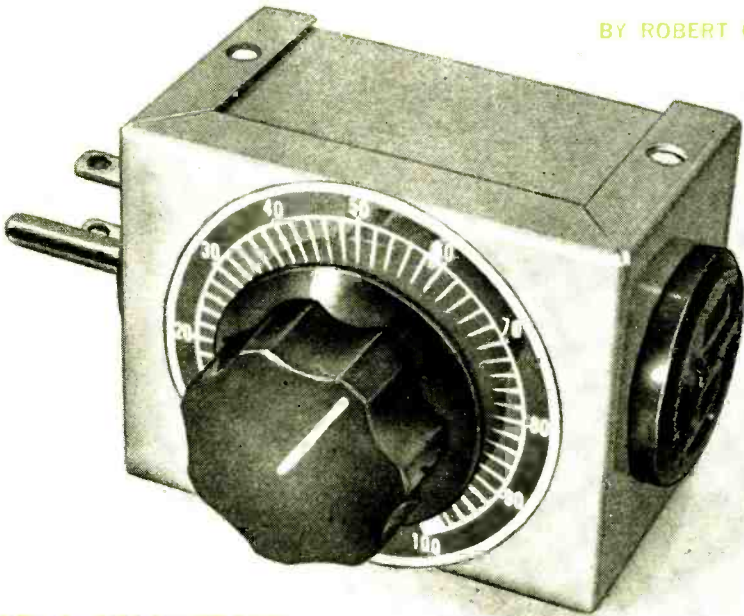

BUILD A SOLID STATE VARIABLE TRANSFORMER

USE A TRIAC FOR SMALL SIZE AND LOW COST

A VOLTAGE-LEVEL control for a.c. is one of the most useful electronic devices you can have around the house. It can serve as a speed control for motor-driven appliances; a heat control for soldering irons; or an incandescent light dimmer.

An ordinary variable autotransformer is commonly used as a voltage-level control. However, such transformers are expensive, bulky, and not very portable. A solid-state circuit, built around a triac, eliminates these objections. It costs about \$8 in parts, fits into the smallest metal utility box, and weighs only a few ounces.

Aptly called a "Solid-State Variable Transformer," the voltage-level control described in the following pages does everything a conventional variable transformer can and does it more efficiently. There are no hysteresis losses, IR losses

are at a minimum, and it operates cool.

Construction. Keep foremost in your mind that the Solid-State Variable Transformer is used to control potentially hazardous a.c. line voltages. Do not substitute parts for those specified in the Parts List. Take extra care when wiring the circuit and do not attempt to power the circuit until after you perform the ohmmeter checkout given in the last section of this article.

Begin construction by machining the utility box to provide mounting holes for *R1*, *P1*, and *SO1* as shown in Figs. 2 and 3. Note that all mounting holes are to be centered in the respective sides of the box.

The quickest and neatest method of making the cutouts for *P1* and *SO1* is to punch them out with a Greenlee No. 732 keyed radio chassis punch (orient the

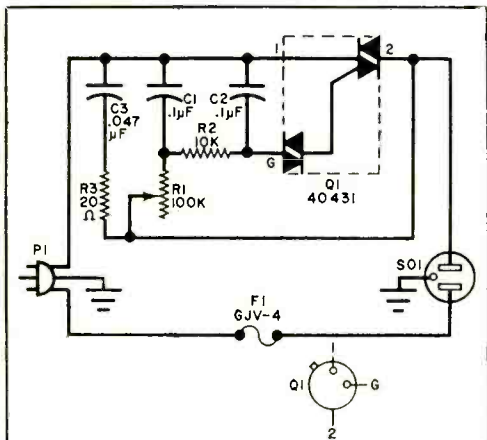

Fig. 1. Triac Q1 actually consists of four-layer diode at G and triac between 1 and 2.

PARTS LIST

- C1, C2—0.1- μ F, 200-volt tubular capacitor
 C3—0.047- μ F, 200-volt tubular capacitor
 F1—Buss No. 6JV-4 fuse
 P1—Three-line a.c. plug (Amphenol No. 160-11)
 Q1—Triac (RCA 40431)
 R1—100,000-ohm, $\frac{1}{2}$ -watt linear taper potentiometer
 R2—10,000-ohm, $\frac{1}{2}$ -watt resistor
 R3—20-ohm, $\frac{1}{2}$ -watt resistor
 SO1—Three-line a.c. receptacle (Amphenol No. 160-10)
 1—Bud No. CU-2100-A metal utility box
 Misc.—Ohmite Type 5000 dial plate (optional); control knob for R1; 2—each three-lug terminal strips (H.H. Smith No. 830, or similar); $1\frac{1}{2}$ "-long x $\frac{1}{4}$ "-diameter heat-shrinkable tubing for F1; hookup wire; solder; etc.

keys toward the bottom of the box). However, if you do not have access to a chassis punch, simply cut out a $1\frac{1}{64}$ "-diameter hole at each of the proper locations. Apply a liberal bead of epoxy cement around the entire perimeter of P1 and SO1. Then insert the plug and receptacle into their respective cutouts, orienting the rounded prong and hole toward the top of the utility box, and snap into place the retainer rings.

After allowing sufficient time for the epoxy cement to set, drill a $\frac{3}{8}$ "-diameter hole through the top of the box for mounting control R1. Then, before setting R1 in place, wrap one turn of 16-gauge solid bare wire around the mounting threads of the control, leaving 2" leads at each end. Insert R1 into its mounting hole, slip on the optional dial plate, fasten down the control, and fasten down the panel knob.

Now, locate the ends of the solid wire previously wrapped around R1. Connect the ends of this wire to the green-coded contacts on P1 and SO1. Snip away any excess wire and the right lug of R1.

Temporarily remove the silver-coded screw from P1, and use this screw to mount a three-lug terminal strip on the rear of the plug. In like manner, use the brass-coded screw on SO1 to mount an identical terminal strip on the rear of the receptacle.

Slip the $1\frac{1}{2}$ " length of shrinkable plas-

Fig. 2. Lug 3 at right of R1 is not used and should be removed to eliminate possibility of short circuits. Also, two terminal strips mount directly on rear of receptacle and plug.

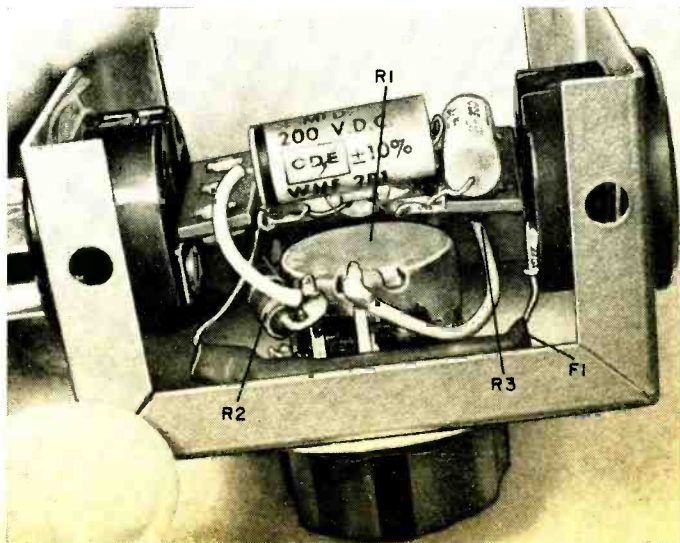
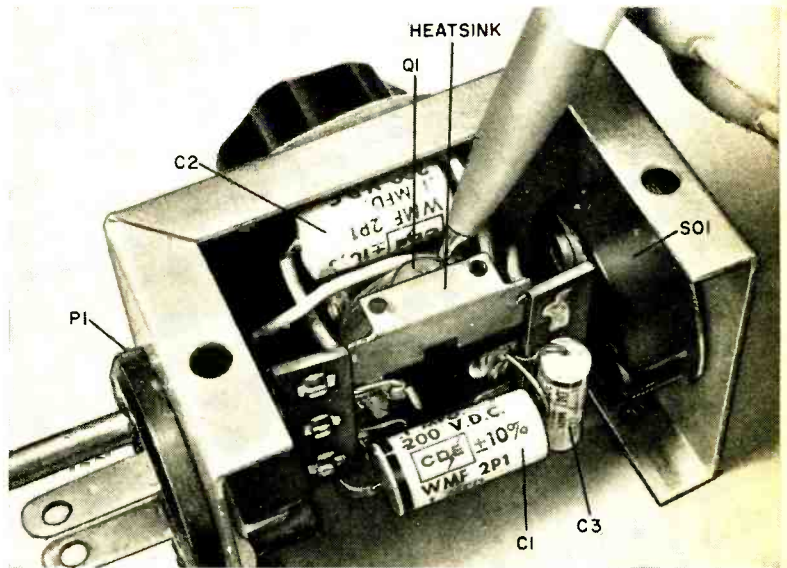

Fig. 3. Once Q1 is properly soldered to heatsink according to directions, set heatsink tabs onto lugs of terminal strip; solder in place.



tic tubing over the fuse, centering it over the body of the fuse, and apply heat until the tubing shrinks snugly around the fuse. Connect one lead of the fuse to the silver-coded contact of *SO1*, the other lead to the solder lug common to the silver-coded contact on *P1*.

Now solder *R2* to the left terminal of *R1* and the center lug of the terminal strip mounted on the rear of *P1*. Slip a 1½" length of plastic insulation over each lead of *C2*. Leaving just ¼" of bare lead exposed, clip off the excess lead lengths. Now, referring to Fig. 3, place *C2* against the top of the utility box, just above *R1*, and solder one lead to the center lug on the left terminal strip and the other lead to the center lug of the right terminal strip.

Solder a 2" length of insulated hookup wire from the center lug of *R1* to the lug common to the brass-coded screw on the *SO1* terminal strip. Then connect *R3* between the two outer lugs, and *C3* from the center lug to the outer lug (near the silver-coded contact of *SO1*) of this same terminal strip.

Connect another 2" length of insulated hookup wire from the brass-coded screw on *P1* to the center lug on the *SO1* terminal strip. Cut one lead of *C1* to 1" in length, the other lead to 1¼" in length. Then slip a 1" length of plastic insulation over the 1¼" lead, and connect this lead to the left lug on *R1*. Solder the remaining lead of *C1* to the center lug of

the *SO1* terminal strip.

Place the solder circle that comes with the triac in the heatsink (sometimes referred to as a heat spreader). Then force the triac between the tab and rear wall of the heatsink, being careful to prevent the Gate and No. 1 lead of the triac from touching the heatsink. Solder the case (terminal 2) of the triac to the heatsink.

Now, liberally tin with solder the upper lugs of both terminal strips (see Fig. 3), place the triac assembly on these lugs as shown, and heat the heatsink to solder the triac assembly firmly in place. Finally, solder lead No. 1 from the triac to the center lug of the *SO1* terminal strip, and the Gate lead to the center lug on the *P1* terminal strip. Check to make sure that neither lead is touching the heatsink, case of *R1*, or each other.

Final Check and Use. Before powering the Solid-State Variable Transformer, check out the circuit with an ohmmeter as follows. With *R1* set for minimum resistance, and the ohmmeter's range switch set to X100K, touch the probes of the ohmmeter to the brass-coded screws on *SO1* and *P1*. Initially, there should be a well-defined deflection of the meter pointer toward the low resistance end of the scale. Thereafter, the pointer should slowly drift back toward the infinity index of the meter scale.

Now, touch the probes to the green-
(Continued on page 117)

Some
Thoughts
On Not
Using
Plywood

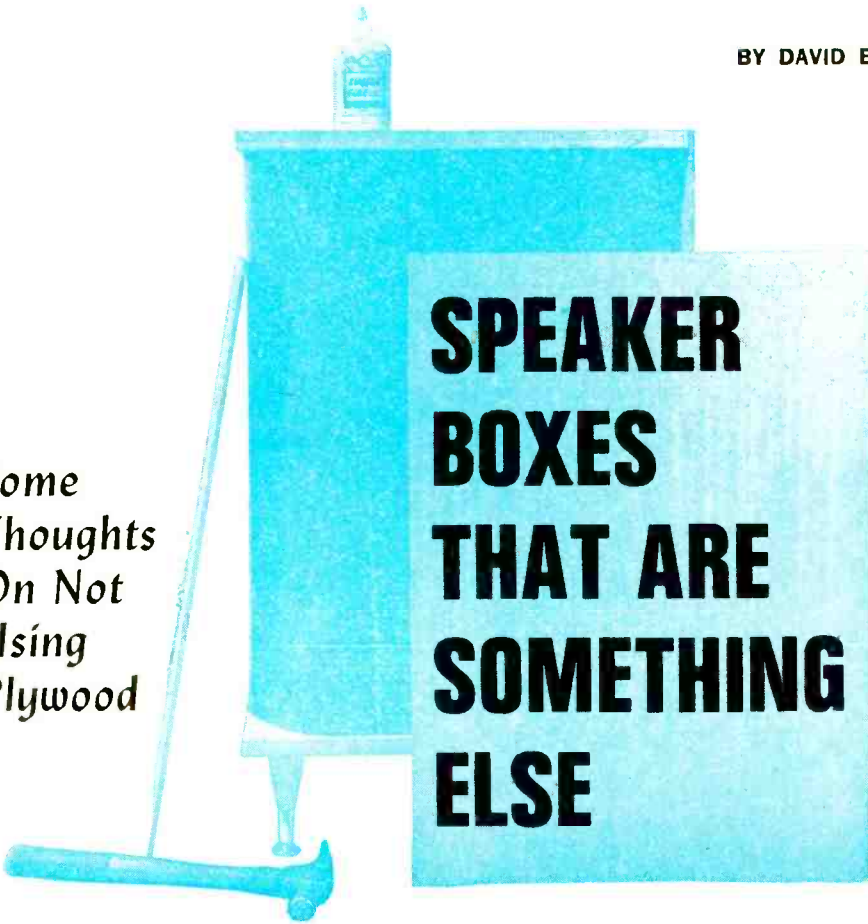

SPEAKER BOXES THAT ARE SOMETHING ELSE

WHETHER by design, accident, or habit, plywood has become the common working material of hi-fi enthusiasts who build their own speaker enclosures. Considering that plywood is stronger than solid lumber of equal thickness and that it is available in large, flat sheets, it is not a bad choice.

Unfortunately, the cost of plywood has skyrocketed over the years—so much so that many hi-fi'ers are beginning to have second thoughts about building their own enclosures. Plywood, however, is not necessarily the only, nor maybe even the best, material for constructing speaker enclosures. There are many other materials that, while not as strong as plywood, have better acoustical damping and resonance characteristics.

If this comes as a surprise, considering that most factory-made enclosures are made of plywood, rest assured that it is an acknowledged truth. Manufacturers

use plywood for two basic reasons. First, labor—not materials—is the greatest expense involved in building an enclosure. Second, some of the substitute materials would not look good in advertising copy. The buying public has come to accept and expect plywood; so plywood enclosures are what they get.

In this article, your attention will be called to some of the better plywood substitutes. Equipped with this information and other pertinent data, you should be able to choose a material that will allow you to cut drastically the cost of your next speaker enclosure project.

Enclosure Basics. The purpose of any speaker enclosure is to isolate the speaker from the room so that sound produced at the rear of the speaker does not interfere with the sound coming from the front. Any material which interrupts the transmission of sound from

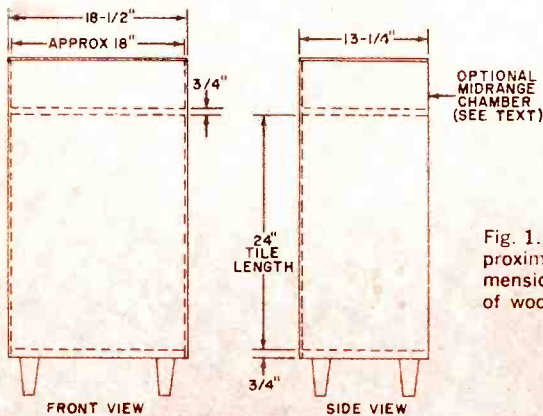
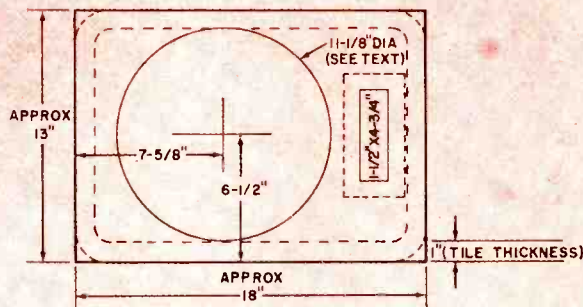

Fig. 1. Dimensions shown are only approximate. They depend on actual dimensions of flue tile and thickness of wood panels used for camouflage.



rear to front will serve the purpose. Only one qualification is necessary to the rule: the material must not vibrate. Vibration of the enclosure walls uses up energy that should go into the production of sound. Worse, it has resonances of its own, resulting in a rough system response curve.

There are actually two resonant characteristics in every enclosure; that of the enclosed air, called "Helmholtz" resonance, and wall resonance. Fortunately, you can avoid the worst effects of each by careful planning of the shape of the enclosure.

On all counts, a cube-shaped box is bad. The path length of sound reflected by opposing walls in such a symmetrical enclosure is the same in all three directions, and five of the six walls have essentially the same resonant frequency. The speaker changes the resonance of the wall on which it is mounted. Five nearly identical walls can add up to some nasty "booming" effects, especially if they are thin and undamped. Consequently, the first rule in enclosure design

is to have a minimum of three different-size walls.

The rectangular box, with its three pairs of different-size walls, is the traditional choice of enclosure builders. Even here, the ideal is to have no two walls with the same resonant frequency. The speaker mounting and its opposing walls present no problems in this area; they naturally have different resonances, although they are identical in outline. All you do is brace *one* wall of each of the remaining two wall pairs to obtain the desired six different resonances.

Another design goal is to make the resonant frequency of the walls as high as possible. In light of the fact that many speaker manufacturers strive to lower the resonance of their speakers, this might at first appear to be a strange approach. There are, however, several good reasons for raising the resonant frequencies of the walls. First, the higher the resonance, the easier it is for the walls to absorb objectionable sound. If the frequency can be raised enough, ordinary acoustical damping material

(such as fiberglass, cotton batting, etc.) in the enclosure will help to cancel resonance effects. Also, there is the bonus that the same methods used to raise the resonance of the walls will increase wall damping.

The resonant frequency of a wall panel is dependent on its size, thickness, stiffness, shape, and (if used) damping material. Consequently, if other factors are equal, a panel of small area has a higher natural resonance than a large panel. This explains why relatively thin materials that are unsuitable for large enclosures can be satisfactory for small enclosures. Thick, stiff walls of unequal length and width tend to have high resonant frequencies, but don't overdo the unequal length and width trick or you will end up with a "pipe" effect, and air column resonance within the enclosure will become a problem. For all practical purposes, the longest internal dimension should be less than three times the shortest dimension.

Substitute Materials. When choosing substitutes for plywood, the denser the better. You have probably seen or heard of excellent speaker enclosures made of concrete, brick, and ceramics. (Aluminum and steel meet the density requirement, but both tend to "ring" and should be avoided.) For example paper is denser than wood. So, you might start with a sheath of paper, a quart of glue, and a

lot of patience and end up with a pretty good enclosure. But there must be a more practical approach.

A common material that has greater density than plywood and which is already being used as a plywood substitute goes under such names as particle board, chip board, etc., implying that it is made of wood chips and sawdust bound into board form with a resin glue binder. The boards are available in different sizes and thicknesses, the most common being 8' x 4' with thicknesses of 1/2", 3/4", and 1". Size for size and thickness for thickness, these boards are considerably less expensive than plywood. Lacking a grain, they are less resonant but less strong than plywood.

Chip board is essentially a semi-finished material. It is cut to size and glued and screwed or nailed together in the same manner as plywood. The only extra step is that it must be finished (painted or covered with a wood-grain plastic veneer or contact material).

The remaining plywood substitutes, with one exception, are laminated materials. If you like the unusual, there are several materials that are more convenient than gluing together sheets of paper. One of these is the corrugated paperboard shipping carton. Of particular value here are the heavy cartons rated as two- and three-ply paperboard that are used to ship large or extra heavy items. A check with your local hardware,

Laminated enclosure walls require wood frame made from pine for support and bracing.

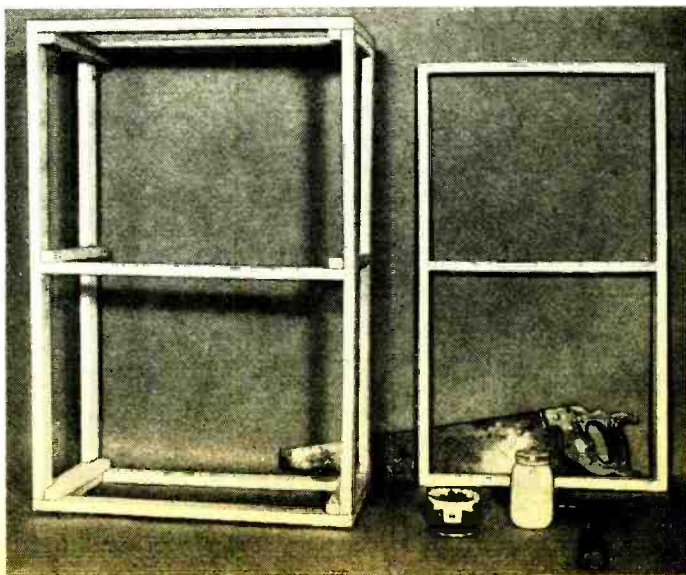

plumbing, or appliance dealer might turn up paperboard of sufficient size that can be laminated to make enclosure walls.

As a point of fact, enclosure walls made of laminated paperboard are roughly comparable in performance to plywood walls of equal thickness. The only problem is that they are more difficult to join at the corners. One method of construction, as shown in the photo on page 47 is to nail and glue the laminated walls to a pine frame. Finishing can be with wallpaper.

Almost any plywood enclosure can be improved by cementing another material, such as celotex or asphalt roofing felt, to the interior walls.

The use of a combination of materials, such as celotex, gypsum wallboard, and thin plywood was discussed in the "Club Sandwich Reflex" speaker system in the November 1962 issue of POPULAR ELECTRONICS. Materials for "sandwich" enclosures need not have great density, particularly if the ratio of stiffness-to-mass is high. One such material is styrofoam. However, it is almost transparent to low frequencies, which defeats the purpose of the enclosure. This also rules out the use of a styrofoam-only enclosure.

G. A. Briggs, the well-known speaker authority with the Wharfedale Wireless Works Ltd., mentions in his "Cabinet Handbook" that he has used a material like styrofoam as a core between $\frac{1}{8}$ "-thick layers of hardboard on one side and plywood on the other side to obtain a very lightweight enclosure that is virtually resonance-free.

Select laminated materials and you can probably duplicate an enclosure at a fraction of the cost of using plywood. Simply follow the published design you want to copy, substituting the laminated material for plywood. Just be sure to plan it so that the interior volume of the enclosure remains the same. This means that if you use a frame for mounting the wall panels, you must compute the cubic displacement of the frame and make suitable adjustments in the sizes of the walls to maintain the design volume.

One remaining plywood substitute worthy of mention is ceramic tile. And in calling out its relative merits, a construction project was devised, the details for which follow.

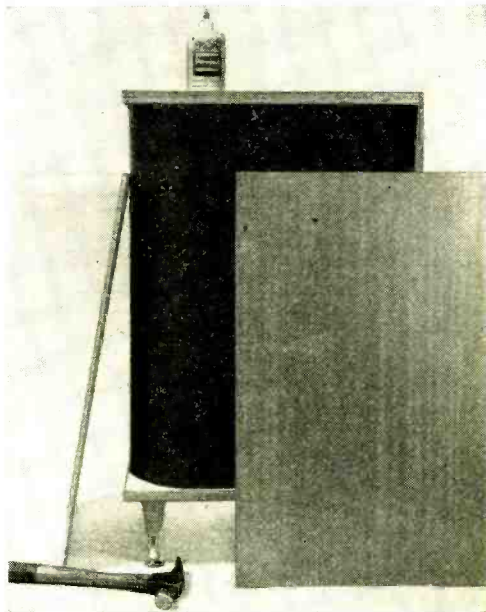

Once plywood end plates are secured to flue tile, glue and nail front and sides to the end plates.

A Flue Tile Speaker System. Several years ago, experimenters in England started putting speakers into lengths of sewer pipe. (An example of such a speaker system was published on these pages under the title "Drain Pipe 8" in June 1962). Although purists criticized these systems because the low frequency radiation was so distinctly separated from the highs and referred to them as "resonant columns," they actually sounded better than they looked.

Another perhaps more practical tile enclosure form is the ceramic flue tile. These tiles are available in various sizes and they are easily adapted to speaker enclosures of usable dimensions, even if the weight of the completed system is a bit unwieldy. Plywood is used in such enclosures very sparingly at the top and bottom open ends of the tile. Further stiffening of the plywood ends can also be obtained by running a threaded rod through the enclosure ends and tightening it down with nuts.

In their freedom from wall vibration, flue tile enclosures are a purist's dream, but they are a decorator's nightmare. One such system, called "Another Ceramic Tile Enclosure (POPULAR ELECTRONICS, April 1963), produced very

good sound but certainly won no awards for appearance.

With a little imagination, you can camouflage the flue tile. The method employed in the project illustrated in Fig. 1 is to extend the plywood plates at the open ends of the tile to a rectangular shape just large enough to accommodate the outer perimeter of the tile. Thin finished wood panels can then be nailed to the plywood ends to hide the flue tile.

You can start construction by cutting two pieces of $\frac{3}{4}$ " plywood to the sizes needed for the end plates. Set one plate aside temporarily, and referring to the bottom drawing in Fig. 1, cut the openings for the port and speaker. (For a 12" woofer, cut an $11\frac{1}{8}$ " opening; for an 8" speaker, cut a 7" opening.) Then prepare two $1\frac{1}{2}$ "-long and two $6\frac{1}{4}$ "-long sides from $1\frac{3}{4}$ " \times $\frac{3}{4}$ " pine for the port. Glue and nail these pieces to the bottom plate over the port opening.

The enclosure is easily assembled with the liberal use of silicone rubber caulking compound. Aside from mechanically joining the two dissimilar materials—wood and ceramic—the caulking compound provides an excellent air seal.

Assembly is best accomplished as follows. First, apply a liberal bead of caulking compound to the lip of the flue tile. Invert the tile onto the blank plywood top plate, and carefully square the two pieces in relation to each other. Allow the compound to set solid as the weight of the tile bears into the silicone rubber.

When the caulking compound has completely set, invert the assembly. Cut a piece of acoustical fiberglass wool to size and cement it to the inner surface of the top plate. Then cement a fiberglass wool liner around the inner surfaces of the tile. This damping material is necessary

to reduce the reflections that would otherwise be caused by the hard, relatively smooth interior surfaces of the tile.

Next, repeating the instructions given above for the top plate, caulk the bottom plate to the open end of the flue tile. After allowing sufficient time for the caulking compound to set, use a sharp knife to pare away any bleed-over silicone rubber that might interfere when the thin wood sides are attached later.

Again invert the assembly, and front-mount the woofer in its cutout as shown in Fig. 2. Bring the speaker cable out through a hole drilled in the bottom plate, and fill the hole with caulking compound.

Now, connect the speaker cable to your amplifier and feed in some music that is heavy on the bass. If the sound is not just right for your taste, drop cut-up pieces of fiberglass wool into the enclosure (through the port) until you are satisfied. Then turn off the music and disconnect the speaker cable.

All that is left to do is camouflage the tile and add a midrange speaker and/or tweeter, if desired. If you plan to incorporate the midrange speaker and/or tweeter, determine how much longer to make the side and front wood panels. Then cut the sides and front to size (the rear of the system does not need a panel, nor should there be a panel at the rear of the midrange speaker/tweeter chamber). Nail and glue the panels to the end pieces of the woofer chamber. Then cut to size and nail and glue a top plate in place.

Finally, wire the midrange speaker and/or tweeter together, and connect a suitable crossover network between the two chambers to make a "system" that can be connected to your amplifier. That's it!

-30-



Fig. 2. Because speaker board is fixed by caulking compound, it is necessary to front-mount woofer. Staple or tack grille cloth over speaker cone to protect it against dust and pets.

What Does An Op Amp Do?

BY JOHN SEGINSKI

THAT versatile building block, the operational amplifier, is the manspring of much of today's most advanced electronic equipment. In computers and automatic control systems, for example, they are indispensable, and they can be made to function in a number of different ways—precision voltage sources, current sources, and voltage adders, to name only a few.

The operational amplifier, or op amp, is an extremely high-gain amplifier with a very high input impedance. The actual gain of a specific circuit is determined by feedback resistors connected around the amplifier. Various characteristics can be achieved by connecting other components and other op amps in the circuit. The numbered sentences and equa-

tions that follow refer to the circuits below. Test your knowledge of op amps by filling in the blanks.

1. $E_{OUT} =$ _____
2. Gain = _____
3. $E_{OUT} =$ _____
4. This is a _____ generator.
5. Gain = _____
6. This is a _____ voltage amplifier.
7. This is an _____.
8. This is a _____.
9. When switches are closed one by one, a _____ is generated.
10. The outputs are _____.

(Answers on page 113)

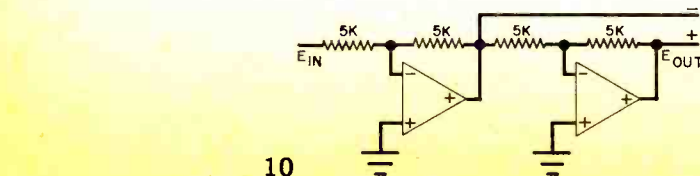
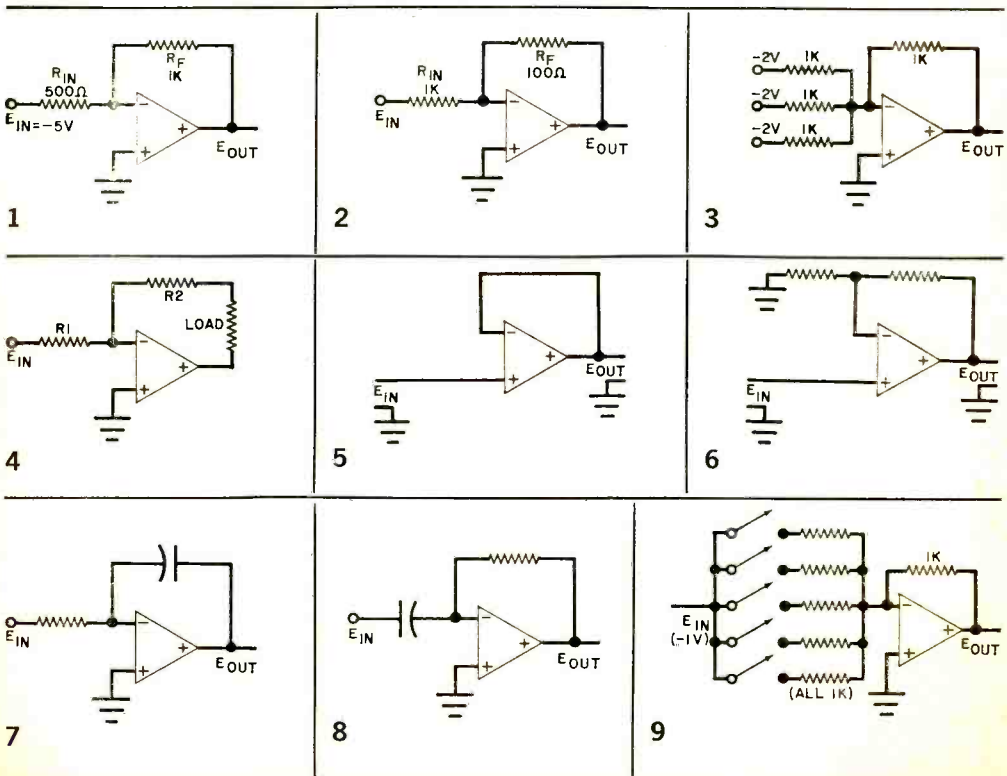

10

Build a DWELL EXTENDER

BY GEORGE MEYERLE

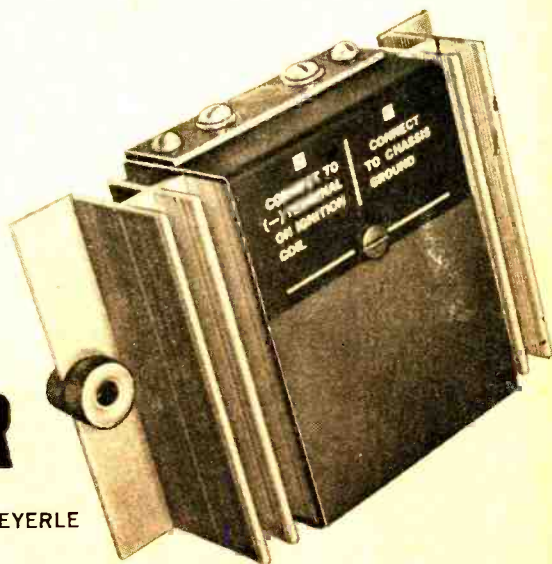

ELECTRONIC ASSIST TO YOUR IGNITION SYSTEM

MANY SCHEMES have been proposed in the last ten years for improving electronically the efficiency of the ignition system of the internal combustion (automobile, boat, etc.) engine. Such proposals, whose basic purpose is to improve overall performance and reduce fuel consumption, are all based on the principle of increasing the spark energy at high engine speeds (see Box). Many of these spark improvement systems have value—whether they are simple switching transistors or elaborate, relatively complex capacitive-discharge circuits. Unfortunately, they also have varying disadvantages of some type.

The "Dwell Extender" described here increases spark energy at high engine speeds by lengthening the dwell time electronically and requires only two connections to the existing system. The patented circuit, shown in Fig. 1, can be used in any car or boat with a negative ground. It can be installed or removed in a matter of minutes and is applicable to any number of cylinders, provided a coil-and-breaker-point system is used. It cannot be used on engines having a magneto ignition or a positive-ground.

What can be expected of this unusual system? Truthfully, not very much if you have a new car that is properly tuned up and if you don't drive at high speeds. However, if your car has a lot of mileage on it and you want additional "zoom" for passing or accelerating on a hill, the Dwell Extender can provide an improvement in your car's performance.

The use of this system in your car will also save you some gasoline due to more efficient burning; and you will find that problems resulting from worn points are reduced since they no longer play such an important part in the ignition system. Spark plugs will last longer too.

Construction. It is important that you use the silicon controlled rectifier (SCR1) called for in the Parts List. It is capable of withstanding the temperature extremes existing near the engine and it can take the reverse voltages that occur when the points open. Similarly, the capacitors must be of the solid tantalum type which can withstand the temperature extremes.

The components are actually mounted

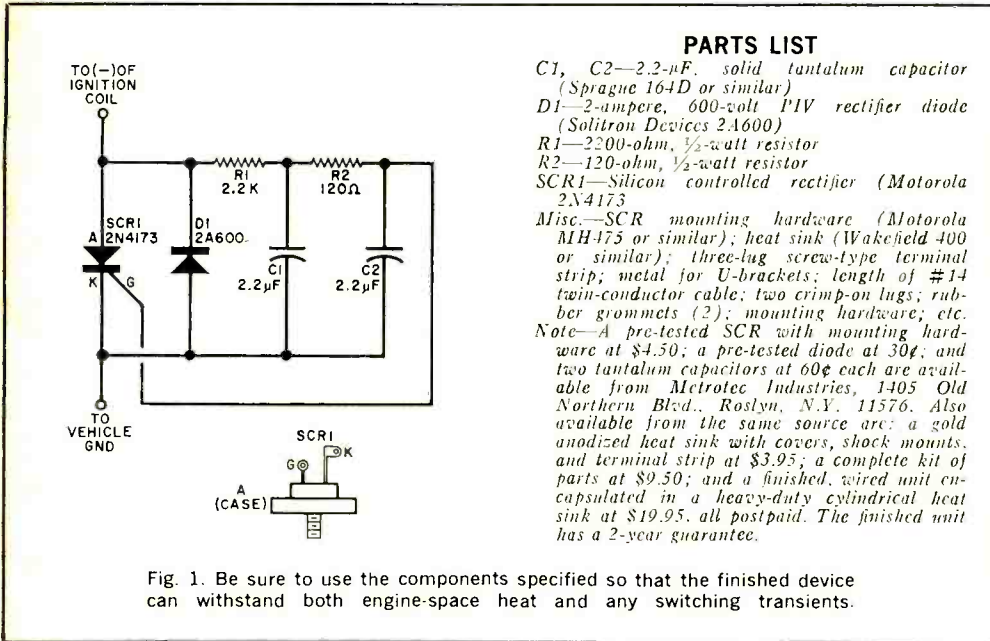

on the heat sink (or similar) prescribed in the Parts List. Drill a hole in the center of the heat sink for SCR1. Mount the SCR with an insulating (mica) washer around the stud on each side of the heat sink and a soldering lug making contact with the case of the SCR on the wiring side of the heat sink. You may also

Fig. 2. Install the SCR so that it is completely insulated from the metal heat sink. Mount a large solder lug between the case and insulator to make the anode contact. All wiring is point to point.

have to use some type of insulating tubing around the stud where it passes through the heat sink to avoid any contact between the two. When you have the SCR mounted, use an ohmmeter to check that there is no contact between the case (anode) of the SCR and the heat sink.

The three-screw terminal is mounted on a U-shaped cover that snaps over the heat sink. Remove center screw and cover the outside hole with a piece of tape. The lug is used as a wiring support only.

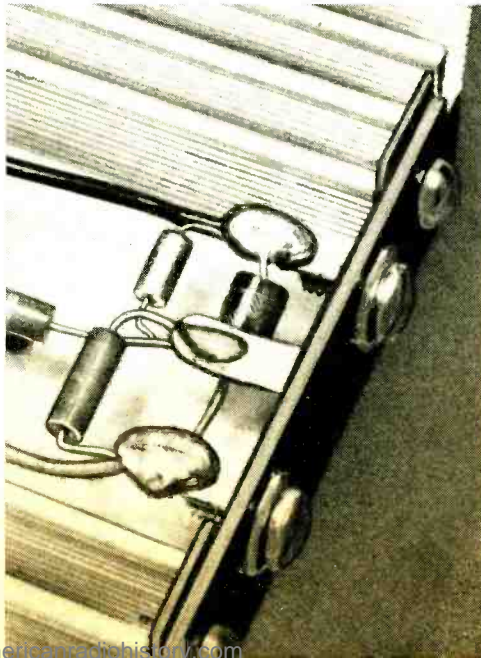
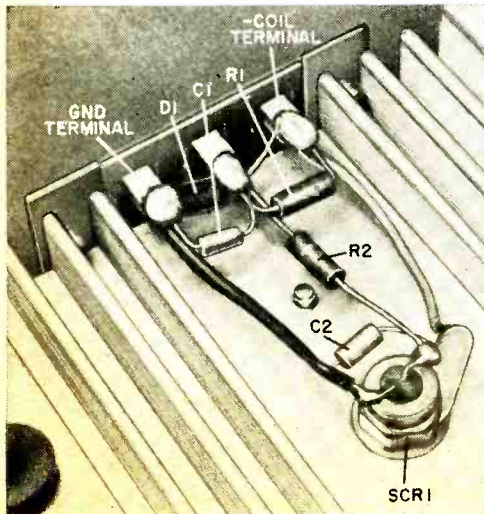

SPARK ENERGY

The efficiency of an internal combustion engine depends, in the final analysis, on the mixture of gasoline and air that is introduced into the cylinder and the successful ignition of that mixture by an electrically induced spark. If we assume that the carburetor is doing its job of providing the proper fuel mixture, then obtaining the right spark energy to fire it is the best way to improve efficiency.

To provide a spark, the majority (about 98%) of conventional engines use the Kettering system, which was developed about 50 years ago (see Fig. A). In this system, battery current is allowed to pass through the primary of an autotransformer (ignition coil) when the break-

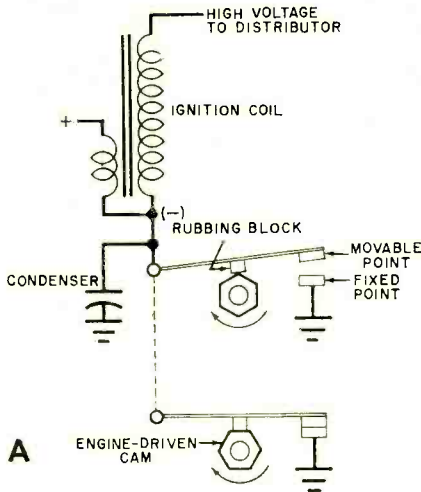

er points are closed. The opening and closing of the points are timed by an engine-driven cam that is designed to open the points whenever a spark is required by a cylinder. When the points are closed, the current flowing through the coil builds up a magnetic field which saturates the coil. When the points open, the current flow stops and the magnetic field collapses. As the field collapses, the magnetic lines of force cut the turns on the other portion of the autotransformer, inducing a very high back e.m.f. This voltage is applied through the distributor to the appropriate cylinder to ignite the gas-air mixture. The time that the points remain closed is called the dwell time and is specified in degrees of dwell for the particular engine.

An ignition system of this type always works (unless something is drastically wrong) but it does have disadvantages, which result primarily in the loss of performance at high engine speeds. This is because, as the engine speeds up, the amount of time that the points remain closed is proportionally reduced. When the engine speed reaches two thousand r/min or more, the points are closed for such a short time that the magnetic field within the ignition coil does not build up to maximum. This results in a much lower "thinner" spark voltage for ignition. As a result the energy in the coil primary drops dramatically as shown in Fig. B. Because the higher engine speeds are used in accelerating and passing, "sluggishness" is noted in many engines when this situation occurs. Since the fuel doesn't burn properly, the condition also wastes gasoline and the spark plugs get fouled up, causing an even further drop in performance.

The purpose of most ignition-improvement systems is to overcome the "droop" in spark energy at high engine speeds.

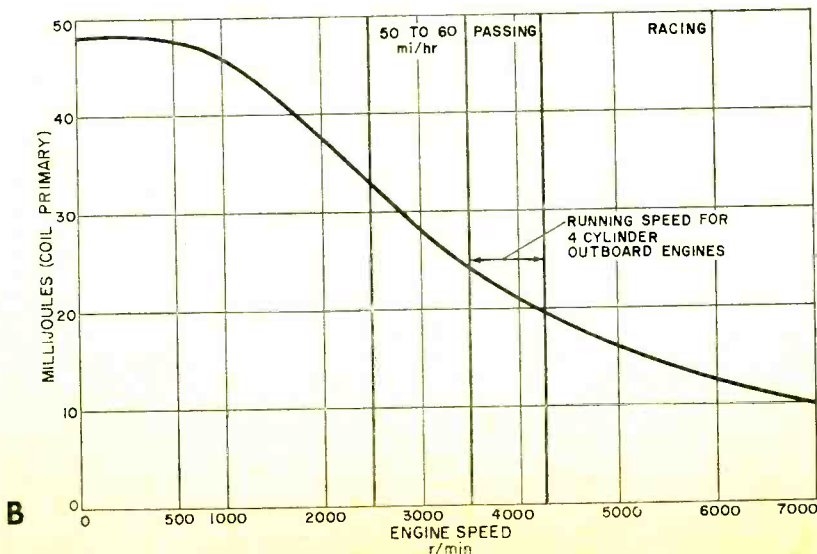

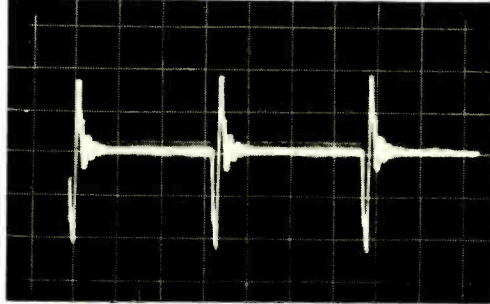
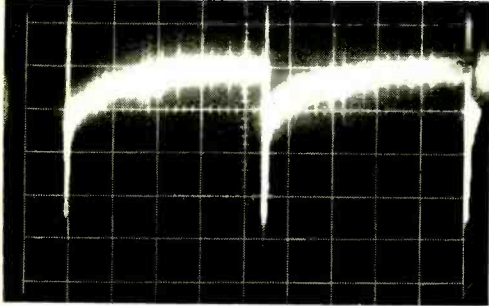
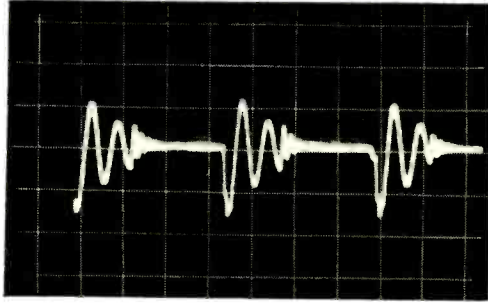
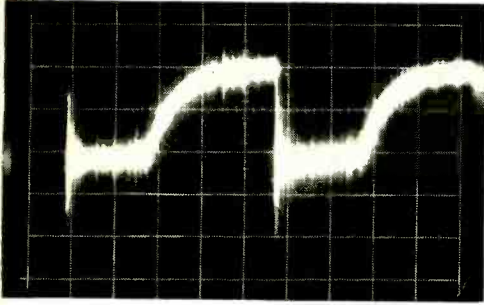

Primary current in the ignition coil without (top) and with (bottom) the Dwell Extender. Calibration is 5 ms per division horizontal, and 2.5 amperes per division vertical. Note the longer time that ignition coil current flows using Dwell Extender.

Secondary voltage of the ignition coil without (top) and with (bottom) the Dwell Extender. Calibration is 1 ms per division horizontal and 10 kV per division vertical. Note the reduced ringing and the higher voltage using the Dwell Extender.

Prepare a U-shaped metal cover to fit over the top of the heat sink and project down over the two sides. Cut out one end of the cover so that a three-lug terminal strip can be mounted on it as shown in Fig. 2. The two outer lugs serve as wiring connections for the internal components and for connection of the external leads. The center lug is used as a standoff insulator for internal wiring which is point-to-point.

Once the circuit is complete, spray the interior with a non-corrosive lacquer to provide protection against moisture. Make another U-shaped cover to fit over the bottom of the heat sink and cover the electronic components.

Drill holes in the ends of the heat sink for mounting and insert rubber grommets in the holes to provide protection against shock and vibration.

Clearly identify the two external connections. Mark them "CHASSIS GROUND" and "(-) TERMINAL OF IGNITION COIL."

Installation. Select a suitable mounting spot for the Dwell Extender—away from the heat of the engine and radiator. The

HOW IT WORKS

When the points are closed, the Dwell Extender is shorted out so that the SCR is non-conducting. During this time, the current through the coil (through the closed points) builds up the magnetic field. When the points open, the back e.m.f. from the collapsing field around the coil creates a voltage high enough to fire the spark plug. However, the instant that the points open, the positive voltage from the battery is applied directly to the anode of the SCR and, through an RC network, to its gate. About 100 microseconds after the points open, the positive pulse reaches the gate, firing the SCR. This closes the points electrically. Shortly afterward, they close mechanically.

The result is that the coil is being charged for almost the entire duty cycle except for the 100 microseconds to allow for spark to occur. The magnetic field built up in the coil is thus stronger and a much larger spark is available at the distributor. In fact, the spark energy is almost doubled at high engine speeds. Diode *D1* bypasses the negative spike that occurs when the points open.

location can be on the sheetmetal wheel covering, the firewall, or even inside the car (or boat). Make sure that rain or snow (or spray if used on a boat) cannot reach the device. A maximum of six feet of wire can be used to connect the circuit to the ignition coil.

(Continued on page 112)

ULD Sine Wave Generator



5 TO 60,000 Hz WITH ULTRA LOW DISTORTION

THERE IS a certain aura of "rightness" about test equipment. Whether we buy a piece of commercial test equipment or assemble a kit, we always assume that the instrument is relatively absolute, that it does what it is supposed to do, and that the readings it provides are correct. We take it for granted that any detectable errors are in the device being tested. It is also customary to assume that a test instrument is more accurate than the device being tested.

Everyone (who has thought about it) knows, of course, that a perfect test instrument doesn't exist and that even very accurate instruments are expensive. However, there is no reason why the electronics experimenter should not use the very best equipment that he can find or build.

In the past, POPULAR ELECTRONICS has presented some remarkably accurate digital test instruments, which, in spite of their relatively low cost, had accuracies that rival those of commercial gear. Described in this article is a low-cost, top-quality ultra-low-distortion audio generator for the serious audio hobbyist

and electronics technician. The specifications shown in the table compare favorably with some of the best available audio generators. (See box on Residual Distortion)

The circuit for the generator is shown in Fig. 1. Like any test instrument, the quality of performance depends on the accuracy of the bridge components (in the lower half of Fig. 1). To provide for ease of dial reading a dual log-taper potentiometer is specified. The bridge capacitors are relatively expensive. The two capacitors with the smaller values (*C10* and *C11*) are polystyrene having tolerances of 0.5%, while the two larger units are metalized Mylar with tolerances of 1%.

The Author

After many years as a professional musician, Jim Bongiorno's interest in basic electronics led him into the field of servicing electronic organs and hi-fi equipment. After working his way up the technical ladder, he is now Chief Engineer, engaged in research and development at Lambert Laboratories, Westfield, N.Y.

The dual log-taper potentiometer (R-26) must track within 1 dB to produce the frequency response and amplitude

stability given in the specifications table. Conventional, over-the-counter dual pots do not track this closely. However, one

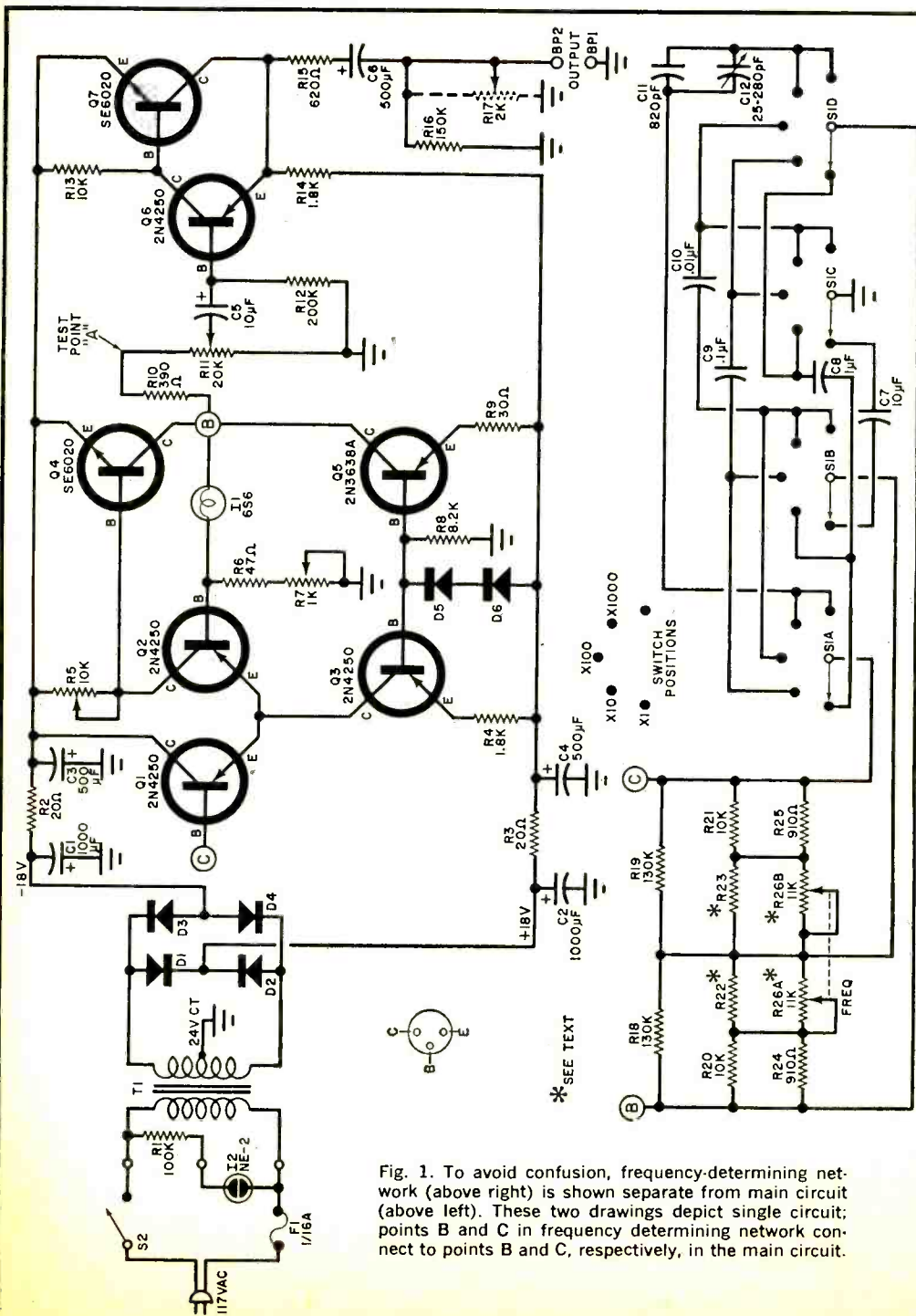

Fig. 1. To avoid confusion, frequency-determining network (above right) is shown separate from main circuit (above left). These two drawings depict single circuit; points B and C in frequency determining network connect to points B and C, respectively, in the main circuit.

is available through the source given in the Parts List. Special close-tolerance capacitors are also available from the same source.

Obviously, if you do not want your generator to have the accuracy shown in the table you can use conventional components with broader tolerances.

PARTS LIST

- BP1, BP2—Five-way binding post, one red, one black*
C1, C2—1000- μ F, 25-volt electrolytic capacitor
C3, C4—500- μ F, 25-volt electrolytic capacitor
C5—10- μ F, 15-volt electrolytic capacitor
C6—500- μ F, 15-volt electrolytic capacitor
*C7—10- μ F, 200-volt, 1% Mylar capacitor**
*C8—1- μ F, 200-volt, 1% Mylar capacitor**
*C9—0.1- μ F, 60-volt, 0.5% polystyrene capacitor**
*C10—0.01- μ F, 60-volt, 0.5% polystyrene capacitor**
C11—820-pF, 60-volt, 5% polystyrene capacitor
C12—25-280-pF trimmer capacitor
D1-D6—100-mA silicon diode (any type)
F1—1/16-ampere fuse and holder
I1—115-volt, 6-watt lamp (GE6S6 or similar)
I2—NE-2 neon lamp
Q1, Q2, Q3, Q6—Transistor (Fairchild 2N4250 or 2N5087)*
Q4, Q7—Transistor (Fairchild SE6020A or RCA 40459)
Q5—Transistor (Fairchild 2N3638A or 2N4354 or RCA 2N4037)
R1—100,000-ohm
R2, R3—20-ohm
R4, R14—1800-ohm
R6—47-ohm
R8—8200-ohm
R9—30-ohm
R10—390-ohm
R12—200,000-ohm
R13—10,000-ohm
R15—620-ohm
R16—150,000-ohm
R18, R19—130,000-ohm, 1%
R20, R21—10,000-ohm, 1%
R22, R23—see text
R24, R25—910-ohm, 1%
R5—10,000-ohm trimmer potentiometer
R7—1000-ohm trimmer potentiometer
R11—20,000-ohm linear taper potentiometer
R17—2000-ohm linear taper potentiometer (optional)
*R26—Dual log potentiometer, 10% (nominally slightly greater than 10,000 ohms)**
S1—4-pole, 5-position rotary switch (Centralab PA1012 or similar)
S2—S.p.s.t. switch
T1—Power transformer; secondary, 24 volts, 0.085 amperes (Stancor P-8394 or similar)

All resistors
 $\frac{1}{2}$ -watt, 5%
 unless noted

Misc.—Heat sink for Q4 and Q5 (Wakefield NF207 or similar); 4" x 5" x 6" steel cabinet; line cord; knobs; frequency dial*; press-on lettering; mounting hardware; etc.

*Etched PC board @ \$4.00, dual potentiometer (R26) @ \$6.25, set of four bridge capacitors @ \$12.00, matched differential pair of 2N4250 @ \$1.25, calibrated dial @ \$6.00, and selected SE6021 @ \$0.75 are available from Lambert Laboratories, 48 Washington St., Westfield, N.Y. 14787. A complete kit of parts is available for \$48.50 from the same source, postage paid.

Construction. The audio generator, including the power supply, is built on a printed circuit board whose actual-size foil pattern is shown in Fig. 2. You can make your own board or buy one as listed in the Parts List. Assemble the components on the board as shown in Fig. 3. Be sure to observe the correct polarities of the electrolytic capacitors and the semiconductors. The arrangement shown in Fig. 3 must be followed to reduce hum to a low level. Place heat sinks on transistors Q4 and Q5.

The prototype generator was constructed in a 6" x 5" x 4" metal enclosure. The front panel was laid out as shown in the photographs. Mount the frequency control potentiometer (dual R26), range switch (S1), level control (R7), output binding posts, power on-off switch (S2), and power-on indicator (I2) on the detachable front panel. Mount the capacitors on the range switch (S1), then wire in the various frequency determining resistors. Make sure that these are wired correctly or Q5 will burn out.

Set R5 (on the PC board) to its approximate center of rotation and temporarily wire the circuit as shown in Fig. 1. Connect a scope to test point "A" and turn the generator on. You should observe a sine wave on the scope. There is a possibility that R7 (on the PC board) may be set for too low a resistance. In this case, adjust R7 through its complete range observing on the scope that the output goes from zero to a clipped sine wave. Set R7 so that a clean sine wave of exactly 5 volts r.m.s. is obtained.

Bridge Component Calibration. As previously stated, the frequency and amplitude accuracies of the generator are only as good as the components. This is particularly true of the decade capacitors associated with S1. You can select these from random capacitors using an accurate RLC bridge to measure the absolute values and, if necessary, paralleling small value capacitors to arrive at a desired value.

The frequency control dual potentiometer (R26) must be calibrated (see below), but first using a very accurate ohmmeter determine its total end-to-end resistance. It should be a little over

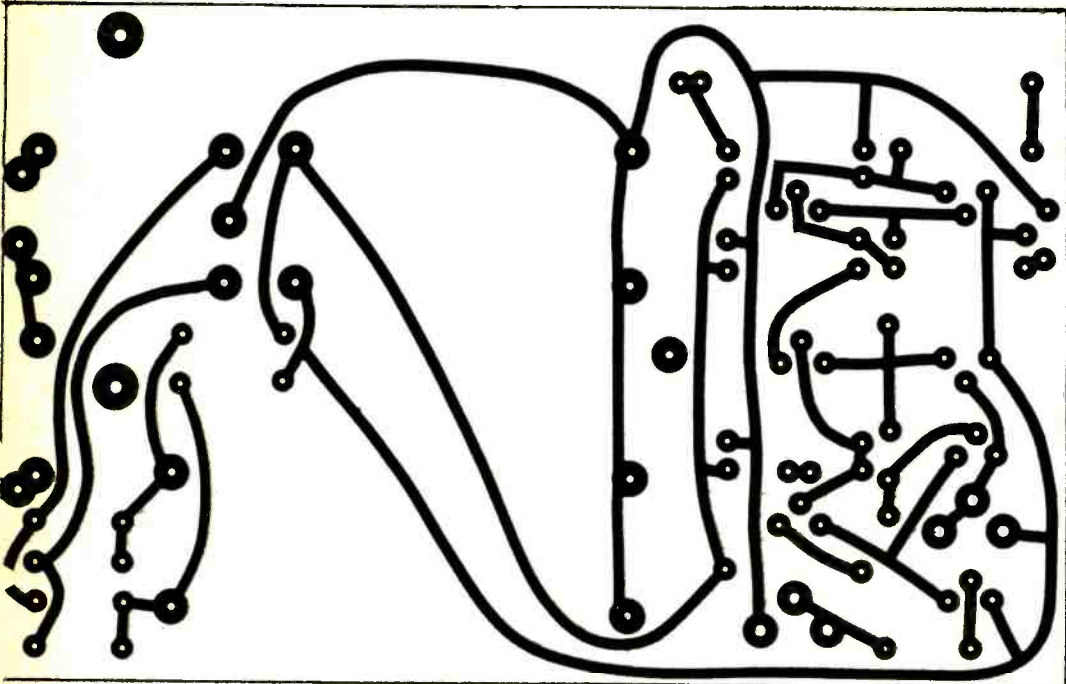

Fig. 2. Printed circuit board speeds assembly. To make your own board, copy actual-size foil pattern.

Fig. 3. Be particularly careful to observe the correct transistor, diode, and capacitor polarities when mounting the parts on the printed circuit board.

10,000 ohms. Connect a larger-value resistor across the potentiometer to bring the total resistance down to exactly 10,000 ohms.

After the potentiometer value has been adjusted, wire it into the circuit and set the range switch (*S1*) to the $\times 1000$ position. Center the rotor of the frequency potentiometer. Adjust output level control *R11* to give a 5-volt r.m.s. output.

If you have access to a distortion analyzer, set the audio generator to the $\times 1000$ position and the frequency potentiometer about one third of the way up (approximately 20 kHz). Connect the generator to the distortion analyzer and allow both to warm up and stabilize. Null the analyzer for a minimum meter indication. Slowly adjust *R5* for a meter minimum. It should be about 0.01%, which is about the residual distortion in most commercial analyzers.

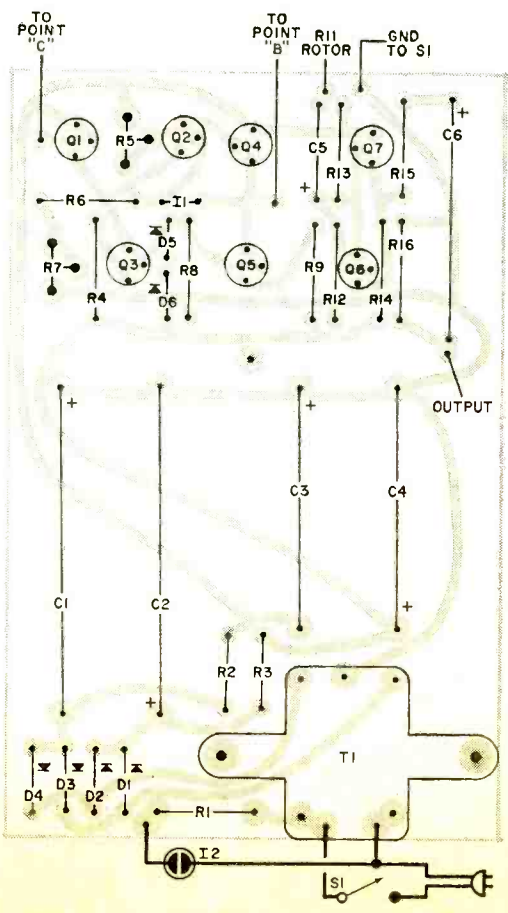

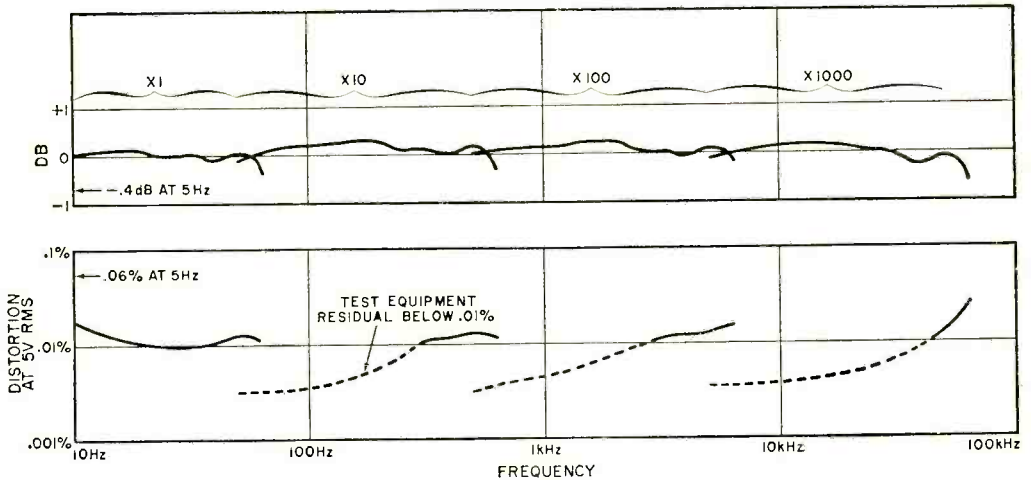

Frequency response (upper) and distortion (lower) curves are typical when close-tolerance components are used in frequency-determining network.

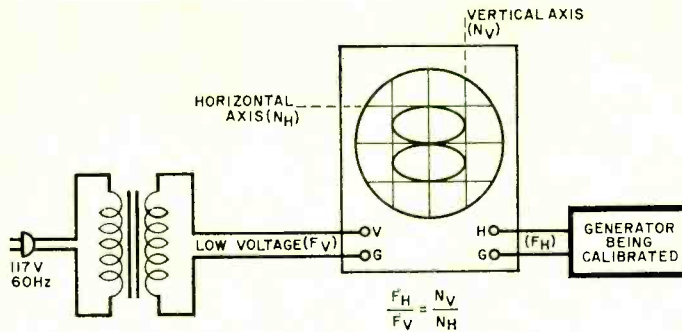

LISSAJOUS PATTERNS

One of the easiest and most accurate methods of determining the frequency of an unknown audio generator is to use an oscilloscope to compare its frequency with that of a known source. The circuit arrangement is shown in the diagram.

The vertical input is taken from the low-voltage secondary of a filament transformer connected to the power line, while the horizontal input is from the audio generator output. This discussion assumes a 60-Hz power line; however, the theory can be used with any other line frequency.

The scope horizontal input should be switched to external input. With the scope and both frequency sources on, adjust the scope controls for an equal vertical and horizontal display. Adjust the controls so that the top of the display just touches one horizontal graticule of the scope screen while the vertical portion of the display just touches a vertical graticule.

Adjust the audio generator frequency control until a circle is formed on the screen. At this point, the audio generator frequency is equal

to the reference frequency. Note that the circle makes one contact with each vertical and horizontal graticule—resulting in a 1:1 ratio.

As the audio generator frequency is reduced, the displayed pattern makes many changes, and at certain points, the pattern becomes stationary. These stationary patterns occur at various reference-to-unknown frequency relationships. By counting the number of horizontal and vertical points of contact during stable pattern intervals the unknown frequency can be determined. Thus, if F_H is the reference frequency, F_V the unknown frequency, N_V the number of contacts on the vertical axis, and N_H the number of contacts on the horizontal axis, then

$$F_H/F_V = N_V/N_H$$

Thus the dial of the generator can be calibrated.

For example, assume one contact on the horizontal axis and three contacts on the vertical. Then, $60/x = 3/1$. So $3x = 60$ and $x = 20$ Hz. Again, assume two contacts on the horizontal axis and three on the vertical. Then $60/x = 3/2$; $3x = 120$; and $x = 40$ Hz.

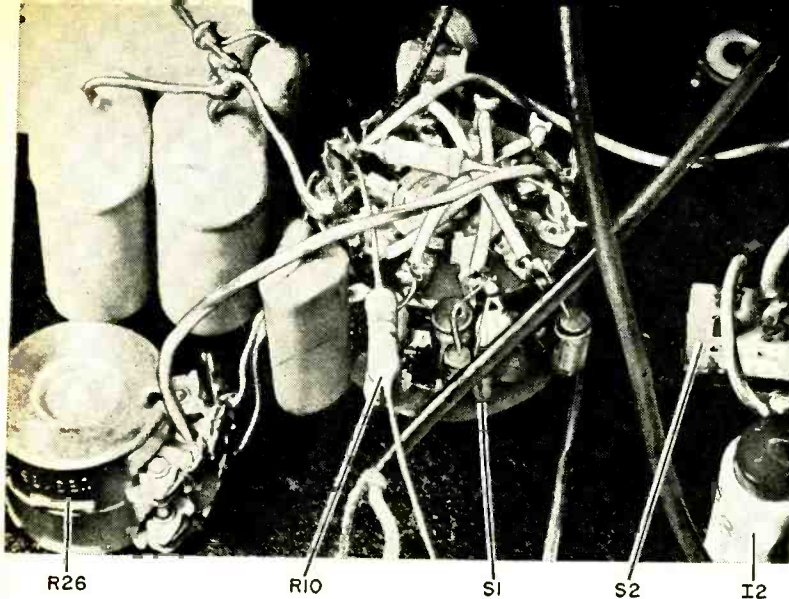

Take your time when wiring range select-or switch S1 (shown at center) to avoid making costly error. If the frequency determining components are not wired in just right, transistor Q5 might burn up.

RESIDUAL DISTORTION

The expression "less than 0.1% distortion" is quite popular with hi-fi manufacturers in describing their products. Sometimes it is desirable to know how much less than 0.1% and what type of distortion is referred to. The residual distortion of this audio generator is less than 0.02% across the audio range; and if you take the time and trouble to trim up certain components, the distortion factor can be reduced to about 0.005% and it will be mostly second and third harmonics.

HOW IT WORKS

The system can be considered to be an operational d.c. amplifier with very high open-loop gain. Transistors Q1 and Q2 form a differential input pair using Q3 as a constant-current source. Transistor Q4 is the output driver, while Q5 acts as a constant current load for Q4. This approach was used instead of a resistor to reduce the distortion and produce a higher output swing. Bias for the two constant-current stages (Q3 and Q5) is provided by diodes D5 and D6. The use of a differential amplifier eliminates the need for a highly regulated power supply since the amplifier requires only a simple positive and negative supply to ground.

The bridged-T network (dashed line box in schematic) is connected in the negative feedback loop while a conventional low-watt incandescent lamp (I1) is used in the positive feedback loop. This makes the range switching arrangement a little unusual, but it saves the cost of three expensive 1% capacitors. However, each range capacitor must be an exact decade multiple for greatest dial accuracy and amplitude linearity.

The bridged-T configuration was selected because it gives better overall performance when compared to the commonly used Wein bridge. Both noise and distortion are reduced. Because this bridge has zero phase shift at only one frequency, the oscillator has an output only at this frequency. Since the bridged-T is a minimum-

transmission network, it must be inserted in the negative feedback loop of the amplifier. The Wein bridge, on the other hand, is a maximum-transmission network and must be used in the positive feedback loop. Since there is a loss of $\frac{2}{3}$ in a Wein bridge, the negative feedback loop would have to have a gain of three to make up for the loss. Because the negative feedback loop (in this case) is not frequency sensitive, the amplifier gain at all frequencies can never be less than three. In the bridged-T approach, however, the negative feedback loop contains the frequency-selective network which has a loss of $\frac{2}{3}$ at one frequency and no loss at other frequencies. This means that an amplifier with unity gain can be used with more feedback.

A conventional low-power incandescent lamp (I1) is used to control the positive feedback. When such a lamp is operated at low power levels, it has a very nonlinear response—a necessity in this circuit.

Since the oscillator portion is d.c. coupled, there are no low-frequency time constants or roll-offs other than the lamp characteristic. This assures a positive start when power is applied.

The output of the oscillator is coupled to a super emitter follower (Q6 and Q7) that is used to isolate the oscillator from loading. The output can drive loads down to 100 ohms with very little increase in distortion.

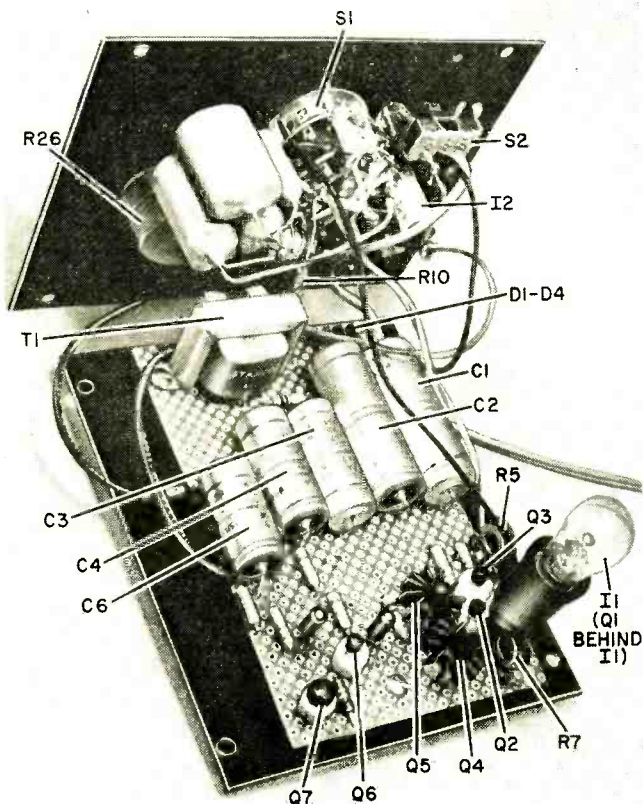

Interconnections between components mounted on front panel and rear panel mounted circuit board should be long enough to permit either panel to be lifted clear of case mounting lip by at least 2" when other panel is in place. Perf board is in prototype rather than PC type.

AUDIO GENERATOR SPECIFICATIONS

- Frequency range:** 5 Hz to 60 kHz in four decade ranges.
- Frequency response:** ± 0.5 dB, 7.5 Hz to 60 kHz; -0.4 dB at 5 Hz.
- Distortion:** Less than 0.02% maximum between 15 Hz and 50 kHz rising to 0.035% at 60 kHz and 0.06% at 5 Hz.
- Amplitude stability:** Practically unmeasurable over short term.
- Frequency stability:** Better than 0.05% (short term).
- Output level:** 5 volts r.m.s. open circuit; 2.5 volts r.m.s. into 600 ohms.
- Total hum and noise:** Better than -100 dB below 5 volts r.m.s.; better than -100 dB at any setting when using optional 2000-ohm output control.



Calibration markings on sweep-frequency control dial (left in above photo) are obtained by interpreting Lissajous patterns produced by 60-Hz line and oscillator output frequencies fed into an oscilloscope.

Frequency Dial Calibration. Once the dial has been mounted on the frequency potentiometer, mark the two extremes of rotation. With the audio generator coupled to the vertical input of an oscilloscope, connect a low-voltage, 60-Hz source to the horizontal input. (This voltage can be obtained from any low-voltage filament transformer). Place the generator range switch on the $\times 1$ position and use Lissajous patterns to calibrate the dial at 60, 30, 20, 15, 12, 10, 7.5, 6, and 5. (see Box on Lissajous Patterns)

If you have a power supply that has 120-Hz ripple, use this ripple as the horizontal input and you can get the 40 indicator. Of course, if you have a first class audio generator at hand, calibration is much easier—simply tune for circles on the CRT. Any type of press-on lettering can be used for both the frequency dial and the other front-panel identification.

We pack your electronics course with kits to make your training fast. You'll enjoy every minute of it.

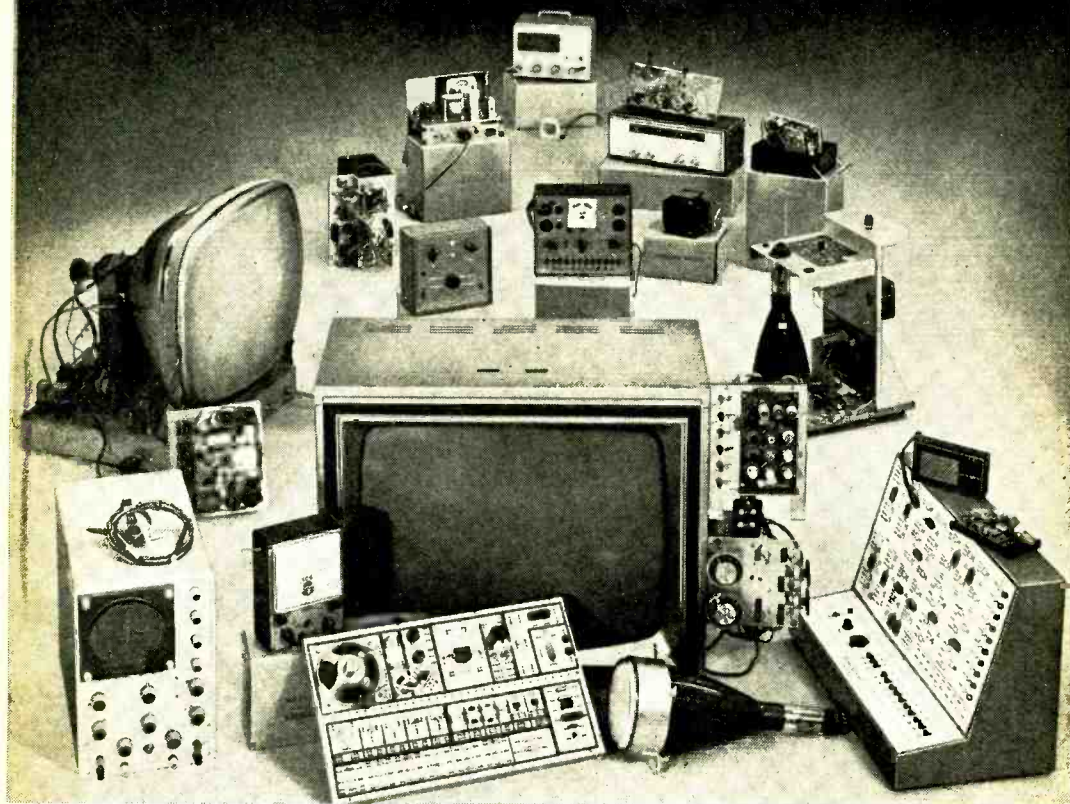

Your NTS success package

Choose a career in electronics: Computers. Color TV Servicing. Automation. Communications. Whatever the field, NTS has a complete home-study package to get you to the top *faster*. 10 thorough training courses. Each includes *everything* to give you the *working* knowledge required of successful technicians.

NTS Project-Method Training is the practical way to learn elec-

tronics. It's a proven combination of lessons and the best professional kit equipment available. NTS provides the *biggest selection of kits ever offered in home-study . . . all at no extra cost*. You'll construct these exciting kits to fully understand electronic circuits, components, and concepts. Our Project-Method lets you build skills by putting theory into practice . . . by working with your hands, as well as your head.

The NTS "learn and practice" approach makes training at home really easy. All it takes is a few hours a week . . . whether you're starting from scratch or in advanced courses. This is the all-inclusive success package that put thousands of men into the best paying jobs . . . or into their own business. If "just a living" isn't good enough for you, now is the time to get something better going for you!

NTS COMPUTER ELECTRONICS

This is the future. And it's happening now. The number of computers will *increase many times* in the next few years.

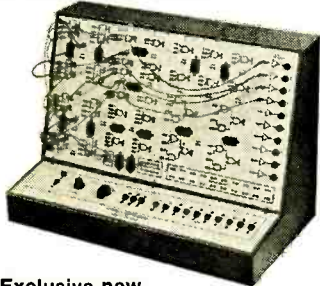

Exclusive new Compu-Trainer®

NTS offers a solid grounding in computer operation, wiring, data processing and programming. One of the 10 important kits included is our exclusive Compu-Trainer®. It's a fully operational computer logic trainer — loaded with integrated circuits — the first ever offered in home study. It introduces you quickly to how, what, when and why of computers . . . from theory to practical servicing techniques. This unit is capable of performing 50,000 operations per second. And it's sent at no extra cost.

NTS COLOR TV SERVICING

This is a broad, easily understood

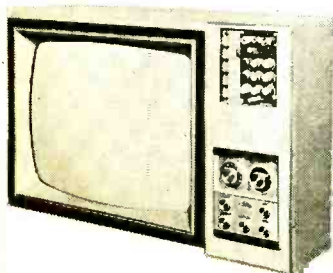

COLOR TV 295 SQ. IN. PICTURE

program designed to make you a complete home-entertainment service technician. Included, at no extra cost, is a color TV that has more features than any

set on the market. You also learn all about stereo, hi-fi, multiplex systems, and become a specialist in Color TV Servicing. Kits also include AM-SW radio, solid-state radio, field-effect transistor volt-ohmmeter, electronic tube tester.

NTS AUTOMATION/ INDUSTRIAL ELECTRONICS

You're trained in the "push-button" electronics that keep industry going and growing . . . from relay type controls to highly advanced systems essential to production. You receive 16 kits including a 5" wide band oscilloscope, and the new NTS electronics lab: a fascinating NTS exclusive experimental laboratory. A complete workshop which makes you familiar with solid-state, miniature, and integrated circuits.

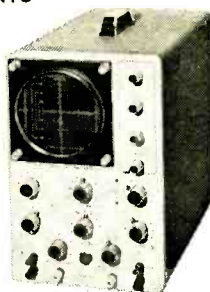

5"
Oscilloscope

NTS ELECTRONIC COMMUNICATIONS

The use of 2-way radio systems in private and commercial applications is skyrocketing. NTS prepares you for the big-money opportunities in the field of transmitting and receiving equipment. *Your tuition will be refunded in full if you cannot pass the FCC exam for a 1st Class Commercial Radio-Telephone License within*

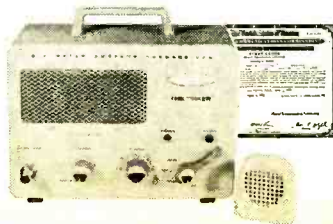

5 Watt AM Transmitter & Receiver

six months after successfully completing this course. You build valuable kits including Amateur-Phone 6 Meter VHF Transceiver, solid-state Radio, and a field-effect transistor volt-ohmmeter.

CLASSROOM TRAINING AT LOS ANGELES

You can take classroom training at Los Angeles in sunny Southern California. NTS occupies a city block with over a million dollars in facilities devoted exclusively to technical training. Check box in coupon.

NATIONAL TECHNICAL SCHOOLS

World-Wide Training Since 1905

4000 South Figueroa Street
Los Angeles, Calif. 90037, U.S.A.

APPROVED FOR VETERANS

Accredited Member: National Association of Trade and Technical Schools, National Home Study Council.

**TODAY, MAIL
COUPON
FOR FREE
COLOR
CATALOG
AND SAMPLE
LESSON.**

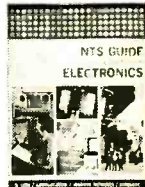

NATIONAL TECHNICAL SCHOOLS
4000 S. Figueroa St., Los Angeles, Calif. 90037

Please rush Free Color Catalog and Sample Lesson, plus information on field checked below. No obligation. No salesman will call.

- MASTER COURSE IN COLOR TV SERVICING
- COLOR TV SERVICING
- MASTER COURSE IN TV & RADIO SERVICING
- PRACTICAL TV & RADIO SERVICING
- MASTER COURSE IN ELECTRONIC COMMUNICATIONS
- FCC LICENSE COURSE
- MASTER COURSE IN ELECTRONICS TECHNOLOGY
- INDUSTRIAL AND AUTOMATION ELECTRONICS
- COMPUTER ELECTRONICS
- BASIC ELECTRONICS

Name _____ Age _____

Address _____

City _____ State _____ Zip _____

- Check if interested in Veteran Training under new G.I. Bill.
- Check if interested ONLY in Classroom Training at Los Angeles. Dept. 205-109



Build a CAPACITANCE METER

CHECK YOUR JUNK-BOX CAPACITORS

BY STANLEY SULA

THE electronics experimenter is notorious for collecting parts from almost every source imaginable, including war surplus bargains and items cannibalized from defunct electronic gear. Among the odds and ends collected is usually a considerable number of capacitors of intermediate values and doubtful "goodness." Many reasonably accurate capacitance measuring instruments are available for checking these items, but most are too expensive for once-in-a-while use. However, for an investment of about \$15 for parts, you can build a capacitance meter that measures capacitance values between a few picofarads and 0.1 microfarad. This range covers most small tubular and virtually all disc, mica, and variable capacitor values—the major types that are used in circuits.

The heart of the capacitance meter is a stepped-frequency multivibrator circuit. The output of the circuit is coupled through the capacitor under test to a sensitive metering circuit. The deflection of the meter pointer provides a direct readout of the capacitor value, interpreted according to the position of the range switch. Zener diode regulation insures stability throughout the entire life of the built-in battery supply.

Construction. Parts layout is not critical. However, for compactness and ease of assembly, it is suggested that you follow the layout illustrated in this article. The circuit was assembled on a 5" × 2 $\frac{3}{4}$ " perforated board which was then mounted inside a standard 5 $\frac{1}{4}$ " × 3" × 2" aluminum chassis box. The cover of the box

accommodates all of the components that are not directly mounted on the circuit board.

Begin construction by machining the top half of the box as shown in Fig. 2 to provide mounting holes for the meter, jacks, and power and range switches. Temporarily set the box aside.

Next, mount the individual components on the board, using "flea" clips where necessary, as shown in Fig. 3. You can begin by mounting the battery clip. Then mount the miniature potentiometers, bending the tabs to fit the holes in the board. Finish up by mounting the transistors and diodes, capacitors, and resistors in that order. When all components are mounted in place, double check your wiring, paying particular attention to diode and transistor polarity and to the absence of accidental short circuits where wires cross; then solder all connections.

Buy or fashion two L-brackets from $\frac{3}{4}$ " \times $\frac{1}{4}$ " \times 18-22 gauge aluminum or brass stock as follows: Bend the two strips at the center to form $\frac{3}{4}$ "-long legs at right angles to each other. Drill a hole through the center of each leg of each L-bracket. Now mount the brackets on alternate corners of the circuit board with #6 hardware.

Referring to Fig. 4, orient the top of the chassis box as shown. Mount the parts in their respective cutouts, and wire D1 into place. Set the circuit board beside the box top, and connect and solder insulated hookup wire from the junctions indicated by two component numbers (C4/R6, etc.) to "flea" clips along the bottom edge of the board. Then complete the wiring, checking your work frequently with Fig. 1.

Fold the circuit board into the top of the box (as shown in Fig. 3), and mark off the mounting holes for the L-brackets

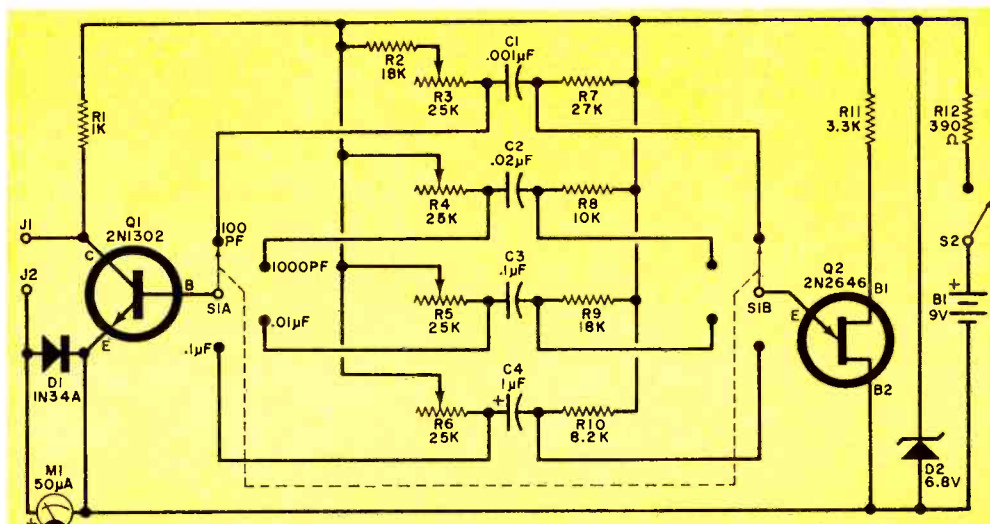

Fig. 1. Circuit consists of a basic multivibrator; for each of the four ranges, a different frequency-determining network can be switched in as required.

PARTS LIST

B1—9-volt transistor battery
 C1—0.001- μ F, 25-volt Mylar capacitor
 C2—0.02- μ F, 25-volt Mylar capacitor
 C3—0.1- μ F, 25-volt Mylar capacitor
 C4—1- μ F, 15-volt electrolytic capacitor
 D1—1N34A diode
 D2—6.8-volt, $\frac{1}{2}$ -watt zener diode
 J1, J2—Banana jack (or substitute five-way binding post)
 M1—0.50 μ A microammeter
 Q1—2N1302 transistor
 Q2—2N2646 unijunction transistor

R1—1000-ohm
 R2, R9—18,000-ohm
 R7—27,000-ohm
 R8—10,000-ohm
 R10—8200-ohm
 R11—3300-ohm
 R12—390-ohm
 R3, R4, R5, R6—25,000-ohm miniature potentiometer (Mullory No. MTC253L4 or similar)
 S1—Four-position, two-pole rotary switch
 S2—S.p.s.t. slide (or toggle) switch
 1— $5\frac{1}{4}$ " \times 3" \times 2" aluminum utility box
 Misc.—Perforated phenolic board; "flea" clips; battery holder; banana plugs (2); 1 brackets; control knob; calibration capacitors (see text); hookup wire; solder; hardware; etc.

All resistors
 $\frac{1}{2}$ -watt, 10%

on the sides of the box. Make sure that there is adequate clearance between the circuit board and box-mounted components and the circuit board and rear section of the box. When satisfied, drill the holes for and mount the circuit board L-brackets to the box with #6 hardware.

Calibration and Use. The simplest method of calibrating the capacitance meter is to use four high-tolerance, good-quality capacitors as "standards." The tighter the tolerance of these standard capacitors, the more accurate will be the calibration of the instrument. Select one capacitance value for each of the four ranges available with the meter. These capacitors should be 100-pF, 1000-pF, 0.01- μ F, and 0.1- μ F values to provide full-scale deflection of the meter pointer when each range is accurately calibrated.

Set the range switch to 100PF, and connect the 100-pF standard capacitor to *J1* and *J2*. Do not use test leads on this range; even the relatively small capacitance of the two leads can be enough to add as much as 20 pF to the true value of the capacitor. (This drawback can be put to good advantage in measuring the capacitance of coaxial cables, test leads,

ABOUT THE CIRCUIT

The operation of the Capacitance Meter (shown schematically in Fig. 1) is based on the principle that the maximum amount of a.c. current passed by a given capacitor is directly proportional to the capacitance value. In the case of the Capacitance Meter described in this article, the a.c. applied to the capacitor under test is in the form of a square wave provided by the *Q1-Q2* multivibrator circuit.

The output of the multivibrator is taken from the collector of *Q1*. From here it is passed through the capacitor under test (connected between *J1* and *J2*) and meter *M1* to the negative circuit buss. The meter, in turn, measures and indicates the maximum amount of a.c. current passed by the test capacitor, converting the current reading directly to a reading on its reworked scale.

Since the different ranges are all multiples of ten, range switching via *S1* is accomplished by changing the operating frequency of the multivibrator. Switch *S1* simply switches in and out of the circuit various combinations of resistors and capacitors.

etc.). Switch on the power and adjust the setting of *R3* (see Fig. 3) for a full-scale deflection of the meter pointer.

Repeat the above calibration procedure for the remaining ranges and their appropriate standard capacitors. Adjust *R4* for the "1000 PF" range, *R5* for the ".01 MF" range, and *R6* for the ".1 MF" range.

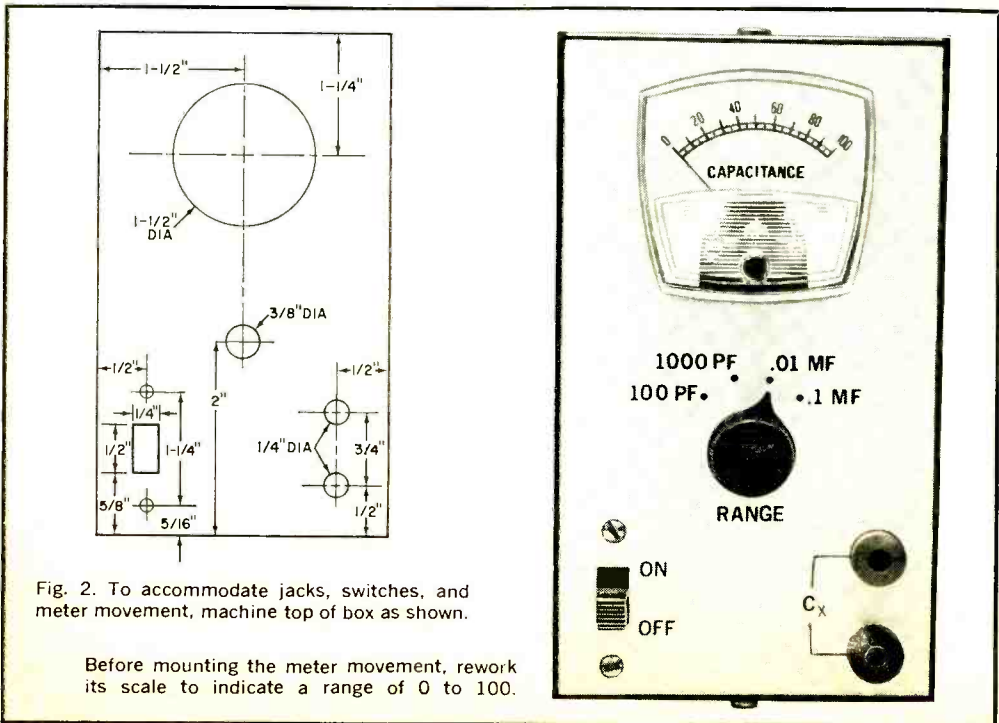

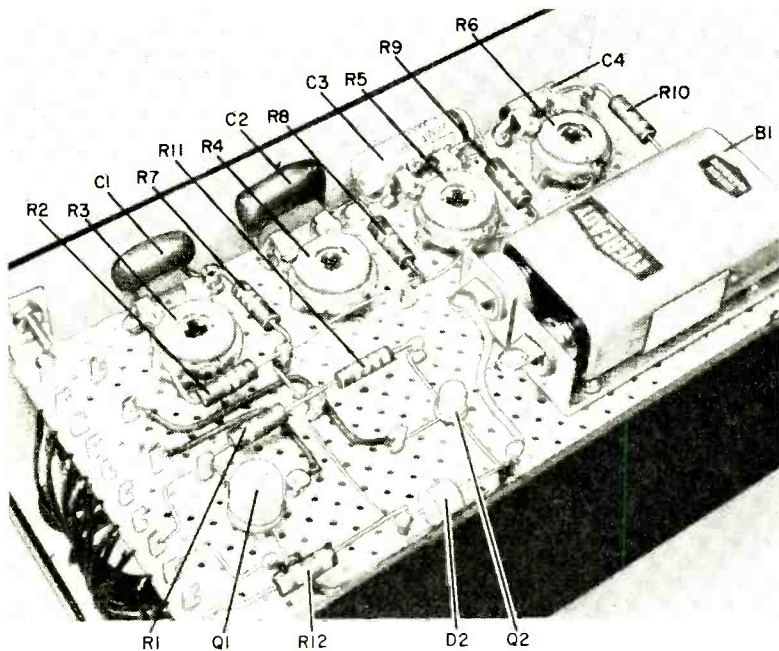

Fig. 3. To speed assembly time and keep project neat, use flea clips for component mounting. Note also common buss wire soldered to the cases of potentiometers.

In all cases, the calibration controls must be set to provide full-scale pointer deflection when the appropriate capacitor and range are used. Failure to obtain full-scale deflections means that you will have to experiment with the value of *R7*, *R8*, *R9*, or *R10*—depending on the range affected.

Avoid touching the exposed leads of the calibration capacitors and capacitors under test as your body capacitance is sure to produce a measuring error—especially noticeable on the lower ranges of the capacitance meter. Also, never attempt to check a capacitor while it is
(Continued on page 110)

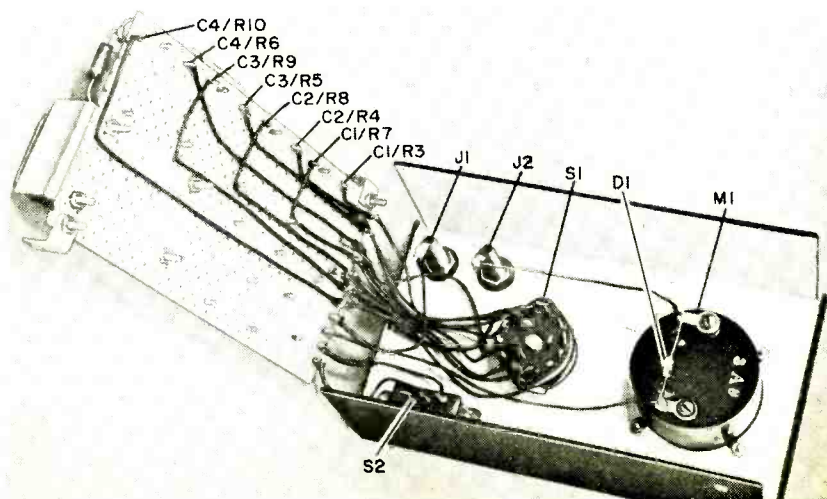
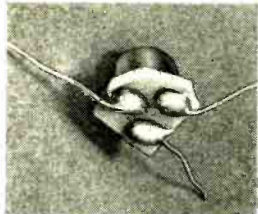

Fig. 4. To simplify wiring on bottom of board, connections labelled with two numbers designate component junctions to be located by observing the component side of board.

tips & techniques

SALVAGE TRANSISTORS SAFELY FROM COMPUTER CIRCUIT BOARDS

Computer circuit boards sold by many surplus parts dealers, although an excellent source of high-quality components, have one great failing—all components have very short leads. Worst of all are the transistors on such boards. Conventional desoldering practices for salvaging these solid-state devices leaves you with a transistor with mini-leads that are no good for breadboarding. Since it is definitely not good practice to solder lead extensions directly to the remaining lead stubs of the transistor (the applied heat will almost certainly damage the transistor), the only worthwhile alternative is to use a nibbling tool to cut away the board around the transistor. Then you can solder lead extensions to the solder pads on the underside as shown. —*Andy Rosen*



ELIMINATE LEAD BREAKAGE IN POTTED ELECTRONIC MODULES

One of the more common hazards associated with using electronic modules is the tendency for the leads to break off, rendering the module useless. However, if you mount the module on a scrap piece of printed circuit board that has been etched and drilled to accommodate it, you can eliminate the problem. If possible, make the board slightly larger than the base of the module so that it can accommodate such outboard components as suggested by the manufacturer (see photo). Then, after all leads are soldered in place, apply a bead of epoxy cement around the entire base of the module where it touches the circuit board. —*A.G. Wood*

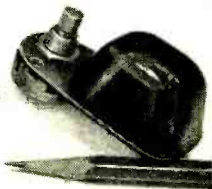

HOMEBREW TRANSISTOR AND IC DESOLDERING TIPS

Successful removal of transistors and IC's from printed circuit boards requires melting the solder pads of all leads simultaneously.

Besides the commercially available tips for this purpose, any standard 10-24 screw can be used with the Type 4045 Ungar high-heat cartridge. A 10-24 screw with a $\frac{7}{16}$ "-diameter flat head is ideal for removing transistors and IC's in TO-5 cases; a smaller diameter head, or one of the $\frac{7}{16}$ " heads filed to a $\frac{1}{8}$ " \times $\frac{3}{8}$ " rectangle, is better for plastic in-line integrated circuits. A bit of Ungar anti-sieze compound rubbed into the threads of the screw before each use keeps the do-it-yourself desoldering tips easy to interchange. —*John Brosemer*



PAPER BAG RETRIEVES "LOST" KIT PARTS

Since most electronic kits consist mainly of small parts and components, it is easy to lose one or more items during unpacking. However, you won't accidentally throw away any small parts with the packing material or during construction if you tape a large brown paper bag to the end of your workbench with top even with edge. Now, as you unpack and build your kit, toss the packing materials into the bag. Keep the bag taped to the end of your workbench until the kit is completely built. (If it is an extra-large kit with a lot of packing material, use two or more paper bags.) If you come up a part or more short, 99 times out of a hundred, you will find them in the waste bag. —*Stephen E. Maziarz*

MAKE HANDY SOLDERING AID FROM DEFUNCT BALL POINT PEN CASE

A handy soldering aid for printed circuit work can be fashioned from one of those old ball-point pen cartridges you normally throw out, some solder, and a cotton swab. First, remove and discard the cartridge; then cut off or ream out the top of the pen case to accept a single-layer coil of solder wound on the stick

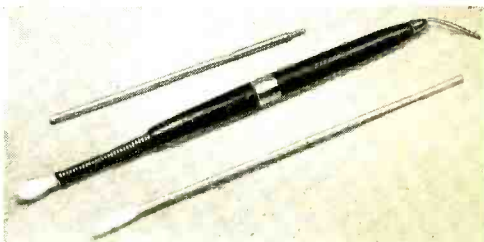

of a swab. About a 5' length of solder closely wound on the swab supplies a full load. Feed the free end of the solder from the end opposite the swab through the tip opening in the pen case. Now you are prepared to go to work. Hold the soldering iron or gun in one hand and the soldering aid in the other hand. Dip the cotton swab into water. Solder a connection. Then touch the soldered joint with the wet swab for fast cooling. As the solder gets used up, simply pull on it and continue soldering. —*L.B. Frisch*

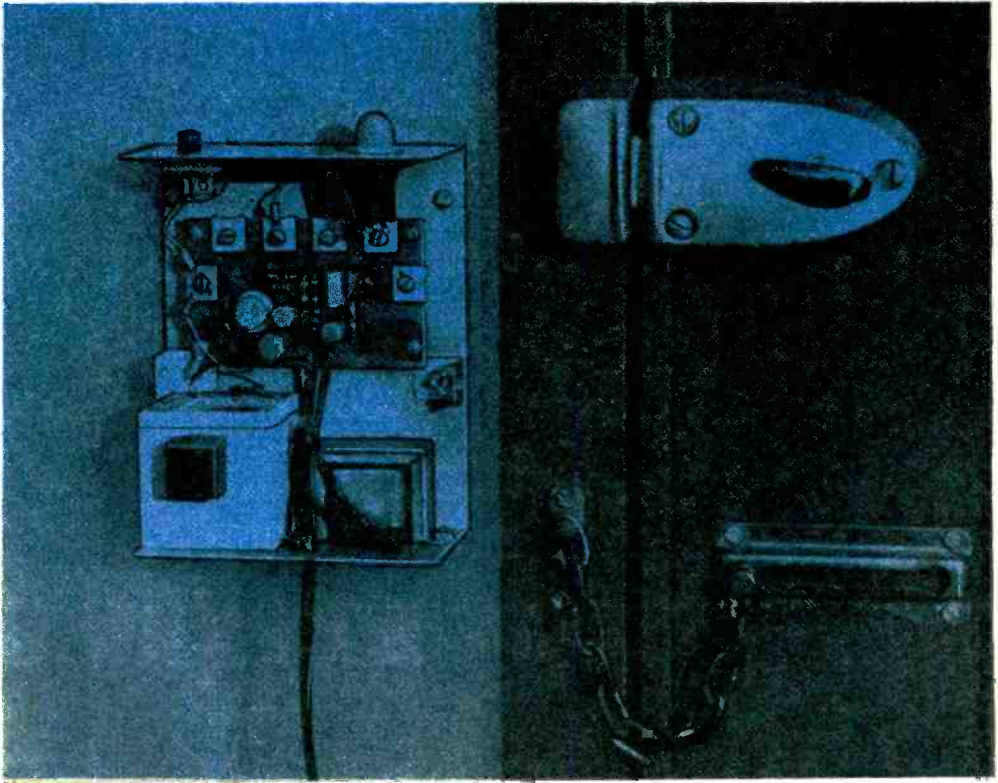

BUILD THE **HOMESTEADER**

PROFESSIONAL BURGLAR ALARM PROTECTION AT LOW COST

BY DAN MEYER

THERE ARE many types of burglar (or intrusion) alarms that you can build—involving proximity switches, infrared beams, breakable wires, etc. They all have their points, but why not use the system that the professionals use? On the windows of most stores and commercial establishments, you will see strips of silvered tape around the edges and, on doors and windows, pressure- or magnetically operated switches.

In such a system, the conductive tape and switches are connected in series and a weak current is flowing through them. When any portion of the loop is either broken or grounded, an alarm sounds. This has been found to be a reliable, easy-to-set, easy-to-use system. The "Homesteader" described here is equivalent to most commercial alarms costing

several hundred dollars if installed by a professional. Depending on how many places are to be protected, you can build this system for under \$40.

Construction. The circuit for the Homesteader alarm is shown in Fig. 1. It can be assembled on the printed circuit board whose foil pattern is shown in Fig. 2. Once the board has been fabricated or purchased, install the components as shown in Fig. 3, taking care to observe the polarities of the electrolytic capacitors and semiconductors. Choose a suitable metal enclosure to house the alarm (about 4½" x 5½" x 2"). You should be able to mount it on a wall.

Mount *I1*, the a.c. power-on indicator and *S1*, the alarm switch, on the upper surface of the enclosure. Attach the

Fig. 2. If you decide to make your own printed circuit board, follow actual-size etching guide shown.



Fig. 3. Mount components on circuit board as shown; then double check polarities of SCR's, transistor, and electrolytic capacitors.

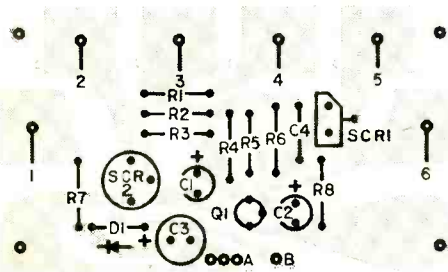

HOW IT WORKS

When switch *S1* is turned on and all external window and door switches in the protection loop are closed, transistor *Q1* is held in a saturated condition by the low current (approximately 2 mA) supplied to its base through the protection loop. The collector voltage of *Q1* is near zero in this condition. If the protection loop is opened, or grounded, base bias is removed from *Q1* and it cuts off. The voltage at the collector of *Q1* and the gate of *SCR2* then rises and the SCR turns on. The current flow through the SCR causes the alarm to sound off. The SCR does not turn off until *S1* is opened to remove the d.c. supply.

The exit door switch makes the system more convenient to use. With all of the protection loop closed except the exit door, *SCR1* fires when *S1* is turned on. This SCR, which is in parallel with the exit door switch keeps *Q1* saturated and the alarm off while the exit door is being closed. Thus you can turn on the alarm system before you leave the house and it remains quiet while you are leaving. When the exit door switch is finally closed, *SCR1* turns off, but *Q1* remains saturated.

Note that although only three trip switches are shown in the schematic, many more can be used in the protection loop (which also includes any conductive tape on window panes) as long as they are all connected in series.

The 6-volt rechargeable battery is included to keep the system operative even if the a.c. power line is cut. The battery is kept trickle charged as long as the a.c. line is plugged in. No primary-power on-off switch is included so that only one switch has to be turned on to activate the system.

than the one called for in the Parts List will require a different type of mounting. Of course, if you do not want to use a battery, which gives you protection in case your a.c. line is cut, the battery can be eliminated.

(Continued on page 114)

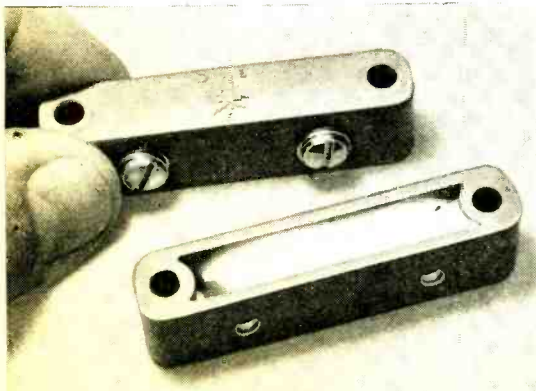

Place switch and magnet into separate plastic housings and seal in place with Silastic.

Metal contacts (Tinnerman nuts) and screws are optional. Connections can be soldered.

October, 1969

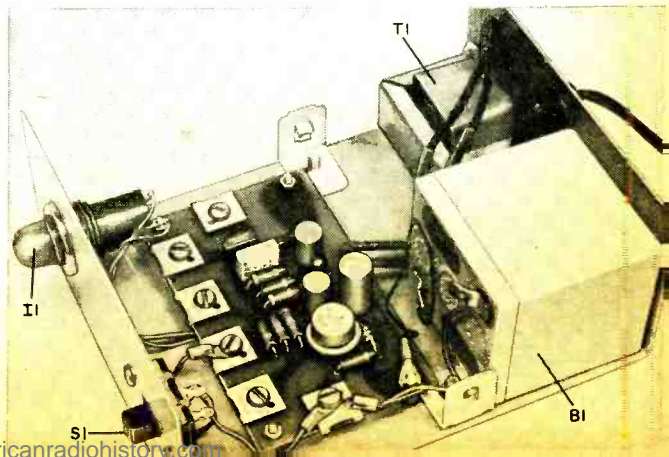

The Stereo Scene

by Charles Lincoln

ALL OF A SUDDEN, IT'S 1970!

THE NEXT TIME you pass a grandfather's clock and you hear it belting out rock-and-roll music, don't bat an eyelash. That's just another example of how grandpa is being updated—with built-in speakers, a tape recorder, a stereo receiver—maybe even a turntable tossed in for good measure.

The next time you're driving with a friend and he presses a switch on his dashboard and the music suddenly changes from Tijuana Brass to the brass of Tchaikovsky's Sixth Symphony and you *know* that was no radio, just keep on looking sophisticated. In the trunk of his car is an eight-track carousel-type automatic cartridge changer—the latest gimmick on the cartridge Stereo Scene from Qatron.

Or maybe you're tooling along with another buddy and he hands you a cartridge-shaped gadget and says, "Load this with a cassette from the glove compartment." Don't let him know you don't know what he's talking about. It's probably an Inmont cassette-to-eight adapter and he's exercising his choice of cassette over eight-track.

And the next time you're visiting your local Hi-Fi Boutique and you see this long, low-slung table-top cabinet with a cutout in the front, make believe you know that behind the cutout is an eight-track cartridge player nestled below a mini-changer that's snuggled next to an AM/FM/FM stereo receiver with 20 watts per channel output. Also don't let on about the speakers—which you don't see facing you. They're there—facing *upward*, but the sound is coming from all around the open ends of the cabinet. You knew all along that the speakers of this Telex-Phonola combo were firing against inverted, funnel-type diffusers to push the sound out at all angles.

The foregoing are hot examples of what you'll be seeing and hearing—along with a lot of other representatives of advances in hi-fi technology—on the Stereo Scene this fall. Many of them won't be as dramatic, but they will certainly be important and they show that the Stereo Scene is forever changing—like the patterns on the color organs that you'll also see in your wanderings.

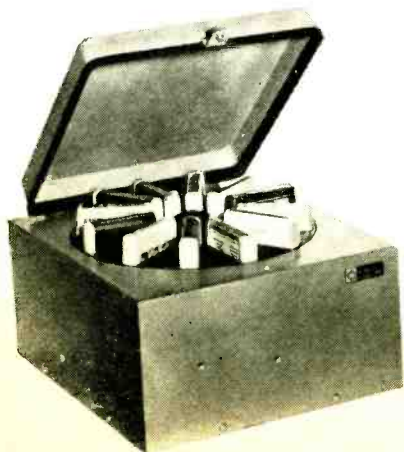

The eight-track stereo tape changer Model 48A by Qatron Corp. (12000 Old Georgetown Rd., Rockville, Md. 20852) is mounted in trunk of your car with a control console attached to the dashboard. It can provide a continuous program of 12 hours without repetition. Model for the home is also available.

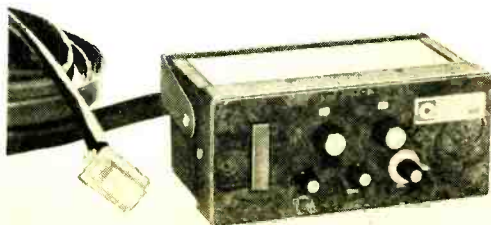

Competition is Advantageous. One of the big reasons for the continuing changes is the heavy competition that exists between suppliers, both domestic and foreign. Be glad about this! It means two things: product innovations (new features that make stereo products more interesting and useful) and prices that keep getting better all the time. For instance, that tape recorder you bought last month for \$250 couldn't have been touched five years ago for less than \$400; and the one you got then would have had fewer features, a poorer frequency response and poorer signal-to-noise specs. And we'll predict that 1971's stereo buyer will be paying more like \$200 for the equivalent of today's \$250 recorder. That's the way producers are chomping at prices to outdo their competitors.

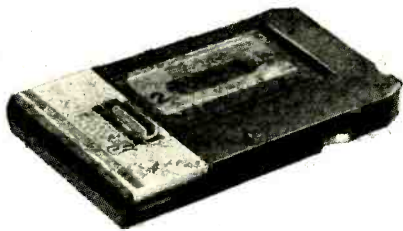

Inmont (Channel Mktg. Inc., 26 Springdale Rd., Cherry Hill, N.J. 08034) adapter permits playback of cassette in eight-track cartridge player.

and you see them in octagonal, hexagonal and just plain cylindrical shapes. You also see them integrated into the ends of cabinets that house the makings of a hi-fi rig, as in models from Zenith and Telex-Phonola.

Also coming on strong are "balls of sound"—speakers shaped like spheres, some totally round, some lopped off a bit and bearing names like "orbital". These come in the JVC-Nivico, Telefunken, Clairtone, and Panasonic lines. We see these as the next big gimmick of the Stereo Scene in the speaker category. Why? Because they make a lot of sense. They give you "sound-all-around." They're good looking. They fit into most any kind of decorating scheme. And they're a refreshing departure from the box shape that's been with us all these years.

Boxes in for Changes. Manufacturers of box-shaped speakers are aware that changes are in order and they've been fancying up their wares too. Last year's boxes now sport new trimmings, mouldings and carvings—many in the Mediterranean style that is so hot on the design scene today. Flashy fabrics are making their way to the fronts of speaker systems to give them pazzazz. And so are intricate plastic and metal grille materials, wrought into all sorts of intriguing and exciting patterns. Some have psychedelic overtones: look at them one way and

Craig Corp. (2303 E. 15th St., Los Angeles, Calif. 90021) uses popular cube shapes in compact Model 1504 three-piece AM/FM stereo table radio.

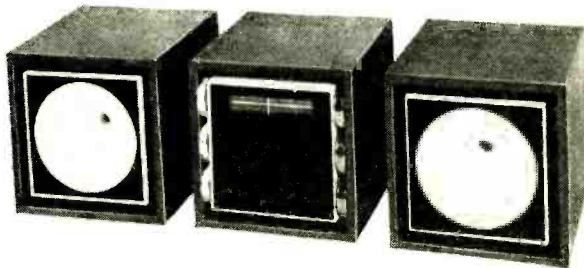

This year's product innovations are mostly a matter of new shapes and forms and variations on existing forms. Last year, for example, Sony "discovered" the cube; and made it into a radio. That radio sold like hotcakes. This year, there's a whole new bunch of radios and stereo ensembles shaped like cubes; and most of them are selling like hotcakes. Cylindrical shapes are also getting a lot of attention this year.

A year or so ago Zenith came up with omnidirectional speaker systems for a new compact stereo outfit. Although they've been around for at least five years in full-size systems (under brand names like Empire), suddenly there's a dozen brands of circle-sounding speakers in the stores as part of the compact Stereo Scene. You see them in the form of upright boxes firing at diffusers;

you see one pattern, turn your head a bit and you see another one.

The traditional shape of so many consoles is also getting an overhaul in today's Stereo Scene. "Make it look like something else" seems to be the motto of a lot of companies. In addition to the grandfather's clock (from Lakewood Industries) mentioned earlier, this year there are captain's desk stereos (Electrohome), vertically and horizontally styled room-divider stereos (Sylvania, Electrohome), chest-shaped stereos (General Electric, Electrohome), cube-shaped stereos (Packard-Bell), fireplace-shaped stereos (Lion, Delmonico, etc.), tea-cart-shaped stereos (Phono-Sonic), and even a hex-shaped stereo console (Masterwork). Al-

though the trend is to housings that take up less floor space, one company (Arvin) has gone the other way and come up with a console stereo ensemble measuring just three inches shy of nine feet!

What about portable phonographs? "Make 'em skinnier, color 'em bright, and make 'em do more" seems to have been the aim of on-the-ball manufacturers. This category has been somewhat overshadowed by tape recorders in the past year or so, but there's still life in it. Consider the colors of the plastic coverings: parrot green, bluebell, rose red, cinnamon, and dandelion (RCA); and the patterns: flowers, stripes, polka dots, and plaids (Emerson). Don't forget also the sets that incorporate features such as cartridge tape players (Motorola), FM stereo tuners (several), or built-in "light shows" (Decca).

When it comes to tape recorders and

there, if you look closely, you'll see that some turn-type controls have to be replaced by slide types. Instead of giving a twist, you give a push to change the volume, balance, bass, or treble. Instruments with such controls have a trim, "pro" appearance which many buffs find appealing. Some of the more intrepid manufacturers have gone the "black glass" route in terms of panels or panel segments. Look at some units and all you see is an expanse of tinted glass or plastic. But flip a switch and you see a tuning dial, meter, or some other form of indicator behind the tinted front, along with, perhaps, a feed slot for cartridges or cassettes.

Some Changes are Invisible. The really important changes are invisible: integrated circuits are now widely used in audio components; modular construction is also employed; and power ratings have been upped.

Four units of this Packard-Bell (12333 W. Olympia Blvd., Los Angeles, Calif. 90064) can be grouped together as shown here or separated around room.



compact, modular stereo ensembles, the word from the brass to the designers has been "pretty them up, load them with functions and features like never before, and make sure the price is right." The end result has been a kind of spillover of categories. For instance, when is a three-piece stereo radio a table-model radio and when is it a compact stereo system? Is a three-piece ensemble that contains a stereo radio and a cassette tape deck a radio or a tape recorder? And what do you call it if you add a fourth unit, a mini-changer? One manufacturer said customer prospects might relate terminology to dollars. "If you see a three-piece stereo radio priced at \$125 or less, it's a stereo radio. If it's over \$125, it's a compact system." Needless to say, the Stereo Scene this year is loaded with multi-function ensembles of all types and maybe the best bet is to forget what they're called and concentrate on what they do.

Audio components this year look pretty much like they did last year, and the year before, and the year before. But here and

(Some power ratings now border on the ridiculous. Most people who buy big-power sets don't use nearly all of the power for reproducing sound. What they bought was "Let's-beat-the-Joneses power.") The use of IC's has made the new audio products more reliable and has helped improve their specs in some ways. The basic change has been in refinements and in a subtle, but noticeable, improvement in performance and reliability.

Aficionados of the Stereo Scene will see a lot of new portable cartridge playback equipment in the stores this fall. It comes in all shapes and sizes, and in one-, two-, and three-piece groupings, with brand names such as Lear, Muntz, Stereo-Magic, Belair, Soundtech, etc. "The word from the top" to designers and engineers has been to make these sets more versatile and more portable; and "the word" has been carried out to the *n*th degree. Consequently the sets can be toted most anywhere and they play anywhere since they run on either batteries or house current. They're small enough not to break your arches in carrying them.



The Panasonic (Matsushita Electric Corp., 200 Park Ave., New York, N.Y. 10017) compact system Orbitone Model RS252S uses spherical speakers.

As an extra added attraction in players for automobiles, Tenna Corp. has come up with a scheme to discourage "Light-Finger Mike" and "Swipe-Em-Quick Joe" from lifting players out of cars. "The Untouchables," Tenna's new players, automatically cause the horn to sound continuously if the wrong person tries to get at them. Other protection systems are on the way.

Another thing you'll see is the start of a trend toward making eight-track a recording as well as a playback medium. You'll find at least a half a dozen cartridge recorders at your local hi-fi emporiums from companies such as Telex, Lear, Muntz, Midland, Panasonic and JVC-Nivico. And as

the year advances, there'll be more. They will be reasonably easy to operate—one, from Muntz, lets you roll your own four and eight-track cartridges.

Also crowding the Stereo Scene will be a bunch of new home cartridge players. Some will be decks for use with your current hi-fi rig or console stereo that has inputs for tape; some will be single-unit self-contained models with built-in side or front speakers; and some will be in the form of ensembles that might also contain a radio tuner and/or phono turntable. The idea behind all of this is that you should be able to enjoy in your living room the same tapes you play in
(Continued on page 102)

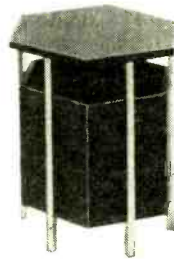

Hexagonal shape is used by Electro-Phonic (9200 Atlantic Ave., Ozone Park, N.Y. 11416) to give its speaker system a fresh look. Model is TG2773.

the product gallery

REVIEWS AND COMMENTARY ON ELECTRONIC GEAR AND COMPONENTS

SINE-SQUARE AUDIO GENERATOR (Heathkit Model IG-18)

WHAT SOME test instruments lack in performance they attempt to make up in an impressive physical appearance. Other instruments with unerring stability and accuracy look like they were designed for field-use in a combat zone. The *Heath Company* (Benton Harbor, Mich. 49022) has recently re-engineered certain items in its line of test gear and has simultaneously repackaged them in highly stylized, truly functional cabinets. Among many other things, the frequently inconvenient top-side handle has been eliminated and the new instruments can be stacked without tumbling off your lab bench.

In keeping with Heath's good name in test gear, all of the items are priced within easy reach of the serious hobbyist/experimenter. One of the newer items we recently assembled and tested was the Model IG-18 solid-state sine-square-wave audio signal generator. It is the 1970 replacement for the vacuum-tube Model IG-82.

Priced at \$67.50 in kit form (\$99.50, factory wired), the IG-18 has the performance characteristics and versatility you would expect in laboratory equipment selling for \$500 or more a few years ago. The generator is an excellent, rock-stable signal source for serious audio experimenting and hi-fi equipment testing and repair. Packaged in its low-silhouette, heavy-gauge metal case, the instrument has the look and feel of professional equipment.

Inside, it has good design all the way. For example, forget about the ordinary bridge-T frequency-determining circuit. The IG-18 employs a differential amplifier and controlled feedback to produce sine waves and a Schmitt trigger, keyed by the sine-wave signals, to produce square waves. The entire system is feedback stabilized for operation over prolonged periods of operation. Frequency selection is determined by an unusual switchable notch filter.

The control complement is realistic. Frequency output is selected simply by setting the tenths, units, tens, and multiplier controls to the desired output frequency. Then the first three switch settings indicate within 5% accuracy the output frequency times the multiplier selected on the fourth switch.

Separate controls are provided for the sine- and square-wave output amplitudes; switched for coarse, potentiometer controlled for fine.

Also located on the front panel is the output volts/dB meter, power indicator lamp, and two sets of five-way binding posts (one for sine- and the other for square-wave outputs). One very helpful and welcome feature of the IG-18 is the fact that both the sine- and square-wave outputs are "live" at all times. Both can be used simultaneously and each can be amplitude controlled separately. Of course, both outputs operate at the same frequency.

Assembly time for the IG-18 is about 8½ hours. The instruction manual is clear and well illustrated and contains a good section on trouble shooting. Once built, the temporary use of a VTVM and oscilloscope is needed to adjust bias, feedback, waveform, symmetry, and meter calibration. This takes only 15 minutes.

Circle No. 94 on Reader Service Page 15 or 115

GENERATOR SPECIFICATIONS

SINE-WAVE OUTPUT

Frequency range: 1-100,000 Hz

Output voltage ranges: 0-0.003, 0.01, 0.03; 0.1, 0.3, 1, 3, 10 volts

Internal load (first six ranges): 600 ohms

dB ranges: -62 to +22 dB; -12 to +2 dB on meter; -50 to +20 dB in 10-dB steps; +2 dB maximum into 600-ohm load

Output variation: ±1 dB, 10-100,000 Hz

Output impedance: 0-1000 ohms, 10-volt range; 800-1000 ohms, 3-volt range; 600 ohms, 1-volt and lower ranges

Distortion: less than 1%, 10-20,000 Hz

Circuit type: differential amp with complementary pair output; notch filter frequency select.

SQUARE-WAVE OUTPUT

Frequency range: 5-100,000 Hz

Output voltage ranges: 0-0.1, 1, and 10 volts peak-to-peak into 2000-ohm or higher load

Output impedance: 52 ohms on 0.1 and 1 volt ranges; up to 220 ohms on 10-volt range

Rise time: less than 50 nanoseconds

**TEMPERATURE-CONTROLLED
SOLDERING TOOL
(Weller Model GT-7A)**

YOU DON'T have to have a prolonged kit or project building session to know how fatiguing using a soldering iron or gun can be. Nor do you have to become fatigued if you have a *Weller Electric Corp.* (100 Wellco Rd., Easton, Pa. 18042) Model GT-7A soldering tool on your workbench. Called the "Tempmatic," the new soldering tool combines the advantages of a lightweight pencil and the fast warm-up time of a gun, and has tip temperature control as well—all in a tool that weighs only seven ounces.

The Tempmatic is actually a two-piece tool, consisting of a comfortable pistol-type

handle and a replaceable plug-in heat cartridge. The handle contains an ejector button for removal of the plug-in "powerhead" heat cartridge, the power line connector, and a handy trigger-type switch. The #7A powerhead supplied with the tool has a plated, long-life $\frac{3}{16}$ " chisel tip and a heating element that limits tip temperature to approximately 700°F. An optional powerhead, the #6B, with a $\frac{1}{8}$ "-reach conical tip that operates at 600°F is also available, with a full range of powerheads planned to meet the demands of virtually any type and size of soldering job.

The GT-7A (with #7A powerhead) tool is priced at \$9.95, while replacement and extra powerheads sell for \$6.95 each.

Circle No. 95 on Reader Service Page 15 or 115

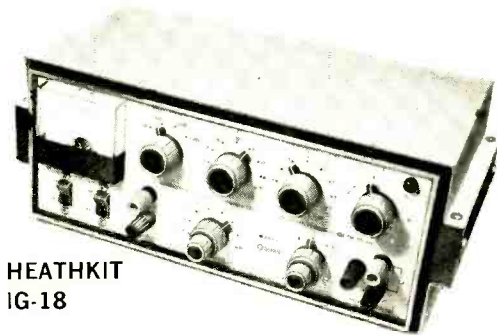

**HEATHKIT
IG-18**

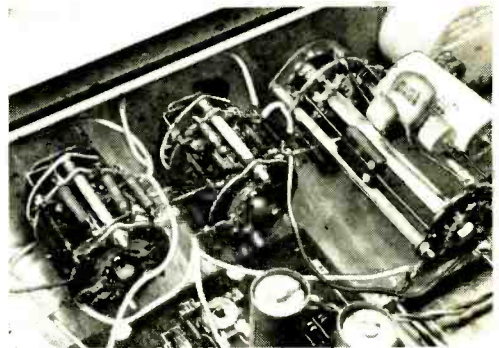

Frequency-determining network components are located on easy-to-wire rotary switches for tenths (not shown), units, tens, and multiplier (left to right).

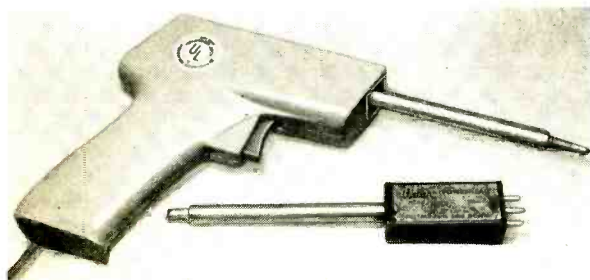

WELLER GT-7A

The Powerhead heat-cartridge/soldering-tip assemblies snap easily into and out of the tool handle for easy replacement. A slide catch located on top of tool handle releases the cartridges quickly.

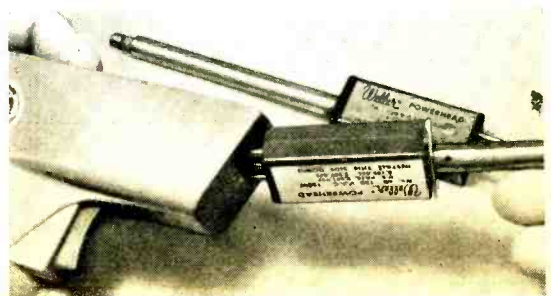

ENGLISH LANGUAGE NEWS BROADCASTS FOR THE MONTH OF OCTOBER

Prepared by ROGER LEGGE

TO EASTERN AND CENTRAL NORTH AMERICA		TO WESTERN NORTH AMERICA	
TIME-EDT	STATION AND LOCATION	TIME-PDT	STATION AND LOCATION
	FREQUENCIES (MHz)		FREQUENCIES (MHz)
7:00 a.m.	Stockholm, Sweden	8:00 a.m.	Tokyo, Japan
7:15 a.m.	Melbourne, Australia	9:00 a.m.	Stockholm, Sweden
7:45 a.m.	Copenhagen, Denmark	6:30 p.m.	Tokyo, Japan
8:00 a.m.	Peking, China	7:00 p.m.	Melbourne, Australia
8:15 a.m.	Montreal, Canada	7:30 p.m.	Bonaire, Neth. Antilles
7:00 p.m.	London, England		Johannesburg, South Africa
	Montreal, Canada	8:00 p.m.	London, England
	Moscow, U.S.S.R.		Madrid, Spain
8:00 p.m.	Peking, China		Peking, China
	Sofia, Bulgaria		Prague, Czechoslovakia
8:30 p.m.	Johannesburg, South Africa		Seoul, Korea
	Kiev, USSR (Mon., Thu., Sat.)	8:30 p.m.	Taipei, Taiwan
	Stockholm, Sweden		Berlin, Germany
8:50 p.m.	Brussels, Belgium		Stockholm, Sweden
	Vatican City		Tirana, Albania
9:00 p.m.	Berlin, Germany	9:00 p.m.	Budapest, Hungary
	Budapest, Hungary		Havana, Cuba
	Havana, Cuba		Lisbon, Portugal
	London, England		Moscow, USSR (via Khabarovsk)
	Madrid, Spain		Oslo, Norway (Sun.)
	Prague, Czechoslovakia		Peking, China
	Rome, Italy		Sofia, Bulgaria
9:30 p.m.	Berne, Switzerland	9:30 p.m.	Kiev, USSR (Mon., Thu., Sat.)
	Bucharest, Rumania	9:45 p.m.	Berne, Switzerland
	Cologne, Germany		Cologne, Germany
	Tirana, Albania	10:00 p.m.	Havana, Cuba
	Hilversum, Holland (via Bonaire)		Hilversum, Holland (via Bonaire)
10:00 p.m.	Lisbon, Portugal		Quito, Ecuador
	Moscow, U.S.S.R.		Tokyo, Japan
	Oslo, Norway (Sun.)	11:00 p.m.	Moscow, USSR (via Khabarovsk)
	Peking, China	11:30 p.m.	Havana, Cuba



TWO WAY REACTIONS

BY G. H. REESE, KCN6990

PLANNING A GROUP

CITIZENS Two-Way Radio enthusiasts are gregarious, helpful people. They often organize clubs through which they meet other such people. They realize the potential of their radio equipment and are prepared when some emergency situation puts them to the test. The groups that are prepared for the unusual emergency situation through prior planning, such as REACT teams are most helpful.

This prior planning should include the following:

1. Establish a regular monitoring schedule.
2. Develop a working relationship with local police, fire and civil defense authorities. This means an awareness on the part of officials of the interest, availability and capability of CB groups. It also provides CB'ers with an understanding of their role in the chain of command when their services are utilized.
3. Adopt procedures for handling emergencies and train members in their use.
4. Obtain equipment necessary for use in emergencies and become efficient at using it.

Preparedness Pays. The beneficial results of preparedness are reflected in the many

instances in which organized CB'ers have performed uniquely valuable service to the public.

For example, CB radio was recently instrumental in the prevention of injury in Cascade Park, Elyria, Ohio, the site of an annual Fourth of July fireworks display. This year, about 3,500 people were assembled to view the spectacle about 7:30 P.M.

A report of high winds tearing away the antenna of Jack Kelley in Lorain, Ohio prompted William Graw, KNW9905, in Elyria to investigate. Graw, a civil defense official and leader of Lorain County REACT Team, called a special U.S. Weather Bureau number in Cleveland and learned that there was a tornado over Milan and it was expected to touch down in Lorain County. No warnings had been given locally—only a threat of showers.

Graw reported the severe weather warning to Donald Yoder at Cascade Park by CB radio. Yoder, a member of Lorain County Emergency Communications, Inc., was manning a mobile unit at the park. Yoder told officials at the park of the danger. After a hasty conference, Randy Shunk, secretary of the Elyria Chamber of Commerce, used the public address system to disperse the



Denver Metro REACT Team uses completely equipped van and generator to assist the local civic agencies and authorities in many good works.



Using walkie-talkies, the Akron REACT Team members provide safety communications for the annual National Soap Box Derby, which is held in that city.

crowd. Without alarming them, he pointed to threatening clouds overhead and suggested they leave the park, particularly the deep gorges.

After a few ground displays were ignited to satisfy the crowd's desire for fireworks, most of the 3,500 men, women and children left the scene. Minutes later, about 8:10 P.M., high winds swept the area, blowing over trees and seriously damaging the park. Those winds found the park with only a few persons in it because alert CB'ers used their communications tools to get the warning to the proper officials in time.

This incident is a reminder of how organized local CB'ers can cooperate in an emergency for the good of the entire community. Stories of almost every recent disaster carry with them some example of the helpful use of Citizens Two-Way Radio.

When a record nine-day snow storm hit Payson, Arizona, shutting down the power, water and telephone service for five days and closing the main highway for three days, the local REACT team and other CB'ers from all over Arizona cooperated to provide emergency communications. Big-hearted people in Phoenix contributed food and other necessities which were sent into Payson through a campaign organized by CB'ers. Many people will never forget the service performed when downed telephone lines left Citizens Two-Way Radio as the only means of communication.

When the "Silver Bridge" over the Ohio River collapsed a couple of years ago, members of Gallia County CB Radio, Inc. coordinated rescue communications at the scene for thirteen days and nights. With their mobile base station established in a trailer on the Ohio side, additional radios provided communications to the West Virginia side and to amphibious ducks, boats and cranes engaged in the rescue operations.

And when floods ravaged Fairbanks, Alaska in August, 1967, CB radio provided reports on highway washouts and relayed communications requesting medicine, food, and rescue support in outlying areas. Finally, when telephone communications went out, CB was the chief means of communication. A network was set up by the Midnight Sun CB Club at the request of the Civil Defense authorities. Reporting the whereabouts of persons stranded away from home, coordinating airdrops of food and supplies, and routing traffic were some of the functions performed by club members during this emergency.

Community Projects. In addition to emergencies, CB'ers provide unique assistance in many civic and community projects. For example, in Indianapolis recently, the Indiana Citizens Band Association, Inc. participated in the American Cancer Society Telethon. ICBA volunteers provided telephone operators, plus radio dispatched cars to pick up contributions throughout the county area.

Four Points Radio Club of Chicago recently provided communications for the 12th annual Des Plaines River Canoe Marathon. Four Pointers were stationed at various locations along the 25-mile route to monitor the race. As each numbered canoe passed his station, the monitor reported by radio. Thus, the canoes could be checked for location and condition. Accidents were reported and first aid and canoe pick-ups requested.

(Continued on page 111)



South Suburban REACT (Midlothian, Ill.) serves the Chicago suburban area from this elaborate base station. In addition to monitoring Channel 9, two-way communications are established with local, state, and county sheriff police. Team also monitors fire department communications and U.S. Weather Bureau.



SHORT-WAVE LISTENING

By **HANK BENNETT**, W2PNA/WPE2FT
Short-Wave Editor

QATAR BROADCASTING SERVICE

AN INFORMATIVE letter from Taher Shihabi, Deputy Director of Broadcasting tells more about the Qatar Broadcasting Service. Mr. Shihabi says that the station bearing the callsign *Qatar min el Doha* is a three-transmitter organization and, at press time, is currently operating on 9570 kHz. This, the first of the three transmitters, is rated at 100 kW and feeds into a quadrant (?) antenna array. Facilities are available for frequency changes to 6135, 7150, 9550 and 11,710 kHz.

The second transmitter is rated at 50 kW and feeds into a quarter-wave tower; a medium-wave outlet, it operates on 674 kHz.

The third transmitter is rated at 10 kW and serves as a stand-by transmitter for the medium-wave unit. It utilizes a "T" antenna.

Service areas include territory in the Middle East within a radius of 2500 kilometers (about 1560 miles) for the short-wave transmissions, and Qatar and neighboring Arab countries on the medium-wave outlet.

The schedule shows operations daily at 0300-0600 (to 0735 Friday) and 1300-1900. Programming is listed as being mainly governmental in nature, with local, regional and foreign news, education, music and drama. The only language employed at present is Arabic.

The station is owned by Shaikh Ahmed bin Ali Althani and went on the air on June 25, 1968. Reception reports are not requested; however, when they are received they are answered by confirmation letters. Reports should be detailed, as vague reports cannot and will not be answered. No QSL cards are available at present. Send reports to Qatar Broadcasting Service, P. O. Box 1414, Doha, Qatar.

Mystery Stations and Others. Numerous reports are being received concerning a new time-signal station operating on 6100 kHz. All reports indicate best listening time to be around 0500-0730. Your Editor has not yet heard any Morse identification but there is a voice announcement in Spanish or Portu-

guese which ends with the word "Nacional". One SWL club lists it tentatively as the Portuguese Naval Observatory, presumably in Lisbon. Any positive information will be appreciated.

Speaking of time stations, William Matthews, WPE3GWQ, of Houston, Pa., received a QSL letter from JAQ56, a time station in Oyama, Japan, in which it was stated that the station ceased operations on April 30, 1969. JAQ56 had been on the air since 1957 with 10 kW and a directional antenna beamed to Europe, with transmissions daily at 1215-1230. It was on 16,170 kHz.

Danny Edwards, WPE4JDJ, is one of our enthusiastic monitors of utility stations, especially those operating with Morse code. He is asking for help in obtaining the addresses of the various radio networks for the European countries. Danny further asks: "Whatever has happened to those mysterious point-to-point stations J8S and AØL? Has anyone ever found out who they were and where they were located?" Your Editor has heard both of these stations on many occa-



Twenty-five verifications from 18 countries is the record of Lindy Smith, WPE4DON, Haines City, Fla. He has a Knight R-100 and plans on a Heath GR-81.

sions and every attempt to learn their locations has proven futile. Often their signal strength was such as to make a person believe that they were local. If anyone can answer Danny's questions, please write him at 4556 Indiana Avenue, Chesapeake, Virginia 23320.

CURRENT REPORTS

The following is a resume of current reports. At time of compilation all reports were as accurate as possible, but stations change frequency and/or schedule with little or no advance notice. All times shown are Greenwich Mean Time (GMT) and the 24-hour system is used. Reports should be sent to Short-Wave Listening, P. O. Box 333, Cherry Hill, N.J. 08034, in time to reach Your Short-Wave Editor by the fifth of each month; be sure to include your WPE identification and the make and model number of your receiver.

Angola—CR6RV, *R. Clube do Moxico*, Luso, last noted on 5137 kHz, has moved to 5192 kHz where they are heard with a Portuguese program at 0543 A *Voz do Angola*, Luanda, 5960 kHz, is heard at 0500 s/on with IS, anthem, and 1D in Portuguese. CR6RF, *R. Clube de Benguela*, 5042 kHz, opens at 0545 with a full 1D in Portuguese and a complete program summary. Eight reports to them have proven futile for a QSL.

Antilles, Netherlands—Here is the complete schedule for *Trans World Radio*, Bonaire: Arabic and Armenian to the Middle East at 0445-0515 on 25 and 31 meters; Eastern European languages to Europe at 0430-0445 on 25 and 31 meters; English to the Far East at 0030-0120 on 25 meters, 0225-0350 to N.A. on 19 meters and 1100-1235 (1230-1500 Sunday only) to N.A. on 19 meters. All of the following are to South America except as noted: French at 2200-2215 on 19 meters; German at 0030-0100 on 25 meters, 0900-0930 on 49 meters and 2330-2355 on 19 meters; Portuguese at 0800-0900 on 49 meters and 2300-2330 and 2355-0010 on 19 meters; Russian at 0100-0130 on 19 meters and at 0400-0430 (to Russia) on 25 and 31 meters; Spanish at 0010-0025, 0130-0220, 2220-2300 and 2355-0010 on 19 meters, 0900-0930 on 49 meters, 0930-1100 on 31 meters and 2330-0020 (to Central America) on 31 meters. Available frequencies: 19 meters: 15,140, 15,345 and 15,350 kHz; 25 meters: 11,745, 11,790 and 11,820 kHz; 31 meters: 9545, 9605, 9695 and 9730 kHz; 49 meters: 6110 kHz. A test broadcast to South Africa has been noted on 6095 kHz at 0402, after s/on, and they are requesting reports.

Ascension Island—BBC *Atlantic Relay* noted on 9510 kHz to the Americas at 2200 with news, "The World Today", "London Newspaper" and folk music.

Australia—VLX9, Perth, is good at times on 9610 kHz at 1100-1215. VLM4, Brisbane, 4920 kHz, was

(Continued on page 103)

DX ALL-ZONE AWARDS PRESENTED

To be eligible for one of the new DX All-Zone Awards designed for WPE Monitor Certificate holders, you must have verified stations in 10, 20, 30 or 40 of the world radio zones. The following recently received their awards.

10 ZONES VERIFIED

Michael Wheeler (WPE7CSY), Portland, Ore.
 Ronald Boestfleisch (WPE2NRJ), College Point, N. Y.
 John Mac Donald (WPE2QOV), East Orange, N. J.
 Frank Gorman, Jr. (WPE8KAY), Cincinnati, Ohio
 David La Cure (WPE9CSX), Aurora, Ill.
 Scott Brockway (WPE2QJP), Rome, N. Y.
 Martin Miron (WPE8JTN), Warren, Mich.
 Craig Seufert (WPE1HNS), Newtown, Conn.
 Mitchell Hyman (WPE20PK), Rosedale, N. Y.
 Edward Sue (WPE1HMA), Brookline, Mass.
 Craig Begg (WPE0FHG), St. Louis, Mo.
 Rimas Sakalas (VE3PE2KK), Hamilton, Ont.
 Jay Miller (WPE4JQV), Memphis, Tenn.
 Mark Maersch (WPE3HEK), Severna Park, Md.
 Gary Cooper (WPE7CQV), Nampa, Idaho
 John Flynn (WPE2NME), Brooklyn, N. Y.
 Stanley Newman (WPE2PJS), Brooklyn, N. Y.
 Joseph Breton (WPE1HKW), Methuen, Mass.
 Mike Mickes (WPE7CVF), Gooding, Idaho
 David Perry (WPE2QFK), Pleasant Valley, N. Y.
 Paul Moeller (VE3PE2NQ), Harrow, Ont.
 Mike Lynch (WPE2QEA), Auburn, N. Y.
 Timothy Gjenwick (WPE9ILO), Brookfield, Wis.
 Bruce Roberts (WPE4KAH), Waynesboro, Va.
 Rick Schiffer (WPE3HLL), Franklin, Pa.
 Harry Hines, Jr. (WPE2OFS), Newark, N. J.
 Arthur Skopec (WPE2PQJ), Whitesone, N. Y.
 Charles Stroud (WPE4JZU), Paducah, Ky.
 Paul Roddy (WPE5EYH), Edna, Texas
 Don Moman (VE6PE8C), Clive, Alta.
 David Lubar (WPE9JFD), Elmwood, Ill.
 Diana Loomis (WPE6HLT), Sherman Oaks, Cal.
 David Peters (WPE6HDM), Modesto, Cal.
 Joel Bahl (WPE9JFY), Hometown, Ill.
 Benny Loveless (WPE9JLO), Frankfort, Ind.
 Donald Appling (WPE7CNG), Spokane, Wash.
 Gary Mc Nelly (WPE9IRG), Cohokia, Ill.
 Steve Hope (WPE5EZG), Houston, Texas
 William Coleman (WPE4JNW), Jacksonville, Fla.
 David Purdy (WPE2PEC), Canandaigua, N. Y.
 William Groves (WPE4KAV), Covington, Ky.
 Eugen Floda (WPE2OFH), New York, N. Y.
 Charles Schwerin (WPE8HYH), Bay City, Mich.

20 ZONES VERIFIED

Robert French (WPE8FGH), Bellaire, Ohio
 Jeff Utter (WPE6HDJ), Carlsbad, Cal.
 Bob Estand (WPE5FAV), El Paso, Texas
 George Sprout (WPE3GMW), Reading, Pa.
 Kendall Porter (WPE0EVD), Overland Park, Kan.
 Robert Asbury (WPE2PYT), Williston Park, N. Y.
 Parks Redwine (WPE4HCO), Fayetteville, Ga.
 Alan Harris (WPE8JTY), Oak Park, Mich.
 Gary Cooper (WPE7CQV), Nampa, Idaho
 James Pogue (WPE9HLL), Farmland, Ind.
 Michael Plihcik (WPE2JDF), Elmhurst, N. Y.
 Brian Begg (WPE2JFR), New Brunswick, N. J.
 James Daley, Jr. (WPE4JVR), Atlanta, Ga.
 Robert Rothberg (WPE2QQO), Long Beach, N. Y.
 Clarke Thacher (WPE9IXP), Mishawaka, Ind.
 Rev. John Peiza (WPE6HCP), Ojai, Cal.
 Ron Budziack (WPE9JHK), Cicero, Ill.
 Arthur Martin (WPE0EJY), St. Paul, Minn.
 Eugen Floda (WPE2OFH), New York, N. Y.
 David Simon (WPE2PQP), Brooklyn, N. Y.
 Francis Wheeler (WPE6HLK), Sacramento, Cal.
 William Blue (WPE7CTW), Seattle, Wash.
 Fred Lynch (WPE9JHD), Girard, Ill.
 David Johnson (WPE0ELO), Denver, Colo.
 Rick Heavey (WPE8IYR), Detroit, Mich.
 Leslie Nice (WPE5DRL), Dallas, Texas
 Allan Keizer (WPE2QCS), Brooklyn, N. Y.
 Marshall Brooks (WPE2POW), Rochester, N. Y.
 Frank O'Donnell (WPE6HFD), La Habra, Cal.
 Scott Brockway (WPE2QJP), Rome, N. Y.

30 ZONES VERIFIED

C. Vernon Hyson (WPE0CNF), Somerville, N. J.
 Richard Davis (WPE0AKR), Denver, Colo.
 Richard Pistek (WPE9HOA), Chicago, Ill.
 Jack Winther (WPE6BJD), Moraga, Cal.
 F. R. Cook (VE3PE1WX), Willowdale, Ont.
 Gary Ligon (WPE4JAX), Cliffside, N. C.
 David Conder (WPE9IHV), Centralia, Ill.
 Donald Gross (WPE7CQX), Roseburg, Ore.
 Charles Matterer (WPE6DGA), San Leandro, Cal.
 Jack Bacon, Jr. (WPE0FDJ), Bloomington, Minn.
 Marion Lilienthal (VE3PE2DO), Waterloo, Ont.

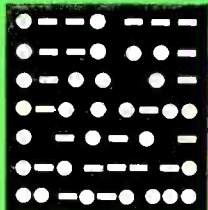

AMATEUR RADIO

By **HERB S. BRIER**, W9EGQ
Amateur Radio Editor

OPERATION PHONE PATCH

READERS of this column are well aware that Senator Barry Goldwater (R-Ariz.) is one of the country's greatest proponents of amateur radio. As further evidence, here is a story reported by William Eccles, K7MJG, in "Ham Monitor," which is edited and published by Bob Lange, WØILB, in Salina, Kansas.

Barry, K7UGA/AF7UGA, and ten of his amateur friends decided to assist in the running of phone patches from Southeast Asia to the U.S. so that servicemen could talk to their families and friends back home. The Armed Services assign men, equipment,

and Military Affiliate Radio Service (MARS) frequencies to handle calls at their end of the line. To help out here at home, Barry supplied two Collins 75-S3C receivers and 32-S3 SSB/CW excitors; a 30-S1, 2-kW, PEP linear amplifier; and a 77-foot-high rotating "Christmas-tree" antenna containing 4-element, full-size beams for 10, 15, 20, and 40 meters.

After getting their station on the air and joining the Air-Force MARS (to work areas where amateur radio or amateur third-part traffic is forbidden), Barry and his friends found that they needed more help. So they

AMATEUR STATION OF THE MONTH



Larry, WA9UMU, and Ralph, WA9UDZ, Evans, 8657 N. Point Dr., Milwaukee, Wis. 53217, have an impressive amount of equipment to share. In just over a year, Larry (above) has worked over 171 countries, with 140 confirmed, using a Swan SSB/CW transceiver and three antennas—a Hy-Gain TH-6-DXX beam, 18-HT vertical for 80 meters, and a home-built phase vertical array for 40 meters. Other equipment includes another Swan transceiver, Knight-Kit R-100 receiver, Hallicrafters HT-40 and Heathkit DX-60B transmitters, EICO electronic keyer, Hallicrafters SX-71 receiver, professional tape recorder, etc. We are sending a 1-year subscription to POPULAR ELECTRONICS to WA9UMU for winning this month's Amateur Station of the Month photo contest. You can enter by sending a clear photo (preferably black and white) of yourself at the controls of your station with some details about your amateur career to Amateur Photo Contest, c/o Herb S. Brier, W9EGQ, Amateur Radio Editor, POPULAR ELECTRONICS, P.O. Box 678, Gary, Indiana 46401.

recruited another 15 amateurs to join the group. They also found that the amateur beams didn't work too well on MARS frequencies far from the amateur bands. So Barry obtained a Hy-Gain, military-type, wide-band, log-periodic rotary beam. When it was mounted on the mast with the other beams, however, the performance of the new beam was poor so they ordered a 71-foot, Tri-ex "sky needle," which was installed with the new Hy-Gain some distance from the original antennas.

A 3.5-kW, PEP, linear amplifier was also acquired and modified for use on the MARS channels. In addition, Barry purchased another complete station—Drake T-4X transmitter, R-4B receiver, and Henry 2K-B amplifier—for normal contacts and phone patches.

Between August 1967 and April 1969, the group handled 21,000 phone patches and they have been running at the rate of 2000 to 2500 a month since then!

Since Barry returned to the Senate last fall, the group has been re-organized into the "Bash-Hal-Ne-Ae" (Navajo Indian for "metal that talks") Amateur Radio Club to carry on the work. He still underwrites the expenses, however, and sits in on the activities when he has a chance.

Of course, this is not the only amateur station working with MARS to donate many hours a week running phone patches—there are hundreds of them. If you wonder why you don't hear some of the well-known, big-signal men on the DX "pileups" these days, it's because they are spending all of their time phone patching on the MARS channels.



Senator Barry Goldwater, K7UGA/AF7UGA, and the men that keep the station on almost constantly to run phone patches from servicemen overseas.

Million-dollar TVI Suit. On May 29, after a series of legal maneuvers, the \$1,000,000 suit filed against Ansel "Grid" Gridley, W4GJO, by a neighbor for alleged television interference (even though Grid's equipment was given a clean bill of health by the Federal

Communications Commission) was remanded for trial to the Sarasota Circuit Court by the Tampa Federal court. Grid and his attorneys have appealed the ruling.

The importance of the appeal to all radio licensees—amateur, broadcast, CB, business radio, etc.—is that, if the higher courts should uphold Judge Lieb's ruling, their operations will be controlled by local courts, rather than by federal law and the Federal Communications Commission. The Sarasota Amateur Radio Association, Inc., P. O. Box 3323, Sarasota, Florida 33578, is acting as trustee for contributions from amateurs and others to help defray the costs of fighting this vitally-important case—and costs are already well over the \$2000 mark!



Lloyd Holm, WNBZZL, Farmington, Mich., has worked 28 states and three countries on 40 meters with a Hallicrafters HT-40 and National HRO combination.

Inconclusive Returns. Examining the results of the 1969 Florida QSO Party in *Florida Skip* allows one to prove almost anything he might wish about amateur operating trends. In brief, the number submitting logs increased 18 per cent over last year, but CW logs decreased five per cent. On the other hand, CW logs still exceeded phone logs by a 3:2 ratio. Furthermore, the 10 highest Florida CW operators outscored the high phone men by 11 per cent. Outside of Florida, however, the high phone men outscored the high CW men by 20 per cent! Logs were received from 11 countries, by the way.

Detroit to Moscow. George H. Goldstone, W8AP, writing in "Reflected and Directed" in the June issue of the Detroit Amateur Radio Club *DARA Bulletin*, counters the action of one U.S. amateur who refuses to work Russian amateurs (because Russia aids North Vietnam) with the following: "All the reports of U.S. hams who have

(Continued on page 99)



SOLID STATE

By LOU GARNER, Semiconductor Editor

THE AGE OF AQUARIUS OR SOLID STATE?

ACCORDING to astrologers, we are entering the 2500-year-long Age of Aquarius. From a technological viewpoint, however, we are well into the Age of Solid State, for, almost daily, new semiconductor-operated products are introduced into every phase of human activity. Linemen, doctors, construction workers, machinists, office personnel, and many others are now using complex electronic equipment.

Before too long, telephone linemen may be using a futuristic space-age "gun" similar to the unit shown in the photo. Developed by the Bell Telephone Laboratories (BTL), the instrument can be used to locate pin-point breaks in overhead cables. Older telephone cables often are pressurized with dry air to prevent water damage should the sheath be broken. If the sheath is punctured, there is an almost inaudible hiss containing energy at ultrasonic frequencies. The new device, complete with sights for aiming, uses highly directional parabolic reflectors to direct this faint sound into the ultrasonic microphone. Here, the signal is detected, then "translated" to audible frequencies and amplified by solid-state circuitry before being fed to the headphone.

In the medical area, thousands of heart patients who once would have been bedridden are now leading useful, normal lives, their hearts triggered by electrical signals from implanted solid-state "pacemakers." The near-deaf have access to miniature hearing aids a fraction of the size of vacuum-tube models, but more efficient and much more powerful than the early units. Solid-state laser "canes" and sonar-like instruments are being developed for the blind.

Metal-working shops are using solid-state instruments to control precision lathes, milling machines, drills, and other machine tools to increase production efficiency. The technique . . . called "numerical control" . . . permits the precise, but rapid, duplication of complex parts in accordance with programmed instructions prerecorded on magnetic or punched paper tapes.

Carpenters, plumbers, electricians and other construction workers are using vari-

able-speed, semiconductor-controlled power tools, while architects, civil engineers, and contractors employ computers in their design work, electronic instruments to test materials, and two-way radios for field communications. Both industrial and automobile mechanics can choose from a variety of solid-state diagnostic instruments, including vibration detector-amplifiers, stop-motion and speed measuring stroboscopes, and comprehensive engine analyzers.

Banks, libraries, realtors, manufacturing firms, restaurant chains, etc., are using solid-state data processing equipment and computers for payroll records, billing, inventory control, cataloging, and production scheduling, while more and more offices are installing automated typing and production systems.

Looking to the future, the present trend is likely to continue at an even faster pace, as engineers develop new types of equipment using less expensive, but more efficient devices and as semiconductor manufacturers continue to introduce increasingly versatile solid-state integrated circuits.

Reader's Circuit. Originally designed for use in a privately published project manual, the lie detector circuit illustrated in Fig. 1 was contributed by its developer, Marshall



Solid-state sensing "gun" with parabolic reflector can be used to spot punctures in telephone lines.

**“He’s a good worker.
I’d promote him
right now if he had
more education
in electronics.”**



Could they be talking about you?

You'll miss a lot of opportunities if you try to get along in the electronics industry without an advanced education. Many doors will be closed to you, and no amount of hard work will open them.

But you can build a rewarding career if you supplement your experience with specialized knowledge of one of the key areas of electronics. As a specialist, you will enjoy security, excellent pay, and the kind of future you want for yourself and your family.

Going back to school isn't easy for a man with a

full-time job and family obligations. But CREI Home Study Programs make it possible for you to get the additional education you need without attending classes. You study at home, at your own pace, on your own schedule. You study with the assurance that what you learn can be applied to the job immediately.

CREI Programs cover all important areas of electronics including communications, radar and sonar, even missile and spacecraft guidance. You're sure to find a program that fits your career objectives.



NEW!
Expanded coverage of solid state electronics including integrated circuits!

You're eligible for a CREI Program if you work in electronics and have a high school education. Our FREE book gives complete information. Mail postpaid card for your copy. If card is detached, use coupon at right or write: CREI, Dept. 1210H 3224 16th St., N.W., Washington, D.C. 20010.



**CREI, Home Study Division
McGraw-Hill Book Company
Dept. 1210H, 3224 Sixteenth Street, N.W.
Washington, D.C. 20010**

Please send me FREE book describing CREI Programs. I am employed in electronics and have a high school education.

NAME _____ AGE _____
 ADDRESS _____
 CITY _____ STATE _____ ZIP CODE _____
 EMPLOYED BY _____

TYPE OF PRESENT WORK _____ G.I. BILL

- I am interested in
 Electronic Engineering Technology Computers
 Space Electronics Nuclear Engineering Technology
 NEW! Digital Communications
 NEW! Industrial Automation

APPROVED FOR TRAINING UNDER NEW G.I. BILL

Dudley (2711-25 Sutherland, Knoxville, Tennessee 37919). Easily assembled in one or two evenings or on a weekend, the completed project may be used for experiments, demonstrations, or party games.

As a general rule, a person's skin resistance drops during periods of emotional stress, as when telling a lie. Marshall has relied on this human characteristic in developing his instrument, which is essentially a modified non-linear ohmmeter, designed for maximum response to resistance changes relative to a preset value.

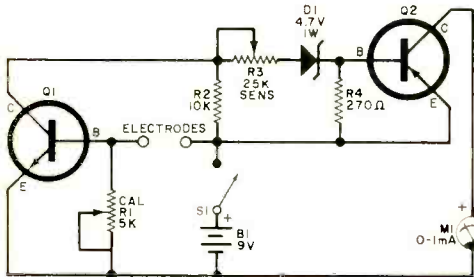

Fig. 1. Basic circuit of lie detector is a non-linear ohmmeter with the base bias of Q1 determined by the changing resistance of the subject's skin.

Referring to the schematic diagram, the unit consists of a direct-coupled complementary amplifier, Q1-Q2, a reference diode, D1, a d.c. power source, B1, and an indicating device, meter M1. Calibration (bias) and sensitivity controls, R1 and R3, respectively, are provided to permit adjustments for different individuals, while electrodes attached to the subject's fingers serve to monitor skin resistance.

In operation, Q1's base bias is determined by a voltage-divider made up of R1 and the test subject's skin resistance. The resulting collector current of Q1 develops a voltage drop across load resistor R2 which, in turn, can serve as a base bias source for Q2 if of sufficient amplitude to overcome D1's breakdown voltage. Sensitivity control R3 and bias control R1 are preset while the subject is calm so that R2's voltage drop just equals D1's rating. Afterward, any decrease in skin resistance results in a corresponding increase in Q1's base bias and, therefore, in R2's voltage drop, thus applying a base bias to Q2 through R3 and D1. With base bias applied, Q2's collector current increases sharply, causing the meter's needle to deflect upward.

Marshall has specified standard components in his design. Both Q1 and Q2 are general purpose small-signal npn and pnp transistors, respectively, such as International Rectifier types TR-09 and TR-05.

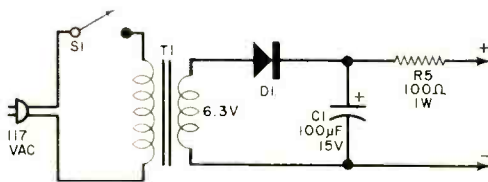

Fig. 2. This power supply circuit can be used to replace the battery in the lie detector in Fig. 1.

With neither parts positioning nor wiring arrangement critical, the lie detector circuit may be assembled on a suitable etched circuit board, on a small chassis, on perf board, or even breadboard fashion, if preferred for experimental purposes. The electrodes are small copper discs about the size of pennies soldered to lengths of flexible hook-up wire. The completed instrument may be housed conveniently in a commercial, sloping-front meter case.

The battery and switch may be replaced by a line-operated power supply such as illustrated in Fig. 2.

Although the lie detector's adjustment procedure is fairly simple, each step is important for optimum performance. First, adjust R1 and R3 to minimum resistance. Moisten the subject's index and middle fingers of one hand. Attach a copper disc electrode to each moistened finger, securing with plastic tape. The tape should be tight enough to insure good contact, but not so tight as to cut blood circulation. Close S1 and advance R1 until the meter's needle jumps from zero to full-scale. With the subject calm, readjust R1 for a meter reading of from one-tenth to one-third full-scale. Next, adjust R3 slowly, watching for meter movement, as you ask the subject questions which may excite him emotionally. With R3 properly adjusted, the meter should read full-scale only when the subject is excited or telling a lie. Some experimentation may be needed to achieve the proper setting.

Manufacturer's Circuit. With a range of from 10 to 100 seconds, the solid-state timing circuit shown in Fig. 3 is suitable for use in photography, scientific experiments, and a variety of other applications. It is one of a dozen hobby projects featured in the new CALECTRO HANDBOOK (published by GC Electronics, Inc., 3225 Exposition Place, Los Angeles, California 90018). A combination reference manual and catalog, the booklet includes hints on selecting loudspeakers and microphones, tips on using various components, suggestions for installing antennas, and a unique built-in Ohm's law slide-rule. Among the other projects described are several receivers, a light-controlled relay, AM and FM wireless micro-



**Experimenters
Hobbyists
Servicemen**

Whatever your direction, let RCA show you the way

...with RCA's New Linear IC Variety Pack — KD2117

Here's a great way to extend your integrated circuit know-how — Kit KD2117 provides a basic introduction to practical applications of these intriguing devices and an inexpensive way to build useful projects. The pack includes 2 KD2114 transistor arrays; 1 KD2115 audio amplifier; 2 KD2116 transistor arrays. Also, instructions for 12 useful circuits, schematics, parts lists, etc.

...with New Crystal and Zener Diodes

In addition to its quality line of SK replacement transistors, rectifiers, and integrated circuits, RCA now offers 4 zener diodes and 5 crystal diodes!

...with RCA Hobby Circuits News, HCN-3900

This is an exciting new publication loaded with interest for hobbyists and experimenters...published periodically.

...with KD Experimenter's Kits, Manuals, and Publications

Your RCA Distributor can be your one-source headquarters for Experimenter's Kits, Hobby and Experimenter Manuals, Hobby Circuits News, and RCA's Solid-State Replacement Guide, SPG-202G, a cross reference for almost 13,000 solid-state devices that RCA's SK's replace. Available from your RCA Distributor. RCA Electronic Components, Harrison, N.J. 07029

RCA

Sound us out

... and you will be listening to the most brilliant sound reproduction you can get from an automatic turntable.

The BSR McDonald 600.

Its precision British craftsmanship can be seen... and heard.

There's anti-skate control. And a tone arm that's so finely counterbalanced, this superb turntable can even play upside-down, and still track perfectly.

A pause control lever allows you to stop playing anywhere on the record and then repositions to the exact same groove.

Groovy.

And when the last record has played, the Decor-Matic power switch on the base shuts off both the turntable and the complete system automatically.

The BSR McDonald 600 must already be sounding pretty good to you. So when you're in the market for a hi-fi stereo system, be sure your dealer demonstrates it with a BSR McDonald turntable.

It'll speak for itself.

Write for detailed specifications on the 600 and all the BSR McDonald Automatic Turntables.



BSR (USA) LTD., BLAUVELT, N.Y. 10913



CIRCLE NO. 7 ON READER SERVICE PAGE

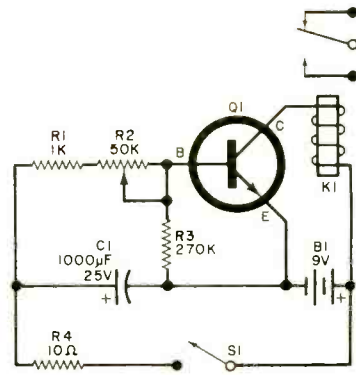

Fig. 3. Solid-state timing circuit has a range of 10 to 100 seconds determined by the setting of R2.

phones, amplifiers, a CPO, and a line-operated regulated d.c. power supply, with both schematic and pictorial diagrams provided in each case. Priced at a nominal fifty cents per copy, the booklet is available from any of the more than 800 CALECTRO distributors across the nation.

Referring to Fig. 3, the circuit features a low-leakage npn silicon transistor, Q1, as a common-emitter current amplifier controlled by a common RC timing network. A s.p.d.t. electromagnetic relay (K1) serves as Q1's collector load.

Without base bias, Q1's collector current is extremely small and the relay remains open. When S1 is closed momentarily, C1 is charged rapidly by B1 through current limiting resistor R4 and, thereafter, can serve as Q1's base bias source until discharged. With bias applied, there is a corresponding large increase in Q1's collector current, actuating K1. The relay remains closed for a period proportional to C1's discharge time which, in turn, depends on the network's RC time constant... that is, C1's value and the total resistance in its discharge path, R1, R2, and R3, shunted by Q1's base-emitter impedance. With fixed resistors used for R1 and R3, R2's setting determines C1's discharge time and hence this resistor serves as the circuit's timing range control.

Conventional parts are used in the project. A CALECTRO type K4-506 silicon transistor is used for Q1. Relay K1 is a 1000-ohm sensitive type (CALECTRO No. D1-962).

With neither layout nor lead dress critical, the timer is well suited to both breadboard and perf-board construction techniques, with the former preferred for demonstration or experimental applications. If desired, the unit may be housed in a small metal or plastic box for laboratory or darkroom work. Various settings of R2 may be calibrated by using a stopwatch (or even a regu-

EXCLUSIVE

NEW CB DESIGN

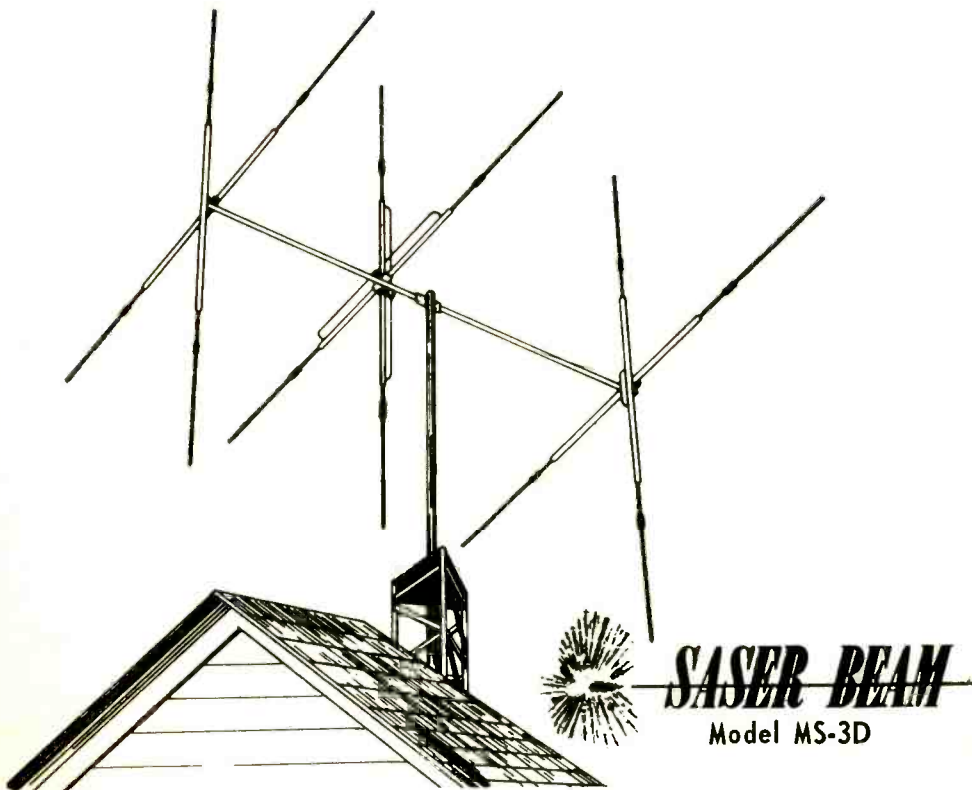

The Mosley Saser Beam cuts through CB interference like a laser cuts through steel. Switch polarization on this antenna and you cut down noise and interfering signals as much as 25 db. And you can count on its sturdy construction because, although it may look and act like a quad, it's built like a beam, with six crossed elements and no wires. It's miniaturized

like a Mosley Mini-Beam to save you space and cash.

Where can you get base station antenna value like this in only 43 cubic yards of air space? See the Saser Beam at your nearest Mosley dealer. For free brochure, with complete specifications and performance data, write factory direct Dept 188.

Mosley Electronics Inc.

4610 N. LINDBERGH BLVD., BRIDGETON MD. 63042

CIRCLE NO. 22 ON READER SERVICE PAGE



**1969—WINTER \$1.25
ELECTRONIC EXPERIMENTER'S
HANDBOOK**

148 pages of the most fascinating and challenging construction projects for the electronics hobbyists. All with complete schematics, illustrations, parts list, and easy-to-follow instructions that guarantee you perfect finished products.

**1969—SPRING \$1.25
ELECTRONIC EXPERIMENTER'S
HANDBOOK**

Another big package containing the most challenging, fun-to-build electronics projects ever! Be sure to order this one today!

1969 STEREO/HI-FI DIRECTORY \$1.25

Giant 180 page buyer's guide listing more than 1,600 individual Stereo/Hi-Fi components by 176 manufacturers. Nine individual sections complete with specs, photos, prices—the works!

6 Vital Components

*For Knowledge...
For Profit... For Sheer
Electronics Enjoyment!*



1969 TAPE RECORDER ANNUAL \$1.35

Over 130 pages covering every aspect of tape recording. Complete buyer's guide to the brands and models on the market. Expert tips on equipment—making better tapes—editing—copying—everything you want and need to know about tape recording.

**1969 \$1.35
COMMUNICATIONS HANDBOOK**

148 fact packed pages for the CB, SWL or HAM. Equipment buyer's guide—photos—tables—charts—getting a license—everything to make this the world's most complete guide to communications.

**1969 \$1.35
ELECTRONICS INSTALLATION &
SERVICING HANDBOOK**

Covers all 8 areas of consumer electronics servicing—all the tricks of the trade in one complete guide. The industry's "how-to" book for installing and servicing consumer electronics equipment.

ZIFF-DAVIS SERVICE DIVISION • Dept. W
595 Broadway, New York, N.Y. 10012

Please send me the annuals I've checked below:

- 1969 Electronic Experimenter's Handbook - Winter
- 1969 Electronic Experimenter's Handbook - Spring
- 1969 Stereo/Hi-Fi Directory
- 1969 Tape Recorder Annual
- 1969 Communications Handbook
- 1969 Electronics Installation & Servicing Handbook

I am enclosing \$_____ My remittance includes an additional 25¢ per copy for shipping and handling (Outside U.S.A. all magazines are \$2.00 per copy, postpaid.)

PE-10

print name _____

address _____

city _____

state _____ zip _____

PAYMENT MUST BE ENCLOSED WITH ORDER

lar watch with a sweep-second hand) as a standard.

In operation, the relay's contacts are used to control an external circuit, such as an enlarger's lamp.

New Devices. Two different technologies are combined in a small vidicon recently developed by RCA Electronic Components (Lancaster, Pa. 17604). Although the device is basically a vacuum tube, it utilizes a silicon diode array photoconductive target to achieve extremely high sensitivity. Tentatively identified as the type C23136 camera tube, the unit features magnetic-focus and magnetic-deflection, offers high resolution, and can withstand temperatures up to 200°C. With a nominal 1" diameter and an overall length of just over 6 inches, it is ideal for compact camera designs.

Radiation, Inc. (Melbourne, Florida 32901), a division of the Harris-Intertype Corporation, which earlier this year introduced the first off-the-shelf line of radiation-hardened integrated circuits (POPULAR ELECTRONICS, June 1969), has added five new TTL logic circuits to its line. The new devices include a Dual Type D Flip-Flop, a Quad 2-input NAND Gate, a Dual 2-input and/or INVERT Gate, a Dual 4-input NAND Gate, and a Quad 2-input AOI Gate. All the units are in standard TO-86 flat packages with Radiation's special dielectric isolation construction.

A new linear integrated circuit designed to provide the color difference signals in a color-TV set is being offered by the Sprague Electric Company (115 Northeast Cutoff, Worcester, Mass. 01606). Designated type ULN-2114K, the new device employs two fully balanced quadrature detectors and is assembled in compact TO-100 package.

Motorola Semiconductor Products, Inc. (P. O. Box 955, Phoenix, Arizona 85001) has introduced a number of new devices, including two pairs of low-cost plastic encapsulated silicon power transistors, a line of voltage-variable capacitance diodes, and a monolithic voltage/current regulator capable of kilovolt operation.

The new power transistors are designed for use in 20- and 35-watt complementary audio amplifiers. Types MJE205 and MJE-105 are 5-ampere, *nnp* and *pnnp* units, respectively, have a V_{CE0} rating of 50 volts and a power dissipation specification of 65 watts. The corresponding 10-ampere units are types MJE2801 (*nnp*) and MJE2901 (*pnnp*), with a V_{CE0} of 60 volts and a power dissipation rating of 90 watts.

Designated as types MV2101 through MV2115, Motorola's new line of plastic encapsulated tuning diodes cover the capacitance range of 6.8 to 100 pF nominal, with

typical tuning ratios of 3, measured at reverse voltages of 2 and 30 volts. With Q's as high as 450 minimum, the units are ideal for tuning and AFC applications.

Motorola's new integrated circuit voltage current regulator, type MC/1566L, is designed to control an external power transistor and will operate at any voltage or current level which the power transistor can handle. The unit has automatic crossover, remote sensing, remote programming, and both line and load voltage regulation of 0.01% plus 1 mV, with a current regulation of 0.1% plus 1 mA. Its high voltage capability is achieved by using a "floating" circuit design, with its operating voltage obtained from a separate isolated supply of about 25 volts d.c.

Transitips. You needn't look to special fast-acting fuses or expensive circuit breakers to protect your semiconductor devices from current overloads when testing experimental circuits if you'll borrow a tip from an "old-timer's" notebook. Just use a reliable, low-cost, linear, solid-state component—the common resistor.

The technique is relatively simple if, as is often the case, the protected device is operated at a fraction of its maximum rating in the test circuit. Just connect a resistor in

series with one side of the power source, by-passing with a moderately large capacitor.

As an example, let's assume you are checking an audio amplifier stage which requires a current of 1 ampere from a 12-volt source and, further, that your power transistor has a maximum rating of, say, 6 amperes. With a 2-ohm, 100-watt, resistor connected in series with the power source, the supply voltage is reduced by only 2 volts . . . not enough to affect any but the most critical circuits. Should a circuit wiring error or defect occur, however, the *maximum* current is held to 6 amperes for, at this value, the full source voltage is dropped across the series resistor. If circuit behavior is normal, the series resistor can be shorted for final tests.

In general, you can determine the resistance needed by applying Ohm's law. Divide the source voltage by the protected device's maximum current rating to establish resistance value, then multiply the maximum current and voltage values to obtain wattage, using the next higher standard wattage rating. Smaller . . . and less expensive . . . resistors may be paralleled to obtain higher wattage values at minimum cost. In the example given, 5 inexpensive 10-ohm, 20-watt resistors, connected in parallel, replaces a single 2-ohm, 100-watt unit. —Lou.

NEW

New Monitoradio Scanner can be push button *programmed* to search your choice of emergency frequency channels. It presents fascinating, lighted display for any or all of 1 to 8 crystal controlled frequencies. Scanner locks on active signal—resumes signal search at end of transmission. Performs manually or automatically, base or mobile, with complete ability to monitor complex simulcast or duplex FM base/mobile networks.



CIRCLE NO. 41 ON READER SERVICE PAGE

YOU are needed now for a BIG PAY JOB in ELECTRONICS!

Look at the ads in your newspapers! Check the BIG MONEY OPPORTUNITIES that await the man who knows ELECTRONICS!



TRAIN AT HOME SPARE TIME
Keep present job and income and you prepare for best pay jobs in this booming field!

EARN while you LEARN

A few months after enrolling you can be doing spare time Electronics repair jobs paying up to \$25 to \$35 for an evening's work!



PREPARE TO STEP INTO JOBS LIKE THESE:

Industrial Controls Maintenance
• Your Own Electronics Service Shop • Closed Circuit T.V. Installation Service • Electronic Computer Maintenance • Communications • Aerospace Work • Automation Electronics Installation... and hundreds more we'll tell you about!

LEARN BY DOING

Build and keep vital electronics test equipment from big kits we supply. All yours to use and keep!



Climb up into big pay as an Electronics Technician Specialist! Computers, communications, alarm systems, aircraft, space, machinery control... these are just a few places you can fit into Electronics with a secure, top paying job. You enjoy reading about Electronics... why not make it your career! We will train you as we have trained so many others. Earn while you learn at home in spare hours. The I. T. I. practical, learn-by-doing method prepares you as fast as you want to learn. Plan ahead for a big profit business of your own or a good job where the demand is so great there just aren't enough men to go around.

If you enjoy working with your hands as well as your mind, you can succeed in Electronics with I. T. I. practical home study Training. Your instructor works closely with you. Unlimited Consultation Service. Easy I. T. I. Work Sheets make learning fast and easy. Depend on more than 40 year's experience. Find out free and without obligation what ELECTRONICS can do for you!



FREE MAIL COUPON FOR BIG FACT BOOK

Get big Free fact pack! See how you learn fast at home; start earning fast! Rush coupon today!



I. T. I. APPROVED FOR TRAINING UNDER NEW G.I. BILL

MAIL COUPON FOR ELECTRONICS MONEY MAKING FACTS

Industrial Training Institute, Dept. 65189
815 Rosecrans, Los Angeles, Calif. 90059

Rush me big FREE BOOK, "Get Into Big Pay Electronics." Show how I can learn Electronics at home spare time

Name _____

Address _____

City _____ State _____ Zip _____

CIRCLE NO. 16 ON READER SERVICE PAGE

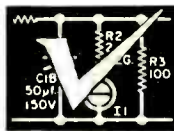

OPERATION ASSIST

Through this column we try to make it possible for readers needing information on outdated, obscure, and unusual radio-electronics gear to get help from other P.E. readers. Here's how it works: Check the list below. If you can help anyone with a schematic or other information, write him directly—he'll appreciate it. If you need help, send a postcard to Operation Assist, POPULAR ELECTRONICS, One Park Avenue, New York, N.Y. 10016. Give maker's name and model number of the unit. If you don't know both the maker's name and the model number, give year of manufacture, bands covered, tubes used, etc. State specifically what you want, i.e., schematic, source for parts, etc. Be sure to print or type everything legibly, including your name and address. Do not send an individual postcard for each request; list all requests on one postcard. Because we get so many inquiries, none of them can be acknowledged. POPULAR ELECTRONICS reserves the right to publish only those items not available from normal sources.

McMurdo Silver Model 802 receiver and 803 preamp. 1947. Schematics needed. (George B. Publow, Box 590, Picton, Ontario, Canada)

Hallicrafters SX-110 receiver. **Emerson** BJ-200 radio. Operating manuals and schematics needed. (Pete Vinci, 237 Oak St., New Britain, CT 06051)

RCA Radiola III A-1923. Horn type speaker plus WD-11 or UV-199 tubes needed. (Andy Brewer, 4917 Monte Vista Dr., Knoxville, TN 37914)

Eico Model 322 signal generator. Schematic and operating manual needed. (Rene Limue, 515 Dumaubin St., Drummondville, Que., Canada)

Bell Model 2256 amp. and 2255 FM/AM tuner; schematics needed. **GE** Model 704; operating instructions needed. (B.F. Slayman, 4122 Canyon Rd., Lafayette, CA 94549)

Webcor Model EP2611-1 recorder. Schematic needed. (Sid Wistrick, 416 East Charles St., Oelwein, IA 50662)

Simpson Electric Model 480 genescoper. **Precision** sweep generator Series E-400. Schematics and operator's manuals needed. (Leslie Shanks, 4810 Alma St., Corpus Christi, TX 78411)

Motorola Model H13-1AH handie-talkie. Any information needed. (Greg Newell, 19749 Elkhart, Harper Woods, MI 48236)

Hallicrafters Model S-39 Sky Ranger. Metal Cabinet needed. (V.E. Lingbloom, Elsie, NB 69134)

Recordio Corp. Model R-602 recorder. Service instructions and schematic needed. (P. Kitchin, 369 Nigel Ave., Vancouver 10, B.C., Canada)

RCA Victor Model 45-EY-2 Victrola. Schematic and parts list needed. (Allan Cronin, 3654 So. Marshfield Ave., Chicago, IL 60609)

Admiral Model =22C5A AM/FM stereo receiver with stereo phono input. Schematic, parts list and source for parts needed. (Dana G. Frisbee, P.O. Box 123, Glens Falls, NY 12801)

Stewart Warner Model R1885 AM-SW. Schematic needed. (Cliff Davis, 1122 Highland Dr., Grand Prairie, TX 75050)

AMATEUR RADIO

(Continued from page 86)

Hickok Model 600 tube tester. Instruction manual and updating information needed. (John Wilson, 10755 Thornview Dr., Sharonville, OH 45211)

DuMont oscilloscope Type 247. Instruction book needed. (M.C. Harman, 1418 Touhy Ave., Chicago, IL 60626)

Hallicrafters Model S-38B SW receiver. Schematic needed. (Larry Rasinski, Rt. #4, Box 76, Little Falls, MN 56345)

Power Instruments Inc. Model 920 show strobe and **Wabash Instruments** Model E-10 high intensity strobe; schematic and parts list needed. (J. Reese Brown III, 25 Berkshire Dr., Warren (Plainfield R.D. #1) NJ 07060)

Westinghouse Model H70ACS1 record player. Working 45 rpm spindle needed. (Margaret T. Foster, 14218 Orinoco Ave., East Cleveland, OH 44112)

Browning Labs Model RV-10A FM mono tuner. **Muntz TV Model 721TS** (1956) VHF only. Schematics and/or manual needed for both. (Daniel Meijer, 1438 Geranium St. NW, Washington, DC 20012)

Bell Model 360 professional tape recorder. Schematic and manual needed. (George R. Swieringa, 821 Kennedy St. NW, Washington, DC 20011)

Philco Model 7019 junior scope, circa late 40's. Instruction manual and schematic needed. (Tony Anderson, Box 17152, San Diego, CA 92117)

Morrow Model 5 BR-2 converter-tuner. Translucent calibrated slide rule dial plate or address of mfg. where it can be purchased needed. (Mack D. Baxter, P.O. Box 397, Marble Falls, TX 78654)

Telmar Model MA-105 walkie-talkie. Schematic and source for crystals needed. (Jeff Corey, 6606 N. Ridge, Chicago, IL 60626)

Pyramid Model CRA-2 capacity resistance analyzer. Manual and schematic needed. (H. R. Day, 1429 E. Griswold Rd., Phoenix, AZ 85020)

United Reproducers Corp. "Peerless Dynamic" field coil speaker, serial No. E 44641. Large coil and 6 terminals; no magnet. Power supply needed, but voltage and specs unknown. (Jeff Peters, 919 St. George Ave., Niagara Falls, Ont., Canada)

Zenith Model J880 AM/FM chassis 8H20Z. Power transformer needed. **Grundig "Transistor Box 59"**. Schematic and parts list needed. **Crescent Model R-25** steno wire recorder. Wire, reels, service data and operating manual needed. (Tom Hirsch, Holt Summit, MO 65043)

Mercury Model 1700 VTVM. Schematic and calibrating instructions needed. **Rutherford Model 400** citizen's radiophone. Schematic and alignment data needed. (James Murray, 14509 Cameo, Norwalk, CA 90650)

Zenith Model 5-S-119 SW receiver. Source for parts and dial hands needed. (Bob Patton, 2800 Elm, Parsons, KS 67357)

Mobile Communications Co. Model MFM-150 receiver and Model MFM-25-150 transmitter "taxi talkie". Schematics and any additional information needed. (K.A. McCrimmon, 114A Aliso Hall, California Polytechnic, Kellogg, Pomona, CA 91766)

Eico mono tuner. Eico MX99 adapter to convert tuner from mono to stereo needed. (W.E. Bumgarney, Box 62, Arcadia, MO 68815)

visited Russian hams give the impression that they are typical hams, personable and hospitable. And if Russian hams are 'our sort of guys,' isn't it possible that a lot of Russians are like Americans?

"Somehow, we'd like to reach out to the hearts and minds of Russian hams (and others behind the Iron Curtain). We plan to have special QSL's for Iron Curtain contacts. They are going to be overprinted on the nicest picture postcards of the Detroit area we can find. Believe me, any ham behind the Iron Curtain who gets my QSL card is going to get a first rate picture of a little bit of the United States—in particular, where I live! I'd like to see P. O. Box 88, Moscow, (address of the Russian QSL Bureau) flooded with such QSL's from all over the United States to show Russian hams (and any of their friends who looked over their QSL's) what it is like over here. We may not be able to carry on long conversations with Russian Hams (although some of them on 20 meter SSB do talk to Americans at some length), but let's remember the old axiom of one picture being worth a thousand words!"

VK/ZL/Oceania DX Contest. Phone, 1000 GMT (4:00 a.m., EST) October 4, until 1000 GMT, October 5. CW, 1000 GMT, October 11, until 1000 GMT, October 12. Some stations may be worked once per band to exchange usual signal reports and requested contest information. Send scores to: J. M. White, ZL2GX, Contests and Awards Man-

AUTOMATICALLY SCANS 8 PRE-PROGRAMMED CHANNELS — WITH PRIORITY CHANNEL FEATURE **SONAR AUTO-SCAN** **FM MONITOR RECEIVERS**



A highly dependable performer with superior professional features. AUTO-SCAN searches and locks automatically on any of 8 pre-programmed channels. Priority Channel locks to the exclusion of other signals. • Mobile Callbacks are heard because of carrier delay. • Designed for rugged use over wide temperature range. • Narrow band operation. • Operates from 117VAC or 12VDC, negative or positive ground. • Noise free squelch. • 8 crystal positions.

designed for:

- Police, Fire and Municipal Depts.
- County, State & Federal agencies
- Commercial & Industrial applications
- Other unlimited uses

FR-2514
(25-50MHz)

FR-2515
(150-175MHz)

Comes with AC and DC power cables, mounting bracket, less crystals. Crystals \$5.00 ea.

\$189⁹⁵

SONAR RADIO CORP., 73 Wortman Ave., Bklyn, N. Y. 11207

Please send information on Sonar AUTO-SCAN FM Monitor Receivers.

Name _____ Dept. 402

Address _____

City _____ State _____

CIRCLE NO. 33 ON READER SERVICE PAGE

ager, New Zealand Association of Radio Transmitters, Inc. (NZART), 152 Lytton Rd., Gisborne, N.Z.

Demagnetizing Screwdrivers. If your screwdriver has picked up enough magnetism to hang on to a screw you are trying to start in a tight corner, Phil Pichette, VE7ADW, suggests in the *Beaver Valley Clicks*, Beaver Valley ARC, Fruitvale, B.C. Canada, that you pull the trigger of your soldering gun and slowly insert the screwdriver blade in the wire tip of the gun and then slowly withdraw the blade. Do not release the solder-gun trigger until the screwdriver is completely outside the magnetic field of the tip; otherwise, you may magnetize rather than demagnetize the screwdriver tip.

NEWS AND VIEWS

John Jensen, VE3DDJ, 391 Sentinel Rd., Apt. 121, Downsview 466, Toronto, Ont., Canada, makes the best of a poor antenna situation with a Webster Band-Spanner mobile antenna mounted outside his window. It is 15 feet high. Feeding it with a Heathkit DX-60B transmitter, John worked 14 U.S. and two Canadian stations his first eight days on the air. Other VE3DDJ equipment includes Heathkit HR-10B receiver, HD-10 electronic keyer, and SB-600 monitor-scope. Of interest to those who have forgotten (or never knew) that 11 meters was once an amateur band—and still is in many parts of the world—John has an 11-meter trans-

ceiver and 3-element beam on the Canadian 11-meter amateur band . . . **Mark Dankoff, WN2HVV**, 1629 Clover St., Rochester, N.Y. 14618, says the ham whose idea of a QSO is "The weather here is . . . 73," is his pet peeve. Mark much prefers the chats in which the operators get to know each other. His Knight-Kit T-60 transmitter, Hammarlund HQ-70 receiver, and Gotham vertical antenna have worked 20 states, all confirmed, and all on 40 meters . . . **Tim Vandagriff, WN2GTQ**, (son) and **Clent Vandagriff, WN2GTS**, (father) 88 Boxwood Drive, Rochester, N.Y. 14617, received their Novice licenses together last summer. And if the schedule worked out as planned, they now have their Advanced tickets. Dad has 30 states and three countries confirmed. Their antenna sounds interesting—a homebrew, "broadband," 80-, 40-, and 15-meter inverted-V, 45 feet high. The family station consists of a Heathkit DX-60B transmitter and a HR-10B receiver. By the way, father and son both have 20-WPM code proficiency certificates.

Dan O'Connell, WN7LTA, Eugene, Oregon, really went all out when his amateur license arrived. In seven weeks, he worked 43 states and 19 countries. The 19 countries included 65 Japanese contacts, four Russians, and five New Zealanders. Dan uses a Hallicrafters HT-40 transmitter, Hammarlund HQ-110C receiver, and a 40-meter inverted-V dipole antenna on a single frequency on 15 meters. Undoubtedly the reason that Dan's antenna works so well is that he put it up in a cold rain with three feet of snow on the ground! . . . Another lad who knows what a ham license is for is **Dave Dolaway, WN3MDY**, 21 Lorana Ave., Bradford, Pa. 16701. In three weeks, he has confirmed 25 states and four countries mostly on 15 meters. He uses a Johnson Ranger transmitter, Mosley CM-1 receiver, and dipole antennas . . . **Martin Silverton, WN6MYT**, 1464 N. First Ave., Upland, Calif. 91786, started on the air with a borrowed Elmac trans-

CBERS' POLICEMEN FIREMEN NEWSMEN PHOTOGRAPHERS EMERGENCY GROUPS



TUNAVERTERS® WITH BUILT IN SQUELCH FOR NOISE FREE MONITORING!!

CONVERTERS ARE OUR BUSINESS—NOT A SIDE LINE!

Radio Frequency converters that enable your regular AUTO and HOME BROADCAST radios to be Excellent Sensitive, Selective HF, VHF, and UHF RECEIVERS! Tunable and/or crystal controlled—by just plugging in the NEW TUNAVERTER into the antenna input of the auto radio! (Use coupling loop for home and transistor radios).

—NO SOLDERING—NO SPECIAL ANTENNA—INSTALLS IN MINUTES

- Policemen • Firemen • Amateurs • CB'ers • Civil Defense • Emergency Groups • Sheriffs
- Detectives • Industry • Paging • Mobile Telephone • Shortwave • Marine • and others!

100% American Parts—output on 1500 kcs

SENSITIVITY—usable signal of 1/2 microvolt below 60 mcs., .9 microvolt above 60 mcs.

NEW PRO LINE!

- Built in SQUELCH!
- 2 selectable frequencies!
- Both Crystal controlled!
- 12 volt powered.

The perfect solution for low cost noiseless reception for any 1 or 2 frequencies between 100 to 175 mcs. Frequencies must be within 3% of each other. Complete with mount, coax, crystals as ordered, and instructions.

- Fully adjustable switch, • 4 1/2" X 2" X 3" inches.
- Crystals interchangeable within present range.
- Please state EXACT Listening Frequency!

PRO with one crystal, complete . . . \$39.95

PRO with two crystals, complete . . . \$44.95

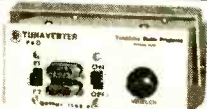

NEW SC LINE!

• Now an Economical single frequency converter available from 26 to 250 mcs!

Simple, foolproof converter that will do an excellent job on any one frequency. Squelch can be added!

- 12 volt powered, • 4" X 1 1/2" X 2 1/2"
- Complete with crystal, mount, and cable.
- Please state EXACT Listening Frequency.

Model SC, single channel . . . \$24.95

Model SC (W) for 182.35 mc weather only . . . \$19.95

Coupling Loop & Extension Antenna for using all Tunaverters with Home and Transistor radios . . . \$3.95

Order direct from—

Prompt shipment from stock!

HERBERT SALCH AND COMPANY
Marketing Division of Tompkins Radio Products
Woodsboro PF, Texas 78393

Prepaid orders postpaid.
\$0.80 each extra for Air Mail.
2 week Money-Back Guarantee!

FAMOUS S LINE!

- Tunable control or Crystal control at the Flip of a switch!
- Interchangeable crystals within band coverage!
- Built in SQUELCH!
- 12 volt powered!

- 3 section tuning capacitor, • King of the Converters! Save on built-in features!
- 6-1 reduction tuning, • Includes coax & mount
- 1 year guarantee, • 4 1/2" X 2 1/2" X 3 1/4" inches.

This space age Tunaverters S COMBINES the advantages of a drift free Crystal converter, the Versatility of a Tunable converter, and the Quietness of a Receiver with its many EXCLUSIVE features! Even OUTSHINES other crystal converters with its interchangeable crystals and ability to Peak Signal for maximum performance! YES, the performance of a receiver—yet with Economy & Small size of a converter and NO special antenna needed!

For: Model: Coverage: ONLY
Police, Fire & 348 S 33-48 mcs. \$44.95 ea.
VHF weather, etc. 15618 150-164 mcs.
Aircraft, towers, 1828S 118-128 mcs. (less crystals)

FAMOUS T LINE! Tunable only, 9 volt powered.

Marine 2 to 2.85 mcs. . . . \$19.95

Shortwave SWL 9.5 to 16 mcs. . . . \$19.95

SHORTWAVE & CHU; SWL C 7.335-16 mcs. . . . \$24.95

CRYSTALS for X, S, & PRO lines, 1,000 in stock! Ppd. State EXACT Listening frequency, output 1500kcs . . . \$5.10

Coupling Loop & Extension Antenna for using all Tunaverters with Home and Transistor radios . . . \$3.95



mitter until he acquired his own Johnson Ranger. His receiver is a Lafayette HA-350. He operates the three lower Novice bands and has 32 states and four countries worked. Martin's pet peeve is the Extra class operators who insist on sending directly on top of the WIAW code-practice sessions. As he says, "Strange, but it seems they start transmitting as soon as code practice begins. Just a coincidence, of course. Or is it?"



Jim Volstad, WNØTRY, Edina, Minn., really has to crank down the power on his Johnson Valiant transmitter to stay in the 75-watt Novice power limit.

Jim Volstad, WNØTRY, 7221 West Shore, Edina, Minn. 55435, uses a Newtronics 4-BTV vertical antenna on the 80-, 40-, and 15-meter Novice bands. Driving it with a Johnson Valiant transmitter and receiving on a Hallcrafters SX-100. Jim has racked up 37 states and two countries in eight months. He keys with a homebuilt I.C. keyer and will be glad to demonstrate how it works to you, if you need a Minnesota contact . . . **Stirling Whitcker, WN7JHO**, 315 North Burton, Burley, Idaho 83318, found Friday the 13th to be his lucky day. He passed his General class exam that day. His Novice log contained a record of 33 states worked with an Elnac AF-67 transmitter and a Hallcrafters SX-71 receiver in concert with a 40-meter dipole and a Hy-Gain 18-V vertical on 15 meters . . . From **Ed Gribi, WB6IZF**, Publicity Chairman of the WCARS net on 7255 kHz: WA6TKE/mobile reported an accident with injuries near Salinas, Calif., at 11:50 p.m., local time. Skip was long; so the information was relayed via WA9UWV, WB2RQP, and K4LD to K60AM, Palo Alto, Calif., who phoned the California Highway Patrol. Within 20 minutes of his original call, WA6TKE reported that help had arrived. Also, XE2EP, Baja California, Mexico, relayed the information from the Mexican police to the California authorities that a lost 7-year old American youngster had been found dead in the desert south of Mexicali, Mexico . . . **David Harris, WN1IGE**, 12 Bates St., Lexington, Mass. 02173, had worked 42 stations his first week as a Novice when he passed his General exam. "Keeping his hand in" while waiting for the new ticket to arrive, Dave has worked 25 states, three Canadian provinces, and Angola, Africa, (CR6LK). He uses a Heathkit HX-11 transmitter, a National NC-155 receiver, and separate dipoles for the Novice bands.

Will your "News and Views" or picture be in "Amateur Radio" next month? The first step is up to you. Have you written or sent the picture (preferably black and white)? We also appreciate being put on or kept on the mailing list to receive your club papers and announcements. The address is: Herb S. Brier, W9EGQ, Amateur Radio Editor, POPULAR ELECTRONICS, P.O. Box 678, Gary, Ind. 46401.

73, Herb, W9EGQ.

Which of these 4 fascinating Radio-TV careers

interests
you?

- disc jockey
- newscaster
- sportscaster
- announcer

**Our Free Voice Analysis Tells You
Whether You Have The Talent To
Become A Broadcast Personality!**

IMMEDIATE DEMAND • Radio-TV stations everywhere need both men and women to take over important good-paying jobs right now. **NATIONWIDE PLACEMENT ASSISTANCE** at No Extra Cost.

TRAIN AT HOME OR IN ONE OF OUR STUDIO SCHOOLS • You can study broadcast techniques at home, in your spare time, or in one of our many studio schools throughout the country under the supervision of our Directing Faculty of 11 Famous Broadcasters. Accredited Member National Home Study Council and National Association of Trade and Technical Schools.

**Approved for Veterans' Educational
Assistance Benefits ("G.I. Bill")!
Check coupon for special information**

Send to CAREER ACADEMY's division
of famous broadcasters for free book-
let, record and voice analysis details!

CAREER ACADEMY

825 North Jefferson Street • Studio 453
Milwaukee, Wisconsin 53202

I want to know if I have broadcasting aptitude
worth developing. Please rush more information.

name age

address phone

city/state/zip

07N087209

I am interested in: Home Study
 School Study G. I. Bill



CIRCLE NO. 9 ON READER SERVICE PAGE

It's yours free

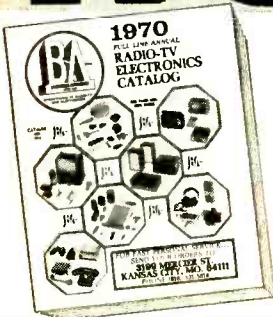

**GIANT 274 PAGE
1970
RADIO-TV
ELECTRONICS
CATALOG**

Write to:

**BURSTEIN-APPLEBEE CO.,
DEPT. PE-J 3199 MERCIER ST.,
KANSAS CITY, MO. 64111**

Name _____

Address _____

City _____

State _____ Zip Code _____

CIRCLE NO. 8 ON READER SERVICE PAGE

1400-PC. GLASS FIBER OPTIC KIT

It's FUN! It's Educational! It's Gifty!



\$4.88

- ★ Make light "pipes"
- ★ Dazzling displays
- ★ Triggers photo & infra-red cells

OPTICAL SCIENTIFIC BREAKTHRU!
Allows "hair thin" glass fibers (2-ft. long) to transmit & receive cold light energy of any color, by internal reflection. Bundled, jacketed, it guides, snoots, pipes light around corners, walls, even in circles, triggering such devices as light sensitive transistors, diodes, sers. It CUTS, BENDS, ACTS like wire. Only one's imagination controls its 1000+ of uses. FREE: 12-pc. accessory kit, with "how-to-do booklet".

- \$25 SURPRISE PAK: transistors, rect. diodes, etc. .. \$1
- 50 GERMANIUM GLASS DIODES, 1N34, 1N48 no test \$1
- 40 TOP HAT SILICON RECTIFIERS, no test asst values \$1
- 25 EPOXY RECTIFIERS, silicon asst, no test \$1
- 40 PRECISION RESISTORS, 1/2-2W, 1% asst values .. \$1
- 30 TRANSISTORS, rf, if, audio, osc, no test \$1
- 60 TUBULAR CONDENSERS, to .5mf to 1KV, asst ... \$1
- 50 DISC CONDENSERS, to .05mf npo, temp coef, asst \$1
- 30 POWER RESISTORS, to 25 watts, to 24K ohms \$1
- 10 VOLUME CONTROLS, to 1 meg, switch too! \$1
- 10 ELECTROLYTICS, to 100mf, tubulars too, asst ... \$1
- 50 RADIO & TV KNOBS, asst'd colors & styles \$1
- 10 TRANS'OR ELECTROLYTICS to 100mf, asst values \$1
- 50 COILS AND CHOKES, if, rf, ant, osc, peaking, etc \$1
- 65 HALF WATTERS, to 1 meg, 5% popular values too \$1
- 2 FIELD EFFECT TRANSISTORS, n channel, hobby \$1
- 10 PANEL SWITCHES, toggle, slide, micro, rotary .. \$1
- 3 "SUN" BATTERIES, for 100's of lite sens proj's ... \$1
- 5 "IBM" COMPUTER BOARDS, many trans, diodes, \$1
- 40 "MICRO" CONDENSERS, for transistor circuitry \$1
- 50 TERMINAL STRIPS, 1 to 8 lug types \$1
- 4 PHOTO ELECTRIC CELLS, hi. imp., schematic \$1
- 40 "TINY" RESISTORS, 1/10W, 5% too! to 1 meg, \$1

ADD POSTAGE, avg. wt: 1/2 lb. CATALOG 10¢

POLY PAKS
P.O. BOX 942E
LYNNFIELD, MASS.
01940

CIRCLE NO. 27 ON READER SERVICE PAGE

STEREO SCENE

(Continued from page 77)

your car. (Incidentally, when you do, you'll discover that the tapes may not sound as clear and clean in your living room as they do in the car, where road and engine noise mask their imperfections.)

Many New Cassette Machines. The Scene in cassette tape recorders this year is bright with new machines, most looking like last year's but with some notable exceptions. For example, Ampex, Bell & Howell and Wollensak have gone all out to provide eye-appealing units. You'll find the biggest assortment ever offered, and you may be confused at first because many of the sets fall into the compact category, as mentioned earlier. The best bet is to figure out what you want your recorder to do and then find one that will do it. You'll have a big range of prices from which to pick—again a result of competition among manufacturers.

In reel recorders you'll find a smaller supply on store shelves, the prices generally will be a bit under last year's, and there will be more high-priced units of "pro" calibre (in line with the greater sophistication of "Mr. Stereo Buyer"). Since the industry is in a state of transition, there will be a lot of really hot buys in reel recorders this fall. The hottest will be in self-contained stereo units with built-in or detachable speakers.

As with some of the other products, the important changes in reel recorders are in refinements and subtle improvements. Perhaps the most noticeable trends are those involving automatic reversing and easier tape threading.

All in all, the Stereo Scene this fall and winter is an interesting and exciting one. Go out and see for yourself. -30-

It's Show Time, Folks!

All the latest in stereo systems, components, etc., will be on view October 1 to 5 at the Los Angeles Hi-Fi Show in the Ambassador Hotel. A feature of the Show is a series of seminars on such topics as "Changers, Turntables and Cartridges," "The Stereo Sensation," and "Speakers and Amplifiers."

Canadian stereo fans will be able to make the scene October 16 to 19 when the "Stereo 70" Hi-Fi Home Entertainment Show, sponsored by electron magazine will be held at the Sheraton Mount Royal Hotel in Montreal.

POPULAR ELECTRONICS

SHORT-WAVE LISTENING

(Continued from page 84)

logged at 1016-1115 with piano music and news and at 1300-1320 with BEC news, home news, and classical music.

Belgium—Brussels noted on a new frequency of 11.714 kHz at 2315 with an IS and a multi-lingual s/on.

Biafra—R. Biafra noted on 7300 kHz at 0500 with ID. 0529 with drum IS. 0530 time signal, bugle call and news and 0540 with ID. This may vary slightly upward in frequency.

Bolivia—CP110. R. Norte, Montero, has returned, after an absence of several months, to 4871 kHz where it is heard after 2300 in Spanish.

Brazil—R. Marajoara, Belem, is testing on 4956 kHz with complete ID's being given often; try around 0450.



Jeff Falconer, VE3PE2PG, Clinton, Ontario, has logged 25 countries and 30 states using his Trio 705 receiver driving a 130-foot longwire antenna.

Canada—CFVP, 6030 kHz, 100 watts, relays CFCN, 1060 kHz, Calgary. CFRX, 6070 kHz, Toronto, is often good in the northeastern states during daylight hours. CHNX, 6130 kHz, Halifax, is good at 0115-0200 with music and a religious program. CFCW, Montreal, is very good on 6005 kHz most evenings. (Editor's note: an overseas publication has listed this outlet as CFCW. This is incorrect. CFCW is a medium-wave outlet, 10 kW power, on 790 kHz in Camrose, Alberta. The correct call for the short-wave outlet on 6005 kHz is CFCX. Please amend your logbooks and listings accordingly.)

Chile—If you have trouble logging this country, try for amateur station CE8AE, which often operates around 0700 in the lower end of the 40-meter ham band with xmsn's in single-sideband. Reports, if you're lucky enough to hear him, go to Radio Club of Chile, Box 13630, Correo 15, Santiago, Chile.

China—R. Peking was noted on 15.090 kHz at 1400-1555 s/off (broken at 1455-1500) with English news, commentaries and music.

Cuba—In addition to the English language schedule listed last month, *Radio Havana Cuba* also has English to northern Europe at 2010-2140 on 17.855 kHz.

Ecuador—HCJB, Quito, is good on 15.200 kHz at 2245-2259 in Russian and to 2330 in German, beam-

October, 1969

THROW AWAY THE SOLDER OR MY DADDY USES CUSS WORDS

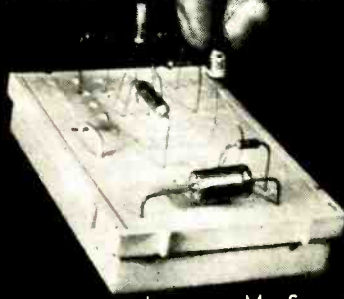

Some years ago two men, Mr. S. and Mr. deC had an idea. Wearing white hats they dutifully offered it to the giant electronics conglomerate under whose roof they laboured. He sneered so they left and developed it on their own.

It's a solderless breadboard and the secret lies in a precision clip of firm grasp and low resistance. These clips are leafspring contacts of phosphor bronze or silverplate.



As with all good things customers came up with more ideas in using S-DeCs than the originators believed possible and the demand for added flexibility resulted in a box with two interlocking S-DeCs known as DeCSTOR, (pronounced Deck-Store). Not content with this, users circuits outgrew the DeCSTOR and so a 4-DeC kit was created for the man with ideas bigger than his breadboard. Today there is a whole range of DeC solderless breadboards covering conventional and integrated circuit requirements.

So, if you need to throw away the solder, keep the skin on your fingers and the black words buried down below, write to us for more information, or better still send us a check.

INTRATEC

399 Jefferson Davis Highway
Arlington, Virginia 22202

Please send me postage paid:

..... S-DeC's	@ \$5.75 each
..... DeC STOR's	@ \$11.75 each
..... 4-DeC's	@ \$20.75 each

I enclose a check/money order for \$.....

Va. residents add 4% sales tax

I am interested in the IC versions. Send literature and prices.

Name

Address

City

State Zip Code

Box PE-10

CIRCLE NO. 17 ON READER SERVICE PAGE

ed to L.A. and Brazil. In parallel was 17,890 kHz but the listed parallel of 15,115 kHz was evidently superseded by this new frequency of 15,200 kHz. HCIRF. Canal Manabita, Portoviejo, has moved slightly upward to 4821 kHz where they feature light music to past 0700.

Egypt—New frequencies in use by Cairo include 11,790 kHz, testing from 1830-2300 in Arabic, French, German, English and Italian; 15,090 kHz, testing to N.A. in French and Arabic but announced as being only on 11,815 kHz; but at 0220-0230; and on 21,685 kHz at 1630-1650 with usual native Arabic music and speech.



Temporarily a resident of Kingston, Jamaica, Glenn Little, WPE4IYC, has a 20-state DX Award. He uses a Hallicrafters S-38, Onkyo OS-175, 2X4+ Superhet.

El Salvador—*La Voz del Camerico* (?), YSV, Santa Ana, noted often on 9576 kHz around 1345-1630; may also identify as *R. Comercial*.

England—The European Service of the *BBC* in single-sideband with Russian at 0053, an English ID at 0100, and back into language is on 12,180 kHz. The regular Asian Service to Malaya and Singapore is often good on 15,375 kHz at 2300-2315 with English news and commentary and, from 2315, in Indonesian.

Estonia—A tentative logging is that of *R. Tallinn*, 17,700 kHz, at 1800 with the regular Moscow IS and in a strange language, perhaps Estonian, until 1820, and with music until 2029.

Finland—OIX4, Pori, has English to N.A. at 2300-2330 with news, discussions, DX tips and other

features, on 15,185 kHz. At 2330 they go into Finnish.

France—Paris is good on a new frequency of 11,965 kHz from 0030 s/on in Spanish and French to L.A. and from 0215-0230 in French and from 0230 in Spanish. Other channels monitored include 11,915 kHz with English news at 0525 and into French with news and music to 0546 s/off; 15,120 kHz at 1930 with news and music; and on 17,740 kHz at 0525-0545 with English news and light music.

Ghana—*R. Ghana*, Accra, has English to N.A. at 2000 on 9760 kHz; reception here and on parallel 11,850 kHz is generally good.

Holland—*R. Nederland*, Hilversum, has replaced 11,730 kHz with 15,220 kHz at 2125-2250, dual to 15,425 kHz in English to N.A. with world and local news, commentary, editorial information, light music and other features.

Honduras—HRVC, Tegucigalpa, carries English daily at 0300-0400 on 4820 kHz. This station, operated by American Baptists, programs religious features. Other xmsn's are in Spanish to L.A. areas. The medium-wave outlet, heard at times in Southern states, is on 1380 kHz with 1000 watts. Reports go to Box 270, Tegucigalpa.

Indonesia—*R. Republik Indonesia*, Menado, is often noted on 5987 kHz from 0800 to past 1100. This 10-kW station is heard best, of course, on the West Coast.

Iran—*R. Tehran* carries Russian at 1730-1800, Turkish 1800-1830, Arabic 1830-1900, German 1900-1930, French 1930-2000 and English 2000-2030, all on 17,735 and 15,135 kHz. The former is a new frequency for this service.

Ivory Coast—*R. Abidjan*, 11,920 kHz, was logged at 1835 with English and French ID's, English news to 1843 and African music to 1900.

Korea (North)—*R. Pyongyang* was noted on 9613 kHz at 0900 with an IS and anthem, ID in Russian, and into news to 0910. Dual to 11,765 kHz, it was not heard on either of its other parallel channels, 6480 or 7580 kHz.

Malagasy Republic—Tananarive was heard with its IS at 0329 and into usual programming at 0330 on 4960 kHz.

New Caledonia—*R. Noumea*, 7170 kHz, is fair to good in western areas at 1005-1100 with Dixieland

SHORT-WAVE ABBREVIATIONS

anmt—Announcement	kW—Kilowatts
BBC—British Broadcasting Corp.	L.A.—Latin America
EST—Eastern Standard Time	N.A.—North America
GMT—Greenwich Mean Time	QRM—Interference
ID—Identification	R—Radio
IS—Interval Signal	s/on—Sign-on
kHz—Kilohertz	xmsn—Transmission
	xmtr—Transmitter

PROFESSIONAL TYPE MOBILE MONITOR RECEIVER

Solid State FM / Crystal Controlled / 6 Channels..... \$99⁹⁵

LESS
CRYSTALS



SEND
FOR FREE LITERATURE



This expertly engineered, all solid-state, crystal controlled FM receiver provides instant monitoring of the VHF frequencies between 39 and 46 mcs or 153 to 157 mcs. Outdating all of the bulky tube-type monitors which take up needed space under dashboards, the compact Ameco Model MRT-6 high band or MRT-7 low band unit measures only 2-1/8" high by 5-5/16" wide by 7-7/8" deep. It's a professional type receiver with latest double conversion super-heterodyne circuitry providing 3/4 microvolt sensitivity for 20 db quieting. Has built-in speaker and mobile mounting bracket. Optional AC power supply available.

DIVISION OF AEROTRON / BOX 6527 / RALEIGH, N. C. 27608

CIRCLE NO. 1 ON READER SERVICE PAGE

and classical music selections; news in French is aired at 1055 and s/off is at 1100.

Nicaragua—The new *R. Nacional de Nicaragua*, Managua, continues to be well heard on 11,875 kHz at 1640-1655 with pop music. 1810-1820 with French-Spanish language lessons. 1940-2000 with variety music and ID's and, at times a series of chimes, and at 2100-2230 with classical and light music and news in Spanish. This outlet relays the medium-wave YNM. 615 kHz.

Peru—OAX4V. *R. America*, Lima. 9505 kHz, was logged at 0050-0100. 0200-0208 and 0358-0416 with L.A. music, commercials, frequent ID's and short newscasts. Do not confuse with *R. Continental de Arequipa* on 9452 kHz; this latter station often relays *R. America* even to the point of including *R. America* at the start and close of newscasts.

Poland—*R. Warsaw* has English to N.A. at 0315-0345 Saturday (Friday evening, EST) on 11.870

SHORT-WAVE CONTRIBUTORS

Stanley Mayo (WPEIGMF), Portland, Maine
 Arthur Bouduc (WPEIHQV), Biddeford, Maine
 Rick Mills (WPEHSA), Berwick, Maine
 C. A. Bugbee (WPEUO), Manchester, N. H.
 Peter Macinta (WPE2ORB), Kearny, N. J.
 Gary Becker (WPE3FPF), E. Northport, N. Y.
 Steve Celli (WPE2PSK), Baldwin, N. Y.
 William Szabo (WPE2QVF), Rochelle Park, N. J.
 Robert Arnold (WPE2QPR), Canastota, N. Y.
 Rev. Michael Mayer (WPE2QUV), New York, N. Y.
 Ronald Shopinski (WPE3DK1), Mt. Carmel, Pa.
 Matt Zahner (WPE3EH), Baltimore, Md.
 Scott Moeller (WPE3HLS), Villanova, Pa.
 Thomas Gongaware (WPE3HUU), Latrobe, Pa.
 Dan Ferguson (WPE4AUL), Coral Gables, Fla.
 Grady Ferguson (WPE4BC), Charlotte, N. C.
 Joey Leonard (WPE4KAF), Winston-Salem, N. C.
 Terry Luttrell (WPE4KBS), Columbia, Tenn.
 Richard Fortson (WPE5EWX), Edinburg, Texas
 Terry Ward (WPE5EZX), El Paso, Texas
 Charles Bennett (WPE5SW), Sumrall, Miss.
 Stewart Mac Kenzie (WPE6AA), Huntington Beach, Cal.
 Jim Young (WPE6EVA), Wrightwood, Cal.
 Winston Klontz (WPE6EVO), Los Angeles, Cal.
 Chuck Sadoian (WPE6HHG), Dinuba, Cal.
 Bob Wisner (WPE6HIC), Watsonville, Cal.
 Nick Chinn (WPE6HKB), San Leandro, Cal.
 Bob Brulte (WPE6HLP), Ontario, Cal.
 Chris Taylor (WPE7CLE), Puyallup, Wash.
 David Williams (WPE7CWE), Astoria, Ore.
 Philip Mader (WPE8KI), Cleveland, Ohio
 Daniel Leahy (WPE8KH1), Detroit, Mich.
 Bob Moser (WPE9ASH), Chicago, Ill.
 Joseph Gibson (WPE9CVM), Milwaukee, Wis.
 Gerry Dexter (WPE9HDB), Lake Geneva, Wis.
 Richard Pistek (WPE9HOB), Chicago, Ill.
 Richard Slonina (WPE9ILD), Chicago, Ill.
 Joseph Wojnowski (WPE9JMU), Worth, Ill.
 John Patterson (WPE9JOL), Oswego, Ill.
 Curtis Knight (WPE9JNK), Appleton, Wis.
 Dave Newkirk (WPE9JSH), Norridge, Ill.
 A. R. Niblack (WPE9KMI), Vincennes, Ind.
 John Beaver (WPE9QAE), Pueblo, Colo.
 Jim Randles (WPE9QWK), Cunningham, Kan.
 Jim Honan (WPE9QUS), Florissant, Mo.
 Martin Fossum (WPE9PFF), Cass Lake, Minn.
 John Van Engelenhoven (WPE9FNM), Oskaloosa, Iowa
 Jack Perolo (PY2PEIC), Sao Paulo, Brazil
 John Griffin (VE6PEV), Calgary, Alta.
 Yitzhak Weinbaum (4X1PE1V), Tel-Aviv, Israel
 Leo Alster, Rahway, N. J.
 Kevin Banet, Calumet City, Ill.
 David Citron, Hollywood, Fla.
 Robert Devine, Honolulu, Hawaii
 Rick Dressel, Wilmington, Del.
 Ronald Dudinski, Wilkes-Barre, Pa.
 Dan Finigan, Fairfax Station, Va.
 John Hedstrom, Wheaton, Ill.
 John Hudak, Oakville, Ont.
 Bill Martin, Wilmington, Del.
 C. R. Patterson, Decatur, Ga.
 Richard Sewell, Gaylord, Mich.
 Kenneth Shaw, Somerville, N. J.
 Dan Tschopp, Humble, Texas
 Bill Wulff, Eau Claire, Wis.

Build this magnificent Schober Theatre Organ

for only
* \$1550!



*Includes finished walnut console. Amplifier, speaker system, optional accessories extra. Only \$1150.50 if you build your own console.

You couldn't touch an organ like this in a store for less than \$3500—and there hasn't been a musical instrument with this vast variety of genuine Theatre Organ voices since the days of the silent movies! If you've dreamed of the grandeur of authentic big-organ sound in your own home, you won't find a more satisfying instrument anywhere—kit or no kit.

You can learn to play it. And you can build it, from Schober Kits, world famous for ease of assembly without the slightest knowledge of electronics or music, for design and parts quality from the ground up, and—above all—for the highest praise from musicians everywhere.

Send right now for your copy of the full-color Schober catalog, containing specifications of the five Schober Organ models, beginning at \$599.50. No charge, no obligation—but lots of food for a healthy musical appetite!

The Schober Organ Corp., Dept. PE-31
 43 West 61st Street, New York, N.Y. 10023

- Please send me Schober Organ Catalog and free 7-inch "sample" record.
 Enclosed please find \$1.00 for 12-inch L.P. record of Schober Organ music.

NAME _____

ADDRESS _____

CITY _____ STATE _____ ZIP _____

CIRCLE NO. 32 ON READER SERVICE PAGE

FREE 1970 CATALOG.

1001 Bargains—Speakers—Parts—Tubes—High Fidelity Components—Record Changers—Tape Recorders—Kits—Everything in Electronics. Write:

McGEE RADIO COMPANY
 P.E. 1901 McGee Street,
 Kansas City, Missouri 64108.

GET INTO ELECTRONICS

V.E.T. training leads to success as technicians, field engineers, specialists in communications, guided missiles, computers, radar, automation. Basic & advanced courses. Electronic Engineering Technology and Electronic Technology curricula both available. Associate degree in 20 months. B.S. obtainable. G.I. approved. Start September, February. Dorms campus. High school graduate or equivalent. Catalog.

VALPARAISO TECHNICAL INSTITUTE
 DEPARTMENT PE, VALPARAISO, INDIANA 46383





Better than
9 out of 10
CIE men win
their "ticket"
the very first
time they try
NATIONAL AVERAGE
IS ONLY 1 OUT OF 3!

Cleveland Institute of Electronics

WARRANTY

of success in obtaining a
Government FCC License

The Cleveland Institute of Electronics hereby warrants that upon completion of the Electronics Technology, Broadcast Engineering, or First-Class FCC License course, you will be able to pass the FCC examination for a First Class Commercial Radio Telephone License (with Radar Endorsement);

OR upon completion of the Electronic Communications course you will be able to pass the FCC examination for a Second Class Commercial Radio Telephone License;

AND in the event that you are unable to pass the FCC test for the course you select, on the very first try, you will receive a FULL REFUND of all tuition payments.

This warranty is valid for the entire period of the completion time allowed for the course selected.

G. O. Allen

Dr. G. O. Allen
President

You can earn more money if you get an FCC License

...and here's our famous CIE warranty that you will get your license if you study with us at home

NOT SATISFIED with your present income? The most practical thing you can do about it is "bone up" on your electronics. pass the FCC exam, and get your Government license.

The demand for licensed men is enormous. Ten years ago there were about 100,000 licensed communications stations, including those for police and fire departments, airlines, the merchant marine, pipelines, telephone companies, taxicabs, railroads, trucking firms, delivery services, and so on.

Today there are over a million such stations on the air, and the number is growing constantly. And according to Federal law, no one is permitted to operate or service such equipment without a Commercial FCC License or without being under the direct supervision of a licensed operator.

This has resulted in a gold mine of new business for licensed service technicians. A typical mobile radio service contract pays an average of about \$100 a month. It's possible for one trained technician to maintain eight to ten such mobile systems. Some men cover as many as fifteen systems, each with perhaps a dozen units.

Coming Impact of UHF

This demand for licensed operators and service technicians will be boosted again in the next 5 years by the mushrooming of UHF television. To the 500 or so VHF television stations now in operation, several times that many UHF stations may be added by the licensing of UHF channels and the sale of 10 million all-channel sets per year.

Opportunities in Plants

And there are other exciting opportunities in aerospace industries, electronics manufacturers, telephone companies, and plants operated by electronic automation. Inside industrial plants like these, it's the licensed technician who is always considered first for promotion and in-plant training programs. The reason is simple. Passing the Federal government's FCC exam and getting your license is widely accepted proof that you know the fundamentals of electronics.

So why doesn't everybody who "tinkers" with electronic components get an FCC License and start cleaning up?

The answer: it's not that simple. The government's licensing exam is tough. In fact, an average of two out of every three men who take the FCC exam fail.

There is one way, however, of being pretty certain that you will pass the FCC exam. And that is to take one of the FCC home study courses offered by the Cleveland Institute of Electronics.

CIE courses are so effective that better than 9 out of every 10 CIE-trained graduates who take the exam pass it. That's why we can afford to back our courses with the iron-clad Warranty shown on the facing page: you get your FCC License or your money back.

There's a reason for this remarkable record. From the beginning, CIE has specialized in electronics courses designed for home study. We have developed techniques that make learning at home easy, even if you've had trouble studying before.

In a Class by Yourself

Your CIE instructor gives his undivided personal attention to the lessons and questions you send in. It's like being the only student in his "class." He not only grades your work, he analyzes it. Even your correct answers can reveal misunderstandings he will help you clear up. And he mails back his corrections and comments the same day he receives your assignment, so you can read his notations while everything is still fresh in your mind.

It Really Works

Our files are crammed with success stories of men whose CIE training has gained them their FCC "tickets" and admission to a higher income bracket.

Mark Newland of Santa Maria, Calif., boosted his earnings by \$120 a month after getting his FCC License. He says: "Of 11 different correspondence courses I've taken, CIE's was the best prepared, most interesting, and easiest to understand."

Once he could show his FCC License, CIE graduate Calvin Smith of Salinas, California, landed the mobile phone job he'd been after for over a year.

Mail Card for Two Free Books

Want to know more? The postpaid reply card bound-in here will bring you free copies of our school catalog describing opportunities in electronics, our teaching methods, and our courses, together with our special booklet, "How to Get a Commercial FCC License." If card has been removed, just mail the coupon at right.

THESE CIE MEN PASSED THE FCC LICENSE EXAM... NOW THEY HAVE GOOD JOBS

Matt Stuczynski,
Senior Transmitter
Operator, Radio
Station WBOE



"I give Cleveland Institute credit for my First Class Commercial FCC License. Even though I had only six weeks of high school algebra, CIE's AUTO-PROGRAMMED® lessons make electronics theory and fundamentals easy. I now have a good job in studio operation, transmitting, proof of performance, equipment servicing. Believe me, CIE lives up to its promises."

Chuck Hawkins,
Chief Radio
Technician, Division
12, Ohio Dept.
of Highways



"My CIE Course enabled me to pass both the 2nd and 1st Class License Exams on my first attempt. I had no prior electronics training either. I'm now in charge of Division Communications. We service 119 mobile units and six base stations. It's an interesting, challenging and rewarding job. And incidentally, I got it through CIE's Job Placement Service."

ENROLL UNDER NEW G.I. BILL: All CIE courses are available under the new G.I. Bill. If you served on active duty since January 31, 1955, OR are in service now, check box on reply card for G.I. Bill information.

Cleveland Institute of Electronics
1776 E. 17th St., Cleveland, O. 44114

Please send me without cost or obligation: Your 44-page book "How To Succeed in Electronics" describing the job opportunities in Electronics today, and how your courses can prepare me for them. Your book on "How To Get A Commercial FCC License."

I am especially interested in:

- | | |
|--|--|
| <input type="checkbox"/> Electronics Technology | <input type="checkbox"/> Electronic Communications |
| <input type="checkbox"/> Broadcast Engineering | <input type="checkbox"/> Industrial Electronics |
| <input type="checkbox"/> First Class FCC License | <input type="checkbox"/> Electronics Engineering |

Name _____ (PLEASE PRINT)

Address _____

City _____

State _____ Zip _____ Age _____

Check here for G.I. Bill information

PE-89

2 NEW CIE CAREER COURSES

1. **BROADCAST (Radio and TV) ENGINEERING**...now includes Video Systems, Monitors, FM Stereo Multiplex, Color Transmitter Operation and CATV.

2. **ELECTRONICS ENGINEERING**...covers steady-state and transient network theory, solid state physics and circuitry, pulse techniques, computer logic and mathematics through calculus. A college-level course for men already working in Electronics.

CIE Cleveland Institute of Electronics
1776 East 17th Street, Cleveland, Ohio 44114

CIRCLE NO. 10 ON READER SERVICE PAGE

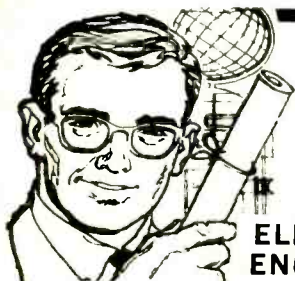

Earn Your Degree ELECTRONICS ENGINEERING through HOME STUDY

HIGHLY EFFECTIVE HOME STUDY COURSES IN:

- ELECTRONICS ENGINEERING TECHNOLOGY
- ELECTRONICS ENGINEERING MATHEMATICS

Earn your Associate in Science Degree in Electronics Engineering and upgrade your status and pay to the engineering level. Complete college level courses in Electronics Engineering. We're a forward looking school. Outstanding lesson material—thorough and easy to understand. Engineering taught on the basis of application and understanding rather than on the basis of memorization. Up to date in every respect. Acquire the knowledge and ability that means the difference between a low paying technician job and a high paying engineering position. Low tuition cost with low monthly payments. Free engineering placement service for our graduates. Write for free descriptive literature. Ask for bulletin G, no salesman will call on you.

COOK'S INSTITUTE of Electronics Engineering



Southwest Regional Office
P.O. Box 36185

Houston, Texas 77036

Established 1945

Formerly

Cook's School of Electronics

CIRCLE NO. 11 ON READER SERVICE PAGE

COLOR ORGAN ONE KILOWATT-FOUR CHANNELS ULTRA - COMPACT - LOW COST

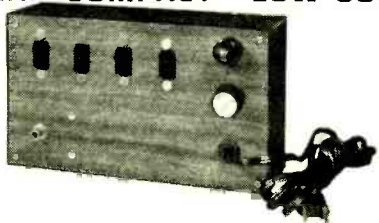

Printed Circuit Board Kit..... \$ 49.95
Factory Assembled..... \$ 65.00

NEW: 2.4 KILOWATTS-FOUR CHANNELS

(600 watts per channel)

TUNABLE R-C FILTERS-TRIAC POWER STAGES

Printed Circuit Board Kit..... \$ 85.00
Factory Assembled..... \$100.00

FOUR KILOWATTS-FOUR CHANNELS

(1Kw per channel)

Factory Assembled..... \$200.00

Add \$2.00 For Handling And Shipping Costs

N. J. Residents Add 3% Sales Tax

(Payment Must Accompany Order)

EDISON INSTRUMENTS, INC.

54 West Cherry Street • Rahway, N. J. 07065

(201) 381-0140

CIRCLE NO. 13 ON READER SERVICE PAGE

kHz with news, talks, a stamp program and national music.

Rwanda—*Deutsche Welle* relay. Kigali, has been tuned at 1745 s/on in English on 15.435 kHz, 0600 s/on in English on 11.785 kHz, and at 2030 s/on in German on 15.380 kHz. Test xmsn's have been found on 17.865 kHz at 0050 to past 0230 with amts in German, English, French and another, unidentified, language.

Solomon Islands—VQO4. Honaira, is often good in the west at 1100-1130 with news, British press review and a religious program. This is on 3995 kHz and listeners may experience hamband QRM.

South Africa—R. RSA, Johannesburg, is now utilizing 9715 kHz, dual to next-door 9705 kHz, from 2330 s/on in English to Newfoundland and Eastern N.A.

Turkey—R. Ankara continues to be fairly well heard on 15.160 kHz in English to N.A. at 2200-2230. Monitoring reports indicate considerable QRM from *Voice of America*; other reporters state the frequency to be now relatively clear of interference.

USSR—Kalinin is reported on 15.470 kHz at 0054 in Russian, at 0106 in Spanish, a horn IS at 0130, in language at 0330 and with music at 0539. Further xmsn's in Russian are said to be at 1850 under the *Radio Peace and Progress* ID, R. Yakutsk, Siberia, is noted on 4395 kHz from 1241-1301 in Russian amts and classical music. Some sources list this frequency as bearing the call sign RV214, though we've never heard it used.

Vatican City—*Vatican Radio* has another new channel in service, it being 17.800 kHz, as tuned at 2330 s/on in Spanish to L.A. and from 0110 in French. This is in addition to 17,810 kHz.

CAPACITANCE METER

(Continued from page 69)

still in a circuit; any resistance, voltage, or other capacitance in the circuit will result in a false reading, and any external voltage might damage the meter movement.

You use the capacitance meter in much the same manner as you would use an ohmmeter to measure resistance. Simply set the range switch to the position desired, connect the capacitor to be tested, and interpret the value from the position of the meter pointer and the range multiplier.

Don't be surprised if many of your capacitors seem way off from their rated values. Many capacitors have much greater tolerances than other electronic components, and some of the less expensive ones may even be rated at +80%, -20% tolerance. This would mean that a 0.01- μ F capacitor could have a value anywhere between 0.008 μ F and 0.018 μ F and still be considered good. Of course, if a different tolerance is stamped on the capacitor case, the final reading should be within those limits.

-30-

POPULAR ELECTRONICS

REACTIONS

(Continued from page 82)

A total of 53 two-man mobile units plus an 18-foot trailer base station including generator were supplied by the Four Points Club for this operation.

Among the many clubs that assist with parade communications, is the Nutmeg Citizens Radio Association of Bridgeport, Connecticut. They provide communications for the Annual Barnum Festival Parade held on the Fourth of July in Bridgeport.

This time of year, the Nutmeg Club and many others are planning for the annual "Pumpkin Patrol". On Halloween night, CB'ers in cooperation with the local law enforcement agencies patrol the streets of the town and report any suspicious mischief-making goblins. This activity reduces vandalism and leaves the police free to handle more serious police business. Citizens Radio mobile units are located at potential trouble spots, mostly schools. These lookouts spot possible vandals and report them to the police department. The presence of adults in a car usually prevents vandalism.



Capital City Citizens Band Communications, Inc. (Atlanta, Ga.) assists law enforcement authorities controlling traffic during "Atlanta 500" auto race.

CB Who's Who. As Citizens Two-Way Radio grows, we would like to compile a list of prominent people in all areas who use CB. If you know of any such persons, celebrities, political figures, business leaders, entertainers, sports stars, etc., please send us their names and call letters if known. We will put together a list and publish it when appropriate. While you're at it, be sure to send us news of your CB club, or any other news of interest to CB'ers everywhere. Address it to: Editor, Two-Way REACTIONS, c/o REACT National Headquarters, 205 West Wacker Drive, Chicago, Illinois 60606.

—30—

ABOUT YOUR SUBSCRIPTION

Your subscription to POPULAR ELECTRONICS is maintained on one of the world's most modern, efficient computer systems, and if you're like 99% of our subscribers, you'll never have any reason to complain about your subscription service.

We have found that when complaints do arise, the majority of them occur because people have written their names or addresses differently at different times. For example, if your subscription were listed under "William Jones, Cedar Lane, Middletown, Arizona," and you were to renew it as "Bill Jones, Cedar Lane, Middletown, Arizona," our computer would think that two separate subscriptions were involved, and it would start sending you two copies of POPULAR ELECTRONICS each month. Other examples of combinations of names that would confuse the computer would include: John Henry Smith and Henry Smith; and Mrs. Joseph Jones and Mary Jones. Minor differences in addresses can also lead to difficulties. For example, to the computer, 100 Second St. is not the same as 100 2nd St.

So, please, when you write us about your subscription, be sure to enclose the mailing label from the cover of the magazine—or else copy your name and address exactly as they appear on the mailing label. This will greatly reduce any chance of error, and we will be able to service your request much more quickly.

CONTROLLED
QUALITY
CRYSTALS by



CRYSTEK



The "On-Channel" Crystals

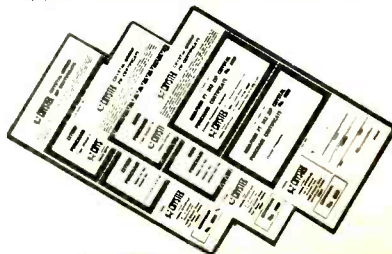

NOW ZIP-ORDER CRYSTALS

Your dealer has new, fast, direct-factory ZIP Order Purchase Certificates to enable you to get CRYSTEK CB, Monitor or Amateur Crystals mailed direct to you promptly. Ask about them.

CRYSTEK formerly Texas Crystals
Div. of Whitehall Electronics Corp.

1000 Crystal Drive
Fort Myers, Florida 33901

4117 W. Jefferson Blvd.
Los Angeles, California 90016

CIRCLE NO. 12 ON READER SERVICE PAGE

111

now... a better way to drive and adjust hex socket screws

...IN PRECISION WORK

With the tools in this new, compact convertible screwdriver set, you can turn all types of hex socket screws... in all types of locations... faster, easier than with conventional keys.

Handy midgets are ideal for such delicate, precision work as assembly and servicing of instruments and controls. Remarkable "piggyback" torque amplifier handle adds grip, reach, and power needed for other applications, lets you do more jobs with fewer tools.

PS-89 SET

8 midgets (hex size .028" thru 1/8") plus hollow, "piggyback" handle. Slim, trim, see-thru plastic case fits pocket or tool box, doubles as bench stand.

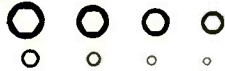

REQUEST COMPLETE HAND TOOL CATALOG

which includes information on other Xcelite Compact Sets, too — slot tip/ Phillips/Scrulox® screwdrivers, nutdrivers, and combinations.

Nationwide availability through local distributor



XCELITE, INC., 20 Bank St., Orchard Park, N. Y. 14127

Send complete tool catalog, which includes information on all Xcelite Compact Sets.

name _____
address _____
city _____ state & zip _____

In Canada contact Charles W. Pointon, Ltd.

CIRCLE NO. 40 ON READER SERVICE PAGE

DWELL EXTENDER

(Continued from page 54)

Identify the connections on the ignition coil. There are usually three wires: one (large diameter coming from the insulated top of the coil) carries the high voltage to the distributor; one goes to the ignition switch and may be marked (+) or "BATT"; and the third goes to the distributor (where the points are) and is marked (-) or "DIST." This last connection is the one you want. Loosen the nut that secures this lead to the coil and insert the lead from the proper terminal on the Spark Injector. Do not remove any existing wires. Tighten the nut, making sure that all of the leads are making good contact with the coil terminals. Locate a convenient ground screw or nut. Loosen it and insert the ground lead from the Spark Injector. Retighten the screw or nut.



Mount the Dwell Extender in relatively cool place (in this case on sheet-metal wheel housing) using suitable mounting hardware and shock-absorbing rubber grommets at two heat-sink mounting holes. The two-wire connecting cable can use same mounting hardware as the conventional engine wiring system.

Use #14 insulated wire to make these electrical connections. A spade lug can be soldered to each wire to make it easier to connect to the proper points.

When new points are installed or you want to check dwell time, disconnect the Dwell Extender by removing the one wire to the ignition coil. Once the dwell has been checked or reset, reconnect the Dwell Extender lead.

POPULAR ELECTRONICS

OP AMP QUIZ ANSWERS

(Quiz is on page 50)

1. The gain of an operational amplifier as shown can be determined by dividing the value of the feedback R_F by the value of the input resistor R_{IN} . Therefore the gain of the circuit is $1000/500=2$. Note that the input connects to the input terminal marked (-) and the output connects to the output terminal marked (+). The circuit is thus an inverting amplifier. Since the input is -5 volts, E_{OUT} is +10 volts.
2. The gain of this inverting amplifier is also determined by dividing the feedback resistance by the input resistance. Thus, $gain=100/1000=0.1$. Since the amplifier inverts, the gain is actually -0.1.
3. Operational amplifiers can be used to "sum" or algebraically add the voltages at their inputs. In this circuit, the gain of each input leg is one. The output voltage is the sum of the amplified inputs and is inverted. Thus E_{OUT} is +6 volts.
4. Operational amplifiers can be used as current generators if the current in the feedback loop is utilized. The load must be connected into the feedback loop as shown in the circuit.
5. The gain of the voltage follower is one. The input impedance of this circuit is very high and the output impedance is very low. The circuit is non-inverting.
6. Notice that E_{IN} connects to the input terminal marked (+) and E_{OUT} connects to the output terminal marked (+). Therefore this is a non-inverting amplifier.
7. The circuit is an integrator because the effective output is that which appears across the capacitor.
8. The circuit is a differentiator because the effective output is that which appears across the resistor.
9. As the switches are closed one by one, the inputs are inverted and summed, one on top of the other in sequence, generating a positive staircase waveform.
10. The first of these two unity-gain amplifiers inverts the input signal. The second inverts the output of the first. Therefore, the outputs are balanced.

New sound column



High Fidelity Speaker System

Looks beautiful, sounds excitingly different! Sound column design uses scientific focusing principle to add extra projection to high tones, re-create music with startling fidelity. Ideal for stereo. $33\frac{1}{4}$ " h. x $10\frac{1}{2}$ " w. x 4" d. 4 Jensen speakers - 2 specially-designed high compliance woofers, 2 direct radiator tweeters. 50 to 17,000 cps. Cabinet of genuine walnut with oiled finish . . . designed to hang on the wall like a picture.

The Astra

\$49.95
each
audiophile
net

Write for free catalog
showing Argos systems
for every purpose

Argos
PRODUCTS COMPANY

Dept. C 600 S. Sycamore St., Genoa, Ill. 60135
CIRCLE NO. 3 ON READER SERVICE PAGE

SAVE ON EVERYTHING IN ELECTRONICS!

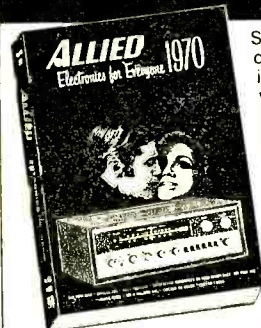

Stereo hi-fi • Tape recorders & tape, electronic & hobby kits. • CB 2-way radios • Radios • Shortwave • Phonographs • Amateur gear • Automotive electronics • Tools & hardware • Tubes, transistors, parts, batteries, books . . . and much more!

FREE

ALLIED 1970 ELECTRONICS CATALOG

Huge 552-page book, our biggest ever—right off the press and crammed with values! Mail coupon now for free copy!

ALLIED RADIO Dept. 544
P.O. Box 4398, Chicago, Ill. 60680

Please
Print

NAME First Middle Last

STREET ADDRESS or ROUTE & BOX NO.

CITY

STATE

ZIP

CIRCLE NO. 4 ON READER SERVICE PAGE

HOMESTEADER

(Continued from page 73)

Protection Loop. The protection loop is a simple series circuit using switches and/or conductive window tape on the inside surface of the glass. Almost any type of switch can be used—including magnetic types in which the switch is mounted on either the window or window jamb and the operating magnet is mounted so that it operates (closes) the switch when the window is closed. (Magnetic switches are suggested because of their long life.)

The conductive window tape is cemented across or around the perimeter of the glass and terminated in contacts on the window frame. When the window is closed, the contacts are made. If the window is broken by an intruder, the tape shears very easily, opening the circuit and operating the alarm.

Wiring the protection loop may present a problem, depending on the type of construction of the building being pro-

ected. If the wires connecting switches, tape, or breakwire contacts cannot be run through the walls or ceiling, they can be routed up a seam in paneling or covered with tape and painted over. The interconnecting wiring can be fine-gauge wire since current flow through the loop is only about 2 mA.

The exit door can be protected with either a magnetic switch (as described above for the windows) or a mechanical, normally open switch that is closed when the door is closed. Besides switches, there are many other ways in which a contact can be made while a door is closed and broken when the door is open. Use your imagination. All you have to remember is that the circuit between terminals 4 and 5 on the PC board must be complete for the alarm to work and the exit door switch must make a complete circuit between terminals 5 and 6.

It is also possible to make a "silent alarm" by replacing the local alarm bell with a remote bell or light. In this way, the intruder will not know that you are aware of his presence, and you can take any action you deem necessary. —30—

Patented components . . . a 30-year reputation for innovative design . . . a consistently creative approach to sound reproduction . . . this is where it all comes together, in the creation of extraordinary speakers such as the 312.

A glance at its specifications will tell you the 312 is an exceptionally fine reproducer. Unfortunately, they won't begin to show you how extraordinarily pleasing the sound is that flows from it. You must discover that for yourself, by listening. It's not inexpensive. Still, it's only about half what you'd expect to pay. Hear the 312 soon. Find out why we call it: "the speaker your other components will be proud of."

Specifications: Model 312 3-way 12" Diffaxial Speaker. **Frequency response:** 28 to well over 40,000 Hz. **Patented Sphericon tweeter** is flat within 2 db to 22,000 Hz. **Power rating:** 35 watts integrated program material. **Impedance:** 8-16 ohms. **Crossover:** 1000 Hz (mechanical), 3000 Hz (electrical). **Dimensions:** 13" overall dia 6 1/2" deep. **Mounting:** Front or rear baffle. **Special Features:** Rigid, die-cast frame. Wide-angle dispersion by patented Sphericon Super Tweeter and exclusive Diffusicone principle. Rigid cup baffle (eliminates tweeter-woofer interference). High compliance suspension with University's exclusive Critical Edge Damping.



UNIVERSITY SOUND
A DIVISION OF LTV LING ALTEC, INC.
P. O. Box 26105, Oklahoma City, Okla. 73126

This is where it all comes together

"Listen . . .
University
Sounds
Better."



CIRCLE NO. 39 ON READER SERVICE PAGE

POPULAR ELECTRONICS READER SERVICE PAGE

free information service:

Here's an easy and convenient way for you to get additional information about products advertised or mentioned editorially (if it has a "Reader Service Number") in this issue. Just follow the directions below... and the material will be sent to you promptly and free of charge.

1. On coupon below, circle the number(s) that corresponds to the key number(s) at the bottom or next to the advertisement or editorial mention that is of interest to you. (Key numbers for advertised products also appear in the Advertisers' Index.) Print or type your name and address on the lines indicated.

2. Cut out the coupon and mail it to: POPULAR ELECTRONICS, P.O. Box 8391, Philadelphia, PA 19101.

note: If you want to write to the editors of POPULAR ELECTRONICS about an article on any subject that does not have a key number, write to POPULAR ELECTRONICS, One Park Avenue, New York, N.Y. 10016. Inquiries concerning circulation and subscriptions should be sent to POPULAR ELECTRONICS, Portland Place, Boulder, Colo. 80302.

VOID AFTER NOVEMBER 30, 1969

POPULAR ELECTRONICS

P.O. BOX 8391
PHILADELPHIA, PA. 19101

1 2 3 4 5 6 7 8 9 10 11 12 13 14 15 16 17 18 19 20
21 22 23 24 25 26 27 28 29 30 31 32 33 34 35 36 37 38 39 40
41 42 43 44 45 46 47 48 49 50 51 52 53 54 55 56 57 58 59 60
61 62 63 64 65 66 67 68 69 70 71 72 73 74 75 76 77 78 79 80
81 82 83 84 85 86 87 88 89 90 91 92 93 94 95 96 97 98 99 100

NAME (Print clearly) _____

ADDRESS _____

CITY _____ STATE _____ ZIP CODE _____

10 ¢

Olson ELECTRONICS FREE Catalog

Fill in coupon for a FREE One Year Subscription to OLSON ELECTRONICS' Fantastic Value Packed Catalog — Unheard of LOW, LOW PRICES on Brand Name Speakers, Changers, Tubes, Tools, Stereo Amps, Tuners, CB, and other Values. Credit plan available.

NAME _____
ADDRESS _____
CITY _____ STATE _____
GIVE ZIP CODE _____

If you have a friend interested in electronics send his name and address for a FREE subscription also.

OLSON ELECTRONICS
486 S. FORGE STREET, AKRON, OHIO 44308

CIRCLE NO. 25 ON READER SERVICE PAGE

THREE COURSES FOR TECHNICIANS WITH EXTENSIVE LABORATORY TRAINING!

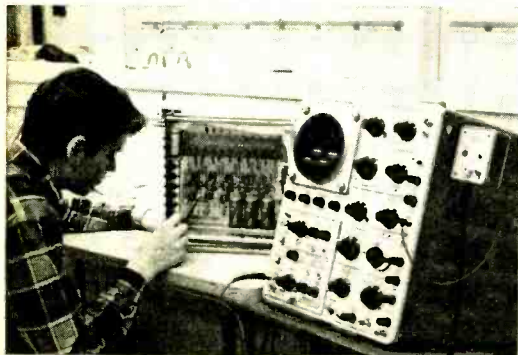

All Courses approved for Veterans' training
Electronics Technician 80 weeks
Broadcast Engineer 60 weeks
Radiotelegraph Operator 60 weeks
 1969-1970 dates:

September 2, 1969, January 19, 1970,
June 8, 1970, November 9, 1970

New Sessions follow in 20 week intervals from dates listed.

PORT ARTHUR COLLEGE

1500 Proctor, Box 310, Port Arthur, Texas 77640

FREE BROCHURE

CIRCLE NO. 28 ON READER SERVICE PAGE

LIBRARY (Continued from page 14)

cent larger than its predecessor. The new manual is an authoritative reference on bipolar transistors besides giving information on FET's, SCR's, triacs, diacs, etc. Four sections make up the Manual: Text chapters provide basic tutorial information on the operation, application, and testing of semiconductor devices. This is followed by the Technical Data section listing more than 900 devices, technical data, and curves. Next comes a practical Circuits section, covering many useful electronic devices you can build. The remaining section, Other Features, gives dimensional outlines and hardware information.

Published by Commercial Engineering, RCA Electronic Components, Harrison, N.J. 07029. Soft cover. 656 pages. \$2.50.

DIGITAL COMPUTER PRINCIPLES, Second Edition

Put together by the Staff of the Technical Training Department, Burroughs Corp., this second edition continues to provide a broad survey of the principles of digital computers and the elements of both large and small computing systems. Extensively revised and reorganized, the book covers not only numbering systems, logic, Boolean algebra, and computer electronics, but also the latest input/output devices and other peripheral equipment. The updated contents include new material on thin-film cryotron memories, IC's, modularity concepts, displays, executive and control programs, multiprogramming, and multiprocessing. Solid-state circuits have replaced the vacuum-tube circuits of the first edition. A more detailed analysis of computer organization is presented and new material on system control concepts has been added.

Published by McGraw-Hill Book Co., 330 West 42 St., New York, N.Y. 10036. Hard cover. 578 pages. \$8.95.

KNOW YOUR VOM-VTVM

by Joseph A. Risse

Everyone who uses a VOM or VTVM should have a good working knowledge of its use, care, maintenance, and principles of operation. Hence, this book is designed to provide just such information. It explains the major features common to test meters, and gives you an idea of what features to look for when you are shopping around for a new meter as well as how to make the most of the meter you already have. The first chapter is devoted to the uses of meters in general. Succeeding chapters deal separately with the VOM and VTVM, its operation and use. And the final chapter discusses modern solid-state meters. End-of-chapter review questions and an answer key are provided.

Published by Howard W. Sams & Co., Inc., 4300 West 62 St., Indianapolis, Ind. 46206. Soft cover. 159 pages. \$3.50.

POPULAR ELECTRONICS

VARIABLE TRANSFORMER

(Continued from page 44)

coded screws of *SO1* and *P1*; the meter should indicate zero resistance—even on the lowest range setting. The resistance registered between the two brass-coded screws should be zero ohms.

HOW IT WORKS

Referring to Fig. 1, with *R1* set for maximum resistance, the charge across *C2* is not sufficient to cause the integral trigger diode (at terminal *G* of *Q1*) to conduct. Therefore, no pulse is available to trigger the triac (between terminals 1 and 2 of *Q1*) into conduction. Consequently, no voltage can be dropped across a load connected to *SO1* because *Q1* is essentially an open switch.

Now, as the resistance of *R1* is decreased, a point will be reached at which the amplitude of the voltage across *C2* will be sufficient to cause the trigger diode to conduct and fire the triac for a portion of each a.c. cycle. The amplitude of the voltage dropped across the load is thus controlled by the point in each half cycle at which *Q1* triggers on. Decrease the resistance setting of *R1* even further, and you increase the average load voltage amplitude.

To improve circuit performance, *R2* allows *C1* to charge to a higher voltage than does *C1*. This allows the charge on *C2* to be partially restored once during each half cycle of the a.c. power by the charge on *C1*. The RC network consisting of *R3* and *C2* provides stability to the circuit when an inductive load is connected to *SO1*.

To use the Solid-State Variable Transformer, assemble the utility box. (It's also a good idea to anchor the two sections of the box together with sheet-metal screws to prevent the box from coming apart while you're removing it from a wall outlet.) Plug *P1* into a convenient a.c. outlet. Almost any electrical device that consumes less than 360 watts of power (3 amperes) can be operated via the Solid-State Variable Transformer. The only exceptions to the general rule are fluorescent lamps and devices that require a large starting current.

The markings on the control dial plate can be used only as a rough guide because *R1* is not linear at its low-resistance end. The best approach to using the control is to remember the settings most often used by different appliances. Or you can mark your favorite settings right on the dial plate.

-30-

NEW AND IMPORTANT SAMS BOOKS

1-2-3-4 Servicing Automobile Stereo

The "1-2-3-4 Method" is a simple, logical step-by-step process which helps do the servicing job in the easy way and the right way. This book first applies the Method to both mechanical and electrical equipment, and then proceeds to cover the electronic and mechanical principles of automobile stereo, fm multiplex, and tape cartridge systems. Finally, the book shows how to apply the "1-2-3-4 Method" to auto stereo systems.
Order 20737, only.....\$3.95

Color-TV Training Manual

A practical and excellent guide for anyone interested in or preparing to service color-TV receivers. Clearly and fully describes the science of color, requirements and make-up of the composite color signal, latest types of color circuits, and the most effective methods for diagnosing trouble and repairing color-TV receivers. Includes full-color picture tube photos to aid in setup and alignment procedures as well as troubleshooting.
Order 20736, only.....\$6.95

Closed-Circuit Television Handbook. 2nd Ed.

Explains in practical terms the basic concepts of CCTV systems. Describes the versatile applications of closed-circuit television, and the equipment used. Subjects include cameras, monitors, video recorders, lighting, and signal transmission. Order 20726, only.....\$5.95

CB Radio Servicing Guide. 2nd Ed.

Provides a comprehensive guide to CB radio servicing. Shows troubleshooting procedures for rapid solutions to problems in single-channel and multi-channel receivers and transmitters. Illustrated with CB radio schematics, test equipment diagrams, and charts showing how much range you can expect from CB radio.
Order 20722, only.....\$3.95

101 Questions & Answers About Amateur Radio

A handy and practical reference source providing the answers to the most frequently asked questions about ham radio. An invaluable book for both the newcomer and the old-timer. Order 20731, only.....\$2.95

Record Changer Servicing Guide

This book provides a complete understanding of record changers, how they operate, and the various systems employed. Provides detailed instructions on how to track down troubles encountered in record changers and how to repair them in the fastest and most effective way. Order 20730, only.....\$3.95

RECENT BESTSELLING BOOKS

Tube Substitution Handbook. 12th Ed. 20700.....	\$1.75
How to Build Speaker Enclosures. 20520.....	3.50
Citizens Band Radio Handbook. 3rd Ed. 20569.....	4.25
Color-TV Servicing Guide. 20358.....	4.25
Tape Recorders—How They Work. 2nd Ed. 20445.....	4.50
How to Repair Major Appliances. 20650.....	4.95
Audio Cyclopeda. 2nd Ed. 20675.....	29.95
Know Your VOM-VTVM. 2nd Ed. 20676.....	3.50
Lasers and Masers. 20559.....	4.95

—HOWARD W. SAMS & CO., INC.—

Order from any Electronic Parts Distributor, or mail to Howard W. Sams & Co., Inc., Dept. PE-10
4300 W. 62nd St., Indianapolis, Ind. 46268

Send the following books: Nos. _____

\$ _____ enclosed

Send FREE 1970 Sams Book Catalog

Name _____

Address _____

City _____ State _____ Zip _____

CIRCLE NO. 31 ON READER SERVICE PAGE

PRODUCTS

(Continued from page 24)

tory-assembled phones of comparable quality. Comfortable foam-cushioned earcups help seal out room noises, while the adjustable headband can be set for maximum comfort. Large 3½" dynamic elements in the earcups deliver clean, clear sound with full fidelity from very low bass (20 Hz) up to highs of 16,000 Hz. Separate volume controls in each earpiece permit perfect balance setting and make it unnecessary for the listener to leave his chair to adjust amplifier volume. The 4-16-ohm impedance head-phone set is supplied with an 8' cord with standard ¼" phone plugs soldered, and full instructions for assembly and use.

Circle No. 90 on Reader Service Page 15 or 115

BASIC AUDIO POWER AMPLIFIER

The Model 80 basic hi-fi power amplifier made by *Dynaco, Inc.*, maximizes performance, reliability, and flexibility, even into such reactive loads as



electrostatic speaker systems. The Stereo 80 is rated at 40 watts r.m.s. power/channel across the entire audio spectrum with both channels driven simultaneously into 8 ohms. Harmonic distortion is less than 0.5%—i.m. distortion is less than 0.1%—at rated output and is even better at lower levels. The two output channels of the Stereo 80 can be paralleled for 80-watt, 4-ohm monophonic operation when both inputs are simultaneously paralleled. In kit form, the Stereo 80 has factory-assembled and in-circuit tested printed circuit boards which include all critical circuitry.

Circle No. 91 on Reader Service Page 15 or 115

HIGH-PERFORMANCE COMPACT AM/FM TUNER

The use of a field-effect transistor in the front end, plus advanced design techniques in the multi-stage i.f. section makes the Model TX-500 budget-priced AM/FM tuner by *Pioneer Electronics U.S.A. Corp.* a best buy for low-investment, high-quality components. This solid-state stereo tuner utilizes low-noise silicon transistors with multiplex circuitry designed to provide wide channel separation and excellent frequency response. A special noise filter circuit reduces undesirable multiplex broadcast noise. A front-panel control allows the user to switch the filter into and out of the circuit. Technical specifications: 55 dB at 98 MHz FM image rejection; 2.5µV FM sensitivity; 50-dB signal-to-noise ratio. The FM reception is characterized by minimum interference and zero cross modulation.



Circle No. 92 on Reader Service Page 15 or 115

NEW-CONCEPT SPEAKER SYSTEM DESIGN

Full-frequency, three-dimensional stereo effect throughout any listening room is the big feature claimed for the *H.H. Scott, Inc.*,

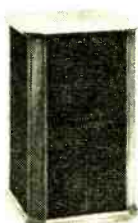

"Quadrant" Model 100 speaker system. To accomplish this, Scott has mounted a pair of 8" woofers on opposite sides of the enclosure and a 3" mid-range/tweeter (in individual air-suspension chambers) on each of the four sides. The woofers disperse sound through a 180° arc, the mid-range/tweeters through a 90° arc, to provide a full 360° of

full-range coverage and eliminate the "point source." Technical specifications: frequency range—38-20,000 Hz; impedance—6-8 ohms; power handling capacity—80 watts; crossover frequency—2000 Hz; crossover network—LC-type with 12 dB/octave; air-suspension enclosure; tweeter level control; minimum amplifier power required—10 watts; recommended amplifier damping factor—10.

Circle No. 93 on Reader Service Page 15 or 115

990 MODEL

Mercury

NEW COMPACT TUBE TESTER

OUTPERFORMS MANY HIGHER PRICED INSTRUMENTS

- Full Conductance Cathode Test • Has All The Latest Sockets
- Tests Over 3000 Tubes • Special, Unique Open-Circuit 12-Button Master Selection Slide-Switch Row Makes Unit Truly Obsolescent Proof • Tests Multiple Element Terminations Quickly, Easily
- Complete With Latest Tube Test Data That Is Permanently Kept Up-To-Date.

All Mercury Test Equipment Guaranteed For One Full Year!

Write for complete catalog of Mercury Test and Repair Equipment, and name of your nearest dealer.

MERCURY ELECTRONICS CORPORATION

315 Roslyn Road • Mineola, N.Y. 11501 • (516) 742-5400

CANADA: William Cohen Corp.



Power Req.: 115V, 50/60 Hz 50W
Hi-impact molded case, 6½ x 7½ x 3½ - 4 lbs.

ONLY
21.95
KIT
34.95 WIRED
American Made

CIRCLE NO. 20 ON READER SERVICE PAGE

ELECTRONICS MARKET PLACE

COMMERCIAL RATE: For firms or individuals offering commercial products or services. \$1.15 per word (including name and address). Minimum order \$11.50. Payment must accompany copy except when ads are placed by accredited advertising agencies. Frequency discount: 5% for 6 months; 10% for 12 months paid in advance. **READER RATE:** For individuals with a personal item to buy or sell. 70c per word (including name and address). No Minimum! Payment must accompany copy.

FOR SALE

FREE! Giant bargain catalog on transistors, diodes, rectifiers, SCR's, zeners, parts. Poly Paks, P.O. Box 942, Lynnfield, Mass. 09140.

GOVERNMENT Surplus Receivers, Transmitters, Sniperscopes, Radios, Parts, Picture Catalog 25c. Meshna, Nahant, Mass. 09108.

ROCKETS: Ideal for miniature transmitter tests. New illustrated catalog, 25c. Single and multistage kits, cones, engines, launchers, trackers, rocket aerial cameras, technical information. Fast service. Estes Industries, Dept. 18, Penrose, Colorado 81240.

LOWEST Prices Electronic Parts. Confidential Catalog Free. **KNAPP**, 3174 8th Ave. S.W., Largo, Fla. 33540.

EUROPEAN and Japanese bargains catalogs. \$1 each. Dee, 10639E Riverside, North Hollywood, Calif. 91602.

MECHANICAL, ELECTRONIC devices catalog 10c. Greatest Values—Lowest Prices. Fertik's, 5249 "D", Philadelphia, Pa. 19120.

MUSIC LOVERS, CONTINUOUS, UNINTERRUPTED BACKGROUND MUSIC FROM YOUR FM RADIO, USING NEW INEXPENSIVE ADAPTOR. FREE LITERATURE. ELECTRONICS, 11500-Z NW 7th AVE., MIAMI, FLORIDA 33168.

WE SELL CONSTRUCTION PLANS. TELEPHONE: Answering Machine, Speakerphone, Carphone, Phonevision, Legal Connector, Auto Dialer, Central Dial System. **TELEVISION:** \$35.00 Color Converter, Tape Recorder, 3DTV. \$25.00 Camera. **DETECTIVE:** Infinity Transmitter, Tail Transmitter, Police Radar Detector. **HOBBYIST:** Electron Microscope, 96 Hour Tape Music System, Ultrasonic Dishwasher, Radar-Oven, Electronic Tranquilizer. Plans \$4.95 each. **COURSES:** Telephone Engineering \$39.50, Detective Electronics \$22.50, Anti-Detective Electronics \$27.50. **SUPER HOBBY CATALOG** 25c. Don Britton Enterprises, 7906 Santa Monica Blvd., Hollywood, Calif. 90046.

WEBBER LAB'S. Police & Fire Converters. Catalog 10c. 72 Cottage Street, Lynn, Mass. 09105.

RADIO—T.V. Tubes—33c each. Send for free catalog. Cornell, #213 University, San Diego, Calif. 92105.

WHOLESALE COMPONENTS: Manufacturers and distributors only. Request free catalog on business letterhead. **WESCOM**, Box 2536, El Cajon, California 92021.

INVESTIGATORS, LATEST ELECTRONIC AIDS. FREE LITERATURE. CLIFTON, 11500-L NW 7th AVE., MIAMI, FLORIDA 33168.

TV CAMERA PRICE BARRIER BROKEN: Complete solid-state TV camera kit now only \$116.95. Starter kits \$18.95 up. Plans 25c up. Easy-educational-economical. Also vidicons, lenses, modules, etc. Catalog **FREE. ATV RESEARCH, 1301 Broadway, Dakota City, Nebr. 68731.**

FREE ELECTRONICS PARTS FLYER. Large catalog \$1.00 deposit. **BIGELOW ELECTRONICS, BLUFFTON, OHIO 45817.**

JAPAN & HONG KONG DIRECTORY. Electronics, all merchandise. World trade information. \$1.00 today. Ippano Kaisha Ltd., Box 6266, Spokane, Washington 99207.

CIRCUIT Boards, Parts for "Poptronics" projects. Free catalog. S.W. Technical, Box 16297, San Antonio, Texas 78216.

LINEAR AMPLIFIERS: "Hawk"—25 watts output—\$59.95; "Hornet" 50 watts output—\$98.50; "Raider"—100 watts—\$139.50; "Maverick-250"—250 watts—\$244.95; AM and SSB. "Scorpion"—50 watt 12 V. Mobile amplifier—\$99.95; "Bandit II"—12 V. Mobile Amplifier—\$169.95. Frequency range 20-35 megacycles (illegal for class D 11 meters.) Dealer inquiries invited. D & A Manufacturing Co., 1217 Avenue C, Scottsbluff, Nebraska 69361.

FREE Catalog low priced, high performance subminiature listening devices direct from manufacturer. Emery LT-10, 156 Fifth Avenue, New York, N. Y. 10010.

GENERAL INFORMATION: First word in all ads set in bold caps at no extra charge. Additional words may be set in bold caps at 10c extra per word. All copy subject to publisher's approval. Closing Date: 1st of the 2nd preceding month (for example, March issue closes January 1st). Send order and remittance to: Hal Cymes, **POPULAR ELECTRONICS**, One Park Avenue, New York, New York 10016.

ULTRA-SENSITIVE AND POWERFUL METAL DETECTORS—join the many who are finding buried coins, minerals, relics and artifacts. Don't buy till you see our **FREE** catalog of new models. Write Jetco, Box 132-PE, Huntsville, Texas 77340.

LASER parts catalog 60c. Moynihan, 107 North Brighton, Atlantic City, New Jersey 08401.

"GIZMOTCHY" CB beams, dealers wanted Box 1820, Huntington Beach, Calif. 92647.

PSYCHEDELIC catalog. Posters, lighting, etc. Send 25c for handling to Hole In The Wall, 6055PE Lankershim, North Hollywood, Calif. 91606.

PSYCHEDELIC STROBES 200 flashes per-min. \$14.95 Guaranteed. Zipcom, 5620 W. 12, L.R., Arkansas 72204.

NEW heavy duty CD ignition system. Details free. Kit, \$28.95; assembled, \$39.95. Delta International, Ltd., Box 1946Z, Grand Junction, Colo. 81501. Dealers invited.

CONSTRUCTION PLANS: LASER . . . \$2.00. Surveillance Devices—two F.M. Bugging Transmitters . . . \$1.00. Tail Transmitter . . . \$1.00. Bug Detector . . . \$1.00. Surveillance equipment and kits available. Howard, 20174 Ward, Detroit, Michigan 48235.

SENCORE TEST EQUIPMENT UNBELIEVABLE PRICES. FREE CATALOG AND PRICE SHEET. FORDHAM RADIO, 265 EAST 149TH STREET, BRONX, N.Y. 10451.

FM BACKGROUND MUSIC! Miniaturized adapter connects to any FM Radio Tuner. Brings in hidden commercial free programs. Performance guaranteed. \$29 postpaid. K-Lab. Dept. Z, Box 572, S. Norwalk, Conn. 06856.

"ELECTRONICS" HEADACHE! Play **ELECTROGRAM!** . . . game of schematic diagraming. Relaxing educational! \$5.00 postpaid. **ATV RESEARCH, 1301 Broadway, Dakota City, Nebr. 68731.**

RESISTOR PROBLEMS? Too expensive? No longer! 1/2w only 8c; 10/60c assorted. Garrett Industries, 4504 Nunnswood, Lakeland, Florida 33803.

THE ART OF DE-BUGGING—\$5.95. TRON-X PUBLICATIONS, P.O. BOX 38155, HOLLYWOOD, CALIFORNIA 90038.

POCKET monitor receiver, crystal controlled, low priced. Free catalog. JMD Electronics, 328 Madison Avenue, West Hemp., N.Y. 11552.

POLICE—FIRE RADIO-DISPATCHER DIRECTORIES! Exclusive latest CONFIDENTIAL listings. Official CALLSIGNS. FREQUENCIES! Catalog for stamp. Communications, Box 56-PE, Commack, N.Y. 11725.

CONVERT any television to sensitive, big-screen oscilloscope. Only minor changes required. No electronic experience necessary. Illustrated plans, \$2.00. Relco-A33, Box 10563, Houston, Texas 77018.

BURGLAR—fire alarm. Southeastern largest supplier. Schematic, wiring instructions 25c. **SILMAR, 3476-E N.W. 7th Street, Miami, Florida 33125.**

COMPONENTS? Kits? Hardware? Free catalog! Truvue Paks, Box 275, Chelsea, Mass. 02150.

DIAGRAMS, service manuals, TV, radio, HiFi. \$1.06. Technical Services Associates, Box 1167, Berkeley, Calif. 94701.

SUBMINIATURE LISTENING DEVICES. SEND \$1.00 FOR CATALOG, REFUNDABLE. INTRADCO, BOX 3285, TULSA, OKLA. 74101.

FREE information on many interesting semiconductor projects. CCS, Box 1051, Plant City, Florida 33566.

HOW a tube amplifies \$.50. The hybrid coil \$.50. Free catalog. **BECO, Box 27011, Minneapolis, Minnesota 55427.**

50 TELETYPE pictures for \$1.00. Perforated and audio tapes available. W9DGV, 2210-30th Street, Rockfill Island, Ill. 61201.

SURPLUS electronic equipment catalogue 10¢. Bob-Frank Electronics, P.O., Box 1327, Harrisburg, Pa 17105.

ELECTRONIC ignition, various types. Free literature. Anderson Engineering, Epsom, N.H. 03239.

POWER SUPPLIES, SAVE UP TO NINETY PER-CENT on precision Industrial power supplies, Semi-regulated and regulated. The buy of a lifetime. For full information write **BOB'S ELECTRONICS**, 1418 W. Polk, Phoenix, Arizona 85007.

TRIMPOTS Ten assorted, \$3.00. Small Salvage, Box 9502, Norfolk, Va. 23505.

NEW! Low cost aluminum UHF-VHF towers. **COFFELT**, 909 Hayter, Dallas, Oregon 97338.

PROXIMITY switch. Detects nearness of human body. Free information. Claremont Products, 860 Reed, Claremont, Calif. 91711.

FREE TV TUNER REPAIR TRICKS, Plans, Details, Complete Courses. Frank Bocek, Box 3236A, Redding, Calif. 96001.

NEW! PHONE PATCH with automatic switch. Now you can record those important conversations automatically. **ONLY \$12.95**. Chelco Electronics, 11835 Wilshire Blvd., Los Angeles, Calif. 90025.

AMATEUR SCIENTISTS, Electronics Hobbyists, Experimenters, Students . . . Construction Plans—all complete, including drawings, schematics, parts lists with prices and sources . . . Laser—Build your own coherent-light optical laser. Operates in pulsed mode, visible light range—\$6.00 . . . Radar—Build your own ultrasonic doppler radar. Detect motion of people, automobiles, even falling rain drops. Transistorized, uses standard small 9-volt battery—\$4.00 . . . Long-Range "Sound Telescope"—This amazing device can enable you to hear conversations, birds and animals, other sounds hundreds of feet away. Very directional. Transistorized. Uses 9V battery—\$3.00 . . . Or send 25¢ coin (no stamps) for complete catalog. Other items include Psychedelic strobes, light shows, robots . . . 38 different projects. Technical Writers Group, Box 5994, State College Station, Raleigh, N.C. 27607.

PLANS AND KITS

KITS, metal detector \$5.95. Audio Telescope \$5.95, others. Lectonix, Box 42, Madison Heights, Michigan 48071.

SOLAR FLYING SAUCERS. (Brand New Solid State Engine, Fantastic Performance, Flies Miles on Sun's Power, lifts animals, sends messages, parachutes. Build many, easily, inexpensively with everyday materials. Complete plans, descriptions, drawings, plus **FREE** Space-tronics **CATALOG \$1**. Single Catalog 25¢. Spacetronics, Box 31043-PES, San Francisco, California 94131.

RADAR INTRUDER ALARM detects human movement thirty feet away. **TRANSISTORIZED. BUILD YOURSELF** with complete instructions. Parts, kits and assembled units also available. Plans \$3.00. Microwave Research Co., Box 10147, St. Petersburg, Florida 33733.

"DISTANCE CRYSTAL SET CONSTRUCTION" Handbook—50¢ "Coil Winding"—50¢. Catalog. Laboratories, 12041-L Sheridan, Garden Grove, Calif. 92640.

SUB-CARRIER MUSIC ADAPTER for commercial-free music. 6-transistor circuit uses standard components. Plans and 3x4½" etched circuit board \$4.50. Wallace Enterprises, Inc., 83-15 98th Street, Woodhaven, N.Y. 11421.

INTEGRATED CIRCUIT KITS: COMPUTER, AUDIO, Others. New catalog free. **KAYE ENGINEERING**, Box 3932-A, Long Beach, California 90803.

COLOR Organ Kit \$7.50, Power Supplies \$3.98. Catalog. Murphy, 204 Roslyn Ave., Carle Place, N.Y. 11514.

ELECTRO MAGNETIC MOTOR: A patented magnetic phenomenon. Send for complete "Build-It-Yourself" assembly kit with all parts, instructions and drawings—**ONLY \$2.00** Post Paid. T & DW Company, Box 3203 P, Federal Way, Wash. 98002.

KITS GALORE! Free catalog subscription. Aلسync PE-109, 171 South Main, Natick, Mass. 01760.

SURVEILLANCE DEVICES IN KIT FORM: Telephone Transmitter, FM Spy Transmitter, Telephone-Recorder Actuator, Tail Transmitter, Bug Detector. Complete Kits Send \$15.00 each. **ELECTRONIC SECURITY SYSTEMS**, 1101 West Rosecrans Avenue, Gardena, California 90247.

SHORTWAVE LISTENING

POLICE—FIRE—AIRCRAFT—MARINE-AMATEUR—ETC. CALLS on your broadcast radio with **TUNAVERTER!** Tunable-crystal controlled! Free catalog. Salch Co., Woodsboro PECC, Texas 78393.

SWL Antenna Model 86D, \$17.95 pp. A new listening pleasure. See February issue **Popular Electronics** write-up. Murch Electronics, Franklin, Maine 04634.

HIGH FIDELITY

FREE! Send for money saving stereo catalog # P10E, lowest quotations on your individual component, tape recorder, or system requirements. Electronic Values, Inc., 200 W. 20th St., New York, N.Y. 10011.

DON'T THROW YOUR OLD CARTRIDGE AWAY. Send us \$19.95 and any old cartridge. We will ship **PREPAID** any one of the following top rated elliptical diamond stereo cartridges **NEW**: Shure M75E, M91E, M92E, M93E, Empire 888E, Pickering V15AME3, XV15 ATE, ADC 660E, 550E. Write for lowest quotations all stereo components. Send \$1.00 for our discount catalog. **DEFA ELECTRONICS**, 2207 Broadway, New York, N.Y. 10024.

HI-FI Components, Tape Recorders, at guaranteed "We Will Not Be Undersold" prices. 15-day money-back guarantee. Two-year warranty. No Catalog. Quotations Free. Hi-Fidelity Center, 239 (P) East 149th Street, New York 10451.

LOW, Low quotes: all components and recorders. HiFi, Roslyn, Penna. 19001.

TAPE RECORDERs, Hi-Fi, components, Sleep Learning Equipment, tapes. Unusual Values. Free Catalog. Dressner, 1523R, Jericho Turnpike, New Hyde Park, N.Y. 11040.

DON'T THROW YOUR OLD CARTRIDGE AWAY. Send us \$50.00 and any old used cartridge and we will ship you via **Prepaid** anywhere any one of the following Top Stereo Cartridges: Shure V-15 Type II, Empire 999VE, ADC 10EMK 11, Stanton 681EE. Write for lowest quotations all stereo components. Send \$1.00 for our discount catalog. **DEFA ELECTRONICS**, 2207 Broadway, New York, N.Y. 10024.

WANTED

CASH PAID! Unused tubes, electronic equipment. Barry, 512 Broadway, NYC 10012.

QUICKSILVER, Platinum, Silver, Gold, Ores Analyzed. Free Circular. Mercury Terminal, Norwood, Mass. 02062.

CASH PAID for all tubes. **DAMESCO**, 308 Hickory, Arlington, N.J. 07032.

TUBES

TUBES "Oldies", latest. Lists free. Steinmetz, 7519 Maplewood, Hammond, Indiana 46324.

RECEIVING & INDUSTRIAL TUBES, TRANSISTORS. All Brands—Biggest Discounts. Technicians, Hobbyists, Experimenters—Request **FREE** Giant Catalog and **SAVE!** **ZALYTRON**, 469 Jericho Turnpike, Mineola, N.Y. 11501.

TUBE Headquarters of World! Send 10¢ for Catalog (tubes, electronic equipment) Barry, 512 Broadway, N.Y.C. 10012.

RADIO & T.V. Tubes—33¢ each. Send for free list. Cornell, 4213 University, San Diego, Calif. 92105.

THOUSANDS and thousands of types of electronic parts, tubes, transistors, instruments, etc. Send for Free Catalog. Arcturus Electronics Corp., MPE, 502-22nd St., Union City, N.J. 07087.

TUBES—lowest prices in the world. Hard to get British, German, Foreign and American obsolete and present day special purpose transmitting tubes. Send for giant tube and parts catalog. United Radio Co., Dept. Y-56 Ferry Street, Newark, N.J. 07105.

TV TUBES NEW BOXED UP TO 80% OFF LIST. For catalog price sheets send \$1.00. T & T Sales Co., 4802 Ave. K, Brooklyn, N.Y. 11234.

TAPE AND RECORDERS

TAPES . . . blank recording . . . pre-recorded music. Catalog 10¢. Tower, Lafayette Hill, Pa. 19444.

BEFORE Renting Stereo Tapes try us. Postpaid both ways—no deposit—immediate delivery. Quality—Dependability—Service—Satisfaction—prevail here. If you've been dissatisfied in the past, your initial order will prove this is no idle boast. Free Catalog. Gold Coast Tape Library, Box 2262, Palm Village Station, Hialeah, Fla. 33012.

RENT 4-Track open reel tapes—all major labels—3,000 different—free brochure. Stereo-Parti, 55 St. James Drive, Santa Rosa, Ca. 95401.

TAPEMATES makes available to you **ALL 4-TRACK STEREO TAPES—ALL LABELS**—postpaid to your door—at tremendous savings. For free brochure write: **TAPEMATES**, 5727 W. Jefferson Blvd., Los Angeles, California 90016.

TAPE RECORDER SALE. Brand new nationally advertised brands. \$10.00 above cost. Amazing discounts on stereo components. Arky Electronics, 1028-C Commonwealth Avenue, Boston, Mass. 02215.

STEREO TAPES. Save 30% and up; no membership or fees required; postpaid anywhere U.S.A. Free 70-page catalog. We discount batteries, recorders, tape/cassettes. Beware of slogans, "not undersold", as the discount information you supply our competitor is invariably reported to the factory. **SAXITONE**, 1776 Columbia Road, N.W., Washington, D.C. 20009.

STEREO TAPES, CARTRIDGES, CASSETTES, REELS, 33% DISCOUNT. UNAVAILABLE ELSEWHERE. MAIL 20¢—CATALOGS. STAR RECORDINGS-PE, BOX 1055, EL PASO, TEXAS 79946.

CASSETTE blanks, also educational and language, accessories and recorders. Literature—Write **CASSETTES UNLIMITED**, P.O. Box 13119-P, Pittsburgh, Pa. 15243.

OLD radio programs on tape \$8.00 for 6 hours. Catalog for 50¢. Don Maris, 824 Owl, Norman, Okla. 73069.

OLD RADIO PROGRAMS on Tape. Jack Armstrong, Whistler, Gangbusters, hundreds more. Sample 2-hr. \$6.00, 4-hr. \$9.00. Catalog \$1.25 or free with sample. **NOSTALGIA**, 9875 S.W. 212 St., Miami, Fla. 33157.

REPAIRS AND SERVICES

TV Tuners rebuilt and aligned per manufacturers specification. Only \$9.50. Any make UHF or VHF Ninety day written guarantee. Ship complete with tubes or write for free mailing kit and dealer brochure. **JW Electronics**, Box 51C, Bloomington, Indiana 47401.

PROTOTYPE printed circuit boards. 1 or more. Silk screening, no job too small. 3123 East 17th, Spokane, Wash. 99203.

PRINTED CIRCUITS to specifications. Write requirements, Vico, Box 1581, Los Angeles, California 90053.

PERSONALS

MAKE FRIENDS WORLDWIDE through international correspondence. Illustrated brochure free. Hermes, Berlin 11, Germany.

INVESTIGATORS, LATEST ELECTRONIC AIDS. FREE LITERATURE. CLIFTON, 11500-K NW 7th AVE., MIAMI, FLORIDA 33168.

FREE Catalog low priced, high performance subminiature listening devices direct from manufacturer. Dealers welcome. Emery A-10, 156 Fifth Avenue, New York, N. Y. 10010.

REMAILING, personal \$1.00 monthly, no limit. Jones, Box 563-P, Silverado Canyon, Calif. 92676.

SECURE LOANS BY MAIL. Borrow \$100 to \$1500 for any good reason in absolute privacy. No interviews, no endorsers, no co-signers. Fast service. Write Dial Finance Co., Dept. K-593, 410 Kilpatrick Bldg., Omaha, Nebraska 68102.

INSTRUCTION

LEARN ACCIDENT INVESTIGATION. Train at home to earn \$750 to \$1,000 monthly. Car furnished. Expenses paid, no selling. No college needed. Full or spare time. Men urgently needed. Free placement service. Write for **FREE** information. No obligation, Universal Schools CZ-10, 6801 Hillcrest, Dallas, Texas 75205.

LEARN ELECTRONIC ORGAN SERVICING at home all makes including transistor. Experimental kit—trouble-shooting. Accredited NHSC, Free Booklet. **NILES BRYANT SCHOOL**, 3631 Stockton, Dept. A, Sacramento, Calif. 95820.

FCC First Class License in six weeks—nation's highest success rate—approved for Veterans Training. Write Elkins Institute, 2603B Inwood Road, Dallas, Texas 75235.

R.E.I.'s famous (5) week course for the First Class Radio Telephone License in the shortest, most effective course in the nation. Over 98% of R.E.I. graduates pass F.C.C. exams for 1st class license. Total tuition \$360.00. Job placement free. Write for brochure. Radio Engineering Incorporated Schools, 1336 Main Street, Sarasota, Florida 33577—or 3123 Gillham Road, Kansas City, Missouri 64109 —or 809 Caroline Street, Fredericksburg, Virginia 22401—or 625 E. Colorado Street, Glendale, California 91205.

FCC FIRST CLASS LICENSE THROUGH TAPE RECORDED LESSONS. Our seventeenth year teaching FCC license courses. Radio License Training, 1060D Duncan, Manhattan Beach, Calif. 90266.

CLASSIFIED ADVERTISING ORDER FORM

Please refer to heading on first page of this section for complete data concerning terms, frequency discounts, closing dates, etc.

1	2	3	4	5
6	7	8	9	10
11	12	13	14	15
16	17	18	19	20
21	22	23	24	25
26	27	28	29	30
31	32	33	34	35

Words { @ 70¢ (Reader Rate) } = \$ _____
 { @ \$1.15 (Commercial Rate) }

Insert _____ time(s) Total Enclosed \$ _____

NAME _____

ADDRESS _____

CITY _____ STATE _____ ZIP _____

Signature _____

WORD COUNT: Include name and address. Name of city (Des Moines) or of state (New York) counts as one word each. Zip Code numbers not counted. (Publisher reserves right to omit Zip Code if space does not permit.) Count each abbreviation, initial, single figure or group of figures or letters as a word. Symbols such as 35mm, COD, P.O. AC, etc., count as one word. Hyphenated words count as two words.

PE-1069

LEARN WHILE ASLEEP, Hypnotize! Strange catalog free. Auto-suggestion, Box 24-ZD, Olympia, Washington 98501.

DEGREE in Electronics Engineering earned mostly by correspondence. Free brochure. Dept. G-9, Grantham School of Engineering, 1505 N. Western Ave., Hollywood, California 90027.

FOLLOW THE LEADER—the nation's original four week F.C.C. 1st Class License Course. Tuition: \$295.00. Results guaranteed. Tennessee Institute of Broadcasting, 2106-A 8th Ave., South, Nashville, Tenn. 37204, or, Technical Institute of Broadcasting, 800 Silver Lane, East Hartford, Conn. 06106.

ART talent? Be your own boss. Earn \$200.00 weekly free-lancing. Free brochure. Famous American Studios, Dept. PE Spring Park, Minn. 55384.

F.C.C. License training by correspondence. G.I. Bill approved. Money-Back Warranty. Free brochure. Write: Dept. Z-9, Pathfinder School of Electronics, 1505 N. Western Ave., Hollywood, Calif. 90027.

INVENTIONS WANTED

INVENTIONS wanted. Patented; unpatented. Global Marketing Service, 2420-P 77th, Oakland, Calif. 94605.

PATENT Searches including Maximum speed, full airmail report and closest patent copies, \$6.00. Quality searches expertly administered. Complete secrecy guaranteed. Free Invention Protection forms and "Patent Information." Write Dept. 9, Washington Patent Office Search Bureau, 711 14th Street, N.W., Washington, D.C. 20005.

INVENTORS! OUR FREE EXPERT ANALYSIS of your invention can save valuable time, help you realize full sale value. Strictly confidential. **FREE INVENTION CERTIFICATE.** Write today: Pioneer Invention Service, Dept. 35, 150 Broadway, New York, N.Y. 10038.

INVENTORS! Sell your invention for cash or royalties! Our client manufacturers eagerly seek new items. Patented. Unpatented. Financial assistance if needed. 25 years proven performances. For free information, write Dept 20, Gilbert Adams, Invention Broker, 80 Wall St., New York, N.Y. 10005.

FREE "Directory of 500 Corporations Seeking New Products." For information regarding development, sale, licensing of your patented/unpatented invention. Write: Raymond Lee Organization, 230-GR Park Avenue, New York City 10017.

INVENTORS: Protect your ideas! Free "Recommended Procedure". Washington Inventors Service, 422T Washington Building, Washington, D.C. 20005.

PATENT SEARCHES, including copies of related United States Patents. Inventors, attorneys, manufacturers use our "World-Wide" Airmail service. Free: "Invention Record" form and "Information Every Inventor Needs", Hayward Company, 1029HR Vermont, Washington, D.C. 20005.

FREE PAMPHLET: "Tips on Safeguarding Your Invention." Write: United States Inventors Service Company, 501-H Thirteenth Street N.W., Washington, D.C. 20004.

INVENTORS! Don't sell your invention, patented or unpatented, until you receive our offer. Eagle Development Company, Dept. P. 79, Wall Street, N.Y., N.Y. 10005.

GOVERNMENT SURPLUS

JEeps Typically From \$53.90 . . . Trucks From \$78.40 . . . Boats, Typewriters, Airplanes, Multimeters, Oscilloscopes, Transceivers, Electronics Equipment. Wide Variety, Condition. 100,000 Bid Bargains Direct From Government Nationwide Complete Sales Directory and Surplus Catalog \$1.00. (Deductible First \$10.00 Order). Surplus Service, Box 820-J, Holland, Michigan 49423.

GOVERNMENT Surplus How and Where to Buy in Your Area. Send \$1.00 to: Surplus Information PE, Headquarters Building, Washington, D.C. 20036.

BOOKS

FREE catalog aviation/electronic/space books. Aero Publishers, 329PE Aviation Road, Fallbrook, California 92028.

UNUSUAL Books! Catalog free! International, Box 7798 (PE), Atlanta, Georgia 30309.

AMAZING self help books. Write Lynn, Box 1573, Waco, Texas 76703.

FREE Book Prophet Elijah Coming Before Christ. Wonderful Bible Evidence. PE Megiddo Mission, Rochester, New York 14619.

MAGAZINES

BACK DATE MAGAZINES! Send needs. Midtown, Box 917-PE, Maywood, N.J. 07607.

HYPNOTISM

FREE Hypnotism, Self-Hypnosis, Sleep Learning Catalog! Drawer H400, Ruidoso, New Mexico 88345.

"MALE-FEMALE HYPNOTISM" EXPOSED, EXPLAINED! "SECRET METHOD"—THEY NEVER KNOW! \$2, RUSHED, GUARANTEED! ISABELLA HALL, SILVER SPRINGS, FLORIDA 32688.

HYPNOTIC sleep learning recordings produce fabulous results. Details Free. ASR Foundation, Box 7021eg Henry Clay Station, Lexington, Ky. 40502.

MAGNETS

MAGNETISM (100) page script newly discovered magnetic principles (\$3.00). Jesse Costa, Box 26, Waquoit, Mass. 02536.

PHOTOGRAPHY—FILM, EQUIPMENT, SERVICES

SCIENCE Bargains Request Free Giant Catalog "CJ"—148 pages—Astronomical Telescopes, Microphones, Lenses, Binoculars. Kits. Parts. War surplus bargains. Edmund Scientific Co., 300 Edscorp Bldg., Barrington, New Jersey 08007.

FINE GRAIN PROCESSING 90¢. B&W 8x10's 75¢. 35mm **SPE-CIALISTS**, P.O.B. #5871, Pasadena, Calif. 91107.

DYNACHROME, ANSCOCROME film—save by mail, free price list. Hillis Products, Box 1182, Kokomo, Indiana 46901.

INTRODUCTORY SPECIAL—12 exposure Kodacolor developed and printed for \$2.00 with this ad. Expires April 1, 1970. Paul Bunyan Photo, Box 309Q31, Brainerd, Minnesota 56401.

RECORDS

SPECIAL INTEREST RECORDS AVAILABLE, PRODUCED BY THE EDITORS OF THE WORLD'S LEADING SPECIAL INTEREST MAGAZINES. SEND FOR FREE CATALOG. RECORD CATALOG-PE, ZIFF-DAVIS PUBLISHING COMPANY, ONE PARK AVENUE, NEW YORK, N.Y. 10016.

POPULAR organ albums factory direct. Concert Recording, Lynwood, Calif. 90262.

OLDIES—45RPM original hits. Over 4000 available. Catalog 25¢. C & S Record Sales, Box 197, Wampsville, N.Y. 13163.

PRINTING

FREE LITERATURE: Address labels, business cards, printing, Rubber Stamps. **JORDAN's**, 552 West O'Connor, Lima, Ohio 45801.

RUBBER STAMPS

RUBBER ADDRESS STAMP \$2.00. Signature \$3.50. Free catalog. Jackson, Box 443-G, Franklin Park, Ill. 60131.

STAMPS

RUSSIA High-Value Collection. 32 different Russia—some over 50 years old! Commemoratives, Czarist Issues, Airmails. Catalog price \$2.50. Special Get-Acquainted Offer—all for only 10¢! H. E. Harris, Dept. GG-54, Boston, Mass. 02117.

PINEAPPLE, Mangoes, Triangles, Gorilla, Greenland, 25 others 10¢. Approvals. Lichvar, 11808 Princeton, Cleveland, Ohio 44105.

EMPLOYMENT INFORMATION

FOREIGN and **USA** job opportunities available now. Construction, all trades. Earnings to \$3,000.00 monthly. Paid overtime, travel bonuses. Write: Universal Employment, Woodbridge, Conn. 06525.

CENTRAL INTELLIGENCE AGENCY. Various employment opportunities, U.S., Overseas. Information, forms, instructions \$1.00. Western Distributors, Box 6293-G, San Jose, California 95150.

BUSINESS OPPORTUNITIES

RAISE Rabbits for us on \$500 month plan. Free details. White's Rabbitry, Mt. Vernon, Ohio 43050.

FREE CATALOGS. Repair air conditioning, refrigeration. Tools, supplies, full instructions. Doolin, 2016 Canton, Dallas, Texas 75201.

PIANO TUNING learned quickly at home. Tremendous field! Musical knowledge unnecessary. GI Approved. Free information. Empire School, Miami, Florida 33145.

FREE Book "990 Successful Little Known Businesses" Work home. Plymouth 345M, Brooklyn, N.Y. 11218.

ELECTROPLATING Equipment and supplies. All types for home workshops and industrial. Send \$2.00 (refundable) for equipment guide formulas, operating data, catalog. HBS Equipment Division 90, 3543 East 16th, Los Angeles, California 90023.

I MADE \$40,000.00 Year by Mailorder! Helped others make money! Start with \$10.00—Free Proof. Torrey, Box 318-N, Ypsilanti, Michigan 48197.

\$200.00 DAILY In Your Mailbox! Your opportunity to do what mail-order experts do. Free details. Associates, Box 136-J, Holland, Michigan 49423.

MAILORDER! How to prepare your own catalog for pennies . . . without merchandise investment! Free catalog! Obie, 5711-EO 14th, Brooklyn, New York 11219.

RADID-TELEVISION Dealers & Repairmen. Want sales increased? Proven copyrighted system. \$5.00. Speaver's, Drawer C, New Sarpy, Louisiana 70078.

BIG EARNINGS selling Hertel Bibles. New 3-dimension cover, finest reference edition sells fast. Demonstrator furnished. Big commissions. International Book, Dept. PE, Box 118, Wichita, Kansas 67201.

FREE Selling Outfit. Office supplies, furniture & equipment. Oseco, 15-PE North Jefferson, Chicago 60606.

\$75.00 THOUSAND, Home Addressing! Longhand. Typewriter. Information, send stamped self-addressed envelope. Brewster, Box 1348-SM, Clearwater, Florida 33517.

MAKE BIG MONEY raising chinchillas, rabbits, guinea pigs for us. Catalog—25¢. Keeney Brothers, New Freedom, Pa. 17349.

PLASTICS

NEW Liquid Plastic hardens like glass without heat. Clear. Colors. Embed real flowers, photos, coins. Create unusual craft objects for big profits at home. Illustrated. **HOW** Booklet—25¢. Dept. 9/105L, CASTDLITE, Woodstock, Ill. 60098.

MAGIC

AMAZING color vanishing card trick, plus catalog. Send \$1.00. Ace Magic, Box 329, Evanston, Illinois 60204.

REAL ESTATE

FREE . . . 232 page FALL-WINTER CATALOG! Describes and pictures hundreds of farms, ranches, town and country homes, businesses coast to coast! Specify type property and location preferred. Zip code, please. **UNITED FARM AGENCY**, 612-EP West 47th St., Kansas City, Mo. 64112.

DO-IT-YOURSELF

BUILD your own clocks; modernize old clocks. Movements complete with hands and instructions, cordless, \$5.95; electric \$3.95 ppd. Send 10¢ for catalog. Morse Products, Box 38930-B, Hollywood, California 90038.

MUSIC

PLAY ORGAN EASILY, AMAZING METHOD, free information. Kegley, 1016-PE Kelly, Joliet, Illinois 60435.

MISCELLANEOUS

WINEMAKERS: Free illustrated catalog of yeasts, equipment. Semplex, Box 12276, Minneapolis, Minn. 55412.

POPULAR ELECTRONICS SUBSCRIBER SERVICE

Please include an address label when writing about your subscription to help us serve you promptly. Write to: Portland Pl., Boulder, Colo. 80302

CHANGE OF ADDRESS: Please let us know you are moving at least four to six weeks in advance. Affix magazine address label in space to the right and print new address below. If you have a question about your subscription, attach address label to your letter.

TO SUBSCRIBE: Check below.

5 yrs. \$21 3 yrs. \$15

1 yr. \$6 **New** **Renewal**

Specify: Payment enclosed

You get 1 extra issue

per year as a **BONUS!**

Bill me later.

If you have no label handy, print OLD address here.

name _____ please print
address _____
city _____
state _____ zip code _____

← AFFIX LABEL →

print name _____ 0359

address _____

city _____

state _____ zip code _____

Add'l postage: \$1 per year outside U.S., its possessions & Canada.

BILLS paid without borrowing—Nobody refused up to \$10,000.00. Bad credit no problem, not a Loan Company. Write for free application. **INTERNATIONAL ACCEPTANCE**, Dept. 50-A, 5133 N. Central Ave., Phx., Arizona 85012; 2511 E. 46th Street, Indianapolis, Ind., 46205; 711 14th St., N.W., Washington, D.C. 20005; 507 Carondelet St., New Orleans, La. 70130.

32 PAGE big illustrated joke and novelty catalog. 25¢. Joke, Box 7212JJ, Chicago 60680.

AUTO Dri-Kleener washes without water, leaves auto sparkling clean in minutes. Simple, easy to use anywhere. \$2.25 postpaid. House of Nivlac, 103 Lola Drive, Newport News, Va. 23606. Dept. 11.

MAIL ORDER OPPORTUNITIES WAITING FOR YOU!

Classified Advertisers—Find more outlets for your product and service advertising in Ziff-Davis Electronics Publications.

Whether in a monthly publication: **POPULAR ELECTRONICS**, **ELECTRONICS WORLD**, **STEREO REVIEW** . . . or in **ELECTRONIC EXPERIMENTER'S HANDBOOKS**, Classified Advertising is responded to regularly by an affluent audience of active electronics enthusiasts.

Prove to yourself the effectiveness of Classified Advertising in Ziff-Davis Electronics Publications. Write today to:

Hal Cymes, Classified Advertising Manager
Ziff-Davis Publishing Company
One Park Avenue, New York, N. Y. 10016

UNUSUAL BARGAINS

FREE!
GIANT
CATALOG

... MANY U. S. GOV'T SURPLUS

BLACK LIGHT/FLUORESCENT STROBE!



First time available! Giant 4' fixture for wide area strobing. Low initial cost—low maintenance. Accepts regular 48" Fluorescents or Black Light Tube listed below. Adjustable flash (from 4 to 15 per sec.). Perfect for electrically embelishing discotheques, dance floors, stage effects, posters, gogo cages, etc. Full length moveable reflector, on-off switch, intensity control, all metal construction.

No. 80.123AV (49" x 2 1/2" W x 4" H) \$72.50 Ppd.
48" BLACK LIGHT TUBE—30 W. filter type
No. 80.116AV \$10.50 Ppd.

SUPER 6" SPACE CONQUEROR



Share the wonders of space exploration. Features aluminumized & overcoated 6" f/8 ground and polished pyrex parabolic mirror accurate to 1/2 wave. 48 P.L. X achromatic finder scope. 4 eyepieces 48X, 96X, 192X. Barlow to double or triple power—rack & pinion focusing mount. Electric clock drive w/minimal slow-motion control. Setting circles. Heavy-duty equatorial mount. Industrial. Compares to \$295-\$340 models.

Stock No. 85.086AV \$239.50 FOB
Stock No. 85.109AV 4 1/2" REFLECTOR TELESCOPE \$29.50 Ppd.
Stock No. 85.050AV 3" REFLECTOR TELESCOPE \$29.95 Ppd.

NEW LOW-COST ULTRASONIC CLEANER



Top-quality hard plant unit for only \$39.95. Cleans dirt, grime completely, quickly, safely. Small delicate parts, precision electronic items, lab instruments, jewelry, coins, even dentures sparkle like new. American-made—operates on regular house current. Solid state generator w/automatic current. Power regulating knob. NO shocks. NO radio interference. 6" x 4" x 4" stainless.

Stock No. 71.003AV \$39.95 Ppd.
LARGE INDUSTRIAL 1 1/2 GAL. SIZE
Stock No. 85.128AV (Wt. 37 lbs.) \$249.95 FOB

'BRIGHT IDEAS' in UNIQUE LIGHTING



Big, new 100-page handbook packed with facts, loaded with illustrations. All latest developments, applications, equipment. Covers strobes, sources, black light, projectors, crystal and organic slides, color organs, mirrors, polarized color, screens, light boxes, Music-Vision, etc. Rare find for business, home, hobby. Ideal for display houses, colleges, experimenters, hobbyists. 8 1/2" x 11" loose-leaf paper punched to fit 3 ring binder.

Stock No. 9100AV \$3.00 Ppd.

ASTRONOMICAL TELESCOPE KITS



Grind your own mirror for powerful telescopes. Kits contain fine annealed pyrex mirror blank, tool, abrasives, diagonal mirror, and eyepiece lenses. Instruments you build are valued up to \$100's.

4 1/4" DIAMETER—3/4" THICK No. 70.003AV \$9.75 Ppd.
6" DIAMETER—1" THICK No. 70.004AV \$12.95 Ppd.
8" DIAMETER—1 1/4" THICK No. 70.005AV \$21.00 Ppd.
10" DIAMETER—1 3/4" THICK No. 70.006AV \$34.25 FOB

LONG-WAVE BLACK LIGHT FIXTURE



Extremely versatile, compactly designed, long wave (3200-4000 angstroms) black light (ultraviolet) fixture. Has 6-watt, 110-V lamp with built-in filter—eliminates harmful shorter wave ultraviolet rays. Use to identify minerals, fungi, bacteria—check for surface flaws, oil and gas leakage—perfect for displays with fluorescent paper, paints, chalk, crayons, trace powder, incl. adjustable aluminum reflector. Mount vert., horz., or on corner. 16" L., 1 1/2" W., 1 1/4" H.

Stock No. 70.364AV \$12.50 Ppd.
Stock No. 60.124AV \$4.50 Ppd.

Order by Stock No.—Check or M.O.—Money-Back Guarantee
EDMUND SCIENTIFIC CO., 300 EDCORP BLDG., BARRINGTON, N.J. 08007

WRITE FOR GIANT FREE CATALOG "AV"



Completely new 1969 edition. New items, categories, illustrations, 148 easy-to-read pages packed with 4000 unusual items. Dozens of electrical and electromagnetic parts, accessories. Enormous selection of Astronomical Telescopes, Microscopes, Binoculars, Magnifiers, Magnets, Lenses, Prisms. Many war surplus items; for hobbyists, experimenters, workshops, factory. Write for catalog "AV". Include Zip.

ORDER BY STOCK NUMBER • SEND CHECK OR MONEY ORDER • MONEY-BACK GUARANTEE
EDMUND SCIENTIFIC CO. 300 EDCORP BUILDING
BARRINGTON, NEW JERSEY 08007

CIRCLE NO. 14 ON READER SERVICE PAGE

POPULAR ELECTRONICS

OCTOBER 1969

ADVERTISERS INDEX

READER SERVICE NO.	ADVERTISER	PAGE NO.
1	AMECO, Division of Aertron, Inc.	104
4	Allied Radio	113
3	Argos Products Company	113
5	Avanti Research & Development, Inc.	8
6	B & K	25
7	BSR	94
	Bell & Howell Schools	9
43	British Industries (GARRARD)	5
8	Burstein-Applebee Company	102
	CREI, Home Study Division, McGraw-Hill Book Company	88, 89, 90, 91
9	Career Academy	101
10	Cleveland Institute of Electronics	106, 107, 108, 109
11	Cook's Institute of Electronics Engineering	110
12	Crystek	111
13	Edison Instruments	110
14	Edmund Scientific Co.	124
18	Electro-Voice, Inc.	FOURTH COVER
	Grantham School of Electronics	12
15	Heath Company	36, 37, 38, 39
16	Industrial Training Institute	98
17	Intratec	103
2	Johnson Company, E.F.	THIRD COVER
19	Lafayette Radio	125, 126
20	Mercury Electronics Corp.	118
21	Midland International Corporation	26
22	Mosley Electronics, Inc.	95
23	Motorola HEP Program	7
	McGee Radio Co.	105
	National Radio Institute	SECOND COVER, 1, 2, 3
	National Technical Schools	62, 63, 64, 65
25	Olson Electronics	116
26	Pioneer Electronics Co.	11
27	Poly Paks	102
28	Port Arthur College	116
42	RCA Electronic Components & Devices	23
	RCA Electronic Components & Devices	93
	RCA Institutes	18, 19, 20, 21
29	Radio Shack	6
41	Regency Electronics	97
30	Saleh & Co., Herbert	100
31	Sams & Co., Inc., Howard W.	117
32	Shober Organ Corporation, The	105
33	Sonar Radio Corporation	99
35	Tram Corporation	16
36	Turner Company, Inc.	14
37	UNGAR/Division of Eldon Industries	13
	U.S. Army	17
38	United Audio Products, Inc.	10
39	University Sound	114
	Valparaiso Technical Institute	105
40	Xcelite, Inc.	112

CLASSIFIED ADVERTISING 119, 120, 121, 122, 123

Printed in U.S.A.

CIRCLE NO. 19 ON READER SERVICE PAGE →

-----Mail This Card Today-->

LAFAYETTE 1970 Catalog 700 Our 49th Year

FREE!

BETTER THAN EVER
Your Complete Buying Guide to
Everything in Electronics

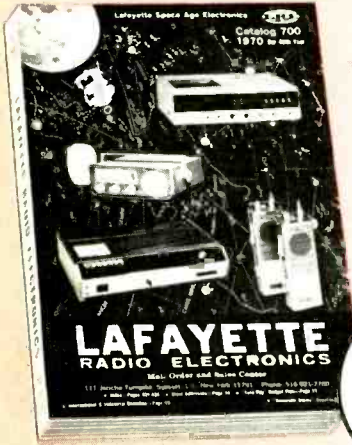

496
PAGES!

Featuring Everything in Electronics for
• HOME • INDUSTRY • LABORATORY
from the "World's Hi-Fi & Electronics Center"

Use LAFAYETTE'S Easy-Pay
Budget Plan **NO MONEY DOWN** ...
Up to 24 Months to Pay

Satisfaction guaranteed
or Money Refunded

-----Mail This Card Today for Your Friend-->

STORE LOCATIONS

NEW YORK
Brooklyn
Jamaica
Lynbrook
Lake Grove
New Rochelle
Manhattan
Rochester
Scarsdale
Syosset

NEW JERSEY
Newark
Paramus
Plainfield

MASSACHUSETTS
Boston
Natick
Saugus

PENNSYLVANIA
King of Prussia
Monroeville
Philadelphia
Pittsburgh

CONNECTICUT
Hamden
W. Hartford

WASHINGTON, D.C.
(Area)
Falls Church, Va.
Mt. Rainier, Md.

Mail the Coupon today for your
FREE 1970 Lafayette Catalog 700

LAFAYETTE Radio ELECTRONICS

Dept. 35109 P.O. Box 10
Syosset, L.I., N.Y. 11791

Please Send the FREE 1970 LAFAYETTE CATALOG 700

Name

Address

City

State

Zip

(Please Give Your Zip Code No.)

Mail This
Card Today
For Your

FREE!

LAFAYETTE 1970 Catalog 700

Dept. 35109

Name

Address

City

State

Zip

(Please Give Your Zip Code No.)

Dept. 35109

Name

Address

City

State

Zip

(Please Give Your Zip Code No.)

FREE!



Mail The Card
Today for Your

FREE!

LAFAYETTE 1970 Catalog 700

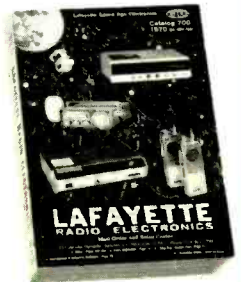

Mail This Card Today For Your

FREE!

1970 LAFAYETTE
CATALOG 700



496
Pages



Shop At the "World's Hi-Fi
& Electronics Center"
For Widest Selection, Low Prices

Stereo Hi-Fi • Citizens Band • Ham Gear • Tape
Recorders • Test Equipment • TV and Radio
• Phonographs, Accessories • Intercoms and PA
• Closed Circuit TV • Tubes and Parts • Cameras
• Auto Accessories • Musical Instruments • Tools
• Books

Featuring Everything in Electronics for
• HOME • INDUSTRY • LABORATORY
from the "World's Hi-Fi & Electronics Center"

REVOLUTIONARY NEW



Electronic Miracle
of the Space Age



Award winning LR-1500T
IC solid state Receiver



New! Revolutionary "IC"
2-Way Radios
"IC" (Integrated Circuit)



New!
Dyna Com
Series
Super
Walkie-Talkies



New!
Musical
Instruments and
Accessories

Do A Friend A Favor . . .

Have a friend interested in hi-fi or electronics? Send us his name and address and we will send him his own personal copy of the 1970 Lafayette Catalog 700.

FREE! MAIL THE CARD TODAY!

LAFAYETTE
RADIO ELECTRONICS

P.O. BOX 10
SYOSSET, L.I., N.Y. 11791

PLACE
STAMP
HERE

LAFAYETTE
RADIO ELECTRONICS

P.O. BOX 10
SYOSSET, L.I., N.Y. 11791

PLACE
STAMP
HERE

E. F. JOHNSON CO.
WASECA, MINNESOTA 56093



- 4 watts output at 13.8 VDC ■ Accessories for portable use
- World's smallest panel configuration—1 1/4" by 4 1/2", just 7" deep
- 5 push button channels—no knobs ■ side-lever vol. and squelch

Features

Only the famous Johnson "talk-power" is big as ever on Johnson's radically new Messenger 125! Virtually every vehicle on the road, including the 1969 and 1970 models, can easily accommodate this versatile new radio. Its far-ahead features make operation extremely simple and enjoyable. Best of all, we sliced the most out of the price!



Johnson Messenger 125 **\$99.95**



**It took more than skill
to design the world's
smallest complete mobile
5-watt CB
transceiver**

7 arguments in favor of building your own speaker system from scratch.

1. You choose from an almost infinite variety of sizes and levels of performance. Your system will exactly reflect your specific listening preferences.
 2. You save space by building speakers into walls, ceilings, closet doors, even in floors! Or use existing cabinets or custom-built enclosures that better suit your decor than any mass-produced system.
 3. You enhance the illusion of "live" music by hiding or disguising the sound source. You listen to the music — not the speakers.
 4. You can update your component system as often as you wish to meet advances in the state of the art.
 5. You save money by paying only for performance.
- The easiest way to buy high fidelity speakers may not always be the best. Because a complete pre-packaged system may be far from what you need. Consider some of the advantages of separate component loudspeakers:
6. You end the conflict between fine sound and handsome decor by making the speaker system an integral part of the room or the furniture.
 7. You can use the building-block method of planned improvement as your budget permits. There's no problem of being "stuck" with a compact that fits today's budget but can't meet your ultimate listening goals.
- Take a few minutes to study the variety of Electro-Voice component speakers. 21 models from \$14.00 to \$250.00. From super-tweeters to giant 30" woofers. Consider how they can aid in creating a speaker system that uniquely expresses your musical needs. And ask your Electro-Voice high fidelity specialist for his recommendation. Finally, take the time to listen carefully.
- Freedom of choice. It's at the very nub of high fidelity.

ELECTRO-VOICE, INC., Dept. 1094P
630 Cecil St., Buchanan, Michigan 49107

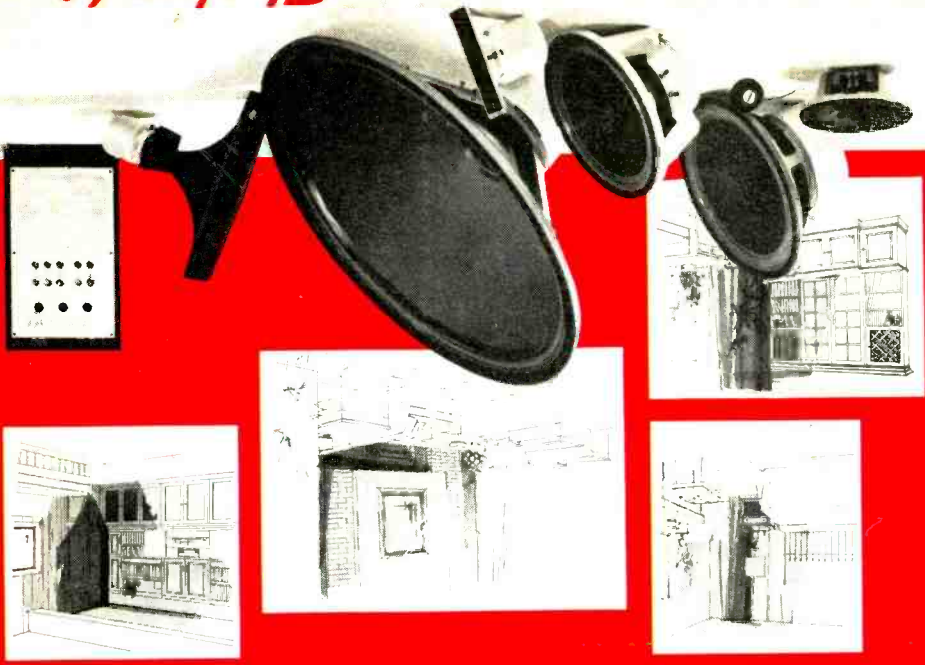

Electro-Voice
A SUBSIDIARY OF GULTON INDUSTRIES, INC.

CIRCLE NO. 18 ON READER SERVICE PAGE

OLUMIL