

COLOR ORGAN—Multi-Channel/Multi-Lamp

POPULAR ELECTRONICS

SEPTEMBER
1969

50
CENTS



STEREO COMPACTS

THE EVOLUTION

HQ-200 & SX-122A

FIELD TRIALS

BUILD MINI-6

BETTER STEREO DISPERSION

SILICON CONTROLLED SWITCH

UNDERSTANDING

STATION WINB

ANGRY VOICE FROM RED LION

METAL LOCATOR

FINDS HIDDEN NAILS

POLA-TESTERS

FOR LOGIC CIRCUITS

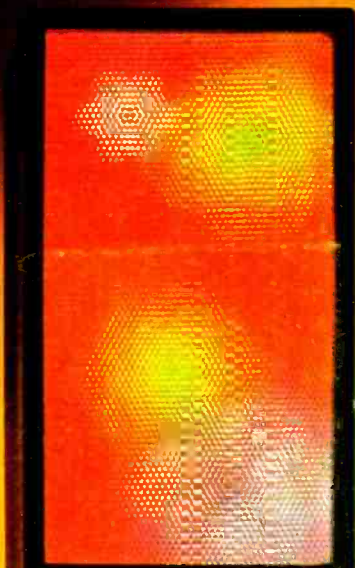

4
69
E 0 69A04 26016664 AND 08268
8 51380 DAY 43531097 NOV69 0

NRI "hands-on" training in TV-Radio, Electronics can give you as much as 2 years of on-the-job experience.

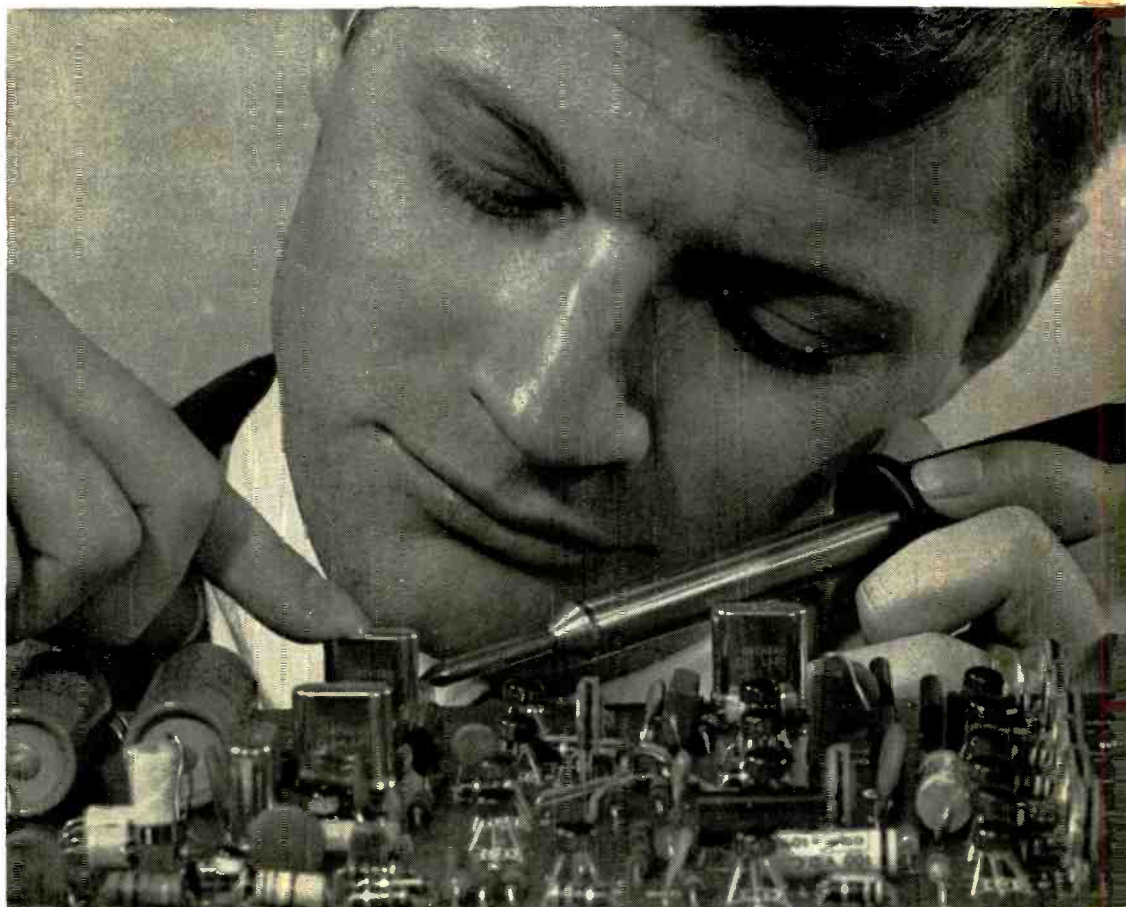

EARN YOUR FCC LICENSE – OR YOUR MONEY BACK

NRI Communications training programs will qualify you for a First Class Commercial Radiotelephone License issued by the FCC. If you fail to pass the FCC examinations for this license after successfully completing an NRI Communications course we will, on request, refund in full the tuition you have paid. This agreement is valid for the period of your active student membership and for *six months* after completion of your training. No school offers a more liberal FCC License agreement.

Experience is still your best teacher

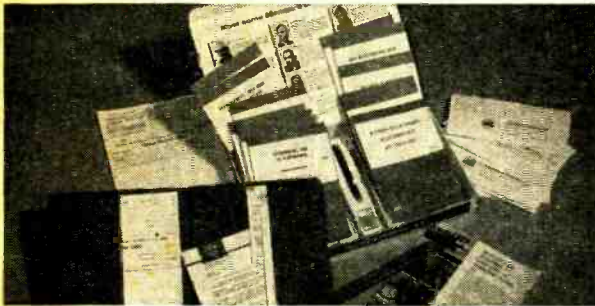

NRI Achievement Kit is educator-acclaimed and the original "starter" kit in home study training. Imitated but never duplicated, this kit is designed and personalized for you and your training objective. It has one purpose — to get you started quickly and easily.



"Bite-Size" Texts average an easily-digested 40 pages of well-illustrated, scientifically prepared subject matter in the course of your choice. Questions in each book are carefully hand-graded and returned to you with helpful instructional notes. You get unlimited personal help from the day you enroll.



Designed-For-Learning Equipment

Like this phone-cw transmitter (Kit #7 in the Communications course) is engineered from chassis up to demonstrate principles you must know. NRI does not use modified hobby kits for training, but the finest parts money can buy, professionally and educationally applied.

...here's how you get it with unique NRI training at home

Ask any teacher, job counselor, engineer, technician or prospective employer about the need for practical application of theory in Electronics. He'll tell you Electronics is as much a "hands-on" profession as dentistry or chemistry. That's how you learn at home with NRI. You prove the theory you read in "bite-size" texts, by actual experimentation with the type of solid-state, transistor and tube circuits you'll find on the job today — *not* hardware or hobby kits. You introduce circuit defects, analyze results, discover quickly the kind of trouble-shooting and design techniques that will make you employable in Electronics.

Train with the leader — NRI

NRI lab equipment is designed from chassis up for effective, fascinating training — not for entertainment. The fact that end results are usable, quality products is a bonus. In Communications, for example, you build and analyze, stage by stage, your own 25-watt phone/cw transmitter. It's suitable for use on the 80-meter amateur band, if you have an interest in ham radio. In TV-Radio Servicing your practical training gives you your choice of monochrome or color TV sets. All training equipment is included in the low tuition — you pay nothing extra. Discover for yourself the ease, excitement and *value* of NRI training. Mail postage-free card today for new NRI Catalog . . . or use the coupon below. No obligation. No salesman will call on you. NATIONAL RADIO INSTITUTE, Washington, D.C. 20016.

APPROVED UNDER NEW GI BILL

If you have served since January 31, 1955, or are in service now, check GI line on postage-free card or in coupon.

MAIL THIS COUPON IF CARD IS GONE



NATIONAL RADIO INSTITUTE

Washington, D.C. 20016

1-099

Please send me your new NRI Catalog. I understand no salesman will call and there is no obligation.

Name _____ Age _____

Address _____

City _____ State _____ Zip _____

Check for facts on new GI Bill

ACCREDITED MEMBER NATIONAL HOME STUDY COUNCIL

POPULAR ELECTRONICS

VOLUME 31 NUMBER 3

SEPTEMBER, 1969

WORLD'S
LARGEST-SELLING
ELECTRONICS
MAGAZINE

SPECIAL CONSTRUCTION PROJECT

PSYCHEDELIA 1

The ultimate in color organs

FEATURE ARTICLES

MINI-SIX ADD-ON

New dispersion-type speaker system

BUILD A BLINKY-BLINKER

Emergency flashing lamp

A LOOK AT THE HQ-200 & 5X-122A

Short-wave receivers

POPULAR ELECOMICS

POLA-TESTERS

Probes for logic circuits

BRIDGE FUNCTION QUIZ

CARPENTER'S MATE

Tiny metal locator

ANGRY VOICE FROM RED LION

International short-wave station

GETTING TO KNOW THE SCS

A SELF-POWERED PULSE GENERATOR

THE STEREO SCENE

The new compacts

THE PRODUCT GALLERY

Heathkit Model IT-18 Transistor Tester

Leverage Tools LeverWrench

National Tel-Tronics Coax Connectors

Eico Model 385 Color Bar Generator

ENGLISH-LANGUAGE NEWS BROADCASTS TO N.A.

AMATEUR RADIO

TWO-WAY REACTION

SHORT-WAVE LISTENING

SOLID STATE

DEPARTMENTS

LETTERS FROM OUR READERS

ELECTRONICS LIBRARY

READER SERVICE PAGES

NEW LITERATURE

NEW PRODUCTS

CITIZENS RADIO JAMBOREE CALENDAR

OUT OF TUNE

Build the PE Universal Frequency Counter

OPERATION ASSIST

27	Don Lancaster
45	David B. Weems
51	Lyman E. Greenlee
55	Oliver P. Ferrell
58	
59	E. B. Beach
68	Robert P. Balin
69	John S. Simanton, Jr.
73	Thomas J. R. Kent
75	Frank H. Tooker
78	
79	Charles Lincoln
83	
86	Roger Legge
87	Herb S. Brier, W9EGQ
93	G. H. Reece, KCN6990
95	Hank Bennett, W2PNA
97	Lou Garner
8	
14	
15, 115	
16	
22	
105	
110	
113	

POPULAR ELECTRONICS is indexed
in the Readers' Guide
to Periodical Literature

Copyright © 1969 by ZIFF-DAVIS PUBLISHING COMPANY. All rights reserved.

This month's cover photo by
Justin Kerr

POPULAR ELECTRONICS, September 1969, Volume 31, Number 3, Published monthly at 307 North Michigan Avenue, Chicago, Illinois 60601. One year subscription rate for U.S., U.S. Possessions and Canada, \$5.00 - all other countries, \$6.00. Second class postage paid at Chicago, Illinois and at additional mailing offices. Authorized as second class mail by the Post Office Department, Ottawa, Canada and for payment of postage in cash. Subscription service and Forms 3579: Portland Place, Boulder, Colorado 80302. Editorial offices for manuscript contributions, reader inquiries, etc.: One Park Ave., New York, N.Y. 10016.

**Unless you are an advanced CBer,
you probably can't use Johnson's
new solid state Messenger 124**



New Messenger 124 full-function, 23-channel base station. \$289⁹⁵
(less mike)

If you're an operator with a purpose . . . consider this, the most sophisticated of all Johnson 27 MHz base stations . . . from the largest and most experienced of all manufacturers of citizens and industrial two-way radio.

To the advanced CB operator, the Messenger 124 means complete mastery of the equipment—a degree of control and measurement that permits, for the first time, full utilization of all the enormous power, hairline selectivity, sensitivity and noise suppression of which the incomparable Johnson circuitry is capable.

Whatever your requirement, the Messenger 124 offers a new experience in base station performance.

Features

- ± 3 kHz Delta fine tuning • Adjustable microphone gain with modulation adjustment to 100% • 2½" four-way professional meter, measures SWR, output, % modulation and receive • 4.3 MHz crystal filter for unequalled selectivity • Built-in speech compression • Panel-controlled, series-type threshold noise limiter • Built-in tone control • Built-in 117 VAC/12 VDC power supply • 14 tuned circuits • FET for superior gain • Dual conversion receiver

E. F. JOHNSON COMPANY

Waseca, Minnesota 56093



CIRCLE NO. 17 ON READER SERVICE PAGE

FOR MEN WHO NEED WEATHER INFO

RADIO SHACK

*Invents the
World's
1st and Only*
**Instant
Weather
Radio**

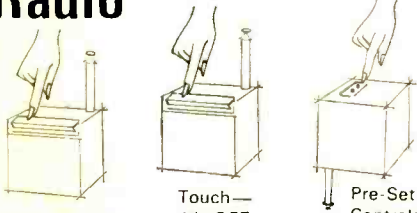

Touch — It's ON

Touch —
It's OFF

Pre-Set
Controls

*Unique 3" Square
"Talking Barometer"* **14⁹⁵** Post
Paid

From your desk or deck—monitor the new U.S. Gov't 24-hour VHF weathercasts on 162.55 MHz with a palm-size cube radio that's battery-operated and PRE-SET for instant automatic listening. Invented by 47-year-old Radio Shack for its brilliant "Realistic" line. Volume, fine tuning controls hidden under the set! Just touch the Play Bar to turn on and off! Rosewood details. Solid state circuit. An unusual and inexpensive gift.

**AVAILABLE COAST TO COAST
IN 600 RADIO SHACK STORES***

* See phone book. Or order by mail.



Free Color Catalog

See what's really new in electronics

RADIO SHACK

DIV. OF TANDY CORP.

EAST: 730 Comm. Ave., Boston, Mass. 02215
MID: P.O. Box 9027, Ft. Worth, Texas. 76107
WEST: 7340 Lampson, Garden Grove, Calif. 92641

- Weatheradios @ 14.95 Postpaid
 FREE Radio Shack 1970 Catalog

Dept. ZK

Name (print) _____

Street _____

City _____ State _____ Zip _____

CIRCLE NO. 34 ON READER SERVICE PAGE

POPULAR ELECTRONICS

PHILLIP T. HEFFERNAN

Publisher

OLIVER P. FERRELL

Editor

LESLIE SOLOMON

Technical Editor

JOHN R. RIGGS

Managing Editor

EDWARD I. BUXBAUM

Art Director

ALEXANDER W. BURAWA

Associate Editor

ANDRE DUZANT

Technical Illustrator

PATTI MORGAN

Assistant Editor

SHARON SOTZKY

Editorial Assistant

H. BENNETT, W2PNA

H. S. BRIER, W9EGQ

L. E. GARNER, JR.

G. H. REESE, KC6G990

Contributing Editors

RICHARD J. HALPERN

Advertising Manager

ARDYS C. MORAN

Advertising Service Manager

LAWRENCE SPORN

Associate Publisher

ZIFF-DAVIS PUBLISHING COMPANY

Editorial and Executive Offices

One Park Avenue, New York, New York 10016
212 679-7200

Midwestern Office

307 North Michigan Avenue, Chicago, Illinois 60601
312 726-0892

Midwestern Advertising Manager, JAMES WEAKLEY

Western Office

9025 Wilshire Boulevard, Beverly Hills, California 90211
213 CRestview 4-0265; BRadshaw 2-1161

Western Advertising Manager, BUD DEAN

Japan: James Yagi

Ishikawa Mansion, #4, Sakuragaoka
Shibuya-ku, Tokyo, 462-2911-3

Circulation Office

Portland Place, Boulder, Colorado 80302

William Ziff, President

W. Bradford Briggs, Executive Vice President

Hershel B. Sarbin, Senior Vice President

Philip Sine, Financial Vice President

Walter S. Mills, Jr., Vice President, Circulation

Stanley R. Greenfield, Vice President, Marketing

Phillip T. Heffernan, Vice President, Electronics Division

Frank Pomerantz, Vice President, Creative Services

Arthur W. Butzow, Vice President, Production

Edward D. Muhlfield, Vice President, Aviation Division

Irwin Robinson, Vice President, Travel Division

Furman Hebb, Administrative Vice President

George Morrissey, Vice President

Sydney H. Rogers, Vice President

ZIFF-Davis also publishes *Airline Management and Marketing*, *Boating*, *Business & Commercial Aviation*, *Car and Driver*, *Cycle*, *Electronics World*, *Flying*, *Modern Bride*, *Popular Photography*, *Skine*, *Skating Area News*, *Skating Trade News*, *Stereo Review*, and *Travel Weekly*.

Forms 3579 and all subscription correspondence should be addressed to POPULAR ELECTRONICS, Circulation Department, Portland Place, Boulder, Colorado 80302. Please allow at least six weeks for change of address. Include your old address, as well as new—enclosing if possible, an address label from a recent issue.

EDITORIAL CONTRIBUTIONS must be accompanied by return postage and will be handled with reasonable care; however, publisher assumes no responsibility for return or safety of art work, photographs or manuscripts.



Member Audit Bureau
of Circulations

NOW YOU CAN EXPERIMENT WITH

FIELD EFFECT TRANSISTORS

Motorola HEP does it again! With our new FET Experimenter Kit, you can now work with these important, unique devices at a cost you can afford.

This new Motorola HEP kit includes:

- One Audio J-FET
- One RF J-FET
- One NPN Silicon Transistor
- One PNP Silicon Transistor
- One "Tips On Using FET's" Brochure

ALL FIVE
JUST
\$3.95

ALSO

The "Tips on Using FET's" brochure includes detailed theory of Field Effect Transistors, tips on their applications, a glossary of terms, FET cross reference guide, and 9 FET project circuits.

Check with your HEP supplier now to get this new HEK-2 Kit. If you can't find a HEP distributor near you, just drop us a line. We'll send you a list of HEP suppliers in your area.



MOTOROLA HEP SEMICONDUCTORS

P. O. Box 20924 / Phoenix, Arizona 85034

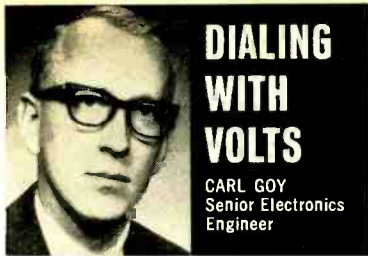

DIALING WITH VOLTS

CARL GOY
Senior Electronics
Engineer

One of a series of brief discussions by Electro-Voice engineers

There's a new way to dial your favorite FM station now being introduced. It has just two moving parts—a potentiometer and a meter. The key component in this unusual system is a device called a varactor.

A varactor is simply a diode whose capacity varies inversely with voltage applied across the junction. For instance, as the voltage rises from about 4 to 24 volts, capacity drops from about 20 to 10 pf. Increasing the control voltage serves to increase the frequency of the tuned circuit and accomplishes the same basic task as opening the plates of a conventional air variable capacitor.

In the case of a new Electro-Voice FM receiver, Model 1482, pairs of varactors are used to achieve the desired capacity in each circuit. A total of four "gangs" are employed including an antenna tuning capacitor, two interstage RF tuning capacitors, and the RF oscillator capacitor. Because each dual varactor is only about $\frac{1}{4}$ " square in size, the bulk of the tuning apparatus can be sharply reduced.

To control the voltage across the varactors a single potentiometer is needed. Precision multi-turn pots are employed with about 15 turns from minimum to maximum voltage. In the receiver in question, a total of ten of these potentiometers are used, with nine mounted on a push-button array. Each push button selects and varies a potentiometer to provide tuning to any point on the dial, thus permitting FM push-button tuning of high accuracy and repeatability. In addition, one potentiometer is connected to a conventional tuning knob to permit normal manual tuning.

Performance of the tuner with varactor tuning is quite similar to that optimally achieved with ordinary air variable capacitors. But in addition to the saving in size and increase in flexibility of component location, it is also easier to provide higher "Q" in the RF stages to achieve better selectivity. Elimination of mechanical parts and linkages insures better long-term reliability. The hermetically sealed diodes also are preferable in high humidity environments.

As a result of the use of varactors, a completely new tuning indicator has also been introduced. Rather than a pointer on a string, a sensitive D'Arsonval drum meter is employed, driven from the same voltage used to control the varactors. Similar in appearance to a "ribbon type" automotive speedometer, it instantly provides accurate readout of frequency for either manual or push-button tuning on both AM and FM.

For reprints of other discussions in this series, or technical data on any E-V product, write: ELECTRO-VOICE, INC., Dept. 993P, 630 Cecil St., Buchanan, Michigan 49107

Electro-Voice®

A SUBSIDIARY OF GULTON INDUSTRIES, INC.

CIRCLE NO. 14 ON READER SERVICE PAGE

letters

FROM OUR READERS

CB BACKLASH

In response to the letters by J. Hanley and Jeff Luther ("Letters From Our Readers," May and June 1969), I would like to make myself heard on the subject of CB radio. Two or three years ago, I thought I might be interested in qualifying for a ham license; so I bought a short-wave receiver and listened in on the ham bands for a few weeks. In a very short time, it became clear to me that the only operators active on the ham bands were the type that have been condemned as CB'ers. For several nights there was continuous controversy between two groups over the use of a specific frequency. A group of about 15 or 20 operators claimed "squatters rights" and violently objected to another group attempting to operate within a few kilohertz of the squatters. I quickly came to the conclusion that if this is amateur radio, it was properly named, and I wanted no part of it.

Both letter writers take issue with the manner in which CB'ers operate and apparently feel that it is all the fault of the CB'er. But I say let's put the blame squarely where it belongs—in the lap of the FCC. Imagine the chaos that would result if the Federal Road Commission attempted to influence the operation of the Interstate Road System to give unlimited preference to "hot rodders" and other "good-time-Charlies" but prohibited the general public from using the roads except under the most stringent and restrictive conditions. This is just the kind of attitude the FCC is taking with respect to the various radio services.

The current situation is not hopeless nor irreversible. What we need most is a slate of FCC Commissioners who will fully discharge their responsibilities to the people they are supposed to serve. A change to sensible rules would have a virtual immediate effect for the better. In the meantime, I intend to use CB radio in the spirit and intent for which the service was authorized. And I will continue to work for the public interest with members of any local groups, including radio amateurs who express a real desire to serve the community.

R.M. LEWIS, KKD7237
Huntsville, Ala.

I am in agreement with Jeff Luther on such things as operators on 11 meters running power and constructing antennas that are way above the legal limit set by the FCC. I must disagree, however, with his statement that all CB'ers rag-chew. There are many of us on 11 meters who do our best to operate

from Technician to ENGINEER

Advance beyond the technician level

Become an electronics engineer

In the Grantham electronics engineering program, you can earn the Degree of *Associate in Science in Electronics Engineering* (the ASEE) mostly by home study — and can continue in resident classes to earn your BSEE. In this program you can acquire an extensive knowledge of engineering, for greater prestige and better pay.

In America's race to the moon and outer space, *more and more* engineers are needed. By becoming an electronics engineer, you can move into the forefront of technology and engineering, and be an important part of this exciting age. You can help make things happen and be properly rewarded for doing so.

The demand for engineers continues to increase; electronics engineers are needed in the space program and in many other military and domestic projects. In a recent survey conducted by the Engineering Manpower Commission of the Engineers Joint Council, it was found that engineering employment in the electrical and electronics industries is expected to increase by 40% in ten years. The need for engineers is increasing faster than the population as a whole. The survey report indicates that in the next decade, employers expect to need almost *twice as many* new engineering graduates as are likely to be available.

If you have the desire to be an engineer, the determination to stick to your objective, and a reasonably good aptitude for mathematics and technology, the Grantham educational program can produce the wanted results for you. But make no mistake about it, to become an electronics engineer requires work. You must be willing to do that work; otherwise you can never reach your objective, regardless of what course of instruction you may choose.

Grantham School of Engineering

Specializing in Electronics since 1951

1505 N. Western Ave.
Hollywood, Calif. 90027

Telephone:
(213) 469-7878



September, 1969

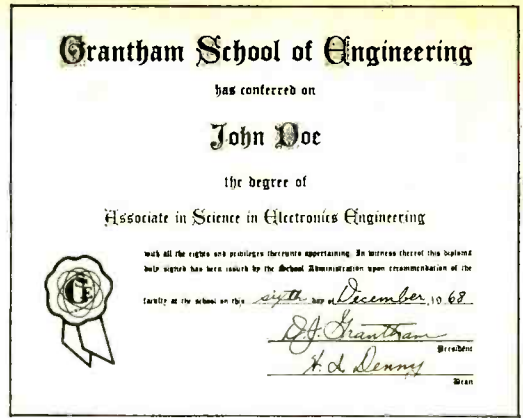

The Grantham *home study* program in electronics engineering consists of five "correspondence semesters" made up of a total of 360 lessons, followed by a two-week period of review and examination at the School. The prerequisite for enrollment in this program is high school graduation (or equivalent) and at least one year of experience as an electronics technician.

This *accredited* ASEE Degree program covers a review of basic electronic circuits and systems, applied engineering mathematics (including algebra, trigonometry, and calculus), classical and modern physics, technical writing, computer systems, electrical networks, and semiconductor circuit analysis and design. The ASEE Degree is awarded upon satisfactory completion of the 360 correspondence lessons and the final two-week residency at the School.

The Grantham educational program in electronics places heavy stress on fundamental concepts of logic and mathematics rather than on superficial manipulative skills. Since these fundamental ideas are largely unfamiliar to many electronics technicians, it is necessary to develop them in a systematic manner.

Accreditation and G.I. Bill Approval

Grantham School of Engineering is *accredited* by the Accrediting Commission of the National Home Study Council, *is approved* under the G.I. Bill, and *is authorized* under the laws of the State of California to grant academic degrees.

Grantham School of Engineering PE-9-69
1505 N. Western Ave., Hollywood, Calif. 90027

Please mail your free Bulletin, which explains how the Grantham educational program can prepare me for my Associate in Science Degree in Electronics Engineering.

Name _____ Age _____

Address _____

City _____ State _____ Zip _____

They'll never build a better Toscanini.



Or Flagstad. Or Charlie Parker.
Or Bessie Smith.

Technology helps us build better
stereo equipment. But not better artists.

Your records are the most irreplaceable part of your sound system. (They could be your biggest high fidelity investment, too.)

That's why we build our least expensive automatic turntable—the \$79.50 Dual 1212—with no less precision than our most expensive model.

So that you can use the finest cartridges, and track them at their lowest recommended force. (The 1212 is "compatible with...the most compliant cartridges available today," said Stereo Review.)

And so that you can enjoy such features as cue-control "for a very gentle lowering of the pickup onto... any portion of the record," (according to High Fidelity).

Of course, not all the 1212's features were put there just to make life easier for your records. Some (for instance, pitch-control) are there to make life—and listening—more pleasant for you. Our literature will tell you all about them.

United Audio Products, Inc.,
535 Madison Ave., New York,
New York 10022.

Dual

LETTERS

(Continued from page 8)

according to the restrictions set forth in Part 95 of the Rules and Regulations. Our equipment is well maintained and strictly legal.

There are many of us on 11 meters who would like to see the FCC get tough and help clear up the so-called mess. We would like to see a testing procedure initiated for licensing an applicant.

There are many things wrong with CB radio, and the serious CB'er is the first to admit it. However, CB has many good points which are too often overlooked.

KEN MOSES, KPD3705
El Monte, Calif.

TAPES-VERSUS-DISCS READER FEEDBACK

With reference to "The Stereo Scene" (June 1969), I'm afraid that Charles Lincoln has fed us a long list of fallacies concerning magnetic recording tapes. As evidenced by the statements made in the article, I can only conclude that Mr. Lincoln is not an expert on tapes and discs.

First, tapes cost less—not more—than discs for the same program length. The open-reel tape man who records material from borrowed discs and off the air can get four \$5 disc albums on a single \$3 tape, doubling the program length for a small added investment by switching over to 2400' tapes. And a boxed 7" reel of tape is not heavier or bulkier than four record albums as opposed to what the article would have us believe.

Next, it is at least as easy to place a reel of self-threading tape onto a machine and let the machine go to work as it is to stack four or five discs onto a record player. You even have access to both sides of an album simultaneously.

Finally, Mr. Lincoln can't even get the advantages of tapes to us intact. True, tapes last longer and require less care than discs, but the really unique advantage of tape is that it can be used where you wouldn't dare use records, such as in a car.

I can see that Mr. Lincoln is sold on cassettes, and I must give him credit for this. But in looking back, I can see a few errors in that section of the column as well. I am really sorry for the person who decides against open reel tapes because of this article.

TODD BOYLE, WA7DCZ
Phoenix, Ariz.

Authors of featured columns in POPULAR ELECTRONICS must be experts in their subject areas and Charles Lincoln is definitely an expert in hi-fi. What you failed to note is that the article deals with prerecorded tapes which contain only one album each and on the average cost more than their disc counterparts. Consequently, you would need at least as many boxed tapes as you would albums for the same program length. Also, each open-reel tape would have to be threaded onto a playback machine individually. The key phrase is "same program length."

Pump up your mobile installation performance with this

Professional "SPRING" TUNE-UP!

Here's the professional touch to dress up and power up your mobile rig! Famous high-performance, low-noise A/S base loaded design . . . 17-7PH stainless steel whip (bend it in a full circle, snaps back to perfect vertical) . . . fine-tuning adjustment built-in. Functional stainless steel shock spring adds a handsome, professional touch. Famous "Quick-Grip"® trunk mount—no holes to drill, cable completely hidden, permanent installation yet removable!

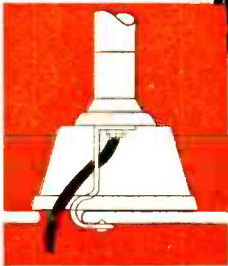
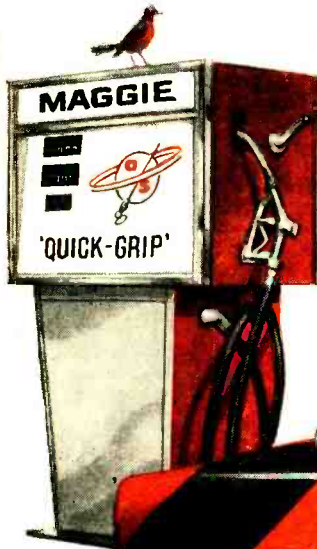

Famous Quick Grip® mount — clamps on trunk lip . . . no holes to drill . . . no soldering . . . cable completely hidden!

MODEL M-176 "MAGGIE MOBILE"

CB antenna. Suggested resale: \$21.95

the antenna specialists co.

Div. of Allen Electric and Equipment Co.
12435 Euclid Ave., Cleveland, Ohio 44106



"Stripes of Quality"®

10 New Exciting Kits For Home & Hobby



NEW
Kit ID-29
\$29.95*



NEW
Kit TD-17
\$12.95*

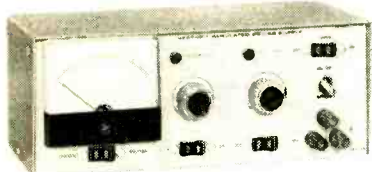

NEW
Kit IP-28
\$47.50*



\$49.95*
each

NEW
Kit GR-88

NEW
Kit GR-98



NEW
Kit GR-38
\$32.95*



NEW Kit GD-209A
\$149.95*

NEW Heathkit Solid-State Auto Tune-Up Meter . . . Measures Dwell, RPM And DC Voltage

The new Heathkit ID-29 is most versatile . . . really three automotive test instruments in one . . . and its low price makes it even a better value. Measures Dwell on all 4-cycle 3, 4, 6, or 8 cylinder engines . . . measures RPM in two ranges 0-1500 and 0-4500 . . . measures DC voltage from 0 to 15 volts. And no batteries are needed . . . running engine provides both signal and power. Easy to use . . . on both 6 and 12 volt system without changing leads. It's lightweight, easy to carry . . . comes equipped with black polypropylene case that has a built-in lead storage compartment and is resistant to virtually everything. Fast, simple assembly . . . takes just one evening. The perfect accessory for the handyman who wants to do his own car tune-up, emergency road service personnel, or shop mechanics . . . order your ID-29 now. 4 lbs.

NEW Heathkit Electronic Metronome

The new Heathkit TD-17 is a low cost, precise performing electronic Metronome . . . a handy helper for any music student. Battery operated . . . no springs to wind . . . accurate, steady calibration is always maintained . . . from 40 to 210 beats per minute. Instruction label on bottom gives conversion from time signature and tempo to beats per minute. Stylish fruit wood finished cabinet. Easy solid state circuit board construction . . . assembles and calibrates in only 2-3 hours. The new Heathkit TD-17 Electronic Metronome is so low in cost every music student can afford one . . . order yours now. 1 lb.

NEW Heathkit 1-30 VDC Solid-State Regulated Power Supply

The new modestly priced IP-28 is an excellent power supply for anyone working with transistors whether it be in a laboratory or in a home workshop . . . and its low price makes it the ideal power supply for classroom use. Compact brown and beige. Heathkit instrument styling with large easy-to-read meter . . . with two voltage ranges 10 v. and 30 v. . . and two current ranges 100 mA, 1 A. External sensing permits regulation of load voltage rather than terminal voltage. Adjustable current limiting prevents supply overloads and excessive load current. Convenient standby switch. Fast, easy assembly with one circuit board and wiring harness. Order yours today. 9 lbs.

NEW Heathkit GR-88 Solid-State Portable VHF-FM Monitor Receiver

Tunes both narrow and wide band signals between 154-174 MHz . . . for police, fire, most any emergency service. Exceptional sensitivity and selectivity, will outperform other portable receivers. Features smart compact styling . . . with durable brown leatherette case, fixed station capability with accessory AC power supply, variable tuning or single channel crystal control, collapsible whip antenna, adjustable squelch control and easy circuit board construction. The new GR-88 receiver is an added safety precaution every family should have . . . order yours today. 5 lbs.

NEW Heathkit GR-98 Solid-State Portable Aircraft Monitor Receiver

Tunes 108 through 136 MHz for monitoring commercial and private aircraft broadcasts, airport control towers, and many other aircraft related signals. Has all the same exceptional, high performance features as the GR-88 above. The perfect receiver for aviation enthusiast . . . or anyone who wants to hear the whole exciting panorama of America in flight. 5 lbs. GRA-88-1, AC Power Supply \$7.95

NEW Heathkit GR-38 Solid-State AM Clock Radio

Discover An Easier Way To Get Up In The Morning . . . with the new GR-38. Set the front panel switch to "Alarm" to hear both alarm and news & music of AM radio, or use "Auto" position for only the radio. The "Snooze" alarm lets you turn off the alarm for ten minutes but keeps the radio on to wake you up gradually, and cycles continuously until selector switch is reset. The accurate, dependable clock controls the accessory AC socket so you can have coffee perking or lights turned on in the morning. The all solid-state radio really pulls in those stations and runs cool, maintenance-free. AGC keeps stations at a constant volume and a full wave transformer power supply eliminates power line hum. Styled in coral with matching grille. There IS a better way to get up in the morning . . . with the Heathkit GR-38 . . . order yours now. 6 lbs.

NEW Heathkit Deluxe Radio-Controlled Screw-Drive Garage Door Opener Semi-Kit

The next best thing to a personal doorman. The "wireless" factory assembled transmitter operates up to 150 feet away. Just push the button and your garage door opens and the light turns on . . . and stays on until you're safely inside your home. The giant 7 ft. screw mechanism coupled with the 1/2 HP motor mean real power and reliability, and the adjustable spring-tension clutch automatically reverses the door when it meets even the smallest obstruction . . . extra safety for kids, pets, bikes, even car tops. Assembles completely without soldering in just one evening. Easy, fast installation on any 7' overhead track door and jamb & pivot doors with GDA-209-2 Adaptor at \$7.95. Order yours now. 66 lbs.

From The Leader



NEW Heathkit Ultra-Deluxe "681" Color TV With AFT . . . Power Channel Selection & Opt. RCA Hi-Lite Matrix Tube

The new Heathkit GR-681 is the world's most advanced Color TV with more built-in features than any other set on the market. Automatic Fine Tuning on all 83 channels . . . power push button VHF channel selection, built-in cable-type remote control . . . or you can add the optional GRA-681-6 Wireless Remote Control any time . . . plus the built-in self-servicing aids that are standard on all Heathkit color TV's. Other features include high & low AC taps to insure that the picture transmitted exactly fits the "681" screen, automatic degaussing, 2-speed transistor UHF tuner, hi-fi sound output, two VHF antenna inputs, top quality American brand color tube with 2-year warranty. With optional new RCA Matrix picture tube that doubles the brightness, Model GR-681MX only \$535.00.

GRA-295-4, Mediterranean Cabinet shown . . . \$124.95*

Heathkit "295" Color TV

With Optional RCA Matrix Tube . . . with the same high performance features and built-in servicing facilities as GR-681 above . . . less AFT, VHF power tuning and built-in cable-type remote control. You can add the optional GRA-295-6 Wireless Remote Control at any time. New optional RCA Matrix tube doubles the brightness, Model GR-295MX, \$485.00.

GRA-295-1, Contemporary Walnut Cabinet shown . . . \$64.95*

Both the GR-681 and GR-295 fit into the same Heath factory assembled cabinets; not shown Early American style at \$109.95*

NEW Deluxe Heathkit "581" Color TV With AFT

The new Heathkit GR-581 will add a new dimension to your TV viewing. Brings you color pictures so beautiful, so natural, so real . . . puts professional motion picture quality right into your living room. Has the same high performance features and exclusive self-servicing facilities as the GR-681, except with 227 sq. inch viewing area, and without power VHF tuning or built-in cable-type remote control. The optional GRA-227-6 Wireless Remote Control can be added any time you wish. And like all Heathkit Color TV's you have a choice of different installations . . . mount it in a wall, your own custom cabinet, your favorite B&W TV cabinet, or any one of the Heath factory assembled cabinets.

GRA-227-2, Mediterranean Oak Cabinet shown . . . \$109.95*

Heathkit "227" Color TV

Same as the GR-581 above, but without Automatic Fine Tuning . . . same superlative performance, same remarkable color picture quality, same built-in servicing aids. Like all Heathkit Color TV's you can add optional Wireless Remote Control at any time (GRA-227-6). And the new Table Model TV Cabinet and roll around Cart is an economical way to house your "227" . . . just roll it anywhere, its rich appearance will enhance any room decor.

GRS-227-5, New Cart and Cabinet combo shown . . . \$54.95*

Both the GR-581 and GR-227 fit into the same Heath factory assembled cabinets; not shown, Contemporary cabinet \$64.95*

NEW Heathkit Deluxe "481" Color TV With AFT

The new Heathkit GR-481 has all the same high performance features and exclusive self-servicing aids as the new GR-581, but with a smaller tube size . . . 180 sq. inches. And like all Heathkit Color TV's it's easy to assemble . . . no experience needed. The famous Heathkit Color TV Manual guides you every step of the way with simple to understand instructions, giant fold-out pictorials . . . even lets you do your own servicing for savings of over \$200 throughout the life of your set. If you want a deluxe color TV at a budget price the new Heathkit GR-481 is for you.

GRA-180-1, Contemporary Walnut Cabinet shown . . . \$49.95*

Heathkit "180" Color TV

Feature for feature the Heathkit "180" is your best buy in color TV viewing . . . has all the superlative performance characteristics of the GR-481, but less Automatic Fine Tuning. For extra savings, extra beauty and convenience, add the table model cabinet and mobile cart. Get the value-packed GR-180 today.

GRS-180-5, Table Model Cabinet & Cart combo . . . \$42.50*

Both the GR-481 and GR-180 fit the same Heath factory assembled cabinets; GRA-180-2, Early American Cabinet \$94.95*

Add the Comfort And Convenience Of Full Color Wireless Remote Control To Any Rectangular Tube Heathkit Color TV . . . New Or Old!

Kit GRA-681-6, for Heathkit GR-681 Color TV's . . . \$64.95*

Kit GRA-295-6, for Heathkit GR-295 & GR-25 TV's . . . \$69.95*

Kit GRA-227-6, for Heathkit GR-581; GR-481 & GR-180 Color TV's . . . \$69.95*

Now There Are 6 Heathkit® Color TV's To Choose From

2 Models In 295 Sq. Inch Size

NEW
Kit GR-681
With AFT
\$499.95*
(less cabinet)



Kit GR-295
\$449.95*
(less cabinet)

2 Models In 227 Sq. Inch Size

NEW
Kit GR-581
with AFT
\$419.95*
(less cabinet)



Kit GR-227
NOW ONLY
\$379.95*
(less cabinet
& cart)

2 Models In 180 Sq. Inch Size

NEW
Kit GR-481
with AFT
\$359.95*
(less cabinet)



Kit GR-180
NOW ONLY
\$329.95*
(less cabinet & cart)

Reception Is Simulated
On All Sets Shown



NEW

FREE 1970 CATALOG!

Now with more kits, more color. Fully describes these along with over 300 kits for stereo hi-fi, color TV, electronic organs, electric guitar & amplifier, amateur radio, marine, educational, CB, home & hobby. Mail coupon or write Heath Company, Benton Harbor, Michigan 49022.

HEATH COMPANY, Dept. 10-19

Benton Harbor, Michigan 49022

Enclosed is \$ _____ plus shipping.

Please send model (s).

Please send FREE Heathkit Catalog.

Please send Credit Application.

Name _____

Address _____

City _____

State _____

Zip _____

*Mail order prices; F.O.B. factory. Prices & specifications subject to change without notice.

CL-365

CIRCLE NO. 15 ON READER SERVICE PAGE

ELECTRONICS library

QUIET

SPACE-AGE TECHNOLOGY SERIES

Consisting of five volumes, each dealing with a different phase of space-age technology, this series is a complete "programmed learning" course put together by Training & Retraining, Inc. Individual volume titles, authors, and prices are: "Inertial Guidance Systems," Robert L. Gates, \$4.95; "Controlled Guidance Systems," Hal Hellman, \$4.95; "Synchros And Servos," Robert J. Brite and Carlo H. Fiorenelli, \$4.95; "Lasers and Masers," Charles A. Pike, \$4.95; "Microminiature Electronics," Israel Kalish, \$5.75. The entire series deals with the basics of space-age technology in a non-mathematical treatment. The format of the text is eminently suited to home study.

Published by Howard W. Sams & Co., Inc. 4300 West 62 St., Indianapolis, Ind. 46268. All volumes soft cover. Entire five-volume set in heavy-duty slipcase, \$24.95.

HOW TO USE GRID-DIP OSCILLATORS Second Edition

by Rufus P. Turner

In the hands of an ingenious user, the grid-dip oscillator is an extremely versatile test and measurement instrument. It is the purpose of this book to help you become an "ingenious" user of the GDO in all areas of electronics dealing with r.f. The text is arranged for both study purposes and to serve as a quick guide for use of the GDO in specific applications. Some of the uses covered include determination of resonant frequencies of tuned circuits, capacitance, inductance, Q, bandwidth, and properties of antennas, transmission lines, crystals, and filters. This book also describes how to use the GDO as a signal source, monitor, and field strength meter. The revised material in this edition takes into account solid-state GDO's and use of the GDO in transistor circuits.

Published by Hayden Book Co., Inc., 116 West 14 St., New York, N.Y. 10011. Soft cover. 111 pages. \$2.95.

WORKING WITH SEMICONDUCTORS

by Albert C. W. Saunders

In contrast to the usual textbook approach, this new book avoids the dry, theoretical mathematical technique—it simply tells how and why things work in plain, everyday language, with numerous illustrations. The book

(Continued on page 118)

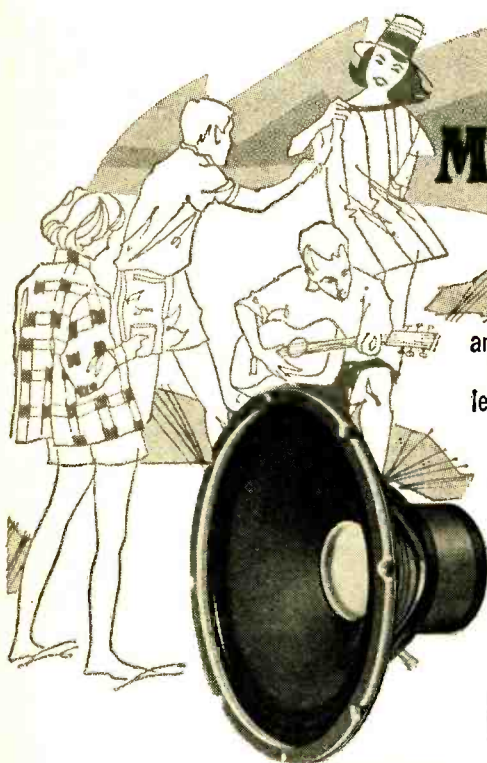

MAKING "WAVES"

CADENCE—the musical instrument speakers

Making better, clearer, amplified sound waves is the **THING** Cadence does... better than anything else in the industry. Cadence Speakers are built to withstand heat from sustained notes at a high power level and the vibrations and stresses which are continually placed upon them. Cadence is guaranteed **one full year** at the power level specified. This proven speaker family has been selected by the manufacturers of most of the world's fine amplified music instruments.

If making beautiful, clear sound waves is your thing, ask for **CADENCE SPEAKERS**. For complete information and the name of your Cadence Dealer, write:



UTAH ELECTRONICS DIVISION
Utah-American Corporation
1124 East Franklin Street
Huntington, Indiana 46750

CIRCLE NO. 32 ON READER SERVICE PAGE

POPULAR ELECTRONICS READER SERVICE PAGE

free information service:

Here's an easy and convenient way for you to get additional information about products advertised or mentioned editorially (if it has a "Reader Service Number") in this issue. Just follow the directions below... and the material will be sent to you promptly and free of charge.

1. On coupon below, circle the number(s) that corresponds to the key number(s) at the bottom or next to the advertisement or editorial mention that is of interest to you. (Key numbers for advertised products also appear in the Advertisers' Index.) Print or type your name and address on the lines indicated.

2. Cut out the coupon and mail it to: POPULAR ELECTRONICS, P.O. Box 8391, Philadelphia, PA 19101.

note: If you want to write to the editors of POPULAR ELECTRONICS about an article on any subject that does not have a key number, write to POPULAR ELECTRONICS, One Park Avenue, New York, N.Y. 10016. Inquiries concerning circulation and subscriptions should be sent to POPULAR ELECTRONICS, Portland Place, Boulder, Colo. 80302.

POPULAR ELECTRONICS

P.O. BOX 8391
PHILADELPHIA, PA. 19101

VOID AFTER OCTOBER 31, 1969

1 2 3 4 5 6 7 8 9 10 11 12 13 14 15 16 17 18 19 20
21 22 23 24 25 26 27 28 29 30 31 32 33 34 35 36 37 38 39 40
41 42 43 44 45 46 47 48 49 50 51 52 53 54 55 56 57 58 59 60
61 62 63 64 65 66 67 68 69 70 71 72 73 74 75 76 77 78 79 80
81 82 83 84 85 86 87 88 89 90 91 92 93 94 95 96 97 98 99 100

NAME (Print clearly) _____

ADDRESS _____

CITY _____ STATE _____ ZIP CODE _____

9 a

avanti

*ASTRO
PLANE



**MORE THAN
4 db GAIN...
MUCH MORE!**

\$29.95

*Patent Pending

Compact omni-directional design . . . no long drooping radial elements that can break or bend under wind or icing . . . no coils to burn or short out . . . no need to climb tower to straighten or replace radials. Carries Avanti's exclusive 1 year guarantee.

SPECIFICATIONS

Gain: 4.46 db
Weight: 3½ lbs.
Height: 12'
SWR: Less than 1.4:1
Material: Aircraft quality seamless aluminum construction
Maximum Power: 1000 watts
Wind Survival: 120 mph

90% TOP RADIATION

Astro Plane is the only omni-directional antenna that can generate maximum signal strength at the very top of the full legal antenna height limit (see diagram).



Ordinary collinear or ground plane antenna signals are blocked . . . they radiate from the bottom.



Astro Plane gets its signal over obstacles . . . it radiates from the top.

SOLD BY: ECHO COMMUNICATIONS
1038 S. WASHINGTON
CEDARBURG, WISCONSIN 53012
DEALER INQUIRIES INVITED

CIRCLE NO. 6 ON READER SERVICE PAGE

TAKE ONE



new literature

To obtain a copy of any of the catalogs or leaflets described below, simply fill in and mail the coupon on page 15 or 115.

The entire line of Endeco desoldering/re-soldering irons, tips, and kits is illustrated and described in Bulletin No. 69 just published by *Enterprise Development Corp.* Among the items listed are the Model 100A iron with temperature control for continuous heavy-duty and industrial service and pencil-style Model 400 iron for removing and replacing miniature components. Thirteen replaceable tips (with a run-down of their inside and outside dimensions) and desoldering kits that include everything needed to handle any soldering job are also listed.

Circle No. 75 on Reader Service Page 15 or 115

"Every tape recorder owner ought to have his head examined!"—tape head, that is. This is the theme of pamphlet No. 7260 available from *Nortronics Company, Inc.* The pamphlet outlines the three-step procedure for checking tape head wear—look, touch, and listen.

Circle No. 76 on Reader Service Page 15 or 115

Catalog No. 695 available from the *Edmund Scientific Co.* is a treasure-trove of interesting and exciting items for the fun-seeker, experimenter, and serious amateur astronomer. Listed and described are thousands of items, such as "MusicVision," Edmund's own line of electronically driven colored-light displays; a dry copier; fiber optics, diffraction gratings, and thermoplastic sheets designed to produce moire patterns; photography accessories; etc. The line of toys and educational toys has been greatly expanded, and there is even a line of laser and laser kits for the really technically minded experimenter.

Circle No. 77 on Reader Service Page 15 or 115

J.W. Miller Co. has just published Catalog 170, containing 196 pages of coil replacement guide information. The 120-page cross-reference section is the most comprehensive and authoritative coil replacement guide for color and monochrome TV receivers and home and car radio receivers. More than 35,000 replacement listings are included. The catalog gives specifications and prices for more than 3400 coils and components.

Circle No. 78 on Reader Service Page 15 or 115

POPULAR ELECTRONICS

FREE!

1970
CATALOG
NO. 700

JUST OFF THE PRESS!!
SEND FOR YOUR EXCITING COPY NOW!

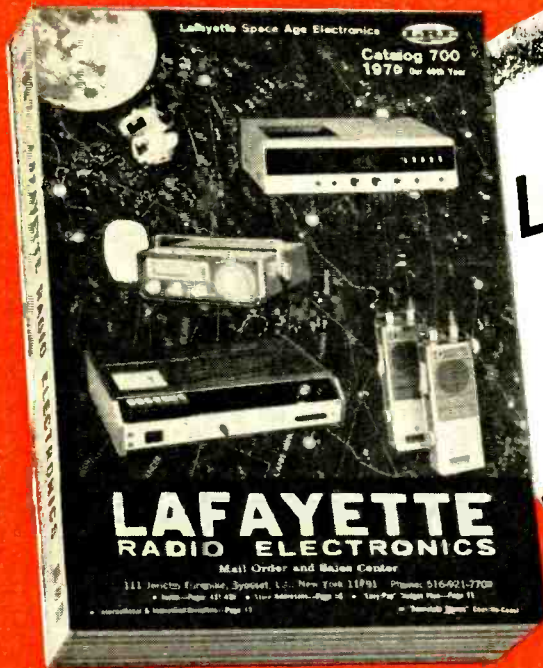

Latest Releases!
Best Bargains!
496 Pages

YOUR 1st GUIDE TO
EVERYTHING IN
ELECTRONICS

- ★ CITIZENS BAND
2-WAY RADIO
 - ★ STEREO/HI-FI
COMPONENTS
 - ★ MUSICAL INSTRUMENTS
AND AMPLIFIERS
- ★ PUBLIC ADDRESS
 - ★ AMATEUR RADIO
 - ★ TEST EQUIPMENT
 - ★ PARTS
 - ★ PORTABLE AND
TABLE RADIOS
- ★ PHOTO EQUIPMENT
 - ★ TOOLS—BOOKS
 - ★ AUTO ACCESSORIES
 - ★ EDUCATIONAL
AND OPTICAL
 - ★ TV AND ANTENNAS

Your Complete Buying Guide to Everything in Electronics

LAFAYETTE Radio ELECTRONICS
Dept. 35099, P.O. Box 10
Syosset, L.I., N.Y. 11791

Send me the FREE 1970 LAFAYETTE Catalog 700 35099

Name

Address

City State

Zip

(please include your Zip Code No.)

Mail the Coupon Today
for your FREE 1970 Lafayette
Catalog 700

CIRCLE NO. 18 ON READER SERVICE PAGE

How to become a “Non-Degree Engineer”



In today's electronics boom the demand for men with technical education is far greater than the supply of graduate engineers. Thousands of real engineering jobs are being filled by men without engineering degrees—provided they are thoroughly trained in basic electronic theory and modern application. The pay is good, the future is bright... and the training can now be acquired at home—on your own time.

THE ELECTRONICS BOOM has created a new breed of professional man—the non-degree engineer. Depending on the branch of electronics he's in, he may "ride herd" over a flock of computers, run a powerful TV transmitter, supervise a service or maintenance department, or work side by side with distinguished scientists on a new discovery.

But you do need to know more than soldering connections, testing circuits and replacing components. You need to really know the fundamentals of electronics.

How can you pick up this necessary knowledge? Many of today's non-degree engineers learned their electronics at home. In fact, some authorities feel that a home study course is the best way. *Popular Electronics* said:

"By its very nature, home study develops your ability to analyze and extract information as well as to strengthen your sense of responsibility and initiative."

Cleveland Method Makes It Easy

If you do decide to advance your career through home study, it's best to pick a school that *specializes* in the home study method. Electronics is complicated enough without trying to learn it from texts and lessons that were designed for the classroom instead of the home.

Cleveland Institute of Electronics concentrates on home study exclusively. Over the last 30 years it has developed tech-



niques that make learning at home easy, even if you once had trouble studying. Your instructor gives the lessons and questions you send in his undivided personal attention—it's like being the only student in his "class." He not only grades your work, he analyzes it. And he mails back his corrections and comments the same day he gets your lessons, so you read his notations while everything is still fresh in your mind.

Students who have taken other courses often comment on how much more they learn from CIE. Says Mark E. Newland of Santa Maria, Calif.:

"Of 11 different correspondence courses I've taken, CIE's was the best prepared, most interesting, and easiest to understand. I passed my 1st Class FCC exam after completing my course, and have increased my earnings by \$120 a month."

Always Up-to-Date

Because of rapid developments in electronics, CIE courses are constantly being revised. This year's courses include up-to-the-minute lessons in Microminiaturization, Laser Theory and Application, Suppressed Carrier Modulation, Single Sideband Techniques, Logical Troubleshooting, Boolean Algebra, Pulse Theory, Timebase Generators...and many more.

CIE Assures You an FCC License

The Cleveland method of training is so successful that better than 9 out of 10 CIE

graduates who take the FCC exam pass it. This is despite the fact that, among non-CIE men, 2 out of every 3 who take the exam fail! That's why CIE can promise in writing to refund your tuition in full if you complete one of its FCC courses and fail to pass the licensing exam.

This Book Can Help You

Thousands who are advancing their electronics careers started by reading our famous book, "How To Succeed in Electronics." It tells of many non-degree engineering jobs and other electronics careers open to men with the proper training. And it tells which courses of study best prepare you for the work you want.

If you would like to cash in on the electronics boom, let us send you this 44-page book free.

Just fill out and mail the attached postpaid card. Or, if the card is missing, mail the coupon at right.

NEW COLLEGE-LEVEL CAREER COURSE FOR MEN WITH PRIOR EXPERIENCE IN ELECTRONICS

ELECTRONICS ENGINEERING... covers steady-state and transient network theory, solid state physics and circuitry, pulse techniques, computer logic and mathematics through calculus. A college-level course for men already working in Electronics.

CIE
Cleveland Institute of Electronics
 1776 East 17th Street
 Cleveland, Ohio 44114

Please send me without cost or obligation:
 Your 44-page book "How To Succeed In Electronics" describing the job opportunities in Electronics today, and how your courses can prepare me for them.
 Your book on "How To Get A Commercial FCC License."

I am especially interested in:

- Electronics Technology
- Broadcast Engineering
- First Class FCC License
- Electronic Communications
- Industrial Electronics
- Electronics Engineering

Name _____ (PLEASE PRINT)

City _____

Address _____

State _____

Zip _____ Age _____

ENROLL UNDER NEW G.I. BILL. All CIE courses are available under the new G.I. Bill. If you served on active duty since January 31, 1955, or are in service now, check box on card or in this coupon for G. I. bill information. PE-88

CIRCLE NO. 10 ON READER SERVICE PAGE



NEW PRODUCTS

Additional information on products covered in this section is available from the manufacturers. Each new product is identified by a code number. To obtain further details on any of them, simply fill in and mail the coupon on page 15 or 115.

COLOR BAR/PATTERN GENERATOR

"Up-to-the-minute" is the most appropriate description for the new *Heathkit* Model IG-28 solid-state color bar/pattern generator for color TV receiver servicing. The IG-28 employs 15 J-K flip-flops that count down from a crystal-controlled master oscillator to eliminate flicker, bounce, and jitter in the display. The divider chain never needs adjusting. All six standard patterns are available from the IG-28—dots, cross hatch, shading bars, color bars, vertical lines, and horizontal lines—in both nine-by-nine and three-by-three displays. A clear raster is also available for adjusting purity without disturbing the receiver a.g.c. Featured are front-panel tuning for TV channels 2-6, variable positive and negative video output, sync output, two a.c. convenience outlets, built-in gun-shorting circuits and grid jacks, vectorscope capability, switchable crystal-controlled sound carrier, and regulated power supply.



Circle No. 79 on Reader Service Page 15 or 115

8-TRACK CARTRIDGE TAPE CHANGER

The world's first automatic changer for 8-track stereo tape cartridges is now available in both home and mobile models from *Qatron Corp.* Both changers, commonly designated the Models 48H, accept up to 12 standard tape cartridges and will play in three different selectable sequences. Individual cartridges can be "dialed in" manually, and any cartridge can be rejected or repeated at will. The *Qatron* 48H is designed around a removable circular magazine (similar in principle to those used on many modern slide projectors). Additional magazines for storage of large tape collections are also available. Technical specifications: frequency response—50-15,000 Hz ± 3 dB; output power—24 watts peak (12

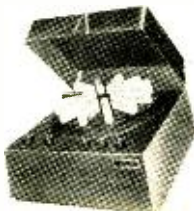

watts/channel); total harmonic distortion—less than 1% at 5 watts; signal-to-noise ratio—50 dB; flutter—less than 0.25%; cartridge change cycle—2 seconds nominal (to adjacent cartridge).

Circle No. 80 on Reader Service Page 15 or 115

SOLID-STATE CB MICROPHONE

A modern-styled base station microphone with built-in preamplifier and compression amplifier (to prevent over-modulation) is being introduced as the Model "Plus Three" by the *Turner Company*. The new mike allows the user to set volume level with a ten-position control for any desired modulation level. The compression amplifier circuit then allows the user to talk close to, or far from, the mike without varying the output signal or transmitter modulation. Frequency range of the Plus Three is 300-3000 Hz, tailored for best voice-signal transmission. A touch-to-talk switch and lock-lever are built into the base. The Plus Three is wired to function with both relay-operated and electronic switching sets (a booklet included with the mike provides installation instructions for more than 100 popular transceiver models). The preamplifier circuit provides up to 35 dB of gain.



Circle No. 81 on Reader Service Page 15 or 115

REVERB SYSTEM FOR AUTOMOBILES

Allied Radio Corporation's Deluxe Solid-State Stereo Reverberation System adds a new dimension in sound to any mobile stereo tape player or stereo FM receiver. It even creates a pleasing stereo-like effect from mono broadcasts. The reverb system mixes the sound from each stereo channel and delays it through the rear speaker to fill the "hole in the middle" with full reverberating sound. Controls are provided on the front panel for volume level, balance, and degree of reverberation, and pilot lamps indicate "on" and "stereo" mode. Measuring 8" \times 5 $\frac{3}{4}$ " \times 1 $\frac{3}{4}$ ", the reverb system easily mounts under the dash of most cars. A 6" round speaker mounted on a 6" \times 9" adapter board with chrome grille is supplied for rear mounting.



Circle No. 82 on Reader Service Page 15 or 115

CB BASE STATION ANTENNA

The *Avanti Research & Development, Inc.*, "Moonraker" is a new CB base station antenna designed along the lines of antennas used to pinpoint signals on "moon bounce." The new antenna combines half-wave cross-dipole elements with a reflector. A switch box (in-

The New 1969 Improved Model 257 **A REVOLUTIONARY NEW TUBE TESTING OUTFIT**

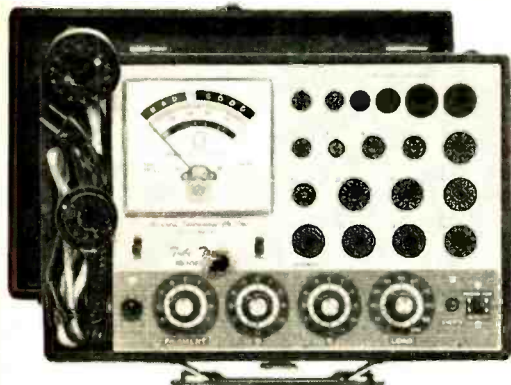

COMPLETE WITH ALL ADAPTERS AND ACCESSORIES, NO "EXTRAS"

STANDARD TUBES:

- ✓ Tests the new Novars, Nuvistors, 10 Pins, Magnovals, Compactrons and Decals.
- ✓ More than 2,500 tube listings.
- ✓ Tests each section of multi-section tubes individually for shorts, leakage and Cathode emission.
- ✓ Ultra sensitive circuit will indicate leakage up to 5 Megohms.
- ✓ Employs new improved 4½" dual scale meter with a unique sealed damping chamber to assure accurate, vibration-less readings.
- ✓ Complete set of tube straighteners mounted on front panel.

The Model 257 is housed in a handsome, sturdy, portable case. Comes complete with all adapters and accessories, ready to plug in and use. No "extras" to buy. Only

\$47.50

BLACK AND WHITE PICTURE TUBES:

- ✓ Single cable used for testing all Black and White Picture Tubes with deflection angles 50 to 114 degrees.
- ✓ The Model 257 tests all Black and White Picture Tubes for emission, inter-element shorts and leakage.

COLOR PICTURE TUBES:

- ✓ The Red, Green and Blue Color guns are tested individually for cathode emission quality, and each gun is tested separately for shorts or leakage between control grid, cathode and heater. Employment of a newly perfected dual socket cable enables accomplishments of all tests in the shortest possible time.

NOTICE

We have been producing radio, TV and electronic test equipment since 1935, which means we were making Tube Testers at a time when there were relatively few tubes on the market, way before the advent of TV. The model 257 employs every design improvement and every technique we have learned over an uninterrupted production period of 32 years.

Accurate Instrument Co., Inc.

SEND NO MONEY WITH ORDER PAY POSTMAN NOTHING ON DELIVERY

Try it for 10 days before you buy. If completely satisfied you may remit \$47.50 plus postage and handling charge. If you prefer you may use our **EASY PAYMENT PLAN**. If not completely satisfied, return to us, no explanation necessary.

ACCURATE INSTRUMENT CO., INC.

Dept. 689 2435 White Plains Road, Bronx, N. Y. 10467

Please rush me one Model 257. If satisfactory I agree to remit \$47.50 plus postage and handling charge. (If you prefer you may use our **EASY PAYMENT PLAN**) If not satisfactory, I may return for cancellation of account.

Name _____

Address _____

City _____ Zone _____ State _____

Save Money! Check here and enclose \$47.50 with this coupon and we will pay all shipping and charges. You still retain the privilege of returning after 10 day trial for full refund.

CIRCLE NO. 1 ON READER SERVICE PAGE

PRODUCTS (Continued from page 22)

cluded) permits operation in either the horizontal or the vertical polar mode. Moonraker employs only a 15' boom thus eliminating the efficiency loss inherent in multiple in-line quad setups with longer lengths. The shorter boom length also helps to keep weight and turning radius to a minimum, allowing the use of an ordinary TV-type antenna rotation system. Technical specifications: gain—14.5 dB; SWR—1.20:1; impedance—50 ohms; power handling capability—1000 watts; front-to-back separation—38 dB; vertical-to-horizontal separation—25 dB; wind survival—90 mi/hr.

Circle No. 83 on Reader Service Page 15 or 115

COMPACT HOME STEREO MUSIC SYSTEM

Concord Electronics Corp. has just introduced its Model HES-35 Stereo Home Music System for AM/FM/stereo FM listening, recording and playing. Included in the system are a powerful AM/stereo FM receiver, built-in Concord cassette tape deck, and a pair of matching bookshelf speaker systems. The 35-watt receiver has a FET front end for



increased sensitivity; automatic muting on stereo FM; separate tone and volume controls for each channel; a.f.c. for locked-in tuning; and built-in AM and FM antennas. Frequency range of the receiver is 20-25,000 Hz and stereo reception is better than 65 dB at 1.9 kHz. The frequency range of the cassette tape deck is 50-12,000 Hz, with wow and flutter less than 0.2% and signal-to-noise ratio better than 45 dB. A full complement of stereo inputs allows the user to record off-the-air, from a microphone, or from a modern record player.

Circle No. 84 on Reader Service Page 15 or 115

IC BREADBOARD SOCKET

A new device for breadboarding 14-pin dual-in-line integrated circuits is now available from Vector Electronics Company, Inc. The No. 507G breadboard IC socket consists of a 2.63" X 1.33" epoxy-glass PC-type board on which is mounted a standard IC socket. The tabs of the socket are soldered to two adjacent rows of solderless Springclip terminals, each of which are numbered to correspond to the numbered socket contacts. Two pins mounted on the bottom of



the board permit the 507G to be plugged into the holes of standard Vector "AA" perforated board. Breadboarding is easy with the 507G; as many as four solderless connections can be made to any terminal pin with ordinary hookup wire. And for discrete components, the adjacent perforated board can serve as a regular breadboard.

Circle No. 85 on Reader Service Page 15 or 115

TWELVE-CHANNEL MONITOR RADIO

Regency Electronics has developed a new 12-channel, all solid-state monitor radio that is designed to be operated from either a.c. or d.c. sources for base and mobile applications. The compact Model TMR-12 receiver is capable of monitoring any of 12 channels within an 8-MHz range within the entire 152-174 MHz band. Plug-in crystals are available for easy frequency change. The TMR-12 is sold with a.c. and d.c. power cords, a mobile mounting bracket, a removable telescoping antenna, built-in 4" speaker, external antenna jack, and remote speaker terminals. Technical specifications: 1.5 μ V sensitivity; 50 dB at 15 kHz selectivity; 3 watts of audio output power; one ampere required for full audio power from 12-volt input, 9 watts required from 117-volt a.c.



Circle No. 86 on Reader Service Page 15 or 115

PUSHBUTTON MULTIMETER

Pushbutton range and function switches and a taut-band meter movement that assures greater accuracy and extended meter life are features of the new Olson Electronics Inc. Model TE-235 multimeter. In addition, the expanded-scale meter has a built-in mirror for parallax. Technical specifications: sensitivity—30,000 ohms/volt; d.c. ranges—0 to 1, 2.5, 10, 50, 250, 1000 volts and 0-50 μ A, 100 mA, 250 mA, 500 mA, 10A; a.c. ranges—0 to 2.5, 10, 50, 250 volts and -10 to +36 dB; resistance ranges—0 to 5 K, 50 K, 500 K, 5 megohms; size—8 $\frac{1}{2}$ " X 5 $\frac{1}{8}$ " X 2 $\frac{3}{16}$ ". The meter is supplied complete with batteries and test leads.

Circle No. 87 on Reader Service Page 15 or 115



CO-PHASE BOOSTS ANTENNA EFFICIENCY

A complete coaxial harness system designed to co-phase two mobile antennas for an efficiency increase of 25% is now available from Avanti Research and Development, Inc. By mounting two mobile antennas on opposite sides of any land vehicle, a much wider aper-

(Continued on page 116)

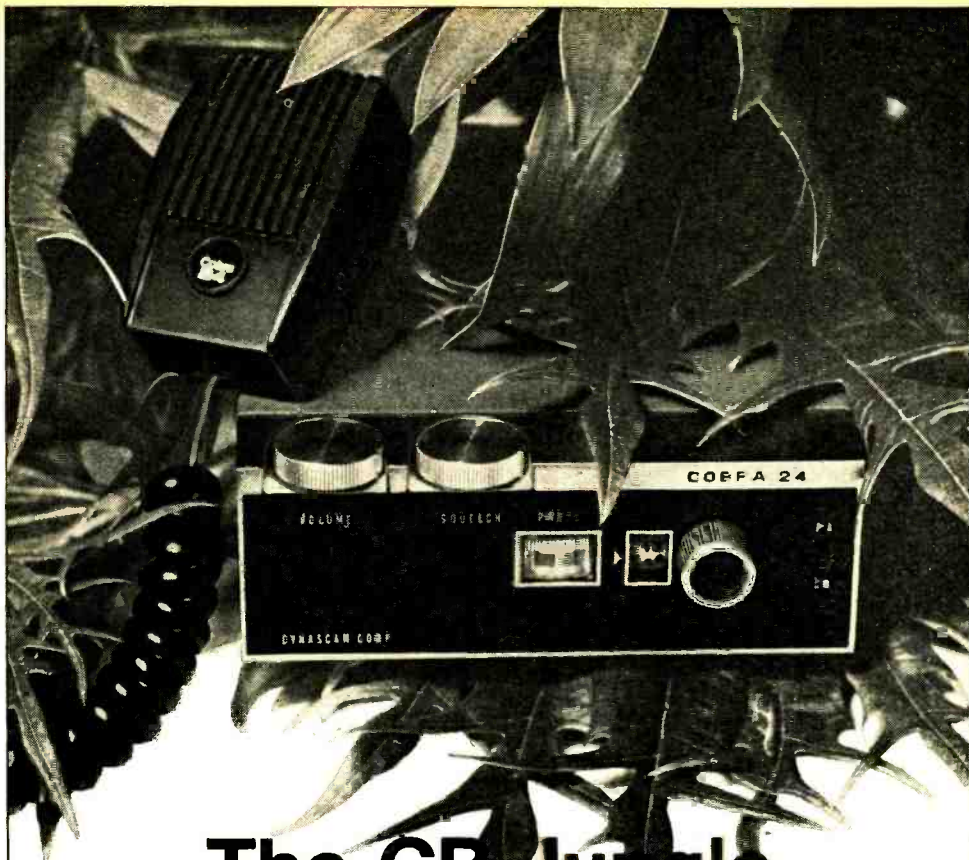

The CB Jungle is suddenly still...

There's a new Cobra Lurking!

The new Cobra 24: with more power, intelligence, and beauty than any of the others in its class!

The Cobra 24 preys on the others' weaknesses. With *more talk power*—a full, legal-limit 5-watt input and exclusive Dynascan DYNA-BOOST Speech Compression. And a selective dual-conversion superhet receiver with ceramic filter to give outstanding selectivity and gain.

And *more intelligence*—it always gets the message through crisp and sharp, even when others are garbled and unclear. Crystal-controlled transmit and receive on all 23 channels. (No extra crystals to buy!)

And *more beauty*—a striking, no-nonsense exterior. Designed for attack...with a push-to-talk mike, automatic noise limiter,

and positive or negative ground operation without internal wiring changes, featuring reverse polarity protection. There's a PA/CB switch with adjustable volume. And the illuminated channel selector and "S" meter makes even night transmission easy. Beautiful, with all silicon transistor, F.E.T. and integrated circuit. It uses 12 volt DC; AC adapter available. Meets FCC requirements. It even comes with its own mounting bracket.

See your dealer or write us for full details.



Cobra 24 Net \$169.95.

Product of DYNASCAN CORPORATION
1801 W. Belle Plaine, Chicago, Illinois 60613



Midland transceivers go the distance for you

...with solid state dependability, extra power, warranted service!



3-Channel, 100 mw. Solid state. Call Signal®, AC adaptor jack. Channel 11 crystals, earphone and battery included. Model 13-428 **\$16.95 ea.**



2 Watts, 3 Channels. Integrated circuit, separate speaker/mike, Call Signal®, squelch. Charger and AC adaptor jacks. Model 13-724 **\$44.95 ea.**

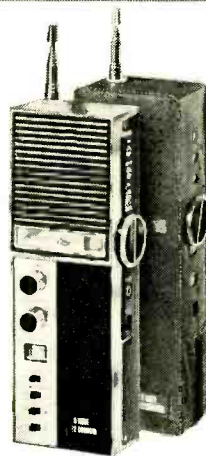

5 Watts, 12 Channels. Integrated circuit, 3-way meter, Call Signal®, battery saver. Jacks for PA, antenna, AC. Model 13-772 **\$79.95 ea.**

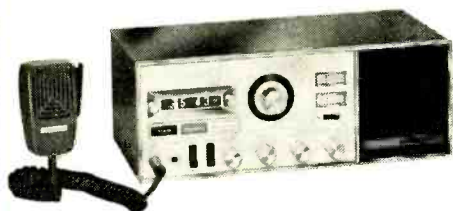

AC/DC 23-Channel, 5-Watt CB. Built-in digital clock. 4 solid state integrated circuits, F.E.T. front end RF amplifier. Delta tuning, SWR meter with forward/reverse switch. Model 13-877 **\$189.95**

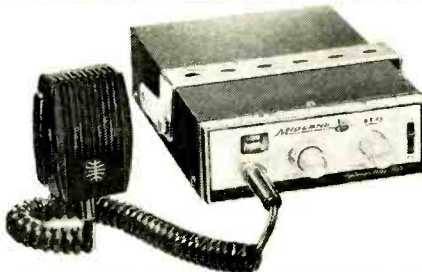

23-Channel, 5-Watt Base/Mobile CB. Instant all-channel operation. Integrated circuit. Dual conversion receiver with filter. RF/signal meter, PA switch, squelch. Model 13-870C **\$139.95**

Prices shown are suggested retail

MIDLAND
INTERNATIONAL®
CIRCLE NO. 20 ON READER SERVICE PAGE

Free color brochure!
Write: 1909 Vernon, North
Kansas City, Mo. 64116

PSYCHEDELIA 1

*Color Organ Designed for the 70's
Opens New Vistas in Display of Sound*

BY DON LANCASTER

THIS IS the day of the color organ. By combining the visual stimuli of multi-color lighting with the aural stimuli of hi-fi sound you can make your living room or den into a psychedelic showcase. Of course, you can now buy a color organ (some even physically looking pretty much like the one described here) but for a modest investment you can build a more versatile color organ with greater sensitivity and power handling capacity.

By employing new design techniques, the latest semiconductors, and computer-derived audio filtering—the ultimate in color organs has been designed. It's called Psychedelia 1 and can control up to 600 watts of vari-colored light per channel. The input signal to the Psychedelia 1 can be a hi-fi system loudspeaker output, a contact microphone, tape recorder output, or just about any audio source. The Psychedelia 1 will add no distortion. The visual display of Psychedelia 1 is distinctive and eye-catching—(see cover photo).

The basic 600-watt Psychedelia 1 described in this issue consists of three

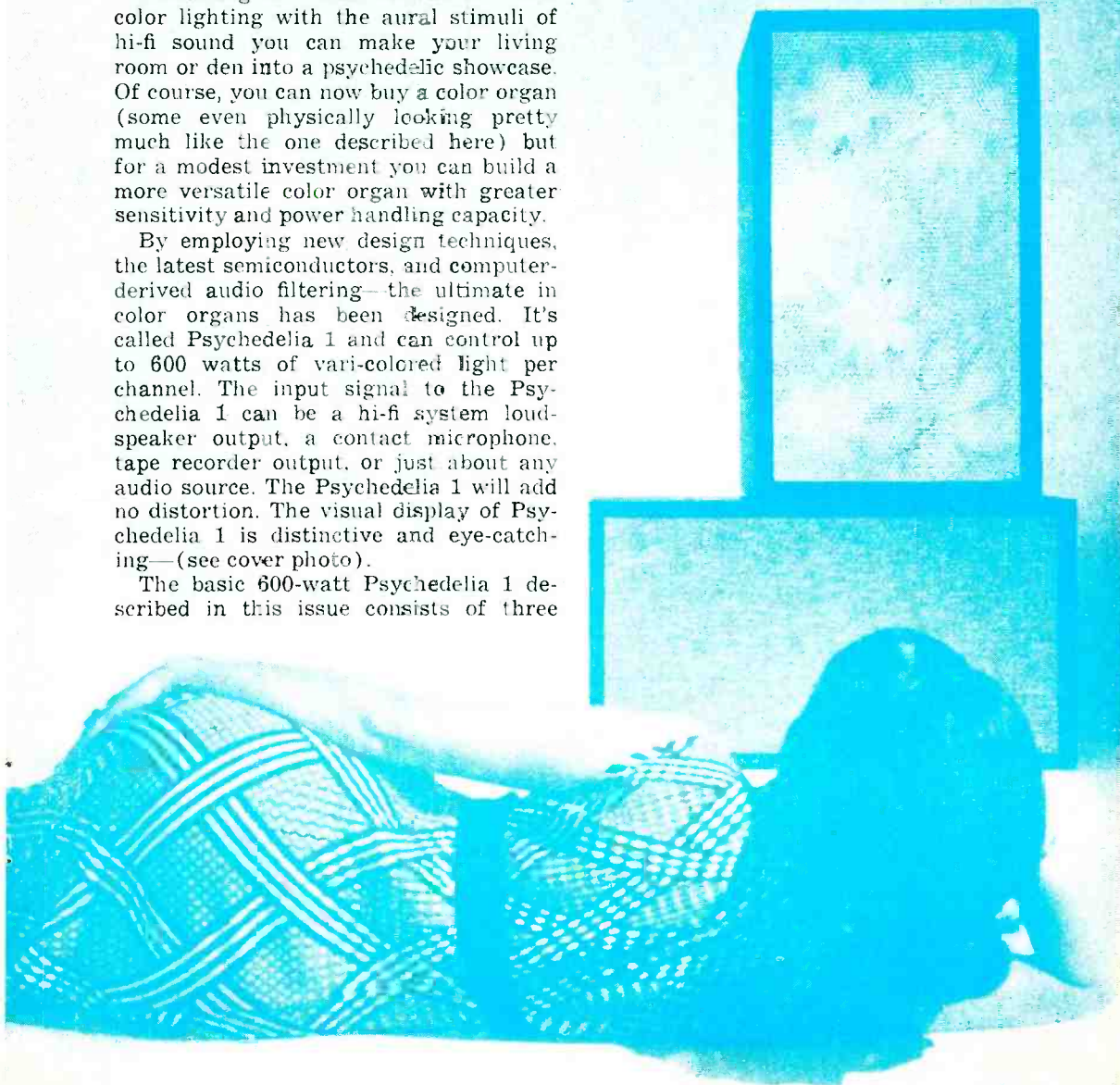

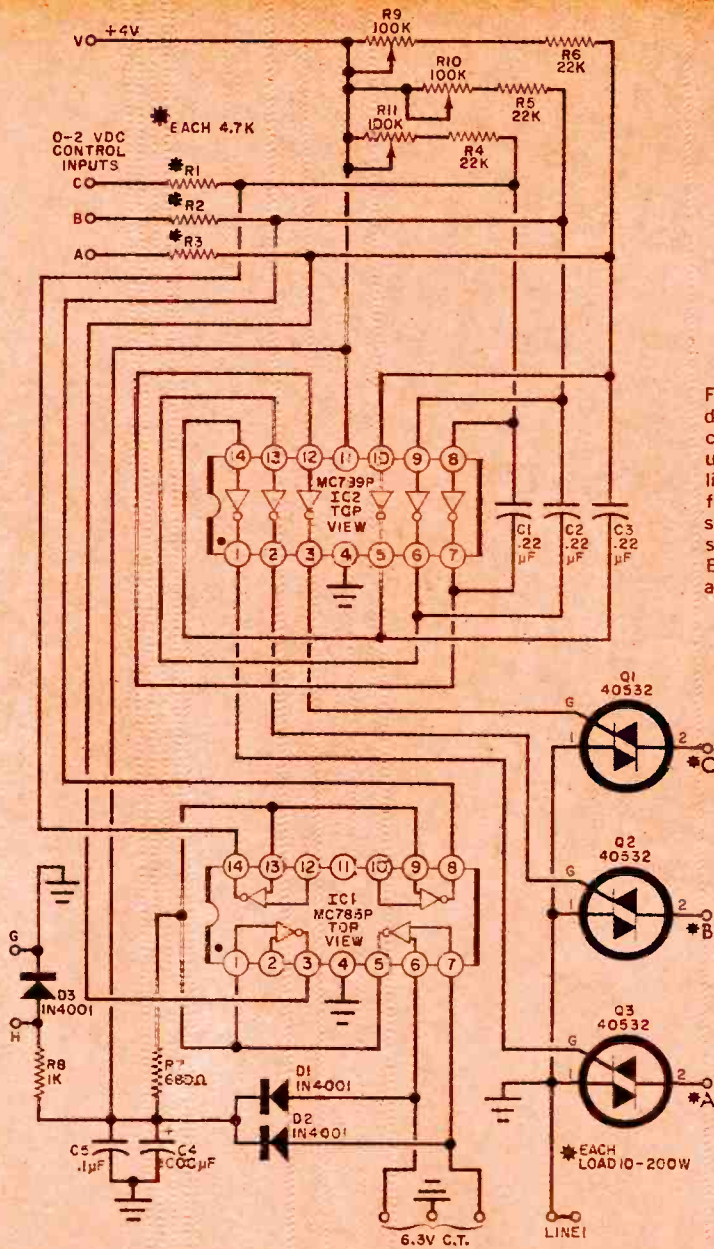

Fig. 1. Capable of handling up to 200 watts per channel, the PCU can be used as an independent light dimmer or driven from any 0- to 2-volt source: Note different sizes of lettering of A, B, and C for the input and output terminals.

PARTS LIST POWER CONTROL UNIT

- C1-C3—0.22- μ F, 57-volt Mylar capacitor (see text)
 C4—1000- μ F, 5-volt electrolytic capacitor
 C5—0.1- μ F, disc ceramic capacitor
 D1-D3—30-volt, 500-mA silicon power diode (1N4001 or similar)
 IC1—MRTL quad two-input expander (Motorola MC785P)
 IC2—MRTL hex inverter (Motorola MC789P)
 Q1-Q3—Triac (RCA 40532, no substitute)
 R1-R3—4700-ohm, $\frac{1}{4}$ -watt resistor

- R4-R6—22,000-ohm, $\frac{1}{4}$ -watt resistor
 R7—680-ohm, $\frac{1}{4}$ -watt resistor
 R8—1000-ohm, $\frac{1}{4}$ -watt resistor
 R9-R11—100,000-ohm trimmer potentiometer (CTS U-261 or similar)

- Misc.—Male quick-disconnect PC terminals (Keystone \mp 1256 or \mp 1257 or similar, 3 required); mounting hardware; solder, etc.
 Note—The following are available from Southwest Technical Products, Box 16297, San Antonio, Texas, 78216: etched and drilled PC board, #501, \$2.80; complete kit of all parts, #501-K, \$13.90; postpaid in U.S.A. Individual parts and assembled and tested units are also available.

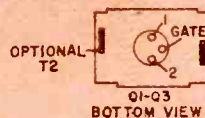
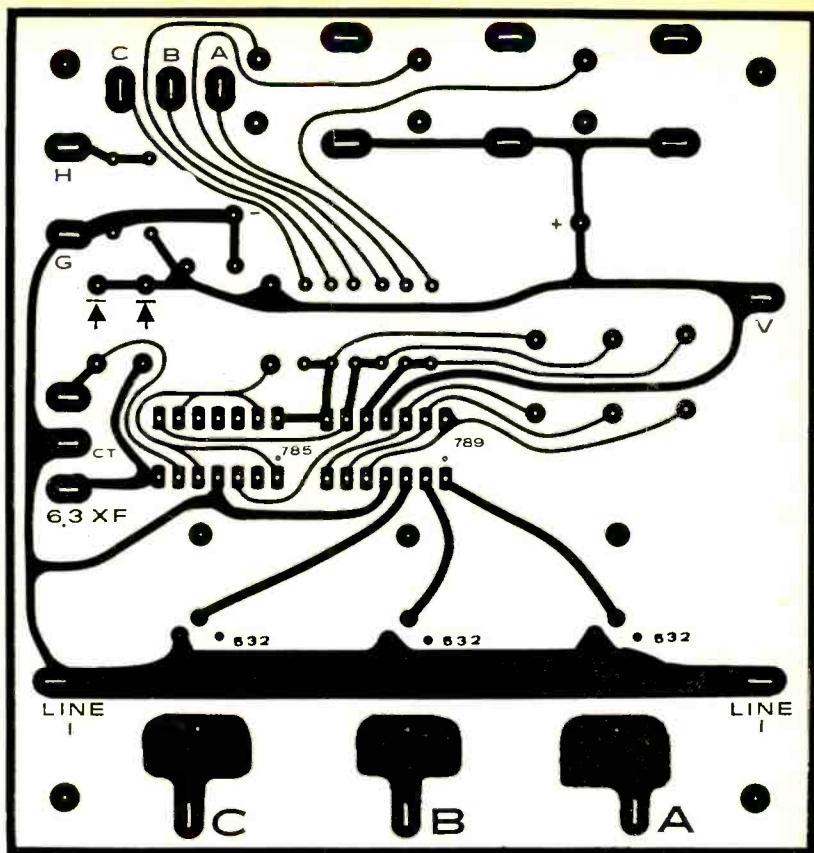

Fig. 2. This foil pattern for the PCU PC board is actual-size and can be reproduced.



elements: a power control unit (PCU), a quality filter unit (QFU), and a holographic bookshelf display. This is all you need for a "starter" system.

Power Control Unit. This is a three-channel (200 watt per channel) full-wave proportional (or strobe) a.c. power controller. It uses three triacs and two

IC's in a unique (patent pending) circuit. It has continuous gate drive for the triacs, eliminating channel-to-channel interaction; it is very sensitive and requires only 0-2 volts d.c. for operation; and it is mechanically simple. The triacs have their own built-in heat sinks and require no insulation or mounting hardware. Three background control po-

The three background controls can either be finger or screwdriver adjusted. They are physically isolated from the power line for maximum safety in adjustments. The three triac heat sinks may be "hot" to ground, depending on polarity of line.

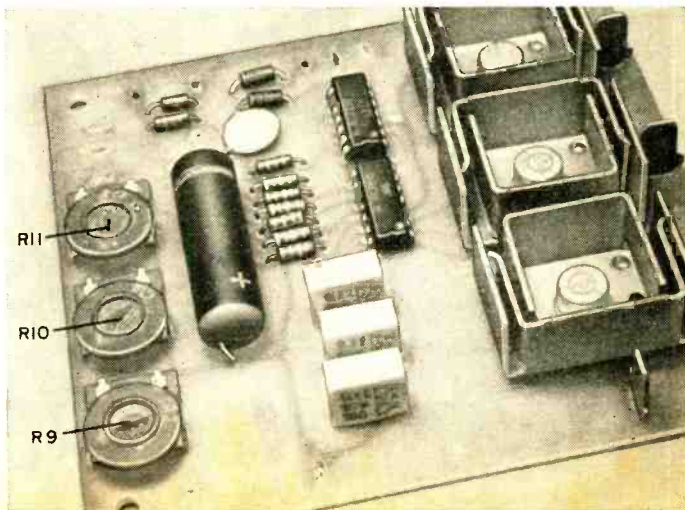

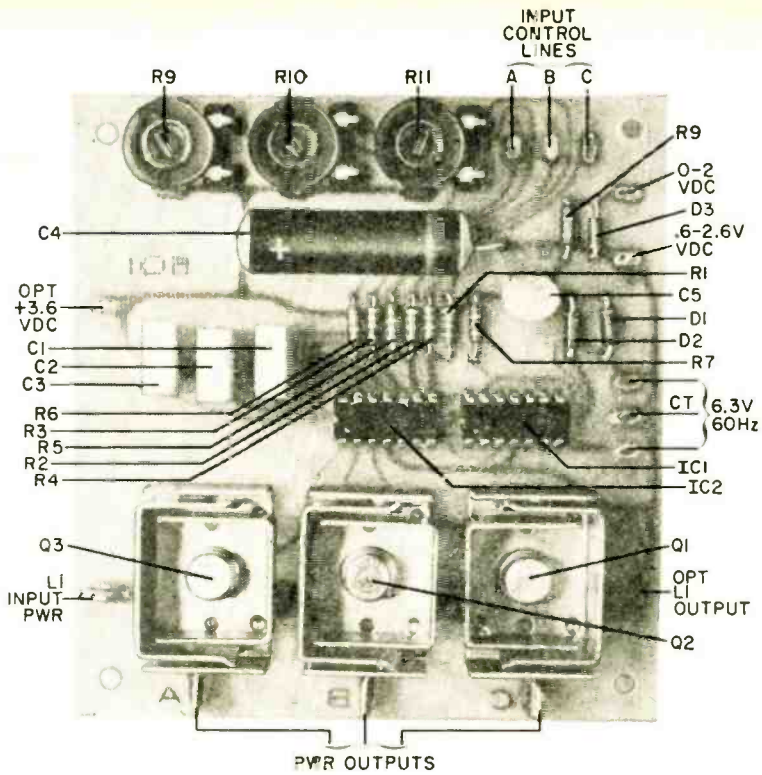

Fig. 3. To install the components, follow the arrangement shown here. Soldered-in, slip-on power terminals are to be used for the output.

HOW IT WORKS POWER CONTROL UNIT

As shown in the simplified schematic, in the Power Control Unit, Inverter A is a single *npn* gain stage which, with capacitor C1 forms a ramp generator. The amplitude of the ramp is at a maximum each time the reference or a.c. line voltage passes through zero. The build-up and decay of the ramp are determined, as we shall see, by other elements in the circuit.

Inverter B operates whenever the ramp voltage drops below 0.6 volt. Above 0.6 volt, the inverter holds the triac in the nonconducting state and below 0.6 volt, the triac is conducting. In this way, the triac gate is either clamped to ground or to a positive voltage so that the possibility of gate interactions is eliminated. Inverter B also isolates the loading effect of the triac from the ramp generator.

The triac acts as a series switch between the supply and the load, automatically turning off when the a.c. line passes through zero. Once it is off, the triac stays off until the ramp voltage drops below 0.6 and the inverter supplies a gate signal. The decay time of the ramp voltage is determined by the size of the input control voltage E_{IN} and the resultant input current. The higher the input, the faster the ramp decays and the sooner the triac turns on during each cycle. Thus more power is supplied to the load and the light is brighter.

The ramp generator is reset each time the supply goes through zero by a synchronizing signal provided by transformer T1 and gate expander C. Each time the supply passes through

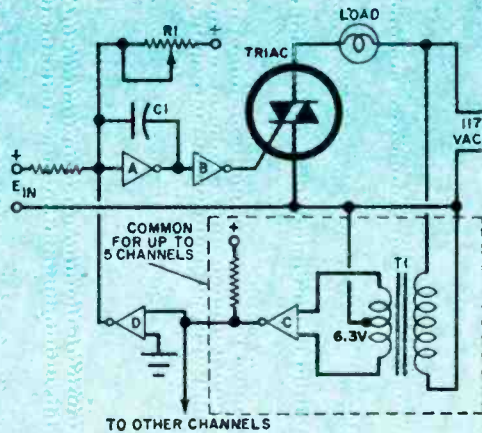

zero, a 0.5-millisecond positive pulse drives expander D to recharge capacitor C1 and return the ramp to its initial positive value. Only one synchronizer circuit is required for 5 or less channels.

Background control is obtained by applying a constant d.c. level in parallel with the input through potentiometer R1.

Strobe or on-off operation of the Psychedelia 1 can be obtained by decreasing the background control to a minimum. This produces an abrupt switching action. The switching action can be made even faster by eliminating capacitor C1.

tentiometers permit the user to preset the "off" level of the display lamps.

The schematic of the PCU is shown in Fig. 1. The unit is assembled on a fiberglass PC board using the foil pattern shown actual-size in Fig. 2. Once the board has been made or purchased, mount the components as shown in Fig. 3. Observe the notch, dot, and lead code on the semiconductors and polarity

Quality Filter Unit (QFU). This circuit takes a relatively low-level audio input, divides it into three isolated frequency bands, and provides three proportional control voltages for the PCU. The QFU is considerably more complex than most color organ filters, but it gives the finest filtering ever offered for a lighting display. Usual filter problems involving display washout, multiple-channel tracking, input loading, distortion, requirements for high input levels, nonlinearity and limited dynamic range have been eliminated.

Among the unique features of the QFU are active filters with very steep slopes and narrow guard bands between channels, and the use of an averaging detector.

An averaging detector responds to the average value of a signal for a few milliseconds instead of instantaneous peak values. This makes the display less susceptible to radical input variations and eliminates threshold nonlinearity.

The filters are a combination of transistors and passive components called a "two-pole Tschebyscheff." They would require two high-Q, load-isolated inductors per channel if conventional parts were used.

Guard bands are "holes" between the filter responses. These no-response areas between the channels eliminate multiple-channel tracking on a single loud passage or a dominant instrument. Because of the high harmonic content of most music, the guard bands lose very little of the music. Usually there is *too much* "information" in most music for a psychedelic light display to handle. If a little of the music information is thrown away, the display action is much livelier and is without washout or multiple tracking.

Since transistors are used for the fil-

markings on the electrolytic capacitors. The case lead ($T2$) on each triac may be cut short since the $T2$ connection is made when the heat sink is soldered in place on the board. The triacs come with an integral heat sink and require no insulation from the board. Install quick-disconnect male terminals at the triac outputs, which are marked A, B, and C beside each heat sink.

ters in the QFU, they also provide gain. The result is excellent sensitivity, no noticeable loading of the input circuit, and no noticeable distortion since the input impedance is resistive at all frequencies of interest.

Resistor $R44$ (see Fig. 4) provides input protection and also serves as a sensitivity adjustment. For normal audio listening levels with a 5- to 20-watt amplifier, use the 47-ohm resistor specified. For lower power levels, $R44$ can be reduced to 12 ohms, 1 watt. For high-power systems, increase $R44$ to at least 100 ohms, 10 watts. The resistor should be the largest ohmic value that still gives acceptable sensitivity to minimum-volume passages.

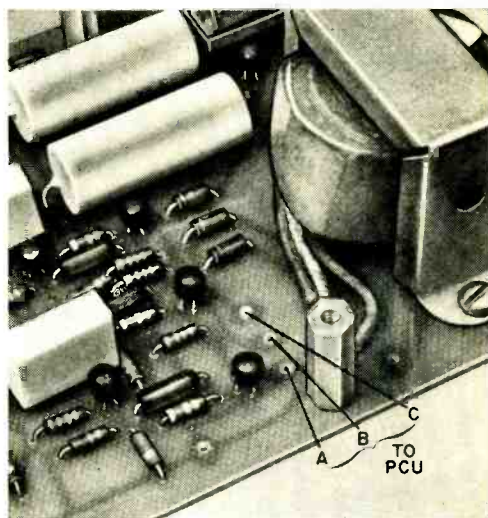

Holes marked A, B, and C on QFU provide outputs to PCU. The single spacer shown here is one of four used to attach PCU and QFU boards together.

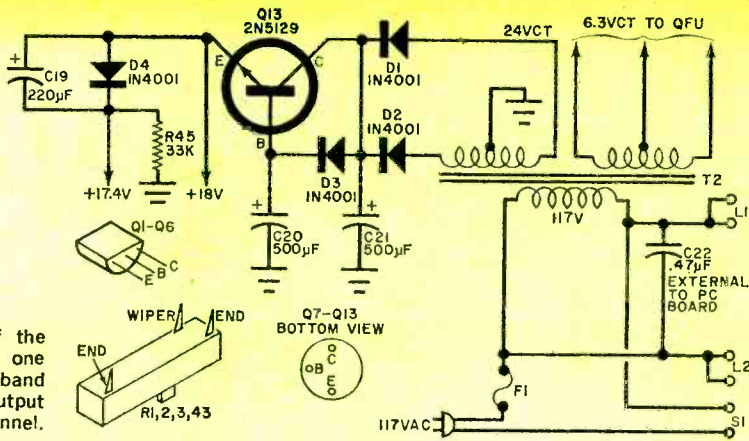
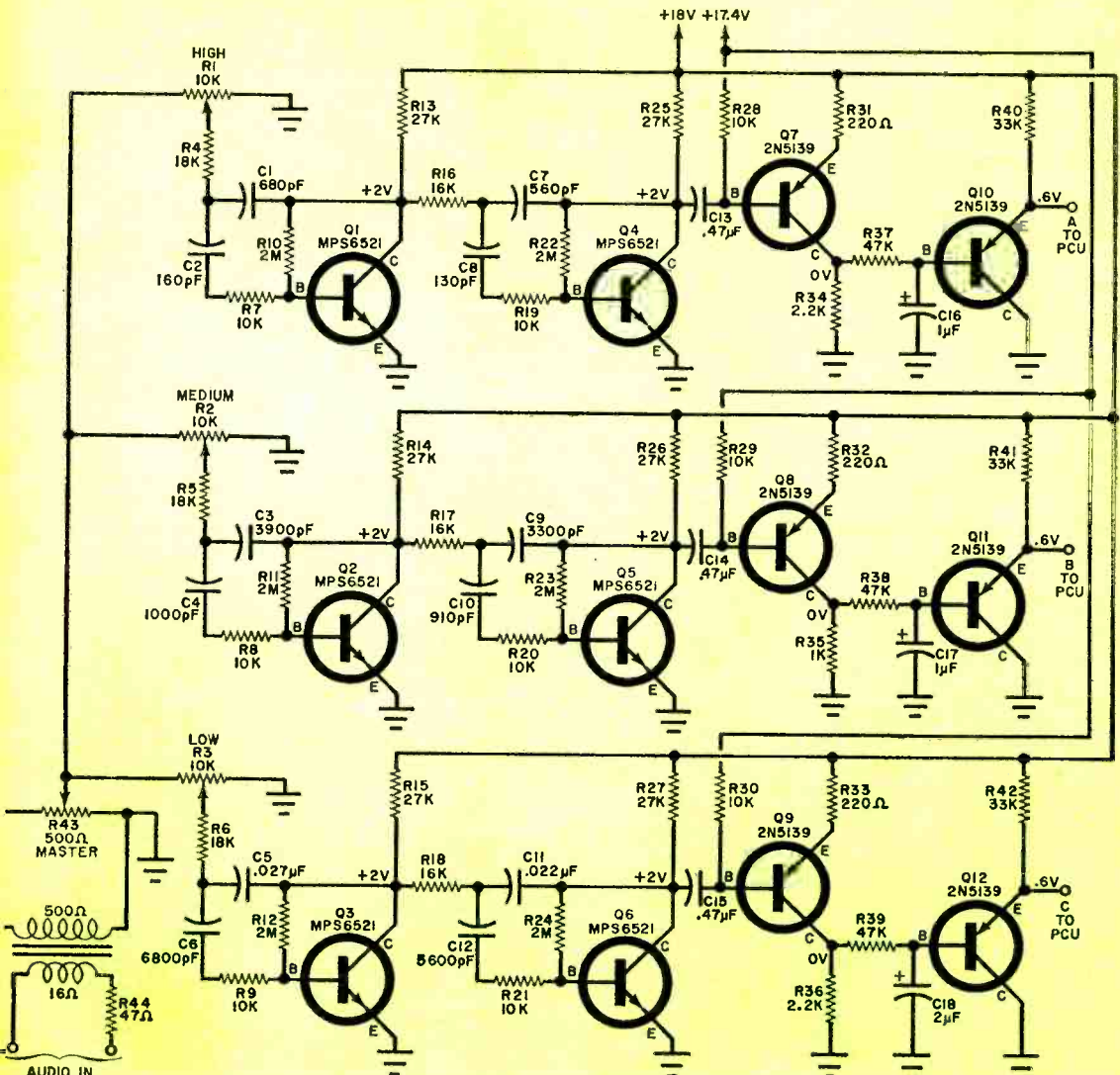

Fig. 4. Each channel of the QFU encompasses about one octave with small guard band between them. Each output drives its own PCU channel.



PARTS LIST

QUALITY FILTER UNIT (QFU)

- C1—680-pF, 5% mica or polystyrene capacitor
 C2—160-pF, 5% mica or Mylar capacitor
 C3—3900-pF, 5% Mylar or polystyrene capacitor
 C4—1000-pF, 5% Mylar or polystyrene capacitor
 C5—0.027- μ F, 5% Mylar or polystyrene capacitor
 C6—6800-pF, 5% Mylar or polystyrene capacitor
 C7—560-pF, 5% Mylar or polystyrene capacitor
 C8—130-pF, 5% Mylar or polystyrene capacitor
 C9—3300-pF, 5% Mylar or polystyrene capacitor
 C10—910-pF, 5% mica or polystyrene capacitor
 C11—0.022- μ F, 5% Mylar or polystyrene capacitor
 C12—5600-pF, 5% Mylar or polystyrene capacitor
 C13-C15—0.47- μ F Mylar capacitor (do not substitute an electrolytic)
 C16, C17—1- μ F, 6-volt tantalum or electrolytic capacitor
 C18—2- μ F, 6-volt tantalum or electrolytic capacitor
 C19—220- μ F, 6-volt electrolytic capacitor
 C20, C21—500- μ F, 20-volt electrolytic capacitor
 C22—47- μ F, 600-volt high-quality Mylar capacitor
 D1-D4—1-ampere, 50-PIV silicon power diode (1N4001 or similar)
 F1—Fuse to suit load, clip mounted to board
 Q1-Q6—Transistor (Motorola MPS6521, no substitute)
 Q7-Q12—Transistor (National 2N5139)
 Q13—Transistor (National 2N5129)
 R1-R3—10,000-ohm, color-coded slide potentiometer, one each red, blue, and green (Southwest Technical #S-10K-R, S-10K-B and S-10K-G or similar rotary equivalent or stack pole slide-trol)
 R4-R6—18,000-ohm, 5%
 R7-R9, R19-R21—10,000-ohm, 5%
 R10-R12, R22-R24—2-megohm
 R13-R15, R25-R27—27,000-ohm
 R16-R18—16,000-ohm
 R28-R30—10,000-ohm
 R31-R33—220-ohm
 R34, R36—2200-ohm
 R35—1000-ohm
 R37-R39—47,000-ohm
 R40-R42, R45—33,000-ohm
 R43—500-ohm, white-coded slide potentiometer (Southwest Technical S-500-W or similar rotary equivalent or stackpole slide-trol)
 R44—47-ohm, 2-watt resistor
 S1—S.p.s.t. switch
 T1—Input transformer: 8- or 16-ohm primary, 500-ohm secondary, 5 watts, 500-volt winding-to-winding insulation. (Knight 54F1425, Southwest Technical PSY-T1 or similar)
 T2—Power transformer: secondaries, 24 VCT at 100 mA and 6.3 VCT at 100 mA (Southwest Technical PSY-T2 or two separate filament transformers such as Knight 54F1416 (6.3 VCT) and 54F710 (24 VCT) or similar)
 Misc.—Fuse mount; male quick-disconnect terminals (15); transformer rivets or hardware; mounting hardware; spacers for PCU; clamp for C22; solder; etc.
- Note—The following are available from Southwest Technical Products, Box 16297, San Antonio, Texas 78216: etched and drilled PC board, #502, \$5.50; complete kit of all parts, #502-K, \$29.50; postpaid in U.S.A. Individual parts and assembled and tested units are also available.

All resistors
1/4-watt

The three resistors called out here cannot be seen in the top view as they are hidden by the three capacitors. Also shown are two of the four spacers that join the PCU to the QFU.

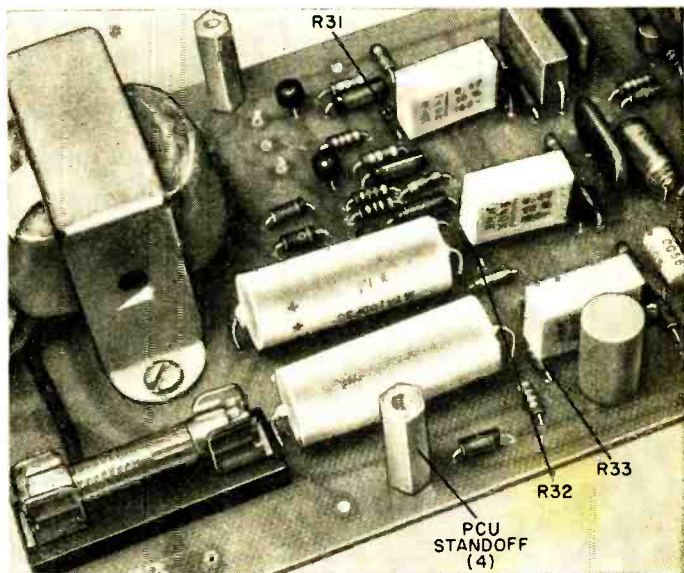

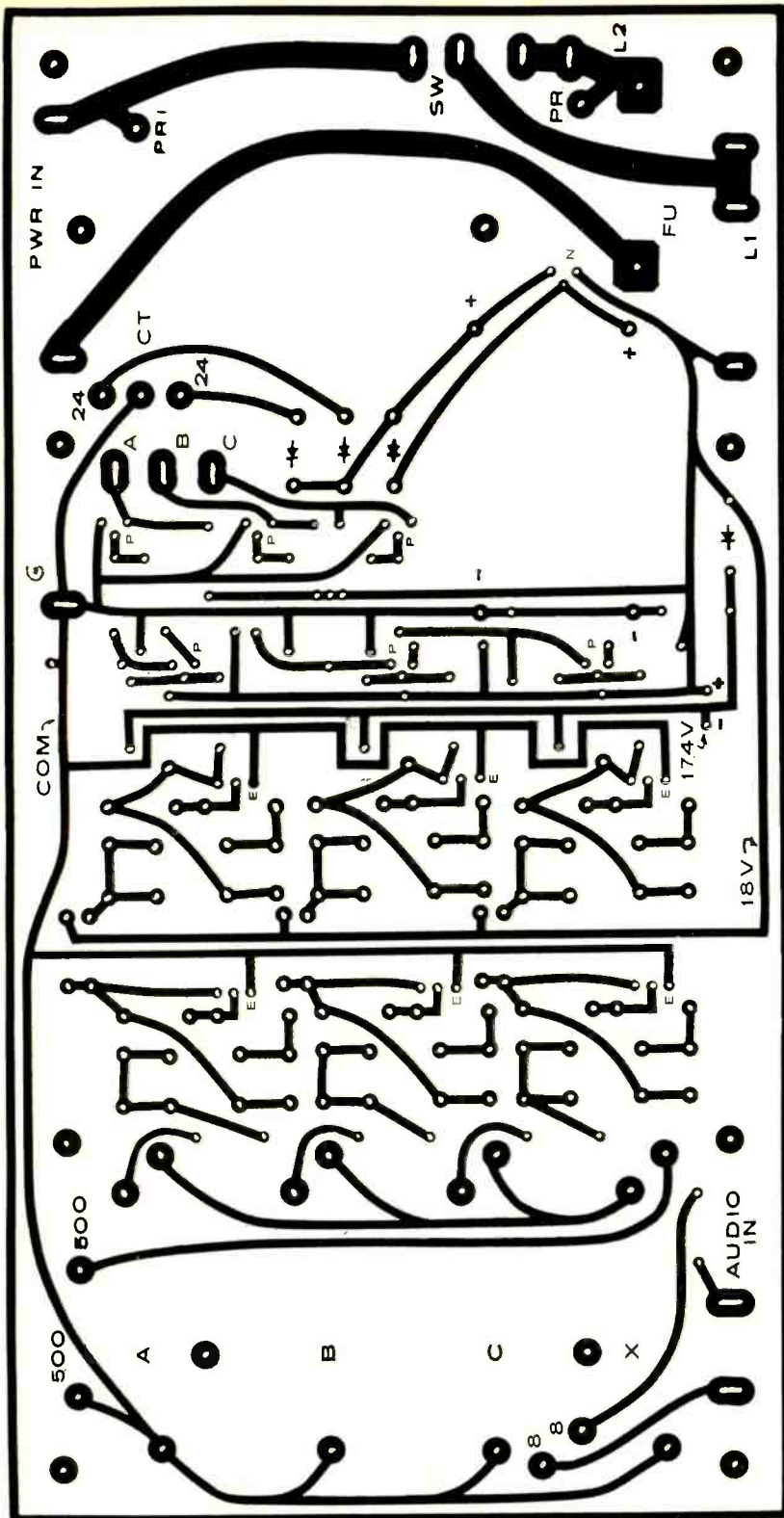

Fig. 5. You can copy this actual-size foil pattern for the QFU PC board or buy the board ready-made.

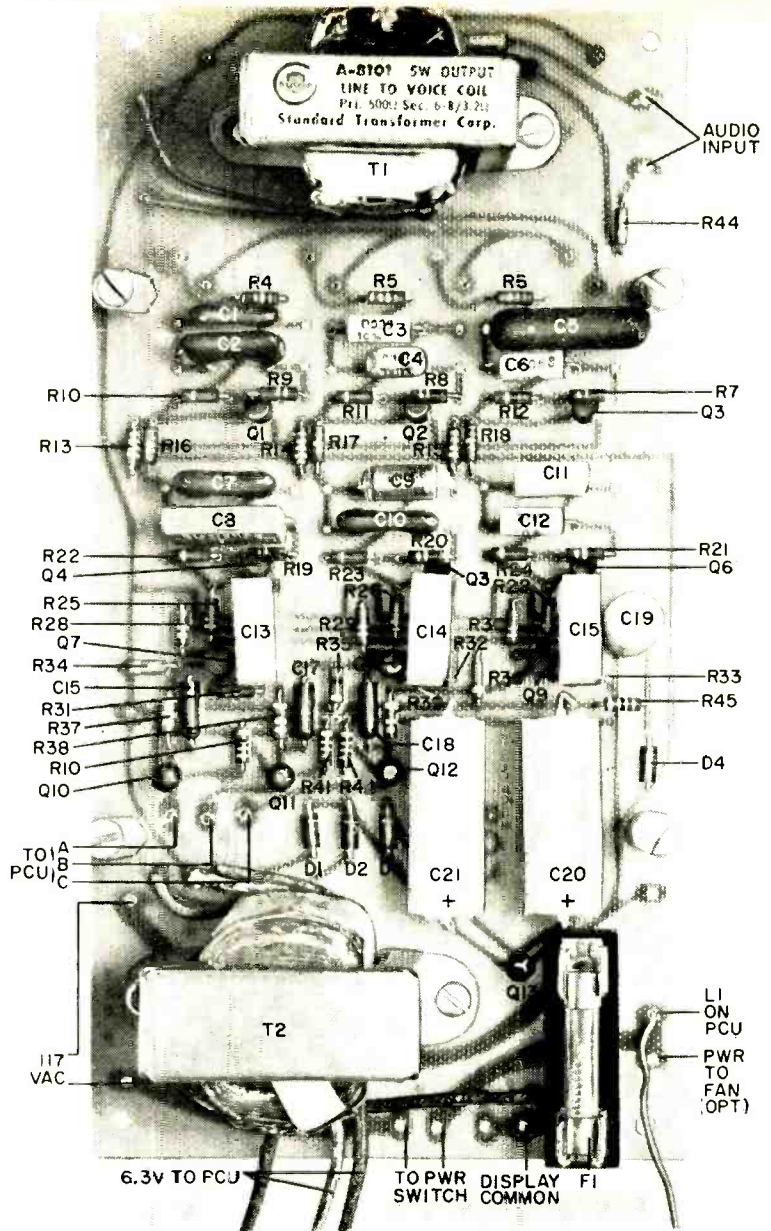

Fig. 6. Component installation on QFU PC board. Also shown are connections made to the board.

Construction of the QFU. The schematic of the QFU is shown in Fig. 4 and an actual-size foil pattern for the PC board is in Fig. 5. Components are installed on both sides of the PC board. The units on the foil side are shown in Fig. 6. Install the four slide potentiometers with the blue at *R1*, green at *R2*, red at *R3*, and white at *R4*. The components on the other side of the board are shown in Fig. 7. Transformers *T1* and *T2* are pop-

riveted or bolted in place on the component side of the board. Except for the three leads to the 6.3-volt winding of *T2*, all transformer leads terminate on the *PC* board.

Do not be disturbed by what appear to be extra holes near the active filter capacitors. These holes permit the use of capacitors of different physical sizes at each stage. Use the holes that fit the capacitors you have. If you alter the *PC*

Can you solve these two basic problems in electronics?

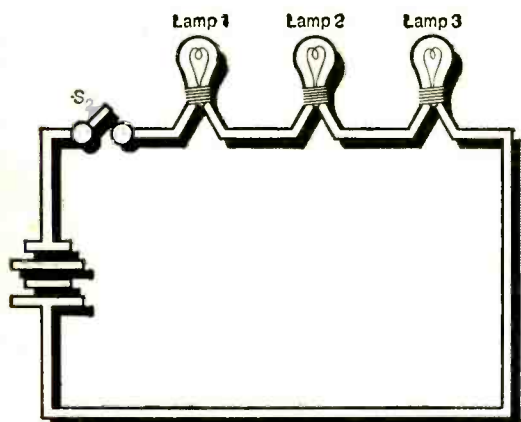

This one is relatively simple:

When Switch S_2 is closed, which lamp bulbs light up?

Note: If you had completed only the first lesson of any of the RCA Institutes Home Study programs, you could have solved this problem.

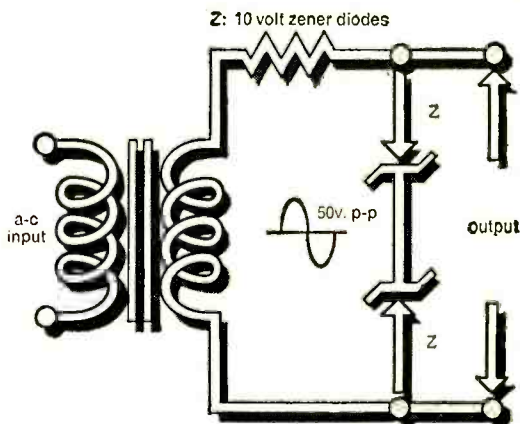

This one's a little more difficult:

What is the output voltage (p-p)?

Note: If you had completed the first lesson in the new courses in Solid State Electronics, you could have easily solved this problem.

These new courses include the latest findings and techniques in this field. *Information you must have if you are to service today's expanding multitude of solid state instruments and devices used in Television, Digital, and Communications Equipment.*

If you had completed an entire RCA Institutes Home Study Course in Semiconductor Electronics, Digital Electronics, or Solid State Electronics, you should now be qualified for a good paying position in the field you choose. Send for complete information. Take that first essential step now by mailing the attached card.

ANSWERS: Problem 1—they all light up. Problem 2—20 Volts (p-p)

RCA Institutes Autotext learning method makes problem-solving easier... gets you started faster towards a good-paying career in electronics

Are you just a beginner with an interest in electronics? Or, are you already making a living in electronics, and want to brush-up or expand your knowledge? In either case, RCA has the training you need. And Autotext, RCA Institutes' own method of Home Training will help you learn more quickly and with less effort.

Wide Range of Courses

Select from a wide range of courses. Pick the one that suits you best and check it off on the attached card. Courses are available for beginners and advanced technicians.

- Electronics Fundamentals
- Black & White Television Servicing (Transistorized TV Kit Available)
- Color Television Servicing (Color TV Kit Available)
- FCC License Preparation
- Automatic Controls
- Automation Electronics
- Industrial Electronics
- Nuclear Instrumentation
- Electronics Drafting
- Computer Programming

Plus these new up-to-the-minute courses

- Semiconductor Electronics
- Digital Electronics
- Solid State Electronics
- Communications Electronics

Prepare for good paying positions in fields like these

- Television Servicing
- Telecommunications
- Mobile Communications
- CATV
- Broadcasting
- Marine Communications
- Nuclear Instrumentation
- Industrial Electronics
- Automation
- Computer Programming
- Solid State
- Electronics Drafting



Build and keep this valuable oscilloscope.

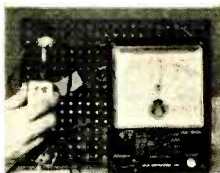

In the new program on Solid State Electronics you will study the effects of temperature and leakage characteristics of transistors.



Valuable Equipment—Yours To Keep

A variety of RCA Institutes engineered kits are included in your program of study. Each kit is yours to keep when you've completed the course. Among the kits you construct and keep is a working signal generator, a multimeter, a fully transistorized breadboard superheterodyne AM receiver, and the all-important oscilloscope. These 4 kits are at no extra cost. Compare this selection with other home study schools.

Convenient Payment Plans

RCA Institutes offers liberal monthly payment plans to suit your budget.

Classroom Training Also Available

RCA Institutes operates one of the largest technical schools of its kind. Day and evening classes. No previous training is required. Preparatory courses are available. Classes start four times a year.

Job Placement Service, Too!

Companies like Bell Telephone Labs, GE, Honeywell, IBM, RCA, Westinghouse, Xerox, and major radio and TV networks have regularly employed graduates through RCA Institutes' own placement service.

All RCA Institutes courses and programs are approved for veterans under the new G.I. Bill.

Send Attached Postage Paid Card Today. Check Home Study or Classroom Training.

Accredited Member National Home Study Council.

IF REPLY CARD IS DETACHED, SEND THIS COUPON

RCA Institutes Inc.
 Home Study Dept. PE-99
 320 West 31 Street
 New York, N.Y. 10001

Please send me FREE illustrated career catalog.

Name _____ Age _____
(please print)

Address _____

City _____ State _____ Zip _____

HOW IT WORKS QUALITY FILTER UNIT

The heart of the QFU is an active filter with the basic configuration shown in the schematic. The transistor must have a very high gain for best operation. This circuit produces a single resonant peak such as that shown at B. Two of the

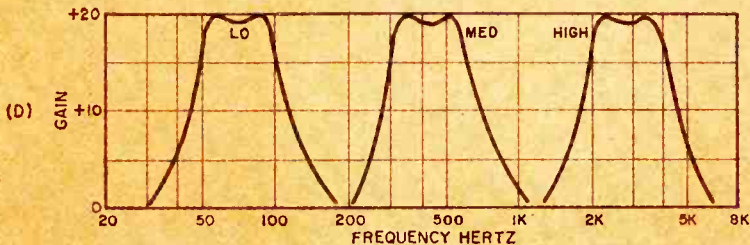
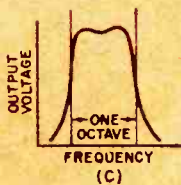
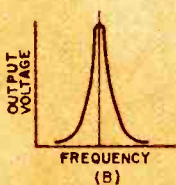
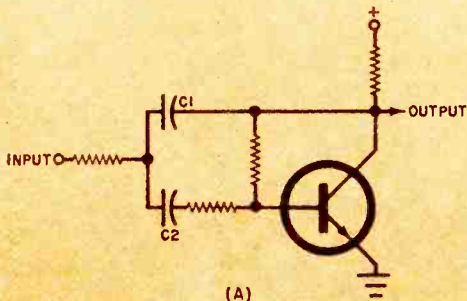

filter stages are cascaded for each channel and the responses are slightly staggered to produce a steep-skirted, flat-topped, octave-wide response such as that at C.

The values of capacitors $C1$ and $C2$ determine both the Q of the circuit and the center frequency. The capacitors used in the Psychedelia 1 were selected to produce the response shown at D. To experiment or add more channels, divide each capacitor value by the ratio of old to new center frequencies. For example, the low channel shown covers 50 to 100 Hz. To change it to cover 100 to 200 Hz, each capacitor value would be divided by 2. Do not change the ratios between capacitor values or the Q and bandpass values will be changed.

The output of each cascaded filter is applied to a detector transistor biased so that it is almost, but not quite, conducting. A negative-going audio signal turns the detector on, and vice versa. This type of detector produces some gain with a very low threshold offset. The detected signal is smoothed by an RC filter and coupled to the PCU through an emitter follower. The medium-frequency channel detector has half the gain of the others ($R35$ is lower in value than either $R34$ or $R36$). This compensates for the greater amount of medium frequencies than either high or low in most music.

D.c. supply is obtained from a regulated supply powered by transformer $T2$. Dynamic regulator $Q13$ insures excellent low-frequency bypassing. Transformer $T2$ also provides 6.3 volts, center-tapped for the PCU. To prevent coupling hum in the low channel, $T1$ and $T2$ must be located at least $5\frac{1}{2}$ " apart.

board layout, be sure that $T1$ and $T2$ are at least $5\frac{1}{2}$ " apart and that $T1$ is at least 10" away from any other source of a.c. hum (motors, power transformers, etc.). Do not substitute for transistors $Q1$ through $Q6$ and use only polystyrene, Mylar, or mica capacitors for the filter elements. Above all, do not delete $T1$ since it provides power-line isolation as well as impedance matching for the audio input.

Capacitor $C22$ is a noise reducing filter and can be mounted wherever convenient off the PC board. It must be a high-quality, 600-volt Mylar type.

Assembly. The PCU board can be mounted directly above the QFU board to form a control console. Use 1" spacers at each of the four corners of the PCU

and mount the PCU on the four holes of the larger QFU board as shown in Fig. 8. Note how the two boards are aligned—component side of the QFU facing the foil side of the PCU with the triacs adjacent to $T1$. Short spacers can be used to mount the combined board on the front panel of the console you select. Only the four level potentiometers are exposed.

Make the board-to-board connections as shown in Fig. 9. For testing, connect three 25- to 40-watt lamps to the system as shown in Fig. 9. These are not the lamps used in the final display. They are for testing only.

Caution is advised from here on since portions of the PCU are referenced to ground and severe shock can be experienced if you touch certain leads.

Fig. 7. The three color-level and the master-level slide potentiometers are mounted on the foil side of the QFUPC board.

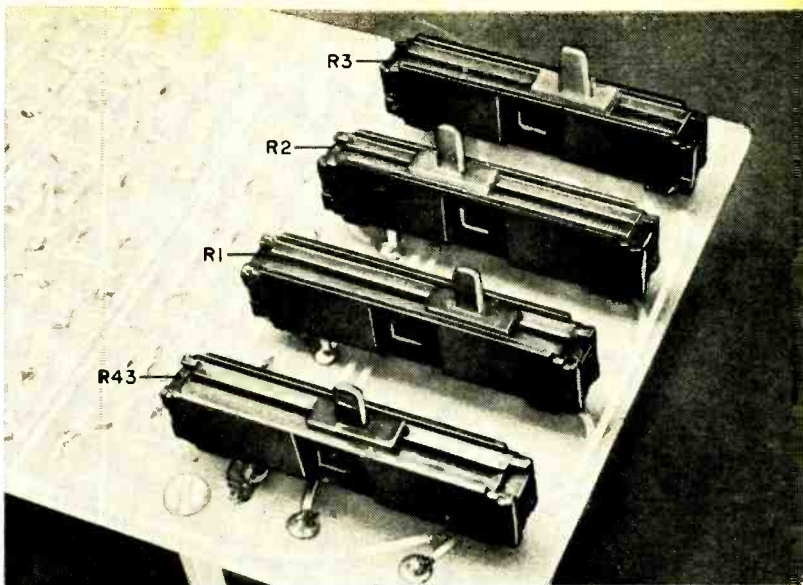

With the primary a.c. power turned on but no audio applied, the three lamps may or may not glow. Adjustment of the three background controls on the bottom of the PCU (*R9*, *R10*, and *R11*) should cause the respective lamps to vary in brightness from out to almost fully lit. Set the three controls so that the lamps barely glow.

With the audio input coupled to the

speaker leads of a radio or other power amplifier, turn up the volume to the source. Slide control *R43* is the master gain control and can be set at about $\frac{3}{4}$ of the way up. Adjustment of each of the channel slide potentiometers will cause the respective lights to glow in proportion to the amount of power in that frequency range. Each control must be checked for smooth operation.

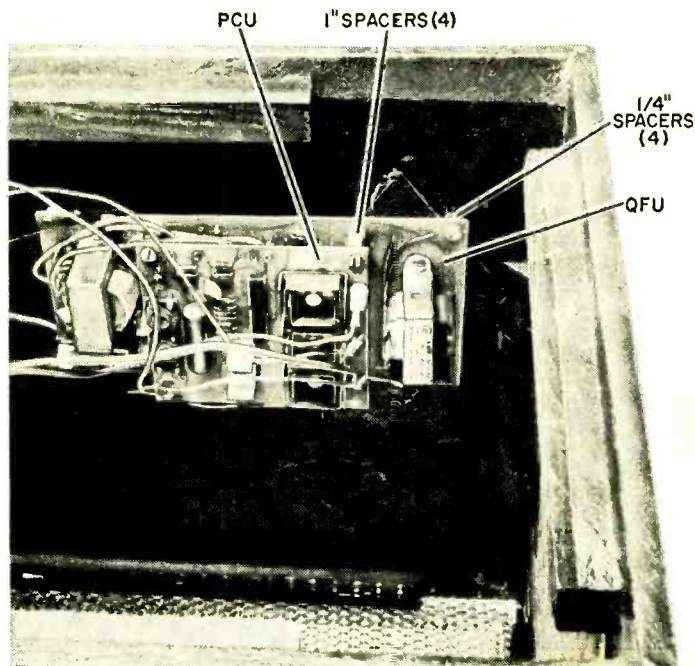

Fig. 8. Four 1" spacers are used to assemble the PCU and QFU boards together. Then use smaller spacers to mount the two of them on the top of the cabinet with the four sliders accessible through a cut slot.

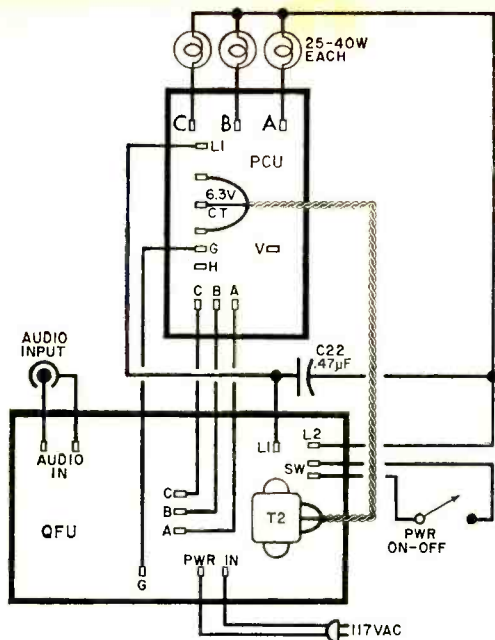

Fig. 9. Interconnection of the complete system. Capacitor C22 is added to reduce switching noise in a radio if that is the source of the signal.

If noise is created in the audio system, install capacitor C22 as shown in Fig. 9. Some localized interference may be heard on the AM broadcast band, particularly if long display cables are used.

Holographic Bookshelf Display (HBD).

A suggested display unit for the Psychodelia 1 is shown in the photos. It is 15" x 16" x 24" with a durable vinyl covering and an attractive holographic imaging system. The HBD can be built as an integral unit with internal QFU and PCU units or it can be built separately for remote control. A maximum of four HBD's can be powered by one QFU/PCU combination.

Keys to successful display in the HBD are the holographic imaging panel and the lamp placement. The imaging panel is a rigid transparent plastic sheet with hexagonal lenses made up of individual wedge-shaped elements. If you look at a single colored lamp through the panel you see a six-petaled flower. The bulb diameter and the spacing of the bulb from the plastic sheet govern the size, shape, and petal details of the flowers.

Constructing the Display. The imaging

panel is a light diffuser for fluorescent lighting usually suspended from the ceiling ("T-Bar" or "Grid Lume"). You can buy it at your local hardware or building supplier in an 18" x 24" sheet.

The HBD case is a box made of 4 particle board panels 1/2" thick. You can buy the panels already prepared as mentioned in the Parts List or you can buy the material and have it cut (or cut it yourself) according to the details given in Fig. 10. Cleats are added to the panels to strengthen the corners and provide a means of attaching the rear panel. The panels are assembled around the imaging panel using nails and glue.

The interior of the cabinet may be painted all flat black, black on the sides and white on the rear panel, or all gloss white. A solid black background accentuates the flower pattern produced by the lamps; while a completely white interior increases the overall brightness and mutes the flower pattern. Painting the rear panel gloss white increases the light output slightly but does not mute or blend the patterns. The cover photo was taken with a white interior.

SIX- OR TWELVE-CHANNEL OPERATION.

You can operate the six lamps in the Psychodelia 1 individually by using two PCU units and two QFU's. However, the capacitors in the QFU must be changed to the values given below.

	QFU #1	QFU #2
C1	1200 pF	470 pF
C2	270 pF	110 pF
C3	5600 pF	2200 pF
C4	1500 pF	620 pF
C5	0.047 µF	0.015 µF
C6	0.012 µF	4200 pF
C7	910 pF	390 pF
C8	220 pF	62 pF
C9	4700 pF	2000 pF
C10	1300 pF	560 pF
C11	0.039 µF	0.012 µF
C12	0.01 µF	3300 pF

All capacitors are 5% mica, Mylar or polystyrene types.

You can use only one bulb per channel in one display unit or you can use two units side-by-side with three channels in each. For a super-duper 12-channel stereo display, use 4 PCU's and 4 QFU's.

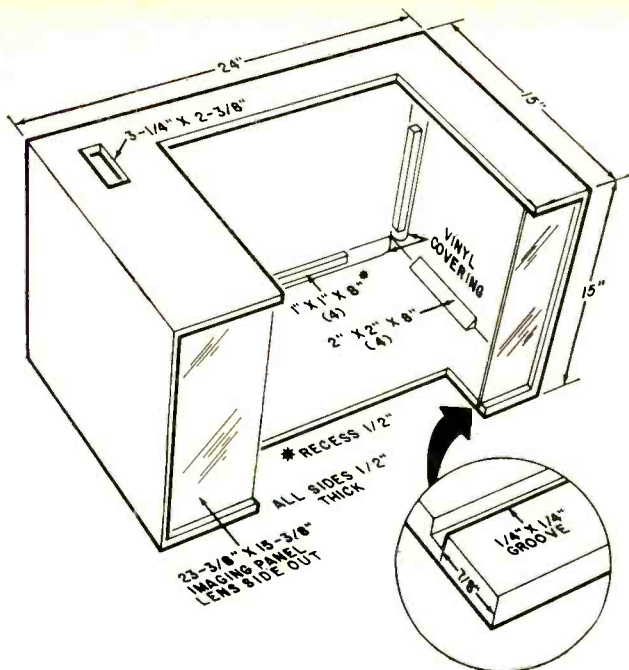

Fig. 10. General construction details of a display cabinet. Any other dimensions can be used. The controls are accessible through a small cutout in the top of the cabinet. Display can be viewed either horizontally or vertically.

If a built-in PCU and QFU are used, a suitable access hole should be added to one side. The rear panel supports the lamps and optional fan, and is shown in photos. The five 2" x 3" posts on the inside of the rear panel range in height from 3/4" to 8 1/2". They support the sockets for the lamps and should be spaced in a random manner to give the most pleasing pattern.

The Edison lamp sockets are mounted with wood screws on the posts with a sixth socket attached to the rear panel

itself. The higher wattage bulbs go to the rear. The prototype uses 7 1/2- and 25-watt red bulbs for the low frequencies, two 25-watt green bulbs for the medium frequencies, and 7 1/2- and 40-watt blue bulbs for the highs. You can experiment to obtain what you think are the most dramatic effects.

Wiring. Using 16- or 18-gauge wire, parallel the two similarly colored lamps for each channel. Connect one side of each pair to each other and then to ter-

CABINET BILL OF MATERIALS

Lumber

- 2—24" x 15" pieces of 1/2" particle board
- 2—15" x 15" pieces of 1/2" particle board
- 1—22 7/8" x 14 7/8" piece of 1/2" particle board
- 4—2" x 2" x 8" triangular pine moulding
- 4—1" x 1" x 8" pine
- 1—4" x 3" x 3/4" pine
- 1—3/4"
- 1—3 1/2"
- 1—4 1/2" } 3" x 2" pine
- 1—7 1/2" }
- 1—8 1/2" }

Electrical

- 6—Edison cleat sockets for 117-volt lamps
- 2—40-watt, 117-volt lamps, one red, one blue
- 2—25-watt, 117-volt lamps, both green
- 2—7 1/2-watt, 117-volt lamps, one red, one blue
- 1—Cooling fan, whisper type, 55 CFM (optional)
- 1—6-pin female chassis mounting socket, polarized (Cinch-Jones S-306-AB or similar)

- 1—6-pin male plug, polarized (Cinch-Jones P-306-AB or similar)
- 3—Quick disconnect female terminals

Integral Master Unit

- 1—Line cord and strain relief
- 1—Phono jack
- 1—Rocker switch (6 amperes, 117-volts)

Slave Unit

- 1—6-pin female chassis mounting socket, polarized (Cinch-Jones S-306-AB or similar)

Misc.—23 3/8" x 15 3/8" panel of "T-Bar" or "Grid Lume" (for imaging panel); cloth-back upholstery vinyl 21" x 84"; vinyl glue; wood glue; nails; no-skid feet (4); paint; wood screws.

Note—An assembled cabinet, less lamps and not wired, is available from Southwest Technical Products, Box 16297, San Antonio, Texas 78216 for \$26.50. Item is shipped express or truck, collect only. Specify type of shipment desired.

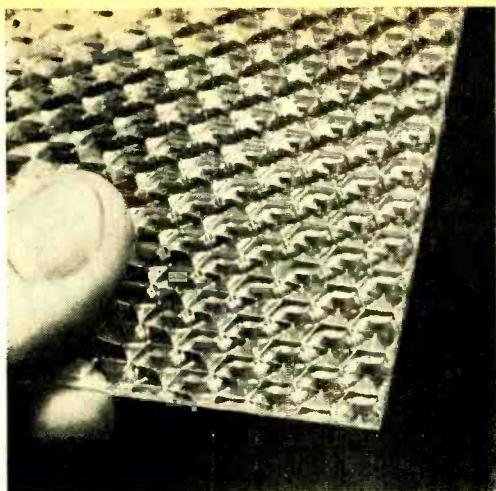

The imaging panel is made up of hexagonal lenses that make each lamp appear as a flower.

The lamps are arranged in any random pattern around the rear panel. Secure wiring to hold it in place and avoid shorts.

Three different lamp heights are used as shown here. The stands are made from wood.

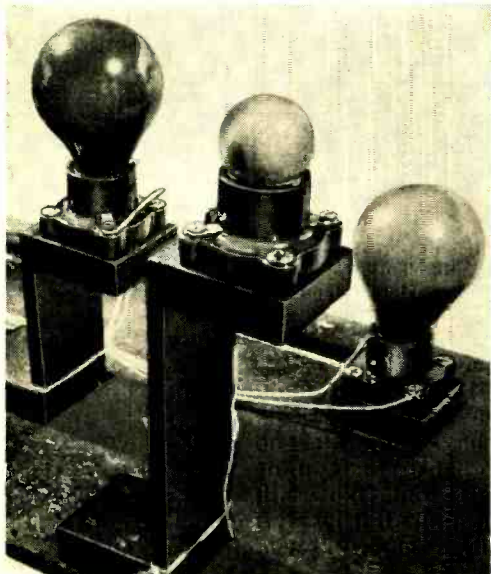

minate $L2$ on the QFU board. Connect the other sides of the pairs to female quick-disconnect terminals to mate with the male terminals at **A**, **B**, and **C** on the PCU board.

The colors that you put on the respective channels is up to you. Once the system is operating, you can change the colors by switching the quick-disconnect terminals around. Be sure that primary power is turned off before touching these terminals. The system doesn't require any warm-up time, so there is no need to rush.

Connect a suitable length of shielded audio cable between the input bracket audio jack and the QFU board. Connect capacitor $C22$ (Fig. 9) between the $L1$ and $L2$ terminals of the QFU boards to reduce switching noise.

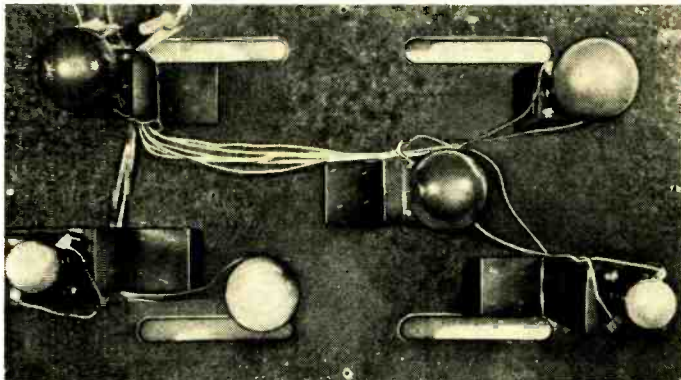

Final Assembly. When the wiring is completed and checked, mount the electronics assembly to the cutout on the inside of the display cabinet so that the slide potentiometers are accessible from the outside. Use spacers at the four holes on the corners of the QFU board to support the assembly. The power on-off switch can be mounted anywhere that is convenient.

Connect the audio input cable and turn on the power. Set the amplifier to a reasonable listening level. (Make sure that $R44$ has been selected to match the audio system as explained previously.) The white slide potentiometer controls the master level, while the three colored slide potentiometers can be adjusted to obtain the desired interplay of colors. The display is best viewed directly from the front. The cabinet can be mounted either horizontally or vertically. -50-

MINI-SIX ADD-ON

*Try new dispersion
technique for better stereo*

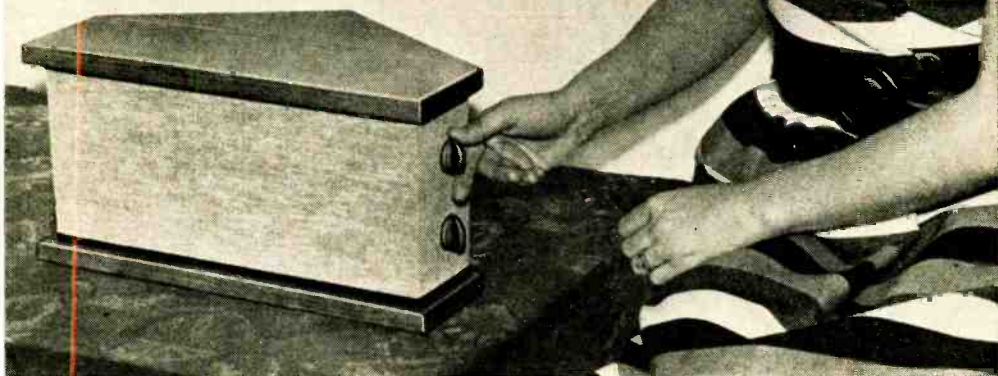

BY DAVID B. WEEMS

SINCE high fidelity first came on the scene, some critical listeners have complained that most music systems produce sound that appears to come through a hole in the wall. The advent of stereo gave us two openings for music and added the phrase "hole in the middle" to the hi-fi vocabulary.

As good as they are, loudspeakers still sound more like loudspeakers than musical instruments. One reason for this is that the sound reaching the listener at a live performance is rich in both direct and reflected sound waves. But in the optimum listening position for most stereo systems, the predominant effect is produced by direct sound waves.

The directivity of loudspeakers gives a satisfactory left-to-right perspective in locating individual voices or musical instruments. However, there is a tendency to aim the sound in only one direction—

particularly the high frequencies—often in stereo compressing the sources into two separate "points."

Dealing With The Problem. Several approaches have been tried to eliminate the "point source." Some of the earlier ones were: adding a center channel to stereo systems; removing the back of the speaker enclosure to gain reflections

The Author

While Dave Weems was getting his Bachelor of Science degree at the University of California at Los Angeles, he worked as research assistant in a physics laboratory which was next door to an acoustics lab. That was when he started building amplifiers and speaker systems. He has taught mathematics, physics, and chemistry and is now a free-lance consultant and writer on the design of speaker systems.

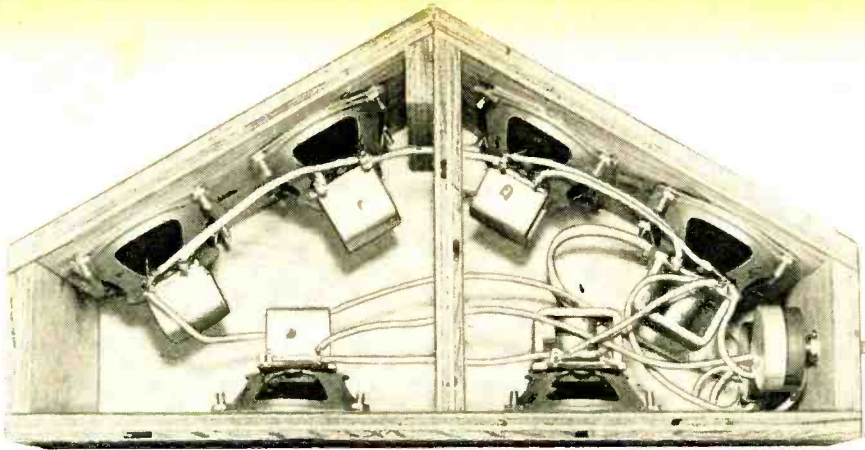

Four speakers (top) are mounted on angled baffles facing back. The other two speakers face the front. Individual L-pad controls for two sets of speakers are mounted on side.

from the rear; using speaker columns to produce a line source for wider horizontal distributions and reflections; and developing nondirectional tweeters.

A new approach, described by some enthusiasts as "revolutionary" is offered by the Bose Model 901 speaker system. This system contains nine 4" loud speakers—eight of them located on baffles that are mounted on angles at the rear of the small enclosure. A single speaker faces forward. The purpose of this rather unorthodox arrangement is to produce 89% reflected and 11% direct sound waves. The Bose Corporation claims that this is the optimum ratio for the reproduction of recorded sound.

Each of the nine speakers in the Bose system handles the full range of frequencies without crossover networks. A solid-state "active equalizer" is used to tailor the response to that preferred by the listener as well as to compensate for the inherent base rolloff caused by the small enclosure.

Even if you are a critical listener, you will notice that the "character" of the sound produced by the Bose system does not change as much as you might expect it to as you move about the listening room. And the feeling of spaciousness adds a depth of sound not evident with conventional speaker systems.

A minor drawback of this unique speaker system is the necessity of locating the Model 901 about 12" away from the wall to obtain the proper reflection pattern. There is also the question of the

reflecting surface itself. If it is smooth you can confidently expect the reflected sound content to approach the optimum of 89%. But a rough surface or the presence of even a small amount of drapery or other sound absorbing material could alter this ratio. The exact percentage of reflected sound might not be critical, but listening rooms present a wide variety of acoustical environments.

Taking the above into consideration, it is desirable to provide a means for varying the direct/reflected sound ratio produced by the speaker system. This would allow the listener to optimize the ratio to his particular listening room and personal tastes.

The "Mini-Six," the add-on speaker system described here, is designed to be adjusted to the environment. Utilizing the reflected sound principle employed in the Bose 901, it permits the listener to vary the ratio of direct/indirect sound to match his room acoustics.

The Mini-Six, unlike the Bose system, is not a full-range speaker system; rather, it is an add-on for existing hi-fi speaker systems, the latter being used only to reproduce the bass range. This stratagem minimizes material cost and satisfies limited space requirements.

The add-on consists of 3" × 5" replacement-type 8-ohm oval speakers selling for about a dollar apiece. Each has a magnet weight of 1.47 ounces. Four of the speakers are mounted on angled boards facing the rear of the enclosure, and two face the front.

The rear speakers are connected in series-parallel to maintain a normal 8-ohm impedance, while the front speakers are wired in series to provide a 16-ohm impedance. The two sets of speakers are then wired in parallel to provide a total impedance between 5 and 6 ohms.

The front speakers would normally dissipate 33% of the power with this hookup. However, a 16-ohm L-pad controls the output to any desired level up to about 33% of the total sound.

While the low-frequency response of the replacement-type speakers is limited by their small size and high cone resonance (over 200 Hz), their performance in the high-frequency range is fairly good. When used as designed to reproduce the midrange and high-frequencies from 300 Hz up, the sound reproduction does not betray the low cost of the speakers.

A simple home-made crossover network permits you to utilize your present speaker system as a woofer. Because the crossover point is at 300 Hz, the position of the big speaker system is not critical. And the addition of an 8-ohm L-pad allows you to match the output of the Mini-Six to that of your woofer.

Construction. Although building the Mini-Six (Fig. 1) appears to be an exer-

cise in making 60° miter cuts, construction is quite simple. A table saw or an adjustable portable rotary saw, set for 30°, will do the job easily. If you elect to use a sabre saw for the cutting operations, be very careful to keep the cuts straight and go very slowly. Always make a few practice passes at the cutting angle through some scrap 1/2"-thick plywood.

Now, referring to Fig. 1, prepare each of the eight major pieces that make up the enclosure according to the dimensions provided. The center panel that separates the two interior chambers of the enclosure (see drawing at upper right) should be cut from a 6 3/4" x 8" piece of 1/2" plywood. The excess strip (illustrated) can then be reversed and secured to the center panel with glue and screws, forming a double angled surface to accommodate the rear panels. Then drill about 30 1/4"-diameter holes on 1" center-to-center squares through the panel.

Rub chalk around the gasket of one speaker. Then firmly press the speaker onto a piece of heavy cardboard to obtain a pattern for the speaker cutouts. Cut the cardboard along the inner outline. Then punch a small hole through the center of the pattern.

Place the pattern over each of the

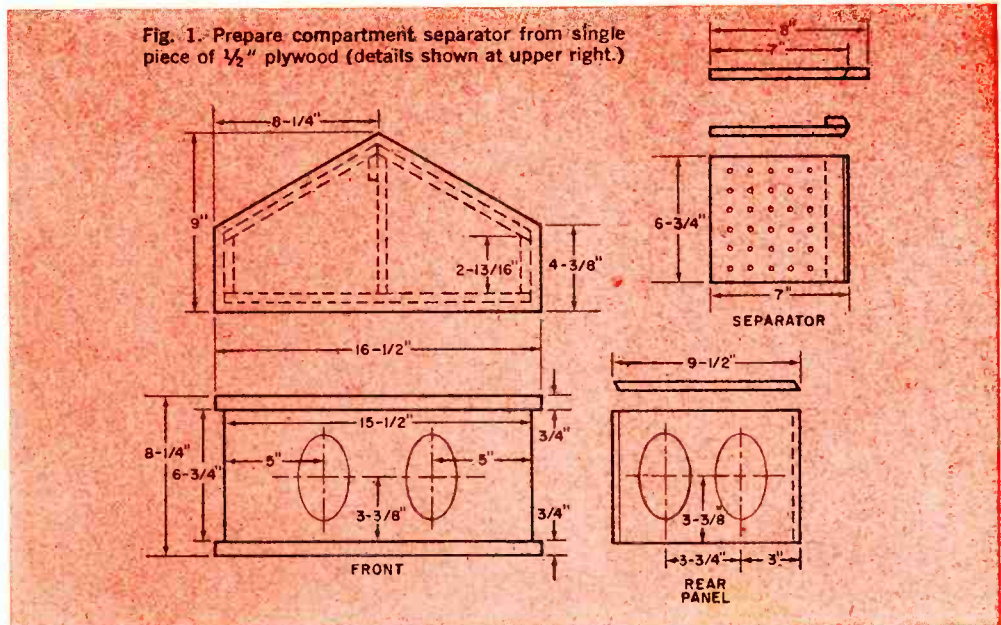

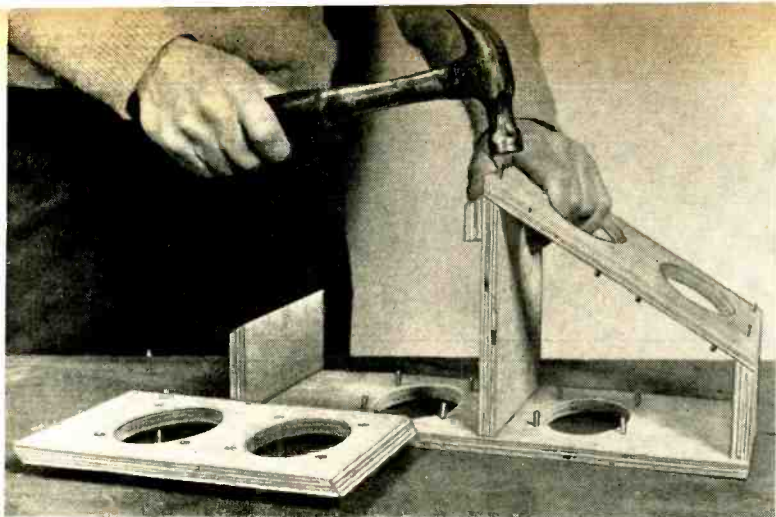

Fig. 2. Except for top plate, all parts should be joined using wood glue and finish nails.

speaker locations on the front and rear panels of the enclosure to make the outlines for the speaker cutouts. Then cut the outline holes. Set a speaker over each cutout and mark the positions of the speaker mounting holes. Now drill a $\frac{3}{16}$ " hole through the front and rear enclosure panels at each marked location. Mount the bolts, and check the speakers for proper fit.

Anchor the sides and center panel to the enclosure front plate with glue and screws. Then attach the rear panels with glue and finishing nails as shown in Fig. 2. Apply a coat or two of flat black paint to all exterior surfaces and the insides of the speaker cutouts. Allow the paint to dry.

Next, invert the enclosure shell onto

the inverted top panel. Carefully center the shell; then mark the outline of the interior shell surfaces on the top panel (see Fig. 3). Again, carefully center the bottom panel over the enclosure shell, and glue and nail the bottom panel to the shell.

Prepare $\frac{3}{4}$ " \times $\frac{3}{4}$ " pine cleats to fit the *inside* of the shell outline on the top panel at the front and rear, and glue and screw together as in Fig. 4. Locate and drill holes through the front and two rear panels to permit screws to be driven through the shell and into the cleats to hold down the top panel. Stain and finish the top and bottom panels.

The screw-type terminal strip mounts on the bottom of the enclosure, centered near the side on which you plan to install

Fig. 3. To locate positions of top cleats, invert top plate, center enclosure shell on it, and strike pencil lines along edges of inner walls of shell.

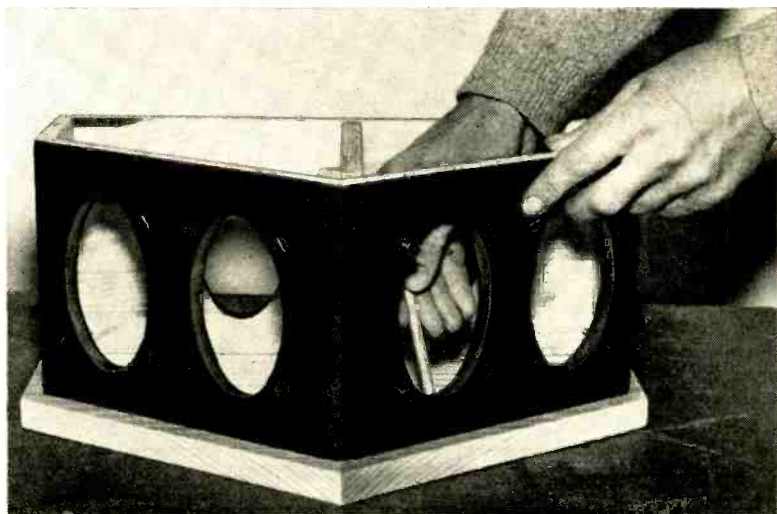

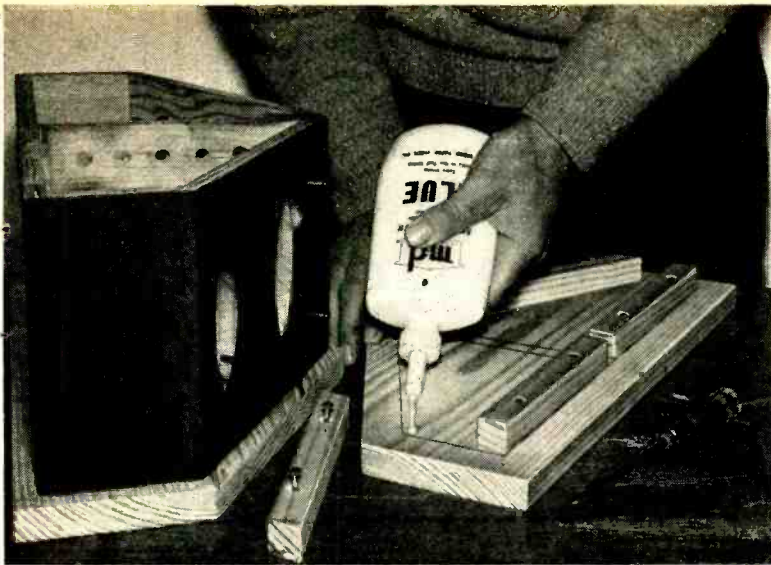

Fig. 4. Fasten cleats along only front and rear locator lines on top plate. Leave appropriate breaks in cleat to accommodate the chamber vertical separator.

the L-pads. First, drill two $\frac{1}{4}$ " holes through the enclosure bottom panel, removing enough wood to accommodate both the solder lugs and screw ends of the terminal strip. Next, solder one conductor of a 15" length of zip cord to each solder lug on the terminal strip. Then mount the terminal strip on the outside surface of the bottom panel with glue and screws.

Invert the enclosure and attach to the bottom panel three rubber bumpers. These bumpers should be large enough to provide adequate clearance for the speaker wires and screw connections at the terminal strip when the Mini-Six is placed on a flat surface right side up.

Wiring and Testing. Set the LP8 L-pad down with the shaft pointing away from you and the solder lugs pointing downward. The lugs in this orientation are numbered 1, 2, and 3, left to right. (This same orientation and numbering procedure also applies to the LP-16 control.)

Solder a 10" wire and one of the terminal strip conductors to lug 1; a 16" and a 7" wire to lug 2; and the remaining terminal strip conductor to lug 3.

Now place before you the LP16 control. Connect and solder a 5" wire to lug 1 and an 11" wire to lug 2.

Drill the holes for and mount the two controls, locating the LP16 at the top. Connect and solder the loose end of the 7" wire from lug 2 of the LP8 pad to lug

3 of the LP16 control. The remaining loose wire ends will be connected later, after the speakers are mounted inside the enclosure.

Carefully unpack the speakers and determine the voice coil polarity of each with a 1.5-volt battery. To determine the polarity, momentarily touch the contacts of the battery across each pair of speaker terminals, and observe the direction of cone movement at the moment of contact. If the cone moves outward, mark the terminal adjacent to the positive pole of the battery with a permanent identifying mark (red dot or scribed plus sign). Inward movement of the cone indicates that the terminal adjacent to the negative pole of the battery should be marked.

Now install the speakers on the front and rear mounting boards, pointing the solder terminals on the speakers toward the top of the enclosure. (If all speakers are the same brand name and model number, all identifying marks will likely be either on the left or the right, greatly simplifying wiring.) Note that you will have to remove the four mounting bolts nearest the chamber separator panel before mounting the speakers on the rear panels of the enclosure.

When you tighten the mounting hardware, do not apply excessive force or you will deform the speaker baskets.

Finish wiring the Mini-Six according to Fig. 5. After wiring is completed,

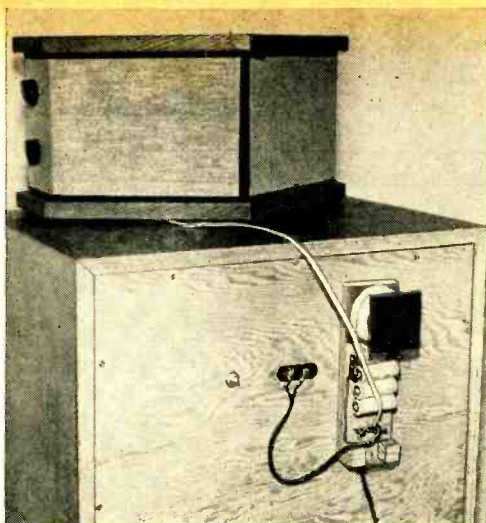

System crossover network mounts on rear of woofer enclosure; connecting wires are routed as desired.

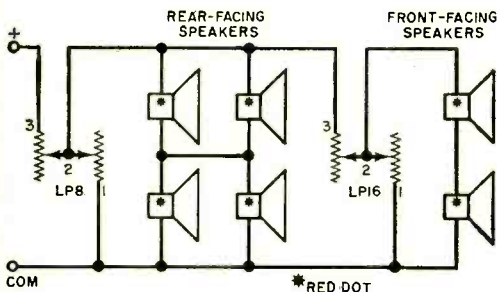

Fig. 5. Combination series-parallel hookup is used to obtain a system impedance between 4 and 8 ohms.

BILL OF MATERIALS

- 6—5" x 3" replacement-type 8-ohm speakers
- 1—8-ohm L-pad (Calrad LP8, or similar)
- 1—16-ohm L-pad (Calrad LP16, or similar)
- 1—100- μ F nonpolarized capacitor (see text)
- 1—1-lb spool #18 magnet wire
- 1—Two-terminal screw-type terminal strip
- 1—15½" x 6¾" piece of ½" plywood for front panel
- 2—9½" x 6¾" pieces of ½" plywood, edges cut at 60° angle, for sides
- 2—6¾" x 2 13/16" pieces of ½" plywood, one edge cut at 60° angle, for compartment separator panel
- 1—6¾" x 1¼" piece of ½" plywood for separator panel (see text)
- 2—16½" x 9" pieces of ¾" clear pine shelving for top and bottom
- 1—36" length of ¾"-square pine for cleats
- 8—1¼" x #8 flathead wood screws to anchor cleats to top of enclosure
- 2 doz—1" x #8 flathead wood screws
- 2 doz—1" x 3/16" flathead stove bolts for speaker mounting
- Misc.—Grille cloth; three-penny finishing nails; wood glue; nuts for stove bolts; wire; solder; etc.

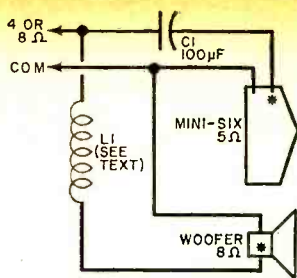
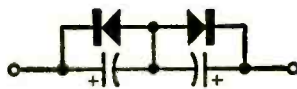

Fig. 6. Homemade crossover network must be connected between Mini-Six and woofer as shown.

DIODES "DE-POLARIZE" POLARIZED CAPACITORS

A low-cost method of obtaining the equivalent of a high-capacity non-polarized capacitor was recently suggested by Don Purland in a recent issue of "Electronic Design" magazine. As shown in the diagram, two polarized capacitors, each twice the desired value and connected back-to-back, cancel out the polarizing effect. But to prevent an undesirable reverse voltage appearing across either capacitor (even though each is "protected" by the other), connect a silicon diode in reverse polarity across each capacitor.



The capacitors in this arrangement will never "see" the reversed voltage since the diode shorts out the capacitor that is connected into the circuit backwards.

Although untested at this writing, the suggestion seemingly has great merit since it permits the use of cheaper capacitors of more common values.

check the polarity of the system by the same method used for the individual speakers, and identify the positive screw terminal with a permanent mark. Check that all cones move in a common direction.

Connect the Mini-Six to the 4- or 8-ohm output of your amplifier to check for "buzzes" and "rattles." A sweep-frequency test record is ideal here, but you can substitute a variety of music programs in a pinch. If you detect a buzz or rattle, locate the speaker causing it and loosen or tighten the mounting hardware until the problem clears up.

Now check the LP8 and LP16 controls
(Continued on page 117)



BY LYMAN E. GREENLEE

BUILD A

Blinky Blinker

EMERGENCY FLASHING LAMP FOR YOUR CAR

MOST ACCIDENTS are preventable, and the best way to prevent one is to display a warning signal whenever and wherever a hazardous condition exists. The best warning device you can use is the universally accepted flashing red emergency light which most people associate with the message: "Danger. Proceed with caution."

With the incidence of preventable accidents on the rise, it pays every motorist and home owner to have an emergency light. It could save his life some night when changing a tire at the side of the road or it could prevent a costly law suit when a sidewalk is broken or blocked.

In fact, there are dozens of uses for the emergency light, including a few that are just utilitarian—such as guiding you back to your campsite at night or locating your car in a crowded parking lot.

The emergency lights available at auto supply and marine stores are generally very simple devices, consisting essentially of a battery, switch, and thermal flasher lamp in series. With such systems, battery life is short because the flasher lamp is almost constantly connected to the battery (off time of the lamp is very short). The "Blinky Blinker" emergency flasher light, on the other

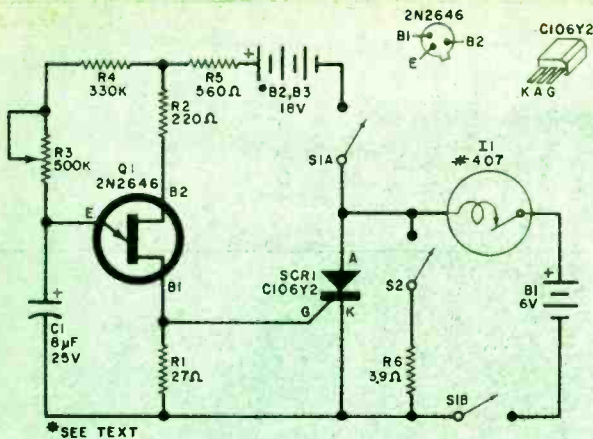

Fig. 1. The 18-volt source for Q1 circuit consists of two 9-volt transistor batteries connected in series. Power for I1 is supplied by independent long-life 6-volt lantern-type battery.

PARTS LIST

- B1—6-volt lantern battery
- B2, B3—9-volt transistor battery
- C1—8- μ F, 25-volt electrolytic capacitor
- I1—Flasher lamp (GE #407)*
- Q1—2N2646 unijunction transistor*
- R1—27-ohm resistor
- R2—220-ohm resistor
- R4—330,000-ohm resistor
- R5—560-ohm resistor
- R6—3.9-ohm resistor
- R3—500,000-ohm potentiometer (Mallory #MTC-551.1)*
- S1—D.p.s.t. slide or toggle switch

- S2—S.p.s.t. slide or toggle switch
- SCR1—Silicon controlled rectifier (GE #C106Y2)*

- 1—5" X 4" X 3" aluminum utility box
- Misc.—Red trailer clearance lamp assembly; lamp socket to fit #407 lamp; 2" X 2 1/2" X 1/8" linen Bakelite or perforated phenolic board (or substitute printed circuit board—see text); "flea" clips (omit if PC board is used); rubber feet; 1/2" rubber grommet; 1"-wide X 22-gauge soft aluminum strip for battery holders; 9-volt battery clips*; #6 hardware; 1/2" metal spacers (2); hookup wire; solder; etc.
- *These parts available postpaid for \$3.50 from Lyman E. Greenlee, PO Box 1036, Anderson, Ind. 46015.

hand, employs an electronic triggering/switching circuit that extends the off time of the lamp up to 12 seconds.

The extended off time of the lamp in the Blinky Blinker eliminates the costly objection of short battery life. In addition, the flasher has two repetition speeds—one variable between 6 and 12 seconds between flashes; the other flashing about once a second. Consequently battery life should average about 2000 hours on the slow flash and about 200 hours on the fast flash. Compare these figures to those you can expect from other emergency flasher lights, and you can readily see that the extended battery life more than makes up for the difference in cost.

How It Works. As shown in Fig 1, the circuit of the Blinky Blinker consists of a unijunction transistor oscillator (Q1) that drives a silicon-controlled-rectifier power switching stage (SCR1). Triggering SCR1 into conduction applies independent power source B1 across special flasher lamp I1.

With S1 set to ON and S2 set to FAST,

the blinker circuit is contained within the series loop consisting of R6, B1, and I1. As soon as S2 is closed (set to FAST), power from B1 lights I1. Thereafter, I1 flashes on and off at a rate determined by its built-in bimetallic strip. Resistor R6 limits the current flowing through the series loop and drops the source voltage from 6 volts to the 4.9-volt level required for operation of I1.

Leaving S1 in the ON position and moving S2 to the SLOW position transfers control over the flash repetition rate

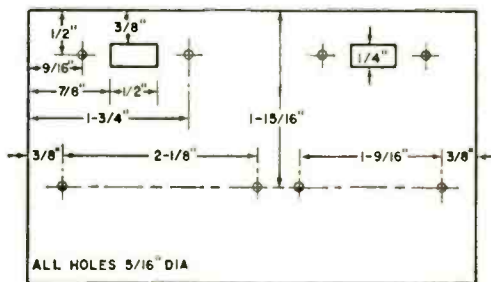

Fig. 2. Cutouts in front of box. If toggle switches are used, substitute round holes for rectangular.

to the $Q1$ oscillator circuit. At the instant $S2$ is switched to SLOW, the oscillator charging circuit is completed, allowing $C1$ to charge up at a rate determined by the series resistances. $R3$, $R4$, and $R5$. At some point during the charge cycle, the voltage level across $C1$ becomes great enough to cause $Q1$ to fire, discharging the capacitor through the E-B1 junction of $Q1$ and $R1$ to the common negative buss.

The sudden firing and discharge action of the oscillator circuit produces a sharp pulse at the B1 terminal of the UJT. This pulse, coupled to the gate of $SCR1$, triggers the SCR into conduction, placing the power from $B1$ across $I1$ and lighting the lamp. From here, the bimetallic strip in the lamp takes over, opening the lamp circuit and interrupting the power through $SCR1$, preparing the circuit for a repeat cycle.

Meanwhile, as the lamp circuit is being operated, the charge cycle of the oscillator is repeating. The entire series—charge, discharge, SCR firing—repeats indefinitely as long as power is applied. With the component values given in Fig. 1 and specified in the Parts List, the SLOW repetition rate of the blink cycle can be varied between 6 and 12 seconds simply by changing the setting of $R3$. The on time of the lamp remains strictly a function of the characteristics of the lamp's bimetallic strip.

Construction. Begin fabricating the Blinky Blinker by modifying an ordinary trailer clearance lamp assembly as follows. First remove the lens and remove and discard the lamp that comes with the assembly. Then pry away the lamp socket with pliers, leaving only the base of the assembly shell.

Next, drill a $\frac{1}{2}$ " hole through the center of the base of the shell and through the center of the top of the utility box. Drill two more smaller holes through the base of the assembly shell, spacing them equidistant from—and on opposite sides of—the large center hole. Set the assembly base over the hole in the utility box, mark the locations of the smaller holes, and drill the same size holes through the box top at the marked positions.

Now mount the base of the shell in place, fastening it down with #6 hard-

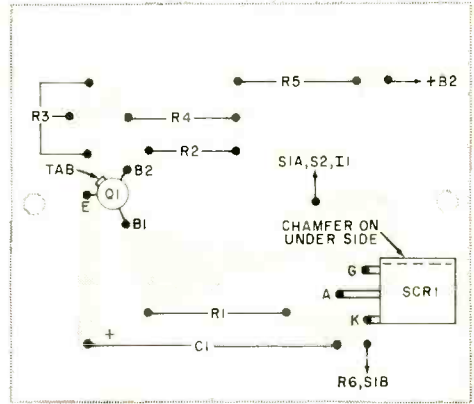
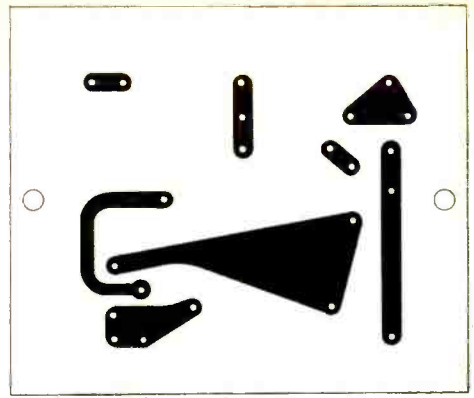
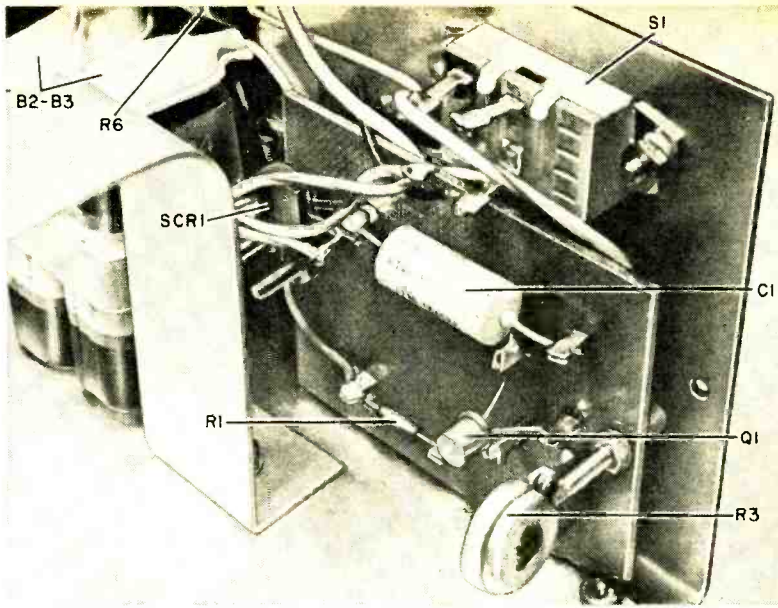

Fig. 3. Upper drawing is actual-size etching guide for PC board; lower drawing shows parts placement.

ware. Place a $\frac{1}{2}$ " rubber grommet in the center hole, and force a lamp socket (compatible with the base of the #407 flasher lamp) through the rubber grommet from the inside of the box. Screw in the new lamp and replace the lens.

Referring to Fig. 2, machine the front of the utility box as shown. The rectangular switch cutouts and mounting holes are symmetrically located on each side near the top of the box half section. (Note: if you prefer, you can substitute toggle switches. In this event, only two holes are required, their centers spaced $1\frac{1}{8}$ " in from the sides and $\frac{1}{2}$ " down from the top.) Mount the switches in their respective holes.

Component placement inside the utility box is not critical. Consequently, you can use any method of wiring that best suits your needs. If you plan to board-mount the components, an etching guide and component placement diagram are provided in Fig. 3. (The author cut to



Mount circuit board on utility box with $\frac{1}{2}$ "-long spacers. Metal U bracket (at the left) is for B1.

size and drilled a piece of linen Bakelite for his prototype, locating components on the top and bottom of the board. If you prefer this method, drill lead holes for the components in approximately the same locations shown for the PC board layout.)

Wire the components together as illustrated. Then double check the connections of *C1* for polarity and *Q1* and *SCR1* for proper orientation. The component layout diagram in Fig. 3 shows

the proper orientation of the transistor tab and SCR chamfer for the PC board wiring.

Bend strips of aluminum around the lantern battery and the sandwiched-together 9-volt batteries to form mounting brackets. Leave about $\frac{3}{4}$ " of excess metal on both ends of each bracket, bending the excess to form mounting tabs. Now drill holes through the tabs of the small mounting bracket and through the tabs of the large mounting bracket and the bottom and rear of the utility box. Set the batteries in place (also place a piece of corrugated cardboard between the 9-volt batteries and front of the box), slip on the mounting brackets, and fasten them down with #6 hardware.

Now interconnect the batteries, lamp, switches, and circuit board. Then mount the circuit board to the front of the box with $\frac{1}{2}$ " metal spacers and #6 hardware.

To test the circuit, set *S2* to FAST and *S1* to ON. The lamp should flash on and off at a regular, fairly rapid rate. Now set *S2* to SLOW. This time the lamp should remain extinguished for between 6 and 12 seconds, flash on for a short time, and extinguish for another 6-12 seconds before repeating the cycle. If the SLOW off time is too fast or too slow for your needs, simply adjust the setting of *R3* as desired. Finally, assemble the utility box.

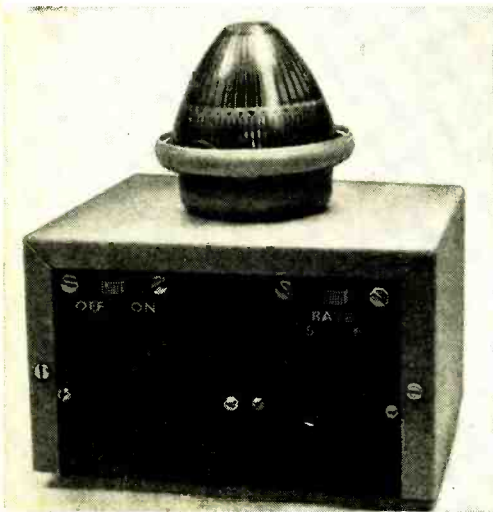

After assembling project, label *S1* and *S2* as shown.

A LOOK AT THE HQ-200 & SX-122A

RESULTS OF OUR COMMUNICATIONS-RECEIVER FIELD TRIAL

BY OLIVER P. FERRELL

TO MANUFACTURERS, most side-by-side comparisons of their products are odious. However, to the potential buyer, such comparisons provide valuable insight that is not otherwise obtainable. This story reports how two recently "upgraded" communications receivers were operated side-by-side for several weeks. The receivers are similar only in tuning range, looks, and popularity. Otherwise, they are as alike as an orange and a pineapple. Readers of this article—it is assumed—will be intrigued by subtle differences between the Hallicrafters SX-122A and Hammarlund HQ-200 receivers, as reflected in the \$145 price differential.

"A" Is to "200." The up-graded SX-122A is only slightly different from the SX-122—which it now replaces. To all intents and purposes the comments here apply to the older model as well as the "A". The HQ-200 is an improved HQ-100, a receiver that has been with us for quite a few years (see POPULAR ELECTRONICS, February 1957). It has been improved and repackaged and labeled HQ-200.

Hard-Core Differences. In the photos and captions of this story are some of the more obvious differences between these two receivers. However, there are



CAPSULE CIRCUIT INFORMATION

Hallicrafters SX-122A: A dual-conversion superhet (all tubes) with 4 nearly continuous tuning ranges (0.54-34.0 MHz) with bandswitching at 1.6, 4.9, and 12.6 MHz. There is no coverage between 1.6 and 1.75 MHz due to the first i.f. channel. The second i.f. is at 50 kHz and is R/C decoupled to permit bandwidth options (panel selected) at 5.0, 2.5, and 0.5 kHz. There is calibrated electrical bandspread on 5 ham bands. Built-in 100-kHz crystal calibrator is an optional extra. Tunable BFO and product detector for CW/SSB reception. Built-in series-type noise limiter. Price \$395.00 (without speaker).

Hammarlund HQ-200: A single conversion superhet (all tubes) with 4 continuous tuning ranges (0.54-30.0 MHz) with band switching at 1.8, 4.0, and 10.0 MHz. A Q multiplier affords continuously adjustable selectivity and is tunable across i.f. channel. Calibrated electrical bandspread on 5 ham bands. Tunable BFO and product detector for CW/SSB reception. Built-in shunt-type noise limiter. Price \$259.50 (without speaker).

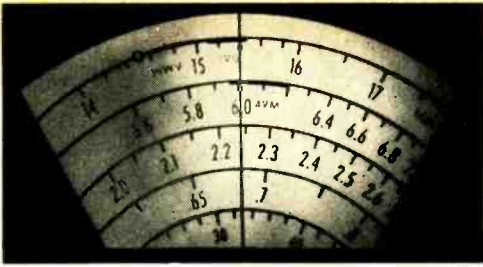

Main Tuning. The Hammarlund HQ-200 (below) tunes 550 kHz to exactly 30.0 MHz in four ranges. The Hallicrafters SX-122A (above) tunes 540 kHz to 34.0 MHz. Single rotation of main turning knob on SX-122A tunes about 600 kHz at 10.0 MHz and 270 kHz at 4.0 MHz. A knob rotation of the HQ-200 tunes 1100 kHz at 10.0 MHz and 450 kHz at 4.0 MHz. The least number of kHz tuned per knob rotation favors ease of difficult DX'ing for the SWL.

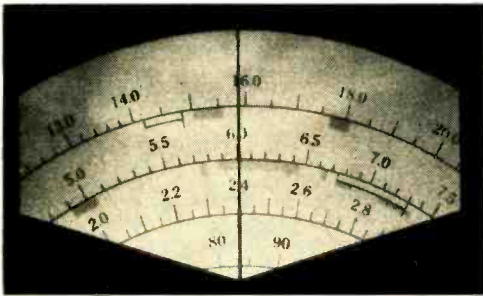

three characteristics that deserve editorial comment: image rejection, sensitivity, and selectivity.

In regard to image rejection—which neither manufacturer rates in his literature—the SX-122A walks off with all honors. Image rejection is the ability of the receiver to suppress the image of a desired signal that is removed from the signal by twice the i.f. The HQ-200 being a single-conversion receiver does have images—they are quite tolerable, but they do exist. The SX-122A being a dual-conversion receiver has none that are detectable. Presumably they do exist, but if so, they are too weak to possibly interfere with short-wave reception.

The sensitivity of these two receivers for straight AM reception is approximately the same and both should be able to dig weak signals out of the background atmospheric noise. In view of the extreme crowding in the various radio bands it is the question of selectivity rather than sensitivity that should be of greatest importance to the SWL.

Selectivity. The HQ-200 (above) and SX-122A (below) offer two different answers to the problem of achieving good selectivity—Q-multiplication in the HQ-200 and a unique R/C network in the SX-122A. Selectivity on the HQ-200 is continuously adjustable from the receiver normal bandwidth of about 7 kHz (at -6 dB) to 400 Hz. The Hallicrafters SX-122A model has 3 preset switched positions.

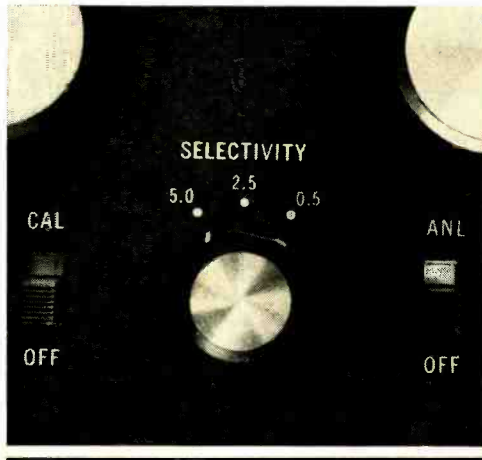

A NICE RECEIVER, BUT—



For the past few years POPULAR ELECTRONICS has been intrigued by the absence from the American marketplace of the British communications receivers manufactured by Eddystone. After establishing that there was no importer for the Eddystone SWL and ham receivers, we purchased a popular Model EC-10 from the factory and subjected it to a battery of tests—lab and field trials.

The EC-10 is an all-solid-state 5-band receiver with self-contained loudspeaker and battery pack (6 D cells). It has continuous coverage from 0.55 to 30.0 MHz with band switching at 1.5, 3.5, 8.4, and 18.0 MHz. There is no noise limiter, "antenna" tuning, electrical bandspread (see below), or selectivity adjustment. Special features include an a.f. filter for CW operation and the renowned Eddystone slow-motion dial which is flywheel-loaded, gear-trained, and operates at a reduction of 110 to 1.

In tests, the Model EC-10 was slightly less sensitive than we had expected. Since sensitivity appeared to vary from excellent to fair throughout the tuning ranges, we are left to assume that this may be due to the lack of a tuning adjustment (usually referred to as "antenna") in the first r.f. stage. Selectivity was only fair and measured at 8.0 kHz at -6 dB and somewhat wider than 25 kHz at -40 dB. Image rejection was fair to good and disconcerting above 18.0 MHz.

On the plus side, POPULAR ELECTRONICS was impressed by the clean, sturdy craftsmanship in the EC-10 construction. As expected, the Eddystone mechanical bandspread proved to be somewhat less versatile than electrical bandspread (as in the Hq-200 and SX-122A), but nevertheless fairly free of backlash and with a high order of "resetability." Although not as "pretty" as comparably priced transistorized consumer portables with multiple bands, the EC-10 looks and feels professional. The EC-10 is a superb CW receiver—due primarily to the stability of solid-state and the a.f. filter. Although the EC-10 lacks a product detector, we had no difficulty with SSB signals.

The suggested American retail price for the EC-10 will be about \$180.00. Although no importer had been appointed at this writing, POPULAR ELECTRONICS is assured that valid inquiries will be answered through our Reader Service.

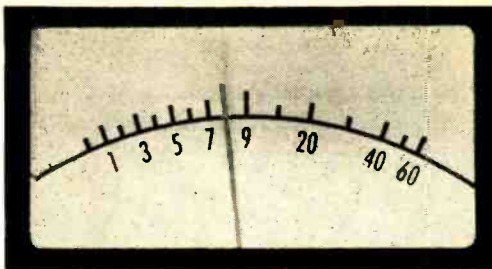

Tuning Meter. The S-meter on the SX-122A is clean, well-illuminated and accurately calibrated at 50 μ V input to read (S)9. If you didn't know what the meter indicated, could you make sense out of a 1,3, 5,7,9, etc. scale without your electronic expertise?

A true communications-type receiver must feature excellent selectivity—preferably adjustable. The HQ-200 and SX-122A offer two different approaches—Q multiplication in the HQ-200 and a very low i.f. with high-Q transformers in the SX-122A. The width of the nose of
(Continued on page 112)



Bandspread. Each receiver has reasonably accurate bandspread dial calibration for the 10, 15, 20, 40, and 75/80 meter ham bands. The HQ-200 (above) has a special logging scale to assist SWL's tuning the international broadcast bands. Single rotation of the bandspread knob of SX-122A tunes 400 kHz on 10 meters; 50 kHz on 20 meters; and 40 kHz on 40 meters. The HQ-200 single rotation is 400 kHz on 10; 120 kHz on 20; and 105 kHz on 40 meters.

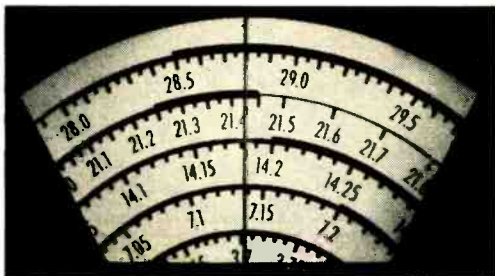



POPULAR ELEComics

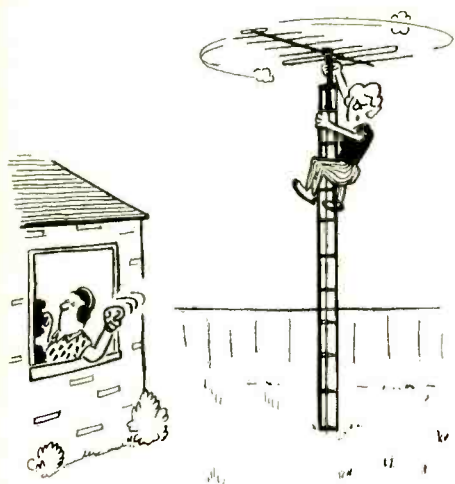
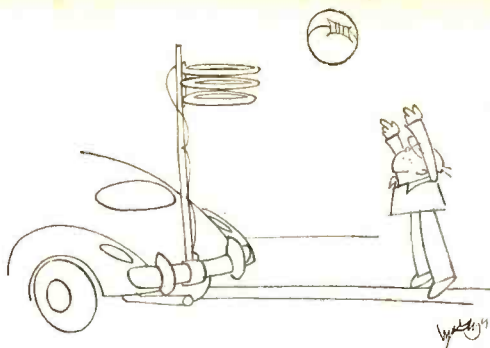

Speed it up Marconi,
I have to get supper ready.



It's a QSL card—they got
our message in the bottle.

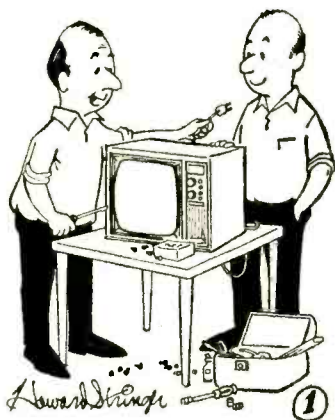

There, finished. Plug it in,
and we'll see what happens.

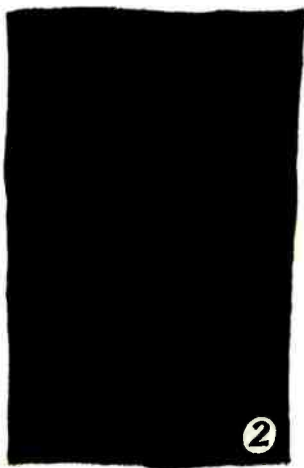

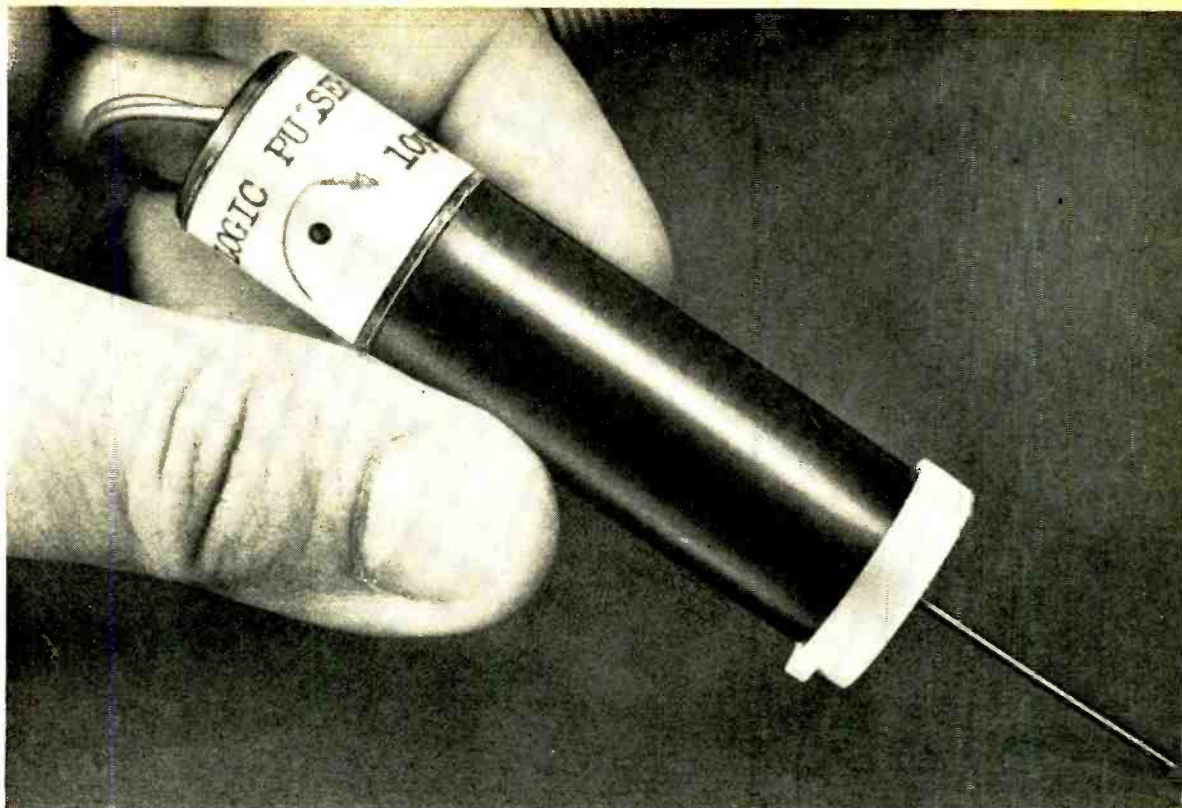

POLA-Testers

SURPLUS CONTAINERS MAKE HANDY PROBES

BY E. B. BEACH

ONE OF the more vexing problems facing the electronics experimenter is finding a way to house small, odd-sized projects. The author, for example, designed a series of very useful, low-cost test instruments that occupy very little space and must be held in the hand during use. The novel packaging scheme he devised can be seen in the photographs. All three of the devices shown are packaged in discarded Polaroid® print coat containers. The containers are of generous proportions and fit well in the hand when used as probes. If you don't happen to have a Polaroid camera, you certainly know someone who would save you a couple of the containers since they are normally discarded. If that source is

dry, you can use any small plastic container of the type used for pills.

If you are using the coater containers, remove and discard the used spreader and leave the cap off the container for a few days to allow the chemical to dry thoroughly. If this is not done, the chemicals in the coating compound will corrode soldered connections and leads, which may eventually lead to trouble.

After the container and cap have dried out, scrape the dried material from inside the container and the lip of the cap. Make sure that both are clean, inside and out.

The three test instruments which employ this unique packaging scheme are used with the many RTL digital IC

projects recently published in this magazine. Several other, non-digital instruments are presently being designed and will appear in future issues. To use these

instruments, connect the +3.6-volt lead to the power supply of the circuit being tested and the ground lead to the board ground.

Logic Probe



Connect the power leads to the respective terminals on the digital board being tested, then follow digital signal around the board, observing the lamp. Each time trace signal goes positive, the small lamp glows.

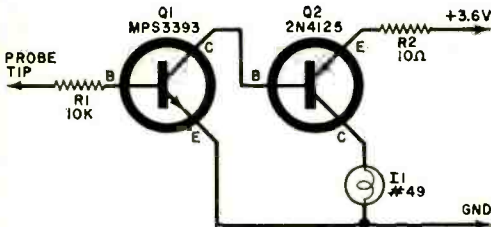
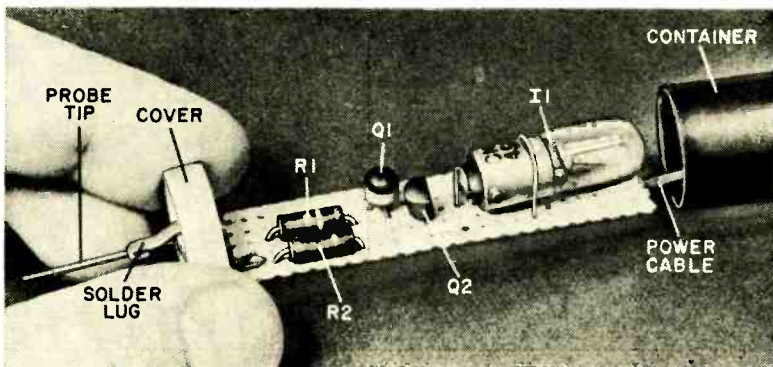

Fig. 1. In this simple electronic switch, resistor R_1 isolates the probe from the circuit under test.

Fig. 2. Lamp is strapped down with a small piece of wire while other components are lead mounted.

Logic Probe. The purpose of a logic probe is to detect the presence of the discrete voltage outputs (1 and 0) in a digital circuit without having to disassemble the device. Place the tip of the logic probe on the proper point in the circuit and, when the voltage switches up and down according to the logic, a small lamp within the probe will blink on and off. A positive voltage lights the lamp.

The circuit for this simple probe is shown in Fig. 1. Any low-cost *npn* silicon transistor can be used for Q_1 , while any low-cost *pnp* transistor can be used for Q_2 . Using the specified value for R_1



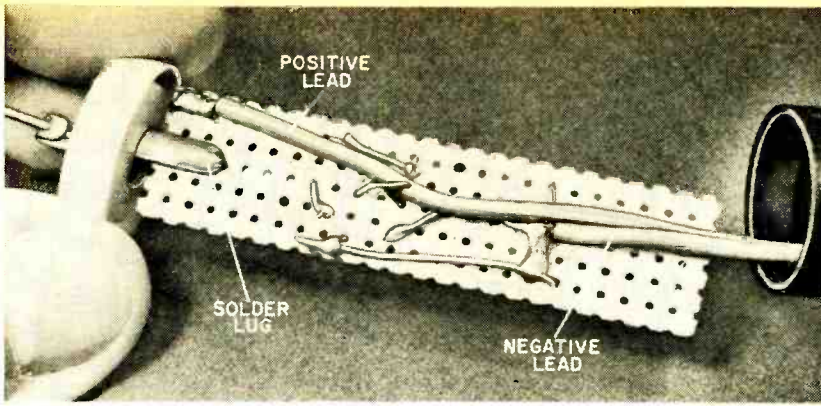

Fig. 3. The underside of the probe board showing the two power connections, and the solder lug that connects to the probe through cover mounted hardware.

gives an input sensitivity of about 0.8 volt. Resistor $R2$ limits the current flow and gives degenerative stability to the circuit.

The circuit is assembled on a $2\frac{3}{8}'' \times \frac{1}{16}''$ piece of perforated phenolic board having a 0.1" grid of 0.042" holes. The lamp is strapped down at one end using a small piece of bare wire. The other components are installed as shown in Fig. 2. Connections are made using component leads protruding through the board. The underside of the board is shown in Fig. 3. Two small holes must be made in the closed end of the plastic case—one for the two color-coded power leads and one

through which the lamp can be easily seen.

The probe tip is made from a piece of a paper clip soldered to a lug which is secured to the cap with a 4-40 screw and nut. A second solder lug on the inside of the cap is connected to $R1$. The board assembly is rotated and slipped into the plastic case so that the lamp is opposite its viewing hole. The cap then fits snugly on the container.

As a finishing touch, make up a type-written label describing the device, identifying the color code on the power leads, and telling what the lamp does. Attach the label to the container with transparent tape.

Logic Pulser

Logic Pulser. This is an astable multivibrator made from a dual-buffer IC which is adjustable from about one pulse per second to about 10 pulses per second. It is capable of driving as many as 80 milliwatt RTL gates or 26 medium-power IC gates for testing purposes. It re-

ceives its primary power from the circuit being tested.

The circuit for the pulser is shown in Fig. 4. It is also built on a $2\frac{3}{8}'' \times \frac{1}{16}''$ piece of perforated phenolic board having a 0.1" grid of 0.042" holes. The integrated circuit ($IC1$) fits directly into

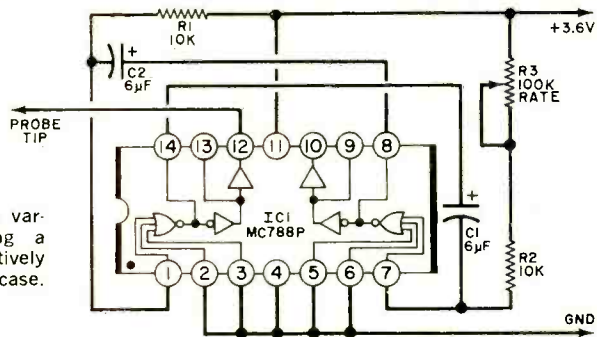
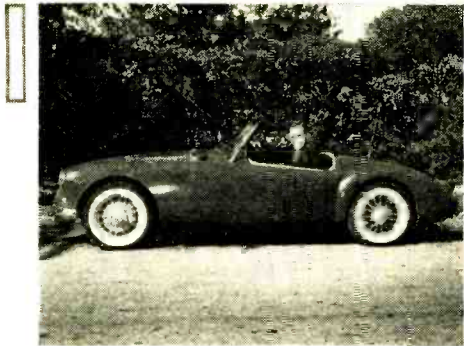

Fig. 4. $IC1$ is coupled up as a variable-frequency oscillator having a buffer output. Even this relatively complex circuit fits the small case.

6 good reasons to get into electronics:



Want more reasons? Read on...

A future? Electronics *is* the future. Build your career in a field that's growing this fast, and you should grow fast.

Security? When you're an electronics technician, you have the kind of security a man really wants: the knowledge that there now are more good jobs in your field than men to fill them.

Travel? Excitement? Advancement? Yes. Electronics has the good things you're looking for . . . and maybe even a few more that will surprise you.

Don't forget money. There's money in electronics. You can make a good living. And when it comes right down to it, that's what a career is all about.

What's the catch?

Just this: nobody can do it for you. You have to want to get into electronics. You can't become a highly-paid electronics technician by just saying a magic word.

It takes some work. But we can teach you what you need to know—in one of our schools—or at home, by mail. It's probably a lot easier and a lot faster than you think. Why not find out? Make the first move. Send in the post card . . . and make things start happening!

DE VRY INSTITUTE OF TECHNOLOGY
4141 BELMONT AVENUE, CHICAGO, ILLINOIS 60641

119R



ONE OF THE

BELL & HOWELL SCHOOLS

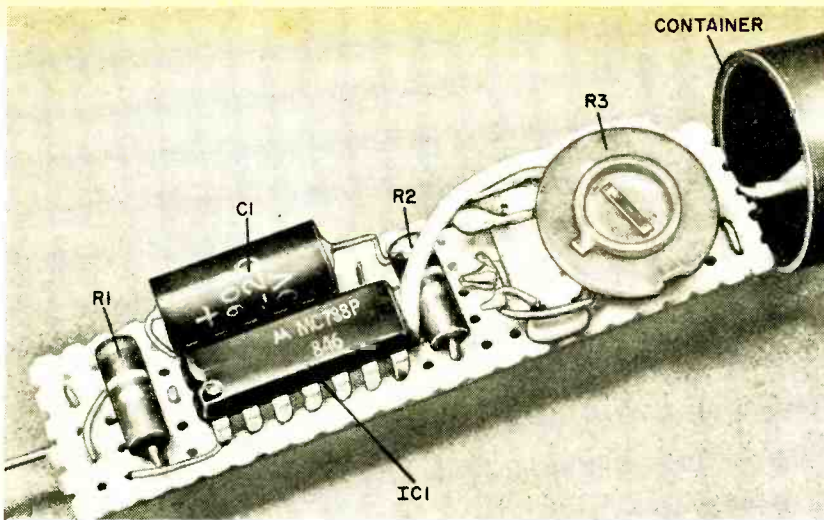

Fig. 5. The parts fit the small board easily if you follow the layout shown here. Make sure you have a small hole in the container to make screwdriver adjustments of R3 as required during operation.

the board holes and is positioned as shown in Fig. 5. Bend a couple of leads over to keep the IC in place while assembling the other components. Mount C1 beside the IC and mount C2 on the other side of the board as shown in Fig. 6. Be sure that these two capacitors are not larger than $\frac{5}{16}$ " in diameter or the completed circuit will not fit into the container. Potentiometer R3 is held on the board by the wiring to its three terminals.

The probe tip for this instrument is

made from a length of paper clip. Make a hook in one end of the probe to fit through a hole in the board. A small piece of bare wire soldered to the hook of the paper clip will hold the probe in place while it is connected to pin 12 of IC1. Make a small hole in the center of the plastic cap for the probe tip to pass through. Make one small hole in the end of the container for the power leads and another small hole in such a position that R3 can be adjusted with a screwdriver when the circuit is mounted.

Fig. 6. Underside view showing placement of C2. When selecting both C1 and C2, make sure that they are no larger than $\frac{5}{16}$ " diameter so that they will fit the container. Note how the probe is supported.

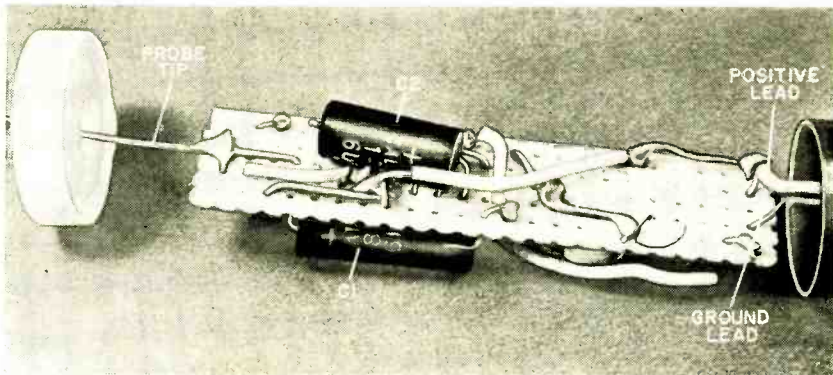

Logic Switch

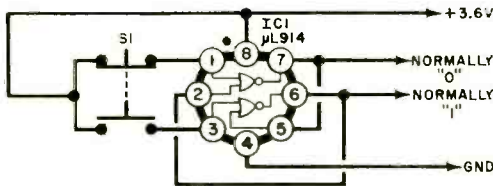

Fig. 7. The circuit is a basic "bounceless switch" made up of one small IC. It produces a clean pulse.

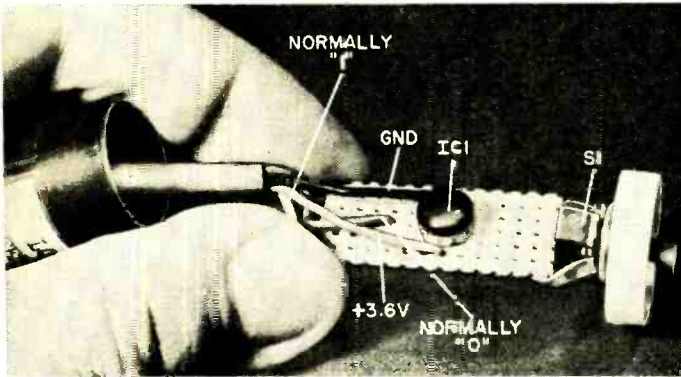
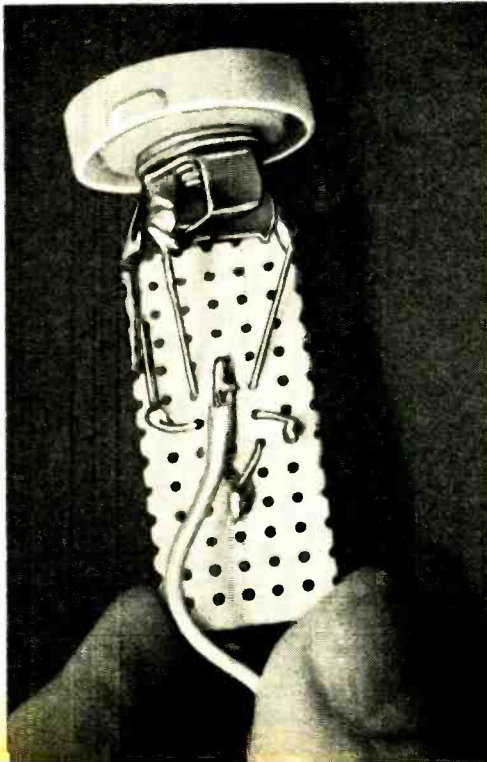

Fig. 8. All that's in the circuit is the IC and a switch. Four-lead flexible cable couples to board.

Fig. 9. Underside of the board showing method of mounting the switch using its circuit connections.



The pushbutton switch fits in a hole drilled in container cover. Like other testers, a typewritten label identifies leads and explains operation.

Logic Switch. One difficulty encountered in triggering an RTL circuit with low noise immunity is the erratic count that occurs when a conventional noisy mechanical switch generates the trigger. This noise can be eliminated by using a mechanical single-pole double-throw pushbutton switch to operate a set-reset flip-flop. This insures that a clean, noise-free, single pulse is generated each time the pushbutton is operated.

The circuit for the logic switch is shown in Fig. 7. It is built on a $1\frac{1}{4}'' \times \frac{1}{2}''$ piece of perforated phenolic board. Mount the s.p.d.t. pushbutton switch in a hole centered in the plastic cover. Drill a hole in the closed end of the container for a four-wire cable. The circuit is wired (Fig. 8) so that it holds the switch at the end of the board. Another view is shown in Fig. 9.

Bridge Function Quiz

BY ROBERT P. BALIN

Many electronic components—vacuum tubes, transistors, diodes, thermistors, etc.—are often connected in the form of a bridge, which can make a particular circuit more sensitive and efficient. With the bridge balanced, one gets a zero-current-consuming indication of relationships between components in the circuit. To test your knowledge of bridge circuits, match the functions (1-10) to the proper diagrams (A-J).

<p style="text-align: right;">A</p>	<ol style="list-style-type: none"> 1. Amplifier <input type="checkbox"/> 2. Band-pass filter <input type="checkbox"/> 3. Band-suppression filter <input type="checkbox"/> 4. Capacitance measurement <input type="checkbox"/> 5. Frequency measurement <input type="checkbox"/> 6. Inductance measurement <input type="checkbox"/> 7. Modulator <input type="checkbox"/> 8. Oscillator <input type="checkbox"/> 9. Rectifier <input type="checkbox"/> 10. Resistance measurement <input type="checkbox"/> <p>(Answers on page 114)</p>	<p style="text-align: right;">G</p>
<p style="text-align: right;">B</p>		<p style="text-align: right;">H</p>
<p style="text-align: right;">C</p>		<p style="text-align: right;">I</p>
<p style="text-align: right;">D</p>		<p style="text-align: right;">J</p>
<p style="text-align: right;">E</p>	<p style="text-align: right;">F</p>	

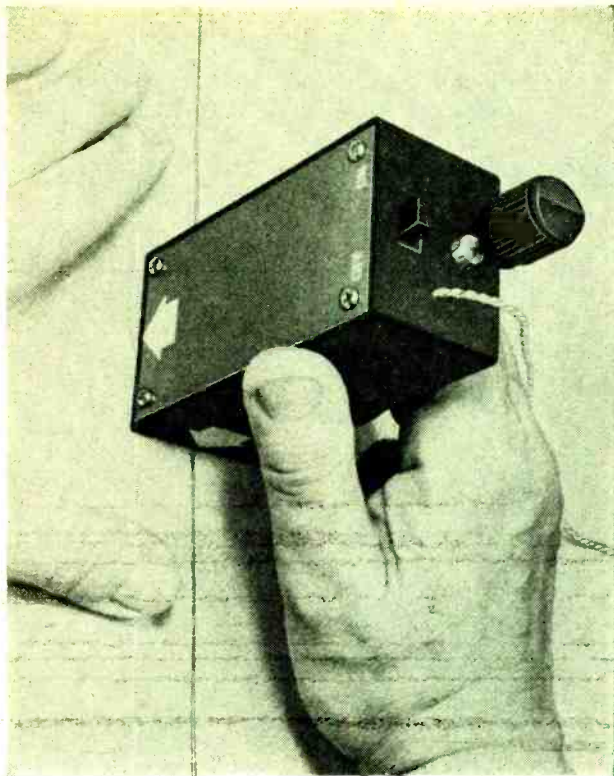

Carpenter's Mate

TINY METAL LOCATOR FOR TINY METAL

BY JOHN S. SIMONTON, JR.

THOSE LITTLE magnetic gadgets that carpenters use to locate studs work fine if you're looking for ferrous nails. They won't do the job, though, for a boat owner trying to avoid sanding and sawing the brass hardware used on his craft.

If you have this problem, you can save some of the time you're spending developing a sailor's vocabulary and some of the money you use replacing chewed up saw blades by building the "Carpenter's Mate." It locates ferrous or non-ferrous metals quickly and easily.

The Carpenter's Mate, not much bigger than a pack of cigarettes, works just the same as larger types of metal locators except that it has a very restricted range and better resolution (pin-point accuracy). By using a small search coil (mounted inside the plastic case) maximum range has been reduced to about 2 inches while resolution is increased so that even a small wire brad—detected head on—can be spotted. The Carpenter's Mate slips easily into your shirt pocket and can be put into operation as fast as you can turn it on.

Construction. The circuit of the Carpenter's Mate is shown in Fig. 1. Layout is critical and since radio frequencies are involved, good wiring practice should be followed and all leads should be as short as possible. A circuit board simplifies the construction. You can make your own using Fig. 2 as a guide or you can buy one.

Parts placement on the board is shown in Fig. 3. The leads of *Q1* and *Q2* are bent so that the flat sides of their bodies can be placed adjacent to one another and glued together. This helps to maintain the two transistors at the same temperature to stabilize the relative frequencies of the two oscillators.

The sensing coil, *L1*, is made by modifying a standard J.W. Miller #6300 or equivalent High-Q variable inductor. Make the modification by removing the tuning slug and carefully cutting the threaded brass tuning screw off flush with the ferrite core material. Then carefully unsolder the lead wires from the terminals on the side of the coil and use a sharp knife to cut the form so that the coil winding is centered between the ends

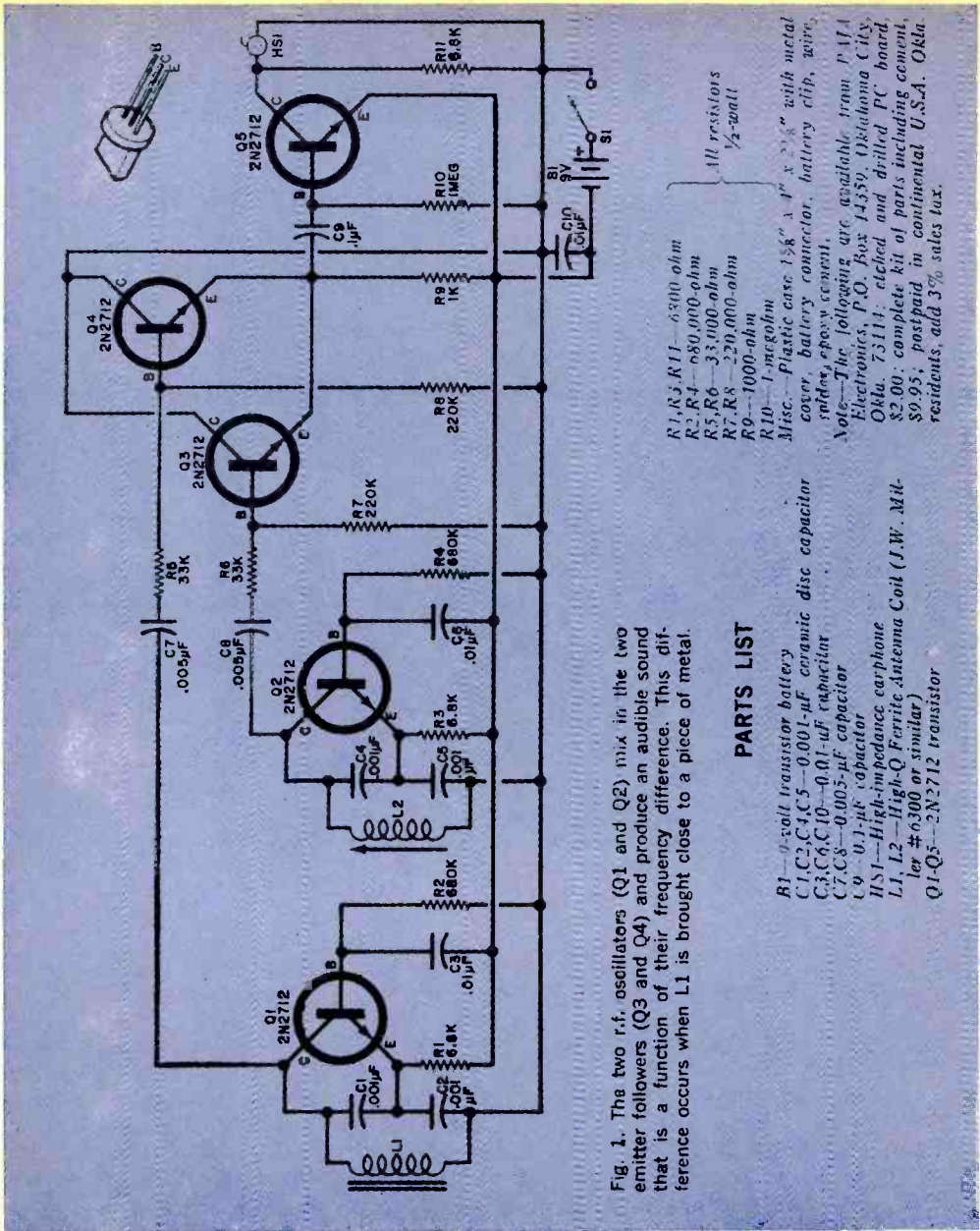

Fig. 1. The two r.f. oscillators (Q1 and Q2) mix in the two emitter followers (Q3 and Q4) and produce an audible sound that is a function of their frequency difference. This difference occurs when L1 is brought close to a piece of metal.

PARTS LIST

- R1—0.5-volt transistor battery
- C1, C2, C4, C5—0.001- μ F ceramic disc capacitor
- C3, C6, C10—0.001- μ F capacitor
- C7, C8—0.005- μ F capacitor
- C9—0.1- μ F capacitor
- L1, L2—High-Q Ferrite Antenna Coil (J.W. Miller #6300 or similar)
- Q1-Q5—2N2712 transistor

- R1, R3, R11—6200 ohm
- R2, R4—680,000-ohm
- R5, R6—33,000-ohm
- R7, R8—220,000-ohm
- R9—1000-ohm
- R10—1-megohm

Misc.—Plastic case $1\frac{5}{8}'' \times 1'' \times \frac{3}{8}''$ with metal cover, battery connector, battery clip, wire, solder, epoxy cement.
 Note—The following are available from P.V.A. Electronics, P.O. Box 14359, Oklahoma City, Okla. 73111: etched and drilled PC board, \$2.00; complete kit of parts including cement, \$9.95; postpaid in continental U.S.A. Okla. residents, add 3% sales tax.

of the form. Slide the ferrite slug back into the coil and center it before securing it in place with a dab of cement.

The completed unit is housed in a $1\frac{5}{8}'' \times 4'' \times 2\frac{1}{8}''$ plastic utility box (see Fig. 4). To prevent tone changes associated with touching exposed metal hardware, all internal components, including L1, S1, and the PC board are glued in place with epoxy cement. Clean all mat-

ing surfaces thoroughly with steel wool before gluing. Blow away all steel-wool debris to avoid shorts. Drill a hole for S1 at one end of the box and glue it in place. Then drill a hole on the same end for the mounting clip of L2 and snap it into place. Drill a small hole near these two to pass the earphone cord. Make a knot at the inside end of the cord to prevent it from being pulled through.

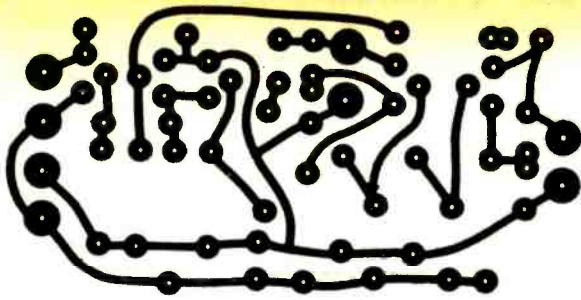
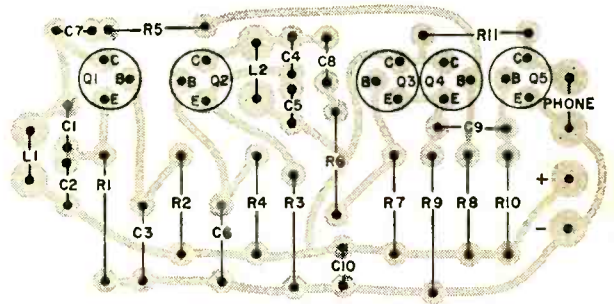

Fig. 2. Actual-size foil pattern to be used in making the PC board.

Fig. 3. Other than transistors, component polarities are not critical.



Mount *L1* at the center of the un-drilled end of the box, using epoxy cement. Before mounting, make sure that the leads are long enough to reach the terminals on the PC board. If they are not, either unwind a little wire from the

coil or solder on short extensions. Before mounting the PC board, connect up the circuit and put a small knob on the protruding shaft of *L2*. Turn on the power and adjust *L2* until a whistle is heard in the earphone. Once you hear this whistle,

Fig. 4. The entire instrument is easily mounted in a small plastic box. Place arrowheads to indicate the center of the search coil. All parts mount with epoxy.

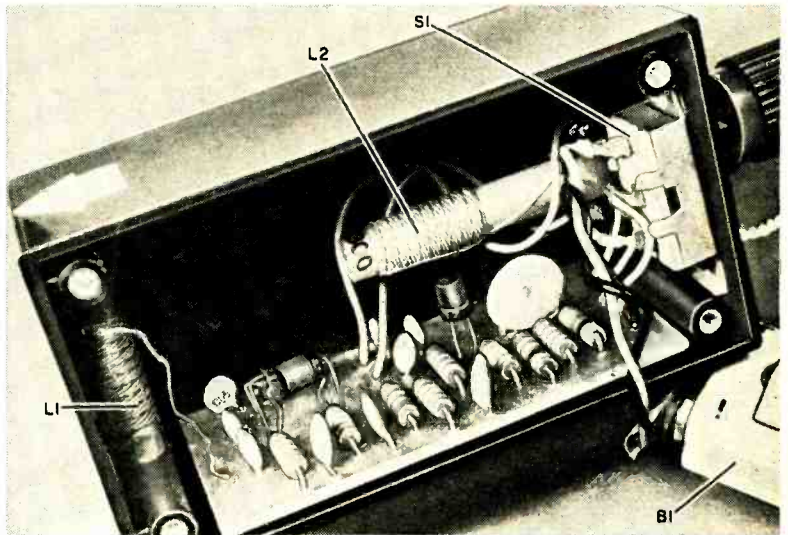

you know that the circuit is operating. Turn off the power and cement the board in place using a drop of cement at each corner.

When attaching the battery clip to the cover, place it slightly off center to keep it from interfering with the circuit board components when the cover is in place.

Operation. Hold the unit clear of any metal, turn it on, and insert the earphone in your ear. Withdraw the core from $L2$ by turning its adjusting screw knob counterclockwise. As the slug passes through the coil, you will hear a rising and falling tone. While any position of the slug which produces a tone may be used as an operating point, the most desirable setting can be found in the following manner. Start with the slug screwed out about an inch. At approximately this point, a tone considerably louder than the others will be heard. Continue to withdraw the core until a null is reached. Slightly before this null point is the best position for locating non-ferrous metals. In this case, the presence of a non-ferrous metal causes a slight increase in the oscillator frequency, causing the signal to go toward the null point. For detection of ferrous materials, withdraw the slug so that the tone is slightly beyond the null point. The presence of a ferrous object then decreases the oscillator frequency, again bringing the tone down to the null. By positioning the slug on either side of the

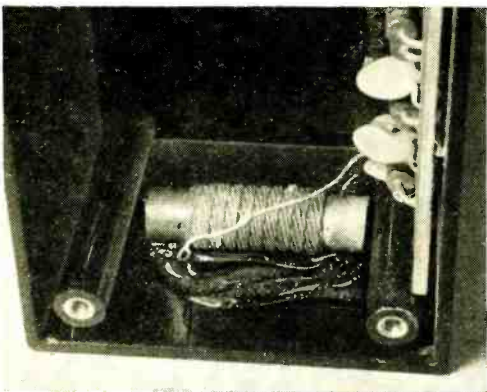

Coil $L1$ should be mounted with epoxy cement on the blank end of the box in exact orientation shown.

HOW IT WORKS

Transistors $Q1$ and $Q2$ and their associated components form two independent Colpitts oscillators. The outputs of these oscillators are combined in the mixer composed of $Q3$ and $Q4$ and the resulting signal appears across the common load resistor $R9$. Since the mixer is non-linear, the output signal contains the two original frequencies and also the sum and difference of the two. However, only the difference signal is within the range of human hearing. This signal is amplified by $Q5$ and used to drive the high-impedance crystal earphone.

When a metallic object (either ferrous or non-ferrous) comes close enough to $L1$ to intercept and distort the magnetic field surrounding the coil, there is a change in the effective inductance of the coil. This causes a change in the frequency of the "sense" oscillator ($Q1$). This relatively small change in the frequency of the oscillator can be heard as a significant change in the tone in the earphone.

To minimize "pulling" of the oscillators and the tendency of the two to lock on to the same frequency, the "local" oscillator ($Q2$) is adjusted to run at about twice the frequency of the "sense" oscillator.

null, it is possible to identify either ferrous or non-ferrous materials. If you leave the slug so that a relatively low audio frequency is heard, the frequency will go up or down depending on the metal detected.

To get some practice using the Carpenter's Mate, use a test surface which you know contains a piece of brass hardware. With the case held so that the side adjacent to the sensing coil is pressed lightly against the test surface, move the device over the area. The tone will decrease noticeably when the sensing coil is directly over the brass. With the proper adjustment of $L2$, the null point will be reached when the metal is detected.

Four clearly visible arrows can be drawn or pasted on the sides of the box at the $L1$ end so that scribe marks can be made on the test surface to locate the detected metal under the center of the coil. If the coil is exactly centered in the end of the box, the arrows should be centered on the sides. It is possible to orient $L1$ so that it butts against the end of the box. In this case, the sensitive area is greatly reduced permitting more accuracy in location. However, with this arrangement there is always the chance that the coil will be dislodged when the instrument is moved about.

-30-



MAYBE FREEDOM OF SPEECH SHOULD
END AT OUR BORDER

BY THOMAS J. R. KENT

RED LION, Pennsylvania, is a small, quiet town not far from Harrisburg. Few of its five thousand citizens, many of whom work at nearby furniture and cigar factories give any thought to WINB, the short-wave broadcasting station on the edge of town. Perhaps they should know it better. The programming and policies of WINB have brought Red Lion international attention.

WINB, *World International Broadcasters*, is the smallest of America's three privately-owned international stations.¹ Through complex corporate arrangements, WINB is one of three radio stations associated with Dr. Carl McIntire, an ex-Presbyterian minister who has been accused of right-wing and anti-minority group views. A number of civic organizations, including the Pennsylvania AFL-CIO, the Catholic Community Relations Council, and the Anti-Defamation League of B'nai B'rith charges that McIntire is using some of these sta-

tions to air his own personal stands on major political issues without acknowledging or representing the opposite side. The FCC has been petitioned to cancel the stations' licenses.

The Presbyterian Office of Information says that Carl J. McIntire was "deposed" (about 1936—Editor) and has made a career of maligning the leadership and programs of major church bodies in this country and abroad. Evangelist Billy Graham has been a target of abuse.

In 1945, his tabloid newspaper, the *Christian Beacon*, carried the statement that "one would be better off in a Communistic society than in a Roman Catholic fascist set-up," but his friends say the remark was "taken out of context" and does not represent any anti-Catholic viewpoint. McIntire denies being anti-Semitic, but his comments about Jews have been found offensive by Jewish organizations. According to the Presbyterian Office of Information, he has attacked Negroes, UNICEF, John F. Kennedy, Lyndon Johnson, the United Nations, Post Office Department, the Internal Revenue Service, and Billy Graham in the past few years alone.

1. Oddly enough, all three are owned and operated by religious organizations. WNYW is reportedly financed by the Mormon Church and KGEI by the Far East Broadcasting Corporation, a Baptist Church affiliate.

McIntire promotes his ideas through his private broadcasting empire, a growing operation headquartered in Collingswood, N.J. His own radio program, the *Twentieth-Century Reformation Hour*, is heard over 500-600 AM stations. He apparently also indirectly controls three radio stations, WXUR in Media, Pa. and WGCB in Red Lion, plus short-wave station WINB. Because of the international audience WINB gains for Dr. McIntire, it has received special attention from his many critics.

What does WINB broadcast? Although the station is on the air daily to southern Europe, the Mediterranean, the Middle East, and North Africa, areas where English is not commonly spoken, less than 4 hours of foreign language programming is broadcast per week. The majority of WINB broadcasts are in English, most of them prepared in advance by organizations which presumably pay WINB for their transmission. Many of the broadcasts are religious, either Christian evangelical programs or ones that mix religion with politics. Typical of the latter group are McIntire's *Reformation Hour* and the *Christian Crusade*, "the world's largest Christian anti-Communist movement." Virtually all political programs take a right-wing, strongly anti-communist attitude, and some of them indicate that the United States is already in the grip of a sinister Communist conspiracy. *Lifeline* and *The Manion Forum*, two programs with reputations for far-right views, are also heard throughout the shortwave target area.

The fact that such fare is broadcast overseas should be disturbing to many Americans. The FCC requires that private international stations "reflect the culture of this country and promote international goodwill, understanding, and cooperation." WINB's attacks against the U.S. government hardly comply with this regulation, and must confuse foreigners used to government-controlled short-wave stations.

Also, federal law states that programs designed specifically for American audiences are not acceptable as programming for international stations.² Programs

such as *Lifeline* and the *Twentieth Century Reformation Hour* are, it seems, in this category; the requests that listeners write their Congressmen or attend rallies in major U.S. cities would indicate that the programs are not produced with the foreign listener in mind.

In the past few years, the activities of Dr. McIntire and the stations said to be associated with him have brought protests from many of his listeners. In a petition currently before the FCC, nineteen civic groups, led by the Greater Philadelphia Council of Churches, claim that WXUR, the Media, Pa. fundamentalist right-wing station, presents a one-sided view of major issues, violating FCC fairness doctrine requirements. WXUR officials, however, insist that they do offer equal time to groups with differing views, but that the groups have refused the opportunities to use WXUR facilities.³

Radio-Minister Dr. McIntire's critics feel that he has abused his right to free speech and should be either taken off the air or forced to comply with FCC fairness requirements. The FCC is wary of such action, however, because censorship is a controversial subject and the Commission does want to protect its licensee's constitutional rights. According to the FCC, the entire matter of international broadcasting is under review, and new requirements for private short-wave stations may be forthcoming. In the meantime, however, Carl McIntire, his associated stations, and his international network continue on the air.

The size of WINB's overseas audience is hard to estimate, but the 50-kW signal is heard well in Europe and WINB personnel report receiving "thousands" of listeners' letters per year. The station solicits reception reports and verifies by QSL card but, due to a limited staff, reports may not be answered for a long time. Transmissions are from 1700-2000 GMT on 17,720 kHz and from 2000-2200 GMT on 11,795 kHz. The 2000 GMT program may often begin as late as 2004 or 2005 GMT because of time needed for transmitter bandswitching.

3. Apparently WXUR was able to convince retired Hearing Examiner H. Gifford Irion that they had been "extremely circumspect" and license renewal was recommended by Examiner Irion in late 1968. This immediately brought forward a blast from the FCC's own Broadcast Bureau who characterized Irion's actions as "an attempt to write the great American broadcasting novel."

2. However, this "rule" is probably also violated by WINB IV.

Getting to Know THE SCS

MYRIAD OF USES FOR THE SILICON CONTROLLED SWITCH

BY FRANK H. TOOKER

ONE OF THE MOST useful semiconductor devices on the market today is neglected by the majority of experimenters and circuit designers. That device is the SCS—silicon controlled switch. The neglect is not due to cost since at least one SCS (the 3N84) has a catalog price of only \$1.98. More likely, it is due to a lack of understanding of what the SCS is, how it works, and what it can do.

The SCS, shown schematically at (A) in Fig. 1, is actually a simple device. It has a *pnp* structure, as shown at (B) in Fig. 1, and thus resembles the SCR—with one important difference. It has a fourth connection, called the anode gate, brought out from the third layer of the "sandwich." The more conventional SCR has only a cathode gate. The anode gate gives the SCS a versatility which the SCR does not possess. (For some applications, this fourth lead can be overlooked and then, in fact, the SCS becomes a miniature SCR. In this case, the 3N84, for example, can handle 175 mA

with a maximum anode-to-cathode d.c. potential of 40 volts.)

A Convenient Assumed Circuit. Probably the easiest way to understand the SCS is to think of it as an integrated circuit composed of two transistors—one *nnp* and one *pnp*—with the circuit configuration shown in Fig. 2. The SCS is not really made this way; but in many cases, it behaves as if it were. Note that the cathode of the SCS is now the *nnp* emitter, the cathode gate is the *nnp* base and *pnp* collector, the anode gate is the *nnp* collector and *pnp* base, and the anode is the *pnp* emitter.

To become acquainted with the SCS, construct the circuits shown in Fig. 3. Before applying power to either circuit, set the potentiometer to maximum resistance. Then with power applied, adjust the potentiometer to produce a gate current reading of 2 mA on the 5-mA meter. In each case note the base (cathode gate) and collector (anode gate) currents. You will find the *nnp* has a d.c.

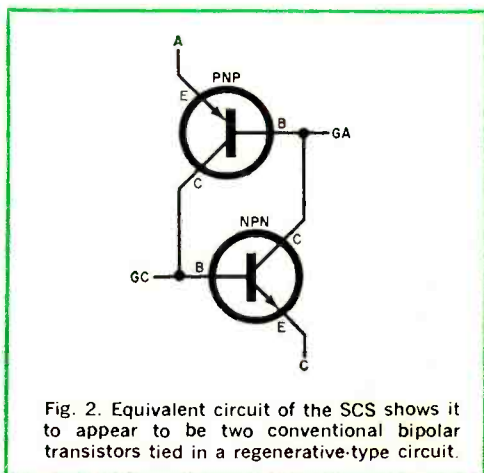
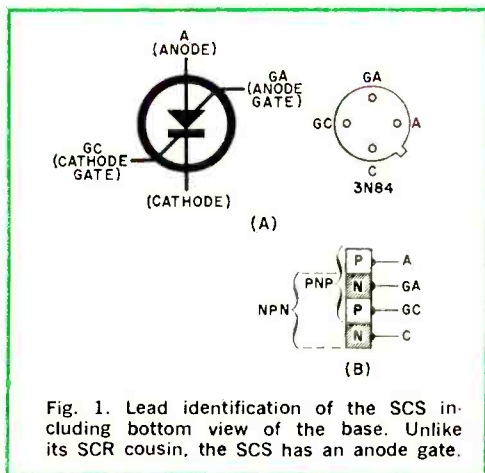

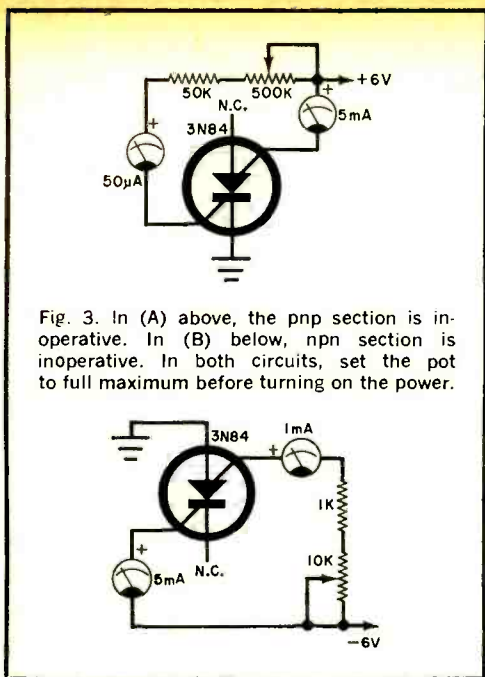

Fig. 3. In (A) above, the pnp section is inoperative. In (B) below, npn section is inoperative. In both circuits, set the pot to full maximum before turning on the power.

current gain of about 40, while that of the *pnp* is only about 1.5 or 2. These experiments will give you a "feel" for what goes on inside the SCS, enabling you to employ it more skillfully in circuits of your own design.

Regenerative Turn-On. The turn-on characteristics of the SCS are highly sensitive because of regenerative action. If you study the circuit of Fig. 2 for a moment, you'll see that the two transistors are connected so that there is a closely-coupled positive feedback. The output at the collector of the *nnp* feeds into the base of the *pnp*, while the output at the collector of the *pnp* completes the circle by feeding into the base of the *nnp*.

Obviously, if such a circuit is connected to a d.c. power supply and a signal of proper polarity is introduced, a "whirlwind" of amplification and reamplification (regeneration) takes place, ending in a very short time with the circuit locked up in a state of maximum conduction.

This is exactly what happens when the SCS turns on. It goes from what is essentially a no-conduction state between anode and cathode to a maximum-conduction state. In other words, it be-

haves like a switch, except that the action is electronic not mechanical.

In this respect, there is one important point which should always be kept in mind when experimenting with or using an SCS: be sure there is sufficient resistance in series with either the anode or the cathode to limit current flow to a safe value when the SCS turns on. If this is not done, the SCS, acting as a switch, will tend to short-circuit the power supply; and one or the other, or both, will either overheat or burn out.

Controlled Regeneration. Thanks to the availability of the anode-gate connection, it is possible to control positive feedback in the SCS. To study how this works, build the circuit in Fig. 4. It uses the *nnp* portion of the SCS as an amplifier with the emitter current of the *pnp* portion controlled by potentiometer *R2*. This resistance introduces negative feedback which acts to offset the positive feedback previously described.

With potentiometers *R1* and *R2* both set at maximum resistance, connect the 9-volt power supply, being careful to observe the indicated polarity. Advance *R1* to obtain a reading of 1 mA on meter *M1*.

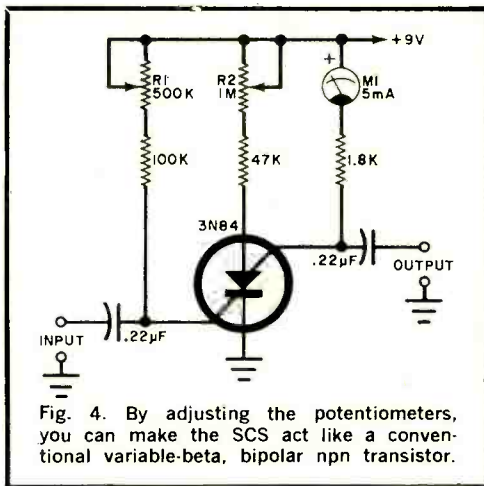

Fig. 4. By adjusting the potentiometers, you can make the SCS act like a conventional variable-beta, bipolar npn transistor.

With potentiometer *R2* set at maximum resistance, the circuit operates as an *nnp* transistor amplifier. With *R2* set on minimum resistance, the circuit is simply a turned-on SCS. In between these extremes, the circuit is regenerative, with its gain increasing as the value of *R2* is made smaller.

With $R2$ set at maximum resistance and $R1$ set for an anode-gate current of 1 mA, advance $R2$ and note that, as the setting approaches minimum-resistance in the circuit, anode-gate current rises rapidly to between 4 and 5 mA.

What we have here now is actually a variable- β npn transistor amplifier. To see how it works, connect an audio signal

vided by positive feedback through the pnp section of the SCS.

Simple Switching. Now that we have a good concept of what is inside an SCS and how it works regeneratively, let's study its switching properties. To see how sensitive the SCS is to turn-on at its cathode gate, build the circuit shown at (A) in Fig. 5. With the 6-volt supply switched on, note that the meter reads zero. The SCS is in its off state. Actually, a small current does flow in this condition, but it is only a few microamperes and does not indicate on the meter. For most practical purposes, we can assume that the off current of the SCS is zero.

With your eye on the meter, touch your fingertip to the cathode-gate terminal. Immediately, the meter needle swings up to about mid-scale, indicating a current flow of about 2.5 mA. The SCS is now switched on, and it took no more than the touch of your finger to do it.

Now remove your finger from the terminal and you will note that the reading on the meter does not change. The SCS stays on. To turn it off, momentarily disconnect the power supply by opening switch $S1$ (which should be a normally closed pushbutton switch).

To demonstrate turn-on with the anode gate, hold one finger of one hand on any grounded part of the circuit and touch a finger of the other hand to the anode-gate terminal of the SCS. Turn-off is again accomplished by momentarily opening $S1$. In either of these experiments, turn-off may also be accomplished by momentarily shorting the cathode gate to the cathode or the anode gate to the anode.

So sensitive is the SCS to turn-on that even a mild switching transient can accomplish it. In the circuit of Fig. 5(A), the transient response is subdued by capacitor $C1$. To prove this, with the power supply on but with the SCS in its off state, press and release $S1$ several times and note that the meter needle remains at zero. Now do the same with capacitor $C1$ removed from the circuit. Note that the meter needle promptly swings up to about mid-scale, indicating that even the transient produced by switching the power supply off and on is sufficient to turn on the SCS. The only way to keep it off is to open the switch.

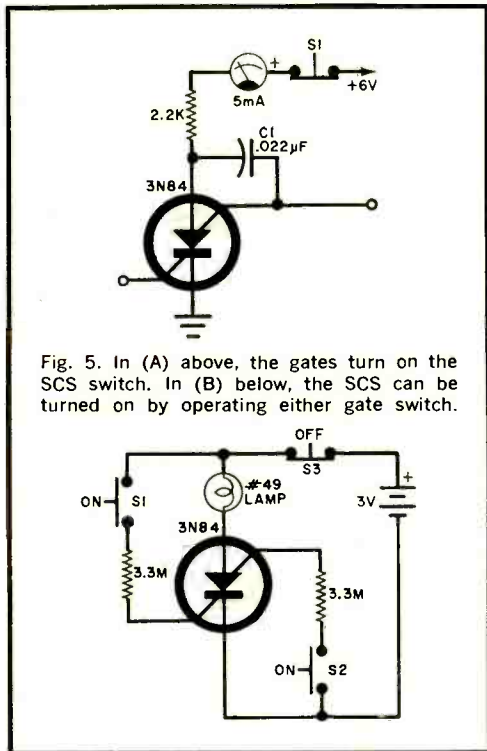

Fig. 5. In (A) above, the gates turn on the SCS switch. In (B) below, the SCS can be turned on by operating either gate switch.

generator to the input terminals and an audio VTVM to the output terminals. Set $R1$ for a reading of 1 mA on $M1$ and set $R2$ at maximum resistance. Set the VTVM on its 1-volt range and feed a 50-mV signal at 1000 Hz into the circuit. The reading of the audio VTVM should be somewhere around 0.25 volts, indicating that the circuit has a signal-voltage gain of about 50.

Now slowly advance the setting of $R2$, observing the VTVM. The meter reading should increase, indicating increasing voltage gain in the amplifier. With care, it should be possible to set $R2$ for a full-scale (1-volt) reading on the audio VTVM. With a 50-mV input, the gain of the circuit is now 200! This fourfold increase in gain is due to regeneration pro-

and leave it open. The moment it is closed, the SCS will turn on. Capacitor *C1* prevents this by applying the same potential to the anode and the anode gate simultaneously during the brief interval when the power supply is switched on.

An SCS is always easy to turn on; and as long as it is conducting only a milli-ampere or two, turn-off is not too difficult. As higher currents are drawn, however, turn-off becomes more of a

problem. In the circuit of Fig. 5(B), for example, where about 40 mA is pulled through the 3N84, shorting the cathode gate to the cathode or the anode gate to the anode will not turn it off. On the other hand, opening the power supply circuit is always effective.

The circuit of Fig. 5(B) can be turned on by closing either *S1* or *S2* momentarily. Very little gate current (only a
(Continued on page 110)

A SELF-POWERED PULSE GENERATOR

HERE IS a spike-pulse generator using an SCS and operating directly from the output terminals of a sine-wave audio signal generator—and it requires no other source of power! It has a range of 100 to 10,000 pps (pulses per second), producing one positive-going pulse for each cycle of the input signal. The sine-wave input-signal level may be anywhere between 1 and 4 volts r.m.s. You'll find it particularly useful for triggering digital logic circuits.

How It Works. While the sine-wave input signal is going through its positive alternation, diode *D1* conducts and charges up one of three capacitors, *C1*, *C2*, or *C3*, depending on the setting of switch *S1*. Simultaneously, the anode gate of *Q1* is made positive by the input so that the SCS is kept turned off.

When the input signal goes negative,

the sine-wave input signal goes positive again, the cycle repeats.

How to Use. Connect the output of an audio signal generator to the input of the pulse generator. Connect the output of the pulse generator to the vertical input terminals of an oscilloscope. Set the pulse generator's output level control, *R3*, for maximum output (toward the cathode of *Q1*). Set potentiometer *R2* at about midposition.

Set the signal generator at any frequency between 100 and 10,000 Hz and run its output up to about 2.5 volts r.m.s. Observing the trace on the oscilloscope, set switch *S1* to the position which provides the best spike waveform. Then adjust potentiometer *R2* to improve it, if necessary. The largest value of capacitance (*C1*) is best for the lowest frequencies, and vice versa.

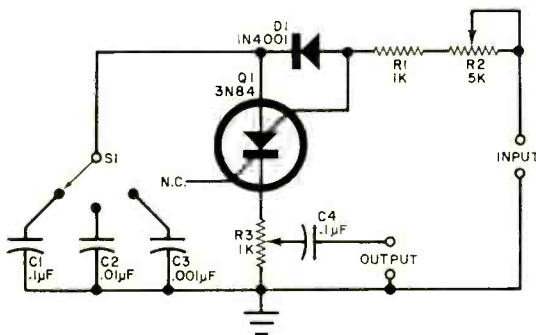

This simple self-powered pulse generator can be built directly into an existing audio sine-wave generator. The output pulses can be used to trigger experimental digital circuits or, if accurately calibrated, scope trace times.

diode *D1* is back-biased and ceases to conduct. At the same time, the anode gate is made negative with respect to the cathode. The SCS is thus turned on and the capacitor (*C1*, *C2*, or *C3*) discharges through potentiometer *R3*. When

If the output pulse is broad, set *S1* at a smaller value of capacitance. If multiple pulses appear, set *S1* to a large capacitance. With each change in the setting of *S1*, adjust *R2* to get the best obtainable waveform.

-30-



The Stereo Scene

by Charles Lincoln

USUALLY, every technology, as it grows, moves from the clumsy, lumbering approach to the lithe and elegant. Often this refinement in techniques and materials is accompanied by a marked improvement in performance, reliability and versatility. So has it been with high-fidelity sound.

The earliest radios and phonographs in which designers paid any attention to sound quality were large, cumbersome, noisy and power-hungry. Compare that with a typical "compact" system of today: reception of FM and stereo-FM broadcasts, either of which have considerably greater information-carrying capacity than standard medium-wave AM, and hence greater fidelity; perhaps AM thrown in as an extra; 3- or 4-speed record changer with fidelity comparable to the best FM broadcasts (typical playing times 25 minutes per side); tape playback and sometimes recording, usually in the form of cassettes which store up to 2 hours of material in two sets of two independent stereo tracks, with bandwidth and noise comparable to much of today's average-quality broadcasting and recording.

The invention of FM radio, multiplexing, tape recording and the transistor are the major innovations around which the high-fidelity recording, reproduction and broadcasting of sound are centered. As for the rest, a steady procession of relatively minor refinements adds up to a significant overall improvement in quality.

A Logical Evolution. It is interesting, and very much to the point, to examine the history of hi-fi and discover that the *compact* system of today is not a throwback to a more primitive stage of sound technology inherently inferior to the separate-component system. The compact from a technical as well as merchandising standpoint, represents perfectly logical evolution. The sep-

arate-component system is not the final answer to good sound quality, but in a transitional stage, just as the discrete transistor is rapidly being superseded by the integrated circuit—a functional "black box" that does a desired job without the need for laborious interconnection of elements.

In both cases, the transitional stage was a necessary part of the evolutionary process, of finding out how the components work, how to improve them, and how to relate them to one another.

Various engineers and experimenters in the 1940's discovered that one of the most easily improvable elements in the sound-reproducing chain was the amplifier, and so we saw the introduction of negative feedback and various interesting wide-band, low-distortion circuit designs like the Williamson and the McIntosh Unity-Coupled amplifiers. In the 1930's Armstrong was at work on VHF wide-band FM, which, besides its wider frequency response, was much less sensitive to natural and man-made interference than AM.

The introduction of the long-playing fine-groove 33 $\frac{1}{3}$ -rpm record in 1948, with significantly less background noise and much longer playing time than the 78-rpm disc was another transition. The better records demanded more precise pickups with lighter stylus forces and lower moving masses. Speakers also got their share of attention. In the 1950's, the refinement of the Helmholtz resonator type of enclosure, and especially the introduction of the acoustic-suspension principle, rapidly demolished the notion that good bass could come only from huge speaker systems.

Components Made Their Mark. Each part of the sound system was more or less separately improved. It was quite natural that the record lover who wanted the best system

the state of the art had to offer purchased the best amplifier, best speaker, best tuner, best pickup and so forth, very likely each the product of a different manufacturer. He did so because he had no choice, not because there was any particular magic in having separate components. There were (and still are) those who delight in owning a complex array of hardware, and it is partly through them that the mystique of the all-separate components hi-fi system arose. Still, components did once represent the best available, and, with the help of the advertiser's magic brush, the word "components" took up a lofty semantic perch, seeming to distinguish between the true believers and the mere dabblers in home music systems.

But the components created a new problem. Manufacturers naturally sought wider markets for their products, since it was,

after all, a business and not a hobby for them. There was obviously a rising interest in hi-fi recorded sound, but many potential customers were discouraged by the apparent complexity of selecting and assembling components for a sound system.

Bit by bit the separately improved components were re-integrated. First came the all-in-one consoles, generally far superior to the department-store radio-phonograph, and usually made by a manufacturer who had a good reputation in home sound. Various combinations of components began to reappear: the tuner plus preamp/control center, the preamp/control center plus power amplifier (the integrated amplifier), and of course the receiver—a tuner with complete audio control and switching facilities plus a power amplifier.

Many such combinations, especially when

ASSAYING A STEREO COMPACT

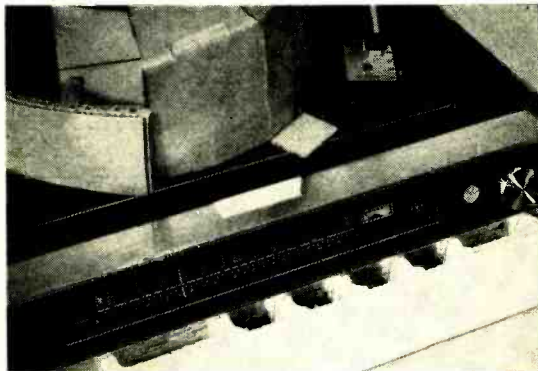

Packaging. Typical stereo compact is delivered to purchaser in carefully designed, fully protective cardboard or styrofoam cocoon. This Scott Model 2505 also has plastic protective screen over dial.



Set and Forget. Two important, but rarely used controls are under the Scott 2505. Three-position "Balance" switch enables listener to compensate for the acoustic differences in room that might interfere with output of speakers. Thumb wheel miniature potentiometer is for setting "Meter Zero" of the tuning meter.

made by the lesser-rank manufacturers, were simplified, somewhat downgraded devices, intended to reach a public that was deemed not to be as critical as the component-type hi-fi buyer. But as the technology continued to improve, as the market expanded and hi-fi became a major industry, it became possible to buy integrated stereo receivers that were the equal of separate-component systems in the same price range. They occupied less space, they were pre-assembled, and were a little less formidable to operate than comparable separate units.

Transistors Make the Difference. The development of transistor technology pushed the process along. Using transistors, it was possible to build high-power amplifiers in much less space than earlier tube designs—partly because of the elimination of the

large and heavy output transformer, and partly because transistors, besides being inherently smaller than the tubes required to do the same job, threw off a lot less heat and needed less ventilation. Other circuit elements were made smaller and it was soon possible to crowd more parts into the same space. Complete stereo receivers, with FM, AM and multiplex circuits and two independent amplifier channels are now smaller than monaural FM/AM receivers of 10 years ago.

The mid-1960's saw the introduction of the tabletop unit that included a record changer and a complete receiver (and now also, frequently, a cassette tape unit) in a space not much greater than that occupied formerly by a turntable or changer alone. The audio quality of the better tabletop units is at least as good as the best equip-



Turntable Holddown. Auto turntable is restrained from bouncing and possibility of motor damage by two "transit screws." The screws may seem to be in backwards—counterclockwise turn to restrain, clockwise to release. Turntable is Garrard 2025TC.

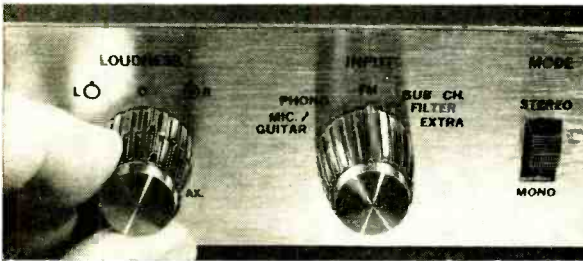

Signal Sources. A variety of inputs is possible with typical stereo compact. Besides FM and phono, the user has an extra input for tape and separate microphone/guitar inputs. A special position of input control switches in FM sub-carrier filter. Loudness dual controls for individual channels are clutch-type and, once set, turn in unison.

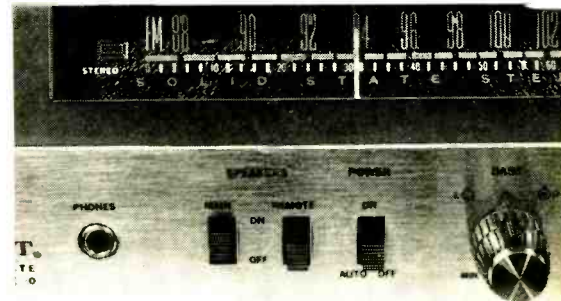

Sound Distribution. Two pairs of speakers may be fed from the 2505, controlled by rocker switches on front panel. Options include main speakers only, remote speakers only, or both sets simultaneously.

ment available 10 years ago, and compares very favorably with today's middle-bracket component systems. Only the speakers remain separate. The minimum spacing necessary for good stereo effect, about 4 feet or so, is too great to allow the speakers to be built into a single unit. That would defeat the purpose of a tabletop compact. Also, acceptable bass reproduction still requires an enclosed volume of at least a cubic foot or thereabouts, which would again produce an uncomfortably large unit.

The arrangement makes sense from another point of view. Together in the tabletop unit are all the components that require control or manipulation. The speakers, which have no controls, are off at some acoustically and/or esthetically suitable places, which may be inconvenient otherwise.

To Compensate or Not. Another interesting feature of some compacts is the "systems" approach used in their design. One school of sound-system design has held that it is legitimate to compensate for deficiencies in the frequency response of one element in a system with reciprocal equalization in another element. This approach appalled some purists, who felt that this is "cheating" and that every element of a system should be "perfect" by itself. Yet every amplifier for home sound systems has sound controls and we all tinker with the frequency response of the sound channel—as do the engineers who make the records and tapes we buy. (Although a friend of mine once remarked that you can always tell an audio purist by the fact that his amplifier's tone controls are set precisely at their "flat" positions!)

Several manufacturers, notably KLH, have produced remarkably fine sound from very small speaker systems by incorporating a carefully controlled amount of fixed bass boost in the amplifier circuit. Needless to say, this works properly only if the speaker's characteristics are accurately known and consistent, which is true only when the speakers are supplied as part of the system and designed into it. The compensated amplifier would probably sound terrible with a different speaker system. But, does that make it bad, or do we have to establish new criteria for judging the quality of whole systems?

It seems clear to me that we do. The individual specifications of components that are wedded together in a compact have relatively little meaning. The essential judgment on the quality of a sound system must be *how it sounds*. The variety of numbers we use to describe the performance of a sound system—frequency response, distortion, power

bandwidth, etc.—are only guides. They are attempts to measure aspects of performance and describe them in definite, repeatable, consistent and comparable ways. But one can fake with numbers—one can play games, create hoaxes, even outright lies, just as easily with numbers and mathematics as with words.

Numbers Don't Count. In addition, there are two other difficulties with numbers. First, the numbers may be very accurate and used in good faith, yet still not mean much. For example, "1% total harmonic distortion at 1 kHz and 50 watts output" is necessarily incomplete, because just how noticeable that 1% distortion is depends on how much of it is second, or third, or fifth, or thirteenth harmonic, the kind of program material, the hearing acuteness of the listener, the loudness level of the program, and the system frequency response. Second, it takes a good deal of knowledge and insight to understand what the numbers purport to describe. How many people can intelligently judge an amplifier's quality by reading its published specifications? Can you?

So the advent of the compact system cuts two ways. It may bring to more people than ever before a higher grade of audio quality in a simple, relatively inexpensive package, while it frees them from the confusion generated by a kaleidoscopic variety of separate components, each with its own set of specifications to be read and digested. At the same time, the consumer audio industry is at a crossroads. Having struggled for 20 years to validate the name and concept of high fidelity and differentiate it from mere "radio" or "record-playing", and having built up a huge market demand for products that call themselves hi-fi, the industry could well begin to abuse its hard-won good will. Let us hope that profits will not mean emphasizing compacts more and more—compacts which are sold as complete systems, and about which, little can be said that is meaningful about the individual components in them.

As the market grows, the temptation to exploit it unfairly grows also. It is well to remember that the hi-fi industry is a business just like any other, and its principle motivation is profit.

There is only one immediate answer, and that is for you, the potential buyer of audio equipment, to learn to be intelligently critical of what you buy. If indeed the trend is toward the compact with decreasing emphasis on individual components with measured and published specifications, you will have to learn to depend on your ears to tell you what is acceptable to you and what is not. But that's another subject.

the product gallery

REVIEWS AND COMMENTARY ON ELECTRONIC GEAR AND COMPONENTS

IN/OUT-OF-CIRCUIT TRANSISTOR TESTER (Heathkit Model IT-18)

The experimenter who works with transistor circuits labors at a disadvantage without the aid of a transistor tester. Most reliable transistor testers are designed for bench use and have laboratory-equipment price tags to match. Not so with the Heathkit (Heath Company, Benton Harbor, Mich. 49022) Model IT-18 In-Circuit/Out-of-Circuit Transistor tester. Feature for feature, the IT-18 is as good a field/bench transistor tester as you are likely to find at twice its kit price of only \$24.95.

The IT-18 features Heath's "new" look in test equipment. Built into a rugged one-piece plastic case, the instrument will bear up to the abuse of field use. Open the snap-handle case, and you have access to all controls, transistor sockets, and auxiliary leads for in-circuit tests. The large $4\frac{1}{2}$ " meter makes meter reading a cinch.

Inside, the circuit of the IT-18 employs precision components, including 1% tolerance resistors and a ten-turn BETA CALIBRATE control potentiometer. Wiring is point-to-point.

But considering the simplicity of the circuit, total construction time should not exceed 3 hours for even the most inexperienced kit builder.

Electronically, the performance of the IT-18 matches that of good bench-type transistor testers. It measures d.c. *beta* both in and out-of-circuit, collector-to-emitter and collector-to-base leakage out-of-circuit, and diode condition. In addition, it also identifies transistors according to type, and is even self-calibrating.

Circle No. 95 on Reader Service Page 15 or 95

TECHNICAL SPECIFICATIONS

D.c. *beta*—X1 range: 2-100; X10 range: 20-1000

Accuracy—Out-of-circuit: $\pm 5\%$; in-circuit: indicates good or bad

Collector-to-emitter and collector-to-base leakage (out-of-circuit only)—0.5 mA (midscale 1000 μ A)

Diode testing—In-/out-of-circuit tests indicate whether good, shorted, or open

Power— $1\frac{1}{2}$ -volt, size D cell

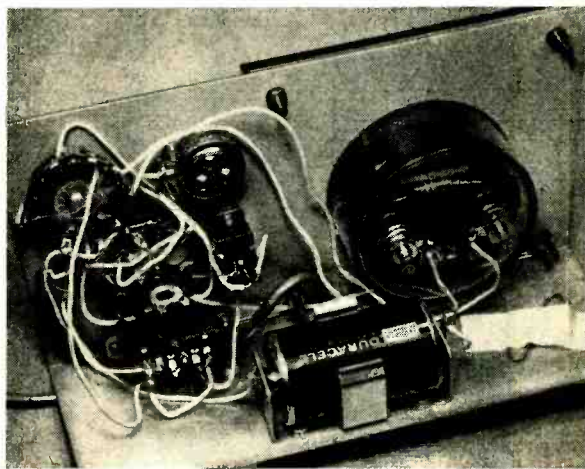

Chart in top of transistor tester case provides guide to case sizes and pin arrangements. In photo at right, a resistor for use in set calibration is shown under the piece of white tape.

(More Product Gallery overleaf)

LEVERAGE TOOLS "LEVERWRENCH" (Model #6)

THIS EQUIPMENT reviewer is an admirer of ingenious tool manufacturing. This is coupled with a belief that too many hobbyists fail to realize the advantages of using the right tool at the right time. Who knows how many otherwise attractive construction projects have been scarred by makeshift tools.

One particular tool that too few hobbyists have at their fingertips is a pair of clamping or grasping pliers—pliers that can be locked. It was with great interest that this reviewer

tried out something new in jaw-locking pliers—the LeverWrench automatic model #6 (\$3.95).

Locking pliers have been around for a few years, but they have a built-in deficiency—you must reset the jaws for varying thicknesses and pressure application. Too light a pressure and your work slips, too tight and the work is scarred or fractured.

The LeverWrench surmounts the varying thickness problem with a special patented "sensing plate" and automatically grasps anything from shim stock to $\frac{7}{8}$ " (or $1\frac{1}{8}$ " in the larger Model #10). If you have any doubts about the pressure, you need only adjust a knurled nut about $\frac{1}{8}$ turn!

This is a tool that belongs on every workbench or in every tool box. If you want to rigidly hold something in place and you might otherwise try to hold it in gas pliers, the LeverWrench is your answer.

Circle No. 96 on Reader Service Page 15 or 115

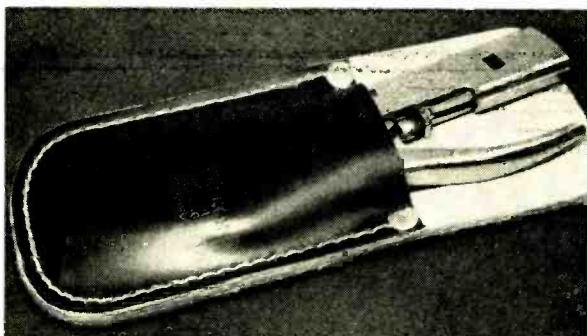

Smaller size LeverWrench will grip anything from thin shim stock to $\frac{7}{8}$ " in diameter. Lower handle flips down and away for quick release. Closing the handle applies pressure automatically to any object held in jaws. Each LeverWrench is supplied in sturdy cowhide leather pouch (see above). Tab on pouch is split for carrying it on your work belt.

SOLDERLESS COAX CONNECTORS (NT-T No. 6-80-58 and 6-80-2)

If you want to escape the somewhat hazardous task of soldering coax braid to a PL-259 plug, try the new National Tel-Tronics connectors. The connectors are designed to enable completely solderless splicing and termination of either RG-58 or RG-59 coax cables.

To use them, simply strip off $\frac{1}{2}$ " of the black vinyl jacket and $\frac{1}{4}$ " of the braid and inner insulation. Fan out the braid and insert a special Delrin insulator over the inner insulator to compress the braid. Lastly, twist

the center wire into a miniature pigtail and screw in the Delrin-insulated plug. Tighten the plug and your connector is finished without soldering. The splicer works in the same fashion.

The connectors are designed so that wire impedance is maintained. They are made of silver plated brass.

Three connectors are available. No. 6-80-2 is a splicer for RG-58 cable. No. 6-80-8 is a plug for RG-58 cable. No. 6-80-8 is a plug for RG-8 cable.

Circle No. 97 on Reader Service Page 15 or 115

COLOR BAR GENERATOR (Eico Model 385)

Every so often, a manufacturer of test equipment announces a "new" color bar generator for color TV receiver servicing. Needless to say, not all such instruments are novel; in fact, the great majority are based on a tried and true design principle. Following this line of reasoning (keyed rainbow) is the Eico Model 385 "Color Mate" generator selling for \$79.95 as a kit or \$109.95 factory wired.

The Model 385 is a rugged instrument, housed in a heavy-duty metal case that has ample storage room for the gun-killer and r.f. cable assemblies. Electronically, the Model 385 generates an r.f. signal on TV channel 3. The patterns that can be impressed on this r.f. signal include individual horizontal and vertical lines; crosshatch lines; dots; and ten-bar keyed rainbow. Each pattern is clear and well-defined, although the very dark portions of the picture-tube display

do not fade to the blackest of black.

Checking inside the 385, you will find a large, roomy printed circuit board and printed switch that speed construction time and practically eliminate the possibility of wiring errors. The battery holders for the six C cells that power the circuit are arranged on the rear apron of the enclosure. Once the instrument is assembled, however, it is difficult to insert or remove the batteries without removing the case.

The function switch and gun-killer switches are conventional. We feel there should have been r.f. gain control and video output. Also, the plug and socket supplied with the gun-killer cable assembly are not for the "now" standard wire-pin CRT bases.

All-in-all, the 385 is a sturdy color bar generator servicing kit that will take a lot of wear and tear.

Circle No. 98 on Reader Service Page 15 or 115

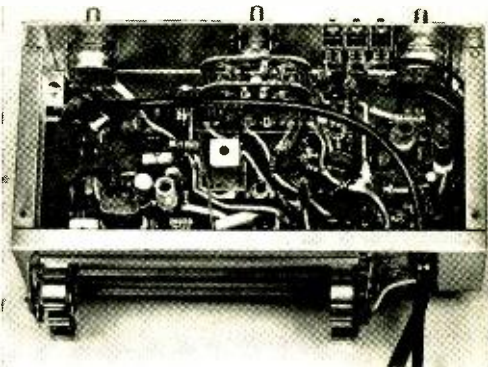

In the view of the Color Bar chassis, above right, the printed circuit selector switch is at the top of the photo while battery clamps on back of chassis are at bottom.

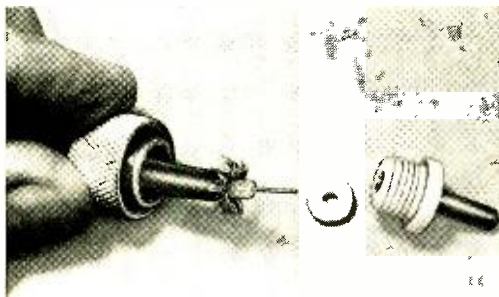

The small white insulator ring in the center fits over the inner insulation to compress and hold the braid when the plug (right) is screwed into holder.

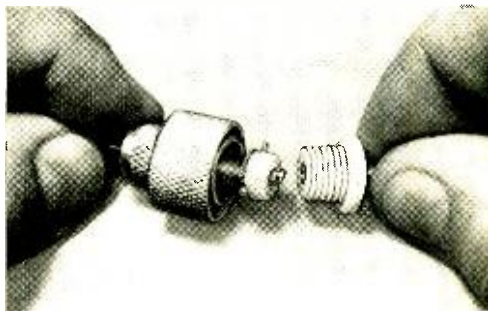

When assembly of the coax connector plug is complete, all contacts are assured and impedance of the cable is maintained at its specified value.

ENGLISH LANGUAGE NEWS BROADCASTS FOR THE MONTH OF SEPTEMBER

Prepared by **ROGER LEGGE**

TO EASTERN AND CENTRAL NORTH AMERICA		TO WESTERN NORTH AMERICA	
TIME-EDT	STATION AND LOCATION	TIME-PDT	STATION AND LOCATION
	FREQUENCIES (MHz)		FREQUENCIES (MHz)
7:00 a.m.	Stockholm, Sweden	7:00 a.m.	Tokyo, Japan
7:15 a.m.	Melbourne, Australia	9:00 a.m.	Stockholm, Sweden
7:45 a.m.	Copenhagen, Denmark	6:30 p.m.	Tokyo, Japan
8:15 a.m.	Montreal, Canada	7:00 p.m.	Melbourne, Australia
7:00 p.m.	Moscow, U.S.S.R.	7:30 p.m.	Bonaire, Neth. Antilles
7:30 p.m.	Johannesburg, South Africa	8:00 p.m.	Johannesburg, South Africa
8:00 p.m.	London, England		London, England
	Peking, China		Madrid, Spain
	Sofia, Bulgaria		Peking, China
8:30 p.m.	Kiev, USSR (Mon., Thu., Sat.)		Prague, Czechoslovakia
	Stockholm, Sweden		Seoul, Korea
8:50 p.m.	Brussels, Belgium	8:30 p.m.	Taipei, Taiwan
	Vatican City		Stockholm, Sweden
9:00 p.m.	Berlin, Germany		Tirana, Albania
	Budapest, Hungary	9:00 p.m.	Budapest, Hungary
	Havana, Cuba		Havana, Cuba
	Madrid, Spain		Lisbon, Portugal
	Prague, Czechoslovakia		Moscow, USSR (via Khabarovsk)
	Rome, Italy		Peking, China
9:30 p.m.	Berne, Switzerland		Sofia, Bulgaria
	Cologne, Germany	9:30 p.m.	Kiev, USSR (Mon., Thu., Sat.)
	Tirana, Albania	9:45 p.m.	Berne, Switzerland
9:45 p.m.	Copenhagen, Denmark		Cologne, Germany
10:00 p.m.	Hilversum, Holland (via Bonaire)	10:00 p.m.	Havana, Cuba
	Lisbon, Portugal		Hilversum, Holland (via Bonaire)
	London, England		Quito, Ecuador
	Moscow, U.S.S.R.		Tokyo, Japan
	Peking, China	11:00 p.m.	Moscow, USSR (via Khabarovsk)
10:30 p.m.	Beirut, Lebanon	11:30 p.m.	Havana, Cuba

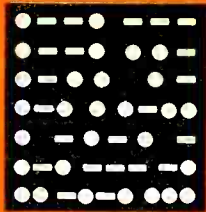

AMATEUR RADIO

By **HERB S. BRIER**, W9EGQ
Amateur Radio Editor

THE NEW RADIO SEASON

JUST AS January 1 starts the calendar year, September 1 traditionally starts a new radio year. As the sun moves back toward the south after spending the summer up north, static levels go down, daytime maximum usable frequencies (MUF) increase, and nighttime frequencies decrease. There may be two peaks in the current sunspot cycle and DX conditions on the amateur 21-MHz band should be as good or better than they were last year (when they were very good). Conditions on the 28-MHz band should be just about as good as they were last year. Both bands, however, will probably open for DX a little later in the morning and close a little earlier in the afternoon or evening than they did during the 1968-1969 season.

The slightly lower level of sunspot activity means that the chances for 50-MHz trans-Atlantic or trans-Pacific DX this season are virtually nil, but there probably will be a number of 50-MHz openings between the United States and Central and South America before next spring. On lower frequencies, conditions on 14-MHz should be little different from last season but night-

time conditions on the 7-, 3.5-, and 1.8-MHz bands should improve a little. All in all, many DXCC certificates will be filed by amateurs working 100 or more countries on each of five amateur bands.

W6MLZ and the International Handicappers Honored. Harold Russell, Chairman of the President's Committee on Employment of the Handicapped, has appointed Ray Meyers, W6MLZ, a member of the committee. Russell also named the International Handicappers an organizational committee in recognition of the net's "brilliant record of Public Service." Ray, the only American holder of the International Columbus Gold Medal Award for Humanitarian Service, organized the International Handicappers ten years ago and has since issued several thousand membership certificates. The Handicapper Net operates daily on 7280 and 14287 kHz and cooperates with other public service nets.

W6MLZ is Civil Defense director for San Gabriel, California, and writes a weekly "Ham on the Air" column for the Los Angeles *Herald Examiner*. Incidentally, "Hire

AMATEUR STATION OF THE MONTH



Noah L. Cottfried, WA2URS, 955 Franklin Lakes Rd., Franklin Lakes N.J. 07417, went from Novice to Advanced in six weeks, working 32 states and eight countries in the meantime. Having to attend school (8th grade) slowed him down a little. Noah has a Heathkit DX-60B transmitter and Realistic DX-150 receiver. A Hy-Gain 18-V vertical antenna, 30' high, handles the outside work. We are sending WA2URS a 1-year subscription to *POPULAR ELECTRONICS* for winning our Amateur Station Photo Contest this month. You can enter the contest by sending us a clear photo (black and white preferred) of you at the controls of your station. Include some details of your radio career and send to Amateur Station Photo Contest, c/o Herb S. Brier, Post Office Box 678, Gary, Ind. 46401.

We pack your electronics course with kits to make your training fast. You'll enjoy every minute of it.

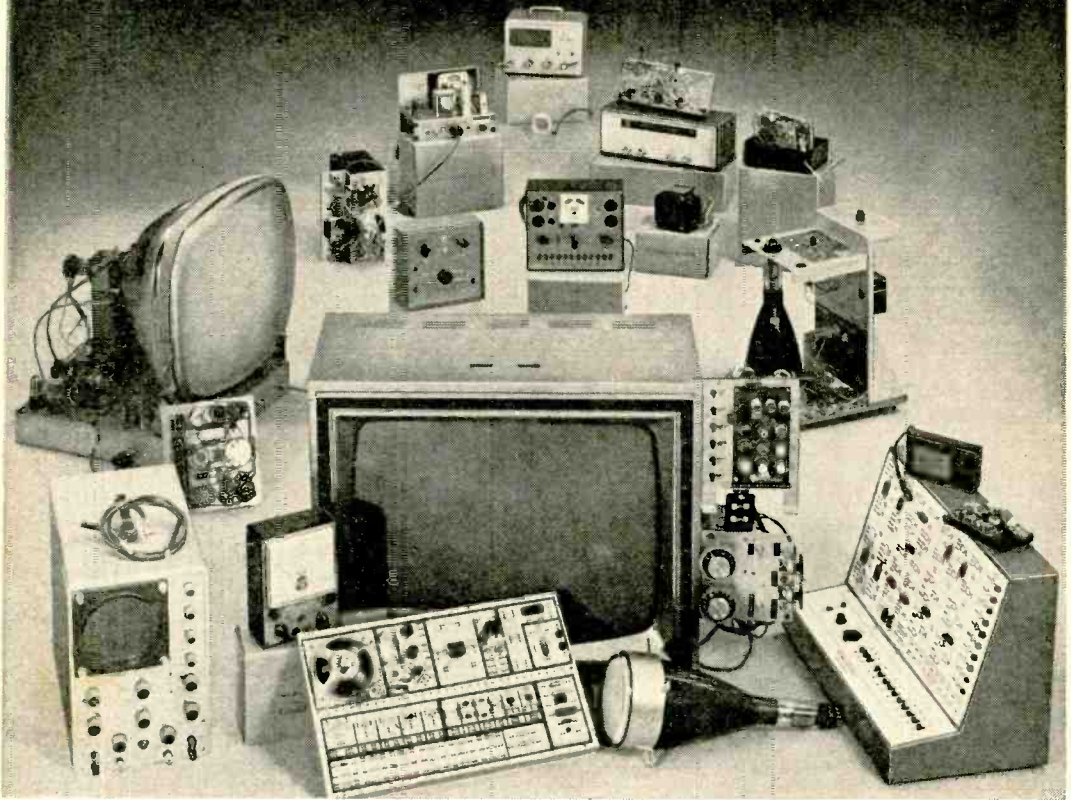

Your NTS success package

Choose a career in electronics: Computers. Color TV Servicing. Automation. Communications. Whatever the field, NTS has a complete home-study package to get you to the top *faster*. 10 thorough training courses. Each includes *everything* to give you the *working* knowledge required of successful technicians.

NTS Project-Method Training is the practical way to learn elec-

tronics. It's a proven combination of lessons and the best professional kit equipment available. NTS provides the *biggest selection of kits ever offered in home-study . . . all at no extra cost*. You'll construct these exciting kits to fully understand electronic circuits, components, and concepts. Our Project-Method lets you build skills by putting theory into practice . . . by working with your hands, as well as your head.

The NTS "learn and practice" approach makes training at home really easy. All it takes is a few hours a week . . . whether you're starting from scratch or in advanced courses. This is the all-inclusive success package that put thousands of men into the best paying jobs . . . or into their own business. If "just a living" isn't good enough for you, now is the time to get something better going for you!

NTS COMPUTER ELECTRONICS

This is the future. And it's happening now. The number of computers will increase many times in the next few years.

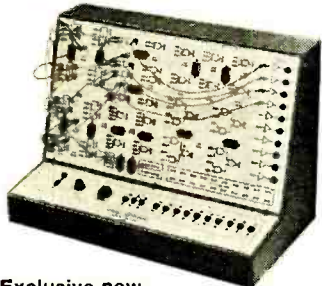

Exclusive new Compu-Trainer®

NTS offers a solid grounding in computer operation, wiring, data processing and programming. One of the 10 important kits included is our exclusive Compu-Trainer®. It's a fully operational computer logic trainer — loaded with integrated circuits — the first ever offered in home study. It introduces you quickly to how, what, when and why of computers . . . from theory to practical servicing techniques. This unit is capable of performing 50,000 operations per second. And it's sent at no extra cost.

NTS COLOR TV SERVICING

This is a broad, easily understood

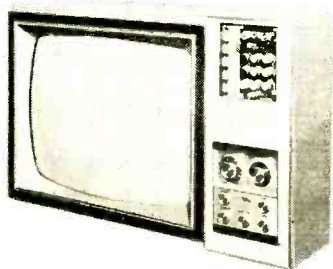

COLOR TV 295 SQ. IN. PICTURE

program designed to make you a complete home-entertainment service technician. Included, at no extra cost, is a color TV that has more features than any

set on the market. You also learn all about stereo, hi-fi, multiplex systems, and become a specialist in Color TV Servicing. Kits also include AM-SW radio, solid-state radio, field-effect transistor volt-ohmmeter, electronic tube tester.

NTS AUTOMATION/ INDUSTRIAL ELECTRONICS

You're trained in the "push-button" electronics that keep industry going and growing . . . from relay type controls to highly advanced systems essential to production. You receive 16 kits including a 5" wide band oscilloscope, and the new NTS electronics lab: a fascinating NTS exclusive experimental laboratory. A complete workshop which makes you familiar with solid-state, miniature, and integrated circuits.

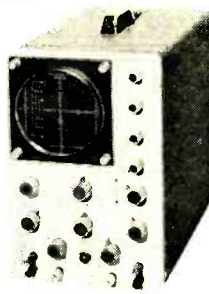

5" Oscilloscope

NTS ELECTRONIC COMMUNICATIONS

The use of 2-way radio systems in private and commercial applications is skyrocketing. NTS prepares you for the big-money opportunities in the field of transmitting and receiving equipment. *Your tuition will be refunded in full if you cannot pass the FCC exam for a 1st Class Commercial Radio-Telephone License within*

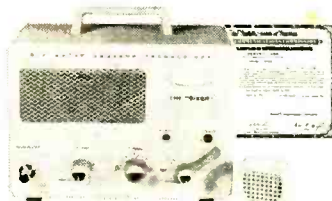

5 Watt AM Transmitter & Receiver

six months after successfully completing this course. You build valuable kits including Amateur-Phone 6 Meter VHF Transceiver, solid-state Radio, and a field-effect transistor volt-ohmmeter.

CLASSROOM TRAINING AT LOS ANGELES

You can take classroom training at Los Angeles in sunny Southern California. NTS occupies a city block with over a million dollars in facilities devoted exclusively to technical training. Check box in coupon.

NATIONAL TECHNICAL SCHOOLS

World-Wide Training Since 1905
4000 South Figueroa Street
Los Angeles, Calif. 90037, U.S.A.

APPROVED FOR VETERANS

Accredited Member: National Association of Trade and Technical Schools, National Home Study Council.

TODAY, MAIL COUPON FOR FREE COLOR CATALOG AND SAMPLE LESSON.

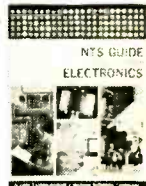

NATIONAL TECHNICAL SCHOOLS
4000 S. Figueroa St., Los Angeles, Calif. 90037

Please rush Free Color Catalog and Sample Lesson, plus information on field checked below. No obligation. No salesman will call.

- MASTER COURSE IN COLOR TV SERVICING
- COLOR TV SERVICING
- MASTER COURSE IN TV & RADIO SERVICING
- PRACTICAL TV & RADIO SERVICING
- MASTER COURSE IN ELECTRONIC COMMUNICATIONS
- FCC LICENSE COURSE
- MASTER COURSE IN ELECTRONICS TECHNOLOGY
- INDUSTRIAL AND AUTOMATION ELECTRONICS
- COMPUTER ELECTRONICS
- BASIC ELECTRONICS

Name _____ Age _____

Address _____

City _____ State _____ Zip _____

- Check if interested in Veteran Training under new G.I. Bill.
- Check if interested ONLY in Classroom Training at Los Angeles. Dept. 205-99

the Handicapped Week" is October 1 through 7.

FCC and ARRL Actions. Last spring, the Federal Communications Commission scheduled public hearings on the proposal to modify the amateur regulations to allow: radioteletype operation in the 28-28.5-MHz segment of the 28-29.7-MHz band; to shift the 2-meter CW band from 147.9-148 MHz to 144-144.1 MHz; and to permit U.S. amateurs to operate maritime-mobile on the high seas in the 7-7.1 MHz segment of the 40-meter band—the only portion of the band assigned to the worldwide amateur service. Unless unexpected opposition to these proposals is developed, the changes should go into effect shortly.

The reason for moving the 2-meter CW sub-band to the low-frequency edge of the band is that virtually all international 2-meter communications via the moon, satellites, meteor showers, etc., are on code; and in many parts of the world, the only amateur 2-meter assignment is 144 to 146 MHz.

At the recent board meeting of the American Radio Relay League, Inc. (ARRL), it was voted to ask the FCC to open the entire 144-MHz band to Technician class operators and authorize Technicians to operate between 29.5 and 29.7 MHz. The board also recommended that the FCC reduce from two years to one year the period that an amateur must hold a license of a grade higher than Technician before he is eligible to apply for an Extra class license.

W9EGQ personally favors the three ARRL proposals, but we suspect that the FCC will reject the proposal to permit Technician operation in the 10-meter band, as it has rejected several similar proposals in recent years. In any event, the red tape involved will probably delay any ruling on these matters for some months.

On the operating front, the ARRL board authorized its headquarters station, W1AW,

to transmit code practice on the usual W1AW frequencies in the mornings for a 6-month trial period to determine whether or not there is any demand for code practice transmissions at this time of day. It also authorized a new 5-band WAS (Worked All States) award to parallel the 5-band DXCC award authorized last year.

Items From Here and There. Although Great Britain has 50 per cent more amateurs than any other European country, one of amateur radio's mysteries is why G's, GM's, GW's, etc., are so scarce on the bands when other Europeans are coming through. The G's themselves blame TV Channel One on 42 MHz. They say this channel, being so close to the 28-29.7 MHz amateur band and being in the second and third harmonic shadows of the 21- and 14-MHz amateur bands, creates a difficult TVI (television interference) problem.

Well, things are looking up for the G's. Starting in mid-November, all English VHF TV programs will be duplicated on the UHF channels. Later, the VHF channels will be phased out of service. The change is expected to be 75 to 80 per cent complete in the large population centers by the early 1970's. There will be some educational TV programs on the VHF's until the early 1980's.

Is the world's oldest licensed amateur an Englishman? *Radio Communications* (London) reports that over 72 years ago, Will Badman, G2ZG, then 18 years old, charged the batteries that Marconi used in his successful 1897 experiments to transmit wireless signals across the Bristol Channel. Now 91 years old, G2ZG can truly say that he has been associated with wireless or radio from its earliest days.

Ray Meyers, W6MLZ, was also intimately associated with an early radio pioneer. In 1914, Ray—then a young Navy sailor—climbed some 600-foot towers to string up
(Continued on page 100)

This is where Explorer Post V of the Boy Scouts meets in Oklahoma City through the courtesy of Clyde Johnson, WA5VIL. The Collins KWM-2 transceiver is fitted with a crystal adapter for Novice operation. A Hallicrafters TR-46 and a complete Drake KW SSB/CW are also available for Scouts to use.





TWO WAY REACTIONS

BY G. H. REESE, KC6990

ESTABLISHED by Hallicrafters in 1963 as a community program to provide organized Citizens Two-Way Radio communications in local emergencies, REACT is now sponsored as a public service by General Motors Research Laboratories. With almost 1500 locally organized teams in all 50 states and over 40,000 members, we receive considerable information about the entire field of Citizens Radio. We will attempt to bring to this column news of all activities of CB clubs, government, and news events that have a bearing on those using this means of communication. In all of this, we will emphasize the positive public-service aspects.

Citizens Two-Way Radio is growing in popularity. Latest statistics show that about three million radios are in use with 15,000 to 20,000 new licenses granted each month. Approximately 100,000 new licenses were granted during the first half of 1969. Licensees operate at least two and sometimes three transceivers. It is estimated that one car out of 60 is now equipped with Citizens Two-Way Radio. In 1968, REACT teams alone reported to authorities over 1,200,000 automotive emergencies, 27% of which were accidents.

New Booklet. A very informative booklet

NOTE

This is the first of a series of monthly columns devoted to news and developments in Citizens Two-Way Radio. POPULAR ELECTRONICS is pleased that REACT National Headquarters will be able to prepare these columns. News of Citizens Two-Way Radio appearing in this column will not be confined to REACT activities, but will encompass the gamut of the largest radio communications service in the world.

Editor, POPULAR ELECTRONICS

has been published by the Citizens Two-Way Radio Section of the Electronic Industries Association. We recommend it to those who wish to learn more about this communications medium. It is ideal for use by the active enthusiast in explaining the service to others. REACT National Headquarters has a limited supply and will be happy to send one without charge to anyone forwarding a stamped, self-addressed envelope (#10 size for business letters) to: E.I.A. Booklet, c/o REACT National Headquarters, 205 West Wacker Drive, Chicago, Ill. 60606.

Highway Safety. With the overall objective of improving highway safety, General Motors Research Laboratories has been ex-



The Ozark REACT team is justly proud of its emergency truck. It provides a mobile base for operations—especially valuable in search and rescue work.



This typical REACT base station is that of the Honolulu team. Monitor radio, rosters, and emergency telephone numbers are all within easy arm's reach.

ploring the problem of two-way communication from automobiles for over ten years. During this time, they have tested the practicality of Citizens Two-Way Radio. The medium has been incorporated into several experimental designs for highway guidance systems. In an extensive operational test, an emergency network was established in 1966 to monitor the John C. Lodge Freeway in Detroit. This service proved so valuable on the twelve miles of freeway that the system

was expanded under the control of the Detroit Department of Streets and Traffic to cover the entire city of Detroit in April 1968.

Today, the Detroit CB Radio Aid Network handles as many as 1000 calls per month. This includes reports of traffic accidents, requests for road conditions and routing information.

Through all of this, the significant result has been the unquestioned value of Citizens Two-Way Radio for improved communications and greater safety on the highway. Now, with the sponsorship of REACT, GMRL has expanded its research in this communications area to the entire country.

REACT introduces one additional element to the past experiments—*volunteer service*. REACT teams aim to monitor the Citizens Radio Channel 9, 24 hours per day. They operate on a strictly voluntary basis. Cooperating with local authorities, they are prepared to provide emergency communication in disasters such as floods, tornadoes, fires, etc. In addition, they assist in communications for special events such as parades, fairs, rodeos, etc.

Arthur Underwood, KNM1243, who is Manager of GM Research Laboratories, states the sponsor's attitude toward REACT: "While REACT has built an amazing record of usefulness in its relatively brief history, it has the potential for still further growth. We at GM Research, as a public service, are going to help REACT realize that potential. No matter how far science and technology take us in our ability to cope with highway problems, there will al-

(Continued on page 105)



Members of the Ozark REACT team contributed considerable amounts of own time, money and effort to purchase and equip their emergency truck.



SHORT-WAVE LISTENING

By **HANK BENNETT**, W2PNA/WPE2FT
Short-Wave Editor

ECUADOR, SANTO DOMINGO, BRAZIL, AND BONAIRE

HCJB Increases Service. The number of daily broadcast hours of HCJB has been increased to 50. Two additional hours have been assigned to Spanish; four additional hours to English. Russian, Rumanian and Japanese programming hours have been increased.

A new program "Northwest Alert" begins at 0500 and joins the "Southern Cross Salute" until 0800. The target areas are Canada and Alaska. The frequency for this service is 15,255 kHz. The second new program is "Calling India" and is beamed to India and Southeast Asia from 0000-0130 on 11,765 kHz and from 0130 on 11,795 kHz. "Caribbean Call" now begins at 2200 using 11,765 kHz until 2330, then adding frequencies in the 16- and 19-meter bands.

More on HISD. A letter has been received from Lawrence Brandon, Universal Broadcasting Corporation, 310 Madison Avenue, New York, 10017, in which he states that his organization has been operating HISD, Santo Domingo, Dominican Republic, since February 25, 1968. The schedule that Mr. Brandon sent shows English in use from "11:00 a.m. to 11:00 p.m." (presumably this is EST; the GMT equivalent is 1600-0400) daily on 9505 kHz (50 kW), 6090 kHz (20 kW) and 3215 kHz (7.5 kW). Mr. Brandon says that the station would like to receive reports from as many countries as possible and that "anyone correctly identifying one of the programs will receive a card of acknowledgement". However, send all reception reports to the New York address, not to Santo Domingo.

Once in a Lifetime. One of our Detroit monitors told us that he logged *Trans World Radio*, Bonaire, Netherland Antilles, the other evening. This in itself would not seem to be a news item because many DX'ers can easily tune this 800-kHz medium-wave outlet. However, this particular reporter lives almost in the shadow of the antenna of CKLW, Windsor, Ontario. This station also operates on 800 kHz with 50 kW power. Fortunately, CKLW was off the air with antenna trouble between 0230-0400, thus af-

fording those in Michigan, Ontario, Ohio, and surrounding areas an unusual opportunity to log Bonaire.

ZYK-33 Wants Reports. Snr. A.S. Miranda of station ZYK-33, Recife, Brazil, has requested reception reports. Snr. Miranda is the technician in charge of this station. He lists daily transmissions at 1200-0030 on 15,145 kHz with programming in Portuguese. All correct reports will be verified if sent directly to Snr. A.S. Miranda, ZYK-33, P.O. Box 1332, Recife, PE., Brazil. He requests a self-addressed envelope and one IRC.

CURRENT STATION REPORTS

The following is a resume of current reports. At time of compilation all reports were as accurate as possible, but stations change frequency and/or schedule with little or no advance notice. All times shown are Greenwich Mean Time (GMT) and the 24-hour system is used. Reports should be sent to Short-Wave Listening, P. O. Box 333, Cherry Hill, N. J. 08034, in time to reach *Your Short-Wave Editor* by the fifth of each month; be sure to include your WPE identification and the make and model number of your receiver.

Afghanistan—"That is the end of the news from



Danny Hubert, way up in La Tuque, Quebec, uses a Trio 9R-59 for tuning the ham bands, a Hallicrafters S-200 for general short-wave listening, and a Hitachi TH-812 for the medium waves. Danny, his family, and most of the neighbors are also CB operators—there's a mobile unit on the dog sled.

Radio Afghanistan—Is the ID noted at 1805 at the close of English news on 15.264 kHz. This new frequency then goes into music. S/off time is currently 1830.

Algeria—A recent schedule from *Radiodiffusion Television Algerienne*, Algiers, reads: Arabic on 11,810 kHz at 0600-0900 and 1100-0000; Kabyl on 9685 kHz at 0600-0800 and 1200-2230 (Sunday 0600-2230), 11,835 kHz at 0600-0800, 1200-1400 and 1700-0000 (Sunday 0600-0000) and on 9510 kHz at 0600-0800 and 1200-0000 (Sunday 0600-0000); French on 6080 kHz at 0600-0800 (Sunday until 0900) and 1700-0000 and on 15,200 kHz at 1200-1700 (Sunday 0900-1700).

Angola—*R. Clube da Huila*, CR6RH, Sa da Bandeira, 5024 kHz, has been logged with lengthy classical music periods and few anmt's around 2130 in Portuguese.

Bolivia—*R. El Condor, La Voz del Ferroviario*, Oruro, 6070 kHz, features L.A. pop tunes and the usual Bolivian format until 0330 (varies) s/off.

Bulgaria—*R. Sofia* noted on 17,830 kHz with IS at 2104; ID in Bulgarian and English and news followed. This was dual to 15,310 kHz.

Burma—*R. Rangoon*, 4725 kHz, has been noted often from the West Coast from 1223-1327 but only in Burmese and with no music.

Cameroon—A good catch in the middle of the 75-meter ham band, if you can log it, is *R. Buea*, Buea, 3971 kHz. It has been noted before its listed s/on time at 0500; there is an English newscast at 0515. Otherwise programs are in mixed vernaculars and French.

Canada—Canadian Broadcasting Corp xmsn's to Africa at 1832-1915 and 1915-1958 and to Europe at 2000-2044 and 2045-2152 have been moved from 15320 kHz to 15,325 kHz. Other xmsns noted: 11,765 kHz in French at 0624, dual to 9625 kHz, and 17,720 kHz at 2300 in English news.

Cuba—Havana has English for the Americas at 2050-2150 on 15,285 and 17,715 kHz, 0100-0450 on 9525 kHz, 0100-0600 on 15,285 kHz, 0330-0600 on 11,760 kHz and 0630-0800 on 11,930 kHz. Reports to P. C. Peraza, Apartado 6240, Havana. The *Voice of Vietnam* program in English can be heard on 11,760 kHz at 0400-0600 and there is a newscast at 0500. French at 1755 and Spanish news at 1913 is the result of our tuning on 15,195 kHz.

Denmark—Copenhagen operates to N.A. at 1145-1215 on 15,165 kHz and at 0145-0215 on 9520 kHz. "DX Window" is heard on Mondays.

UTILITY STATIONS

Dean Frey, VE6PE7N of Fort Saskatchewan, Alberta, sends this list of recently copied Morse stations:

Ethiopia—NKA, U. S. Naval Station, Asmara, has a CW tape on 17,510 kHz at 1700. Power is 10 kW.

Japan—JCU/JCT and JCS, Choshi, verifies by card. The station operates on 17 frequencies, including 13,105, 12,878 and 12,826.5 kHz.

Poland—SPA4, Gdynia, has a CQ tape of 8482 kHz around 0630. The transmitter is 20 kW and the antenna vertical and non-directional.

Sao Tome—CQK55 is a CW station on 17,455 kHz. Verification is by letter and is signed by the postmaster general. The power is 5 kW and best listening time is at about 1900.

Dean would also like assistance in obtaining city locations for the following: CCS on 6980 kHz at 0745 (probably Chile), TGA on 5788 kHz at 0500 (Guatemala), BBE3 on 18,400 kHz at 2300, YVG on 17,460 kHz at 2100 (Venezuela) and UKD on 11,887 kHz at 0030 (Russian).

Ecuador—New frequencies in use by HCJB, Quito, include 9710 kHz with an English ID and time pips at 0600, then into German with religious music: 11,795 kHz at 0700 in English with a religious story and drama; and 15,255 kHz with religious music at 0707, dual to 11,755 kHz.

Egypt—Cairo, too, has several new channels in service. English with pop music is noted at 2225 on 9778 kHz. Arabic news after a clock strike for 1 a.m. was heard at 2200 on 11,908 kHz. An all-Arabic xmsn to the Middle East, N. Africa and W. Europe at 2200-2300 is broadcast on 15,090 kHz. This latter xmsn includes chanting, orchestral Arabic music and some brief anmts.

England—The World Service from London is on two new frequencies: 15,140 kHz, dual to 11,780 kHz and the Ascension Island relay on 9510 kHz, and all to N.A. at 2300-0000; news at 2300, "Jazz Time" to 2344 and "Letter From America" to 2359; and on 15,290 kHz, dual to 21,550 kHz, to the West Indies, Central and South America at 2200-2300; news at 2200, talks and folk music to 2245 and sports news to 2259.

Ethiopia—*R. Voice of the Gospel*, Addis Ababa, has this current English schedule: (Xmtr 1) 0530-0555 to W. Africa on 11,890 kHz, 1330-1345 to India on 15,315 kHz, 1655-1710 to Ethiopia on 6065 kHz, 1930-1945 and 1945-2015 to W. Africa on 11,910 kHz. (Xmtr 2) 0400-0425 to E. Africa on 9680 kHz, 1330-1345 and 1345-1400 to India on 15,150 kHz, 1700-1715 to E. Africa on 9695 kHz, 1800-1815 and 1815-1855 to S. Africa on 9705, kHz.

France—*Ici Paris*, 15,135 kHz, noted with this ID at 0000; news followed and this was dual to 15,120 kHz.

Germany (East)—*R. Berlin International* has changed its schedule to N.A. Broadcasts to the East Coast are at 0100 and 0230 on 9730 and 11,890 kHz and to the West Coast at 0330 on 11,840, 11,970 and 15,450 kHz.

Guinea—*R. Conakry* was heard on 7125 kHz at 2330-0000 s/off in French; they repeat *La Voix de la Revolution* several times at s/off. The same frequency, dual to 15,310 kHz at 0711 and 0823 in French and/or African languages.

Holland—The former English xmsn to N.A. at 2055-2150 is now aired at 2125-2250 daily except Sunday on 15,425 kHz, dual to 11,730 kHz. The always popular "Happy Station Program" with Eddie Startz has been drastically moved, time-wise; the N.A. version is now aired via Bonaire Mondays at 0155-0320 on 11,730 kHz; the West Coast program is also Mondays 0455-0620 on 11,730 and 9715 kHz. Your Editor opposes the change from the previous long-time schedule; the new program hasn't been heard at our listening post for over a month!

India—*All India Radio*, Delhi, was noted with English to Europe at 1945 on 11,620 kHz.

Italy—At press time, Rome has English news and music to N.A. at 0100-0120 on 11,810 and 9575 kHz.

Kuwait—*R. Kuwait* has been found at 1600 with an IS, a clock strike for 7 p.m., an English ID and into pop music on a new frequency of 15,405 kHz.

Lebanon—Beirut was monitored on 17,815 kHz at 0037-0100 with anmt's, talks and music, in Spanish; on 15,285 kHz to N.A. at 0130 in French and 0230 in English; and on 11,825 kHz in English to Europe and N.A. with news to 0230 and "Spotlight" following.

New Zealand—*R. New Zealand*, Wellington, has replaced 11,705 kHz with 6080 kHz to Australia from 0900-1145. English news was tuned at 1000 on 6080 and 9520 kHz.

Pakistan—Karachi has been heard on 15,405 kHz at 2015 when ending English news, and on 15,265 kHz with IS and an ID in Turkish at 1845, an anthem and anmt's, and into Indian music.

Panama—Currently the best time to log HOU31, *La Voz del Barú*, David, 6045 kHz, is around 1030 when it has frequent ID's in Spanish and native music.

(Continued on page 102)

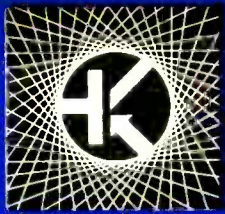

SOLID STATE

By LOU GARNER, Semiconductor Editor

SSOLID-STATE electronics has played a significant role in establishing America's commanding lead in the space race. Without the reduced bulk, weight and power requirements of communications gear, telemetry equipment, space vehicle computers, and control systems made possible by semiconductor circuits, our astronauts might have waited for years for the development of more powerful rocket propulsion systems to take them to the moon.

Past achievements, no matter how spectacular, are but stepping stones to greater goals. Even today, scientists and engineers are busy developing new electronic equipment which may be needed by future space technicians.

An experimental version of one suggested control unit, developed by RCA's Advanced Technology Laboratories, Camden, NJ, was displayed at the 23rd Annual Convention of the Armed Forces Communications Electronics Association (AFCEA) held last June in Washington, D.C.

So advanced that it might have been a science-fiction creation, the new control system was designed to enable a future astronaut to move about in space *merely by speaking* directional commands, thus freeing his hands for other tasks. Operating on voice recognition patterns, the demonstration model weighed approximately 25 pounds and required a container about the size of an average suitcase. RCA's engineers are confident, however, that a production model can be developed which will weigh less than 5 pounds (on Earth, naturally) and occupy only 100 cubic inches.

Farewell to Tubes. Although at least one major manufacturer (Motorola) has a broad line of fully transistorized TV receivers and a number of others produce partially transistorized designs, only about 5% of the circuits used in the millions of sets produced in the U.S. during 1968 employed transistors. However, 1969 may be the year of the big swing to solid state, according to Texas Instruments' Director of Applications, Howard Bonner. He predicts that there will be a substantial increase in the number of

semiconductor units used in TV sets during 1969-70, with IC's, transistors, and related devices gradually edging vacuum tubes out of the television receiver market. As many as 70% of all U.S. produced circuits may be fully transistorized (or "IC'ed") by 1971.

Until recently, most manufacturers have balked at the higher prices of suitable semiconductor devices as compared to vacuum tubes, as well as the major engineering costs that would be incurred by a switch to solid-state designs. However, transistor and IC prices have continued to drop while tube prices have remained static, with the result that transistor costs, in general, have dropped far below those of tubes. Today, then, circuit redesign is not only feasible, but almost mandatory from an economic viewpoint, to compete with the rising tide of low-cost imported sets, most of which are solid state.

Inventor's Corner. A lot of guys get good ideas for circuits or mechanisms that they feel are really worthwhile. Unfortunately, they feel that, until they get a patent, they



Caught in a moment of high spirits, Lou Garner (on the left) presents an award to Frank Reel, Vice President of Metromedia Producers Corp. Award was made during the Conference of the Society of Technical Writers and Publishers. Metromedia won for TV's "The Undersea World of Jacques Cousteau".

can't talk about anything for fear of having the idea stolen. Now, a new service, provided for inventors by the U.S. Patent Office, provides for the acceptance and preservation for a limited time of "Disclosure Documents" as evidence of the dates of conception of inventions.

Under the new "Disclosure Document Program", a paper disclosing the invention and signed by the inventor may be forwarded to the Patent Office where it will be retained for two years and then destroyed unless it is referred to in related patent applications. This disclosure is not a patent application. When the inventor is ready to submit his patent application, he can refer to the disclosure document in his letter of transmittal.

Other details of the program are outlined in a brochure available from the U.S. Patent Office, Office of Information Service, Washington, D.C. 20231. Ask for "Disclosure Document Program."

Reader's Circuit. Widely used in switching, control and power-supply applications, the silicon controlled rectifier (SCR) is seldom encountered in other types of circuits, for its "all or nothing" conduction characteristic limits its use in oscillator and amplifier arrangements. Thus, the circuit shown in Fig. 1—a linear (sawtooth) sweep generator—is a somewhat unusual application for this device. Reader Nyle A. Steiner (K7NUH, 186 "S" Street, Salt Lake City, Utah 84103), who submitted the design, has achieved this unique mode of operation by combining the electrical characteristics of an SCR with those of a neon lamp. According to Nyle, the circuit will deliver a sawtooth signal of sufficient amplitude to provide direct horizontal drive for the typical cathode-

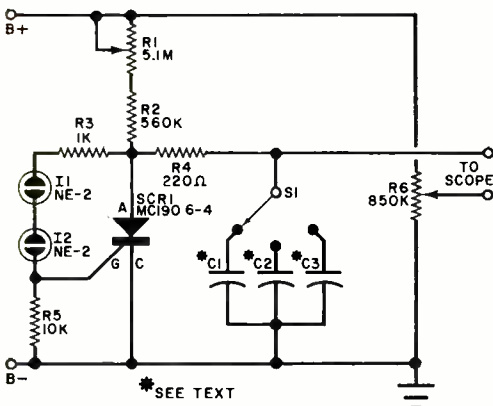

Fig. 1. An SCR is used in a rather unusual application in this linear (sawtooth) sweep generator.

ray tube used in most general-purpose oscilloscopes.

In common with most relaxation oscillators, Nyle's circuit utilizes the charge-discharge features of an RC network to form the familiar sawtooth waveform. Referring to Fig. 1, SCR1 and neon lamps (I1 and I2) are in a non-conducting (open) state when d.c. is first applied. A capacitor selected by S1, is charged slowly by the d.c. source through R1, R2 and R4 until its voltage equals the combined ionization voltages of the neon lamps. At this point, the neon lamps "fire," furnishing gate current to SCR1 through current limiting resistor R3, switching the SCR to a conducting status. This discharges the capacitor through R4. With the capacitor discharged, SCR1 reverts to its non-conducting status, the neon lamps are extinguished, and the cycle repeats.

Potentiometer R6 is not a functioning part of a basic circuit. It is included to provide a d.c. reference for beam centering when the circuit is used to furnish direct drive to a CRT's plates.

The circuit's repetition rate (frequency) depends on the supply voltage, the neon lamps' combined ionization voltage and, of course, on the time constant of the RC network which includes R1, R2, R4 and the selected capacitor. The value of R4 is relatively small, and therefore, can be ignored. A variable resistor is used for R1 to serve as a fine frequency control, while selector switch S1 provides a choice of capacitors (C1, C2, or C3) and thus acts as a coarse control or range switch.

All the parts used are readily available. Resistors R2, R3, R4 and R5 are half-watt resistors; I1 and I2 are type NE-2 or NE-51 neon lamps; and SCR1 is a Motorola type MCR1906-4 or equivalent with, at least, a 200-volt rating. The timing capacitors, C1, C2 and C3, should be good quality 400-volt plastic film or paper tubulars, with their values determined experimentally to provide the desired range of operating frequencies; generally, values from 0.01 μF to 0.25 μF will be used.

Neither parts nor wiring arrangements are critical and the circuit can be assembled using any of a variety of construction methods. The neon lamps should be shielded to exclude light, for these devices may be photosensitive. Virtually any well-filtered d.c. source furnishing in excess of 200 volts may serve as a power supply, but Nyle suggests at least 350 volts be used to insure a linear output signal.

Manufacturer's Circuit. Originally designed for use as a video amplifier in a monochrome TV receiver, the circuit shown in Fig. 2 could serve either as an untuned r.f.

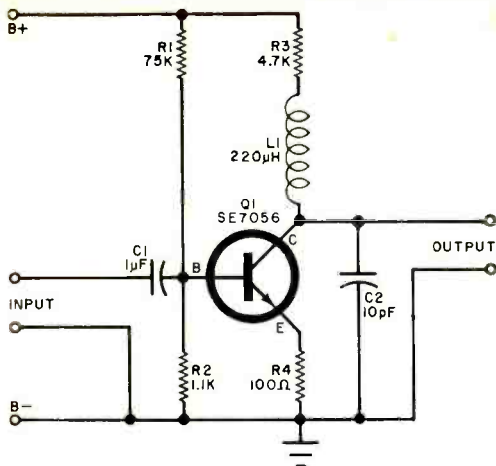

Fig. 2. This versatile amplifier, with its 3-dB point at 2.6 MHz, is described in the text below.

amplifier in a broadcast-band receiver or as a general-purpose wide-band amplifier in a transistorized cathode-ray oscilloscope, signal tracer, a.c. voltmeter, or similar test instrument. Abstracted from Fairchild Semiconductor's application manual for the TCSO123 series of high-voltage silicon planar transistors, its 3-dB point is 2.6 MHz, but this can be extended by modifying the peaking network.

A conventional common-emitter configuration, the circuit itself is not unusual, but it does illustrate what can be achieved by the application of professional engineering design techniques. In operation, $Q1$'s base bias is established by voltage-divider $R1$ - $R2$ in conjunction with emitter resistor $R4$. Resistor $R3$ serves as the collector load, with the circuit's frequency response extended by peaking network $L1$ - $C2$. A moderately large input coupling capacitor ($C1$) insures good low-frequency response.

The circuit may be assembled from conventional commercial components. Transistor $Q1$ is a Fairchild SE7056 *npn* type. Composition resistors should be used throughout, with $R1$ a 1-watt, $R3$ a 2-watt, and both $R2$ and $R4$ half-watt units. Any commercial 220- μ H peaking coil can be used for $L1$. Coupling capacitor $C1$ is a 400-volt plastic film or tubular paper type and $C2$ a 400-volt mica or ceramic capacitor.

Although either etched circuit or perf board may be used, layout and lead dress are reasonably critical and good wiring practice should be observed during assembly. Signal carrying leads should be kept short and direct to minimize both distributed capacitances and stray inductances. A low-ripple, 150-volt d.c. source should be used as the circuit's power supply.

New Devices. A new hybrid IC video amplifier has been developed by the Amprex Electronic Corporation (Cranston, Rhode Island). Intended for use in tape recorders, video circuits, comparators, broadband amplifiers, frequency selective instruments and active filters, the new unit, illustrated in Fig. 3, is designed around low-noise LID semiconductors and features a sputtered thin-film process. Designated type ATF-416, the device offers a gain of approximately 52 dB from d.c. to 10 MHz and has a common mode rejection of at least 40 dB. Its bandwidth with a 1000-ohm, 20-pF load is 8 MHz. The ATF-416's input section is a 3-stage d.c.-coupled differential amplifier, while its output is a 2-stage cascaded d.c. amplifier. This arrangement permits a designer to use the device either as a gain- or bandwidth-controlled unit, or as a straight broadband amplifier.

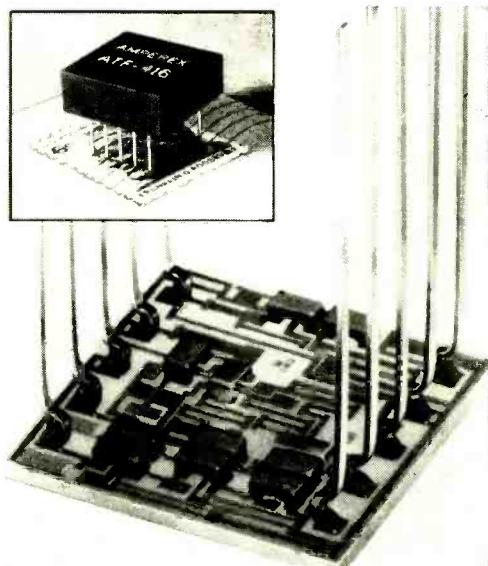

Fig. 3. Hybrid IC video amplifier features a gain of approximately 52 dB from d.c. to 10 megahertz.

Plastic 4-ampere SCR's that can operate at rated currents at case temperature as high as 97°C., and with current-stage ratings 50% higher than other competitive plastic devices are now available from Motorola Semiconductor Products, Inc. (P.O. Box 20912, Phoenix, Arizona 85036). The high-temperature specifications of these new units, designated the MCR406 series, reduce the need for costly heat sinking, while the 50% higher current-surge capability improves operating reliability in critical applications (such as motor starting and in-rush lamp turn-on). The complete series
(Continued on page 111)

YOU are needed now for a BIG PAY JOB in ELECTRONICS!

Look at the ads in your newspapers! Check the BIG MONEY OPPORTUNITIES that await the man who knows ELECTRONICS!



TRAIN AT HOME SPARE TIME
Keep present job and income and you prepare for best pay jobs in this booming field!

EARN while you LEARN

A few months after enrolling you can be doing spare time Electronics repair jobs paying up to \$25 to \$35 for an evening's work!



PREPARE TO STEP INTO JOBS LIKE THESE:

Industrial Controls Maintenance • Your Own Electronics Service Shop • Closed Circuit T.V. Installation Service • Electronic Computer Maintenance • Communications • Aerospace Work • Automation Electronics Installation... and hundreds more we'll tell you about!

LEARN BY DOING

Build and keep vital electronics test equipment from big kits we supply. All yours to use and keep!



FREE

MAIL COUPON FOR BIG FACT BOOK

Get big Free fact pack! See how you learn fast at home; start earning fast! Rush coupon today!



I. T. I. APPROVED FOR TRAINING UNDER NEW G. I. BILL

MAIL COUPON FOR ELECTRONICS MONEY MAKING FACTS

Industrial Training Institute, Dept. 65188
815 Rosecrans, Los Angeles, Calif. 90059

Rush me big FREE BOOK, "Get Into Big Pay Electronics." Show how I can learn Electronics at home spare time

Name _____

Address _____

City _____

State _____

Zip _____

CIRCLE NO. 16 ON READER SERVICE PAGE

AMATEUR RADIO

(Continued from page 92)

an antenna for Dr. Lee De Forest, the inventor of the triode tube. The antennas were needed to demonstrate some wireless equipment to the Navy. Ray was promised \$25.00 when De Forest got some money—something he never seemed to have.



Bob Collom, WNØTWL, 2600 9th St., Boulder, Colo., has a Drake T-4 transmitter/R-4 receiver combination and teaches his son in Vietnam code by tape recorder so they can have a father/son station.

NEWS AND VIEWS

Ken Martin, WA7KJV, 225 Hardy Ave., Eugene, Ore. 97402, kept his Novice transmitter—a Knight-Kit T-150—as a standby rig when he got his General ticket. His new big gun is a Galaxy-5 SSB/CW transceiver running 300 watts to dipoles on 40 and 20 meters plus a 2-element beam or a dipole on 15 meters. Ken sticks to SSB on 40 and 15 but uses both SSB and CW on 20 meters. He just completed working all states and is gunning for Europe and Africa for a Worked All Continents certificate. He plans to have his Advanced ticket when you read this. . . . **Ronald Tomo, WA2COL**, 82 Burtis Ave., Rockville Center, N.Y. 11570, especially enjoys ragchewing and running overseas "phone patches" for our military personnel overseas. Ron has worked the U.S. Carriers, *Yorktown*, *Forrestal*, and *New Jersey*, as well as the Hospital Ship *Hope* in a harbor in Ceylon. Running a Drake T-4XB transmitter, 2C receiver, and an MN-4 antenna coupler in conjunction with a 2-element, 15-meter beam and a Hy-Gain 14-AVQ vertical antenna 50 feet high, Ron has worked all continents and all states, and holds a 20-WPM code certificate. . . . **Richard Henderson, WN1JLK**, 112 Arch Parkway, Meriden, Conn. 06450, hit the 80-, 40-, and 15-meter Novice bands hard when his ticket arrived. In six weeks, he worked 35 states (31 confirmed) and nine countries. He has a Drake 2-NT transmitter, backed up by an old Johnson Adventurer, Hammarlund HQ-145 receiver, 15-meter dipole, and 80/40 meter vertical antenna. Check with Dick, if you need a Connecticut QSL card; he QSL's 100 per cent.

Steve Barrymore, WN5YBX, 4760 NW 24 Apt. 124, Oklahoma City, Okla. 73127, calls both W5CML

and W50TZ "uncle." He has parlayed a Johnson Ranger transmitter, Hallicrafters SX-111 receiver, 80/40 meter "trap" dipole and a 15-meter dipole into 28 states in seven weeks on the air. Twenty-seven of them were worked on 40 meters. Steve figures that after getting WAS on 40 meters, he'll do the job again on the other bands—ARRL's new 5-band WAS may have been designed with Steve in mind. . . . **Scott Marzolf, WN2IZF**, 903 Coach Road, Blackwood, N.J. 08012, doesn't rate his "all-band" vertical as much of an antenna. Nevertheless, his Heathkit DX-60 transmitter and Lafayette HA-700 receiver have racked up seven states in three weeks. A better antenna is in the planning stage; besides, a friend up the street says that he can come over and use his Mosley tribander beam and 80/40 meter dipole—both 90 feet high—when he wishes. We bet, though, that Scott will discover there is more thrill working a new state on your own equipment than working around the world on another ham's station. . . . **Doug Goodman, WN9AVY**, 1324 S. Main St. Lombard, Ill. 60148, had just passed his General test and is speculating if his new call letters will be WB9AVY. As a Novice, Doug's Knight-Kit T-60 transmitter and Sky Roamer receiver fed a dipole antenna to work 23 states and two Canadian provinces—mostly on 80 meters.



Jack Jackson, WA4LDM, Florence, S.C., works unusual DX but with low power. See story below.

If you think that it takes high power, extra-fancy equipment and high-gain beam antennas on 20, 15, and 10 meters to work a lot of DX, you will never believe the record of **Jack Jackson, WA4LDM**, 1402 Azalea Drive, Florence, S. C. 29501. For openers, he has worked 15 countries (six on AM phone) and 47 states on 160 meters, running 50 watts. He has 49 states and 25 countries worked on 80 meters, and has worked all states and continents—119 countries, total—on both AM and CW on 40, 20, 15, and 10 meters, always using a power under 100 watts. Jack's main equipment includes a Knight-Kit T-150A transmitter and a Knight-Kit R-100A receiver, plus the usual array of surplus and homebrew accessories. Antennas include inverted-V's for 160 and 80 meters, verticals for the other bands, and a homebrew 2-element beam on 28 MHz. Of course, Jack holds many DX certificates and is gunning for the "big one" now—an Extra class ticket. With a 30-WPM code certificate on the wall, he is not much worried about the code test. . . . If you haunt the 80-meter Novice band early Saturday mornings, check 3740 kHz at 1100 GMT (6:00 a.m., EST) for the Early-Bird Net

Weller® simplifies soldering



New TEMPMATIC® Temperature Controlled Soldering Tool

Combines all the advantages of a pencil iron, a fast heating soldering gun, and tip temperature control. Exclusive removable Powerhead contains Weller's temperature control system. Protects components even in the most delicate work situations. Tool weighs 7 oz. Use it for light or heavy duty soldering. Model GT-7A has 700°F. 3/16" chisel point Powerhead. Model GT-6B has 600°F. 1/8" conical point Powerhead.



The original Dual Heat Guns

Fast heating. Long-life tips. Exclusive trigger-controlled dual heat. High soldering efficiency. Spotlight. 3 models from 100/140 watts to 240/325 watts.



Dependable MARKSMAN Irons

They outperform other irons of their size and weight. Long-reach stainless steel barrels. Replaceable tips. 5 models from 25 watts to 175 watts.



Weller 25-watt Iron for intricate work

Industrial rated. Weighs 1 3/4 oz. Delivers tip temperatures to 860°F. Cool, impact-resistant handle. Model W-PS with 1/16" tip.

Weller®

WELLER ELECTRIC CORP., Easton, Pa.
WORLD LEADER IN SOLDERING TOOLS

sponsored by WN3KIHG, WN4KSG, and WN3LTB. ... Ron Marra, WB8BTU, 24963 S. Sylbert Ct., Detroit, Mich. 48239, kept the electrons hopping during his Novice career. In four months, he worked 47 states and 41 countries! The band was 15 meters; the equipment was a Heathkit DX-60B transmitter, a Heathkit HR-10B receiver, and a dipole antenna.



Daniel A. Johnson, WA9YOH, P.O. Box 443, Marion, Ind. 46952, works SSB with Galaxy 300 transceiver and CW with an Elmac AF-67 transmitter and a Mosley CM-1 receiver, for 45 states, 7 countries.

We invite your "News and Views" and pictures (black and white, please) for your column, and we thank you who have continued mailing your club papers and bulletins to us and would appreciate being put on the mailing list, if we are not already on yours. The address is: Herb S. Brier, W9EGQ, Amateur Radio Editor, POPULAR ELECTRONICS, P. O. Box 678, Gary, Ind. 46401.

73, Herb, W9EGQ.

SHORT-WAVE LISTENING

(Continued from page 96)

Peru—OAZ4L, R. Del Pacifico, Lima, is a new logging on 9675 kHz. heard at 0115-0135 and around 0220 with religious programming and a singing ID by a chorus of girls' voices. OAX7T, R. Sicuani, Sicuani, 4967 kHz, has moved from 4837 kHz and is heard at times around 0200. Do not confuse with a Colombian on 4965 kHz or R. San Juan, Piura, Peru, on 4967 kHz. OAZ4C, R. Andina, Huancayo, has moved from 6244 kHz to 4995 kHz and is irregularly noted to past 0000 with listener requests and very few ID's. Do not confuse with R. Abancay, Peru, on 4997 kHz. OEX7H, Ondas del Titicaca, Puno, 4921 kHz, was heard with Andean music during a listener request program that ran to past 0300.

Poland—Warsaw has been found on 11.815 kHz at 0010-0100 with American pop music and in language.

South Africa—R. RSA, Johannesburg, has English to N.A. at 2330, 0030, 0130 and 0230 on 9705, 6075 and 5980 kHz. Other English xmsns: 0415-0427 to Kenya. Uganda, Tanzania, Ethiopia and Sudan on 9525 and 7270 kHz; 0430-0442 to the Middle East on 15,220 and 11,900 kHz; 0500-0512 to Rhodesia, Zambia and Malawi on 5980 and 4895 kHz; 0515-0527 to Middle East on 17,805 and 15,220 kHz; 0645-0657 to Nigeria and Ghana on 15,220 and 11,900 kHz; 1100-1450 to Africa (English and Afrikaans) on 21,535, 17,805, 15,220 and 11,900 kHz; 1600-1650 to Rhodesia, Zambia and Malawi on 9525 and 7270 kHz; 1700-1750 to Middle East. Kenya, Uganda, Tanzania.

Patented components . . . a 30-year reputation for innovative design . . . a consistently creative approach to sound reproduction . . . this is where it all comes together, in the creation of extraordinary speakers such as the 312.

A glance at its specifications will tell you the 312 is an exceptionally fine reproducer. Unfortunately, they won't begin to show you how extraordinarily pleasing the sound is that flows from it. You must discover that for yourself, by listening. It's not inexpensive. Still, it's only about half what you'd expect to pay. Hear the 312 soon. Find out why we call it: "the speaker your other components will be proud of."

This is where it all comes together

"Listen . . .
University
Sounds
Better."



UNIVERSITY SOUND
A DIVISION OF LTV LING ALTEC, INC.
P. O. Box 26105, Oklahoma City, Okla. 73126

CIRCLE NO. 31 ON READER SERVICE PAGE

Ethiopia and Sudan on 21,535 and 15,220 kHz; 2100-2150 to Ghana and Nigeria on 15,360 and 11,900 kHz; 1800-1850 to United Kingdom and Ireland on 21,500 and 17,795 kHz; 0800-0850 to New Zealand on 21,535 and 17,825 kHz; and 1000-1050 to Australia on 21,535, 17,825 and 15,220 kHz.

Sudan—R. Omdurman has a 100-kW xmtr on 11,835 kHz for testing but Algeria on the same channel makes for heavy QRM.

Sweden—R. Sweden, Stockholm, has this schedule in effect: (English only) to Europe at 1100-



Raul Menchaca Falcon, XE1PE1K, Mexico City, Mexico uses a Philips Vivaldi and Blaupunkt Deluxe 40175. He has 19 countries that are verified.

1130 on 9625 kHz and 2045-2115 on 6065 kHz. To the Middle East at 1600-1630 on 21,585 kHz and 1900-1930 on 11,860 kHz. To the Far East at 1230-1300 on 15,105 kHz. 2045-2115 on 11,705 kHz and 0745-0815 on 15,155 kHz. To Africa at 1230-1300 on 21,690 kHz and 1900-1930 on 15,240 kHz. To Asia at 1400-1430 on 21,585 kHz and 0515-0545 on 17,840 kHz. To South America at 2245-2315 on 11,705 kHz. To Eastern N.A. at 1100-1130 and 1400-1430 on 15,315 kHz and 0030-0100 and 0200-0230 on 11,950 kHz. To Western N.A. at 1600-1630 on 15,315 kHz and 0330-0400 on 11,705 kHz.

SHORT-WAVE ABBREVIATIONS

anmt—Announcement	kHz—Kilohertz
BBC—British Broadcasting Corp.	kW—Kilowatts
CBC—Canadian Broadcasting Corp.	L.A.—Latin America
CW—Morse Code	N.A.—North America
GMT—Greenwich Mean Time	QRM—Station Interference
ID—Identification	R—Radio
IS—Interval Signal	s/off—Sign-off
	s/on—Sign-on
	xmtr—Transmitter

Switzerland—Berne presents this English schedule: to Australia and New Zealand at 0700, 0800 and 0830 on 9590 and 11,775 kHz. To Africa at 1000 and 1100 on 15,305, 17,795 and 21,520 kHz and at 1815 and 1915 on 15,180 and 17,795 kHz. To N.A. at 0130, 0230 and 0300 on 9535, 11,715 and 15,305 kHz and at 0445, 0545 and 0615 on 9720 and 11,715 kHz. To United Kingdom and Ireland at 1130, 1230, 1300, 1930 and 2030 on 9665 and 11,865 kHz. To Far East, India, Pakistan, Japan and China at 1315, 1415 and 1445 on 15,135, 17,845 and 21,520 kHz. To Near and Middle East at 1500, 1600 and 1630 on 15,305 and

EXCLUSIVE NEW CB DESIGN

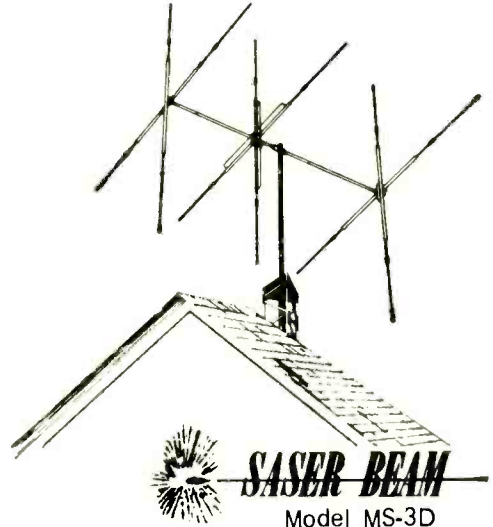

The Mosley Saser Beam cuts through CB interference like a laser cuts through steel. Switch polarization on this antenna and you cut down noise and interfering signals as much as 25 db. And you can count on its sturdy construction because, although it may look and act like a quad, it's built like a beam, with six crossed elements and no wires. It's miniaturized like a Mosley Mini-Beam to save you space and cash.

Where can you get base station antenna value like this in only 43 cubic yards of air space? See the Saser Beam at your nearest Mosley dealer. For free brochure, with complete specifications and performance data, write factory direct Department 187

Mosley Electronics Inc.

4610 N. Lindbergh Blvd., Bidgeton Mo. 63042
CIRCLE NO. 21 ON READER SERVICE PAGE

SAMS BOOKS

on SPACE SCIENCE



Space Age Technology Series

Prepared under the guidance of
Training and Retraining, Inc.

Inertial Guidance Systems. by Robert L. Gates. Fully describes the inertial guidance systems used in all U.S. ballistic missiles as well as in space projects. The basic theory and equipment techniques of these systems are also being applied to aircraft operation. Discusses coordinate systems and earth effects, inertial sensors, the inertial-measurement unit, the guidance computer, and system operation. 176 pages. Order 20605.....\$4.95

Controlled Guidance Systems. by Hal Hellman. This programmed text covers the fundamentals of guidance systems, including ballistic trajectory, hyperbolic guidance, motion, translation, proportional navigation, celestial navigation, and stellar-inertial guidance. Explains principles, construction, and operation of various systems. 224 pages. Order 20573.....\$4.95

Synchros and Servos. by Robert J. Brite & Carlo H. Fiorenelli. A programmed text presenting the basic principles of synchro and servo motors and generators and their applications. Includes maintenance and troubleshooting methods. 192 pages. Order 20533.....\$4.95

Lasers and Masers. by Charles A. Pike. This programmed text describes in detail the basic operating principles of the laser and maser. Also covers the early history and development of atomic structure which provides the framework for the development of laser and maser devices. 176 pages. Order 20559.....\$4.95

Microminiature Electronics. by Israel Kalish. Presents the basics of this vital new field which is playing an increasingly important role in space, military, commercial, and industrial electronic equipment design. The text is programmed and supported by numerous illustrations. 304 pages. Order 20582.....\$5.75

SPECIAL OFFER! All 5 Volumes at a savings, in beautiful slip case. Order 20724, only.....\$24.95

Howard W. Sams & Co., Inc.

Order from any Sams Distributor or bookstore, or mail to Howard W. Sams & Co., Inc., Dept. PE-9, 4300 West 62nd St., Indianapolis, Ind. 46268

Send me the following books:

- 20605 20533 20582 \$ _____
 20573 20559 20724 enclosed

Name _____

Address _____

City _____ State _____ Zip _____

CIRCLE NO. 26 ON READER SERVICE PAGE

17,830 kHz. Omnidirectional xmsns are at 0700, 0800 and 0830 on 6165 and 9535 kHz.

Turkey—Ankara is often good on 15.160 kHz in French at 2130-2200 and in English from 2200-2230.

USSR—R. Kiev lists a new schedule calling for English to N.A. at 0030 on 17,900, 17,760, 15,260 and 11,700 and at 0430 on 12,010, 11,960, 11,730 and 9600 kHz. English to Western Europe is listed at 1930 on 15,170, 15,160 and 11,700 kHz.

Vatican City—Two more new frequencies for *Vatican Radio* include 17.810 kHz from 0000 s/on in Spanish, and 11,745 kHz from 2200 s/on in English.

Venezuela—A new logging is that of *Vallos del Tuy*, location not yet determined, on 6129 kHz. It's been noted with native music and ads for General Electric, in Spanish, with a most abrupt s/off at 0045 or shortly thereafter. There are frequent ID's but QRM is heavy. R. *Barquisimeto* is often good on 4990 kHz until 0400 s/off with L.A. and N.A. music and in Spanish.

Vietnam (North)—Hanoi is still wandering from 15,010 to 15,020 kHz and noted at 1545-1550 in language, 1834 to 2000 in language and from 2000 to at least 2021 in English with news and commentaries.

Vietnam (South)—A new frequency for Saigon is 7175 kHz, found fair to weak in language at 1109 but with heavy ham radio QRM.

SHORT-WAVE CONTRIBUTORS

Jack Rouse (WPE1AK), Wallingford, Conn.
 Christopher Lobdell (WPE1GC1), Reading, Mass.
 Stephen Ruggles (WPE1HCH), Lunenburg, Mass.
 Joseph Smith, Jr. (WPE1HRA), Saugus, Mass.
 Paul Kinnaly, Jr. (WPE1HRJ), Dedham, Mass.
 Riley Sundstrom (WPE2AJ), Willingboro, N. J.
 Peter Macinta (WPE2ORB), Kearny, N. J.
 Roger Wink (WPE2PXT), Pennfield, N. V.
 Jack Graham (WPE2QNT), New Milford, N. J.
 John MacDonald (WPE2QOJ), East Orange, N. J.
 William Reynolds (WPE2OUG), West Seneca, N. Y.
 Michael Szoke (WPE2QUM), South River, N. J.
 Ivan Wautle (WPE2QVD), St. Johnsville, N. Y.
 Paul Sojka, Jr. (WPE2QXJ), Elizabeth, N. J.
 Rick Weibezahl (WPE2QYH), Washington, N. J.
 Grady Ferguson (WPE4BC), Charlotte, N. C.
 Neil Sommerfeld (WPE4TZ), West Palm Beach, Fla.
 John Carson (WPE4JZB), Lenoir, N. C.
 David Weronka (WPE4KBE), Durham, N. C.
 Richard Fortson (WPE5EIK), Edinburg, Texas
 Charles Bennett (WPE5SH), Sumrall, Miss.
 Jim Young (WPE6NA), Wrightwood, Calif.
 W. W. Mosby (WPE6EAJ), San Jose, Calif.
 Alan Raul (WPE6HIO), Santa Maria, Calif.
 Mark Sadacca (WPE6HRN), San Bernardino, Calif.
 Robert Schultz (WPE6HLV), Whittier, Calif.
 Ray Lantz (WPE7BBT), Carmichael, Calif.
 Steve Frantz (WPE7CHC), Auburn, Wash.
 Mark Noline (WPE7CWF), Salem, Ore.
 John Czupowski (WPE7ETD), Cicero, Ill.
 Gerry Dexter (WPE9HDB), Lake Geneva, Wis.
 Richard Pistek (WPE9HOA), Chicago, Ill.
 George Trapp (WPE9IWS), Evergreen Park, Ill.
 John Patterson (WPE9IOL), Oswego, Ill.
 A. R. Niblack (WPE9KM), Vincennes, Ind.
 John Beaver (WPE9AE), Pueblo, Colo.
 C. Vernon Hyson (WPE9CNF), Somerville, N. Y.
 Charles Chambers (WPE9EGD), Springfield, Mo.
 Tim Nelson (WPE9FXO), Jamestown, N. D.
 Jack Perolo (PY2PE1C), Sao Paulo, Brazil
 Andre Lavigne (VE2PE1NO), La Salle, Que.
 David Clark (VE3PE1CE), Toronto, Ont.
 Paul Cau (VE3PE2OZ), St. Catharines, Ont.
 R. D. Gee (VE7PE1EG), Victoria, B. C.
 Leo Alster, Rahway, N. J.
 Frederick Baumgartner, Eau Claire, Wis.
 Tony Deliberato, Cleveland, Ohio
 M. F. Dressler, Jacksonville, Fla.
 Marc Ennis, Hollywood, Fla.
 Dan Finegan, Fairfax Station, Va.
 James Hagan, Palm Bay, Fla.
 Gert Schultz, Goteborg, Sweden
 Fred Schulz, La Mesa, Calif.
 Russ Stafford, Newark, Del.
 Charles Webking, St. Louis, Mo.
Radio Voice of the Gospel, Addis Ababa, Ethiopia
Radio Sweden, Stockholm, Sweden
Swiss Broadcasting Corp., Berne, Switzerland
Radio RSA, Johannesburg, South Africa

TWO-WAY REACTIONS

(Continued from page 94)

ways be a need for vigilant, life-saving REACT teams. We are sometimes asked why GM should sponsor REACT. The answer is that GM is in the transportation business and is interested in any program that can improve motoring safety and traffic flow. REACT fulfills a great need in highway communications."

CURRENT NEWS

Since the change in sponsorship of REACT in March of 1969, a concerted effort has been made to improve substantially the support that local REACT teams receive from REACT National Headquarters. Managing Director Gerald (Jerry) H. Reese, KC6990, has been added to direct the day-to-day organizational activities. National Director, Henry B. (Pete) Kreer, KPK1386, is still at his old post.

More frequent and direct communication with the FCC and other agencies whose activities affect the Citizens Radio user are now possible through the strengthening of REACT National Headquarters.

New procedures have been introduced so that all Headquarters' services to member teams are handled more efficiently. The first issue of the National REACTer published since October 1967 was sent out free to all teams for distribution to their members. This is the official news publication of REACT National Headquarters. It is now bigger and better than ever and has received many favorable comments from REACT teams everywhere. Another issue is about ready to be mailed and issues will be published on a regular quarterly basis.

Denver, Colo.—Members of the Denver Metro REACT Team recently cooperated with the Jefferson County sheriff's office in apprehending three people who were charged with theft of clothing and household items deposited in collection boxes for donation to Goodwill Industries. One Sunday night, 22 team members in 12 cars kept the home of the suspects and 10 collection booths under surveillance, reporting the movements of the suspects as they traveled in their pickup truck to and from seven booth locations. The monitoring log showed the team sighting the truck at 6:39 p.m. and the sheriff's deputies making the arrests at 8:27 p.m.

New Miami, Ohio—Unusual atmospheric conditions affecting radio transmissions caused the REACT monitor here to receive an emergency call recently from a motorist who was reporting a two-car collision 15 miles south of Cheyenne, Wyoming. The New Miami monitor called the local sheriff's office and the Ohio State Highway Patrol. They could not help. Finally, a long-distance call was placed to the Wyoming State Police. By this time they had been informed and help was on the way. When you ask for help on Channel 9 in southern Ohio, you get it.

Festus, Mo.—Members of the Ozark Citizens Band Radio Club, a REACT team, have been very active in this community. Monitoring Channel 9 for emergencies, a frequent report is that livestock is on the highway. It may be funny to city slickers, but it's not funny when you collide with a cow or a horse at highway speeds! In addition to handling the usual traffic calls, the club's emergency truck is used under the supervision of the county conservation commissioner to patrol the area during the deer hunting season on the lookout for unlawful night hunting.

We Need Your Help—There is a definite meaning to the title of this column—"Two-Way REACTIONS." It does, of course, refer to Citizens Two-Way Radio and to REACT. It also means that we are interested in your reactions to this column and, even more important, in your contributions. News of all phases of Citizens Two-Way Radio is welcome. Send us information, photos, and anything you would like to see in print. REACT is operated on the basis of organized team membership. If your group is interested in learning how you can become an active REACT team, we will be happy to send you the information.

All correspondence should be sent to: Editor, Two-Way REACTIONS, c/o REACT National Headquarters, 205 West Wacker Drive, Chicago, Ill. 60606.

CITIZENS RADIO JAMBOREE CALENDAR

September 13 and 14, Emergency Citizens Band Monitors, Huntsville, Ala. Fall Festival at Madison County Coliseum. Contact: Emergency Citizens Band Monitors, PO Box 1542, Huntsville, Alabama 35807.

September 27 and 28, West Virginia Citizens Band Radio Association. First State Jamboree. Beckley Radio Club Grounds, Crow, W. Virginia. Contact: Ted England, KPN8419, PO Box 628, Beckley, W. Virginia.

ADDED MOBILE POWER WHEN
YOU NEED ADDITIONAL COVERAGE
FOR CLEAR COMMUNICATIONS



170 WATT INPUT

Complete with remote power switch and indicator control panel plus mounting brackets.

FCC TYPE ACCEPTED
Parts 89, 91, 93

\$119⁹⁵
12 VDC

SMALL PACKAGED MOBILE POWER LINEAR R.F. POWER AMPLIFIER

Covers greater distances with increased transmit power. Can be used with SONAR BR20, FM40 or any similar FCC approved equipment with 1-15 watt output. Designed with top performance and dependable service when you need it. Automatic standby/transmit switching • Covers 25-50MHz range • transistorized power supply — negative ground • Used on amateur 28MHz for FM-AM-SSB. Small, compact, rugged design. Size: 2"H x 6"W x 8"D. Wt. 3 lbs. 12 VDC

SONAR RADIO CORP., 73 Wortman Avenue, Bklyn, N.Y. 11207
Please send information on Model BR 2906 Linear Amplifier.

Name Dept. 258
Address.....
City..... State Zip.....

CIRCLE NO. 27 ON READER SERVICE PAGE

**“Get more
education
or
get out of
electronics
...that’s my advice.”**



NEW!

Expanded
coverage of
solid state
electronics
including
integrated
circuits!



Ask any man who really knows the electronics industry.

Opportunities are few for men without advanced technical education. If you stay on that level, you'll never make much money. And you'll be among the first to go in a layoff.

But, if you supplement your experience with more education in electronics, you can become a specialist. You'll enjoy good income and excellent security. You won't have to worry about automation or advances in technology putting you out of a job.

How can you get the additional education you must have to protect your future—and the future of those who depend on you? Going back to school isn't easy for a man with a job and family obligations.

CREI Home Study Programs offer you a practical way to get more education without going back to school. You study at home, at your own pace, on your own schedule. And you study with the assurance that what you learn can be applied on the job immediately to make you worth more money to your employer.

You're eligible for a CREI Program if you work in electronics and have a high school education. Our FREE book gives complete information. Mail postpaid card for your copy. If card is detached, use coupon below or write: CREI, Dept. 1209H, 3224 Sixteenth Street, N.W., Washington, D.C. 20010.

Founded 1927



Accredited Member of the National Home Study Council



**CREI, Home Study Division
McGraw-Hill Book Company
Dept. 1209H, 3224 Sixteenth Street, N.W.
Washington, D.C. 20010**

Please send me FREE book describing CREI Programs. I am employed in electronics and have a high school education.

NAME _____ AGE _____

ADDRESS _____

CITY _____ STATE _____ ZIP CODE _____

EMPLOYED BY _____

TYPE OF PRESENT WORK _____ G.I. BILL

I am interested in

- Electronic Engineering Technology Computers
- Space Electronics Nuclear Engineering Technology
- NEW! Digital Communications NEW! Industrial Automation

APPROVED FOR TRAINING UNDER NEW G.I. BILL

Olson ELECTRONICS FREE Catalog

Fill in coupon for a **FREE** One Year Subscription to **OLSON ELECTRONICS'** Fantastic Value Packed Catalog — Unheard of **LOW, LOW PRICES** on Brand Name Speakers, Changers, Tubes, Tools, Stereo Amps, Tuners, CB, and other Values. Credit plan available.

NAME _____
ADDRESS _____
CITY _____ STATE _____
GIVE ZIP CODE _____

If you have a friend interested in electronics send his name and address for a **FREE** subscription also.

OLSON ELECTRONICS

466 S. FORGE STREET, AKRON, OHIO 44308

CIRCLE NO. 24 ON READER SERVICE PAGE

NEW ROOF SHATTERING POWER! Thunder Columns

Never before has a sound reproduction device been designed to handle enormous power with such effortless ease and fidelity! Thunder Columns are scientifically-designed true sound columns, with every component perfectly matched to project maximum undistorted sound to your audience. Argos Thunder Columns are musician speakers in every sense of the word.

- 200 and 300 watt models •
- True focused sound for the serious musician •
- Fuse protected against accidental power overloads •
- Hidden steel grille crash protects speakers •
- Rugged upholstery grade vinyl finish •
- Heavy duty electronic instrument speakers

Argos
PRODUCTS COMPANY

600 So. Sycamore, Genoa, Ill. 60135

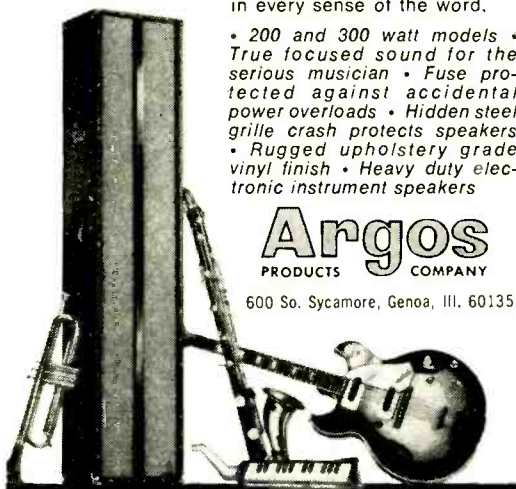

CIRCLE NO. 5 ON READER SERVICE PAGE

KNOW THE SCS

(Continued from page 78)

microampere) is required for turn-on. If desired, a 100-pF capacitor can be substituted for the 3.3-megohm resistor in either gate circuit. This is a useful substitution when d.c. isolation is required.

Turning an SCS off by opening the power-supply circuit requires a switch in a position to break the full load current

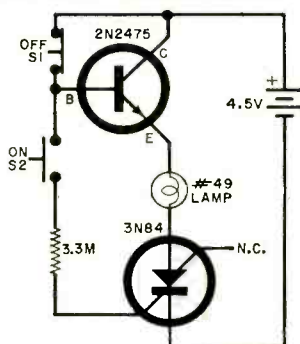

Fig. 6. A conventional npn transistor can be used in place of a power switch to turn the SCS on and off. Any type of mechanical contacts can be used for switches S1 and S2.

flowing through the SCS. This is not always practical if you want to use a very small switch. For such applications, it is better to use a transistor to switch the load current with a small mechanical switch to turn the transistor off and on.

Now to Work. The SCS is such a versatile device that its applications are limited only by your imagination. One typical application is described on page 78.

-30-

OUT OF TUNE

"Build the POPULAR ELECTRONICS Universal Frequency Counter" (March 1969). Capacitor C5, in Fig. 13, page 45, is connected backwards. The negative side should be connected to the junction of D3 and D4, the positive side to ground.

SOLID STATE

(Continued from page 99)

consists of eight devices, with peak forward blocking-voltage ratings from 30 to 200 volts. All are sensitive-gate devices which permit direct triggering without additional stages of signal amplification, thus making them suitable for use with low-level signal sensors such as thermistors and photocells.

RCA Electronic Components (Harrison, NJ 07029) has introduced a new IC amplifier array consisting of four independent a.c. amplifiers on a single monolithic silicon substrate. Designated type CA3052, the array can be used as a stereo tape head or full-function stereo preamp. With internal and external feedback features to facilitate equalization and tone control, each of the four amplifiers has an equivalent input noise voltage of only 4 microvolts, a voltage gain of 58 dB, an input resistance of 90 kilohms, an output resistance of 1,000 ohms, and an open-loop bandwidth of 300 kHz. They can deliver an undistorted output signal of 2.4 volts r.m.s.

Transitips. We've received a number of letters from readers asking why low-cost, pocket-size transistorized receivers generally feature push-pull audio amplifiers, while moderately priced auto sets more often employ simpler single-ended output stages. At first glance, the design differences are rather surprising, for automobile receivers may cost from ten to twenty times more than a pocket set, and, as a general rule, one expects a more expensive product to use a more complex circuit. But there are valid engineering as well as economic reasons for the differences.

First, there is the matter of efficiency. A single-ended stage must be operated as a class-A amplifier. While delivering an exceptionally "clean" (distortion-free) signal,

a class-A stage is notoriously inefficient. A 1-watt class-A amplifier, for example, requires *two watts* from its power source . . . with the power drain *remaining unchanged* whether or not it is delivering an output (audio) signal. With a 12-volt power supply, a 1-watt class-A amplifier would require a steady current of approximately 166 mA while, with a 9-volt source, it would require about 222 mA.

A class-AB or class-B amplifier, on the other hand, is much more efficient and has the added advantage that its power supply requirements are very small when the stage is operating with zero signal—a fraction of its peak requirements. A class AB or B amplifier however must be operated as a push-pull stage to keep distortion levels within acceptable limits.

With the small batteries used in pocket-sized sets unable to supply large currents on a continuous basis, the use of an efficient class-AB or class-B stage is mandatory.

Second, how about cost? A class-A single-ended amplifier draws a relatively large steady d.c. Its output transformer must have a fairly large iron core to resist saturation. A class-B push-pull stage, on the other hand, will operate efficiently with a much smaller output transformer, even when delivering substantial audio power.

In practice, then, a 1-watt class-A output transformer, alone, may be more costly than a complete 1-watt class-B stage, including both transistors and a small drive transformer.

Since a car battery/generator can deliver relatively large currents with little effort, as opposed to those available from a miniature 9-volt battery, there is no real need to seek the higher efficiency of a class-AB or class-B push-pull amplifier. In addition, a cost-conscious manufacturer is more interested in total component costs than circuit complexity, and, therefore, prefers to use the least costly approach . . . that is, a class-B push-pull stage. —Lou

990 MODEL



Mercury **NEW COMPACT TUBE TESTER**
OUTPERFORMS MANY HIGHER PRICED INSTRUMENTS

- Full Conductance Cathode Test • Has All The Latest Sockets
- Tests Over 3000 Tubes • Special, Unique Open-Circuit 12-Button Master Selection Slide-Switch Row Makes Unit Truly Obsolete-Proof • Tests Multiple Element Terminations Quickly, Easily
- Complete With Latest Tube Test Data That Is Permanently Kept Up-To-Date.

ONLY **21.95** KIT
34.95 WIRED

All Mercury Test Equipment Guaranteed For One Full Year!

Write for complete catalog of Mercury Test and Repair Equipment, and name of your nearest dealer.

MERCURY ELECTRONICS CORPORATION
315 Roslyn Road • Mineola, N.Y. 11501 • (516) 742-5400
CANADA: William Cohen Corp. • 8900 Park Ave. • Montreal-11

Power Reg.: 115V, 50/60 Hz 50W
Hi-impact molded case, 6 1/2 x 7 1/2 x 3 1/2 — 4 lbs. American Made

COLOR ORGAN

ONE KILOWATT-FOUR CHANNELS
ULTRA - COMPACT - LOW COST



Printed Circuit Board Kit..... \$ 49.95
Factory Assembled..... \$ 65.00

NEW: 2.4 KILOWATTS-FOUR CHANNELS
(600 watts per channel)

TUNABLE R-C FILTERS-TRIAC POWER STAGES
Printed Circuit Board Kit..... \$ 85.00
Factory Assembled..... \$100.00

FOUR KILOWATTS-FOUR CHANNELS
(1Kw per channel)

Factory Assembled..... \$200.00

Add \$2.00 For Handling And Shipping Costs
N. J. Residents Add 3% Sales Tax
(Payment Must Accompany Order)

EDISON INSTRUMENTS, INC.
54 West Cherry Street • Rahway, N. J. 07065
(201) 381-0140

CIRCLE NO. 12 ON READER SERVICE PAGE

IT COSTS ONLY
1/100 OF 1¢ MORE
PER SOLDER JOINT
TO KNOW YOU ARE USING THE
WORLD'S FINEST CORED SOLDER



New Easy
Dispenser
Pak
60/40
18 S.W.G.



Latest PC
(Printed
Circuit) Pak
60/40 Extra Thin
22 S.W.G.—.028"

each only 69¢ per package at your dealer

ERSIN *Multicore* FIVE-CORE
SOLDER

MULTICORE SALES CORP., WESTBURY, N.Y. 11590
CIRCLE NO. 23 ON READER SERVICE PAGE

HQ-200 & SX-122A

(Continued from page 57)

the selectivity curve of the HQ-200 is continuously variable from a width of 7-8 kHz (at 6 dB down) to a claimed 400 Hz, or less. The SX-122A has three switched selectivity options; 5.0 kHz, 2.5 kHz, and 0.5 kHz (also at 6 dB down).

Of more importance in dealing with selectivity is the shape of the curve (flat-top or like a church steeple) and width of the curve 40, 50, or 60 dB down. Technically this is the "shape factor", or to put it into SWL'ing terms, the ability to separate two very strong stations only 10 kHz apart.

In this category, the SX-122A is very selective and the i.f. bandpass (switch at 5.0 kHz) is only 12 kHz wide at -40 dB and 14.5 kHz wide at -60 dB. Without Q multiplication the HQ-200 is 12 kHz wide at -20 dB and 8 kHz with the Q multiplier switched on. This can be reduced (at -20 dB) to about 2 kHz, however if the signals are strong, the selectivity curve on the HQ-200 at -40 dB is starting to widen rapidly.

In field trials, the HQ-200 demonstrated its ability to separate two S5 to S9 signals, but when one signal was S5 and the other 20 dB over S9 only the SX-122A could make the weaker 100% readable.

Conclusions. Space does not permit a more exhaustive or critical appraisal of these two different—but same—receivers. The sameness is in the frequency coverage and flexibility, the differences are numerous and important. Probably this can be best summarized by pointing out that the extra cost of the SX-122A is reflected in refinements. The HQ-200 is an excellent basic receiver for the beginning SWL or Novice ham. The SX-122A is cut for the discriminating SWL or ham. Both represent good dollar value.

-30-

For Hallicrafters SX-122A:
Circle No. 92 on Reader Service Page 15 or 115
For Hammarlund HQ-200:
Circle No. 93 on Reader Service Page 15 or 115

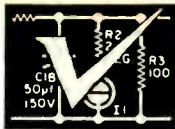

OPERATION ASSIST

Through this column we try to make it possible for readers needing information on outdated, obscure, and unusual radio-electronics gear to get help from other P.E. readers. Here's how it works: Check the list below. If you can help anyone with a schematic or other information, write him directly—he'll appreciate it. If you need help, send a postcard to Operation Assist, POPULAR ELECTRONICS, One Park Avenue, New York, N.Y. 10016. Give maker's name and model number of the unit. If you don't know both the maker's name and the model number, give year of manufacture, bands covered, tubes used, etc. State specifically what you want, i.e., schematic, source for parts, etc. Be sure to print or type everything legibly, including your name and address. Do not send an individual postcard for each request; list all requests on one postcard. Because we get so many inquiries, none of them can be acknowledged. POPULAR ELECTRONICS reserves the right to publish only those items not available from normal sources.

Pentron Model PT-1 stereo recorder. Instructions, schematic, and source for parts needed. (Larry Berk, 2576 Ashurst Rd., University Hgts., OH 44118)

Collins Type 180 K loading coil Series 705. Schematic and instructions needed. (Paul Bilodeau, Box 635, Friendswood, TX 77546)

Webster-Chicago Model 181. Parts, schematic and owners manual needed. (William Bonn, 42 Clover Ln., Bloomfield, NJ 07003)

Clough-Bregle Model CRA oscilloscope. Schematic, specs and source for parts needed. (Walter Yates, Virginia Polytechnic Institute, Ambler Johnston, Box 5006, Blacksburg, VA 24061)

Madison Fielding Series 440 stereo receiver and amp. Schematic and owner's manual needed. (Alan Boritz, 80 Cheshire Rd., Bethpage, NY 11714)

DuMont Model 5108C 12" rack mount TV monitor and Model 5110A power supply. Service manual, parts list, schematic and additional information needed. (S. Thomas Dorey, 708 Henderson Rd., King of Prussia, PA 19106)

Hoffman Mark V black and white TV with color converter and phono inputs. Schematic, tube layout and type CX-299 or UX-199 tube needed. (Steve Swift, 6211 Gladiator Dr., Olympia, WA 98501)

Heath Model V1A vacuum tube voltmeter. **Johnson** Viking Adventurer transmitter. Construction manual needed for both. (Tom Dornback, 19W167 21st Pl., Lombard, IL 60148)

Kellogg radio; 1927. Tubes type 401 and 403 needed. (C. E. Miller, R-3, Box 209B, Platteville, WI 53818)

Lumatron Model 220 sampling converter. Manual needed. (R. Zahorcak, 29 Parker Ave., Passaic, NJ 07055)

RCA Model 86E receiver. **Gonset** G-11 communicator. Schematics needed. (Gordon Betts, Baid Cove, Winterport, ME 04496)

Bell Model 2145 amp. Schematic needed. (Arthur H. Baily, 805 Castle Pt. Terrace, Hoboken, NJ 07030)

GC Model 36-600A tube tester. Schematic needed. (George A. Kee, 32 Constitution Blvd., New Castle, DE 19720)

September, 1969

1400-PC. GLASS FIBER OPTIC KIT

It's FUN! It's Educational! It's Gifty!



\$4.88
★ Make light "pipes"
★ Dazzling displays
★ Triggers photo & infra-red cells

OPTICAL SCIENTIFIC HIFAKTRU!
Allows "hair thin" glass fibers (2-ft. long) to transmit & receive cold light energy of any color, by internal reflection. Bundled, jacketed, it guides, amazes, wires light around corners, walls, even in circles, triggering such devices as light sensitive transistors, diodes, etc. IT CUTS, HEALS, ACTS like wire. Only one's imagination controls its 1000's of uses. PRICE: 12-pc. accessory kit, with "how-to-do booklet".

- \$25 SURPRISE PAK: transistors, rect, diodes, etc. .. \$1
- 50 GERMANIUM GLASS DIODES, 1N34, 1N48 no test \$1
- 40 TOP HAT SILICON RECTIFIERS, no test/asst values \$1
- 25 EPOXY RECTIFIERS, silicon asst, no test \$1
- 40 PRECISION RESISTORS, 1/2-2W, 1% asst values .. \$1
- 30 TRANSISTORS, rf, if, audio, osc, no test \$1
- 60 TUBULAR CONDENSERS, to .5mf to 1KV, asst \$1
- 50 DISC CONDENSERS, to .05mf npo, temp coef, asst \$1
- 30 POWER RESISTORS, to 25 watts, to 24K ohms \$1
- 10 VOLUME CONTROLS, to 1 meg, switch too! \$1
- 10 ELECTROLYTICS, to 100mf, tubulars too, asst \$1
- 50 RADIO & TV KNOBS, asst'd colors & styles \$1
- 10 TRANS-TOR ELECTROLYTICS to 100mf, asst values \$1
- 50 COILS AND CHOKES, if, rf, ant, osc, peaking, etc \$1
- 65 HALF WATERS, to 1 meg, 5% popular values too \$1
- 2 FIELD EFFECT TRANSISTORS, n channel, hobby \$1
- 10 PANEL SWITCHES, toggle, slide, micro, rotary .. \$1
- 3 "SUN" BATTERIES, for 100's of lite sens projs \$1
- 5 "IBM" COMPUTER BOARDS, many trans, diodes, .. \$1
- 40 "MICRO" CONDENSERS, for transistor circuitry .. \$1
- 50 TERMINAL STRIPS, 1 to 8 lug types \$1
- 4 PHOTO ELECTRIC CELLS, hi. imp., schematic \$1
- 40 "TINY" RESISTORS, 1/10W, 5% too! to 1 meg. .. \$1

ADD POSTAGE, avg. wt. 1/2 lb. CATALOG 10¢

POLY PAKS

P.O. BOX 942E
LYNNFIELD, MASS.
01940

CIRCLE NO. 25 ON READER SERVICE PAGE

FREE



GIANT 1970
RADIO-TV
ELECTRONICS
CATALOG
270 GIANT
VALUE-PACKED
PAGES

WRITE FOR YOUR FREE COPY TODAY

BURSTEIN-APPLEBEE CO., DEPT. PE-J
3199 MERCIER ST., K.C., MO. 64111

NAME _____

ADDRESS _____

CTY _____ STATE _____ ZIP _____

CIRCLE NO. 8 ON READER SERVICE PAGE

The best base station microphone in the world.



Turner +3

Modern styling. Transistorized pre-amp. Volume control. Modu-Gard™: a compression amplifier circuit that guarantees you cannot over-modulate. Clear signal, always. No interference with adjacent channels, regardless of volume setting. 300-3,000 Hz frequency response for best voice transmission. Relay or electronic switching. Push-to-talk bar. Lock lever. The Best. At your local dealers, list price \$75.00.

The TURNER Company, Inc.

A subsidiary of Conrac Corporation
909 17th St. N.E., Cedar Rapids, Iowa 52402

BRIDGE FUNCTION QUIZ ANSWERS

(Quiz is on page 68)

1-E. A half-bridge amplifier circuit is used in vacuum-tube voltmeters to provide high sensitivity and high input impedance. A "zero set" potentiometer balances no-signal tube currents.

2-D. This quartz-crystal full bridge is a band-pass filter employed in SSB transmitters to obtain the narrow bandwidth required. Within the passband, the impedances of the two pairs of crystals, 1-4 and 2-3, differ widely due to their different resonant frequencies, thus causing the bridge to be unbalanced and permit a large signal output.

3-B. A Wien-bridge band-suppression filter employs series and parallel RC circuits to keep the bridge unbalanced outside the rejection band. Within the band, the impedances of the RC circuits change in opposite directions to balance the bridge and attenuate the output.

4-G. This capacitance measurement circuit is a Schering bridge using standard capacitors to determine the unknown capacitance. Capacitor C1 balances out the resistance of the unknown while C2 is calibrated to indicate the unknown capacitance when the bridge is balanced.

5-C. A Wien-bridge frequency measurement circuit employs two calibrated potentiometers, R1 and R2, varied simultaneously in equal increments to indicate the unknown frequency when the bridge is balanced.

6-A. An inductance measurement circuit is a Maxwell bridge for measuring the inductance of low-Q coils (10 or less) by balancing the reactance of a fixed standard capacitor against that of the coil.

7-J. A modulator circuit using a shunt-type full bridge balances out the r.f. input so that the r.f. carrier is always suppressed and only the upper and lower sidebands are present in the output signals.

8-F. A Wien-bridge RC oscillator circuit for frequency stabilization employs one tube, V1, as an oscillator and a second, V2, to provide a frequency-selective, 180-degree feedback signal.

9-I. A full-bridge rectifier is employed to obtain full-wave rectification of an a.c. signal.

10-H. A resistance measurement circuit in the form of a Wheatstone bridge employs a calibrated potentiometer to indicate the value of an unknown high resistance when the bridge is balanced.

CIRCLE NO. 29 ON READER SERVICE PAGE

POPULAR ELECTRONICS READER SERVICE PAGE

free information service:

Here's an easy and convenient way for you to get additional information about products advertised or mentioned editorially (if it has a "Reader Service Number") in this issue. Just follow the directions below...and the material will be sent to you promptly and free of charge.

1. On coupon below, circle the number(s) that corresponds to the key number(s) at the bottom or next to the advertisement or editorial mention that is of interest to you. (Key numbers for advertised products also appear in the Advertisers' Index.) Print or type your name and address on the lines indicated.

2. Cut out the coupon and mail it to: POPULAR ELECTRONICS, P.O. Box 8391, Philadelphia, PA 19101.

note: If you want to write to the editors of POPULAR ELECTRONICS about an article on any subject that does not have a key number, write to POPULAR ELECTRONICS, One Park Avenue, New York, N.Y. 10016. Inquiries concerning circulation and subscriptions should be sent to POPULAR ELECTRONICS, Portland Place, Boulder, Colo. 80302.

POPULAR ELECTRONICS

P.O. BOX 8391
PHILADELPHIA, PA. 19101

VOID AFTER OCTOBER 31, 1969

1 2 3 4 5 6 7 8 9 10 11 12 13 14 15 16 17 18 19 20
21 22 23 24 25 26 27 28 29 30 31 32 33 34 35 36 37 38 39 40
41 42 43 44 45 46 47 48 49 50 51 52 53 54 55 56 57 58 59 60
61 62 63 64 65 66 67 68 69 70 71 72 73 74 75 76 77 78 79 80
81 82 83 84 85 86 87 88 89 90 91 92 93 94 95 96 97 98 99 100

NAME (Print clearly) _____

ADDRESS _____

CITY _____ STATE _____ ZIP CODE _____

9 b

NEW PRODUCTS

(Continued from page 24)

ture is obtained, resulting in a boost in antenna efficiency. The complete co-phasing kit includes a precision-cut cable and coaxial connectors.

Circle No. 88 on Reader Service Page 15 or 115

HAM/SWL COMMUNICATIONS RECEIVER

Wrapping up the best in both hamming and SWL'ing is the new *Hallcrafters* Model SX-133 communications receiver. For example, the SX-133 has calibrated bandspreading on the four most important SWL bands (49, 31, 25, and 19 meters). Also included in the basic receiver is a two-position crystal-select switch, S-meter, product detector for CW/SSB, noise limiter, etc. A crystal calibrator for checking band edges is an optional extra.

Overall tuning range of the SX-133 is 535-1610 kHz and 1825-31,500 kHz. Mounted on the front panel is a convenient headphone jack. An external speaker is required. This tube-type 117-volt a.c. communications receiver requires only 48 watts input.

Circle No. 89 on Reader Service Page 15 or 115

HOME AND MOBILE CASSETTE PLAYERS

A mini-compact stereo cassette system and a mobile cassette player have been introduced by *Crown-Industrial Suppliers Co.* The a.c./d.c. Model SHC-44 cassette component ensemble for the home consists of a recorder deck, AM/stereo FM tuner, and a pair of speaker systems—all housed in matching teak cabinets. The deck features piano-key-type function controls, cassette eject button, digital tape counter, record-level/battery-condi-



tion indicator, and volume, tone, and selector controls. Frequency range is 100-10,000 Hz; speaker systems each handle up to 5 watts of power. The mobile cassette Model CSC-1000 "Musicruiser" player has a peak power output rating of 20 watts and features easy loading and operation. Other features of the CSC-1000 include a play indicator lamp, balance control, two-step stop and ejection key, etc.

Circle No. 90 on Reader Service Page 15 or 115

"NATURAL SOUND" SPEAKER SYSTEMS

Yamaha International Corp. recently announced the addition of two new models to their "Natural Sound" hi-fi speaker system lineup. Designated the Models NS-15 and NS-

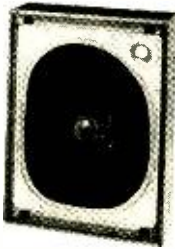

10, these new systems are enclosed in walnut cabinets and are designed to fit into corners or on bookshelves. Unlike conventional cone-type loudspeakers, the Natural Sound speakers are based on the same principle as used in a piano sounding board; they are irregularly shaped and flat instead

of deep. The edge of the speaker cone is locked into an aluminum casting which enables the cone to develop various full-range vibrations through bending motions. Sound reproduction is said to be extremely clear and mellow, with the richness and timbre of a fine musical instrument.

Circle No. 91 on Reader Service Page 15 or 115

NEW/CB TRANSCEIVER SOLID STATE PRE-AMP



- Improves CB Base Station Performance
- Works on tube or transistor equipment
- No Modification to CB unit
- On-the-air sign automatically lights when transmitting

Model PCB with built-in power supply, transfer relay, connecting cables, wired and tested..... \$59.95

Write for free literature



AMECO / DIVISION OF AEROTRON, INCORPORATED
P. O. BOX 6527 • RALEIGH, NORTH CAROLINA 27608

CIRCLE NO. 2 ON READER SERVICE PAGE

MINI-SIX

(Continued from page 50)

for proper operation. Rotating the LP8 clockwise should increase the total volume of sound; clockwise rotation of the LP16 should increase the sound level coming from the two front speakers only.

Final Assembly. Disconnect the amplifier, and fill the enclosure with small cut-up pieces of fiberglass batting. Then cement felt or weather stripping to the top edges of the shell to provide a proper sealing gasket for the enclosure. Set the top panel in place and screw it down.

Starting and ending at the apex of the rear panels, wrap the sides of the enclosure with grille cloth. Cover the exposed edges with 1/4"-wide velvet ribbon or other finishing material.

If you do not have a suitable cross-over network, a simple coil-capacitor arrangement as shown in Fig. 6 will suffice. Capacitor *C1* is a 100- μ F nonpolarized type (if you cannot obtain this value, parallel-connect three 33- μ F, 25-volt nonpolarized capacitors). The coil, *L1*, is homemade, consisting of 1 pound of #18 magnet wire (about 500 turns) wound on a 1"-diameter by 1 1/2"-long coilform made of wood doweling and Masonite. When connecting the Mini-Six to your present speaker system, disconnect the LC network in the system.

When using the Mini-Six, place it so that the apex of the enclosure is about 12" from the reflecting surface. Now, set the LP8 control so that a proper balance is obtained between the bass speaker and the Mini-Six. Then have someone adjust the setting of the LP16 as you move about the room. This control is properly set when a minimum change in the high-frequency response of the system can be detected as you cross the listening area. (For the stereo version, set each Mini-Six system independently.)

As you listen to the composite speaker system in different locations in your listening room, you will come to realize that your favorite listening chair is not so special any more. The big change you will notice is that the Mini-Six adds a feeling of depth and spaciousness that was missing before.

-30-

September, 1969



**Which of these
4 fascinating
Radio-TV
careers**

**interests
you?**

- disc jockey
- newscaster
- sportscaster
- announcer

**Our Free Voice Analysis Tells You
Whether You Have The Talent To
Become A Broadcast Personality!**

IMMEDIATE DEMAND • Radio-TV stations everywhere need both men and women to take over important good-paying jobs right now. **NATIONWIDE PLACEMENT ASSISTANCE** at No Extra Cost.

TRAIN AT HOME OR IN ONE OF OUR STUDIO SCHOOLS • You can study broadcast techniques at home, in your spare time, or in one of our many studio schools throughout the country under the supervision of our Directing Faculty of 11 Famous Broadcasters. Accredited Member National Home Study Council and National Association of Trade and Technical Schools.

**Approved for Veterans' Educational
Assistance Benefits ("G.I. Bill")!**
Check coupon for special information

Send to CAREER ACADEMY's division
of famous broadcasters for free book-
let, record and voice analysis details!

CAREER ACADEMY

825 North Jefferson Street • Studio 452
Milwaukee, Wisconsin 53202



I want to know if I have broadcasting aptitude
worth developing. Please rush more information.

name _____ age _____

address _____ phone _____

city/state/zip _____



I am interested in: Home Study
 School Study G. I. Bill

07N087208

CIRCLE NO. 9 ON READER SERVICE PAGE

117

If you want to get into Electronics

DO IT
THE
RIGHT
WAY!

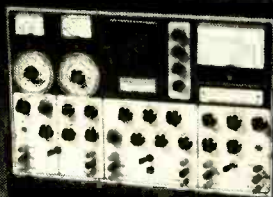

GO TECHNIPAC!

Electronics and Technipac—the right combination. ■ The Technipac System combines a thorough knowledge of electronics with practical application in a progressive and well defined series of Technipacs. A modern program for a modern field. ■ Whether you are a beginner or have had experience in electronics, the Technipac System is designed to meet your individual requirements. ■ *Go electronics with Technipac!*

Technical Training International



203 Lincoln Broadway Bldg.
1475 North Broadway
Walnut Creek, Calif.

Name _____
Address _____
Zip _____ Age _____

CIRCLE NO. 28 ON READER SERVICE PAGE

**COOPERATE WITH
THE ZIP CODE
PROGRAM OF THE
POST OFFICE
DEPARTMENT.
USE ZIP CODE
IN ALL ADDRESSES**

HEAT-SHRINKABLE TUBING

Sale—100 pcs. for \$1.00, ppd.

1" long, 3/16" i.d. shrinks to 3/32" i.d.
Ideal for insulating splices, terminals, and other wiring installations.

SCHAAL ASSOCIATES
4 A STREET, BURLINGTON, MASS. 01803
Tel. 617-272-3250



Self-Contained PG 610 PULSE GENERATOR

Wide Frequency Range—10Hz to 2MHz in 6 overlapping ranges. Compatible with TTL, DTL and RTL. High output duty cycle capability. Short circuit protected. Integral regulated power supply. Rise/fall time typically 15ns. 6.25" x 3.75" x 2.5". Repairable. Send check or M.O. include \$1.00 ea. for postage and handling.

\$119.90 STV 1-3

The New Generation

SHIPMENT
10 DAYS ARO

COMPUTER PRODUCTS 8
Post Office Box 23049
Ft. Lauderdale, Florida 33307
Telephone (305) 565-9565

LIBRARY

(Continued from page 14)

starts the ball rolling by covering the basics of semiconductor devices, starting with the simple PN junction. It then proceeds through progressively more complex circuit explanations, concluding with a thorough discussion of logic-circuit counting and binary arithmetic. Some of the semiconductor devices dealt with in the text include conventional rectifiers, bipolar transistors, field effect transistors, unijunction transistors, tunnel diodes, and silicon controlled rectifiers.

Published by Tab Books, Blue Ridge Summit, Pa. 17214. 224 pages. \$7.95 hard cover; \$4.95 soft cover.

CONDENSED COMPUTER ENCYCLOPEDIA

by Philip B. Jordain

It begins with the phrase, "abnormal statement," and ends with "zone punch," but in the intervening 571 pages, it presents an almost totally new language. This remarkable encyclopedia (it's too detailed to be a dictionary) is everyman's guide to an understanding of what computer programmers and technicians talk about. The author has an unusual grasp of computer technology and has produced a standard reference for anyone working with, in, or around computers—business or scientific.

Published by McGraw-Hill Book Co., 330 West 42 St., New York, N.Y. 10036. Hard cover. 580 pages. \$14.50.

THE RADIO COMMUNICATION HANDBOOK Fourth Edition

Although the two American ham radio handbooks are very popular in Great Britain and the Continent, few hams on this side of the pond realize that the Radio Society of Great Britain (RSGB) publishes an electronics handbook that is no slouch. This Handbook is about twice as wordy and thorough (in the same subject areas) as the ARRL Handbook. This is not to say that the British are long-winded—only that the concepts and circuits are discussed with greater thoroughness. If you have misgivings about the language and terms—don't. A few minutes and a little common sense will make you conversant in British as well as American electronic terminology.

Vacuum tubes play a big part in this Handbook, but solid-state devices are given plenty of recognition. The flow of subject material is smooth and natural and there are approximately 1000 circuit diagrams with parts values. If you use ham radio handbooks as reference material, you shouldn't be without this one.

Published by Radio Society of Great Britain. Available from Comtec, Box 592, Amherst, New Hampshire 03031. Hard cover. 832 pages. \$11.95.

ELECTRONICS MARKET PLACE

COMMERCIAL RATE: For firms or individuals offering commercial products or services. \$1.15 per word (including name and address). Minimum order \$11.50. Payment must accompany copy except when ads are placed by accredited advertising agencies. Frequency discount: 5% for 6 months; 10% for 12 months paid in advance.
READER RATE: For individuals with a personal item to buy or sell. 70c per word (including name and address). No Minimum! Payment must accompany copy.

FOR SALE

FREE! Giant bargain catalog on transistors, diodes, rectifiers, SCR's, zeners, parts. Poly Paks, P.O. Box 942, Lynnfield, Mass. 09140.

GOVERNMENT Surplus Receivers, Transmitters, Snooperscopes, Radios, Parts, Picture Catalog 25¢. Meshna, Nahant, Mass. 09108.

BUG DETECTOR: WILL DETECT AND LOCATE SURREPTITIOUS TRANSMITTING DEVICES IN CONFERENCE ROOMS, HOME AND OFFICES, ETC. WRITE FOR DETAILS. WJS ELECTRONICS, 737 NORTH SEWARD, HOLLYWOOD, CALIF. 90038.

ROCKETS: Ideal for miniature transmitter tests. New illustrated catalog. 25¢. Single and multistage kits, cones, engines, launchers, trackers, rocket aerial cameras, technical information. Fast service. Estes Industries, Dept. 18, Penrose, Colorado 81240.

LOWEST Prices Electronic Parts. Confidential Catalog Free. **KNAPP, 3174 8th Ave. S.W., Largo, Fla. 33540.**

TREASURE Hunters! Prospectors! Relco's new instruments detect buried gold, silver, coins. Kits, assembled models. Transistorized. Weighs 3 pounds. \$119.95 up. Free catalog. Relco-A33, Box 10839, Houston, Texas 77018.

EUROPEAN and Japanese bargains catalogs. \$1 each. Dee, 10639E Riverside, North Hollywood, Calif. 91602.

MECHANICAL, ELECTRONIC devices catalog 10¢. Greatest Values—Lowest Prices. Fertik's, 5249 'D', Philadelphia, Pa. 19120.

MUSIC LOVERS, CONTINUOUS, UNINTERRUPTED BACKGROUND MUSIC FROM YOUR FM RADIO, USING NEW INEXPENSIVE ADAPTOR. FREE LITERATURE. ELECTRONICS, 11500-Z NW 7th AVE., MIAMI, FLORIDA 33168.

WE SELL CONSTRUCTION PLANS. TELEPHONE: Answering Machine, Speakerphone, Carphone, Phonovision, Legal Connector, Auto Dialer, Central Dial System. **TELEVISION:** \$35.00 Color Converter, Tape Recorder, 3DV. \$25.00 Camera. **OBJECTIVE:** Infinity Transmitter, Tail Transmitter, Police Radar Detector. **HOBBYIST:** Electron Microscope, 96 Hour Tape Music System, Ultrasonic Dishwasher, Radar-Oven, Electronic Tranquilizer. Plans \$4.95 each. **COURSES:** Telephone Engineering \$39.50, Detective Electronics \$22.50, Anti-Detective Electronics \$27.50. **SUPER HOBBY CATALOG 25¢.** Don Britton Enterprises, 7906 Santa Monica Blvd., Hollywood, Calif. 90046.

WEBBER LAB's. Police & Fire Converters. Catalog 10¢. 72 Cottage Street, Lynn, Mass. 09105.

RADIO—T.V. Tubes—33¢ each. Send for free catalog. Cornell, 4213 University, San Diego, Calif. 92105.

WHOLESALE COMPONENTS: Manufacturers and distributors only. Request free catalog on business letterhead. **WESCOM, Box 2536, El Cajon, California 92021.**

INVESTIGATORS, LATEST ELECTRONIC AIDS. FREE LITERATURE. CLIFTON, 11500-L NW 7th AVE., MIAMI, FLORIDA 33168.

CONVERT any television to sensitive, big-screen oscilloscope. Only minor changes required. No electronic experience necessary. Illustrated plans, \$2.00. Relco-A33, Box 10563, Houston, Texas 77018.

TV CAMERA PRICE BARRIER BROKEN: Complete solid-state TV camera kit now only \$116.95. Starter kits \$18.95 up. Plans 25¢ up. Easy-educational-economical. Also vidicons, lenses, modules, etc. Catalog FREE. **ATV RESEARCH, 1301 Broadway, Dakota City, Nebr. 68731.**

ELECTRONIC ignition, various types. Free literature. Anderson Engineering, Epsom, N.H. 03239.

FREE ELECTRONICS PARTS FLYER. Large catalog \$1.00 deposit. **BIGELOW ELECTRONICS, BLUFFTON, OHIO 45817.**

GENERAL INFORMATION: First word in all ads set in bold caps at no extra charge. Additional words may be set in bold caps at 10c extra per word. All copy subject to publisher's approval. Closing Date: 1st of the 2nd preceding month (for example, March issue closes January 1st). Send order and remittance to: Hal Cymes, **POPULAR ELECTRONICS, One Park Avenue, New York, New York 10016.**

HOBBYISTS, EXPERIMENTERS, amateur scientists, students . . . Construction Plans—All complete including drawings, schematics, parts list with prices and sources . . . Laser—Build your own coherent-light optical laser. Operates in the visible light range, pulsed mode—\$6.00 . . . Radar—Build your own ultrasonic doppler radar. Detect motion of people, automobiles, even falling rain drops. Transistorized, uses standard small 9-volt battery—\$4.00 . . . Tic Tac Toe Machine—You play against machine. Automatic. Can you beat the machine? Sometimes yes, usually no—\$4.00 . . . Long Range "Sound Telescope"—This amazing device can enable you to hear conversations, birds, other sounds hundreds of feet away. Very directional. Transistorized, uses 9-volt battery—\$3.00 . . . Or send 25¢ coin or stamps for complete catalogue . . . Technical Writers Group, Dept. C, Box 5994, State College Station, Raleigh, N.C. 27607.

JAPAN & HONG KONG DIRECTORY. Electronics, all merchandise. World trade information. \$1.00 today. Ippano Kaisha Ltd., Box 6266, Spokane, Washington 99207.

CIRCUIT Boards, Parts for "Poptronics" projects. Free catalog. S.W. Technical, Box 16297, San Antonio, Texas 78216.

LINEAR AMPLIFIERS: "Hawk"—25 watts output—\$59.95; "Hornet" 50 watts output—\$98.50; "Raider"—100 watts—\$139.50; "Maverick-250"—250 watts—\$244.95; AM and SSB. "Scorpion"—50 watt 12 V. Mobile amplifier—\$99.95; "Bandit II"—12 V. Mobile Amplifier—\$169.95. Frequency range 20-35 megacycles (illegal for class D 11 meters.) Dealer inquiries invited. D & A Manufacturing Co., 1217 Avenue C, Scottsbluff, Nebraska 69361.

FREE Catalog low priced, high performance subminiature listening devices direct from manufacturer. Emery LT-9, 156 Fifth Avenue, New York, N. Y. 10010.

ULTRA-SENSITIVE AND POWERFUL METAL DETECTORS—join the many who are finding buried coins, minerals, relics and artifacts. Don't buy till you see our **FREE** catalog of new models. Write Jetco, Box 132-PE, Huntsville, Texas 77340.

LASER parts catalog 60¢. Moynihan, 107 North Brighton, Atlantic City, New Jersey 08401.

DIAGRAMS—Radios \$1.50, Television \$3.00. Give make and model. Diagram Service, Box 1151PE, Manchester, Conn. 06042.

"GIZMOTCHY" CB beams, dealers wanted Box 1820, Huntington Beach, Calif. 92647.

ULTRA-SENSITIVE TELEPHONE ADAPTOR \$2.00. Deluxe model \$3.00. Protecto Phone-X-9, 156 Fifth Avenue, New York, N.Y. 10010.

STROBES, COLOR ORGANS, THE INCREDIBLE STROBIT. Factory prices. Save 25-50%. Catalog 25¢, refunded first order. Teletronics, Box 1266, South Lake Tahoe, CA 95705.

GERMAN and Japanese tubes and parts. Send \$1.00 for price list. The Matthews Company, Box 151, Lawton, Oklahoma 73501.

PSYCHEDELIC catalog. Posters, lighting, etc. Send 25¢ for handling to Hole In The Wall, 6055PE Lankershim, North Hollywood, Calif. 91606.

PSYCHEDELIC STROBES 200 flashes per-min. \$14.95 Guaranteed. Zipcom, 5620 W. 12, L.R., Arkansas 72204.

NEW heavy duty CD ignition system. Details free. Kit, \$28.95; assembled, \$39.95. Delta International, Ltd., Box 1946Z, Grand Junction, Colo. 81501. Dealers invited.

CONSTRUCTION PLANS: LASER . . . \$2.00. Surveillance Devices—two F.M. Bugging Transmitters . . . \$1.00. Tail Transmitter . . . \$1.00. Bug Detector . . . \$1.00. Surveillance equipment and kits available. Howard, 20174 Ward, Detroit, Michigan 48235.

SENCORE TEST EQUIPMENT UNBELIEVABLE PRICES. FREE CATALOG AND PRICE SHEET. FORDHAM RADIO, 265 EAST 149TH STREET, BRONX, N.Y. 10451.

CONVERT any television into Oscilloscope (simplest), **SECRET** Automatic Telephone Recorder, **REMOTE** Telephonic Intrusion Alarm. Detailed, Illustrated Plans \$1.95 each. 3 for \$4.95. **WESTERN**, 28 E. 5199 Kearny Villa, San Diego, California 92123.

INTEGRATED circuits, transistor circuit design. Informative solid state articles. Cates Electronics, Rt. 2, Box 13A, Doniphan, Mo. 63935.

FREE CATALOG over 80 different solid state electronic products. **NEW** Electronic Strobe Kit, \$9.95 ppd. See complete line of Bowman solid state products at your local authorized dealer. **BOWMAN ELECTRONICS, INC.**, 155 E. 1st Ave., Roselle, N. J. 07203.

RECHARGEABLE EVEREADY NI-CAD BATTERY, 8.75 vdc 1/2 amp. hr. 1 3/8" diameter by 2 3/4" long. \$2.95 ea., 6 for \$15.00. Peak Electronics Co., 122 Herricks Rd., Mineola, N.Y. 11501.

FM BACKGROUND MUSIC! Miniaturized adapter connects to any FM Radio Tuner. Brings in hidden commercial free programs. Performance guaranteed. \$29 postpaid. K-Lab, Dept. Z, Box 572, S. Norwalk, Conn. 06856.

RELAYS: Latching, reed, etc. Computer quality. Information available. **GREATER DETROIT ELECTRONICS**, 22051 Ivanhoe, Southfield, Michigan 48075.

"ELECTRONICS" HEADACHE? Play **ELECTROGRAM!** . . . game of schematic diagraming. Relaxing-educational! \$5.00 postpaid. **ATV RESEARCH**, 1301 Broadway, Dakota City, Nebr. 68731.

FREE TV TUNER REPAIR TRICKS, Plans, Details, complete courses: Frank Bocek, Box 3236A, Redding, Calif. 96001.

RESISTOR PROBLEMS? Too expensive? No longer! 1/2w only 8¢; 10/60¢ assorted. Garrett Industries, 4504 Nunnwood, Lakeland, Florida 33803.

SONAR Monitor Receivers unsurpassed. Fire, police, ambulance, Taxi, highway patrol communications. Free antenna offer. Griffin's 322 West State, Ithaca, N.Y. 14850.

HEAR POLICE or FIRE CALLS with a **TROJAN MOBILE CONVERTER** in your car. **HIGH SENSITIVITY**. Crystal controlled for **NO DRIFT**. Complete with **NEW NOISE GATE** to help eliminate noise. **GUARANTEED**. VHF-150-174 Mhz with 1 crystal—\$34.95, 2 crystals \$39.95. UHF-450-475 Mhz 1 crystal only—\$34.95. Give exact frequency. Banner Corporation, Box 18065-A1, Indianapolis, Indiana 46218.

TECH MANUALS, and service data for Surplus Electronics. Thousands of publications on hand, covering Army, Navy, and Air Force equipment. Sorry no catalogs, but will rush price and availability quotes for specific literature that you may need. Propagation Products Corp., P.O. Box 242, Jacksonville, Florida 32201.

PLANS AND KITS

KITS, metal detector \$5.95. Audio Telescope \$5.95, others. Lectronix, Box 42, Madison Heights, Michigan 48071.

SOLAR FLYING SAUCERS. (Brand New Solid State Engine, Fantastic Performance, Flies Miles on Sun's Power, lifts animals, sends messages, parachutes. Build many, easily, inexpensively with everyday materials. Complete plans, descriptions, drawings, plus **FREE Space-tronic CATALOG** \$1. Single Catalog 25¢. Spacetrronics, Box 31043-PES, San Francisco, California 94131.

RADAR INTRUDER ALARM detects human movement thirty feet away. **TRANSISTORIZED. BUILD YOURSELF** with complete instructions. Parts, kits and assembled units also available. Plans \$3.00. Microwave Research Co., Box 10147, St. Petersburg, Florida 33733.

"ONE TUBE OX HANDBOOK"—50¢. "Coil Winding"—50¢. Catalog. Laboratories, 12041-L Sheridan, Garden Grove, Calif. 92640.

LOW COST 115V AC inverter combination battery charger. Boats, autos, emergency power 500W plans \$1.50. Ken Electric, 922 S. Toledo, Tulsa, Okla. 74112.

SUPER Distance AM Broadcast Reception. "Music Magnet" Kit \$2.95. Information 25¢. Rand Laboratories, Winthrop, Maine 04364.

TESIA COIL—40" SPARKS! Plans \$5.00. Information 50¢. Huntington Electronics, Box 9-P, Huntington, Conn. 06484.

DECIMAL COUNTING UNIT-RTL-ZM1000 Tube Readout. Kit \$32.98. Catalogue 10¢. Export Inquiries. Kappa, Box 191, Station "T", Toronto 19, Ontario.

MINIATURE combination electronic lock. Computer logic with IC's Automatic alarm/disabler against incorrect combination. Auto. store, anywhere, under \$15 to build. Plans 50¢. Logan, 403 Lakewood Circle, Virginia Beach, Virginia 23451.

AUDIO your hobby? Details on advanced plans, projects free. Sonic, 307 Dickinson, Swarthmore, Pa. 19081.

INTEGRATED CIRCUIT KITS: COMPUTER, AUDIO. Others. New catalog free. **KAYE ENGINEERING**, Box 3932-A, Long Beach, California 90803.

COLOR Organ Kit \$7.50, power supplies \$3.98. Catalog. Murphy, 204 Roslyn Ave., Carle Place, N.Y. 11514.

SHORTWAVE LISTENING

POLICE—FIRE—AIRCRAFT—MARINE-AMATEUR—ETC. CALLS on your broadcast radio with **TUNAVERTER!** Tunable-crystal controlled! Free catalog. Salch Co., Woodsboro-PECC, Texas 78393.

HIGH FIDELITY

FREE! Send for money saving stereo catalog ±P9E, lowest quotations on your individual component, tape recorder, or system requirements. Electronic Values, Inc., 200 W. 20th St., New York, N.Y. 10011.

DON'T THROW YOUR OLD CARTRIDGE AWAY. Send us \$19.95 and any old cartridge. We will ship **PREPAID** any one of the following top rated elliptical diamond stereo cartridges **NEW:** Shure M75E, M91E, M92E, M93E, Empire 888E, Pickering V15AME3, XV15 ATE, ADC 660E, 550E. Write for lowest quotations all stereo components. **DEFA ELECTRONICS**, 2207 Broadway, New York, N.Y. 10024.

HI-FI Components, Tape Recorders, at guaranteed "We Will Not Be Undersold" prices. 15-day money-back guarantee. Two-year warranty. No Catalog. Quotations Free. Hi-Fidelity Center, 239 (P) East 149th Street, New York 10451.

LOW, Low quotes: all components and recorders. HiFi, Roslyn, Penna. 19001.

TAPE RECORDERS, Hi-Fi, components, Sleep Learning Equipment, tapes. Unusual Values. Free Catalog. Dressner, 1523R, Jericho Turnpike, New Hyde Park, N.Y. 11040.

DON'T THROW YOUR OLD CARTRIDGE AWAY. Send us \$50.00 and any old used cartridge and we will ship you via air Prepaid anywhere any one of the following Top Stereo Cartridges: Shure V-15 Type II, Empire 999VE, ADC 10EMK 11, Stanton 681EE. Write for lowest quotations all stereo components. **DEFA ELECTRONICS**, 2207 Broadway, New York, N.Y. 10024.

WANTED

CASH PAID! Unused tubes, electronic equipment. Barry, 512 Broadway, NYC 10012.

QUICKSILVER, Platinum, Silver, Gold, Ores Analyzed. Free Circular. Mercury Terminal, Norwood, Mass. 02062.

CASH PAID for all tubes. **DAMESCO**, 308 Hickory, Arlington, N.J. 07032.

TUBES

TUBES "Oldies", latest. Lists free. Steinmetz, 7519 Maplewood, Hammond, Indiana 46324.

RECEIVING & INDUSTRIAL TUBES, TRANSISTORS. All Brands—Biggest Discounts. Technicians, Hobbyists, Experimenters—Request **FREE** Giant Catalog and **SAVE!** **ZALYTRON**, 469 Jericho Turnpike, Mineola, N.Y. 11501.

TUBE Headquarters of World! Send 10¢ for Catalog (tubes, electronic equipment) Barry, 512 Broadway, N.Y.C. 10012.

RADIO & T.V. Tubes—33¢ each. Send for free list. Cornell, 4213 University, San Diego, Calif. 92105.

THOUSANDS and thousands of types of electronic parts, tubes, transistors, instruments, etc. Send for Free Catalog. Arcturus Electronics Corp., MPE, 502-22nd St., Union City, N.J. 07087.

TUBES—lowest prices in the world. Hard to get British, German, Foreign and American obsolete and present day special purpose transmitting tubes. Send for giant tube and parts catalog. United Radio Co., Dept. Y-56 Ferry Street, Newark, N.J. 07105.

TV TUBES UP TO 75% OFF LIST. For catalog price sheets send 30¢ stamps. T & T Sales Co., 4802 Ave. K, Brooklyn, N. Y. 11234.

RADIO & TV TUBES. 35¢. send for free lists. Micro Electron Tube Co., Box 55, Paterson, N.J. 07503.

TAPE AND RECORDERS

TAPES . . . blank recording . . . pre-recorded music. Catalog 10¢. Tower, Lafayette Hill, Pa. 19444.

BEFORE Renting Stereo Tapes try us. Postpaid both ways—no deposit—immediate delivery. Quality—Dependability—Service—Satisfaction—prevail here. If you've been dissatisfied in the past, your initial order will prove this is no idle boast. Free Catalog. Gold Coast Tape Library, Box 2262, Palm Village Station, Hialeah, Fla. 33012.

RENT 4-Track open reel tapes—all major labels—3,000 different—free brochure. Stereo-Parti, 55 St. James Drive, Santa Rosa, Ca. 95401.

TAPEMATES makes available to you **ALL 4-TRACK STEREO TAPES—ALL LABELS**—postpaid to your door—at tremendous savings. For free brochure write: **TAPEMATES**, 5727 W. Jefferson Blvd., Los Angeles, California 90016.

TAPE RECORDER SALE. Brand new nationally advertised brands. \$10.00 above cost. Amazing discounts on stereo components. Arkay Electronics, 1028-C Commonwealth Avenue, Boston, Mass. 02215.

STEREO TAPES. Save 30% and up; no membership or fees required; postpaid anywhere U.S.A. Free 70-page catalog. We discount batteries, recorders, tape/cassettes. Beware of slogans. "not undersold", as the discount information you supply our competitor is invariably reported to the factory. **SAXITONE**, 1776 Columbia Road, N.W., Washington, D.C. 20009.

STEREO TAPES, CARTRIDGES, CASSETTES, REELS. 33% DISCOUNT. UNAVAILABLE ELSEWHERE. MAIL 20¢—CATALOGS. STAR RECORDINGS-PE, BOX 1055, EL PASO, TEXAS 79946.

CASSETTE blanks, also educational and language, accessories and recorders. Literature—Write **CASSETTES UNLIMITED**, P.O. Box 13119-P, Pittsburgh, Pa. 15243.

REPAIRS AND SERVICES

TV Tuners rebuilt and aligned per manufacturers specification. Only \$9.50. Any make UHF or VHF Ninety day written guarantee. Ship complete with tubes or write for free mailing kit and dealer brochure. **JW Electronics**, Box 51C, Bloomington, Indiana 47401.

PERSONALS

MAKE FRIENDS WORLDWIDE through international correspondence. Illustrated brochure free. **Hermes**, Berlin 11, Germany.

INVESTIGATORS, LATEST ELECTRONIC AIDS. FREE LITERATURE. CLIFTON, 11500-K NW 7th AVE., MIAMI, FLORIDA 33168.

SECRET LOANS BY MAIL. Borrow \$100 to \$1500 for any good reason in absolute privacy. No interviews, no endorsers, no co-signers. Fast service. Write **Dial Finance Co.**, Dept. J-593, 410 Kilpatrick Bldg., Omaha, Nebraska 68102.

SECRET plans revealed. Free brochure, **Audiotronix E9**, 156 Fifth Avenue, New York, N.Y. 10010.

INSTRUCTION

LEARN ACCIDENT INVESTIGATION. Train at home to earn \$750 to \$1,000 monthly. Car furnished. Expenses paid, no selling. No college needed. Full or spare time. Men urgently needed. Free placement service. Write for **FREE** information, No obligation, **Universal Schools CZ-9**, 6801 Hillcrest, Dallas, Texas 75205.

SHIP RADIO OFFICER TRAINING—SHIPS have been held up awaiting needed personnel, train now at Long Beach, the home of the **Queen Mary**. Radio Officers earn a large base pay plus overtime. Write for free information, **Western Technical School**, 4940 Long Beach Blvd., Long Beach, Calif. 90805, Desk B. Approved for Veterans.

LEARN ELECTRONIC ORGAN SERVICING at home all makes including transistor. Experimental kit—trouble shooting. Accredited **NHSC**. Free Booklet. **MILES BRYANT SCHOOL**, 3631 Stockton, Dept. A, Sacramento, Calif. 95820.

FCC First Class License in six weeks—nation's highest success rate—approved for **Veterans Training**. Write **Elkins Institute**, 2603B Inwood Road, Dallas, Texas 75235.

R.E.I.'s famous (5) week course for the **First Class Radio Telephone License** in the shortest, most effective course in the nation. Over 98% of **R.E.I.** graduates pass **F.C.C.** exams for 1st class license. Total tuition \$360.00. Job placement free. Write for brochure. **Radio Engineering Incorporated Schools**, 1336 Main Street, Sarasota, Florida 33577—or 3123 Gillham Road, Kansas City, Missouri 64109—or 809 Caroline Street, Fredericksburg, Virginia 22401—or 625 E. Colorado Street, Glendale, California 91205.

FCC FIRST CLASS LICENSE THROUGH TAPE RECORDED LESSONS. Our seventeenth year teaching **FCC** license courses. **Radio License Training**, 1060D Duncan, Manhattan Beach, Calif. 90266.

DEGREE in **Electronics Engineering** earned mostly by correspondence. Free brochure. Dept. G-9, **Grantham School of Engineering**, 1505 N. Western Ave., Hollywood, California 90027.

YOU CAN LEARN ELECTRONICS—GUARANTEED write to **Adamson Educational Services**, 921 South Fircroft, West Covina, Calif. 91790.

CLASSIFIED ADVERTISING ORDER FORM

Please refer to heading on first page of this section for complete data concerning terms, frequency discounts, closing dates, etc.

1	2	3	4	5
6	7	8	9	10
11	12	13	14	15
16	17	18	19	20
21	22	23	24	25
26	27	28	29	30
31	32	33	34	35

Words { @ 70¢ (Reader Rate) } = \$ _____
 { @ \$1.15 (Commercial Rate) }

Insert _____ time(s) Total Enclosed \$ _____

NAME _____

ADDRESS _____

CITY _____ STATE _____ ZIP _____

Signature _____

WORD COUNT: Include name and address. Name of city (Des Moines) or of state (New York) counts as one word each. Zip Code numbers not counted. (Publisher reserves right to omit Zip Code if space does not permit.) Count each abbreviation, initial, single figure or group of figures or letters as a word. Symbols such as 35mm, COD, PO, AC, etc., count as one word. Hyphenated words count as two words.

PE-969

HIGHLY effective home study courses in Electronics Engineering Technology and Electronics Engineering Mathematics. Earn your Degree. Write for Free Descriptive Literature. Cook's Institute of Electronics Engineering (Dept. 16), P.O. Box 10634, Jackson, Miss. 39209. (Established 1945.)

LEARN WHILE ASLEEP, Hypnotize! Strange catalog free. Auto-suggestion, Box 24-ZD, Olympia, Washington 98501.

FOLLOW THE LEADER—the nation's original four week F.C.C. 1st Class License Course. Tuition: \$295.00. Results guaranteed. Tennessee Institute of Broadcasting, 2106-A 8th Ave., South, Nashville, Tenn. 37204, or, Technical Institute of Broadcasting, 800 Silver Lane, East Hartford, Conn. 06106.

AUTHORS' SERVICES

AUTHORS! Learn how to have your book published, promoted, distributed. FREE booklet "ZD," Vantage, 120 West 31 St., New York 10001.

INVENTIONS WANTED

INVENTORS wanted. Patented; unpatented. Global Marketing Service, 2420-P 77th, Oakland, Calif. 94605.

PATENT Searches including Maximum speed, full airmail report and closest patent copies, \$6.00. Quality searches expertly administered. Complete secrecy guaranteed. Free Invention Protection forms and "Patent Information." Write Dept. 9, Washington Patent Office Search Bureau, 711 14th Street, N.W., Washington, D.C. 20005.

INVENTORS! OUR FREE EXPERT ANALYSIS of your invention can save valuable time, help you realize full sale value. Strictly confidential. **FREE INVENTION CERTIFICATE.** Write today: Pioneer Invention Service, Dept. 35, 150 Broadway, New York, N.Y. 10038.

INVENTORS! Sell your invention for cash or royalties! Our client manufacturers eagerly seek new items. Patented. Unpatented. Financial assistance if needed. 25 years proven performances. For free information, write Dept 20, Gilbert Adams, Invention Broker, 80 Wall St., New York, N.Y. 10005.

FREE "Directory of 500 Corporations Seeking New Products." For information regarding development, sale, licensing of your patented/unpatented invention. Write: Raymond Lee Organization, 230-GR Park Avenue, New York City 10017.

INVENTORS: Protect your ideas! Free "Recommended Procedure". Washington Inventors Service, 422T Washington Building, Washington, D.C. 20005.

PATENT SEARCHES, including copies of related United States Patents. Inventors, attorneys, manufacturers use our "World-Wide" Airmail service Free: "Invention Record" form and "Information Every Inventor Needs", Hayward Company, 1029HR Vermont, Washington, D.C. 20005.

FREE PAMPHLET: "Tips on Safeguarding Your Invention." Write: United States Inventors Service Company, 501-H Thirteenth Street N.W., Washington, D.C. 20004.

INVENTORS! Don't sell your invention, patented or unpatented, until you receive our offer. Eagle Development Company, Dept. P, 79, Wall Street, N.Y., N.Y. 10005.

GOVERNMENT SURPLUS

JEEPS Typically From \$53.90 . . . Trucks From \$78.40 . . . Boats, Typewriters, Airplanes, Multimeters, Oscilloscopes, Transceivers, Electronics Equipment. Wide Variety, Condition. 100,000 Bid Bargains Direct From Government Nationwide Complete Sales Directory and Surplus Catalog \$1.00. (Deductible First \$10.00 Order). Surplus Service, Box 820-J, Holland, Michigan 49423.

GOVERNMENT Surplus How and Where to Buy in Your Area. Send \$1.00 to: Surplus Information PE, Headquarters Building, Washington, D.C. 20036.

BOOKS

FREE catalog 950 aviation/electronic/space books. Aero Publishers, 329PE Aviation Road, Fallbrook, California 92028.

UNUSUAL Books! Catalog free! International, Box 7798 (PE), Atlanta, Georgia 30309.

AMAZING self help books. Write Lynn, Box 1573, Waco, Texas 76703.

FREE Book Prophet Elijah Coming Before Christ. Wonderful Bible Evidence. PE Megiddo Mission, Rochester, New York 14619.

MAGAZINES

BACK DATE MAGAZINES! Send needs. Midtown, Box 917-PE, Maywood, N.J. 07607.

MAGIC MAGAZINE—Monthly since 1936. 44 pages. All phases. 3 month trial \$1.00. Genii, P.O. Box 36068, Los Angeles, CA 90036.

HYPNOTISM

FREE Hypnotism. Self-Hypnosis, Sleep Learning Catalog! Drawer H400, Ruidoso, New Mexico 88345.

"MALE-FEMALE HYPNOTISM" EXPOSED, EXPLAINED! "SECRET METHOD"—THEY NEVER KNOW! \$2, RUSHED. GUARANTEED! ISABELLA HALL, SILVER SPRINGS, FLORIDA 32688.

HYPNOTIC sleep learning recordings produce fabulous results. Details Free. ASR Foundation, Box 7021eg Henry Clay Station, Lexington, Ky. 40502.

HYPNOTIZE MALES, FEMALES!—Unnoticed! Quickly! Nerves! Exciting! \$2.25. Research Enterprises, 29-SN21 Samoset, Woburn, Mass. 01801.

MAGNETS

MAGNETISM (100) page script newly discovered magnetic principles (\$3.00). Jesse Costa, Box 26, Waquoit, Mass. 02536.

MAGNETS. All types. Special—20 disc magnets, or 2 stick magnets, or 10 small bar magnets, or 8 assorted magnets, \$1.00 Maryland Magnet Company, 5412-H Gist, Baltimore, Maryland 21215.

PHOTOGRAPHY—FILM, EQUIPMENT, SERVICES

SCIENCE Bargains Request Free Giant Catalog "CJ"—148 pages—Astronomical Telescopes, Microphones, Lenses, Binoculars, Kits, Parts. War surplus bargains. Edmund Scientific Co., 300 Edscorp Bldg., Barrington, New Jersey 08007.

FINE GRAIN PROCESSING 90¢. B&W 8x10's 75¢. 35mm SPECIALISTS, P.O.B. #5871, Pasadena, Calif. 91107.

BLOW-UP—rush any photo—receive giant poster 2' x 3' \$4.98, 3' x 4' \$7.98. Refundable. Stoadry, Whitestone, New York 11357.

INTRODUCTORY SPECIAL—12 exposure Kodacolor developed for \$2.00 with this ad. Expires March 1, 1970. Paul Bunyan Photo, Box 309P31, Brainerd, Minnesota 56401.

DYNACHROME, ANSCOCHROME film—save by mail, free price list. Hillis Products, Box 1182, Kokomo, Indiana 46901.

RECORDS

SPECIAL INTEREST RECORDS AVAILABLE, PRODUCED BY THE EDITORS OF THE WORLD'S LEADING SPECIAL INTEREST MAGAZINES. SEND FOR FREE CATALOG. RECORD CATALOG-PE, ZIFF-DAVIS PUBLISHING COMPANY, ONE PARK AVENUE, NEW YORK, N.Y. 10016.

OLDIES—45RPM original hits. Over 4000 available. Catalog 25¢. C & S Record Sales. Box 197, Wampsville, N.Y. 13163.

POPULAR organ albums factory direct. Concert Recording, Lynwood, Calif. 90262.

PRINTING

FREE LITERATURE: Address labels, business cards, printing, Rubber Stamps. JORDAN's, 552 West O'Connor, Lima, Ohio 45801.

RUBBER STAMPS

RUBBER ADDRESS STAMP \$2.00. Signature \$3.50. Free catalog. Jackson, Box 443-G, Franklin Park, Ill. 60131.

STAMPS

RUSSIA High-Value Collection. 32 different Russia—some over 50 years old! Commemoratives, Czarist Issues, Airmails. Catalog price \$2.50. Special Get-Acquainted Offer—all for only 10¢! H. E. Harris, Dept. GG-54, Boston, Mass. 02117.

EMPLOYMENT INFORMATION

FOREIGN and USA job opportunities available now. Construction, all trades. Earnings to \$3,000.00 monthly. Paid overtime, travel bonuses. Write: Universal Employment, Woodbridge, Conn. 06525.

BUSINESS OPPORTUNITIES

RAISE Rabbits for us on \$500 month plan. Free details. White's Rabbitry, Mt. Vernon, Ohio 43050.

FREE CATALOGS. Repair air conditioning, refrigeration. Tools, supplies, full instructions. Doolin, 2016 Canton, Dallas, Texas 75201.

PIANO TUNING learned quickly at home. Tremendous field! Musical knowledge unnecessary. GI Approved. Free Information. Empire School, Miami, Florida 33145.

FREE Book "990 Successful Little Known Businesses" Work home. Plymouth 345J, Brooklyn, N.Y. 11218.

ELECTROPLATING Equipment and supplies. All types for home workshops and industrial. Send \$2.00 (refundable) for equipment guide formulas, operating data, catalog. HBS Equipment Division 90, 3543 East 16th, Los Angeles, California 90023.

MADE \$40,000.00 Year by Mailorder! Helped others make money! Start with \$10.00—Free Proof. Torrey, Box 318-N, Ypsilanti, Michigan 48197.

\$200.00 DAILY In Your Mailbox! Your opportunity to do what mail-order experts do. Free details. Associates, Box 136-J, Holland, Michigan 49423.

SELL HERTEL BIBLES—Part Time. Finest reference Bible available. Demonstrator and supplies furnished. Excellent commissions. Write International Book, Dept. PE, Box 118, Wichita, Kansas 67201.

MAILORDER. . . . Positively No Investment in products! Details: Methods, 1418-F.D. Lafayette Hill, Pennsylvania 19444.

HOW TO FINANCE YOUR OWN BUSINESS. 1000 sources. \$500 to \$200,000. Free details. Counselor-48, Kerrville, Texas 78028.

MAILORDER! How to prepare your own catalog for pennies . . . without merchandise investment! Free catalog! Obie, 5711-ES 14th, Brooklyn, New York 11219.

RADIO-TELEVISION Dealers & Repairmen. Want sales increased? Proven copyrighted system. \$5.00. Speaver's, Drawer C, New Sarpy, Louisiana 70078.

REAL ESTATE

NEW . . . FALL-WINTER CATALOG! Describes and pictures hundreds of farms, ranches, town and country homes, businesses coast to coast! Specify type property and location preferred. Zip code, please. **UNITED FARM AGENCY**, 612-EP West 47th St., Kansas City, Mo. 64112.

PLASTICS

NEW Liquid Plastic hardens like glass without heat. Clear. Colors. Embed real flowers, photos, coins. Create unusual craft objects for big profits at home. Illustrated. **HOW** Booklet—25¢. Dept. 9/105K, **CASOLITE**, Woodstock, Ill. 60098.

MISCELLANEOUS

WINEMAKERS: Free illustrated catalog of yeasts, equipment. Semplex, Box 12276, Minneapolis, Minn. 55412.

BILLS paid without borrowing—Nobody refused up to \$10,000.00. Bad credit no problem, not a Loan Company. Write for free application. **INTERNATIONAL ACCEPTANCE**, Dept. 50-A, 5133 N. Central Ave., Phx., Arizona 85012; 2511 E. 46th Street, Indianapolis, Ind., 46205; 711 14th St., N.W., Washington, D.C. 20005; 507 Carondelet St., New Orleans, La. 70130.

UP to \$151 daily track wins with scientific computer. \$2 stakes. Proof supplied. Free details: RH-P11, 5715, Carmel, Calif. 93921.

BEERS, PEACH BRANDY, WINES—Strongest Formulas. \$2.25. (hydrometers and brew supplies catalog included)—Research Enterprises, 29-D Samoset, Woburn, Mass. 01801.

SKIBOBING!! EXCITINGEST WINTER SPORT!! EQUIPMENT WHOLESALE-RETAIL. LITERATURE 50¢. 1704 MARYLAND, ST. PAUL, MINNESOTA 55106.

32 PAGE big illustrated joke and novelty catalog. 25¢. Joke, Box 7212JJ, Chicago 60680.

ABOUT YOUR SUBSCRIPTION

Your subscription to **POPULAR ELECTRONICS** is maintained on one of the world's most modern, efficient computer systems, and if you're like 99% of our subscribers, you'll never have any reason to complain about your subscription service.

We have found that when complaints do arise, the majority of them occur because people have written their names or addresses differently at different times. For example, if your subscription were listed under "William Jones, Cedar Lane, Middletown, Arizona," and you were to renew it as "Bill Jones, Cedar Lane, Middletown, Arizona," our computer would think that two separate subscriptions were involved, and it would start sending you two copies of **POPULAR ELECTRONICS** each month. Other examples of combinations of names that would confuse the computer would include: John Henry Smith and Henry Smith; and Mrs. Joseph Jones and Mary Jones. Minor differences in addresses can also lead to difficulties. For example, to the computer, 100 Second St. is not the same as 100 2nd St.

So, please, when you write us about your subscription, be sure to enclose the mailing label from the cover of the magazine—or else copy your name and address exactly as they appear on the mailing label. This will greatly reduce any chance of error, and we will be able to service your request much more quickly.

POPULAR ELECTRONICS SUBSCRIBER SERVICE

Please include an address label when writing about your subscription to help us serve you promptly. Write to: Portland Pl., Boulder, Colo. 80302

CHANGE OF ADDRESS: Please let us know you are moving at least four to six weeks in advance. Affix magazine address label in space to the right and print new address below. If you have a question about your subscription, attach address label to your letter.

TO SUBSCRIBE: Check below.

5 yrs. \$20 3 yrs. \$13
 1 yr. \$5 New Renewal

Specify: Payment enclosed

—You get 1 extra issue per year as a BONUS!

Bill me later.

If you have no label handy, print OLD address here.

name _____

address _____

city _____

state _____

zip code _____

AFFIX LABEL 0358

print name _____

address _____

city _____

state _____ zip code _____

Add'l postage: \$1 per year outside U. S., its possessions & Canada.

UNUSUAL BARGAINS

FREE!
GIANT
CATALOG

... MANY U. S. GOV'T SURPLUS

CATCH THAT STROBE ACTION!



(2 1/2 lb.) Wrinkle-finished metal case. Stock No. 71,174AV

It's wild. Spectacular stop-action lighting effects will make a party, create a light show, turn the "swingers" into psychedelic performers. Top quality, low-cost, solid state electronic strobe. Adjustable flash rate from 2 to 16 flashes per second. Clear plastic lens protects long life Xenon lamp—up to 10,000,000 flashes. 60° high lustre reflector covers 2,000 sq. ft. area—even in dark of night-club. Rugged but compact (6" sq.) & lightweight (110-120 V. AC). \$89.95 Ppd.

SUPER SPACE CONQUEROR



Share the wonders of space exploration. Capable of revealing faint stars of nearly 12th magnitude, split double stars separated by less than 1 sec. of arc. Features aluminum & overcoated F/8 ground and polished pyrex parabolic mirror accurate to 1/4 wave. 48 F.L. 6X achromatic finder scope. 4 eyepieces—48X Kellner, .66X & 1.4 192X Ramsdens. Barlow to double or triple power—range 110X. Focusing mount. 47% aluminum tube. Electric clock drive with manual slow-motion control. Setting circles. Heavy-duty equatorial mount. Fastest 1 line. Stock No. 85,086AV \$199.50 F.O.B. Stock No. 85,105AV 4 1/2" REFLECTOR TELESCOPE. \$84.50 F.O.B. Stock No. 85,050AV 3" REFLECTOR TELESCOPE. \$29.95 Ppd.

TUNE IN AND TURN ON YOUR OWN



Psychedellic Light Show. Take one bookshelf sized conservative looking oil/walnut finished light box—with its built-in kicker, an inch, controlled 3 channel color organ. Activate by attaching to hi-fi or stereo speakers. Plug in and turn on! Music fills the room and the prismatic screen traps into pulsating life. Patterns are wild and wonderful or soft and soothing—responding to direct in time and intensity to music. Perfect home entertainment. Little lights or corches. House current. Stock No. 80,126AV. (18" Wx12" Hx9" D) \$49.95 Ppd.

'BRIGHT IDEAS' in UNIQUE LIGHTING



Big, new 100-page handbook packed with facts, loaded with illustrations. All latest developments, applications, equipment. Covers strobes, sources, black light, projectors, crystal and organic slides, color organs, mirrors, polarized color, wireless, light boxes, reflectors, etc. Rare find for business, home, hobby. Ideal for display booths, company, experimental hobbyists. 8 1/2" x 11" looseleaf paper bound to fit 3 ring binder... add new developments as they happen. Stock No. 9100AV \$3.00 Ppd.



NEW! Projection Kaleidoscope. Infinite variety of brilliant color patterns which do not repeat. Specially designed interchangeable 3" diam. liquid wheel, 3" proj. lens and Edmund Projector make it all possible. Easily operated. Large screen image at short projection distance perfect for backgrounds. Light show parties, etc. Front or rear projection. Stock No. 71,121AV \$94.50 Postpaid

LONG-WAVE BLACK LIGHT FIXTURE

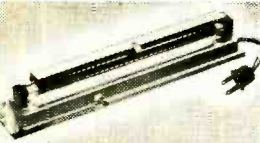

Extremely versatile, compactly designed, long wave (3200-4000 angstroms) black light (ultraviolet) fixture. Has 6-watt, 110-V lamp with built-in filter—eliminates harmful shorter wave ultraviolet rays. Use to identify minerals, fungi, bacteria—check for surface flaws, oil and gas leakage—perfect for displays with fluorescent paper, paints, chalk, crayons, trace powder. Incl. adjustable aluminum reflector. Mount vert., hor., or on corner. 10" L, 1 1/2" W, 1 1/4" H. Stock No. 73,364AV \$9.85 Ppd. Stock No. 68,124AV (Replacement Bulb) \$3.25 Ppd.

Order by Stock No.—Check or M.O.—Money-Back Guarantee
EDMUND SCIENTIFIC CO., 300 EDSCORP BLDG., BARRINGTON, N.J. 08007

WRITE FOR GIANT FREE CATALOG "AV"



Completely new 1969 edition. New items, categories, illustrations. 108 easy-to-read pages packed with 4000 unusual items. Dozens of electrical and electro-magnetic parts, accessories. Enormous selection of Astronomical Telescopes, Microscopes, Binoculars, Telescopes, Magnifiers, Lenses, Prisms. Many war surplus items for hobbyists, experimenters, workshops, factory. Write for catalog "AV". Include Zip.

ORDER BY STOCK NUMBER • SEND CHECK OR MONEY ORDER • MONEY-BACK GUARANTEE
EDMUND SCIENTIFIC CO., 300 EDSCORP BUILDING
BARRINGTON, NEW JERSEY 08007
CIRCLE NO. 13 ON READER SERVICE PAGE

POPULAR ELECTRONICS

SEPTEMBER 1969

ADVERTISERS INDEX

READER SERVICE NO.	ADVERTISER	PAGE NO.
1	Accurate Instrument Co., Inc.	23
2	AMECO, Division of Aerotron, Inc.	116
3	Allied Radio	125, 126
4	Antenna Specialists Co., The	11
5	Argos Products Company	110
6	Avianti Research & Development, Inc.	16
	Bell & Howell Schools	62, 63, 64, 65
8	Burstein-Applebee Co.	113
	CREI, Home Study Division, McGraw-Hill Book Company	106, 107, 108, 109
9	Career Academy	117
10	Cleveland Institute of Electronics	18, 19, 20, 21
7	Cobra	25
	Computer Products	118
12	Edison Instruments	112
13	Edmund Scientific Co.	124
11	EICO Electronic Instrument Co., Inc.	
	FOURTH COVER	
14	Electro-Voice Inc.	8
	Gantham School of Electronics	9
15	Heath Company	12, 13
16	Industrial Training Institute	100
17	Johnson Company, E.F.	5
18	Lafayette Radio	17
19	Mercury Electronics Corp.	111
20	Midland International Corporation	26
21	Mosley Electronics, Inc.	103
22	Motorola HEP Program	7
23	Multicore Sales Corp.	112
	National Radio Institute SECOND COVER, 1, 2, 3	
	National Technical Schools	88, 89, 90, 91
24	Olson Electronics	110
25	Poly Paks	113
	RCA Electronic Components & Devices	
	THIRD COVER	
	RCA Institutes	36, 37, 38, 39
34	Radio Shack	6
26	Sams & Co., Inc., Howard W.	104
	Schaal Associates	118
27	Sonar Radio Corporation	105
28	Technical Training International	118
29	Turner Company, Inc.	114
30	United Audio Products, Inc.	10
31	University Sound	102
32	Utah Electronics Div. of Utah-American Corp.	14
33	Weller Electric Corp.	101
CLASSIFIED ADVERTISING		119, 120, 121, 122, 123

Printed in U.S.A.

CIRCLE NO. 3 ON READER SERVICE PAGE →

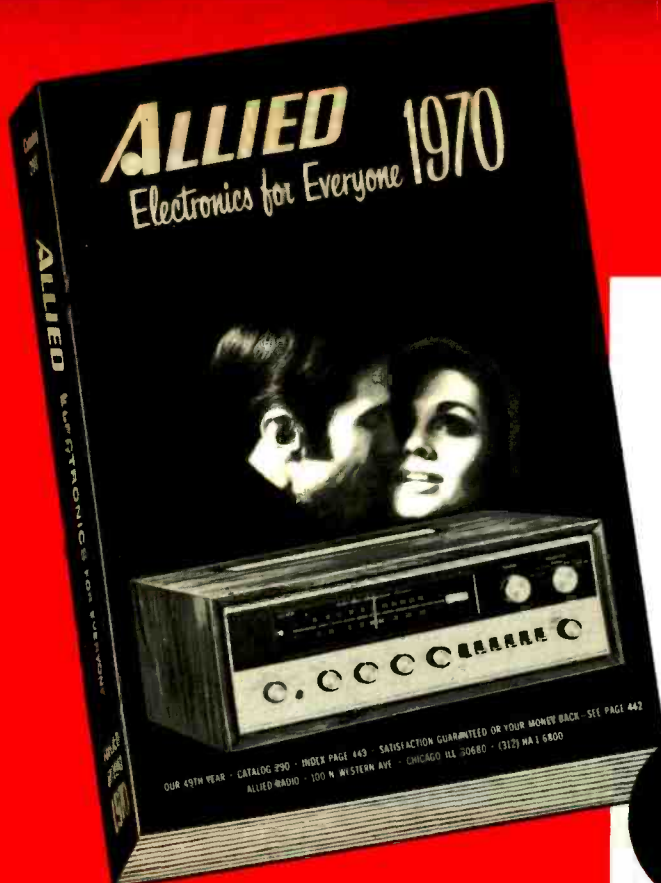

FREE

our biggest catalog ever!

NEW ALLIED 1970 CATALOG

Just off the press: the world's foremost electronics catalog. It has 552 pages. Over 30,000 items. Virtually everything known in stereo hi-fi, tape recorders, CB radios, phonographs, kits, tools, short wave, test equipment and books.

Your personal copy is waiting—simply tear off and mail the card. The catalog is free and there's no obligation to buy. But please hurry: only a limited number are available.

New!
552
Pages

MAIL CARD NOW FOR FREE COPY

IF CARDS ARE ALREADY USED, write Allied Radio, P.D. Box 4398, Chicago, Ill. 60680

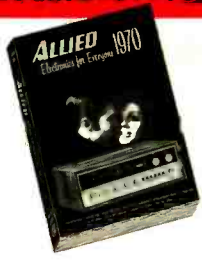

MAIL CARD NOW FOR
FREE
1970 ALLIED
CATALOG!

543

PLEASE PRINT

NAME (first) (Middle) (Last)

ADDRESS or ROUTE and BOX NO.

CITY

STATE ZIP CODE



MAIL CARD NOW FOR
FREE
1970 ALLIED
CATALOG!

543

PLEASE PRINT

NAME (first) (Middle) (Last)

ADDRESS or ROUTE and BOX NO.

CITY

STATE ZIP CODE

THIS CARD IS FOR A FRIEND

THIS CARD IS FOR YOU

FREE ALLIED CATALOG SAVES YOU MONEY ON

STEREO HI-FI ■ HOBBY KITS ■ CB RADIOS
TAPE RECORDERS ■ CAMERAS ■ BOOKS ■ AUTOMOTIVE
TEST EQUIPMENT ■ RADIOS ■ HEADPHONES ■ WIRE & CABLE
METERS ■ SHORTWAVE ■ PUBLIC SERVICE RADIOS ■ INTEGRATED
CIRCUITS ■ PARTS & BATTERIES ■ TUBES & TRANSISTORS ■ TV ■ TOOLS AND
HARDWARE ■ SPEAKERS ■ RECORD CHANGERS ■ NEEDLES ■ COLOR TV ANTENNAS ■ PA &
INTERCOMS ■ MULTI-BAND RECEIVERS . . . PLUS THOUSANDS OF OTHER ITEMS!

. . . and you don't have to be an expert to use our catalog.
Whether or not you have any special knowledge of electronics,
you can shop intelligently from the Allied Catalog. In fact, it's
fascinating just to browse through the catalog.
You'll appreciate the huge selection . . . and the low Allied prices.

MAIL CARD NOW FOR FREE COPY

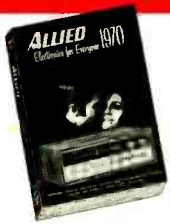

FREE
ALLIED 1970
CATALOG

TO:
ALLIED RADIO
P.O. BOX 4398
CHICAGO, ILLINOIS 60680

PLACE
STAMP
HERE



FREE
ALLIED 1970
CATALOG

TO:
ALLIED RADIO
P.O. BOX 4398
CHICAGO, ILLINOIS 60680

PLACE
STAMP
HERE

All new from every angle ...RCA HI-LITE

You end all doubts and confusion when you specify RCA HI-LITE. Then you can be certain that here is the all-new replacement picture tube from the leader in Color TV. All-new glass...gun...the works.

OEM QUALITY from every angle: the same tubes that go into original equipment sets, incorporating the latest technology of the world's most experienced color picture tube manufacturer. Everything about them exudes know-how, confidence, leadership.

If you've set your sights on quality, then look to RCA HI-LITE for your replacement tube needs. Available in the broadest line of types in the Industry from your Authorized RCA Distributor.

RCA Electronic Components,
Harrison, N. J.



RCA



Dazzle your friends with lightworks.

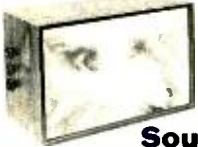

Sound n' Color®

The new dimension to music pleasure. EICO All Electronic Solid-State Audio-Color Organs transform sound waves into moving synchronized color images. Connect easily to speaker leads of hi-fi or radio. From \$29.95.



Translators

The electronics you need to create audio-stimulated light displays to your own imagination. Actuates: Light Display Units, Strobe Lites, any lamp configuration (Xmas trees, patio lights, etc.). From \$24.95 kit, \$39.95 wired.



Strobe Lites

High-intensity bursts of white light from Xenon tube flash in cadence with each beat of audio. From \$24.95 kit, \$39.95 wired.

Build the Stereo Kits praised by experts.

All amplifier power ratings according to IHF standards. Cortina® designed and manufactured in U.S.A. and guaranteed by EICO.



70-Watt AM/FM Stereo Receiver including cabinet. Cortina 3770, \$189.95 kit, \$279.95 wired

70-Watt FM Stereo Receiver including cabinet. Cortina 3570, \$169.95 kit, \$259.95 wired.



150-Watt Silicon Solid-State Stereo Amplifier, including cabinet. For the audio perfectionist. Cortina 3150, \$149.95 kit, \$225 wired.

70-Watt Silicon Solid-State Stereo Amplifier, including cabinet. Cortina 3070, \$99.95 kit, \$139.95 wired.



FM Stereo Tuner including cabinet. Cortina 3200, \$99.95 kit, \$139.95 wired.

Build for fun and use with Eicocraft® jiffy project kits.

The newest excitement in kits. 100% solid-state and professional. Expandable, interconnectable. Excellent as introductions to electronics. No technical experience needed. Finest parts, pre-drilled etched printed circuit boards, step-by-step instructions. 36 kits to select from, \$2.50 to \$9.95. Just released: EC-2600 "Super Snooper" \$8.95; EC-2700 Police & Fire Converter



(lo band) \$7.95; EC-2800 Aircraft Converter \$7.95; EC-2900 Police & Fire Converter (hi band) \$7.95; EC-3100 2-Station Intercom (with cases) \$10.95; EC-3200 "Do-It-Yourself" PC Etching Kit \$4.95; EC-2300 Audio Preamplifier \$8.95; EC-2400 Bullhorn \$8.95; EC-2500 Fuzzbox \$8.95.

EC-1900 TREASURE FINDER \$9.95

EC-1100
FM WIRELESS MIKE \$9.95

Shape up your own car/boat with EICO Engine Analyzer

For all 6V/12V systems; 4, 6, 8-cyl. engines. Now you can keep your car or boat engine in tip-top shape with this solid-state, portable, self-powered universal engine analyzer.

Completely tests your total ignition/electrical system. Complete with comprehensive Tune-up & Trouble-shooting Manual. EICO 888, \$49.95 kit, \$69.95 wired



Be a technocrat with EICO® solid-state test equipment

Only EICO brings you laboratory precision and long life at lowest cost.



EICO 240 Solid-State FET-TVOM \$49.95 kit, \$69.95 wired



EICO 379 Solid-State Sine/Square Wave Generator \$54.95 kit, \$74.95 wired



EICO 242 Solid-State Deluxe FET-TVOM \$59.95 kit, \$79.95 wired



EICO 150 Solid-State Signal Tracer \$49.95 kit, \$69.95 wired



EICO 330 Solid-State RF Signal Generator \$59.95 kit, \$79.95 wired

You save up to 50% with EICO Kits. Since 1945, Best Buys in Electronics. Over 3 Million EICO Instruments Now in Use.

FREE 1969 CATALOG

Send me FREE catalog describing the full EICO line of 200 best buys, and name of nearest dealer.



EICO Electronic Instrument Co., Inc.
283 Malta Street, Brooklyn, N.Y. 11207
EICO Canada Ltd.
20 Millwick Drive, Weston, Ontario

Name _____
Address _____
City _____ State _____ Zip _____

CIRCLE NO. 11 ON READER SERVICE PAGE