

WHAT EVER HAPPENED TO ATWATER KENT?

# POPULAR ELECTRONICS

JULY  
1969

50  
CENTS



**IC SQUARE-WAVE  
GENERATOR**

**40/80 WATT  
STEREO POWER  
AMPLIFIER**

**TORNADO/  
LIGHTNING  
WARNING  
RECEIVER**

**A LOOK AT  
JAPANESE HI-FI  
STEREO SCENE**

**MAKE YOUR OWN  
HIGH-GAIN  
FM/TV  
ANTENNA**



*With his NRI home training*

*as a solid base for success, graduate W. Gerald Kallies of Elliott Lake, Ontario, Canada, has branched into three different areas of Electronics. He is in charge of the complete Electronic automatic control system at Rio Algom Nordic, Ltd., a uranium mining company. Also, he handles operations at CKSO-TV, a satellite station in Elliott Lake, and he owns Gerol TV Sales & Service, which grosses \$60,000 a year.*

*How did Gerald Kallies launch his career? While a high school senior, he faced the fact that college was beyond his financial reach. So he wrote to ten Electronics training schools. He chose NRI. Why? Because, he says, it appeared to be complete training with no short cuts . . . because courses were offered at very reasonable prices . . . and because he was convinced NRI would take a personal interest in him. The results of his training speak for themselves.*

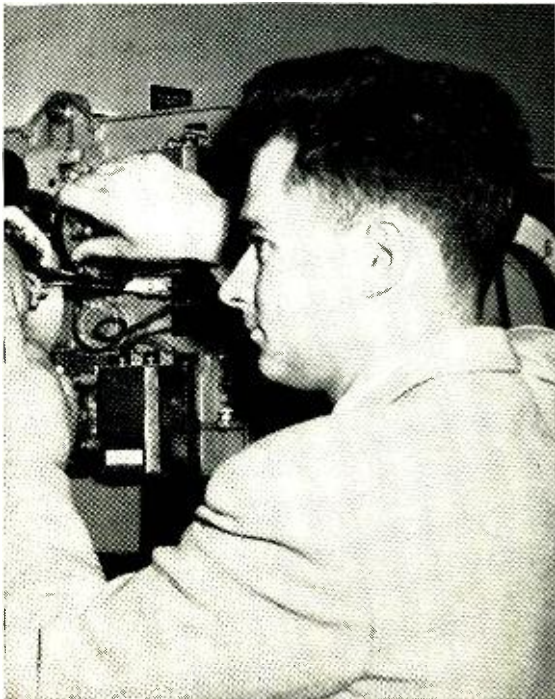

**Experience  
Counts  
Most in Color TV  
Communications  
Electronics**

***Designed-for-training equipment makes learning at home fast and fascinating—builds priceless confidence—as theory you learn comes alive.***



There is an all-important reason why NRI has invested so heavily in the development of equipment for learning Electronics at home. With more than 55 years of home education experience, NRI is convinced that theory alone is not enough. Your hands must be trained as well as your head. To get ahead fast you must have "hands-on" experience as well as "book" knowledge . . . and, you get both in NRI home training programs.

**Learning becomes an absorbing adventure** as you get your hands on professional parts and demonstrate theory you read in "bite-size" texts carefully programmed with NRI designed-for-learning equipment. You'll prove theory by experimentation with the type of solid-state, transistorized and tube circuits you'll find on the job today—not hardware or breadboard hobby kits. Almost without realizing it, the NRI discovery method prepares you for your choice of careers in Color TV Servicing, Communications, Industrial Electronics. With your NRI diploma, you can confidently fill full-time openings in the TV-Radio Servicing business; become a part of the glamorous communication industry; have an important role in business, military or space Electronics or even launch your own full-time business. Many NRI graduates start earning \$5 to \$7 an hour extra soon after they enroll, fixing home Electronics equipment for friends and

neighbors in spare time. NRI's remarkable teaching method simplifies, organizes, dramatizes subject matter so that any ambitious man—regardless of his education—can effectively learn and profit from the Electronics course of his choice.

**You get your FCC License or your money back** NRI is so confident of the effectiveness of its training programs that all Communications courses include a special money-back agreement. You must qualify for a Commercial Radiotelephone License issued by the FCC, after successfully completing your training program, or NRI refunds your tuition in full. Here is just one more example of the value you get when you choose NRI for your Electronics training . . . one more example of why NRI continues to be the country's leading Electronics home-study school. Over three-quarters of a million have enrolled since 1914. Discover for yourself how easy it is to move into Electronics—America's fastest growing industry—with NRI home training. Mail the postage-free card for the new NRI Catalog. There is no obligation. No salesman will call. NRI does not employ salesmen. NATIONAL RADIO INSTITUTE, Washington, D.C. 20016.

**Approved under GI Bill** If you have served since Jan. 31, 1955, or are in service now, check GI line on postage-free card.



**Color TV circuitry is easy** to learn as you build the only Color TV set custom-designed for training purposes. The result is your own high-quality set you keep for years of viewing pleasure. NRI TV-Radio Servicing course includes your choice of color or black-and-white training equipment.



**Communications experience** equal to as much as two years of on-the-job training is yours as you build and use equipment like this phone-cw transmitter suitable for the 80-meter amateur band. You also perform experiments on transmission lines and antenna systems. No other home-study school offers this equipment.

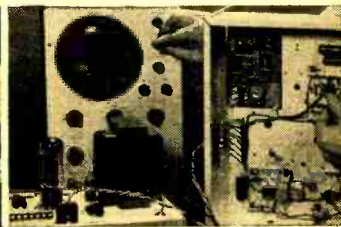

**Competent technical ability** so necessary for careers in Industrial Electronics is easily acquired through NRI training. As you learn, you actually build and use your own motor control circuits, telemetering devices and even digital computer circuits. All major NRI courses include transistors, solid-state devices, printed circuits.

# POPULAR ELECTRONICS

VOLUME 31 NUMBER 1

JULY, 1969

WORLD'S  
LARGEST-SELLING  
ELECTRONICS  
MAGAZINE

## SPECIAL CONSTRUCTION PROJECT

### BUILD THE "PYRAMIDAL" TV/FM ANTENNA

27 George Monser

*Top performance with low cost*

## FEATURE ARTICLES

### WHAT EVER HAPPENED TO ATWATER KENT?

33 Frank Atlee, K4PI

### SQUARING WITH AN IC

43 Philip E. Harms

*Easy-to-build square-wave generator*

### THE PICNICKER'S FRIEND

47 John E. Shepler

*Storm warning system*

### SINE-WAVE TO PULSE CONVERTER

50 Frank H. Tooker

### TIGERS THAT ROAR

51 Dan Meyer

*High-power stereo amplifiers*

### ELECTRONICS "B" QUIZ

64 Robert P. Balin

### THE STEREO SCENE

65 Charles Jackson

*Latest word from Japan*

### THE TIE BOOKSHELF SPEAKER

69 Herman F. Johnson

*Three options on cost*

### ENGLISH-LANGUAGE BROADCASTS TO NORTH AMERICA

79 Roger Legge

### THE PRODUCT GALLERY

*Weathercaster (Radio Communication Corp.)*

*Uniflash Strobe (Mitchell Enterprises)*

*Battery-Boost Regulator (Mark Model BRR-1216)*

*Miniature Breadboarding Kit (Intratec S-DeC)*

80

### SOLID STATE

84 Lou Garner

### SHORT-WAVE LISTENING

87 Hank Bennett, W2PNA

### AMATEUR RADIO

90 Herb S. Brier, W9EGQ

## DEPARTMENTS

### LETTERS FROM OUR READERS

8

### NEW LITERATURE

12

### ELECTRONICS LIBRARY

14

### READER SERVICE PAGES

15, 95

### NEW PRODUCTS

22

### CB JAMBOREE CALENDAR

97

### OUT OF TUNE

88

*"Build a Different Metal Locator" (February 1969)*

POPULAR ELECTRONICS is indexed  
in the Readers' Guide  
to Periodical Literature

This month's cover photo by  
Justin Kerr

Copyright © 1969 by ZIFF-DAVIS PUBLISHING COMPANY. All rights reserved.

POPULAR ELECTRONICS, July 1969, Volume 31, Number 1, Published monthly at 307 North Michigan Avenue, Chicago, Illinois 60601. One year subscription rate for U.S., U.S. Possessions and Canada, \$5.00; all other countries, \$6.00. Second class postage paid at Chicago, Illinois and at additional mailing offices. Authorized as second class mail by the Post Office Department, Ottawa, Canada and for payment of postage in cash. Subscription service and Forms 3579, Portland Place, Boulder, Colorado 80302. Editorial offices for manuscript contributions, reader inquiries, etc.: One Park Ave., New York, N.Y. 10016.

# from Technician to ENGINEER

Advance beyond the technician level

## Become an electronics engineer

In the Grantham electronics engineering program, you can earn the Degree of *Associate in Science in Electronics Engineering* (the ASEE) mostly by home study — and can continue in resident classes to earn your BSEE. In this program you can acquire an extensive knowledge of engineering, for greater prestige and better pay.

In America's race to the moon and outer space, *more and more* engineers are needed. By becoming an electronics engineer, you can move into the forefront of technology and engineering, and be an important part of this exciting age. You can help make things happen and be properly rewarded for doing so.

The demand for engineers continues to increase; electronics engineers are needed in the space program and in many other military and domestic projects. In a recent survey conducted by the Engineering Manpower Commission of the Engineers Joint Council, it was found that engineering employment in the electrical and electronics industries is expected to increase by 40% in ten years. The need for engineers is increasing faster than the population as a whole. The survey report indicates that in the next decade, employers expect to need almost *twice as many* new engineering graduates as are likely to be available.

If you have the desire to be an engineer, the determination to stick to your objective, and a reasonably good aptitude for mathematics and technology, the Grantham educational program can produce the wanted results for you. But make no mistake about it, to become an electronics engineer requires work. You must be willing to do that work; otherwise you can never reach your objective, regardless of what course of instruction you may choose.

## Grantham School of Engineering

Specializing in Electronics since 1951



1505 N. Western Ave.  
Hollywood, Calif. 90027

Telephone:  
(213) 469-7878

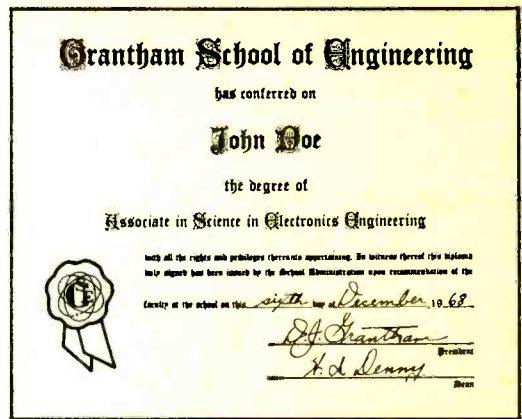

The Grantham *home study* program in electronics engineering consists of five "correspondence semesters" made up of a total of 360 lessons, followed by a two-week period of review and examination at the School. The prerequisite for enrollment in this program is high school graduation (or equivalent) and at least one year of experience as an electronics technician.

This *accredited* ASEE Degree program covers a review of basic electronic circuits and systems, applied engineering mathematics (including algebra, trigonometry, and calculus), classical and modern physics, technical writing, computer systems, electrical networks, and semiconductor circuit analysis and design. The ASEE Degree is awarded upon satisfactory completion of the 360 correspondence lessons and the final two-week residency at the School.

The Grantham educational program in electronics places heavy stress on fundamental concepts of logic and mathematics rather than on superficial manipulative skills. Since these fundamental ideas are largely unfamiliar to many electronics technicians, it is necessary to develop them in a systematic manner.

## Accreditation and G.I. Bill Approval

Grantham School of Engineering is *accredited* by the Accrediting Commission of the National Home Study Council, *is approved* under the G.I. Bill, and *is authorized* under the laws of the State of California to grant academic degrees.

Grantham School of Engineering PE-7-69  
1505 N. Western Ave., Hollywood, Calif. 90027

Please mail your free Bulletin, which explains how the Grantham educational program can prepare me for my Associate in Science Degree in Electronics Engineering.

Name \_\_\_\_\_ Age \_\_\_\_\_

Address \_\_\_\_\_

City \_\_\_\_\_ State \_\_\_\_\_ Zip \_\_\_\_\_



## BENDING THE BEAM

JOHN R. GILLIOM  
Chief Engineer,  
Loudspeakers

One of a series of brief discussions by *Electro-Voice engineers*

Because paging and PA speakers can't always be placed exactly where needed for best sound distribution, it sometimes seems desirable to alter the polar pattern of the speaker to meet specific requirements. Observation of installations in the field discloses a wide variety of methods employed to achieve asymmetrical sound distribution.

These "accessories" vary from small flaps mounted on the horn to large panels. Even an existing wall or ceiling has been used to modify the polar characteristics. Not all of these devices are completely effective, and a brief discussion of why may aid you in making your own experiments.

When an object is placed in the beam of a speaker, the sound striking this beam may do several things, depending on the size of the object relative to the wavelength of the sound. If the object is large with respect to wavelength (say 5 times as large) sound will reflect, much as light reflects from a similar surface. But if the object is small (perhaps 1/2 to 1 wavelength in size) sound will diffract around the object.

Now let us consider the case of a typical paging speaker. With a frequency response range of 250 to 13,000 Kz, it will produce wavelengths varying from 4 feet to 1 inch in length. Our deflector must take into account the entire range of wavelengths if we are to affect the polar pattern over more than a small portion of the sound spectrum.

For instance, if we were to place a 6" square panel at an angle in front of the speaker, it would act effectively as a reflector only for the frequencies at or above 2 or 3 kHz (and only if it were squarely in the center of the horn). Below this point, sound would begin to diffract around the panel. At some frequencies, sound intensities might well be higher *behind* the panel than at any other point due to this diffraction effect. At very low frequencies, the panel would have almost no measurable effect on the polar pattern.

The ability of sound to diffract or reflect—depending on the relative size of the surface with respect to wavelength—can be a useful tool in the design of sound equipment. But it can also be a trap for the unwary, leading to unexpected results if not completely understood.

For reprints of other discussions in this series, or technical data on any E-V product, write: **ELECTRO-VOICE, INC.**, Dept. 793P, 630 Cecil St., Buchanan, Michigan 49107



CIRCLE NO. 15 ON READER SERVICE PAGE

# POPULAR ELECTRONICS

**PHILLIP T. HEFFERNAN**

*Publisher*

**OLIVER P. FERRELL**

*Editor*

**LESLIE SOLOMON**

*Technical Editor*

**JOHN R. RIGGS**

*Managing Editor*

**EDWARD I. BUXBAUM**

*Art Director*

**ALEXANDER W. BURAWA**

*Associate Editor*

**ANDRE DUZANT**

*Technical Illustrator*

**PATTI MORGAN**

*Assistant Editor*

**AURORA NARDOZZI**

*Editorial Assistant*

**H. BENNETT, W2PNA**

**H. S. BRIER, W9EQG**

**L. E. GARNER, JR.**

**M. P. SPINELLO, KHC2060**

*Contributing Editors*

**RICHARD J. HALPERN**

*Advertising Manager*

**ARDYS C. MORAN**

*Advertising Service Manager*

**LAWRENCE SPORN**

*Associate Publisher*

**ZIFF-DAVIS PUBLISHING COMPANY**

*Editorial and Executive Offices*

One Park Avenue, New York, New York 10016  
212 679-7200

*Midwestern Office*

307 North Michigan Avenue, Chicago, Illinois 60601  
312 726-0892

*Midwestern Advertising Manager, JAMES WEAKLEY*

*Western Office*

9025 Wilshire Boulevard, Beverly Hills, California 90211

213 Crestview 4-0265; Bradshaw 2-1161

*Western Advertising Manager, BUD DEAN*

*Japan: James Yagi*

Ishikawa Mansion, #4, Sakuragaoka  
Shibuya-ku, Tokyo, 462-2911-3

*Circulation Office*

Portland Place, Boulder, Colorado 80302

*William Ziff, President*

*W. Bradford Briggs, Executive Vice President*

*Hershel B. Sarbin, Senior Vice President*

*Philip Sine, Financial Vice President*

*Walter S. Mills, Jr., Vice President, Circulation*

*Stanley R. Greenfield, Vice President, Marketing*

*Phillip T. Heffernan, Vice President, Electronics Division*

*Frank Pomerantz, Vice President, Creative Services*

*Arthur W. Butzow, Vice President, Production*

*Edward D. Muhlfeld, Vice President, Aviation Division*

*Irwin Robinson, Vice President, Travel Division*

*Furman Hebb, Administrative Vice President*

*George Morrissey, Vice President*

*Sydney H. Rogers, Vice President*

Ziff-Davis also publishes Airline Management and Marketing, Routing, Business & Commercial Aviation, Car and Driver, Cycles, Electronics World, Flying, Modern Bride, Popular Photography, Skiing, Skiing Area News, Skiing Trade News, Stereo Review, and Travel Weekly.

Forms 3579 and all subscription correspondence should be addressed to POPULAR ELECTRONICS, Circulation Department, Portland Place, Boulder, Colorado 80302. Please allow at least six weeks for change of address. Include your old address, as well as new—enclosing if possible an address label from a recent issue.

EDITORIAL CONTRIBUTIONS must be accompanied by return postage and will be handled with reasonable care; however, publisher assumes no responsibility for return or safety of art work, photographs or manuscripts.



Member Audit Bureau of Circulations

# What could a career in electronics mean to you?

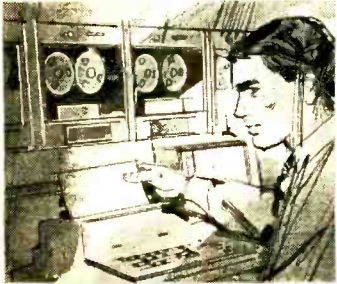

Escape from a dead-end future



Freedom from automation fears

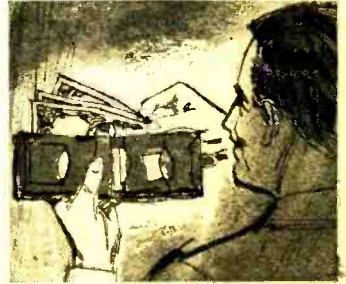

Greatly increased earnings

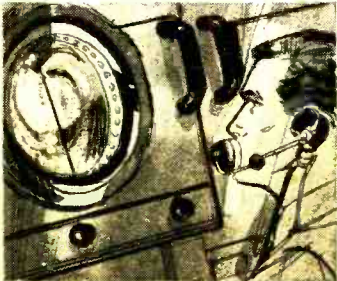

A key spot in a key industry



A better standard of living

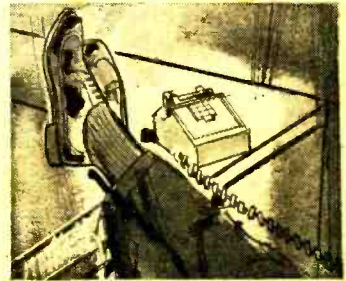

A chance to be your own boss

A great field, electronics. With an even greater future. And—if you have the skills—a good spot for you. At good money. In the growing electronics industry. Or in business for yourself.

DeVry Tech grads have the skills. You can too. Send in the coupon and let us show you what a career in electronics could mean to you.

**DE VRY INSTITUTE OF TECHNOLOGY**  
4141 WEST BELMONT AVENUE, CHICAGO, ILLINOIS 60641



ONE OF THE

**BELL & HOWELL SCHOOLS**

**DE VRY INSTITUTE OF TECHNOLOGY** PE-7A  
4141 WEST BELMONT AVENUE, CHICAGO, ILLINOIS 60641



ONE OF THE

**BELL & HOWELL SCHOOLS**

Please send me your two free booklets and information about preparing for careers in Electronics. I am interested in the following opportunity fields (check one or more):

- |  |   |   |
|--|---|---|
| <input type="checkbox"/> Space & Missile Electronics | <input type="checkbox"/> Radar                  | <input type="checkbox"/> Broadcasting           |
| <input type="checkbox"/> Television and Radio        | <input type="checkbox"/> Automation Electronics | <input type="checkbox"/> Industrial Electronics |
| <input type="checkbox"/> Microwaves                  | <input type="checkbox"/> Communications         | <input type="checkbox"/> Electronic Control     |
|  | <input type="checkbox"/> Computers              |   |

Name \_\_\_\_\_ Age \_\_\_\_\_

Address \_\_\_\_\_ Apt. \_\_\_\_\_

City \_\_\_\_\_

State \_\_\_\_\_ Zip Code \_\_\_\_\_

Veterans: Check here. If you were discharged after Jan. 31, 1955, the "G.I. Bill" may cover the entire cost of your tuition.

# UNUSUAL BARGAINS

FREE!  
GIANT  
CATALOG

... MANY U. S. GOV'T SURPLUS



"See" Your Music in Dazzling Action with

Dramatic Breakthrough in Audio-Visual Enjoyment **Music Vision**

Actually see favorite musical selections translated into fantastic patterns of beautiful color—each individual note creating its own unique, twisting, radiating shape—each shape dancing and prancing, whirling and swirling in perfect time with the music. Easy-tape recorder. Send 25c in coin for 16-page

booklet. **696AV**  
No. 71. **696AV** **DO-IT-YOURSELF KIT** ..... \$22.50 Ppd.  
No. 71. **696AV** **5-T** ..... \$7.50 Ppd.  
No. 71. **696AV** **SHOW SPECIAL EFFECTS PROJECTOR** ..... \$24.50 Ppd.



NEW!

### PROJECTION KALEIDOSCOPE

Infinite variety of brilliant color patterns which do not repeat. Specially designed interchangeable 9" diam. liquid wheels, 3" projection lens and Edmund Projector make it all possible. Easily operated. Large screen image at short projection distance perfect for backgrounds. Light shows, parties, dances, etc. Front or rear projection.

Stock No. 71.121AV ..... \$94.50 Postpaid

### LONG-WAVE BLACK LIGHT FIXTURE



Extremely versatile, compactly designed, long wave (3200-10000 angstroms) black light (ultraviolet) fixture. Has 6-watt, 110-V amp with built-in filter—eliminates harmful shorter wave ultraviolet rays. Use to identify minerals, fungi, bacteria—check for surface flaws, oil and gas leakage—perfect for displays with fluorescent paper, paints, chalk, crayons, trace powder. Incl. adjustable aluminum reflector. Mount vert., hor., or on corner. 10" L., 1 1/2" W., 1 1/4" H.

Stock No. 70.361AV ..... \$9.85 Ppd.  
Stock No. 60.121AV (Replacement Bulb) ..... \$3.25 Ppd.

Order by Stock No.—Check or M.O.—Money-Back Guarantee  
EDMUND SCIENTIFIC CO., 300 EDCORP BLDG., BARRINGTON, N.J. 08007

**GIANT FREE 148 PAGE CATALOG "AV"**  
Includes electrical and electromagnetic parts, accessories, complete section of Astronomical Telescopes, Microscopes, Binoculars, Magnifiers, Magnets, Lenses, Prisms. Many war surplus items for hobbyists, experimenters, v.c.-shop, factory. Write for catalog "AV", include \$1.00. ED-UND, 300 EDCORP BLDG., BARRINGTON, N.J. 08007  
CIRCLE NO. 14 ON READER SERVICE PAGE

# NEW ROOF SHATTERING POWER! Thunder Columns

Never before has a sound reproduction device been designed to handle enormous power with such effortless ease and fidelity! Thunder Columns are scientifically-designed true sound columns, with every component perfectly matched to project maximum undistorted sound to your audience. Argos Thunder Columns are musician speakers in every sense of the word.

- 200 and 300 watt models • True focused sound for the serious musician • Fuse protected against accidental power overloads • Hidden steel grille crash protects speakers • Rugged upholstery grade vinyl finish • Heavy duty electronic instrument speakers

**Argos**  
PRODUCTS COMPANY

600 So. Sycamore, Genoa, Ill. 60135

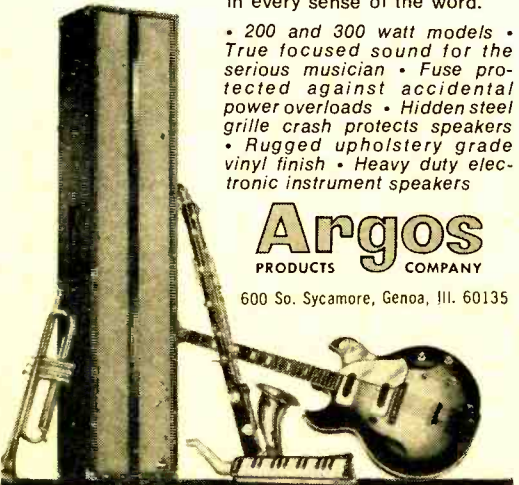

CIRCLE NO. 3 ON READER SERVICE PAGE

# Letters

FROM OUR READERS

### "FLEA POWER" INDEED!

While the "Build A Happy Hybrid" article (March 1969) was actually very good, I really have to laugh at what the author refers to as "flea power." I can just picture some guy bragging about his good signal report from 700 miles away with his ten-watt "flea power" rig. Big deal! With a little rig I pieced together in a single morning, I have worked nine states, my best DX being nearly 1200 miles while using a conventional dipole on 40-meter CW—all on roughly one-watt output power.

You might say this has been done before, but using ten watts of output power it's a cinch. The 6AG7 rig I pieced together cost me

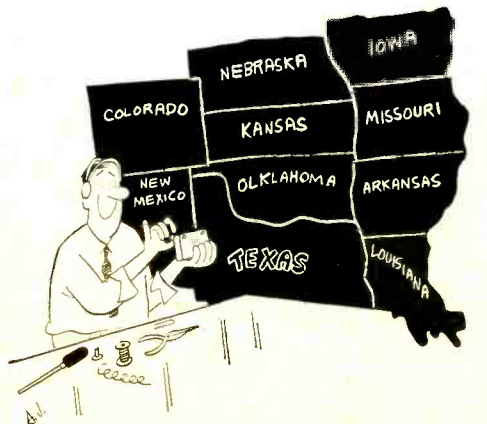

nothing (I used spare parts), as opposed to the ridiculous sum of \$25 needed for the so-called "flea power" hybrid transmitter.

I am convinced that the true "sport" in amateur radio is a thing of the past. When ten watts of power is considered "flea power" amateur radio has had it. In fact, to add weight to this conclusion, I find it sad that every time the letters "QRP" appear in print, they must be explained in parentheses. I would be willing to wager that less than five percent of all radio amateurs operate less than 50 watts out on CW.

I am no pauper. I can easily afford to go QRO, but I like a challenge—a word that seems to be disappearing from the amateur's vocabulary. Everyone seems to be too busy "working" for a WAS, WAC, or DXCC to bother with something that is really challenging. The only challenge here is the ability to



Mighty important news  
from Antenna Specialists...

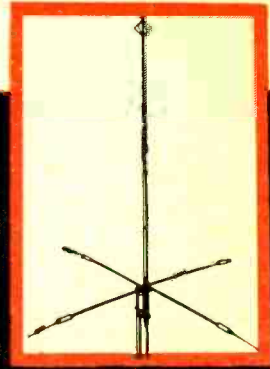

introducing the  
"third generation" of  
the famous A/S MAGNUM family,  
model M-227

# MIGHTY MAGNUM III

CB BASE STATION ANTENNA

Suggested Resale: **\$36<sup>95</sup>**

## 4 dB gain!

More true gain than ever before—increases effective radiated power to 13 watts!

## New Power-Tip radials!

Power-loaded radials provide lower radiation angle, increased range, far more compact configuration!



## New "Stati-Lite Diamond"!

Drastically reduces noise, prevents static charge accumulation, helps to lower angle of radiation.

## Dual Phasing coil!

Optimizes impedance match, for excellent bandwidth characteristics, VSWR less than 1.4 to 1.

# the antenna specialists co.

Division of Allen Electric & Equipment Co. 12435 Euclid Ave., Cleveland, Ohio 44106

Export Offices: 2200 Shames Dr., Westbury, N.Y. 11690

Also available in Canada.

Look for the "Stripes of Quality"



Write for full color,  
illustrated technical brochure today!



CIRCLE NO. 2 ON READER SERVICE PAGE

July, 1969

## LETTERS

(Continued from page 8)

**Which of these  
4 fascinating  
Radio-TV  
careers**



**interests  
you?**

disc jockey  
 newscaster  
 sportscaster  
 announcer

**Our Free Voice Analysis Tells You  
Whether You Have The Talent To  
Become A Broadcast Personality!**

**IMMEDIATE DEMAND** • Radio-TV stations everywhere need both men and women to take over important good-paying jobs right now. **NATIONWIDE PLACEMENT ASSISTANCE** at No Extra Cost.

**TRAIN AT HOME OR IN ONE OF OUR STUDIO SCHOOLS** • You can study broadcast techniques at home, in your spare time, or in one of our many studio schools throughout the country under the supervision of our Directing Faculty of 11 Famous Broadcasters. Accredited Member National Home Study Council and National Association of Trade and Technical Schools.

Approved for Veterans' Educational Assistance Benefits ("G.I. Bill")!  
Check coupon for special information

Send to CAREER ACADEMY's division of famous broadcasters for free booklet, record and voice analysis details!

## CAREER ACADEMY

825 North Jefferson Street • Studio 450  
Milwaukee, Wisconsin 53202

I want to know if I have broadcasting aptitude worth developing. Please rush more information.

name age

address phone

city/state/zip

07N087206

I am interested in:  Home Study  
 School Study  G. I. Bill



CIRCLE NO. 6 ON READER SERVICE PAGE

listen to QRM while everyone charges on the air with their 100- and 250-watt rigs. Maybe to these people ten watts out might be "flea power," but as far as I am concerned, "flea power" indeed!

CHARLES A. BENNER, WA5ROZ  
Garland, Tex.

## FOOD FOR THOUGHT ARTICLES

It is refreshing to pick up an electronics magazine that actually has something in it about electronic devices and how they function. I refer specifically to the two articles in your March 1969 issue—"Ovionics" and "The Not Altogether Forgotten Electret." Articles of this nature provide food for thought and keep the reader up to date on the current trends in electronics. I would like to see a regular section devoted to computer electronics—but I guess there isn't much demand for this sort of thing.

JULIUS R. BRODBECK, JR.  
Cleveland, Ohio

*You hit the nail right on the head—but not quite hard enough. There isn't yet a large demand for a computer section for the hobby-*



*ist or home experimenter. But if you are really interested in computer articles, you might try subscribing to one or more of the more well-known engineering electronics magazines. Almost every issue of these magazines has something about computers.*

## THRIFTY THREE-WAY SYSTEM SPECIFICATIONS

In regard to the power requirements of the "Thrifty Three-Way" speaker system (Feb-  
(Continued on page 98)



## New Weller® TEMPMATIC®

Temperature Controlled Soldering Tool  
for light and heavy duty soldering.

Now one tool combines all the advantages of a lightweight pencil type iron, a fast heating soldering gun, and tip temperature control.

### Features Weller's exclusive new POWERHEAD

The heart of this new tool is its long-life, high efficiency POWERHEAD ... another great innovation from Weller. The POWERHEAD contains Weller's temperature control system (which has been so successful in Weller temperature controlled soldering irons). The result is maximum protection of components even in the most delicate work situations.

The integral points of the POWERHEAD have made over 30,000 solder connections in lab tests.

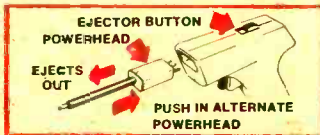

The points have a special premium plating which vastly extends life. And the POWERHEAD completely eliminates filing and frequent tip changes as encountered with conventional

non-temperature controlled tools.

Two POWERHEADS are available: A 700°F.  $\frac{3}{16}$ " chisel point POWERHEAD or a 600°F.  $\frac{1}{8}$ " conical point POWERHEAD. A convenient ejector button makes switching POWERHEADS easy.

The entire tool weighs only 7 ounces. Its trigger turns heat on and off. And the stainless steel barrel has long reach.

Ideal for service, repairs, PC boards, models and hobbies. Order these new Weller TEMPMATIC models now.

*Weller*

WELLER ELECTRIC CORP., Easton, Pa. World leader in soldering tools

CIRCLE NO. 26 ON READER SERVICE PAGE

# introducing . . . S-DeC breadboard

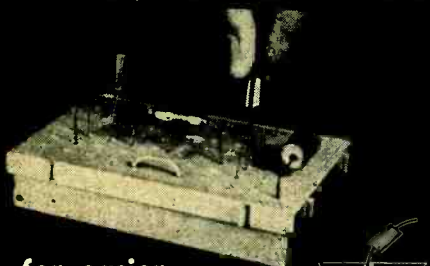

## for easier circuit building



An S-DeC contains 70 push-in contact points which are arranged in two sets of five numbered rows with each five points joined together by a leaf-spring busbar; this pattern is similar to that used in popular wiring boards. Larger circuits can be made by keying units together to form a continuous breadboard of any size.

Components are simply pushed into the sockets where they are held securely by double-leaf phosphor-bronze contacts. This system ensures a good wiping action on insertion and withdrawal, giving low contact resistance. The accessory kit provides solderless connectors to use with controls which are mounted on a panel slotting into the S-DeC base.

S-DeC with control panel, jig, accessories and project leaflet. . . . . **\$5.75** each

DeC STOR—Two decks, control panel, jig, accessories, project leaflet with components tray all in black plastic box. **\$11.75** each

4-DeC Kit—Four decks, two control panels, jigs, accessories, and project book in attractive plastic case. **\$20.75** each

## INTRATEC

399 Jefferson Davis Highway  
Arlington, Virginia 22202

Please send me postage paid:

- ..... S-DeC's @ \$5.75 each
- ..... DeC STOR @ \$11.75 each
- ..... 4-DeC's @ \$20.75 each

enclose a check/money order for \$.....  
Va. residents add 4% sales tax  
Money refunded if not satisfied.

Name .....

Address .....

City .....

State ..... Zip Code .....

Box PE-7

CIRCLE NO. 16 ON READER SERVICE PAGE

TAKE ONE



# new literature

To obtain a copy of any of the catalogs or leaflets described below, simply fill in and mail the coupon on page 15 or 95.

Tab Books, publishers of the Gernsback Library books, has just released its Spring, 1969 catalog. Describing well over 100 current and forthcoming books, the illustrated 16-page catalog covers broadcasting; basic technology; CATV; electric motors; electronic engineering; TV, radio, and electronics servicing; audio and hi-fi; hobby and experiment; test instruments; transistors; and other related electronics books. Among the titles are the recently introduced "Popular Tube/Transistor Substitution Guide" and the "RCA Color TV Service Manual," complete with schematic diagrams and troubleshooting data for 23 TV receiver models.

Circle No. 75 on Reader Service Page 15 or 95

A new eight-page brochure, designated the BI-2166, covering 30 general communications and dictation headphones, and other private listening devices and accessories, is available from *Telex Communications Division*. The two-color brochure contains photos of every product described and provides such information as suggested applications, complete specifications, new catalog number, and the price of each item.

Circle No. 76 on Reader Service Page 15 or 95

An illuminated pushbutton ALCOSWITCH that features easy lamp removal without tools is just one of hundreds of items described in the *Alco Electronic Products, Inc.*, 20-page catalog. Among the items listed and described are an expanded line of miniature electronic switches, keyboard assemblies, and a series of five complete lines of ALCOSWITCH toggle switches. The catalog describes each product group in detail, providing electrical specifications, dimension drawings, and prices.

Circle No. 77 on Reader Service Page 15 or 95

A new literature package available from *Delta Products, Inc.*, offers complete technical details and specifications, including schematic diagrams, on a variety of electronic instruments. Included in the line-up are a FET-VOM, SCR ignition systems, a computerized tachometer, and a high-voltage analyzer.

Circle No. 78 on Reader Service Page 15 or 95

# Is Johnson's new 23-channel Messenger 123 at \$169.95 ... Legal?

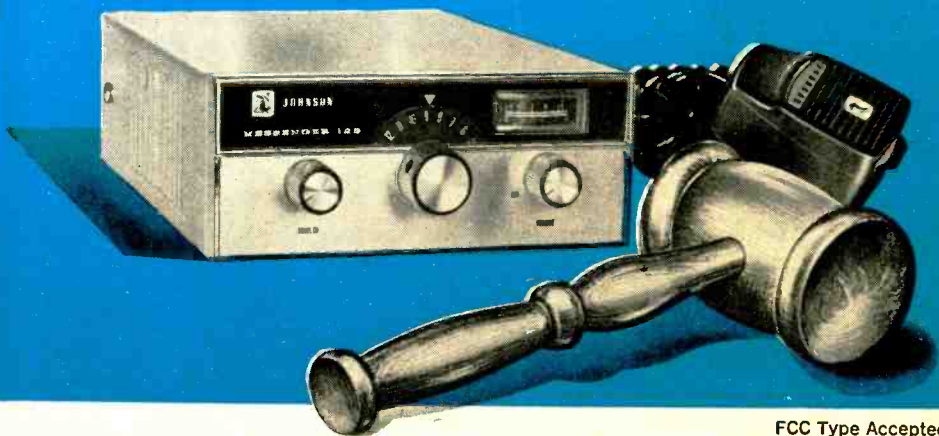

FCC Type Accepted

## *You be the Judge.*

**Is it unfair competition** for Johnson to produce a 23-channel solid state unit with the incomparable Johnson "talk-power" for less money than you had to pay yesterday for a 12-channel unit with crystals?

**Is there a law** against operating a rig whose specifications are close to theoretical perfection—such as 0.4 microvolt sensitivity ... and sharply filtered 7 kHz selectivity?

**Is it a crime** to build in a special speech compression circuit for unsurpassed voice intelligence? Or the famous Johnson high-efficiency noise limiter that virtually wipes out ignition and other extraneous radiated interference?

*We think you'll agree: For sheer value, Messenger 123 is the exception to the rule.*

**E. F. JOHNSON COMPANY**  
WASECA, MINNESOTA 56093



# ELECTRONICS library

QUIET

## ELECTRONICS IN PHOTOGRAPHY

by Byron G. Wels

Most amateur photographers know little more about how a camera functions than how to focus and shoot. But when electronics, which is playing an ever-increasing part in photography, is involved, a murky subject becomes ever murkier. This book was especially written to cast some light on the electronics used in cameras and photography accessories. It is by no means a technical textbook; you learn just enough electronics to help you understand how your electronic photographic equipment works. Beginning with a general introduction to photographic electronics, the text quickly turns to a discussion of the electronics theory involved in photography.

*Published by Howard W. Sams & Co., Inc., 4300 West 62 St., Indianapolis, Ind. 46206. Soft cover. 128 pages. \$3.50.*

## LEARN ELECTRONICS THROUGH TROUBLE-SHOOTING

by Wayne Lemons

This book provides a basic, practical approach to learning the fundamentals of electronics for anyone interested in taking up servicing. It presents the subject matter in terms of practical troubleshooting situations and simple, reproducible experiments to provide the basic groundwork. Not deficient in any fundamental area, the book provides everything in the way of a well-rounded course.

*Published by Howard W. Sams & Co., Inc. 4300 West 62 St., Indianapolis, Ind. 46206. Soft cover. 576 pages. \$7.95.*

## ADVENTURES WITH ELECTRONICS

by Walter B. Ford

This recently published book by an author whose contributions have appeared in POPULAR ELECTRONICS is an attempt to entice more high school students into electronics—either as a career or a hobby. Walt Ford is aware of the gap between the student's burst of initial interest and the satisfaction of having built a working electronics project. This book is aimed toward supplying the necessary details to enable a beginner to construct one or more unusual projects. A choice of 36 different projects is given—four of which have previously appeared in this magazine.

*Published by The Bruce Publishing Co., 400 N. Broadway, Milwaukee, Wisc. 53201. Hard cover. 184 pages. \$4.95.*



## East Coast to West Coast Cobra leads the way in CB Communication

CB has been an integral part of communications for many years. Hobbyists, Government, Business, and Industry have found it to be an invaluable means of exchanging information and ideas.

Today, however, the fast pace of technology has demanded change and originality in all areas of electronics. CB 2-Way Radio Communication has been no exception.

To keep abreast of these changes, DYNASCAN developed the Cobras... CB Transceivers that strike out at maximum range and reliability. Advanced-design circuits, higher "Cobrapower" input for max-

imum range, and a full 23-channel operation make the Cobras the finest professional-quality CB units available. *They devour competition in performance and dependability!*

Drop in to your nearest Cobra distributor today. He'll be glad to show you the complete Cobra line. If you prefer, write to DYNASCAN direct; and we'll send you any and all information you desire.

**Cobra**

Product of DYNASCAN CORPORATION  
1801 W. Belle Plaine • Chicago, Illinois 60613  
Where electronic innovation is a way of life.



COBRA V.  
NET, \$99.95.



COBRA 27.  
NET, \$179.95.



COBRA CAM-88.  
NET, \$219.95.



COBRA 98.  
NET, \$239.95.

CIRCLE NO. 4 ON READER SERVICE PAGE

# POPULAR ELECTRONICS READER SERVICE PAGE

## free information service:

Here's an easy and convenient way for you to get additional information about products advertised or mentioned editorially (if it has a "Reader Service Number") in this issue. Just follow the directions below...and the material will be sent to you promptly and free of charge.

**1.** Print or type your name and address on the lines indicated. Circle the number(s) on the coupon below that corresponds to the key number(s) at the bottom of the advertisement or editorial mention(s) that interest you. (Key numbers for advertised products also appear in the Advertisers' Index.)

**2.** Cut out the coupon and mail it to the address indicated below.

**3.** This address is for our product "Free Information Service" only. Editorial inquiries should be directed to POPULAR ELECTRONICS, One Park Avenue, New York 10016; circulation inquiries to Portland Place, Boulder, Colorado 80302.

**POPULAR  
ELECTRONICS**

VOID AFTER AUGUST 31, 1969

P.O. BOX 8391  
PHILADELPHIA, PA. 19101

1 2 3 4 5 6 7 8 9 10 11 12 13 14 15 16 17 18 19 20  
21 22 23 24 25 26 27 28 29 30 31 32 33 34 35 36 37 38 39 40  
41 42 43 44 45 46 47 48 49 50 51 52 53 54 55 56 57 58 59 60  
61 62 63 64 65 66 67 68 69 70 71 72 73 74 75 76 77 78 79 80  
81 82 83 84 85 86 87 88 89 90 91 92 93 94 95 96 97 98 99 100

NAME (Print clearly) \_\_\_\_\_

ADDRESS \_\_\_\_\_

CITY \_\_\_\_\_ STATE \_\_\_\_\_ ZIP CODE \_\_\_\_\_

7 Na

# 10 Exciting New Kits



**NEW**  
Kit ID-29  
**\$29.95\***



**NEW**  
Kit GD-48  
**\$59.95\***



**NEW**  
Kit TD-17  
**\$12.95\***



**NEW**  
Kit GR-88  
**\$49.95\***  
each

**NEW**  
Kit GR-98



**NEW**  
Kit IP-28  
**\$47.50\***

**NEW** Kit GD-28 **\$59.95\***



## NEW Heathkit Solid-State Auto Tune-Up Meter . . . Measures Dwell, RPM And DC Voltage

The new Heathkit ID-29 is most versatile . . . really three automotive test instruments in one . . . and its low price makes it even a better value. Measures Dwell on all 4-cycle 3, 4, 6, or 8 cylinder engines . . . measures RPM in two ranges 0-1500 and 0-4500 . . . measures DC voltage from 0 to 15 volts. And no batteries are needed . . . running engine provides both signal and power. Easy to use . . . on both 6 and 12 volt system without changing leads. It's lightweight, easy to carry . . . comes equipped with black polypropylene case that has a built-in lead storage compartment and is resistant to virtually everything. Fast, simple assembly . . . takes just one evening. The perfect accessory for the handyman who wants to do his own car tune-up, emergency road service personnel, or shop mechanics . . . order your ID-29 now. 4 lbs.

## NEW Heathkit GD-48 Solid-State Metal Locator

A low cost, versatile, professional metal detector at one-third the cost of comparable detectors. Packed with features for long life, rugged reliability, and dozens of uses. Completely portable, battery operated and weighs only 3 lbs. The GD-48 is highly sensitive, probes to 7 feet, and has an adjustable sensitivity control. Its built-in speaker signals presence of metal; front panel meter gives visual indication. Other features include built-in headphone jack, telescoping shaft for height adjustment, weather protected and splash proof, smartly styled and smartly designed for easy in-hand use and easy assembly. Whether you're an amateur weekend hobbyist or a professional treasure hunter the GD-48 is for you . . . also a great help to contractors, surveyors, Gas, Electric, Telephone and other public Utility Companies. 4 lbs. GD-396, Headphones, 2000 ohm (Suporex) \$3.50\*

## NEW Heathkit Electronic Metronome

The new Heathkit TD-17 is a low cost, precise performing electronic Metronome . . . a handy helper for any music student. Battery operated . . . no springs to wind . . . accurate, steady calibration is always maintained . . . from 40 to 210 beats per minute. Instruction label on bottom gives conversion from time signature and tempo to beats per minute. Stylish fruit wood finished cabinet. Easy solid state circuit board construction . . . assembles and calibrates in only 2-3 hours. The new Heathkit TD-17 Electronic Metronome is so low in cost every music student can afford one . . . order yours now. 1 lb.

## NEW Heathkit GR-88 Solid-State Portable VHF-FM Monitor Receiver

Tunes both narrow and wide band signals between 154-174 MHz . . . for police, fire, most any emergency service. Exceptional sensitivity and selectivity, will outperform other portable receivers. Features smart compact styling . . . with durable brown leatherette case, fixed station capability with accessory AC power supply, variable tuning or single channel crystal control, collapsible whip antenna, adjustable squelch control and easy circuit board construction. The new GR-88 receiver is an added safety precaution every family should have . . . order yours today. 5 lbs.

## NEW Heathkit GR-98 Solid-State Portable Aircraft Monitor Receiver

Tunes 108 through 136 MHz for monitoring commercial and private aircraft broadcasts, airport control towers, and many other aircraft related signals. Has all the same exceptional, high performance features as the GR-88 above. The perfect receiver for aviation enthusiast . . . or anyone who wants to hear the whole exciting panorama of America in flight. 5 lbs. GRA-88-1, AC Power Supply \$7.95

## Heathkit GD-28 8-Track Cartridge Tape Player

The new GD-28 is an ideal addition to any home music system. Plays pre-recorded tapes through any system with a Tape Recorder, Tuner or Auxiliary input. Just push in the 8-track stereo cartridge . . . it starts and changes tracks automatically . . . even shows which track is playing. Changes tracks instantly with the front panel switch too. Goes together quickly on one circuit board, and the playing mechanism is preassembled & adjusted. Attractive wood-grained polyurethane cabinet included. Order yours now. 10 lbs.

## NEW Heathkit 1-30 VDC Solid-State Regulated Power Supply

The new modestly priced IP-28 is an excellent power supply for anyone working with transistors whether it be in a laboratory or in a home workshop . . . and its low price makes it the ideal power supply for classroom use. Compact brown and beige, Heathkit instrument styling with large easy-to-read meter . . . with two voltage ranges 10 v. and 30 v. . . . and two current ranges 100 mA, 1 A. External sensing permits regulation of load voltage rather than terminal voltage. Adjustable current limiting prevents supply overloads and excessive load current. Convenient standby switch. Fast, easy assembly with one circuit board and wiring harness. Order yours today. 9 lbs.



# From The Leader



## NEW Heathkit Ultra-Deluxe "681" Color TV With AFT ... Power Channel Selection & Built-In Cable-Type Remote Control

The new Heathkit GR-681 is the world's most advanced Color TV with more built-in features than any other set on the market. Automatic Fine Tuning on all 83 channels ... eliminates touchy fine tuning forever; power push button VHF channel selection, built-in cable-type remote control ... or you can add the optional GRA-681-6 Wireless Remote Control any time you wish ... plus the built-in self-servicing aids that are standard on all Heathkit color TV's but can't be bought on any other set at any price. Other features include a bridge-type low voltage power supply for superior regulation; high & low AC taps to insure that the picture transmitted exactly fits the "681" screen. Automatic degaussing, 2-speed transistor UHF tuner, hi-fi sound output, two VHF antenna inputs, top quality American brand color tube with 2-year warranty.

GRA-295-4, Mediterranean Cabinet shown ..... \$119.50\*  
**Heathkit "295" Color TV**

Big, Bold, Beautiful ... with the same high performance features and built-in servicing facilities as the GR-681 above ... but less the Automatic Fine Tuning, push button VHF power tuning and built-in cable-type remote control. You can add the optional GRA-295-6 Wireless Remote Control at any time.

GRA-295-1, Contemporary Walnut Cabinet shown ..... \$62.95\*  
Both the GR-681 and GR-295 fit into the same Heath factory assembled cabinets; not shown, Early American style at \$99.95.\*

## NEW Deluxe Heathkit "581" Color TV With AFT

The new Heathkit GR-581 will add a new dimension to your TV viewing. Brings you color pictures so beautiful, so natural, so real ... puts professional motion picture quality right into your living room. Has the same high performance features and exclusive self-servicing facilities as the GR-681, except with 227 sq. inch viewing area, and without power VHF tuning or built-in cable-type remote control. The optional GRA-227-6 Wireless Remote Control can be added any time you wish. And like all Heathkit Color TV's you have a choice of different installations ... mount it in a wall, your own custom cabinet, your favorite B&W TV cabinet, or any one of the Heath factory assembled cabinets.

GRA-227-2, Mediterranean Oak Cabinet shown ..... \$99.50\*

## Heathkit "227" Color TV

Same as the GR-581 above, but without Automatic Fine Tuning ... same superlative performance, same remarkable color picture quality, same built-in servicing aids. Like all Heathkit Color TV's you can add optional Wireless Remote Control at any time (GRA-227-6). And the new Table Model TV Cabinet and roll around Cart is an economical way to house your "227" ... just roll it anywhere, its rich appearance will enhance any room decor.

GRS-227-6, New Cart and Cabinet combo shown ..... \$49.95\*  
Both the GR-581 and GR-227 fit into the same Heath factory assembled cabinets; not shown, Contemporary cabinet \$59.95.\*

## NEW Heathkit Deluxe "481" Color TV With AFT

The new Heathkit GR-481 has all the same high performance features and exclusive self-servicing aids as the new GR-581, but with a smaller tube size ... 180 sq. inches. And like all Heathkit Color TV's it's easy to assemble ... no experience needed. The famous Heathkit Color TV Manual guides you every step of the way with simple to understand instructions, giant fold-out pictorials ... even lets you do your own servicing for savings of over \$200 throughout the life of your set. If you want a deluxe color TV at a budget price the new Heathkit GR-481 is for you.

GRA-180-1, Contemporary Walnut Cabinet shown ..... \$49.95\*

## Heathkit "180" Color TV

Feature for feature the Heathkit "180" is your best buy in color TV viewing ... has all the superlative performance characteristics of the GR-481, but less Automatic Fine Tuning. For extra savings, extra beauty and convenience, add the table model cabinet and mobile cart. Get the value-packed GR-180 today.

GRS-180-5, Table Model Cabinet & Cart combo ..... \$39.95\*  
Both the GR-481 and GR-180 fit the same Heath factory assembled cabinets; GRA-180-2, Early American Cabinet \$75.00.\*

Add the Comfort And Convenience Of Full Color Wireless Remote Control To Any Rectangular Tube Heathkit Color TV ... New Or Old!

Kit GRA-681-6, for Heathkit GR-681 Color TV's ..... \$59.95\*

Kit GRA-295-6, for Heathkit GR-295 & GR-25 TV's ..... \$69.95\*

Kit GRA-227-6, for Heathkit GR-581; GR-481 & GR-180 Color TV's ..... \$69.95\*

## Now There Are 6 Heathkit® Color TV's To Choose From

2 Models In 295 Sq. Inch Size

NEW  
Kit GR-681  
With AFT  
**\$499.95\***  
(less cabinet)



Kit GR-295  
**\$449.95\***  
(less cabinet)

2 Models In 227 Sq. Inch Size

NEW  
Kit GR-581  
with AFT  
**\$419.95\***  
(less cabinet)



Kit GR-227  
NOW ONLY  
**\$379.95\***  
(less cabinet  
& cart)

2 Models In 180 Sq. Inch Size

NEW  
Kit GR-481  
with AFT  
**\$359.95\***  
(less cabinet)



Kit GR-180  
NOW ONLY  
**\$329.95\***  
(less cabinet & cart)



## NEW

### FREE 1969 CATALOG!

Now with more kits, more color. Fully describes these along with over 300 kits for stereo/hi-fi, color TV, electronic organs, electric guitar & amplifier, amateur radio, marine, educational, CB, home & hobby. Mail coupon or write Heath Company, Benton Harbor, Michigan 49022.

HEATH COMPANY, Dept. 10-7  
Benton Harbor, Michigan 49022

Enclosed is \$ \_\_\_\_\_, plus shipping. a Schlumberger company

Please send model (s)  
 Please send FREE Heathkit Catalog.  Please send Credit Application.

Name \_\_\_\_\_

Address \_\_\_\_\_

City \_\_\_\_\_

State \_\_\_\_\_

Zip \_\_\_\_\_

\*Mail order prices; F.O.B. factory. Prices & specifications subject to change without notice.

CL-358 R

CIRCLE NO. 27 ON READER SERVICE PAGE

**We pack your electronics course with kits to make your training fast. You'll enjoy every minute of it.**

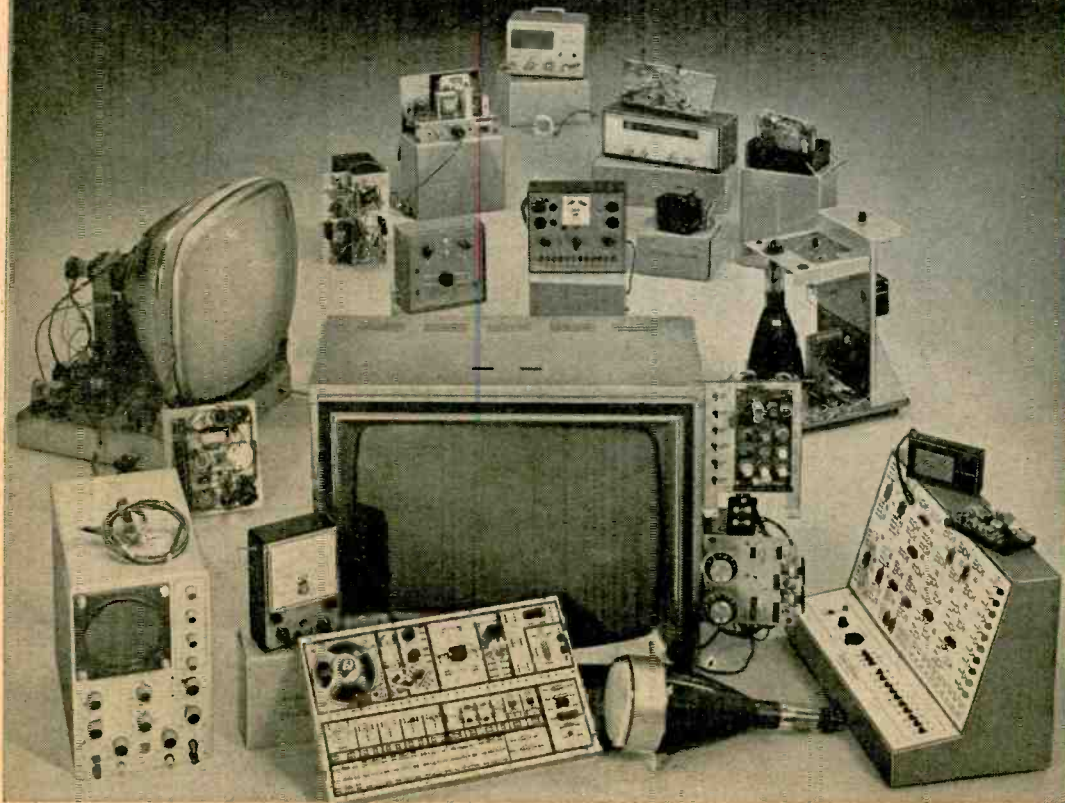

## **Your NTS success package**

Choose a career in electronics: Computers. Color TV Servicing. Automation. Communications. Whatever the field, NTS has a complete home-study package to get you to the top *faster*. 10 thorough training courses. Each includes *everything* to give you the *working* knowledge required of successful technicians.

NTS Project-Method Training is the practical way to learn elec-

tronics. It's a proven combination of lessons and the best professional kit equipment available. NTS provides the *biggest selection of kits ever offered in home-study . . . all at no extra cost*. You'll construct these exciting kits to fully understand electronic circuits, components, and concepts. Our Project-Method lets you build skills by putting theory into practice . . . by working with your hands, as well as your head.

The NTS "learn and practice" approach makes training at home really easy. All it takes is a few hours a week . . . whether you're starting from scratch or in advanced courses. This is the all-inclusive success package that put thousands of men into the best paying jobs . . . or into their own business. If "just a living" isn't good enough for you, now is the time to get something better going for you!

## NTS COMPUTER ELECTRONICS

This is the future. And it's happening now. The number of computers will *increase many times* in the next few years.

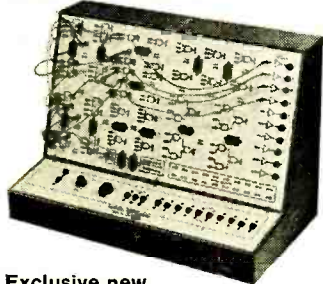

### Exclusive new Compu-Trainer®

NTS offers a solid grounding in computer operation, wiring, data processing and programming. One of the 10 important kits included is our exclusive Compu-Trainer®. It's a fully operational computer logic trainer — loaded with integrated circuits — the first ever offered in home study. It introduces you quickly to how, what, when and why of computers . . . from theory to practical servicing techniques. This unit is capable of performing 50,000 operations per second. And it's sent at no extra cost.

## NTS COLOR TV SERVICING

This is a broad, easily understood

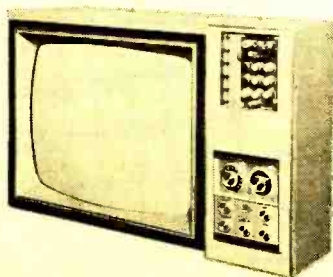

25" COLOR TV

program designed to make you a complete home-entertainment service technician. Included, at no extra cost, is a 25" color TV that has more features than any

set on the market. You also learn all about stereo, hi-fi, multiplex systems, and become a specialist in Color TV Servicing. Kits also include AM-SW radio, solid-state radio, vacuum tube volt meter, electronic tube tester.

## NTS AUTOMATION/ INDUSTRIAL ELECTRONICS

You're trained in the "push-button" electronics that keep industry going and growing . . . from relay type controls to highly advanced systems essential to production. You receive 16 kits including a 5" wide band oscilloscope, and the new NTS electronics lab: a fascinating NTS exclusive experimental laboratory. A complete workshop which makes you familiar with solid-state, miniature, and integrated circuits.

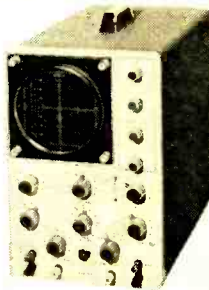

5" Oscilloscope

## NTS ELECTRONIC COMMUNICATIONS

The use of 2-way radio systems in private and commercial applications is skyrocketing. NTS prepares you for the big-money opportunities in the field of transmitting and receiving equipment. *Your tuition will be refunded in full if you cannot pass the FCC exam for a 1st Class Commercial Radio-Telephone License within*

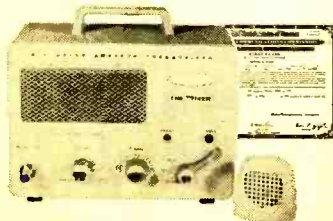

5 Watt AM Transmitter & Receiver

*six months after successfully completing this course.* You build valuable kits including Amateur-Phone 6 Meter VHF Transceiver, solid-state Radio, and a Vacuum Tube Voltmeter.

## CLASSROOM TRAINING AT LOS ANGELES

You can take classroom training at Los Angeles in sunny Southern California. NTS occupies a city block with over a million dollars in facilities devoted exclusively to technical training. Check box in coupon.

## NATIONAL TECHNICAL SCHOOLS

World Wide Training Since 1905

4000 South Figueroa Street  
Los Angeles, Calif. 90037, U.S.A.

## APPROVED FOR VETERANS

Accredited Member: National Association of Trade and Technical Schools, National Home Study Council.

**TODAY, MAIL COUPON FOR FREE COLOR CATALOG AND SAMPLE LESSON.**

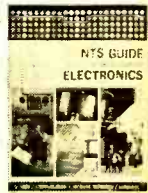

NATIONAL TECHNICAL SCHOOLS  
4000 S. Figueroa St., Los Angeles, Calif. 90037

Please rush Free Color Catalog and Sample Lesson, plus information on field checked below. No obligation. No salesman will call.

- MASTER COURSE IN COLOR TV SERVICING
- COLOR TV SERVICING
- MASTER COURSE IN TV & RADIO SERVICING
- PRACTICAL TV & RADIO SERVICING
- MASTER COURSE IN ELECTRONIC COMMUNICATIONS
- FCC LICENSE COURSE
- MASTER COURSE IN ELECTRONICS TECHNOLOGY
- INDUSTRIAL AND AUTOMATION ELECTRONICS
- COMPUTER ELECTRONICS
- BASIC ELECTRONICS

Name \_\_\_\_\_ Age \_\_\_\_\_

Address \_\_\_\_\_

City \_\_\_\_\_ State \_\_\_\_\_ Zip \_\_\_\_\_

Check if interested in Veteran Training under new G. I. Bill.

Check if interested ONLY in Classroom Training at Los Angeles. Dept. 205-79

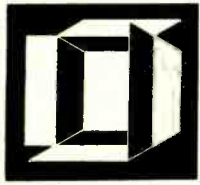

## NEW PRODUCTS

Additional information on products covered in this section is available from the manufacturers. Each new product is identified by a code number. To obtain further details on any of them, simply fill in and mail the coupon on page 15 or 95.

### "PROFESSIONAL STANDARDS" AMPLIFIER

Designed to meet the standards of professional broadcast and recording studio engineers, the *H. J. Leak Ltd.* "Stereo 70" is also said to be the most technically advanced integrated solid-state amplifier available. The

Stereo 70 has a full range of controls and facilities that provide maximum flexibility and convenience of operation. Provisions are

made for the use of remote loudspeakers, stereo headphones, a portable tape deck, turntable, and FM tuner through terminals located on the rear apron. The amplifier is conservatively rated at 35 watts/channel r.m.s. power output and limits distortion to 0.1% at 1000 Hz for all power outputs up to 25 watts/channel. All controls are single-knob, dual-ganged, close tolerance.

Circle No. 79 on Reader Service Page 15 or 95

### RESISTOR SUBSTITUTION BOX

A miniaturized resistor substitution box measuring only 4" X 3" X 2 1/4"—one-third the size of ordinary boxes—providing all 84 standard resistance values has been developed by *Vytell Corp.* The design concept of the "Mini-Box" utilizes a push-on connector and a "keyboard" of resistor leads in place of a control knob switch for resistor value selection. In addition to faster selection of desired resistor values, the new design permits easy, one-hand operation during tests requiring simultaneous use of other equipment. Includes a full range of 84 one-watt, 10% resistors from 2.7 ohms to 22 meg-ohms, each with one lead connected to a common buss. Two outer binding posts have the push-on leads which can be connected to any of the resistor values. This allows selection of up to 3400 non-standard resistor values. The Mini-Box is rated at 500 volts continuous duty.

Circle No. 80 on Reader Service Page 15 or 95

### ELECTRONIC RHYTHM KIT

The "Combo Sideman" (Model KG-392) is a new portable electronic rhythm kit made by *Knight-Kit*. When plugged into an instrument amplifier, it electronically reproduces the sound of bass and snare drums and cymbals with amazing realism. The sounds are generated and mixed in various combinations and timing, controlled by the operator, to produce six precise, perfectly-timed rhythms. The operator taps the stop/start button, and the rhythm starts, always on the first beat of the measure. Any of the various rhythms can be selected or changed while the unit is playing. A tempo control determines the speed of the rhythm, and by holding down the solo button, the operator can produce single, repetitive drum beats and can vary the speed with the tempo control. A volume control adjusts the sound level. The kit comes complete with battery, footswitch, and output cable.



Circle No. 81 on Reader Service Page 15 or 95

### HIGH-LEVEL OUTPUT RECORD CHANGER

Called the "X-10 Module," *Garrard's* new pre-wired automatic turntable is designed to plug into and play through table radios, FM stereo receivers, component stereo systems, TV receivers, and tape machines. The module comes with a stereo ceramic cartridge (with diamond stylus) and is premounted on a *Garrard* base, dust cover included. Among the fea-

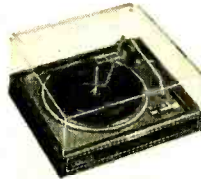

tures available are a single lever cueing and pause control, pencil-thin ultra-low-mass tubular tone arm, interchangeable spindles for manual and automatic play and an oversize turntable. The high-level output of the ceramic cartridge allows the X-10 to be used with audio amplifying equipment which has no preamplifier stages.

Circle No. 82 on Reader Service Page 15 or 95

### STEREO/VIDEO TAPE RECORDER

Now every home can have a "Leisure Activities Center" based on the *Roberts Model 1000* four-track stereo and video tape recorder currently being made by the *Rheem Manufacturing Co.* The Model 1000 is described as the world's first combination stereo/video recorder that can play back pictures and sound on the 1/4" tape commonly used in audio recording—in addition to recording and playing back



# World's largest selling mobile/base CB rig! \$199.



Courier 23 — the most popular mobile/base CB transceiver ever built! A greater value than ever before, with 100% modulation featuring Courier's exclusive Modulation Sampler® — boosts your talk power electronically! Dollar for dollar, offers more of what you want in CB: 23 crystal-controlled channels, dual conversion, built-in solid-state 12v mobile power supply, illuminated S-RF meter and channel selector, PA system, modulation indicator, full-time Range-expand, adjustable noise limiter, super efficient squelch. Heavy-duty triple-plated chrome cabinet with stainless steel front panel. Just \$199 complete with crystals for all 23 channels.

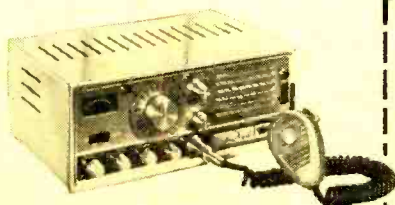

## COURIER ROYALE

All the performance money will buy, no matter what you're willing to spend. The ultimate in power, selectivity, sensitivity, quietness. All 23 channels, with all crystals supplied.

Complete \$299  
(and we mean complete)

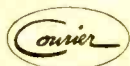

**COURIER COMMUNICATIONS, INC.**  
439 Frelinghuysen Avenue, Newark, N.J. 07114  
a **Whittaker** Company

Yes! I'd like to know all about the Courier 23 — world's largest-selling CB rig!

Send me data on COURIER ROYALE

Name \_\_\_\_\_ PE-97

Address \_\_\_\_\_

City \_\_\_\_\_ County \_\_\_\_\_

State \_\_\_\_\_ Zip \_\_\_\_\_

CIRCLE NO. 10 ON READER SERVICE PAGE

## PRODUCTS (Continued from page 22)

conventional four-track stereo program material. This means that while conventional VTR's using  $\frac{1}{2}$ " tape cost more than a dollar/min of recording time, the Model 1000, using  $\frac{1}{4}$ " tape, costs only 45 cents or less per minute of operating time. In the VTR mode, the system utilizes a helical-scan rotating head system at a tape speed of only 11.25 in./s. In the stereo mode, tape speeds are  $3\frac{3}{4}$  and  $7\frac{1}{2}$  in./s; the automatic reverse facility is standard.

Circle No. 83 on Reader Service Page 15 or 95

### DELUXE FOUR-BAND RECEIVER

The unique feature of *Lafayette Radio Electronics'* new deluxe four-band receiver, Stock No. 99-3563L, is its ability to tune in channels 2 through 13 for reception of the sound portion only of TV transmissions. This makes the receiver ideal for the physically handicapped and for private listening. In addition, the receiver also tunes police and fire broadcasts on 147-175 MHz, and the U.S. Weather Bureau forecasts on 162.55 or 163.275 MHz. The new receiver is designed for portable battery operation, or for home use on line power with an optional a.c. adapter. The circuit employs 14 transistors, three diodes, and one thermistor. Also included with the receiver are a built-in whip antenna, 3" speaker, and provisions for external antenna and carphone.

Circle No. 84 on Reader Service Page 15 or 95

### DYNAMIC STEREO MICROPHONES

A matched pair of low-cost, high-impedance dynamic stereo recording microphones with hi-fi performance specifications is available from the *Turner Company*. Designated Model 2804, the rugged omnidirectional microphones provide a frequency range of 80-12,000 Hz at a -63-dB output level. The microphones are packaged in a handsome carrying case. Complete accessories

are included, and each microphone is equipped with a 12" cable with molded phone plug.

Circle No. 85 on Reader Service Page 15 or 95

### GET BETTER COLOR TV PERFORMANCE

The production of a new device, called the Model 50-172 "Saturn," for the improvement of color TV receiver performance has been announced by *Terado Corporation*. The Saturn is claimed to give life-like color and improve clarity and brightness by correcting

low or changing a.c. line voltages to a normal level. Saturn installs in seconds, and its easy-to-read edge-view meter and six-position switch allow the viewer fingertip control of the line voltage that provides the clearest, sharp, full, and most life-like picture.

Circle No. 86 on Reader Service Page 15 or 95

### SOLID-STATE STEREO AMPLIFIER

The lowest cost stereo amplifier in the *Lafayette Radio Electronics* lineup is the "Stereo 20A," with two integrated circuits, ten transistors, two diodes and two thermistors. Designated by stock No. 20-0947WX, the Stereo 20A has a transformerless complementary-symmetry output which offers low distortion, long life for the transistors, and extended frequency response. Technical Specifications: 30-40,000 Hz  $\pm 3$  dB frequency response; 10 watts/channel at 8 ohms output power; 0.5% harmonic distortion at 1.5 watts IHF power; 105-120 volts a.c., 50/60 Hz, input power. Controls include: bass, treble, balance, volume; phono-tuner switch; stereo-mono switch; main-remote speaker switch; power on/off switch. Outputs available: tape; main speakers; remote speakers; headphones.



Circle No. 87 on Reader Service Page 15 or 95

### LOW-COST ONE-KILOWATT COLOR ORGAN

A modified approach to color organ design by *Edison Instruments, Inc.*, using tunable active RC filters for frequency separation has resulted in a four-channel system capable of operating 250 watts of lighting per channel. The program material for driving the color organ is taken from across the loudspeaker terminals of any audio amplifier by means of clip leads. The system then converts the electrical audio signals into high-power electrical pulses that drive the multi-color lamps in ever-changing color combinations, rhythms, and intensities in step with the tone, pitch, rhythm, and amplitude of the applied signals.



Circle No. 88 on Reader Service Page 15 or 95

### SCREW EXTRACTOR SET

A set of five screw extractors, Kit No. 70007, is the latest problem solving tool available from *Vaco Products Company*. The specially designed extractors remove broken screws, bolts, and studs between  $\frac{1}{4}$ " and  $\frac{5}{8}$ " in diameter with ease—and without damage to the surrounding material. To use the extractor, first a hole is drilled in the broken or buried hardware. Then the correct size extractor is pounded into the drill hole. Finally, with the aid of a wrench, the hardware is screwed out. Special ground flutes on the extractors firmly grip the hardware.

Circle No. 89 on Reader Service Page 15 or 95



# There's a reward

# on their heads.



**FREE:**  
The Copymate Dry Copier, with 20 sheets of copymate paper, with your purchase of the RCA WR-52A Stereo FM Signal Simulator or WO-91C oscilloscope!

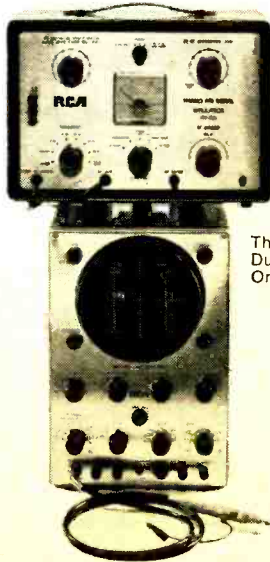

The WR-52A Stereo FM Signal Simulator only \$248.00\*

The WO-91C 5-Inch Dual Band Oscilloscope Only \$269.00\*

Now you can own one of the fastest, most accurate trouble-shooters in the East (West, North and South), and receive, absolutely free, the new all-electric Copymate!

Copymate is the portable dry copier that copies anything—... checks, invoices, schematics, photos, your children's drawings and school work—without liquids, chemicals or sprays!

The Copymate, with paper, has a retail value of \$31.94, but you can get it free... Here's how.

Buy the WR-52A or WO-91C between April 15 and July 15. Mail us your warranty card and the blue label on the outside of the carton no later than July 31st and we'll ship the Copymate to you at once, freight prepaid!

Good deal? You know it is.

Mail your card and label to: RCA Electronic Components, Test Equipment Headquarters, Bldg. 17-2, Harrison, N.J. 07029.

\*Optional distributor resale price.

**CIRCLE NO. 24 ON READER SERVICE PAGE**

# RCA



# 100% BRASS POWER

Words are inherently limited in stimulating the emotions aroused by music. This is especially so in describing how high fidelity components perform.

With cartridges, for example, we speak of flat frequency response, high compliance, low mass, stereo separation. Words like these enlighten the technically minded. But they do little or nothing for those who seek only the sheer pleasure of listening.

We kept both aspects in mind when developing the XV-15 series of cartridges. We made the technical measurements. And we listened.

We listened especially for the ability of

these cartridges to reproduce the entire range of every instrument. With no loss of power. In the case of brasses, this meant a cartridge that could recreate the exact nuances that distinguish a trumpet from a cornet. A trombone from a bass trumpet. A Wagner tuba from a French horn.

We call this achievement "100% brass power."

When you play your records with an XV-15, you won't be concerned with even that simple phrase.

Instead, you'll just feel and enjoy the renewed experience of what high fidelity is really all about.

**PICKERING**



THE NEW PICKERING XV-15/750E.  
PREMIER MODEL OF THE XV-15 SERIES. TRACKS AT 1/2 TO 1 GRAM. DYNAMIC COUPLING FACTOR OF 750 FOR  
USE IN FINEST TONARMS. \$60.00. OTHER XV-15 CARTRIDGES FROM \$29.95. PICKERING & CO., PLAINVIEW, L.I., N.Y.

**CIRCLE NO. 23 ON READER SERVICE PAGE**

POPULAR ELECTRONICS



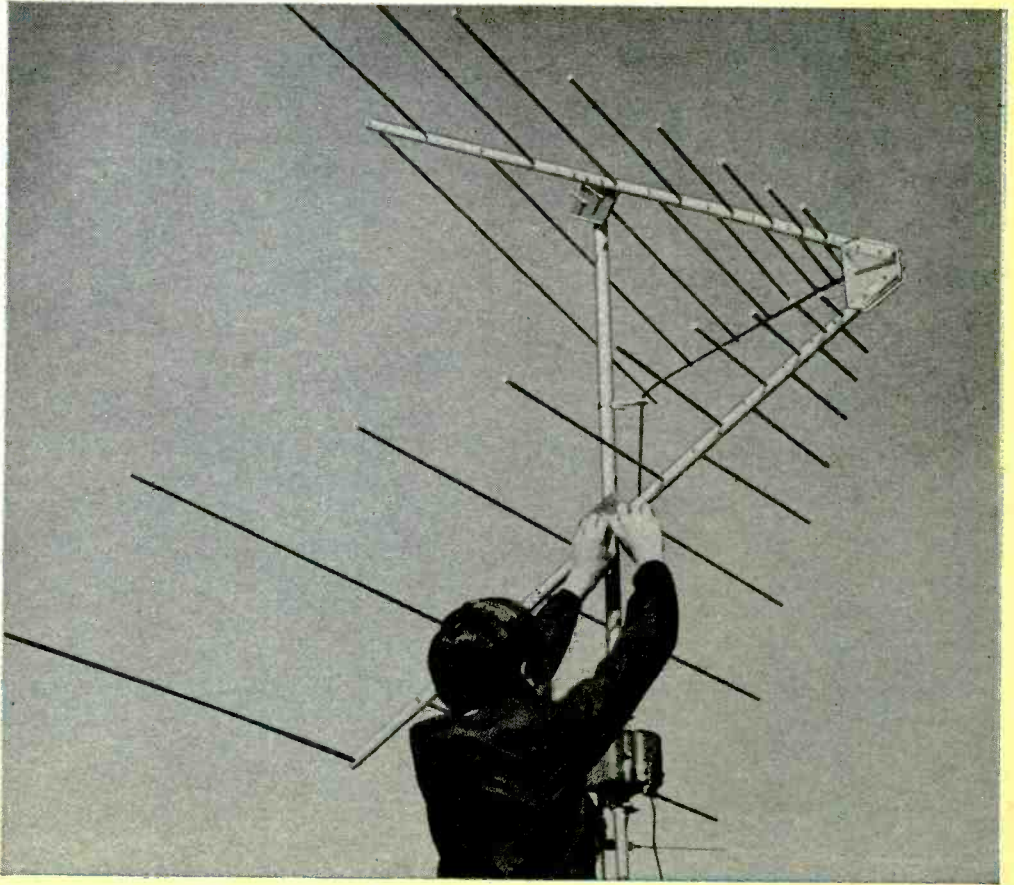

**BUILD THE**

# “PYRAMIDAL” TV/FM ANTENNA

LOW COST AND HIGH GAIN  
ARE FEATURED  
IN UNUSUAL DESIGN

BY GEORGE MONSER

**T**HE RAPID GROWTH of color programming on the TV channels and stereo broadcasting on the FM band has generated an urgent need for an inexpensive high-gain receiving antenna. Unfortunately, most of the really good ready-to-install antennas are relatively expensive. But if you are willing to invest about \$25 for materials and some four hours of your time, you can fabricate a “Pyramidal” antenna that will equal or better the performance of antennas selling for several times the cost of the materials.

The Pyramidal antenna described here is a frequency-independent (log-periodic) design. As opposed to the Yagi antenna that is “peaked up” at certain points within its band, the log-periodic antenna has an essentially constant gain over its entire band. (The Yagi, for example, has 10-13 dB of gain at the peaked frequencies—much less at all other frequencies—while the log-period-

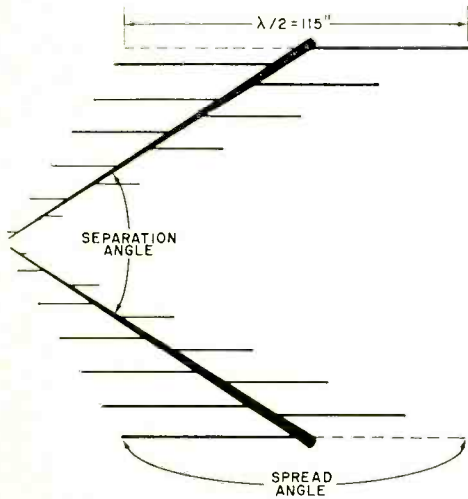

Fig. 1. Antenna gain and pickup characteristics are chiefly determined by spread and separation angles.

ic's gain curve is virtually flat at 8-12 dB over its entire band.)

The unique design of the Pyramidal antenna permits broad band coverage (VHF and UHF TV, and FM broadcast bands), using just 17 elements. The antenna also has sufficient gain to classify it as a "fringe" and "deep fringe" receiving antenna for color TV. Furthermore, the feed impedance almost perfectly matches commonly available 300-ohm lead-in, eliminating the need for expensive coaxial cable and impedance-converting Baluns.

**Antenna Characteristics.** The factors that have the greatest effect on the gain and performance of the Pyramidal antenna are the spread and separation angles (see Fig. 1) and, to a lesser degree, the number of elements used to

cover the band. For a given separation angle, any decrease in the spread angle results in an increase in antenna gain. This increased gain, however, is accomplished only by narrowing the pickup lobe of the antenna, making aiming of the antenna more critical.

To minimize the aiming problems, yet preserve a high degree of gain, some compromise in the design of the antenna must be accepted. Hence, the spread angle is fixed at about 90° (actually closer to 86.5°) for a 60° separation angle. These figures, while they make aiming of the antenna easy, provide about 9 dB of gain—sufficient to qualify the antenna for fringe area use. The graph in Fig. 2 shows how the spread and separation angles affect gain.

Theoretically, the longest element in the array should be cut to one-half wavelength at the lowest operating frequency. In practice, however, this is neither necessary nor desirable since the drop-off of the gain curve is so gradual. For this reason, as shown in Fig. 1, the longest element spans only 115" tip-to-tip, about one-half wavelength at 51 MHz.

Finally, for smoothness of operation over the entire band, a spacing ratio of 0.87 between elements was selected. Again, this is a compromise figure, one selected to provide smooth operation with the minimum number of elements.

**Construction.** Most of the materials needed for fabricating the Pyramidal antenna can be obtained from a hardware store, but you can save a few dollars by buying the tubing from a pipe outlet. The Plexiglass and NEMA G-10 epoxy-fiberglass, of course, should be bought from a plastics supplier.

Start construction by cutting the 3/8"

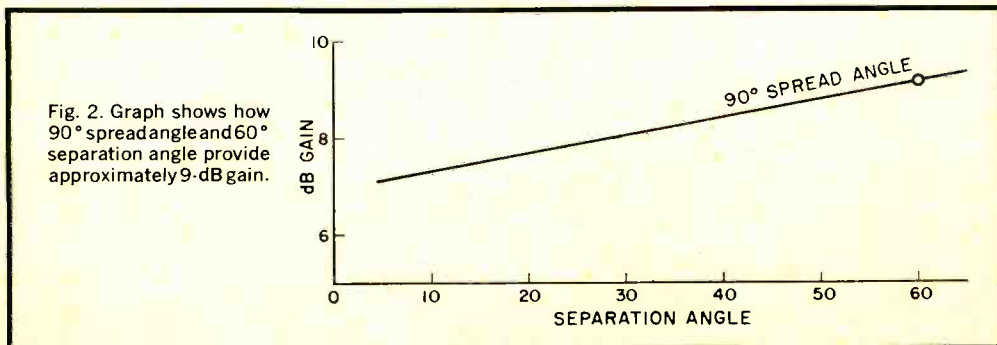

Fig. 2. Graph shows how 90° spread angle and 60° separation angle provide approximately 9-dB gain.

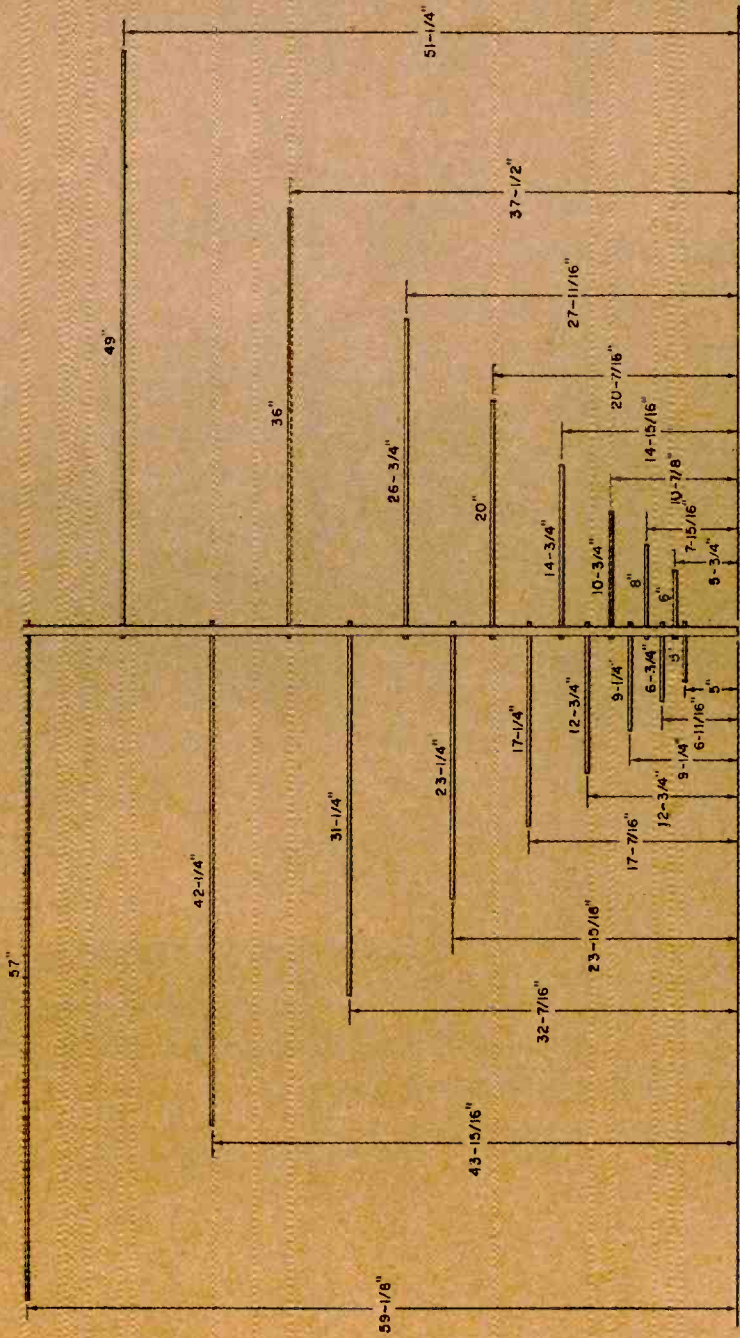

Fig. 3. Lengths given for elements (horizontal bars) are overall; include portions inside boom and projecting beyond boom on opposite side of element proper. Element hole location measurements are referenced from short element end of boom to hole centers. Double check measurements before drilling.

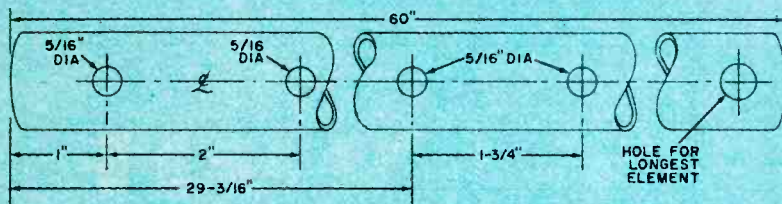

Fig. 4. Holes at left in drawing are for nose supports and at center for U-bracket supports. Reference all your measurements from short element end of boom.

seamless tubing to the lengths specified for the elements in Fig. 3; two of each length are required. Then cut the two 1"-diameter booms to 5' lengths. Mark each of the booms with a small punch at the appropriate locations for the element holes, and drill  $\frac{3}{8}$ " holes through both sides of the booms at the points indicated. Use a small rattail file or a reamer to deburr the exit holes.

Rotate each boom  $90^\circ$  along its axis, and repeat the hole marking procedure outlined above. Make sure these new markings are midway around the circumference of the boom between the  $\frac{3}{8}$ " hole pairs. Then drill #18 holes through only one wall of the booms at these markings.

### BILL OF MATERIALS

- 1—10' length of 1" outer-diameter seamless aluminum TV antenna mast
- 2—5' lengths of 1" outer diameter x 0.035" seamless aluminum tubing for booms
- 70' of  $\frac{3}{8}$ " outer diameter x 0.028" seamless aluminum tubing for elements
- 2—U-bolt mast clamps with spacer, washers, and nuts
- 2—6" x 6" x  $\frac{1}{4}$ " pieces of Plexiglass for nose supports
- 2—4" x 4" x  $\frac{3}{8}$ " NEMA G-10 epoxy-fiberglass (or equivalent) pieces for U-bracket support
- 1—Small plastic cable clamp
- 300-ohm twin-lead lead-in cable (see text)
- Misc.—#8 x  $\frac{3}{4}$ " sheet metal screws;  $\frac{1}{2}$ -20 x  $2\frac{1}{2}$ " machine screws, lock washers, and nuts; #8 solder lugs; 6-32 x  $\frac{1}{2}$ " machine screw, lock washer, and nut; wood dowel or soft plastic (see text); solder; etc.

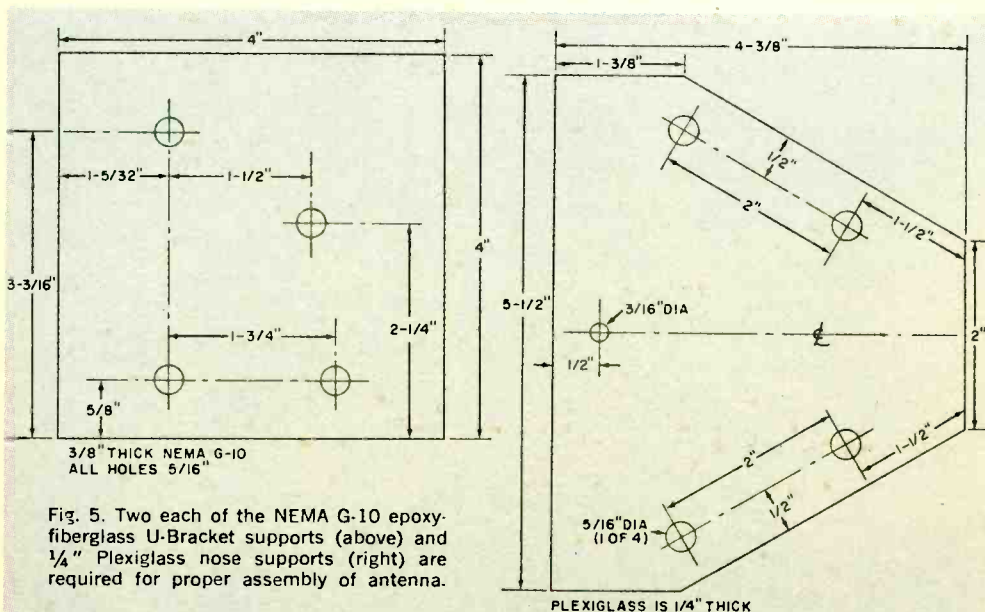
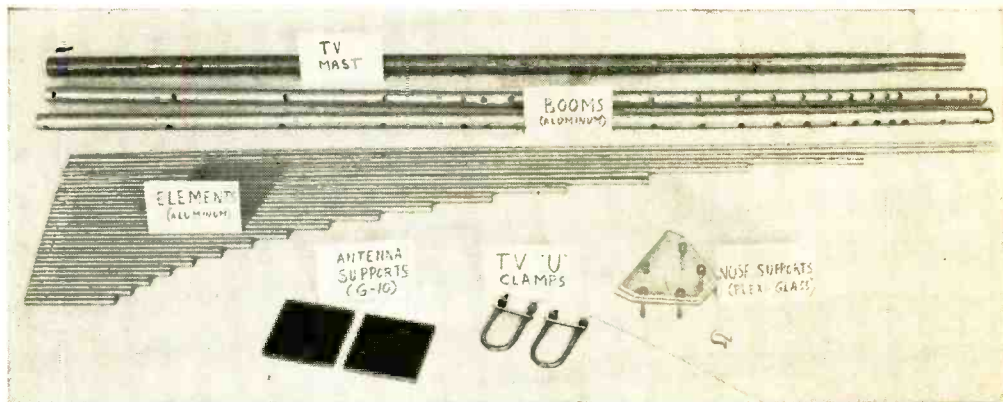

Fig. 5. Two each of the NEMA G-10 epoxy-fiberglass U-Bracket supports (above) and  $\frac{1}{4}$ " Plexiglass nose supports (right) are required for proper assembly of antenna.



Besides parts shown, you will need two 1" antenna mast standoffs and 300-ohm lead-in cable. For best results, choose highest quality lead-in cable available.

Next, referring to Fig. 4, drill  $\frac{5}{16}$ " holes, directly in line with the  $\frac{3}{8}$ " holes, through the booms for the nose and U-bracket supports. Then carefully measure  $\frac{3}{4}$ " in from one end of each element. Mark your measurements with a punch, and drill through the dimples with a #28 drill. Deburr all exit holes on the elements and booms.

Now, pretap the holes in the elements with a #8  $\times$   $\frac{3}{4}$ " sheet metal screw. Insert each element into its proper hole in the boom, and use #8  $\times$   $\frac{3}{4}$ " sheet metal screws to hold them in place; note that a  $\frac{1}{4}$ " stub should project from the boom on the opposite side from the element proper.

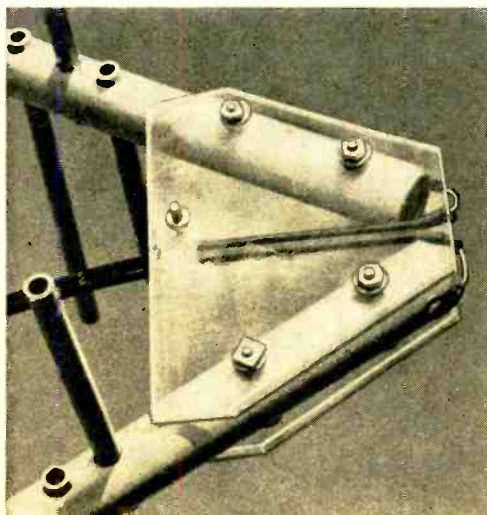

Fig. 6. The nose assembly fastens together with  $\frac{1}{4}$ - $20 \times 2\frac{1}{2}$ " hardware, cable clamp with 6-32 hardware.

Fabricate the two Plexiglass nose supports and two NEMA G-10 U-bracket support assemblies (see Fig. 5 for dimensions). Then drill a #28 hole through one wall of each boom, directly in line with the screws securing the elements in place and  $\frac{1}{4}$ " from the short element ends. Pretap these holes with #8  $\times$   $\frac{3}{4}$ " sheet metal screws. Then plug both ends of each element and both booms with pieces of wood doweling or soft plastic.

Finally, prepare the required length of 300-ohm twin-lead transmission line in the following manner. At the antenna end of the lead-in, split the insulation down the center for a distance of 5". Strip away about  $\frac{1}{4}$ " of insulation from each conductor, and solder a #8 solder lug to each. Then solder a spade lug to each conductor at the opposite end of the cable. (If the lead-in is to be routed through a wall or conduit, solder the spade lugs in place after the cable has been routed.)

**Installation and Aiming.** Take all of the antenna parts, including the mast and lead-in cable, out of doors where you will have plenty of room for final assembly. Assemble the nose pieces and element booms together as illustrated in Fig. 6. Screw down the solder lugs on the lead-in cable, and pass the cable through a small cable clamp. Bolt the clamp to one of the Plexiglass pieces with a 6-32  $\times$   $\frac{1}{2}$ " machine screw, lockwasher, and nut.

Place a plastic or rubber cap over the large-diameter end of the antenna mast section. Then fasten the mast section to the antenna as shown in Fig. 7. Be sure

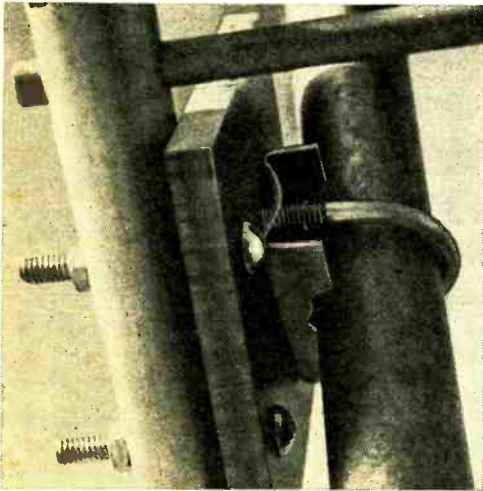

Fig. 7. To prevent antenna from shorting against mast, mount standoff between mast and NEMA board.

to use the U-bracket spacer between the epoxy-fiberglass plates and mast to prevent the antenna from shorting out against the mast through the mounting hardware.

Now, mount the antenna on your rotator by slipping the small-diameter end of the mast into the rotator ferrule. (Note: because the Pyramidal antenna is highly directional, an antenna rotator is almost an absolute must, especially in fringe reception areas.)

Route the lead-in cable to your TV receiver, or if you are simply replacing your present antenna, connect the present lead-in cable to the element booms via the sheet metal screws. Then connect the other end of the lead-in to your TV receiver. Turn on your receiver, and point the *small element end* of the antenna array at a known strong or local TV station (use the positioning control of your rotator.) Now rock the positioning control back and forth to determine the position that provides best reception. (The angular sector off the nose, or apex, of the antenna for best reception is approximately  $60^\circ$  wide; so the final aiming angle can be taken to encompass TV stations within the  $60^\circ$  spread.)

Set the channel selector to a weak-signal channel in your area and again rotate the antenna for best reception. In like manner, check for best reception on all of the VHF TV channels. If you

desire, you can indicate on the rotator control dial which positions provide best reception for each channel.

In some areas where direct-path reception is obstructed by large buildings, hills, etc., siting is best accomplished by employing "scatter" reception. To do this, point the antenna toward objects such as metal water tanks, other TV antennas, or even buildings that have an unobstructed view of the TV station.

Checking out the reception of the UHF TV channels is a little trickier than for the VHF channels. You will have to set the channel selector as near as possible to the UHF channel position desired, rock the rotator control back and forth until you have a picture, and touch up both the channel selector and positioning control as needed for best results. The same procedure applies to FM reception.

In tests in the New York-New Jersey area, the Pyramidal antenna was certainly impressive. For example, in comparison to a "standard" Yagi array of seven VHF TV elements and 14 UHF TV elements, the Pyramidal antenna was better on channels 5 through 13, and literally tremendous on FM. There was also a slight to modest improvement in UHF TV reception.

For its price, size, and ease of construction, the Pyramidal is very likely the best antenna you can use for touchy color TV and stereo FM reception. So, if you are in the market for a good high-gain receiving antenna—whether for VHF TV, UHF TV, or FM broadcast—look no further, the Pyramidal is it!

-30-



BY FRANK ATLEE,  
K4PI

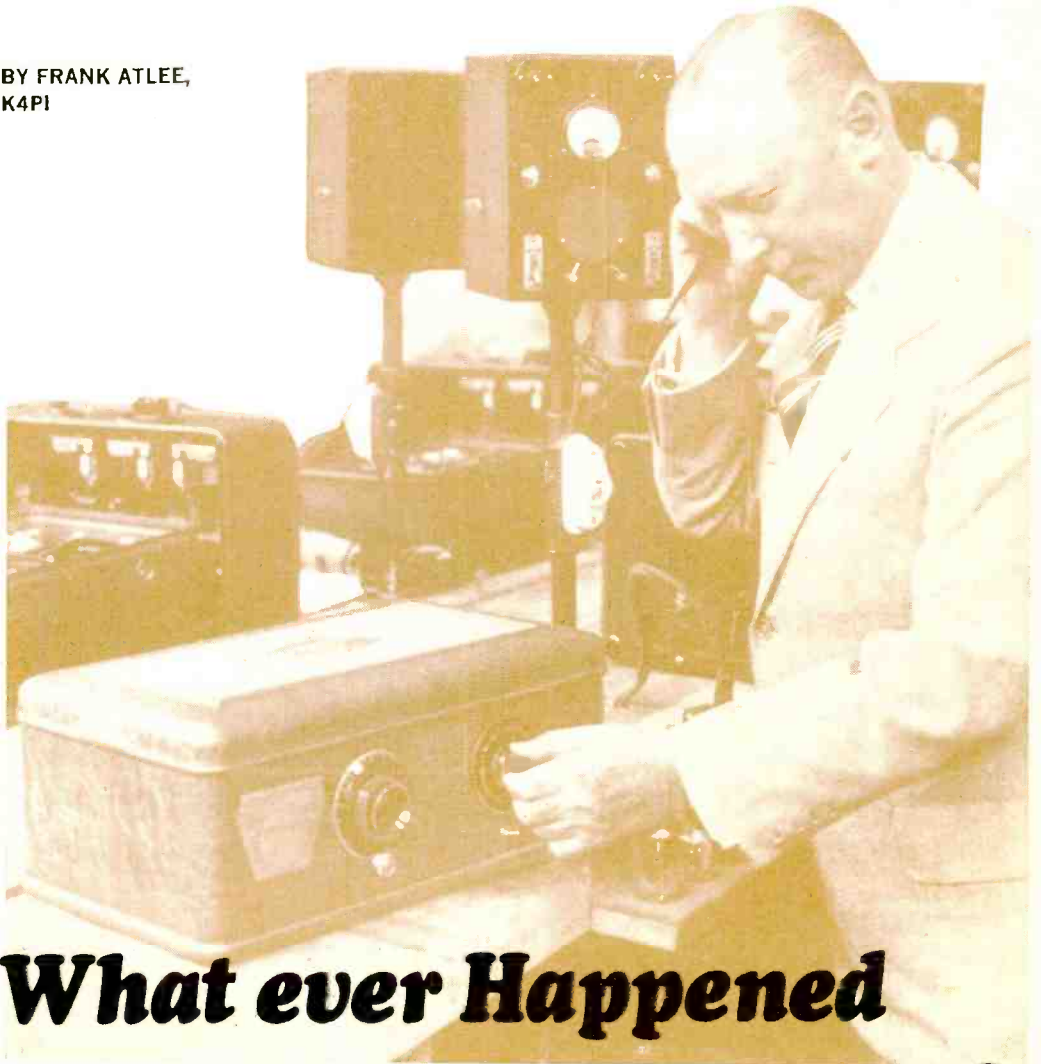

## What ever Happened to Atwater Kent ?

WORLD RENOWN . . . MANUFACTURER OF 5,000,000 RECEIVERS . . .  
FAMOUS FOR QUALITY . . . BUT HE CLOSED THE DOORS AND WALKED AWAY

**A**LTHOUGH more than 40 years have elapsed since the name Atwater Kent was a household word, the radio receivers he manufactured were so well made that thousands are still in existence and in operating condition. Many more Atwater Kent receivers are unearthed daily from cellars and attics to be restored by antique-radio collectors and made conversation pieces for modern living rooms.

The story of this unusual man and his company in many ways parallels the heyday of mass production ascribed to the Ford Motor Company. At one time, Atwater Kent was a company known the world over and even the most conservative estimate of its manufacturing facilities indicates that it produced well over 5,000,000 radio receivers.

The Atwater Kent Company was a well-established manufacturing business



The A-K Model 37 was a 7-tube a.c. operated receiver with the popular 2 r.f., detector, 2 audio circuit.

nearly 20 years before the first radio broadcast. Starting with the making of voltmeters for telephone linemen, the company gradually expanded to include the manufacture of ignition systems, starters and generators for pre-World War I automobiles.

Residing on the "Main Line," then the home of many wealthy Philadelphians able to purchase the fine cars of the day, Kent observed that ignition systems and electric starters (if any) were usually under-designed and subject to frequent failures. Kent purchased several dozen used cars on which to work toward developing improved electrical systems. In a short time, he had invented the "Unisparker" and in 1914 received a medal from the Franklin Institute of Philadelphia. He also developed his type "LA" ignition system for the Model T Ford. Having worked closely with 4- and 6-cylinder engines, Kent predicted that eventually the 4-cylinder engine would be a thing of the past.

**First Expansion.** Sensing that the market for his automotive products was rapidly expanding, in 1914 Kent purchased a large tract of ground north of the Wayne Junction branch of the Reading Railroad in Germantown, Philadelphia. As soon as this factory was completed, he partially switched over production during World War I to the manufacture of gun-sights.

Kent's long-range plans for the post-war economic boom did not materialize and in 1920-21 Kent found himself in a temporary business depression. Scouting around with his usual keen vision for

products to manufacture, he decided to look into the new craze of radio broadcast listening. Kent hired two well-known Philadelphia radio engineers and from a modest start in making transformers he rapidly branched out into the manufacture of tuning units, detectors, and one-to three-tube amplifiers.

Kent even assembled a five-tube radio receiver with all transformers sealed in tar in a metal container about the size of a one pound coffee can.

Labelled the Model 5, 100 of these "breadboard" receivers were sent to each of Kent's nationwide auto parts distributors. A somewhat similar experimental receiver had been presented to President Harding in August, 1921. This was the first radio receiver installed in the White House and it was this type of publicity which Kent used more and more during the "Roaring 20's." Until late 1923, Kent concentrated on the manufacture of individual radio parts, all of beautiful appearance and fine construction. At the same time Kent conducted a vigorous advertising campaign in consumer magazines such as *The Saturday Evening Post*, plus hobby magazines like *Radio News* (now *Electronics World*).

To avoid becoming entangled in the complicated patent situation that existed regarding radio circuits, Kent purchased, for a moderate sum, the rights to a number of inventions of his previous patent attorney and hired a new attorney to help plan for future developments.

**Mass Production.** Quick to watch for business opportunities and to consider suggestions from his nationwide distributors, Kent announced, for the Christmas buying season of 1923, his famous Model 10 radio. This was a five-tube receiver with all parts mounted on an attractive wooden board and the wiring channeled out of sight beneath the board. The immediate demand for this receiver was tremendous and some months later, Kent modified and improved the original Model 10 and added a four-tube Model 9 receiver to his line.

In late 1924 at the insistence of his distributors and in view of the competition from the growing number of makers of console-style receivers, Kent announced the Model 20—a five-tube TRF receiver in an attractive mahogany cab-



inet with a gold-color nameplate. By the spring of 1925, his engineers had designed an almost identical receiver about half the physical size, which Kent personally named the "20 Compact." Kent felt that this name was a concession and an attraction to the growing number of women who had become fascinated by listening to radio broadcasts.

Kent now envisioned an unlimited increase in demand for radio receivers and decided to enlarge his manufacturing facilities. He purchased a large vacant parcel of ground on Wissahickon Avenue in Germantown. The new factory was a single-story modern (then) building with good lighting for both factory and office employees. There were imposing entrances and when one passed through the reception area, practically the entire office force was visible and the heads of departments were located so that they could keep an eye on the lower echelons of office workers. This is not to say that the arrangement was designed to encourage staff heads to spy on employees; as a matter of fact, all desks were well separated and office employees were treated with more consideration than those of competitive radio manufacturers.

Kent himself occupied a complete suite of offices including a dining room, kitchen and dressing room. This arrangement was used to great advantage since every day Kent invited to lunch a number of his company executives. Many of the

important future plans were announced over the luncheon table with Mr. Kent speaking in a semi-New England accent with the intermittent broad *a*.

**The Peak Years.** From the time of his move into the larger new factory until the depression of late 1929, the Atwater Kent business expanded by leaps and bounds. While progress was being made in the design of radio receivers, Kent continued to manufacture ignition systems for the Model T Ford, which itself remained in mass production until late 1928.

The small three-dial console receiver was replaced in early 1926 by the single-dial Model 30, plus variations of the latter such as the Model 33 with a tuned antenna circuit and, later in 1926, the Model 32 with four stages of tuned r.f.

In 1927 Kent turned out a battery eliminator of pleasing appearance to replace the unsightly B batteries, but it was not until RCA developed tubes in which the filaments could operate on alternating current that the true all-household electric radio receivers became a reality at a moderate price. In 1928, Atwater Kent sold nearly 1,000,000 a.c.-operated radio receivers, mostly table models, in metal cabinets with a single tuning dial.

In the early 20's, while still located in the Stenton Avenue plant, Atwater Kent did not make a loudspeaker, only an attachment used to play the output of the

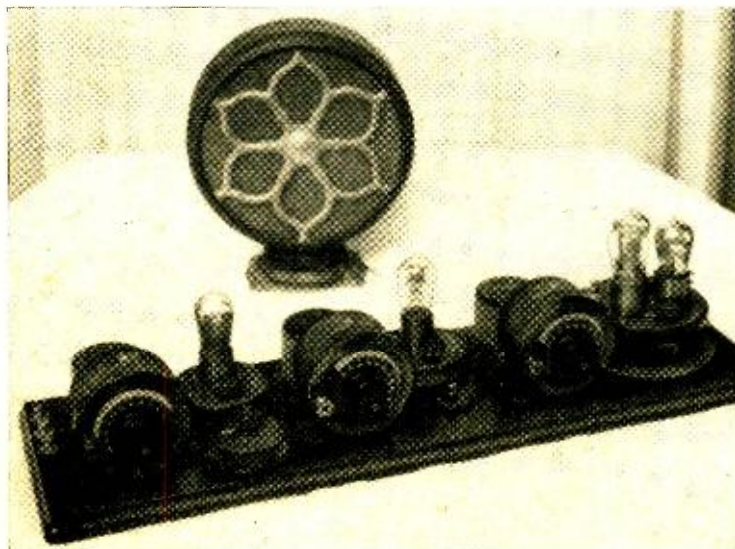

Model 10 was next to the top of the A-K line in 1923 selling for \$80. Open breadboard design with the connecting wires hidden under the fine wooden finish was a particular trademark of A-K. Speaker in background is from another A-K era around 1927 when Kent recognized the importance of selling loudspeakers. (Author's collection)

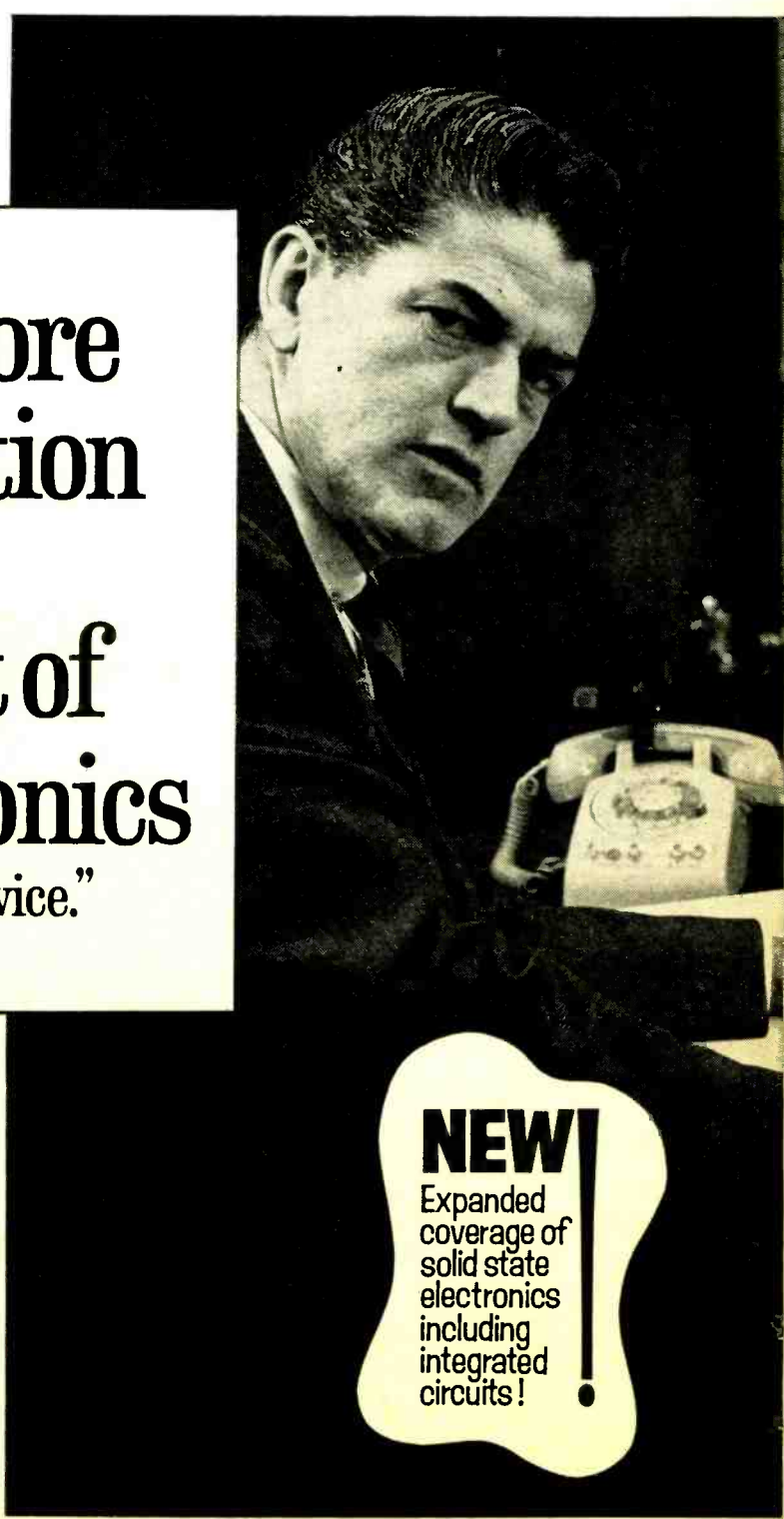

**“Get more  
education  
or  
get out of  
electronics  
...that’s my advice.”**

**NEW!**

Expanded  
coverage of  
solid state  
electronics  
including  
integrated  
circuits!



**Ask any man who really knows the electronics industry.**

Opportunities are few for men without advanced technical education. If you stay on that level, you'll never make much money. And you'll be among the first to go in a layoff.

But, if you supplement your experience with more education in electronics, you can become a specialist. You'll enjoy good income and excellent security. You won't have to worry about automation or advances in technology putting you out of a job.

How can you get the additional education you must have to protect your future—and the future of those who depend on you? Going back to school isn't easy for a man with a job and family obligations.

CREI Home Study Programs offer you a practical way to get more education without going back to school. You study at home, at your own pace, on your own schedule. And you study with the assurance that what you learn can be applied on the job immediately to make you worth more money to your employer.

You're eligible for a CREI Program if you work in electronics and have a high school education. Our FREE book gives complete information. Mail postpaid card for your copy. If card is detached, use coupon below or write: CREI, Dept. 1207H, 3224 Sixteenth Street, N.W., Washington, D.C. 20010.

Founded 1927



Accredited Member of the National Home Study Council



**CREI, Home Study Division  
McGraw-Hill Book Company  
Dept. 1207H, 3224 Sixteenth Street, N.W.  
Washington, D.C. 20010**

Please send me FREE book describing CREI Programs. I am employed in electronics and have a high school education.

NAME \_\_\_\_\_ AGE \_\_\_\_\_

ADDRESS \_\_\_\_\_

CITY \_\_\_\_\_ STATE \_\_\_\_\_ ZIP CODE \_\_\_\_\_

EMPLOYED BY \_\_\_\_\_

TYPE OF PRESENT WORK \_\_\_\_\_  G.I. BILL

- I am interested in  Electronic Engineering Technology  
 Space Electronics  Nuclear Engineering Technology  
 **NEW!** Digital Communications

**APPROVED FOR TRAINING UNDER NEW G.I. BILL**

radio receiver through the horn of a phonograph. These attachments did not do justice to the audio quality of the receiver and in 1924 Kent had his engineers trying to develop a loudspeaker with quality equal to that of the receiver.

At that time, the Timmons Company was doing a brisk business selling a large "Music Master" horn loudspeaker with a wooden bell. The Kent engineers concluded that an all-metal horn loudspeaker could give better performance. A variety of sizes of metal horn loudspeakers was made and they sold in large



Kent followed the Henry Ford thinking and manufactured receivers on an assembly line. Factory conditions were better than most companies of the day.

quantities until the magnetic cone loudspeaker with more pleasing and decorative appearance—as well as excellent reproduction—replaced horn speakers. Many different sizes and finishes of cone speakers were made in 1927-28. Advertisements showing the Atwater Kent receiver and loudspeaker appeared around the world in newspaper, magazine and catalog advertising.

**Competition and the Depression.** Competitors to Atwater Kent were not sitting on the sidelines while such enormous inroads were being made in the volume sales of radio receivers. By 1928 the Majestic Corporation had developed a high-quality dynamic speaker that was capable of reproducing a much lower range of musical notes and in 1929 Kent designed a table model for use with a separate dynamic speaker. The distinctive mark of all of these 1928-29 radio receivers was a goldplated emblem of a full rigged sailing ship secured to the top or lid of the unit. Meanwhile, Kent used up the remainder of his magnetic

speakers by manufacturing a limited quantity of "End Table" metal receivers using the 1928 chassis.

At the annual sales convention in August, 1929, the Kent wholesalers had placed enormous orders in anticipation of a continuing sales boom in radio receivers. After the stock market crash however, orders were cut substantially and Kent was obliged to trim his sails. In early 1930, he had concluded that new aggressive sales techniques and advertising methods were called for.

Meanwhile, his engineers were furiously designing a console-type receiver chassis that would surpass in appearance and performance that of his competitors. At the August, 1930 sales convention in Atlantic City, Kent announced and displayed the famous Model 70 and showed samples of a console cabinet which Kent was not going to manufacture. He informed his distributors at the convention that installation of the chassis into the console was to be made either by the wholesaler or retailer. The entire receiver, which was called the "Radio with the Golden Voice," was promoted in national magazine ads and billboards throughout the country. The dial, in the shape of a large illuminated arc, soon became well-known in the trade and to the general public. The price of this receiver was \$275!

Meantime, a local competitor announced a four-tube table model radio receiver with a rounded top selling at the attractive price of \$59.50. While there was probably little profit in this small receiver, it was intended as a lever for retail salesmen to talk the buyer up to the price level of a console. But, as the depression worsened and it became clear that prosperity was not around the corner, Kent's wholesalers insisted that he make a competitive model. Unfortunately, he held off doing so until the spring of 1931 with the result that receiver sales in 1930-31 were drastically reduced.

Although it had become painfully evident that the boom sales of the early and mid-1920's could no longer be expected, Atwater Kent continued to turn out high-class models, both table and consoles, as well as radio phonographs. In the 30's, Kent also turned out several radios for use in automobiles and to

satisfy the public's interest in short-wave listening, Kent announced various models with two, three or four bands. Later, in 1935, Kent conceived the idea of adding some home appliances to his line of products. The company designed and sold 6000 electric refrigerators. However, the venture was not as successful as had been expected and was abruptly discontinued.

**Big Government and Big Labor.** Atwater Kent treated his employees exceptionally well. Although he paid no bonuses and sold no stock in his company, he realized that public generosity could benefit the image of a multi-millionaire manufacturer. Insofar as his employees were concerned, as early as 1925 Kent had established a "Welfare Fund" and had made sizable contributions to it. When seasonal layoffs were required, this fund was used to tide over his unemployed personnel until full manufacturing production was resumed. Such an arrangement was unique in the days before Social Security and Unemployment Compensation.

Possibly because Atwater Kent was such a staunch Republican and strictly a self-made millionaire, the New Deal programs of President Franklin D. Roosevelt seemed an invasion of his personal

rights. The very idea of enforced Social Security and Unemployment Compensation rubbed Kent the wrong way.

In the fall of 1933, union organizers began to muscle in on the radio manufacturers in the Philadelphia area. This resulted in a short strike at the Atwater Kent Company and it was settled by an agreement involving a 10% pay increase. At the time of the settlement, Kent informed the union leaders that any future attempt to interfere with his management of the business would result in his shutting down the manufacturing plant for good. From then, until June, 1936, the Atwater Kent Company continued to produce new models to conform with the trend of the times, but as sales gradually decreased and profits became marginal, it was abundantly clear that the time left for the company was growing shorter.

Arthur Atwater Kent was then 62 and there was no individual, or group, he felt he could trust to maintain the good name he had built up over the years. Consequently, when union organizers approached Kent in the late spring of 1936, he bluntly informed them that, rather than grant any of their demands, he would close down the manufacturing plant and put the business up for sale. To the several thousands of employees



This is a corner of the author's fine collection of Atwater-Kent and other antique radio receivers, microphones and keys of 1920-25. Author worked at the A-K factory.

still working, this announcement was a tremendous shock. The engineering and production departments had been planning for a vigorous fall selling season and his employees undoubtedly assumed that Kent would make a settlement. When it became clear that Kent was as good as his word, a group of about 20 of his top men pleaded with him to allow them to take over the business. To their mutual dismay, Kent refused and in June, 1936, the doors of the plant were closed for good.

Those employees that had been working for Kent for 20 years were given three months salary as severance pay, but most of the others were fortunate if they could find employment either with competitive radio manufacturers or in the now well-established appliance business.

Kent himself immediately headed for California, bought a palatial estate in the Bel Air section of Los Angeles and proceeded to enjoy the fruits of his many years of highly profitable enterprise. He became well acquainted with many of the celebrities of Hollywood and was noted for the extravagant parties that

### Atwater Kent, the Philanthropist

Always very publicity conscious, Kent's most notable contribution was in promoting the public's interest in music. In particular, he sponsored opera broadcasts on the radio networks. The first of these broadcasts was in October, 1925. In addition, Kent supported local schools of music in Philadelphia and provided scholarships in music to promising local singers, including Philadelphia's Wilbur Evans, who later became nationally famous.

Through his original connections with New England, he contributed liberally to the Perkins School for the Blind; and, toward the end of the manufacturing period for battery-operated radio receivers, he ordered the donation of a large quantity of these receivers to the merchant fishing fleet sailing out of Boston Harbor.

Another step taken by Atwater Kent to prevent his name from becoming forgotten was the establishment of the Atwater Kent museum in a small building on South 6th Street in downtown Philadelphia, not far from his original place of business. The museum does not display his manufactured products but is devoted primarily to historical items of Philadelphia.

His many philanthropic and charitable contributions were not tax deductible since there was no applicable income tax in those days. Considering that the Atwater Kent Manufacturing Company, Inc. was owned and controlled by Mr. Kent himself, with only one other minority stockholder, one can scarcely imagine the profits that were made during the free-spending boom years of 1924-1929.

### Some Highlights in the A-K History

In late 1926, Atwater Kent announced that he had manufactured his one millionth a.c. operated radio receiver. The original of this receiver was allegedly donated to the then King of Spain. However, a sufficient number of these sets (the Model 35) all in a gold-plated finish and all with serial numbers starting at 1,000,000 were shipped to his wholesalers for display.

In 1927, Kent was visited by Helen Keller and her companion. Miss Keller was personally conducted on a tour of the plant and was presented with a special radio receiver and magnetic cone speaker. By pressing her fingers lightly on the speaker cone she was able to enjoy music through the delicate vibrations of the cone.

In the next year, the famous Russian inventor, Leon Theremin, visited the Kent factory with the intention of selling the patent rights to the manufacture of his electrical musical instrument. A working model of the Theremin was in the Atwater Kent laboratories for several months when it was finally decided that the instrument was too much of a novelty. A year later, RCA bought the patent rights, but at a selling price of \$300 per Theremin, the project was a financial failure and gladly forgotten.

In August, 1928, the two millionth radio receiver was given to Mrs. Thomas A. Edison.

he gave on his estate. In the spring of 1949 he became hospitalized with a virus infection and passed away at the age of 75.

At the time of the closing of the Atwater Kent manufacturing plant, the building had been put up for sale and was to include his past advertising, name, trade outlets, and good will—all for a price of \$11,000,000. However, 1936 was not a propitious year for such a sale and it wasn't until 1939 that the Bendix Corporation occupied half of the plant to manufacture war materials. The other half of the plant (the 1929 addition) was soon occupied by the U.S. Signal Corp. as a training school for radio inspectors and a depot for accumulating the amateur radio equipment used by the Armed Forces in 1942-43. After the war, the entire plant building was taken over by the Veterans Administration and is still occupied by that organization. —50—



## SQUARING WITH AN IC

A SQUARE-WAVE GENERATOR THAT'S  
HIGH ON QUALITY, LOW IN COST

BY PHILIP E. HARMS, North American Rockwell

**A** SQUARE-WAVE generator is an invaluable tool for the electronics enthusiast—whether his primary interest is in radio or audio frequencies. The generator can be used as a scope trace calibrator, a driving source for digital pulse circuits or, most important, as a test instrument in checking both broad-band and audio amplifiers.

Unlike a sine-wave generator, whose frequency must be capable of being set precisely and continuously across a particular band, the square-wave generator can be used to "wring out" an amplifier from about  $\frac{1}{10}$ th of the fundamental of the square wave to 10 times this frequency. There are many excellent discussions in the reference books of the procedure for using a square-wave generator to check an amplifier. In simple terms, however, amplifier response char-

acteristics can be determined rapidly by applying the square wave to the input and examining the output on an oscilloscope. The output risetime is determined by the amplifier high-frequency limits, while the square-wave tilt indicates the low-frequency cutoff.

Although there are many ways to build a square-wave generator, the availability of multi-purpose integrated circuits and UJT's makes possible the design of a simple, yet highly efficient circuit, that far surpasses most generators using vacuum tubes or standard transistors. Specifications for this new generator are given in the table.

**Construction.** The circuit for the square-wave generator is shown in Fig. 1. The author built the unit in a 3" × 4" × 5" aluminum box, which was sufficient

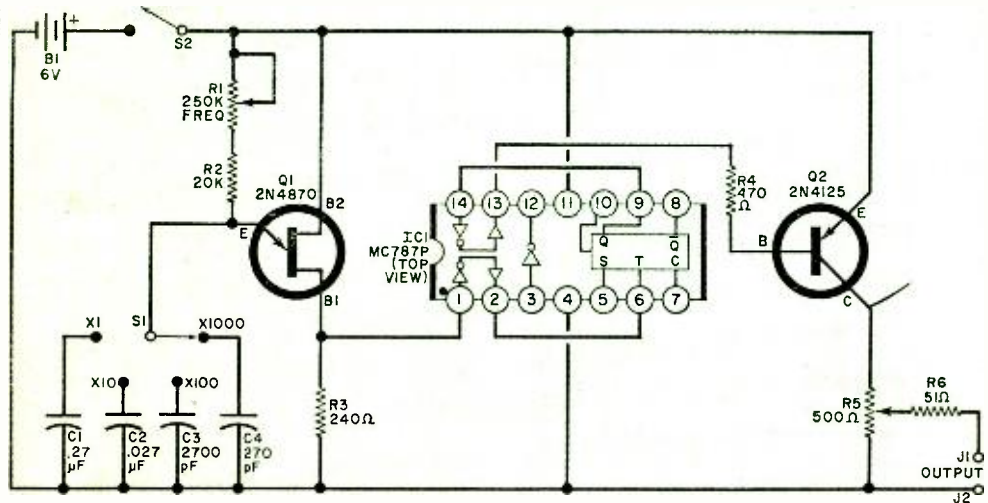
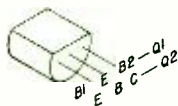

Fig. 1. Sharp spikes, generated by the UJT, are shaped and used to trigger the flip-flop. Its output is a sharp square wave at half the frequency of original.



### PARTS LIST

- R1—Four C or D cells
- C1—0.27- $\mu$ F, 10% capacitor
- C2—0.027- $\mu$ F, 10% capacitor
- C3—0.0027- $\mu$ F, 10% capacitor
- C4—270-pF, 10% capacitor
- IC1—Integrated circuit (Motorola MC787P)
- J1, J2—Banana jack (one black, one red)
- Q1—Unijunction transistor (Motorola 2N4870)
- Q2—Transistor (Motorola 2N4125)
- R1—250,000-ohm, linear taper potentiometer (with S2)

- R2—20,000-ohm,  $\frac{1}{4}$ -watt resistor (see text)
- R3—240-ohm,  $\frac{1}{4}$ -watt resistor
- R4—470-ohm,  $\frac{1}{4}$ -watt resistor
- R5—500-ohm, linear taper potentiometer
- R6—51-ohm,  $\frac{1}{4}$ -watt resistor
- S1—Single-pole, four-position rotary switch (Mallory 3234J or similar)
- S2—S.p.s.t. switch (on R1)
- Misc.—3" x 4" x 5" aluminum box, perf board  $2\frac{3}{4}$ " x 3", PC board terminals or flea clips (5), transistor sockets (2, optional), IC socket (14-pin in-line, optional), battery holder, battery clip, knobs (3), mounting hardware, etc.

to hold the perf board, the controls, and a battery holder. Wiring is not critical, although wire no smaller than #22 AWG should be used to insure a good signal path between components.

As shown in Fig. 2, the author built the electronic portion on a perf board using sockets to mount the IC and the transistors. Although the sockets are not absolutely necessary, they are advantageous to protect the semiconductors from heat during soldering. If you do not use sockets, be very careful when soldering the IC and the transistors, using a heat sink (such as long-nose pliers) between the end of the lead being soldered and the body of the device. Neat, point-to-point wiring is used on the perf board, with clips used as take-off terminals on the board.

The remainder of the components are

mounted on the front panel of the chassis as shown in the photos. The battery holder is mounted on the rear of the cover.

**Design Considerations.** Since the characteristics of the UJT may vary as

### SPECIFICATIONS

- Frequency:** 5 Hz to 50 kHz
- Amplitude:** 0 to 6 volts, variable
- Risetime:** less than 40 nanoseconds
- Falltime:** less than 250 nanoseconds
- Overshoot:** less than 10%
- Undershoot:** negligible
- Non-symmetry:** less than 200 nanoseconds, all ranges
- Output impedance:** 51 ohms, short-circuit protected
- Power supply:** four C cells, current drain 50 mA



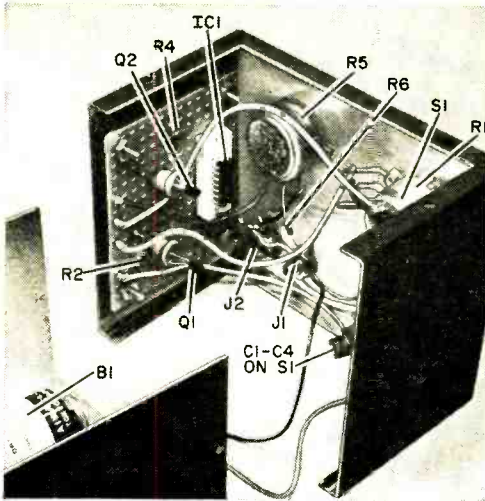
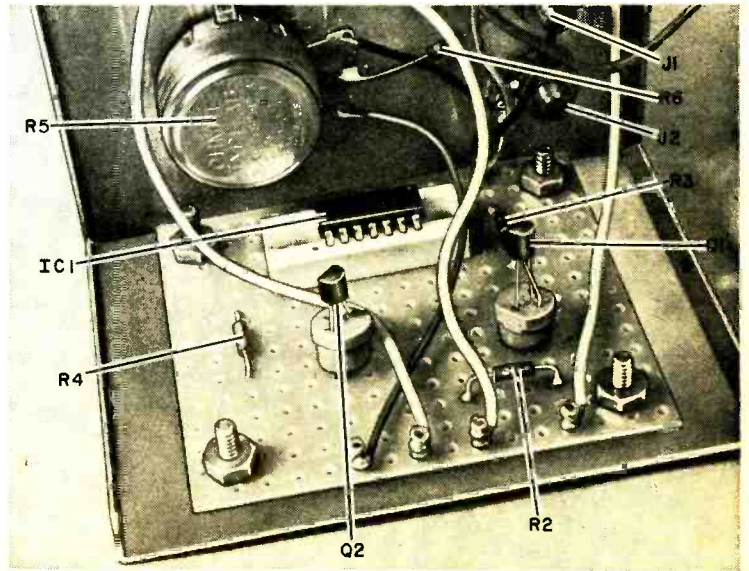

Fig. 2. The entire generator can be mounted in a small aluminum chassis as shown at the left. The four C or D cells are mounted in a holder affixed to the rear of the chassis half. The bulk of the circuit can be constructed on perf board (as shown below) or you can make a printed circuit board. The use of semiconductor sockets prevents heat damage to the semiconductors when installing but is an optional feature of design.



much as 10%, it is difficult to pick components that will result in a frequency range of exactly 5 Hz to 50 kHz. Capacitors *C1* through *C4* influence over-all accuracy; but for most applications, precise frequency increments are not required. If necessary, one, or all, of the timing capacitors can be "juggled" (parallel or series connections) to achieve exact decade intervals. For realistic results, capacitors with 10% tolerances should be used.

Resistor *R2* has a composite value which should give excellent results on all ranges. For exact calibration, *R2* can

be replaced by four separate resistors, selected by using vacant terminals on *S1*. To calibrate these resistors, set *R1* for maximum resistance. Then assuming, for example, that *S1* is on X10, trim the value of *C2* (increasing the capacitance decreases the frequency, and vice versa) to achieve a frequency about 5% above 50 Hz. This is done to allow for slight changes in the value of *R2* in the next step.

Rotate *R1* to its minimum resistance. Select the value of *R2* that will give the correct upper frequency (500 Hz). The value of *R2* will be approximately 20,000

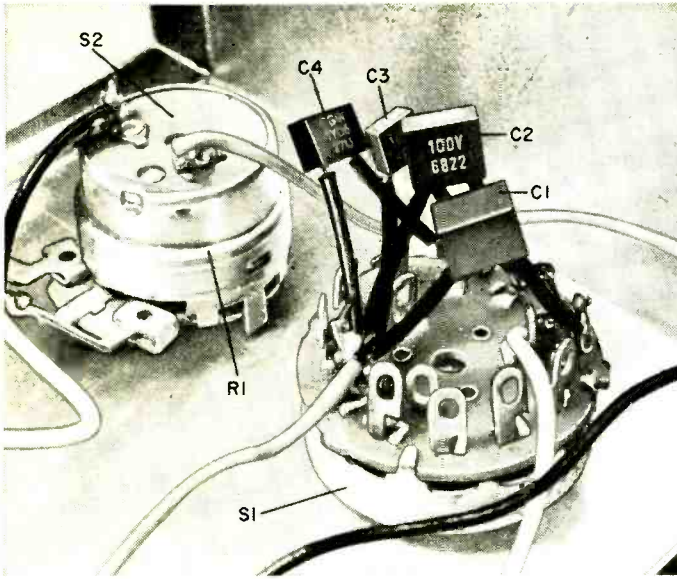

The four timing (octave) capacitors are mounted directly on the selector switch. The closer the capacitors are matched, and the better their tolerance, the more accurate the octave ranges are.

### HOW IT WORKS

The frequency source for the square-wave generator is a unijunction transistor oscillator (Q1) whose frequency is determined by the resistors and capacitors in its emitter circuit. A sharp pulse at the selected frequency is developed across R3 which drives the inverter-buffer in IC1. The IC contains one JK flip-flop, two inverter-buffers, and a single (unused in this case) inverter.

The inverter-buffer squares up the pulse generated in the UJT, and the pulse then triggers the flip-flop. The output waveform of the flip-flop is at half the UJT frequency and is sharply square on both transitions. The second buffer isolates the flip-flop and inverts the output. Transistor Q2 acts as an amplifier isolator to provide an isolated output through R5. This potentiometer provides amplitude adjustment and R6 protects the output circuit against short circuits.

ohms. Once the proper upper frequency has been obtained, increase the resistance of R1 to maximum again and check that the 50-Hz point is correct.

Each range can be calibrated similarly; and each is independent of the others if separate resistors are used for R2. The generator should never be operated without a series resistor (R2) in the UJT emitter circuit or the UJT may be damaged.

Because of the self-contained power supply, the generator output leads can be reversed to produce a negative-going signal. A battery can be used in series with the square-wave output to "bias" the output if desired.

-30-

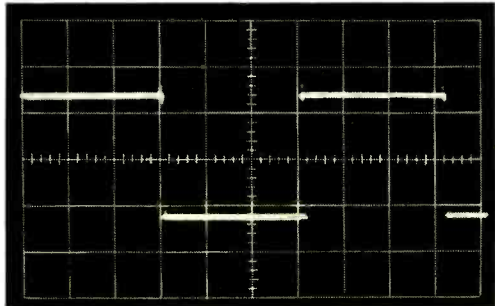
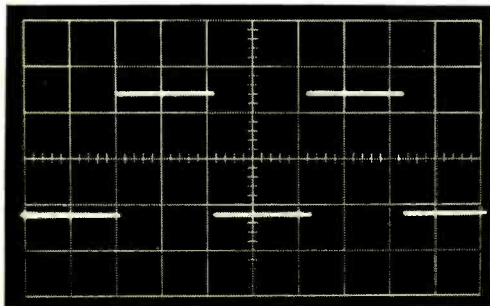

The output waveshape for both low and middle frequencies is shown at the left. Note the almost perfect square wave. For high frequencies, the output (right) is a good square wave with a little overshoot.

# THE PICNICKER'S FRIEND

*It warns you  
of an  
approaching storm*

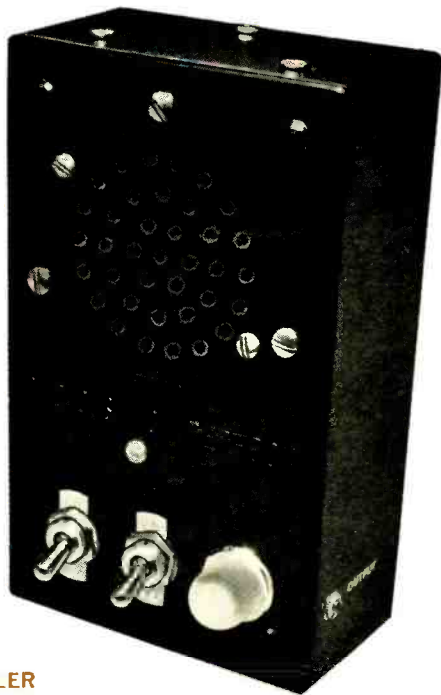

BY JOHN E. SHEPLER

**Y**OU'VE HAD a swim. Now you're enjoying a beer while the wife spreads out the food on the picnic table and—what's that? The first big drops of a thunderstorm fall right in the middle of the table! But you checked all the weather forecasts before you came out.

Obviously, the weather prognosticators can't be depended on when it comes to sudden summer storms. You can depend on the "Picnicker's Friend," however. It senses an approaching thunderstorm at about a 50-mile distance and visually or audibly warns you to start heading for shelter. Your "Friend" needs no adjustments, is self-powered to operate far from civilization, and is ready to function at any time of the day or night. It will also warn you of an approaching tornado—or any violent weather disturbance.

**Construction.** The complete system is divided into three portions: a transistor BCB radio, a trigger circuit, and an optional audio tone module. They are connected together as shown in Fig. 1.

You can leave the radio in its own plastic case or you can take out its print-

ed circuit board and put it in a larger plastic case with sufficient room to hold the trigger circuit and audio module also.

In either case, tune the radio to the low-frequency end of the dial but avoid any station or modulation sidebands of low frequency stations. Once a clear spot has been found, fix the tuning control in this position, either by cementing or mechanically securing the dial in place. Now carefully isolate both leads of the secondary of the output transformer (the ones to the speaker) so that neither lead is connected to the set's ground bus. Connect a pair of leads to these two wires. If you use the audible warning system, you will use the speaker for the output. Connect another pair of leads to the speaker for this purpose.

Remove the battery connector from the radio and attach a pair of color-coded leads, making sure that you can identify the polarities. Save the battery connector for later use. If the radio is being used in its case, there now should be six leads coming from it: two from the transformer secondary, two from the speaker, and two for the power supply.

The trigger circuit can be built on a

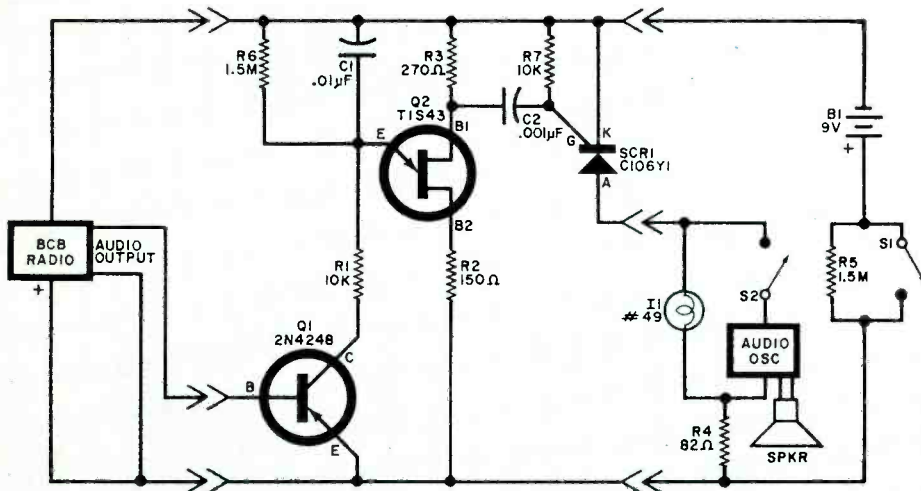

Fig. 1. Circuit is in three basic parts: a standard broadcast band radio, a trigger circuit, and an oscillator module to provide audio output. The speaker and battery can be taken from the original radio.

### PARTS LIST

BCB Radio—Any small transistor radio  
 B1—9-volt transistor radio battery  
 C1—0.01- $\mu$ F ceramic disc capacitor  
 C2—0.001- $\mu$ F ceramic disc capacitor  
 I1—#49 lamp and holder  
 OSC—Oscillator module (Cordover CPO-4 or similar)  
 Q1—2N4248 transistor

Q2—Unijunction transistor (Texas Instruments TIS43)  
 R1, R7—10,000-ohm,  $\frac{1}{2}$ -watt resistor  
 R2—150-ohm,  $\frac{1}{2}$ -watt resistor  
 R3—270-ohm,  $\frac{1}{2}$ -watt resistor  
 R4—82-ohm,  $\frac{1}{2}$ -watt resistor  
 R5, R6—1.5-megohm,  $\frac{1}{2}$ -watt resistor  
 SCR1—Silicon controlled rectifier (GE C106Y1)  
 S1, S2—S.p.s.t. switch  
 Misc.—Suitable plastic cabinet, spacers, mounting hardware, insulated wire, etc.

printed circuit board such as that shown in Fig. 2. (Perf board construction can be used if desired.) Assemble the components on the PC board as shown in Fig. 3. This diagram also shows where the external connections are made to the trigger circuit.

The audio tone module can be one of the many readily available, low-cost audio oscillators currently on the market. They are usually sold as code-practice oscillators or audio signal generators. Follow the instructions provided with the module to assemble it, making sure that any telegraph key or other on-off switch circuit is closed and that the oscillator will work as soon as d.c. power is applied. Mount the module in the case, mount the speaker near it, and connect the two together. Attach color-coded power leads to the appropriate terminals on the module, making sure that you can identify the polarities.

Mount power switch, S1, optional audio module on-off switch S2, and indi-

### HOW IT WORKS

The input for the Picnicker's Friend is obtained from a small transistor superhet of almost any variety—including the very low-cost units sold in discount stores. Sound quality is not important. When it is tuned to the low-frequency end of the dial (not to any station), the radio will pick up static pulses from lightning discharges associated with local thunderstorms.

The audio output of the radio is applied to the base of transistor Q1. This transistor acts as a series switch that, when closed, allows C1 to charge up through R1 at a rate determined by the length of the static burst and the setting of the radio volume control. When no signal is present, Q1 acts as an open switch.

When a long burst of static appears at the radio output, signalling an approaching storm, Q1 remains on long enough for the charge on C1 to build up to the point where unijunction transistor Q2 breaks down. The capacitor then discharges through Q2 and a pulse is generated across R3. The pulse is coupled, through C2, to the gate of SCR1 and causes the SCR to fire. Pilot lamp I1 and the optional audio oscillator are thus energized. Resistor R4 limits the current flow in the SCR circuit.

Once the SCR fires and an audible or visual alarm is given, the only way to turn the SCR off is to open S1 and remove the d.c. power. The switch can then be reclosed for further monitoring. Resistor R5 prevents the transient created when S1 is closed from triggering the circuit.

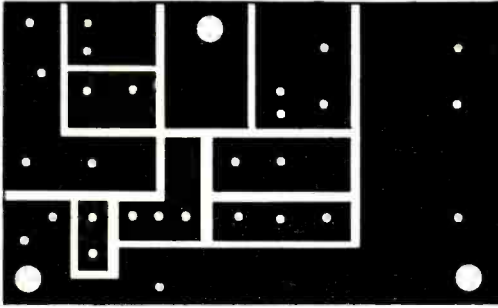

Fig. 2. Actual-size foil pattern for trigger circuit. Three large holes are for chassis mounting.

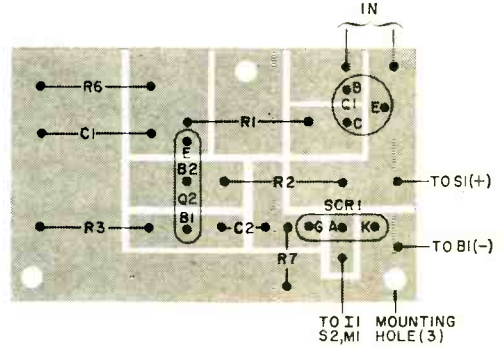

Fig. 3. Install components as shown above. Also illustrated are external connections to be made.

cator lamp *I1* on the upper surface of the case. Wire the system as shown in Fig. 1, with the battery leads wired to the correct terminals on the battery connector. Mount the battery in the case, using a spring clip to support it. Recheck all wiring.

**Adjustment and Operation.** Turn on power switch *S1*, turn on the radio and set its volume control full on. Bring a soldering gun close to the receiver ferrite antenna and click the gun on and off several times. This should cause *I1* to come on (and the audio module to

sound off if *S2* is in the on position). To reset the circuit, turn *S1* off and wait several seconds before turning it on again. As a final check, turn off the transistor radio (using its internal power switch) but leave *S1* on. Leave the system this way for about an hour. If the circuit should trigger on during this time, lower the value of *R6* and/or *R7* slightly. Recheck.

Once the circuit appears to be working correctly, you have to wait for a local thunderstorm to check it further. When you think a thunderstorm is about 50 miles away, turn on the system, and

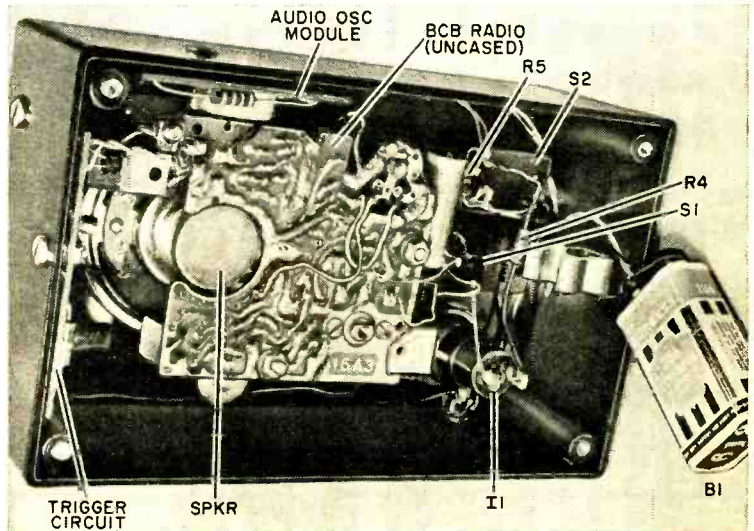

As shown here, the author removed the BCB radio from its case and mounted it, trigger circuit, and audio oscillator with the battery in a plastic case.

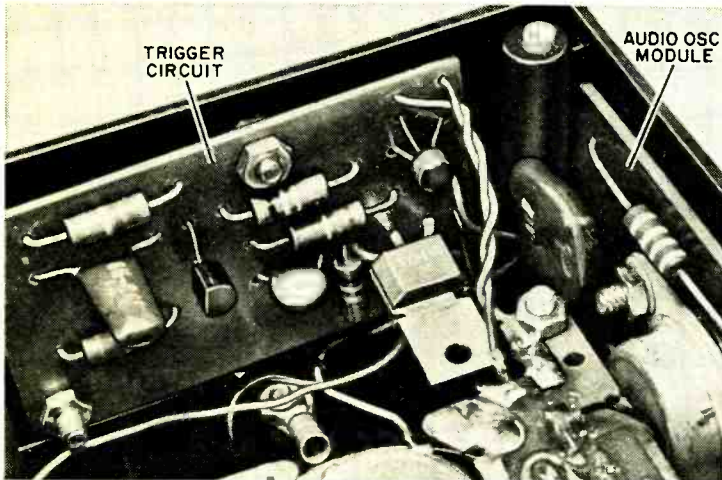

Interior view shows how trigger circuit is mounted to plastic chassis. Use spacers between board and wall. Audio oscillator is a commercial module.

set the radio volume control so that the alarm sounds several seconds after it has been reset. Once the system works properly, make sure that everything is fastened down properly, install a new battery, and wait for your next outing.

There is one point to keep in mind

concerning this project: It is designed to be used outside the reaches of electrical civilization. If you try to use it too close to civilization, it will be triggered by ignition noise from passing cars or electrical noise from motors, neon lamps, or fluorescent lighting.

-30-

## Sine-Wave To Pulse Converter

BY FRANK H. TOOKER

**S**INE WAVES may be converted to pulses of the same frequency by using a two-transistor Schmitt trigger. However, in the audio-frequency range at least, a single unijunction transistor can be used to do the same job. In fact, the waveform present at base-2 of the circuit shown in the schematic very closely resembles that at the output of a conventional Schmitt trigger.

The output at base-2 of the UJT is differentiated by capacitor *C1* and resistor *R3*. The waveform at the output terminals is a very narrow, negative-going spike having an amplitude (with a 3.6-volt r.m.s. 60-Hz input) of about 3 volts. This amplitude does not vary significantly with increases in the input voltage level. The diode and resistor *R4* eliminate the short positive-going spike. The value of the output capacitor *C2* is not critical.

-30-

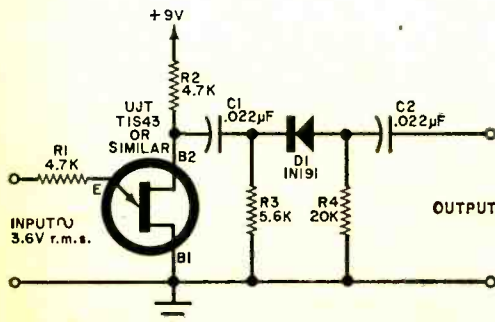

The short positive-going spike from the base-2 terminal of the UJT is eliminated by D1-R4 combination.



# TIGERS THAT ROAR

BUILD 40- TO 100-WATT POWER AMPLIFIERS  
THAT MATCH FET STEREO PREAMP

BY DAN MEYER

**T**HE HI-FI buff's search for the "perfect" amplifier is never ending. New components (particularly semiconductors) and new circuit wrinkles are announced almost daily to spur him on—in the hope that, sooner or later, something close to perfection will be achieved.

Presented here are two new audio power amplifiers ("Tiger" and "Super Tiger") which use the latest advancement in power transistors and up-to-the-minute circuit design. Try one of them and see if you don't think perfection is obtainable.

The two amplifiers are quite similar except that the Tiger delivers 35 watts r.m.s. (40 watts IHF) and the Super Tiger 80 watts r.m.s. (100 watts IHF). Specifications are shown in the table.

**Construction (Tiger).** The 40-watt IHF Tiger amplifier (schematic shown in Fig. 1) is assembled on a printed circuit board (foil pattern shown in Fig. 2). Mount the components on the board using the layout shown in Fig. 3. Be sure to use heat-sink grease between the two output transistors ( $Q1$  and  $Q4$ ) and their heat

sinks. Special clamps are called for in the Parts List to attach diode  $D1$  to the  $Q1$  heat sink and  $D2$  to the  $Q4$  heat sink. Be very careful in connecting the diodes into the circuit—proper polarities must be obtained or the transistors can be ruined. The red dot on the diode case indicates the cathode. Transistor heat sink is Staver V3-5 or similar and diode clamp is RCA SA-2100 or similar.

Two amplifiers must be made if you want a stereo version of the Tiger. Installation of the circuit boards in a cabinet is left to your discretion. The photographs show the author's approach to the packaging. The two boards are mounted on spacers. The bulky power transformer and associated rectifier components are mounted near the rear apron and the filter capacitors are on the front apron. The amplifier shown in the photos is the Tiger, but the same construction can be used for Super Tiger.

Only four external connections are required for the amplifier; two phono connectors for the inputs and a pair of jacks for the loudspeaker connections; or, if desired, a barrier strip or any other

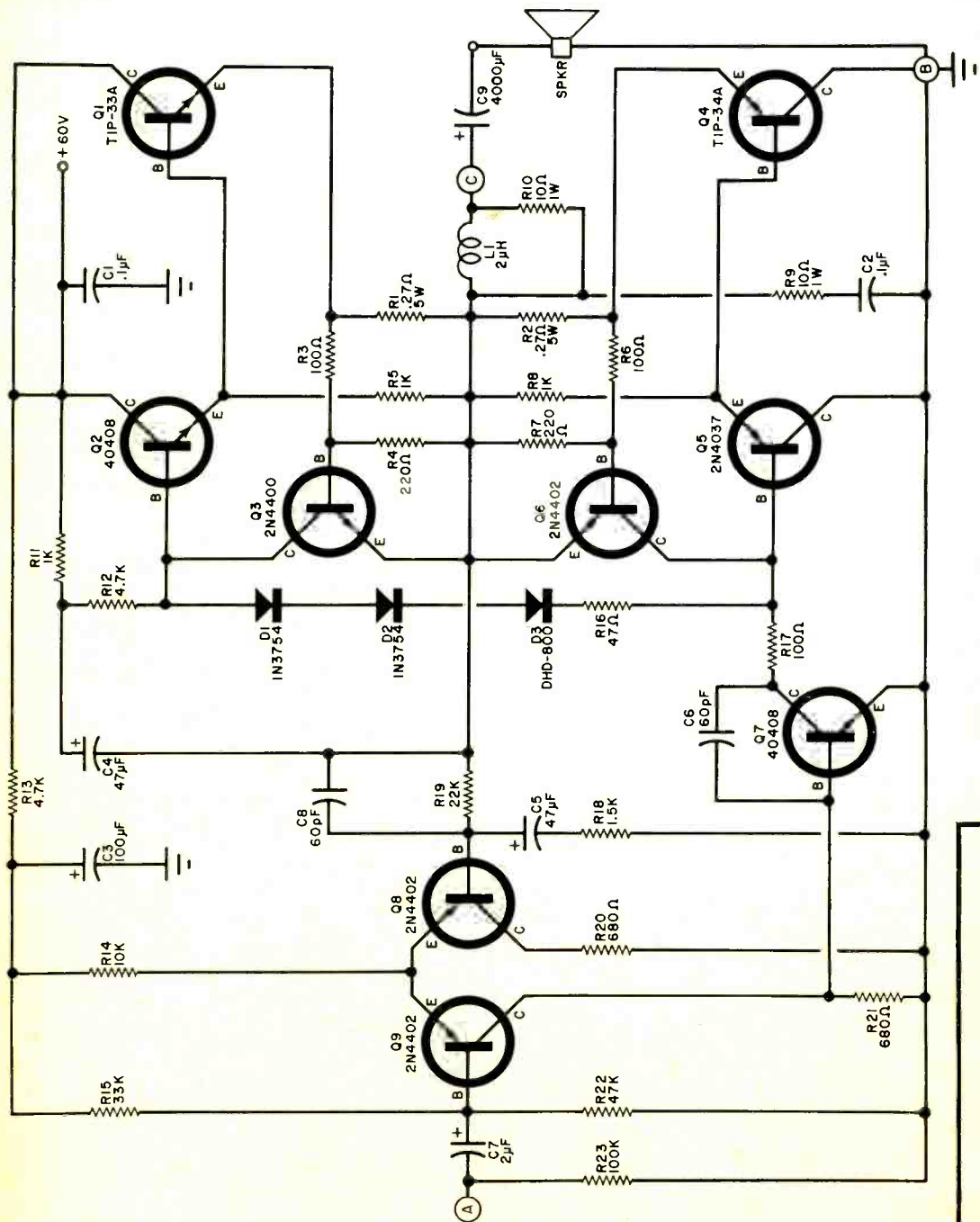

Fig. 1. The Tiger amplifier takes advantage of the latest semiconductors to produce a clean power amplifier that will compete with many commercially available power amplifiers costing many times as much.



## PARTS LIST

- C1, C2*—0.1- $\mu$ F capacitor  
*C3*—100- $\mu$ F, 50-volt capacitor  
*C4, C5*—47- $\mu$ F, 50-volt capacitor  
*C6, C8*—60-pF capacitor  
*C7*—2.2- $\mu$ F, 50-volt capacitor  
*C9*—4000- $\mu$ F, 50-volt capacitor  
*D1, D2*—1N3754 diode  
*D3*—Silicon diode (General Electric DHD-800)  
*L1*—Three turns of  $\pm 20$  or  $\pm 24$  magnet wire on  $\frac{1}{2}$ -inch diameter—approximately 2  $\mu$ H  
*Q1*—Transistor (Texas Instruments TIP-33A)  
*Q2, Q7*—Transistor (Motorola SS-1123, MM3005 or 40408)  
*Q3*—Transistor 2N4400  
*Q4*—Transistor (Texas Instruments TIP-34A)  
*Q5*—Transistor (Motorola SS-1122, MM4005, or 2N4037)  
*Q6, Q8, Q9*—Transistor (Motorola 2N4402)  
*R1, R2*—0.27-ohm, 5-watt resistor  
*R3, R6, R17*—100-ohm  
*R4, R7*—220-ohm  
*R5, R8, R11*—1000-ohm  
*R12, R13*—4700-ohm  
*R14*—10,000-ohm  
*R15*—33,000-ohm  
*R16*—47-ohm  
*R18*—1500-ohm  
*R19*—22,000-ohm  
*R20, R21*—680-ohm  
*R22*—47,000-ohm  
*R23*—100,000-ohm  
*R9, R10*—10-ohm, 1-watt resistor  
 Misc.—Input jacks, output jacks, spacers, hardware, lug strips, heat sinks, clips, wire, solder, etc.

All resistors  
 $\frac{1}{2}$ -watt

*Note*—The following are available from Southwest Technical Products Corp., 219 W. Rhapsody, San Antonio, Texas 78216: Etched and drilled printed circuit board (#160) \$3.10 postpaid; kit for amplifier (board and components for one channel) (#160C) \$16.80 postpaid; complete stereo kit with punched chassis, \$50.00, plus shipping, 9 lb.

## AMPLIFIER SPECIFICATIONS

### "The Tiger"

- Power output:** 35 watts r.m.s., 40 watts IHF per channel  
**Distortion:** Less than 0.5% total harmonic at 30 watts output and 1.0 kHz  
**Sensitivity:** 1.0 volts for full output  
**Input impedance:** 20,000 ohms  
**Output impedance:** Less than 0.1 ohm; damping factor of approximately 20 with 8-ohm speaker  
**Hum and noise:** More than 80 dB below 1-watt output  
**Frequency response:** 10 Hz to 100 kHz (–3 dB points at full output)  
**Power supply:** 60 volts at 2 amperes

### "The Super Tiger"

- Characteristics same as above except:  
**Power output:** 75 watts r.m.s., 100 watts IHF per channel  
**Sensitivity:** 1.25 volts for full output  
**Power supply:** 80 volts at 3 amperes

## HOW IT WORKS

The input stage of the amplifier is a differential amplifier consisting of Q8 and Q9. A circuit like this has an almost constant total current flow through the two transistors due to the large resistance of the common-emitter resistor R14. The current divides between the two transistors, and, if the base voltages are equal, the collector currents are equal. If the base voltages are unequal, the voltages across the collector resistors are unequal but the total current does not change. A voltage divider consisting of R14 and R22 sets the base voltage of Q9 and a d.c. voltage from the output stage is applied to the base of Q8. Any variation between the two base voltages results in a collector current change in both transistors. The differential input is connected so that shifts in output tend to correct the output shift (negative feedback) making the amplifier circuit automatically self-balancing. The emitters of Q1 and Q2 remain at half of the supply voltage no matter what shifts occur in transistor gain due to temperature, etc.

The ratio of R19 to R18 controls the amount of a.c. negative feedback and the overall gain of the circuit. Capacitor C5 controls the low-frequency roll-off point.

Transistor Q7 provides a voltage amplifier stage in a conventional common emitter arrangement. The collector load, R11 and R12 is a bootstrap circuit which provides the amplifier with a constant current even at full positive half-cycle output. Capacitor C6 produces the required high-frequency roll-off above 100 kHz.

Transistors Q3 and Q6 and resistors R3, R4, R6, and R7 limit the current in the output stage. This prevents the output transistors from conducting more than their rated current and being damaged if the output connection is accidentally shorted to ground.

Output current flows through R1 or R2 (depending on the half cycle) and if this current becomes too high, the voltage across R1 or R2 causes the associated transistor to start to conduct. This clamps the driving voltage so that it cannot get any higher. The peak output-transistor current is thus limited.

The output stage consists of two transistor pairs, Q1-Q2 and Q4-Q5 operated as class B amplifiers. They provide the required current gain and match the low-impedance speaker load. Diodes D1, D2, and D3 and resistor R16 provide a small "on" bias to prevent crossover distortion. Two of the diodes (D1 and D2) are mounted directly on the transistor heat sinks so that the bias voltage shifts with changes in the base-emitter voltages of the transistors as they heat up under use.

The network consisting of L1, R10, R9 and C2 is required to insure high-frequency stability under all possible loading conditions.

type of dual connector can be used for the speaker connections. Mount the fuseholder and pass the a.c. line out through a rubber grommet. D.c. voltage for powering an external preamplifier may also be supplied to a barrier strip located on rear apron of chassis.

The power supply for the Tiger is shown in Fig. 4. It is a conventional high-current bridge rectifier with filter to supply 60 volts d.c. for the amplifier. When wiring the power supply to the

# Join "THE TROUBLESHOOTERS"

They get paid top salaries  
for keeping today's  
electronic world running

Suddenly the whole world is going electronic! And behind the microwave towers, push-button phones, computers, mobile radio, television equipment, guided missiles, etc., stand

**THE TROUBLESHOOTERS**  
—the men needed to inspect, install, and service these modern miracles. They enjoy their work, and get well paid for it. Here's how you can join their privileged ranks—without having to quit your job or go to college in order to get the necessary training.

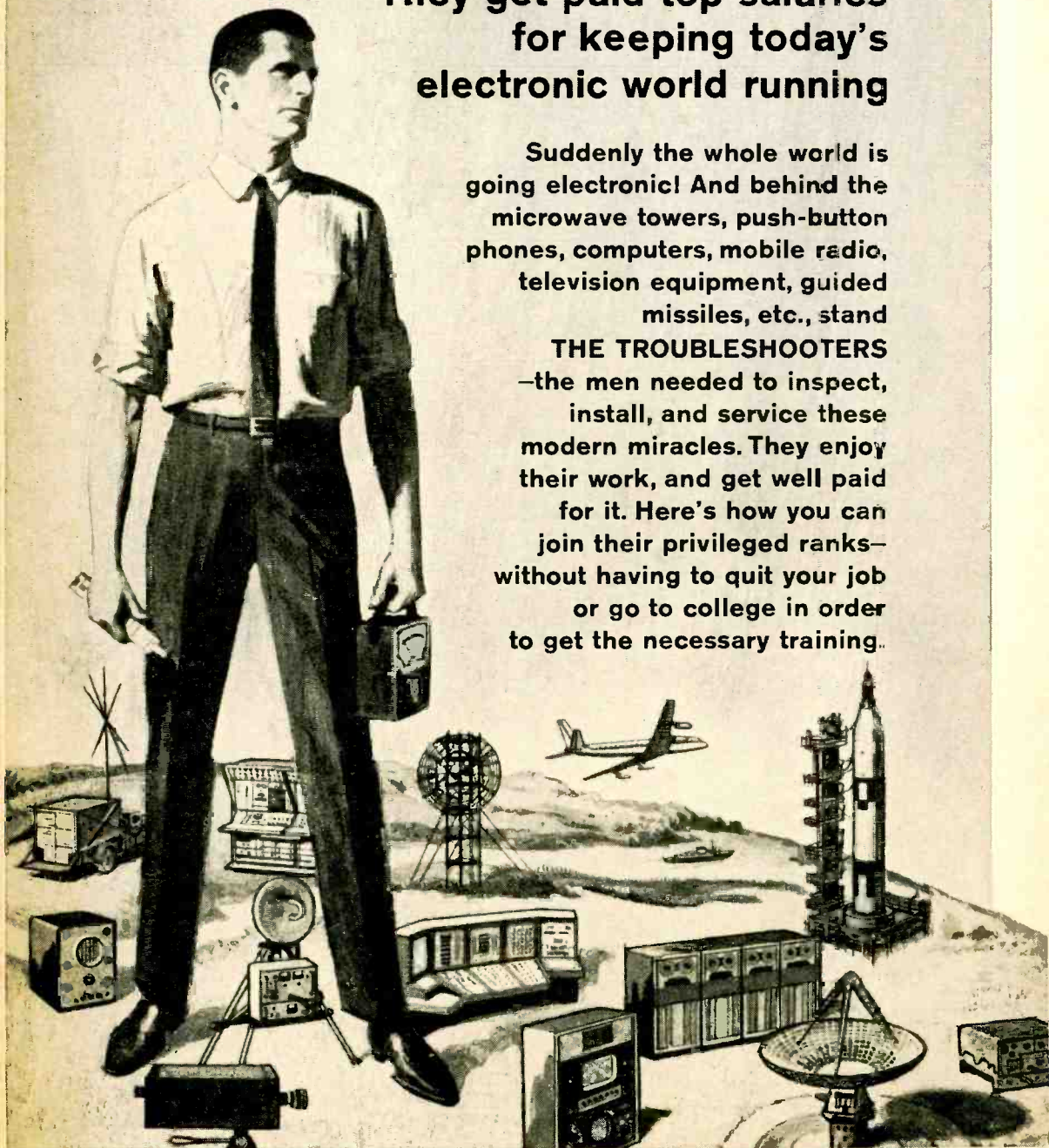

**J**UST THINK how much in demand you would be if you could prevent a TV station from going off the air by repairing a transmitter...keep a whole assembly line moving by fixing automated production controls...prevent a bank, an airline, or your government from making serious mistakes by servicing a computer.

Today, whole industries depend on Electronics. When breakdowns or emergencies occur, someone has got to move in, take over, and keep things running. That calls for one of a new breed of technicians—The Troubleshooters.

Because they prevent expensive mistakes or delays, they get top pay—and a title to match. At Xerox and Philco, they're called Technical Representatives. At IBM they're Customer Engineers. In radio or TV, they're the Broadcast Engineers.

What do you need to break into the ranks of The Troubleshooters? You might think you need a college degree, but you don't. What you need is know-how—the kind a good TV service technician has—only lots more.

### Think With Your Head, Not Your Hands

As one of The Troubleshooters, you'll have to be ready to tackle a wide variety of electronic problems. You may not be able to dismantle what you're working on—you must be able to take it apart "in your head." You'll have to know enough Electronics to understand the engineering specs, read the wiring diagrams, and calculate how the circuits should test at any given point.

Learning all this can be much simpler than you think. In fact, you can master it without setting foot in a classroom...and without giving up your job!

For over 30 years, the Cleveland Institute of Electronics has specialized in teaching Electronics at home. We've developed special techniques that make learning easy, even if you've had trouble studying before. Our AUTO-PROGRAMMED® lessons build your knowledge as easily and solidly as you'd build a brick wall—one brick at a time. And our instruction is personal. Your teacher not only grades your work, he analyzes it to make sure you are thinking correctly. And he returns it the same day received, while everything is fresh in your mind.

### Always Up-To-Date

To keep up with the latest developments, our courses are constantly being revised. This year CIE students are

## **NEW** COLLEGE-LEVEL COURSE IN **ELECTRONICS ENGINEERING**

for men with prior experience in Electronics. Covers steady-state and transient network theory, solid state physics and circuitry pulse techniques, computer logic and mathematics through calculus. A college-level course for men already working in Electronics.

getting new lessons in Laser Theory and Application, Microminiaturization, Single Sideband Techniques, Pulse Theory and Application, and Boolean Algebra.

In addition, there is complete material on the latest troubleshooting techniques including Tandem System, Localizing through Bracketing, Equal Likelihood and Half-Split Division, and In-circuit Transistor Checking. There are special lessons on servicing two-way mobile radio equipment, a lucrative field in which many of our students have set up their own businesses.

### Your FCC License—or Your Money Back!

Two-way mobile work and many other types of troubleshooting call for a Government FCC License, and our training is designed to get it for you. But even if your work doesn't require a license, it's a good idea to get one. Your FCC License will be accepted anywhere as proof of good electronics training.

And no wonder. The licensing exam is so tough that two out of three non-CIE men who take it fail. But our training is so effective that 9 out of 10 CIE graduates pass. That's why we can offer this famous warranty with confidence: If you complete a license preparation course, you get your FCC License—or your money back.

### Mail Card for 2 Free Books

Want to know more? Send for our 44-page catalog describing our courses and the latest opportunities in Electronics. We'll send a special book on how to get a Government FCC License. Both are free—just mail the bound-in postpaid card. If card is missing, use coupon below.

### ENROLL UNDER NEW G.I. BILL

All CIE courses are available under the new G.I. Bill. If you served on active duty since January 31, 1955, or are in service now, check box on card or coupon for G.I. Bill information.

## **CIE** Cleveland Institute of Electronics

1776 East 17th Street, Cleveland, Ohio 44114

### Cleveland Institute of Electronics

1776 East 17th Street, Cleveland, Ohio 44114

Please send me without cost or obligation:

1. Your 44-page book "How to Succeed in Electronics" describing the job opportunities in Electronics today, and how your courses can prepare me for them.
2. Your book on "How To Get A Commercial FCC License."

I am especially interested in:

- |  |   |  |
|--|---|--|
| <input type="checkbox"/> Electronics Technology    | <input type="checkbox"/> Broadcast Engineering  | <input type="checkbox"/> First Class FCC License |
| <input type="checkbox"/> Electronic Communications | <input type="checkbox"/> Industrial Electronics | <input type="checkbox"/> Electronics Engineering |

Name \_\_\_\_\_ (PLEASE PRINT)

Address \_\_\_\_\_

City \_\_\_\_\_ State \_\_\_\_\_ Zip \_\_\_\_\_

Check here for G. I. Bill information.

PE-64

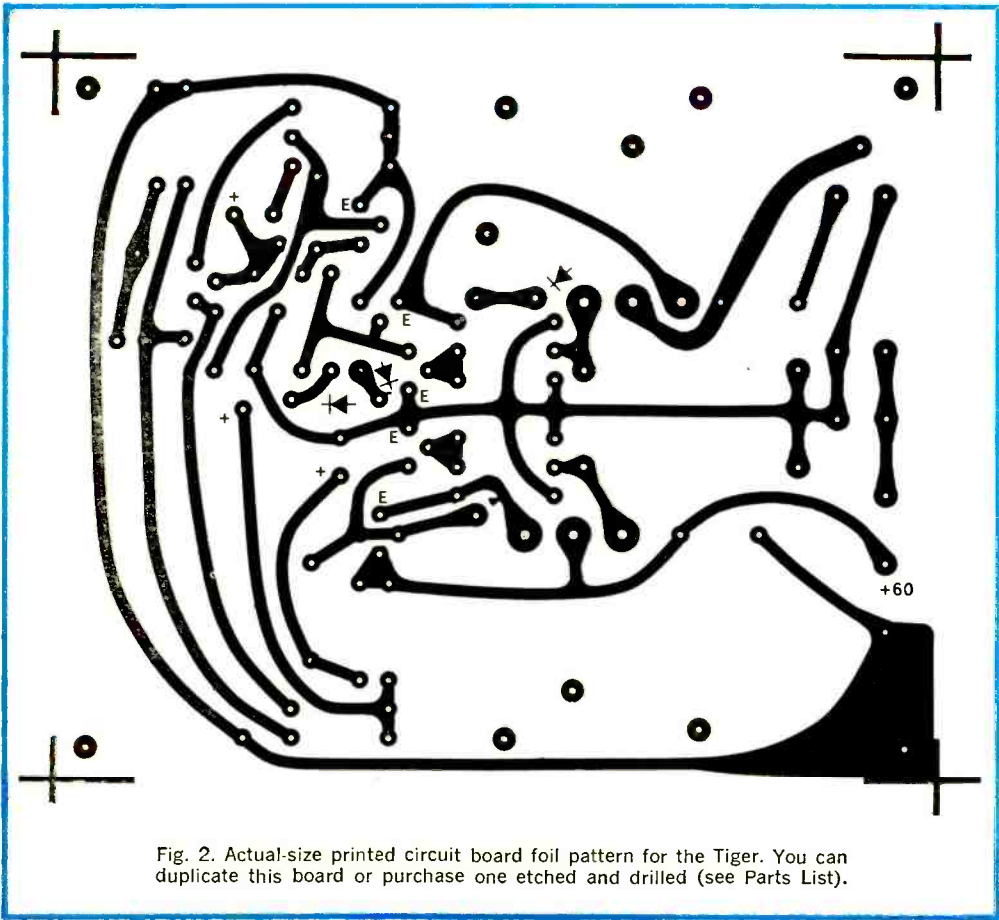

Fig. 2. Actual-size printed circuit board foil pattern for the Tiger. You can duplicate this board or purchase one etched and drilled (see Parts List).

Fig. 3. Component installation. The two holes near the power transistors (Q1, Q4) are mounting holes for the heat sinks. The associated diodes are then clamped to their respective transistor heat sinks.

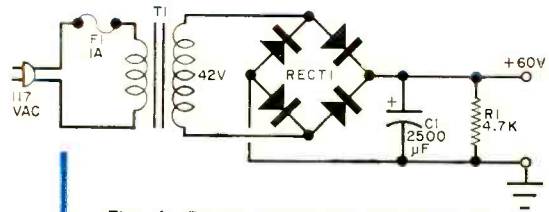
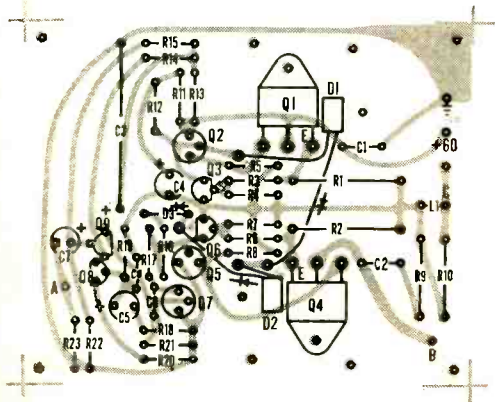
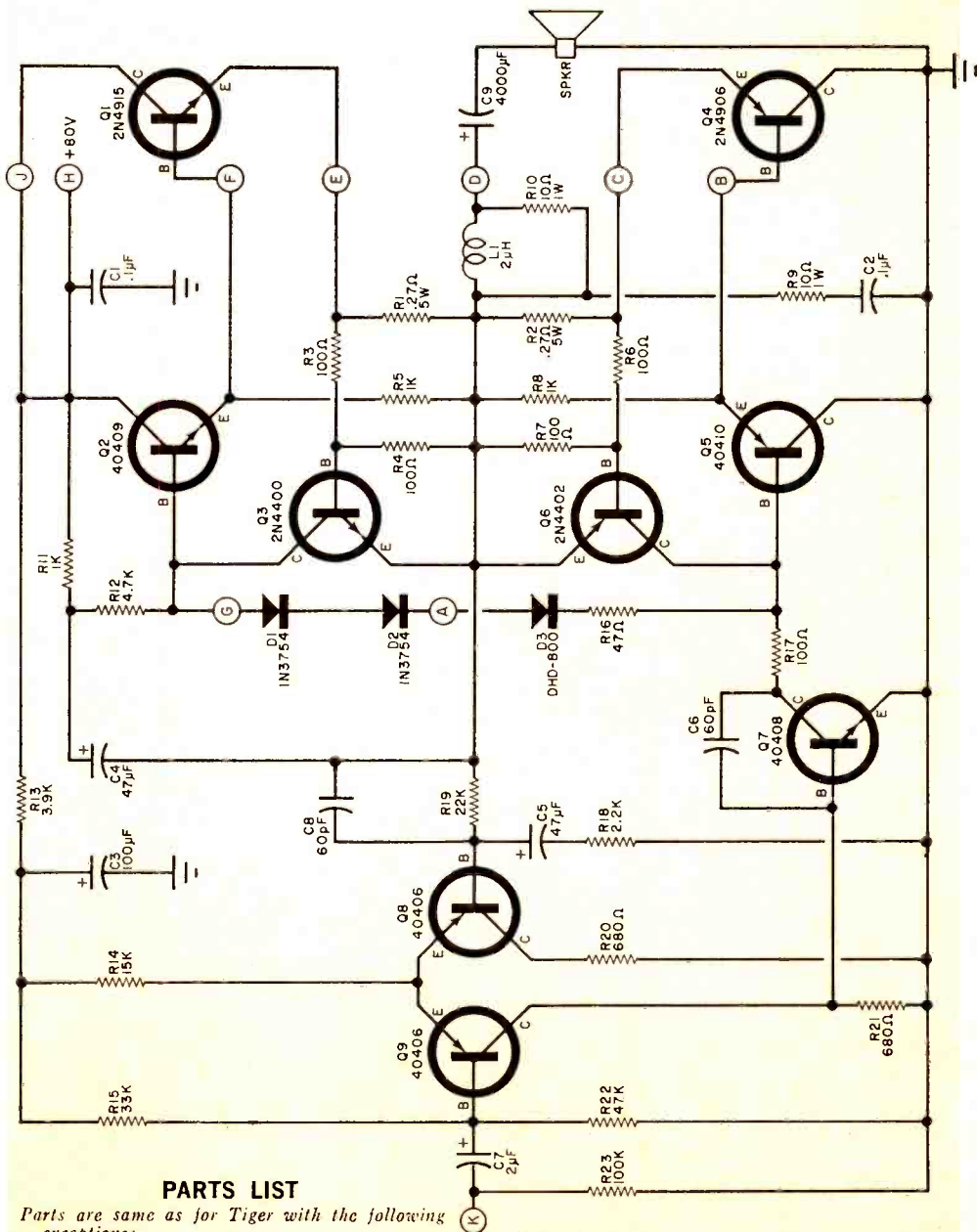

Fig. 4. Power supply for the tiger. It can be wired point-to-point with the components installed within the chassis.

## PARTS LIST

- C1*—2500- $\mu$ F, 75-volt electrolytic capacitor
- F1*—1-ampere fuse and fuseholder
- R1*—4700-ohm, 1-watt resistor
- RECT1*—2-ampere bridge rectifier
- T1*—Power transformer, secondary 42 V at 2 A (SW Tech P-5600 or similar)
- Misc.—S.p.s.t. power on-off switch (optional), power on neon indicator assembly (optional).



### PARTS LIST

Parts are same as for Tiger with the following exceptions:

- C3—100-µF, 100-volt capacitor
  - Q1—Transistor (Motorola or Texas Instruments 2N4915)
  - Q2—Transistor (RCA 40409)
  - Q4—Transistor (Motorola or Texas Instruments 2N4906)
  - Q5—Transistor (RCA 40410)
  - Q7—Transistor (RCA 40408)
  - Q8,Q9—Transistor (RCA 40406)
  - R4,R7—100-ohm
  - R13—3900-ohm
  - R14—15,000-ohm
  - R18—2200-ohm
- All resistors  
½-watt

Note—The following are available from Southwest Technical Products Corp., 219 W. Rhapsody, San Antonio, Texas 78216: Etched and drilled printed circuit board (#160SB) \$2.80 postpaid; kit for amplifier (board and components for one channel) (#160SC) \$22.00 postpaid; complete stereo kit with punched chassis, \$70.00, plus shipping, 14 lb.

Fig. 5. The Super Tiger has same basic circuit as the Tiger, with high-power transistors in the output and a different circuit board.

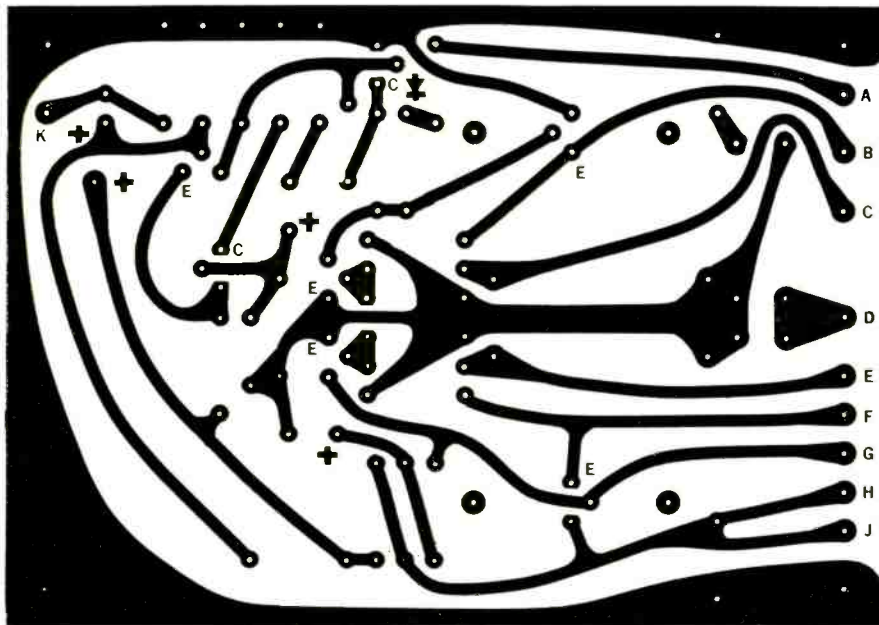

Fig. 6. Foil pattern for the Super Tiger. Like the Tiger PC board, this one is also available etched and drilled (see Parts List for Fig. 5).

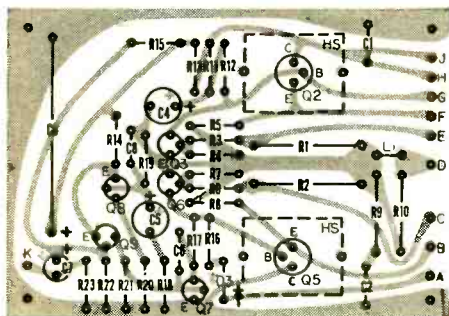
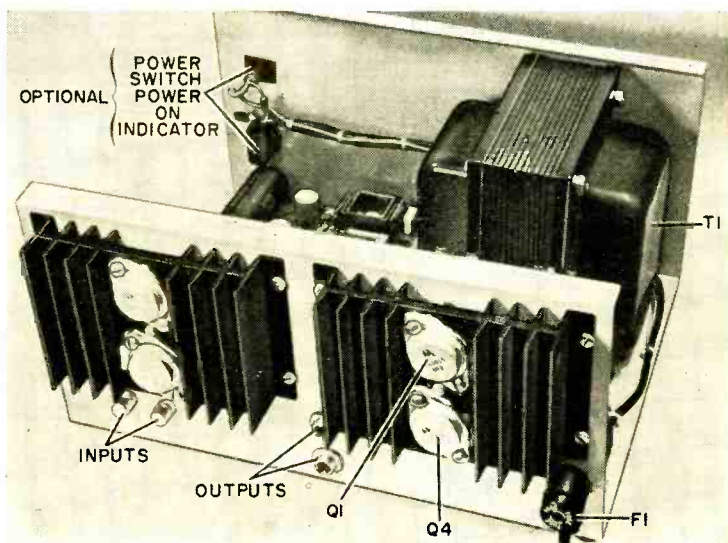

Fig. 7. Component installation for the Super Tiger. Note the location of the two transistor heat sinks (dashed line boxes) that mount on the PC boards.

amplifier, note that there are two ground contacts on the PC board: one marked "B" and the other marked with the ground symbol. The former is the output grounding contact and should be connected directly to the loudspeaker jack along with the signal lead. Use at least a #18 wire for this connection. The other

The Super Tiger arranged for stereo. The optional power switch and indicator can be mounted on the front panel. The speaker outputs are terminated in phone jacks, although a barrier strip can be used.



## PARTS LIST

*C1, C2—4000- $\mu$ F, 50-volt electrolytic capacitor*  
*F1—2-ampere fuse and fuseholder*  
*R1—10,000-ohm, 1-watt resistor*  
*RECT1—4-ampere bridge rectifier*  
*T1—Power transformer, secondary 62 V at 3 A*  
*(SW Tech P-3154 or similar)*  
*Misc.—S.p.s.t. power on-off switch (optional),*  
*power on neon indicator assembly (optional).*

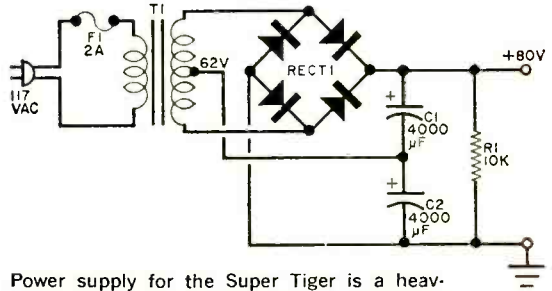

Power supply for the Super Tiger is a heavier version of the one for the Tiger. The Super Tiger takes higher voltage and more current.

ground should be connected to the chassis in the conventional manner. Do not depend on the mounting spacers for a ground connection.

**Construction (Super Tiger).** The 100-watt IHF Super Tiger amplifier is electrically similar to the Tiger except that the heavy-duty output transistors are mounted off the PC board on independent heat sinks. The circuit is shown in Fig. 5 and the foil pattern for the printed circuit board is shown in Fig. 6. Once the board is made, or purchased, mount the components as illustrated in Fig. 7. Note that diodes *D1* and *D2* are on the transistor heat sinks separate from the board and their connections to the board are made through lettered terminals on the

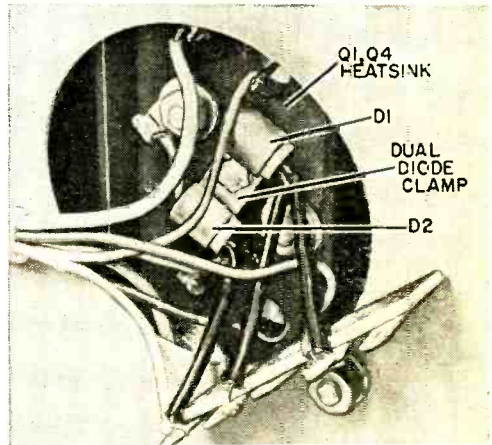

Method of mounting the diodes on power transistor heat sink. When mounting the heat sink, make sure that there is a large hole in the chassis wall so that you can readily mount the diode clamp in place.

General view of one channel of the Tiger amplifier. Note how diodes are clamped to sinks.

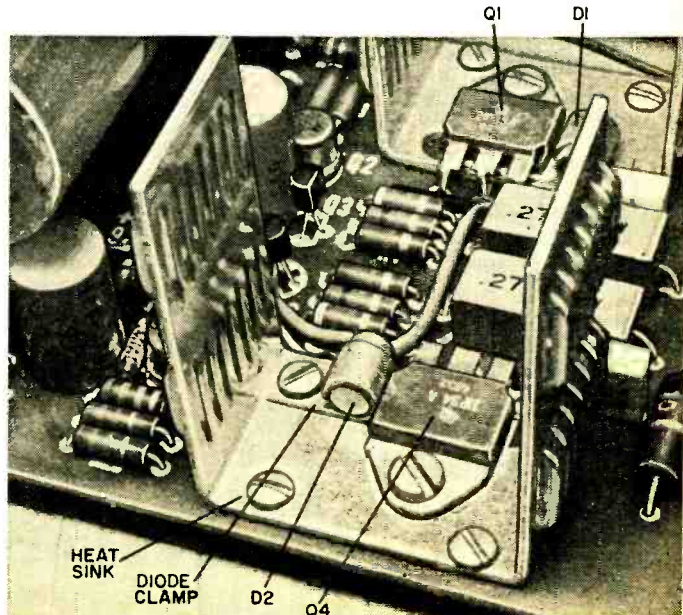

Either Tiger or Super Tiger makes excellent companion for the stereo preamp featured in the May 1969 issue. The power amplifier also supplies d.c. power for stereo preamplifier.

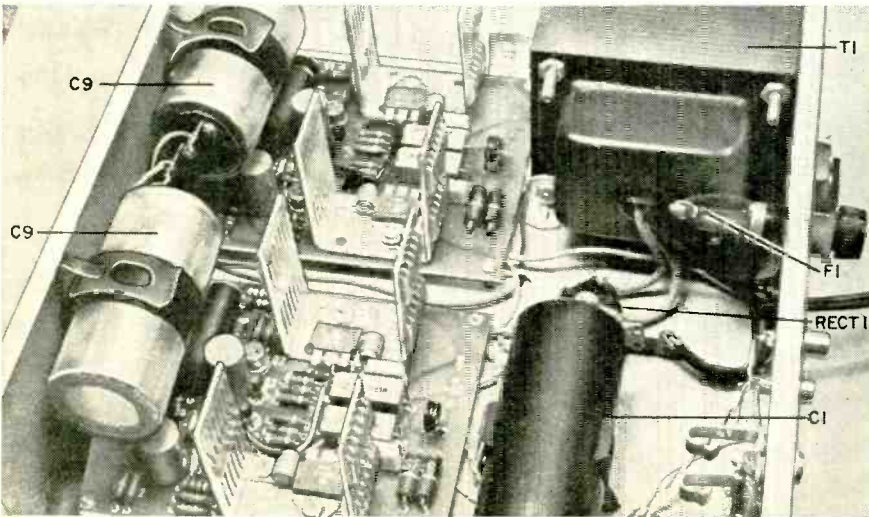
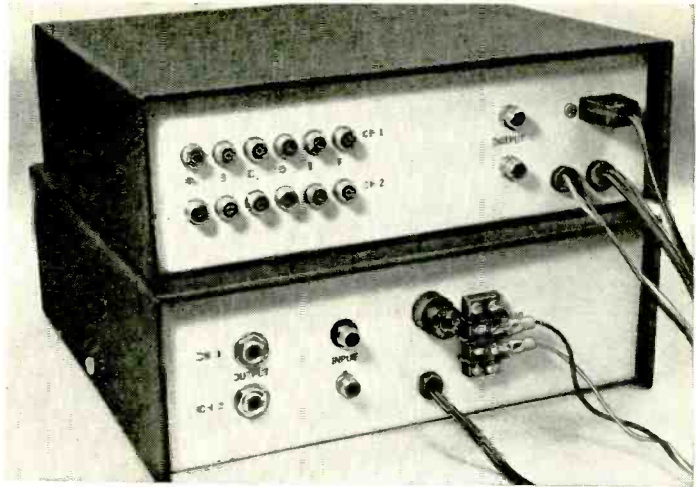

Tiger power amplifier wired for stereo (2 channels). One power supply handles both channels. Two output capacitors are mounted on the rear apron.

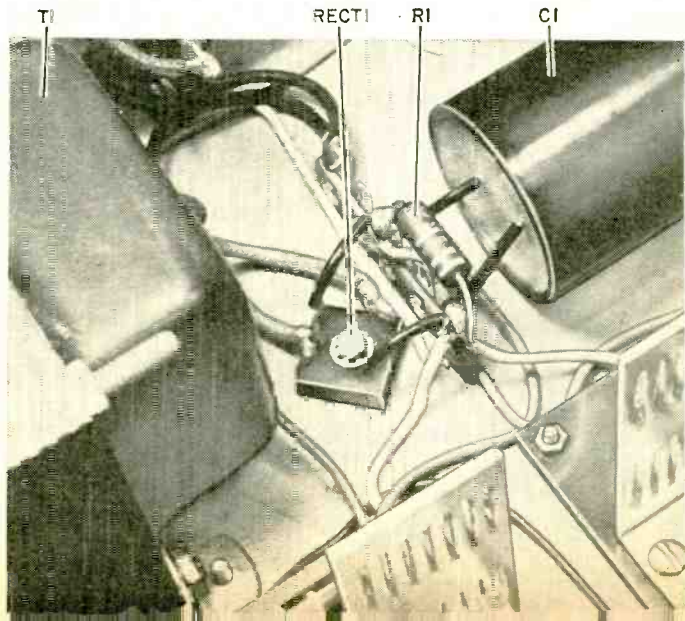

Close up of the power supply. Rectifier module is bolted to chassis and connections are made to a terminal strip.



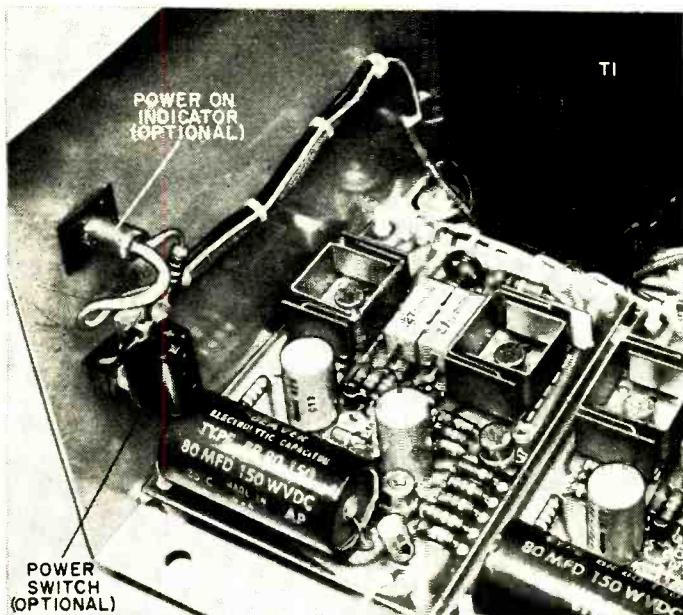

Internal view of Super Tiger amplifier showing placement of optional power-on switch and indicator lamp. The heavy power transistors are mounted on opposite wall of chassis.

RECT I

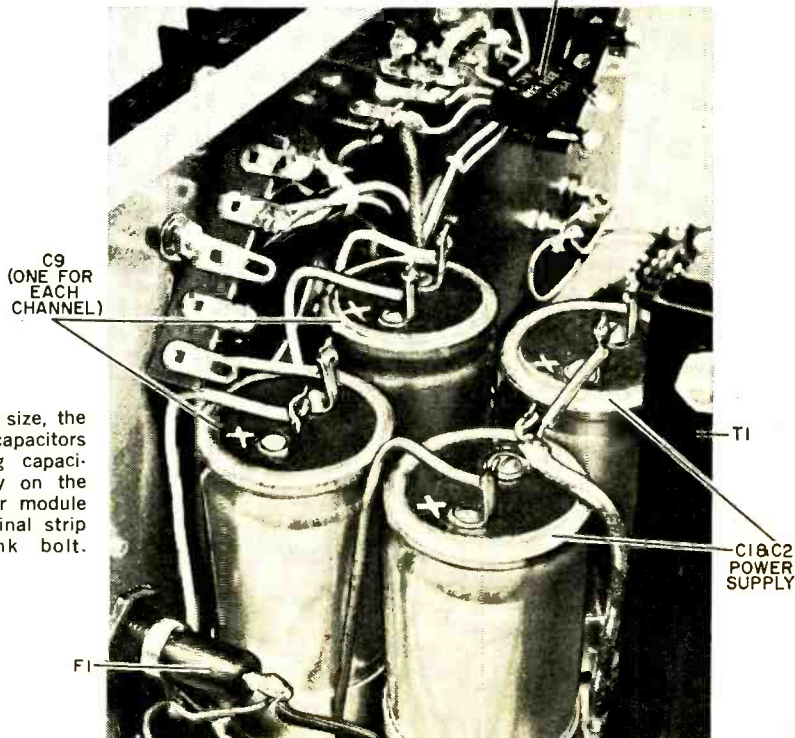

Due to their physical size, the power supply filter capacitors and output coupling capacitors are put directly on the chassis. The rectifier module is mounted on terminal strip held by heat sink bolt.

board. Be sure to observe the correct polarities for all diodes.

The actual physical arrangement of the boards (two for a stereo system) in an enclosure is at the builder's discretion. The bulky power transformer and filter capacitors are mounted separately

from the boards.

The circuit for the power supply for the Super Tiger is shown in Fig. 8. It is a heavy-duty bridge rectifier with associated filter and bleeder circuit. The output to the amplifier is 80 volts.

*(Continued on page 99)*

# Electronics "B" Quiz

BY ROBERT P. BALIN

To test your knowledge of electronic terminology, identify the circuits, objects, etc. in the sketches. Each starts with a "B" and the number of letters is indicated by the spaces.

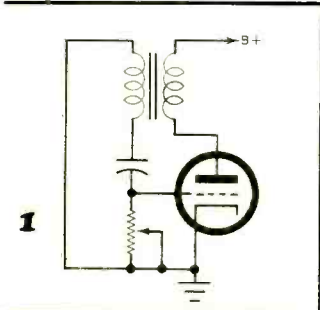

1. An oscillator—B \_ \_ \_ \_ \_
2. A capacitor—B \_ \_ \_ \_ \_
3. A filter circuit—B \_ \_ \_ \_ \_
4. An antenna—B \_ \_ \_ \_ \_
5. An amplifier—B \_ \_ \_ \_ \_
6. A lamp base—B \_ \_ \_ \_ \_
7. A type of coil winding—B \_ \_ \_ \_ \_
8. A coupling transformer—B \_ \_ \_ \_ \_
9. A signal in color TV—B \_ \_ \_ \_ \_
10. A plug—B \_ \_ \_ \_ \_

(Answers on page 100)

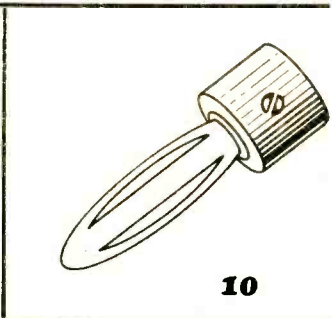
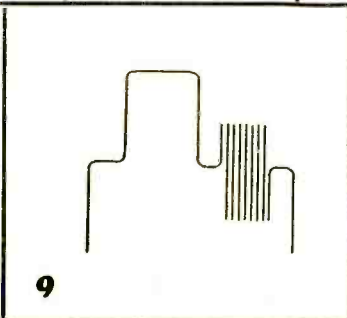
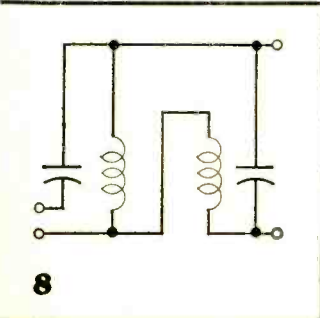
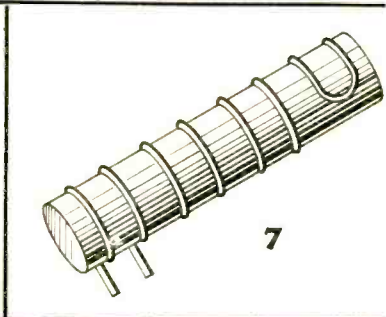
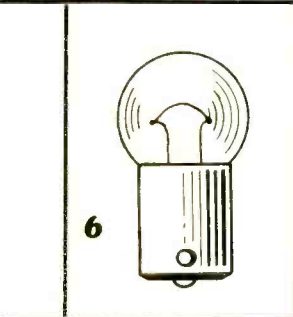
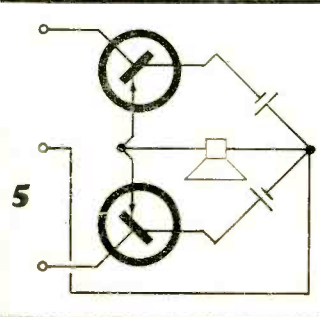
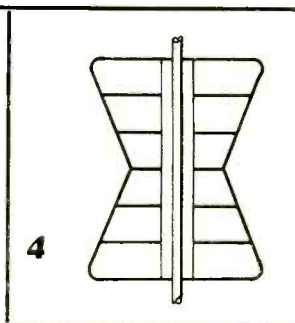
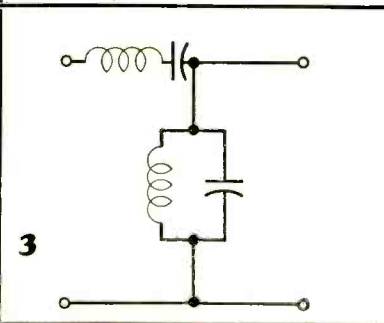
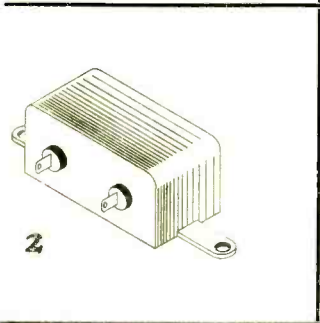

# The Stereo Scene

by Charles Lincoln

## SAYONARA TO THE STIGMA, "MADE IN JAPAN"

**R**EPUTATIONS and first impressions sometimes die hard. Me, I'm a skeptic and I wanted to be personally convinced that the Japanese were as ardent hi-fi enthusiasts and manufacturers as the publicity hoopla made them sound. So for two weeks I toured *The Stereo Scene* in Tokyo and I came away finding it much easier to forget that the Japanese were once adroit copiers. The Japanese appreciate good hi-fi more than Americans and the equipment they use simply reflects that fact.

I was no sooner off the JAL plane than I spotted a streamer glued to the rear window of a taxi. It plugged the products of Pioneer, a pre-WWII electronics manufacturer and probably the world's leading producer of loudspeakers. The streamer was just a sample of how hi-fi surrounds you in the big Japanese cities. You hear good sound everywhere; in coffee houses, tea rooms, restaurants big and small, and in stores, specialty shops, waiting rooms, and train stations. If you wanted to, I don't think you could escape.

Except for a quick, but impressive, factory tour of a comparative newcomer to the audio market, Crown Radio Corp., most of my fact-finding was on a do-it-yourself basis. I spent a lot of time where the action is—in the stores. I walked, looked, compared spec sheets, examined a multitude of products, and spent hours upon hours just listening. I talked to anyone who understood English and hi-fi and translated price tags with a yen-dollar conversion table. An interpreter helped me decipher the subtleties in advertisements and performance statements.

**Price Is No Barrier.** My first impression was that the overall prices of hi-fi gear in Japan are lower than what I would spend for a comparable product in the U.S. I was quickly straightened out on this point, since I had ignored the relationship of price to a wage earner's income. A decent hi-fi rig comprising stereo receiver, turntable, and speaker system (valued at about \$400 U.S. equivalent) might represent three months

These deluxe stereo component ensembles, favorites of Japanese audio buffs, get feature treatment at Yamagiwa, Tokyo's big independent audio retailer.



salary to a Japanese blue collar worker, and two months wages to a white collar worker. The fact that the Japanese are willing to lay out that much money emphasizes the exalted status of hi-fi among the Japanese. Of course, a real love of music is part of the Japanese cultural heritage and the Japanese are naturally proud of their technological status—and hi-fi is a showcase. Lastly, and possibly of far greater importance, these prices mean that the quality and performance must be superb.

One hi-fi enthusiast said, "Most Japanese families like to have one expensive thing in their home. It gives them a sense of accomplishment. It might be an expensive camera, a color television set, or hi-fi system. A car would be the highest status symbol, but many of us can't afford one. A hi-fi system is something that we can enjoy and it is possible for us to buy."

Time payment is the way many Japanese buy expensive hi-fi equipment. Workers anticipate receiving special cash bonuses—if the companies they work for prosper—every three or six months. Many workers splurge these bonuses on hi-fi, but some wait and save, or defer payments, while in the meantime enjoying hi-fi music in the little shops that dispense stereo with tiny cups of coffee.

I would judge that the hi-fi ownership in Japan has reached 30% primarily because the younger generation is sound conscious.



Streamers give price and specifications of audio components. This is a typical discount audio department in Tokyo's Akihabara store section, which resembles New York's old "Radio Row" district.

**Where It Is Sold.** Among my first reactions to Tokyo's stereo scene was surprise that department stores plug hi-fi with such zeal. In American department stores, the home entertainment electronics sections are dominated by TV, big stereo/radio/TV combinations and stereo consoles. There is also a sprinkling of portable phonographs, tape recorders and FM radios.

Practically every Japanese department store I visited offered individual hi-fi components for sale. They are shown in rooms or wall displays and are hooked up ready for A-B comparisons. You rarely see one-piece stereo consoles. There are big component systems, but generally they are usable in small quarters since the speaker system need not take up floor space. Of course many Japanese homes are built with movable screen walls and two small rooms can be opened up into one large room and in effect hi-fi sound can be made to permeate throughout the whole house.

Missing in Japanese hi-fi equipment are record changers. After visiting several dozen stores I realized that I had seen only one record changer. I then discovered that deluxe Japanese audio systems are not sold with record changers. Instead, the deluxe systems utilize precision manual turntables and the mini-systems use a turntable of somewhat lower quality.

It was explained to me that, in the early days of hi-fi, the LP record was exceptionally expensive. Flexible seven-inch 33 $\frac{1}{3}$  r/min discs were developed and these could not be played on record changing equipment. Although the price of LP's has dropped to a more realistic level, the Japanese treasure their records and apparently don't trust record changers. This idea is so deeply ingrained that each of the monthly audio and hi-fi magazines keep repeating that modern changers won't hurt modern LP's.

**Across the Pacific.** Although the Japanese have been making audio components for several decades, it is only within the past several years that an effort has been made to introduce these products in the United States. Some Japanese electronic manufacturers have been around as long as their American counterparts. Victor Company of Japan dates back to 1927 and is the U.S. market place under the JVC brand. Pioneer has been around for over 30 years and Trio (Kenwood in the U.S.) and Sony started around 1944 and 1945, respectively. Sansui was introduced a year later.

As far as I can figure it, the first Japanese hi-fi gear was introduced in the U.S. under various mail-order brand names. The mail-order houses were interested because the "price" was right, but much to their



Prospective customers eye mini-compact systems.

collective amazement, the quality was top-notch and each and every unit worked when unpacked. Customers had become acclimated to the high quality and good performance of transistor portable receivers and had no second thoughts or misgivings. Nevertheless, it wasn't until 1962 that the Japanese got really serious about entering the U.S. market.

Ironically, the Japanese entry was really one of self-defense since at that time there was a strong demand for American-made products in Japan. In fact, American products were selling better in the Japanese au-

dio market than the Japanese products themselves! Here again, the reason was simply one of status and American hi-fi was a "super-status" symbol. Today, the sale of American hi-fi equipment in Japan is minimal. The big reason is the stiff import duty. But imported cars are still status symbols and the Mercedes-Benz is the current favorite.

**Performance and Quality.** Back home in the states, I had some pretty good hi-fi equipment. I knew the specs of the equipment and the current selling prices. To see how this equipment compared with Japanese equivalents, I translated various spec sheets and sales tags and found four different brands that, for the same dollar outlay, I could get more output, better distortion figures, or more functional features.

All of this equipment was solid state, well designed and particularly good looking. The Japanese have a huge reservoir of design and engineering talent. There's probably a higher ratio of design-engineering talent in Japan than in the United States. And, this talent is not drained off into the military service. Further, I was told, the Japanese design-engineering team works as a unit on a given product project and this always leads to quicker development.

In contrast with British, West German and Italian hi-fi gear, practically all Japanese hi-fi components are 100% "Americanized." At five or six feet it's impossible to distinguish a Japanese from an American stereo receiver—the use of plastic and chrome stripping is identical. Even the nomenclature is the same and the Japanese go along with the American terminals and sockets in preference to the European DIN standards.

The Japanese haven't missed a trick in keeping abreast of technological advances

Eliminate the sign at the top of the photo and you might say this was an American audio store, but it's Tokyo. Some of the equipment shown here is available in United States.





Japanese do-it yourselfer likes "raw" component loudspeakers, which he installs in cabinets, in closets, or in the walls of his house.

inherent in hi-fi equipment. There is liberal use of field-effect transistors and hi-fi components using integrated circuits will probably be appearing in the American market place by the time this story is in print. Objectively, no one could call the Japanese "copiers" and one American engineer went so far as to say that it may not be long before some American manufacturers will find it hard to keep up with the Japanese designs.

**What To Look For.** Walk into any hi-fi salon in the United States and you should find at least one of the five principal Japanese hi-fi brand names on the shelves—Sony, Kenwood, Sansui, Pioneer, or JVC. Some stores may carry two or more brands, and even a few of the more progressive stores a choice from three brands. You will find that the hi-fi Japanese equipment is competitively priced and more than likely you will find that feature for feature, spec for spec, quality for quality, there may even be a better buy in Japanese equipment than in comparable domestic products.

As for reliability, the Japanese hi-fi units are certainly as reliable—and possibly a little more so—as any item manufactured in North America. The stronghold of Japanese supremacy has been in top-notch quality

control. They go to extremes to make sure that the products work before they leave the Japanese warehouses. In fact, it is my understanding that the five companies check every single unit on arrival from Japan to make sure that nothing has happened in transit and to serve as a double-check on the quality control measures at the factory itself. As one supplier candidly put it, "Quality control is the thing we do better than your domestic manufacturers. This is how we earned our good reputation and this is the thing that we are continuing."

Product back up of Japanese equipment is certainly comparable to that of domestic companies. All five of the principal manufacturers have nationwide authorized service stations in major cities. Further, all five offer factory service at their principal shipping-warehousing points.

Summing up, the Japanese are doing what they know best—designing and manufacturing superb amplifiers, stereo receivers and tape recorders. They have few turntables, tone arms, or cartridges comparable to those made in the U.S. They have taken a back seat to the Europeans in regard to record changing equipment, and the Japanese speakers—although really quite good—are not "balanced" for American ears. —30—

### VILLAGE RADIO GOES SOLID-STATE

Although most readers of this magazine think of The Hallicrafters Co. (600 Hicks Road, Rolling Meadows, Ill. 60008) as a manufacturer of SWL and ham equipment, it is also a major supplier of two-way radio equipment in the overseas market. Hallicrafters has up-dated its "Village Radio" equipment (see April 1963 POPULAR ELECTRONICS) into a very compact 5-watt, 2-channel, 148-170-MHz transceiver. Numerous accessories are available for this optionally narrow- or wide-band FM system.



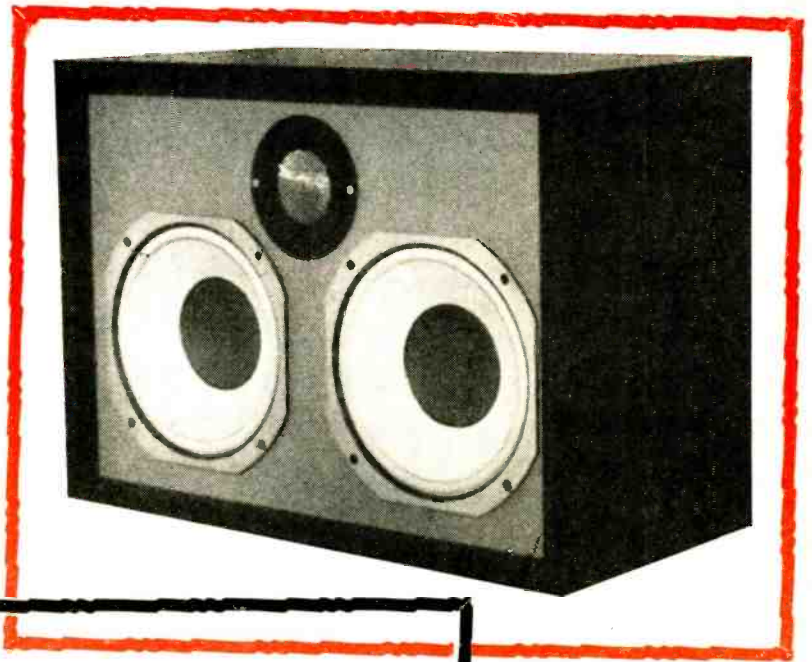

**THE**  
**TIE** **BOOKSHELF**  
**SPEAKER**

**ECONOMY**  
**INTERMEDIATE**  
**TOP-OF-THE-LINE**

*Build the  
Optional  
Component  
System*

BY HERMAN F. JOHNSON

**T**HE TROUBLE with most instructions for constructing bookshelf speaker systems is plain old tradition. For example, tradition (or convention) calls for plywood as the work medium with cleats and wood screws to give structural strength and miter cuts to obtain "finished" edges. In reality, however, these so-called time-saving and economical practices can be stumbling blocks for the once-in-a-while woodworker.

Cleats actually reduce the volume in a small enclosure, require extra time to install, and run up the cost of materials.

Plywood, far from being an easy medium with which to work, is fraught with disadvantages—such as opposing grains, hidden flaws, and different types of lumber. Most important, few hobbyists have the proper cutting tools or adequate experience to turn out precise 45° miter cuts—and just try to get a lumberyard to do it for you!

So what do you do to eliminate these objections to conventional practices? First, toss out cleat supports and substitute the tongue-and-groove method of support (see Fig. 1). In so doing, you

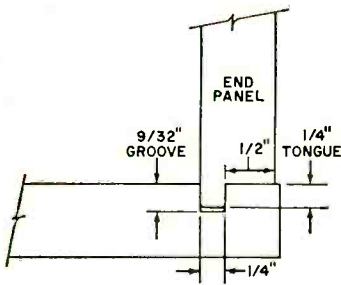

Fig. 1. Tongue-and-groove joint is self-supporting; with glue, is self-fastening.

eliminate the need for screws and cut down on assembly time. Next, use easy-to-work-with prefinished particle board shelving to eliminate the need for miter cuts and still get a neat appearance. Finally, use front-mounting speakers or adapt speakers so that they can be front mounting, and you can build a permanently sealed, "unitized" enclosure.

In following this procedure, the only tool you need (other than a common screwdriver) is a power router. Power routers are available for \$35 and up. However, if you prefer not to buy one, most hardware stores will rent you one.

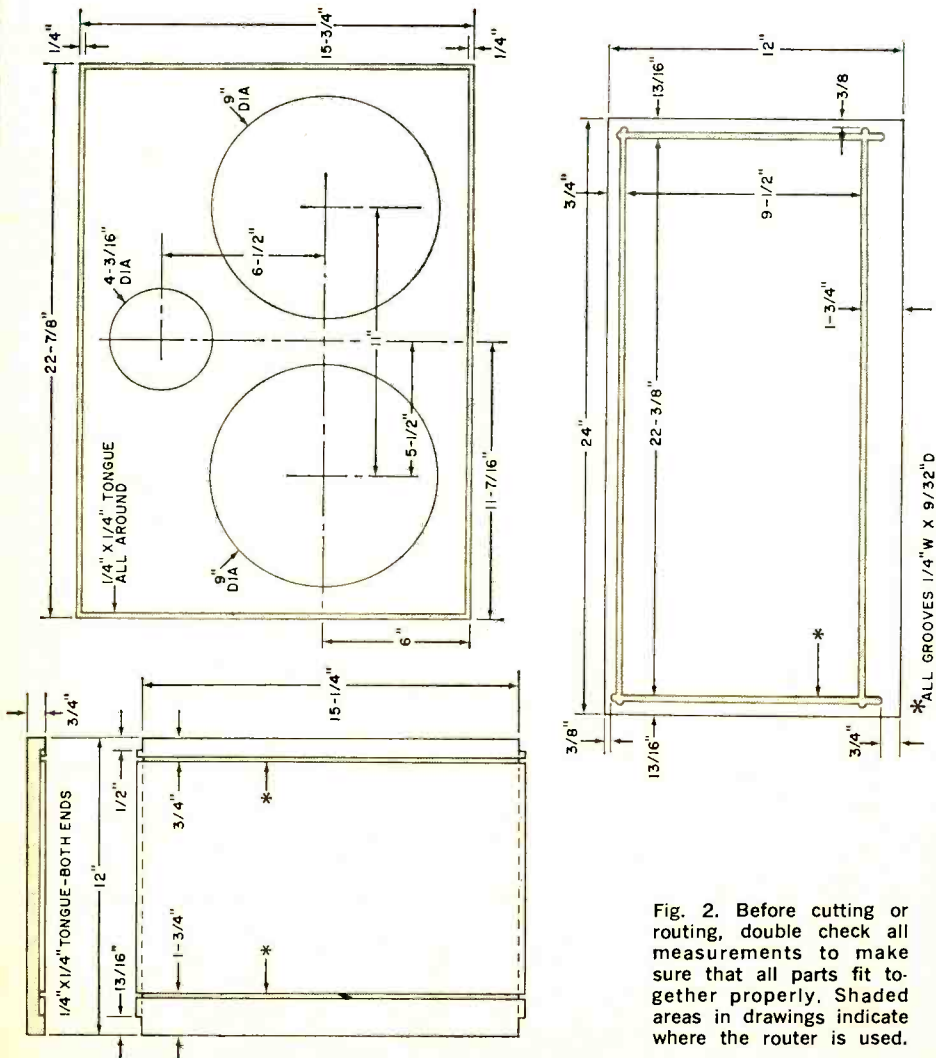

Fig. 2. Before cutting or routing, double check all measurements to make sure that all parts fit together properly. Shaded areas in drawings indicate where the router is used.



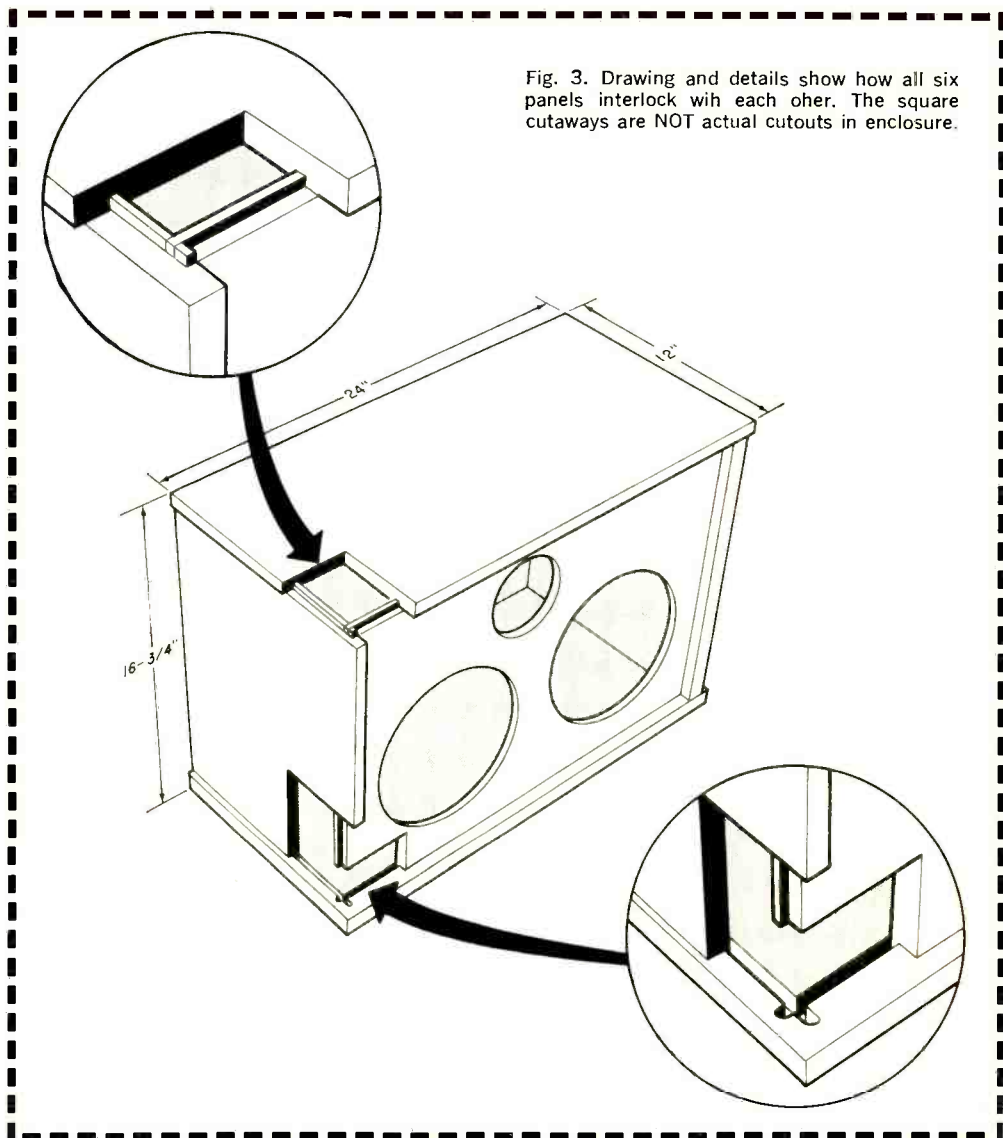

Fig. 3. Drawing and details show how all six panels interlock with each other. The square cutaways are NOT actual cutouts in enclosure.

Following is a description of a flexible speaker enclosure that, when built, is the equal of any professionally made enclosure now on the market. In keeping with this flexibility, three different speaker systems—one for every budget—are suggested.

**Building the Enclosure.** To make the job of finishing the enclosure easier, use prefinished 12"-wide by  $\frac{3}{4}$ "-thick particle board shelving for the top, bottom, and sides of the enclosure. The shelving is available with a variety of woodgrain finishes, in both dark and blond shades;

so choose a combination that best suits your tastes and room decor.

Two 24"-long prefinished shelves (they come in standard lengths) will be used for the top and bottom of the enclosure. Another 36"-long shelf will be cut to size to make the sides of the enclosure with a few inches left over. Finally, two  $22\frac{7}{8}$ "  $\times$   $15\frac{3}{4}$ "  $\times$   $\frac{3}{4}$ " unfinished particle board plates will be used for the speaker mounting board and the rear of the enclosure. Make certain when selecting your shelving that all shelves are the same width, that the ends are square with the sides, and that the two 24"

Someone  
should develop  
an easy way  
to learn  
electronics at  
home

RCA Institutes  
did!

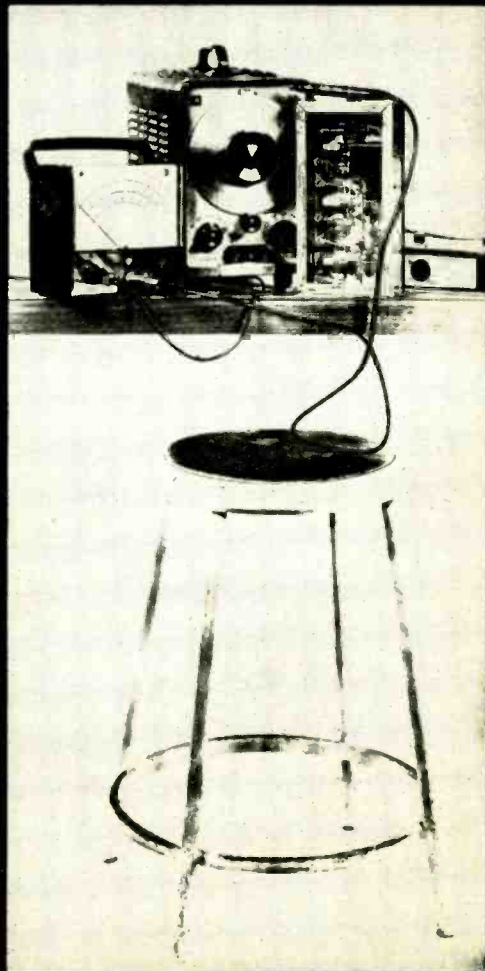

Here is a modern approach to learning electronics at home! RCA Institutes, one of the nation's largest schools devoted to electronics, has developed a faster, easier way for you to gain the skills and the knowledge you need for the career of your choice. Here for the first time is a student-proved, scientifically designed way to learn. If you have had any doubts in the past about home training in electronics—if you have hesitated because you thought you might not be able to keep up—or that electronics was too complicated to learn—here is your answer! Read how RCA Institutes has revolutionized its home training ideas!

**NEW courses  
in Solid State Technology.  
Mail card today  
for full information.**

**ALL CAREER PROGRAMS  
BEGIN WITH "AUTOTEXT"  
INSTRUCTION METHOD!**

**Prepare for the field of your  
choice immediately!  
No previous training or  
experience in electronics  
needed!**

With this new revolutionized method of home training you pick the career of your choice—and RCA Institutes trains you for it. RCA's Career Programs assure you that everything you learn will help you go directly to the field that you have chosen! No wasted time learning things you'll never use on the job! The Career Program you choose is especially designed to get you into that career in the fastest, easiest possible way!

And each Career Program starts with the amazing "AUTOTEXT" Programmed Instruction Method—the new, faster way to learn that's almost automatic! "AUTOTEXT" helps even those who have had trouble with conventional home training methods in the past. This is the "Space Age" way to learn everything you need to know with the least amount of time and effort.

**CHOOSE A CAREER PROGRAM NOW**

**Your next stop may be the job of your choice.** Each one of these RCA Institutes Career Programs is a complete unit. It contains the know-how you need to step into a profitable career. Here are the names of the programs and the kinds of jobs they train you for. Which one is for you?

**Television Servicing.** Prepares you for a career as a TV Technician/Serviceman; Master Antenna Systems Technician; TV Laboratory Technician; Educational TV Technician; CATV Technician.

**FCC License Preparation.** For those who want to become TV Station Engineers, Communications Laboratory Technicians, or Field Engineers.

**Automation Electronics.** Gets you ready to be an Automation Electronics Technician; Manufacturer's Representative; Industrial Electronics Technician.

**Automatic Controls.** Prepares you to be an Automatic Controls Electronics Technician; Industrial Laboratory

Technician; Maintenance Technician; Field Engineer.

**Digital Techniques.** For a career as a Digital Techniques Electronics Technician; Industrial Electronics Technician; Industrial Laboratory Technician.

**Telecommunications.** For a job as TV Station Engineer, Mobile Communications Technician, Marine Radio Technician.

**Industrial Electronics.** For jobs as Industrial Electronics Technicians; Field Engineers; Maintenance Technicians; Industrial Laboratory Technicians.

**Nuclear Instrumentation.** For those who want careers as Nuclear Instrumentation Electronics Technicians; Industrial Laboratory Technicians; Industrial Electronics Technicians.

**Solid State Electronics.** Become a specialist in the Semiconductor Field.

**Electronics Drafting.** Junior Draftsman, Junior Technical Illustrator; Parts Inspector; Design Draftsman Trainee Chartist.

**SEPARATE COURSES**

In addition, in order to meet specific needs, RCA Institutes offers a wide variety of separate courses which may be taken independently of the Career Programs, on all subjects from Electronics Fundamentals to Computer Programming. Complete information will be sent with your other materials.

**CONVENIENT PAYMENT PLANS**

RCA Institutes offers liberal monthly payment plans to suit your budget. Be sure to check out all the RCA extras included at no additional cost.

**VALUABLE EQUIPMENT**

You receive valuable equipment to keep and use on the job—and you never have to take apart one piece to build another.

**Programmed Electronics**

**Breadboard.** You now will receive a scientifically programmed electronic breadboard with your study material. This breadboard provides limitless experimentation with basic electrical and electronic circuits involving vacuum tubes and transistors and includes the construction of a working signal generator and superheterodyne AM Receiver.

**Bonus From RCA—Multimeter and Oscilloscope Kits.** At no additional cost, you will receive with almost every RCA Institutes Career Program the instruments and kit material you need to build a multimeter and oscilloscope. The inclusion of both these kits is an RCA extra.

**CLASSROOM TRAINING  
ALSO AVAILABLE**

RCA Institutes maintains one of the largest schools of its kind in New York City where classroom and laboratory training is available in day or evening sessions. You may be admitted without any previous technical training; preparatory courses are available if you haven't completed high school. Coeducational classes start four times a year.

**JOB PLACEMENT SERVICE, TOO!**

Companies like IBM, Bell Telephone Labs, GE, RCA, Xerox, Honeywell, Grumman, Westinghouse, and major Radio and TV Networks have regularly employed graduates through RCA Institutes' own placement service.

**SEND ATTACHED POSTAGE PAID CARD  
FOR COMPLETE INFORMATION, NO OB-  
LIGATION.**

All RCA Institutes courses and programs are approved for veterans under the new G.I. Bill.

Accredited Member  
National Home Study Council

IF REPLY CARD IS DETACHED—SEND THIS COUPON TODAY

RCA INSTITUTES, Inc., Dept. PE-79  
320 West 31st Street, N.Y., N.Y. 10001

Please rush me FREE sample of a lesson and illustrated catalog. I understand that I am under no obligation.

Name \_\_\_\_\_ Age \_\_\_\_\_

(please print)

Address \_\_\_\_\_

City \_\_\_\_\_

State \_\_\_\_\_ Zip \_\_\_\_\_



shelves are within  $\frac{1}{16}$ " of each other in length.

Check each shelf to determine which sides will be used as the exterior surfaces of the enclosure; mark your choices with pieces of masking tape. Now, carefully cut two  $15\frac{3}{4}$ "-long pieces from the 36" shelf, referencing your measurements from opposite ends of the shelf. This leaves the scrap material in the middle of the shelf and provides you with at least one neatly finished edge per side.

Now, carefully following the directions supplied with your router, chuck a  $\frac{1}{4}$ " straight bit (Stanley No. 1108 or Black & Decker No. U-2501) into place. Again referring to the instruction manual, practice a few dado (groove) and rabbet (tongue) cuts on a piece of scrap lumber to familiarize yourself with the handling of the tool and how to adjust for depth and width of cut.

When you are reasonably confident of producing straight, constant-depth cuts with the router, prepare the four sides and rear of the enclosure and the speaker mounting board according to the dimensions shown in Fig. 2. Note that the shaded areas of each plate indicate where the router is to be used. Make two identical plates for each drawing, but for the rear of the enclosure do not make the circular speaker cutouts.

The recommended procedure for using the router is as follows: First, draw in the groove outlines on the top and bottom panels, marking the start and stop positions with pieces of masking tape. Then, with the router adjusted for the proper width, set the tool down over the stop position of the groove with the bit just touching the masking tape, and strike a pencil line along the router base on the back side (opposite the stop position of the cut).

For uniform groove depth, it is best to cut all grooves that are the same distance from the sides down to  $\frac{1}{4}$ " in all four panels. Then reset the router for  $\frac{3}{32}$ " depth and complete these cuts before changing over to the next width setting.

Now, with the router set for a  $\frac{1}{4}$ "-wide rabbet cut, rout away the material from the outside top and bottom of the side panels to just slightly more than  $\frac{1}{2}$ " depth. (Clamp a  $\frac{3}{4}$ "-thick piece of

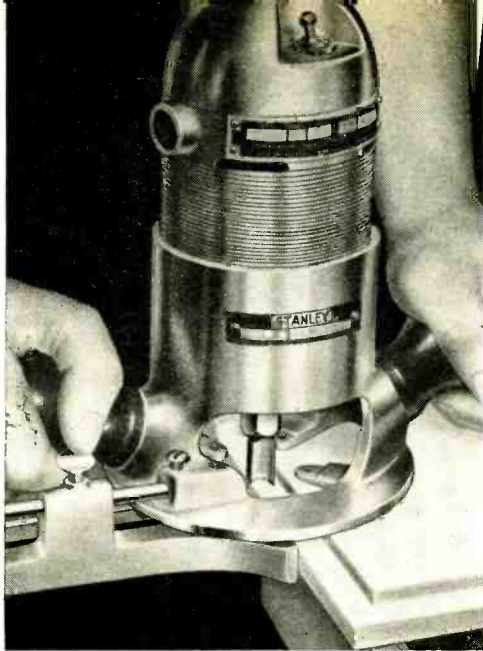

Photo shows the router guide set up for rabbeting to make the tongues. (Photo courtesy of Stanley Works)

scrap lumber to the end-of-the-cut edge to prevent splitting and flaking the finished edge). Then, with a fine-tooth hacksaw, cut off the ends of the tongues for a distance of  $\frac{1}{2}$ " at the rear and  $1\frac{1}{16}$ " at the front edges.

Finally, rout away a  $\frac{1}{4}$ "-wide by slightly more than  $\frac{1}{2}$ "-deep rabbet on all four sides of the speaker mounting board and rear panel. Locate the centers of the hole cutouts on the speaker mounting board and, with the circle guide attachment in place, use the router to make the cutouts.

This completes fabrication of the six enclosure panels. However, it is suggested that you round off the outside corner edges of all tongues with a sanding block to facilitate assembly. Also, apply a coat of resin sealer to all exposed raw edges to prevent flaking.

Temporarily assemble the enclosure to check for proper fit of all members. The tongues should fit snugly in their respective grooves and should not rock back and forth along their lengths (an indication of non-uniform groove depth). All interlocking joints should be perfectly square. If you are satisfied, disassemble the enclosure.

Place the bottom and two side panels

on a level, flat surface. Apply a bead of epoxy cement to the bottom and along the *inside* top edge of each groove. Be just liberal enough with the cement to prevent "bleeding" to the outside surfaces when the panels are assembled. Allow the cement to set for about fifteen minutes. Then set the speaker mounting board and rear panel firmly into place, followed by the side panels.

Apply cement to the grooves in the top panel as described above. Then fit the top panel in place, pressing down to seat all plates firmly, and weight the top of the enclosure or clamp the enclosure together to insure that it is perfectly square as the cement sets. Figure 3 illustrates how all six panels of the basic enclosure lock together. The cutaways in the drawing are provided only to illustrate tongue-and-groove jointing details (not actual cutouts in the enclosure itself). Note also in this illustration that both side panel exterior surfaces are recessed  $\frac{1}{16}$ " from the edges of the top and bottom plates.

**Speaker System Choices.** The three speaker systems described here were selected to provide maximum flexibility and the best possible sound reproduction in the basic enclosure just described. In addition, all systems are of two-way design, and all speakers are front mounted to preclude any necessity for disassembling the enclosure as you go from one system to another.

For the top-of-the-line, the James B. Lansing (hereafter referred to as JBL) "S11" system (plus an optional

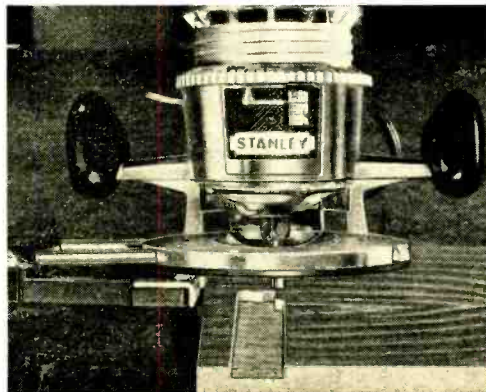

To cut grooves, the router guide is adjusted away from the cutting bit. (Photo courtesy of Stanley Works)

July, 1969

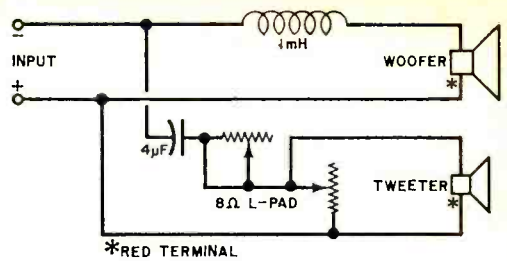

Fig. 4. All speaker systems suggested for basic enclosure are two-way, to be wired together as shown.

radiator) was selected. This system includes the JBL Models LE20 high-frequency transducer; LE10A low-frequency driver; and LX11 crossover network with high-frequency control. The optional passive radiator is designated the Model PR10, also by JBL.

When installing the system, start off by mounting the crossover network and high-frequency control on the rear panel of the enclosure. Mount the LX11 from the inside of the enclosure, over a  $4\frac{1}{4} \times 5\frac{1}{2}$ " cutout. Then mount the LE20 in the  $4\frac{3}{16}$ " hole and the LE10A in one of the 9" holes in the speaker mounting board after wiring the system together according to Fig. 4.

If you decide to use the passive radiator, mount it in the remaining hole. However, if you choose the ported system, you will have to make an adapter flange for the 4"-inner-diameter by  $7\frac{1}{2}$ "-long cardboard mailing tube as shown in Fig. 5. Use  $\frac{3}{8}$ "-thick plywood, white pine, or particle board for the flange, and fix the tube in place with epoxy cement. (The diameter of the tube hole will depend on the outer diameter of the tube selected.)

This system evenly distributes the high-frequencies through a wide angle so that the listeners hear a balanced blend of direct and reflected sound. For the low and midrange frequencies, the bass is robust, there is a wide dynamic range, and response on the whole is smooth and clean well up into the mid-range. And although the passive radiator makes for a better system, substituting the port does not detectably degrade sound reproduction.

The *intermediate* system retains the superior JBL Model LE20 high-frequency transducer, and is complemented by the JBL Models D208 8" full-range

77

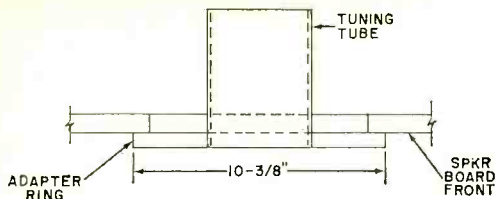

Fig. 5. If a ported enclosure is desired, an adapter ring is required for mounting port in 9" hole.

speaker and LX2 crossover network. This is a ported system requiring the use of a 4"-inner-diameter by 5"-long tube. The tube is mounted to the enclosure's speaker mounting board in the identical manner as above. Similarly, the crossover network has the same requirements as the LX11.

To mount the D208 full-range speaker in place, it is necessary to prepare an adapter ring as illustrated in Fig. 6. The ring serves two purposes: the speaker can be essentially front mounted and you can use the original 9" speaker cutout. The schematic diagram in Fig. 4 serves as the wiring diagram.

### BILL OF MATERIALS SPEAKERS

#### Top-Of-The-Line System (\$114; \$126 with PR10)\*

- 1—JBL Model LE10A 10" woofer
- 1—JBL Model LE20 tweeter
- 1—JBL Model LX11 crossover network
- 1—JBL Model PR10 10" passive radiator (optional, see text)

#### Intermediate System (\$96)\*

- 1—JBL Model D208 8" full-range speaker (and adapter ring—see text)
- 1—JBL Model LE20 tweeter
- 1—JBL Model LX2 crossover network
- 1—4"-inner-diameter x 5"-long cardboard mailing tube and adapter ring (see text)

#### Economy System (about \$15)\*

- 1—5" woofer (Lafayette Radio Electronics No. 99-0155)
- 1—Jensen Mfg. Co. Model TP35V 3½" tweeter
- 1—4"-inner-diameter x 8"-long cardboard mailing tube and adapter ring (see text)
- 1—8-ohm L-pad

### LUMBER & MISCELLANEOUS

- 2—24" x 12" pieces of ¾" unfinished particle board shelving for enclosure top and bottom
- 1—36" x 12" piece of ¾" unfinished particle board shelving for enclosure sides (see text)
- 2—22¾" x 15¾" pieces of ¾" unfinished particle board for enclosure rear panel and speaker mounting board
- Misc.—Zip cord; epoxy cement; ⅜"-thick lumber for adapter rings (if required); hardware: 7'-long x ½"-square pine for grille frame; grille cloth; damping material; etc.

\*Prices listed include speakers and crossover networks only, lumber and miscellaneous extra.

The *economy* system also employs a ported enclosure to complement its two-way speaker system arrangement. The speakers used in this system are a Jensen Manufacturing Company Model TP35V high-frequency radiator and a Lafayette Radio Electronics No. 99-0155 imported 5" low-frequency driver. A 4"-inner-diameter by 8"-long tube, mounted as in Fig. 5, rounds out the system.

It is also necessary to mount the Lafayette Radio speaker on an adapter ring (see Fig. 6, but this time substitute 4¾" for the 7" dimension of the cutout). Mount the TP35V on an adapter ring with the following dimensions: 5¼" outer diameter x 3⅞" cutout diameter. Then mount the assembly over the 4¾" hole in the speaker mounting board.

Refer to Fig. 4 again for wiring instructions. However, be sure you wire a 4-μF capacitor in *series* with the TP35V to isolate it from low-frequency power. Then finish the system off with a suitable L-pad.

Whichever system you build, at least 50% of the interior surfaces of the enclosure should be covered with a 1" or more layer of acoustical fiberglass or other sound absorbent material. The actual thickness and location of the damping material have definite effects on the sound reproduction. As a result, no hard and fast rules are presented here. Just experiment with different thicknesses and locations until your system has the characteristics that most

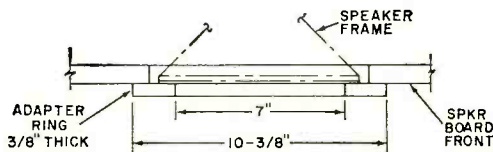

Fig. 6. Another adapter ring permits D208 speaker to be front mounted in one of 9"-diameter cutouts.

suit your tastes. However, if you experience "boomy" bass reproduction, try hanging a curtain of damping material behind the speakers.

When you have everything to your tastes, build a frame (about 22¼" x 15½") of ½"-square pine. Cut your choice of grille cloth to size, stretch it over the frame, and staple or tack it down. Then press-fit the grille assembly in place. That's it!

# ENGLISH LANGUAGE BROADCASTS FOR THE MONTH OF JULY

Prepared by ROGER LEGGE

TO EASTERN AND CENTRAL NORTH AMERICA		TO WESTERN NORTH AMERICA	
TIME-EDT	STATION AND LOCATION	TIME-PDT	STATION AND LOCATION
	FREQUENCIES (MHz)		FREQUENCIES (MHz)
7:00 a.m.	Stockholm, Sweden	8:00 a.m.	Tokyo, Japan
7:15 a.m.	Melbourne, Australia	9:00 a.m.	Stockholm, Sweden
7:45 a.m.	Copenhagen, Denmark	6:30 p.m.	Tokyo, Japan
8:15 a.m.	Montreal, Canada	7:00 p.m.	Melbourne, Australia
7:00 p.m.	Helsinki, Finland	7:30 p.m.	Bonaire, Neth. Antilles
	Montreal, Canada		Johannesburg, South Africa
	Moscow, U.S.S.R.		London, England
8:00 p.m.	London, England	8:00 p.m.	Madrid, Spain
	Oslo, Norway (Sun.)		Moscow, U.S.S.R.
	Peking, China		Peking, China
	Sofia, Bulgaria		Prague, Czechoslovakia
8:30 p.m.	Johannesburg, South Africa		Seoul, Korea
	Stockholm, Sweden		Taipei, Taiwan
	Tirana, Albania	8:30 p.m.	Berlin, Germany
8:50 p.m.	Vatican City		Stockholm, Sweden
9:00 p.m.	Berlin, Germany		Tirana, Albania
	Budapest, Hungary	9:00 p.m.	Budapest, Hungary
	Havana, Cuba		Havana, Cuba
	Madrid, Spain		Lisbon, Portugal
	Prague, Czechoslovakia		Moscow, USSR (via Khabarovsk)
	Rome, Italy		Peking, China
9:30 p.m.	Berne, Switzerland		Sofia, Bulgaria
	Bucharest, Rumania	9:30 p.m.	Bucharest, Rumania
	Cologne, Germany		Kiev, USSR (Mon., Thu., Sat.)
9:45 p.m.	Copenhagen, Denmark	9:45 p.m.	Berne, Switzerland
	Hilversum, Holland (via Bonaire)		Cologne, Germany
10:00 p.m.	Lisbon, Portugal	10:00 p.m.	Havana, Cuba
	London, England		Hilversum, Holland (via Bonaire)
	Moscow, U.S.S.R.		Quito, Ecuador
	Peking, China		Tokyo, Japan
10:30 p.m.	Beirut, Lebanon	11:00 p.m.	Moscow, USSR (via Khabarovsk)
		11:30 p.m.	Havana, Cuba

# the product gallery

REVIEWS AND COMMENTARY ON ELECTRONIC GEAR AND COMPONENTS

## WEATHERCASTER (Radio Communication Corp.)

Several years ago the U.S. Weather Bureau (ESSA) established a new radio broadcasting service. The service operates on 162.55 MHz and broadcasts tape recorded weather synopses and forecasts. At this time, 18 or 19 major cities have this advisory service. They include: New York, Chicago, Los Angeles, San Francisco, Boston, Washington, Norfolk, Kansas City, New Orleans, Honolulu, Baton Rouge, Corpus Christi, Charleston, Atlantic City, etc.

Spotted on a frequency in the VHF hi-band, the broadcasts can be heard on any tunable Business Band receiver. The coverage of the above stations varies, but it is usually better than 30 miles and, in some instances, the broadcasts can be heard 75 to 80 miles at sea. Missing until now from the marketplace has been a fixed-tuned portable receiver set on the weather advisory frequency. The new Radio Communications Corp. "Weathercaster" (\$36.95) is the answer to that problem.

The Weathercaster is a 12-transistor FM superhet receiver with a crystal controlled oscillator. The i.f. is 10.7 MHz. The receiver has only a volume control, collapsible antenna and an earphone jack output. The photographs illustrate the physical size of the unit. (It weighs 10 oz.) Unlike the VHF receiver of another importer, the Weathercaster will stand upright—unsupported!

Two important parameters in judging the "worth" of a fixed-tuned VHF receiver are the audio recovery and amplification circuits. The Weathercaster passes both of these checks with flying colors. The recovery circuit is a ratio detector (as opposed to slope detection used in some less expensive receivers) and the audio output is loud enough to override motor or wind noise when outdoors.

The Weathercaster appears to be solidly constructed and uses a single 9-volt battery. We did not make a life test on battery drain, but it appears to be comparable to that expected from any 12-transistor receiver. Our only criticism of the Weathercaster might well apply to all similar receivers: why not

provide a socket connection for a mast-mounted or other antenna tuned to the VHF band? It would appear to this reviewer that optimized VHF reception at distances over 30 miles calls for the use of a good antenna—or at least better than the extensible whip on the receiver itself. This criticism shouldn't be used to reject the Weathercaster since it is possible to gain slightly more signal by clipping a length of wire or another antenna to the tip of the partially collapsed whip.

Circle No. 90 on Reader Service Page 15 or 95

## "UNIFLASH" STROBE (Mitchell Enterprises)

The word "strobe" has some unfortunate connotations. On one hand, it is used to identify a piece of light-flashing equipment that appears to make rotating objects stand still. Another "strobe" is the very bright flash used by photographers for stop-action shots. The difference between the two is in the brightness (technically "watt-seconds") and flash repetition rate.

The Mitchell "Uniflash" (\$79.95 in kit form, \$104.95 factory assembled) is a photographer's strobe. The light output is around 200 watt-seconds and the re-cycling rate is 6-7 seconds. Flash duration is shorter than 1/125 second. The whole unit can scarcely be called portable, since it weighs 10 pounds and is operated from a 117-volt a.c. line. However, that is far from a disadvantage since this is a piece of amateur/professional photography equipment.

The Uniflash can be assembled by an experienced technician in 2½ hours. A novice builder would do well to read carefully the detailed assembly instructions and study the pictorial drawings—a procedure that should take about another hour. The Uniflash we assembled went together perfectly. All of the individual components are top-quality (Mallory, General Electric, etc.) and the flash should be useful for many years.

The manufacturer is partial to bare-bulb flash photography. This technique is not in too common use because, when shooting color, the reflected light from the strobe has a tendency to pick up the colors in the walls. However, for black-and-white shots, the



## WEATHERCASTER



Radio Communications Corp. Weathercaster is a true FM receiver with 10.7-MHz i.f. and ratio detector. Antenna extends 14 inches and the oscillator is crystal controlled (visible just below battery). Receiver has good sensitivity and also has excellent audio recovery.

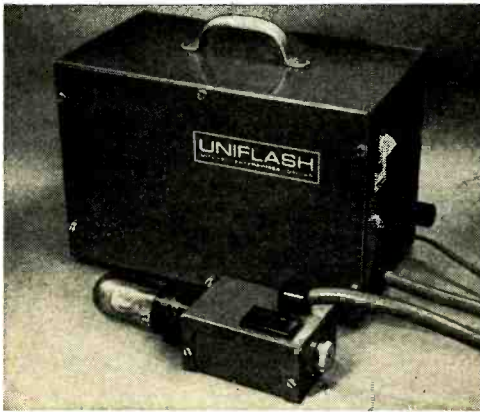

## UNIFLASH

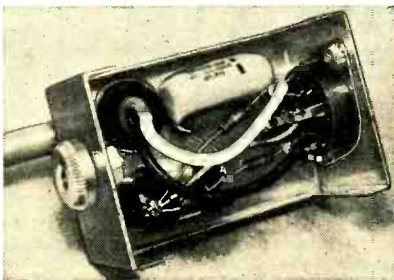

Mitchel Uniflash is designed for bare-bulb photography—no reflection. Flash head is connected to power supply by a heavy-duty 12-ft cable, which is oil and water proof. Power supply weighs about 8 lb. Rocker-arm a.c. switch has built-in neon lamp to show when power is on. Power supply (above) contains 17 parts and is easily assembled. Terminal strip in foreground is pre-wired before mounting and holds silicon rectifiers. Flash head (left) is wired first. Flashtube (Kernlite DX5) plugs in socket and is rated for 200 watt-seconds light output and 1/125 second duration.

scattered reflections fill in around the subject and there is no restriction to the width of the lighted area. In other words, bare-bulb strobes are great for wide-angle or fisheye photography.

Your reviewer has two cautionary notes about the Uniflash—both of which are also mentioned by the manufacturer: (1) Be sure to “form” the capacitors before firing the strobe. This takes 3 to 4 hours. (2) Treat the strobe tube carefully—remember it is exposed at all times.

Circle No. 91 on Reader Service Page 15 or 95

### BATTERY-BOOST REGULATOR (Mark Products Co. Model BBR-1216)

Although the technology in regard to CB transceivers has reached a very high level, there are still a few bugaboos when it comes to mobile operation. One of these is noise and the other is voltage fluctuation. The Mark Products “Battery-Boost Regulator” was designed to cure the voltage problem. It does so in such a novel and successful way that we find ourselves wishing that Mark Products would get to work on curbing mobile noise.

**Why It Is Necessary.** It is normally assumed that, if your car has a 12-volt battery system, you can use that 12 volts to power a CB transceiver. In fact, however, 12 volts is only the nominal rating for the battery and the actual value at various locations in the car varies due to voltage losses in connecting cables and fluctuations traceable to the alternator as the battery is recharged. Thus, the voltage delivered to a CB transceiver may be any value between 11 and 16 volts depending on battery condition, alternator and regulator settings, and whether it is hot or cold, day or night outside the car. It is not surprising that CB'ers soon learn that there are times when their mobile signals just can't be heard. Mark Products claims that, on one CB transceiver they tested, the power output varied from below 1 watt to a high of 6 watts due to car voltage fluctuations.

**What It Does.** The circuit of the Battery-Boost Regulator is similar to the popular “up-verter” scheme for stepping up d.c. voltages (usually 6 to 12 volts). In this instance the input can be anywhere between

11 and 16 volts and it is boosted or regulated to provide a constant output of 15.5. The maximum output current drain is just under 2 amperes which is safely within the ballpark for 95% of all solid-state CB transceivers.

The Battery-Boost Regulator is wired into the d.c. circuit between the transceiver and the car battery or accessory switch. A switch on the panel of the Regulator permits the operator to disengage the unit when desired.

In tests at POPULAR ELECTRONICS, the Battery-Boost Regulator performed as claimed by the manufacturer. Some radio interference from the circuit had been expected, but none was heard that could be considered troublesome in a mobile installation. Three different CB transceivers were used in our tests and the measured output powers were 3.6, 4.4 and 4.9 watts.

Circle No. 92 on Reader Service Page 15 or 95

### MINIATURE BREADBOARDING KIT (Intratec Division “S-DeC”)

A new solderless electronic breadboarding kit is currently being marketed by Intratec Division of British Aircraft Corp. (U.S.A.), Inc. The kit offers a simple, direct way for engineers and experimenters to lay out quickly the prototypes of their circuit designs.

The “S-DeC” breadboard has 14 independent junctions and 70 numbered points and measures only  $4\frac{1}{2}'' \times 3\frac{1}{4}'' \times \frac{3}{4}''$ . It is available for \$5.75 including all accessories. (For larger projects, the “DeC STOR” consisting of two breadboards and accessories and the “4-DeC” kit consisting of four breadboards are available for \$11.75 and \$20.75, respectively.) These multi-DeC kits are supplied with handy plastic storage boxes.

Leaf-spring contact points in the breadboards accept component leads up to 0.04" in diameter. Leads simply plug into pre-drilled holes in the board, saving wear and tear on the components. A special plug-in component bracket is also provided for potentiometers and switches. Slip-on springs hold potentiometer leads solidly in place without soldering. And each kit is provided with an instruction booklet and lead bending jig.

The breadboards are of two-piece heavy-duty plastic construction permanently bonded together, to withstand a great deal of on-the-workbench wear and tear. Each S-DeC also comes equipped with molded-on channel-and-groove projections that are designed to allow two or more breadboards to clip together to accommodate projects that require more space than is available on one board.

Circle No. 93 on Reader Service Page 15 or 95



### BATTERY-BOOST REGULATOR

Mark Products Battery-Boost Regulator is an all solid-state device with 10 transistors, 2 diodes and 1 zener. Maximum current drain is set at the factory to 2 amperes. The Regulator is wired into

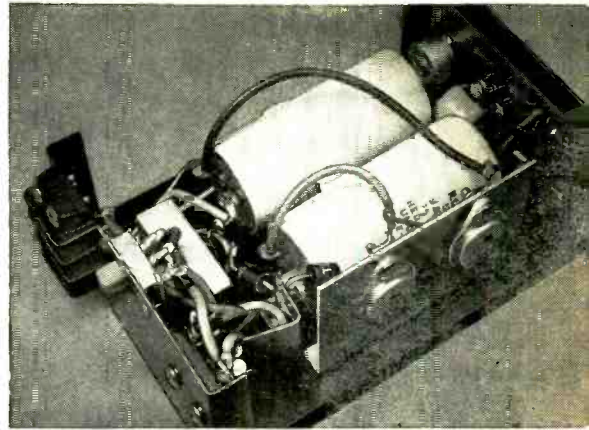

the d.c. line between the 12-volt takeoff point (usually after the accessory switch) and the CB transceiver. Unit is 4" x 3" x 6½" and weighs about 2 lb. Regulator is set for 15.5 volts output regardless of input battery voltage. It is not usable with the older tube-type transceiver.

### S-DeC BREADBOARD

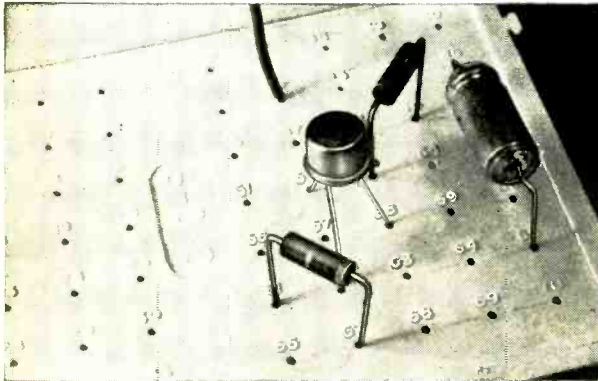

The 70 holes that make up each S-DeC are arranged into 14 common busses, each containing a row of 5 holes. After circuit is worked out according to buss arrangement, component leads are shaped with lead bending jig (supplied with kit) and plugged into proper holes. Leaf-spring contacts on busses at hole locations firmly grip component leads for support and positive electrical contact.

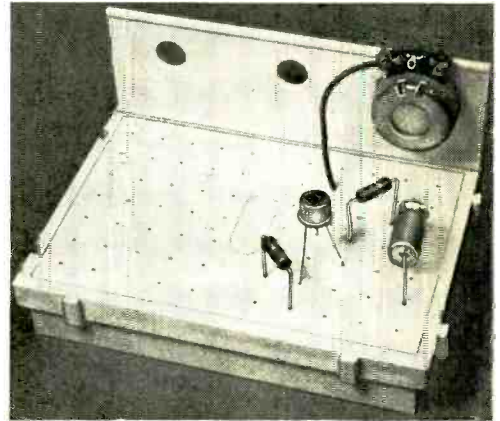

Connections between switches and potentiometers mounted on control bracket are accomplished by a novel spring-tension technique; other end of the wire simply plugs into proper numbered hole on board.

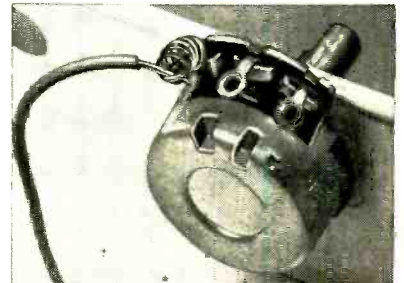

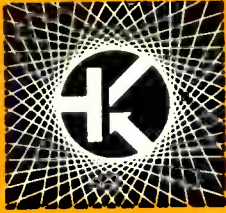

# SOLID STATE

By LOU GARNER, Semiconductor Editor

**B**ACK IN the "good old days" when the vacuum tube was king, we were more or less accustomed to the relatively large size of portable electronic equipment—primarily because of the size of the batteries and power supply circuits. Transistors, with their low power requirements, changed all that and the battery-operated transistor device has been getting smaller and smaller. Now, along comes a transistor that has its own built-in power supply. No more batteries at all!

DANECHO (8901 S.W. 110th St., Miami, FL 33156) claims to have developed a device which combines nuclear energy and semiconductor materials to produce an "everlasting" transistor. They call it the "Electristor" but refuse to discuss its actual operating details. They do state that the device operates in a manner similar to the "electronic battery" which was invented many years ago. The latter used a material that emitted beta radiation, which is easily shielded by foil-thin metal, or even paper, and is reasonably safe for humans. Strontium 90, with a half life of 20 years, was used in the electronic battery.

When a thin wafer of the radioisotope is placed in contact with a wafer made of a semiconductor material, high-energy elec-

trons emitted by the radioisotope bombard the electrons in the semiconductor. The latter gain sufficient energy to break their bonds and become random electrons. For each electron emitted by the radioisotope, hundreds of thousands of electrons are released in the semiconductor. As electrons leave their respective atoms, the atoms become positively charged ions with positively charged "holes" which were vacated by the electrons.

Because of the positive charge of the nucleus and the holes, electrons are attracted from neighboring atoms which, in turn, also become ions when they lose electrons. In this manner, the positive hole travels from atom to atom, creating a flow of positive current in the semiconductor. The wandering electrons, in turn, provide a negative current.

Since antimony is a good conductor of "negative" electricity, a wafer of this material can be joined to the semiconductor. Negative electrons leave the semiconductor and spill into the antimony wafer. Thus, the semiconductor wafer is the positive terminal and the antimony wafer is the negative. Wires can be attached to the respective poles so that current flows through a suitable external circuit.

Testing an electristor in circuit is its inventor, Daniel Earle Speers, director of research, DANECHO Research & Development Laboratories, Inc.



If this description of the electronic battery sounds familiar, it is because the action of electrons and holes closely resembles what takes place inside a junction transistor.

DANECHO scientists are understandably reluctant to discuss the exact nature of the electristor—especially while it is still in the development stage. The company indicates, however, that it has taken advantage of the latest methods of transistor manufacture to produce the device and they hope to make it available within a year.

Some test circuits have been built, among them an oscillator and an amplifier, that have been in constant operation for more than a year with no loss in output.

**"How About That?" Department.** Accustomed as we are to fast-breaking developments in IC's, a recent announcement from Sony really gave us a start. Their new audio IC, currently being tested, is rated for 26 watts maximum output or 18 watts continuous effective power. To add spice to their announcement, Sony spokesmen claim that, with a little more work, they can make an IC capable of delivering 100 watts. No further information regarding price or availability was given.

While we're on the subject of hot new developments, NASA has announced that it is working on a very high contrast TV screen for aircraft. Filters are used to screen out surrounding light, leaving the tube face completely black, except where the signals are. Even in direct sunlight the data is clearly visible. NASA believes that the high-contrast CRT could be used in commercial TV sets if production costs can be reduced.

Meanwhile, Westinghouse announced its new SEC (secondary electron conduction) TV camera tube that will find many applications in space projects. The high gain of the SEC target makes the tube exceptionally sensitive; and when it is coupled to an image intensifier, the combination can produce clear TV pictures in darkness so complete that a person cannot detect a hand in front of his face.

**Reader's Circuit.** One of our good neighbors up north, reader Joseph Kolodziej (R.R. #3, Young St., Smithville, Ont., Canada), submitted the code practice oscillator circuit shown in Fig. 1. Essentially a complementary relaxation oscillator, the project requires a minimum of components and has a loudspeaker output, thus making it suitable for group practice. It can be assembled by the average experimenter in one or two evenings.

Referring to the schematic diagram, *nnp* transistor *Q1* is direct-coupled to *pnp* de-

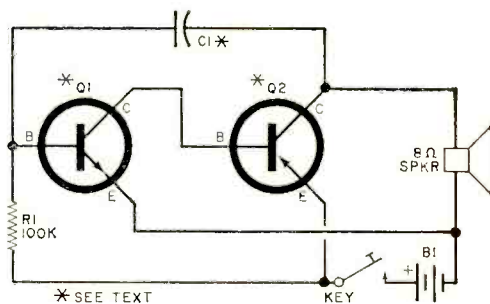

Fig. 1. Simple oscillator circuit with a key for coded practice has audio output for use by group.

vice *Q2*, forming a two-stage complementary amplifier in which *Q2*'s base bias is furnished through *Q1*, and *Q2*'s base-emitter circuit acts as *Q1*'s collector load. Base bias for *Q1* is supplied through resistor *R1*, while the loudspeaker's voice coil serves as *Q2*'s collector load. The in-phase feedback needed to start and maintain oscillation is obtained from *Q2*'s collector and applied back to *Q1*'s base through capacitor *C1*.

The comparatively few components needed for project assembly are readily available through standard parts distributors. Transistor *Q1* is a general-purpose small-signal unit similar to the GE-8, *Q2* is a medium-power type similar to the 2N176, and *C1* is a 25-50-volt disc ceramic capacitor. Almost any PM loudspeaker may be used, from a 3" miniature to an 8" or 10" unit, provided it is equipped with an 8-ohm voice coil winding.

As in most relaxation oscillators, the unit's output signal is a pulse-like waveform rich in harmonic content rather than a sine wave, with its repetition rate (frequency) determined by the circuit's RC time constants. The instrument's output tone, then, may be changed to a higher or lower pitch by using different values for feedback capacitor *C1*. Reader Kolodziej suggests values from 0.005 to 0.02- $\mu$ F. The smaller *C1*'s value, the higher the pitch and vice versa.

Any of several construction methods may be used for assembling a duplicate code practice oscillator, for neither parts arrangement nor wiring dress is critical. The project may be assembled on a small chassis using point-to-point wiring, on perf board, on an etched circuit board, or breadboard fashion, as preferred. Once assembled and checked out, the completed unit can be housed conveniently in a commercial cabinet or even a smaller speaker baffle.

**Manufacturer's Circuit.** Featuring a single integrated circuit and relatively few ad-

ditional discrete components, the phono amplifier circuit illustrated in Fig. 2 may be used in assembling a portable record player or, with minor modifications, a hand-held power megaphone, an intercom, a tape recorder, an audio signal tracer, or similar test instrument. It is one of the circuits described in the applications bulletin for the type TT-1W integrated circuit offered by the Trans-Tek Manufacturing Company, Inc. (4405 South Clinton Ave., South Plainfield, N. J. 07080).

The basic amplifier element, *IC1*, is a monolithic device housed in an 8-lead TO-78 case. Consisting of eight transistors, six diodes, and seven resistors, it is essentially a differential input Darlington amplifier direct-coupled to a quasi-complementary emitter follower power output stage. According to the manufacturer, the device has a closed-loop voltage gain of 20 dB minimum and can be operated on d.c. sources of from 6 to 20 volts, supplying up to one watt to a 16-ohm load at less than 10% harmonic distortion. Provisions are made for external frequency compensation and bootstrapping to achieve relatively high input impedances. In most general applications, the device can provide a flat frequency response from 20 Hz to 200 kHz.

Referring to Fig. 2, the complete phono amplifier circuit includes the ceramic pickup, volume control *R1*, and input coupling capacitor *C1*. Bootstrapping feedback capacitor *C2* insures a high input impedance, while bypass capacitor *C3* provides frequency compensation. D.c. output blocking and signal coupling is furnished by *C4*, with series network *R2-C5* acting as a parasitic suppressor across the load.

Except for *IC1*, a Trans-Tek type TT-1W, standard components are used in the project. The pickup should have a nominal output of at least 0.5 volts r.m.s., while *R1* is a conventional potentiometer having an audio taper. Capacitors *C1*, *C3*, and *C5* are 50-volt disc ceramic capacitors, while *C2* and *C4* are 15-volt electrolytics. The loud-

speaker may have an 8- or 16-ohm voice coil, with the larger value preferred for optimum performance. A nominal 12-volt power supply can be used, but greater power output will be obtained with a 16-volt source.

Although neither layout nor lead dress is critical, the manufacturer recommends that good audio wiring practice be observed during construction, with all signal carrying leads kept short and direct, and reasonable separation provided between the input and output circuits. A heat sink (Wakefield No. 207 or equivalent) should be used with *IC1*. Use the same care to avoid heat damage when installing the integrated circuit as you would when soldering a transistor in place. If the circuit is breadboarded for experimental tests, bypass the d.c. supply points with a 0.1  $\mu$ F, 50-volt capacitor to prevent coupling through the long power supply leads and to reduce transient spikes.

**The Lion Roars.** Faced with increasing world-wide competition, British electronics manufacturers, to borrow an expression from a famous auto rental agency, are "trying harder." Last March, some thirty British firms, a record number, took part in the 1969 IEEE Convention and Exhibition held in New York City, with several of the firms exhibiting equipment designed specifically for the American market. Later, in May, representatives from six British firms which play leading roles in the semiconductor field took part in a two-week business tour of the United States, primarily to encourage American manufacturer interest in their firm's products and services. Finally, more and more British companies are advertising in American trade and engineering journals.

As might be expected, semiconductor devices and solid-state instruments figure prominently in the new offerings by our British friends. Among the items announced in recent months are such products as . . .

(Continued on page 96)

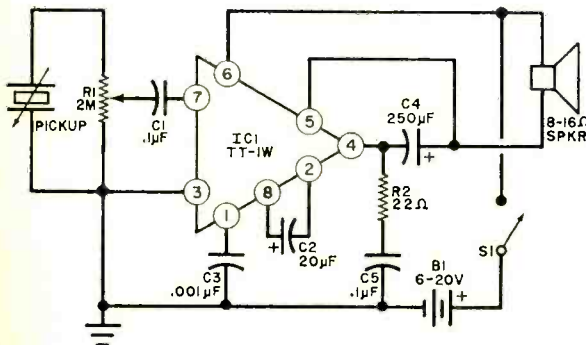

Fig. 2. Amplifier using a single IC can be used in portable record player, hand-held power megaphone, intercom, tape recorder, or simple types of audio test instruments.



# SHORT-WAVE LISTENING

By **HANK BENNETT**, W2PNA/WPE2FT  
Short-Wave Editor

## MORE ON OLDTIME QSL'S

**O**UR April 1969 column showed an old QSL from W9XAA, Chicago, Illinois. The QSL was dated December 8, 1931. Recipient of the QSL, Bill Orr, W6SAI, Menlo Park, California, wondered if readers could produce any earlier QSL's.

We've received a number of interesting letters as a result of the W9XAA card. Many readers would like to see a continuance of the illustrations of old QSL cards. Most of the present day SWL's have never seen QSL's of the stations that were broadcasting 35 or 40 years ago. Other letters included lists of QSL's held by the various contributors.

A variety of QSL's from F. P. Engleking, Aurora, Ill. would no doubt cause many veteran DX'ers to wonder where the years have gone. How many of these did you verify? Log? Or remember? VK3ME, Melbourne, Australia, 9510 kHz, 5 kW; *Station Radio-Coloniale*, Paris, France; ZRK, Klipheувal, South Africa, 9606 kHz; *Radiodifusion Ibero-Americana*, Madrid, Spain, 9860 kHz, 20 kW (high power in those days!); and Philips Radio Laboratories, Eindhoven, Holland, operating experimental PCJ. All of those were from the 1935-1937 era.

Now check this partial list from Joseph Hueter, WPE3EP, Philadelphia, Pa: W6XAI Bakersfield, Calif., 1550 kHz (thirty years ago that portion of the medium-wave band from 1500 to 1600 kHz was considered the "high-fidelity band"); JOBK, Osaka, Japan, 1085 kHz; and LR4, Buenos Aires, Argentina, 990 kHz. Hueter's oldest QSL, dated May 13, 1927, is from KOIN, Portland, Oregon, a station that is still going strong. He recalls that many stations used to attach an EKKO stamp to their verification cards or letters. While EKKO stamps were not a required part of a QSL, such as date, time, or frequency, nonetheless the stamps were highly prized by DX'ers.

Finally, Dave Thomas, QPE8GA, now of Tampa, Fla., writes of some of his prized QSL's: F31CD, 49 meters, Saigon, Indochina (1930); W2XCD (sound) and W2XCR (video), Jenkins Television Corp., Jersey City, N.J. (1930); and, last but not least,

F-PTT, 666 kHz, 500 watts, for reception during International Transatlantic tests. This one has a 1924 date on it and is the oldest one listed from those who wrote. Does anyone have any older QSL's?

**A Visit to Heath.** The other day, this columnist, in company with son, James, had the privilege of being taken on a personally escorted tour of the Heath Company plant in St. Joseph, Michigan. Our tour guide, Mrs. Helen Pries, explained the workings of the company and the processes involved in filling customer orders. From the business office to the production and construction lines, the test department, the five-story components storage area, the quality control department, and the shipping room—everywhere we went, we were impressed by the size of this company and the friendliness of the personnel. Before leaving we were able to see one particular customer's order handled in a most efficient manner. We got James a GR-54 receiver for his birthday. Construction is well under way.

### CURRENT STATION REPORTS

The following is a resume of current reports. At time of compilation all reports were as accurate as possible, but stations change frequency and/or schedule with little or no advance notice. All times shown are Greenwich Mean Time (GMT) and the 24-hour system is used. Reports should be sent to



Lee Stogner (center) and his friend Mark Brown, both of Hartsville, S.C. are shown in Stogner's listening post. Included in the equipment are a Sony tape recorder and Hallicrafters S.120. Lee has 76 countries verified with total of 93 logged.

Short-Wave Listening, P. O. Box 333, Cherry Hill, N. J. 08034, in time to reach us by the fifth of each month; be sure to include your WPE identification and the make and model number of your receiver.

**Albania**—*R. Tirana*, often noted on new frequencies, has two more in service at press time: 9758 kHz around 2300-2330 s/off in language and 7315 kHz in Spanish at 0245.

**Australia**—*R. Australia's* new Darwin outlet on 15.355 kHz has English from 0830 s/on to 1000; Indonesian is noted on this channel at 0820 and on 6050 kHz at 1110.

**Austria**—Vienna is often good on 11,870 kHz at 0340-0400 with music, on 15,385 kHz (repl 11,870 kHz), dual 6155 and 9770 kHz to Central America in German at 0105-0145, and on 6155 and 7245 kHz with music at 0700-0800. Most xmsn's include a multi-lingual ID in English, French and German.

**Biafra**—Enugu, first noted on 4771 kHz, is now on 4671 kHz where it may be heard at times around 0600 after *R. Nacional Espejo* (Ecuador) s/off, in English. This one may prove to be a most difficult catch!

**Bolivia**—CP105, *R. Ibare*, Trinidad, listed for 4955 kHz, is usually a few kHz higher; heard weakly but often in the clear to 0100 closing. This early s/off time will also make this one rough to log.

**Campbell Islands**—This is New Zealand-administered territory located 180 miles southeast of the Auckland Islands. ZLBC, operated by Department of Civil Aviation, has weather traffic on 12,152.5 kHz at 0038. An Australian DX'er reports no luck with a QSL after five months; further, that it is weak even at his location, hence, not likely to be heard in N.A. Utility DX'ers will find this a good challenge.

**Canada**—The current English schedule from the *CBC*, Montreal, reads as follows: (all are daily xmsn's). To Africa via *BBC* at 0715-0745 on 17,820, 15,390 and 11,970 kHz; to Europe at 0715-0745 on 9625 and 5990 kHz; to South Pacific at 0830-0930 on 9630 and 5970 kHz; to Europe on 17,820 kHz, Caribbean areas on 11,720 kHz and to the USA on 9625 kHz, all at 1217-1313; news in English and French but with no target area indicated at 1516-1529 on 21,595 and 17,820 kHz; to Africa at 1832-1914 on 21,595, 17,820 and 15,320 kHz; to Europe at 2115-2152 on 17,820 kHz (this channel s/off at 2148), 15,320 and 11,720 kHz, and to the Caribbean areas, USA and L.A. at 2300-2330 on 15,190, 11,945 and 9625 kHz.

**Canary Islands**—*R. Nacional de Espana*, Tenerife, is noted with consistently good signals around 0200 in Spanish to L.A. on 15,365 kHz. A taped report sent to Madrid netted a QSL in 10 days.

**Colombia**—More details on *Emisoras Nuevo Mundo*, first reported in the April issue: this is the short-wave outlet of HJKC, Bogota, 850 kHz, operating on 4750 kHz (varies) with fair to good signals from around 0200. This station, which does not usually give a full ID or list of frequencies, is a member of the "Caracol" network, hence the "Transmite Caracol" ID at times. Reports go to Calle 19, No. 8-48, Bogota, D. E. The QSL lists a power rating of 1 kW and a frequency of 4755 kHz.

**Comoro Islands**—A report from West Germany lists *R. Moroni* at 0330-0400 and 0900-1030 on 7260 kHz and 1530-1900 on 3331 kHz. Has anyone logged this one?

**Ecuador**—HCJB, Quito, is good at 1200 in Japanese on 11,915 kHz. The station is also noted on 5986.5 and 6050 kHz in an English religious program at 0820, and on 15,050 kHz in English at 2330-0000. HC4RF, *R. Canal Manabita*, Portoviejo, previously unidentified, is the station heard on 4817 kHz with an extensive newscast at 0400 and s/off at 0500 or shortly before. HCCV3, *Ondas del Zamora*, Loja, 4858 kHz (listed 4850 kHz) is heard around 0200 with lengthy musical periods, frequent time checks and some ID's. This was last heard in 1963 on 4900 kHz. It took nine reports to get a QSL from them.

**Egypt**—Cairo has English to Europe daily at 2145-2300 on 9475 and 12,005 kHz; news and commentary is given at 2200 and news headlines at 2258. The station has also been picked up on 9855 kHz at 2110 to past 2130 in language with singing, clock strikes, ID and ann't's.

**Ethiopia**—ETLF, P. O. Box 654, Addis Ababa, sent this new English schedule: (Xmtr I) to W. Africa at 0530-0555 on 11,890 kHz; to India at 1330-1345 on 15,315 kHz; to Ethiopia at 1655-1710 on 6065 kHz; and to W. Africa at 1930-2015 on 11,910 kHz. (Xmtr II) to E. Africa at 0400-0425 on 9680 kHz; to India at 1330-1400 on 15,400 kHz; to E. Africa at 1700-1715 on 9695 kHz; and to S. Africa at 1800-1900 on 9705 kHz.

**Finland**—*Oy Yleisradio Ab* has this partial schedule: At 1200-1315 to Europe on 9550 and 11,805 kHz and to N.A. East Coast on 15,185 kHz with Home Service in Finnish; news at 1200 and 1300; on Mondays a program at 1200-1300 for seamen in Finnish and Swedish; at 1500-1555 to N.A. on 15,185 kHz with news and current events from 1530; at 1800-1830 to Europe (non-directional) in English on 15,185 kHz; and at 2300-0000 to N.A. on 15,185 kHz with English to 2330 and in Finnish to 0000 with news at 2330.



A Hammarlund 105-TR receiver, an Astatic D-104 microphone, Heath Two-meter rig and Hamscan monitor scope are used by Mack Humber, WPE4JKD, of Johns, Alabama. He has logged 30 countries and is now studying for his Novice license examination.

**Germany (East)**—*R. Berlin International* has English to Europe at 1730 on 6080 kHz, 2015 on 6115 kHz and at 2200 on 7185, 7300 and 9730 kHz. English to N.A. East Coast is at 0100 and 0230 on 9500 and 9730 kHz although one late report shows 11,890 kHz in service for this 0100 xmsn; and at 0330 on 6080, 9650 and 9730 kHz.

**Greenland**—A report from New England lists weak reception of *Gronlands Radio*, Godthab, at 1025-1030 with IS, then ID and talks but buried at 1035 with Guyana s/on; this on 5980 kHz. The 5960-kHz outlet was logged at 0235-0241 s/off with a man in Danish and fair signals.

**Guam**—Do you need this country for a DX Award? Tune for *RCA Communications*, KUK25, 15,475 kHz, weekends from 2000-0400 relaying calls from servicemen to the US mainland. It can be identified by its consistent beep tone which is broken by periodic xmsns. Other outlets have been heard at various times between 1100-1600 on 10,610 and 9490 kHz, both beamed to Oakland, Calif.

**Guatemala**—A station that airs much marimba music has been noted from 0130-0235 on 3360 kHz but it's only audible on nights of good reception. One ID seemed to be for TGVN; a reference source lists *La Voz de Nahuala* with 200 watts here. In all Spanish, further checks will be made. TGQB, Quezaltenango, 11,700 kHz, is good from 1350-1430; they QSL'ed in six weeks. Wayne Berger, Station



Engineer at TGN and TGNA in Guatemala City, reports that a third xmnt. TGNE. will be on the air shortly on 9670 kHz. A report from western Pennsylvania lists frequent reception of *R. Mundial*, 700 kHz, until its s/off time of 0603 in Spanish; it's usually under WLW, Cincinnati.

**Haiti**—*R. Capois la Mort*, 4VGA, Port-de-Paix, 5040 kHz, is being logged from 2357-0305 s/off with nearly uninterrupted records including some classical music. In mostly French, it's being reported with strong signals.

**Holland**—*R. Nederland*, Hilversum, is good on 15,425 kHz (repl 9715 kHz) at 2055-2150 in English to N.A. The 7210 kHz outlet is also noted in French with news after 0430 s/on.

**Israel**—The new experimental xmsn to N.A. from *Kol Israel* continues to be widely reported on 9009 kHz at 0400-0415, dual to 9625 kHz. Reports are requested.

**Japan**—*R. Japan*, Tokyo, is good on 17,880 kHz at 0200, 0300 and 0400 in English; Japanese follows 15 minutes later; on 17,825 kHz with English news at 2340 and on 11,875 and 9505 kHz in English at 1400. Armed Forces Service on 11,750 kHz is good at 0800 with news, weather and pop music.

**Lebanon**—More new frequencies from Beirut include 11,820 kHz to N.A. at 0230 in English; formerly 11,785 kHz, this is scheduled 0130-0400; and 17,715 kHz around 0000 in Arabic.

**Liberia**—ELWA, Monrovia, 15,170 kHz, has Arabic to N. Africa at 2145-2215 s/off with talks and news to 2200, then religious program of talks and hymns. An English ID is given at s/off.

**Mexico**—XESE, Mexico City, 2380 kHz, was heard at 0225 with school lessons and at 0330 in Spanish talks.

**Midway Island**—If you need this country for DX Awards, look for Midway Island Radio on 6697 kHz around 0230 with radio checks. They often contact Ivanhoe, Ocean Wave, Archduke, Magic Carpet and Fireside. This is a single-sideband xmsn.

**Monaco**—*Trans World Radio*, Monte Carlo, 11,745 kHz, noted s/on at 1900 in Hebrew; s/off 1915. Reception poor, probably due to being beamed to the Middle East.

**Netherland Antilles**—*Trans World Radio*, Bonaire, 15,190 kHz, noted at 0304-0336 with religious music, DX items and news. *R. Nederland*, Bonaire, good on 6085 kHz with new 300-kW xmnt at 0000-0100 in English and on 15,320 kHz at 2225-2320 in Spanish to Central and South America.

**Peru**—*R. Ciento Cincuenta*, Huancayo, is a new station on 4802 kHz that is usually poor to 0500 s/off. OBX7H, *R. Ondas del Titicaca*, Puno, 4921 kHz, has been on this frequency for six years and is generally fair around 0200 and later with the usual L.A. programming. OAX5V, *R. Villa Rica*, Huancavelica, listed for 4885 kHz, is on 4876 kHz with a poorer signal than when on original 4805-kHz channel. It's noted mostly weekends with listener request period to past 0500 when Dahomey offers some QRM.

**Poland**—*R. Warsaw* is scheduled to N.A. at 0315-0345 on 11,870 kHz on Tuesday in Polish and on Saturday in English. Another outlet on 11,800 kHz is also noted in English at 1600-1625 with news and talks. Reports go to *Polskie Radio*, Al Niepodlegloski 75/77, Warsaw. The xmsn's open with "Revolutionary Etude" by Chopin.

**Rhodesia**—Salisbury was caught with English news at 0405 in their English Service on 5012 kHz, a change from 3396 kHz. This held until fadeout at 0415. Don't confuse with Garoua, Cameroon, tentatively heard on 5010 kHz after 0530 in vernaculars. Salisbury is said to s/off at 0545; Garoua continues on past 0600.

**Singapore**—English noted on 4882 kHz with ID's for *R. Singapore* by a girl at 0100 and 0130; some Victor Sylvester records with stock prices in between; a commentary in English given at 1330.

**South Africa**—The Afrikaans Domestic Service from Johannesburg was noted fair from 0430 s/on

## SHORT-WAVE CONTRIBUTORS

Christopher Lobdell (*WPE1GCI*), Reading, Mass.  
 Bob Raymond (*WPE1HOF*), Bradford, Mass.  
 Riley Sundstrom (*WPE2AJ*), Willingboro, N. J.  
 Gary Becker (*WPE2PFP*), East Northport, N. Y.  
 John Banta (*WPE3PHU*), Bay Shore, N. Y.  
 Howard Rosenberg (*WPE2QPE*), Queens Village, N. Y.  
 Ronald Del Buono (*WPE2PIJ*), Union City, N. J.  
 Robert Kozlarek (*WPE2QDX*), North Arlington, N. J.  
 Lewis Abrams (*WPE2QFS*), Valley Stream, N. Y.  
 Harold Ort (*WPE2QHN*), Gloversville, N. Y.  
 Jim Brenner (*WPE2QUL*), Nutley, N. J.  
 Michael Szoke (*WPE2QUL*), South River, N. J.  
 Henry Borawski (*WPE2QVF*), Brooklyn, N. Y.  
 William Hatas (*WPE2QVO*), Elmhurst, N. Y.  
 Richard Hankison (*WPE2QWU*), Waldwick, N. J.  
 William Matthews (*WPE3GWQ*), Houston, Pa.  
 Dan Ferguson (*WPE4AUL*), Coral Gables, Fla.  
 Grady Ferguson (*WPE4BC*), Charlotte, N. C.  
 Edward Hendrix (*WPE4JHK*), Clemson, S. C.  
 Paul Dougherty (*WPE4JVS*), Birmingham, Ala.  
 Jerry Schmitt (*WPE4JUL*), Fort Myers, Fla.  
 Steve Rubenstein (*WPE4JVU*), Chattanooga, Tenn.  
 Bruce Roberts (*WPE4KAH*), Waynesboro, Va.  
 David Weronka (*WPE4KBE*), Durham, N. C.  
 Del Hirst (*WPE5CFU*), Snyder, Texas  
 Richard Fortson (*WPE5EIVX*), Edinburg, Texas  
 Dean Roche (*WPE5FCB*), Houston, Texas  
 Charles Bennett (*WPE5SW*), Sumrall, Miss.  
 Jim Young (*WPE6ENA*), Wrightwood, Calif.  
 W. W. Mosby (*WPE6EAI*), San Jose, Calif.  
 Trevor Clegg (*WPE6FAF*), Fresno, Calif.  
 Gary Mondirans (*WPE6GDC*), San Bruno, Calif.  
 Arthur Blair (*WPE6GXV*), San Francisco, Calif.  
 Mitch Bademan (*WPE6HAB*), Long Beach, Calif.  
 Stephan McDonald (*WPE7BU*), Las Vegas, Nevada  
 Gilbert Roth (*WPE8KCK*), Brooklyn, Ohio  
 Gary Steele (*WPE8KEQ*), Benton Harbor, Mich.  
 Charles Signer (*WPE9FSG*), Dekalb, Ill.  
 Gerry Dexter (*WPE9HDB*), Lake Geneva, Wisc.  
 Dennis Davenport (*WPE9JLT*), Edwardsville, Ill.  
 A. R. Niblack (*WPE9KAM*), Vincennes, Ind.  
 John Beaver (*WPE9OAE*), Pueblo, Colo.  
 C. Vernon Hyson (*WPE9CNF*), Somerville, N. J.  
 Gary Lovegren (*WPE9FAN*), St. Paul, Minn.  
 Jack Perolo (*PY2PE1C*), Sao Paulo, Brazil  
 Bruce Broisma (*SM5PEIAL*), Uppsala, Sweden  
 Ian Davidson (*VE3PE2ND*), Sarnia, Ont.  
 C. Ver Berkmoes, Biloxi, Miss.  
 Jule Bowles, Moultrie, Ga.  
 William Geist, Kankakee, Ill.  
 William Grant, Worcester, Mass.  
 Michael Grollman, Highland Park, N. J.  
 Dennis Heishanen, Port Arthur, Ont.  
 Peter McNulty, Weston, Conn.  
 Fred Meyer, Blauvelt, N. Y.  
 Howard Myers, Maryville, Tenn.  
 Don Twietmeyer, Rochester, N. Y.  
 American Short-Wave Listeners' Club, Huntington Beach, Calif.  
 Canadian Broadcasting Corp., Montreal, Que.  
 E.T.F. Addis Ababa, Ethiopia  
 National Broadcasting System of Vietnam, Saigon, Vietnam

on 4875 kHz. The Commercial Service was good in English and Afrikaans on 4945 kHz, also from 0430. *R. RSA* has English to W. Africa at 2055-2150 on 21,535 and 17,805 kHz. Portuguese to Angola and Mozambique at 1955-2050 on 15,360 and 17,805 kHz. Other xmsn's heard include French at 0530 on 15,220 kHz and in native languages to E. and Central Africa at 0355 on 9525 kHz.

**Sweden**—*R. Sweden*, Stockholm, operates to N.A. daily at 0000-0230 with English from 0200 on 11,915 kHz. Swedish is given at 0100 and Spanish at 0130.

**Switzerland**—Berne operates in English to the Near- and Mid-East at 1500-1557 on 17,830 and 15,305 kHz. News is given at the beginning of the xmsn.

**Syria**—Two new frequencies are in use from Damascus: 17,865 kHz in Arabic from 2330 s/on, and 15,165 kHz in English as noted at 2230.

**USSR**—*R. Tashkent*, Uzbek SSR, has this daily schedule: on 11,925 and 9600 kHz in English at

(Continued on page 94)

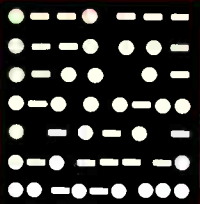

# AMATEUR RADIO

By **HERB S. BRIER, W9EGQ**  
Amateur Radio Editor

## COAST-TO-COAST CALLING AND EMERGENCY NET IN OPERATION

**S**UPPLEMENTING the West Coast Amateur Radio Service (WCARS) net, which has been in successful operation on 7255 kHz for several years, the Mid-West Amateur Radio Service (MWARS) on 7258 kHz and the East Coast Amateur Radio Service (ECARS) on 7255 kHz are now in operation daily from 0800 to 2000.

Each morning at 0800 local time, a net control station (NCS) or "monitor" station accepts calls from other stations who need or are offering help or information—or who are merely announcing their presence. Throughout the day, different amateurs function as control when their schedules permit. During a typical day, hundreds of fixed and mobile stations report in and out

of the net. In addition, many fixed-station operators monitor the net frequency for their area to be of service if needed.

Under normal circumstances, regular messages are never passed nor are long-winded conversations conducted on the net frequency. Instead, the net serves as a convenient place for mobiles to obtain quick, up-to-the-minute road and weather information. It also is a calling channel before moving to another frequency to complete the contact. In an emergency, 7255-7258 kHz is where to call for an immediate reply.

The West Coast Amateur Radio Service has a long record of supplying emergency communications involving everything from

---

## AMATEUR STATION OF THE MONTH



W. Joe Saunders, Jr., K3UAL, 705 Boston Ave., Takoma Park, Md., teaches at Springarm High School, Washington, D.C. and is sponsor/trustee of the school radio club, K3WMA. At home, Joe operates 6 and 2 meters with, among others, an AMECO TX-62 transmitter, Gonset-III transceiver and linear amplifiers, Lafayette HA-650 transistor transceiver, Heathkit Sixer and Monitorscope, and a Cush-craft 5-element beam. He also operates mobile on his 30-ft yacht on Chesapeake Bay. We are sending K3UAL a 1-year subscription for winning this month's Amateur Station Photo Contest. You can enter by sending a clear photo (preferably black and white) of you at the controls of your station and some details about your amateur career to Amateur Station Photo Contest, Herb S. Brier, Amateur Radio Editor, POPULAR ELECTRONICS, Box 678, Gary, Ind. 46401.

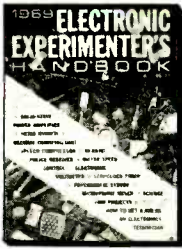

**1969 WINTER ELECTRONIC EXPERIMENTER'S HANDBOOK**

148 pages of the most fascinating and challenging construction projects for the electronics hobbyists. All with complete schematics, illustrations, parts list, and easy-to-follow instructions that guarantee you perfect finished products.

\$1.25

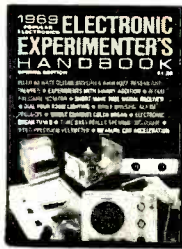

**1969 SPRING ELECTRONIC EXPERIMENTER'S HANDBOOK**

Another big package containing the most challenging, fun-to-build electronics projects ever! Be sure to order this one today!

\$1.25

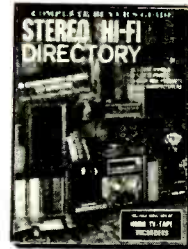

**1969 STEREO/Hi-Fi DIRECTORY**

Giant 180 page buyer's guide listing more than 1,600 individual Stereo/Hi-Fi components by 176 manufacturers. Nine individual sections complete with specs, photos, prices—the works!

\$1.25

**SIX VITAL COMPONENTS**  
*For Knowledge...  
 For Profit... For Sheer  
 Electronics Enjoyment!*



**1969 TAPE RECORDER ANNUAL**

Over 130 pages covering every aspect of tape recording. Complete buyer's guide to the brands and models on the market. Expert tips on equipment—making better tapes—editing—copying—everything you want and need to know about tape recording.

\$1.35

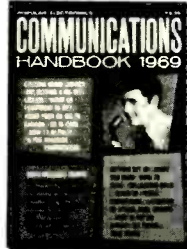

**1969 COMMUNICATIONS HANDBOOK**

148 fact packed pages for the CB, SWL or HAM. Equipment buyer's guide—photos—tables—charts—getting a license—everything to make this the world's most complete guide to communications.

\$1.35

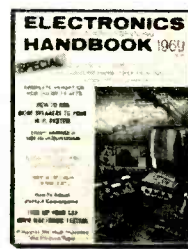

**1969 ELECTRONICS INSTALLATION & SERVICING HANDBOOK**

For the serviceman who is also a businessman—the hobbyist who is also a perfectionist! Covers all 8 areas of consumer electronics servicing—all the tricks of the trade—in one complete, up-to-date guide. This is the industry's "how-to" book for installing and servicing consumer electronics equipment.

\$1.35

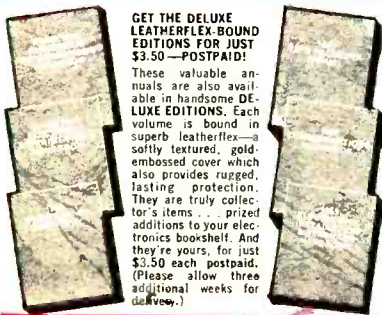

**GET THE DELUXE LEATHERFLEX-BOUND EDITIONS FOR JUST \$3.50—POSTPAID!**

These valuable annuals are also available in handsome DELUXE EDITIONS. Each volume is bound in superb leatherflex—a softly textured, gold-embossed cover which also provides rugged, lasting protection. They are truly collector's items... prized additions to your electronics bookshelf. And they're yours, for just \$3.50 each postpaid. (Please allow three additional weeks for delivery.)

**USE THIS COUPON TO ORDER YOUR COPIES TODAY!**

ZIFF-DAVIS SERVICE DIVISION • Dept. W • 595 Broadway, New York, N.Y. 10012

Please send me the annuals I've checked below:

- |   |   |
|---|---|
| <input type="checkbox"/> Winter 1969 Electronic Experimenter's Handbook, \$1.25     | <input type="checkbox"/> 1969 Stereo/Hi-Fi Directory, \$1.25  |
| <input type="checkbox"/> Deluxe Edition, \$3.50                                     | <input type="checkbox"/> Deluxe Edition, \$3.50               |
| <input type="checkbox"/> Spring 1969 Electronic Experimenter's Handbook, \$1.25     | <input type="checkbox"/> 1969 Tape Recorder Annual, \$1.35    |
| <input type="checkbox"/> Deluxe Edition, \$3.50                                     | <input type="checkbox"/> Deluxe Edition, \$3.50               |
| <input type="checkbox"/> 1969 Electronics Installation & Servicing Handbook, \$1.35 | <input type="checkbox"/> 1969 Communications Handbook, \$1.35 |
| <input type="checkbox"/> Deluxe Edition, \$3.50                                     | <input type="checkbox"/> Deluxe Edition, \$3.50               |

In U.S.A., add 25¢ for shipping and handling for each Regular Edition; Deluxe Editions are postpaid. Outside U.S.A., Regular Editions are \$2.00 each. Deluxe Editions are \$4.50 each, postpaid.

print name \_\_\_\_\_ ENCLOSED \$ \_\_\_\_\_

address \_\_\_\_\_

city \_\_\_\_\_ state \_\_\_\_\_ zip code \_\_\_\_\_

PAYMENT MUST BE ENCLOSED WITH ORDER

PE 79

earthquakes to finding missing children. Last March, for example, WCARS was asked to find the parents of a six-week-old girl, all of whom were travelling from Texas to California. Unknown to the parents, a delayed medical report indicated that the baby would die if not given immediate medical treatment. The family was located in Arizona, and the baby was given a blood transfusion which took her out of danger.



Using a Heathkit HW-16 transceiver to feed an inverted V antenna, Paul Mackinny, WN9YHQ, Wheaton, Ill., has 33 states and a Rag-Chewers' certificate.

The WCARS is monitored by the California Highway Patrol and cooperates with the various news media. The MWARS and ECARS nets have also functioned in several semi-emergency situations and are presently setting up cooperative arrangements with law-enforcement agencies and news media.

The network may be the answer to the long search for a workable system of amateur calling and emergency frequencies on a nationwide basis. In past years, both the FCC and the American Radio Relay League have suggested setting up frequencies in each amateur band. Although the idea never generated much enthusiasm; it now appears that amateur radio will have—at last—a national calling and emergency frequency.

If interested in joining the system, report into your area net. The net control or monitor station will give you the name of the net secretary who will tell you how to receive the net bulletins regularly. Some of the information given here was obtained from the WCARS *Sentinel* and the MWARS *Radio Watch*.

**Items From Here and There.** A constantly repeated complaint of many DX chasers is that foreign stations are poor QSL'ers. Don't

tell that to the members of the San Diego DX Club, who operate the ARRL W6 QSL bureau. They handle 50,000 to 60,000 foreign QSL cards each month for California amateurs and (according to the San Francisco Radio Club *News*) they say that the Japanese amateurs are the fastest to QSL and the Russians are the slowest.

Incidentally, an ARRL study group, appointed to examine the feasibility of the addition of an out-going branch to its QSL bureau to forward U.S. QSL cards to foreign amateurs, has concluded that the disadvantages of the idea outweigh its advantages. However, if you are interested in sending your out-going foreign cards via a QSL bureau, you might drop a note to Jesse Bieberman, W3KT, R.D. 1, Valley Hill Rd., Malvern, PA 19355, for information on his bureau.

Is commercially built equipment better than gear made by the amateur? Not necessarily—in New Zealand, at least. *Breakin* (Auckland, N.Z.) reporting the results of the 1968 NZART frequency measuring tests shows that 17 entrants used commercial measuring equipment while 12 had built their own. Eleven entrants in each group averaged errors of less than 50 parts per million in measuring three unknown frequencies. But, 11 of the 12 contestants using homebuilt gear made more accurate measurements than those using commercial gear! Best accuracies were 1.5 parts per million in the homebuilt category and 2.5 parts per million in the commercial category (with a frequency counter). For what it is worth, the top 20 to 30 scorers in the quarterly ARRL frequency measuring tests usually come up with errors between zero and four parts per ten million.

It is now O.K. to work Thailand. In March the Thai government agreed to allow



Five months after first becoming interested in amateur radio, G. W. Powell, WN5WLI, Jonesboro, Ark., had 30 states and a General license to his credit.



While on leave from the Air Force, Captain Lee W. Cook, USAF, W8BWNK, worked 42 states and 48 countries in 30 days at his home in Westerville, Ohio.

U.S. licensed amateurs residing or based in Thailand to work the United States. At the same time, the FCC announced that it had no objection to U.S. amateurs working those stations. The stations in Thailand we can work are those using their regular "State-side" call letters, followed by "portable Thailand (HS)." Only Vietnam and Cambodia remain on the FCC forbidden list.

Also in March, the FCC ordered one amateur in Missouri and two in Indiana to show cause why their licenses should not be revoked for using profane and obscene language on the air, malicious interference, failure to sign call letters, or signing false call letters, and other actions.

There is a new amateur moon-bounce record for homebrew equipment. Mike, K6MYC, used a 160-element array on the roof of his house and KØMQS had a 700-foot, 8-stack rhombic on the side of an Iowa hill. The record 2-way amateur radiophone was established on 144 MHz. Amateurs have made 2-way contacts on phone via moon bounce, but in the past, one or both of the participants had "borrowed"—on site—the multi-million dollar parabolic antenna at some military, or commercial complex.

## NEWS AND VIEWS

**Alfred Schieler, WB2QEW**, 48 Pershing Drive, Rochester, N. Y. 14609, recently passed his Advanced exam and is now studying for the Extra exam. Using a Hallicrafters HT-37 SSB/CW transmitter to drive a 900-watt, homebuilt amplifier, dipole antennas, and a Drake 2B receiver. Al has worked 47 states on 40 and 15 meters. He also works "mobile" with a Heathkit HW-22 SSB transceiver and a Hustler antenna and six meters with a transmitter built from a POPULAR ELECTRONICS article and an AMECO converter. Under construction is a 15-meter beam. Oh yes, Dave's brother, Don, WB2QEV, also an Advanced class licensee, shares the same equipment . . .

**The Medical Amateur Radio Council (MARCO)** will hold its 3rd annual meeting in New York City on July 17 at the time of the American Medical Association meeting at the Holiday Inn, 430 W. 57th St., N.Y. Joseph J. Boris, Meeting Manager, P. O. Box 229, Manchester, Conn. 06040, has the details . . . **Scott Scheirman, WA1JYU**, 27 Blue Ribbon Drive, Westport, Conn. 06880, has worked 36 states and 25 countries—many as a Novice—using an EICO-723 transmitter. As others before him have discovered, he found that a good receiver can be more important than high power in making contacts. A Heathkit SB-300 was his eye opener . . . **Dick, VE1AHW**, 33 Pictou Rd., Truro, Nova Scotia, Canada, says the 10-10 Net of Southern California operates weekends on 28.8 MHz at 10:00 a.m., PST. In spite of the name, any 10-meter station is invited to join. Send a SASE to Jim Paine, W60I, Corresponding Secretary, 5350 W. 118th St., Inglewood, Calif. 90304, for information on the certificate and bulletin.

**Lloyd Holm, W8BZZL**, 28878 Lorikay, Farmington, Mich. 48024, has a 10-watt, homebrew transmitter and a Hallicrafters HT-40 to go with a Hallicrafters S-85 receiver and a National HRO-50 receiver, plus an 80/40-meter dipole and a vertical antenna. With this equipment, he has worked 28 states and three countries—all on 40 meters. But that isn't all. He uses a Heathkit "Twoer" feeding a homebuilt 4-element beam on two meters, and he has a Collins 32V-2 transmitter waiting for the arrival of his General ticket. He must like being an amateur, because, he says, "Ham radio is the best thing that ever happened to me" . . . **Glyn Thomas, WB8CER**, 302 Faculty Drive, Fairborn, Ohio, has found that one can be too neat for his own good. The operating console he built to house his equipment looked so good that he had to panel the room to match the console! Equipment includes Heathkit Comanche and Cheyenne transmitter/receiver combination, Heathkit "Twoer" and oscilloscope. Three-element beams for 10 and six meters and eight elements on two meters on the roof let the world know that an amateur lives below . . . **Bill Krevchak, WN2GQL**, RD 1, Box 468, Jackson, N. J. 08527, runs 75 watts

# Sonar SENTRY VHF MONITOR NARROW BAND RECEIVERS

With Battery, Earphone, & less Crystals \$5.00 ea.

**\$49.95**

ALSO \$39.95

FR-103-S/106-S

FR-103 150-175 MHz

FR-106 30-50 MHz

**SOLID STATE**

**with ADJUSTABLE SQUELCH**

**POCKET SIZE**

**LISTEN TO: POLICE, FIRE, AIRCRAFT & WEATHER REPORTS!**

**for Industrial, Commercial, Utility & Govt. Use**

**2 CHANNELS • BROADCAST BAND • CRYSTAL CONTROLLED**

Designed and engineered for simplicity of operation, compact enough to fit a shirt pocket yet powerful enough to deliver a clear clean signal—it's dependable • Operates on two crystal controlled VHF channels plus broadcast band • Completely solid state for long life use • Visible battery indicator to show battery condition at all times • Built in antenna • 5 1/8" H x 2 1/2" W x 1 3/8" D. Wt. 11 oz.

**SONAR RADIO CORP., 73 Wortman Ave., Bklyn, N.Y. 11207**

Please send information on VHF Monitor Receivers.

Name \_\_\_\_\_ Dept. 200

Address \_\_\_\_\_

City \_\_\_\_\_ State \_\_\_\_\_

CIRCLE NO. 25 ON READER SERVICE PAGE

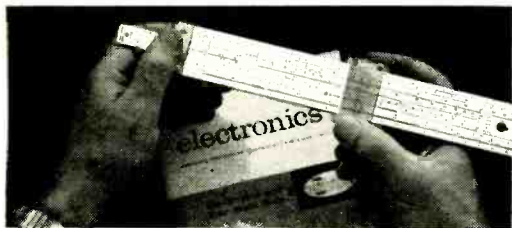

## LOOK! A NEW ELECTRONICS SLIDE RULE WITH COMPLETE INSTRUCTION COURSE

Professional 10" all-metal Electronics Slide Rule. Designed specifically for technicians, engineers, students, hobbyists. Has special scales not found on any other rule. Enables you to solve electronics problems quickly, accurately. Made to our rigid specs by Pickett, Inc. Slide Rule plus four lesson AUTO-PROGRAMMED Instruction Course with grading service, and top-grain leather carrying case . . . a \$50 value for less than \$20! Send coupon for FREE booklet. Cleveland Institute of Electronics, Dept. PE-158 1776 E. 17th St., Cleveland, Ohio 44114.

### SEND COUPON FOR FREE BOOKLET

#### Cleveland Institute of Electronics

1776 E. 17th St., Dept. PE-158  
Cleveland, Ohio 44114

Please send FREE Electronics Slide Rule Booklet. SPECIAL BONUS: Mail coupon promptly and get FREE Pocket Electronics Data Guide, too!



GET THIS FREE!

NAME \_\_\_\_\_ (Please Print)

ADDRESS \_\_\_\_\_ COUNTY \_\_\_\_\_

CITY \_\_\_\_\_ STATE \_\_\_\_\_ ZIP \_\_\_\_\_

A leader in Electronics Training . . . since 1934

CIRCLE NO. 7 ON READER SERVICE PAGE

## ABOUT YOUR SUBSCRIPTION

Your subscription to POPULAR ELECTRONICS is maintained on one of the world's most modern, efficient computer systems, and if you're like 99% of our subscribers, you'll never have any reason to complain about your subscription service.

We have found that when complaints do arise, the majority of them occur because people have written their names or addresses differently at different times. For example, if your subscription were listed under "William Jones, Cedar Lane, Middletown, Arizona," and you were to renew it as "Bill Jones, Cedar Lane, Middletown, Arizona," our computer would think that two separate subscriptions were involved, and it would start sending you two copies of POPULAR ELECTRONICS each month. Other examples of combinations of names that would confuse the computer would include: John Henry Smith and Henry Smith; and Mrs. Joseph Jones and Mary Jones. Minor differences in addresses can also lead to difficulties. For example, to the computer, 100 Second St. is not the same as 100 2nd St.

So, please, when you write us about your subscription, be sure to enclose the mailing label from the cover of the magazine—or else copy your name and address exactly as they appear on the mailing label. This will greatly reduce any chance of error, and we will be able to service your request much more quickly.

to a Drake 2-NT transmitter which feeds a dipole antenna. He receives on a Heathkit HR-10B and has worked 28 states—all on 40 meters . . . **G. W. Powell, WNSWLI**, P. O. Box 662, Jonesboro, Ark. 72401, earned his Novice license and was on the air two months after first becoming interested in amateur radio. Using a Heathkit TX-1 transmitter and a Mohawk RX-1 receiver, a dipole antenna, and a homebuilt electronic keyer, he contacted 30 states in the next three months. He then visited the FCC in Little Rock and passed his General class exam; so he will be sporting a WA5 call when you read this. In the meantime, he hopes to pass his Advanced class exam.

**Don Snortland, WA0QH**, 231 Ninth St., South, Breckenridge, Minn. 56520, uses a Galaxy-III transceiver and a Knight-Kit T-60 in conjunction with a Heathkit HG-10B VFO. A Drake MN-4 antenna coupler and a three-band "trap" dipole completes Don's equipment. He operates 40-meter CW almost exclusively, except for his Army MARS operation where he signs the call of AD0QHL. He has 49 states confirmed . . . **Capt Lee Wm. Cook, USAF, WA8WNK**, has a home address of 7555 Sunbury Rd., Westerville, Ohio 43081, but, except for a 30-day Christmas leave, all his first year on the air was spent at Keesler AFB, Miss. When not in the air, he has been on the air, working 50 states and 70 countries as a portable 5. Just to keep his hand in, the Captain worked 42 states and 48 countries while home on leave! His equipment includes Heathkit HW-100, SB-200, SB-301, and HR-10. Also, Knight-Kit TR-106 6-meter transceiver, a 2-meter FM station, and a complete RTTY station. Oh yes, he also uses the HW-100 transceiver in his car. The captain is now stationed at Craig AFB, Alabama.

Remember that your letters and "News and Views" and photographs are the life of your column. So how about mailing that letter you have been going to write for months and include a picture—preferably black and white—of you and your station to me. Also, please put or keep me on the mailing list to receive your club paper. The address is: Herb S. Brier, W9EGQ, Amateur Editor, POPULAR ELECTRONICS, P. O. Box 678, Gary, Ind. 46401.

73, Herb, W9EGQ.

## SHORT-WAVE LISTENING

(Continued from page 89)

1200-1230 and 1400-1430, Hindi 1300-1330 and 1500-1530, Urdu 1230-1300 and 1330-1400. Persian 1600-1630 and 1700-1730 and Uzbek at 1630-1700.

**Vietnam (North)**—Hanoi, 15,015 kHz (may vary) has been fairly consistent recently with talks in Vietnamese at 1630 and again at 1900. Martial music is played at times along with some oriental melodies. English begins at 2000 for a 30-minute xmsn.

**Vietnam (South)**—A schedule in from Saigon lists these xmsn's: Vietnamese at 2200-1600 on 9620, 6165 and 4877 kHz, Cantonese 0000-0115, 0500-0615 and 1430-1530 on 7245 kHz, Mandarin 0115-0200 and 1400-1430 on 7245 kHz, French 1100-1200, English 2330-0000 and 1230-1300, Cambodian at 0000-0030 and 1015-1100 and Thai at 0000-0030, all on 9755 kHz.

**Unidentified**—An upstate New York DX'er reports reception of a station in German or Russian with fair to poor reception from 2235-2241 fadeout on the medium-wave split frequency of 1245 kHz. Any ideas, anyone?

# POPULAR ELECTRONICS READER SERVICE PAGE

## free information service:

Here's an easy and convenient way for you to get additional information about products advertised or mentioned editorially (if it has a "Reader Service Number") in this issue. Just follow the directions below... and the material will be sent to you promptly and free of charge.

**1.** Print or type your name and address on the lines indicated. Circle the number(s) on the coupon below that corresponds to the key number(s) at the bottom of the advertisement or editorial mention(s) that interest you. (Key numbers for advertised products also appear in the Advertisers' Index.)

**2.** Cut out the coupon and mail it to the address indicated below.

**3.** This address is for our product "Free Information Service" only. Editorial inquiries should be directed to POPULAR ELECTRONICS, One Park Avenue, New York 10016; circulation inquiries to Portland Place, Boulder, Colorado 80302.

**POPULAR  
ELECTRONICS**

VOID AFTER AUGUST 31, 1969

P.O. BOX 8391  
PHILADELPHIA, PA. 19101

1 2 3 4 5 6 7 8 9 10 11 12 13 14 15 16 17 18 19 20  
21 22 23 24 25 26 27 28 29 30 31 32 33 34 35 36 37 38 39 40  
41 42 43 44 45 46 47 48 49 50 51 52 53 54 55 56 57 58 59 60  
61 62 63 64 65 66 67 68 69 70 71 72 73 74 75 76 77 78 79 80  
81 82 83 84 85 86 87 88 89 90 91 92 93 94 95 96 97 98 99 100

NAME (Print clearly) \_\_\_\_\_

ADDRESS \_\_\_\_\_

CITY \_\_\_\_\_ STATE \_\_\_\_\_ ZIP CODE \_\_\_\_\_

7 Na

## SOLID STATE

(Continued from page 86)

\*A new line of thyristors from A.E.I. Semiconductors, Ltd., Carholme Road, Lincoln (U.S. contact: Calvert Electronics, Inc., 220 East 23rd St., N.Y., N.Y.). Units are available with current ratings up to 110 amperes and reverse voltage ratings up to 1200 volts.

\*The Model TT537 Transistor and Diode Tester, introduced by AVO, Ltd., Avocet House, Dover, Kent (U.S. contact: Whit-taker Corporation, 80 Express St., Plain-view, L.I., N.Y. 11803).

\*A solid-state capacitance bridge designed for testing electrolytic and tantalum capacitors, developed by the British Physical Laboratories, Radlett, Hertfordshire (U.S. contact: The Advanced Technology and Systems Corp., 199 Sound Beach Ave., Old Greenwich, Conn. 06870).

\*The Genalex Type E3288 X-band solid-state power generator, produced by The M-O Valve Co., Ltd., Brook Green Works, London W. 6 (U.S. contact: Metropolitan Overseas Supply Corp., 468 Park Ave. South, New York, N. Y. 10016). Featuring a UHF transistor in a temperature-compensated varactor-tuned circuit and a step-recovery diode frequency multiplier, this unit can supply 10 mW at frequencies between 8 and 11 GHz, with a tuning range of 400 MHz.

\*The Type 431 high-gain preamplifier developed by Brookdeal Electronics, Ltd., Myron Place, Lewisham, London S.E. 13 (U.S. contact: Brookdeal of America, Inc., P. O. Box 386, North Falmouth, Mass. 02556). Using 20 input transistors mounted in parallel in a special mu-metal case, the Type 431 will detect signals below one nanovolt from very low impedance sources. Battery

operated, the unit has a maximum gain of 60 dB and a maximum output of 2 volts r.m.s.

\*A new line of compatible linear ICs by Plessey Microelectronics, Cheney Manor, Swindon, Wiltshire (U.S. contact: Plessey Electronics Corp., 170 Finn Court, Farmingdale, L.I., N. Y. 11735). Six devices are offered in the line, including a single sideband AGC generator, a voice-operated gain control, a double-balanced modulator, a wide-band r.f. voltage amplifier, an i.f. amplifier, and a general purpose audio amplifier capable of delivering 250 mW. Designed for use in professional communications equipment, all the devices are encapsulated in standard TO-5 cases.

**New Cross-Reference Guides.** If you're working with either FET's or thyristors (diacs, triacs, and SCR's), you'll want to obtain copies of the specifications/cross-reference guides recently published by two major semiconductor manufacturers.

The *Field-Effect Transistors Selector Guide*, publication No. SG-15, is published by Motorola Semiconductor Products, Inc. (P.O. Box 20924, Phoenix, Arizona 85036). This 6-page, binder-punched folder lists over 100 Motorola JFET and MOSFET devices, categorized by application and cross-referenced to more than 300 general industry type numbers. Useful formulae, basic specifications and other practical design information are included in the guide.

Published by RCA Electronic Components (Harrison, N.J. 07029), the *RCA Thyristors Quick-Reference Guide* is a 12-page booklet containing a group of unique "Quick-Selection" charts, specifications data, a cross-reference directory, and a valuable list of technical term and symbol definitions. The RCA booklet is priced at a nominal 30 cents per copy.

**Transitips.** Word meanings tend to change as time marches on. As a general rule, how-

## NEW/CB TRANSCEIVER SOLID STATE PRE-AMP



Write for free literature



AMECO / DIVISION OF AEROTRON, INCORPORATED  
P. O. BOX 6527 • RALEIGH, NORTH CAROLINA 27608

- Improves CB Base Station Performance
- Works on tube or transistor equipment
- No Modification to CB unit
- On-the-air sign automatically lights when transmitting

Model PCB with built-in power supply, transfer relay, connecting cables, wired and tested.....\$59.95

CIRCLE NO. 1 ON READER SERVICE PAGE



ever, the meanings change quite slowly and only the scholars who study classical books are likely to encounter problems in comprehension. But there are exceptions to the rule. In our fast-moving electronics field, terms can change so rapidly that a student who refers to publications just a few years old may find a number of words which seem inappropriate in view of present day definitions.

The word *hybrid* is an excellent example. When first used in reference to semiconductors, it designated an electronic circuit using both vacuum tubes and transistors. Today, the term refers to thin-film integrated circuits which use a number of discrete components, primarily as a means of distinguishing these from monolithic IC's.

Originally, the expression *junction transistor* was adopted to identify a new (then) type of device which differed from the more familiar, but now obsolete, point-contact transistor. Today, with the increasing use of field-effect transistors, many of which are "junction" types, the term is becoming out-moded and is being replaced by the phrase *bipolar transistor*. The bipolar transistor of today, then, is essentially the same thing as the junction transistor of a few years back. If this isn't confusing enough, the first field-effect transistors were sometimes called *unipolar transistors*.

Virtually all electronics experimenters are familiar with the popular *unijunction transistor*, but how many know that this device was identified, originally, as a *double-base diode*?

The moral? If you refer to technical books or magazines published more than three years ago, don't panic if you encounter an expression that doesn't make sense . . . instead, check the definitions of the technical terms as used when the material was published.

—Lou

#### CITIZENS BAND JAMBOREE CALENDAR

July 5 and 6, York CB Assistance Club, Elicker's Grove Park, Spring Grove, Penn. Contact P.O. Box 814, York, Penn. 17400.

July 13, Nautatuck Valley CB Radio Club, Bethlehem Fair Grounds, Bethlehem, Conn. Contact Mrs. Lorraine Seeley, Fairview Circle, Watertown, Conn. 06795.

July 13, Mahoning County Citizens Radio Club, Holy Trinity Grounds, Rt. 616, Struthers, Ohio. Contact Sam Cole, 190 Chestnut St., Girard, Ohio 44420.

July 19 and 20, Air Capitol CB Club, 4H Bldg., Central & Tyler Rd., Wichita, Kan. Contact J.R. Morrow or Don Sutton, P.O. Box 841, Wichita, Kan. 67201.

July 20, Renova Club, P.O. Box 606, East Liverpool, Ohio 43920.

## COLOR ORGAN

### ONE KILOWATT - FOUR CHANNELS ULTRA - COMPACT - LOW COST

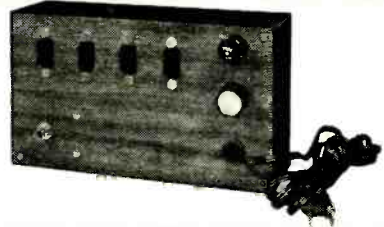

Build Dancing Colored Lighting Displays That Leap And Sparkle In Ever Changing Color Combinations Of Red, Blue, Green And Yellow. Displays Which Dance In Rhythm And Intensity According To The Frequency Content Of The Musical Input Taken From The Loudspeaker Terminals Of Any Audio Amplifier.

#### YEAR ROUND ENJOYMENT

Hi-Fi Enhancement — Lawn Parties — Musical Groups — Display Advertising — Spectacular Christmas Displays.

Features: Tunable Active R-C Filters For Frequency Separation  
• All Silicon Solid State Design  
• Walnut Wood Grain Panel — Compact Bakelite Case That Measures Only 7¾" x 4½" x 2½" Deep.

Easy to Assemble Printed Circuit Board Kit — \$49.95  
Factory Assembled — \$65.00

Add \$2.00 For Handling And Shipping Costs  
N. J. Residents Add 3% Sales Tax  
(Payment Must Accompany Order)

### EDISON INSTRUMENTS, INC.

54 West Cherry Street • Rahway, N. J. 07065  
(201) 381-0140

CIRCLE NO. 13 ON READER SERVICE PAGE

IT COSTS ONLY  
1/100 OF 1¢ MORE  
PER SOLDER JOINT  
TO KNOW YOU ARE USING THE  
WORLD'S FINEST CORED SOLDER



New Easy  
Dispenser  
Pak  
60/40  
18 S.W.G.

Latest PC  
(Printed  
Circuit) Pak  
60/40 Extra Thin  
22 S.W.G.—.028"

each only 69¢ per package at your dealer

ERSIN

**Multicore**

FIVE-CORE  
SOLDER

MULTICORE SALES CORP., WESTBURY, N.Y. 11590

CIRCLE NO. 21 ON READER SERVICE PAGE

LEARN

# ELECTRONICS

## COYNE ELECTRONICS INSTITUTE

Electronics Engineering Technology—Degree (2 Yrs.)  
 Electrical-Electronics Technician—Diploma (40 Wks.)  
 TV-Radio-Electronics Technician—Diploma (48 Wks.)  
 Complete Electronics Technician—Diploma (88 Wks.)  
 Practical Electrical Maintenance—Diploma (32 Wks.)  
 Practical Refrigeration Air Conditioning  
 and Appliance Repair— Diploma (24 Wks.)

Special finance plans. Graduate employment service.

### MAIL COUPON FOR FREE BOOK

Coyne Electronics Institute Dept. B9-C2  
 1501 W. Congress Pkwy., Chicago, Ill. 60607

Send Information as checked below

- HOME TRAINING in TV, Radio and Color TV Servicing.  
 RESIDENT SCHOOL COURSES in Electronics, Electricity, Engineering Technology, Television, Refrigeration, and Air Conditioning.

Name.....Age.....

Address.....

City.....State.....Zip.....

#### APPROVED FOR VETERANS

Accredited Member: National Association  
 Trade and Technical Schools.



CIRCLE NO. 12 ON READER SERVICE PAGE

# FREE

**RADIO-TV  
ELECTRONICS**

**69  
ANNUAL  
CATALOG  
No. 691**

**BURSTEIN-APPLEBEE**  
 WITH STORES IN:  
 \* KANSAS CITY, MISSOURI  
 \* EVANSTON PARK, KANSAS  
 \* SPRINGFIELD, MISSOURI  
 \* CHICAGO, ILLINOIS

228 GIANT VALUE-PACKED PAGES

**GIANT 1969  
RADIO-TV  
ELECTRONICS  
CATALOG**

228 GIANT  
VALUE-PACKED  
PAGES

WRITE FOR YOUR FREE COPY TODAY

BURSTEIN-APPLEBEE CO., DEPT. PE-G  
 3199 MERCIER ST., K.C., MO. 64111

NAME.....

ADDRESS.....

CITY.....STATE.....ZIP.....

CIRCLE NO. 5 ON READER SERVICE PAGE

## LETTERS

(Continued from page 10)

ruary 1969), the amplifier used to drive it should be capable of developing at least ten clean watts of output power. Of course, the variables of room acoustics and size and personal listening habits, might alter this estimate somewhat.

As for the speaker system itself, the woofer is rated by McGee Radio at 50 watts music power and 25 watts r.m.s.; the manufacturer rates it at 35 watts r.m.s. However, my tests indicated that a commercially rated 20-watt speaker system would overload at a power level that could easily be handled by the Thrifty Three-Way. Therefore, the Thrifty Three-Way could conservatively be rated at 25 watts, assuming the enclosure is properly sealed and no mistakes have been made in hooking up the crossover networks.

DAVID E. WEEMS  
 Newtonia, Mo.

### CALIBRATE THE "OP TACH"

The "Op Tach" article ("Build Op Tach," March 1969) describes two methods of calibration that will undoubtedly work. I would like to suggest yet another method; one that is simple and does not require special extra circuitry. Simply hold the Op Tach directly in front of a fluorescent tube or fixture with the power applied, and adjust R7 until the meter indicates 3600 r/min. The tube pulses at a rate of 60 Hz—or 3600 repetitions/min.

RICHARD E. TAVANO  
 Wayne, N.J.

*It's usually the obvious—and easiest—approaches to a problem that slip by us. Your method of calibration will certainly work. Also, the author of the article advises us that he accidentally listed R9 in the project as 680 ohms when it should be 6800 ohms. If any readers built the Op Tach using locally obtained parts and are having trouble with calibration, this resistor is the culprit.*

## OUT OF TUNE

"Build a Different Metal Locator" (February 1969). The form for the vertical coil (as shown in Fig. 2, page 55) should be built up so that it is  $1\frac{1}{2}'' \times 2\frac{3}{4}''$  instead of  $\frac{5}{8}'' \times 2\frac{3}{4}''$ .

In the Solid State column for June, those ubiquitous gremlins got into the second line of type so that the item turned out to be about a transformer (!) amplifier instead of a transistor amplifier.

## TIGERS THAT ROAR

(Continued from page 63)

Follow construction instructions for the Tiger with regard to inputs, outputs, etc.

**Testing.** Before turning on the power, examine each board, the power supply, and the interconnections for proper component installation (including polarities on capacitors and diodes), solder bridges between foil sections, and wiring errors.

Disconnect the d.c. supply to the amplifier—60 volts for the Tiger, 80 volts for the Super Tiger. Connect a d.c. voltmeter to the power supply output and turn on the power. The measured voltages should be about 5 volts above nominal—65 and 85, respectively. Turn off the power and allow the power supply to discharge through the bleeder resistor.

Temporarily connect a 1000-ohm, 1-watt resistor between the positive output of the power supply and the voltage input terminal on the amplifier board (either one in a stereo system). Connect a d.c. voltmeter across the resistor, observing the proper polarities. When the power is turned on, the voltmeter should indicate about 20 volts. If it is more than 25 volts, you have a problem in that channel. Once one channel is found to be OK, perform the same test on the other channel. If you find trouble, one quick check you can make is to measure the voltage at the output transistor emitters. It should be about half the supply voltage.

Once you are satisfied that all is correct, shut down the power, wait a moment for the power supply to discharge, and then connect a 4- or 8-ohm speaker to each output terminal.

Since the input impedance to either amplifier is about 20,000 ohms, the power amplifier can be driven from either a transistor or vacuum-tube preamp. It will work particularly well with the FET Preamp described in the May POPULAR ELECTRONICS.

-30-

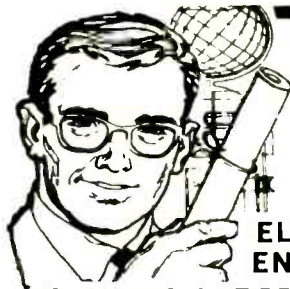

# Earn Your Degree

## ELECTRONICS ENGINEERING

### through HOME STUDY

HIGHLY EFFECTIVE HOME STUDY COURSES IN:  
 • ELECTRONICS ENGINEERING TECHNOLOGY  
 • ELECTRONICS ENGINEERING MATHEMATICS

Earn your Associate in Science Degree in Electronics Engineering and upgrade your status and pay to the engineering level. Complete college level courses in Electronics Engineering. We're a forward looking school. Outstanding lesson material—thorough and easy to understand. Engineering taught on the basis of application and understanding rather than on the basis of memorization. Up to date in every respect. Acquire the knowledge and ability that means the difference between a low paying technician job and a high paying engineering position. Low tuition cost with low monthly payments. Free engineering placement service for our graduates. Write for free descriptive literature. Ask for bulletin K, no salesman will call on you.

## COOK'S INSTITUTE of Electronics Engineering

Southwest Regional Office  
 7650 Clarewood, P.O. Box 36185  
 Houston, Texas 77036  
 Established 1945

Formerly Cook's School of Electronics

CIRCLE NO. 9 ON READER SERVICE PAGE

## —OIL LEASES—

\$15,799.20 - \$10,400.00 - \$9,600.00 - \$8,000.00 - \$7,800.00 - \$7,000.00 profits in recent sales by our clients of U. S. Government Oil & Gas Leases We recommended. If you are a citizen, you qualify. For complete information and how to get your lease write:

FEDERAL OIL LEASE SERVICE, Dept. PE  
 P. O. Box 867, Fort Worth, Texas 76101

## Decimal Counting Unit

- INDICATOR TUBE
- IC DECODER/DRIVER
- TTL DECIMAL COUNTER
- ASSEMBLED & TESTED



MODEL DMS19

\$3180

\$2880

1-3 4-9

Compact (2.5" x 1.75" x .75"). Plug-in compatible with standard 15 position connector (156" spacing). TTL and TTL compatible. Tube - Amperex ZM-1000 (includes decimal point). Send check or M.O. include 50¢ ea. for postage and handling.

COMPUTER PRODUCTS  
 2801 East Oakland Park Blvd  
 Fort Lauderdale, Florida 33306  
 Telephone (305) 565-9565

## GET INTO ELECTRONICS

V.T.I. training leads to success as technicians, field engineers, specialists in communications, guided missiles, computers, radar, automation. Basic & advanced courses. Electronic Engineering Technology and Electronic Technology curricula both available. Associate degree in 28 months. B.S. obtainable. G.I. approved. Start September. February. Dorms, campus. High school graduate or equivalent. Catalog.

VALPARAISO TECHNICAL INSTITUTE  
 DEPARTMENT PE, VALPARAISO, INDIANA 46383



## DELUXE RECORD AND TAPE CASES

Plus *Free* cataloging forms

- Padded back
- Dust proof
- Gold embossed



Decorative and sturdy cases constructed of reinforced fiberboard—covered in rich leatherette to keep your records and tapes from getting damaged. Available in choice of five decorator colors. Record and Tape Cases lend themselves handsomely to the decor of any room. Padded back (in your color choice) is gold tooled in an exclusive design. Sides in standard black leatherette to keep them looking new after constant use. Extra with each case ordered you will receive, free of charge, a specially designed cataloging form with pressure sensitive backing for affixing to side of case. Enables you to list the records to help you locate your albums.

Cases are available in three sizes for 7", 10" and 12" records. Center divider separates records for easy accessibility, holds an average of 20 records in their original jackets. Tape case holds 6 tapes in original boxes.

Ziff-Davis Pub. Co. • Dept. SD • 1 Park Ave. • N.Y., N.Y. 10016

My remittance in the amount of \$ \_\_\_\_\_

Quantity Is enclosed for the Cases indicated below.

\_\_\_\_\_ Tape Case at \$4 ea., 3 for \$11, 6 for \$21.

\_\_\_\_\_ 7" Record Case at \$4 ea., 3 for \$11, 6 for \$21.

\_\_\_\_\_ 10" Record Case at \$4.25 ea., 3 for \$12, 6 for \$22.

\_\_\_\_\_ 12" Record Case at \$4.25 ea., 3 for \$12, 6 for \$22.

ADD \$1.00 PER ORDER FOR SHIPPING AND HANDLING.  
Check color choice for back of case (sides in black only):

Midnight Blue       Red       Spice Brown

Pine Green       Black

Name \_\_\_\_\_ PE-79

Address \_\_\_\_\_

City \_\_\_\_\_ State \_\_\_\_\_ Zip \_\_\_\_\_

PAYMENT MUST BE ENCLOSED WITH ORDER

Live Better Electronically With

# LAFAYETTE RADIO ELECTRONICS

1969 Catalog 690 **FREE!**



Now OFF PRESS  
BETTER THAN EVER  
Over 500 Pages

Stereo Hi-Fi • Citizens Band • Ham Gear • Tape Recorders • Test Equipment • TV and Radio Tubes and Parts • Cameras • Auto Accessories • Musical Instruments • Tools • Books

Featuring Everything in Electronics for  
• HOME • INDUSTRY • LABORATORY  
from the "World's Hi-Fi & Electronics Center"

LAFAYETTE Radio ELECTRONICS  
Dept. 35079 P.O. Box 10  
Syosset, L.I., N.Y. 11791

Send me the FREE 1969 catalog 690. **35079**

Name \_\_\_\_\_

Address \_\_\_\_\_

City \_\_\_\_\_

State \_\_\_\_\_ Zip \_\_\_\_\_

CIRCLE NO. 18 ON READER SERVICE PAGE

## ELECTRONICS "B" QUIZ ANSWERS

(Quiz is on page 64)

- 1 A **BLOCKING** oscillator is a form of RC relaxation circuit using a plate transformer to provide the out-of-phase feedback voltage.
- 2 A **BATHTUB** capacitor is a rugged, hermetically sealed, metal-cased unit designed for aircraft, marine, and tropical applications where the component must operate under severe heat and humidity conditions.
- 3 A **BANDPASS** filter attenuates frequencies to either side of the desired pass band.
- 4 A **BATWING** antenna is an element of the Super Turnstile antenna used in FM broadcasting.
- 5 A **BRIDGE** amplifier circuit balances out supply voltages to prevent d.c. from flowing through the speaker voice coil.
- 6 A **BAYONET** base lamp uses a guide pin designed for use in a slotted sleeve socket.
- 7 A **BIFILAR** winding is folded back on itself so that the mutual and self-inductive emf's cancel to make it effectively noninductive.
- 8 A **BALUN** is an antenna coupling transformer used to match a balanced output circuit to an unbalanced transmission line or vice versa.
- 9 A 3.58-MHz color **BURST** signal is used to synchronize the TV transmitter and receiver color phase reference oscillators.
- 10 A **BANANA** plug uses four phosphor-bronze spring metal leaves to produce a compression fit in a matching jack.

# ELECTRONICS MARKET PLACE

**COMMERCIAL RATE:** For firms or individuals offering commercial products or services. \$1.15 per word (including name and address). Minimum order \$11.50. Payment must accompany copy except when ads are placed by accredited advertising agencies. Frequency discount: 5% for 6 months; 10% for 12 months paid in advance. **READER RATE:** For individuals with a personal item to buy or sell. 70¢ per word (including name and address). No Minimum! Payment must accompany copy.

## FOR SALE

**FREE!** Giant bargain catalog on transistors, diodes, rectifiers, SCR's, zeners, parts. Poly Paks, P.O. Box 942, Lynnfield, Mass. 09140.

**GOVERNMENT** Surplus Receivers, Transmitters, Snooperscopes, Radios, Parts, Picture Catalog 25¢. Meshna, Nahant, Mass. 09108.

**BUG DETECTOR: WILL DETECT AND LOCATE SURREPTITIOUS TRANSMITTING DEVICES IN CONFERENCE ROOMS, HOME AND OFFICES, ETC. WRITE FOR DETAILS. WJS ELECTRONICS, 737 NORTH SEWARD, HOLLYWOOD, CALIF. 90038.**

**ROCKETS:** Ideal for miniature transmitter tests. New illustrated catalog. 25¢. Single and multistage kits, cones, engines, launchers, trackers, rocket aerial cameras, technical information. Fast service. Estes Industries, Dept. 18, Penrose, Colorado 81240.

**LOWEST Prices Electronic Parts.** Confidential Catalog Free. **KNAPP**, 3174 8th Ave. S.W., Largo, Fla. 33540.

**TREASURE Hunters! Prospector!** Relco's new instruments detect buried gold, silver, coins. Kits, assembled models. Transistorized. Weighs 3 pounds. \$19.95 up. Free catalog. Relco-A33, Box 10839, Houston, Texas 77018.

**EUROPEAN** and Japanese bargains catalogs. \$1 each. Dee, 10639E Riverside, North Hollywood, Calif. 91602.

**MECHANICAL, ELECTRONIC** devices catalog 10¢. Greatest Values—Lowest Prices. Fertik's, 5249 "D", Philadelphia, Pa. 19120.

**MUSIC LOVERS, CONTINUOUS, UNINTERRUPTED BACKGROUND MUSIC FROM YOUR FM RADIO, USING NEW INEXPENSIVE ADAPTOR. FREE LITERATURE. ELECTRONICS, 11500-Z NW 7th Ave., MIAMI, FLORIDA 33168.**

**WE SELL CONSTRUCTION PLANS. TELEPHONE:** Answering Machine, Speakerphone, Carphone, Phonevision, Legal Connector, Auto Dialer, Central Dial System. **TELEVISION:** \$35.00 Color Converter, Tape Recorder, 3D TV. \$25.00 Camera. **DETECTIVE:** Infinity Transmitter, Tail Transmitter, Police Radar Detector. **HOBBYIST:** Electron Microscope, 96 Hour Tape Music System, Ultrasonic Dishwasher, Radar-Oven, Electronic Tranquilizer. Plans \$4.95 each. **COURSES:** Telephone Engineering \$39.50, Detective Electronics \$22.50, Anti-Detective Electronics \$27.50. **SUPER HOBBY CATALOG** 25¢. Don Britton Enterprises, 7906 Santa Monica Blvd., Hollywood, Calif. 90046.

**WEBBER LAB's.** Police & Fire Converters. Catalog 10¢. 72 Cottage Street, Lynn, Mass. 09105.

**RADIO—T.V.** Tubes—33¢ each. Send for free catalog. Cornell, 4213 University, San Diego, Calif. 92105.

**WHOLESALE COMPONENTS:** Manufacturers and distributors only. Request free catalog on business letterhead. **WESCOM**, Box 2536, El Cajon, California 92021.

**INVESTIGATORS, LATEST ELECTRONIC AIDS. FREE LITERATURE. CLIFTON, 11500-L NW 7th Ave., MIAMI, FLORIDA 33168.**

**CONVERT** any television to sensitive, big-screen oscilloscope. Only minor changes required. No electronic experience necessary. Illustrated plans, \$2.00. Relco-A33, Box 10563, Houston, Texas 77018.

**RECTIFIERS**, transistors, other components. Catalog 15¢. Electronic Components Co., Box 2902C, Baton Rouge, La. 70821.

**BUILD TV CAMERA IN SINGLE EVENING** using solid-state encapsulated modules. Previous TV knowledge unnecessary. Ideal for students, experimenters, etc. Economical! Exciting details **FREE**. Also request catalog describing other camera kits, plans, etc. **ATV RESEARCH**, 1301 Broadway, Dakota City, Nebr. 68731.

**ELECTRONIC** ignition, various types. Free literature. Anderson Engineering, Epsom, N.H. 03239.

**GENERAL INFORMATION:** First word in all ads set in bold caps at no extra charge. Additional words may be set in bold caps at 10¢ extra per word. All copy subject to publisher's approval. Closing Date: 1st of the 2nd preceding month (for example, March issue closes January 1st). Send order and remittance to: Hal Cymes, **POPULAR ELECTRONICS**, One Park Avenue, New York, New York 10016.

**FREE ELECTRONICS PARTS FLYER.** Large catalog \$1.00 deposit. **BIGELOW ELECTRONICS, BLUFFTON, OHIO 45817.**

**HOBBYISTS, EXPERIMENTERS**, amateur scientists, students . . . Construction Plans—All complete including drawings, schematics, parts list with prices and sources . . . Laser—Build your own coherent-light optical laser. Operates in the visible light range, pulsed mode—\$6.00 . . . Radar—Build your own ultrasonic doppler radar. Detect motion of people, automobiles, even falling rain drops. Transistorized, uses standard small 9-volt battery—\$4.00 . . . Tic Tac Toe Machine—You play against machine. Automatic. Can you beat the machine? Sometimes yes, usually no—\$4.00 . . . Long Range "Sound Telescope"—This amazing device can enable you to hear conversations, birds, other sounds hundreds of feet away. Very directional. Transistorized, uses 9-volt battery—\$3.00 . . . Or send 25¢ coin or stamps for complete catalogue . . . Technical Writers Group, Dept. C, Box 5994, State College Station, Raleigh, N.C. 27607.

**ELECTRONIC** bargain catalog on unusual kits, parts, do-it-yourself, stereo, intercoms. Alcon, P.O. Box 1348-P, Lawrence, Mass. 01843.

**JAPAN & HONG KONG DIRECTORY.** Electronics, all merchandise. World trade information. \$1.00 today. Ippano Kaisha Ltd., Box 6266, Spokane, Washington 99207.

**CIRCUIT Boards, Parts for "Poptronics" projects. Free catalog.** S.W. Technical, Box 16297, San Antonio, Texas 78216.

**LINEAR AMPLIFIERS:** "Hornet" 50 watts output—\$98.50; "Raider"—100 watts—\$139.50; "Maverick-250"—250 watts—\$244.95. AM and SSB. "Scorpion"—50 watt 12 V. Mobile amplifier—\$99.95; "Bandit II"—12 V. Mobile Amplifier—\$169.95. Frequency range 20-35 megacycles (illegal for class D 11 meters.) Dealer inquiries invited. D & A Manufacturing Co., 1217 Avenue C, Scottsbluff, Nebraska 69361.

**SPECIAL** surveillance devices construction diagrams. Includes: olive transmitter, infinity transmitter, telephone/room bugs, ailing devices, debuggers, police speed radar jammer. Send \$2.00. Bylina PE, P.O. Box 09131, Chicago, Illinois 60609.

**FREE** Catalog low priced, high performance subminiature listening devices direct from manufacturer. Emery LT-7, 156 Fifth Avenue, New York, N. Y. 10010.

**ULTRA-SENSITIVE AND POWERFUL METAL DETECTORS**—join the many who are finding buried coins, minerals, relics and artifacts. Don't buy till you see our **FREE** catalog of new models. Write Jetco, Box 132-PE, Huntsville, Texas 77340.

**LASER** parts catalog 60¢. Moynihan, 107 North Brighton, Atlantic City, New Jersey 08401.

**PARTS—KITS—JAPAN'S** low prices catalog \$2.00. International Hobbyist, 1-27 Miharucho, Yokosuka 238, Japan.

**HAM-CB** . . . new—used. Wireless Shop, 1305 Tennessee, Vallejo, Calif. 94590.

**DIAGRAMS**—Radios \$1.50, Television \$3.00. Give make and model. Diagram Service, Box 1151PE, Manchester, Conn. 06042.

**POLICE-FIRE RADIO DISPATCHER DIRECTORIES!** Exclusive **CONFIDENTIAL** listings. **OFFICIAL CALLSIGNS, FREQUENCIES!** Catalog for stamp. Communications, Box 56-PE, Commack, N.Y. 11725.

**ELECTRONIC** kits, cabinets, equipment, wholesale, free literature. **HAZCO**, Box 163, Hazel Park, Mich. 48030.

**CONSTRUCTION PLANS:** Laser . . . \$2.00. Surveillance Devices—Two FM Bugging Transmitters . . . \$1.00. Tail Transmitter \$1.00. Bug Detector \$1.00. Howard, 20174 Ward, Detroit, Michigan 48235.

"GIZMOTCHY" CB beams, dealers wanted Box 1820, Huntington Beach, Calif. 92647.

**UNIQUE** electronic devices and Modules: burglar alarm, metal locator, swimming pool intrusion alarm, shocker, camping protection alarm, bachelor alarm, \$3.50 each. Free catalog. Bac Electronics, 1707 San Bruno, Fairfield, Calif. 94533.

**FM-AM BUGGING DEVICES**, one dozen circuits plus ideas \$3. Dennis, P.O. Box 283, Dayton, Virginia 22821.

**FOUR-CHANNEL COLOR ORGAN, 2400 WATT**, build for \$30.00 in a few hours, electronic frequency discrimination, information and P.C. Board \$3.00, satisfaction guaranteed. **ANDREW**, 312 Pugh, State College, Pa. 16801.

**LAUGH-IN** television scripts \$3.00. 9720 Tunney, Northridge, Calif. 91324.

**1500 VOLT** shocker module \$5.95. Fun, pranks, protection. Uses flashlight batteries. No battery drain until electrodes are touched. Catalog 25¢. Franks Scientific Co., P.O. Box 156, Martelle, Iowa 52305.

**LISTENING**, surveillance, jamming equipment. Made-to-order and standard models. Catalog 20¢. Caltron, Box 6274, Sacramento, California 95860.

**SEVEN** 2½ KVA Leland Alternators Ball Bearing. Best Offer. W. T. YOUNGER, 2233 Woodland Ave., Duluth, Minn. 55803.

**AUTOMOBILE LIGHTS-ON** reminder. Parts total 35¢. Diagrams and instructions for 3 different original circuits. Send \$1.00. Kenneth Hull, 308 St. Joseph, Long Beach, Calif. 90814.

**ELECTRONIC** test equipment—all types, bargains. Send 25¢ for large list. Palen Electronics, Box 1536, San Mateo, California 94401.

**ULTRA-SENSITIVE TELEPHONE ADAPTOR** \$2.00. Delux model \$3.00. Protecto-X7, 1 West 20th Street, New York, N.Y. 10010.

**INTEGRATED CIRCUITS, DC TO DC CONVERTERS**. Informative solid state articles. \$1.50 each. Cates Electronics, Rt 2, Box 13-A, Doniphan, Mo. 63935.

**REPAIR YOUR OWN TV TUNERS**—Color—Transistor—VHF-UHF. Simple, complete course. Six sections, 33 chapters. Field-tested. Jigs, Fixtures, Adapters, "Setting-up". Probes. Quick-checks. Test sets. Repairs without equipment. Unique power supplies. Fast-fix luxuries. Equipment you can build. Tricks. Illustrated. Plans for all items. Troubleshooting. Alignment. All tests and adjustments. Mistakes. How, where buy parts. Common problems. Tuner index. Much more. Major course: Details, introduction, plus two sample lessons \$1., refundable. Optional condensed courses: VHF \$9.50, UHF \$4.50, Transistor tuners \$4.50. Frank Bocek, Box 3236A, Redding, Calif. 96001.

**STROBES, COLOR ORGANS, THE INCREDIBLE STROBIT**. Factory prices. Save 25-50%. Catalog 25¢, refunded first order, Teletronics, Box 1266, South Lake Tahoe, CA 95705.

**GERMAN** and Japanese tubes and parts. Send \$1.00 for price list. The Matthews Company, Box 151, Lawton, Oklahoma 73501.

## PLANS AND KITS

**KITS**, metal detector \$5.95. Audio Telescope \$5.95, others. Lectronix, Box 42, Madison Heights, Michigan 48071.

**SOLAR FLYING SAUCERS**. (Brand New Solid State Engine, Fantastic Performance, Flies Miles on Sun's Power, lifts animals, sends messages, parachutes. Build many, easily, inexpensively with everyday materials. Complete plans, descriptions, drawings, plus **FREE** Space-tronics CATALOG \$1. Single Catalog 25¢. Spacetrronics, Box 31043-PES, San Francisco, California 94131.

**DECADE COUNTER KITS**—\$13.95. Professional quality readout. Free information. Display Electronics, Box 1044, Littleton, Colorado 80120.

"**DISTANCE CRYSTAL SET CONSTRUCTION**" Handbook—50¢. "Coil Winding"—50¢. Catalog. Laboratories, 12041-L Sheridan, Garden Grove, Calif. 92640.

**6-9V DC** power supply kit \$5.95, 20W semi conductor amplifier kit \$4.00. G.E.G., Box 1141, Loomis, Calif. 95650.

**SECURITY DEVICES IN KIT FORM**: Telephone Transmitter, FM Spy Transmitter, Telephone-Tape Recorder Actuator, Burglar Alarm. Complete Kits, \$15.00 each. Construction Plans only \$5.00 each. Easy to Build and Reliable. **ELECTRONIC SECURITY SYSTEMS**, 1101 West Rosecrans Avenue, Gardena, Calif. 90247.

**POWER** Supplies \$2.75-\$8.50, 10 AMP Triac \$1.50. Nixie \$5.00. Counter \$2.00. Catalog. Murphy, 204 Roslyn Ave., Carle Place, N.Y. 11514.

**INTEGRATED CIRCUIT KITS: COMPUTER, AUDIO**, Others. New catalog free. **KAYE ENGINEERING**, Box 3932-A, Long Beach, California 90803.

**TITATTOE** device, electronic, Beats/ties opponent, Easily built. Plans \$2.00. Jebco Electronics, Box 3034, Hollywood, California 90028.

**ELECTRONIC** windshield wiper kits—converts your present electric auto wipers to turn on and off depending on weather conditions—\$8.95. Specify auto make, year, and if single speed wiper. Ideal Engineering, 650 E. 3100 N., Ogden, Utah 84404.

**PLANS**. Analog computer programmed to make optional strategy decision in blackjack. \$5.00. D. Tweedy, Box 11282, Santa Ana, California 92711.

## SHORTWAVE LISTENING

**POLICE—FIRE—AIRCRAFT—MARINE-AMATEUR—ETC.** CALLS on your broadcast radio with **TUNAVERTER!** Tunable-crystal controlled! Free catalog. Salch Co., Woodsboro-PECC, Texas 78393.

**TENA-TUNER** Indoor or Portable **ANTENNA SYSTEM**. Easy installation and operation. Efficient 2.2-30 mHz. Improves selectivity. Guaranteed. \$8.88 postpaid. SWL Guide, 218 Gifford, Syracuse 13202.

## HIGH FIDELITY

**FREE!** Send for money saving stereo catalog #PE7 and lowest quotations on your individual component, tape recorder, or system requirements. Electronic Values, Inc., 200 W. 20th St., New York, N.Y. 10011.

**DON'T THROW YOUR OLD CARTRIDGE AWAY**. Send us \$19.95 and any old cartridge. We will ship **PREPAID** any one of the following top rated elliptical diamond stereo cartridges **NEW!** Shure M75E, M91E, M92E, M93E, Empire 888E, Pickering V15AME3, XV15 ATE, ADC 660E, 550E. Write for lowest quotations all stereo components. **DEFA ELECTRONICS**, 2207 Broadway, New York, N.Y. 10024.

**HI-FI** Components, Tape Recorders, at guaranteed "We Will Not Be Undersold" prices. 15-day money-back guarantee. Two-year warranty. No Catalog. Quotations Free. Hi-Fidelity Center, 239 (P) East 149th Street, New York 10451.

**LOW**, Low quotes: all components and recorders. HiFi, Roslyn, Penna. 19001.

**TAPE RECORDERS**, Hi-Fi, components, Sleep Learning Equipment, tapes. Unusual Values. Free Catalog. Dressner, 1523R, Jericho Turnpike, New Hyde Park, N.Y. 11040.

**DON'T THROW YOUR OLD CARTRIDGE AWAY**. Send us \$50.00 and any old used cartridge and we will ship you via air Prepaid anywhere any one of the following Top Stereo Cartridges: Shure V-15 Type II, Empire 999VE, ADC 10EMK 11, Stanton 681EE. Write for lowest quotations all stereo components. **DEFA ELECTRONICS**, 2207 Broadway, New York, N.Y. 10024.

**250 WATT SOLIO STATE STEREO AMP AND PREAMP** comparable with units costing over \$500.00. Build for \$38.00 per channel in less than ten hours. Latest integrated circuit design. Seven inputs tape earphone outputs. Complete plans amplifier \$5.00 preamp \$4.00 ready to wire circuit boards, amplifier \$5.00 preamp \$5.00. Everything \$15.00. Logical Structure and Design Inc., Box 904, Schenectady, N.Y. 12301.

## WANTED

**CASH PAID!** Unused tubes, electronic equipment. Barry, 512 Broadway, NYC 10012.

**QUICKSILVER**, Platinum, Silver, Gold, Ores Analyzed. Free Circular. Mercury Terminal, Norwood, Mass. 02062.

**WANTED** Atwater Kent model 30 speaker. Sam McCrea, 312 South Harper, Santa Ana, California 92704.

**CASH PAID** for all tubes. **DAMESCO**, 308 Hickory, Arlington, N.J. 07032.

## TUBES

**TUBES** "Oldies", latest. Lists free. Steinmetz, 7519 Maplewood, Hammond, Indiana 46324.

**RECEIVING & INDUSTRIAL TUBES, TRANSISTORS**. All Brands—Biggest Discounts. Technicians, Hobbyists, Experimenters—Request **FREE** Giant Catalog and **SAVE!** **ZALYTRON**, 469 Jericho Turnpike, Mineola, N.Y. 11501.

**TUBE** Headquarters of World! Send 10¢ for Catalog (tubes, electronic equipment) Barry, 512 Broadway, N.Y.C. 10012.

**RADIO & T.V. Tubes**—33¢ each. Send for free list. Cornell, 4213 University, San Diego, Calif. 92105.

**THOUSANDS** and thousands of types of electronic parts, tubes, transistors, instruments, etc. Send for Free Catalog. Arcturus Electronics Corp., MPE, 502-22nd St., Union City, N.J. 07087.

**TUBES**—lowest prices in the world. Hard to get British, German, Foreign and American obsolete and present day special purpose transmitting tubes. Send for giant tube and parts catalog. United Radio Co., Dept. Y-56 Ferry Street, Newark, N.J. 07105.

**JOBBER**—boxed tubes, top brands at 75% off mfr. list prices. Free catalog. CECO, 120 West 18th Street, N.Y.C. 10011.

**TAPE AND RECORDERS**

**HI-FI Components.** Tape Recorders, at guaranteed "We Will Not Be Undersold" prices. 15-day money-back guarantee. Two-year warranty. No Catalog. Quotations Free. HiFidelity Center, 239 (PT) East 149th Street, New York 10451.

**BEFORE** Renting Stereo Tapes try us. Postpaid both ways—no deposit—immediate delivery. Quality—Dependability—Service—Satisfaction—prevail here. If you've been dissatisfied in the past, your initial order will prove this is no idle boast. Free Catalog. Gold Coast Tape Library, Box 2262, Palm Village Station, Hialeah, Fla. 33012.

**RENT** 4-Track open reel tapes—all major labels—3,000 different—free brochure. Stereo-Parti, 55 St. James Drive, Santa Rosa, Ca. 95401.

**TAPE RECORDER SALE.** Brand new nationally advertised brands. \$10.00 above cost. Amazing discounts on stereo components. Arkay Electronics, 1028-C Commonwealth Avenue, Boston, Mass. 02215.

**TAPEMATES** makes available to you ALL 4-TRACK STEREO TAPES—ALL LABELS—postpaid to your door—at tremendous savings. For free brochure write: TAPEMATES, 5727 W. Jefferson Blvd., Los Angeles, California 90016.

**STEREO TAPES,** Save 30% and up; no membership or fees required; postpaid anywhere U.S.A. Free 70-page catalog. We discount batteries, recorders, tape/cassettes. Beware of slogans, "not undersold", as the discount information you supply our competitor is invariably reported to the factory. SAXITONE, 1776 Columbia Road, N.W., Washington. D.C. 20009.

**SCOTCH** Recording Tapes. Wollensak Recorders. Catalog 6¢. Tower, Lafayette Hill, Pa. 19444.

**STEREO TAPES,** Cartridges, Cassettes, Reels, 33% discount. Largest selections unavailable elsewhere. Mail 20¢—Catalogs. Star Recordings-ZD, Box 1055, El Paso, Texas 79946.

**CASSETTE** blanks, also educational and language, accessories and recorders. Literature—Write CASSETTES UNLIMITED, P.O. Box 13119-P, Pittsburgh, Pa. 15243.

**REPAIRS AND SERVICES**

**TV Tuners** rebuilt and aligned per manufacturers specification. Only \$9.50. Any make UHF or VHF Ninety day written guarantee. Ship complete with tubes or write for free mailing kit and dealer brochure. JW Electronics, Box 51C, Bloomington, Indiana 47401.

**CHASSIS:** All types and sizes. Will build to your specifications. Phone 307-532-5752. A & T Manufacturing, Inc. 1902 West C., Torrington, Wyoming 82240.

**PHOTO** etched XXXP from ink drawing. 5"x7" maximum \$2.50. Horning, 1751 Creek Drive, San Jose, California 95125.

**PERSONALS**

**MAKE FRIENDS WORLDWIDE** through international correspondence. Illustrated brochure free. Hermes, Berlin 11, Germany.

**INVESTIGATORS, LATEST ELECTRONIC AIDS. FREE LITERATURE.** CLIFTON, 11500-K NW 7th AVE., MIAMI, FLORIDA 33168.

**SECRET** plans revealed. Free brochure. Audiotronix E7, Fifth Avenue, New York, N.Y. 10010.

**SECRET LOANS BY MAIL.** Borrow \$100 to \$1500 for any good reason in absolute privacy. No interviews, no endorsers, no co-signers. Fast service. Write Dial Finance Co., Dept. G-593, 410 Kilpatrick Bldg., Omaha, Nebraska 68102.

**FREE** Catalog low priced, high performance subminiature listening devices direct from manufacturer. Dealers welcome. Emery A-7 156 Fifth Avenue, New York, N. Y. 10010.

**HANDWRITING** analyzed—50¢. Send sample. Rich, 4074 Mt. Acadia, San Diego 92111.

**CLASSIFIED ADVERTISING ORDER FORM**

Please refer to heading on first page of this section for complete data concerning terms, frequency discounts, closing dates, etc.

1	2	3	4	5
6	7	8	9	10
11	12	13	14	15
16	17	18	19	20
21	22	23	24	25
26	27	28	29	30
31	32	33	34	35

Words { @ 70¢ (Reader Rate) } = \$ \_\_\_\_\_  
 { @ \$1.15 (Commercial Rate) }  
 Insert \_\_\_\_\_ time(s) Total Enclosed \$ \_\_\_\_\_

NAME \_\_\_\_\_

ADDRESS \_\_\_\_\_

CITY \_\_\_\_\_ STATE \_\_\_\_\_ ZIP \_\_\_\_\_

Signature \_\_\_\_\_

**WORD COUNT:** Include name and address. Name of city (Des Moines) or of state (New York) counts as one word each. Zip Code numbers not counted. (Publisher reserves right to omit Zip Code if space does not permit.) Count each abbreviation, initial, single figure or group of figures or letters as a word. Symbols such as 35mm, COD, PO, AC, etc., count as one word. Hyphenated words count as two words.

PE-769

## INSTRUCTION

**LEARN ELECTRONIC ORGAN SERVICING** at home all makes including transistor. Experimental kit—trouble-shooting. Accredited NHSC. Free booklet. **NILES BRYANT SCHOOL**, 3631 Stockton, Dept. A. Sacramento, Calif. 95820.

**FCC First Class License** in six weeks—nation's highest success rate—approved for Veterans Training. Write **Elkins Institute**, 2603B Greenwood Road, Dallas, Texas 75235.

**R.E.I.'s** famous (5) week course for the First Class Radio Telephone License in the shortest, most effective course in the nation. Over 98% of R.E.I. graduates pass F.C.C. exams for 1st class license. Total tuition \$360.00. Job placement free. Write for brochure. **Radio Engineering Incorporated Schools**, 1336 Main Street, Sarasota, Florida 33577—or 3123 Gillham Road, Kansas City, Missouri 64109—or 809 Caroline Street, Fredericksburg, Virginia 22401—or 625 E. Colorado Street, Glendale, California 91205.

**FCC FIRST CLASS LICENSE THROUGH TAPE RECORDED LESSONS.** Our seventeenth year teaching FCC license courses. Radio License Training, 1060D Duncan, Manhattan Beach, Calif. 90266.

**DEGREE** in Electronics Engineering earned mostly by correspondence. Free brochure. Dept. G-9, **Grantham School of Engineering**, 1505 N. Western Ave., Hollywood, California 90027.

**HIGHLY** effective home study courses in Electronics Engineering Technology and Electronics Engineering Mathematics. Earn your degree. Write for Free Descriptive Literature. **Cook's Institute of Electronics Engineering** (Dept. 16), P.O. Box 10634, Jackson, Miss. 39209. (Established 1945.)

**LEARN WHILE ASLEEP**, Hypnotize! Strange catalog free. Auto-suggestion, Box 24-ZD, Olympia, Washington 98501.

**YOU CAN LEARN ELECTRONICS—GUARANTEED** write to **Adamson Educational Services**, 921 South Fircroft, West Covina, Calif. 91790.

## INVENTIONS WANTED

**INVENTORS** wanted. Patented, unpatented. **Global Marketing Service**. 2420-P 77th, Oakland, Calif. 94605.

**PATENT** Searches including Maximum speed, full airmail report and oldest patent copies, \$6.00. Quality searches expertly administered. Complete secrecy guaranteed. Free Invention Protection forms and "Patent Information." Write Dept. 9, **Washington Patent Office Search Bureau**, 711 14th Street, N.W., Washington, D.C. 20005.

**INVENTORS.** We will develop, help sell your idea or invention, patented or unpatented. Our national manufacturer clients are urgently seeking new items for outright cash sale or royalties. Financial assistance available. 10 years proven performances. For free information, write Dept. 41, **Wall Street Invention Brokerage**, 79 Wall Street, New York, N.Y. 10005.

**INVENTORS! OUR FREE EXPERT ANALYSIS** of your invention can save valuable time, help you realize full sale value. Strictly confidential. **FREE INVENTION CERTIFICATE.** Write today: **Pioneer Invention Service**, Dept. 35, 150 Broadway, New York, N.Y. 10038.

**INVENTORS!** Sell your invention for cash or royalties! Our client manufacturers eagerly seek new items. Patented. Unpatented. Financial assistance if needed. 25 years proven performances. For free information, write Dept 20, **Gilbert Adams, Invention Broker**, 80 Wall St., New York, N.Y. 10005.

**FREE "Directory of 500 Corporations Seeking New Products."** For information regarding development, sale, licensing of your patented/unpatented invention. Write: **Raymond Lee Organization**, 230-GR Park Avenue, New York City 10017.

**INVENTORS:** Protect your ideas! Free "Recommended Procedure". **Washington Inventors Service**, 422T Washington Building, Washington, D.C. 20005.

**PATENT SEARCHES**, including copies of related United States Patents. Inventors, attorneys, manufacturers use our "World-Wide" Airmail service Free: "Invention Record" form and "Information Every Inventor Needs", **Hayward Company**, 1029HR Vermont, Washington, D.C. 20005.

**FREE PAMPHLET:** "Tips on Safeguarding Your Invention." Write: **United States Inventors Service Company**, 501-H Thirteenth Street N.W., Washington, D.C. 20004.

## GOVERNMENT SURPLUS

**JEEPS** Typically From \$53.90 . . . Trucks From \$78.40 . . . Boats, Typewriters, Airplanes, Multimeters, Oscilloscopes, Transceivers, Electronics Equipment. **Wide Variety, Condition, 100,000 Bid Bargains Direct From Government Nationwide Complete Sales Directory and Surplus Catalog \$1.00.** (Deductible First \$10.00 Order). **Surplus Service**, Box 820-J, Holland, Michigan 49423.

**GOVERNMENT Surplus How and Where to Buy in Your Area.** Send \$1.00 to: **Surplus Information PE**, Headquarters Building, Washington, D.C. 20036.

**HIGH-AMPERAGE** low voltage 750VA transformer. 24/12 volts 30/60 amps from 115/230 \$10.00. **Nicklecad Batteries 4 AH \$1.95 8 AH \$2.50.** Free catalog with order. **Arrow Sales**, 2534 S. Michigan, Chicago, Illinois 60616.

## BOOKS

**FREE** catalog 950 aviation/electronic/space books. **Aero Publishers**, 329PE Aviation Road, Fallbrook, California 92028.

**UNUSUAL** Books! Catalog free! **International**, Box 7798 (PE), Atlanta, Georgia 30309.

**AMAZING** self help books. Write **Lynn**, Box 1573, Waco, Texas 76703.

**FREE** Book **Prophet Elijah Coming Before Christ.** Wonderful Bible Evidence. **PE Megiddo Mission**, Rochester, New York 14619.

## MAGAZINES

**BACK DATE MAGAZINES!** Send needs. **Midtown**, Box 917-PE, Maywood, N.J. 07607.

**MAGIC MAGAZINE**—Monthly since 1936. 44 pages. All phases. 3 month trial \$1.00. **Genii**, P.O. Box 36068, Los Angeles, CA 90036.

## AUTHORS' SERVICES

**AUTHORS!** Learn how to have your book published, promoted, distributed. **FREE** booklet "ZD." **Vantage**, 120 West 31 St., New York 10001.

## HYPNOTISM

**FREE** Hypnotism, Self-Hypnosis, Sleep Learning Catalog! **Drawer H400, Ruidoso, New Mexico 88345.**

**"MALE-FEMALE HYPNOTISM" EXPOSED, EXPLAINED! "SECRET METHOD"—THEY NEVER KNOW! \$2, RUSHED, GUARANTEED!** **ISABELLA HALL, SILVER SPRINGS, FLORIDA 32688.**

**HYPNOTIC** sleep learning recordings produce fabulous results. Details Free. **ASR Foundation**, Box 7021eg Henry Clay Station, Lexington, Ky. 40502.

**HYPNOTIZE YOURSELF—FRIENDS—EVEN PERFECT STRANGERS SUCCESSFULLY!** Improve memory, habits, dieting etc. **EFFECTIVE 3-WAY RECORDING and ILLUSTRATED COURSE \$5.95. RESULTS ABSOLUTELY GUARANTEED!** **Dr. H. Arthur Fowler**, Box 4396, Woodbury, New Jersey 08096.

**HYPNOTIZE MALES, FEMALES!**—Unnoticed! Quickly! Nerves! Exciting! \$2.25. **Research Enterprises**, 29-SN21 Samoset, Woburn, Mass. 01801.

## MAGNETS

**MAGNETS.** All types. Special—20 disc magnets, or 2 stick magnets, or 10 small bar magnets, or 8 assorted magnets, \$1.00 **Maryland Magnet Company**, 5412-H Gist, Baltimore, Maryland 21215.

**MAGNETISM** (100) page script newly discovered magnetic principles (\$3.00). **Jesse Costa**, Box, Waquoit, Mass. 02536.

## PHOTOGRAPHY—FILM, EQUIPMENT, SERVICES

**MEDICAL** Film—Adults Only—"Childbirth"—1 reel 8 mm \$7.50—16mm \$14.95. **International-E**, Greenvale, L.I., New York 11548.



**SCIENCE** Bargains Request Free Giant Catalog "CJ"—148 pages—Astronomical Telescopes, Microphones, Lenses, Binoculars, Kits, Parts. War surplus bargains. Edmund Scientific Co., 300 Edscorp Bldg., Barrington, New Jersey 08007.

**FINE GRAIN PROCESSING** 90¢. B&W 8x10's 75¢. 35mm **SPECIALISTS**, P.O.B. #5871, Pasadena, Calif. 91107.

## RECORDS

**SPECIAL INTEREST RECORDS AVAILABLE, PRODUCED BY THE EDITORS OF THE WORLD'S LEADING SPECIAL INTEREST MAGAZINES. SEND FOR FREE CATALOG. RECORD CATALOG-PE ZIFF-DAVIS PUBLISHING COMPANY, ONE PARK AVENUE, NEW YORK, N.Y. 10016.**

**OLDIES**—45RPM original hits. Over 4000 available. C & S Record Sales, Box 197, Wampsville, N.Y. 13163.

## PRINTING

**FREE LITERATURE:** Address labels, business cards, printing, Rubber Stamps. **JORDAN's**, 552 West O'Connor, Lima, Ohio 45801.

## EMPLOYMENT INFORMATION

**FOREIGN and USA** job opportunities available now. Construction, all trades. Earnings to \$3,000.00 monthly. Paid overtime, travel bonuses. Write: Universal Employment, Woodbridge, Conn. 06525.

## BUSINESS OPPORTUNITIES

**INVESTIGATE ACCIDENTS:** Earn to \$1000 monthly. Men urgently needed. Car furnished. Business expenses paid. No selling. No College education necessary. Pick own job location. Investigate full time or earn to \$8 hour spare time. Write for **FREE** information. No obligation. Universal Schools, CZ-7, 6801 Hillcrest, Dallas, Texas 75205.

**RAISE** Rabbits for us on \$500 month plan. Free details. White's Rabbitry, Mt. Vernon, Ohio 43050.

**FREE CATALOGS.** Repair air conditioning, refrigeration. Tools, supplies, full instructions. Doolin, 2016 Canton, Dallas, Texas 75201.

**PIANO TUNING** learned quickly at home. Tremendous field! Musical knowledge unnecessary. GI Approved. Free Information. Empire School, Miami, Florida 33145.

**FREE** Book "990 Successful little known Businesses" Work home. Plymouth 345G, Brooklyn, N.Y. 11218.

**ELECTROPLATING** Equipment and supplies. All types for home workshops and industrial. Send \$2.00 (refundable) for equipment guide formulas, operating data, catalog. HBS Equipment Division 90, 3543 East 16th, Los Angeles, California 90023.

**I MADE \$40,000.00** Year by Mailorder! Helped others make money! Start with \$10.00—Free Proof. Torrey, Box 318-N, Ypsilanti, Michigan 48197.

**\$200.00 DAILY** In Your Mailbox! Your opportunity to do what mail-order experts do. Free details. Associates, Box 136-J, Holland, Michigan 49423.

**SELL HERTEL BIBLES**—Part Time. Finest reference Bible available. Demonstrator and supplies furnished. Excellent commissions, Write International Book, Dept. PE, Box 118, Wichita, Kansas 67201.

**MAILORDER . . .** Stop Looking! Start Your Own Business! Methods, 1416-F.D., Lafayette Hill, Pennsylvania 19444.

**SMALL BUSINESS MONEY.** \$500 to \$200,000 loans. Helped others—free details. Counselor-48, Kerrville, Texas 78028.

## PLASTICS

**NEW** Liquid Plastic hardens like glass without heat. Clear, Colors. Embed real flowers, photos, coins. Create unusual craft objects for big profits at home. Illustrated. **HOW** Booklet—25¢. Dept. 9/105H, **CASTOLITE**, Woodstock, Ill. 60098.

## CHEMICALS

**CHEMICAL** lists \$1.00. Deductible first order. Spectro, 1354 Ellison, Louisville, Kentucky 40204.

# POPULAR ELECTRONICS SUBSCRIBER SERVICE

Please include an address label when writing about your subscription to help us serve you promptly. Write to: Portland Pl., Boulder, Colo. 80302

### CHANGE OF ADDRESS:

Please let us know you are moving at least four to six weeks in advance. Affix magazine address label in space to the right and print new address below. If you have a question about your subscription, attach address label to your letter.

**TO SUBSCRIBE:** Check below.

5 yrs. \$20  3 yrs. \$13

1 yr. \$5  New  Renewal

**Specify:**  Payment enclosed

You get 1 extra issue per year as a **BONUS!**

Bill me later.

If you have no label handy, print OLD address here.

name \_\_\_\_\_  
address \_\_\_\_\_  
city \_\_\_\_\_  
state \_\_\_\_\_ zip code \_\_\_\_\_

please print

name \_\_\_\_\_  
address \_\_\_\_\_  
city \_\_\_\_\_  
state \_\_\_\_\_ zip code \_\_\_\_\_

0356

← AFFIX LABEL →

print name \_\_\_\_\_

address \_\_\_\_\_

city \_\_\_\_\_

state \_\_\_\_\_ zip code \_\_\_\_\_

Add'l postage: \$1 per year outside U.S., its possessions & Canada.

## STAMPS

**HOW** to start collecting profitably. Offers, free premiums. 25 outer space, weird countries. Everything 25¢. RoCo Stamps, Box 9523-D3, Phoenix, Arizona 85020.

## REAL ESTATE

**FREE . . .** Big **SUMMER CATALOG!** Describes and pictures hundreds of farms, ranches, town and country homes, businesses coast to coast! Specify type property and location preferred. Zip code, please. **UNITED FARM AGENCY**, 612-EP West 47th St., Kansas City, Mo. 64112.

## MISCELLANEOUS

**WINEMAKERS:** Free illustrated catalog of yeasts, equipment. Semplex, Box 12276, Minneapolis, Minn. 55412.

**BILLS** paid without borrowing—Nobody refused up to \$10,000.00. Bad credit no problem, not a Loan Company. Write for free application. **INTERNATIONAL ACCEPTANCE**, Dept. 50-A, 5133 N. Central Ave., Phx., Arizona 85012; 2511 E. 46th Street, Indianapolis, Ind., 46205; 711 14th St., N.W., Washington, D.C. 20005; 507 Carondelet St., New Orleans, La. 70130.

**MAKING** household fabrics flame resistant. Easy. Send \$1.00. Share Ent., P.O. Box 277, Hollywood, Calif. 90028. Dept. 1A.

**CALENDAR MATHEMATICS.** Entertain friends. Oscar Manzano, 1844 S. Fairfield St., Chicago, Ill. 60608.

**STAMMER**—Stutter—No more. (Dr. Young.) Write Gaucho, Box 9309-E8, Chicago 60690.

**BEERS, PEACH BRANDY, WINES**—Strongest Formulas, \$2.25. (hydrometers and brew supplies catalog included)—Research Enterprises, 29-D Samoset, Woburn, Mass. 01801.

# Olson



**\* FREE**

Fill in coupon for a **FREE** One Year Subscription to **OLSON ELECTRONICS'** Fantastic Value Packed Catalog—Unheard of **LOW, LOW PRICES** on Brand Name Speakers, Changers, Tubes, Tools, Stereo Amps, Tuners, CB, and other Values. Credit plan available.

NAME \_\_\_\_\_  
 ADDRESS \_\_\_\_\_  
 CITY \_\_\_\_\_ STATE \_\_\_\_\_  
 GIVE ZIP CODE \_\_\_\_\_

If you have a friend interested in electronics send his name and address for a **FREE** subscription also.

## OLSON ELECTRONICS

423 S. Forge Street Akron, Ohio 44308

CIRCLE NO. 22 ON READER SERVICE PAGE

**new deluxe**

# CB MINI-BEAM

Gamma 323 Miniature  
 3-Element CB Beam  
 with deluxe coils -  
 Mini-Size, Mini-Cost,  
 Maxi-Performance.  
 Sound too good to  
 be true? Get the  
 whole story . . .

From  
**Mosley**

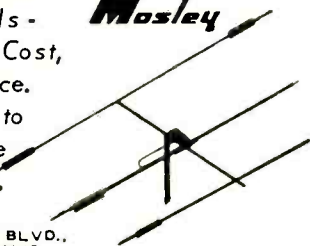

4610 N. LINDBERGH BLVD.,  
 BRIDGETON MD. 63042

Please send me **FREE** information about the new Mosley Deluxe Mini-Beam.

Name \_\_\_\_\_

Address \_\_\_\_\_

City/State \_\_\_\_\_ Zip \_\_\_\_\_

**#173A**

**Mosley Electronics Inc.** 4610 N. Lindbergh Blvd.,  
 Bridgeton Missouri 63042

CIRCLE NO. 20 ON READER SERVICE PAGE

## POPULAR ELECTRONICS

JULY 1969

### ADVERTISERS INDEX

#### READER

SERVICE NO.	ADVERTISER	PAGE NO.
1	AMECO, Division of Aerotron, Inc. ....	96
2	Antenna Specialists Co., The .....	9
3	Argos Products Company .....	8
	Bell & Howell Schools .....	7
5	Burstein-Applebee Co. ....	98
	CREI, Home Study Division, McGraw-Hill Book Company .....	36, 37, 38, 39
6	Career Academy .....	10
7	Cleveland Institute of Electronics .....	94
8	Cleveland Institute of Electronics ...	54, 55, 56, 57
4	Cobra .....	14
	Computer Products .....	99
9	Cook's Institute of Electronics Engineering ...	99
10	Courier Communications Inc. ....	23
12	Coyne Electronics Institute .....	98
13	Edison Instruments .....	97
14	Edmund Scientific Co. ....	8
11	EICO Electronic Instrument Co., Inc. ....	FOURTH COVER
15	Electro-Voice Inc. ....	6
	Federal Oil Lease Service .....	99
	Grantham School of Electronics .....	5
27	Heath Company .....	16, 17
16	Intratec .....	12
17	Johnson Company, E.F. ....	13
18	Lafayette Radio .....	100
20	Mosley Electronics, Inc. ....	106
21	Multicore Sales Corp. ....	97
	National Radio Institute ..	SECOND COVER, 1, 2, 3
	National Technical Schools .....	18, 19, 20, 21
22	Olson Electronics .....	106
23	Pickering & Company .....	26
24	RCA Electronic Components & Devices .....	25
	RCA Electronic Components & Devices .....	THIRD COVER
	RCA Institutes .....	72, 73, 74, 75
25	Sonar Radio Corporation .....	93
	Valparaiso Technical Institute .....	99
26	Weller Electric Corp. ....	11

CLASSIFIED ADVERTISING 101, 102, 103, 104, 105

Printed in the U.S.A.

POPULAR ELECTRONICS



## On a color TV Service Call... GO BY THE BOOK!

Speed up your trouble-shooting and routine service adjustments on 15 makes of 1967 and 1968 model color TV sets with this remarkable book. All the data you usually need on a color service call is right here. Just look up the chassis number of the

set you're working on in the Chassis Index and you'll be guided to the proper sections of the Handbook. Chassis layouts...purity and convergence adjustments...and so much more...you'll find it indispensable for servicing color sets of

recent make. The RCA Color TV Service Handbook (1A1759) is available from your local RCA Tube Distributor. RCA Electronic Components, Harrison, N. J.

**RCA**

# EICO Makes It Possible

Uncompromising engineering — for value does it!  
You save up to 50% with Eico Kits and Wired Equipment.

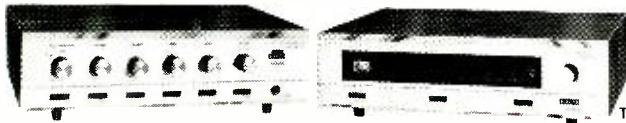

## Cortina Stereo

THE VERDICT IS IN. High fidelity authorities agree:

Cortina's engineering excellence, 100% capability, and compact dramatic esthetics all add up to Total Stereo Performance at lowest cost.

NEW

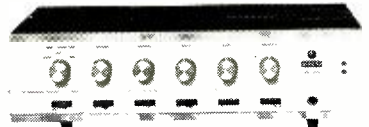

A Silicon Solid-State 70-Watt Stereo Amplifier for \$99.95 kit, \$139.95 wired, including cabinet. Cortina 3070

NEW

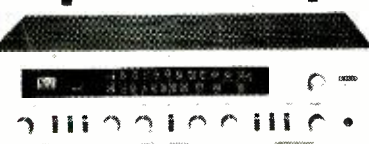

A Solid-State FM Stereo Tuner for \$99.95 kit, \$139.95 wired, including cabinet. Cortina 3200.

A 70-Watt Solid-State FM Stereo Receiver for \$169.95 kit, \$259.95 wired, including cabinet. Cortina 3570.

NEW Silicon Solid State 150-Watt Stereo Amplifier designed for audio perfectionists. Less than 0.1% harmonic distortion, IM distortion. Less than 0.6% at full output. Controls and inputs for every music source. \$149.95 kit, \$225.00 wired including cabinet. Cortina 3150.

NEW 70-Watt Solid State AM/FM Stereo Receiver for \$189.95 kit, \$279.95 wired including cabinet. Cortina 3770.

## Eicocraft

The newest excitement in kits.

100% solid-state and professional.

Fun to build and use. Expandable, interconnectable. Great as "jiffy" projects and as introductions to electronics. No technical experience needed. Finest parts, pre-drilled etched printed circuit boards, step-by-step instructions.

EC-100 Electronic Siren \$4.95, EC-101 Electronic Burglar Alarm \$6.95, EC-102 Electronic Fire Alarm \$6.95, EC-200 Electronic Intercom \$5.95, EC-300 Audio Power Amplifier \$5.95, EC-400 Electronic Metronome \$3.95, EC-500 Tremolo \$9.95, EC-600 Electronic Light Flasher \$3.95, EC-700 Electronic "Mystifier" \$4.95, EC-800 Photo Cell Nite Lite \$4.95, EC-900 Power Supply \$8.95, EC-1000 Code Oscillator \$2.50, EC-1100 FM Wireless Mike \$9.95, EC-1200 AM Wireless Mike \$9.95, EC-1300 Electronic VOX \$8.95, EC-1400 Solid State FM Radio \$9.95, EC-1500 Solid State AM Radio \$8.95, EC-1600 Electronic Bongos \$7.95

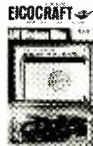

### 6 EXCITING NEW PROJECTS

EC-1700 Ham / CB Vox \$8.95,  
EC-1800 Electronic "TOX" \$8.95,  
EC-1900 "Treasure Finder" \$9.95,  
EC-2000 Electronic Organ \$9.95,  
EC-2100 Electronic "Eye" \$9.95,  
EC-2200 Electronic Touch Switch \$8.95

## Color n' Sound

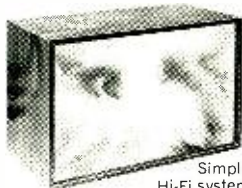

Add a new dimension to your music system. Introducing the first inexpensive solid-state electronic system which provides true synchronization of color with sound. Watch the music you love spring to life as a vibrant, ever shifting interplay of colors.

Simply connect to speaker leads of your Hi-Fi system (or radio). Kit can be assembled in several hours — no technical knowledge or experience necessary. Kit \$49.95, Wired \$79.95.

## Automotive

EICO 888—Car/Boat Engine Analyzer.

For all 6V/12V systems; 4, 6, 8-cyl. engines.



Now you can keep your car or boat engine in tip-top shape with this solid-state, portable, self-powered universal engine analyzer. Completely tests your total ignition/electrical system.

Complete with a Tune-up & Trouble-shooting Manual. Model 888; \$49.95 kit, \$69.95 wired.

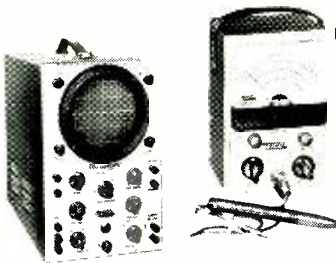

## Test Equipment

100 best buys to choose from.

"The Professionals"  
—laboratory precision at lowest cost.

Model 460 Wideband Direct-Coupled 5" Oscilloscope. DC-4.5mc for color and B&W TV service and lab use. Push-pull DC vertical amp., bal. or unbal. input. Automatic sync limiter and amp. \$99.95 kit, \$149.95 wired.

Model 232 Peak-to-Peak VTVM. A must for color or B&W TV and industrial use. 7 non-skip ranges on all 4 functions. With exclusive Uni-Probe.® \$34.95 kit, \$49.95 wired.

### FREE 1969 CATALOG

PE-7

EICO Electronic Instrument Co., Inc.  
283 Malta Street, Brooklyn, N.Y. 11207

Send me FREE catalog describing the full EICO line of 200 best buys, and name of nearest dealer.

Name \_\_\_\_\_

Address \_\_\_\_\_

City \_\_\_\_\_

State \_\_\_\_\_ Zip \_\_\_\_\_