

BUILD TOP-QUALITY STEREO PREAMP

POPULAR ELECTRONICS

MAY
1969

50
CENTS



- **HOW TO SORT BARGAIN TRANSISTORS**
- **"SUSTAIN" FOR ELECTRIC GUITARS**
- **CAMPER'S 12-TO-117-VOLT POWER INVERTER**
- **BUILD SLOT CAR WIN DETECTOR**
- **BIGGER-THAN-LIFE SPEAKER SYSTEM**
- **AM TUNER USES VARICAPS**
- **BUILD SCR CHECKER**



STEREO PREAMP
(see page 27)

Discover the ease and excitement of learning Electronics with programmed equipment NRI sends you

When you train at home with NRI, you train with your hands as well as your head. You learn the WHY of Electronics, Communications, TV-Radio the NRI pioneering "3-Dimensional" way. NRI training is the result of more than half a century of simplifying, organizing, dramatizing subject matter, and providing personal services unique for a home study school. You get the kind of technical training that gives you priceless confidence as you gain experience equal to many, many months of training on the job.



NRI—The 53 Year Leader in Electronics Training

APPROVED UNDER NEW GI BILL

If you served since January 31, 1955, or are in service, check GI line in postage-free card.

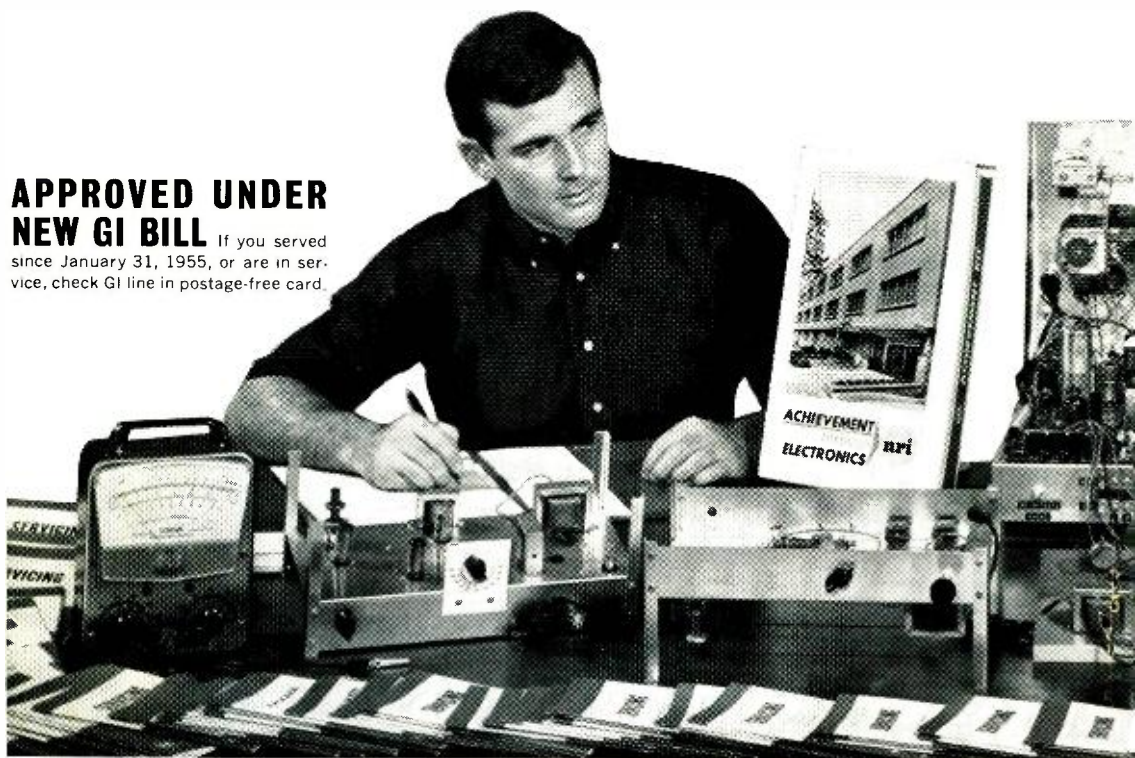

*Earn \$5 or more an hour
spare or full time in*

TV-RADIO SERVICING

Color Television has arrived. Sales are soaring, along with the continuing popularity of other home entertainment equipment like portable radios, tape recorders, hi-fi sets, phonographs and auto radios. TV-Radio servicing is one of your best routes to spare-time earnings, a good paying job or a business of your own. NRI not only trains you quickly and expertly, but also shows you how to get started in Servicing soon after you enroll, earning as you learn. NRI trains you in today's methods of installing and repairing all Electronic equipment for the home—including booming Color TV. You even build, experiment with and keep to enjoy your own solid-state radio and your choice of black-and-white or Color TV receiver. Like thousands of others, you can be earning \$5 or more an hour extra in spare time starting soon.

*There's money and
success awaiting you in*

BROADCASTING— COMMUNICATIONS

The experience you gain from intensely practical NRI training in Complete Communications equals as much as two years of training on the job. With NRI, you can train for a choice of careers ranging from mobile, marine and aviation radio to TV broadcasting and space communications. You learn how to install, maintain and operate today's remarkable transmitting and receiving equipment by actually *doing* it. You build and experiment with test equipment, like a VTVM you keep. You build and operate amplifier circuits, transmission line and antenna systems, even build and use a phone-cw transmitter suitable for transmission on the 80-meter amateur band. Whichever of five NRI Communications courses you choose, you prepare for your FCC License exams, and *you must pass your FCC exams or NRI refunds your tuition in full.*

*Move ahead in America's
fast growing industry as*

ELECTRONICS TECHNICIAN

Electronics touches everyone's lives. This vast field of opportunity is open to you with NRI training. Industrial/Military Electronics training—like all NRI courses—prepares you quickly, thoroughly the practical "hands on" way. You build with, and learn to understand the functions of, today's miracle solid-state components like printed circuits, diodes and transistors. You build and experiment with Electronic circuitry used in automation, data processing, ultrasonics, telemetry. Whatever your interest in Electronics, NRI training can fill your needs. Prove to yourself what nearly a million NRI students could tell you . . . that you get more for your money from NRI. Check the postage-free card and mail it today for your FREE NRI Color Catalog. No salesman will call. NATIONAL RADIO INSTITUTE, Electronics Division, Washington, D.C. 20016.

YOU GET MORE FOR YOUR MONEY FROM NRI — Build, test, explore, discover. Everything you see here is included in one NRI course—including Color TV. Other courses equally complete. And you'll be surprised at the low tuition costs. Text for text, kit for kit, dollar for dollar—you get more for your money from NRI.



POPULAR ELECTRONICS

VOLUME 30 NUMBER 5

MAY, 1969

WORLD'S
LARGEST-SELLING
ELECTRONICS
MAGAZINE

SPECIAL CONSTRUCTION PROJECT

BUILD THE FET PREAMP 27 DAN MEYER

It's real hi-fi and stereo

FEATURE ARTICLES

A HOME FOR OHMS 34 A. J. LOWE

Handy for component storage

THE K TABLE 35 GARY VAN DYK

Solves coil winding problems

BUILD SLOT-CAR WIN DETECTOR 41 W. T. LEMEN

End Finish-Line Quarrels

THE LATE, LATE, LATE Q-SO 46 HAROLD E. HOLLAND

BUILD THE SCR TESTER 47 JAMES W. CUCCIA

Weed out faulty units

LOW-COST AC AMMETER 50 NEIL JOHNSON, W2OLU

A "BIGGER-THAN-LIFE" SPEAKER SYSTEM 53 DAVID B. WEEMS

Beef up your bass

TRANSISTOR SORTER 61 RAYMOND F. ARTHUR

FOR YOUR GUITAR—A COMPRESSION SUSTAINER 63 CRAIG ANDERTON

Big sound like the professionals

BUILD A POWER INVERTER 65 JON COLT

117 volts a.c. from your car battery

ENGLISH-LANGUAGE BROADCASTS TO NORTH AMERICA 68 ROGER LEGGE

VARICAPS 69 A. A. MANGIERI

Voltage-variable capacitors explained

A VARICAP FRONT END AM TUNER 76 A. A. MANGIERI

THE PRODUCT GALLERY 78

Knight-Kit Model KG-645 Multimeter

EICO Model 3440 "Sound n' Color" Organ

SOLID STATE 80 LOU GARNER

AMATEUR RADIO 83 HERB S. BRIER, W9EGQ

Short-skip watching

SHORT-WAVE LISTENING 85 HANK BENNETT, W2PNA

New stations

DEPARTMENTS

LETTERS FROM OUR READERS 8

NEW LITERATURE 12

ELECTRONICS LIBRARY 14

READER SERVICE PAGES 15

NEW PRODUCTS 22

POPULAR ELECTRONICS is indexed
in the Readers' Guide
to Periodical Literature

Copyright © 1969 by ZIFF-DAVIS PUBLISHING COMPANY. All rights reserved.

POPULAR ELECTRONICS, May 1969, Volume 30, Number 5, Published monthly at 307 North Michigan Avenue, Chicago, Illinois 60601. One year subscription rate for U.S., P.S., Possessions and Canada, \$5.00; all other countries, \$6.00. Second class postage paid at Chicago, Illinois and at additional mailing offices. Authorized as second class mail by the Post Office Department, Ottawa, Canada and for payment of postage in cash. Subscription service and Forms 3579; Portland Place, Boulder, Colorado 80302. Editorial offices for manuscript contributions, reader inquiries, etc.: One Park Ave., New York, N.Y. 10016.

This month's cover photo by
Justin Kerr



Pat Powers, Computer Technology



Ronald Wanat, Circuitry Design



Tom Geary, Automation



Robert Kastiger, Broadcasting

These 4 successful men all got started the same way: they sent in a coupon like this

DE VRY INSTITUTE OF TECHNOLOGY
4141 BELMONT AVE. CHICAGO, ILL. 60641

PE-5Z

BELL & HOWELL SCHOOLS

Please send free booklets and information about careers in electronics. I am interested in the following fields (check one or more).

Nuclear Instrumentation Testing
 Automation
 Broadcasting/telecasting
 Radar
 TV-radio service

Name _____ Age _____

Address _____ Apt. _____

City _____ State _____ County _____ Zip Code _____

Veterans: Check here. If you were discharged after Jan. 31, 1955, the "G. I. Bill" may cover the entire cost of your tuition. 118

Why don't you?

Accredited Member, National Home Study Council

DE VRY INSTITUTE OF TECHNOLOGY
4141 BELMONT AVE., CHICAGO, ILL. 60641

BELL & HOWELL SCHOOLS

If you plan to spend less than \$79.50 for a record changer, you're reading the wrong magazine.



Most of the people who read this magazine know that you can't get high fidelity sound from a cheap record changer. Or the peace of mind that comes with knowing that your records are being handled with precision and care.

If you spend less than \$79.50 (the price of the Dual 1212) you won't get a changer that will track a high-compliance cartridge at one gram, flawlessly. Or compensate precisely for skating.

Cheaply made record changers tend to be plagued by audible rumble, wow and flutter. (Rumble, wow and flutter of the Dual 1212 easily surpass NAB standards for broadcast turntables.)

And no cheap changer includes a feathertouch cueing system. Or a variable-speed pitch control that lets you "tune" any record over a half-tone range.

So if you want a high fidelity record changer, and you're willing to spend a few extra dollars to get one, you've just read the right ad.

United Audio Products, Inc.
535 Madison Ave., 
New York, N.Y. 10022.

POPULAR ELECTRONICS

PHILLIP T. HEFFERNAN
Publisher

OLIVER P. FERRELL
Editor

LESLIE SOLOMON
Technical Editor

JOHN R. RIGGS
Managing Editor

EDWARD I. BUXBAUM
Art Director

ALEXANDER W. BURAWA
Associate Editor

ANDRE DUZANT
Technical Illustrator

PATTI MORGAN
Assistant Editor

AURORA NARDOZZI
Editorial Assistant

H. BENNETT, W2PNA
H. S. BRIER, W9EGQ

L. E. GARNER, JR.

M. P. SPINELLO, KMC2060
Contributing Editors

RICHARD J. HALPERN
Advertising Manager

ARDYS C. MORAN
Advertising Service Manager

LAWRENCE SPORN
Associate Publisher

ZIFF-DAVIS PUBLISHING COMPANY

Editorial and Executive Offices

One Park Avenue, New York, New York 10016
212 679-7200

Midwestern Office

307 North Michigan Avenue, Chicago, Illinois 60601
312 726-0892

Midwestern Advertising Manager, JAMES WEAKLEY
GERALD L. TAYLOR

Western Office

9025 Wilshire Boulevard, Beverly Hills, California 90211
213 CRestview 4-0265; BRadshaw 2-1161

Western Advertising Manager, BUD DEAN

Japan: James Yagi

Ishikawa Mansian, #4, Sakuragaoka
Shibuya-ku, Tokyo, 462-2911-3

Circulation Office

Portland Place, Boulder, Colorado 80302

William Ziff, President

W. Bradford Briggs, Executive Vice President

Hershel B. Sarbin, Senior Vice President

Philip Sine, Financial Vice President

Walter S. Mills, Jr., Vice President, Circulation

Stanley R. Greenfield, Vice President, Marketing

Phillip T. Heffernan, Vice President, Electronics Division

Frank Pomerantz, Vice President, Creative Services

Arthur W. Butzow, Vice President, Production

Edward D. Muhlfeld, Vice President, Aviation Division

Irwin Rabinson, Vice President, Travel Division

Furman Hebb, Administrative Vice President

George Morrissey, Vice President

Sydney H. Rogers, Vice President

Ziff-Davis also publishes Airline Management and Marketing, Boating, Business & Commercial Aviation, Car and Driver, Cycle, Electronics World, Flying, Modern Bride, Popular Photography, Skiing, Skiing Area News, Skiing Trade News, Stereo Review, and Travel Weekly.

Forms 3579 and all subscription correspondence should be addressed to POPULAR ELECTRONICS, Circulation Department, Portland Place, Boulder, Colorado 80302. Please allow at least six weeks for change of address. Include your old address, as well as new-enclosure if possible on address label from a recent issue.

EDITORIAL CONTRIBUTIONS must be accompanied by return postage and will be handled with reasonable care; however, publisher assumes no responsibility for return or safety of art work, photographs or manuscripts.



Member Audit Bureau
of Circulations

CIRCLE NO. 27 ON READER SERVICE PAGE

POPULAR ELECTRONICS



**Experimenters
Hobbyists
Servicemen**

Whatever your direction, let RCA show you the way

...with RCA's New Linear IC Variety Pack—KD2117

Here's a great way to extend your integrated circuit know-how—Kit KD2117 provides a basic introduction to practical applications of these intriguing devices and an inexpensive way to build useful projects. The pack includes 2 KD2114 transistor arrays; 1 KD2115 audio amplifier; 2 KD2116 transistor arrays. Also, instructions for 12 useful circuits, schematics, parts lists, etc.

...with New Crystal and Zener Diodes

In addition to its quality line of SK replacement transistors, rectifiers, and integrated circuits, RCA now offers 4 zener diodes and 5 crystal diodes!

...with RCA Hobby Circuits News, HCN-3900

This is an exciting new publication loaded with interest for hobbyists and experimenters...published periodically.

...with KD Experimenter's Kits, Manuals, and Publications

Your RCA Distributor can be your one-source headquarters for Experimenter's Kits, Hobby and Experimenter Manuals, Hobby Circuits News, and RCA's Solid-State Replacement Guide, SPG-202G, a cross reference for almost 13,000 solid-state devices that RCA's SK's replace. Available from your RCA Distributor. RCA Electronic Components, Harrison, N.J. 07029

letters

FROM OUR READERS

LET THERE BE PEACE

I was certainly surprised to find an article such as C.H. Allen's "The Hatfield Hams and the CB McCoys," but my surprise rapidly turned to disgust finding it in such an outstanding magazine as *POPULAR ELECTRONICS* (February 1969). The article seems to lack purpose and, in my opinion, was poorly presented. Why anyone wants to picture hams and legitimate CB'ers as hillbillies is way beyond my comprehension. Also, how any CB'er could possibly be able to handle emergency traffic when 22 out of the 23 CB channels are being used illegally at any given instant is another enigma that defies an answer.

The time to clean up the 11-meter mess should be now, with some articles advising CB'ers on how to operate in a legitimate manner before the FCC orders all CB activity on the band to come to a halt.

J. HANLEY, WN8ZJP
Rochester, Mich.

I became interested in radio communications a few years ago when I received a set of walkie-talkies as a Christmas present. You can imagine how happy I was being able to speak via radio to a friend a few yards away and being able to pick up skip from Colorado. This whetted my appetite and, with the help of two friends, I took the test and passed my Novice license a year ago at age thirteen. So far I have made many friends over the air, having met only two of them "in the flesh." I have worked many hams who also hold CB licenses, and I respect them all. And in many ways I envy them the two licenses (I plan to get my CB license when I turn 18). This short autobiography is provided to show my active interest in ham and CB radio—and set the stage for throwing in my two-cents worth.

The article "The Hatfield Hams and the CB McCoys" brought out many of the things that are wrong with some hams and CB'ers. Sure, I feel that the FCC should crack down on illegal operations on the CB band—but just because these conditions exist is no reason to blame all CB'ers for them. But if the CB'er can help the police and the community-at-large, by all means let him do so. After all, I'm sure that no ham is so proud that he wouldn't let the CB'er step in after a hurricane has put him off the air.

JAMES H. PELOIAN, WN5KKD
Cutler, Calif.

The Hatfields and McCoys were used in the article only to bring home a point—that a

POPULAR ELECTRONICS

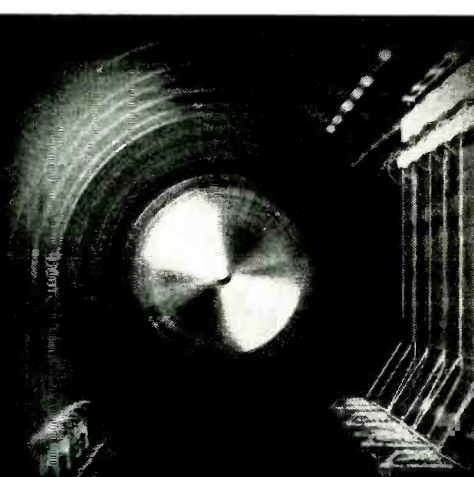

If your record player
today still has
a heavy turntable,
it must have yesterday's motor



Why did Garrard switch from heavy turntables (which Garrard pioneered on automatics) to the scientifically correct low mass turntable on the SL 95? Simply because the synchronous Synchro-Lab™ Motor has eliminated the need for heavy turntables, developed to compensate (by imparting flywheel action) for the speed fluctuations inherent in induction motors. The light, full 1 1/2" aluminum turntable on the SL 95 relieves weight on the center bearing, reduces wear and rumble and gives records proper edge support.

The Synchro-Lab Motor has also made variable speed controls as obsolete as they are burdensome to use. The synchronous section of the motor locks into the rigidly controlled 60 cycle current (rather than voltage) to guarantee constant speed regardless of voltage, warm up, record load and other variables. This means unwavering musical pitch. And the induction section provides instant starting, high driving torque and freedom from rumble.

At \$129.50, the SL 95 is the most advanced record playing unit available today. For Comparator Guide describing all models, write Garrard, Dept. AS138, Westbury, N.Y. 11590.

Garrard®
WORLD'S FINEST

British Industries Co., division of Avnet, Inc.

CIRCLE NO. 17 ON READER SERVICE PAGE

Pump up your mobile installation performance with this

Professional "SPRING" TUNE-UP!

Here's the professional touch to dress up and power up your mobile rig! Famous high-performance, low-noise A/S base loaded design . . . 17-7PH stainless steel whip (bend it in a full circle, snaps back to perfect vertical) . . . fine-tuning adjustment built-in. Functional stainless steel shock spring adds a handsome, professional touch. Famous "Quick-Grip"® trunk mount—no holes to drill, cable completely hidden, permanent installation yet removable!

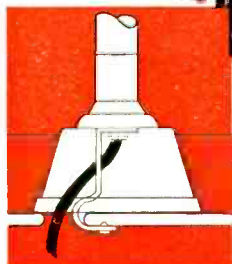
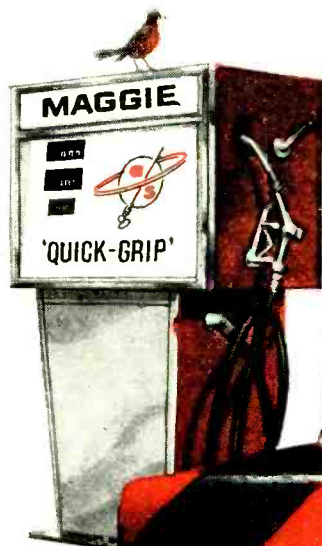

Famous Quick Grip® mount — clamps on trunk lip . . . no holes to drill . . . no soldering . . . cable completely hidden!

MODEL M-176 "MAGGIE MOBILE"

CB antenna. Suggested resale: \$21.95

the antenna specialists co.

Div. of Allen Electric and Equipment Co.
12435 Euclid Ave., Cleveland, Ohio 44106



"Stripes of Quality"®

CIRCLE NO. 3 ON READER SERVICE PAGE

May, 1969

9

NEW AND IMPORTANT SAMS BOOKS

ALL-NEW EDITION OF THE FAMOUS AUDIO CYCLOPEDIA

Completely revised 2nd Edition—the most comprehensive reference now available on audio—by the renowned authority, Dr. Howard W. Tremaine. Fully covers every phase of the subject, including all the latest developments, right down to the newest solid-state and integrated circuits. Contains authoritative, concise explanations of thousands of topics in the fields of acoustics, recording, and reproduction. Virtually a complete reference library on the audio art in a single volume.

Order 20675, only.....\$29.95

Special Pre-Publication Offer. Save—special pre-publication price only \$26.95 (until July 1, 1969)

Transistor Substitution Handbook. New 9th Ed.

Fully updated. Lists thousands of direct substitutions; includes basing diagrams and polarity indications. Covers manufacturers of all transistor types, providing substitutions for U.S. and foreign home entertainment, industrial, and military types. Order 20705, only..\$1.95

Know Your VOM-VTVM. 2nd Ed.

Explains VOM's, VTVM's and solid-state electronic voltmeters in language anyone can understand. Includes full explanations of the circuitry, uses, care and repair of the instruments. Explains how to understand electrical measurements. Order 20676, only..\$3.50

73 Dipole and Long-Wire Antennas

Describes virtually every type of wire antenna; includes dimensions, configuration, and construction data for 73 different types, plus appendices describing construction and operation of noise bridges and antenna line tuners, measuring data, etc.

Order 65071, (Editors & Engineers) only.....\$4.50

Using and Understanding Unijunction Transistors

Explains the construction, operation, and characteristics of the unijunction transistor (UJT). Shows applications and circuits employing UJT's. Separate chapters describe the use of UJT's as oscillators, voltage controls, time delays and flashers, and in sensing circuits. Order 20720, only.....\$2.50

RTL Cookbook

Explains the principles and use of RTL (Resistor-Transistor Logic) digital integrated circuits. Provides the experimenter with an understanding of RTL integrated circuits as they are used in everyday electronic projects. Shows how these circuits work and how to design with them. Order 20715, only.....\$5.25

RECENT BESTSELLING BOOKS

Tube Substitution Handbook. 12th Ed. 20700.....\$1.75
How to Build Speaker Enclosures. 20520.....\$3.50
Citizens Band Radio Handbook. 3rd Ed. 20569.....4.25
Color-TV Servicing Guide. 20358.....4.25
Tape Recorders—How They Work. 2nd Ed. 20445.....4.50
How to Repair Major Appliances. 20650.....4.95
Short-Wave Listener's Guide. 3rd Ed. 20695.....2.25

— HOWARD W. SAMS & CO., INC. —

Order from any Electronic Parts Distributor, or mail to Howard W. Sams & Co., Inc., Dept. PE-5, 4300 W. 62nd St., Indianapolis, Ind. 46268

Send the following books: Nos. _____

_____ \$ _____ enclosed

Send FREE 1969 Sams Book Catalog

Name _____

Address _____

City _____ State _____ Zip _____

CIRCLE NO. 25 ON READER SERVICE PAGE

LETTERS (Continued from page 8)

very real and often serious feud exists between hams and CB'ers. So why not use the best-known example, familiar to all of us, as our analogy?

The CB'er—the one who abides to the letter by all the rules—has more at stake than the ham does when it comes to cleaning up the 11-meter mess. The mess is right on his front doorstep, giving him a bad name he really doesn't deserve.

One gratifying thing: as your editor sifted through the mailbag, it soon became evident that some of the staunchest supporters of the legitimate CB'ers were hams (as Jim's letter demonstrates). And this isn't the first time that's happened—which just goes to show that inroads are being made to resolve the feud.

CHARACTER-TO-CODE CONVERTER

In reference to Ed Petersen's letter ("Letters From Our Readers," July 1968), I thought I would mention that I built a character-to-code converter that your readers might be interested in reproducing. I built my prototype three years ago for a science fair, but it still works very well. The translator sends code at a clear, crisp 16 words/min. The keyboard is a simple wood-and-switch assembly employing plastic keys. And the "memory" circuit consists of a matrix of 96 inexpensive diodes (I used silicon top hats in my prototype, but signal diodes selling for as low as \$1.59 per hundred will work just as well).

For a small fee of fifty cents to cover copying and postage, I will gladly supply any interested reader with completed plans, schematic diagram and parts list. The cost of all the electronic components together should average between \$50 and \$70, depending on where you buy—but you'll find that your investment is well worth it if you work CW a lot.

STEVEN K. ROBERTS, WN4KSW/WPE4JCC
9908 Old Six Mile Lane
Jeffersonstown, Ky. 40299

MANUFACTURER REPLY

While reading through the "Letters From Our Readers" column in the December, 1968, issue, I noticed that one of your readers was asking about an electric shock eliminator. I thought I would pass along the information that the Rucker Electronics "Safety Sentry Fault Circuit Interrupter" is just what Mr. Campbell is looking for. This device has been approved for sale by Underwriters' Laboratories, the Canadian Standards Association, and other leading testing labs.

WILLIAM S. GERRIE
Rucker Electronics
747 Bancroft Way
Berkeley, Calif. 94710

Any reader interested in obtaining information concerning the Rucker Safety Sentry, contact Rucker Electronics direct.

Talk about electronic supermarkets

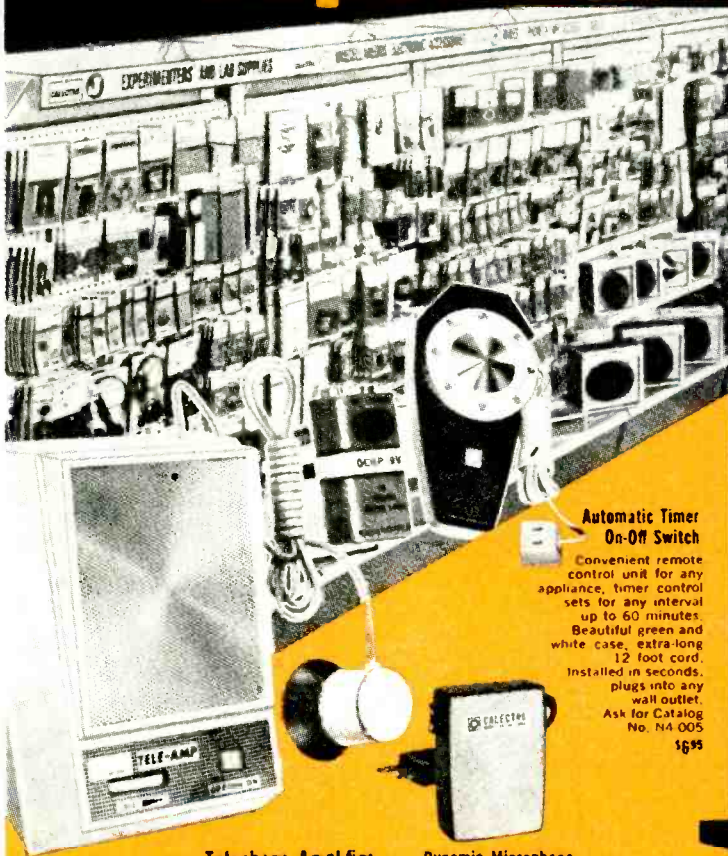

OVER 800 POPULAR, NEW CALECTRO PRODUCTS

for every
household use!

- TEST EQUIPMENT — TOOLS
- EXPERIMENTERS & LAB SUPPLIES
- ELECTRONIC ACCESSORIES
- TAPES — PHONO & TAPE ACCESSORIES
- SPEAKERS & AUDIO ACCESSORIES
- RESISTORS & CONTROLS
- CAPACITORS
- METERS — COILS — RELAYS — TRANSFORMERS
- SWITCHES — LAMPS
- WIRE — CABLES
- ANTENNA HARDWARE
- PLUGS — JACKS — BATTERY HOLDERS

Now at each location, hundreds and hundreds of items for everyone . . . hobbyist, enthusiast, amateur, home owner, executive, do-it-yourselfer. See the SELF-SERVICE G-C CALECTRO display at your CALECTRO ELECTRONIC SUPERMARKET TODAY!

Automatic Timer On-Off Switch

Convenient remote control unit for any appliance, timer control sets for any interval up to 60 minutes. Beautiful green and white case, extra-long 12 foot cord. Installed in seconds, plugs into any wall outlet. Ask for Catalog No. N4-005 \$6.95

Telephone Amplifier for Group Listening

Perfect for family calls at home, conference calls at the office, or "hands-free" operation when taking orders or instructions by phone. Suction cup pickup attaches to outside of phone, brings in conversations loud and clear. Built-in volume control governs loudness. Battery in kit. Ask for Catalog No. N4-103 \$9.95

Dynamic Microphone with switch

For high fidelity recording of words and music. Built in on off switch. Folding desk top stand. Dual plug for most tape recorder inputs. Ask for Catalog No. Q4-186 \$3.95
Frequency Response: 10-8000 cps
Impedance: 700 ohm Sensitivity: -56dB

700 Locations all over the country and Canada

See your electronic parts distributor and SAVE!

LOOK

in the Yellow Pages under "Electronics" and call your Calectro source.



This "G-C CALECTRO HOBBYIST HANDBOOK" is available at G-C CALECTRO ELECTRONIC SUPERMARKETS WRITE TODAY and we'll give you the name of your nearest.



CALECTRO

G-C ELECTRONICS
Division of Hydrometals, Inc.
400 SO. WYMAN ST.
ROCKFORD, ILLINOIS 61101



CIRCLE NO. 28 ON READER SERVICE PAGE

THE TRUTH
about the complete line of
ElectroVoice[®]
HIGH FIDELITY
loudspeakers and electronics.

Over 50 different high fidelity products, including tuners, amplifiers, receivers, speaker systems, and component loudspeakers. Write today.



ELECTRO-VOICE, INC., Dept. 594 P
630 Cecil Street, Buchanan, Michigan 49107

Send my **FREE** product folder on the complete line of Electro-Voice high fidelity components.

Name _____

Address _____

City _____ State _____ Zip _____

CIRCLE NO. 15 ON READER SERVICE PAGE

THE TRUTH
about the
complete line of
ElectroVoice[®]
MICROPHONES



Capsule listings of over 85 microphones for recording, communications, sound reinforcement and radio-TV broadcasting. Send today for this helpful product folder.

ELECTRO-VOICE, INC., Dept. 592 P
630 Cecil Street, Buchanan, Michigan 49107

Send my free product folder on the complete line of Electro-Voice microphones.

Name _____

Address _____

City _____ State _____ Zip _____

CIRCLE NO. 16 ON READER SERVICE PAGE

TAKE ONE



new
literature

To obtain a copy of any of the catalogs or leaflets described below, simply fill in and mail the coupon on page 15.

Now available from *Sencore, Inc.*, is a 12-page catalog listing the company's complete line of advanced electronic test equipment for service and industry. The catalog (No. 458) describes five completely new test instruments including a sweep and marker generator, combination oscilloscope/vectorscope, color bar generator, and two transistor/FET in- or out-of-circuit testers. The other instruments described are field effect meters, tube testers, CRT testers, field-strength meter, and a series of special-purpose instruments. Complete performance data and price listings are provided.

Circle No. 75 on Reader Service Page 15

"The Pacer," a new magazine dedicated to the continuing education of the techno-engineering community and to the distribution of knowledge is now available from *International Correspondence Schools*. Each issue of the new ICS magazine will be devoted to a specific subject in a three-phase format—fundamentals, current applications, and future potentials—by three qualified authorities. "The Pacer" is a bi-monthly publication. It is available for \$15/yr at subscription rates, \$3 in single copies.

Circle No. 76 on Reader Service Page 15

Three groups of fixed and mobile antennas for monitor radio recently introduced by *Hy-Gain Electronics Corp.* are described in a new four-page brochure designated Catalog "D." Listed in the catalog are three mobile and one base antenna for the high band between 130 and 174 MHz, two fixed and one mobile antenna for the low band between 25 and 50 MHz, and three antenna models designed to cover both bands. Models in each group differ mainly in the method of mounting employed. The entire line includes Models MR-1 through MR-9, all of which are factory prepared for optimum performance across all bands specified.

Circle No. 77 on Reader Service Page 15

POPULAR ELECTRONICS

Is Johnson's new 23-channel Messenger 123 at \$169.95 . . . Legal?

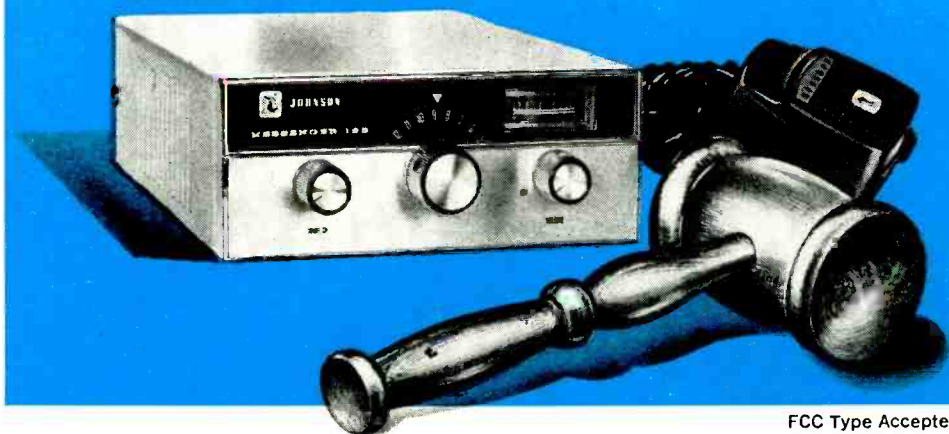

FCC Type Accepted

You be the Judge.

Is it unfair competition for Johnson to produce a 23-channel solid state unit with the incomparable Johnson "talk-power" for less money than you had to pay yesterday for a 12-channel unit with crystals?

Is there a law against operating a rig whose specifications are close to theoretical perfection—such as 0.4 microvolt sensitivity . . . and sharply filtered 7 kHz selectivity?

Is it a crime to build in a special speech compression circuit for unsurpassed voice intelligence? Or the famous Johnson high-efficiency noise limiter that virtually wipes out ignition and other extraneous radiated interference?

We think you'll agree: For sheer value, Messenger 123 is the exception to the rule.

E. F. JOHNSON COMPANY
WASECA, MINNESOTA 56093



Get the last word every time.



Get
Turner's
"+2" series:

+2 base station mike (List Price: \$55.00) and M+2/U mobile mike (List Price: \$39.50). Up to 50 times the modulation of other mikes. No more fade outs. No more static. (Even at great distances). Both "+2" series microphones use a

two-transistor pre-amp and work with all transistor and tube sets. See them at your CB dealer or distributor soon. And get the last word.



TURNER

919-17th Street N.E.,
Cedar Rapids, Iowa 52402
In Canada: Tri-Tel Associates, Ltd.

CIRCLE NO. 55 ON READER SERVICE CARD

ELECTRONICS library

QUIET

POPULAR TUBE & TRANSISTOR SUBSTITUTE GUIDE

If you've ever been confronted with the problem of finding a substitute tube or transistor that is out of production or is available only in a foreign country, you know how welcome a good substitution guide is. Sandwiched between its covers, this book lists some 99% of the tubes and transistors that ever need replacement—along with their substitutes, both foreign and domestic. The book consists of eight sections, equally divided between tubes and transistors. The sections are headed, in numerical order, Popular Receiving Tubes; Industrial and Commercial Tubes; American Substitutes for Foreign Tubes; Tube Circuit and Base Diagrams; Popular Transistors; American Substitutes for Foreign Transistors; General Purpose Transistor Substitutes; and Transistor Base Diagrams and Manufacturer Abbreviations.

Published by Tab Books, Blue Ridge Summit, Pa. 17214. 160 pages. \$4.95 leatherette, \$2.95 paper cover.

LABORATORY COURSE IN PULSE CIRCUITRY

by Joseph B. Berkley, Sr.

This book is especially written to supplement a one-semester sophomore-level course in pulse circuit theory. After a brief presentation of theory, the student is led through a series of experiments requiring observation, comparison, deduction, and conclusions. Then the results of the experiments are reviewed through a series of questions and by the student's completion of reports which test his perceptiveness in relating experimental results to theory and objectives. In effect, the format of the manual forces the student to make decisions and practice logical deduction—both of which are necessary in actual troubleshooting and laboratory work.

Published by Prentice-Hall, Inc., Englewood Cliffs, N.J. 07632. Soft cover. 206 pages. \$7.95.

TRANSISTOR AND DIODE LABORATORY COURSE

by Harry E. Stockman

Structured on engineering concepts and facts, this book develops the course material progressively with preparatory explanations, general discussions, and review questions accompanying each experiment. In the first

(Continued on page 98)

READER SERVICE PAGE

free information service:

Here's an easy and convenient way for you to get additional information about products advertised or mentioned editorially (if it has a "Reader Service Number") in this issue. Just follow the directions below...and the material will be sent to you promptly and free of charge.

1. Print or type your name and address on the lines indicated. Circle the number(s) on the coupon below that corresponds to the key number(s) at the bottom of the advertisement or editorial mention(s) that interest you. (Key numbers for advertised products also appear in the Advertisers' Index.)

2. Cut out the coupon and mail it to the address indicated below.

3. This address is for our product "Free Information Service" only. Editorial inquiries should be directed to POPULAR ELECTRONICS, One Park Avenue, New York 10016; circulation inquiries to Portland Place, Boulder, Colorado 80302.

**POPULAR
ELECTRONICS**

P.O. BOX 8391
PHILADELPHIA, PA. 19101

VOID AFTER JUNE 30, 1969

1 2 3 4 5 6 7 8 9 10 11 12 13 14 15 16 17 18 19 20
21 22 23 24 25 26 27 28 29 30 31 32 33 34 35 36 37 38 39 40
41 42 43 44 45 46 47 48 49 50 51 52 53 54 55 56 57 58 59 60
61 62 63 64 65 66 67 68 69 70 71 72 73 74 75 76 77 78 79 80
81 82 83 84 85 86 87 88 89 90 91 92 93 94 95 96 97 98 99 100

NAME (Print clearly) _____

ADDRESS _____

CITY _____ STATE _____ ZIP CODE _____

5 a

New Kits For Home And Hobby...

NEW
Kit GR-58
\$4795*



Heathkit GR-58 Solid-State AM/FM Clock Radio

An easy way to get up . . . choose news & weather on AM or the bright sound of FM music. AFC for easy FM tuning. Use "Auto" position for only radio, or the "Alarm" setting for alarm & radio. The clock-controlled accessory AC socket will even perk coffee for you in the morning. The "Snooze" button turns off the alarm for 10 minute periods until you move the function switch . . . lets you wake up gradually. Easy circuit board construction. For an easy way to get up, order yours now. 8 lbs.

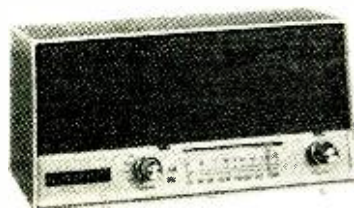

NEW
Kit GR-48
\$3995*

Heathkit GR-48 Solid-State AM/FM Table Radio

An ideal table radio for any room in the house. All solid-state circuitry delivers the same excellent sound as the GR-58 above, but without the clock and alarm functions. An Automatic Frequency Control position on the mode switch locks that FM station in and makes tuning easy. Designer-styled avocado green cabinet with matching grille cloth. Fast, simple circuit board construction. 5 lbs.

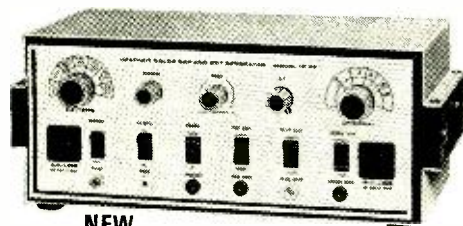

NEW
Kit IG-28
\$7995*

Heathkit IG-28 Solid-State Color-Bar—Dot Generator

The new Heathkit IG-28 is the most advanced instrument of its type available . . . at any price. Computer-type integrated circuitry eliminates divider chain adjustments and instability — no flutter, jitter or bounce . . . ever. Delivers 12 patterns — standard 9x9 dots, cross-hatch, vertical & horizontal lines, color bars & shading bars . . . plus the exclusive Heath "3 x 3" display of all patterns . . . plus a clear raster so necessary for purity adjustments. Also features variable front panel tuning for channels 2 through 6, front panel sync output, two front panel convenience outlets, variable positive or negative video output, built-in gun shorting circuits and grid jacks and vectorscope display capability. 8 lbs.



NEW
kit SB-500
\$17995*

Heathkit SB-500 2-Meter Transverter

The new SB-500 allows owners of Heathkit models SB-101, SB-110A, HW-100 and the SB-301/401 combination to operate on 2-meters without having to buy a complete new rig. It gives complete, reliable SSB & CW facilities from 144 to 148 MHz and features a husky 50 watts output, fast, easy tuning and a 0.2 uV receiver sensitivity. A built-in meter monitors final plate current or relative power. Internal relays eliminate cable changing when switching from LB gear to the SB-500. Step up to "2" now, with the SB-500. 19 lbs.

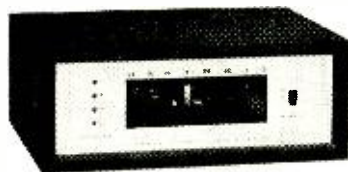

NEW
Kit GD-28
\$5995*

Heathkit GD-28 8-Track Cartridge Tape Player

The new GD-28 is an ideal addition to any home music system. Plays pre-recorded tapes through any system with a Tape Recorder, Tuner or Auxiliary input. Just push in the 8-track stereo cartridge . . . it starts and changes tracks automatically . . . even shows which track is playing. Changes tracks instantly with the front panel switch too. Goes together quickly on one circuit board, and the playing mechanism is preassembled & adjusted. Attractive wood-grained polyurethane cabinet included. Order yours now. 10 lbs.

From The Leader



Now There are 4 Heathkit Color TV's ...
All With 2-Year Picture Tube Warranty

NEW Deluxe "681" Color TV With Automatic Fine Tuning

The new Heathkit "681" is the most advanced color TV on the market. Compare the GR-681 against any other set available, at any price . . . there isn't one that has all of these advanced features . . . Factory assembled Automatic Fine Tuning on all 83 channels that locks in the best color picture in the industry . . . Push-button Power Channel selection on VHF . . . Built-in cable-type remote control for turning set on and off and changing VHF channels . . . Provision for adding Wireless Remote Control at any time . . . Bridge-type low voltage power supply for superior regulation . . . plus the self-servicing features standard on all Heathkit color TV's . . . plus all the features of the GR-295 below. Compare the "681" against the rest . . . and be convinced. 135 lbs.

GRA-295-4, Mediterranean cabinet shown \$119.50*
Other cabinets from \$62.95*

Deluxe "295" Color TV . . . Model GR-295

The GR-295 is packed with performance . . . a top quality American brand 295 sq. in. color tube with improved phosphors and a boosted B + supply deliver brighter, livelier color . . . Automatic degaussing . . . Exclusive Heath Magna-Shield . . . Automatic Color Control & AGC for pure, flutter-free pictures under all conditions . . . preassembled 3-stage IF . . . Deluxe VHF tuner with "memory" fine tuning . . . hi-fi sound output . . . 300 & 75 ohm VHF antenna inputs . . . plus exclusive Heath self-servicing features that can save you hundreds of dollars. 131 lbs.

GRA-295-1, Walnut cabinet shown \$62.95*
Other cabinets from \$99.95*

Deluxe "227" Color TV . . . Model GR-227

Has same high performance & built-in self-servicing features as "295", except for 227 sq. in. screen. And, like the "295", it can be installed three ways — in one of the beautiful Heath factory assembled cabinets, your own custom cabinet or in a wall. 114 lbs.

GRA-227-1, Walnut cabinet shown \$59.95*
Other cabinets from \$36.95*

Deluxe "180" Color TV . . . Model GR-180

The "180" features the same remarkable performance and built-in self-servicing facilities as the "295" except for 180 sq. in. viewing area. Feature for feature, the "180" is easily your best buy in color TV. 102 lbs.

GRS-180-5, table model cabinet and cart \$39.95*
Other cabinets from \$24.95*

Now, Wireless Remote Control For Heathkit Color TV's

New Wireless Remote Control turns your Heathkit color TV on & off, changes VHF channels, adjusts volume, color and tint — all by sonic control. Installs on any rectangular tube Heathkit Color TV, even if you built it years ago. Circuit board/wiring harness construction.

Kit GRA-681-6, 7 lbs., for Heathkit GR-681 Color TV's \$59.95*

Kit GRA-295-6, 9 lbs., for Heathkit GR-295 & GR-25 TV's \$69.95*

Kit GRA-227-6, 9 lbs., for Heathkit GR-227 & GR-180 TV's \$69.95*

Kit GR-681
\$499.95*
(less cabinet)

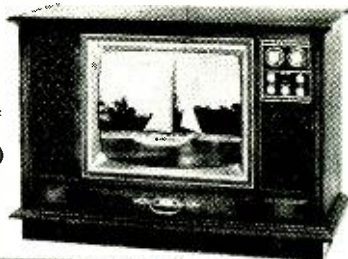

Kit GR-295
\$449.95*
(less cabinet)

Kit GR-227
\$399.95*
(less cabinet)



Kit GR-180
\$349.95*
(less cabinet)



New Wireless
TV Remote Control
For GR-295, GR-227
& GR-180
\$69.95

New Wireless
TV Remote Control
For GR-681
\$59.95



NEW

FREE 1969 CATALOG!

Now with more kits, more color. Fully describes these along with over 300 kits for stereo/hi-fi, color TV, electronic organs, electric guitar & amplifier, amateur radio, marine, educational, CB, home & hobby. Mail coupon or write Heath Company, Benton Harbor, Michigan 49022.



HEATH COMPANY, Dept. 10-5
Benton Harbor, Michigan 49022

Enclosed is \$ _____, plus shipping.

Please send model (s)

Please send FREE Heathkit Catalog.

Please send Credit Application.

Name _____

Address _____

City _____

State _____

Zip _____

*Mail order prices; F.O.B. factory. Prices & specifications subject to change without notice.

CL-356

CIRCLE NO. 18 ON READER SERVICE PAGE

How to get into One of the hottest money-making fields in electronics today— servicing two-way radios!



HE'S FLYING HIGH. Before he got his CIE training and FCC License, Ed Dulaney's only professional skill was as a commercial pilot engaged in crop dusting. Today he has his own two-way radio company, with seven full-time employees. "I am much better off financially, and really enjoy my work," he says. Read here how you can break into this profitable field.

More than 5 million two-way transmitters have skyrocketed the demand for service men and field, system, and R&D engineers. Topnotch licensed experts can earn \$12,000 a year or more. You can be your own boss, build your own company. And you don't need a college education to break in.

HOW WOULD YOU LIKE to start collecting your share of the big money being made in electronics today? To start earning \$5 to \$7 an hour... \$200 to \$300 a week... \$10,000 to \$15,000 a year?

Your best bet today, especially if you

don't have a college education, is probably in the field of two-way radio.

Two-way radio is booming. Today there are more than *five million* two-way transmitters for police cars, fire department vehicles, taxis, trucks, boats, planes, etc. and Citizen's Band uses—

and the number is still growing at the rate of 80,000 new transmitters per month.

This wildfire boom presents a solid gold opportunity for trained two-way radio service experts. Many of them are earning \$5,000 to \$10,000 a year *more* than the average radio-TV repair man.

Why You'll Earn Top Pay

One reason is that the United States Government doesn't permit anyone to service two-way radio systems unless he is *licensed* by the Federal Communications Commission. And there simply aren't enough licensed electronics experts to go around.

Another reason two-way radio men earn so much more than radio-TV service men is that they are needed more often and more desperately. A home radio or television set may need repair only once every year or two, and there's no real emergency when it does. But a two-way radio user must keep those transmitters operating at all times, and *must* have their frequency modulation and plate power input checked at regular intervals by licensed personnel to meet FCC requirements.

This means that the available licensed experts can "write their own ticket" when it comes to earnings. Some work by the hour and usually charge at least \$5.00 per hour, \$7.50 on evenings and Sundays, plus travel expenses. A more common arrangement is to be paid a monthly retainer fee by each customer. Although rates vary widely, this fixed charge might be \$20 a month for the base station and \$7.50 for each mobile station. A survey showed that one man can easily maintain at least 100 stations, averaging 15 base stations and 85 mobiles. This would add up to at least \$12,000 a year.

Be Your Own Boss

There are other advantages too. You can become your own boss—work entirely by yourself or gradually build your own fully staffed service company. Instead of being chained to a workbench, machine, or desk all day, you'll move around, see lots of action, rub shoulders with important police and fire officials and business executives who depend on two-way radio for their daily operations. You may even be tapped for a big job working for one of the two-way radio manufacturers in field service, factory quality control, or laboratory research and development.

How To Get Started

How do you break into the ranks of the big-money earners in two-way radio? This is probably the best way:

1. Without quitting your present job, learn enough about electronics fundamentals to pass the Government FCC Exam and get your Commercial FCC License.
2. Then get a job in a two-way radio service shop and "learn the ropes" of the business.
3. As soon as you've earned a reputation as an expert, there are several ways you can go. You can move *out* and start signing up and servicing your own customers. You might become a franchised service representative of a big manufacturer and then start getting into two-way radio sales, where one sales contract might net

you \$5,000. Or you may even be invited to move *up* into a high-prestige salaried job with one of the major manufacturers either in the plant or out in the field.

The first step—mastering the fundamentals of Electronics in your spare time and getting your FCC License—can be easier than you think.

Cleveland Institute of Electronics has been successfully teaching electronics for over thirty years. Right at home in your spare time, you learn electronics step by step. Our AUTO-PROGRAMMED® lessons and coaching by experienced instructors make everything clear and easy, even for men who thought they were "poor learners." You'll learn not only the fundamentals that apply to all electronics design and servicing, but also the specific procedures for installing, troubleshooting, and maintaining two-way mobile equipment.

Get Your FCC License... or Your Money Back!

Right the time you've finished your CIE course, you'll be able to pass the FCC License Exam with ease. Better than that, out of ten CIE-trained men pass the FCC Exam the first time they try. Although two out of three non-CIE men fail. This startling record of achievement

ment makes possible the famous CIE warranty: you'll pass the FCC Exam upon completion of your course or your tuition will be refunded in full.

Ed Dulaney is an outstanding example of the success possible through CIE training. Before he studied with CIE, Dulaney was a crop duster. Today he owns the Dulaney Communications Service, with seven people working for him repairing and manufacturing two-way equipment. Says Dulaney: "I found the CIE training thorough and the lessons easy to understand. No question about it—the CIE course was the best investment I ever made."

Find out more about how to get ahead in all fields of electronics, including two-way radio. Mail the bound-in postpaid reply card for two FREE books, "How To Get A Commercial FCC License" and "How To Succeed In Electronics." If card has been removed, just mail the coupon below.

ENROLL UNDER NEW G.I. BILL

All CIE courses are available under the new G.I. Bill. If you served on active duty since January 31, 1955, OR are in service now, check box on reply card for G.I. Bill information.

CIE Cleveland Institute of Electronics

1776 East 17th Street, Cleveland, Ohio 44114

Advanced in Electronics Training... Since 1934 • Accredited Member National Home Study Council



2 New CAREER COURSES

BROADCAST (Radio & TV) ENGINEERING...now includes Video Systems, Monitor, FM Stereo Multiplex, Color Transmitter Operation and CATV.

2 ELECTRONICS ENGINEERING... covers steady-state and transient network theory, solid-state physics and circuitry, pulse techniques, computer logic and mathematics through calculus. A college-level course for men already working in Electronics.

Cleveland Institute of Electronics

1776 East 17th Street, Cleveland, Ohio 44114

Please send me without cost or obligation:

Your 40-page book "How To Succeed In Electronics" describing the job opportunities in Electronics today, and how your courses can prepare me for them.
Your book on "How To Get A Commercial FCC License."

I am especially interested in:

- Electronics Technology Electronic Communications
 Broadcast Engineering Industrial Electronics
 First Class FCC License Electronics Engineering

Name _____ (PLEASE PRINT)

Address _____

City _____

State _____ Zip _____ Age _____

Check here for G.I. Bill information.

PE-82

CIRCLE NO. 10 ON READER SERVICE PAGE



NEW PRODUCTS

Additional information on products covered in this section is available from the manufacturers. Each new product is identified by a code number. To obtain further details on any of them, simply fill in and mail the coupon on page 15.

AM/FM STEREO RADIO SYSTEM

An AM/FM stereo receiver and two separate 6½" wide-range speaker systems in matching walnut wood enclosures are featured in Lafayette Radio Electronics' new Model LR-20 Stereo Radio System. The receiver features automatic stereo switching and a stereo indicator light. It has a full complement of

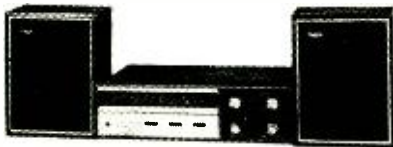

controls, including a function selector for AM, FM, FM a.f.c., and Phono/Aux.; volume/balance; stereo-mono mode switch; tuning; power; and loudness compensator switch. Technical Specifications: 12-watt (6 watts per channel at 8 ohms) output power; 540-1600-kHz AM and 88-108-MHz FM tuning ranges; 7- μ V sensitivity; 36 dB at 400 Hz stereo separation.

Circle No. 78 on Reader Service Page 15

LONG-RANGE ANTENNA FOR CB

Antenna Specialists Company has just released its new Model M-195 quad antenna designed expressly for CB'ers who desire long-range communications. The antenna, dubbed the "Square Rigger," employs a matching system that does not require stubs or ferrites in the element; so rain, snow, or ice do not detune the antenna, and gain remains constant in weather extremes. The unique matching system provides a 30-dB front-to-back ratio. Forward gain of the antenna is a true 7.5 dB, while the VSWR is maintained at 1.3-to-1 or better at band edges, approaching unity at band center for maximum power transfer. The radiating element spreader is 13' long, while the reflecting element spreader is 13'4" long. Use of a 1¾"-diameter boom provides a conservative 100 mi/hr wind rating. The M-195 Square Rigger antenna has a power rating of 1000 watts.

Circle No. 79 on Reader Service Page 15

AMATEUR RADIO SSB TRANSCEIVER

According to *Galaxy Electronics*, their Model GT-550 transceiver creates a whole new level of performance standards in amateur radio communications equipment. The five-band transceiver is designed for both fixed-station and mobile use. And although it measures only 11¼" × 12¾" × 6" and weighs only 17 pounds, the GT-550 puts out a pow-

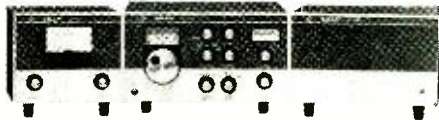

erful 550 watts on SSB, 360 watts on CW. Also available with the GT-550 is a complete line of accessory equipment including a linear amplifier, r.f. console, remote VFO, and speaker console (all shown in photo). Other optional equipment—*a.c.* power supply, mobile power supply, phone patch, CW filter, VOX accessory, calibrator, mobile mounting bracket, and a floorboard adapter.

Circle No. 80 on Reader Service Page 15

CARTRIDGE-TYPE TUNERS

Three new universal plug-in tuners designed by Stereo Magic Division of *Eastern Specialties Corp.* fit all 4- and 8-track mobile and home-type stereo tape players, converting the players to FM, FM/AM, or FM stereo receivers. Each "Stereo Magic" tuner is the size of a conventional tape cartridge and is plugged into the tape player in a similar manner. Operation is instantaneous, and reception is said to be strong and clear as a result of using miniature solid-state circuits. The tuners are supplied with antenna connectors and batteries and they range in price from \$30 to \$50.



Circle No. 81 on Reader Service Page 15

VHF-FM RADIOPHONE

The Model SR-C801S, available from *Standard Communications Corp.*, is the first all-new VHF-FM Radiophone with features that comply with present and projected FCC requirements. The two-way radio provides the full benefits of marine communications in the new 156-162-MHz band. Twelve available channels for complete coverage of the marine band with "capture effect" reception provide interference-free communications. Technical specifications: ± 0.0005 frequency stability; 25-watt output power with facility for reduction to 1 watt for close-range communications; mechanical i.f. filter; 156-162-MHz tun-



CIRCLE NO. 30 ON READER SERVICE PAGE →

World's largest selling mobile/base CB rig! \$199.



Courier 23 – the most popular mobile/base CB transceiver ever built! A greater value than ever before, with 100% modulation featuring Courier's exclusive Modulation Sampler® – boosts your talk power electronically! Dollar for dollar, offers more of what you want in CB: 23 crystal-controlled channels, dual conversion, built-in solid-state 12v mobile power supply, illuminated S-RF meter and channel selector, PA system, modulation indicator, full-time Range-expand, adjustable noise limiter, super efficient squelch. Heavy-duty triple-plated chrome cabinet with stainless steel front panel. Just \$199 complete with crystals for all 23 channels.

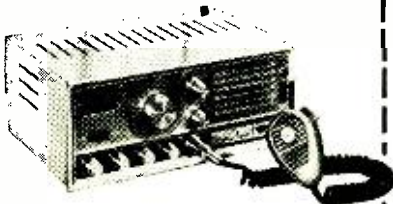

COURIER ROYALE

All the performance money will buy, no matter what you're willing to spend. The ultimate in power, selectivity, sensitivity, quietness. All 23 channels, with all crystals supplied. Complete **\$299**
(and we mean complete)



COURIER COMMUNICATIONS, INC.
439 Frelinghuysen Avenue, Newark, N.J. 07114
a **Whittaker** Company

Yes! I'd like to know all about the Courier 23 – world's largest-selling CB rig!

Send me data on COURIER ROYALE

Name _____ PE-95

Address _____

City _____ County _____

State _____ Zip _____

PRODUCTS (Continued from page 22)

ing range; all solid-state construction, including MOSFET r.f. amplifier. The SR-C801S is supplied with a remote speaker and hand-held microphone. In addition, a full line of compatible accessories is available.

Circle No. 82 on Reader Service Page 15

FOUR-BAND PORTABLE RECEIVER

The Model RA-116 solid-state portable receiver available from *Olson Electronics, Inc.* contains one feature few modern multi-band receivers have—it tunes in the sound-signal-only portion of TV broadcasts on channels 2 through 13. The TV band is divided into two switch-selectable portions—channels 2-6 and channels 7-13. In addition, the RA-116 receiver is

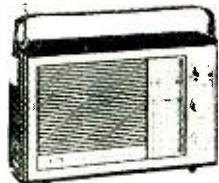

equipped to pull in police broadcasts on the 147-174-MHz band and Standard FM on the 88-108-MHz band. The receiver, housed in a leatherette case, comes complete with telescoping antenna and earphone jack. It can be operated on battery or line power.

Circle No. 83 on Reader Service Page 15

REGULATED D.C. POWER SUPPLY

Automatic protection against overloading is featured in *Lafayette Radio Electronics'* new lab-type regulated d.c. power supply, stock No. 99-5077. Designed specifically for bench use, the power supply is good for servicing portable and automobile transistor radios and for recharging small batteries. Technical Specifications: 5-13 volts and 12-20 volts dual-range, continuously variable d.c. output; up to 2 amperes output current; less than 5 mV r.m.s. ripple at full load; $\pm 1\%$ regulation; 115 or 230 volts a.c. $\pm 10\%$, 50/60 Hz input requirements. The supply includes two D'Arsonval movements that continuously monitor output voltage and current.

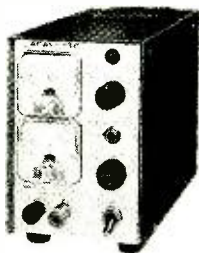

Circle No. 84 on Reader Service Page 15

CUBICAL QUAD ANTENNA FOR CB

"The Big Gun" is a new four-element cubical quad antenna designed by *Hy-Gain Electronics Corp.* especially for Citizens Band base stations. It is furnished with a three-position switch that allows selection of horizontal or vertical polarity, or a separate

omni-directional antenna. Also featured are extended-aperture elements. Technical Specifications: 26.3-dB power multiplication factor; 14.2-dB gain; 38.7-dB front-to-back ratio; 18-dB forward polar selectivity gain; 1.24:1 standing wave ratio at resonance; 52-ohm coax feed; 18-dB vertical-horizontal separation. The Big Gun is provided with a 20'-long by 2"-diameter metal boom that has a wind-survival rating of 90 mi/hr.

Circle No. 85 on Reader Service Page 15

PSYCHEDELIC COLOR ORGAN KIT

Science Workshop's Model LO-103 color organ kit, when assembled and connected to a suitable audio source, converts sound into a continuously changing pattern of vari-colored lights. The "psychedelic" color organ



employs three frequency-selective networks, each containing an SCR that drives a specific color light. Incoming sounds are split into low-, medium-, and high-frequency bands, which trigger the SCR's. The result is a light display that flickers and changes color, at times blending colors, according to the tempo and pitch of the signal. The kit includes only the electronics; power supply and lamps must be obtained separately. However, the instructions provided show the user how to assemble a complete system. Technical Specifications: 300-mV sensitivity; 3000-ohm input impedance; 1-ampere output current per SCR; 16 volts a.c. at 3 amperes input power required for lamps, 11 volts a.c. at 20 mA required for circuit.

Circle No. 86 on Reader Service Page 15

AUTOMOBILE BURGLAR ALARM SYSTEM

The Vehicle Alarm System made by *Astro-Dynamics Electronics* is a burglar alarm device that protects any car equipped with it from tampering or theft. It is tripped simply by opening a door, the hood, or the trunk of the protected vehicle. Once tripped, it pulsates the horn and headlights of the car to provide an unmistakable warning signal. And to prevent battery run-down, the alarm system is timed to shut down and reset itself after 3-5 minutes. The all-silicon-transistor system is easy to install in any vehicle, requiring just five connections and using the car's switches as sensors. The system is supplied with a burglar-proof alarm lock switch—featuring some 80,000 different key combinations—wire, terminal connectors, miscellaneous hardware, easy-to-follow instructions, and, best of all, a five-year warranty.



Circle No. 87 on Reader Service Page 15

CIRCLE NO. 7 ON READER SERVICE PAGE →



**What a Beauty,
What a Build
And Boy!!!!
What Performance!**

**"The Perfect 36" is the
up-top CB antenna
for on-top people, from**

S Shakespeare

C/P Corporation Division, The Shakespeare Co., PFD 3, Columbia, S. C. 29205

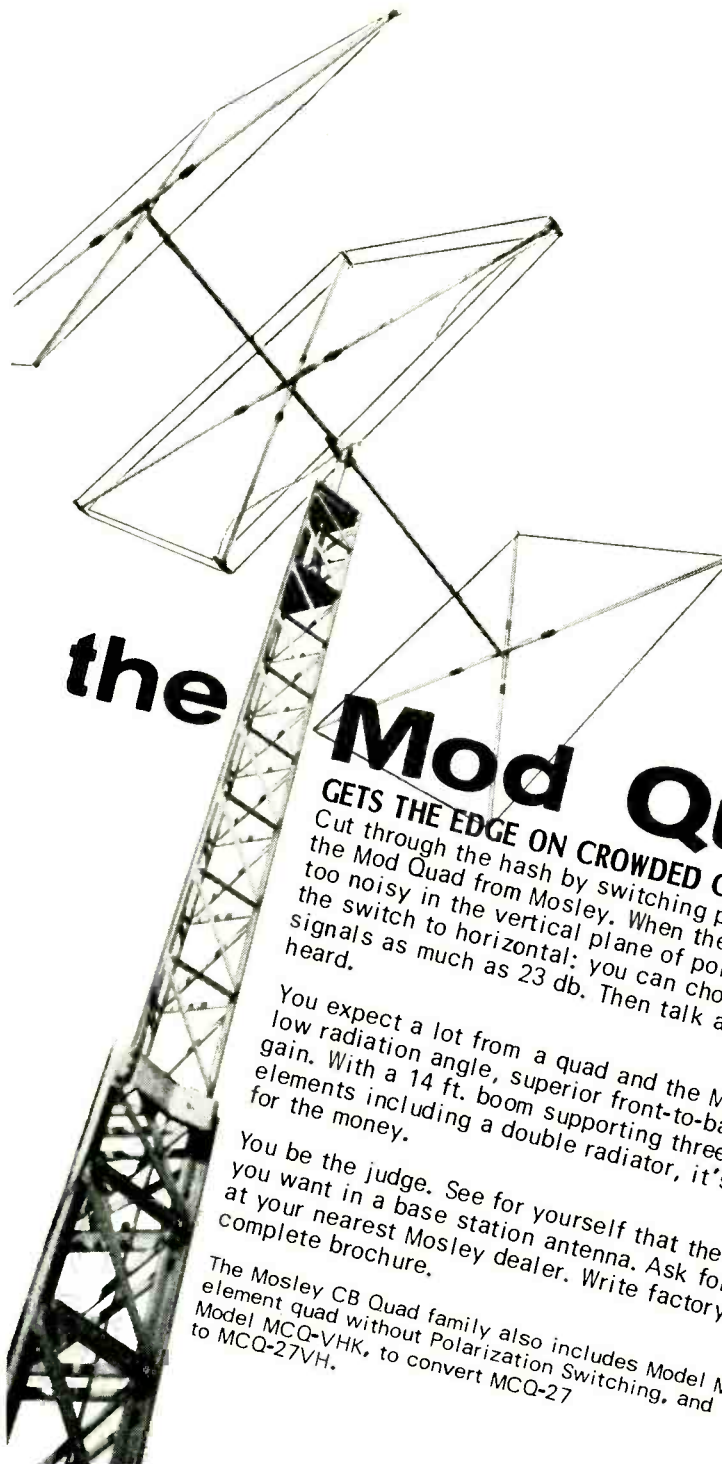

the **Mod Quad**

GETS THE EDGE ON CROWDED CB CHANNELS

Cut through the hash by switching polarization with the Mod Quad from Mosley. When the channels are too noisy in the vertical plane of polarization, flip the switch to horizontal; you can chop off interfering signals as much as 23 db. Then talk and make yourself heard.

You expect a lot from a quad and the Mod Quad's got it: low radiation angle, superior front-to-back ratio, and top gain. With a 14 ft. boom supporting three diamond-shaped elements including a double radiator, it's a lot of antenna for the money.

You be the judge. See for yourself that the Mod Quad is all you want in a base station antenna. Ask for Model MCQ-27VH at your nearest Mosley dealer. Write factory direct for complete brochure.

The Mosley CB Quad family also includes Model MCQ-27, a three-element quad without Polarization Switching, and Model MCQ-VHK, to convert MCQ-27 to MCQ-27VH.

Mosley Electronics, Inc.

Dept. 184

4610 N. LINDBERGH BLVD., BRIDGETON, MO. 63042

CIRCLE NO. 22 ON READER SERVICE PAGE

POPULAR ELECTRONICS



FET PREAMP

NEW DESIGN FOR LOW NOISE AND MINIMUM DISTORTION

BY DAN MEYER

CONSTRUCTION projects and kits for making high-fidelity audio preamplifiers come in many shapes and sizes. Most of them give very good results but none has the quality of the "FET Preamp" described here. Much of the excellent performance obtainable from this preamp is due to the use of silicon field-effect transistors in the amplifier stages. These transistors operate at impedance levels similar to those in vacuum-tube circuits but they have much lower noise and far less distortion than either tubes or conventional junction transistors.

The sensitivity and output impedance of the FET Preamp are suitable for use with almost any power amplifier and full power output can be obtained from any low-level magnetic-cartridge signal source.

A high-power audio amplifier, specifically designed for use with this preamp,

will be described in a forthcoming issue of POPULAR ELECTRONICS.

Six pushbutton switches are used to select the desired input, while there are rocker switches for control of volume-loudness, high- and low-frequency filtering and the 117-volt power supply. A front-panel tape output jack and a microphone input jack are also provided. With the exception of some exotic details, such as phase reversal, every possible useful function has been included in the preamplifier, whose schematic is shown in Fig. 1.

Construction. For a stereo system, two preamplifiers are required. Each is assembled on a printed circuit board whose actual-size foil pattern is shown in Fig. 2. Once the board has been fabricated (or purchased), mount the components as shown in Fig. 3, being careful to ob-

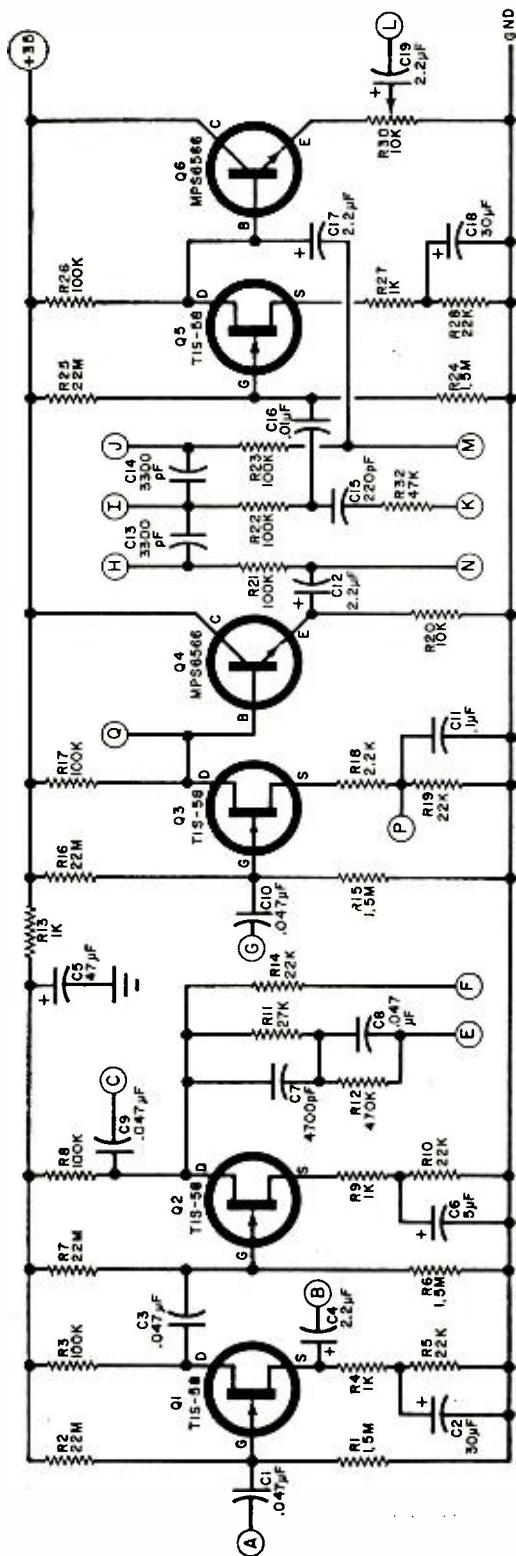

serve the polarities of the electrolytic capacitors and the identifying flats on the semiconductors. When the boards are assembled, put them aside and prepare the chassis.

Although the author used a metal U-shaped chassis 9" x 7" x 2 3/4" (with a suitable wooden cover), any other arrangement can be used. In any case, mount the 12-circuit phono jack assembly (or 12 single phono jacks) on the rear apron of the chassis. Label one set of six jacks "Channel 1" and the other set of six "Channel 2." Also mount a pair of phono jacks for the outputs on the rear apron, along with two conventional 117-volt power sockets and two through-the-chassis strain reliefs (one for the a.c. line and the other for the d.c. supply to the preamp).

The front of the chassis can be prepared as shown in the photos. On the left side, cut a slot large enough to fit the four rocker switches. Mount the switches on a support such as that shown in Fig. 4 so that the four switches can be operated easily from the front.

PARTS LIST

- C1, C3, C8, C9, C10—0.047-µF capacitor
- C2, C18—30-µF, 6-volt electrolytic capacitor
- C4, C12, C17, C19—2.2-µF, 50-V electrolytic capacitor
- C5—47-µF, 50-V electrolytic capacitor
- C6—5-µF, 15-V electrolytic capacitor
- C7—4700-pF capacitor
- C11—0.1-µF, 12-V capacitor
- C13, C14—3300-pF capacitor
- C15—220-pF capacitor
- C16—0.01-µF, low voltage capacitor
- Q1, Q2, Q3, Q5—Field-effect transistor (Texas Instruments TIS58)
- Q4, Q6—Transistor (Motorola MPS6566)
- R1, R6, R15, R24—1.5-megohm
- R2, R7, R16, R25—22-megohm
- R3, R8, R17, R21, R22, R23, R26—100,000-ohm
- R4, R9, R13, R27—1000-ohm
- R5, R10, R14, R19, R28, R32—47,000-ohm
- R11—27,000-ohm
- R12—470,000-ohm
- R18—2200-ohm
- R20—10,000-ohm
- R30—10,000-ohm PC trimmer potentiometer

all resistors
1/2-watt

Note—A printed circuit board (#156) is available from Southwest Technical Products Corp., 219 W. Rhapsody, San Antonio, TX 78216 for \$2.40, postpaid. A complete kit of parts including punched cabinet for stereo version (#156-C) is available from the same source for \$42.50 plus postage for four pounds.

Fig. 1. Four of six semiconductors are low-noise FET amplifiers, and two conventional junction transistors are used as interstage emitter followers.

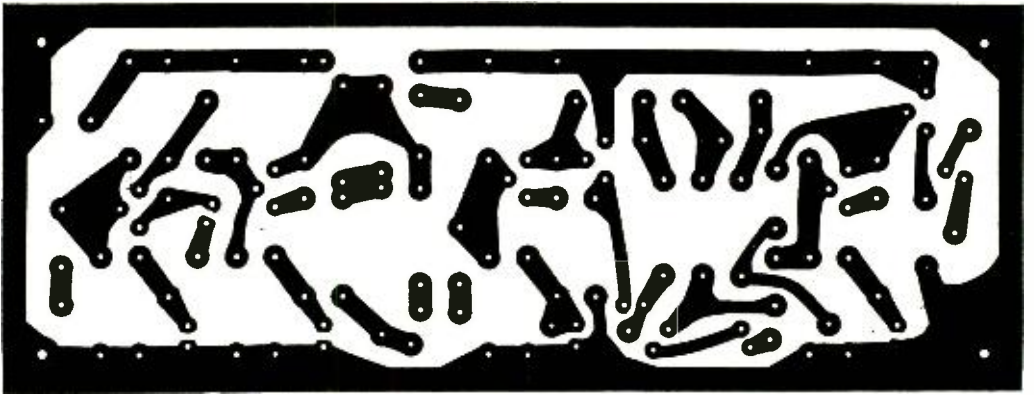

Fig. 2. Actual-size foil pattern for the preamplifier. A pair of boards would be required for stereo.

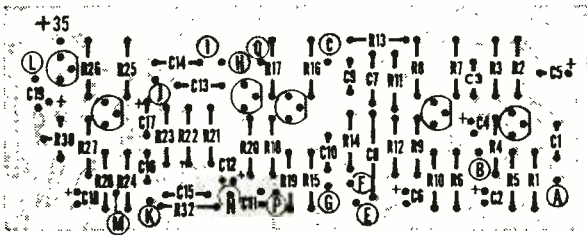

Fig. 3. After making (or buying) the PC board, install the components as shown here, taking care to observe the polarity of semiconductors and electrolytics.

Cut a long slot at the bottom of the front panel for the six pushbutton switches. The switch assembly is held on by a pair of mounting screws from the bottom of the chassis. Next to the pushbuttons, install a pair of phone jacks (one for the microphone input and one for the tape output). The three variable controls, BASS ($R34$), TREBLE ($R35$), and VOLUME ($R33$) are mounted above the pushbutton switches.

In the photographs, the top rocker switch is labeled STEREO-MONO. In the author's final design, however, this switch was used for LOUDNESS-VOL-

UME and a s.p.s.t. switch was added to the tandem volume controls for the stereo-mono selection. The selection is made by pulling out the shaft of the volume control. In this discussion, the top rocker switch is the LOUDNESS-VOLUME control, $S1$. The second rocker switch from the top is the HI cut switch ($S2$); the third is the LO cut switch ($S3$); and the bottom one is the main a.c. on-off switch ($S5$). The chassis com-

View of rear apron showing mounting details of the 12 input jacks and the location of the two resistors used to load each of the phonograph inputs.

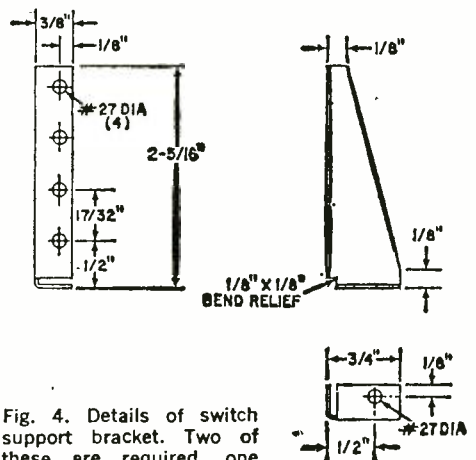
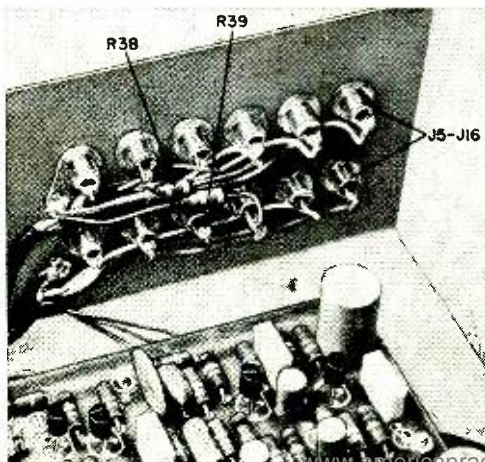

Fig. 4. Details of switch support bracket. Two of these are required, one for each side mounting.

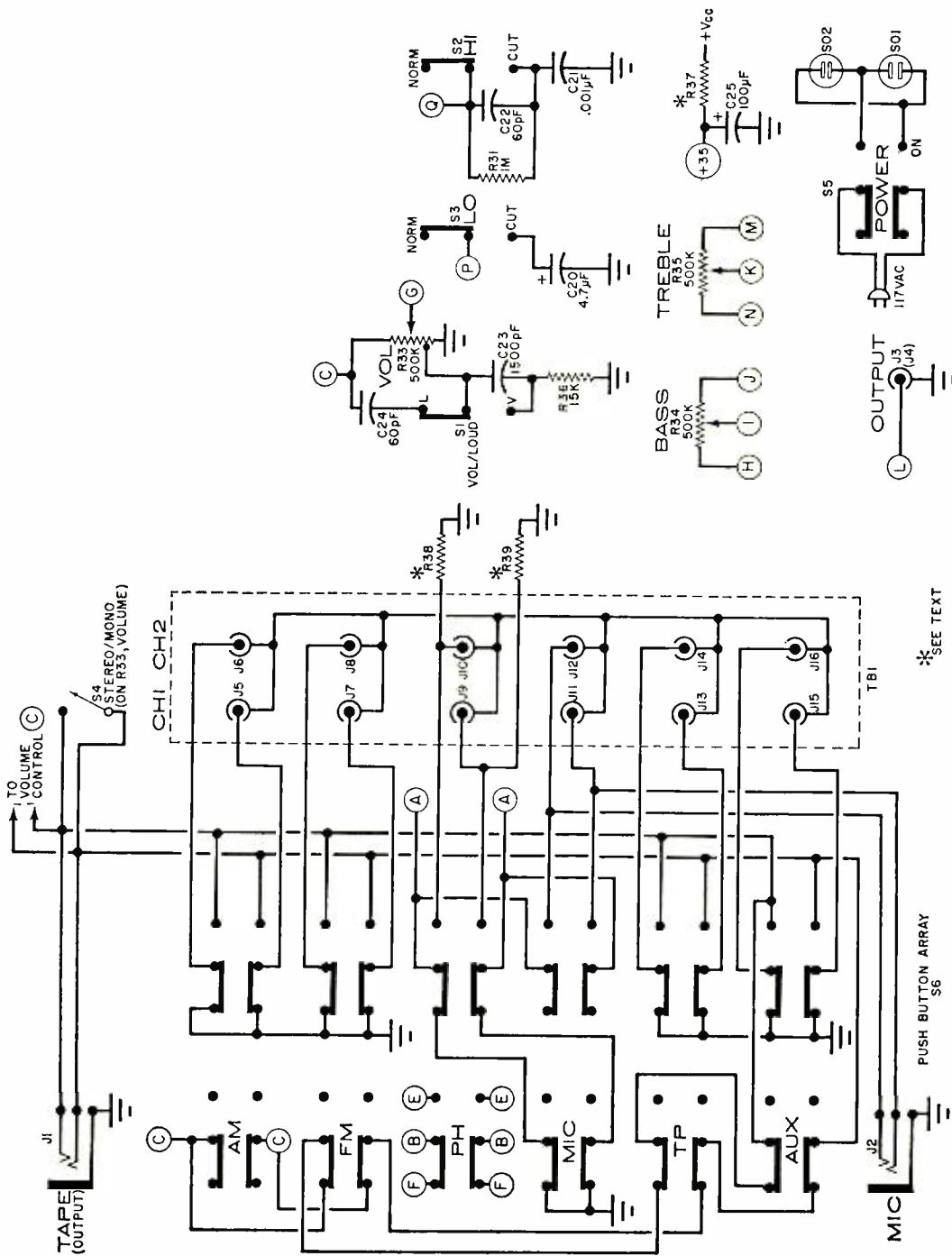
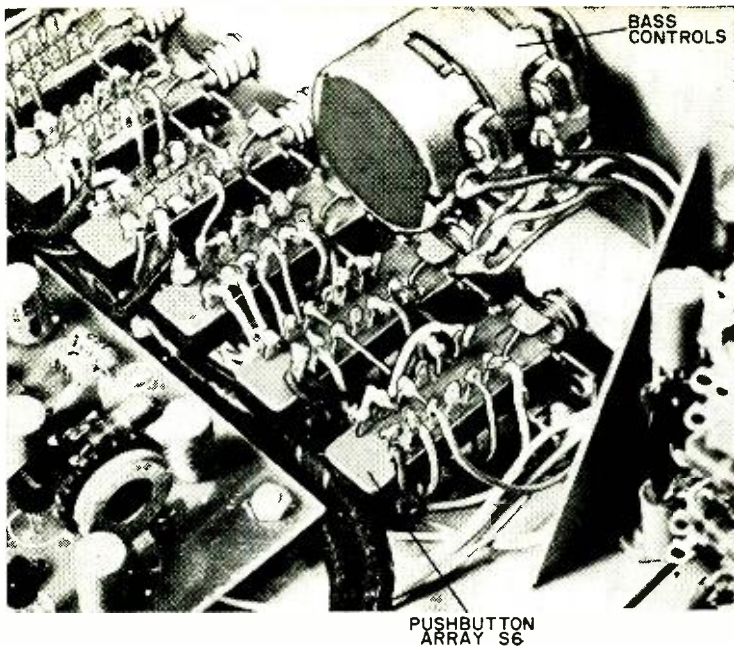

Fig. 5. Wiring of the front and rear panel components. The lettered circles are wired to similar lettered terminals on the boards. The small, individual circuits at the top are the isolated component connections.



Details of one corner of the preamp. Shown here are the tandem bass controls, a portion of pushbutton array S6, and one rocker switch support bracket.

ponents are wired to the boards as shown in Fig. 5.

Mount capacitors *C23* and *C24* and resistor *R36* between the proper terminals on *S1*; and mount *C21*, *C22*, and *R31* on the proper terminals of *S2*. Connect *C20* between *S3* and ground. (The components and connections given in this paragraph must be repeated for each channel of a stereo system.)

Resistors *R38* and *R39* must be connected between the magnetic cartridge

input jacks and ground. The values of these resistors should be as recommended by the cartridge manufacturer. Although many values are specified by the various manufacturers, 47,000 ohms is the most common.

Once all chassis components are mounted, connect the various lettered terminals on the PC boards (see Fig. 5) to their respective controls in neat wire bundles. Mount each PC board on four standoffs, one at each corner.

PARTS LIST

C20—4.7- μ F, low-voltage electrolytic capacitor*
C21—0.001- μ F capacitor*
C22, C24—60-pF capacitor*
C23—1500-pF capacitor*
C25—100- μ F, 50-volt electrolytic capacitor
J1, J2—3-circuit phono jack
J3, J4—Phono jack
J5—12-circuit phono jack assembly
R31—1-megohm, $\frac{1}{2}$ -watt resistor
R33—500,000-ohm tapped potentiometer* (tandem)
R34, R35—500,000-ohm potentiometer* (tandem)
R36—15,000-ohm, $\frac{1}{2}$ -watt resistor*
R37, R38, R39—See text
S1, S2, S3, S5—D.p.d.t. rocker switches
S4—S.p.s.t. switch (on *R33*)
S6—Six button pushbutton switch assembly, each 4 p.d.t.
SO1, SO2—Chassis-mounting 117-volt a.c. outlets
 Misc.—Line cord, strain reliefs (2), spacers, mounting hardware, knobs (3), rubber feet (4), wire, solder, etc.
 *Two required for stereo version.

PREAMPLIFIER SPECIFICATIONS

Frequency response: 10 Hz to 100 kHz (–1 dB point)
Distortion: THD @ 1-V output, less than 0.15% from 15 Hz to 50 kHz.
Hum and noise: Phono and mic., –65 dB below full output; other inputs, –70 dB below full output.
Sensitivity: Phono and mic., 2 mV for 1-V output; other inputs, 0.1V for 1-V output.
Input impedance: Phono, 47,000 ohms (see text); other, 500,000 ohms.
Input before clipping: Phono and mic., 0.1V; other inputs, 10 V.
Maximum output: 5V r.m.s.
Output impedance: less than 1000 ohms.
Channel separation: Greater than 40 dB at 1000 Hz.
High filter: 3 dB down at 10 kHz.
Low filter: 3 dB down at 70 Hz.
Treble control range: ± 15 dB at 10 kHz.
Bass control range: ± 15 dB at 50 Hz.

To reduce the interchannel coupling, a separate voltage-dropping network, *R37* and *C25*, is used for each of the stereo channels.

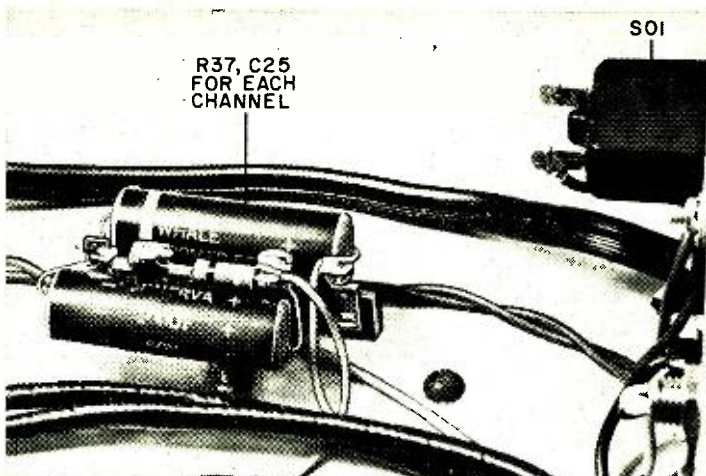

Pass the 117-volt line cord through its strain relief and connect it to switch *S5* and to the power outlets. Line voltage for the power amplifier is taken from one of these outlets; the other can be used for a record player or tape recorder.

D.c. power for the preamplifier should be obtained from a well-filtered 35-volt source. Provisions for this supply are made in the companion power amplifier to be described in a forthcoming issue. If the external power source is higher than 35 volts, resistor *R37* must be used to drop the voltage. To determine the value to use for *R37*, divide the difference between the voltage you have and 35 by 0.006. For example, if the source is 50

volts, the resistance is $50 - 35$, or 15, divided by 0.006, or 2500 ohms. You can use the nearest standard resistance value (2200 or 2700 in the example) at $\frac{1}{2}$ watt. Mount *R37* with its companion filter capacitor *C25* on a multi-lug terminal strip in an open section of the chassis.

Recheck all wiring.

Testing. Connect the two rear-apron output jacks (*J3* and *J4*) to the inputs of the power amplifier, and connect the desired inputs to the two channels of the preamp. Turn on the power to the preamp. (The 117-volt line cord on the power amplifier can be plugged into *S01* or *S02* and switched on and off with *S5* on the preamp.) Check that approxi-

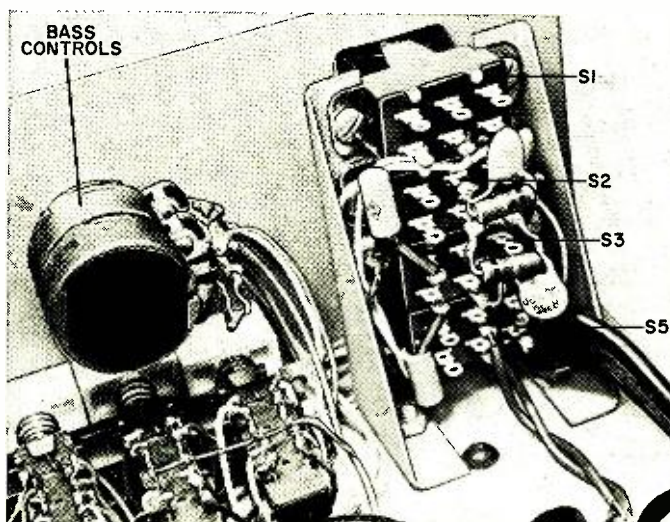

The overall rocker switch support bracket assembly. Components are mounted on switches.

HOW IT WORKS

Input selection is made by a series of pushbuttons, each operating a four-pole, double-throw switch. When a button is "out," the input that the particular button controls is grounded to prevent cross talk from the unused inputs. Pushing "in" any of the four high-level pushbuttons breaks the connection between the first two stages of the preamp and the volume control, and feeds the selected high-level input directly to the volume control. This approach keeps the distortion as low as possible. (In some preamps, the high-level inputs are reduced resistively and all signals are amplified by the complete preamp.) In this preamp, only the microphone and phono input are amplified by the first two stages. In the phono position, the preamp feedback network is switched in and changes the amplifier curve from essentially flat to the required RIAA curve.

The four FET amplifier stages are similar. A common-source circuit having a large-valued source resistor and positive gate bias results in a consistent and stable amplifier. The first two stages (*Q1* and *Q2*) use the RIAA equalization network needed for magnetic phono input. Amplifier *Q2* feeds the volume control (*R33*), which is followed by a FET amplifier (*Q3*) to provide a low-impedance driving source for the tone controls.

The tone-control circuit (between *Q4* and *Q5*)

is a low-distortion Baxendall-type circuit. This feedback type of tone control utilizes the most desirable variable turnover point characteristic.

The controls give bass or treble boost or cut when offset from the normally flat center position. The tone control network, including *Q5*, has unity gain and is followed by emitter follower *Q6*. The low output impedance permits the use of a reasonably long cable between the preamp and its associated power amplifier with reduced attenuation and noise pickup. The low output impedance also insures that the preamp will be able to drive transistor amplifiers with the lowest input impedance. The most desirable situation in an audio system is to have a low impedance driving a higher impedance. This is not efficient as far as power transfer is concerned, but it does result in the lowest possible distortion.

The output level is adjusted by a trimmer potentiometer (*R30*) on each channel to allow balancing without the use of concentric, or clutch-coupled, controls. It also allows exact match for the power amplifier being used.

The high-frequency filter bypasses the highs to ground at the drain of *Q3*, while the low-frequency filter changes the *Q3* source network. The stereo-mono switch is coupled to the volume control which makes it possible to switch to either stereo or mono merely by pulling out the volume control. The loudness compensation switch changes the circuit of the volume control to boost the bass and treble at low volume levels.

Though two are called for, the author mounted only one power outlet (SO1) on rear apron. The preamp controls primary power fed to main amplifier through this outlet, and takes d.c. from the amplifier.

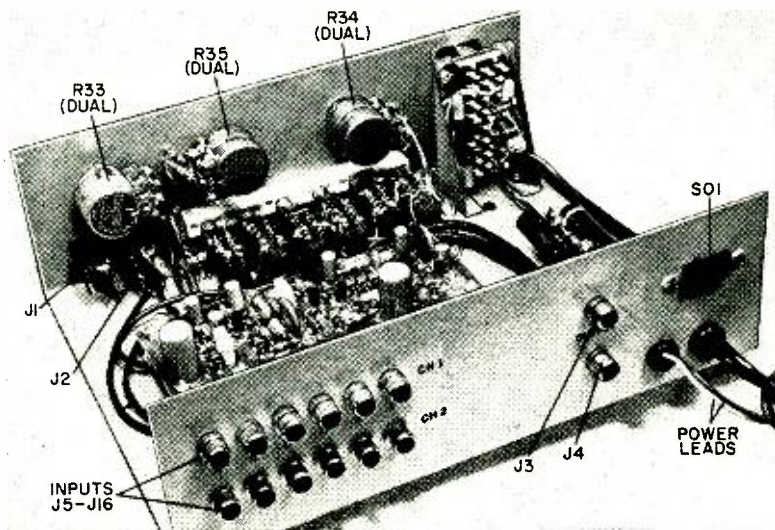

mately 35 volts is present at the +35 terminal on each PC board. Using a high-impedance voltmeter, check that the drain voltage at each FET is between 12 and 18 volts. If any wide variation is found, check the circuit for possible errors in component values.

Depress the appropriate input push-button and operate the VOLUME, BASS, and TREBLE controls as desired. If you want loudness compensation instead of

linear volume action, operate the LOUDNESS-VOLUME rocker switch.

Place the system in MONO (by operating the volume control shaft) and adjust *R30* in each channel to get the same output from each. This is the only balance adjustment that needs to be made.

If there is excessive hum in the system, the preamplifier may be too near a power transformer or a.c. motor. Proper orientation reduces interference. —30—

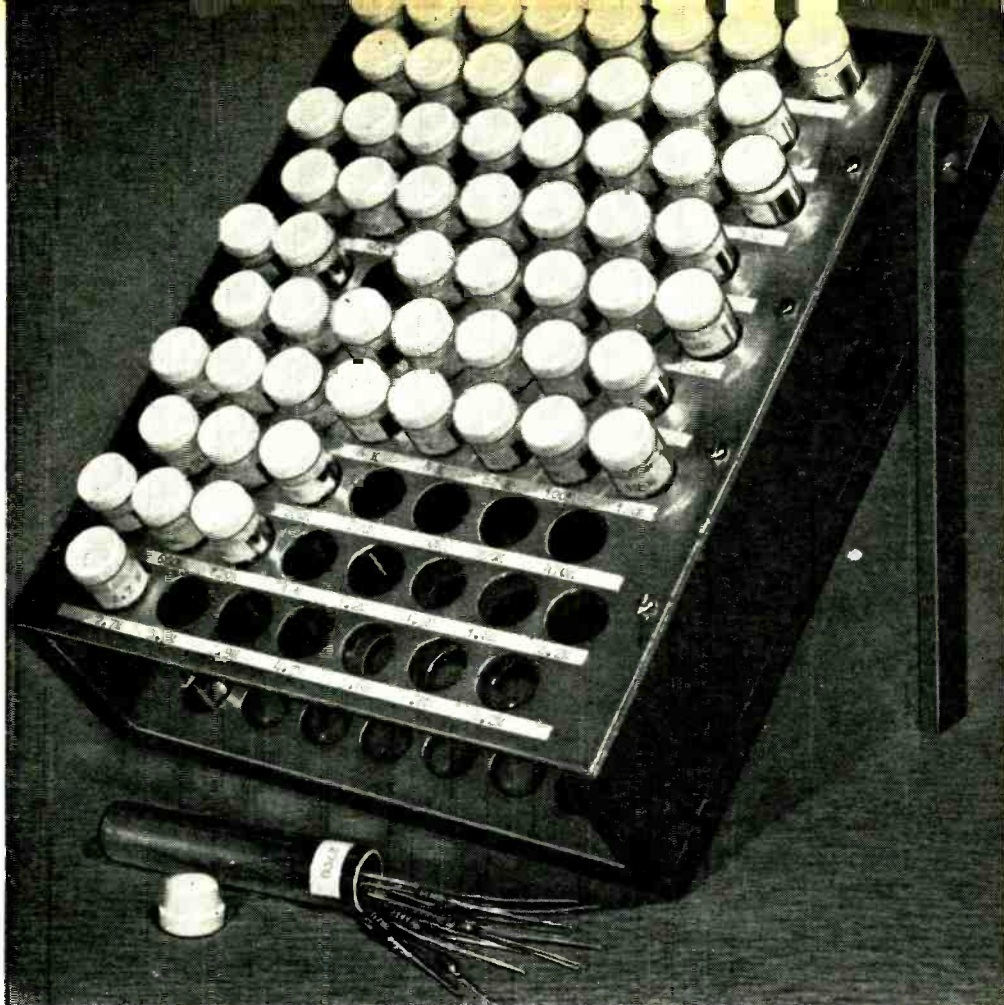

A Home For Ohms

BY A. J. LOWE

A PLACE FOR EVERYTHING AND EVERYTHING IN ITS PLACE

UNLIKE most other electronic components, the physical size of a resistor does not vary from value to value of resistance in a given power rating. This "sameness" can cause you to waste a great deal of time if you have to locate a specific resistance value in a well-stocked but haphazardly arranged spare parts supply. Ideally each value of resistance should have its own bin—not an easy thing to arrange if space is limited, but the rack shown in the photo is perfect for compact, easy-access storage of resistors and other small parts.

Called a "Home for Ohms" because of

its obvious value for resistor storage, the facility consists of 75 individual bins (actually pill containers) and a perforated rack. At most, the rack, with all bins in place, occupies only about 80 square inches of space and can accommodate 1200 or more resistors.

The pill containers used for the bins should measure about $3\frac{1}{2}$ " long by $\frac{5}{8}$ " diameter. The best source of supply for the pill containers is your local drug store. If you can't get them, however, try substituting stoppered test tubes.

The rack is made of two $10" \times 8"$ sheets of $\frac{1}{8}"$ aluminum, pine spacers,

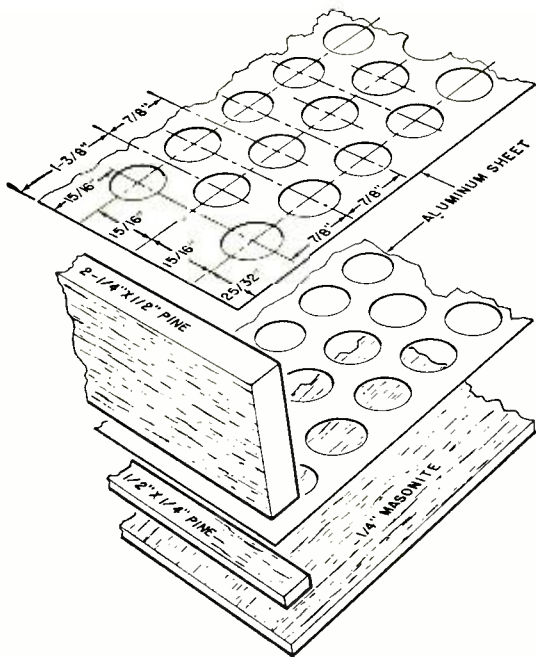

To maintain maximum strength, stagger the holes in the aluminum sheets as illustrated in this drawing.

and a Masonite bottom plate. Use an $\frac{1}{16}$ " chassis punch to make the holes according to the dimensions provided in the drawing. The rows of holes should be staggered to retain maximum strength in the aluminum sheets. And for accurate hole alignment, it is a good idea to clamp the aluminum sheets together while drilling the pilot holes for the chassis punch; then separate the sheets and punch each hole separately.

When assembling the rack (see drawing), use flat-head wood screws on the bottom and oval-head wood screws on the top. The optional 8" legs shown in the photo should be allowed to swivel flush with the sides of the rack so that it can lie flat for storage.

Each container—not cap—and each hole should finally be labeled with the value of the resistor (or other component) it contains to provide a quick locator system. If you don't wish to stock 75 different values of resistors, you can utilize the extra containers for signal diodes, tubular capacitors, or other small components. —30—

The K Table

BY GARY VAN DYK

IT SOLVES ALL YOUR COIL PROBLEMS

HAVE YOU ever been confronted by "the coil problem"? That's when a circuit design calls for a single-layer coil consisting of so many turns of such-and-such wire evenly spaced over a coil form of specific length and diameter and you don't have a form with the correct diameter. You may have other sizes but how can you determine the proper number of turns for a different diameter? The thing to do is use the "K Table" described here.

The K Table is a set of constants relating the length, diameter, and number of turns of a coil to its inductance. There is nothing magic about the table, it is

DERIVATION OF EQUATION

$$L = \frac{0.2n^2a^2}{3a + 9b}$$

$$L(3a + 9b) = (0.2a^2)n^2$$

$$\left(\frac{3a + 9b}{0.2a^2}\right)L = n^2$$

$$n = \sqrt{(3a + 9b)/0.2a^2} \times \sqrt{L}$$

$$n = K \sqrt{L}$$

a = coil diameter (inches)
b = coil length (inches)
n = number of turns
L = inductance (microhenries)

10 Reasons why RCA Home Training is your best investment for a rewarding career in electronics:

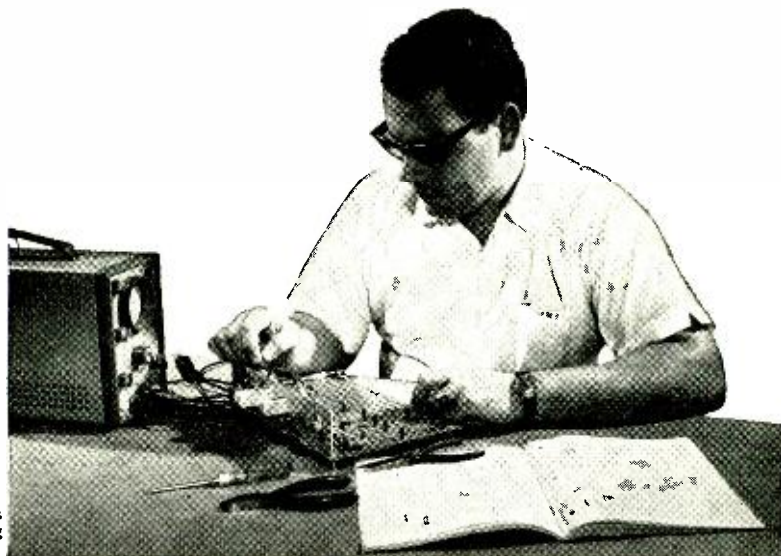

Performing transistor experiments on programmed breadboard — using oscilloscope

1 LEADER IN ELECTRONICS TRAINING

When you think of electronics, you immediately think of RCA... a name that stands for dependability, integrity and pioneering scientific advances. For over a half century, RCA Institutes, Inc., a service of Radio Corporation of America, has been a leader in technical training.

2 RCA AUTOTEXT TEACHES ELECTRONICS FASTER, EASIER, ALMOST AUTOMATICALLY

Beginner or refresher, AUTOTEXT, RCA Institutes' own method of programmed Home Training will help you learn electronics more quickly and with less effort, even if you've had trouble with conventional learning methods in the past.

3 THOUSANDS OF WELL PAID JOBS ARE NOW OPEN TO MEN SKILLED IN ELECTRONICS

RCA Institutes is doing something positive to help men with an interest in electronics to qualify for rewarding jobs in this fascinating field. Every year, literally thousands of high paying jobs in electronics go unfilled just because not enough men take the opportunity to train themselves for these openings.

4 WIDE CHOICE OF CAREER PROGRAMS

Start today on the electronics career of your choice. On the attached card is a list of "Career Programs", each of which starts with the amazing AUTOTEXT method of programmed instruction. Look the list over, pick the one best suited to you and check it off on the card.

5 SPECIALIZED ADVANCED TRAINING

For those already working in electronics or with previous training, RCA Institutes offers advanced courses. You can start on a higher level without wasting time on work you already know.

6 PERSONAL SUPERVISION THROUGHOUT

All during your program of home study, your training is supervised by RCA Institutes experts who become personally involved in your efforts and help you over any "rough spots" that may develop.

7 VARIETY OF KITS YOURS TO KEEP

To give practical application to your studies, a variety of valuable RCA Institutes engineered kits are included in your program. Each kit is complete in itself. You never have to take apart one piece to build another. At no extra cost, they're yours to keep and use on the job.

8 FROM RCA INSTITUTES TRANSISTORIZED TV KIT, VALUABLE OSCILLOSCOPE

Those enrolled in RCA's television course or program receive complete transistorized TV Kit. All students receive a valuable oscilloscope—both at no extra cost and only from RCA Institutes.

9 CONVENIENT PAYMENT PLANS

RCA Institutes offers a unique tuition plan that lets you progress at your own pace. You only pay for lessons as you order them. You don't sign a contract obligating you to continue the course. There's no large down-payment to lose if you decide not

to continue. However, if you desire, RCA Institutes also offers a convenient monthly payment plan.

10 RCA INSTITUTES GRADUATES GET TOP RECOGNITION

Thousands of graduates of RCA Institutes are now working for leaders in the electronics field; many others have their own profitable businesses. This record is proof of the high quality of RCA Institutes' training.

CLASSROOM TRAINING ALSO AVAILABLE

If you prefer, you can attend classes at RCA Institutes Resident School, one of the largest of its kind in New York City. Coeducational classroom and laboratory training, day and evening sessions, start four times a year. Simply check "Classroom Training" on the attached card for full information.

JOB PLACEMENT SERVICE, TOO!

Companies like IBM, Bell Telephone Labs, GE, RCA, Xerox, Honeywell, Grumman, Westinghouse, and major Radio and TV Networks have regularly employed graduates through RCA Institutes' own placement service.

SEND ATTACHED POSTAGE PAID CARD TODAY! FREE DESCRIPTIVE BOOK YOURS WITHOUT OBLIGATION! NO SALESMAN WILL CALL!

All RCA Institutes courses and programs are approved for veterans under the New G.I. Bill.

RCA INSTITUTES, DEPT. PE-59
320 West 31st Street,
New York, N.Y. 10001

Accredited Member National Home Study Council

RCA

Construction of Multimeter.

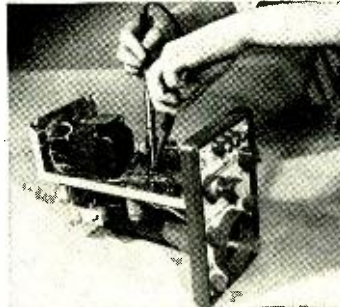
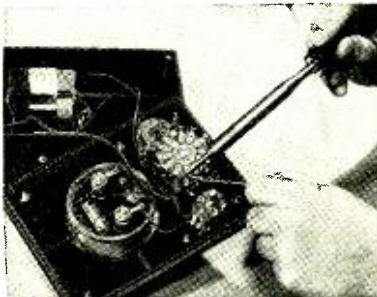

Construction of Oscilloscope.

Temperature experiment with transistors.

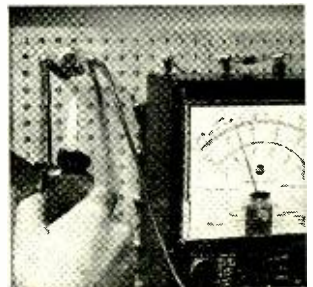

a	b	1/8	1/4	3/8	1/2	3/4	1	2	3
1/8	1/8	21.9089	28.9827	34.6410	39.4968	47.7493	54.7722	76.6812	93.5949
1/4	1/4	12.2474	15.4919	18.1659	20.4939	24.4949	27.9285	38.7298	47.1169
3/8	3/8	8.9443	10.9545	12.6491	14.1421	16.7332	18.9737	26.0768	31.6228
1/2	1/2	7.2457	8.6603	9.8742	10.9545	12.8452	14.4914	19.7484	23.8747
3/4	3/4	5.4772	6.3246	7.0711	7.7460	8.9443	10.0000	13.4164	16.1245
1	1	4.5415	5.1235	5.6458	6.1237	6.9821	7.7460	10.2470	12.2474
1 1/4	1 1/4	3.9497	4.3818	4.7749	5.1381	5.7966	6.3875	8.3427	9.9197
1 1/2	1 1/2	3.5355	3.8730	4.1833	4.4721	5.0000	5.4772	7.0711	8.3666
2	2	2.9843	3.2113	3.4233	3.6228	3.9922	4.3301	5.4772	6.4226
2 1/2	2 1/2	2.6268	2.7928	2.9496	3.0984	3.3764	3.6332	4.5166	5.2536
3	3	2.3717	2.5000	2.6220	2.7386	2.9580	3.1623	3.8730	4.4721
10	10	1.2475	1.2698	1.2918	1.3134	1.3555	1.3964	1.5492	1.6882
15	15	1.0124	1.0247	1.0368	1.0488	1.0724	1.0954	1.1832	1.2649

When you take the classical inductance equation, and feed it into a computer along with the various parameters of the equation, you get this work saver.

merely a simplification of the standard equation for the inductance of a single-layer coil.

The equation is

$$L = (0.2n^2a^2)/(3a + 9b)$$

where a is the diameter of the coil from wire center to wire center, b is its length, n is the number of turns, and L is the inductance in microhenries. (The spacing between the turns is not a critical factor but it must be uniform.) Solving the equation for n ,

$$n = \sqrt{(3a + 9b)/0.2a^2} \times \sqrt{L}$$

If we call the first radical term on the right side of the equation K , then

$$n = K \sqrt{L}$$

Also

$$L = n^2/K^2$$

And for two coils of the same inductance,

$$n_1/n_2 = K_1/K_2$$

Now K can be calculated for a number of values of a and b with the results shown in the table. The use of the table greatly reduces the amount of math required to solve almost any inductance problem.

Examples of Use. To illustrate the use of the K Table, assume that you want to determine the inductance of a coil 1" long with a diameter of $3/4$ " and containing 10 turns of wire evenly spaced. Therefore, $a = 3/4$, $b = 1$, and $n = 10$. Using the table, we find that $K = 10$. The inductance is

$$L = n^2/K^2 = 100/100 = 1 \mu\text{H}$$

As another example, assume that the circuit calls for a coil having 10 turns on a form $1/2$ " long with a diameter of $1/4$ ". Unfortunately, all you have is a form with a $3/8$ " diameter (of sufficient length to accommodate the coil). To determine how you can use this form, first find the K of the original coil from the table. For $a = 1/4$ and $b = 1/2$, $K = 20.4939$ (or 20.5). Call this K_1 . For the new coil ($a = 3/8$ and $b = 1/2$) the table shows that $K = 14.1421$ (14.14). Call this K_2 . Now the number of turns for the new coil n_2 can be found from

$$n_2 = n_1 (K_2/K_1) = 10(14.14/20.5) = 6.9 \text{ turns}$$

This answer can be checked by calculating the inductance for each coil to be sure they are the same. In this case, $L = 0.238$.

BUILD **SLOT-CAR** **WIN DETECTOR**

A FINISH-LINE
JUDGE
THAT CAN'T
BE TRICKED

BY W. T. LEMEN

VISUAL determination of the winner in a close, fast slot-car race is almost impossible—the usual result is a heated discussion between the two participants. What you need is a photoelectric “Win Detector” that will end all the arguments by detecting the winner even if the two cars are separated by only $1/32$ of an inch. You can build one from an integrated circuit (IC) and two fast-acting photo pickups mounted at the finish line.

The Win Detector uses its own battery and works in normal room lighting—the winner is indicated by a glowing lamp. Because only a single switch controls the operation, the Win Detector can be used by small fry easily and safely.

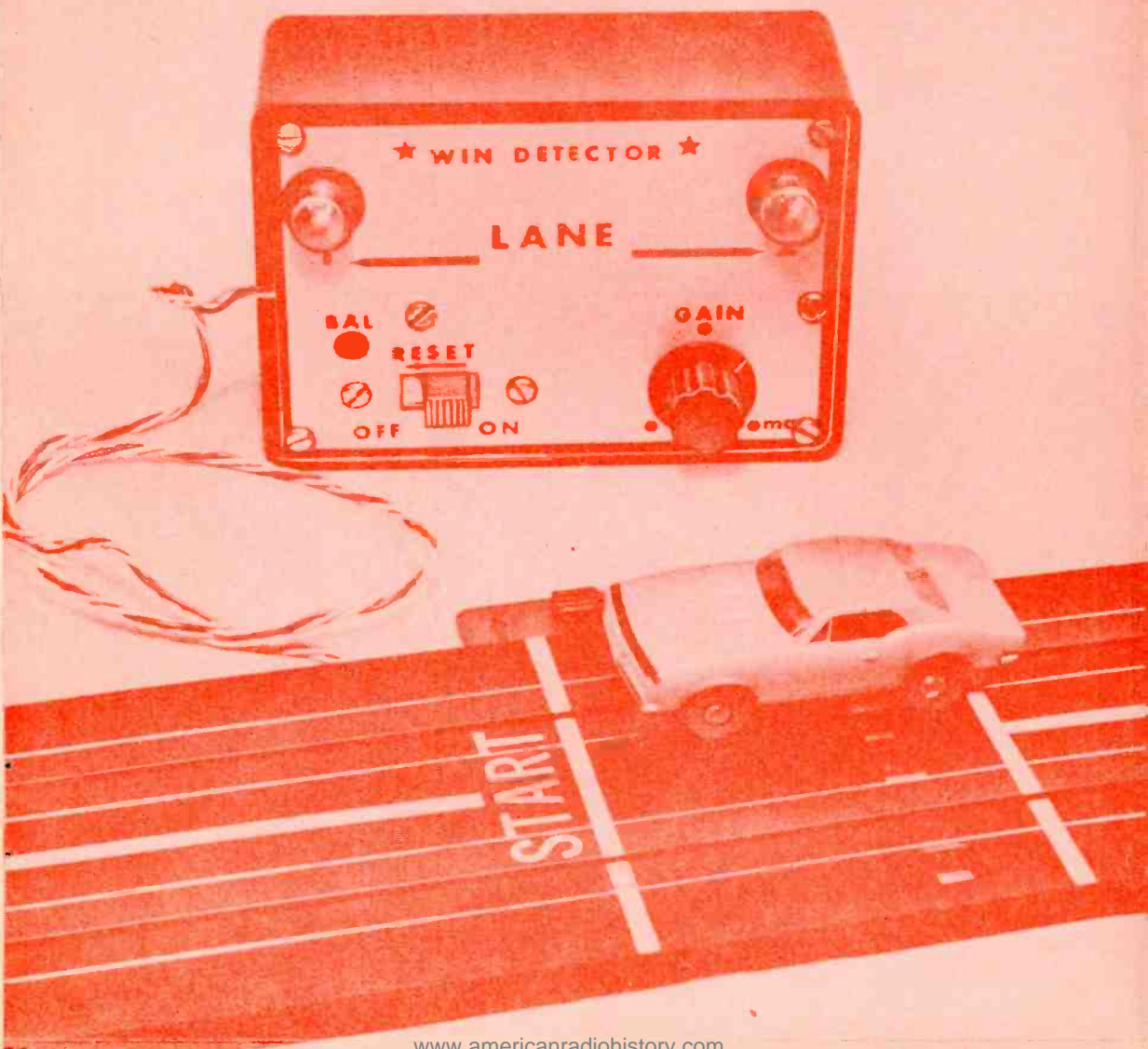

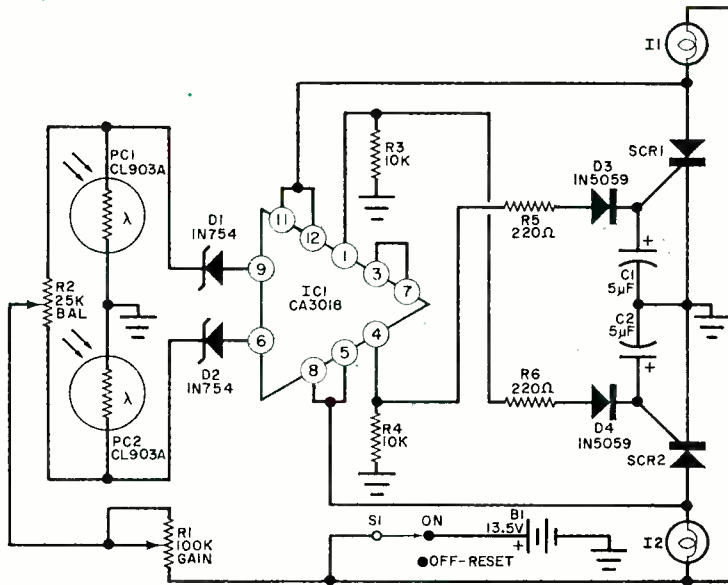

Fig. 1. The IC contains two independent circuits whose external components are arranged so that, when one of the two circuits operates, the other is automatically deactivated. This insures that only one track is winner.

PARTS LIST

B1—13.5-volt battery (Burgess XX9 or similar)
 C1, C2—5- μ F, 15-volt electrolytic capacitor
 D1, D2—1N754 zener diode
 D3, D4—1N5059 diode
 I1, I2—14-volt lamp (#330) with suitable holder (Dialco 0931-502)
 IC1—Integrated circuit (RCA CA-3018 or KD 2114)
 PC1, PC2—Photoresistor (Claircx CL903A or similar)
 R1—100,000-ohm potentiometer
 R2—25,000-ohm printed-circuit potentiometer (Mallory MTC)

R3, R4—10,000-ohm, $\frac{1}{4}$ -watt resistor
 R5, R6—220-ohm, $\frac{1}{4}$ -watt resistor
 S1—S.p.s.t. slide switch
 SCR1, SCR2—Silicon controlled rectifier (Texas Instruments TIC-46)
 Misc.—Plastic case 4" x 2 $\frac{3}{8}$ " x 1 9/16" (Harry Davies #220); 1/16" aluminum panel 3 $\frac{3}{4}$ " x 2 $\frac{3}{8}$ "; length of three-conductor cable; $\frac{3}{4}$ " fiber spacers (2); battery connector; $\frac{1}{4}$ " diameter fiber tubes 7/16" long (2) and wood block for photo pickups; knob; mounting hardware; etc.

Construction. The circuit for the Win Detector is shown in Fig. 1. Most of the components are mounted on the printed circuit board whose foil pattern is shown in Fig. 2. Figure 3 shows how the components are located. Observe the polarities on diodes and capacitors. To install the IC, make a "spider" formation of its leads, bending them about $\frac{1}{16}$ " below the case so that they go out radially. Then about $\frac{3}{16}$ " out from the case bend them down again so that they fit in the holes of the circuit board. Note that leads 2 and 10 of IC1 are not used and that a mounting hole is provided for pin 2 to keep the IC properly located. Lead 10 can be cut short at the case. The tab on the IC is located at lead 12 and the other leads are numbered clock-

wise from there looking at the case from the bottom.

After forming the leads of the IC into a spider, insert it on the board, making sure that the orientation is correct. Also be sure that the SCR's are properly oriented. Connections to the panel-mounted components are also shown in Fig. 3.

The Win Detector can be mounted in any type of chassis. Parts placement and circuit layout are not critical. If you want to duplicate the author's prototype, make the metal front plate according to the diagram in Fig. 4. It can be fabricated from a piece of $\frac{1}{16}$ " aluminum. Conventional dry transfer lettering can be used to make an attractive panel. Mount S1, R1, I1, and I2 on the metal panel and wire them to the circuit board

Fig. 2. Printed circuit board can be made from this actual-size pattern. The number "one" on the IC pattern is for pin 1.

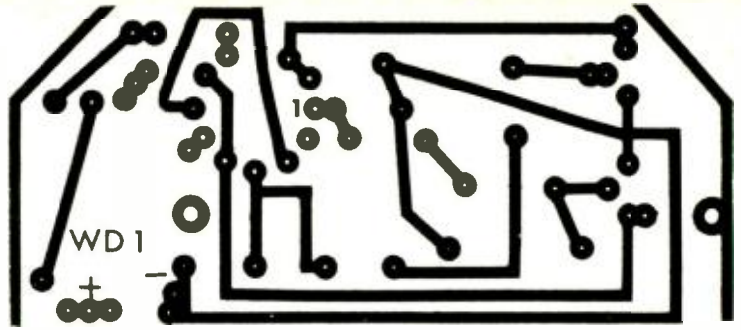

allowing enough wire to mount the board about $\frac{3}{8}$ " below the panel. Cut a small hole in the side of the plastic box to accommodate the three leads to the photo pickups. The three-conductor cable between the chassis and the photo-pickup assembly can be any reasonable length.

Attach the circuit board to the front panel using a pair of $\frac{3}{4}$ " insulated (fiber) spacers and appropriate hardware. The battery should fit inside the plastic case between the board and one long wall of the case.

The design of the photo-pickup assembly is contingent on the physical layout of the track you are using. If your finish line can be made to be at a raised portion of the track, you can use the layout shown in Fig. 5. In this case, the only two dimensions not given in the

diagram are the width of the overall wooden block and the center-to-center distance between the two $\frac{1}{4}$ " holes. The block should be cut to fit snugly under and between the track edges at the finish line and the $\frac{1}{4}$ " holes should be spaced so that they are directly under the centers of the lanes. Press fit the photo pickups into the fiber tubes; then fit the fiber tubes into the $\frac{1}{4}$ " holes in the wooden block.

Connect the three leads from the electronic assembly to the photo pickups as shown in Fig. 1 and Fig. 3. Solder and insulate these leads to prevent accidental loosening or shorting. The photo-pickup assembly can be attached to the track now. A three-terminal disconnect plug may be used between the detector and pickups to permit the track to be

Fig. 3. Once the board has been made, install the various components as shown here. Observe polarity of diodes and capacitors.

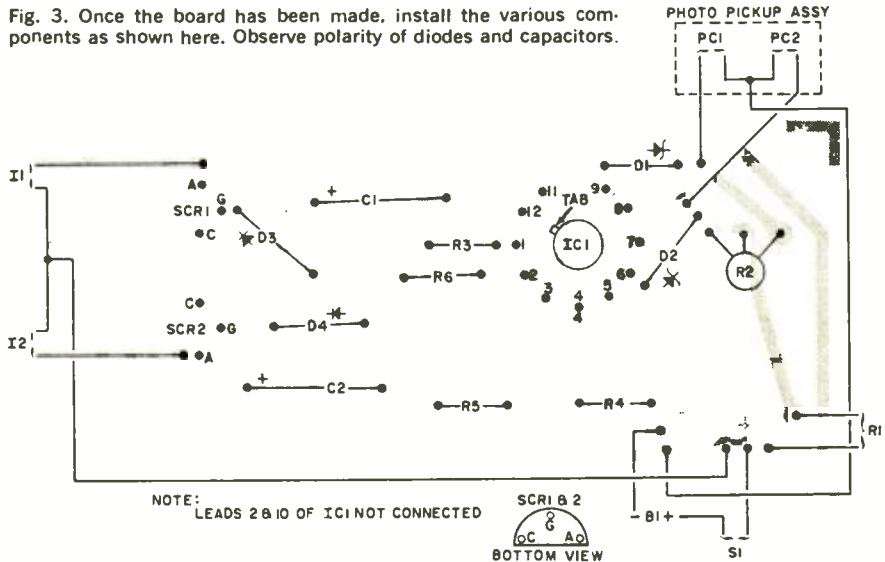

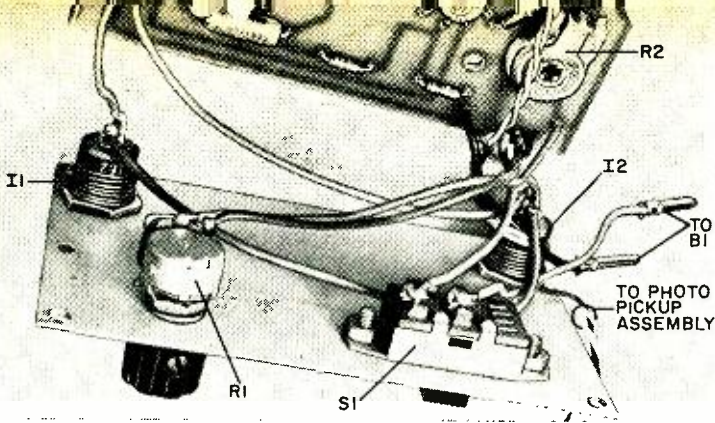

Interior of the author's prototype. Access to R2 is through a small hole in the metal front panel.

disconnected from the detector for storage.

For the more common plastic tracks, drill $\frac{1}{4}$ "-diameter holes adjacent to each track pin slot so that the car must pass over the hole to block the ambient light. Mount the two photo pickups, one at each track, and secure them in place with cement. Wire the pickups to the electronic assembly as described above.

Operation. With the slot-car track in position, be sure that the photo-pickup assembly is in unobstructed light. Place the RESET switch, S1, in the ON position and set GAIN control R1 to its maximum. One of the lights should come on. With R1 at maximum, flip S1 between the OFF and ON positions, simultaneously adjusting R2 (through the hole in the cover) until one light or the

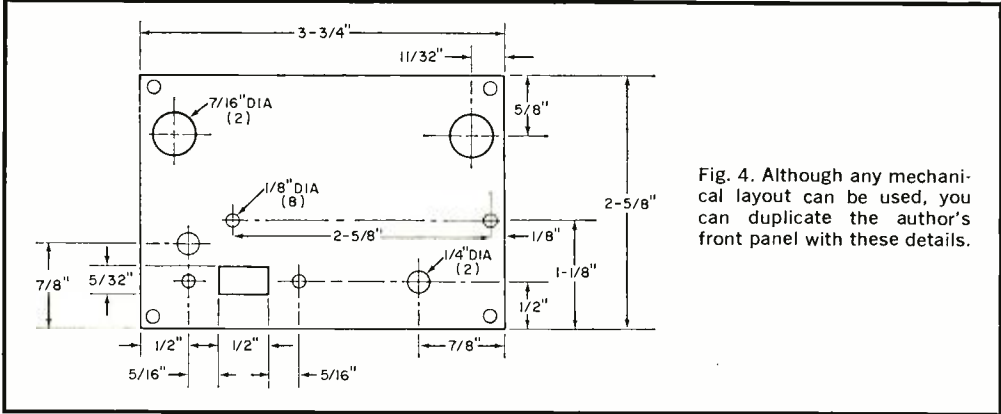
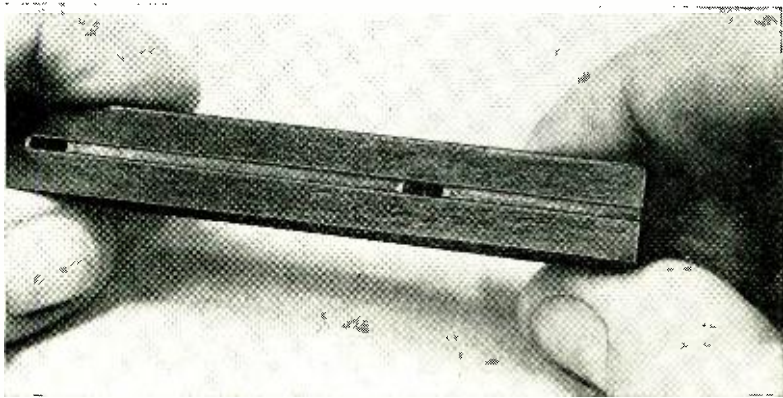

Fig. 4. Although any mechanical layout can be used, you can duplicate the author's front panel with these details.

Lengths of opaque tape are used to narrow the field of view of the two cells for more accuracy.



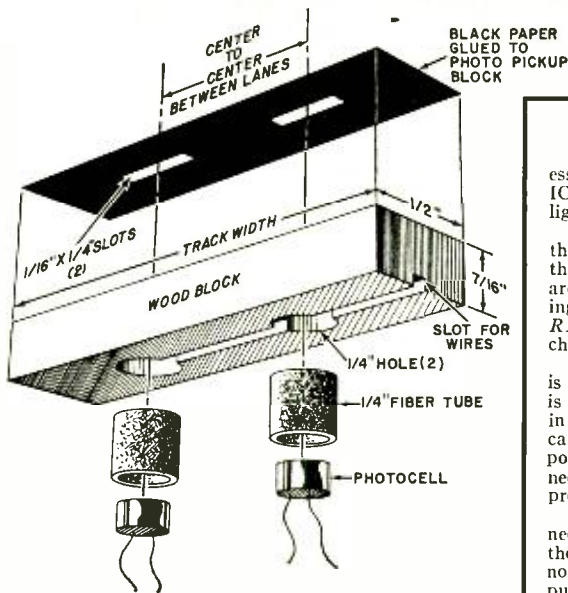

Fig. 5. If you have a raised track, make the photo pickup assembly as shown here. If you have a plastic track, mount the photocells in drilled holes.

other comes on when *S1* is on. It is possible to balance the system so accurately that both lights come on. Back off on *R1* until operation of *S1* does not cause either light to come on.

Test the system by passing your hand across the photo pickups in one direction (causing one light to come on). Then reset the system and pass your hand over the block in the other direction to turn the other light on. You may have to adjust the setting of the GAIN control for best operation. Once a light comes on, it will remain on regardless of

HOW IT WORKS

The electronic portion of the Win Detector is essentially two balanced amplifiers (within one IC) with photo pickups as sensors and indicator lights driven by SCR's.

Photo pickups *PC1* and *PC2* are connected to the bases of the two input transistors of *IC1* through zener diodes *D1* and *D2*. The pickups are connected to battery *B1* through the balancing potentiometer *R2* and the gain potentiometer *R1*. The balance control adjusts for lighting changes and circuit differences.

In operation, *R1* is adjusted (after the circuit is balanced) so that the potential at either zener is just slightly below its firing level. A reduction in the amount of light reaching either pickup causes an increase in its resistance and raises the potential on the zener diode to which it is connected. This causes the zener to break down and provide a signal at the input to the IC.

The outputs of the IC (pins 1 and 4) are connected as emitter followers with *R3* and *R4* as their loads. The voltages at pins 1 and 4 are normally zero. When either amplifier has an input from its photo pickup, its output fires the associated SCR and turns on the indicator light. The IC outputs are connected to the SCR's through current-limiting resistors *R5* and *R6* and blocking diodes *D3* and *D4*.

Note that the positive supply for each half of the IC is taken from the junction of each lamp and its associated SCR and not from the battery. These points are normally positive when the lamps are off, but the potential drops to zero when the SCR conducts. In this way, when either lamp turns on, the power to the opposite channel is cut off so that it cannot be energized. Therefore, the first channel to operate shuts down the other one, providing a definite indication of the winner.

Capacitors *C1* and *C2* are transient filters which assure turn off of the SCR's when the RESET switch is operated.

any other pass of the hand (or slot car) until the RESET switch is operated.

If you are using undersized slot cars or if you want faster triggering, reduce the values of capacitors *C1* and *C2*. -30-

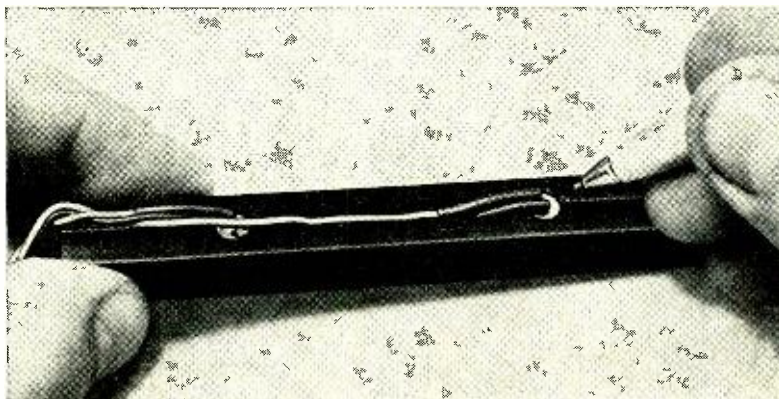

After photocells are wired together, they are friction fitted into the two holes drilled into a wooden block. The slot accommodates 3 wires.

The Late, Late, Late Q-SO

*By the way
WAZ YKK*

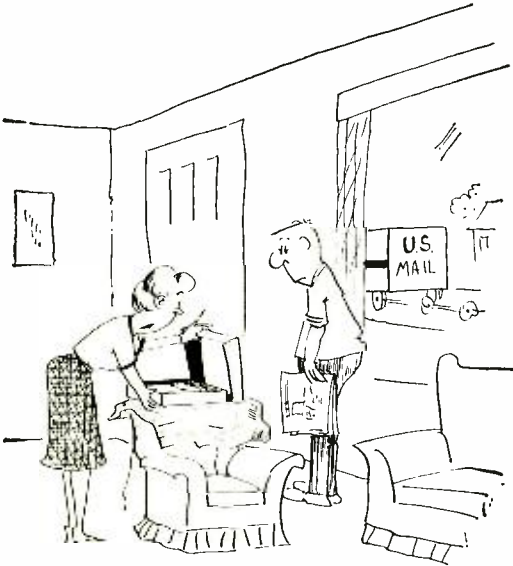

It's a birthday gift from your sister.
What in the world will you do with pajamas!



There's nothing wrong with your receiver.
Everyone has gone to bed.



Oh, don't apologize for
keeping me on, Fred.
It's time I was getting up anyhow.

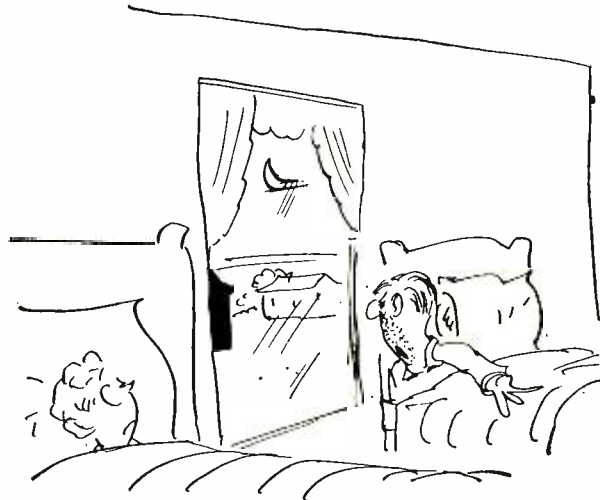

It must be after five.
I don't see a light in Fred's radio shack.

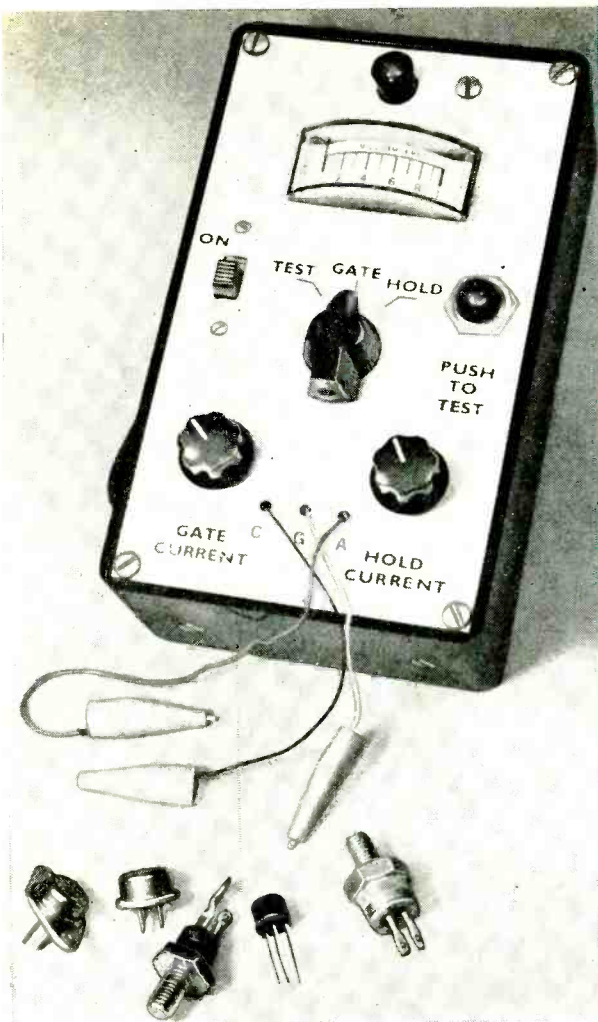

BUILD THE SCR TESTER

BY JAMES W. CUCCIA

PLAN TO RE-USE AN SCR?
YOU'LL WANT TO CHECK IT OUT FIRST

SILICON controlled rectifiers (SCR's) are becoming very popular with the electronics experimenter. However, there is one major drawback. Once you have a couple of used SCR's lying around, how do you test them? Conventional transistor testers can't do the job, and there are no low-cost SCR testers on the market.

For about \$12, you can make an excellent SCR tester that will tell you whether or not a particular SCR is good or not. (Since SCR's fail catastrophically, there is no such thing as testing them for "weakness" or degradation.) This tester will also tell you how much gate

current is required to fire an SCR and how much anode current is required to hold it in conduction once it has fired. Knowing whether or not an SCR is good, and having values for its minimum gate triggering current and minimum anode holding current, you are ready to put it to use.

You can't determine the SCR's maximum current rating since, in doing so, you might very easily ruin it. Maximum current and voltage ratings can be found in the manufacturer's literature.

Construction. The author built his version in a $6\frac{1}{4}'' \times 3\frac{3}{4}'' \times 1\frac{7}{8}''$ plastic

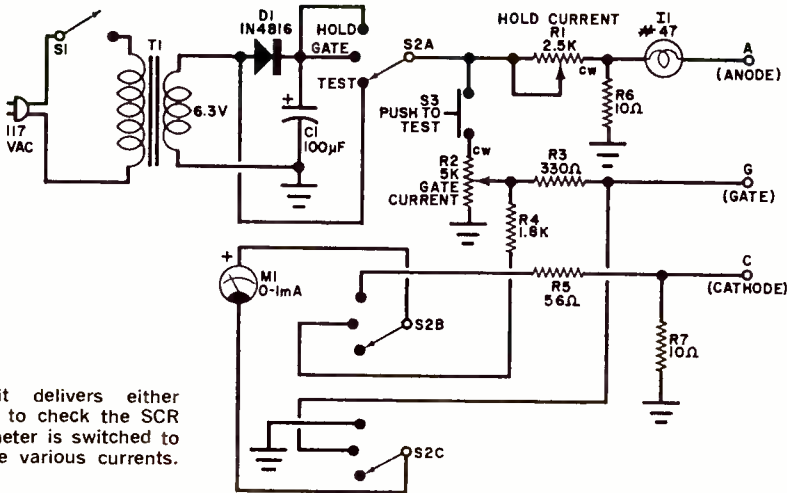

Test circuit delivers either a.c. or d.c. to check the SCR while the meter is switched to measure the various currents.

PARTS LIST

- C1—100- μ F, 15-volt electrolytic capacitor
 D1—1-amp, 50-volt diode rectifier (1N4816 or similar)
 I1—6.3-volt, 150-mA pilot lamp (#47 or similar)
 M1—1-mA d.c. ammeter (Emico Model 13, substitution requires change in R4 and R5)
 R1—2500-ohm, 2-watt potentiometer
 R2—5000-ohm, 2-watt potentiometer
 R3—330-ohm, $\frac{1}{2}$ -watt resistor
 R4—1800-ohm, $\frac{1}{2}$ -watt resistor

- R5—56-ohm, $\frac{1}{2}$ -watt resistor
 R6, R7—10-ohm, $\frac{1}{2}$ -watt resistor
 S1—S.p.s.t. switch
 S2—4-pole, 3-position rotary switch (Mallory 3243J or similar)
 S3—Momentary pushbutton switch (Switchcraft 103 or similar)
 T1—Filament transformer, secondary 6.3 volts
 Misc.—Line cord; lamp holder; screws; knobs; plastic case (Harry Davies 240 or similar) with metal cover; short lengths of thin insulated wire; three small, insulated alligator clips.

case, while the various controls, switches, meter and pilot light assembly are mounted and wired point-to-point on the metal front cover. The front-view photograph shows the panel layout used, al-

though any other arrangement will do. The three SCR connectors (C, G, and A) are brought out through three small holes using lengths of insulated wire terminated in small insulated alligator clips. Make a small knot in each wire, just inside the cover, to act as a strain relief. Because of the many different lead configurations that are used on SCR's, a socket is not prescribed.

Take care when drilling the transformer mounting holes in the plastic case since the plastic chips very easily. Countersink the two holes on the outside of the case and mount the transformer with flat-head screws so that the finished unit can be used in either a vertical or horizontal position. Note that a three-pole, three-position switch is used for S2, but a four-pole switch is called for in the Parts List. The connectors on the spare pole are used to mount the resistors.

Operation. Place S2 in the TEST position, rotate GATE CURRENT control R2 full counterclockwise, and set HOLD

HOW IT WORKS

With switch S2 in the TEST position, 60-Hz power is applied to the anode-cathode circuit of the SCR, in series with lamp I1. The GATE CURRENT control, R2, is adjusted clockwise to increase the applied gate current until the SCR fires. This is indicated by the turning on of I1. Returning R2 to its counterclockwise position reduces the applied gate current to the point where the SCR will not conduct and I1 will not come on. This test merely indicates whether or not the SCR is good or bad.

The GATE position of S2 is used to determine the minimum gate current required to fire the SCR. The controlled gate supply is increased slowly until the SCR fires. The amount of current required is indicated on the meter and should be read just before the SCR fires.

To measure the holding current, the meter is connected in the cathode circuit of the SCR. The correct current measurement is obtained by firing the SCR, removing the gate voltage and then increasing the resistance in series with the anode until the SCR cuts off.

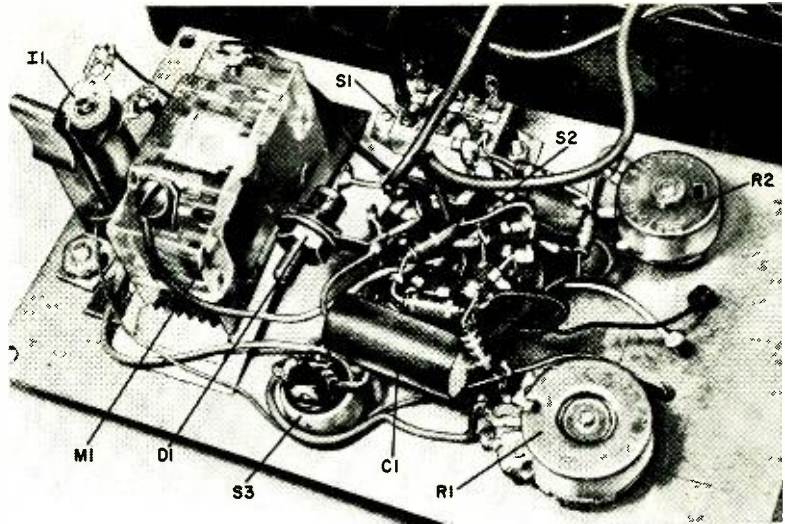

The entire tester can be mounted on the front panel of the chassis selected. Connections to the external SCR are made via three color-coded insulated test leads.

CURRENT control *R1* full clockwise. Connect the C lead to the cathode of the SCR, the G lead to the gate, and the A lead to the anode. Turn on the power to the tester. Depress the PUSH TO TEST switch, *S3*, and slowly rotate the GATE CURRENT control clockwise until lamp *I1* comes on. When you release the PUSH TO TEST button, the lamp should go off. If the lamp does not light, or if it remains lit at all times, the SCR is defective.

To determine the SCR's minimum gate firing current, place *S2* in the GATE position. Set the GATE CURRENT control full counterclockwise and the HOLD CURRENT control full clockwise. Depress the PUSH TO TEST button and slowly rotate the GATE CURRENT control clockwise until the lamp comes on. The correct gate current can be read on the meter *just before* the lamp comes on. The current will drop back when the SCR fires and the lamp lights. In the circuit shown, the meter indicates 10 milliamperes full scale. If you miss the meter reading when doing this test, place *S2* in the TEST position and then return it to the GATE position, and repeat the test.

The third test measures the SCR's minimum anode holding current. Place *S2* in the HOLD position, GATE CURRENT control full counterclockwise, and the HOLD CURRENT control full clockwise. Depress the PUSH TO TEST switch and

advance the GATE CURRENT control slowly until the lamp lights. Release the PUSH TO TEST switch and slowly rotate the HOLD CURRENT control counterclockwise until the meter indication drops to zero. The current reading *just before* the current drops is the correct holding current for the SCR. This current can be checked by advancing the HOLD CURRENT control full clockwise. Then if the meter returns to full scale, the holding current has not been reached. If the meter still indicates zero, the test is valid. Maximum on the meter scale for this test is 100 milliamperes. -30-

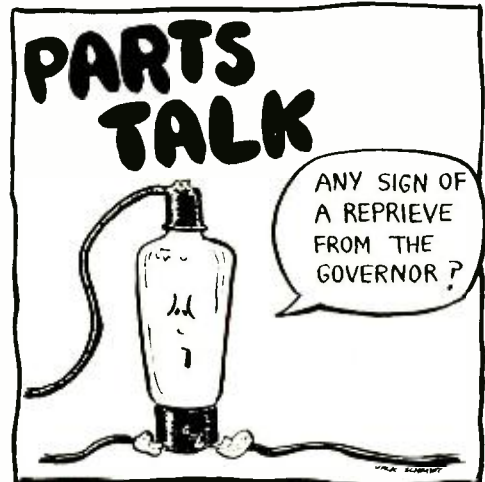

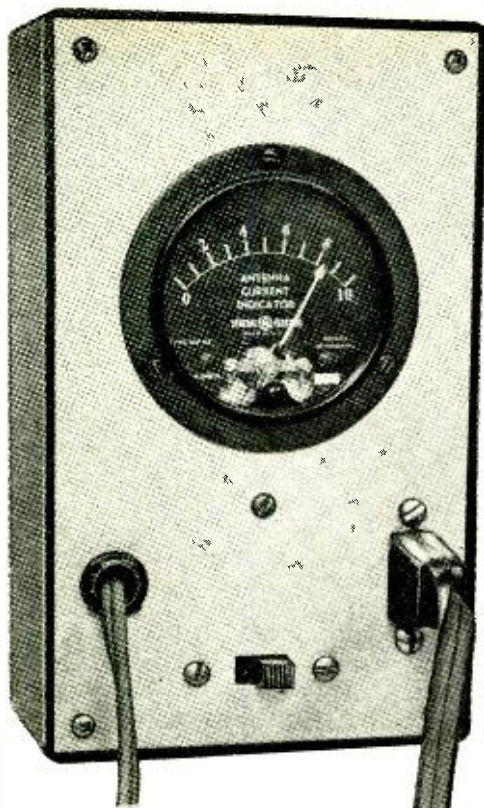

Low-Cost A.C. Ammeter

*Measures up to
5 amperes
with \$3 outlay*

BY NEIL JOHNSON, W20LU

YOU SEE all sorts of meters and indicating instruments in ham shacks and electronics experimenters' workshops, but you very seldom see an a.c. ammeter. Obviously, lots of people could put one to good use—the trouble is, they are too expensive.

A reasonably good a.c. ammeter sells for about \$12 and, in most cases, at least two of them are required in order to make a broad range of measurements. This is because the commonly used a.c. instrument works on the moving vane principle and the low end of the scale is severely compressed. On most 0-5-ampere a.c. ammeters, indications below 1 ampere are next to useless. So, in addition to a 5-ampere meter, you have to have a 1-ampere instrument to cover the full range adequately.

You can build yourself a good, wide-range ammeter very inexpensively, if you take advantage of some government surplus items that are widely available. Part of every "command set" used in

airplanes at one time was an "Antenna Current Indicator" (military nomenclature: BC-442). The current meter used in this device has a nonlinear scale and is more sensitive at the low end of the scale than at the high end. This prevents crowding at the low end of the scale—a feature not found in conventional a.c. indicating instruments.

The BC-442 comes with a built-in thermocouple about the size of a small domino. When the thermocouple is heated (in any way), it generates a small d.c. current at its output. An input to the thermocouple of half a volt generates enough current to deflect the companion d.c. meter to full scale—about 5 milliamperes. When operating together, the thermocouple and d.c. meter are reasonably accurate over a wide range of frequencies and essentially linear over a large part of the meter scale.

To extend the meter range to 4.5 amperes, a meter shunt of 0.1375 ohm is required. This resistance can be fabri-

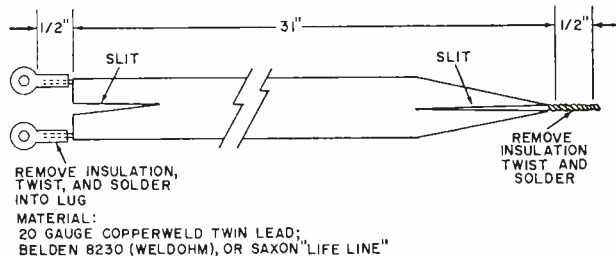
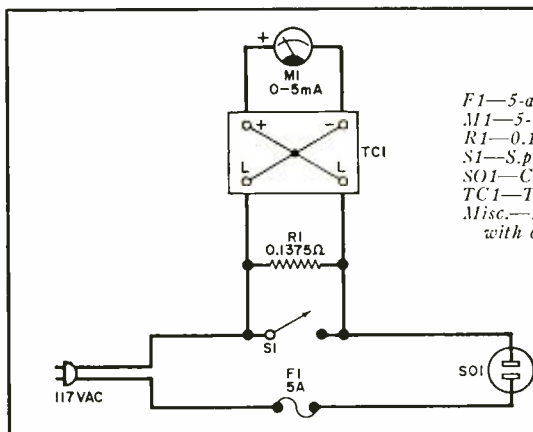
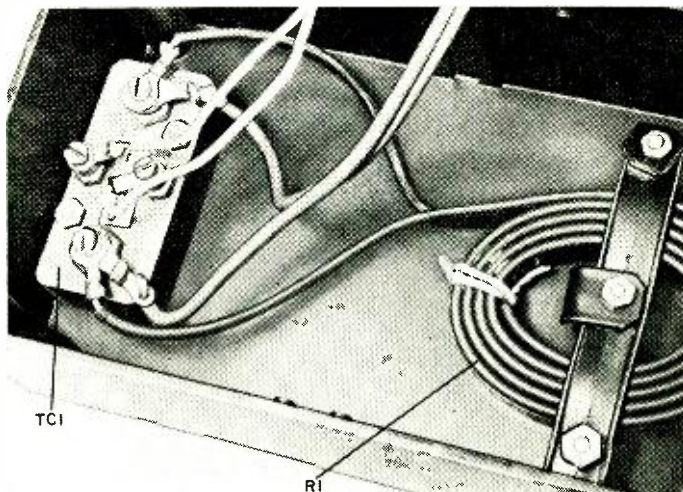

Fig. 1. Though primarily used as TV lead in, twin lead can be used to make a high-quality, low-value resistor (0.1375 ohm).

The shunt can be rolled up and mounted at one end of the case. This makes for a non-inductive resistor that can be used at frequencies far above 60 Hz.



PARTS LIST

- F1*—5-ampere fuse (not slow-blow)
- M1*—5-m.A meter from BC-442
- R1*—0.1375-ohm precision resistor (see text)
- S1*—S.p.s.t. switch 3-ampere rating
- SO1*—Conventional a.c. outlet
- TC1*—Thermocouple from BC-442 (0.75-A r.f.)
- Misc.*—Mounting cabinet, fuse holder, line cord with attached plug.

Fig. 2. Circuit operation is simple. Current passing through the thermocouple heats the dissimilar metal junction producing a small current which is indicated on the meter. The low-value shunt resistor (R1) bypasses most of the heavy current.

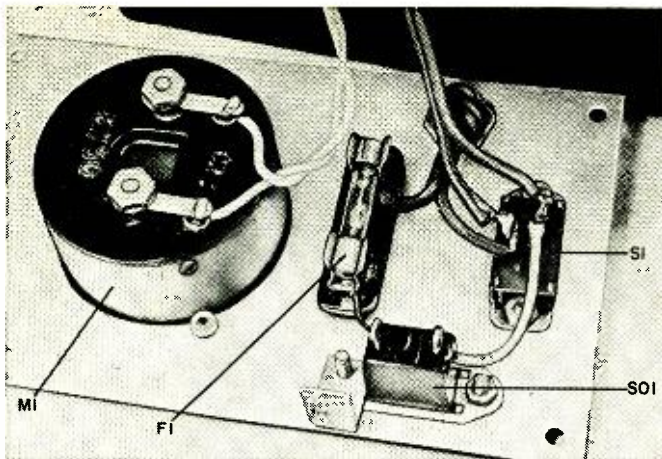

Other than the shunt and thermocouple, the remainder of the components are mounted on the metal front panel as shown here.

cated at a meter shop at high cost or you can use a series-parallel arrangement of 10 one-ohm precision resistors—also at a high cost. A cheaper way is to use a length of ordinary TV twin lead of Copperweld fabrication. The two conductors are well insulated and the wattage developed at maximum current is easily handled. Best of all, a “precision” resistor can be made using only a ruler. Instructions for making the shunt are given in Fig. 1. Follow the measurements carefully. It is recommended that you make up the shunt and solder it to its connector lugs at some distance from the thermocouple since the thermocouple calibration can be affected by soldering heat. When the shunt is finished, coil it into a small circular form and secure it with plastic insulating tape. The coiled-up shunt can be mounted on the rear of the meter case using a bolt and some scrap plastic to support it. Since this homebrew resistor is noninductive, the completed instrument can be used at frequencies much higher than 60 Hz.

Wire the shunt, the thermocouple and the meter as shown in Fig. 2. Note that, for safety's sake, a fuse and a shorting switch have been added to the circuit.

METER SCALE	AMPERES
0.5	0.6
1.0	0.75
1.5	0.90
2.0	1.00
3.0	1.25
4.0	1.50
5.0	1.80
6.0	2.20
7.0	2.50
8.0	3.00
9.0	3.70
10.0	4.50

Any 5-ampere fuse can be used as long as it is not a “slow-blow” type. The shorting switch shorts out the meter when first trying an unknown load. Once the device has been built, recalibrate the meter face to the values shown in the table.

Depending on where you buy the BC-442, the total cost of the meter will run about \$3. At a nominal 117 volts, the meter will measure loads varying from 60 to 540 watts. If desired, and if you are using only the normal 117-volt power line, you can calibrate the meter in watts instead of amperes.

—50—

BASIC ELECTRONIC INSTRUMENTATION

A three-week course in electronic instrumentation will be given from July 19 to August 9, 1969, at Polytechnic Institute of Brooklyn. Supported in part by the National Science Foundation, the course is open to anyone with a basic understanding of college physics. The text is “Electronics for Scientists” by Malmstadt, Enke and Toren. Lecture, laboratory, and discussion topics include: basic electrical measurements, power supplies, solid-state amplification elements, oscillators, servo-controlled devices, operational amplifiers, analog simulation, and electronic digital systems. Tuition is \$500. Contact: Prof. Kenneth Jolls, Office of Special Programs, Polytechnic Institute of Brooklyn, 333 Jay St., Brooklyn, N.Y. 11201.

A "BIGGER- THAN-LIFE" SPEAKER SYSTEM



BY DAVID B. WEEMS

REALLY "BIG" SOUND FROM A MODEST-SIZE ENCLOSURE

SPEAKER SYSTEM BASS response is generally equated with enclosure size; the greater the enclosure volume, the better the bass. The "Bigger-Than-Life Speaker System," however, is a medium-size enclosure that succeeds in providing big, natural-sounding bass. To be more specific, the system's 6000-cu in. volume is tuned to provide the sound normally expected of a system with an 8000-cu in. volume.

If you find this hard to believe, try the following experiment. Test the system resonance of a sealed-enclosure speaker system in a bare box and test it again after filling it with acoustical pad-

ding. You will find that the resonant frequency is lower in the latter case by as much as 10 Hz—or more.

To understand how this is possible, it is necessary to study the physics of sound propagation. Sound is produced in air as a series of "waves" which consist of an area of compression followed by an area of rarefaction or partial vacuum. Compressing air causes an increase in temperature (a fact familiar to anyone who has ever pumped up a tire). Conversely, a reduction of air pressure results in a temperature drop. A sound wave, therefore, is composed of a continuous train of compressions and rare-

We pack your electronics course with kits to make your training fast. You'll enjoy every minute of it.

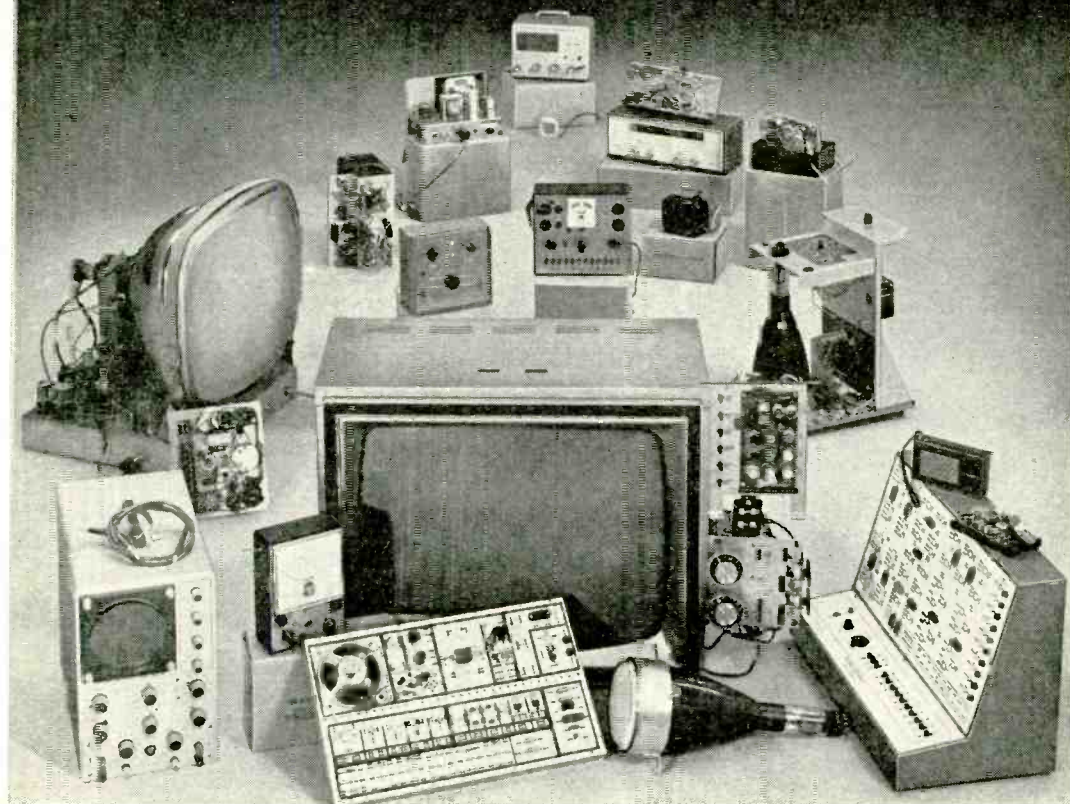

Your NTS success package

Choose a career in electronics: Computers. Color TV Servicing. Automation. Communications. Whatever the field, NTS has a complete home-study package to get you to the top faster. 10 thorough training courses. Each includes *everything* to give you the *working* knowledge required of successful technicians.

NTS Project-Method Training is the practical way to learn elec-

tronics. It's a proven combination of lessons and the best professional kit equipment available. NTS provides the *biggest selection of kits ever offered in home-study . . . all at no extra cost*. You'll construct these exciting kits to fully understand electronic circuits, components, and concepts. Our Project-Method lets you build skills by putting theory into practice . . . by *working* with your hands, as well as your head.

The NTS "learn and practice" approach makes training at home really easy. All it takes is a few hours a week . . . whether you're starting from scratch or in advanced courses. This is the all-inclusive success package that put thousands of men into the best paying jobs . . . or into their own business. If "just a living" isn't good enough for you, now is the time to get something better going for you!

NTS COMPUTER ELECTRONICS

This is the future. And it's happening now. The number of computers will *increase many times* in the next few years.



Exclusive new Compu-Trainer®

NTS offers a solid grounding in computer operation, wiring, data processing and programming. One of the 10 important kits included is our exclusive Compu-Trainer®. It's a fully operational computer logic trainer — loaded with integrated circuits — the first ever offered in home study. It introduces you quickly to how, what, when and why of computers . . . from theory to practical servicing techniques. This unit is capable of performing 50,000 operations per second. And it's sent at no extra cost.

NTS COLOR TV SERVICING

This is a broad, easily understood

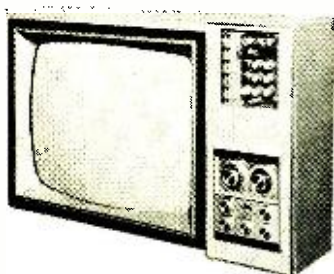

25" COLOR TV

program designed to make you a complete home-entertainment service technician. Included, at no extra cost, is a 25" color TV that has more features than any

set on the market. You also learn all about stereo, hi-fi, multiplex systems, and become a specialist in Color TV Servicing. Kits also include AM-SW radio, solid-state radio, vacuum tube volt meter, electronic tube tester.

NTS AUTOMATION/ INDUSTRIAL ELECTRONICS

You're trained in the "push-button" electronics that keep industry going and growing . . . from relay type controls to highly advanced systems essential to production. You receive 16 kits including a 5" wide band oscilloscope, and the new NTS electronics lab: a fascinating NTS exclusive experimental laboratory. A complete workshop which makes you familiar with solid-state, miniature, and integrated circuits.



5" Oscilloscope

NTS ELECTRONIC COMMUNICATIONS

The use of 2-way radio systems in private and commercial applications is skyrocketing. NTS prepares you for the big-money opportunities in the field of transmitting and receiving equipment. *Your tuition will be refunded in full if you cannot pass the FCC exam for a 1st Class Commercial Radio-Telephone License within*

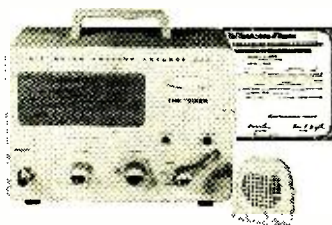

5 Watt AM Transmitter & Receiver

six months after successfully completing this course. You build valuable kits including Amateur-Phone 6 Meter VHF Transceiver, solid-state Radio, and a Vacuum Tube Voltmeter.

CLASSROOM TRAINING AT LOS ANGELES

You can take classroom training at Los Angeles in sunny Southern California. NTS occupies a city block with over a million dollars in facilities devoted exclusively to technical training. Check box in coupon.

NATIONAL TECHNICAL SCHOOLS

World-Wide Training Since 1905
4000 South Figueroa Street
Los Angeles, Calif. 90037, U.S.A.

APPROVED FOR VETERANS

Accredited Member: National Association of Trade and Technical Schools, National Home Study Council.

TODAY, MAIL
COUPON
FOR FREE
COLOR
CATALOG
AND SAMPLE
LESSON.

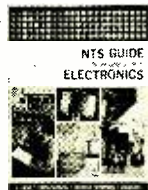

NATIONAL TECHNICAL SCHOOLS
4000 S. Figueroa St., Los Angeles, Calif. 90037
Please rush Free Color Catalog and Sample Lesson, plus information on field checked below. No obligation. No salesman will call.

- MASTER COURSE IN COLOR TV SERVICING
- COLOR TV SERVICING
- MASTER COURSE IN TV & RADIO SERVICING
- PRACTICAL TV & RADIO SERVICING
- MASTER COURSE IN ELECTRONIC COMMUNICATIONS
- FCC LICENSE COURSE
- MASTER COURSE IN ELECTRONICS TECHNOLOGY
- INDUSTRIAL AND AUTOMATION ELECTRONICS
- COMPUTER ELECTRONICS
- BASIC ELECTRONICS

Name _____ Age _____

Address _____

City _____ State _____ Zip _____

- Check if interested in Veteran Training under new G.I. Bill.
- Check if interested ONLY in Classroom Training at Los Angeles. Dept. 205-59

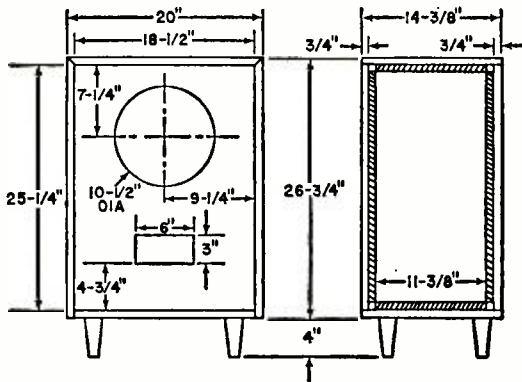

Fig. 1. Except for furniture legs, entire enclosure is made of $\frac{3}{4}$ "-thick plywood and $\frac{3}{4}$ "-square pine.

BILL OF MATERIALS

- 1—Olson Electronics Model S-971 Deluxe three-way speaker^a
- 3 pkgs.—Olson Electronics No. HF-17 acoustical Fiberglass^a
- 2— $26\frac{3}{4}$ " x $14\frac{3}{8}$ " pieces of $\frac{3}{4}$ " plywood for enclosure sides (see text)
- 1— 20 " x $14\frac{3}{8}$ " piece of $\frac{3}{4}$ " plywood for enclosure top (see text)
- 1— $18\frac{1}{2}$ " x $14\frac{3}{8}$ " piece of $\frac{3}{4}$ " plywood for enclosure bottom
- 2— $25\frac{1}{4}$ " x $18\frac{1}{2}$ " pieces of $\frac{3}{4}$ " plywood for enclosure rear and speaker mounting board
- 4— $11\frac{3}{8}$ " pieces of $\frac{3}{4}$ " x $\frac{3}{4}$ " pine for corner glue blocks
- 4— $18\frac{1}{2}$ " pieces of $\frac{3}{4}$ " x $\frac{3}{4}$ " pine for cleats
- 4— $23\frac{3}{4}$ " pieces of $\frac{3}{4}$ " x $\frac{3}{4}$ " pine for cleats
- Misc.—#8 x $1\frac{1}{4}$ " flathead wood screws (7 doz); #12 x 1" panhead screws (4); 4" furniture legs (4); grille cloth; expanded aluminum (optional); decorative trim; glue; zip cord; solder; etc.

^aAvailable from Olson Electronics, 260 S. Forge St., Akron, Ohio 44308.

factions at slightly different temperatures.

Heat flows from a high- to a low-temperature area. But in the case of sound waves within the range of 20 to 20,000 Hz in air, the wavelength is too long and thermal conductivity of the air too small for heat transfer to take place. Hence, the waves are said to be adiabatic (constant heat) rather than isothermal (constant temperature).

Now, when the speaker enclosure is stuffed with acoustical padding, an interesting change takes place. The stuffing absorbs and gives up heat, which changes

the operation of the air from adiabatic to isothermal. And when sound is isothermally propagated in air, its velocity decreases. Because the wavelength of sound is directly proportional to its velocity, reducing one also reduces the other. Or, looking at the situation from the standpoint of a loudspeaker in a box, the reduction in wavelength means that the enclosure is "larger" by comparison to wavelength.

Through the proper application of enclosure design and selection of stuffing material, the "Bigger-Than-Life Speaker System" performs as though it is actually bigger than it really is.

Overall System. Now that the general principle has been described, the next step, obviously, is to apply it to a specific speaker enclosure. This is exactly what has been done in the Bigger-Than-Life Speaker System described here. The dimensions of the system enclosure are modest—a mere 6000 cu in. However, the system is designed around a high-quality three-way speaker and employs a $3" \times 6"$ port (see Fig. 1) that tunes the fully stuffed enclosure to a 45-Hz resonance. (A port of this size would normally require an enclosure volume of about 8000 cu in. to be correctly tuned to the same frequency.)

In this speaker system, the port is tuned to a higher frequency than the speaker's free-air resonance to insure that the system will provide good performance in the 45- to 125-Hz range.



Fig. 2. Start assembly by joining cleats to bottom (left) and cleats and glue blocks to side (right).



Fig. 3. Attach all cleats and glue blocks; glue and screw together top, bottom, and sides of enclosure.

[As was pointed out in the "Tune Up Your Bass Reflex" article (July 1968), many experts recommend tuning a bass reflex enclosure to a frequency above that of the speaker when the speaker's resonance is very low. Thus, the chance of "weak" bass is avoided by the simple expedient of enlarging the port.]

If this enclosure performs as though it were one-third larger than it really is, something has to give—in this case it's efficiency. After all, you can't get something for nothing. The loss in efficiency is due to the fact that a stuffed enclosure absorbs more power than a conventional bass reflex enclosure of larger volume. However, if space is a problem, you will most likely be happy to make the trade.

Construction. Assembling the system after all of the parts have been cut to the sizes illustrated in Fig. 1 and specified in the Bill of Materials is fairly simple. In effect, you just put together a box, install a speaker, and drop in the proper amount of stuffing.

The walls of the enclosure are $\frac{3}{4}$ "-thick plywood, joined together with glue and screws through the corner blocks. The top edges of the sides, and the edges of the top that mate with the sides,

should be miter cut to 45° angles. If you do not have the equipment for making miter cuts, you can employ butt-joint construction. However, make absolutely certain that whichever method you use you maintain the same inner dimensions shown in the illustration.

Begin construction by attaching cleats to the bottom and cleats and glue blocks to the sides of the enclosure as shown in Fig. 2. Then join the top and one side together (Fig. 3) with glue and screws, driving the screws through the corner block and into the top plate. Glue and screw the other side in place.

Invert the assembly, coat mating surfaces with glue, and attach the bottom. Note that the bottom butts against the inner walls of the sides. It can be secured in place with nails driven through the bottom into the cleats, followed by screws for greater strength. The nails will hold the parts in place while the screws are being installed.

Apply a coat or two of flat black paint to the outer surface of the speaker mounting board and the edges of the

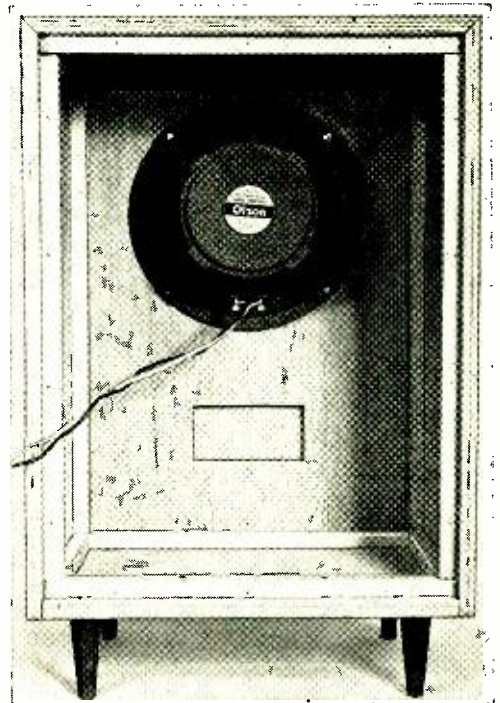

Fig. 4. After enclosure is assembled, attach furniture legs to bottom and install speaker as shown.



Expanded aluminum grille/picture-frame assembly goes into place only after grille cloth has been tacked onto speaker mounting board. You can use wire brads or ornamental screws to fasten the assembly down.

speaker and port cutouts. Then install the speaker mounting board in the enclosure with glue and screws. Affix a set of 4" furniture legs to the bottom of the enclosure as shown in Fig. 4. Then tack your choice of grille cloth and trim in place, and sand, stain and varnish the enclosure.

If you decide to use large-pattern expanded aluminum to set off the grille cloth, plan space for it behind the front trim. An easy method of accommodating the expanded aluminum is to employ picture-frame molding with a $\frac{3}{16}$ " rear groove. The groove is just the right depth for the job.

Now, for a striking appearance, you might want to paint the molding flat black and use a brightly colored grille cloth. Decorator burlap is attractive—and inexpensive. When installing the grille cloth, stretch it slightly before tacking it in place.

Use a thick, "hard-set" cement (such as liquid solder) to secure the expanded aluminum to the picture-frame molding. Then attach the grille assembly to the front of the enclosure with finishing nails and cement or with ornamental screws.

Set the enclosure flat on its front, install the speaker with panhead screws, and solder a length of zip cord to the

speaker terminals. Now, fold each of the packages of fiberglass stuffing into three equal layers. Cut a hole through the center of all three layers of one package of fiberglass, pass the zip cord and control through the hole, and lay the fiberglass flat over the speaker in the enclosure. Do the same with the remaining two packages of fiberglass. There is no need to tack the fiberglass in place; it is stiff enough to stand unsupported when the rear wall is screwed down.

Do not substitute any other brand of fiberglass fill unless you are prepared to perform tests to determine exactly how much of the substitute to use. The reason is that fiberglass is available in various densities, and each density requires more or less fill. Also, remember that three packages of the fiberglass fill specified in the Bill of Materials must be used inside each enclosure.

Finally, mount the control and bring out the speaker leads through holes drilled through the rear wall of the enclosure. Then fill in the hole through which the speaker wire exits with cement to maintain an air-tight enclosure, and fasten it down with screws.

That's it! Connect the speaker system to your amplifier, and you're ready to enjoy room-filling sound. -50-

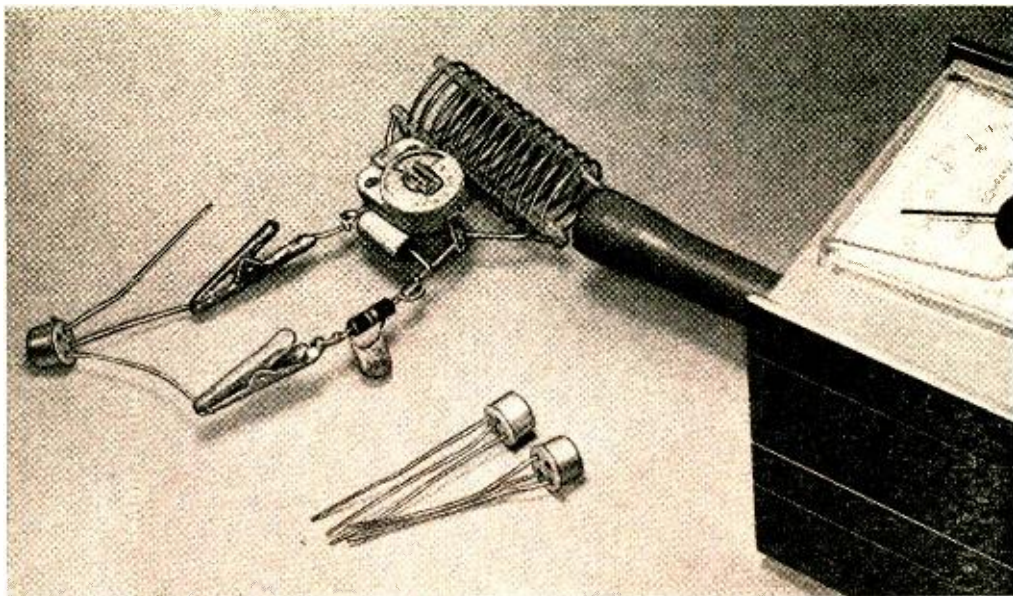

Transistor Sorter

ARE THEY AUDIO, LOW R.F., OR VHF?

FIND OUT WITH THIS SIMPLE TESTER

BY RAYMOND F. ARTHUR

MANY ELECTRONICS hobbyists have accumulated signal transistors from bargain packs, surplus computer boards, and other sources. The problem is that most such transistors lack "2N" identification markings, and in the cases where user production numbers are provided, the problem is only compounded. Sure, almost any transistor tester will show whether an unknown transistor is *npn* or *ppn* and provide gain data. But how do you find out if it's suitable for audio or r.f. applications?

Well, if you own or can get your hands on a grid-dip oscillator, you can sort your transistors into application categories (audio, i.f., h.f., etc.). This type of sorting is possible because the shunting action of the base-to-collector capacitance of the *pn* junction causes transistor gain to drop off as frequency is increased. Relating this phenomenon to application sorting, the lower the junction capacitance (less pronounced dropoff in gain with increasing frequency), the higher

the frequency at which the transistor can be operated.

In addition to a grid-dip oscillator, you will need a parallel-resonant tank circuit (*L1* and *C1* in Fig. 1) to sort transistors according to application. With the alligator clips open-circuited, *L1* and *C1* should resonate at a frequency of about 30 MHz. Any added capacitance (connected between the clips) lowers the resonant frequency of the tank circuit and causes a correspondingly lower dip point on the GDO.

The *L1-C1* tank circuit, when properly assembled, should be self-supporting as shown in photo. For *L1*, use a 16-turn length of Barker and Williamson #3015 "Miniductor" (1" coil diameter, 16 turns/in. of #21 wire). Unwrap one turn from each end of the coil, leaving 14 complete turns and ending up with two 2" leads oriented perpendicular to the axis of the coil.

Slip the unwrapped leads through the solder lugs of trimmer capacitor *C1* and

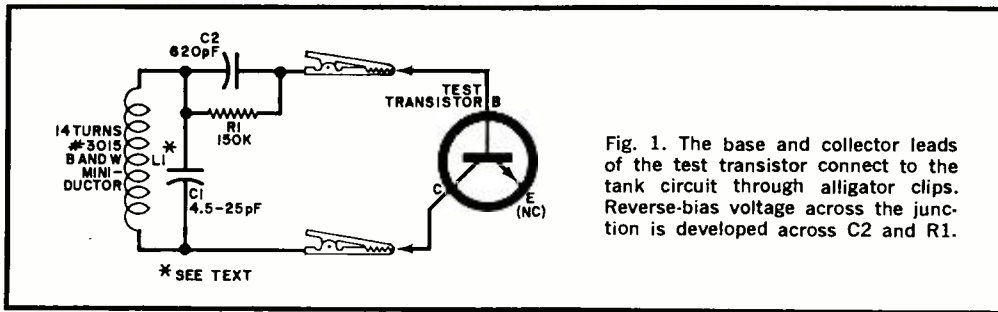

Fig. 1. The base and collector leads of the test transistor connect to the tank circuit through alligator clips. Reverse-bias voltage across the junction is developed across C2 and R1.

solder into place 1½" from the coil. Then solder a miniature alligator clip to one of the coil leads. Clip off the excess length of the other coil lead at C1, and solder C2 and R1 to C1; make sure the leads of C2 and R1 are clipped short. Finally, solder another alligator clip to the unconnected sides of R1 and C2.

In use, the tank circuit should be placed in a small plastic box to permit easy alignment of the axes of L1 and the coil of the GDO. With the alligator clips open-circuited and positioned where they can accept the leads of a transistor, gently adjust C1 for a dip at 30 MHz. Shorting

the alligator clips together should shift the dip to 3 MHz.

Connect the base and collector leads of the transistor to be tested to the alligator clips; it doesn't matter which lead goes to which clip. Now, avoiding over-coupling between the tank circuit and GDO, determine the frequency at which the GDO pointer dips.

Refer to the graph provided in Fig. 2 for measured capacitance or transistor type. This graph indicates a general trend of very low capacitance for UHF transistors to higher capacitance for audio transistors. It is not practical to indicate precise regions for various transistor types on the graph because of overlaps and other factors that might affect the high-frequency operation of transistors.

Although collector capacitance plays an important part in setting the upper frequency limit of transistors, other factors such as current gain, base resistance, and overall power gain are also important. If current gain is known and two transistors show about the same output capacitance, but have widely differing gains (say 30 and 300), the lower gain transistor should be rated downward in frequency capability.

The graph of Fig. 2 is intended for use with low-power transistors—not power transistors. With a few exceptions, all transistors you check will produce a dip on the GDO. Failure to obtain a dip may indicate a very leaky transistor, an unusually low collector-to-base breakdown voltage, or unusually low Q of the junction capacitance.

Considering its simplicity and low cost, the GDO method of sorting transistors affords the experimenter and hobbyist with a simple and useful means of judging the relative frequency capabilities of small unidentified transistors.

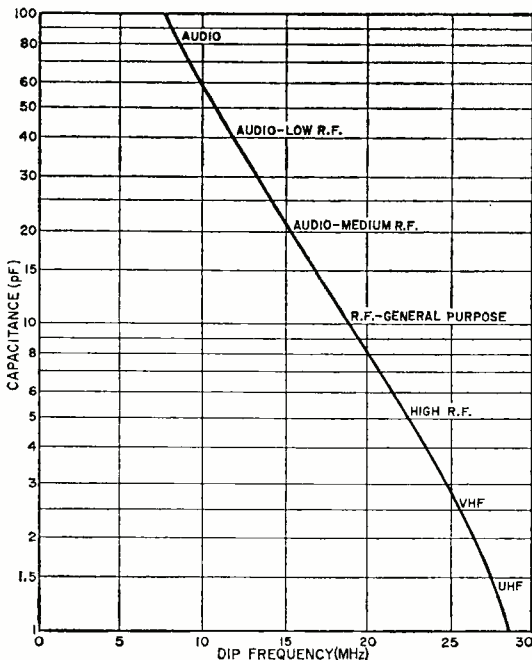
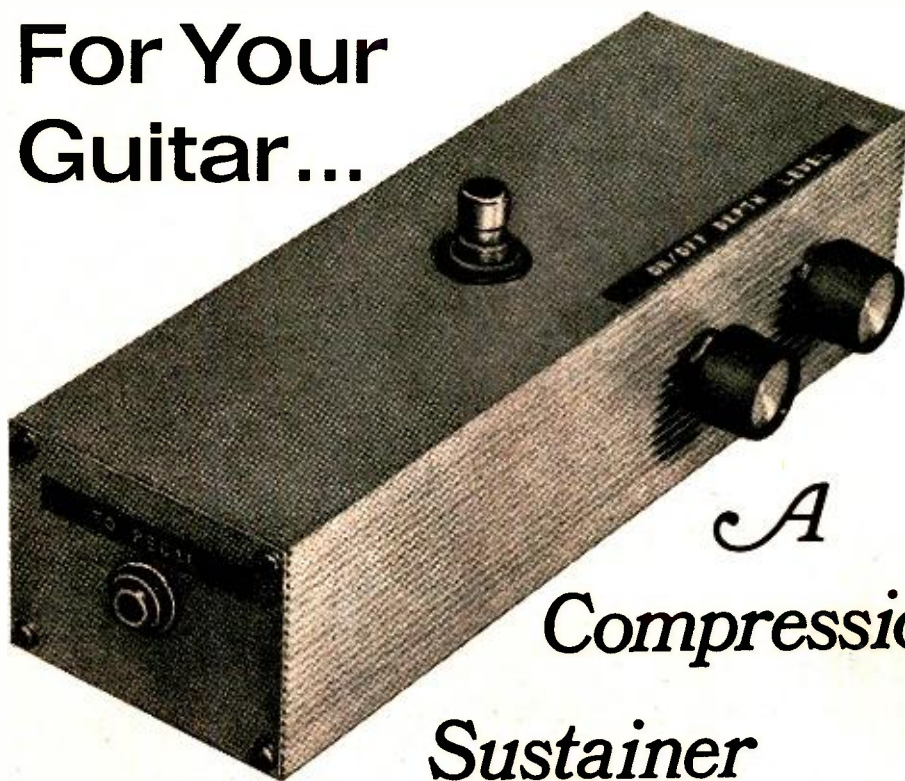

Fig. 2. For low-power transistors, junction capacitance is shown as a function of the dip frequency.

For Your Guitar...



A Compression Sustainer

BY CRAIG ANDERTON

MAKE MUSIC LIKE THE GREATEST

Having trouble competing with the top guitarists and bassists? The chances are your instrument doesn't have the lazy, sustained sound that is mandatory these days. Fuzztone doesn't always help since it is unsuitable for chording and, quite often, the distortion it produces on a solo isn't wanted.

How do the stars do it? For one thing, they use plenty of volume; but volume is expensive (even counting only the ruptured speakers and eardrums). A much better way to get all the sound you want is to build a compression sustainer.

The sustainer brings up the level of the soft, low-level passages; the softer you play, the more it amplifies. All the little instrument nuances feed into the amplifier at the same volume as the loudest chords you play. Because of the compressing action, when a note starts to decay, the amplification goes up. This

characteristic is what produces sustain. Best of all, the unit is physically small, self-powered, and can be built for around \$20 if you don't have a suitable compressor or for less than \$5 for extra parts if you do.

The compressor the author used was originally featured in the February 1968 issue of *POPULAR ELECTRONICS* in the article "Add Comply to Your Tape Recorder." Of all the compressors the author tried, the Comply unit is the most practical in terms of size, noise figure, and smooth compressing action. But a few modifications must be made before it can be used for a musical instrument.

It is doubtful that you would require compression all the time (although, after using this device for a while, you may) so a means must be included for switching it in and out. A foot-switch is preferable. The packaging must be exceptionally sturdy, not only to survive the

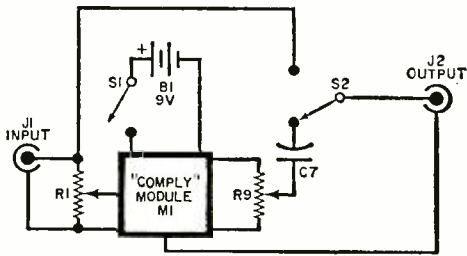

Fig. 1. Compressor circuit is built around Comply module, and aside from foot-operated switch, uses same components. One position of S2 bypasses the Comply, and the other position introduces sustain.

PARTS LIST

- B1—9-volt battery
- C7—On Comply module
- J1, J2—Open-circuit phone jack
- M1—Comply module (see POPULAR ELECTRONICS, February 1968)*
- R1, R9—On Comply module
- S1—On Comply module with R1
- S2—Heavy-duty s.p.d.t. foot-operated switch
- Misc.—Heavy-duty metal enclosure approximately 8" x 2½" x 2" (optional, see text) or simple metal enclosure and small, but strong metal box for footswitch (see text), connecting cable, battery holder, mounting hardware.
- *A complete kit of parts for the original Comply module including circuit board, pre-punched cabinet, all components, hardware, wire and solder, but less battery is available for \$18.50, plus shipping from Calingella Electronics, Inc., P.O. Box 327, Upland, CA 91786.

rigors of road travel but also to withstand the pressure from the footswitch.

The switching circuit used with the Comply unit is shown in Fig. 1. This arrangement produces no annoying clicks in the amplifier output.

Construction. Packaging the compressor can be accomplished in one of two ways. The first is to mount the entire subsystem in a very strong metal box with the footswitch (S2) on the top and the other controls and input-output jacks on either the sides or ends. Since this scheme requires an exceptionally strong metal box, you may prefer the second

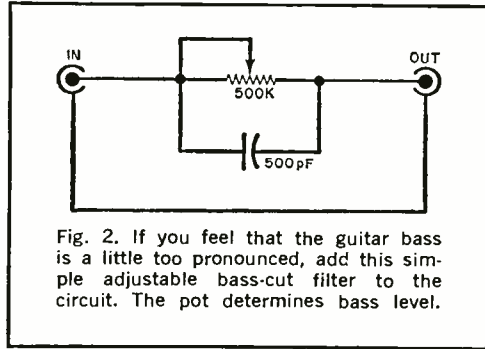
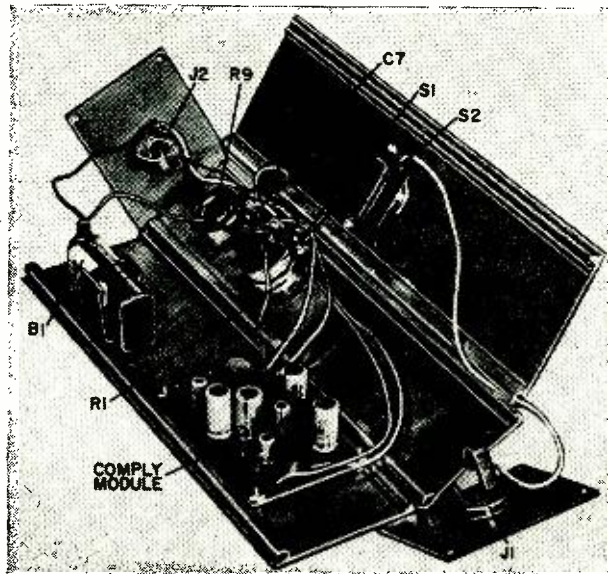

Fig. 2. If you feel that the guitar bass is a little too pronounced, add this simple adjustable bass-cut filter to the circuit. The pot determines bass level.

method. In this approach, the compressor is built in a conventional aluminum or sheet metal enclosure and the foot-switch is mounted in a small, strong metal box that can take the punishment. A cable is then used to connect the foot-switch to the electronics package.

Assemble the compressor as described in the previous article (see Parts List). Mount the input jack (J1), the input level control (R1 with attached power on-
(Continued on page 100)

The author built his version in a metal box, strong enough to take foot-switch punishment. You can build the sustainer in a lighter weight box and use a smaller, stronger box to house the foot-switch.



BUILD A

POWER INVERTER

*117 volts a.c. from
your car battery*

BY JON COLT



ALTHOUGH most of us live in a 117-volt 60-Hz world, there are many—campers, boat owners, long-distance truck drivers, and trailer dwellers, for example—whose only source of power is 12 volts d.c. One of the biggest drawbacks in the use of low-voltage d.c. power is the cost of appliances and equipment which operate on such power. Equipment that uses 117 volts a.c. is much lower in cost and more readily available.

With the Power Inverter described here, you can change your world from d.c. to a.c. and, if you like, shave in your car using an ordinary electric shaver.

The Power Inverter, whose schematic is shown in Fig. 1, takes 12-volt d.c. from a battery and delivers approximately 117 volts at nearly 60 Hz. (Actual voltage and frequency depend on the load.) Its 100-watt load capability can handle most common appliances.

Construction. Although almost any reasonably strong case can be used (transformer *T2* weighs slightly more than 6 pounds), the author used a 6" × 5" metal enclosure, with four rubber feet on the bottom.

If you want to duplicate this unit, use the photo above as a guide for the front panel. The pilot light is used to indicate

when the inverter is running, and is optional. The two power-input binding posts are also optional—a pair of heavy leads capable of carrying 10 or 11 amperes from the battery to the inverter could be used (14 gauge minimum recommended). The holes immediately above the two power outlets (*SO1* and *SO2*) are for the use of devices with three-prong plugs.

One transistor is mounted on each side of the U-shaped case. Use a shoulder insulator and a solder lug at one collector (case) terminal on each transistor and make sure that the base and emitter holes provide plenty of clearance. Each transistor must be insulated from the metal case by a mica washer, with silicone grease on both sides. Mount the various components and install the two transformers with the heavier *T2* on the bottom of the chassis and *T1* on the top. Wire the inverter in accordance with Fig. 1. The wires going to the transistor emitters and collectors should be at least 18 gauge and should be flexible since they go to a demountable portion of the case. Clip the transistor base and emitter leads to about 1/4". In soldering to the transistor leads use a heat sink (such as long-nose pliers) to keep the body of the transistor from overheating and being severely damaged.

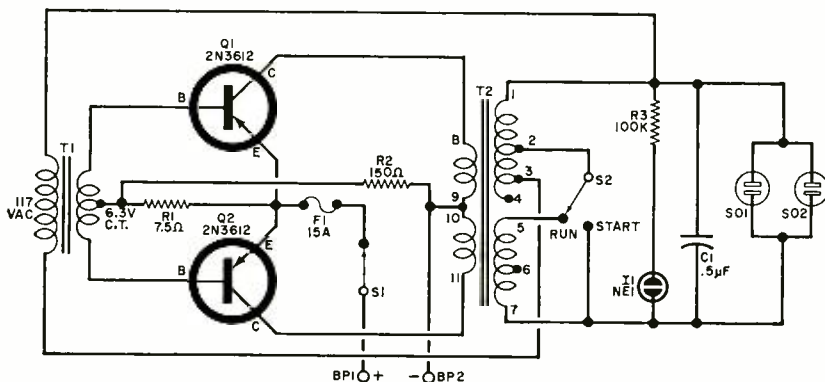

Fig. 1. A basic low-frequency (approximately 60 Hz), 100-watt power oscillator, the inverter also has dual power position to save drain on the battery.

PARTS LIST

BP1, BP2—5-way binding post (optional, see text)

C1—0.5- μ F, 400-volt capacitor

F1—15-ampere fuse and fuseholder

I1—Neon lamp (optional)

Q1, Q2—2N3612 transistor

R1—7.5-ohm, 5-watt resistor

R2—150-ohms, 2-watt resistor

R3—100,000-ohm, $\frac{1}{2}$ -watt resistor (optional)

S1—D.p.d.t. 10-ampere switch

S2—S.p.d.t. switch

SO1, SO2—117-volt power receptacle, chassis mounting (one is optional)

T1—Filament transformer, 117-volt primary, 6.3-volt, 1.2-ampere secondary

T2—Rectifier transformer (Knight 54F2333)*

Misc.—6" x 5" x 4" metal case, rubber feet (4) three-lug terminal strip, silicone grease (Dow #4 or similar), power transistor mica washer insulating kit (2), shoulder insulators (2), solder lugs (2), mounting hardware, length of 18-gauge insulated flexible wire, length of 14-gauge insulated wire pair, automobile cigarette plug (optional), heavy-duty crocodile clips (2, optional)

*Available from Allied Electronics, 100 N. Western Ave., Chicago, Ill. 60680, part number 54F2333, \$10.24.

Check-out. If the inverter is to operate properly (oscillate), the two transformers must be phased. To do this, apply 12 volts d.c. from a 10- to 11-ampere source, making sure the polarity is correct; and connect an incandescent lamp of 60 watts or so (be sure it is switched on) to either SO1 or SO2. Place S2 in the START po-

sition and turn on S1. If the lamp does not light immediately, turn the power off. Reverse the connections of T1 to the bases of the transistors and try again. The lamp should come on. Place S2 on RUN to obtain full output. If the lamp still does not come on, check fuse F1 and then the rest of the circuit for faulty

HOW IT WORKS

The operation of the power-oscillator inverter depends on T2, a conventional power transformer with many taps and a tendency to oscillate near line frequency (60Hz) when connected in the circuit. Transformer T1 is a filament transformer used to provide feedback for the two-transistor oscillator. The oscillator starting network is made up of resistors R1 and R2. Capacitor C1 absorbs the damaging high-energy spikes which can occur at the transistor collectors under light or no-load conditions.

The taps on the secondary of T2 (and the switching between them) are used in two different ways. The first use is to improve the efficiency of the circuit. If a filamentary load (conventional lamp) is used, the starting network has to be much heavier than is necessary to drive a pure resistive load of the same wattage. This would normally produce an attendant increase in

constant power loss. A filament has a much lower resistance when cold than when hot (measured cold resistance of a 100-watt bulb is about 10 ohms—calculated hot resistance is about 137 ohms). With S2 in the START position, a heavy load is reflected back to the primary of T2 as a much lighter load, giving the inverter a chance to start. Once these types of loads have started, S2 is switched to RUN for normal operation. In this way, S2 permits the use of a much lighter starting network than would be possible if the taps on T2 were not available.

The taps on T2 and the switching provided by S2 also provide a means of reducing the drain on the battery. With S2 on START, the drain on the battery is low and any lamp connected to the load receives lower current than when the switch is on RUN. Thus, any lamp used with the inverter can be considered to be a "two-way" type and can be operated on "low" when battery conservation is important.

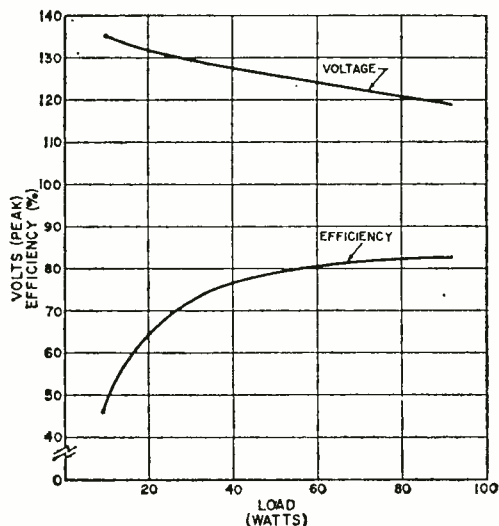

Fig. 2. Output voltage decreases slightly as the inverter is loaded while the efficiency improves.

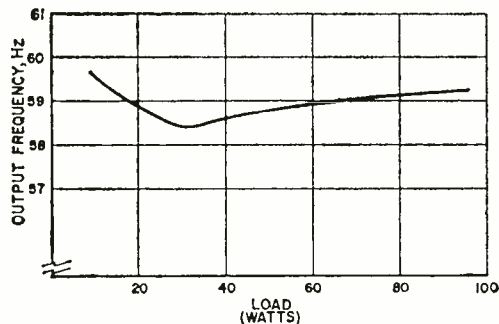
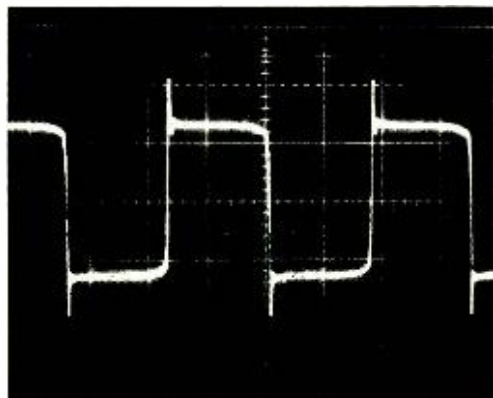

Fig. 3. The output frequency remains reasonably constant as the load varies from minimum to maximum.



Although output waveform is far from being a sine wave, it is useful for a number of applications.

components or poor solder connections. The fuse protects only the vehicle's battery system because transistors short out much faster than the fuse can blow. Therefore, you can't count on the fuse to protect the transistors if you overload the inverter.

There are a few precautions that must be observed to avoid damaging the inverter. First, always provide adequate wiring to the inverter input (capable of carrying 11 amperes). Second, never turn on the inverter without a load connected to it. Third, always make sure that the switch on the load is on and avoid a moderate overload. The inverter can take a very heavy overload such as a short
(Continued on page 97)

Interior of author's prototype. Any method of construction can be used as long as you remember that T2 weighs six pounds, therefore should be mounted on the bottom. Locate R1 and R2 so that they are air cooled.

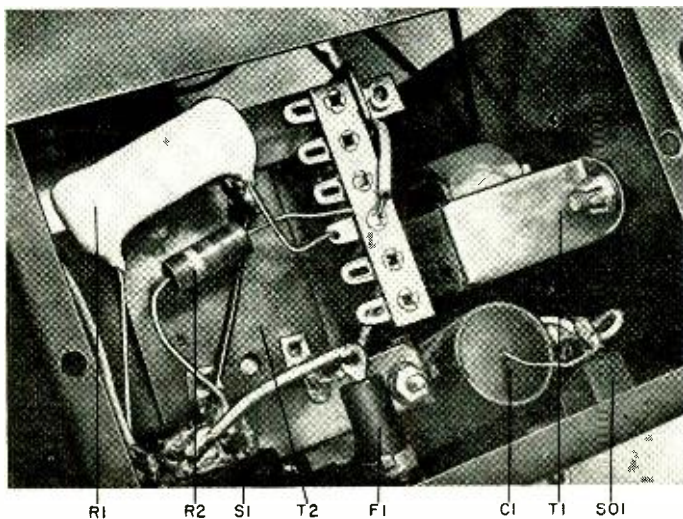



THE WHY'S AND WHEREFORE'S OF VOLTAGE-VARIABLE CAPACITANCE DIODES

BY A. A. MANGIERI

SOME OF the most significant and important devices in the history of electronics have been developed in the past few years. One of these devices is the voltage-variable capacitance diode; also referred to as the "varicap" or "varactor" diode.

The varicap (to settle on one convenient name) is the solid-state equivalent of the conventional tuning (variable) capacitor commonly used in radio receivers. In the consumer market, the varicap is found in the tuning circuits of r.f. receiver sections, in a.f.c. circuits, and as frequency multipliers. (Several of the top-quality FM receiver manufacturers are employing varicap tuning, usually providing multi-station pushbutton tuning, and at least one varicap TV tuner is available.)

A varicap-potentiometer tuning circuit has several important advantages. It is more compact, lighter in weight, and more rugged than the conventional tuning capacitor. In addition, fabrication of the varicap is less critical (to provide a

predetermined capacitance range) than the capacitor.

The varicap is actually a semiconductor diode. But it differs from the ordinary diode in that it is specifically designed to function as a capacitor under the right conditions. To see how this is accomplished, a brief review of capacitor fundamentals and *p-n* junction semiconductor physics is in order.

In its simplest form, a conventional fixed capacitor consists of two conductive plates separated by an insulator (dielectric) as shown in Fig. 1. When a d.c. voltage is applied to the plates, current flows until the capacitor charges up to the applied voltage level. A change in the amplitude, or a reversal of the polarity, of the applied voltage does not affect the value of the capacitor.

To change the value of a capacitor, you must change the area of the plates, the distance between the plates (dielectric thickness), or the dielectric material. For example, as illustrated in Fig. 2,

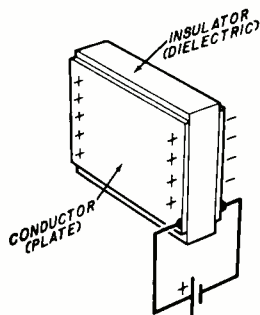

Fig. 1. Simplest capacitor consists of two conductive plates separated by an insulating dielectric.

doubling the dielectric thickness reduces the value by half, and reducing the dielectric thickness by half doubles the capacitance value. A ganged tuning capacitor employs the change-of-plate-area technique; physical rotation of the shaft meshes and unmeshes the plates, thereby increasing and decreasing capacitance. (Changing the dielectric material is generally not considered as a practical means of varying capacitance value because of the obvious problems involved.)

The varicap accomplishes capacitance changes through a system of variable reverse biasing instead of through a physical change. This phenomenon is directly related to the physics of the *p-n* junction in semiconductors.

All materials are classified as conductors, semiconductors, or insulators according to the quantity of "free" electrons available in them. (An electron that can easily be freed from its atom or molecule through the application of a voltage is termed a "free" electron. Obviously, these free electrons must be in the outermost, or valence, rings where they are least tightly bound.)

Consequently, for a good conductor there are a great many free electrons available. (Copper, for example, has one free electron for every 13 atoms.) A good insulator may have only one free electron for several billion atoms or molecules. The semiconductor has an intermediate number of free electrons, more than an insulator but less than a conductor.

Semiconductor materials like germanium and silicon are basically poor conductors because of their lack of a large

quantity of free electrons. However, during the manufacture of a *p-n* junction, small measured amounts of impurity elements can be added to the semiconductor crystal by a process known as "doping" to form positive (*p*-type) and negative (*n*-type) materials. (The impurities introduce mobile electric charges into the semiconductor crystal to step up conductivity. The doping also adds an equal number of stationary charges, fixed by the immovability of atoms in the crystal.)

Now consider a 9-volt reverse bias applied to the *p-n* junction illustrated in the drawing at left in Fig. 3. Current flows as the mobile charges become rearranged, with the positive and negative mobile charges both moving toward the junction. At the junction, the opposite-polarity charges pair up and neutralize each other (all within specific zones on both sides of the junction) leaving a depletion region of fixed charges.

Recall now that an insulator (dielectric) lacks movable charges, just as does the depletion region. The depletion region thus acts as the dielectric of the diode capacitor.

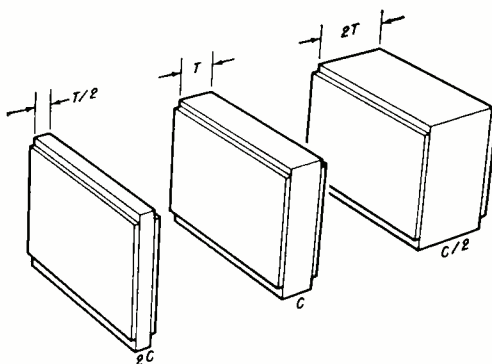

Fig. 2. Changing dielectric thickness (plate separation) causes inverse change in capacitance value.

The uncovered fixed charges in the depletion region, negative in the *p* material and positive in the *n* material, set up a space charge or internal voltage that is opposite in polarity to the applied voltage. This zone widens sufficiently to uncover enough fixed charges to build up a barrier voltage equal to but of opposite polarity to the applied voltage. Notice now that the fixed charges and battery polarity in Fig. 3 match those of the charged fixed capacitor shown in Fig. 1.

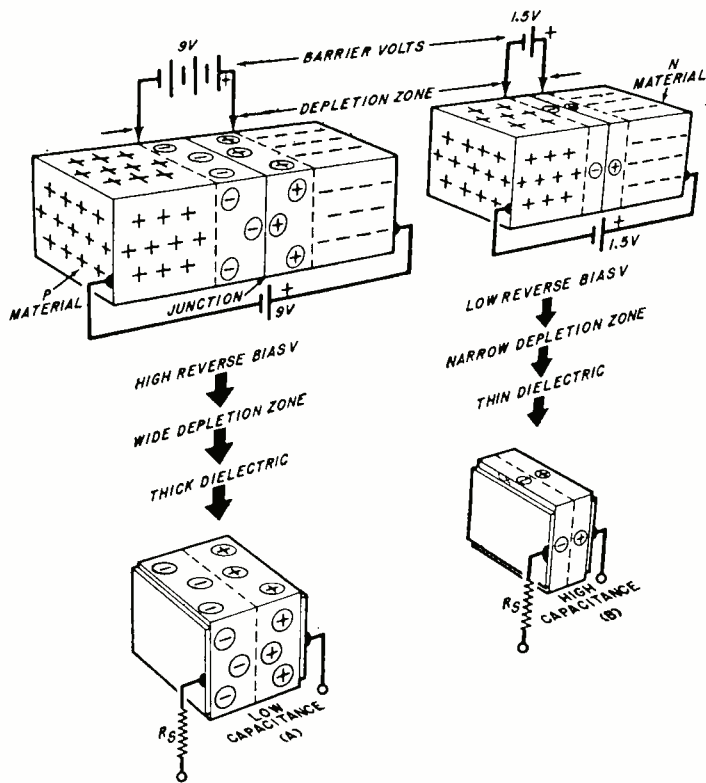

Fig. 3. When reverse bias is applied, p-n junction exhibits capacitance effects. Large amplitude bias voltage (left) causes low-value capacitance, while low amplitude voltage (right) produces proportionally higher capacitance value.

It is this set of conditions that provides the p-n junction with a capacitive effect.

With 1.5 volts of reverse bias on the junction as shown at right in Fig. 3, a smaller number of fixed charges need be uncovered in the depletion region to build up the bucking barrier voltage of 1.5 volts. As a result, the region width is narrower than if the reverse bias were 9 volts. The narrower depletion region corresponds to a thinner dielectric and a higher capacitance value (similar to Fig. 2 where dielectric thickness was reduced by half to double capacitance). It is now obvious that reverse-bias voltage can be varied from a high to a low amplitude to cause corresponding changes in junction capacitance.

With no bias voltage applied to the junction, some of the movable positive and negative charges nearest the junction manage to attract each other to produce an even narrower depletion region. This results in a built-in barrier voltage of about 0.25 volts for germanium and 0.6 volts for silicon diodes.

Next, those portions of the p and n

materials outside the depletion region still have both movable and fixed charges. These portions have the ability to conduct but also have some resistance. This resistance is shown as R_s in Fig. 3. What distinguishes the varicap from other types of diodes is that R_s is maintained as low as possible to reduce losses in the "capacitor."

Because all semiconductor devices include at least one p-n junction, all also exhibit some degree of voltage-variable capacitance. The group includes all bipolar transistors, FET's, all semiconductor diodes, and SCR's and other solid-state switching devices. Junction capacitance which hampers high-frequency operation in many semiconductor devices can be put to good use in voltage-variable capacitance diode applications.

On the following pages you will find a practical hobby application of the varicap. The project is a one-transistor super-regenerative AM broadcast band tuner, using the varicap as the tuning capacitor in conjunction with a potentiometer. -50-

**“Get more
education
or
get out of
electronics
...that’s my advice.”**



NEW!

Expanded
coverage of
solid state
electronics
including
integrated
circuits!

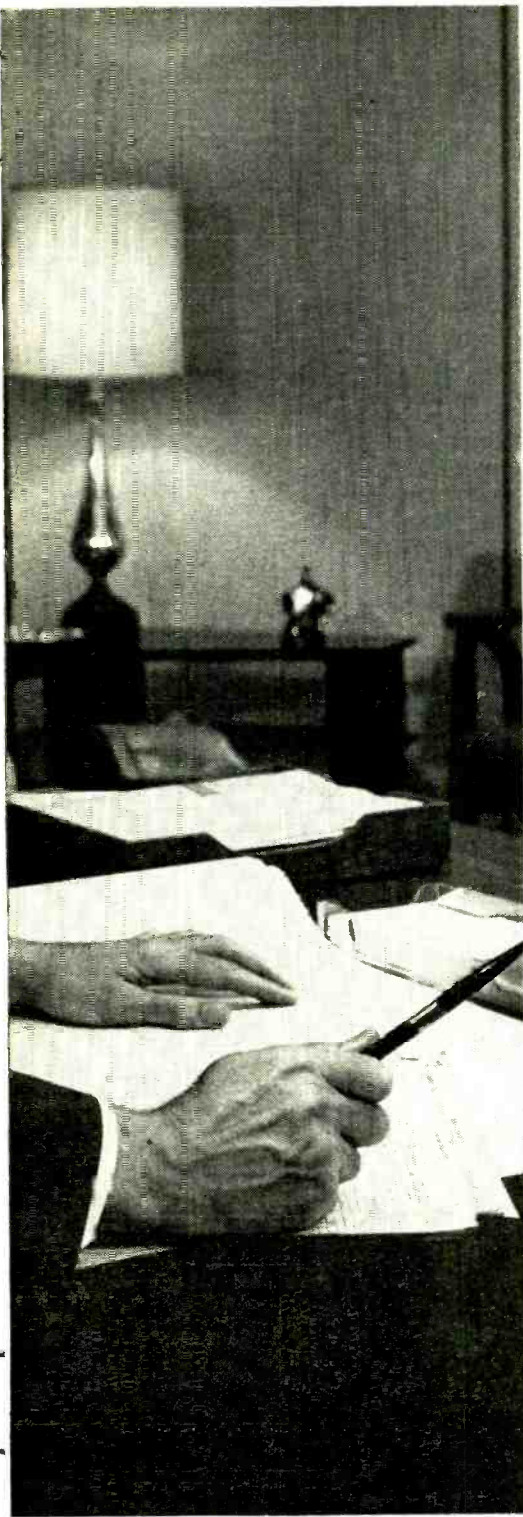

Ask any man who really knows the electronics industry.

Opportunities are few for men without advanced technical education. If you stay on that level, you'll never make much money. And you'll be among the first to go in a layoff.

But, if you supplement your experience with more education in electronics, you can become a specialist. You'll enjoy good income and excellent security. You won't have to worry about automation or advances in technology putting you out of a job.

How can you get the additional education you must have to protect your future—and the future of those who depend on you? Going back to school isn't easy for a man with a job and family obligations.

CREI Home Study Programs offer you a practical way to get more education without going back to school. You study at home, at your own pace, on your own schedule. And you study with the assurance that what you learn can be applied on the job immediately to make you worth more money to your employer.

You're eligible for a CREI Program if you work in electronics and have a high school education. Our FREE book gives complete information. Mail postpaid card for your copy. If card is detached, use coupon below or write: CREI, Dept. 1205H, 3224 Sixteenth Street, N.W., Washington, D.C. 20010.

Founded 1927



CREI, Home Study Division
McGraw-Hill Book Company
Dept. 1205H, 3224 Sixteenth Street, N.W.
Washington, D.C. 20010

Please send me FREE book describing CREI Programs. I am employed in electronics and have a high school education.

NAME _____ AGE _____

ADDRESS _____

CITY _____ STATE _____ ZIP CODE _____

EMPLOYED BY _____

TYPE OF PRESENT WORK _____ G.I. BILL

I am interested in Electronic Engineering Technology
 Space Electronics Nuclear Engineering Technology
 NEW! Digital Communications

APPROVED FOR TRAINING UNDER NEW G.I. BILL

A Varicap Front End AM Tuner

BY A.A. MANGIERI

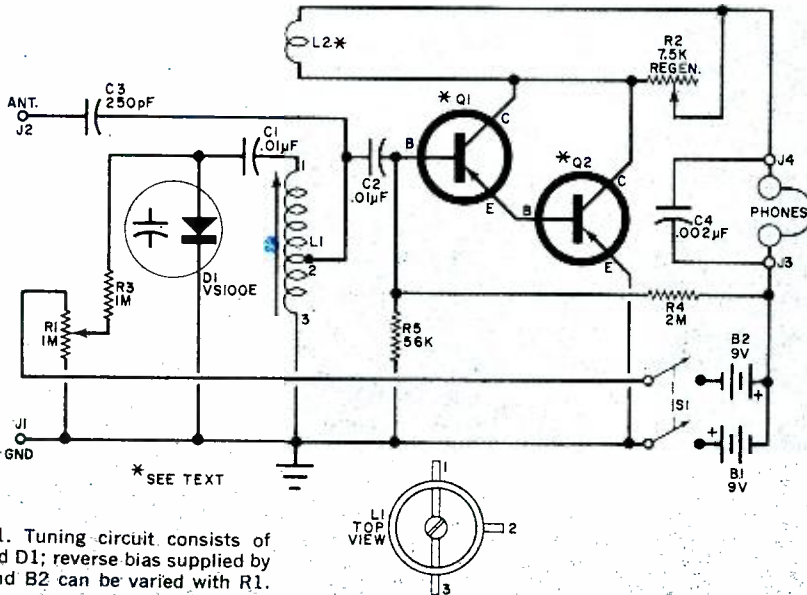

Fig. 1. Tuning circuit consists of L1 and D1; reverse bias supplied by B1 and B2 can be varied with R1.

PARTS LIST

B1, B2—9-volt battery
 C1, C2—0.01- μ F disc capacitor
 C3—250-pF mica capacitor
 C4—0.002- μ F disc capacitor
 D1—Varicap (Allied Electronics No. 49D33 V100E, see text)
 L1—Tapped antenna loopstick (Superec VET 240)
 L2—Feedback coil (see text)
 Q1, Q2—General-purpose pnp germanium β transistor (see text)

R1—Log taper potentiometer (see text)
 R2—7500-ohm potentiometer
 R3—1-megohm
 R4—2-megohm
 R5—50,000-ohm } all resistors
 S1—D.p.s.t. switch
 Misc.—Magnetic headphones; perforated phenolic board; solderless terminals, #28-#32 magnet wire for L2; audio power module (optional); loudspeaker (optional), etc.

THE REGENERATIVE AM broadcast band tuner described here employs a varicap diode in place of the common ganged capacitor. Tuning, as mentioned earlier, is accomplished by adjusting a potentiometer.

Although only one tuned circuit is used, regeneration is sufficient to provide remarkable sensitivity and selectivity. A simple 3'-long test-lead "antenna" will suffice for reception of most local stations. The author tried a 20'-long antenna and obtained excellent results, pulling in a station known to be some 1400 miles distant.

The tuner (shown schematically in Fig. 1) consists of a single tuned regenerative amplifier/detector arrangement. Varicap diode D1 is connected in parallel with L1 with C1 serving as a d.c. blocking device for L1. Batteries B1 and B2 provide the reverse-bias source for D1, while potentiometer R1—the tuning control—facilitates continuously variable bias. Also, resistor R3 in the wiper circuit of R1 prevents the r.f. signal voltage from shorting out through the bias supply.

Transistors Q1 and Q2 are connected in a complementary arrangement to sim-

ulate a single very-high-gain transistor. And to maintain the required high Q in the $L1$ circuit, the base of $Q1$ is connected to the low-impedance tap on $L1$.

Feedback winding $L2$ serves as a regeneration link that feeds back some of the amplified signal voltage to $L1$ for re-amplification. The amount of feedback, or regeneration, is controlled by potentiometer $R2$.

Construction. During construction of the tuner, neither component placement nor orientation is critical. The breadboard arrangement shown in Fig. 2 is provided only as a guide. You can make the project more compact—small enough to fit into a shirt pocket—if you desire.

A word of advice: before installing $R1$ and $R2$ in the circuit, use an ohmmeter to check these pots while slowly rotating the shafts from stop to stop several times. If there are any abrupt resistance changes or indications of erratic operation, try a new pot. Potentiometer $R1$ must have an audio taper, but it can have a value anywhere between 50,000 ohms and 2 megohms.

Then, when installing the $R1$ control, connect the left terminal to ground and the right terminal to the negative lead of $B2$ (pot viewed with shaft pointing toward you). Now, connect $R2$ into the circuit so that resistance increases with a clockwise rotation of the shaft. It is a good idea to use an ohmmeter to double check for proper shaft rotation.

Close-wind $L2$ centered over $L1$, wind-

ing clockwise (as viewed from the end of the coil opposite the slug screw). Start winding from the lug end of $L1$. Then connect the starter lead to $J4$ and the other lead to the transistor collectors.

Any of various types of germanium r.f. amplifier transistors will perform well for $Q1$ and $Q2$. Do NOT use non-linear converter/mixer transistors. If you have specification sheets for your transistors or a transistor beta tester, select transistors with betas between 40 and 100. If you use a very-high-gain transistor—say one with a beta of 200—pair it with a low-gain unit.

Connect the cathode (banded end) of $D1$ directly to ground; the other lead to the junction of $C1$ and $R3$. (If you have some surplus high-current, low-leakage silicon power diodes, you might want to try substituting one of these for the varicap. Many such rectifiers will perform satisfactorily, though with a lesser tuning range, if the r.f. losses and d.c. leakage are sufficiently low. Diodes in the greater-than-five-ampere range may even possess sufficient junction capacitance to cover the entire AM broadcast band with the coil specified.)

Alignment. Tuning and adjustment of the tuner will have to be by trial and error. However, once accomplished, the tuner should provide stable performance over a considerable length of time.

First, back out the coil slug about $\frac{5}{8}$ ", connect an antenna and earth ground to $J1$ and $J2$, and connect a pair of headphones to $J3$ and $J4$. Set $R2$ fully counterclockwise, and close $S1$. Now, slowly rock $R1$ back and forth while advancing $R2$ clockwise until you hear a whistle or beat note. Tune in a station. Then back off $R2$ to eliminate the whistle while re-adjusting $R1$ to bring in the station clearly and at maximum volume.

If you are unable to hear a station, or if you hear a loud distorted audio tone, you may have to experiment with the values of $R4$ and $R5$ to compensate for transistor gain and leakage current variations. Then, when you obtain the proper results, connect a d.c. milliammeter in series with the headphone lead at $J3$ and observe the indication; it should lie between 1 and 2.5 mA when $R2$ is fully counterclockwise.

(Continued on page 96)

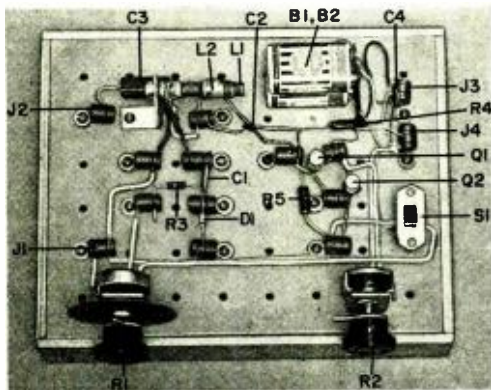

Fig. 2. Breadboard assembly is provided as component layout guide; if you prefer, you can assemble your project in a substantially smaller volume space.

the product gallery

REVIEW - JUNE 1961

GENERAL-PURPOSE MULTIMETER KIT (Knight-Kit Model KG-645)

While the vacuum-tube voltmeter is generally thought to be the best test instrument for in-shop use, few people will deny that the general-purpose volt-ohm-milliammeter (VOM) is best for all-around use. The VOM is independent of line power; its compact, lightweight construction makes it ideal for portability; and it provides all of the most needed functions for troubleshooting and testing. As a result of these features, the VOM has retained its popularity even in the face of the stiff competition of the transistor VOM, the newest member of the low-cost meter family.

The Knight-Kit Model KG-645 VOM follows in the same tradition that has made the multimeter an almost indispensable item in the shop and in the field. It features voltage measuring capabilities over a range of 0-5000 volts in both the a.c. and d.c. functions. Additionally, it is capable of measuring a.c. and d.c. current from 0 to 1 ampere, resistance between 0 and 100,000 ohms, and decibels covering a range of -20 to +65 dB. Voltage measuring sensitivity is 1000 ohms/volt.

Assembly time for the KG-645 multimeter kit should average about four hours for the beginner, considerably less for the experienced kit builder. The various precision components used in the instrument are, logically, wired to or between the function and range switches as shown in the interior view photo on the opposite page.

A rugged Bakelite case, equipped with a sturdy plastic handle, is used to house the VOM circuitry. The kit is also supplied with a pair of test leads and an operating instructions booklet—all for only \$19.95.

Although the KG-645 VOM is essentially a very good starter instrument, its convenience features can easily make it the first choice in appliance and vacuum-tube circuit troubleshooting and repair. It will certainly come in handy when you have to troubleshoot or repair electrical/electronic gear where no source of line power is available.

Circle No. 89 on Reader Service Page 15

"Sound n' Color" ORGAN (EICO Cortina Model 3440)

The most modern hi-fi systems have "total concept" reproduction, harmoniously blending acoustic reproduction with a visual accompaniment. Any hi-fi system (or AM/FM receiver) can provide total concept hi-fi with the simple addition of an electronic color organ. The color organ converts audio signals into a pattern of light that changes in color and intensity in much the same way that a loudspeaker reproduces every beat, tone, pitch, and intensity change in the music. The result is a ballet in light accompanying a symphony in sound.

Until fairly recently, the cost of a commercially available color organ was quite high. Now, however, several low-cost ones have become available—notably, the EICO Cortina Model 3440 "Sound n' Color" audio color organ selling for \$49.95 in kit form and \$79.95 factory assembled. The 3440 is a three-channel color organ, splitting the audio spectrum into three ranges through the use of frequency-selective circuits. The low end of the spectrum is assigned the color blue, while red and green are on the mid- and high-frequency ranges, respectively.

The "Sound n' Color" organ is designed with a high-impedance input that connects directly to the output of a hi-fi amplifier without affecting the sound coming from the speaker system. Three controls are provided: one is an on/off switch and sensitivity control, while the other two are intensity controls.

The entire system of lamps and electronics in the 3440 is housed in an attractive Danish walnut enclosure. The front is a special multi-lens plastic panel that diffuses the colored light.

In building the kit version of the 3440, your reviewer found that it went together easily in less than four hours—thanks to a well-illustrated and well-written instruction manual. In addition, the chassis/reflector assembly is large enough to provide the builder with plenty of space so that tricky manipulations in tight corners and burnt insulation are avoided.

Circle No. 88 on Reader Service Page 15

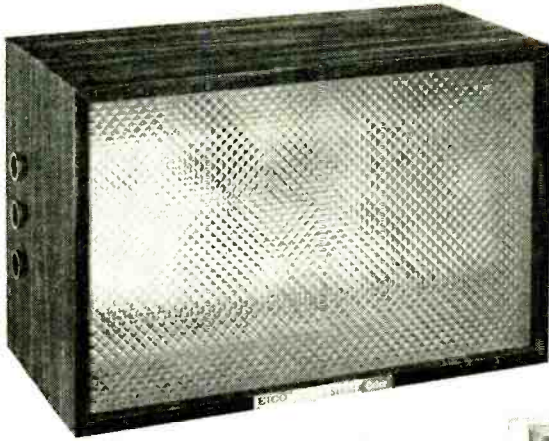

EICO CORTINA
"Sound n' Color" ORGAN

Built in an attractive cabinet (above), the Cortina color organ features a multi-lens front that is specifically designed to display the colored light as star and snow-flake-like patterns. Inside (photo at right), a large, roomy chassis accommodates all components, including three high-intensity lamps at center and control bracket at far right. Directly behind the chassis is a wall-to-wall aluminum reflector that accommodates six additional colored pilot-type lamps and sockets.

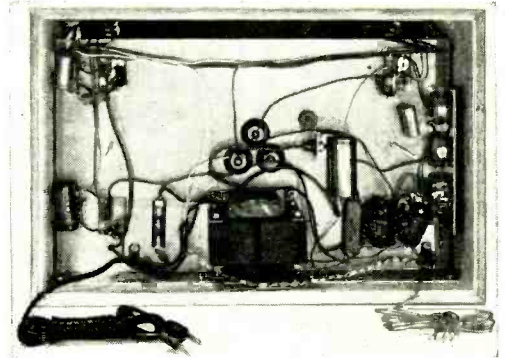

KNIGHT-KIT MULTIMETER

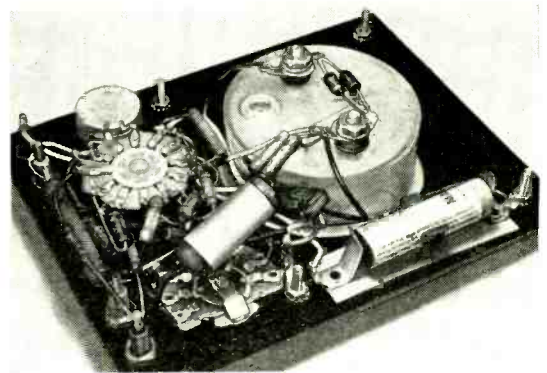

Rugged plastic case, flexible carrying handle, and large, easy-to-read meter provide the newest Knight-Kit VOM with the look of a professional field instrument. As shown in photo directly above, all components conveniently mount directly to three controls and jacks. A pair of diodes, connected across meter lugs, provide overload protection.

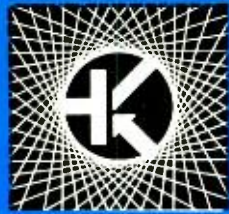

SOLID STATE

By LOU GARNER, Semiconductor Editor

ARE YOU ready for this? The electric shaver shown in Fig. 1 is transistorized! Besides the shaver motor, it contains a pair of transistors, three diodes, 6 resistors, 2 capacitors, a neon lamp, and a high-frequency cup-core transformer. It is Shick's Solid-State Electric Shaver and the electronic components are more than window dressing or an advertising gimmick. They take the place of a bulky, heavy, and relatively expensive step-down transformer.

As shown in the schematic in Fig. 2, the circuit has a line-operated d.c. power supply, a 25-kHz common-emitter d.c./d.c. converter, a pair of long-life rechargeable nickel cadmium cells (*B1*), and an efficient permanent-magnet d.c. motor (*M*). Requiring approximately 2 amperes at 2.5 volts, the motor can be driven by *B1* alone for cordless applications or primarily by the transistorized converter when a.c. line power is available. The converter is also used to recharge *B1*.

When the instrument is connected to a line receptacle, 117-volt a.c. power applied through series limiting resistor *R1* is rectified by silicon diode *D1* and filtered by electrolytic capacitor *C1* to deliver a relatively high d.c. voltage which, in turn, is supplied through current-limiting resistor *R3* to a 25-kHz push-pull squarewave os-

cillator, *Q1-Q2*. Transistor base bias is established by voltage-divider *R5-R6*, bypassed by *C2*, while a multi-winding transformer (*T1*) provides the feedback needed for oscillation and reduces voltage. The lower voltage is rectified by fast-recovery diodes *D2* and *D3* and used to charge the built-in battery. All the transformer windings are on the same ferrite cup core, with the step-down windings shown separately in Fig. 2 simply to clarify the diagram. A conventional neon pilot lamp assembly, *I1* and *R2*, is used to indicate when line power is applied to the circuit.

There are three basic modes of operation. With a.c. power applied, but the shaver off (*S1A* open), *B1* is trickle charged by the d.c./d.c. converter. When the shaver is turned on, *S1B* shunts *R4* across current-limiting resistor *R3*, thus increasing the converter's output power and permitting it to handle the major portion of the motor load. For cordless operation, *B1* alone furnishes motor power.

In practice, the complete d.c./d.c. converter circuit, including input resistors *R3* and *R4* as well as rectifier diodes *D2* and *D3*, is encapsulated in epoxy as a self-contained module (Fig. 3) having a volume of less than half a cubic inch and weighing only 0.6 ounces. This represents a size and weight reduction of about ten to one compared to the transformer type of 60-Hz power adaptors used in earlier cordless shavers.

The instrument's mechanical design is also ingenious. Instead of a separate case, a sliding outer sleeve mechanically actuates folding covers which protect the critical shaving head and, at the same time, operates switch *S1*. It is impossible, then, to leave the unit "on" with its covers closed.

Reader's Circuit. The FM wireless microphone circuit illustrated in Fig. 4 is a modified version of the "TV Sound Transmitter" described here in June 1968. The new circuit, submitted by Gary P. Golio (15 Ogden Place West, Dobbs Ferry, NY 10522), has a range of approximately 50 feet when used with a short antenna and a typical FM broadcast-band receiver.

As in the original design, the circuit is essentially a Hartley oscillator with the feed-



Fig. 1. Electric shaver uses solid-state components to eliminate big transformer.

most RCA component distributors at a nominal price of thirty-five cents.

The basic control device is a high-voltage silicon triac (*Q1*) having an integral trigger element. Either of two basic sensor configurations may be used. With the arrangement shown in (a) the circuit is energized only when light falls on the photocell; on (b) only when the photocell is dark. The configuration used in a specific project depends on the intended application. For example, circuit (a) might be used to control production machinery when a light beam is reflected from a passing object, while circuit (b) could be used to operate a door opener when a light beam is broken.

Referring first to circuit (a), photocell *PC1* and resistor *R1* form a voltage-divider supplying charge capacitor *C1*. With *PC1* dark, the peak voltage developed across *C1* is inadequate to trigger the triac's gate electrode into conduction. Light falling on the photocell reduces its resistance. This permits a higher peak voltage to be developed across *C1*, triggers the triac, and energizes the load.

The second circuit, (b), operates similarly except that the roles of the photocell and fixed resistor are reversed. Here, the voltage across *C1* is kept below *Q1*'s trigger value by the photocell's low resistance when it is illuminated. When *PC1* is dark, however, its resistance increases appreciably, changing the voltage division with respect to *R2* and developing sufficient peak voltage across *C1* to trigger *Q1* into conduction.

Conventional parts and devices are used in the circuit. The load may be a lamp, a.c. solenoid, small motor, heavy-duty relay, or virtually any similar a.c. operated device, as long as maximum ratings are observed.

Neither parts arrangement nor wiring dress are critical in the basic control or in either sensor configuration. However, since the a.c. line is connected directly into the control circuit, all components should be insulated from the chassis on which the circuit is mounted or the case in which it is housed. If this simple precaution is followed, any conventional construction technique may be used. The triac should be heat-sinked if

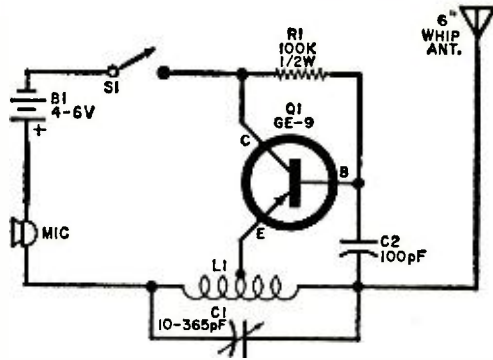

Fig. 4. Wireless FM mike has range about 50 feet when used with a short antenna and standard tuner.

operated at near maximum ratings or under high ambient temperature conditions.

As in most instruments operated by photocells, careful installation is essential for optimum performance. A focused, rather than a broad, control light source is preferred, while a suitable shade should be used on the photocell to exclude extraneous or ambient light and prevent false triggering.

New Publications. Motorola Semiconductor Products, Inc. has announced the publication of a new 264-page manual, the *Semiconductor Power Circuits Handbook*. Prepared especially for users of power devices, the book covers some 150 new circuits which have been specially designed, constructed and evaluated in the company's applications test laboratories. The handbook is divided into six chapters: (1) motor speed controls, (2) inverters and converters, (3) regulator, (4) static switches, (5) audio and servo amplifiers, and (6) miscellaneous thyristor and transistor switch applications. Well worth the low price of only \$2.00 per copy, the book may be ordered direct from Motorola, Inc., Box 20924, Phoenix, AZ 85036.

A new *Zener Diode Handbook* has been published by International Rectifier's Semi-
(Continued on page 99)

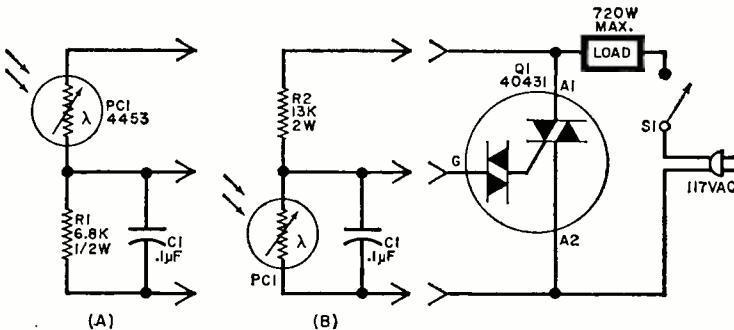
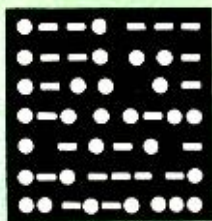

Fig. 5. Circuit at (A) is energized when light falls on photocell; (B) when photocell is dark. Both use silicon triac with inner trigger element.



AMATEUR RADIO

By **HERB S. BRIER**, W9EGO
Amateur Radio Editor

ANNUAL 6-METER SHORT-SKIP WATCH IS ON

MANY TIMES during the next four months, the 6-meter band will suddenly erupt from its normal calm with an avalanche of unbelievably strong signals from distances up to 1000 miles and greater suddenly filling the band. The eruption may last a few minutes or a few hours before subsiding as suddenly as it began; or the distant signals may ebb and flow unpredictably, from this direction and that, before finally fading out.

Omitting the whys and the wherefores, small patches of the E layer of the ionosphere (about 6 miles high) sporadically and mysteriously become so heavily ionized that 6-meter sky-wave signals that normally go through the ionosphere and into outer

space are reflected back to the earth. Sporadic-E or "short-skip" propagation can occur at any time, but in North America it occurs most often from May through August at any hour of the day or night; although there is a slight peak in the forenoon hours.

Each year, 6-meter operators with simple equipment end the short-skip season with 20 to 30 states in their log books. And old timers watch for the first short-skip opening of the season like fishermen waiting for the spring salmon run. They know that the big trick in taking advantage of the openings is to be on the air at the right time. Not only do they listen a lot when the band seems dead, they also call "CQ" every five or 10 minutes when they are around the ham

AMATEUR STATION OF THE MONTH



With all those QSL cards, Gary Dage, W8ZCC, 8078 Lochdale, Dearborn Heights, Mich. 48127, makes working DX look so easy. His first day on the air, he worked all continents! After a year, he has 132 countries and 37 DX zones worked. A Johnson Viking Challenger transmitter, Hammarlund HQ-129X receiver, Telrex TC-99D rotary beam and 40-meter dipole do the work. W8ZCC gets a 1-year subscription to POPULAR ELECTRONICS for winning this month's Amateur Station Photo Contest. You can enter by sending a clear photograph (preferably black and white) of you at the controls of your station and some details of your radio career to: Amateur Photo Contest, c/o Herb S. Brier, POPULAR ELECTRONICS, P.O. Box 678, Gary, Ind. 64601.

shack so that an opening will not pass unnoticed.

Incidentally, sporadic-E propagation effects are not limited to the 6-meter band, nor are they greeted with universal acclaim. Low channel (2-6) TV station operators in particular get more pain than pleasure from it because distant TV stations sharing the same channel tear up each other's pictures during "short-skip" openings. On the other hand, in many areas of the world—especially near the equator where sporadic-E propagation is an almost daily, year-round phenomenon—many TV viewers see practically all their TV programs from stations hundreds of miles away via sporadic-E propagation.



In the little time that his career as a medical specialist leaves him to get on the air, Sigurd Meng, DL2HI, Munich, Germany, likes to chase DX. The unit on top of the Drake T-4B transmitter is a homemade SWR bridge. A Drake R-4A and Shure microphone round out this neat appearing station.

A Helpful Whirly-Bird. The problem facing members of the RAF Amateur Radio Club, Cape Gata, Akrotiri, Cyprus, was how to get their new Mosley TA-33 rotary beam on top of its tower. "If we just had a helicopter," someone said wistfully. Without quite knowing how it happened, ZC4TK was delegated to ask the base Flight Commander, "May we borrow a helicopter for a few minutes?" Unexpectedly, he said "Yes!"

The TA-33 beam was assembled on the ground. As the 'copter hovered overhead, Roley, ZC4RB, attached its dangling winch hook to the beam, getting a dust bath from the whirling chopper blades in the process. The machine lifted the beam up and over the top of the tower to which ZC4TK had lashed himself. He guided the beam into position as the pilot deftly lowered it to the tower. Then ZC4TK detached the "sky hook," and the helicopter flew off less than five min-

utes after the beam was first lifted off the ground. (From RSGB *Radio Communication*.)

Lightning Power. James W. Voorhes, W8EGR/WB8BYX described in the Detroit Amateur Radio Association's *DARA Bulletin* what happened when lightning struck his station. The a.c. distribution transformer was knocked off a utility pole and lightning shredded the pole supporting the end of his rhombic antenna. Fifteen hundred feet of copper-clad steel wire in the antenna disappeared.

All antennas had been disconnected from the equipment and grounded; as a result, none of the r.f. sections of the gear was damaged. However, all power supplies that remained plugged into the a.c. power line were either damaged or destroyed, unless both sides of the power cords were fused. In this event, the only damage was blown fuses. Incidentally, all a.c. outlet sockets in the house were damaged—some blown completely out of the walls—and contacts of the control relays in the air conditioner, washing machine, and similar household appliances were welded together.



Bumper stickers bearing this legend are appearing on cars in the Sarasota/Bradenton, Florida area. Stickers are supplied by the liquor dealer who's suing "Grid" Gridley, W4GJO for \$1,000,000 in "nuisance" damages. Besides stickers, newspaper advertisements have been published denouncing the activities and equipment used by radio amateurs. Lawsuit, now in a civil court, may be set over to a Federal court by the time this appears in print. Next-door neighbor for several years, the plaintiff apparently became interested in DX'ing color TV and refused to have his preamp-receiver TVI proofed.

Jim's story shows again the tremendous power in a lightning stroke. It also emphasizes the importance of disconnecting and grounding the antenna and pulling the power plug of a piece of amateur equipment when you leave for an extended time or when an electrical storm threatens. It is a simple insurance against damage.

CW Forever? Code buffs should have read Ron Schneiderman's report in *Electronic* (Continued on page 91)



SHORT-WAVE LISTENING

By **HANK BENNETT**, W2PNA/WPE2FT
ShortWave Editor

NEW STATIONS ARE IN THE NEWS

Several new broadcasting stations are either under construction or being contemplated. With a few exceptions (as noted), most of these are for medium-wave service.

A 16-million dollar contract has been awarded to an American firm for furnishing and installing a transmitter and receiving site near Kavala, Greece, to be used by the *Voice of America* for broadcasts to Africa, Central Europe and the Middle East. Target date is set for late 1971.

In Vietnam, a multi-million dollar project is planned for construction of a nationwide radio network. Outlets are listed for Saigon, Da Nang, Qui Nhon, and Nha Trang. These stations will be built by the U. S. Agency for International Development (AID) and are subject to confirmation by the present Administration.

If not already in operation, a new station will go on the air shortly from Tinang, Philippines. This is a 250-kW transmitter to be operated by VOA and beamed to all of S.E. Asia, Red China and points deep within central and eastern Russia. The Far East Broadcasting Co., Manila, also plans a new 100-kW transmitter to be placed in service in mid-1969.

France plans a new high-power station for broadcasts to the Americas from somewhere in the Antilles. This is a result of the joining of forces of the External Service of ORTF and the Office de Cooperation Radio-phonique.

According to a French magazine article, there will be new transmitters installed in Tahiti and other South Pacific islands. One unit of 25 kW is to be set up on 730 kHz; transmitters of 25 kW and 4 kW are to be placed in service in the tropical bands. No dates or other details have been given.

Other planned new stations include:

Malaysia—three units of 50 kW each, for use in Johore Bahru.

India—Medium-wave transmitters of 1000 kW each in Calcutta and Rajkot; four other units of 100 kW each to be located in other towns.

Belgium—A new 50-kW short-wave transmitter at Brussels.

At a site as yet unnamed, the *BBC* will install a new high-powered station to serve as a relay point to cover the Persian Gulf and south and central Asia.

The National Radio Club reports that a new station in Colombia, callsign and lo-



The new studio and office building of *Trans World Radio*, Bonaire, Netherlands Antilles, is one of the most advanced of its type in the world. It is unique in that it has acoustical floating walls, reverberation control, absorption panels and sound proofing. The gigantic antenna complex was erected several years ago.

cation not determined at press time, is being heard well in the U. S. on 1040 kHz but we haven't logged it as yet. One source lists the identity as *R. Tropical*.

Surinam—*Stichting Radio Omroep Suriname*, Paramaribo, is new on the airwaves on 725 kHz. This 50-kW station is being very widely reported in N.A. evenings (your local time) with signal strength exceeding that of many of the much nearer broadcast stations.

Charles McCormick. The DX world has lost another of its well-known men. Charles McCormick, Jr., of Baltimore, Md., passed away very unexpectedly. He was Editor of the Utilities column of the Newark News Radio Club and was well-known for his knowledge of virtually all phases of Utility stations. His successor will be Robert French, WPE8FGH, Bellaire, Ohio.

CURRENT STATION REPORTS

The following is a resume of current reports. At time of compilation all reports were as accurate as possible, but stations change frequency and/or schedule with little or no advance notice. All times shown are Greenwich Mean Time (GMT) and the 24-hour system is used. Reports should be sent to Short-Wave Listening, P. O. Box 333, Cherry Hill, N. J. 08034, in time to reach Your Short-Wave Editor by the fifth of each month; be sure to include your WPE identification and the make and model number of your receiver.

Albania—*R. Tirana*, currently varying from 9498 to 9505 kHz, was logged in English from 0137-0154 s/off with talks and news, and at 0705 in Portuguese. *R. Peking* (supposedly operating via Tirana's xmtr) is new on 7070 kHz at 0105 with English news; good but fuzzy.

Austria—The "A" and "B" schedules from Vienna have been combined; four xmtrs of 100 kW each are now on the air for a total of 74 hours daily. News in German and English is planned as are separate programs for Europe and overseas points. The station also plans German language courses in English, French, Spanish, Arabic, Russian, and Czech. Latest loggings include 17.775 kHz at 1359 and 6155 and 9770 kHz at 0200.

Belgium—Two new channels in use by Brussels are 9550 kHz at 2115 in language with multi-lingual anmt's but no English and at 2210 with the English "Belgium Speaking" program, and on 11.945 kHz to N.A. from 2315 s/on with ID's in French and Dutch. Also heard well is the 9615-kHz outlet at 2205-2215 to N.A.

Bolivia—CP105, *R. Ibare*, Beni, listed for 4885 kHz, is operating currently on 4938 kHz with 500 watts and a s/off time of 0100. This one is very weak. CP88, *R. Amboro*, Santa Cruz, has moved up to 4912 kHz with Spanish to 0400 closing. This one suffers badly from QRM from a Brazilian station.

Brazil—*R. Marajoara*, Belem, has opened a new channel in the 60-meter band, heard irregularly around 0000 and asking for reports. The frequency varies from 4955 to 4960 kHz. Beware of another Brazilian on 4955 kHz. *Radiodifusora de Jatui*, Jatui, is a new outlet that opened last year in the 120-meter band on 2465 kHz. It was logged weakly to 0200 closing with Portuguese and the usual L. A. programming. *R. Nacional*, Brasilia, noted on 15.445 kHz with a clear ID at 0300.

Bulgaria—Sofia noted in English with news starting at 2130 on 9635 kHz, a new channel.

China—*R. Peking* is good in Korean at 1130 to past 1205 with excellent signals on 5975 kHz.

Colombia—Seemingly new HJSF, *R. Guatapuri*, Valledupar, 4915 kHz, is noted but not regularly, from 0225 with ID and 0400-0459 s/off with music and anmt's. Other Colombians reported this month include HJKJ, *R. Cadena Nacional*, 6160 kHz at 0445-0510 with news in Spanish at 0500-0507; HJWT, *R. Nacional*, 6180 kHz, at 0400; HJDH, *R. Colosal*, 4945 kHz, at 0500; HJAF, *R. Santa Fe*, 4965 kHz, at 0430; HJCQ, *R. Nacional*, 4955 kHz, at 0200. All are located in Bogota except NJDH, Neiva.

Cuba—At press time, Havana had English scheduled for the Americas at 2050-2150 on 17.750 and 15.285 kHz, 0100-0450 on 9525 kHz, 0100-0600 on 15,-



WPE4JQQ is the identification on the Monitor Registration Certificate of Bruce Tindall of Chapel Hill, N.C. To date he has 17 countries verified using a Zenith Trans Oceanic receiver and a 75-foot longwire antenna. He hopes to have his Novice amateur license very soon.

285 kHz, 0330-0600 on 11,760 kHz and 0630-0800 on 11,930 kHz.

Ecuador—A previously unidentified station has been identified by a Swedish source as *Emisora Luz y Vida*, Loja, 4812 kHz. It is heard early mornings. *La Voz del Rio Carrizal*, Calceta, 3570 kHz, was picked up at 0110 with music; a clear ID was noted at 0113. Being again heard regularly is HCXZ1, *Radiodifusora Nacional del Ecuador*, Quito, on 4940 kHz with cultural programs and in Spanish to past 0330.

Egypt—A new frequency for Cairo is 11,710 kHz, heard with Arabic music at 2343-2350. Other recent tunings include 9475 kHz at 0200-0330 and 12,905 kHz at 2145-2255 with English to Europe.

El Salvador—YSV, *La Voz de Comercio*, Santa Ana, now has a short-wave outlet on 9576 kHz as noted at 1310 with many commercials and a religious program in Spanish.

Ethiopia—New channels in use by ETLF, Addis Ababa, include 11,730 kHz at 0327 with music and in French to Madagascar; 11,910 kHz at 1930 with English news and talks to 2012 close, and 15,270 kHz at 1515 with music and from 1516 with a language religious program.

Germany (East)—*R. Berlin International* was heard on 9570 kHz at 0659 with IS and an abrupt s/off at 0700.

Gilbert And Ellice Islands—Tarawa, 4912.5 kHz, was found at 0700 s/on with an anthem, news in language, music at 0706, some ads, more music and anmt's to 0729. Three chimes were rung at 0730, then South-Sea music.

(Continued on page 88)

Our new Cobra 98 is the best Cobra you can buy. It may be the best CB you can buy, period.

Consider all the different brands of CB transceivers. If you want the best, you pay more. But do you have to go as high as the \$350-\$400 transceiver?

This is where the Cobra 98 fits—it sells for \$240. It's top-of-the-line new. And it bites like a Cobra. With a combination of new features nobody else has quite been able to put together.

Like the illuminated 3-in-1 master meter: An accurate SWR scale for reading power out of your cable/antenna. An "S" scale for received signal strength. And a third scale for power output.

There's also a new pre-amplifier that increases the strength of incoming voice signals.

And Cobra's exclusive Dyna-Boost circuit controls voice modulation to get maximum talking power.

It sounds as if the Cobra 98 may be the best CB you can buy—either base or mobile. Ask your distributor for the "snake" or write us for detailed information.



1801 W. Belle Plaine • Chicago, Illinois 60613
Where electronic innovation is a way of life.

COBRA 98—Five-watt power input, 23-channel crystal-controlled CB transceiver. Complete with all crystals for immediate operation. Transistorized universal AC-DC power supply. Jack for earphones or P.A. system. Plug-in microphone included. Net: \$239.95.



CIRCLE NO. 5 ON READER SERVICE PAGE

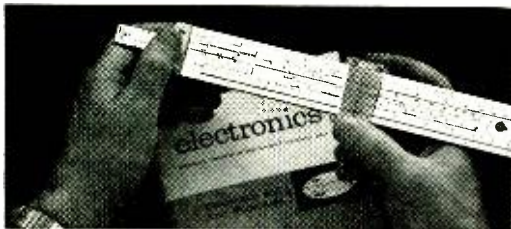

LOOK! A NEW ELECTRONICS SLIDE RULE WITH COMPLETE INSTRUCTION COURSE

Professional 10" all-metal Electronics Slide Rule. Designed specifically for technicians, engineers, students, hobbyists. Has special scales not found on any other rule. Enables you to solve electronics problems quickly, accurately. Made to our rigid specs by Pickett, Inc. Slide Rule plus four lesson AUTO-PROGRAMMED Instruction Course with grading service, and top-grain leather carrying case. . . . a \$50 value for less than \$20! Send coupon for FREE booklet. Cleveland Institute of Electronics, Dept. PE-156, 1776 E. 17th St., Cleveland, Ohio 44114.

SEND COUPON FOR FREE BOOKLET

Cleveland Institute of Electronics

1776 E. 17th St., Dept. PE-156,
Cleveland, Ohio 44114

Please send FREE Electronics Slide Rule Booklet. SPECIAL BONUS: Mail coupon promptly and get FREE Pocket Electronics Data Guide, too!



GET THIS FREE!

NAME _____ (Please Print)
ADDRESS _____ COUNTY _____
CITY _____ STATE _____ ZIP _____

A leader in Electronics Training . . . since 1934

CIRCLE NO. 9 ON READER SERVICE PAGE

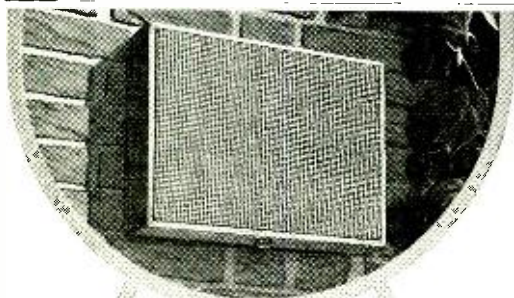

New **Patio**
outdoor speaker
in timeless redwood
\$14.95 Audiofile net

- Silicone-treated speaker.
- 10-watt, full-range, 8-ohms.
- Handy, built-in volume control.
- Weather-resistant cane grille.
- 14" x 10½" x 3½" fits in any sheltered space.

Write for
FREE **Argos**
CATALOG PRODUCTS COMPANY

Dept. C, 600 So. Sycamore St., Genoa, Illinois 60135
CIRCLE NO. 4 ON READER SERVICE PAGE

SHORT-WAVE LISTENING

(Continued from page 86)

Holland—Hilversum is noted on 17,730 kHz at 1753 in Dutch to Africa and Europe; music followed.

India—*All India Radio*, Delhi, observed on 9535 kHz with IS at 1215, then into language but with an annit of programs in English at 1225.

Israel—A Canadian ham operator, VE3MR, Toronto, has been pushing for English xmsn's to N.A. in his contacts with 4X4DK, an Israeli ham. As a result, *Kol Israel* has begun experimental xmsn's to N.A. on 9009 kHz at 0400-0415 with a rhombic antenna beamed on New York City. Program content is mainly news and comment. Reports are urgently requested (please show times in your own local time zone) and send them to Box 1082, Jerusalem.

Japan—*R. Japan*, Tokyo, is on 15,445 kHz (repl 15,135 kHz) at 2345-0045 to East Coast N.A. with news, talks, commentaries and some music.

Kenya—*V. of Kenya*, Nairobi, is again audible on 4915 kHz from 0310-0325 with native music, a soft African language, and commercials.

Korea (North)—*R. Pyongyang* has been found on 15,408 kHz with s/on in English and following with



Glenn Brinks, WPE2QBM, Granite Springs, N.Y., has an impressive layout of equipment, including a National NC-400, a Hammarlund HQ-145, a Heath FM tuner, a 1947 Zenith Radiorgan, a 21" TV and a General Electric medium-wave tuner. He is currently hunting a source of technical manuals for the NC-400 receiver and his Sylvania SG 30/up oscilloscope.

Spanish programming at 0100; news is given to 0112, then music. Another outlet, on 15,518 kHz, was heard once with English news at 0201 but with heavy QRM from Dacca (Pakistan).

Kuwait—*R. Kuwait* is evidently not observing their listed 1730 s/off on 11,920 kHz for many listeners report hearing them until past 1800 in English. News is given at 1615.

Malaysia—*V. of Malaysia*, Kuala Lumpur, 15,280 kHz, was noted well in the Indonesian service at 1200-1230. The *BBC* relay station on 9580 kHz was pulled in at 1736 with a religious program and a very strong signal.

Nepal—Many recent checks indicate the station on 11,970 kHz to be Kathmandu. Noted from 0220 s/on with programming similar to that of *All India Radio*, the IS consists of a piano and other as yet

POPULAR ELECTRONICS

unidentified instruments and possibly a gong. News in language is given at 0250 and in English at 0300, then back into language with native music at 0310.

Netherlands Antilles—*Trans World Radio*, Bonaire, was found on 9730 kHz at 0929 with IS, then Spanish music and *amnt's* with some religious music. The medium-wave outlet on 800 kHz was much stronger, even on the extreme West Coast.

Nicaragua—A very late tuning on 5935 kHz shows up with *Radiodifusora Nacional de Nicaragua Managua America Central* at 2345 u/in with old pop music.

SHORT-WAVE ABBREVIATIONS

<i>amnt</i> —Announcement	QRM—Interference
BBC—British Broadcasting Corp.	R—Radio
B/C—Broadcasting	rep—replacing
ID—Identification	s/off—Sign-off
IS—Interval Signal	s/on—Sign-on
kHz—Kilohertz	t in—Tune-in
kW—Kilowatts	V—Voice
L.A.—Latin America	VOA—Voice of America
N.A.—North America	xm-n—Transmission
	xmtr—Transmitter

Nigeria—*V. of Nigeria*, Lagos, has this schedule: 0600-0730 English on 7275, 15,265 and 21,455 kHz; 1330-1430 French on 7275, 9690, 11,770 and 21,455 kHz; 1430-1530 Hausa and 1930-2030 French on 7275, 9690, 11,770 and 15,365 kHz; 1530-1700 English on 7275, 9690, 15,365 and 21,455 kHz; 1700-1800 Arabic on 7275, 15,365, and 21,455 kHz; and 1800-1930 English on 7275, 11,770, 15,365 and 21,455 kHz.

Pakistan—Karachi was heard on 11,965 kHz ending English at 1516; this is another new frequency.

Peru—Silent for several months. OAX5Q, *R. Abancay*, Abancay, is again active on 4997 kHz with listener request music and Spanish *amnt's* until last 0300.

Portugal—*Emissora Nacional*, Lisbon, is now on a new frequency of 21,735 kHz where it is heard at 1300-1315 and 1615-1630 dual with 21,700 kHz. The 11,935 kHz outlet is usually good around 0400 with a press round-up. *R. Ribatejo*, Santarem, is being heard in eastern N.A. around 1100 on medium-wave channel 1322 kHz. The schedule is 0900-2000 in Portuguese, the power is 500 watts, and correct reports will be verified promptly by Jamie Valerie Santos, owner, who stated that all equipment in the station is home-made.

Qatar—*Qatar B/C Service*, P. O. Box 1414, Doha, is verifying by letter only after making detailed checks of the reception reports. Reports may be sent to Taher Shihabi, Director. Additional tentative loggings have been made at 1330-1415 fade with typically Arabic programming on 9570 kHz. Their power is reported to be 100 kW with a non-directional antenna.

Rwanda—*Deutsche Welle* relay, Kigali, 11,795 kHz, has language to N.A. with mostly uninterrupted band music at 0220-0240 and jazz to 0245; news items are given to 0255 followed by an anthem and s/off.

Sweden—*R. Sweden*, Stockholm, has an English mailbag at 1905 on 11,865 kHz.

Syria—Damascus can occasionally be heard on 9585 kHz around 2030 in Arabic; signals at best are only fair to good.

Tunisia—Tunis, 5985 kHz, was logged at 0630-0700 with Arabic vocals, dual to 15,215 kHz.

Vatican City—Two more new frequencies are in use by *Vatican Radio*: 6145 kHz at 0047-0105 in English to N.A. with religious talks, and 9615 kHz at 2327-2343 in Spanish to Central America with similar programming.

Venezuela—Two new stations to report from this country include *R. Carora*, Carora, 5018 kHz, from 2340 with music and ID's and *R. Occidente*, location

Which of these
4 fascinating
Radio-TV
careers
interests
you?
 disc jockey
 newscaster
 sportscaster
 announcer

Our Free Voice Analysis Tells You Whether You Have The Talent To Become A Broadcast Personality!

IMMEDIATE DEMAND • Radio-TV stations everywhere need both men and women to take over important good-paying jobs right now. **NATIONWIDE PLACEMENT ASSISTANCE** at No Extra Cost.

TRAIN AT HOME OR IN ONE OF OUR STUDIO SCHOOLS • You can study broadcast techniques at home, in your spare time, or in one of our many studio schools throughout the country under the supervision of our Directing Faculty of 11 Famous Broadcasters. **Accredited Member National Home Study Council and National Association of Trade and Technical Schools.**

Approved for Veterans' Educational Assistance Benefits ("G.I. Bill")! Check coupon for special information

Send to CAREER ACADEMY's division of famous broadcasters for free booklet, record and voice analysis details!

CAREER ACADEMY

825 North Jefferson Street • Studio 373
Milwaukee, Wisconsin 53202

I want to know if I have broadcasting aptitude worth developing. Please rush more information.

name _____ age _____

address _____ phone _____

city/state/zip _____



I am interested in: Home Study
 School Study G. I. Bill

CIRCLE NO. 8 ON READER SERVICE PAGE

Have your own Radio Station!

Learn AMATEUR RADIO



AT HOME IN YOUR SPARE TIME

Get your Amateur Radio license and "go on the air." NRI, leader in Electronics home training for more than 50 years, offers a choice of training plans leading to required FCC licenses, ranging from Basic Amateur Radio for the beginner to Advanced Amateur Radio for the ham who already has a license and wants to move up.

HAM RADIO EQUIPMENT INCLUDED

NRI's beginner's course includes your own Novice Class 25-watt transmitter, 3-band receiver and transistorized code practice oscillator with code key and headset. You learn code using special I.P. records. Choose from 3 Amateur Radio courses. Low tuition. Monthly payment plans. Get all the facts. Mail coupon. No salesman will call. NATIONAL RADIO INSTITUTE, Washington, D.C. 20016.



.....MAIL COUPON TODAY.....

NATIONAL RADIO INSTITUTE 058-059
Washington, D.C. 20016
Please send me information on Amateur Radio training.

Name _____ Age _____
Address _____
City _____ State _____ Zip _____

ACCREDITED MEMBER NATIONAL HOME STUDY COUNCIL

Cut The Cost Of Printed Circuits



Our new production techniques and rapid service saves you delay time and research cost.

We can produce single and small quantity orders extremely economically. Our quality is unsurpassed, and orders are usually processed within three days from receipt of the order. Large quantity orders receive the same fast service.

HOW TO ORDER

Layout your circuit board to scale in exact proportion to the size you desire. We can enlarge or reduce the copy to your specifications. Copy can be an ink drawing or laid out with the new circuit tapes. NOTE: The board we produce can only be as accurate as the copy we receive; so be sure to double check. Specify rigid or flexible board.

SEND FOR FREE SAMPLE OR
QUOTATIONS TODAY - NO OBLIGATION

American Engraving Inc.

MANGUM, OKLAHOMA 73554

CIRCLE NO. 2 ON READER SERVICE PAGE

not yet determined, on 3225 kHz from 0112-0200 s/off.

Unidentified—Numerous stations are being noted in the 10-meter band, all of them in Russian except as noted. If anyone can come up with any definite information on these, we'd appreciate having it. They are being heard on 30,280 kHz at 0032; 29,520 kHz at 0024; 28,780 kHz at 0000 with musical tone and music; 28,495 kHz at 0021; 28,490 kHz at 2355 with music and at 0102 with talks; 28,380 kHz in Spanish at 0018; 28,350 kHz at 2353; 28,280 kHz at 0017 with singing; 28,250 kHz at 0028; and 28,280 kHz at 2350 with an unidentifiable ID, a musical tone at 0100 and into Russian programming.

SHORT-WAVE CONTRIBUTORS

Wayne Rosenfield (WPE1HHY), Springfield, Mass.
Tim Bilodeau (WPE1HHK), Auburn, Maine
Paul Curran (WPE1HNV), East Boston, Mass.
Jim Rentrow (WPE1HOU), New Canaan, Conn.
Kim Stenson (WPE1HPU), Wilmington, Vt.
Darryl Stanford (WPE2KJD), New York, N. Y.
Bernie Lansing (WPE2PBA), Rochester, N. Y.
Carl Becker (WPE2PFP), East Northport, N. Y.
John Banta (WPE2PHU), Bay Shore, N. Y.
Robert Arnold (WPE2PQR), Canastota, N. Y.
Martin Shuiman (WPE2QHF), Spring Valley, N. Y.
Harold Ort, Jr. (WPE2QHN), Gloversville, N. Y.
Ori Siegel (WPE2QIX), Toronto, Ont.
Jack Graham (WPE2QNT), New Milford, N. J.
Lloyd Zeidner (WPE2QRC), Bayside, N. Y.
Dr. Charles Schwartzbard (WPE2TA), Clifton, N. J.
Tim Ohrman (WPE3HHA), Monroeville, Pa.
Scott Moeller (WPE3HLS), Villanova, Pa.
Peter Romeika (WPE3HMV), Rosemont, Pa.
Jan Epstein (WPE3HTT), Drexel Hill, Pa.
Dan Ferguson (WPE4AUL), Coral Gables, Fla.
Grady Ferguson (WPE4BC), Charlotte, N. C.
Bruce Tindall (WPE4JQU), Chapel Hill, N. C.
Steve Rubenstein (WPE4JYU), Chattanooga, Tenn.
Bill White (WPE4JWR), Union, S. C.
David Potter (WPE4JXO), Key West, Fla.
Bob Penn (WPE4KAP), Atlanta, Ga.
Leslie Reeves (WPE4KAQ), Calhoun, Ga.
David Weronka (WPE4KBE), Durham, N. C.
Donald Hill (WPE5EDY), Stillwater, Okla.
David King (WPE5EYJ), Monroe, La.
Charles Bennett (WPE5SW), Sumrall, Miss.
Bill Flynn (WPE6AF), Mountain View, Calif.
Jim Young (WPE6ENA), Wrightwood, Calif.
Wallace Glavich (WPE6EPX), Eureka, Calif.
Jeff Utter (WPE6HDI), Carlsbad, Calif.
Craig Anderson (WPE6HIU), Pasadena, Calif.
L. E. Kunej (WPE6AD), Detroit, Mich.
Jonathan Tara (WPE6KBT), Detroit, Mich.
James Fravel (WPE6KCP), Canton, Ohio
Gerry Dexter (WPE6HDB), Lake Geneva, Wis.
Richard Pistek (WPE6HOA), Chicago, Ill.
Andrew Pappas (WPE6ISQ), Chicago, Ill.
Fred Lynch (WPE6JHD), Girard, Ill.
A. R. Niblack (WPE6KJM), Vincennes, Ind.
John Beaver (WPE6OAE), Pueblo, Colo.
Jim Randles (WPE6CWK), Cunningham, Kan.
David Schmidt, Jr. (WPE6FHV), St. Joseph, Mo.
Jerry McMahan (WPE6SS), Cedar Rapids, Iowa
Jack Perolo (PY2PEIC), Sao Paulo, Brazil
Alain Miville-de Chene (VE2PEIX), Quebec, Que.
Bernard Maguire (VE6PE7K), Edmonton, Alta.
Yitzhak Weinbaum (IX4PEY), Tel-Aviv, Israel
Charles Albertson, Scottsdale, Ariz.
Loe Alster, Rahway, N. J.
Larry Ayers, Quincy, Ill.
Bruce Brandt, Stevens Point, Wis.
Edward Colby, Lynn, Mass.
David Gomez, Philadelphia, Pa.
Alan Herbach, Oak Park, Mich.
George Holubeck, Calumet City, Ill.
Daniel Kosko, Maple Heights, Ohio
Randy Lucht, St. Cloud, Minn.
David Miller, Albany, N. Y.
D. M. Rees-Thomas, Blair, Ont.
Martin Rosenthal, Toronto, Ont.
Reid Rowlett, Greensboro, N. C.
Richie Scalco, Wheaton, Md.
David Stamm, Richmond, Ind.
Gary Steele, Benton Harbor, Mich.
Ivan Wauhle, St. Johnsville, N. Y.
Radio New York Worldwide, New York, N. Y.
Sweden Calling DX'ers Bulletin, Stockholm, Sweden

AMATEUR RADIO

(Continued from page 84)

News that CW is the final back-up communications system for the up-coming U.S. landing on the moon. Each control position of the Lunar Module, which will actually land on the moon, is equipped with a 512-kHz CW transmitter complete with its own little antenna and a "25-word per minute key."

Mountain Rescue. Newspapers and radio/TV programs frequently tell of dramatic search and rescue operations for persons lost or injured in rugged mountain terrain after skiing accidents, storms, plane crashes, etc. Writing in the Denver Amateur Radio Club, Inc. *Round Table*, Walt Hane, W4HXC, reports that these rescue missions are usually performed by organized mountain rescue units. Of course, radio communication is mandatory for the success of the missions. Walt says that Amateur Radio became an integral part of a Colorado mountain rescue in 1968. Single sideband on 3990 kHz is used for communication between rescue groups in the field and headquarters in Denver. With an average of 15 mountain rescue missions a year, there are plenty of opportunities for interested Colorado amateurs to become a part of such operations.



Using a National NCX-3 transceiver and Knight-Kit T-150 transmitter, Roger Hehr, WA3JYM, Reading, Pa. got a Novice in April '68, Advanced in July.

WB6RBR Not Guilty! In our January column, we had a note that the FCC had suspended the amateur license of Michael S. Ingram, WB6RBR, San Diego, Calif. We are happy to report that, in a further hearing requested by Mr. Ingram (Docket No. 18304)

May, 1969

Enjoy Relaxing Background Music at Home with NO COMMERCIALS!



Our SCA-1 Decoder makes possible reception of this "private" musical programming, transmitted by nearly 400 FM stations around the country. YOUR FM tuner or receiver can receive this "hidden" music with the simple addition of an SCA-1. Hook-up in minutes—full instructions supplied. SCA-1 is self-powered . . . uses all solid-state circuitry (FET's, IC's, NPN's). Works with any quality FM Tuner or Receiver.

Send check or m.o. for either . . .

SCA-1K (Kit, all needed parts)	\$49.95
SCA-1PC (As shown, includes power supply)	\$49.95
SCA-1 (Wired, ready to use)	\$64.50
Etched, drilled P.C. Board plus special IC and full construction plans	\$12.50

*One year parts guarantee
Prohibited for commercial benefit
Sold for use in private home only*

Free Brochure & SCA Station list upon request

SCA Services Co.

Box 601, Port Washington, N.Y. 11050

CIRCLE NO. 24 ON READER SERVICE PAGE

ABOUT YOUR SUBSCRIPTION

Your subscription to POPULAR ELECTRONICS is maintained on one of the world's most modern, efficient computer systems, and if you're like 99% of our subscribers, you'll never have any reason to complain about your subscription service.

We have found that when complaints do arise, the majority of them occur because people have written their names or addresses differently at different times. For example, if your subscription were listed under "William Jones, Cedar Lane, Middletown, Arizona," and you were to renew it as "Bill Jones, Cedar Lane, Middletown, Arizona," our computer would think that two separate subscriptions were involved, and it would start sending you two copies of POPULAR ELECTRONICS each month. Other examples of combinations of names that would confuse the computer would include: John Henry Smith and Henry Smith; and Mrs. Joseph Jones and Mary Jones. Minor differences in addresses can also lead to difficulties. For example, to the computer, 100 Second St. is not the same as 100 2nd St.

So, please, when you write us about your subscription, be sure to enclose the mailing label from the cover of the magazine—or else copy your name and address exactly as they appear on the mailing label. This will greatly reduce any chance of error, and we will be able to service your request much more quickly.

FREE

RADIO-TV ELECTRONICS
ANNUAL CATALOG No. 691
 BURSTEIN-APPLEBEE
 3199 MERCIER ST., KANSAS CITY, MO. 64111



**GIANT 1969
 RADIO-TV
 ELECTRONICS
 CATALOG**
 228 GIANT
 VALUE-PACKED
 PAGES.

WRITE FOR YOUR FREE COPY TODAY

BURSTEIN-APPLEBEE CO., DEPT. PE-E
 3199 MERCIER ST., K.C., MO. 64111

NAME _____
 ADDRESS _____
 CITY _____ STATE _____ ZIP _____

CIRCLE NO. 6 ON READER SERVICE PAGE

Olson

*** FREE ***

Fill in coupon for a **FREE** One Year Subscription to **OLSON ELECTRONICS' Fantastic Value Packed Catalog—Unheard of LOW, LOW PRICES on Brand Name Speakers, Changers, Tubes, Tools, Stereo Amps, Tuners, CB, and other Values. Credit plan available.**

NAME _____
 ADDRESS _____
 CITY _____ STATE _____
 GIVE ZIP CODE _____

If you have a friend interested in electronics send his name and address for a **FREE** subscription also.

OLSON ELECTRONICS
 383 S. Forge Street Akron, Ohio 44308

CIRCLE NO. 23 ON READER SERVICE PAGE

the Commission found the charges against him groundless and terminated the proceedings. Our congratulations to WB6RBR on his vindication, and our sincere regrets that we did not receive the Federal Communications Commission Memorandum and Order terminating Docket No. 18304 earlier.

Navy Radio for Amateurs. On Armed Services Day, May 17, Navy Radio, Washington, D. C. will mark its 44th year of broadcasts to amateurs. Hams are invited to man the guest operator positions at Communications Station Headquarters, Cheltenham, Md. All equipment is furnished, although personal "bugs," keyers and headphones are allowed. If you can't join the activities in person, contact NSS during the crossband tests or listen for a message from the Secretary of Defense. A certificate is awarded to those submitting a perfect copy of the CW/RTTY broadcast. Navy Radio will monitor the following frequencies: RTTY—3.620, 7.080, 14.100, 21.055; CW—3.700, 7.150, 14.150, 21.100; SSB—3.966(LSB), 7.285 (LSB), 14.300(USB), 21.375(USB).

NEWS AND VIEWS

Dr. med. Sigurd Meng, DL2HI, 8 Munchen 90, Candidstrasse 18/VI, Germany, operates 80 through 10 meters with a Drake T-4X transmitter and R-4B receiver. He runs 200 watts feeding a "W3DZZ" (trap) dipole on 80 and 40 meters and a Mosley tri-band vertical on 10, 15, and 20 meters. Living on the 6th floor of a 96-family apartment building,



Joe Rutledge, WB4ESE, Lewisburg, Tenn., may be figuring out how to get the last three QSL cards he needs for a Worked All States certificate. He uses a Drake TR-4 transceiver feeding two dipoles and a vertical antenna—not all at once, of course.

Sigurd looks down on his antennas and most of Munich. Being a specialist in pulmonary diseases, he does not have too much time to get on the air but still loves amateur radio as much as he did when he first started in 1924 when he was 14. Although not a certificate collector, Sigurd likes to chase DX and work different U.S. counties. Eighty

VIEW

The RCA WO-33A Super-Portable 3-Inch Oscilloscope helps solve virtually any electronics servicing problem, inside or outside the shop. Its combination of exceptionally low cost and high performance have already made it popular as a monitoring and trouble shooting 'scope in black and white and color TV broadcasting studios, and in professional service. And why not? Here's a 3-inch 'scope that meets your requirements for gain, bandwidth, transient response, accuracy, versatility, and portability. AND IT'S ONLY \$139.00.* Also available in an easy to assemble kit, WO-33A (K).

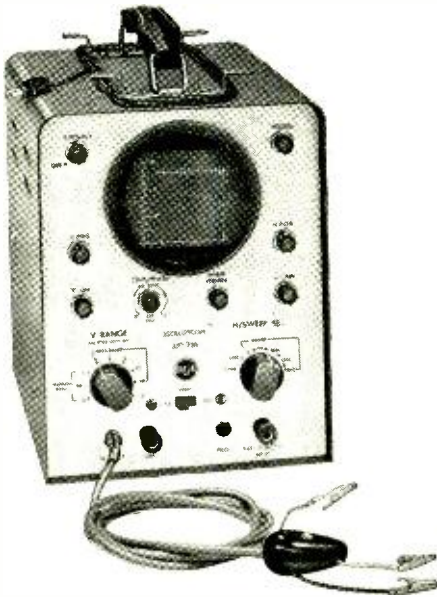

The RCA WO-91C 5-inch Dual Band Oscilloscope is a reliable, heavy-duty, precision 'scope in use in thousands of installations from classrooms to TV distribution systems...from service benches to broadcast stations. You probably can't find a better value. Applications include waveform analysis, peak-to-peak voltage measurement, square-wave testing, and observation of circuit characteristics. A front-panel switch gives you an easy choice of wide-band or narrow-band (high sensitivity) operation. It's easily portable, AND IT'S ONLY \$269.00.* The WO-91C-V1 is available for 240V operation, no increase in price.



*Optional Distributor resale price. Prices may be slightly higher in Alaska, Hawaii, and the West.

Write for a catalog with complete descriptions and specifications for all RCA test equipment: RCA Electronic Components, Commercial Engineering, Department No. E133W, Harrison, N. J. 07029
LOOK TO RCA FOR INSTRUMENTS TO TEST/MEASURE/VIEW/MONITOR GENERATE

CIRCLE NO. 31 ON READER SERVICE PAGE

RCA

per cent of his work is on CW, the rest on SSB, although he would work more SSB, if English-speaking stations—especially "W's"—didn't say their call letters so rapidly. . . . **John Thier, WN3JZB**, RD #2, Dallas, Pa. 18612, invites anyone interested in a new Novice traffic net on 7185 kHz to write to him for details. . . . **Norman L. Fox, WN4KER**, Allensville, Ky. 42204, works 80 and 40 meters. Norm did not mention his antenna, but his in-the-shack equipment includes a Heathkit DX-60 transmitter, a Heathkit HR-10 receiver, and a homebrew, 15-watt transmitter. Thirty-seven states worked and 31 confirmed indicate that he is doing things right.

Fred Roeber, WA9WPE, 4344 N. Mozart, Chicago, Ill. 60618, is an enthusiastic graduate of the Chicago Area Radio Club's code and theory classes. The club meets twice a month in Room 202, Horner Park Fieldhouse, California and Montrose Aves., Chicago. Fred is a member of the QRP (low-power) club and of the Rag Chewers' Club. His Knight-Kit T-50 transmitter, Heathkit HR-10B receiver and dipole antenna have worked 17 states.

. . . **Noel Schnell, WN4LCV**, 1081 Stage Ave., Memphis, Tenn., received his Novice license the end of September and passed the General class test in early January but was still waiting for the new ticket when he wrote. Noel receives on a Hallicrafters SX-140 and transmits on a Heathkit DX-60 running 75 watts. He has worked 30 states on 40 and 15 meters.

. . . **Rob Hummel, WN9ZTY**, 104 East Oak Grove St., Juneau, Wis., works the four Novice bands. A Globe-Chief 90A transmitter, a Hallicrafters SX-43 receiver, and dipole antennas cover the lower frequencies; a Heathkit HW-30, modified for CW operation covers the 145-147-MHz range. At first, Rob didn't get out so well, but after putting new coaxial feed lines on his antennas, he began getting his share of S8 and S9 reports.

Eric Smith, K3YWJ, reporting from KA7CW, Box 7422, APO, San Francisco, Calif. 96502, says KA-7CW near Fukuoka City, Kyushu, Japan, has been active for a year. Equipment at the station includes a Yaesu Musem FTDX-100 transceiver, FLDX-2000, linear amplifier, and FTV-650, 6-meter transverter, and a FTDX-400. More familiar names include a Hallicrafters HT-37 transmitter, SX-111 receiver, Heathkit "Warrior" amplifier, SB-101 transceiver, and SB-200 amplifier, and a Hy-Gain TH-3 tri-band beam 70 feet high. KA7CW has worked all 50 states, 90 countries, and 36 of the 40 DX "zones." The boys frequently look for Novices on 21,215 kHz and are always on the lookout for "W" QSO's on all bands. . . . In W1BB's 160-meter DX Bulletin, Australian shortwave listener, **George Allen** reports missing the call letters of weak DX stations who send too slowly, because static or fading takes out letters or parts of letters. . . . **Timothy, WN2GTQ**, (son) and **Clent, WN2GTS**, (father) Vandagriff, 88 Boxwood Drive, Rochester, N.Y. 14617, got their licenses at the



Leon (W8PJH) and Eileen (8VSL) Stuber are pictured on the U.S. Steel Company's Great Lakes ore ship "Widener." Leon, a Chief Marine Engineer, operates mobile on the lake each summer using a Heathkit SB-300 receiver, and SB-400 transmitter.

same time last July. They operate the 80, 40, and 15-meter Novice bands with a Heathkit DX-60B transmitter and an HR-10B receiver in conjunction with a home-constructed "trap" dipole, 45 feet high. Clent has 30 states and three countries confirmed; Tim has 39 states and five countries confirmed. They plan to take their General exams this summer; both have 20-WPM code-proficiency certificates, so the code test should be no problem.

David K. Rigsbee, WN9YAS, Route 3, Plymouth, Ill., started out with a Globe Chief 90 transmitter and a "surplus" ARC/5 "Command" receiver. He now uses a Hallicrafters SX-110 receiver. Antennas are 80 and 15-meter dipoles, and Dave has a Rag Chewers Club certificate and cards from 30 states on the shack wall. . . . **Steve Bryant, WN2DFT**, Star Route, Central Bridge, N.Y. 12035, has worked 20 states on 80 meters feeding his B & W 5100 transmitter into a dipole antenna 10 feet high. He uses a different antenna on 40 meters; he has worked a total of 37 states. An old Hammarlund HQ-120 and an ancient Hallicrafters "Super Sky-raider" do the receiving.

Thrill your amateur friends—let them read about you in "News and Views." Write us a letter and include a sharp picture (preferably black and white) if possible. We also appreciate being added to or kept on your club paper mailing list. Address: Herb S. Brier, W9EGQ, Amateur Radio Editor, POPULAR ELECTRONICS, P. O. Box 678, Gary, Ind. 46401.

73, Herb, W9EGQ.

NEW/CB TRANSCEIVER SOLID STATE PRE-AMP



- Improves CB Base Station Performance
- Works on tube or transistor equipment
- No Modification to CB unit
- On-the-air sign automatically lights when transmitting

Model PCB with built-in power supply, transfer relay, connecting cables, wired and tested.....\$59.95

Write for free literature



AMECO / DIVISION OF AEROTRON, INCORPORATED
P. O. BOX 6527 • RALEIGH, NORTH CAROLINA 27608

CIRCLE NO. 1 ON READER SERVICE PAGE

Boy, do they. Stuff like HetroSync® Circuitry that substantially reduces spurious frequencies.

A Pearce-Simpson exclusive.

Our dual conversion superhet receiver that pulls in signals where others fade. Nuvistor front end that gives you a very fine signal to noise ratio. The result: the biggest ears in the industry.

Automatic speech clipping by high level saturation limiting. Big, easy to read dual function S Meter and RF Output Meter. Illuminated channel selector. Modulation indicator. Transistorized AC/DC power supply. Not to mention complete hand wired circuitry.

But what really frosts them is how we put all of these goodies into a compact, 23-channel beauty like the Guardian—include crystals, microphone, power cords and mounting cradle—and beat the daylight out of their prices:

Guardian 23 (which is both a mobile and base unit) with palm microphone, \$269.90. Guardian 23B (base station with built-in preamp), \$264.90. With Super Mod ceramic desk microphone, \$279.90.

Write us and we'll send you a spec sheet on the whole line. Pearce-Simpson Inc., P.O. Box 800, Biscayne Annex, Miami Fla. 33152. Dept. PE-569

Our competitors hate our guts.

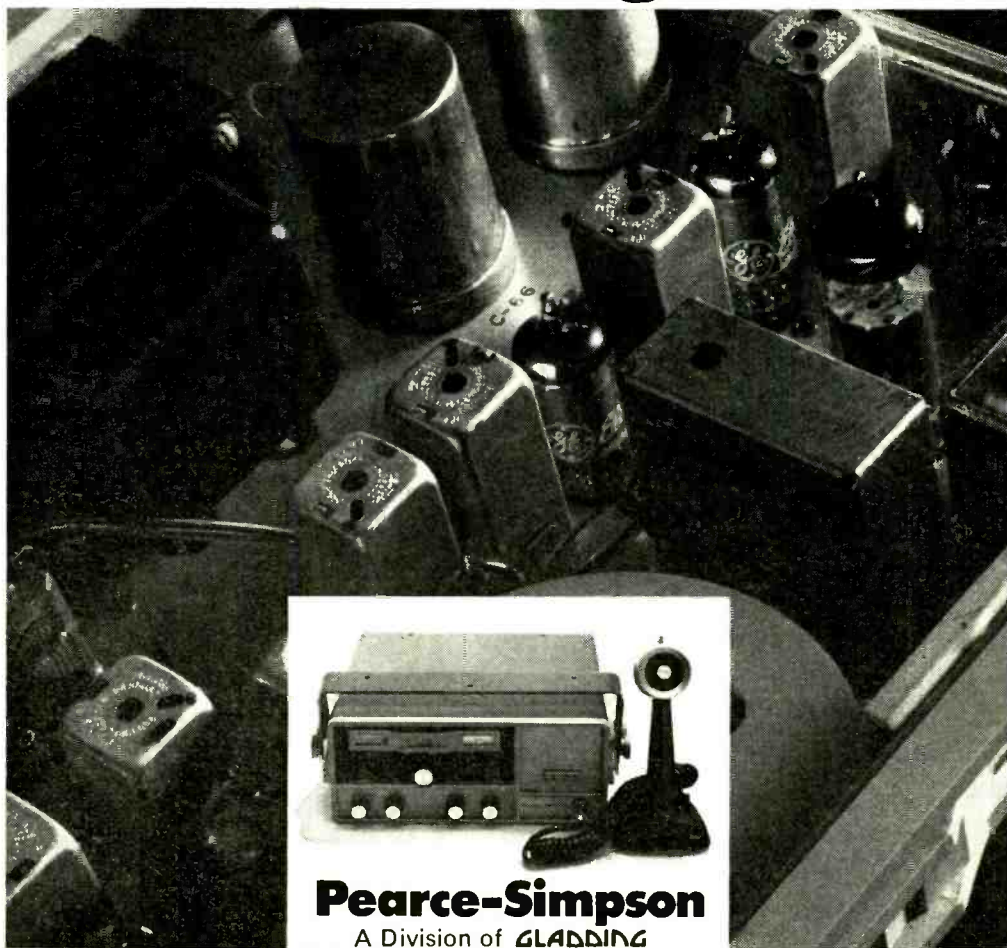

Pearce-Simpson

A Division of GLADDING
CIRCLE NO. 32 ON READER SERVICE PAGE

Live Better Electronically With

LAFAYETTE RADIO ELECTRONICS

1969 Catalog 690 **FREE!**



Now OFF PRESS
BETTER THAN EVER
Over 500 Pages

Stereo Hi-Fi • Citizens
Band • Ham Gear • Tape
Recorders • Test Equip-
ment • TV and Radio Tubes
and Parts • Cameras •
Auto Accessories • Musical
Instruments • Tools • Books

Featuring Everything in Electronics for
• HOME • INDUSTRY • LABORATORY
from the "World's Hi-Fi & Electronics Center"
LAFAYETTE Radio ELECTRONICS
Dept. 35059 P.O. Box 10
Syosset, L.I., N.Y. 11791

Send me the FREE 1969 catalog 690. **35059**

Name

Address

City

State Zip

CIRCLE NO. 21 ON READER SERVICE PAGE



Earn Your Degree

ELECTRONICS ENGINEERING

through HOME STUDY

HIGHLY EFFECTIVE HOME STUDY COURSES IN:
• ELECTRONICS ENGINEERING TECHNOLOGY
• ELECTRONICS ENGINEERING MATHEMATICS

Earn your Associate in Science Degree in Electronics Engineering and upgrade your status and pay to the engineering level. Complete college level courses in Electronics Engineering. We're a forward looking school. Outstanding lesson material—thorough and easy to understand. Engineering taught on the basis of application and understanding rather than on the basis of memorization. Up to date in every respect. Acquire the knowledge and ability that means the difference between a low paying technician job and a high paying engineering position. Low tuition cost with low monthly payments. Free engineering placement service for our graduates. Write for free descriptive literature. Ask for bulletin **K** no salesman will call on you.

COOK'S
INSTITUTE of Electronics Engineering



Southwest Regional Office
7650 Clarewood, P.O. Box 36185
Houston, Texas 77036

Established 1945

Formerly Cook's School of Electronics

CIRCLE NO. 12 ON READER SERVICE PAGE

VARICAPS

(Continued from page 77)

In the event that the meter reading is greater than 2.5 mA, interchange $Q1$ and $Q2$ and/or adjust the value of $R4$ to bring it into line. However, if the problem still persists—even when $R4$ is short circuited—one or both of the transistors is leaking too much current and must be replaced.

Conversely, if the meter reading is too low, try increasing the value of $R5$ or decreasing the value of $R4$, or both. Then, when the reading is within the 1 to 2.5 mA range, check tuning and regeneration as described above. If you still cannot tune in a station, or separate one station from another, reverse the connections of and/or add more turns to $L2$. If all else fails, you can assume that the $Q1-Q2$ combination has insufficient gain, and one or both must be replaced.

After proper operation is obtained, for smoothest control or regeneration, reduce the number of turns on $L2$, one at a time, enough to produce the beat note or whistle on all stations before $R2$ is advanced to its maximum clockwise position.

Operation. The tuner will cover about half of the AM broadcast band since the capacitance range of the varicap diode is rather limited. However, you can tune $L1$ to cover the portion of the band you desire. If you find that very strong signals "swamp" the tuner, simply reduce the value of $C3$ to 100 or 50 pF.

Finally, if the tuner tends to either "motorboat" or "plop" into or out of critical regeneration, try shifting the operating current as described earlier and reduce the number of turns on $L2$.

For speaker operation, the tuner will have to be converted to a receiver. The easiest way to accomplish this is to connect the output to any one of the various low-cost audio amplifier modules available. To do this, disconnect the headphones and replace them with a 3000 to 6000-ohm, 1/2-watt resistor. The signal can then be tapped from $J4$ via a d.c. blocking capacitor and ground. —30—

POPULAR ELECTRONICS

POWER INVERTER

(Continued from page 67)

because it simply won't oscillate. A moderate overload permits the transistors to switch but the operation is in their linear region resulting in excessive heat generation and subsequent destruction.

For non-permanent use in a car, trailer, or truck, use a length of at least #14 wire and a cigarette lighter plug for the power input. For semi-permanent use, substitute a pair of heavy-duty crocodile clips for the lighter plug. In this case, connection can be made directly to the battery. In both cases, observe the polarity!

If the inverter produces "hash" on the vehicle's power system and interferes with radio operation, connect a 250- to 500- μ F, 25-volt electrolytic capacitor across the inverter input terminals. Be sure to get the polarities correct on the capacitor.

Finally, remember that the inverter is not a substitute for the commercial 117-volt supply under all circumstances. For example, the voltage output is peak output, not r.m.s. Peak voltage of the commercial 117-volt line is about 161 volts. Hence, if you are using a device containing a peak rectifier, you can expect some reduced performance.

The output voltage is a function of the applied load as shown in Fig. 2. The frequency of the output varies with load as shown in Fig. 3. Bear this in mind when using devices whose operation depends on power-line frequency (synchronous motors, for example).

GENERAL MOTORS TAKES OVER REACT

National sponsorship of REACT—the CB emergency corps—has been assumed by the GM Research Laboratories. At the latest estimate, REACT comprised 1300 teams and 40,000 individual members. GMRL reportedly will expand the operation.

REACT has generally been accepted as the one "good thing" about CB. Started by the Hallicrafters Company, REACT has been instrumental in assisting proper authorities with a wide variety of local emergencies.

REACT offices are now at 205 West Wacker Drive, Chicago, Illinois 60606.

introducing . . . S-DeC breadboard



for easier
circuit building



An S-DeC contains 70 push-in contact points which are arranged in two sets of five numbered rows with each five points joined together by a leaf-spring busbar; this pattern is similar to that used in popular wiring boards. Larger circuits can be made by keying units together to form a continuous breadboard of any size.

Components are simply pushed into the sockets where they are held securely by double-leaf phosphor-bronze contacts. This system ensures a good wiping action on insertion and withdrawal, giving low contact resistance. The accessory kit provides solderless connectors to use with controls which are mounted on a panel slotting into the S-DeC base.

S-DeC with control panel, jig, accessories and project leaflet. \$5.75 each

DeC STOR—Two decks, control panel, jig, accessories, project leaflet with components tray all in black plastic box. \$11.75 each

4-DeC Kit—Four decks, two control panels, jigs, accessories, and project book in attractive plastic case. \$20.75 each

INTRATEC

399 Jefferson Davis Highway
Arlington, Virginia 22202

Please send me postage paid:

..... S-DeC's @ \$5.75 each
..... DeC STOR @ \$11.75 each
..... 4-DeC's @ \$20.75 each

I enclose a check/money order for \$.....
Va. residents add 4% sales tax
Money refunded if not satisfied.

Name

Address

City

State Zip Code

Box PE-5

CIRCLE NO. 19 ON READER SERVICE PAGE

LEARN

ELECTRONICS

COYNE ELECTRONICS INSTITUTE

Electronics Engineering Technology—Degree (2 Yrs.)
 Electrical-Electronics Technician—Diploma (40 Wks.)
 TV-Radio-Electronics Technician—Diploma (48 Wks.)
 Complete Electronics Technician—Diploma (88 Wks.)
 Practical Electrical Maintenance—Diploma (32 Wks.)
 Practical Refrigeration Air Conditioning
 and Appliance Repair— Diploma (24 Wks.)

Special finance plans. Graduate employment service.

MAIL COUPON FOR FREE BOOK

Coyne Electronics Institute Dept. 59-C2
 1501 W. Congress Pkwy., Chicago, Ill. 60607

Send Information as checked below

- HOME TRAINING in TV, Radio and Color TV Servicing.
 RESIDENT SCHOOL COURSES in Electronics, Electricity, Engineering Technology, Television, Refrigeration, and Air Conditioning.

Name.....Age.....

Address.....

City.....State.....Zip.....

APPROVED FOR VETERANS

Accredited Member: National Association
 Trade and Technical Schools.



CIRCLE NO. 13 ON READER SERVICE PAGE

UNUSUAL BARGAINS

... MANY U.S. GOV'T SURPLUS

FREE!
GIANT
CATALOG



"See" Your Music in Dazzling Action with

Dramatic Breakthrough in
 Audio-Visual Enjoyment



Actually see favorite musical selections translated into fantastic patterns of beautiful color—each individual note creating its own unique, twisting, radiating shape. Each shape dancing and prancing, whirling and swirling in perfect time with the music. Easy-

ly attached to stereo, radio, tape recorder. Send 25c in coin for 16-page booklet. #9096AV.
 No. 71,009AV 8" DO-IT-YOURSELF KIT.....\$22.50 Ppd.
 No. 71,032AV 12" SET.....\$7.50 Ppd.
 No. 71,057AV 500W SPECIAL EFFECTS PROJECTOR.....\$24.50 Ppd.



NEW!

PROJECTION KALEIDOSCOPE

Infinite variety of brilliant color patterns which do not repeat. Specially designed interchangeable 9" diam. liquid wheel, 3" proj. lens and Edmund Projector make it all possible. Easily operated. Large screen image at short projection distance. Perfect for backgrounds, light shows, parties, dances, etc. Front or rear proj.

Stock No. 71,121AV.....\$94.50 Postpaid

LONG-WAVE BLACK LIGHT FIXTURE



Extremely versatile, compactly designed, long wave (3200-4000 angstroms) black light (ultraviolet) fixture. Has 6-watt, 110-V lamp with built-in filter—eliminates harmful shorter wave ultraviolet rays. Use to identify minerals, fungi, bacteria—check for surface flaws, oil and gas leaks—perfect for displays with fluorescent paper, paints, chalk, crayons, trace powder, incl. adjustable aluminum reflector. Mount vert., horr., or on corner.

Stock No. 70,364AV.....\$9.85 Ppd.
 Stock No. 60,124AV (Replacement Bulb).....\$3.25 Ppd.

Order by Stock No.—Check or M.O.—Money-Back Guarantee
 EDMUND SCIENTIFIC CO., 300 EDSCORP BLDG., BARRINGTON, N.J. 08007



GIANT FREE 148 PAGE CATALOG "AV"
 Dozens of electrical and electromagnetic parts, accessories. Enormous selection of Astronomical Telescopes, Microscopes, Binoculars, Magnifiers, Magnets, Lenses, Prisms. Many War surplus items for hobbyists, experimenters, workshops, factory. Write for catalog "AV". Include Zip. EDMUND, 300 EDSCORP BLDG., BARRINGTON, N.J. 08007

CIRCLE NO. 14 ON READER SERVICE PAGE

LIBRARY

(Continued from page 14)

half of the book, experiments provide a basic groundwork in transistor technology, covering such areas as: plotting characteristic curves; measuring parameters of the three basic transistor configurations; and analyzing the audio-amplifier, phase-splitter, and output stages. Then the remaining experiments deal with relatively intricate transistor networks, such as the theory and operation of multivibrators and the concept of parametric action.

Published by Hayden Book Co., Inc., 116 West 14 St., New York, N.Y. 10011. Soft cover. 128 pages. \$3.95

MOST-OFTEN-NEEDED 1969 TELEVISION SERVICING INFORMATION (Volume TV-28)

compiled by M. N. Beitman

Aside from a good knowledge of troubleshooting procedures and the proper test equipment, one of the most valuable assets a TV serviceman can have is a ready reference source of all current TV chassis and schematics. This book, a veritable encyclopedia of current servicing information on all top-name-brand monochrome TV receivers, fills the bill admirably. In addition to providing schematic diagrams, the manual is lavishly illustrated with photographs and printed circuit board illustrations that help the reader to locate quickly any part or subchassis in any TV receiver presented. Also provided are: by-the-number disassembly, adjustment, and alignment instructions; lists of test equipment needed; and the proper oscilloscope waveshapes that should be observed.

Published by Supreme Publications, 1760 Balsam Rd., Highland Park, Ill. 191 pages. Soft cover. \$4.

KNOW YOUR TUBE AND TRANSISTOR TESTERS

by Robert G. Middleton

Tube and transistor testers are as important to modern troubleshooting as are the VTVM and multimeter. It is essential, therefore, that the serviceman who has to rely on these instruments know their proper usage, their capabilities, and—above all—their limitations. This book has been written to provide a complete non-mathematical course or review of the essentials of these testers. The first chapter, for example, is devoted to "Tube and Transistor Testing Requirements." From here, the book proceeds to describe the various types of transistor testers available—including the use of the oscilloscope as a curve tracer. The final two chapters are devoted to tube tester types. A number of review questions are given at the end of each chapter.

Published by Howard W. Sams & Co., Inc., 4300 West 62 St., Indianapolis, Ind. 46206. Soft cover. 142 pages. \$3.50.

POPULAR ELECTRONICS

SOLID STATE

(Continued from page 82)

conductor Division. Fully illustrated with schematics, graphs and tables, the 74-page book covers semiconductor theory and reverse breakdown phenomena, dynamic resistance, temperature-compensated zeners, thermal considerations, a.c. and d.c. applications, audio and r.f. applications, and circuit protection. A special chapter is devoted to computer and instrumentation applications. The handbook, HB-20B, is priced at \$3.00 per copy and may be purchased through franchised distributors or ordered from International Rectifier, 233 Kansas St., El Segundo, CA 90245.

The *Solid State Lamp Manual*, No. 3-8270, recently published by GE's Miniature Lamp Department (Nela Park, Cleveland, OH 44112), is one of the best we've seen, for the explanations are given in plain language without resort to abstruse mathematical expressions. Other chapters are devoted to such practical topics as lamp characteristics, opto-electronics, and circuit applications. An excellent glossary, a short bibliography, and a table of commercial lamp specifications are included in this 60-page manual. The booklet is \$2.00 per copy.

New Devices. A number of semiconductor manufacturers offer transistors in "family groups"—that is, a series of closely related devices with almost identical general specifications and maximum ratings, but different gain values. Knowing this, many hobbyists and experimenters attempt to improve the performance of magazine or home-developed projects by substituting high-gain devices for corresponding low-gain units. Theoretically, such a move could increase the sensitivity of a receiver or result in higher gain in an amplifier. In practice, however,

the experimenter is often disappointed with the final results. There may be little, if any, increase in sensitivity, or in an audio circuit, the output signal may be distorted.

Although the substitution of high-gain devices may be practicable in some projects, it seldom can be accomplished simply by substituting one transistor for another.

First, the unit's base bias must be readjusted for optimum performance. Otherwise, the high-gain unit may be biased to near saturation, causing distortion, clipping, etc.

Second, some readjustment of load values may be necessary, for circuit impedances can change when different transistors are used. Here, any effective increase in gain may be more than offset by circuit losses due to inter-stage impedance mismatch.

Third, the succeeding circuits must be capable of handling signals of increased amplitude. A power amplifier with a maximum output of 5 watts will not deliver more power just because high-gain transistors are used in its preamp stages.

Fourth, the increased gain, if achieved, must be sufficient to cause a noticeable change in the characteristics of the equipment. A modest increase in gain in an audio amplifier, for example, may be difficult to identify due to the logarithmic response characteristics of the human ear.

In general, then, it is best to use specified components in home-assembled projects. If substitutions are made, the builder must be prepared to readjust bias and load values to achieve optimum performance—with the net result, quite often, no better than the original design.

That's it for this month, except this—if you're a Technical Writer or Editor attending the 16th International Technical Communications Conference to be held at Maricott Twin Bridges, May 14-17, in Washington, D.C., drop by the Press Room and say "Hi!" Yours truly will be hanging his hat there—at least part of the time.—Lou

Sonar SENTRY VHF MONITOR NARROW BAND RECEIVERS

LISTEN TO: POLICE, FIRE, AIRCRAFT & WEATHER REPORTS!
for Industrial, Commercial, Utility & Govt. Use
2 CHANNELS • BROADCAST BAND • CRYSTAL CONTROLLED

Designed and engineered for simplicity of operation, compact enough to fit a shirt pocket yet powerful enough to deliver a clear clean signal—it's dependable • Operates on two crystal controlled VHF channels plus broadcast band • Completely solid state for long life use • Visible battery indicator to show battery condition at all times • Built in antenna • 5 7/8" H x 2 1/2" W x 1 3/8" D. Wt. 11 oz.

With Battery Earphone, & less Crystals \$5.00 ea. **\$49.95** SOLID STATE WITH ADJUSTABLE SQUELCH POCKET SIZE

ALSO **\$39.95** FR-103 | FR-106
150-175 MHz | 30-50 MHz

SONAR RADIO CORP., 73 Wortman Ave., Bklyn, N.Y. 11207
Please send information on VHF Monitor Receivers. Dept. 734

Name _____
Address _____
City _____ State _____

POPULAR ELECTRONICS SUBSCRIBER SERVICE

Please include an address label when writing about your subscription to help us serve you promptly. Write to: Portland Place, Boulder, Colo. 80302

CHANGE OF ADDRESS:

Please let us know you are moving at least four to six weeks in advance. Affix magazine address label in space to the right and print new address below. If you have a question about your subscription, attach address label to your letter.

TO SUBSCRIBE:

Check boxes below.

- New Renewal
 5 years \$20
 3 years \$13
 1 year \$5

SPECIFY:

- Payment enclosed
 —You get 1 extra issue per year as a BONUS!
 Bill me later.

AFFIX LABEL

If you have no label handy, print OLD address here.

name
address
city
state
zip-code

please print

Add'l postage: \$1 per year outside U.S., its possessions & Canada.

name 0954

please print

address

city

state zip-code

**COOPERATE WITH THE
ZIP CODE PROGRAM
OF THE POST OFFICE
DEPARTMENT. USE ZIP
CODE IN ALL ADDRESSES**

GET INTO ELECTRONICS

V.T.I. training leads to success as technicians, field engineers, specialists in communications, guided missiles, computers, radar, automation. Basic & advanced courses. Electronic Engineering Technology and Electronic Technology curricula both available. Associate degree in 29 months. B.S. obtainable. G.I. approved. Start February, September. Dorms, campus. High school graduate or equivalent. Catalog.

VALPARAISO TECHNICAL INSTITUTE
 DEPARTMENT PE, VALPARAISO, INDIANA 46383



COMPRESSION SUSTAINER

(Continued from page 64)

off switch *S1*), the output level control (*R9*), and the output jack (*J2*) on the selected cabinet. (All of these controls and jacks are called out in the February 1968 article.) Mount the footswitch either on top of the circuit box or in its own box.

Some people may find that the compressor brings the bass level up too high. In this case, add the bass-cut control circuit shown in Fig. 2. This simple filter may be used either in the compressor electronics package or at the guitar.

Operation. Set the footswitch so that the compressor is not in the circuit. With the guitar (or other electronic instrument) attached to the compressor input, strike a chord and note the approximate level of the volume peaks. Hit the footswitch to introduce the compressor, and adjust *R1* approximately one-quarter turn clockwise (volume up). Then adjust the output control (*R9*) until the level of the music peaks is slightly higher than the level previously noted when the compressor was out of the circuit.

When using the compressor, you will notice instrument sounds that were barely audible before. If the thump sound at the attack of a note is disturbing, simply lower the gain with *R1*. If you set *R1* at slightly more than halfway, you may get spurious feedback because of the high system gain.

The compressor may be used in conjunction with any guitar accessory, such as wa-wa or fuzz. In both cases, the effect is magnified, and you must practice using the compressor to learn how to get the most from it. Also, the guitar volume control has a decreased effect since, as you turn it down, the compressor amplifies more. Because of this, the guitar volume control can be used as a vernier for the compression.

The modified compressor has been used by a number of well-known rhythm groups with great success and should provide the user with a "new sound" for his guitar.

—50—

ELECTRONICS MARKET PLACE

COMMERCIAL RATE: For firms or individuals offering commercial products or services. \$1.15 per word (including name and address). Minimum order \$11.50. Payment must accompany copy except when ads are placed by accredited advertising agencies. Frequency discount: 5% for 6 months; 10% for 12 months paid in advance.
READER RATE: For individuals with a personal item to buy or sell. 70¢ per word (including name and address). No Minimum! Payment must accompany copy.

FOR SALE

FREE! Giant bargain catalog on transistors, diodes, rectifiers, SCR's, zeners, parts. Poly Paks, P.O. Box 942, Lynnfield, Mass. 09140.

GOVERNMENT Surplus Receivers, Transmitters, Snooperscopes, Radios, Parts, Picture Catalog 25¢. Meshna, Nahant, Mass. 09108.

BUG DETECTOR: WILL DETECT AND LOCATE SURREPTITIOUS TRANSMITTING DEVICES IN CONFERENCE ROOMS, HOME AND OFFICES, ETC. WRITE FOR DETAILS. WJS ELECTRONICS, 737 NORTH SEWARD, HOLLYWOOD, CALIF. 90038.

ROCKETS: Ideal for miniature transmitter tests. New illustrated catalog, 25¢. Single and multistage kits, cones, engines, launchers, trackers, rocket aerial cameras, technical information. Fast service. Estes Industries, Dept 18, Penrose, Colorado 81240.

LOWEST Prices Electronic Parts. Confidential Catalog Free. **KNAPP**, 3174 8th Ave. S.W., Largo, Fla. 33540.

TREASURE Hunters! Prospectors! Relco's new instruments detect buried gold, silver, coins. Kits, assembled models. Transistorized. Weighs 3 pounds. \$19.95 up. Free catalog. Relco-A33, Box 10839, Houston, Texas 77018.

EUROPEAN and Japanese bargains catalog. \$1 each. Dee, 10639E Riverside, North Hollywood, Calif. 91602.

MECHANICAL, ELECTRONIC devices catalog 10¢. Greatest Values—Lowest Prices. Fertik's, 5249 "D", Philadelphia, Pa. 19120.

MUSIC LOVERS, CONTINUOUS, UNINTERRUPTED BACKGROUND MUSIC FROM YOUR FM RADIO, USING NEW INEXPENSIVE ADAPTOR. FREE LITERATURE. ELECTRONICS, 11500-Z NW 7th AVE., MIAMI, FLORIDA 33168.

WE SELL CONSTRUCTION PLANS. TELEPHONE: Answering Machine, Speakerphone, Carphone, Phonevision, Legal Connector, Auto Dialer, Central Dial System. **TELEVISION:** \$35.00 Color Converter, Tape Recorder, 30TV. \$25.00 Camera. **DETECTIVE:** Infinity Transmitter, Tail Transmitter, Police Radar Detector. **HOBBYIST:** Electron Microscope, 96 Hour Tape Music System, Ultrasonic Dishwasher, Radar-Oven, Electronic Tranquilizer. Plans \$4.95 each. **COURSES:** Telephone Engineering \$39.50, Detective Electronics \$22.50, Anti-Detective Electronics \$27.50. **SUPER HOBBY CATALOG** 25¢. Don Britton Enterprises, 7906 Santa Monica Blvd., Hollywood, Calif. 90046.

WEBBER LAB's, Police & Fire Converters. Catalog 10¢. 72 Cottage Street, Lynn, Mass. 09105.

RADIO—T.V. Tubes—\$3¢ each. Send for free catalog. Cornell, 4213 University, San Diego, Calif. 92105.

WHOLESALE COMPONENTS: Manufacturers and distributors only. Request free catalog on business letterhead. **WESCOM**, Box 2536, El Cajon, California 92021.

CONVERT any television to sensitive, big-screen oscilloscope. Only minor changes required. No electronic experience necessary. Illustrated plans, \$2.00. Relco-A33, Box 10563, Houston, Texas 77018.

RECTIFIERS, transistors, other components. Catalog free. Electronic Components Co., Box 2902C, Baton Rouge, La. 70821.

BUILD TV CAMERA IN SINGLE EVENING using solid-state encapsulated modules. Previous TV knowledge unnecessary. Ideal for students, experimenters, etc. Economical! Exciting details **FREE**. Also request catalog describing other camera kits, plans, etc. **ATV RESEARCH**, 1301 Broadway, Dakota City, Nebr. 68731.

ELECTRONIC ignition, various types. Free literature. Anderson Engineering, Epsom, N.H. 03239.

INVESTIGATORS, LATEST ELECTRONIC AIDS. FREE LITERATURE. CLIFTON, 11500-L NW 7th AVE., MIAMI, FLORIDA 33168.

GENERAL INFORMATION: First word in all ads set in bold caps at no extra charge. Additional words may be set in bold caps at 10¢ extra per word. All copy subject to publisher's approval. Closing Date: 1st of the 2nd preceding month (for example, March issue closes January 1st). Send order and remittance to: Hal Cymes, POPULAR ELECTRONICS, One Park Avenue, New York, New York 10016.

DIAGRAMS—Radios \$1.50. Television \$3.00. Give make and model. Diagram Service, Box 1151PE, Manchester, Conn. 06042.

GARRARD Record Changers, Hi-Fi Components, Cartridges, Needles, Tape, TV Parts, Schematics. Write for Unbelievable Prices. Gregg Electronics, P.O. Box 184, Glen Head, N.Y. 11545.

FREE ELECTRONICS PARTS FLYER. Large catalog \$1.00 deposit. **BIGELOW ELECTRONICS, BLUFFTON, OHIO 45817.**

HOBBYISTS, EXPERIMENTERS, amateur scientists, students . . . Construction Plans—All complete including drawings, schematics, parts list with prices and sources . . . Laser—Build your own coherent-light optical laser. Operates in the visible light range, pulsed mode—\$6.00 . . . Radar—Build your own ultrasonic doppler radar. Detect motion of people, automobiles, even falling rain drops. Transistorized, uses standard small 9-volt battery—\$4.00 . . . Tic Tac Toe Machine—You play against machine. Automatic. Can you beat the machine? Sometimes yes, usually no—\$4.00 . . . Long Range "Sound Telescope"—This amazing device can enable you to hear conversations, birds, other sounds hundreds of feet away. Very directional. Transistorized, uses 9-volt battery—\$3.00 . . . Or send 25¢ coin or stamps for complete catalogue . . . Technical Writers Group, Dept. C, Box 5994, State College Station, Raleigh, N.C. 27607.

POLICE-FIRE RADIO STATION DIRECTORIES! Exclusive "confidential" call signs, frequencies. Now all areas. Official listings. Catalog for stamp. Communications, Box 56-PE, Commack, N.Y. 11725.

ELECTRONIC bargain catalog on unusual kits, parts, do-it-yourself, stereo, intercoms. Alcon, P.O. Box 1348-P, Lawrence, Mass. 01843.

JAPAN & HONG KONG DIRECTORY. Electronics, all merchandise. World trade information. \$1.00 today. Ippano Kaisha Ltd., Box 6266, Spokane, Washington 99207.

CIRCUIT Boards, Parts for "Poptronics" projects. Free catalog. S.W. Technical, Box 16297, San Antonio, Texas 78216.

LINEAR AMPLIFIERS: "Hornet" 50 watts output—\$98.50; "Raider" 100 watts—\$139.50; "Maverick-250" 250 watts—\$244.95. AM and SSB. "Scorpion"—50 watt 12 V. Mobile amplifier—\$99.95; "Bandit II"—12 V. Mobile Amplifier—\$169.95. Frequency range 20-35 megacycles (illegal for class D 11 meters.) Dealer inquiries invited. D & A Manufacturing Co., 1217 Avenue C, Scottsbluff, Nebraska 69361.

CHASSIS—New "Bracket-Box" chassis packages electronic equipment easily, neatly. For literature write Seiling, 1635 E. 5th St., Dayton, Ohio 45403.

SPECIAL surveillance devices construction diagrams. Includes: olive transmitter, infinity transmitter, telephone/room bugs, tailing devices, debuggers, police speed radar jammer, Send \$2.00. Bylina PE, P.O. Box 09131, Chicago, Illinois 60609.

FREE Catalog low priced, high performance subminiature listen-in devices direct from manufacturer. Dealers welcome. Emery A-5, 156 Fifth Avenue, New York, N. Y. 10010.

ULTRA-SENSITIVE AND POWERFUL METAL DETECTORS—join the many who are finding buried coins, minerals, relics and artifacts. Don't buy till you see our **FREE** catalog of new models. Write Jetco. Box 132-PE, Huntsville, Texas 77340.

CONVERT any T.V. into an oscilloscope. Instructions \$2. Redmond, P.O. Box 38397, Los Angeles, Calif. 90038.

TV CAMERA used. Sacrifice \$125. 1431 West Avenue, Fullerton, California 92633.

LASER parts catalog 60¢. Moynihan, 107 North Brighton, Atlantic City, New Jersey 08401.

SURVEILLANCE EQUIPMENT: complete component and building information, not just diagrams, including the **LISTENING LAMP**. Only \$4.00. George's Electronics, Box 217, Roosevelt, L.I., New York 11755.

PSYCHEDELIC catalog. Posters, lighting etc. Send 25¢ for handling to Hole In The Wall, 6055PE Lankershim, North Hollywood, Calif. 91606.

CLOSEOUTS! Distributor's Entire Electronic Inventory. Send 25¢ for lists. **ESCO**, Box 6-E, Mount Union, Penna. 17066.

LASER & Maser Independent Research Company. Laser Blueprints for sale \$45.00. Professor John Harris, 4552 North Dover Street, Chicago, Illinois 60640.

CONVERT any television to sensitive big-screen oscilloscope. Minor changes require no electronic experience. **SECRET** automatic telephone recorder. Illustrated plans \$1.95 each. Both for \$2.65. **WESTERN**, 28E5199 Kearny Villa, San Diego, California 92123.

1200 VOLT shocker module \$5.95. Fun, pranks, protection. Uses flashlight batteries. No battery drain until electrodes are touched. Catalog 25¢. Franks Scientific Co., P.O. Box 156, Martelle, Iowa 52305.

TRANSISTORS, capacitors, miniature electronic parts. Catalog 25¢. **ECD** Company, Box 5231, Lansing, Michigan 48905.

PLANS AND KITS

KITS, metal detector \$5.95. Audio Telescope \$5.95, others. Lectronix, Box 42, Madison Heights, Michigan 48071.

OSCILLOSCOPE improvement kits. High speed Triggersweep eliminates sync problems. Dual trace FET switch displays two wave-forms together. Solid-State Services, P.O. Box 901, Cupertino, California 95014.

PROXIMITY TACHOMETER, for pick up from signal magnets. Plans \$3.00. **REB** Engineering, P.O. Box 276, Monroeville, Pa., 15146.

"DISTANCE CRYSTAL SET CONSTRUCTION" Handbook—50¢. "Coil Winding"—50¢. Catalog. Laboratories, 12041-L Sheridan, Garden Grove, Calif. 92640.

SOLAR FLYING SAUCERS. (Brand New Solid State Engine, Fantastic Performance, Flies Miles on Sun's Power, lifts animals, sends messages, parachutes. Build many, easily, inexpensively with everyday materials. Complete plans, descriptions, drawings, plus **FREE** Space-tronics **CATALOG \$1**. Single Catalog 25¢. Spacetrronics, Box 31043-PES, San Francisco, California 94131.

INTEGRATED CIRCUIT KITS: COMPUTER, AUDIO, Others. New catalog free. **KAYE ENGINEERING**, Box 3932-A, Long Beach, Calif. 90803.

TELSA COIL—40" SPARKS! Plans \$5.00 Information 50¢. Huntington Electronics, Box 9-P, Huntington, Conn. 06484.

DECADE COUNTER KITS—\$13.95. Professional quality readout. Free information. Display Electronics, Box 1044, Littleton, Colorado 80120.

HIGH FIDELITY

FREE! Send for money saving stereo catalog #P5E and lowest quotations on your individual component, tape recorder, or system requirements. Electronic Values, Inc., 200 W. 20th St., New York, N.Y. 10011.

DON'T THROW YOUR OLD CARTRIDGE AWAY. Send us \$19.95 and any old cartridge. We will ship **PREPAID** any one of the following top rated elliptical diamond stereo cartridges **NEW:** Shure M75E, M91E, M92E, M93E, Empire 888E, Pickering V15AME3, XV15 ATE, ADC 660E, 550E. Write for lowest quotations all stereo components. **DEFA ELECTRONICS**, 2207 Broadway, New York, N.Y. 10024.

HI-FI Components, Tape Recorders, at guaranteed "We Will Not Be Undersold" prices. 15-day money-back guarantee. Two-year warranty. No Catalog. Quotations Free. Hi-Fidelity Center, 239 (P) East 149th Street, New York 10451.

LOW, Low quotes: all components and recorders. HiFi, Roslyn, Penna. 19001.

TAPE RECORDERS, Hi-Fi, components, Sleep Learning Equipment, tapes. Unusual Values Free Catalog. Dressner, 1523R, Jericho Turnpike, New Hyde Park, N.Y. 11040.

DON'T THROW YOUR OLD CARTRIDGE AWAY. Send us \$50.00 and any old used cartridge and we will ship you via air Prepaid anywhere any one of the following Top Stereo Cartridges: Shure V-15 Type II, Empire 999VE, ADC 10EMK 11, Stanton 681EE. Write for lowest quotations all stereo components. **DEFA ELECTRONICS**, 2207 Broadway, New York, N.Y. 10024.

WANTED

CASH PAID! Unused tubes, electronic equipment. Barry, 512 Broadway, NYC 10012.

QUICKSILVER, Platinum, Silver, Gold, Ores Analyzed. Free Circular. Mercury Terminal, Norwood, Mass. 02062.

TUBES

TUBES "Oldies", latest. Lists free. Steinmetz, 7519 Maplewood, Hammond, Indiana 46324.

RECEIVING & INDUSTRIAL TUBES, TRANSISTORS. All Brands—Biggest Discounts. Technicians, Hobbyists, Experimenters—Request **FREE** Giant Catalog and **SAVE! ZALYTRON**, 469 Jericho Turnpike, Mineola, N.Y. 11501.

TUBE Headquarters of World! Send 10¢ for Catalog (tubes, electronic equipment) Barry, 512 Broadway, N.Y.C. 10012.

RADIO & T.V. Tubes—33¢ each. Send for free list. Cornell, 4213 University, San Diego, Calif. 92105.

THOUSANDS and thousands of types of electronic parts, tubes, transistors, instruments, etc. Send for Free Catalog. Arclurus Electronics Corp., MPE, 502-22nd St., Union City, N.J. 07087.

TUBES—lowest prices in the world. Hard to get British, German, Foreign and American obsolete and present day special purpose transmitting tubes. Send for giant tube and parts catalog. United Radio Co., Dept. Y-56 Ferry Street, Newark, N.J. 07105.

TAPE AND RECORDERS

HI-FI Components. Tape Recorders, at guaranteed "We Will Not Be Undersold" prices. 15-day money-back guarantee. Two-year warranty. No Catalog. Quotations Free. HiFidelity Center, 239 (PT) East 149th Street, New York 10451.

BEFORE Renting Stereo Tapes try us. Postpaid both ways—no deposit—immediate delivery. Quality—Dependability—Service—Satisfaction—prevail here. If you've been dissatisfied in the past, your initial order will prove this is no idle boast. Free Catalog. Gold Coast Tape Library, Box 2262, Palm Village Station, Hialeah, Fla. 33012.

RENT 4-Track open reel tapes—all major labels—3,000 different—free brochure. Stereo-Parti, 55 St. James Drive, Santa Rosa, Ca. 95401.

TAPE RECORDER SALE. Brand new nationally advertised brands \$10.00 above cost. Amazing discounts on stereo components. Arkey Electronics, 1028-C Commonwealth Avenue, Boston, Mass. 02215.

TAPEMATES makes available to you **ALL 4-TRACK STEREO TAPES—ALL LABELS**—postpaid to your door—at tremendous savings. For free brochure write: **TAPEMATES**, 5727 W. Jefferson Blvd., Los Angeles, California 90016.

STEREO TAPES, Save 30% and up; no membership or fees required; postpaid anywhere U.S.A. Free 70-page catalog. We discount batteries, recorders, tape/accessories. Beware of slogans, "not undersold", as the discount information you supply our competitor is invariably reported to the factory. **SAXITONE**, 1776 Columbia Road, N.W., Washington, D.C. 20009.

REPAIRS AND SERVICES

TV Tuners rebuilt and aligned per manufacturers specification. Only \$9.50. Any make UHF or VHF Ninety day written guarantee. Ship complete with tubes or write for free mailing kit and dealer brochure. **JW Electronics**, Box 51C, Bloomington, Indiana 47401.

CHASSIS: All types and sizes. Will build to your specifications. Phone 307-532-5752. A & T Manufacturing, Inc. 1902 West C., Torrington, Wyoming 82240.

PERSONALS

MAKE FRIENDS WORLDWIDE through international correspondence. Illustrated brochure free. Hermes, Berlin 11, Germany.

INVESTIGATORS, LATEST ELECTRONIC AIDS. FREE LITERATURE.
CLIFTON, 11500-K NW 7th AVE., MIAMI, FLORIDA 33168.

SURE fire way of getting out of Debt. Send \$1.50 to B & G Enterprises, 815 Tamarack Ave., Carlsbad, Calif. 92008.

INSTRUCTION

LEARN While Asleep, hypnotize with your recorder, phonograph. Astonishing details, sensational catalog free! Sleep-learning Association, Box 24-ZD, Olympia, Wash. 98501.

LEARN ELECTRONIC ORGAN SERVICING at home all makes including transistor. Experimental kit—trouble-shooting. Accredited NHSC. Free Booklet. **NILES BRYANT SCHOOL**, 3631 Stockton, Dept. A, Sacramento, Calif. 95820.

FCC First Class License in six weeks—nation's highest success rate—approved for Veterans Training. Write Elkins Institute, 2603B Inwood Road, Dallas, Texas 75235.

R.E.I.'s famous (5) week course for the First Class Radio Telephone License is the shortest, most effective course in the nation. Over 98% of R.E.I. graduates pass F.C.C. exams for 1st class license. Total tuition \$360.00. Job placement free. Write for brochure. Radio Engineering Incorporated Schools, 1336 Main Street, Sarasota, Florida 33577—or 3123 Gillham Road, Kansas City, Missouri 64109—or 809 Caroline Street, Fredericksburg, Virginia 22401—or 625 E. Colorado Street, Glendale, California 91205.

SHIP RADIO OFFICER TRAINING—SHIPS have been held up awaiting needed personnel, train now at Long Beach, the home of the Queen Mary. Radio officers earn to \$1800.00 monthly. Write for free information. Western Technical School, 5459 Atlantic Ave., Long Beach, Calif. 90805, Desk B. Approved for veterans.

FCC FIRST CLASS LICENSE THROUGH TAPE RECORDED LESSONS. Our seventeenth year teaching FCC license courses. Radio License Training, 1060D Duncan, Manhattan Beach, Calif. 90266.

BECOME PROFICIENT with the electronic components color code the copyrighted Memo-Max Method. \$1.00. **INNOVATION**, 1612 N. Ricketts, Sherman, Texas 75090.

HIGH PAY—begin career in computer field with self-study course used by IBM programmers. No math background necessary. Set of eight books plus proficiency exam \$18.50 postpaid. Computer Education, 60 East 42nd, New York, N.Y. 10017.

LEARN CODE! Sail the seven seas! Become a ham! Beginner to 15 wpm, complete. Two hour 3 3/4 ips tape \$5.49. LP's \$8.95. Rand Laboratories, Winthrop, Maine 04364.

DEGREE in Electronics Engineering earned mostly by correspondence. Free brochure. Dept. G-9, Grantham School of Engineering, 1505 N. Western Ave., Hollywood, California 90027.

INVENTIONS WANTED

INVENTIONS wanted. Patented; unpatented. Global Marketing Service, 2420-P 77th, Oakland, Calif. 94605.

PATENT Searches including Maximum speed, full airmail report and closest patent copies, \$6.00. Quality searches expertly administered. Complete secrecy guaranteed. Free Invention Protection forms and "Patent Information." Write Dept. 9, Washington Patent Office Search Bureau, 711 14th Street, N.W., Washington, D.C. 20005.

QUALITY Patent Searches Preferred by Professional Inventors, Lawyers, Manufacturers. "Confidential Report" Including related United States patent copies "Airmailed Certified." **FREE** information! United States Inventors Service Company, 501-H Thirteenth Street, N.W., Washington, D.C. 20005.

INVENTORS. We will develop, help sell your idea or invention, patented or unpatented. Our national manufacturer clients are urgently seeking new items for outright cash sale or royalties. Financial assistance available. 10 years proven performances. For free information, write Dept. 41, Wall Street Invention Brokerage, 79 Wall Street, New York, N.Y. 10005.

INVENTORS! OUR FREE EXPERT ANALYSIS of your invention can save valuable time, help you realize full sale value. Strictly confidential. **FREE INVENTION CERTIFICATE.** Write today: Pioneer Invention Service, Dept. 35, 150 Broadway, New York, N.Y. 10038.

INVENTORS! Sell your invention for cash or royalties! Our client manufacturers eagerly seek new items. Patented. Unpatented. Financial assistance if needed. 25 years proven performances. For free information, write Dept 20, Gilbert Adams, Invention Broker, 80 Wall St., New York, N.Y. 10005.

FREE "Directory of 500 Corporations Seeking New Products." For information regarding development, sale, licensing of your patented/unpatented invention. Write: Raymond Lee Organization, 230-GR Park Avenue, New York City 10017.

INVENTORS: Protect your ideas! Free "Recommended Procedure". Washington Inventors Service, 422T Washington Building, Washington, D.C. 20005.

CLASSIFIED ADVERTISING ORDER FORM

Please refer to heading on first page of this section for complete data concerning terms, frequency discounts, closing dates, etc.

1	2	3	4	5
6	7	8	9	10
11	12	13	14	15
16	17	18	19	20
21	22	23	24	25
26	27	28	29	30
31	32	33	34	35

_____ Words { @ 70¢ (Reader Rate) } = \$ _____
 { @ \$1.15 (Commercial Rate) }

Insert _____ time(s) Total Enclosed \$ _____

NAME _____

ADDRESS _____

CITY _____ STATE _____ ZIP _____

Signature _____

WORD COUNT: Include name and address. Name of city (Des Moines) or of state (New York) counts as one word each. Zip Code numbers not counted. (Publisher reserves right to omit Zip Code if space does not permit.) Count each abbreviation, initial, single figure or group of figures or letters as a word. Symbols such as 35mm, COD, PO, AC, etc., count as one word. Hyphenated words count as two words.

PE-569

PATENT SEARCHES, including copies of related United States Patents. Inventors, attorneys, manufacturers use our "World-Wide" Airmail service Free: "Invention Record" form and "Information Every Inventor Needs", Hayward Company, 1029HR Vermont, Washington, D.C. 20005.

FREE PAMPHLET: "Tips on Safeguarding Your Invention." Write: United States Inventors Service Company, 501-H Thirteenth Street N.W., Washington, D.C. 20004.

GOVERNMENT SURPLUS

JEEPS Typically From \$53.90 . . . Trucks From \$78.40 . . . Boats, Typewriters, Airplanes, Multimeters, Oscilloscopes, Transceivers, Electronics Equipment. Wide Variety, Condition. 100,000 Bid Bargains Direct From Government Nationwide. Complete Sales Directory and Surplus Catalog \$1.00. (Deductible First \$10.00 Order). Surplus Service, Box 820-J, Holland, Michigan 49423.

GOVERNMENT Surplus How and Where to Buy in Your Area. Send \$1.00 to: Surplus Information PE, Headquarters Building, Washington, D.C. 20036.

FREE CATALOG 145PE loaded with electronic bargains. Arrow Sales, 2534 South Michigan, Chicago, Illinois 60616.

BOOKS

FREE catalog 950 aviation/electronic/space books. Aero Publishers, 329PE Aviation Road, Fallbrook, California 92028.

UNUSUAL Books! Catalog free! International, Box 7798 (PE), Atlanta, Georgia 30309.

FREE Book Prophet Elijah Coming Before Christ. Wonderful Bible Evidence. PE Megiddo Mission, Rochester, New York 14619.

FREE CATALOG. BOOKS FOR ADULTS. CATALOG, 2217 LACKLAND, ST. LOUIS, MISSOURI 63114.

AMAZING self help books. Write Lynn, Box 1573, Waco, Texas 76703.

FREE! List of low cost popular books. Success, happiness, personality, wealth, personal problems. Hilltop House, Dept. 19, Clive, Iowa 50053.

MAGAZINES

BACK DATE MAGAZINES! Send needs. Midtown, Box 917-PE, Maywood, N.J. 07607.

MAGNETS

MAGNETS. All types. Special—20 disc magnets, or 2 stick magnets, or 10 small bar magnets, or 8 assorted magnets, \$1.00 Maryland Magnet Company, 5412-H Gist, Baltimore, Maryland 21215.

AUTHORS' SERVICES

AUTHORS! Learn how to have your book published, promoted, distributed. FREE booklet "ZD," Vantage, 120 West 31 St., New York 10001.

MUSIC

PLAY ORGAN EASILY. AMAZING METHOD. FREE INFORMATION. KEGLEY, 1016-PE KELLY, JOLIET, ILLINOIS 60435.

HYPNOTISM

FREE Hypnotism, Self-Hypnosis, Sleep Learning Catalog! Drawer H400, Ruidoso, New Mexico 88345.

"MALE-FEMALE HYPNOTISM" EXPOSED, EXPLAINED! "SECRET METHOD"—THEY NEVER KNOW! \$2, RUSHED. GUARANTEED! ISABELLA HALL, SILVER SPRINGS, FLORIDA 32688.

HYPNOTIC sleep learning recordings produce fabulous results. Details Free. ASR Foundation, Box 702leg Henry Clay Station, Lexington, Ky. 40502.

AMAZING HYPNOTIC record kit releases fantastic mental power! Free offer expires soon. Write: Forum, Studio AA5, 333 North Michigan, Chicago 60601.

HYPNOTIZE MALES, FEMALES!—Unnoticed! Quickly! Nerves! Exciting! \$2.25. Research Enterprises, 29-SN21 Samoset, Woburn, Mass. 01801.

HYPNOTIZE SUCCESSFULLY! "By Telephone"—"Instantaneous"—"One Word"—"Against Will" methods exposed! 10" Hypnodisk. "Secret Nerve Pressure Technique"—They never know! \$2.00 **RESULTS ABSOLUTELY GUARANTEED!** Fowler, Box 5396, Woodbury, N.J. 08096.

REAL ESTATE

FREE . . . New **SUMMER CATALOG!** Describes and pictures hundreds of farms, ranches, town and country homes, businesses coast to coast! Specify type property and location preferred, Zip code, please. **UNITED FARM AGENCY, 612-EP West 47th St., Kansas City, Mo. 64112.**

PHOTOGRAPHY—FILM, EQUIPMENT, SERVICES

SCIENCE Bargains Request Free Giant Catalog "CJ"—148 pages—Astronomical Telescopes, Microphones, Lenses, Binoculars, Kits, Parts. War surplus bargains. Edmund Scientific Co., Barrington, New Jersey 08007.

MEDICAL Film—Adults Only—"Childbirth"—1 reel 8mm \$7.50—16mm \$14.95. International-E, Greenvale, L.I., New York 11548.

SELL your photos. Report tells how and where. Color Slide Markets. Only \$1.00. L. L. Kimbler Co., 635 Leesburg Road, Ft. Wayne, Indiana 46808.

RECORDS

SPECIAL INTEREST RECORDS AVAILABLE, PRODUCED BY THE EDITORS OF THE WORLD'S LEADING SPECIAL INTEREST MAGAZINES. SEND FOR FREE CATALOG. RECORD CATALOG-PE ZIFF-DAVIS PUBLISHING COMPANY, ONE PARK AVENUE, NEW YORK, N.Y. 10016.

19¢ RECORDS from your tapes. Write Concert Recording, Lynwood, California 90262.

FREE 40 PAGE CATALOG offers hundreds of recordings of rare Renaissance, Baroque and Classical music. Some records priced as low as \$1.00 each! All late recordings in stereo only. **MHS RECORDS, Box 932-PE, New York, New York 10023.**

PRINTING

THERMOGRAPHED business cards, \$3.49—1,000, free samples. Gables—405A Clifton, Glenshaw, Pa. 15116.

FREE LITERATURE: Address labels, business cards, printing, Rubber Stamps. **JORDAN'S, 552 West O'Connor, Lima, Ohio 45801.**

1000 GUMMED address labels \$1.00. Newman, 684D Queen S.W., Atlanta, Georgia 30310.

SUMMER CAMPS

CAMP SKYCREST. 24th year. 90 boys, 6-16. Pocono Mountains. Learn Radio and Electronics, Astronomy, Auto Mechanics, Biology, Chemistry, Photography, Metal, Woodworking. Get ham license. All sports: Karting. Heated pool. Friendly staff. Nurse. Modern cabins. Write: Dr. F. E. Brown, 17 Doxey Drive, Glen Cove, New York 11542. 516-676-2190.

BUSINESS OPPORTUNITIES

INVESTIGATE ACCIDENTS: Earn to \$1000 monthly. Men urgently needed. Car furnished. Business expenses paid. No selling. No College education necessary. Pick own job location. Investigate full time or earn to \$8 hour spare time. Write for **FREE** information. No obligation. Universal Schools, CZ-5, 6801 Hillcrest, Dallas, Texas 75205.

RAISE Rabbits for us on \$500 month plan. Free details. White's Rabbitry, Mt. Vernon, Ohio 43050.

FREE CATALOGS. Repair air conditioning, refrigeration. Tools, supplies, full instructions. Doolin, 2016 Canton, Dallas, Texas 75201.

PIANO TUNING learned quickly at home. Tremendous field! Musical knowledge unnecessary. GI Approved. Free Information. Empire School, Miami, Florida 33145.

FREE Book "990 Successful little-known Businesses." Work home. Plymouth 345Y, Brooklyn, N.Y. 11218.

ELECTROPLATING Equipment and supplies. All types for home workshops and industrial. Send \$2.00 (refundable) for equipment guide formulas, operating data, catalog. HBS Equipment Division 90, 3543 East 16th, Los Angeles, California 90023.

I MADE \$40,000.00 Year by Mailorder! Helped others make money! Start with \$10.00—Free Proof. Torrey, Box 318-N, Ypsilanti, Michigan 48197.

\$200.00 DAILY In Your Mailbox! Your opportunity to do what mail-order experts do. Free details. Associates, Box 136-J, Holland, Michigan 49423.

OPERATE a business of your own from home. Everything furnished. Royce, Box 204-J, Dolton, Illinois 60419.

SELL HERTEL BIBLES—Part Time. Finest reference Bible available. Demonstrator and supplies furnished. Excellent commissions. Write International Book, Dept. PE, Box 118, Wichita, Kansas 67201.

MAILORDER . . . Operate cash-in-advance business! Details. Methods, 1414-F.D., Lafayette Hill, Pennsylvania 19444.

SMALL BUSINESS MONEY. 1000 sources. \$500 to \$2 million. Free details. Counselor-48, Harlingen, Texas 78550.

PROVEN import and mailorder procedures. Revealing, profitable, practical. Write: N.D.B.R., Box 13011-C, Kansas City, Missouri 64199.

RAISE hard to get colored Canaries, Budgies. Exciting profitable hobby or business. Big profits. We furnish everything. Details free. Glenmere Aviaries, Box 417, Grahamsville, New York 12740.

EMPLOYMENT OPPORTUNITIES

BOOMING AUSTRALIA wants You—Good jobs. Adventure. Forms and Australian Handbook (1969) describing Australian assisted passage, passport-visa, advantages, opportunities \$1.00. Buckeye, Box 1032TS, Fairborn, Ohio 45324.

PLASTICS

CASTOLITE Liquid Plastic pours like water and hardens like glass without heat. Clear, colors. Embed real flowers, butterflies, photos, coins. Also new molding formulas for perfect reproductions. Illustrated booklet shows **HOW**. Send 25¢—Dept. 9C5E, CASTOLITE, Woodstock, Ill. 60098.

SHORTWAVE LISTENING

POLICE—FIRE—AIRCRAFT—MARINE—AMATEUR—ETC. CALLS on your broadcast radio with **TUNAVERTER!** Tunable-crystal controlled! Free catalog. Salch Co., Woodsboro-PECC, Texas 78393.

NEW HOW to LISTEN to the WORLD, \$3.95. World Radio TV Handbook, \$5.95. Antennas and Tuning Units. SWL Guide, 218 Gifford, Syracuse, N.Y. 13202.

MOVIE FILMS

LATEST CATALOG featuring Exciting **SPORTS ACTION. 8/SUPER 8, COLOR. SPORTLITE FILMS-PE,** Box 500, Speedway, Indiana 46224.

MISCELLANEOUS

WINEMAKERS: Free illustrated catalog of yeasts, equipment. Semplex, Box 7208, Minneapolis, Minn. 55412.

STOP BURGLARS THE EASY WAY!! Affix authentic "Protected by Electronic Sentry Alarm" Decals to auto windows, door & windows of home, retail stores, vending machines, etc. Whether you have an alarm or not—thieves stay away! Only \$1.00 each set of two. J. Ross, 80-34 Kent St., Jamaica, N.Y. 11432, Dept. PE.

DELUXE RECORD AND TAPE CASES

Plus *Free* cataloging forms

- Padded back
- Dust proof
- Gold embossed



Decorative and sturdy cases constructed of reinforced fiberboard—covered in rich leatherette to keep your records and tapes from getting damaged. Available in choice of five decorator colors. Record and Tape Cases lend themselves handsomely to the decor of any room. Padded back (in your color choice) is gold tooled in an exclusive design. Sides in standard black leatherette to keep them looking new after constant use. Extra with each case ordered you will receive, free of charge, a specially designed cataloging form with pressure sensitive backing for affixing to side of case. Enables you to list the records to help you locate your albums. Cases are available in three sizes for 7", 10" and 12" records. Center divider separates records for easy accessibility, holds an average of 20 records in their original jackets. Tape case holds 6 tapes in original boxes.

Ziff-Davis Pub. Co. • Dept. SD • 1 Park Ave. • N.Y., N.Y. 10016

My remittance in the amount of \$ _____

Quantity is enclosed for the Cases indicated below.

_____ Tape Case at \$4 ea., 3 for \$11, 6 for \$21.

_____ 7" Record Case at \$4 ea., 3 for \$11, 6 for \$21.

_____ 10" Record Case at \$4.25 ea., 3 for \$12, 6 for \$22.

_____ 12" Record Case at \$4.25 ea., 3 for \$12, 6 for \$22.

ADD \$1.00 PER ORDER FOR SHIPPING AND HANDLING. Check color choice for back of case (sides in black only):

Midnight Blue Red Spice Brown

Pine Green Black

Name _____ PE-59

Address _____

City _____ State _____ Zip _____

■ PAYMENT MUST BE ENCLOSED WITH ORDER ■

EMPLOYMENT Resumes. Get a better job & earn more! Send only \$2.00 for expert, complete Resume Writing Instructions. J. Ross, 80-34 Kent St., Jamaica, N.Y. 11432, Dept. PE.

BILLS paid without borrowing—Nobody refused up to \$10,000.00. Bad credit no problem, not a Loan Company. Write for free application. **INTERNATIONAL ACCEPTANCE,** Dept. 50-A, 5133 N. Central Ave., Phx., Arizona 85012; 2511 E. 46th Street, Indianapolis, Ind., 46205; 711 14th St., N.W., Washington, D.C. 20005; 507 Carondelet St., New Orleans, La. 70130.

INSTANT PROTECTION AGAINST MUGGERS, VICIOUS ANIMALS! Effective as Mace but legal to carry. Nationally advertised. Guaranteed effective. Aerosol \$2.00. Three assorted \$5.00. J. Ross, 80-34 Kent Street, Jamaica, New York 11432. Dept. PE.

STAMMER — Stutter — No more. (Dr. Young.) Write Gaucho, Box 9309-E8, Chicago 60690.

MAIL ORDER OPPORTUNITIES WAITING FOR YOU!

Classified Advertisers find more outlets for their product and service advertising in Ziff-Davis Electronics Publications than in any other media.

Whether in a monthly publication: **POPULAR ELECTRONICS, ELECTRONICS WORLD, STEREO REVIEW** . . . or in **ELECTRONIC EXPERIMENTER'S HANDBOOKS,** Classified Advertising is responded to regularly by an affluent audience of active electronics enthusiasts.

Prove to yourself the effectiveness of Classified Advertising in Ziff-Davis Electronics Publications. Write today for information, assistance or sample copies to:

Hal Cymes, Classified Advertising Manager
Ziff-Davis Publishing Company
One Park Avenue, New York, N. Y. 10016



**1969—WINTER \$1.25
ELECTRONIC EXPERIMENTER'S
HANDBOOK**

148 pages of the most fascinating and challenging construction projects for the electronics hobbyists. All with complete schematics, illustrations, parts list, and easy-to-follow instructions that guarantee you perfect finished products.

**1968—SPRING \$1.25
ELECTRONIC EXPERIMENTER'S
HANDBOOK**

Another big package containing over 30 of the most challenging, fun-to-build electronics projects ever! Be sure to order this one today!

1969 STEREO/HI-FI DIRECTORY \$1.25

Giant 180 page buyer's guide listing more than 1,600 individual Stereo/Hi-Fi components by 176 manufacturers. Nine individual sections complete with specs, photos, prices—the works!

6 Vital Components

*For Knowledge...
For Profit... For Sheer
Electronics Enjoyment!*



1969 TAPE RECORDER ANNUAL \$1.35

Over 130 pages covering every aspect of tape recording. Complete buyer's guide to the brands and models on the market. Expert tips on equipment—making better tapes—editing—copying—everything you want and need to know about tape recording.

**1969 \$1.35
COMMUNICATIONS HANDBOOK**

148 fact packed pages for the CB, SWL or HAM. Equipment buyer's guide—photos—tables—charts—getting a license—everything to make this the world's most complete guide to communications.

**1969 \$1.35
ELECTRONICS INSTALLATION &
SERVICING HANDBOOK**

Covers all 8 areas of consumer electronics servicing—all the tricks of the trade in one complete guide. The industry's "how-to" book for installing and servicing consumer electronics equipment.

ZIFF-DAVIS SERVICE DIVISION • Dept. W
595 Broadway, New York, N.Y. 10012

Please send me the annuals I've checked below:

- 1969 Electronic Experimenter's Handbook - Winter
- 1968 Electronic Experimenter's Handbook - Spring
- 1969 Stereo/Hi-Fi Directory
- 1969 Tape Recorder Annual
- 1969 Communications Handbook
- 1969 Electronics Installation & Servicing Handbook

I am enclosing \$_____ My remittance includes an additional 25¢ per copy for shipping and handling (Outside U.S.A. all magazines are \$2.00 per copy, postpaid.)

PE-59

print name _____

address _____

city _____

state _____ zip _____

PAYMENT MUST BE ENCLOSED WITH ORDER

POPULAR ELECTRONICS

MAY 1969

ADVERTISERS INDEX

READER SERVICE NO.	ADVERTISER	PAGE NO.
1	AMECO, Division of Aerotron, Inc.	94
2	American Engraving, Inc.	90
3	Antenna Specialists Co., The	9
4	Argos Products Company	88
5	B & K	87
	Bell & Howell Schools	5
6	Burnstein-Applebee Co.	92
7	C/P Corporation	25
	CREI, Home Study Division, McGraw-Hill Book Company	72, 73, 74, 75
8	Career Academy	89
9	Cleveland Institute of Electronics	88
10	Cleveland Institute of Electronics ...	18, 19, 20, 21
12	Cook's Institute of Electronics Engineering ...	96
30	Courier Communications Inc.	23
13	Coyne Electronics Institute	98
14	Edmund Scientific Co.	98
11	EICO Electronic Instrument Co., Inc.	FOURTH COVER
15	Electro-Voice Inc.	12
28	G C Electronic Co., Calectro Division ...	11
17	Garrard	8
18	Heath Company	16, 17
19	Intratec	97
20	Johnson Company, E.F.	13
21	Lafayette Radio	96
22	Mosley Electronics, Inc.	26
	National Radio Institute ...	SECOND COVER, 1, 2, 3, 90
	National Technical Schools ...	54, 55, 56, 57
23	Olson Electronics	92
32	Pearce-Simpson	95
	RCA Electronic Components & Devices ...	THIRD COVER
29	RCA Electronic Components & Devices ...	7
31	RCA Electronic Components & Devices ...	93
	RCA Institutes, Inc.	36, 37, 38, 39
24	SCA Services Company	91
25	Sams & Co., Inc., Howard W.	10
26	Sonar Radio Corporation	99
55	Turner Company, Inc.	14
27	United Audio Products, Inc.	6
	Valparaiso Technical Institute ...	100

CLASSIFIED ADVERTISING 101, 102, 103, 104, 105

Printed in the U.S.A.

POPULAR ELECTRONICS

All new from every angle ...RCA HI-LITE

You end all doubts and confusion when you specify RCA HI-LITE. Then you can be certain that here is the all-new replacement picture tube from the leader in Color TV. All-new glass...gun...the works.

CEM QUALITY from every angle: the same tubes that go into original equipment sets, incorporating the latest technology of the world's most experienced color picture tube manufacturer. Everything about them exudes know-how, confidence, leadership.

If you've set your sights on quality then look to RCA HI-LITE for your replacement tube needs. Available in the broadest line of types in the industry from your Authorized RCA Distributor.

RCA Electronic Components,
Harrison, N. J.



RCA

EICO Makes It Possible

Uncompromising engineering — for value does it!
You save up to 50% with Eico Kits and Wired Equipment.



Cortina Stereo

THE VERDICT IS IN. High fidelity authorities agree:

Cortina's engineering excellence, 100% capability, and compact dramatic esthetics all add up to Total Stereo Performance at lowest cost.

NEW

A Silicon Solid-State 70-Watt Stereo Amplifier for \$99.95 kit, \$139.95 wired, including cabinet. Cortina 3070

NEW

A Solid-State FM Stereo Tuner for \$99.95 kit, \$139.95 wired, including cabinet. Cortina 3200.

A 70-Watt Solid-State FM Stereo Receiver for \$169.95 kit, \$259.95 wired, including cabinet. Cortina 3570.

NEW Silicon Solid State 150-Watt Stereo Amplifier designed for audio perfectionists. Less than 0.1% harmonic distortion, IM distortion. Less than 0.6% at full output. Controls and inputs for every music source. \$149.95 kit, \$225.00 wired including cabinet. Cortina 3150.

NEW 70-Watt Solid State AM/FM Stereo Receiver for \$189.95 kit, \$279.95 wired including cabinet. Cortina 3770.

Eicocraft

The newest excitement in kits.

100% solid-state and professional. Fun to build and use. Expandable, interconnectable. Great as "jiffy" projects and as introductions to electronics. No technical experience needed. Finest parts, pre-drilled etched printed circuit boards, step-by-step instructions.

EC-100 Electronic Siren \$4.95, EC-101 Electronic Burglar Alarm \$6.95, EC-102 Electronic Fire Alarm \$6.95, EC-200 Electronic Intercom \$5.95, EC-300 Audio Power Amplifier \$5.95, EC-400 Electronic Metronome \$3.95, EC-500 Tremolo \$9.95, EC-600 Electronic Light Flasher \$3.95, EC-700 Electronic "Mystifier" \$4.95, EC-800 Photo Cell Nite Lite \$4.95, EC-900 Power Supply \$8.95, EC-1000 Code Oscillator \$2.50, EC-1100 FM Wireless Mike \$9.95, EC-1200 AM Wireless Mike \$9.95, EC-1300 Electronic VOX \$8.95, EC-1400 Solid State FM Radio \$9.95, EC-1500 Solid State AM Radio \$8.95, EC-1600 Electronic Bongos \$7.95



6 EXCITING NEW PROJECTS

EC-1700 Ham/CB Vox \$8.95,
EC-1800 Electronic "TOX" \$8.95,
EC-1900 "Treasure Finder" \$9.95,
EC-2000 Electronic "Organ" \$9.95,
EC-2100 Electronic "Eye" \$9.95,
EC-2200 Electronic Touch Switch \$8.95

Color n' Sound

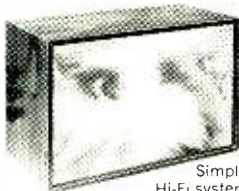

Add a new dimension to your music system. Introducing the first inexpensive solid-state electronic system which provides true synchronization of color with sound. Watch the music you love spring to life as a vibrant, ever shifting interplay of colors.

Simply connect to speaker leads of your Hi-Fi system (or radio). Kit can be assembled in several hours — no technical knowledge or experience necessary. Kit \$49.95, Wired \$79.95.



Model 232 Peak-to-Peak VTVM. A must for color and B&W TV and industrial use. 7 non-skip ranges on all 4 functions. With exclusive Uni-Probe.® \$34.95 kit, \$49.95 wired.

Automotive

EICO 888—Car/Boat Engine Analyzer.

For all 6V/12V systems; 4, 6, 8-cyl. engines.



Now you can keep your car or boat engine in tip-top shape with this solid-state, portable, self-powered universal engine analyzer. Completely tests your total ignition/electrical system.

Complete with a Tune-up & Trouble-shooting Manual. Model 888; \$49.95 kit, \$69.95 wired.

Test Equipment

100 best buys to choose from.

"The Professionals" — laboratory precision at lowest cost.

Model 460 Wideband Direct-Coupled 5" Oscilloscope, DC-4.5mc for color and B&W TV service and lab use. Push-pull DC vertical amp., bal. or unbal. input. Automatic sync limiter and amp. \$99.95 kit, \$149.95 wired.

FREE 1969 CATALOG

PE-5

EICO Electronic Instrument Co., Inc.
283 Malta Street, Brooklyn, N.Y. 11207

Send me FREE catalog describing the full EICO line of 200 best buys, and name of nearest dealer.

Name _____

Address _____

City _____

State _____ Zip _____

CIRCLE NO. 11 ON READER SERVICE PAGE