

BUILD DON LANCASTER FREQUENCY COUNTER

POPULAR ELECTRONICS

**MARCH
1969**

**50
CENTS**



EVONICS—NEW ERA IN SEMICONDUCTORS

BUILD SOUND-WITH-SOUND MIXER

HYBRID 40-METER RIG

IC STEREO PREAMP

HOW MUCH MATH IS ENOUGH?

A PEEK INTO THE FUTURE OF HAM RADIO



**BUILD
OP-TACH
PHOTOELECTRIC
TACHOMETER**

(page 27)



nri **firsts**

**make learning
Electronics at home
fast and fascinating—
give you priceless
confidence.**

Some NRI **firsts** in training equipment



first to give you Color Television training equipment engineered specifically for education — built to fit NRI instructional material, *not* a do-it-yourself hobby kit. The end product is a superb Color TV receiver that will give you and your family years of pleasure. You “open up and explore” the functions of each color circuit as you build.

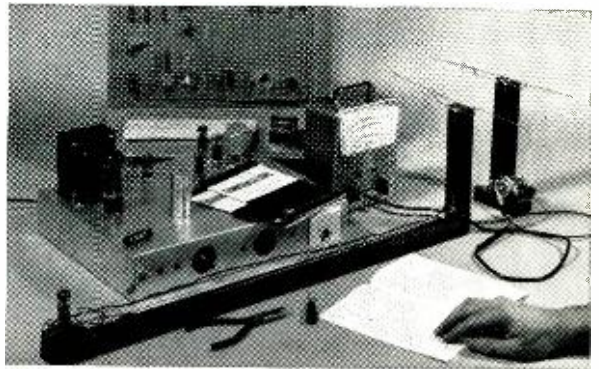

first to give you transmission lines and antenna systems that include experiments not otherwise attempted outside of college physics laboratories. The experience gained with this kind of Communications training equipment is matched only by months — sometimes years — of on-the-job experience.

NRI's "discovery" method is the result of over half a century of leadership simplifying and dramatizing training at home

The FIRSTS described below are typical of NRI's half century of leadership in Electronics home training. When you enroll as an NRI student, you can be sure of gaining the in-demand technical knowledge and the priceless confidence of "hands-on" experience sought by employers in Communications, Television-Radio Servicing and Industrial and Military Electronics. Everything about NRI training is designed for your education . . . from the much-copied, educator-acclaimed Achievement Kit sent the day you enroll, to "bite-size" well-illustrated, easy to read texts programmed with designed-for-learning training equipment.

YOU GET YOUR FCC LICENSE OR YOUR MONEY BACK

There is no end of opportunity for the trained man in Electronics. You can earn \$6 or more an hour in spare time, have a business of your own or qualify quickly for career positions in business, industry, government. And if you enroll for any of five NRI courses in Communications, NRI prepares you for your FCC License exams. *You must pass* or NRI refunds your tuition in full. No school offers a more liberal money-back agreement. The full story about NRI leadership in Electronics training is in the new NRI Catalog. Mail postage-free card today. No salesman is going to call.
NATIONAL RADIO INSTITUTE, Washington, D.C. 20016

APPROVED UNDER NEW GI BILL If you have served since January 31, 1955, or are in service, check GI line on postage-free card.

designed from chassis up for your education

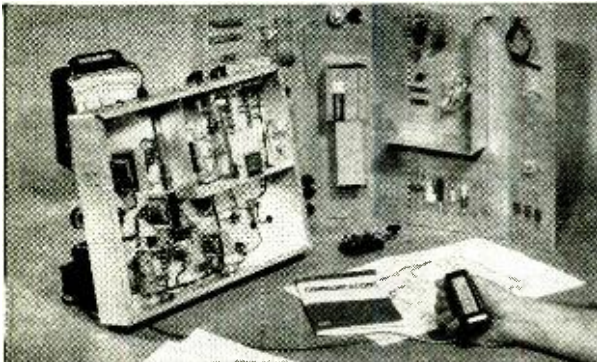

first to give you true-to-life experiences as a communications technician. Every fascinating step you take in NRI Communications training, including circuit analysis of your own 25-watt, phone/cw transmitter, is engineered to help you prove theory and later apply it on the job. Studio equipment operation and troubleshooting become a matter of easily remembered logic.



first to give you completely specialized training kits engineered for business, industrial and military Electronics. Shown above is your own training center in solid state motor control and analog computer servo-mechanisms. Telemetry circuits, solid-state multi-vibrators, and problem-solving digital computer circuits are also included in your course.

POPULAR ELECTRONICS

VOLUME 30 NUMBER 3

MARCH, 1969

WORLD'S
LARGEST-SELLING
ELECTRONICS
MAGAZINE

SPECIAL CONSTRUCTION PROJECTS

- BUILD OP-TACH** 27 JOHN S. SIMONTON, JR.
Hand-held instrument to count revolutions
- BUILD THE POPULAR ELECTRONICS
UNIVERSAL FREQUENCY COUNTER** 33 DON LANCASTER
High-accuracy IC instrument measures to 2 MHz

FEATURE ARTICLES

- HOW'S YOUR $E = IR$?** 32 ROBERT P. BALIN
Ohm's Law quiz
- BUILD A HAPPY HYBRID** 48 DEE LOGAN, WB2FBF
Ten-watt rig for 40 meters
- IC STEREO PREAMPLIFIER** 52 PAUL B. JARRETT, M.D.
- OVONICS** 55 JOHN P. ROBERTSON, JR.
Latest wrinkle in semiconductors
- SOUND-WITH-SOUND MIXER** 59 DOUG DEMAW, W1CER
- MATH, DOORWAY TO HIGHER PAY** 67 DAVID L. HEISERMAN
How much math for an electronics career?
- THE NOT ALTOGETHER FORGOTTEN ELECTRET** 70 HERBERT & PHYLLIS COHEN
Dielectric with fixed electrostatic field
- NO PLACE TO GO BUT UP** 75 RICHARD HUMPHREY
A challenge for amateur radio
- ENGLISH-LANGUAGE BROADCASTS TO NORTH AMERICA** 80 ROGER LEGGE
- THE PRODUCT GALLERY** 81
- Heathkit Color TV (GR-681)*
- Wireless Remote (GRA-681-6)*
- ON THE CITIZENS BAND** 84 MATT P. SPINELLO, KHC2060
Monitour '69
- SHORT-WAVE LISTENING** 85 HANK BENNETT, W2PNA
- AMATEUR RADIO** 87 HERB S. BRIER, W9EGQ
Another DX journey
- SOLID STATE** 93 LOU GARNER
- ## DEPARTMENTS
- LETTERS FROM OUR READERS** 8
- ELECTRONICS LIBRARY** 14
- READER SERVICE PAGES** 15, 115
- NEW LITERATURE** 16
- NEW PRODUCTS** 22

POPULAR ELECTRONICS is indexed
in the Readers' Guide
to Periodical Literature

Copyright © 1969 by ZIFF-DAVIS PUBLISHING COMPANY. All rights reserved.

This month's cover photo by
Justin Kerr

POPULAR ELECTRONICS, March 1969, Volume 30, Number 3, Published monthly at 307 North Michigan Avenue, Chicago, Illinois 60601. One year subscription rate for U.S., U.S. Possessions and Canada, \$5.00; all other countries, \$6.00. Second class postage paid at Chicago, Illinois and at additional mailing offices. Authorized as second class mail by the Post Office Department, Ottawa, Canada and for payment of postage in cash. Subscription service and Forms 3579: Portland Place, Boulder, Colorado 80302. Editorial offices for manuscript contributions, reader inquiries, etc.: One Park Ave., New York, N.Y. 10016.



Pat Powers, Computer Technology



Ronald Wanat, Circuitry Design



Tom Geary, Automation



Robert Kastiger, Broadcasting

These 4 successful men all got started the same way: they sent in a coupon like this

DE VRY INSTITUTE OF TECHNOLOGY
MEMBER NATIONAL HOME STUDY COUNCIL

BELL & HOWELL SCHOOLS

Please send free booklets and information about careers in electronics. I am interested in the following fields (check one or more).

Nuclear Instrumentation Testing PE-3A
 Automation
 Broadcasting/telecasting
 Radar
 TV-radio service

Name _____ Age _____
 Address _____ Apt. _____
 City _____ State _____ County _____ Zip Code _____

Veterans: Check here. If you were discharged after Jan. 31, 1955, the "G. I. Bill" may cover the entire cost of your tuition. 118

Why don't you?

Accredited Member, National Home Study Council

DE VRY INSTITUTE OF TECHNOLOGY
4141 BELMONT AVE., CHICAGO, ILL. 60641

 BELL & HOWELL SCHOOLS



HORNING IN

RAY NEWMAN
Senior Product
Engineer

One of a
series of
brief
discussions
by
Electro-Voice
engineers

In recent years great interest has been evidenced in large output speaker systems exhibiting a high order of durability. The demand has come from the acceptance of electronically amplified musical instruments and the development of new musical idioms involving these instruments.

Typical products in this field are cone speakers, re-engineered to handle greater input power, and commonly installed in direct radiator ported enclosures. These systems have the advantage of simple construction and generous mid-bass response. However, at very low frequencies the enclosure usually offers little acoustical loading of the speaker diaphragm, limiting bass response, and permitting excessive excursions that seriously affect power handling and durability. Designs offered ranged from acoustical nonsense to a few systems of good physical design, depending on the acoustical sophistication of the company involved.

Before producing speakers for the modern music market, Electro-Voice first defined the characteristics of the ideal speaker system: 1) Low distortion at high power output; 2) Durability at high power inputs; 3) Maximum conversion efficiency; 4) Wide, uniform frequency response, beyond the usual 5kHz limit of most instrument speakers; 5) Good physical durability and moderate weight for portability.

It was felt that a sophisticated front-loaded all-horn system offered the greatest potential for improvement. It should be noted that such designs are not undertaken lightly, as design demands are rigorous, requiring extensive investments in experience and equipment to be successful.

Examination of such a design indicated the following advantages over conventional direct radiator types: 1) Conversion efficiency of 25-30% compared to about 10% for direct radiator systems. With about 4 db more output for equivalent input, this more than doubles the available amplifier power; 2) Low distortion at high output levels due to small diaphragm amplitudes insured by the high conversion efficiency and effective diaphragm loading at all frequencies resulting from good horn design; 3) Durability at high output levels as horn loading provides high sound levels with moderate diaphragm excursions, even at very low frequencies. Additionally, sturdy SRO15 woofers are used in the system; 4) Extended frequency range insured by multiple horns, each designed to cover a specific range efficiently; 5) Rugged physical design at reasonable weight as a result of a design created solely for this market.

Two speaker systems evolved from this study: the Eliminator 1 and Eliminator 2. Both are sophisticated multi-horn units that take full advantage of horn loading. The Eliminator 1 is a three-way system with response extending beyond audibility. The Eliminator 2 is a two-way system with useful response to 10kHz and unusually high power handling capability.

For reprints of other discussions in this series, or technical data on any E-V product, write: ELECTRO-VOICE, INC., Dept. 393P, 630 Cecil St., Buchanan, Michigan 49107

Electro-Voice

A SUBSIDIARY OF GULTON INDUSTRIES, INC.

CIRCLE NO. 37 ON READER SERVICE PAGE

POPULAR ELECTRONICS

PHILLIP T. HEFFERNAN
Publisher

OLIVER P. FERRELL
Editor

LESLIE SOLOMON
Technical Editor

JOHN R. RIGGS
Managing Editor

EDWARD I. BUXBAUM
Art Director

ALEXANDER W. BURAWA
Associate Editor

ANDRE DUZANT
Technical Illustrator

PATTI MORGAN
Assistant Editor

AURORA NARDOZZI
Editorial Assistant

H. BENNETT, W2PNA
H. S. BRIER W9EQG

L. E. GARNER, JR.

CHARLES J. SCHAUERS, W6QLV

M. P. SPINELLO, KHC2060
Contributing Editors

RICHARD J. HALPERN
Advertising Manager

ARDYS C. MORAN
Advertising Service Manager

LAWRENCE SPORN
Associate Publisher

ZIFF-DAVIS PUBLISHING COMPANY

Editorial and Executive Offices

One Park Avenue, New York, New York 10016
212 679-7200

Midwestern Office

307 North Michigan Avenue, Chicago, Illinois 60601

312 726-0892

Midwestern Advertising Manager, JAMES WEAKLEY

GERALD L. TAYLOR

Western Office

9025 Wilshire Boulevard, Beverly Hills, California 90211

213 CResview 4-0265; BRADshaw 2-1161

Western Advertising Manager, BUD DEAN

Japan: James Yagi

Ishikawa Mansion, #4, Sakuragaoka

Shibuya-ku, Tokyo. 462-2911-3

Circulation Office

Portland Place, Boulder, Colorado 80302

William Ziff, President

W. Bradford Briggs, Executive Vice President

Hershel B. Sarbin, Senior Vice President

Philip Sine, Financial Vice President

Walter S. Mills, Jr., Vice President, Circulation

Stanley R. Greenfield, Vice President, Marketing

Phillip T. Heffernan, Vice President, Electronics Division

Frank Pomerantz, Vice President, Creative Services

Arthur W. Butzow, Vice President, Production

Edward D. Muhlfield, Vice President, Aviation Division

Irwin Robinson, Vice President, Travel Division

Furman Hebb, Administrative Vice President

George Morrissey, Vice President

Sydney H. Rogers, Vice President

Ziff-Davis also publishes Airline Management and Marketing, Boating, Business & Commercial Aviation, Car and Driver, Cycle, Electronics World, Flying, Stereo Review, Modern Bride, Popular Photography, Skiing, Skiing Area News, and Skiing Trade News. (Travel Weekly is published by Robinson Publications, Inc. a subsidiary of Ziff-Davis Publishing Company.)

Forms 3579 and all subscription correspondence should be addressed to POPULAR ELECTRONICS, Circulation Department, Portland Place, Boulder, Colorado 80302. Please allow at least six weeks for change of address. Include your old address, as well as new-enclosing if possible an address label from a recent issue.

EDITORIAL CONTRIBUTIONS must be accompanied by return postage and will be handled with reasonable care; however, publisher assumes no responsibility for return or safety of art work, photographs or manuscripts.



Member Audit Bureau
of Circulations

Grantham School of Engineering PE-3-69
1505 N. Western Ave., Hollywood, Calif. 90027

Please mail me your free Bulletin, which explains how the Grantham educational program can prepare me for my Associate in Science Degree, and my Bachelor of Science Degree in Electronics Engineering.

Name _____ Age _____

Address _____

City _____ State _____ Zip _____

2

Grantham School of Engineering

has conferred on

John Doe

the degree of

Associate in Science in Electronics Engineering

With all the rights and privileges thereunto appertaining. In witness thereof this diploma duly signed has been issued by the School Administration upon recommendation of the faculty at the School on this



First day of October, 1968
D.J. Grantham
President
E. J. Mathis
Acting Dean

3

Grantham School of Engineering

has conferred on

John Doe

the degree of

Bachelor of Science in Electronics Engineering



With all the rights and privileges thereunto appertaining. In witness thereof this diploma duly signed has been issued by the School Administration upon recommendation of the faculty at the school on this

sixth day of December, 1968
D.J. Grantham
President
H. J. Lounsbury
Dean

Grantham School of Engineering

Specializing in Electronics since 1951

1505 N. Western Ave.
Hollywood, Calif. 90027

Telephone:
(213) 469-7878



March, 1969

Three Big Steps to Success...

in

ELECTRONICS ENGINEERING

There they are — three big steps that lead electronics technicians to *greater success* — three deliberate steps to *greater recognition* and *more income*. Your future is shaped by the moves you make — by the steps you take. Begin now with Step #1.

STEP #1 is a simple request for full information on the Grantham Electronics Degree Program. You take this first step by filling out and mailing the coupon. Then, we *mail* our catalog to you; we do not send a salesman.

STEP #2 is earning your Associate in Science Degree in Electronics Engineering (the ASEE). If you have completed at least one year of fulltime experience as a bona fide electronics technician, you may earn your ASEE Degree almost entirely by correspondence — including a minimum resident attendance of only two weeks.

STEP #3 is earning your Bachelor's Degree in Electronics Engineering. Success in engineering requires heavy emphasis on fundamental concepts of logic and mathematics, rather than on superficial manipulative skills. Since these fundamental ideas are relatively unfamiliar to electronics technicians, they are developed in a systematic manner in the Grantham Electronics Degree Program.

Accreditation and G.I. Bill Approved

Grantham School of Engineering is *accredited* by the Accrediting Commission of the National Home Study Council, is *approved* under the G.I. Bill, and is *authorized* under the laws of the State of California to grant academic degrees.

Grantham School of Engineering is a *specialized*, college-level, educational institution — established in 1951. Grantham specializes in teaching engineering by the so-called "new approach" — the method (often referred to by names such as "independent study") that has recently created great interest among college educators. Actually, this "new approach" is not new at all. Grantham and many other good schools have been using it for years, under such names as "home study" and "correspondence instruction".

Now that the method has become "respectable" and is being used by reputable colleges to lead to bachelor's degrees, Grantham can offer you the opportunity to study for your ASEE and BSEE mostly by correspondence. Since you are already a technician and know the "hardware" side of electronics, you can upgrade from technician to engineer while you continue your present employment in electronics. Get complete details. Mail the coupon for our free Bulletin.

**\$99.90
buys you
Panther.
3 lbs. of
great
radio.**



Panther, new from Pearce-Simpson.

Small pricetag: \$99.90.

Small radio: just 3 compact lbs., in a high-impact Cyclac® cabinet.

But big value: 5-channel solid state CB radio with a Class B push-pull audio amplifier, super-sensitive receiver, full powered transmitter (4 watts output), a noise limiting circuit that virtually eliminates ignition and alternator noise, very low current drain (0.3 amps received).

All backed up by Pearce-Simpson.

You can get Panther with a palm microphone at no extra cost; with a telephone handset its a little more.

Panther. From Pearce-Simpson.

Sleek.

FCC type accepted.

Pearce-Simpson, Inc./ P.O. Box 800
Biscayne Annex, Miami, Fla. 33152 PE-369

Gentlemen: Please send me complete information about Panther and your other new CB radios, plus a list of dealers nearest me.

Name

Address

City

State

Zip

Pearce-Simpson

Div. of the GLADING Corp.

CIRCLE NO. 25 ON READER SERVICE PAGE

letters

FROM OUR READERS

SOLDERING TOOL PROBLEMS

I have assembled the soldering equipment as per the instructions provided in the "Resistance Soldering" article (September, 1968). When making the electrode assembly, I took particular care to follow the text of the article and Fig. 3. Then, when the system was completely assembled, I performed the outlined meter check. Since both the primary and secondary circuits checked out good in all three positions of the power range switch, I decided to tackle my first soldering job.

Immediately, I noticed a problem. A few seconds after applying power to the soldering tool, the fuse blew and the solder barely became hot enough to flow. What is my problem?

H. H. LAWLEY, JR.
Box 745
Elizabethton, Tenn.

Several readers have advised us that their Resistance Soldering tools either failed to operate or operated improperly. In most cases, the difficulties outlined were blown fuses and/or test leads that heated up while the electrodes remained cold.

After carefully checking into the problem and rebuilding the prototype exactly according to the instructions provided in the article, your editor finds that the tool should operate as described. However, to clear up the problems, the following advice is given: First, use only extra-heavy-duty test lead cable between the power supply and electrode assembly. Next, make sure your soldering electrodes are sharpened to fine points and that only the points touch the terminal to be soldered. This will assure that the high resistance to the flow of current is at the electrode tips and not inside the power supply or test leads.

MANNERLY TABLE LAMP IMPROVEMENT

The "Mannerly Table Lamp" article that appeared in the November, 1968, issue of POPULAR ELECTRONICS intrigued me. However, I do not particularly care to have the thermal relay drawing power while the lamp is off—even if it is only three watts. By adding a second relay to the basic circuit (K2 in the schematic diagram), power can be disconnected from the circuit automatically following a short delay of 15 seconds after the lamp is turned off.

Although two relays take up more space than one, if you stick to the Amperite miniature thermal relays, there should be suf-

POPULAR ELECTRONICS

Dominate the Airwaves with Antenna Specialists' new "SQUARE RIGGER"

27 MHz Basic Quad Antenna Model M-195

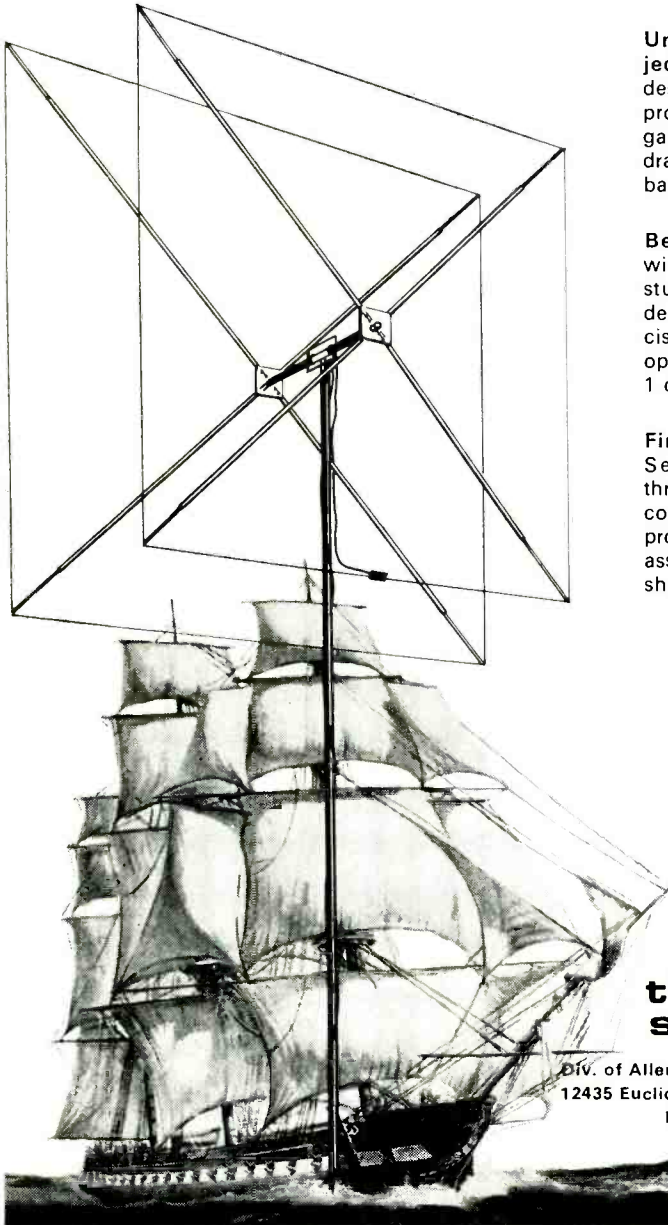

Unsurpassed Gain and Rejection! New "maximum focus" design (larger reflector element) produces 7.5 dB true forward gain . . . reduces interference drastically with 30 dB front-to-back ratio!

Best Basic Reliability! Split wire matching eliminates loading stubs—rain, snow, ice cannot de-tune the Square Rigger! Precision matching also provides optimum VSWR at center, 1.3 to 1 or better at band edges!

Finest Basic Construction! Seamless aluminum tubing throughout . . . dipoles are steel-core, copper-clad cable. Fool-proof assembly—pre-aligned to assure positive element relationship.

***Lifesaver
of a basic price!***

only
\$49⁹⁵
suggested
resale

"Stripes of Quality"®



**the antenna
specialists co.**

Div. of Allen Electric & Equipment Company
12435 Euclid Avenue, Cleveland, Ohio 44106
Export Offices: 2200 Shames Dr.,
Westbury, N.Y. 11690

CIRCLE NO. 4 ON READER SERVICE PAGE

Talk about electro

CAPACITORS ■ RESISTORS & CONTROLS ■ METERS — COILS — RELAYS — TRANSFORMERS ■ WIRE

OVER 800 POPULAR, NEW

Now at each location, hundreds and hundreds of items for everyone . . .
 hobbyist, enthusiast, amateur, executive, home-owner,
 do-it-yourselfer. See the SELF-SERVICE G-C CALECTRO display at your
 CALECTRO ELECTRONIC SUPERMARKET TODAY!



700 Locations

all over the country
and Canada

See your electronic parts distributor
and SAVE!

LOOK

In the Yellow Pages under "Electronics"
and call your Calectro source.

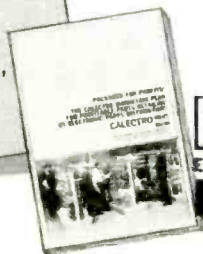

This "G-C CALECTRO HOBBYIST
HANDBOOK" is available at G-C
CALECTRO ELECTRONIC SUPER-
MARKETS. WRITE TODAY and we'll
give you the name of your nearest.



CALECTRO

GC ELECTRONICS
Division of Hydrometals, Inc.
400 SO. WYMAN ST.
ROCKFORD, ILLINOIS 61101

nic supermarkets

— CABLES ■ SWITCHES — LAMPS ■ ANTENNA HARDWARE ■ PLUGS — JACKS — BATTERY HOLDERS

CALECTRO PRODUCTS *for every household use!*



Telephone Amplifier for Group Listing

Perfect for family calls at home, conference calls at the office, or "hands-free" operation when taking orders or instructions by phone.

Suction cup pickup attaches to outside of phone, brings in conversations loud and clear. Built-in volume control governs loudness. Battery in kit.

Ask for Catalog No. N4-103

\$995



Automatic Timer On-Off Switch

Convenient remote control unit for any appliance, timer control sets for any interval up to 60 minutes.

Beautiful green and white case, extra-long 12 foot cord.

Installed in seconds, plugs into any wall outlet.

Ask for Catalog No. N4-005

\$695

Remote Control Extension Speaker for TV or Radio

Listen to radio or TV in bed without disturbing others. Remotely switch main speaker on or off, has a built-in volume control, separate earphone jack for privacy. Install in minutes.

Ask for Catalog No. N4-009

\$650



Dynamic Microphone with switch

For high fidelity recording of words and music. Built-in on-off switch. Folding desk top stand. Dual plug for most tape recorder inputs.

Ask for Catalog No. Q4-186

\$395



CIRCLE NO. 38 ON READER SERVICE PAGE

If you plan to spend less than \$79.50 for a record changer, you're reading the wrong magazine.



Most of the people who read this magazine know that you can't get high fidelity sound from a cheap record changer. Or the peace of mind that comes with knowing that your records are being handled with precision and care.

If you spend less than \$79.50 (the price of the Dual 1212) you won't get a changer that will track a high-compliance cartridge at one gram, flawlessly. Or compensate precisely for skating.

Cheaply made record changers tend to be plagued by audible rumble, wow and flutter. (Rumble, wow and flutter of the Dual 1212 easily surpass NAB standards for broadcast turntables.)

And no cheap changer includes a feathertouch cueing system. Or a variable-speed pitch control that lets you "tune" any record over a half-tone range.

So if you want a high fidelity record changer, and you're willing to spend a few extra dollars to get one, you've just read the right ad.

United Audio Products, Inc.
535 Madison Ave.,
New York, N.Y. 10022.



LETTERS

(Continued from page 8)

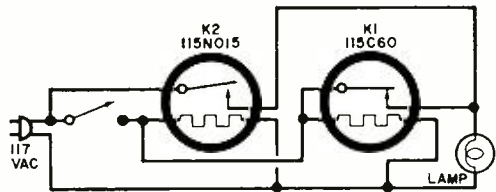

efficient room for mounting both in the bases of most lamps. Amperite type numbers are given in the schematic.

ALAN R. MOYER
Country Club Hills, Ill.

Your slight change should certainly eliminate current drain from the line and shut the entire circuit down as described.

CHANGES IN DVM AND FLUORESCENT LAMP

Since the appearance of the DVM ("Build the POPULAR ELECTRONICS Digital Volt-Ohmmeter," December, 1968), I have decided to improve the performance of the Gate module by increasing the value of C_4 from 0.001 to 0.005 μ F. Also, R8 in Fig. 1 should be 33 k— not 3.3 k.

I would also like to bring to light the fact that D1 in Fig. 3 of the "Battery-Powered Fluorescent Lamp" article (December, 1968) is shown incorrectly connected. To rectify the problem, the arrow should point in the opposite direction to that shown.

DON LANCASTER
Goodyear, Ariz.

LET PAPA PAY

Being only 16 years of age and an audio enthusiast, I was very pleased when I saw the "Build The Sonolite" article in the May, 1968, issue of POPULAR ELECTRONICS. Before the article appeared, I had three #49 lamps connected in series with the speakers in my audio system; it was quite a display. Then, when I received my May issue, I began to collect the components needed for my own Sonolite. For a chassis, I used a piece of wood, a piece of aluminum for the heat sink, and old TV potentiometers for the controls. The whole project cost me a grand total of \$4.50.

While my finished project works just fine, I don't see much of it since it is connected to my parents' stereo system. So here I am again, stuck with my #49 lamp display. Thanks anyway for a great article.

MILTON G. PULIS
San Diego, Calif.

If your parents like the Sonolite so much, why not try convincing them that you can build a more professional one if they buy new parts? Then, you can keep the old one and get rid of the #49 lamps.

Our Research People



Golf clubs . . . fishing rods . . . antennas . . . bows and arrows . . . vaulting poles . . . pool cues and hot sticks have all evolved from Shakespeare's genius with fiberglass. Expert research reliability and people proven dependability let Shakespeare put a world-wide reputation for quality on the line with each product.

Want the best? . . . get a dependable Shakespeare fiberglass WonderShaft antenna. There's one for your requirement.



The Citizen Band 345 "Perfect 36" is only one of our complete line of people proven fiberglass antennas.



C/P CORPORATION

a subsidiary of

Shakespeare

R.F.D. 3, Columbia, South Carolina 29205

Telephone (803) 787-8710



CIRCLE NO. 13 ON READER SERVICE PAGE

ELECTRONICS library

QUIET

OUTLINE OF DC CIRCUIT ANALYSIS

by Phillip Cutler

One of a projected series of outline-type textbooks, this book should satisfy the needs of technical institutes, junior colleges, and "go-it-alone" students for a practical text/workbook. As the title suggests, this book is devoted to the essentials of d.c. circuit theory. The format used is as practical as it is logical. Each chapter in the book is devoted to a specific topic, which is first introduced and discussed. Then step-by-step problem solving techniques are presented. This is followed by a battery of questions written to hammer home the essentials of the topic just discussed. In addition to its functions of text and workbook, this book can as well serve as a reference for d.c. formulas.

Published by McGraw-Hill Book Co., 330 West 42 St., New York, N.Y. 10036. Soft cover. 200 pages. \$3.95.

THE INTEGRATED CIRCUITS DATA BOOK

This book contains complete data for all standard digital and linear IC's manufactured by Motorola Semiconductor Products, Inc., at the time of publication. In addition to listing complete data sheets and other applications and test data for these IC's, the book also contains a valuable interchangeability guide to IC types of all major manufacturers. The guide lists manufacturer type numbers in alphanumerical order by product family and cross references each to the Motorola direct replacement. Other extras in this book include a digital applications selection guide, arranged by function for Motorola's eleven logic families. Separate sections are devoted to MECL, MHTL, MTTL, MDTL, MRTL, MOS, and linear IC data sheets, plus a 12-gate complex array. Supplements to the data book will be periodically released to keep the information up to date.

Published by Motorola Semiconductor Products, Inc., Dept. TIC, Box 20924, Phoenix, Ariz. 85036. Hard cover. 960 pages. \$3.95.

99 WAYS TO USE YOUR OSCILLOSCOPE

by A. C. W. Saunders

The picture-text guide, accompanied by step-by-step instructions, employed in this book encompasses just about every service application of the oscilloscope. The book shows how to determine waveform frequency and amplitude, measure inductance and inductive (Continued on page 116)

NOW YOU CAN
UNSOLDER...



NEW LOW PRICE *

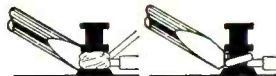

FOR SOLDERING AND DESOLDERING

uniline mark VII

SOLDER AND DESOLDER WITH ONE TOOL!

The Uniline Mark VII is a dual purpose pencil soldering-desoldering tool. This truly revolutionary system allows you to solder and desolder any joint with finger tip ease and control. Simply press the button to desolder. How about that!

The tool is composed of three basic components that give it unprecedented versatility. You can select what you need from: **FOUR DIFFERENT COLORS OF HANDLES, FOUR INTERCHANGEABLE HEAT CARTRIDGES (20-30-40 & 50 WATTS), DOZENS OF DIFFERENT TIPS IN MANY DIFFERENT STYLES AND SHAPES.**

How's that for a combination tool? Exciting, isn't it! If you are interested in saving time and money you need one right now. See your local distributor today, and tomorrow start enjoying cost reduction you never thought possible.

AS LOW AS *
\$9.95

SEE YOUR LOCAL DISTRIBUTOR TODAY!

Vanguard ELECTRONIC TOOLS INC. UNILINE DIVISION
NEWTON, KANSAS

CIRCLE NO. 33 ON READER SERVICE PAGE

READER SERVICE PAGE

free information service:

Here's an easy and convenient way for you to get additional information about products advertised or mentioned editorially (if it has a "Reader Service Number") in this issue. Just follow the directions below... and the material will be sent to you promptly and free of charge.

1. Print or type your name and address on the lines indicated. Circle the number(s) on the coupon below that corresponds to the key number(s) at the bottom of the advertisement or editorial mention(s) that interest you. (Key numbers for advertised products also appear in the Advertisers' Index.)

2. Cut out the coupon and mail it to the address indicated below.

3. This address is for our product "Free Information Service" only. Editorial inquiries should be directed to POPULAR ELECTRONICS, One Park Avenue, New York 10016; circulation inquiries to Portland Place, Boulder, Colorado 80302.

**POPULAR
ELECTRONICS**

P.O. BOX 8391
PHILADELPHIA, PA. 19101

VOID AFTER APRIL 30, 1969

1 2 3 4 5 6 7 8 9 10 11 12 13 14 15 16 17 18 19 20
21 22 23 24 25 26 27 28 29 30 31 32 33 34 35 36 37 38 39 40
41 42 43 44 45 46 47 48 49 50 51 52 53 54 55 56 57 58 59 60
61 62 63 64 65 66 67 68 69 70 71 72 73 74 75 76 77 78 79 80
81 82 83 84 85 86 87 88 89 90 91 92 93 94 95 96 97 98 99 100

NAME (Print clearly) _____

ADDRESS _____

CITY _____ STATE _____ ZIP CODE _____

3 a

UNUSUAL BARGAINS

FREE!
GIANT
CATALOG

MANY U.S. GOV'T SURPLUS



"See" Your Music in Dazzling Action with

Dramatic Audio-
Visual Breakthrough



Adds a spectacular new dimension to world of music, display, entertainment. Actually see music translated into fantastic patterns of beautiful color on each individual note creating its own unique, twisting, radiating shape. . . each shape dancing in perfect line with the music. Combines science, art and electronics with amazing results. First new development in converting music to a visible image since color organ was invented in 1902. For on small screens, large walls, stages, whole auditoriums. Attaches in seconds to radio, tape recorder, hi-fi or stereo with 15-watt amplifier clips. Loads of fun! Practical for Great for parties, "see-us" special effects for bands, dances, exhibits, sales meetings, classroom. Complete line available from 10-15-100 WATT KITS to 12" SETS and self-contained, portable MINI-MODELS to CON-SOLETS. Order by Stock No. listed below. Money-back guarantee if not 100% satisfied. Full details in FREE CATALOG or send 25¢ in coin for new, fully illustrated 16-page booklet No. 9063AV "Introduction to Music Vision."

- No. 71.009AV 8" DO-IT-YOURSELF KIT \$22.50 Ppd.
- No. 71.030AV 8" SET 45.00 Ppd.
- No. 71.032AV 12" SET 46.50 Ppd.
- No. 71.124AV COMPACT MINI-MODEL 57.50 Ppd.
- No. 85.181AV WALNUT CABINET MODEL 99.50 F.O.B.
- No. 71.057AV 500 WATT SPECIAL EFFECTS PROJECTOR 24.50 Ppd.
- No. 71.002AV REMOTE CONTROL PROJECTOR 39.50 Ppd.



NEW! PROJECTION KALEIDOSCOPE

Infinite variety of brilliant color patterns which do not repeat. Specially designed interchangeable disc, liquid wheel, 3" projection lens and Edmund Projector make it all possible. Easily operated. Large screen image at short projection distance perfect for backgrounds, light shows, parties, dances, etc. Front or rear port.

- Stock No. 71.121AV \$24.50 Postpaid
- SOLID MULTI-COLORED GLASS ACCESSORY WHEEL
- Stock No. 71.122AV—(9" Diam.) \$15.00 Ppd.

LONG-WAVE BLACK LIGHT FIXTURE



Extremely versatile, compactly designed, long wave (3200-4000 angstroms) black light (ultraviolet) fixture. Has 6-watt, 110-V lamp with built-in filter—eliminates harmful shorter wave ultraviolet rays. Use to identify minerals, fungi, bacteria—check for surface flaws, oil and gas leakage—perfect for displays with fluorescent paper, paints, chalk, crayons, trace powder. In adjustable aluminum reflector, push-pull switch, connecting plug. Mount vert., horz., or on corner. 10" x 12" x 4" \$9.85 Ppd.

- Stock No. 70.364AV \$9.85 Ppd.
- No. 60.124AV (Replacement Bulb) \$3.25 Ppd.

NEW LOW-COST ULTRASONIC CLEANER



Top-quality 1/2rd pint unit for only \$39.95! Cleans dirt, grime, completely, quickly, safely. Small delicate parts, precision electronic items, lab instruments, jewelry, coins, even dentures sparkle like new. American-made—operates on regular house current. Solid state generator w/automatic turn-off. Power regulating knob. No radio interference. 6" x 4" x 4" stainless. \$39.95 Ppd.

- Stock No. 71.003AV \$39.95 Ppd.
- LARGE INDUSTRIAL 1 1/2 GAL. SIZE
- No. 85.128AV (Wt. 37 lbs.) \$249.95 FOB

3" Astronomical Telescope



See the stars, moon, phases of Venus, planets close up. 60 to 180 power. Aluminized and over-coated 3" diameter f/10 primary mirror, ventilated cell. Equatorial mount with locks on both axes. Equipped with 40x eyepiece and mounted Barlow lens. 3X finder telescope, hardwood tripod. Included: "STAR CHART", 272-page "HANDBOOK OF HEAVENS". \$29.95 Ppd.

- Stock No. 85.050AV \$29.95 Ppd.
- Stock No. 85.105AV 4 1/2" REFLECTOR \$84.50 FOB
- Stock No. 85.086AV 6" REFLECTOR \$199.50 FOB

Order by Stock No.—Check or M.O.—Money-Back Guarantee
EDMUND SCIENTIFIC CO., 300 EDSORP BUILDING
BARRINGTON, NEW JERSEY 08007

GIANT FREE CATALOG "AV"



Completely new 1969 edition. New items, categories. Illustrations, 148 easy-to-read pages packed with 4000 unusual items. Dozens of electrical and electromagnetic parts, accessories. Extensive selection of Astronomical Telescopes, Microscopes, Binoculars, Magnifiers, Magnets, Lenses, Prisms. Many war surplus items; for hobbyists, experimenters, workshops, factory. Write for catalog "AV", include Zip.

ORDER BY STOCK NUMBER - SEND CHECK OR MONEY ORDER - MONEY-BACK GUARANTEE
EDMUND SCIENTIFIC CO. 300 EDSORP BUILDING
BARRINGTON, NEW JERSEY 08007
CIRCLE NO. 15 ON READER SERVICE PAGE

TAKE ONE

new literature

To obtain a copy of any of the catalogs or leaflets described below, simply fill in and mail the coupon on page 15 or 115.

Jensen Manufacturing Division has just published Concert and Viking series loudspeaker Catalog No. 1090-C listing a wide variety of available speakers. Among those listed are: the "Concert-Vibranto" line for electronic musical instruments; a special automotive speaker designed for in-a-door mounting with waterproofing of the diaphragm and coil-form assembly; and a flame-retardant aircraft speaker.

Circle No. 75 on Reader Service Page 15 or 115

The 1969 Team Electronics 132-page catalog is a colorful listing of thousands of electronic items for the home, car, and business. Included are brand-name hi-fi and stereo components, two-way communications equipment, TV receivers, auto tape cartridge players, closed-circuit TV systems, intercom systems, etc. In fact, nearly everything in consumer and industrial electronics, including hundreds of component items, are listed.

Circle No. 76 on Reader Service Page 15 or 115

Miniature strip chart recorders, Series 200, are described in a new catalog from Rustrak Instrument Division. The line of more than 30 models are for recording current, voltage, power, events, pressure, temperature, or almost any parameter which can be converted to voltage or current. All are housed in rugged die-cast aluminum cases and feature the unique Rustrak dry writing process. The catalog also includes detailed information on chart paper, drive motor specifications, accessories, optional features, dimensions, weights, and ordering instructions.

Circle No. 77 on Reader Service Page 15 or 115

Handy workbench reference booklet published by Amphenol for hobbyists gives complete information on how to solder, how to interpret schematic symbols, how to read resistor color codes, etc. The new four-color "How-To Handbook" has been written specifically to serve as a handy workbench reference guide for the young hobbyist and experimenter. It is available free on request from the Amphenol Distributor Division.

Circle No. 78 on Reader Service Page 15 or 115

The New 1969 Improved Model 257 **A REVOLUTIONARY NEW TUBE TESTING OUTFIT**

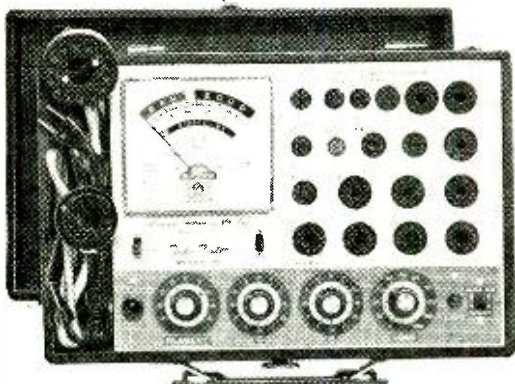

COMPLETE WITH ALL ADAPTERS AND ACCESSORIES, NO "EXTRAS"

STANDARD TUBES:

- ✓ Tests the new Novars, Nuvistors, 10 Pins, Magnovals, Compactrons and Decals.
- ✓ More than 2,500 tube listings.
- ✓ Tests each section of multi-section tubes individually for shorts, leakage and Cathode emission.
- ✓ Ultra sensitive circuit will indicate leakage up to 5 Megohms.
- ✓ Employs new improved 4½" dual scale meter with a unique sealed damping chamber to assure accurate, vibration-less readings.
- ✓ Complete set of tube straighteners mounted on front panel.

The Model 257 is housed in a handsome, sturdy, portable case. Comes complete with all adapters and accessories, ready to plug in and use. No "extras" to buy. Only

• Tests all modern tubes including Novars, Nuvistors, Compactrons and Decals.

• All Picture Tubes, Black and White and Color

ANNOUNCING...for the first time

A complete TV Tube Testing Outfit designed specifically to test all TV tubes, color as well as standard. Don't confuse the Model 257 picture tube accessory components with mass produced "picture tube adapters" designed to work in conjunction with all competitive tube testers. The basic Model 257 circuit was modified to work compatibly with our picture tube accessories and those components are not sold by us to be used with other competitive tube testers or even tube testers previously produced by us. They were custom designed and produced to work specifically in conjunction with the Model 257.

BLACK AND WHITE PICTURE TUBES:

- ✓ Single cable used for testing all Black and White Picture Tubes with deflection angles 50 to 114 degrees.
- ✓ The Model 257 tests all Black and White Picture Tubes for emission, inter-element shorts and leakage.

COLOR PICTURE TUBES:

- ✓ The Red, Green and Blue Color guns are tested individually for cathode emission quality, and each gun is tested separately for shorts or leakage between control grid, cathode and heater. Employment of a newly perfected dual socket cable enables accomplishments of all tests in the shortest possible time.

\$47⁵⁰

NOTICE

We have been producing radio, TV and electronic test equipment since 1935, which means we were making Tube Testers at a time when there were relatively few tubes on the market, way before the advent of TV. The model 257 employs every design improvement and every technique we have learned over an uninterrupted production period of 32 years.

Accurate Instrument Co., Inc.

SEND NO MONEY WITH ORDER PAY POSTMAN NOTHING ON DELIVERY

Try it for 10 days before you buy. If completely satisfied then send \$10.00 and pay the balance at the rate of \$10.00 per month until the total price of \$47.50 (plus P.P., handling and budget charge) is paid. If not completely satisfied, return to us, no explanation necessary.

ACCURATE INSTRUMENT CO., INC.

Dept. 629 2435 White Plains Road, Bronx, N. Y. 10467

Please rush me one Model 257. If satisfactory I agree to pay \$10.00 within 10 days and balance at rate of \$10.00 per month until total price of \$47.50 (plus P.P., handling and budget charge) is paid. If not satisfactory, I may return for cancellation of account.

Name _____

Address _____

City _____ Zone _____ State _____

Save Money! Check here and enclose \$47.50 with this coupon and we will pay all shipping charges. You still retain the privilege of returning after 10 day trial for full refund.

CIRCLE NO. 1 ON READER SERVICE PAGE

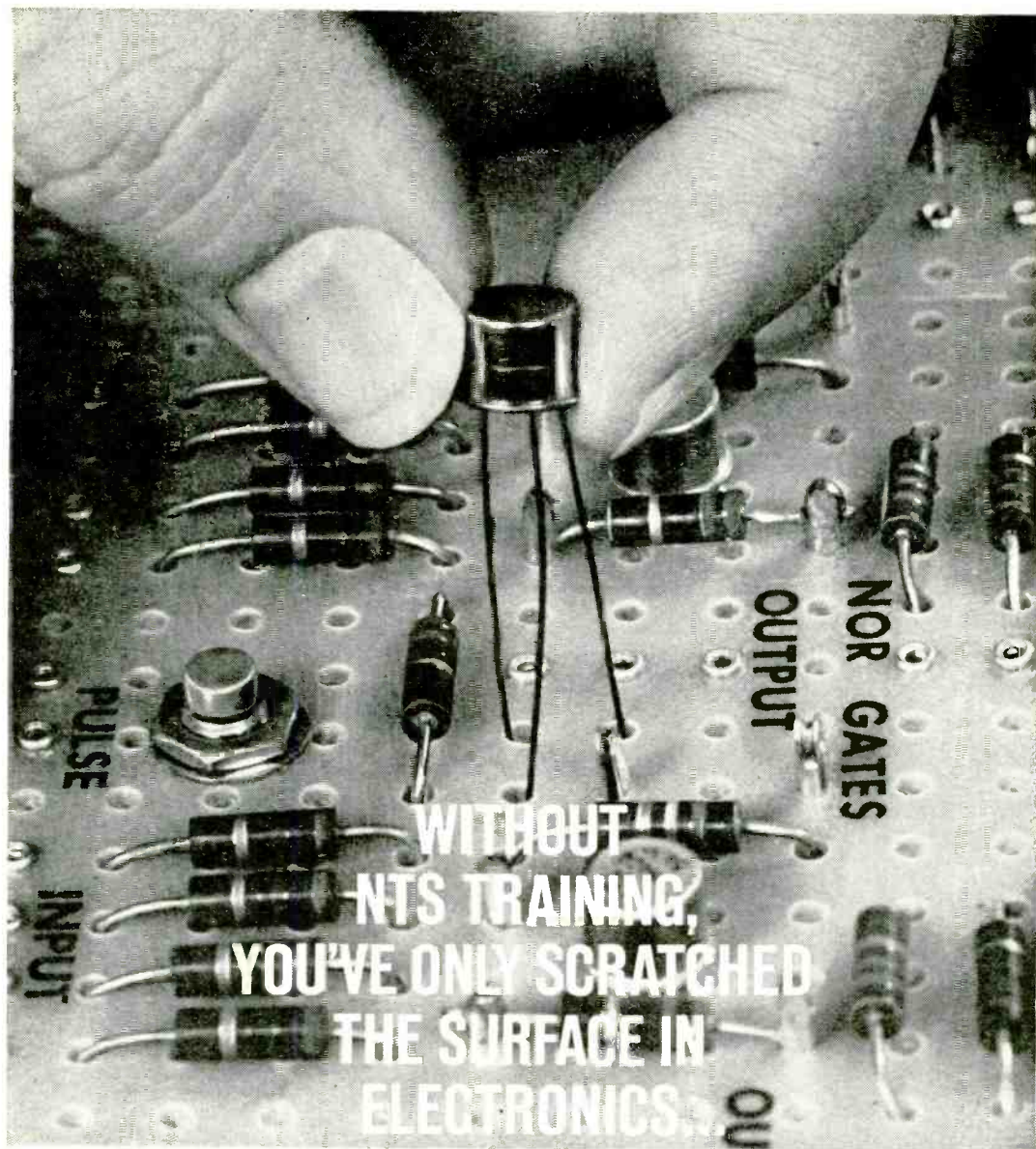

Only NTS penetrates below the surface. Digs deeper. Example? Take the above close-up of the first transistorized digital computer trainer ever offered by a home study school.

It's called The Compu-Trainer®—an NTS exclusive. Fascinating to assemble, it introduces you to the exciting world of computer electronics. Its design includes advanced solid-state NOR circuitry,

flip-flops, astable multivibrators and reset circuits. Plus two zener and transistorized voltage-regulated power supplies. The NTS Compu-Trainer® is capable of performing 50,000 operations per second.

Sound fantastic? *It is!* And at that, it's only one of many *ultra-advanced* kits that National Technical Schools offers to give you incomparable, in-depth career training.

PROVE IT YOURSELF. SEND FOR OUR NEW CATALOG. SEE THE LATEST, MOST ADVANCED KITS AND COURSES EVER OFFERED BY A HOME STUDY SCHOOL.

NTS...THE FIRST HOME STUDY SCHOOL TO OFFER LIVE EXPERIMENTS WITH INTEGRATED CIRCUIT KITS

You build a computer sub-system using the new, revolutionary integrated circuits. Each one, smaller than a dime, contains the equivalent of 15 resistors and 27 transistors.

And your kits come to you at no extra cost. These kits are the foundation of the exclusive *Project-Method* home study system...developed in our giant resident school and proven effective for thousands of men like yourself.

With Project-Method, all your kits are carefully integrated with lesson material. Our servicing and communication kits are *real* equipment—not school-designed versions for training only. As you work on each of the projects, you soon realize that even the most complicated circuits and components are easy to understand. You learn *how* they work. You learn *why* they work.

NTS Project-Method is a practical-experience approach to learning. The approach that works *best!* An all-theory training program can be hard to understand—difficult to remember. More than ever before you need the practical experience that comes from working with real circuits and components to make your training stick.

NTS SENDS YOU KITS TO BUILD THESE IMPORTANT ELECTRONICS UNITS!

- ◆ 25" COLOR TV
- ◆ 21" BLACK & WHITE TV
- ◆ SOLID-STATE RADIO
- ◆ AM-SW TWIN-SPEAKER RADIO
- ◆ TUBE-TESTER
- ◆ TRANSCEIVER
- ◆ COMPU-TRAINER®
- ◆ VTVM
- ◆ SIGNAL GENERATOR
- ◆ 5" OSCILLOSCOPE

See them all illustrated in
the new NTS Color Catalog.

CLASSROOM TRAINING AT LOS ANGELES: You can take classroom training at Los Angeles in sunny California. NTS occupies a city block with over a million dollars in facilities devoted exclusively to technical training. Check box in coupon.

NATIONAL TECHNICAL SCHOOLS

WORLD-WIDE TRAINING SINCE 1905
4000 So. Figueroa Street, Los Angeles, Calif. 90037

APPROVED FOR VETERANS

Accredited Member: National Home Study Council
Accredited Member: National Association of
Trade and Technical Schools



COMMUNICATIONS

This transceiver is included in Communications courses. You build it. With it, you easily prepare for the F.C.C. license exam. You become a fully-trained man in communications, where career opportunities are unlimited.

25" COLOR TV ▼

Included in Color TV Servicing Courses. With it you advance yourself into this profitable field of servicing work. Color is the future of television, you can be in on it with NTS training.



YOUR OPPORTUNITY IS NOW

New ideas, new inventions, are opening whole new fields of opportunity. The electronic industry is still the fastest growing field in the U.S. There's a bigger, better place in it for the man who trains today. So, whatever your goals are—advanced color TV servicing, broadcasting, F.C.C. license, computers, or industrial controls, NTS has a highly professional course to meet your needs.

GET THE FACTS! SEE ALL NEW COURSES AND KITS OFFERED IN THE NEW NTS COLOR CATALOG. SEND THE CARD OR COUPON TODAY!

There's no obligation. You enroll by mail only. No salesman will call.



DEPT. 205-39

NATIONAL TECHNICAL SCHOOLS

4000 S. Figueroa St., Los Angeles, Calif. 90037
Please rush Free Color Catalog and Sample Lesson, plus information on field checked below. No obligation.

- | | |
|---|--|
| <input type="checkbox"/> MASTER COURSE IN COLOR TV SERVICING | <input type="checkbox"/> FCC LICENSE COURSE |
| <input type="checkbox"/> COLOR TV SERVICING | <input type="checkbox"/> MASTER COURSE IN ELECTRONICS TECHNOLOGY |
| <input type="checkbox"/> MASTER COURSE IN TV & RADIO SERVICING | <input type="checkbox"/> INDUSTRIAL & AUTOMATION ELECTRONICS |
| <input type="checkbox"/> PRACTICAL TV & RADIO SERVICING | <input type="checkbox"/> COMPUTER ELECTRONICS |
| <input type="checkbox"/> MASTER COURSE IN ELECTRONIC COMMUNICATIONS | <input type="checkbox"/> BASIC ELECTRONICS |

NAME _____ AGE _____

ADDRESS _____

CITY _____ STATE _____ ZIP _____

Check if interested in Veteran Training under new G. I. Bill.

Check if interested ONLY in Classroom Training at Los Angeles.



NEW PRODUCTS

Additional information on products covered in this section is available from the manufacturers. Each new product is identified by a code number. To obtain further details on any of them, simply fill in and mail the coupon on page 15 or 115.

GUITAR AMPLIFIER/SPEAKER SYSTEM

An integrated solid-state guitar amplifier/speaker system capable of developing 240 watts peak power is now available from *Heath Company*. Designated the Model TA-38, the new system contains two 12" heavy-duty speakers that have 6.75 lb. of magnet weight between them. The amplifier is rated at 120 watts EIA music power, 100 watts continuous. The speakers are custom designed for Heath to reproduce the complete frequency range of bass guitars, organs, and other bass instruments at extremely high sound levels with very low distortion. The TA-38 has two bass inputs, volume control, bass and treble controls, and depth and presence switches—all conveniently mounted on the front panel, as are the power and hum-minimizing line reverse switch. The system is housed in a 3/4" thick pressed-wood cabinet that is covered with black vinyl and has removable, locking casters.



Circle No. 79 on Reader Service Page 15 or 115

BENCH-TYPE POWER SUPPLIES

RCA Electronic Components recently entered the solid-state power supply market with the introduction of their Models WP-700A and WP-702A bench-type regulated power supplies. Both supplies are identical in design, except that the latter contains two WP-700A supplies on a single chassis. The dual-supply design is equipped with separate controls, output terminals, and meter, and both supply sections are electrically isolated from each other. Output voltages of the two models are variable between 0 and 20 volts at up to 200 mA. The outputs are automatically limited to prevent overload-current damage; no damage can occur even



if the output terminals are short circuited. A special overload indicator begins to glow when the current drain approaches 200 mA, increasing in brilliance as it passes this mark. The meter function is switch-selectable to indicate either current or voltage.

Circle No. 80 on Reader Service Page 15 or 115

AUTO-REVERSE STEREO TAPE RECORDER

In addition to automatic reversing, the new *Allied Radio Corp.* Model TR-1080 stereo tape recorder features sound-on-sound and sound-with-sound for special effects. The solid-state TR-1080 can be "programmed" for one complete play only, continuous replay, or automatic stop at any predetermined point. Complete with preamplifiers for both record and play functions, power amplifiers, solenoid operation, and a full complement of input and output jacks, the recorder is supplied with two microphones, two extension speakers, audio cable, and sensing tape. Specifications: 7 1/2, 3 3/4, and 1 7/8 in./s speeds; two each microphone and auxiliary inputs; preamp, extension speakers, and headphones outputs; 40-19,000 Hz at 7 1/2 in./s frequency range; less than 0.15% at 7 1/2 in./s wow and flutter; automatic equalization on all speeds.



Circle No. 81 on Reader Service Page 15 or 115

SQUELCH FOR RF CONVERTER

The first squelch control for providing noise-free monitoring on HF and VHF "Tunaversers" has just been released by *Tompkins Radio Products*. This new solid-state squelch makes possible receiver-type squelch performance with economical converter usage. It requires only one coaxial cable connection to the AM broadcast-band radio or converter with which it is to be used. The squelch is available

in two models: Model ST fastens to the bottom of a Tunaverter, and Model SU comes with its own mounting bracket. Each has complete electronic control without relays, fully adjustable squelch settings, on/off power switch, small size, and a choice of 9- or 12-volt battery operation.

Circle No. 82 on Reader Service Page 15 or 115

METER ATTACHMENT FOR LOW RESISTANCE

A meter attachment, Model 870-3, from *Amphenol Distributor Division* converts all Amphenol "Millivolt Commander" instruments and most other 10-ohm center-of-scale meters to indicate resistances of one ohm or less. This is a particularly handy feature for checking out voltage dropping resistors in solid-state power supplies and transformer-

(Continued on page 24)

They hide under dashboards and bite way out with striking power. The CB solid-state Cobras.

Coiled up under your dash ready to strike. Mysteriously attractive, but all business. Their bite radiates a long way. Penetrates through layers of interference.

When a Cobra bites, you'll be surprised at all the people who know about it.

Because tucked away in the Cobra's throat is the exclusive Dyna-Boost circuit that fills out the sidebands to give you a lot more talking range. Full 5 watts input. 100% modulation.

Both Cobra 27 and Cobra V are all solid state. Which means all solid-state switching. Switching that can't wear out, can't corrode. Solid state also means thick-skinned reliability. Extremes in temperature and humidity have practically no effect on performance and life span.

Cobras are also very sensitive and receptive to the human voice. Very

selective, too, when it comes to rejecting adjacent channel interference. And a Cobra will give you a sharper bite, because all channels are crystal controlled.

If you go solid state, get the bite of the Cobra. For base station as well as mobile applications. (Ask your distributor for the snake or write us for detailed information.)

Cobra 27, 23-channel CB transceiver, complete with all necessary crystals ready for immediate operation on all 23 channels. **\$179.95**

Cobra V, 5-channel CB transceiver. (Channel 11 crystal supplied) **\$99.95**



A Division of DYNASCAN CORPORATION
1801 W. Belle Plaine · Chicago, Illinois 60613
Where electronic innovation is a way of life.

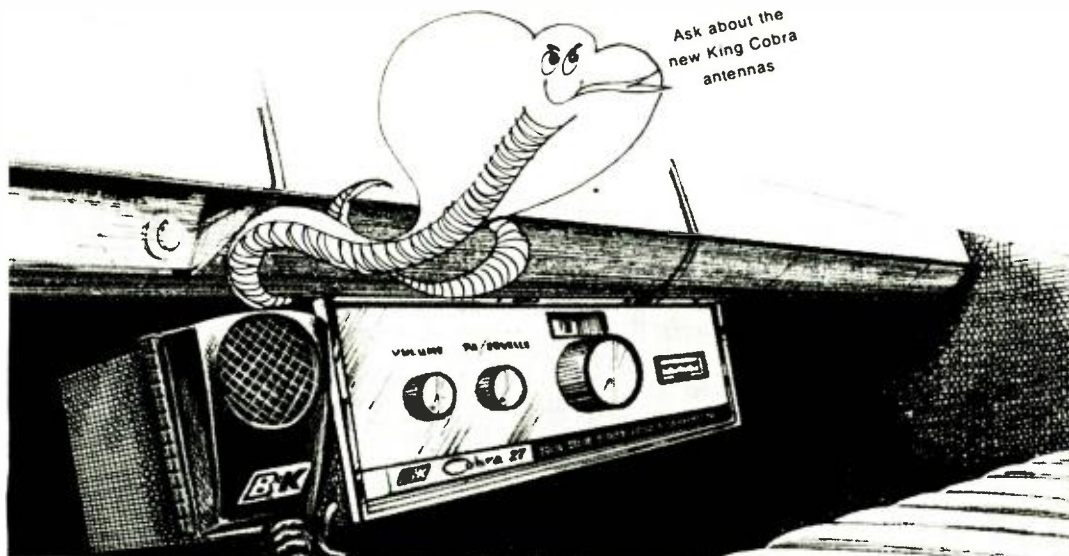

Ask about the
new King Cobra
antennas

PRODUCTS (Continued from page 22)

less power amplifiers where the output resistance is usually on the order of 0.4 to 0.6 ohms. The attachment almost completely negates the normal in-circuit lead resistance and protects the device under test—MOS-FET, IC, etc.—against accidental burnout by limiting current to 1 mA across 1 ohm.

Circle No. 83 on Reader Service Page 15 or 115

AM/FM CLOCK RADIO KIT

An all-solid-state AM/FM clock radio kit, Model GR-58, has recently been introduced by the *Heath Company*. Among its many features are a clock-controlled auxiliary a.c. socket on the rear panel for a coffee pot or bedside lamp and a "snooze" button. Ten minutes before the alarm goes on, the radio starts, allowing gradual wake-up. Then the alarm is shut off by depressing the "snooze" button, but the radio remains on. This cycle repeats itself until the FUNCTION switch is set to another position. The FM section features a.f.c., three-stage i.f. for better reception, and a built-in antenna, while the AM section has a two-stage i.f., amplified a.g.c., and built-in ferrite rod antenna. The clock dial is back lighted for easier reading at night. And both the AM and FM tuners are provided factory wired and aligned for simpler construction.

Circle No. 84 on Reader Service Page 15 or 115

LOW-COST 3" OSCILLOSCOPE

A new low-cost oscilloscope, Model 536A, with a 3" CRT has been introduced by *Data Instruments Division*. The new scope has solid-state, multistage, d.c. coupled amplifiers that are fully compensated for optimum response. Also featured are a three-step attenuator with variable trimmer and a built-in 5% calibrator to stabilize time and voltage. Specifications: vertical amplifier—2 Hz to 1.5 MHz on a.c. (d.c. to 1.5 MHz on d.c.) bandwidth; sensitivity, better than 20 mV/cm; ± 0.5 dB accuracy; input impedance, 1 megohm/22 pF. Horizontal amplifier—2 Hz to 500 kHz bandwidth; better than 300 mV/cm sensitivity. Sweep/cm is 10 μ s to 10 ms in 4 ranges.

Circle No. 85 on Reader Service Page 15 or 115

STEREO CASSETTE DECK

Capable of recording four-track stereo and two-track mono, *Lafayette Radio Electronics'* Model RK-550 solid-state pushbutton cassette deck plays back both four- and two-track pre-



recorded stereo and mono cassettes. Features include a unique jam-proof 1 7/8 in./s tape drive system; pushbutton controls for all tape modes of operation; tape counter with reset button; two illuminated VU meters, and a safety record button. Technical specifications: 40-12,000-Hz frequency range; better than 45-dB signal-to-noise ratio; less than 0.25% wow and flutter; better than 32-dB channel separation; 1/4-track record/play tape head; and 1/2-track double-gapped erase head. The deck is housed in a simulated walnut grain metal cabinet with a brushed-aluminum, gold-anodized front panel.

Circle No. 86 on Reader Service Page 15 or 115

ELECTRONIC ORGAN KIT

Compact and low in cost, the "Studio Organ" kit made by *Schober Organ Corporation* is nonetheless a genuine musical instrument designed for a wide variety of light music. In addition to two keyboards that provide two different pitches for accompaniment and melody, there are 14 voices, ranging from smooth flutes and reeds, adjustable vibrato, and a spring reverberation system. The 29-note accompaniment manual goes down to C below middle C, while the 36-note solo manual goes up to third E above middle C, and the lowest of the 13 foot pedals produces the same 32.7-Hz bass pitch characteristic of larger, more expensive organs. The system is rounded out with a built-in 25-watt (steady-state sine-wave power) solid-state amplifier and a two-way speaker system, including an LC crossover network which gives full reproduction of the musical range.

Circle No. 87 on Reader Service Page 15 or 115

IC/FET AM/FM STEREO RECEIVER

Two integrated circuits and a field-effect transistor have been designed into the Model RA-999 AM/FM stereo receiver from *Olson Electronics, Inc.* The tuning ranges of the receiver on AM and FM are 535-1605 kHz and 88-108 MHz, respectively. Features include recorder jacks, dual tuning meters for precise center-of-channel tuning, FM stereo indicator light, front panel headphone jack, flip-tab switches, illuminated slide rule dial, main and remote speaker

(Continued on page 117)



measure



The RCA WV-38A Volt-Ohm Milliammeter is a rugged, accurate, and extremely versatile instrument. We think it's your best buy. Only \$52.00.* Also available in easy to assemble kit, WV-38A (K).

The RCA WV-77E Volt-Ohmyst® can be used for countless measurements in all types of electronic circuits. Reliability for budget price. Only \$52.00.* Also available in an easy to assemble kit, WV-77E (K).

The RCA WG-412A R-C circuit box can help you speed the selection of standard values for resistors and capacitors, either separately or in series or parallel R C combinations. Only \$30.00.* It's easy to use, rugged, and compact.

The RCA-500A all solid state, battery operated VoltOhmyst eliminates warm-up time, eliminates zero-shift that can occur in tube operated voltmeters. Completely portable. Only \$75.00.* Comes with shielded AC/DC switch probe and cables.



The RCA-WT-501A in-circuit out-of-circuit transistor tester is battery operated, completely portable. It tests both low and high power transistors, has NPN and PNP sockets for convenient transistor matching for complementary symmetry applications. Only \$66.75.*

The RCA WC-506A transistor-diode checker offers a fast, easy means of checking relative gain and leakage levels of out-of-circuit transistors. Compact and portable, it weighs 14 ounces, measures 3¾ by 6¼ by 2 inches. Only \$18.00.*

The RCA WV-98C Senior VoltOhmyst is the finest vacuum-tube voltmeter in the broad line of famous RCA VoltOhmysts. Accurate, dependable, extremely versatile, it is a deluxe precision instrument. Only \$88.50.* Also available in an easy to assemble kit, WV-98C (K).

For a complete catalog with descriptions and specifications for all RCA test instruments, write RCA Electronic Components, Commercial Engineering, Dept. C133W, Harrison, N.J. 07029.

*Optional Distributor resale price. Prices may be slightly higher in Alaska, Hawaii, and the West.

LOOK TO RCA FOR INSTRUMENTS TO TEST/MEASURE/VIEW/MONITOR/GENERATE
CIRCLE NO. 27 ON READER SERVICE PAGE

RCA

To celebrate
the introduction
of the new Johnson
Lifetime .002 Crystal . . .

Johnson has crystal-ized 3 fabulous deals for you!



Buy a Messenger 100 or Messenger III at the suggested CB net price—and get a **complete set** of the new Johnson LIFETIME Crystals **ABSOLUTELY FREE!** (Don't need a new rig just now? Buy any Johnson accessory for **20% off!**)

It's Johnson's way of dramatically acquainting you with the incomparable new Johnson LIFETIME .002 Crystal, whose precision and frequency stability are *guaranteed for life . . .*

offer expires April 30th

Available from participating Johnson Distributors

DEAL #1 Save **\$29.⁵⁰**
ON A
Messenger 100
including all 12 crystals!

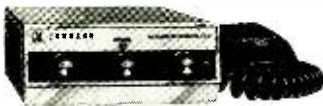

Exceptional buy on an outstanding, proven 6-channel performer!

Reg. price with all 12 crystals
installed: \$159.45

Sale price: \$129.95

DEAL #2 Save **\$64.⁹⁰**
ON A
Messenger III
including all 24 crystals!



The great 12-channel mobile champion at an unheard of price!

Reg. price with all 24 crystals
installed: \$224.85

Sale price: \$159.95

DEAL #3 Save **20%** on any JOHNSON ACCESSORY
with this **CERTIFICATE!**
Clip out this certificate and take it to your E. F. Johnson Distributor or Dealer for a **full 20% discount** off the suggested CB net price of any Johnson accessory.



E. F. JOHNSON COMPANY
WASECA, MINNESOTA 56093

COVER STORY
BY JOHN S. SIMONTON, JR.

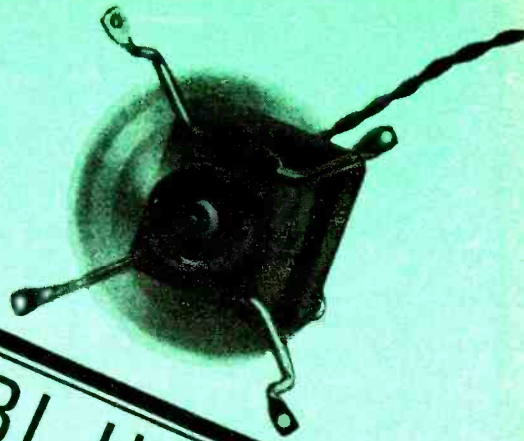

BUILD "OP-TACH"

COUNT REVOLUTIONS WITH HAND-HELD INSTRUMENT

WHEREVER there is a wheel spinning or a motor shaft turning, the chances are that, sooner or later, somebody is going to ask how fast it is revolving. To find out, he'll have to use a tachometer of some sort. Most commercial and industrial tachometers are designed for a specific purpose and are either permanently installed or fairly expensive, or both. In the home workshop, the experimenter needs a low-cost, portable tachometer that can be used with any motor or engine when he is tuning up or testing.



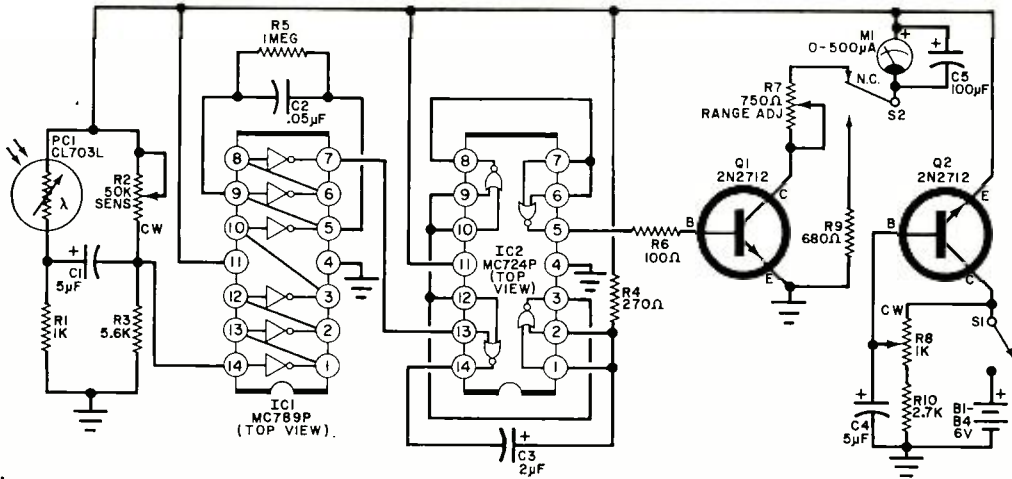

Fig. 1. The meter indicates the average current flowing through Q1 as a result of the number of light pulses striking PC1. Capacitor C5 permits the system to operate only on light pulses and not be affected by the amount of ambient light.

PARTS LIST

B1-B4—1.5-volt AA cell (penlight)
 C1, C4—5-µF, 6-volt electrolytic capacitor
 C2—0.05-µF, ceramic disc capacitor
 C3—2-µF, 6-volt electrolytic capacitor
 C5—100-µF, 6-volt electrolytic capacitor
 IC1—Integrated circuit (Motorola MC789P)
 IC2—Integrated circuit (Motorola MC724P)
 M1—0-500-µA meter, 100-ohm internal impedance
 PC1—Photocell (Clairex CL 703L or similar)
 Q1, Q2—2N2712 transistor

R1—1000-ohm
 R3—5600-ohm
 R4—270-ohm
 R5—1-megohm
 R6—100-ohm
 R9—680-ohm
 R10—2700-ohm
 R2—50,000-ohm linear taper potentiometer
 R7—750-ohm trimmer potentiometer
 R8—1000-ohm linear taper potentiometer with switch attached
 S1—S.p.s.t. switch (part of R8)
 S2—S.p.d.t. pushbutton switch
 Misc.—Case (6½" x 3¾" x 2", plastic with mating aluminum cover), hardware, dual battery holder (2), wire, solder, 5-dram plastic pill container with cover, PC board*, etc.
 *The following are available from PAIA Electronics, P.O. Box 14359, Oklahoma City, Okla. 73120: printed circuit board, \$2.50; meter with RPM x 10 designation on dial, \$5.25; complete kit of parts with PC board, hardware and case (not machined), \$18.50. Oklahoma residents, add 3% sales tax.

All resistors
 ½-watt

There are very few tachometers of this type.

Here's one, however, that will measure the speed of practically anything that rotates in the lab or workshop. It's called the "Op-Tach" and is battery-operated, wholly self-contained and handheld. A beam of light senses the speed of the rotating object. In many cases, using the Op-Tach is simply a matter of pointing the instrument at the rotating object and reading the speed in revolutions per minute directly from the meter.

Construction. The schematic diagram for the Op-Tach is shown in Fig. 1. As with any project using integrated circuits, you will be ahead of the game if you use a printed circuit board. You can make your own, using Fig. 2 as a guide,

or you can buy one (see Parts List of Fig. 1). In assembling components on the circuit board (Fig. 3) be sure that both the board and your soldering iron are as clean as possible and keep them that way. In inserting the integrated circuits, notice that the notches on the IC's correspond to the semicircular locating marks on the PC board. When all soldering is complete, a coat of spray acrylic or clear nail polish will keep the copper circuit from oxidizing.

To protect the photocell from high levels of ambient light and restrict its field of view, the photocell is glued to the bottom of the inside of a 5-dram pill container which has been painted flat black on the inside. A pair of holes is drilled for the photocell leads. The pill container is then mounted in an appropriate

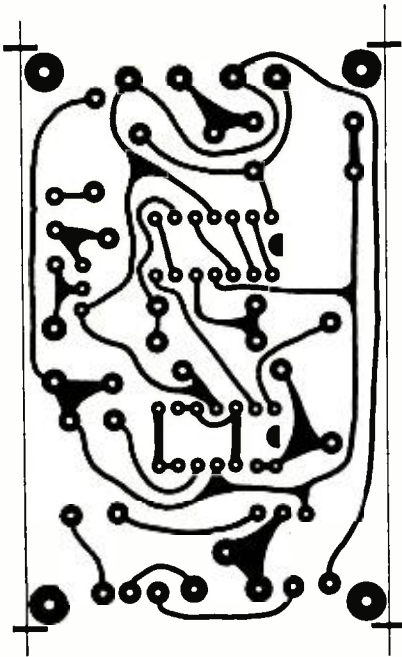

Fig. 2. Actual size printed-board foil pattern for the Op-Tach. Note the semi-circular end identifiers for the IC's.

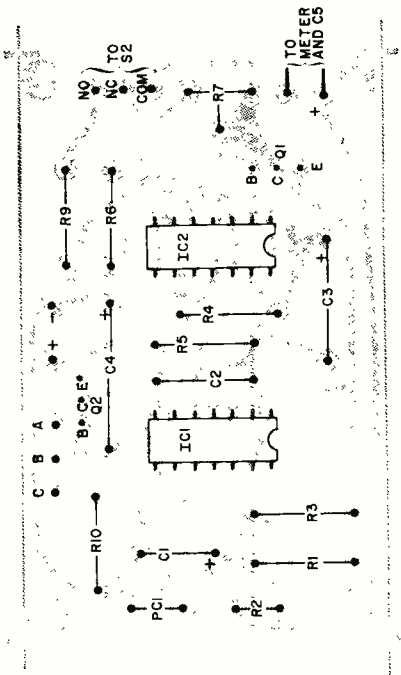

Fig. 3. Component installation. Observe correct polarity for the indicated parts.

size hole in one end of the $6\frac{1}{2}'' \times 3\frac{3}{4}'' \times 2''$ plastic utility box which houses the instrument. To conserve space, mount it so that approximately half of the pill bottle protrudes from the case. Save the cap from the container and use it as you would the lens cap on a camera—to prevent dust from settling on the photocell.

The two dual-battery holders are mounted on opposite sides of the case so that, when the cover is in place, the meter is between them. The PC board should be mounted with 6-32 screws and raised from the bottom of the case with short spacers. The meter, switch $S2$ and controls ($R2$ and $R8$, with $S1$ attached) are mounted on the aluminum faceplate of the utility box as shown in Fig. 4. In the author's prototype this faceplate was covered with a mahogany-grain, contact-adhesive paper and labels were applied using dry transfers. All wires from the PC board to the controls and meter were run through a piece of large tubing, but they could be laced together in a neat bundle. Be sure to make these leads long enough to permit removal of the front cover. Notice that capacitor $C5$ is mounted directly on the meter terminal lugs and not on the printed circuit board.

The suggested meter has scale markings from 0 to 500. Carefully remove the

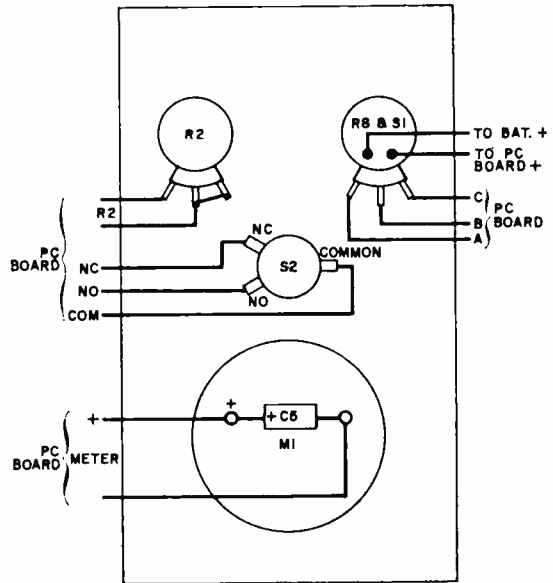
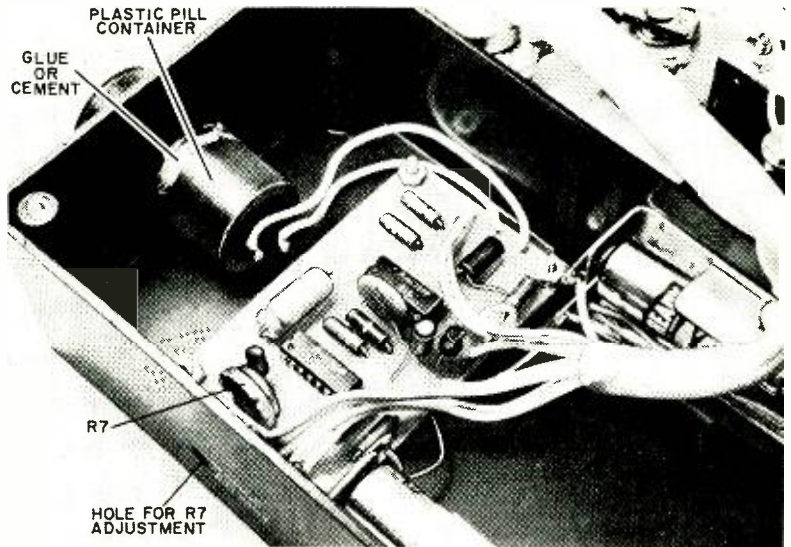

Fig. 4. Layout of rear of front panel. As circuit layout is not critical, any arrangement can be used.

Two holes must be drilled in the plastic case. One is for the pill container that mounts PC1, while the other is for making R7 adjustments. For maximum rigidity, mount the pill container half way in the case and use high-quality cement. Use the pill container cover as a cap when the Op-Tach is not in use. This keeps dust away from the photo cell.



clear plastic front of the meter and use a pencil eraser to remove the "D.C. MICROAMPERES" marking. You can then use either pen and ink or dry transfers to relabel the meter "RPM $\times 10$ ". If at all possible, remove the scale before doing any lettering on it and, in any case, be very careful not to bend the meter needle or damage the movement.

Calibration. The best way to calibrate the Op-Tach is by comparing it to a tachometer of known accuracy, but if such an instrument is not available, you can use one of the following methods:

Signal-Generator Method. Figure 5 shows a calibration setup using an audio signal generator. Set the generator for an output of 50 Hz and 1.5 volts peak-to-peak. Turn on the Op-Tach and set R8 so that the meter reads 500 with S2 depressed. Release S2 and set sensitivity control R2 at its least sensitive point (counterclockwise). You may get a reading with the sensitivity control at this position but if you don't, advance R2 slowly until the meter shows a steady reading. Adjust the range potentiometer, R7, to give a reading of 3000 RPM (the equivalent of 50 Hz). While you have the equipment set up, you may want to check the tachometer at several other frequencies. Remember that indicated RPM is frequency times 60.

The electronic portion of the Op-Tach is inherently linear above about 500 RPM so any nonlinearity you may

find is in the meter movement. Since most inexpensive meters have a nominal accuracy of 5%, you can expect an error of less than 250 r/min on the 5000 RPM range (usually much less).

Power-Line Method. If you don't have a signal generator, the best thing to do is to use a filament transformer and a voltage divider set up as shown in Fig.

HOW IT WORKS

Each time a sharp change of light hits the Op-Tach's photocell, the resistance of PC1 changes and a voltage pulse is created at terminal 14 of IC1. This pulse is amplified and shaped by the six inverters in IC1. SENSITIVITY control, R2, is used to set the amount of forward bias in the first inverter in IC1. Capacitor C2 isolates the last two inverters from any cascaded d.c. bias in the first four stages; and R5 prevents an excess charge from accumulating on C2, which would reverse bias the last two inverter stages.

The output at pin 7 of IC1 triggers a monostable multivibrator composed of R4, C3, and two of the four logic gates in IC2. Even though the reflected light detected by PC1 varies in duration and intensity, the output of the multivibrator is a pulse of constant height and width whose frequency is determined by the number of times that the reflected light strikes PC1.

The pulses are squared up and buffered by the other two gates in IC2 and applied to the base of Q1. When a pulse is applied to Q1, it is turned on and a short pulse of current flows through meter M1. As the speed of the object increases, the pulses become closer together and the average value of current flowing through M1 increases. Capacitor C5 smooths this waveform and helps keep the meter needle from jiggling.

When pushbutton S2 is pressed, the meter is taken out of the collector circuit of Q1 and put in series with R9. The voltage across the meter is then determined by Q2 and can be varied by adjusting R8. Variations in battery output due to aging are eliminated by setting R8 for a current flow of 500 microamperes before each reading.

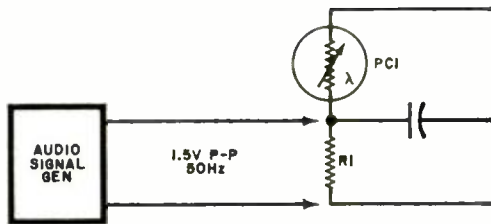

Fig. 5. To calibrate, use an audio signal generator delivering 1.5 volts peak-to-peak at 50 Hz as the input and adjust R7 (through its hole) for 3000 RPM.

6. The procedure is the same as that above except that you adjust R7 for a meter reading of 3600. (Unless you happen to have a power line with a 50-Hz frequency; in which case, the reading would be 3000 RPM.)

Of course the meter doesn't have to be calibrated for a full-scale reading of 5000 RPM. You can set R7 for 10,000 or 15,000 RPM and change the meter scale markings accordingly. However, you will have to use an audio signal for calibration in the higher ranges. Select a frequency near the center of the range. For instance, for a 10,000-RPM scale, use 83 Hz, which is equivalent to 4980 RPM (make the setting for 5000). Don't try to get a full-scale range of more than 15,000 RPM or you may run into serious nonlinearities.

Operation. The Op-Tach can be used in one of two ways: by reflection or by transmission of light.

Reflective. In the first method, light is reflected from a rotating spot which is

of a different reflectivity from the rest of the object. The shafts of some motors have flats machined on them and these serve as good reflective spots. In most cases, however, the contrasting area must be made artificially. You can use a small piece of aluminum foil attached with clear cellophane tape or simply a piece of paper of a color which contrasts with the background. A small area painted in contrast will also be satisfactory.

Position the Op-Tach so that light is reflected from the surface of the rotat-

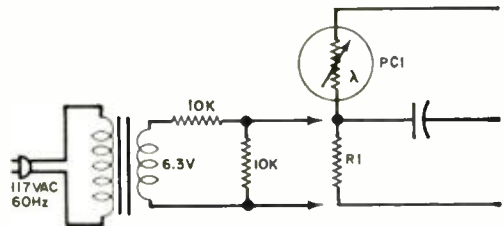
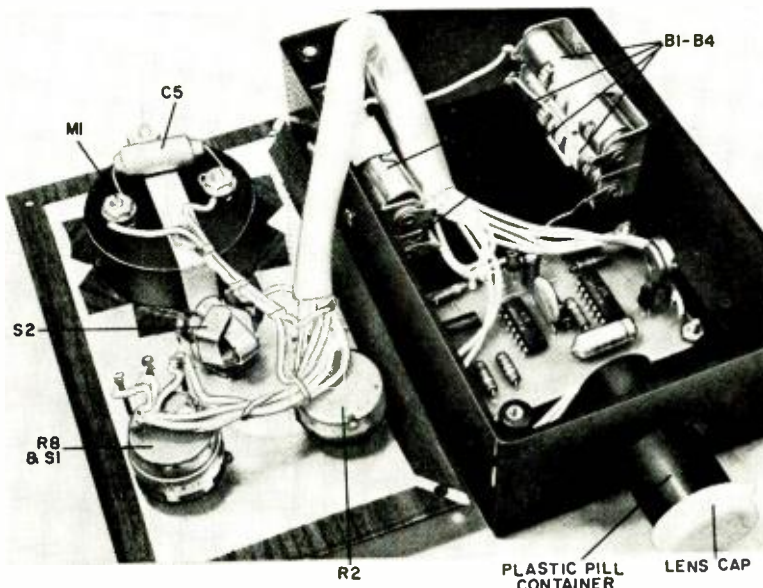

Fig. 6. You can use the commercial 60-Hz power line as a calibration source, with the divider network shown here, to calibrate the Op Tach to 3600 RPM.

ing body into the photocell. A light source is not included as part of the instrument since quite often ambient light is sufficient. If it is not, use an auxiliary light such as a flashlight or drop light.

Look at the rotating object from the direction and position in which the tachometer is located. If you can see a direct reflection from the light source, you can use the Op-Tach. If not, change the position of the light or the tachometer, or both. You can hold the Op-Tach in your
(Continued on page 113)



The wiring between the PC board and the front panel can be made neat by passing it through a piece of plastic tubing.

How's Your E=IR?

BY ROBERT P. BALIN

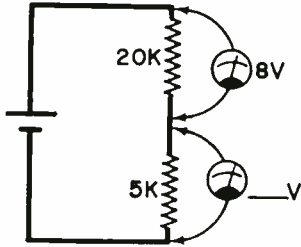

1.

Ohm's Law is the most valuable tool in electronics. It tells how voltage, current, and resistance are related to each other in a closed electrical loop. Test your knowledge of Ohm's Law in d.c. circuits by solving for the unknown voltage, current, or resistance in each of the ten circuits shown here. Assume that the meters have no effect on the circuits. Answers to quiz can be found on page 112.

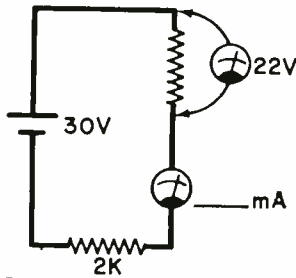

2.

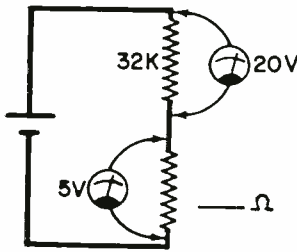

3.

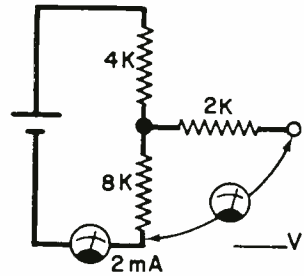

4.

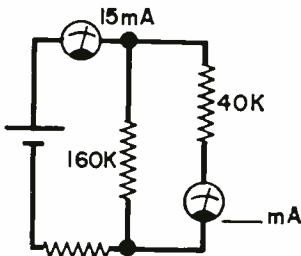

5.

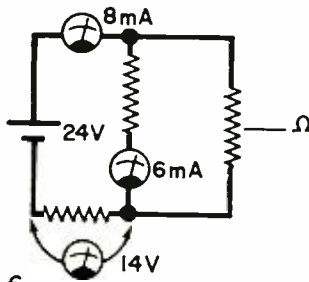

6.

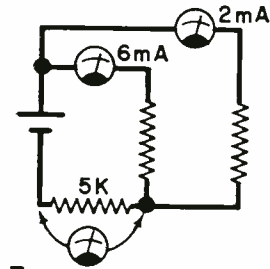

7.

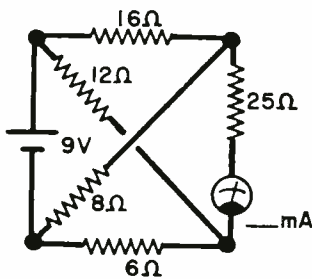

8.

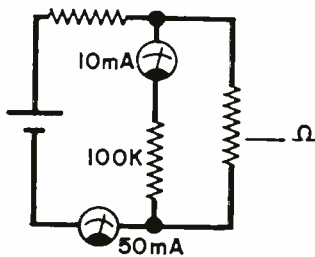

9.

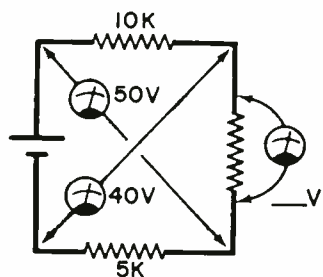

10.

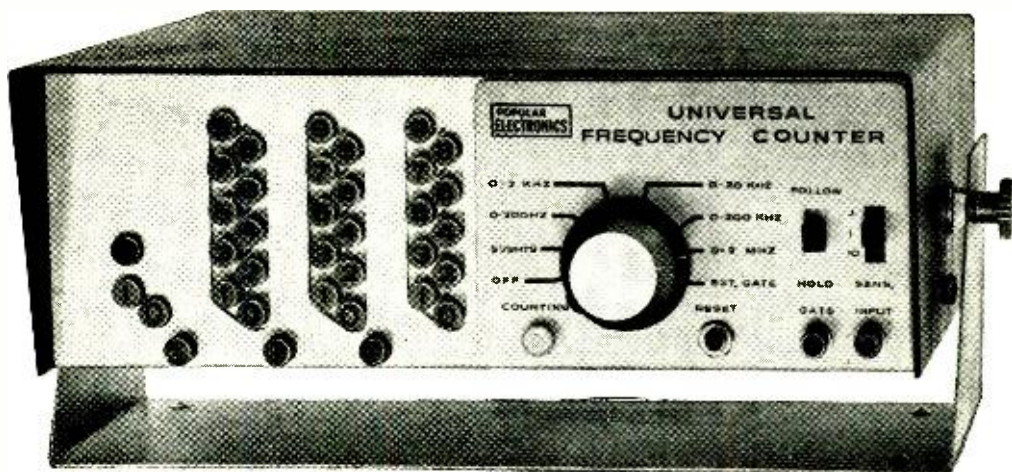

BUILD THE

Popular Electronics Universal Frequency Counter

HIGH-ACCURACY
COUNTING
TO 2 MHz

BY DON LANCASTER

PART 1 OF 2 PARTS

HOW OFTEN do you come across a frequency counter like this: maximum range—2 MHz; cost—less than \$200? The answer is very rarely, and that's why the POPULAR ELECTRONICS Universal Frequency Counter will be of prime interest to project builders in all areas. Its list of attributes doesn't end, however, with frequency range and price: it has seven counting ranges (200 Hz to 2 MHz), a choice of three automatically sequencing time bases (0.1, 1 and 10 seconds), and a comparator with built-in noise immunity and guarded input. The latter provides excellent sensitivity to sine waves, square waves or narrow pulses of either polarity, regardless of duty cycles. A special electronic synchronizer eliminates variations in the display of the last digit (known as bobble) and an overrange light indicates when the counter's capacity is exceeded.

With the Universal Frequency Counter, you can count events, measure frequencies from 0.1 Hz to over 2 MHz or you can gate the instrument externally so that it can be used as a stopwatch or to measure the ratio of two frequencies. The basic instrument has 0.1% accuracy with a 3½-digit display (3 digits plus overrange indication) and a line-operated time base similar to most commercial counters in the "under \$600" category.

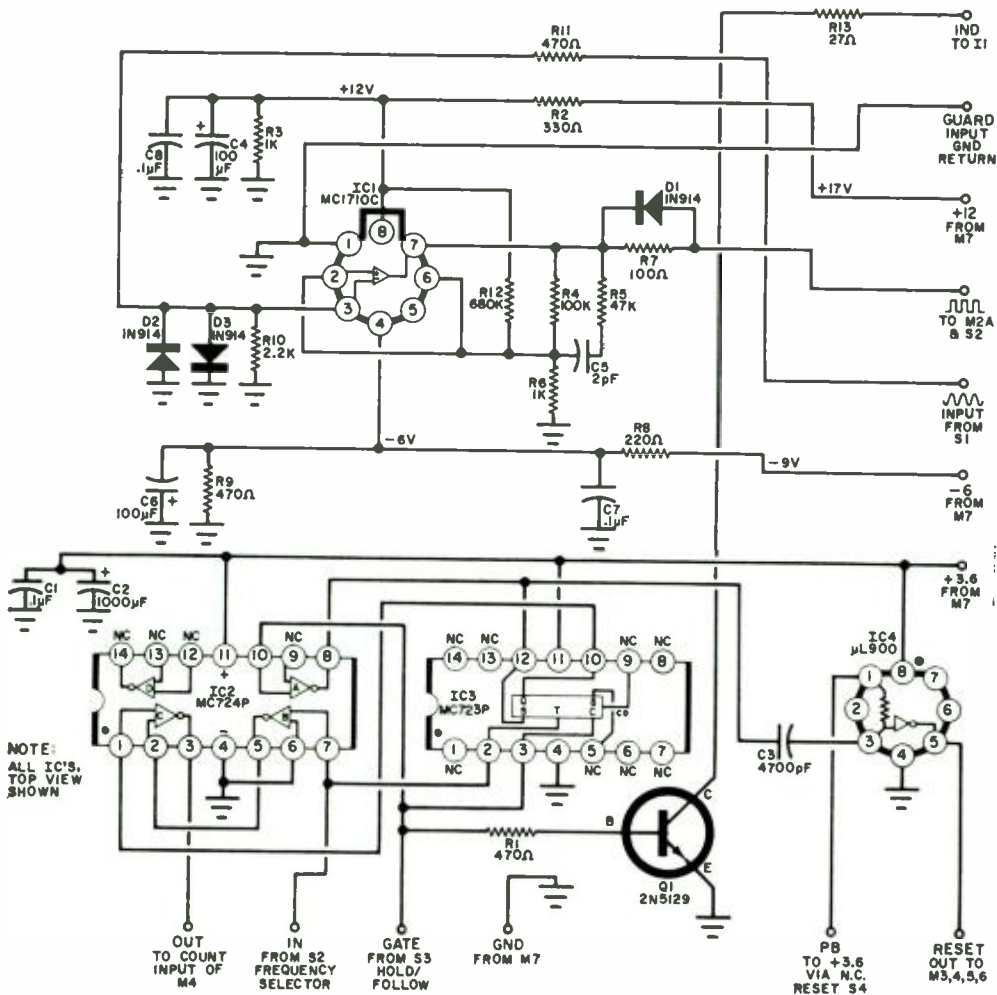

FIG. 1. The comparator module actually contains three separate circuits: input signal comparator (IC1), signal-time base synchronizing circuit (IC2 and IC3), and automatic reset generator IC4.

PARTS LIST COMPARATOR MODULE

- C1, C7, C8—0.1- μ F, 10-volt disc ceramic capacitor
 C2—1000- μ F, 3-volt electrolytic capacitor
 C3—4700-pF polystyrene, Mylar, or disc ceramic capacitor
 C4, C6—100- μ F, 15-volt electrolytic capacitor
 C5—2-pF mica capacitor
 D1-D3—1N914 silicon computer diode or equivalent
 IC1—Operational amplifier (Motorola MC1710C)
 IC2—Quad two-input gate (Motorola MC724P)
 IC3—JK flip-flop (Motorola MC723P)
 IC4—RTL buffer (Fairchild μ L900)
 Q1—Transistor (National 2N5129)

- R1, R9, R11—470-ohm
 R2—330-ohm
 R3, R6—1000-ohm
 R4—100,000-ohm
 R5—47,000-ohm
 R7—100-ohm
 R8—220-ohm
 R10—2200-ohm
 R12—680,000-ohm
 R13—27-ohm

All resistors
 1/4-watt

Misc.—PC terminal (USECO 1310B, optional, not provided in kits, 13), #24 wire for jumper, solder.

Note.—The following are available from Southwest Technical Products, Box 16297, San Antonio, Texas 78216: etched and drilled fiber-glass circuit board, #M1b, \$3.20; complete kit of all parts required, #M-1, \$14.65, plus postage, 6 oz.

Fig. 2. Actual-size printed board for the comparator module. Because of the complexity of the circuit, printed boards are a must for this project.

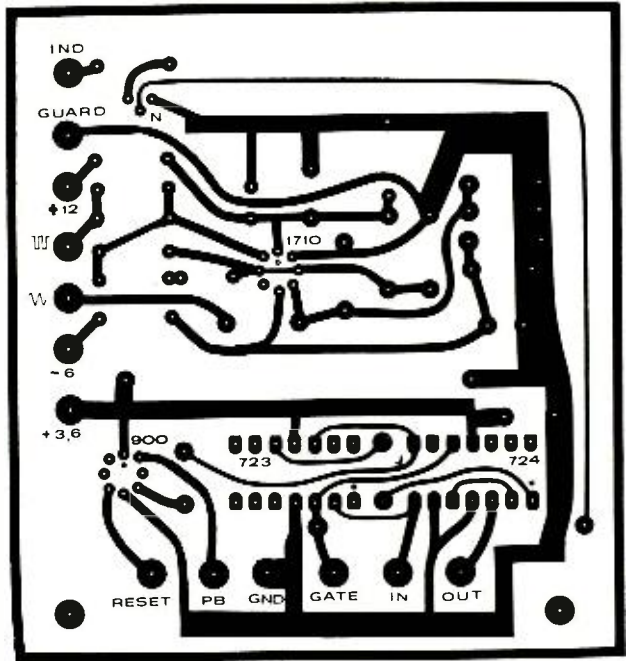

Modular construction permits easy addition of extra decades or use of a more accurate, crystal time base. For instance, the time base used in POPULAR ELECTRONICS' Electronic Stopwatch (March 1968) and Sports Timer (October 1968) can be easily adapted for use in the counter. It is also possible to add divide-by-ten scalars to extend the counter's basic range to 20 or 200 MHz, direct reading.

While the Universal Frequency Counter is probably the most complex construction project ever presented in a hobby electronics magazine, the extensive use of integrated circuits and modular construction greatly simplifies the project. It is not a project for beginners but the procedure is relatively simple and straightforward. Parts and a complete kit are readily available as noted in the parts lists.

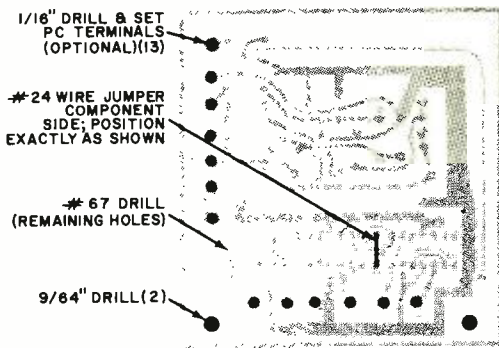

Fig. 3. Drill the board as shown here, and install the single jumper on the component side of board.

*CONNECT TO FLOATING INPUT COMMON TERMINAL ONLY

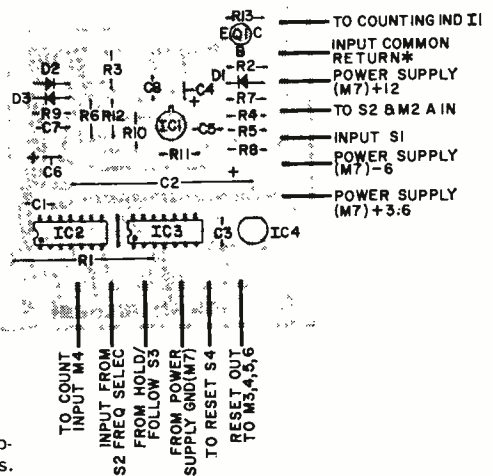
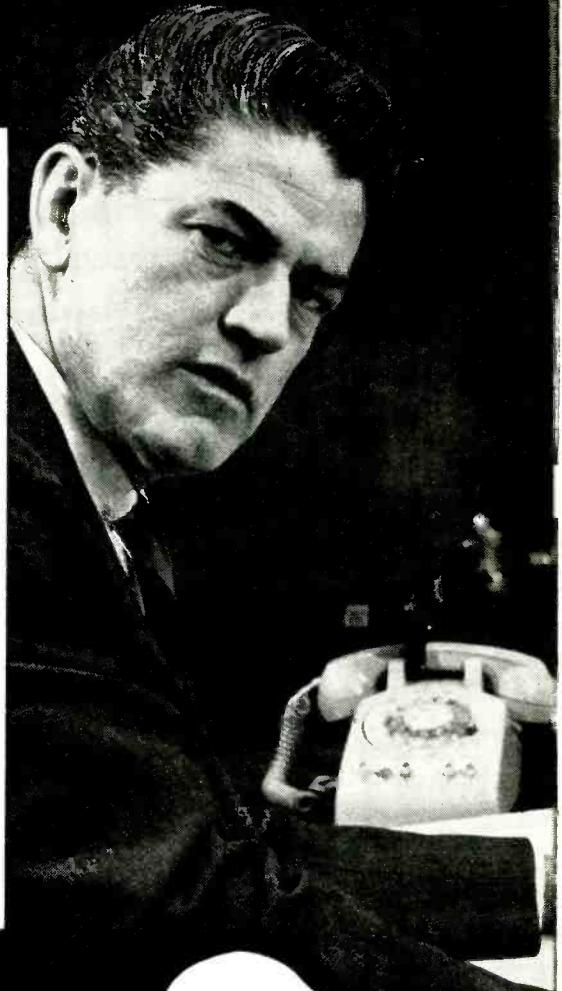

Fig. 4. Install the components taking care to observe polarities of semiconductors and capacitors.

**“Get more
education
or
get out of
electronics
...that’s my advice.”**



NEW!

Expanded
coverage of
solid state
electronics
including
integrated
circuits!

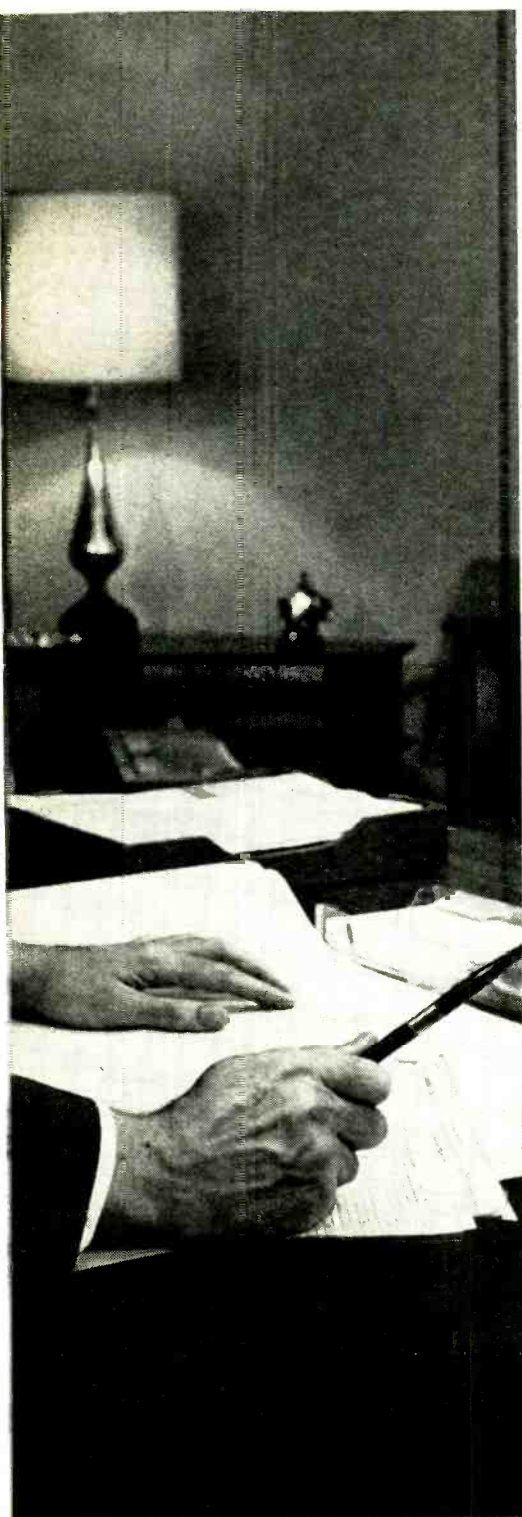

Ask any man who really knows the electronics industry.

Opportunities are few for men without advanced technical education. If you stay on that level, you'll never make much money. And you'll be among the first to go in a layoff.

But, if you supplement your experience with more education in electronics, you can become a specialist. You'll enjoy good income and excellent security. You won't have to worry about automation or advances in technology putting you out of a job.

How can you get the additional education you must have to protect your future—and the future of those who depend on you? Going back to school isn't easy for a man with a job and family obligations.

CREI Home Study Programs offer you a practical way to get more education without going back to school. You study at home, at your own pace, on your own schedule. And you study with the assurance that what you learn can be applied on the job immediately to make you worth more money to your employer.

You're eligible for a CREI Program if you work in electronics and have a high school education. Our FREE book gives complete information. Mail postpaid card for your copy. If card is detached, use coupon below or write: CREI, Dept. 1203H, 3224 Sixteenth Street, N.W., Washington, D.C. 20010.

Founded 1927



CREI, Home Study Division
 McGraw-Hill Book Company
 Dept. 1203H, 3224 Sixteenth Street, N.W.
 Washington, D.C. 20010

Please send me FREE book describing CREI Programs. I am employed in electronics and have a high school education.

NAME _____ AGE _____

ADDRESS _____

CITY _____ STATE _____ ZIP CODE _____

EMPLOYED BY _____

TYPE OF PRESENT WORK _____ G.I. BILL

- I am interested in Electronic Engineering Technology
 Space Electronics Nuclear Engineering Technology
 NEW! Digital Communications

APPROVED FOR TRAINING UNDER NEW G.I. BILL

HOW IT WORKS COMPARATOR MODULE

There are actually three circuits in the Comparator module: a comparator, a synchronizing circuit, and a reset generator.

The comparator (*IC1*) is a high-gain operational amplifier that compares two input signals and provides a digital output signal generated by the difference between the signal input and a reference signal. The reference is derived from the output of the comparator by positive feedback and is either 10 or 30 millivolts positive. When the instantaneous value of the input signal is more than 30 millivolts, the output of the comparator goes to ground, helped along by a dropping reference voltage through positive feedback. If the input signal drops below 10 millivolts, the comparator output goes positive, again aided by feedback. This two-level action is called hysteresis, and it permits the comparator to operate with inputs that are noisy or are very low-frequency sine waves without producing a noisy output.

The comparator is protected on the input side by diodes *D2* and *D3*, which also act to restore

the d.c. level for narrow pulse inputs. Feedback is provided by *R4*, *R5*, and *C5* and is both a.c. and d.c. Other components in the comparator circuit provide power supply decoupling and output load matching.

The synchronizing circuit consists of four gates and a JK flip-flop. The circuit delays the input measure command until the first input signal arrives and holds the measure command until one more input signal passes through the switch, after the measure command ceases. In this way, the measuring interval is locked to the signal to be counted. This eliminates a one-count bobble that might take place if the measurement command were turned on at random either just before or just after an input signal arrived. Transistor *Q1* is used to drive the COUNTING indicator light.

The reset generator, *IC4*, is a buffer connected as a half-monostable circuit. It generates a 2-microsecond reset pulse at the beginning of the measure command to reset the counters to zero. Operation of the RESET pushbutton, interrupts the positive supply to pin 1 of *IC4* and provides a longer positive output voltage. Either the automatic pulse or the manual reset causes the readouts to drop to zero.

Construction. The Universal Frequency Counter consists of seven modules, plus the case and some panel components. Module 1 is the comparator, module 2 is the Scaler, module 6 is the Gate, and module 7 is the Power Supply. The construction of these modules is given in detail here. Modules 3, 4, and 5 are decimal counting units that are fully described in the Winter 1969 ELECTRONIC EXPERIMENTER'S HANDBOOK and the details of their construction will not be given here.

It is advisable to build each module separately following the instructions carefully. Each module has its own schematic, parts list, and circuit board pattern. Note that round IC's are identified by a tab, flat, or color dot beside pin 8, while the rectangular (inline) units have a notch or dot at one end. In the schematic diagrams, they are shown from the top and the pins are numbered counterclockwise from the identifying mark. Be sure that all IC's are properly positioned before soldering connections. Also be careful to observe the polarities of diodes and electrolytic capacitors. Use fine solder and a low-power (25-35 watts) soldering iron.

Comparator (*M1*) The schematic for this module is shown in Fig. 1. A printed circuit board is a must. You can make your own, using the foil pattern in Fig. 2 or purchase one etched and drilled (see Parts List for Fig. 1). Install the single jumper on the component side as shown

in Fig. 3. To mount the components on the board, follow the layout in Fig. 4.

Scaler (*M2*) The schematic for the Scaler is shown in Fig. 5. Construction will be greatly simplified by use of the circuit board whose pattern is shown in Fig. 6. Install the 12 jumpers on the component side of the board as shown in Fig. 7. The four jumpers marked with an asterisk should be insulated with small pieces of sleeving. Install the nine IC's and two capacitors as shown in Fig. 8.

Gate (*M6*) The Gate module schematic is shown in Fig. 9. Once again, construction will be greatly simplified by the use of a PC board. You can make your own using the pattern in Fig. 10. Mount the four jumpers on the component side as

A NOTE ON DCU'S

The Universal Frequency Counter can only use the new, low-power decimal counting units described fully in the Winter 1969 edition of ELECTRONIC EXPERIMENTER'S HANDBOOK. Module kits sold by Southwest Technical Products since October 1968 are of the new type.

Here's how to tell what you have: (1) if your DCU has only three IC's, you have the new unit; (2) if it has four IC's but no 1-watt resistors, you have a medium-power unit, modification of which is suggested but not essential; (3) if it has four IC's and two 1-watt resistors, you have the original version which must be modified if it is to be used in the counter. Modification kits with complete instructions are available from Southwest Technical Products, Box 16297, San Antonio, Texas 78216, for \$1 per module.

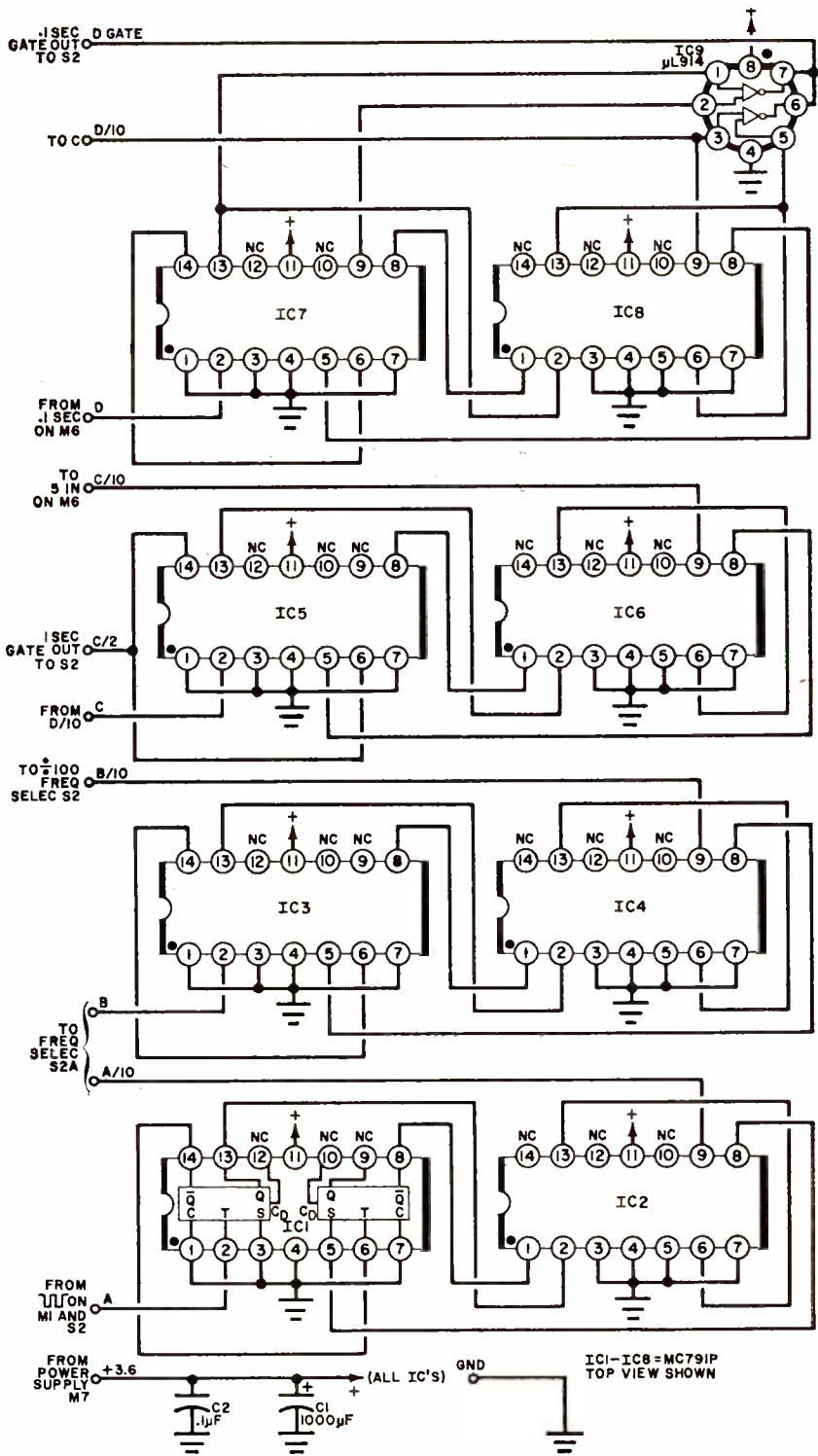

Fig. 5. The scaler module contains four independent divide-by-10 circuits, with IC1-IC4 scaling (divide by 10 or 100) the input frequency, while IC5-IC8 does the same for the timer circuit.

PARTS LIST SCALER MODULE

C1—1000- μ F, 3-volt electrolytic capacitor
 C2—0.1- μ F, 10-volt disc ceramic capacitor
 IC1-IC8—MRTL dual JK flip-flop (Motorola MC791P)
 IC9—RTL dual two-input gate (Fairchild μ L914)
 Misc.—#24 wire (12 jumpers), insulated sleeving for jumpers (4), PC terminals (USECO 1310B, optional, 12, not provided in kit), solder.
 Note.—The following are available from Southwest Technical Products, Box 16297, San Antonio, Texas 78216: etched and drilled fiberglass circuit board. \pm M-2b, \$2.85; complete kit of all parts required. \pm M-2, \$21.90, plus postage, 6 oz.

HOW IT WORKS SCALER MODULE

There are four independent divide-by-ten or decade counters in the Scaler module. Each counter, or scaler, consists of four JK flip-flops in a "modulo-10 minimum-hardware" circuit, the simplest possible decade divider.

Of the four scalers, units A and B are used to divide the input frequency by a factor of 10 or 100 as necessary. Scalers C and D are used in the timing circuit to generate measure commands. Scaler C has a divide-by-two output, which provides the 1-second measure command; scaler D has a 1-of-10 decoder (IC9), which provides the 0.1-second measure command.

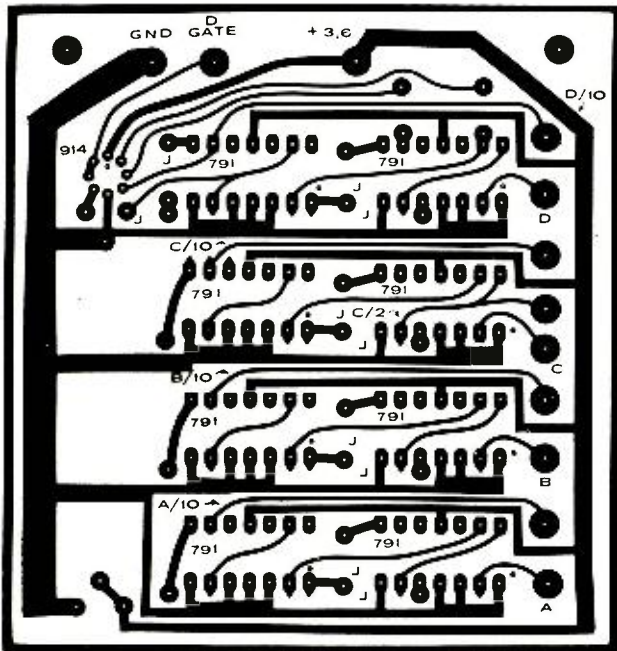

Fig. 6. Actual-size foil pattern for scaler module. This board, like all others is available etched and drilled (see Parts List).

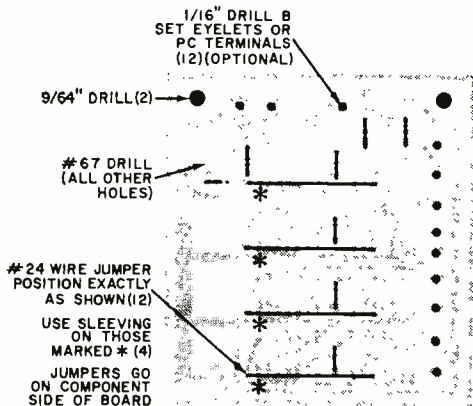

Fig. 7. After drilling the PC board, install the 12 jumpers on the component side in positions shown.

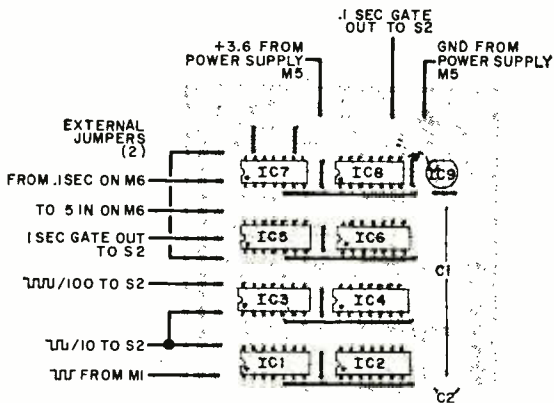

Fig. 8. When installing in-line IC's, observe the notch and code dot. Round IC has a flat at pin 8.

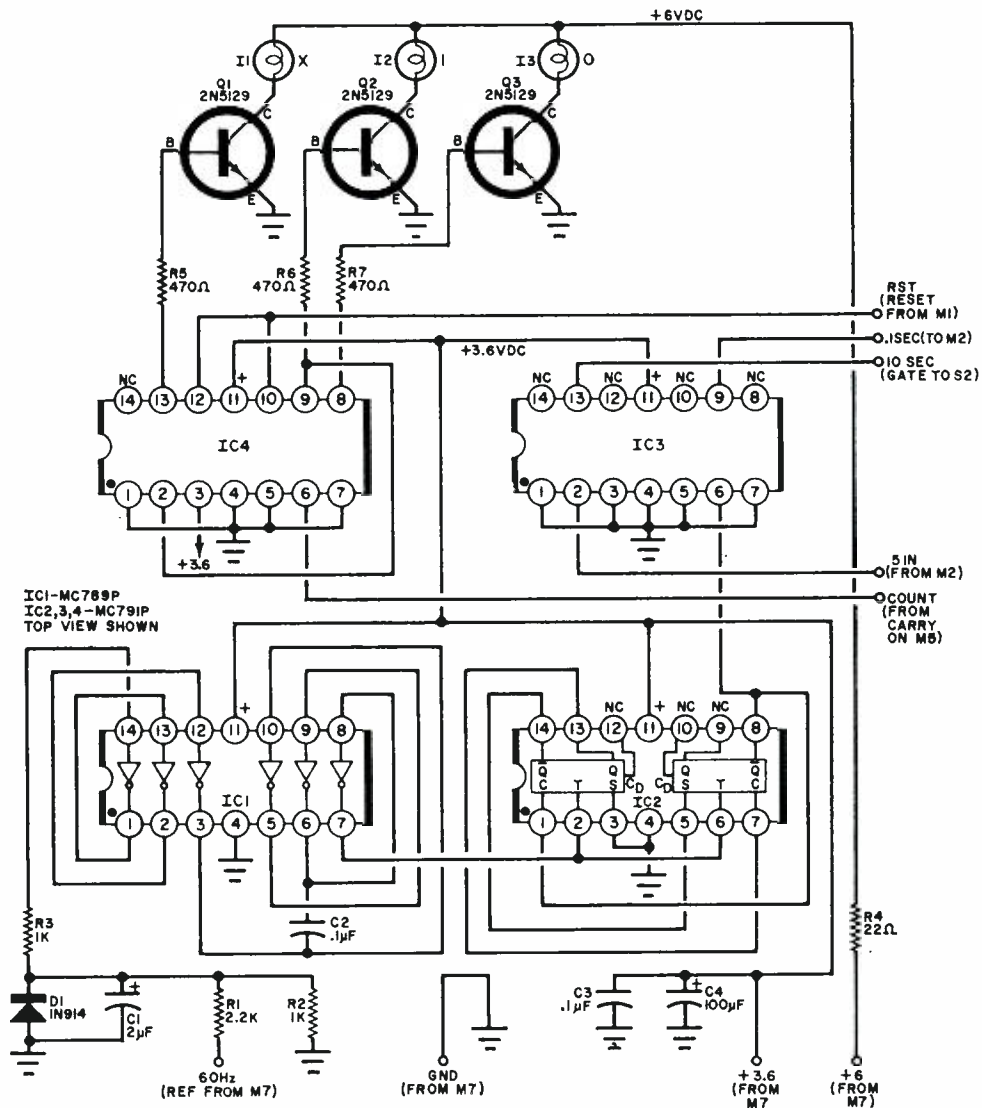

Fig. 9. The gate module performs three functions: accepts, shapes, and converts 60 Hz to 20 Hz; produces .1- and 10-second gates (IC3); and mounts 0.1 and overflow circuit (IC4, Q1, Q2, Q3).

PARTS LIST GATE MODULE

- C1—2- μ F, 10-volt electrolytic capacitor
- C2, C3—0.1- μ F, 10-volt disc ceramic capacitor
- C4—100- μ F, 15-volt electrolytic capacitor
- D1—1N914 silicon computer diode
- I1-I3—6.3-volt, 50-mA indicator lamp assembly, two orange, one red (Southwest Technical 0-6.3 and R-6.3, respectively, or similar)
- IC1—MRTL hex inverter (Motorola MC789P)
- IC2-IC4—MRTL dual JK flip-flop (Motorola MC791P)

- Q1-Q3—Transistor (National 2N5129)
- R1—2200-ohm
- R2, R3—1000-ohm
- R4—22-ohm
- R5-R7—470-ohm

All resistors
1/4-watt

Misc.—#24 wire (4 jumpers), insulated sleeving (1 inch), bracket and mounting hardware for lamps, PC terminals (USECO 1310B, optional, 9, not provided in kit), solder.

Note:—The following are available from Southwest Technical Products, Box 16297, San Antonio, Texas 78216: etched and drilled circuit board, #M-6b, \$2.35; complete kit of all parts required, #M-6, \$13.85, plus postage, 5 oc.

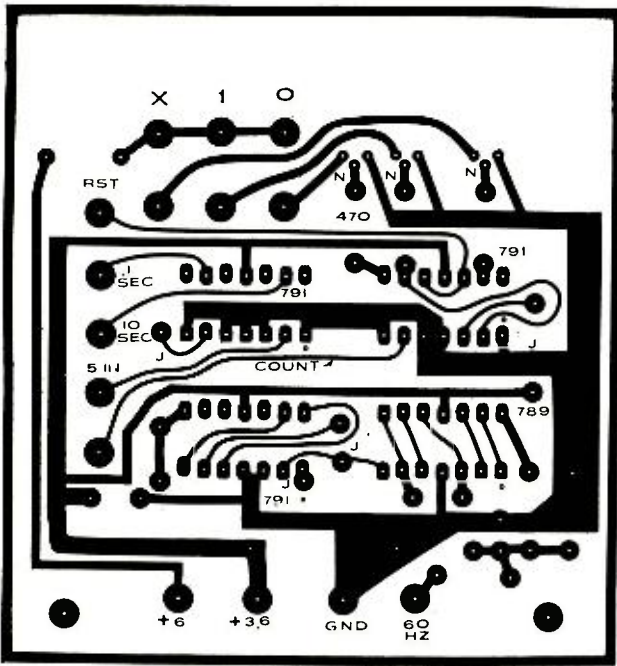

Fig. 10. Actual-size foil pattern for the gate module. As in the other foil patterns, each input-output termination and semiconductors are marked.

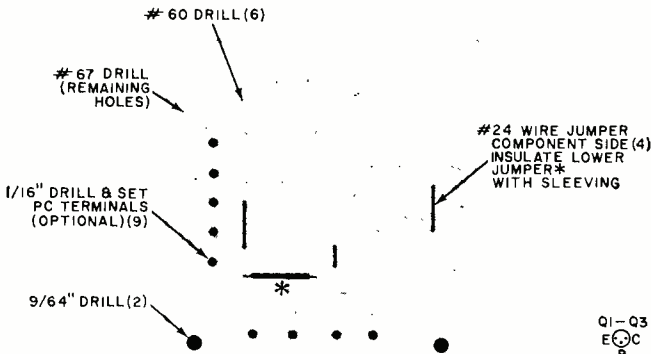

Fig. 11. Mount four jumpers on the component side of the board, making sure the indicated jumper is insulated to prevent short circuiting IC2.

shown in Fig. 11. Insulate the lower jumper with suitable sleeving. Mount the components as shown in Fig. 12.

A mounting bracket is required for this module to hold the three indicator lights. Details for this part appear in "Low-Cost Counting Unit," *ELECTRONIC EXPERIMENTER'S HANDBOOK*, Winter 1969 and "Digital Volt-Ohmmeter," *POPULAR ELECTRONICS*, December 1968. The bracket is mounted by match drilling to the PC board, then pop-rieveting using #4 hardware. An orange plastic lens can be used for both the 0 and 1 indicators and a red lens for the \bullet verrange indicator.

Power Supply (M7) Most of the power supply, whose schematic is shown in Fig. 13, is assembled on the PC board shown

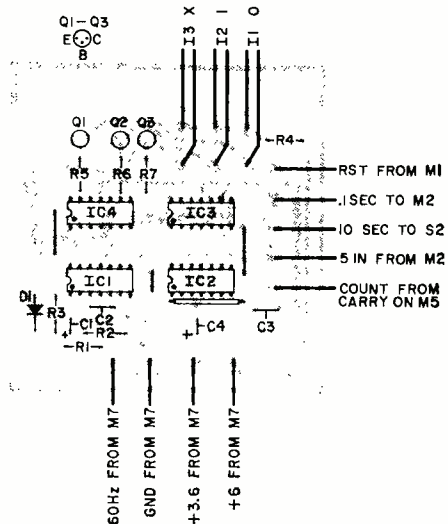

Fig. 12. Mount the board components as shown here, once again taking care to observe all polarities.

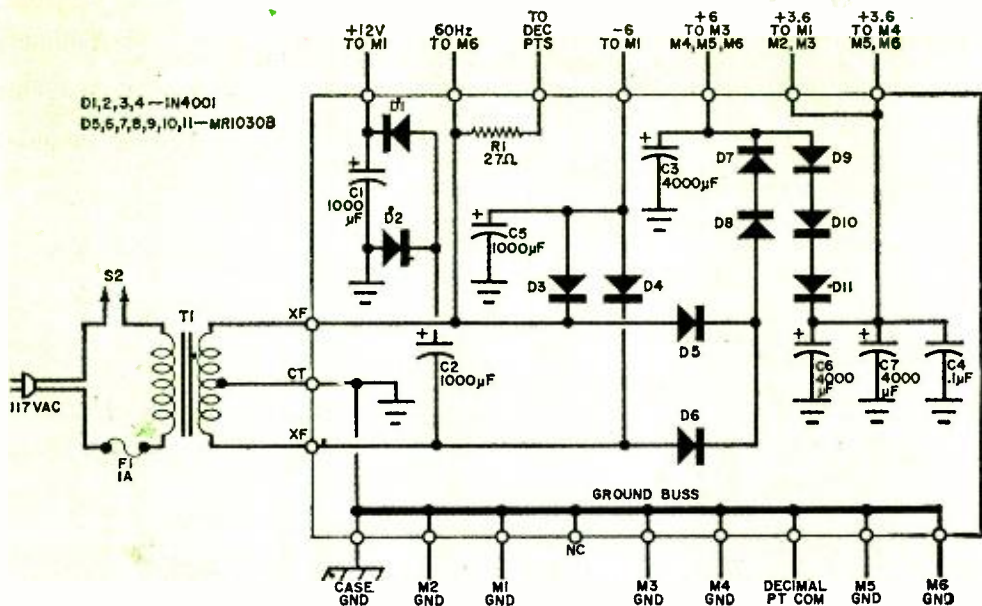

Fig. 13. Note the eight connections to the ground buss. This is done to reduce stray coupling between the various modules. Each module ground should be run on a short, heavy lead.

PARTS LIST POWER SUPPLY MODULE

- C1, C2, C5—1000-µF, 25-volt electrolytic capacitor*
C3, C6, C7—4000-µF, 6-volt electrolytic capacitor
C4—0.1-µF, 10-volt disc ceramic capacitor
D1-D4—1-ampere, 50-PIV silicon diode, 1N4001 or equivalent
D5-D11—3-ampere average, 24-ampere peak, 50-PIV silicon rectifier (Motorola MR1030B, do not substitute)

- F1—1-ampere fuse*
R1—27-ohm, ¼-watt carbon resistor
T1—12.6-volt center-tapped, 2-ampere filament transformer
Misc.—PC mounting spacers and hardware, PC terminals (USECO 1310B, optional, 19, not provided in kit), line cord with strain relief, fuse-holder and mounting hardware, solder.
Note:—The following are available from Southwest Technical Products, Box 16297, San Antonio, Texas 78216: etched and drilled fiberglass circuit board, #M-7b, \$3.50; complete kit of all parts required, #M-7, \$19.10 plus postage, 3 lb.

HOW IT WORKS GATE MODULE

The Gate module contains three circuits: the gate generator, the 10-second measure command generator, and the 0-1 counter and overflow latch with indicators. The first two circuits, together with scalers C and D in the Scaler module, provide the time base, while the last circuit extends the range of the counter by half a digit and provides an indication to call attention to the fact that the input signal has exceeded the full counter capacity.

The gate generator accepts the 60-Hz power-line reference from the power supply module, filters and clamps it, and then applies it to a hex-inverter squaring circuit, IC1. Positive feedback, via C2, provides additional edge steepening, to

provide the 100-nanosecond rise and fall times required by the next stage.

A divide-by-three counter (IC2) uses a pair of flip-flops to reduce the 60-Hz input to a 20-Hz square wave. This circuit is twisted slightly from a "normal" divide-by-three circuit to save some PC board jumpers. The first flip-flop in IC3 divides the 20-Hz time-base signal into 10 Hz (a 0.1-sec period) which is the reference required to run scalers C and D on the Scaler module. The second flip-flop converts the output of scaler C which has a 10-sec period into a 10-sec on and 10-sec off measure command as required for the 0-200-Hz range.

The 0-1 counter and overrange latch is made up of IC4 driving transistors Q1 through Q3, which supply power to the appropriate front-panel indicator lamps.

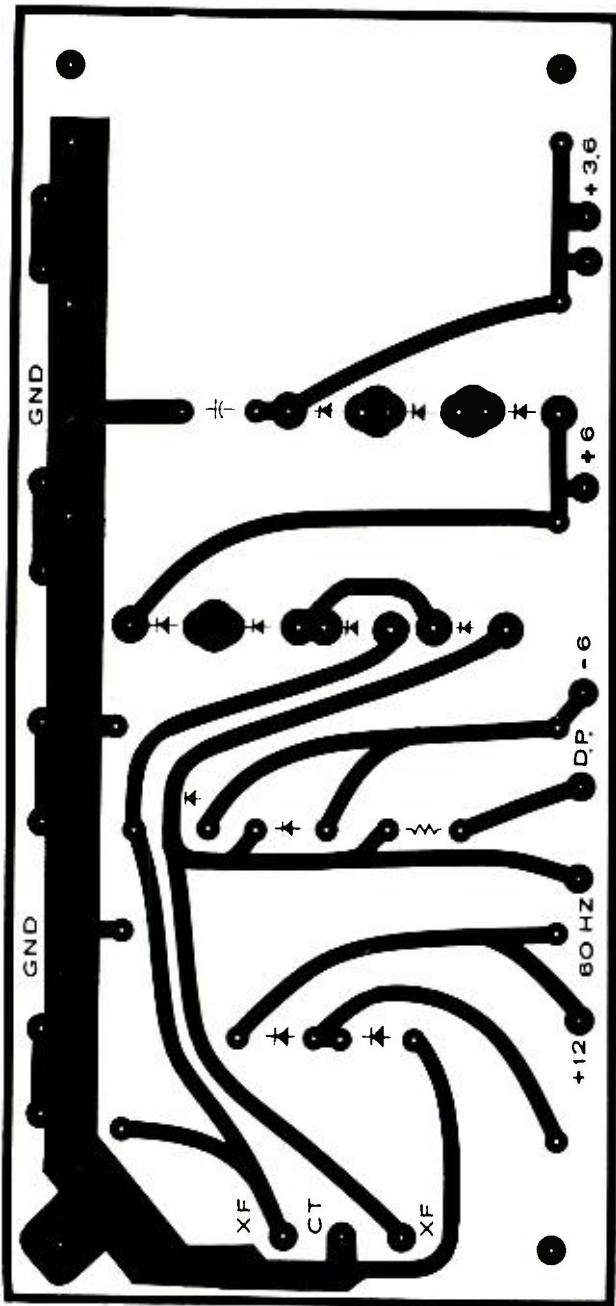

Fig. 14. Power supply foil pattern is the largest one in the instrument. It should be made on fiberglass to avoid heat damage from power diodes. To assist cooling, mount all diodes slightly off the board to allow cool air to circulate around them to dissipate the heat. Also, do not allow the diodes to touch the capacitors.

in Fig. 14. The power transformer (*T1*) and the fuse (*F1*) are mounted on the counter chassis. Use a G-10 fiberglass base for this circuit board so that it can withstand the heat generated by the power diodes. Drill holes as shown in Fig. 15.

To avoid stray coupling between modules through ground connections, it is

very important that all module grounds be isolated from each other and at very low impedance. For this reason, a wide ground buss is provided on the power supply circuit board, with a separate terminal for connections to each of the other modules. A separate #16 (or other heavy-gauge) wire should be run from each module to the ground buss. All

HOW IT WORKS POWER SUPPLY

The power supply must provide more than an ampere of current at 3.6 volts d.c. and other lower current supplies at +6, -6, and +12 volts. It also provides a.c. to the decimal point lamp and the Gate module.

To obtain all these voltages from a single power transformer requires a few more diodes than would normally be needed with a multi-winding transformer.

The +12-volt supply is derived from a voltage doubler consisting of *D1*, *D2*, *C1*, and *C2*. The supply is actually about 17 volts at the out-

put terminal; it is reduced to 12 volts by the decoupling network in the Comparator module. Similarly the full-wave rectifier made up of *D3*, *D4*, and *C5* provides about -9 volts, which is reduced to -6 volts in the Comparator.

A second full-wave rectifier (*D5* and *D6*) produces +6 volts with diodes *D7* and *D8* acting as a dynamic regulator. This supply is reduced by *D9*, *D10*, and *D11* to provide +3.6 volts for the integrated circuits. While the average current through diodes *D5* through *D11* is about one ampere, the peak current is much larger—high enough to damage ordinary silicon power diodes. That is why three-ampere silicon rectifiers are specified in the Parts List.

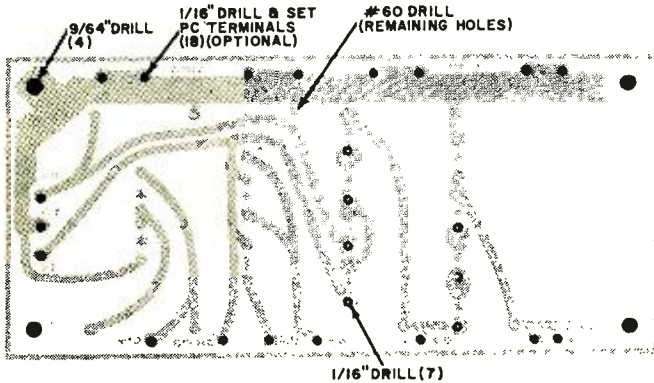
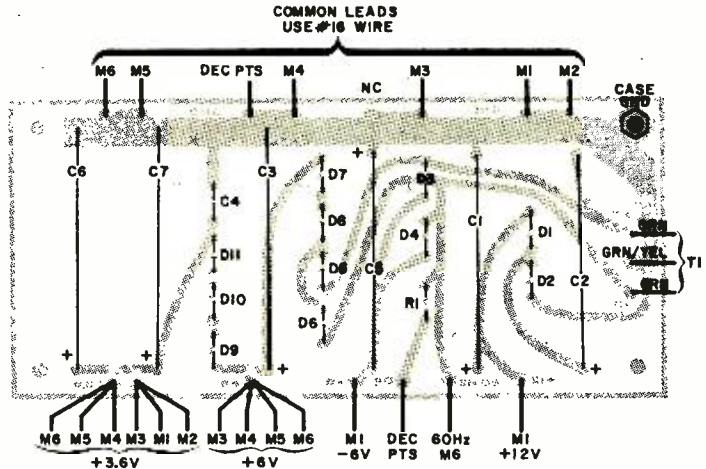

Fig. 15. There are no jumpers on the power supply board. After it is drilled, mount the components.

Fig. 16. Finish the power supply by mounting the components. Note that each module ground is made via an independent #16 gauge wire and one connection is made to counter case (upper right).



ground leads should be kept as short as possible.

Components are installed on the power supply board as shown in Fig. 16. Note that *C5* is upside down with respect to the polarity of the other capacitors. Note also that all diodes point in the same direction. Be sure that there is sufficient cooling space between the diodes and the

electrolytic capacitors since the latter can be damaged by diode heat generation.

Connect the power supply module to the case through a single ground lead. Do not run any other ground leads to the chassis except the return for *J1*, the INPUT jack.

NOTE: Final assembly, alignment, and calibration will be given next month.



Build a HAPPY HYBRID

TEN WATTS
FROM TUBES AND
TRANSISTORS

BY DEE LOGAN, WB2FBF

IT'S NO disgrace to operate the 40-meter band with a low-power rig—in fact, many veteran hams use flea-power transmitters just to see how well they can do. The secret, of course, is knowing when and how to operate.

The "Happy Hybrid" is a low-cost, low-power 40-meter transmitter that should interest both newcomer and veteran ham. It combines a voltage-regulated transistorized crystal oscillator and buffer, cou-

pled to a compactron vacuum tube containing both buffer and final amplifier. Despite its small physical size, the rig delivers 10 watts of clean, crisp CW.

Using a conventional half-wave dipole antenna, this transmitter has made itself heard over 700 miles away with excellent signal reports. By choosing your operating time with care, even greater distances can be reached.

A built-in power supply (see Fig. 1)

PARTS LIST

C1—68-pF silver mica capacitor
C2—82-pF silver mica capacitor
C3—110-pF silver mica capacitor
C4, C7, C8, C10, C11, C13, C14, C15—0.01- μ F disc ceramic capacitor
C5, C6—100-pF silver mica capacitor
C9—5.50-pF trimmer capacitor
C12—0.001- μ F disc capacitor
C16—325-pF variable capacitor (Hammarlund MC-325-M or similar)
C17—Dual 365-pF variable capacitor (both sections in parallel)
C18, C19—250- μ F, 20-volt electrolytic capacitor
C20, C21—50- μ F, 450-volt electrolytic capacitor
D1, D2—Silicon rectifier (GE A14F)
D3—9.1-volt zener diode (GE Z4XL9.1 or 1N1770)
D4, D5—1N5062 silicon rectifier diode
I1—6.3-volt pilot lamp (#44)
J1—Coaxial connector (SO-239)
J2—Phono jack
L1—30 turns #24 enameled wire on National XR-50 slug-tuned form
L2—20 turns #18 wire, 16 turns per inch, 1 $\frac{1}{4}$ " diameter (B&W Miniductor 3019)
L3—7-henry, 50-mA choke (Stancor C1707 or similar)
M1—0-50-mA meter
Q1, Q2—2N3859 transistor

Q3—Thyrector (GE X14)
R1, R7—27,000-ohm, 1/2-watt resistor
R2—10,000-ohm, 1-watt resistor
R3—470-ohm, 1/2-watt resistor
R4—6400-ohm, 1/2-watt resistor
R5—3300-ohm, 1/2-watt resistor
R6—200-ohm, 1/2-watt resistor
R8—10,000-ohm, 5-watt resistor
R9—47,000-ohm, 1/2-watt resistor
R10—15,000-ohm, 10-watt resistor
R11—5.1-ohm, 1-watt resistor
R12—220-ohm, 1-watt resistor
R13, R14—20-ohm, 5-watt resistor
R15—100,000-ohm, 10-watt resistor
RFC1-RFC4—2.5-mH r.f. choke (National R-50 or similar)
S1—S.p.s.t. switch
T1—Transformer: see, 460-0-460 V, 50 mA and 6.3 V, 2.5 A (Stancor PC-8418 or similar)
V1—6AD10 compactron
XTAL—7-MHz crystal
Z1—9 turns #16 wire on 1-watt, high-resistance resistor
Misc.—Masonite 4" x 6", metal chassis 3" x 7" x 12", crystal socket, transistor socket (2), 2-lug terminal strip none grounded (for Q3), multi-lug terminal strips, compactron socket, 7.5-watt lamp with socket and short length of coaxial cable and connector #12 bare copper wire, solder lugs, 3/4" insulated standoffs, rubber grommets, mounting hardware, etc.

delivers flameht, 9-volt, and B+ voltages using only one power transformer. Best of all, you can build the Happy Hybrid for about \$25 if you salvage some odd parts from your junk box.

Construction. The Happy Hybrid is designed to be built in three stages: the

oscillator, the power supply, and the r.f. amplifier. This method of construction permits you to test each section as it is built.

Oscillator. To make the oscillator board, cut a piece of pressed wood (masonite) into a 4" x 6" rectangle. Mount a 1/4" insulated standoff at each corner,

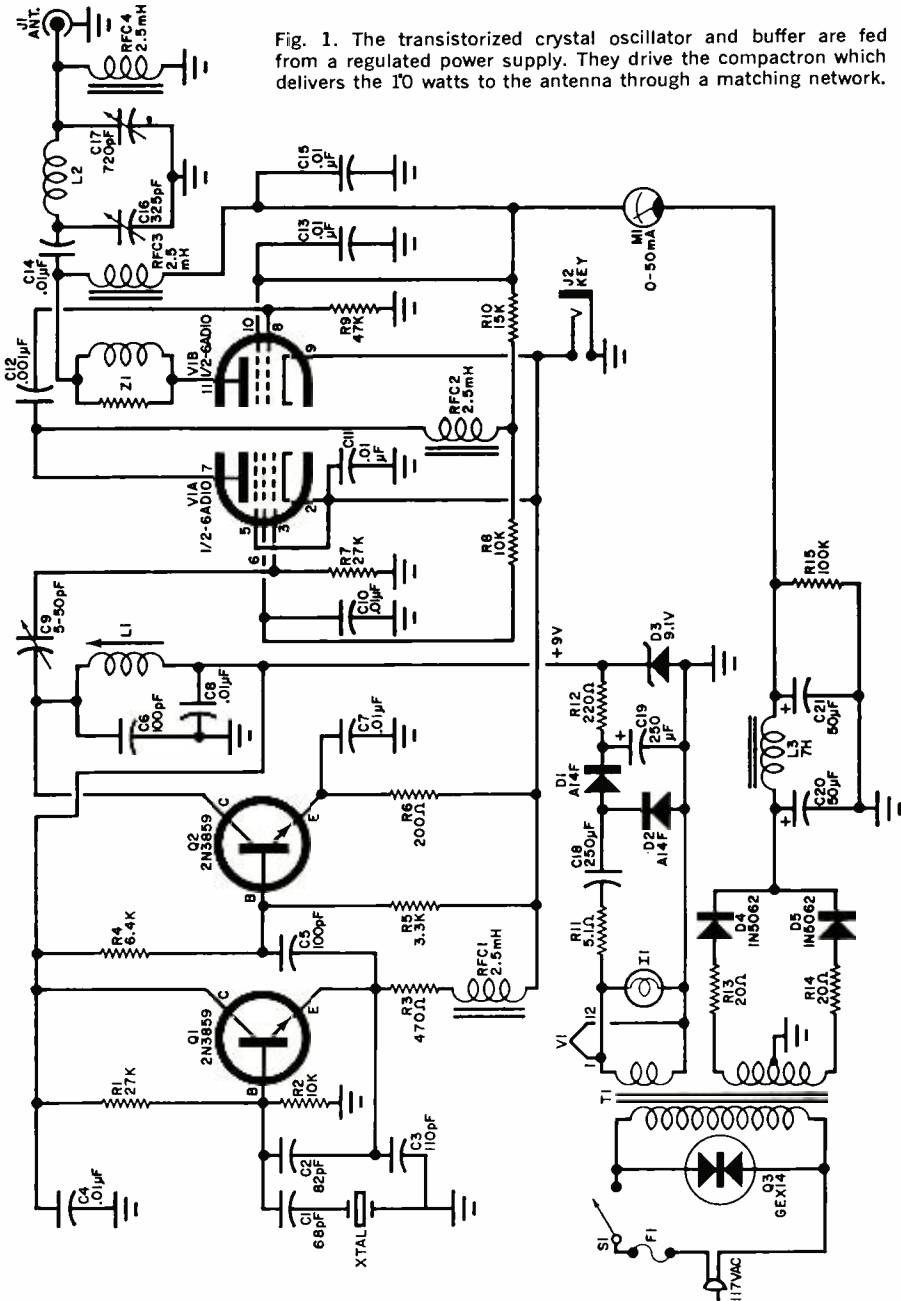

Fig. 1. The transistorized crystal oscillator and buffer are fed from a regulated power supply. They drive the compactron which delivers the 10 watts to the antenna through a matching network.

putting a solder lug between each stand-off and the board. Run a length of #12 bare wire around the bottom edge of the board, attaching it to the solder lug at each stand-off. This serves as a ground buss.

Mount the oscillator components as shown in Fig. 2, drilling holes in the board for each component. Use sockets for the transistors. Circuit wiring is point-to-point, with the component leads used where they are long enough. Use insulated hookup wire for the rest of the circuit. Be careful to dress all components and leads close to the board to avoid shorts when the board is mounted on the metal chassis.

Tank coil *L1* consists of 30 turns of #42 enameled wire on a National XR-50 slug-tuned form. A small piece of plastic electrical tape (or coil dope) can be used to secure the winding. Once installed in the circuit, check the resonant frequency of the coil with a grid-dip meter to make sure that it resonates in the 7-MHz band. You may have to trim the coil if a junk-box coil form has been used instead of the XR-50.

Besides the common ground connection, you will need a common tie point

for the keying ground, one for the r.f. output of *C9*, and one for the 9-volt connection.

Once the oscillator is complete, install the crystal and transistors and connect a conventional 9-volt transistor radio battery between the 9-volt connection and the common ground. Test the oscillator by shorting the keying connection to ground and listening for the CW signal in a nearby receiver, tuned to the crystal frequency. Once the oscillator is working properly, put it aside and build the rest of the circuit in the metal chassis.

Power Supply. Power transformer *T1* and choke *L3* are mounted at the top rear of the chassis while power switch *S1* and pilot light *I1* are on the front apron. The keying jack, *J2*, can be placed anywhere you wish. Mount fuse holder *F1* on the rear apron of the chassis and use multi-lug terminal strips to mount the rest of the power supply components under the chassis near the transformer (see Fig. 3). When soldering the diodes in the power supply, use a long-nose pliers as a heat sink on the leads to avoid thermal damage to the semiconductors. Also, be sure to observe the cor-

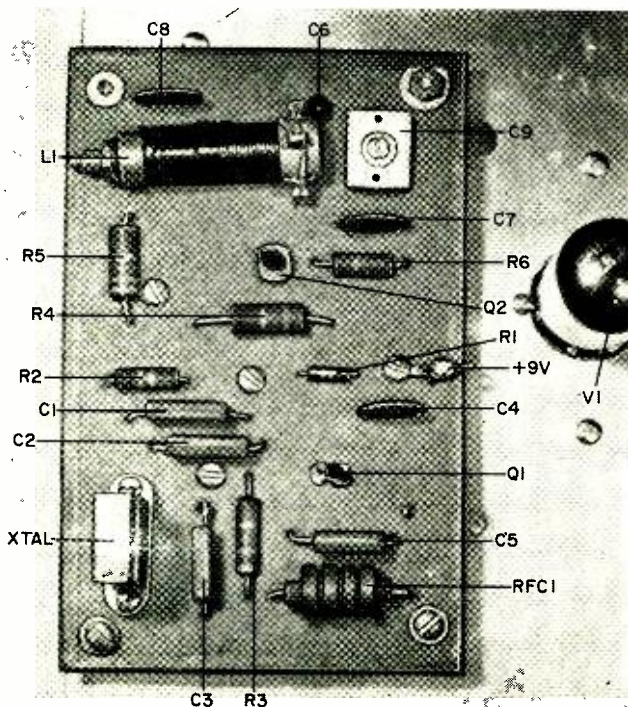
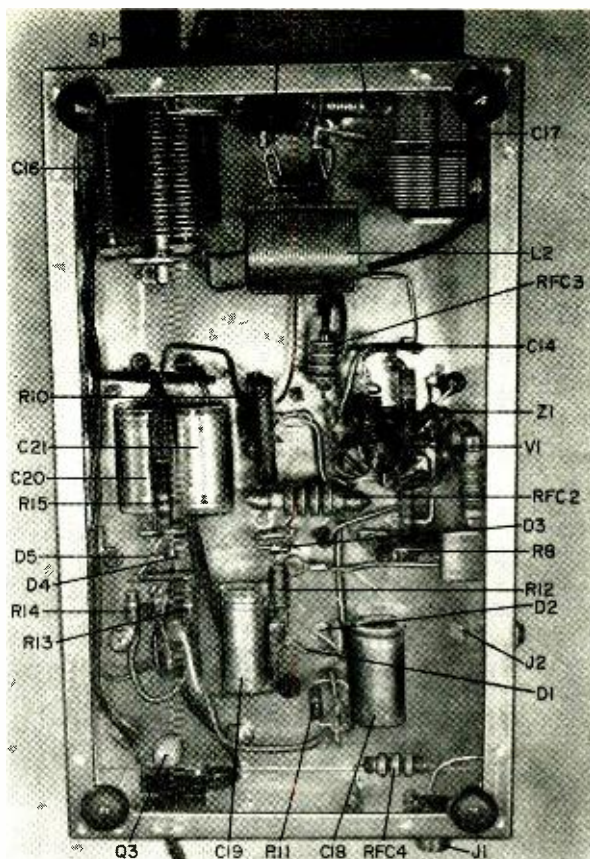

Fig. 2. The oscillator is built up perf-board style, using a piece of fiber board as the chassis. Interconnection is made via component leads or short pieces of wire. There are two different grounds, one for actual ground and the other for the keying lead. The +9 volts and the keying lead are passed through the metal chassis via a rubber grommet, as is the r.f. drive for the tube.

Fig. 3. Use good r.f. wiring practice when assembling the final amplifier and antenna circuit. Keep all r.f. leads as short as possible and use heavy wire from the plate of V1B to the antenna. Although the keying jack (J2) is shown at one side, it can be mounted anywhere.



HOW IT WORKS

The circuit consists of a two-transistor broad-band crystal oscillator and buffer (Q1 and Q2) driving a vacuum-tube buffer and power amplifier (V1).

The oscillator is designed for broad-band operation with crystals in the 3- to 20-MHz range, with further experimentation possible on other amateur bands by modification of the tank circuit. The r.f. signal is generated in the circuit containing Q1 and is buffered by Q2 to raise it to a level sufficient to drive the vacuum tube. Trimmer capacitor C9 is used to set the maximum driving level of the tube.

The first half of the tube, V1A, is a buffer pentode and the second is an amplifier which increases the signal level to feed the antenna through a pi-coupling network (L2, C16, and C17). This tank combination will match a fairly wide range of antenna impedances.

A conventional full-wave rectifier composed of D4 and D5 with associated filtering components supplies the B+ (about 250 volts) for the vacuum tube. The voltage from the filament winding of T1 heats the filament of V1 and is also applied to a doubler circuit (D1 and D2) to generate a d.c. voltage high enough to avalanche the 9-volt zener diode, D3. This is the power source for the transistors.

Protection against incoming line transients that could damage the semiconductor components is provided by thyrector Q3, which effectively removes the spikes before they get into the power transformer.

rect polarities of the electrolytic capacitors and rectifiers diodes.

R.F. Section. There is nothing critical about the parts placement in this section but good pre-planning for tie points is important. The two pi-network variables (C16 and C17) are mounted at the front of the chassis, as is meter M1. Put antenna connector J1 on the rear apron of the chassis. Parasitic suppressor Z1 is made by winding nine turns of #16 wire on a 1-watt resistor body. Although the resistor is used only as a coil form, it should not be too low in value or it will affect the operation of the suppressor—1000 ohms or more should do.

You can follow the author's layout of the tube socket and r.f. components, using good r.f. wiring practice. After all r.f. wiring has been completed, check the frequency of the pi network using a grid dip meter and adjusting the coil turns (if necessary) for proper frequency.

Connect the B+ to the r.f. section and
(Continued on page 111)

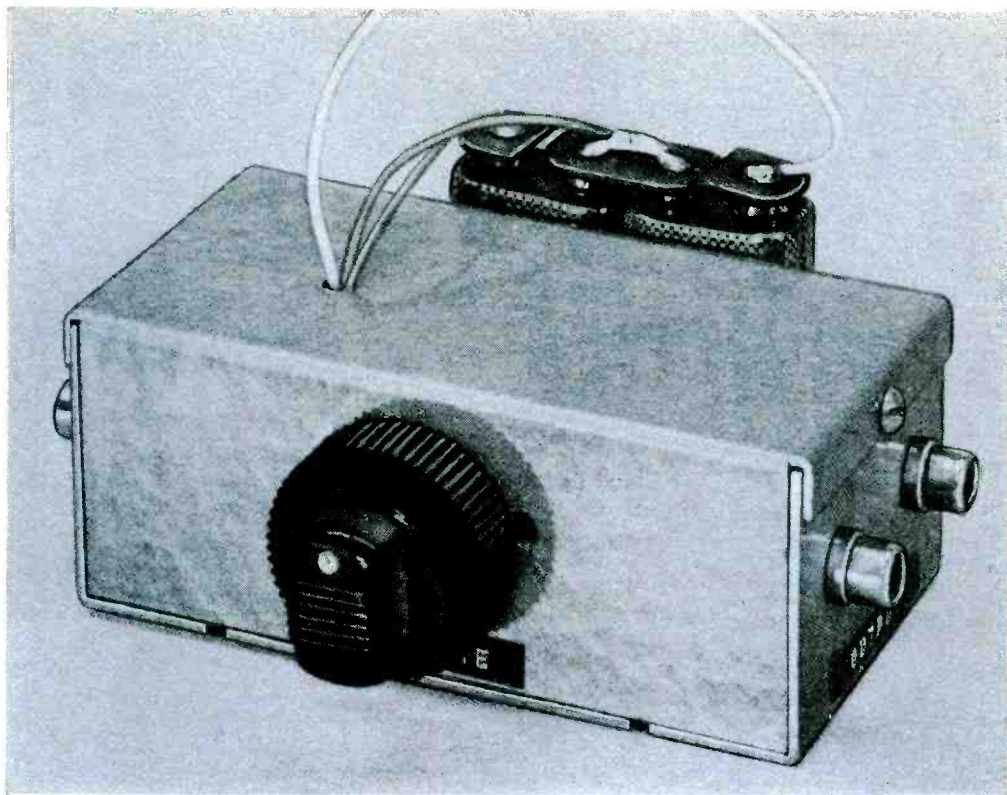

IC Stereo Preamplifier

PROVIDES HIGH-QUALITY AMPLIFICATION FOR NAB TAPE, RIAA PHONO, AND BROADBAND AUDIO

BY PAUL B. JARRETT, M.D.

DO YOU need a good, new stereo preamplifier with all kinds of "extras"? Here is an IC Stereo Preamp that has provisions for NAB tape-head equalization (for both $3\frac{3}{4}$ and $7\frac{1}{2}$ in./s) and RIAA magnetic phono inputs. It can also be used as a general-purpose broadband preamplifier.

Built around a recently developed integrated circuit, the preamplifier has very low input noise (half a microvolt, typically), an output of 4.5 volts r.m.s., and

a channel separation of 60 dB minimum at 10 kHz. The design is also short-circuit proof. The preamp is small enough to fit under the chassis of a small power amplifier. Power requirements are so modest that the preamp can be driven by a pair of transistor radio batteries if desired.

The integrated circuit used here (Motorola MC1303P) actually contains a matched pair of preamp circuits with identical characteristics.

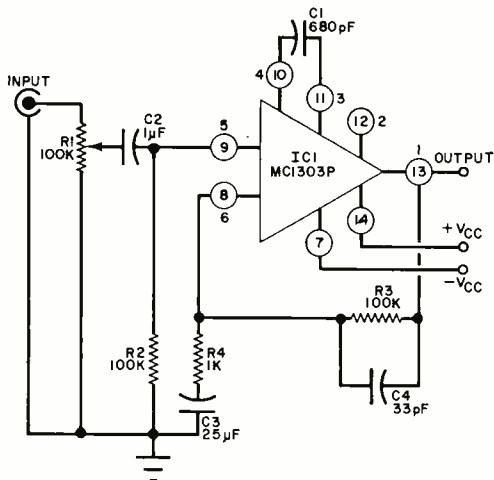

Fig. 1. The general-purpose broadband preamplifier is useful for microphone and tuner inputs. Only half of stereo system is shown in all diagrams.

PARTS LIST

- C1—680-pF capacitor*
 - C2—1- μ F, 3-volt electrolytic capacitor*
 - C3—25- μ F, 3-volt electrolytic capacitor*
 - C4—33-pF capacitor
 - IC1—Dual stereo preamplifier integrated circuit (Motorola MC1303P)
 - R1—Dual (concentric), audio-taper, 100,000-ohm potentiometer
 - R2, R3—100,000-ohm, $\frac{1}{2}$ -watt resistor*
 - R4—1000-ohm, $\frac{1}{2}$ -watt resistor*
 - Misc.—RCA phono jacks (4), 14-contact, in-line IC socket (Augat 314-A61D or similar), metal chassis, perf board, set of concentric knobs, wire, etc.
- *Two required—one for each channel.

Circuits. For a broadband, general-purpose preamplifier, use the circuit shown in Fig. 1. Only half of the circuit is shown with the terminal connections to the IC shown in the circles. For the second channel, duplicate the circuit, but use the IC pin numbers that are outside the circles in Fig. 1. Note that pins 2 and 12 are not used and that the volume controls for the halves are concentric.

For an NAB tape-head equalized preamp, use the circuit shown in Fig. 2. Again, only half of the circuit is shown, connected to the circled pin numbers of the IC. The duplicate half of the circuit uses the uncircled pin numbers. The value of C4 depends on the tape speed. Both values are given in the Parts List and you can use both, with a switch, if necessary.

To make a magnetic phono playback preamp with RIAA equalization, use the circuit in Fig. 3. If you have trouble ob-

taining the 750,000-ohm resistor used in this circuit, use one of 820,000 ohms.

Construction. The author used perf board construction in a small aluminum case. With a little care, you could also build your own printed circuit board and mount the complete preamp in any type of chassis. You can even mount it on standoffs in the power amplifier and probably obtain operating power from the amplifier power supply.

To prevent possible damage to the IC, you may find it advantageous to use a 14-contact, in-line IC socket (see Parts List for Fig. 1). You can then complete the wiring of the circuit and examine it for possible errors without subjecting the IC to the possibility of heat damage or accidental voltage reversal. Note that the IC has a standard orientation mark on one end. Looking down at the top of the IC, the pins are numbered from 1 to 14

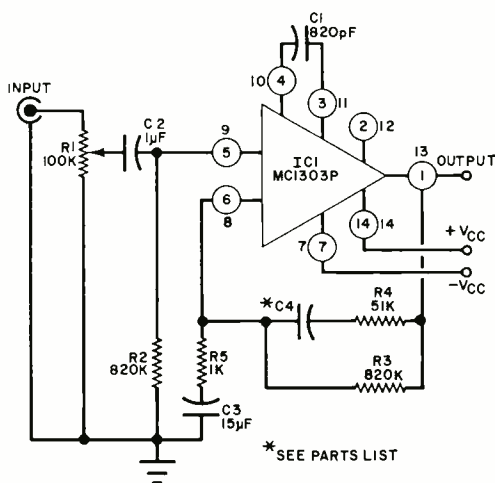
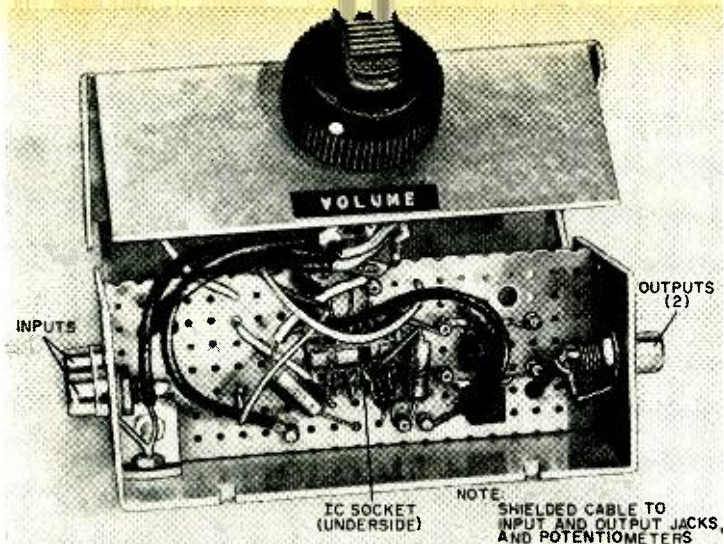

Fig. 2. This NAB tape-head equalized preamp can be preset for either 3 $\frac{3}{4}$ in./s or 7 $\frac{1}{2}$ in./s depending on value selected for C4 (can be switch selected).

PARTS LIST

- C1—820-pF capacitor*
 - C2—1- μ F, 3-volt electrolytic capacitor*
 - C3—15- μ F, 3-volt electrolytic capacitor*
 - C4—1500-pF capacitor* (3 $\frac{3}{4}$ in./s, see text)
 - C4—910-pF capacitor* (7 $\frac{1}{2}$ in./s, see text)
 - IC1—Dual stereo preamplifier integrated circuit (Motorola MC1303P)
 - R1—Dual (concentric), audio-taper, 100,000-ohm potentiometer
 - R2, R3—820,000-ohm, $\frac{1}{2}$ -watt resistor*
 - R4—51,000-ohm, $\frac{1}{2}$ -watt resistor*
 - R5—1000-ohm, $\frac{1}{2}$ -watt resistor*
 - Misc.—See Fig. 1.
- *Two required—one for each channel



The IC preamplifier can be fabricated on perf board. A 14-lead in-line socket may be used to save possible damage to IC while soldering it into the circuit. Use shielded leads for the input and output, and to (coaxial) potentiometers.

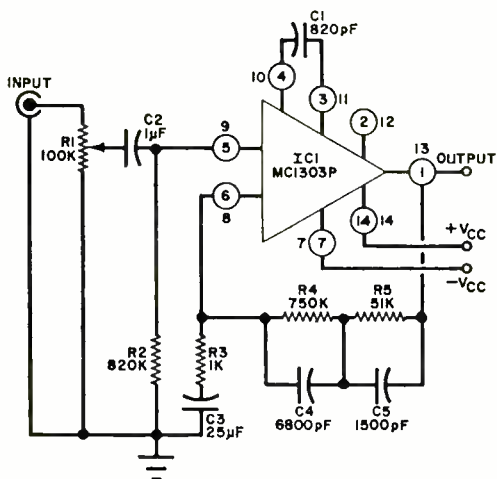

Fig. 3. This circuit is used for RIAA equalization for magnetic phono playback. A slight change in R4 value can be made (see text) without doing harm.

PARTS LIST

- C1—820-pF capacitor*
- C2—1-µF, 3-volt electrolytic capacitor*
- C3—25-µF, 3-volt electrolytic capacitor*
- C4—6800-pF capacitor*
- C5—1500-pF capacitor*
- IC1—Dual stereo preamplifier integrated circuit (Motorola MC1303P)
- R1—Dual (concentric, audio-taper, 100,000-ohm potentiometer
- R2—820,000-ohm, ½-watt resistor*
- R3—1000-ohm, ½-watt resistor*
- R4—750,000-ohm, ½-watt resistor*
- R5—51,000-ohm, ½-watt resistor*
- Misc.—See Fig. 1.
- *Two required—one for each channel.

counterclockwise from the identifying mark.

The entire circuit, with the exception of the input and output jacks and the

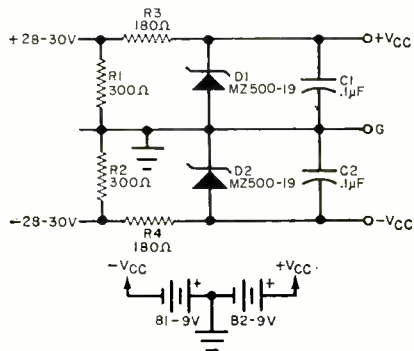

Fig. 4. The preamplifier can be powered either by a zener-regulated circuit (top) or a pair of nine-volt conventional transistor radio batteries (lower).

PARTS LIST

- B1,B2—9-volt transistor radio battery (optional)
- C1,C2—0.1-µF capacitor
- D1,D2—Zener diode, 13-volt (Motorola MZ-500-19 or similar)
- R1,R2—300-ohm, 3-watt resistor
- R3,R4—180-ohm, 2-watt resistor

concentric volume control, is constructed on the perf (or PC) board. Use shielded leads between the input and output connectors and the potentiometer, and between the potentiometer and the first component in the circuit.

For a power supply, the author used a pair of 9-volt transistor batteries. The two batteries were connected in series, with the common center connected to ground. The +V_{cc} was then +9 volts and -V_{cc} was -9 volts. If you are using a conventional power amplifier with a power supply of 28 to 30 volts, use the reduction circuit shown in Fig. 4. -30-

OVSHINS

Does the Ovshinsky Effect signify a new era in semiconductors?

BY JOHN P. ROBINSON, JR.

DOES THE IDEA of a miniaturized computer so small it could be used in your home, the classroom, or even your automobile sound interesting? Or, if you were an electronic equipment manufacturer, do you think electronic switches and memory cells that are smaller and less expensive than transistors would sound appealing? Would military equipment that is resistant to radiation make the Department of Defense happier?

All of these things can be achieved through the use of a hitherto neglected semiconductor material—glass! This may sound strange. Glass is used in telescopes, microscopes, drinking utensils, windows, and a host of other applications. But as a semiconductor—never!

It's perfectly possible, says Stanford R. Ovshinsky, a remarkable, self-educated man of 46 who lives in Troy, Michigan, a suburb of Detroit, with his wife Iris, who has her PhD in biochemistry. Leading physicists from all over the world apparently agree with him and are cautiously calling his devices a major breakthrough greater than the tunnel diode, possibly exceeding the laser.

The principle on which the new devices are based is called the Ovshinsky Effect. Briefly stated, it is the ability of certain boron- and oxide-based glasses and materials composed of tellerium and/or arsenic (in combination with other elements including germanium and silicon) to function as semiconductors. (In the 1950's, a Russian team at Leningrad conducted intensive experiments on these materials—but unsuccessfully. Despite their painstaking investigations, they missed being the first to discover the Ovshinsky Effect.)

These materials are called amorphous (shapeless) or disordered because of their random, irregular, and unpredictable atomic structure. They contrast sharply with conventional semiconductor materials which are crystalline in atomic structure and are therefore regular, orderly, geometric, predictable, and measurable. The latter are the materials used to make transistors and diode rectifiers with which we are so familiar; and semiconductor research for the last 20 years has been concentrated in this area. Little attention has been given to



Stanford R. Ovshinsky, President, and Dr. Iris M. Ovshinsky, Vice President, of Energy Conversion Devices, Inc. visualize a great future for Ovonics.

semiconductors that are amorphous in structure.

Now, threshold switches and memory cells are being manufactured and tested at Ovshinsky's plant, Energy Conversion Devices. Called "Ovonic" devices, each unit consists of a thin film of amorphous, semiconductor glass connected to two leads. The unit, or cell, suddenly changes from a nonconductor to a conductor when a preset voltage is applied. By varying the composition or the thickness of the vacuum-deposited glassy film, the firing voltage can be made to be anywhere between two and two hundred volts.

It is claimed that Ovonic memory units can store information for prolonged periods of time even though power has been removed. Conventional memory cells must have electric power applied constantly. Tests made on Ovonic memories seemingly prove both their ability to store information for a minimum period of six years and their durability, inasmuch as information has been stored on them and then erased over a million times.

Ovshinsky has attracted the attention of eminent scientists from many parts of Europe. One of them is Sir Nevill

Mott, director of the Cavendish Laboratory at Cambridge University, England, who, early in November, reportedly called the Ovshinsky development one of the newest, biggest, most exciting discoveries in the physical sciences at the present time. There is some indication that the Ovshinsky Effect represents a completely new area of knowledge. Others interested in Ovonics are Isador Rabi, Nobel Laureate and retired professor of physics at Columbia University; physicists at Stanford, Harvard, Penn State and Delaware; as well as Jan Tauc of the Czechoslovak Academy of Sciences in Prague.

Who is Ovshinsky? Not a scientist in the formal sense of having a degree, Ovshinsky graduated from Hower Trade School in Akron, Ohio and has worked as a machinist. Despite his lack of formal education, his colleagues in the physical sciences are quick to admit how well read he is and how extensive is his knowledge of physics.

Although he had been experimenting with amorphous materials since 1958 and started up his modest firm in 1960 to continue his research and manufacture Ovonic devices, the prime information on their chemical composition was a closely guarded secret until 1966 when he was granted the first of his patents. Once he had received patent protection, he decided to publish a short technical paper explaining his discovery. This paper appeared in *Physical Review Letters*, November 11, 1968. Until that time the physical data behind his discovery was unknown except to a few companies with whom he had licensing agreements, granted with the proviso that any security leaks nullified the agreement.

In his recently published paper, Ovshinsky described components which switch from a nonconducting to a con-

Editor's Note: The unusual solid-state effect discussed in this article has been described as a phenomenon shrouded in mystery. Few unbiased scientists will comment on the Ovshinsky Effect; some researchers have reported parallel developments, but mostly our "sources" adopted a wait-and-see attitude. For what it's worth—here are the facts as they stand on December 15, 1968.

ducting condition in the incredible time of only 150 trillionths of a second. A typical Ovonic device which consists of 48% tellerium, 30% arsenic, 12% silicon and 10% germanium is made up of a microscopic layer of this material sandwiched between two electrodes. This material acts as a barrier until the voltage reaches a predetermined level. Conduction starts and continues until the voltage drops below the firing level.

There is a second type of glassy material developed at Energy Conversion Devices which remains in the conducting state indefinitely, without the necessity for continued application of external voltage. To return this device to its nonconducting state, all that is needed is the application of a second voltage pulse.

OVshinsky has made it very clear that the principle he discovered is not based on transistor technology, and furthermore, he is not competing with transistors.

Another characteristic of these devices is their ability to operate on alternating current, a virtue not possessed by crystalline semiconductors, which are unidirectional and can only operate on direct current. Conventional semiconductors require at least two units to function efficiently on a.c.—one for the positive cycle, the other for the negative cycle.

Easy to Manufacture. Industrially, the new materials have practical advan-

tages. Manufacture is relatively cheap and simple. The chemicals for the devices are weighed out on a simple scale, mixed with a paddle, and then put into an oven to bake for 24 hours until they fuse into a lump of opaque glass having a dark gray color.

This is a simple procedure compared to the very careful methods used to manufacture conventional semiconductor devices, which have to have a high degree of purity, must be grown from "seeds," and then precisely doped with very carefully measured impurities.

Conventional crystals are easy to work with because their atomic structures are arranged in such predictable patterns that the various changes that take place in them can be measured with high accuracy. Because of this measurable characteristic, it was possible during the last two decades to improve the techniques of manufacture of transistors, diodes, and integrated circuits.

In spite of technical advancements in the preparation of crystalline semiconductors, however, many are rejected because of flaws of one kind or another. Alternatively, amorphous semiconductors do not have to be doped because their conduction characteristics are inherent in the device itself. For this reason, plus some of the other advantages mentioned above, technologists conclude that the amorphous devices are cheaper and easier to manufacture.

James Perschy of the Applied Physics

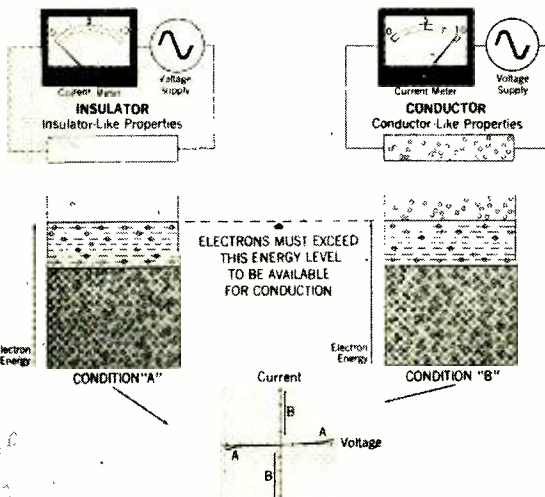

The Ovonic device has a voltage sensitive threshold and, in the absence of any applied voltage, the device acts like an insulator. If voltage is applied across the Ovonic device, the electron energy in the thin film is increased until a point is reached where conduction takes place. This transition from the property of an insulator to a conductor takes place in an incredibly short time. The threshold may be adjusted by the chemical mix in the very thin film. Some Ovonic devices even remain "on" after the applied voltage has been removed.

Looking into the future, a flat screen TV picture may evolve using Ovonic devices. The face of the tube would be prepared in a matrix involving conducting strips, phosphor and Ovonic threshold switches. The TV picture quality would be similar to that obtained through a shadow mask used in color TV transmissions.

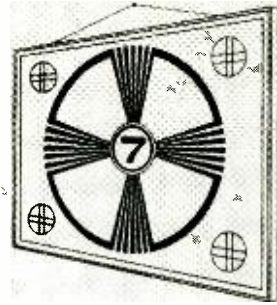
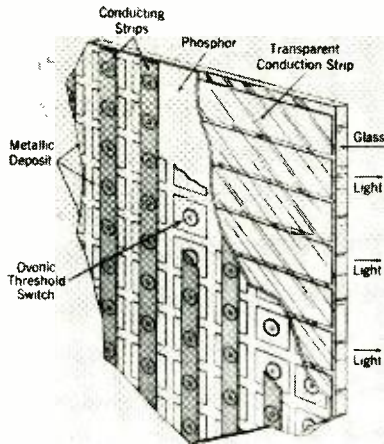

Laboratory at Johns Hopkins University, where glass semiconductor switches are being tested in memory addressing circuits, has stated that the devices are potentially very reliable because they can probably be manufactured in batches. This means they require fewer processing steps than are needed to prepare conventional semiconductor circuits. Perschy said this reliability results because the glass material does not require a junction between dissimilar metals, as some conventional semiconductors do.

It is Ovshinsky's feeling that the carriers (holes and electrons) in glass semiconductors do not hop like those in crystals. Instead, they polevault or play leapfrog. By selecting glassy materials having strong covalent bonds, the scientist is able to work with carriers which are locked in place. The degree of locking is related directly to the energy band gap in the material. This determines the threshold voltage needed to dislodge the carriers. When the carriers are knocked out of their locked-in position by the proper voltage, they bombard other carriers and dislodge them. This starts an

avalanche effect and conduction begins.

In crystalline semiconductors, carrier collisions and thermal effects recombine electrons and holes, thereby cutting off carrier movement. In glass semiconductors, this does not seem to take place. The reason, according to Ovshinsky, is the exceptionally high mobility of the carriers which lowers their mass allowing them to zoom past or through the recombination centers.

Physicists admit that much remains to be learned about the "how" and the "why" of the physics of glass semiconductors, but they are working on them with zeal and enthusiasm.

In the area of miniaturization, it is felt that Ovonic devices can be integrated into other circuits easily in that a glass chip in the amorphous state can be applied over another device.

Scientists, industrialists, financiers and even average citizens are watching with great interest the activities going on under Mr. Ovshinsky's direction. Perhaps something as memorable will emerge from the American Troy as that which came from ancient Troy. -50-

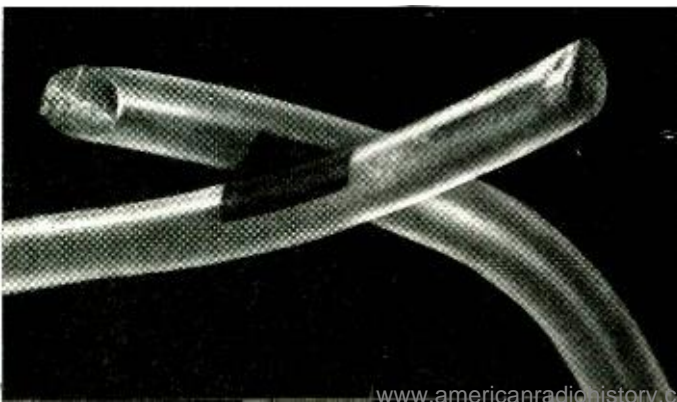

This highly magnified view is of a rudimentary Ovonic device. Between the two wire conductors is a thin film insulating ion with Ovonic qualities. At some low voltage threshold the insulator switches over to conduction. Manufacturing Ovonic devices is claimed to be easy.

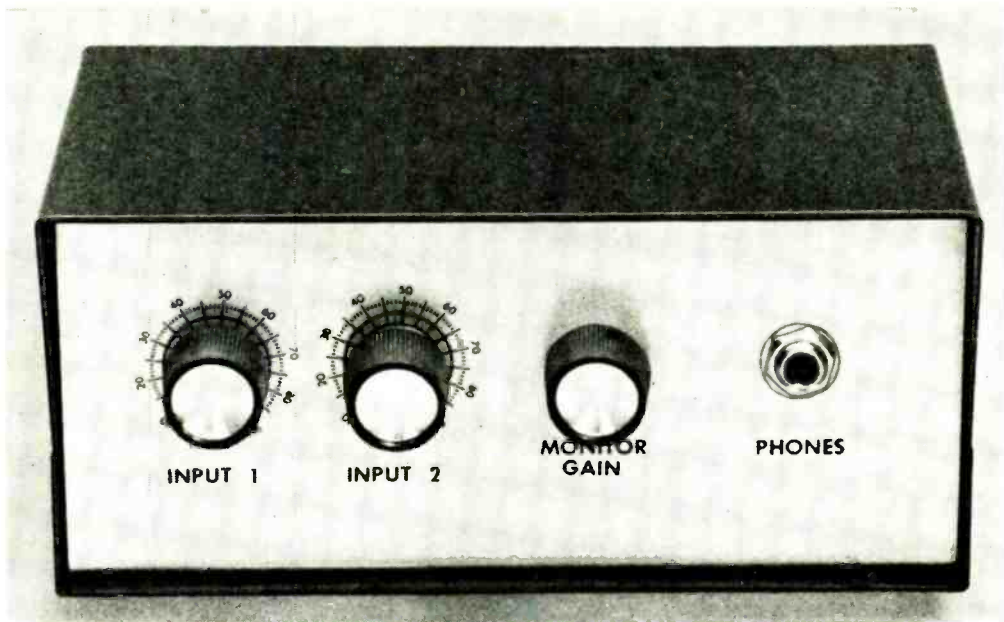

SOUND-WITH-SOUND MIXER

With Pre-Record Monitoring

BY DOUG DeMAW, W1CER

WHY NOT produce "at home" recordings comparable to those of a professional studio? You can with this simple "Sound-With-Sound Mixer." The secret is in monitoring the output of the mixer and listening to what the recording is going to record—rather than using the ordinary monitoring system of guessing or listening after the tape is made.

You will find many other advantages to the Mixer besides improving the quality and versatility of your recordings. Short-wave listeners, for instance, can use it to make station reports or prepare a permanent log. (Many SWL's are preparing tape archives by recording off the air and adding personal comments—including dates, times, etc.—over the desired signal.) Or, why not spark up your blasé voice letters by mixing from two microphones or adding some novel sounds or music to the tape?

Adding a background to taped letters

is far from new. But until now, the most common method of adding it to the voice track was through acoustical pickup from a speaker system. The problems encountered with this method are numerous: room acoustics may not be ideal, noise may interfere, and the frequency range is limited to that of the microphone. As a result, the background sounds "dead" because of sound degradation.

To obtain high-quality recording, a direct electrical hookup is best, and the Sound-With-Sound Mixer was designed to do just that. In addition to providing amplification and mixing, it also has a monitor output that lets you hear what you're recording before it gets into the tape recorder.

The background source can be an FM or AM tuner or short-wave receiver. No preamplification of the signal is required. You simply plug the source into one channel of the Mixer and set the level; then plug in the microphone and set its

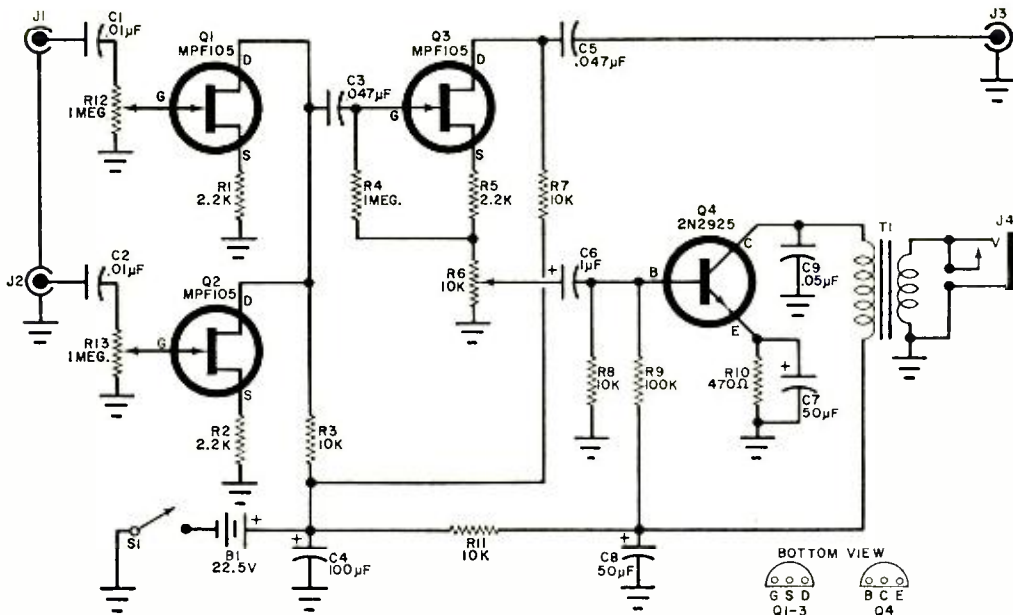

After preamplification and mixing take place in Q1 and Q2, signal is fed to output through Q3; Q4 is monitor amp.

PARTS LIST

- B1—22.5-volt battery
 C1, C2—0.01- μ F disc capacitor
 C3, C5—0.047- μ F disc capacitor
 C4—100- μ F, 25-volt electrolytic capacitor
 C6—1- μ F, 6-volt electrolytic capacitor
 C7—50- μ F, 6-volt electrolytic capacitor
 C8—50- μ F, 25-volt electrolytic capacitor
 C9—0.05- μ F disc capacitor
 J1-J3—Phono jack
 J4—Phone jack
 Q1-Q3—Field effect transistor (Motorola MPF-105)
 Q4—Transistor (General Electric 2N2925)
 R1, R2, R5—2200-ohm
 R3, R7, R8, R11—10,000-ohm
 R4—1-megohm
 R9—100,000-ohm
 R10—470-ohm
 R6—10,000-ohm linear-taper potentiometer
 R12, R13—1-megohm audio-taper potentiometer
 S1—S.p.s.t. switch (part of R6)
 T1—Impedance-matching transformer, 1000-ohm primary, 8-ohm secondary
 Misc.—Printed circuit board; battery clip; $\frac{1}{2}$ " metal spacers; 7"x3 $\frac{3}{8}$ "x3 $\frac{1}{2}$ " aluminum utility box; wire; solder; knobs; hardware, etc.

crophone or guitar-pickup mixer. It can even be used as a private listening system so that you don't disturb others around you.

Construction. The use of a printed circuit board (etching guide shown full-size in Fig. 1) greatly simplifies and speeds construction of the Mixer. All components, except for input and output jacks, the controls, and the battery mount directly on the circuit board as shown in Fig. 2.

Except that the signal leads between the circuit board and the jacks and controls must be as short as possible, construction is not critical. When you have mounted all components on the board, mount the circuit board, using four sets of machine hardware and $\frac{1}{2}$ " metal spacers as shown in Fig. 3. Then mount J1, J2, and B1 on the rear apron of the metal box and J3, J4, and the controls on the front apron.

Assemble the metal box, and identify the various controls and jacks with a tape writer or a dry-transfer lettering kit, and the Sound-With-Sound Mixer is ready.

How To Use. Since high impedances are involved, it is necessary that you use

level so that the voice signal can easily fade in and out or override the background.

The Mixer can be used with virtually any tape recorder, tape deck, or audio amplifier that has a high-impedance input (usually the microphone input). It can also be used as a two-channel mi-

Fig. 1. In this actual-size printed circuit board etching and drilling guide, minimum amount of copper is removed from the board. Extra copper provides good heat sink during soldering and helps economize on etchant.

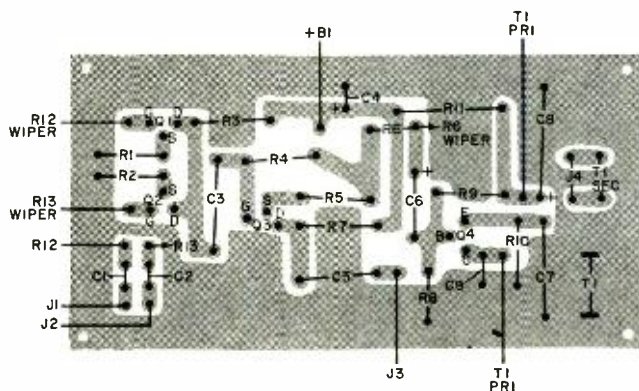
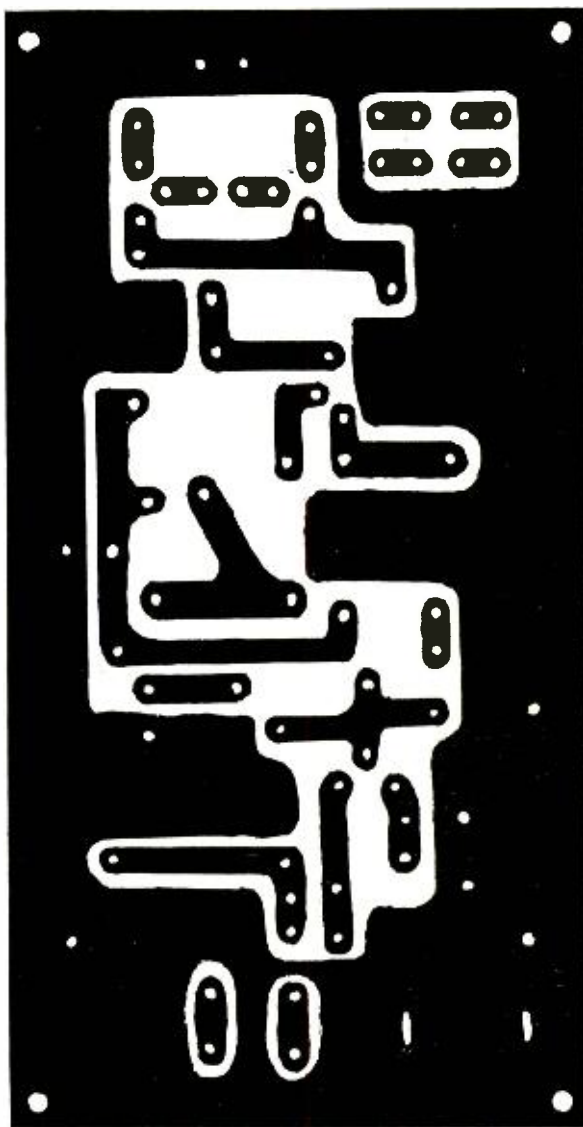

Fig. 2. In wiring circuit board, connect negative lead of B1 and remaining terminal of control R6 to chassis ground or ground foil on the board. Insert and solder tabs of T1 in oblong holes that are designated for T1 in drawing.



50 functions in a single chip. The functions of 50 separate transistors, diodes, resistors and capacitors can now be performed by the tiny dot in the center of the integrated circuit held by the tweezers.

The "Chip" ...will it make or break your job future?

TINY ELECTRONIC "CHIPS," each no bigger than the head of a pin, are bringing about a fantastic new Industrial Revolution. The time is near at hand when "chips" may save your life, balance your checkbook, and land a man on the moon.

Chips may also put you out of a job...or into a better one.

"One thing is certain," said *The New York Times* recently. Chips "will unalterably change our lives and the lives of our children probably far beyond recognition."

A single chip or miniature integrated circuit can perform the function of 20 transistors, 18 resistors, and 2 capacitors. Yet it is so small that a thimbleful can hold enough circuitry for a dozen computers or a thousand radios.

Miniature Miracles of Today and Tomorrow

Already, as a result, a two-way radio can now be fitted inside a signet ring. A complete hearing aid can be worn entirely inside the ear. There is a new desk-top computer, no bigger than a typewriter yet capable of 166,000 operations per second. And it is almost possible to put the entire circuitry of a color television set inside a man's wristwatch case.

And this is only the beginning!

Soon kitchen computers may keep the housewife's refrigerator stocked, her menus planned, and her calories counted.

Money may become obsolete. Instead you will

simply carry an electronic charge account card. Your employer will credit your account after each week's work and merchants will charge each of your purchases against it.

Doctors will be able to examine you internally by watching a TV screen while a pill-size camera passes through your digestive tract.

New Opportunities for Trained Men

What does all this mean to someone working in Electronics who never went beyond high school? It means the opportunity of a lifetime—if you take advantage of it.

It's true that the "chip" may make a lot of manual skills no longer necessary.

But at the same time the booming sales of articles and equipment using integrated circuitry has created a tremendous demand for trained electronics personnel to help design, manufacture, test, operate, and service all these marvels.

There simply aren't enough college-trained engineers to go around. So men with a high school education who have mastered the fundamentals of electronics theory are being begged to accept really interesting, high-pay jobs as engineering aides, junior engineers, and field engineers.

How To Get the Training You Need

You can get the up-to-date training in electronics fundamentals that you need through a carefully

POPULAR ELECTRONICS

chosen home study course. In fact, some authorities feel that a home study course is the best way. "By its very nature," stated one electronics publication recently, "home study develops your ability to analyze and extract information as well as to strengthen your sense of responsibility and initiative." These are qualities every employer is always looking for.

If you do decide to advance your career through spare-time study at home, it makes sense to pick an electronics school like the Cleveland Institute of Electronics. We teach only Electronics—no other subjects. And our courses are designed especially for home study. We have spent over 30 years perfecting techniques that make learning Electronics at home easy, even for those who previously had trouble studying.

Your instructor gives your assignments his undivided personal attention. He grades your work, analyzes it, and he mails back his comments the same day he gets your lessons, while everything is still fresh in your mind.

Always Up-to-Date

Because of rapid developments in Electronics, CIE courses are constantly being revised. This year, for example, CIE students are receiving exclusive up-to-the-minute lessons in Microminiaturization, Logical Troubleshooting, Laser Theory and Application, Single Sideband Techniques, Pulse Theory and Application, and Boolean Algebra. For this reason CIE courses are invaluable not only to newcomers in Electronics but also for "old timers" who need a refresher course in current developments.

Get FCC License or Money Back

No matter what kind of job you want in Electronics, you ought to have your Government FCC License. It's accepted everywhere as proof of your education in Electronics. And no wonder—the Government licensing exam is tough. So tough, in fact, that without CIE training, two out of every three men who

Tiny TV camera for space and military use is one of the miracles of integrated circuitry. This one weighs 27 ounces, uses a one-inch vidicon camera tube, and requires only four watts of power.



take the exam fail. But better than 9 out of every 10 CIE graduates who take the exam pass it.

This has made it possible to back our FCC License courses with this famous Warranty: you *must* pass your FCC exam upon completion of the course or your tuition is refunded in full.

Mail Card for Two Free Books

Want to know more? The postpaid reply card bound in here will bring you a free copy of our school catalog describing today's opportunities in Electronics, our teaching methods, and our courses, together with our special booklet on how to get a commercial FCC License. If card is missing, use the coupon below.

ENROLL UNDER NEW G.I. BILL

All CIE courses are available under the new G.I. Bill. If you served on active duty since January 31, 1955, or are in service now, check box on reply card for G.I. Bill information.

CIE Cleveland Institute of Electronics

1776 East 17th Street, Cleveland, Ohio 44114

NEW COLLEGE-LEVEL COURSE IN ELECTRONICS ENGINEERING

for men with prior experience in Electronics. Covers steady-state and transient network theory, solid state physics and circuitry, pulse techniques, computer logic and mathematics through calculus. A college-level course for men already working in Electronics.

Cleveland Institute of Electronics
1776 East 17th Street, Cleveland, Ohio 44114

Please send me without cost or obligation:

1. Your 44-page book "How To Succeed In Electronics" describing the job opportunities in Electronics today, and how your courses can prepare me for them.
2. Your book on "How To Get A Commercial FCC License."

I am especially interested in:

- | | | |
|--|---|--|
| <input type="checkbox"/> Electronics Technology | <input type="checkbox"/> Broadcast Engineering | <input type="checkbox"/> First Class FCC License |
| <input type="checkbox"/> Electronic Communications | <input type="checkbox"/> Industrial Electronics | <input type="checkbox"/> Electronics Engineering |

Name _____ Age _____

Address _____

City _____ State _____ Zip _____

Check here for G.I. Bill information.

PE-80

Accredited Member National Home Study Council • A Leader in Electronics Training... Since 1934

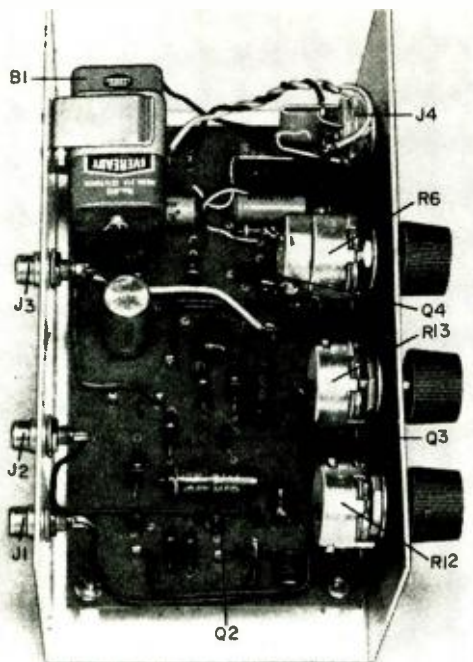

Fig. 3. Metal spacers should be used to support the circuit board away from the chassis. Mount the board as shown; then wire the controls, battery, and jacks into the circuit.

HOW IT WORKS

Each input stage of the mixer contains a field effect transistor (*Q1* and *Q2* in the schematic) that preserves the proper high-impedance match required by the input transducers (microphone, guitar pickup, etc.). With power applied to the Mixer, separate audio signals fed in through *J1* and *J2* are amplified by the respective FET stages. The amount of gain for *Q1* is controlled by *R12*, while *R13* controls *Q2*'s gain. (Each channel produces about 6 dB of gain, suggesting that the mixer could be used as a straight pre-amplifier should the need ever arise.)

Since the drain leads of *Q1* and *Q2* are parallel connected, after amplification the two discrete signals from these transistors mix, producing a single composite signal. The new signal is then coupled into phase-splitter *Q3*, then out to the tape recorder through *J3*.

Additionally, a portion of the composite signal is coupled to monitor amplifier stage *Q4* to provide a convenient source-monitor output through *J4* to low-impedance headphones. Any amplification provided by this stage is in addition to that obtained from *Q1* and/or *Q2*, and overall amplification is independently controlled by *R6*.

shielded cables for interconnections between the Mixer and other equipment to minimize hum pickup. Also, these cables should be as short as practical.

When using the Mixer with a tape recorder or deck, always set the "Record

Gain" control as suggested for normal operation with a microphone. Then, while feeding the desired signals into the mixer, adjust the gain control of the channel you want to predominate for full recording level as indicated on the recording monitor.

The level of the remaining Mixer channel can then be adjusted while you listen through the monitor amplifier output. Then any further adjustments of gain, such as for fade-ins and fade-outs, should be made with *R12* and *R13* on the Mixer.

If you should encounter any high-level hum problems when using the mixer with a line-operated recorder or amplifier, reverse the a.c. plug. Should this fail to clear up the problem, connect a separate grounding lead from the chassis of the mixer to the chassis of the recorder or amplifier.

The Sound-With-Sound Mixer is capable of a fairly wide frequency range, and its output signal is free of most noise and distortion. Current drain under normal operation is on the order of 8 mA, so battery life should be long—provided the power is turned off when the Mixer is not in use. —50—

MATH

Doorway to Higher Pay

DON'T BE SCARED
OUT OF A GREAT CAREER

BY DAVID L. HEISERMAN

MATHEMATICS is an indispensable tool in electronics technology. It is the medium through which engineers and technicians learn, understand, and apply the abstract theories of electronics. Lacking the proper training in, or the proper attitude toward higher mathematics, confines you to half-true analogies, oversimplified theories, and limits your efficiency to the frustration of trial-and-error techniques.

If you are planning to start a career in electronics or have decided to update and upgrade your professional standing, chances are that your math background needs refurbishing. Certainly, if you expect to compete for the sophisticated, higher-paying positions in modern electronics, your mastery of mathematics will have to go beyond high school algebra and trigonometry.

The purpose of this article is twofold: to reaffirm that mathematics is the

language and shorthand of electronics, and to demonstrate that it is a system of logic ideally suited to electronics technology. You will find here an idea of the level of math proficiency required for a mastery of electronics theory in several areas of specialization. Finally, if you feel the need for more math training, we suggest an appropriate course from one of the home-study schools listed in this article.

Only you can decide how far you want to pursue a career in electronics. If you decide to forge ahead, your knowledge will always be in demand; if not, your present education may become obsolete.

A Language And System of Logic. Just as a picture can take the place of a thousand words, a mathematical equation can accomplish the same thing in electronics technology. In fact, mathematics is the language (and shorthand) of science and technology. It is unsurpassed in accuracy and—believe it or not—simplicity.

The mathematically untrained electronics technician, for example, does not usually appreciate that the Ohm's Law equation $E = I \times R$, represents a brief, accurate summary of all the relationships that exist between voltage, current, and resistance in d.c. circuits.

Mathematics doesn't just trade prose for endless complicated equations. Using math as a system of logic, the number of equations that a technician must memorize is reduced to a handful, from which many other equations can be derived. You memorize Ohm's Law for voltage, but you derive by mathematical logic—mainly algebra—the current formula ($I = E/R$) and resistance formula ($R = E/I$).

You will often encounter a problem that contains two or more factors that do not fit neatly into one all-inclusive formula. In this case, logic dictates that you combine as many of the given factors as you can in an appropriate equation, and if necessary, work from there with other equations.

The ability to interpret the language of mathematics gives you the advantage of continuing your education without having to return to school every few years. You can tackle undiluted abstract technical literature to become familiar

with current devices, developments, and techniques. Mathematics is the key to understanding and applying electronics theory, the language of the best electronics textbooks, and the system of logic for the design and analysis of circuits.

CORRESPONDENCE SCHOOLS

Schools offering complete math training programs:

American School
Drexel Avenue at 58th Street
Chicago, Ill. 60637

American Technical Society
850 E. 58th Street
Chicago, Ill. 60637

Britannica Schools, Inc.
425 N. Michigan Avenue
Chicago, Ill. 60611

Capitol Radio Engineering Institute
3224 16th Street, N.W.
Washington, D.C. 20010

DeVry Institute of Technology
4141 Belmont Avenue
Chicago, Ill. 60641

International Correspondence Schools
Scranton, Pa. 18515

National Radio Institute
3939 Wisconsin Avenue, N.W.
Washington, D.C. 20016

National School of Home Study
229 Park Avenue South
New York, New York 10003

National Schools
Figueroa and Santa Barbara Avenues
Los Angeles, Calif. 90037

Schools offering math as part of their electronics training programs. Individual math courses not available:

Cleveland Institute of Electronics
1776 E. 17th Street
Cleveland, Ohio 44114

Grantham School of Electronics
1505 N. Western Avenue
Hollywood, Calif. 90027

Radio Television Training of America
229 Park Avenue South
New York, New York 10003

REQUIREMENTS FOR VARIOUS ELECTRONICS JOBS AND POSITIONS

PROFESSION OR JOB TITLE	ELECTRONICS SKILLS	REQUIRED MATHEMATICS	SAMPLE EQUATION
Radio-TV repairman	Troubleshoot and repair r.f. and a.f. circuits	Algebra: basic operations powers and roots Trigonometry: knowledge of sine, cosine, and tangent functions	$P = \frac{E^2}{R}$
Communications maintenance and repair; FCC license	Troubleshoot and repair r.f. and a.f. circuits; some circuit modification and design	Algebra: mastery, including logarithms Trigonometry: basic operations	$P_x = 20 \log \frac{P_o}{P_i}$
Industrial electronics maintenance and repair	Troubleshoot and repair logic and control circuits and systems; a great deal of modification and some design	Algebra: mastery Trigonometry: mastery Calculus: understand basic terminology	$i = \frac{V}{R(1 - e^{-t})}$
Laboratory or research assistant (not necessarily electronics labs)	Maintain, troubleshoot, and repair standard and specialized electronic equipment; extensive circuit modification and some design	Algebra: complete mastery Trigonometry: complete mastery Calculus: familiarity with basic operations Some specialized math	$q = \int_0^T i dt$
Electronic design and associate engineer	Primarily circuit design and modification; usually require an associate degree, but available if you have extensive experience and are thoroughly grounded in electronics theory	Algebra: complete mastery Trigonometry: complete mastery Calculus: knowledge of differential and integral techniques	$f(x) = \left(\frac{1}{2\pi}\right)^{1/2} \int g(t)e^{jxt} dt$

How Much Math Is Enough? As you probably have deduced, the more math you master, the better will be your grasp of electronics. But to find out how much is actually enough depends on what area of specialization you pursue, what is required of you on the job, and a multitude of other things that vary from employer to employer. Even within the same specialty, more mathematics background can be required of one technician than that required of another.

There are different levels in the technician echelon. For example, there is the "service" technician whose main job is to repair consumer and some commercial items; he can get by on high school

algebra and trigonometry. Then there is the "line" technician whose duties are to check and align completed electronic devices; he needs essentially the same math background as the service technician with possibly some elements of advanced algebra. Finally there is the "engineering" or "lab" technician whose duties may include simple design, fabrication, modification, and test and calibration work; he, obviously, needs to know a great deal more math than either the service or line technician. In fact, engineering technicians must have a firm grasp of college-level mathematics, such as calculus, statistics and probability.

(Continued on page 114)

BY HERBERT
& PHYLLIS COHEN

The Not Altogether Forgotten ELECTRET

*Renewed interest in charged dielectric
brings back memory of
invention that never made it*

THE HISTORY of electronics is also a history of curious discoveries that flashed on the scene, enjoyed short popularity, and faded into oblivion. Some discoveries, such as the Lilienfeld "transistor," were made too early to be appreciated. Other temporarily forgotten discoveries (the reflex circuit, for example) have been reactivated to serve short-term needs.

One nearly forgotten discovery has recently been dusted off so that scientists can take another look at its use in electronics. Called an "electret," this physics curiosity is the electrostatic analog of the permanent magnet. Just as a permanent magnet exhibits a fixed magnetic field; an electret has a fixed *electrostatic* field.)

When first discovered, the electret was expected to replace the magnet in motors, generators, microphones, loudspeakers, etc. Experimental devices using electrets as high-voltage generators have been built. The Japanese used electret sound-powered telephones during World War II. And in the mid-1930's, Dr. Andrew Gant reported making an electret string

voltmeter with a deflection sensitivity of 0.1"/volt and an input resistance of 10,000 megohms.

A new telephone microphone using an electret and a solid-state amplifier is now being tested by the Northern Electric Laboratories, Ottawa, Canada. The electret capacitor microphone may enable a 90% reduction in the normal telephone operating current. Further experiments using the electret in electrostatic speakers are also taking place.

How an Electret Is Formed. Some similarity exists between the action of a capacitor and the forming of an electret. If a capacitor is charged from a d.c. source, the excess of electrons on the negative plate will repel the orbiting electrons in the atoms of the dielectric material. Conversely, the lack of electrons on the positive plate will attract the orbiting electrons of the dielectric toward the positive plate. The electrons in the dielectric will never break away from their atoms, but the polarizing charge will distort their orbits about the individ-

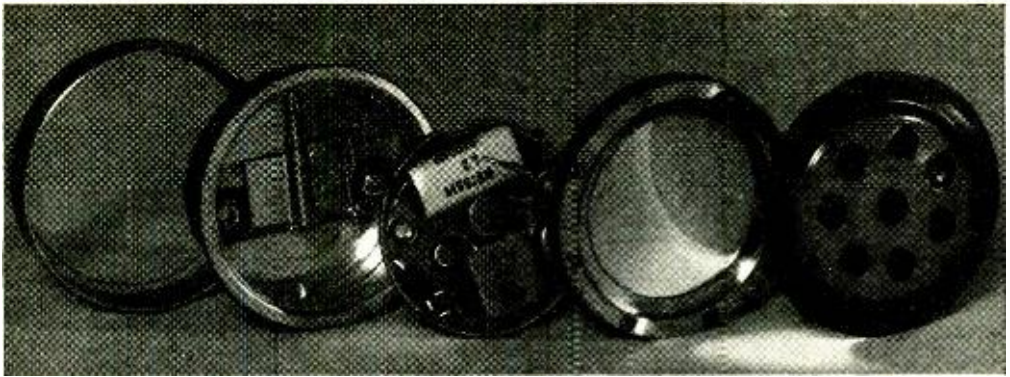

Electret telephone microphone developed by Northern Electric Co. Ltd. of Canada reduces normal operating current by 90%, offers good quality reproduction. Electret diaphragm is shown second from right.

ual atoms. In addition, crystal lattices will also shift from their original positions and attempt to align themselves with the voltage field (orientation polarization). When the capacitor is discharged, the electrical conditions return to normal and the dielectric resumes its neutral state.

Suppose that once the dielectric is polarized it can be "frozen" in its new state; and after discharging the capacitor, the dielectric maintains its charge. Under this condition, the capacitor can be discharged again and again with no loss in the dielectric charge. (This does not mean that the capacitor would become a battery. Current will flow only at the instant of discharge.)

The First Electret. In 1925 the first permanently charged dielectric was made by the Japanese physicist, Dr. Eguchi, bringing into existence the first electret in history. To make his electret, Dr. Eguchi melted carnauba wax between two metal plates; and while the wax was still molten, he applied a high voltage to the plates. The wax was then cooled while the high-voltage remained on the plates.

When the wax had solidified and the high voltage was removed from the plates, the wax was tested for a surface charge. The newly formed electret had a large electrostatic charge which after a few days remained constant for several months. The wax had picked up what was later called a hetero-charge. The face of the wax closest to the high-voltage (positive) anode had picked up a

negative charge, the other side a positive charge.

Dr. Eguchi also found that when a carnauba wax electret was formed in a greater than 10,000-volt/cm field its initial hetero-charge decayed to zero within two weeks, then reversed polarity and grew in amplitude in the opposite direction. After several weeks the new charges reached the level of the original hetero-charge, but in the opposite polarity, and remained constant.

These new charges were called homo-charges since the reversed polarity of the electrical field exhibited the same polarity as the field that formed the electret. The homo-charge was found to be far

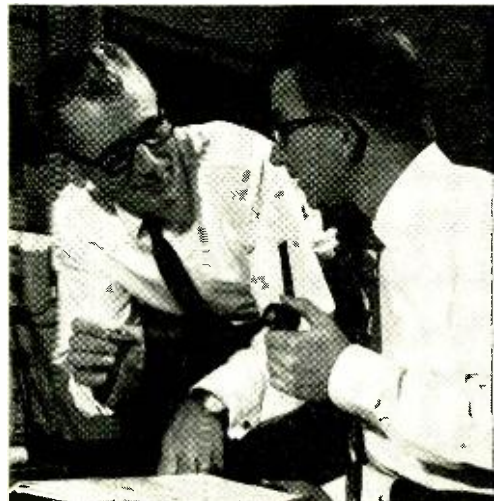

Peter Fatovic (l.) and Kees Reedyk (r.) of Northern Electric Laboratories examine electret transducer.

more permanent than the original hetero-charge, lasting as long as several years.

One experimenter's carnauba wax electret was formed in a 20,000-volt/cm field. Tested periodically by drawing a spark from it the electret after 12 years showed no apparent loss of charge.

What Is an Electret? Ever since the first electret was formed, several theories have been advanced as to its nature. None of these theories has been proven, but the ones most widely accepted were put forth by Dr. Gamant and Bernard Gross, which—if not identical—are basically the same. Both suggest that there are different mechanisms that cause the hetero- and homo-charges to be formed.

The hetero-charge is said to result from orientation polarization of dipole groups and ion displacement. The homo-charge is formed by free positive and negative charges developed on the surface of the electret during the forming process. These positive and negative charges then travel through the electret and compensate for the hetero-charges.

As the electret cools and solidifies in the presence of a high-voltage field, crystal lattices are formed, becoming aligned in the direction of the field. Called

oriented dipoles, the crystal lattices also exhibit positive and negative charges. At the same time, the high potential gradient between the electrodes and the electret surfaces produces ions and free electrons on the opposite surfaces of the electret material.

After the electret is formed and stored away for aging, the free charges travel through it and try to compensate for the oriented dipoles. On the positively charged surface, a cloud of negative charges forms, but after some time the net negative charges cancel out half of the positive charges of the oriented dipoles. This does not mean, however, that all charges are neutralized. The negative charges are on a different energy level than the dipoles and can only hover around them, preventing the dipole field from appearing on the electret surface.

The surface charge is 50% negative and 50% positive. Therefore, the total charge is zero. As the charges that appear on the surface to compensate for the dipoles increase, the electret's surface charge reverses and converts from a hetero- to a homo-charge. The free charges help to keep the dipoles in place and give the homo-charge a much longer useful life.

One of the strange problems with electrets is the "short-circuit" effect. As soon as a newly formed electret is removed from the charging field, its active surfaces must be short-circuited by wrapping the electret in metal foil, or by sandwiching it between two metal plates that are electrically shorted together. The electret must be kept short-circuited at all times when not in use, because if it is left exposed it will rapidly lose its charge. Although most of the charge can be recovered by reshorting the electret after a few minutes of exposure, repeated exposures will result in cumulative permanent loss.

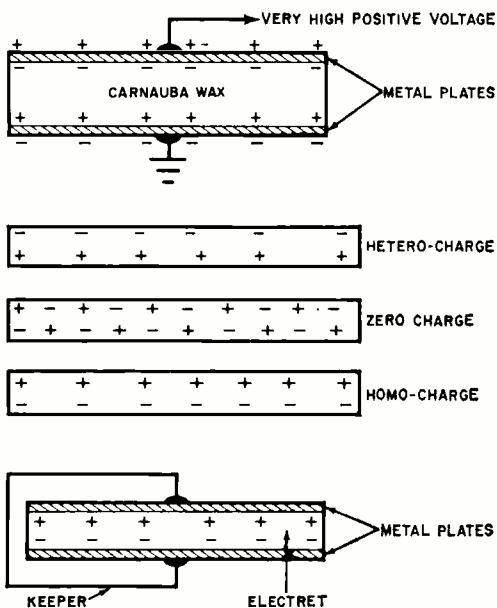

Electret is formed in high-voltage field (top). Original charge reverses polarity after two weeks (center). Charge losses are minimized by keeper (bottom).

Electret Materials. Not all dielectric (insulating) materials exhibit electret properties. Glass, paraffin wax, and many plastics have no electret properties whatever. Other materials, such as resins and sulphur, develop only hetero-charges no matter how high a charging voltage is applied to them. But the list of materials that develop both hetero- and homo-charges is long and still growing.

Electret properties have been found to exist in many vegetable waxes, beeswax, shellacs, lacquers, sugar, and even ice. Recently, excellent results have been obtained from such plastics as lucite, nylon, neoprene, and polymethyl, and a great deal of interest has been generated by mylar and teflon film electrets.

A search for ceramic electrets is also under way—with the objective of finding a material that exhibits a high charge density, improved temperature stability, and longer life. Most of the titanate family seems to have electret properties, especially calcium titanate, bismuth titanate, and steatite. These three ceramics have unique characteristics that may in-

dicate a breakthrough in electret technology. Their one great advantage is that they do not have to be short-circuited to preserve their charge after being formed.

It now remains to find practical and economical uses for the electret in electronics. Certainly, the electret has proved—if only experimentally—to be a rugged, long-life transducer. But whether or not it will find a place in modern electronics, possibly even become a basic ingredient in modern technology, is now in the hands of scientists, engineers and experimenters working with it. Who knows, the electret may even turn out to be as important as the transistor. —30—

Making an Experimental ELECTRET

YOU CAN MAKE an electret from readily available materials in the privacy of your home workshop. The “forming” equipment consists of a simple oven (a can of Sterno “liquid heat” plus a hotplate platform will do) and a very-high-voltage power supply. A 6” square by $\frac{1}{8}$ ” thick piece of lucite is ideal for the electret itself.

After cutting the lucite square to the proper size, clean it thoroughly to remove dirt, grease, and other foreign matter. Then dry the lucite and set aside in a clean, dry place.

Prepare the oven (see Fig. 1) using several bricks and an 11” x 8” x $\frac{1}{8}$ ” aluminum plate. First thoroughly clean the aluminum plate. Then construct the hotplate supports, spacing the two rows of bricks 10” apart. Set the plate over the bricks, and slide a can of Sterno under the aluminum plate. Measure the distance between the top of the can and the plate; it should not be less than 8”.

Place the lucite at the center of the aluminum plate, open the can of Sterno, and ignite the liquid. Heating the lucite to the proper consistency for forming will take a half hour or more. In the mean time, you can proceed with setting up the very-high-voltage power

supply. (You can build an appropriate supply from scratch as described in an upcoming article, or you can use the very-high-voltage power supply in your portable TV receiver.)

If you use the TV power supply, move the receiver over to your work bench. DO NOT plug in the line cord. Remove the back cover of the TV set and locate, but do not touch, the high-voltage anode connection. This connection is usually made directly to the flared section of the picture tube (see Fig. 2).

Bear in mind that in the following steps you will be dealing with potentials on the order of 14,000 volts or more.

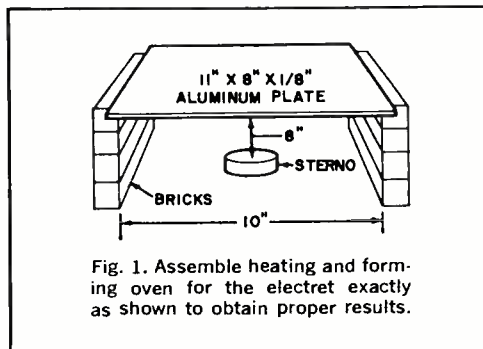

Fig. 1. Assemble heating and forming oven for the electret exactly as shown to obtain proper results.

Caution cannot be overstressed. Even if you have to go to extremes, be careful when working around or with the high-voltage power supply. If you have a pair of electricians' rubber gloves, so much the better.

First, cut away 6" of insulation from one end and about 1/2" from the other end of a 3' length of stranded, heavy-duty hookup wire. Firmly wrap the 6" of bared wire around the metal shaft of a plastic handle screwdriver (preferably

lead cable. Clip one cable to the high-voltage anode connection, and cover both the alligator clip and connection thoroughly with high-voltage tape. The other end of this cable will be connected later.

Place the TV set with its back facing and about 2' from the oven. Then connect the remaining cable from chassis ground of the TV set to the aluminum plate of the oven.

Check the lucite. If it is done, you

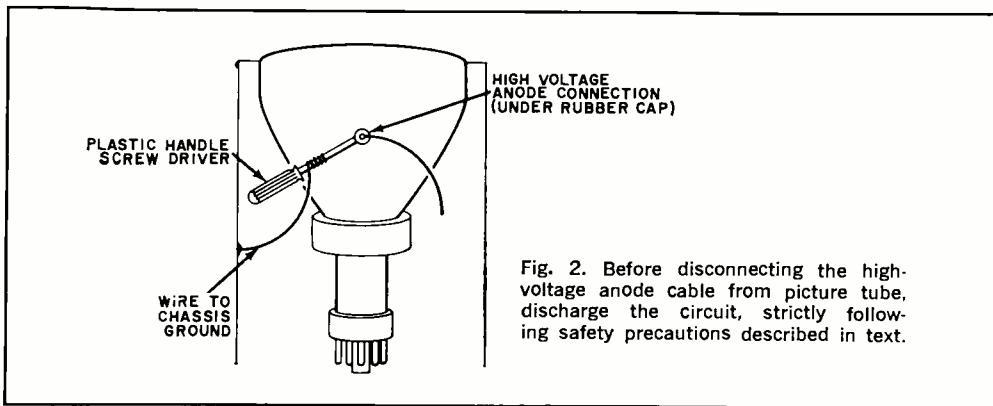

Fig. 2. Before disconnecting the high-voltage anode cable from picture tube, discharge the circuit, strictly following safety precautions described in text.

one with an extra rubber or neoprene grip), and hold it in place with a couple of layers of tape. Then, solder an alligator clip to the other end of the wire.

If you have rubber gloves, don them now. If not, wear a long-sleeve shirt, buttoned at the cuffs, and put the hand you will not be using into your pocket. In either case, however, do not allow any part of your body to touch the chassis of the TV set under any circumstances.

Connect the alligator clip directly to the chassis of the TV set, and carefully grasping the screwdriver by the handle only, slide the flat blade under the rubber suction cap of the anode connector as shown. When you see a spark at the blade and/or hear the snapping sound of sudden discharge, remove the screwdriver. Immediately disconnect the anode cable by firmly squeezing the suction cap and pulling outward. Touch the exposed metal "hooks" under the anode cap several times to the chassis to completely discharge the high-voltage rectifier circuit.

Now, solder an alligator clip to each end of two lengths of heavy-duty test

should detect a strong odor of acetone and, when it is touched with the blade of a screwdriver, the lucite should have the consistency of soft rubber. If the lucite appears to be ready for forming, place a 4"-square of aluminum foil directly over the center so that 1" of the plastic is showing on all sides.

Touch contact the bare alligator clip from the high-voltage anode cable to the center of the aluminum foil. Carefully drape this cable to prevent it from touching or even coming near the aluminum plate. Extinguish the flame in the Sterno can. (Read the instructions on the can to determine the proper procedure for extinguishing the flame.)

Plug the line cord of the TV receiver into a nearby a.c. outlet and turn on the set's power switch. As the high voltage builds up, the aluminum foil will electrostatically cling to the lucite and a high-voltage hissing may be heard. The hissing is only corona noise and is nothing to worry about.

Once the TV set's power switch is turned on, stay several feet away from the oven and high-voltage lead at all

(Continued on page 113)

NO PLACE TO GO, BUT

THE PROUD HERITAGE OF AMATEUR RADIO SUFFERS FROM LETHARGY

"HERE WE ARE in 1969," a ham friend of mine said the other day, "and incentive licensing is a fact of life. AM is out the window and you can't find DX on 20 nohow—what are we going to do about it?"

I hadn't witnessed so much confusion since the time Fred Brown sold his Reo and used the money to build an amateur radio station—the first in our neighborhood. Everyone was glad to see the Reo go because, when Fred opened that cut-out, it was something! The ham station was lots quieter though some people were sure we'd all get struck by lightning what with all those wires around.

To us kids, though, the thought that good old Fred had a radio station right in his own basement was stupefying.

"He talks to a guy in England. I heard him!" Eyes would grow big and round and the whole gang would creep around to Fred's cellar window and crouch still-voiced as the mysterious crackles and squeals of short-wave radio came to our ears.

I was quite a bit older before I got to know Fred *real* well—before he and I would sit in his basement and talk about the early days of radio.

"Looky here," he'd say, waving a yellowing copy of *Electrician & Mechanic* or maybe *McClure's*. "This fellow Branly was real put out when Marconi pat-

ented the coherer. It was a tube," Fred would explain, "full of metal filings with a connector at each end and Marconi made it self-restoring." He'd turn a dusty page. "Branly claimed *he'd* invented it. Only thing was, a man named Hughes invented it before *him*. In 1878, says here."

Called charlatan and opportunist by many contemporaries, Irish-Italian Marconi (his mother was a Jameson from County Wexford) made practical sense of the existing hodge-podge of radio knowledge and came up with an exciting new way for man to communicate.

He was an enthusiastic yachtsman, so it was only natural that many of his achievements involved the sea—his contacts with Italian warships in the Mediterranean; the relaying to New York newspapers of the 1899 America's Cup race results (Sir Thomas Lipton's first-of-a-line of *Shamrocks* lost three straight to the *Columbia*). Thus, it came as no surprise when Marconi prepared to bridge the Atlantic with his "invention."

As if that code-letter "S" flashed from England to Newfoundland in 1901 meant "Start," the tinker-minded American male was off in a race to imitate, improvise and improve. The ham was born and the appeal was universal.

Magazines (even the *Woman's Home Companion* and the *Atlantic Monthly*)



First of the "Expedition Hams," Don Mix, W1TS went to the Arctic with Commander MacMillan in 1923. Subsequent expeditions to the polar regions always included hams. Don is still active and works in ham radio at ARRL headquarters in Newington, Conn.

were infected with the excitement of radio and well over a hundred articles in the first four years of the 1900's made America aware something was afoot.

"God's power is loosed," thundered one editorial. "Does Man know what he is doing?" Man didn't know, but there was only one way to find out—experiment!

The disputed coherer was left behind as Fessenden invented the "liquid bar-

retter" and Marconi devised the magnetic detector. Pickard discovered the strange ability of silicon to detect radio signals and General Dunwoody found that carborundum would do the same. Poulson was burning out carbon microphones modulating a high-frequency spark (Fessenden and Collins had some success earlier) proving the human voice could be sent through the air.

Then 33-year-old Lee DeForest stole everyone's thunder by performing major surgery on Fleming's "valve" and inserting that vital third element, the grid, which made modern radio possible. In this wonderful, enchanting time it seemed miracles would never cease.

Jamming is Born. "It was a mess," recalls one pioneer ham. "Whenever a commercial station would come on the air, I would jump right down his throat. The only time he got a message through was when I was asleep!"

The U.S. Navy stations didn't get any better treatment at the hands of radio hams. It was total war. Twenty-eight bills to regulate radio had been introduced into Congress by 1912. The Alexander bill passed and was signed into law by President Taft on August 17, 1912. The hams were taken firmly by the hand and led up the frequency path, a road they were to travel many times.

Revenge was sweet as the Department of Commerce and Labor banished the amateur to the forbidding land of 200 meters. There, the ham ate crow and, to his surprise, found it pretty good—200 meters was better than 500 meters! With a sly smile on his face, he went to work to see just how far he *could* go.

America went to war and the amateur had work to do. The ARRL dramatically found 500 radio operators for the Navy in ten days and over 4000 experimenters went to war. In Paris, Armstrong invented the superheterodyne. After that, it looked as if the ham might be off the air for good. Commercial stations were released from the war-imposed shutdown on March 1, 1920. The ham was told he could *listen* on April 20.

Then, on September 26, 1920, all amateur restrictions were lifted and workshops sprang up everywhere as people began building radio receivers and transmitters of all sorts—

You'd be sitting in the living room reading the evening paper when a scream from the basement would make you jump and you'd know Dad had gotten across the high voltage again.

You'd go downstairs, pick him up, dust him off and give him a glass of water. He'd shake his head, go "ugh" and stagger back to the bench—and darned if he wouldn't do it all over again!

America was in the fabulous twenties. Excitement was everywhere. New things were happening and everyone wanted to be part of it all.

Even staid Bristol, Connecticut caught the fever when it learned the young radio operator at 40 Stearns Street had been chosen to go to the arctic with Commander MacMillan. First of a long line of "Expedition Hams," Donald H. Mix (1TS) was aboard when the schooner

Bowdoin sailed from Wiscasset, Maine in June 1923. From Greenland's remote Refuge Harbor, Don Mix (using a Zenith-donated station and the call WNP) made the first ham-style arctic contact Sept. 9 with Jack Barnsley (9BP) in Prince Rupert, British Columbia.

The first amateur trans-Atlantic two-way took place on November 27, 1923 between Leon Deloy (8AB) in Nice, France, and Reinartz and Schnell (1XAM) in Connecticut. Fellow Yankee, Don Mix knew about it right away. Greetings from Deloy were relayed to him (8AB/1XAM/1HX/6XAD/9BP/WNP) that same evening!

But there was more involved than the spanning of the Atlantic. *This historic QSO took place on 100 meters.*

"That was the important thing," a two-letter ham writes, "100 meters. If that hadn't happened we'd still be there on 200. Hams are hard to move!"



This is what a portable transceiver looked like in 1933. The antenna was mounted on a wooden pole supported by the car radiator—not exactly a mobile installation. (Photo: National Radio Company, Inc.)

Allocations Are Made. The department of Commerce (by then amateur radio's Great White Father) took advantage of the momentum and made the following amateur allocations in 1924:

75-80 meters	3500-4000 kHz
40-43 "	7000-7500 "
20-22 "	13600-15000 "
4-5 "	60000-75000 "

Not only were the hams going *up*, they were going *way up*! The 4-5-meter band was in the never-never land and the Department of Commerce *hoped* they'd take the bait. But the hams had other ideas. Their beloved infant, spark, was forbidden on the new bands.

"Bad enough to put us so high in frequency," said the disgruntled ham, "that we're bound to get a nosebleed every time we call CQ, they gotta take spark away from us. I might not even renew my license!"

"I have news, cousin," cooed the Department of Commerce. "To use these bands you'll have to get a *new* license. One that states which band you're going to use and *you have to have the equipment to do it!*"

The ham's jaw dropped. New licenses? Not him! They could keep the whole shootin' match. Nevertheless, the following year the bands were changed to:

1500-2000 kHz
3500-4000 "
7000-8000 "
14000-16000 "
56000-64000 "

Later, in 1925, 400-401 *megacycles* (now megahertz) was authorized. This left most amateurs cold.

The new bands proved their worth, however, and DX took its place in the sun. Station 6AWT was using 5400 watts d.c. input! But all hams were amazed when Loren Windom (8GZ) in Columbus, Ohio made 0.567 watts reach 10,100 miles to A5BG on December 30, 1925. Windom followed this up, using 0.54 watts, to contact Capetown, South Africa and 0.493 watts to work George Shrimpton (Z2XA) in Wellington, New Zealand.

In 1927, the Federal Radio Commission took over from the Department of Commerce and came out of the International Radiotelegraph Conference with the first truly "amateur" regulations. Although the treaty that resulted from

that conference wasn't to be effective until Jan. 1, 1929, General Order #24 (March 7, 1928) made the following allocations:

1715-2000 kHz
3500-4000 "
7000-7300 "
14000-14400 "
28000-30000 "
56000-60000 "

The "harmonic ladder" pattern was now firmly established. So was the governmental hand in ham affairs. The twenties were going, the thirties were coming and, if you looked closely, you could see cracks beginning to appear in the framework of amateur radio.

Old voices and familiar fists began to disappear one by one as amateur radio found itself in the depression doldrums. For some reason the second World War didn't have the same effect on amateur radio that the first one did. To make matters worse a plague of locusts descended on the hobby after World War II. Television interference (TVI) appeared to harass the ham. The bands festered and exploded in a rash of grass fires. Incentive licensing proposals jostled their way through the ranks trying to sep-

When electronic surplus was dumped on the market after World War II, it looked as if hamdom on the VHF/UHF might have an explosive growth; but it did not. Some VHF/UHF equipment was too specialized and most people went back to lower frequencies. This surplus APS/13 cost WA2NDN only one dollar —the tube shields alone are worth more than that.

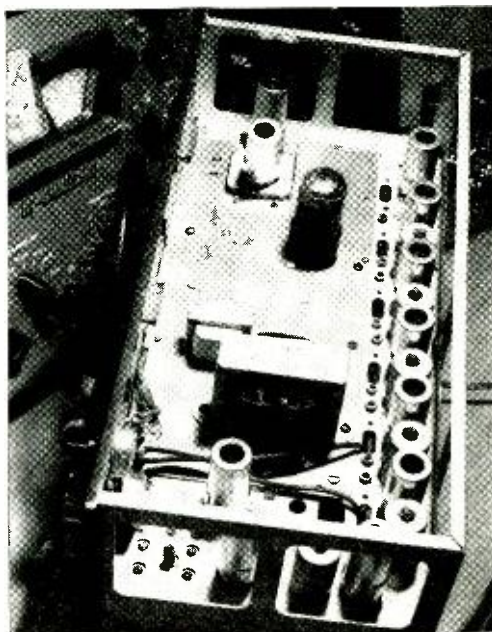

arate the technical sheep from the rag-chewing goats. Dissatisfaction with ARRL policies added to the confusion and SSB vs AM spats cut the ham hocks to ribbons. Somewhere along the line something had happened to ham radio.

The Slums on Radio. "The present ham bands—and by that I mean 80, 40, and 20—have become slum areas," says an FCC engineer (and ham). "It's an electronic ghetto! Why do they stay on these same three bands. Look here," as he opened Part 97, "at what they have in UHF."

It's a vast, unexplored territory, inhabited by a small handful of hardy souls who get awfully lonely. Experimenters in VHF and UHF don't have time to talk about incentive licensing. They're wrapped up in the wonder and excitement of the new things they're finding every day.

Look at it another way:

BAND	SPREAD
220-225 MHz	25 MHz
420-450 "	30 "
1215-1300 "	85 "
2300-2450 "	150 "
3300-3500 "	200 "
5650-5925 "	325 "
10000-10500 "	500 "
21000-22000 "	1000 "

Now the 80 through 10 spectrum:

BAND	SPREAD
3500-5000 kHz	500 kHz
7000-7300 "	300 "
14000-14350 "	350 "
21000-21450 "	450 "
28000-29700 "	1700 "

A total frequency spread of 3300 kHz—less than 1/10th the spread on just one (220-225 MHz) "VHF-and-up" band!

Life in the Higher Altitudes. But there's more to these frequencies than just the lure of the unknown and plenty of space to roam around. First, they can be tailor-made to suit your individual purpose. With low power and vertically polarized antennas (and FM emission) the VHF/UHF are admirably suited for local work. This gives hams an interference-free talk-tool for local nets. CB'ers have made hams look foolish while providing emergency communications using battery-powered minaturized equipment. They would have all of the marbles if it

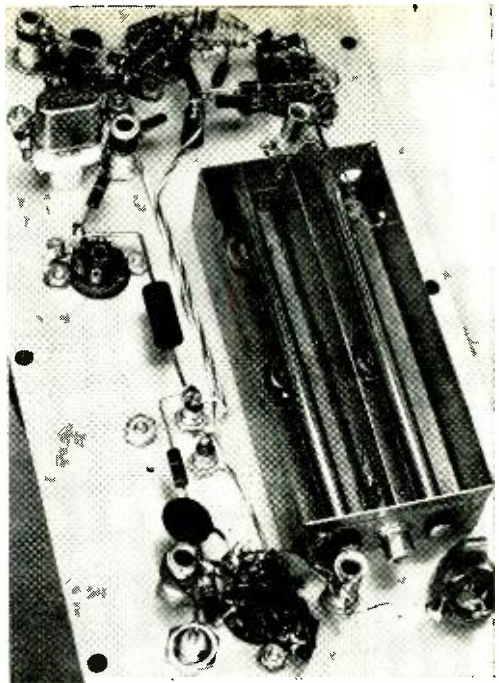

Tank circuit from ARRL Handbook is an example of UHF simplicity. Not complex—more hams could find building this type of equipment a real challenge.

weren't for the QRM. The VHF/UHF arena is the ideal spot for equipment experimentation. Hams have the frequency space—but the 80, 40, and 20 diehards lack initiative.

What About Propagation? There is still a lot we don't know about VHF/UHF DX'ing, or scatter, or sporadic-E, or auroral refractions, etc. And moon bounce is just getting interesting—those two dozen hams working here certainly aren't complaining about QRM.

There's nothing to stop a ham from building his own radar or satellite tracking station. Amateur TV was going places until someone thought up the idea of low-frequency slow-scan (that's right, diehards, don't push VHF/UHF). Antennas directly coupled to solid-state devices are coming on strong, but hams aren't experimenting with them.

The enchanting aura of the adventure of amateur radio clings to every particle of VHF, UHF, SHF, and EHF. If hams fail to heed its siren call, they fail as radio amateurs!

The time has come to turn to the frontiers of radio as hams once did. *There* is where history is being made!

ENGLISH-LANGUAGE BROADCASTS TO NORTH AMERICA FOR THE MONTH OF MARCH

Prepared by ROGER LEGGE

TO EASTERN AND CENTRAL NORTH AMERICA		TO WESTERN NORTH AMERICA	
TIME—EST	STATION AND LOCATION	TIME—PST	STATION AND LOCATION
	FREQUENCIES (MHz)		FREQUENCIES (MHz)
7:15 a.m.	Melbourne, Australia	7:00 a.m.	Tokyo, Japan
	9.58, 11.71		15.32, 17.84, 21.74
7:45 a.m.	Montreal, Canada	6:00 p.m.	Melbourne, Australia
	9.625, 11.72		15.235, 17.825, 21.64
7:45 a.m.	Copenhagen, Denmark	6:30 p.m.	Tokyo, Japan
	15.165		9.695
5:30 p.m.	Vilnius, U.S.S.R. (Fri., Sun.)		Bonaire, Neth. Antilles
	9.61, 11.90		9.705, 11.875, 15.22
6:00 p.m.	Montreal, Canada	7:00 p.m.	Johannesburg, South Africa
	9.625, 11.945, 15.19		6.11, 9.58, 11.78
6:45 p.m.	Tokyo, Japan		6.13, 9.76
	15.135, 17.825		15.095, 17.675, 17.795
7:00 p.m.	London, England		9.745, 11.765, 15.115
	6.11, 9.58, 11.78		15.43
7:00 p.m.	Moscow, U.S.S.R.		15.125, 15.345, 17.89
	9.61, 11.87, 11.90		15.14, 15.18, 17.775
7:30 p.m.	Sofia, Bulgaria	7:20 p.m.	Yerevan, U.S.S.R. (via Khabarovsk)
	9.70		(Tues., Wed., Fri., Sat.)
7:30 p.m.	Budapest, Hungary		6.08, 9.65, 9.73
	9.833, 11.91, 15.16		5.93, 7.345, 9.54, 11.99
7:30 p.m.	Johannesburg, South Africa	7:30 p.m.	Berlin, Germany
	9.705, 11.875, 15.22		11.705
7:30 p.m.	Kiev, U.S.S.R. (Mon., Thu., Sat.)		6.20, 7.30
	11.735, 11.90		9.525
7:50 p.m.	Stockholm, Sweden		6.025, 9.68, 11.935
	11.805		11.87, 15.18, 17.775
7:50 p.m.	Brussels, Belgium		15.095, 17.675, 17.795
	6.125		9.70
8:00 p.m.	Vatican City		9.833, 11.91, 15.16
	9.615, 11.895, 15.285		9.61, 11.90
8:00 p.m.	Berlin, Germany		9.72, 11.715
	9.50, 9.73		6.145, 9.545, 11.945
8:00 p.m.	Havana, Cuba		9.525, 11.76
	9.525		15.105
8:00 p.m.	Peking, China		11.87, 15.18, 17.775
	7.12, 9.78, 17.713		11.93
8:00 p.m.	Prague, Czechoslovakia		
	5.93, 7.345, 9.54, 11.89		
8:30 p.m.	Rome, Italy		
	9.575, 11.81		
8:30 p.m.	Berne, Switzerland		
	6.12, 9.535, 11.715		
8:30 p.m.	Cologne, Germany		
	6.185, 9.64, 11.945		
8:30 p.m.	Hilversum, Holland (via Bonaire)		
	9.59, 11.73		
9:00 p.m.	Tirana, Albania		
	6.20, 7.30, 9.50		
9:00 p.m.	Cairo, Egypt		
	9.475		
9:00 p.m.	Lisbon, Portugal		
	6.025, 9.68, 11.935		
9:00 p.m.	London, England		
	6.11, 9.58, 11.78		
9:30 p.m.	Melbourne, Australia		
	15.32, 17.84		
9:30 p.m.	Quito, Ecuador		
	9.745, 11.765, 15.115		
10:00 p.m.	Beirut, Lebanon		
	11.785		
10:00 p.m.	Moscow, U.S.S.R.		
	9.61, 9.70, 11.735		

the product gallery

REVIEWS AND COMMENTARY ON ELECTRONIC GEAR AND COMPONENTS

HEATHKIT COLOR TV (GR-681) WIRELESS REMOTE (GRA-681-6)

It's hard to be the leader. Your fans expect you to stay out in front and your detractors are equally as anxious for you to fall flat on your face. For the past dozen and a half years the Heath Company (Benton Harbor, Mich. 49022) has earned a .980 batting average in the development of electronic kits. Most of the Heath competitors keep hoping that they'll go into a slump; instead Heath keeps producing winners. This season it's the deluxe GR-681 color TV kit (\$499.95). Couple this receiver with the GRA-681-6 ultrasonic remote control (\$59.95), put it in a cabinet, and you've got more convenience and color picture fidelity than you can buy for nearly twice the money!

The GR-681 is the outgrowth of about 6 years of producing color TV receiver kits. Starting with the GR-53A (now an antique), Heath has manufactured a variety of kits with medium and large screen diagonals. The closest precedent to the GR-681 is the GR-295 and to a modest extent there is some similarity. The GR-681 has a 295 sq. in. viewing area picture tube (so has the GR-295) and the mechanical layout of the two is almost identical. The improvements in the GR-681 are essentially refinements including the addition of a motor drive on the shaft of the VHF tuner, integrated-circuit AFT (automatic fine tuning), solid-state retrace blanking, a much better UHF tuner, and superior power supply regulation.

Going Together. At least 4 out of 5 readers of POPULAR ELECTRONICS have assembled a Heathkit. They are aware of the thoroughness of the Heath Assembly Manuals and require no introduction to this important fact. If you have never assembled a Heathkit and want to start with the GR-681, don't hesitate. It can be built with full assurance that it will function perfectly—providing you know how to follow step-by-step instructions.

Your reviewer assembled the whole GR-

681 in 19½ hours. Another 3½ hours were spent on the GRA-681-6 ultrasonic remote control. (The wireless remote control can be used with any of the 4 presently cataloged Heathkit color TV receivers—after modification. If you are assembling a color TV receiver and remote control simultaneously, you can save construction time by eliminating certain steps and replacing them with appropriate steps from the remote control Assembly Manual. This is not an easy task and should only be attempted by the experienced kit builder.) If you are wondering how it is possible to build a complex project in such short order (and haven't read the fine print in the Heath advertisements) you will be delighted to find that the very critical parts of the receiver are supplied pre-assembled, tested, and, where important, pre-aligned. This includes the high-voltage power supply, both tuners, the video i.f. strip, and the new AFT printed circuit board.

Reams have been written about the money-saving possibilities of building a Heath color TV receiver kit; about the educational aspects; and about the fun. But one idea that this reviewer has not seen prominently mentioned is that ease in assembly is cumulative when the builder has worked on more than one kit in the same family—test equipment, ham rig, etc. If you've built the GR-180 or GR-227, you've all the basic knowledge to converge, set gray scale, set a.g.c., mount the yoke, etc. of the GR-681. You will save time, eliminate possible errors, and have the receiver operating in tip-top shape for the Sunday Night Movie. For example, the GR-681 was this reviewer's third color TV kit and the convergence time dropped from 50 minutes involved in the first kit to 8 minutes! And, we did a much better job to boot!

Those Refinements. Automatic fine tuning eliminates one major bug-a-boo in color TV reception. Once it is set there is no need to fiddle with the fine tuning control when changing channels. Every channel is tuned for maximum color fidelity. This is made possible through the use of an RCA integrated circuit (type CA3044VI) in a wide-band amplifier phase-detector configuration. The AFT circuit samples the output of the

(Photos overleaf.)

Story continued on page 110)

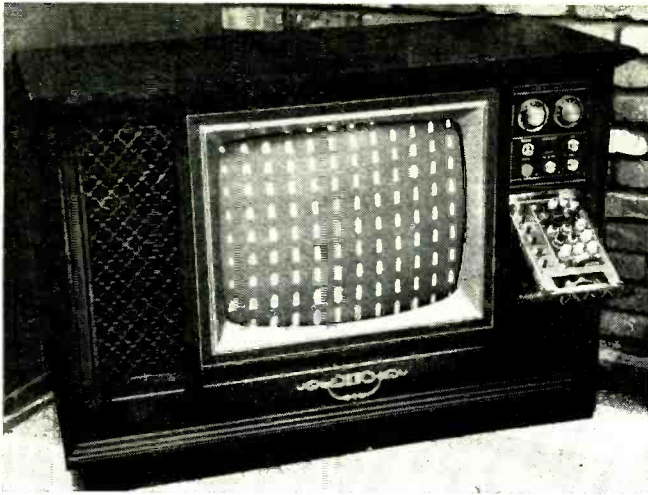

HEATHKIT
COLOR TV
(GR-681)

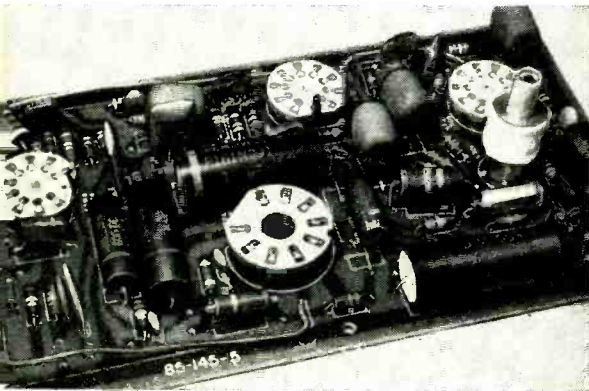

All of the more difficult and critical circuits in a Heath color TV receiver are either pre-assembled (and pre-aligned) or built on printed circuit boards. Each board is very carefully silk-screened and just about 100% error proof. Even slug-tuned coils are provided pre-aligned and rarely need touchup.

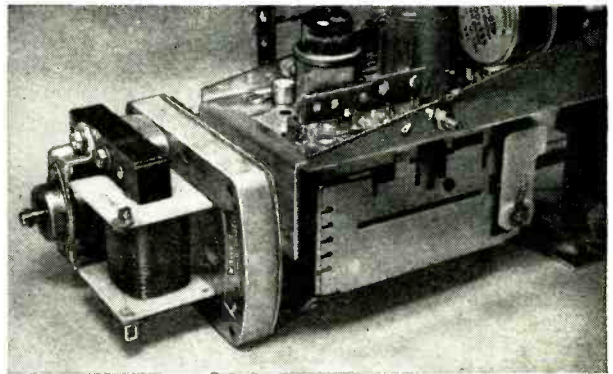

Motor to rotate VHF tuner channel selector is included in basic GR-681 kit. Also supplied is control cable and remote switch. Odd looking wafer at right center of photo is the AFT defeat switch.

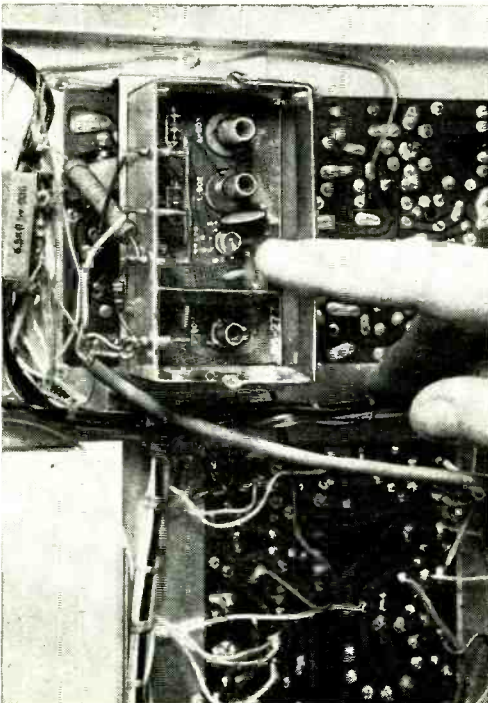

Automatic fine tuning (AFT) printed circuit board is contained in separate pre-assembled shielded compartment. It is mounted over the foil side of i.f. printed circuit board. Builder can adjust AFT after shield top is in place with plastic alignment tool. Output of AFT feeds diodes in tuners.

POPULAR ELECTRONICS

If you build the TV receiver and wireless remote simultaneously, you can save some time by wiring in the Color and Tint motors while assembling the tuner bracket. The motors are visible behind and above the tube shield. Combining the two Manuals is a job that should only be attempted by a more experienced builder. By the way, the wireless remote may be attached to any of the color TV receivers in the Heath catalog.

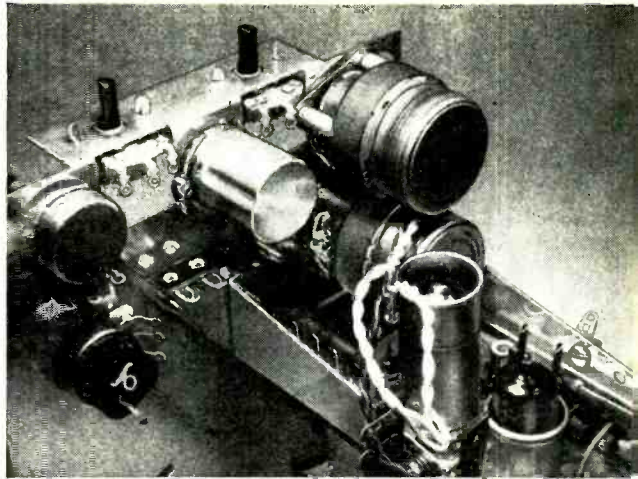

Probably the greatest convenience of any TV receiver is this drop panel mounted to the back of the loudspeaker. After setting height, a.g.c., sync, convergence, etc. the panel is pushed back into place. Built-in dot generator (pattern on screen) is Heathkit innovation and eliminates necessity for obtaining color TV dot and bar generator.

WIRELESS REMOTE (GRA-681-6)

For maximum viewing convenience, Heathkit offers a special ultrasonic transmitter and receiver to control the GR-681 from your easy chair. The palm-size transmitter (cover removed) is shown at the right. Transducer is in lower left corner. Three rocker arm switches are clearly visible.

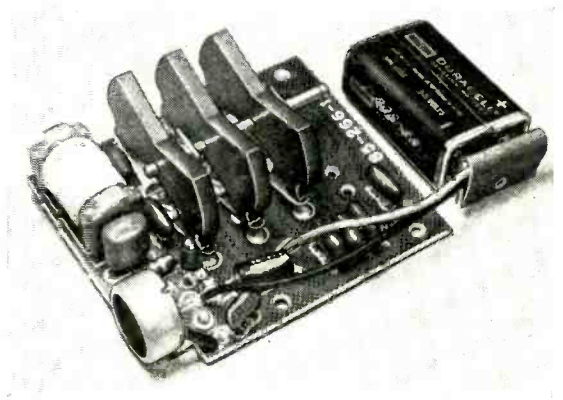

Receiver for remote is assembled in 3½ hours. Microphone pickup (not shown) is mounted near loudspeaker. Integrated circuit in receiver feeds six detectors and control circuits. Each control circuit responds to pre-selected frequency (On-Off—40 kHz, color increase—42 kHz, tint toward green—34 kHz, etc.). Remote will operate receiver from distance of 20 ft.



ON THE CITIZENS BAND

By MATT P. SPINELLO, KHC2060, CB Editor

MONITOUR '69

The response to the POPULAR ELECTRONICS 1968 Monitour (in-person monitoring of the CB channels in various parts of the U.S. by your CB editor) has generated enough interest to prompt us to repeat the process in 1969. Our kick-off stop was a short visit to Washington, D.C.

Whether District of Columbia operators roll with the rules by choice or because they live in the FCC's back yard, we don't know, but our monitoring showed that several large and apparently well organized groups of CB'ers operate within the rules most of the time. During a discussion with Pete Brenenstuhl, KBL3886, and John Wharen, KQI3285, we learned that there are violators, but perhaps not as many as we have observed in other parts of the country. Some of the skip signals received in Washington included senile "Tumbleweed" and the "Old Fisherman" from the Carolinas. And, there is purportedly a 63-year-old D.C. operator pressing his luck with a 65-watt linear amplifier attached to his transmitter output.

The D.C. Police Reserve Communications group is led by Communications Officer D. C. Wahl, KPV0051. For riot control and other necessary communications needs, the group employs 52 CB units. The Sixth Precinct operates on channel 18 with the call KPV0005, and the Eighth Precinct as KBM0706 on channel 16. There are reportedly 350 REACT members also active in the Washington area.

Monitour '69 includes a longer stopover in the Washington area later in the year. Other cities tentatively slated for Monitour observations within the next 3 months include Portland, Ore.; Kansas City, Mo.; San Francisco, Calif.; Denver, Colo.; New York, N.Y.; and Boston, Mass. Additional stops to fill out the year will be announced.

We are most anxious to revisit Boston. A number of responses did not agree with our award to Boston as the "most legalized operating area" for 1968. David Yetman, KOA5995, Massachusetts Director of the S-9 International Emergency Team, North

Reading, Mass., stated "—the reason for this letter is not only to invite you to this area again, but to dare you to return. Your article was read at a recent club meeting and you never heard so much booing in your life. We are not saying you don't know your business, all we think is that you were here at the wrong time."

Another complaint was received from a lady who filled in some statistical gaps we could not possibly have gathered during our Monitour visit. Since the letter was unsigned, merely postmarked Boston, Mass., we are unable to say how much it might contribute to moving "Beantown" down the statistical ladder. If the lady, who fears for the safety of her family, home, cars and CB equipment, will drop your CB editor a note with her name, address, and phone number, we will keep the information confidential. We will contact her either by phone or in person.

(Continued on page 96)



J. D. Rice, KDH1183, Stuart, Florida, has a pretty complete setup with at least two CB transceivers and enough tools to rewire or rebuild the works.



SHORT-WAVE LISTENING

By HANK BENNETT, W2PNA/WPE2FT
Short-Wave Editor

A WORD ABOUT NEW SWL CLUBS

ON THE AVERAGE of once a month this columnist receives literature from newly-formed SWL clubs. I am to give a free publicity plug to these clubs. Most of them have only been in operation for a month or two and are not fully organized. Membership runs from one to a dozen persons, dues are listed as minimal and a bulletin published at regular intervals is promised.

This column is not a medium to publicize these new clubs. The people running these clubs simply do not comprehend that there is *work* involved in running a SWL club. The expenditure of money in order to get a new club completely organized is always several times the amount received from dues.

Publishing a club bulletin, even monthly, means that you have to have individuals who can write columns of interest to your membership. These editors must meet this task each month or the club fails in its duties and responsibilities to the membership. There must be a financial secretary to account for every penny received and spent. There must be a membership secretary who can account for the membership requirements and rosters. And, of most importance, there must be a committee to get the club bulletin mimeographed, the pages collated, folded, inserted into envelopes, stamped, addressed and delivered to the post office.

In 1968 a half-dozen SWL clubs folded, including two clubs that had been in more-or-less successful operation for several years. When you are ready to join an SWL club, make sure that it is properly organized and in good operating condition. There are several in North America that have been around for many years.

Your columnist has a leaflet available (Leaflet H—Clubs and Publications) which lists the clubs who are known to be dependable. Please include a SAE with your request for this leaflet.

Red Cross Tests. The International Committee of the Red Cross, 7 Avenue de la Paix, 1211 Geneva 1, Switzerland, will again be testing in 1969. Dates listed include March 24, 26 and 28, May 19, 21 and 23, July 21,

23 and 25, September 22, 24 and 26, and November 24, 26 and 28. Each transmission is of 60 minutes duration and is in French, English and Spanish. The times listed are 0600, 1130, 1700 and 2300 and all broadcasts are on 7210 kHz. Forms for reception reports are available upon request to the ICRC.

CURRENT STATION REPORTS

The following is a resume of current reports. At time of compilation all reports were as accurate as possible, but stations change frequency and/or schedule with little or no advance notice. All times shown are Greenwich Mean Time (GMT) and the 24-hour system is used. Reports should be sent to Short-Wave Listening, P. O. Box 333, Cherry Hill, N. J. 08034, in time to reach Your Short-Wave Editor by the fifth of each month; be sure to include your WPE identification and the make and model number of your receiver.

Afghanistan—Kabul has been heard on a new frequency of 11,800 kHz with English at 1800.

Angola—"A Voz do Angola" is a separate network of *Emisora Oficial*. Luanda. They are scheduled to operate at 0500-0700 (Sunday 0600-0800) and 1100-1300 on 6175 and 9660 kHz and 1700-2000 on 6175 kHz.

Ascension Island—Two new frequencies in use from London's relay station in the South Atlantic include 17,740 kHz with s/on at 1630, and on 9510 kHz (repl. 11,865 kHz) at 0000-0100 with world news, "Radio Newsreel", and music. A dual chan-

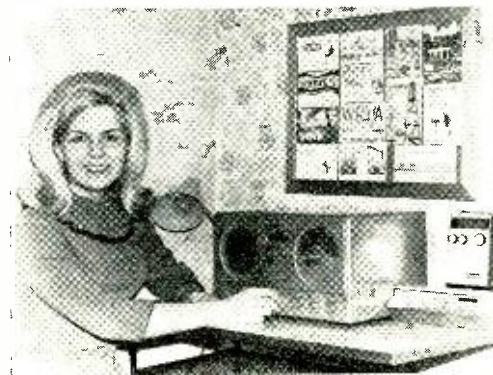

In two years of listening, Jan McClure, WPEØFAF, Thayer, Mo. has logged 47 countries. She uses a National NC-57 receiver primarily with a Hallcrafters transistor portable and Realtone recorder.

nel to the latter xmsn is 15.260 kHz, also from Ascension.

Australia—*R. Australia*, Melbourne, is good at 2140-2230 on 17,715 kHz with music, English news, "Morning Melodies" and another newscast at 2230 in the beam to East Asia and North Pacific areas.

Canada—In a special news bulletin from *R. Canada*, Montreal, it was stated that the present three 50-kW xmters at Sackville, New Brunswick, will be replaced by seven new 250-kW xmters. The change will be completed during 1970 or early 1971.

Ceylon—*R. Ceylon*, Colombo, 11,800 kHz, has music and language annets at 1250; in Tamil from 1312-1330 followed by a xmsn in Hindi. Another xmsn was logged at 1700-1730 with Indian musical selections. No English was reported on any of these segments.

China—*R. Peking* was logged on a new frequency of 11,720 kHz in Cantonese from 2300-2330 and in Indonesian to 0000; both periods had news, talks and native and military-type music.

Colombia—*R. Nacional*, Bogota, has returned to the air on two new channels, 6200 and 9620 kHz with

a schedule that is irregular at best. Noted in all Spanish at 2300-0100, the programs featured frequent ID's and a variety of L.A. music. At press time these xmsns appear to be more of a test nature.

Costa Rica—A station is being heard on 6150 kHz at 0150-0250 and 0500-0700 with good music and many commercials for N.A. products; the ID appears to be *R. Atenas en San Jose* although some sources claim it to be *R. Titania*. Further checks are being made.

Dominican Republic—Here's another one that is confusing our monitors: a station on 3215 kHz is reported by some as *R. Ventas* and by others as *R. Libertad*. All reports agree on the programming as being sports at 0230 and a religious program at 0330. *R. Onda Musical*, Santo Domingo, 4795 kHz, was logged with usual L.A. music and Spanish annets after 0200.

Ecuador—Two new frequencies for HCJB, Quito, are 11,765 kHz, at 0200 in English to N.A. and at 1130-1200 in English and from 1200 in Japanese,

(Continued on page 98)

MEDIUM WAVES

With the coming of spring and longer hours of daylight it becomes increasingly more difficult to hear DX on the medium waves. However, as a parting shot to the recent winter DX season, you might look for some of these. They have all been heard on the East Coast and with favorable conditions are also audible in the Midwest. (Times are E.S.T.)

BEST BETS

- 725 Paramaribo, Surinam; variety of languages including English; best in early evenings.
- 737 "R. Nacional de Espana," Barcelona, Spain; all Spanish nonstop-type programming.
- 755 "Emissora Nacional", Lisbon, Portugal; in foreign languages including English "Voice of the West"; best early evenings and after midnight.
- 764 Dakar, Senegal; French and native languages; early evenings and after 0100.
- 845 Rome; nonstop programming in a variety of languages.
- 935 Agadir, Morocco; Arabic only; often strong in early evenings and after 0100.
- 1235 ZBM1, Bermuda; nonstop English programming; heard nightly.
- 1554 Nice, France; French only.
- 1586 Langenburg, Germany; in German only.

DIFFICULT BUT OFTEN POSSIBLE

- 650 KORL, Hawaii; best time Monday after WSM s/off at 0300.
- 746 Hilversum, Holland; in Dutch early evenings and after 0000; don't confuse with East Germany, also here.
- 818 Batra, Egypt; Arabic only; early evenings and from 2300 s/on. "R. Des Valles," Andorra, also here in early evenings in French and Spanish.
- 1205 Bordeaux, France; French; around sunset and after 0000.
- 1313 Stavanger, Norway; audible at times after 0100 in Norwegian.
- 1457 BBC, London, Home Service; several sta-

tions carry parallel programming and often audible after 0100.

VERY DIFFICULT

(These stations were heard and logged by Gordon Nelson, Watertown, Mass., using only a special home-made receiver and a special loop antenna.)

- 620 Canary Islands; relay of *R. Nacional Espana* heard at 0145 s/on. Has also been heard around sunset.
- 790 Armed Forces Caribbean Network, Fort Clayton, Canal Zone; Armed Forces programming around 0300. Much QRM.
- 1020 HJDP, "R. Colosal," Neiva, Colombia; recently moved here from 1170 kHz and heard in Spanish with chime IS at 0230.
- 1030 LS10, "R. Libertad," Buenos Aires, Argentina (no relation to the clandestine by the same name); best time is Monday after WBZ s/off at 0100; Spanish with many US pop tunes; QRM from XEQR, "R. Centro," Mexico City.
- 1070 Cayenne, French Guiana; one of the rarest medium wave countries in this hemisphere; logged at 0415 s/on with "La Marseillaise," IS and calypso-type music.
- 1205 Freetown, Sierra Leone; moved from 1200 kHz; often good at 0100 s/on with a new IS and in English; QRM may be caused by French Station in Bordeaux.
- 1313 A new Spanish station at Zaragoza has been heard around 0200 with some QRM from Stavanger, Norway. This station has a power rating of only 5 kW.

Mr. Nelson also reports first known North American reception of the new high-power Syrian xmttr (reportedly more than 500 kW) around 1745 in Arabic until 1830 or later. This station drifts in frequency and causes severe QRM with CSB9, Portugal, on 782 kHz. The frequency of the Syrian is also given as 782 kHz.

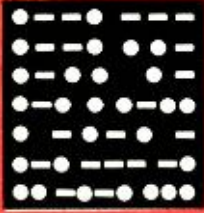

AMATEUR RADIO

By **HERB S. BRIER**, W9EGQ
Amateur Radio Editor

FROM SOUTH CAROLINA TO JAPAN

Another DX Journey. Gus Browning, W4BPD, Cordova, S.C., was scheduled to leave Feb. 1 on another worldwide DX-pedition. Gus says it will continue until he runs out of money, or countries to operate from. His *modus operandi* will follow that of his previous DX-pedition—obtain permission from the appropriate authorities to set up his station in a country with little regular amateur operation. He will then operate “contest style” on phone and CW using the six amateur bands between 1.8 and 29.7 MHz. This will give all DX chasers of the world a chance to work the country he is in before moving on.

Incidentally, Gus has promised to vary

his operating frequencies from time to time; so that all classes of U.S. amateurs (including Novices) licensed to operate below 50 MHz will have a chance. Because all his contacts are limited to exchanging call letters and signal reports—with no time spent on “non-essentials” like exchanging names or talking about the country and the people he is visiting—Gus can easily work several stations a minute when things are really rolling. Being a sleepless wonder, he has worked a fabulous number of stations in a week, the minimum length of time he plans to operate from any country.

E. C. “Ack” Atkerson, W4ECI, World Radio Propagation Study Association, 3101

AMATEUR STATION OF THE MONTH



Bert Zater, OX5BA, RCA/BMSWR, Box 484, APO, N.Y., N.Y. 09023, spent 10 months designing and assembling his amateur station with all the comforts of home in remote Thule, Greenland. His all-Heathkit station includes an SB-301 receiver, SB-401 transmitter, SB-201 amplifier, and a monitorscope. Power input is 280 watts. Using a 16-foot antenna on 20 meters, Bert worked 31 countries and many states in 12 days. We are sending him a 1-year subscription to POPULAR ELECTRONICS for winning this month's Amateur Station Photo Contest. You can enter the contest by sending a clear photograph (preferably black and white) of your station with you at the controls, including some details of your radio career to: Amateur Photo Contest, c/o Herb S. Brier, W9EGQ, Amateur Radio Editor, POPULAR ELECTRONICS, Box 678, Gary, Ind. 46401.

"Performance-Plus" Kits For Home And



NEW
kit AD-27
\$169⁹⁵



NEW
kit AD-17
\$109⁹⁵

HEATHKIT AD-27 FM Stereo Compact

The new Heathkit "27" Component Compact was designed to change your mind about stereo compact performance. How? By sounding as if it were made of top quality stereo components . . . which in fact it is. Heath engineers took their highly rated AR-14 solid-state Stereo Receiver, modified it physically to fit the cabinet, and matched it with the precision BSR McDonald 500A Automatic Turntable. Performance? Here's the AD-27 in detail. The amplifier delivers 30 watts music power . . . 15 honest watts per channel — enough to drive any reasonably efficient speaker system. Response is virtually flat from 12 Hz to 60 kHz, and Harmonic & IM distortion are both less than 1% at full output. Tandem Volume, Balance, Bass & Treble controls give you full range command of all the sound. Select the FM stereo mode with a flick of the rocker-type switch and tune smoothly across the dial, thanks to inertia flywheel tuning. You'll hear stations you didn't know existed in your area, and the clarity and separation of the sound will amaze you. The adjustable phasing control insures best stereo separation at all times. And the automatic stereo indicator light tells you if the program is in stereo. AFC puts an end to drift too. The BSR Automatic Turntable has features normally found only in very expensive units, like cueing and pause control, variable anti-skating device, stylus pressure adjustment and automatic system power too. Comes complete with a famous Shure diamond stylus magnetic cartridge. The handsome walnut cabinet with sliding tambour door will look sharp in any surroundings, and the AD-27 performs as well as it looks. For the finest stereo compact you can buy, order your "27" Component Compact now, 41 lbs.

HEATHKIT AD-17 Stereo Compact

Using the component approach of the AD-27, Heath engineers took the solid-state stereo amplifier section of the AD-27, matched it with the high quality BSR-400 Automatic Turntable and put both of these fine components in a handsomely styled walnut finish cabinet. The result is the "17" — featuring 30 watts music power, 12 Hz to 60 kHz response, auxiliary & tuner inputs, less than 1% Harmonic & IM distortion, adjustable stylus pressure & anti-skate control and much more. Order your "17" now, 27 lbs.

HEATHKIT TA-38 Solid-State Bass Amplifier

The new Heathkit TA-38 is the hottest performing bass amp on the market, for quite a few reasons. First, there's all solid-state circuitry for reliability. Then there's the tremendous power — the TA-38 puts out 120 watts of EIA music power, 240 watts peak, or 100 watts continuous. Extremely low harmonic & IM distortion too. Many amps suffer from "blow-out" problems, but not the new TA-38 — *YOU CAN'T BLOW IT* . . . it boasts two 12" heavy duty special design speakers with giant 3 pound 6 ounce magnet assemblies mounted in a completely sealed, heavily damped 3/4" pressed wood cabinet — those speakers will take every watt the amp will put out, and still not blow. Sound? The TA-38 is tailored to reproduce the full range of bass frequencies delivered by bass guitars and its sound with combo organs and other instruments is remarkable. Easy 15 hour assembly to the wildest bass amp on the market. Order one now and surprise the guys with the high-priced gear, 130 lbs.

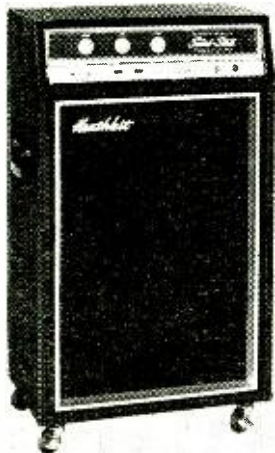

NEW
kit TA-38
\$225⁰⁰

HEATHKIT GR-58 Solid-State AM/FM Clock Radio

The easy way to get up in the morning. Choose the morning news & weather on AM or the bright sound of FM music. AFC makes FM tuning easy. The "Auto" position on the Telechron™ clock turns only the radio on, or use the "Alarm" setting for both the radio and the alarm. You can even enjoy fresh coffee when you awake in the morning, thanks to the clock-controlled accessory AC socket on the back of the new GR-58. The handy "snooze" alarm feature lets you wake up gradually for ten minutes to the sound of the radio, then the alarm goes on . . . push the "snooze" button to silence the alarm for ten minutes more of music or news — the alarm sounds automatically every ten minutes and the "snooze" button turns it off, cycling continuously until the selector switch is moved to another position. Fast, easy circuit board construction, smart blue hi-impact plastic cabinet and top reliability make this GR-58 the clock radio for you, 8 lbs.

NEW
kit GR-58
\$47⁹⁵



HEATHKIT IG-18 Solid-State Sine-Square Wave Generator

A precision source of sine or square waves at a low kit price . . . that's the new solid-state IG-18 from Heath. Delivers 5% accuracy thru the wide range of 1 Hz to 100 kHz. The sine wave section features less than 0.1% distortion thru the audio range, 8 output voltage ranges from 0.003 to 10V, switch-selected internal 600 ohm load or external load and metered output of both voltage & dB. The square wave section has a 50 nS rise time and three output voltage ranges from 0.1 to 10 V P-P. Both sine & square waves are available simultaneously and the frequency is switch-selected for constant repeatability and fast operation. Circuit board construction makes the new IG-18 easy to build . . . new Heathkit styling and engineering excellence make it easy to use. Put the new IG-18 on your bench now, 10 lbs.

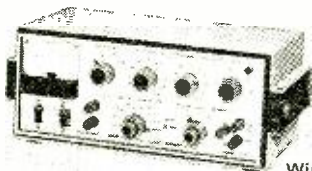

NEW
kit IG-18
\$67⁵⁰
Wired IGW-18
\$99⁵⁰

Hobby... From The Leader



Now There are 4 Heathkit Color TV's...
All With 2-Year Picture Tube Warranty

NEW Deluxe "681" Color TV With Automatic Fine Tuning

The new Heathkit GR-681 is the most advanced color TV on the market. A strong claim, but easy to prove. Compare the "681" against every other TV — there isn't one available for any price that has all these features. Automatic Fine Tuning on all 83 channels... just push a button and the factory assembled solid-state circuit takes over to automatically tune the best color picture in the industry. Push another front-panel button and the VHF channel selector rotates until you reach the desired station, automatically. Built-in cable-type remote control that allows you to turn the "681" on and off and change VHF channels without moving from your chair. Or add the optional GRA-681-6 Wireless Remote Control described below. A bridge-type low voltage power supply for superior regulation; high & low AC taps are provided to insure that the picture transmitted exactly fits the "681" screen. Automatic degaussing, 2-speed transistor UHF tuner, hi-fi sound output, two VHF antenna inputs... plus the built-in self-servicing aids that are standard on all Heathkit color TV's but can't be bought on any other set for any price... plus all the features of the famous "295" below. Compare the "681" against the others... and be convinced.

GRA-295-4, Mediterranean cabinet shown... \$119.50
Other cabinets from \$62.95

Deluxe "295" Color TV... Model GR-295

Big, Bold, Beautiful... and packed with features. Top quality American brand color tube with 295 sq. in. viewing area... new improved phosphors and low voltage supply with boosted B + for brighter, livelier color... automatic degaussing... exclusive Heath Magna-Shield... Automatic Color Control & Automatic Gain Control for color purity, and flutter-free pictures under all conditions... preassembled IF strip with 3 stages instead of the usual two... deluxe VHF tuner with "memory" fine tuning... three-way installation — wall, custom or any of the beautiful Heath factory assembled cabinets. Add to that the unique Heathkit self-servicing features like the built-in dot generator and full color photos in the comprehensive manual that let you set-up, converge and maintain the best color picture at all times, and can save you up to \$200 over the life of your set in service calls. For the best color picture around, order your "295" now.

GRA-295-1, Walnut cabinet shown... \$62.95
Other cabinets from \$99.95

Deluxe "227" Color TV... Model GR-227

Has same high performance features and built-in servicing facilities as the GR-295, except for 227 sq. inch viewing area. The vertical swing-out chassis makes for fast, easy servicing and installation. The dynamic convergence control board can be placed so that it is easily accessible anytime you wish to "touch-up" the picture.

GRA-227-1, Walnut cabinet shown... \$59.95
Mediterranean style also available at \$99.50

Deluxe "180" Color TV... Model GR-180

Same high performance features and exclusive self-servicing facilities as the GR-295 except for 180 sq. inch viewing area. Feature for feature the Heathkit "180" is your best buy in deluxe color TV viewing... tubes alone list for over \$245. For extra savings, extra beauty and convenience, add the table model cabinet and mobile cart.

GRS-180-5, table model cabinet and cart... \$39.95
Other cabinets from \$24.95

Now, Wireless Remote Control For Heathkit Color TV's

Control your Heathkit Color TV from your easy chair, turn it on and off, change VHF channels, volume, color and tint, all by sonic remote control. No cables cluttering the room... the handheld transmitter is all electronic, powered by a small 9 v. battery, housed in a small, smartly styled beige plastic case. The receiver contains an integrated circuit and a meter for adjustment ease. Installation is easy even in older Heathkit color TV's thanks to circuit board wiring harness construction. For greater TV enjoyment, order yours now.

kit GRA-681-6, 7 lbs., for Heathkit GR-681 Color TV's... \$59.95
kit GRA-295-6, 9 lbs., for Heathkit GR-295 & GR-25 TV's... \$69.95
kit GRA-227-6, 9 lbs., for Heathkit GR-227 & GR-180 TV's... \$69.95

kit GR-681

\$499⁹⁵

(less cabinet)



kit GR-295

now only

\$449⁹⁵

(less cabinet)

kit GR-227

now only

\$399⁹⁵

(less cabinet)



kit GR-180

now only

\$349⁹⁵

(less cabinet)



New Wireless
TV Remote Control
For GR-295, GR-227
& GR-180

\$69⁹⁵

New Wireless
TV Remote Control
For GR-681

\$59⁹⁵



NEW

FREE 1969 CATALOG!

Now with more kits, more color. Fully describes these along with over 300 kits for stereo/hi-fi, color TV, electronic organs, electric guitar & amplifier, amateur radio, marine, educational, CB, home & hobby. Mail coupon or write Heath Company, Benton Harbor, Michigan 49022.

HEATH COMPANY, Dept. 10-3
Benton Harbor, Michigan 49022
In Canada, Daystrom, Ltd.

Enclosed is \$ _____, plus shipping.

Please send model (s) _____

Please send FREE Heathkit Catalog.

Please send Credit Application.

Name _____

Address _____

City _____

State _____

Zip _____

Prices & specifications subject to change without notice.

CL-350

CIRCLE NO. 16 ON READER SERVICE PAGE

Fourth Ave., South, Birmingham, Ala., is W4BPD's QSL manager. If you want a QSL confirming your 20-second contact, mail your card and a postpaid reply envelope to Ack. Be sure to indicate the date and time (in GMT) of the contact accurately. As with all DX-peditions, any contribution you wish to include with your card to help defray expenses will be welcome. But whether you contribute or not *will not* affect your chances of having your contact confirmed.



Ron J. Hessler, VE1SH, Sackville, New Brunswick, Canada, started as Canada's youngest amateur. He is now a life member of the Quarter Century Wireless Assoc. The equipment is Collins: KWM-2, 32S-3, 75S-3B, 30L-1. The lovely lady is his wife, Donna.

Five-Band DXCC Award. The American Radio Relay League, Inc., (ARRL) recently announced a supplement to its popular DX Century Club Award in the form of a 5-Band DXCC Award. To qualify, the applicant must submit written proof of having worked a minimum of 100 countries on each of five different amateur bands since Jan. 1, 1969. If it were not for the Jan. 1 starting date, a few amateurs could immediately qualify for the new award. Howie, W2QHH, Hamilton, N.Y., could qualify several times over with cards from stations worked with less power than used by the average Novice. But the Jan. 1, 1969 starting date gets everyone off the starting blocks at the same time.

Progress of Sunspot Cycle #20. Evidence continues to accumulate that the current sunspot cycle #20 apparently topped out last summer, and the average sunspot number is now dropping. The next minimum is predicted to occur around 1974. Since the average sunspot number and the maximum usable frequency (MUF) for long-distance operation rise and fall together, DX conditions on 28 MHz will probably be more erratic in 1970 than they were this year, especially into northern Europe and

Asia. Thus, it would seem wise for anyone interested in working 10 meters to make hay while the sun shines (no pun) before the normal summer 10-meter DX fadeout.

FCC and Related News. *FCC Report* via the Amateur Radio News Service *Bulletin* says that two of the three Kentucky amateurs indicted for using obscene, profane, and indecent language on the 75-meter phone band did not contest the charges. They received \$100 fines and three-month prison sentences. The prison sentences were suspended, however. The third defendant pleaded not guilty, but was found guilty on seven counts. He was fined \$700 and sentenced to six months in prison. Apparently his prison sentence has not been suspended. Incidentally, four CB operators have been indicted on similar charges.

Have you ever wondered what would happen if you acted as a volunteer examiner for an amateur by-mail examination and the examination papers were lost in the mail? Wonder no more. This experience recently befell your Amateur Radio Editor. Seven weeks after administering the Novice examination to an applicant and mailing the papers to Gettysburg, an ominous-looking official letter arrived by certified mail. The FCC wanted to know where the examination papers were and outlined the various penalties for willful violation of FCC regu-



Although John Koning, WB6VQE, Norco, Calif., has an advanced license and equipment for the low-frequency bands, he spends the most time on 144 MHz with a Hallicrafters SR-42A transceiver and HA-26 VFO.

lations. The possibilities included suspension of amateur privileges, a fine, and the withdrawal of the right to act as a volunteer examiner.

I replied by certified mail giving the date on which I had given the examination and mailed the material back to the Commis-

(Continued on page 101)



SOLID STATE

By LOU GARNER, Semiconductor Editor

WITH THE CRIME rate at an all time high, many engineers and designers are working feverishly to develop new types of electronic crime-control equipment. Not all of this work is for purely altruistic reasons, however, for the Omnibus Crime Control and Safe Streets Act of 1968 provides substantial federal grants for the purchase of crime-fighting equipment—\$36 million for fiscal 1969, \$300 million for fiscal 1970, and gradually increasing to about a billion dollars annually in the late 1970's. Most of the equipment being produced or developed uses semiconductor circuitry and solid-state devices.

Among the new items are:

- A *weapons detector* developed by Lockheed Missiles & Space Co. and now being tested by the Air Transport Association, with a view toward reducing the number of airplane hijackings. The Lockheed unit uses a special thin-film magnetic sensor designed to detect the movement of magnetic fields associated with ferrous metal objects, whether concealed in clothing or in carry-on luggage.

- A *wireless closed-circuit TV camera* suitable for flexible, inexpensive surveillance installations. Developed by the GBC Closed Circuit TV Corporation (New York, N.Y.), the unit can transmit for short distances to any conventional TV receiver without direct wire connections, thus simplifying installation and reducing the need for special monitors. Solid-state and lightweight, the new camera features a crystal-controlled transmitter and lists for less than \$500.00.

- *Video motion detectors* which combine TV surveillance with computer analysis to sound an alarm if physical movement takes place within a protected room or other area. Similar, but not identical, units are offered by Squires-Sanders, Inc. (Martinsville Road, Liberty Corner, N.J. 07938) and Jackson & Church Electronics Co. (2247 NASA Boulevard, Melbourne, Florida 32901).

- A *counter-sniper radar* system designed to detect and track bullets in flight as well as to pinpoint the source of fire. Developed by the Cornell Aeronautical Laboratories, the system is still experimental, but field tests have demonstrated the overall capability of tracking shotgun slugs and pellets

in addition to 22 caliber and larger bullets. The eventual goal is a compact mobile system compatible with the power and space available in a typical automobile or patrol car, and with a range of 300 yards, or more. Future refinements may include the automatic transmission of sniper locations to police receivers and the operation of fast moving bullet-proof shields to protect the intended victim.

- Proposed *transponders for vehicles* which, combined with suitable transmitter/receiver networks, central control computers, and display equipment, could provide dispatchers with constant information on all vehicle locations, thus simplifying the routing of police cars, ambulances, fire engines, or other emergency vehicles to trouble areas. Part of a larger program dubbed PULSE (for Public Urban Locator Service), the proposal is being studied by two consulting firms under a \$200,000 HUD grant.

- A *pulsed-beam laser alarm system* suitable for both indoor and outdoor security applications. Developed by RCA under a U.S. Air Force research contract, the system includes a gallium arsenide injection laser transmitter, an optical receiver, and an alarm indicator. The basic transmitter and receiver units are each about the size of a cigarette package, including their own battery power supplies. A remote alarm indicator may be connected to the receiver either through direct lines or by means of a radio link.

There are, of course, a variety of other electronic crime-control devices either proposed or in the active design, development or test stages. Space permitting, we'll report on other interesting units in the future.

Reader's Circuit. Ideal for use as a Science Fair project, the audible thermometer circuit illustrated in Fig. 1 was submitted by an overseas reader, Bruce Morton (1 Wallace Fields, Ewell, Epsom, Surrey, England). Easily assembled in a single evening or on a weekend, the instrument sounds beeps at a rate which varies directly with its ambient temperature—that is, the higher the temperature, the greater the number of beeps per minute.

Referring to the schematic diagram, Q1

and $Q2$, *pnp* and *npn* types respectively, are used as a two-stage, direct-coupled complementary blocking oscillator. Transformer $T2$ serves to match the loudspeaker's voice coil winding to $Q2$'s collector circuit and, at the same time, to provide the feedback signal needed to start and sustain oscillation. The feedback signal is coupled to $Q1$'s base-emitter circuit through impedance-matching input transformer $T1$ and series level control $R1$, while $C1$ and $R2$ form a secondary amplitude control network. Unbypassed emitter resistor $R3$ acts both to raise $Q1$'s effective input impedance and to limit $Q2$'s base current when $Q1$ is conducting.

In operation, the germanium transistors serve as the instrument's heat sensors. As the ambient temperature rises, the transistors' internal impedances are lowered, reducing the blocking interval and thereby increasing the circuit's effective repetition rate (or frequency). A similar, but opposite, effect takes place as the temperature drops. According to Bruce, his model exhibited a reasonably linear frequency vs. temperature relationship from about 30° F to over 100° F, with the "beep rate" ranging from 10 to approximately 70 per minute.

Inexpensive, readily available components are used in the project. Transistor $Q1$ is a general purpose *pnp* germanium transistor similar to types 2N107, CK722, 2N1191 or 2N1265, while $Q2$ is a corresponding *npn* unit similar to types 2N168, 2N169 or 2N170. Both $T1$ and $T2$ are identical transistor output transformers with 2000-ohm primary and 10-ohm secondary windings.

Bruce writes that neither layout nor lead dress are critical and, therefore, the circuit can be assembled breadboard fashion for demonstration purposes or, if desired, on a small chassis, etched circuitry, or perf board for more permanent applications. If the unit is to be used as an outdoor thermometer, the basic electronic circuitry should be

mounted in a small weatherproof case, with the loudspeaker, battery, and switch in a separate cabinet for indoor installation. The two units may be connected together with any suitable 4-conductor cable.

A calibration chart may be made up for the completed instrument by using a conventional thermometer as the test standard and a stop-watch to time the beat rate at various temperatures. Bruce suggests that the calibration procedure be started by first presetting $R2$ for a satisfactory tone quality and $R1$ for approximately 40 beats/minute at normal room temperature (70° F).

Manufacturer's Circuit. Suitable for use in a receiver, a portable phonograph, an intercom, a practice guitar amplifier, or a low-power p.a. system, the 6-watt audio amplifier circuit illustrated in Fig. 2 was abstracted from a Mallory Integrated Circuits Catalog, published by Mallory Distributor Products Co. (Box 1558, Indianapolis, Indiana 46206). It is designed for operation on a 10.5- to 14.5-volt d.c. source (such as a 12-volt car or lantern battery), and has less than 10% distortion at full output and a frequency response essentially flat from 25 Hz to 15 kHz. Delivering 2 watts output with an input signal of only 100 mV, the circuit uses a silicon monolithic integrated circuit and a single *pnp* power transistor.

Referring to Fig. 2, $C1$ serves as an input coupling capacitor and $R1$ as an isolation resistor. The integrated circuit assembly, $IC1$, is used as a high gain driver, while $Q1$ is a class A output power amplifier. Emitter resistor $R3$ provides stabilization, while shunt feedback is furnished through $R2$. A parallel collector load arrangement is used to minimize d.c. flow through the loudspeaker's voice coil winding, with $R4$ and choke $L1$ connected in shunt across the speaker.

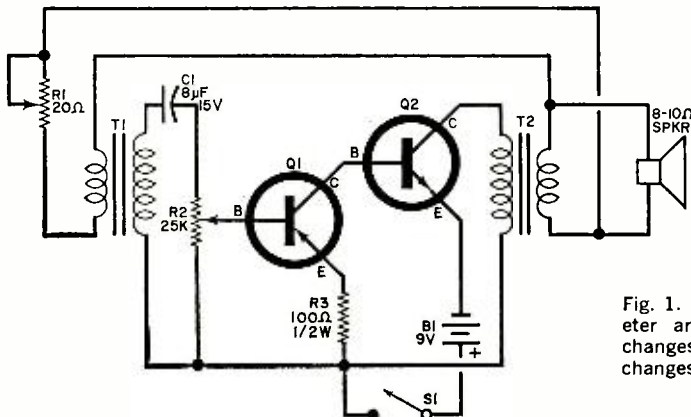
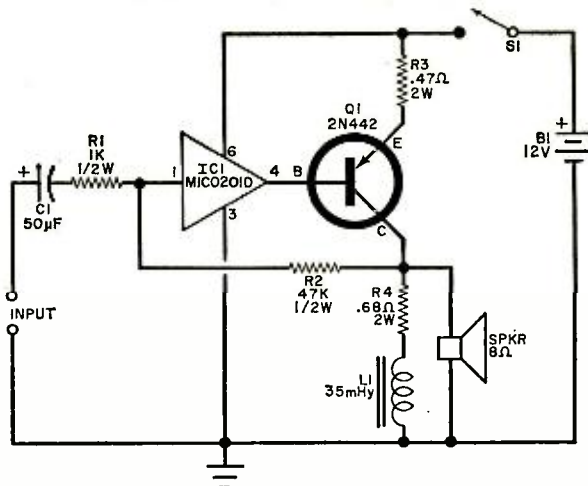

Fig. 1. Heat sensors in audible thermometer are $Q1$ and $Q2$; as temperature changes, number of beats/min at speaker changes in almost same proportion.

Fig. 2. In this audio power amplifier, IC1 is a high-gain driver, Q1 is class A power amplifier, and R3 in emitter circuit of Q1 provides stabilization.



Standard parts are specified in the design. The integrated circuit is a Mallory type MIC 0201D, while Q1 is a type 2N442 or equivalent transistor. A heavy-duty power supply is preferred for B1, for the current drain is a little over 1 ampere.

Neither parts nor wiring arrangements are overly critical but, of course, good audio wiring practice should be observed, with all signal carrying leads kept short and direct. Chassis-type construction is preferred over perf board or etched circuitry to provide an adequate mounting base for the choke (L1). A suitable heat sink should be provided for Q1. The completed amplifier may be used with any standard tuner or preamp capable of furnishing up to 500 mV to a 1000-ohm load.

Industry Items. There's good news for all IC fans. RCA is now making available its KD2117 "Linear Integrated Circuits Variety Pack," at all RCA distributors for \$4.40. For this low price, you get five linear IC's. Two of these are KD2114's each containing two isolated transistors and a Darlington connected pair; two are KD2116's, which contain a dual Darlington array; and the last is a KD2115 multi-purpose wideband amplifier.

With the package you get a detailed application booklet outlining the construction for 12 starter projects. These include a 500-mW audio amplifier, various types of r.f. and audio oscillators, mixers, a thermometer, an excellent wireless mike, a marine-band converter, and a suggested power supply to operate the IC's. If you have ever had the urge to try linear IC's, but couldn't afford them, this is the way to get your feet wet.

Motorola Semiconductor Products, Inc. (P.O. Box 20912, Phoenix, Arizona 85036)

March, 1969

has introduced a new unijunction transistor characterized for operation on sources as low as 4 volts. Designated type 2N5431, the new unit is assembled in a hermetically sealed TO-18 case (see Fig. 3), and has very low emitter leakage and peak-point currents. It has a tight intrinsic-standoff-ratio and a small base-to-base resistance. With a maximum reverse emitter voltage rating of 30 volts and a maximum emitter current of 50 mA, the 2N5431 has a maximum power dissipation rating of 300 mW.

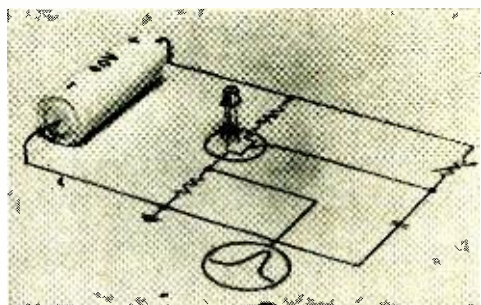

Fig. 3. The new 2N5431 UJT can be operated on as little as 4 volts, has maximum emitter current of 50 mA, and can dissipate up to a maximum of 300 mW.

In another area, Motorola has also announced the availability of a new linear integrated circuits design kit which offers two each of 12 different circuit types, covering nearly all linear applications, together with a complete technical library on everything in the company's linear IC line. The 24 devices are contained in trays for easy accessibility, while the carrying case is of sturdy leatherette. Although the devices included have a total value of \$361.00, the kit will

(Continued on page 103)

ON THE CB

(Continued from page 84)

As we have pointed out before, we use statistics obtained while monitoring in a given area. We are well aware of the amount of rule-breaking activity in each of these areas. Among the cities visited last year, Boston produced the *least* number of offenses during our monitoring sessions. The area was not free from offenders. If Bostonians feel our decision was incorrect, they should hear the CB in other places.

About Club Newspapers. We are often asked which CB club publishes the *best* newspaper. "Best" covers a lot of territory, but there are many clubs that put perfectionist efforts into their publications. Then there are too many clubs that shouldn't be wasting money and time on their attempts.

Based on layout, article content, and how material is slanted for the CB'er, we like the *REACTER*, published by REACT of Calgary, Alberta, Canada. The bulletin is continually clean-cut, intelligent, and full of informative news for the members.

The *Dixie Citation*, published by the Dixie Communications Club, Decatur, Georgia, has published a newsworthy club paper for longer than we can remember. The *Citation* seems always to have a front-page photo calling attention to news to be found within, and is generally well-illustrated. The club is deeply involved in local, area, and statewide activities.

The biggest hang-up with the newsletters that don't quite make the grade remains the

use of off-color jokes, full pages of "in" jokes recognizable only by a few members (like "Guess who got a flat tire when he was supposed to be picking up Marcey Su for a date and never bothered to use his mobile CB radio to let her know?"), etc. etc. And



Paul Gromyko, KQA0400, left, and Joseph Koslowski, KQA2075, at the S-9 International Emergency Team's control center. The club has been active in the New England area for six years, with associate members in Rumford Point, Maine, and all over the Northeastern states. Members patrol area highways and are available for search work and fire control.

nothing is worse to a reader than a newspaper that has been stencilled from an original made on a typewriter with clogged keys. As any editor knows, "If it can't be read, it's dead!"

The CB club newspaper should reflect the club's goals and activities and promote information that spotlights its progress to outsiders.

I'll CB'ing you.

—Matt, KHC2060

2

EASY-TO-BUILD
TABLE RADIOS
FOR UNDER

\$14



MODEL K-50

Five tube, a-c, broadcast superhet. Build and test instructions, parts, wire, solder, prepunched chassis, and cabinet. \$11.95

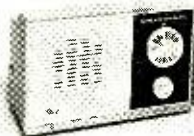

MODEL K-65

Deluxe printed circuit six transistor table radio. Instructions, parts, wire, solder, circuit board, cabinet. Specify K-65 for 120V a-c or K-65P for battery operation (battery included). \$13.50

See your local distributor or send check or money order, with model number, your name and address, to:

Kits

INDUSTRIES INC.

729 Ceres Avenue
Los Angeles, Calif. 90021
for fast postpaid delivery.
Sorry, no C.O.D.'s.

CIRCLE NO. 18 ON READER SERVICE PAGE

Announcing the **NEW STANDARD** in Stereo Testing!

Get the All-New Model SR12 STEREO TEST RECORD

The most complete...most sophisticated...most versatile
Test Disc available today... **For Just \$4.98!**

Who Needs the New Model SR12?

If you've read this far, you do. Whether you're an avid audiophile who'll settle for nothing but peak performance from his stereo components... a casual listener who'd like more insight into the challenging world of stereo reproduction... or a professional technician who needs precise standards for lab testing... the new MODEL SR12 will be the most important disc in your entire collection.



Like its predecessor Model 211, MODEL SR12 has been produced by Stereo Review Magazine (formerly HiFi/Stereo Review) as a labor of love — by music lovers... for music lovers who want immediate answers to questions about the performance of their stereo systems and how to get the best possible sound reproduction.

Now greatly expanded and updated with the most modern engineering techniques, MODEL SR12 is the most complete test record of its kind — containing the widest range of checks ever included on one test disc. An ear-opener for every serious listener!

You'll make these important stereo checks BY EAR... (no test instruments of any kind required)

- ▶ Frequency response—a direct warble-tone check of nineteen sections of the frequency spectrum, from 20 to 20,840 Hz, which will pinpoint any frequency response defects in your system.
- ▶ Separation—an ingenious test which indicates whether you have adequate separation for good stereo.
- ▶ Cartridge tracking—the most sophisticated tests ever devised for checking the performance of your cartridge, stylus and tone arm.
- ▶ Channel balance—two broad-band, random-noise signals which permit you to eliminate any imbalances originating in cartridge, amplifier, speakers or room acoustics.
- ▶ Hum and rumble—foolproof tests that help you evaluate the actual audible levels of rumble and hum in your system.
- ▶ Flutter—a sensitive “musical” test to check whether your turntable's flutter is low, moderate, or high.

PLUS! ● Cartridge and Speaker Phasing ● Anti-Skating Adjustment ● “Gun Shot Test” for Stereo Spread ● Multi-purpose Musician's “A” ● Equal-tempered Chromatic Octave ● Guitar-tuning Tones.

Don't waste another minute on less-than-perfect stereo—Order Your Model SR12 Stereo Test Record NOW!

Consider the hundreds—even thousands—you've spent on your set-up and you'll agree \$4.98 is a small price to pay for the most valuable performance tool ever made. So to be sure your order is promptly filled from the supply available, mail the coupon at right with your remittance... today!

AND, for the ultimate in stereo testing, 7 critical TEST EQUIPMENT checks...

Attention professionals: Stereo Review's new Model SR12 Stereo Test Record is also designed to be used as a highly efficient design and measurement tool. In the following tests, recorded levels, frequencies, etc. have been controlled to laboratory tolerances—affording accurate numerical evaluation when used with oscilloscope, chart recorder, output meter, intermodulation-distortion meter and flutter meter.

- 1,000-Hz square waves to test transient and high-frequency response of phono pickups.
- 500 to 20,000 Hz frequency-response sweep.
- Sine-wave tone-bursts to test transient response of pickup.
- Intermodulation test using simultaneous 400-Hz and 4,000-Hz signals.
- Intermodulation sweep to show distortion caused by excessive resonances in tone arm and cartridge.
- 1,000-Hz reference tones to determine groove velocity.
- 3,000-Hz tone for flutter and speed tests.

Sample waveforms—illustrating both accurate and faulty responses are provided in the Instruction Manual for comparison with the patterns appearing on your own oscilloscope screen.

FREE Instruction Manual Includes Detailed Instructions, Charts, Tables and Diagrams.

Nothing is left to chance... or misinterpretation. Every segment of every band is fully, clearly, graphically explained. You'll know exactly what responses to listen for in each test. Which sounds and patterns indicate accurate performance... which ones spell trouble... as well as the cause of trouble and precise corrective measures to follow and help you pinpoint, analyze and cure your stereo headaches!

Stereo Test Record • P. O. Box 3110
Church St. Station, New York, N. Y. 10008

PE-39

Please send _____ test records at \$4.98 each, postpaid.
My check (or money order) for \$ _____ is enclosed.
(Outside U.S.A. please send \$7.00 per record ordered.) N. Y. State residents please add local sales tax.

Print Name _____

Address _____

City _____

State _____

Zip _____

PAYMENT MUST BE ENCLOSED WITH ORDER

Free Sound Catalog

The largest selection of speaker system components. Anywhere.



Send for your free copy...today! **Jensen**

Jensen Manufacturing Division, The Muter Company
5655 West 73rd Street • Chicago, Illinois 60638

NAME _____

ADDRESS _____

CITY _____

STATE _____

ZIP _____

CIRCLE NO. 35 ON READER SERVICE PAGE

The Active One...

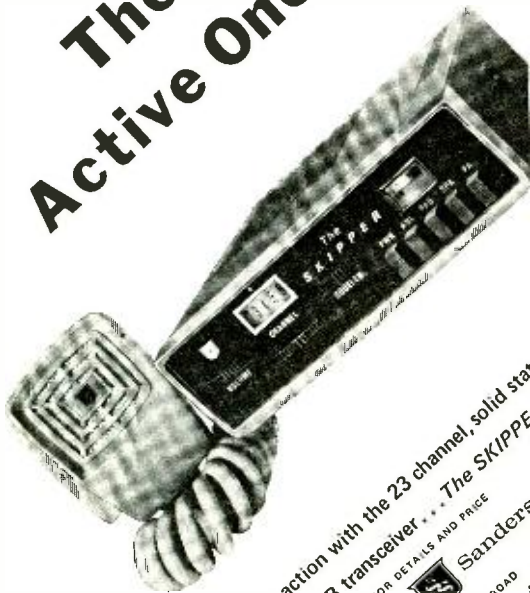

get in on the action with the 23 channel, solid state full 5 watt CB transceiver... The SKIPPER

WRITE FOR DETAILS AND PRICE
SQUIBB'S SANDERS
MARTINSVILLE ROAD
LIBERTY CORNER, N. J.
07938

CIRCLE NO. 31 ON READER SERVICE PAGE

SHORT-WAVE LISTENING

(Continued from page 86)

and on 17,855 kHz at 2130 in Spanish. *R. Luz Y Vida*, Loja, was noted weakly on 4712 kHz around 0130 with L.A. pop tunes and very few ID's.

England—Two new frequencies for the *BBC*. London: 9600 kHz in World Service to South America at 2345-0100 with news, "R. Newsreel", editorials and music, and 6150 kHz to S. E. Asia at 0000-0030 with news, amnts, "R. Newsreel" and further amnts; this latter xmsn is dual to 9410 kHz. Both xmsns were in English.

Ethiopia—A new channel for ETLF, Addis Ababa, is 11,905 kHz, logged at 1930 with multilingual ID, then English news.

Germany (West)—*Deutsche Welle*, Cologne, now uses 6130 kHz in German to Central America at 0145, and 6075 kHz, dual to 6100 kHz, at 2355-0100 to N.A. in German with news, commentary, light and semi-classical music and documentary features. You may find 6075 kHz QRM'ed by *R. Sutatena*, Colombia.

Guatemala—TGQB, Quezaltenango, is up slightly to 11,705 kHz where it can be heard nearly any time of the day in all Spanish programming. TGNA, Box 601, Guatemala City, has English religious programming at 0300-0430 on 5955 kHz. Medium wave DX'ers might watch for their 730 kHz outlet, TGN.

Holland—*R. Nederland*, Hilversum, also has two new frequencies in service: 6085 kHz (repl. 15,320 kHz) and 9715 kHz (repl. 17,810 kHz) in a xmsn to the West Indies in Portuguese, Spanish, Dutch and English at 2310-0005. News in English is given at 2353. The 9715 kHz also replaces 15,425 kHz at 2055-2150 to N.A. in English, dual to 11,730 kHz, with world and home news, music and "Actuality" features.

India—*All India Radio* was noted from Delhi. 15,250 kHz, at 1230 in English news, talk and music to Europe; from Madras on 6085 kHz at 1345 with "Vividh Bharati" program with Indian vocal and instrumental music to 1415; from Calcutta on 4820 kHz at 1205-1340 with Indian musical selections and talks in local dialects; and from Bombay on 15,150 kHz with English news at 1800 and on 4840 kHz from 1245-1300 with English stock market reports and into local programming.

SHORT-WAVE ABBREVIATIONS

amnt—Announcement	N.A.—North America
BBC—British Broadcasting Corp.	QRM—Interference
ID—Identification	R—Radio
IS—Interval Signal	repl—Replacing
kHz—Kilohertz	s/off—Sign-off
kW—Kilowatts	s/on—Sign-on
L.A.—Latin America	xmsn—Transmission
	xmtr—Transmitter

Iran—A new schedule from *R. Iran*, Teheran, shows Home Service on 7064 and 3998 kHz (if your editor has interpreted this schedule correctly, this service operates 24 hours daily). Foreign Service on 11,730 and 15,135 kHz in Russian at 1730, Turkish at 1800, Arabic 1830, German 1900, French 1930 and in English at 2000-2030. Regional stations include *R. Tabriz* on 6155 kHz at 0220-2030 with Armenian at 1800-1830 and *R. Rezaieh*, 6940 kHz, at 0630-1030 and 1330-1730 with Turkish at 1500-1600 and Assyrian at 1600-1630. Languages on other xmsns is not specified. Medium wave channels used include 592, 650, 690, 976, 985, 1060, 1090, 1325 and 1390 kHz. Power of 100 kW is used on 650, 985 and 1390 kHz.

Iraq—*R. Baghdad*, 6095 kHz, was logged at 1335-

POPULAR ELECTRONICS

1401 with anmts and Arabic vocal and instrumental music, and at 2100-2145 with Arabic music alternating with anmts and commentary in French.

Israel—The English broadcasts of *Kol Israel* have been extended to 45 minutes, now being 2015-2100 to Europe followed by French on 9009, 9625 and 9725 kHz.

Japan—*Nippon Hoso Kyokai*, Tokyo has moved to 15,445 kHz (repl. 15,135 kHz) dual with 17,825 kHz at 2345-0045 to N.A. in English.

Kuwait—*R. Kuwait* has moved its 1600-1730 xmsn to 11,920 kHz; this English broadcast runs past 1730 at times.

Lebanon—A new schedule, sent by registered mail, shows this line-up: to Africa daily on 15,350 kHz at 1830 English, 1900 Arabic and 2000 French with s/off at 2030; to So. America on 15,340 kHz daily at 2300 Portuguese, 2330 Arabic and 0030 Spanish with s/off at 0100; to N.A., Mexico, Antilles and Europe daily on 11,785 kHz at 0130 French, 0200 and 0300 Arabic, 0230 English and 0330 Spanish with s/off at 0400; and a daily omni-directional broadcast at 0430-0730 and 1625-1820 on 5980 kHz and 0925-1600 on 9545 kHz.



James Daley, Jr., WPE4JVR, Atlanta, Ga., uses a Hallicrafters SX-43 receiver and has verified 29 out of 33 states heard and 33 out of 48 countries. He is a member of the "Radio Budapest" SWL Club.

Libya—Tripoli, 7165 kHz, was heard from 1335-1427 fade with their Arabic Home Service; they feature considerable Arabic instrumental and vocal music.

Luxembourg—Not often heard, *R. Luxembourg*, Junglinster, 6090 kHz, has been noted recently from 0415 s/on with piano IS and into German religious programming on a Sunday. Look for good conditions from Europe in order to hear this one.

Morocco—Long-wave DX'ers might keep an ear tuned to 209 kHz where this country is said to be operating a new 400-kW xmtr at 0630-0000; this is probably in all Arabic.

Nigeria—We've received a newer schedule than that listed last month; it shows English at 0600-0730, 1530-1700 and 1800-1930; French 1330-1430 and 1930-2030; Arabic 1700-1800; Hausa 1430-1530; all on 21,455, 15,365, 11,770, 9690 and 7275 kHz. This is to Europe but often receivable well in the U. S. Another outlet, on 3986 kHz, was noted on the East Coast at 2140 with an English talk but a poor signal.

Norway—Oslo operates to N.A. on Sundays at 1600-1630 on 25,900 and 21,730 kHz and 2000-2030 on 21,730, 15,175 and 11,850 kHz, and on Mondays at 0000-0030, on 11,735 and 9645 kHz, 0200-0230 on 9610

March, 1969

NEW AND IMPORTANT SAMS BOOKS

NEW 12TH EDITION OF THE FAMOUS Tube Substitution Handbook

Lists over 12,000 direct substitutions. A complete guide to substitutions for receiving, picture tube, miniature, industrial, and communications types; includes foreign tubes. Tells how and when to make proper substitutions. Order 20700, only.....\$1.75

Short-Wave Listener's Guide, 3rd Ed.

Lists all short-wave stations by country, city, call letters, frequency, power, and transmission time. Includes Voice of America and Radio Free Europe stations, and stations operating behind the Iron Curtain. With conversion chart and handy log. Order 20695, only.....\$2.25

Ham Antenna Construction Projects, 2nd Ed.

The antennas described in this book are either home-made or represent major modifications of manufactured antennas. All designs are practical, and include improved new versions of the Marconi, Yagi, and 8JK, primarily for 10-500 watt PEP class rigs. Order 20654, only.....\$3.95

49 Easy Entertainment & Science Projects, 2 Vols.

Shows how to build unusual and instructive electronic circuits. Some are for practical use around the house; others are for science fair projects, toys, weird effects, and general entertainment. With full parts lists, diagrams, and instructions for each project.

Vol. 1 Order 20703, only.....\$2.50
Vol. 2. Order 20704, only.....\$2.50

Learning Electronics Through Troubleshooting

Provides a thorough grasp of electronics theory through the technique of solving practical troubleshooting problems. Includes two appendices containing valuable reference data. Order 20651, only.....\$7.95

Novel Electronic Circuits

Offers 77 unusual circuits and devices for the experimenter, ham, or technician. Designs range from simple, functional devices to unusual scientific types. Includes both vacuum tube and semiconductor circuits with detailed descriptions and instructions. Order 20692, only.....\$2.50

RECENT BESTSELLING BOOKS

49 Easy Transistor Projects. 20617.....\$1.75
How to Repair Major Appliances. 20650.....4.95
How to Build Speaker Enclosures. 20520.....3.50
Tape Recorders—How They Work. 2nd Ed. 20445...4.50
Walkie-Talkie Handbook. 20572.....3.95
Lasers and Masers. 20559.....4.95
ABC's of Computers. 2nd Ed. 20012.....2.95
Citizens Band Radio Handbook. 3rd Ed. 20569....4.25
101 Easy CB Projects. 20663.....3.25
Electronics in Photography. 20672.....3.50
Color-TV Servicing Guide. 20358.....4.25
Record Changers—How They Work. 20661.....3.95
So You Want to Be a Ham. 4th Ed. 20607.....4.50

— HOWARD W. SAMS & CO., INC. —

Order from any Electronic Parts Distributor, or mail to Howard W. Sams & Co., Inc., Dept. PE-3, 4300 W. 62nd St., Indianapolis, Ind. 46268

Send the following books: Nos. _____

_____ \$ _____ enclosed

Send FREE 1969 Sams Book Catalog

Name _____

Address _____

City _____ State _____ Zip _____

CIRCLE NO. 28 ON READER SERVICE PAGE

FREE

RADIO-TV ELECTRONICS

BA

69

ANNUAL CATALOG No. 691

BURSTEIN-APPLEBEE

WITH STORES IN...

ANNAPOLIS, MD. • BALTIMORE, MD. • BOSTON, MA. • CHICAGO, ILL. • CINCINNATI, OH. • CLEVELAND, OH. • DALLAS, TEX. • DENVER, CO. • DETROIT, MI. • HOUSTON, TEX. • KANSAS CITY, MO. • LOS ANGELES, CALIF. • MINNEAPOLIS, MINN. • NEW YORK, N.Y. • PHOENIX, ARIZ. • PORTLAND, ORE. • RICHMOND, VA. • ST. LOUIS, MO. • TAMPA, FLA. • WASHINGTON, D.C. • WICHITA, KAN.

FOR FAST FORWARDING TO YOUR HOME OR OFFICE, WRITE TO:
5195 MERCER ST., KANSAS CITY, MO. 64111



GIANT 1969
RADIO-TV
ELECTRONICS
CATALOG
228 GIANT
VALUE-PACKED
PAGES

WRITE FOR YOUR FREE COPY TODAY

BURSTEIN-APPLEBEE CO., DEPT. P.E.C.
3199 MERCER ST., K.C., MO. 64111

NAME _____

ADDRESS _____

CTY _____ STATE _____ ZIP _____

CIRCLE NO. 7 ON READER SERVICE PAGE

NEW! ROOF SHATTERING POWER! Thunder Columns

Never before has a sound reproduction device been designed to handle enormous power with such effortless ease and fidelity! Thunder Columns are scientifically-designed true sound columns, with every component perfectly matched to project maximum undistorted sound to your audience. Argos Thunder Columns are musician speakers in every sense of the word.

- 200 and 300 watt models • True focused sound for the serious musician • Fuse protected against accidental power overloads • Hidden steel grille crash protects speakers • Rugged upholstery grade vinyl finish • Heavy duty electronic instrument speakers

Argos
 PRODUCTS COMPANY

600 So. Sycamore, Genoa, Ill. 60135

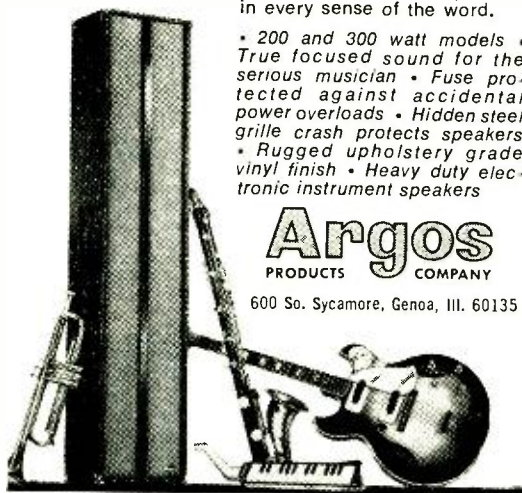

CIRCLE NO. 5 ON READER SERVICE PAGE

and 9580 kHz and 0100-0430 on 9645 and 9610 kHz. These xmsns are in English.

Pakistan—R. *Pakistan*, Dacca, is now found on 15,518 kHz, up from our listing of 15,455 kHz last month, from 0100 s/on with IS, six pips, and an ID for Dacca. English news is given at 0210-0220 with another ID at 0230 for Dacca.

Peru—OAX7A, R. *Cuzco*, Cuzco, is again active on 6250 kHz as found at 0230 with ID and into typically native programming.

South Africa—R. *RSA*, Johannesburg, is noted at times around 1700-1730 in English beamed to the Middle East on 25,790 kHz. When this 11-meter xmr is audible it is usually at excellent level.

Togo—Radiodiffusion du Togo, Lome, is often very good on 5047 kHz with music at 0645 and again around 2200-2300 s/off with light uninterrupted music with scattered ID's in French. The signal indicates that the 100-kW xmr is being used here for it is one of the easiest Africans to log.

Uruguay—R. *Sarandi*, Montevideo, 15,385 kHz, was logged at 0300 with talks and ID's in Spanish. Not easy to hear, it often alternates on the frequency with DZF3, Manila, P. I.

Vatican City—A new frequency for R. *Vaticano* is 9615 kHz, noted at 0025-0045 in Spanish to the Americas with church news and music, and from 0050 in English with music by Bach, prayers and news.

Venezuela—R. *Libertador*, Caracas, was good on 3245 kHz at 0700 with Spanish and American music.

Yugoslavia—R. *Belgrade* is audible on 9620 kHz with English news at 2200-2210 but QRM is generally heavy here.

SHORT-WAVE CONTRIBUTORS

Dave Rose (WPEIHEF), East Hampton, Conn.
 Al Sauerbier (WPE2YDA), Washington, N. J.
 Richard Stevens (WPE2OIS), Rochester, N. Y.
 Howard Rosenberg (WPE2POE), Queens Village, N. Y.
 Larry Fudalik (WPE2PRW), Cheektowaga, N. Y.
 Mike Szymanowicz (WPE2QGI), Kearny, N. J.
 Harold Ort, Jr. (WPE2QHS), Gloversville, N. Y.
 Peter Komeika (WPE3HMV), Rosemont, Pa.
 Terry Petrarca (WPE3IUF), Derry, Pa.
 Dan Ferguson (WPE4AUL), Coral Gables, Fla.
 Grady Ferguson (WPE4BC), Charlotte, N. C.
 Howard Kitzmiller (WPE4VVF), South Daytona, Fla.
 Bill White (WPE4WR), Union, S. C.
 David Potter (WPE4XO), Key West, Fla.
 Lucille Blair (WPE4YN), St. Petersburg, Fla.
 Ken Brookner (WPE5EM), Wichita Falls, Texas
 Charles Bennett (WPE5SW), Sumrall, Miss.
 W. W. Mosby (WPE6EXA), San Jose, Calif.
 Glen Whitney (WPE6GOY), Canoga Park, Calif.
 Edward Shaw (WPE6HCD), La Mesa, Calif.
 Gerry Dexter (WPE6HDB), Lake Geneva, Wisc.
 Richard Pistek (WPE6HOA), Chicago, Ill.
 Richard Doering (WPE6IXG), Hinsdale, Ill.
 Jim Bochantin (WPE6JDI), Du Bois, Ill.
 David Lubar (WPE6JFD), Elmhurst, Ill.
 Charles Rann (WPE6JFO), Wheaton, Ill.
 Fred Lynch (WPE6JHD), Girard, Ill.
 A. R. Niblack (WPE6KMI), Vincennes, Ind.
 John Beaver (WPE6LAE), Pueblo, Colo.
 C. Vernon Hyson (WPE6OCNF), Somerville, N. J.
 Bud Whitlock (WPE6OCOS), Augusta, Kansas
 Ted Larson (WPE6FCO), Milaca, Minn.
 Jack Perolo (WPE6PIC), Lake Geneva, Wisc.
 Paul Moeller (WPE6NO), Harrow, Ont.
 Jim Brenner, Nutley, N. J.
 Douglas Dominic, Streator, Ill.
 Steve Fraatz, Auburn, Wash.
 John Glover, Weston, Mass.
 Leo Graf, Franklin Lakes, N. J.
 William Halas, Elmhurst, N. Y.
 Chris Marchlewski, Lockport, Ill.
 Thomas Reza, Brooklyn, N. Y.
 Gert Schultz, Goteberg, Sweden
 Philip Scribani, Maspeth, N. Y.
 Sweden Calling DX'ers Bulletin, Stockholm, Sweden

POPULAR ELECTRONICS

AMATEUR RADIO

(Continued from page 92)

sion. My assurance that the examination had been received and remailed was accepted immediately, and a new examination was supplied to be administered to the applicant. (He passed and now has his license.)

MARS had a birthday. A little late, we at POPULAR ELECTRONICS join then President Lyndon B. Johnson, Governor John H. Chafee of Rhode Island, and many others in congratulating the Military Affiliate Radio System (MARS) which celebrated its 20th birthday last November 26.



Ray K. Owen, W5UYQ, Oklahoma City, Okla. has his Extra license. His station equipment includes the Drake T4-R4 twins and Heathkit SB-201 linear amplifier. (Photo courtesy Oklahoma City VHF Club.)

There are 135,000 licensed radio amateurs in Japan. Speaking at the last Region III meeting of the International Amateur Radio Union in Sydney, Australia, Kenich Kajii, JA1FG, president of the Japanese Amateur Radio League, reported that, when Japanese amateurs were again allowed in 1952 (after World War II), just 30 amateurs got on the air. Approximately 65,000 amateur stations are now in use.

The three classes of Japanese amateur licenses are: Telephone and Telegraph class authorizing a transmitter power output of 10 watts; Second class, 100 watts output; and First class, 500 watts output. The licenses are obtained by passing the appropriate examination—given twice a year—or satisfactorily completing a study course for the class of license desired. The JARL sponsors many of these amateur classes in different parts of Japan each year, and the

March, 1969

Which of these 4 fascinating Radio-TV careers

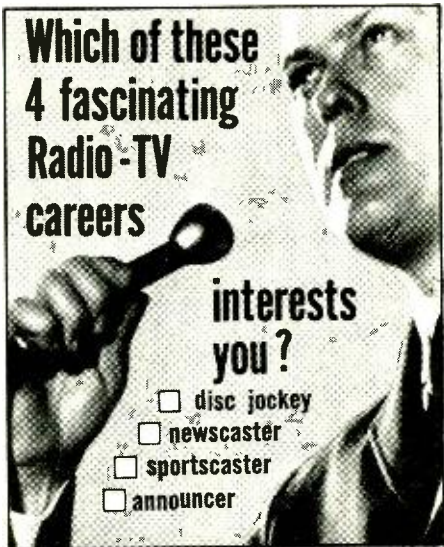

interests
you?

- disc jockey
- newscaster
- sportscaster
- announcer

Our Free Voice Analysis Tells You Whether You Have The Talent To Become A Broadcast Personality!

IMMEDIATE DEMAND • Radio-TV stations everywhere need both men and women to take over important good-paying jobs right now. **NATIONWIDE PLACEMENT ASSISTANCE** at No Extra Cost.

TRAIN AT HOME OR IN ONE OF OUR STUDIO SCHOOLS • You can study broadcast techniques at home, in your spare time, or in one of our many studio schools throughout the country under the supervision of our Directing Faculty of 10 Famous Broadcasters. **Accredited Member National Home Study Council and National Association of Trade and Technical Schools.**

Approved for Veterans' Educational Assistance Benefits ("G.I. Bill")!
Check coupon for special information

Send to CAREER ACADEMY's division of famous broadcasters for free booklet, record and voice analysis details!

CAREER ACADEMY

825 North Jefferson Street • Studio 308
Milwaukee, Wisconsin 53202

I want to know if I have broadcasting aptitude worth developing. Please rush more information.

name age

address phone



city/state/zip

I am interested in: Home Study 07N087202
 School Study G. I. Bill

CIRCLE NO. 8 ON READER SERVICE PAGE

101

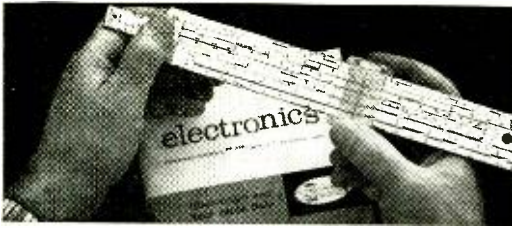

LOOK! A NEW ELECTRONICS SLIDE RULE
WITH COMPLETE INSTRUCTION COURSE

Professional 10" all-metal Electronics Slide Rule. Designed specifically for technicians, engineers, students, hobbyists. Has special scales not found on any other rule. Enables you to solve electronics problems quickly, accurately. Made to our rigid specs by Pickett, Inc. Slide Rule plus four lesson AUTO-PROGRAMMED Instruction Course with grading service, and top-grain leather carrying case . . . a \$50 value for less than \$25! Send coupon for FREE booklet. Cleveland Institute of Electronics, Dept. PE-154, 1776 E. 17th St., Cleveland, Ohio 44114.

SEND COUPON FOR FREE BOOKLET

Cleveland Institute of Electronics
1776 E. 17th St., Dept. PE-154,
Cleveland, Ohio 44114

Please send FREE Electronics Slide Rule Booklet. SPECIAL BONUS: Mail coupon promptly and get FREE Pocket Electronics Data Guide, too!

GET THIS FREE!

NAME _____ (Please Print)
ADDRESS _____ COUNTY _____
CITY _____ STATE _____ ZIP _____

A leader in Electronics Training . . . since 1934
CIRCLE NO. 12 ON READER SERVICE PAGE

number of people taking and passing them is increasing.

It is now OK for U.S. amateurs to work Indonesia (YB). The Indonesian government notified Geneva in November that it no longer objects to its amateurs' working foreign amateurs. But Cambodia, Thailand (Siam), and Vietnam remain on the U.S. forbidden list. In addition to these countries, Canadian amateurs cannot legally work Laos and Jordan.



Here are a few of the members of the WHHS Radio Club, Evansville, Ind., discussed below in News and Views. Bob Gibson, WA9HOY, front, is now enrolled in the Massachusetts Institute of Technology, and Madge Van Ness, right, in Louisiana State.

IT COSTS ONLY
1/100 OF 1¢ MORE
PER SOLDER JOINT
TO KNOW YOU ARE USING THE
WORLD'S FINEST CORED SOLDER



New Easy Dispenser Pak
60/40
18 S.W.G.

Latest PC (Printed Circuit) Pak
60/40 Extra Thin
22 S.W.G.—.028"

each only 69¢ per package at your dealer



MULTICORE SALES CORP., WESTBURY, N.Y. 11590
CIRCLE NO. 22 ON READER SERVICE PAGE

NEWS AND VIEWS

Joe Pearlstein, WA3IJZ, 7214 Bradford St., Philadelphia, Pa. 19149, spends most of his time on 15-meter SSB. But he works 20-, 40-, and 80-meter CW occasionally to keep his code speed up for the Extra class exam. His 90-watt, Heathkit HX-20 transmitter, HR-10 receiver, Hy-Gain TH-3 beam antenna, and long-wire antenna have been used to put 48 states and 35 countries in the WA3IJZ logbook . . . **David L. Jones, WA3JLT**, 8 Raymond Rd., Broomall, Pa. 19008, works the amateur bands between 3.5 and 148 MHz with a collection of commercial and home-built gear. Included in the gear are a Hammarlund HQ-110AC receiver, Hallcrafters HT-10A transmitter, Utica 650A, 6-meter transceiver, and a homebrew, 6- and 2-meter transmitter. His antenna farm presently sprouts a Hy-Gain 18V vertical, a 6-meter dipole, an "all-band" dipole, and an end-fed wire. Of the 45 states he has confirmed, 35 were worked on 80 meters.

WA9RRG, the amateur station of the William Henry Harrison High School Amateur Radio Club, Room 215, Evansville, Ind. 47715, claims to have the first and only high-school amateur TV station. The club members built it from much-modified surplus military and commercial equipment. Transmission is on 445 MHz from an omnidirectional antenna on an 80' tower with an input power of 100 watts. Less-exotic gear includes a Heathkit Apache transmitter, a National NC-300 receiver, and 80- and 15-meter dipoles. Six of the club's 26 members have General class licenses. John W. Lenn, W9IVE, is club sponsor. **Bob Hadjak, WA3JDT**, 4 Homer St., Greenville, Pa. 16125 has worked as far on 144 MHz as some hams do on the lower frequencies. His Heathkit Twoer feeding a 9-element TV beam

has worked Florida—a distance of 1000 miles. He also has four other states confirmed on 144 MHz. Bob also has a 3-element beam in his bedroom that he uses on occasion. (When the family wants to watch TV?) On the lower frequencies, Bob uses a Hallicrafters SX-99 receiver and an EICO 720 transmitter and is manager of the 7-MHz, WAS net on 7170 MHz . . . Before 1914, **Frank Keefe, W2AFB/NØFYX**, 411 Chemung St., Waverly, N.Y. 14892, was a telegraph operator in England. During WW-I, he operated for the British War Office. Later coming to the U.S.A., he became a Western Union telegrapher; he got his amateur license in the early '30's. In WW-II, he worked in an FCC monitoring and direction-finding station, intercepting German submarine and other suspect CW transmissions. When he retired from the FCC in 1963, he was Administrative Assistant to the Chief of the Field Engineering Bureau. Today, Frank is still an avid amateur and Navy MARS traffic handler. He receives on a Hammarlund HQ-129X and transmits on a variety of homebuilt and kit transmitters running 50 to 150 watts.

Cal Jensen, WNØTPH/6, 100 Oak Rim Way, Los Gatos, Calif. 95030, had 37 states, including Alaska and Hawaii, confirmed from Kansas City before moving and having to start over. He lived in a basement apartment and could not have a permanent outside antenna; therefore, he used an indoor "Hamstick" antenna on 15 meters. However, for his all-night 40-meter sessions, he would set up a Hy-Gain 14AVQ vertical on the patio. Of course, it disappeared with the dawn. A Heathkit DX-60 transmitter and a Hallicrafters SX-101 receiver handle Cal's amateur operations. He uses a Hallicrafters SX-43 for SWL'ing. His stint as a Navy radio operator in WW-II helps explain the 25-wpm code certificate on his shack wall . . . **Rick Harrison, WA2ODI**, is another one whose moving interrupted his hamming. His move was from Seaford, N.Y., to an army post in Germany—8th Admin. Co. (AMB), APO 09111, N.Y.—where he is a Computer Systems Engineer. He has a year to go before returning to his Heathkit HW-32 transceiver, Hammarlund HQ-170C receiver, Mosley TA-33 beam, and assorted other gear. In the meantime, he would like to hear from a few old ham friends by mail . . . **Russ Korenthal, WN6NHG**, 115 Harvard Lane, Seal Beach, Calif. 90740, just completed the first two weeks of what he expects to be a long amateur career by making 125 contacts in ten states. A 20-watt, homebrew transmitter feeding a vertical wire on 40 meters and a National NC-183D receiver.

Will your radio friends have the pleasure of reading about you or seeing your picture in your column? The first step is to send us your "News and Views" and a sharp photograph (preferably black and white). Also, please keep us on your club paper mailing list or put us on it. The address is: Herb S. Brier, W9EGQ, Amateur Radio Editor, POPULAR ELECTRONICS, P. O. Box 678, Gary, Indiana 46401.
73, Herb, W9EGQ.

SOLID STATE

(Continued from page 95)

sell for under \$100.00 through franchised Motorola distributors.

Two radically new stereo phono cartridges featuring semiconductor devices have been developed by Toshiba, a major Japanese manufacturer of electronic equipment. One unit features a pair of phototransistors and a self-contained light source and is dubbed, appropriately, the "Photoelectronic Cartridge C-100P." In operation, audio signals

March, 1969

Looking for INTEGRATED CIRCUITS At Hobbyist-Experimenter Prices??

We've got 'em!

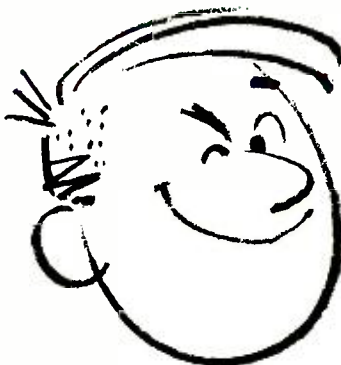

Power Amplifiers	Wide Band Amp Discriminators	3-Input Gates
Stereo Preamps	J-K Flip-Flops	Dual Buffers
OP Amps	Dual J-K Flip-Flops	Bias Drivers
RF Amplifiers	4-Input Gates	Quad Gates
IF Amplifiers	Dual 2-Input Gates	Half Adders

plus . . .

14 Pin, 10 Pin, and 8 Pin I.C. sockets
to put them in!

All at prices you can afford!!

Get HEP...Check into the Integrated Circuits available from your local Motorola HEP Distributor. Pick up a free copy of "Tips On Using IC'S" while you're there; it includes a good IC Cross Reference Guide, and eight IC Project Circuits. If you can't find a Motorola HEP Distributor near you, write us.



MOTOROLA HEP SEMICONDUCTORS
HOBBYIST • EXPERIMENTER • PROFESSIONAL
P. O. BOX 20924 / PHOENIX, ARIZONA 85034

CIRCLE NO. 21 ON READER SERVICE PAGE

Olson



*** FREE**

Fill in coupon for a **FREE One Year Subscription to OLSON ELECTRONICS' Fantastic Value Packed Catalog—Unheard of LOW, LOW PRICES on Brand Name Speakers, Changers, Tubes, Tools, Stereo Amps, Tuners, CB, and other Values. Credit plan available.**

NAME _____
ADDRESS _____
CITY _____ STATE _____
GIVE ZIP CODE _____

If you have a friend interested in electronics send his name and address for a **FREE** subscription also.

OLSON ELECTRONICS

346 S. Forge Street Akron, Ohio 44308

CIRCLE NO. 24 ON READER SERVICE PAGE

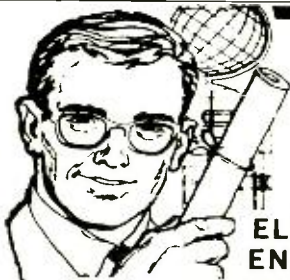

Earn Your Degree

ELECTRONICS ENGINEERING

through HOME STUDY

HIGHLY EFFECTIVE HOME STUDY COURSES IN:

- ELECTRONICS ENGINEERING TECHNOLOGY
- ELECTRONICS ENGINEERING MATHEMATICS

Earn your Associate in Science Degree in Electronics Engineering and upgrade your status and pay to the engineering level. Complete college level courses in Electronics Engineering. We're a forward looking school. Outstanding lesson material—thorough and easy to understand. Engineering taught on the basis of application and understanding rather than on the basis of memorization. Up to date in every respect. Acquire the knowledge and ability that means the difference between a low paying technician job and a high paying engineering position. Low tuition cost with low monthly payments. Free engineering placement service for our graduates. Write for free descriptive literature. Ask for bulletin K, no salesman will call on you.

COOK'S INSTITUTE of Electronics Engineering

Southwest Regional Office
7650 Clarewood, P.O. Box 36185
Houston, Texas 77036

Established 1945

Formerly Cook's School of Electronics

CIRCLE NO. 14 ON READER SERVICE PAGE

are developed by the phototransistors as light is reflected to their sensitive surfaces through a stylus-operated screen. The second cartridge, the "IC Cartridge C-300F," is only slightly larger in diameter than a kitchen match, and is described as the smallest stereo cartridge in the world. The C-300F has a solid-state pickup element and high-gain IC amplifiers.

IBM's research laboratories in Zurich, Switzerland, has developed a new Schottky-barrier field-effect transistor capable of operating well up in the microwave range. Named the MESFET (for METAL Semiconductor Field Effect Transistor), the new unit has a maximum oscillation frequency of 12 GHz, and can supply up to 2 dB gain at 10 GHz. The new device consists of a silicon substrate covered with an *n*-type epitaxial silicon film between 0.2 and 0.3 microns thick which serves as the conducting channel. A 0.2-micron gold-chromium-nickel sandwich enclosing the central drain serves as the gate contact. With its exceptional high frequency characteristics, the new MESFET may become a replacement for low power traveling-wave tubes (TWT's).

If you've had a yen to work with injection laser diodes, but have hesitated because of the comparatively high prices of these units, you'll find it worthwhile to check into the devices now being offered by Laser Diode Laboratories, Inc. (205 Forrest St., Metuchen, N. J. 08840). Their Model LD11, which carries a unit price of \$18.00, is a gallium arsenide unit capable of emitting coherent infrared radiation when pulsed in the forward-biased region. With a 5-watt minimum peak power rating at 27° C, the LD11 can be pulsed at rates up to 1 kHz if the pulse width is maintained within 200 nanoseconds. Its maximum peak operating current is 75 amperes and threshold current is 25 amperes.

Transistors. Although fairly expensive when compared to rectifier diodes, the Zener diode, nonetheless, is the typical experimenter's first—perhaps his only—choice when assembling a simple shunt-regulated d.c. power supply. Little known is the fact that low-cost rectifiers can perform admirably as voltage regulators if forward biased (Zeners are reverse biased). In practice, the diode's junction voltage remains remarkably constant with comparatively large changes in junction current. Often, a string of six to ten rectifiers will cost less than a single Zener having the same power-handling capability.

Although space limitations prevent our discussing the theoretical considerations in detail, the actual techniques of assembling a shunt regulator are relatively straightforward.

POPULAR ELECTRONICS

The first step is to determine the diode's junction voltage at the required current level. A good rule of thumb is to select a bias current approximately twice the *average* anticipated load current, but not more than half the diode's maximum rating. A miniature 1-ampere diode, for example, can be safely biased at 500 mA and used in power supplies with average load requirements of 250 mA.

The diode's junction voltage can be determined by using the technique illustrated in Fig. 4(a). A d.c. power source (batteries, for example) supplies the bias current, which is limited by series resistor R_1 . The diode's junction voltage is measured by connecting a high-impedance, low-range d.c. voltmeter directly to its anode and cathode terminals, as shown. R_1 's value can be approximated by using Ohm's law, the battery voltage, and the desired bias current.

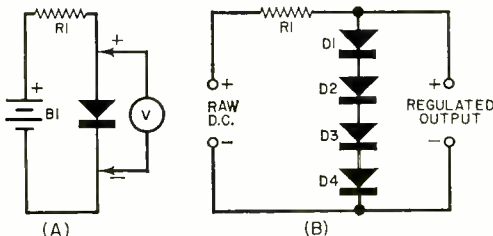

Fig. 4. Test setup for determining diode's forward-bias voltage drop is shown in (A); several diodes can be series connected (B) to provide Zener-type regulation at necessary load voltage requirements.

Using this technique, a 6-volt lantern battery, a 15-ohm series resistor, and a type 8D4 rectifier, your columnist measured 0.75 volts across the diode.

Once the diode's junction voltage has been established, just use the number of diodes required to obtain the needed output voltage. Assuming 0.75 volts per junction, 4 series-connected diodes would be required for, say, a 3-volt d.c. regulator. A typical arrangement is illustrated in Fig. 4(b). Here, the series resistor value must be lowered to compensate for the difference in bias current.

An experimental regulator circuit was assembled to check out the technique, using the circuit shown in Fig. 4(b), four series-connected 8D4 rectifiers (D_1 through D_4), a 5-ohm, 10-watt resistor (for R_1), and a 6-volt lantern battery as the d.c. source. The regulated output voltage, open load, checked out at 3.1 volts. With a 10-ohm load resistor, the output voltage dropped to only 2.95 volts . . . a change of less than 5%! How about that for regulation! —Lou

March, 1969

Build this exciting Schober Consolette Organ for only * \$925!



*Includes finished walnut console. (Only \$716 if you build your own console.) Amplifier, speaker system, optional accessories extra.

You couldn't touch an organ like this in a store for less than \$1800—and there never has been an organ of the Consolette II's graceful small size with 22 such pipelike, versatile voices, five-octave big-organ keyboards, and 17 pedals! If you've dreamed of an organ of your own, to make **your own** beautiful music, even if your home or budget is limited, you'll get more joy from a Schober Consolette II than any other "home size" organ—kit or no kit.

You can learn to play it. And **you** can build it, from Schober Kits, world famous for ease of assembly without the slightest knowledge of electronics or music, for design and parts quality from the ground up, and—above all—for the highest praise from musicians everywhere.

Send **right now** for the full-color Schober catalog, containing specifications of all five Schober Organ models, beginning at \$599.50. No charge, no obligation. If you like music, you owe yourself a Schober Organ!

The *Schober* Organ Corp., Dept. PE-29
43 West 61st Street, New York, N.Y. 10023

- Please send me Schober Organ Catalog and free 7-inch "sample" record.
 Enclosed please find \$1.00 for 12-inch L.P. record of Schober Organ music.

NAME _____

ADDRESS _____

CITY _____ STATE _____ ZIP _____

CIRCLE NO. 29 ON READER SERVICE PAGE

TELEVISION RADIO COLOR TV

MAIL COUPON FOR FREE BOOK

Coyne Electronics Institute Dept. 39-C2
1501 W. Congress Pkwy., Chicago, Ill. 60607

Send information as checked below

- HOME TRAINING in TV • Radio • Color TV • Electronics
 RESIDENT SCHOOL COURSES in Electronics, Electricity, Engineering, Radio-TV, Color TV, Refrigeration, and FCC

Name.....

Address.....

City..... State..... Zip.....

Phone..... Age.....

VA Approved—GI Bill

Two more examples of how RCA Institutes provides up-to-the-minute Home Training in all phases of electronics:

NEW CATV LESSONS

The demand is heavy for technicians in the booming field of CATV (Community Antenna Television Systems).

CATV was initially used to make it possible for large numbers of television receiver users to get good reception in remote areas through the use of a common antenna. It now brings to more people more programs than are available from local stations. It also improves reception where multipath signal transmission exists.

RCA Institutes includes two comprehensive lessons, covering the practical phases of CATV systems and servicing in Television Servicing and Communications courses and programs at no additional total tuition cost. Get in on the ground floor of this rewarding and expanding field. Send for full information today!

Prepare yourself for a career in the expanding field of CATV.

NEW COLOR TV KIT

To make courses even more practical and to better prepare you for a more rewarding future, RCA Institutes now includes an exciting Color TV Kit in both the beginner's program and the advanced course in color TV servicing. The cost of the kit is included in the tuition—nothing extra to pay. You also get five construction/experiment manuals plus a comprehensive service manual.

You'll receive all the materials and components to perform over 50 information-packed experiments. When you finish you'll have constructed an 18" (measured diagonally) high quality, color TV set, complete with rich cabinet in wood grain design.

Get all the details on RCA Institutes' valuable new Color TV Kit!

SEND THE ATTACHED CARD TODAY!

This is the high quality color TV set you construct, complete with rich cabinet in wood grain design.

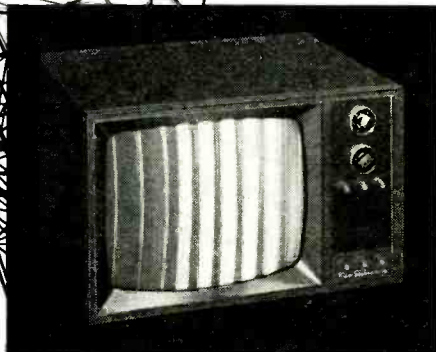

Learn electronics at home faster, easier, almost automatically—with RCA AUTOTEXT

Are you just a beginner with an interest in the exciting field of electronics? Or, are you already earning a living in electronics and want to brush-up or expand your knowledge in a more — rewarding field of electronics? In either case, AUTOTEXT, RCA Institutes' own method of Home Training will help you learn electronics more quickly and with less effort, even if you've had trouble with conventional learning methods in the past.

THOUSANDS OF WELL PAID JOBS ARE OPEN NOW TO MEN SKILLED IN ELECTRONICS!

Thousands of well paid jobs in electronics go unfilled every year because not enough men have taken the opportunity to train themselves for these openings. RCA Institutes has done something positive to help men with an aptitude and interest in electronics to qualify for these jobs.

HOME STUDY CAN TRAIN YOU FOR REWARDING CAREER OPPORTUNITIES

To help fill the "manpower gap" in the electronics field, RCA Institutes has developed a broad scope of Home Training courses, all designed to lead to a well paying career in electronics in the least possible time. You also have the opportunity to enroll in an RCA "Career Program" exclusively created to train you quickly for the job you want! Each "Career Program" starts with the amazing AUTOTEXT Programmed Instruction Method. And, all along the way, your program is supervised by RCA Institutes experts who become personally involved in your training and help you over any "rough spots" that may develop.

VARIETY OF KITS ARE YOURS TO KEEP

To give practical application to your studies, a variety of valuable RCA Institutes engineered kits are included in your program. Each kit is complete in itself, and yours to keep at no extra cost. You get the new Programmed Electronics Breadboard for limitless experiments, including building a working signal generator, multimeter, and a fully transistorized superheterodyne AM receiver.

ONLY FROM RCA INSTITUTES— TRANSISTORIZED TV KIT— VALUABLE OSCILLOSCOPE

All students receive a valuable oscilloscope. Those enrolled in the Television program receive the all-new transistorized TV Kit. Both at no extra cost and only from RCA Institutes.

CHOOSE THE "CAREER PROGRAM" THAT APPEALS MOST TO YOU

Start today on the electronics career of your choice. Pick the one that suits you best and mark it off on the attached card.

- Television Servicing
- Telecommunications
- FCC License Preparation
- Automation Electronics
- Automatic Controls
- Digital Techniques
- Industrial Electronics
- Nuclear Instrumentation
- Solid State Electronics
- Electronics Drafting

ADVANCED TRAINING

For those already working in electronics, RCA Institutes offers advanced courses. You can start on a higher level without wasting time on work you already know.

2 CONVENIENT PAYMENT PLANS

RCA Institutes offers a unique tuition plan that lets you progress at your own pace. You only pay for lessons as you order them. You don't sign a contract obligating you to continue the course.

There's no large down-payment to lose if you decide not to continue.

However, if you desire, RCA Institutes also offers a convenient monthly payment plan.

CLASSROOM TRAINING ALSO AVAILABLE

If you prefer, you can attend classes at RCA Institutes Resident School, one of the largest of its kind in New York City. Coeducational classroom and laboratory training, day and evening sessions, start four times a year. Simply check "Classroom Training" on the attached card for full information.

JOB PLACEMENT SERVICE, TOO!

Companies like IBM, Bell Telephone Labs, GE, RCA, Xerox, Honeywell, Grumman, Westinghouse, and major Radio and TV Networks have regularly employed graduates through RCA Institutes' own placement service.

SEND ATTACHED POSTAGE PAID CARD TODAY. FREE DESCRIPTIVE BOOK YOURS WITHOUT OBLIGATION. NO SALESMAN WILL CALL.

All RCA Institutes courses and programs are approved for veterans under the new G.I. Bill.

Accredited Member
National Home Study Council

IF REPLY CARD IS DETACHED—SEND THIS COUPON TODAY
RCA INSTITUTES, Inc., Dept. PE-39
320 West 31st Street, N.Y., N.Y. 10001

Please rush me FREE illustrated catalog. I understand that I am under no obligation, and that no salesman will call.

Name _____ Age _____
(please print)

Address _____

City _____

State _____ Zip _____





**DEALERS!
HOBBYISTS!**

**NEW AND
FREE
FROM WINEGARD**

Our giant catalog of TV and FM antennas, mounts, wire, couplers, amplifiers, wall plates and antenna systems equipment!

Now, for the first time ever, you can have Winegard's sensational 52-page Catalog illustrating and describing the world's most complete line of high quality antennas and MATV equipment for homes, and commercial buildings. That's right! Even if you're not in the electronics business, you can use this Catalog to select famous Winegard products. Send for your FREE copy today, plus the name of your nearest Winegard distributor.



Winegard
ANTENNA SYSTEMS

WINEGARD COMPANY, 3023-1 Kirkwood Street
Burlington, Iowa 52601

Gentlemen: Please send me your FREE Catalog.

Electronics is my business. Electronics is my hobby.

NAME (please print)

ADDRESS

CITY STATE ZIP

CIRCLE NO. 34 ON READER SERVICE PAGE

**NEW!
SOLID STATE KITS**

METAL-MINERAL DETECTOR
IN EASY-TO-BUILD KIT FORM

Treasure Locator

MODEL TRL-1 KIT . . . \$29.95

Detects objects as small as a dime.
Sensitive stable circuit uses
3 FET's and 2 silicon transistors.
Unique 6" etched circuit search coil.
Smooth vernier tuning control.
Weights only 24 oz.
3-ft. handle folds in half.
Adjustable search coil.
9-volt battery operated.
Complete with all parts,
headphone, instructions.
Build in only 3 hours.
No test equipment needed.
Shipping weight: 2½ lbs.

Order direct or request free
data sheets on TRL-1 and
other kits.



CARINGELLA ELECTRONICS, Inc.
P.O. Box 327 ■ Upland, California 91786
Phone 714-985-1540

CIRCLE NO. 9 ON READER SERVICE PAGE

COLOR TV

(Continued from page 81)

third video i.f. stage and applies a correcting voltage to Varicap diodes in the VHF and UHF tuners. The builder makes one simple adjustment on the AFT printed circuit board and all manual fine tuning adjustments are henceforth eliminated. If the GR-681 had only one improvement over all other TV receivers (and kits), we'd vote wholeheartedly for AFT. It works, and your wife will love it.

Each GR-681 is sold with a cable-type remote control (On-Off and Channel-change), but if you really want to swing, the wireless remote (GRA-681-6) is your baby. Using a hand-held mini-watt ultrasonic transmitter and a separate 6-channel receiver (selecting 34, 36, 38, 40, 42, or 44 kHz) the GRA-681-6 will turn the receiver on or off (and even reduce the volume in two steps), increase or decrease color and tint, and change channels—from anywhere in your den or living room. The wear and tear you will save on the rug, furniture, and yourself will soon pay for the wireless remote.

The addition of only a single transistor in series with the cathode of the video output stage has enabled Heath to eliminate or blank the faint vertical retrace line completely. This has improved picture fidelity at high brightness levels. Modifying the power supply from a 2-diode full-wave rectifier to a 4-diode bridge has noticeably stabilized voltage regulation.

The Little Extras. The GR-681 has a number of improvements over previous TV receiver kits that are not as sensational as those above. Included among them we might mention the tapped primary of the power transformer to step up voltages in locales where the line voltage is notoriously low. There is also a push-button on the front panel to utilize the VHF tuner motor drive and change channels without the remote control.

And, as with all color TV receiver kits sold by Heath, a choice of cabinets is available at very reasonable prices. The Mediterranean (or Spanish) oak shown in the photos with this review is an exceptionally handsome piece of furniture. In your reviewer's home, this cabinet is an exact match to a cellarette about half the size and costing over twice as much. If you are so inclined, Heath supplies liberal drawings for ease in making custom installations—even building your own cabinet.

Circle No. 92 on Reader Service Page 15 or 115

HAPPY HYBRID

(Continued from page 51)

the 9 volts to the oscillator board. Then make the oscillator circuit ground and connect the oscillator keying circuit to the r.f. keying circuit. Connect the two to the isolated terminal of *J2*. Check over the entire circuit for correct component placement, shorts, wiring errors, etc.

Before inserting *V1* in its socket, test the oscillator section. Plug a key in *J2*, turn the power on, and depress the key. You should hear a CW signal on a receiver tuned to the crystal frequency. Using a voltmeter, check the 9-volt supply to the oscillator. If it is less than 9 volts, reduce the value of *R12* slightly to get the right voltage.

Now listen to the signal on the receiver and, watching the S-meter, adjust trimmer capacitor *C9* to obtain a maxi-

mum signal. Release the key.

Using a standard socket and a short length of coaxial cable with the appropriate plug, connect a 7.5-watt light bulb to *J1*. This is the dummy load for testing. Insert *V1* in its socket and allow it to warm up. Set *C16* and *C17* to maximum capacitance (fully meshed) and close the key. The meter should indicate some current flow. Adjust *C16* until the dummy load glows and a dip occurs in the current meter reading. Slowly tune *C17* to increase the brightness of the lamp while re-adjusting *C16* for resonance (meter indication at minimum). When changes in *C17* no longer increase the brightness of the lamp, loading is correct.

Operation. For best results with the Happy Hybrid, be sure to use it with a well-matched half-wave dipole. Mismatching means that power meant for the antenna is lost in the pi network.

-30-

Patented components . . . a 30-year reputation for innovative design . . . a consistently creative approach to sound reproduction . . . this is where it all comes together, in the creation of extraordinary speakers such as the 312.

A glance at its specifications will tell you the 312 is an exceptionally fine reproducer. Unfortunately, they won't begin to show you how extraordinarily pleasing the sound is that flows from it. You must discover that for yourself, by listening. It's not inexpensive — about half what you'd expect. Hear the 312 soon. Find out why we call it: "the speaker your other components will be proud of."

Specifications: Model 312 3-way 12" Diffaxial Speaker. **Frequency response:** 28 to well over 40,000 Hz. **Patented Sphericon tweeter** is flat within 2 db to 22,000 Hz. **Power rating:** 35 watts integrated program material. **Impedance:** 8-16 ohms. **Crossover:** 1000 Hz (mechanical), 3000 Hz (electrical). **Dimensions:** 13" overall dia 6 1/2" deep. **Mounting:** Front or rear baffle. **Special Features:** Rigid, die-cast frame. Wide-angle dispersion by patented Sphericon Super Tweeter and exclusive Diffusicone principle. Rigid cup baffle (eliminates tweeter-woofer interference). High compliance suspension with University's exclusive Critical Edge Damping.



UNIVERSITY® SOUND
A DIVISION OF LTV LING ALTEC, INC.
P. O. Box 26105, Oklahoma City, Okla. 73125

This is where it all comes together

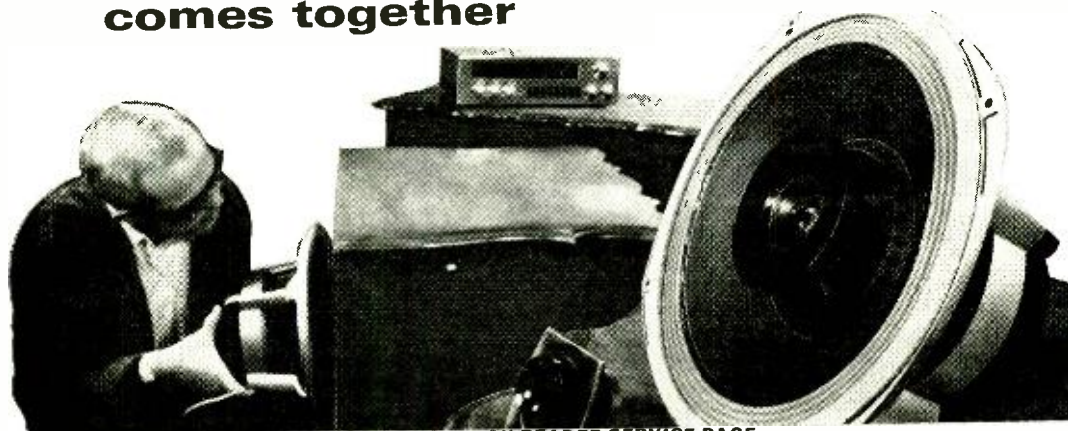

CIRCLE NO. 36 ON READER SERVICE PAGE

Deluxe POPULAR ELECTRONICS MAGAZINE CASES

DESIGNED TO HOLD A FULL YEAR'S COPIES

These decorative cases are just what you've been looking for to keep your copies of Popular Electronics Magazine in easy-to-find order.



Constructed of reinforced fibreboard and covered in rich leatherette, these durable cases guard against soiling and tearing of your magazines while lending themselves handsomely to the decor of any room. The magazine cases are available with embossed gold lettering in either all black or attractive maroon back with black sides.

\$3.50 ea., 3 for \$10, 6 for \$19

FULLY GUARANTEED!

Ziff-Davis Publishing Co., Dept. SD

1 Park Ave., N.Y., N.Y. 10016

Please send me _____ Popular Electronics Magazine

Files as checked below:

All black, gold embossed

Maroon back, gold embossed/black sides

NAME _____

ADDRESS _____

PE-39

CITY _____

STATE _____

ZIP _____

Enclosed is \$ _____ at \$3.50 per case, 3 for \$10, 6 for \$19 (Quantity prices apply for combination orders of more than one title). Orders outside U.S.A. \$4.50 ea., 3 for \$13, 6 for \$25.

(Payment must accompany order)

ABOUT YOUR SUBSCRIPTION

Your subscription to POPULAR ELECTRONICS is maintained on one of the world's most modern, efficient computer systems, and if you're like 99% of our subscribers, you'll never have any reason to complain about your subscription service.

We have found that when complaints do arise, the majority of them occur because people have written their names or addresses differently at different times. For example, if your subscription were listed under "William Jones, Cedar Lane, Middletown, Arizona," and you were to renew it as "Bill Jones, Cedar Lane, Middletown, Arizona," our computer would think that two separate subscriptions were involved, and it would start sending you two copies of POPULAR ELECTRONICS each month. Other examples of combinations of names that would confuse the computer would include: John Henry Smith and Henry Smith; and Mrs. Joseph Jones and Mary Jones. Minor differences in addresses can also lead to difficulties. For example, to the computer, 100 Second St. is not the same as 100 2nd St.

So, please, when you write us about your subscription, be sure to enclose the mailing label from the cover of the magazine—or else copy your name and address exactly as they appear on the mailing label. This will greatly reduce any chance of error, and we will be able to service your request much more quickly.

HOW'S YOUR E-IR? QUIZ ANSWERS

(Quiz appears on page 32)

1. In a series circuit, voltage drops are directly proportional to the resistances across which they are measured: $E_1R_1 = E_2R_2$; $E/5k = 8V/20k$; $E = 2V$.

2. Current through a resistance is equal to the voltage drop across the resistance divided by the resistance value: $I = E/R = 8V/2k = 4mA$.

3. Total current flows through all components in a series circuit: $I = E/R = 20V/32k = 6.25mA$; $R = E/I = 5V/6.25mA = 8000\text{ ohms}$.

4. Components that do not form a complete electrical loop have no voltage drop across them: $E = I/R = 2mA(8k) = 16V$.

5. The currents in parallel branches are inversely proportional to the resistance in each branch: $I_1R_1 = I_2R_2$; $I(40k) = (15 - I)160k$; $I = 12mA$.

6. An unknown resistance is found by dividing the voltage drop across it by the current through it: $R = E/I = 10V/2mA = 5000\text{ ohms}$.

7. The voltage drop across a resistance is the product obtained by multiplying the total current through it by the resistance value: $E = IR = 8mA(5k) = 40V$.

8. The voltage drop between the mid-points of a balanced bridge is zero; hence the current is also zero.

9. Voltage drops across parallel branches are all equal: $E = IR = 10mA(100k) = 1000V$; $R = E/I = 1000V/(50mA - 10mA) = 1000V/40mA = 25,000\text{ ohms}$.

10. The sum of the voltage drops in a closed loop exactly equals the applied voltage: $50V + E_{5k} = 40V + E_{10k} = E_{\text{applied}}$. Hence, $E_{10k} = 2(E_{5k})$; $50V + E_{5k} = 40V + 2E_{5k}$; $E_{5k} = 10V$; $E = 40V - 10V = 30V$.

OP-TACH

(Continued from page 31)

hand if it is sufficiently steady to get constant readings. Otherwise, place the Op-Tach on a solid surface. For the best accuracy, always have the tachometer case in a position as close to horizontal as possible.

Turn on the Op-Tach by rotating *R8* clockwise until *S1* turns on. This supplies power to the meter. Depress *S2* and continue to rotate *R8* until you get a full-scale deflection. Then release *S2*. With the photocell pointed at the rotating body, advance the SENSITIVITY control (*R2*) until you get a steady reading. If the sensitivity is made too high, the photocell will begin to pick up minor differences in reflectivity due to surface imperfections. This results in an erratic reading on the meter, which can be cured by decreasing the sensitivity.

If the rotation being measured is below about 500 RPM the meter may "dance" somewhat. This effect is not objectionable, however, until the speed is below 200 RPM. To avoid this problem, try using more than one contrasting area on the rotating object. This has the effect of multiplying the speed of the object by the number of reflecting surfaces you add, and the speed read on the meter can be converted to true speed by dividing by that number. For instance, if you have placed six contrasting strips on a rotating object and the tachometer reads 1200 RPM. Then the true speed is 1200 divided by 6 or 200 RPM.

Transmissive. The measurement method using the transmission of light through a rotating object to the Op-Tach works extremely well for slowly rotating fans. The light source is placed on one side of the fan and the Op-Tach on the other so that each blade interrupts the beam as it passes between the source and the tachometer. The instrument is turned on and the voltage is adjusted as before. Because of the extreme difference in light levels, the sensitivity adjustment may have to be increased slightly. The indicated RPM must be divided by the number of times the beam is interrupted during one revolution of the fan (number of blades). -50-

ELECTRET

(Continued from page 74)

times. Keep applying high voltage to the electret for a full hour to insure that the lucite electret is thoroughly charged as it cools. Should arcing occur during this time, however, carefully determine where it is taking place, and then turn off the TV set immediately. (Arcing will occur normally between the aluminum foil and plate.) Remove the line cord from the a.c. outlet, and with your rubber gloves on, disconnect the ground lead from the plate and short it to the anode lead's alligator clip to discharge the high-voltage supply. (If you don't have rubber gloves, use the

Ranked #1 in lightweight tracking ability¹

Able to track the toughest test-record bands at 0.8 gram²...
With a frequency response flat within +2.5, -2 db from 20 to 20k Hz^{1, 2}...
And 30 db of stereo separation^{1, 2}...
Plus a flawless square wave^{1, 2}...

EMPIRE's 999 VE

The Long-Playing Cartridge • \$74.95

1. *HiFi/Stereo Review*, July 1968. 2. *High Fidelity*, June 1968.

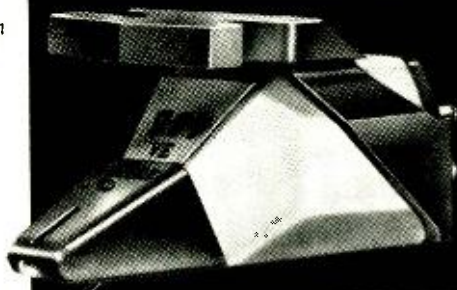

Empire Scientific Corp.,  **EMPIRE**
1055 Stewart Avenue, Garden City, N.Y. 11530

CIRCLE NO. 38 ON READER SERVICE PAGE

screwdriver/cable setup described earlier to touch the anode clip.)

After discharging the power supply, tear off a 1/2"-diameter piece of the foil in the location where the arcing occurred. If by this time the lucite has cooled, reheat it until it is soft before reapplying the high voltage.

When the forming process is complete, turn off the TV set and discharge the high-voltage line. Lift the electret from the aluminum plate; you will notice that the aluminum foil clings to it. It is permissible, but not necessary, to remove this foil. Then immediately wrap the electret tightly in aluminum foil, and allow it to age for at least a week before using it for experiments.

To reassemble the TV set, first discharge the residual charge in the picture tube with the screwdriver/chassis-cable assembly. Then, using only one hand as before, reconnect the anode cable. Replace the rear plate of the TV set. -30-

MATH

(Continued from page 69)

and—in some cases—binary math, Boolean algebra, and matrix algebra.

Because of the sophistication and flexibility of his knowledge, the engineering technician is usually the most highly paid. Then comes the line technician, the service technician, and a grouping that we will call the "nuts-and-bolts" technicians. The latter do mechanical

operations, following the dictates of their intuition and trial-and-error techniques.

What of the Future? At present, engineers and technicians are at a premium. The colleges and technical institutes cannot cope with the growing demand, and at the same time the industry is suffering from growing pains. The consensus of opinion is that as electronics becomes more sophisticated and circuits and systems more complex, more and more will be demanded of the technician. Right now, many engineering technicians are performing tasks that only a decade ago were the sole responsibility of the engineer.

The number of engineering technicians available must multiply many times over to keep abreast of current developments. New devices and techniques are introducing a revolution in electronics that can be met only through proficiency in higher mathematics. One thing is definite: the man who trains now for tomorrow's electronics job is insuring his future.

Where Do You Stand Now? If you don't know, you can find out simply enough. Go to your reference library and check your technical knowledge against the latest electronics theory textbooks on the shelves. If you find yourself at a loss after a few chapters and decide you need to upgrade your math background, you should start on a home-study course—either as a package with theory in electronics or just basic math—through one of the schools listed in the table. -30-

Remote Controlled Fleet Fueling



Positive protection and accurate accounting for remote fueling of fleet vehicles. Telemetering unit relays amount taken at outdoor pump and records it on office console. On-off switch at console activates pump. Intercom allows identification of user. Stops pilfering, saves manpower, provides accurate records. Ideal for automobile dealers, contractors, dairies, police, fire, etc. Send for colorful brochure today. Prices start under \$500. Dealerships available.

CONTROLATOR • Division of Aerotron, Inc.

P. O. BOX 6527 / RALEIGH, NORTH CAROLINA 27608

CIRCLE NO. 2 ON READER SERVICE PAGE

READER SERVICE PAGE

free information service:

Here's an easy and convenient way for you to get additional information about products advertised or mentioned editorially (if it has a "Reader Service Number") in this issue. Just follow the directions below... and the material will be sent to you promptly and free of charge.

1. Print or type your name and address on the lines indicated. Circle the number(s) on the coupon below that corresponds to the key number(s) at the bottom of the advertisement or editorial mention(s) that interest you. (Key numbers for advertised products also appear in the Advertisers' Index.)

2. Cut out the coupon and mail it to the address indicated below.

3. This address is for our product "Free Information Service" only. Editorial inquiries should be directed to POPULAR ELECTRONICS, One Park Avenue, New York 10016; circulation inquiries to Portland Place, Boulder, Colorado 80302.

**POPULAR
ELECTRONICS**

P.O. BOX 8391
PHILADELPHIA, PA. 19101

VOID AFTER APRIL 30, 1969

1 2 3 4 5 6 7 8 9 10 11 12 13 14 15 16 17 18 19 20
21 22 23 24 25 26 27 28 29 30 31 32 33 34 35 36 37 38 39 40
41 42 43 44 45 46 47 48 49 50 51 52 53 54 55 56 57 58 59 60
61 62 63 64 65 66 67 68 69 70 71 72 73 74 75 76 77 78 79 80
81 82 83 84 85 86 87 88 89 90 91 92 93 94 95 96 97 98 99 100

NAME (Print clearly) _____

ADDRESS _____

CITY _____ STATE _____ ZIP CODE _____

3 b

Live Better Electronically With

LAFAYETTE RADIO ELECTRONICS

1969 Catalog 690 FREE!



Now OFF PRESS
BETTER THAN EVER
Over 500 Pages

Stereo Hi-Fi • Citizens Band • Ham Gear • Tape Recorders • Test Equipment • TV and Radio Tubes and Parts • Cameras • Auto Accessories • Musical Instruments • Tools • Books

Featuring Everything in Electronics for
• HOME • INDUSTRY • LABORATORY
from the "World's Hi-Fi & Electronics Center"

LAFAYETTE Radio ELECTRONICS
Dept. 35039 P.O. Box 10
Syosset, L.I., N.Y. 11791

Send me the FREE 1969 catalog 690.

35039

Name
Address
City
State Zip

CIRCLE NO. 19 ON READER SERVICE PAGE

ELECTRONIC EXPERIMENTER'S HANDBOOK



The most fascinating and challenging construction projects for the electronics hobbyist. Over 148 pages.

1968 Winter Edition #50
1967 Spring Edition #49
1966 Fall Edition #39
1966 Spring Edition #36
1965 Fall Edition #9

Titles listed above \$1.25 each

Order by number from

Ziff-Davis Service Div., 595 Broadway • New York, N.Y. 10012. Enclosed add'l 15¢ per copy for shipping and handling (50¢ for orders outside U.S.A.)

PAYMENT MUST BE ENCLOSED WITH ORDER

LIBRARY (Continued from page 14)

reactance, check for gain and distortion in an amplifier, and make any other measurement within the capability of the oscilloscope. More specialized uses for the oscilloscope, such as testing SCR's and tunnel diode oscillators and multivibrators, aligning i.f. and chrominance circuits, etc., are also discussed. The book shows, in diagram form, where to make circuit connections and provides waveform photos of ideal results. This is a well illustrated book, containing more than 100 drawings and 200 waveform photos.

Published by Tab Books, Blue Ridge Summit, Pa. 17214. Hard and soft cover. 192 pages. \$6.95 hard cover, \$4.95 soft cover.

REFERENCE DATA FOR RADIO ENGINEERS, Fifth Edition

In its latest edition, this "Bible of the Electronics Industry," has been expanded by 50% over the 1956 edition. The book covers an extremely broad field, encompassing all phases of electrical and electronic engineering information. It has been enlarged in areas that required further discussion, and completely new chapters on microminiature electronics, space communications, switching and traffic concepts, reliability and life testing, quantum electronics, navigational aids, and international telecommunication recommendations have been added. This book is the one recognized authoritative encyclopedia, dictionary, or what have you not only for the practicing engineer but for the advanced technician and experimenter as well. More than 100 engineers have helped to put together this edition, producing a book of extremely broad spectrum.

Published by Howard W. Sams & Co., Inc., 4300 West 62 St., Indianapolis, Ind. 46206. Hard cover. \$20.00.

ELECTRONICS HANDBOOK FOR THE ELECTRICIAN

by Leo G. Sands

If you are looking for a "starter" book in electronics for a friend, look no further. This book, in its simple non-mathematical format, introduces the least informed beginner to electronics. It is not, per se, a tutorial book designed to instruct the reader in electronics principles and theory. Rather it is an introductory textbook that explains the phases and areas of electronics. No mathematics is used, nor are any formulas developed. This book was written specifically for the electrician who, lacking an electronics education, is now faced with the task of specifying, installing, and maintaining electronic equipment and systems. But for the young student, this book can also serve as a career guide to electronics.

Published by Chilton Book Co., 401 Walnut St., Philadelphia, Pa. 19016. Hard cover. 220 pages. \$5.95.

GET INTO ELECTRONICS

V.T.I. training leads to success as technicians, field engineers, specialists in communications, guided missiles, computers, radar, automation. Basic & advanced courses. Electronic Engineering Technology and Electronic Technology curricula both available. Associate degree in 29 months. B.S. obtainable. G.I. approved. Start February, September. Dorms, campus. High school graduate or equivalent. Catalog.

VALPARAISO TECHNICAL INSTITUTE
DEPARTMENT PE, VALPARAISO, INDIANA 46383



PRODUCTS

(Continued from page 24)

terminals, and inputs for tape recorder heads. Technical specifications: 1.5 μ V for 30 dB quieting sensitivity; more than 30 dB stereo separation; 150 watts IHF, 75 watts/channel, power output; 30-20,000 Hz \pm 3 dB frequency response; 50 Hz \pm 12 dB bass, 10 kHz \pm 10 dB treble tone compensation; +13 db at 50 Hz, +4 dB at 10 kHz loudness compensation; -55 dB magnetic phono hum and noise; 4-, 8-, and 16-ohm output impedances.

Circle No. 88 on Reader Service Page 15 or 115

SELECTIVE CB TRANSCEIVER

A delta tuning facility, backed up by a Collins mechanical filter, enables the Model GT-523 CB transceiver made by *Regency Electronics, Inc.*, to pull in weak and off-frequency signals. Although the GT-523 is designed primarily for mobile use, an optional power supply is available to make it usable as a base station. The on/off/volume, squelch, channel selector, and delta

tune controls are conveniently located on the front panel, while the rear panel contains external speaker terminals. Technical specifications: transmitter, \pm 0.005 carrier frequency accuracy, 3-watt output for maximum legal 5-watt input; receiver, double-conversion superheterodyne performance, fully variable squelch control circuit, less than 1 μ V for 10-dB signal-to-noise ratio. The GT-523 comes complete with coil-cord microphone, mobile mounting bracket, and synthesized crystal circuit for all 23 channels.

Circle No. 89 on Reader Service Page 15 or 115

BOOKSHELF THREE-WAY SPEAKER SYSTEM

Topping off the 1969 line of Allied Radio Corporation's line of shelf-type speaker systems is the new Model 2370 three-way acous-

tic-suspension speaker system. It has a 12" acoustic suspension woofer, compression-type midrange speaker with diffraction horn, and compression-type, wide-dispersion diffraction horn tweeter. The speakers are housed in a $\frac{3}{4}$ " hardwood (with walnut veneer) enclosure.

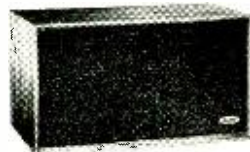

The Model 2370 also contains a crossover network for frequencies at 1000 and 5000 Hz and individual level controls for the mid-range speaker and tweeter. Technical specifications: overall frequency range, 20 Hz to beyond audio range; power capacity, 35 watts (70 watts peak); system impedance, 8 ohms. The kit, Model 2370K, contains all elements, finishing oil, and instructions.

Circle No. 90 on Reader Service Page 15 or 115

EIGHT-BAND SOLID-STATE RECEIVER

Allied Radio Corporation's Model 2682 receiver pulls in eight of the most popular medium-wave, short-wave, VHF, and FM bands. The receiver is equipped with a built-in squelch that silences the receiver between VHF calls and provides between-station muting on FM. A fine-tune control separates stations on the crowded medium and shortwave bands. Also included in the receiver are a world map/time chart, a.n.l., a.f.c., tone control, local-distance switch, and a tuning-battery meter. The receiver is supplied with dual telescoping antennas for FM and VHF reception; built-in antennas for AM and marine reception. Bands covered: 540-1600 kHz standard AM; 1.7-5 MHz medium wave (marine); 5-12 and 12-24 MHz international short-wave and ham; 88-108 MHz standard FM; 29-50 and 147-176 MHz VHF police/public service; and 107-136 MHz VHF aircraft.



Circle No. 91 on Reader Service Page 15 or 115

KEEP IN TOUCH
WITH THE ACTION!

SONARCOM
VHF-FM 2 WAY
TRANSCEIVER

(132-174 MHz)

FCC TYPE
ACCEPTED
for parts 89,91,93 and
part 21 telephone use
Also DOT ACCEPTED
for Canadian use

\$375 with
1 pair
of crystals and
penlite batteries



INSTANT 2 Way Communications To All Points!

**YOU ALWAYS GET THROUGH . . . OPERATES ANYWHERE!
INDOORS, OUTDOORS, IN STEEL BUILDINGS**

More performance and features than much higher priced units • engineered with space age techniques and military type components for high reliability, superior performance and long life • Provides instant voice contact with base stations, mobile units and other portable transceivers • compatible with all VHF narrowband systems • exclusive 'Push-to-Talk' mike • Full frequency range for all public safety, industrial and land transportation services • single or split channel operation • 1.6 watts output.

SONAR RADIO CORP., 73 Wortman Ave., Brooklyn, N.Y. 11207
Please send information on Model 2301—the SONARCOM. Dept. 925

Firm Name _____ Title _____
Address _____ Phone _____
City _____ State _____ Zip _____

ELECTRONICS MARKET PLACE

COMMERCIAL RATE: For firms or individuals offering commercial products or services. \$1.15 per word (including name and address). Minimum order \$11.50. Payment must accompany copy except when ads are placed by accredited advertising agencies. Frequency discount: 5% for 6 months; 10% for 12 months paid in advance.
READER RATE: For individuals with a personal item to buy or sell. 70¢ per word (including name and address). No Minimum! Payment must accompany copy

FOR SALE

FREE! Giant bargain catalog on transistors, diodes, rectifiers, SCR's, zeners, parts. Poly Paks, P.O. Box 942, Lynnfield, Mass. 01940.

GOVERNMENT Surplus Receivers. Transmitters, Snooperscopes. Radios. Parts. Picture Catalog 25¢. Meshna, Nahant, Mass. 01908.

BUG DETECTOR: WILL DETECT AND LOCATE SURREPTITIOUS TRANSMITTING DEVICES IN CONFERENCE ROOMS, HOME AND OFFICES, ETC. WRITE FOR DETAILS. WJS ELECTRONICS, 737 NORTH SEWARD, HOLLYWOOD, CALIF. 90038.

ROCKETS: Ideal for miniature transmitter tests. New illustrated catalog. 25¢. Single and multistage kits, cones, engines, launchers, trackers, rocket aerial cameras, technical information. Fast service. Estes Industries, Dept 18, Penrose, Colorado 81240.

LOWEST Prices Electronic Parts. Confidential Catalog Free. **KNAPP**, 3174 8th Ave. S.W., Largo, Fla. 33540.

TREASURE Hunters! Prospectors! Relco's new instruments detect buried gold, silver, coins. Kits, assembled models. Transistorized. Weighs 3 pounds. \$19.95 up. Free catalog. Relco-A33, Box 10836, Houston, Texas 77018.

EUROPEAN and Japanese bargains catalogs. \$1 each. Dee, 10639E Riverside, North Hollywood, Calif. 91602.

TRANSISTORIZED CONVERTER KITS: Two models, converts car radio. Receive 30-50mc or 100-200mc (one mc tuning) \$5.00 with simple instructions. Crystal \$2.50. Meshna, No. Reading, Mass. 01864.

MECHANICAL, ELECTRONIC devices catalog 10¢. Greatest Values—Lowest Prices. Fertik's, 5249 "D", Philadelphia, Pa. 19120.

MUSIC LOVERS, CONTINUOUS, UNINTERRUPTED BACKGROUND MUSIC FROM YOUR FM RADIO, USING NEW INEXPENSIVE ADAPTOR. FREE LITERATURE. ELECTRONICS, 11500-Z NW 7th AVE., MIAMI, FLORIDA 33168.

WE SELL CONSTRUCTION PLANS. TELEPHONE: Answering Machine, Speakerphone, Carphone, Phonevision, Legal Connector, Auto Dialer, Central Dial System. **TELEVISION:** \$35.00 Color Converter, Tape Recorder, 3DTV. \$25.00 Camera. **DETECTIVE:** Infinity Transmitter, Tail Transmitter, Police Radar Detector. **HOBBYIST:** Electron Microscope, 9¢ Hour Tape Music System, Ultrasonic Dishwasher, Radar-Oven, Electronic Tranquilizer. Plans \$4.95 each. **COURSES:** Telephone Engineering \$39.50, Detective Electronics \$22.50, Anti-Detective Electronics \$27.50. **SUPER HOBBY CATALOG** 25¢. Don Britton Enterprises, 7906 Santa Monica Blvd., Hollywood, Calif. 90046.

WEBBER LAB's. Police & Fire Converters. Catalog 10¢. 72 Cottage Street, Lynn, Mass. 01905.

RADIO—T.V. Tubes—33¢ each. Send for free catalog. Cornell, 4213 University, San Diego, Calif. 92105.

WHOLESALE COMPONENTS: Manufacturers and distributors only. Request free catalog on business letterhead. **WESCOM**, Box 2536, El Cajon, California 92021.

CONVERT any television to sensitive, big-screen oscilloscope. Only minor changes required. No electronic experience necessary. Illustrated plans, \$2.00. Relco-A33, Box 10563, Houston, Texas 77018.

RECTIFIERS, transistors, other components. Catalog free. Electronic Components Co., Box 2902C, Baton Rouge, La. 70821.

BUILD TV CAMERA IN SINGLE EVENING using solid-state encapsulated modules. Previous TV knowledge unnecessary. Ideal for students, experimenters, etc. Economical! Exciting details **FREE**. Also request catalog describing other camera kits, plans, etc. **ATV RESEARCH**, 1301 Broadway, Dakota City, Nebr. 68731.

GENERAL INFORMATION: First word in all ads set in bold caps at no extra charge. Additional words may be set in bold caps at 10¢ extra per word. All copy subject to publisher's approval. Closing Date: 1st of the 2nd preceding month (for example, March issue closes January 1st). Send order and remittance to: Hal Cymes, **POPULAR ELECTRONICS**, One Park Avenue, New York, New York 10016.

WPE—HAM—CB QSL's samples 25¢. Dick, W8VXX, Gladwin, Mich. 48624.

LINEAR AMPLIFIERS: "Hornet" 50 watts output—\$98.50; "Raider"—100 watts—\$139.50; "Maverick-250"—250 watts—\$244.95. AM and SSB. "Scorpion"—50 watt 12 V. Mobile amplifier—\$99.95; "Bandit II"—12 V. Mobile Amplifier—\$169.95. Frequency range 20-35 megacycles (illegal for class D 11 meters.) Dealer inquiries invited. D & A Manufacturing Co., 1217 Avenue C, Scottsbluff, Nebraska 69361.

WRITE now for free 1969 catalog. McGee Radio Company. 1001 bargains. Speakers—Parts—Tubes—High Fidelity Components—Record Changers—Tape Recorders—Kits. Everything in Electronics. 1901 McGee Street, Kansas City (GE), Missouri 64108.

ELECTRONIC ignition, various types. Free literature. Anderson Engineering, Epsom, N.H. 03239.

DIAGRAMS—Radios \$1.50, Television \$3.00. Give make and model. Diagram Service, Box 1151PE, Manchester, Conn. 06042.

GARRARD Record Changers, Hi-Fi Components, Cartridges, Needles, Tape, TV Parts, Schematics. Write for Unbelievable Prices. Gregg Electronics, P.O. Box 184, Glen Head, N.Y. 11545.

SEND ONLY 25¢ for TWO new & unique gift catalogs of unusual items for home & auto. You'll also receive certificate for \$1.00 refund on your first order. Great ideas! Send now! J. Ross, 80-34 Kent St., Jamaica, N.Y. 11432. Dept. PE.

INVESTIGATORS, LATEST ELECTRONIC AIDS. FREE LITERATURE. CLIFTON, 11500-L NW 7th AVE., MIAMI, FLORIDA 33168.

LABORATORY chemicals supplies 1969 catalog has over 400 listings. Many scientific publications catalogues \$25. Casco, Dept. X, P.O. Box 77, Riverdale, New Jersey 07457.

FREE ELECTRONICS PARTS FLYER. Large catalog \$1.00 deposit. **BIGELOW ELECTRONICS, BLUFFTON, OHIO 45817.**

SPECIAL surveillance devices construction diagrams. Includes: olive transmitter, infinity transmitter, telephone/room bugs, tailing devices, debuggers, police speed radar jammer. Send \$2.00. Bylina PE, P.O. Box 09131, Chicago, Illinois 60609.

HOBBYISTS, EXPERIMENTERS, amateur scientists, students . . . Construction Plans—All complete including drawings, schematics, parts list with prices and sources . . . Laser—Build your own coherent-light optical laser. Operates in the visible light range, pulsed mode—\$6.00 . . . Radar—Build your own ultrasonic doppler radar. Detect motion of people, automobiles, even falling rain drops. Transistorized, uses standard small 9-volt battery—\$4.00 . . . Tic Tac Toe Machine—You play against machine, Automatic. Can you beat the machine? Sometimes yes, usually no—\$4.00 . . . Long Range "Sound Telescope"—This amazing device can enable you to hear conversations, birds, other sounds hundreds of feet away. Very directional. Transistorized, uses 9-volt battery—\$3.00 . . . Or send 25¢ coin or stamps for complete catalogue . . . Technical Writers Group, Box 5994, State College Station, Raleigh, N.C. 27607.

AMAZING Performance! Newest Models—Treasure Detectors. Sensational low prices! Complete models and kits from \$14.95 to \$129.50. Let us prove it. Free catalog. Jetco Electronics, Box 132-PE, Huntsville, Texas 77340.

FIND BURIED TREASURE with the most popular transistorized metal detector in the country. Treasure Probe available as kit (\$14.88), assembled (\$18.88), with powerful built in speaker (\$24.88). Schematic, parts list, and step by step instructions \$1.00. Ten day money back guarantee. Free catalog available. Treasure Probe, Dept. PGL, P.O. Box 64, Lakewood, New Jersey 08701.

NOW motors, tubes, chassis, gear units, components, government and industrial surplus. Catalog 20¢. Mechtronics, Dept. 5PE 25260 Gratiot, Roseville, Mich. 48066.

POLICE-FIRE RADIO STATION DIRECTORIES! Exclusive "confidential" call signs, frequencies. Now all areas. Official listings. Catalog for stamp. Communications, Box 56-PE, Commack, N.Y. 11725.

BUILD F.M. Bugging Devices, two revolutionary schematics \$1.00. Laser Construction Plans: Visible beam, operational in pulsed mode. \$2.00. Howard, 20174 Ward, Detroit, Michigan 48235.

"IMPOSSIBLE" scientific breakthrough! Reversible electric motor without windings! Easily built: difficult to understand. Plans \$3; Model \$10. "A guide to over 700 Electronics Construction Projects" —\$5. **BEL ENTERPRISES**, Box 381-PE, Bellflower, Calif. 90706.

ELECTRONIC bargain catalog on unusual kits, parts, do-it-yourself, stereo, intercoms. Alcon, P.O. Box 1348-P, Lawrence, Mass. 01843.

FREAK OUT with an unfiltered blacklight. One 20 inch ultraviolet tube costs only \$4.00! Send to: Karol, 12688 Schaefer, Detroit, Michigan 48227.

DESIGN TRANSISTOR CIRCUITS 25 page article. Anyone can design successful projects. Send \$1.00. Cates Electronics R#2 Box 13A, Doniphan, Mo. 63935.

LASER material catalog 60c. Moynihan, 107 North Brighton, Atlantic City, New Jersey 08401.

TRACKING UNITS. Government Surplus. 1/3 Government cost \$45.00. P.O. Box 2147, Bakersfield, Calif.

STROBES, COLOR ORGANS, THE UNIQUE STROBIT. Factory prices. Save 25%-50%. Catalog 25c, refunded first order. Teletronics, Box 1266, South Lake Tahoe, California 95705.

CIRCUIT Boards, Parts for "Poptronics" projects. Free catalog. S.W. Technical, Box 16297, San Antonio, Texas 78216.

PSYCHEDELIC catalog. Posters, lighting etc. Send 25c for handling to Hole In The Wall, 6055PE Lankershim, North Hollywood, Calif. 91606.

ZENERS 1W 3.3V-200V, $\pm 5\%$, 2/\$1.00; 12/\$5.00. Box 1577, Boulder, Colorado 80302.

JAPAN HONG KONG DIRECTORY. Electronics, all merchandise. World trade information. \$1.00 today. Ippano Kaisha Ltd., Box 6266, Spokane, Washington 99207.

PLANS AND KITS

BUILD-IT-YOURSELF. Save big dollars. Transistor stereo amplifiers. Color organs. Speakers. Write Workshop, Box 393, Bethpage, New York 11714.

KITS, metal detector \$5.95. Audio Telescope \$5.95, others. Lecronix, Box 42, Madison Heights, Michigan 48071.

SOLAR FLYING SAUCERS. (brand new, solid state engine, fantastic performance, flies for miles on sun's power, lifts animals, send messages, parachutes, build easily for next to nothing with everyday materials, many sizes, many designs). Complete plans, descriptions, drawings. \$1.00. Spacetrronics, Box 31043-PE, San Francisco, Calif. 94131.

OSCILLOSCOPE improvement kits. High speed Triggersweep eliminates sync problems. Dual trace FET switch displays two wave-forms together. Solid-State Services, P.O. Box 901, Cupertino, California 95014.

"16 TESTED TRANSISTOR PLANS"—25c. "Coil Winding" Handbook—50c. Catalog. Laboratories, 12041-L Sheridan, Garden Grove, Calif. 92640.

SUB-CARRIER MUSIC ADAPTER for uninterrupted commercial-free music. 6-transistor circuit uses standard components. Inexpensive and easy to build. Connects easily to any FM tuner. Complete plans and 3x4 1/2" etched circuit board \$4.50. Wallace Enterprise, Inc., 83-15 98th Street, Woodhaven, N.Y. 11421.

TINY ROCKETS from ordinary paper soda-straws blast in smoke and flame nearly out of sight. Copyrighted Instructions \$1.00. Micro-rockets, RR2A, Hagerstown, Indiana 47346.

INTEGRATED CIRCUIT KITS: COMPUTER, AUDIO, Others. New catalog free. **KAYE ENGINEERING**, Box 3932-A, Long Beach, California 90803.

ALLWAVE kit tube and transistor, \$4.00. Headset \$1.75. Ekeradio, Box 131, Temple City, Calif. 91780.

REDUCE your measurements electronically—no exercising! Build transistor muscle reducer and toner. Plans \$2.00. Youssi, Rt. 1, Box 868—44, Amarillo, Texas 79106.

UNBEATABLE electronic tic-tac-toe, plans \$1.00. Box 3034, Hollywood, California 90028.

HIGH FIDELITY

FREE! Send for money saving stereo catalog #P3E and lowest quotations on your individual component, tape recorder, or system requirements. Electronic Values, Inc., 200 W. 20th St., New York, N.Y. 10011.

HI-FI Components, Tape Recorders, at guaranteed "We Will Not Be Undersold" prices. 15-day money-back guarantee. Two-year warranty. No Catalog. Quotations Free. Hi-Fidelity Center, 239 (P) East 149th Street, New York 10451.

LOW, Low quotes: all components and recorders. HiFi, Roslyn, Penna. 19001.

TAPE RECORDERS, Hi-Fi, components, Sleep Learning Equipment, tapes. Unusual Values Free Catalog. Dressner, 1523R, Jericho Turnpike, New Hyde Park, N.Y. 11040.

DON'T THROW YOUR OLD CARTRIDGE AWAY. Send us \$19.95 and any old cartridge. We will ship **PREPAID** any one of the following top rated elliptical diamond stereo cartridges **NEW:** Shure M75E, M91E, M92E, M93E, Empire 888E, Pickering V15AME3, XV15 ATE, ADC 660E, 550E. Write for lowest quotations all stereo components. **DEFA ELECTRONICS**, 2207 Broadway, New York, N.Y. 10024.

NEW Record Changers. BSR-\$13; V.M.—\$16; Garrard—\$22; Radio-Phone stereo—\$15. "CHANGERS-PE", 2737 Third Ave., Bronx, N.Y. 10451.

ACOUSTIC RESEARCH products now available to overseas personnel, diplomats, and citizens of foreign countries. Write for full product and dealer information. AR International, Dept. PE, 24 Thorndike St., Cambridge, Mass. 02141.

DON'T THROW YOUR OLD CARTRIDGE AWAY. Send us \$50.00 and any old used cartridge and we will ship you via air Prepaid anywhere the following Top Stereo Cartridges: Shure V-15 Type II, Empire 999VE, ADC 10EMK II, Stanton 681EE. Write for lowest quotations all stereo components. **DEFA ELECTRONICS**, 2207 Broadway, New York, N.Y. 10024.

WANTED

CASH Paid! Unused tubes, electronic equipment. Barry, 512 Broadway, NYC 10022.

QUICKSILVER, Platinum, Silver, Gold, Ores Analyzed. Free Circular. Mercury Terminal, Norwood, Mass. 02062.

TUBES

TUBES "Oldies", latest. Lists free. Steinmetz, 7519 Maplewood, Hammond, Indiana 46324.

RECEIVING & INDUSTRIAL TUBES, TRANSISTORS. All Brands—Biggest Discounts. Technicians, Hobbyists, Experimenters—Request **FREE** Giant Catalog and **SAVE!** ZALYTRON, 469 Jericho Turnpike, Mineola, N.Y. 11501.

TUBE Headquarters of World! Send 10¢ for Catalog (tubes, electronic equipment) Barry, 512 Broadway, N.Y.C. 10012.

RADIO & T.V. Tubes—33¢ each. Send for free list. Cornell, 4213 University, San Diego, Calif. 92105.

THOUSANDS and thousands of types of electronic parts, tubes, transistors, instruments, etc. Send for Free Catalog. Arcturus Electronics Corp., MPE, 502-22nd St., Union City, N.J. 07087.

TUBES—lowest prices in the world. Hard to get British, German, Foreign and American obsolete and present day special purpose transmitting tubes. Send for giant tube and parts catalog. United Radio Co., Dept. Y-56 Ferry Street, Newark, N.J. 07105.

TAPE AND RECORDERS

HI-FI Components. Tape Recorders, at guaranteed "We Will Not Be Undersold" prices. 15-day money-back guarantee. Two-year warranty. No Catalog. Quotations Free. HiFidelity Center, 239 (PT) East 149th Street, New York 10451.

BEFORE Renting Stereo Tapes try us. Postpaid both ways—no deposit—immediate delivery. Quality—Dependability—Service—Satisfaction—prevail here. If you've been dissatisfied in the past, your initial order will prove this is no idle boast. Free Catalog. Gold Coast Tape Library, Box 2262, Palm Village Station, Hialeah, Fla. 33012.

RENT 4-Track open reel tapes—all major labels—3,000 different—free brochure. Stereo-Parti, 55 St. James Drive, Santa Rosa, Ca. 95401.

TAPE RECORDER SALE. Brand new nationally advertised brands, \$10.00 above cost. Amazing discounts on stereo components. Arkay Electronics, 1028-C Commonwealth Avenue, Boston, Mass. 02215.

STEREO TAPE CLUB: AVERAGE COST \$3.78—\$4.20. Cartridges, Cassettes, Reels, No minimum monthly purchases. Mail—10¢—catalog. Star Recordings, Box 1055, El Paso, Texas 79946.

TAPEMATES makes available to you **ALL 4-TRACK STEREO TAPES—ALL LABELS**—postpaid to your door—at tremendous savings. For free brochure write: **TAPEMATES**, 5727 W. Jefferson Blvd., Los Angeles, California 90016.

STEREO TAPES, Save 30% and up; no membership or fees required; postpaid anywhere U.S.A. Free 70-page catalog. We discount batteries, recorders, tape/accessories. Beware of slogans, "not undersold", as the discount information you supply our competitor is invariably reported to the factory. **SAXITONE**, 1776 Columbia Road, N.W., Washington, D.C. 20009.

REPAIRS AND SERVICES

TV Tuners rebuilt and aligned per manufacturers specification. Only \$9.50. Any make UHF or VHF. Ninety day written guarantee. Ship complete with tubes or write for free mailing kit and dealer brochure. **IW Electronics**, Box 51C, Bloomington, Indiana 47401.

MAKE money with your camera. How and where to sell your photos. Send \$1.00. **Rowe Enterprises**, 22636 Ocean Ave., #A, Torrance, California 90505.

ASSEMBLE and repair kits any manufacturer. Build custom equipment your design or mine. **DNS Electronics**, 4023 Myerwood Lane, Dallas, Texas 75234.

CHASSIS: All types and sizes. Will build to your specifications. Phone 307-532-5752. **A & T Manufacturing, Inc.**, 1902 West C., Torrington, Wyoming 82240.

PERSONALS

LEMURIAN VIEWPOINT—Meaningful discussions of Cosmic Truth: the purpose of human life, reincarnation, man's place in a Higher Plan, and subjects from the Lemurian Philosophy. Send for **FREE** copy. Lemurian Fellowship, Dept. 912, Box 397, Ramona, Calif. 92065.

MAKE FRIENDS WORLDWIDE through international correspondence. Illustrated brochure free. **Hermes**, Berlin 11, Germany.

INVESTIGATORS, LATEST ELECTRONIC AIDS. FREE LITERATURE. **CLIFTON**, 11500-K NW 7th Ave., MIAMI, FLORIDA 33168.

SECRET plans revealed. Free brochure. **Audiotronix E3**, 156 Fifth Avenue, New York, N.Y. 10010.

INSTRUCTION

LEARN While Asleep, hypnotize with your recorder, phonograph. Astonishing details, sensational catalog free! **Sleep-learning Association**, Box 24-ZD, Olympia, Wash. 98501.

LEARN ELECTRONIC ORGAN SERVICING at home all makes including transistor. Experimental kit—trouble-shooting. Accredited **NHSC**. Free Booklet. **NILES BRYANT SCHOOL**, 3631 Stockton, Dept. A, Sacramento, Calif. 95820.

ASSOCIATE Degree in Electronics Engineering earned through combination correspondence-classroom educational program. Free brochure. **Grantham Technical Institute**, 1505 N. Western Ave., Hollywood, Calif. 90027.

FCC First Class License in six weeks—nation's highest success rate—approved for Veterans Training. Write **Elkins Institute**, 2603B Inwood Road, Dallas, Texas 75235.

R.E.I.'s famous (5) week course for the First Class Radio Telephone License is the shortest, most effective course in the nation. Over 98% of R.E.I. graduates pass F.C.C. exams for 1st class license. Total tuition \$360.00. Job placement free. Write for brochure. **Radio Engineering Incorporated Schools**, 1336 Main Street, Sarasota, Florida 33577—or 3123 Giltham Road, Kansas City, Missouri 64109—or 809 Caroline Street, Fredericksburg, Virginia—22401—or 625 E. Colorado Street, Glendale, California 91205.

SHIP RADIO OFFICER TRAINING—SHIPS have been held up awaiting needed personnel, train now at Long Beach, the home of the **Queen Mary**. Radio officers earn to \$1800.00 monthly. Write for free information. **Western Technical School**, 5459 Atlantic Ave., Long Beach, Calif. 90805, Desk B. Approved for veterans.

LEARN AVIONICS (Aircraft Electronics) G.I. APPROVED. Catalog. **ACADEMY AVIONICS**, Stead Airport, Reno, Nevada 89506.

INVENTIONS WANTED

INVENTIONS wanted. Patented; unpatented. **Global Marketing Service**, 2420-P 77th, Oakland, Calif. 94605.

CLASSIFIED ADVERTISING ORDER FORM

Please refer to heading on first page of this section for complete data concerning terms, frequency discounts, closing dates, etc.

1	2	3	4	5
6	7	8	9	10
11	12	13	14	15
16	17	18	19	20
21	22	23	24	25
26	27	28	29	30
31	32	33	34	35

Words { @ 70¢ (Reader Rate) } = \$ _____
 { @ \$1.15 (Commercial Rate) }

Insert _____ time(s) Total Enclosed \$ _____

NAME _____

ADDRESS _____

CITY _____ STATE _____ ZIP _____

Signature _____

WORD COUNT: Include name and address. Name of city (Des Moines) or of state (New York) counts as one word each. Zip Code numbers not counted. (Publisher reserves right to omit Zip Code if space does not permit.) Count each abbreviation, initial, single figure or group of figures or letters as a word. Symbols such as 35mm, COD, PO, AC, etc., count as one word. Hyphenated words count as two words.

PE-369

PATENT Searches including Maximum speed, full airmail report and closest patent copies, \$6.00. Quality searches expertly administered. Complete secrecy guaranteed. Free Invention Protection forms and "Patent Information." Write Dept. 9, Washington Patent Office Search Bureau, 711 14th Street, N.W., Washington, D.C. 20005.

QUALITY Patent Searches! Preferred by Professional Inventors, Lawyers, Manufacturers. "Confidential Report" Including related United States patent copies "Airmailed Certified." **FREE** information! United States Inventors Service Company, 501-H Thirteenth Street, N.W., Washington, D.C. 20005.

INVENTORS. We will develop, help sell your idea or invention, patented or unpatented. Our national manufacturer clients are urgently seeking new items for outright cash sale or royalties. Financial assistance available. 10 years proven performances. For free information, write Dept. 41, Wall Street Invention Brokerage, 79 Wall Street, New York, N.Y. 10005.

INVENTORS! OUR FREE EXPERT ANALYSIS of your invention can save valuable time, help you realize full sale value. Strictly confidential. **FREE INVENTION CERTIFICATE.** Write today: Pioneer Invention Service, Dept. 35, 150 Broadway, New York, N.Y. 10038.

INVENTORS! Sell your invention for cash or royalties! Our client manufacturers eagerly seek new items. Patented. Unpatented. Financial assistance if needed. 25 years proven performances. For free information, write Dept 20, Gilbert Adams, Invention Broker, 80 Wall St., New York, N.Y. 10005.

FREE "Directory of 500 Corporations Seeking New Products." For information regarding development, sale, licensing of your patented/unpatented invention. Write: Raymond Lee Organization, 230-GR Park Avenue, New York City 10017.

PATENT SEARCHES, including copies of related United States Patents. Inventors, attorneys, manufacturers use our "World-Wide" Airmail service! Free: "Invention Record" form and "Information Every Inventor Needs", Hayward Company, 1029HR Vermont, Washington, D.C. 20005.

GOVERNMENT SURPLUS

JEEPS Typically From \$53.90 . . . Trucks From \$78.40 . . . Boats, Typewriters, Airplanes, Multimeters, Oscilloscopes, Transceivers, Electronics Equipment. Wide Variety, Condition. 100,000 Bid Bargains Direct From Government Nationwide. Complete Sales Directory and Surplus Catalog \$1.00. (Deductible First \$10.00 Order). Surplus Service, Box 820-J, Holland, Michigan 49423.

GOVERNMENT Surplus How and Where to Buy in Your Area. Send \$1.00 to: Surplus Information PE, Headquarters Building, Washington, D.C. 20036.

BOOKS

FREE catalog 950 aviation/electronic/space books. Aero Publishers, 329PE Aviation Road, Fallbrook, California 92028.

UNUSUAL Books! Catalog free! International, Box 7798 (PE), Atlanta, Georgia 30309.

FREE Book Prophet Elijah Coming Before Christ. Wonderful Bible Evidence. PE Megiddo Mission, Rochester, New York 14619.

FREE CATALOG. BOOKS FOR ADULTS. CATALOG, 2217 LACKLAND, ST. LOUIS, MISSOURI 63114.

AMAZING self help books. Write Lynn, Box 1573, Waco, Texas 76703.

MAGAZINES

BACK DATE MAGAZINES! Send needs. Midtown, Box 917-PE, Maywood, N.J. 07607.

AUTHORS' SERVICES

AUTHORS! Learn how to have your book published, promoted, distributed. **FREE** booklet "ZD," Vantage, 120 West 31 St., New York 10001.

MUSIC

POEMS wanted for new songs. Nashville Music Institute, Box 532-E, Nashville, Tennessee 37202.

Buy 10 PAKS & CHOOSE 1 FREE

<input type="checkbox"/> \$25 SURPRISE PAK: transistors, rect., diodes, etc. . .	\$1
<input type="checkbox"/> 50 MICA CONDENSERS, to .1mf, silvers too!	\$1
<input type="checkbox"/> 10 KODAK LENSES, convex, piano, etc. Hobby must	\$1
<input type="checkbox"/> 50 GERMANIUM GLASS DIODES, 1N34, 1N48 no test	\$1
<input type="checkbox"/> 40 TOP HAT SILICON RECTIFIERS, no test/asst values	\$1
<input type="checkbox"/> 25 EPOXY RECTIFIERS, silicon asst, no test	\$1
<input type="checkbox"/> 40 PRECISION RESISTORS, 1/2-W, 1/2 asst values	\$1
<input type="checkbox"/> 30 TRANSISTORS, rf, if, audio, osc, no test	\$1
<input type="checkbox"/> 60 TUBULAR CONDENSERS, to .5mf to 1KV, asst	\$1
<input type="checkbox"/> 50 DISC CONDENSERS, to .05mf npo, temp coef, asst	\$1
<input type="checkbox"/> 60 TUBE SOCKETS, receptacles, plugs, audio, etc.	\$1
<input type="checkbox"/> 30 POWER RESISTORS, to 25 watts, to 21K ohms	\$1
<input type="checkbox"/> 60 CERAMIC CONDENSERS, discs, npo's, to .05	\$1
<input type="checkbox"/> 40 "MICRO" RESISTORS, for transistor circuitry	\$1
<input type="checkbox"/> 10 VOLUME CONTROLS, to 1 meg, switch too!	\$1
<input type="checkbox"/> 10 ELECTROLYTICS, to 100mf, tubulars too, asst	\$1
<input type="checkbox"/> 50 RADIO & TV KNOBS, asst colors & styles	\$1
<input type="checkbox"/> 10 TRANSFORMER ELECTROLYTICS to 100mf, asst values	\$1
<input type="checkbox"/> 50 COILS AND CHOKES, if, rf, ant, osc, peaking, etc	\$1
<input type="checkbox"/> 65 HALF WATTERS, to 1 meg, 1/2 popular values too	\$1
<input type="checkbox"/> 60 HI-QUALITY RESISTORS, 1/2, 1, 2W asst values	\$1
<input type="checkbox"/> 10 RCA PHONO PLUGS & JACK SETS, tuners, etc.	\$1
<input type="checkbox"/> 35 TWO WATTERS, asst incl: A-B, etc total	\$1
<input type="checkbox"/> 2-PC INFRA-RED DETECTOR & FILTER SET/science proj	\$1
<input type="checkbox"/> 2 FIELD EFFECT TRANSISTORS, n channel, hobby	\$1
<input type="checkbox"/> 50 TERMINAL STRIPS, 1 to 8 lug types	\$1
<input type="checkbox"/> 3 PHOTO ELECTRIC CELLS, hi. imp., schematic	\$1
<input type="checkbox"/> 3 TRANSFORMER AMPLIFIER, WIRE, 3x2x3/4" schematic	\$1
<input type="checkbox"/> 10 PRINTED CIRCUIT BOARDS, copper clad, 100 uses	\$1
<input type="checkbox"/> 10 TRANSFORMER SOCKETS, for pnp & npn types	\$1
<input type="checkbox"/> 10 PANEL SWITCHES, toggle, slide, micro, rotary	\$1
<input type="checkbox"/> 5 "SUN" BATTERIES, for 100's of lite sens proj	\$1
<input type="checkbox"/> 20 NE 2 BULBS, GE, for 100's of proj's Hobby must	\$1
<input type="checkbox"/> 30 MOLDED COND'S, mylar, pore, black beauty	\$1
<input type="checkbox"/> 6 "IBM" COMPUTER BOARDS, many trans, diodes	\$1
<input type="checkbox"/> 40 "MICRO" CONDENSERS, for transistor circuitry	\$1
<input type="checkbox"/> 40 CORNING "LOW NOISE" resistors, asst.	\$1
<input type="checkbox"/> 2- CLAIRES "DISC" PHOTO ELECTRIC CELLS	\$1

ADD POSTAGE, avg. wt: 1/2 lb. CATALOG 10¢

POLY PAKS

P.O. BOX 942E
LYNNFIELD, MASS.
01940

CIRCLE NO. 26 ON READER SERVICE PAGE

MUSICAL INSTRUMENTS

ACCORDIONS, GUITARS, AND INSTRUMENTS! Save to 50%. Terms. Trades. Free Trial. Free catalog. Mention instrument. Music Mart, 5535-PE Belmont, Chicago 60641.

HYPNOTISM

FREE Hypnotism, Self-Hypnosis, Sleep Learning Catalog! Drawer H400, Ruidoso, New Mexico 88345.

"MALE-FEMALE HYPNOTISM" EXPOSED, EXPLAINED! "SECRET METHOD"—THEY NEVER KNOW! \$2, RUSHED, GUARANTEED! ISABELLA HALL, SILVER SPRINGS, FLORIDA 32688.

AMAZING HYPNOTIC record kit releases fantastic mental power! Free offer expires soon. Write: Forum, Studio AA3, 333 North Michigan, Chicago 60601.

HYPNOTIC sleep learning recordings produce fabulous results. Catalogue Free. ASR Foundation, Box 7021eg Henry Clay Station, Lexington, Ky. 40502.

PHOTOGRAPHY—FILM, EQUIPMENT, SERVICES

MEDICAL Film—Adults Only—"Childbirth"—1 reel 8mm \$7.50—16mm \$14.95. International-E, Greenvale, L.I., New York 11548.

SCIENCE Bargains Request Free Giant Catalog "CJ"—148 pages—Astronomical Telescopes, Microphones, Lenses, Binoculars, Kits, Parts. War surplus bargains. Edmund Scientific Co., Barrington, New Jersey 08007.

MAGNETS

MAGNETISM as I see it—by Jesse Costa—a 100 page pictorial manuscript describing my latest theories and experiments in basic magnetism. (\$3.00) Box 26, Waquoit, Massachusetts 02536.

MAGNETS. All types. Special—20 disc magnets, or 2 stick magnets, or 10 small bar magnets, or 8 assorted magnets, \$1.00 Maryland Magnet Company, 5412-H Gist, Baltimore, Maryland 21215.

PLASTICS

NEW LIQUID PLASTICS for creating unusual gifts with real flower embedments, photographs, special collections. Reproducing originals. Hundreds of other profitable ideas. New Manual 25c. Castolite, Dept. 9C5C, Woodstock, Ill. 60098.

RECORDS

SPECIAL INTEREST RECORDS AVAILABLE, PRODUCED BY THE EDITORS OF THE WORLD'S LEADING SPECIAL INTEREST MAGAZINES. SEND FOR FREE CATALOG. RECORD CATALOG-PE ZIFF-DAVIS PUBLISHING COMPANY, ONE PARK AVENUE, NEW YORK, N.Y. 10016.
19¢ **RECORDS** from your tapes. Write Concert Recording, Lynwood, California 90262.

REAL ESTATE

400,000,000 ACRES government public land located in 25 states. Low as \$1.00 acre detailed 1969 report. Send \$1.00. Land Information 422-PE3, Washington Building, Washington, D.C. 20005.

FREE . . . 232 page Spring 1969 CATALOG! Describes and pictures hundreds of farms, ranches, town and country homes, businesses coast to coast! Specify type property and location preferred. Zip code, please. **UNITED FARM AGENCY**, 612-EP West 47th St., Kansas City, Mo. 64112.

PRINTING

THERMOGRAPHED business cards, \$3.49—1,000, free samples. Gables—405A Clifton, Glenshaw, Pa. 15116.

FREE LITERATURE: Address labels, business cards, printing. Rubber Stamps. **JORDAN'S**, 552 West O'Connor, Lima, Ohio 45801.

BUSINESS OPPORTUNITIES

INVESTIGATE ACCIDENTS: Earn to \$1000 monthly. Men urgently needed. Car furnished. Business expenses paid. No selling. No College education necessary. Pick own job location. Investigate full time or earn to \$8 hour spare time. Write for **FREE** information. No obligation. Universal Schools, CZ-3, 6801 Hillcrest, Dallas, Texas 75205.

RAISE Rabbits for us on \$500 month plan. Free details. White's Rabbitry, Mt. Vernon, Ohio 43050.

FREE CATALOGS. Repair air conditioning, refrigeration. Tools, supplies, full instructions. Doolin, 2016 Canton, Dallas, Texas 75201.

PIANO TUNING learned quickly at home. Tremendous field! Musical knowledge unnecessary. GI Approved. Free information. Empire School, Miami, Florida 33145.

FREE Book "990 Successful little-known Businesses." Work home. Plymouth 345W, Brooklyn, N.Y. 11218.

ELECTROPLATING Equipment and supplies. All types for home workshops and industrial. Send \$2.00 (refundable) for equipment guide formulas, operating data, catalog. HBS Equipment Division 90, 3543 East 16th, Los Angeles, California 90023.

I MADE \$40,000.00 Year by Mailorder! Helped others make money! Start with \$10.00—Free Proof. Torrey, Box 318-N, Ypsilanti, Michigan 48197.

\$200.00 DAILY In Your Mailbox! Your opportunity to do what mail-order experts do. Free details. Associates, Box 136-J, Holland, Michigan 49423.

SELL HERTEL BIBLES—Part Time. Finest reference Bible available. Demonstrator and supplies furnished. Excellent commissions. Write International Book, Dept. PE, Box 118, Wichita, Kansas 67201.

MAILORDER . . . Positively No Investment in products! Details: Methods, 1412-F.D. Lafayette Hill, Pennsylvania 19444.

EARN \$240.00 a month at home, spare time, doing only two \$5.00 Invisible Mending jobs a day. Big money paid for service that makes cuts, tears disappear from fabrics. Steady demand. Details free. **FABRICON**, 1572 Howard, Chicago 60626.

SELL America's Biggest value wedding line! Big 40% profit showing wedding invitations and over 50 exciting accessory items. Side-line for printing. Christmas card salesmen. Free display album. Elmcraft, 7201 S. Cicero, Dept. EW-187, Chicago, Illinois 60629.

MAKE money with your camera. How and where to sell your photos. Send \$1.00. Rowe Enterprises, 22636 Ocean Ave., #7A, Torrance, California 90505.

HOW AND WHERE to get finance capital, loans, grants, cash to start a business. Free details—helped others. Counselor-48, Harlingen, Texas 78550.

EMPLOYMENT OPPORTUNITIES

BOOMING AUSTRALIA wants You—Good jobs. Adventure. Forms and Australian Handbook (1969) describing Australian assisted passage, passport-visa, advantages, opportunities \$1.00. Buckeye, Box 1032TQ, Fairborn, Ohio 45324.

SHORTWAVE LISTENING

POLICE—FIRE—AIRCRAFT—MARINE—AMATEUR CALLS on your broadcast radio with **TUNAVERTER!** Tunable and crystal in one! Guaranteed! Free catalog. Salch Co., Woodsboro-PEC, Texas 78393.

EMPLOYMENT INFORMATION

FOREIGN and **USA** job opportunities available now. Construction, all trades. Earnings to \$3,000.00 monthly. Paid overtime, travel bonuses. Write; Universal Employment, Woodbridge, Conn. 06525.

STAMPS

SURPRISE COLLECTION! Exotic mint British Colonials, absolutely free with approvals. **VIKING**, Great Neck 50, N.Y. 11021.

125 FOREIGN stamps, guaranteed over \$12.00 catalogue value, \$2.00. Lakeshore, Box 162-E, Concord, Tennessee 37720.

MISCELLANEOUS

WINEMAKERS: Free illustrated catalog of yeasts, equipment. Semplex, Box 7208, Minneapolis, Minn. 55412.

BILLS PAID WITHOUT BORROWING—Nobody refused up to \$18,000.00. Bad credit no problem—Not a Loan Company. Write for **FREE** application—**INTERNATIONAL ACCEPTANCE**, Dept. 50A, Phoenix, Arizona 85012—711 14th St., N.W., Washington, D.C. 20005—507 Carondelet St., New Orleans, La. 70130.

STOP BURGLARS THE EASY WAY!! Affix authentic "Protected by Electronic Sentry Alarm" Decals to auto windows, door & windows of home, retail stores, vending machines, etc. Whether you have an alarm or not—thieves stay away! Only \$1.00 each set of two. J. Ross, 80-34 Kent St., Jamaica, N.Y. 11432, Dept. PE.

EMPLOYMENT Resumes. Get a better job & earn more! Send only \$2.00 for expert, complete Resume Writing Instructions. J. Ross, 80-34 Kent St., Jamaica, N.Y. 11432, Dept. PE.

"ADULT" Books, Magazines . . . Free illustrated catalogue. Clifton's, Box 1068-E5, Saugus, Calif. 91350.

STAMMER — Stutter — No more. (Dr. Young.) Write Gaucho, Box 9309-E8, Chicago 60690.

CLASSIFIED ADVERTISING IN POPULAR ELECTRONICS—Your best bet for outstanding mail order sales. These pages are read thoroughly each month by electronic hobbyists seeking those products and services found only in the **ELECTRONICS MARKET PLACE**. **POPULAR ELECTRONICS** readers respond readily—they know they can rely on the advertisers appearing in the pages of their favorite magazine. Your low cost ad will result in increased mail order response for you! Send copy and payment to: Hal Cymes, Classified Advertising Mgr., **POPULAR ELECTRONICS**, 1 Park Ave., New York, N.Y. 10016.

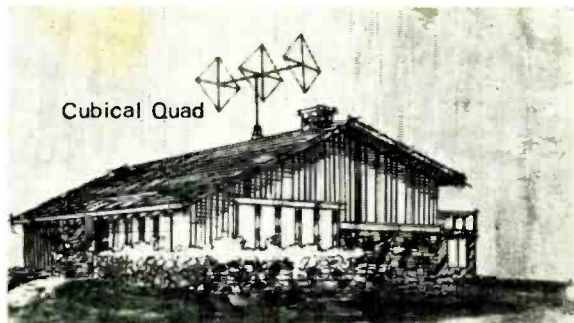

Cubical Quad



Vertical Ground Plane



Stacked Beams

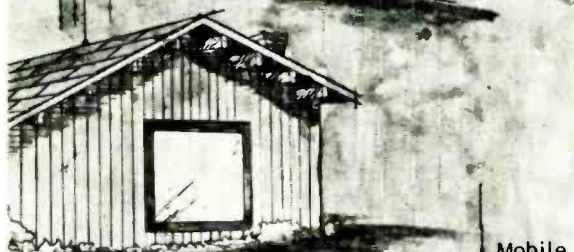

Miniature Beam



Mobile Antenna



Marine Antenna

The Finest CB Transceiver Made

Is Only As Good As Your Antenna.

And the most trusted name in communications antennas today is **Mosley**. . . your guarantee of quality.

Mosley. . . Manufacturer of antennas for Citizens Band, amateur, military, industrial and commercial radio.

Mosley. . . Known and respected by the leaders: White House, U.S.A.F., N.A.S.A., Pan American Airlines, M.I.T., and many more.

Mosley. . . Assuring you of the very most for your CB dollar with an ever-growing line of antennas.

Illustrated here are examples of the many different **Mosley** CB antennas available.

Find out how **Mosley** can meet your specific CB antenna needs.

See your nearest authorized **Mosley** dealer for detailed information. Or indicate area of interest and write for free literature.

Dept. 178

Mosley Electronics, Inc.

4610 North Lindbergh Blvd.,
Bridgeton, Missouri 63042

Because we beat the heat you can play it cool with the 6LQ6/6JE6C...

Yes, you play it cool when you replace a 6JE6A, B or C tube in the demanding horizontal-deflection-amplifier socket of your customer's color TV set. RCA's 6LQ6/6JE6C Novar beam power tube beats the overheating problem common to the other tubes.

As a matter of fact, it can actually withstand 200 W plate dissipation for 40 seconds because of design improvements that include repositioned getters, cavity plate designed for better plate dissipation, and larger diameter screen grid wire which reduces screen grid temperature and improves the high voltage cutoff characteristic.

So play it cool. Replace with the RCA 6LQ6/6JE6C. And watch your customers warm up. More confidence from them... fewer call-backs for you.

Innovations and improvements that make your service operation more reliable, efficient and profitable are our constant aim. See your Authorized RCA Tube Distributor for quality RCA receiving tubes.

RCA Electronic Components,
Harrison, N.J. 07029

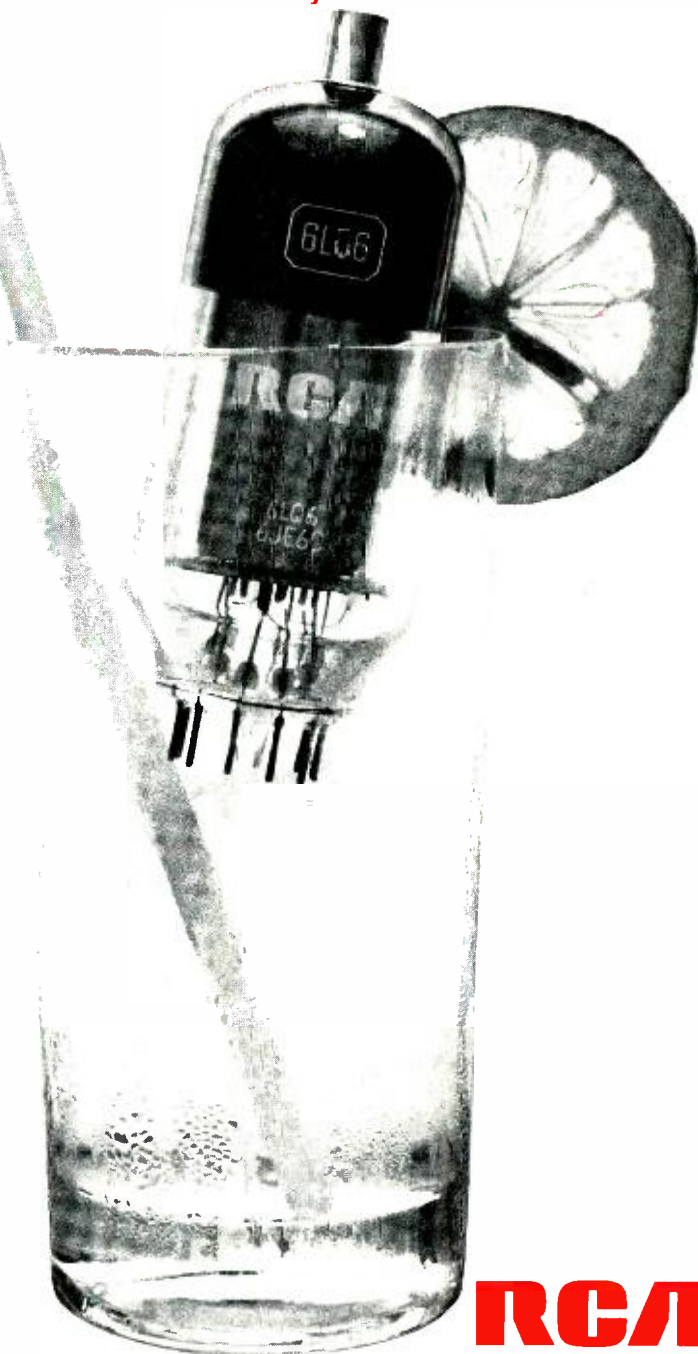

RCA

EICO Makes It Possible

Uncompromising engineering — for value does it!
You save up to 50% with Eico Kits and Wired Equipment.



Cortina Stereo

THE VERDICT IS IN. High fidelity authorities agree:

Cortina's engineering excellence, 100% capability, and compact dramatic esthetics all add up to Total Stereo Performance at lowest cost.

NEW



A Silicon Solid-State 70-Watt Stereo Amplifier for \$99.95 kit, \$139.95 wired, including cabinet. Cortina 3070

NEW

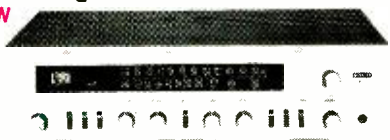

A Solid-State FM Stereo Tuner for \$99.95 kit, \$139.95 wired, including cabinet. Cortina 3200.

A 70-Watt Solid-State FM Stereo Receiver for \$169.95 kit, \$259.95 wired, including cabinet. Cortina 3570.

NEW Silicon Solid State 150-Watt Stereo Amplifier designed for audio perfectionists. Less than 0.1% harmonic distortion, 1M distortion. Less than 0.6% at full output. Controls and inputs for every music source. \$149.95 kit, \$225.00-wired including cabinet. Cortina 3150.

NEW 70-Watt Solid State AM/FM Stereo Receiver for \$189.95 kit, \$279.95 wired including cabinet. Cortina 3770.

Eicocraft The newest excitement in kits.

100% solid-state and professional.
Fun to build and use. Expandable, interconnectable. Great as "jiffy" projects and as introductions to electronics. No technical experience needed. Finest parts, pre-drilled etched printed circuit boards, step-by-step instructions.

EC-100 Electronic Siren \$4.95, EC-101 Electronic Burglar Alarm \$6.95, EC-102 Electronic Fire Alarm \$6.95, EC-200 Electronic Intercom \$5.95, EC-300 Audio Power Amplifier \$5.95, EC-400 Electronic Metronome \$3.95, EC-500 Tremolo \$9.95, EC-600 Electronic Light Flasher \$3.95, EC-700 Electronic "Mystifier" \$4.95, EC-800 Photo Cell Nite Lite \$4.95, EC-900 Power Supply \$8.95, EC-1000 Code Oscillator \$2.50, EC-1100 FM Wireless Mike \$9.95, EC-1200 AM Wireless Mike \$9.95, EC-1300 Electronic VOX \$8.95, EC-1400 Solid State FM Radio \$9.95, EC-1500 Solid State AM Radio \$8.95, EC-1600 Electronic Bongos \$7.95



6 EXCITING NEW PROJECTS

EC-1700 Ham/CB Vox \$8.95, EC-1800 Electronic "TOX" \$8.95, EC-1900 "Treasure Finder" \$9.95, EC-2000 Electronic Organ \$9.95, EC-2100 Electronic "Eye" \$9.95, EC-2200 Electronic Touch Switch \$8.95

Color n' Sound

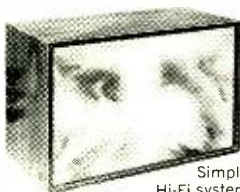

Add a new dimension to your music system. Introducing the first inexpensive solid-state electronic system which provides true synchronization of color with sound. Watch the music you love spring to life as a vibrant, ever shifting interplay of colors.

Simply connect to speaker leads of your Hi-Fi system (or radio). Kit can be assembled in several hours — no technical knowledge or experience necessary. Kit \$49.95, Wired \$79.95.

Automotive

EICO 888—Car/Boat Engine Analyzer.

For all 6V/12V systems; 4, 6, 8-cyl. engines.

Now you can keep your car or boat engine in tip-top shape with this solid-state, portable, self-powered universal engine analyzer. Completely tests your total ignition/electrical system.

Complete with a Tune-up & Trouble-shooting Manual. Model 888; \$49.95 kit, \$69.95 wired.



Test Equipment **EICO**

100 best buys to choose from.

"The Professionals"
—laboratory precision at lowest cost.

Model 460 Wideband Direct-Coupled 5" Oscilloscope. DC-4.5mc for color and B&W TV service and lab use. Push-pull DC vertical amp., bal. or unbal. input. Automatic sync limiter and amp. \$99.95 kit, \$149.95 wired.

Model 232 Peak-to-Peak VTVM. A must for color or B&W TV and industrial use. 7 non-skip ranges on all 4 functions. With exclusive Uni-Probe.® \$34.95 kit, \$49.95 wired.

FREE 1969 CATALOG

PE-3

EICO Electronic Instrument Co., Inc.
283 Malta Street, Brooklyn, N.Y. 11207

Send me FREE catalog describing the full EICO line of 200 best buys, and name of nearest dealer.

Name _____

Address _____

City _____

State _____ Zip _____

CIRCLE NO. 11 ON READER SERVICE PAGE