

CATV NEEDS MANPOWER—HOW ABOUT YOU?

POPULAR ELECTRONICS

NOVEMBER
1968

50
CENTS



BUILD METRONOME WITH ACCENTED BEAT

SOLVE SUPPLY PROBLEMS WITH ZENER DIODE

DECADE COUNTER USES NIXIE® READOUT

PROWLER ALARM FOR INDOOR/OUTDOOR USE

**TWO BUILD-IT-YOURSELF
CHEMISTRY LAB
EQUIPMENT
PROJECTS**



E0970 3901365E9131M09L
D STEVENS
9131 MANSFIELD AV
MORTON GROVE IL 60053

You get more for your money from NRI—

America's oldest and largest Electronic, Radio-Television home-study school

Compare. You'll find—as have so many thousands of others—NRI training can't be beat. From the delivery of your first lessons in the remarkable, new Achievement Kit, to "bite size," easily-read texts and carefully designed training equipment . . . NRI gives you more value.

Shown below is a dramatic, pictorial example of training materials in *just one* NRI Course. Everything you see below is included in low-cost NRI training. Other major NRI courses are equally complete. Text for text, kit for kit, dollar for dollar—your best home-study buy is NRI.

All this is yours—from Achievement Kit to the only Color TV specifically designed for training—when you enroll for NRI's TV-Radio Servicing course. Other courses are equally complete. But NRI training is more than kits and "bite-size" texts. It's also personal services which have made NRI a 50 year leader in the home-study field. Mail the postage-free card today.

Approved under GI BILL
If you served since Jan. 31, 1955, or are in service, check GI line in postage-free card.



GET A FASTER START WITH NRI'S NEW EXCLUSIVE ACHIEVEMENT KIT

The day your enrollment is received your Achievement Kit will be on its way to you. It contains everything you need to make an easy, fast start in the Electronics training of your choice. This attractive, new starter kit is an outstanding, logical way to introduce you to home-study the way NRI teaches it . . . backed by a dedicated staff and the personal attention you should expect of a home-study school. It is your first special training aid . . . designed to make your adventure into Electronics absorbing, meaningful. Your Achievement Kit contains your first group of lesson texts; rich vinyl desk folder to hold study material; the industry's most complete Radio-TV Electronics Dictionary; valuable reference texts; lesson answer sheets; envelopes; pencils, pen; engineer's ruler—even postage. No other school has anything like it.

OVER 50 YEARS OF LEADERSHIP



LEARNING BECOMES AN ABSORBING ADVENTURE WITH NRI TRAINING KITS

What better way to learn than by doing? NRI pioneered and perfected the "home lab" technique of learning at home in your spare time. You get your hands on actual parts and use them to build, experiment, explore, discover. Electronics come alive! NRI invites comparison with training equipment offered by any other school. Begin NOW this exciting, practical program. It's the best way to understand the skills of the finest technicians—and make their techniques your own. Whatever your reason for wanting to increase your knowledge of Electronics . . . whatever your field of interest . . . whatever your education . . . there's an NRI instruction plan for you, at low tuition rates to fit your budget. Get all the facts about NRI training plans, NRI training equipment. Fill in and mail the attached postage-free card today.

NATIONAL RADIO INSTITUTE, Wash-
ington, D.C. 20016.

IN ELECTRONICS TRAINING

Accredited by the Accrediting Commission of the National Home Study Council

NEW COLOR TV

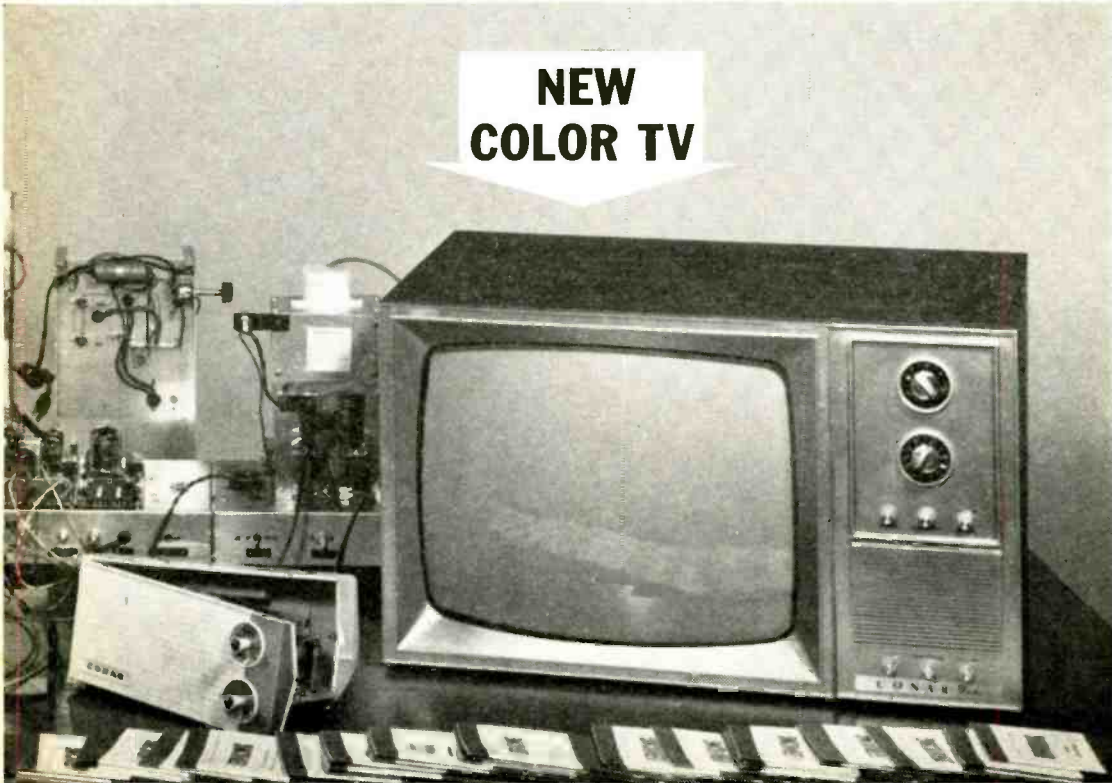

POPULAR ELECTRONICS

VOLUME 29 NUMBER 5

NOVEMBER, 1968

WORLD'S
LARGEST-SELLING
ELECTRONICS
MAGAZINE

SPECIAL CONSTRUCTION PROJECTS

- SOLID-STATE pH METER** 33 R. C. DENNISON
BUILD VARIABLE-SPEED MAGNETIC STIRRER 43 R. C. DENNISON
Bringing electronics into the chemistry lab

SPECIAL FEATURE

- 10,000 TECHNICIAN JOBS IN CATV** 27 EDWARD A. LACY
There's a shortage—and maybe a place for you

FEATURE ARTICLES

- POPULAR ELECOMICS** 32 HOWARD STRINGER
CRACKERJACK OR CLOWN 46 VIC BELL
Test your knowledge of electronic servicing
THE PROWLER HOWLER 47 GLENN M. RAWLINGS
An easy-to-build intruder alarm
FOUR-BAND SWL ANTENNA 50 THOMAS M. TURNER, K8WBL
GETTING TO KNOW THE ZENER DIODE 51 NORMAN CRAWFORD
Put this unique device to use
THE UBIQUITOUS NEON LAMP 55 JIM KYLE
CHECKING THE MOSFET BARRIER 58 FRANK H. TOOKER
BUILD ELECTRONIC METRONOME WITH ACCENTED BEAT 59
A must for musicians and photographers
ALL-PURPOSE NIXIE READOUT 67 LESLIE SOLOMON/
ALEXANDER BURAWA
A basic decimal counter with many uses
FET REJUVENATES VOM 72 SOL D. PRENSKY
Adapter improves sensitivity
THE PRODUCT GALLERY 74
Squires-Sanders "Skipper" CB Transceiver
Regency Model MR-10D Monitoradio
SOLID STATE 76 LOU GARNER
MANNERLY TABLE LAMP 79 JACK SMALL
Time delay turns it off
ENGLISH-LANGUAGE BROADCASTS TO NORTH AMERICA 80 ROGER LEGGE
SHORT-WAVE LISTENING 81 HANK BENNETT, W2PNA
Tristan Da Cunha is on the air
AMATEUR RADIO 83 HERB S. BRIER, W9EGQ
New frequency allocations
INFORMATION CENTRAL 86 CHARLES J. SCHAUERS, W6QLV
- ## DEPARTMENTS
- LETTERS FROM OUR READERS** 8
ELECTRONICS LIBRARY 14
READER SERVICE PAGES 15, 115
NEW LITERATURE 16
NEW PRODUCTS 22
TIPS AND TECHNIQUES 92
OPERATION ASSIST 102

POPULAR ELECTRONICS is indexed
in the Readers' Guide
to Periodical Literature

This month's cover photo by
Conrad Studios

Copyright © 1968 by ZIFF-DAVIS PUBLISHING COMPANY. All rights reserved.

POPULAR ELECTRONICS, November 1968, Volume 29, Number 5, Published monthly at 307 North Michigan Avenue, Chicago, Illinois 60601. One year subscription rate for U.S., U.S. Possessions and Canada, \$5.00; all other countries, \$6.00. Second class postage paid at Chicago, Illinois and at additional mailing offices. Authorized as second class mail by the Post Office Department, Ottawa, Canada and for payment of postage in cash. Subscription service and Forms 3579: Portland Place, Boulder, Colorado 80302. Editorial offices for manuscript contributions, reader inquiries, etc.: One Park Ave., New York, N.Y. 10016.



Pat Powers, Computer Technology



Ronald Wanat, Circuitry Design



Tom Geary, Automation



Robert Kastiger, Broadcasting

These 4 successful men all got started the same way: they sent in a coupon like this

DE VRY INSTITUTE OF TECHNOLOGY
4141 BELMONT AVE. CHICAGO, ILL. 60641

BELL & HOWELL SCHOOLS

Please send free booklets and information about careers in electronics. I am interested in the following fields (check one or more).

- Nuclear Instrumentation Testing
- Automation
- Broadcasting/telecasting
- Radar
- TV-radio service

PE-11-Y

Name _____ Age _____

Address _____ Apt. _____

City _____ State _____ County _____ Zip Code _____

Veterans: Check here. If you were discharged after Jan. 31, 1955, the "G. I. Bill" may cover the entire cost of your tuition. 118

Why don't you?

Accredited Member, National Home Study Council

DE VRY INSTITUTE OF TECHNOLOGY
4141 BELMONT AVE., CHICAGO, ILL. 60641



BELL & HOWELL SCHOOLS



THE HEATED COIL

JOHN R. GILLIOM
Chief Engineer,
Loudspeakers

One of a series of brief discussions by *Electro-Voice engineers*

In many ways, the Electro-Voice Model 30W is an impressive loudspeaker. Its size alone sets it apart: 30" in diameter and over 13" deep. The 30W weighs 34 lbs., and employs 9 lbs., 4 oz. of ceramic magnet.

While the 30W was originally intended for high fidelity music reproduction, its unusual bass capability has earned it a place in other applications. It is used by major pipe organ constructors as an electronic substitute for bulky and expensive 32" pipes needed for the lowest range of the pipe organ. In addition it is used extensively as a bass speaker in non-pipe organs.

Recently the popular music field has taken note of the unusual sonic characteristics of the 30W. Its extreme low range and high efficiency is of interest to musicians seeking new sounds and higher volume levels. In addition they are attracted by the high power handling capacity of the 30W. Nominal peak power rating is 240 watts, and 70 watts continuous sine wave.

This high power handling capacity results from the achievement of several design goals. These include: high mechanical strength of moving parts, the reduction of excessive localized stresses, and the control of heat generated as a by-product of the conversion of electrical energy into cone movement.

The 30W has several natural advantages that help to improve heat dissipation at high power levels. It uses a massive magnetic structure totalling 23 pounds. This conducts away much of the heat generated in the voice coil gap. In addition, the voice coil itself weighs 20 grams, and this relatively massive edgewise-wound copper coil can absorb more heat than smaller coils. The coil is mounted to a 2-ply fiberglass form, impregnated with high-temperature polyester to further reduce the effects of high heat.

It might be pointed out that air convection cooling is of little consequence as relative air motion is slight in a well-designed speaker structure. In experiments with extremely high power, temperatures as high as 300°F have been measured in the gap of speakers that successfully survived the tests. In one test, however, a 30W literally burst into flames at the end of a popular music concert. Its failure was understandable since the guitar amplifier driving the speaker was providing as much as 300 watts of continuous sine wave power. Temperature in the gap was estimated at 600°F, the flash point for the materials involved!

Although study of methods to raise the temperature limit for high power speakers is continuing, there is a practical limit to advances in this direction. As temperature rises, speaker efficiency drops. This is a direct result of higher magnet temperature as well as increased resistance in the voice coil wire. The resultant lower efficiency encourages the use of multiple drivers in order to maintain effective use of amplifier power. Nevertheless, better thermal stability will result in greater reliability when high power operation is attempted.

For reprints of other discussions in this series, or technical data on any E-V product, write: **ELECTRO-VOICE, INC.**, Dept. 1183P, 630 Cecil St., Buchanan, Michigan 49107

Electro-Voice®

A SUBSIDIARY OF GULTON INDUSTRIES, INC.

CIRCLE NO. 16 ON READER SERVICE PAGE

POPULAR ELECTRONICS

PHILLIP T. HEFFERNAN
Publisher

OLIVER P. FERRELL
Editor

LESLIE SOLOMON
Technical Editor

JOHN R. RIGGS
Managing Editor

EDWARD I. BUXBAUM
Art Director

ALEXANDER W. BURAWA
Associate Editor

ANDRE DUZANT
Technical Illustrator

PATTI MORGAN
Assistant Editor

AURORA NARDOZZI
Editorial Assistant

H. BENNETT, W2PNA
H. S. BRIER W9EGQ

L. E. GARNER, JR.

CHARLES J. SCHAUERS, W6QLV
M. P. SPINELLO, KHC2060

Contributing Editors

RICHARD J. HALPERN
Advertising Manager

ARDYS C. MORAN
Advertising Service Manager

LAWRENCE SPORN
Associate Publisher

ZIFF-DAVIS PUBLISHING COMPANY

Editorial and Executive Offices
One Park Avenue, New York, New York 10016

212 679-7200

Midwestern Office

307 North Michigan Avenue, Chicago, Illinois 60601

312 726-0892

Midwestern Advertising Manager, JAMES WEAKLEY

GERALD L. TAYLOR

Western Office

9025 Wilshire Boulevard, Beverly Hills, California 90211

213 Crestview 4-0265; BRadshaw 2-1161

Western Advertising Manager, BUD DEAN

Japan: James Yagi

Ishikawa Mansion, #4, Sakuragaoka

Shibuya-ku, Tokyo, 462-2911-3

Circulation Office

Portland Place, Boulder, Colorado 80302

William B. Ziff, Chairman of the Board (1946-1953)

William Ziff, President

W. Bradford Briggs, Executive Vice President

Hershel B. Sarbin, Senior Vice President

Philip Sine, Financial Vice President

Walter S. Mills, Jr., Vice President, Circulation

Stanley R. Greenfield, Vice President, Marketing

Phillip T. Heffernan, Vice President, Electronics Division

Frank Pomerantz, Vice President, Creative Services

Arthur W. Butzow, Vice President, Production

Edward D. Muhlfeld, Vice President, Aviation Division

Irwin Robinson, Vice President, Travel Division

Furman Hebb, Administrative Vice President

George Morrissey, Vice President

Sydney H. Rogers, Vice President

Ziff-Davis also publishes Airline Management and Marketing, Boatline, Business & Commercial Aviation, Car and Driver, Cycle, Electronics World, Flying, Stereo Review, Modern Bride, Popular Photography, Skating, Skating Area News, and Skating Trade News. (Travel Weekly is published by Robinson Publications, Inc. a subsidiary of Ziff-Davis Publishing Company.)

Forms 3579 and all subscription correspondence should be addressed to POPULAR ELECTRONICS, Circulation Department, Portland Place, Boulder, Colorado 80302. Please allow at least six weeks for change of address. Include your old address, as well as a new enclosing if possible an address label from a recent issue.

EDITORIAL CONTRIBUTIONS must be accompanied by return postage and will be handled with reasonable care; however, publisher assumes no responsibility for return or safety of art work, photographs or manuscripts.



Member Audit Bureau of Circulations

This is the biggest coupon in this magazine because we wouldn't want you to miss a big opportunity to make something of yourself.

Here is the chance of a lifetime to start earning extra money fast. All you need is just a few weeks' training in your own home and in your spare time and your income will go up \$10, \$20, \$30 a week or more. RTTA will show you how easily and how quickly you can do this.

You'll get a complete set of easy-to-read, easy-to-understand lessons that will let you earn money almost from the very beginning. You'll get a complete set of the most modern test equipment; a vacuum-tube voltmeter, a scope, a signal generator — everything you need to help qualify you as a highly-paid electronics technician.

WITHIN ONE WEEK AFTER YOU START YOU'LL BE WORKING WITH ELECTRONICS!

And look at these extras at no additional charge:

- advisory placement service and technical service booklets: • student discount card
- complete electronics workshop tool kit

Act now! All of this equipment and the bonus extras can be yours to keep and to use. The extra money you earn or a new or better job can be yours. Fill in the coupon for full information and start your way up.

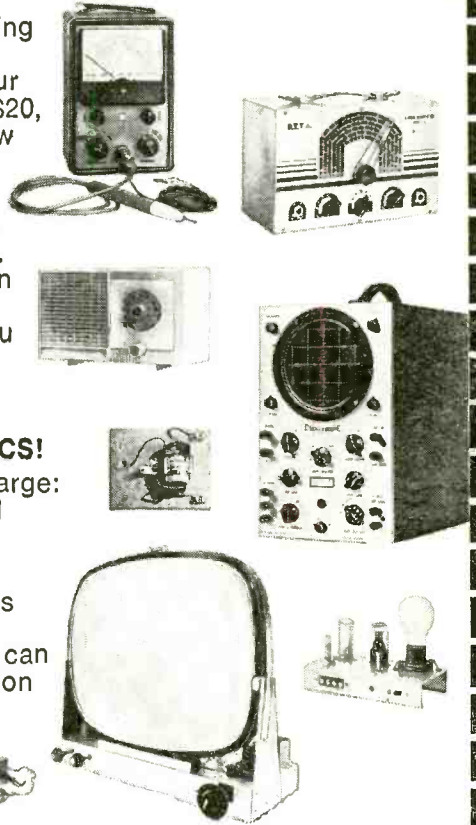

16 KITS
Yours to build
and keep

Radio-Television Training of America 229 Park Avenue South, New York, N. Y. 10003

Name _____ Age _____

Address _____

City _____ State _____ Zip _____

Phone _____ pe-11

APPROVED FOR VETERANS

Licensed by the New York State Department of Education
Member of the National Home Study Council

letters

FROM OUR READERS

ARE PULSES INVERTED?

Mr. Robert E. Devine's Article, "Your Own Little Photoplethysmograph" (July, 1968) excellently explains the electrical operation of the photoplethysmo-transducer. The only thing I find at fault is the fact that the peripheral pulse tracings shown on the CRT of the oscilloscope (cover photo) are physiologically impossible. Assuming that the sweep on the oscilloscope was from the left to the right, the pulses are shown inverted. This condition can be corrected simply by switching the polarity of the input to the oscilloscope.

JAMES J. GREENE
ST. ELIZABETH HOSPITAL
UTICA, N. Y.

The orientation of the pulses seems to be a matter of interpretation. However, you are wrong about changing the connections to the oscilloscope to invert the waveshape. The special bridge circuit will still show the pulses as they are displayed on the front cover.

LOW-COST SUBSTITUTE

The article "Build The Automobile Omni-Alarm" that appeared in the August, 1968, issue of POPULAR ELECTRONICS is excellent. Our "Bleptone," however, will functionally replace this circuit. The "Bleptone" is essentially a ready-made "Omni-Alarm;" you simply mount it and connect the external circuits. The output signal of the "Bleptone," is in the high-sensitivity frequency range of the human ear—a feature that comes in handy to get your attention. The "Bleptone" sells for \$5.35 from C.A. Briggs Company, P.O. Box 151, 114 Keswick Ave., Glenside, Pa. 19038. (Sent COD or prepaid)

C.A. BRIGGS
President, C.A. Briggs Co.

SHOW A LITTLE COOPERATION!

After reading many articles on Amateur radio and Citizens Band radio I have discovered that hams profess a general dislike for CB'ers. What is worse, the same dislike is reciprocated by CB'ers toward hams. Hams feel that CB'ers are guys who just couldn't make the grade. But, in an emergency, which one is most prepared and organized to help with communications?

It is not my intention to chew out either group. Instead, my point is that hams and CB'ers should get together to determine how their concerted efforts can best be utilized by

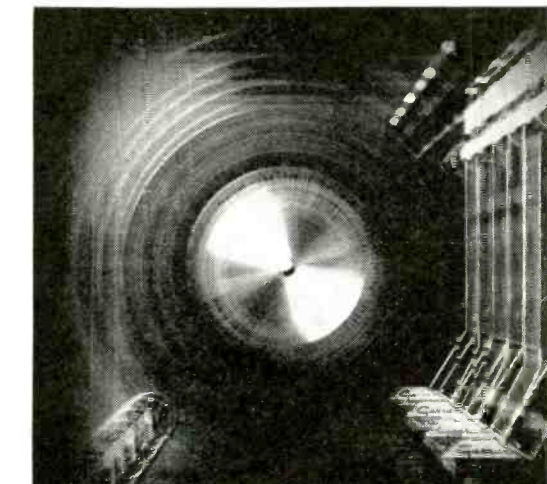

If your record player
today still has
a heavy turntable,
it must have yesterday's motor



Why did Garrard switch from heavy turntables (which Garrard pioneered on automatics) to the scientificaly correct low mass turntable on the SL 95? Simply because the synchronous Synchro-Lab™ Motor has eliminated the need for heavy turntables, developed to compensate (by imparting flywheel action) for the speed fluctuations inherent in induction motors. The light, full 11½" aluminum turntable on the SL 95 relieves weight on the center bearing, reduces wear and rumble and gives records proper edge support.

The Synchro-Lab Motor has also made variable speed controls as obsolete as they are burdensome to use. The synchronous section of the motor locks in to the rigidly controlled 60 cycle current (rather than voltage) to guarantee constant speed regardless of voltage, warm up, record load and other variables. This means unwavering musical pitch. And the induction section provides instant starting, high driving torque and freedom from rumble.

At \$129.50, the SL 95 is the most advanced record playing unit available today. For Comparator Guide describing all models, write Garrard, Dept. AE134, Westbury, N.Y. 11590.

Garrard[®]
WORLD'S FINEST

British Industries Co., division of Avnet, Inc.

CIRCLE NO. 19 ON READER SERVICE PAGE

Here's a new, complete ICS course in TV Servicing that costs less than \$100.

With the first two texts, you can repair 70 percent of all TV troubles.

You need no previous experience to take this complete, practical course in TV Repairing.

You don't even have to know a vacuum tube from a resistor. Yet in a matter of months, you can be doing troubleshooting on color sets!

Course consists of 6 texts to bring you along quickly and easily. 936 pages of concise, easy-to-follow instruction, plus 329 detailed illustrations. You also receive a dictionary of TV terms geared directly to course material so you'll understand even the most technical terms.

Instruction is simple, very easy to grasp. Photos show you what a TV screen looks like when everything is normal, and what it looks like when trouble fouls it up. The texts tell you how to remedy the problem, and why that remedy is best.

Quizzes are spotted throughout the texts so you can check your progress. At the end of the course,

you take a final examination. Then you get the coveted ICS® diploma, plus membership in the ICS TV Repairman Association.

By the time you've finished the course, you should be able to handle tough, multiple TV problems, on color sets as well as black and white.

This new TV Servicing and Repair Course has been approved by National Electronic Associations for use in their Apprenticeship program. Because of its completeness, practicality and price, it is the talk of the industry. The cost is less than \$100—just slightly over ½ the price of any comparable course on the market today.

Remember, the sooner you get started on your course, the sooner you'll be turning your spare time into real money. Fill out the coupon and mail today. We'll rush you complete information at no obligation to you.

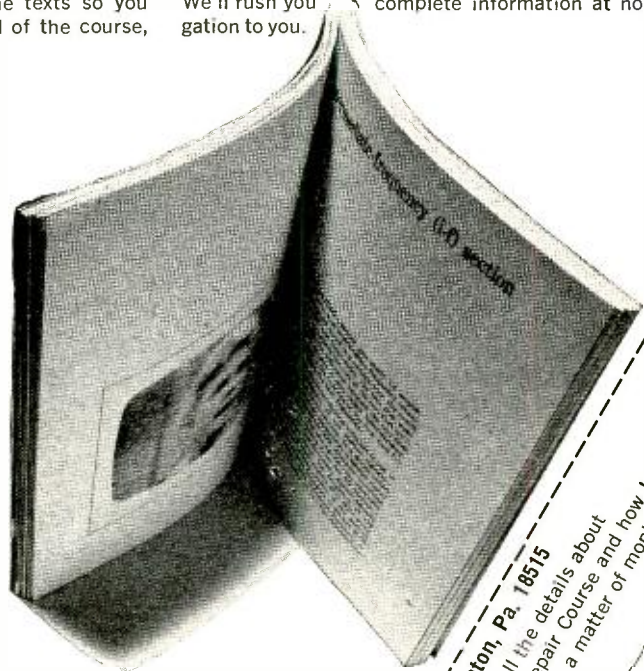

ICS, Dept. J9468K, Scranton, Pa. 18515
Yes, I would like to have all the details about
your new TV Servicing/Repair Course and how I
can break into TV work in a matter of months.

Name _____
Street _____
City _____
State _____
Zip _____

LETTERS (Continued from page 8)

the communities in which they live. Let's face it, hams have the equipment and power, and CB'ers have the organization. If they would try to help instead of eliminate each other, what a useful union would result. The union could be accomplished if each side would just show a little cooperation.

DIRK EDWARDS, WN7HMN
Beaverton, Ore.

"BIG BROTHER" READS P.E.

POPULAR ELECTRONICS did a nice job on my Soviet electronics story ("Soviet Electronics: A 1968 Reappraisal," September, 1968). Many thanks. You misspelled my name, but I guess that was because you didn't want the "bad guys" (the Russians) to know who I am.

THEODORE M. HANNAH
Silver Spring, Md.

PHOTOCELL OR PHOTORESISTOR

In the Parts List for the "Build Your Own Little Photoplethysmograph" article (July, 1968), PC1 is referred to as a photocell. However, in the text it is referred to as a photoresistor. Which is it?

GREGG COLASARDO
Canoga Park, Calif.

This is an either/or case. The part referred to can be described by either one name or the other. Almost all light-activated devices are,

by definition, photocells. However, there are different types of photocells available. In this case, PC1 is a photoresistor-type photocell. The Parts List specifies photocell because this is the name the manufacturer lists his product under. We could just as easily have specified photoresistor, making it a bit more difficult to locate in the mail-order catalogs.

INDEPENDENT SUPPLIER

I can supply a complete kit of wood parts for the "Mighty-Mag Speaker System" (March, 1968). All parts are cut to fit, and enclosure walls are $\frac{3}{4}$ " furniture-grade Philippine plywood with beautifully grained Narra, Dao, or Philippine mahogany. Dao has the fine grain and texture of teak. To the first two takers, I will throw in a hand-carved figurine. Cost of the kit of parts is \$10.90 postpaid (allow about 30 days for surface mail to San Francisco). Also, I can make available wood parts cut to order for any other type of enclosure at low cost.

I would like to swap two sets of enclosures for just one set of Maximus woofer and TS-6070 tweeter.

ROLAND R. TRINIDAD
64, 12 Ave.
Quezon City, Philippines

NIMBUS/ESSA ENTHUSIASTS

I'm in the process of building an automatic picture taking reception station for the current Nimbus and ESSA series of weather satellites. My station is the type being built for amateur use (similar to the one designed

Add LIFE to your color TV, stereo radio and electronic equipment

 DELWYN™

Whisper Fan®

- Made especially for cooling transistors, tubes and other heat generating components
- Helps guard against part failure
- Ensures trouble-free life — peak performance
- Costs only a few pennies to operate — saves dollars in repair bills
- So quiet and noise-free, you have to feel the breeze to know it is at work
- Quickly and easily installed

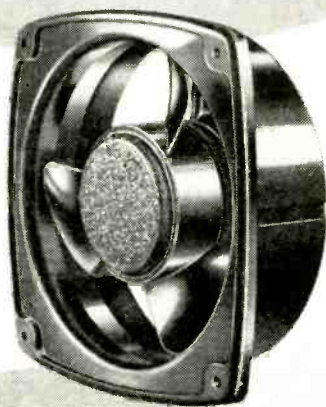

Only
\$14.85
Complete!

Ask your dealer to demonstrate how the Delwyn Whisper Fan will pay for itself in savings on just one heat-caused repair bill.

 DELWYN

BOX 195 B, Route 28
Kingston, New York 12401



CIRCLE NO. 13 ON READER SERVICE PAGE

measure

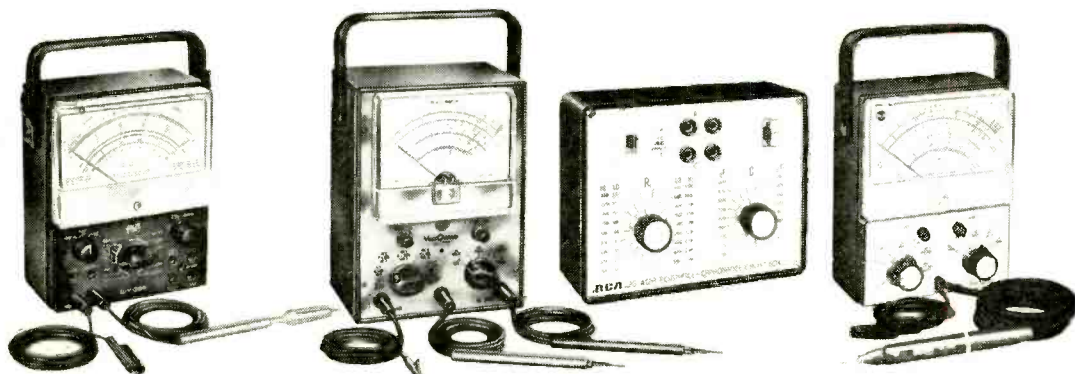

The **RCA WV-38A** Volt-Ohm Milliammeter is a rugged, accurate, and extremely versatile instrument. We think it's your best buy. Only \$52.00.* Also available in easy to assemble kit, WV-38A (K).

The **RCA WV-77E** Volt-Ohmyst® can be used for countless measurements in all types of electronic circuits. Reliability for budget price. Only \$52.00.* Also available in an easy to assemble kit, WV-77E (K).

The **RCA WG-412A** R-C circuit box can help you speed the selection of standard values for resistors and capacitors, either separately or in series or parallel R C combinations. Only \$30.00.* It's easy to use, rugged, and compact.

The **RCA-500A** all solid state, battery operated VoltOhmyst eliminates warm-up time, eliminates zero-shift that can occur in tube operated voltmeters. Completely portable. Only \$75.00.* Comes with shielded AC/DC switch probe and cables.



The **RCA-WT-501A** in-circuit out-of-circuit transistor tester is battery operated, completely portable. It tests both low and high power transistors, has NPN and PNP sockets for convenient transistor matching for complementary symmetry applications. Only \$66.75.*

The **RCA WC-506A** transistor-diode checker offers a fast, easy means of checking relative gain and leakage levels of out-of-circuit transistors. Compact and portable, it weighs 14 ounces, measures 3¾ by 6¼ by 2 inches. Only \$18.00.*

The **RCA WV-98C** Senior VoltOhmyst is the finest vacuum-tube voltmeter in the broad line of famous RCA VoltOhmysts. Accurate, dependable, extremely versatile, it is a deluxe precision instrument. Only \$88.50.* Also available in an easy to assemble kit, WV-98C (K).

For a complete catalog with descriptions and specifications for all RCA test instruments, write RCA Electronic Components, Commercial Engineering, Dept. K133W, Harrison, N.J. 07029.

*Optional Distributor resale price. Prices may be slightly higher in Alaska, Hawaii, and the West.

LOOK TO RCA FOR INSTRUMENTS TO TEST/MEASURE/VIEW/MONITOR/GENERATE

CIRCLE NO. 27 ON READER SERVICE PAGE

RCA

Viewed from a dollar and sense standpoint

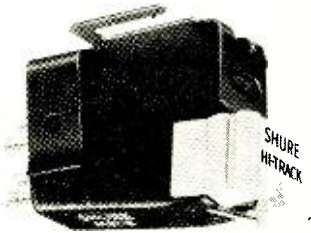

You can't get a better buy for your new hi-fi system than a Shure cartridge, whether it's the renowned "Super Track" V-15 Type II at \$67.50 or the new M91E Easy-Mount "Hi-Track" at \$49.95, made in the tradition of all fine Shure cartridges. If you're new to hi-fi, benefit from the published opinions of experts the world over: the **Shure V-15 Type II** Super Track makes a decidedly hearable difference. If you want to spend less, the M91E is right for you. You can always "trade-up" to a V-15 Type II at a later date. Shure Brothers, Inc., 222 Hartrey Avenue, Evanston, Illinois 60204.

NEW! M91E Hi-Track Elliptical Cartridge with optimized design parameters for trackability second only to the incomparable V-15 Type II. Bi-radial .0002" x .0007" diamond stylus. 20-20,000 Hz. Channel Separation: more than 25 db @ 1 KHz. Tracking force range $\frac{3}{4}$ to 1½ grams. Trackability specifications @ 1 gram: 20 cm/sec @ 400 Hz.; 28 cm/sec @ 1 KHz.; 25 cm/sec @ 5 KHz.; 18 cm/sec @ 10 KHz. \$49.95.

© 1968 SHURE BROTHERS, INC.

CIRCLE NO. 33 ON READER SERVICE PAGE

LETTERS (Continued from page 10)

by K2RNF in 1965). I would like to contact other readers—especially those in clubs that have already been formed—who share my interest in this hobby. Can you help me?

CONRAD J. BARANOWSKI
109 Peterborough St.
Boston, Mass. 02215

We have included your complete name and address so that interested readers can contact you direct.

ACKNOWLEDGEMENT IS ONLY FAIR RETURN

I have replied to several readers who requested information about out-dated electronic equipment through "Operation Assist" without once receiving an acknowledgement. I feel that the reader who uses your column to make a request should be obligated to answer all replies he receives in answer to his request.

WILLIAM H. KELLEY
Hempstead, N.Y.

This subject has cropped up several times in the past, and all we can say is that we support your suggestion. After all, those who answer such requests are doing so because they want to help, and such help given deserves at least a word of thanks. However, from the volume of enthusiastic mail we receive concerning "Operation Assist," we must conclude that the great majority of readers who have had requests answered were well mannered enough to show their appreciation.

PLYWOOD IS BEST

Why is it that $\frac{3}{4}$ "-thick plywood is stipulated for building speaker enclosures. Wouldn't solid lumber be as good? Also, where can I get tubing for the ports in ducted enclosures?

CONRAD PHILLIPS
Bunkie, La.

Ideally, any speaker enclosure should be as rigid as possible. An elastic enclosure will readily resonate, and resonance has the effect of coloring the sound reproduction. For this reason, plywood, which is much more rigid than solid board of similar thickness, is the most commonly used enclosure material. In fact, flakeboard, when its surfaces are properly treated, is even better than plywood.

Aside from the acoustical advantages plywood has over solid lumber, there are other things that make it more desirable. It is much more durable, easier to work with, and is less expensive than hardwoods. True, plywood finishes are generally less than ideal for the finished furniture look, but plywood can be finished with a thin veneer to suit any taste.

As for where you can obtain tubing, you might try a stationery store that sells mailing tubes. Of course, the tube you use should be fairly heavy.

Everybody bulls, bluffs and brags about their tape recorders.

This new Ampex will clear the air.



It seems like all tape equipment manufacturers chatter about all sorts of features.

One talks automatic threading. Others boast automatic reverse. Still more hit you with 4 heads, sound-with-sound, dual capstan drive, automatic tape lifters, 3-speed operation and on and on.

It makes the mind boggle.

Because the fact is that no one has all these features on *one* stereo machine. Except us. Ampex.

Our new model 1461 has automatic threading. And automatic reverse. And 4 deep-gap heads. And sound-with-sound. And dual capstan drive. And tape monitoring. And automatic tape lifters. And 3-speed operation. And two omni-directional dynamic microphones.

And lots more. Like full-dimensional stereo cube speakers that nest inside the unit for portable use and separate up to 20 feet.

Automatic shut-off.

Even stereo headphone output.

Just one great feature after another.

Sure, you can find some of these features on other machines. But not all on *one* machine. Except ours. So see an Ampex Sound Idea Dealer today. He has the outfit that has it all.

Ampex.
The
Sound
Idea
People.

AMPEX

AMPEX CORPORATION
CONSUMER & EDUCATIONAL PRODUCTS DIVISION
2221 LUNT AVENUE
ELK GROVE, ILLINOIS 60007

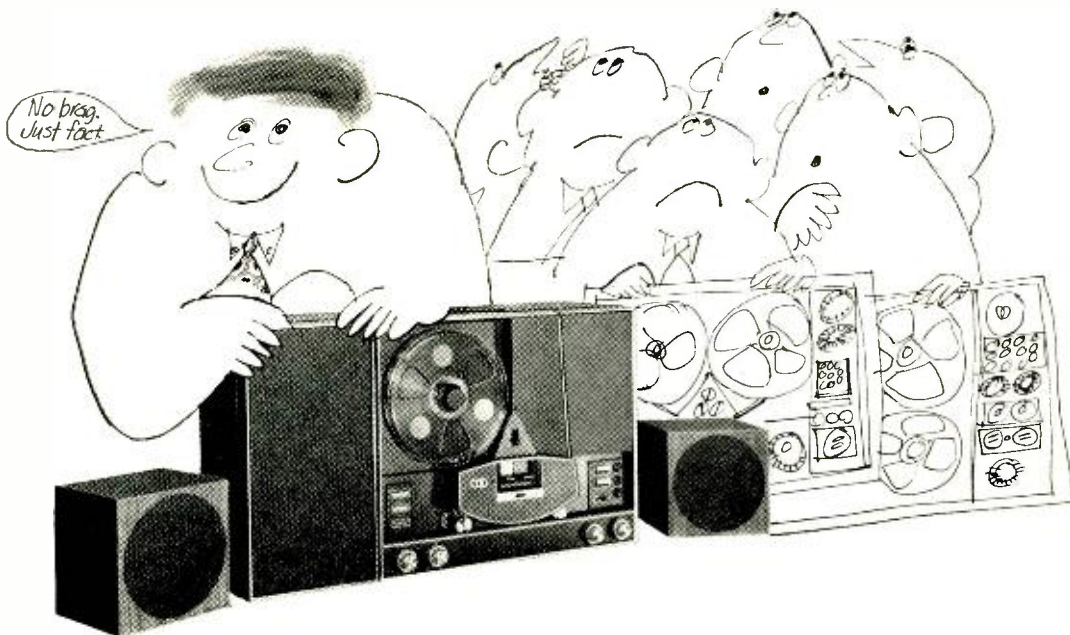

ELECTRONICS library

QUIET

VOLTAGE AND POWER AMPLIFIERS

by Robert E. Sentz

Written primarily for technical institutes and junior colleges, this book is also well suited for home study. An integrated transistor/vacuum-tube approach places emphasis on transistors, keeping in step with current technology. This is an intermediate-level textbook for students who understand a.c. and d.c. network theorems and transistors and vacuum tubes as single-stage amplifiers. A working knowledge of algebra and trigonometry is required; differential calculus is helpful but not essential. Hybrid circuit equivalents are employed extensively for small-signal transistor amplifier analyses, and the high-frequency hybrid-pi equivalent is used where applicable. Graphical analysis is employed as an aid in analyzing large-signal amplifiers. The scope of this book makes it a must for advanced hobby-

ists, junior engineering students, and technicians.

Published by Holt, Rinehart and Winston, Inc., 383 Madison Ave., New York, N.Y. 10017. 282 pages. Soft cover. \$3.95.

PULSE AND LOGIC CIRCUITS

by Angelo C. Gillie

In three broad categories, this book gives a comprehensive treatment of both pulse and logic circuits. Categories include passive pulse circuits; switching circuits; and matrix, counting, and register circuits. Since nonsinusoidal waveforms are a basic foundation for much of the text, the first chapter introduces and defines the basic nonsinusoidal waveforms without mathematics. All circuit analysis is developed so that it is equally appropriate for integrated and discrete circuits. Only solid-state circuits are considered in the analysis of switching and logic systems. The only prerequisite for understanding the material presented is a basic understanding of elementary algebra.

Published by McGraw-Hill Book Co., 330 West 42 St., New York, N.Y. 10036. Hard cover. 401 pages. \$9.95.

FUNDAMENTALS OF INTEGRATED CIRCUITS

by Lothar Stern

Although the IC is still in its infancy, its
(Continued on page 112)

small wonder...

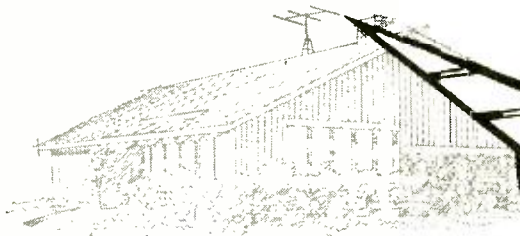

... it's from **Mosley**

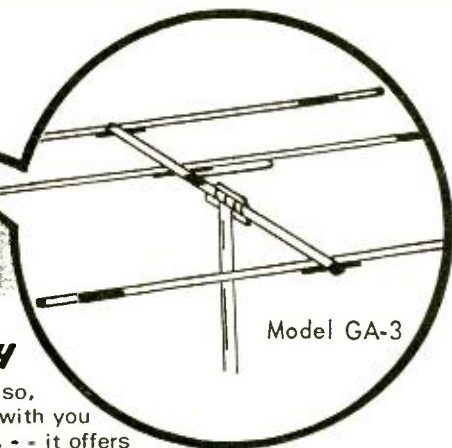

CB'ers! Economy-minded? Cramped for Space? If so, Mosley's Gamma 323 is the Mini-Beam designed with you in mind. This antenna is unique among CB beams - - it offers you all the advantages of a big beam with none of the problems. You reap dividends from its modest size: install with low-cost TV antenna mount and rotor - assemble easily in 15 minutes with preassembled parts and solid-state gamma match - stack conveniently for double gain (stacking kits available).

It's truly a small wonder. But small wonder - - it's from MOSLEY, the name you can rely on in Quality Communication Antennas. Prove it to yourself: see your nearest authorized Mosley dealer or write factory direct for detailed brochure.

Dept. 177 **Mosley Electronics, Inc.** 4610 N. Lindbergh Blvd. Bridgeton, Mo. 63042

CIRCLE NO. 24 ON READER SERVICE PAGE



POPULAR ELECTRONICS READER SERVICE PAGE

free information service:

Here's an easy and convenient way for you to get additional information about products advertised or mentioned editorially (if it has a "Reader Service Number") in this issue. Just follow the directions below... and the material will be sent to you promptly and free of charge.

1. Print or type your name and address on the lines indicated. Circle the number(s) on the coupon below that corresponds to the key number(s) at the bottom of the advertisement or editorial mention(s) that interest you. (Key numbers for advertised products also appear in the Advertisers' Index.)

2. Cut out the coupon and mail it to the address indicated below.

3. This address is for our product "Free Information Service" only. Editorial inquiries should be directed to POPULAR ELECTRONICS, One Park Avenue, New York 10016; circulation inquiries to Portland Place, Boulder, Colorado 80302.

**POPULAR
ELECTRONICS**

VOID AFTER DECEMBER 31, 1968

P.O. BOX 8391
PHILADELPHIA, PA. 19101

1 2 3 4 5 6 7 8 9 10 11 12 13 14 15 16 17 18 19 20
21 22 23 24 25 26 27 28 29 30 31 32 33 34 35 36 37 38 39 40
41 42 43 44 45 46 47 48 49 50 51 52 53 54 55 56 57 58 59 60
61 62 63 64 65 66 67 68 69 70 71 72 73 74 75 76 77 78 79 80
81 82 83 84 85 86 87 88 89 90 91 92 93 94 95 96 97 98 99 100

NAME (Print clearly) _____

ADDRESS _____

CITY _____ STATE _____ ZIP CODE _____

11 a

First of a
new breed
—from Sherwood

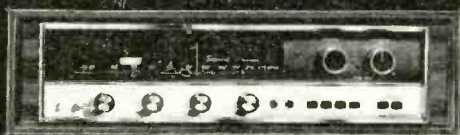

Model S-8800a \$399.50

This is what high performance is all about. A bold and beautiful new FM Stereo Receiver bred to leave the others behind. 160 crisp, clean watts—power in reserve. Up-front, ultra-now circuitry featuring Field-Effect Transistors and microcircuitry. Front-panel, push-button command of main, remote, or mono extension speakers and loudness contour. Sherwood high-fidelity—where the action is—long on reliability with a three-year warranty.

Sherwood

Sherwood Electronic Laboratories, Inc.
4300 North California Avenue,
Chicago, Illinois 60618 Write Dept. 11P
CIRCLE NO. 32 ON READER SERVICE PAGE

TAKE ONE



**new
literature**

To obtain a copy of any of the catalogs or leaflets described below, simply fill in and mail the coupon on page 15 or 115.

The 1968 edition of the *Lafayette Radio Electronics* annual catalog, 512 pages, is a complete buying guide for almost everything in electronics for the home, car, or workshop. The catalog features Lafayette's own brand of hi-fi equipment, the latest in ham gear and two-way CB radios, test equipment, optics, etc. In addition to the Lafayette-brand listings, the catalog gives complete rundown of all major hi-fi components made by leading manufacturers.

Circle No. 75 on Reader Service Page 15 or 115

Three complete sound systems for the traveling entertainer and professional musician are illustrated and technically described in *Altec Lansing's* brochure number AL-1370-1. The 16-page booklet lists 585-, 365-, and 145-watt (peak music power) systems, all of which are built around Altec Lansing's "Voice of the Theatre" speaker systems. The music systems include all-solid-state mixer/power amplifier consoles which have built-in reverb and are capable of controlling five independent inputs.

Circle No. 76 on Reader Service Page 15 or 115

An illustrated four-page Monitor Brochure describing its line of monitor receivers is available from the *Hallcrafters Company*. The brochure gives details on the frequency coverage and special features of the new Models CRX portable hand-held and table-type receivers. Written for the prospective user of monitor equipment, the brochure answers many questions he might have concerning monitor radio.

Circle No. 77 on Reader Service Page 15 or 115

"Professional Methods For Record Care And Use," by Cecil E. Watts, is a recently revised edition of a book that has long been a favorite of record collectors. As its title implies, the booklet describes the modern record, how to care for it, and the devices used to keep it in good shape. The format used in the book is semi-technical, aimed at the person who really appreciates recordings. For a copy of this book, send 50c to Elpa Marketing Industries, Inc., New Hyde Park, N.Y. 11040.

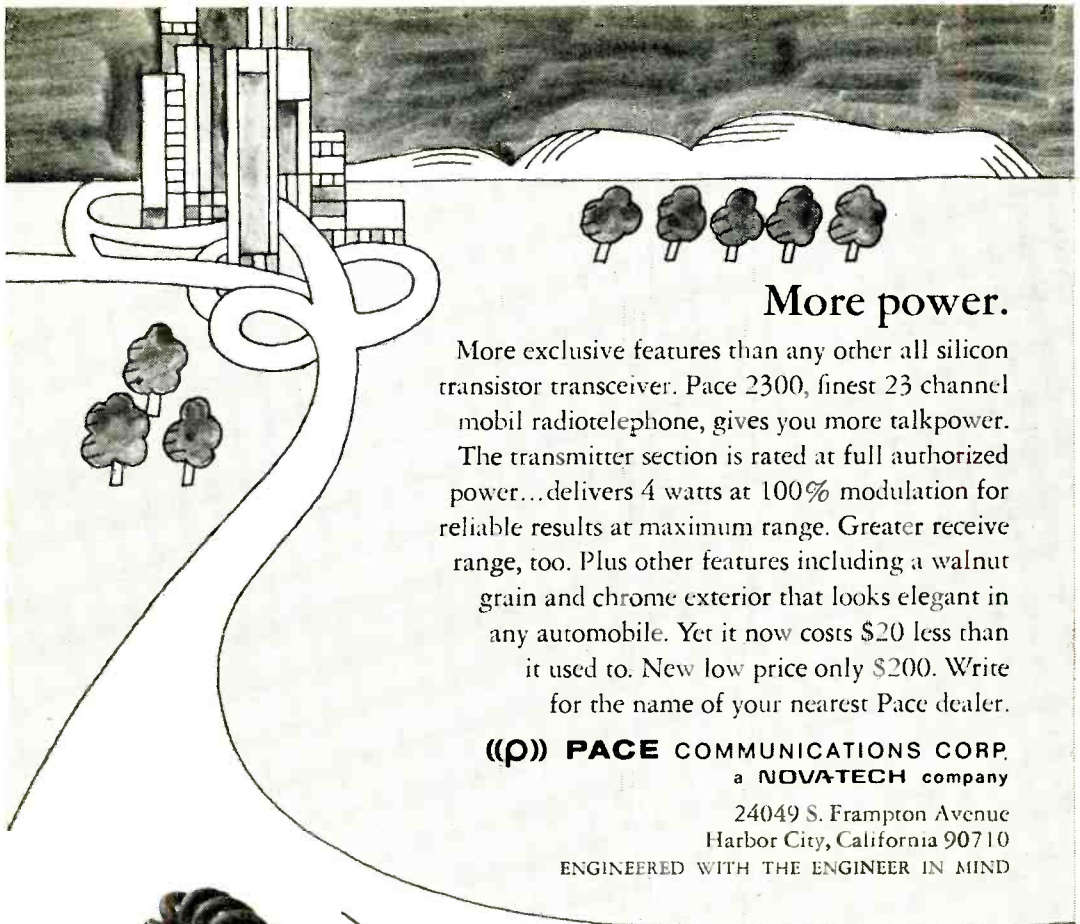

More power.

More exclusive features than any other all silicon transistor transceiver. Pace 2300, finest 23 channel mobil radiotelephone, gives you more talkpower. The transmitter section is rated at full authorized power...delivers 4 watts at 100% modulation for reliable results at maximum range. Greater receive range, too. Plus other features including a walnut grain and chrome exterior that looks elegant in any automobile. Yet it now costs \$20 less than it used to. New low price only \$200. Write for the name of your nearest Pace dealer.

((P)) PACE COMMUNICATIONS CORP.
a **NOVATECH** company

24049 S. Frampton Avenue
Harbor City, California 90710

ENGINEERED WITH THE ENGINEER IN MIND

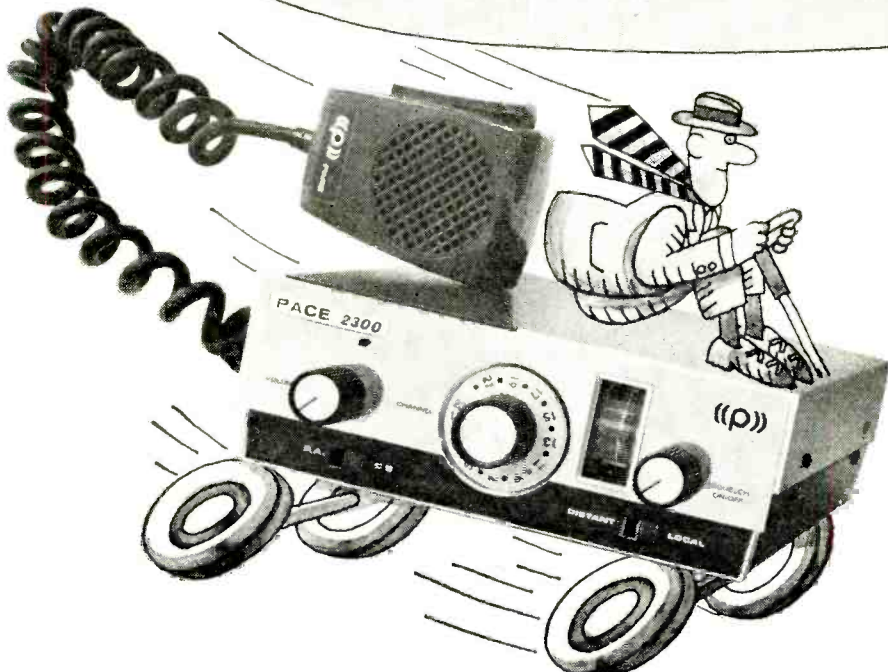



Only NTS penetrates below the surface. Digs deeper. Example? Take the above close-up of the first transistorized digital computer trainer ever offered by a home study school.

It's called The Compu-Trainer®—an NTS exclusive. Fascinating to assemble, it introduces you to the exciting world of computer electronics. Its design includes advanced solid-state NOR circuitry,

flip-flops, astable multivibrators and reset circuits. Plus two zener and transistorized voltage-regulated power supplies. The NTS Compu-Trainer® is capable of performing 50,000 operations per second.

Sound fantastic? *It is!* And at that, it's only one of many *ultra-advanced* kits that National Technical Schools offers to give you incomparable, in-depth career training.

PROVE IT YOURSELF. SEND FOR OUR NEW CATALOG. SEE THE LATEST, MOST ADVANCED KITS AND COURSES EVER OFFERED BY A HOME STUDY SCHOOL.

NTS...THE FIRST HOME STUDY SCHOOL TO OFFER LIVE EXPERIMENTS WITH INTEGRATED CIRCUIT KITS

You build a computer sub-system using the new, revolutionary integrated circuits. Each one, smaller than a dime, contains the equivalent of 15 resistors and 27 transistors.

And your kits come to you at no extra cost. These kits are the foundation of the exclusive *Project-Method* home study system...developed in our giant resident school and proven effective for thousands of men like yourself.

With Project-Method, all your kits are carefully integrated with lesson material. Our servicing and communication kits are *real* equipment—not school-designed versions for training only. As you work on each of the projects, you soon realize that even the most complicated circuits and components are easy to understand. You learn *how* they work. You learn *why* they work.

NTS Project-Method is a practical-experience approach to learning. The approach that works *best!* An all-theory training program can be hard to understand—difficult to remember. More than ever before you need the practical experience that comes from working with real circuits and components to make your training stick.

NTS SENDS YOU KITS TO BUILD THESE IMPORTANT ELECTRONICS UNITS!

- ◆ 25" COLOR TV
- ◆ 21" BLACK & WHITE TV
- ◆ SOLID-STATE RADIO
- ◆ AM-SW TWIN-SPEAKER RADIO
- ◆ TUBE-TESTER
- ◆ TRANSCEIVER
- ◆ COMPU-TRAINER®
- ◆ VTVM
- ◆ SIGNAL GENERATOR
- 5" OSCILLOSCOPE

See them all illustrated in
the new NTS Color Catalog.

CLASSROOM TRAINING AT LOS ANGELES: You can take classroom training at Los Angeles in sunny California. NTS occupies a city block with over a million dollars in facilities devoted exclusively to technical training. Check box in coupon.

NATIONAL TECHNICAL SCHOOLS

WORLD-WIDE TRAINING SINCE 1905

4000 So. Figueroa Street, Los Angeles, Calif. 90037

APPROVED FOR VETERANS

Accredited Member: National Home Study Council
Accredited Member: National Association of
Trade and Technical Schools



COMMUNICATIONS

This transceiver is included in Communications courses. You build it. With it, you easily prepare for the F.C.C. license exam. You become a fully-trained man in communications, where career opportunities are unlimited.

25" COLOR TV ▼

Included in Color TV Servicing Courses. With it you advance yourself into this profitable field of servicing work. Color is the future of television, you can be in on it with NTS training.



YOUR OPPORTUNITY IS NOW

New ideas, new inventions, are opening whole new fields of opportunity. The electronic industry is still the fastest growing field in the U.S. There's a bigger, better place in it for the man who trains today. So, whatever your goals are—advanced color TV servicing, broadcasting, F.C.C. license, computers, or industrial controls, NTS has a highly professional course to meet your needs.

GET THE FACTS! SEE ALL NEW COURSES AND KITS OFFERED IN THE NEW NTS COLOR CATALOG. SEND THE CARD OR COUPON TODAY!

There's no obligation. You enroll by mail only. No salesman will call.

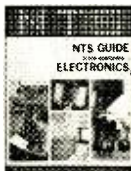

DEPT. 205-118

NATIONAL TECHNICAL SCHOOLS

4000 S. Figueroa St., Los Angeles, Calif. 90037

Please rush Free Color Catalog and Sample Lesson, plus information on field checked below. No obligation.

- | | |
|---|--|
| <input type="checkbox"/> MASTER COURSE IN COLOR TV SERVICING | <input type="checkbox"/> PRACTICAL TV & RADIO SERVICING |
| <input type="checkbox"/> COLOR TV SERVICING | <input type="checkbox"/> FCC LICENSE COURSE |
| <input type="checkbox"/> MASTER COURSE IN TV & RADIO SERVICING | <input type="checkbox"/> INDUSTRIAL & COMPUTER ELECTRONICS |
| <input type="checkbox"/> MASTER COURSE IN ELECTRONIC COMMUNICATIONS | <input type="checkbox"/> STEREO, HI FI & SOUND SYSTEMS |
| | <input type="checkbox"/> BASIC ELECTRONICS |

NAME _____ AGE _____

ADDRESS _____

CITY _____ STATE _____ ZIP _____

- Check if interested in Veteran Training under new G. I. Bill.
 Check if interested ONLY in Classroom Training at Los Angeles.



NEW PRODUCTS

Additional information on products covered in this section is available from the manufacturers. Each new product is identified by a code number. To obtain further details on any of them, simply fill in and mail the coupon on page 15 or 95.

SOLID-STATE COMMUNICATIONS RECEIVERS

A new line of low-cost table model monitor receivers is available from the *Halicrafters Company*. Models CRX-103, CRX-104, and CRX-105 are ideal for firemen on call, policemen, private pilots, emergency civil defense workers, businessmen, or just plain radio enthusiasts. The CRX-103 tunes the low band (27-50



MHz), while the CRX-104 portable aviation communications center tunes 108-135 MHz. The frequency band between 144 and 174 MHz is available with the CRX-105 receiver. The receivers are all solid-state, featuring stable operation, noise-eliminating squelch controls, and class-B push-pull amplifiers. The tunable superheterodyne circuits receive both AM and FM signals with high sensitivity and extended range.

Circle No. 78 on Reader Service Page 15 or 115

IN-CIRCUIT TRANSISTOR TESTER

The *Heath Company's* new Model IT-18 transistor tester measures d.c. beta both in and out of circuit in two ranges and $I_{c_{eo}}$ and $I_{c_{bo}}$ leakage in transistors out of circuit. It also checks diodes in and out of circuit for forward and reverse current to indicate open or short circuits. In addition to matching transistors of the same or opposite types, the IT-18 also identifies *npn* and *npn* transistors and the anodes and cathodes of unmarked diodes. All tests are non-destructive—even if the device under test is connected improperly. Other features include a 4½" 200- μ A meter movement, ten-turn calibration control, and complete line-independent portable operation.



Circle No. 79 on Reader Service Page 15 or 115

AUTOMATIC TURNTABLE

Constant synchronous speed under all conditions, regardless of voltage variations, is

the big feature in *Garrard's* new Model SL95 automatic transcription turntable. The Syn-



chro-Lab motor that forms the heart of the turntable is actually two motors in one. An induction section imparts instant start and high driving torque, and a synchronous section automatically locks on

to the 60-Hz line frequency, thus eliminating the need for a heavy turntable platter. A low-mass dynamically balanced pickup arm that rests on gimbaled pivots for minimal friction eliminates pickup arm vibration. An auto-rise platform allows records to be played automatically, yet can be lowered into the floor of the turntable when the turntable is used manually.

Circle No. 80 on Reader Service Page 15 or 115

COMBINATION SCOPE

With the flick of a switch, the Model PS148 "Combination Scope" available from *Sencore, Inc.* converts from a conventional wide-band oscilloscope to a professional vectorscope. The PS148, a versatile TV service instrument, produces vector patterns that enable technicians to view patterns at the chroma detector, besides facilitating alignment of the chroma section of color TV receivers. The combination scope can also be used to touch up bandpass amplifier alignment with the aid of any conventional color bar generator. Vertical amplifier response of the instrument is flat to 6 MHz.

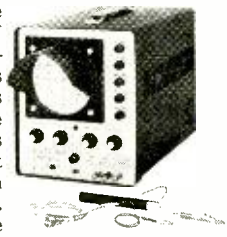

Circle No. 81 on Reader Service Page 15 or 115

LOW-COST HI-FI STEREO HEADPHONES

The "Encore" Model EN-5 stereo headphones made by *Tele. Communications Division* are said to be the only less-than-ten-dollar headphones on the market with a frequency response of from 50 to 18,000 Hz. They have removable foam-filled cushions, an 8'-long super-flexible cord, and a molded three-circuit plug. The EN-5 is lightweight, molded from tough, durable Cyclocac plastic.



Circle No. 82 on Reader Service Page 15 or 115

HIGH-PERFORMANCE CB CAMPER ANTENNA

An easy-to-install, high-performance two-way mobile CB antenna, designed for pickup trucks with campers, camping trailers, vans,

Cobra 98

the new standard of CB quality.

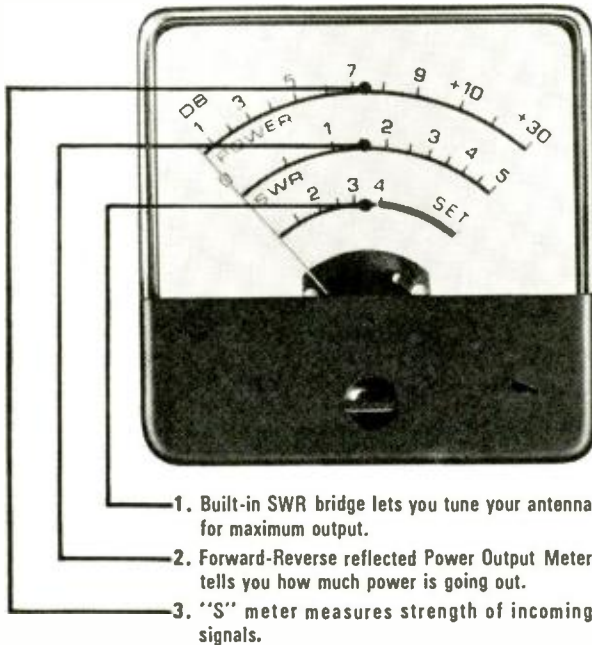

1. Built-in SWR bridge lets you tune your antenna for maximum output.
2. Forward-Reverse reflected Power Output Meter tells you how much power is going out.
3. "S" meter measures strength of incoming signals.



Outgrown your present CB? Step up to the new B&K Cobra 98, the new, 23-channel, fully deluxe CB that's built to outperform and outvalue most other rigs. The new triple scale (shown above) is only part of the story . . . the Cobra 98 looks like a million! The heavy die-cast aluminum front panel is magnificently finished in black and brushed aluminum.

And the Cobra 98 has all the power and performance features B&K is famous for—including exclusive Dyna-Boost that intensifies speech signals and extends range even farther!

Cobra—the big name in CB—now brings you the flagship of the line—the COBRA 98—it's the most! **\$239.95**

*B&K Division of Dynascan Corporation
1801 W. Belle Plaine Avenue/Chicago, Illinois 60613*



Where Electronic Innovation Is A Way Of Life

CIRCLE NO. 5 ON READER SERVICE PAGE

PRODUCTS (Continued from page 22)

and buses, is available from *Antenna Specialists Company*. The new Model M-189 antenna employs "Maggie Mobile" designs, utilizing a precision-wound true-base loading coil to provide extremely low VSWR for maximum range. Universal mounting bracket has a large bearing area for sturdy mounting, and an angle adjustment allows the CB'er to mount the antenna in any position on the side or the roof of his camper. Base-loaded antenna has a stainless steel whip, mounting bracket, RG-58 coax and PL-259 connector.

Circle No. 83 on Reader Service Page 15 or 115

MEDIUM-PRICED RECORD CHANGER

Top-of-the-line features are incorporated in the *Dual Model 1212* medium-priced record changer. These features include a balanced pickup arm, variable pitch control, direct-dial tracking force, anti-skating, automatic cuing, constant-speed motor, and a non-ferrous, cast platter. The tracking force range is 0.5-5.5 grams. The pickup arm can track as low as 1 gram, qualifying it for use with high-compliance cartridges. Anti-skating is synchronized to tracking force so that when tracking force is set for any number of grams, the required amount of anti-skating is set simultaneously by a special coupling. The variable pitch control allows all three speeds (33 $\frac{1}{3}$, 45, and 78 r/min) to be varied over a range of 6%. The high-torque motor maintains a 0.1% speed tolerance even if voltage varies between 80 and 135 volts. The heavy 3 $\frac{3}{4}$ -pound platter has an anti-static mat with ribbed rim.



Circle No. 84 on Reader Service Page 15 or 115

SOLID-STATE VOM

The high input impedance of the VTVM and the convenience of VOM battery operation come together in *Simpson Electric Company's* Model 313 solid-state VOM. The meter's FET input circuit can handle large overloads, while its 7" taut-band meter movement is varistor protected against even 200,000% overloads. The 313 provides eight ranges for each of the a.c. and d.c. voltage functions—from 0-0.3 volts to 0-1000 volts, $\pm 3\%$ full-scale accuracy. Input impedance on d.c. is 11 megohms; on a.c. 10 megohms. The d.c. current ranges are: 0-0.1, 1, 10, 100, and 1000 mA. Seven resistance ranges (RX1 to RX1 meg), with measure-

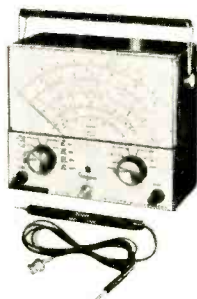

ment accuracy of $\pm 3^\circ$ of arc, are also provided.

Circle No. 85 on Reader Service Page 15 or 115

HAM AND SWL RECEIVER

Designed for the SWL as well as the ham, *Allied Radio's* Model A-2515 solid-state receiver tunes from 150 kHz to 30 MHz in five selectable ranges. The r.f. section of the receiver



utilizes two FET's to provide 2 μ V sensitivity (3.2 μ V for standard AM broadcast band). Four mechanical filters are used for sharp station separation.

Also featured are a built-in BFO and product detector for clear reception of CW and SSB. Visual tuning is made easy with an illuminated S-meter and an illuminated slide-rule dial (has calibrated band-spread). The receiver can be operated on 117 volts a.c. and 12 volts d.c. Selectivity is 1.5 kHz bandwidth at 6 dB down and 5 kHz at 50 dB down; signal-to-noise ratio is 30 dB down; and i.f. rejection is 40 dB. Audio output is 1.3 watts.

Circle No. 86 on Reader Service Page 15 or 115

STEREO HEADSET

The Clark/300 headset, retailing for just \$19 from *David Clark Company, Inc.*, puts quality stereo reproduction within reach of even the most modest budget. The frequency range of the headset is 20-17,000 Hz with a sensitivity for 1 mW input at 1000 Hz of 105 dB reference 0.0002 dyne/sq cm. Each of the two earpieces will handle a maximum power input of 1 watt. Nominal impedance is 8 ohms. The headset comes with a coiled cord which is terminated in a molded-on plug.

Circle No. 87 on Reader Service Page 15 or 115

RECEIVER/TAPE-DECK HI-FI CENTER

The Model TDC33 receiver/tape-deck home recording studio available from *Harman-Kardon* is said to be the first such combination on the market. Dubbed the "Nocturne," it has an FM-stereo receiver and the TD-3 three-speed, three-head tape deck. The balanced-coil tape heads have extremely narrow gaps to provide extended record/playback frequency response. Receiver technical specifications: 60-watts power output (IHF) into 4 ohms; 8-45,000-Hz ± 1 db frequency response at 1 watt; less than 1% harmonic distortion; 2.5- μ V FM sensitivity; 45-db FM image and 70-db spurious response rejection; 80-db FM i.f. rejection; and 30-db multiplex separation. Tape speeds are 7 $\frac{1}{2}$, 3 $\frac{3}{4}$ and 1 $\frac{1}{2}$ in/sec with frequency responses of 30-22,000 Hz at 7 $\frac{1}{2}$ in/sec and 30-15,000 Hz at 3 $\frac{3}{4}$ in/sec. Cross-talk is better than 60 dB.



Circle No. 88 on Reader Service Page 15 or 115

CIRCLE NO. 12 ON READER SERVICE PAGE →

COURIER ROYALE.



The upper limit in CB. \$279.

All the performance money will buy . . .
no matter what you're willing to spend!

Take today's most advanced electronic concepts. Add today's most wanted CB conveniences. Put them together with surgical precision. And you've got the 23-channel COURIER Royale. Years ahead of any other all-channel CB transceiver — including the ones with stratospheric prices!

The Royale is a marriage of power, sensitivity, and selectivity — with every conceivable signal-enhancing feature. Everything hand-wired, hand-soldered. All 23 channels, with all crystals supplied. Rugged chassis with 16 tube performance (including a space-age NdVistor). Cascade front end. A superb ceramic filter for razor-sharp selectivity. Full time range expand and speech compressor. Exclusive Courier Modulation Sampler[®] for full-time 100% modulation. Distortion-free reception. Tone control. Exceptional noise suppression. Transmitter designed to help pierce "skip."

Plus: real versatility. An over-powered transformer for base operation . . . a solid state 12V DC power supply for mobile . . . and built-in public address facility. Triple-duty "S/RF/½MOD" meter . . . transmit and receive indicators . . . standby and band spread controls. Luxurious styling. Distinctive, protective cloth pouch. And much, much more.

So much more, in fact, that you must get the full "dream-rig" story. Mail this coupon today!

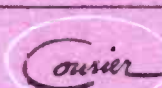

COURIER COMMUNICATIONS, INC.

439 Frelinghuysen Avenue, Newark, N.J. 07114
a subsidiary of **Whetstone** Corporation

Yes, I want all the facts on the Courier Royale.

Name PE-811

Address

City State Zip

Talk to the

POWERFUL

CB MAN

(Your Squires-Sanders Dealer)

Your Squires-Sanders dealer is **POWERFUL FRIENDLY** . . . talks to you straight . . . answers all those questions competently. He will show you how Squires-Sanders CB equipment delivers top performance. Your Squires-Sanders dealer is **POWERFUL FAST** . . . he keeps a fresh stock of equipment and accessories . . . his trained technicians will get your new rig perking in a hurry or quickly provide top flite service. He knows you will be satisfied with Squires-Sanders CB equipment.

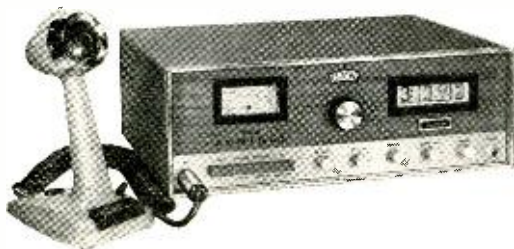

The **ADMIRAL**: luxurious new all solid state 23 channel CB base station • highly sensitive receiver • Pulse Eliminator • 5 watt transmitter • Speech Compression • +2 mike • dual antenna • HiLo sensitivity • Public Address • Delta Tune • adjustable squelch • ON-THE-AIR light • illuminated S meter • digital panel clock • ear-phone jack • regulated AC power supply • 9 lbs: 5¼ x 13¾ x 10¾ \$329.95

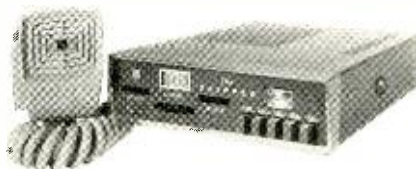

The **SKIPPER**: new low priced solid state 23 channel CB transceiver • superb dual conversion FET/IC no-overload receiver • advanced design noise limiting • illuminated S meter and channel • solid state T/R switching • Speech Clipping • 100% modulation • P.T.T. mike • Local/Distant sensitivity • external speaker jack • Public Address • Exclusive "All Position" Safety Breakaway Mount • 3 lbs: 1¾ x 6 x 8 \$159.95



The **CHIEF**: Full 5 watt Professional CB transceiver in a rugged, portable configuration. Two crystal controlled channels (ch 7 supplied). ½ μ v sensitivity, effective AGC, adjustable squelch. Excellent quality audio with 100% modulation. Beeper call. Relative power/battery test meter. Operates on penlite batteries. Telescoping antenna and handsome die cast case. 3 x 8 x 1¾, under 2 lbs. \$189.95 per pair

Write today for the name of the **POWERFUL** Squires-Sanders dealer in your area.

Squires  Sanders

SQUIRES-SANDERS, INC., Martinsville Road, Liberty Corner, New Jersey 07938

CIRCLE NO. 35 ON READER SERVICE PAGE

POPULAR ELECTRONICS



10,000 TECHNICIAN JOBS IN CATV

*Cable TV is here to stay
and a technician
shortage is
in the offing*

BY EDWARD A. LACY

WITH HUNDREDS OF COMMUNITY antenna television (CATV) systems springing up all over North America, there are thousands of job opportunities for electronics technicians. Regardless of the outcome of numerous court cases pending on CATV and probable Congressional legislation regulating CATV, the fact remains that it is here to stay.

While favorable court decisions may give CATV a tremendous boost, it's obvious that CATV has already created a demand for good technicians to keep the systems running. Jobs probably exist now in your hometown or nearby; and you don't have to go hundreds of miles to find an opportunity.

The story is the same all over the country: "Virtually every system in the United States and Canada is confronted with a shortage of trained technicians," says Patrick T. Pogue, co-publisher of *TV Communications* magazine and president of National Cable Television Institute.

In Minnesota, Gary Nelson, manager of Winona TV Signal, says: "There is, always has been, and no doubt always will be a great shortage of good technicians in the CATV industry." In Arkansas H. R. Lindsey, manager of Trans-Video of Arkansas, says: "There is a definite deficiency of good men for the jobs." In New Hampshire, Richard L. Blais, general manager of Paper City TV Cable Corp., reports: "Last spring we put an ad in a national CATV publication for a chief technician 'in the Northeast.' We had only two answers—one was checking the pay, the other had just been fired."

eration, and when these systems become operational, approximately 5400 more jobs should open up.

As CATV systems start originating their own studio-type productions, there will be an even greater need for CATV technicians. Most CATV systems already have an automatic time, weather, and music channel which they produce. Recently, however, about 10 percent of the systems have gone into local productions, primarily for public service programming: city council meetings, PTA, Little League baseball, etc. As more and more systems go into local program production, there will be new jobs for techni-

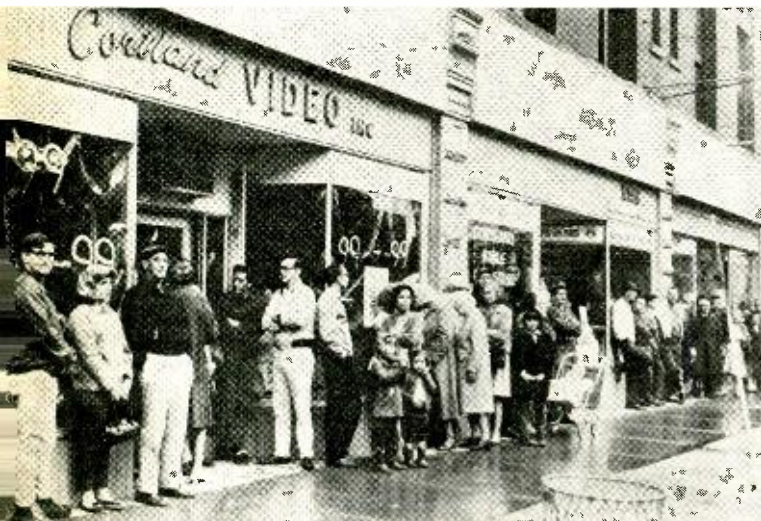

When the CATV system in Cortland, N. Y., offered a special of 99¢ instead of the usual \$25 for hook-up charges, hundreds lined up, despite the rain, to take advantage of the bargain.

And in Texas, Byron D. Jarvis, president of National Trans-Video, Inc., says: "Currently there is a terrible deficiency of qualified people and this situation is going to become even worse in the next few years."

No one knows for sure just how many technicians are needed, but look at it this way: The number of technicians employed in a CATV system varies from one to twenty, depending of course on system size. A typical smaller CATV system will employ a chief technician, two technicians, and two installers.

With more than 2000 CATV systems (plus 350 in Canada) now in operation, an average of only three technicians per system gives an estimated total of over 6000 technicians currently employed in CATV. But franchises have been granted for another 1800 systems not yet in op-

erations to set up cameras, lighting, sets, audio and video tape recorders, etc.

One system reports that, as they expand and go into more cablecasting, they expect to double their technician crew, from four to eight. Even if most systems will not require this many additional technicians, most of them will probably need at least one additional technician to take care of the increased workload caused by cablecasting.

The present demand for CATV technicians, however, is almost insignificant compared to future demands. Approximately 2300 applications for CATV franchises are now pending. Many of these applications have been frozen by the FCC. A nervous FCC recently asserted its jurisdiction over CATV and stopped its expansion into the top 100 markets (which essentially are the top 100 pop-

ulation centers in the country). Probably 92% of the TV sets in America are within these cities. To provide CATV for these sets, the CATV industry would need many more technicians.

"When the FCC's freeze is lifted, the demand for CATV technicians will resemble the California gold rush," says William J. Bresnan, executive vice president of Jack Kent Cooke, Inc., the parent company of American Cablevision. "Should the FCC's restrictions be lifted at this time, it's reasonable to assume a minimum of 20,000 CATV technicians would be required in the next five years."

Job Titles and Duties. The work performed by CATV technicians varies with the size and complexity of the system. All CATV systems have one objective: to keep the customer happy by providing him with more TV channels than he can get with an outdoor antenna. They must of course give him dependable reception, free of ghosts, snow, and smears.

Once the customer obtains excellent reception, he expects it to be consistently available, just like water and electricity. A cable TV blackout or breakdown may result in hundreds of phone calls from disappointed, even enraged, customers.

Last year during the Chicago White Sox and Boston Red Sox game in the American League pennant race, a Florida CATV system went blank and dozens of fans went through the ceiling. More than 200 customers immediately reported the failure. One of the disappointed fans was the manager of the CATV firm!

After a major breakdown, prominent newspaper articles the next day give the gory details of the blackout, which certainly shows how important CATV is to some communities. It shows too the responsibility the technicians have for keeping the system relatively trouble-free.

To keep the public happy, a CATV technician needs to be part technician and part salesman. A major part of his work is making troubleshooting calls to a customer's home. Such calls can require considerable tact since most customer complaints are found to be the fault of the receiver and not the cable. And, the smaller the system, the more likely it is that the technician has a wide variety of duties.

Low man in the system is the *installer*, who connects customers to the system, relocates outlets, performs disconnections, and helps construct line extensions. (In some systems, installation work may be subcontracted to local TV servicemen.)

Presently, most CATV cables are above ground, on utility poles. Consequently, installers and technicians in some systems must learn to use pole-climbing equipment. (A ladder is a nuisance and is too slow.) Bucket-lift and cherry-picker trucks are useful in some areas but can't be used in backyards, etc. As CATV moves into the larger cities, however, many of the cables may be placed underground, so that climbing ability may not be so important.

The *technician* repairs equipment, adjusts amplifier levels (balances the system), makes troubleshooting calls, and performs routine monthly maintenance checks. He may be involved in trunk maintenance, head-end maintenance, or in bench work. The equipment he maintains may include wideband amplifiers, microwave relay, performance monitoring devices, and miles and miles of coax cable.

A Jerrold technician (installer) prepares a receiver for connection to the CATV system.



Much of the troubleshooting is now done with a simple field-strength meter and a portable TV (color for color TV customers). However, more sophisticated test equipment such as time-domain reflectometers and spectrum analyzers is being used in some of the larger systems.

"As CATV systems become more sophisticated in the programming field and auxiliary services," says Gary Nelson, "the technicians will very likely be faced with an ever-expanding number of responsibilities or duties."

Already some systems are gradually breaking their men into cablecasting. In cablecasting, CATV technicians must learn TV camera, lighting, switching, and video-tape recording techniques, as well as simple television programming.

Once the technician gets a few years experience, he may be able to advance to *chief technician*, where he has overall responsibility for service and preventive maintenance of the system; as a foreman, he assigns duties to technicians and

of the totem pole, earn from \$1.60 to \$3.92 per hour. Technicians make from \$90 to \$190 a week, and a chief technician makes from \$150 to \$200 a week.

Education and Experience. "Almost any kind of electrical experience or education would qualify a man to break into CATV," reports one CATV executive. "However, if his experience or education is extremely limited, he may start out as an installer and then eventually work up to a position of technician. We have found that experience in radio and television broadcasting and television repair work provides a very helpful background for CATV technicians."

James R. Palmer, chairman of the Technical Training Committee of the National Cable Television Association and also president of C-COR Electronics, Inc., says: "The electronics experience and education required runs the full gamut from a graduate engineer to a man off the street who, with a few hours

At Telemation, manufacturer of cablecasting equipment, a technician checks video-tape recording instruments.

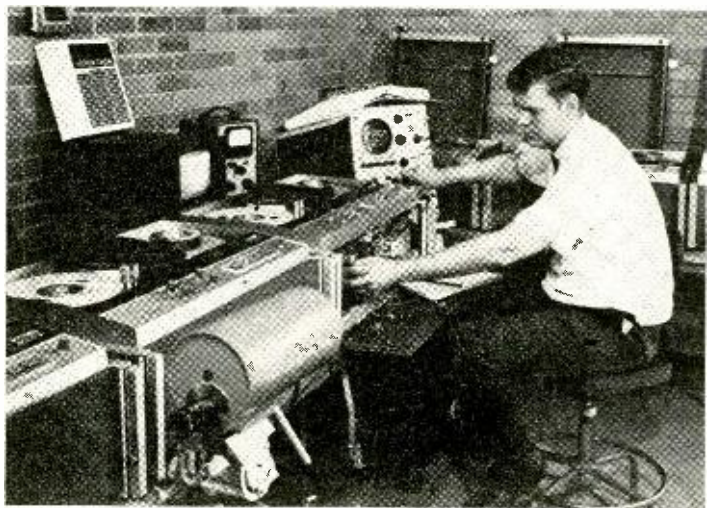

installers. He may be called upon to design a system layout and to direct the bulk of the purchasing of new system equipment. In a small system, he also does most of the bench work.

What Do CATV Technicians Earn? Salaries depend on geographical location and on the size of the system; the chance of promotion and the pay are better in large systems. Installers, at the bottom

of training, can start at the bottom of the ladder as an installer. Many positions are filled with on-the-job trainees but the better jobs, of course, are for those who have a trade school background or a two-year associate-degree program. Many chief technicians have completed the two-year associate education and have a few years experience."

A large operating system can often take on inexperienced technicians; how-

ever, a small system in the planning stage requires personnel with relatively high training and experience levels.

While two or more years of trade school or military electronics school or at least a basic knowledge of electronics is a minimum requirement for CATV technicians, sometimes it is waived; on-the-job training is still important.

"The more electronics experience and education, obviously the better," says H. R. Lindsey. "However, we now operate a successful system, and we have trained all of our technicians ourselves. None of them had previous experience or electronics backgrounds."

The only formal training for CATV technicians until recently has been the short training courses given by manufacturers like Blonder-Tongue and Jerrold to insure the proper use of their equipment. But, within the past year, two resident schools—Colorado Electronic Training Center and Pennsylvania State University—have begun courses in CATV.

Robert W. White, president of the Colorado Electronic Training Center, Manitou Springs, Colorado, describes their CATV course: "It presupposes no background in electronics and teaches basic circuit theory with necessary math along with vacuum-tube- and transistor-amplifier theory, basic television theory, and transmission-line theory. The last four weeks of the 16-week course are devoted to making measurements on our system mock-up as well as field work on the local CATV system. During this time, the student learns system and subsystem troubleshooting techniques using typical test equipment."

The College of Engineering of Pennsylvania State University has developed for the Pennsylvania Community Antenna Television Association a two-part training program for CATV installation-service and technical-service personnel. These courses will be given at eight cities in Pennsylvania.

In contrast to the resident school courses, home study courses have been considered to be of little direct benefit to fledgling CATV technicians, other than to provide basic electronic knowledge, since the courses have not offered specific lessons on CATV.

"Home study courses provide some of

the education required, but can never completely serve," according to James R. Palmer. "Home study courses combined with on-the-job training with an alert supervisor, could perhaps provide a man with a good background."

However, new developments may change the industry's opinion about correspondence courses.

The RCA Institute's Home Study School plans to add CATV lessons to its TV and communications courses this fall. Within the past year, a new correspondence school—the National Cable Televi-



In a week-long seminar conducted by Jerrold's CATV Systems Div. for its chief technicians, Jack Forde discusses some of the details of CATV system layout.

(This photo and those on pp. 27 and 29 courtesy Jerrold Electronics.)

sion Institute—has started courses in CATV. The Institute's catalog describes its two main courses as follows:

"*CATV Installer/Technician*. Covers the basic fundamentals of electronics, television, CATV, and customer relations. Specifically designed for the beginner who has just entered, or desires to enter, the cable television field, the course shows how to make a drop installation, check amplifier levels, select tap devices.

"*CATV Chief Technician*. Deals with state-of-the-art cable television and proper operation and maintenance of a system. It includes a study of advanced sys-

(Continued on page 118)

Popular EleComics

BY HOWARD STRINGER

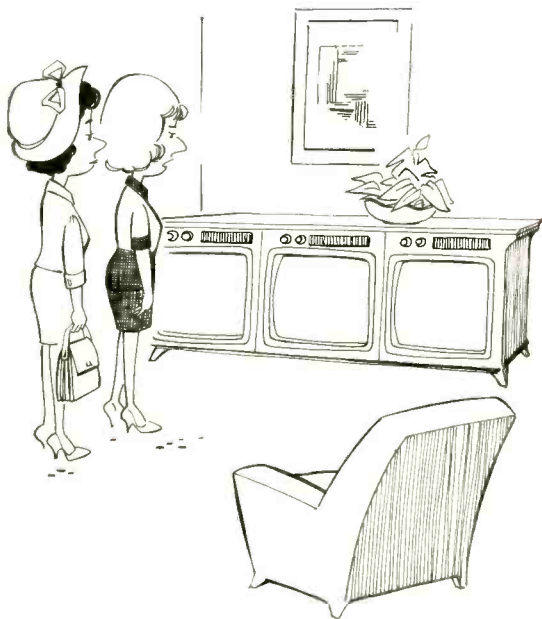

It's one of my husband's inventions—
specially adapted for the football season.



Now I can see how I was able to get
this mail-order ham set for \$3.98.



Love—Uncle—Nan—Charlie—How!



Very ingenious. But there are a lot of things
I need more than an AM/FM toaster.

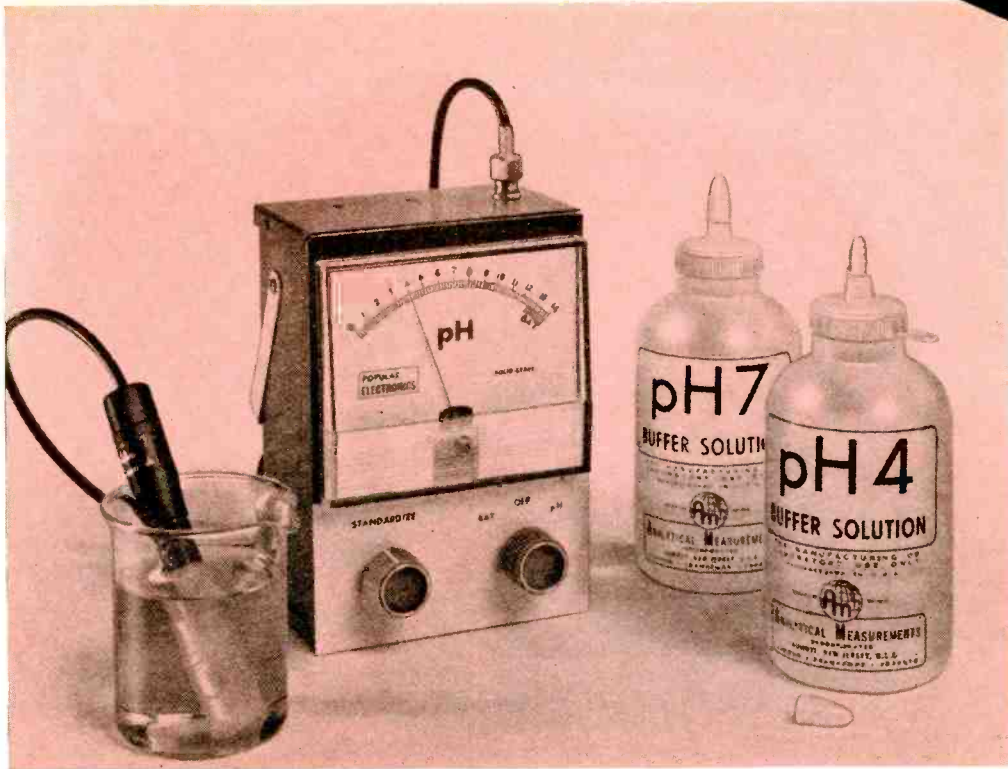

solid-state pH meter

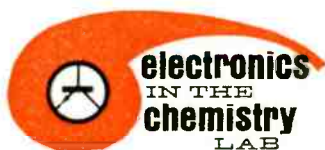

ACID OR ALKALINE? HOW MUCH? THIS
LOW-COST, HIGHLY ACCURATE PROJECT
HAS DIRECT READOUT

COVER STORY BY R. C. DENNISON

THE HIGH COST of pH meters (\$100 to \$500) has ruled out their use in many small schools and laboratories. Now, through the use of low-cost metal-oxide-semiconductor field-effect transistors (MOSFET's), it is possible for any amateur scientist to have his own high-quality pH meter. It can be built for about \$26. The recommended pH probe (see Parts List) is specially designed for student use with its delicate glass electrode surrounded by a protective polyethylene shield. Its price of \$20 is about half that of most other probes.

The circuit (see Fig. 1) uses two MOSFET's in a differential-amplifier

configuration. An advantage of this symmetrical circuit is that temperature and drain-voltage variations tend to affect the currents in $Q1$ and $Q2$ equally and are effectively cancelled in their effect on the meter reading. Stability is further improved by the use of a zener diode ($D1$) to regulate the drain voltage.

A portion of the meter scale (between pH 12.5 and pH 14) is colored green and is used to determine whether or not the battery is in good condition. With the function switch ($S1$) in the BAT position, only the battery with normal loading is connected to the meter. The battery's condition is good if the meter

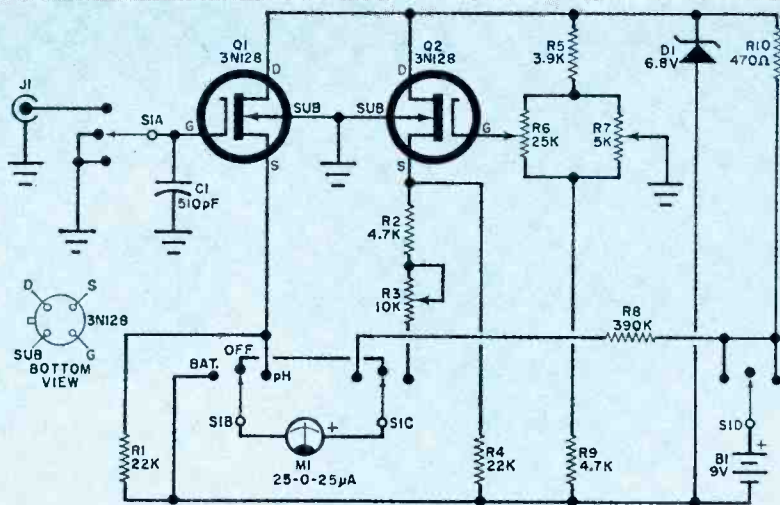

Fig. 1. The symmetrical configuration of the differential amplifier circuit cancels errors caused by temperature and drain-voltage variations in MOSFET'S.

PARTS LIST

B1—9-volt battery
 C1—510-pF, dipped mica capacitor
 D1—6.8-volt, 400-mW zener diode (T1 1N3514 or similar)
 J1—BNC jack, UG-1094/U
 M1—25-0-25 microammeter, 4½-inch
 Q1, Q2—3N128 n-channel MOSFET (RCA)
 R1, R4—22,000-ohm
 R2, R9—4,700-ohm
 R5—3,900-ohm
 R8—390,000-ohm
 R10—470-ohm
 R3—10,000-ohm, trimmer potentiometer, (Mal-lory MTC 14L1 or similar)
 R6—25,000-ohm, ½-watt linear potentiometer

All
 resistors
 ½-watt

R7—5,000-ohm, trimmer potentiometer (Mal-lory MTC53L1 or similar)

S1—Five-pole, three-position, non-shorting ce-ramic switch (Centralab PA-2015) (Do not substitute.) Note only four of the poles are used.

Misc.—3" x 5" x 7" metal cabinet (Bud CU-3008-A or similar), aluminum handle, thumb-screw, ¼" metal spacers, knobs, battery con-necter, screws, nuts, wire, solder, Print-Kote, etc.

The following items are available from Analyt-ical Measurements, Inc., 31 Willow St., Chut-ham, N. J. 07928: pH probe with BNC fitting —\$20; KCl refill solution for pH probe, 4-oz bottle—\$1; buffer kit, (3) 500-ml plastic bot-tles, 3 pkgs each of powdered buffer salts, 4, 7, 9 pH—\$6. Include postage & N. J. tax.

reading is in the green portion of the scale.

When S1 is in the OFF position, the meter is shunted to protect the sensitive movement during transportation. All pH measurements are made with S1 in the pH position.

Construction. The transistors, resistors, and other small components are mounted on a printed-circuit board shown full size in Fig. 2. Use glass-epoxy-base copper-clad board instead of the ordinary paper-phenolic type to maintain high input resistance in humid weather. After the board is etched, wash it at least ½ hour in running water; then dry it thoroughly and drill it. Install all components, ex-

cept the transistors, but including one circuit jumper and two temporary jumpers as shown in Fig. 3. A finished board is shown in Fig. 4.

MOSFET's are easily damaged by static electric charges unless certain pre-cautions are observed. They are shipped with their leads inserted in a metal fer-rule. Do not remove this ferrule until you are ready to solder the transistor to the board. Solder all the other com-ponents in place first. Make sure that the temporary wire jumpers are in place as shown in Fig. 3. These jumpers protect the MOSFET's during assembly and wir-ing. Now remove the ferrules and bend the MOSFET leads to fit into the holes in the board. Get the soldering iron hot but

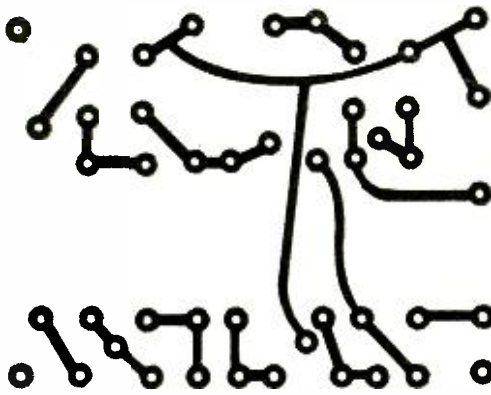

Fig. 2. Use best-quality copper-clad glass-epoxy-base board to maintain high input resistance of pH meter.

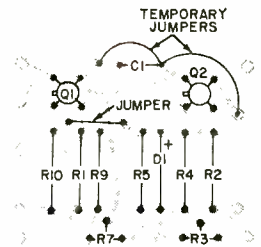

Fig. 3. To protect MOSFET's against damage, connect temporary jumpers as shown until meter is fully assembled.

WHAT IS pH?

An acid is a substance that yields hydrogen ions (H^+) when dissolved in water. Actually, each hydrogen ion attaches itself to a molecule of water to form a hydronium ion (H_3O^+). The concentration of hydronium ions in a solution is a measure of the strength of the acid.

Chemists usually measure concentration in moles per liter. For example, 0.1 molar hydrochloric acid contains 3.65 grams (0.1 mole) of hydrogen chloride in one liter of solution because the molecular weight of hydrogen chloride is 36.5. Since HCl tends to dissociate completely into ions in solution, the concentration of hydronium ions in this solution would also be 0.1 mole per liter. Some substances dissociate only slightly. Thus, in acetic acid, only 1.36% of the molecules in a 0.1 molar solution dissociate. Therefore, the hydronium ion concentration would be 0.00136 moles per liter.

To avoid the use of such small, inconvenient numbers, it is customary to express the hydronium-ion concentration in terms of pH values defined by the equation

$$pH = \log (1/H_3O^+)$$

where H_3O^+ is the hydronium ion concentration in moles per liter. Thus, in the examples above, the 0.1 molar solutions of hydrochloric and acetic acid have pH values of 1.0 and 2.87 respectively.

The pH scale is a logarithmic scale similar to that of the decibel. Each 10-fold change in acidity changes the pH value one unit. The pH values of some common substances are shown on the accompanying scale. From this, we see that orange juice is 1000 times more acidic than milk. Note that the scale runs from 0 to 14. Pure water is neutral with a pH of 7. Lower pH values indicate an acidic substance while higher values indicate alkalinity.

Many chemical processes are greatly affected by small changes in the degree of acidity or pH value. Some examples are the speed of chemical reactions, the growth of micro-organisms, the quality of electroplated deposits, the polymerization of synthetic rubber, the growth of

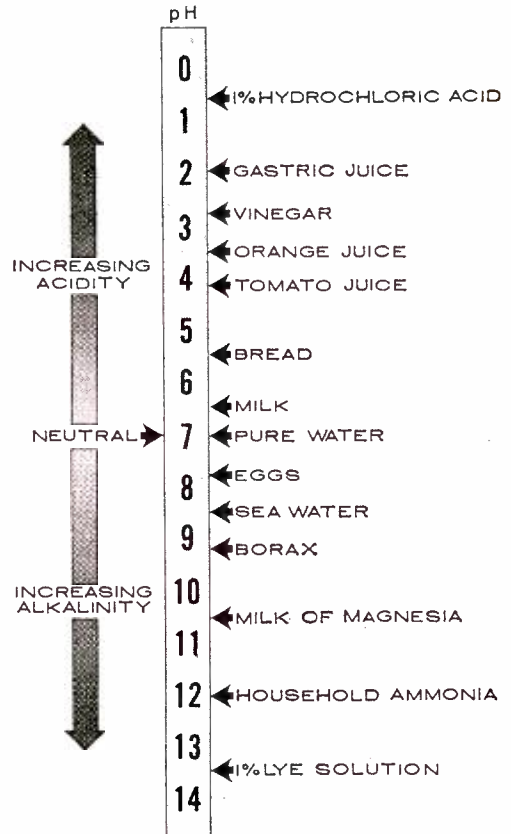

plants and the tendency of jellies to gel. Thus the accurate measurement of pH assumes great importance in chemical laboratories, medical and biological research, food preparation, agriculture, and industrial quality control. Often, pH instrumentation is used in continuous closed-loop (feedback) systems in process control.

**“Get more
education
or
get out of
electronics
...that’s my advice.”**



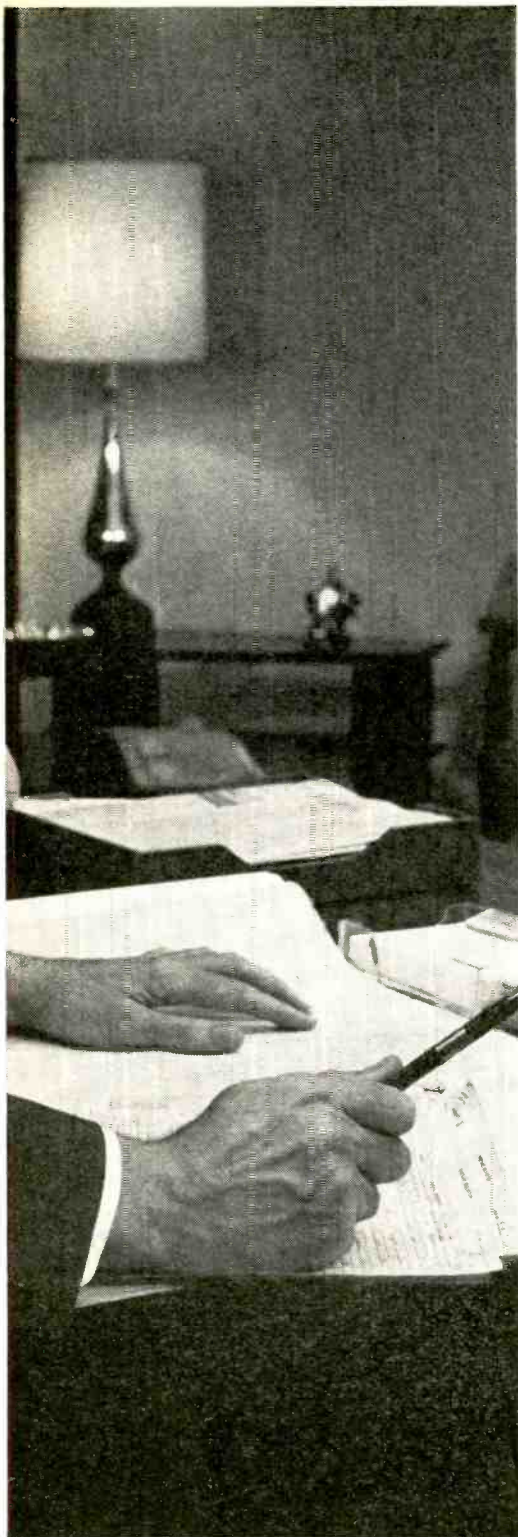

Ask any man who really knows the electronics industry.

Opportunities are few for men without advanced technical education. If you stay on that level, you'll never make much money. And you'll be among the first to go in a layoff.

But, if you supplement your experience with more education in electronics, you can become a specialist. You'll enjoy good income and excellent security. You won't have to worry about automation or advances in technology putting you out of a job.

How can you get the additional education you must have to protect your future—and the future of those who depend on you? Going back to school isn't easy for a man with a job and family obligations.

CREI Home Study Programs offer you a practical way to get more education without going back to school. You study at home, at your own pace, on your own schedule. And you study with the assurance that what you learn can be applied on the job immediately to make you worth more money to your employer.

You're eligible for a CREI Program if you work in electronics and have a high school education. Our FREE book gives complete information. Airmail postpaid card for your copy. If card is detached, use coupon below or write: CREI, Dept. 1211G, 3224 Sixteenth Street, N.W., Washington, D.C. 20010.

Founded 1927



Accredited Member of the National Home Study Council



**CREI, Home Study Division
McGraw-Hill Book Company
Dept. 1211G, 3224 Sixteenth Street, N.W.
Washington, D.C. 20010**

Please send me FREE book describing CREI Programs. I am employed in electronics and have a high school education.

NAME _____ AGE _____

ADDRESS _____

CITY _____ STATE _____ ZIP CODE _____

EMPLOYED BY _____

TYPE OF PRESENT WORK _____ G.I. BILL

- I am interested in Electronic Engineering Technology
- Space Electronics Nuclear Engineering Technology
- Industrial Electronics for Automation
- Computer Systems Technology

APPROVED FOR TRAINING UNDER NEW G.I. BILL

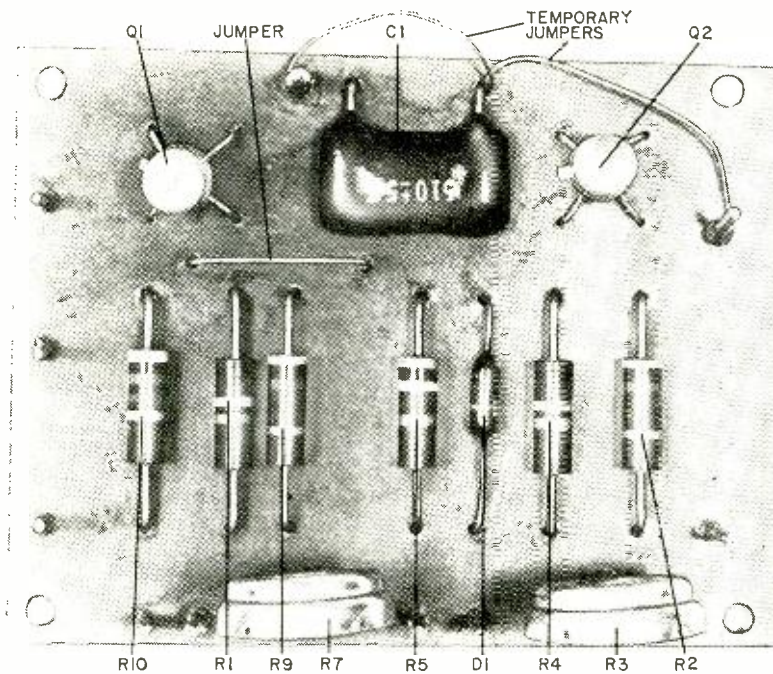

Fig. 4. Make sure that temporary jumpers are in place before soldering the MOSFET's into the circuit. When handling Q1 and Q2, and when mounting them on circuit board, do not remove the shorting rings. See text for precautions to take while soldering.

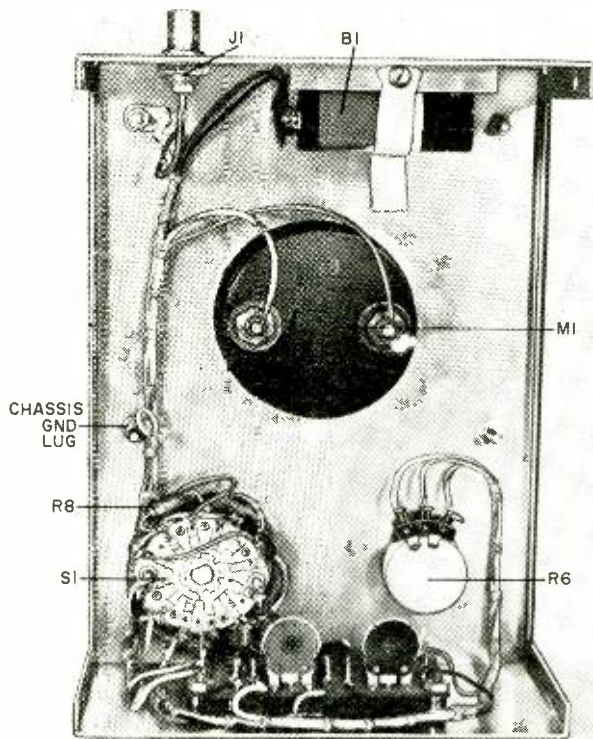

Fig. 5. After components and circuit board are mounted in their respective locations on the metal box, wire them together. To obtain a neat, professional appearance, use lacing cord to bundle the wires into harness configuration as shown in this photo.

then unplug it while soldering the transistors to the board. You may have to re-heat the iron to get all of the connections made, but be sure to have it unplugged while attaching the transistors. Failure to do so may result in permanent damage to the gates of the MOSFET's.

As in all work with printed circuits and semiconductors, use a low-wattage iron (25 to 35 watts) to avoid damage due to excessive temperatures. Remove all flux from both sides of the board using alcohol and a clean cloth. Dry the board thoroughly and then coat both sides with a silicone resin such as GC Print Kote to moisture-proof the board.

Mount potentiometer *R6*, switch *S1*, and BNC connector *J1* to the front of the chassis as shown in Fig. 5. The battery is supported on a 2" × 1" × 1/4" block of plastic by a piece of 3/8"-wide dressmaker's elastic secured to the plastic with screws. The elastic band holds the battery securely, and the plastic base insulates the battery from the metal chassis.

The original scale of the meter must be removed and replaced with a linear scale calibrated from zero to 14 with 7 in the middle. Subdivide each major seg-

ment into five minor segments. (See photo of meter front panel.) The section between 12.5 and 14 should be colored green for the battery test described earlier.

Mount the board to the bottom of the chassis using 1/4" metal spacers and appropriate hardware. Complete the wiring using only high-quality wire. If the wire from *J1* to *S1* is to be laced with the other wiring, it should have teflon, polystyrene, or polyethylene insulation. If the wires are laced, coat the wire harness with low-loss coil dope to exclude moisture. Do not substitute a phenolic switch for the ceramic switch specified. Keep all insulation clean and free of grease and soldering flux. A small packet of silica-gel desiccant may be kept inside the pH meter to remove the last traces of moisture.

The handle is made from a piece of 1/2" × 1/16" aluminum and may be secured in any position by means of a thumbscrew on one side. The thumbscrew engages a small piece of threaded brass which is held in place by flat-headed screws. The other side of the handle is fastened to the case by a free-turning

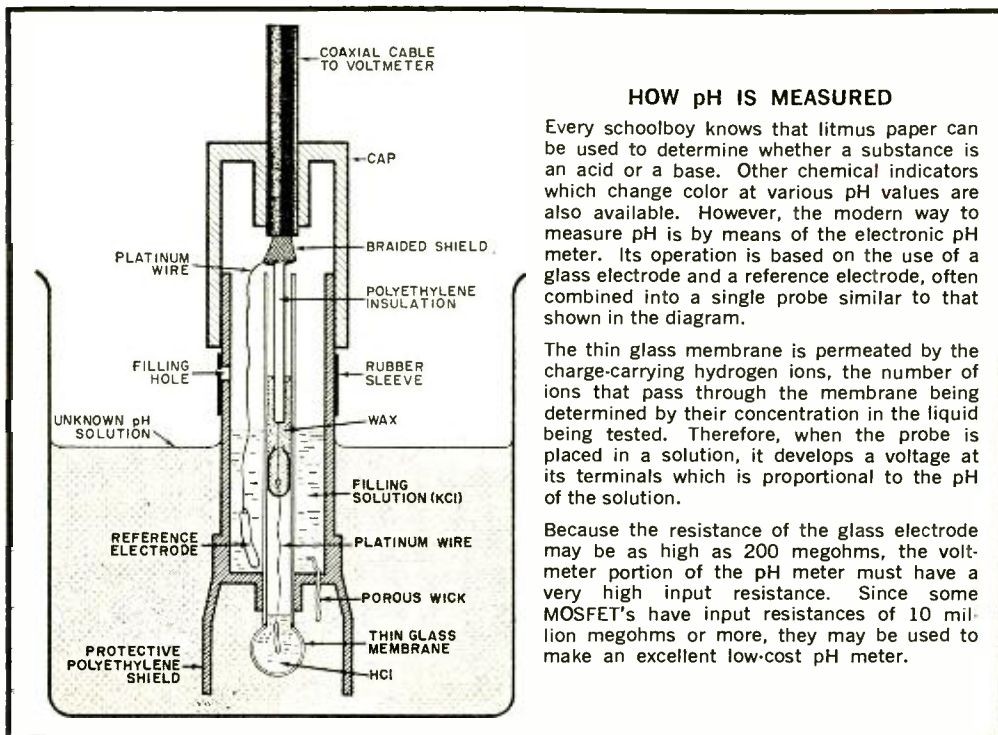

HOW pH IS MEASURED

Every schoolboy knows that litmus paper can be used to determine whether a substance is an acid or a base. Other chemical indicators which change color at various pH values are also available. However, the modern way to measure pH is by means of the electronic pH meter. Its operation is based on the use of a glass electrode and a reference electrode, often combined into a single probe similar to that shown in the diagram.

The thin glass membrane is permeated by the charge-carrying hydrogen ions, the number of ions that pass through the membrane being determined by their concentration in the liquid being tested. Therefore, when the probe is placed in a solution, it develops a voltage at its terminals which is proportional to the pH of the solution.

Because the resistance of the glass electrode may be as high as 200 megohms, the voltmeter portion of the pH meter must have a very high input resistance. Since some MOSFET's have input resistances of 10 million megohms or more, they may be used to make an excellent low-cost pH meter.

screw. This lockable handle can be used to support the pH meter in a tilted position to make it easier to use and read.

Adjustment and Calibration. After all wiring has been carefully checked, snip out the jumper associated with *Q2*. Rotate the STANDARDIZE control, *R6*, and the zero-adjust potentiometer, *R7*, to their mid-positions and set the calibrate potentiometer, *R3*, to maximum resistance. With *S1* set to OFF, install the battery. Put *S1* in the BAT position and check that the meter deflects nearly full scale (within the green region). Turn *S1* to the pH position and rotate the zero-adjust potentiometer to bring the meter pointer to center scale (pH7). Turn *S1* off and snip out the other temporary jumper (around *C1*). A note of caution: to protect the input MOSFET, *Q1*, switch *S1* shunts the gate to ground in both the OFF and BAT positions. Do not turn the switch to the pH position unless the pH probe is connected and immersed in a solution. (An exception to this rule occurs during calibration. Follow the calibration instructions below carefully to avoid damaging *Q1*.)

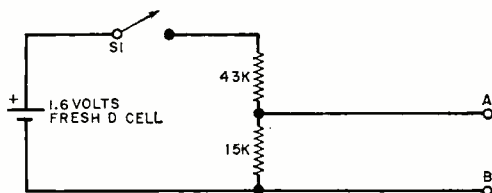

Fig. 6. The outboard calibration circuit for pH meter must be assembled around new, fresh D cell.

The meter is calibrated using the circuit shown in Fig. 6. Make sure the meter is off while making the following connections. Connect point B to the metal case of the meter and connect point A to the center terminal of the meter input jack, *J1*. Alligator-type clips are ideal for these test leads. Place the function switch on pH and adjust the STANDARDIZE control if necessary to make the meter read pH7. Close switch *S1* on the calibration circuit and the meter should deflect toward the left. Adjust calibration potentiometer *R3* to make the meter indicate 0 pH. Turn the function switch to OFF and disconnect the test circuit. The pH meter is now cali-

brated for use with solutions having a temperature of 25°C, which is typical room temperature. A formula to be given later can be used to correct the meter reading for temperatures other than 25°C.

Standardizing Buffers. Before the pH of a solution can be measured, it is necessary to standardize the meter. This is done by dipping the pH probe into a solution of known pH and rotating the STANDARDIZE control until the meter indicates the known pH. After the meter is thus standardized, the probe is rinsed in distilled water, wiped dry with a lint-free cloth, and then placed in the solution whose pH is to be measured. These standardizing solutions are called *buffer* solutions and are selected on the basis of their tendency to maintain a constant pH value in spite of small amounts of contamination or dilution during use. You can buy buffer solutions at a reasonable cost or you can make your own. For greatest accuracy, choose a buffer whose pH is close to that of the unknown.

- Buffer No. 1. pH = 4.01. Dissolve 5.1 grams of potassium hydrogen phthalate in sufficient water to make 500 milliliters of solution.

- Buffer No. 2. pH = 6.86. Dissolve 1.7 grams of potassium dihydrogen phosphate and 1.77 grams of anhydrous disodium hydrogen phosphate in sufficient water to make 500 milliliters of solution.

- Buffer No. 3. pH = 9.18. Dissolve 1.85 grams of sodium tetraborate decahydrate in sufficient water to make 500 milliliters of solution.

Use distilled water and keep the buffer in a tightly stoppered bottle. A small crystal of thymol may be added to the bottle to inhibit the growth of mold.

Temperature Compensation. Assume the temperature of the standardizing buffer and the unknown is T (in degrees centigrade). The error in instrument reading, to be subtracted from the indicated pH, is then

$$\text{pH error} = \frac{(T-25) (\text{pH}_i - \text{pH}_s)}{T + 273}$$

where pH_i is the instrument reading and pH_s is the pH of the buffer. -30-

BUILD **VARIABLE-SPEED MAGNETIC STIRRER**

COVER STORY
BY R. C. DENNISON

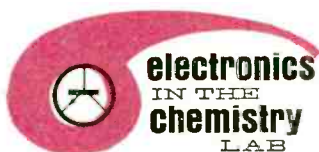
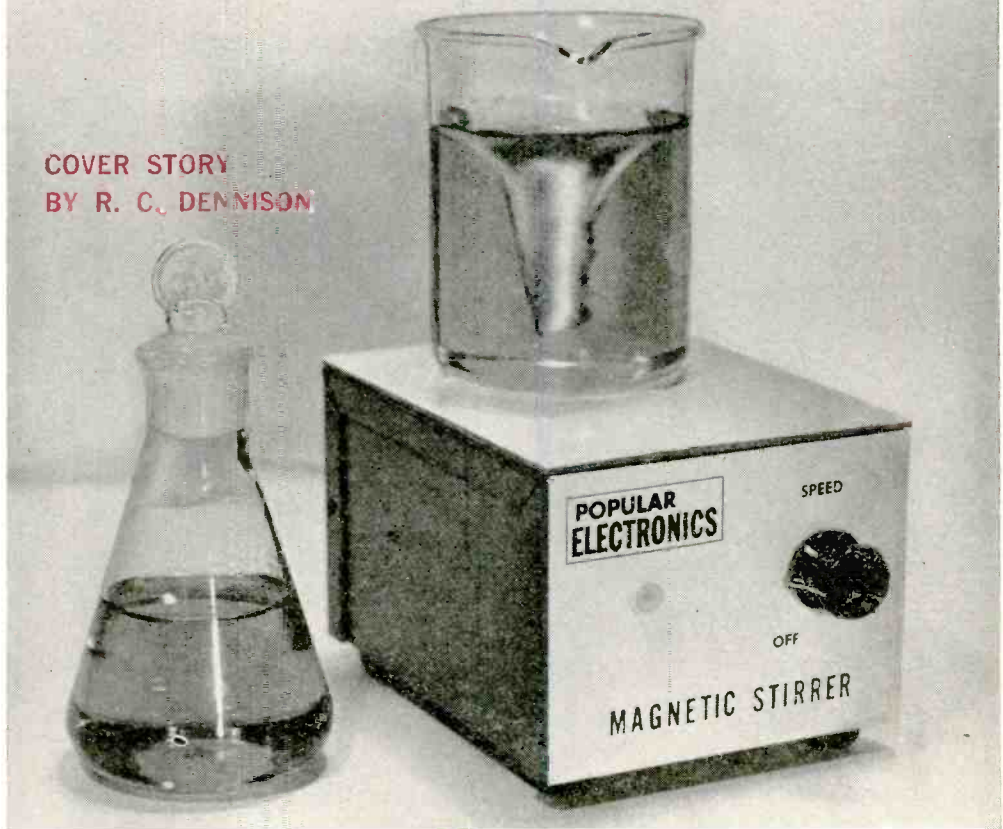

UNIFORM MIXING AND STIRRING WITH ELECTRONICS

A MAGNETIC STIRRER that mixes chemical solutions smoothly, thoroughly, and without splashing is here. A photographer can use it to mix developers or hypo, and chemists, pharmacists, biologists, and other lab workers will find many uses for it.

Laboratory procedures are speeded up, or made more exact, by uniform stirring action while reagents are being added or while various ingredients are

being blended. For example, during a titration, an acid or base is added to a solution until the proper pH is obtained. (See article on page 33.) Without constant stirring, it is easy to overshoot the balance point and thus waste time and materials. Other applications involve mixing or stirring toxic, volatile, or flammable solutions which must be kept stoppered and mixing dyes or colored solutions before they are analyzed in a

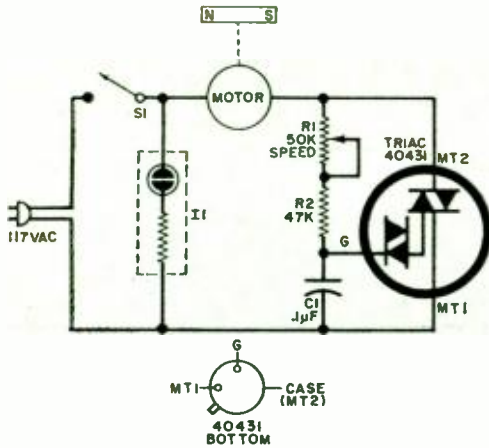

Fig. 1. Use of a triac with built-in trigger simplifies circuit design and provides smooth control of motor speed from creep to maximum.

PARTS LIST

- C1*—0.1- μ F, 200-volt capacitor
- I1*—Neon indicator lamp with resistor assembly (117-volt)
- Motor*—Shaded-pole a.c. motor (R.M.S. MARK or similar)
- R1*—50,000-ohm linear potentiometer (with attached switch)
- R2*—47,000-ohm, 1/2-watt resistor
- SI*—S.p.s.t. switch, part of *R1*
- Triac*—RCA type 40431 (do not substitute)
- Misc.*—Triac heat sink (Wakefield 254-S1 or similar), aluminum posts 1/4" diameter by 1 1/2" long internally threaded for 6-32 screws (H. H. Smith 8349 or similar) two required, 6-32 binding-head screws (four required), 4-lug terminal strip, aluminum box 5" x 4" x 3", sheet of thin (1/16"-thick) cork to cover top of box, self-adhesive plastic (white), epoxy glue, grommet, rectangular driving magnet 1" x 1/2" x 1/4", stirring magnet, wire, rubber feet (4), knob.
- Note:* Plastic-coated stirring magnets and retrievers are available from Arthur H. Thomas Co., Box 779, Philadelphia, Penna. The driving magnet is available from Maryland Magnet Co., 5412 Gist Ave., Baltimore, Md. 21215.

colorimeter. One non-chemical use has been suggested—mixing alcoholic drinks without a shaker!

The magnetic stirrer consists of two magnets, a low-power a.c. motor, and an electronic motor-speed control. One of the magnets (called the driver) is attached to the shaft of the motor so that it rotates in a horizontal plane as the motor revolves. The other magnet (called the stirrer) is placed within the beaker, flask, bottle, or other non-magnetic container which is placed atop the magnetic stirrer, directly over the driver magnet.

As the motor and the driver magnet rotate, the stirrer magnet attempts to keep in magnetic alignment, and in the process, constantly stirs the liquid in the container.

There are many ways to control the speed of the motor. The simplest would be to use a power rheostat in series with the motor. While this is low in cost, it generates heat which might be undesirable in some applications. A Variac could be used, but this is a bulky, relatively expensive component. By making use of a triac, however, a simple low-cost elec-

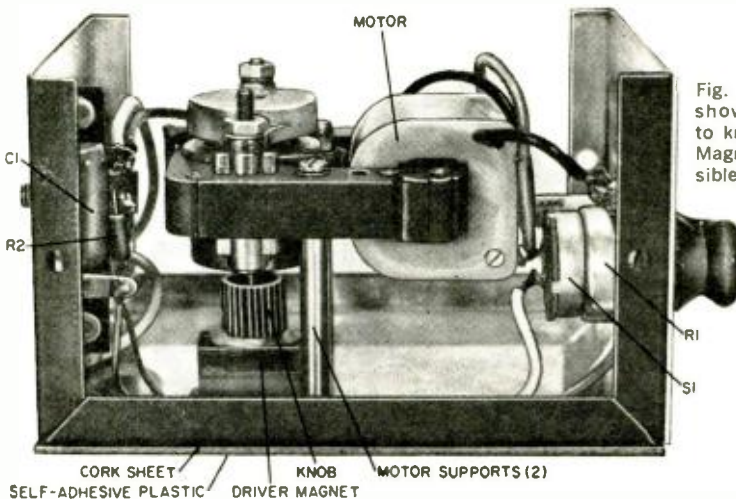

Fig. 2. View of inverted chassis shows driver magnet fixed to knob secured to motor shaft. Magnet must be as close as possible to non-magnetic frame top.

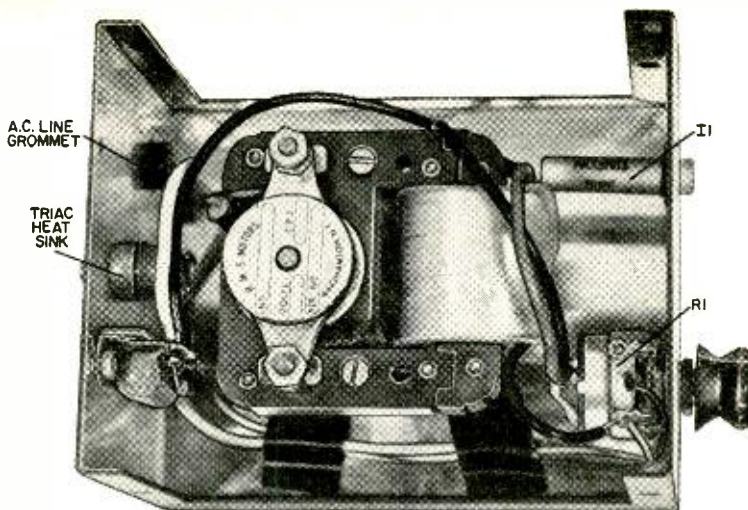

Fig. 3. When testing the magnetic stirrer with the top off, be sure not to touch any of the wiring since all of the circuit is connected to the a.c. power line. Do not use the metal chassis as a common tie point for any of the circuit.

tronic circuit such as that shown in Fig. 1 can be constructed. This circuit does not generate heat and provides for infinite variation of motor (therefore, stirring) speed. Remember that a triac is similar to an SCR, but has the advantage of being bidirectional so that only one triac is required for full-wave control. Gating of the triac and actual speed are controlled by the phase-shifting network consisting of $R1$, $R2$, and $C1$.

Construction. The motor and speed-control circuit are assembled in a 5" \times 4" \times 3" aluminum box as shown in Figs. 2 and 3. To get a good fit within the close confines of the box, shorten the motor shaft by approximately $\frac{3}{8}$ ". A small knob from an old radio is used to attach the driver magnet to the motor shaft. To do this, first enlarge the hole in the knob until it is a snug fit on the motor shaft. Slide the knob on the shaft, and hold the $\frac{1}{4}$ -inch thick driver magnet to the top of the knob. The distance from the top of the magnet to the laminations of the motor should be slightly less than $1\frac{1}{2}$ ". Using a good quality cement, preferably epoxy, secure the knob on the shaft. Then cement the driver magnet to the upper surface of the knob taking care to center it for good balance. Place the finished motor assembly to one side and allow the cement to dry.

Drill a hole in the side of the chassis to accept the triac heat-sink mounting bolt, then secure the heat sink to the chassis (see Fig. 3). Mount the four-lug terminal strip near the heat sink. Slide the triac into the heat sink and secure it in place using a flat spring. The heat sink has a built-in insulator so that no external insulating washers are needed. Mount capacitor $C2$ and resistor $R2$ on the terminal strip. On the other side of the chassis, drill holes to mount potentiometer $R1$ and power-on indicator $I1$.

Using the two mounting holes on the motor as a guide, drill two holes in the upper surface of the chassis. Making sure that the driver magnet is secure to the knob and that the knob is firm on the motor shaft, mount the motor to the chassis using 6-32 binding-head screws and two internally threaded aluminum mounting posts $\frac{1}{4}$ " in diameter by $1\frac{1}{2}$ " long. The driver magnet should be free to rotate as close to the top of the chassis as possible. Wire the circuit as shown in Fig. 1. Triac MT2 terminal is the case of the triac which is plated to accept a soldered connection. Use a low-wattage soldering iron to make this connection, so as not to damage the triac by overheating it. Pass the a.c. line through the chassis using a rubber grommet as an insulator.

(Continued on page 116)

Crackerjack OR Clown?

TEST YOUR KNOWLEDGE OF THE ELECTRONIC SERVICING BUSINESS

By VIC BELL

(Answers on page 113)

- 1 Servicing transistorized equipment requires more test instruments than servicing vacuum tube equipment. TRUE _____ FALSE _____
- 2 The sync separator in a TV receiver separates horizontal and vertical sync pulses. TRUE _____ FALSE _____
- 3 A good black-and-white TV technician does not need additional test equipment to service color-TV receivers. TRUE _____ FALSE _____
- 4 Inability to get good color-TV convergence is generally caused by a convergence board malfunction. TRUE _____ FALSE _____
- 5 The color killer circuit blocks color noise sometimes present in color broadcasts. TRUE _____ FALSE _____
- 6 Since the color signal goes through more stages, the luminance signal is delayed with a delay line. TRUE _____ FALSE _____
- 7 Color convergence generators must have both dots and bars if the technician is to do the best possible job setting up a color set. TRUE _____ FALSE _____
- 8 It is not yet practical to transmit color TV on UHF channels. TRUE _____ FALSE _____
- 9 If the delay line in a color set opens, the color signal can still be seen on the screen. TRUE _____ FALSE _____
- 10 Mostly vertical-rate waveforms are used in the convergence circuitry to correct misconvergence. TRUE _____ FALSE _____
- 11 Vertical linearity and height adjustments may be changed without affecting convergence. TRUE _____ FALSE _____
- 12 25-inch color sets use about 40 kV at the CRT ultor anode. TRUE _____ FALSE _____
- 13 The horizontal stripes often seen across a color picture are generally caused by poor bandpass transformer alignment. TRUE _____ FALSE _____
- 14 If you remove the back panel of a tube-type color TV receiver you will increase the set's life. TRUE _____ FALSE _____
- 15 In 1968, for the first time, color TV receivers will out-sell all other TV consoles. TRUE _____ FALSE _____



THE PROWLER HOWLER

ALARM SYSTEM
WARNS OF INTRUDERS

ONE THING ABOUT sleeping in the woods—you never know when one of our furry friends is going to seek the warmth of the campfire or the leftovers from the evening meal. Sometimes just the thought of it can keep you awake all night. But thoughts like that are not peculiar to sleeping in the woods. Worrying about prowlers or fire even when you're safe in your own bed can cause many a sleepless night.

What you need is a warning system to alert you to any intrusion or impending danger. The "Prowler Howler" does just that simply and economically. It can be operated from a low-voltage battery or commercial line power when it is available and can be constructed in a single evening. Maximum cost is \$15 and depends on what you can scrounge from your old junk box.

The sensing system depends basically on the use of a very thin wire, which is broken by an intruder. This may seem at first to be a rather crude way of doing

things—ultrasonic warning systems having been so widely touted—but tests have shown that the very thin wire breaks with relatively little pressure and, in almost all cases, without the intruder's knowledge. The wire is almost invisible, is easily concealed, and costs very little. In fact, most cheap spools contain a mile or more of wire. Long lengths of very thin wire can be salvaged from old transformers or other windings at no cost.

Construction. The Prowler Howler is constructed on a piece of perf board cut to fit a 3" × 6" plastic utility case. The components of the circuit shown in Fig. 1 are mounted on the perf board and on the front panel as shown in Fig. 2. The BATT-AC switch *S1*, fuse *F1*, indicator lamp *I1*, and the Sonalert *A1* are mounted on the front panel. A pair of binding posts is located on one side of the box for connecting the exterior sensing loop.

The sensing loop is part of a closed

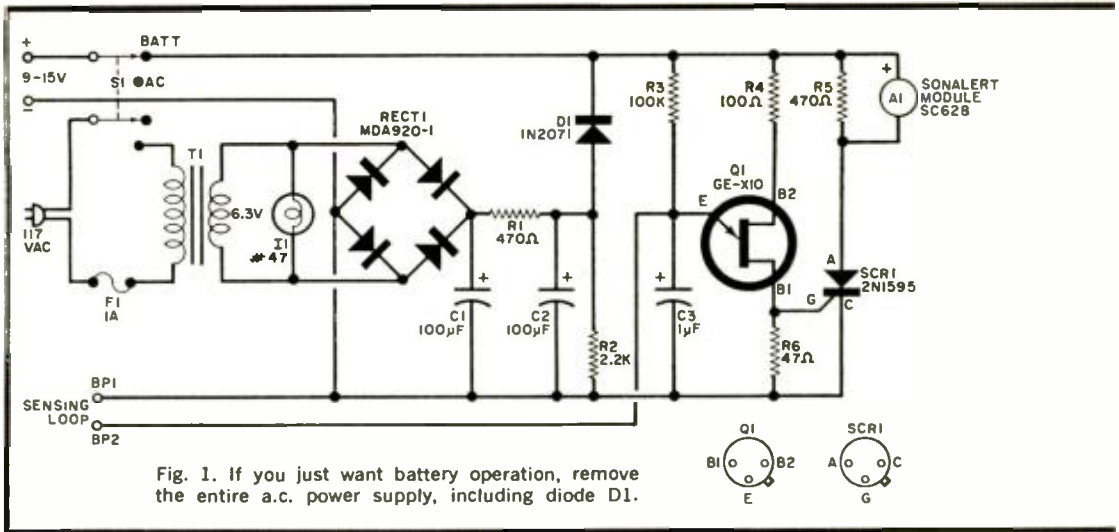

circuit that does not allow the Prowler Howler to sound off until the circuit is broken. Depending on the installation, there are several ways in which the closed loop can be produced. A typical home installation is shown in Fig. 3. For windows and doors, you can stretch a length of very fine wire (#38 magnet wire is recommended) across the opening, with each end secured by a piece of

adhesive tape, thumbtacks, or small brads or nails. If desired, a normally open, pressure-sensitive switch can be installed at each window or door so that, if it is opened, the circuit continuity is broken.

An alternative is to use a low-cost magnetic-reed switch with a permanent magnet attached to the door or window. Then, when the opening is closed, the

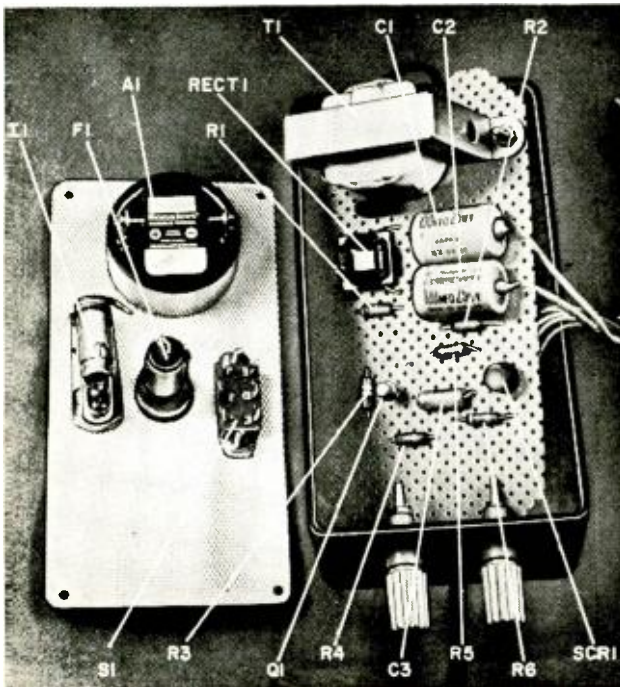

Fig. 2. The Prowler Howler is built in a 3" x 6" x 2" plastic case as shown here. If you elect to use battery only operation, the space now occupied by the a.c. power supply components can be used to mount a conventional 9-volt radio battery.

PARTS LIST

A1—Sonic alarm module (Mallory SC628 Sona-
 lert, Minilert Sensilarm, or similar)
BP1, BP2—Five-way binding posts
C1, C2—100- μ F, 25-volt electrolytic capacitor
C3—1- μ F, 25-V electrolytic capacitor
D1—1N2071
F1—1-A fuse and holder
I1—#47 lamp and holder
Q1—Unijunction transistor (GE-X10 or similar)
R1, R5—470-ohm
R2—2200-ohm
R3—100,000-ohm
R4—100-ohm
R6—47-ohm
 } all resistors
 } 1/2-watt
RECT1—Full-wave bridge rectifier (MDA920-1
 or similar)
S1—D.p.s.t. switch
SCR1—2N1595 silicon controlled rectifier
T1—Filament transformer; secondary 6.3-V
 (Stancor P-6465 or similar)
 Misc.—3" \times 6" \times 2" case with cover, perf board
 to fit case, spool of #38 wire, hookup wire,
 line cord, etc.

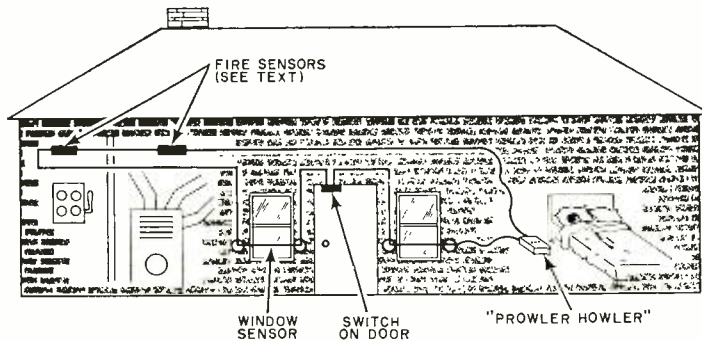

Fig. 3. Suggested layout for house intruder and fire protection. Almost any method of sensing will suffice as long as you remember that the system operates when any part of the closed loop is opened.

magnet keeps the reed switch closed; and when the door or window is opened, the reed switch is opened.

Fire or excessive-heat sensors can be built in accordance with Fig. 4. The thin sensing wire is stretched taut between two joists and secured with thumb tacks. A wood block is suspended by a rubber band and a short distance above the sensing wire. When the rubber band is heated ex-

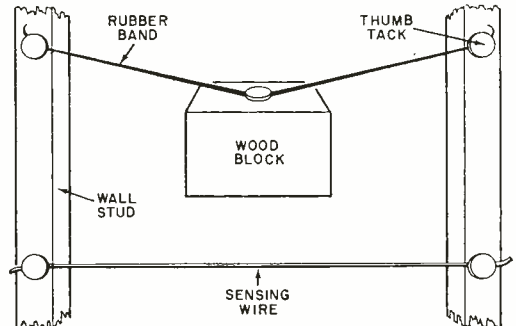

Fig. 4. Simple fire sensor. Make sure that when the wooden block comes down, it breaks the alarm wire.

HOW IT WORKS

The circuit uses *SCR1* to apply power to the SonaAlert module *A1*. The SCR does not conduct unless triggered by a signal from unijunction transistor *Q1*. The transistor circuit is actually an oscillator which does not oscillate as long as capacitor *C3* is shorted out by the sensing loop. When the loop is broken, *Q1* starts oscillating and a triggering signal is applied to *SCR1*.

The alarm module can be replaced with a 12-volt, low-current relay whose contacts are used to supply power to lights or other alarm devices. Diode *D1* is included to keep current consumption at a minimum when operating on battery power.

When using the alarm outdoors, string the sensing wire in a loop between bushes and trees surrounding your campsite. The height of the wire above the ground depends on what type of animal you expect as an intruder. This alarm has been operated with six miles of wire surrounding the campsite.

—30—

Four-Band SWL Antenna

RESONANT DIPOLES FOR 60-, 41-, 19-, AND 13-METER BANDS

BY THOMAS M. TURNER, K8VBL

IF YOU DO ANY SWL'ING, why make do with a 65-70' piece of wire hung between two trees? You can put the same area to better use with a low-cost dipole antenna that can be made to resonate on four of the more important international short-wave broadcasting bands.

Essentially, this antenna consists of two dipole sections, one about 65' long that resonates on 41 meters, and a second just under 100' that resonates on 60 meters. The ends of the longer dipole section droop so that it requires a cleared path of only about 70'. As a bonus, the 41-meter dipole is very efficient on its third harmonic and thus makes an excellent receiving antenna for the 13-meter international broadcasting band.

Even though the ends of the 60-meter dipole section droop, the third harmonic of this antenna occurs at 19 meters. Thus you have four efficient antennas for the price of two.

Construction. For ease in assembling and erecting your four-band SWL antenna, the two fundamental dipole sections are cut from 300-ohm open-wire transmission line. This is the sort of line commonly used for long runs to UHF-VHF TV antennas.

Measure off 82' of the 300-ohm transmission line. Measure in 33' from one end and snip one of the parallel wires. Do the same from the other end, but snip the wire on the other side of the transmission line. (See Fig. 1). Now remove all of the plastic spreader bars from the center section between the two cut wires.

Remove one plastic spreader bar from each end of the 82' section. If enameled, clean off the wires at these two ends and twist together to make a pig-tail lead.

Bring the two ends of the 82' section around and loop them through the holes (Continued on page 58)

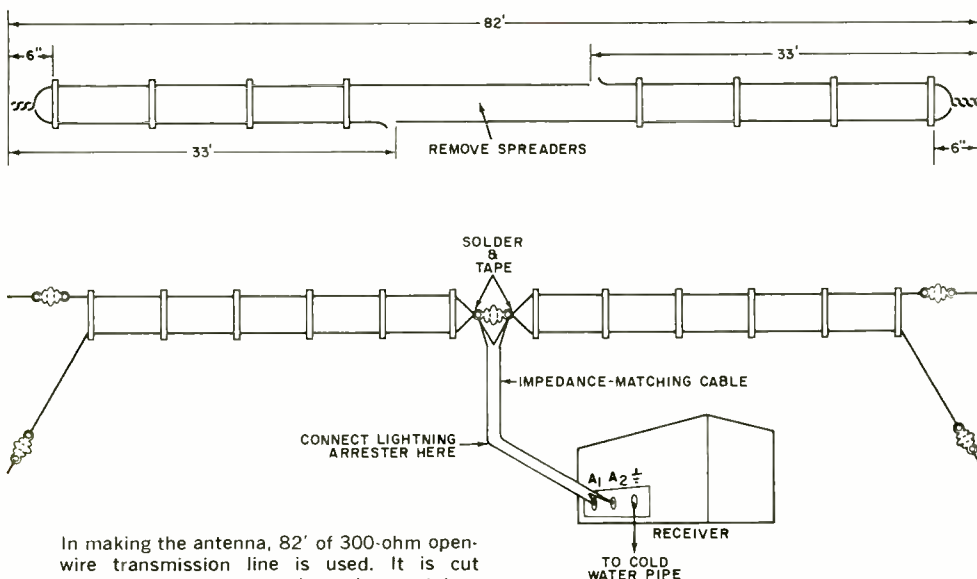

In making the antenna, 82' of 300-ohm open-wire transmission line is used. It is cut and spacers are removed as shown at top, folded and connected together as at bottom.

Getting To Know The Zener Diode

Unique Component Disregards Ohm's Law

BY NORMAN CRAWFORD

AMONG THE SCORES of semiconductor devices available to the modern electronics enthusiast, none seems to be more underestimated and misunderstood than the zener diode. Since the zener diode has the unique ability to regulate voltage within precise limits, regardless of changes in load impedance or supply voltage, this is indeed a strange situation.

The zener diode is not only unique among solid-state devices: it is also one of the most important in terms of circuit efficiency and safety. The experimenter or hobbyist who fails to take advantage of its properties works under a handicap. Even so, its relatively uncommon usage suggests that many experimenters do not fully understand how the zener diode works—or they dismiss it as being of dubious value.

While there are several good books on the market dealing with zener diodes, most of them are written for engineering-level readers. The few books that are less technical rarely do more than inform the reader that such devices exist. This article bridges the gap between little or no useful information and information

that is unnecessarily top-heavy with technical details.

Voltage-regulator circuits are most commonly employed in electronic power supplies, but they are applicable to any circuit in which a constant-level voltage is required. To understand why voltage regulation is so important, it is necessary to review the conditions that exist when there is no regulation.

Consider the output circuit of an unregulated electronic power supply. In its simplest schematic representation, the circuit consists of an input voltage, a supply resistance, and an output resistance. The input "sees" the two resistances as a voltage-divider network. If both resistances are of equal value—say, 1000 ohms—the output voltage is just half of the input. Therefore, with 10 volts input, the output is 5 volts; for 15 volts input, the output is 7.5 volts, and so on.

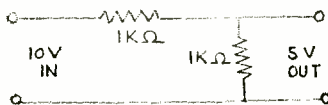

The important point to bear in mind here is that these output voltages are ideal; no load has been connected across the output. Now, replace the output resistor with a 5-volt zener diode, and apply 10 volts to the input.

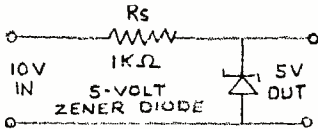

As before with the two 1000-ohm resistors in the circuit, the voltage divides exactly in half so that 5 volts appears at the output. What happens when the input potential is raised to 15 volts? Oddly enough, the output remains at 5 volts as a result of the regulatory ability of the zener diode.

In the voltage-divider circuit, according to Ohm's law ($I = E/R$), current flow through the circuit is 5 mA when the input is 10 volts. Therefore, the output potential must be $E_{out} = I \times R = 0.005 \times 1000 = 5$ volts.

By applying Ohm's law for a 15-volt input, it can be determined that the current flow becomes 7.5 mA and output voltage jumps up to 7.5 volts.

When a 5-volt zener diode is substituted for the output resistor, however, a strange phenomenon takes place when the input voltage is increased. With a 10-volt input, 5 mA must circulate to produce a 5-volt output.

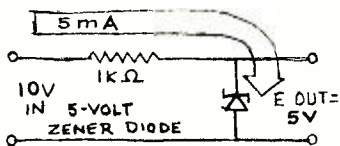

Thus, the same current-voltage relationship as in the voltage divider network exists when the zener diode is substituted and a 10-volt potential is applied to the input.

Raising the input to 15 volts causes the zener diode to conduct more current so that 10 mA must flow through it to maintain a 5-volt output.

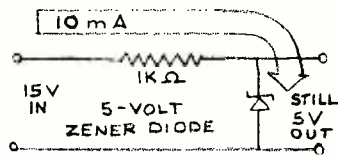

This shows that, while a resistor behaves according to Ohm's law, the zener diode disregards it, changing its effective resistance as needed to provide a constant output voltage.

To see how this unique ability of the zener diode can be put to good use, consider a hypothetical power supply whose 5-volt output (unloaded) is unregulated.

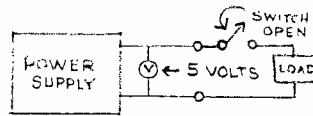

When the load is switched into the output circuit of the power supply, its output drops to 4 volts.

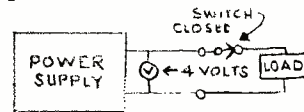

Now, give a few values to the hypothetical components inside the power supply: 1000 ohms each for the supply and output resistances, and 10 volts for the source. To keep the example simple, assume that the load is an ordinary 2000-ohm resistor.



With the switch open and the load disconnected, the output is 5 volts with 5 mA in the output resistor. Closing the switch puts the 2000-ohm load in parallel with the output resistor so that the 6 mA now drawn from the source divides: 4 mA through the output resistor and 2 mA through the load resistor.

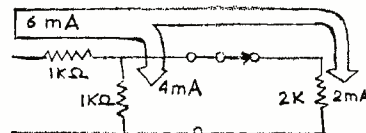

Using Ohm's law, $E_{out} = 2000 \times 0.0002 = 4$ volts. What happens is that the load resistance shunts the output resistance, decreasing the total resistance "seen" by the source and reducing the voltage drop across the load.

How can the zener diode help? Well, first, substitute a 5-volt zener diode for the output resistor. With the switch open, there is a 5-volt drop across the diode as in the example discussed earlier. The difference is that, when the switch is closed and the load is connected to the output of the power supply, the current still divides—2.5 mA going to the zener diode, and 2.5 mA going to the load.

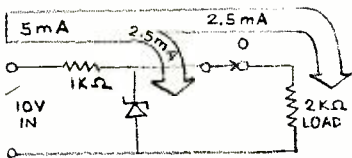

The reduction in current through the zener diode has little or no effect on it (up to a certain point), and the diode maintains a constant 5-volt output. As a result, the 2000-ohm load has 5 volts across it. Because the load is a resistor (it can be any other type of load for that matter), it cannot ignore Ohm's law, so it draws current: $I_{load} = E/R = 5/2000 = 2.5$ mA.

At this point, you might well ask what would happen if the load were to drop to 1000 ohms. To find out, simply apply the above formula again, substituting 1000 ohms for the 2000 ohms in the denominator. Thus, the current now required by the load is 5 mA; but with this new drain, the zener diode is completely deprived of current.

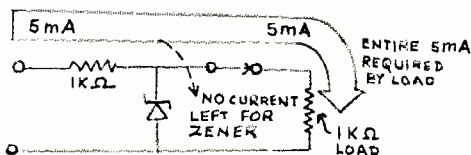

With no current available for the zener diode, it ceases to conduct, and the voltage across the load begins to decrease with further decreases in load resistance.

Even before complete current starvation, however, most zener diodes indicate their inability to maintain regulation by allowing the output voltage to sag.

A good rule of thumb is to keep about 20% of the zener diode's maximum current flowing through it when the load is heavy. To determine maximum current handling ability, you need only apply the power formula: $P = IE$. Let us assume you have a 5-volt, 1/2-watt zener diode and you want to know its maximum current handling ability. Since $P = IE$, $I = P/E = 0.5/5 = 100$ mA. The current through the diode should not be allowed to fall below 20 mA.

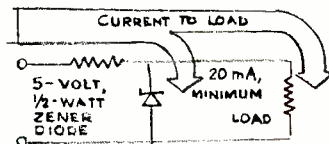

All of the foregoing may be very interesting, but what practical applications are there for zener-diode regulation?

One of the more common uses for the zener diode is in reducing and maintaining voltages to and at a safe level. To demonstrate, let us say that you have a portable radio receiver that requires a 9-volt d.c. supply and you wish to operate it from the 12-volt cigarette lighter accessory in your car. Obviously, you need a 9-volt zener diode.

Designing the regulator circuit is relatively easy. If the radio receiver draws 5 mA of current, and the battery potential is 12 volts, you must first determine the maximum zener diode current allowable. Let's take a guess and start with a 1/4-watt zener diode. Using the power formula, $I_{max} = P/E = 0.25/9 = 27.8$ mA. Twenty percent of 27.8 is 5.56 mA. Hence, 10.5 mA must be drawn from the voltage source—5 mA for the load, and 5.5 mA (minimum) for the diode.

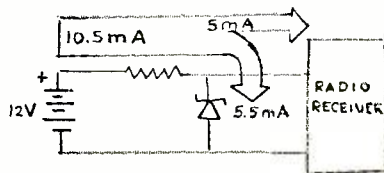

We know now that 10.5 mA must flow

through the resistor, that the battery is holding 12 volts on one side of the resistor, and that the drop across the diode is 9 volts.

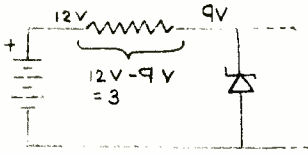

The result is that 3 volts is dropped across the resistor. Ohm's law now tells us the value of the resistor: $R = E/I = \text{voltage drop}/\text{current} = 3/0.0105 = 286$ ohms. Because 286 is not a standard ohmic value, we would use a 300-ohm resistor. Next, we use the power formula to determine the power rating required: $P = 0.0105 \times 3 = 31.5$ mW. Almost any commercially-made 300-ohm resistor can be used; it just has to dissipate more than 31.5 mW.

While the circuit components thus selected will almost certainly work, let's find out how they will bear up under "worst-case" conditions. First, assume that power is suddenly disconnected from the receiver.

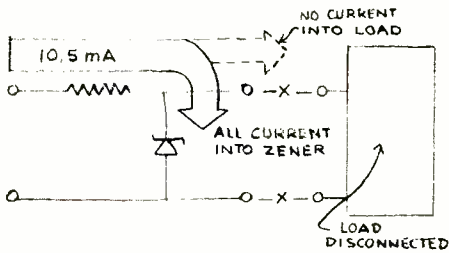

Just as suddenly, the entire 10.5 mA is now diverted to the zener diode—and while we're at it, let's assume that the input voltage chooses this instant to jump up to 13 volts.

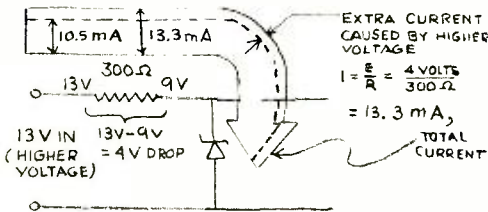

As you can see, the current through the diode jumps to 13.3 mA. Back to the

power formula; $P = 0.0133 \times 9 = 119.7$ mW—still well below the ¼-watt (250 mW) maximum for the zener diode.

But we're not finished yet. We still have to check on what is happening to the resistor; $P = 0.0133 \times 4 = 53.2$ mW—again well within the maximum ¼-watt rating. Everything checks out.

Now, assume that 1 or 2 mA more current is drawn (as a receiver with a class-B output circuit is likely to do on high-volume settings) and that the source suddenly decides to drop to 11 volts.

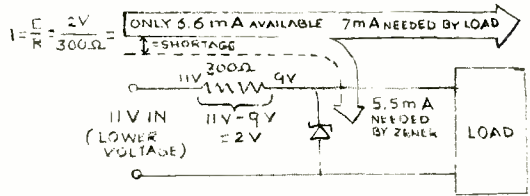

This leaves only 2 volts, dropped across the source resistor, to drive the current through the resistor. As a result, current drops to about 6.67 mA.

Unfortunately, the receiver requires 7 mA to operate properly. Deprived of current, the zener diode stops regulating, and the output voltage drops until there is enough of a drop across the resistor to supply the receiver's needs. As the supply voltage drops, the receiver will probably operate less than satisfactorily. The regulator circuit is a failure, and something has to be done to rectify the problem.

All is not lost, and because of the simplicity of the circuit, the solution is also simple. Something must obviously be done about the resistor. Since we know that the zener diode requires 5.5 mA of current to operate and the receiver requires an additional 7 mA, 12.5 mA must come through the resistor.

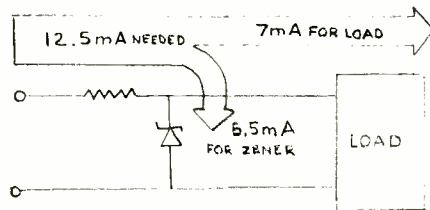

(Continued on page 117)

The Ubiquitous NEON LAMP

BY JIM KYLE

Voltage Regulation. The maintaining voltage of a neon diode is almost constant over the full operating range of current. With proper design, the voltage can be held to within 0.5 volt—and even an indicator neon will hold voltage constant within 5 volts under most circumstances.

This fact makes the neon lamp an excellent source of reference voltage for any type of voltage-regulator circuit. For low-current operation, the lamp can be used in the same manner as a VR tube. Such an application is shown in Fig. 12. Here, a neon lamp regulates the

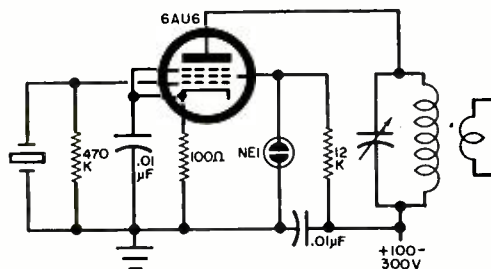

Fig. 12. In a crystal oscillator circuit such as this, the constant maintaining voltage of the neon lamp is used to regulate the screen voltage on the 6AU6, thus providing improved frequency stability.

screen voltage for a crystal oscillator to provide improved frequency stability.

For moderate-current applications, the circuit of Fig. 13 can be used. The 6U8A tube specified is capable of providing up to 20 mA to a load, and output voltage may be set to any value between 75 and 150 volts. Regulation is to within 1.5 volts under worst conditions; when output voltage is set to 75 (best case), voltage drops by only 0.5 volt at maximum

load. For slightly more current, a 6JT8 may be substituted with modification of the pin connections, or separate 6AU6 and 6AQ5 tubes may be employed.

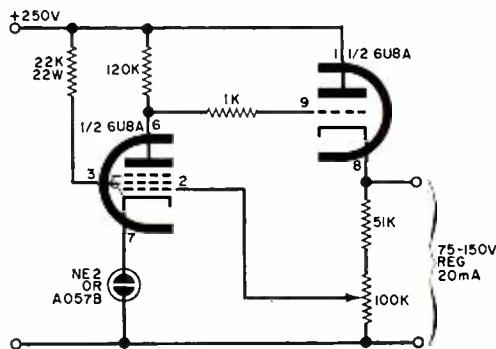

Fig. 13. Here the neon lamp holds a constant voltage on the anode of the first stage of a 20-mA regulated supply. The output is adjustable from 75 to 150 volts due to the feedback to the screen grid. Regulation 0.5 volt for the 75-volt output.

An unusual precision voltmeter which makes use of a neon lamp as its voltage reference is diagrammed in Fig. 14. This circuit's requirements are critical when it comes to the neon; the Z82R10 Signalite unit specified provides a reference voltage across $R2$ of 1 ± 0.012 volt. Resistor $R1$ must be initially adjusted to provide calibration, but the circuit then maintains its accuracy indefinitely. The unknown input is applied to voltage di-

Editor's Note. Part I of this article appeared in our September issue. In it, the author discussed the theory of operation and characteristics of neon lamps with applications in oscillator circuits, frequency dividers, timers, and digital devices. The story continues here with other applications.

vider R_3 and compared to the accurate reference. When the null indicator (an inexpensive 50-0-50 μ A FM tuning indicator, zero-center) indicates zero, the input voltage is equal to the ratio of the total resistance of R_3 to the resistance between its rotor and ground. If a 10-

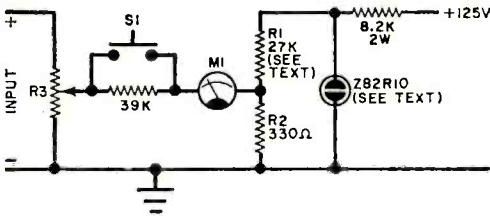

Fig. 14. The neon lamp specified here provides a reference voltage across R_2 of 1 ± 0.012 volt. This is compared to the input in the null-indicating meter, making a highly accurate precision voltmeter.

turn indicator and an accurate 10-turn potentiometer are used, voltage can be read directly. The 39,000-ohm resistor avoids damage to the null indicator in initial stages; when the null is approached, S_1 shorts out this resistor to provide maximum sensitivity.

Miscellaneous Applications. The list of ways in which neon lamps can be used (in addition to the general circuit applications already discussed) is virtually endless. Some specific circuits designed for various purposes are described here.

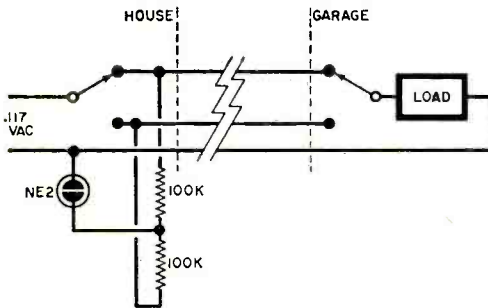

Fig. 15. In a circuit designed to indicate when a remote load is energized, the neon lamp is lit only when switches at both ends are connected to the same side of the power line. The neon indicating circuit can be repeated at load end of the line.

If you have three-way switches in your home or business, you may frequently have wondered whether the circuit they control is *off* or *on*. Since the *off* position is determined entirely by the position of

the remote second switch, there's no direct way of determining the position of this switch. But one neon, used as an indicator, together with two resistors, provides a pilot light which may be installed at either end of the circuit. A bonus is the fact that the condition of the bulb or device operated by the switches is also indicated.

The circuit is shown in Fig. 15. It may be duplicated at both switches if desired although the illustration shows only one. Operation depends on the neon's requirement for breakdown voltage before firing. When both switches connect to the same line, both the load and the neon are across the 117-volt circuit and both are on. One of the resistors limits neon-lamp current while the other is disconnected. When the switches are on opposing lines, the load is *off*. Should the load circuit form a voltage divider which permits only half the line voltage to be applied to the lamp; this is insufficient to fire it and it remains dark indicating that the load is *off*. Should the load circuit open, as in the case of a burned-out light bulb, one of the two resistors is disconnected and the neon lamp lights.

Thus, if the neon is *on* and stays *on* when the switch is operated, the load circuit is open. If the neon is *on* but goes *off* when the switch is operated, the circuit is complete but *on*. If the neon is *off*, the circuit is complete and the load is *off*.

Another neon-indicator circuit provides indication of the sequence in which four s.p.s.t. switches are operated. This circuit, shown in Fig. 16 and requiring a dozen neon lamps, can become the basis of a game to test individual reaction time or can also be applied to more serious problems.

All switches are single-pole single-throw with locking action. The first switch to close causes all three lamps connected to it to light. Each of these three is in parallel with one lamp of another switch, and the supply voltages for these other lamps are reduced to below the breakdown point. Thus, the second switch permits only two lamps to light. This reduces voltage for a second lamp associated with each of the remaining switches, so that the third switch lights only one lamp. Similarly, the final switch cannot light any indicators.

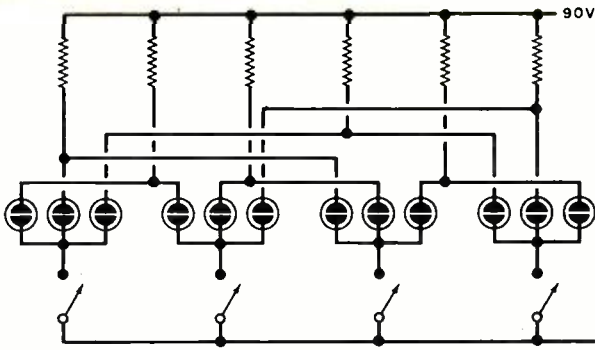

Fig. 16. In this sequencing circuit, when only one switch is closed, three lamps associated with it are lit. Subsequent closing of another switch lights only two of its lamps due to lowered voltage drop across one resistor. Last switch lights no lamps.

Resistor values are not critical—anywhere from 10,000 ohms to 1 megohm should suffice—and neon lamps need be matched only to the extent necessary to assure that none of them breaks down at a level less than the maintaining voltage of any of the others.

An inexpensive VTVM capable of indicating either 9 or 12 volts with an accuracy of 0.2 volt, yet having no moving parts is shown in Fig. 17. While a zener diode is shown for voltage reference, it could be replaced by a third neon lamp and voltage divider if desired. In operation, both plate-circuit lamps glow; and, if the input voltage is correct, both glow with equal brightness. If the input voltage is higher than desired, the HI lamp glows brighter; and vice versa.

The final circuit is a safety tester to check leakage current of a.c.-operated devices. According to Consumers' Union, a leakage current of 100 μ A r.m.s. is acceptable, 100 μ A to 1 mA is dangerous,

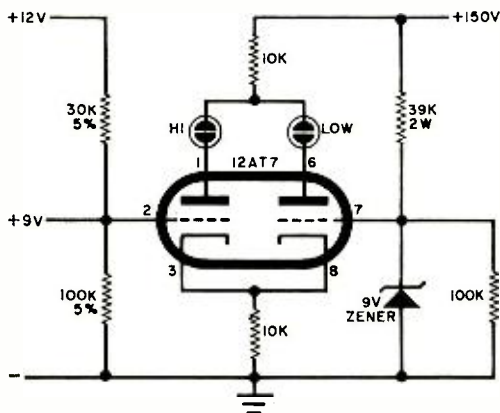

Fig. 17. Inexpensive VTVM has two lamps that glow with equal brightness if the 9- or 12-volt input is correct. If input is high, HI lamp glows brighter, and vice versa. Third neon could be used to replace zener diode as voltage reference if desired.

1 to 5 mA shows that repair is needed, and greater than 5 mA is unacceptable. The circuit, shown in Fig. 18 tests for 200 μ A, 1 mA, and 5 mA with three different probes. The battery and voltage divider maintain voltage across the neon just below the breakdown level. The

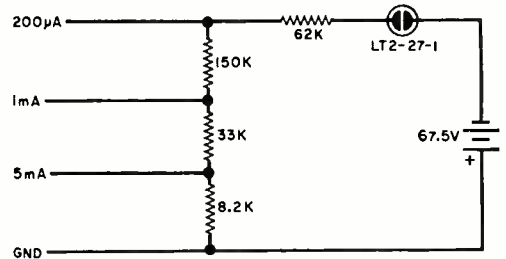

Fig. 18. To check a.c.-operated devices for safety where leakage currents are concerned, this simple circuit uses one neon lamp in series with a 67.5-volt battery. Three separate probes are used. If lamp lights when the 5-mA probe is used, leakage is too high and device is considered unacceptable.

ground (GND) lead is fastened to the ground point against which leakage is to be checked, power is applied to the device to be tested, and the probes are touched to the device case one at a time, starting with the 5-mA probe.

If leakage current exceeds the probe rating, the voltage developed across that part of the voltage divider by the leakage current brings the neon-lamp voltage above breakdown and it fires; otherwise it remains dark and the next more sensitive probe can be tried. If the lamp remains dark for all three probes, leakage current is well within bounds.

Summing Up. Neon lamps have far more uses than most of us suspect. Those given here, although extensive, are only a small sampling chosen to illustrate the variety of possible applications. -30-

SWL ANTENNA

(Continued from page 50)

of a porcelain- or glass-center dipole antenna insulator. Clip the remaining two leads near the drooping extensions (see Fig. 2) and twist them around an appropriate insulator. Put an insulator at the end of each drooping antenna section. To feed this antenna, use a 72-ohm

transmission line (such as Belden #822). This line should be split for about 6", the ends stripped for about 2" and then twisted and soldered securely to the wires at the dipole center insulator. The "down" part of the lead-in should run at right angles to the dipole for at least 30-40'. From that point it may be attached to a house wall by TV-type standoff insulators. A TV-type lightning arrester should be connected to the lead-in and grounded outside of the house with #8 aluminum wire. -50-

Checking the MOSFET Barrier

BY FRANK H. TOOKER

THE PRINCIPAL DIFFERENCE between a JFET (junction field-effect transistor) and a MOSFET (metal-oxide-semiconductor field-effect transistor) is that the former employs a reverse-biased junction (gate to source and drain) to obtain its high input resistance, while the gate of a MOSFET is electrically insulated from the rest of the device by a thin oxide film. The barrier caused by this film gives the MOSFET an input resistance many times greater than that of the JFET.

Since it takes very little electrical power to puncture the oxide film in a MOSFET—even common electrostatic potentials will do it—great care must be taken in the use of these transistors. A very small puncture in the film may not affect a MOSFET's performance signifi-

cantly but a larger hole can reduce the input impedance to that of a JFET biased normally in the reverse direction. A MOSFET in this condition can still be used in a number of applications.

A serious rupture in a MOSFET's gate insulation can reduce its input resistance to a value similar to that of a JFET biased in the *forward* direction. A transistor in this condition cannot be used as a JFET, however, and is fit only for the trash can!

Testing for Damage. The circuit shown here can be used to check the condition of a MOSFET's gate insulation. If the transistor is usable, there will be no deflection of the meter needle (other than that occasioned by initial charging of the capacitor) regardless of the polarity of the potential applied to the gate. A *sustained* deflection of the meter needle, even though small, indicates a serious rupture of the barrier.

It is best to check an *n*-channel MOSFET with the gate positive and a *p*-channel MOSFET with the gate negative, although a seriously damaged transistor of either type will usually show a needle deflection regardless of the polarity. If the MOSFET has a lead brought out from its substrate, connect it to the source lead during the test.

The capacitor between the gate and the source in the schematic protects the MOSFET from damage due to transients during testing. Note that no connection is made to the drain of the transistor. -50-

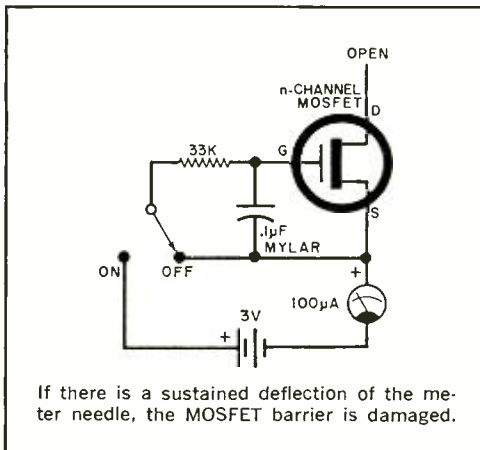



BUILD
Electronic
Metronome

WITH ACCENTED BEAT

Solid-state portability in a convenient package

WHETHER YOU ARE musically inclined or not, you have probably heard or seen a conventional mechanical metronome. Traditionally, the metronome involves a pyramid-shaped case, containing a clockwork mechanism. A spindle emerging from the base of the metronome supports an upright steel pendulum that carries a weight which can be locked in any desired position.

When set in motion, the pendulum oscillates from side to side at a rate governed, externally at least, by the position of the weight. In so doing, it produces an audible click which can serve as a guide to musical tempo or beat.

In this electronic age, many people who might not otherwise buy or build a metronome are attracted by the idea of building an electronic equivalent. Tran-

sistors lend themselves particularly well to producing a compact, portable, line-independent electronic metronome. The "Electronic Metronome With Accented Beat" described in the following pages not only provides an average of between 50 and 160 clicks/min, it also accents certain clicks in a sequence that simulates the down-beat at the beginning of each musical bar. A simple adjustment lets you accent every beat, one beat in two, and so on up to one beat in ten, as desired.

This accented-beat feature will be appreciated by photographers as well as musicians. Preset for a specific accented beat sequence, the metronome can "tell" the photographer when to move on to the next step in his darkroom while the darkroom is in total darkness.

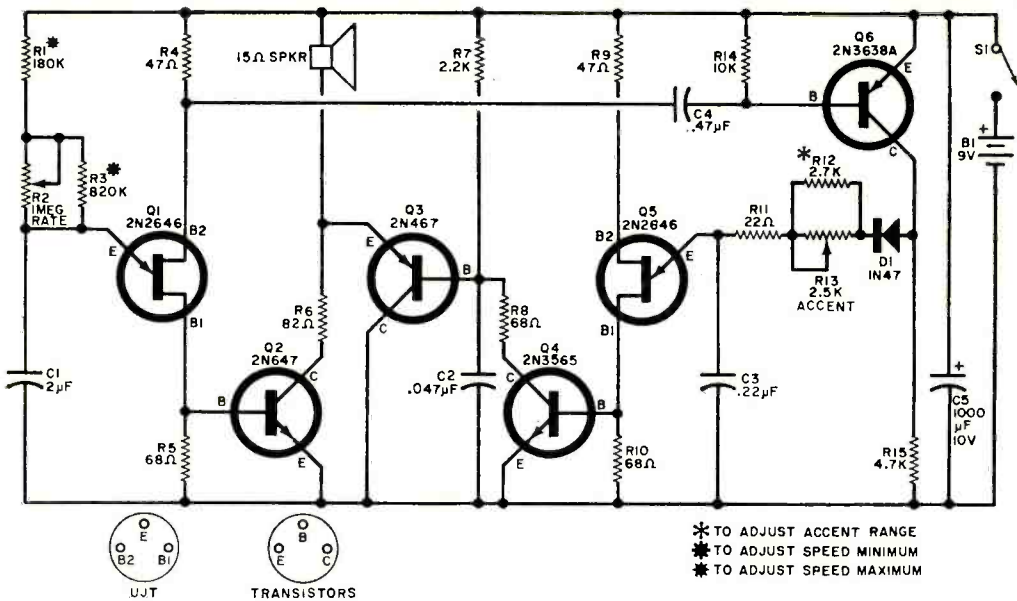

Fig. 1. Beat rate is established by relaxation oscillator Q1, amplified by Q2. The beat is accentuated by circuit Q3 to Q6.

PARTS LIST

- B1—9-volt battery
- C1—2- μ F, 10-volt plastic capacitor
- C2—0.047- μ F ceramic capacitor
- C3—0.22- μ F ceramic capacitor
- C4—0.47- μ F ceramic capacitor
- C5—1000- μ F, 10-volt electrolytic capacitor
- D1—1N47 silicon diode (30 mA, 150 PIV)
- Q1, Q5—2N2646 unijunction transistor
- Q2—2N647 transistor
- Q3—2N467 transistor
- Q4—2N3565 transistor
- Q6—2N3638A transistor
- R1—180,000-ohm, 1/2-watt, 5% resistor
- R2—1,000,000-ohm, linear-taper potentiometer
- R3—2500-ohm, linear-taper potentiometer
- R4—47 ohms
- R5, R8, R10—68 ohms
- R6—82 ohms
- R7—2200 ohms
- R11—22 ohms
- R12—2700 ohms
- R14—10,000 ohms
- R15—4700 ohms
- S1—S.p.s.t. switch
- SPKR—3"-diameter, 15-ohm speaker
- 1—6 1/2" x 4 1/2" x 2" metal chassis
- 1—20-pair (min.) tag strip or terminal board
- Misc.—Control knobs (2); extruded-aluminum grill for speaker; brass or copper strap for battery and tag-board brackets; hookup wire; solder; hardware; etc.

All
1/2-watt
5%
resistors

About the Circuit. The basic beat output of the metronome is produced by relaxation oscillator Q1 and power switching transistor Q2. The characteristics of unijunction transistor (UJT) Q1 are such that virtually zero emitter current flows until Q1 is triggered into conduction (see Fig. 1).

When S1 is closed, C1 begins to charge at a rate determined by the combined resistance of R1, R2 and R3 in series with it and the battery. Charging action continues until the potential across C1 is great enough to cause Q1 to conduct. When Q1 does conduct, C1 immediately discharges through the low resistance presented by the UJT's emitter-to-base-one junction, supplying a current pulse to the base of Q2. As a result, Q2 switches into full conduction, producing an audible click at the speaker.

The charge-and-discharge cycle continues indefinitely as long as S1 is closed and power is applied to the circuit. The rate of charge—and thus the operating frequency of the relaxation oscillator—can be varied over the metronome's entire beat range by changing the setting of RATE control R2. (The limits on the basic beat rate could be expanded to cover a wider range, but limiting it provides the advantage of less critical ad-

justments of $R2$ and consequently greater accuracy.)

Accentuation of selected beats is produced by the circuitry beyond $Q2$. When $Q1$ conducts, its B1-B2 current momentarily increases. A series of negative-going pulses (in step with the selected beat rate) is then available at the B2 electrode. These pulses, coupled through $C4$, drive $Q6$ into full conduction and deliver a +9-volt pulse (for each pulse received) to $R15$.

Unijunction transistor $Q5$ is in a circuit similar to that of $Q1$ except that $Q5$ has $C3$ in its base circuit. In addition, the charging path is through $D1$ instead of directly from $B1$. Thus, $C3$ charges only in short "staircase" pulses resulting from the on-off action of $Q6$.

The extent to which $C3$ charges during each pulse is controlled by the total resistance of $R11$, $R12$ and $R13$. The charge rate can be varied by adjusting the setting of the ACCENT control, $R13$, which in effect varies the height of the steps (amplitude of pulses).

Between pulses, the charge on $C3$ remains fairly constant and is prevented from leaking off by the blocking action of $D1$ and the emitter-to-base-one re-

sistance of $Q5$, which is very high when the UJT is cut off.

When the potential across $C3$ reaches some critical amplitude, $Q5$ conducts, allowing $C3$ to discharge. After that, the action of the $Q4$ - $Q5$ circuit combination is identical to that of $Q1$ - $Q2$. In $Q3$, the output pulses of $Q4$ are "stretched" so that they produce an output click that has significantly higher energy than those coming from $Q2$. Proper adjustment of $R13$ allows the stretched pulses to be superimposed upon and thus accentuate the selected pulses of the basic beat.

Construction. The relatively small size of the cabinet specified in the Parts List accounts for the portability of the metronome. Construction is reasonably simple, with all components and subassemblies being fixed to the front panel as shown in Fig. 2. The speaker, power switch, and RATE and ACCENT controls are mounted directly on the front panel. (A piece of extruded aluminum grill of a suitable size should be sandwiched between the speaker and the panel to protect the speaker cone.)

With the exception of $R12$ which is

Fig. 2. Except for controls on the front panel, battery, speaker, and one resistor, all circuit components are mounted on a terminal board tag strip (seen at the very bottom of this photo).

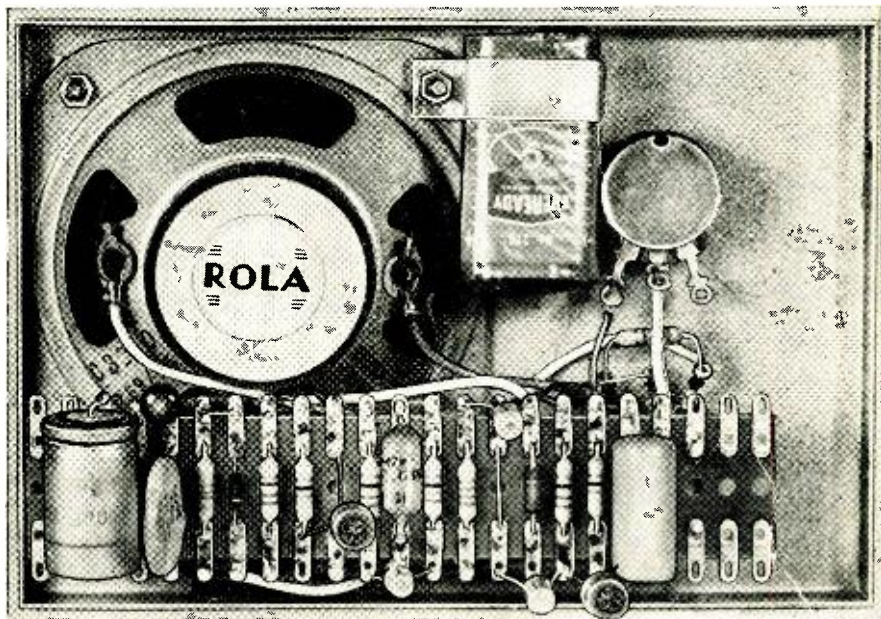



"CIE training helped pay for my new house," says Eugene Frost of Columbus, Ohio

Gene Frost was "stuck" in low-pay TV repair work. Then two co-workers suggested he take a CIE home study course in electronics. Today he's living in a new house, owns two cars and a color TV set, and holds an important technical job at North American Aviation. If you'd like to get ahead the way he did, read his inspiring story here.



IF YOU LIKE ELECTRONICS—and are trapped in a dull, low-paying job—the story of Eugene Frost's success can open your eyes to a good way to get ahead.

Back in 1957, Gene Frost was stalled in a low-pay TV repair job. Before that, he'd driven a cab, repaired washers, rebuilt electric motors, and been a furnace salesman. He'd turned to TV service work in hopes of a better future—but soon found he was stymied there too.

"I'd had lots of TV training," Frost recalls today, "including numerous factory schools and a semester of advanced TV at a college in Dayton. But even so, I was stuck at \$1.50 an hour."

Gene Frost's wife recalls those days all too well. "We were living in a rented double," she says, "at \$25 a month. And there were no modern conveniences."

"We were driving a six-year-old car," adds Mr. Frost, "but we had no choice. No matter what I did, there seemed to be no way to get ahead."

Leans of CIE

Then one day at the shop, Frost got to talking with two fellow workers who were taking CIE courses... pre-

paring for better jobs by studying electronics at home in their spare time. "They were so well satisfied," Mr. Frost relates, "that I decided to try the course myself."

He was not disappointed. "The lessons," he declares, "were wonderful—well presented and easy to understand. And I liked the relationship with my instructor. He made notes on the work I sent in, giving me a clear explanation of the areas where I had problems. It was even better than taking a course in person because I had plenty of time to read over his comments."

Studies at Night

"While taking the course from CIE," Mr. Frost continues, "I kept right on with my regular job and studied at night. After graduating, I went on with my TV repair work while looking for an opening where I could put my new training to use."

His opportunity wasn't long in coming. With his CIE training, he qualified for his 2nd Class FCC License, and soon afterward passed the entrance examination at North American Aviation. "You can imagine how I felt," says Mr. Frost. "My new job paid \$228 a month more!"

Currently, Mr. Frost reports, he's an inspector of major electronic systems, checking the work of as many as 18 men. "I don't lift anything heavier than a pencil," he says. "It's pleasant work and work that I feel is important."

Changes Standard of Living

Gene Frost's wife shares his enthusiasm. "CIE training has changed our standard of living completely," she says.

"Our new house is just one example," chimes in Mr. Frost. "We also have a color TV and two good cars instead of one old one. Now we can get out and enjoy life. Last summer we took a 5,000 mile trip through the West in our new air-conditioned Pontiac."

"No doubt about it," Gene Frost concludes. "My CIE electronics course has really paid off. Every minute and every dollar I spent on it was worth it."

Why Training is Important

Gene Frost has discovered what many others never learn until it is too late: that to get ahead in electronics today, you need to know more than soldering connections, testing circuits, and

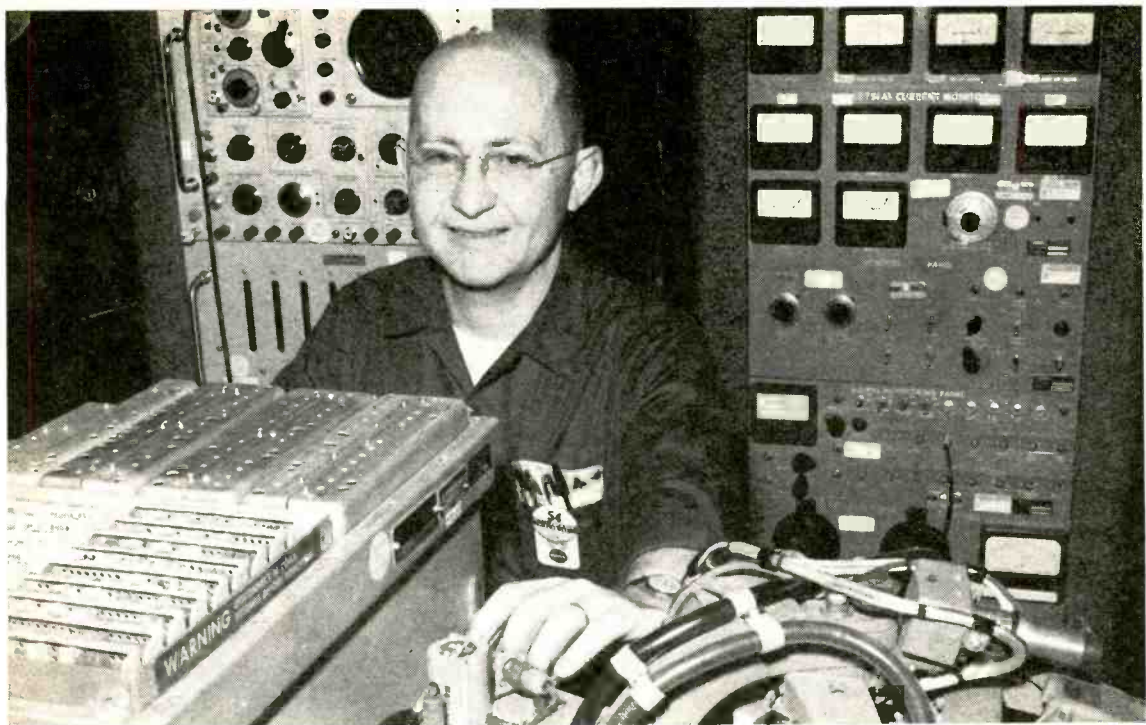

replacing components. You need to really know the fundamentals.

Without such knowledge, you're limited to "thinking with your hands" ... learning by taking things apart and putting them back together. You can never hope to be anything more than a serviceman. And in this kind of work, your pay will stay low because you're competing with every home handyman and part-time basement tinkerer.

But for men with training in the fundamentals of electronics, there are no such limitations. They think with their heads, not their hands. They're qualified for assignments that are far beyond the capacity of the "screw-driver and pliers" repairman.

The future for trained technicians is bright indeed. Thousands of men are desperately needed in virtually every field of electronics, from 2-way mobile radio to computer testing and troubleshooting. And with demands like this, salaries have skyrocketed. Many technicians earn \$8,000, \$10,000, \$12,000 or more a year.

How can you get the training you need to cash in on this booming demand? Gene Frost found the answer in CIE. And so can you.

Send for Free Book

Thousands who are advancing their electronics careers started by reading our famous book, "How To Succeed In Electronics." It tells of the many electronics careers open to men with the proper training. And it tells which courses of study best prepare you for the work you want.

If you'd like to get ahead the way Gene Frost did, let us send you this 40-page book free. With

it we'll include our other helpful book, "How To Get A Commercial FCC License." Just fill out and mail the attached card.

If the card is missing, use the coupon below.

ENROLL UNDER G.I. BILL

All CIE courses are available under the new G.I. Bill. If you served on active duty since January 31, 1955, or are in service now, check box on reply card for G.I. Bill information.

CIE Cleveland Institute of Electronics

1776 East 17th Street, Cleveland, Ohio 44114

NEW

COLLEGE-LEVEL CAREER COURSE FOR MEN WITH PRIOR EXPERIENCE IN ELECTRONICS

ELECTRONICS ENGINEERING ... covers steady-state and transient network theory, solid state physics and circuitry pulse techniques, computer logic and mathematics through calculus. A college-level course for men already working in Electronics.

Cleveland Institute of Electronics
1776 East 17th Street, Cleveland, Ohio 44114

Please send me without cost or obligation:

1. Your 40-page book "How To Succeed In Electronics" describing the job opportunities in Electronics today, and how your courses can prepare me for them.
2. Your book on "How To Get A Commercial FCC License."

I am especially interested in:

- | | | |
|--|---|--|
| <input type="checkbox"/> Electronics Technology | <input type="checkbox"/> Broadcast Engineering | <input type="checkbox"/> First Class FCC License |
| <input type="checkbox"/> Electronic Communications | <input type="checkbox"/> Industrial Electronics | <input type="checkbox"/> Electronics Engineering |

Name _____ (Please Print)

Address _____

City _____ State _____ Zip _____

Check here for G.I. Bill information. PE-72

CIRCLE NO. 10 ON READER SERVICE PAGE

wired directly across the ACCENT control, all small components are wired to a tag strip or terminal board as shown in Fig. 3. The job will be easier if you wire the resistors in place first, then the diode, capacitors, and transistors, in that order. Be sure to mount C3 on the underside of the tag strip and route under the strip the wiring shown by the dashed lines.

The components should be kept as close as possible to the tag strip, and transistor leads should be shortened so that the tops of the transistors are no more than an inch from the strip.

Now, remove the machine nuts from the upper-right and lower-left speaker mounting screws (viewed from rear). Bend a fairly heavy-gauge, 1/2"-wide copper, brass or aluminum strap around the battery, forming two 1/2"-wide tabs at the ends. Drill a hole through both tabs, and mount the battery in place over the upper-right speaker mounting screw. Solder the positive lead from the battery to one side and a 3"-long piece of hookup wire to the other side of the power switch.

Form two U brackets from the same material used for the battery clamp. The crown of the bracket should be about 1/2" across, the legs 1" long, and the tabs 1/2" wide. Drill a hole through the crown of each bracket, and bolt the brackets at opposite ends of the tag strip. Solder or bolt the tabs to the front panel.

Finally, complete the wiring of the metronome, using Figs. 1 and 3 as guides. Assemble the cabinet, rotate the RATE control fully clockwise, and set the power switch to ON. Time the number of clicks/min produced by the metronome—there should be 150-160 of them. Set the control to its maximum counterclockwise position and again count the number of clicks/min—there should be 46-50.

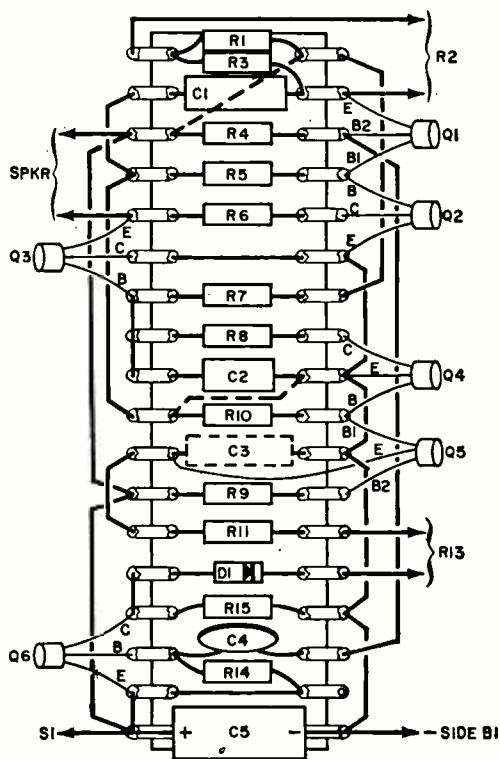

Fig. 3. Route capacitor C3 and wiring indicated by dashed lines along the underside of the tag strip.

Calibrate the ACCENT control as follows: Starting with the control set fully clockwise, adjust the setting for an accent every beat, and mark this position. Then locate and mark the position of the control that produces accentuation every second beat, and so on up to every tenth beat. The Electronic Metronome With Accented Beat is now ready for use.

-30-

Acknowledgment. This article is reprinted with permission from *Electronics Australia*.

SEMICONDUCTOR CROSS-REFERENCE GUIDE

Almost 18,000 semiconductor device numbers with their equivalents from Motorola Semiconductor Products' HEP line are listed in the Semiconductor Cross-Reference Guide. This new 64-page guide lists 1N and 2N, foreign, and many "equal-or-better" house number replacements. Copies of the Semiconductor Cross-Reference Guide, No. HMA07-4, are available for 25¢ from Motorola distributors, or by writing to Motorola Semiconductor Products Inc., Technical Information Center, P.O. Box 2094, Phoenix, Ariz. 85036.

ALL-PURPOSE

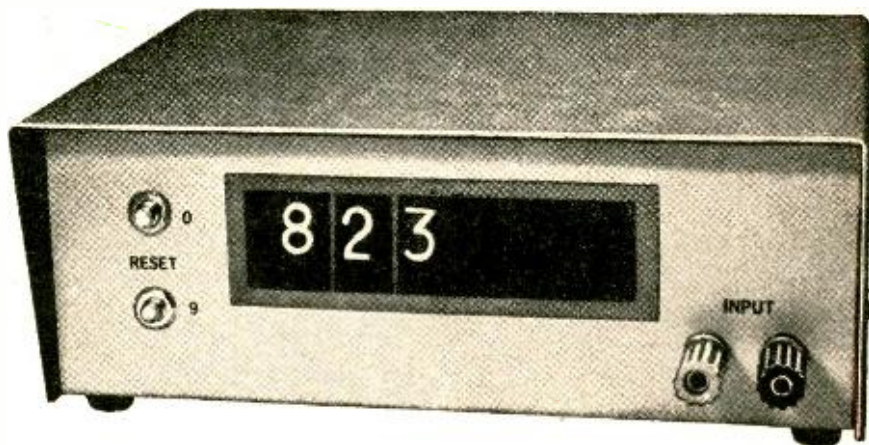

NIXIE® READOUT

*Minimum-component decimal counting unit
uses high-visibility glow-discharge tube*

By **LESLIE SOLOMON**

Technical Editor

and **ALEXANDER W. BURAWA**

Associate Editor

THE APPEARANCE of the decimal-counting unit article by Don Lancaster ("Build a Low Cost Counting Unit," February, 1968) intrigued thousands of hobbyists, experimenters, and engineers. We at POPULAR ELECTRONICS have since been deluged with mail telling us of literally hundreds of unusual circuit applications in which readers have used the DCU. And many requests have been coming in asking us for instructions for converting the original DCU from readouts using incandescent lamps to glow-discharge (Nixie® tube) readout.

The major objection to converting the original DCU to Nixie tubes is cost—it would have been almost twice the original kit price. Add to this the facts that the circuit would be overly complex and the circuit-board size would be increased.

Hence, a totally new DCU had to be developed. The "Professional DCU" described here is the result of the new design.

Nixie-tube readout is a distinct improvement over the incandescent readout. The circuit-board dimensions are smaller, and whereas the original DCU required four IC's, seven transistors, six resistors, and ten incandescent lamps, the new unit uses only two IC's, one resistor, and a Nixie tube. Although fewer parts are required, the new DCU is somewhat more expensive than the original circuit. However, for \$30, you can construct a professional DCU that has all of the advantages of many commercial units costing two or three times as much.

The DCU described here has other advantages: Transistor-transistor logic

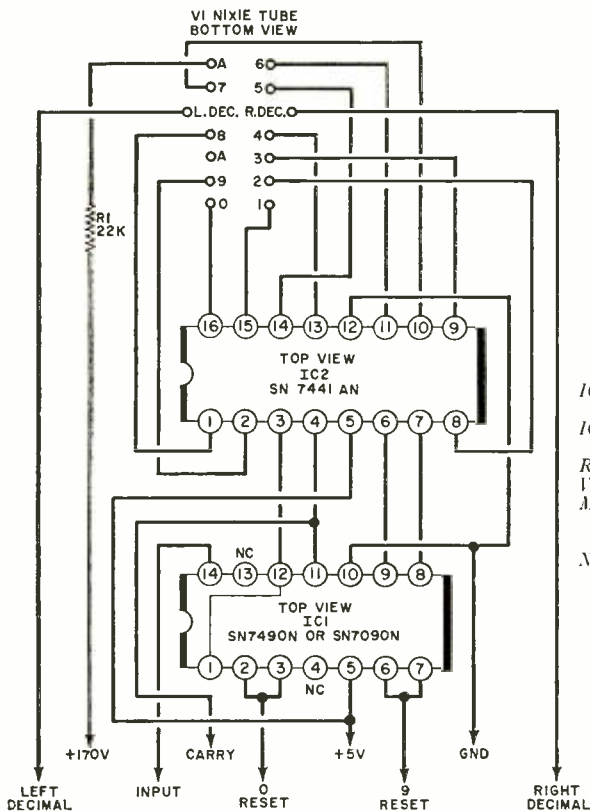

Fig. 1. Entire counting circuit is made up of four components—demodulator IC1, driver IC2, glow-discharge tube V1, and current-limiting resistor R1. Value used for R1 is determined by number of counting units operated from a given power supply, as described in text.

PARTS LIST

- IC1—Integrated-circuit decade counter, (Texas Instruments SN7490N or SN7090N)
 - IC2—Integrated-circuit decoder driver, (Texas Instruments SN7441AN)
 - R1—22,000-ohm, 1/2-watt resistor (see text)
 - V1—Nixie indicator tube, (Burroughs B-5750)
 - Misc.—Printed-circuit board, wire for jumpers, PC-board edge connector (Amphenol 142-010-01 or similar)
- Note: A complete kit of DCU components, including PC board, is available from Southwest Technical Products Corp., 219 W. Rhapsody, San Antonio, Texas 78216, for \$30. The PC board alone is available for \$2.25. A cabinet for mounting six DCU's with power supply components capable of driving six DCU's is available for \$12. A special Polaroid window is also supplied with the cabinet kit.

(TTL) is used; this gives the unit an operational speed of 18 MHz, twice that of the older circuit, which uses resistor-transistor logic (RTL). Also, because TTL requires a much larger input trigger level, erratic indications due to line transients or other electrical noise have been almost eliminated.

Construction. The DCU, whose schematic is shown in Fig. 1, is best assembled on a printed-circuit board similar to that shown actual size in Fig. 2. Once the board has been made or purchased (see Parts List), the two IC's, one resistor, one jumper, and the Nixie readout are mounted on the board as shown in Fig. 3. Note that the terminals on the board for the Nixie tube are not arranged in the same pattern that they are on the tube itself. (The actual Nixie-tube terminal arrangement is shown in Fig. 1.) Also, the PC board has been arranged so that it can be connected either directly into a circuit (via soldered connections)

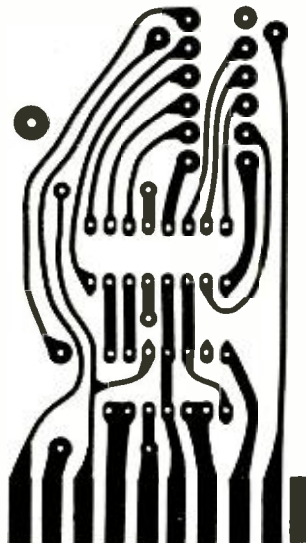
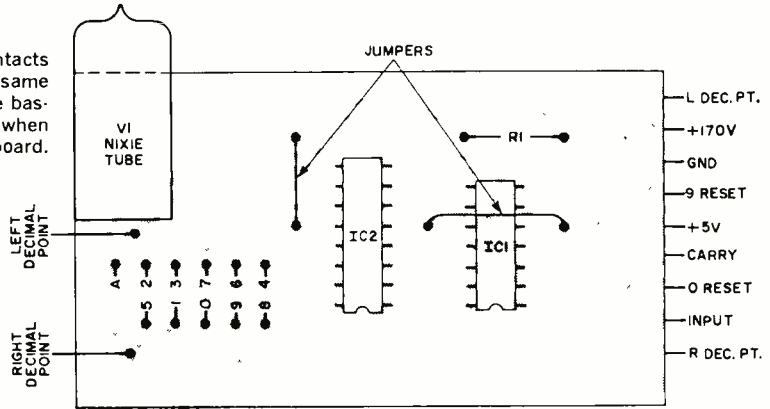

Fig. 2. This actual-size etching guide is used for circuit board employing edge connector (heavy mark at lower right serves as connector key), or for circuit board to be soldered into circuit.

Fig. 3. Circuit board contacts for Nixie tube are not in same arrangement as actual tube basing. Keep this in mind when soldering V1's leads to board.



or used with a PC-board edge connector. After mounting and soldering *IC1* in place, install the second jumper.

A 22,000-ohm resistor is specified for *R1* in Fig. 1. This resistance is used when three or less DCU's are operated from the suggested power supply and it keeps the Nixie from being too bright. If four or more DCU's are driven from the same power supply, reduce the value of *R1* to 10,000 ohms.

The Nixie tube is mounted on its side as shown in the photos. Be sure that the viewing side is placed as shown. The plastic pin guide that comes with the Nixie tube can be secured to the PC

board with a bead of cement; do not cement the glass to the board. Install the Nixie tube by first bending the "left decimal" lead directly at the pin guide and feeding it into its hole on the board. Put the leads of the first row into the appropriate holes, using insulating tubing over each lead. Finish with the upper row of leads and the "right decimal" lead. Note that there are two anode leads on the tube. The anode connected to pin 10 is not used and can be cut off at the base. The short leads will be sufficient to support the tube.

Power Supply. Each counter requires

Fig. 4. Up to six DCU's can be efficiently driven with power supply shown here. Don't skimp on component quality in +5-volt circuit, or DCU's will operate erratically.

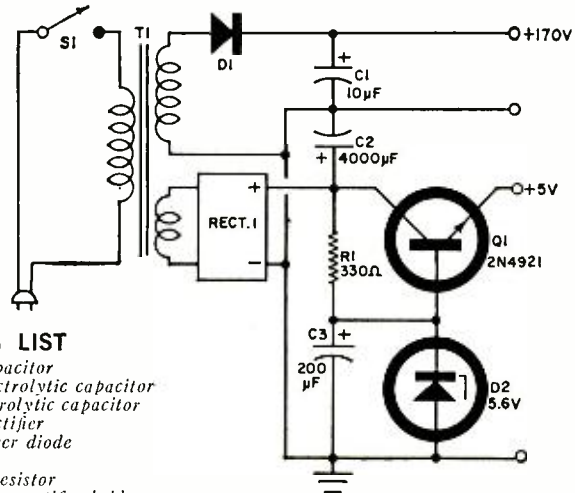

PARTS LIST

- C1—10- μ F, 250-volt capacitor
- C2—4000- μ F, 6-volt electrolytic capacitor
- C3—200- μ F, 6-volt electrolytic capacitor
- D1—1-ampere silicon rectifier
- D2—5.6-volt, 1-watt zener diode
- Q1—2N4921 transistor
- R1—330-ohm, $\frac{1}{2}$ -watt resistor
- RECT.1—2-ampere silicon rectifier bridge
- T1—Power transformer. Secondary: 125 and 6.3 volts.

Note: A complete power-supply kit with chassis is available. See Parts List for Fig. 1.

170 volts d.c. to drive the Nixie readout, and 5 volts d.c. for the IC's. The schematic of a power supply sufficient for six DCU's is shown in Fig. 4. If any other power supply is used, be sure that its outputs do not exceed 170 and 5 volts, since the Nixie tube and the IC's can be irreparably damaged by voltages that are too high.

The power supply is assembled in the case as shown in Fig. 5. The various components are mounted on terminal strips and point-to-point wiring is used. Use an insulated mica washer and silicone grease when mounting transistor Q1.

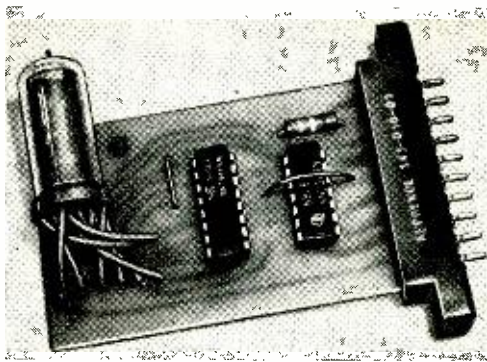

The jumper wire shown at center of photo should not be allowed to touch case or leads of decoder.

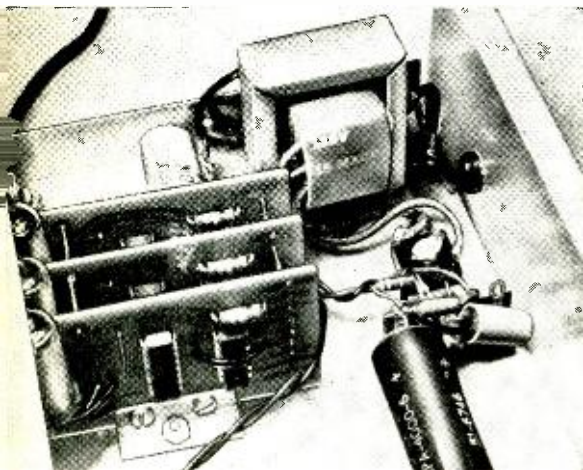

Fig. 5. Terminal strips and point-to-point wiring should be employed when assembling power supply.

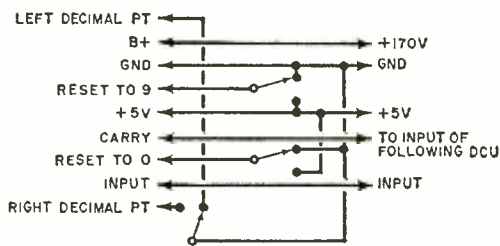

Fig. 6. Prior to wiring them into chassis, test individual DCU's using this circuit.

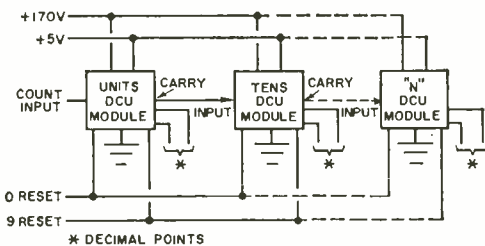
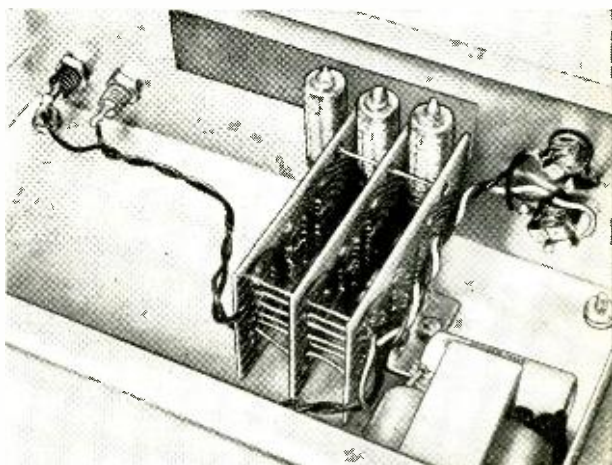
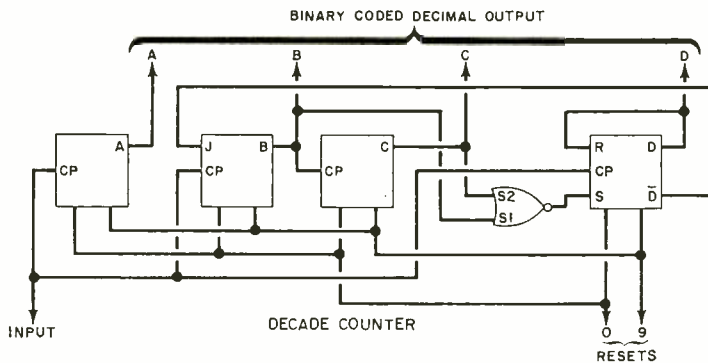

Fig. 7. Carry output of each module provides input for following module. As many modules as desired can be used; units, tens, hundreds, etc., modules.



By mounting DCU's side by side so "common" holes line up with each other, assembly is simplified, and possibility of wiring errors is minimized.



HOW IT WORKS

Decade Counter. Integrated circuit IC1 is a decade counter consisting of four master-slave flip-flops with gating and internal connections designed to perform the desired counting functions. The output is a binary-coded-decimal signal which drives the companion decoder-driver module.

The monolithic counter uses transistor-transistor logic with a counting rate of about 18 MHz. It will accept positive-going input pulses of 2 volts or more and the shape of the input waveform is not important.

Decoder-Driver. Integrated circuit IC2 is a monolithic BCD-to-decimal decoder having relatively high-voltage output transistors for direct driving of gas-filled readouts, miniature lamps, or low-power relays.

It has ten output transistors which are connected to the appropriate terminals of the readout tube. The BCD input is decoded and applied to the appropriate output transistor to turn it on and supply current to the proper element in the tube.

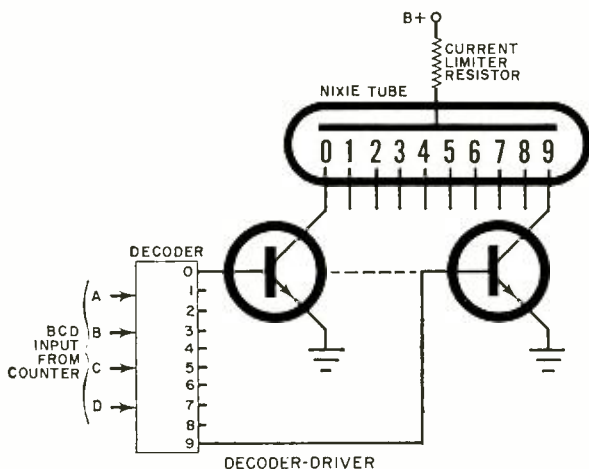

Testing. Connect the DCU to a test circuit such as that shown in Fig. 6. Operating the zero-reset switch should cause the Nixie tube to indicate the numeral zero. Operating the nine-reset switch should produce a nine indication on the tube. (The nine-reset connection is used in "nines complement" decimal operations.) Operating the decimal-point switch should cause either the right or the left decimal point to glow. Reset the unit to zero before making the next test.

Any a.c. waveform that has a magnitude of at least 2 volts can be used to test the DCU. A low-frequency audio generator makes a convenient source for an input signal. Apply a signal of less than 10 Hz to the input of the DCU and you should see the numerical progression in the Nixie tube. During the transition from 9 to 0, a pulse should be observed

at the "carry" output. This pulse is used to drive succeeding Nixie-readout stages.

A number of DCU's can be connected together as shown in Fig. 7. All power leads and resets are connected in parallel, while only the units module receives the input signal to be counted. The carry output of this module is fed to the input of the second (or tens) module. The carry of the tens module drives the hundreds module, etc. The decimal points are connected to a switching system (optional) to indicate the correct decimal point position.

Various auxiliary circuits for use with the Professional DCU will appear in future issues of POPULAR ELECTRONICS. We will also show how circuits and components can be combined to make up digital voltmeters, frequency counters, etc.

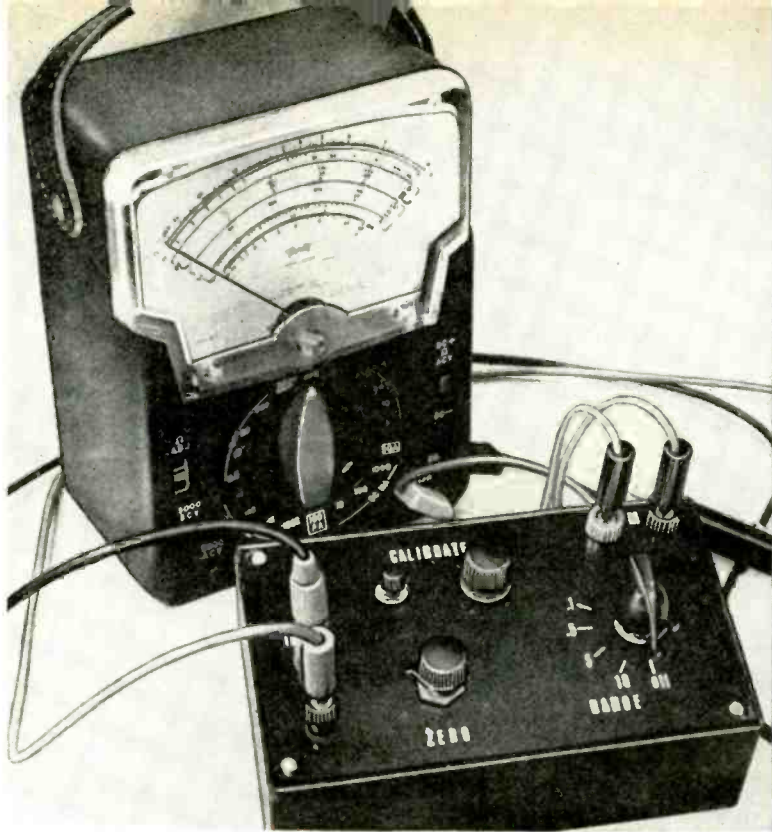

FET REJUVENATES VOM

ADAPTERS IMPROVE SENSITIVITY OF ORDINARY VOLT-OHMMETER

BY SOL D. PRENSKY

THE OVER-WORKED VOM has been the best friend of the electronics experimenter for many years. While usable for most measurements, there comes a time when the faithful VOM must be shunted aside for the VTVM, especially when it comes to measuring the low-level voltages in semiconductor circuits, or when probing around in high-impedance circuits.

The reason for dropping the VOM by the wayside? Low input resistance—typically 20,000 ohms per volt—which puts an excessive load on critical circuits under test and produces false voltage indications. Also the VOM lacks sufficiently low full-scale voltage ranges. Most VOM's cannot measure below 1.0 or 1.5 volts at best. Since voltages in

some semiconductor circuits do not exceed 0.1 volt, it is impossible to read them on a VOM, even if it has a suitably high input resistance to avoid circuit loading. Even VTVM's have their faults—the older ones do not have low enough full-scale voltage ranges.

Now the field-effect transistor (FET) has come along to allow the VOM to retrieve its rightful place on the workbench. A pair of FET's can be added to your VOM to convert it into a very high-input-resistance (10 megohms) voltmeter and also give it two more low-voltage ranges—0.5 and 0.1 volt full scale. Because both the FET adapter (powered by internal batteries) and the VOM require no power, you are not dependent on the a.c. power line.

PARTS LIST

BP1-BP4 5-way binding post, two black, two red
 B1—6.75-volt mercury battery (2), (Mallory TR235R or similar; see text)
 D1—5.6-volt zener diode 1N5232 (Motorola) or 1N1520 (International Rectifier)
 Q1, Q2—N-channel FET T1S58 (Texas Instruments) or MPP103 (Motorola)
 R1—8-megohm
 R2—1.8-megohm
 R3, R4—100,000-ohm
 R5—50,000-ohm
 R6, R8—15,000-ohm
 R7—2000-ohm
 R9—10-megohm
 R10—220-ohm
 R11—2700-ohm
 R12—47-ohm

all resistors $\frac{1}{2}$ -watt, 5%

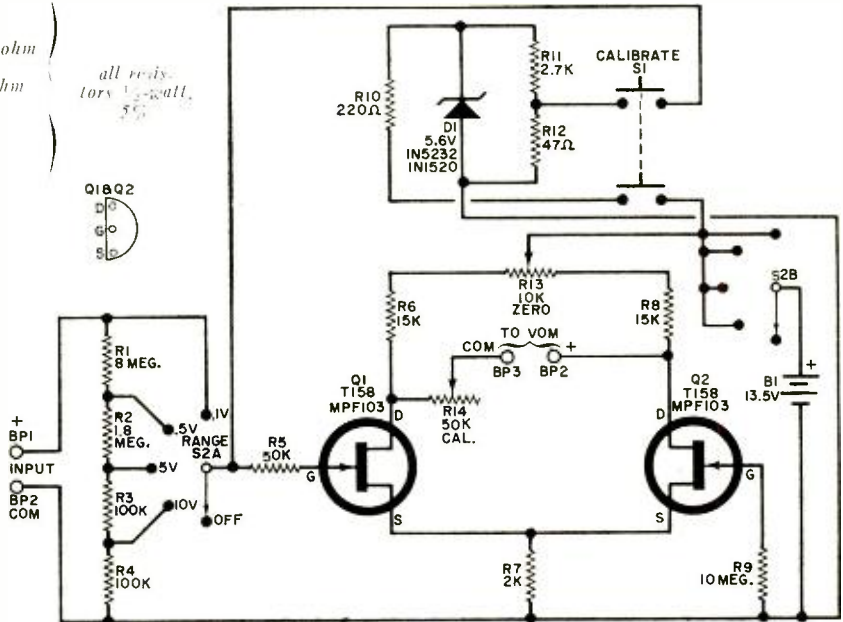

Fig. 1. Designed for use with 20,000 ohms/volt VOM's equipped with a 0-1-volt d.c. range, this circuit provides the VOM with effective input resistance of 10 megohms.

PARTS LIST

BP1-BP4—5-way binding post, two black, two red
 B1—6.75-volt mercury battery (2), (Mallory TR235R or similar; see text)
 Q1, Q2—N-channel FET T1S59 (Texas Instruments)
 R1, R3—4.7-megohm
 R2—2000-ohm
 R4, R5—3600-ohm
 R6—10,000-ohm linear potentiometer
 R7—50,000-ohm linear potentiometer
 S1—S.p.s.t. switch
 Misc.—Plastic case, transistor sockets (2), perf board, knobs, mounting hardware, etc.

all resistors $\frac{1}{2}$ -watt, 5%

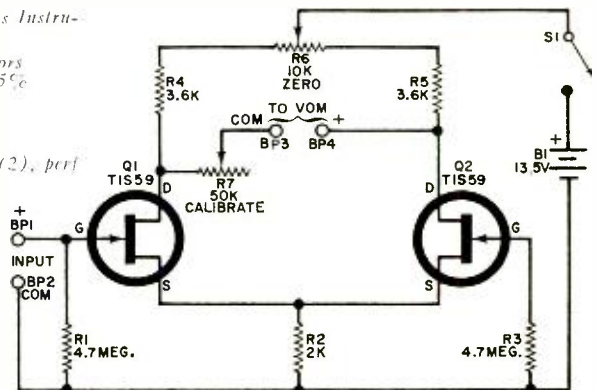

Fig. 2. For VOM's with only 1000 ohms/volt sensitivity, this simple circuit is used to provide d.c. input resistances on the order of five megohms.

R13—10,000-ohm linear potentiometer
 R14—50,000-ohm linear potentiometer
 S1—D.p.s.t. momentary pushbutton switch (Lafayette 99H6183 or similar)
 S2—5-position, 2-pole rotary switch (Lafayette 30H4234 or similar)
 Misc.—Plastic case, transistor sockets (2), perf board, knobs, mounting hardware, etc.

Construction. If your VOM is of the popular 20,000-ohms-per-volt type, use the circuit shown in Fig. 1. If you have a 1000-ohms-per-volt VOM, use the circuit in Fig. 2. Note that the Fig. 2 circuit provides only 1-volt full-scale range at five megohms input resistance.

The circuit may be assembled on a perf board which is then mounted in a plastic case. The case also contains the
 (Continued on page 114)

the product gallery

REVIEWS AND COMMENTARY ON ELECTRONIC GEAR AND COMPONENTS

CB MOBILE TRANSCEIVER (Squires-Sanders "Skipper")

When your reviewer first looked at one of the new "Skipper" CB transceivers, it occurred to him that, if this industry keeps shrinking the size of its products, we'll be carrying them in our watch pockets. We haven't seen every 12-volt-input CB unit, but we find it hard to believe that there is anything smaller than the Skipper. What makes the Skipper so amazing is that it is a 23-channel rig with a measured 3.1-watt output crammed into a pancake measuring 1 $\frac{3}{4}$ " high, 6 $\frac{1}{4}$ " wide, and 7 $\frac{1}{4}$ " deep.

Squires-Sanders, Inc. (Martinsville Rd., Liberty Corner, N. J. 07938) is not a Johnny-come-lately on the CB scene. A manufacturer of quality radio equipment, Squires-Sanders has announced a new line of CB gear wherein each unit bears a "nautical" name. Just so you don't get the impression that the modestly priced Skipper is for maritime use only, let's state right here that it's a very fine mobile for any car with a 12-volt negative-ground electrical system.

From a compactness viewpoint, it's obvious that the Skipper is 100% solid-state. Liberal use is made of silicon transistors, including several field-effect transistors in the front end of the receiver. An integrated circuit is used for one of the i.f. amplifiers. The 12-volt power input is safety-protected from accidentally reversed polarity and the main voltage feed to the critical circuits is regulated to 9.1 volts by a zener diode.

Receiver selectivity is excellent due to the special high-Q i.f. stage transformers. Noise limiting and squelch operation are more than adequate for normal mobile operation.

The frequency-synthesis transmitter portion of the "Skipper" uses no changeover relay and features a modulator with built-in speech compression and limiting. So-called "talk power" is very good. Our test model had an output of 3.1 watts at 50 ohms.

Functionally, the Skipper has a lot of plus features going for it. The VOLUME, CHANNEL, and SQUELCH controls are thumb wheels and positioned on the front panel so that any adjustment is easy even

in total darkness. Below the S-meter are five pushbuttons switching (from left to right) power on-off, internal speaker to external speaker, noise limiter on-off, receiving attenuator on-off, and public address on-off.

Maybe it's one of our eccentricities, but we particularly like the PWR control switch. This pushbutton turns the 12-volt power on and off and is a welcome relief from the switch that is usually part of the rotatable volume control. Once the Skipper is set for optimum volume and squelch, you can leave it that way indefinitely.

Squires-Sanders has also come up with something new in a mounting bracket. It's called a "breakaway" mount and the idea is that, should anything strike the face of the Skipper, the unit slips backward under the dashboard. It sounds like a good idea and should save many a kneecap.

POLICE MONITOR (Regency Model MR-10D)

A newly styled version of the Regency MR-10D (Regency Electronics, Inc., 7900 Pendleton Pike, Indianapolis, Ind. 46226) high-band police receiver is now seen on many dealers' shelves. Although the basic receiver circuit remains much the same—the tube rectifier has been replaced by a pair of diodes—the MR-10D features a smart-looking new dial, unlike anything seen on comparable receivers. The dial reads not only frequency and has a logging scale, but has also been divided graphically into 5 bands. The frequency limits of particular radio services are screened in on the glass in several colors. The services are: Weather, Common Carrier, Police, Fire, and Marine. Gone are "dot" markers of the old MR-10. The volume of the receiver cabinet has been cut by at least 25% and the new styling is in gold.

The receiver is a straightforward superhet with 2 i.f. stages and a single r.f. stage. There is an FM ratio detector and a very sensitive squelch circuit. Compared to other police/fire receivers, the MR-10D is very quiet, sensitive and somewhat more selective than you might expect for a receiver with 10.7-MHz i.f. stages.

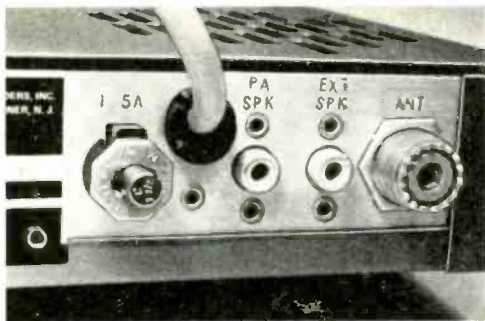

SQUIRES-SANDERS "SKIPPER"

Slim pancake design is featured in this new transceiver. Tube in lower right corner is for comparison purposes. Circuit uses 19 transistors and one integrated circuit. Controls on panel are either thumb wheels or push buttons. Rear view of this unit shows that fuse is not in-line type, but a special fuse that can only be inserted in this particular holder. This extra protection is for safety should car battery polarity be reversed.

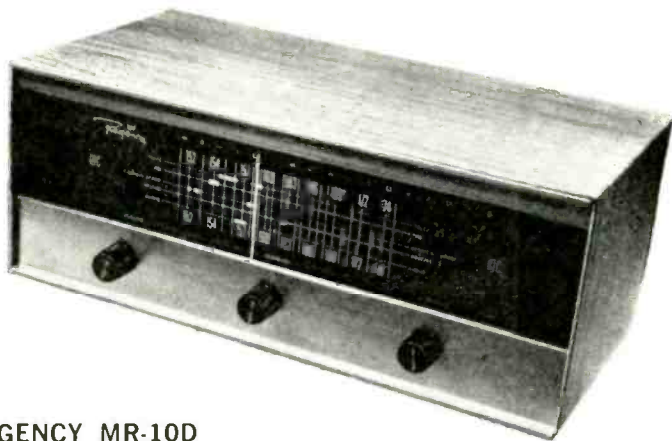

REGENCY MR-10D MONITORADIO

Newly-styled receiver features sliderule tuning dial. Five of the VHF services are shown in attractive colors for easy identification. Police, Fire, Marine and Weather markings denote obvious services. The Common Carrier service pertains to mobile radiotelephones. This type of dial is new to VHF receivers and is long overdue.

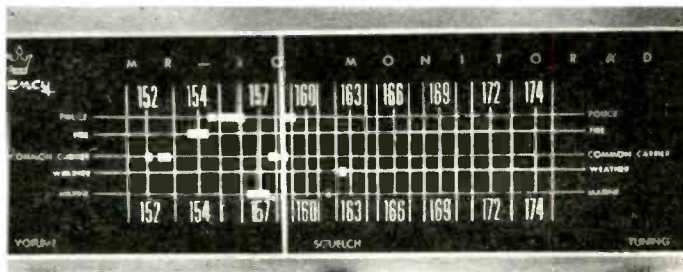



SOLID STATE

By LOU GARNER, Semiconductor Editor

ALTHOUGH a number of TV receiver manufacturers continue to use vacuum-tube circuitry in their main chassis, the majority is shifting to solid-state "front ends" or tuners. In fact, if you've purchased a new TV set recently (or plan to buy one in the near future), the odds are virtually overwhelming that it will be equipped with a semiconductor-operated tuner, even if the rest of it uses tubes.

Four firms supply most of the TV tuners used by U.S. set manufacturers: Standard Kollsman Industries (Melrose Park, Ill. and Syosset, N.Y.), Oak Electro/Netics (Crystal Lake, Ill.), Sarkes Tarzian (Bloomington, Ind.), and General Instrument Corp. (Chicopee, Mass.). The last firm concentrates exclusively on the design and production of UHF types.

In our August, 1968 issue, we described the new varactor-tuned TV front-end introduced by Standard Kollsman at the IEEE Convention. As a result, we received a mildly chiding letter from Bob Brown, public relations representative for Oak Electro/Netics, pointing out that his firm also manufactures solid-state tuners. With engineering research facilities in Madison, Wis. and the Netherlands and production facilities in Crystal Lake, Ill., Hong Kong, and near Seoul, Korea, Oak is considered by some to be the largest TV tuner manufacturer in the world. The firm offers a variety of solid-

state tuners, many of which are custom modifications of basic designs to meet individual customer requirements.

One recent Oak innovation is a thick-film hybrid IC which removes practically all discrete components (except for tuning elements) from the basic tuner-switch assembly. A sealed unit about the size of a matchbox, it contains every transistor, resistor, and capacitor essential for complete VHF TV tuner operation. A complete tuner is assembled simply by coupling the IC module to a suitable inductance channel-selector switch as shown in Fig. 1. Currently, the two basic IC tuners have been developed. One uses a common-base r.f. amplifier while the other has a typical common-emitter configuration.

Another new development from Oak is the industry's first competitive all-channel VHF/UHF TV tuner. Previously, two separate tuners had been required in each set to meet the demand for both VHF and UHF reception. Often the consumer was unaware of this dual-tuner requirement because VHF is predominant in many areas and the common panel styling tends to make channel tuning appear to be a single operation.

Designated the Mark IV all-channel tuner, Oak's new unit measures $1\frac{1}{8}'' \times 3\frac{1}{2}'' \times 4''$. It has tuned r.f. amplification in addition to oscillator and mixer circuits and employs three active transistors. A unique switching concept made the all-channel design practicable.

Inside the Mark IV, stator lines from the UHF tuner enter the VHF area through a metallic shield which divides the tuner into two sections. When the tuner is switched to UHF, a plastic cam spreads apart two flexible leaves of each stator line until positive contact is made with the chassis-ground wall section, converting the tuning capacitor stator into a tuned quarter-wave UHF transmission line. When switched to VHF, the stator's flexible switching leaves are trapped between the rotor blades of a modified switch element, converting the previous UHF transmission line section into a low-loss capacitor which, in turn, tunes VHF coils located on the rotary switch section.

According to Oak Electro/Netics, the

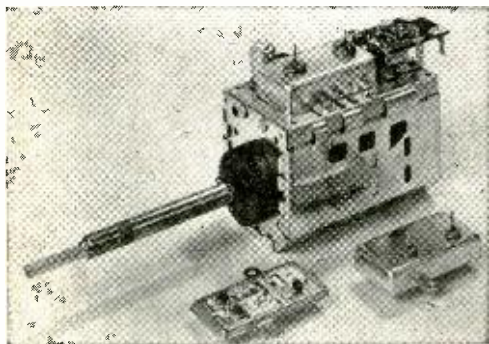

Fig. 1. New VHF tuner by Oak Electro/Netics has basic tuner in a thick-film hybrid integrated circuit which combines with channel-selector switch.

Mark IV tuner has unusually low oscillator energy radiation, reduced cross-modulation, improved noise figure, and superior image rejection, when compared to more conventional designs.

Reader's Circuit. Challenged by a friend to devise an electronic fishing lure, a 16-year-old reader, Paul Schmitt, Jr. (5562 N. Bay Ridge, Whitefish Bay, Wis. 53217), picked up the gauntlet and did just that. His circuit, shown in Fig. 2, is a modified collector-coupled multivibrator with two *npn* power transistors. Feedback capacitors *C1* and *C2* are chosen for asymmetrical operation to insure an harmonic-rich pulse-like output waveform which simulates the sounds produced by some insects. Operating power is furnished by a 9-volt battery, while a conventional 1000-ohm earphone serves as an output transducer. Conventional components are specified in the design.

With neither layout nor lead dress critical, the circuit may be assembled using point-to-point wiring, printed-circuit, or perf-board construction. Paul writes that he assembled his original unit on a small PC board, cementing the earphone to a half-inch hole in the cover of a water-tight jar. The circuit board and battery were further protected by a small plastic bag.

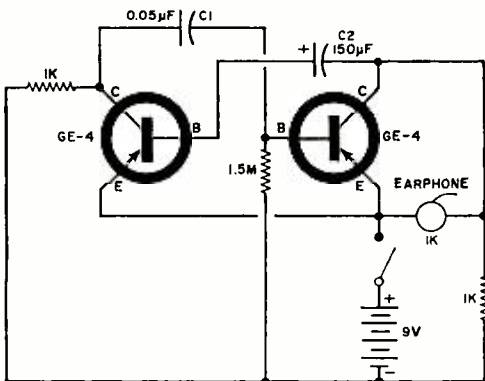

Fig. 2. Two power transistors are combined in a collector-coupled multivibrator to produce an audio output for use in an electronic fishing lure.

In use, Paul suggests that a string be tied to the jar, with the entire assembly lowered about 12 feet into the water. He reports excellent results, especially with large game fish.

Manufacturer's Circuit. At first glance, the circuit shown in Fig. 3 may appear to be a familiar single-stage audio amplifier. Actually, it is an unusual circuit with quite

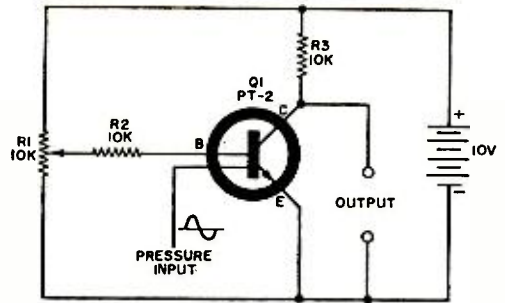

Fig. 3. The Pitran is a pressure-sensitive transducer which can be used in a standard transistor audio-amplifier circuit for various applications.

literally dozens of potential applications in laboratory, industrial, and commercial equipment. One of several related circuits described in an eight-page catalog/brochure published by Stow Laboratories, Inc. (Stow, Mass. 01775), its versatility lies not in the circuit itself but in the characteristics of its active component, *Q1*, which is not a conventional transistor but a solid-state pressure-sensitive transducer called a *Pitran* (for piezotransistor).

Relatively expensive at present, the Pitran is essentially a silicon *npn* planar transistor that has its emitter-base junction mechanically coupled to a diaphragm on top of the small metal can. When pressure (or point force) is applied to the diaphragm, a large but reversible change is produced in the device's characteristics. With an excellent high-frequency response as far as electromechanical devices are concerned, the Pitran is extremely sensitive to both mechanical movement and pressure differentials and can deliver comparatively large output-voltage swings. It may be used as the sensing transducer in such products as phonographs, high-intensity microphones, load cells, accelerometers, flow meters, electronic scales, displacement meters, and level gauges.

As shown in the diagram, *Q1* is a type PT-2 Pitran and bias control *R1* is a linear potentiometer. Bias limiting is provided by *R2* and collector loading by *R3*. If the bias is adjusted for a 2-volt d.c. output level, a mechanical input of as little as 1/4-gram point force will produce a 1-volt output variation, with excellent linearity over the range (1% typical).

Transitips. The contents of our mail bag indicate a healthy reader interest in the characteristics of *regenerative* and *reflex* circuits. Unfortunately, a number of readers seem to feel that these two types of circuits are identical—that the names, in fact, are

more or less interchangeable. Such is not the case, though there are some similarities: both circuits are attempts to squeeze maximum performance from one or more stages; both employ feedback techniques; and both are used extensively in simple receiver designs.

The basic difference between regenerative and reflex circuits lies in the *type* of feedback signal. In a regenerative circuit, a portion of the amplified output signal is coupled back to reinforce the input and thus to help reduce circuit losses. If the feedback is of sufficient amplitude, the circuit becomes a self-sustaining generator—that is, an oscillator. In a reflex circuit, on the other hand, the feedback signal is a *modified* version of the original input and is handled as if it were an entirely different signal. In effect, the stage simply amplifies two different signals at the same time.

A typical regenerative circuit with a *pnp* transistor is shown in Fig. 4(a). Component values vary with the supply voltage, type of transistor used, and other factors.

In operation, r.f. signals picked up by the antenna-ground system are coupled from *L1* to tuned circuit *L2-C1* and applied to *Q1*'s base-emitter circuit. Base bias is established by *R1* (bypassed by *C2*) in conjunction with emitter resistor *R2* (bypassed by *C3*). A portion of the amplified r.f. signal is coupled back in phase with the input by feedback coil *L3*, thus reinforcing the input and developing a stronger output signal. As signal amplitude increases, detection takes place and an audio output signal is developed across collector load resistor *R3*, bypassed for r.f. by *C4*.

The reflex circuit illustrated in Fig. 4(b) is similar in some respects. R.f. signals picked up by the antenna-ground system are coupled from *L1* to tuned circuit *L2-C1* and applied to *Q1*'s base-emitter circuit with an amplified output signal developed across *T1*'s primary winding, tuned by *C3*. Base bias is established by *R1* (bypassed by *C4*) in conjunction with emitter resistor *R3* (bypassed by *C2*). Note, however, that there is no r.f. feedback. Instead the r.f. signal is coupled through *T1* to diode detector *D1*, with an audio signal developed across diode load *R4*, bypassed for r.f. by *C6*. This detected audio signal is then coupled back to *Q1*'s input circuit through d.c. blocking capacitor *C5* and isolation resistor *R2*. The detected (audio) signal is amplified by *Q1*, with the audio output developed across the earphone serving as the collector load for audio.

In effect, the reflex circuit uses *Q1* as both an r.f. and an audio amplifier at the same time. Coil *L2* is virtually a short as far as audio signals are concerned, and *C1* represents an open circuit. Similarly, *T1*'s primary is essentially a short at audio frequencies and *C3* is an open circuit. Neither the feedback network (*R2-C5*) nor the audio load have any effect on the r.f. signal since these circuits are bypassed (for r.f.) by *C4* and *C7* respectively.

With practice, you should have no trouble recognizing the difference between regenerative and reflex circuits. Just identify the type of feedback signal—if it is identical to the input signal, you are dealing with a regenerative circuit, and if different (whether

(Continued on page 98)

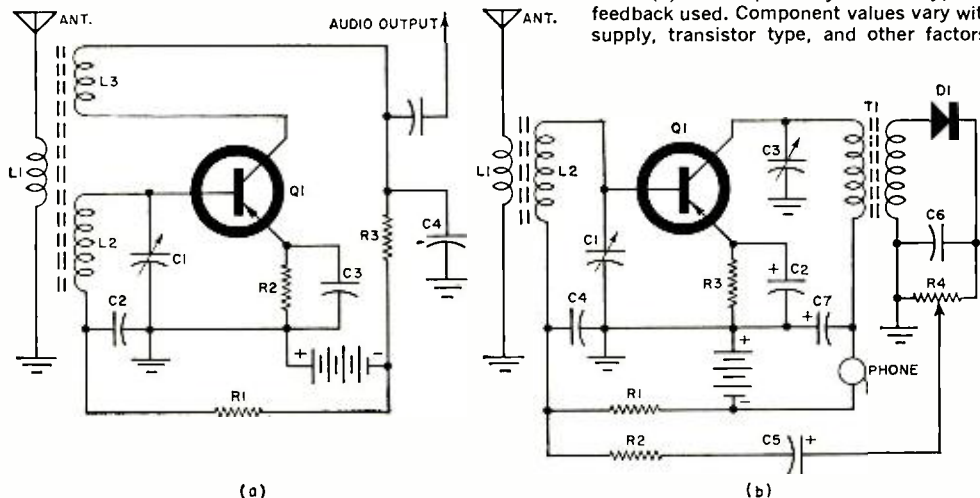

Fig. 4. Regenerative (a) and reflex circuits (b) differ primarily in the type of feedback used. Component values vary with supply, transistor type, and other factors.

BY JACK SMALL

Mannerly Table Lamp

TIME-
DELAY
TRICKERY



THE TABLE LAMP described here was designed to be a safety device for the home. The lamp is said to have “manners” because, when it is switched off, the light remains lit long enough for you to get into bed or leave the room before it is automatically extinguished. Objects you would not ordinarily see in the dark can be avoided.

The circuit for the “Lamp with Manners,” shown schematically below, is simple and virtually foolproof. When *S1* is ON, a.c. power is applied to the lamp and the heater element of thermal relay *K1* is out of the circuit. When *S1* is OFF, both the heater of *K1* and the lamp are in the circuit. As power is applied to *K1*, the bimetallic contacts open, and power is removed from the lamp.

Once *S1* is set to OFF, power is continuously applied to the relay's heater (which uses less than 3 watts). As a result *K1*'s contacts remain open until shortly after *S1* is returned to ON.

Almost any hollow-based table lamp can be equipped with manners. The only additional parts you need are a miniature thermal time-delay relay, a nine-pin

tube socket, a s.p.d.t. switch, and some hardware.

The relay with the time delay desired can be selected from Amperite's 115C series (115C30T for 30 seconds, 115C60T for 60 seconds, and 115C120T for two minutes). Other delay times are also available.

The method used to mount the switch and relay depends on the amount of space available inside the lamp's base. One suitable method is shown in the
(Continued on page 97)

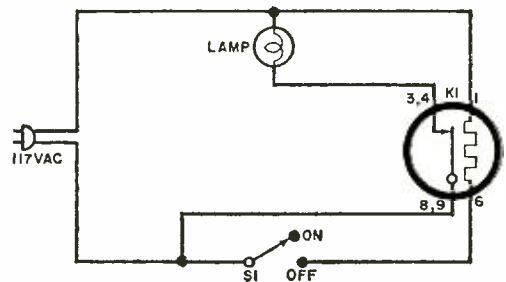

With *S1* at OFF, lamp and *K1* receive power until thermal action opens relay's bimetallic contacts.

ENGLISH-LANGUAGE BROADCASTS TO NORTH AMERICA FOR THE MONTH OF NOVEMBER

Prepared by ROGER LEGGE

TO EASTERN AND CENTRAL NORTH AMERICA		TO WESTERN NORTH AMERICA	
TIME—EST	STATION AND LOCATION	TIME—PST	STATION AND LOCATION
	FREQUENCIES (MHz)		FREQUENCIES (MHz)
7:15 a.m.	Helsinki, Finland (Sat., Sun.) Melbourne, Australia Montreal, Canada	7:00 a.m. 6:00 p.m.	Tokyo, Japan Melbourne, Australia Quito, Ecuador Taipei, Taiwan
7:45 a.m.	Copenhagen, Denmark		Tokyo, Japan
6:00 p.m.	Montreal, Canada	6:30 p.m.	Johannesburg, South Africa
6:45 p.m.	Tokyo, Japan	7:00 p.m.	London, England
7:00 p.m.	London, England Moscow, U.S.S.R.		Madrid, Spain Peking, China
	Sofia, Bulgaria		Seoul, Korea
7:30 p.m.	Budapest, Hungary Johannesburg, South Africa	7:20 p.m.	Yerevan, U.S.S.R. (via Khabarovsk)
	Kiev, U.S.S.R. (Mon., Thu., Sat.)		(Tues., Wed., Fri., Sat.)
	Stockholm, Sweden	7:30 p.m.	Berlin, Germany
7:50 p.m.	Brussels, Belgium		Bonaire, Neth. Antilles
	Vatican City		Stockholm, Sweden
8:00 p.m.	Berlin, Germany		Havana, Cuba
	Havana, Cuba	8:00 p.m.	Lisbon, Portugal
	Madrid, Spain		Moscow, U.S.S.R. (via Khabarovsk)
	Peking, China		Peking, China
	Rome, Italy		Sofia, Bulgaria
8:30 p.m.	Berne, Switzerland	8:30 p.m.	Bucharest, Rumania
	Bucharest, Rumania		Budapest, Hungary
	Cologne, Germany		Kiev, U.S.S.R. (Mon., Thu., Sat.)
	Hilversum, Holland (via Bonaire)	8:45 p.m.	Berne, Switzerland
	Tirana, Albania		Cologne, Germany
9:00 p.m.	Cairo, Egypt	9:00 p.m.	Havana, Cuba
	Lisbon, Portugal		Tokyo, Japan
	London, England	10:00 p.m.	Moscow, U.S.S.R. (via Khabarovsk)
	Melbourne, Australia	10:30 p.m.	Havana, Cuba
	Moscow, U.S.S.R.		
	7.15, 9.665, 9.685		9.505
	9.58, 11.71		15.32, 17.84
	9.625, 11.72		9.745, 11.915, 15.115
	15.165		15.125, 15.345, 17.89
	9.625, 11.725, 15.19		15.235, 17.825, 21.64
	15.135, 17.825		9.705, 11.875, 15.22
	6.11, 9.58, 11.78		6.11, 7.13, 9.58
	7.15, 9.665, 9.685		6.13, 9.76
	9.70		15.095, 17.675, 17.795
	6.235, 9.833, 11.91		15.43
	9.705, 11.875, 15.22		11.85, 15.18, 17.88
	9.665, 9.685		
	5.99		9.56, 9.65
	6.125		9.695
	6.145, 9.69, 11.76		11.705
	9.50, 9.73		9.525
	9.525		6.025, 9.68, 11.935
	6.13, 9.76		11.85, 15.18, 17.88
	15.06, 17.675, 17.90		15.095, 17.675, 17.795
	9.575, 11.81		9.70
	6.12, 9.535, 11.715		5.985, 9.675, 11.94
	5.985, 9.675, 11.94		6.235, 9.833, 11.91
	9.64, 11.945		9.665, 9.685
	9.59		6.12, 9.72
	6.20, 7.30		9.545, 11.945
	9.475		9.525
	6.025, 9.68, 11.935		15.105
	6.11, 7.13, 9.58		9.54, 11.755, 11.85
	15.32, 17.84		9.655
	7.15, 9.665, 9.685		



SHORT-WAVE LISTENING

By **HANK BENNETT**, W2PNA/WPE2FT
Short-Wave Editor

TRISTAN DA CUNHA IS ON THE AIR

ANOTHER OF THOSE really rare stations has turned up in the DX news. It's *Tristan Radio* located on Tristan da Cunha, near the settlement area on the northwest corner of the island. Alan Hemming, ZD9BE, Director of Broadcasting, writes that the station, with a call sign of ZOE, is operating with 40 watts on 3290 kHz with English scheduled for Wednesday, Friday and Sunday at 1900-2200 GMT. Programming, of a local nature, is intended only for listeners within a radius of 250 miles although reports have been received from ships 700 miles away. The signature tune is "Scottish Soldier" (sung). International Reply Coupons (exact number not stated, but send two—Ed.) are requested for confirmation of reception reports.

Tristan da Cunha is located in the South Atlantic, roughly 2200 miles west-southwest of Cape Town, South Africa and nearly on longitude zero. Your Editor has not seen any actual reports of reception of this station but it's a good one to try for during the winter period of early darkness. You'll need a sharp receiver and a good antenna-ground system on this one!

Another country that's very rarely heard on the airwaves is Qatar. This Persian Gulf shiekhdom is reported to be on the air with *Qatar Radio*, Doha, with 100 kW on 9570 kHz. The transmission schedule is reportedly 0430-0600 (Fridays until 0800) and 1500-1800 in Arabic only. Tests have been said to be at 1300-1500. A medium-wave outlet is listed for 674 kHz. Again, we've seen no reports on this station. Has anyone heard it?

Program to Continue. A statement in a recent issue of a foreign publication said that 1968 would be the concluding year of "The Happy Station Program," which has been produced and conducted by Eddie Startz for the past 40 years. The program is aired Sundays by *R. Nederland*. More recently it has been learned that Mr. Startz completely denied the story of his retirement and that he will continue to do the program. While we do not wish to state that our good

friend Eddie certainly does not deserve a well-earned vacation, I'm sure that many of us will be pleased to know that he will continue to brighten up the world every Sunday for many years to come. And congratulations, too, Eddie, on your 40th anniversary this month!

A letter has been received from B. L. Manohar, a monitor in India, regarding *Radio Nepal*. In the letter he states that this station definitely has its 100-kW transmitter on the air. Sign-on time is at 1325 on 9590 kHz with Nepali, Hindi songs and commercials; sign-off is at 1620 and there are no parallel channels in use on either 7105 or 4600 kHz. These latter two channels continue to operate mornings with s/on at 0220 in Nepali; the medium-wave outlet on 1500 kHz also continues to operate as usual.

Returning to *R. Nederland*, they are building a new station in Bonaire which will use two 300-kW transmitters. These will be able to be coupled together for 600 kW and will



Wayne Ayers, WPE4JND, a student at Indiana University's Graduate School, is shown seated near his Drake SW-4 receiver and a Sony Super Sensitivity receiver. Wayne also uses a Panasonic tape recorder. He has verified 23 countries out of 53 logged.

be in service to North, Central and South America, the Pacific and West Africa. Completion date is set for February, 1969.

From the Swiss Broadcasting Corp., Berne: "Due to a temporary shortage of staff and the impending reorganization of our Listener's Mail Service, we will, unfortunately, not be in a position to answer letters and verify reports for some weeks to come. However, all accurate reports will be forwarded for evaluation to the Engineering Department . . . Your requests for program schedules and report forms will be filled in due



One listener post halfway around the world is capably manned by Samson Voron, VK2PE2R, of Coogee, New South Wales, Australia. Samson has a National NC-88 receiver and an antenna that is 30-36 yd long. A member of the Australian Radio DX club, Samson would like a correspondent in any age group.

course . . . 'Melody Train' requests, 'Mailbag' questions and DX queries will be handled by the respective program producers."

One of our servicemen in Vietnam sent us a list of medium-wave stations that would make good DX catches especially since they all operate on standard US channels rather than on split channels. West Coast listeners might give these a try from time to time: Saigon, 540 kHz; Qui Nhon, 650 kHz; Da Nang, 870 kHz or Chu Lai, 1200 kHz, all with 10 kW, or Pleiku, 570 kHz, 50 kW. Reception reports are definitely welcomed.

CURRENT STATION REPORTS

The following is a resume of current reports. At time of compilation, all reports were as accurate as possible, but stations change frequency and/or schedule with little or no advance notice. All times shown are Greenwich Mean Time (GMT) and the 24-hour system is used. Reports should be sent to Short-Wave Listening, P. O. Box 333, Cherry Hill, N.J. 08034, before the fifth of each month; be sure to include your WPE identification and the make and model number of your receiver.

Afghanistan—*R. Afghanistan*, 15,265 kHz, has been logged from 1758 with IS of flute and native instruments until 1827 s/off with news and weather, Afghan music, commentary, talks, jazz and pop music. This English service is beamed to Europe and was well received, but with some polar flutter, in mid-U.S.A.

Angola—*Emisora Oficial*, Luanda, noted on 7235 kHz prior to s/on at 0500 with IS on a xylophone-type instrument, the anthem and into pop music.

Bolivia—*R. La Cruz del Sur*, La Paz, is good on 5025 kHz from 0115-0301 s/off with classical and light music, news in Spanish; English programming noted from 0230. An English ID is given at s/off.

Botswana—ZND, Gaborones, 3356 kHz, was heard with pop tunes in African and European languages to 0500 when they had an ID, an English time check and news. They verify promptly by personal letter.

Brazil—*R. Nacional de Brasilia* has a new international service in Portuguese Monday through Saturday at 2035-2130, 0000-0100 and 1235-1330 on 6065, 9665, 11,720 and 15,445 kHz. Reports go to the station at Av. W-3, Setor de Radio e Televisao, C.P. 1620, Brasilia, D.F., Brazil. Return postage required. A low powered station being heard at times on 3285 kHz is *Emissora da Educacao*, Rural, Natal, in Portuguese with s/off time, at least on weekends, at 0200. To date they have not verified.

Ceylon—*R. Ceylon*, Commercial Service, Colombo, has a relay of BBC news at 0200 on 9675 and 15,230 kHz. At 0210 "The Musical Clock" program continues until another newscast at 0300; all in English.

Chile—CE956, *R. Portales*, Santiago, is good on 9560 kHz at 0100-0204 in Spanish with news and talks. The station on 9700 kHz is listed as *R. La Voz de Chile* but ID's are definitely *R. Cooperativa*, *R. Sociedad Nacional de Mineria*, Santiago, 9753 kHz, is good at 0100 with Esso news, sports, "El Moticiero Anaconda," weather, home and world news, editorials and light music. "Musica en la Noche" is presented from 0300-0400 and s/off is at 0430.

Colombia—A new station is *R. Reloj*, Bogota, 4795 kHz, heard 0100-0500 with music, commercials and brief anmts. It is a member of "Caracol" network.

Cyprus—Your Editor has noted for a number of Sundays a series of tests from Nicosia on 17,820 kHz from 1445-1500 or later with variety music and all English anmts.

Ecuador—HCFA4, *La Voz de Manabi*, Portoviejo, listed for 4810 kHz, is on 4825 kHz with L.A. pop tunes and a few anmts after 0200. Do not confuse with *R. San Jose*, Peru, which closes daily at 0200. HCJS1, *Ondas El Angel*, El Angel, 4829 kHz, has listeners' request music and time checks around 0320.

England—The BBC Morning Service, beamed to Europe, is aired on single-sideband on 12,180 kHz, in Czech at 0515 and in Bulgarian at 0530.

Finland—Helsinki has Swedish to N.A. on Tuesday at 1300-1310. Another xmsn has Finnish around 1246 with music and talking. Both xmsns were on 15,185 kHz.

France—Paris has French with pop music at 1400 on 21,525 kHz and English with news and commentary at 0600 on 15,445 kHz.

Germany (West)—*Radio Free Europe*, Biblis, 17,735 kHz, is on this new frequency in Rumanian beamed to Rumania and Eastern Europe from 2145-2230.

Greece—*R. Athens* is now in English to Cyprus at 0700-0815, 1030-1300 and 1830-1900 on 7295 and 9605 kHz, to the Near East at 1630-1700 and to Turkey at 1330-1515 on the same channels; to Egypt at 0900-1000 on 9605 and 11,720 kHz; to France and United Kingdom at 1730-1800 and to N. W. Europe at 1930-2100 on 11,720 and 15,345 kHz.

Grenada—*Windward Islands Broadcasting Ser-*
(Continued on page 100)

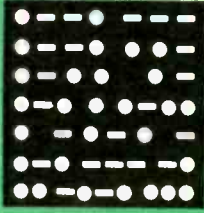

AMATEUR RADIO

By **HERB S. BRIER**, W9EGQ
Amateur Radio Editor

NEW AMATEUR FREQUENCIES

MARK 3:00 A.M., EST, November 22, 1968, on your calendar in big red letters. At that hour (2:00 a.m. CST, 1:00 a.m. MST, 12:00 midnight PST), the new amateur frequency assignments as shown in the table go into effect.

The two amateur groups apparently most concerned by the changed frequency allocations are the dedicated DX chasers and some phone operators—especially the 75-meter net operators. The DX chasers fear that not being able to operate in the bottom 25-kHz

slots of the 80-, 40-, and 15-meter CW bands and the 75- and 15-meter phone bands will be a handicap in working rare DX, especially in contests. Many 75-meter phone nets that have been operating in the Advanced and Extra class segments of the band have already or soon will be moved above 3.9 MHz. On the other hand, the number of amateurs who have qualified for Advanced and Extra class licenses indicates that the new segments will not lack for activity after November 22. Incidentally, there is no truth

AMATEUR STATION OF THE MONTH



George R. Clark, WA5QYK, 2212 W. 25 St., Oklahoma City, Okla. 73107, waited until he was 76 (two years ago) to discover amateur radio! He is active on 50 MHz with a Knight-Kit TR-106 transceiver, and in Navy MARS with a Heathkit HW-12A transceiver and a DX-40 transmitter and Hallicrafters SX-117 receiver. George should have his General license by the time you read this. We are awarding WA5QYK a one-year subscription to POPULAR ELECTRONICS for submitting the winning entry in our Monthly Amateur Station Photo Contest. To enter the contest, send a clear photo (black and white preferred) of you at the controls of your station and details of your amateur career to: Herb S. Brier, W9EGQ, Amateur Radio Editor, POPULAR ELECTRONICS, P. O. Box 678, Gary, Indiana 46501.

AMATEUR FREQUENCIES

(Nov. 22, 1968 to Nov. 21, 1969)

CLASS OF LICENSE	FREQUENCIES
Novice	3.7-3.75, 7.15-7.2, 21.1-21.25, and 145-147 MHz (CW only)
Technician	All amateur frequencies above 50.1 MHz*
Conditional & General	All amateur frequencies except 3.5-3.525, 3.8-3.885, 7-7.025, 7.2-7.225, 14-14.025, 14.2-14.235, 21-21.025, 21.25-21.3, and 50-50.1 MHz*
Advanced	All amateur frequencies except 3.5-3.525, 3.8-3.825, 7-7.025, 14-14.025, 21-21.025, and 21.25-21.275 MHz
Extra	All amateur frequencies

*FCC has not ruled on ARRL's requested postponement of requiring an Advanced or Extra class license to operate on 50-50.1 MHz.

to the story passed around by a few phone men that General class operators will still be allowed to operate CW in the Extra and Advanced class segments of the phone bands after November 22.

Contests. Two of the year's most popular amateur contests occur in the next few weeks: CQ's "World-Wide DX Contest," and ARRL's "Section-Sweepstakes (SS) Contest." Both are divided into phone and CW weekends. The phone section of the DX contest starts at 0000 GMT, October 26 (7:00 p.m. EST, October 25) and ends at 2400 GMT, October 27 (7:00 p.m. EST, October 26); and the CW contest occurs between the same hours on the weekend of November 23-24. Work any or all amateur bands and exchange contest numbers with foreign stations. Each exchange consists of sending a signal report and your zone number and receiving the same information from the station worked. Each station may be worked once per band.

If you plan on winning either the phone or CW section of the contest, send a large, stamped envelope (18 cents postage) to CQ WW DX Contest, 14 Vanderventer Ave., Port Washington, N. Y. 11050, for scoring rules (which are a little tricky), free zone map, and log sheets. DX men will be watching the CW half of the WW DX contest with close interest because it will be the first major contest held under the new frequency allocations. Will the Extra class operators run away with the U.S. scores?

For the ARRL Sweepstakes Contest (the 35th annual event), the phone weekend is from 2100 GMT (4:00 p.m. EST) Saturday,

November 9 to 0300 GMT (10:00 p.m. EST) Monday, November 11. The CW portion will be the same period the following week. The goal in this contest is to work as many different stations as possible in the 73 ARRL sections in the U.S. (and territories) and Canada, exchanging "message preambles" with each station worked. Two points are earned for each 2-way exchange; the total score is the number of points multiplied by the number of different sections worked, multiplied by 1.25 if your power is less than 150 watts on CW. The multiplier is 1.5 for phone. Novices are especially invited to participate in the Sweepstakes, and high-scoring Novices are eligible for certificates. Write to the Communications Dept., American Radio Relay League, Inc., 225 Main St., Newington, Conn. 06111, for official ARRL SS log sheets and rules (which were not finalized when this was written).

Other November contests of interest include: YLRL Anniversary Phone Party, for YL operators only, Nov. 6-7; OK (Czechoslovakian) CW Contest, Nov. 9-10; RSGB 7-MHz Phone Contest.

Digital Communications. What will be the next big advance in amateur communications after SSB? Writing in *Auto Call*, Editor R. V. "Andy" Anderson, KØNL, predicts that it will be digital communications. In digital phone communications, the audio signal is fed into a group of filters that produce a series of pulses to be transmitted. At the receiver, these pulses control audio oscillators that reconstitute the original audio signal. Among the claimed advantages of digital communications are narrow bandwidth, high efficiency, and good immunity

(Continued on page 110)



Francis Rose, G2DRT, operates GB2BP in behalf of English High Wycombe Boy Scouts at their annual September show. At home, G2DRT likes to ragchew on 21 and 28 MHz—no "rubber-stamp contacts."

FREE!

1969
CATALOG
No. 690

**JUST OFF THE PRESS!!
SEND FOR YOUR EXCITING COPY NOW!**



**BIGGER
& BETTER
THAN EVER**
OVER **500** PAGES!

**YOUR 1st GUIDE TO
EVERYTHING IN
ELECTRONICS**

- ★ CITIZENS BAND 2-WAY RADIO
- ★ STEREO/HI-FI COMPONENTS
- ★ MUSICAL INSTRUMENTS AND AMPLIFIERS

- ★ PUBLIC ADDRESS
- ★ AMATEUR RADIO
- ★ TEST EQUIPMENT
- ★ PARTS
- ★ PORTABLE AND TABLE RADIOS

- ★ PHOTO EQUIPMENT
- ★ TOOLS
- ★ AUTO ACCESSORIES
- ★ EDUCATIONAL AND OPTICAL
- ★ TV AND ANTENNAS
- ★ BOOKS

LAFAYETTE Radio ELECTRONICS
Dept. 35118, P.O. Box 10
Syosset, L.I., N.Y. 11791

Please send the FREE 1969 LAFAYETTE Catalog 690 35118

Name

Address

City State

Zip

(please include your Zip Code No.)

**Mail This Coupon Today
For Your 1969 Catalog
No. 690.**

CIRCLE NO. 23 ON READER SERVICE PAGE



INFORMATION CENTRAL

By CHARLES J. SCHAUERS, W6QLV

Wireless Intercom Interference. *I bought and installed two wireless intercoms. When I use my AM radio, I can pick up conversations from the intercoms at about 600 kHz. The signals are very weak, but I was wondering if our neighbors could also hear the intercom conversations on their radios—this might prove embarrassing.*

I doubt it. You are probably picking up a harmonic of the low-frequency output of the intercom and this would not travel far. But for peace of mind, why not check with the neighbors? If one of your neighbors has the same intercoms and both of your homes are supplied via the same power line, you could hear each other's conversation if the sets are tuned to the same frequency.

DX-40 Choke Burn-Out. *As you no doubt know, Novice hams try to save money by buying second-hand equipment. Well, I have a Heath DX-40 transmitter which I obtained for \$40.00. After I used it a while, the parasitic choke on the final tube burned up. Can you tell me why?*

Improper loading of the final could be the cause or perhaps a very high VSWR.

Generator Differences. *What is the principal difference between a signal generator and a sweep generator?*

The signal generator puts out a signal on one particular frequency whereas the sweep generator not only puts out an r.f. signal on a given frequency (center frequency) but its output is FM-modulated, resulting in a signal that varies up and down from the center frequency.

SB2-LA Noise. *I just bought a used SB2-LA linear amplifier, and I am using an SR-150 transceiver to drive it. In the standby position, there is some receiver hash. How can I get rid of this hash?*

First, check the bias adjustment. During the receiving function, some bias is applied to the tubes (6JE6's) to prevent receiver noise. On transmit, this bias is reduced for proper linear operation. Also, make certain that the tubes are good and are matched types. A weak or "unbalanced" tube will cause the load to be unevenly distributed

and thus lower r.f. output efficiency. Check the tubes on a good mutual conductance tester; the amplification factor (μ) of each tube should be in the same range.

CB R.F. Output. *My CB transceiver is not fitted with an r.f. output indicator. Because I would like to know if it is putting out, please suggest a simple means of measuring r.f.*

Although a relative field-strength meter is preferred to indicate transmitter output be-

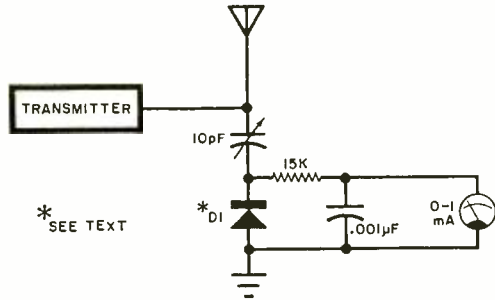

cause it also tells what the antenna is doing, the circuit shown above can be wired into your rig. The diode, D1, can be almost any signal diode you have at hand.

Tonal Quality Determination. *What determines the tonal quality of sound? Is it the harmonic content?*

It has been demonstrated that the attack and decay times have much more to do with tonal quality than harmonic content. Transient or "staccato" sounds can and do contribute to distortion in a system that can generally reproduce sounds with fine tonal quality. A sound system must have no phase distortion, very wide frequency range, and little "hangover," if distortionless reproduction of short sound pulses is to be accomplished.

Inexpensive L-Pad. *Where can I buy an inexpensive L-pad for use as a brilliance control (to vary the tweeter level) in my hi-fi system?*

(Continued on page 96)

Scott's new LR-88 receiver takes the



out of kit building

Building a kit used to be something you couldn't do with ladies and children present, but Scott's new LR-88 AM/FM stereo receiver kit has changed all that. First, there's the instruction manual. In clear and simple language, it leads you, step-by-step, through every stage of the assembly process. And each stage is illustrated . . . full-size, full-color. Next, there's Scott's ingenious new Kit-Pak®. The parts for each assembly stage are in individual compartments, keyed to the instructions. All wires are color-coded, and pre-cut and pre-stripped to the proper sizes. Difficult or critical sections are pre-wired, pre-aligned, pre-tested, and factory-mounted on printed circuit boards. Is soldering your bugaboo? Scott has provided push-on solderless connectors for the hard-to-get-at spots.

About thirty painless hours after you've started, you've completed one great receiver. The LR-88 is the 100-Watt kit brother to Scott's finest factory-wired beauties. It includes the famous Scott silverplated Field Effect Transistor front end, Integrated Circuit IF strip, all-silicon output circuitry . . . in fact, all the goodies that would cost you over a hundred dollars more if Scott did all the assembling. Performance? Just check the specs below . . . and you'll be amazed at how great a receiver sounds after you've built it yourself. Treat yourself to a weekend of fun and years of enjoyment . . . see the Scott LR-88 at your dealer's today.

LR-88 Control Features: Dual Bass and Treble; Loudness; Balance; Volume compensation; Tape monitor; Mono/stereo control; Noise filter; Interstation muting; Dual speaker switches; Stereo microphone inputs; Front panel headphone output; Input selector; Signal strength meter; Zero-center meter; Stereo threshold control; Remote speaker mono/stereo control; Tuning control; Stereo indicator light. **LR-88 Specifications:** Music Power rating (IHF), 100 Watts @ 4 Ohms; Usable sensitivity, 2.0 μ V; Harmonic distortion, 0.6%; Frequency response, 15-25,000 Hz \pm 1.5 dB; Cross modulation rejection, 80 dB; Selectivity, 45 dB; Capture ratio, 2.5 dB; Signal/noise ratio, 65 dB; Price, \$334.95.

You'll swear by it



Write for complete information on the new Scott components and kits.

H.H. Scott, Inc., Dept. 520-11,
Maynard, Mass. 01754
Export: Scott International,
P.O. Box 277,
Maynard, Mass. 01754

Walnut case optional extra

SCOTT®

© 1968, H.H. Scott, Inc.

CIRCLE NO. 31 ON READER SERVICE PAGE

November, 1968

87

Two more examples of how RCA Institutes provides up-to-the-minute Home Training in all phases of electronics:

NEW CATV LESSONS

The demand is heavy for technicians in the booming field of CATV (Community Antenna Television Systems).

CATV was initially used to make it possible for large numbers of television receiver users to get good reception in remote areas through the use of a common antenna. It now brings to more people more programs than are available from local stations. It also improves reception where multipath signal transmission exists.

RCA Institutes includes two comprehensive lessons, covering the practical phases of CATV systems and servicing in Television Servicing and Communications courses and programs at no additional total tuition cost. Get in on the ground floor of this rewarding and expanding field. Send for full information today!

Prepare yourself for a career in the expanding field of CATV.

NEW COLOR TV KIT

To make courses even more practical and to better prepare you for a more rewarding future, RCA Institutes now includes an exciting Color TV Kit in both the beginner's program and the advanced course in color TV servicing. The cost of the kit is included in the tuition—nothing extra to pay. You also get five construction/experiment manuals plus a comprehensive service manual.

You'll receive all the materials and components to perform over 50 information-packed experiments. When you finish you'll have constructed an 18" (measured diagonally) high quality, color TV set, complete with rich cabinet in wood grain design.

Get all the details on RCA Institutes' valuable new Color TV Kit!

SEND THE ATTACHED CARD TODAY!

This is the high quality color TV set you'll construct, complete with rich cabinet in wood grain design.

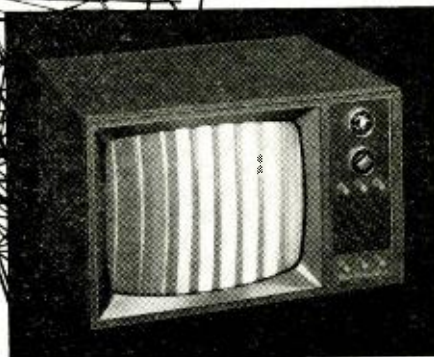

Learn electronics at home faster, easier, almost automatically—with RCA AUTOTEXT

Are you just a beginner with an interest in the exciting field of electronics? Or, are you already earning a living in electronics and want to brush-up or expand your knowledge in a more rewarding field of electronics? In either case, AUTOTEXT, RCA Institutes' own method of Home Training will help you learn electronics more quickly and with less effort, even if you've had trouble with conventional learning methods in the past.

THOUSANDS OF WELL PAID JOBS ARE OPEN NOW TO MEN SKILLED IN ELECTRONICS!

Thousands of well paid jobs in electronics go unfilled every year because not enough men have taken the opportunity to train themselves for these openings. RCA Institutes has done something positive to help men with an aptitude and interest in electronics to qualify for these jobs.

HOME STUDY CAN TRAIN YOU FOR REWARDING CAREER OPPORTUNITIES

To help fill the "manpower gap" in the electronics field, RCA Institutes has developed a broad scope of Home Training courses, all designed to lead to a well paying career in electronics in the least possible time. You also have the opportunity to enroll in an RCA "Career Program" exclusively created to train you quickly for the job you want! Each "Career Program" starts with the amazing AUTOTEXT Programmed Instruction Method. And, all along the way, your program is supervised by RCA Institutes experts who become personally involved in your training and help you over any "rough spots" that may develop.

VARIETY OF KITS ARE YOURS TO KEEP

To give practical application to your studies, a variety of valuable RCA Institutes engineered kits are included in your program. Each kit is complete in itself, and yours to keep at no extra cost. You get the new Programmed Electronics Breadboard for limitless experiments, including building a working signal generator, multimeter, and a fully transistorized superheterodyne AM receiver.

ONLY FROM RCA INSTITUTES— TRANSISTORIZED TV KIT— VALUABLE OSCILLOSCOPE

All students receive a valuable oscilloscope. Those enrolled in the Television program receive the all-new transistorized TV Kit. Both at no extra cost and only from RCA Institutes.

CHOOSE THE "CAREER PROGRAM" THAT APPEALS MOST TO YOU

Start today on the electronics career of your choice. Pick the one that suits you best and mark it off on the attached card.

- Television Servicing
- Telecommunications
- FCC License Preparation
- Automation Electronics
- Automatic Controls
- Digital Techniques
- Industrial Electronics
- Nuclear Instrumentation
- Solid State Electronics
- Electronics Drafting

ADVANCED TRAINING

For those already working in electronics, RCA Institutes offers advanced courses. You can start on a higher level without wasting time on work you already know.

2 CONVENIENT PAYMENT PLANS

RCA Institutes offers a unique tuition plan that lets you progress at your own pace. You only pay for lessons as you order them. You don't sign a contract obligating you to continue the course.

There's no large down-payment to lose if you decide not to continue.

However, if you desire, RCA Institutes also offers a convenient monthly payment plan.

CLASSROOM TRAINING ALSO AVAILABLE

If you prefer, you can attend classes at RCA Institutes Resident School, one of the largest of its kind in New York City. Coeducational classroom and laboratory training, day and evening sessions, start four times a year. Simply check "Classroom Training" on the attached card for full information.

JOB PLACEMENT SERVICE, TOO!

Companies like IBM, Bell Telephone Labs, GE, RCA, Xerox, Honeywell, Grumman, Westinghouse, and major Radio and TV Networks have regularly employed graduates through RCA Institutes' own placement service.

SEND ATTACHED POSTAGE PAID CARD TODAY. FREE DESCRIPTIVE BOOK YOURS WITHOUT OBLIGATION. NO SALESMAN WILL CALL.

All RCA Institutes courses and programs are approved for veterans under the new G.I. Bill.

Accredited Member
National Home Study Council

IF REPLY CARD IS DETACHED—SEND THIS COUPON TODAY
RCA INSTITUTES, Inc., Dept. PEQ-N8
320 West 31st Street, N.Y., N.Y. 10001

Please rush me FREE illustrated catalog. I understand that I am under no obligation, and that no salesman will call.

Name _____ Age _____
(please print)

Address _____

City _____

State _____ Zip _____

Free Sound Catalog

The largest selection of speaker system components. Anywhere.



Send for your free copy...today! **jensen**

Jensen Manufacturing Division, The Muter Company
5655 West 73rd Street • Chicago, Illinois 60638

NAME _____

ADDRESS _____

CITY _____

STATE _____

ZIP _____

CIRCLE NO. 22 ON READER SERVICE PAGE

SYDMUR

The Last Word In Ignition Systems



SAVE MONEY
on GAS! COILS!
SPARK PLUGS!
TUNE-UPS!

The most advanced solid state C.D. ignition systems available. Take advantage of the latest technology... Get the most out of your car's engine.

- Increased Mileage
- Greatly Extended Spark Plug Life
- Longer Battery Life
- Fewer Tune-ups

Rugged construction and conservatively rated components.

Every Sydmur unit is pre-tested and guaranteed. The easy to install Sydmur—is fully adaptable: 6 or 12 volt systems, positive or negative ground. Available in either kit or assembled form.

Fly-away assembled \$60.00 prepaid*

Fly-away kit 44.50 prepaid*

And the smaller "COMPAC" unit (6 or 12V, negative ground only) designed for automobiles, motorcycles, go karts, outboard motors, etc.

Compac assembled \$34.75 plus 75¢ handling*

Compac kit 24.95 plus 75¢ handling*

(*New York State residents add sales tax.)

Recommended by many of the world's leading automotive manufacturers. Send check or money order today.

For free literature, write:

SYDMUR ELECTRONIC SPECIALTIES

1268 East 12th Street Brooklyn, N.Y. 11230

CIRCLE NO. 36 ON READER SERVICE PAGE

PARTS/METHODS/IDEAS/GADGETS/DEVICES

tips & techniques

EMERGENCY COAX CONNECTOR

What do you do when you have to connect a PL259 plug to a UG 261/U BNC-type jack? Well, you could change the connector on either the cable or the piece of equipment the cable must be connected to. However, this means you'll just have to change the connector again when you're finished. A quick

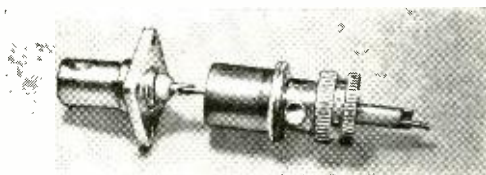

way out of this problem is to make an adapter. A type UG 261/U single-hole mounting BNC connector makes a good slip fit into the stem of a PL259 plug for the adapter assembly. First, solder a length of bare, solid hookup wire into the BNC connector, and slide the wire through the stem of the PL259 plug as shown in the photo. Now, bend the end of the wire over the center contact of the PL259, bringing the flange of the BNC into contact with the PL259 plug. Solder the wire in place and also solder together the outer conductors of both connectors. For this application you can discard the shell of the PL259. Shrink some heat-shrinkable tubing over the assembly, and you have a good emergency adapter.

—Robert Runnels, WASUGT

ADD POWER LAMP/STROBE ACCESSORY TO YOUR TURNTABLE

You can add a power indicator light and strobe light accessory to your turntable for making quick and frequent checks of turntable speed. If your turntable doesn't already have a power indicator, mount a bayonet socket (with built-in resistor for operating neon lamps at 117 volts) on the front skirt of the turntable's base. At one end of the length of coaxial cable, solder a plain bayonet socket; at the other end a spare bayonet-type lamp base. In both cases, the center conductor of the coax goes to the "hot" contact, while the coax braid goes to the shell or "common" contact. Insulate any exposed metal with heat-shrinkable tubing. Plug the coax into the turntable-mounted lamp socket, and in-

POPULAR ELECTRONICS

Ask your audio retailer which turntable is the most trouble-free.

We'll save you the time ...it's BSR McDonald.

**That's why BSR McDonald can give you
the only over-the-counter replacement guarantee
plus a one-year warranty on parts and labor.**

Every BSR McDonald automatic turntable is precision made in Great Britain to the most exacting engineering specifications. As a matter of fact, practically every one of the hundreds of parts are fabricated by us—to assure uniform excellence.

Upon their arrival in the U.S., every model is unpacked and retested under actual playing conditions. Even the tiniest flaw cannot escape our unique detection system. That's why BSR service calls are the lowest in the industry...and perhaps that also explains why BSR sells more turntables than anyone else in the world.

Because of the extra precautions we take in our quality re-test program, we deliver the most trouble-free turntable in the industry. That's why we can back up this claim with the strongest guarantee ever offered. If any defect is found in a BSR McDonald automatic turntable, your retailer will replace it immediately with a brand new unit with no charge and no questions asked.

On top of this, you get a one year guarantee on every part except the cartridge—including labor as well. Who else dares offer this unique quality guarantee?



Please send FREE detailed literature on all BSR McDonald automatic turntables. K

Name _____

Address _____

City _____ State _____ Zip _____



PRECISION CRAFTED IN GREAT BRITAIN
BSR (USA) LTO., BLAUVELT, N.Y. 10913

CIRCLE NO. 6 ON READER SERVICE PAGE

FREE

RADIO-TV ELECTRONICS

BA 60
ANNUAL CATALOG
No. 691

BURSTEIN-APPLEBEE QUICK INDEX
WITH STORES IN...
KANSAS CITY MISSOURI
ST. LOUIS MISSOURI
SPRINGFIELD MISSOURI
ST. JOHNS MOBILE ALA.
MEMPHIS TENNESSEE

FOR FAST PERSONAL SERVICE • MONEY ORDER REFUNDING 24 HOURS
3199 MERCIER ST., KANSAS CITY, MO. 64111



**GIANT 1969
RADIO-TV
ELECTRONICS
CATALOG**
228 GIANT
VALUE-PACKED
PAGES

WRITE FOR YOUR FREE COPY TODAY

BURSTEIN-APPLEBEE CO., DEPT. PEW
3199 MERCIER ST., K. C., MO. 64111

NAME _____

ADDRESS _____

CTY _____ STATE _____ ZIP _____

CIRCLE NO. 8 ON READER SERVICE PAGE

NEW THUNDER SHATTERING POWER! Thunder Columns

Never before has a sound reproduction device been designed to handle enormous power with such effortless ease and fidelity! Thunder Columns are scientifically-designed true sound columns, with every component perfectly matched to project maximum undistorted sound to your audience. Argos Thunder Columns are musician speakers in every sense of the word.

- 200 and 300 watt models • True focused sound for the serious musician • Fuse protected against accidental power overloads • Hidden steel grille crash protects speakers • Rugged upholstery grade vinyl finish • Heavy duty electronic instrument speakers

Argos
PRODUCTS COMPANY

600 So. Sycamore, Genoa, Ill. 60135

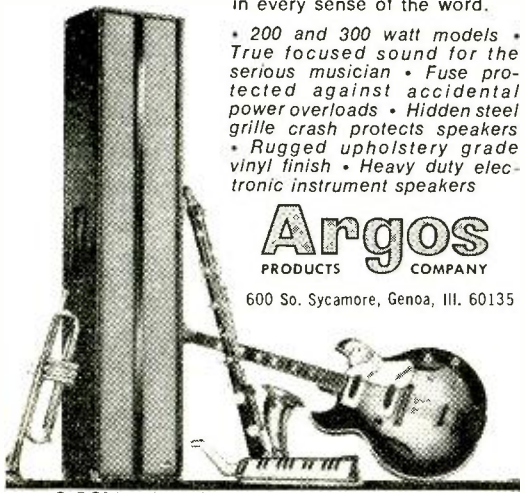

CIRCLE NO. 4 ON READER SERVICE PAGE

TIPS

(Continued from page 92)

sert an NE51 or NE51H (if you want a brighter light, choose sockets to accept the brighter NE51H lamp.) Then read turntable speed with a conventional strobe disc.

—Henry R. Rosenblatt

TV LEAD-IN DOUBLES AS CABLE TIES

One of the most unsightly—and possibly most dangerous—things in ham shacks and workshops is dangling wires and cables. If you have some extra 300-ohm twin-lead TV lead-in cable handy, however, you can fabricate your own cable tie/hangers and eliminate the problems. Cut the lead-in to the approximate lengths needed, square at one end, and at an angle at the other end. Then punch a hole at the squared end to facilitate hanging, and a slot (slightly shorter than the twin-lead is wide) directly below the hole. (See photo for details.)



Wrap the fabricated cable tie/hanger around the cables to be bundled together and pass the angled end of the tie through the slot. Pull tight and anchor the tie with a nail or screw where desired. For low voltage, use the twin-lead as is; for high voltage, tear or cut out the conductors.

—Stan Mosher





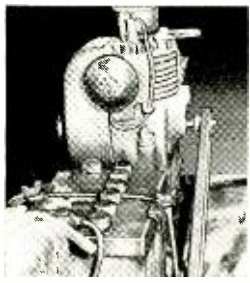

MOWER ENGINE SAVES GAS WHEN CHARGING BATTERY

The camper usually has to rely on his car's electrical system for power to operate lights and radios, and this generally means that his car's engine must be kept running to keep the battery fully charged. However, with the aid of an old lawn mower engine and some hardware, the battery can be kept fully charged with a very small outlay for gas. First, use four heavy bolts to mount a metal plate semipermanently inside the car's engine near the generator or alternator. Then mount the mower engine on the metal plate. In use, you simply remove and save the fan belt, and run another belt from mower engine to generator. The generator's mounting bracket provides belt adjustment. Overcharging is prevented by the car's voltage regulator. When not in use, the fan belt goes back in place and the mower engine stores neatly away in your car's trunk.



—Harry I. Miller

POPULAR ELECTRONICS

M-11  Solid State Units All Silicon Transistor VHF-FM Pre-amplifier — 20 dB, 300 ohm In — 75 ohm Out	M-19  Solid State Units All Silicon Transistor FM Pre-amplifier — 20 dB, 75 ohm In — 75 ohm Out	M-116  Solid State Units 82-channel solid state — 25 dB Dist. Amplifier Separate UHF and VHF 75 ohm inputs.	M-118  Solid State Units All Silicon Transistor VHF-UHF Home Amplifier — Four 75 ohm Outputs	M-108  Solid State Units All Silicon Transistor VHF 40 dB Distribution Amplifier	M-403  Solid State Units UHF to VHF Crystal Controlled Converter
--	---	---	--	--	--

FINCO

MATV

EQUIPMENT

...THE COMPLETE LINE

M-170  Solid State Units Single Channel Strip Amplifier 40 dB Gain	M-248  82-Channel Antenna Mounted Transformer — Die-Cast Housing
M-22  Solid State Units 82-Channel Mast Mounted Pre-amplifier, 15 dB	M-261  Four-Way Back Match 82-Channel Splitter/indoor
M-206  Four-Way Back Match Splitter/indoor	M-210  Eight-Way Back Match Splitter

from the largest
broad-band or single-channel
strip amplifier...
to the smallest
connector
or any one of
over 200 items!

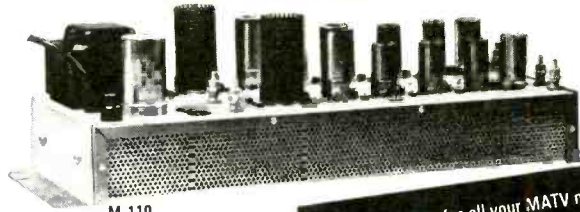







M-304
Dual Output Plate
75 ohm outlet TV
300 ohm outlet FM



M-110
1 Volt per Channel on
9 Channels, 60 dB
Distribution Amplifier

- A single source for all your MATV needs.
- Silicon solid state design.
- Built to the highest standards.
- Free MATV layout service.
- Heavy duty 75 ohm MATV Antennas.

M-214  Matched Line Drop Tap — Outdoor Cast Housing	M-213  Matched Line Drop Tap/indoor	M-526  Hi-Q Single Carrier Trap, 60 dB Attenuation	M-303 C  Single 300 Ohm output Wall Outlet Plate — VHF	M-552  Variable Attenuator 0 to 32 dB in 1 dB Steps	M-550  Transistorized Field Strength Meter VHF
---	---	--	--	---	--

Illustrations represent a cross section of over 200 MATV items

USE FINCO MATV ANTENNA SYSTEMS FOR: HOTELS • MOTELS • SCHOOLS
HOSPITALS • STORES • OFFICE BUILDINGS • APARTMENTS • HOMES



THE FINNEY COMPANY

FINCO is the maker of the world famous Color Spectrum™ Antennas

Send for FINCO'S FREE 45-page
illustrated MATV catalogue
and layout information forms.

THE FINNEY COMPANY
34 W. Interstate Street • Dept. P-E
Bedford, Ohio 44146

NEW! SOLID STATE KITS

Automatic Recording-Level Control

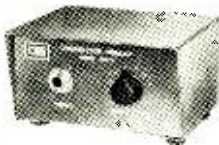

FOR ANY TAPE RECORDER

Low-noise distortionless compressor — preamp easily installs in mike line. Easy-to-build kit with complete instructions.

MODEL ACP-1 KIT \$18.50

Voice/Sound Actuated Controller

Voice operate any tape recorder, ham and CB transmitter. Ideal for intrusion alarms. Built-in relay switches up to 1 amp. Easy-to-build kit with complete instructions.

MODEL VOX-1 KIT \$18.50

Other Kits

Audio Amplifiers ■ Power Supplies ■ Test Equipment ■ Treasure Locators ■ and many others

FREE Data sheets with circuit description, diagram, and specifications for all kits.



CARINGELLA ELECTRONICS, Inc.
P.O. Box 327 ■ Upland, California 91786
Phone 714-985-1540

CIRCLE NO. 9 ON READER SERVICE PAGE



LOOK! A NEW ELECTRONICS SLIDE RULE WITH COMPLETE INSTRUCTION COURSE

Professional 10" all-metal Electronics Slide Rule. Designed specifically for technicians, engineers, students, hobbyists. Has special scales not found on any other rule. Enables you to solve electronics problems quickly, accurately. Made to our rigid specs by Pickett, Inc. Slide Rule plus four lesson AUTO-PROGRAMMED Instruction Course with grading service, and top-grain leather carrying case . . . a \$50 value for less than \$25! Send coupon for FREE booklet. Cleveland Institute of Electronics, Dept. PE-150, 1776 E. 17th St., Cleveland, Ohio 44114.

SEND COUPON FOR FREE BOOKLET

Cleveland Institute of Electronics

1776 E. 17th St., Dept. PE-150
Cleveland, Ohio 44114

Please send FREE Electronics Slide Rule Booklet. SPECIAL BONUS: Mail coupon promptly and get FREE Pocket Electronics Data Guide, too!



GET THIS FREE!

NAME _____ (Please Print)

ADDRESS _____ COUNTY _____

CITY _____ STATE _____ ZIP _____

A leader in Electronics Training . . . since 1934

CIRCLE NO. 11 ON READER SERVICE PAGE

INFORMATION CENTRAL

(Continued from page 86)

Lafayette Radio has one for \$1.19 (99 H 6134 for 8 ohms and 99 H 6135 for 16 ohms). Most of the other major parts distributors also have good values.

Tubes To Transistors? *Is it possible to replace the tubes in my EICO Model 232 VTVM with transistors?*

It is possible but not practical; a complete re-design of the unit would be involved.

Downward Modulation of 525A. *I have a Lafayette CB transceiver (Model 525A), and I have been experiencing downward modulation. What could be the cause?*

Generally, overloading the final too heavily. Keep the loading down below that recommended by the manufacturer.

Converted Transceiver Use. *I modified a pair of 1-watt CB transceivers (hand-held) for operation on the 10-meter band and they work very well. May my son, who has no ham license, operate one of the sets on 10 meters legally because of the low power involved? Also, if I use the sets in another call area for a couple of months,*

The answer to your first question is no; regardless of power, operation in the Amateur Radio Service requires a license. Yes, to your second question.

6146B and 6146 In Parallel? *Can I connect a 6146 and a 6146B in parallel without ill effects?*

This practice is not recommended if you want maximum power output. The two tubes, although close in characteristics, are not the same.

Disappointing Hi-Fi. *When I use my stereo tape recorder as an amplifier with my good Grado cartridge and Garrard turntable the sound lacks bass. Even re-recording records and discs sounds lifeless. Can't I solve this problem without an expensive amplifier?*

Your problem is one of lack of equalization in the tape recorder amplifier. In all probability that amplifier was not designed to work from a phono cartridge. Look into the possibility of buying an Olson (record equalization) preamplifier—Model AM-297. They are not too expensive and it will permit you to use most of your present equipment.

POPULAR ELECTRONICS

MANNERLY LAMP

(Continued from page 79)

photo. A clamp is used to hold the relay in place. First wrap a couple of layers of adhesive tape around the envelope of the relay, slip the relay into the clamp, and

anchor the assembly to the lamp with appropriate hardware. Tighten the hardware just enough to hold the relay in place—not too tight, or the glass envelope may fracture. Now, affix a heat-resistant cover plate over the base of the lamp. Stiff fiberboard or two thicknesses of sheet asbestos will be perfect.

That's it! You now have a lamp with manners. —30—

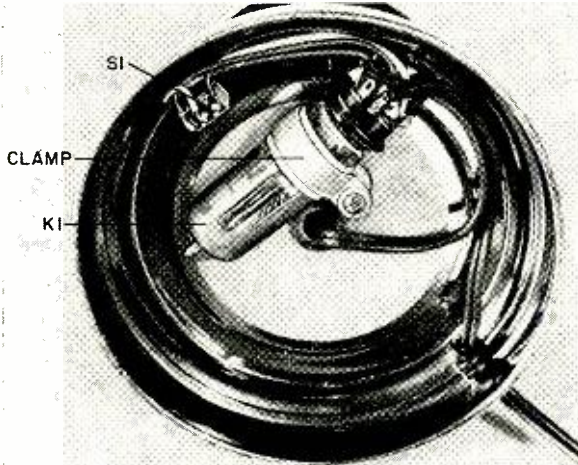

Thermal relay and switch can be conveniently mounted inside hollow base of most lamps. Glue sheet asbestos and layer of felt over base to conceal tube and a.c. line cord.

“Hey look, I just built a radio in 2 minutes.”

With new Lectron transistorized magnetic blocks, it's easy to put a solid-state radio together. Then take apart and build an electronic organ in minutes, or a burglar alarm, automatic night light, rain indicator, Morse code transmitter, intercom and many more that really work. Simply match symbols on Lectron see-thru blocks with circuit diagrams in 68-page manual. No wiring. No tools. No experience needed to have hours of fun while you learn electronics. Completely safe. Lectron sets begin under twelve dollars wherever fine toys are sold.

lectron
makes electronics
child's play

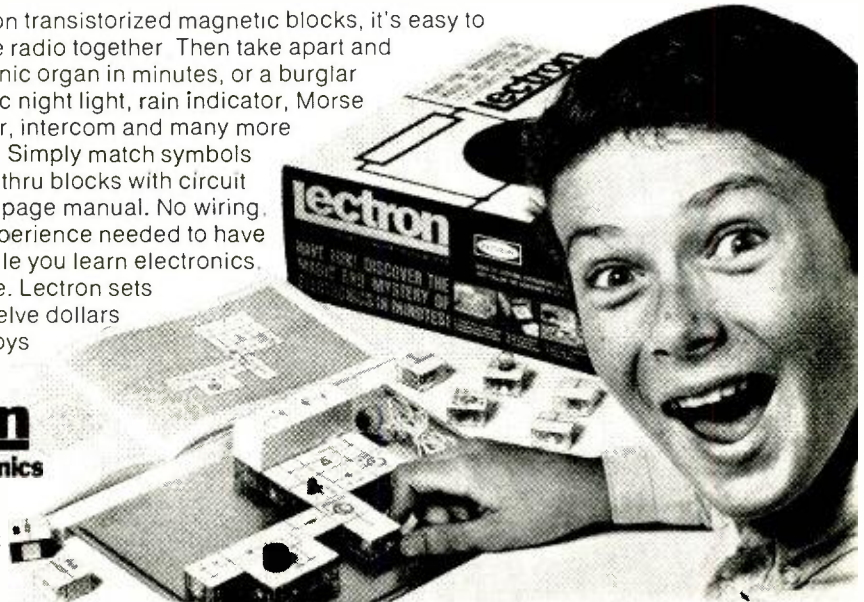

Raytheon Education Company, Dept. 30, 186 Third Avenue, Waltham, Mass 02154.

CIRCLE NO. 29 ON READER SERVICE PAGE

Valuable SAMS BOOKS

USE THIS HANDY ORDER FORM

JUST PUBLISHED! IMPORTANT!

- How to Build Electronics Projects.** Fully describes methods and tools used in constructing electronics projects; explains proper circuit layout, metal chassis and panel layout, drilling and punching. Includes special data on semiconductor circuits and etched circuit board construction. Order 20670, only.....\$2.95
- Record Changers—How They Work.** Provides full data on motors and their differences, cartridges, and needles. Describes installation procedures and information on upgrading changers for use with improved cartridges. Order 20661, only.....\$3.95
- Electronics for the Beginner.** 2nd Ed. Avoids dry theory; introduces the beginner to the construction of electronic devices in a practical way. All projects described are fully transistorized, and increase in difficulty as the beginner proceeds. Crystal-clear diagrams, plus templates and complete parts lists make building easy and enjoyable. Order 20677 (hardbound), only.....\$5.25
Order 20664 (softbound), only.....\$3.95
- 101 Easy Ham Radio Projects.** A selection of easy-to-build, inexpensive circuits for a variety of worthwhile ham devices. Provides brief descriptions, construction hints, diagrams, and parts lists; includes substitution guide appendix. Order 20674, only.....\$3.95
- North American Radio-Television Station Guide.** New 5th Ed. Lists call letters, frequencies, locations, etc., for all a-m, f-m, and tv stations (both vhf and uhf) in the U. S. and possessions, Canada, Cuba, Mexico, and the West Indies. Order 20635, only.....\$2.95
- Transistor TV Training Course.** Provides a complete understanding of modern transistor television circuitry by progressive analysis of each stage of a typical receiver. Includes review questions. Order 20619, only.....\$3.95
- Citizens Band Radio Handbook.** Enlarged 3rd edition. Covers latest CB equipment and circuits, antenna systems, fixed and mobile installations, maintenance and repairs, FCC rules, etc. Order 20569, only.....\$4.25
- How to Build Speaker Enclosures.** Provides a wealth of both practical and theoretical information for constructing high-performance enclosures for speaker systems. Order 20520, only.....\$3.50
- Tape Recorders—How They Work.** 2nd Ed. 20445.....\$4.50
- 99 Ways to Improve Your CB Radio.** 20515.....2.95
- How to Read Schematic Diagrams.** 2nd Ed. 20568.....3.50
- Know Your Oscilloscope.** 2nd Ed. 20549.....3.50
- 101 Ways to Use Your VOM & VTVM.** 2nd Ed. 20510.....3.50
- Modern Dictionary of Electronics.** 3rd Ed. 20600.....9.95
- So You Want to Be a Ham.** 4th Ed. 20607.....4.50
- Short Wave Listener's Guide.** 2nd Ed. 20542.....1.95
- 101 Easy Audio Projects.** 20608.....3.50
- 49 Easy Transistor Projects.** 20617.....1.75
- Walkie-Talkie Handbook.** 20572.....3.95

FAMOUS ABC'S BOOKS

- Computers. 20012.....\$2.95
- Lasers & Masers. 20262.....2.95
- Transistors. 20440.....2.75
- CB Radio. 20019.....\$2.50
- Tape Recording. 20395.....2.50
- Boolean Algebra. 20055.....2.75

— HOWARD W. SAMS & CO., INC. —

Order from any Electronic Parts Distributor, or mail to Howard W. Sams & Co., Inc., Dept. PE-11 4300 W. 62nd St., Indianapolis, Ind. 46268

Send books checked above. \$ _____ enclosed.

Send FREE Sams Book Catalog.

Name _____
PLEASE PRINT

Address _____

City _____ State _____ Zip _____

CIRCLE NO. 30 ON READER SERVICE PAGE

SOLID STATE

(Continued from page 78)

a detected audio signal or d.c. components), a reflex circuit. But watch out for those combination regenerative-reflex designs!

Modified Design. An improved version of the headphone amplifier circuit given in our January, 1968 column is shown in Fig. 5. This modified design was abstracted from Application Bulletin APP-157, published by Fairchild Semiconductor (313 Fairchild Dr., Mountain View, Calif. 94040).

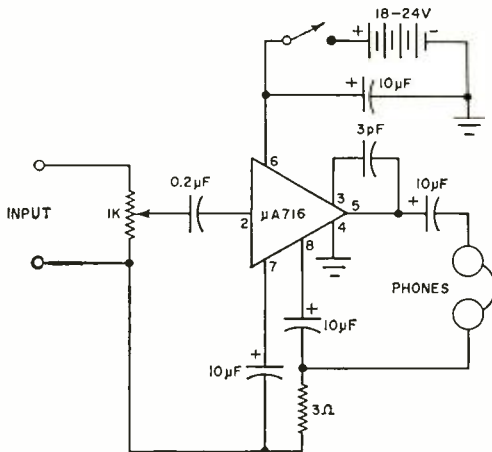

Fig. 5. Integrated-circuit headphone amplifier has good match to 600-ohm headset for high efficiency.

Like the earlier circuit, the amplifier has a rated gain of 100 and an output of approximately 50 mW. It differs from the previous design, however, in that it provides a better match to a 600-ohm headset, thus insuring higher efficiency and better quality of reproduction. It may be paired for use in stereo headphone systems or used singly for tape monitoring, in communications work or in language laboratories.

The amplifier may be assembled on a suitably designed etched circuit board or wired on perf board. Neither layout nor lead dress is critical, but good audio wiring practice should be observed, with all d.c. polarities noted and ample spacing provided between the input and output circuits. The assembled amplifier may be housed in a small metal or plastic case with commercial jacks for the input and output connections.

Who's On First? If there were a World Series among semiconductor manufacturers,

the umpires would have a difficult job, indeed, in deciding who deserved first place. The firm which manufactures the most powerful silicon transistor, for example, might be completely out of the running in terms of voltage rating or high-frequency response. In addition, with competition keen and design engineers working overtime, there's a good chance the standings would have to be revised on a month-to-month, if not a day-to-day, basis.

From the standpoint of voltage ratings, the present leader would be Motorola with its 1500-volt MJE 8401 *nnp* power transistor. On the other hand, Westinghouse would take first place in both the power dissipation and collector current contests with its 625-watt type 1401 and its 150-ampere (at 120 volts) type 1441. The present champion in terms of microwave power, however, is TRW Semiconductors with a newly introduced series capable of delivering up to 30 watts at 2 GHz.

In the SCR (or thyristor) games, General Electric would be unchallenged with its 1200-ampere, 1800-volt water-cooled type C500X1, but Westinghouse would be the top contender in the air-cooled league with its 550-ampere, 1500-volt type 282.

The price wars would find such firms as Motorola, Texas Instruments, and RCA slugging it out. Motorola would win a double header with its new budget-priced MPF106 and MPT107 *n*-channel FET's. With a noise figure of only 2.0 dB at 100 MHz, Motorola's new units can be used as amplifier's from d.c. to above 400 MHz, yet sell for as little as 75¢ each in quantities over 100. Texas Instruments, on the other hand, can counter with its new line of plastic-encapsulated *nnp* and *pnp* complementary silicon power transistors. These units are rated for 30 to 90 watts power dissipation at 40 or 60 volts, depending on type, yet sell for as little as 70¢ each in moderate quantities. But competition is tough, for RCA can offer an unbroken series of wins with its metal-cased, hermetically sealed PHP series of silicon planar transistors, ranging from a mere 19¢ for the 2N5183 (in OEM quantities of 1000 up) 1-ampere, general-purpose amplifier to 39¢ for the 2N5179 low-noise UHF amplifier.

Over in the IC league, Motorola and Fairchild are fighting a see-saw battle for first place in terms of digital devices, while RCA has nearly everyone "running scared" with perhaps the most comprehensive line of low-cost linear devices in the industry.

If the situation seems confused, it is! There's a pretty good chance that almost any semiconductor manufacturer could be considered the leader, at least as far as a specific type of device is concerned.

Play ball!

-Lou

November, 1968

NOW OFFERED FOR THE FIRST TIME TO THE PUBLIC **GRAYMARK** ELECTRONICS PROJECTS

Hobbyist / Experimenter / Student

For years, teachers have used Graymark classroom projects to provide (1) the basics of electronics theory and (2) valuable and workable end products. Now, for the first time, Graymark offers certain of these projects to the public. You can now embark on your own exciting, step-by-step journey toward the building of your own highly professional, eight-transistor or five-tube radio . . . besides learning a great deal about electronics. Each project comes complete with all parts and easy-to-follow instructional manual. All parts fully warranted.

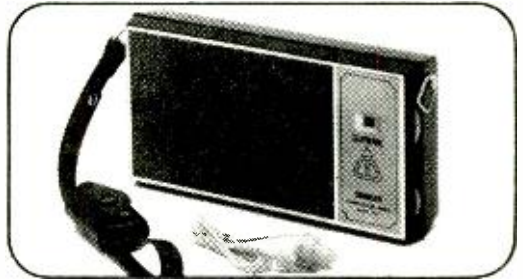

"COMACHO" EIGHT-TRANSISTOR RADIO. Project provides basics of superheterodyne transistor theory operation. Builds into an attractive printed circuit-board radio, mounted in plastic case. Compares favorably with more expensive units. Earphone included. \$19.95 each.

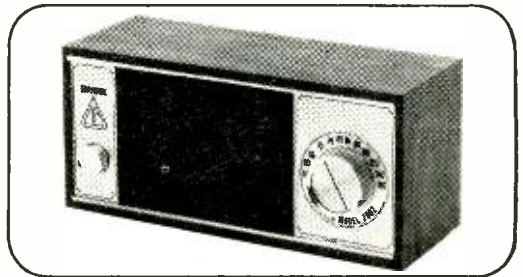

"SCALLON" FIVE-TUBE RADIO. Easy-to-understand project approach to superheterodyne circuitry. Assembles into a distinctive table-type radio. Tubes, contemporary walnut cabinet included. \$21.95 each.

Send order today to:
GRAYMARK Enterprises, Incorporated
Dept. 101, P.O. Box 54343, Ter. Annex, Los Angeles, Calif. 90054

Send Projects Checked

- COMACHO (\$19.95 ea.) SCALLON (\$21.95 ea.)
 Send Postpaid. Enclosed find check/money order for full amount. (Calif. Res. add 5% to total purchase)
 Send C.O.D. I will pay full amount, plus postage.

Name _____

Address _____

City & State _____ Zip _____

CIRCLE NO. 20 ON READER SERVICE PAGE

99

SHORT-WAVE LISTENING

(Continued from page 82)

vice, St. Georges, is good on 15.095 kHz at 1613 with commentary and religious program. 2100-2300 with music requests and 2250-2300 with sports roundup. A new channel in use is 21.690 kHz found at 2035 with news to the British Isles.

Honduras—Jack Bacon in Minnesota reports that HRN, *La Voz de Honduras*, Tegucigalpa, often overrides WMAQ, a 50-kW Chicago station on 670 kHz. The 5875-kHz outlet is also good at times around 1200 in Spanish.

India—All India Radio, New Delhi, is excellent on 15,235 kHz at 2300-0115 s/off in English to N.E. Asia.

Indonesia—Djakarta, 6045 kHz, was good at 1200 with an organ IS, 1201 news, 1212 a "magazine" type program and some music until 1230. This is dual to 9770 kHz and is the Indonesian National Program.

Italy—Rome has a new channel: 17.795 kHz, as tuned at 0350 with English news and 0440 with an ID and music. The 11.810 kHz has been noted at 2230 in Spanish.

Jordan—Amman to So. Am. is on 15.170 kHz from 2330 s/on in Spanish to 0000 and to 0025 in Arabic. If it'll help, the opening ID is "Huna Amman, Idhasat Al Mamlakate Al Urdoniete Al Hashe-niyya . . ."

Lebanon—Beirut has English to N. A. daily at 0230-0300 on 15,285 kHz. New frequencies in service include 17,750 kHz at 0020 with ID and into Arabic, and 21,610 kHz at 1905 closing English and to 1928 in Arabic.

Malagasy Republic—Tananarive, 3288 kHz, opens in French at 0330 with a full ID and anthem and follows with variety pop tunes until fadeout at 0400.

Malaysia—R. Malaysia, Kuala Lumpur, 9665 kHz, has pop music at 1255. "Malaysian Gazette" at 1315. "Top Tunes" at 1330, sports scores at 1345. English news at 1400 and a commentary at 1410. Throughout the program are sprinkled ID's and commercials. The program is in English but the ID, in Malay, is "Ini-lah Radio Malaysia."

Netherlands Antilles—*Trans World Radio*, Bonaire, has been logged on 9590 kHz at 0730 with news in Dutch, on 11,820 kHz at 0050 with an English religious program, on 15,180 kHz at 2030-2055 in German and to 2125 in English, and on 15,435 kHz in English to Europe at 2100.

New Hebrides—R. Vila is currently scheduled as follows: Tuesday to Friday at 0030-0115 on 7260 kHz and 0600-0720 on 3905 kHz. Programs are in English, Pidgin and French. French is aired from 0700 to s/off which varies between 0710-0720.

New Zealand—The schedule given last month for R. New Zealand was incomplete. Please add: To Samoa at 0720-0750 Tuesday and to the Cook Islands at 0810 Wednesday on 6080 and 9540 kHz. No English is given on either xmsn. Also please change the Australian xmsn to read: 2000-2145 on 11,705 kHz and 2300-0545 on 17,770 kHz.

Nigeria—Lagos, 21,450 kHz, is using this 13-meter outlet for their external service between 1300-1400 French, 1500-1600, and 1800-1900 English, 1400-1500 Hausa and 1600-1700 Arabic. We've found this one easy to log during their English xmsn. The 15,155-kHz channel is also noted at good level at 0600 with English news and commentary.

Papua/New Guinea—R. Bougainville, Kieta, 3322.5 kHz, 3600 watts, operates 0800-1105 weekdays (to 1205 Saturdays); Midwestern reports indicate it is being heard at 1035-1055 with pop music and in vernacular. VL9BR, R. Rabaul, 3385 kHz, is also heard in the Midwest mornings in Pidgin and English.

Peru—OBZ4I, R. Erpa, Canete, is a seldom-heard station, but pop music may be heard at times along with usual L.A. style programming at 0200; amnts are in Spanish and the frequency is 3320 kHz.

Portugal—R. Lisboa has been found on a new and unlisted frequency of 15,315 kHz in Portuguese to Brazil and L.A., at 2230-0000; pop Portuguese music, documentary, news and pop/folk music make up the program. This channel operates parallel to 11,840 kHz.

SHORT-WAVE ABBREVIATIONS

annt—Announcement	kW—Kilowatts
BBC—British Broad-casting Corp.	L.A.—Latin America
GMT—Greenwich Mean Time	N.A.—North America
ID—Identification	R—Radio
IS—Interval Signal	s/off—Sign-off
kHz—Kilohertz	s/on—Sign-on
	xmsn—Transmission
	xmtr—Transmitter

USSR—Petrovavlovsk was heard in Russian with a drama at 0850 on 4485 kHz and running dual to 7380 kHz and, at times, to 9500 kHz. Six time-pips are given at 0900, the usual Moscow ID and into music at 0901.

Vatican City—R. Vaticano has an 1840 s/on in language on seldom-heard 15,185 kHz. New channels in use include 15,200 kHz at 1650 in Arabic and 21,570 kHz at 2315 in Portuguese and 2330 in Spanish to L.A.

Vietnam (North)—Hanoi is weak in language at 1400 on 15,018 kHz. Others report it on 15,044 kHz at 1400 with time-pips, news at 1401, a march at 1405, commentary at 1406, Vietnamese folk music at 1410, a speech at 1411, and a talk at 1424. This is the Vietnamese Home Service and the ID is "Day la Tieng Noi Viet-Nam phat thanh to Hano."

Ranked #1 in lightweight tracking ability¹

Able to track the toughest test-record bands at 0.8 gram^{2, . . .}
 With a frequency response flat within +2.5, -2 db from 20 to 20k Hz^{1, 2, . . .}
 And 30 db of stereo separation^{1, 2, . . .}
 Plus a flawless square wave^{1, 2, . . .}

EMPIRE's 999VE

The Long-Playing Cartridge • \$74.95

1. HiFi/Stereo Review, July 1968 2. High Fidelity, June 1968

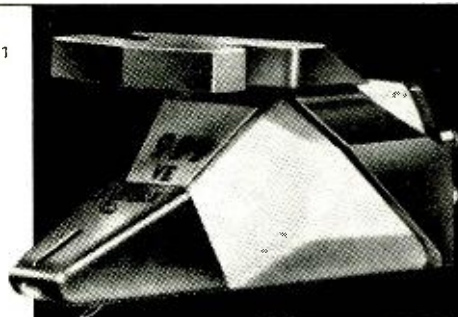

Empire Scientific Corp. 
 1055 Stewart Avenue, Garden City, N.Y. 11530

CIRCLE NO. 17 ON READER SERVICE PAGE

Clandestine—A QSL has been received from *R. Libertad, La Voz Anticomunista de America*; the reception report had been sent to NTS, 125 bis Rue Blomet, Paris 15, France; the QSL was postmarked Caracas, Venezuela. Mailing addresses as indicated on the QSL itself are P. O. Box 2214, Miami Beach, Fla. and P. O. Box 5650, Caracas. The return address on the envelope is DYTA, Apartado 20.064, z.p. 5, Caracas. The QSL card, printed by an American Ham radio card printer, had a message on the back indicating that the operation is a function of the NTS, a secret organization dedicated to overthrowing the Communist government of the USSR. Waiting time for the QSL was five months.

We've also received one report in the past few days that showed *R. Americas*, Swan Island, to be operating again on 6000 kHz. However, this report is thought to be in error since operations there ceased last May.

73. Hank, WPE2FT/W2PNA

SHORT-WAVE CONTRIBUTORS

William Bancroft (WPE1CLK), Pittsfield, Mass.
 Chris Lobdell (WPE1GCI), Reading Mass.
 Bob Raymond (WPE1HOE), Bradford, Mass.
 Ronald Christen (WPE2XZI), Cheektowaga, N. Y.
 Peter Macinta (WPE2ORB), Kearny, N. J.
 Robert Kennicutt, Jr. (WPE2PRR), Port Crane, N. Y.
 Andy Kodau (WPE2PRK), Hewlett, N. Y.
 Daniel Girard (WPE2QEV), Utica, N. Y.
 David Perry (WPE2QFK), Pleasant Valley, N. Y.
 James Farrell (WPE2QII), Ridgefield Park, N. J.
 Tom Shultz (WPE2QJJ), Cherry Hill, N. J.
 Marc Bacharach (WPE3HEM), Philadelphia, Pa.
 Henry Eagles (WPE3JN), Philadelphia, Pa.
 Dan Ferguson (WPE4AUL), Coral Gables, Fla.
 Grady Ferguson (WPE4BC), Charlotte, N. C.
 James Hawkins (WPE4HD), FPO (Vietnam)
 Wayne Ayers (WPE4JVD), Decatur, Ga.
 Randy Flynn (WPE4JVB), Vienna, Va.
 David Potter (WPE4JVO), Key West, Fla.
 Ray Lindquist (WPE4JVB), Miami, Fla.
 Paul Roddy (WPE5VH), Edna, Texas
 Stewart MacKenzie (WPE6IA), Huntington Beach, Calif.
 Don Kenney (WPE6AET), Santa Monica, Calif.
 Bruce Brotsma (WPE6GMD), Northridge, Calif.
 Steve Higgins (WPE6HLS), Covina, Calif.
 Dan Seibel (WPE6HCU), San Leandro, Calif.
 George Schnabel (WPE6EMO), Rochester, N. Y.
 Wendell Way (WPE6HVV), Canton, Ohio.
 Henry Gac (WPE6JST), Detroit, Mich.
 Louis Schulman (WPE6JTX), Cleveland Heights, Ohio
 William Jordan (WPE6JNL), Newbury, Mich.
 Gerry Dexter (WPE6HDB), Lake Geneva, Wis.
 Richard Pi-tek (WPE6HOA), Chicago, Ill.
 Richard Doring (WPE6HNG), Hinsdale, Ill.
 Gary Bullinger (WPE6JGZ), Aurora, Ill.
 Greg Buchanan (WPE6JGK), South Bend, Ind.
 Donald Zank (WPE6JGM), Milwaukee, Wis.
 Fred Lynch (WPE6JHD), Girard, Ill.
 Dwight Snyder (WPE6JHY), Farmersville, Ill.
 A. K. Niblack (WPE6KAE), Vincennes, Ind.
 John Beaver, Sr. (WPE6KAE), Pueblo, Colo.
 Bud Whitlock (WPE6COS), Augusta, Kansas
 Jack Bacon, Jr. (WPE6FDJ), Bloomington, Minn.
 David Schmidt (WPE6FHU), St. Joseph, Mo.
 Jack Perolo (PY2PE1C), Sao Paulo, Brazil
 Leo Alster, Rahway, N. J.
 Bruce Baer, Yankton, S. D.
 Alex Calabrese, Vineland, N. J.
 Dave Christensen, Seattle, Wash.
 John Ehrmann, Chicago, Ill.
 Gary Freeman, Moberly, Mo.
 George Holmes, Laurel, Md.
 Marc Kartrant, Bensenville, Ill.
 Steve Keegan, Eau Claire, Wis.
 Al Kosinski, Lathan, N. Y.
 R. Lucht, Key West, Fla.
 Larry Miller, Sheboygan, Wis.
 Gordon Nelson, Watertown, Mass.
 John Patterson, Oswego, Ill.
 Bob Penn, Atlanta, Ga.
 Jim Renfrew, New Canaan, Conn.
 Leo Song, Jr., Los Angeles, Calif.
 Brian Walk, Fullerton, Calif.
Radio New Zealand, Wellington, N. Z.
Sweden Calling DXers Bulletin, Stockholm, Sweden

Deluxe POPULAR ELECTRONICS MAGAZINE CASES

DESIGNED TO HOLD A FULL YEAR'S COPIES

These decorative cases are just what you've been looking for to keep your copies of Popular Electronics Magazine in easy-to-find order.

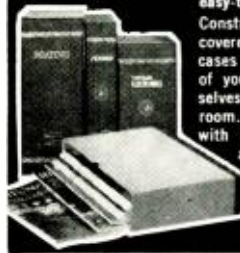

Constructed of reinforced fibreboard and covered in rich leatherette, these durable cases guard against soiling and tearing of your magazines while lending themselves handsomely to the decor of any room. The magazine cases are available with embossed gold lettering in either all black or attractive maroon back with black sides.

\$3.50 ea., 3 for \$10, 6 for \$19

FULLY GUARANTEED!

Ziff-Davis Publishing Co., Dept. SD

1 Park Ave., N.Y., N.Y. 10016

Please send me _____ Popular Electronics Magazine

Files as checked below:

- All black, gold embossed
 Maroon back, gold embossed/black sides

NAME _____ PE-118

ADDRESS _____

CITY _____

STATE _____ ZIP _____

Enclosed is \$ _____ at \$3.50 per case, 3 for \$10, 6 for \$19 (Quantity prices apply for combination orders of more than one title). Orders outside U.S.A. \$4.50 ea., 3 for \$13, 6 for \$25.

(Payment must accompany order)

NEW! 1969 EDITION—WRL ELECTRONIC EQUIPMENT CATALOG

FREE

Brand New!
 Filled with amazing buys in electronic equipment including dozens of new and exclusive items you can't buy anywhere else!

Anything in the book on easy credit terms, TOO!

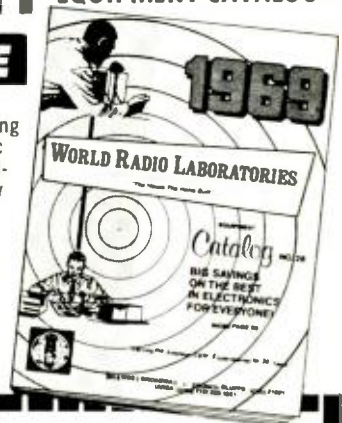

World Radio Laboratories

3415 West Broadway

Council Bluffs, Iowa 51501 PE-q11

Gentlemen:

Please send me your Free 1969 Catalog.

Name _____

Address _____

City _____ State _____ Zip _____

CIRCLE NO. 38 ON READER SERVICE PAGE

UNUSUAL BARGAINS EXCELLENT XMAS GIFTS!

... MANY U. S. GOV'T SURPLUS

STE YOUR MUSIC IN DAZZLING ACTION with



MUSIC VISION

Dramatic Breakthrough In Audio-Visual Enjoyment

Now you can have a thrilling, psychedelic "see-in" fight in your own home, club, school or business—in fact—anywhere! Colored light beams dance and prance, whirl and swirl in perfect time with the music—each individual note creating its own unique twisting, radiating shape. Adds a spectacularly wild, new dimension to the world of music and entertainment. Combines electronics, science and art with dramatic results. Attaches in seconds to your radio, tape recorder, hi-fi or stereo with two alligator clips. Can be used on small screens, large wall, stages and whole auditoriums. Build your own MusicVision® with low-cost Do-It-Yourself Kit. Loads of fun! Fast! Easy! All you need is a light source. If you don't have one, the versatile Edmund 35mm and Watt Projector is a terrific bargain. All kinds of other uses too—set up to accept motorized accessories. Also available in 15" x 15" x 27" Walnut Cabinet Model, Tube Unit, or 8" and 12" Sets which include enclosed electronics, Motondizer, Color Wheel and set of apertures for use with your own 35mm projector. Large 12" set provides fabulous effects for commercial applications. Order by stock number listed below. Money-back guarantee. Complete information in new catalog. Send 25¢ in coin for fully illustrated, 16-page Booklet No. 9096AV "Introduction to MusicVision®".

- 8" DO-IT-YOURSELF KIT, Stock No. 71.009AV \$22.50 Postpaid
EDMUND 300 WATT 35mm PROJECTOR, Stock No. 71.057AV \$24.50 Postpaid
WALNUT VENERED CABINET MODEL, Stock No. 85.181 \$45.00 F.O.B.
8" SET (Motondizer, color wheel, apertures) Stock No. 71.030AV \$45.00 Postpaid
12" SET (same as above w/larger Motondizer) Stock No. 71.032AV \$57.50 Postpaid

TOP-QUALITY LOW-COST STROBE



Create spectacular psychedelic lighting effects with this genuine electronic strobe. Perfect for parties, special occasions, experiments... perfect for combos, night clubs, dances, exhibitions. Adjusts from 1 to 10 short-duration flashes per second—not a make-shift mechanical device. Amaze friends with old-time movie effects. Best party ice-breaker ever—"freeze" the action and "unfreeze" your guests. Practical—check action of moderate speed machinery. Xenon lamp gives one million flashes. 6 1/2" diam. reflector. Uses reg. 110-120 volt A.C. current. Handsome solid walnut cabinet. 9 1/4" x 6 1/2" by 4". Send for Bulletin #75—describes other starting. Buy new unique lighting effects.

Stock No. 70.989AV \$79.95 Ppd.

NEW LOW-COST ULTRASONIC CLEANER

Now a top-quality unit for only \$39.95. Cleans dirt, grime completely, quickly, safely. Small delicate parts, precision electronic items, lab instruments, jewelry, coins, even dentures sparkle like new. 1/2 gal. capacity. Operates on regular house current. Precision American-made. Full 1 year guarantee. Solid state generator with automatic turn-off to prevent overheating. Power control regulating knob, grounded to prevent shock. No radio interference. 17 1/2" x 14" x 4". Steel and metal cabinet.



Stock No. 71.003AV \$39.95 Ppd.
Stock No. 85.128AV (Wt. 37 lbs.) \$249.95 FOB

3" ASTRONOMICAL TELESCOPE



See the stars, moon, phases of Venus, planets close up. 60 to 180 power. Aluminized and over-coated 3" diameter f/10 primary mirror, ventilated cell. Equatorial mount with locks on both axes. Equipped with 60X eyepiece and mounted Barlow lens. 3X finder telescope, hardwood tripod. Included FREE: "STAR CHART"; 272-page "HANDBOOK OF HEAVENS"; "HOW TO USE YOUR TELESCOPE" book.

Stock No. 85.050AV \$ 29.95 Ppd.
Stock No. 85.086AV 3/4" REFLECTOR \$ 84.50 FOB
Stock No. 85.086AV 6" REFLECTOR \$199.50 FOB

Order by Stock No.—Check or M.O.—Money-Back Guarantee
**EDMUND SCIENTIFIC CO., 300 EDSORP BUILDING
BARRINGTON, NEW JERSEY 08007**

GIANT FREE CATALOG "AV"

Completely new 1969 edition. New items, categories, illustrations. 148 easy-to-read pages packed with 4000 unusual items. Dozens of electrical and electromagnetic parts, accessories. Enormous selection of Astronomical Telescopes, Microscopes, Binoculars, Magnifiers, Magnets, Lenses, Prisms. Many war surplus items; for hobbyists, experimenters, workshops, factory. Write for catalog "AV". Include Zip.



ORDER BY STOCK NUMBER • SEND CHECK OR MONEY ORDER • MONEY-BACK GUARANTEE
**EDMUND SCIENTIFIC CO., 300 EDSORP BUILDING
BARRINGTON, NEW JERSEY 08007**
CIRCLE NO. 15 ON READER SERVICE PAGE

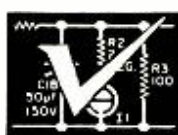

OPERATION ASSIST

Through this column we try to make it possible for readers needing information on outdated, obscure, and unusual radio-electronics gear to get help from other P.E. readers. Here's how it works: Check the list below. If you can help anyone with a schematic or other information, write him directly—he'll appreciate it. If you need help, send a postcard to Operation Assist, POPULAR ELECTRONICS, One Park Avenue, New York, N.Y. 10016. Give maker's name and model number of the unit. If you don't know both the maker's name and the model number, give year of manufacture, bands covered, tubes used, etc. State specifically what you want, i.e., schematic, source for parts, etc. Be sure to print or type everything legibly, including your name and address. Because we get so many inquiries, none of them can be acknowledged. POPULAR ELECTRONICS reserves the right to publish only those items not available from normal sources.

Power Unit PE-103-A. Radio Transceiver BC-222. Operating manuals and schematics needed. (Marvin D. Foster, 901 Orchard Dr., Fayetteville, N.C. 29303)

Butler Bros. Model 921-S TV. Schematic and source for parts needed. (Robert Layton, 118 N. Locust St., Pauls Valley, Okla. 73075)

Hallcrafters Model 5R33A. Schematic and manual needed. Emerson Model BM206. Schematic, manual, and parts source needed. (William G. Murray, 96 Brush Hill Rd., Milton, Mass. 02187)

Precise Model 315B oscilloscope. Replacement of power transformer needed. (Thomas L. Keister, Jr., 1046 Mathews St., Jackson, Miss. 39209)

Gonset G-66 mobile receiver. Schematic and operating manual needed. (William H. Hardy, Jr., 204 Sunset Dr., Lower Burrell, Pa. 15065)

Gonset 50 six-meter transceiver. Schematic and operating manual needed. (H. Vandergrift, Warwick Hotel, St. Louis, Mo. 63103)

Sonar Model MR-3 10, 20, and 80 meter receiver. **Harvey Wells Electronics** Model AT-3B-12 transmitter. Schematics and service data needed. (George C. French, 4326 Avon Dr., La Mesa, Calif. 92041)

Harvey-Wells TBS-50-D deluxe bandmaster, circa 1950-55. Schematic, alignment, and operating instructions needed. (Bruce Hibbert, 559 Oriole Ln., Corona, Calif.)

DeForests Training 2', 3-tube CRT oscilloscope. Schematic and parts list needed. (Richard Mundwiler, 20122 Nightbird Trail, Crosby, Texas 77532)

Knight-Kit T-60 transmitter. Manual needed. (Arthur Fisher, Rte. 4, College Ave., Ellicott City, Md. 21031)

Sparton Model 301 radio, 1933. Schematic needed. (John Kusek, 821 E. Hector St., Conshohocken, Pa. 19428)

Pilot Model T 601 FM "Pilotuner." Schematic and hook-up instructions needed. (Thomas K. McNally, Pine Rd., High Bridge, N.J. 08829)

Pentron Pacemaker tape recorder; belts by Telton. New belts needed. (John F. Wittlinger, 248 E. 293 St., Willowick, Ohio 44094)

Hallcrafters Model S-38. Schematic, operating manual, and alignment data needed. (Paul Tran, 1126 Miles Ave., Pacific Grove, Calif. 93950)

Heathkit Model O-S oscilloscope. Schematic and operating manual needed. (Rick Rumack, 7941 W. Lake St., Morton Grove, Ill. 60053)

Radio City Products Model 664 VTVM. Schematic needed. (Donald Rochford, 3560 Olinville Ave., Bronx, N.Y. 10467)

Triumph Model 830 3" oscilloscope; Navy type CTU 60018. Schematic needed. (Don Jeppesen, 2318 Second Ave., Council Bluffs, Iowa 51501)

RCA Model ARSSD receiver. Manual, schematic, and source for parts needed. (Robert R. Collins, 490-A Esteli Dr., MCAS Beaufort, S.C. 29902)

Heath Model DX-20 transmitter. Schematic and operating manual needed. (Bernard Skoch, 1001 N. Gray, Jacksonville, Ark. 72076)

Philco Model 38-116 receiver. Schematic, operating manual, tuning instructions, and source for parts needed. (Bill Harrison, 2020 Olga Ave., Nashville, Tenn. 37216)

Truetone CB radio. 12-channel. Schematic and manual needed. (Andy Fredlund, 5324 Malibu Ct., Cape Coral, Fla. 33904)

Brunswick Model 22 floor model radio. Circuit diagram needed. (William Pepe, 112 N. 17 St., Bloomfield, N.J.)

Atwater Kent Model 82. Schematic and source for plug-in electrodynamic speaker needed. Also operating instructions and alignment data. (John Szychulda, 13937 Bora Dr., La Mirada, Calif. 90638)

Aviola Model 502 receiver. Schematic, source for parts, and any information needed. (Karl Salmon, 2915 5th Ave., York, Pa. 17402)

Packard-Bell Model 861 phonocord radio and disc recorder. Schematic and source of parts for a General Industries automatic record changer and disc cutter needed. (Keith Headley, 10514 Buford Ave., Lennox, Calif. 90304)

Hallicrafters Model S-22 receiver. Schematic and alignment data needed. (Douh Zimmer, 14332 35th N.E., Seattle, Wn. 98125)

Heathkit Model EA-2 amplifier and preamp. Schematic and operating manual needed. (Stephan Perhacs, 5201 Shirley St., Verona, Pa. 15147)

Barker & Williamson Model 380B T-R switch. Operating manual and/or schematic needed. (Robert F. Malone, Jr., 21 Joysan Terr., RFD #1, Freehold, N.J. 07728)

Crestwood Model 404 mono tape deck. Source for parts needed. (Paul Gottlieb, 3224 Grand Concourse, Bronx, N.Y. 10458)

National Model NC100A. Schematic and operating manual needed. (Mike Corrigan, 82S 8th St., S.W., Rochester, Minn. 55901)

GE Model RC125 FM. Schematic, tune-up, and tube location needed. Industrial Model HM-PS40 two-way radio. Schematic, tube line-up and tune-up needed. (Ed Galovic, 86 Egbert Rd., Bedford, Ohio 44146)

Hallicrafters Sky Ranger Model S-39 receiver. Schematic and alignment data needed. (Bing Zamora, P.O.B. 2154, 431 Sales St., Sta. Cruz, Manila, Philippines)

GE Model CRO-3A oscilloscope. Schematic needed. (Donald B. Price, 141 Court St., Chardon, Ohio 44024)

Superior Instruments Model 670A super meter. New D'Arsonval movement or circuit to be used with conventional meter needed. (T.A. Harmon, 1020 Barbara Pl., #2, Salt Lake City, Utah 84102)

Philco Model 39-116 with remote control. Schematic, service manual, and source for parts needed. (Marlin D. Strickland, 443 Claudia Dr., Sonoma, Calif. 95476)

Philco Model 635 receiver, code 121. Power transformer, schematic, and parts list needed. (Ken Croston, 1603 N. High, Independence, Mo. 64050)

Crosley Model J13 AM/SW radio; made by Mohawk Radio. Schematic needed. (Lawrence Meikle, R.R. #1, Richmond Hill, Ont., Canada)

Precise Model 630 RF-AF and TV marker generator. Schematic, alignment instructions, and other information needed. **Trio** Model TR-2M antenna rotator. Schematic of control head needed. (Robert Vlcek, 2325 Bellevue Ave., Maplewood, Mo. 63143)

Harvey-Wells Model R9A receiver. Schematic and instruction manual needed. (Howard M. Rickert, 1916 18th Pl., Yuma, Ariz. 85364)

E.H. Scott AM/SW receiver, circa 1937; has 15 tubes; tunes .55-22 mHz in 4 bands. Operating manual and schematic needed. (Wesley Bacon, 114 Andover St., N. Wilmington, Mass. 01887)

Hallicrafters Model 5R10A receiver. Schematic and instruction manual needed. (Cliff Reno, 75 Parish Rd., New Canaan, Conn. 06840)

Atwater Kent Model 35, 1926-1938. Schematic, power supply data, and source for tubes (CK-301-A) needed. (Gerald W. Rutter, 3413 Clayton Ave., Wilmington, Dela. 19808)

RCA Model 813K SW receiver. Schematic, operating manual, and cabinet design needed. (Mark Carro, 539 Acton Rd., Columbus, Ohio 43214)

RCA Model AR-88 communications receiver. Alignment instructions needed. (Dale Hall, Box 3631 HSRC, Hot Springs, Ark. 71901)

"Echomatic" microphone tape unit built by Meazzi Co. of Italy. Schematic needed. (George H. Winter, 21 Briarwood, Tuscaloosa, Ala. 35401)

Weston Model 772 type 1 analyzer. Schematic and operating manual needed. (Peter Delenick, P.O. Box 665, Pottsville, Penn. 17901)

Paco Model S55 oscilloscope. Power transformer and 5U1 CRT or junk scope for parts needed. (Robert Wurth, 495 Myrtle, Florissant, Mo. 63031)

Triumph Model 839 oscillograph. Operating manual and schematic needed. (Stan Sudol, 1009 Grandridge Ave., Monterey Park, Calif. 91751)

Superior Model TV-12 tube tester. Operating manual and latest roll chart needed. (John Meador, 2621

(Continued on page 104)

NEW/CB TRANSCEIVER SOLID STATE PRE-AMP



Write for free literature



AMECO / DIVISION OF AEROTRON, INCORPORATED
P. O. BOX 6527 • RALEIGH, NORTH CAROLINA 27608

- Improves CB Base Station Performance
- Works on tube or transistor equipment
- No Modification to CB unit
- On-the-air sign automatically lights when transmitting

Model PCB with built-in power supply, transfer relay, connecting cables, wired and tested..... \$49.95

CIRCLE NO. 1 ON READER SERVICE PAGE



Winter 1968 ELECTRONIC EXPERIMENTER'S HANDBOOK

Special 10th Anniversary Issue! Complete schematics, illustrations, parts lists and easy-to-follow instructions that guarantee you perfect finished products.

Spring 1968 ELECTRONIC EXPERIMENTER'S HANDBOOK

Another big package containing over 30 of the most challenging, fun-to-build electronics projects ever! Be sure to order this one today!

1968 STEREO/HI-FI DIRECTORY

A giant 182-page buyer's guide to virtually every new audio component on the market today. Over 1600 products in all! Includes valuable "what to look for—how to buy" advice!

6 Vital Components

For Knowledge...
For Profit... For Sheer
Electronics Enjoyment!

ONLY \$1.25 EACH



1968 TAPE RECORDER ANNUAL

Contains over 130 pages, 19 complete features, covering every aspect of tape recording. PLUS complete directories of machines and accessories!

1968 COMMUNICATIONS HANDBOOK

For the ham, CB'er, SWL'er or business radio operator. 150 pages of "how to do it better" information. Directories of ham and CB gear!

1968 ELECTRONICS INSTALLATION & SERVICING HANDBOOK

Now, get the tricks of the trade for servicing everything. A 140-page "encyclopedia" that's a must for every serviceman and serious hobbyist!

ZIFF-DAVIS SERVICE DIVISION • Dept. W
595 Broadway, New York, N.Y. 10012

Please send me the annuals I've checked below:

- Winter 1968 Electronic Experimenter's Handbook
 Spring 1968 Electronic Experimenter's Handbook
 1968 Stereo/Hi-Fi Directory
 1968 Tape Recorder Annual
 1968 Communications Handbook
 1968 Electronics Installation & Servicing Handbook

\$1.25 each. In U.S.A., add 15c each for shipping and handling. Outside U.S.A., add 50c each.

TOTAL ENCLOSED \$ _____

print name _____

address _____

city _____ PE-118

state _____ zip _____

PAYMENT MUST BE ENCLOSED WITH ORDER

ASSIST

(Continued from page 103)

Drakestone, Oklahoma City, Okla. 73120)

Pentron Model XP-60 tape recorder. Parts needed. (Paul F. Earhart, 5127 Florence Blvd., Omaha, Neb. 68110)

Airline Model 8A55 SW/AM receiver. Schematic, manuals, and 6U5 tuning eye needed. (Pat Griffith, 2956 Elliot Circle, #4, Westminster, Colo. 80030)

Link type 2210 ED-2 FM transceiver. Schematic and servicing information needed. (Tom Lucas, 410 E. Bellefonte Ave., Alexandria, Va. 22301)

Lafayette Model 20k AM/FM tuner, amplifier. Tube location and/or instruction manual needed. (Gary Epstein, 1252 N. Pierce Ave., N. Bellmore, N.Y. 11710)

Sparton Model 3498 AC7 receiver. Schematic, tube location chart, input voltages, and input terminal information needed. **Tuska** Model 300 receiver. Schematic and tube numbers needed. **Crosley** Tridyn 3-R-3 #65547 receiver, circa 1914. Schematic, tube numbers, and operating voltages needed. (John M. Rosenbaum, 25245 Roosevelt Rd., South Bend, Ind. 46614)

Heathkit Model A-7 amplifier. Schematic needed. (Bill Mangahas, 1010 Ocean Ave., Brooklyn, N.Y. 11226)

Magnavox tuner chassis CR321-A, amp 111-A. RCA Model 9K. Schematics, parts lists, and other information needed. (John A. Graham, Jr., 2160 Cowley Way, San Diego, Calif. 92110)

Philco tropic Model 29-750. Schematic, operating manual, alignment data, and source for Philco "E" tubes needed. (Irving Leiboff, 667 E. 34 St., Brooklyn, N.Y. 11203)

Zenith Model 5DO15Z "long distance" receiver. Operating manual and output transformer (Zenith part 202-549) needed. (Robert Gormley, 5 Cantioe Rd., Yonkers, N.Y. 10710)

Majestic Model 92 receiver. Model G-3 speaker and schematic needed. (Terry Loving, RR #1, Loami, Ill. 62661)

Philco Model 90 radio receiver. Schematic, parts, list, and source for parts needed. (B. J. Maxwell, 139 Oswald St., Breaux Bridge, La. 70517)

Atwater Kent Model 42. Schematic, tubes, service data, history needed. **Atwater Kent** Model 33, CX301 tube, schematic, service data, and history needed; also tube diagrams and filament voltages for CX301A, CX371A, UX280, UX226, and UY227, (Eugene P. Schmitt, 2401 W. Glenbrook Ln., Mequon, Wis. 53092)

Melody Masters Model J-700 radio. Schematic or size of selenium rectifier and electrolytic capacitor and connections to both. (James P. Clark, 107 N. 23rd St., Kenilworth, N.J. 07033)

RCA Radiola Model 18 BCB receiver, circa 1927. Volume control needed. (Michael D. Brooks, 111th Ave., Rte. 1, Box 45B, Allegan, Mich. 49010)

Gonset Model G-33 receiver. Schematic and service manual needed. **Heath** Model AR-3 receiver. Operating Manual and source for parts needed. (T. Mangels, S. King St., Danbury, Conn. 0690)

National Radio Model RCL receiver, circa 1940. Alignment information and coils for first band needed. **Hallcrafters** Model SX-28 receiver, circa 1940. Alignment information, S meter, and selectivity switch needed. (Paul Mendoza, 4030 Laconia Ave., Bronx, N.Y. 10466)

Eico Model HF-87 dual power amplifier. Construction manual needed. (Peter E. Parker, 615 NE 160 Terr., N. Miami Beach, Fla. 33162)

Delco Model R-1179 receiver. Schematic and servicing data needed. (Peter E. Sparks, 1012 Avalon Ln., Chesterfield, Ind. 46017)

Acrosound Model S-1001 preamplifier and Model 20/20 dual 20-W power amplifier. Manuals and/or schematics needed. (M. Friess, Box 6411, Surfside, Fla. 33154)

Heathkit® Christmas Gifts

HEATHKIT AD-27 FM Stereo Compact

The new Heathkit "27" Component Compact was designed to change your mind about stereo compact performance. How? By sounding as if it were made of top quality stereo components . . . which in fact it is. Heath engineers took their highly rated AR-14 solid-state Stereo Receiver, modified it physically to fit the cabinet, and matched it with the precision BSR McDonald 500A Automatic Turntable. Performance? Here's the AD-27 in detail. The amplifier delivers 30 watts music power . . . 15 honest watts per channel — enough to drive any reasonably efficient speaker system. Response is virtually flat from 12 Hz to 60 kHz, and Harmonic & IM distortion are both less than 1% at full output. Tandem Volume, Balance, Bass & Treble controls give you full range command of all the sound. Select the FM stereo mode with a flick of the rocker-type switch and tune smoothly across the dial, thanks to inertia flywheel tuning. You'll hear stations you didn't know existed in your area, and the clarity and separation of the sound will amaze you. The adjustable phasing control insures best stereo separation at all times. And the automatic stereo indicator light tells you if the program is in stereo. AFC puts an end to drift too. The BSR Automatic Turntable has features normally found only in very expensive units, like cueing and pause control, variable anti-skating device, stylus pressure adjustment and automatic system power too. Comes complete with a famous Shure diamond stylus magnetic cartridge. The handsome walnut cabinet with sliding tambour door will look sharp in any surroundings, and the AD-27 performs as well as it looks. For the finest stereo compact you can buy, order your "27" Component Compact now. 41 lbs.

NEW
kit AD-27
\$169⁹⁵



NEW
kit AD-17
\$109⁹⁵



HEATHKIT AD-17 Stereo Compact

Using the component approach of the AD-27, Heath engineers took the solid-state stereo amplifier section of the AD-27, matched it with the high quality BSR-400 Automatic Turntable and put both of these fine components in a handsomely styled walnut finish cabinet. The result is the "17" — featuring 30 watts music power, 12 Hz to 60 kHz response, auxiliary & tuner inputs, less than 1% Harmonic & IM distortion, adjustable stylus pressure & anti-skate control and much more. Order your "17" now. 27 lbs.

HEATHKIT Miniature Speaker System

Miniature in size, but not in performance. This new Heathkit acoustic suspension system features two Electro-Voice speakers . . . a 6" woofer and a 2 1/2" tweeter for 60 Hz to 20 kHz response. Handles 25 watts of program material. Adjustable high frequency balance control lets you adjust the sound to what you like. The 8 1/4" H x 15 1/2" W x 6 1/2" D walnut cabinet is protected by clear vinyl for lasting good looks. Pick a pair of these performers for stereo compacts. 16 lbs.

HEATHKIT Solid-State Tachometer

The new Heathkit MI-18 has advanced performance features like unique inductive pickup for connection to any spark-type engine and any ignition system, 0-6000 & 0-9000 RPM ranges, temperature compensated ±4% accuracy, stainless steel hardware, splashproof black & chrome case. Pick the MI-18-1 for panel mounting, or the MI-18-2 with case and hardware. Send for yours now. 4 lbs.

NEW kit AS-18
\$32⁹⁵



HEATHKIT GR-17 Solid-State AM-FM Portable

Everything you want in AM/FM portable. The all solid-state circuit delivers clear, stable AM from distances the mini-portables can't match, and the FM section, with its 34' whip antenna, three IF stages and 5 uV sensitivity performs like a high priced table model receiver. AFC for drift-free listening and easy tuning too. All critical circuits preassembled and pre-aligned, and the circuit board wiring harness assembly makes construction even easier. For the greatest sound around, get your GR-17 today. 5 lbs.

NEW kit GR-17
\$43⁹⁵



NEW kit MI-18
\$29⁹⁵
(panel mount)
\$32⁹⁵
(case mount)

HEATHKIT Low Cost Solid-State Organ

Put the sound of live music in your home now with this low cost, all solid-state Heathkit Thomas Organ. It features all genuine Thomas factory-fabricated parts and 5-year warranty on the plug-in tone generators. Ten true organ voices . . . variable repeat percussion . . . 13 note heel and toe bass pedals for C1 to C2 range . . . two overhanging 37-note keyboards, range C2 thru C5 each . . . Color-Glo keylights . . . 75 watt peak music power amplifier . . . 12" speaker . . . vibrato . . . manual balance control. Thousands of people have already experienced the thrill and unique personal satisfaction of building this sophisticated, beautiful sounding musical instrument, and you can too. It takes no special skills or knowledge — the famous Heathkit manual with its easy to follow instructions and giant fold-out pictorials make the 50 hour assembly enjoyably simple. Comes with finished walnut cabinet and 40-lesson self-teacher course. Put the sound of music in your home this Christmas with the GD-325C from Heathkit. 172 lbs.

kit GD-325C
\$439⁹⁵



CIRCLE NO. 21 ON READER SERVICE PAGE

There's A Heathkit® Gift

Now There Are 4 Heathkit Color TV's . . .
All With 2-Year Picture Tube Warranty



kit GR-681

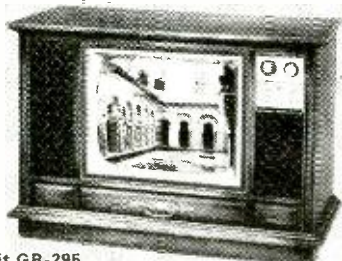

kit GR-295



kit GR-227



kit GR-180



New Wireless
TV Remote Control
For GR-295, GR-227
& GR-180

\$69⁹⁵

New Wireless
TV Remote Control
For GR-681

\$59⁹⁵

Wish Your Family Merry Christmas This Year
With A New Heathkit Color TV . . . A Better
Buy Than Ever With New Lower Prices

New GR-681 Deluxe Color TV
With Automatic Fine Tuning

kit GR-681
\$499⁹⁵
(less cabinet)

The new Heathkit GR-681 is the most advanced color TV on the market. A strong claim, but easy to prove. Compare the "681" against every other TV — there isn't one available for any price that has all these features. Automatic Fine Tuning on all 83 channels . . . just push a button and the factory assembled solid-state circuit takes over to automatically tune the best color picture in the industry. Push another front-panel button and the VHF channel selector rotates until you reach the desired station, automatically. Built-in cable-type remote control that allows you to turn the "681" on and off and change VHF channels without moving from your chair. Or add the optional GRA-681-6 Wireless Remote Control described below. A bridge-type low voltage power supply for superior regulation; high & low AC taps are provided to insure that the picture transmitted exactly fits the "681" screen. Automatic degaussing, 2-speed transistor UHF tuner, hi-fi sound output, two VHF antenna inputs . . . plus the built-in self-servicing aids that are standard on all Heathkit color TV's but can't be bought on any other set for any price . . . plus all the features of the famous "295" below. Compare the "681" against the others . . . and be convinced. See GR-295 below for cabinet selections & order now.

Deluxe "295" Color TV... Model GR-295

now only
\$449⁹⁵
(less cabinet)

Big, Bold, Beautiful . . . and packed with features. Top quality American brand color tube with 295 sq. in. viewing area . . . new improved phosphors and low voltage supply with boosted B+ for brighter, livelier color . . . automatic degaussing . . . exclusive Heath Magna-Shield . . . Automatic Color Control & Automatic Gain Control for color purity, and flutter-free pictures under all conditions . . . preassembled IF strip with 3 stages instead of the usual two . . . deluxe VHF tuner with "memory" fine tuning . . . three-way installation — wall, custom or any of the beautiful Heath factory assembled cabinets. Add to that the unique Heathkit self-servicing features like the built-in dot generator and full color photos in the comprehensive manual that let you set-up, converge and maintain the best color picture at all times, and can save you up to \$200 over life of set in service calls.

GRA-295-4, Mediterranean cabinet shown . . . **\$119.50**
Other cabinets from \$62.95

Deluxe "227" Color TV... Model GR-227

now only
\$399⁹⁵
(less cabinet)

Has same high performance features and built-in servicing facilities as the GR-295, except for 227 sq. inch viewing area. The vertical swing-out chassis makes for fast, easy servicing and installation. The dynamic convergence control board can be placed so that it is easily accessible anytime you wish to "touch-up" the picture.

GRA-227-1, Walnut cabinet shown . . . **\$59.95**
Mediterranean style also available at \$99.50

Deluxe "180" Color TV... Model GR-180

now only
\$349⁹⁵
(less cabinet)

Same high performance features and exclusive self-servicing facilities as the GR-295 except for 180 sq. inch viewing area. Feature for feature the Heathkit "180" is your best buy in deluxe color TV viewing . . . tubes alone list for over \$245. For extra savings, extra beauty and convenience, add the table model cabinet and mobile cart.

GRA-180-5, table model cabinet and cart . . . **\$39.95**
Other cabinets from \$24.95

Now, Wireless Remote Control For Heathkit Color TV's

Control your Heathkit Color TV from your easy chair, turn it on and off, change VHF channels, volume, color and tint, all by sonic remote control. No cables cluttering the room . . . the handheld transmitter is all electronic, powered by a small 9 v. battery, housed in a small, smartly styled beige plastic case. The receiver contains an integrated circuit and a meter for adjustment ease. Installation is easy even in older Heathkit color TV's thanks to circuit board-wiring harness construction. For greater TV enjoyment, order yours now.

kit GRA-681-6, 7 lbs., for Heathkit GR-681 Color TV's . . . **\$59.95**
kit GRA-295-6, 9 lbs., for Heathkit GR-295 and GR-25 Color TV's . . . **\$69.95**
kit GRA-227-6, 9 lbs., for Heathkit GR-227 and GR-180 Color TV's . . . **\$69.95**

Idea For Every Budget

HEATHKIT AR-15 Deluxe Solid-State Receiver

The Heathkit AR-15 has been highly praised by every leading audio and electronics magazine, every major testing organization and thousands of owners as THE stereo receiver. Here's why. The powerful solid-state circuit delivers 150 watts of music power, 75 watts per channel, at ± 1 dB, 8 Hz to 40 kHz response. Harmonic & IM distortion are both less than 0.5% at full rated output. The world's most sensitive FM tuner includes these advanced design features . . . Cascade 2-stage FET RF amplifier and an FET mixer for high overload capability, excellent cross modulation and image rejection . . . Sensitivity of 1.8 uV or better . . . Harmonic & IM distortion both less than 0.5% . . . Crystal Filters in the IF section give a selectivity of 70 dB under the most adverse conditions. Adjustable Phase Control for maximum separation . . . elaborate noise operated squelch . . . stereo only switch . . . stereo indicator light . . . two front panel stereo headphone jacks . . . front panel input level controls, and much more. Easy circuit board construction. For the finest stereo receiver you can buy anywhere, order your AR-15 now. 34 lbs. Optional walnut cabinet, AE-16. 10 lbs. . . \$24.95

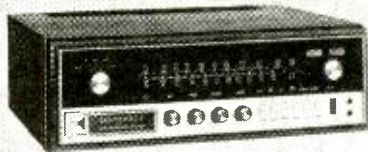

kit AR-15
\$339⁹⁵
(less cabinet)

Wired ARW-15
\$525⁰⁰
(less cabinet)

HEATHKIT Deluxe Stereo FM Tuner

The remarkable solid-state FM stereo tuner section from the famous Heathkit AR-15. If you already own a fine stereo amplifier, the AJ-15 is the stereo FM tuner for you. It has the exclusive design Heathkit FET FM tuner with two FET RF amplifiers and an FET mixer for 1.8 uV sensitivity and excellent cross modulation. The tuner section is completely factory assembled and aligned for easier construction too. Other features include the exclusive Heathkit Crystal filters in the IF section for perfect bandpass shape, noise-operated squelch, stereo threshold control, "Black Magic" panel lights and more. Put the world's best FM stereo tuner in your system now . . . the AJ-15. 18 lbs. Optional walnut cabinet AE-18, 8 lbs. . . \$19.95



kit AJ-15 \$189⁹⁵
(less cabinet)

HEATHKIT AA-15 Deluxe Stereo Amplifier

The powerful solid-state amplifier section from the famous Heathkit AR-15. If you already have a fine stereo tuner, the AA-15 is the perfect mate for it. It features 150 watts of music power — 75 watts per channel . . . virtually flat response from 8 Hz to 40 kHz . . . less than 0.5% Harmonic & IM distortion at full output . . . individual input level controls . . . two front panel stereo headphone jacks . . . a tone-flat switch that bypasses the wide-range tone controls . . . loudness switch . . . positive circuit protection that makes the power amplifier circuits virtually short-circuit proof and "Black Magic" panel lighting. Put the world's best stereo amplifier in your system now . . . the AA-15. 28 lbs. Optional walnut cabinet, AE-18, 8 lbs. . . \$19.95



kit AA-15 \$169⁹⁵
(less cabinet)

HEATHKIT AS-10 Acoustic Suspension System

The Heathkit AS-10 system features the extended bass response, smooth high frequency response and low distortion that has made acoustic suspension systems a favorite of audio enthusiasts the world over. The 10" woofer with ceramic magnet delivers rich, full bodied bass down to 30 Hz, and the two 3 1/2" cone tweeters in dispersed array produce clear, lifelike highs to 15,000 Hz. Handles from 10 to 40 watts of program material. The high frequency level control lets you adjust the high frequency response. The AS-10 can be installed either vertically or horizontally and comes in both handsome walnut finish or unfinished wood. You'll need two for superb stereo. 43 lbs.

kit AS-10U
\$59⁹⁵

kit AS-10W
\$64⁹⁵



HEATHKIT AS-16 2-Way System

The AS-16 is an outstanding performer with any equipment and in any surroundings. It features an 8" Electro-Voice® woofer for complete bass response to 45 Hz and two 3 1/2" tweeters that give clear, open highs up to 20,000 Hz. The high frequency level control on the back of the handsome walnut veneer cabinet lets you adjust the high frequency to suit your taste. Handles from 10 to 25 watts of program material. Speakers are already cabinet-mounted . . . just wire the crossover network and enjoy the sound. Buy two for stereo. 22 lbs.

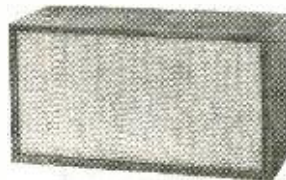

kit AS-16
\$49⁹⁵



NEW
FREE 1969 CATALOG!
Now with more kits, more color. Fully describes these along with over 300 kits for stereo, hi-fi, color TV, electronic organs, electric guitar & amplifier, amateur radio, marine, educational, CB, home & hobby. Mail coupon or write Heath Company, Benton Harbor, Michigan 49022.

HEATH COMPANY, Dept. 10-11
Benton Harbor, Michigan 49022

In Canada, Daystrom Ltd.

Enclosed is \$_____ plus shipping.

Please send model(s):

Please send FREE Heathkit Catalog

Please send Credit Application.

Name _____

Address _____

City _____

State _____

Zip _____

Prices & specifications subject to change without notice.

CL-347

CIRCLE NO. 21 ON READER SERVICE PAGE



Now, what's the best way to play your records for under \$80?

For years the AR manual turntable, at \$78,* has been the only truly fine record playing mechanism you could buy for under \$80.

But now, you'll have to take one other product into consideration.

The new automatic Dual 1212 At \$74.50**

Just like the AR, the Dual 1212 exceeds every NAB standard for broadcast turntables in rumble, wow, flutter, and speed accuracy. And its balanced tonearm can track any cartridge flawlessly.

But, in addition, the Dual has a convenient cueing control. A variable-speed pitch control. Built-in anti-skating. Automatic start and stop, with one record or a stack of six.

So now you've got a decision to make.

Do you want to play your records with a host of Dual convenience features, for \$74.50... or without them, for \$78?

United Audio Products Inc.,
535 Madison Ave., New York, N.Y.
10022.



*Including base and dust cover.
**Base and dust cover are extra.

CIRCLE NO. 37 ON READER SERVICE PAGE

AMATEUR RADIO

(Continued from page 84)

to distortion and interference. Digital techniques are already in use on long-distance telephone circuits.

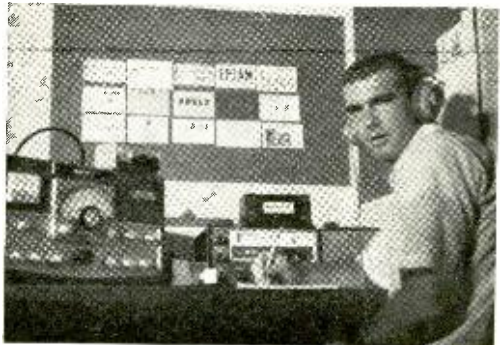

Steve Glickman, WB4HFJ, worked 150-plus countries in 8 months as a General (see "News And Views").

FCC News. In late July, the Federal Communications Commission proposed that anyone who has not held an amateur license within the past 12 months will be eligible for a Novice license. The action was taken as the Commission denied the petition of the Amateur Radio Committee of the Electronic Industries Association (EIA) to make the Novice license good for 5 years, renewable, to decrease the code-speed requirements, to continue Novice 2-meter phone privileges after November 22, and to permit Novice phone operation on 10 meters. Undoubtedly, the FCC will hold hearings before setting the date when the new proposal becomes law.

Also in July, the FCC authorized slow-scan television in Advanced and Extra class sections of the amateur phone bands. The SSTV signals cannot occupy more channel width than a normal amateur phone signal.

NEWS AND VIEWS

Jim Kassel, WN9YQC, 2280 Mayflower St., Aurora, Ill. 60506, uses the rain gutter around his house for an antenna. Although only eight feet high and fed with 300-ohm TV lead-in, the antenna has been used to work 28 states, including Alaska, in the first month on the air. The Heathkit DX-60B transmitter and HR-10B receiver combination complete Jim's station. . . . **Ann Zarodnansky, WA2BUU,** P.O. Box 2016, Trenton, N.J., takes issue with women who object to their ham husbands spending too much time in their shacks fooling around with their ham gear. Ann says, "Much better than having them running around fooling with other women!" Ann once had a ham husband—what happened to him, she didn't say—and, now that she's 40 with her own General license she wishes she had another.

er. Guess we're habit forming . . . **Mike Hindson, WN6IDP**, 5041 Dovewood Dr., Huntington Beach, Calif. 92647, receives on a Knight-Kit Star Roamer and transmits on an EICO 723. A Hy-Gain 14-AVQ vertical antenna does the radiating. His record is eight states in five days of operation.

Via Ray Meyers, W6MLZ's column "Ham on The Air" in the Los Angeles *Herald Examiner*, the U.S. Hospital Ship *Repose* stationed off the coast of Vietnam can be heard on 14.345 kHz at 1500 GMT most mornings. **Cpl. Frank J. Ayd, USMC, WA3JLR**, signing "Maritime Mobile Region 3," is the operator. Captain Engle of the *Repose* reports that the messages and phone patches handled by its amateur station are the biggest morale boosters on the ship . . . **John Pokluda, WN2GMP**, 1212-91 St., North Bergen, N.J. 07047, worked 25 states, including Alaska, plus Sweden his first 17 days on the air. A Johnson Valiant transmitter cranked down to 75 watts, a National NC-303 receiver, and a trap vertical antenna in the back yard made all contacts on the single frequency of 21.250 kHz . . . **Joe Rutledge, WB4ESE**, P.O. Box 211, Lewisburg, Tenn. 37091, started as a Novice in 1966 and now has his Advanced ticket. Joe's Drake TR-4 transceiver can be fed into either of two dipoles or into a vertical antenna. Although Joe prefers working in traffic nets or ragchewing to DX'ing, he has 47 states and a number of foreign countries confirmed. Oh yes, WB4ESE is the Net Control Station (NCS) of the Tennessee Teen-Age Net on 40 meters and is a member of Navy MARS.

Amateurs and would-be amateurs in the Detroit, Michigan, area interested in joining a live-wire club might investigate the Oak Park Amateur Radio Club. Meetings are the second Monday of each month at the Oak Park, Mich., Community Center, 14300 Oak Park Boulevard. Contact **Jerry Blumenthal, W8TWJ**, by phone (353-7529) or **Jeff Mazur, WN8ZZZ**, 14231 Vernon, Oak Park, Mich. 43237, for more information . . . **Greg Rainwater, WN7JEG**, 12 W. Inter-city Ave., Everett, Wash. 98201, has worked New Zealand and the Marshall Islands running 50 watts on 15 meters. He uses a homebrew ten watt to ragchew with the locals on 80 meters and also works a little 40 meters . . . In two months as a Novice and eight as a General, **Steve Glickman, WB4HFJ**, 7835 SW 133 St., Miami, Fla. 33156, has earned Worked All States (WAS). Worked All Continents (WAC), RagChewers' Club (RCC), and DX Century Club (DXCC) certificates. He has also picked up a 25-wpm code certificate along the way. Steve had 119 countries confirmed out of the 150+ worked when he wrote. All work is on CW with a Johnson Valiant transmitter and a Drake 2C receiver. The first 75 countries were worked with a vertical antenna, the rest with a tri-band, 2-element Quad, 33 feet high on a home-built tower . . . **Gary Cohen, WN1JBB**, 70 Kenwood Drive, New Britain, Conn. 06052, excites 15- and 40-meter dipoles



Jim Kassel, WN9QYC, has worked 28 states in a month—using the house rain gutter for an antenna. no less! For information, see "News and Views."

with an ancient Heatkit DX-40 transmitter, and he receives on an even older Hammarlund HQ-129X receiver. His record of 43 states and nine countries indicates that Gary knows how to use the equipment. A General class license is on the way . . . Do you like SPAM? SWL Mrs. George P. Douglass, 2232 Dunseath Ave., N.W., Apt. I-5, Atlanta, Ga. 30318, does. SPAM is the "Society For The Preservation of Advanced Modulation" against SSB. W4CJL is the president of the group. Mrs. Douglass has a valid point in saying that shortwave listeners usually can tune in AM signals easier than SSB signals; however, few amateurs—whether they use CW, AM, SSB, FM, or RTTY—select their mode of transmission primarily for the convenience of SWL's, although I don't know of any who object to SWL's listening to their transmissions . . . **Page Pyne, WA3EOP**, 717 Oak Hill Drive, Hagerstown, Md. 21740, after two years as a Technician, has obtained his General ticket and spends much of his time on the QRP'ers (Low Power Club) frequency of 7040 kHz. As a Tech, he worked 20 states on 50, 144, and 220 MHz with low-power Tecraft equipment. He worked 150 miles on 220 MHz, but he found little activity on that band, except in various VHF contests.

Whatever sections of the bands you operate in these days, may you have a fine Thanksgiving. Keep your "News and Views," pictures, and club bulletins coming; so your friends can read about you in these pages. The address is: Herb S. Brier, W9EGQ, Amateur Radio Editor, POPULAR ELECTRONICS, P.O. 678, Gary, Ind. 46401.

73, Herb, W9EGQ.



Eaglette



Dept. 1, 1269 Union Avenue, Laconia, New Hampshire 03245
Telephone (603) 524-5451

Keep in touch with the Browning Eagles this Fall!

STOP - LOOK - LISTEN The airways are filling with EAGLES . . .

These Browning Eagles fly together with peak performance and quality that only 30 yrs. of research in the field can provide. Each unit offers a 23 channel selection. The Golden Eagle provides: 1) auto-gain control for Distance, Normal or Local positions; 2) Filter for more than 80DB adjacent channel rejection; 3) Ultra-fine tuning; 4) Easy-to-read meters and selectors; 5) highly accurate plug-in crystals; and many other outstanding features.

Golden Eagle



(write for tech. info. and Serv. Ctr. nearest you)

CIRCLE NO. 7 ON READER SERVICE PAGE



SAVE BIG MONEY ON ELECTRONICS



Buy from RADIO SHACK, America's biggest nationwide electronics store chain. Send now for your free copy of our new 1969 bargain-packed electronics catalog... plus a year of special bargain bulletins. Write to —

RADIO SHACK®

2727 West 7th St., Dept. YR
Fort Worth, Texas 76107

FREE CATALOG AND BARGAIN BULLETINS

Name

Address

City State Zip

Radio Shack — subsidiary of Tandy Corporation
Over 300 stores coast to coast

CIRCLE NO. 28 ON READER SERVICE PAGE



technological impact has been so dramatic that it already heralds a new era in electronics. This book, therefore, provides the basic information needed to bring the benefits of the IC to all areas of electronics. It bridges the gap between the design and marketing concepts associated with discrete-component equipment and the considerations involved in the use of integrated systems. Every area of the electronics industry is treated—from engineering to servicing, from equipment to product marketing—to provide each with an understanding of its role. With mathematics kept to a minimum, the reader needs only a basic knowledge of electronics and a familiarity with semiconductor principles. Numerous charts, graphs, and tables highlight key points.

Published by Hayden Book Company, Inc., 116 West 14 St., New York, N.Y. 10011. Hard cover. 198 pages. \$8.95.

INTEGRATED CIRCUITS FUNDAMENTALS AND PROJECTS

by Rufus P. Turner

While integrated circuits have only recently become available to the average hobbyist, there is already a pressing need for an authoritative book to explain their many facets. In doing just that, this book gives the historic background of the development of the IC, explains its characteristics, discusses the types of IC's available, and gives some examples of IC applications. Written in a non-technical style, the book is easy enough for even a novice to electronics to understand. Included are complete assembly details for six IC projects.

Published by Allied Radio Corp., 100 N. Western Ave., Chicago, Ill. 60680. Soft cover. 95 pages. 75¢.

MODERN TV CIRCUIT AND WAVEFORM ANALYSIS

by Stan Prentiss

This book emphasizes the efficiency of the triggered-sweep oscilloscope for diagnosing color and monochrome TV circuit troubles. The discussions include both the tube-type TV chassis as well as the newest in solid-state (including IC) chassis. The text leads off with an analysis of basic and typical waveforms that are found in the average TV receiver. Then, each chapter includes descriptions of various types of circuits, liberally illustrated with the waveforms that would be observed when typical troubles develop. For the more hardy professional TV service technician, just enough math is included to promote a working knowledge of basic principles.

Published by Tab Books. Blue Ridge Summit, Pa. 17214. Hard cover. 256 pages. \$7.95 (soft cover, \$4.95).

ELECTRONIC EXPERIMENTER'S HANDBOOK



The most fascinating and challenging construction projects for the electronics hobbyist. Over 148 pages.

- 1968 Winter Edition #50
- 1967 Spring Edition #49
- 1966 Fall Edition #39
- 1966 Spring Edition #36
- 1965 Fall Edition #9

Titles listed above \$1.25 each
Order by number from

Ziff-Davis Service Div., 595 Broadway • New York, N.Y. 10012. Enclosed add'l 15¢ per copy for shipping and handling (50¢ for orders outside U.S.A.)

PAYMENT MUST BE ENCLOSED WITH ORDER

POPULAR DECEMBER 1968 ELECTRONICS

AS PROMISED!!!

DIGITAL VOLT-OHMMETER

COMPLETE CONSTRUCTION PLANS IN THE DECEMBER ISSUE

The equal of test instruments selling for an average of \$450. You can build it for less than 1/6th that figure!

This DVM is self-calibrating... self-zeroing... totally immune to 60-cycle

hum due to multiple slope integrating design... readable down to 10 millivolts and up to 200 volts... four ohm-meter ranges—useful from one ohm to 200,000 ohms.

DECEMBER 1968 ISSUE GOES ON SALE NOVEMBER 19

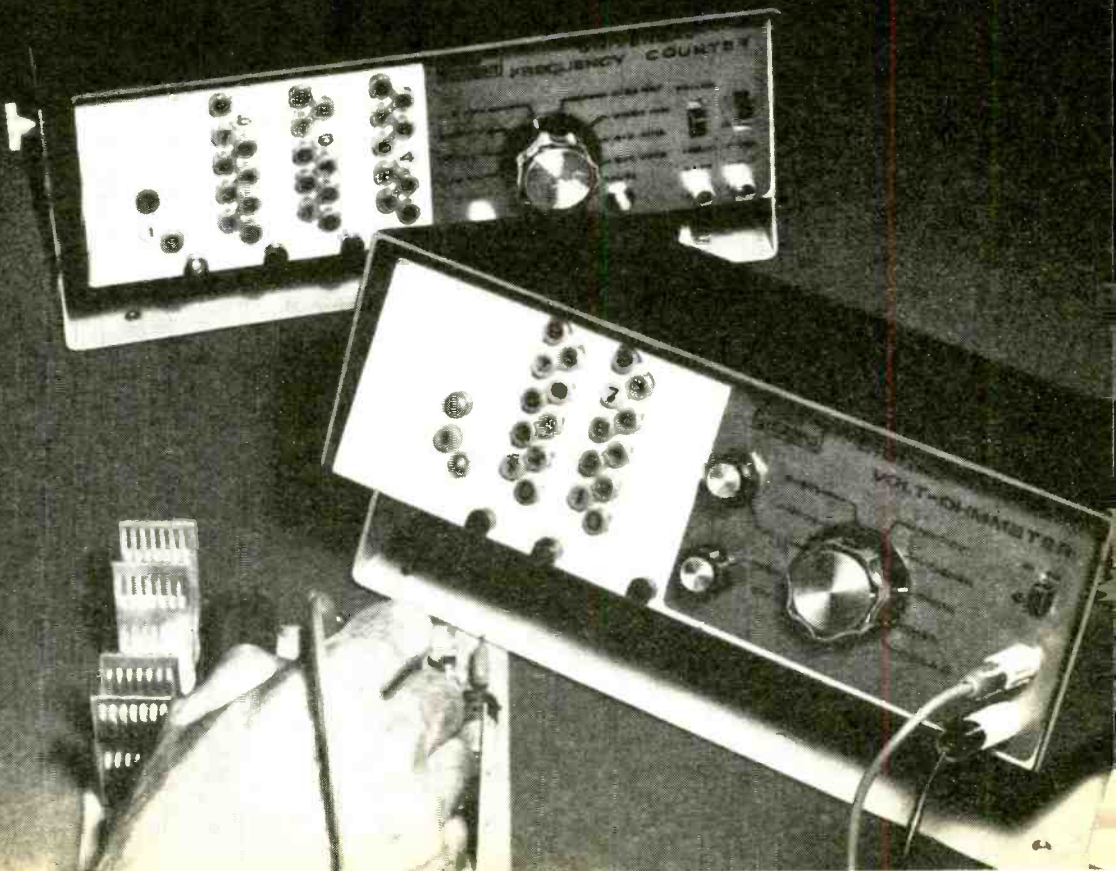

FET REJUVENATES VOM

(Continued from page 73)

batteries used for power. Although the author used a pair of 6.75-volt mercury cells, you can use any combination of batteries to produce between 9 and 13 volts for satisfactory operation. The two FET's draw only 0.5 mA during a measurement, while the seldom-used calibration circuit takes 15 mA. Batteries should last a long time.

Operation. Place the VOM range switch in the 1-volt d.c. position, then connect the VOM to the FET adapter output binding posts, making sure that proper polarity is observed. Connect a pair of test leads to the adapter input binding posts and short these two leads together. Then place the FET adapter RANGE switch (*S2*) in any position other than OFF. Rotate the ZERO potentiometer (*R13*) until the VOM needle is on zero.

Separate the two test leads on the input of the adapter and place the RANGE switch in the 0.1-V position. Depress the CALIBRATE pushbutton (*S1*) and adjust the CALIBRATE potentiometer (*R14*) until the VOM indicates exactly 1-volt d.c. Release the pushbutton.

If your VOM has a full-scale range of 1.2 or 1.5 volts, adjust *R14* for an exact 1-volt reading. In either case, the scale markings of the VOM must be multiplied by 100 to give you a reading in millivolts. Once calibration has been performed for the 0.1-V position of *S2*, the calibration will hold true for the other three ranges.

In the case of the 0.5-V position, multiply the VOM reading by 500 to obtain the value in millivolts (or divide by two to get the value in volts); in the 5-V position, multiply the VOM scale by 5 to get the value in volts; and in the 10-V position, multiply the VOM scale by 10 for the value in volts.

Because of the very high input resistance and the 0.1-volt full-scale lowest range, the FET adapter can be used to measure very small current flow through a circuit. This is done by measuring the voltage drop across a resistor with a low ohmic value in series with the current flow. Apply Ohm's Law ($E=I/R$) to find the current.

-50-

HOW IT WORKS

The circuit takes advantage of the very high input impedance of FET's to provide a 10-megohm non-loading impedance to the circuit under test and also supply power to a low-input-impedance VOM. The circuit is a differential amplifier using a common source resistor (*R7*, see Fig. 1), with the variable d.c. input to one FET (*Q1*) compared with the fixed gate voltage of the other FET (*Q2*). Once both FET's have the same d.c. drain voltage, determined by zero control *R13*, any difference between the gate voltages is reflected as a change in drain current between the FET's. The voltage difference produced by the change in drain current is measured on the VOM.

A voltage divider at the input—*R1* through *R4*—is used to select the measured range. The VOM adapter is not required for voltage measurements above 10 volts because above this voltage range the input impedance of the VOM is quite sufficient for most applications. For example, a 20,000-ohm-per-volt VOM on the 1200-volt range has an input resistance of 2 megohms, while a 1000-ohm-per-volt VOM on the same range has an input resistance of 100,000 ohms.

Zener diode *D1*, voltage-divider *R11* and *R12*, and resistor *R10* form a calibration circuit. The 13.5 volts of battery *B1* is converted to a precise 100-mV source and is fed to input FET *Q1* when pushbutton switch *S1* is operated. This enables precise setting of the calibration control (*R14*) so that the external VOM will indicate exactly 1 volt.



Perfect For
POLICE • FIRE
Other Law Agencies • Tow Trucks
• Civil Defense •

Complete with AC and DC power cables, Mounting bracket, less crystals. Crystals \$5.00 ea.

FR-104
(25-50 MHz)
FR-105
(150-175 MHz)

\$140⁰⁰

LISTEN TO: POLICE & FIRE REPORTS

FOR INDUSTRIAL, COMMERCIAL, UTILITY AND GOVERNMENT USE

CRYSTAL CONTROLLED • DUAL CONVERSION • LOW POWER DRAIN

Specifically designed for simplicity of operation and efficiently engineered for dependable service. Fits the smallest autos yet powerful enough to deliver a clean clear signal. Features: 6 crystal controlled frequencies, Dual Limiter, Quadruple tuned RF stage for greater image rejection, Noise Free squelch, PLUG IN crystals for instant freq. change. Compatible with all major continuous tone systems. Operates on 117VAC & 12VDC. Size: 6 3/4" x 2 3/8" x 8 1/2" / Wt: 3 lbs. 8 oz.

SONAR RADIO CORP., 73 Wortman Ave., Bklyn, N. Y. 11207
Please send information on FR-104/105 FM Monitor Receivers. Dept. 720

Name _____

Address _____

City _____

State _____

CIRCLE NO. 34 ON READER SERVICE PAGE



READER SERVICE PAGE

free information service:

Here's an easy and convenient way for you to get additional information about products advertised or mentioned editorially (if it has a "Reader Service Number") in this issue. Just follow the directions below... and the material will be sent to you promptly and free of charge.

1. Print or type your name and address on the lines indicated. Circle the number(s) on the coupon below that corresponds to the key number(s) at the bottom of the advertisement or editorial mention(s) that interest you. (Key numbers for advertised products also appear in the Advertisers' Index.)

2. Cut out the coupon and mail it to the address indicated below.

3. This address is for our product "Free Information Service" only. Editorial inquiries should be directed to POPULAR ELECTRONICS, One Park Avenue, New York 10016; circulation inquiries to Portland Place, Boulder, Colorado 80302.

**POPULAR
ELECTRONICS**

VOID AFTER DECEMBER 31, 1968

P.O. BOX 8391
PHILADELPHIA, PA. 19101

1 2 3 4 5 6 7 8 9 10 11 12 13 14 15 16 17 18 19 20
21 22 23 24 25 26 27 28 29 30 31 32 33 34 35 36 37 38 39 40
41 42 43 44 45 46 47 48 49 50 51 52 53 54 55 56 57 58 59 60
61 62 63 64 65 66 67 68 69 70 71 72 73 74 75 76 77 78 79 80
81 82 83 84 85 86 87 88 89 90 91 92 93 94 95 96 97 98 99 100

NAME (Print clearly) _____

ADDRESS _____

CITY _____ STATE _____ ZIP CODE _____

11 b

Olson



*** FREE**

Fill in coupon for a **FREE One Year Subscription to OLSON ELECTRONICS' Fantastic Value Packed Catalog—Unheard of LOW, LOW PRICES on Brand Name Speakers, Changers, Tubes, Tools, Stereo Amps, Tuners, CB, and other Values. Credit plan available.**

NAME _____
ADDRESS _____
CITY _____ STATE _____
GIVE ZIP CODE _____

If you have a friend interested in electronics send his name and address for a **FREE** subscription also.

OLSON ELECTRONICS

987 S. Forge Street Akron, Ohio 44308

CIRCLE NO. 25 ON READER SERVICE PAGE

LEARN DRAFTING AT HOME

U.S. Labor Dept. says "42% more Draftsmen needed next 10 years." Send for **FREE "DRAFTING CAREER KIT."** No salesman will call.

NAME _____ AGE _____
ADDRESS _____
CITY _____ STATE _____ ZIP _____

NORTH AMERICAN SCHOOL OF DRAFTING, Dept. 134 B

Accredited National Home Study Council 4500 Campus Drive, Newport, California 92660

COMMUNICATIONS HANDBOOK

World's most complete guide to communications. 148 fact packed pages of features by experts in each category.

1968 . . . \$1.25 . . . #53

1967 . . . \$1.25 . . . #47

Order by number from

Ziff-Davis Service Div., 595 Broadway, New York, N.Y. 10012. Enclose add'l 15¢ per copy for shipping and handling (50¢ for orders outside U.S.A.)

GET INTO ELECTRONICS

V.T.I. training leads to success as technician, field engineer, specialist in communications, guided missiles, computer, radio, automation. Basic & advanced courses. Electronic Engineering Technology and Electronic Technology curricula both available. Associate degree in 29 months. B.S. obtainable. G.I. approved. Start February. Semester. Terms, courses. High school graduate or equivalent. Catalog.

VALPARAISO TECHNICAL INSTITUTE
DEPARTMENT PE, VALPARAISO, INDIANA 46383



MAGNETIC STIRRER

(Continued from page 45)

Clean the top outside surface of the chassis, and glue on a sheet of $\frac{1}{16}$ "-thick cork that just covers the top. The appearance of the stirrer will be enhanced by covering the cork surface with white self-adhesive plastic sheet. White is used so that the true color of the liquid being stirred is visible. Allow the cork cement to dry thoroughly before applying the plastic or wrinkles will appear.

Testing and Use. Apply power to the circuit by rotating the speed-control potentiometer (*R1*) until switch *S1* closes and power-on indicator *I1* lights. As *R1* is rotated, the motor (and driving magnet) should spin faster and faster. Make sure when you wire the potentiometer, that the slowest motor speed occurs just after *S1* turns on. Turn off the power before the next step.

Fill a small beaker with water and place it on the white upper surface of the magnetic stirrer, directly above the driver magnet. Drop in a steel paper clip or small bar magnet. It will instantly align itself with the driver magnet. Position the beaker until the paper clip or bar magnet is centered within the beaker. As *R1* is rotated and power comes on, the stirring magnet will start to rotate (with the motor), and as *R1* is rotated up its range, the stirrer will rotate faster and produce a vortex in the water.

To avoid chemical interactions with the liquid being stirred, especially with corrosive or very active solutions, it is best to use a stirring magnet having a protective plastic coating. A magnet with a teflon coating is available (see Parts List).

A very handy gadget to have is a stirring-magnet retriever. This enables you to extract the stirring magnet without putting your fingers in the solution (with possible disastrous results if the solution happens to be corrosive or toxic). You can make a retriever by sealing a small magnet within a long plastic tube, or you can purchase one at low cost (see Parts List).

-50-

ZENER DIODE

(Continued from page 54)

We also know there is only two volts driving the current through the resistor.

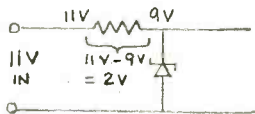

Ohm's law tells us that $R = E/I = 2/0.0125 = 160$ ohms. To handle our "worse case" conditions, the resistor value must be halved. Such a large change requires us to determine what would happen if someone disconnects the receiver and battery voltage is up to 13 volts.

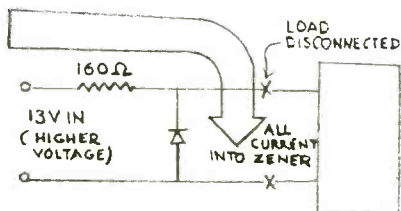

Fortunately, Ohm's law shows that a $\frac{1}{4}$ -watt resistor will adequately handle the current. Now we have a regulator circuit we can build with confidence.

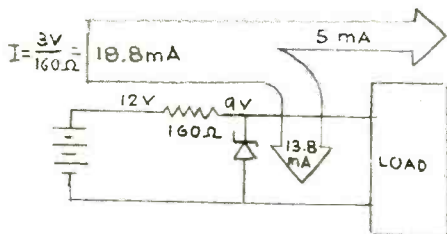

We have paid a price for our regulator, however, in the form of 13.8 mA wastage current through the zener diode. The advantage is that the receiver will operate reliably no matter what happens.

Now you know what a zener diode is and, more important, how it is used effectively. Our hypothetical example revolved around a radio-receiver load. But the load could just as easily have been a hi-fi amplifier, oscillator, or even a test instrument.

-30-

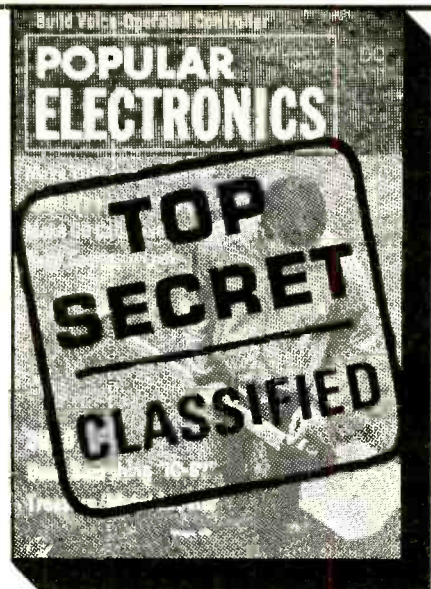

...not by a long shot it isn't !!

There's certainly nothing top secret about the classified pages in Popular Electronics Magazine. They're wide open to the searching eyes of every buyer who's in the market for the product or service that he knows can be found in Popular Electronics' Electronics Market Place.

The more than 400,000 buyers of Popular Electronics, largest readership of any electronics magazine in the world, are your guarantee of knowing that your ad is being read by people who are constantly looking for and buying electronics products. It is these people to whom you MUST direct YOUR advertising as do the many key advertisers appearing in this issue and in each issue throughout the year.

No doubt about it—there's a vast market of buyers searching the classified advertising pages of Popular Electronics and it's important that your ad be exposed to this prime buying audience. Prove to yourself that the leading electronics magazine **MUST ALSO** be the leader in sales responses to the many classified ads presently enhancing its pages—it makes a great deal of sense—give it a try.

There's complete rate information for your convenience in the classified section of this issue. Or, if you'd like a little personal service, it's right up our alley. Just write to

HAL CYMES
Classified Advertising Manager
ZIFF-DAVIS PUBLISHING COMPANY
One Park Avenue • New York, New York 10016

CRACKERJACK QUIZ ANSWERS

(Quiz appears on page 46)

- 1 False. The well-equipped shop can service transistorized equipment with no additional instruments. However, equipment specially designed for transistor service can make the job easier.
- 2 False. Sync separator circuits separate the composite sync from the video signal.
- 3 False. Optimum convergence can only be obtained with the proper test equipment.
- 4 False. Convergence circuitry is rarely responsible for poor convergence. The cause is almost invariably the service technician himself or the yoke and the picture tube, in that order.
- 5 False. The color killer disables the color circuits and prevents color noise during monochrome broadcasts.
- 6 False. Although the delay line is added for timing, the color signal is slowed because it travels through narrow bandpass amplifiers.
- 7 False. Bars, dots, or both may be used by the set up technician. It's a matter of preference.
- 8 False. Several areas of this country rely on UHF TV entirely. Color transmission and reception in UHF areas is as good as in VHF areas.
- 9 True. With the luminance gone, color is still visible on the screen; however, the picture will be distorted due to the missing luminance (Y) signal.
- 10 True. Many outputs are taken from the vertical output transformer and vertical output tube cathode circuit to operate convergence circuitry.
- 11 False. Changing height or linearity almost always causes a change in convergence.
- 12 False. Most color sets develop 25 kV for the picture tube.
- 13 False. Horizontal stripes are generally caused by slight recording head phase shifts on video tape recorded shows.
- 14 True. The life may be extended but the extra dust, and the potential electric hazard of an open receiver rule against removal of the back panel.
- 15 False. Color TV consoles have outsold monochrome consoles for the past three years.

CATV

(Continued from page 31)

tem concepts, television signal analysis, antennas, wave propagation, head-end theory and operation, and amplifier operation and maintenance. Course was written for men with a minimum of two years practical experience as a Cable Technician (not merely an installer) or men with an FCC First Class Radiotelephone License."

RECOMMENDED READING

101 Questions and Answers About CATV and MATV, Robert E. Baum and Theodore E. Baum. Howard W. Sams & Co., Inc., 1968. softbound, 96 p., \$2.50. Provides a good, brief view of the industry.

CATV System Engineering, 2nd edition. William A. Rheinfelder, TAB Books, 1967. hardbound, 256 p., \$12.95. Gives a good, theoretical background without getting into a mathematical approach. More practical information, however, is in **CATV System Maintenance**, Robert B. Cooper, Jr., TAB Books, 1967, comb-bound, 192 p., \$12.95. It concentrates on how to locate and correct equipment failures and has chapters on antenna and head-end requirements, the service drop, troubleshooting and measuring equipment, auxiliary services, and technician-customer relations.

The magazine **TV Communications**, published by the parent company of National Cable Television Institute, is called "the professional journal of cable television" and includes a "CATV Technician" section, which can certainly keep a technician up to date.

Future. What's the future of CATV? "CATV is a young, dynamic industry offering a tremendous opportunity for bright, sincere technicians to get in on the ground floor," says William J. Brennan. "I emphasize bright and sincere because being a service business, it is extremely important that the system be operated in a reliable and responsible manner. There are thousands of technicians in the electronics industry who cannot or will not apply themselves in such a manner as to provide this type of service."

"But for those who can," one CATV executive told the author, "there is no limit to the opportunities for advancement in the CATV field. The technician of today can become a fully-qualified engineer, or go into sales or management depending solely on his ability to learn and his determination to become fully conversant with all phases of CATV."

ELECTRONICS MARKET PLACE

COMMERCIAL RATE: For firms or individuals offering commercial products or services. \$1.15 per word (including name and address). Minimum order \$11.50. Payment must accompany copy except when ads are placed by accredited advertising agencies. Frequency discount: 5% for 6 months; 10% for 12 months paid in advance.

READER RATE: For individuals with a personal item to buy or sell. 70c per word (including name and address). No Minimum! Payment must accompany copy.

GENERAL INFORMATION: First word in all ads set in bold caps at no extra charge. Additional words may be set in bold caps at 10c extra per word. All copy subject to publisher's approval. Closing Date: 1st of the 2nd preceding month (for example, March issue closes January 1st). Send order and remittance to: Hal Cymes, POPULAR ELECTRONICS, One Park Avenue, New York, New York 10016.

FOR SALE

FREE! Giant bargain catalog on transistors, diodes, rectifiers, SCR's, zeners, parts. Poly Paks, P.O. Box 942, Lynnfield, Mass. 01940.

GOVERNMENT Surplus Receivers, Transmitters, Snooperscopes, Radios, Parts, Picture Catalog 25¢. Meshna, Nahant, Mass. 01908.

R.F. CONVERTERS. World's largest selection. Also CCTV cameras, etc. Lowest factory prices. Catalog 10¢. Vanguard 196-23 Jamaica Ave., Hollis, N.Y. 11423.

BUG DETECTOR: WILL DETECT AND LOCATE SURREPTITIOUS TRANSMITTING DEVICES IN CONFERENCE ROOMS, HOME AND OFFICES, ETC. WRITE FOR DETAILS. WJS ELECTRONICS, 737 NORTH SEWARD, HOLLYWOOD, CALIF. 90038.

ROCKETS: Ideal for miniature transmitter tests. New illustrated catalog, 25¢. Single and multistage kits, cones, engines, launchers, trackers, rocket aerial cameras, technical information. Fast service. Estes Industries, Dept. 18, Penrose, Colorado 81240.

LOWEST Prices Electronic Parts. Confidential Catalog Free. **KNAPP**, 3174 8th Ave. S.W., Largo, Fla. 33540.

CRYSTALS . . . largest selection in United States at lowest prices. 48 hr. delivery. Thousands of frequencies in stock. Types include HC6/U, HC18/U, FT-241, FT-243, FT-171, etc. Send 10¢ for catalog with oscillator circuits. Refunded on first order. Jan Crystals, 2400F Crystal Dr., Fort Myers, Fla. 33901.

TREASURE Hunters! Prospectors! Relco's new instruments detect buried gold, silver, coins. Kits, assembled models. Transistorized. Weighs 3 pounds. \$19.95 up. Free catalog. Relco-A33, Box 10836, Houston, Texas 77018.

DIAGRAMS—Radios \$1.50, Television \$3.00. Give make and model. Diagram Service, Box 1151PE, Manchester, Conn. 06042.

EUROPEAN and Japanese bargain catalogs. \$1 each. Dee, 10639E Riverside, North Hollywood, Calif. 91602.

TRANSISTORIZED CONVERTER KITS: Two models, converts car radio. Receive 30-50mc or 100-200mc (one mc tuning) \$5.00 with simple instructions. Crystal \$2.50. Meshna, No. Reading, Mass. 01864.

MECHANICAL, Electronic devices catalog 10¢. Greatest Values—Lowest Prices. Fertik's, 5249 'D', Philadelphia, Pa. 19120.

MUSIC LOVERS, CONTINUOUS, UNINTERRUPTED BACKGROUND MUSIC FROM YOUR FM RADIO, USING NEW INEXPENSIVE ADAPTOR. FREE LITERATURE. ELECTRONICS, 11500-Z NW 7th AVE., MIAMI, FLORIDA 33168.

NEW Sensitive Treasure Metal Detectors. New low prices. Professional models from \$29.95 to \$129.50. Write for free catalog today. Jetco Electronics, Box 132-E, Huntsville, Texas 77340.

JAPANESE or EUROPEAN DIRECTORY 200 firms \$1.00. **SURVEILLANCE EQUIPMENT,** Catalog 25¢. Wireless **SNOOPERMICKE** \$25.00. **SUBMINIMICKE** $\frac{3}{8}$ x $\frac{3}{8}$ x $\frac{3}{16}$ \$4.00. **SIERRATRONICS,** Box 7497, Las Vegas, Nev. 89101.

WE SELL CONSTRUCTION PLANS. TELEPHONE: Answering Machine, Speakerphone, Carphone, Phonevision, Legal Connector, Auto Dialer, Central Dial System. **TELEVISION:** \$35.00 Color Converter, Tape Recorder, 3DTV, \$25.00 Camera. **DETECTIVE:** Infinity Transmitter, Tail Transmitter, Police Radar Detector. **HOBBYIST:** Electron Microscope, 96 Hour Tape Music System, Ultrasonic Dishwasher, Radar-Oven, Electronic Tranquillizer. Plans \$4.95 each. **COURSES:** Telephone Engineering \$39.50, Detective Electronics \$22.50, Anti-Detective Electronics \$27.50. **SUPER HOBBY CATALOG** 25¢. Don Britton Enterprises, 7906 Santa Monica Blvd., Hollywood, Calif. 90046.

CIRCUIT Boards, Parts for "Poptronics" projects. Free catalog. S.W. Technical, Box 16297, San Antonio, Texas 78216.

SURVEILLANCE COUNTERMEASURES BROCHURE \$1.00. ENGINEERING LABORATORIES, BOX 1036, ANDERSON, INDIANA 46015.

WEBBER LAB's, Police & Fire Converters. Catalog 10¢. 72 Cottage Street, Lynn, Mass. 01905.

PROXIMITY switch. Detects nearness of human body! Free information. Claremont Products, 860 Reed, Claremont North, Calif. 91711.

RADIO—T.V. Tubes—33¢ each. Send for free catalog. Cornell, 4213 University, San Diego, Calif. 92105.

SECURITY AND PRIVACY PROTECTION DEVICES. FREE DATA: SECURITY ELECTRONICS PE, 15 EAST 43RD STREET, NEW YORK, N.Y. 10017.

WHOLESALE COMPONENTS: Manufacturers and distributors only. Request free catalog on business letterhead. **WESCOM,** Box 2536, El Cajon, California 92021.

CONVERT any television to sensitive, big-screen oscilloscope. Only minor changes required. No electronic experience necessary. Illustrated plans, \$2.00. Relco-A33, Box 10563, Houston, Texas 77018.

TELEVISION CAMERA KITS! Wide selection tube and transistor models. Starter kits, \$18.95 up. Complete kits \$149.50 up. Plans available separately; tube camera \$3.00, transistor camera \$5.00, TV station \$1.00, ATV literature anthology \$2.50. Catalog **FREE. ATV RESEARCH,** 13th & Broadway, Dakota City, Nebraska 68731.

THOUSANDS and thousands of types of electronic parts, tubes, transistors, instruments, etc. Send for Free Catalog. Arcturus Electronics Corp., MPE, 502-22nd St., Union City, N.J. 07087.

RECTIFIERS, transistors, other components. Catalog free. Electronic Components Co., Box 6266, Baton Rouge, La. 70821.

JAPAN DIRECTORY. Electronics products and parts. General merchandise and Asia trade information. Just \$1.00 today. Ippano Kaisha Ltd., Box 6266, Spokane, Washington 99207.

LAW ENFORCEMENT AGENTS AND LEGAL INVESTIGATORS ONLY. FREE LITERATURE, LATEST ELECTRONIC AIDS. REQUEST MUST BE ON YOUR OFFICIAL LETTERHEAD. R. CLIFTON, 11500-L NW 7TH AVE., MIAMI, FLORIDA 33168.

LINEAR AMPLIFIERS: "Hornet" 50 watts output—\$98.50; "Raider"—100 watts—\$139.50; "Maverick-250"—250 watts—\$244.95. AM and SSB. "Scorpion"—50 watt 12 V. Mobile amplifier—\$99.95; "Bandit II"—12 V. Mobile Amplifier—\$169.95. Frequency range 20-35 megacycles (illegal for class D 11 meters.) Dealer inquiries invited. D & A Manufacturing Co., 1217 Avenue C, Scottsbluff, Nebraska 69361.

BARGAIN FLYER AND SIX NEW RESISTORS—25¢ (stamp or coin). **BIGELOW ELECTRONICS, BLUFFTON, OHIO 45817**

WRITE now for free 1969 catalog, McGee Radio Company. 1001 bargains. Speakers—Parts—Tubes—High Fidelity Components—Record Changers—Tape Recorders—Kits. Everything in Electronics. 1901 McGee Street, Kansas City (GE), Missouri 64108.

ELECTRONIC ignition, various types. Free literature. Anderson Engineering, Epsom, N.H. 03239.

POLICE FIRE VHF automobile converter. Under the dash mounting. 90 days unconditional guaranty. State frequency desired. Crystal and battery included. HI and LO band. \$25.45. **AUDIO-DIGITAL,** 24 Genetti, Bedford, Mass. 01730.

WPE—HAM—CB QSL's samples 25¢. Dick, W8VXK, Gladwin, Mich. 48624.

ETCH your own Printed Circuit Boards. Save time, money. **COMPLETE INSTRUCTIONS** \$2.00. Logue, Box 82, Bayville, N.Y. 11709.

TOROID POWER SUPPLY. Build your own mobile supply 300v 250ma. Toroid transformer with diagram \$5.50 P.P. Wesearch Electronics, P.O. Box 306, Tamiami Station, Miami, Florida 33144.

FIGHT crime. Alarms. Components. Accessories. Professional Do-It-Yourself Kit \$69.95. Annunciator kit \$29.95. Auto alarm \$9.95. Monthly brochures. Free writing letterhead. Otherwise \$1.00 refundable with first order. Silmar Electronics, 3476 N.W. 7th Street, Miami, Florida 33125.

JUST out! Interesting catalog of unusual gadgets, projects, plans, kits, 20¢. Franks Scientific Co., P.O. Box 156, Martelle, Iowa 52305.

TELEPHONE RECORDER-ACTUATOR (TWI-007) AUTOMATICALLY TURNS TAPE RECORDER ON WHEN TELEPHONE IN USE. \$22.85. TELEPHONE "BUG" (TWI-004) \$21.95. SURVEILLANCE RECORDERS: (TWI-1000, TWI-1010). CONNECTED ANYWHERE ON LINE. SIMPLE INSTRUCTIONS INCLUDED. TWILIGHT ELECTRONICS, BOX 11595-Z, ST. LOUIS, MISSOURI 63105.

DIAGRAMS, Service Manuals, TV, Radio, HiFi, \$1.00. Technical Services Associates, Box 1167, Berkeley, Calif. 94701.

CONTROL panels—modernize your Electronic Equipment with a professional aluminum name plate made from your specifications. Free Sample—Prerepco, P.O. Box 95, South Willington, Conn. 06265.

INTEGRATED circuits opened and mounted on tie-tac in the popular turtle motif. Chip presents jewel-like sparkle. Specify gold or silver mounting. \$2.00 each. Sartori, 183 Easton, Buffalo, New York 14215.

REMOTE BURGLAR ALARM USES TELEPHONE, TIN CAN & PENCIL. FULLY ILLUSTRATED METHOD \$10. HERMITRONICS, 2783 E Market, San Diego, California 92102.

PRINTED circuit board kits, materials. Free catalog. Seneca Electronics, P.O. Box 2022A, Kokomo, Indiana 46901.

COLOR TV CROSSHATCH GENERATOR. Make money covering color TV's only \$34.95. For details write Linear Electronics, Box 284, East Setauket, N.Y. 11733.

REGULATED POWER SUPPLIES, need only transformer. 5V-15V .6-4A, \$2.75—\$8.50. GE Triac 10A \$1.75. Catalog. Murphy, 204 Roslyn, Carle Place, New York 11514.

SLEEK GENUINE SEALSKIN KEY HOLDER \$3.98. Dept. 22, P.O. Box 2007, Van Nuys, Calif. 91404.

HOBBYIST. NEED AN ELECTRONIC DEVICE for one of your projects? Send us a written verbal description and \$1.00 for estimate to Bronson Engineering, Box 1203, Northland Center Sta, Southfield, Mich. 48075.

CATHODIC protection instructions \$1.00. F.F. Knapp, P.O. Box 854, Scottsdale, Arizona 85252.

GARRARD Record Changers, Hi-Fi Components, Cartridges, Needles, Tape, TV Parts, Schematics. Write for Unbelievable Prices. Gregg Electronics, P.O. Box 184, Glen Head, N.Y. 11545.

A GUIDE TO OVER 700 ELECTRONIC CONSTRUCTION PROJECTS! 4 years in the making; covers plans to every project imaginable! \$3.95. BEL ENTERPRISES, P.O. Box 381-E3, Bellflower, Calif. 90706.

EXCITING values in Portable Monitor Receivers, Ameco Converters, accessories. Details. Free Antenna Offer: Griffin's, 322 West State, Ithaca, N.Y. 14850.

PLANS AND KITS

BEGINNERS Allwave \$5.00, Two Band \$5.00, F-M Tuner Chassis \$10.00, Headset \$2.50, Two Band Wired \$10.00. Ekeradio, Box 131, Temple City, Calif. 91780.

BUILD-IT-YOURSELF. Save big dollars. Transistor stereo amplifiers. Color organs. Speakers. Write Workshop, Box 393, Bethpage, New York 11714.

"COIL WINDING" Handbook—50¢. Experimenter's catalog includes 250 exclusive items—25¢, refundable. Laboratorie, 12041-L Sheridan, Garden Grove, Calif. 92640.

CUT out TV commercials—plans, \$3.00. Griffins Electronics, P.O. Box 2213, Huntsville, Texas 77340.

INTEGRATED CIRCUIT KITS; COMPUTER CIRCUIT KITS; Others. New catalog free. KAYE ENGINEERING, Box 3932-A, Long Beach, California 90803.

TRANSISTOR amplifiers, psychedelic lighting shows, strobes. Send stamp for list. PLANS, 1336 Louisiana, Akron, Ohio 44314.

IN-CIRCUIT TRANSISTOR CHECKER. You can build. Plans \$1.50. Lab Electronics, P.O. Box 6213, San Diego, Calif. 92106.

HIGH FIDELITY

FREE! Send for money saving stereo catalog #P11E and lowest quotations on your individual component, tape recorder, or system requirements. Electronic Values, Inc., 200 W. 20th St., New York, N.Y. 10011.

HI-FI Components, Tape Recorders, at guaranteed "We Will Not Be Undersold" prices. 15-day money-back guarantee. Two-year warranty. No Catalog. Quotations Free. Hi-Fidelity Center, 239 (P) East 149th Street, New York 10451.

CLASSIFIED ADVERTISING ORDER FORM

Please refer to heading on first page of this section for complete data concerning terms, frequency discounts, closing dates, etc.

1	2	3	4	5
6	7	8	9	10
11	12	13	14	15
16	17	18	19	20
21	22	23	24	25
26	27	28	29	30
31	32	33	34	35

_____ Words { @ 70¢ (Reader Rate) } = \$ _____
 { @ \$1.15 (Commercial Rate) }

Insert _____ time(s) Total Enclosed \$ _____

NAME _____

ADDRESS _____

CITY _____ STATE _____ ZIP _____

Signature _____

WORD COUNT: Include name and address. Name of city (Des Moines) or of state (New York) counts as one word each. Zip Code numbers not counted. (Publisher reserves right to omit Zip Code if space does not permit.) Count each abbreviation, initial, single figure or group of figures or letters as a word. Symbols such as 35mm, COD, PO, AC, etc., count as one word. Hyphenated words count as two words. PE-1168

LOW, Low quotes: all components and recorders. HiFi, Roslyn, Penna. 19001.

TAPE RECORDERS, Hi-Fi, components, Sleep Learning Equipment, tapes. Unusual Values Free Catalog. Dressner, 1523R, Jericho Turnpike, New Hyde Park, N.Y. 11040.

STEREO Components, Tape Recorders, Tapes, Citizen Band Transceivers, Brand Names, Free Catalog, Free Quotations. **GLOBE ELECTRONICS SALES INC.**, 1160 Globe Avenue, Mountainside, New Jersey 07092.

NEW BSR record changers—\$13. Garrards—\$22. Radio-phono stereo receivers—\$15. "Changers PE", 2737 3rd Ave., Bronx, N.Y. 10454.

SHORTWAVE LISTENING

POLICE—FIRE—AIRCRAFT—MARINE—AMATEUR CALLS on your broadcast radio with **TUNAVERTER!** Tunable and crystal in one! Guaranteed! Free catalog. Salch Co., Woodsboro-PEC, Texas 78393.

WANTED

CASH Paid! Unused tubes, electronic equipment. Barry, 512 Broadway, NYC 10012.

QUICKSILVER, Platinum, Silver, Gold, Ores Analyzed. Free Circular. Mercury Terminal, Norwood, Mass. 02062.

CASH for terminals—red, blue, yellow. **HALCAP**, Box 19183, Houston, Texas 77024.

TUBES

TUBES "Oldies", latest. Lists free. Steinmetz, 7519 Maplewood, Hammond, Indiana 46324.

RECEIVING & INDUSTRIAL TUBES, TRANSISTORS. All Brands—Biggest Discounts. Technicians, Hobbyists, Experimenters—Request **FREE** Giant Catalog and **SAVE!** **ZALYTRON**, 469 Jericho Turnpike, Mineola, N.Y. 11501.

TUBE Headquarters of World! Send 10¢ for Catalog (tubes, electronic equipment) Barry, 512 Broadway, N.Y.C. 10012.

RADIO & T.V. Tubes—33¢ each. Send for free list. Cornell, 4213 University, San Diego, Calif. 92105.

DON'T BUY TUBES—Radios TV-Xmitting, special-purpose types until you get our price list! Lowest prices in U.S.A. 5,000 types—Guaranteed Brand New. Send postcard for TV-Special Purpose Price List. **UNITED RADIO COMPANY, P.O. BOX 1000, NEWARK, N.J. 07101.**

TAPE AND RECORDERS

BEFORE Renting Stereo Tapes try us. Postpaid both ways—no deposit—immediate delivery. Quality—Dependability—Service—Satisfaction—prevail here. If you've been dissatisfied in the past, your initial order will prove this is no idle boast. Free Catalog. Gold Coast Tape Library, Box 2262, Palm Village Station, Hialeah, Fla. 33012.

HI-FI Components, Tape Recorders, at guaranteed "We Will Not Be Undersold" prices. 15-day money-back guarantee. Two-year warranty. No Catalog. Quotations Free. HiFidelity Center, 239 (PT) East 149th Street, New York 10451.

WHOLESALE—4-8 track **STEREOTAPES**—Car, Home **PLAYERS**—CB, Recorders. **MUSICO**, Box 11045, Montgomery, Alabama 36105.

RENT 4-Track open reel tapes—all major labels—3,000 different—free brochure. Stereo-Parti, 55 St. James Drive, Santa Rosa, Ca. 95401.

STEREO TAPES, Save 30% and up; no membership or fees required; postpaid anywhere U.S.A. Free 70-page catalog. We discount batteries, recorders, tape/accessories. Beware of slogans, "not undersold", as the discount information you supply our competitor is invariably reported to the factory. **SAXITONE**, 1776 Columbia Road, N.W., Washington, D.C. 20009.

TAPE RECORDER SALE. Brand new nationally advertised brands, \$10.00 above cost. Amazing discounts on stereo components. Arkay Electronics, 1028-C Commonwealth Avenue, Boston, Mass. 02215.

STEREO TAPE CLUB: Average cost \$3.78—\$4.20. Cartridges, Cassettes, Reels. No minimum monthly purchases. Free brochure—catalog. Star Recordings, Box 1055, El Paso, Texas 79946.

EXCLUSIVE! NORELCO CONFERENCE 'CARRY-CORDER'. Four hour recording on C-120 cassette. Unique accessories. Free data: Security Electronics-PER, 15 East 43 Street, New York, N.Y. 10017.

TAPEMATES makes available to you **ALL 4-TRACK STEREO TAPES—ALL LABELS**—postpaid to your door—at tremendous savings. For free brochure write: **TAPEMATES**, 5727 W. Jefferson Blvd., Los Angeles, California 90016.

STEREO TAPE—"Modern Car Buying Psychology." Fast Action! "Pro's" in live discussions. Learn all their Tricks, Jargon and Double-Talk. Profitable, entertaining. Two hours at 3-¾ ips. Post-paid \$10.00. Scheller Sales, 5204 North Lamon Avenue, Chicago, Illinois 60630.

REPAIRS AND SERVICES

TV Tuners rebuilt and aligned per manufacturers specification. Only \$9.50. Any make UHF or VHF. Ninety day written guarantee. Ship complete with tubes or write for free mailing kit and dealer brochure. JW Electronics, Box 51C, Bloomington, Indiana 47401.

SPEAKER REPAIR. Hi-Fi, guitar, organ speakers reconed good as new at fraction of new speaker price. For details and reconing center in your area write: Waldom Electronics, Inc., Dept PE, 4625 W. 53rd St., Chicago, Ill. 60632.

CHASSIS: All types and sizes. Will build to your specifications. Phone 307-532-5752. A & T Manufacturing, Inc., 1902 West C., Torrington, Wyoming 82240.

INSTRUCTION

LEARN While Asleep, hypnotize with your recorder, phonograph. Astonishing details, sensational catalog free! Sleep-learning Association. Box 24-2D, Olympia, Wash. 98501.

LEARN ELECTRONIC ORGAN SERVICING at home all makes including transistor. Experimental kit—trouble-shooting. Accredited NHSC, Free Booklet. **NILES BRYANT SCHOOL**, 3631 Stockton, Dept. A, Sacramento, Calif. 95820.

ASSOCIATE Degree in Electronics Engineering earned through combination correspondence-classroom educational program. Free brochure. Grantham Technical Institute, 1505 N. Western Ave., Hollywood, Calif. 90027.

ABOUT YOUR SUBSCRIPTION

Your subscription to **POPULAR ELECTRONICS** is maintained on one of the world's most modern, efficient computer systems, and if you're like 99% of our subscribers, you'll never have any reason to complain about your subscription service.

We have found that when complaints do arise, the majority of them occur because people have written their names or addresses differently at different times. For example, if your subscription were listed under "William Jones, Cedar Lane, Middletown, Arizona," and you were to renew it as "Bill Jones, Cedar Lane, Middletown, Arizona," our computer would think that two separate subscriptions were involved, and it would start sending you two copies of **POPULAR ELECTRONICS** each month. Other examples of combinations of names that would confuse the computer would include: John Henry Smith and Henry Smith; and Mrs. Joseph Jones and Mary Jones. Minor differences in addresses can also lead to difficulties. For example, to the computer, 100 Second St. is not the same as 100 2nd St.

So, please, when you write us about your subscription, be sure to enclose the mailing label from the cover of the magazine—or else copy your name and address exactly as they appear on the mailing label. This will greatly reduce any chance of error, and we will be able to service your request much more quickly.

ART TALENT? Make money right away. A course may not be necessary. Free Brochure. Famous American Studios, Spring Park, Minnesota 55384.

R. E. I.'s famous (5) week course for the first class radio telephone license is the shortest, most effective course in the nation. Over 98% of R.E.I. graduates pass F.C.C. exams for 1st class license. Total tuition \$350.00. Job placement free. Write for brochure Radio Engineering Incorporated Schools, 1336 Main Street, Sarasota, Florida 33577—or 3123 Gillham Road, Kansas City, Missouri 64109—or 809 Caroline Street, Fredericksburg, Virginia 22401.

HIGHLY EFFECTIVE home study course in Electronics Engineering Mathematics with circuit application. Earn your Associate in Science Degree. Free Literature. Cook's Institute of Electronics Engineering, P.O. Box 36185, Houston, Texas 77036. (Established 1945.)

RADIO AND TELEVISION REPAIR COURSE, BASIC TEST EQUIPMENT AND INSTRUCTION NECESSARY FOR STARTING PROFITABLE BUSINESS. WRITE HOOSIER TECHNICAL INSTITUTE, BOX 88401, INDIANAPOLIS, INDIANA 46208.

LEARN GUITAR. Just released. Send self-addressed, stamped envelope for information, R.D. Bowen, G-3 Dutch Village, Blacksburg, Virginia 24060.

FCC First Class License in six weeks—nation's highest success rate—approved for Veterans Training. Write Elkins Institute, 2603B Inwood Road, Dallas, Texas 75235.

PERSONALS

MAKE FRIENDS WORLDWIDE through international correspondence. Illustrated brochure free. Hermes, Berlin 11, Germany.

LAW ENFORCEMENT AGENTS AND LEGAL INVESTIGATORS ONLY. FREE LITERATURE, LATEST ELECTRONIC AIDS. REQUEST MUST BE ON YOUR OFFICIAL LETTERHEAD. R. CLIFTON, 11500-K NW 7TH AVE., MIAMI, FLORIDA 33168.

LEMURIAN VIEWPOINT—Meaningful discussions of Cosmic Truth: the purpose of human life, reincarnation, man's place in a Higher Plan, and subjects from the Lemurian Philosophy. Send for **FREE** copy. Lemurian Fellowship, Dept. 815, Box 397, Ramona, Calif. 92065.

WANTED: PUZZLE-CONTEST SOLVERS! Up to \$18 hourly! **IGY-POSHADLO, 23243 LAWRENCE, DEARBORN, MICH. 48128.**

WE crave any free mail. Pat Ickes, Box 7009, APO New York 09856 and Ken Bateman, RT. 3 Box 208B, Colorado Springs 80908.

INVENTIONS WANTED

MANY million dollar corporations have authorized us to locate new products. **FREE "Directory of 500 Corporations Seeking New Products."** For information regarding development, sale, licensing of your patented/unpatented invention. Write: Raymond Lee Organization, 230-GR Park Avenue, New York City 10017.

INVENTIONS wanted. Patented; unpatented. Global Marketing Service, 2420-P 77th, Oakland, Calif. 94605.

PATENT Searches including Maximum speed, full airmail report and closest patent copies, \$6.00. Quality searches expertly administered. Complete secrecy guaranteed. Free Invention Protection forms and "Patent Information." Write Dept. 9, Washington Patent Office Search Bureau, 711 14th Street, N.W., Washington, D.C. 20005.

QUALITY Patent Searches! Preferred by Professional Inventors, Lawyers, Manufacturers. "Confidential Report" Including related United States patent copies "Airmailed Certified." **FREE** information! United States Inventors Service Company, 501-H Thirteenth Street, N.W., Washington, D.C. 20005.

INVENTORS. We will develop, help sell your idea or invention, patented or unpatented. Our national manufacturer clients are urgently seeking new items for outright cash sale or royalties. Financial assistance available. 10 years proven performances. For free information, write Dept. 41, Wall Street Invention Brokerage, 79 Wall Street, New York N.Y. 10005.

PATENT SEARCHES. FREE "INVENTION RECORD"/Information. Hayward Company, 1029HR Vermont, District of Columbia 20005.

INVENTORS! OUR FREE EXPERT ANALYSIS of your invention can save valuable time, help you realize full sale value. Strictly confidential. **FREE INVENTION CERTIFICATE.** Write today: Pioneer Invention Service, Dept. 35, 150 Broadway, New York, N.Y. 10038.

INVENTIONS WANTED. Electronic or Electrical by established manufacturer, Patented or Pat. Pending. Write Voron Electronics, 1230 E. Mermaid Lane, Phila. 19118 or call (215) CH 8-4900.

INVENTORS! Sell your invention for cash or royalties! Our client manufacturers eagerly seek new items. Patented. Unpatented. Financial assistance if needed. 25 years proven performances. For free information, write Dept. 20, Gilbert Adams, Invention Broker, 80 Wall St., New York, N.Y. 10005

GOVERNMENT SURPLUS

GOVERNMENT Surplus How and Where to Buy in Your Area. Send \$1.00 to: Surplus Information PE, Headquarters Building, Washington, D.C. 20036.

JEPS Typically From \$53.90 Trucks From \$78.40 Boats, Typewriters, Airplanes, Multimeters, Oscilloscopes, Transceivers, Electronics Equipment, Used. 100,000 Bid Bargains Direct From Government Nationwide. Complete Sales Directory and Surplus Catalog \$1.00 (Deductible First \$10.00 Order). Surplus Service, Box 820-J, Holland, Michigan 49423.

BOOKS

FREE catalog 950 aviation/electronic/space books. Aero Publishers, 329PE Aviation Road. Fallbrook, California 92028.

UNUSUAL Books! Catalog free! International, Box 7798 (PE), Atlanta, Georgia 30309.

FREE Book Prophet Elijah Coming Before Christ. Wonderful Bible Evidence. PE Megiddo Mission, Rochester, New York 14619.

FREE CATALOG. BOOKS FOR ADULTS. CATALOG, 2217 LACKLAND, ST. LOUIS, MISSOURI 63114.

FREE BOOK CATALOG. Television, Radio, Communication, Photography, Films. George Brown, Box 7146, Toledo, Ohio 43615.

ADULT books, magazines. Free illustrated catalogue. Clifton's, Box 1068-EE, Saugus, Calif. 91350.

AUTHORS' SERVICES

AUTHORS! Learn how to have your book published, promoted, distributed. **FREE** booklet "ZD," Vantage, 120 West 31 St., New York 10001.

MUSIC

POEMS wanted for new songs. Nashville Music Institute, Box 532-E, Nashville, Tennessee 37202.

POEMS, songs wanted for new song hits and recordings by America's most popular studio. Tin Pan Alley, 1650-PE Broadway, New York, N.Y. 10010.

MUSICAL INSTRUMENTS

ACCORDIONS, GUITARS, AND INSTRUMENTS! Save to 50%. Terms. Trades. Free Trial. Free catalog. Mention instrument. Music Mart, 5535-PE Belmont, Chicago 60641.

RUBBER STAMPS

RUBBER ADDRESS STAMPS \$1.50. SIGNATURE \$3.50. FREE CATALOG. JACKSON, BOX 443-G, FRANKLIN PARK, ILL. 60131.

NAME and address rubber stamp \$1.25 guaranteed. Coulese Enterprises, 104 Mechanic St., Bellingham, Mass. 02019.

MAGNETS

MAGNETS. All types. Special—20 disc magnets, or 2 stick magnets, or 10 small bar magnets, or 8 assorted magnets, \$1.00 Maryland Magnet Company, 5412-H Gist, Baltimore, Maryland 21215.

PHOTOGRAPHY—FILM, EQUIPMENT, SERVICES

MEDICAL Film—Adults Only—"Childbirth"—1 reel 8mm \$7.50—16mm \$14.95. International-E, Greenvale, L.I., New York 11548.

SCIENCE Bargains—Request Free Giant Catalog "CJ"—148 pages—Astronomical Telescopes, Microphones, Lenses, Binoculars, Kits, Parts. War surplus bargains. Edmund Scientific Co., Barrington, New Jersey 08007.

RECORDS

SPECIAL INTEREST RECORDS AVAILABLE, PRODUCED BY THE EDITORS OF THE WORLD'S LEADING SPECIAL INTEREST MAGAZINES. SEND FOR FREE CATALOG. RECORD CATALOG-PE ZIFF-DAVIS PUBLISHING COMPANY, ONE PARK AVENUE, NEW YORK, N.Y. 10016. OLDIES 45RPM. Original Hits. Over 1500 available. Catalog 25¢ C & S Record Sales, Box 197, Wampsville, N.Y. 13163.

HYPNOTISM

FREE Hypnotism, Self-Hypnosis, Sleep Learning Catalog! Drawer H400, Ruidoso, New Mexico 88345.

"MALE-FEMALE HYPNOTISM" EXPOSED, EXPLAINED! "SECRET METHOD"—THEY NEVER KNOW! \$2, RUSHED. GUARANTEED! ISABELLA HALL, SILVER SPRINGS, FLORIDA 32688.

AMAZING HYPNOTIC record kit releases fantastic mental power! Free offer expires soon. Write: Forum, Studio AA11, 333 North Michigan, Chicago 60601.

ADULTS ONLY—HYPNOTIZE SUCCESSFULLY! "Instantaneous"—"One Word"—"Against Will" methods exposed! Complete illustrated course—including "Secret Nerve Pressure Technique"—Self-Hypnosis—10" Hypnodisk—\$2.00. **RESULTS ABSOLUTELY GUARANTEED!** Fowler, Box 4396, Woodbury, New Jersey 08096.

FEMALE, MALE HYPNOTISM! Easily! Instantly! Secret Nerve Centers! \$2.20. Brugenheimer, Box 158-E30, Lexington, Mass. 02173.

HYPNOTIZE MALES, FEMALES!—Unnoticed! Quickly! Nerves! Exciting! \$2.25. Research Enterprises, 29-SN21 Samoset, Woburn, Mass. 01801.

PLASTICS

CASTOLITE Liquid Plastic pours like water and hardens like glass without heat. Clear, Colors. Embed real flowers, butterflies, photos, coins. Also new molding formulas for perfect reproductions, Illustrated booklet shows **HOW**. Send 25¢—Dept. 68-108M. **CASTOLITE**, Woodstock, Ill. 60098.

EDUCATIONAL OPPORTUNITIES

LEARN WHILE ASLEEP. Miraculously build Mind Power, achieve Self-Confidence, improve Health, gain Success. Method 92% effective. Details free. ASR Foundation, Box 7021EG Henry Clay Sta., Lexington, Kentucky 40502.

PRINTING

THERMOGRAPHED business cards, \$3.49—1,000, free samples. Gables—405A Clifton, Glenshaw, Pa. 15116.

FREE LITERATURE: Address labels, business cards, printing, Rubber Stamps. **JORDAN'S**, 552 West O'Connor, Lima, Ohio 45801.

PRINTING??? Speed—Quality—Economy. Samples. JLP, Box 817, Fort Lauderdale, Florida 33301.

REMAILING SERVICE

ENTERSULL, Your secret address. Prompt. Confidential, Box 206E, Forsyth, Georgia 31029.

BUSINESS OPPORTUNITIES

INVESTIGATE ACCIDENTS: Earn to \$1000 monthly. Men urgently needed. Car furnished. Business expenses paid. No selling. No College education necessary. Pick own job location. Investigate full time or earn to \$8 hour spare time. Write for **FREE** information. No obligation. Universal Schools, CZ-11, 6801 Hillcrest, Dallas, Texas 75205.

RAISE Rabbits for us on \$500 month plan. Free details White's Rabbitry, Mt. Vernon, Ohio 43050.

FREE CATALOGS, Repair air conditioning, refrigeration. Tools, supplies, full instructions. Doolin, 2016 Canton, Dallas, Texas 75201.

PIANO TUNING learned quickly at home. Tremendous field! Musical knowledge unnecessary. GI Approved. Free Information. Empire School, Miami, Florida 33145.

TUBES! CORNELL TUBES!

FREE Send For FREE
CORNELL'S
New 1968
CATALOG
Many New Items

30¢ per tube
IN LOTS OF 100

33¢ per tube
WE SELL PICTURE TUBES

4219 UNIVERSITY AVE., SAN DIEGO, CALIF. 92105

FREE Book "990 Successful little-known Businesses." Work home. Plymouth 245K, Brooklyn, N.Y. 11218.

ELECTROPLATING Equipment and supplies. All types for home workshops and industrial. Send \$1.00 (refundable) for equipment guide formulas, operating data, catalog. HBS Equipment Division 90, 3543 East 16th, Los Angeles, California 90023.

MADE \$40,000.00 Year by Mailorder! Helped others make money! Start with \$10.00—Free Proof. Torrey, Box 318-N, Ypsilanti, Michigan 48197.

\$200.00 DAILY In Your Mailbox! Your opportunity to do what mail-order experts do. Free details. Associates, Box 136-J, Holland, Michigan 49423.

SELL LIFETIME, Metal, Social Security Plates. Big profits! Sample and Sales Kit Free. Russell, Box 286-PE, Pulaski, Tennessee 38748.

SELL HERTEL BIBLES—Part Time. Finest reference Bible available. Demonstrator and supplies furnished. Excellent commissions, Write International Book, Dept. PE, Box 118, Wichita, Kansas 67201.

MAILORDER . . . Operate cash-in-advance business! Details. Methods, 1408-F.D., Lafayette Hill, Pennsylvania 19444.

AMAZING ways to start and operate successful small business. Details free. Lynn, Box 1573, Waco, Texas 76703.

MAKE MONEY home, in Mail Order Business. I'll show you how! Free Details. **HAVEN HOUSE (E)**, 51 Providence St., New Haven, Conn. 06513.

HOW AND WHERE to get capital. No red-tape. 1001 easy sources. Free details, Counselor-48, Harlingen, Texas 78550.

REAL ESTATE

FREE . . . Big **FALL-WINTER CATALOG!** Describes and pictures over 2,000 farms, ranches, town and country homes, businesses in 32 states coast to coast! Specify type property and location preferred. Zip code, please. **UNITED FARM AGENCY**, 612-EP West 47th St., Kansas City, Mo. 64112.

STAMPS

RUSSIA-HIGH-VALUE COLLECTION. 32 different Russia—some over 50 years old! Commemoratives. Czarist Issues, Airmails. Catalog price \$2.99. Special Get-Acquainted Offer—all for only 10¢! H.E. Harris, Dept. GG-13, Boston, Mass. 02117.

HELP! Fill collection, 100 diff. U. S. commemoratives, plus more: 50¢—approvals—Tomiko's, P.O. Box 45251, L.A., Calif. 90045.

TAXIDERMY

NEW, complete, improved, and illustrated methods. Request free information and samples, Taxidermy Success Training, Rt. 1, Box 5815, Bossier City, Louisiana 71010.

MISCELLANEOUS

WINEMAKERS: Free illustrated catalog of yeasts, equipment. Semplex, Box 7208, Minneapolis, Minn. 55412.

BILLS PAID WITHOUT BORROWING—Nobody refused up to \$18,000.00. Bad credit no problem—Not a Loan Company. Write for **FREE** application—**INTERNATIONAL ACCEPTANCE**, Dept. 50A, Phoenix, Arizona 85012—711 14th St., N.W., Washington, D.C. 20005—507 Carondelet St., New Orleans, La. 70130.

WINEMAKERS . . . COMPLETE catalog \$1.00, complete equipment \$6.98. Department PE, 100 Sandringham, Rochester, New York 14610.

EMPLOYMENT Resumes. Get a better job & earn more! Send only \$2.00 for expert, complete Resume Writing Instructions. J. Ross, 80-34 Kent St., Jamaica, N.Y. 11432, Dept. PE.

STOP BURGLARS THE EASY WAY!! Affix authentic "Protected by Electronic Sentry Alarm" Decals to auto windows, door & windows of home, retail stores, vending machines, etc. Whether you have an alarm or not—thieves stay away! Only \$1.00 each set of two. J. Ross, 80-34 Kent st., Jamaica, N.Y. 11432 Dept. PE.

BEERS, PEACH BRANDY, WINES—Strongest Formulas, \$2.25. (complete brew supplies hydrometers catalog included)—Research Enterprises, 29-D Samoset, Woburn, Mass. 01801.

STAMMER — Stutter — No more. (Dr. Young.) Write Gaucho, Box 9309-E8, Chicago 60690.

MAIL ORDER OPPORTUNITIES WAITING FOR YOU!

Classified Advertisers find more outlets for their product and service advertising in Ziff-Davis Electronics Publications than in any other media.

Whether in a monthly publication: **POPULAR ELECTRONICS**, **ELECTRONICS WORLD**, **STEREO REVIEW** . . . or in an annual: **COMMUNICATIONS HANDBOOK**, **ELECTRONIC EXPERIMENTER'S HANDBOOK**, **ELECTRONICS INSTALLATION AND SERVICING HANDBOOK**, or **TAPE RECORDER ANNUAL**—Classified Advertising is responded to regularly by an affluent audience of active electronics enthusiasts.

Prove to yourself the effectiveness of Classified Advertising in Ziff-Davis Electronics Publications. Write today for information, assistance or sample copies to:

Hal Cymes, Classified Advertising Manager
Ziff-Davis Publishing Company
One Park Avenue, New York, N. Y. 10016

POPULAR ELECTRONICS SUBSCRIBER SERVICE

Please include an address label when writing about your subscription to help us serve you promptly. Write to: Portland Place, Boulder, Colo. 80302

CHANGE OF ADDRESS:

Please let us know you are moving at least four to six weeks in advance. Affix magazine address label in space to the right and print new address below. If you have a question about your subscription, attach address label to your letter.

TO SUBSCRIBE:

Check boxes below.

- New Renewal
 5 years \$20
 3 years \$13
 1 year \$5

SPECIFY:

- Payment enclosed
 —You get 1 extra issue per year as a **BONUS!**
 Bill me later.

← AFFIX LABEL →

If you have no label handy, print OLD address here.

please print

name

address

city

state

zip code

Add'l postage: \$1 per year outside U.S., its possessions & Canada.

name please print 0306

address _____

city _____

state _____ zip-code _____

124

Printed in U.S.A.

POPULAR ELECTRONICS

NOVEMBER 1968

ADVERTISERS INDEX

READER

SERVICE NO.	ADVERTISER	PAGE NO.
1	AMECO, Division of Aeroftron, Inc	103
2	Allied Radio	125, 126
3	Amplex Corporation	13
4	Argos Products Company	94
5	B & K	23
6	BSR (USA) Ltd., McDonald Division	93
	Bell & Howell Schools	5
7	Browning Laboratories, Inc	111
8	Burstein-Applebee Co	94
	CREI, Home Study Division, McGraw-Hill Book Company	36, 37, 38, 39
9	Caringella Electronics, Inc	96
10	Cleveland Institute of Electronics	62, 63, 64, 65
11	Cleveland Institute of Electronics Cornell	96 123
12	Courier Communications, Inc	25
13	Delwyn	10
14	EICO Electronic Instrument Co., Inc	

FOURTH COVER

15	Edmund Scientific Co	102
16	Electro-Voice, Inc	6
17	Empire Scientific Corp	100
18	Finney Company, The	95
19	Garrard	8
20	Graymark Enterprises, Incorporated	99
21	Heath Company	105, 106, 107, 108, 109
	ICS	9
22	Jensen Manufacturing Division	92
23	Lafayette Radio Electronics	85
24	Mosley Electronics, Inc	14
	National Radio Institute . . . SECOND COVER 1, 2, 3	
	National Technical Schools	18, 19, 20, 21
	North American School of Drafting	116
25	Olson Electronics	116
26	Pace Communications Corp	17
27	RCA Electronic Components and Devices	11
	RCA Electronic Components and Devices	

THIRD COVER

	RCA Institutes, Inc	88, 89, 90, 91
28	Radio Shack	112
	Radio-Television Training of America	7
29	Raytheon Education Company	97
30	Sams & Co., Inc., Howard W	98
31	Scott, Inc., H.H.	87
32	Sherwood Electronics Laboratories, Inc	16
33	Shure Brothers, Inc	12
34	Sonar Radio Corp	114
35	Squires-Sanders, Inc	26
36	Sydmur Electronics Specialists	92
37	United Audio Products, Inc	110
	Valparaiso Technical Institute	116
38	World Radio Laboratories	101

Classified Advertising 119, 120, 121, 122, 123, 124

CIRCLE NO. 2 ON READER SERVICE PAGE →

FREE

ALLIED ELECTRONICS FOR EVERYONE 1969

OUR 48TH YEAR · CATALOG 280 · INDEX PAGE 451

Catalog 280
ALLIED ELECTRONICS FOR EVERYONE

536
pages

ALLIED RADIO

100 N. WESTERN AVE. - CHICAGO, ILL. 60600 - WA 1-8800 (AREA CODE 312)

SATISFACTION
GUARANTEED OR
YOUR MONEY BACK
SEE PAGE 459

New 1969 Allied Catalog

Brand new! Fresh off the press! Allied's 1969 Catalog... 536 fascinating pages jam-packed with the very latest in Hi Fi, Tape Recorders, CB, Kits, Radios, Tools, Electronic Parts, Books. Probably nowhere else on earth will you find such a complete selection of everything in electronics... and virtually all new as tomorrow! Literally thousands of items... many of them never shown before. Allied's all new 1969 Catalog makes wonderful reading... and it's yours absolutely FREE! Tear off the card... mail it in today... and we'll rush you your own personal copy of the newest and most complete book of what's new in electronics... Allied's 1969 Catalog!

NO MONEY DOWN—24 MONTHS TO PAY!
Low Monthly Payments to fit your budget.

DO A FRIEND A FAVOR—give him this card to send for his FREE ALLIED CATALOG

063

fill this card out!

PLEASE PRINT

NAME _____
First Middle Last

ADDRESS _____

CITY _____

STATE _____ ZIP _____

MAIL IT NOW!

free!
**ALLIED
1969
CATALOG**

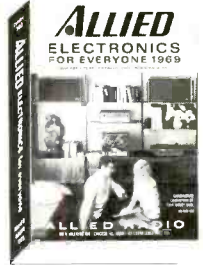

WORLD'S LARGEST SELECTIONS. SATISFACTION
GUARANTEED OR YOUR MONEY BACK

064

fill this card out!

PLEASE PRINT

NAME _____
First Middle Last

ADDRESS _____

CITY _____

STATE _____ ZIP _____

MAIL IT NOW!

free!
**ALLIED
1969
CATALOG**

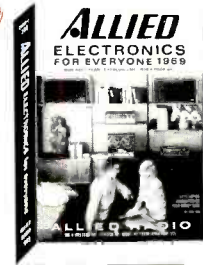

WORLD'S LARGEST SELECTIONS. SATISFACTION
GUARANTEED OR YOUR MONEY BACK

FREE

1969
ALLIED
CATALOG

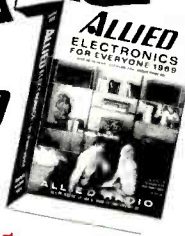

TO:
ALLIED RADIO
P.O. BOX 4398
CHICAGO, ILLINOIS 60680

PLACE
STAMP
HERE



Why Buy by Mail from **ALLIED?**

Because you buy from the
most unique store in the world!

Why do hundreds of thousands of people... electronics experimenters, music lovers, engineers, Amateur operators, professional radio-TV servicemen, kit builders, hobbyists, hi-fi fans, and just plain "bargain-hunters"... *order tens of millions of dollars* worth of merchandise-by-mail from ALLIED each year?

Variety, selection, price, and quality-testing are the answers! If we can satisfy the experts... we can satisfy you! Our continuous program of quality-testing assures you that everything you buy meets the highest standards. And nowhere else on the face of the earth are so many famous brands (and so many different models of every brand), gathered together to choose from. When it comes to *parts* that both beginners and experts need... ALLIED is the one source that has them *all*.

Thousands and thousands of items to choose from... and you'll like shopping from ALLIED because you do it in your easy chair. Our entire stock is spread before you, as it could never be in a conventional store. It takes ALLIED over 500,000 square feet of floor-space (with merchandise stacked to the ceiling!), to keep on hand all the items you hold in *one hand* when you pick up an ALLIED catalog.

You never had shopping so good, as when you do it at home with this famous book to guide you. No clerk, no expert, no salesman in all the world could begin to supply you with the wealth of facts, the exact specifications, the comparable data—all at your fingertips in this popular book. Almost anything you may want or need or have an interest in... is pictured, priced, and described in detail. You'll discover things you never knew existed. You'll find bargains unmatched anywhere else you may shop. You'll revel in choices, varieties, and selections beyond imagination. You'll find a whole new way to buy both the commonplace and the rare, the inexpensive and the luxurious.

Best of all—with an ALLIED Credit Fund Account, you pay no money down, and take up to 2 years to pay!

Shop Where the Experts Buy— Choose from the Biggest and Most Fabulous Selection Ever Gathered Together:

STEREO HI-FI
ELECTRONIC
& HOBBY KITS
TAPE RECORDERS
AND TAPES
CITIZENS BAND
EQUIPMENT
WALKIE-TALKIES
SHORTWAVE
RECEIVERS
PHONOGRAPHS
SPEAKERS
RECORD CHANGERS

FM, AM & VHF
RADIOS
PORTABLE
TV SETS
AMATEUR GEAR
INTERCOMS
P.A. EQUIPMENT
TEST EQUIPMENT
ANTENNAS
TUBES AND
TRANSISTORS
AUTOMOTIVE
ELECTRONICS

TOOLS &
HARDWARE
BOOKS
CAMERAS
NEEDLES
HEADPHONES
MICROPHONES
INTEGRATED
CIRCUITS
WIRE &
CABLE
PARTS AND
BATTERIES

FREE

1969
ALLIED
CATALOG

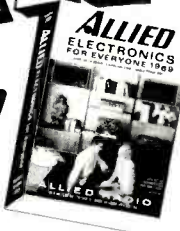

TO:
ALLIED RADIO
P.O. BOX 4398
CHICAGO, ILLINOIS 60680

PLACE
STAMP
HERE

Come and get it!

Technical Series RC-26

RCA Receiving Tube Manual

\$175

Suggested
Price

The RC-26 is the biggest and best receiving tube manual in the industry! Newly revised and updated, it now has 656 pages of vital data... information on the complete RCA line of home-entertainment receiving tubes, color and black-and-white picture tubes, voltage-regulator tubes and voltage-reference tubes... expanded Circuits Section featuring several circuits that illustrate the various stages of a complete color-television receiver... extremely handy Applications Guide... Technical Data section with comprehensive data and curves for all active RCA receiving tubes.

See your RCA Distributor today for your copy of the RC-26. It's the best yet. Be sure to ask your customers "WHAT ELSE NEEDS FIXING"?

RCA Electronic Components,
Harrison, N. J. 07029

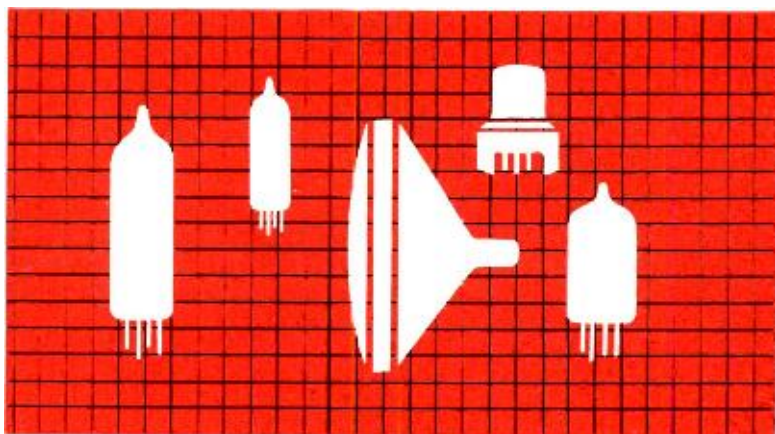

RCA

This is more amplifier than you may think you need.

But after you see the price, why settle for less.

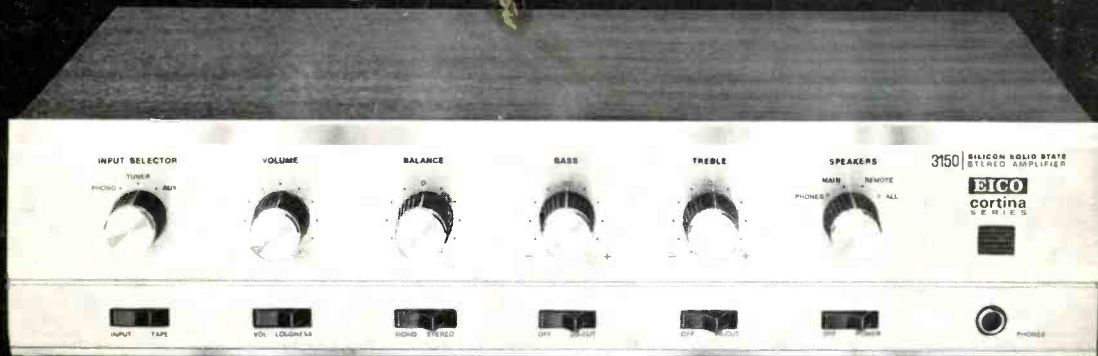

The EICO "Cortina 3150" all-silicon solid-state 150 watt stereo amplifier is truly a lot of amplifier. It combines wide-range preamplifiers, controls, and power amplifiers, all on one uniquely compact chassis. It delivers clean power to two sets of speaker systems, stereo headphones (for which there is a jack on the front panel) and a tape recorder. The Cortina "3150" gives you complete control facilities.

Most people think that, while all this would be very nice to have they don't want to pay a lot of extra money for it.

We agree. That's why we designed the "3150." Fully wired it costs \$225.00. If you want to buy it as a kit — and it is a particularly easy kit to assemble because of our advanced modular circuitry techniques — it's a mere \$149.95. The beautiful Danish

walnut vinyl clad cabinet is included at no additional cost. At these prices, the "3150" is no longer a luxury. It's virtually a necessity. The power delivered by the "3150" is enough to give faithful reproduction of the highest peaks in music even when it is used with inefficient speaker systems.

The "3150" gives you more than just power. With both channels driven the harmonic distortion is less than 0.1%, IM distortion is less than 0.6%, frequency response is ± 1.5 db, 5Hz to 30 KHz, all at full output, hum and noise 75db below rated output; channel separation is more than 50db; input sensitivity is 4.7MV at magnetic phono input, 280MV at all other inputs.

Phase shift distortion is negligible due to the differential amplifier input circuit and the transformerless driver and output

circuits. All electronic protection (no fuses) of output transistors and speakers makes overloads and shorts impossible.

The "3150" also provides ten versatile control facilities: volume, balance, full range bass and treble controls. Input Selector (phono, tuner, aux), tape monitor, loudness contour, low and high cut filters, and speakers system selector switches.

See and hear this most advanced of all silicon solid-state amplifiers at your EICO dealer. We are confident it will quickly change your mind as to how much amplifier you really need.

cortina by EICO
Designed, manufactured in U.S.A. and guaranteed by EICO.

See the complete Cortina® Line at your EICO Dealer.



"The EICO Cortina Series are low-cost audio components that look and sound like high cost components."

Popular Science Magazine.

Cortina 3070 a full capability 70-Watt All Silicon Solid-State Stereo Amplifier for \$99.95 kit, \$139.95 wired, including cabinet.

Cortina 3200 Solid-State Automatic FM Stereo Tuner for \$99.95 kit, \$139.95 wired, including cabinet.



Sound n' Color is an exciting innovation in the home entertainment field. It adds a new dimension to your musical enjoyment. See the music you hear spring to life as a vibrant, ever shifting interplay of colors.

See every tone, every note, every combination of instruments create its own vivid pattern. EICO Model 3440—Kit \$49.95, Wired \$79.95.



Cortina 3570 70-Watt All Solid-State FM Stereo Receiver for \$169.95 kit, \$239.95 wired, including cabinet.

Pre-assembled and pre-aligned front end, multiplex, and IF circuits speed and simplify assembly — you'll enjoy building this deluxe kit.



New Cortina 3770 70-Watt All Solid-State AM/FM Stereo Receiver for \$189.95 kit, \$279.95 wired, including cabinet.

EICO Electronic Instrument Co., Inc. PE-11
283 Malta Street, Brooklyn, N.Y. 11207

- Tell me where I can have a free Cortina demonstration.
 Send me free 32-page catalog on EICO's 200 "best-buys."

Name _____

Address _____

City _____

State _____ Zip _____

CIRCLE NO. 14 ON READER SERVICE PAGE

www.americanradiohistory.com