

**BUILD DIRECT READOUT SPORTS TIMER**

# POPULAR ELECTRONICS

OCTOBER  
1968

50  
CENTS



**NEW!**

**PASSIVE RADIATOR  
SPEAKER SYSTEM**

**HURRAH!**

**MAKING PC BOARDS  
THE EASY WAY**

**WOW!**

**REPORT ON SWL  
DREAM RECEIVERS**

**EXCITING!**

**FREQUENCY SELECTIVE  
PHOTOELECTRIC LOCK**



**GREAT!**

**BUILD IGNITION  
NOISE ELIMINATOR**



E0569 640520MIN0508BOWSK  
M WEINERT JR  
508 BORNEN ST  
PITTSBURGH PA 15215

# NRI "hands-on" training in TV-Radio, Electronics can give you as much as 2 years of on-the-job experience.

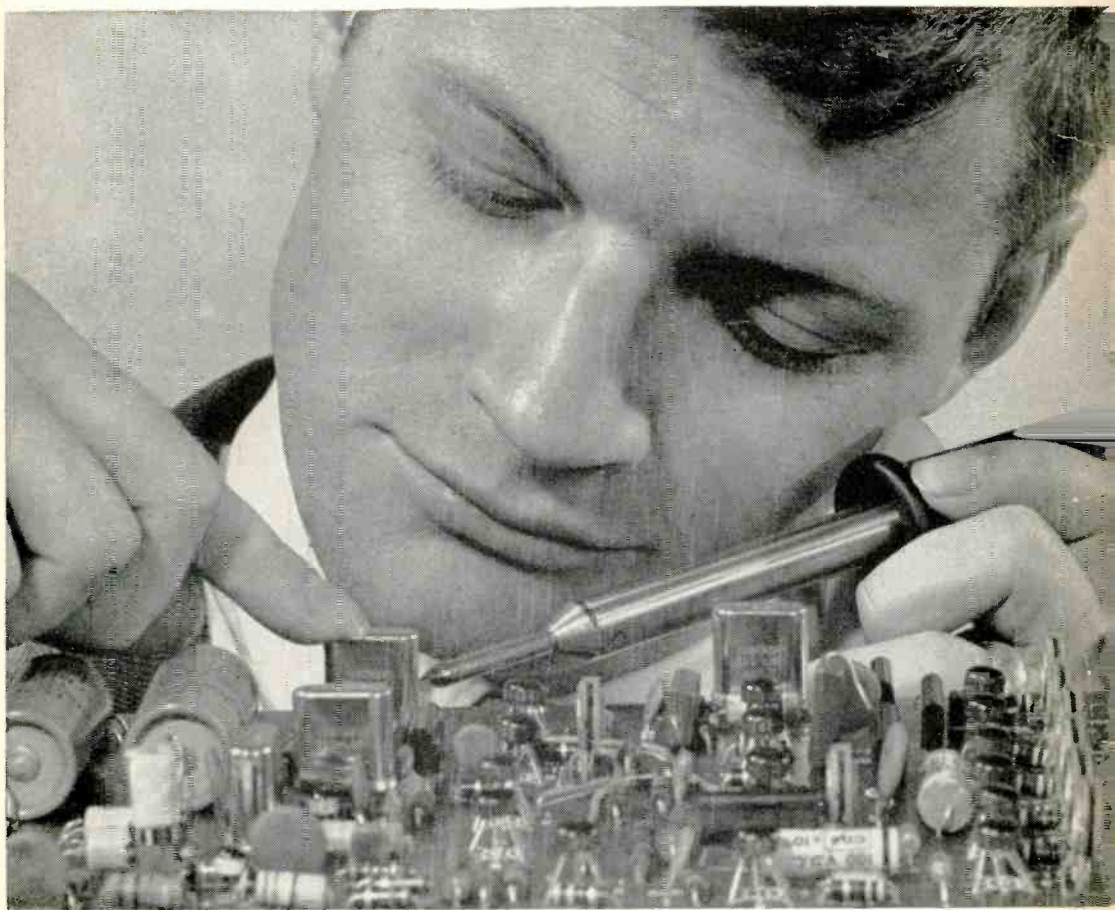

## EARN YOUR FCC LICENSE – OR YOUR MONEY BACK

NRI Communications training programs will qualify you for a First Class Commercial Radiotelephone License issued by the FCC. If you fail to pass the FCC examinations for this license after successfully completing an NRI Communications course we will, on request, refund in full the tuition you have paid. This agreement is valid for the period of your active student membership and *for six months* after completion of your training. No school offers a more liberal FCC License agreement.



# Experience is still your best teacher



**NRI Achievement Kit** is educator-acclaimed and the original "starter" kit in home study training. Imitated but never duplicated, this kit is designed and personalized for you and your training objective. It has one purpose — to get you started quickly and easily.



**"Bite-Size" Texts** average an easily-digested 40 pages of well-illustrated, scientifically prepared subject matter in the course of your choice. Questions in each book are carefully hand-graded and returned to you with helpful instructional notes. You get unlimited personal help from the day you enroll.



## Designed-For-Learning Equipment

Like this phone-cw transmitter (Kit #7 in the Communications course) is engineered from chassis up to demonstrate principles you must know. NRI does not use modified hobby kits for training, but the finest parts money can buy, professionally and educationally applied.

*...here's how you get it with unique NRI training at home*

Ask any teacher, job counselor, engineer, technician or prospective employer about the need for practical application of theory in Electronics. He'll tell you Electronics is as much a "hands-on" profession as dentistry or chemistry. That's how you learn at home with NRI. You prove the theory you read in "bite-size" texts, by actual experimentation with the type of solid-state, transistor and tube circuits you'll find on the job today — *not* hardware or hobby kits. You introduce circuit defects, analyze results, discover quickly the kind of trouble-shooting and design techniques that will make you employable in Electronics.

## Train with the leader—NRI

NRI lab equipment is designed from chassis up for effective, fascinating training — not for entertainment. The fact that end results are usable, quality products is a bonus. In Communications, for example, you build and analyze, stage by stage, your own 25-watt phone/cw transmitter. It's suitable for use on the 80-meter amateur band, if you have an interest in ham radio. In TV-Radio Servicing your practical training gives you your choice of monochrome or color TV sets. All training equipment is included in the low tuition — you pay nothing extra. Discover for yourself the ease, excitement and *value* of NRI training. Mail postage-free card today for new NRI Catalog . . . or use the coupon below. No obligation. No salesman will call on you. NATIONAL RADIO INSTITUTE, Washington, D.C. 20016.

### APPROVED UNDER NEW GI BILL

If you have served since January 31, 1955, or are in service now, check GI line on postage-free card or in coupon.

MAIL THIS COUPON IF CARD IS GONE



### NATIONAL RADIO INSTITUTE

Washington, D.C. 20016

1-108

Please send me your new NRI Catalog. I understand no salesman will call and there is no obligation.

Name \_\_\_\_\_ Age \_\_\_\_\_

Address \_\_\_\_\_

City \_\_\_\_\_ State \_\_\_\_\_ Zip \_\_\_\_\_

Check for facts on new GI Bill

ACCREDITED MEMBER NATIONAL HOME STUDY COUNCIL

# POPULAR ELECTRONICS

VOLUME 29 NUMBER 4

OCTOBER, 1968

WORLD'S  
LARGEST-SELLING  
ELECTRONICS  
MAGAZINE

## SPECIAL CONSTRUCTION PROJECT

**BUILD THE SPORTS TIMER** 31  
*Professional accuracy for any event*

## SPECIAL FEATURE

**DREAM RECEIVERS FOR THE SWL** 53 OLIVER P. FERRELL  
*POPULAR ELECTRONICS surveys \$300-\$1200 models*

## FEATURE ARTICLES

- POPULAR ELECOMICS** 42
- FREQ-OUT ELECTRONIC LOCK** 43 JOHN D. SIMONTON, JR.  
*Protect your home with the latest wrinkle*
- BUILD NOISE BLANKER** 49 A. E. MCGEE, JR., K5LLI  
*A suppressor to use in any troublespot*
- SEALED-REFLEX SPEAKER SYSTEM** 59 DAVID B. WEEMS  
*Provides a unique warmth of tone*
- TRANSIENT VOLTAGE QUIZ** 68 ROBERT P. BALIN  
*What do you know about capacitor circuits?*
- MAKING PC BOARDS FROM THE PRINTED PAGE** 69 THOMAS R. ROSICA  
*A real how-to photocopying method*
- COLOR TV THAT ISN'T** 73 LAURENCE R. GRIFFIN  
*Subjective response creates color from black and white*
- THE PRODUCT GALLERY** 76  
*Heathkit "Jaguar" Combo Organ Kit*
- INFORMATION CENTRAL** 78 CHARLES J. SCHAUERS, W6QLV
- SHORT-WAVE LISTENING** 79 HANK BENNETT, W2PNA  
*News about DX awards program*
- ON THE CITIZENS BAND** 81 MATT P. SPINELLO, KHC2060  
*A CB group devoted to service*
- AMATEUR RADIO** 82 HERB S. BRIER, W9EGQ  
*Horizontal "vertical" antennas*
- ENGLISH-LANGUAGE BROADCASTS TO NORTH AMERICA** 84 ROGER LEGGE
- SOLID STATE** 85 LOU GARNER

## DEPARTMENTS

- LETTERS FROM OUR READERS** 8
- OPERATION ASSIST** 12
- ELECTRONICS LIBRARY** 14
- READER SERVICE PAGES** 15, 115
- NEW PRODUCTS** 22
- TIPS AND TECHNIQUES** 26
- OUT OF TUNE** 99  
*"Tune Up Your Boss Reflex"*

POPULAR ELECTRONICS is indexed  
in the Readers' Guide  
to Periodical Literature

This month's cover photo by  
Conrad Studios

Copyright © 1968 by ZIFF-DAVIS PUBLISHING COMPANY. All rights reserved.

POPULAR ELECTRONICS, October 1968, Volume 29, Number 4, Published monthly at 307 North Michigan Avenue, Chicago, Illinois 60601. One year subscription rate for U.S., U.S. Possessions and Canada, \$5.00; all other countries, \$6.00. Second class postage paid at Chicago, Illinois and at additional mailing offices. Authorized as second class mail by the Post Office Department, Ottawa, Canada and for payment of postage in cash. Subscription service and Fulcrum 3379, Portland Place, Boulder, Colorado 80302. Editorial offices for manuscript contributions, reader inquiries, etc.: One Park Ave., New York, N.Y. 10016.



# Everybody bulls, bluffs and brags about their tape recorders.

## This new Ampex will clear the air.

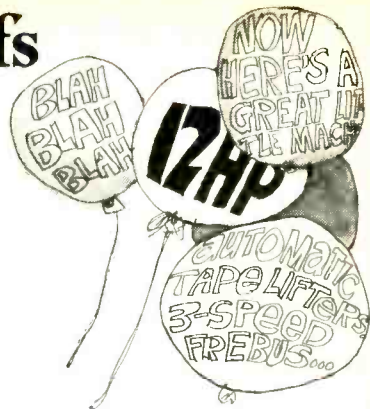

It seems like all tape equipment manufacturers chatter about all sorts of features.

One talks automatic threading. Others boast automatic reverse. Still more hit you with 4 heads, sound-with-sound, dual capstan drive, automatic tape lifters, 3-speed operation and on and on.

It makes the mind boggle.

Because the fact is that no one has all these features on *one* stereo machine. Except us. Ampex.

Our new model 1461 has automatic threading. And automatic reverse. And 4 deep-gap heads. And sound-with-sound. And dual capstan drive. And tape monitoring. And automatic tape lifters. And 3-speed operation. And two omni-directional dynamic microphones.

And lots more. Like full-dimensional stereo cube speakers that nest inside the unit for portable use and separate up to 20 feet. A 1-year overall warranty and 3-year head warranty. Automatic shut-off. Even stereo headphone output.

Just one great feature after another.

Sure, you can find some of these features on other machines. But not all on *one* machine. Except ours. So see an Ampex Sound Idea Dealer today. He has the outfit that has it all.

AMPEX.  
The  
Sound  
Idea  
People.

**AMPEX**

AMPEX CORPORATION  
CONSUMER & EDUCATIONAL PRODUCTS DIVISION  
2201 LUNT AVENUE  
ELK GROVE, ILLINOIS 60007

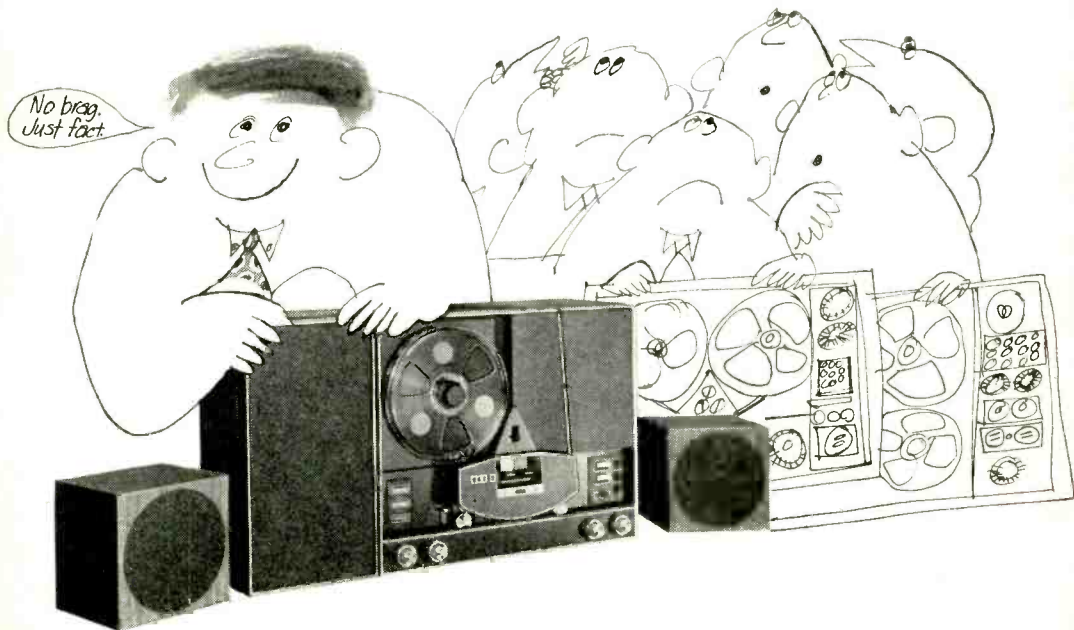



This is the booklet Popular Electronics' readers have been turning to since the beginning of high fidelity to see the most advanced developments in record playing equipment.

It's Garrard's Comparator Guide and an entirely new edition is just off the press.

In it, you'll read about Garrard's new Synchro-Lab Motor™ and the exciting new series of automatic turntables it powers... the Synchro-Lab Series.™

Write today for your complimentary copy.

# Garrard®

Dept. R138A, Westbury, N.Y. 11590.  
Please send Comparator Guide.

Name \_\_\_\_\_  
Address \_\_\_\_\_  
City \_\_\_\_\_ State \_\_\_\_\_ Zip \_\_\_\_\_

British Industries Corp., a division of Avnet, Inc.

CIRCLE NO. 22 ON READER SERVICE PAGE

# POPULAR ELECTRONICS

**PHILLIP T. HEFFERNAN**  
*Publisher*

**OLIVER P. FERRELL**  
*Editor*

**LESLIE SOLOMON**  
*Technical Editor*

**JOHN R. RIGGS**  
*Managing Editor*

**EDWARD I. BUXBAUM**  
*Art Director*

**ALEXANDER W. BURAWA**  
*Associate Editor*

**ANDRE DUZANT**  
*Technical Illustrator*

**PATTI MORGAN**  
*Assistant Editor*

**AURORA NARDOZZI**  
*Editorial Assistant*

**H. BENNETT, W2PNA**  
**H. S. BRIER W9EQQ**  
**L. E. GARNER, JR.**  
**CHARLES J. SCHAUERS, W6QLV**  
**M. P. SPINELLO, KHC2060**  
*Contributing Editors*

**RICHARD J. HALPERN**  
*Advertising Manager*

**ARDYS C. MORAN**  
*Advertising Service Manager*

**LAWRENCE SPORN**  
*Associate Publisher*

**ZIFF-DAVIS PUBLISHING COMPANY**

Editorial and Executive Offices  
One Park Avenue, New York, New York 10016  
212 679-7200

Midwestern Office  
307 North Michigan Avenue, Chicago, Illinois 60601  
312 726-0892

Midwestern Advertising Manager, JAMES WEAKLEY  
GERALD L. TAYLOR

Western Office  
9025 Wilshire Boulevard, Beverly Hills, California 90211  
213 CRestview 4-0265; BRadshaw 2-1161  
Western Advertising Manager, BUD DEAN

Japan: James Yagi  
Ishikawa Mansion, #4, Sakuragaoka  
Shibuya-ku, Tokyo, 462-2911-3

Circulation Office  
Portland Place, Boulder, Colorado 80302

William B. Ziff, Chairman of the Board (1946-1953)  
William Ziff, President

W. Bradford Briggs, Executive Vice President  
Hershel B. Sarbin, Senior Vice President  
Philip Sine, Financial Vice President

Walter S. Mills, Jr., Vice President, Circulation  
Stanley R. Greenfield, Vice President, Marketing  
Phillip T. Heffernan, Vice President, Electronics Division

Frank Pomerantz, Vice President, Creative Services  
Arthur W. Butzow, Vice President, Production

Edward D. Muhlfeild, Vice President, Aviation Division  
Irwin Robinson, Vice President, Travel Division

Furman Hebb, Administrative Vice President  
George Morrissey, Vice President  
Sydney H. Rogers, Vice President

Ziff-Davis also publishes Airline Management and Marketing, Boating, Business & Commercial Aviation, Car and Driver, Cycle, Electronics World, Flying, HiFi/Stereo Review, Modern Bride, Popular Photography, Skiing, Skiing Area News, and Skiing Trade News. (Travel Weekly is published by Robinson Publications, Inc. a subsidiary of Ziff-Davis Publishing Company.)

Forms 3579 and all subscription correspondence should be addressed to POPULAR ELECTRONICS, Circulation Department, Portland Place, Boulder, Colorado 80302. Please allow at least six weeks for change of address. Include your old address, as well as new—enclosing if possible an address label from a recent issue.

EDITORIAL CONTRIBUTIONS must be accompanied by return postage and will be handled with reasonable care; however, publisher assumes no responsibility for return or safety of art work, photographs or manuscripts.



Member Audit Bureau of Circulations

POPULAR ELECTRONICS

# Could you make it in electronics?

## Why not...

**Because you're not a genius?** So What? All you need is a good mind and the desire to learn. We can help you learn what you need to know to get the kind of job you want. And we can help you land the job, too. We've done it before. *Thousands* of times.

**Because you can't quit your job?** Keep it. If you can't come to our resident schools, we'll come to you, by mail. Take the courses you need, at home. In our schools or at home, you'll get an excellent, practical education in electronics.

**Because you think it's too tough?** Too slow? Too expensive? Because you're afraid maybe we can't help you get a good job? Fill in the coupon, and *make us prove it!*

DE VRY INSTITUTE OF TECHNOLOGY  
4141 BELMONT AVE., CHICAGO, ILL. 60641

 **BELL & HOWELL SCHOOLS**

ACCREDITED MEMBER, NATIONAL HOME STUDY COUNCIL

DE VRY INSTITUTE OF TECHNOLOGY Dept. PE-10Y  
4141 BELMONT AVE., CHICAGO, ILL. 60641

### **BELL & HOWELL SCHOOLS**

Please send me your two free booklets, "Pocket Guide to Real Earnings," and "Electronics in Space Travel;" also include information about preparing for careers in Electronics. I am interested in the following opportunity fields (check one or more):

- |  |   |
|--|---|
| <input type="checkbox"/> Space & Missile Electronics | <input type="checkbox"/> Communications         |
| <input type="checkbox"/> Television and Radio        | <input type="checkbox"/> Computers              |
| <input type="checkbox"/> Microwaves                  | <input type="checkbox"/> Broadcasting           |
| <input type="checkbox"/> Radar                       | <input type="checkbox"/> Industrial Electronics |
| <input type="checkbox"/> Automation Electronics      | <input type="checkbox"/> Electronic Control     |

Name \_\_\_\_\_ Age \_\_\_\_\_

Address \_\_\_\_\_ Apt. \_\_\_\_\_

City \_\_\_\_\_

State \_\_\_\_\_ Zip Code \_\_\_\_\_

Veterans: Check here. If you were discharged after Jan. 31, 1955, the "G.I. Bill" may cover the entire cost of your tuition.

106



Signal Power On Top Means  
More Distance—No Dead Spots...

avanti  
ASTRO PLANE  
ANTENNA



The Avanti Astro Plane's big signal power on top assures full omni-directional communications. No more dead spots or loss of mobile contact in areas where nearby buildings block signals from ordinary antennas—ASTRO PLANE gets its signal over these obstacles. Performance tests have proven Astro Plane superior to  $\frac{3}{8}$  wave length antennas when installed at the same tip height. The short, sturdy radials at the tip of the Astro Plane direct an extremely low angle signal take off for maximum distance in all directions.

Ordinary collinear or ground plane antenna signals are blocked . . . they radiate from the bottom.



Astro Plane gets its signals over obstacles . . . it radiates from the top.



• 4 db. gain • only 3½ lbs. • no coils to short or burn out • up to 1000 watt power • no noise — no detuning in damp, humid weather • 120 mph wind survival • no long drooping radials

Write for Complete Information

**a avanti**

research and development, inc.

Dept. G, 45 West Fullerton Ave., Addison, Ill. 60101

CIRCLE NO. 6 ON READER SERVICE PAGE

# letters

FROM OUR READERS

## DIGITAL MULTIMETER WANTED

Congratulations on your new series of construction articles featuring Don Lancaster's "Low Cost Counting Unit" (February, 1968). Now I am particularly looking forward to an article describing how to build a digital multimeter. As an engineer, I am constantly frustrated in my attempts to make measurements to 1% tolerances with conventional meters. The only thing that has thus far prevented me from buying a digital multimeter is the high prices asked for them. I sincerely hope that POPULAR ELECTRONICS can come up with a price-smashing digital instrument.

FRED MOORE  
ROCKVILLE, MD.

*During the past few months, we have received literally scores of requests asking us to publish construction plans for a digital volt/multimeter. These requests have not gone unheeded, and those readers who want such an article to appear will not have too long to wait—one is already in the works. We cannot say exactly when the article will appear nor how much the kit of parts will cost. But rest assured that, when the article does appear, construction and parts costs will be only a fraction of the prices demanded for comparable commercial instruments.*

## WHAT'S INSIDE THE IC'S?

If anything can make me lose interest in a construction project published in POPULAR ELECTRONICS it is the use of integrated circuits which leave too much to the imagination. When I see an IC project, I just pass it by. However, if you showed a schematic diagram of the interior of the IC's you use, it might not be so bad.

J. F. LYCETT  
ELCO, PA.

*There are two important reasons why we do not show schematic diagrams of the components inside the IC's that appear in our project articles. The first of these is space limitations. Consider, if you will, the modern IC; it usually contains a dozen to several score components—some contain as many as 40 transistors, maybe a dozen diodes, and a multitude of resistors. Including a schematic diagram of even a simple IC is out of the question if all outboard components are to be shown. Add to this the fact that a bad component in an IC usually means replacement of the entire IC—repairs are impossible.*

POPULAR ELECTRONICS

# Success in Electronics Comes as Naturally as 1-2-3 through Education

1

There they are — three big steps — three deliberate steps which lead directly to success in electronics. Your future is shaped by the moves *you* make — by the steps *you* take. Begin now with Step #1.

**STEP #1** is a simple request for full information on the Grantham Associate Degree Program in Electronics. You take this step by filling out and mailing the coupon. We mail our catalog to you; we do not send a salesman.

**STEP #2** is earning your FCC first class radiotelephone LICENSE and radar endorsement. You complete this step in the first two semesters of the Grantham educational program (by correspondence or in residence). Train with the school which gives associate-degree credits for your license training, offering you the opportunity to advance beyond the FCC license level to a college degree in electronics.

**STEP #3** is earning your ASEE DEGREE. This degree is conferred when you have earned credit for all six semesters of the Grantham curriculum.

The Grantham Associate Degree Program offers in-depth technical education, and prepares you for employment as an *engineering* technician—a big step above an ordinary technician. (Most of our students are already technicians when they begin the course.) Engineering technicians usually work directly with scientists and engineers, analyzing and solving engineering problems. *You can make more money as an engineering technician!*

## Accreditation, and G.I. Bill Approval

Grantham School of Electronics is *accredited* by the Accrediting Commission of the National Home Study Council, and is *approved* for both correspondence and resident training under the G.I. Bill. Just mail the coupon, or write or telephone us for full information without obligation.

## Grantham School of Electronics

1505 N. Western Ave.                      818 18th Street, N.W.  
Hollywood, Calif. 90027                      or                      Washington, D.C. 20006

Telephone:  
(213) 469-7878

Telephone:  
(202) 298-7460

**Grantham School of Electronics** PE 10-68  
1505 N. Western Ave., Hollywood, Calif. 90027

Please mail me your free catalog, which explains how Grantham training can prepare me for my FCC License and Associate Degree, in electronics. I understand no salesman will call.

Name \_\_\_\_\_ Age \_\_\_\_\_  
Address \_\_\_\_\_  
City \_\_\_\_\_ State \_\_\_\_\_ Zip \_\_\_\_\_

2



3

**Grantham School of Electronics**  
has conferred on  
**John Doe**  
the degree of  
**Associate in Science in Electronics Engineering**

with all the rights and privileges thereunto appertaining. In witness thereof this diploma duly signed has been issued by the School Administration upon recommendation of the faculty at the School on this  
*first day of October, 1965*

 *D.J. Grantham* President  
*E. White* Acting Dean

## LETTERS (Continued from page 8)

In addition to space limitations, there is another good reason for leaving out the schematics of IC's: they really aren't necessary. There are only three important things you have to know when using an integrated circuit: the characteristics of the input, the characteristics of the output, and the power requirements. What happens inside the IC is incidental. Either it operates as it should or it doesn't—no other information is necessary.

A great deal of thought has gone into our diagram format for IC projects. As it now stands, *POPULAR ELECTRONICS* provides more information in the schematic diagrams than the great majority of electronics magazines.

### HOW TO CHECK DIODES WITH TEST ADAPTER

The "Transistor Test Adapter For Your VTVM" (July, 1968) is very useful for checking transistors, but how about diodes? Can it be used for checking diodes, and if so, what steps must be followed?

RICHARD W. ORAM  
URBANA, ILL.

The test adapter can serve only as a "short/open/good" indicator for diodes. First, connect the diode to be tested to the *EMIT-*

*TER* and *COLLECTER* binding posts. Set *S3* to any position, *S4* to *TEST* and *S5* to *Icco/h<sub>FE</sub>*. Now, move *S1* from one position to the other (*NPN* and *PNP*) while observing the meter. If the diode is good, the meter should indicate slightly less than the supply voltage with *S1* in one position, and essentially zero volts in the other position. The same supply voltage reading in both positions of *S1* indicates that the diode is shorted; zero voltage readings in both positions of the switch indicate that the diode is open.

### "PEOPLE DETECTOR" ANTENNA

What is the green and gold device that is shown mounted atop the "Amazing People Detector" (cover photo, June, 1968)?

HAROLD C. HAMPTON  
WASHINGTON, D.C.

The device referred to is the antenna and support column for the "People Detector." The gold sections are the antenna elements, while the green acrylic rod is an insulated support. A thin wire, connected at one end to the antenna elements, terminates at the bottom threaded section of the support to allow the screw protruding from the cover to make contact with the elements. The antenna elements shown were fabricated from brass channeling. The antenna design shown was selected for esthetic appeal—not to suggest the best possible configuration.

# Add LIFE to your color TV, stereo radio and electronic equipment

 DELWYN™

*Whisper Fan*®

- Made especially for cooling transistors, tubes and other heat generating components
- Helps guard against part failure
- Ensures trouble-free life — peak performance
- Costs only a few pennies to operate — saves dollars in repair bills
- So quiet and noise-free, you have to feel the breeze to know it is at work
- Quickly and easily installed

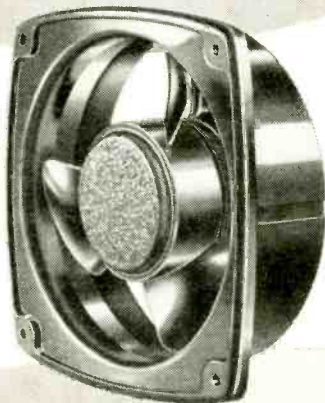

Only  
\$14.85  
Complete!

Ask your dealer to demonstrate how the Delwyn Whisper Fan will pay for itself in savings on just one heat-caused repair bill.

 DELWYN

BOX 195 B, Route 28  
Kingston, New York 12401





# This is the biggest coupon in this magazine because we wouldn't want you to miss a big opportunity to make something of yourself.

Here is the chance of a lifetime to start earning extra money fast. All you need is just a few weeks' training in your own home and in your spare time and your income will go up \$10, \$20, \$30 a week or more. RTTA will show you how easily and how quickly you can do this.

You'll get a complete set of easy-to-read, easy-to-understand lessons that will let you earn money almost from the very beginning. You'll get a complete set of the most modern test equipment; a vacuum-tube voltmeter, a scope, a signal generator — everything you need to help qualify you as a highly-paid electronics technician.

## WITHIN ONE WEEK AFTER YOU START YOU'LL BE WORKING WITH ELECTRONICS!

And look at these extras at no additional charge:

- advisory placement service and technical service booklets: • student discount card
- complete electronics workshop tool kit

Act now! All of this equipment and the bonus extras can be yours to keep and to use. The extra money you earn or a new or better job can be yours. Fill in the coupon for full information and start your way up.



**16 KITS**  
Yours to build  
and keep



## Radio-Television Training of America 229 Park Avenue South, New York, N.Y. 10003

Name \_\_\_\_\_ Age \_\_\_\_\_  
Address \_\_\_\_\_  
City \_\_\_\_\_ State \_\_\_\_\_ Zip \_\_\_\_\_

Phone \_\_\_\_\_ pe-10

**APPROVED FOR VETERANS**

Licensed by the New York State Department of Education  
Member of the National Home Study Council

# UNUSUAL BARGAINS

... MANY U. S. GOV'T SURPLUS

**SEE** YOUR MUSIC IN DAZZLING ACTION with



## MUSIC VISION

Dramatic New Break-through In Audio-Visual Enjoyment.

Now you can have a thrilling, psychedelic "see" in your own home, club, school or business—

in fact—anywhere you want to add sensational "mod" effects. Colored light beams dance and prance, whirl and swirl in perfect time with the music—each individual note creating its own unique twisting, radiating shape. Adds a spectacularly wide new dimension to the world of music and entertainment. Combines electronics, science and art with dramatic results. Attaches in seconds to your radio, tape recorder, hi-fi or stereo with two alligator clips. Can be used on small screens, large walls, stages and whole auditoriums. Build your own MusicVision\* with low-cost Do-It-Yourself Kit. Loads of fun! Fast! Easy! All you need is a light source if you don't have one, the versatile Edmund 35mm 500 Watt Projector is a terrific bargain. All kinds of other uses too—set up to accept motorized accessories. Also available in 12" or 15" x 22" Walnut Cabinet Model, Tube Unit, or 8" and 12" Sets which include encased 8" or 12" Motionizer. Color Wheel and set of apertures for use with your own 35mm projector. Laric 12" set provides fabulous effects for commercial applications. Order by stock number listed below. Money-back guarantee. Complete information in new catalog available September 10. If you want additional details now, send \$36 in coin for fully illustrated, 16-page booklet No. 9096AV "Introduction to MusicVision".

- \*Patent pending.
- 8" DO-IT-YOURSELF KIT, Stock No. 71.009AV \$22.50 Postpaid
- EDMUND 500 WATT 35mm PROJECTOR, Stock No. 71.057AV \$24.50 Postpaid
- WALNUT VENERED CABINET MODEL, Stock No. 85.181 \$99.50 F.O.B.
- 8" SET (Motionizer, color wheel, apertures) Stock No. 71.030AV \$39.00 Postpaid
- 12" SET (same as above w/larger Motionizer) Stock No. 71.032AV \$57.50 Postpaid

### TOP-QUALITY LOW-COST STROBE



Create spectacular psychedelic lighting effects with this genuine electronic strobe. Terrific for parties, special occasions, experiments, exhibitions. Adjusts from 1 to 10 short-duration flashes per second—not a mike-switch mechanical device. Amaze friends with one-time effects. Best party ice-breaker ever—"freeze" the action and "unfreeze" your guests. Practical too—check action of moderate speed machinery. Xenon lamp gives one million flashes. 6 1/2" diam. reflector. Uses reg. 110-120 volt A.C. current. Handsome solid walnut cabinet.

8" x 9 1/2" x 5 1/2" by 4". Send for Bulletin #75—describes other startlingly new unique lightings effects. Stock No. 70.989AV \$79.95 Ppd.

### NEW LOW-COST ULTRASONIC CLEANER

Now a top-quality unit for only \$39.95. Cleans dirt, grime completely, quickly, safely. Small delicate parts, precision electronic items, lab instruments, jewelry, coins, even dentures sparkle like new. 1/3rd pint capacity. Operates on regular house current. Precision American-made. Full 1 year guarantee. Solid state generator with automatic turn-off to prevent overheating. Power control, recasting knob. Grounded to prevent shock. No radio interference. 6"x4"x4" stainless steel and metal cabinet.



Stock No. 71.003AV \$39.95 Ppd.  
LARGE INDUSTRIAL 1 1/2 GAL. SIZE (Wt. 37 lbs.) \$249.95 FOB  
Stock No. 85.128AV

### 3" ASTRONOMICAL TELESCOPE



See the stars, moon, phases of Venus, planets close up. 60 to 180 power. Aluminized and overcoated 3" diameter f/10 primary mirror, ventilated cell. Equatorial mount with locks on both axes. Equipped with 60X eyepiece and mounted Barlow lens. 3X finder telescope, hardwood tripod. Included FREE: "STAR CHART"; 272-page "HANDBOOK OF HEAVENS"; "HOW TO USE YOUR TELESCOPE" book.

Stock No. 85.050AV \$29.95 Ppd.  
Stock No. 85.105AV \$84.50 F.O.B.  
Stock No. 85.086AV 4 1/2" REFLECTOR \$199.50 FOB  
6" REFLECTOR

Order by Stock No.—Check or M.O.—Money-Back Guarantee  
EDMUND SCIENTIFIC CO., 300 EDCORP BUILDING  
BARRINGTON, NEW JERSEY 08007

### GIANT FREE CATALOG "AV"

Completely new 1969 edition. New items, categories, illustrations. 148 easy-to-read pages packed with 4000 unusual items. Dozens of electrical and electromagnetic parts, accessories. Enormous selection of Astronomical Telescopes, Microscopes, Binoculars, Magnifiers, Magnets, Lenses, Prisms. Many war surplus items: for hobbyists, experimenters, workshops, factory. Write for catalog "AV". Include Zip.



ORDER BY STOCK NUMBER • SEND CHECK OR MONEY ORDER • MONEY-BACK GUARANTEE  
EDMUND SCIENTIFIC CO., 300 EDCORP BUILDING  
BARRINGTON, NEW JERSEY 08007  
CIRCLE NO. 17 ON READER SERVICE PAGE

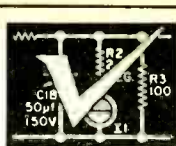

## OPERATION ASSIST

Through this column we try to make it possible for readers needing information on outdated, obscure, and unusual radio-electronics gear to get help from other P.E. readers. Here's how it works: Check the list below. If you can help anyone with a schematic or other information, write him directly—he'll appreciate it. If you need help, send a postcard to Operation Assist, POPULAR ELECTRONICS, One Park Avenue, New York, N.Y. 10016. Give maker's name and model number of the unit. If you don't know both the maker's name and the model number, give year of manufacture, bands covered, tubes used, etc. State specifically what you want, i.e., schematic, source for parts, etc. Be sure to print or type everything legibly, including your name and address. Because we get so many inquiries, none of them can be acknowledged. POPULAR ELECTRONICS reserves the right to publish only those items not available from normal sources.

RCA Model V-215 superhet receiver, 1942 anniversary model. Schematic, parts list, and any other information needed. (Dale E. Wimmer, Rte. #3, Box 350-28, Springfield, Mo. 65804)

Grundig TK819 tape recorder. Schematic needed. (Paul Christie, 44-10 MacNish St., Elmhurst, N.Y.)

Heathkit Model DX-20 transmitter. Manual and instructions needed. (Joe Gabai, 1112 Glenview St., Philadelphia, Penna. 19111)

E.F. Johnson "Pacemaker" SSB transmitter. Operating manual needed. (Clayton Laster, 10915 Burr Oak Dr., San Antonio, Texas 78230)

Paco Model ST-26 FM tuner-amplifier. Source for parts needed. (Sgt. Philip I. Roberts, 2093238, USMC, NROTC Unit, University of Utah, Salt Lake City, Utah 84115)

Philco Model 610 receiver. Schematic and source for parts needed. (Dennis Guza, 22919 Fureon St., Clair Shores, Mich. 48082)

Crosley Model 179 receiver. Schematic, operating instructions, and source for parts needed. (Chuck Kellum, RRI, Box 3, Mooresville, Ind. 46158)

RCA Radiola 46 Model AR596. Service manual, instruction book, schematic, and parts list needed. (William Boston, 5702 Second Ave., Vienna, W. Va. 26101)

Webcor Model EP2612-1 tape recorder. Operating manual and schematic needed. (John J. McKelvey, III, 5916 N. Marvne St., Philadelphia, Penna. 19141)

Heathkit Model GR-91 SW receiver. Instruction manual needed. (William Goble, 330 Wood St., Clarion, Penna. 16214)

Atwater Kent Model 70 type L chassis. Schematic, operating instructions, and source for parts R14-17 needed. (Michael McFarlane, 422 S. Marks St., Ft. William, Ont., Canada)

Herbert H. Horn Radio Mfg. Co. Model 66MT receiver, circa 1935 or earlier; has 6 tubes; tunes BC and 49 to 16 meters. Schematic needed. (Earl A. Edwards, 518 E. First St., Tucson, Ariz. 85705)

# Cobra 98

the new standard of CB quality.

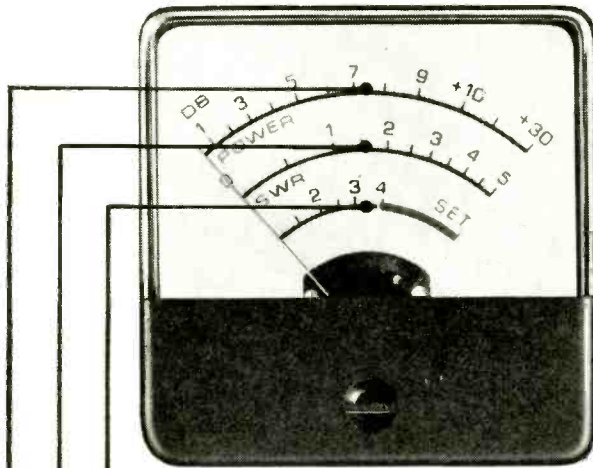

1. Built-in SWR bridge lets you tune your antenna for maximum output.
2. Forward-Reverse reflected Power Output Meter tells you how much power is going out.
3. "S" meter measures strength of incoming signals.



Outgrown your present CB? Step up to the new B&K Cobra 98, the new, 23-channel, fully deluxe CB that's built to outperform and outvalue most other rigs. The new triple scale (shown above) is only part of the story . . . the Cobra 98 looks like a million! The heavy die-cast aluminum front panel is magnificently finished in black and brushed aluminum.

And the Cobra 98 has all the power and performance features B&K is famous for—including exclusive Dyna-Boost that intensifies speech signals and extends range even farther!

Cobra—the big name in CB—now brings you the flagship of the line—the COBRA 98—it's the most! **\$239.95**

**B&K Division of Dynascan Corporation**  
1801 W. Belle Plaine Avenue/Chicago, Illinois 60613



*Where Electronic Innovation Is A Way Of Life*

**CIRCLE NO. 7 ON READER SERVICE PAGE**



# ELECTRONICS library

QUIET

## SEMICONDUCTOR HANDBOOK, Second Edition

by Robert B. Tomer

Behind most of the rapid changes taking place in industrial electronics are transistors and integrated circuits. This book brings together most of the pertinent information needed to understand the many types of semiconductors now on the market, their operating characteristics, circuit design procedures, and typical applications. A general discussion, including the basic physics and chemistry used in making transistors, is presented to help the reader select the devices best suited to his needs. In its new edition, this book includes the most recent aspects of industrial electronics—including IC's, thermoelectricity, and solar-energy conversion.

Published by Howard W. Sams & Co., Inc.,  
4300 West 62 St., Indianapolis, Ind. 46206. Soft  
cover. 288 pages. \$5.25.

## PIN-POINT TV TROUBLES IN 10 MINUTES

by Howard P. Manly

This book is so well illustrated with text, photos, schematic diagrams, and drawings of oscilloscope waveform patterns that even a beginner to TV servicing should have little difficulty in pinpointing the more than 700 TV receiver troubles described. To really simplify troubleshooting, more than 50 charts spotted throughout the book are keyed to an all-inclusive, five-page master chart designed to help locate quickly the correct chart to use. For certain faults requiring special location and correction measures, suggested troubleshooting procedures are clearly presented. The beginning of each section in the book gives information on circuit peculiarities, methods of improving performance, making service tests and adjustments, and checking components.

Published by Tab Books, Blue Ridge Summit,  
Pa. 17214. Soft cover. 372 pages. \$6.95.

## MATHEMATICS FOR ELECTRONICS

by Forrest Barker and Gershon J. Wheeler

To provide the basic mathematics needed for the study and practice of applied electronics, this book was written as a text for formal training curricula. However, it is also especially suited for self-study. Each section is self-contained to allow maximum flexibility in coverage. The book offers all of the popular methods of circuit analysis used in modern electronics, demonstrating mathematics as a practical, time-saving tool for the electronics



## Our A.P. Van Meter designed the PRO-120 so well, he had to go through the indignity of being double checked.

Who ever heard of double checking the head project engineer, just because his design seemed too good to be true? Yet, that's exactly what happened when A.P. first submitted the specifications on his new Studio Pro-120 FM Stereo Receiver.

"A.P." management said, "we believe you, but why should anyone else? These specs are simply too good to be true in a receiver that sells for \$379.50!"

And that's when they got the idea for the double check.

They called Nation-Wide Consumer Testing (a division of no less august body than the U.S. Testing Labs) for an impartial analysis of A.P.'s work.

Then somebody in sales got another bright idea, "Why not ask them to certify that the Pro-120 will meet or exceed its published specifications?"

The men from U.S. Testing agreed, but on one condition. They wouldn't test a Pro-120 at their lab. (After all, anyone who cares can "tune-up" a unit just as you would a car.) Instead, they would come to University in Oklahoma City and pull units at random off the production lines.

And that's how the University Studio Pro-120 came to be the world's first and only certified receiver. Just because it seemed too good to be true.

What about A.P.?

Well, getting his baby certified made believers out of lots of people. Including the boss. So, instead of a double check, A.P. now has the dignity of a doubled check.

## Graduate to University



**UNIVERSITY SOUND**  
A DIVISION OF LTV LING ALTEC, INC.

9500 West Reno, Oklahoma City, Oklahoma 73126

CIRCLE NO. 46 ON READER SERVICE PAGE

POPULAR ELECTRONICS

# POPULAR ELECTRONICS READER SERVICE PAGE

## free information service:

Here's an easy and convenient way for you to get additional information about products advertised or mentioned editorially (if it has a "Reader Service Number") in this issue. Just follow the directions below... and the material will be sent to you promptly and free of charge.

**1.** Print or type your name and address on the lines indicated. Circle the number(s) on the coupon below that corresponds to the key number(s) at the bottom of the advertisement or editorial mention(s) that interest you. (Key numbers for advertised products also appear in the Advertisers' Index.)

**2.** Cut out the coupon and mail it to the address indicated below.

**3.** This address is for our product "Free Information Service" only. Editorial inquiries should be directed to POPULAR ELECTRONICS, One Park Avenue, New York 10016; circulation inquiries to Portland Place, Boulder, Colorado 80302.

**POPULAR  
ELECTRONICS**

VOID AFTER NOVEMBER 30, 1968

P.O. BOX 8391  
PHILADELPHIA, PA. 19101

1 2 3 4 5 6 7 8 9 10 11 12 13 14 15 16 17 18 19 20  
21 22 23 24 25 26 27 28 29 30 31 32 33 34 35 36 37 38 39 40  
41 42 43 44 45 46 47 48 49 50 51 52 53 54 55 56 57 58 59 60  
61 62 63 64 65 66 67 68 69 70 71 72 73 74 75 76 77 78 79 80  
81 82 83 84 85 86 87 88 89 90 91 92 93 94 95 96 97 98 99 100

NAME (Print clearly) \_\_\_\_\_

ADDRESS \_\_\_\_\_

CITY \_\_\_\_\_ STATE \_\_\_\_\_ ZIP CODE \_\_\_\_\_

10 b



**Now, what's the best way  
to play your records  
for under \$80?**

For years the AR manual turntable, at \$78\*, has been the only truly fine record playing mechanism you could buy for under \$80.

But now, you'll have to take one other product into consideration.

The new automatic Dual 1212  
At \$74.50\*\*

Just like the AR, the Dual 1212 exceeds every NAB standard for broadcast turntables in rumble, wow, flutter, and speed accuracy. And its balanced tonearm can track any cartridge flawlessly.

But, in addition, the Dual has a convenient cueing control. A variable-speed pitch control. Built-in anti-skating. Automatic start and stop, with one record or a stack of six.

So now you've got a decision to make.

Do you want to play your records with a host of Dual convenience features, for \$74.50 . . . or without them, for \$78?

**United Audio Products Inc.,**  
535 Madison Ave., New York, N.Y.  
10022.



\*Including base and dust cover.  
\*\*Base and dust cover are extra.

**CIRCLE NO. 45 ON READER SERVICE PAGE**

enthusiast and student. Many of the problems given are based on actual electronic equipment to provide a motivation for the student to pursue his studies.

*Published by Addison-Wesley Publishing Co., Reading, Mass. 01867. Hard cover. 742 pages. \$12.50.*

**MODERN ELECTRONIC CIRCUIT DESIGN**

*by James D. Long*

The author establishes for engineers and engineering-level hobbyists the principles and laws required for circuit design and demonstrates how to apply them to typical design problems. Circuit designers are shown, in step-by-step fashion, the exact procedure to follow in planning efficient and effective practical electronic circuits. Almost every design procedure illustrated is accompanied by a worked-out example. The book is virtually complete in its presentation, including not only the design ideas, but also the mathematics that goes with them.

*Published by McGraw-Hill Book Company, 330 West 42 St., New York, N. Y. 10036. Hard cover. 284 pages. \$12.50.*

**ELECTRONIC ENGINEERING NOMOGRAMS**

*by Max H. Applebaum*

A nomogram is a graphical means of determining an unknown value when two or more interdependent values in the same formula are known. Engineers, technicians and hobbyists have found that nomograms simplify design work where very precise accuracy is not required. This book is an encyclopedia of nomograms dealing with vacuum tubes, transistors, conversion tables, transmission lines, filters, etc. The spiral binding of this book permits it to lie flat and the extra large pages eliminate uncertainties in checking values.

*Published by Tab Books, Blue Ridge Summit, Pa. 17214. Hard cover with wire spiral spine. 175 pages. \$9.95.*

**UNDERSTANDING ELECTRONICS UNITS  
AND STANDARDS**

*by Earl J. Waters*

It is impossible to really understand electronics unless you know exactly what is meant by such terms as volt, ohm, ampere, etc. This book is devoted to the nonmathematical explanation of the terms commonly used in electronics. Starting with basic fundamentals of atomic structure and units of measurement, it progresses through current, voltage, resistance, energy and power, capacitance, inductance, time, and frequency. Each of the ten chapters closes with review questions that will help the reader to further understand the subject covered.

*Published by Howard W. Sams & Co., Inc., 4300 West 62 St., Indianapolis, Ind. 46206. Soft cover. 128 pages. \$3.25.*



# Our CB success has gotten out of hand.



MODEL M 2300



MODEL  
XM 2300

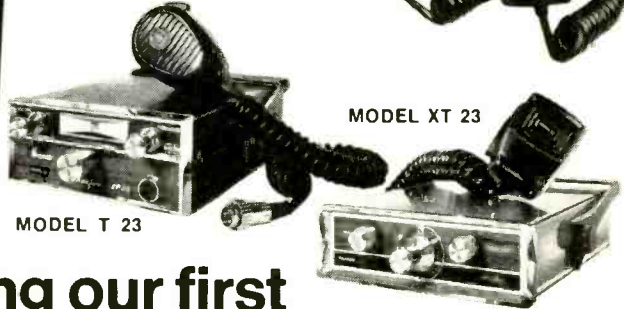

MODEL T 23

MODEL XT 23

## Introducing our first great line of 5W base/mobile rigs.

Fanon, world leader in hand-held CB and intercommunication is ready with its first great line of base station/mobile rigs.

Not the largest line in the field—but the finest. Carefully and skillfully developed and engineered for top performance. Units you can place your confidence in...and all made in the U.S.A.



### and the finest hand-held CB rig ever produced.

**MODEL IC-5000.** 3 space age IC Circuits for the ultimate in range and performance. 5 watts & 6 channels. Power boost antenna. Range booster. PA facility. Converts to base station with optional AC power supply. **\$99.95**

**MODEL M 2300**—18 tube performance. Unique modulation sampler. Range expand. All 23 channels. Dual conversion. Built-in PA system — transistorized power supply. **\$189.95**

**MODEL XM 2300**—19 tube performance. Cascode front end. Nivistor mixer. All 23 channels. Our most sensitive and quiet rig. **\$199.95**

**MODEL T 23** — Solid state engineering for unsurpassed reliability. 23 channels. Fiberglass epoxy circuit board with silicon transistors. Beautiful wood graining. Light-compact-powerful. Unique signal light tells you when S6 signal or better is received. **\$159.95**

**MODEL XT 23**—The finest solid state mobile rig on the market. All 23 channels. Unsurpassed adjacent channel rejection. Helps pierce "skip"

Protected against overload, mismatched antenna and incorrect polarity. Base reflex type audio. Push/pull on-off switch with volume control.

Push/pull noise limiter and squelch. True PA system. **\$199.95**

(All prices shown are East Coast suggested retail.)



FANON ELECTRONIC INDUSTRIES, 439 Frelinghuysen Ave., Newark, N.J. 07114

Your new line looks great! Please send me additional information. I'm especially interested in:

M 2300  XM 2300  T 23  XT 23  IC 5000

Name \_\_\_\_\_  
Address \_\_\_\_\_

City \_\_\_\_\_  
State \_\_\_\_\_ County \_\_\_\_\_ Zip \_\_\_\_\_

CIRCLE NO. 20 ON READER SERVICE PAGE

# Two more examples of how RCA Institutes provides up-to-the-minute Home Training in all phases of electronics:

## NEW CATV LESSONS

The demand is heavy for technicians in the booming field of CATV (Community Antenna Television Systems).

CATV was initially used to make it possible for large numbers of television receiver users to get good reception in remote areas through the use of a common antenna. It now brings to more people more programs than are available from local stations. It also improves reception where multipath signal transmission exists.

RCA Institutes includes two comprehensive lessons, covering the practical phases of CATV systems and servicing. In Television Servicing and Communications courses and programs at no additional total tuition cost. Get in on the ground floor of this rewarding and expanding field. Send for full information today!

Prepare yourself for a career in the expanding field of CATV.

## NEW COLOR TV KIT

To make courses even more practical and to better prepare you for a more rewarding future, RCA Institutes now includes an exciting Color TV Kit in both the beginner's program and the advanced course in color TV servicing. The cost of the kit is included in the tuition—nothing extra to pay. You also get five construction/experiment manuals plus a comprehensive service manual.

You'll receive all the materials and components to perform over 50 information-packed experiments. When you finish you'll have constructed an 18" (measured diagonally) high quality, color TV set, complete with rich cabinet in wood grain design.

Get all the details on RCA Institutes' valuable new Color TV Kit!

SEND THE ATTACHED CARD TODAY!

This is the high quality color TV set you'll construct, complete with rich cabinet in wood grain design.

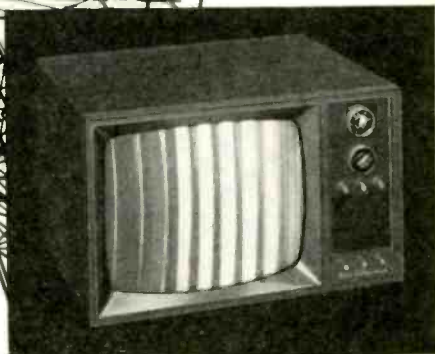

# Learn electronics at home faster, easier, almost automatically—with RCA AUTOTEXT

Are you just a beginner with an interest in the exciting field of electronics? Or, are you already earning a living in electronics and want to brush-up or expand your knowledge in a more rewarding field of electronics? In either case, AUTOTEXT, RCA Institutes' own method of Home Training will help you learn electronics more quickly and with less effort, even if you've had trouble with conventional learning methods in the past.

## THOUSANDS OF WELL PAID JOBS ARE OPEN NOW TO MEN SKILLED IN ELECTRONICS!

Thousands of well paid jobs in electronics go unfilled every year because not enough men have taken the opportunity to train themselves for these openings. RCA Institutes has done something positive to help men with an aptitude and interest in electronics to qualify for these jobs.

## HOME STUDY CAN TRAIN YOU FOR REWARDING CAREER OPPORTUNITIES

To help fill the "manpower gap" in the electronics field, RCA Institutes has developed a broad scope of Home Training courses, all designed to lead to a well paying career in electronics in the least possible time. You also have the opportunity to enroll in an RCA "Career Program" exclusively created to train you quickly for the job you want! Each "Career Program" starts with the amazing AUTOTEXT Programmed Instruction Method. And, all along the way, your program is supervised by RCA Institutes experts who become personally involved in your training and help you over any "rough spots" that may develop.

## VARIETY OF KITS ARE YOURS TO KEEP

To give practical application to your studies, a variety of valuable RCA Institutes engineered kits are included in your program. Each kit is complete in itself, and yours to keep at no extra cost. You get the new Programmed Electronics Breadboard for limitless experiments, including building a working signal generator, multimeter, and a fully transistorized superheterodyne AM receiver.

## ONLY FROM RCA INSTITUTES—TRANSISTORIZED TV KIT—VALUABLE OSCILLOSCOPE

All students receive a valuable oscilloscope. Those enrolled in the Television program receive the all-new transistorized TV Kit. Both at no extra cost and only from RCA Institutes.

## CHOOSE THE "CAREER PROGRAM" THAT APPEALS MOST TO YOU

Start today on the electronics career of your choice. Pick the one that suits you best and mark it off on the attached card.

- Television Servicing
- Telecommunications
- FCC License Preparation
- Automation Electronics
- Automatic Controls
- Digital Techniques
- Industrial Electronics
- Nuclear Instrumentation
- Solid State Electronics
- Electronics Drafting

## ADVANCED TRAINING

For those already working in electronics, RCA Institutes offers advanced courses. You can start on a higher level without wasting time on work you already know.

## 2 CONVENIENT PAYMENT PLANS

RCA Institutes offers a unique tuition plan that lets you progress at your own pace. You only pay for lessons as you order them. You don't sign a contract obligating you to continue the course.

There's no large down-payment to lose if you decide not to continue.

However, if you desire, RCA Institutes also offers a convenient monthly payment plan.

## CLASSROOM TRAINING ALSO AVAILABLE

If you prefer, you can attend classes at RCA Institutes Resident School, one of the largest of its kind in New York City. Coeducational classroom and laboratory training, day and evening sessions, start four times a year. Simply check "Classroom Training" on the attached card for full information.

## JOB PLACEMENT SERVICE, TOO!

Companies like IBM, Bell Telephone Labs, GE, RCA, Xerox, Honeywell, Grumman, Westinghouse, and major Radio and TV Networks have regularly employed graduates through RCA Institutes' own placement service.

**SEND ATTACHED POSTAGE PAID CARD TODAY. FREE DESCRIPTIVE BOOK YOURS WITHOUT OBLIGATION. NO SALESMAN WILL CALL.**

All RCA Institutes courses and programs are approved for veterans under the new G.I. Bill.

Accredited Member  
National Home Study Council

IF REPLY CARD IS DETACHED—SEND THIS COUPON TODAY

RCA INSTITUTES, Inc., Dept. PEQ-08  
320 West 31st Street, N.Y., N.Y. 10001

Please rush me FREE Illustrated catalog. I understand that I am under no obligation, and that no salesman will call.

Name \_\_\_\_\_ Age \_\_\_\_\_  
(please print)

Address \_\_\_\_\_

City \_\_\_\_\_

State \_\_\_\_\_ Zip \_\_\_\_\_



# NEW PRODUCTS

Additional information on products covered in this section is available from the manufacturers. Each new product is identified by a code number. To obtain further details on any of them, simply fill in and mail the coupon on page 15 or 95.

## STEREO TUNER AND AMPLIFIER COMPONENTS

The famous Model AR-15 stereo receiver made by the *Heath Company* is available as separate components—a tuner and an amplifier—for the component stereo buff. The Model AJ-15 tuner features preassembled, prealigned front end; 1.8- $\mu$ V sensitivity; two crystal filters in the i.f. strip for a perfect response curve (no alignment ever needed); and a



stereo-threshold switch for selection of the most acceptable stereo quality. A noise-operated squelch hushes between-station noise, and a stereo-only switch automatically rejects mono programs during tuning. The companion Model AA-15 stereo amplifier, capable of 150 watts of output power (8-40,000 Hz $\pm$ 1 dB at 1 watt) has virtually the same specifications and controls as the amplifier built into the AR-15 receiver. Both new units are fully solid-state and have "Black Magic" panel lighting.

Circle No. 75 on Reader Service Page 15 or 115

## KIT THAT TEACHES RECEIVER THEORY

The "Comancho" Model 2001 eight-transistor superheterodyne receiver kit made by Graymark Enterprises, Inc., is designed to teach the basics of superhet receiver theory. Despite the compactness of the completed kit, the "Comancho" provides ample volume, high selectivity, and good sensitivity. A 36-page instruction manual, supplied with the kit, contains schematic and block diagrams and provides an easy-to-understand project approach to assembly and circuitry/function comprehension.



Circle No. 76 on Reader Service Page 15 or 115

## ACOUSTIC—SUSPENSION SPEAKER SYSTEM

*Allied Radio Corporation's* Model 2300CK three-way acoustic-suspension speaker system has an overall frequency response of 25-

20,000 Hz; yet it sells for less than \$100. The system consists of a 12" woofer with a 2" voice coil and 6.75-lb. ceramic magnet assembly; compression-type mid-range speaker with diffraction horn; tweeter designed for wide-angle dispersion; balance control for

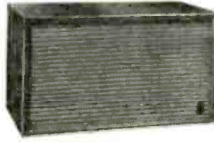

adjustment of highs to room acoustics; and 1000/5000-Hz electrical crossover network. The cabinet is made of 3/4" paneling with sculptured walnut molding, and a special-weave grille cloth is used to provide unrestricted passage of all audio frequencies. The speaker system is available fully built and in kit form.

Circle No. 77 on Reader Service Page 15 or 115

## TRANSISTORIZED TELEPHONE AMPLIFIER

A transistorized amplifying device that fits almost any telephone earpiece is available from *Saxton Products, Inc.* The "Astro-Com" telephone amplifier has a snug-fitting band for attachment and is small enough to fit into a pocket or purse. Volume is adjustable and a normal speaking voice can be amplified up to five times, making it especially suited to high-noise areas in the home, office, or factory. It comes complete with a 25-hour B-103 Saxitone Battery.



Circle No. 78 on Reader Service Page 15 or 115

## STEREO RECEIVER/SPEAKER COMBO

A pair of two-way bookshelf-size speaker systems and a 30-watt solid-state AM/FM stereo receiver make up *Kenwood Electronics' Model KS-33* hi-fi package. The tuner has a 2.5- $\mu$ V sensitivity with 0.6% harmonic distortion. Input terminals to the amplifier section are provided for phono, auxiliary, and tape record and playback. The receiver incorporates automatic, silent switching from stereo to mono, an automatic stereo light, and an illuminated tuning meter. The matching speaker systems are housed in heavy, hermetically-sealed walnut enclosures. Two speakers are in each enclosure: a 6 1/2" air-suspension woofer and a 2 3/4" cone-type tweeter.



Circle No. 79 on Reader Service Page 15 or 115

## THE "SIGHT" OF SOUND

Beams of light in brilliant, ever-changing colors swirl and whirl, spill and splash with every beat and blast of music with the

Talk to the

# POWERFUL

## CB MAN

(Your Squires-Sanders Dealer)

Your Squires-Sanders dealer is **POWERFUL SMART** . . . he knows the best in CB transceivers . . . and how to get the best performance from your base—or mobile. He recommends Squires-Sanders CB equipment. Your Squires-Sanders dealer is also **POWERFUL DEPENDABLE** . . . he is well established and will be around for a long time to serve you . . . like the Squires-Sanders CB equipment he recommends.



THE ADMIRAL

The ADMIRAL: luxurious new all solid state 23 channel CB base station • highly sensitive receiver • Pulse Eliminator • 5 watt transmitter • Speech Compression • +2 mike • dual antenna • HiLo sensitivity • Public Address • Delta Tune • adjustable squelch • ON-THE-AIR light • illuminated S meter • digital panel clock • ear-phone jack • regulated AC power supply • 9 lbs: 5¼ x 13¾ x 10¾ **\$329.95**

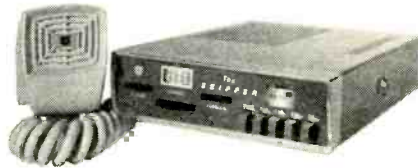

The SKIPPER

The SKIPPER: new low priced solid state 23 channel CB transceiver • superb dual conversion FET/IC no-overload receiver • advanced design noise limiting • illuminated S meter and channel • solid state T/R switching • Speech Clipping • 100% modulation • P.T.T. mike • Local/Distant sensitivity • external speaker jack • Public Address • Exclusive "All Position" Safety Breakaway Mount • 3 lbs: 1¾ x 6 x 8 **\$159.95**

Write today for the name of the **POWERFUL** Squires-Sanders dealer in your area.

Squires  Sanders

SQUIRES-SANDERS, INC., Martinsville Road, Liberty Corner, New Jersey 07938  
CIRCLE NO. 42 ON READER SERVICE PAGE

## PRODUCTS (Continued from page 22)

"MusicVision" color organs recently introduced by *Edmund Scientific Company*. Made up of very few parts, the MusicVision projects light patterns that are motivated by changes in the frequency and intensity of the sound waves. It works as follows: sound vibrations generated by a speaker cause a flexible mirrored surface to oscillate. Then a beam of light that first passes through a revolving color wheel is focused onto the mirrored surface. Several "MusicVision" systems are available, ranging from the most elaborate console model to a very inexpensive do-it-yourself experimenter's kit.

Circle No. 80 on Reader Service Page 15 or 115

### PROFESSIONAL SPEAKER COLUMN



The *Argos Products Company's* "Thunder Column" Model 200 portable speaker system is especially designed for today's demanding musician who wants the sound to be focused toward his audience. The system will handle up to 200 watts peak power with a frequency response of 60-13,500 Hz. An exclusive "Cretian Trap" internal baffling system effectively dampens high-frequency bleed-off and virtually eliminates rear-port feedback. The system is fuse protected to accept power overloads without damage, and the speakers are "crush" protected by a steel grille.

Circle No. 81 on Reader Service Page 15 or 115

### FM STEREO HEADSET

Based on the use of integrated circuits, the Model RF-10 FM stereo headset available from *Panasonic* contains its own receiver,



speakers, and power source. The RF-10 has tuning, balance, tone, and power controls in addition to a mono-stereo switch. The padded headphones contain a telescoping whip antenna that extends from over each earpiece. The over-the-head connecting band can be adjusted to fit any wearer. The RF-10 is powered by three "AA" batteries.

Circle No. 82 on Reader Service Page 15 or 115

### PA/HOME RECORDING MICROPHONES

Three series of public-address microphones suitable for home recording are available from *Astatic Corporation*. The Series 810 are ultra-cardioid microphones, while the Series 820 and 840 are omnidirectional probe and



lavalier microphones, respectively. Each microphone is available with or without switches and in brushed chrome or brushed-satin gold finish. Model 810 has a 25-dB front-to-back ratio, and its unidirectional pickup pattern

minimizes reverberation problems in difficult installations. Its frequency response is 40-15,000 Hz, and its impedance can be quickly changed to high or low. Model 820, with the same frequency response, is particularly suited for hand-held use. Model 840 is a low-impedance microphone featuring a 50-12,000-Hz lavalier and 50-16,000-Hz hand-held frequency response. The switched version model number of each microphone series is suffixed by the letter "S".

Circle No. 83 on Reader Service Page 15 or 115

### PUBLIC SERVICE BAND RECEIVER

Professional quality reception of the police, fire, and civil-defense bands is claimed for a new public service band receiver available from *Trojan Electronics, Inc.* The receiver



is designed to pick up signals of one to six requested frequencies anywhere in the 150-174 MHz band. Interference is overcome by an adjustable squelch control.

A delta fine tuning control is provided for minimum-distortion reception even in difficult and distant areas. The receiver has a 0.5- $\mu$ V sensitivity, and its solid-state circuitry is designed to operate from a 117-volt a.c. source. Also, instead of the common 90-day warranty, the new receiver is guaranteed on parts and labor for a full year.

Circle No. 84 on Reader Service Page 15 or 115

### SOLID-STATE RHYTHM BOX

Nine rhythms are featured in the *Olson Electronics, Inc.* Model X-81 rhythm instrument. These include waltz; swing; surf'n; twist;



bossa-nova; samba; rumba; mambo; and cha-cha. The instruments simulated are: bass drum; conga drum; tom-tom; claves; cymbals; maracas; and snare drum. Other features

include tempo and volume controls, pushbutton rhythm selector, and on/off switch. The Rhythm Instrument can play through guitar, hi-fi, or almost any other type of audio amplifier. It automatically selects the instruments to match the rhythms; two rhythm patterns can even be mixed to create one new pattern. Foot controls are also provided for turning on and off the rhythms.

Circle No. 85 on Reader Service Page 15 or 115



# NEW FINCO<sup>®</sup> COLOR SPECTRUM<sup>™</sup> antennas are "signal customized" for better color reception...

"the ANTENNA that captures the RAINBOW"

FINCO has developed the Color Spectrum Series of antennas—"Signal Customized"—to exactly fit the requirements of any given area. There is a model scientifically designed and engineered for your area.

Check this chart for the FINCO "Signal Customized" Antenna best suited for your area.

STRENGTH OF UHF SIGNAL AT RECEIVING ANTENNA LOCATION	Strength of VHF Signal at Receiving Antenna Location				
	NO VHF	VHF SIGNAL STRONG	VHF SIGNAL MODERATE	VHF SIGNAL WEAK	VHF SIGNAL VERY WEAK
NO UHF →		 CS-V3 \$11.50	 CS-V5 CS-V7 \$18.50 \$25.95	 CS-V10 \$37.95	 CS-V15 CS-V18 \$50.95 \$59.50
UHF SIGNAL STRONG →	 CS-U1 \$10.50	 CS-A1 \$19.95	 CS-B1 \$31.50	 CS-C1 \$45.95	 CS-C1 \$45.95
UHF SIGNAL WEAK →	 CS-U2 \$15.95	 CS-A2 \$23.95	 CS-B2 \$41.95	 CS-C2 \$54.50	 CS-D3 \$73.50
UHF SIGNAL VERY WEAK →	 CS-U3 \$22.95	 CS-A3 \$32.50	 CS-B3 \$52.50	 CS-C3 \$62.95	 CS-D3 \$73.50

All Prices Subject to Change

NOTE: In addition to the regular 300 ohm models (above), each model is available in a 75 ohm coaxial cable downlead where this type of installation is preferable. These models, designated "XCS", each come complete with a compact behind-the-set 75 ohm to 300 ohm balun-splitter to match the antenna system to the proper set terminals.



**THE FINNEY COMPANY**  
34 West Interstate Street  
Dept. PE • Bedford, Ohio 44146

Send for free brochure  
Name \_\_\_\_\_  
Address \_\_\_\_\_  
City \_\_\_\_\_ State \_\_\_\_\_ Zip \_\_\_\_\_

# Olson



**\* FREE**

Fill in coupon for a **FREE One Year Subscription to OLSON ELECTRONICS' Fantastic Value Packed Catalog—Unheard of LOW, LOW PRICES on Brand Name Speakers, Changers, Tubes, Tools, Stereo Amps, Tuners, CB, and other Values. Credit plan available.**

NAME \_\_\_\_\_  
ADDRESS \_\_\_\_\_  
CITY \_\_\_\_\_ STATE \_\_\_\_\_  
GIVE ZIP CODE \_\_\_\_\_

If you have a friend interested in electronics send his name and address for a **FREE** subscription also.

## OLSON ELECTRONICS

966 S. Forge Street Akron, Ohio 44308

**CIRCLE NO. 31 ON READER SERVICE PAGE**

**TANG INC. HI-FI SPEAKER**

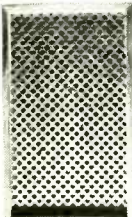

MODEL SP5A

Excellent music and voice reproduction needs a good speaker system derived from current state of art and classical design. Free of obsolescence. Patent applied for. Now offering two models with several styles to choose.

**TANG SP5AX** A new speaker with "controlled impedance" for transistorized amplifiers.

- 1) Linearized speaker impedance vs. frequency relationship.
- 2) 45 — 18500 Hz = 3 db at 16 ohms; system resonance 40 Hz.
- 3) Rear exit to couple to walls as low frequency horn.
- 4) Acoustical chamber and diffracting grill in front of speaker.
- 5) High efficiency 5" special speaker with heavy magnet enclosed in solid walnut cabinet 10" x 7" x 6" **\$39.95 each**

**TANG SP5A** Same as above except without impedance control, Response 45 — 18500 ± 4 db at 8 ohms **\$29.95 each**

Style 2 with fluffy white grill cloth add \$5.00 each.

At your dealers or inquire direct

**TANG INCORPORATED**

P. O. Box 162

Framingham Center, Mass. 01701

Direct mailing service available if no dealer in your area.

**CIRCLE NO. 43 ON READER SERVICE PAGE**

PARTS/METHODS/IDEAS/GADGETS/DEVICES

# tips & techniques

## PIGTAILS FOR 3AG FUSES

It is often difficult to obtain pigtail-type fuses from local electronics parts dealers—they just aren't as common as they used to be. So, what do you do if you need to replace this type of fuse in a hurry? You can solder

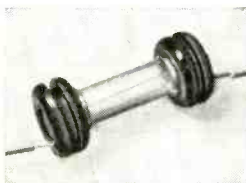

wires to the caps of conventional fuses, taking the chance that this will not "blow" the fuse as a result of the applied heat. A second and safer alternative is to secure pigtails to the fuse

caps with snug-fitting rubber grommets. You simply force 3/16" rubber grommets over the fuse caps, wedging the wire pigtails between the grommets and caps. This home-brew technique will suffice temporarily until you can stock up on regular pigtail-type fuses.

*Tom Wagner*

## MONO ADAPTER FOR STEREO HEADPHONES

Chances are that you have comfortable headphones which you would like to use with your communications receiver without changing the plug on the headphones or the jack in the receiver. This can be accomplished by mounting a two-circuit jack and a one-circuit plug at opposite ends of a 35-mm color film canister. The plug should be offset to one side of the canister as



shown in the photo so that, when the canister is closed, the jack won't interfere with the plug. (Also, the offset phono plug allows the adapter to be used with receivers, such as the Drake SW-4A, that have a panel extension.) Wire the two "signal" contacts on the jack and the "signal" contact on the plug together. Do the same for the "common" contacts. Finally, screw on the canister top, and the adapter is ready to use. —A. A. Wicks

## INEXPENSIVE ISOLATION TRANSFORMER

Many hobbyists and experimenters have hesitated to buy a line-isolation transformer because of the high price. Yet, for less than \$9, you can assemble a 120 volt-ampere isolation

# here's the real low-down on radiation angle:

How do you increase the "reach power" of a CB base antenna? One way is to design a *low down angle of radiation*—a technique antenna engineers have wrestled with for years

## **Radical new approach—the Mini-Skirt!**

Another engineering first from A/S—a new and highly effective counterpoise capacity loaded "skirt" that drastically lowers the radiation pattern . . . effectively concentrates radiated power where you want it (*out*, not up!) . . . produces an excellent 3+dB gain for greater communications range.

## **Compact . . . looks great . . . mounts anywhere!**

Small, graceful, Mini-Skirt "fits" anywhere. Only 12'-6" tall, skirt radius just 32"!

## **Professional design, electrically, mechanically!**

Mini-Skirt employs a professional-type coaxial feed for maximum power transfer impedance matching. It is constructed of polished aluminum with solid aluminum radials and skirt linkage ring (wind rating over 90 MPH!) yet weighs only 5 lbs VSWR: a professional-standard 1.5:1 or better!

The  
spectacular new

# MINI- SKIRT

Model M-200  
coaxial-feed CB Base  
Station Antenna

Suggested Resale:  
**\$19.95**

Stripes of Quality®



**the antenna  
specialists co.**

Div. of Allen Electric & Equipment Co.  
12435 Euclid Ave., Cleveland, Ohio 44106  
Export Offices: 2200 Shames Dr., Westbury, N.Y. 11590

CIRCLE NO. 4 ON READER SERVICE PAGE



FIRST AND ONLY

# compact scrulox® screwdriver sets

Increasing use of Scrulox square recess screws in appliances, radios, TV sets, electronic instruments . . . even the control tower at Cape Kennedy . . . has created a need. A need for compact, versatile driver sets. Small enough to tuck in a pocket. Complete enough to be practical on shop bench or assembly line.

Now, here they are . . . from Xcelite, of course.



**PS44**  
COMPACT  
CONVERTIBLE SET

Five color coded midget Scrulox drivers — #00 thru #3  
One midget nutdriver — 1/4" hex  
"Piggyback" torque amplifier handle increases reach and driving power  
See thru plastic case doubles as bench stand

**99SL**  
INTERCHANGEABLE  
BLADE KIT



Five Scrulox blades — #00 thru #3. Shockproof, break-proof. Service Master handle. Durable, see-thru plastic case

## XCELITE®

XCELITE INC. • 20 BANK ST., ORCHARD PARK, N. Y.

Send Bulletin N1065 on Scrulox Screwdriver Sets.

name \_\_\_\_\_

address \_\_\_\_\_

city \_\_\_\_\_

state & zone \_\_\_\_\_

CIRCLE NO. 48 ON READER SERVICE PAGE

28

## TIPS

(Continued from page 26)

transformer setup and have taps spotted at 24-volt intervals as a bonus. What you need are five 117-volt primary/24-volt, 1-ampere secondary transformers—available for as low

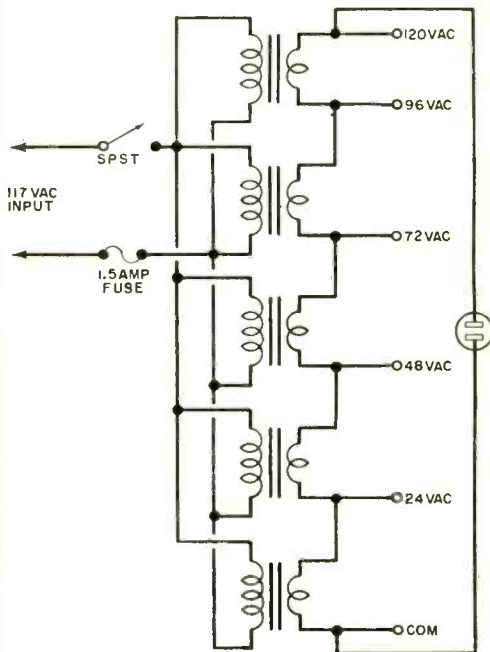

as \$1.79 each from Lafayette Radio Electronics (catalog number 99 H 6266). Wire all primary windings in parallel with each other; wire the secondaries in series in the proper phase as shown in the schematic drawing. Then, protect the setup by inserting a 1.5-ampere fuse in one of the lines of the primary circuit. Attach a line cord across the primary and an a.c. receptacle across the entire string formed by the secondaries.

—Frank H. Tooker

## HEAT-SHRINKABLE TUBING COUPLES PHOTOCELL TO LIGHT SOURCE

The next time you build a project that uses a photocell control circuit, use heat-shrinkable tubing to join the lamp and photocell mechanically end-to-end to produce a light-tight coupling. After butting the lamp and photocell together, slip a length of the heat-shrinkable tubing over the two. The length of tubing used should be adequate enough to allow 1/4" overhang at the ends of the lamp and photocell. Shrink the tubing, making sure the overlap makes a good seal.

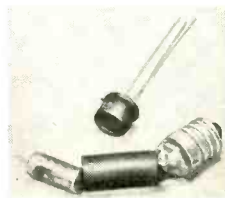

—Royland Petterson

POPULAR ELECTRONICS

Technical Series HM-90

\$175

Suggested Price

# RCA SOLID-STATE Hobby Circuits Manual

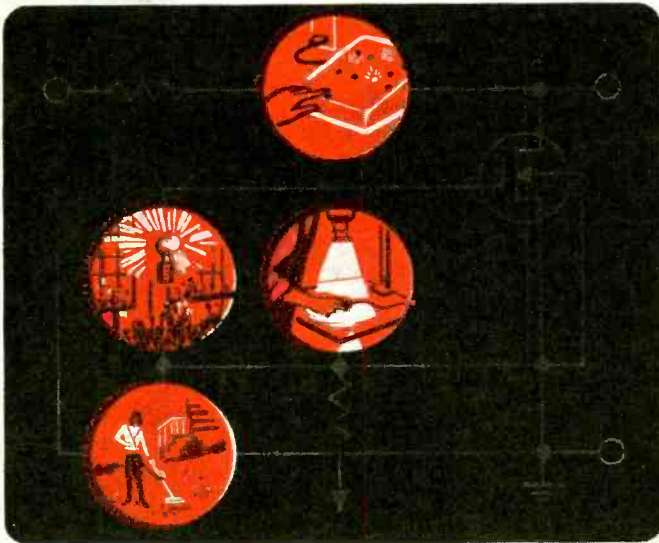

# RCA

*Novice or expert...*

## Here are many new, exciting solid-state hobby projects

For you, in this new manual from RCA, are 35 construction projects to satisfy your hobby interests for the coming months.

This newest addition to the expanding RCA technical library, the RCA Solid-State HOBBY CIRCUITS MANUAL, HM-90, has "something for everyone"—from beginner to expert. The 35 circuits are of interest to electronic experimenters including hams, motorists, photographers, home owners, and music and hi-fi buffs. Circuits are described in detail with circuit schematics, layouts, templates, parts lists and photographs. In addition, there are sections on theory and practical applications of solid-state devices—including integrated circuits and MOS/FET units as well as a section on trouble shooting and testing.

Typical circuits include:  
electronic slot machine •  
electronic dice • metal detector •  
single-voice organ • electronic  
metronome • code-practice  
oscillator • automatic keyer •  
enlarger exposure meter • lamp  
dimmer • electronic "fuzz" box •  
audio amplifier • automobile  
tachometer • motor speed  
control • electronic flasher •  
light minder for automobiles, and  
twenty other interesting circuits.

See your RCA Distributor today for your copy of HM-90, published by RCA Electronic Components, Harrison, N. J. 07029

# RCA

Scott's new LR-88 receiver takes the



out of kit building

Building a kit used to be something you couldn't do with ladies and children present, but Scott's new LR-88 AM/FM stereo receiver kit has changed all that. First, there's the instruction manual. In clear and simple language, it leads you, step-by-step, through every stage of the assembly process. And each stage is illustrated . . . full-size, full-color. Next, there's Scott's ingenious new Kit-Pak®. The parts for each assembly stage are in individual compartments, keyed to the instructions. All wires are color-coded, and pre-cut and pre-stripped to the proper sizes. Difficult or critical sections are pre-wired, pre-aligned, pre-tested, and factory-mounted on printed circuit boards. Is soldering your bugaboo? Scott has provided push-on solderless connectors for the hard-to-get-at spots.

About thirty painless hours after you've started, you've completed one great receiver. The LR-88 is the 100-Watt kit brother to Scott's finest factory-wired beauties. It includes the famous Scott silverplated Field Effect Transistor front end, Integrated Circuit IF strip, all-silicon output circuitry . . . in fact, all the goodies that would cost you over a hundred dollars more if Scott did all the assembling. Performance? Just check the specs below . . . and you'll be amazed at how great a receiver sounds after you've built it yourself. Treat yourself to a weekend of fun and years of enjoyment . . . see the Scott LR-88 at your dealer's today.

**LR-88 Control Features:** Dual Bass and Treble; Loudness; Balance; Volume compensation; Tape monitor; Mono/stereo control; Noise filter; Interstation muting; Dual speaker switches; Stereo microphone inputs; Front panel headphone output; Input selector; Signal strength meter; Zero-center meter; Stereo threshold control; Remote speaker mono/stereo control; Tuning control; Stereo indicator light. **LR-88 Specifications:** Music Power rating (IHF), 100 Watts @ 4 Ohms; Usable sensitivity, 2.0  $\mu$ V; Harmonic distortion, 0.6%; Frequency response, 15-25,000 Hz  $\pm$  1.5 dB; Cross modulation rejection, 80 dB; Selectivity, 45 dB; Capture ratio, 2.5 dB; Signal/noise ratio, 65 dB; Price, \$334.95.

You'll swear by it

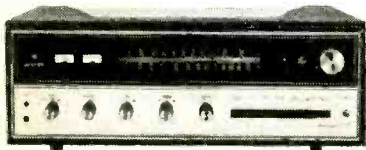

Write for complete information on the new Scott components and kits.

H.H. Scott, Inc., Dept. 520-10,  
Maynard, Mass. 01754  
Export: Scott International,  
P.O. Box 277,  
Maynard, Mass. 01754

Walnut case optional extra

**SCOTT**

© 1968, H.H. Scott, Inc.  
CIRCLE NO. 38 ON READER SERVICE PAGE



# BUILD THE SPORTS TIMER

Get thousandths-  
of-a-second  
accuracy up to 10  
minutes—useful  
for a variety  
of sports events



THE AVAILABILITY OF LOW-COST decimal-readout counting units has created an entirely new "ball park" of experimentation for the advanced electronics hobbyist. This new area is digital-readout instruments and we will be publishing several articles on such projects in the months to come. The first is the "Sports Timer," a real-time clock, described here.

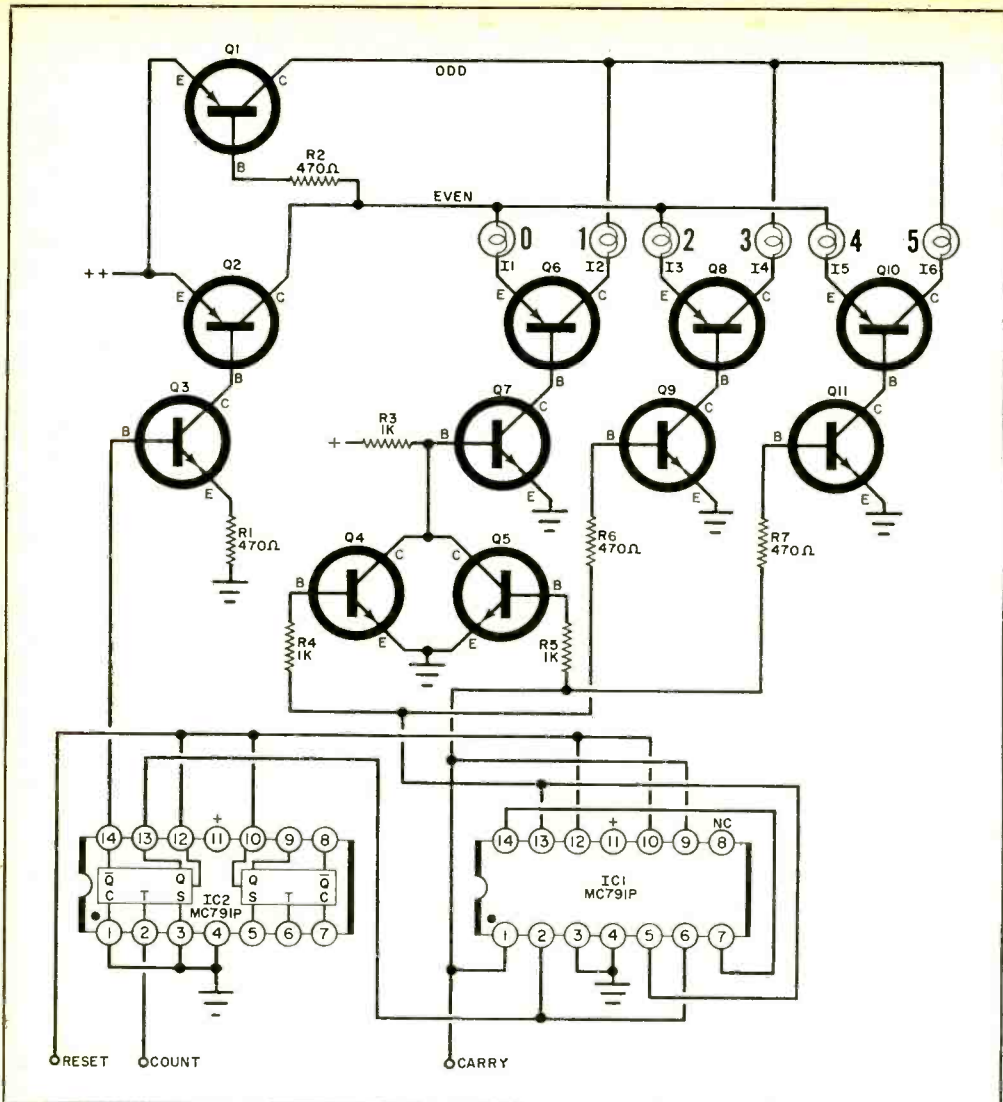

Fig. 1. The modulo-6 counter indicates only up to five, then returns to zero. Simultaneously, it passes a carry (trigger) pulse to the next decade counter.

### PARTS LIST

- 11-16—6.3-volt, 50-mA pilot light and cap assembly (Southwest Technical Products #0-6.3 or similar)  
 IC1, IC2—MC791P dual JK flip-flop integrated circuit (Motorola)  
 Q1, Q2, Q4, Q6, Q8, Q10—MPS3638 or 2N5139  
 Q3, Q5, Q7, Q9, Q11—MPS2923 or 2N5129  
 R1, R2, R6, R7—470-ohm, 1/2-watt resistor  
 R3, R4, R5—1000-ohm, 1/2-watt resistor  
 A complete kit of parts for the modulo-6 counter is available from Southwest Technical Products Corp., 219 W. Rhapsody, San Antonio, Texas 78216, for \$10.00, postpaid in U.S.A.

The clock is basically a combination of two previous projects ("Low-Cost Counting Unit," February 1968, page 27, and "Ultra-Fast Electronic Stopwatch," March 1968, page 27) with the addition of a modulo-6 counter that counts, and indicates, to 5 and then returns to zero. This counter is required in real-time measurements in order to get the 5 needed in measuring 59 seconds or 59 minutes before switching to the next register. (Remember that the original counter reads out to 9 before returning to zero.)

The "Sports Timer" is designed to read out to 9 minutes and 59.999 seconds,

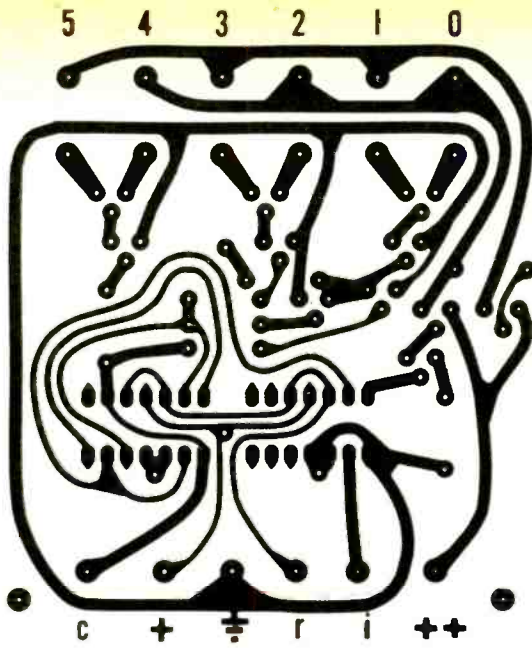

Fig. 2. Actual-size foil pattern for the modulo-six counter. It is the same size as the boards used for the other circuits (see text) simplifying construction of timer.

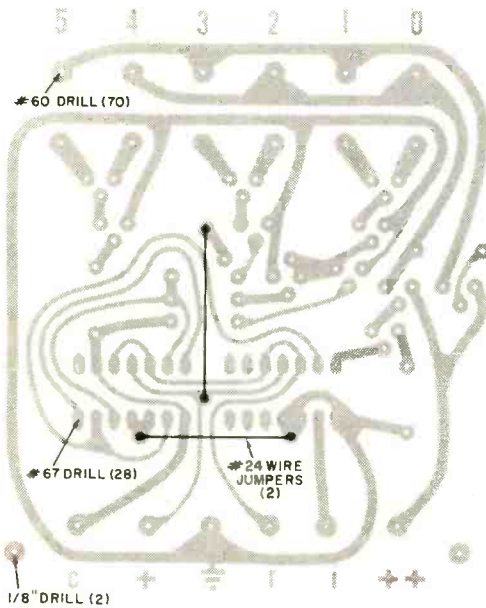

Fig. 3. Drill the PC board as shown here, and add the two insulated jumpers on component side of board.

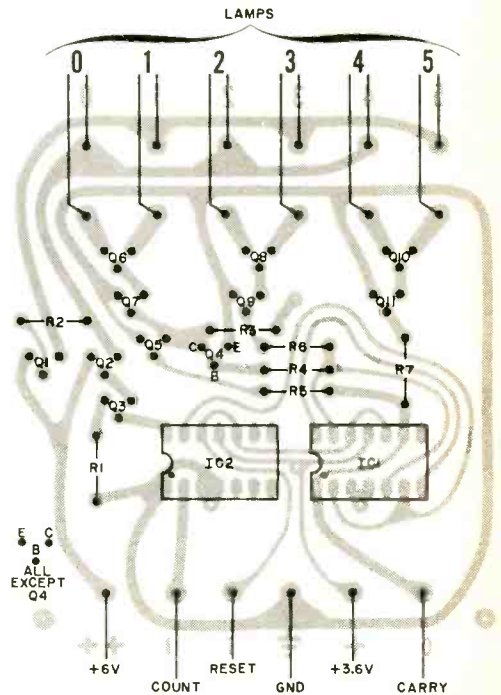
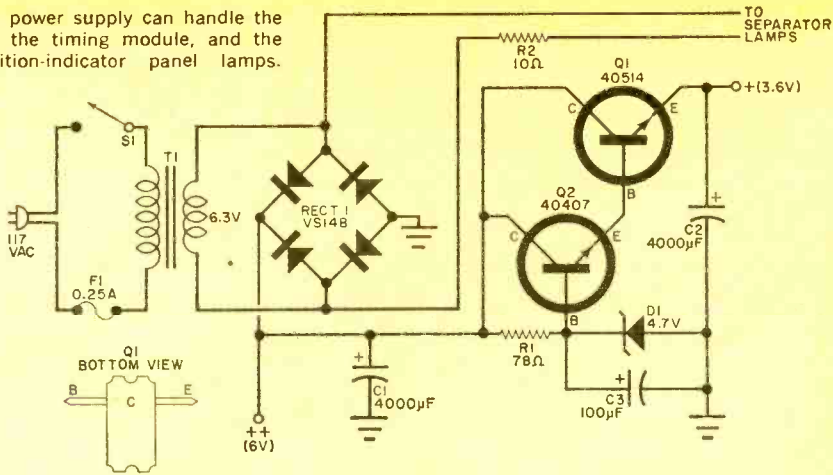

Fig. 4. Mount the components as illustrated here making sure that you orient the semiconductors properly. Note Q4 is not installed in same way as Q1-Q11.



Fig. 5. The power supply can handle the six DCU's, the timing module, and the three position-indicator panel lamps.



### PARTS LIST

- C1, C2—4000- $\mu$ F, 6-V electrolytic capacitor
- C3—100- $\mu$ F, 15-V electrolytic capacitor
- D1—4.7-V zener diode
- F1—0.25-A fuse
- R1—78-ohm, 1-W resistor (two 39-ohm, 1-W resistors in series)
- R2—10-ohm,  $\frac{1}{2}$ -W resistor
- RECT1—Full-wave bridge rectifier (Varo VS148, or similar)

- S1—S.p.s.t. switch
  - T1—Filament transformer; secondaries 6.3 V, 2 A
  - Q1—40514 power transistor (RCA)
  - Q2—40407 transistor (RCA)
  - Misc.—Heat sink for Q1, fuse holder, silicone grease, wire, solder, four standoffs, etc.
- A complete kit of parts is available from Southwest Technical Products Corp., 219 W. Rhapsody, San Antonio, Texas 78216, for \$9.75, postpaid in U.S.A.

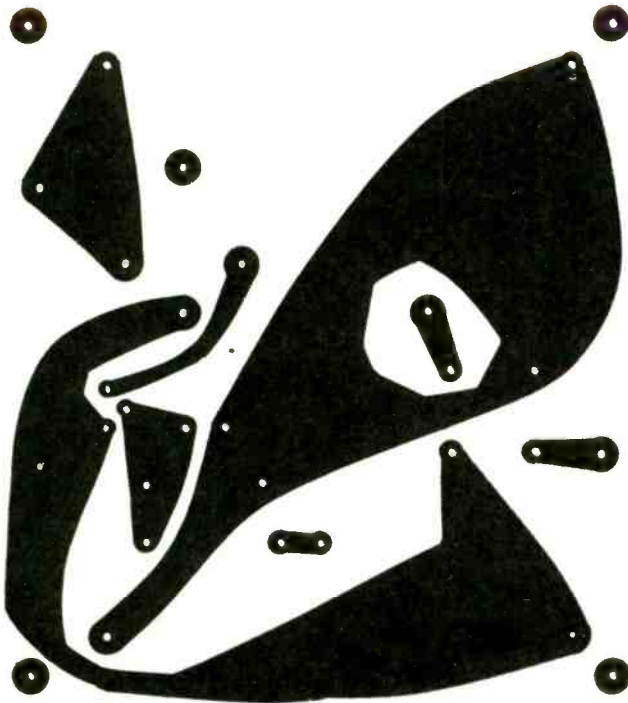

Fig. 6. Actual-size foil pattern for power supply. Like all the other PC boards, this one is also available etched and drilled (see Parts List for ordering details).

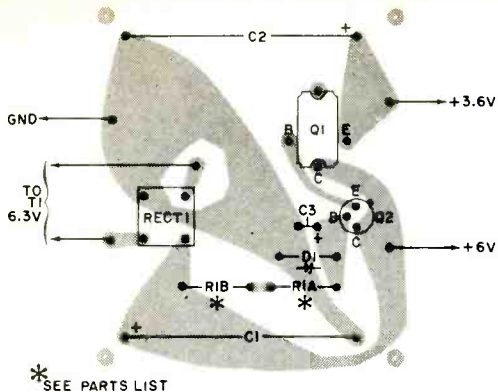

Fig. 7. Component installation on the power supply PC board. Note that R1 is two resistors in series.

which should be sufficient for the majority of track events, auto races, swimming contests, ski runs, etc. If desired, however, the maximum time can be extended to read up to 9 hours, 59 minutes and 59.999 seconds. Besides sporting events, the clock can be used to time tape recordings and speeches and has applications in laboratories, photo darkrooms, or any other activity where an illuminated readout clock capable of measuring to small parts of a second can be used.

The clock can be started and stopped in a variety of ways. A photoelectric start-and-stop circuit (described in this article) is one way; others include the operation of mechanical contacts, such as pushbutton switches or step-on doormat switches. If desired, the clock can be started from a microphone and amplifier system adjusted to pick up the crack of the starter's pistol. The number of triggering methods possible is limited only by the imagination of the user.

**Construction.** Because the decade counting units and the crystal-controlled timing circuit have already been described in detail (see the previously mentioned issues of POPULAR ELECTRONICS) only the modulo-6 counter will be covered here.

The basic modulo-6 counter (schematic shown in Fig. 1) uses two low-cost IC's, eleven transistors, 7 resistors, and six incandescent bulbs. Cost of this counter is \$10 (see Parts List). An actual-size printed-circuit-board foil pattern is shown in Fig. 2, while Fig. 3 shows how the board is to be drilled and the location

of the two jumpers required. These jumpers are made from #24 solid wire and are added on the component side of the board.

When mounting the components, as shown in Fig. 4, be sure to observe the correct positioning of all semiconductors, noting that the IC's are identified by a notch and dot code at one end. Use a low-wattage soldering iron and fine solder to make all connections.

If desired, a readout-lamp display bracket can be cut and bent from a piece of  $\frac{1}{32}$ " aluminum similar to that shown in the February issue. Pop rivets can be used to secure the bracket to the board. Press the plastic lamp covers into the six holes, then press the bulbs into the plastic covers. After each bulb is wired to its correct terminals, use black "instant transfer" numerals to identify them, coating the numbers with a clear acrylic spray to prevent accidental removal.

Note that, in the finished clock, lamp mounting brackets are not used on any of the readouts, but holes are drilled in the front panel using the lamp brackets (provided with each kit) as a template. If you select this method of construction, be sure to leave *all* lamp leads as long as possible before soldering the far ends to the PC boards.

To duplicate the "Sports Timer" shown in the photos, you will need five 0-9 counting units, one 0-5 counting unit, a crystal-controlled timer, three 6.3-volt lamps and plastic covers, a power supply, and a chassis.

**Power Supply.** The power supply provides 3.6 volts at very low ripple for use by the IC's, 6 volts for the numerical-display incandescent lamps, and approximately 6.3-volts a.c. for the three position-indicator lamps (two making up the colon, and one for the decimal point). A suitable supply, shown in Fig. 5 consists of a transformer-powered bridge rectifier followed by a two-transistor, zener-diode-controlled regulator. The separator lamps get power from T1 through dropping resistor R2.

The power supply can be assembled on the printed board shown actual size in Fig. 6. All parts, with the exception of power transformer T1, fuse F1, and dropping resistor R1 are mounted on the board as shown in Fig. 7.

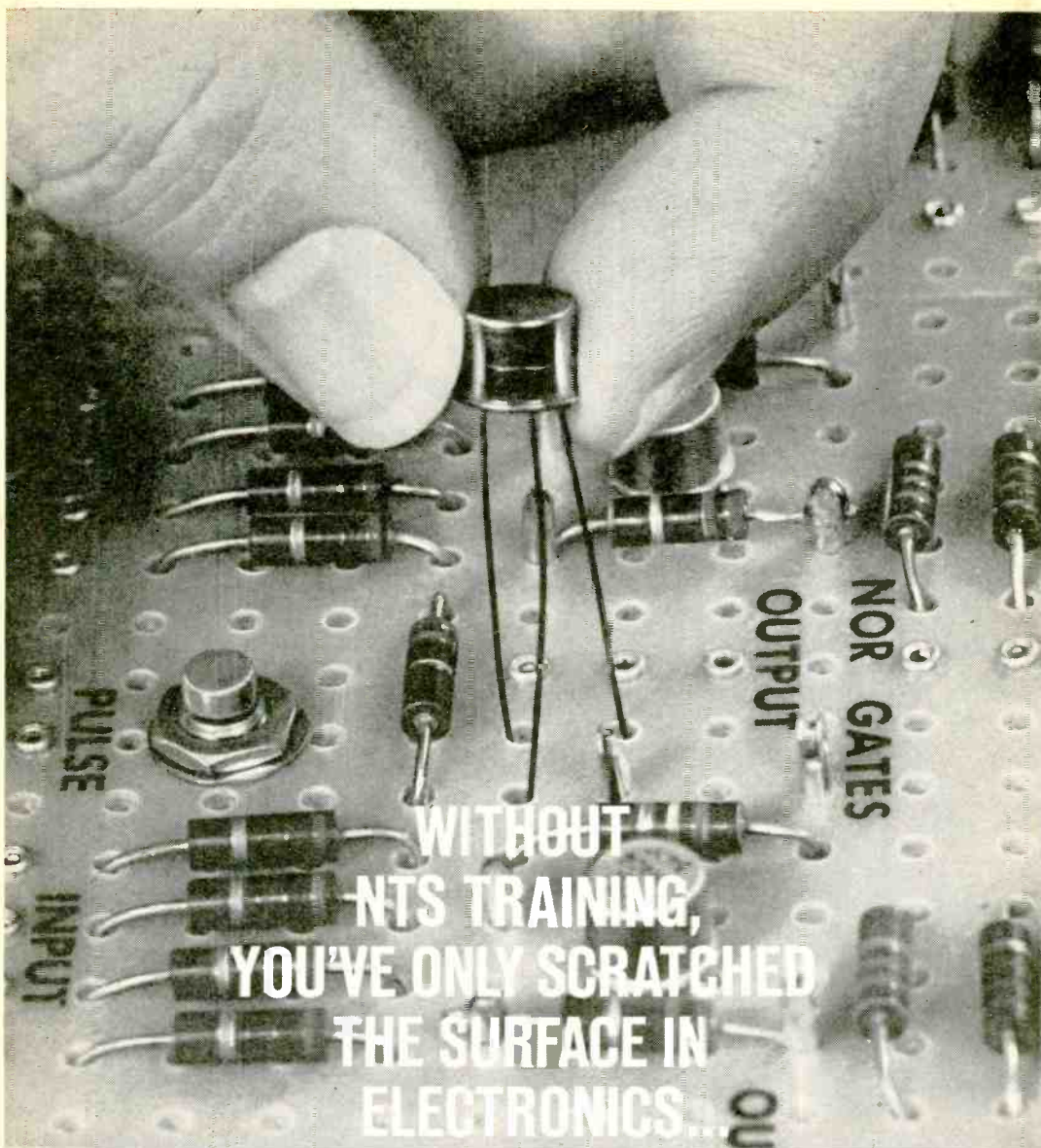

Only NTS penetrates below the surface. Digs deeper. Example? Take the above close-up of the first transistorized digital computer trainer ever offered by a home study school.

It's called The Compu-Trainer®—an NTS exclusive. Fascinating to assemble, it introduces you to the exciting world of computer electronics. Its design includes advanced solid-state NOR circuitry,

flip-flops, astable multivibrators and reset circuits. Plus two zener and transistorized voltage-regulated power supplies. The NTS Compu-Trainer® is capable of performing 50,000 operations per second.

Sound fantastic? *It is!* And at that, it's only one of many *ultra-advanced* kits that National Technical Schools offers to give you incomparable, in-depth career training.

**PROVE IT YOURSELF. SEND FOR OUR NEW CATALOG. SEE THE LATEST, MOST ADVANCED KITS AND COURSES EVER OFFERED BY A HOME STUDY SCHOOL.**



## NTS...THE FIRST HOME STUDY SCHOOL TO OFFER LIVE EXPERIMENTS WITH INTEGRATED CIRCUIT KITS

You build a computer sub-system using the new, revolutionary integrated circuits. Each one, smaller than a dime, contains the equivalent of 15 resistors and 27 transistors.

And your kits come to you at no extra cost. These kits are the foundation of the exclusive *Project-Method* home study system... developed in our giant resident school and proven effective for thousands of men like yourself.

With Project-Method, all your kits are carefully integrated with lesson material. Our servicing and communication kits are *real* equipment—not school-designed versions for training only. As you work on each of the projects, you soon realize that even the most complicated circuits and components are easy to understand. You learn *how* they work. You learn *why* they work.

NTS Project-Method is a practical-experience approach to learning. The approach that works *best!* An all-theory training program can be hard to understand — difficult to remember. More than ever before you need the practical experience that comes from working with real circuits and components to make your training stick.

### NTS SENDS YOU KITS TO BUILD THESE IMPORTANT ELECTRONICS UNITS!

- ◆ 25" COLOR TV
- ◆ 21" BLACK & WHITE TV
- ◆ SOLID-STATE RADIO
- ◆ AM-SW TWIN-SPEAKER RADIO
- ◆ TUBE-TESTER
- ◆ TRANSCEIVER
- ◆ COMPU-TRAINER®
- ◆ VTVM
- ◆ SIGNAL GENERATOR
- ◆ 5" OSCILLOSCOPE

See them all illustrated in  
the new *NTS Color Catalog*.

**CLASSROOM TRAINING AT LOS ANGELES:** You can take classroom training at Los Angeles in sunny California. NTS occupies a city block with over a million dollars in facilities devoted exclusively to technical training. Check box in coupon.

## NATIONAL TECHNICAL SCHOOLS

WORLD-WIDE TRAINING SINCE 1905  
4000 So. Figueroa Street, Los Angeles, Calif. 90037

### APPROVED FOR VETERANS

Accredited Member: National Home Study Council  
Accredited Member: National Association of Trade and Technical Schools



### COMMUNICATIONS

This transceiver is included in Communications courses. You build it. With it, you easily prepare for the F.C.C. license exam. You become a fully-trained man in communications, where career opportunities are unlimited.

### 25" COLOR TV ▼

Included in Color TV Servicing Courses. With it you advance yourself into this profitable field of servicing work. Color is the future of television, you can be in on it with NTS training.

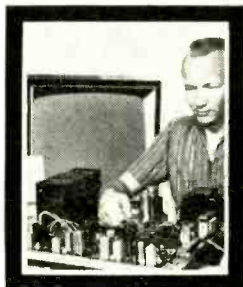

### YOUR OPPORTUNITY IS NOW

New ideas, new inventions, are opening whole new fields of opportunity. The electronic industry is still the fastest growing field in the U.S. There's a bigger, better place in it for the man who trains today. So, whatever your goals are — advanced color TV servicing, broadcasting, F.C.C. license, computers, or industrial controls, NTS has a highly professional course to meet your needs.

GET THE FACTS! SEE ALL NEW COURSES AND KITS OFFERED IN THE NEW NTS COLOR CATALOG. SEND THE CARD OR COUPON TODAY!

There's no obligation. You enroll by mail only. No salesman will call.



DEPT. 205-108

### NATIONAL TECHNICAL SCHOOLS

4000 S. Figueroa St., Los Angeles, Calif. 90037  
Please rush Free Color Catalog and Sample Lesson, plus information on field checked below. No obligation.

- |   |  |
|---|--|
| <input type="checkbox"/> MASTER COURSE IN COLOR TV SERVICING        | <input type="checkbox"/> PRACTICAL TV & RADIO SERVICING    |
| <input type="checkbox"/> COLOR TV SERVICING                         | <input type="checkbox"/> FCC LICENSE COURSE                |
| <input type="checkbox"/> MASTER COURSE IN TV & RADIO SERVICING      | <input type="checkbox"/> INDUSTRIAL & COMPUTER ELECTRONICS |
| <input type="checkbox"/> MASTER COURSE IN ELECTRONIC COMMUNICATIONS | <input type="checkbox"/> STEREO, HI FI & SOUND SYSTEMS     |
|   | <input type="checkbox"/> BASIC ELECTRONICS                 |

NAME \_\_\_\_\_ AGE \_\_\_\_\_

ADDRESS \_\_\_\_\_

CITY \_\_\_\_\_ STATE \_\_\_\_\_ ZIP \_\_\_\_\_

- Check if interested in Veteran Training under new G. I. Bill.  
 Check if interested ONLY in Classroom Training at Los Angeles.

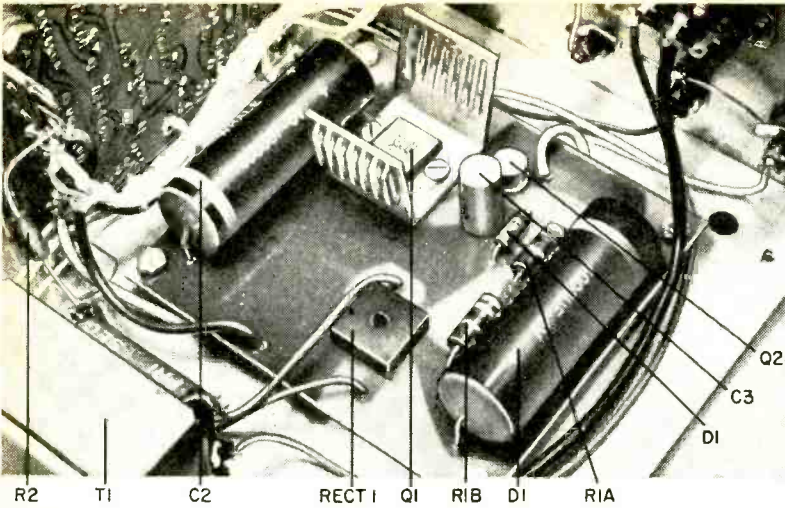

To prevent components from shorting against chassis, install spacers between the chassis and the power supply board.

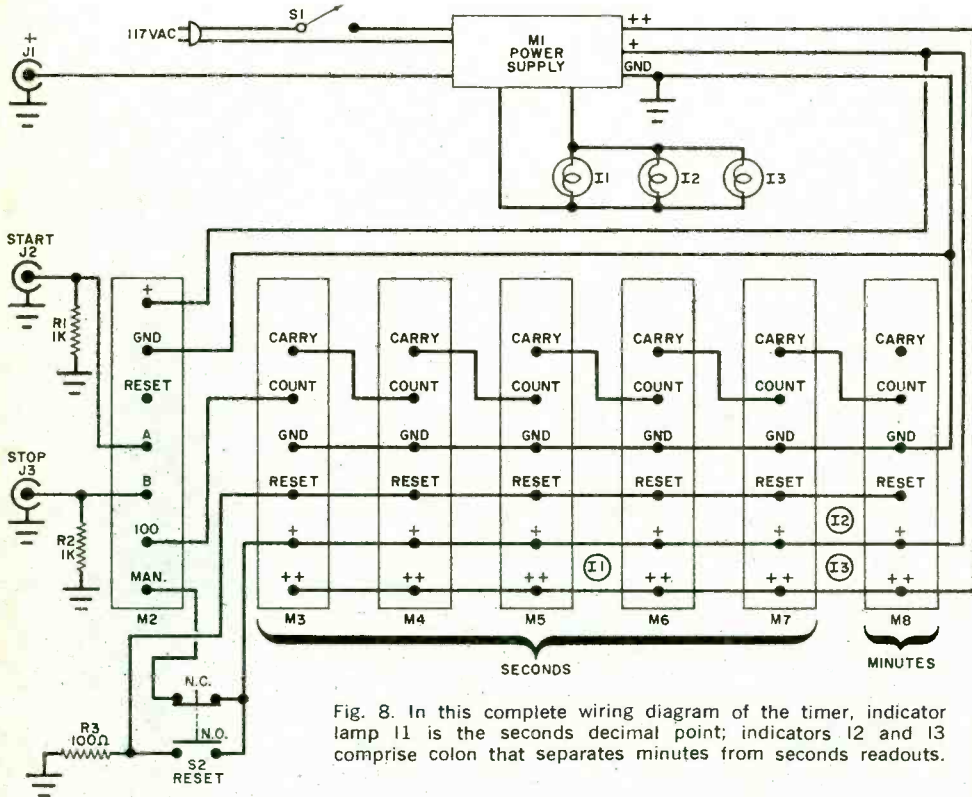

Fig. 8. In this complete wiring diagram of the timer, indicator lamp I1 is the seconds decimal point; indicators I2 and I3 comprise colon that separates minutes from seconds readouts.

### PARTS LIST

- I1, I2, I3—6.3-V, 50-mA pilot light and cap assembly, two green, one red (Southwest Technical Products #0-6.3, or similar)
- J1, J2, J3—Phono jacks, RCA types
- M1—Power supply
- M2—Timing module
- M3, M4, M5, M6, M8—Decade counting unit
- M7—Modulo-6 counter
- R1, R2—1000-ohm, 1/2-W resistor
- R3—100-ohm, 1/2-W resistor

- S1—S.p.s.t. switch
  - S2—S.p.s.t. momentary pushbutton switch
  - Misc.—Chassis, mounting hardware, line cord, adhesive-contact plastic (optional), wire, solder, etc.
- The following parts are available from Southwest Technical Products Corp., 219 W. Rhapsody, San Antonio, Texas 78216: Timing module kit with 100-kHz, 0.005% crystal, \$24; decade counters, \$12; chassis, punched, primer coated, and with covering material for top, \$6.50.

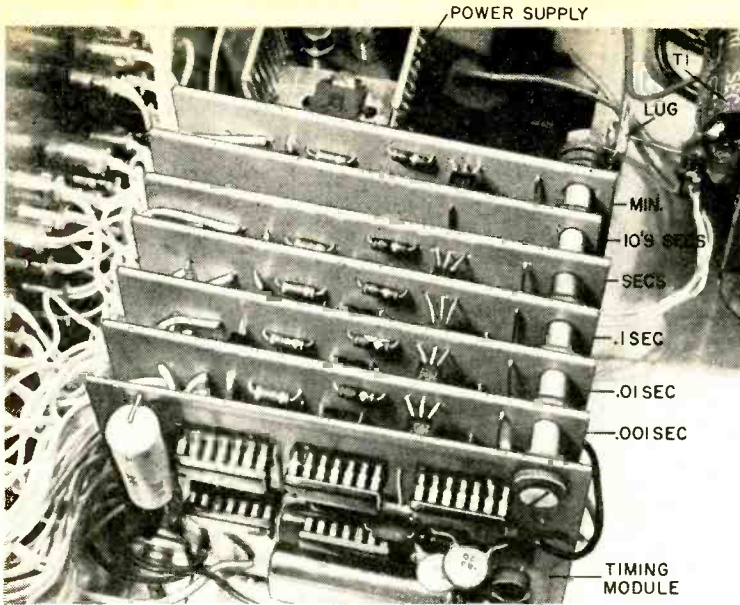

Fig. 9. Timing module and DCU circuit boards should be stacked for space conservation and neatness. Use  $\frac{1}{2}$ "-long insulated spacers (or metal spacers and fiber washers) between each board for adequate separation. Board designations from bottom to top are M2 through M8.

**Assembly.** The 10" wide by  $3\frac{1}{2}$ " high by 7" deep metal chassis, used by the author consists of two U-shaped sections. One serves as the mounting chassis for the completed circuit (Fig. 8) and the other is used as the cover.

Start the assembly by drilling the required holes in the front panel for the readouts, using the lamp bracket as a template. The plastic lamp covers are press-fit into the holes, and the lamps are press-fit into their covers. Therefore, when assembling the counters, use the full length of wire provided with each lamp. Don't forget to drill the three holes for the position identifier lamps. Drill a hole to accept the RESET push-button *S2*, power ON-OFF switch *S1*, and three phono jacks *J1*, *J2* and *J3*.

Before mounting any components on the front panel but after drilling the required holes, cover the entire front panel with a contact-adhesive plastic coating whose pattern or color appeals to you. Use a sharp knife to remove the material from the area where the holes are. Apply the front panel markings with any type of instant-transfer lettering. The box outline was made with thin black tape. The author used a red plastic cover for the decimal indicator (*I1*) and a green cover for the colon indicator (*I2*, *I3*).

The interior layout is shown in Fig. 9. The seven printed boards are separated from each other with  $\frac{1}{4}$ " spacers at the two rear mounting holes. If metal  
(Continued on page 112)

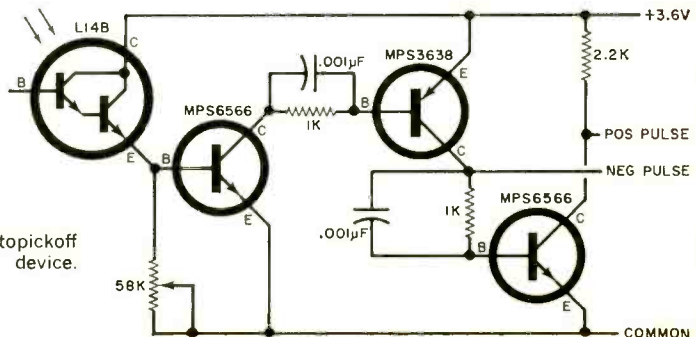

Fig. 10. Suggested photopickoff for use as a start/stop device.





# POPULAR ELEComics



Here's my license. May I see your license to operate a radar unit?



It has an awful hollow, ringing sound.



George, you forgot to turn off your burglar alarm.

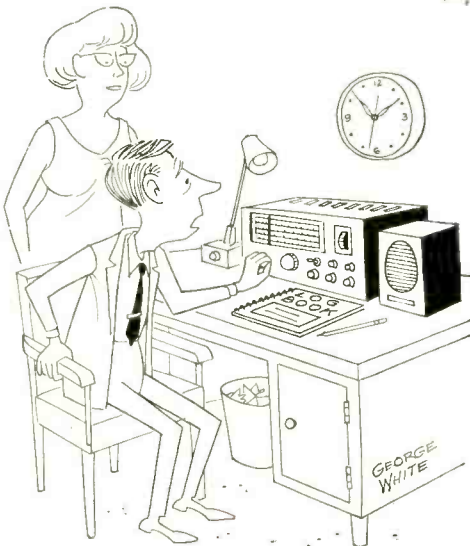

Everytime I log a Chinese station, an hour later I want to log another.

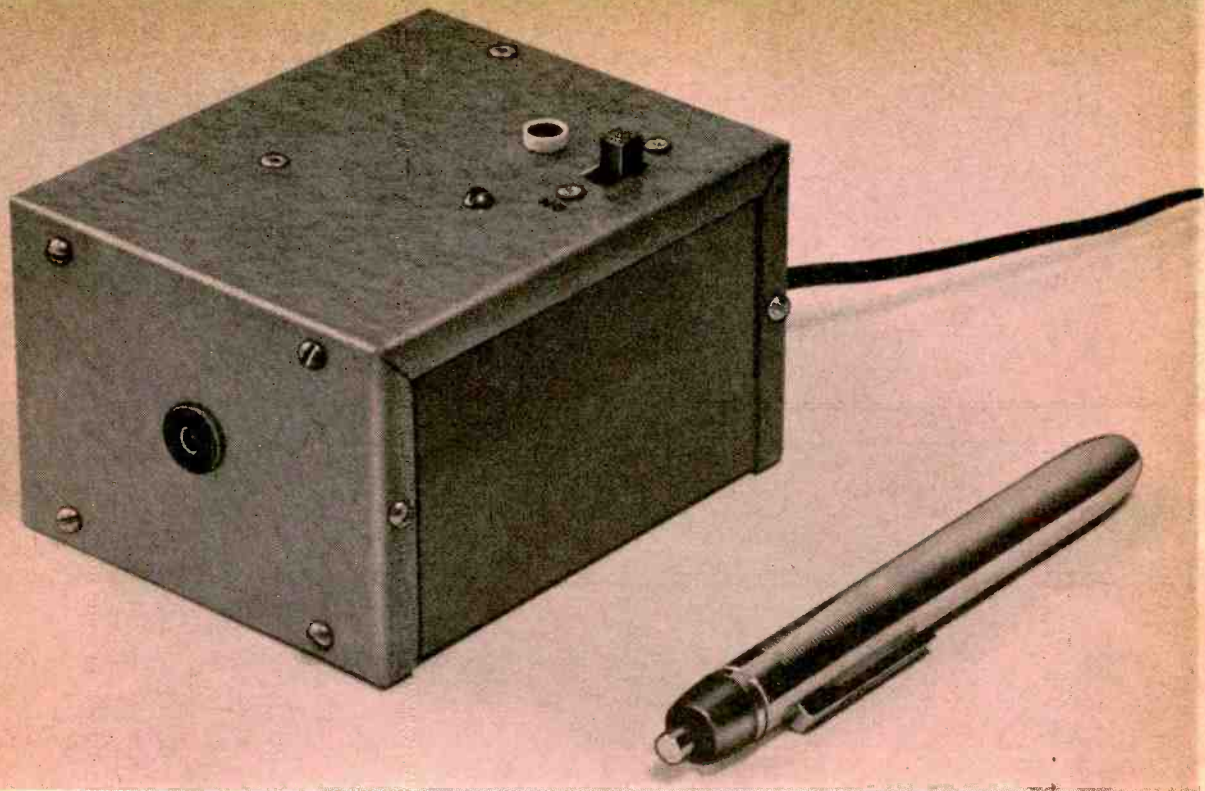

## Blow Your Mind With Our **FREQ-OUT** ELECTRONIC LOCK

SUPER-SECRET PHOTOELECTRIC LOCK USES  
MODULATED LIGHT BEAM KEY

BY JOHN S. SIMONTON, JR.

**T**HERE ARE ALL KINDS of electrical and electronic locks. None of them, however, is quite like the "Freq-Out." The "key" to this lock is a modulated beam of light which is turned on and off at a rate of about 2000 times a second. The key, using an inexpensive integrated circuit, is about the size of a pocket penlight. The Fotolock circuit can't be fooled by incandescent or fluorescent lights operating on 60-Hz power, and no amount of vigorous hand waving can break a light beam fast enough to open this lock.

While the operating range of the key described here is two or three feet, experiments with a well-focused beam from a larger flashlight indicate that the principle could be applied to longer-range operations—such as a remote control garage-door opener. Under normal lighting conditions, a much greater distance can be covered with the modulated beam than with one which is unmodulated.

The Freq-Out itself uses 117-volt a.c. line power and can be used as an intrusion alarm which cannot be bypassed

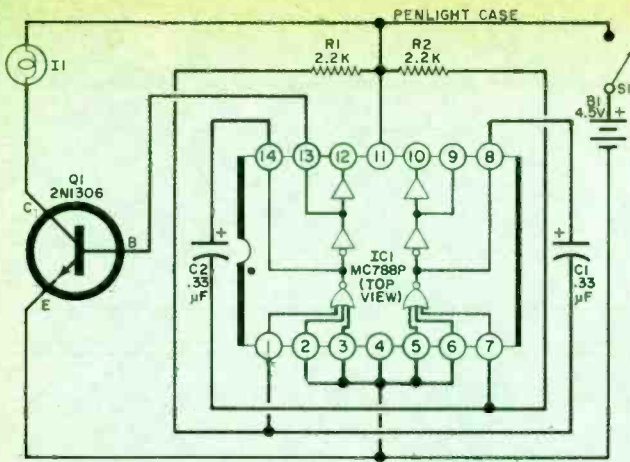

Fig. 1. The IC and associated components form a 2-kHz oscillator. This drives the transistor which in turn powers the flashlight lamp. In operation, the lamp flashes are so fast that the lamp appears to be turned on all of the time.

### PARTS LIST

- B1—1.5-volt hearing-aid batteries (Mallory M-76 or similar)
- C1, C2—0.33  $\mu$ F, 35-volt tantalum capacitor (Kemet KR33C35 or similar)
- I1—#222 flashlight lamp
- IC—Dual-buffer integrated circuit, MC788P (Motorola)
- Q1—2N1306 transistor
- R1, R2—2200-ohm,  $\frac{1}{4}$ -watt resistor

Misc.—Evcready #315 penlight, insulating tape, styrofoam, etc.

Note—The following parts are available from PAA Electronics, Inc., Box 14359, Oklahoma City, Okla. 73114: penlight modulator board \$1.10; PC for high-power modulator \$2; kit of parts for penlight modulator with penlight less batteries \$6.50; kit of parts for high-power modulator less lamp, reflector, and power supply \$7.50.

with an ordinary flashlight. It is insensitive to ambient light conditions and there are no finicky sensitivity adjustments to be made.

**Modulator.** If you plan to build the penlight key or modulator (Fig. 1) a printed circuit board is an absolute must. You can make your own using Fig. 2 as a guide, or you can purchase a PC board (see Parts List). When soldering compo-

nents to the board, use a clean iron and lots of patience. Note that the location of the notch on the integrated circuit is keyed with a small dot on the circuit board.

As shown in Fig. 2, there are only three external connections to be made to the printed circuit in the modulator. These go to the negative side of the battery, the tip contact of the lamp, and the penlight case. For simplicity, you may

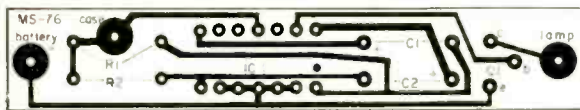

Fig. 2. Actual-size printed board for the modulator. It will fit into the penlight case with room to spare.

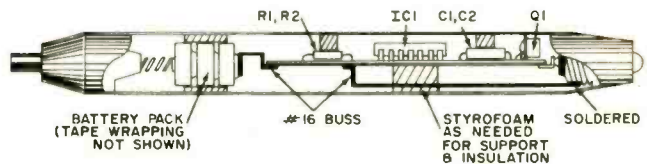
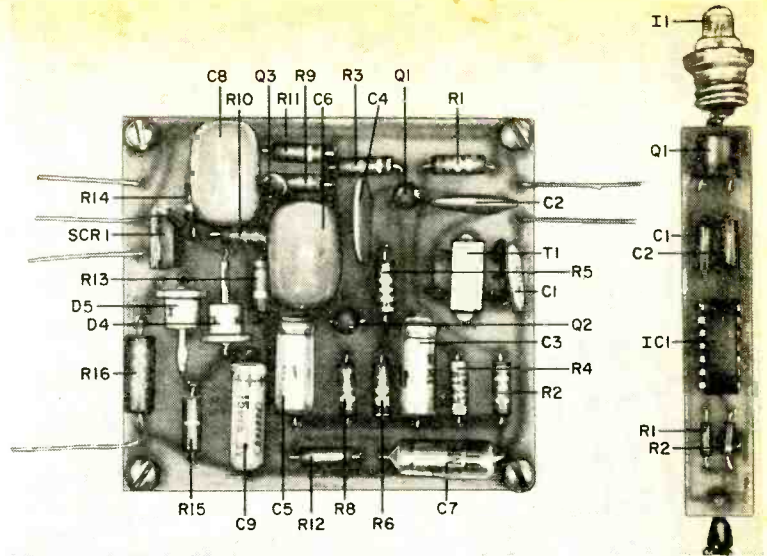

Fig. 3. The entire modulator is assembled within the penlight using styrofoam cut to make a tight fit.



The completed demodulator (left) and penlight modulator (right) before installing them in their packaging. Because some transistors have "hot" cases, it may be necessary to insulate Q1 of modulator, using plastic tape.



prefer to run a piece of #16 wire from the circle marked "case" on the printed circuit board to the rim contact of the lamp, thereby making the connection to the case through the base of the lamp. The lamp used in the modulator is the same #222 lamp supplied with most penlights.

Contacts for the battery and lamp can be formed of #16 wire and soldered directly to the large circles provided for them on the ends of the board. These contacts will be able to withstand greater stress if small tabs are formed on the ends of the wires and inserted into the holes in the board before soldering. The 2N1306 used for Q1 is in a standard TO-5 package and can be fitted into the penlight case if care is used. Some manufacturers connect one of the elements of this transistor to the case so you may need to wrap a layer of tape around it

to prevent shorting to the penlight case.

Power for the modulator is supplied by three MS-76 hearing-aid cells wired in series. Form the cells into a battery pack by stacking them and wrapping their outer edges with a piece of electrical tape. The tape not only holds the cells together, but also prevents the edges from shorting out against the penlight case.

The completed key device is assembled as shown in Fig. 3. Use as much electrical tape and styrofoam as necessary to prevent shorts between the board and the penlight case. Although the printed circuit board shown was designed for an Eveready #315 penlight, there is no reason why it shouldn't fit in any case designed to use two AA batteries. Be sure that the penlight switch disconnects both the point marked "case" on the PC board

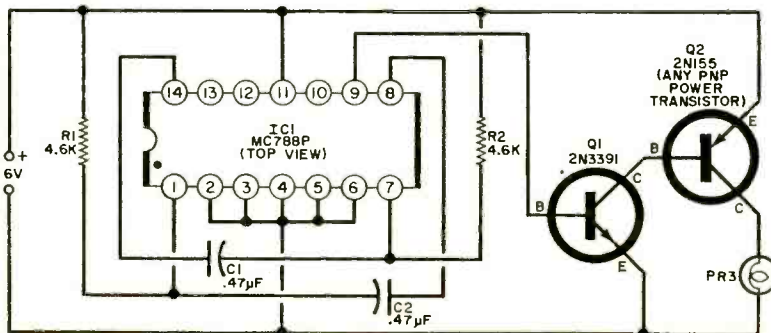

Fig. 4. This high-power modulator has a greater range than the penlight version. If the lamp is mounted within a three-inch, or larger, reflector, it can be used as an intrusion warning alarm.

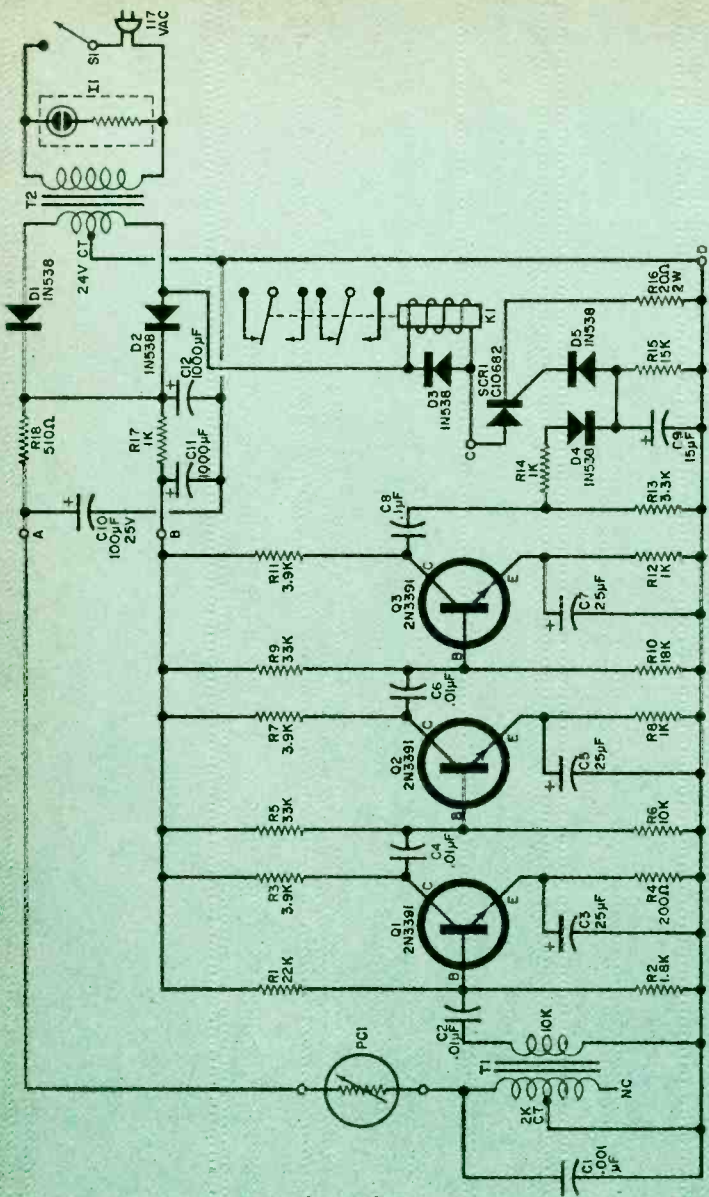

Fig. 8. Because the demodulator is a high-gain amplifier, take care that the input circuit is not loaded where it can pick up stray signals. This could lead to erratic operation. The lettered and open small circles on the diagram are the printed-board connections.

**PARTS LIST**

- C1—001- $\mu$ F capacitor
- C2, C4, C6—01- $\mu$ F capacitor
- C3, C5, C7—25- $\mu$ F, 3-volt electrolytic capacitor
- C8—0.1- $\mu$ F capacitor
- C9—15- $\mu$ F, 3-volt electrolytic capacitor
- C10—100- $\mu$ F, 25-volt electrolytic capacitor
- C11, C12—1000- $\mu$ F, 25-volt electrolytic capacitor
- for
- D1-D5—1N538 diode
- I1—Neon lamp assembly (with resistor for 117 volts)
- K1—D.p.d.t. relay, 6-volt d.c. coil
- PCI—Photoconductor (Clarex CL703L or similar)

- Q1, Q2, Q3—2N3391 transistor
- R1—22,000-ohm
- R2—1800-ohm
- R3, R7, R11—3900-ohm
- R4—200-ohm
- R5, R9—33,000-ohm
- R6—10,000-ohm
- R8, R12, R14, R17—1000-ohm
- R10—18,000-ohm
- R13—3300-ohm
- R15—15,000-ohm
- R18—510-ohm
- R16—20-ohm, 2-watt resistor
- S1—S.p.d.t. switch

All Resistors  
1/2 watt

SCR1—Silicon controlled rectifier (GE C106B2 or similar)  
 T1—Transformer driver transformer; 10,000-ohm primary, 2000-ohm C.T. secondary  
 T2—Pilot lamp transformer; secondary 24 volts C.T., 1 ampere  
 Misc.—Standoffs, rubber grommet, strain relief, line card, utility box, wire, solder, etc.  
 Note—The following parts are available from PAIA Electronics, Inc., Box 14359, Oklahoma City, Okla. 73114: demodulator PC board \$2.50; kit of electronic parts and circuit board for demodulator less power supply, case, and relay \$16.50.

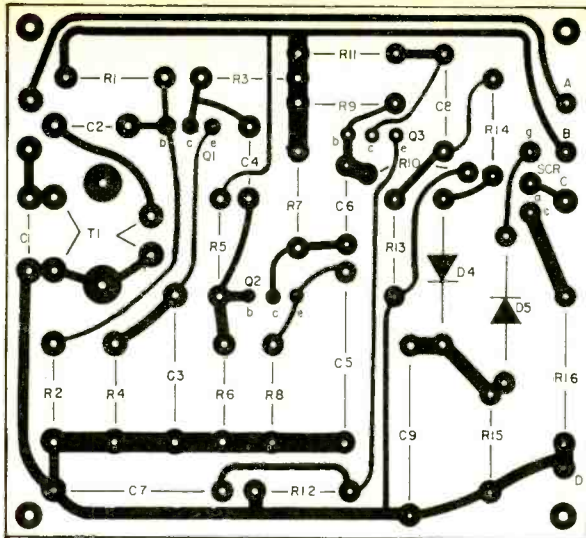

Fig. 6. Actual-size printed board for the demodulator. This also shows where the various components are to be installed on the finished circuit board.

and the outer lamp contact from the positive side of the battery pack.

For applications requiring greater range than is possible with the penlight, a larger flashlight and reflector should be used. Adapting the PC board for use in a flashlight which holds two D cells should be no problem. A PR-6 lamp should be substituted for the 222 usually used in the penlight.

If the Freq-Out is to be used as an intrusion alarm, the modulator requires a larger source of power. The schematic

shown in Fig. 4 is for a unit of this type which has worked well for the author. Either a 6-volt lantern battery or a suitable power supply is used in this case. A 3½-inch reflector salvaged from an old flashlight and a PR-3 lamp are required.

**Demodulator.** Because the first three stages of the demodulator form a high-gain amplifier (Fig. 5), care should be taken in construction to avoid unintentional feedback and subsequent parasitic

Fig. 7. Two relay configurations that may be used. In (A), the relay remains closed even after the light beam has been restored. In (B), the relay may be latched on in the presence of light, latched on in the absence of light, or operated as usual in the normal mode.

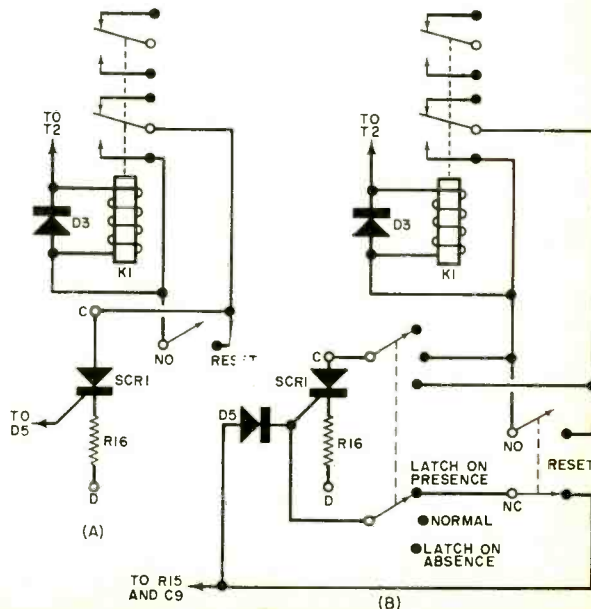



oscillation. You may make your own PC board using Fig. 6 or you can purchase one (see Parts List).

The wiring of the circuit board is straightforward, though you should use the usual precautions when soldering the semiconductors in place. Notice that transformer *T1* has been turned around so that one half of what would ordinarily be the secondary is used as the primary. It is not important which half of the secondary you use. Cut off the unused lead on the transformer so that it doesn't come in contact with some other component.

In the unit shown in the photos, the PC board is mounted on ceramic stand-offs in one end of a conventional 3" × 4" × 5" utility box. There should be sufficient clearance behind the board to mount the photocell in a rubber grommet.

The power-supply components in the prototype unit were soldered to a six-lug terminal strip (no grounded lugs) which was then fastened to the otherwise unused section of the utility box. Choose the location for the terminal strips carefully so that, when the two halves of the box are united, there will be no physical contact between components in the two halves. Tying all the wires going to the power supply into a cable not only gives a neat, professional appearance, but also helps prevent short circuits.

The line cord is brought into the case through an insulated strain relief. One side of the line is connected directly to *S1* and the other to *T2* through a single, ungrounded lug. Be very careful that neither side of the a. c. power line is grounded to the utility box.

When mounting *K1*, note that diode *D3* is wired directly to the coil terminals of the relay and is not on the printed circuit board. It is very easy to get the polarity of this diode wrong, so be very careful. In some applications the Freq-Out may be used to control power-line voltages, so the author mounted a multi-contact plug on the back of the case for the relay contact circuits. With this arrangement, there are never any current-carrying conductors exposed.

**Applications.** Most applications of the Freq-Out require only that it act as a simple switch which closes in the pres-

## HOW IT WORKS

**Modulator.** The basis for the light-beam modulator is a dual-buffer integrated circuit (Motorola MC788P). The addition of *R1*, *C1*, *R2*, and *C2* converts the IC into an astable multivibrator having a frequency of approximately 2 kHz. One of the buffered outputs of the oscillator is used to switch transistor *Q1* and its load, *L1*.

**Demodulator.** The modulated light beam striking *PC1* allows a varying current to flow in the low-Q, resonant circuit composed of *C1* and the primary of *T1*. This circuit is tuned to the operating frequency of the modulator. The output of *T1* is amplified in three stages which are designed to pass only frequencies above about 800 Hz. The output of the amplifier is detected and filtered by *D1* and *C9* before being used to turn on *SCR1*. Resistor *R14* provides a slight time delay in the voltage built up across *C9* to prevent relay chatter due to sudden transients. The SCR is a half-wave rectifier used to energize relay *K1*.

Resistors *R18* and *R17* are used to filter the power supply and also to decouple the photocell from the amplifier. Resistor *R18* also limits the current flow through *PC1* under high ambient light conditions.

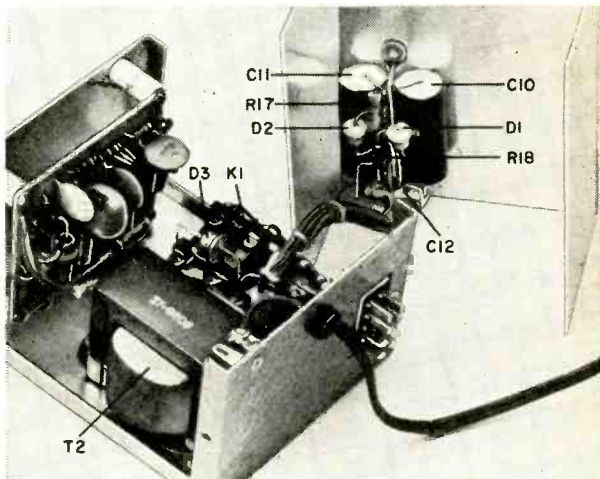

Assemble PC board and other components in the box as shown, with connector on one end for relay circuits.

ence of the modulated light beam and opens again when the light is interrupted. To use it as an electric door lock, connect one of the sets of normally open contacts on *K1* in series with a standard electric door-latch assembly. Locate the Freq-Out in a position where it can "look" out a window, but not too far from the key beam.

For some uses you may wish to have the electronic portion of the Freq-Out concealed in a closet or drawer and the photocell at some remote location. The

(Continued on page 116)



# Build NOISE BLANKER

Impulse noise suppressor  
can be added to any  
SWL, Ham or CB receiver

BY A. E. McGEE, Jr., K5LLI

**A**UTOMOBILE-IGNITION and electrical-impulse noise is a serious problem for the ham station operator or SWL who lives near a busy street. Most commercial receivers have noise clipping provisions, but the circuit used is not effective for SSB or CW operation. Some receivers have no noise limiter of any kind. If your receiver is deficient in this respect and if you are bothered by ignition noise or other noise created by electrical impulses, the "Audio Noise Blanker" is what you need.

The noise blanker works equally well with SSB, AM, and CW signals. It accepts a signal that is nearly indistinguishable because of impulse noise and makes it 90% readable. It is not necessary to modify your receiver; the noise blanker is connected between the low-impedance output of the receiver (3.2 to 16 ohms) and the speaker. The noise blanker itself requires no external power sup-

ply. An audio amplifier, which is used to raise the low-level output of the blanker to a comfortable speaker level, does require a power supply.

**Construction.** The circuit of the noise blanker is shown in Fig. 1. It can be assembled on a printed circuit board, on perf board, or with point-to-point wiring on multi-tab standoffs. The author's version, shown in Fig. 2, uses perf board. (Most of the board is taken up by the audio amplifier, which will not be described here since any type of circuit can be used. Even the compact audio modules available at low cost from any electronics distributor will do. Remember, however, that you must supply power for this audio amplifier.)

Transformer *T1* is a 50L6 audio output transformer, but any other type can be used if it has a low-impedance speaker winding and a 2000- to 5000-ohm pri-

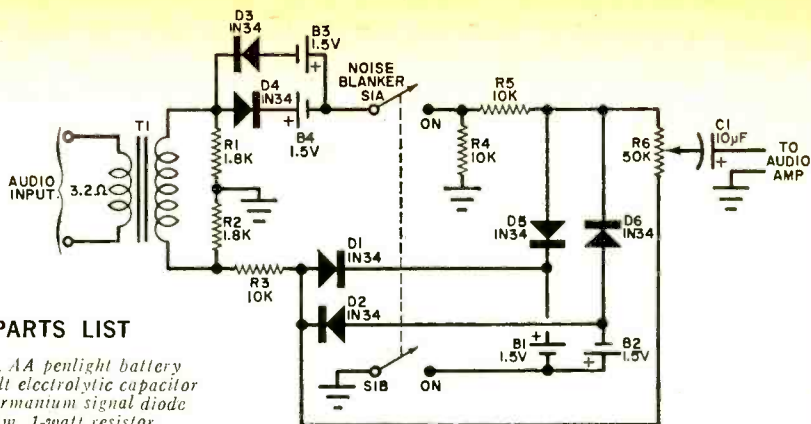

### PARTS LIST

- B1-B4—1½-volt, AA penlight battery  
 C1—10µF, 15-volt electrolytic capacitor  
 D1-D6—1N34 germanium signal diode  
 R1, R2—1800-ohm, 1-watt resistor  
 R3, R4, R5—10,000-ohm, ½-watt resistor  
 R6—50,000-ohm miniature potentiometer  
 S1—D.p.s.t. switch  
 T1—50L6 transformer (see text)  
 Misc.—Suitable perf board, PC board, or other wiring method, battery holders, chassis, hookup wire, etc.

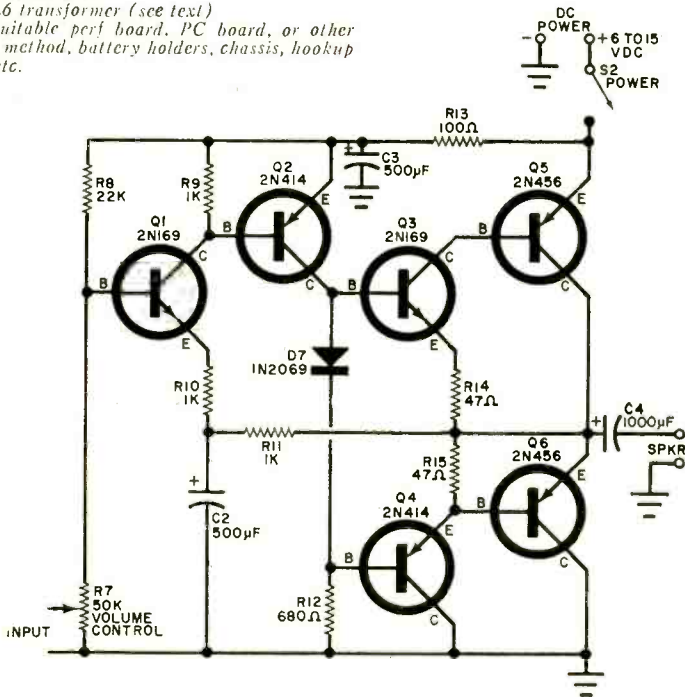

### PARTS LIST

- C2, C3—500-µF, 15-volt electrolytic capacitor  
 C4—1000-µF, 15-volt electrolytic capacitor  
 D7—1N2069 silicon rectifier diode  
 Q1, Q3—2N169 transistor  
 Q2, Q4—2N414 transistor  
 Q5, Q6—2N456 transistor  
 R7—50,000-ohm potentiometer  
 R8—22,000-ohm  
 R9, R10, R11—10,000-ohm  
 R12—680-ohm  
 R13—100-ohm  
 R14, R15—47-ohm  
 S2—S.p.s.t. switch

All resistors  
 ½-watt

Fig. 1. Diode circuits in the noise blanker (top) clip the audio input to eliminate noise represented by spikes. Clean signal is then amplified in the audio amplifier (bottom).



mary winding. Diodes *D1* through *D6* can be any general-purpose, germanium, signal units—such as 1N34. Be sure to observe the polarities on the diodes, and, when soldering, use a heat sink on the leads.

**Adjustment.** Balance potentiometer *R6* can be adjusted by ear, or, for more exact results, with an oscilloscope. Connect the low-impedance output of the receiver speaker to the blanker input (see Fig. 3) and connect the blanker output to the

audio amplifier. Turn on the receiver and the amplifier and place noise-blanker switch *S1* in the OFF position. Set the receiver volume control to its normal position and turn the audio amplifier gain up so that you can hear a signal. Adjust the Noise Blanker amplifier gain to a comfortable listening level and turn *S1* ON. Turn up the receiver volume control until the speaker output is very distorted. Adjust balance control *R6* until the audio output is at a minimum. This will be close to the mid-position of *R6*. Once

### HOW IT WORKS

Assume that a high-level noise pulse, whose amplitude greatly exceeds the blanking level, enters the system. After passing through transformer *T1*, where it is split into two identical signals 180° out-of-phase with each other, the signal takes two different paths as shown in the diagram.

In the lower path, the signal (waveform A) passes through a peak clipper consisting of diodes *D1* and *D2* which are connected in opposite polarity and are in parallel with the signal path and ground. When the noise-pulse amplitude reaches the voltage level equal to the reverse bias on the diodes, both diodes conduct and shunt everything above this level to ground. The truncated signal (waveform B) is then passed to potentiometer *R6*. This type of circuit is called a peak clipper, and similar circuits are found in many receivers.

The other input signal, waveform C, is fed to a base clipper consisting of a pair of diodes, *D3* and *D4*, connected in opposite polarity and in series with the signal path. The arrangement does

not allow the signal to pass until its amplitude exceeds the blanking level. The portion of the signal that exceeds the level (waveform D) is passed to a peak clipper consisting of reverse-biased diodes *D5* and *D6* which are connected in opposite polarity between signal and ground. Operation is the same as in the *D1*, *D2* peak clipper.

The two clipped output signals, waveforms B and E, are applied to opposite ends of balance potentiometer *R6*. If the rotor of this potentiometer is adjusted to receive signals of equal amplitude, the composite signal appearing as the audio output then looks like waveform F. Note that this signal contains far less power than the original input waveform, and even less power than a peak-clipped waveform.

The result is that, regardless of how great the noise is compared with the desired signal, any noise pulse that exceeds the blanking level will not only be greatly reduced, but will in fact have an audio power less than that of the desired signal. Thus the noise can hardly be heard.

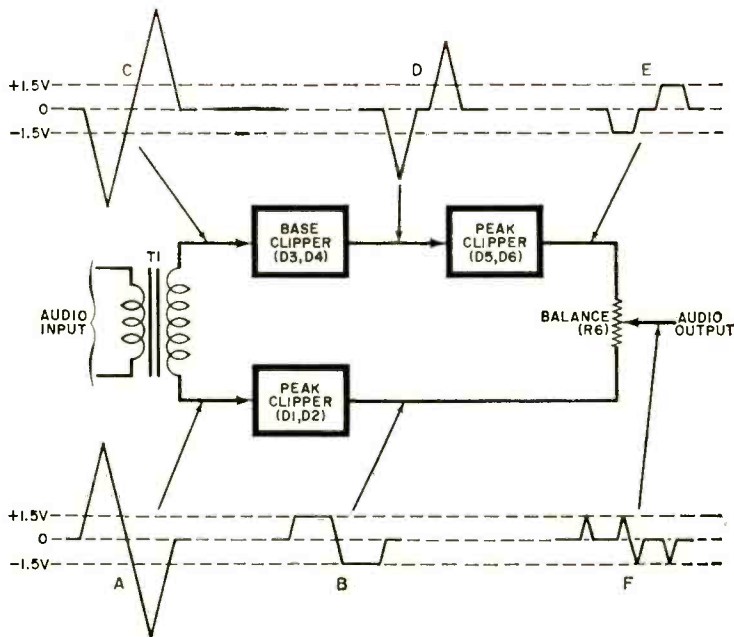

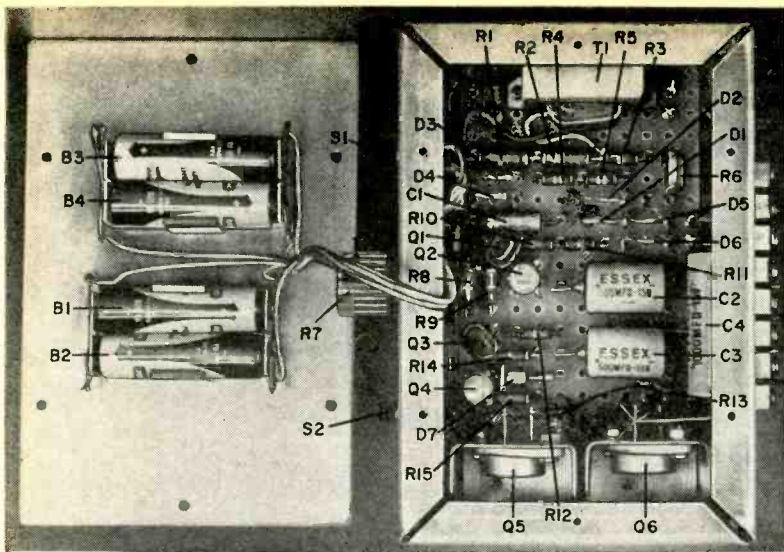
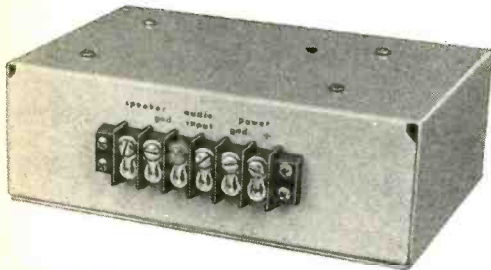

Fig. 2. In layout used by the author, much of the circuit is part of the audio amplifier. If a separate amplifier module is used, the blanker assembly is made smaller. Arrangement of components is not critical. The four batteries are for the noise blanker only. The amplifier requires a separate battery or a power-supply unit.



Connections to the circuit are made through a six-terminal barrier strip.

*R6* is adjusted, it will remain correct for a long period of time unless components age or are replaced.

**Operation.** Tune in a signal, set the external audio amplifier gain for a comfortable listening level, and advance the re-

ceiver volume control until some audio distortion is noticed. At this point, back off the receiver volume control slightly until the audio is clear. This means that the noise blanker is operating properly; the receiver volume control is now the blanking-level control, and the audio output level is controlled by the gain control on the Noise Blanker amplifier.

When you tune in very weak or very strong signals, the receiver volume control may need to be readjusted, depend-

ing on the effectiveness of the receiver a.g.c. system. If the receiver volume control is set too low, the noise blanker will not be as effective as desired; if the receiver audio control is too high, the desired audio will be distorted.

The noise blanker does not begin to work until the amplitude of the impulse noise is greater than that of the signal; it works best when the noise amplitude is several times that of the signal. Therefore, it is important that the noise pulse not be limited or suppressed by the receiver. In some cases, turning off the receiver a.g.c. may improve the noise suppression characteristics of the system.

The noise blanker has been used very successfully with a mobile SW receiver in an automobile having no ignition-noise suppression. In this case, reception with-

out the blanker was nearly impossible unless the signal was exceptionally strong. With the blanker, even the weakest signals are not bothered by the ignition noise.

Batteries *B1* through *B4* will last approximately as long as their shelf life since the current drawn by the reverse-biased diodes is only a few micro-amperes. Fresh batteries will last about a year before showing signs of leakage—an indication that they must be replaced.—30—



Fig. 3. The noise blanker connects between the receiver loudspeaker output and external audio amplifier.

# DREAM RECEIVERS

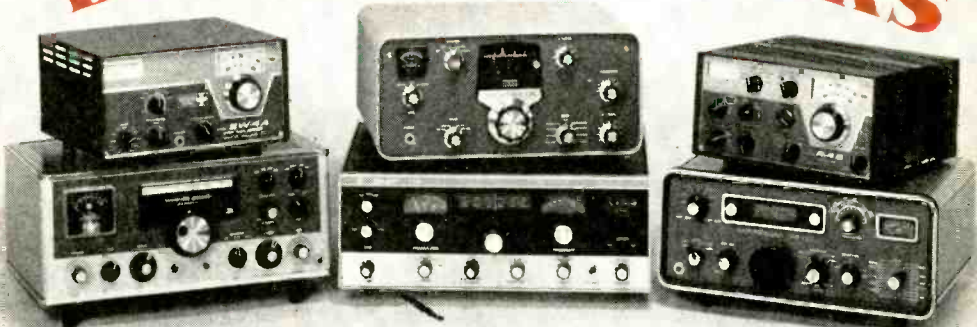

## FOR THE SWL

POPULAR ELECTRONICS LOOKS AT THE \$300-\$1200 CLASS  
AND FINDS SOME INTERESTING SURPRISES

BY OLIVER P. FERRELL

**S**HORT-WAVE LISTENING is one of the oldest forms of electronic experimentation. Although some people think that SWL'ing has seen its heyday, they are unaware of the growing importance attached to SWL'ing by scores of foreign countries. To the non-SWL, communism is remote and detached; but to the SWL, it is an ideology that is preached, practiced, and proclaimed each and every minute—from Havana to Tashkent and from Berlin to Peking.

Although Americans have little reason to believe that they are fed "prepared" news, there is a positive resurgence in SWL'ing among people who want to be informed. Obviously, some of the information broadcast on short waves is strictly propaganda, but the intensity of feeling and the magnitude of the undercurrent frequently tells more than words alone.

The quality of short-wave programming has improved vastly in the past few years; today the technique of deluging the listener with diatribe is largely reserved for Radio Peking. Almost all of the programs of the communist-bloc broadcasters have entertainment and cultural and informative value. Listeners' contests abound and only a few broadcasters don't publish program guides or encourage letters from listeners.

Of course, listening to the friendly and not-so-friendly broadcasters outside the communist bloc has its own rewards and fascination. While Radio Australia discusses the serious implications in Southeast Asia, Radio RSA justifies apartheid, and the Voice of Nigeria, the suppression of Biafra. For the SWL the events of the day are not words on a printed page.

**Getting on Frequency.** When short-wave broadcasters were fewer and schedules more haphazard, the necessity for the

In the photo above the receivers (reading from left to right, top and bottom) are: SW-4A, SS-1BS, SB-310, R-530, R-4B, and HQ-225.



## CAPSULE CIRCUIT INFO

**R.L. Drake SW-4A:** A hybrid (6 tubes, 7 transistors, 8 diodes) dual-conversion 11-band superhet tuning a mix of long wave (150-500 kHz), AM broadcast (450-1550 kHz), and international short-wave broadcasting bands (49, 41, 31, 25, 19, 16, 13, and 12 meters) in 500-kHz wide crystal-controlled segments. Fixed 5-kHz wide selectivity. No built-in calibrator, noise limiter, blanker, or provision for SSB/CW reception. Manual fine adjustment for dial calibration. \$289.00.

**R.L. Drake R-4B:** Big brother of the SW-4A, the R-4B is basically a 6-band ham receiver with provision to tune 10 additional 500-kHz wide segments between 1.5 and 30.0 MHz. (These could be the 120, 90, 60, 49, 31, 25, 19, 16, 13, and 12 meter bands.) Dual-conversion, the hybrid (10 tubes, 10 transistors, 2 IC's, 17 diodes) R-4B features a tunable pass-band filter with four selectivity positions (4.8, 2.4, 1.2, and 0.4 kHz). Built-in 25-kHz calibrator and noise blanking. Built-in tunable "notch" filter useful for attenuating interfering heterodynes. Tunable BFO for SSB and CW reception. Manual fine adjustment for dial calibration. \$430.00.

**Galaxy R-530:** All solid-state (52 transistors, 31 diodes) dual-conversion superhet with 59 tuning ranges each 500-kHz wide (0.5-30.5 MHz, inclusive). Unusual front-end design features first mixer fed by "phase-lock" oscillators. Operator manually presets desired 500-kHz tuning segment. Indicator tells when oscillators are locked and dial calibration is accurate. Three selectivity options (6.0, 2.1, and 0.5 kHz). Built-in 50-kHz calibrator. Reception of SSB and CW signals, crystal-controlled and variable BFO, respectively. Built-in noise blanking adjusted for SSB and CW. Adjustable attenuator in r.f. stage for preventing signal overload. Manual fine adjustment for dial calibration. \$695.00.

**Hammarlund HQ-225:** All solid-state (26 transistors, 15 diodes) dual-conversion superhet tuning 24 segments 200 kHz wide in the spectrum 3.4-30.0 MHz. Very similar to ham-band receiver HQ-215, but tuning 60, 49, 41, 31, 25, 19, 16, 13, and 12-meter bands. Built-in 100-kHz calibrator and self-adjusting noise limiter. Three selectivity options (6.0, 2.1, and 0.5 kHz). Reception of SSB and CW signals, crystal-controlled and variable BFO, respectively. Built-in tunable "notch" filter for heterodyne reduction. Manual fine adjustment for dial calibration. \$569.50.

**Heathkit SB-310:** A dual-conversion superhet (all tubes) with 9 tuning ranges each 500-kHz wide. As purchased, the SB-310 tunes 75, 49 (5.7-6.2 MHz as opposed to 6.0-6.5 MHz in all other receivers mentioned here), 41/40, 31, 25, 20 (ham), 19, 16, and 11 (CB) meter bands. Three selectivity options (5.0, 2.1, or 0.4 kHz). Built-in 100-kHz calibrator. No noise limiting or blanking. Reception of SSB and CW signals, crystal-controlled and variable BFO, respectively. \$249.00 (kit only). (Kit to substitute 13-meter band for CB also available from manufacturer.)

**Squires-Sanders SS-1BS:** Dual-conversion superhet (all tubes) custom-made and primarily designed for international and regional short-wave broadcast reception. Tunes 9 bands (75, 49, 41, 31, 25, 19, 16, 13, and 12 meters in 500-kHz wide segments), plus fixed tuned to 10.0 MHz WWV. Features unusual front-end circuit to attain freedom from cross-modulation and overload from nearby transmitters. Built-in three-position selectivity (8.0, 5.0, and 2.5 kHz). Built-in 100-kHz calibrator. Reception of SSB and CW signals, crystal-controlled and variable BFO, respectively. Built-in noise limiter for SSB and CW only. Noise silencer (outboard) optional, cost extra. Motor drive on tuning dial for fast frequency change. Digital-counter frequency readout—not adjustable. \$1225.00.

SWL to have an accurately calibrated receiver was minimal. But, as international broadcasters doubled, redoubled and tripled the number of watts pumped into the ionosphere, and as the number of stations quadrupled, receiver requirements began to change. Selectivity is now as important as—or more a necessity than—sensitivity. Calibration—knowing either the frequency on the receiver dial, or tuning to the frequency announced in the broadcaster's schedule—is rapidly becoming of paramount importance.

For years, SWL's have struggled with non-SWL bandsread dials, or out of sheer desperation have prepared graph calibrations to match arbitrary bandsread dial markings. Radio amateurs

have always been fortunate in having receivers more or less accurately calibrated to the five major ham bands. And in the early 1960's when a receiver manufacturer introduced a combination ham/SWL flipover, calibrated bandsread dial, it unfortunately was equally disliked by both hams and SWL's.

Accurate dial calibration is of little advantage if it is not augmented by stability. The best proven way of achieving this objective is through the use of a crystal-controlled oscillator. Thus, by its very nature, a good, rock-stable, accurately calibrated receiver—for either ham or SWL—must be dual conversion; one of the two mixing oscillators must be crystal controlled. Of course, attaining stability by this method also means that



Squires-Sanders IBS receiver has the eight main international broadcast bands calibrated on a slide rule dial. Figures visible in window are on digital rotary wheels and denote kilohertz. Three position selectivity control is also seen. This custom-made receiver is used by the VOA.

Hammarlund HQ-225 dial scale is printed on the edge of a large rotating wheel. Receiver tunes in 200-kHz segments. Knob to left of the scale is adjustment for positioning the hairline. Knob to the right is a dimmer control for dial lamps. Both HQ-225 and SS-IBS have smooth dial mechanisms and fingertip control.

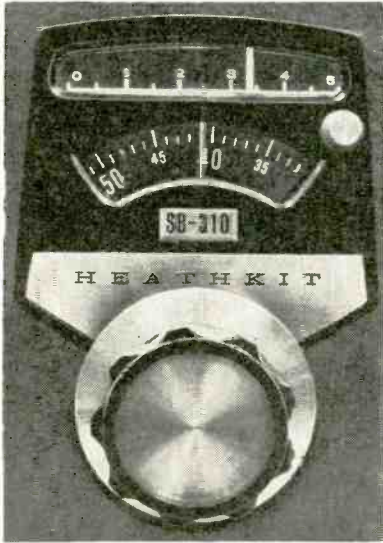

Using Heathkit SB-310 (left) the operator would read hundreds in top window and single kilohertz increments below. A full report on this kit was in the April 1968 issue of POPULAR ELECTRONICS.

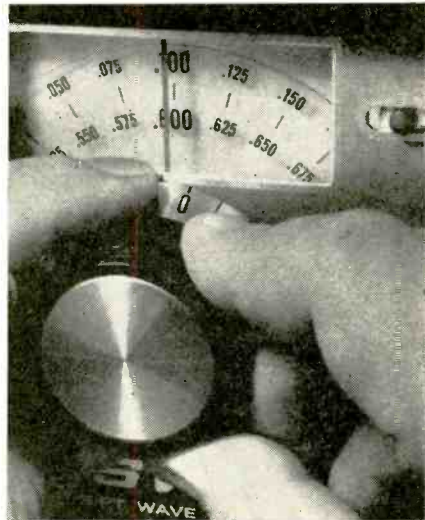
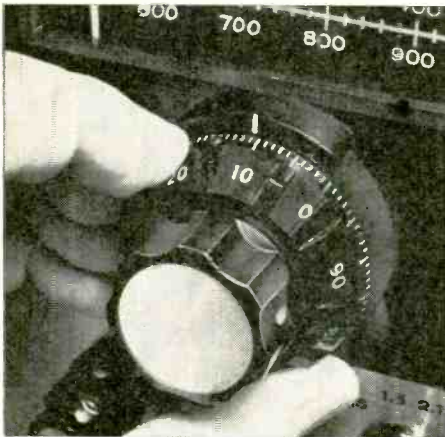

Two-speed dial knob is featured in brand-new Galaxy R-530. Skirt of knob reads in one kilohertz increments. Hairline may be shifted back and forth for adjusting dial calibration. The slide-rule dial above reads 0-500 or 500-1000.

Drake SW-4A and R-4B has two separate adjustments for setting dial accuracy. Hairline can be moved by button in upper right. Skirt of tuning knob may be slipped so that 0-25 scale agrees with hairline and pointer.



some limit must be set for the range of the tunable oscillator—since it is the dial of the tunable oscillator that will be linearly calibrated. In the receivers discussed in this article, the tunable limit is either 200 or 500 kHz. Thus, tuning ranges in “dream” receivers are sharply segmented and not 3 or 4 continuous bands as in receivers selling for under \$150.

**How They Do It.** The simplest and most direct approach to combining calibration accuracy, stability, and selectivity is seen in the Heathkit SB-310. The circuit in this receiver includes a crystal-controlled (9 selections) first oscillator and a carefully fabricated “Linear Master Oscillator” (LMO) as the 500-kHz calibrated second oscillator. The principal i.f. is 3.395 kHz and selectivity is a function of crystal filters. The nominal AM bandwidth is 5 kHz at -6 dB and 15 kHz at -60 dB. In tests, the SB-310 dial calibration was within  $\pm 1.0$  kHz.

The Drake SW-4A also employs a simple circuit, but with an entirely different approach. The fixed-frequency second oscillator is made crystal-controlled and the first oscillator frequency is the difference between another crystal stage (11 selections) and a tunable 500-kHz wide VFO. Selectivity is controlled by a crystal lattice between the two mixer stages and the two 455-kHz i.f. stages. Nominal bandwidth is 5 kHz at -6 dB and 16 kHz at -60 dB. Dial calibration of the SW-4A under test was better than  $\pm 1.5$  kHz.

The essential differences between the SW-4A and Drake R-4B are reflected in the number of crystal selections (16) and the special second i.f. of 50 kHz. Incorporated in the 50-kHz i.f. is a notch filter and a passband tuner of four high-Q LC circuits. Although this tuner and filter combination is basic to SSB reception, the SWL can make good use of them to “move out from under” interfering heterodynes in the international broadcast bands. Nominal AM selectivity on the R-4B is 4.8 kHz at -6 dB and 20 kHz at -60 dB, but the SWL may find the sharper 2.4 kHz at -6 dB (8.2 kHz at -60 dB) more advantageous. Dial calibration of the R-4B was better than  $\pm 1.5$  kHz.

The straightforward design of the SB-310 is refined in the new Hammar-

Jund HQ-225. Up to twenty-four crystals may be switched into the first oscillator circuit. The tunable second oscillator covers only 200 kHz, thus breaking the frequency spectrum into more segments and spreading the linear tuning scale over a considerable span. The second i.f. is 455 kHz and selectivity is controlled by Collins mechanical filters. The nominal AM selectivity is 6 kHz at -6 dB and about 13 kHz at -60 dB. Built into the HQ-225 is an “inverted” Q-multiplier which provides a tunable notch (40 dB deep) across the 455-kHz i.f. Dial calibration on the HQ-225 receiver that was tested by POPULAR ELECTRONICS was within  $\pm 0.5$  kHz.

If you took all of the essential ingredients in the SB-310 and HQ-225 and refined them to the Nth detail, you would probably come up with the Squires-Sanders IBS. Ten crystals set the frequency of the first oscillator while the second oscillator is a remarkably accurate and stable “Variable Local Oscillator” (VLO). Both mixers use the special 7360 beam deflection tube in balance output circuits. The second i.f. is at 1.0 MHz and selectivity is controlled by a multiple section 2.5-kHz crystal bandpass filter. A combination of high Q i.f. transformers and switch-selectable “bottom inductance” add the 5.0 and 8.0 kHz bandwidths. The nominal 5 kHz bandwidth is at -6dB and about 25 kHz at -60 dB; however on the sharper 2.5 kHz position, the -60 dB width is only 5.0 kHz. Dial calibration of the IBS was better than  $\pm 0.2$  kHz.

**Something New Has Been Added.** In each of the five receivers discussed above, the number of tuning ranges was limited by the number of crystals that could be switched into the first oscillator circuit. A method of avoiding this difficulty has been known for several years, but until the introduction of the Galaxy R-530, these receivers were both complex and very expensive. While the R-530 is far from uncomplicated, it does make use of a first oscillator circuit that provides 59 tuning ranges each 500-kHz wide. Calibration and stability of this first oscillator are achieved by beating two crystals and purposely generating a large number of difference-frequency harmonics. These harmonics (Galaxy calls this





One revolution of SS-1BS dial tunes 10 kHz. Rapid frequency shifting possible with motor drive. Buttons on right goes up frequency, left button down.

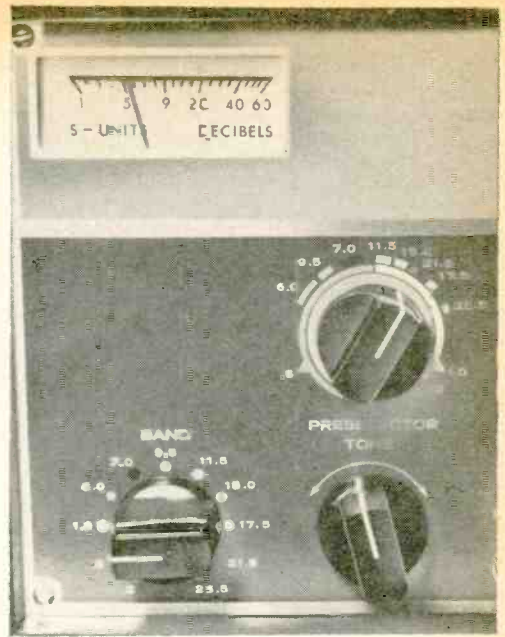
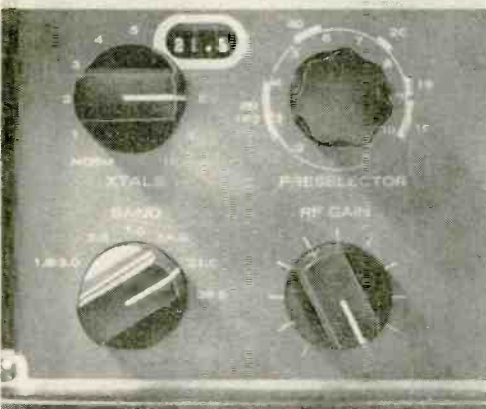

Controls on SW-4A are few and far between. Eleven tuning ranges are identified by dots and bars in various colors. The SW-4A was the only one of group with a tone control.

Drake R-4B (left) is a ham band receiver, with provision to tune 10 additional 500 kHz segments. Band identification appears in peek-a-boo window as switch labelled XTALS is rotated. Put switch is NORM position and R-4B reverts to ham receiver.

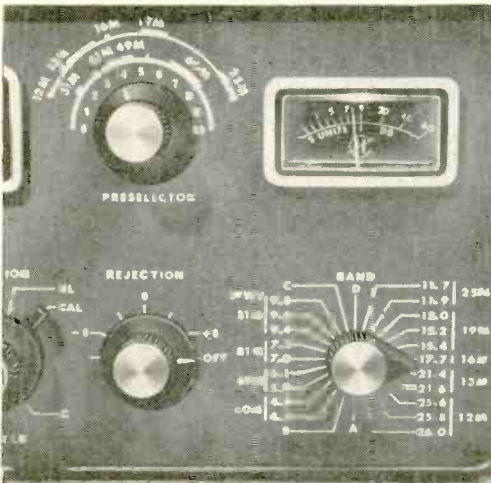

Hammarlund HQ-225 has busy-looking bandswitch because it tunes 200-kHz segments to provide extra bandspread. Control REJECTION kills heterodynes.

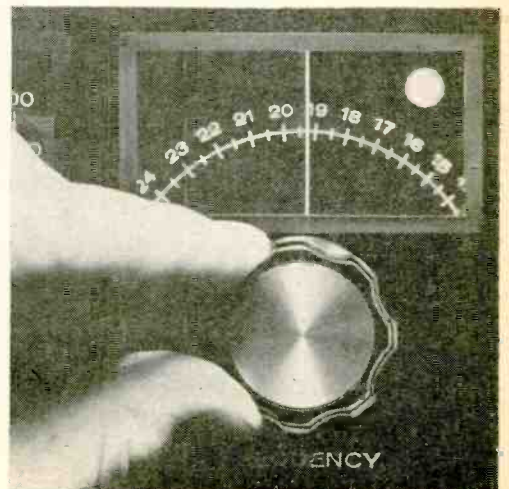

Galaxy R-530 uses "phase lock" principle to set 59 separate tuning bands each 500 kHz wide. The R-530 is the only all-band SWL receiver reported on in this article.

## THERE ARE OTHERS

This article was written to emphasize the trend toward specialized SWL receivers. Similar products are offered by other manufacturers. The National HRO-500 (see *POPULAR ELECTRONICS*, August, 1965) and the two Collins receivers (51S-1 and 75S-3C) are particularly good examples.

A wide variety of medium-priced communications receivers is available to the SWL from Allied Radio, Hallicrafters, Lafayette Electronics, and Radio Shack.

a "Spectrum Generator") are used to establish accurately the true frequency of a tunable oscillator that is really the first oscillator. The principle of finding the right harmonic is called "phase lock."

Once the first oscillator frequency has been chosen, the remainder of the R-530 circuit is largely straightforward. The second oscillator is tunable and the i.f. is at 9.0 MHz. Selectivity is a function of crystal lattice filters with the nominal AM filter 5 kHz at -6 dB. Dial calibration on the R-530 tested was about  $\pm$  1.0 kHz on most bands.

**Likes and Dislikes.** For various periods of time, ranging from a few days to several months, each receiver discussed in this article was put through its paces. Our logs show the reception of 78 countries on the international broadcasting bands between April 1 and July 30. Here are a few subjective opinions about this equipment.

*Liked:* The slide-rule dial scale of the SS-IBS—the one receiver truly calibrated for the SWL. *Liked:* Soft lighting and ease of handling of the SW-4A—simplicity personified. *Disliked:* Lack of pre-selector band identification on the SB-310. *Disliked:* Stiff dial mechanism of the R-530—although this may have been due to the "newness" of the receiver tested. *Liked:* S-meter honesty of the SS-IBS, SW-4A, an R-4B. *Disliked:* Touchy pre-selector tuning on HQ-225—could have used a vernier drive here. *Liked:* Ease of tuning in SSB on SS-IBS—smoothest receiver of all. *Liked:* HQ-225 where receiving antenna was disconnected when tuning for crystal calibrator harmonics. *Liked:* All receivers with headphone jack on front panel—although R-4B recently

moved this jack to side of receiver, user can rewire it to front panel. *Liked:* Notch and pass-band controls on R-4B—just great when you have two signals only 5 kHz apart. *Disliked:* Total absence of noise limiting or blanking on SW-4A and SB-310—a great shame since not every listener has an electrically quiet receiving location.

*Disliked:* Outboard noise silencer (optional, cost extra) for SS-IBS—cranky. *Liked:* Modern functional styling of HQ-225—a very attractive piece of equipment. *Liked:* All band coverage of R-530—gives the SWL a chance to tune something other than broadcasters. *Disliked:* Low frequency coverage of SW-4A—appears to lack the signal punch expected for a receiver of this capability. *Liked:* Instant warm-up of R-530 and HQ-225—a by-product of use of solid-state units. *Liked:* Tuning the ham bands on the R-530, R-4B, and SB-310.

*Disliked:* Tuning knob on HQ-225—definitely needs fluted edges. *Liked:* AM broadcast-band coverage of the R-530 and SW-4A. *Liked:* Sharp, clean voice quality of SB-310 audio—great on ham bands. *Liked:* Tuning knobs sufficiently free to be spun with a fingertip (HQ-225 and SS-IBS). *Disliked:* Peek-a-boo window for band identification on R-4B. *Liked:* Motor drive on SS-IBS tuning dial—a luxury, but proved itself handy. *Liked:* All receivers with main tuning dial to the right and preselector dial to the left—especially for right-handed people. *Disliked:* Complete lack of band identification on bandswitch of SS-IBS.

**The Next Generation.** Not too much is missing from this combination of SWL receivers that they shouldn't fail to please the earnest DX'er, or even the casual listener. However, selectivity should be wider than 2.5 or 2.1 kHz—but not as wide as 5 or 6 kHz. To the author, a compromise selectivity of 3.5 or 4.0 kHz would be welcomed—or, if and when the technology permits, a truly variable selectivity function permitting the operator to vary selectivity continuously to suit the frequency and the interference.

Also, since most SWL's use two or three antennas, a front-panel selector switch for antenna changeover would be a very worthwhile addition. —30—



# SEALED-REFLEX

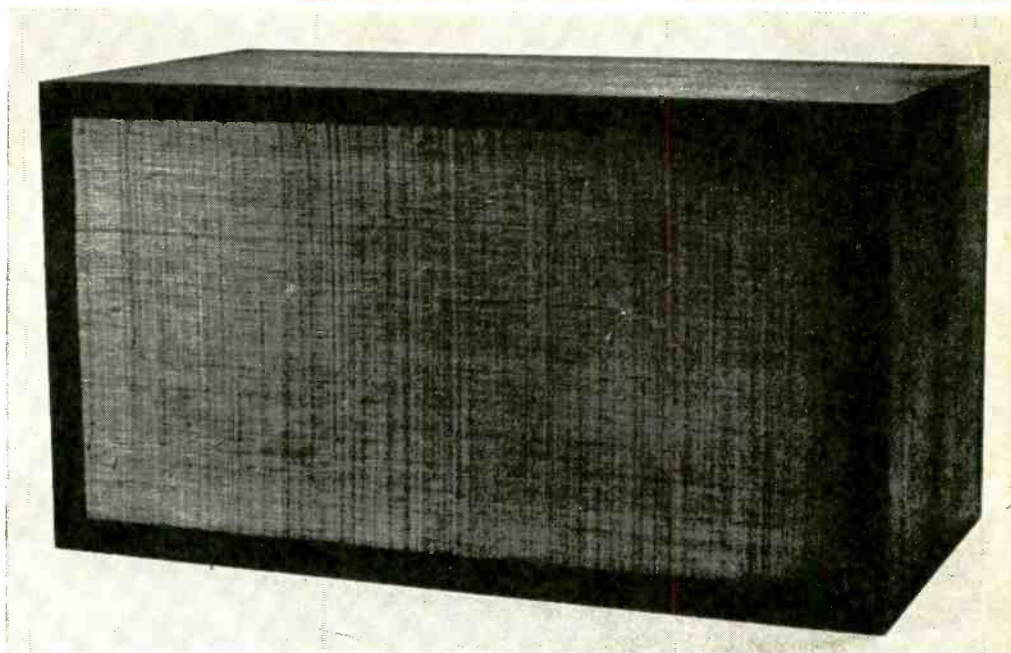

## SPEAKER SYSTEM

*Build something new in hi-fi—a passive radiator that provides better bass, dynamics, and efficiency*

BY DAVID B. WEEMS

**I**F YOU'VE BEEN PLANNING to build a compact speaker system but can't decide between using a bass reflex or a sealed enclosure, why not build a sealed reflex? By adding an extra "speaker cone" to your enclosure, you can obtain increased bass performance without using ducts or ports.

Experiments to add "free" bass performance have been going on for more than 15 years in projects called by such names as "drone cone," "auxiliary bass radiator," and "passive radiator." The common denominator of each of these projects has been the addition of a freely suspended speaker cone (speaker minus its magnet assembly and voice coil) to a sealed enclosure. Some of the results obtained from these experiments have giv-

en rise to the sealed-reflex speaker system described here. The system consists of a full-range 8" loudspeaker and a complementary cone which the manufacturer, James B. Lansing, terms a "passive radiator."

**About the System.** The sealed reflex offers several advantages over the conventional compact speaker system. Noticeably improved bass response is possible in the sealed enclosure with the use of a passive radiator. While an ordinary bass reflex will provide approximately the same results, there are a few differences.

The air in the port of a bass-reflex system does not necessarily move in phase with the movement of the speaker cone at all frequencies nor even at all



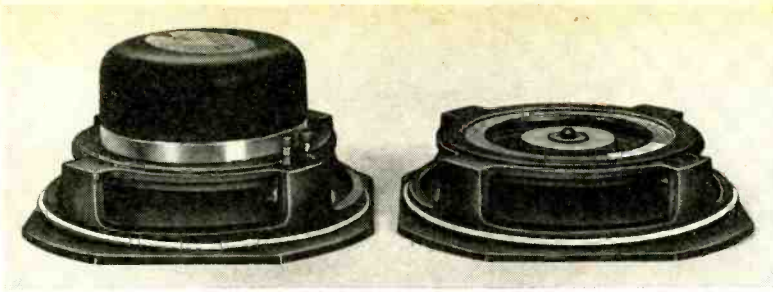

The PR8 (right) is nothing more than heavy speaker cone without voice coil and magnet. Cone is tuned by adding circular weights.

points across the port. The passive radiator, on the other hand, maintains an in-phase movement of air over its entire surface and throughout its effective range. Thus the possibility of unwanted mid-range reflections through an open port is eliminated. Proponents of the sealed-reflex system claim that it gives a "warmer" tonal quality to the sound than does the bass-reflex system.

Any cone mounted inside a sealed enclosure produces extra bass at some frequencies, but its range and freedom from distortion are determined by the mass and suspension of the cone. The suspension must be linear and compliant because the passive radiator, having no electromagnetic control, moves much farther than a driven speaker's cone. The JBL passive radiator, Model PR8, used in this system, was designed for free movement and is tunable to various en-

closure sizes by a change in its mass. When used with the JBL Model LE8T complementary 8" loudspeaker it is possible to obtain low-distortion wide-range response with greater efficiency and dynamic range than with the usual compact speaker system.

**Construction.** The enclosure for the passive radiator system features unitized construction; each wall of the enclosure is permanently bonded and sealed to the other walls. This procedure is possible because the speakers are front mounting. The hardware (T-nuts and machine screws) for the speakers is supplied.

To achieve a clean professional appearance when assembling the enclosure, bevel the mating edges of the top, bottom, and two side plates at a 45° angle. Leave the front and rear edges of these plates square. If you have no facilities in

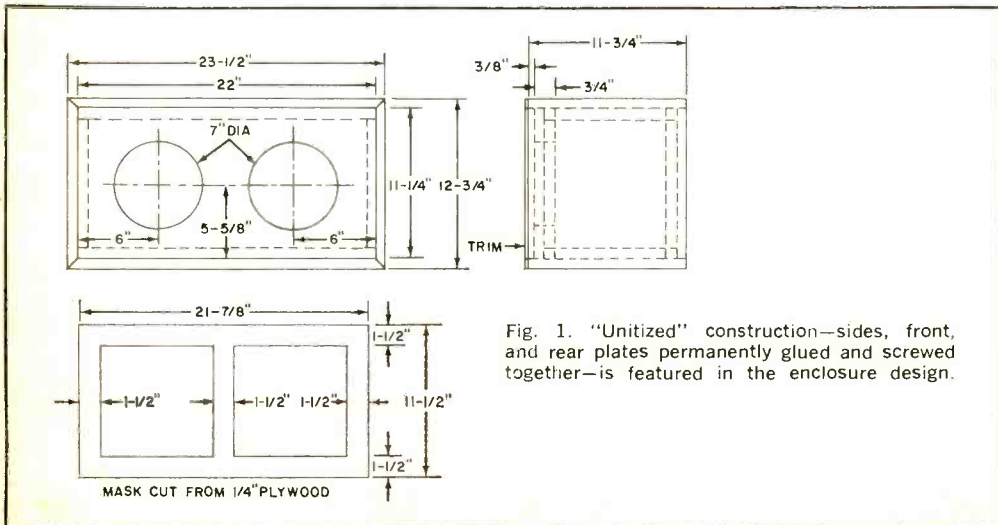

Fig. 1. "Unitized" construction—sides, front, and rear plates permanently glued and screwed together—is featured in the enclosure design.

your workshop for making the beveled edges, be sure to adjust the sizes of the plates used so that the enclosure has the same inside dimensions called out in Fig. 1.

After cutting the lumber to size, prepare the speaker mounting board as follows. First cut the two 7"-diameter speaker holes. Then drill  $\frac{11}{64}$ " guide holes every 4" apart and  $\frac{3}{8}$ " in from the edges of the mounting board. Temporarily set the speakers into the holes from the *front* of the board and mark the location of the mounting holes. Remove the speakers.

Now, carefully drill the mounting holes at 90° angles to the surface of the board (if you have a drill press, use it) with a  $\frac{7}{32}$ " or  $\frac{15}{64}$ " drill. Install the T-nuts by driving them into the holes from the *inside* surface of the board.

Replace the speakers into their respective holes, and temporarily screw in the machine screws to check for proper fit. Finally, remove the hardware and speakers and set the speakers aside in a safe place. When handling the speakers, be careful not to touch the cones or aluminum domes.

Prepare the rear plate by drilling  $\frac{11}{64}$ " guide holes every 4" around the edges, recessing them  $\frac{3}{8}$ " in from the edges as done with the speaker mounting board. Drill two small holes near the center of this plate, and insert two tight-fitting bolts to serve as terminals for connection to the speaker. Code the bolts by

using one brass and one steel bolt, or by some other method so that you can identify the polarity of the speaker. Connect a 24" length of twin-lead cable to the screws.

Next, cut the cleats and corner blocks to size, and drill  $\frac{11}{64}$ " holes, along their center lines, in one direction every 4" apart. Set the cleats aside, and drill the same size holes through the corner blocks in the other direction every 4" apart; alternate these new holes with those already drilled. (The  $\frac{11}{64}$ " guide holes should be used only in a construction member that holds the head of the screw. Use  $\frac{7}{64}$ " or  $\frac{1}{8}$ " guide holes for the part receiving the threads. Also, countersink all  $\frac{11}{64}$ " holes to provide a flush surface over the screw heads.)

The quickest and most efficient way to obtain a good seal is to use glue liberally between all surfaces to be joined. Therefore, glue and screw the long cleats to the long sides, leaving a margin of  $\frac{3}{4}$ "

#### BILL OF MATERIALS

- 1—James B. Lansing Model LEST 8" loud-speaker\*
- 1—James B. Lansing Model PR8 8" passive radiator\*
- 2— $23\frac{1}{2}$ " x  $11\frac{3}{4}$ " x  $\frac{3}{4}$ " pieces of interior-grade plywood for sides
- 2— $12\frac{3}{4}$ " x  $11\frac{3}{4}$ " x  $\frac{3}{4}$ " pieces of interior-grade plywood for top and bottom plates
- 2— $22$ " x  $11\frac{1}{4}$ " x  $\frac{3}{4}$ " pieces of interior-grade plywood for speaker mounting board and rear plate
- 1— $21\frac{3}{8}$ " x  $11\frac{1}{8}$ " x  $\frac{1}{4}$ " piece of plywood for mask; see text
- 4— $22$ " x  $\frac{3}{4}$ " x  $\frac{3}{4}$ " pieces of pine for side cleats
- 4— $9\frac{3}{4}$ " x  $\frac{3}{4}$ " x  $\frac{3}{4}$ " pieces of pine for top and bottom cleats
- 4— $8\frac{3}{8}$ " x  $\frac{3}{4}$ " x  $\frac{3}{4}$ " pieces of pine for corner blocks
- Misc.— $\frac{3}{4}$ "-wide trim cut to size; 6-doz. #8 flat-head wood screws; glue; fiberglass wool; carpet tacks; grille cloth; two-conductor cable; stain; etc.

\*James B. Lansing loudspeaker and passive radiator are available from most well-stocked hi-fi centers or can be ordered through franchised JBL retailers.

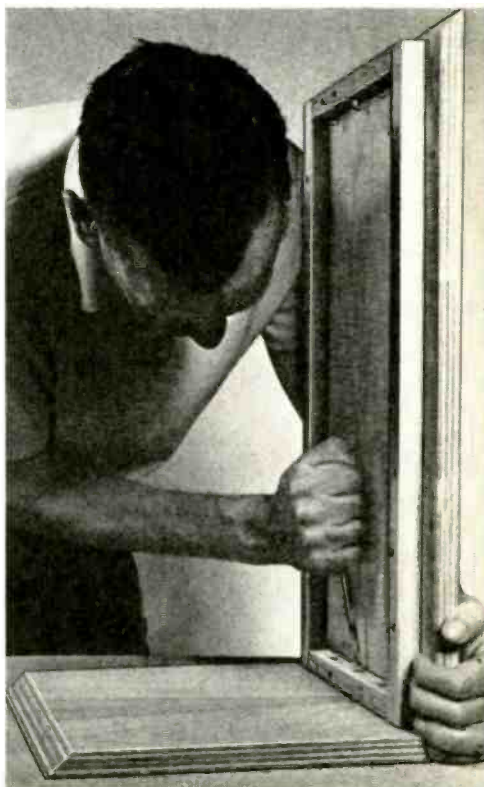

Fig. 2. Corner blocks, drilled in two directions, must be used to anchor sides to top and bottom.

**“He’s a good worker.  
I’d promote him  
right now if he had  
more education  
in electronics.”**



## **Could they be talking about you?**

You'll miss a lot of opportunities if you try to get along in the electronics industry without an advanced education. Many doors will be closed to you, and no amount of hard work will open them.

But you can build a rewarding career if you supplement your experience with specialized knowledge of one of the key areas of electronics. As a specialist, you will enjoy security, excellent pay, and the kind of future you want for yourself and your family.

Going back to school isn't easy for a man with a

full-time job and family obligations. But CREI Home Study Programs make it possible for you to get the additional education you need without attending classes. You study at home, at your own pace, on your own schedule. You study with the assurance that what you learn can be applied to the job immediately.

CREI Programs cover all important areas of electronics including communications, radar and sonar, even missile and spacecraft guidance. You're sure to find a program that fits your career objectives.





You're eligible for a CREI Program if you work in electronics and have a high school education. Our FREE book gives complete information. Airmail postpaid card for your copy. If card is detached, use coupon at right or write. CREI, Dept. 1210G, 3224 16th St., N.W., Washington, D.C. 20010.



**CREI, Home Study Division  
McGraw-Hill Book Company  
Dept. 1210G, 3224 Sixteenth Street, N.W.  
Washington, D.C. 20010**

Please send me FREE book describing CREI Programs. I am employed in electronics and have a high school education.

NAME \_\_\_\_\_ AGE \_\_\_\_\_

ADDRESS \_\_\_\_\_

CITY \_\_\_\_\_ STATE \_\_\_\_\_ ZIP CODE \_\_\_\_\_

EMPLOYED BY \_\_\_\_\_

TYPE OF PRESENT WORK \_\_\_\_\_  G.I. BILL

- I am interested in  Electronic Engineering Technology  
 Space Electronics  Nuclear Engineering Technology  
 Industrial Electronics for Automation  
 Computer Systems Technology

**APPROVED FOR TRAINING UNDER NEW G.I. BILL**



Fig. 3. Two screws, inserted through rear of enclosure, serve as electrical connections.

at the rear and  $1\frac{1}{8}$ " at the front. Do the same with the corner blocks.

Set up a long side and either the top or bottom plate with the beveled edges matching. Mark the points where the screws from the corner block will enter the top or bottom plate. Drill the small guide holes about  $\frac{3}{8}$ " deep at these locations. Glue and screw the two pieces together (see Fig. 2), and repeat this process until both sides and top and bottom are assembled.

Now glue and screw the  $9\frac{3}{4}$ " cleats to the top and bottom plates. These cleats must fit snugly between the longer cleats to prevent air leaks when the enclosure is fully assembled. Glue and screw the rear plate in place as shown in Fig. 3.

#### PASSIVE RADIATOR TUNING TABLE

0.75-1.0 cu. ft.	use two discs
1.0-1.5 cu. ft.	use one disc
1.5-2.0 cu. ft.	use no discs

Line the top, bottom, sides and rear wall of the enclosure with a 2"-thick layer of acoustical fiberglass. Glue and screw the speaker mounting board to the front of the enclosure. This board should be recessed from the front edges of the enclosure by approximately  $\frac{1}{8}$ " at this time.

Cut four pieces of  $\frac{3}{4}$ "-wide wood trim to size, and frame the front edges of the enclosure; use glue to hold the trim in place. Sand and stain all outer surfaces—except speaker mounting board. If you use wider trim, it should be secured as the final step in assembly when the grille cloth is in place.

Before mounting the passive radiator, remove the screw that anchors the discs at the rear of the radiator. Remove one of the discs. Then reassemble one disc, the large washer, the small lock washer, and the screw in proper sequence, and tighten the screw back in place—but don't over tighten. The passive radiator is now tuned to the enclosure.

Connect the speaker cable to the speaker, taking care to note polarity. Mount the passive radiator and speaker in their respective holes as shown in Fig. 4. You will notice that the edges of the speakers protrude about  $\frac{1}{4}$ " in front of the speaker mounting board. For this reason it is necessary to fabricate a mask from  $\frac{1}{4}$ "-thick plywood, following the dimensions provided in Fig. 1. This mask should be slightly smaller than the speaker mounting board—how much smaller will be determined by the thickness of the grille cloth.

Drive several  $\frac{5}{8}$ " carpet tacks through the front of the mask. Set the side of the mask with the tack heads showing over the grille cloth, fold the edges of the grille cloth over the edges of the mask, and staple. Set the mask over the speakers, pushing the tacks into the speaker mounting board to anchor it solidly. If you are using larger than  $\frac{3}{4}$ "-wide trim, now is the time to glue it in place.

**Conclusion.** This enclosure offers a good compromise between space and performance requirements. The LEST/PR8 combination can be used in any enclosure from less than one cubic foot to two cubic feet in volume. According to JBL, a two-cubic-foot passive radiator system



Fig. 4. T-nuts and machine screws are provided to facilitate passive radiator and loudspeaker mounting. Note that the LE8T and PR8 are designed for mounting through the front of the speaker mounting board.

#### HOW DOES IT SOUND?

This is probably the most expensive hi-fi speaker-system construction project published in POPULAR ELECTRONICS. The author and his colleagues all report that the sound from the JBL LE8T-PR8 combination is "pleasing." The bass may be less heavy than in certain other compact systems (selling at about the same price this system costs to build), but it seems natural. Transient response is particularly good and there is little doubt this system has the "edge" in dynamic range. In fact, this combination is thought to be more lively than a well-known system selling for \$25 more than construction costs. There is a feeling of "warmth" of tone in the sound—especially in the reproduction of the lower string notes.

will equal the performance of a four- or five-cubic-foot bass reflex system. If you wish to use a different size enclosure, tune the passive radiator according to the table shown on page 66.

Although the tuning specifications specified are those recommended by JBL, you can vary them to match your own tastes. You might also want to experiment with more or less fiberglass padding. When you obtain the quality of sound you want, you're in business. The sealed reflex system will handle up to 20 watts of power but it is efficient and may be used with a low-power amplifier.

-30-

#### PROFESSIONAL SOUND CALCULATOR

The Jensen Sound Products "Professional Sound Calculator I" shown in the photo at right can make short work of problem solving when you are designing loudspeaker system installations. The sliderule calculator converts sound pressure in dynes/sq cm to sound pressure level (SPL) in dB and computes SPL, distance, or power input to loudspeakers for known conditions. "Range Expander" and "Summation" tables show SPL changes for large distance and power ratios, and total SPL for two known signal levels, respectively. Detailed procedures on the front and back of the 7½"-long calculator describe how typical computations are performed. Precision in the results obtained

from the sound calculator are more than adequate for most problems encountered. To obtain the calculator and instructions describing how to use it, send \$1 to Jensen Manufacturing Division, Muter Company, 5655 West 73 St., Chicago, Ill. 60638.

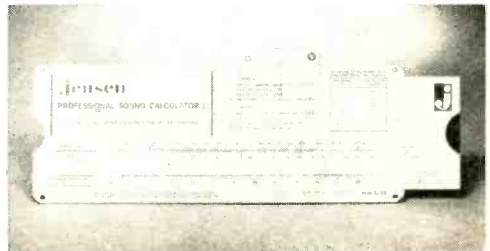



# Transient Voltage Quiz

BY ROBERT P. BALIN

Voltages in circuits containing capacitors increase or decrease as the capacitors charge and discharge. These transient voltages may be useful or destructive depending on where or when they occur. To test your knowledge of how transients develop and decay, match the circuits (1-10) to the output voltages (A-J). In each case, the switch is held in position 1 until a steady state is reached, then in position 2 for the same length of time. Don't consider differences in component values.

(Answers on page 104)

<p>1. _____</p>	<p>2. _____</p>	<p>A</p>	<p>B</p>
<p>3. _____</p>	<p>4. _____</p>	<p>C</p>	<p>D</p>
<p>5. _____</p>	<p>6. _____</p>	<p>E</p>	<p>F</p>
<p>7. _____</p>	<p>8. _____</p>	<p>G</p>	<p>H</p>
<p>9. _____</p>	<p>10. _____</p>	<p>I</p>	<p>J</p>



# MAKING PC BOARDS FROM THE PRINTED PAGE



**Low-cost photocopying method  
can be used by experimenter**

**D**UPLICATING PRINTED-CIRCUIT foil patterns for home-built construction projects has always been a laborious chore. Some experimenters try painfully to duplicate the foil pattern on a PC board using liquid resist and a sharp pen, only to find that it is not as easy as it appears at first glance. Others prefer the trusty razor blade and a set of stick-down strips and dots. Both of these systems are tiresome and seldom produce a pattern that looks like the one in the magazine. By the time a PC board has been redone a couple of times, a lot of project interest goes down the drain. This is why many novice experimenters invest in a commercially etched and drilled printed board usually made available with many projects.

Now, with just a little painting skill, a simple piece of homemade equipment, and a few easily available chemicals, you can fabricate a printed board that will look exactly like the one in the magazine in a very short time.

The heart of this process is a new photo-sensitive resist that comes in a pressurized aerosol can and is simply sprayed on a clean, cut-to-size copperclad board. Because this resist is sensitive to the ultra-violet portion of the spectrum it can be handled in subdued lighting, and it is not necessary to have a photographic darkroom. There are no critical temperatures to worry about.

**Equipment Required.** The basic chemicals were developed for industrial application by the Dynachem Corp., and you will need their photo resist (in a 16-oz aerosol can, \$5), dye (also in a 16-oz aerosol can, \$2.50), and developer (in a gallon can, \$2.50). These are available from any Dynachem representative shown in the table. The basic kit will suffice for about 25 square feet of PC board—enough for quite a large number of circuits. Also available is a Photo Resist Trial Kit (\$5) that includes reduced proportions of photo resist, dye, devel-

**by Thomas R. Rosica**  
Sylvania Entertainment Products

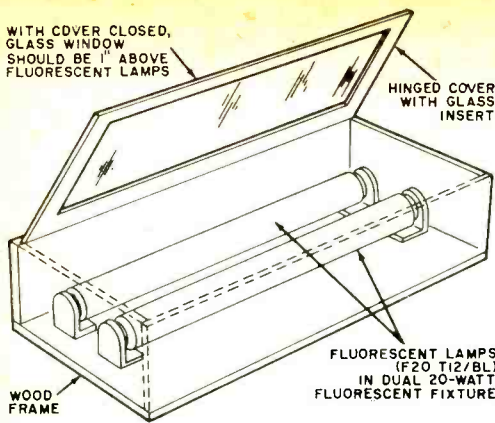

Fig. 1. Suggested printing frame houses the two UV fluorescent lamps and their associated circuitry.

oper, a developing tray, a test negative, three copper-clad boards, and a set of instructions.

You will also need a source rich in ultra-violet light to expose the photo resist. This source can be a high-intensity light source, a mercury-vapor lamp, or a pair of low-cost black-light fluorescent lamps (Sylvania F20 T12/BL) available at most electrical supply houses. A pair of these lamps, mounted side-by-side in a conventional two-lamp 20-watt fluorescent fixture, can properly expose a PC board in three minutes.

Although not essential, a printing frame can be built to simplify the procedure. This consists of a wooden frame housing the dual-lamp fixture, with a window-glass cover that can be set one-inch above the lamps. The basic arrangement is shown in Fig. 1. Otherwise, the negative and the treated PC board can be "sandwiched" between a pair of glass sheets held together with rubber bands.

**Preparing the Negative.** To make a negative of the foil pattern as it appears in the magazine, you can either have a photographer make a negative (on a transparent background), or you can make your own negative using opaque paint on a sheet of thin clear acetate (available at all art stores). If you make your own negative, place the sheet of acetate over the foil pattern as it appears in the article; then using the opaque paint and a fine-pointed brush, carefully cover all the areas in which the copper

has to be removed. Always remember, you are making a negative, so the parts to be left copper must be transparent, while the parts to be etched away must be opaque. Because the art work in the magazine is usually black, use a contrasting color of opaque paint for drawing clarity. Don't forget a tiny dot of color where holes will have to be drilled through the foil. A razor blade edge can be used to "clean up" any slight mistakes. India ink is not recommended, as it may bead on most plastics and may not produce a sufficiently opaque coating. A typical sequence is illustrated in Fig. 2. While the paint is drying, prepare the copper-clad board.

**Preparing The Board.** Cut the PC board so that the entire circuit, plus a small border, will fit within the area. Thoroughly clean the copper surface using a household abrasive (not a detergent, as the wetting agents in the detergent may form a film which might hinder further applications). You can use a piece of fine steel wool for the cleaning. Once the copper surface has been cleaned, let it dry and from then on handle the copper-clad board only by its edges to avoid contaminating the shiny copper surface with natural body oils. You can lay the cleaned board on a sheet of cardboard if you have to move it around.

The board can now be coated with the photo resist. This should be done in a semi-dark room illuminated by a 40-watt incandescent lamp at least eight feet away. A yellow bug lamp, or a photographic safe lamp is fine. Place a sheet of newspaper behind the board to prevent the aerosol spray from getting on any other surface. Shake the can of photo resist to stir the contents, then spray the copper surface of the board from a distance of 6 to 8 inches. The coating should be as uniform as possible. Try to avoid having any running droplets. After coating, keep the board away from any other light and allow it to dry to a tack-free consistency. To speed up the drying process, place the board in an oven set for 115°F for about 15 minutes. Then remove the board from the oven and allow it to cool. Keep the area reasonably dark during this process and don't allow any light to fall on the board. Remember that the board is now light sensitive.





Fig. 2. If you are making your own negative, the first step in preparing a PC board is to place a piece of transparent plastic over the foil pattern. Using opaque paint, fill in areas where copper is to be removed. When it is completed, . . .

. . . the plastic sheet will look like this. Don't forget to put a small dot of paint at each component mounting hole. Use the method described in the text to expose and dye the PC board. After etching is done, . . .

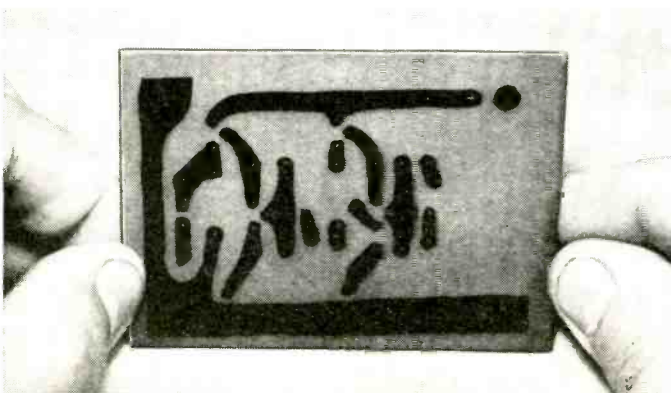
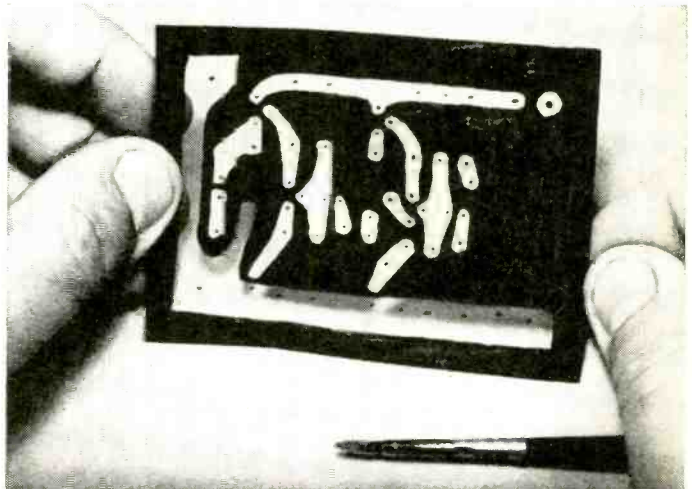

. . . the finished board will be an exact duplicate of the one in the magazine. The foil will be covered with black resist. Use steel wool to remove the dyed resist from the copper. Drill the required mounting holes and assemble components.

**Determining Exposure Time.** If a light source other than the F20 T12/BL fluorescent lamps is to be used, the required exposure time will have to be determined. To do this, take a small piece of scrap PC board and spray it with the photo resist. (Don't forget about the safe light!) Then take a spare piece of the transparent acetate, and using the opaque paint, make a small design (cross, circle, etc.) on it. After the board has dried completely, lay the design over it and expose the pair to the light source at some fixed, close distance, for 2 minutes. Then place the exposed board on the developer for about 30 seconds, remove, and spray it with the black dye. Allow the dye to remain for a few seconds, then wash the board in running cold water. This not only stops development, but enables you to see the condition of the pattern on the board in normal room light. At this point, the board is no longer light sensitive. The dyed pattern should be clean and true. If not, dip the board back into the developer and wipe it clean. Reclean and dry the board, go back to the safe light, and repeat the exposure process lengthening the exposure time by one minute, until you get a good, clean pattern of resist. In this way, you will be able to determine the optimum exposure time for the light source and distance you are using. Record the type of light source, distance between the light and the board, and the optimum exposure time required. This will be used whenever you make a printed circuit board using that light source.

**Making The Board.** With the light source turned off, lay the foil negative on the light-frame window. Remember that the magazine usually shows the foil as seen from the bottom of the PC board, so place the pattern with the painted side up. Place the sensitized surface of the board on top of the negative, aligning it as required. You can place a small weight on top of the board to make sure that the negative and board are lying in close proximity and are flat.

If you are using the fluorescents, turn them on for three minutes. If you are using some other light source, refer to the previously noted exposure time and distance and expose the required time.

After exposure, place the board in a

## DYNACHEM REPRESENTATIVES

Chem Etch Products 1781 Oakton Blvd. Des Plaines, Ill. 60018	Litho Supply Co. 1900 Vassar, N.E. Albuquerque, N.M. 87106
Chemical Etching Equip. & Supply Co. 7629 Crawford Court Alexandria, Va. 22310	Mercer Industrial Sales U.S. Highway 206 Princeton, N.J. 08540
Clrplex Enterprise 524 W. Rosecrans Gardena, Calif. 90247	Photo Reproduction Materials 19166 Glendale Ave. Detroit, Mich. 48223
Etchomatic, Inc. 151 Newton St. Waltham, Me. 02154	Precision Industries 13410 Enterprise Cleveland, Ohio 44135
E. J. Foley & Assoc. 3840 N. Jokake Dr. Scottsdale, Ariz. 85251	Wolcott Park, Inc. 1149 E. Ridge Road Rochester, N.Y. 14621
Franklin Sales Co. 2149 S. Clermont Denver, Colo. 80222	Lew Wenzel & Company 520 S. Peoria Tulsa, Okla. 74120
T. K. Gray, Inc. 1812 S. Sixth St. Minneapolis, Minn. 55404	Lew Wenzel & Company 1700 Levee Street Dallas, Texas 75207
Hi Co. Associates 415 St. Andrews St. Winter Park, Fla. 32790	Lew Wenzel & Company 712 W. Gray Houston, Texas 70019
	Imperial West Chemi- cal Co. 1701 Wilbur Ave. Antioch, Calif. 94509

metal or glass tray containing the developer, and allow it to stay there for about 30 seconds. DO NOT use a plastic tray, as the developer is a solvent for certain types of plastics.

After developing, remove the board from the developing tray and using the newspaper again as a backdrop, shake the aerosol can of dye, and spray the wet board. In 5 to 10 seconds, an image of the pattern will appear. At this point, rinse the board in cold water—preferably a water spray—for about half a minute or so. Shake the board clear of water and allow it to dry. DO NOT use a towel or any other cloth to dry the board at this stage, as the plastic forming the resist is soft and can be destroyed by the abrasive action.

Once dry, the board is ready for the etchant. Almost any etchant can be used as directed by its instructions. Incidentally, if you want to speed up the etching process, use a thin-walled plastic or glass tray to hold the required amount of etchant, and place this tray in a sink and run hot tap water around the tray. Lay

*(Continued on page 117)*

# COLOR TV- THAT ISN'T

OPTICAL ILLUSION CREATES COLOR IMPRESSION IN VIEWER'S MIND

By LAURENCE R. GRIFFIN

**C**AN AN ORDINARY black-and-white TV receiver reproduce a color image? "No," you say. Wrong! Believe it or not, the answer is a resounding yes—provided the telecast is in "electronic" color using the Color-Tel subjective color process\*.

Developed by James F. Butterfield, Sherman Oaks, California, electronic color is a remarkable TV broadcasting technique using relatively unknown optical principles to transmit a monochrome picture that appears to be in color when viewed on an ordinary black-and-white TV receiver. Actually, no color appears on the TV screen—it exists only subjectively in the brain of the viewer. Although most viewers see colors, there are some viewers who do not—for reasons not completely understood. On the other hand, normally color-blind people frequently report being able to see the electronic subjective color display.

**Light.** Light waves are a form of radiant electromagnetic energy of which the visible spectrum is only a small part spanning the apparent color range from red to violet. Each color has a distinctive wave length, from violet at 16 millionths of an inch, to red at 32 millionths of an inch. Outside of this very narrow band of frequencies lie the optically invisible radiations that include ultraviolet, infrared, X rays, and even radio waves.

Vision begins when light strikes the retina, a light-sensitive nerve membrane covering the hemispherical back wall of the eyeball. Composed of three layers, the retina contains two types of special sensory bodies called rods and cones. These nerve cells respond to light stimu-

lation by "telegraphing" a pulsing sequence of coded information along the optic nerves to the brain's sight center in the occipital lobe of the cerebral cortex. All color perception occurs in the cones and by evaluating the varying frequencies of the neuron impulses, the cortex is able to distinguish what hues are acting on the retina.

Slightly over 15 years ago, Butterfield reasoned that, if the frequencies of the nerve codes for specific colors could be mathematically analyzed, it would be possible to feed the cortex synthetic color data. This could be accomplished by stimulating the cones with flickering pulses of white light, keyed to match the known nerve frequency for a given hue. If the theory was correct, such flickering white light would then appear to the viewer to have color.

Television camera equipped with a Color Translator transmits pictures which appear to the viewer to be in color on a standard black-and-white receiver.

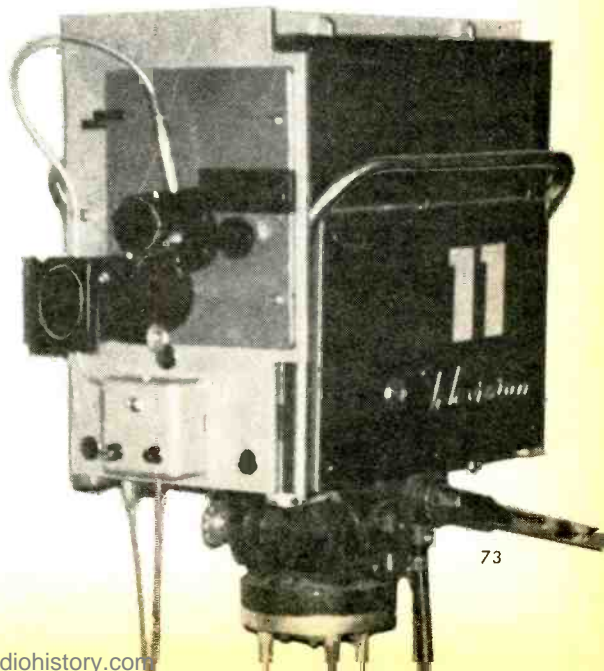

\*U.S. Patent 3,311,699, and other patents and patent applications outstanding in the United States and foreign countries.



**Subjective Color.** Experiments in subjective color have taken place throughout the past one and one-half centuries. The first known experiment appears to have been conducted by the French monk, Benedict Provost, who discovered that when a black-and-white object was moved through a ray of sunlight in a darkened room, a spectrum of colors mysteriously appeared. In 1838, Gustav T. Fechner, a German physicist, using a disc composed of black-and-white areas discovered that, when the disc was rotated, portions of the disc "subjectively" appeared in colors. Fechner advanced a theory to explain the mechanism of the

phenomenon. Helmholtz, among others, investigated this strange effect.

At the end of the nineteenth century, C. E. Benham devised a disc which presented these colors in a very striking manner. In appearance, the Benham disc is half black and half white. The white area is subdivided into three equal sections, each containing a black design composed of two closely-spaced parallel curving lines. A facsimile of the Benham disc is shown in Fig. 1. You can cut out this pattern and paste it on a piece of cardboard. Pin the center of the disc to a pencil eraser so that the disc may spin freely. As you spin the disc in a clock-

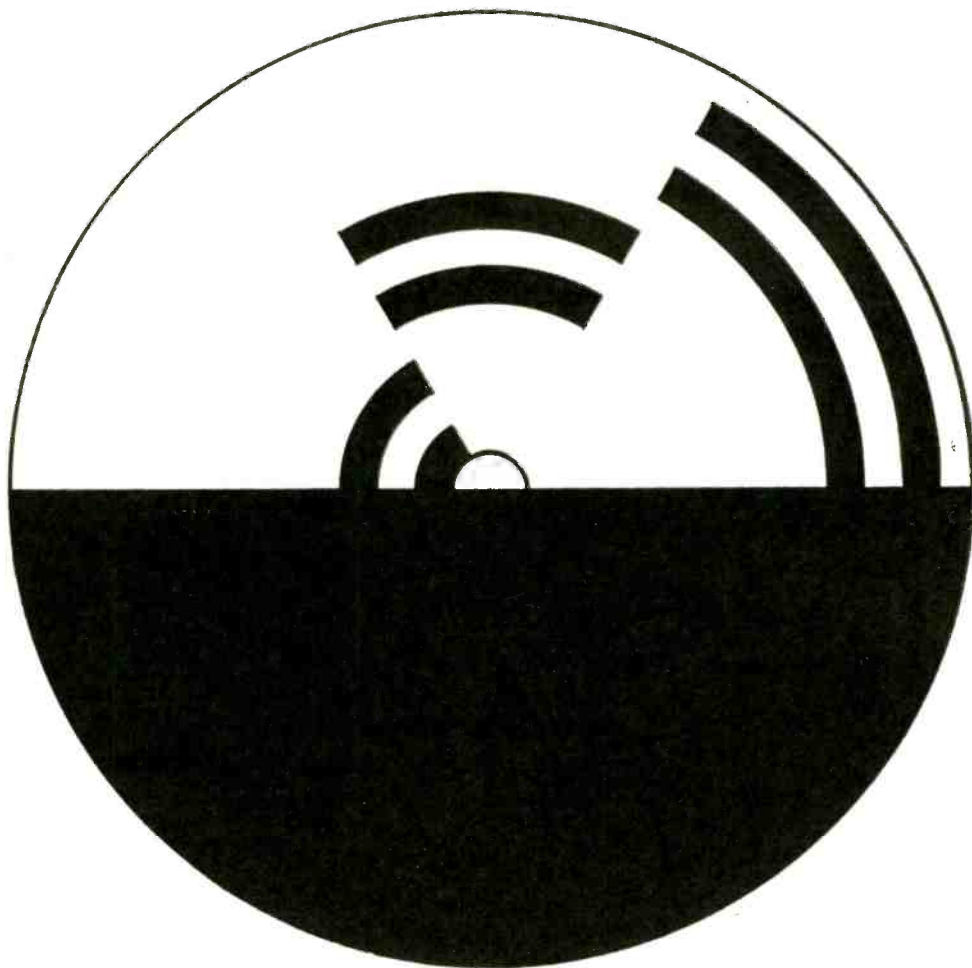

Fig. 1. Cut out or copy this duplicate of the Benham disc. Use rubber cement to adhere disc to a circular piece of cardboard. Punch a hole in the exact center of the disc and support it on a pushpin stuck in the eraser of a lead pencil. Rotate the disc at speeds between 3 and 10 rotations per second. The speed of rotation will affect hue and saturation of the colors. Changing direction of rotation reverses the colors.

wise direction as you face it, you will see subjective color just as Benham saw it 75 years ago.

As the disc rotates, the black lines—almost as if by magic—appear to take on shimmering colors. The lines nearest the hub are reddish, the middle lines appear greenish, and the outer lines are bluish. If this isn't sufficiently surprising, rotate the disc in the opposite direction and watch the display of colors reverse, blue nearest the hub and red on the outside.

In 1953, Butterfield consulted a Dr. Derek H. Fender and asked the famed eye expert to help analyze the Benham disc phenomenon so that it might be used to generate synthetic color codes.

**TV Applications.** When Butterfield and Fender had completed their tests, the next step was to apply their theory of subjective color to TV broadcasting. This resulted in the development of the Color Translator, a special TV-camera attachment that contains a modified form of the Benham disc. The disc is inserted in the light path between the scene being viewed and the TV camera lens. As shown in Fig. 2 what would have been the white section of the Benham disc is instead comprised of three tinted filter sections. Viewed from the front, the filters are, from right to left, cyan (blue-green), magenta (purple), and yellow, each a complementary color of red, green and blue respectively. When a colored object is seen through a tinted filter of a complementary color, the subject appears black against a pale background.

The Butterfield disc is rotated at 5 rev/m which means that one of the 12 filter elements is between the scene being viewed and the TV camera lens for 60 TV fields. When the cyan filter is in the light path, all red light is blocked out and only green and blue light appears. Therefore, all red areas are transmitted as black. The green, blue, and white areas pass through this filter and correspond to the white spaces of the original Benham disc. The magenta filter blocks out green light (which is transmitted as black), and passes the red and blue light which now acts as the white areas. The yellow filter blocks out the blue light.

Mixed colors are combinations of two or three primary hues and when they appear in the scene, they cause some

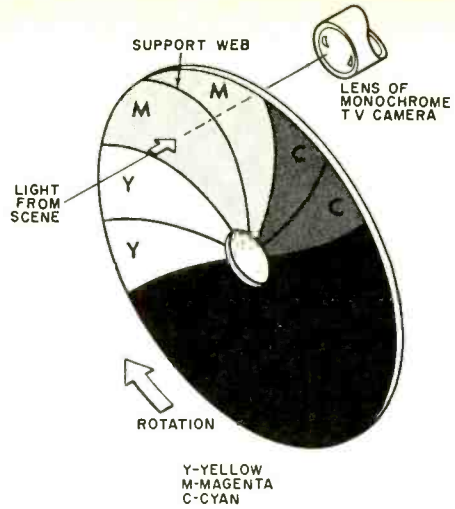

Fig. 2. Disc for use in TV has three sectors in colors that are complements of those seen on reception.

grey or black to be transmitted in the subjective color primaries. When the Color Translator is in operation, a flickering color picture of medium saturation and fidelity can be seen on a black-and-white TV receiver. The flickering is the result of two different effects. First, there is the opaque half of the disc that blocks out all light reaching the TV camera for 50% of the time. This causes a black flicker at 5 Hz (rotational speed of the disc). Secondly, the subjective red, green, and blue colors are each produced during a different sixth of a revolution of the disc. These color areas appear white during the remaining third of the disc revolution. This causes a white flicker in the color area. Mixed colors do not have the latter type of flicker since they are combinations of more than one primary color. Red seems to flicker more than green or blue, but this appears to be a physiological effect.

While Butterfield isn't the first to come up with a workable subjective-color process for black-and-white TV, his method is, by far, the most efficient and flexible system yet devised. The Nagler process, patented in 1958, requires specially prepared film to achieve the desired subjective-color effect. Butterfield's system, on the other hand, needs, no pre-processed material, and can be used to shoot live color sequences, make color

(Continued on page 118)

# the product gallery

REVIEWS AND COMMENTARY ON ELECTRONIC GEAR AND COMPONENTS

## "JAGUAR" COMBO ORGAN KIT (Heathkit Model TO-68)

When rock groups started searching for a "new" sound several years ago, the electronic organ was selected. There was one drawback—electronic organs of that period were as portable as a spinet piano. Because the sound was more important than the furniture, the organ was stripped down to its essentials—a keyboard and a handful of "voices" feeding an outboard high-power amplifier and speaker system. The result is the so-called "combo" organ—an electronic organ in a small package.

Things have changed. The Heath Company, in its inimitable way, has come up with a modern combo organ in low-cost kit form. Its "Jaguar" combo organ, Model TO-68, is a true electronic organ but is only 36" wide, 22" deep, and 7½" thick. It comes with a pair of detachable chrome legs, making it 35½" high in use. Total weight of organ and legs, each in its own suitcase-size package is only 42 pounds.

The "Jag," at \$299, has most of the features of combo organs costing twice as much. Its 49-note keyboard covers four full octaves, with the 12 bass keys playing a dual role. They can be used either as an extension of the regular keyboard, or they can introduce the deep bass tones normally associated with foot pedals.

Four pleasing "voices" are selected by rocker switches—flute, bright, bass, and mellow. One, or any combination of these voices can be used at will, while a vibrato switch introduces a warbling sound normally heard only on the higher-priced organs. An innovation is the use of a "bass/chord" switch. In one position, the lower 12 keys produce a multi-octave chord including a special low bass note. In the other position, the keys only produce deep bass notes. A separate bass note output is provided for either a rhythm or "stereo" effect. Overall organ volume is controlled by a foot-operated potentiometer which is connected between the organ and an external amplifier system.

Construction time should average about 35 hours. The bulk of the electronics consists of the assembly of 11 tone-generator boards and a small power-supply subsystem. Heath supplies one tone generator com-

pletely wired and tuned for use as a tune-up standard.

Assembly is far simpler than a scope or amplifier kit, and even an amateur at building kits should have no troubles. The instruction book is very complete and has more than enough illustrations to help make a first-class construction job. Installation of the keyboard calls for a small amount of mechanical skill, but if you follow the instructions carefully and don't run off on your own, there will be no problems. The manual is excellent in this respect.

What does the organ sound like? In one word—great. It's hard to believe that so much versatility can be built into such a small package. Its very light key touch and many voices, plus that extra bass extension, make the "Jag" sound like a mighty Wur-litzer.

The TA-17 solid-state combo amplifier—the suggested companion for the "Jag"—is a high-quality audio system with a music power rating of 120 watts (240-watts peak) into a 4-ohm load, and 90 watts (180-watts peak) into an 8-ohm load. Construction of the amplifier is in the 20-hour range, and typical of Heath, instructions are simple and complete.

The TA-17 has five independent inputs; one for the organ, one for an electric guitar, one for a bass guitar, one for a mike, and one for a phono pickup. Each input has its own bass, treble, and volume controls (the organ and guitar share a set). The organ/guitar channel also features a tremolo having adjustable rate and depth and a variable reverb system. These channels also include a "brightness" control that really makes the mid-range pop out, while a "fuzz" switch gives you all the distortion you need.

Prices for the individual components in the organ/amplifier system are as follows: Model TO-68 "Jag" available only in kit form—\$299.00; TA-17 amplifier kit—\$175; TA-17 factory wired—\$275; TA-17-1 loud-speaker kit \$120; and the TA-17-1 factory wired is \$150. Also available are "systems" arranged for price savings. Model TOS-1, consisting of organ, amplifier, and speaker kits, sells for \$580. The semi-kit, Model TOS-2, consisting of the organ kit, assembled amplifier and speaker systems, sells for \$698.

—50—



## "JAGUAR" COMBO ORGAN KIT



The combo organ is played standing up, using right or left foot to control volume. Organ must be fed into power amplifier. Legs are detachable and can be carried in their own case. A cover snaps over the keys and the organ becomes a second suitcase. In background is Heathkit TO-17 high-power amplifier featuring variety of inputs and speaker unit.

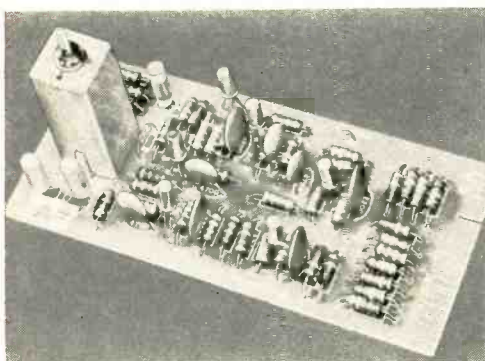

Each tone-generating board contains a basic audio oscillator and three divider circuits. Resistive matrixing between the circuits give the "Jag" its distinctive tone. Each board is slipped into place behind keyboard (see photo at right). Tuning generators is simple task.

It just looks complicated. Wiring and assembly of the TO-68 is relatively simple, but time consuming. Builder wires 11 tone generator boards and sets in the keys. Rocker arm switches and other controls are at the very far end of the keyboard.





# INFORMATION CENTRAL

By CHARLES J. SCHAUERS, W6QLV

**RG-65/U Coaxial Cable.** *I bought a hundred feet of coaxial cable marked "RG-65/U" at a surplus outlet. The salesman told me it has an impedance of 52 ohms and is similar to RG-8/U. Is this so?*

No, take your cable back. This cable has an impedance of 950 ohms (not 52!) although it has the same outside diameter as RG-8/U (0.405"). RG-65/U is video cable and is used as a delay line.

**Ground System.** *I live in a second-floor apartment. Is it permissible and desirable to use a hot-water radiator as a ground for my CB equipment?*

In your area it may be permissible, but it is not desirable. A cold water pipe should be used, and then with caution, for plastic pipes may be installed in conjunction with the metallic ones. Use an outside ground and connect to it with heavy copper wire (#6 or larger). A good ground will have a resistance of 20 ohms or less.

**Amplifier Failure.** *I have a 10-year-old 20-watt hi-fi amplifier. Recently, when I turned on the set, it would coast along at reduced volume for about five minutes before operating at full volume. Then, after about 30 minutes, distortion and hum appeared. The transformer failed, and I replaced it. I had good operation for a few days, then the old trouble returned. I changed tubes, but that didn't help. What else can I do?*

First, check your power supply electrolytic capacitors. You will probably find them leaky and bad. If not, check the inter-stage coupling capacitors.

**Talk-Back in V MK2.** *Some time ago I bought a Galaxy V MK2 transceiver, and I have always received fine reports. However, since I moved to a new location (an apartment house), I get some "talk back" when I load the set on the 21-MHz band. I use a trap antenna. What could be wrong?*

R.f. rectification in the audio output circuits is taking place. Check the SWR of your antenna, and make sure you have a good ground. I advocate using a balun with any trap-type antenna, because it saves a lot of mismatch headaches.

**Erratic Tube Tester.** *After adjusting the line voltage on my tube tester, and I use the tester for a few minutes, the meter readings become erratic. What could be the cause?*

A dirty or bad a.c. line rheostat, or bad or dirty filament tap switch contacts might be the culprits. A bad transformer should be suspected next. If none of these is at fault, check the d.c. power supply components, especially aging resistors.

**No Power Receiver.** *Because transistors can function on such low voltages and currents, I have heard that it is possible to build a transistorized radio receiver with no batteries. Can you show a schematic?*

Yes, it is possible, as shown by the schematic below. You should use a long wire antenna, 100-feet or more, and a good ground. The tuning coil is a conventional ferrite AM

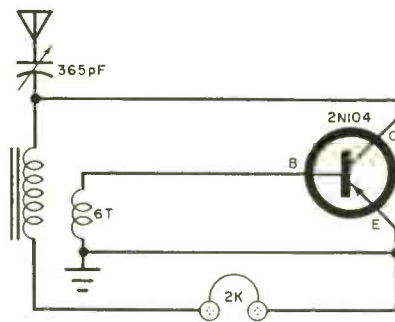

BCB loopstick with about six turns of #22 wire wound at one end of the coil. You may have to reverse the connections to the secondary winding to get best results.

**Power Supply Kit.** *I am a new electronics enthusiast who got his start in a fascinating hobby by building kits. I'm hooked! Can you recommend a power supply that I can use with my transistor experiments which I can build from a kit? I want a unit which will supply at least 20 volts and 300 milliamperes. Output voltage must be adjustable.*

Check the catalogs of the major electronics parts distributors. There are many good low-cost power supplies available. -30-



# SHORT-WAVE LISTENING

By **HANK BENNETT**, W2PNA/WPE2FT  
Short-Wave Editor

## THE DX AWARDS PROGRAM—PHASE FOUR

**F**OR THE PAST several years POPULAR ELECTRONICS has been conducting an Awards Program for its SWL readers. Working hand-in-hand with our Monitor Registration Program, the DX Awards Program concerns only those who have registered their listening posts with us and who have a Monitor Registration Certificate. If you have not yet registered, consult the 1969 COMMUNICATIONS HANDBOOK which will be available in late November for details.

The Monitor Certificate has five blank spaces for award seals. Each space is for a different category. Three of these categories are already available, a fourth is described below, and the fifth is yet to be determined.

The first phase of the Awards Program is for the number of countries from which the applicant has received bonafide verifications (QSL's). This phase is set up for award seals for 25, 50, 75, 100, and 150 countries verified. Separate Letters of Certification are being issued to those applicants who have more than 150 countries verified, in additional steps of 10 countries. The seals for the country awards are attractively printed in blue on a gold background and show the number of countries verified. Subsequent country award seals are placed over the previous seal thereby showing the greatest total at any time.

Phase two is for individual states verified and is available in steps of 20, 30, 40, and 50 states. This seal is printed in red on a gold background.

The third phase is an All-Canada Award and is available in steps of 6, 8, 10, and 12 Canadian areas verified. This seal is printed in green on a gold background.

At the request of many readers we've decided to make the fourth phase an *All-Zones Award*. In the world of hams and SWL's, there are 40 radio zones, some of which are well populated and easy to hear and verify. Others, being less populated and more distant, are considerably more difficult to get into your logbook as heard and verified. For the newcomers, a 10-zone award; for the experts, a 40-zone seal; and in between, award seals for 20 and 30 zones. The color for the

new seal has not yet been determined, but we are sure that they will be attractive.

The 1969 COMMUNICATIONS HANDBOOK will have a completely new and revised Official Country List which will also incorporate the

### DX Award Honor Roll

*Here are the leaders in the DX Honor Roll. The figures indicate, from left to right, the number of countries, states and Canadian areas verified.*

<b>James Young</b> (WPE6ENA) Wrightwood, Calif.	230	50	12
<b>Chuck Edwards</b> (WPE4BNK) Fort Lauderdale, Fla.	190	50	12
<b>Mike Mandrick</b> (WPE2GVF) Rochester, N. Y.	160	50	10
<b>Ed Fellows</b> (WPE7BLN) Seattle, Wash.	200	0	12
<b>Paul Kilroy</b> (WPE3FOB) Washington, D. C.	150	50	12
<b>Charles Matterer</b> (WPE6DXC) Los Angeles, Calif.	150	50	12
<b>Don Jensen</b> (WPE9EZ) Racine, Wis.	190	20	0
<b>L. E. Kuney</b> (WPE8AD) Detroit, Mich.	150	50	10
<b>Bernard Hughes</b> (G2PE6D) Worcester, England	170	40	0



A recent newcomer to short-wave listening is young Charlie Rann, WPE9JFQ, Wheaton, Ill. His receiver is a Knight-Kit Star Roamer. He has nine QSL's now.



## DX ALL-CANADA AWARDS PRESENTED

To be eligible for one of the DX All-Canada Awards designed for WPE Monitor Certificate holders, you must have verified stations in 6, 8, 10, or 12 different Canadian areas. The following recently qualified for and have received awards.

### 6 CANADIAN AREAS VERIFIED

Roy Carroll (WPE2QAA), Neptune, N. J.  
Roland Wahlgren (VE7PE1CR), N. Vancouver, B. C.  
Richard Spear (WPE3HEI), Baltimore, Md.  
Duane Hayes (WPE0FGM), Denver, Colo.  
Arnold Rosett (WPE3HIF), Philadelphia, Pa.  
Douglas Meyer (WPE2OUS), New Rochelle, N. Y.  
Don Zimmerman (WPE0FDR), Madison, S. D.  
Warren Bussard (WPE6GTV), Tulare, Cal.  
Jon Pearkins, Jr. (VE7PE1CQ), Burnaby, B. C.  
Mitchell Hyman (WPE2OPK), Brooklyn, N. Y.  
Ken Ascher (WPE8JYA), Detroit, Mich.  
Mark Nelson (WPE0FHU), Canton, S. D.  
Jerry Heien (WPE9BDD), Berkeley, Ill.  
Gary Fredricks (WPE7CGG), Eugene, Oregon  
James Bochantin (WPE9JDA), Du Bois, Ill.

### 8 CANADIAN AREAS VERIFIED

David Conder (WPE9IHV), Centralia, Ill.  
Jack Dardes (WPE3EGL), State College, Pa.  
Marion Lilienthal (VE3PE2DO), Waterloo, Ont.  
David Hagerman (WPE2PWK), Delaware, N. J.

Roy Carroll (WPE2QAA), Neptune, N. J.  
David Hailey (WPE4ENX), Nashville, Tenn.  
Donald Gross (WPE7CQX), Roseburg, Oregon  
Bernard Niderost (WPE6GXR), Mad River, Calif.  
Romona Hagerman (WPE2OBV), Delaware, N. J.  
Timothy Armstrong (WPE6GGJ), Suisun, Cal.

### 10 CANADIAN AREAS VERIFIED

Mike Mandrick (WPE2GVF), Rochester, N. Y.  
Carl Bruesch (WPE1HJK), New Canaan, Conn.  
Robert French (WPE8FGH), Bellaire, Ohio  
Thomas Creery (WPE2PHZ), Conklin, N. Y.  
Sgt. Robert Combs (WPE2PJU), APO, New York, N. Y.  
Bill Wright (VE3PE2HS), Delta, Ont.  
Robert Gage (WPE9IXZ), Lafayette, Ind.

### 12 CANADIAN AREAS VERIFIED

Chuck Edwards (WPE4BNK), Fort Lauderdale, Fla.  
Edward Panish (WPE9JAZ), Western Springs, Ill.  
Charles Matterer (WPE6DGA), San Leandro, Calif.  
Donald Gross (WPE7CQX), Roseburg, Oregon

number of the zone in which each country is located. We suggest that our readers consult the handbook carefully before making applications for zone awards; there will be some specific variations in the zone listings that differ from other zone listings now available. We have adopted, with permission, the Official Country List and Zone List of the Newark News Radio Club. Its country and zone committee has recently completed a thorough and exhaustive overhaul of the zone listings, and we feel that it is by far the most accurate listing now available.

All of the various awards have a few regulations which must be followed by those applying. You must have the required number of verifications in your possession to qualify for the award for which you are applying. You must be registered and have your WPE identification certificate. You must submit a list of stations for the award you desire, including country, state, Canadian area, or zone, call letters or name of the individual stations, their frequencies, dates they were heard, and dates of the verifications. You do NOT have to send your QSL's unless specifically requested for purposes of clarification. These are always returned. Finally, your application and list of stations must be accompanied by a 50¢ fee in coins, unused U.S. stamps, or postal money order. No personal checks or IRC's.

All applications, whether for Monitor Registration, DX Awards, or information on either program should be sent to the Short-Wave Editor at the address which appears at the beginning of "Current Station Reports."

## CURRENT STATION REPORTS

The following is a resume of current reports. At time of compilation all reports were as accurate as possible, but stations change frequency and/or schedule with little or no advance notice. All times shown are Greenwich Mean Time (GMT) and the 24-hour system is used. Reports should be sent to Short-Wave Listening, P. O. Box 333, Cherry Hill, N.J. 08034, in time to reach your Short-Wave Editor by the fifth of each month; be sure to include your WPE identification and the make and model number of your receiver.

**Abu Dhabi**—An overseas source reports that the Abu Dhabi Broadcasting Service is advertising for a senior broadcast engineer to supervise installation and operation of high-power medium- and short-wave xmitters for the Government of Abu Dhabi. (Editor's note: our atlas shows Abu Dhabi to be on the Persian Gulf, in Oman, rather than a country in itself. Can anyone confirm this report?)

**Algeria**—Algiers, 11.835 kHz, has an extended schedule until 0000 with mixed pop and Arabic music. There is a complete ID in French at s/off time. For medium-wave DX'ers, the 300 kW outlet on 529 kHz has moved to 575 kHz.

**Angola**—*Emissora Oficial de Angola*, Luanda, is on 11.925 kHz with a new 100-kW xmttr where it is heard with English and pop records at 1500-1505; this follows a brief newscast in Portuguese.

**Argentina**—LRX, *R. El Mundo*, Buenos Aires, is good at times on 9710 kHz around 2300. This is now heard rather consistently with Spanish music.

**Bolivia**—CP88, *R. Amboro*, Santa Cruz de la Sierra, 4900 kHz, was noted recently with a lengthy political talk running past the normal s/off time to 0413. DX'ers are reminded that they have an opportunity to log this country in English. Check 5025 kHz for *R. La Cruz del Sur*, La Paz, around 0230-0245 and again during its bilingual s/off at 0300.

**Brazil**—PRL8, *R. Nacional do Brasilia*, 11,720 kHz, is noted infrequently around 0013 with an ID in English along with a request for reception reports. Further checks moments later found only the usual Portuguese ID's.

**Ceylon**—The 0630 xmsn to Europe has been de-

(Continued on page 105)



# ON THE CITIZENS BAND

By MATT P. SPINELLO, KHC2060, CB Editor

## HUNTSVILLE IN THE CB SPOTLIGHT

The Emergency Citizens Band Monitors, Inc., Huntsville, Alabama, was organized in February, 1966 and incorporated as a non-profit, public-service organization in March. In just over 2½ years, the membership has taken giant strides toward living up to its motto, *Pro Bono Publico* (for the good of the public). Since the Huntsville area was already being served by an active rescue squad, the ECBM set its organizational sights on basic communications and participation in civic, public service, and charitable projects.

In May, 1966, ECBM received its REACT charter from national headquarters, and authorization to participate in HELP (Highway Emergency Locator Plan). In August of the same year, the Federal Communications Commission issued a special-condition Class D CB license to ECBM for 80 units under the call letters KOM6753. According to ECBM, this was the first such special-condition license to be issued in the northern Alabama area.

By September, 1966, the growth of the organization made it possible to activate both the REACT and HELP programs on channel 9 on a daily 24-hour basis. The programs have been in effect without interruption for two years. In the interim the ECBM has responded to hundreds of calls for assistance and emergency communications handling.

In addition to its 24-hour monitoring service, the membership participates in charitable activities, and to date has been active in four area-wide telethons. ECBM is also represented on the board of directors of the cerebral palsy and multiple sclerosis health services.

The ECBM is entirely self-supporting, and finances most of its activities through two annual projects. The first involves the compilation and publication of an annual CB call book for the Huntsville area. This project, under a plan developed by the ECBM, produces from \$600 to \$1000 net income per year. In fact, ECBM feels the plan is so successful that it is offering it to other

clubs. You can get a copy of the current call book and the plan by mailing \$1.00 to ECBM, P. O. Box 1542, Huntsville, Alabama 35807. The second annual fund raising project undertaken by ECBM is a Fall Festival CB Jamboree. We would imagine their efforts in this area are as successful as their publishing projects, especially since this year's grand prize was a weekend trip for two to Las Vegas.

The ECBM has an active membership of 80, and recently occupied new and larger quarters on the 12th floor of the Times Building in downtown Huntsville. Current officers for the group are: Ken Cowley, Sr., KQM6634, president; Randy Duck, KQM-1025, vice president; Ed Clift, Jr., KON0704, treasurer; Madelyn Schanhoff, KON0529, secretary; and five board members.

ECBM'ers feel they have established a firm foothold as an influential element in the Huntsville-area CB community in a  
(Continued on page 96)



Ken Cowley, KQM6634, (seated) is the president and Ty Wilkinson, KOM1337, is past-president of Huntsville's ECBM, a group devoted to community service. Obviously, ECBM's equipment, which includes 3 CB transceivers, 2 FM receivers, and an antenna control bay, gives them plenty of gear to work with.

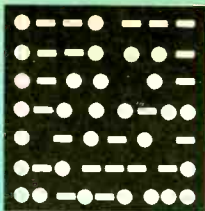

# AMATEUR RADIO

By **HERB S. BRIER**, W9EGQ  
Amateur Radio Editor

## HORIZONTAL "VERTICAL" ANTENNAS

In a recent letter, Gerard, K1STP, asked about the possibility of using two 40-meter, mobile "loaded whip" antennas back-to-back as a horizontal, fixed-station antenna. Gerard's idea seemingly offers no electrical problems. Mount the two whips in line horizontally so that their bottom ends are separated from each other by an inch or so. Feed the two whips with 52-ohm (nominal) coaxial cable by connecting the center conductor of the cable to the base of one antenna and the outer conductor to the other antenna. Adjust the loading coils in the two mobile whips for minimum SWR.

Assuming the mobile whips are of normal length, you will have a loaded antenna with an overall length of slightly under 20 feet. Like all shortened antennas, its radiating efficiency will be inversely related to its length compared to a full-size antenna cut for the same frequency. Consequently, efficiency will be poor on 80 meters, fair on 40 meters, good on 20 meters, and excellent on 10 and 15 meters. Of course, the proper loading coils for the band in question must be used. Also, the antenna height above ground will have an important effect on how well it gets out.

---

## AMATEUR STATION OF THE MONTH



Dr. P. J. Lester, WN9UCM, 204 N. Park St., Streator, Ill., finds amateur radio an ideal relaxation from his dental practice. Doc works CW with an old Heathkit transmitter and receives on a Hammarlund HQ-100. He has made close to 1000 contacts in most states and a handful of foreign countries, so he gets good use out of the low power. He uses a Hallicrafters SR-42A transceiver for local ragchews on 2 meters. A 1-year subscription to POPULAR ELECTRONICS goes to WN9UCM for winning this month's Amateur Station Photo Contest. You can enter the contest by sending a clear photograph of yourself at the controls of your station with some details about your amateur career to: Amateur Station Photo Contest, c/o Herb S. Brier, W9EGQ, Amateur Radio Editor, POPULAR ELECTRONICS, Box 678, Gary, Ind. 46401.





Operators and Italian visitors at 11DFD, the Amateur Radio Club station of the Southern European Task Force base at Vicenza, Italy. Using Hallicrafters equipment and 300 watts to a 75-foot high rotary beam, the station puts out a walloping signal on the 7-through 29.7-MHz bands. (U.S. Army Photograph.)

**Multi-band Vertical Antennas as Horizontals.** Some months ago, in the German amateur radio magazine *DL-QTC*, a German ham described his use of a standard, multi-band vertical antenna (Hy-Gain 14-AVQ) in the horizontal position. The antenna was supported horizontally on brackets, and the ground-plane system was replaced by horizontal wires  $\frac{1}{4}$ -wavelength long for each band. These wires terminated at an insulator near the base of the antenna. The far ends of the wires were supported by strong, shrink-proof cords far enough apart that they could not touch or twist together in the wind.

The antenna was fed with coaxial cable in the normal manner, with the center conductor going to the base of the "vertical" antenna and the shield to a common terminal of the  $\frac{1}{4}$ -wavelength wires. Careful adjustment brought the transmission-line SWR down to a low value on all bands. An impressive list of stations contacted with low power proves that this unusual antenna does perform.

**The Horizontal Antenna as a Grounded Vertical.** Applying the above idea in reverse, B.A. Watling, G3RNL, used half of a conventional horizontal "trap" dipole as a semi-vertical antenna operated against ground. Reporting in *Radio Communications* (London) for March, 1968, G3RNL concluded that this arrangement was a better all-around 80-, 40-, and 20-meter antenna than four other multi-band antennas with which it was compared.

The antenna consisted of a 32' 6" vertical section, the "trap," and a 21' 6" horizontal section. The trap consisted of 23

turns of wire on a  $1\frac{1}{4}$ " diameter form paralleled with a 50-pF capacitor. Although not specified, #14 enamelled wire should be satisfactory for the trap, which should be "grid dipped" to the middle of the 40-meter band. In operation, the center conductor of the 52-ohm coaxial feeder (which may lay on the ground) is connected to the bottom of the antenna, and its shield is grounded to a metal stake driven into the earth directly under the antenna.

**FCC News.** In late June, the Federal Communications Commission reversed a rule that prohibited the connection to a telephone of any device not supplied by the telephone company. The new ruling apparently means that amateur phone patches—devices to connect a transmitter and a receiver to a telephone line—are completely legal as long as they do not interfere with the normal operation of the telephone. As far as the amateur is concerned, the ruling is academic because phone companies have rarely objected to amateur phone patches.

Also in June, Congress sent to the President a bill to authorize the FCC to control devices such as electric motors, automobiles, etc., capable of interfering with radio communications. The bill, which the President will probably have signed when you read this, is the first big step towards reducing the unnecessary electrical noise pollution that plagues all radio services.

**Sounds Too Easy.** In the July, 1968, *XTRA News Letter* (Bonita, Calif.), Max Adler, ZS1ACD, Capetown, South Africa, says that he learned the code well enough to  
(Continued on page 98)

# ENGLISH-LANGUAGE BROADCASTS TO NORTH AMERICA FOR THE MONTH OF OCTOBER

Prepared by **ROGER LEGGE**

TO EASTERN AND CENTRAL NORTH AMERICA		TO WESTERN NORTH AMERICA	
TIME—EDT	STATION AND LOCATION	TIME—PDT	STATION AND LOCATION
	FREQUENCIES (MHz)		FREQUENCIES (MHz)
7:00 a.m.	Stockholm, Sweden	8:00 a.m.	Tokyo, Japan
7:15 a.m.	Melbourne, Australia	7:00 p.m.	Melbourne, Australia
8:15 a.m.	Montreal, Canada		Oslo, Norway (Sun.)
8:45 a.m.	Copenhagen, Denmark		Quito, Ecuador
12 noon	London, England		Taipei, Taiwan
7:00 p.m.	Heisinki, Finland	7:30 p.m.	Tokyo, Japan
	London, England	8:00 p.m.	Johannesburg, South Africa
7:45 p.m.	Tokyo, Japan		London, England
8:00 p.m.	Moscow, U.S.S.R.		Madrid, Spain
	Sofia, Bulgaria		Peking, China
8:30 p.m.	Budapest, Hungary	8:20 p.m.	Seoul, Korea
	Johannesburg, South Africa		Yerevan, U.S.S.R. (via Khabarovsk)
	Kiev, U.S.S.R. (Mon., Thu., Sat.)		(Tues., Wed., Fri., Sat.)
	Stockholm, Sweden	8:30 p.m.	Berlin, Germany
	Brussels, Belgium		Bonaire, Neth. Antilles
8:50 p.m.	Vatican City		Prague, Czechoslovakia
	Havana, Cuba		Stockholm, Sweden
9:00 p.m.	Berlin, Germany	9:00 p.m.	Havana, Cuba
	Madrid, Spain		Lisbon, Portugal
	Peking, China		Moscow, U.S.S.R. (via Khabarovsk)
	Prague, Czechoslovakia		Peking, China
	Rome, Italy		Sofia, Bulgaria
9:30 p.m.	Berne, Switzerland	9:15 p.m.	Bangkok, Thailand
	Bucharest, Rumania	9:30 p.m.	Bucharest, Rumania
	Cologne, Germany		Budapest, Hungary
	Hilversum, Holland	9:45 p.m.	Kiev, U.S.S.R. (Mon., Thu., Sat.)
	Tirana, Albania		Berne, Switzerland
10:00 p.m.	Cairo, Egypt	10:00 p.m.	Cologne, Germany
	Lisbon, Portugal		Havana, Cuba
	London, England	11:00 p.m.	Tokyo, Japan
	Melbourne, Australia	11:30 p.m.	Moscow, U.S.S.R. (via Khabarovsk)
	Moscow, U.S.S.R.		Havana, Cuba
10:30 p.m.	Beirut, Lebanon		

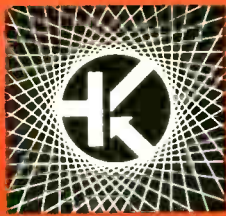

# SOLID STATE

By LOU GARNER, Semiconductor Editor

**A** RELATIVELY QUIET, but far-reaching, revolution is taking place in the design of electrical products as more and more consumer manufacturers switch to solid-state electronic controls.

Just a few short years ago, it was hard to find a single "electronic" product in the average home or family car that wasn't either an entertainment or communications instrument. True, radio receivers were standard accessories in most cars, and nearly every home had a radio or TV set (or both). Most of them also had record players or elaborate hi-fi systems, but only the well-to-do or the technically inclined hobbyists had anything more elaborate.

Today, inexpensive light fixtures may have triac or SCR dimmers; hobbyist drills, sanders, and electric garden tools have solid-state speed controls; and semiconductor electronic controls are likely to be found in washers, dryers, refrigerators, freezers, etc. Automobiles are equipped with transistorized electronic tachometers and complex automatic cruise (speed) controls. The familiar d.c. generator has been replaced by an a.c. alternator fitted with semiconductor diode rectifiers, and the VW can now be obtained with a computerized electronic fuel control system.

Manufacturers of all these products haven't changed to electronic controls for purely altruistic reasons. Their prime goal is to make profits by delivering reliable, attractive products at reasonable prices. Competition is keen and the changeover to electronic controls became desirable *only* when semiconductor circuits became competitive both in price and reliability with conventional electromechanical controls.

Comparatively few appliance and tool manufacturers maintain their own electronic design staffs or circuit manufacturing facilities. Rather, they rely on modular circuits purchased from electronic specialty suppliers. The original equipment manufacturers buy their circuits as "black boxes" capable of performing specified functions. If the module does the job and the price is right, they don't care what's inside it.

Specialized module suppliers include such well-known firms as Amperex Electronic Corporation, Controls Company of America, GE, Fairchild Semiconductor, RCA, Motorola, and North American Philips (Norelco).

Electronic marketing experts estimate that from 15% to 25% of the major appliances sold during 1968 will incorporate some type of electronic control, with the figure rising to 60% or 75% in 1969.

In the future, the increased use of electronic control and amplifier modules in home appliances and other consumer products may result in a real windfall for the experimenter and do-it-yourselfer. Often, functioning modules can be salvaged from appliances which are damaged mechanically and, in addition, yearly model changes may result in the availability of low-cost surplus modules. Even today, one can purchase fully assembled audio-amplifier modules across-the-counter at prices below the cost of the individual components used in the circuits.

**Reader's Circuit.** The unusual automatic light-switch circuit shown in Fig. 1 was submitted by reader George L. Garvin (10384 E. Jefferson, Osceola, Ind. 46561), who developed it to satisfy a personal need for a

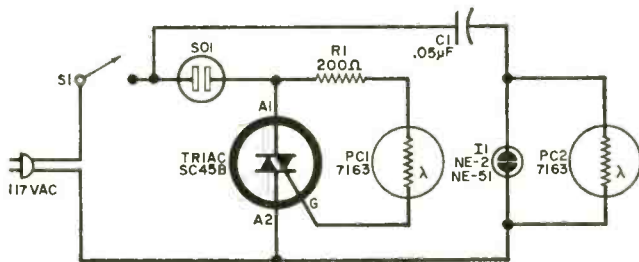

Fig. 1. Automatic light-switch circuit uses medium-power triac and light-sensitive controls to handle loads to 1000 watts.



light switch with a greater power handling capacity than is available in conventional designs or commercial units. Requiring relatively few components, the circuit can be assembled in a single evening, yet, according to George, it is capable of handling loads up to 1000 watts and has more than adequate sensitivity.

George has used a light-coupled control circuit in conjunction with a medium power triac. Capacitor *C1* and photocell *PC2* form a capacitive-resistive voltage divider to supply power to neon lamp *II* which, in turn, is used to illuminate photocell *PC1*. The gate of the bi-directional triac, which serves as the main power-switching device, is controlled by *PC1* in series with current limiting resistor *R1*. Daylight falling on *PC2* holds it in a low-resistance state in which the voltage drop across it is not sufficient to

may be assembled on a conventional chassis, in a small case, or, for semi-permanent installations, in a standard electrical outlet or switch box.

**Manufacturer's Circuit.** The sine-to-square-wave converter and audio oscillator circuits illustrated in Figs. 2(a) and (b) respectively, were abstracted from Technical Bulletin 85.15, published by GE's Semiconductor Products Department (Electronics Park, Syracuse, N.Y. 13200). Either, or both, may be assembled for use as auxiliary test instruments in the home electronics workshop or laboratory. They each employ a three-stage silicon integrated circuit (*IC1*) which features a two-stage Darlington configuration direct-coupled to a common-emitter amplifier.

In Fig. 2(a), *IC1* is used as a saturated

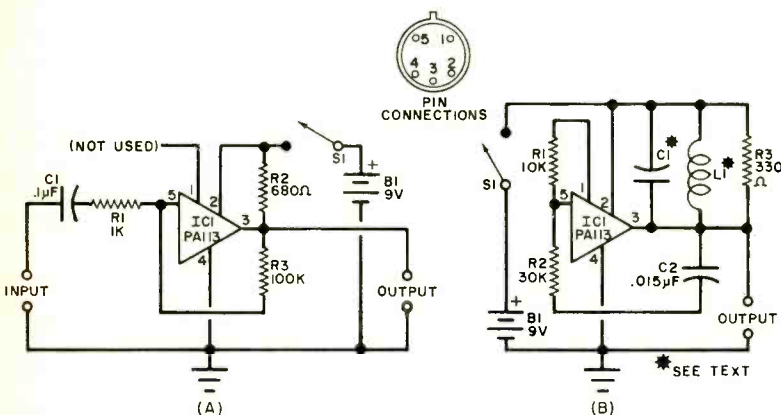

Fig. 2. Integrated-circuit square-wave converter (left) and audio oscillator can be built for auxiliary testing use in the home workshop.

fire the neon lamp. Photocell *PC1* remains dark and, therefore, in a high-resistance state, limiting the triac's gate current below the level needed to turn it on. As darkness falls, *PC2*'s resistance (and its voltage drop) increases, turning on the neon lamp and illuminating *PC1*. The resulting drop in *PC1*'s resistance permits a corresponding increase in the triac's gate current, switching it to a conducting state and furnishing power to the external lamp load connected to *SO1*.

Standard, readily available parts are used in the control. The triac is a GE type SC45B, while *PC1* and *PC2* are both RCA type 7163 CdS photocells. A type NE-2 or NE-51 neon bulb is used for *II*. Resistor *R1* is 1 watt, and *C1* is a 200- to 600-volt paper or ceramic capacitor.

Wiring dress and parts arrangement are not critical, though George recommends that the triac be heat-sinked and that *PC1* and *II* be mounted close together and shielded to exclude external light. Only *PC2* should be exposed to the ambient light. The circuit

amplifier. The sine-wave drive signal is coupled to the input stage through d.c. blocking capacitor *C1* and limiting resistor *R1*, while the square-wave output signal is developed across load resistor *R2*. Resistor *R3* serves both as a bias source for the first stage and to provide some signal feedback.

According to GE's notes, the sine-to-square-wave converter requires a 1-volt (r.m.s.) drive signal and has a frequency response from 50 Hz to 1 MHz, delivering a square-wave with a 110-nanosecond rise time and a 200-nanosecond fall time.

The sine-wave oscillator circuit shown in Fig. 2(b) utilizes reactive elements *C1* and *L1* in conjunction with load resistor *R3* as part of its output load. The feedback needed to start and maintain oscillation is provided through *C2* and *R2*, while input-stage bias is supplied through *R1*.

A GE type PA113 integrated circuit is used as *IC1* in both cases. All resistors are half-watt types, while the capacitors may be good-quality ceramic or tubular paper types.

(Continued on page 92)

The modern Army goes to school, and there's a place in class for you.

In fact, high school graduates have more than 300 job training courses to choose from.

And if you qualify for the Army's enlistment program, we guarantee your course selection *before* you step forward and raise your hand.

There's still another plus. The training is great. A leading American university credits the Armed Forces with one of the most advanced and comprehensive educational programs in the world.

Job training in the Army could be the opportunity you need to acquire a vital and rewarding skill. At the same time, you fulfill your military obligation.

We can give you more than 300 good reasons for joining the Army.

But all you need to choose is one.

Your future, your decision...choose **ARMY**.

Army Opportunities  
Dept. 200  
Hampton, Va. 23369

PE 10-68

Please send me your free 40-page booklet.  
I understand there's no obligation  
attached to this request.

Name \_\_\_\_\_ Age \_\_\_\_\_

Address \_\_\_\_\_

City \_\_\_\_\_ County \_\_\_\_\_

State \_\_\_\_\_ Zip \_\_\_\_\_

Phone \_\_\_\_\_ Education \_\_\_\_\_

# Enroll in the Army.









**A Government FCC License can help you bring home up to \$10,000, \$12,000, and more a year. Read how you can prepare for the license exam at home in your spare time—with a passing grade assured or your money back.**

**I**F YOU'RE OUT TO BAG A BETTER JOB in Electronics, you'd better have a Government FCC License. For you'll need it to track down the choicest, best-paying jobs that this booming field has to offer.

Right now there are 80,000 new openings every year for electronics specialists—jobs paying up to \$5, \$6, even \$7 an hour... \$200, \$225, \$250, a week... \$10,000, \$12,000, and up a year! You don't need a college education to make this kind of money in Electronics, or even a high school diploma.

But you *do* need knowledge, knowledge of electronics fundamentals. And there is only one nationally accepted method of measuring this knowledge... the licensing program of the FCC (Federal Communications Commission).

**Why a license is important**

An FCC License is a legal requirement if you want to become a Broadcast Engineer, or get into servicing any other kind of transmitting equipment—two-way mobile radios, microwave relay links, radar, etc. And even when it's not legally required, a license proves to the world that you understand the principles involved in *any* electronic device. Thus, an FCC "ticket" can open the doors to thousands of exciting, high-paying jobs in communications, radio and broadcasting, the aerospace program, industrial automation, and many other areas.

So why doesn't everyone who wants a good job in Electronics get an FCC License and start cleaning up?

The answer: it's not that simple. The government's licensing exam is tough. In fact, an average of two out of every three men who take the FCC exam fail.

There is one way, however, of being pretty certain that you will pass the FCC exam. And that is to take one of the FCC home study courses offered by Cleveland Institute of Electronics.

CIE courses are so effective that better than 9 out of 10 CIE graduates who take the exam pass it. That's why we can back our courses with this iron-clad Warranty: Upon completing one of our FCC courses, you must be able to pass the FCC exam and get your license—or you'll get your money back!

**They got their licenses and went on to better jobs**

The value of CIE training has been demonstrated time and again by the achievements of our thousands of successful students and graduates.

**2 NEW CIE CAREER COURSES**

**1. BROADCAST (Radio and TV) ENGINEERING**... now includes Video Systems, Monitors, FM Stereo Multiplex, Color Transmitter Operation and CATV.

**2. ELECTRONICS ENGINEERING**... covers steady-state and transient network theory, solid state physics and circuitry, pulse techniques, computer logic and mathematics through calculus. A college-level course for men already working in Electronics.

Ed Dulaney, Scottsbluff, Nebraska, for example, passed his 1st Class FCC License exam soon after completing his CIE training...and today is the proud owner of his own mobile radio sales and service business. "Now I manufacture my own two-way equipment," he writes, "with dealers who sell it in seven different states, and have seven full-time employees on my payroll."

Daniel J. Smithwick started his CIE training while in the service, and passed his 2nd Class exam soon after his discharge. Four months later, he reports, "I was promoted to manager of Bell Telephone at La Moure, N.D. This was a very fast promotion and a great deal of the credit goes to CIE."

Eugene Frost, Columbus, Ohio, was stuck in low-paying TV repair work before enrolling with CIE and earning his FCC License. Today, he's an inspector of major electronics systems for North American Aviation. "I'm working 8 hours a week less," says Mr. Frost, "and earning \$228 a month more."

**Send for FREE book**

If you'd like to succeed like these men, send for our FREE 24-page book "How To Get A Commercial FCC License." It tells you all about the FCC License... requirements for getting one... types of licenses available... how the exams are organized and what kinds of questions are asked... where and when the exams are held, and more.

With it you will also receive a second FREE book, "How To Succeed In Electronics." To get both books without cost or obligation, just mail the attached postpaid card. Or, if the card is missing, just mail the coupon below.

**ENROLL UNDER NEW G.I. BILL.** All CIE courses are available under the new G.I. Bill. If you served on active duty since Jan. 31, 1955, or are in service now, check box on reply card for complete details.

**CIE Cleveland Institute of Electronics**

1776 E. 17th St., Cleveland, Ohio 44114

Accredited Member National Home Study Council  
A Leader in Electronics Training... Since 1934



**Cleveland Institute of Electronics**  
1776 East 17th Street, Cleveland, Ohio 44114

Please send me without cost or obligation:  
Your 40-page book "How to Succeed In Electronics" describing job opportunities in Electronics today, and how your courses can prepare me for them.  
Your book on "How To Get A Commercial FCC License."

I am especially interested in:

<input type="checkbox"/> Electronics Technology	<input type="checkbox"/> Electronic Communications
<input type="checkbox"/> Broadcast Engineering	<input type="checkbox"/> Industrial Electronics
<input type="checkbox"/> First Class FCC License	<input type="checkbox"/> Electronics Engineering

Name \_\_\_\_\_ (PLEASE PRINT)  
Address \_\_\_\_\_  
City \_\_\_\_\_  
State \_\_\_\_\_ Zip \_\_\_\_\_ Age \_\_\_\_\_

Check here for G.I. Bill information **PE-71**

**CIRCLE NO. 11 ON READER SERVICE PAGE**

# NEW! SOLID STATE KITS

## Automatic Recording-Level Control



FOR ANY TAPE RECORDER

Low-noise distortionless compressor — preamp easily installs in mike line. Easy-to-build kit with complete instructions.

MODEL ACP-1 KIT ..... \$18.50

## Voice/Sound Actuated Controller

Voice operate any tape recorder, ham and CB transmitter. Ideal for intrusion alarms. Built-in relay switches up to 1 amp. Easy-to-build kit with complete instructions.

MODEL VOX-1 KIT ..... \$18.50

## Other Kits

Audio Amplifiers ■ Power Supplies ■ Test Equipment ■ Treasure Locators ■ and many others

FREE Data sheets with circuit description, diagram, and specifications for all kits.



CARINGELLA ELECTRONICS, Inc.

P.O. Box 327 ■ Upland, California 91786  
Phone 714-985-1540

CIRCLE NO. 10 ON READER SERVICE PAGE

## New sound column



## High Fidelity Speaker System

Looks beautiful, sounds excitingly different! Sound column design uses scientific focusing principle to add extra projection to high tones, re-create music with startling fidelity. Ideal for stereo. 33¼" h. x 10½" w. x 4" d. 4 Jensen speakers — 2 specially-designed high compliance woofers, 2 direct radiator tweeters. 50 to 17,000 cps. Cabinet of genuine walnut with oiled finish . . . designed to hang on the wall like a picture.

The Astra

**\$49<sup>95</sup>**  
each  
audiophile  
net

**Argos**  
PRODUCTS COMPANY

Write for free catalog showing Argos systems for every purpose

600 S. Sycamore St., Genoa, Ill. 60135

CIRCLE NO. 5 ON READER SERVICE PAGE

## SOLID STATE

(Continued from page 86)

Components *C1* and *L1* in Fig. 2(b) have values of 0.05- $\mu$ F and 50 mH respectively, and, with these values, deliver a signal at approximately 2 kHz. Other *LC* combinations can be used for different audio frequencies.

Neither layout nor lead dress are especially critical in the two circuits, and both are well suited to either perf or etched-circuit board construction. Good wiring practice should be observed, of course, with signal-carrying leads kept short and direct. Care should be taken to avoid over-heating the IC leads when soldering this device in place. The completed circuit may be housed conveniently in a small metal or plastic instrument case.

**Overseas Developments.** Moderately priced 400-Hz servo systems similar to those used in industrial, marine, aircraft, and space applications, have been developed by Feedback, Ltd. (Sussex, England). Designed primarily for educational applications in technical institutes and advanced high schools and colleges, they consist of two basic units—a transistorized power supply and amplifier and an electromechanical servo (see Fig. 3). Full theory and experimental instructions are furnished with the systems, with a minimum of auxiliary test

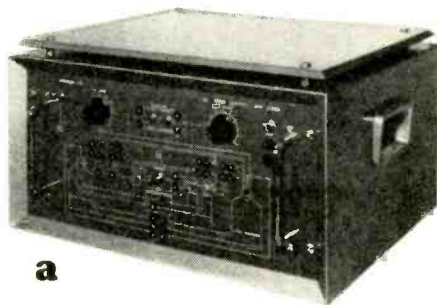

a

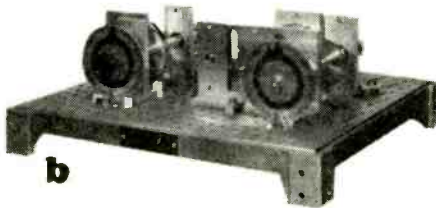

b

Fig. 3. Transistorized power supply and amplifier (a) and servo board (b) for educational purposes.

POPULAR ELECTRONICS

# The New 1968 Improved Model 257 **A REVOLUTIONARY NEW TUBE TESTING OUTFIT**

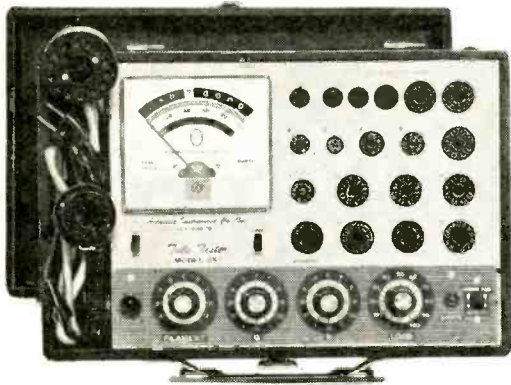

**COMPLETE WITH ALL ADAPTERS AND ACCESSORIES, NO "EXTRAS"**

### STANDARD TUBES:

- ✓ Tests the new Novars, Nuvistors, 10 Pins, Magnovals, Compactrons and Decals.
- ✓ More than 2,500 tube listings.
- ✓ Tests each section of multi-section tubes individually for shorts, leakage and Cathode emission.
- ✓ Ultra sensitive circuit will indicate leakage up to 5 Megohms.
- ✓ Employs new improved 4½" dual scale meter with a unique sealed damping chamber to assure accurate, vibration-less readings.
- ✓ Complete set of tube straighteners mounted on front panel.

The Model 257 is housed in a handsome, sturdy, portable case. Comes complete with all adapters and accessories, ready to plug in and use. No "extras" to buy. Only . . . . .

### BLACK AND WHITE PICTURE TUBES:

- ✓ Single cable used for testing all Black and White Picture Tubes with deflection angles 50 to 114 degrees.
- ✓ The Model 257 tests all Black and White Picture Tubes for emission, inter-element shorts and leakage.

### COLOR PICTURE TUBES:

- ✓ The Red, Green and Blue Color guns are tested individually for cathode emission quality, and each gun is tested separately for shorts or leakage between control grid, cathode and heater. Employment of a newly perfected dual socket cable enables accomplishments of all tests in the shortest possible time.

**\$47<sup>50</sup>**

## NOTICE

Accurate has been producing radio, TV and electronic test equipment since 1935, which means they were making Tube Testers at a time when there were relatively few tubes on the market, "way before the advent of TV. The model 257 employs every design improvement and every technique learned over an uninterrupted production period of 32 years.

Maxon Electronics, Inc.

# SEND NO MONEY WITH ORDER PAY POSTMAN NOTHING ON DELIVERY

Try it for 10 days before you buy. If completely satisfied then send \$10.00 and pay the balance at the rate of \$10.00 per month until the total price of \$47.50 (plus P.P., handling and budget charge) is paid. If not completely satisfied, return to us, no explanation necessary.

### MAXON ELECTRONICS, INC.

Dept. D-104 2435 White Plains Road. Bronx, N. Y. 10467

Please rush me one Model 257. If satisfactory I agree to pay \$10.00 within 10 days and balance at rate of \$10.00 per month until total price of \$47.50 (plus P.P., handling and budget charge) is paid. If not satisfactory, I may return for cancellation of account.

Name \_\_\_\_\_

Address \_\_\_\_\_

City \_\_\_\_\_

Zone \_\_\_\_\_

State \_\_\_\_\_

Save Money! Check here and enclose \$47.50 with this coupon and we will pay all shipping charges. You still retain the privilege of returning after 10 day trial for full refund.

CIRCLE NO. 29 ON READER SERVICE PAGE





# FREE!

1969  
CATALOG  
No. 690

**JUST OFF THE PRESS!!  
SEND FOR YOUR EXCITING COPY NOW!**



**BIGGER  
& BETTER  
THAN EVER**  
OVER **500** PAGES!

**YOUR 1st GUIDE TO  
EVERYTHING IN  
ELECTRONICS**

- ★ CITIZENS BAND 2-WAY RADIO
- ★ STEREO/HI-FI COMPONENTS
- ★ MUSICAL INSTRUMENTS AND AMPLIFIERS
- ★ PUBLIC ADDRESS
- ★ AMATEUR RADIO
- ★ TEST EQUIPMENT
- ★ PARTS
- ★ PORTABLE AND TABLE RADIOS
- ★ PHOTO EQUIPMENT
- ★ TOOLS
- ★ AUTO ACCESSORIES
- ★ EDUCATIONAL AND OPTICAL
- ★ TV AND ANTENNAS
- ★ BOOKS

LAFAYETTE Radio ELECTRONICS  
Dept. 35108, P.O. Box 10  
Syosset, L.I., N.Y. 11791

**Mail This Coupon Today  
For Your 1969 Catalog  
No. 690.**

Please send the FREE 1969 LAFAYETTE Catalog 690 35108

Name .....

Address .....

City ..... State.....

Zip .....

(please include your Zip Code No.)

CIRCLE NO. 28 ON READER SERVICE PAGE

# First of a new breed —from Sherwood

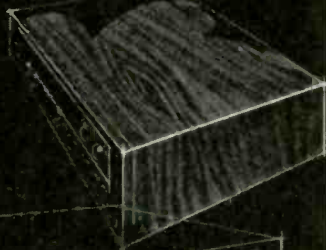

Model S-8800a \$399.50

This is what high performance is all about. A bold and beautiful new FM Stereo Receiver bred to leave the others behind. 160 crisp, clean watts—power in reserve. Up-front, ultra-now circuitry featuring Field-Effect Transistors and microcircuitry. Front-panel, push-button command of main, remote, or mono extension speakers and loudness contour. Sherwood high-fidelity—where the action is—long on reliability with a three-year warranty.

## Sherwood

Sherwood Electronic Laboratories, Inc.  
4300 North California Avenue,

Chicago, Illinois 60618 Write Dept. 10P  
CIRCLE NO. 39 ON READER SERVICE PAGE

## ON THE CITIZENS BAND

(Continued from page 81)

very short time. The ECBM has been cited by city and county authorities and Civil defense, for its activities during disaster conditions. The association is well-known for its participating support of charitable and civic projects and has been recognized by the federal government as a nonprofit public-service organization.

But, according to its president Ken Cowley, "ECBM is not resting on its laurels. There is still much to do, not only with respect to station equipment and operating procedures, but concerning our basic objective: *Pro Bono Publico*."



An active REACT team on location with its mobile base complete with Zeus portable power generator.

**REACT Age-Limit Policy Defined.** In response to requests for clarification of the age limits on REACT-team membership, National REACT Director Henry B. Kreer, KPK1386, has replied as follows:

"Every REACT team is required to have among its actual membership at least 3 licensed CB'ers. Beyond that, the membership may include any number of responsible individuals, including teenagers, assuming they are operating legal equipment owned by their parents.

"In other words, REACT would accept membership of . . . teenage group(s) under the *direct supervision* of . . . (an established REACT team) as an integral part of that team. Please be assured that REACT is interested in young people who genuinely wish to perform public service through REACT."

**1968 OTCB Club Roster.** With this summer's schedule of jamborees and vacations



safely tucked away, CB club activity is increasing and new CB associations are being formed. The following are new additions to our 1968 club roster. If your group was formed recently or if it has not reported to us in the last 12 months, ask your publicity people to furnish us with the statistics. Include current membership totals, club officers, and activities. Send along photos when available (good, clear Polaroids are acceptable). Mail material to Matt P. Spinello, CB Editor, POPULAR ELECTRONICS, One Park Ave., New York, N. Y. 10016.

**Indianapolis, Ind.** The Indiana Citizens Band Association, Inc., chartered by the State of Indiana, publishes a clean-cut, well-written monthly, *ICBA News*, edited by Floyd Shively, aided by an assistant editor, design and layout personnel, a photographer, and two writers.

**Oceanside, Calif.** Seacoast Citizens Band Radio Association's Publicity Chairman Jo Cooper, K0X3607, reports club extremely active in public-service functions. Group has sponsored annual "Operation Happiness" since 1964, with special emphasis on helping needy families during the holiday season with drives to collect clothing, food, toys, etc. and donations for the Pala Indian Reservation and needy families in North San Diego county. Group has also handled emergency communications for the San Diego County Fair for the last three annual events.

**Decatur, Ga.** *The Dixie Citation*, official voice of the Dixie Communications Club reports that the DCC, the CB Monitor, and the North Atlanta Monitor, have joined to form the DeKalb County CB Association. Since all three clubs have aided authorities in search and rescue operations in the past, often with overlapping communications assignments and activities, they decided to organize an association through which field exercises could be coordinated. Current officers are: Dave Isom, Chairman; Maurice Krugman, vice-chairman; and Allen Copeland, secretary.

**Stratford, N.J.** Georgianna Weiss, corresponding secretary, KCD0668, reports on the success of the United Citizens Band Radio Club's annual jamboree, at which the proceeds from an attendance of over 1500 made it possible for the club to purchase wheelchairs for the local school for handicapped children. Current officers of the group are: Jerry Lisse, KOG0241, president; Ed Matlack, KKG 2547, first vice-president; Joseph Tulini, KOG0847, second vice-president; Vi Boody, KOG1878, recording secretary; and Walter Mathis, Sr., KKG0366, treasurer.

I'll CB'ing you,

—Matt, KHC2060

## Valuable SAMS BOOKS

### USE THIS HANDY ORDER FORM JUST PUBLISHED! IMPORTANT!

- 101 Easy CB Projects.** Offers a wide variety of do-it-yourself projects for simple, inexpensive, yet practical citizens band radio equipment and accessories. Each device is a useful addition to the CB operator's gear; each is covered by a full description, complete parts list and instructions for easy building. Order 20663, only ..... \$3.25
- Using Scopes in Transistor Circuits.** Tells when and how to use oscilloscopes to analyze and/or troubleshoot transistor circuits. Emphasizes waveform analysis; covers circuit theory in transistor oscillators, amplifiers, waveshaping circuits, monochrome and color TV, and computers. Order 20662, only ..... \$4.50
- Practical Design with Transistors.** Provides a direct approach to the design of a wide variety of solid-state circuits. Covers biasing, feedback, and high-frequency considerations, as well as methods of coupling. Includes new applications of FET's. Order 20659, only ..... \$5.95
- Second-Class Radiotelephone License Handbook.** New 3rd edition; complete study course for elements I, II and III of the latest FCC exams. Helps you earn the license you need for communications and two-way radio work. Order 20316, only ..... \$5.75
- Color-TV Servicing Made Easy.** Full explanation of color principles, circuitry, setup adjustments and servicing of all color-TV sets. Takes the mystery out of servicing color-TV.
- Vol. 1. Order 20135, only ..... \$3.95
- Vol. 2. Order 20523, only ..... \$4.95
- Citizens Band Radio Handbook.** Enlarged 3rd edition. Covers latest CB equipment and circuits, antenna systems, fixed and mobile installations, maintenance and repairs, FCC rules, etc. Order 20569, only ..... \$4.25
- Color TV Training Manual.** 2nd edition. Best guide for technicians preparing to service color TV. Includes detailed explanation of color principles, circuits, setup procedures, alignment, and troubleshooting; full-color illustrations. Order 20472, only ..... \$6.95
- How to Build Speaker Enclosures.** Provides a wealth of both practical and theoretical information for constructing high-performance enclosures for speaker systems. Order 20520, only ..... \$3.50
- Tape Recorders—How They Work.** 2nd Ed. 20445 ..... \$4.50
- 89 Ways to Improve Your CB Radio.** 20515 ..... 2.95
- How to Read Schematic Diagrams.** 2nd Ed. 20568 ..... 3.50
- Know Your Oscilloscope.** 2nd Ed. 20549 ..... 3.50
- 101 Ways to Use Your VOM & VTVM.** 2nd Ed. 20510 ..... 3.50
- Modern Dictionary of Electronics.** 3rd Ed. 20600 ..... 9.95
- So You Want to Be a Ham.** 4th Ed. 20607 ..... 4.50
- Short Wave Listener's Guide.** 2nd Ed. 20542 ..... 1.95
- 101 Easy Audio Projects.** 20608 ..... 3.50
- 49 Easy Transistor Projects.** 20617 ..... 1.75
- Walkie-Talkie Handbook.** 20572 ..... 3.95

#### FAMOUS ABC'S BOOKS

- Computers. 20012 ..... \$2.95
- Lasers & Masers. 20262 ..... 2.95
- Transistors. 20440 ..... 2.75
- CB Radio. 20019 ..... \$2.50
- Tape Recording. 20395 ..... 2.50
- Boolean Algebra. 20053 ..... 2.75

### — HOWARD W. SAMS & CO., INC. —

Order from any Electronic Parts Distributor, or mail to Howard W. Sams & Co., Inc., Dept. PE—10 4300 W. 62nd St., Indianapolis, Ind. 46268

Send books checked above. \$ \_\_\_\_\_ enclosed.

Send FREE Sams Book Catalog.

Name \_\_\_\_\_

PLEASE PRINT

Address \_\_\_\_\_

City \_\_\_\_\_ State \_\_\_\_\_ Zip \_\_\_\_\_

CIRCLE NO. 36 ON READER SERVICE PAGE

# Weller®

...the soldering tools professionals depend on



### The original Dual Heat Soldering Guns

Preferred by technicians for their fast heating copper tips, exclusive trigger-controlled dual heat, and high soldering efficiency. Available in 3 watt-age sizes, each with spotlight.

100/140-watt Model 8200, 145/210-watt Model D-440, and 240/325-watt Model D-550. Also in complete kits:

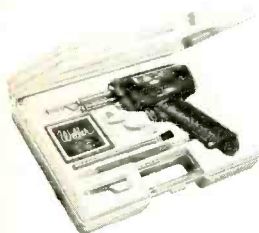

Utility Kit includes Weller 100/140 watt gun, extra tips, tip-changing wrench, flux brush, soldering aid and solder. Model 8200PK



Heavy-Duty Kit features Weller 240/325 watt gun with soldering, cutting and smoothing tips, wrench and solder. Model D-550PK

### Dependable MARKSMAN Irons in a size for every job



Ideal for deep chassis work and continuous-duty soldering, Marksmann irons outperform others of comparable size and weight. All five feature long-reach stainless steel barrels and replaceable tips.

- 25-watt, 1 1/4-oz. Model SP-23 with 1/8" tip (1n kit with extra tips, soldering aid, solder—Model SP-23K)
- 40-watt, 2-oz. Model SP-40 with 1/4" tip
- 80-watt, 4-oz. Model SP-80 with 3/8" tip
- 120-watt, 10-oz. Model SP-120 with 1/2" tip
- 175-watt, 16-oz. Model SP-175 with 5/8" tip

Complete Weller Line includes replacement tips and solder

**WELLER ELECTRIC CORPORATION, Easton, Pa.**  
WORLD LEADER IN SOLDERING TOOLS

CIRCLE NO. 47 ON READER SERVICE PAGE

## AMATEUR RADIO

(Continued from page 83)

pass the South African 12-wpm code test after two hours of intensive code practice. Max sees nothing unusual about this feat. He is a musician and orchestra leader and since childhood, he has had to learn long and intricate musical sounds by ear, and the code alphabet is nothing more than 26 rhythmic sound patterns.



"GB" Baker, W5QPX, Dalhart, Texas, is QSL manager for FG7XJ, YN4JAB, FM7WI, CR6FW, and FG7XZ. See "News and Views" for his home address and more information about his various amateur activities.

### Amateur Radio Correspondence Course.

Under the supervision of Byron C. Sharp, W9BE, The Hadley School for the Blind, 700 Elm St., Winnetka, Ill. 60093, offers blind people a free correspondence course in amateur radio leading to a General class amateur license. The taped course is based on the AMECO *Radio Theory Course* and code lessons. The theory lessons will also soon be available in Braille for those who prefer that form. Sharp reports that there are presently 85 students enrolled in the course; although it has been offered for only a short time, several students have already earned their amateur licenses. The Hadley School amateur call letters are WA9WHS. Listen for them Saturdays at 10:00 a.m., CST, on 14290 kHz SSB.

### NEWS AND VIEWS

Dave Read (address unknown) after taking the Novice exam disputes our statement that all ama-

(Continued on page 102)

POPULAR ELECTRONICS

# OUT OF TUNE

TUNE UP YOUR BASS REFLEX, July, 1968. The "Simplified Design Chart For Bass Reflex Enclosures" as published on the lower half of page 50 might prove a bit difficult to interpret without some additional information. The chart should be divided into two discrete parts as indicated by the shaded and

unshaded areas in the chart reproduced below. The shaded portion defines the lower (left figure) and upper (right figure) length limits for the 3"-diameter port tube to be used. The blank spaces for the 35- and 40-Hz free-air resonance columns (1 cu. ft. volume) indicate that no port is to be used and the enclosure is to be sealed. The unshaded portion of the chart gives approximate figures for simple port areas in square inches. Two or three figures are given for port area. The figure you use depends on the shapes of the enclosure and port.

SIMPLIFIED DESIGN CHART FOR BASS REFLEX ENCLOSURES																					
VOLUME	A	B	C	A	B	C	A	B	C	A	B	C	A	B	C	A	B	C			
6 cu. ft.	9	12	25	12	18	32	20	28	36	28	40		56	75							
5 cu. ft.	7	9	20	10	14	28	15	20	24	20	30	40	36	50							
4 cu. ft.	3/4		2	7	10	20	11	15	20	14	20	24	26	36	45	80					
3 1/2 cu. ft.	1		3 3/4		1 1/2	8	11	16		12	16	20	20	28	32	45					
3 cu. ft.	2		4 3/4		2	5	8	12		9	12	18	15	22	26	36	40	80			
2 1/2 cu. ft.	2		5	2	4 3/4		2			5	8	12	12	16	20	28	30	40			
2 cu. ft.	4		8	2	5	1	3 3/4			2	7	10			12	18	18	25			
1 1/2 cu. ft.	7		10	4	8	3	5	2		4 3/4		2	8	11	14	20					
1 cu. ft.						6	8	4		7	2	4	1	2	5	10					
	35			40			45			50			60			70			80		
	FREE AIR RESONANCE OF SPEAKER (f.)																				
<p>A — Approximate port area in square inches for rectangular port (length to width ratio—4:1)</p> <p>B — Approximate port area in square inches for square or circular port</p> <p>C — Maximum port area in square inches for increased bass output. This tunes enclosure above speaker resonant frequency, but is permissible if resonance is below 50 Hz</p>																					

To use design chart, find fr as described in text, and determine enclosure volume (use inside dimensions). Locate intersection of volume row and fr column, and read lengths of 3"-inner-diameter tubing to try (or port area in sq. in. if intersection is in unshaded portion of chart). Tune enclosure as described in text.

## the new ELPA PE-2020 Automatic Turntable lets you escape from the ordinary

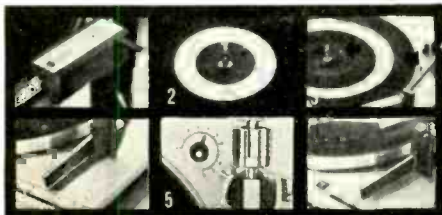

**Here's Why:** (1) The exclusive 15° vertical tracking angle adjustment — permits the precision tracking of a manual transcription turntable. (2) Stylus protection—tonearm never lowers on an empty platter. (3) Automatic scanning —automatically determines size of record on platter and adjusts tonearm accordingly . . . automatically. (4) Simplicity of operation — one lever for all modes of operation. (5) Anti-skating—the finest of any automatic turntable. (6) Motor driven cueing — never damages record grooves or stylus.

**AND THERE ARE MANY MORE SUPERLATIVE FEATURES ON THE NEW ELPA PE-2020**

Don't make a buying decision on an automatic turntable without seeing the finest . . . the new ELPA PE-2020. See it at your hi-fi retailer, or write for full literature and name of nearest franchised dealer.

ELPA MARKETING INDUSTRIES, INC. New Hyde Park, N.Y. 11040



CIRCLE NO. 18 ON READER SERVICE PAGE



Compact solid-state transceivers,  
all guaranteed for ten years!



### COURIER TR-5

5 channels

A lot of performance for under \$100. The top performer for those who don't need 23 channels.

Silicon transistors throughout, just like our finest solid-state rigs. Illuminated channel selector, transmit indicator, auxiliary speaker jack, single-knob tuning, modulation indicator, external channel sockets, RF noise blanker, 100% modulation, triple-plated chrome cabinet. Plus exclusive Courier Safety Circuits® to protect against mismatched antenna, incorrect polarity, and overload. Compact price, compact size: 5¾" x 1⅞" x 6¼".

**\$99**

*complete with crystals  
for Channel 9*

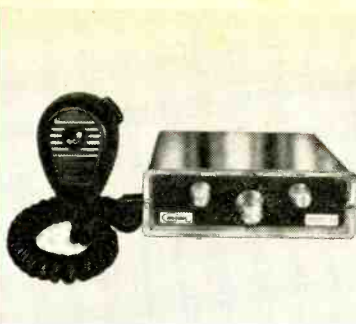

### COURIER TRAVELLER

23 channels

World's smallest all-channel transceiver—with exclusive Incoming Signal Indicator.

A miracle of miniaturization—all 23 channels in a housing only 5¾" x 1⅞" x 6¼". Exclusive new Incoming Signal Indicator that lights up when receiving S-6 or better signal—lets you mind your driving instead of minding a meter. Silicon transistors throughout. Super-efficient transmitter designed to help pierce "skip". Built-in noise limiter, 100% modulation, true automatic IF noise blanker, triple-plated chrome cabinet. Exclusive Courier Safety Circuits®.

**\$149**

*complete with crystals  
for all 23 channels*



### COURIER CLASSIC

23 channels

There'll never be anything better until Courier builds it!

Engineered for total reliability, designed to look sharp and work perfectly ten years from now. Silicon transistors throughout. Super-efficient transmitter designed to help pierce "skip". Adjustable noise limiter and noise-cancelling microphone. 100% modulation. Built-in PA system. And more. Everything we know about CB is built into this compact 6½" x 2½" x 8½" unit.

**\$199**

*complete with crystals  
for all 23 channels*

### COURIER PORT-A-PAK

Makes your Courier TR-5 and Traveller solid-state transceivers completely portable.

**\$59<sup>95</sup>**

### BASE STATION POWER CHARGER

Model PS-1. Operate your Courier solid-state CB transceiver as a base station.

**\$29<sup>95</sup>**

# There's a Courier for the pro and the novice, the spender and the saver.

All Courier CB transceivers made in U.S.A.

*Rugged heavy-duty tube-type CB with exclusive Modulation Sampler®—boosts your talk power electronically!*



## COURIER 23

23 channels

America's largest-selling CB rig!

Courier 23 deserves every bit of its popularity. Dollar for dollar, it offers more of what you want in CB: 23 crystal-controlled channels, dual conversion, transistorized power supply, illuminated S-RF meter, illuminated channel selector, PA system, auxiliary speaker jack, modulation indicator, full-time range-expander, triple-plated chrome cabinet. 100% modulation.

Ready-to-go—mobile and base.

**\$189**

complete with crystals  
for all 23 channels

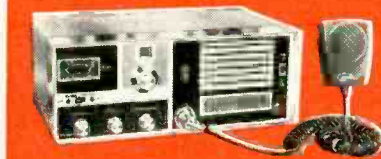

## COURIER 23-PLUS

23 channels

Greater sensitivity, more talk-power, less interference than any CB transceiver at its price!

New cascode front end and nuvistor mixer pull in all 23 channels louder and clearer than any other tube rig in its class. Full 5-watt input. Transistorized AC and DC power supply. Illuminated S-RF meter and channel selector. Modulation indicator. Automatic volume control. Floating gate squelch circuit. 100% modulation. PA system. Automatic noise limiter and noise-cancelling microphone. Triple-plated chrome cabinet. Full-time range-expander. Ready-to-go—mobile and base.

**\$199**

complete with crystals  
for all 23 channels



## COURIER ROYALE

23 channels

The dream rig! Finest CB unit you can buy.

Everything hand-wired, hand-soldered. Rugged chassis with 19 tubes (including a Nuvistor) and an over-powered transformer. All 23 channels, with all crystals supplied. Highly efficient ceramic filter for the ultimate in selectivity. Cascode front end for increased sensitivity. Adjustable noise limiter. Enough? There's more! A new, exclusive full-time range-expander and speech compressor. Triple-duty meter. Transmit and Receive Indicators. Every feature for convenience, versatility. 100% modulation. Ready-to-go—mobile and base.

Complete, very complete: **\$279**

# The man who has everything and the CB'er just making a start.



**COURIER COMMUNICATIONS, INC.**

439 Frelinghuysen Avenue, Newark, N. J. 07114

a subsidiary of **Whittaker** Corporation

Please send me the full story on:

- Courier TR-5    Courier Classic    Courier 23-Plus    Port-A-Pak®  
 Courier Traveller    Courier 23    Courier Royale    Power Charger

Name \_\_\_\_\_

PE-810

Address \_\_\_\_\_

City \_\_\_\_\_ County \_\_\_\_\_

State \_\_\_\_\_ Zip \_\_\_\_\_

**CIRCLE NO. 14 ON READER SERVICE PAGE**



# DEMCO

— the ultimate in CB radios!



**Satelite** Base station with 23 channels, instant "ON," ground plane to beam switch, C.A.P. oscillator, voice tone control, dual conversion, delta tuning, auto/manual A.N.L., mode lights, Power Modulator/Speaker — many other features and options.

## Ravelle 23



23 channels, dual conversion, electronic switching, mode lights, P.A. switch on front, speaker jack, DC or AC — many other features. Also 6-channel model available.

DEMCO ELECTRONICS • BRISTOL, IND. 46507  
Please send information about CB Radios

Name \_\_\_\_\_  
Address \_\_\_\_\_  
City \_\_\_\_\_  
State \_\_\_\_\_ Zip \_\_\_\_\_

CIRCLE NO. 16 ON READER SERVICE PAGE



**WE DON'T  
CLAIM OUR  
ELECTRONIC  
IGNITION  
SYSTEM  
IS BEST...**

**OUR  
CUSTOMERS DO!**

WRITE TODAY FOR FREE LITERATURE

**JUDSON**

RESEARCH AND MFG. CO.  
CONSHOHOCKEN, PA. U.S.A.



CIRCLE NO. 27 ON READER SERVICE PAGE

## AMATEUR RADIO

(Continued from page 98)

teur examinations contain questions about transistors. His exam did not, which proves that all examinations for the same class amateur license may not contain exactly the same questions . . .

**G. L. "GB" Baker, W5QPX**, 413 Maple Ave., Dalhart, Texas 79022, calls his station the "Fifty Watts of Friendship." He operates all bands, phone and CW, between 3.5 and 39.7 MHz with a Hallicrafters HT-37 transmitter and Hammarlund HQ-170 receiver in conjunction with an assortment of home-built doublet and beam antennas. He likes to DX (has DXCC), rag chew, and handle traffic; and he sends radio parts and technical magazines, etc., to foreign amateurs unable to obtain such things in their own countries . . . **David Cantor, WB4EFE**, 4207 Martha Ave., Louisville, Ky. 40220, has built up quite a record since being licensed in 1966. Running 75 watts to a Johnson Ranger transmitter and receiving on a Drake 2-B, he has all states confirmed and 149 countries worked. A 2-element, 15-meter Quad and a Hy-Gain 18-AVQ vertical antenna do the outside work. Dave is QSL Manager for VP2DAJ and VP2SG, both very active on 15 meters.

**Mike Martz, WA8RQA**, 804 Foraker Ave., Sidney, Ohio, has worked 41 states and eight countries in nine months as a Novice and six as a General. He transmits using a Hallicrafters HT-40 transmitter, receives on a Hallicrafters S-108, and radiates via a Hy-Gain 18-V vertical . . . **Richard Spritz, WN3IPE**, 7928 Montgomery Ave., Elkins Park, Pa. 19117, has worked 37 states and four countries with his home-brew 50-watt transmitter. He receives on a National NC-60A fitted with Q-multiplier and noise limiter. His antenna is a secret weapon—at least he didn't mention what it was. A 10-watt, home-built 220-MHz transmitter and a helical antenna with theoretical gain of 20 dB (100 times) await the arrival of his next class of license so he can put them on the air . . . **C. Waters, W9JNA**, 3141 N. Julia St., Milwaukee, Wisc., covers 40 through 10 meters with a Mosley TA-31, 1-element "beam" and a Hy-Gain 14-AVQ vertical. The TA-31 is rotated by a Cornell-Dubilier TR-44 rotator. W9JNA uses a Galaxy SSB/CW transceiver to drive four 572B's in a linear amplifier so he is not in the flea-power class; but he has worked all states and all continents in a short time with this setup. He was first licensed as a Novice in "four land" back in 1953.

**Patrick Wong, WH6GKC**, 2471 Saint Louis Drive, Honolulu, Hawaii, works 15 and 40 meters with a home-built 75-watter driving a Hy-Gain 14-AVS vertical. Pat receives on a Drake 2-B and reports that west-coast signals come into Hawaii with good strength on 40 meters. His best U.S. DX's have been Florida and Michigan on 40 . . . **Gilbert Kunster, Jr., WB2DKZ**, 225 W. 232 St. Bronx, N.Y., spent only five weeks as a Novice. But in that time, he made 110 contacts. Thirteen states and two Canadian provinces were included in the total. A Knight-Kit T-60 transmitter and R-55A receiver, plus an 80-meter doublet antenna, were his tools.

**Kirk V. Dahl, WAØRTD**, 511 Aldrich Ave. South, Minneapolis, Minn. 55419 practiced the code mentally while simultaneously doing his job as a professional drummer; he just passed his General exam. As a Novice with limited time, Kirk worked 16 states on 40 meters using a Knight-Kit T-60 to excite a "long-wire" antenna. A Hammarlund HQ-129X handles the receiving. A desire to be a traffic (message) handler was one of the things that spurred Kirk on to get his General ticket . . . **Stewart Perry, W1BB**, Winthrop, Mass., worked his 100th country on 160 meters last spring, but three of the countries were worked prior to 1945. Stew.



# There has never been a better color-bar generator than the RCA WR-64B...

**until now!**



The RCA WR-502A CHRO-BAR color-bar generator is all solid-state, battery operated... Provides color bars, dots, crosshatch, vertical lines, horizontal lines, blank raster... has rock-solid stability. It's the greatest yet. The CHRO-BAR. \$168.00\*.

RCA Electronic Components, Harrison, N. J.

\*Optional Distributor resale price. Prices may be slightly higher in Alaska, Hawaii and the West.

# RCA

CIRCLE NO. 34 ON READER SERVICE PAGE

October, 1968

103

# THE LAST WORD

IN CB QUAD DESIGN —

— and with it you can have the last word in CB communications.

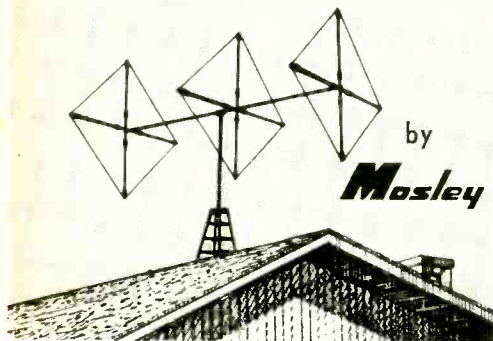

## Model MCQ-27

Right now the cubical quad is the hottest thing in antenna design. But having "the last word" in antennas doesn't guarantee you'll get the last word in copy. Mosley engineers have put their combined 145 years of know-how in the field of radio antenna design into the development of the Quality Quad MCQ-27. This antenna incorporates the very latest advances - - to assure you of the last word in all-around performance.

Get the most from your power output with the Mosley 3-element cubical quad. Cut side and back interference, achieve maximum distance and, when the channels get too noisy in the vertical plane of polarization, you can switch to the horizontal with a special optional accessory. Rest assured the MCQ-27's super-strength construction will stand up to the rigors of climate and long use.

Make sure you have the last word. Get the MOSLEY Cubical Quad. See your authorized Mosley dealer or write factory direct for detailed brochure.

**Mosley Electronics Inc.** 4610 N. Lindbergh Blvd.,  
Bridgeton Missouri 63042

Please send me FREE detailed information on the Mosley CB CUBICAL QUAD Dept. 176

Name \_\_\_\_\_

Address \_\_\_\_\_

City/State \_\_\_\_\_ Zip \_\_\_\_\_

**Mosley Electronics Inc.** 4610 N. Lindbergh Blvd.,  
Bridgeton Missouri 63042

CIRCLE NO. 30 ON READER SERVICE PAGE

therefore, has three countries to go for his 160-meter DXCC certificate. Will he make it this season? . . . **Douglas B. Miller, WN8ANV**, 3748 Northampton Rd., Cleveland Hts., Ohio 44121, has tooted up his Hallicrafters HT-40 transmitter and SX-140 receiver twins to work 31 states and six countries. A Hy-Gain 14-AVQ vertical does the radiating. . . **Larry D. Sweet, WN5TVO**, P. O. Box 51, Hobbs, New Mexico 88240, is the first New Mexico contact for many of the stations he works. If you need New Mexico, Larry spends most of his time on 40 meters, although he can work both 80 and 15 meters. Seventy-five watts to a Heathkit DX-60 transmitter, a Hallicrafters SX-101A receiver, and a Hy-Gain 18-AVQ vertical antenna are Larry's connection with the ionosphere. . . **Rickey D. Hughes, WN4IUA**, 430 TFS. CMR., Box 7425, Homestead AFB, Fla.



**Dave Hershberger, WA9QCH**, Sycamore, Ill., operates on both CW and SSB with an EICO 753 transmitter. With a Hy-Gain vertical for 40 and doublets for 75 and 20 meters, he had 44 states worked.

33030, celebrated passing his General exam by investing in a new electronic keyer. With his EICO 720 transmitter, Hallicrafters SX-110 receiver, and Hustler vertical antenna, Rickey works 40 and 15 meters. He closed out his Novice career with 40 states and 25 countries worked. . . **Bill Duemling, WN8AEM**, 776 Lakepointe, Grosse Point Park, Mich. 48230, has a common pet peeve: operators who promise to QSL contacts and then never do so. Bill has 38 states and Canada worked; 31 states are confirmed. He uses a Heathkit DX-60A transmitter and a Heathkit HR-10 receiver. A dipole antenna completes the amateur part of his station. But he also SWL's with the aid of a BC/SW/FM receiver and a tape recorder.

If your "News and Views" have not been printed in these pages, the reason might be that you haven't written that letter yet. Include a sharp black and white photo with your letter if possible. Thanks also for continuing to send your club bulletins and club papers. Send all news to: Herb S. Brier, W9EGQ, Amateur Radio Editor, POPULAR ELECTRONICS, P. O. Box 578, Gary, Indiana 46101.

73. Herb, W9EGQ

## ANSWERS Transient Voltage Quiz

- |     |      |
|-----|------|
| 1—G | 6—D  |
| 2—I | 7—B  |
| 3—F | 8—J  |
| 4—C | 9—H  |
| 5—A | 10—E |

## SHORT-WAVE LISTENING

(Continued from page 80)

leted; this 17,815-kHz program will reportedly be on at a later hour. The S.E. Asia xmsn at 1100-1200 on 17,830 kHz and the Commercial Service on 15,230 kHz, heard 1530-1700, are still going strong. Check for "DX Panorama", a new DX series, at 1100-1115 on the second and last Saturdays of each month on 17,830 kHz.

**Chile**—The tentative listing last month for *R. El Morro* on 9520 kHz is definite; tune for it to as late as 0313-0400 with music and anmts in Spanish. Other Chileans being heard include CE975, *R. Minería*, Santiago, on 9750 kHz with pop music at 0400, news 0420 and s/off 0430; they have many commercials. CE970, *R. Cooperativa*, Santiago, 9700 kHz, may be identified with their IS of "Pomp And Circumstance"; try around 0210-0230. They verify promptly (send two IRC's).

**Congo**—*R. Kinshasa* is on 15,245 kHz at 2230-0000 in French to West Africa and Western Europe. Other reports indicate this to be a relay from Paris beamed to the U.S. based on a listing in a recent schedule from Paris.

**Dominican Republic**—HISD, Santo Domingo, is now identifying as *Radio Christian International* with outlets on 3125, 6090 and 9505 kHz but extensive checking has failed to find any sign of a signal on 3125 kHz. S/off time currently is 0355.

**Ecuador**—HCJTI, *R. Tulcan*, 3340 kHz, has L.A. pop tunes and a few anmts at 0300-0350. HCJA5, *La Voz del Rio Tarqui*, Cuenca, 3995 kHz, has listener's request music from 0320-0400, or later. Confusion exists on 4772 kHz: HCMX4, *R. Cenit*, Portoviejo, does operate here to 0500 s/off; *R. Cenit*,

*de Bahia* in Caraquez is on 4865 kHz. *R. Bolivar*, Venezuela, also operates on 4772 kHz so take care to avoid a misidentification.

**Finland**—Helsinki is good on 15,185 kHz at 2300-0000 to N.A. with English for first half-hour. English to Europe is at 1800-1830 (Sunday 1600-1630) on 9550, 11,805 and 15,185 kHz.

**Holland**—A projected xmsn schedule from *R. Nederland* shows English to Eastern N.A. at 2130-2250 on 15,425 and 11,730 kHz. From the Bonaire relay, Dutch at 0030-0150 and English at 0200-0320, both to Eastern N.A. on 9590 kHz. Dutch to Western N.A. at 0330-0450 on 9715 kHz and Spanish to Mexico at the same time on 9590 kHz and, lastly, English to Western N.A. at 0500-0620 on both 9715 and 9590 kHz. This schedule is expected to go into effect next month.

**Hong Kong**—All short-wave operations have been terminated; the 3925-kHz outlet is no longer in use.

**India**—*All India Radio*, New Delhi, noted s/off in English on 15,035 kHz at 1100 but a late report shows that the 1000-1100 xmsn has moved to 15,430, 17,705 and 17,870 kHz. The station has begun a "Hindi By Radio" program and they would like to know of those who want to take part; please include your age, profession and education when writing to the station at P. O. Box 500, New Delhi.

### SHORT-WAVE ABBREVIATIONS

anmt—Announcement	N.A.—North America
ID—Identification	QRM—Station interference
IRC—International reply coupon	R—Radio
IS—Interval signal	s/off—Sign-off
kHz—Kilohertz	xmsn—Transmission
kW—Kilowatts	smtr—Transmitter
L.A.—Latin America	W—Watts

### ELECTRONIC EXPERIMENTER'S HANDBOOK

The most fascinating and challenging construction projects for the electronics hobbyist. Over 148 pages.

1968 Winter Edition	..... #50
1967 Spring Edition	..... #49
1966 Fall Edition	..... #39
1966 Spring Edition	..... #36
1965 Fall Edition	..... 9

### ELECTRONICS INSTALLATION & SERVICING HANDBOOK

The only complete guide for servicemen and hobbyists to every major phase of consumer electronics servicing. Over 132 pages of the latest electronics information.

1968	..... #58
1967	..... #43
1966	..... #32

### TAPE RECORDER ANNUAL

The only buyers guide of its kind available to the brands and models on the market. Over 132 pages of full information on over 250 models plus articles covering every aspect of tape recording.

1968	..... #59
1967	..... #42

### STEREO/HI-FI DIRECTORY

Giant 180 page buyers guide to virtually every new audio component on the market — amplifiers • changers and turn tables • receivers • tuners • tape machines • speakers, etc.

1968	..... #56
1967	..... #45

### COMMUNICATIONS HANDBOOK

World's most complete guide to communications. 148 fact packed pages of features by experts in each category.

1968	..... #53
1967	..... #47

Order by number from Ziff-Davis Service Division—Department W • 595 Broadway, New York, N. Y. 10012  
Enclosed additional 15¢ per copy for shipping and handling (50¢ for orders outside U.S.A.).

PAYMENT MUST BE ENCLOSED WITH ORDER

## Ranked #1 in lightweight tracking ability<sup>1</sup>

Able to track the toughest test-record bands at 0.8 gram<sup>2</sup>...  
With a frequency response flat within +2.5, -2 db from 20 to 20k Hz<sup>1, 2</sup>...  
And 30 db of stereo separation<sup>1, 2</sup>...  
Plus a flawless square wave<sup>1, 2</sup>...

## EMPIRE's 999VE

The Long-Playing Cartridge • \$74.95

1. *HiFi/Stereo Review*, July 1968. 2. *High Fidelity*, June 1968.

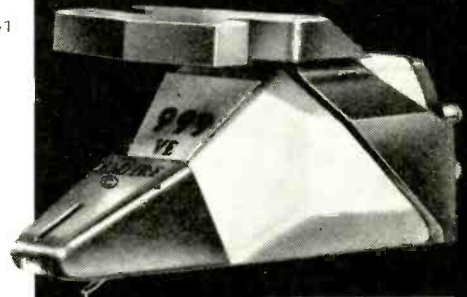

Empire Scientific Corp.,  **EMPIRE**  
1055 Stewart Avenue, Garden City, N.Y. 11530

CIRCLE NO. 19 ON READER SERVICE PAGE



# Look What's New In Your

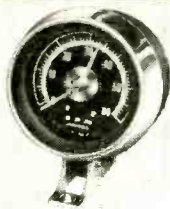

NEW kit MI-18-1

**\$29<sup>95</sup>**

NEW kit MI-18-2

**\$32<sup>95</sup>**

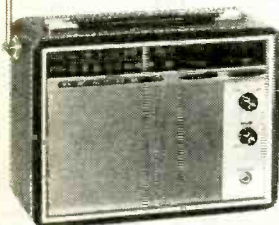

NEW kit GR-17

**\$43<sup>95</sup>**



NEW kit AD-27

**\$169<sup>95</sup>**

NOW, THE TUNER AND AMPLIFIER OF  
THE FAMOUS HEATH AR-15 RECEIVER ARE  
AVAILABLE AS SEPARATE COMPONENTS

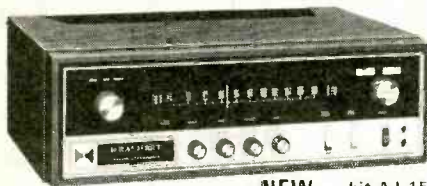

NEW kit AJ-15

**\$189<sup>95\*</sup>**



NEW kit AA-15

**\$169<sup>95\*</sup>**

## Heathkit Solid-State Tachometer

The Professional Tach. That's the new Heathkit MI-18. In Design: breaker point, "tach" lead or unique inductive pickup connection; use it with any spark-type engine and any ignition system, 2 cycle 1-6 cyl. engines or 4 cycle, 2-8 cyl. engines . . . all electronics are in the tach itself. In Performance: 0-6000 & 0-9000 RPM ranges . . . 250° edge-lighted dial . . . temperature-compensated,  $\pm 4\%$  accuracy from 0° - 120° . . . adjustable red line pointer . . . 10.5 to 17.5 VDC operation. In Styling: stainless steel hardware, splash-proof black & chrome case and scratch-proof glass face for use in rugged conditions. The MI-18-1 mounts in your dash — requires only a 3/4" hole & 2/4" depth. The MI-18-2 comes with mounting case & hardware. Put a Professional Tach in your car, boat, dune-buggy, or bike now — the Heathkit MI-18! Shpg. wt. 3 lbs.

## Heathkit AM-FM Portable Radio

Here's performance others can't match. The new Heathkit GR-17 portable has 12 transistor, 7 diode circuit with the same front end as Heathkit hi-fi tuners: 3-stage IF; big 4" x 6" speaker; tone control; AFC on FM and amplified AGC on AM; built-in AM rod antenna plus telescoping 34" FM antenna; 350 milliwatt output; and 200-300 hour battery life. Shpg. wt. 5 lbs.

## Heathkit FM Stereo COMPONENT-COMPACT

This new Heathkit AD-27 stereo compact has features not found in other units costing twice as much for one very simple reason. It wasn't engineered to meet the usual level of compact performance. Instead, Heath took one of its standard stereo/hi-fi receivers, the AR-14, and re-arranged it physically to fit a compact configuration. The result is performance that is truly high fidelity without compromise. It features 31 transistor, 10 diode circuitry with 15 watts per channel dynamic music power (enough to let you choose most any speaker systems you prefer), full-range tone controls, less than 1% distortion, and 12 to 60,000 Hz response. The pre-assembled FM stereo tuner section with 4-stage IF offers 5  $\mu$ V sensitivity, excellent selectivity, AFC, and the smoothest inertia tuning. The BSR McDonald "500" turntable offers features usually found only in more expensive units . . . like low mass tubular aluminum tone arm, anti-skate control, cueing and pause control, plus a Shure magnetic cartridge with diamond stylus. It's all housed in a smart oiled walnut cabinet with sliding tambour door that disappears inside the cabinet. For value and performance choose the AD-27, the new leader in stereo compacts. Shpg. wt. 41 lbs.

## HEATHKIT AJ-15 Deluxe Stereo Tuner

For the man who already owns a fine stereo amplifier, and in response to many requests, Heath now offers the superb FM stereo tuner section of the renowned AR-15 receiver as a separate unit. The new AJ-15 FM Stereo Tuner has the exclusive design FET FM tuner for remarkable sensitivity, the exclusive Crystal Filters in the IF strip for perfect response curve and no alignment; Integrated Circuits in the IF for high gain, best limiting; elaborate Noise-Operated Squelch; Stereo-Threshold Switch; Stereo-Only Switch; Adjustable Multiplex Phase, two Tuning Meters; two variable output Stereo Phone jacks; one pair variable outputs plus two fixed outputs for amps., recorders, etc.; front panel mounted controls; "Black Magic" panel lighting; 120/240 VAC operation. 18 lbs. \*Walnut cabinet AE-18, \$19.95.

## HEATHKIT AA-15 Deluxe Stereo Amplifier

For the man who already owns a fine stereo tuner, Heath now offers the famous amplifier section of the AR-15 receiver as a separate unit. The new AA-15 Stereo Amplifier has the same superb features: 150 watts Music Power; Ultra-Low Harmonic & IM Distortion (less than 0.5% at full output); Ultra-Wide Frequency Response ( $\pm 1$  dB, 8 to 40,000 Hz at 1 watt); Ultra-Wide Dynamic Range Preamp (98 dB); Tone-Flat Switch; Front Panel Input Level Controls; Transformerless Amplifier; Capacitor Coupled Outputs; Massive Power Supply; All-Silicon Transistor Circuit; Positive Circuit Protection; "Black Magic" Panel Lighting; new second system Remote Speaker Switch; 120/240 VAC. 26 lbs. \*Walnut cabinet AE-18, \$19.95.

# Free 1969 Heathkit® Catalog

New Lower Prices On Heathkit Color TV  
Make Them A Better Buy Than Ever!

Deluxe "295" Color TV...Model GR-295 **now only \$449.95**  
(less cabinet)

New improved phosphors and low voltage supply with boosted B+ for maximum color fidelity and operation • automatic degaussing • exclusive Heath Magna-Shield • AGC and AGC assures color purity. flutter-free pictures under all conditions • preassembled IF with 3 stages instead of the usual 2 • deluxe VHF turret tuner with "memory" fine tuning • choice of installation—wall, custom or optional Heath factory assembled cabinets • Easy to assemble.

Big, Bold, Beautiful... With Advanced Features and Exclusive Heathkit Self-Servicing. Top quality, American brand color tube... 295 sq. inch viewing area. The built-in dot generator and full color photos and simple instructions let you set-up, converge and maintain the best color pictures at all times. Add to this the detailed trouble-shooting chart in the manual and you put an end to costly TV service calls for periodic picture convergence and minor repairs.

GRA-295-4, Mediterranean cabinet shown ..... \$119.50  
Other cabinets from \$62.95

Deluxe "227" Color TV...Model GR-227 **now only \$399.95**  
(less cabinet)

Has same high performance features and built-in servicing facilities as the GR-295, except for 227 sq. inch viewing area. The vertical swing-out chassis makes for fast, easy servicing and installation. The dynamic convergence control board can be placed so that it is easily accessible anytime you wish to "touch-up" the picture.

GRA-227-1, Walnut cabinet shown ..... \$59.95  
Mediterranean style also available at \$99.50

Deluxe "180" Color TV...Model GR-180 **now only \$349.95**  
(less cabinet)

Same high performance features and exclusive self-servicing facilities as the GR-295 except for 180 sq. inch viewing area. Feature for feature the Heathkit "180" is your best buy in deluxe color TV viewing... tubes alone list for over \$245. For extra savings, extra beauty and convenience, add the table model cabinet and mobile cart.

GRA-180-5, table model cabinet and cart ..... \$39.95  
Other cabinets from \$24.95

## Now, Wireless Remote Control For Heathkit Color TV's

Control your Heathkit Color TV from your easy chair, turn it on and off, change VHF channels, volume, color and tint, all by sonic remote control. No cables cluttering the room... the handheld transmitter is all electronic, powered by a small 9 v. battery, housed in a small, smartly styled beige plastic case... feather-light and contoured to fit comfortably in your hand for easy pushbutton operation. The receiver contains an integrated circuit (15 resistors, 10 transistors, 1 diode) and a meter for adjustment ease. Circuit board construction and plug-in wire harness make installation of receiver and control motors easy. For greater TV enjoyment, order yours now.

kit GRA-295-6, 9 lbs., for Heathkit GR-295 and GR-25 Color TV's ..... \$69.95  
kit GRA-227-6, 9 lbs., for Heathkit GR-227 and GR-180 Color TV's ..... \$69.95

## FREE 1969 Heathkit Catalog

Shows these and over 300 other easy-to-build kits that save up to 50%... Electronic Organs, Stereo, Marine, CB, Ham Radio, Test, Photography, Educational for home & hobby. No skills or experience needed. Send for your free copy today. Mail coupon or write Heath Co., Benton Harbor, Michigan 49022.

3 HEATHKIT® COLOR TV'S  
NOW! ALL WITH 2-YEAR  
WARRANTY ON PICTURE TUBE

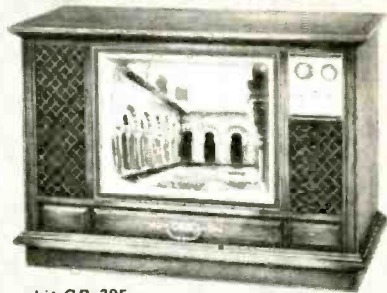

kit GR-295



kit GR-227



kit GR-180



NEW Wireless  
TV Remote Control

**\$69.95**

HEATH COMPANY, Dept. 10-10  
Benton Harbor, Michigan 49022  
In Canada, Daystrom Ltd.

Enclosed is \$....., plus shipping.  
Please send model(s).  
 Please send FREE Heathkit Catalog.  
 Please send Credit Application.

Name \_\_\_\_\_  
Address \_\_\_\_\_  
City \_\_\_\_\_ State \_\_\_\_\_ Zip \_\_\_\_\_

Prices & specifications subject to change without notice. CL-343



# BREAKTHROUGH



## IN ELECTRONICS CALCULATING

Still plodding through math and electronics problems the slow pencil-and-paper way? Smash the paperwork barrier with this new Electronics Slide Rule.

Even if you've never used a slide rule before, you can whip through resonant frequency calculations and inductive or capacitive reactance problems. You can find reciprocals for resistance formulas instantly. You can even locate tricky decimal points in a jiffy.

You can also work regular math problems in a flash: multiplication...division...square roots...logarithms...trigonometry. Anyone can use this sturdy 12-inch, all-metal slide rule. We show you how with our complete 4-lesson instruction course. Slide rule, course, and handsome leather carrying case deliberately priced low as our way of making friends with men in Electronics. FREE booklet gives full details. Mail coupon below today.

### MAIL THIS COUPON FOR FREE BOOKLET

**CIE** Cleveland Institute of Electronics  
1776 East 17th Street, Cleveland, Ohio 44114

Please send me your FREE booklet describing the Electronics Slide Rule and 4-lesson instruction course. Also FREE if I act at once—a handy pocket-sized Electronics Data Guide.

Name \_\_\_\_\_  
Address \_\_\_\_\_ (PLEASE PRINT)  
City \_\_\_\_\_  
State \_\_\_\_\_ Zip \_\_\_\_\_

PE-149

CIRCLE NO. 12 ON READER SERVICE PAGE

## ABOUT YOUR SUBSCRIPTION

Your subscription to POPULAR ELECTRONICS is maintained on one of the world's most modern, efficient computer systems, and if you're like 99% of our subscribers, you'll never have any reason to complain about your subscription service.

We have found that when complaints do arise, the majority of them occur because people have written their names or addresses differently at different times. For example, if your subscription were listed under "William Jones, Cedar Lane, Middletown, Arizona," and you were to renew it as "Bill Jones, Cedar Lane, Middletown, Arizona," our computer would think that two separate subscriptions were involved, and it would start sending you two copies of POPULAR ELECTRONICS each month. Other examples of combinations of names that would confuse the computer would include: John Henry Smith and Henry Smith; and Mrs. Joseph Jones and Mary Jones. Minor differences in addresses can also lead to difficulties. For example, to the computer, 100 Second St. is not the same as 100 2nd St.

So, please, when you write us about your subscription, be sure to enclose the mailing label from the cover of the magazine—or else copy your name and address exactly as they appear on the mailing label. This will greatly reduce any chance of error, and we will be able to service your request much more quickly.

**Indonesia**—*R. Angkatan Udara*, operated by the Indonesian Air Force, is being heard in N.A. and reports go to 51 Djalan Tjiptinang, Tjempedak I, Djatinegara, Diakarta. They will verify all correct reports. The current schedule is 0430-0730 and 0930-1330 on 2475 kHz (500 W) and 11,940 kHz (actually heard on 11,905 kHz) (7.5 kW).

**Israel**—*Kol Israel*, Jerusalem, has English to Europe at 2115-2130 on 9009 and 9725 kHz. To Africa at 2015-2030 on 9009 kHz, and French to Europe at 2045-2115 and 2145-2215 on 9009 and 9725 kHz.

**Italy**—Rome has Spanish to L.A. at 0305 on 15,340 kHz and Italian to the same areas at 1810-1905 on 21,560 kHz.

**Ivory Coast**—*Radiodiffusion Television Ivoirienne*, Abidjan, was logged on 3242 kHz from 2320-0000 s/off with ID's at 2330, 2315 and 0000; there was some Coast Guard QRM from 3240 kHz. Reports to B. P. 2261, Abidjan.

**Japan**—The General Service from *R. Japan*, Tokyo, is good at 2200-2215 in English and to 2230 in Japanese on 17,785 kHz to N.A., 15,195 kHz to Asia and 9700 kHz to Europe.

**Kuwait**—This country is experimenting with what seems to be a new high-power xmtr drifting from 21,475 to 21,525 kHz between 1750 and 0000. Some English has been noted around 1750-1820 and 2250-2315; they are requesting reports. Your Editor has not as yet heard this one but we did hear the ID via telephone from one of our monitors. Reports go to Box 397, Kuwait.



A 19-year-old college student, Edward Pyatt, of Atlanta, GA., uses a Hallicrafters S-120 and has heard 65 countries with 55 of them verified. He is a member of the North American Short Wave Association and the American SWL Club and has Monitor Certificate WPE41GG, with a 25 Country Award Seal on it.

**Maldiv Islands**—A schedule has been received which shows only the starting time of each xmsn. It reads as follows: transmitter of 2.7 kW on 7150 kHz at 0100 and 0930 and on 6150 kHz at 0300 and 1200; xmtr of 7 kW on 9552 kHz at 0700 and on 3321 kHz at 1330; xmtr of 30 kW on 4740 kHz at 1530 and on Tuesday and Wednesday at 1545.

**Nepal**—Xmtrs of 100 kW are now being used on 7165 and 9590 kHz with the former listed as operating at 1400-1600; the latter channel, according to a report from India, is being used at 1515-1620 s/off with "some English possible".

**New Caledonia**—A report from Paris says that the broadcasting center at Noumea will be replaced by a new center at Sainte-Marie. To be in operation in about a year, the center will have three xmtr's of 20 kW each on 1420, 3355, 4913, 7170 and 9510 kHz.

**New Zealand**—The current schedule from Wellington (P. O. Box 2396) reads: to Pacific Islands at 1700-1945 on 6080 and 9520 kHz, 2000-0545 on 15,110 kHz and 0600-0845 on 6080 and 9540 kHz; to

POPULAR ELECTRONICS



Australia at 2000-2230 on 11,705 kHz. 2245-0545 on 17,770 kHz and 0900-1145 on 9520 and 11,705 kHz; to Antarctica at 0815-0845 on 6080 kHz. Sunday only; to Niue Island at 0745 on 6080 and 9540 kHz on alternate Fridays.

**Nigeria**—*R. Nigeria*, Lagos, can be heard at times between 0450-0530 in their Commercial Service on 3986 kHz with pop music and commercials.

**Peru**—*R. Nacional del Peru* has been found on a new frequency of 17,890 kHz at 0900 with news in Spanish. OAZAR. *R. San Juan*, Tarma, is the station on 4891 kHz, not *R. Villarica* as claimed by some. It is noted weakly to 0430. *R. Villarica*, Huancavelica, has moved from 4805 to 4876.5 kHz where it has request music from 0500-0600.

**Portugal**—Lisbon was logged in their Portuguese Service to Brazil from 0050 on 17,760 kHz.

**South Africa**—*R. South Africa* (not *R. RSA*). Johannesburg, has English at 0500 to past 0530 with news, weather, time annts and pop music on 3965 kHz.

**Sweden**—French xmsn's from Stockholm: to Europe at 0930-1000 on 9625 kHz. to the Middle East at 0930-1000 on 21,690 kHz. to Africa at 1800-1830 on 15,240 kHz. to Asia at 1500-1530 on 21,585 kHz and 0545-0615 on 17,845 kHz. to Eastern N.A. at 1500-1530 on 17,760 kHz. and to Western N.A. at 0300-0330 on 11,705 kHz.

**Switzerland**—English xmsn's from Berne: to Australia and New Zealand at 0700-0800 on 9590 and 11,775 kHz. to Europe (weekdays only) at 0700-0800 on 3985, 6165 and 9535 kHz. to Japan and China at 0845-0945 on 17,830 and 21,520 kHz. to Africa at 1000-1100 on 15,305, 17,855 and 21,520 kHz and 1815-1915 on 15,180 and 17,845 kHz. to United Kingdom and Ireland at 1130-1230 and 1930-2030 on 9665 and 11,865 kHz. to S. and S.E. Asia at 1315-1415 on 15,305, 17,845 and 21,520 kHz. to the Near East at 1500-1600 on 15,305, 17,830 and 21,540 kHz. to Eastern N.A. at 0130-0230 on 9535, 11,715 and 15,305 kHz. and to Western N.A. at 0445-0545 on 9720 and 11,715 kHz.

**Tunisia**—*R. Televisione Tunisienne*, Tunis, has news to Africa in French at 1709 on a new frequency of 21,475 kHz.

**Vatican City**—A new program from *Vatican Radio* is "Tell Me How You Sing", 30 minutes in length on Sunday evenings: pop music and 'protest' songs and hits are to be presented with an aim of putting this station within the reality of everyday life. We'd appreciate the exact time and frequencies. Spanish in noted at 0030 on a new frequency of 11,895 kHz as well as at 2330 on 21,580 kHz. also new.

**Clandestine**—*R. Portugal Livre* was noted on 11,508 kHz at 2342 in Portuguese. very weak: it s/off at 2348.

**Gaelic Freedom Marchers**, said to be located on an island near Scotland, is reportedly operating from 0400 in Gaelic with some English ID's on 7258 kHz and Fridays from 0200-0500 on 8402 kHz.

*R. Euzkadi, The Voice of the Basque Underground*, is issuing QSL's (with a waiting time of 8 to 23 months!) with a schedule of 2030, 2130 and 2230 on 13,250 and 15,080 kHz. At one time we voiced an opinion that this station was believed to be mobile; their QSL card, with a photo of a permanently installed antenna tower located in tree-covered mountains would seem to indicate otherwise. The exact location, according to the QSL card, is near the west coast of Europe on or near the Spanish-French border. Reports go to E. P. 59, Poste Centrale, 75-Paris (16), France.

73, Hank, WPE2FT/W2PNA

### SHORT-WAVE CONTRIBUTORS

Vincent Geraci (*WPE1HMP*), Shelton, Conn.  
 Peter Macinta (*WPE2ORB*), Kearny, N. J.  
 Arthur Skopec (*WPE2PQJ*), Whitestone, N. Y.  
 Roger Wink (*WPE2PXF*), Penfield, N. Y.  
 Michael Flamm (*WPE2QDE*), New York, N. Y.  
 Harold Ort, Jr. (*WPE2QHN*), Gloversville, N. Y.  
 Robert Nagle (*WPE3DIX*), Allentown, Pa.  
 Paul Kilroy (*WPE3FOB*), Washington, D. C.  
 Henry Egges (*WPE3JN*), Philadelphia, Pa.  
 Dan Ferguson (*WPE4AUL*), Coral Gables, Fla.  
 Chuck Edwards (*WPE4BNK*), Fort Lauderdale, Fla.  
 John Brunst (*WPE4BO*), Neptune Beach, Fla.  
 Harry Helms, Jr. (*WPE4HNA*), Fort Mill, S. C.  
 Paul Buchanan (*WPE4IBG*), Charlotte, N. C.  
 Kirk Randall (*WPE4JQI*), McLean, Va.  
 Glenn Little (*WPE4JYC*), Kingston, Jamaica  
 David Potter (*WPE4JXO*), Key West, Fla.  
 Stewart MacKenzie (*WPE6AA*), Huntington Beach, Cal.  
 Trevor Clegg (*WPE6FAF*), Fresno, Cal.  
 Bruce Broisma (*WPE6GMD*), Northridge, Cal.  
 Bruce Smith (*WPE6HCR*), San Diego, Cal.  
 Jim Lacko (*WPE6HCX*), Arleta, Cal.  
 Jeff Uiter (*WPE6HDI*), Carlsbad, Cal.  
 Wayne Anderson (*WPE7CXP*), Tucson, Ariz.  
 Bill Eisinger (*WPE7COO*), Gooding, Idaho  
 Greg Scheurman (*WPE7CPO*), Cheyenne, Wyo.  
 Louis Schulman (*WPE8JTX*), Cleveland Heights, Ohio  
 Gerry Dexter (*WPE9HDB*), Lake Geneva, Wis.  
 Gary Bullinger (*WPE9JCZ*), Aurora, Ill.  
 A. R. Niblack (*WPE9KAI*), Vincennes, Ind.  
 John Beaver (*WPE0AE*), Pueblo, Colo.  
 Frederik Klaassen (*KP4PE2V*), Santurce, P. R.  
 Jack Perolo (*PY2PE1C*), Sao Paulo, Brazil  
 Fred Baines (*VE1PE2C*), New Glasgow, N. S.  
 Lembit Lellup (*VE3PE2MI*), Castleton, Ont.  
 Ian Davidson (*VE3PE2ND*), Sarnia, Ont.  
 Jeff Wilson (*VE3PE2NL*), Sarnia, Ont.  
 Richard Lavolette (*VE7PE2M*), Kelsey Bay, B. C.  
 Leo Alster, Rabway, N. J.  
 Rusty Clements, Del Mar, Calif.  
 Carey Fisher, Albany, Ga.  
 Mike Manry, Houston, Texas  
*Kol Israel*, Jerusalem, Israel  
*Radio New York Worldwide*, New York, N. Y.  
*Sweden Calling DX'ers Bulletin*, Stockholm, Sweden

KEEP IN TOUCH WITH THE ACTION!

**SONARCOM**  
 VHF-FM 2 WAY  
 TRANSCEIVER

(132-174 MHz)

FCC TYPE  
 ACCEPTED

for parts 89,91,93 and  
 part 21 telephone use  
 ALSO DOT ACCEPTED  
 for Canadian use

**\$375** with  
 1 pair  
 of crystals and  
 penlite batteries



**INSTANT 2 Way Communications To All Points!**

**YOU ALWAYS GET THROUGH . . . OPERATES ANYWHERE!  
 INDOORS, OUTDOORS, IN STEEL BUILDINGS**

More performance and features than much higher priced units • engineered with space age techniques and military type components for high reliability, superior performance and long life • Provides instant voice contact with base stations, mobile units and other portable transceivers • compatible with all VHF narrowband systems • exclusive "Push-to-Talk" mike • Full frequency range for all public safety, industrial and land transportation services • single or split channel operation • 1.6 watts output.

**SONAR RADIO CORP., 73 Wortman Ave., Brooklyn, N.Y. 11207**  
 Please send information on Model 2301—the SONARCOM. Dept. 713

Firm Name \_\_\_\_\_ Title \_\_\_\_\_  
 Address \_\_\_\_\_ Phone \_\_\_\_\_  
 City \_\_\_\_\_ State \_\_\_\_\_ Zip \_\_\_\_\_

CIRCLE NO. 41 ON READER SERVICE PAGE

WORLD'S SMALLEST

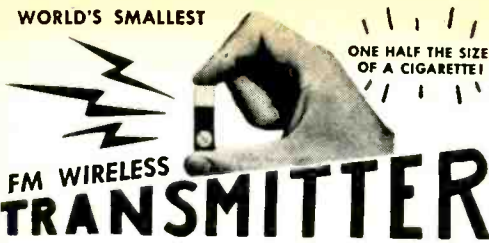

# FM WIRELESS TRANSMITTER

**"LISTEN-IN" ON ANY FM RADIO!**

This miniature electronic marvel picks up the slightest sounds and clearly transmits them to any standard FM radio up to 150 feet away! Latest engineering advances in micro-miniaturization have reduced this unit to ONE HALF THE SIZE OF A REGULAR LENGTH CIGARETTE! Completely self contained unit including sensitive sub-miniature mike and battery!

Many uses include: Portable public address system, burglar alarm, improve sales talks, personal baby sitter, guitar amplifier, etc. Comes complete including battery and plastic screwdriver for changing frequency (88-108mcs).

**29<sup>95</sup>**

ORDER NOW! ALL ORDERS RUSHED BY RETURN MAIL!  
10 DAY FREE TRIAL! Dealer inquiries invited!

© 1968

SONIC DEVICES Dept. PE-10  
69-29 Queens Blvd., Woodside, N. Y. 11377

Please rush my transmitter! I will examine it in my home for 10 full days and if I am not 100% satisfied I will return it for a full and prompt refund.

Name.....City.....

Address.....State & Zip.....

Please rush new 1968 Catalogue of Listening Devices. \$1.00 enclosed.

## FIVE COURSES FOR TECHNICIANS WITH EXTENSIVE LABORATORY TRAINING!



ALL Courses approved for Veterans' training

- Electronics Technician ..... eight, 10-week sessions
- Electronics Mechanic ..... six, 10-week sessions
- Broadcast Engineer ..... six, 10-week sessions
- Radiotelegraph Operator ..... five, 10-week sessions
- Radio-TV Servicing ..... four, 10-week sessions

1968 date: November 11  
1969 dates: January 20, March 31, June 9,  
September 2, and November 10

## PORT ARTHUR COLLEGE

1500 Procter, Box 310, Port Arthur, Texas 77640

FREE BROCHURE

CIRCLE NO. 32 ON READER SERVICE PAGE

112

## SPORTS TIMER

(Continued from page 41)

spacers are used, place a non-conducting washer between each spacer and the adjacent foil section to avoid any chance of short circuits. Use 3"-long thin bolts to fasten the boards together. The bolt passing through the bottom portions has a small L bracket at each end to secure the bottom edges of the boards to the base of the chassis. A similar pair of L brackets is used to secure the outer boards at the front. Mount an insulated single-lug terminal strip at the nut end of the upper mounting bolt as shown in Fig. 9 to support resistor R2.

Drill suitable holes in the base to mount the fuse holder, power transformer, and power supply as shown in the photo. Mount the power supply using four small standoffs, then secure the transformer and the fuse holder.

Once all components have been mounted, insert the bulbs in the respective plastic holders and wire the components as shown in Fig. 8.

**Testing.** Once final assembly is complete, turn on the power (S1) and note that the decimal point and the colon indicator lamps come on. The various counters will be at some random numerical indication. Depressing the RESET button should cause all readouts to indicate zero.

Being very careful, use a small piece of wire to make an electrical contact between the center contact of the (+) jack J1 and the similar contact on START jack J2. As soon as this is done, the counters will start to operate. The counter on the far right (thousandths of a second) will assume a dim, blurred condition, indicative of very fast counting. The counters to the left of it will operate much slower. The second to the left indicates hundredths of a second and the third indicates tenths of a second. The counter to the left of the decimal point indicates unit seconds, while the next counter to the left is tens of seconds. The latter is the modulo-6 counter that only goes to 5. At the 60th second, all counters to the right of the colon drop

POPULAR ELECTRONICS



to zero with the minutes counter advancing to the next count. The counters will not stop, and you will see them proceed to 9 minutes, 59.999 seconds and repeat.

To stop the counter at any time, insert the wire jumper between the center contact of *J1* and the similar contact on the STOP jack *J3*. The various counters will stop and the real time can be read on the front-panel indicator lamps. Depressing the RESET button will zero the count. If the RESET button is depressed while the counting is taking place, the indicated time value will drop to zero, but immediately start up again as soon as the RESET button is released. This push-button has no effect on the three fixed indicator lamps. To shut the system down, turn *S1* to OFF.

Before assembling the cover on the chassis, use contact-adhesive plastic to give it a finished look.

**Starting and Stopping.** There are many ways to start the clock, and all depend on providing the START input jack with a positive-going pulse. For races of all types, you can use the photopickoff shown in Fig. 10 at either the start or finish line. Place a light source on one side of the track, focused either by a lens or a length of tubing in front of the lamp so that the light beam strikes the photo-Darlington transistor. A similar lens system, or length of tubing can be placed over the photo transistor to prevent triggering by ambient light. The switch shown in Fig. 10 is used to select either the presence or absence of light as the trigger.

The (+) jack is used to provide 3.6 volts to power any external trigger circuit.

**Modifications.** The timing unit kit is supplied with a 100-kHz, 0.005% tolerance crystal. With this crystal, the last digit on the right will not be accurate, although it can be used as a relative time indicator. Replacing the 0.005% crystal with one with an accuracy of 0.001% will produce the correct timing in the thousandths column.

If you want to read times up to one hour, add another modulo-6 counter at the left, driven by the "carry" of the minutes counter M8. The clock will now

October, 1968

# Free Sound Catalog

The largest selection of speaker system components. Anywhere.



Send for your free copy...today! **jensen**

Jensen Manufacturing Division, The Muter Company  
5655 West 73rd Street • Chicago, Illinois 60638

NAME \_\_\_\_\_

ADDRESS \_\_\_\_\_

CITY \_\_\_\_\_

STATE \_\_\_\_\_

ZIP \_\_\_\_\_

CIRCLE NO. 26 ON READER SERVICE PAGE

# FREE



**GIANT 1969  
RADIO-TV  
ELECTRONICS  
CATALOG**  
228 GIANT  
VALUE-PACKED  
PAGES

WRITE FOR YOUR FREE COPY TODAY

BURSTEIN-APPLEBEE CO., DEPT. PEV  
3199 MERCIER ST., K. C., MO. 64111

NAME \_\_\_\_\_

ADDRESS \_\_\_\_\_

CTY \_\_\_\_\_

STATE \_\_\_\_\_

ZIP \_\_\_\_\_

CIRCLE NO. 9 ON READER SERVICE PAGE



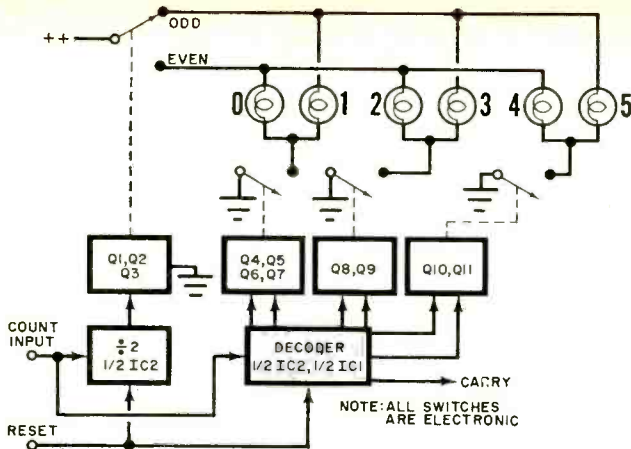

### HOW IT WORKS

Operation of the decimal counting unit was described in the February 1968 issue and the timing unit in March 1968; therefore, only the operation of the modulo-6 counter will be described here.

The input pulse train is fed to a divide-by-two counter (half of IC2), a flip-flop which changes state with each input pulse. One state of the flip-flop indicates an odd number, while the other indicates an even number. The odd-even signal is processed by transistors Q1, Q2, and Q3 so that, on even numbers, the "even" bus is energized, and on odd numbers, the "odd" bus is energized. The five state-indicating incandescent lamps are connected in pairs to the odd and even buses, and each pair is connected to ground through a set of switching transistors. These transistors act as open switches when they are cut off and closed switches when saturated, thus determining when each bulb is lit.

After passing through the divide-by-two stage, the input signal goes to a decoder consisting of the other half of IC2 and half of IC1. This counter determines whether the number being counted is 0 or 1, 2 or 3, or 4 or 5. The correct switching signals are then passed to three sets of switching transistors which connect the bulbs to ground.

As an example of how the counter works, assume that the count has reached the number 4. The divide-by-two counter has determined that this is an even number and has supplied power to the even bus. The decoder has determined that it is either a 4 or 5, and thus turns on the Q8-Q9 combination. The other two switches are left open. Under these conditions, only bulb 5 is illuminated.

On each sixth input pulse, the counter automatically cycles back to the zero state, and supplies an output pulse to the "carry" terminal. This pulse is used as the count input for any succeeding counters.

read to 59 minutes, 59.999 seconds. If you want to read up to 10 hours, add both the tens-of-minutes counter and another decade counter driven by the last "carry" output. The clock will now read to 9 hours, 59 minutes, and 59.999 seconds.

This should be enough for almost any race. To convert the clock to read only hours, minutes, and seconds, as does a conventional clock, requires a little more logic and may be the subject of another article.

-30-



*Eaglelette*



Dept. J, 1269 Union Avenue, Laconia, New Hampshire 03246  
Telephone: (603) 544-5495

Keep in touch with the Browning Eagles this Fall!

### STOP - LOOK - LISTEN The airways are filling with EAGLES . . .

These Browning Eagles fly together with peak performance and quality that only 30 yrs. of research in the field can provide. Each unit offers a 23 channel selection. The Golden Eagle provides 1) auto-gain control for Distance, Normal or Local positions; 2) Filter for more than 80DB adjacent channel rejection; 3) Ultra-fine tuning; 4) Easy-to-read meters and selectors; 5) highly accurate plug-in crystals; and many other outstanding features.

*Golden Eagle*



(write for tech. info. and Serv. Ctr. nearest you)

CIRCLE NO. 8 ON READER SERVICE PAGE

# POPULAR ELECTRONICS READER SERVICE PAGE

## free information service:

Here's an easy and convenient way for you to get additional information about products advertised or mentioned editorially (if it has a "Reader Service Number") in this issue. Just follow the directions below... and the material will be sent to you promptly and free of charge.

**1.** Print or type your name and address on the lines indicated. Circle the number(s) on the coupon below that corresponds to the key number(s) at the bottom of the advertisement or editorial mention(s) that interest you. (Key numbers for advertised products also appear in the Advertisers' Index.)

**2.** Cut out the coupon and mail it to the address indicated below.

**3.** This address is for our product "Free Information Service" only. Editorial inquiries should be directed to POPULAR ELECTRONICS, One Park Avenue, New York 10016; circulation inquiries to Portland Place, Boulder, Colorado 80302.

**POPULAR  
ELECTRONICS**

P.O. BOX 8391  
PHILADELPHIA, PA. 19101

VOID AFTER NOVEMBER 30, 1968

1 2 3 4 5 6 7 8 9 10 11 12 13 14 15 16 17 18 19 20  
21 22 23 24 25 26 27 28 29 30 31 32 33 34 35 36 37 38 39 40  
41 42 43 44 45 46 47 48 49 50 51 52 53 54 55 56 57 58 59 60  
61 62 63 64 65 66 67 68 69 70 71 72 73 74 75 76 77 78 79 80  
81 82 83 84 85 86 87 88 89 90 91 92 93 94 95 96 97 98 99 100

NAME (Print clearly) \_\_\_\_\_

ADDRESS \_\_\_\_\_

CITY \_\_\_\_\_ STATE \_\_\_\_\_ ZIP CODE \_\_\_\_\_

10 b

# Build this pipelike Schober Recital Organ

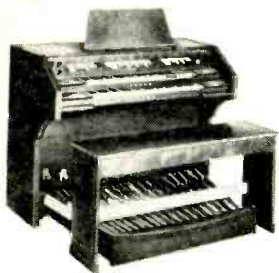

for only  
\* \$1725!

\*Includes finished walnut console. (Only \$1361 if you build your own console.) Amplifier, speaker system, optional accessories extra.

You couldn't touch an organ like this in a store for less than \$4,000—and there never has been an electronic instrument with this vast variety of genuine pipe-organ voices that you can add to and change any time you like! If you've dreamed of the sound of a large pipe organ in your own home, if you're looking for an organ for your church, you'll be more thrilled and happy with a Schober Recital Organ than you could possibly imagine—kit or no kit.

You can learn to play it—and a full-size, full-facility instrument is easier to learn on than any cut-down "home" model. And you can build it, from Schober Kits, world famous for ease of assembly without the slightest knowledge of electronics or music, for design and parts quality from the ground up, and—above all—for the highest praise from musicians everywhere.

Send right now for the full-color Schober catalog, containing specifications of all five Schober Organ models, beginning at \$599.50. No charge, no obligation. If you like music, you owe yourself a Schober Organ!

The *Schober* Organ Corp., Dept. PE-27  
43 West 61st Street, New York, N.Y. 10023

- Please send me Schober Organ Catalog and free 7-inch "sample" record.  
 Enclosed please find \$1.00 for 12-inch L.P. record of Schober Organ music.

NAME \_\_\_\_\_

ADDRESS \_\_\_\_\_

CITY \_\_\_\_\_ STATE \_\_\_\_\_ ZIP \_\_\_\_\_

CIRCLE NO. 37 ON READER SERVICE PAGE

## HEAVY DUTY WELDER



Does work of \$85.00 welder

yet costs only **1895**  
POST PAID

Fits ordinary 110V outlet  
3 welding heats

Weld, braze, solder or cut most anything made of metal. No experience needed. Follow simple instructions. Uses standard  $\frac{3}{16}$ " rods to weld iron, steel, brass, bronze, aluminum, other metals. 3 welding heats . . . not just one as with other low priced models. New HEAVY DUTY circuit gives higher heat . . . 4 times the heat needed to melt toughest iron. More welding power than ever before. Comes complete with welder's mask, \$2.00 pack of rods, flux, carbons, automatic arc striker, etc. NOTHING ELSE TO BUY. Approved for homes, garages, shops, factories. 10 day MONEY BACK trial. Guaranteed against burnouts. Send \$2.00 and pay \$16.95 plus small C.O.D. when delivered. or send \$18.95 cash, c.k., M.O. for postpaid shipment.  
WEL-DEX MFG. CO., Dept. W-50 Box 10776, Houston, Texas 77010

## FREQ-OUT

(Continued from page 48)

photocell is small enough to be hidden easily in decorative woodwork and may be separated from the modulator by a considerable distance as long as co-axial line is used to connect the two.

Some applications may require a set of contacts which close when the demodulator is actuated and remain closed until some specific action is taken to reset the relay. This can be done using external circuits, of course, but it is easier to do it by replacing *D5* with a wire jumper. Then the relay will automatically latch in once it has been actuated. A single-pole, normally closed switch placed in the lead between *K1* and point *C* on the *PC* board will serve as a reset switch.

There are some applications, such as garage door openers, which require contacts that alternate states on successive activations. This can be accomplished in the Freq-Out by substituting an impulse relay (such as Potter and Brumfield type *PC11D*) for *K1*. For applications where a stepping relay is required, a Guardian type *IR-705-12P-6D* is small and relatively inexpensive.

Most intrusion-alarm applications require that the relay be closed under normal conditions because of the light beam falling on the photocell. When the beam is interrupted, the relay opens and an alarm is sounded. It is also desirable to have the relay remain open after the light beam has been restored. The Freq-Out may be made to operate in this way by breaking the connection from point *C* on the *PC* board to *K1* and wiring the free ends to one of the normally open contacts on the relay. In addition, a normally open single-pole pushbutton switch should be wired across these contacts to serve as a reset [see Fig. 7(A)].

A more versatile system is shown in Fig. 7(B). With this arrangement, using a three-position switch, the relay may be latched on in the presence of a light signal, latched on in the absence of light, or operated in the normal mode. A common reset for both latching modes is also provided.

Operation. Once you have selected the



type of Freq-Out you want and have built the modulator and demodulator, setting up the system is easy. Simply plug in the demodulator, turn it on and shine the light on the photocell. If you wish, you can use mirrors to bend the light beam and lenses to focus the beam. The Freq-Out is designed to operate in the near-infrared portion of the spectrum so you can make the beam almost invisible by filtering it through several layers of red cellophane. The operation of the unit will not be affected.

Although the circuits in the Freq-Out are insensitive to normal variations in ambient lighting, bright sunlight should not be allowed to fall directly on the photocell. If necessary, a shield of cardboard or plastic should be used to protect the photocell.

-30-

## PC BOARDS

(Continued from page 72)

the panel, copper side up, in the tray and occasionally tip the tray back and forth so that the etchant keeps moving. Use a plastic rod to tilt the tray, as most etchants will discolor skin or clothes they contact. Once etched (all the copper has been removed from the unwanted areas), wash the panel in running cold water for a few minutes.

There are two ways to remove the dyed resist. You can dip the board in the developer then wipe it clean using a towel or other cloth; or, you can use some fine steel wool to remove the dyed resist. If you use the former method, make sure that you go over the copper pattern with fine steel wool to prepare the surface for soldering (after the holes are drilled). If you use the latter process, you can, if desired, use steel wool to remove the black dyed resist from a small area immediately surrounding the soldering holes. In this way, when the board is finished, the pattern will stand out in a distinctive black.

After some use, the developer will develop a "skin". This means that it should be disposed of and a new batch of developer used.

-30-

October, 1968

# NOW OFFERED FOR THE FIRST TIME TO THE PUBLIC GRAYMARK ELECTRONICS PROJECTS

Hobbyist / Experimenter / Student

For years, teachers have used Graymark classroom projects to provide (1) the basics of electronics theory and (2) valuable and workable end products. Now, for the first time, Graymark offers certain of these projects to the public. You can now embark on an exciting, step-by-step journey toward the building of your own highly professional, eight-transistor or five-tube radio . . . besides learning a great deal about electronics. Each project comes complete with all parts and easy-to-follow instructional manual. All parts fully warranted.

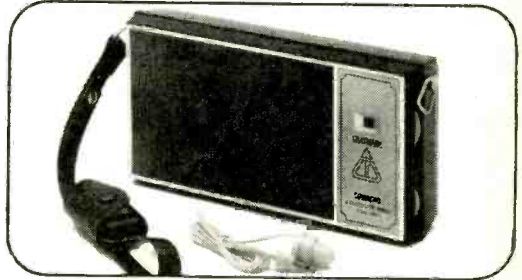

**"COMACHO" EIGHT-TRANSISTOR RADIO.** Project provides basics of superheterodyne transistor theory operation. Builds into an attractive printed circuit-board radio, mounted in plastic case. Compares favorably with more expensive units. Earphone included. \$19.95 each.

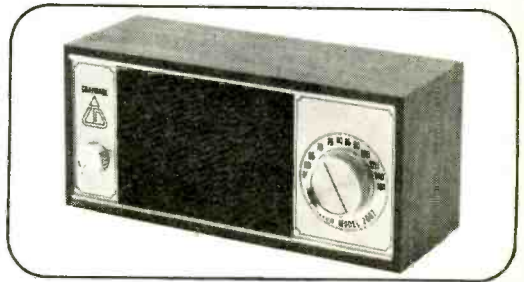

**"SCALLON" FIVE-TUBE RADIO.** Easy-to-understand project approach to superheterodyne circuitry. Assembles into a distinctive table-type radio. Tubes, contemporary walnut cabinet included. \$21.95 each.



Send order today to:  
**GRAYMARK Enterprises, Incorporated**  
Dept. 101, P.O. Box 54343, Ter. Annex, Los Angeles, Calif. 90054

Send Projects Checked

COMACHO (\$19.95 ea.)  SCALLON (\$21.95 ea.)  
 Send Postpaid. Enclosed find check/money order for full amount. (Calif. Res. add 5% to total purchase)

Send C.O.D. I will pay full amount, plus postage.

Name \_\_\_\_\_

Address \_\_\_\_\_

City & State \_\_\_\_\_

Zip \_\_\_\_\_

**CIRCLE NO. 24 ON READER SERVICE CARD**

117



## SAVE BIG MONEY ON ELECTRONICS

**FREE**

Buy from RADIO SHACK, America's biggest nationwide electronics store chain. Send now for your free copy of our new 1969 bargain-packed electronics catalog... plus a year of special bargain bulletins. Write to—



### RADIO SHACK®

2727 West 7th St., Dept. YZ  
Fort Worth, Texas 76107

### FREE CATALOG AND BARGAIN BULLETINS

Name .....

Address .....

City ..... State ..... Zip .....

Radio Shack—subsidiary of Tandy Corporation  
Over 300 stores coast to coast

**CIRCLE NO. 49 ON READER SERVICE PAGE**

### COMMUNICATIONS HANDBOOK

World's most complete guide to communications. 148 fact packed pages of features by experts in each category.

1968...\$1.25...#53

1967...\$1.25...#47

Order by number from

Ziff-Davis Service Div., 595 Broadway, New York, N.Y. 10012. Enclose add'l 15¢ per copy for shipping and handling (50¢ for orders outside U.S.A.)

## GET INTO ELECTRONICS

V.T.I. training leads to success as technicians, field engineers, specialists in communications, guided missiles, computers, main automation. Basic & advanced courses. Electronic Engineering Technology and Electronic Technology curricula both available. Associate degree in 29 months. B.S. obtainable. G.I. approved. Start February, September, Dorms, campus. High school graduate or equivalent. Catalog.

**VALPARAISO TECHNICAL INSTITUTE**  
DEPARTMENT PE, VALPARAISO, INDIANA 46383



## COLOR TV—THAT ISN'T

(Continued from page 75)

video-tape recordings, or even, if fitted to a motion-picture camera, turn out full-color movies, on black-and-white film.

**What Next?** While this optical system will broadcast pictures in natural color, it has a number of inherent flaws that have to date restricted the use of electronic color to certain types of "special effects" commercials.

The slow speed of the filter rotation—necessary for color definition—also makes the picture shimmer, flash and appear generally unsteady. The color quality isn't uniform and some viewers see hues almost as saturated as those of a conventional color TV receiver. Other viewers discern only one or two tints, and a minority of viewers apparently can detect no color whatsoever.

Yet despite its shortcoming, electronic color does seem to be a commercial success, and Color-Tel Corporation, Hollywood, California, is using the Butterfield process to make successful television commercials.

When electronic color was first publicly demonstrated in the Los Angeles area over KNXT, no prior announcement had been made at the request of a soft-drink manufacturer sponsoring the test. The beverage firm wanted its color commercials to be a complete surprise to viewers of black-and-white receivers. And, the telecasts were that, to say the very least. Within hours of the electronic-color broadcast, thousands of viewers began asking the same question, "What happened? Did I really see color on my black-and-white receiver? Or am I having hallucinations?"

Right now, Color-Tel engineers are checking into the possibility of using electronic color for such things as color radar displays, color computer readouts, and perhaps even color sonar pictures. It may be true that, in its present stage of development, Butterfield's process is nothing but a scientific curiosity—however, 25 years ago, so was television. —30—



# ELECTRONICS MARKET PLACE

**COMMERCIAL RATE:** For firms or individuals offering commercial products or services. \$1.15 per word (including name and address). Minimum order \$11.50. Payment must accompany copy except when ads are placed by accredited advertising agencies. Frequency discount: 5% for 6 months; 10% for 12 months paid in advance.

**READER RATE:** For individuals with a personal item to buy or sell. 70¢ per word (including name and address). No Minimum! Payment must accompany copy.

## FOR SALE

**FREE!** Giant bargain catalog on transistors, diodes, rectifiers, SCR's, zeners, parts. Poly Paks, P.O. Box 942, Lynnfield, Mass. 01940.

**GOVERNMENT Surplus Receivers, Transmitters, Snooperscopes, Radios, Parts, Picture Catalog 25¢.** Meshna, Nahant, Mass. 01908.

**R.F. CONVERTERS.** World's largest selection. Also CCTV cameras, etc. Lowest factory prices. Catalog 10¢. Vanguard 196-23 Jamaica Ave., Hollis, N.Y. 11423.

**BUG DETECTOR: WILL DETECT AND LOCATE SURREPTITIOUS TRANSMITTING DEVICES IN CONFERENCE ROOMS, HOME AND OFFICES, ETC. WRITE FOR DETAILS.** WJS ELECTRONICS, 737 NORTH SEWARD, HOLLYWOOD, CALIF. 90038.

**ROCKETS:** Ideal for miniature transmitter tests. New illustrated catalog, 25¢. Single and multistage kits, cones, engines, launchers, trackers, rocket aerial cameras, technical information. Fast service. Estes Industries, Dept. 18, Penrose, Colorado 81240.

**LOWEST Prices Electronic Parts.** Confidential Catalog Free. **KNAPP**, 3174 8th Ave. S.W., Largo, Fla. 33540.

**CRYSTALS** . . . largest selection in United States at lowest prices. 48 hr. delivery. Thousands of frequencies in stock. Types include HC6/U, HC18/U, FT-241, FT-243, FT-171, etc. Send 10¢ for catalog with oscillator circuits. Refunded on first order. Jan Crystals, 2400F Crystal Dr., Fort Myers, Fla. 33901.

**TREASURE Hunters! Prospectors!** Relco's new instruments detect buried gold, silver, coins. Kits, assembled models. Transistorized. Weighs 3 pounds. \$19.95 up. Free catalog. Relco-A33, Box 10836, Houston, Texas 77018.

**DIAGRAMS**—Radios \$1.50, Television \$3.00. Give make and model. Diagram Service, Box 1151PE, Manchester, Conn. 06042.

**EUROPEAN** and Japanese bargain catalogs. \$1 each. Dee, 10639E Riverside, North Hollywood, Calif. 91602.

**TRANSISTORIZED CONVERTER KITS:** Two models, converts car radio. Receive 30-50mc or 100-200mc (one mc tuning) \$5.00 with simple instructions. Crystal \$2.50. Meshna, No. Reading, Mass. 01864.

**MECHANICAL,** Electronic devices catalog 10¢. Greatest Values—Lowest Prices. Fertik's, 5249 "D", Philadelphia, Pa. 19120.

**MUSIC LOVERS, CONTINUOUS, UNINTERRUPTED BACKGROUND MUSIC FROM YOUR FM RADIO, USING NEW INEXPENSIVE ADAPTOR. FREE LITERATURE.** ELECTRONICS, 11500-Z NW 7th Ave., MIAMI, FLORIDA 33168.

**NEW Sensitive Treasure Metal Detectors.** New low prices. Professional models from \$29.95 to \$129.50. Write for free catalog today. Jetco Electronics, Box 132-E, Huntsville, Texas 77340.

**JAPANESE or EUROPEAN DIRECTORY** 200 firms \$1.00. **SURVEILLANCE EQUIPMENT,** Catalog 25¢. Wireless **SNOOPERMIKE** \$25.00. **SUBMINIMIKE** 3/8 x 3/8 x 3/16 \$4.00. **SIERRATRONICS,** Box 7497, Las Vegas, Nev. 89101.

**WE SELL CONSTRUCTION PLANS. TELEPHONE:** Answering Machine, Speakerphone, Carphone, Phonevision, Legal Connector, Auto Dialer, Central Dial System. **TELEVISION:** \$35.00 Color Converter, Tape Recorder, 3DTV, \$25.00 Camera. **DETECTIVE:** Infinity Transmitter, Tail Transmitter, Police Radar Detector. **HOBBYIST:** Electron Microscope, 96 Hour Tape Music System, Ultrasonic Dishwasher, Radar-Oven, Electronic Tranquilizer. Plans \$4.95 each. **COURSES:** Telephone Engineering \$39.50, Detective Electronics \$22.50, Anti-Detective Electronics \$27.50. **SUPER HOBBY CATALOG** 25¢. Don Britton Enterprises, 7906 Santa Monica Blvd., Hollywood, Calif. 90046.

**CIRCUIT Boards, Parts** for "Poptronics" projects. Free catalog. S.W. Technical, Box 16297, San Antonio, Texas 78216.

**GENERAL INFORMATION:** First word in all ads set in bold caps at no extra charge. Additional words may be set in bold caps at 10¢ extra per word. All copy subject to publisher's approval. Closing Date: 1st of the 2nd preceding month (for example, March issue closes January 1st). Send order and remittance to: Hal Cymes, POPULAR ELECTRONICS, One Park Avenue, New York, New York 10016.

**SURVEILLANCE COUNTERMEASURES BROCHURE \$1.00. ENGINEERING LABORATORIES, BOX 1036, ANDERSON, INDIANA 46015.**

**WEBBER LAB'S.** Police & Fire Converters. Catalog 10¢. 72 Cottage Street, Lynn, Mass. 01905.

**PROXIMITY** switch. Detects nearness of human body! Free information. Claremont Products, 860 Reed, Claremont North, Calif. 91711.

**RADIO—T.V.** Tubes—33¢ each. Send for free catalog. Cornell, 4213 University, San Diego, Calif. 92105.

**SONAR** Monitor Receivers unsurpassed. Fire, police, ambulance, taxi, highway patrol communications, exceptional values. Griffin's, 322 West State, Ithaca, N.Y. 14850.

**SECURITY AND PRIVACY PROTECTION DEVICES. FREE DATA: SECURITY ELECTRONICS PE, 15 EAST 43RD STREET, NEW YORK, N.Y. 10017.**

**WHOLESALE COMPONENTS:** Manufacturers and distributors only. Request free catalog on business letterhead. **WESCOM,** Box 2536, El Cajon, California 92021.

**CONVERT** any television to sensitive, big-screen oscilloscope. Only minor changes required. No electronic experience necessary. Illustrated plans, \$2.00. Relco-A33, Box 10563, Houston, Texas 77018.

**TELEVISION CAMERA KITS!** Wide selection tube and transistor models. Starter kits, \$18.95 up. Complete kits \$149.50 up. Plans available separately; tube camera \$3.00, transistor camera \$5.00, TV station \$1.00, ATV literature anthology \$2.50. Catalog **FREE.** **ATV RESEARCH,** 13th & Broadway, Dakota City, Nebraska 68731.

**THOUSANDS** and thousands of types of electronic parts, tubes, transistors, instruments, etc. Send for Free Catalog. Arclurus Electronics Corp., MPE, 502-22nd St., Union City, N.J. 07087.

**RECTIFIERS,** transistors, other components. Catalog free. Electronic Components Co., Box 2902C, Baton Rouge, La. 70821.

**JAPAN DIRECTORY.** Electronics products and parts. General merchandise and Asia trade information. Just \$1.00 today. Ippano Kaisha Ltd., Box 6266, Spokane, Washington 99207.

**DIAGRAMS, Parts List, Etc.**—TV \$2.00. Radio, CB, Hi-Fi, Etc. \$1.00. Airmail. Evergreen Electronics, P.O. Box 2233, Everett, Washington 98201.

**NEW BSR** record changers—\$13. Garrards—\$22. Radio-phonos stereo receivers—\$15. "Changers PE", 2737 3rd Ave., Bronx, N.Y.

**CB EQUIPMENT and ACCESSORIES.** All makes. Transceivers, Antennas, Crystals, Mikes, etc. Lowest Prices, Write for Price Quote. Evergreen Electronics, P.O. Box 2232, Everett, Washington 98201.

**LINEAR AMPLIFIERS:** "Hornet" 50 watts output—\$98.50; "Raider" 100 watts—\$139.50; "Maverick-250"—250 watts—\$244.95. AM and SSB. "Scorpion"—50 watt 12 V. Mobile amplifier—\$99.95; "Bandit II"—12 V. Mobile Amplifier—\$169.95. Frequency range 20-35 megacycles (illegal for class D 11 meters.) Dealer inquiries invited. D & A Manufacturing Co., 1217 Avenue C, Scottsbluff, Nebraska 69361.

**LAW ENFORCEMENT AGENTS and LEGAL INVESTIGATORS ONLY. FREE LITERATURE, LATEST ELECTRONIC AIDS. REQUEST MUST BE ON YOUR OFFICIAL LETTERHEAD.** R. CLIFTON, 11500-L NW 7th Ave., MIAMI, FLORIDA 33168.

**TRANSISTOR RADIO BATTERY SUBSTITUTE.** DC Power Supply plans and complete parts. Send \$6.50 to Dept. 1, New Britain-Hartford Av Sales, 33 Elam St. Box 3, New Britain, Conn.

**BARGAIN FLYER and SIX NEW RESISTORS—25¢** (stamp or coin). **BIGELOW ELECTRONICS, BLUFFTON, OHIO 45817**



**WRITE** now for free 1969 catalog, McGee Radio Company. 1001 bargains. Speakers—Parts—Tubes—High Fidelity Components—Record Changers—Tape Recorders—Kits. Everything in Electronics. 1901 McGee Street, Kansas City (GE), Missouri 64108.

**TRANSISTOR** amplifiers, psychedelic lighting shows, strobes. Send stamp for list. **PLANS**, 1336 Louisiana, Akron, Ohio 44314.

**FM-AM** Nine transistor pocket radios. No cabinets, speakers, but a great buy. \$3.95. Guaranteed. Shoretronics, 3690 Shore Parkway, Brooklyn 11235.

**PARTS FOR ALL PUBLISHED PROJECTS PAST AND PRESENT.** Popular Electronics, Electronics Illustrated, any electronic hobby magazines. Also hard-to-get Integrated Circuits, FETs and other semiconductors—Small or Large quantities. Send type, description and quantity or project magazine, date and page. ARS Enterprises, P.O. Box 555, Tempe, Arizona 85258.

**PHASERS**, Laser Cannons, catalog 10¢. XenoX, 5848 67th St., Sacramento, California 95824.

**POLICE FIRE VHF** automobile converter. Under the dash mounting. 90 days unconditional guaranty. State frequency desired. Crystal and battery included. HI and LO band. \$25.45. **AUDIO-DIGITAL**, 24 Genetti, Bedford, Mass. 01730.

**NOW!! AMAZING** New Invention **MAKES AUTOMOBILES THEFT AND TAMPER PROOF** for Only \$7.95! Protects Car, Contents, Accessories. **FREE** Brochure. **WRITE TODAY!** International Distributors; Box 1138-P; Monroe, Louisiana 71201.

**POLICE AND FIRE RADIO DIRECTORIES.** Frequencies, call-signs! Catalog, send stamp. Communications, Box 56-PE, Commack, N.Y. 11725.

**AMAZING** Psychedelic Sound Translator. Operates Musical Lights from any radio, hi-fi or P.A. 300 watt capacity. Completely wired. Fully guaranteed. Only \$14.95 postpaid. Willy's Electronic Supply, 1636 D Ave., National City, Calif. 92050.

**FREE** catalog of unusual electronic, scientific gadgets, parts, plans for the experimenter. Frank Scientific Co., P.O. Box 156, Martelle, Iowa 52305.

**ELECTRONIC** ignition, various types. Free literature. Anderson Engineering, Epsom, N.H. 03239.

**BARGAINS** in Surplus Electronic Parts, Semiconductors, Tubes, Etc., **DISCOUNT PRICES, FREE CATALOG.** REDCO SALES CO., Box 294, Needham, Mass. 02194.

## PLANS AND KITS

**BEGINNERS** Allwave \$5.00, Two Band \$5.00, F-M Tuner Chassis \$10.00, Headset \$2.50, Two Band Wired \$10.00. Ekeradio, Box 131, Temple City, Calif. 91780.

**BUILD-IT-YOURSELF.** Save big dollars. Transistor stereo amplifiers. Color organs. Speakers. Write Workshop, Box 393, Bethpage, New York 11714.

**16 TESTED TRANSISTOR PLANS—25¢.** "Coil Winding Handbook"—50¢. Catalog. Laboratories, 12041-L Sheridan, Garden Grove, Calif. 92640.

**SUPERSENSITIVE MOVEMENT DETECTOR.** Over 100 foot range day or night. Construction details free. Minilert, Box 446B, Miami, Florida 33137.

**INTEGRATED CIRCUIT KITS; COMPUTER CIRCUIT KITS;** Others. New catalog free. **KAYE ENGINEERING**, Box 3932-A, Long Beach, California 90803.

**STILL** using brute force power? New E/I **CONTROLLER** provides short proof regulation for battery charger/eliminator. Bonus—0.05 ohm ohmmeter; power diode curves. Plans \$3.50. Kits. **ALSYNCO**, Dept. PE-83, 171 S. Main, Natick, Mass. 01760.

## SHORTWAVE LISTENING

**POLICE—FIRE—AIRCRAFT—MARINE—AMATEUR CALLS** on your broadcast radio with **TUNAVERTER!** Tunable and crystal in one! Guaranteed! Free catalog. Salch Co., Woodsboro-PEC, Texas 78393.

## HIGH FIDELITY

**FREE!** Send for money saving stereo catalog #P10E and lowest quotations on your individual component, tape recorder, or system requirements. Electronic Values, Inc., 200 W. 20th St., New York, N.Y. 10011.

**HI-FI** Components. Tape Recorders, at guaranteed "We Will Not Be Undersold" prices. 15-day money-back guarantee. Two-year warranty. No Catalog. Quotations Free. Hi-Fidelity Center, 239 (P) East 149th Street, New York 10451.

**LOW**, Low quotes: all components and recorders. HiFi, Roslyn, Penna. 19001.

## CLASSIFIED ADVERTISING ORDER FORM

Please refer to heading on first page of this section for complete data concerning terms, frequency discounts, closing dates, etc.

1	2	3	4	5
6	7	8	9	10
11	12	13	14	15
16	17	18	19	20
21	22	23	24	25
26	27	28	29	30
31	32	33	34	35

Words { @ 70¢ (Reader Rate) } = \$ \_\_\_\_\_  
 { @ \$1.15 (Commercial Rate) }

Insert \_\_\_\_\_ time(s) Total Enclosed \$ \_\_\_\_\_

NAME \_\_\_\_\_

ADDRESS \_\_\_\_\_

CITY \_\_\_\_\_ STATE \_\_\_\_\_ ZIP \_\_\_\_\_

Signature \_\_\_\_\_

**WORD COUNT:** Include name and address. Name of city (Des Moines) or of state (New York) counts as one word each. Zip Code numbers not counted. (Publisher reserves right to omit Zip Code if space does not permit.) Count each abbreviation, initial, single figure or group of figures or letters as a word. Symbols such as 35mm, COD, PO, AC, etc., count as one word. Hyphenated words count as two words.

PE-1068

**TAPE RECORDERS**, Hi-Fi, components, Sleep Learning Equipment, tapes. Unusual Values Free Catalog. Dressner, 1523R, Jericho Turnpike, New Hyde Park, N.Y. 11040.

**ACOUSTIC RESEARCH** products now available to citizens of foreign countries, overseas personnel, diplomats, government employees, etc. Write for full product and dealer information, **AR INTERNATIONAL**, Dept. PE, 24 Thorndike St., Cambridge, Mass. 02141.

**STEREO** Components, Tape Recorders, Tapes, Citizen Band Transceivers, Brand Names, Free Catalog, Free Quotations. **GLOBE ELECTRONICS SALES INC.**, 1160 Globe Avenue, Mountainside, New Jersey 07092.

## WANTED

**CASH Paid!** Unused tubes, electronic equipment. Barry, 512 Broadway, NYC 10012.

**QUICKSILVER**, Platinum, Silver, Gold, Ores Analyzed. Free Circular. Mercury Terminal, Norwood, Mass. 02062.

**CASH** for terminals—red, blue, yellow. **HALCAP**, Box 19183, Houston, Texas 77024.

**AR2 Speaker**. Ramsdell, 3728 S.W. Condor Ave., Portland, Or. 97201.

## TUBES

**TUBES** "Oldies", latest. Lists free. Steinmetz, 7519 Maplewood, Hammond, Indiana 46324.

**RECEIVING & INDUSTRIAL TUBES, TRANSISTORS**. All Brands—Biggest Discounts. Technicians, Hobbyists, Experimenters—Request **FREE** Giant Catalog and **SAVE!** **ZALYTRON**, 469 Jericho Turnpike, Mineola, N.Y. 11501.

**TUBE** Headquarters of World! Send 10¢ for Catalog (tubes, electronic equipment) Barry, 512 Broadway, N.Y.C. 10012.

**RADIO & T.V. Tubes**—33¢ each. Send for free list. Cornell, 4213 University, San Diego, Calif. 92105.

**DDN'T BUY TUBES**—Radios TV-Xmitting, special-purpose types until you get our price list! Lowest prices in U.S.A. 5,000 types—Guaranteed Brand New. Send postcard for TV-Special Purpose Price List. **UNITED RADIO COMPANY, P.O. BOX 1000, NEWARK, N.J. 07101**.

**TUBES** all types, 6146-A \$3.00. Price list 50¢. Torson Electronics, Box 11-171, Bangkok, Thailand.

**TUBES**, RCA, Sylvania. Eico kits. Electronic parts. Free catalog. Yankee Electronics, 257 Huntington Ave., Boston, Mass. 02115.

## TAPE AND RECORDERS

**BEFORE** Renting Stereo Tapes try us. Postpaid both ways—no deposit—immediate delivery. Quality—Dependability—Service—Satisfaction—prevail here. If you've been dissatisfied in the past, your initial order will prove this is no idle boast. Free Catalog. Gold Coast Tape Library, Box 2262, Palm Village Station, Hialeah, Fla. 33012.

**HI-FI** Components. Tape Recorders, at guaranteed "We Will Not Be Undersold" prices. 15-day money-back guarantee. Two-year warranty. No Catalog. Quotations Free. HiFidelity Center, 239 (PT) East 149th Street, New York 10451.

**WHOLESALE**—4-8 track **STEREOTAPES**—Car, Home **PLAYERS**—**CB**, Recorders. **MUSICO**, Box 11045, Montgomery, Alabama 36105.

**RENT** 4-Track open reel tapes—all major labels—3,000 different—free brochure. Stereo-Parti, 55 St. James Drive, Santa Rosa, Ca. 95401.

**STEREO TAPES**, Save 30% and up; no membership or fees required; postpaid anywhere U.S.A. Free 70-page catalog. We discount batteries, recorders, tape/accessories. Beware of slogans, "not under-sold", as the discount information you supply our competitor is invariably reported to the factory. **SAXITONE**, 1776 Columbia Road, N.W., Washington, D.C. 20009.

**TAPE RECORDER SALE**. Brand new nationally advertised brands, \$10.00 above cost. Amazing discounts on stereo components. Arkay Electronics, 1028-C Commonwealth Avenue, Boston, Mass. 02215.

**STEREO TAPE CLUB**: Average cost \$3.78—\$4.20. Cartridges, Cassettes, Reels. No minimum monthly purchases. Free brochure—catalog. Star Recordings, Box 1055, El Paso, Texas 79946.

**TAPEMATES** makes available to you **ALL 4-TRACK STEREO TAPES—ALL LABELS**—postpaid to your door—at tremendous savings. For free brochure write: **TAPEMATES**, 5727 W. Jefferson Blvd., Los Angeles, California 90016.

**EXCLUSIVE! NORELCO CONFERENCE 'CARRY-CORDER'**. Four hour recording on C-120 cassette. Unique accessories. Free data: Security Electronics-PER, 15 East 43 Street, New York, N.Y. 10017.

**RECEIVE** monthly **STEREO GO-GO TAPES!** Join Teen Tape Club, 4622 Redman Street, #1, Omaha, Nebr. 68104. \$3.00 per year.

## REPAIRS AND SERVICES

**TV Tuners** rebuilt and aligned per manufacturers specification. Only \$9.50. Any make UHF or VHF. Ninety day written guarantee. Ship complete with tubes or write for free mailing kit and dealer brochure. **JW Electronics**, Box 51C, Bloomington, Indiana 47401.

**SPEAKER REPAIR**. Hi-Fi, guitar, organ speakers reconed good as new at fraction of new speaker price. For details and reconing center in your area write: **Waldom Electronics, Inc.**, Dept PE, 4625 W. 53rd St., Chicago, Ill. 60632.

**CHASSIS**: All types and sizes. Will build to your specifications. Phone 307-532-5752. **A & T Manufacturing, Inc.**, 1902 West C., Torrington, Wyoming 82240.

**TV AID SEND SYMPTOMS, MAKE MODEL, CHASSIS NUMBER. INDIVIDUAL DIAGNOSIS. \$5.00. TELAID, BOX 16, MIDDLETOWN, DE. 19709.**

## PERSONALS

**MAKE FRIENDS WORLDWIDE** through international correspondence. Illustrated brochure free. **Hermes**, Berlin 11, Germany.

**FREE** Catalog low priced, high performance subminiature listen-in devices direct from manufacturer. Dealers welcome. **Audiotronix-E**, 156 Fifth Avenue, New York, N.Y. 10010.

**LAW ENFORCEMENT AGENTS AND LEGAL INVESTIGATORS ONLY. FREE LITERATURE, LATEST ELECTRONIC AIDS. REQUEST MUST BE ON YOUR OFFICIAL LETTERHEAD. R. CLIFTON, 11500-K NW 7TH AVE., MIAMI, FLORIDA 33168.**

**LEMURIAN VIEWPOINT**—Meaningful discussions of Cosmic Truth: the purpose of human life, reincarnation, man's place in a Higher Plan, and subjects from the Lemurian Philosophy. Send for **FREE** copy. **Lemurian Fellowship**, Dept. 812, Box 397, Ramona, Calif. 92065.

## INSTRUCTION

**LEARN** While Asleep, hypnotize with your recorder, phonograph. Astonishing details, sensational catalog free! **Sleep-learning Association**. Box 24-ZD, Olympia, Wash. 98501.

**LEARN ELECTRONIC ORGAN SERVICING** at home all makes including transistor. Experimental kit—trouble-shooting. Accredited **NHSC**, Free Booklet. **NILES BRYANT SCHOOL**, 3631 Stockton, Dept. A, Sacramento, Calif. 95820.

**ASSOCIATE** Degree in Electronics Engineering earned through combination correspondence-classroom educational program. Free brochure. **Graham Technical Institute**, 1505 N. Western Ave., Hollywood, Calif. 90027.

**R. E. I.'s** famous (5) week course for the first class radio telephone license is the shortest, most effective course in the nation. Over 98% of **R.E.I.** graduates pass **F.C.C.** exams for 1st class license. Total tuition \$350.00. Job placement free. Write for brochure **Radio Engineering Incorporated Schools**, 1336 Main Street, Sarasota, Florida 33577—or 3123 Gillham Road, Kansas City, Missouri 64109—or 809 Caroline Street, Fredericksburg, Virginia 22401.

**HIGHLY EFFECTIVE** home study course in Electronics Engineering Mathematics with circuit application. Earn your Associate in Science Degree. Free Literature. **Cook's Institute of Electronics Engineering**, P.O. Box 36185, Houston, Texas 77036. (Established 1945.)

**ART TALENT?** Make money right away. A course may not be necessary. Free Brochure. **Famous American Studios**, Spring Park, Minnesota 55384.

**RADIO AND TELEVISION REPAIR COURSE, BASIC TEST EQUIPMENT AND INSTRUCTION NECESSARY FOR STARTING PROFITABLE BUSINESS. WRITE HOOSIER TECHNICAL INSTITUTE, BOX 88401, INDIANAPOLIS, INDIANA 46208.**

FCC First Class Phone License in six weeks. \$333.00 complete tuition. Guaranteed. Write Electronics Institute, 2202 West Erwin, Tyler, Texas 75701.

**DRYFING**—home courses \$25.00. Send \$2.00 first lesson. Prior, Inc., 23-09 169th Street, Whitestone, New York 11357.

## INVENTIONS WANTED

**INVENTIONS** wanted. Patented; unpatented. Global Marketing Service, 2420-P 77th, Oakland, Calif. 94605.

**PATENT** Searches including Maximum speed, full airmail report and closest patent copies. \$6.00. Quality searches expertly administered. Complete secrecy guaranteed. Free Invention Protection forms and "Patent Information." Write Dept. 9, Washington Patent Office Search Bureau, 711 14th Street, N.W., Washington, D.C. 20005.

**INVENTORS.** We will develop, help sell your idea or invention, patented or unpatented. Our national manufacturer clients are urgently seeking new items for outright cash sale or royalties. Financial assistance available. 10 years proven performances. For free information, write Dept. 41, Wall Street Invention Brokerage, 79 Wall Street, New York N.Y. 10005.

**MANY** million dollar corporations have authorized us to locate new products. **FREE** "Directory of 500 Corporations Seeking New Products." For information regarding development, sale, licensing of your patented/unpatented invention. Write: Raymond Lee Organization, 239-GR Park Avenue, New York City 10017.

**PATENT SEARCHES \$15.00! FREE "INVENTION RECORD" /**Information. Hayward Company, 1029HR Vermont, District of Columbia 20005.

**INVENTORS! OUR FREE EXPERT ANALYSIS** of your invention can save valuable time, help you realize full sale value. Strictly confidential. **FREE INVENTION CERTIFICATE.** Write today: Pioneer Invention Service, Dept. 35, 150 Broadway, New York, N.Y. 10038.

**INVENTORS! Sell your invention for cash or royalties! Our client manufacturers eagerly seek new items. Patented. Unpatented. Financial assistance if needed. 25 years proven performances. For free information, write Dept. 20, Gilbert Adams, Invention Broker, 80 Wall St., New York, N.Y. 10005.**

**INVENTORS! Don't sell your invention, patented or unpatented, until you receive our offer.** Eagle Development Company, Dept. P, 79 Wall Street, N.Y., N.Y. 10005.

**QUALITY Patent Searches \$15.00! Preferred by Professional Inventors, Lawyers, Manufacturers. "Confidential Report" Including related United States patent copies "Airmailed Certified." FREE information! United States Inventors Service Company, 501-H Thirteenth Street, N.W., Washington, D.C. 20005.**

## GOVERNMENT SURPLUS

**GOVERNMENT Surplus How and Where to Buy in Your Area.** Send \$1.00 to: Surplus Information PE, Headquarters Building, Washington, D.C. 20036.

**JEEPS** Typically From \$53.90 . . . Trucks From \$78.40 . . . Boats, Typewriters, Airplanes, Multimeters, Oscilloscopes, Transceivers, Electronics Equipment, Used. 100,000 Bid Bargains Direct From Government Nationwide. Complete Sales Directory and Surplus Catalog \$1.00 (Deductible First \$10.00 Order). Surplus Service, Box 820-J, Holland, Michigan 49423.

## AUTHORS' SERVICES

**AUTHORS! Learn how to have your book published, promoted, distributed. FREE booklet "ZD," Vantage, 120 West 31 St., New York 10001.**

## MUSIC

**POEMS** wanted for new songs. Nashville Music Institute, Box 532-E, Nashville, Tennessee 37202.

**POEMS,** songs wanted for new song hits and recordings by America's most popular studio. Tin Pan Alley, 1650-PE Broadway, New York, N.Y. 10010.

## MUSICAL INSTRUMENTS

**ACCORDIONS, GUITARS, AND INSTRUMENTS! Save to 50%. Terms. Trades. Free Trial. Free catalog. Mention instrument. Music Mart, 5535-PE Belmont, Chicago 60641.**

## BOOKS

**FREE** catalog 950 aviation/electronic/space books. Aero Publishers, 329PE Aviation Road, Fallbrook, California 92028.

**UNUSUAL** Books! Catalog free! International, Box 7798 (PE), Atlanta, Georgia 30309.

**FREE** Book Prophet Elijah Coming Before Christ. Wonderful Bible Evidence. PE Megiddo Mission, Rochester, New York 14619.

**FREE CATALOG. BOOKS FOR ADULTS. CATALOG, 2217 LACKLAND, ST. LOUIS, MISSOURI 63114.**

**ADULT** books, magazines. Free illustrated catalogue. Clifton's, Box 1068-E, Saugus, Calif. 91350.

## HYPNOTISM

**FREE** Hypnotism, Self-Hypnosis, Sleep Learning Catalog! Drawer H400, Ruidoso, New Mexico 88345.

**"MALE-FEMALE HYPNOTISM" EXPOSED, EXPLAINED! "SECRET METHOD"—THEY NEVER KNOW! \$2, RUSHED. GUARANTEED! ISABELLA HALL, SILVER SPRINGS, FLORIDA 32688.**

**SELF-HYPNOSIS** for self-improvement. Safe, effective! Free literature. McKinley, Dept. T-4, Box 3038, San Bernardino, California 92404.

**AMAZING HYPNOTIC** record kit releases fantastic mental power! Free offer expires soon. Write: Forum, Studio AA10, 333 North Michigan, Chicago 60601.

**HYPNOTIZE MALES, FEMALES!—Unnoticed! Quickly! Nerves! Exciting! \$2.25.** Research Enterprises, 29-SN21 Samoset, Woburn, Mass. 01801.

**FEMALE, MALE HYPNOTISM!! Easily! Instantly! Secret Nerve Certers! \$2.20.** Brugenheimer, Box 158-E30, Lexington, Mass. 02173.

## RUBBER STAMPS

**RUBBER ADDRESS STAMPS \$1.50. SIGNATURE \$3.50. FREE CATALOG. JACKSON, BOX 443-G, FRANKLIN PARK, ILL. 60131.**

## PHOTOGRAPHY—FILM, EQUIPMENT

**MEDICAL** Film—Adults Only—"Childbirth"—1 reel 8mm \$7.50—16mm \$14.95. International-E, Greenvale, L.I., New York 11548.

**SCIENCE** Bargains—Request Free Giant Catalog "CJ"—148 pages—Astronomical Telescopes, Microphones, Lenses, Binoculars, Kits, Parts. War surplus bargains. Edmund Scientific Co., Barrington, New Jersey 08007.

## RECORDS

**SPECIAL INTEREST RECORDS AVAILABLE, PRODUCED BY THE EDITORS OF THE WORLD'S LEADING SPECIAL INTEREST MAGAZINES. SEND FOR FREE CATALOG. RECORD CATALOG-PE ZIFF-DAVIS PUBLISHING COMPANY, ONE PARK AVENUE, NEW YORK, N.Y. 10016.**

**OLDIES 45RPM.** Original Hits. Over 1500 available. Catalog 25¢ C & S Record Sales, Box 197, Wampsville, N.Y. 13163.

## PLASTICS

**CASTOLITE** Liquid Plastic pours like water and hardens like glass without heat. Clear, Colors. Embed real flowers, butterflies, photos, coins. Also new molding formulas for perfect reproductions. Illustrated booklet shows **HOW.** Send 25¢—Dept. 68-108L. CASTOLITE, Woodstock, Ill. 60098.

## EDUCATIONAL OPPORTUNITIES

**LEARN WHILE ASLEEP.** Miraculously build Mind Power, achieve Self-Confidence, improve Health, gain Success. Method 92% effective. Details free. ASR Foundation, Box 7021EG Henry Clay Sta., Lexington, Kentucky 40502.

## PRINTING

**FREE LITERATURE:** 1000 Address Labels \$1.00, 1000 Business Cards \$4.95. Printing, Rubber Stamps. Jordan's 552 West O'Connor, Lima, Ohio 45801.



**MIMEO OWNERS:** turn your mimeograph into a printing press with electronic stencils. Free instructions, samples, introductory offer. Seaview-E, 212-26 48th Avenue, Bayside, N.Y. 11364.

**THERMOGRAPHED** business cards, \$3.49-1,000, free samples. Gables-405A Clifton, Glenshaw, Pa. 15116.

## MAGAZINES

**FACTS** on vintage car values. Unique magazine for vintage car enthusiasts listing thousands of Classic, Antique, & Special interest cars with photographs. (Compiled from actual sales.) Used by Banks & Insurance Companies. Informative restoration hints. Vintage cars for investment. Classified, listing vintage cars for sale. Listing, all American cars since 1895. Published semi-annually. New Fall Edition now available. One copy \$3.00. One Year \$5.00; three Years \$12.00. Send cash, check or M.O. to **OLD CAR VALUE GUIDE**, P.O. Box 105, Prescott, Ariz. 86301.

**BACK DATE MAGAZINES!** Send Needs. Middtown, Box 934-PE, Maywood, New Jersey 07607.

## REAL ESTATE

**FREE. . . Big FALL-WINTER CATALOG!** Describes and pictures over 2,000 farms, ranches, town and country homes, businesses in 32 states coast to coast! Specify type property and location preferred. Zip code, please. **UNITED FARM AGENCY**, 612-EP West 47th St., Kansas City, Mo. 64112.

## BUSINESS OPPORTUNITIES

**INVESTIGATE ACCIDENTS:** Earn to \$1000 monthly. Men urgently needed. Car furnished. Business expenses paid. No selling. No College education necessary. Pick own job location. Investigate full time or earn to \$8 hour spare time. Write for **FREE** information. No obligation. Universal Schools, CZ-10, 6801 Hillcrest, Dallas, Texas 75205.

**RAISE** Rabbits for us on \$500 month plan. Free details White's Rabbitry, Mt. Vernon, Ohio 43050.

**FREE CATALOGS.** Repair air conditioning, refrigeration. Tools, supplies, full instructions. Doolin, 2016 Canton, Dallas, Texas 75201.

**PIANO TUNING** learned quickly at home. Tremendous field! Musical knowledge unnecessary. GI Approved. Free Information. Empire School, Miami, Florida 33145.

**ELECTROPLATING** Equipment and supplies. All types for home workshops and industrial. Send \$1.00 (refundable) for equipment guide formulas, operating data, catalog. HBS Equipment Division 90, 3543 East 16th, Los Angeles, California 90023.

**I MADE \$40,000.00 Year by Mailorder!** Helped others make money! Start with \$10.00—Free Proof. Torrey, Box 318-N, Ypsilanti, Michigan 48197.

**\$200.00 DAILY** In Your Mailbox! Your opportunity to do what mail-order experts do. Free details. Associates, Box 136-J, Holland, Michigan 49423.

**FREE** Book "990 Successful little-known Businesses." Work home. Plymouth 245M, Brooklyn, N.Y. 11218.

**SELL LIFETIME**, Metal, Social Security Plates. Big profits! Sample and Sales Kit Free. Russe!!l, Box 286-PE, Pulaski, Tennessee 38748.

**BIG EARNINGS** selling Hertel Bibles. New 3-dimension cover, finest reference edition sells fast. Demonstrator furnished. Big commissions. International Book, Dept. PE, Box 118, Wichita, Kansas 67201.

**AMAZING** ways to start and operate successful small business. Details free. **LYNN**, Box 1573, Waco, Texas 76703.

**MAILORDER . . .** Stop Looking! Start Your own Business! Methods, 1407-F.D., Lafayette Hill, Pennsylvania 19444.

## STAMPS

**RUSSIA HIGH-VALUE COLLECTION.** 32 different Russia—some over 50 years old! Commemoratives. Czarist Issues, Airmails. Catalog price \$2.99. Special Get-Acquainted Offer—all for only 10¢! H.E. Harris, Dept. GG-13, Boston, Mass. 02117.

**MILLIONS FOREIGN STAMPS** 2¢ each! Send for gigantic approvals! ABC, Box 6000-DD, San Francisco, California 94101.

### INTEGRATED CIRCUITS

**LINEAR CIRCUITS**

FM IF Amplifier.....\$ .90  
702C Wide Band DC Ampl.....\$3.50  
709C Operational Ampl.....\$4.50  
710C Hi Sped Diff.  
Comparator.....\$5.00  
711C Dual Comparator.....\$5.50

**DIGITAL RTL CIRCUITS**

2-914 Quad 2 Input Gates.....\$ .80  
900 Buffer.....\$1.25  
925 Dual 2 input gate expander.....\$1.25  
923 JK Flip Flop.....\$1.25

**Silicon Power Rectifiers**

PRV	1A	12A	40A
100	.07	.30	.75
200	.09	.50	1.25
400	.12	.70	1.50
600	.18	.00	1.80
800	.22	1.25	
1000	.35	1.50	

Similar to 2N2419. RBB of 5-7, stand off ratio of .6 and Ip of 12, with data sheet. \$1.50

**TRIACS T0-66  
5 AMP**

PRV	
100	.90
200	1.40
300	1.75
400	2.25
500	2.60

Terms: FOB Cambridge, Mass. Send check or Money Order. Include postage. Average Wt. per package 1/2 lb. NO C.O.D.s. MIN. ORDER \$3.00.

SEND FOR FALL CATALOGUE \$2.20 if no order is included

POST OFFICE BOX 74F  
SOMERVILLE, MASS. 02143

Featuring transistors, rectifiers  
Business Address: 325 Elm St.  
Cambridge, Mass.

CIRCLE NO. 40 ON READER SERVICE PAGE

400 FINE mixed U.S. 15c. Wright, Box 753-X, Hagerstown, Maryland 21740.

**HELP!** Fill collection, 100 diff. U. S. commemoratives, plus more: 50¢-approvals-. Tomiko's, P.O. Box 45251, L.A., Calif. 90045.

## REMAILING SERVICE

**ENTERSULL.** Your secret address. Prompt. Confidential, Box 206E, Forsyth, Georgia 31029.

## EMPLOYMENT INFORMATION

**OVERSEAS** Jobs all trades and professions. Free information write: National Employment Service, Box 2235 A.M.F., Miami, Florida 33159.

**AUSTRALIA.** Opportunity. Adventure. Jobs. New Life. Government Shares Passage. Information \$1. Pacifico, Box 43485-R, Los Angeles, Calif. 90043.

## TAXIDERMY

**TAXIDERMY SUCCESS TRAINING** sure, easy way into Taxidermy. Complete training, no skipping, all steps illustrated. Request information and free samples—Box 5815, Bossier City, Louisiana 71010.

## MISCELLANEOUS

**WINEMAKERS:** Free illustrated catalog of yeasts, equipment. Semplex, Box 7208, Minneapolis, Minn. 55412.

**BILLS PAID WITHOUT BORROWING**—Nobody refused up to \$18,000.00. Bad credit no problem—Not a Loan Company. Write for **FREE** application—**INTERNATIONAL ACCEPTANCE**, Dept. 50A, Phoenix, Arizona 85012—711 14th St., N.W., Washington, D.C. 20005—507 Carondelet St., New Orleans, La. 70130.

**EMPLOYMENT Resumes.** Get a better job & earn more! Send only \$2.00 for expert, complete Resume Writing Instructions. J. Ross, 80-34 Kent St., Jamaica, N.Y. 11432. Dept. PE.

**STOP BURGLARS THE EASY WAY!!** Affix authentic "Protected by Electronic Sentry Alarm" Decals to auto windows, door & windows of home, retail stores, vending machines, etc. Whether you have an alarm or not—thieves stay away! Only \$1.00 each set of two. J. Ross, 80-34 Kent st., Jamaica, N.Y. 11432 Dept. PE.

**TEN Winemaking Recipes and Winemaking supplies catalog** 10¢ Country Winemaker, Box 191E, RFD 1, Mattapoisett, Mass. 02739.

**BEERS, PEACH BRANDY, WINES**—Strongest Formulas, \$2.25. (complete brew supplies hydrometers catalog included)—Research Enterprises, 29-D Samoset, Woburn, Mass. 01801.

## MAIL ORDER OPPORTUNITIES WAITING FOR YOU!

Classified Advertisers find more outlets for their product and service advertising in Ziff-Davis Electronics Publications than in any other media.

Whether in a monthly publication: **POPULAR ELECTRONICS**, **ELECTRONICS WORLD**, **HIFI STEREO REVIEW** or in an annual: **COMMUNICATIONS HANDBOOK**, **ELECTRONIC EXPERIMENTER'S HANDBOOK**, **ELECTRONICS INSTALLATION AND SERVICING HANDBOOK**, or **TAPE RECORDER ANNUAL**—Classified Advertising is responded to regularly by an affluent audience of active electronics enthusiasts.

Prove to yourself the effectiveness of Classified Advertising in Ziff-Davis Electronics Publications. Write today for information, assistance or sample copies to:

**Hal Cymes, Classified Advertising Manager**  
Ziff-Davis Publishing Company  
One Park Avenue, New York, N. Y. 10016

## POPULAR ELECTRONICS SUBSCRIBER SERVICE

Please include an address label when writing about your subscription to help us serve you promptly. Write to: Portland Place, Boulder, Colo. 80302

**CHANGE OF ADDRESS:** Please let us know you are moving at least four to six weeks in advance. Affix magazine address label in space to the right and print new address below. If you have a question about your subscription, attach address label to your letter.

### TO SUBSCRIBE:

Check boxes below.

- New  Renewal  
 5 years \$20  
 3 years \$13  
 1 year \$5

### SPECIFY:

- Payment enclosed  
 —You get 1 extra issue per year as a BONUS!  
 Bill me later.

AFFIX LABEL

name  
address  
city  
state  
zip code

please print

If you have no label handy, print OLD address here.

Add'l postage: \$1 per year outside U.S., its possessions & Canada.

name 0304  
 please print

---

address

---

city

---

state zip-code

## POPULAR ELECTRONICS OCTOBER 1968 ADVERTISERS INDEX

READER SERVICE NO.      ADVERTISER      PAGE NO.

1	Aerotron, Controlator	94
2	Allied Radio	125, 126
3	Ampex Corp	5
4	Antenna Specialists Co., The	27
5	Argos Products Company	92
6	Avanti Research & Development, Inc	8
7	B & K	13
	Bell & Howell Schools	7
8	Browning Labs	114
9	Burstein-Applebee Co	113
	CREI, Home Study Division, McGraw-Hill Book Company	62, 63, 64, 65
10	Caringella Electronics, Inc	92
11	Cleveland Institute of Electronics	88, 89, 90, 91
12	Cleveland Institute of Electronics	110
14	Courier Communications, Inc	100, 101
15	Delwyn	10
16	Demco Electronics, Inc	102
17	Edmund Scientific Co	12
13	Electro-Voice, Inc	FOURTH COVER
18	Elpa Marketing Industries, Inc	99
19	Empire	105
20	Fanon	17
21	Finney Company, The	25
22	Garrard	6
	Grantham School of Electronics	9
24	Graymark Enterprises, Incorporated	117
25	Heath Company	106, 107, 108, 109
26	Jensen Mfg. Co	113
23	Johnson Company, E.F.	THIRD COVER
27	Judson Research and Mfg. Co	102
28	Lafayette Radio Electronics	95
29	Maxon, Inc	93
30	Mosley Electronics, Inc	104
	National Radio Institute	SECOND COVER, 1, 2, 3
	National Technical Schools	36, 37, 38, 39
31	Olson Electronics Incorporated	26
32	Port Arthur College	112
33	RCA Electronic Components and Devices	29
34	RCA Electronic Components and Devices	103
	RCA Institutes, Inc	18, 19, 20, 21
49	Radio Shack	118
	Radio Television & Training Association	11
36	Sams & Co., Inc., Howard W	97
37	Schober Organ Corporation, The	116
38	Scott, Inc., H.H.	30
39	Sherwood Electronics, Inc	96
40	Solid State Sales	123
41	Sonar Radio Corporation	111
	Sonic Devices	112
42	Squires-Sanders, Inc	23
43	Tang, Inc	26
44	U.S. Army	87
45	United Audio Products, Inc	16
46	University Sound	14
	Valparaiso Technical Institute	118
	Wel-Dex	116
47	Weller Electric Corporation	98
48	Xcelite, Inc	28

Classified Advertising 119, 120, 121, 122, 123, 124

Printed in U.S.A.

CIRCLE NO. 2 ON READER SERVICE PAGE →

# FREE

## ALLIED ELECTRONICS FOR EVERYONE 1969

OUR 48TH YEAR · CATALOG 280 · INDEX PAGE 451

Chicago 200  
ALLIED ELECTRONICS box

536  
pages

### ALLIED RADIO

100 N. WESTERN AVE. - CHICAGO, ILL. 60680 - MA 1-800 (AREA CODE 312)

SATISFACTION  
GUARANTEED OR  
YOUR MONEY BACK  
SEE PAGE 458

## New 1969 Allied Catalog

Brand new! Fresh off the press! Allied's 1969 Catalog... 536 fascinating pages jam-packed with the very latest in Hi Fi, Tape Recorders, CB, Kits, Radios, Tools, Electronic Parts, Books. Probably nowhere else on earth will you find such a complete selection of everything in electronics... and virtually all new as tomorrow! Literally thousands of items... many of them never shown before. Allied's all new 1969 Catalog makes wonderful reading... and it's yours absolutely FREE! Tear off the card... mail it in today... and we'll rush you your own personal copy of the newest and most complete book of what's new in electronics... Allied's 1969 Catalog!

**NO MONEY DOWN—24 MONTHS TO PAY!**  
**Low Monthly Payments to fit your budget.**

▶ **A FRIEND A FAVOR—give him this card to send for his FREE ALLIED CATALOG** ▶

061

*fill this card out!*

PLEASE PRINT

NAME \_\_\_\_\_  
First Middle Last

ADDRESS \_\_\_\_\_

CITY \_\_\_\_\_

STATE \_\_\_\_\_ ZIP \_\_\_\_\_

**MAIL IT NOW!**

*free!*  
**ALLIED  
1969  
CATALOG**

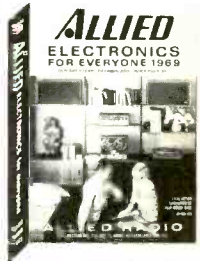

WORLD'S LARGEST SELECTIONS. SATISFACTION  
GUARANTEED OR YOUR MONEY BACK

062

*fill this card out!*

PLEASE PRINT

NAME \_\_\_\_\_  
First Middle Last

ADDRESS \_\_\_\_\_

CITY \_\_\_\_\_

STATE \_\_\_\_\_ ZIP \_\_\_\_\_

**MAIL IT NOW!**

*free!*  
**ALLIED  
1969  
CATALOG**

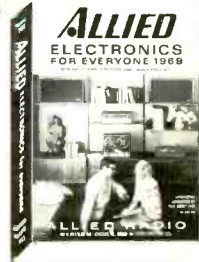

WORLD'S LARGEST SELECTIONS. SATISFACTION  
GUARANTEED OR YOUR MONEY BACK



# FREE

## 1969 ALLIED CATALOG

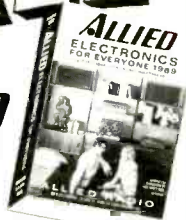

TO:  
**ALLIED RADIO**  
P.O. BOX 4398  
CHICAGO, ILLINOIS 60680

PLACE  
STAMP  
HERE



## Why Buy by Mail from **ALLIED?**

Because you buy from the  
most unique store in the world!

**Why do hundreds of thousands of people...** electronics experimenters, music lovers, engineers, Amateur operators, professional radio-TV servicemen, kit builders, hobbyists, hi-fi fans, and just plain "bargain-hunters"... *order tens of millions of dollars* worth of merchandise-by-mail from ALLIED each year?

**Variety, selection, price, and quality-testing** are the answers! If we can satisfy the experts... we can satisfy you! Our continuous program of quality-testing assures you that everything you buy meets the highest standards. And nowhere else on the face of the earth are so many famous brands (and so many different models of every brand), gathered together to choose from. When it comes to *parts* that both beginners and experts need... ALLIED is the one source that has them *all*.

**Thousands and thousands of items to choose from...** and you'll like shopping from ALLIED because you do it in your easy chair. Our entire stock is spread before you, as it could never be in a conventional store. It takes ALLIED over 500,000 square feet of floor-space (with merchandise stacked to the ceiling!), to keep on hand all the items you hold in *one hand* when you pick up an ALLIED catalog.

**You never had shopping so good,** as when you do it at home with this famous book to guide you. No clerk, no expert, no salesman in all the world could begin to supply you with the wealth of facts, the exact specifications, the comparable data—all at your fingertips in this popular book. Almost anything you may want or need or have an interest in... is pictured, priced, and described in detail. You'll discover things you never knew existed. You'll find bargains unmatched anywhere else you may shop. You'll revel in choices, varieties, and selections beyond imagination. You'll find a whole new way to buy both the commonplace and the rare, the inexpensive and the luxurious.

**Best of all**—with an ALLIED Credit Fund Account, you pay no money down, and take up to 2 years to pay!

## Shop Where the Experts Buy— Choose from the Biggest and Most Fabulous Selection Ever Gathered Together:

- |                             |                           |                        |
|-----------------------------|---------------------------|------------------------|
| STEREO HI-FI                | FM, AM & VHF<br>RADIOS    | TOOLS &<br>HARDWARE    |
| ELECTRONIC<br>& HOBBY KITS  | PORTABLE<br>TV SETS       | BOOKS                  |
| TAPE RECORDERS<br>AND TAPES | AMATEUR GEAR              | CAMERAS                |
| CITIZENS BAND<br>EQUIPMENT  | INTERCOMS                 | NEEDLES                |
| WALKIE-TALKIES              | P.A. EQUIPMENT            | HEADPHONES             |
| SHORTWAVE<br>RECEIVERS      | TEST EQUIPMENT            | MICROPHONES            |
| PHONOGRAPHS                 | ANTENNAS                  | INTEGRATED<br>CIRCUITS |
| SPEAKERS                    | TUBES AND<br>TRANSISTORS  | WIRE &<br>CABLE        |
| RECORD CHANGERS             | AUTOMOTIVE<br>ELECTRONICS | PARTS AND<br>BATTERIES |

# FREE

## 1969 ALLIED CATALOG

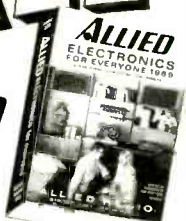

TO:  
**ALLIED RADIO**  
P.O. BOX 4398  
CHICAGO, ILLINOIS 60680

PLACE  
STAMP  
HERE

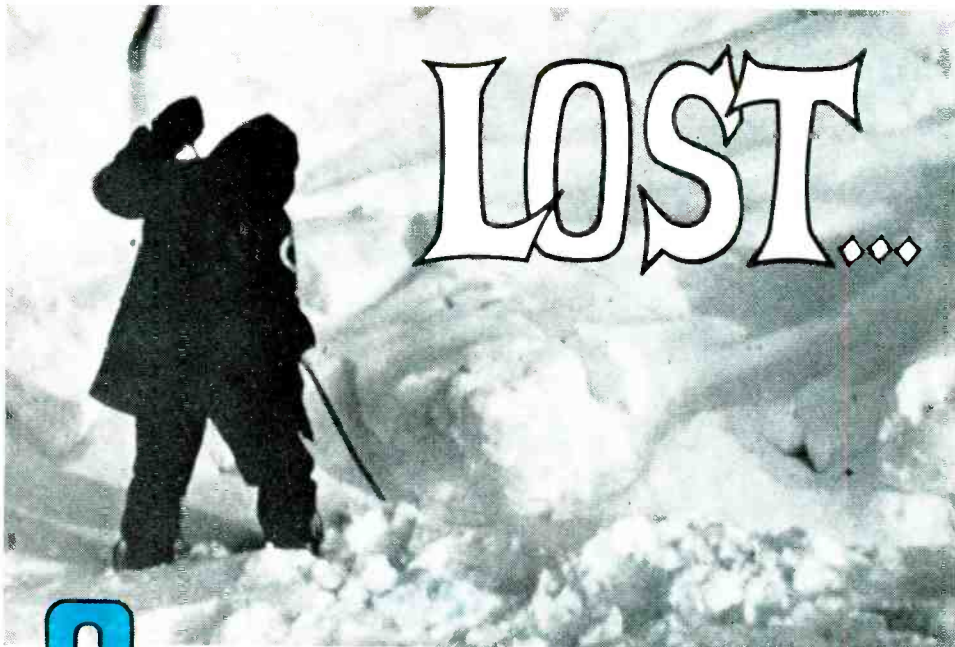

# 2

## JOHNSON MESSENGER III Field Packs at latitude 83° 10' N

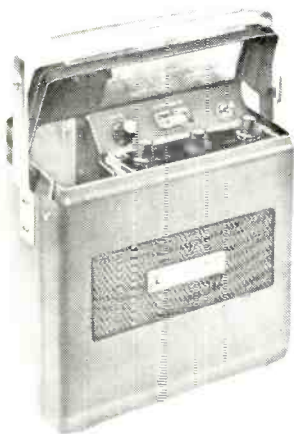

Johnson Messenger III Field Pack

Five Messenger III Field Packs were brought to the Arctic by the 1968 Plaisted Polar Expedition. There, they performed admirably through blizzards,  $-30^{\circ}$  cold, and other Arctic hardships. Even a generator malfunction that blew out all the lights in three base camp buildings did not affect the performance of the Johnson units.

Because of aircraft weight limitations, two had to be left behind when the Plaisted group went home after the first successful assault on the North Pole since Perry. If you'd like two perfectly good Messenger III Field Packs, you can pick these up at Ward Hunt Island...  $83^{\circ} 10' N$  latitude!

Or you can stop in and see your nearest Johnson Dealer. He'll be glad to tell you all about the *complete Johnson line*... including the new 23 channel, tube type Messenger 223, the new 23 channel, solid state Messenger 320 or the new 2 channel, 3 watt Messenger 109 hand-held. Besides, you'll find *his* reception a lot warmer than the one you'd get at Ward Hunt Island!



### E. F. JOHNSON COMPANY

2476 Tenth Ave. S.W., Waseca, Minnesota 56093

Providing nearly a half-century of communications leadership

CIRCLE NO. 23 ON READER SERVICE PAGE



## The woofer that lost its whistle



## ...and other stories.

**(E-V)** The woofer cone in a very small enclosure must move a long way to provide all the bass you want to hear. In the new E-V EIGHT, for instance, the 6-inch cone moves back and forth over one-half inch. But in most woofers something strange happens as it moves. It whistles!

You see, the air trapped inside the speaker is literally "pumped" in and out past the voice coil. The whistle is almost inevitable. Except, that is, in the E-V EIGHT.

We did two things almost nobody else bothers to do. First, we vented the woofer. Air can't be trapped inside. Then we punched six big holes in the voice coil form. Air can't be pumped back and forth. And that's how the E-V EIGHT lost its whistle (and gained almost 2 db extra efficiency in the low bass in the bargain!)

The E-V EIGHT tweeter was another story. We aimed to eliminate the "buzz" and "fuzz" so typical of modestly priced speaker systems. What was needed was a better way to control cone motion at very high frequencies. And it literally took years of testing to solve the problem.

The answer looks deceptively simple. We put a ring of short-fiber polyester felt behind

the cone, and a precisely measured amount of viscous vinyl damping compound under the edge. Plus a light-weight aluminum voice coil to extend the range to the limits of your hearing. Highs are remarkably uniform and as clean as a (oops!) whistle!

Even the E-V EIGHT enclosure is unusual. Examine the walnut grain carefully, especially at the corners. It's a perfect match because we use one long piece of wood, folded to form the cabinet! And we add a clear vinyl shield on every finished surface, to protect the E-V EIGHT from the mars and scratches of day-to-day living.

There are so many good ideas inside the tiny new E-V EIGHT, you may wonder how we found room for them all. Chalk it up to top-notch engineering talent and facilities, plus a very real dedication to the ideal of better value in every product.

Listen to the E-V EIGHT with the whistle-free woofer at your nearby Electro-Voice high fidelity showroom today. Then ask the price. At no more than \$44.00 it's the best story of all.

**ELECTRO-VOICE, INC.**, Dept. 1084P,  
630 Cecil St., Buchanan, Michigan 49107

high fidelity speakers and systems • tuners, amplifiers, receivers  
• public address loudspeakers • phonograph needles and cartridges  
• microphones • organs • space and defense electronics

**Electro-Voice**

CIRCLE NO. 13 ON READER SERVICE PAGE

[www.americanradiohistory.com](http://www.americanradiohistory.com)