

**Build: High-Intensity Psychedelic Strobe**

# POPULAR ELECTRONICS

MARCH  
1968

50  
CENTS



**Build 7-30 MHz  
SWL Preselector**

**Build FET  
Audio Mixer**

**Build BCB  
Antenna Tuner**

**Build Electronic  
Windshield Wiper**

**Build Low-Cost  
Time Interval/Event  
Counter**

**FASTER THAN A  
SPEEDING BULLET!**

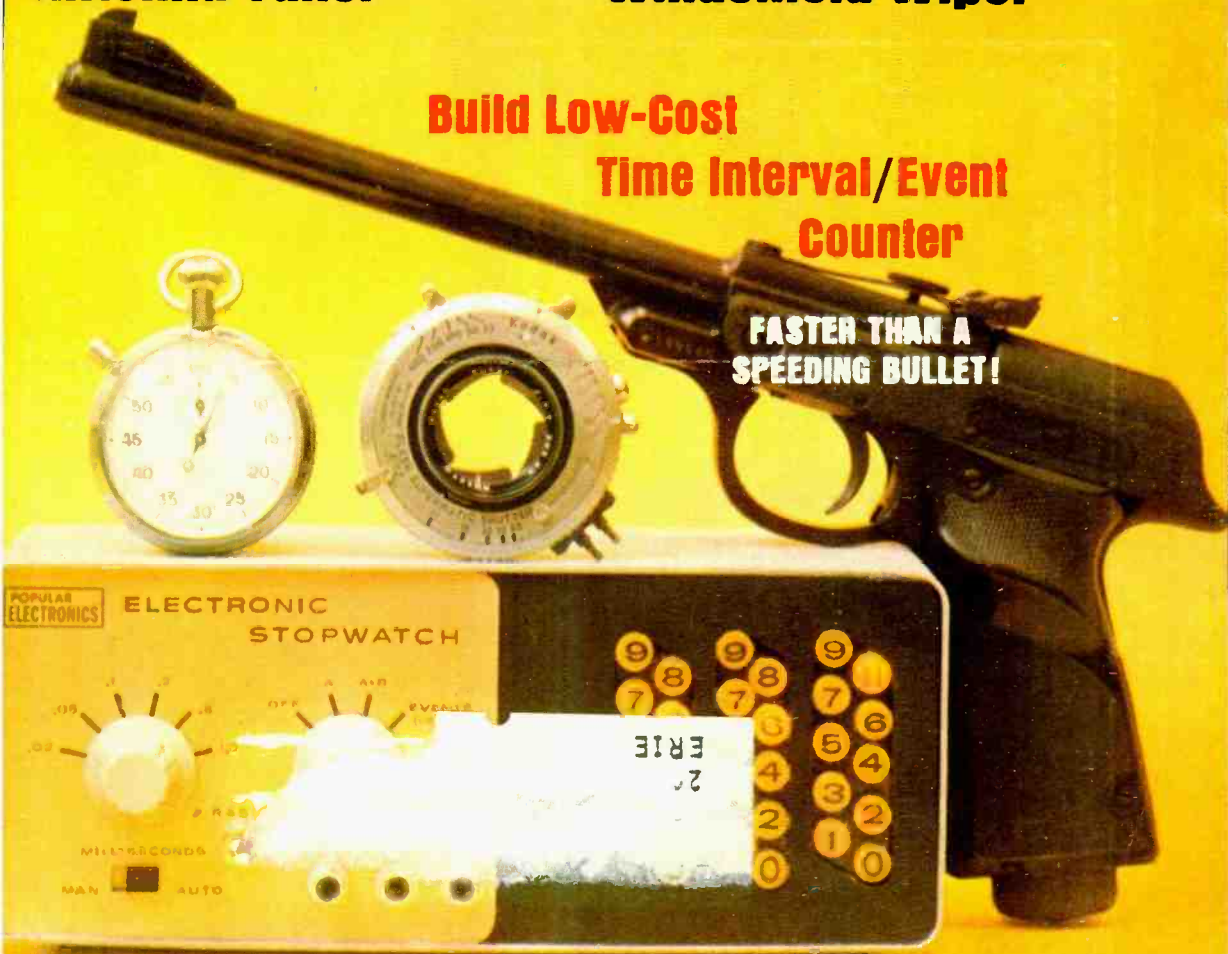

# Discover the ease and excitement of learning Electronics with programmed equipment NRI sends you

When you train at home with NRI, you train with your hands as well as your head. You learn the WHY of Electronics, Communications, TV-Radio the NRI pioneering "3-Dimensional" way. NRI training is the result of more than half a century of simplifying, organizing, dramatizing subject matter, and providing personal services unique for a home study school. You get the kind of technical training that gives you priceless confidence as you gain experience equal to many, many months of training on the job.



*NRI—The 53 Year Leader in Electronics Training*

## APPROVED UNDER NEW GI BILL

If you served since January 31, 1955, or are in service, check GI line in postage-free card.

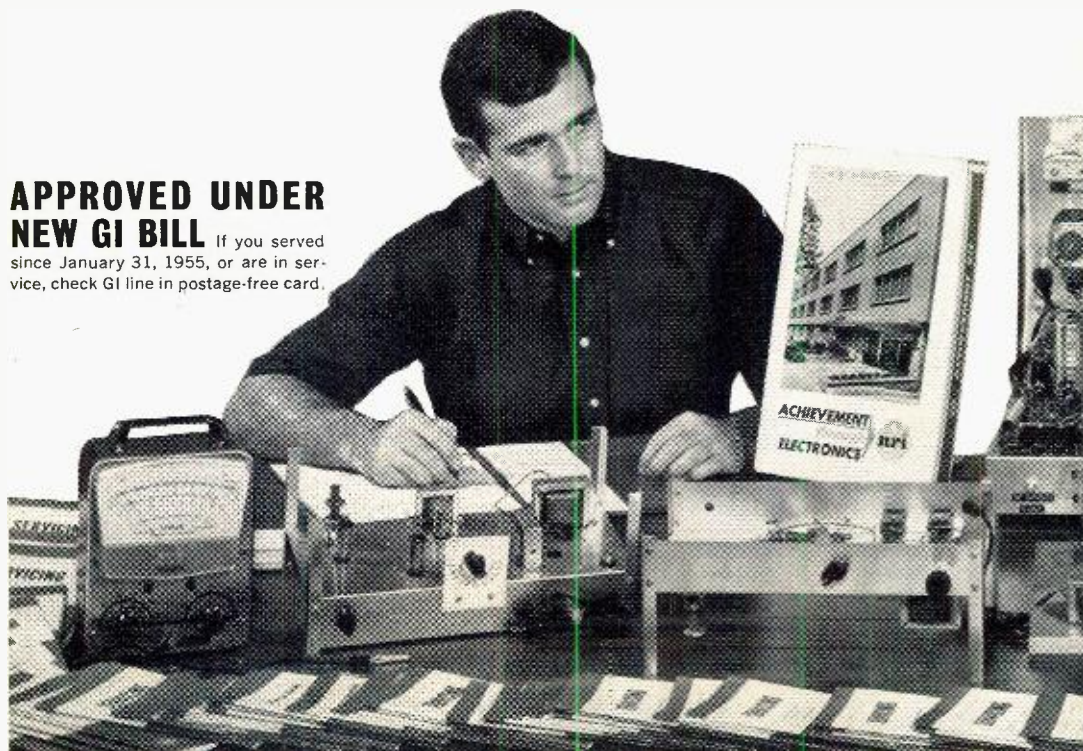

*Earn \$5 or more an hour  
spare or full time in*

## **TV-RADIO SERVICING**

Color Television has arrived. Sales are soaring, along with the continuing popularity of other home entertainment equipment like portable radios, tape recorders, hi-fi sets, phonographs and auto radios. TV-Radio servicing is one of your best routes to spare-time earnings, a good paying job or a business of your own. NRI not only trains you quickly and expertly, but also shows you how to get started in Servicing soon after you enroll, earning as you learn. NRI trains you in today's methods of installing and repairing all Electronic equipment for the home—including booming Color TV. You even build, experiment with and keep to enjoy your own solid-state radio and your choice of black-and-white or Color TV receiver. Like thousands of others, you can be earning \$5 or more an hour extra in spare time starting soon.

## *There's money and success awaiting you in* **BROADCASTING— COMMUNICATIONS**

The experience you gain from intensely practical NRI training in Complete Communications equals as much as two years of training on the job. With NRI, you can train for a choice of careers ranging from mobile, marine and aviation radio to TV broadcasting and space communications. You learn how to install, maintain and operate today's remarkable transmitting and receiving equipment by actually *doing* it. You build and experiment with test equipment, like a VTVM you keep. You build and operate amplifier circuits, transmission line and antenna systems, even build and use a phone-cw transmitter suitable for transmission on the 80-meter amateur band. Whichever of five NRI Communications courses you choose, you prepare for your FCC License exams, and you *must pass your FCC exams or NRI refunds your tuition in full.*

## *Move ahead in America's fast growing industry as* **ELECTRONICS TECHNICIAN**

Electronics touches everyone's lives. This vast field of opportunity is open to you with NRI training. Industrial/Military Electronics training—like all NRI courses—prepares you quickly, thoroughly the practical "hands on" way. You build with, and learn to understand the functions of, today's miracle solid-state components like printed circuits, diodes and transistors. You build and experiment with Electronic circuitry used in automation, data processing, ultrasonics, telemetry. Whatever your interest in Electronics, NRI training can fill your needs. Prove to yourself what nearly a million NRI students could tell you . . . that you get more for your money from NRI. Check the postage-free card and mail it today for your FREE NRI Color Catalog. No salesman will call. NATIONAL RADIO INSTITUTE, Electronics Division, Washington, D.C. 20016.

**YOU GET MORE FOR YOUR MONEY FROM NRI** — Build, test, explore, discover. Everything you see here is included in one NRI course—including Color TV. Other courses equally complete. And you'll be surprised at the low tuition costs. Text for text, kit for kit, dollar for dollar—you get more for your money from NRI.



# POPULAR ELECTRONICS

VOLUME 28 NUMBER 3

MARCH, 1968

WORLD'S  
LARGEST-SELLING  
ELECTRONICS  
MAGAZINE

## SPECIAL CONSTRUCTION PROJECT

**BUILD ULTRA-FAST ELECTRONIC STOPWATCH**  
*Lab or Science Fair project par excellence*

27 DON LANCASTER

## FEATURE ARTICLES

**BUILD A MODULATION MONITOR**  
**TRUE OR FALSE**

35 R. L. WINKLEPLECK, WA9IGU

40 VIC BELL

**THE "FERRET" DRAGS THEM IN**  
*R.f. preselector tunes 7-30 MHz for better SWL DX*

41 GEORGE J. WHALEN

**UNIVERSAL STROBE GOES PSYCHEDELIC**  
*Trigger this strobe to the musical beat*

45 JAMES CUCCIA

**BUILD A FET MIXER**  
*Three-channel mixer provides gain and isolation*

49 DON M. WHERRY, W6EUM

**PI-SECTION COUPLER SOLVES ANTENNA PROBLEMS**  
*Tune your SWL "any length" antenna*

53 ROY A. WALTON

**BUILD FET CRYSTAL CALIBRATOR**  
*Plenty of harmonics from your 100-kHz bar*

56 FRANK TOOKER

**SLOW KICK YOUR WINDSHIELD WIPERS**  
*Even Detroit hasn't thought of this one*

59 DONALD K. BELCHER

## POLARITY QUIZ

66 ROBERT P. BALIN

**MIGHTY-MAG SPEAKER SYSTEM**  
*Something new in miniature hi-fi speaker systems*

67 DAVID B. WEEMS

## UNIQUE PATENTS: ELECTRIC GUN

71

## THE PRODUCT GALLERY

*Comments on Olson RA-23 TV-sound receiver, Heath-kit IM-17 solid-state VOM, Electromation ultrasonic cleaner, and Allied Radio TD-1030 tape deck*

72

## INFORMATION CENTRAL

76 CHARLES J. SCHAUERS, W6QLV

## AMATEUR RADIO

*Amateur radio in Thailand*

79 HERB S. BRIER, W9EGQ

## ON THE CITIZENS BAND

*G.R.S. News Award*

81 MATT P. SPINELLO, KHC2060

## ENGLISH-LANGUAGE BROADCASTS TO NORTH AMERICA

## SHORT-WAVE LISTENING

*Broadcasting station news around the world*

82 ROGER LEGGE

83 HANK BENNETT, W2PNA

## SOLID STATE

84 LOU GARNER

## DEPARTMENTS

LETTERS FROM OUR READERS

8

OPERATION ASSIST

14

READER SERVICE PAGE

15

NEW PRODUCTS

22

TIPS & TECHNIQUES

87

ELECTRONICS LIBRARY

94

NEW LITERATURE

95

READER SERVICE PAGE

97

115

POPULAR ELECTRONICS is indexed  
in the Readers' Guide  
to Periodical Literature

This month's cover photo by  
Irv Tiebet

Copyright © 1968 by ZIFF-DAVIS PUBLISHING COMPANY. All rights reserved.

POPULAR ELECTRONICS, March 1968, Volume 28, Number 3. Published monthly at 307 North Michigan Avenue, Chicago, Illinois 60601. One year subscription rate for U.S., U.S. Possessions and Canada, \$5.00; all other countries, \$6.00. Second class postage paid at Chicago, Illinois and at additional mailing offices. Authorized as second class mail by the Post Office Department, Ottawa, Canada and for payment of postage in cash. Subscription service and Forms 3579: Portland Place, Boulder, Colorado 80302. Editorial offices for manuscript contributions, reader inquiries, etc.: One Park Ave., New York, N.Y. 10016.



A SUBSIDIARY OF  BELL-HOWELL

# SEE WHY so many DeVry-trained Men Step Into Electronics Jobs the Day after Graduation!

## **EVERY GRADUATE CAN ALSO RECEIVE EMPLOYMENT HELP THROUGH HIS ENTIRE CAREER, AT NO ADDED COST**

DeVry's greatest claim to fame is the progress of its graduates. Our aim is to prepare a man so thoroughly that we can recommend him to employers . . . ready to step into a job the day after graduation. If we expect to continue to help employers, our graduates have to be good! That is why we provide top quality instruction—followed by career-long employment service at no added cost.

### **For FREE Information**

Lack of technical experience is no barrier to the man who wants to prepare for a career in ELECTRONICS. Send coupon for two FREE booklets and find out why.

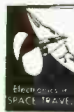

DeVry's educational programs are designed to prepare men 17-45 in their spare time at home or in any of our three well-equipped, modern resident schools in Chicago, Phoenix or Canada. Why not fill in and mail coupon for free facts today?

*Approved for Veterans.*

**DeVRY INSTITUTE of TECHNOLOGY**  
4141 Belmont Avenue, Chicago, Ill. 60641, Dept. PE-3-Y

Please give me your two free booklets, "Pocket Guide to Real Earnings," and "Electronics in Space Travel"; also include details on how to prepare for a career in Electronics. I am interested in the following opportunity fields (check one or more):

- |  |   |
|--|---|
| <input type="checkbox"/> Space & Missile Electronics | <input type="checkbox"/> Communications         |
| <input type="checkbox"/> Television and Radio        | <input type="checkbox"/> Computers              |
| <input type="checkbox"/> Microwaves                  | <input type="checkbox"/> Broadcasting           |
| <input type="checkbox"/> Radar                       | <input type="checkbox"/> Industrial Electronics |
| <input type="checkbox"/> Automation Electronics      | <input type="checkbox"/> Electronic Control     |

Name \_\_\_\_\_ Age \_\_\_\_\_

Address \_\_\_\_\_ Apt. \_\_\_\_\_

City \_\_\_\_\_ State or Province \_\_\_\_\_ Zone or Zip Code \_\_\_\_\_

Check here if you are under 16 years of age.

**HOME STUDY AND RESIDENT SCHOOL PROGRAMS  
AVAILABLE IN CANADA. SEND FOR DETAILS.**

2106

Accredited Member of National Home Study Council

**DeVRY INSTITUTE OF TECHNOLOGY**

4141 BELMONT AVENUE, CHICAGO, ILLINOIS 60641

# INCOMPARABLE PACE 2300



## 23 CHANNEL MOBILE CB RADIOTELEPHONE

Here is the ultimate in efficient, ultra-reliable solid state two-way Citizens Band radio communication, with more exclusive features than any other all-silicon transceiver.

Transmitter—equipped with heavy silicon diamond output transistor, rated at full authorized power (5 watts) • delivers 4 watts (typical) with 100% modulation • double conversion superheterodyne receiver with narrow band, shaped audio response • custom styled to match interior auto decor—handsome walnut grain metal case and chrome bezel • all 23 channels installed and factory tuned • full size "S" meter installed and calibrated • local/distance receiver sensitivity control • exclusive noise limiting • Public Address and loud hailer facility with front panel control and separate speaker jacks • equipped for "Private Caller" selective call accessory • quick-snap power cord and bracket for easy transfer to other vehicle • new locking latch rack • full year guarantee on all parts, plus lifetime guarantee on glass fiber circuit board.

**\$219.95**

Write for complete information:

**((P)) PACE**

**COMMUNICATIONS CORP.**  
24049 Frampton Ave., Harbor City, Calif. 90710  
Export Div.: 64-14 Woodside Ave., Woodside, N.Y.  
Also available in Canada

CIRCLE NO. 22 ON READER SERVICE PAGE

# POPULAR ELECTRONICS

**PHILLIP T. HEFFERNAN**  
*Publisher*

**OLIVER P. FERRELL**  
*Editor*

**LESLIE SOLOMON**  
*Technical Editor*

**MARGARET MAGNA**  
*Managing Editor*

**EDWARD I. BUXBAUM**  
*Art Director*

**ALEXANDER W. BURAWA**  
*Associate Editor*

**ANDRE DUZANT**  
*Technical Illustrator*

**PATTI MORGAN**  
*Assistant Editor*

**AURORA NARDOZZI**  
*Editorial Assistant*

**H. BENNETT, W2PNA**  
**H. S. BRIER W9EGQ**

**L. E. GARNER, JR.**  
**CHARLES J. SCHAUERS, W6QLV**  
**M. P. SPINELLO, KHC2060**  
*Contributing Editors*

**LAWRENCE SPORN**  
*Advertising Sales Manager*

**ARDYS C. MORAN**  
*Advertising Service Manager*

## ZIFF-DAVIS PUBLISHING COMPANY

Editorial and Executive Offices  
One Park Avenue, New York, New York 10016  
212 679-7200

Eastern Advertising Manager, RICHARD J. HALPERN

Midwestern Office  
307 North Michigan Avenue, Chicago, Illinois 60601  
312 726-0892

Midwestern Advertising Manager, JAMES WEAKLEY  
ROBERT J. UR

Western Office  
9025 Wilshire Boulevard, Beverly Hills, California 90211  
213 CRestview 4-0265; BRadshaw 2-1161  
Western Advertising Manager, BUD DEAN

Japan: James Yagi  
Ishikawa Mansion  
#4, Sakuragaoka  
Shibuya-ku, Tokyo  
462-2911-3

Circulation Office  
Portland Place  
Boulder, Colorado 80302

William B. Ziff, Chairman of the Board (1946-1953)  
William Ziff, President

W. Bradford Briggs, Executive Vice President

Hershel B. Sarbin, Senior Vice President

Philip Sine, Financial Vice President

Walter S. Mills, Jr., Vice President, Circulation

Stanley R. Greenfield, Vice President, Marketing

Phillip T. Heffernan, Vice President, Electronics Division

Frank Pomerantz, Vice President, Creative Services

Arthur W. Butzow, Vice President, Production

Edward D. Muhlfeld, Vice President, Aviation Division

Irwin Robinson, Vice President, Travel Division

Ziff-Davis also publishes *Airline Management and Marketing*, *Boating*, *Business & Commercial Aviation*, *Car and Driver*, *Cycle*, *Electronics World*, *Flying*, *Hi/Stereo Review*, *Modern Bride*, *Popular Photography*, *Skating*, *Skating Area News*, and *Skating Trade News*. (*Travel Weekly* is published by Robinson Publications, Inc. a subsidiary of Ziff-Davis Publishing Company.)

Forms 3579 and all subscription correspondence should be addressed to POPULAR ELECTRONICS, Circulation Department, Portland Place, Boulder, Colorado 80302. Please allow at least six weeks for change of address. Include your old address, as well as new—enclosing if possible an address label from a recent issue.

EDITORIAL CONTRIBUTIONS must be accompanied by return postage and will be handled with reasonable care; however, publisher assumes no responsibility for return or safety of art work, photographs or manuscripts.















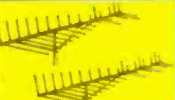





Member Audit Bureau  
of Circulations

# NEW FINCO® COLOR SPECTRUM™ antennas are "signal customized" for better color reception...

"the ANTENNA that captures the RAINBOW"

FINCO has developed the Color Spectrum Series of antennas—"Signal Customized"—to exactly fit the requirements of any given area. There is a model scientifically designed and engineered for your area.

Check this chart for the FINCO "Signal Customized" Antenna best suited for your area.

STRENGTH OF UHF SIGNAL AT RECEIVING ANTENNA LOCATION ▼	Strength of VHF Signal at Receiving Antenna Location				
	NO VHF ▼	VHF SIGNAL STRONG ▼	VHF SIGNAL MODERATE ▼	VHF SIGNAL WEAK ▼	VHF SIGNAL VERY WEAK ▼
NO UHF →		 CS-V3 \$10.95	 CS-V5 CS-V7 \$17.50 \$24.95	 CS-V10 \$35.95	 CS-V15 CS-V18 \$48.50 \$56.50
UHF SIGNAL STRONG →	 CS-U1 \$9.95	 CS-A1 \$18.95	 CS-B1 \$29.95	 CS-C1 \$43.95	 CS-C1 \$43.95
UHF SIGNAL WEAK →	 CS-U2 \$14.95	 CS-A2 \$22.95	 CS-B3 \$49.95	 CS-C3 \$59.95	 CS-O3 \$69.95
UHF SIGNAL VERY WEAK →	 CS-U3 \$21.95	 CS-A3 \$30.95	 CS-B3 \$49.95	 CS-C3 \$59.95	 CS-O3 \$69.95

NOTE: In addition to the regular 300 ohm models (above), each model is available in a 75 ohm coaxial cable downlead where this type of installation is preferable. These models, designated "XCS", each come complete with a compact behind-the-set 75 ohm to 300 ohm balun-splitter to match the antenna system to the proper set terminals.



**THE FINNEY COMPANY**  
34 West Interstate Street  
Dept. PE • Bedford, Ohio 44146

Send for free brochure

Name \_\_\_\_\_

Address \_\_\_\_\_

City \_\_\_\_\_ State \_\_\_\_\_ Zip \_\_\_\_\_

CIRCLE NO. 33 ON READER SERVICE PAGE

# Weller®

...the soldering tools  
professionals depend on



## The original Dual Heat Soldering Guns

Preferred by technicians for their fast heating copper tips, exclusive trigger-controlled dual heat, and high soldering efficiency. Available in 3 wattage sizes, each with spotlight.

100/140-watt Model 8200, 145/210-watt Model D-440, and 240/325-watt Model D-550. Also in complete kits:

- **Model 8200PK** includes 100/140 watt gun, extra tips, tip-changing wrench, flux brush, soldering aid and solder
- **Model D-550PK** heavy-duty 240/325 watt gun kit with soldering, cutting and smoothing tips, wrench and solder

## Dependable MARKSMAN Irons in a size for every job



Ideal for deep chassis work and continuous-duty soldering, Marksman irons outperform others of comparable size and weight. All five feature long-reach stainless steel barrels and replaceable tips.

- 25-watt, 1¾-oz. Model SP-23 with ¼" tip (In kit with extra tips, soldering aid, solder—Model SP-23K)
- 40-watt, 2-oz. Model SP-40 with ¼" tip
- 80-watt, 4-oz. Model SP-80 with ⅜" tip
- 120-watt, 10-oz. Model SP-120 with ½" tip
- 175-watt, 16-oz. Model SP-175 with ⅝" tip

## NOW a BATTERY OPERATED IRON for field servicing

Use this lightweight service tool for automotive wiring, model planes, or mobile communications. Works from any 12 volt battery or 12-14 volt AC/DC supply. Supplied complete with long-life patented "Temperature Sensing" tip, 12-ft. power cord and terminal clips. Model TCP-12—12 volt; Model TCP-24—24-28 volts.



Complete Weller Line includes replacement tips and solder at your Electronic Parts Distributor

**WELLER ELECTRIC CORPORATION**  
Easton, Pa.

WORLD LEADER IN SOLDERING TOOLS  
CIRCLE NO. 30 ON READER SERVICE PAGE

# letters

FROM OUR READERS

Address correspondence for this department to:  
Letters Editor, POPULAR ELECTRONICS  
One Park Avenue, New York, N. Y. 10016

## EQUAL RIGHTS, EQUAL RESPONSIBILITIES

With regard to "Why Not A Ham License Just For Ladies?" (December, 1967), I say **BUNK!** Why should the FCC grant special privileges to the ladies? Every time they turn around, these same ladies are crying equality, and I'm all for giving it to them. But along



with their equal rights, they should accept equal responsibilities.

At the present time, there are many women who hold Advanced and Extra Class licenses. Any woman who wants extra privileges probably hasn't seen a key since the day she received her license. She may never have held a soldering iron in her hand—much less know what to do with one. And if she has any home-built equipment in her shack, chances are her OM built it for her.

LAWRENCE T. HARDIMAN  
Brooklyn, N.Y.

## GROUND COMMUNICATIONS

In the article "How To Use Ground Communications" (January, 1968), you state that a 3:1 turns ratio would be needed to match a 24-ohm load to an 8-ohm amplifier output tap. What is needed, however, is not a 3:1 turns ratio, but a 3:1 *impedance* ratio—an entirely different thing. Since the impedance ratio is computed from the square root of the turns ratio, what is needed is a transformer with a 1.7:1 turns ratio, and the secondary should have a 200-volt output.

M. BLAKE-KNOX  
Ottawa, Ontario, Canada

Why doesn't the author of "How To Use Ground Communications" suggest using an amplifier—even if only a single-stage unit—at the receiving end of the setup (instead of



# IN ELECTRONICS AND ELECTRICITY THIS AMAZING NEW SLIDE RULE SEPARATES THE MEN FROM THE BOYS!

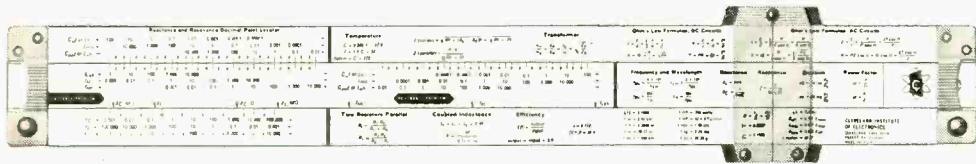

## LOOK WHAT YOU GET...

**YOU GET...** a patented\*, high-quality, all-metal 10" electronics slide rule. "Your computer in a case". Has special scales for solving sticky reactance and resonance problems... an exclusive "fast-finder" decimal point locator... widely-used electronics formulas and conversion factors. PLUS... all the standard scales you need for non-electronic computations such as multiplication, division, square roots, logs, etc.

**YOU GET...** a complete, "AUTO-PROGRAMMED" self-tutoring instruction course. Four fast-moving lessons with hundreds of easy-to-understand examples and diagrams. You'll learn how to find quick, accurate answers to complex electronics problems... soon be your outfit's slide rule "expert". Free examination and consultation service if you want it plus a Graduation Certificate! **THIS COURSE ALONE IS WORTH FAR MORE THAN THE PRICE OF THE COMPLETE PACKAGE!**

**YOU GET...** a sturdy, handsome carrying case. It's made of genuine top-grain leather, doubly reinforced at the "wear-spots", features heavy duty liner for extra slide rule protection, has a removable belt loop for convenient carrying. "Quick-Flip" cover makes it easy to get your rule in and out of the case. Stamps you as a real "pro" in electronics.

**A \$50.00 VALUE FOR LESS  
THAN \$25.00**

\*Under U. S. Patent #3,120,342

NOW... take full advantage of what you know about electronics and electricity... solve complex problems in seconds while others plod along the old-fashioned "pad and pencil" way!

## READ WHY OTHERS CALL THIS REMARKABLE NEW SLIDE RULE PACKAGE TODAY'S BIGGEST BARGAIN IN ELECTRONICS.

The Editor of Popular Electronics, Mr. Oliver P. Ferrell says:  
"Why didn't someone think of this before. The convenience of having all relevant formulas imprinted right on the slide rule saved me time the very first day!"

A student, Mr. Jack Stegleman says:  
"Excellent, I couldn't say more for it. I have another higher-priced rule but like the CIE rule much better because it's a lot easier to use."

The Head of the Electrical Technology Dept., New York City Community College, Mr. Joseph J. DeFrance says:  
"I was very intrigued by the 'quicker' electronics problem solutions. Your slide rule is a natural."

## SPECIAL BONUS OFFER:

**ANYONE WHO SENDS IN THIS COUPON WILL RECEIVE, ABSOLUTELY FREE, A HANDY POCKET ELECTRONICS DATA GUIDE.**

It's a useful, pocket-sized electronics "encyclopedia"... jam-full of valuable facts, formulas and other helpful information. Carry it with you... when it comes to electronics, you'll be the "man-with-the-answer"!

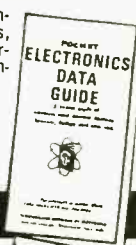

**Cleveland Institute  
of Electronics**  
Dept. PE-142, 1776 E. 17th St., Cleve. Ohio 44114

**ACT NOW! SEND SPECIAL "NO-RISK" COUPON TODAY!**

**CIE** Cleveland Institute of Electronics  
1776 E. 17th Street, Dept. PE-142, Cleveland, Ohio 44114

Please send FREE illustrated Slide Rule Booklet and FREE Pocket Electronics Data Guide.

NAME \_\_\_\_\_ (Please Print)

ADDRESS \_\_\_\_\_ COUNTY \_\_\_\_\_

CITY \_\_\_\_\_ STATE \_\_\_\_\_ ZIP \_\_\_\_\_

A leader in Electronics Training... since 1934

**GET  
BOTH FREE!**

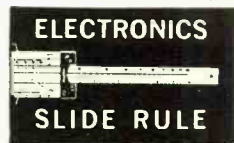

CIRCLE NO. 8 ON READER SERVICE PAGE

# INTRODUCING: THE Lip Stick (It's All HellCAT)

- New base loaded mobile CB antenna mounts on the lip of your trunk looks as sleek as a "silver 47" stick. It's the lip stick.
- Photographically etched-copper high efficiency loading coil for the most powerful signal, the sleekest low-profile design, under the sun.
- 17-7 PH stainless steel whip is the finest money can buy.

Run down to the best distributor under the sun, the one who carries Hellcats. Ask him for the Lip Stick Hellcat 4. He won't stick you up for it.

THE  
**HELLCAT 4**  
FROM  
**Hy-Gain**

Highway 6 at Stevens Creek,  
Lincoln, Nebraska 68501  
Dept. BA-3



THE STRONGEST SIGNAL UNDER THE SUN.

CIRCLE NO. 15 ON READER SERVICE PAGE

## LETTERS

(Continued from page 8)

a high power amplifier at the transmitter end) to increase transmission distance? It would be a lot less expensive approach.

CLYDE E. WADE, JR.  
North Little Rock, Ark.

*We obviously goofed. Other readers have also written in to remind us that impedance ratio is the square root of turns ratio. Our thanks to all of you.*

*There is a very good reason for using a high power amplifier at the transmitter end instead of an amplifier at the receiver end to increase transmission distance. As the distance from the transmitter increases, the transmitted signal is rapidly attenuated. If the distance is great enough, man-made and "natural" noises generated close to the receiver location will drown out the transmitted signal. Using an amplifier at the receiver end would amplify the intensity of the transmitted signal, but it would also proportionally amplify the noises.*

### LI'L ATLAS IN SCIENCE FAIR

I built the "Li'l Atlas" (May, 1966) and entered it in my school's Science Fair. However, instead of using a selenium photocell, I substituted a photomultiplier transistor in series with a 1½-volt battery. With this arrangement, I can suspend objects ¾" below the coil. I am enclosing a picture of my version of "Li'l Atlas" in action.

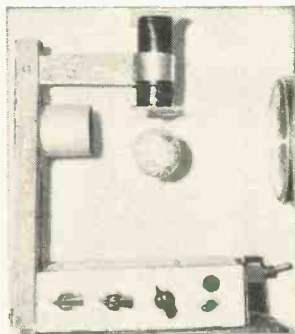

JIMMY STRATIGOR  
Gainesville, Ga.

### SECURITY IN ELECTRONICS INDUSTRIES

Author Ronald L. Ives mentions in "The Electronic Technician Shortage" article (September, 1967) that "security" is the reason why many technicians from Canada and Mexico are not employed or eligible for employment in U.S. electronic industries. However, it should be pointed out that most of these people have a better-than-average education in electronics. I believe that for positions where security is at a minimum, technically prepared Canadians and Mexicans should be "cleared" with little difficulty. I must agree with Mr. Ives' plan to at least partially ease the technician shortage in the United States.

AUGUSTIN DE LA GARZA  
Monterrey, N.L., Mexico

*Augustin, what you say about Canadian and Mexican technicians is probably true.*

---

**what do you expect for \$99.95, miracles?**

---

# YES



*New Cobra V, 5 watt solid state CB. Created to perform miracles in performance.*

---

Just what you'd expect from B&K, the people who developed and built the famous Cobra CAM 88: new standards of performance in selectivity, in sensitivity, in miniaturization. Talk power? Dependability? Beauty? This one you've got to see and hear . . . to believe. Cobra V, the neatest little package of punch, power and performance to hit the CB industry yet. 5 channels, 100% modulation . . . it's a miracle for only \$99.95. You can hear it demonstrated at your B&K Distributor.



**A DIVISION OF DYNASCAN CORPORATION**

1801 W. Belle Plaine, Chicago, Illinois 60613

WHERE ELECTRONIC INNOVATION IS A WAY OF LIFE

Canada: Atlas Radio Corp., Ltd., Ontario  
Export: Empire Exporters, Inc., 123 Grand Street, New York, N.Y. 10013  
**CIRCLE NO. 6 ON READER SERVICE PAGE**

# GET MORE ACTION WITH

**MULTI-ELMAC  
PRECISION MADE,  
POPULAR PRICED  
CB UNITS!**

**CITI-FONE SS \$16950**

**FULL  
23 CHANNEL**

AC-DC Operation,  
Illuminated Meter  
& Channel Selector,  
Triple Tuned RF,  
"Noise Immune"  
Squelch, Double  
Tuned IF's, Ready to Operate



**CITI-FONE 99 \$9950**

**FULL  
8 CHANNEL**

AC-DC Operation,  
Delayed AVC,  
Electronic Switching,  
2 Stage Pre-Amp  
Illuminated "S"  
Meter. Complete  
with Crystal for 1 Channel



**CITI-FONE II \$4995**

**SOLID STATE  
Transmitter-Converter**

Compact 5 3/4 x  
4 3/8 x 1 1/2, 9  
Transistor, 2  
Diodes, 5 Watt  
Input (FCC Max.)  
100% Modulation, 12 VDC  
Operation. Complete with Crystal for  
1 Channel



Please send further information on Citi-Fone SS , 99 , II

**MULTI-ELMAC CO.**

21470 Coolidge • Oak Park, Michigan 48237

NAME \_\_\_\_\_

ADDRESS \_\_\_\_\_

CITY \_\_\_\_\_

STATE \_\_\_\_\_ ZONE \_\_\_\_\_

**CIRCLE NO. 19 ON READER SERVICE CARD**

## LETTERS (Continued from page 10)

But whether they are good security risks or not is for the U.S. Government—and in some cases the industries—to decide. We can only present the facts as they appear to be. However, we have reason to believe that this "Letters" column is regularly read by many of the top people in the electronics industries, and in the government, as well. So, your words should not go entirely unheeded in the quarters where they can count.

### RUBBER GROMMETS, ANYONE?

I had some free time yesterday, so I decided to build a "Clatter Stopper" like the one that appeared in your June, 1967, issue. After I got all the parts together, however, I noticed that I still needed a small rubber grommet. When I sent my husband to the

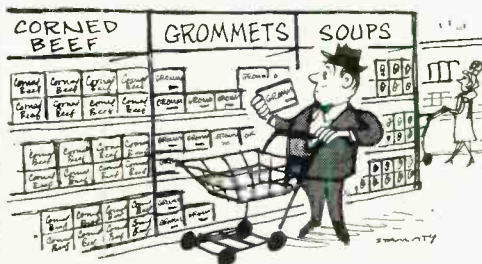

supermarket, I asked him to bring one back. He told me that supermarkets don't sell rubber grommets and that he wasn't sure just where to buy them. In fact, he wasn't sure what a rubber grommet was. But he remembered that there was a clannish group down near Idabelle named Grommet, and that they claimed to come from Mars in a flying saucer.

I told my husband that the type of grommet that I needed didn't come from Mars, that it was the type you fit into a hole in a cabinet for wires to go through. He didn't understand.

"Listen, stupid," I said, "do you want the clatter in your receiver stopped or don't you?"

He hadn't realized until then that there was any clatter in his receiver. He thought all along that it was our son practicing his guitar with the amplifiers turned on full blast.

BETTY BULLA  
Oklahoma City, Okla.

### ATTENTION: ALL WOULD-BE SWL'S

I hope this letter will inspire some of your readers who, due to financial reasons, have been unable to buy even an inexpensive receiver. I also lack the finances to buy an inexpensive receiver, but nevertheless have been able to pursue my SWL hobby.

Using only a General Electric clock radio and a 35'-long outdoor antenna, I have logged 84 BCB stations in the U.S., Canada, and Mexico in just a little over a month, and I have

(Continued on page 119)

# THE ONLY COMPLETE AND UP-TO-DATE GUIDE TO THE EXCITING WORLD OF SPECIALIZED RADIO COMMUNICATIONS!

Whether you're a ham, short wave listener, CB'er or business radio operator . . . a newcomer to the fascinating world of radio communications or an oldtimer who cut his teeth on crystal sets . . .

## You need a copy of the new 1968 COMMUNICATIONS HANDBOOK!

It's packed with over 150 pages of "how to do it—how to do it better" features written by the experts in each category. From choosing your field . . . to learning the code . . . to getting your license . . . to selecting your equipment . . . to setting up your own station . . . to winning awards!

### And note this:

You also get valuable directories of the latest ham and CB equipment for both novice and technician class—PLUS hundreds of photos, charts, lists and tables . . . everything you need to get the most enjoyment from your hours on the air!



**THE 1968 COMMUNICATIONS HANDBOOK IS READY RIGHT NOW.  
Use the coupon below to order your copy TODAY! It's just \$1.25.**

### GET THE HANDSOME LEATHERFLEX-BOUND EDITION for just \$3 POSTPAID!

The 1968 COMMUNICATIONS HANDBOOK is also available in a splendid deluxe edition. Rugged Leatherflex cover provides lasting protection yet is softly textured and gold-embossed for the look of elegance. A collector's item—a superb addition to your permanent reference library. And it's yours, for just \$3 postpaid, when you check the appropriate box on the order form.



ZIFF-DAVIS SERVICE DIVISION • DEPT. CH • 595 B'way • N.Y., N.Y. 10012

OK! Send me the new 1968 COMMUNICATIONS HANDBOOK.

- \$1.25 enclosed, plus 15c for shipping and handling. Send me the regular edition. (\$1.75 for orders outside the U.S.A.)
- \$3.00 enclosed. Send me the Deluxe Leatherflex-bound edition, postpaid. (\$3.75 for orders outside the U.S.A.) Allow three additional weeks for delivery.

print name \_\_\_\_\_

address \_\_\_\_\_

PE-38

city \_\_\_\_\_

state \_\_\_\_\_

zip code \_\_\_\_\_

**PAYMENT MUST BE ENCLOSED WITH ORDER**

# FREE!

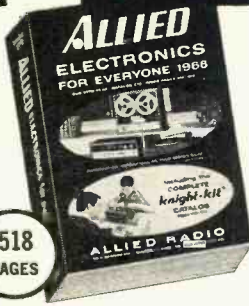

## 1968 ALLIED CATALOG

### SAVE ON:

- Famous Knight-Kits®
- Stereo Hi-Fi
- Tape Recorders, Tape
- CB 2-Way Radios
- Walkie-Talkies
- FM-AM & AM Radios
- Shortwave Receivers
- Portable TV
- Phonographs
- Amateur Gear
- Intercoms & PA
- Automotive Electronics
- Test Instruments
- TV Antennas & Tubes
- Power Tools, Hardware
- Tubes, Transistors
- Parts, Batteries, Books

518  
PAGES

Shop by mail and save at Allied, world's largest electronics headquarters. Hundreds of money-saving values. NO MONEY DOWN. Up to 2 years to pay!

### MAIL COUPON BELOW

ALLIED RADIO, Dept. 3C

P.O. Box 4398, Chicago, Ill. 60680

NAME (Please Print) \_\_\_\_\_

ADDRESS \_\_\_\_\_

CITY \_\_\_\_\_

STATE \_\_\_\_\_

ZIP \_\_\_\_\_

CIRCLE NO. 2 ON READER SERVICE PAGE

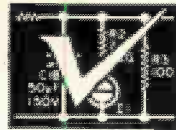

## OPERATION ASSIST

Through this column we try to make it possible for readers needing information on outdated, obscure, and unusual radio-electronics gear to get help from other P.E. readers. Here's how it works: Check the list below. If you can help anyone with a schematic or other information, write him directly—he'll appreciate it. If you need help, send a postcard to Operation Assist, POPULAR ELECTRONICS, One Park Avenue, New York, N.Y. 10016. Give maker's name and model number of the unit. If you don't know both the maker's name and the model number, give year of manufacture, bands covered, tubes used, etc. State specifically what you want, i.e., schematic, source for parts, etc. Be sure to print or type everything legibly, including your name and address. Because we get so many inquiries, none of them can be acknowledged. POPULAR ELECTRONICS reserves the right to publish only those items not available from normal sources.

**Six-Sixty** 4-track mono continuous-play tape deck. Source of tape cartridges needed. (Allen Padwa, Rock Hill, N.Y. 12775)

**Multi-Elmac** Model AF6 transmitter; covers 160-10 meter amateur bands. Schematic and operating manual needed. (George T. Palecek, 1351 Ironton St., Aurora, Colo. 80010)

**Stewart Warner** Model 325 receiver; has five 4-pin tubes. Any available information wanted. (Donald Rogers, RFD #2, Box 583A, Plattsburgh, N.Y. 12901)

**Philco** Model 37-610 EZ, code 121, circa late 1930's; has 5 tubes; tunes 550 kHz to 22 MHz in 3 bands. Schematic, alignment data, and power transformer (part No. 32-7585N, 220-volt primary) needed. **Zenith** Model 6S819T, circa 1940; tunes 550 kHz to 22 MHz in 4 bands; has 6 tubes. Schematic and alignment data needed. (R.G. Paton, 125 Aotea St., Mission Bay, Auckland 5, N.Z.)

**R-48/TRC-8** (Signal Corps) receiver. Schematic and operating manual needed. (Larry Rybacki, 41 3rd Ave., N Tonawanda, N.Y. 14120)

**Echophone** Model #4 battery-operated broadcast receiver. Schematic and other data needed. (Robert Soukup, 1417 E. 8th St., Long Beach, Calif. 90813)

**Triumph** Model 830 oscillograph. Schematic and operating manual needed. (Milton Chemers, 4232 Main St., Skokie, Ill. 60076)

**Hickok** Model 533 dynamic mutual conductance tube tester. 1956. Schematic, operating manual, and information for updating needed. (D.M. Shindell, 1535 W. Weldon Ave., Phoenix, Ariz. 85015)

**Hammarlund** Model HQ-170, circa 1963-65; covers 6-160 meters. Operating manual needed. (Albert Lane, 13845 Long Lake Dr., Sparta, Mich. 49345)

**Dumont** oscilloscope, Type 208. Operating instructions, schematic, and probes needed. (Joseph Dobrzanski, 2903 98th Ave., Tampa, Fla. 33612)

**BC639** AM radio, including power supply and xtal calibrator units. Schematic needed, plus information on adding tube or diode detector to unit for FM reception. (R. Roth, 13617 Bell Rd., Caledonia, Wis. 53108)

(Continued on page 16)

POPULAR ELECTRONICS

IT ONLY COSTS  
1/100 OF 1¢ MORE  
PER SOLDER JOINT  
TO KNOW YOU ARE USING THE  
WORLD'S FINEST CORED SOLDER



New Easy  
Dispenser  
Pak  
60/40  
18 S.W.G.



Latest PC  
(Printed  
Circuit) Pak  
60/40 Extra Thin  
22 S.W.G.—.028

each only 69¢ per package at your dealer

ERSIN **Multicore**  
FIVE-CORE  
SOLDER

MULTICORE SALES CORP., WESTBURY, N.Y. 11590  
CIRCLE NO. 20 ON READER SERVICE PAGE

# POPULAR ELECTRONICS READER SERVICE PAGE

## free information service:

Here's an easy and convenient way for you to get additional information about products advertised or mentioned editorially (if it has a "Reader Service Number") in this issue. Just follow the directions below... and the material will be sent to you promptly and free of charge.

**1.** Print or type your name and address on the lines indicated. Circle the number(s) on the coupon below that corresponds to the key number(s) at the bottom of the advertisement or editorial mention(s) that interest you. (Key numbers for advertised products also appear in the Advertisers' Index.)

**2.** Cut out the coupon and mail it to the address indicated below.

**3.** This address is for our product "Free Information Service" only. Editorial inquiries should be directed to POPULAR ELECTRONICS, One Park Avenue, New York 10016; circulation inquiries to Portland Place, Boulder, Colorado 80302.

**POPULAR  
ELECTRONICS**

VOID AFTER APRIL 30, 1968

P.O. BOX 8391  
PHILADELPHIA, PA. 19101

1 2 3 4 5 6 7 8 9 10 11 12 13 14 15 16 17 18 19 20  
21 22 23 24 25 26 27 28 29 30 31 32 33 34 35 36 37 38 39 40  
41 42 43 44 45 46 47 48 49 50 51 52 53 54 55 56 57 58 59 60  
61 62 63 64 65 66 67 68 69 70 71 72 73 74 75 76 77 78 79 80  
81 82 83 84 85 86 87 88 89 90 91 92 93 94 95 96 97 98 99 100

NAME (Print clearly) \_\_\_\_\_

ADDRESS \_\_\_\_\_

CITY \_\_\_\_\_ STATE \_\_\_\_\_ ZIP CODE \_\_\_\_\_

3 a



*...not by a long  
shot it isn't !!*

There's certainly nothing top secret about the classified pages in Popular Electronics Magazine. They're wide open to the searching eyes of every buyer who's in the market for the product or service that he knows can be found in Popular Electronics' Electronics Market Place.

The more than 400,000 buyers of Popular Electronics, largest readership of any electronics magazine in the world, are your guarantee of knowing that your ad is being read by people who are constantly looking for and buying electronics products. It is these people to whom you MUST direct YOUR advertising as do the many key advertisers appearing in this issue and in each issue throughout the year.

No doubt about it—there's a vast market of buyers searching the classified advertising pages of Popular Electronics and it's important that your ad be exposed to this prime buying audience. Prove to yourself that the leading electronics magazine **MUST ALSO** be the leader in sales responses to the many classified ads presently enhancing its pages—it makes a great deal of sense—give it a try.

There's complete rate information for your convenience in the classified section of this issue. Or, if you'd like a little personal service, it's right up our alley. Just write to

HAL CYMES

*Classified Advertising Manager*

ZIFF-DAVIS PUBLISHING COMPANY

One Park Avenue • New York, New York 10016

## ASSIST

(Continued from page 14)

**Dumont Model RA-109-A1 TV/FM receiver.** Replacement Mallory "Inductuner" variable inductor, Dumont part #89003002, Mallory part #235027 needed. (W.J. Reynolds, 3450 Nicholson Dr., Baton Rouge, La. 70802)

**Regency Model FM-100 FM tuner.** Schematic needed. (Michael Satterlee, 4746 Nicolet Ave., Fremont, Calif.)

**RME-69 receiver.** Schematic and operating manual needed. (Gary Turner, 10854 Tonibar, Norwalk, Calif. 90650)

**GE Model GD-41 "Universal" receiver.** Tube layout needed. (Jerry Monroe, 1305 Greenfield Dr., Alden, N.Y. 14004)

**Crosley Model 11-127 receiver, circa 1950.** Schematic and parts source needed. (Greg Rickmar, 4100 Livingston St., N.W., Washington, D.C. 20015)

**Candle Model MT-510A transistor TV made by Tokyo Transistor, Ltd.** Schematic and instruction manual needed. (Allen Jochem, 2017 College Ave., Quincy, Ill. 62301)

**Doss Model 250 Pioneer Horizontal Sweep Analyst.** Instruction manual and schematic needed. (Pat Brown, 209 W. Second St., Claremore, Okla. 74017)

**Philharmonic Radio Model 1200 TV receiver, circa 1949.** Schematic, service data, alignment instructions, and source for parts needed. (Ken Yarber, 315 Crawford St., Middletown, Ohio 45042)

**Bogen Model E14 p.a. amplifier, circa 1948-1952.** Schematic, servicing manual, and operating instructions needed. (Roger Urbanik, 11 Creekward Dr., Buffalo, N.Y. 14224)

**Radio Shack Model TK-109 "Miniscope" oscilloscope (3" unit offered in kit form a few years ago).** Schematic and/or manual needed. (Dave Klein, 107 Benham Rd., Groton, Conn. 06340)

**King Neutrodyne radio receiver, early 1920's; has 5 tubes.** Schematic needed. **Kingston Type 2 B battery converter, 110 volts 60 cycles.** Tubes needed for operation; also schematic. (Bertrand L. Lavoie, 17 Stone St., Brunswick, Me. 04011)

**E.M. Sargent Model 21 MA receiver, circa 1930-40.** Schematic needed. (Herschel D. Williams, 11780 Preston Ln., Yucaipa, Calif. 93299)

**Heathkit Model AA-100 stereo amplifier kit.** Assembly manual needed. (Ken Chapman, Rte. 1, Box 596F, Thibodaux, La. 70301)

**Harvey Wells Z Match "Bandmaster."** Schematic and parts data plus instruction manual for antenna tuner needed. (Raymond R. Hill, 309 Sycamore St., Greencastle, Ind. 46135)

**Ford Model 04BT truck radio, circa 1961; has 4 tubes and 2N1227A output transistor.** Audio output transformer (Bendix part N2090849-2) needed. (Gus A. Green, 12692 Green St., Boron, Calif. 93516)

**Zenith "Consoltone" receiver, circa 1940; tunes BC and SW (1.8 to 5.5 MHz).** Schematic, operating manual, and source for parts needed. (Robert Gormley, 5 Cantitoe Rd., Yonkers, N.Y. 10710)

**Heathkit Model AT-1 transmitter.** Schematic and operating manual needed. (Kent Harris, 4307 Myerwood, Dallas, Texas 75234)

**Globe Star Model 4463 CB unit.** Schematic and any available information wanted. (Roy Alexander, 551 Santa Clara Ave., Alameda, Calif. 94501)

**Precision Apparatus Model 920 tube tester.** Roll charts needed (preferably chart DRC G2B). (Joseph E. Long, 534 Alice Pl., Woodbridge, N.J. 07095)

**USM-24A Navy oscilloscope.** High voltage transformer and/or scope suitable for parts source needed. **Meissner Model EX signal shifter.** Operating information and/or schematic needed. (Ambrose Barry, 135 N.W. Dr., Patrick AFB, Fla. 32925)

(Continued on page 96)



# The SKIPPER...so much...for so little!

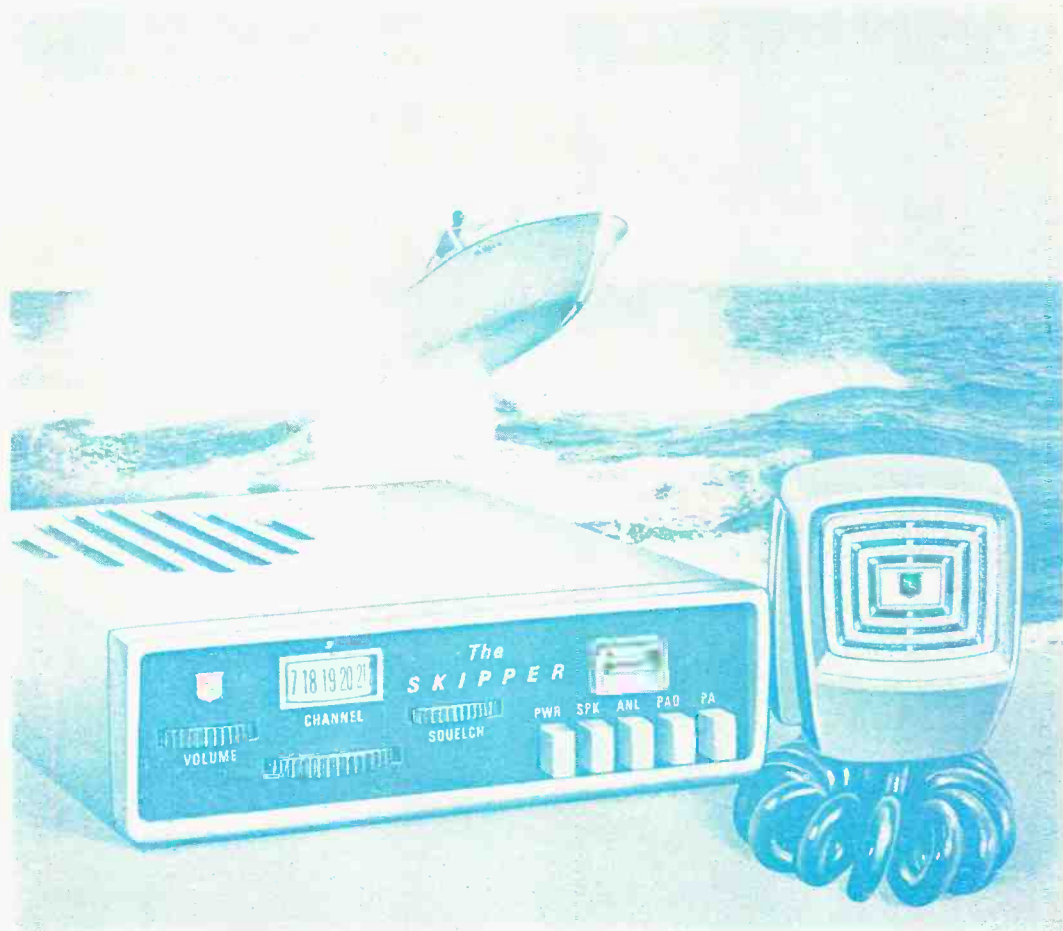

**A** FABULOUS new 23 channel CB transceiver . . . at a new low price . . . with features not found in other units irrespective of price! Squires-Sanders has taken the best of its latest technical innovations . . . developments that the company is noted for in exotic military equipment . . . to give you for the **FIRST** time: • superb no overload receiver with space age dual conversion FET and IC circuit design • advanced design noise limiting • illuminated S meter and channel readout • solid state T/R switching • effective Speech Clipping • 100% modulation • new American P.T.T. mike • Local/Distant sensitivity control • provision for external speaker • switchable Public Address • positive push button switches • Exclusive "All Position" Safety Breakaway Mount • Water-proof treated speaker • recessed controls • satin chrome die-cast panel • only 3 lbs.; 1 1/4 x 6 x 7-7/8". Write today or see your distributor for full color, detailed literature. Made in U.S.A.

PRICE: \$159.95

Squires



Sanders

Squires-Sanders, Inc., Box A, Liberty Corner, N.J. 07938

March, 1968

CIRCLE NO. 29 ON READER SERVICE PAGE

SQUIRES-SANDERS, INC. A  
Gentlemen: Please rush detailed 4 color literature on the fabulous new SKIPPER. I am interested in using it in  Private auto  Business Vehicle  Boat  
Name \_\_\_\_\_  
Street \_\_\_\_\_  
City \_\_\_\_\_ State \_\_\_\_\_ Zip \_\_\_\_\_

# NTS PUTS YOU WHERE THE MONEY IS ... FAST!

NTS Home-Study training is for men in a hurry to move up! NTS Electronics Courses are geared to the needs of the electronics industry. This is up-to-date training. As modern as tomorrow.

Our close working relationship with electronics companies all over the country is the key. They tell us what you need to know to be a top-flight technician. They

keep us informed of new, exciting career opportunities. With this information, we constantly revise our courses to keep our home-study students one step ahead. In an industry that moves so rapidly, advancement comes quickly to the man with NTS training.

Since 1905, NTS has been leading ambitious men to where the money is. Join them.

## **EXCLUSIVE! ONLY FROM NTS! ALL NEW KITS... MAKE IT FUN TO LEARN, EASIER TO EARN.**

For the first time! The greatest lineup of electronics kits ever offered to train you for the space-age. Only NTS has them. Designed for tomorrow... each has all

the latest electronics advances built in. NTS trains you better. NTS makes it fun to learn, easier to earn more, TODAY.



**25" COLOR TV:** Included in Color TV servicing courses ...to prepare you for the big demand for qualified service technicians. This is where the big money is. More than 16 million homes will have color TV by the end of this year. You can cash in on the boom. You can take a giant step ahead with professional training from NTS.



**COMMUNICATIONS:** Transceiver included in Communications Courses. This modern equipment is an important element in communications. You get it, you build it. With it you easily prepare for the F.C.C. License Exam. You become a fully trained man in communications, where career opportunities are unlimited.

**ALL  
NEW KITS!  
ALL NEW  
COURSES!**

**DESK-TOP COMPUTER:** Professionally designed exclusively for NTS. Included with your Industrial and Computer Electronics Course. You can't get this type of kit, or anything like it, anywhere else. The special

computer and integrated circuitry of the training kits prepare you for a big career in this giant industry. These are the first kits offered by any school which include actual integrated circuits.

POPULAR ELECTRONICS

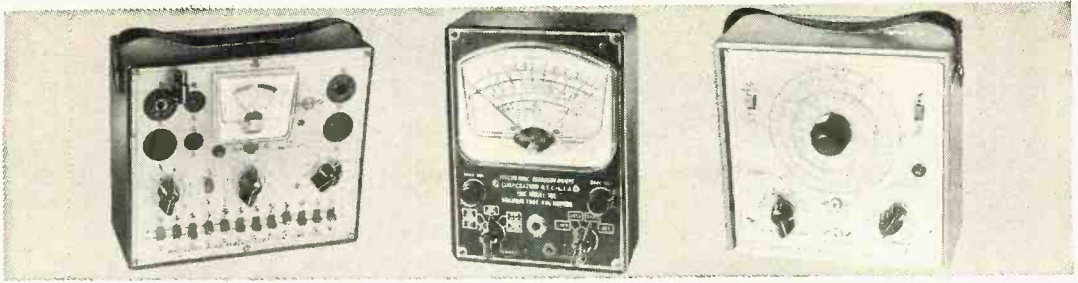

## LEARN MORE, EARN MORE—IN ELECTRONICS

### SIGNAL GENERATOR, VTVM, AND TUBE CHECKER

INCLUDED WITH NTS ELECTRONICS COURSES. These are invaluable instruments for all kinds of Electronic and TV-radio servicing work. You learn to use them early in your training. Begin trouble-shooting work to earn money even before you've completed your course. Many of our students have more than paid for their NTS home-training this way—even before they graduated!

With these professional instruments, you are well-equipped to go into a business of your own. They're all you need to pinpoint most of the trouble spots in TV, Radio, or other electronic components. You get them at no extra cost—as part of your NTS training.

### YOUR OWN BUSINESS

The big jobs belong to the men who prepare for them. You can earn money—learn how to start a business of your own—with NTS home training.

NTS starts you out right with the exclusive **Project Method Career Kit**. Contains everything you need to make your training easy. Keeps you organized. You learn faster. You move ahead that much sooner.

You can get all the details on the many advantages of NTS **Project Method** home training. It's all in the NTS catalog, along with pictures and information on all the equipment and exciting kits you receive and keep. Tells you all you need to know to get started.

### CLASSROOM TRAINING AT LOS ANGELES:

You can take classroom training at Los Angeles in sunny Southern California. NTS occupies a city block with over a million dollars in facilities devoted exclusively to technical training. Check special box in coupon.

### HIGH SCHOOL AT HOME



National offers accredited high school programs. Take only subjects you need. Study at your own pace. Everything included at one low tuition. Check special high school box in coupon for full information and FREE catalog.

### MAIL REPLY CARD OR COUPON FOR NEW COLOR CATALOG & SAMPLE LESSON. *THEY'RE FREE!*

You enroll by mail only. No salesman will call.



## NATIONAL **TECHNICAL** SCHOOLS

WORLD-WIDE TRAINING SINCE 1905

4000 So. Figueroa St., Los Angeles, Calif. 90037

Accredited Member National Home Study Council

Accredited Member National Association of Trade & Technical Schools

9  
**TRAINING PROGRAMS**

## NATIONAL **TECHNICAL** SCHOOLS

4000 S. Figueroa St., Los Angeles, California 90037

**APPROVED FOR VETERANS**



Please rush Free Color Catalog and Sample Lesson, plus detailed information on field checked below. No obligation.

- Master Course in Color TV Servicing
- Color TV Servicing for Qualified Technicians
- Master Course in TV & Radio Servicing
- Practical TV & Radio Servicing
- Master Course in Electronic Communications
- FCC License Course
- Industrial & Computer Electronics
- Stereo, Hi-Fi & Sound Systems
- Basic Electronics     High School at Home

NAME \_\_\_\_\_ AGE \_\_\_\_\_

ADDRESS \_\_\_\_\_

CITY \_\_\_\_\_ STATE \_\_\_\_\_

Please fill in Zip Code for fast service

Check if interested in Veteran Training under new G. I. Bill. (Dept. 205-38)

Check if interested **ONLY** in Classroom Training at Los Angeles.



## NEW PRODUCTS

Additional information on products covered in this section is available from the manufacturers. Each new product is identified by a code number. To obtain further details on any of them, simply fill in and mail the coupon on page 15 or 115.

### COMMUNICATIONS RECEIVER

Although designed for professional application, the *Galaxy R-530* is a high-frequency communications receiver priced within reach of the discriminating radio amateur and serious SWL. Having a continuous frequency coverage of 0.5 to 30 MHz, the solid-state unit offers reception of selectable upper or lower sideband, AM, CW, and RTTY signals. It incorporates a phase-locked fundamental oscill-

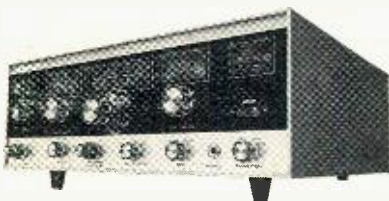

lator, permeability-tuned-oscillator variable frequency control, adjustable BFO control, variable r.f. attenuator, and an adjustable noise blander. Frequency stability: less than 100 Hz drift after turn-on. Frequency accuracy: 1 kHz throughout the range. The use of crystal lattice high-frequency filters makes for optimum selectivity.

Circle No. 75 on Reader Service Page 15 or 115

### AM/FM RADIO AND CASSETTE RECORDER

You can tune in any station in the AM or FM broadcast bands, and just listen to it, or press a button and record for up to two hours with *Concord Electronics' Model F-103 "Radio-*

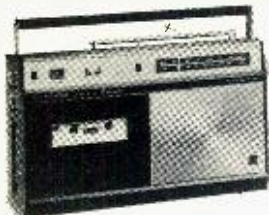

*recorder."* A single control in this portable, all-transistor radio/recorder system is used to start, stop, and rewind the cassette tape. A telescoping whip antenna is built-in for the FM section of the superhet receiver, and an a.f.c. circuit makes for good reception. The recorder section features capstan drive, 1½

in/s tape speed, remote control dynamic microphone, record level/battery condition meter, and automatic shut-off in the play and fast wind modes. An acoustically matched speaker (with external output and monitor switch) is provided.

Circle No. 76 on Reader Service Page 15 or 115

### SOLID-STATE STEREO TUNER

Excellent selectivity (42 dB) and capture ratio (2.5 dB) are made possible by the inclusion of an integrated circuit i.f. strip in *H. H. Scott's* low-cost Model 315B stereo tuner; the strip uses the equivalent of 20 transistors. In addition, the silver-plated FET

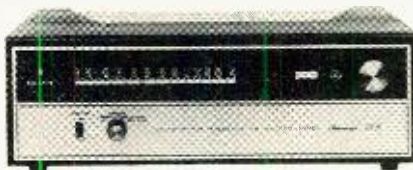

front-end is said to virtually eliminate interference, as well as provide a sensitivity of 2.2 µV and freedom from drift. Time-switching multiplex instantly and silently switches the unit to stereo mode, and the 315B incorporates a stereo indicator light which operates only on a true stereo signal, never on noise.

Circle No. 77 on Reader Service Page 15 or 115

### SOLID-STATE 5-WATT TRANSCEIVER

Successor to *Lafayette Radio Electronics' well-known HE-20 series* is the Model HE-20T—an FCC-Type-Accepted solid-state CB transceiver with 12 crystal-controlled transmit channels plus 23 tunable receive chan-



nels. Features include a 455-kHz mechanical filter, variable squelch, automatic series-gate noise limiter, relative r.f. output "S"-meter, spotting switch, p.a. and selective calling provisions, and built-in 117-volt a.c. and 12-volt d.c. positive or negative ground power supplies. The HE-20T is furnished with a PTT dynamic microphone, channel 9 crystals, and an adjustable mobile mounting bracket.

Circle No. 78 on Reader Service Page 15 or 115

### STATIC STRAPS

Static straps introduced by *Hallett* are said to add miles to a car radio's reception range by minimizing static discharges. They bond (Continued on page 24)

We admit it. We're tough to work for.

But we get results.

The brand new Companion IV, for instance. It's smaller. [2¼ (h) x 8½ (w) x 6¾ (d)]

And lighter in weight. [3¾ pounds]

But it's jam-packed full of the good things a good radio should be full of. Sample:

Front, bottom *and* telephone handset speakers which, for the first time, guarantee unobstructed sound no matter where the radio is mounted. And which give an extra measure of tone fidelity, plus increased volume with less distortion than ever before.

Four more channels than its predecessor. Ten in all.

Touch-tap tuning which allows you to change

channels just like that.

A greatly improved noise limiting circuit. And we mean greatly improved.

Electronic switching.

Receive and transmit indicator light.

L-C filter for razor-sharp selectivity.

Two R-F stages in the receiver.

And a choice of either palm microphone or telephone handset at no extra cost.

The price: \$139.90.

The point: Buy it. It's a great little radio.

See the Companion IV at your authorized Pearce-Simpson Dealer Showroom. Or mail this coupon for a free brochure on the entire line of Pearce-Simpson Citizens Band Radios and a list of dealers in your area.



The Companion IV

## Our Motto:

**If you can't put 10 channels and 3 speakers into a \$139.90 radio, you're not Pearce-Simpson material.**

PEARCE-SIMPSON, INC.  
P.O. Box 800/Biscayne Annex, Miami, Fla. 33152  
Gentlemen: I like your motto. Please send your brochure. PE-368

Name \_\_\_\_\_

Address \_\_\_\_\_

City \_\_\_\_\_

State \_\_\_\_\_

Zip \_\_\_\_\_

Overseas military personnel may write for special price list.

CIRCLE NO. 23 ON READER SERVICE PAGE

F. C. C. Type Acceptance pending

## PRODUCTS (Continued from page 22)

the hood to the firewall, engine to frame, trunk lid to body, etc., and are available in lots of four 8" and four 6" straps, plus 16 hex bolts with self-contained lock washers. Complete installation instructions are furnished.

Circle No. 79 on Reader Service Page 15 or 115

### ELECTRIC AUTO ANTENNAS

Two models of electric auto antennas, plus an extension kit, are being offered by the *Brach Division* of JFD Electronics. Model 86-6753 is a front-mount antenna, and Model 86-6756 is a rear-mount antenna. Both have a 5-section, 46" mast, and an 18-20 lb. thrust developing motor which raises or lowers the antenna even in sub-zero weather. The rear-mount extension kit, Model 86-6755, is optional with the front-mount antenna. It consists of a 180" cable extension and a 180" electric harness extension with an up-and-down control switch, bracket, and adapter pad.

Circle No. 80 on Reader Service Page 15 or 115

### EXCLUSIVE AUTOMATIC TURNTABLE

Perfect tracking during either manual or automatic play is claimed for the *Elpa* PE-2020 turntable: an exclusive control in the cartridge allows you to set a 15° vertical tracking angle for every record. Among the



PE-2020's other features are an automatic anti-skating device, a cartridge shell that accepts all cartridges with an exact slide-fit mounting, a single-lever command center

(for start, stop, repeat, cueing, and lift), automatic start and automatic shut-off with either a single record or a stack of them. The PE-2020 is also said to have the lowest record drop in automatic operation of any automatic turntable.

Circle No. 81 on Reader Service Page 15 or 115

### SOLID-STATE TV PREAMPLIFIERS

According to *JFD Electronics*, its two new mast-mounted preamplifiers can handle twice as strong an input signal than any previously developed solid-state preamplifier. The "Snowplow" Model SP2300 uses 300-ohm twin lead; the "Snowplow" Model SP2700, 75-ohm coaxial cable. Designed to meet the stringent requirements of color TV, these preamps can handle up to 40 dBmV on the high band, insuring no overload from strong local station signals. Gain is 15 dB on all VHF/FM channels, and output is adequate to supply signals to two or more TV or FM receivers. Both

units are shipped complete with remote power supplies and mounting hardware.

Circle No. 82 on Reader Service Page 15 or 115

### SIX-BAND RADIO RECEIVER

With the imported "Star-Fire VI" 18-transistor receiver available from *Lafayette Radio Electronics*, you can listen to three short-wave broadcast bands (1.6 to 23 MHz), the



AM and FM broadcast bands, and the VHF-FM police band. Designed to operate on four "D" batteries (or on 117 volts a.c. with an optional adapter), the "Star-Fire VI" has two 4" built-in hi-fi speakers and a world-wide short-wave time zone chart (see photo). Other features:

a.f.c. to eliminate drift on FM, push-button controls, signal strength tuning meter, and earphone jack. The unit is supplied with earphone, batteries, and a booklet containing listings of short-wave stations all over the world.

Circle No. 83 on Reader Service Page 15 or 115

### TEFLON "CUT-OFFS" AND PIPE SEAL

Teflon "cut-offs" are being offered by *Edmund Scientific* in a variety of blocks and/or tubular and solid rods for all sorts of uses. You can make miniature bearings or washers, use them for weatherproofing or as anti-friction liners for drawers, windows, etc., or as special insulators. They come by the pound. Also being offered by Edmund is Teflon tape pipe thread seal for making leak-proof pipe joints—it's available in a 300" roll, 1/2" wide x 0.0035" thick.

Circle No. 84 on Reader Service Page 15 or 115

### CB/AMATEUR RADIO ANTENNAS

Three new antennas have been introduced by *Mosley*, one of which—the "Lancer 23"—is a deluxe CB mobile antenna intended also for the CB'er who wants to become a ham, and for the ham who works the CB channels. For the CB'er, the "Lancer 23" is equipped with a 10-meter coil; the amateur can purchase it with interchangeable coils for 10 to 75 meters. The second antenna—for Novice hams—is the X-15, a two-element, easily constructed, do-it-yourself antenna. When a Novice becomes a General, he can adapt the X-15 for 10 meters by a simple readjustment of the elements according to the instructions given. And, finally, there is the "Classic 10-15": an amateur radio antenna which covers the popular daytime 15-meter DX band as well as 10 meters. The "Classic 10-15" can also be stacked with 20 and/or 40-meter beams if desired.

Circle No. 85 on Reader Service Page 15 or 115

# SPECIAL 10th ANNIVERSARY ISSUE

All-new  
Winter  
1968  
Edition!

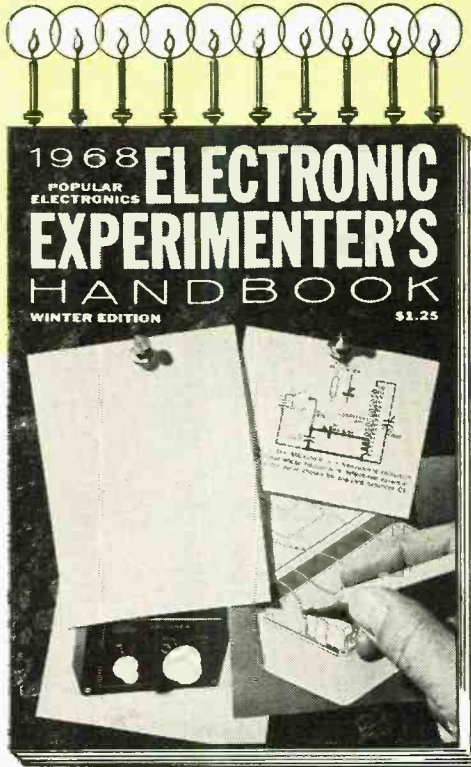

Over 145  
Pages!

28 New  
Projects!

It's our anniversary . . . but you get the present: 250 fascinating, fun-filled hours with the all-new Winter 1968 **ELECTRONIC EXPERIMENTER'S HANDBOOK!** A big surprise package of 28 challenging do-it-yourself construction projects for • your home and auto • audio, stereo, hi-fi • SWL, CB and Ham • science fair projects • lab and test equipment.

You'll build such valuable units as . . . a solid-state CD ignition system . . . a sequence-operated lock . . . a metal locator . . . a two-by-two stereo preamplifier . . . a 70 watt per

channel hi-fi amplifier . . . a VOM range splitter . . . an IC binary counter . . . and Tesla's thermomagnetic motor!

Each has complete schematics, illustrations, parts lists and easy-to-follow instructions that guarantee you perfect finished products. PLUS expert tips 'n techniques designed to build your electronics skill. You'll keep up with the latest advances in

the field, learn many professional methods and shortcuts . . . and develop that extra technical know-how you get only from practical, first hand experience.

In short, Happy Anniversary to us . . . means Happy Hobbying to you. For this big 10th Anniversary edition of the **ELECTRONIC EXPERIMENTER'S HANDBOOK** is the best yet—sure to be grabbed up by electronics enthusiasts everywhere. Use the coupon below to order your copy today!

GET THE  
DELUXE  
LEATHERFLEX-  
BOUND EDITION  
for just \$3 POSTPAID!

The Winter 1968 **ELECTRONIC EXPERIMENTER'S HANDBOOK** is

also available in a splendid deluxe edition. Rugged Leatherflex cover provides lasting protection yet is softly textured and gold-embossed for the look of elegance. A collector's item — a superb addition to your electronics bookshelf. And it's yours, for just \$3 postpaid, when you check the appropriate box on the order form.

1968 **ELECTRONIC  
EXPERIMENTER'S  
HANDBOOK**

Only  
\$1.25

ZIFF-DAVIS  
SERVICE

DIVISION, DEPT. EEHF

595 B'way, N.Y., N.Y. 10012

OK! Send me the all-new Winter 1968 **ELECTRONIC EXPERIMENTER'S HANDBOOK.**

\$1.25 enclosed, plus 15c for shipping and handling. Send me the regular edition. (\$1.75 for orders outside the U.S.A.)

\$3.00 enclosed. Send me the Deluxe Leatherflex-bound edition, postpaid. (\$3.75 for orders outside the U.S.A.) Allow three additional weeks for delivery.

name \_\_\_\_\_ PLEASE PRINT

address \_\_\_\_\_

city \_\_\_\_\_ PE. 38

state \_\_\_\_\_ zip code \_\_\_\_\_

I missed the big Spring 1967 edition. Please send me the  regular edition  Deluxe Leatherflex-bound edition. (Prices same as above.)

**PAYMENT MUST BE ENCLOSED WITH ORDER.**

For Superior  
Base Station  
Communication  
Power . . .

# **avanti** **ASTRO PLANE** antenna

The Only Antenna That  
RADIATES FROM THE TOP . . .



Ordinary collinear or ground plane antenna  
signals are blocked . . . they radiate from  
the bottom.



Astro Plane gets its signal over obstacles . . .  
it radiates from the top.

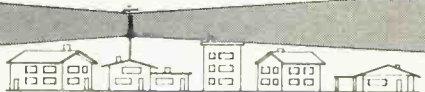

The Avanti Astro Plane is a revolutionary innovation in omnidirectional, base station antenna design. Astro Plane concentrates radiation on top to pack maximum signal strength at the highest, most efficient position. Ordinary collinear or ground plane antennas spread radiation near the long drooping radials at their base and develop little or no signal strength at the top.

Astro Plane's power on top feature provides a special interest for CB'ers. It's the only antenna that can generate signal strength at the very top of the full legal antenna height limit. Astro Plane's unique design assures getting maximum signal power over nearby buildings, power lines or difficult terrain that block performance of ordinary antennas.

Astro Plane, like the Avanti PDL (Polar Diversity Loop) is another example of how electronic research provides superior antenna performance — See them both at your favorite CB Dealer or write for information.



antenna division

**avanti**

research & development, inc.

Dept. G 45 West Fullerton Ave.  
Addison, Illinois 60101



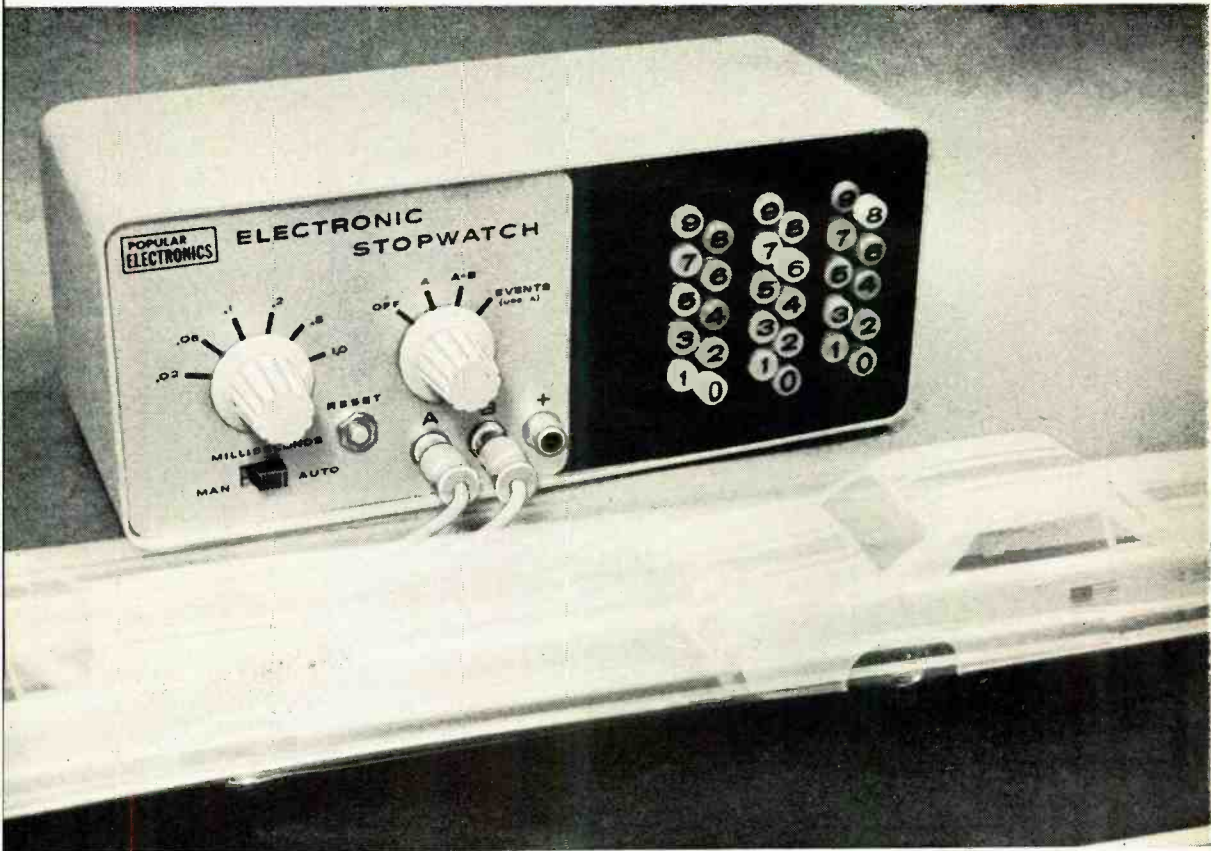

# Build Ultra-Fast Electronic Stopwatch

BY DON LANCASTER

USING OUR  
LOW-COST  
DECIMAL COUNTING  
UNIT

PROBABLY the most accurate time measurement instrument ever to be made available to the electronics experimenter, this "Electronic Stopwatch" is a small-size, precision, multi-use instrument that can count events from 0 to 999 at any speed up to 10 million counts per second. It can accurately time the *duration* of any single event with 0.1% accuracy, or it can indicate the time interval *between* two different events with both occurring within a one-second time interval—in fact, it can very easily time a speeding bullet in flight!

Fig. 1. The timing module is made up of six IC's, a crystal, five capacitors, and a couple of resistors.

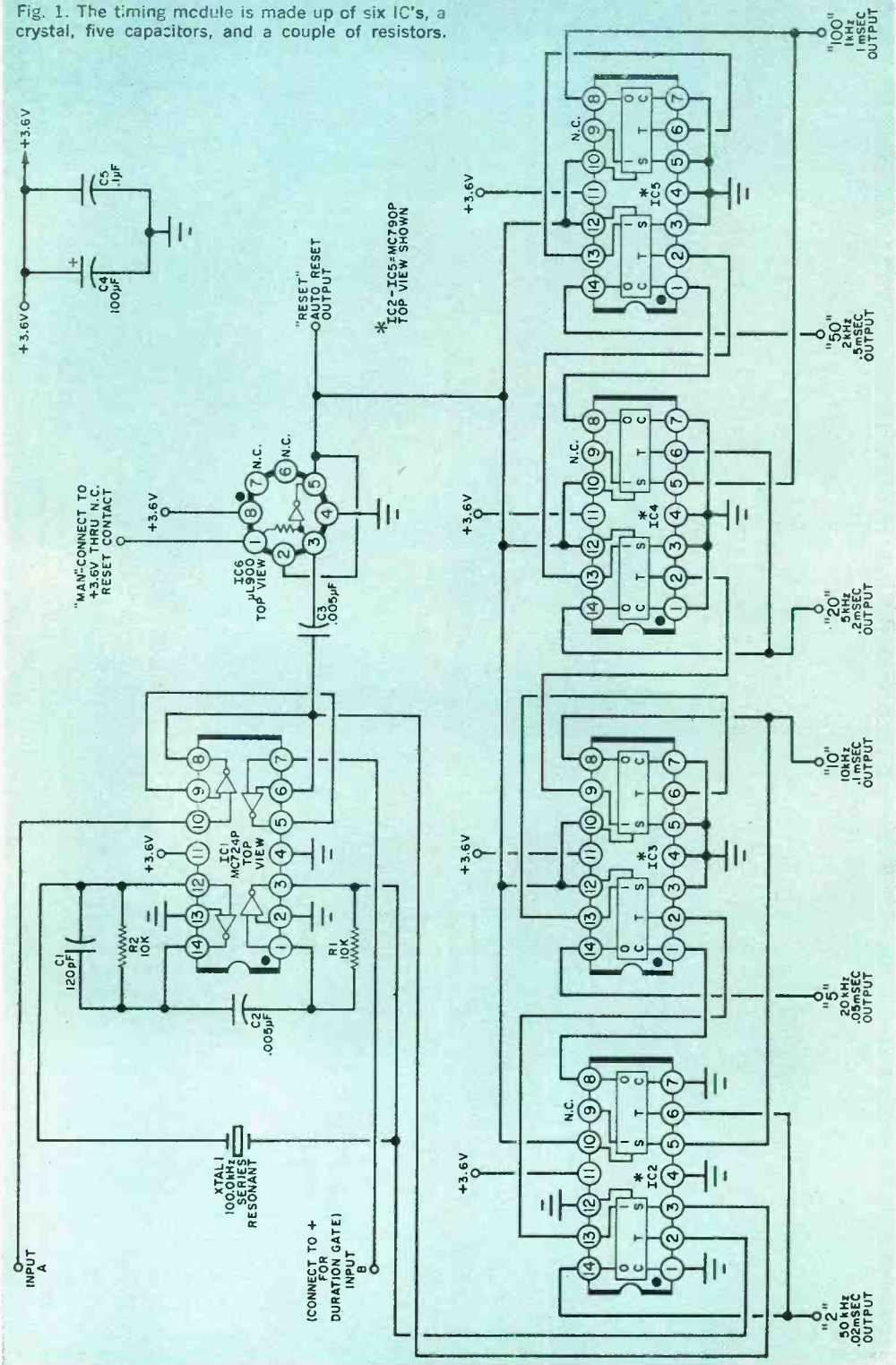

## TIMING MODULE PARTS LIST

*C1*—120-pF, dipped mica capacitor  
*C2, C3*—0.005- $\mu$ F, 50-volt Mylar capacitor  
*C4*—100- $\mu$ F, 6-volt electrolytic capacitor  
*C5*—0.1- $\mu$ F, 10-volt disc capacitor  
*IC1*—Quad two-input gate (Motorola MC724P)  
*IC2, IC3, IC4, IC5*—Dual JK flip-flop (Motorola MC790P)  
*IC6*—Buffer (Fairchild  $\mu$ L900)  
*R1, R2*—10,000-ohm,  $\frac{1}{4}$ -watt resistor  
*XTAL*—100.0-kHz series-resonant crystal  
*1*— $1\frac{1}{16}$ " x 3" x  $3\frac{1}{2}$ " printed circuit board—see text  
*Misc.*—Crystal clip (1), small eyelets (2), #22 solid wire jumpers (7), PC terminals (14), mounting hardware, solder

**NOTE:** The following are available from Southwest Technical Products Corp., Box 16297, San Antonio, Texas, 78216: Etched and drilled PC board, \$3.25; complete kit of timing module parts, \$24.00.

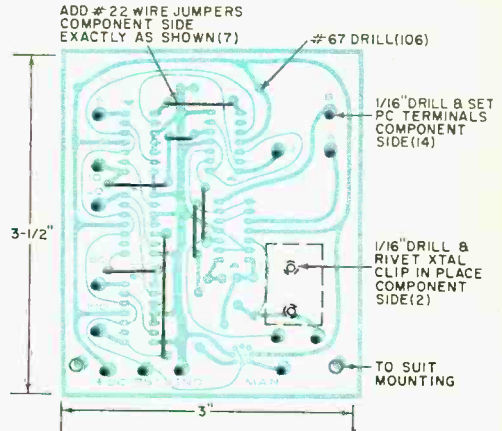

Fig. 3. Drilling guide for the timing module PC board. Mount parts called out on component side.

There are six built-in switch-selectable time resolutions ranging from 20 microseconds to one millisecond; or, you can select external manual timing up to as long as you want. Readout is on a series of three decimal counters (see "Low-Cost Counting Unit," Feb., 1968).

The circuit includes a special synchronizer that prevents any last digit "bobble," while a reset selector allows either

automatic or manual resetting of the instrument, or will allow the reading to pile up for long-term accuracy.

If desired, you can add an optional output jack to get very precise one-second timing pulses for use in electronic clocks or other timing applications. You can also scale any input frequency by 10, 100, or 1000, as well as use the instrument as a highly accurate oscilloscope

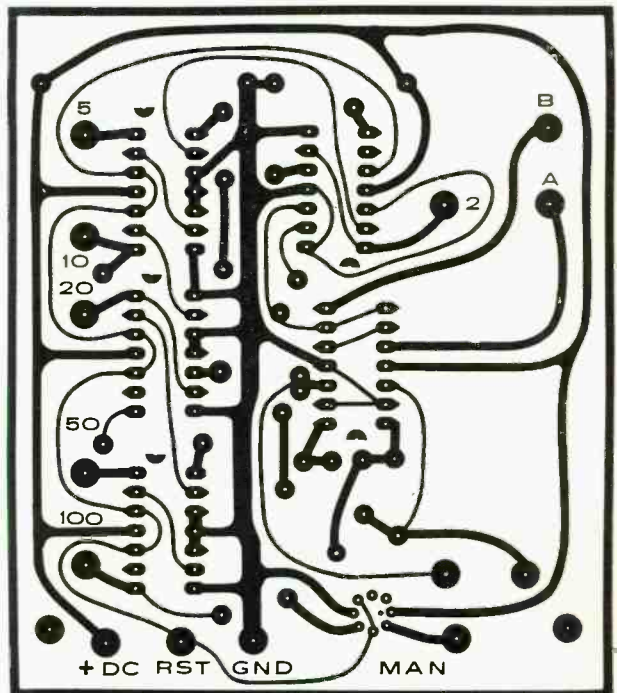

Fig. 2. Actual-size printed board for the timing module. This board is the same size as that used for the decimal counting unit, greatly simplifying the packaging of the completed stopwatch.

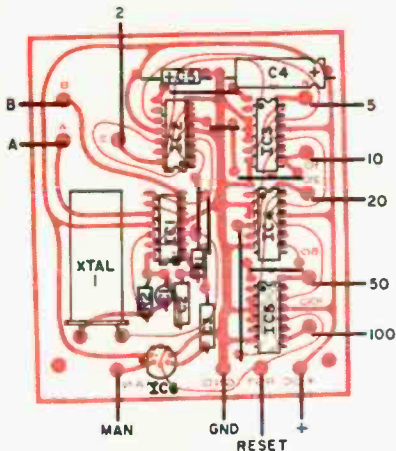

Fig. 4. Timing module components. Observe polarity of the capacitors and alignment of the six IC's.

sweep time calibrator. It even generates random three-digit numbers for contests or probability studies, and it does all this powered by either the a.c. line or a six-volt battery.

Cost of this project? You can build one complete for \$50 to \$80 depending

on how fancy a cabinet and finish you want. Dialplates, circuit boards, and complete kits are available (see Parts Lists). While not a beginner's project, the stopwatch is not difficult to construct; and when it is finished, you will have a piece of test equipment equal in performance to units costing ten times as much.

**Timing Module.** Because complete construction information for the decimal counting unit was given in the February issue, only the remainder of the "Electronic Stopwatch" will be covered here: the timing module; associated power supply; and all internal switching.

The schematic for the timing module is shown in Fig. 1. As with the decimal counters, because of the complexity of the circuit, the printed circuit board shown actual-size in Fig. 2 should be used. The board should be drilled and the seven wire jumpers installed as shown in Fig. 3. Then, install the components in accordance with Fig. 4.

Use a small, clean soldering iron and fine solder, double-check the orientation of all parts, and make clean solder joints.

### POWER SUPPLY PARTS LIST

- C1, C2—18,000- $\mu$ F, 10-volt computer-grade electrolytic capacitor (Sprague 183G010AC or similar)
- C3, C4—0.1- $\mu$ F, 10-volt disc capacitor
- D1, D2—1N4001, 1-ampere, 50-volt silicon power diode
- F1—0.5-ampere fuse
- RECT 1—1.5-ampere, full-wave bridge rectifier (Motorola MDA942-1 or similar)
- T1—Filament transformer, 6.3 volts, 1.2 amperes (Knight 54B1419, Stancor P6134, Thordarson 26F60 or similar)
- Misc.— $\frac{1}{2}$ " x 3" x 3" aluminum mounting bracket; 10 suit enclosure, capacitor mounting clips (2), fuse holder, small terminal board, pop rivets (4), ground lug, #6 hardware, terminals for C1, C2, wire, solder

NOTE: A complete kit of all the above parts is offered by Southwest Technical Products Corp., Box 16297, San Antonio, Texas 78216 for \$11.00 (plus 2 pounds postage).

### Optional Parts for battery operation

- D1—1N4001 diode
- F2—1-ampere slow-blow fuse
- S1—S.p.d.t. slide switch
- Misc.—Fuse holder, rear case terminals and battery connectors, 6-volt automotive storage battery, optional mounting for BATT/A.C. switch

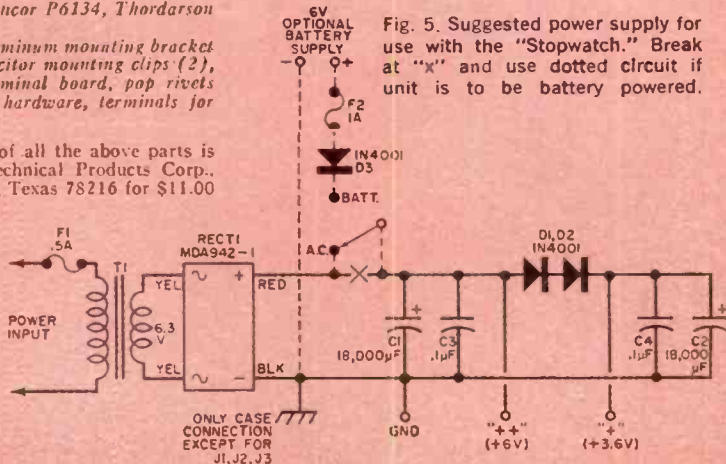

Fig. 5. Suggested power supply for use with the "Stopwatch." Break at "x" and use dotted circuit if unit is to be battery powered.

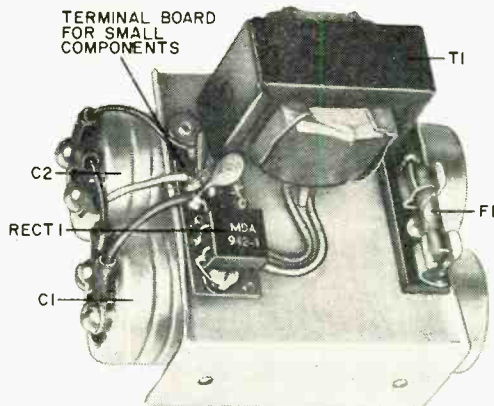

Fig. 6. The power supply is built on a 3" x 3" piece of heavy-gauge aluminum with a 1½" mounting lip.

### STOPWATCH PARTS LIST

- J1, J2, J3—Phono jack (RCA type)  
 M1—Electronic stopwatch timing module  
 M2, M3, M4—Decimal counter module (see "Low-Cost Counting Unit," February, 1968)  
 M5—Power supply module  
 R1—47-ohm, ½-watt resistor  
 R2, R3—1000-ohm, ¼-watt resistor  
 R4—100-ohm, ¼-watt resistor  
 S1—Three-pole, four-position, non-shorting selector switch (Mallory 32341 or similar)  
 S2—Single-pole, six-position non-shorting selector switch (Mallory 32261 or similar)  
 S3—S.p.d.t. slide switch  
 S4—S.p.d.t. push-button switch  
 Misc.—Case, chassis, line cord and strain relief, knobs (2), backup plate for controls, sect. module mounting hardware, trim panel, wire nut, wire, solder

NOTE: Hard anodized aluminum dialplate available from Reill's Photo Finishing, 4627 N. 11th St., Phoenix, Arizona 85014, as Stock ESW-1; in silver for \$2.75; red, gold, or copper for \$3.25; postpaid in U.S.A.

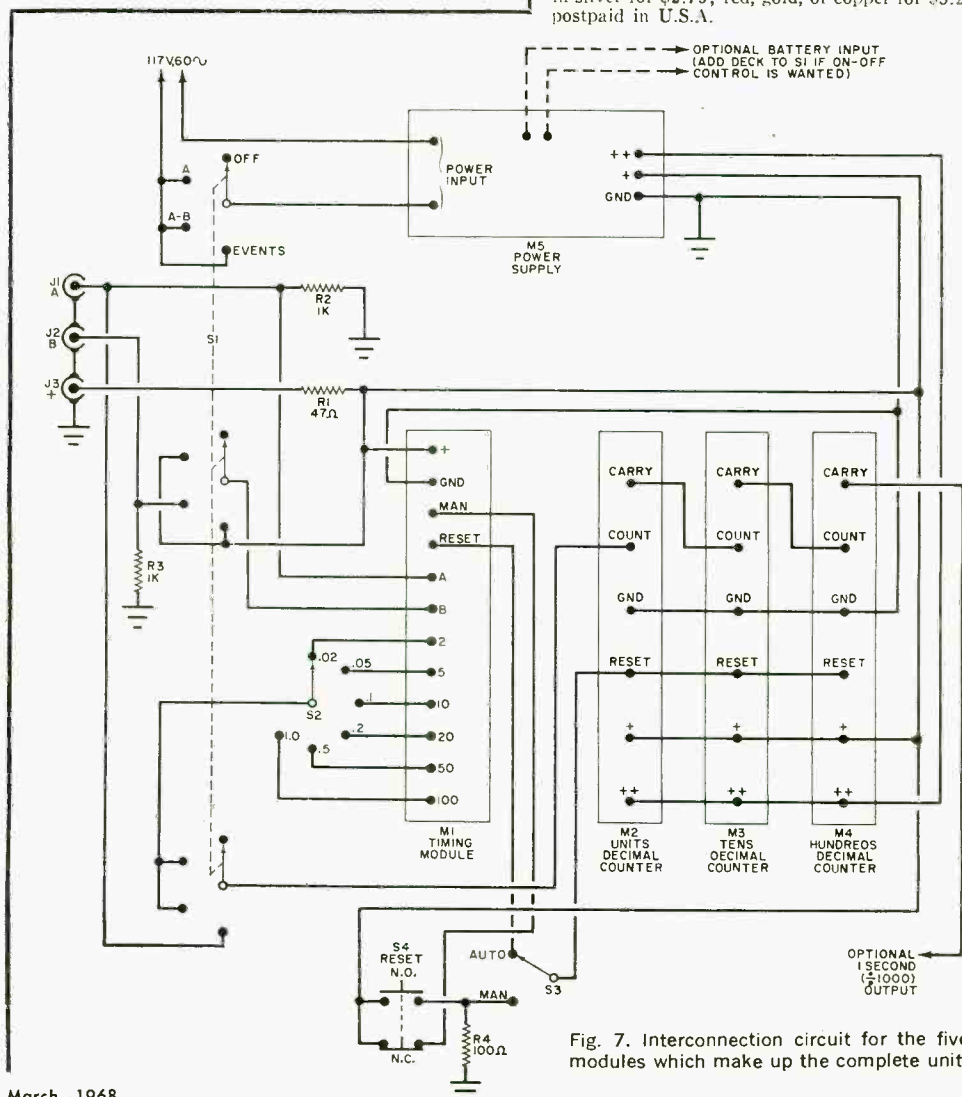

Fig. 7. Interconnection circuit for the five modules which make up the complete unit.

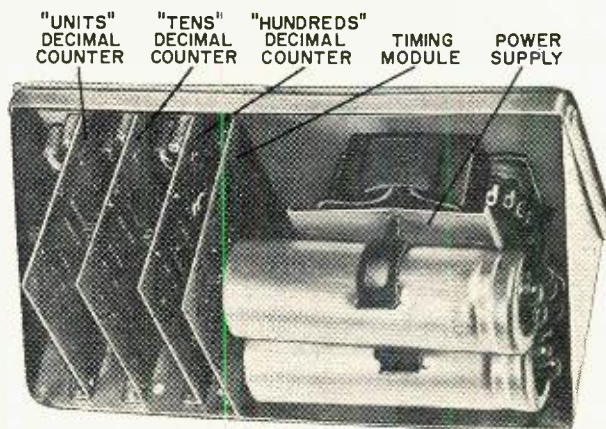

Fig. 8. Rear of author's "Stopwatch" before wiring. Looking from the front, the "units" counter is on the right, the "tens" counter in the center, and the "hundreds" counter at left. Power supply occupies the empty area behind the switching.

Note that all rectangular IC's are identified by a notch and dot code on one end, while the one round one (IC6) has a flat side opposite pin 8.

**Power Supply.** The power supply has to supply both 3.6 volts (+) and 6 volts (++) at one ampere and with a low ripple. A suitable supply, shown in Fig. 5, consists of a transformer-powered bridge rectifier followed by a capacitor-input dynamic two-diode regulator. Do not skimp on the value of C1 or C2, as the values given are the smallest satisfactory capacitance values.

It is probably best to build the power supply on its own small subchassis, as illustrated in Fig. 6, which is simply an L-shaped aluminum bracket, cut to suit your particular case. Mount all components on this bracket, using a small terminal board to support the smaller electronic components. Make certain that you use only one ground lug (as shown in Fig. 5), and make sure that no other wiring touches the metal chassis.

If you desire the convenience of battery operation (6 volts only), add the circuit shown by the dotted lines of Fig. 5. The power supply circuit must be broken at point "X" and a battery/a.c. selector switch installed so as to switch the filter circuit from either the a.c. power source, or the external battery d.c. source.

**Overall Assembly.** Figure 7 is the complete stopwatch interconnection schematic diagram. The overall assembly

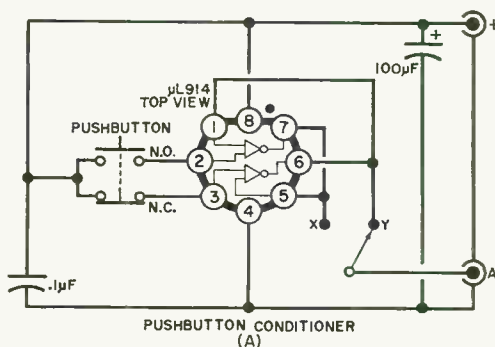
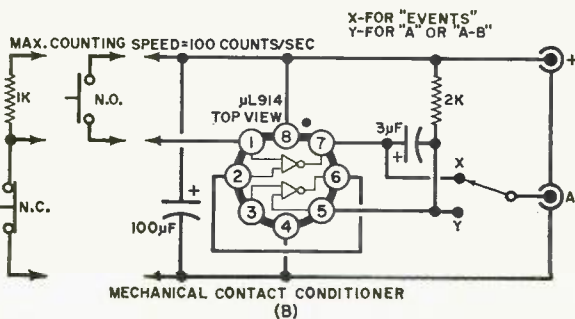

Fig. 9. A push-button signal conditioner is shown above (a), while a mechanical contact signal conditioner is shown at left (b). Both of these circuits provide a bounceless pulse each time they are operated by the external switches.



consists of three decimal counter modules, the timing module, the power supply module, four resistors, four switches, and three input jacks.

Almost any case configuration can be used for the instrument, and the photo on page 27 shows the one used by the author. A commercially available dial-plate (see Parts List) can be used as a layout guide for the front-panel selector switches and input jacks. Figure 8 shows the author's version before the interconnections were made.

Wire the various modules and switches together in accordance with Fig. 7. Use color-coded leads, and note that the deci-

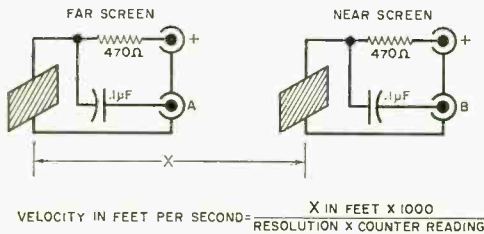

Fig. 10. For ballistic velocity measurement (vehicle, projectile, or other speeding object), use a break-wire contact. Set the "Stopwatch" in the "A-B" position to make the measurement. Break-wire "A" must be broken before break-wire "B" for correct operation.

mal counters are wired from left to right, viewed from the rear—so that when viewed from the front (in the normal operating position), "unit's" are indicated on the right, "ten's" on the middle, and "hundred's" on the left counter.

**Preliminary Checkout.** Once you are sure that all wiring is correct, place the function switch (*S1*) in any position other

than "OFF." One lamp in each counter should light. Depressing the "RESET" push button (*S4*) should return all counters to "000."

Place the function switch in the "A" position, and the timing switch (*S2*) in the 1.0 millisecond position. Plug a phono cable into the front-panel "+" jack and touch the other end of the cable (center contact) to the "A" input internal contact. The counters should cycle only during the time that this connection is made.

Note that the "unit's" indicator lamps have a dull glow (signifying very rapid counting), the "ten's" lamps flicker slowly, while the "hundred's" counter ripples from 0 to 9 (and repeats) once each second. Rotating the timing switch progressively through the .5-, .2-, .1-, .05-, and .02-millisecond positions produces a corresponding speedup of the flicker on all counters.

Place the function switch in the "A-B" position and "RESET" for all zeros on the counters. Return the timing switch to 1.0 for best viewing of the counters. Using the phono cable, application of the "+" to input "A" should start the counters cycling, and they should continue cycling even after the cable is removed from "A." Inserting the "+" to input "B" should stop the counters.

Place the function switch in the "EVENTS" position, and "RESET" for all zeros. Place the "MAN/AUTO" switch (*S3*) in the "MAN" position. In this mode, the instrument will count once for each time that you apply the "+" to the "A" input. This count will be erratic since there is no way that you can keep from bouncing the contact as you make and break it; this is also why you have

Author's unit before the power supply was mounted and interconnections made. Any other arrangement can be used depending on cabinet available. The dial-plate will give exact front-panel layout, and also has switch position identification.

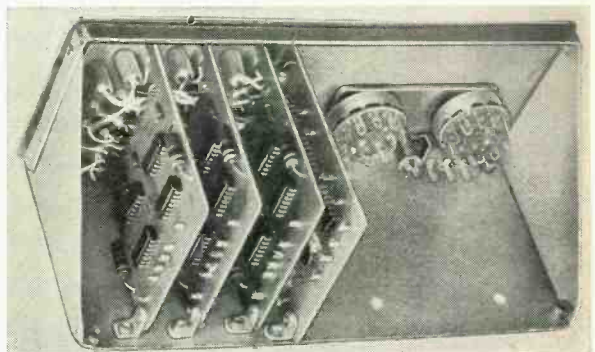

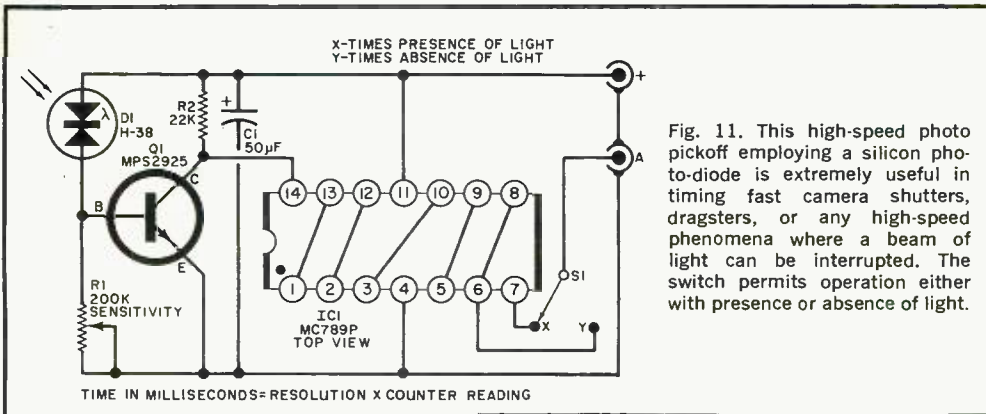
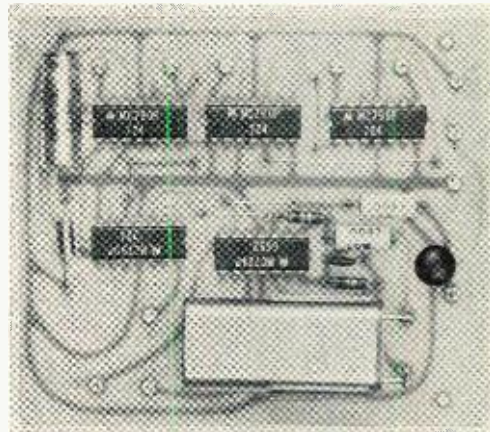

Fig. 11. This high-speed photo pickoff employing a silicon photo-diode is extremely useful in timing fast camera shutters, dragsters, or any high-speed phenomena where a beam of light can be interrupted. The switch permits operation either with presence or absence of light.

### PHOTO PICKOFF PARTS LIST

- C1—50- $\mu$ F, 6-volt electrolytic capacitor
- D1—Silicon photodiode (Texas Instruments H-38)  
—Do NOT substitute)
- IC1—Hex inverter (Motorola MC789P)
- Q1—MPS2925 transistor (Motorola)
- R1—200,000-ohm miniature potentiometer
- R2—22,000-ohm,  $\frac{1}{4}$ -watt resistor
- S1—S.p.d.t. slide switch
- Misc.—Photocell shroud, interconnecting cables, phono plugs, solder

NOTE: A complete photo pickoff kit is available from Southwest Technical Products, Box 16297, San Antonio, Texas 78216, for \$8, postpaid in U.S.A.



Top view of the timing module PC board with all components mounted. Connections to the board are made via the PC terminals affixed to the board.

to “condition” all inputs for meaningful measurements.

**Signal Conditioning.** Proper signal conditioning is a *must* for accurate use of the stopwatch. As the counters “read” each input pulse, the input signal must be bounceless; that is, there must be one, and only one, pulse for each time that the sensor operates.

A signal conditioner for use with a mechanical push button is shown in Fig. 9(a), while Fig. 9(b) shows one method of signal conditioning for use with a mechanical contact.\*

**Velocity Measurement.** For a ballistic velocity meter (bullet or “break-wire” pickoff), use the circuit shown in Fig. 10. In this case, make sure that event “A” stops before event “B” starts, and that the spacing between the two pick-

offs is measured to within 0.1% accuracy, if you want your instrument to be that accurate.

If you are going to measure the speed of a bullet, place the first screen (“A” input) far enough from the gun muzzle to avoid blast effects. As the bullet passes through the first screen, it starts the “Stopwatch”—when it passes through the second screen the instrument stops.

To measure the velocity of a car, or other speeding objects, make sure that the same portion of the object whose speed is being measured breaks both wires. The velocity in feet-per-second for an object traveling between the screens is clearly shown in Fig. 10. For example, if counter resolution is set at .02 milli-

(Continued on page 92)

\*A few signal-conditioning circuits were shown in Fig. 7 of the “Counting Unit” article which appeared in the February 1968 issue. Figure 7(a) and (b) showed two approaches with mechanical switches, while Fig. 7(c) and (d) illustrated two methods of signal conditioning with sine-wave generators.





## BUILD A *Modulation Monitor* FOR HAM AND CB TRANSMISSIONS

BY R. L. WINKLEPLECK, WA9IGU

**M**ANY HAMS AND CB'ERS would clean up their phone rigs if they could hear what their transmissions really sound like. Unfortunately, those who do monitor their signals via a receiver in the shack forget that overloading of the receiver can produce distortion. Worse still, the receiver tends to be insensitive to the things that are so annoying to distant listeners.

Day-to-day monitoring, however, is an excellent idea. A simple crystal receiver and audio amplifier module (Lafayette Radio Electronics No. 99 H 9039, or similar) as shown in the schematic diagram will do the job. You need only apply power to the amplifier and clamp a pair of headphones over your ears to monitor your own modulation—certainly a lot simpler than having a friend across town try to explain what's wrong with your signal.

The monitor can be built inside any convenient-size metal utility box. Mount the volume control/power switch (*R2-S1*), the headphone jack, and the tuning capacitor (*C1*) on the front panel as shown in the photo on page 99. Secure the battery holder in place, and mount the amplifier module (use fiber spacers to prevent the module from shorting out against the bottom of the box.) Coil *L2*—14 turns of Air Dux No. 506T, tapped 4 turns from the bottom—can be fastened to the rear of *C1*'s frame, and *L1* consists of two turns of hookup wire wound around the grounded end of *L2*. Ground one end of *L1*.

If you decide to make coil *L2* at home, use #18 wire. Wind the wire on a 5/8"-diameter coil form, carefully spacing six turns per inch. Use plastic or phenolic rods to support the equally spaced turns  
(Continued on page 99)

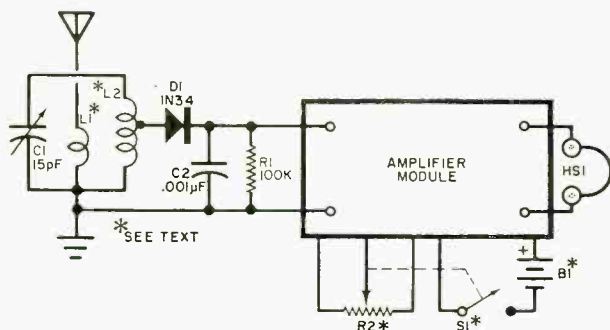

Circuit of the modulation monitor consists of simple crystal detector coupled to audio amplifier module.

**“Get more  
education  
or  
get out of  
electronics  
...that’s my advice.”**

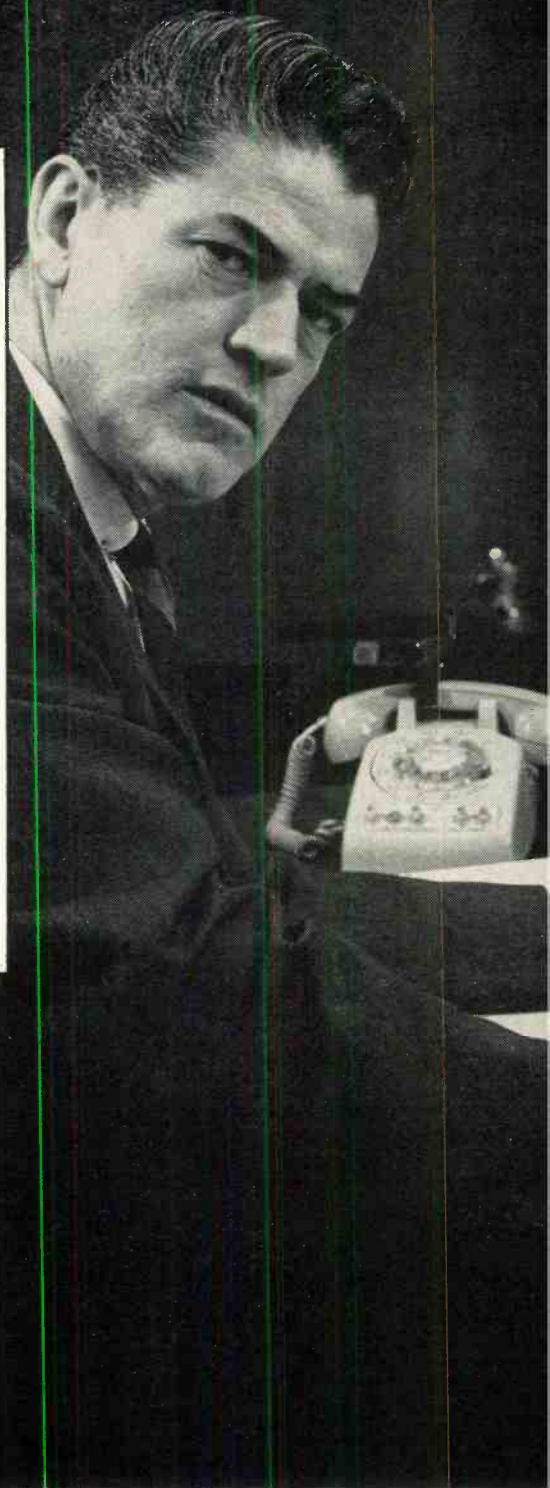



Founded 1927  
**CREI**  
Accredited Member  
of the National Home Study Council

**Ask any man who really knows the electronics industry.**

Opportunities are few for men without advanced technical education. If you stay on that level, you'll never make much money. And you'll be among the first to go in a layoff.

But, if you supplement your experience with more education in electronics, you can become a specialist. You'll enjoy good income and excellent security. You won't have to worry about automation or advances in technology putting you out of a job.

How can you get the additional education you must have to protect your future—and the future of those who depend on you? Going back to school isn't easy for a man with a job and family obligations.

CREI Home Study Programs offer you a practical way to get more education without going back to school. You study at home, at your own pace, on your own schedule. And you study with the assurance that what you learn can be applied on the job immediately to make you worth more money to your employer.

You're eligible for a CREI Program if you work in electronics and have a high school education. Our FREE book gives complete information. Airmail post-paid card for your copy. If card is detached, use coupon below or write: CREI, Dept. 1203G, 3224 Sixteenth Street, N.W., Washington, D.C. 20010.



**The Capitol Radio Engineering Institute**  
A Division of McGraw-Hill, Inc.  
Dept. 1203G, 3224 Sixteenth Street, N.W.  
Washington, D.C. 20010

Please send me FREE book describing CREI Programs. I am employed in electronics and have a high school education.

NAME \_\_\_\_\_ AGE \_\_\_\_\_

ADDRESS \_\_\_\_\_

CITY \_\_\_\_\_ STATE \_\_\_\_\_ ZIP CODE \_\_\_\_\_

EMPLOYED BY \_\_\_\_\_

TYPE OF PRESENT WORK \_\_\_\_\_  G.I. BILL

I am interested in  Electronic Engineering Technology  
 Space Electronics  Nuclear Engineering Technology  
 Industrial Electronics for Automation  
 Computer Systems Technology

**APPROVED FOR TRAINING UNDER NEW G.I. BILL**

# TRUE or FALSE ?

## TEST YOUR KNOWLEDGE OF HOME ENTERTAINMENT ELECTRONICS

(Answers on page 100)

BY VIC BELL

- 1 A poorly converged color TV receiver will reproduce acceptable black-and-white pictures. TRUE \_\_\_\_\_ FALSE \_\_\_\_\_
- 2 A man 40 years old has better hearing and therefore is more critical of his hi-fi than a man 50 years old. TRUE \_\_\_\_\_ FALSE \_\_\_\_\_
- 3 Television receivers generally fail during an extended period of operation. TRUE \_\_\_\_\_ FALSE \_\_\_\_\_
- 4 Most home entertainment products (TV, hi-fi, etc.) are designed to operate from an average 110-volt a.c. line. TRUE \_\_\_\_\_ FALSE \_\_\_\_\_
- 5 Spark gaps are often installed in color TV receivers to prevent damage to the CRT. TRUE \_\_\_\_\_ FALSE \_\_\_\_\_
- 6 A "glitch" is another name for a Barkhausen line. TRUE \_\_\_\_\_ FALSE \_\_\_\_\_
- 7 Several speakers in parallel reproduce sound more faithfully than one. TRUE \_\_\_\_\_ FALSE \_\_\_\_\_
- 8 A 25" rectangular color CRT displays a picture about 2" wider than a 21" round color CRT. TRUE \_\_\_\_\_ FALSE \_\_\_\_\_
- 9 Stereo phonograph cartridges are more sensitive to rumble than earlier monaural cartridges. TRUE \_\_\_\_\_ FALSE \_\_\_\_\_
- 10 Operating a vacuum cleaner near a color TV receiver can cause poor purity. TRUE \_\_\_\_\_ FALSE \_\_\_\_\_
- 11 Malfunctions in parallel-filament TV receivers can cause problems not possible in series filament string TV receivers. TRUE \_\_\_\_\_ FALSE \_\_\_\_\_
- 12 The SCR and reed relay are new components not found in entertainment products. TRUE \_\_\_\_\_ FALSE \_\_\_\_\_
- 13 If a wall switch is used to operate an "instant-on" TV receiver, the instant-on feature is defeated. TRUE \_\_\_\_\_ FALSE \_\_\_\_\_
- 14 The purpose of the cage around a flyback transformer is to protect the user and service technician from radiation. TRUE \_\_\_\_\_ FALSE \_\_\_\_\_
- 15 Automatic hue control is available on several color receivers now on the market. TRUE \_\_\_\_\_ FALSE \_\_\_\_\_
- 16 More deflection power is required to sweep a 110-degree CRT than a 90-degree CRT. TRUE \_\_\_\_\_ FALSE \_\_\_\_\_



# The "FERRET" Drags Them In

SINGLE-CONTROL PRESELECTOR  
PEPS UP SHORT-WAVE  
RECEPTION

BY GEORGE J. WHALEN, K2BIE

If you're an avid SWL or ham with a general-coverage receiver in the "under \$100 class," chances are you've discovered that the sensitivity of your receiver falls off rapidly as you tune above 14 MHz, especially if the receiver lacks an r.f. amplifier stage. What is worse, however, image rejection also drops off sharply with increasing frequency, making such a receiver highly susceptible to interference and annoying heterodynes.

Obviously, even the best antenna and a good Q-multiplier can't make up for deficiencies in the receiver's front-end. This is the job of an r.f. preselector, a unit combining high-gain r.f. amplification with a selective tuned circuit, inserted between the antenna and the receiver's antenna input terminals. It is the equivalent of adding a new front-end to your receiver, and the results can be astonishing.

The *Ferret* is such a unit. It is a high-gain, solid-state r.f. preselector designed to boost the sensitivity and selectivity of moderately priced short-wave receivers tuning the 7- to 30-MHz range. It consists of a two-stage amplifier, employing a high-frequency FET and a *npn* bipolar transistor, in combination with a high-Q tuned circuit which covers the 7- to 30-MHz range in a single sweep of the tuning dial.

The *Ferret* features a uniform gain of at least 30 dB throughout its tuning range and has a noise figure of better than 3 dB at 30 MHz. The high-Q coil in the *Ferret* input circuit and the universal input circuitry permit a good match to most antenna types and the *Ferret* will even operate efficiently with an antenna made up of a dozen feet of hookup wire.

The prototype *Ferret* (see Fig. 1) is housed in a 5" x 4" x 3" gray-hammer-tone-finish aluminum box, with all major components mounted on a 3" x 3" printed circuit board. A single-section 10-365 pF variable capacitor mounted on the board and the on-off toggle switch secured to the front panel of the box are the only controls. Terminal strips on the rear wall of the box permit connection to any antenna type and to the receiver's input terminals.

**Construction.** Putting the *Ferret* together shouldn't take more than a few

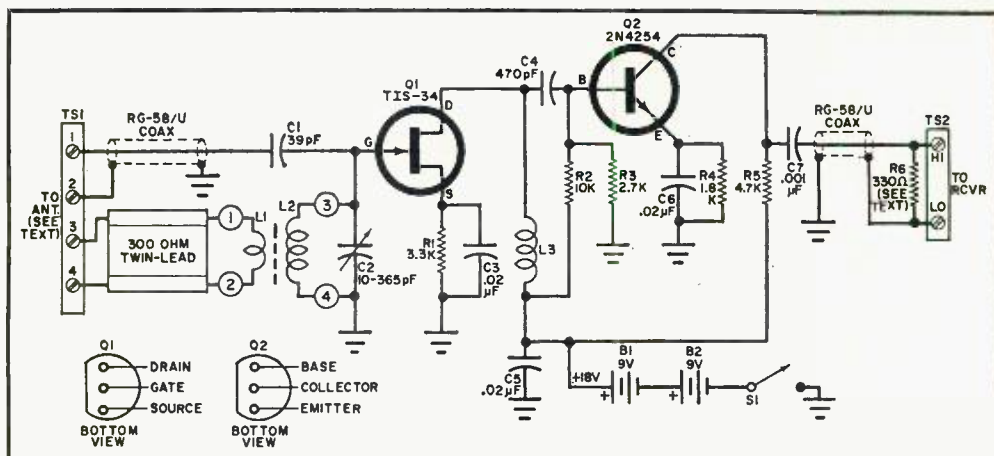
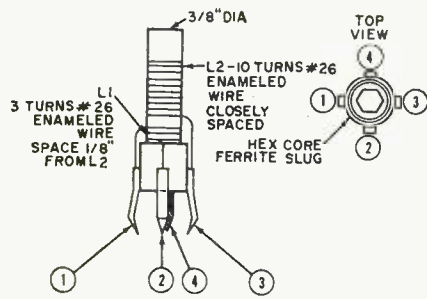

Fig. 1. The "Ferret" short-wave preselector has three optional inputs: one for single-wire-fed antennas, a second for coax-fed antennas, and a third for balanced 300-ohm twin lead.

The coil for the "Ferret" is hand-wound according to the plan detailed below. Carefully observe winding direction and connections to terminals. Coil is tuned by ferrite slug.



### PARTS LIST

- B1, B2—9-volt battery (Burgess P6 or similar)
- C1—39-pF disc ceramic capacitor
- C2—10-365 pF variable capacitor (Lafayette 32 H 1103)
- C3, C5, C6—0.02- $\mu$ F disc ceramic capacitor
- C4—470-pF disc ceramic capacitor
- C7—0.001- $\mu$ F disc ceramic capacitor
- L1, L2—See coil drawing
- L3—55- $\mu$ H r.f. choke (J. W. Miller 4629 or similar)
- Q1—Texas Instruments TIS-34 n-channel field effect transistor
- Q2—2N4254 transistor
- R1—3300-ohm,  $\frac{1}{2}$ -watt resistor
- R2—10,000-ohm,  $\frac{1}{2}$ -watt resistor
- R3—2700-ohm,  $\frac{1}{2}$ -watt resistor
- R4—1800-ohm,  $\frac{1}{2}$ -watt resistor
- R5—4700-ohm,  $\frac{1}{2}$ -watt resistor
- R6—330-ohm,  $\frac{1}{2}$ -watt resistor (optional—see text)
- S1—S.p.s.t. toggle switch
- TS1—4-point terminal board
- TS2—2-point terminal board
- Misc.—Printed circuit board\*, battery holder, metal box,  $\frac{1}{2}$ " spacers, RG-58/U coaxial cable, 300-ohm twin lead, hookup wire, solder, nuts, bolts

\*An etched and drilled printed circuit board is available from Southwest Technical Products, 219 W. Rhapsody, San Antonio, Texas 78216, for \$2, post-paid.

evenings' work, provided you use an exact duplication of the author's printed circuit board, wiring, and parts layout—which is especially important in high-gain r.f. circuitry. You can make the PC board yourself, using the actual-size layout in Fig. 2, or purchase it etched and drilled (see Parts List).

Before starting on the printed circuit board, lay out the box as shown in Fig. 3. Drill the required holes and remove burrs and ragged edges with a tapered reamer and warding file. Then install the dual battery-holder on the rear wall of the box using two short 4-40 screws and nuts. Mount terminal strips TS1 and

TS2 in their respective positions and check that each lug clears the edges of the mounting holes. Install toggle switch S1 on the front wall of the box as shown in the photographs. Solder a jumper between the top two terminals of the dual battery holder, so that the holders are placed in series.

Next, connect a length of insulated hookup wire to the bottom left terminal of the dual battery holder and run it forward along the box surface to one terminal of toggle switch S1. Attach a solder lug to a short length of hookup wire and connect the free end to the other terminal of the toggle switch. Secure

Fig. 2. Actual-size foil pattern for the printed circuit board (right). If you don't want to make your own, you can buy an etched and drilled board from the supplier listed in the Parts List on facing page.

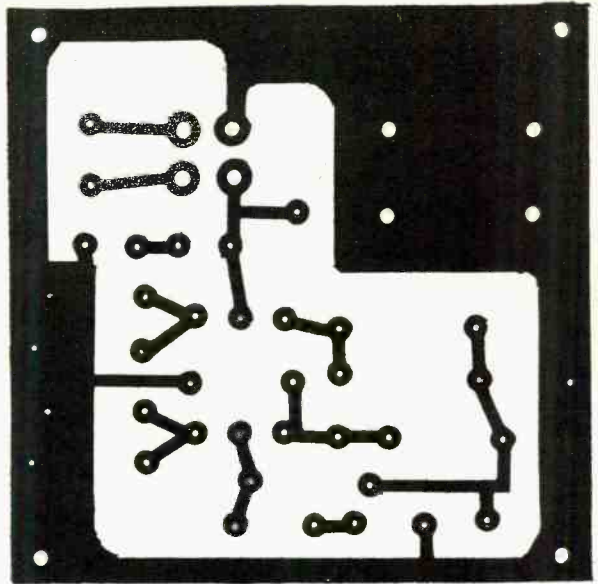
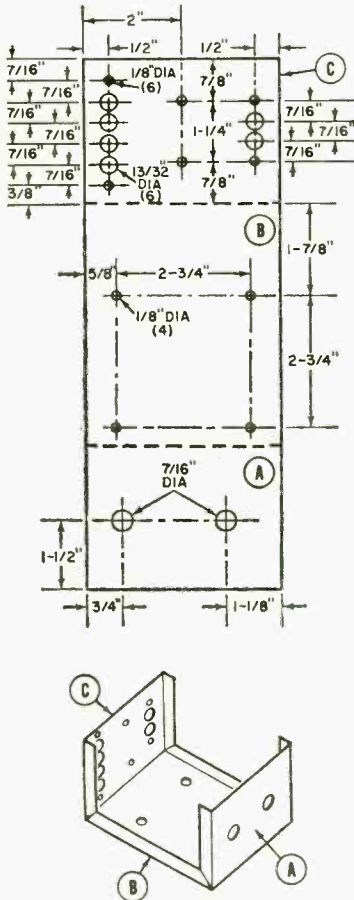

Fig. 3. If you build your "Ferret" in the same type box used by the author, follow the drilling and cutting plan below. Not shown on side B are holes for four mounting feet (holes are not really necessary since 3M adhesive bumpers can be used).



the solder lug to the box surface with a 4-40 screw and nut to make a solid ground connection to the box. Scribe a minus (-) sign near the bottom left

Fig. 4. This is how the components should appear as you look up through the PC board. Rotate coils L1-L2 so that coil pins 1 and 2 face the left-hand side of the board (looking up). The coil mounting holes must be enlarged to pass the terminals.

terminal of the battery holder and a plus (+) sign next to the bottom right terminal as a reminder to install batteries B1 and B2 correctly.

Begin assembly of the parts on the PC board by installing variable capacitor C2. First bend the four stator lugs up against the side of the capacitor to prevent interference when mounting. Then install C2 using four short 6-32 screws inserted through the board holes into the tapped holes in the underside of the capacitor frame. Tighten the screws sufficiently to make a good ground contact with the printed pattern on the underside of the board and to prevent vibration of the capacitor.

Now install the coil assembly on the board, being careful to insert the four

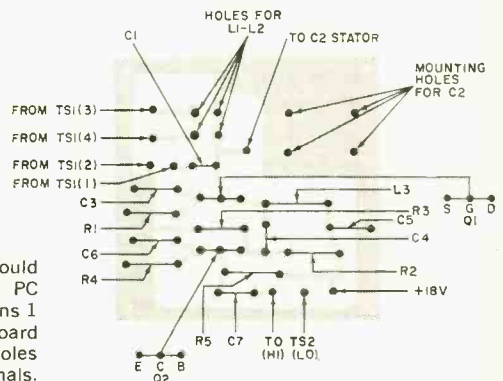

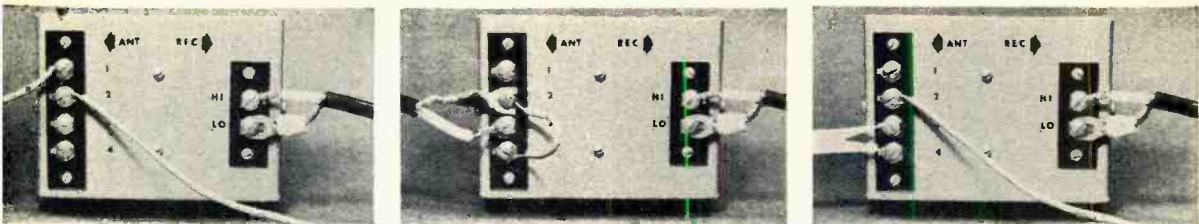
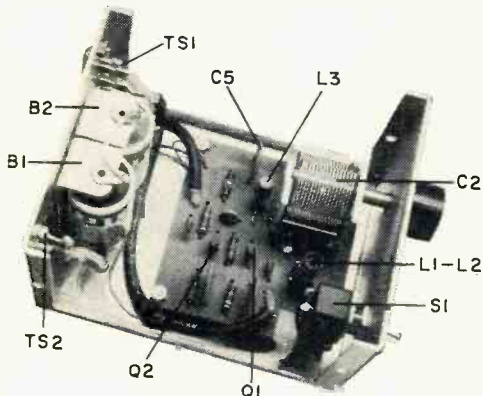
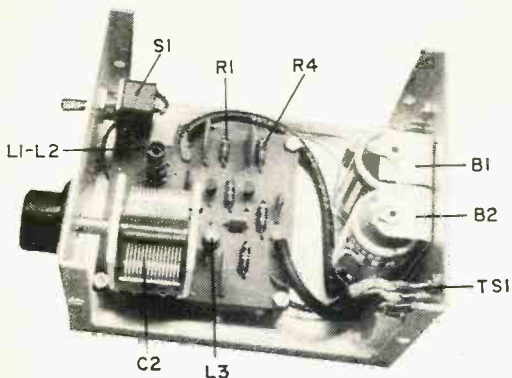

Fig. 5. The three methods of connecting an antenna to the preselector. At left, a single-wire lead-in is connected to ANT terminal 1 and a ground to terminal 2. In center photo, a coax-fed antenna is connected to terminal 3 and the shield connected to terminals 2 and 4. At right, a balanced 300-ohm twin-lead input is connected to terminals 3 and 4. A ground connection from terminal 2 is optional.



The "Ferret" fits snugly in metal box. You'll have to adjust the height of the metal spacers to permit the shaft of tuning capacitor C2 to clear hole.

terminals of the coil form into the proper holes in the board. Solder the terminals to their respective printed conductors, using just enough solder to make a good secure connection. Then proceed to install the remaining components shown in Fig. 4.



Although battery drain is small, it's a good idea to shut off the power when the "Ferret" is not in use. You should be able to build it in four hours.

## HOW IT WORKS

In the *Ferret*, FET Q1 operates in the common-source mode, and is biased by resistor R1, bypassed for r.f. by capacitor C3. Unlike the conventional bipolar transistor, the gate input impedance of Q1 is substantially higher than a megohm, permitting tuned circuit L2-C2 to be connected directly to the gate. Variable capacitor C2 resonates L2 at any frequency between 7 and 30 MHz.

Primary winding L1 and capacitor C1 each provide a path through which signal currents in the antenna may be introduced into tuned circuit L2-C2; capacitor C1 provides a moderately high impedance path, while L1 offers a fairly low impedance, inductively-coupled path into the tuned circuit. An amplified version of the signal appears across the 55- $\mu$ H r.f. choke (L3), which is self-resonant at a frequency below 7 MHz. Capacitor C5 decouples the d.c. applied to the drain of Q1 and supplies a return path for r.f. current, preventing feedback through the common impedance of series-connected batteries B1 and B2.

The amplified r.f. output of Q1 is coupled to the base of Q2 through C4, which has no appreciable reactance at the signal frequency. Transistor Q2 operates in the common-emitter mode to contribute best gain. Emitter current limiting is provided by R4, bypassed for r.f. by C6. The operating point of Q2 is established by base-bias divider resistors R2 and R3, with collector current maintained at 1.5 mA.

The output of Q2 appears across R5. Capacitor C7 couples the amplified signal to output terminal strip TS2 through a short length of coaxial cable to prevent unwanted coupling between output and input circuits. The short-wave receiver's input circuitry provides the tuned circuit load for the *Ferret*. And resistor R6 (nominally 300 ohms) shunts the output terminals of the preselector, providing a mutual terminating impedance for the preselector and receiver.

When the resistors and capacitors have been installed (except for R6), check the parts layout and schematic to make sure that none were missed or installed in the wrong position. If everything checks, install transistors Q1 and Q2.

Then cut two 6-inch lengths of RG-58/U coaxial cable and one 6-inch length of 300-ohm twin lead. Strip both ends of all cables. Connect one of the lengths of coax to the board points provided  
(Continued on page 105)



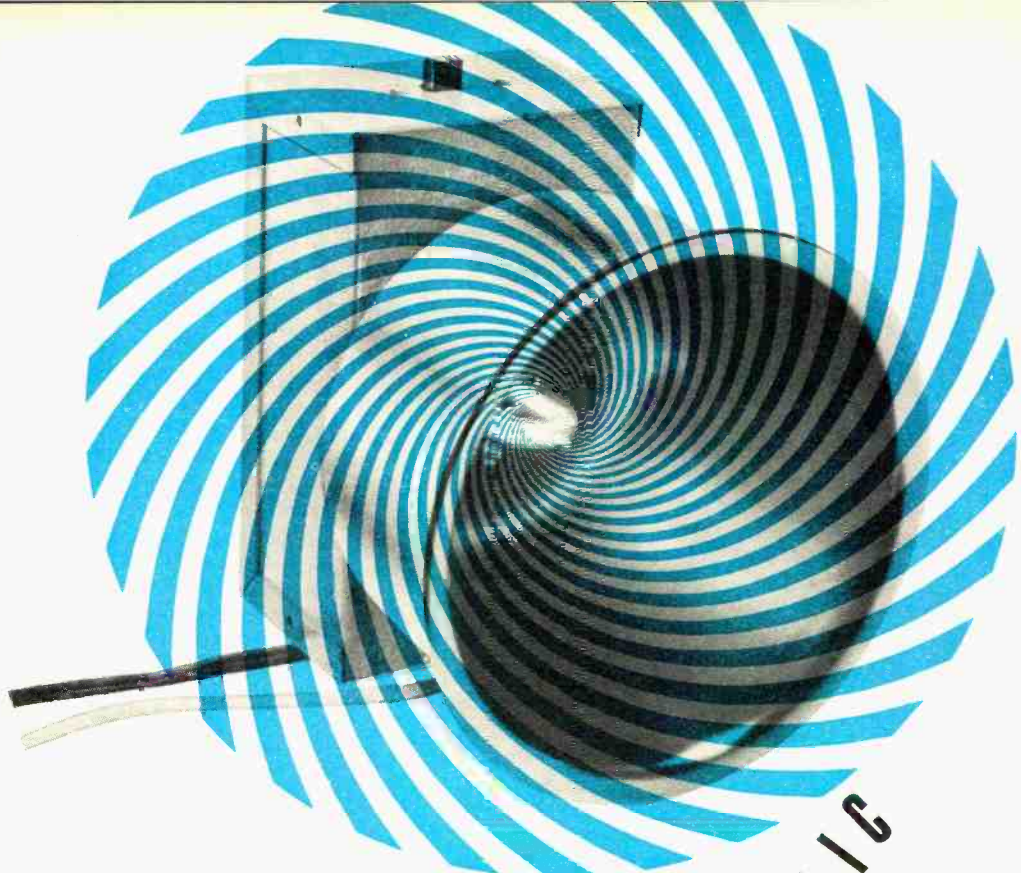

# UNIVERSAL STROBE GOES PSYCHEDELIC

BY JAMES CUCCIA

- EXCITES DANCERS
- STOPS MOTION
- TAKES PICTURES
- TIMES ENGINES

#### EDITOR'S NOTE

Medical opinion concerning the use of strobe lighting in darkened rooms is "cautionary." Prolonged use may induce hallucinations or trigger undesired side-effects. It should not be used in the presence of anyone subject to epilepsy.

ONE OF THE MOST interesting of the new "turned on" type of lighting effects is strobe lighting. By using a strobe light system flashing at the proper rate in a semi-darkened room, a visual flicker effect similar to that found in old-time movies can be seen as people walk or dance in the light of the flash. Since the action seems to take place as a series of "still" frames, a very unreal atmosphere can be created.

The "Universal Psychedelic Strobe" described in this article will not only be the hit of your next party, but can also earn its keep by performing other, less glamorous duties. It will serve as an auto-

mobile timing light, a slave flash for your camera, or a general-purpose strobe light for stop-motion observation of moving mechanical elements.

**Construction.** The circuit (Fig. 1) can be built on a single printed board, such as the one shown actual-size in Fig. 2. The components are mounted on the board in accordance with the layout of Fig. 3. Carefully solder all components to the board using resin-core solder.

Be extra careful when mounting the flashtube as it is made of glass and can be broken if it is accidentally dropped, or hit with a metal tool. Orient the trigger coil (*L1*) so that the tab with the red dot points toward the flashtube. (The flashtube is mounted as shown in Fig. 4 with its trigger lead soldered directly to this coded tab to prevent a voltage breakdown on the printed board.) And be sure to observe the proper polarity when

mounting all semiconductors and electrolytic capacitors.

Then mount the finished wired board in a 3" x 5" x 2" metal enclosure using half-inch spacers. The flashtube should extend above the top of the enclosure, but not high enough to short the leads when the cover is attached. On-off switch *S1* is mounted on one end of the box, while the a.c. power lead and audio cable extend from the other end. Note the location of *R10* and drill a hole in the enclosure wall so that *R10* can be screw-driver-adjusted from the outside.

Carefully measure the location of the flashtube, and, allowing some clearance on all sides, make a cut in the cover of the metal enclosure of a size that will permit the cover to pass easily over the flashtube. Obtain some form of metal reflector—the one shown in the author's prototype is a stainless steel half-quart container—and cut a slot in its bottom

### PARTS LIST

- C1*—0.02- $\mu$ F, 50-volt disc capacitor
  - C2*—30- $\mu$ F, 15-volt electrolytic capacitor
  - C3*—1- $\mu$ F, 15-volt electrolytic capacitor
  - C4*—0.02- $\mu$ F, 400-volt disc capacitor
  - C5*—20- $\mu$ F, 350-volt electrolytic capacitor
  - C6*—10- $\mu$ F, 150-volt electrolytic capacitor
  - C7*—10- $\mu$ F, 15-volt electrolytic capacitor
  - D1, D2*—1N34 diode
  - D3, D4, D5*—1N4003 silicon diode or similar
  - FT1*—Xenon flashtube (Southwest Technical Type 110)
  - L1*—Trigger coil (Southwest Technical Type TL2)
  - Q1*—2N4870 unijunction transistor
  - R1*—100 ohms
  - R2*—22,000 ohms
  - R3*—10,000 ohms
  - R4*—180 ohms
  - R5*—220 ohms
  - R6*—100,000 ohms
  - R7*—120,000 ohms
  - R8*—27,000 ohms
  - R9*—20 ohms, 5 watts
  - R10*—50,000-ohm potentiometer
- } All resistors  
} 1/2-watt unless  
} otherwise stated

*S1*—S.p.s.t. switch

*SCR1*—2N3528 silicon-controlled rectifier

*T1*—Interstage transformer, 2000 ohms, CT, to 10,000 ohms (Southwest Technical TT10-2 or similar)

Misc.—Circuit board, metal enclosure, metal reflector, audio cable, power cable, spacers, wire, solder, etc.

NOTE: An etched and drilled PC board is available from Southwest Technical Products Corp., 219 W. Rhapsody, San Antonio, Texas 78216, for \$2.25; complete kit of parts, PC board, and enclosure for \$12.75 (less reflector).

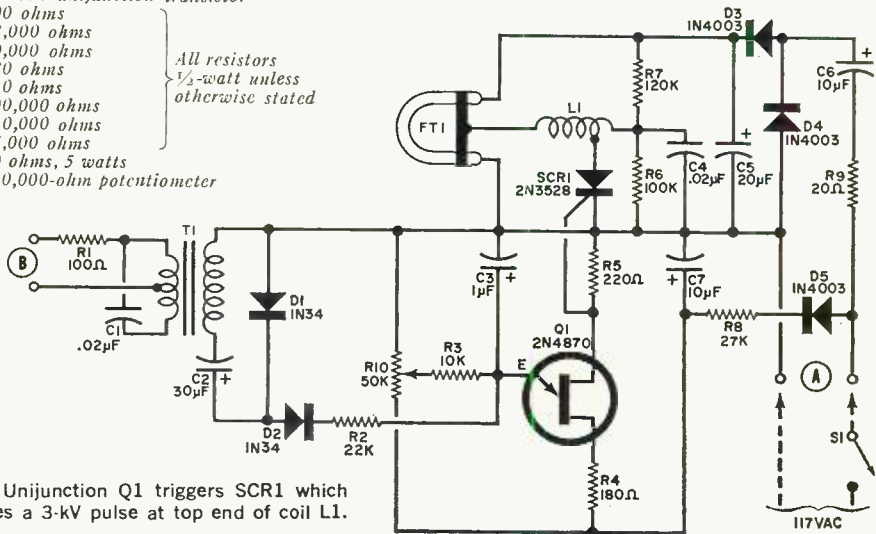

Fig. 1. Unijunction *Q1* triggers *SCR1* which produces a 3-kV pulse at top end of coil *L1*.

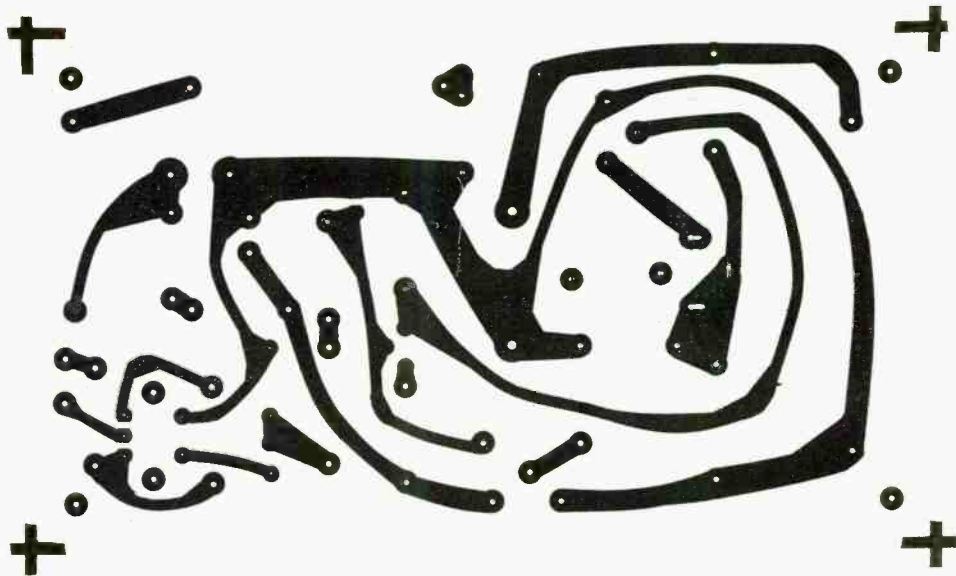

Fig. 2. Actual-size printed circuit board. You can make the board yourself or purchase it (see Parts List). If you make your own board, drill the holes as shown.

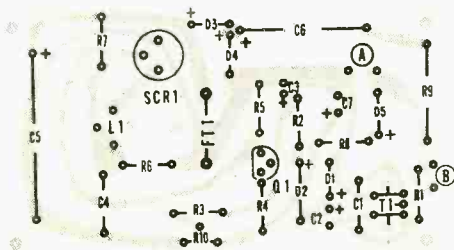
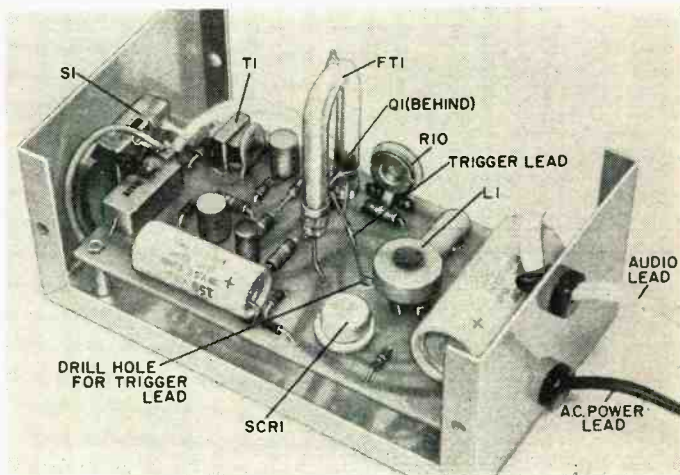

Fig. 3. Component mounting for the strobe. The terminals marked "B" are for the audio input, those marked "A" for power input.

Fig. 4. The finished strobe before the top cover and reflector are assembled. Note that a hole must be drilled in the PC board to accommodate the lamp trigger.



Be especially careful when installing the strobe tube as it is fragile and it cannot withstand mechanical shock.

### HOW IT WORKS

The heart of the strobe is a low-cost xenon flashtube that can be operated from a 250- to 300-volt d.c. voltage source. This voltage is produced by a voltage doubler consisting of *D3*, *D4*, *C5*, and *C6*, with *R9* limiting the surge current flow. However, the flashtube will not fire until its trigger electrode is provided with a 3000-volt pulse, which is generated in a "flyback" type pulse generator consisting of auto transformer *L1* and *SCR1*.

When the power is first turned on, the SCR is in its non-conducting state; thus *C4* is allowed to charge up to the power supply potential. If the gate of the SCR is furnished with a positive-going trigger pulse, the SCR goes almost instantaneously into conduction and allows *C4* to discharge through the lower end of inductor *L1*. The auto transformer action of *L1* produces a 3- to 4-kV pulse at its high-voltage end which triggers the flash tube on.

The SCR is triggered by unijunction transistor (*Q1*). This UJT is connected as a conventional relaxation oscillator in which *C3* discharges through the UJT every time the voltage across *C3* exceeds the firing potential of the UJT. The rate of charge of *C3* is determined by potentiometer *R10* and series resistor *R3*. As *R10* is set to a higher voltage, capacitor *C3* reaches the required firing voltage faster, making the UJT oscillate at a faster rate. The positive-going pulses generated at the UJT *B1* lead put the SCR into conduction.

Once the SCR conducts, the voltage at its anode momentarily drops to zero, allowing the SCR to switch to its non-conducting state, and be ready for the next gate trigger pulse. Supply voltage for the UJT is obtained from a separate power source (consisting of diode *D5*, resistor *R8*, and filter capacitor *C7*) to prevent the sudden current surge produced by the flashtube from firing the transistor.

To make the flash rate follow a given audio level, transformer *T1* isolates the strobe from any external grounds (remember that it is a line-operated device), and couples the UJT circuit into an audio amplifier. The audio signal applied to *T1* is rectified by diodes *D1* and *D2*, and the resulting d.c. is applied through *R2* to the emitter of the UJT. Capacitor *C3* is also charged by a voltage generated by the input signal. If *R10* is set properly, every time that the d.c. on the emitter reaches the required firing voltage, the UJT triggers, producing a flash.

Cut a slot in both cover and reflector so that tube can easily slip through. Be careful also when installing cover or the tube, or its leads, may be damaged.

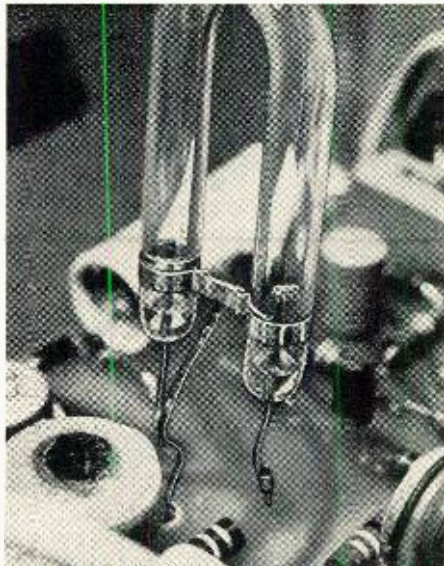

surface similar in size to that made in the enclosure cover. Bolt the reflector to the metal cover, carefully aligning the two slots. Now, still being very careful, mount the cover-reflector combination on the remainder of the enclosure.

**Operation.** Point the strobe reflector so that it will not flash directly into your eyes. Connect the power lead to a source of 117 volts a.c. and turn on *S1*. A slight rotation of *R10* should start the flash operating. The frequency of the flash is dependent on the setting of *R10*.

To make the strobe follow a musical beat, connect the audio leads in parallel  
(Continued on page 98)

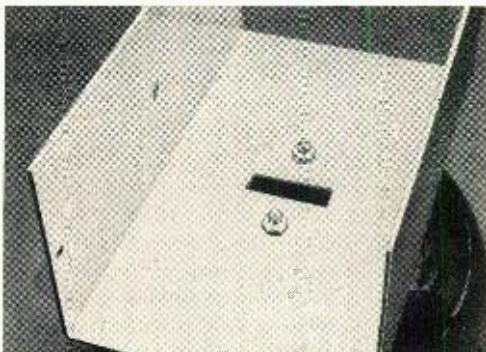

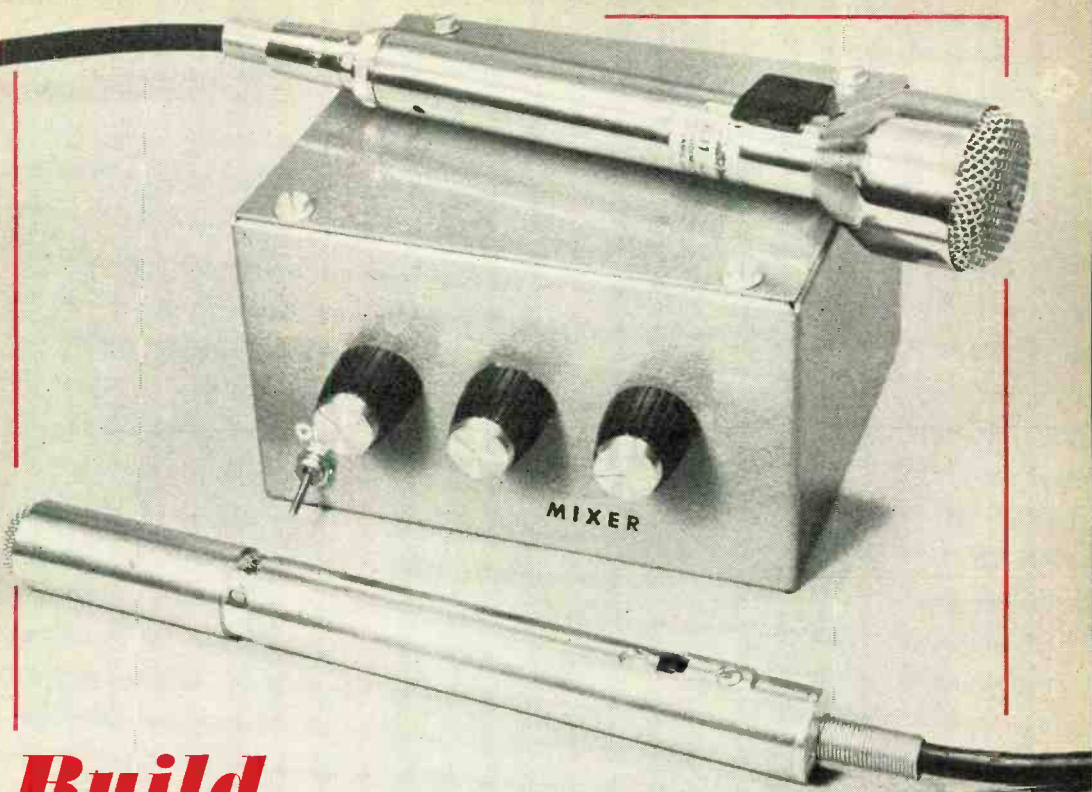

# Build

## a FET Mixer

LOW-COST FETs MAKE PERFECT 3-CHANNEL MIXER

BY DON M. WHERRY, W6EUM

**H**AVE YOU EVER asked yourself, "Isn't there some easy way of mixing two or three microphones?" Would you like to mix several program sources, or just simply combine voice and music so that the result is "professional" sound? Yes, there are microphone mixers you can buy, but why go to that expense when in two evenings of work you can build your own.

The little *FET Mixer* shown in Fig. 1 will do the work of a microphone mixer selling for \$50. It has three separate inputs, each isolated from the output FET source-follower stage by a low-cost FET. The output of the *FET Mixer* is a

fairly low impedance—suitable for use with most tape recorders and hi-fi amplifiers. Battery-operated, the mixer is free of a.c. hum and is of sufficiently small size to be portable as well as sturdy and trouble-free.

**Why So "Fancy"?** There are many ways of mixing two or more audio signals. At least one commercially available microphone mixer uses the circuit shown in Fig. 2. Obviously, this circuit has no gain, and the advantage of being able to mix is offset by the higher volume control settings (more noise possible) in the tape recorder. This mixer also is plagued

Fig. 1. Not shown in this diagram are three  $0.05\text{-}\mu\text{F}$  capacitors that can be wired in parallel with resistors R2, R5, and R9. If these capacitors are installed, they will make a slight increase in the gain of the mixer. However, in most applications, the extra capacitors are unnecessary. If a 15-volt battery is used at B1, the value of resistor R3 should be decreased to about 6800 ohms, which will result in a 3 dB loss of overall gain.

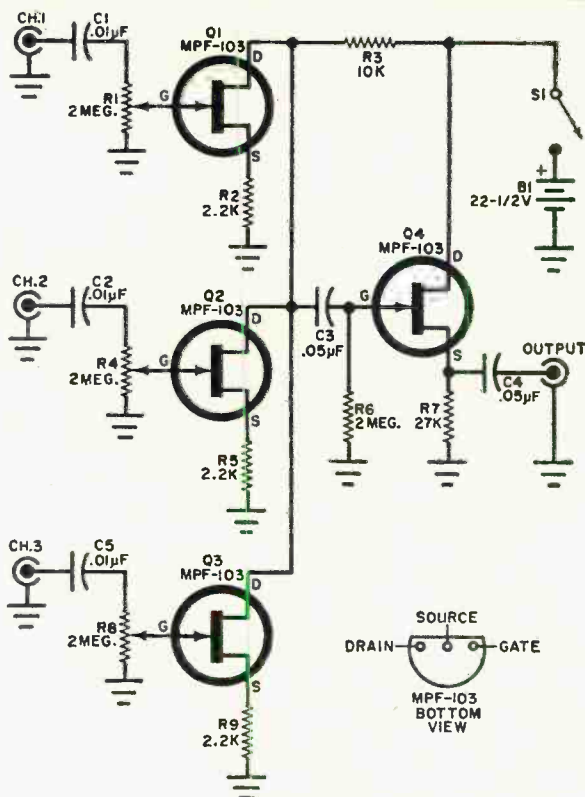

by the chance interaction between inputs.

Another commercially available mixer uses a single transistor (similar to the circuit surrounding  $Q_4$  in Fig. 1) to provide gain, but since the input connections are the same as in the simplified version (Fig. 2), there is still the chance of microphone interaction and feedback.

The *FET Mixer* provides isolation and gain. With a  $22\frac{1}{2}$ -volt battery, the gain is about 8 dB. Frequency response is virtually flat from about 20 to 40,000 hertz. Interaction between channels is not measurable and, using the transistors indicated in the Parts List, the noise generated by the mixer is well below  $-64$  dB for 1-volt output.

**Construction.** The author built his *FET Mixer* using a printed circuit board. This board is detailed in Fig. 3, actual size. No provision has been made to make the board available to readers, since the project is simple enough to permit PC board experimentation. Also, if you don't feel capable of working up your own PC

#### PARTS LIST

- B1—22½-volt battery
- C1, C2, C5—0.01-µF capacitor
- C3, C4—0.05-µF capacitor
- Q1, Q2, Q3, Q4—Motorola MPF-103 junction field effect transistor
- R1, R4, R8—2-megohm linear potentiometer (IRC Q13-139)
- R2, R5, R9—2200-ohm, ½-watt resistor
- R3—10,000-ohm, ½-watt resistor
- R6—2-megohm, ½-watt resistor
- R7—27,000-ohm, ¼-watt resistor
- S1—S.p.s.t. miniature toggle switch
- Misc.—Phono jacks (4), cabinet, printed circuit board, spacers, knobs (5), solder, nuts, bolts, etc.

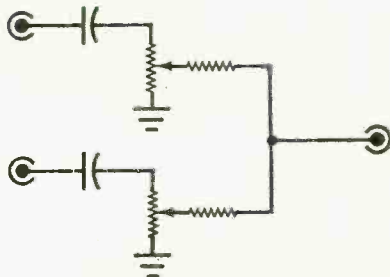

Fig. 2. Buy a cheap mixer and the circuit will look like this one. Isolation between the channels is poor, and you're bound to lose half the signal.

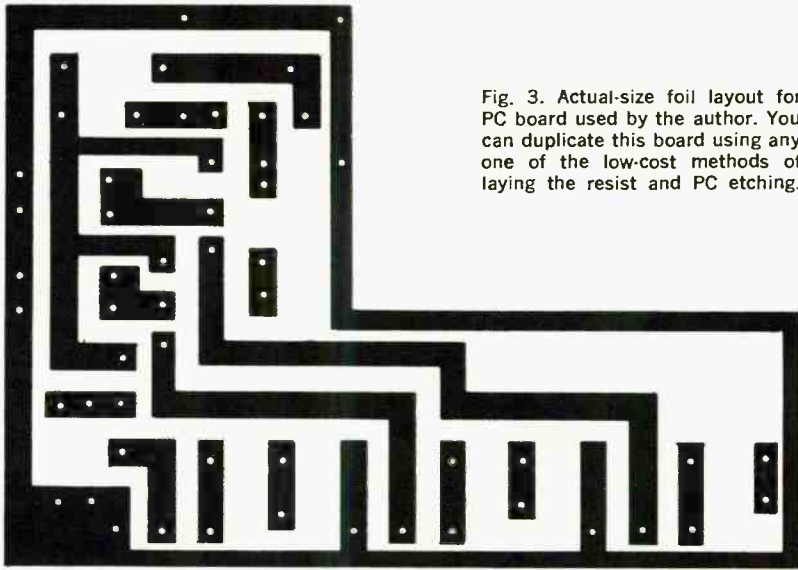

Fig. 3. Actual-size foil layout for PC board used by the author. You can duplicate this board using any one of the low-cost methods of laying the resist and PC etching.

board, the *FET Mixer* can be assembled on a perforated board (with flea clips), or even terminal strips.

If you try to duplicate the author's construction, note that the board is actually mounted on and held in place by the three gain controls. Be sure to use the type of control called out in the Parts List. These controls have lug terminals and are specially desirable for mounting PC boards.

You should be able to mount all of the *FET Mixer* circuit, plus battery, in a

small aluminum box. The author mounted the unit in a locally made box measuring 5" x 3½" x 3". A separate on-off switch (*S1*) is employed, although one of the channel input controls could be backed with a switchplate. Use simple decal markings on the face of *FET Mixer* box, or knobs that are marked so that the controls can be approximately reset with ease. Most of your work will be done with the controls set between readings equivalent to 10 and 2 o'clock.

You could build a simple 117-volt a.c.

NOTE: This drawing shows the location of the components when you look up through the PC board—not down on the board as is frequently the case with other PC boards shown in this magazine. The extra holes near R2, R5, and R9 are for the three capacitors mentioned in the caption for Fig. 1. These capacitors are not usually required, since the mixer has an 8 dB gain without them.

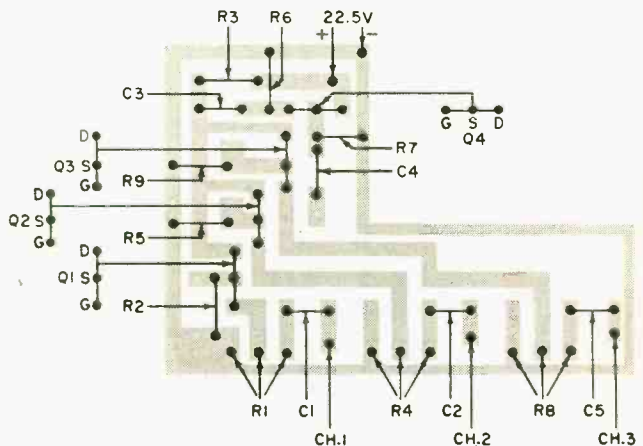

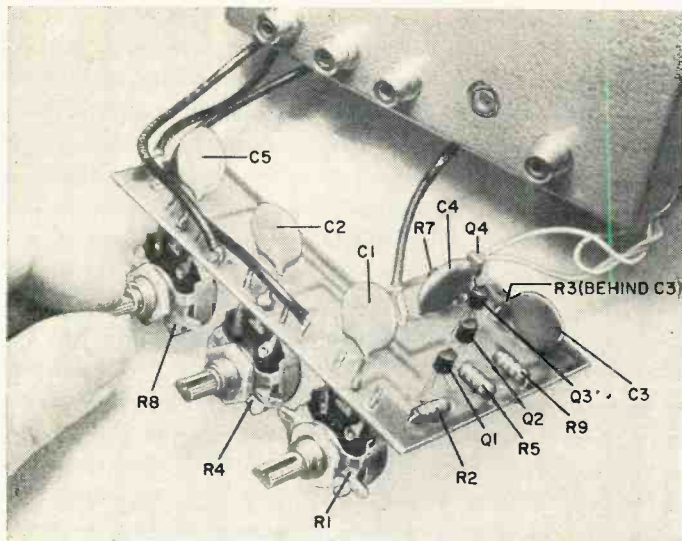

Top view of mixer shows location of some of the components. Potentiometers are soldered in place right onto the printed circuit board. Enlarge the holes for soldering to the lugs of the potentiometers. Hole in back of metal box is for a clamp to secure the battery in place. Carefully observe lead orientations of transistors.

This is how the mixer looks when you turn the board over. Coax cables to the jacks are cut a little long and soldered in place. Since the board is held by the potentiometer lugs, holes for the shafts are drilled last in the box panel.

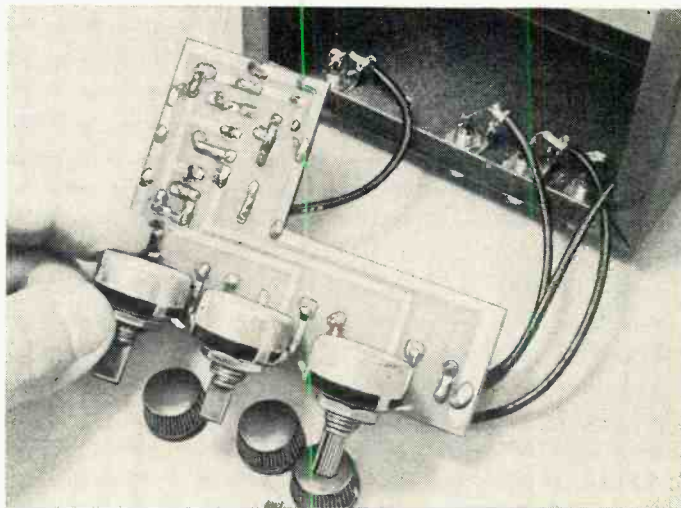

power supply to operate the *FET Mixer*, but you might encounter a.c. hum problems, and you would be adding an extra unnecessary a.c. cable.

**Using the Mixer.** Practice using the *FET Mixer* before making a valuable recording. Normally the microphone input control on your tape recorder should be set to its usual position. Connect the mixer output to the tape recorder and set all three channel input controls to zero.

Bring up the level of one channel to give you a normal recording level as

seen on the built-in indicator of your tape recorder. Note the dial reading and return this control to zero and bring up the level of the second input. Return this control to zero and repeat the process if you are using a third input. If only two inputs are used, leave the level of the third input at zero at all times.

Now bring up both mixer levels to their noted positions. Generally speaking, you should not find it necessary to back off on the tape record input level—even though it may appear that twice the input should require a drastic input level reduction.

-50-



BY ROY A. WALTON



# **-Section Coupler Solves**

## **Antenna Problems**

INEXPENSIVE GADGET TUNES ANTENNA FOR BETTER DX

**A**LMOST any receiver covering 540 kHz to 1600 kHz is suitable for broadcast band DX'ing, and there are a lot of them. But the antenna is another matter. If you are new to the hobby, or if you have been having trouble DX'ing those really difficult stations, you may find the answer to your reception problems in a properly constructed long-wire antenna—and the “ $\pi$ -Section Coupler.”

Normally, the best receiving antenna is considered to be a resonant antenna—one that resonates at a particular frequency. The length of such a BCB antenna would range between 865 and 290 feet—much too long for the space most listeners have available. That's the big problem. The solution is to build the

long-wire “ $\pi$ -Section Coupler” and get the maximum signal transfer out of the antenna you have erected.

If you use a “ $\pi$ -Section Coupler,” your antenna can be as short as 30 feet or as long as 100 feet. The combination can be made to work efficiently at all frequencies between 500 and 6800 kHz.

**The Antenna.** Construction of a long-wire antenna is simple if you just remember and adhere to the following rules of safety. Never construct your antenna so that it could fall on power lines or they on it. Always use a lightning arrester; this not only can save your equipment but may improve the signal, since it drains static electricity from the an-

Even with a Hammarlund SP-600, the author credits much of his good BCB DX to the pi-section coupler/tuner.



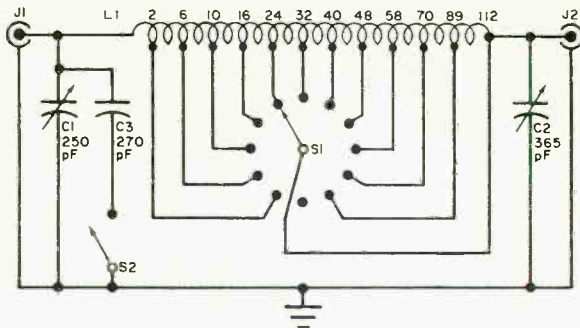

## PARTS LIST

- C1—250-pF variable capacitor
- C2—365-pF variable capacitor
- C3—270-pF capacitor
- J1, J2—RCA phono jack
- L1—112 turns of 1 $\frac{1}{4}$ "-diameter, 4 $\frac{3}{16}$ "-long 18-gauge wire, tapped as indicated
- S1—1-pole, 12-position shorting switch
- S2—S.p.s.t. switch

Fig. 1. The coupler is particularly useful in matching the erratic (sometimes high, sometimes low, as you tune various bands) impedance of a single wire antenna.

tenna. Never use wire or metal cable to support the antenna ( $\frac{1}{4}$ " nylon line is your best bet).

A long-wire antenna receives best from the directions perpendicular to its sides. Erect the antenna N-S to receive E-W. It should be at least 30' long and made of multi-strand copper antenna wire supported a *minimum* of 15 feet off the ground. A "long-wire" works best 60 feet above electrical ground (40 to 50 feet above land surface). Egg-type insulators should be used to physically connect the antenna to the supports. To prolong the

tubing. If you can't drill holes in the house, try drilling a  $\frac{1}{4}$ " hole in a window sash, inserting a  $\frac{1}{4}$ "-o.d., 1" length of Bakelite tubing into the hole, running the feed line through this tubing, and sealing the hole with a nonconductive caulking compound.

The lightning arrester should be wired into the feed line according to the manufacturer's directions, which are packed with the arrester. Lightning arrestors can be bought for as little as 59 cents.

Terminal "G" or "ground" on the receiver should be connected to a good

Fig. 2. The author mounted all the coupler components in a transparent refrigerator box. The numerals refer to some of the rotary switch positions.

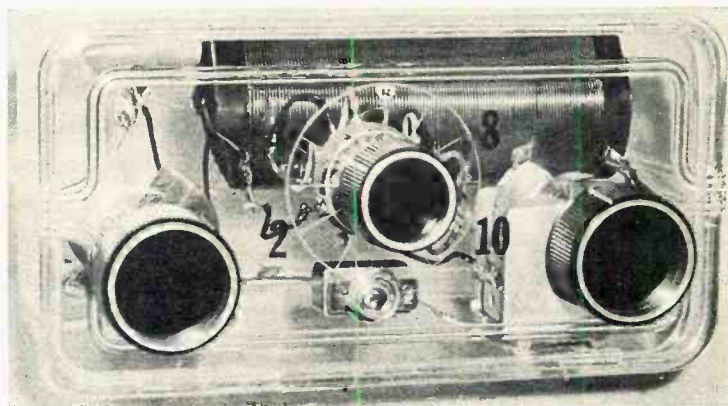

life of the antenna, coat all solder connections with plastic rubber.

Bringing the signal from the antenna to the receiver calls for the use of insulated copper wire of 16 to 18 gauge. It should be wrapped (to afford mechanical strength) and soldered to the end of the antenna at the insulator closest to the receiver.

The proper feed line entrance into a house is through a wall using an "All Weather Wall Thru Bushing" or similar

ground. A good ground is a cold water pipe (never use hot water pipes, gas pipes, or the telephone company's ground). Clean the cold water pipe with emory cloth at the point where you wish to place a "Ground Clamp" (clamps cost approximately 50 cents). Secure the clamp tightly and affix a length of 16-gauge insulated wire sufficiently long to go to "Ground" on the receiver. Then coat the ground clamp connections with rubber glue.

**Building the Coupler.** If you have never built electronic gear before—don't despair—you can build this coupler. Not only will you greatly increase the incoming signal, but you will also gain experience in apparatus construction. The only prerequisites are reading, soldering, and about \$6.00.

The author assembled his coupler in a refrigerator box. In selecting a box, make sure it is large enough to accept the components. Mark and drill mounting and rotor shaft holes in the box for *C1*, *C2*, *S1*, *S2*, *J1*, and *J2* (see Figs. 1 and 2).

Start making up the coil by drilling two holes in the coil form to pass the coil wire. Insert the wire through these holes, leaving 4" extra protruding (which will be used for hookup later). The holes are intended to hold the wire secure during the winding operation.

Wind tightly two turns of coil wire and drill a hole adjacent to the second

around the switch. Remember that lug #1 is on the coil end with only two turns. Cut the wires soldered to the switch terminals so that they will just reach the corresponding lugs when the switch is one inch from the coil. Strip  $\frac{1}{4}$ " of insulation from these wires and solder them to their corresponding lugs on *L1*.

The outer conductors of *J1* and *J2* are "ground," as are the terminals associated with the rotor plates in the capacitors. Solder the necessary wires to the proper points to connect the remaining components. Then connect the receiver to *J1* and the antenna to *J2* using a coax cable.

**Using the Coupler.** To operate the coupler, set *C1* and *C2* at the half-open position and rotate *S1* until the signal is strongest. Adjust *C1* and *C2* to peak the signal to maximum (while adjusting

Winding the coil is probably the most difficult operation in assembling a duplicate of this coupler. If you follow instructions, you should have no trouble winding a coil that will look like the one in this photo. Solder the leads to switch *S1* before mounting in box.

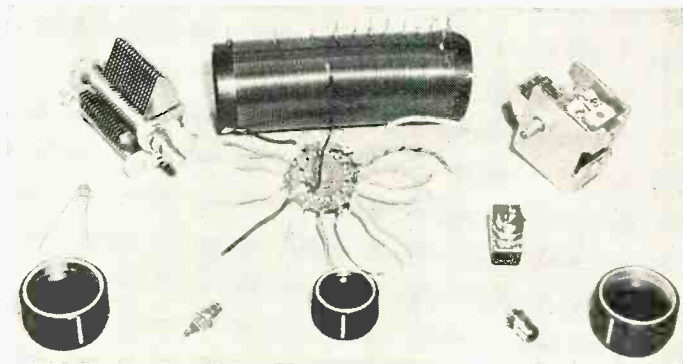

turn to press-fit a brass nail, used as a lug. Scrape the wire adjacent to the lug hole, insert a lug (this is lug #1), and solder to the coil.

Wind four more turns, drill another adjacent lug hole, scrape the wire, insert the lug (this is lug #2), and solder. Proceed in this manner, winding the specified number of turns as shown in Fig. 1 until the coil is complete. Secure the coil winding through two more holes, leaving 4" extra wire protruding.

Now cut 11 5" lengths of hookup wire and strip  $\frac{1}{4}$ " insulation from one end of each. Solder them to the terminals of *S1*, leaving one terminal bare. The bare terminal is #0. The terminal next to #0 (count in either direction) is terminal #1, the one next to it is #2, and so on,

*C1*, switch *S2* on and off to find its best setting; *C2* will have no appreciable effect at some frequencies).

The coupler is basically an attempt to effect a more efficient transfer of signal energy from the random length of antenna to the receiver. At some frequencies the coupler will seemingly have no effect, which means that the antenna and receiver are matched as closely as possible. At other—or most—frequencies the coupler will have a very decided and noticeable effect. Capacitor *C2* should be switched in and out of the circuit when the coupler seems to have the least effect—especially at the lower frequencies.

The dial settings should be logged to simplify retuning.

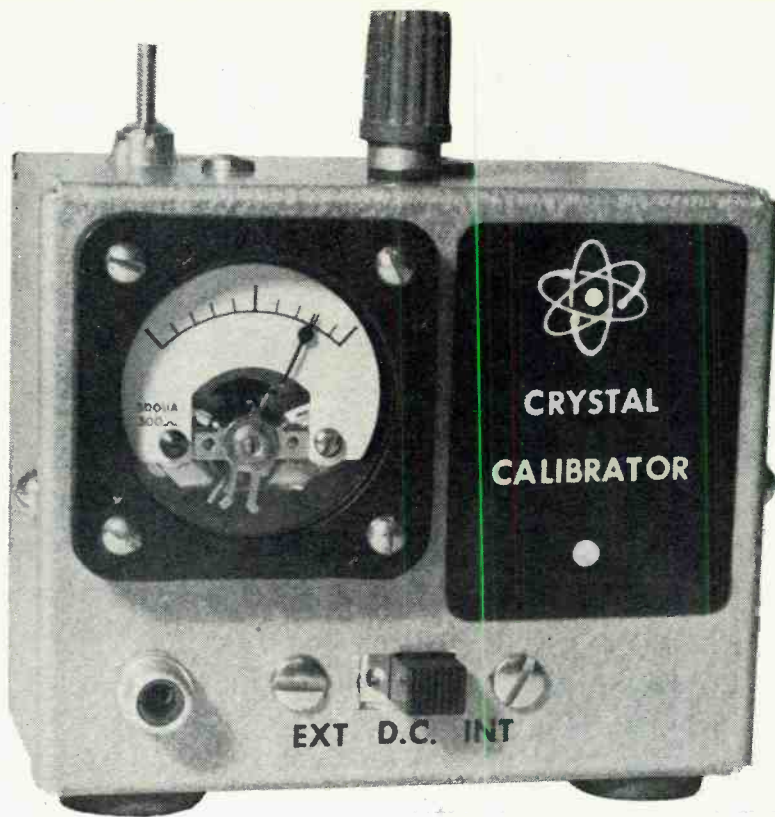

## **Build FET Crystal Calibrator**

COMBINATION OF FET AND  
DRIFT-FIELD TRANSISTOR  
WILL PRODUCE 100-kHz  
HARMONICS GALORE

---

BY FRANK H. TOOKER

---

**I**F YOU WANT a 100-kHz frequency calibrator designed for just that purpose, and therefore probably better than average, this project is for you. It uses the latest technological advancement in transistors—the field-effect transistor—as an oscillator and incorporates a harmonic generator to provide usable signals well into the MHz range. Temperature stability of the FET calibrator is excellent, and total power consumption is about 400 microamperes at 9 volts, or approximately 3.6 milliwatts.

A built-in meter monitors the performance of the calibrator by providing a continuous indication of current consumption. This meter isn't otherwise essential to the performance of the calibrator, and may be omitted, if desired. Although a meter is useful in the initial adjustment of the calibrator, an external meter, temporarily connected in series with the battery, can be used for this purpose.

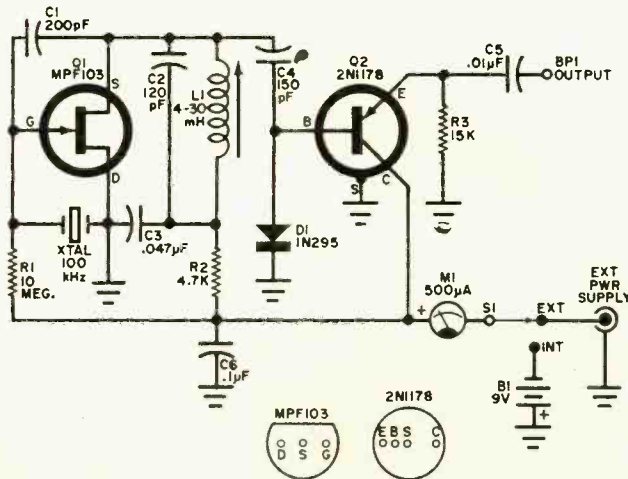

### PARTS LIST

B1—9-volt transistor battery  
 BP1—5-way binding post  
 C1—200-pF silver mica capacitor  
 C2—120-pF silver mica capacitor  
 C3—0.047- $\mu$ F Mylar capacitor  
 C4—150-pF silver mica capacitor  
 C5—0.01- $\mu$ F ceramic disc capacitor  
 C6—0.1- $\mu$ F ceramic disc capacitor  
 D1—1N295 diode  
 J1—Panel-mount phono jack  
 L1—Variable inductor, 4 to 30 mH  
 (Miller No. 6315 or similar)

M1—500- $\mu$ A meter movement (optional)  
 Q1—Motorola MPF103 junction field-effect transistor  
 Q2—2N1178 transistor  
 R1—10-megohm,  $\frac{1}{2}$ -watt resistor  
 R2—4700-ohm,  $\frac{1}{2}$ -watt resistor  
 R3—15,000-ohm,  $\frac{1}{2}$ -watt resistor  
 S1—S.p.d.t. slide switch  
 XTAL—100-kHz frequency-standard crystal  
 (Peterson Z-6A or similar)  
 Misc.—Cabinet ( $3\frac{3}{4}$ " x 3" x  $2\frac{1}{8}$ " ), etched circuit board, crystal socket, battery clip, battery connector, wire terminals, wire, solder, etc.

Circuit of the FET calibrator is designed around commonly available solid-state components. A phono jack on the front panel permits operation of the calibrator from an external power source.

An ordinary transistor battery, such as the VS323, 2U6, 216, etc., can be used if necessary, but an alkaline battery, such as the Mallory "Duracell" MN1604B, will make for better frequency stability because of its superior voltage regulation in the course of aging.

**Construction.** Almost any technique that meets two requirements—short leads and a minimum of stray capacitance across the crystal—can be used to build this calibrator. Stray capacitance across the crystal reduces its operating frequency and contributes to frequency instability. Long leads in the signal circuits attenuate the amplitude of higher frequency harmonics.

Components of the calibrator shown in the photos are mounted partially on a  $2\frac{1}{8}$ " by  $1\frac{1}{2}$ " etched circuit board and partially point-to-point. With the excep-

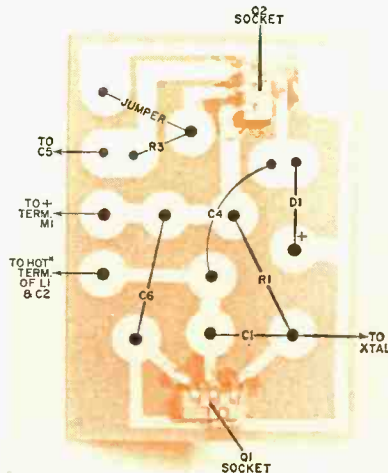

Although the author used this PC board layout, you could build the FET calibrator on a sturdy perforated board.

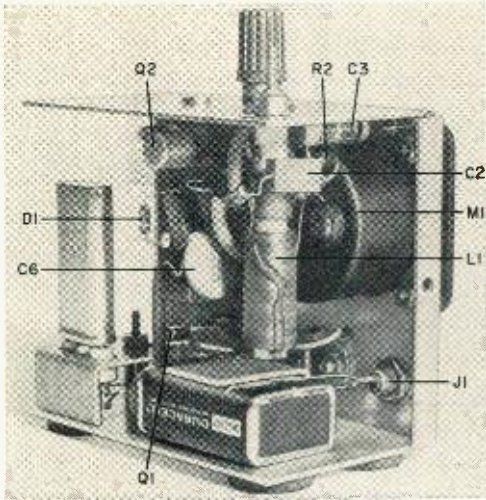

Inside-of-box view of the author's prototype. Aluminum bracket prevents battery from jarring loose. Output is via the binding post on the unit's cover.

tion of  $C2$ , which is connected directly across the terminals of  $L1$ , all sensitive components are mounted on the etched circuit board. An etched circuit board is, in fact, a "natural" for this type of instrument (even in experimental setups),

### HOW IT WORKS

A 100-kHz crystal ( $XTAL$ ) is connected in a Colpitts oscillator circuit, utilizing an n-channel junction field effect transistor,  $Q1$ , in a common-drain configuration. The gate of  $Q1$  is at a very high impedance, and the crystal, connected between gate and drain, operates—largely unrestricted by loading—in its parallel-resonant mode.

Resistor  $R2$  limits  $Q1$ 's starting current. Provided r.f. feedback is adequate, oscillation occurs when the power supply voltage is sufficient to operate  $Q1$  above the "knee-point" in its characteristic curve. Once oscillations begin, drain current drops abruptly, for the circuit generates its own bias, and in this way adjusts itself automatically for operation at maximum efficiency. Transistor  $Q1$  oscillates quite cleanly, although harmonic generation is restricted. On the other hand, harmonics are needed for frequency checking and calibration purposes. Output is taken from the relatively low-impedance source of  $Q1$  and fed through coupling capacitor  $C4$  to the harmonic generator and limiter circuit  $D1-Q2$ .

Diode  $D1$  advances the clipping of the positive-going alternations of the oscillator output voltage begun by  $Q1$ , while drift-field transistor  $Q2$  clips the negative-going alternations. Clipping of both positive and negative peaks is quite sharp and very nearly equal. Thus, the signal appearing at the output terminal ( $BP1$ ) is a well-sheared sine wave full of harmonics. With a 9-volt battery, or other power source, and the clipping level employed in this instrument, the signal voltage at the output terminal is approximately 3 volts peak-to-peak.

for it not only provides for the shortest possible leads but also insures lead rigidity—another important consideration in calibrator frequency stability.

Inductor  $L1$  should be located where its adjusting screw is easily available with the back/sides cover of the cabinet in place. In the author's instrument,  $L1$  is snapped into a hole in the top left rear corner of the  $3\frac{3}{4}$ " x  $3$ " x  $2\frac{1}{8}$ " cabinet housing the calibrator. Keep the winding at least the diameter of the coil away from nearby sheet metal (such as the back and sides of the enclosure).

**Adjustment.** After the calibrator is assembled, check to make certain that there are no errors or omissions, then install the transistors, the crystal, and the battery. Put the back/sides cover in place and tighten the mounting screws. Run the core of  $L1$  about one-third of the way out of the winding, and switch  $S1$  to  $INT$ . If all is well, the meter will read anywhere from 300 to 350 microamperes—indicating that  $Q1$  is drawing its maximum limited value of current because it is not oscillating, and  $Q2$  is drawing only its leakage current.

While observing the meter, turn the screw on  $L1$  slowly in the direction that will move the core into the winding. A point will soon be reached where the meter needle deflects suddenly up-scale to about  $450\ \mu A$ . This increase in current is the net result of  $Q1$  going into oscillation and  $Q2$  increasing its collector current. Advance the core of  $L1$  another two complete turns into the winding, and the meter reading should settle down to about  $400\ \mu A$ .

Switch  $S1$  to  $EXT$  (to turn the calibrator "off"), wait a moment or two, then switch it back to  $INT$ . The meter needle should swing up-scale and come to rest immediately at about  $400\ \mu A$ . If the needle swings up to a higher value, and hesitates briefly before dropping back, advance the core of  $L1$  one more full turn into the winding.

The exact value of the meter readings may vary *slightly* with a different set of transistors, a different meter, or a battery other than the "Duracell" but the *direction of deflection* and the *approximate extent of the deflections* during the adjustment procedure should be the same.

—50—

# SLOW KICK

**YOUR WINDSHIELD**

# WIPERS

**BY DONALD K. BELCHER**

● **NEW CIRCUIT PROVIDES  
TIMER TO WIPE WINDSHIELD  
IN LIGHT SNOW OR DRIZZLE**

**H**AVE YOU EVER driven in the rain when the drizzle was heavy enough to require the use of windshield wipers, yet light enough to cause the wipers to squeak, bounce, and shake because there was not enough liquid on the windshield to keep the wiper blades properly lubricated? Even two-speed wipers do not solve this problem, as you find yourself constantly turning the wipers on and off. Under such marginal driving conditions, it would be convenient to have your wipers automatically turn themselves on and off periodically. They can do it if your car uses electric wipers and

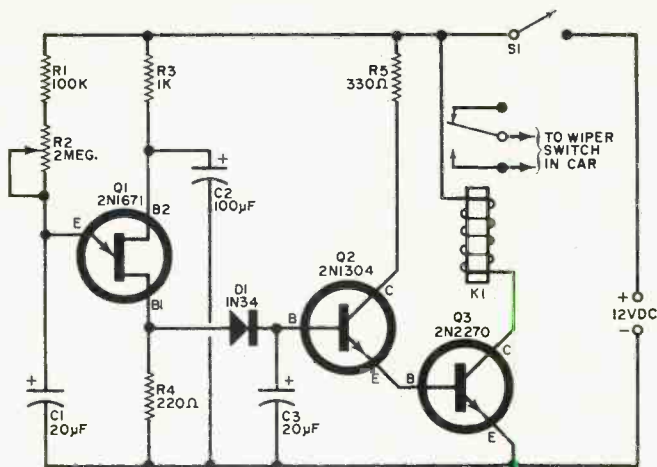

Each time relay K1 closes, it allows the wiper to make one full sweep, at full torque, before returning to its rest position.

### HOW IT WORKS

The actuator circuit is essentially a low-frequency relaxation oscillator consisting of UJT *Q1* free-running at a frequency determined by *R1*, *R2*, and *C1*. Every time the UJT discharges *C1*, a positive-going pulse is generated across *R4*. These pulses are passed by diode *D1* to charge *C3*. Capacitor *C3* cannot discharge back through *D1* since the diode is now reversed-biased and offers a very large resistance to any such current flow.

The positive voltage appearing at the base of *Q2* and *Q3* causes both *Q2* and *Q3* to conduct. As *Q3* conducts, it draws collector current through the coil of relay *K1*. If the normally-open contacts of *K1* are connected across the auto wiper switch, every time the relay closes the relay contacts simulate the wiper on/off switch and complete the wiper motor circuit. The wiper motor makes one complete cycle, even though the relay contacts (or wiper switch) are opened immediately after starting the motor. Thus, the wipers will make one "sweep" for each pulse generated by *Q1*.

As potentiometer *R2* determines the firing rate of *Q1*, it also determines how often the wipers make a sweep. Resistor *R3* and capacitor *C2* acts as a filter to remove any high-voltage "spikes" that may occur as the relay contacts turn the inductive load (the wiper motor) on and off.

### PARTS LIST

- C1*—20- $\mu$ F, 12-volt electrolytic capacitor
- C2*—100- $\mu$ F, 15-volt electrolytic capacitor
- C3*—20- $\mu$ F, 6-volt electrolytic capacitor
- D1*—1N34 diode
- K1*—12-volt d.c. relay, 150-250 ohm coil resistance
- Q1*—2N1671 unijunction transistor
- Q2*—2N1304—see text
- Q3*—2N2270—see text
- R1*—100,000-ohm,  $\frac{1}{2}$ -watt resistor
- R2*—2-megohm potentiometer
- R3*—1,000-ohm,  $\frac{1}{2}$ -watt resistor
- R4*—220-ohm,  $\frac{1}{2}$ -watt resistor
- R5*—330-ohm,  $\frac{1}{2}$ -watt resistor
- S1*—S.p.s.t. switch
- Misc.— $5\frac{1}{4}$ " x 3" x  $2\frac{1}{8}$ " metal box, perforated phenolic board, solder, hardware, etc.

you build this automatic windshield wiper actuator.

Most electric wipers have a built-in "return" feature, i.e., once the wipers have been started, even if the power has been shut off, they will make one full sweep and then return to their seated position and shut themselves off. This "return" feature is the basis for the automatic wiper actuator whose electronic circuitry (above) momentarily simulates the "closed" wiper switch, then "opens" the switch and allows the wipers to make one complete sweep. The rate of sweep is determined by the adjustment of potentiometer *R2*.

**Construction.** The entire unit can be built for \$12 or less, and none of the components is critical, although reasonably good quality electrolytic capacitors should be used for *C1* and *C3* to avoid leakage problems. Since transistor biasing is not used, the circuit is flexible and permits a wide variety of transistor types to be substituted. Transistor *Q1* is a conventional unijunction transistor, while transistors *Q2* and *Q3* can be any general-purpose *npn* audio transistors. Note, however, that *Q3* should have a dissipation of at least 300 mW.

The unit can be housed in a small metal box with the circuit elements mounted



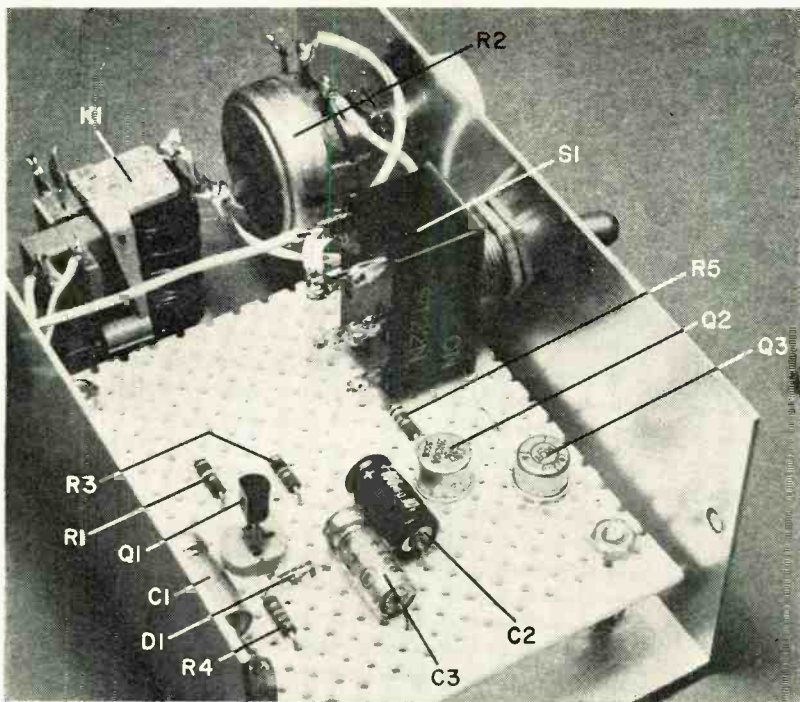

Author's unit was assembled on a perf board, then mounted in small metal cabinet.

on a small phenolic board. The on-off switch (*S1*) and speed control potentiometer *R2* should be mounted on the front panel. Since the activator is a low-frequency system, lead dress is not critical.

Any 12-volt d.c. relay having a coil resistance between 150 and 250 ohms can be used. The relay remains closed for a period of time determined by the capacitance of *C3* (and also by the sensitivity of the relay). To lengthen the time of contact closure, increase *C3*'s value; to shorten the time, reduce the value. Relay *K1* needs to remain closed only long enough to effectively start the windshield wipers on their sweep. With the

values shown, *K1* will be closed for approximately  $\frac{3}{4}$  of a second.

**Operation.** After the unit has been completed, apply 12 volts to the correct leads, turn the power on, and set *R2* to its minimum value. Relay *K1* should close momentarily approximately every  $1\frac{1}{2}$  seconds. When the activator is functioning normally, the period of operation can be varied from about once every  $1\frac{1}{2}$  seconds, to once every 50 seconds, depending on the setting of *R2*.

The simplest method of installation is to connect the two normally-open relay contact leads across the windshield wiper on-off switch.

-30-

### ***Ham Radio Correspondence Course***

The FCC has issued an amateur radio station license to the Hadley School for the Blind, 700 Elm St., Winnetka, Ill. 60093. The school intends to use this license to augment its correspondence course called "Amateur Radio." This is the first correspondence course

designed exclusively for people who are blind. The school provides the student with a taped and braille edition of the License Manual using raised line drawings. Hadley has over 100 courses devoted to teaching the blind—it is an accredited private home study school.

# You can earn more money if you get an FCC License

...and here's our famous CIE warranty that you will get your license if you study with us at home

NOT SATISFIED with your present income? The most practical thing you can do about it is "bone up" on your electronics, pass the FCC exam, and get your Government license.

The demand for licensed men is enormous. Ten years ago there were about 100,000 licensed communications stations, including those for police and fire departments, airlines, the merchant marine, pipelines, telephone companies, taxicabs, railroads, trucking firms, delivery services, and so on.

Today there are over a million such stations on the air, and the number is growing constantly. And according to Federal law, no one is permitted to operate or service such equipment without a Commercial FCC License or without being under the direct supervision of a licensed operator.

This has resulted in a gold mine of new business for licensed service technicians. A typical mobile radio service contract pays an average of about \$100 a month. It's possible for one trained technician to maintain eight to ten such mobile systems. Some men cover as many as fifteen systems, each with perhaps a dozen units.

## Coming Impact of UHF

This demand for licensed operators and service technicians will be boosted again in the next 5 years by the mushrooming of UHF television. To the 500 or so VHF television stations now in operation, several times that many UHF stations may be added by the licensing of UHF channels and the sale of 10 million all-channel sets per year.

## Opportunities in Plants

And there are other exciting opportunities in aerospace industries, electronics manufacturers, telephone companies, and plants operated by electronic automation. Inside industrial plants like these, it's the licensed technician who is always considered first for promotion and in-plant training programs. The reason is simple. Passing the Federal government's FCC exam and get-

ting your license is widely accepted proof that you know the fundamentals of electronics.

So why doesn't everybody who "tinkers" with electronic components get an FCC License and start cleaning up?

The answer: it's not that simple. The government's licensing exam is tough. In fact, an average of two out of every three men who take the FCC exam fail.

There is one way, however, of being pretty certain that you will pass the FCC exam. And that is to take one of the FCC home study courses offered by the Cleveland Institute of Electronics.

CIE courses are so effective that better than 9 out of every 10 CIE-trained men who take the exam pass it... on their very first try! That's why we can afford to back our courses with the iron-clad Warranty shown on the facing page: you get your FCC License or your money back.

There's a reason for this remarkable record. From the beginning, CIE has specialized in electronics courses designed for home study. We have developed techniques that make learning at home easy, even if you've had trouble studying before.

## In a Class by Yourself

Your CIE instructor gives his undivided personal attention to the lessons and questions you send in. It's like being the only student in his "class." He not only grades your work, he analyzes it. And he mails back his corrections and comments the same day he receives your assignment, so you can read his notations while everything is still fresh in your mind.

## Mail Card for Two Free Books

Want to know more? The postpaid reply card bound-in here will bring you free copies of our school catalog describing opportunities in electronics, our teaching methods, and our courses, together with our special booklet, "How to Get a Commercial FCC License." If card has been removed, just send your name and address to us.

**Matt Stuczynski,**  
Senior Transmitter  
Operator, Radio  
Station WBOE



"I give Cleveland Institute credit for my First Class Commercial FCC License. Even though I had only six weeks of high school algebra, CIE's AUTO-PROGRAMMED™ lessons make electronics theory and fundamentals easy. I now have a good job in studio operation, transmitting, proof of performance, equipment servicing. Believe me, CIE lives up to its promises."



**Chuck Hawkins,**  
Chief Radio  
Technician, Division  
12, Ohio Dept.  
of Highways

"My CIE Course enabled me to pass both the 2nd and 1st Class License Exams on my first attempt...I had no prior electronics training either. I'm now in charge of Division Communications. We service 119 mobile units and six base stations. It's an interesting, challenging and rewarding job. And incidentally, I got it through CIE's Job Placement Service."

**Glenn Horning,**  
Local Equipment  
Supervisor, Western  
Reserve Telephone  
Company



"There's no doubt about it. I owe my 2nd Class FCC License to Cleveland Institute. Their FCC License Course really teaches you theory and fundamentals and is particularly strong on transistors, mobile radio, troubleshooting and math. Do I use this knowledge? You bet. We're installing more sophisticated electronic gear all the time and what I learned from CIE sure helps."

## ENROLL UNDER G.I. BILL

All CIE courses are available under the new G.I. Bill. If you served on active duty since January 31, 1955, or are in service now, check box on reply card for G.I. Bill information.

**CIE** Cleveland Institute of Electronics  
1776 E. 17th St., Dept. PE-64, Cleveland, Ohio 44114

Accredited by the Accrediting Commission of the National Home Study Council, and the only home study school to provide complete coverage of electronics fundamentals plus such up-to-date applications as: Microminiaturization • Laser Theory and Application • Suppressed Carrier Modulation • Single Sideband Techniques • Logical Troubleshooting • Boolean Algebra • Pulse Theory • Timebase Generators...and many more.



Cleveland Institute of Electronics

# WARRANTY

of success in obtaining a  
Government FCC License

The Cleveland Institute of Electronics hereby warrants that upon completion of the Electronics Technology, Broadcast Engineering, or First-Class FCC License course, you will be able to pass the FCC examination for a First Class Commercial Radio Telephone License (with Radar Endorsement) ;

OR upon completion of the Electronic Communications course you will be able to pass the FCC examination for a Second Class Commercial Radio Telephone License;

AND in the event that you are unable to pass the FCC test for the course you select, on the very first try, you will receive a FULL REFUND of all tuition payments.

This warranty is valid for the entire period of the completion time allowed for the course selected.

*G. O. Allen*

G. O. Allen  
President

CIRCLE NO. 9 ON READER SERVICE PAGE

# Polarity Quiz

BY ROBERT P. BALIN

Electronics technicians and hobbyists must be able to determine the polarity of a generated voltage or voltage drop to really understand how a circuit operates. They must also be able to determine the polarity of the supply voltage to be applied to a circuit, and how to install correctly a polarized component such as a diode, meter, or electrolytic capacitor. Test your ability to handle polarity problems correctly by selecting either "positive" or "negative" in each of the following statements. *(Answers appear on page 119)*

- 1 To produce a north pole at the top of this electromagnet, the (positive\_\_negative\_\_) d.c. supply terminal must be applied at point A.
- 2 When the permanent magnet is dropped through the coil, the polarity of the voltage generated at point A will be (positive\_\_negative\_\_) with respect to point B.
- 3 The direction of the electron flow through  $R_L$  will be indicated when the polarity of the instantaneous voltage at point A is (positive\_\_negative\_\_) with respect to point B.
- 4 Voltage at point A of this rectifier is (positive\_\_negative\_\_) with respect to ground.
- 5 To bypass the emitter resistor properly, connect the (positive\_\_negative\_\_) terminal of the electrolytic capacitor to the emitter.
- 6 To bias the collector circuit of this transistor amplifier properly, a battery must be inserted so that its (positive\_\_negative\_\_) terminal is connected to the collector?
- 7 The nonsymmetrical waveform appearing on this d.c. scope indicates that most of the signal has a (positive\_\_negative\_\_) polarity.
- 8 For the plate current meter in this circuit to deflect correctly, the plate lead must be connected to the (positive\_\_negative\_\_) terminal of the ammeter.
- 9 The polarity of the voltage at point A of this bridge circuit will be (positive\_\_negative\_\_) with respect to point B.
- 10 The voltage at point A is (positive\_\_negative\_\_) with respect to ground.

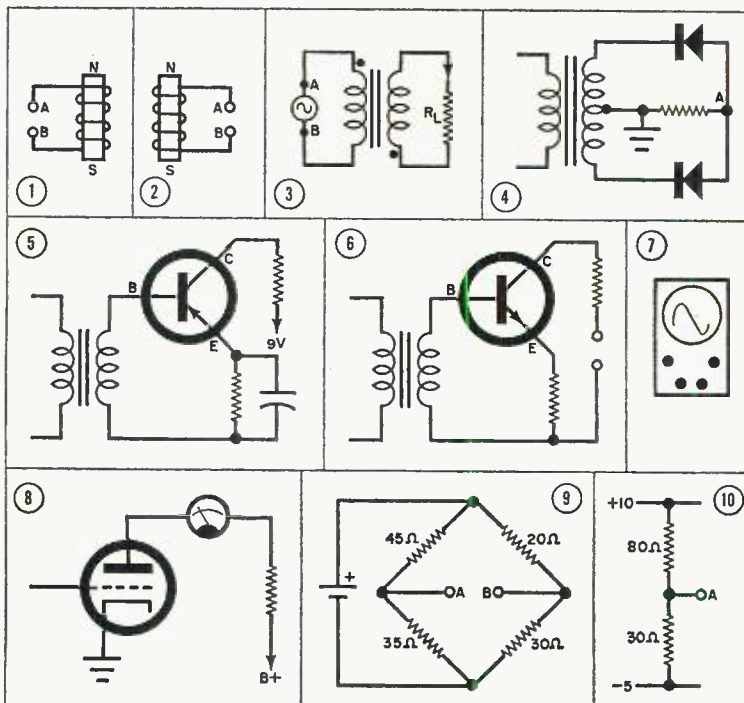

# Mighty- Mag Speaker System

BUILD YOUR OWN  
ULTRA-COMPACT HI-FI  
SPEAKER ENCLOSURE

BY DAVID B. WEEMS

WHEN the *Maximus I*\* broke the sound barrier for shoe-box size hi-fi speaker systems about three years ago, it had two strikes against it from the start. Common sense insisted that it was just too small and the price of \$59.50 too high. Yet, thousands of apartment dwellers who valued compactness as well as good sound invested in the *Maximus I*.

What was really unique about the *Maximus I* was the woofer. Unlike the woofers of some small sealed speaker systems, this one—built by Goodmans of England—was strictly first class in quality of material and design. Various POPULAR ELECTRONICS readers have asked if there were an equally good woofer that could be purchased as a separate component. Now, for the first time, the original woofer with its 3½-lb magnet structure and fundamental resonance below 45 Hz is available, and you can use it to build a small hi-fi speaker system comparable in performance to the original *Maximus I* at less than half its cost.

In order to achieve the goal of high performance at low cost, a lower cost tweeter has been substituted, the same

\*Trade name, UTC Sound Division.

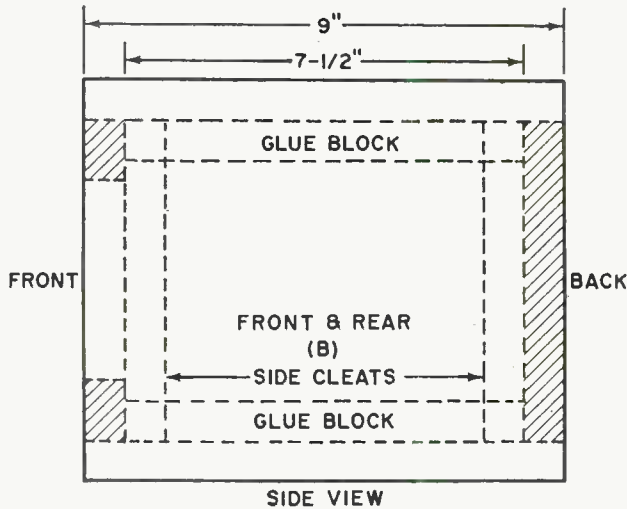
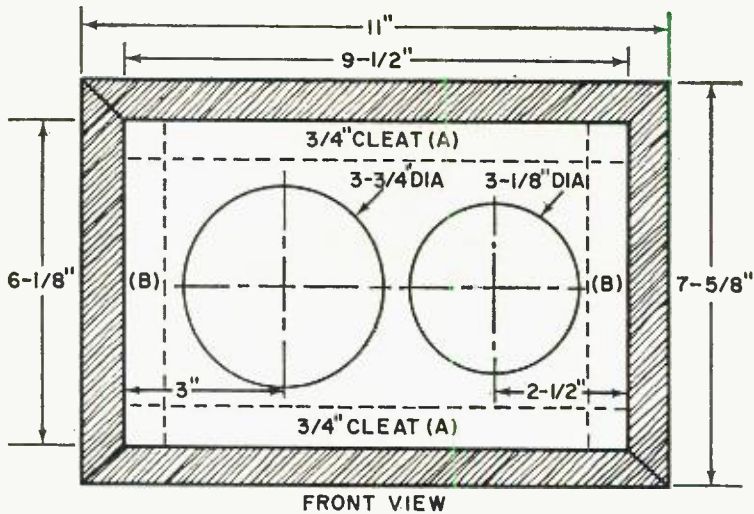

Details for assembling the enclosure are shown above. The small-diameter woofer and tweeter are only available from McGee Radio, 1901 McGee St., Kansas City, Mo. 64108. When you order, mention that you saw this story in the March issue of POPULAR ELECTRONICS.

### BILL OF MATERIALS

- 1—Maximus 4" woofer (McGee Radio Co. Stock No. 41VF MAX-1, \$14.95)
- 1—Tweeter (McGee Radio Co. Stock No. TS-6070, \$3.95)
- 2—9" x 11" lengths of 3/4" plywood for enclosure walls, beveled 45° at each end
- 2—9" x 7 5/8" lengths of 3/4" plywood for enclosure walls, beveled 45° at each end
- 2—6 1/8" x 9 1/2" lengths of 3/4" plywood for front and back
- 4—8" lengths of 3/4" x 3/4" pine for "A" cleats
- 4—6 1/8" lengths of 3/4" x 3/4" pine for "B" cleats
- 4—6" lengths of 3/4" x 3/4" pine for corner glue blocks
- 4—3/16" x 1 1/4" flathead bolts (for woofer mounting)
- 4—3/4" x #8 panhead screws (for tweeter mounting)
- 20—1 1/4" x #8 flathead wood screws (for front and back mounting)
- Misc.—Trim, grille cloth, glue

one used for the Cinderella speaker systems.<sup>22</sup> This tweeter, which has always seemed a good value, now has a fiberglass lining behind the cone to improve response smoothness, and using it results in another economy; the tweeter's built-in high-pass filter, a 5- $\mu$ F capacitor, eliminates the need for a more expensive crossover network.

**Construction.** It is not practical to try to equal the compactness of the *Maximus I* system unless you are a skilled metal worker; the front baffle in the factory unit was made of a special alloy only slightly more than  $\frac{1}{16}$ -inch in thickness. Plywood for even a small enclosure should have a minimum thickness of  $\frac{1}{2}$ -inch. Full  $\frac{3}{4}$ -inch material was selected here, partly to avoid vibration, but mainly because it is more widely available with hardwood veneer. This thickness also allows a special method of construction in which the beveled corners

provide enough surface area contact between the parts to be held by wood glue alone.

First, cut out the parts. Then install the front and back cleats, positioned  $\frac{3}{4}$ -inch away from the edges of the sides, top, and bottom to leave space for the front and back panels. These  $\frac{3}{4}$ " x  $\frac{3}{4}$ " cleats can be mounted with screws and glue or, if C-clamps are used, with nails and glue. The kind of nails that are stocked by building supply houses for use with dry wall house interior construction are just long enough to hold without penetrating the sides.

Corner glue blocks (6" long) can now be inserted from cleat to cleat at the interior corners of each of the smaller sides. The enclosure parts should be set on edge on a table top at several stages of their preparation to check their fit. After the glue has set on the cleats and blocks, the basic enclosure can be assembled by coating each joining surface with wood glue, setting the sides together, and applying pressure while the glue

<sup>22</sup>Build the "Cinderella," POPULAR ELECTRONICS, October, 1965, page 49.

After the cleats have been mounted, the sides, top, and bottom of the enclosure are glued and forced together. Apply equal pressure using a canvas strap.

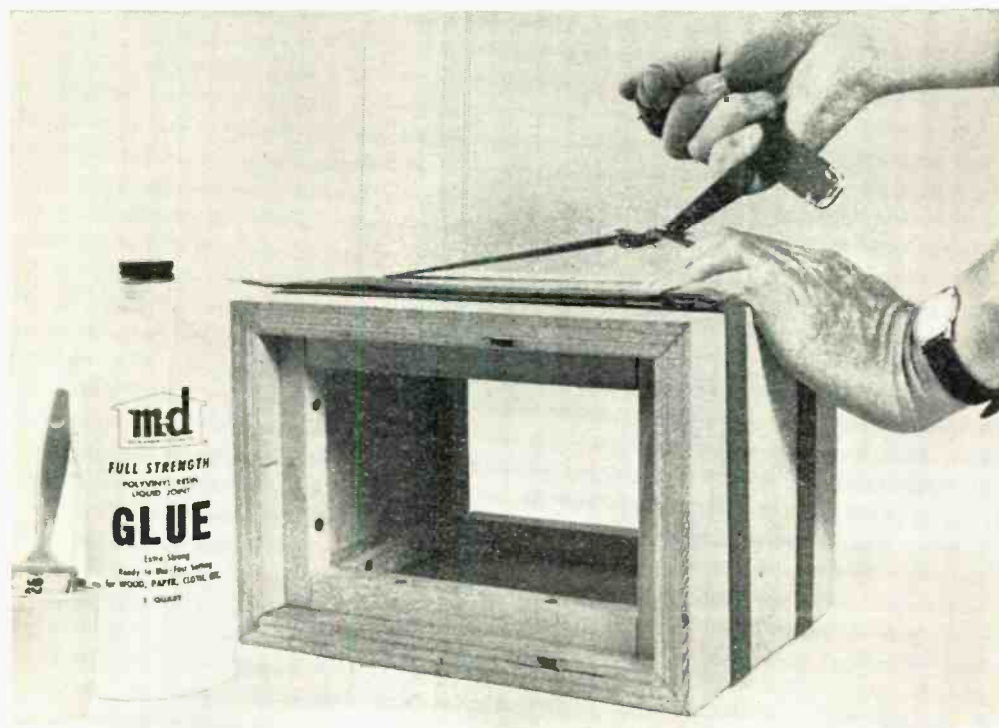

sets. One of the most convenient methods of applying pressure is to use two 48-inch canvas straps. When tightened, the straps force the sides into position for a perfect fit.

Next, the board cut for the front baffle should be set in place and an outline of the front cleats marked on it. The outline shows the space allowed for the speakers. Set the speakers in position and mark the location of the woofer mounting bolts. When these holes are drilled, diagonal lines between opposite holes will precisely locate the center of the woofer opening, which should approximate the point shown on the scale drawing. The tweeter cutout is less critical.

After the cutouts are made and the woofer bolts inserted, the panel should be painted flat black. Then the panel can be mounted with plenty of glue and 10 screws, three along each long edge of the piece and two at each end.

**Finishing Touches.** The plywood sides can now be sanded and finished, and grille cloth can be attached with tacks or, if used sparingly, contact cement. Any suitable trim will cover the raw edges of the plywood; the author used pre-finished picture frame molding. The frame was assembled and glued to the enclosure with contact cement, leaving no nail holes to fill.

Now install the speakers, using the bolts for the woofer, panhead screws for the tweeter. The speakers should be wired in phase, in this case a matter of connecting the left post on the woofer to the left post of the tweeter. The wires should be brought out the back of the cabinet without introducing an air leak. One method is to drill two small holes and screw tight-fitting bolts through the holes, after slipping the bolts through solder lugs to receive the speaker leads.

The interior of the cabinet is filled with acoustical felt, cotton batting, or

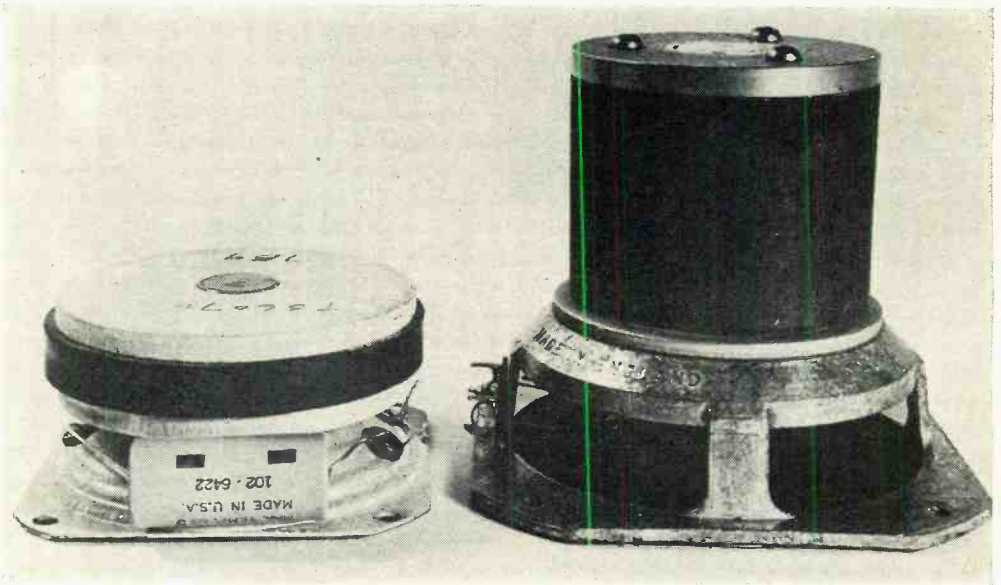

Massive magnet size of both tweeter (left) and woofer are apparent in this photo. Although low cost, these speakers are of modern design and capable of very good sound.

fiberglass. And, finally, the back can be installed; a gasket of thin cork, felt, or caulking compound around the rear cleats is desirable to eliminate air leaks.

Was it an extravagance for Goodmans to put a 3½-lb magnet structure on a 4-inch woofer? When you hear the smoothness of this little system, you'll know why they did it.

-30-



## UNIQUE PATENTS

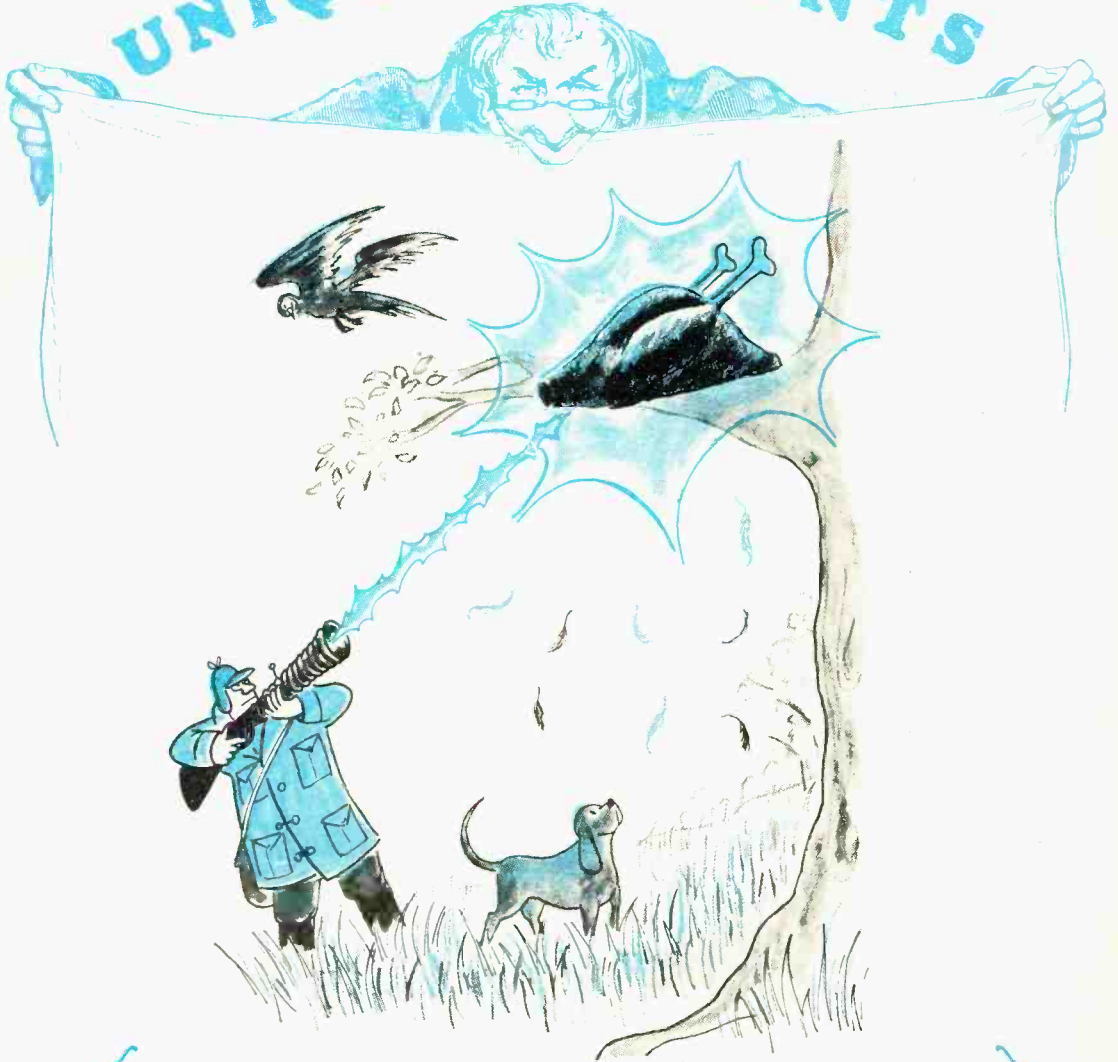

## Electric Gun

Invented by Henry F. Shartzer    Patented Nov. 5, 1918—No. 1,284,155

At first glance, the "electric gun" might seem to be one of H. G. Wells' science fiction weapons. In reality, the invention of the electric gun marked one of the early attempts to use Hertzian (radio) waves. The inventor visualized a portable spark gap transmitter feeding a helical antenna. The antenna was mounted on a gun stock and a magnifying lens positioned at the end of the coil. The inventor made several patent claims, including the idea of using the "directed" radio waves to detonate explosions, or stop/start a mechanical device at a safe distance. Of greatest interest was the claim that the lens could focus the radio wave energy and cause generation of intense heat at the focal point of concentration.

# the product gallery

REVIEWS AND COMMENTARY ON ELECTRONIC GEAR AND COMPONENTS

## TV SOUND-ONLY RECEIVER (Olson Model RA-23)

If you can't possibly live without your favorite TV program, but absolutely must drive around town while it's on the air, what do you do? Suffer? You won't have to any longer. Olson Electronics (260 S. Forge St., Akron, Ohio 44308) will sell you the perfect answer to the problem—a transistorized portable radio receiver that tunes in the sound from TV channels 2 through 13.

It is reported to your reviewer that TV "non-watching" (but listening to the sound channel) is catching on. This may indeed be true since there are numerous TV programs where viewing is not a prerequisite (soap operas, panel shows, news, etc.). For \$39.98, you can join this growing clan of the "in people" who don't watch TV.

The Model RA-23 is an 11-transistor FM receiver with three VHF tuning bands. The first band tunes from about 54 to 90 MHz, the second band from 86 through 112 MHz, and the third band from 176 to about 220 MHz. Thus, not only are all 12 VHF TV channels tuned, but the regular FM broadcasting band as well.

In our tests, the Model RA-23 demonstrated good sensitivity with the short antenna collapsed while your reviewer listened in on all TV channels at a distance of 30 miles from the Empire State building in mid-Manhattan. Extending the antenna permitted TV sound reception out to a distance of 50 miles (possibly further; we didn't try). Sound quality on both regular FM and TV was very good considering the physical size of the receiver.

As with practically all imported transistorized portable receivers, an earphone is included (does anyone ever use them?).

Circle No. 86 on Reader Service Page 15 or 115

## SOLID-STATE MULTIMETER (Heathkit Model IM-17)

In one fell sweep during 1967, a new breed of solid-state volt-ohmmeters was introduced on the market by almost every major manufacturer of test equipment. These new VOM's have all the sensitivity (11 megohms input impedance) and versatility of a vacuum-tube voltmeter, coupled

with the ease of operation and portability of a conventional multimeter. The first solid-state multimeters on the market were too expensive—and some still are—for the average hobbyist or experimenter. But a price breakthrough was announced that may well lead to the retirement of all conventional VOM's and VTVM's.

As 1967 drew to a close, the Heath Company (Benton Harbor, Mich. 49022) introduced and began marketing a less-than-\$20 solid-state VOM kit. Designated the IM-17, this new kit has a high-impedance FET input (11 megohms—identical to the input impedance of Heath's more sophisticated Models IM-16 and IM-25 solid-state multimeters selling for \$44.95 and \$80, respectively, in kit form).

Other technical specifications of the IM-17 are as impressive as those for a conventional VTVM. Each of the d.c., a.c., and ohms functions have four ranges. In the d.c. function, accuracy is  $\pm 3\%$  full scale on each of the 0-1 volt, 0-10 volt, 0-100 volt, and 0-1000 volt ranges. In the a.c. function, the frequency response of the IM-17 is  $\pm 1$  dB from 10 Hz to 1 MHz, and accuracy is  $\pm 5\%$ . Except for the first range, which is 0-1.2 volts, all a.c. ranges are the same as those for the d.c. mode. Input capacitance on the a.c. ranges up to 100 volts is 100 pF. On the 0-1000 volt range, the capacitance is 38 pF, and overall input impedance on all a.c. ranges is 1 megohm. The four ohms ranges— $\times 1$ ,  $\times 100$ ,  $\times 10K$ , and  $\times 1M$ —are adequate for most applications. The meter movement is a 200- $\mu A$ , 100° deflection unit.

The IM-17 is one of the easiest meter kits to build. Construction and alignment time is less than four hours, and even a novice kit builder should have little difficulty assembling the unit in a single evening. The electronic components are mounted on a large printed circuit board. Even wiring the range/function switch is a breeze.

There are only two areas where the IM-17 falls short in your reviewer's opinion. Because the IM-17 is a battery-operated unit, it should be equipped with a device to automatically turn off the power when the unit is closed—and panel or probe identification of the test leads would be most helpful.

(Continued on page 74)

## OLSON TV SOUND-ONLY RECEIVER

At first glance the Olson Model RA-23 transistorized portable radio receiver looks just like another portable. However, the tuning dial shows that the receiver tunes the FM broadcast band and all of the TV channels from 2 through 13. Tuning is easy, the sound quality better than average, and the sensitivity is excellent. Price is \$39.98.



## HEATHKIT IM-17 SOLID-STATE VOM

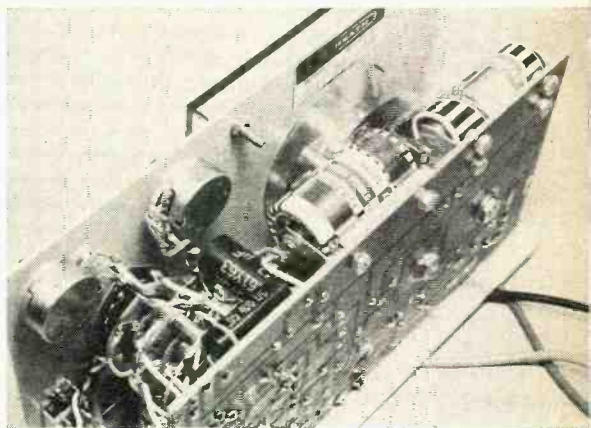

This less-than-\$20 transistorized VOM is expected to usher in a new era of portable test instruments. Test leads are permanently wired to the VOM—one lead for grounding, one for d.c. volts, a third for a.c. volts and ohms. The VOM is housed in special tough plastic case. Two batteries are required to power the solid-state circuit. Assembly takes about four hours. The IM-17 features a panel-mounted polarity-reversing switch.

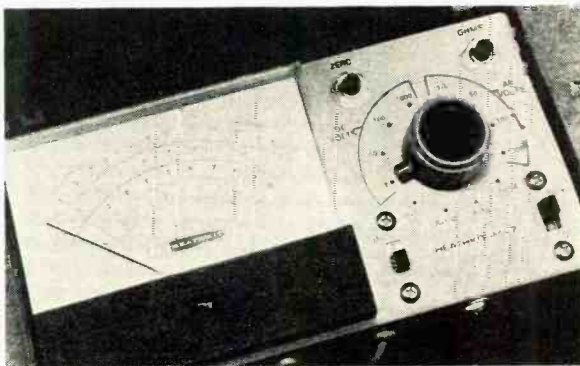

But even with these small deficiencies, the IM-17 still remains today's answer to today's needs in electronics for hobbyists and technicians alike.

Circle No. 87 on Reader Service Page 15 or 115

### HOUSEHOLD ULTRASONIC CLEANER (E/MC<sup>c</sup> Model LP-2)

There is a certain mystique to ultrasonic cleaning. The housewife visualizes ultrasonic cleaning as a space-age dishwasher, while the handyman-around-the-house expects ultrasonics to cleanse the uncleanable. Between these two extremes is the real value and purpose of ultrasonic cleaning. Possibly in an attempt to put ultrasonics in its proper perspective, the Electromation Components Corp. (84 Toledo St., Farmingdale, N.Y. 11735) has introduced a very-low-cost (\$39.95) cleaner that will do some of the things a bigger unit can do—but, only on a very small scale.

Ultrasonic cleaning involves the 100% immersion of the object to be cleaned in a bath of specially selected detergents. The tank holding the solution is excited to cavitation\* by an electronic ultrasonic generator—usually tuned to about 90 kHz. The bigger the tank, the more powerful must be the generator. About 30 watts output is needed to cavitate a one-pint tank and about 100-120 watts output for a one-gallon tank. As a rule of the thumb, the bigger the tank capacity, the bigger the object(s) you can clean; but, simultaneously, the bigger the tank, the bigger the generator output required, and the more the installation will cost.

The Electromation Model LP-2 ultrasonic cleaner is the first instrument of its kind designed for use in the home. With a tank capacity of about one-third pint, the Model LP-2 is capable of cleaning jewelry (charm bracelet, or smaller), dentures, small paint brushes, electric shaver heads, etc. Samples of two suggested cleaning detergents are included in the package with each cleaner.

From a circuit viewpoint, the Model LP-2 is a simple spark gap transmitter roughly

tuned to 90 kHz. A thumbwheel varies the gap distance, thus providing a means of compensating for spark gap erosion. The transducer is cemented to the underside of a stainless steel "well" and excites the glass beaker through a thin layer of water used as an impedance coupling. Radio interference generated by the spark gap appears minimal on all frequencies from 540 kHz through 176 MHz.

To someone expecting much more cleansing action, the Model LP-2 could be a disappointment. However, if the size of the tank is kept in mind (along with the modest power output of the ultrasonic generator), the Model LP-2—with the assistance of appropriate detergents—will effectively clean small pieces of jewelry and dentures.

Circle No. 88 on Reader Service Page 15 or 115

### SOLID-STATE STEREO TAPE DECK (Allied Model TD-1030)

The advent of the stereo receiver has caused a resurgence in the installation and use of tape decks. Due to improved production techniques, lower component costs, and the rapidly growing consumer demand, tape deck prices have been plummeting. In 1968 you can expect to see more quality at lower prices than at any time in the past five years.

Among the many recently introduced tape decks is the Model TD-1030 deluxe three-speed tape deck bearing the Allied name (Allied Radio Corp., 100 N. Western Ave., Chicago, Ill. 60680). For the sum of \$129.95, you get an all-solid-state tape deck, walnut-finished furniture base, dust cover, reel holders, cables, empty 7" reel, and splicing tape—a lot of goods for so little money.

Subjective listening tests consisting of the playback of prerecorded commercial tapes, and of tapes recorded by the TD-1030, show this tape deck to be the equal of most tape decks in the \$150-200 price range. The overall sound quality is crisp and vibrant—not slushy as is occasionally the case with similar priced decks. The hum and noise from this tape deck is quite low at all but the highest volume settings.

The listening tests at the three speeds of the TD-1030 produced the following results: at 7½ in/s—very good dynamic range and sound fidelity; at 3¾ in/s—good to fair dynamic range and fidelity on music, excellent speech recording and playback; at 1⅞ in/s—good background music reproduction of limited fidelity, but still very good speech characteristics. Equalization for playback at 7½ in/s appeared to be well within accepted hi-fi standards with no peaks or dips.

(Continued on page 104)

\*Ultrasonic cleaning is possible through the principle of cavitation. As the term implies, the liquid is agitated to form minute pockets of very low pressure (cavities). The collapse of these cavities produces a sudden impulse pressure that shakes loose insoluble dirt.



## E/MC<sup>®</sup> ULTRASONIC CLEANER

Small Electromation ultrasonic cleaner is sold complete with instruction booklet, samples of recommended detergents, etc. The glass dish is placed in recessed well on top of cleaner; object to be cleaned is immersed in warm water in the dish. Plastic sponge covers dish.

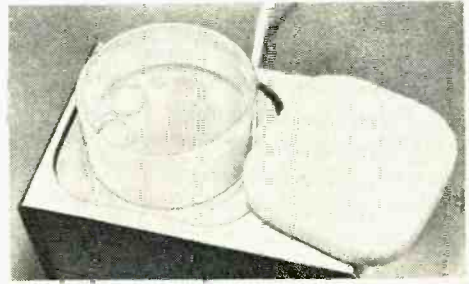

## ALLIED TAPE DECK

Low-cost 4-channel stereo tape deck is new addition to line of hi-fi gear sold by Allied Radio. Microphone jacks and recording level controls are hidden behind small drop panel. Each channel has vu-meter to enable easy balance of recording level. Deck has three speeds and, in tests, performed remarkably well. A glamour version with speakers and amplifiers is sold for only \$40 more.

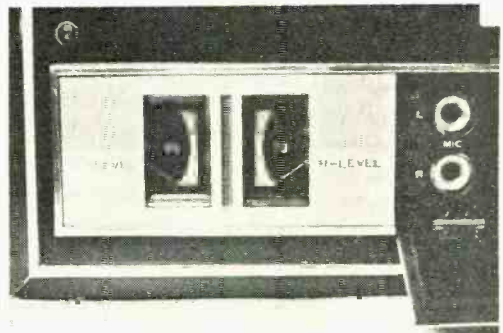
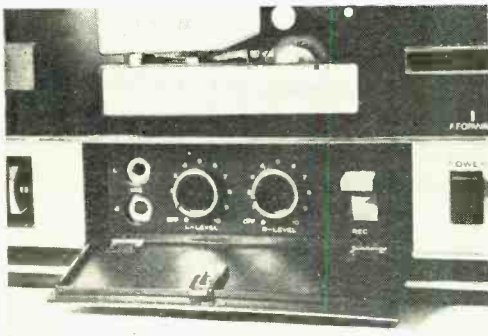



# INFORMATION CENTRAL

By CHARLES J. SCHAUERS, W6QLV

**A** NUMBER of readers have requested that your *Information Central* Editor supply them with details on troubleshooting integrated circuits (IC's) and how to make repairs. The IC's themselves *cannot* be repaired but must be replaced. However, components in a circuit in addition to the IC (resistors, capacitors, coils, etc.) can be tested and, if necessary, replaced.

Troubleshooting IC circuits is difficult. Unsoldering them (if they are not socket-mounted) is tricky and can lead to module damage. Substitution of a new module is the easiest way to determine whether or not the IC itself is defective.

Where a number of IC's are mounted on a circuit board, replacement of the *entire* board may be necessary, unless each module is socket-mounted. Experimenters should always try to use sockets in mounting IC's. Although IC's are now available in a number of different packages, including TO-5, TO-18, and flat-epoxy containers, sockets or clips are available for mounting each type.

Heat is the greatest destroyer of the IC, followed by voltage transients and incorrect voltages. As time goes on, special test equipment for IC's will no doubt become available and will probably operate much as tube or transistor testers do.

**P.A. System Interference.** *I live near a church and my 150-watt ham transmitter interferences with the church public address system, especially when I work on the 10- and 15-meter bands. I have a low-pass filter on my transmitter and the set is well grounded. What could be causing the interference?*

Your r.f. signal could be getting into the p.a. amplifier via the a.c. power lines, mike cords, or even the speaker lines. No doubt grid rectification is taking place in the p.a. amplifier in one or more stages. By inserting 75,000-ohm resistors in the grids of the preamplifier stages, and bypassing them to ground with a 0.001- $\mu$ F ceramic capacitor, it is possible to eliminate the interference. Or you may have to insert coaxial capacitors (0.1- $\mu$ F) in series with the p.a. amplifier a.c. line. An r.f. choke (2 $\frac{1}{2}$ -mH) in series with the hot mike lead and bypassed to ground with a 0.001- $\mu$ F ceramic capacitor will also help, and may be all that is needed. If the trouble is speaker line pickup, it

can be cured by installing 0.001- $\mu$ F ceramics in series across the line at the amplifier and grounding the center connection.

**Portable Antenna System.** *As a traveling salesman and a ham, I would like to obtain a portable antenna system that I can use when staying at hotels and motels. What I have in mind is a vertical of some sort that can be shoved out the window of my room. I am interested mainly in 40, 80, and 20 meters, and I use an SB-34 transceiver. Can you print a diagram of a suitable antenna system?*

The diagram below shows a simple system; you can use a SWR bridge to make tuning easier. For 80 meters, the whole coil

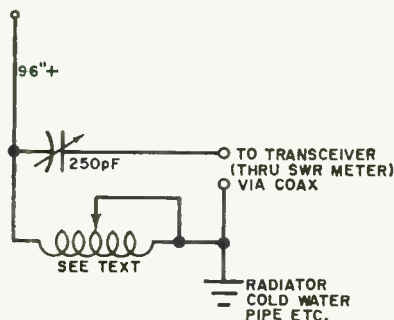

can be used (depending on frequency). Adjust the coil tap and tune the variable capacitor for lowest reflected power. A collapsible whip antenna can be employed, provided that it is 96 inches or longer. The coil is made of 30 turns of #14 wire, 8 turns per inch, 2 $\frac{1}{2}$ " in diameter.

**Checking Low-Voltage Electrolytics.** *Is there a simple way to check low-voltage electrolytic capacitors?*

Use your ohmmeter. If a capacitor is shorted, the meter will read full scale when the prods are connected to either end. If the capacitor is all right, the meter needle will kick over and gradually drop down on the high range scale—if the prod polarity is correct; if it is not, reversing the prods will cause the needle to move. A leaky capacitor will be indicated (with ohmmeter on high resistance scale) by a lower than normal reading, and the needle will take somewhat



interference is reduced in areas where the signal is not wanted.

**Radio "Fox-Hunter."** *Can you supply a diagram of a simple radio (AM) direction finder for use on 28 MHz? I want to participate in the "foxhunts" we have in our area.*

Hidden transmitter hunting can be a lot of fun, and the unit shown below should do

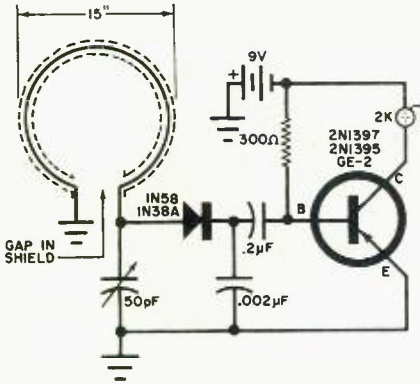

a good job for you. It is sensitive enough to track a hidden station for about 1 mile.

**NCX-3 R.F. Feedback.** *I recently acquired a used NCX-3 transceiver. This set, when fully loaded into the antenna, exhibits r.f. feedback as I turn up the mike gain. Also, the plate meter jumps up to 300 mA without audio input and sometimes the oscillation can be heard on the signal. What should I do?*

First, add a 0.003- $\mu$ F, 500-volt ceramic capacitor from the hot side of the mike jack to ground. Then add a 0.001- $\mu$ F, 500-volt ceramic capacitor from pin #2 of V7A (6GH8) to ground. If your NCX-3 uses a 6AN8 instead of the 6GH8, the connection should be from pin #8. If the r.f. feedback continues, add an additional 0.001- $\mu$ F, 500-volt capacitor from pin #2 of the V6B (12AT7) speech amplifier to ground. Make the leads of these capacitors as short as possible. And if you use a coiled mike cable, try changing the cord to a straight one.

**Telemetry Antennas.** *What type of antennas are generally used for radio telemetry work? What frequencies are utilized, and what is the average gain (lowest to highest)?*

A number of antennas are used for telemetry purposes. Among them are the omnidirectional discone, helicone, directional corner reflector, bifilar, multihelix, parabolic, and broadband log periodics. Frequencies from 108-140 MHz to 2.5-3.0 GHz are covered by the antennas mentioned. Gain varies from 2 dB for an omnidirectional discone antenna to as much as 33.4 dB for a 10-

foot, circular-polarized parabolic antenna operating between 2100 and 2300 MHz.

**R-55A Receiver Problem.** *I have a Knight R-55A receiver, the noise limiter of which has stopped operating. I replaced the 6AL5 tube but this did not help. What do you suggest I do next?*

Check resistors R21, R22, R26, R27, R28, and R29, and the capacitors bypassing them. Also check switch S4 for a short. Incidentally, we have had numerous inquiries as to how to improve the selectivity and sensitivity of this popular little set. A preselector would help.

**Counter-Timer.** *I am a science and physics teacher in a small high school and we need an electronic timer-counter which has a range of at least 10 MHz. Our budget is limited. What can you recommend?*

Take a look at the counter which is presented on page 27 in this issue.

**Relay Contact Arcing.** *Is there a good way to prevent relay contact arcing, which eventually destroys the contact points?*

There are a number of "arcing suppressors" on the market. The homemade one shown here uses a neon lamp. When there is a sudden surge of counter-e.m.f. as the contacts open, the neon lamp ignites. The stored energy in the coil then discharges quickly through the lamp. The voltage across the coil is held to the maintaining voltage of the lamp until the counter-e.m.f. of the coil falls below this voltage. The lamp will stop conducting at this point. Arcing is prevented across the contact points (normal spacing), because while the lamp

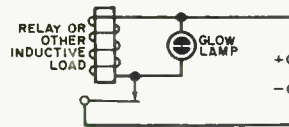

is operating the voltage is maintained at an adequate low level. Choosing a neon lamp for a specific relay depends on the operating voltage and current of the relay in the circuit.

**Requests to Readers.** Please do NOT send to *Information Central* schematics or any other material which must be returned—the volume of mail to be handled is just too great. Please continue to use postcards—one question to a card. And if you have a "tip," or answer to a specific problem, which you think may be of interest to other hobbyists, forward it to us for possible publication.



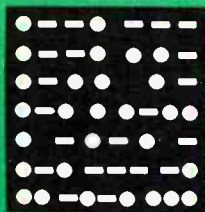

# AMATEUR RADIO

By HERB S. BRIER, W9EGO  
Amateur Radio Editor

## AMATEUR RADIO IN THAILAND

**O**FFICIALLY, the Thai government does not license radio amateurs and has invoked Article 41 of the International Telecommunications Union regulations against communications between Thai amateurs and foreign amateurs. Nevertheless, Thailand has not "banned" amateur radio. Instead, the government looks the other way while the Radio Amateur Society of Thailand issues call letters, administers the QSL Bureau, supplies addresses to the *Callbook*, etc.

In turn, Thailand's 45 or so amateurs carefully observe ITU rules and frequency allocations and FCC operating and technical standards. In addition, on the theory that other amateurs should know the attitudes of their governments regarding contacts with HS stations, they usually wait for foreign amateurs to call them before making international contacts. (As far as is known, only

Canada and the United States forbid their amateurs to work Thailand.)

To date, the Thai government's response to all efforts to persuade it to modify its position has been no official recognition but quiet tolerance of amateur radio. As long as this situation prevails (especially the invocation of ITU regulation 41), United States and Canadian amateurs court disciplinary actions, including possible fines and license suspensions, by calling or working HS stations. So don't take a chance!

The above information was received via *Newsletter # 8* of the International Amateur Radio Club, Geneva, Switzerland, in which Art Goddard, HS1CW/K1AII, discussed amateur radio in Thailand.

**Who Invented Radio?** Your Amateur Radio Editor's mention of Thomas Appleby's

## AMATEUR STATION OF THE MONTH



Bob Lauzon, WB2NSD, Pittsford, N.Y., started as a Novice in 1964 and is now studying "like crazy" for an Extra Class amateur license. Bob works 80 through 10 meters with a Collins 32S-3 driving a National NCL-2000 and a Collins 75S-3 receiver. He also works 6 meters with a Gonset IV, 2 meters with a Hallicrafters SR-42, and mobile with a Hallicrafters SR-160 SSB transceiver in his "Barracuda." With WAS, and WAC under his belt, Bob needs only five more counties for all U.S. counties worked. WB2NSD will receive a one-year subscription for submitting the winning entry for March in our Amateur Station of the Month Photo Contest. To enter the contest, send a clear photo of your station with you at the controls and some details on the equipment you use and your ham radio career to Amateur Radio Contest, % Herb S. Brier, Amateur Radio Editor, P. O. Box 678, Gary, Indiana, 46401.

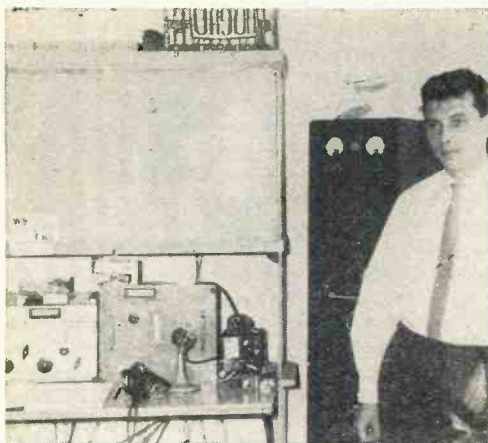

Vladis Novosibirsk, UA9OH, Siberia, puts out an excellent SSB signal that can be heard on 14 MHz in the United States. He uses a home-brew 200-watt filter transmitter feeding a "Swiss Quad" antenna.

Two-thirds of the ingredients needed for a successful DX station are a good operator, like Sanford Hutson, K5QHS, below, and good equipment, like that made by Heath. The third ingredient, a good antenna (rotary beam by Mosley), is on Sanford's roof.



book, "Mahlon Loomis, Inventor of Radio," last November prompted Tom to research further the statement in the book that Loomis had transmitted 400 miles by wireless. He found it to be a garbled report of a 40-mile wire transmission by atmospheric electricity. As stated elsewhere in the book, the correct distance is 18 miles.

Also, Tom did not quite say that Marconi may have gotten the idea of using elevated antennas from Loomis. Rather, he said that, although some authorities give Marconi credit for the discovery of the kite antenna, Marconi apparently read about Loomis' kite antenna in Loomis' patent papers before filing his own patent application—which culminated in Marconi's practical wireless system.

But Nick Basura of Los Angeles dismisses both Loomis' and Marconi's claims with the statement that a 1943 U.S. court decision declared Nikola Tesla to be "the true father of radio." And we were not surprised to receive an airmail letter in Russian from Vladis, UA9OH, Siberia, who—like most Russians—thinks that Aleksandr Stepanovich Popov is the "father" of radio. But Vladis wrote to talk about his home-built SSB transmitter, not about what had happened 75 to 102 years ago.

While Marconi, Tesla, and Popov (and others) went much beyond Loomis, in 1866—when Loomis actually transmitted 18 miles by wireless—Marconi had not yet been born, Tesla was 10, and Popov was 7 years old.

**Skip Is Legal—Amen!** Although we don't have any figures to support an acclamation, your Amateur Radio Editor feels that Squires-Sanders deserves a vote of thanks from the amateur radio fraternity. In case you haven't noticed, Squires-Sanders has been promoting to CB'ers the idea that if you want to work skip, the ham bands are the place to do it. Of course, this program is

tied in with an advertising campaign on the manufacturer's Clegg transceivers for 6 and 2 meters, but even so, it is a positive contribution toward straightening out the mess on the CB channels.

If you have a CB'er friend whom you think is a potential ham, steer him toward one of the radio stores with the Squires-Sanders counter display. Tell him about the free code learning record and set of ARRL manuals that will help him get a ham license. Maybe then you can convince your friend that securing a ham ticket is not *that* difficult.

**FCC News.** Effective January 15, simpler FCC rules governing the signing of amateur call letters went into effect. Under the new rules:

(1) As has always been true on CW, portable and mobile phone stations now need only give the call area in which they are operating. Example: "This is W9EGQ, portable (or mobile) 9."

(2) Maritime mobile stations (outside the continental United States) are to follow their call letters with "Region 1, 2, or 3," depending upon where in the world they are operating. This change eliminates the dilemma that faced maritime mobile operators when FCC regulations required transmitting their exact locations, and military security

(Continued on page 101)



# ON THE CITIZENS BAND

By **MATT P. SPINELLO**, KHC2060, CB Editor

**Y**OUR CB Editor was notified during the closing hours of 1967 that he had been selected by the South Western General Radio Association, London, Ontario, Canada, for presentation of the G.R.S. News Award for 1967. In an open letter to the S.W.G.R.A., submitted to *SCOPE*, the General Radio Service Journal, your CB Editor replied as follows:

“... We cannot praise enough the emergency and public service actions by GRS/CB operators... The serious operators have proven the need for the ‘CB communications link’ in time of emergency—in most instances, beyond the call of voluntary duty. Clubs such as the S.W.-G.R.A., and news vehicles such as *SCOPE*, are the motivating forces by which the good of CB can be brought to the eyes of the general public, governmental agencies, and others using the communications spectrum...”

“... Although the hundreds of CB/GRS newspapers published monthly throughout the U.S., Canada, Australia, etc., are but a handful of positive voices for the good of the services, they are the only means of enlightening a misinformed public that has been intentionally misled by publishers who appear incapable of producing good copy, and must, therefore, survive financially on sensationalism, exposé, and negative reports.

“It is the individual GRS/CB'er, working collectively with team or club members, in time of emergency or as public servant, who makes the club newspaper possible. Without his voluntary efforts, the club publication becomes—in most cases—a couple of recipes, a few off-color jokes, and a collection of valueless tidbits to act as fillers.

“There is no denying the probability that rules violators may at times outnumber the [legal operators] on the 11-meter band. We take a lot of verbal abuse because of violators' actions on the air. You must have noticed, however, how quickly derogatory

reflections die down when someone relates how CB'ers handled complete communications for several days when an entire community was left without power following storm conditions; how the life of a small child was saved when a CB communications network put hundreds of searchers on foot to hunt for the child; and how CB'ers delivered first aid, food, clothing and communications facilities to families stricken by tornadoes, floods, and hurricanes.

“We are honored to have been considered for an award from a highly active, certainly successful, GRS club. We are reasonably sure that the [decision] must have been generated by the stand we have taken on the side of the GRS/CB'er whose primary interest is in using his communications know-how and equipment to serve those in need.

“Therefore, any award presented to this editor has been made possible by worthwhile volunteer actions, and rightfully belongs to those who have made the presentation possible. In fact, this editor will accept such recognition only by posing as a representative of those deserving commendation for their public service actions.

“If reporting the true facts on emergency assistance by GRS/CB operators has made this award possible, we look forward to more presentations in the future, so long as GRS/CB'ers' actions make possible the sort of print that will continue to establish both services as respected and needed facilities by local, public service, and governmental agencies.”

**Club Chatter.** *The Dixie Citation*, monthly publication of the Dixie Communications Club, Decatur, Ga., reports that the Georgia Citizens Band Radio Council, Inc. currently sports a membership of 24 clubs throughout the state. Council call-sign for those in need of service while en route through any part

(Continued on page 111)



# ENGLISH-LANGUAGE BROADCASTS TO NORTH AMERICA FOR THE MONTH OF MARCH

Prepared by ROGER LEGGE

TO EASTERN AND CENTRAL NORTH AMERICA		TO WESTERN NORTH AMERICA	
TIME—EST	STATION AND LOCATION	TIME—PST	STATION AND LOCATION
	FREQUENCIES (MHz)		FREQUENCIES (MHz)
7:15 a.m.	Helsinki, Finland (Sat., Sun.)	7 a.m.	Tokyo, Japan
	Melbourne, Australia	8 a.m.	Stockholm, Sweden
	Montreal, Canada	6 p.m.	Melbourne, Australia
7:45 a.m.	Copenhagen, Denmark		Taipei, China
6 p.m.	London, England		Tokyo, Japan
	Montreal, Canada	6:30 p.m.	Johannesburg, South Africa
	Moscow, U.S.S.R.	7 p.m.	London, England
6:45 p.m.	Tokyo, Japan		Madrid, Spain
7 p.m.	Sofia, Bulgaria		Oslo, Norway (Sun.)
7:30 p.m.	Budapest, Hungary		Peking, China
	Johannesburg, South Africa		Seoul, Korea
	Kiev, U.S.S.R. (Mon., Thurs., Fri.)	7:20 p.m.	Yerevan, U.S.S.R. (Tues., Wed., Fri., Sat.)
	Stockholm, Sweden	7:30 p.m.	Bonaire, Netherlands Antilles
7:50 p.m.	Vatican City		Prague, Czechoslovakia
8 p.m.	Berlin, Germany		Stockholm, Sweden
	Havana, Cuba	7:45 p.m.	Berlin, Germany
	Madrid, Spain	8 p.m.	Havana, Cuba
	Peking, China		Lisbon, Portugal
	Prague, Czechoslovakia		Moscow, U.S.S.R. (via Khabarovsk)
	Rome, Italy		Peking, China
8:30 p.m.	Berne, Switzerland		Sofia, Bulgaria
	Bucharest, Rumania		Bangkok, Thailand
	Cologne, Germany		Bucharest, Rumania
	Hilversum, Holland	8:15 p.m.	Budapest, Hungary
	Tirana, Albania	8:30 p.m.	Kiev, U.S.S.R. (Mon., Thurs., Sat.)
	Copenhagen, Denmark		Berlin, Germany
8:45 p.m.	Cairo, Egypt		Cologne, Germany
9 p.m.	Lisbon, Portugal		Havana, Cuba
	London, England	9 p.m.	Tokyo, Japan
	Melbourne, Australia		Berne, Switzerland
	Moscow, U.S.S.R.	9:15 p.m.	Moscow, U.S.S.R. (via Khabarovsk)
	Stockholm, Sweden	10 p.m.	Havana, Cuba
9:30 p.m.	Beirut, Lebanon	10:30 p.m.	
			15.185
			11.71
			9.625, 11.72
			15.165
			6.11, 9.58, 11.78
			9.625, 11.945, 15.19
			7.15, 9.665, 9.685
			15.135, 17.825
			9.70
			6.235, 9.833, 11.91
			11.875, 15.22
			9.665, 9.685
			5.99
			7.25, 9.69, 11.76
			9.50, 9.60
			9.525
			6.13, 9.76
			15.06, 17.68, 17.795
			7.345, 9.63, 11.99
			9.575, 11.81
			6.12, 9.535, 11.715
			6.15, 9.51, 11.94
			9.64, 11.945
			9.59 (Bonaire relay)
			6.187, 7.30
			9.52
			9.475
			6.025, 9.68, 11.935
			6.11, 9.58, 11.78
			15.22, 17.84
			7.15, 9.655, 9.685
			5.99
			11.925
			9.505
			15.24
			15.22, 17.84
			15.125, 15.345, 17.89
			15.135, 15.235
			9.705, 11.875
			6.11, 9.58, 11.78
			6.13, 9.76
			11.85
			11.82, 15.095, 17.68
			15.43
			11.82
			7.345, 9.63, 11.99
			11.705
			9.56, 9.65
			6.135, 9.525
			6.025, 9.68, 11.935
			9.54, 11.85, 15.18
			11.82, 15.095, 17.68
			9.70
			11.91
			6.15, 9.51, 11.94
			6.235, 9.833, 11.91
			9.61, 9.685
			9.56, 9.65
			6.135, 9.525
			15.105
			9.545, 11.945
			6.12, 9.695
			9.54, 11.755, 11.85
			9.655



# SHORT-WAVE LISTENING

By **HANK BENNETT**, W2PNA/WPE2FT  
Short-Wave Editor

## BROADCASTING STATION NEWS AROUND THE WORLD

**T**HE Australian Broadcasting Commission has a 250-kW booster station under construction in Darwin, Northern Territory, for use on the short waves. A nearby receiving station is also being built to pick up programs from the Shepparton facilities which will be relayed to Darwin by a microwave link system. If this off-the-air pickup is unsatisfactory due to propagation conditions, local programs will be used.

*Radio Emissora de Piratininga*, Sao Paulo, Brazil, under the new directorship of Daniel Medeiros, is building a 100-kW transmitter for the 11,745-kHz outlet (ZYR65). A substantial power increase for the 49-meter outlet (ZYN63, 6025 kHz) is also planned. Both units are currently rated at 10 kW.

The Brazilian Radio Clube Ceara, ZYN6, 6105 kHz, recently received a tape recording of one of its transmissions from Joseph Hueter, Sr., Philadelphia, Pa. The station operators were surprised but pleased to learn that their 5000-watt transmitter was even being heard in the United States. They verified the report and retained the tape recording as a souvenir.

*Radio Denmark* recently introduced a DX program called "The DX Window." Twenty minutes in length, it is broadcast Sundays in English at 1015-1035 on 9520 kHz, and repeated on Mondays. The program is produced in cooperation with the Danish Short-wave Club International.

According to a press report, the Rhodesia Broadcasting Corporation intends to introduce a new commercial service in English sometime in 1968. It will probably be called *Radio Jacaranda*, and will have a format similar to that of South Africa's *Springbok Radio*.

A report received from *Radio New York Worldwide* indicates that the *Voice of the Arabs*, largest and most powerful radio station in the Middle East, is being dropped by President Nasser and will be turned over in toto to the Arab League. Entirely in Egyptian hands until now, the station has been widely blamed for keeping the Arab world split, since it reportedly voiced only Nasser's viewpoints. In the future, the 13 countries involved in the League are to have equal say

(Continued on page 112)



Impressive array of equipment? It is all located at Mountainside Communications in Somerville, N.J., and is operated by Roger Schroeder, WPE2LOC. At far left, bottom to top, are two Squires-Sanders FM Alert emergency receivers, and a "Nonsense Box" (?) which was built to POPULAR ELECTRONICS specifications. At center, left, is a Knight-Kit R-100A general-coverage receiver, topped by a Squires-Sanders 23'er, power supply, and Heath "Twoer" 2-meter transceiver. At center, right: a 23-channel Citizens Band transmitter, a Heath 140-10 monitor scope, and a Lafayette TM-58 SWR power meter. At the right: a Clegg 22'er, topped by Plectron fire monitor, Heath HD-15 phone patch, microphone preamp, power supply, and S-meter.



# SOLID STATE

By LOU GARNER, Semiconductor Editor

AMONG the new solid-state devices announced during the past few months are two units which may have a profound effect on future technology: a semiconductor "inductor," and an infrared-to-visible light converter. The first was developed in Japan, the latter in the United States.

Evolved by a research group headed by Shohei Kataoka at Japan's Electrotechnical Laboratory in Tokyo, the solid-state inductor may revolutionize many IC designs. For engineers, heretofore, have had to rely on external discrete coils where inductive reactances were needed in their monolithic circuits. The device may make it possible to include inductors as integral parts of IC chips along with resistors, capacitors, diodes and transistors. Although still experimental, the new unit has undergone extensive tests.

Essentially a modified Hall-effect device, the inductor consists of a flat slab of special

*n*-type material, such as indium antimonide, equipped with four terminals, one on each of its edges, as illustrated in Fig. 1. A fixed capacitor (*C*) is connected between one pair of terminals and a strong magnetic field is established perpendicularly through the slab by a permanent magnet.

In operation, an a.c. flow through the slab between the main terminals causes a relatively small voltage drop but develops, at the same time, a much larger voltage between the second pair of terminals as a result of the Hall-effect induced by the fixed magnetic field. This "Hall voltage" causes a corresponding current flow through the fixed capacitor which leads the voltage by 90 electrical degrees. The leading Hall current, in turn, induces a *secondary* Hall voltage between the main terminals which leads the applied a.c. by approximately 90 degrees, thus establishing the basic phase relationship of an inductive reactance.

In more advanced units, the Hall terminals are eliminated by using a sandwich-like semiconductor construction which makes the capacitor an integral part of the device. Small ferrite magnets are attached to the slab to provide the needed magnetic field. Effective inductances as high as 0.5 mH at 1 kHz have been achieved in the initial experiments.

The infrared-to-visible light converter diagrammed in Fig. 2, was developed at MIT's famous Lincoln Laboratory. An integrated multilayer device, it not only has potential applications in test and research instruments and exotic weapon systems, but may be the

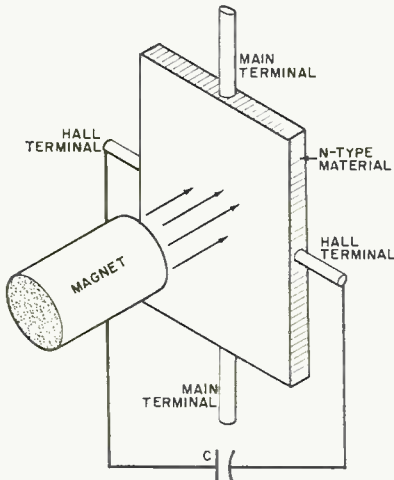

Fig. 1. Japanese researchers have successfully simulated a tuned circuit using the Hall-effect, a development which may be the forerunner of tuned circuits in IC's.

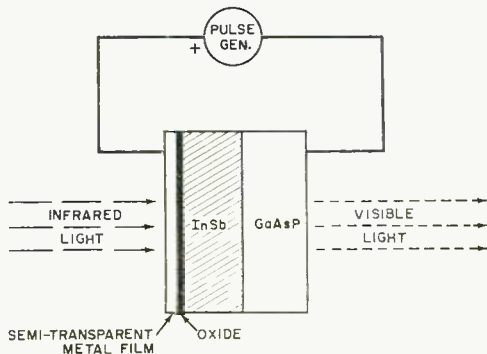

Fig. 2. This American development is a solid-state infrared-to-visible light converter that could lead to many new camera concepts, techniques and applications.

forerunner of a variety of energy converters with widespread applications in television broadcasting and reception, communications, and industry.

The basic unit is made up of four layers: a thin semi-transparent metallic film, an insulating oxide region, and adjacent areas of indium antimonide (*InSb*) and gallium arsenide-phosphide (*GaAsP*). Electrically, the device is equivalent to a fixed capacitor in series with photodetector and photoemitter diodes.

In operation, infrared radiation applied through the transparent metal film generates a low-level current by photodetector action. This current is stored by the capacitor section and delivered to the light emitter diode in short, high-current bursts when the device is driven by an external pulse generator, causing photoemission and the radiation of visible light.

**Readers' Circuit.** Among the most popular of projects is the code practice oscillator, which can continue its useful life long after its owner has mastered the radiotelegraph code. As a self-contained audio signal source, it can be modified for use as a test instrument and, in this capacity, can be used for checking intercoms, record players, modulators, and similar audio amplifiers—or, equipped with a loudspeaker, it can be used as a substitute for a human “helper” in determining optimum microphone placement for recording sessions or p.a. installations.

The two-transistor circuit in Fig. 3 was submitted by reader Charles A. Rankin, WA2HMM (217 Grand St., Westbury, N.Y. 11590). Featuring loudspeaker output, the design differs from “run-of-the-mill” circuits in that it uses an RC phase-shift oscillator rather than the more familiar Hartley, Colpitts, or tickler-feedback arrangements.

Transistor *Q1* serves as an oscillator and *Q2* as a power amplifier. The feedback needed to maintain oscillation is supplied by a network made up of *C1*, *C2*, and *C3* in conjunction with *R2*, *R4*, and *Q1*'s base-emitter resistance. Base bias current is established by *R1*, while *R3* serves as the collector load. Oscillator *Q1*'s output signal is coupled through d.c. blocking capacitor *C4* to the power amplifier which, in turn, drives the PM speaker through impedance matching transformer *T1*. Base bias to *Q2* is furnished through *R5*. Circuit d.c. power is supplied by *B1*, controlled by the hand key.

Transistors *Q1* and *Q2* are general-purpose *npn* types (2N1306's or similar). The resistors are all half-watt units, and the capacitors are low-voltage ceramic, plastic film, or paper types. Output transformer *T1* has a 2000-ohm primary and a secondary chosen to match the speaker voice coil (typically, Lafayette No. 99 H 6101 for a 10-ohm voice

coil). A 9-volt battery can be used, or, if preferred, six series-connected penlight or flashlight cells. If you want to use the completed unit as an audio signal source rather than as a CPO, a s.p.s.t. toggle, slide, or rotary switch would take the place of the hand key.

With neither layout nor wiring dress critical, almost any size speaker will do. A small metal box, plastic case, or sloping front meter cabinet is suitable for housing the unit.

Charles writes that his original model operated at approximately 750 Hz. The actual

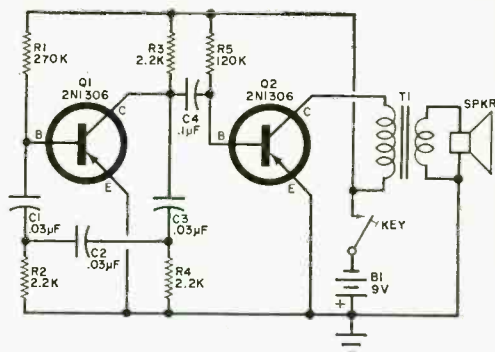

Fig. 3. The two-transistor CPO devised by Charles Rankin utilizes an RC phase-shift oscillator operating at an approximate frequency of 750 Hz.

operating frequency will vary, however, depending on component tolerances, and can be changed at will by changing the values of the capacitors in the feedback network (*C1*, *C2*, and *C3*). Smaller (value) capacitors here will raise the frequency, and vice versa.

**Manufacturer's Circuit.** Suitable for use at frequencies from 1 to 25 MHz, depending on the crystal, the wide-range oscillator circuit in Fig. 4 is one of more than a half-dozen crystal oscillator designs illustrated in a catalog issued by JAN Crystals (2400 Crystal Dr., Fort Myers, Fla. 33901). This basic circuit can be used as the first stage in a transmitter, as a stable CW signal generator, or for instrument and receiver calibration.

Referring to Fig. 4, *npn* transistors *Q1* and *Q2* act together as an emitter-coupled two-stage oscillator. Base bias for *Q1* is established by voltage divider *R1-R2*, bypassed by *C1*. Direct coupling is used between stages, with *Q2*'s base bias determined by *R3* and *Q1*'s collector current. Diodes *D1* and *D2* serve as *Q1*'s split emitter load and *R4* as *Q2*'s emitter load, while the feedback needed to maintain oscillation is supplied through isolation capacitors *C2* and

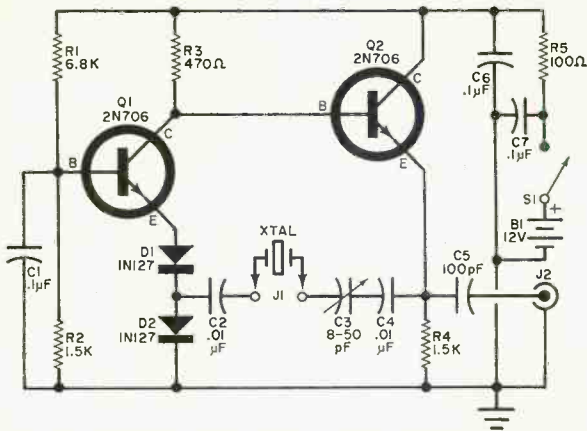

Fig. 4. Suggested by JAN Crystals, this wide-range oscillator has no tuned circuits, yet is suitable for operation from 1 to 25 MHz. It can be used as the crystal oscillator in a transmitter, as a stable CW signal generator, or as a calibrator for a communications receiver.

C4, trimmer C3, and the crystal (XTAL). An optional pi-filter made up of C6, R5, and C7 isolates d.c. power supply B1, which is controlled by s.p.s.t. switch S1.

Transistors Q1 and Q2 are 2N706's while D1 and D2 are 1N127's. All resistors are half-watt units and all capacitors, except for C3, are disc ceramics. Trimmer C3 is an 8-50 pF unit. Either a slide, toggle, or rotary switch can be used for S1, while the 12-volt power source (B1) can be batteries or a line-operated rectifier/filter supply.

Although layout and lead dress are not overly critical, good r.f. wiring practice should be followed when assembling the crystal oscillator, with all signal leads kept short and direct and care taken to minimize distributed wiring capacities. Either perforated board, chassis, or etched circuit construction techniques can be employed. If assembled as a self-contained instrument rather than as part of a transmitter, the unit can be housed in a small metal box.

**Rule Britannia!** Great Britain's financial crisis, climaxed last November by the devaluation of the pound, has not affected the abilities nor ingenuity of its scientists and engineers, at least not those working in solid-state technology, for new developments and products have been announced on an almost week-to-week basis. Recent items from the British Isles include:

- An announcement that a British electronics engineer, C.D. Dobson, of Standard Telecommunication Laboratories, Ltd. (Harlow, England), has developed a semiconductor laser capable of radiating 150-watt peak pulses and developing a one-watt mean output level. These very high powers—for a semiconductor laser—were achieved by using a relatively large diode junction of unique design and operating the device at the temperature of liquid nitrogen (77°K).

- The development and production of a solid-state UHF/SHF signal generator op-

Developed in England, the Type 400 UHF/SHF signal generator covers a range from 8 to 16 GHz, and employs a Gunn-effect diode. See text below.



erating in the 8 to 16 GHz range. The instrument features a Gunn-effect oscillator coupled to a broadband high-Q coaxial resonator. Designated as the Type 400 signal generator by the manufacturer, Flann Microwave Instruments, Ltd. (Old Bridge St., Kingston upon Thames, Surrey, England), the unit measures 17" wide by 4½" high by 10" deep and weighs only 15 pounds. It can be powered either by batteries or a low-voltage line-operated d.c. supply.

- Introduction of a comparatively low cost modular servo system training kit featuring solid-state circuitry. The Model MS 150 kit is furnished with a steel-surfaced base board and nine modular units, including an a.c./d.c. power supply, servo amplifier, push-pull preamp, error potentiometers, operational amplifier, dual channel attenuator, motor with tach-generator and gearbox, and a loading unit. A detailed instruction manual is supplied with the kit, which is intended for technical and high school use. The MS 150 is distributed in the U.S. by the manufacturer's subsidiary, Feedback, Inc. (1101 Bristol Rd., Mountainside, N.J.)

- Production of a new compact broadcast quality color TV camera by E.M.I. Electronics Ltd. (Hayes, Middlesex, England). It measures only 29" long by 15" square, including its integral zoom lens system. The small size is made possible by the use of solid-state circuitry in conjunction with a direct imaging optical system featuring a lightweight prealigned prism assembly.

(Continued on page 104)



# tips & techniques

## OHMMETER "TELLS" YOU WHETHER A TRANSISTOR IS NPN OR PNP

Using an ohmmeter, you can determine whether a transistor is *npn* or *npn*—if you know transistor theory or can compare the readings obtained with those of a known type of transistor. While this is the common practice, there is an easier way to do it. Determine the polarity of your meter's probes (in most cases, *but not all*, the *C O M M O N* probe is negative). Mark the negative probe jack on the meter case with a "B" for base and the positive probe with an "E" for emitter. Now, mark the low resistance end of the ohms scale with the legend "*npn*" and the high resistance end with "*nnp*." Touch the negative (or "B") probe to the base of the unknown transistor, and the other probe to the emitter. The meter's pointer will deflect to "*npn*" or remain at "*nnp*," telling you what type the transistor is.

—Robert E. Kelland

## REPAIR DAMAGED PAINT FINISH ON YOUR ELECTRONIC PROJECTS

If the finish on one of your projects becomes marred during or after assembly, you can repair it quickly and easily. All you need is a small artist's paint brush and an aerosol spray paint of the same type and color as the one you used on the project originally. Spray a small amount of paint on the brush, and carefully work over the marred surface, using short, light strokes. Apply as many coats of paint as you feel are needed, but allow

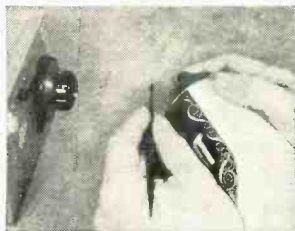

adequate drying time between each application. With a little practice and patience, you'll be surprised at how good a job you can do.

—Frank H. Tooker

## CLEAR UP CB AND HAM TVI

One cause of television interference (TVI) from many amateur radio and Citizens Band stations can be traced to the use of monitors or field strength meters. These devices employ diodes which rectify some of the r.f. and often generate enough harmonics to produce TVI radiation. Grounding the case of the monitor and moving it farther away from the transmitter will usually reduce—and possibly eliminate—the interference.

—James E. Arconati

## CONVERT AUTO RADIO INTO PERSONAL PORTABLE

Instead of installing a portable radio in your car, how about converting a car radio into a portable? It isn't as difficult as it may sound. You'll need a telescoping antenna, a 55-pF mica capacitor, and six 1.5-volt penlight cells in addition to an all-transistor auto radio. To minimize current drain and prolong battery life, disconnect the dial light inside the radio. Then install the radio in a suitable cabinet (I used a cigar box, covered with a decorative adhesive-backed vinyl). Finally, connect the batteries and antenna to the appropriate terminals on the radio, and solder the capacitor between the antenna and chassis of the radio to permit peaking the antenna trimmer. You'll find that the converted radio has excellent sensitivity and selectivity, good sound (especially if it has a tone control), and more than enough power for comfortable listening.

—William S. Gohl

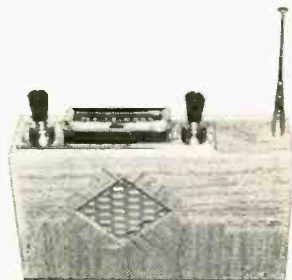

## YOU CAN MAKE YOUR OWN FLOOR-TYPE MICROPHONE STAND

Need a floor stand for your microphone? You could buy a regular mike stand, but a collapsible music or camera stand and a mike stand adapter (Calrad No. MH 300, or similar) can do the job just as well and at a lot lower cost. First, remove the music rack or camera adapter, and drill an 11/64" hole through the top of the stand. Next, disassemble the adapter, and bolt the part that cradles the microphone to the stand, passing the adapter bolt through the hole, and securing it in place with a wing nut. Slide the microphone in place, and you're in business.

—Steven D. Koons

**Confused by all the ads for  
home training in electronics?**

**find out what it's really  
all about from the leader...**

With RCA Institutes Home Training Programs you get:

- As many as 24 valuable kits at no extra cost.
- The AUTOTEXT programmed method of learning electronics faster, easier, almost automatically.
- A unique easy-pay Tuition Plan.

CLASSROOM TRAINING ALSO AVAILABLE. For special catalog and full information, simply check the appropriate box on the attached card.

All courses approved under the new G.I. Bill.  
Accredited Member National Home Study Council.

RCA INSTITUTES, DEPT. ZPE-38  
320 West 31st Street, New York, N.Y. 10001

**RCA**

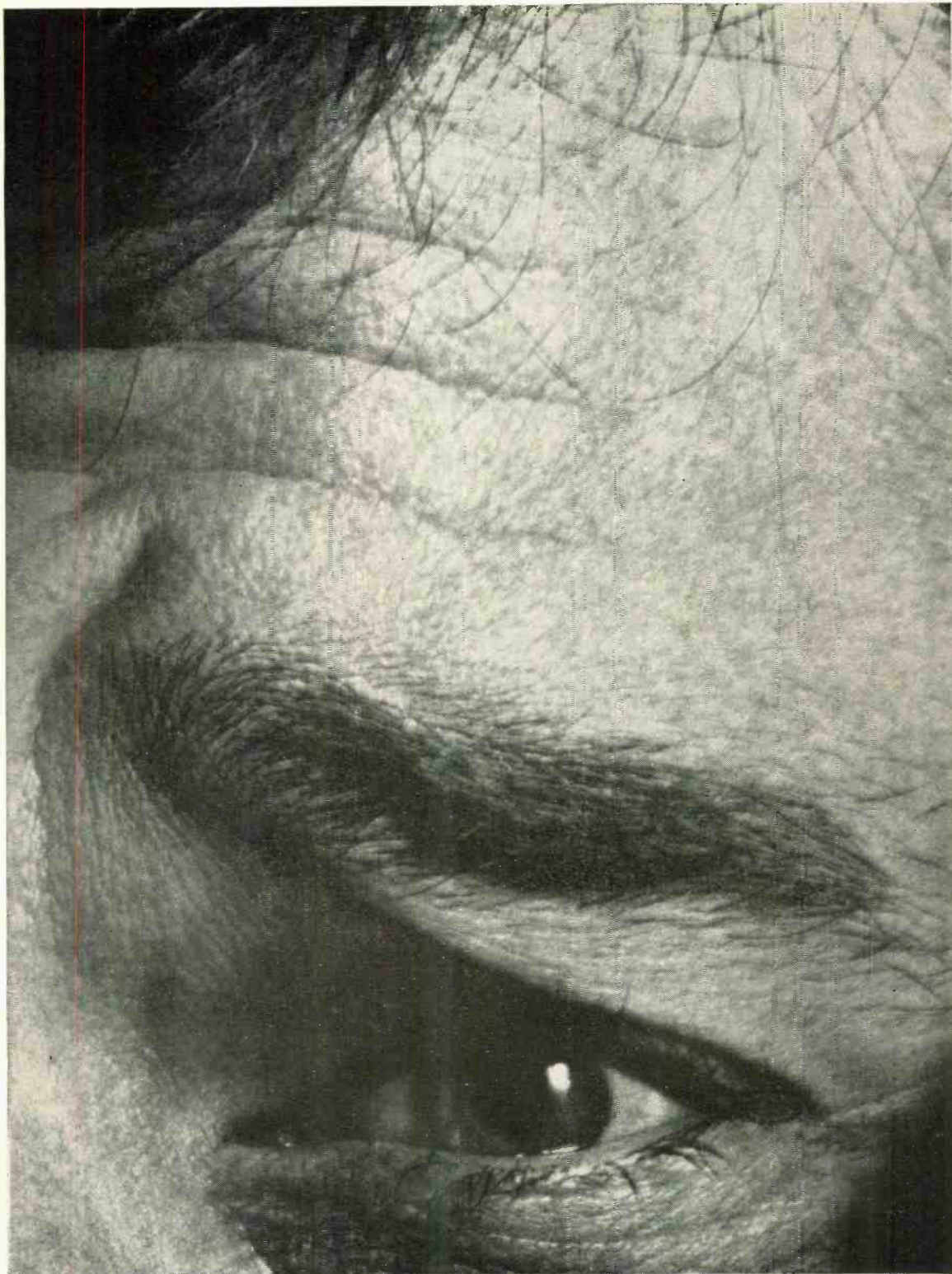

# ELECTRONIC STOPWATCH

(Continued from page 34)

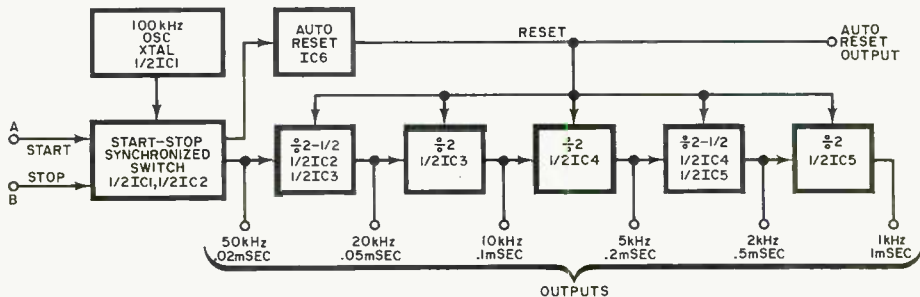

## HOW IT WORKS

Operation of a decimal counting unit was described in the February 1968 issue; therefore, only the operation of the timing module will be described here.

As shown above, the basic timing circuit consists of a 100-kHz crystal-controlled oscillator consisting of one-half of IC1—two of its four gates are biased to their class-A region and capacitor-coupled to form the oscillator—in conjunction with a 100-kHz crystal. The oscillator output pulses drive a synchronizing switch made up of one flip-flop of IC2.

If allowed to run freely, the synchronizer switch would merely divide the oscillator output by two, and drive the remainder of the divider chain. However, a set-reset gate, made up of the two remaining gates of IC1, determines how long the synchronizer switch remains open. Operation of the set-reset gate, in turn, is controlled by signals applied to its two inputs—"A" (start) and "B" (stop)—which are located on the front panel of the electronic stopwatch.

A positive-going voltage pulse applied to input "A" will open the synchronizing gate and allow the 100-kHz oscillator pulses to pass down the divider chain until a positive-going signal applied to input "B" shuts down the set-reset gate, thus preventing the oscillator signals from reaching the divider chain. When input "B" is connected to a constant positive voltage source, the set-reset gate becomes a duration gate that remains open, allowing the oscillator pulses to pass down the divider only as long as a signal is applied to input "A."

Because the synchronizer switch is basically a flip-flop, it automatically divides the 100-kHz oscillator signal by two, producing a 50-kHz output. (Divide the frequency in kHz into 1 to get the time period in milliseconds; in this case, the 50-kHz output is also the 0.02 millisecond output.) The remaining divider chain produces outputs at 20 kHz (0.05 msec), 10 kHz (0.1 msec), 5 kHz (0.2 msec), 2 kHz (0.5 msec), and 1 kHz (1.0 msec). The final IC (IC6) is the reset generator which synchronizes the low frequency outputs and provides an automatic reset signal for the decimal counters.

The 100-kHz crystal may be replaced with almost any other low-frequency unit if a different set of output frequencies (or pulse time intervals) is desired.

seconds, and an eight-foot screen spacing is used (accurate to  $\frac{1}{16}$ "), a counter indication of 162 will correspond to a velocity of 2470 feet per second.

**Photo Pickoff.** A photo pickoff is shown in Fig. 11. The pickoff selector switch decides whether the "Stopwatch" operates on the presence or absence of light at the sensor. You must use a high-speed photocell for this circuit, as conventional cadmium sulfide cells are too slow for accurate timing. To test the speed of camera shutters, place the coun-

ter function switch in the "A" position, and allow the camera shutter to interrupt the light from the light source to the photocell.

For timing dragster or other vehicle races, two photo pickoffs can be used with the "Stopwatch" function switch at the "A-B" position. One pickoff starts the timer at the "A" input, while the second pickoff stops the timer at the "B" input. The elapsed time in milliseconds equals the numerical value on the timing switch multiplied by the decimal counter indication. For example, the timing switch at

### MODES OF OPERATION

When the function switch is in the "A" position, the presence of a +3-volt signal at input "A" turns on an internal gate which routes a precise, known reference frequency into the counters for *only* the period of time that the d.c. signal on input "A" is present. The count stops when this signal is removed. The front-panel "MAN/AUTO" switch can be placed either in the "MAN" position to retain the count indication, or in the "AUTO" position to provide automatic clearing at the beginning of the next measurement; or the counters can be set to zero by manually depressing the "RESET" push button.

If the function switch is placed in the "A-B" position, the application of a positive-going pulse at input "A" will start the counters operating. The counters keep on operating after the stimulus has been removed from input "A" until a positive-going pulse is applied to input "B." The electronic stopwatch will then indicate the time interval between these two events.

When the function switch is in the "EVENTS" position, properly conditioned positive-going input pulses applied to input "A" are connected directly to the cascaded counters. Each input pulse advances the counters one step and the total count at any time will appear on the counter readouts. The "AUTO/MAN" switch should be set to "MAN," or the counters will reset to zero at each input pulse. The counters can be manually zeroed at any time merely by depressing the "RESET" push button.

The recorded time in milliseconds is determined by multiplying the indicated numerical value by the value of the time switch position. For example, assume that the readouts show 765 and the time switch is in the 1.0 position. The actual time value is then 765 milliseconds or 0.765 second.

To calibrate the sweep time of an oscilloscope, extract the desired timing pulse from the stopwatch timing module printed board and apply this signal to the scope vertical terminals. For example, if it is desired to calibrate the scope horizontal sweep in milliseconds per centimeter (or inch, or graticule marker), use the "1 msec" output of the board (see Fig. 1). As these pulses are one millisecond apart, the scope horizontal sweep circuit should be adjusted until one timing pulse lies on the desired graticule markers. For other speeds, select the appropriate timing output of the module.

To generate random (to three digit) numbers, place the function switch in the "A-B" position and apply a positive-going pulse to input "A". The timing switch should be placed in one of the faster speeds, so as to blur the decimal counter indicator lamps. At some random time after starting the timer, apply a positive-going pulse to the "B" input to stop the counting.

1.0 millisecond and the counters at 725 means a total time value of 725 milliseconds or 0.725 second.

If desired, the optional one-second output line in Fig. 7 can be used to drive an external "seconds" counter. -30-

**CIRCLE NO. 31 ON READER SERVICE PAGE →**

**When you write for our  
condensed high fidelity  
SPEAKER, ELECTRONICS  
or MICROPHONE catalogs...**



**you really get a  
brief progress  
report on the state  
of the art in sound.**

Both **FREE**  
for the asking,  
of course.



**ELECTRO-VOICE, INC.**, Dept. 383P  
630 Cecil Street, Buchanan, Michigan 49107

Please send me the latest word on

E-V high fidelity  E-V microphones

I am particularly interested in E-V Model \_\_\_\_\_

Name \_\_\_\_\_

Address \_\_\_\_\_

City \_\_\_\_\_ State \_\_\_\_\_ Zip \_\_\_\_\_

# LEARN COMPUTING AT HOME!

Now you can learn the computer programming profession *at home* without leaving your job. No math or technical training needed.

Industry and government desperately need 50,000 programmers. In less than a year you can be trained to fill a \$7,000 starting position. In three years you can earn \$10,000 a year . . . or even more!

Yes, computer programming is a way to move ahead fast. You can become an in-demand professional programmer with just a few hours of home study a week. Mail the coupon today for full details.

## FREE BOOK TELLS ALL

Computer Usage Education, Dept. 520  
51 Madison Avenue, New York, N. Y. 10010  
Send me full information about learning computer programming at home.

PRINT

NAME \_\_\_\_\_

ADDRESS \_\_\_\_\_

CITY \_\_\_\_\_

STATE \_\_\_\_\_ ZIP \_\_\_\_\_

CIRCLE NO. 10 ON READER SERVICE PAGE

## POLICE • FIRE • MARINE AIRCRAFT • AMATEUR CALLS

—TUNABILITY—USABILITY—QUALITY—



### TUNAVERTERS

TUNABLE, CALIBRATED solid state converters to change your auto and home radios into excellent, sensitive, selective, calibrated Amateur and VHF receivers!

"Of all of the converters tested by POPULAR ELECTRONICS there is little doubt that the "TRP Tunaverters" is the most versatile."—POPULAR ELECTRONICS, August, 1967.

- 6-1 reduction tuning!
- HF—2 gang tuning!
- VHF—3 gang tuning!
- FREE 24" conn. coax!
- Plug into auto radial
- American Model
- 9 volt btry. powered!
- Size 2 1/4 x 3 1/2 x 4 1/2"
- 2 WEEK MONEY BACK GUARANTEE!

MODELS FOR AM & FM	BAND	MODEL	COVERS	OUTPUT	PRICE
Marine	Marine		2.0-2.85 mc	550 kc	\$19.95 ppd
SW & WWV		SWL	9.3-10 mc	550 kc	\$19.95 ppd
CB & 10 M		273	26.9-30 mc	1500 kc	\$29.95 ppd
6 meters		504	50-54 mc	1500 kc	\$29.95 ppd
2 meters		1450	144-150 mc	1500 kc	\$29.95 ppd
Police	}}}	308	30-38 mc	1500 kc	\$29.95 ppd
fire, &		375	37-50 mc	1500 kc	\$29.95 ppd
Marine		1564	150-164 mc	1500 kc	\$29.95 ppd
Aircraft		1828	118-128 mc	1500 kc	\$29.95 ppd
Radiation loop & Ext. Antenna for using with home radios					\$ 3.95 ppd

Order from: **HERBERT SALCH & CO.** Fast AIR MAIL add \$ .85 ea.

Marketing Division of  
Woodsboro PE-3, Texas 78393  
Tompkins Radio Products

CIRCLE NO. 25 ON READER SERVICE PAGE

# ELECTRONICS library

QUIET

## THE RADIO AMATEUR'S LICENSE MANUAL, Fifty-Eighth Edition

The 58th edition of the ARRL's well-known license manual has been extensively updated to include study questions and answers for the recently reinstated Advanced Class amateur license and revised questions for the Extra Class license. Incorporating all of the latest FCC rule changes, *The Radio Amateur's License Manual* continues to be an indispensable licensing guide for anyone who wants to earn—or upgrade—a ham license.

Published by American Radio Relay League, Inc., 225 Main St., Newington, Conn. 06111. Soft cover. 112 pages. 50 cents.

## HOW TO USE SIGNAL GENERATORS IN THE LABORATORY

by John D. Lenk

This book was written with a twofold purpose: it is intended to serve as a basic textbook for student technicians; and as a guidebook for experienced technicians. It takes the reader through step-by-step procedures on how to measure swept-frequency attenuation, impedance, and power; and covers the use of sweep techniques, time-domain reflectometry, checking of electronic components, and the use of dip adapters. To get the most out of this book, you should be familiar with signal generator and electronics fundamentals. However, the text is well illustrated with block diagrams so that even a novice trainee can understand the test procedures, each of which is preceded by a realistic description of the *why* and *where* for the particular test.

Published by John F. Rider Publisher, Inc., 116 West 14 St., New York, N.Y. 10011. Soft cover. 109 pages. \$3.25.

## UNDERSTANDING AND USING YOUR OSCILLOSCOPE

Allied Radio's newest book, edited by Bill Stocklin of ELECTRONICS WORLD, has an easy, fluid style that novices and veterans alike will enjoy. The text covers basic oscilloscope theory and usage, and tells you how to interpret waveforms. This book belongs alongside your oscilloscope.

Published by Allied Radio Corp., 100 N. Western Ave., Chicago, Ill. 60680. Soft cover. 128 pages. 75 cents.

POPULAR ELECTRONICS

TAKE ONE



# new literature

To obtain a copy of any of the catalogs or leaflets described below, simply fill in and mail the coupon on page 15 or 115.

All technical data for four new Challenger "CHS" solid-state p.a. amplifiers is given in a colorful 6-page catalog issued by *Bogen Communications Division* of Lear Siegler Inc. The information is presented clearly and graphically by means of charts and photographs. Various accessories available are also listed and pictured.

Circle No. 90 on Reader Service Page 15 or 115

A new TV/FM antenna and audio accessories catalog has been announced by *Mosley Electronics*. There are over 100 lead-in components available for all lead-in types of cable (coax, shielded, and other heavy-duty twin lead cables, and flat twin lead) and a "Whole House TV/FM Wiring Kit" for simultaneous operation of two or more receivers. Matching transformers, splitters, plugs, wall plates, and many more items are shown and described.

Circle No. 91 on Reader Service Page 15 or 115

*Lee Electric, Inc.* has released a new 20-page (8½" x 11") catalog on Tonepak® bells, buzzers, chimes, sirens, relays, and the like. Featured are burglar alarm components: control instruments, contact devices, and accessories. Fire alarm components are also covered.

Circle No. 92 on Reader Service Page 15 or 115

Of special interest in *Alco Electronic Products'* new 12-page catalog on design ideas for engineers are "pull-to-unlock" lever switches for safeguarding against accidents. Also featured are 3- and 4-pole miniature push-button, miniature motor start power, and 12-position adjustable-stop miniature rotary switches, plus an isolation relay for industrial remote control applications.

Circle No. 93 on Reader Service Page 15 or 115

The latest *Cush Craft* CB antenna catalog lists complete specifications on a full line of base station beams, ground planes, coax lightning arresters, and Ringo verticals. Also included are general application and Business Band communication antennas.

Circle No. 94 on Reader Service Page 15 or 115

March, 1968



## The 'CADETS' Citizens Band Antennas by MOSLEY

Increasing numbers of campers are finding Citizens Band communications ideal for 'Keeping-In-Touch'.

For reliable communications, use a quality CB antenna by Mosley. Consider a Cadet (shown). Ideal for use on campers, boats, cars, trailers. The Cadet SUC-1 with suction cup for quick temporary installation, the Cadet PER-1 for permanent mounting.

Send for FREE Mosley CB Catalog no. 124

**Mosley Electronics, Inc.**

4610 N. Lindbergh Blvd.,  
Bridgeton, Missouri 63042

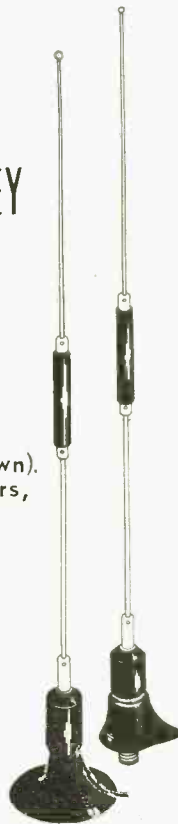

CIRCLE NO. 18 ON READER SERVICE PAGE

# FREE!



## BRAND NEW SPRING & SUMMER RADIO-TV ELECTRONICS CATALOG



YOUR BUYING GUIDE  
FOR: • Stereo & Hi-Fi  
Systems & Components  
• Tape Recorders • Electro-  
nic Parts, Tubes, Tools  
• Phonos & Records  
• Ham Gear • Test In-  
struments & Kits • Cam-  
eras & Film • PA • Citi-  
zens Band • Radio & TV  
Sets • Musical Instru-  
ments

MAIL TODAY TO:

**BURSTEIN-APPLEBEE**

Dept. PEO 1012 McGee, Kansas City, Mo. 64106

Name \_\_\_\_\_  
Address \_\_\_\_\_  
City \_\_\_\_\_  
State \_\_\_\_\_ Zip Code \_\_\_\_\_

CIRCLE NO. 7 ON READER SERVICE PAGE

## Audio-Color

Lets you see your music

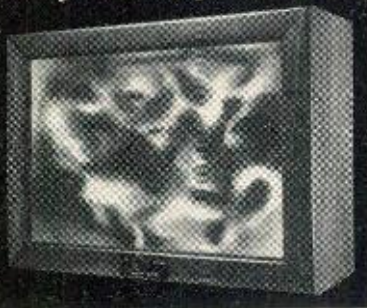

**ASSEMBLED**      **KIT FORM**  
**\$54.95**              **\$44.95**  
**\$5 DOWN — \$5 MONTH**

Walnut finished cabinet included / Shipped REA Collect  
Easy to build, easy to install. All transistor AUDIO-COLOR adds a visual dimension to musical enjoyment. A brilliantly moving panorama of color casts dancing images on a soft frosted screen, reflecting rising and falling volume with each beat of the music. Here's a truly unique and exciting new musical experience. Make check or money order to CONAR.

SEND FOR FREE CONAR CATALOG

**CONAR** Division of National Radio Institute,  
Dept. CA8C 3939 Wisconsin Ave.,  
Washington, D.C. 20016

## ASSIST

(Continued from page 16)

**Hickok Model 188X** r.f. signal generator, 1944. **Hickok Model 198** (formerly I-151) a.f. signal generator, 1942. **Precision Model E-200** r.f. signal generator. Operating manuals needed. (Albert J. Baier, 1646 Michigan St., Oshkosh, Wis. 54901)

**Gemark** tape recorder, circa 1961-62. Power transformer and parts source needed. (D. Herbert, 401 E. 89 St., New York, N.Y. 10028)

**Howard Radio Model DL** receiver, circa 1930, has 16 tubes and short-wave converter type 1. Schematic needed. (M.W. McMicken, 120 Monatiquot Ave., Braintree, Mass. 02184)

**Atwater Kent Model 184** radio receiver. Schematic needed. (Donald O. Christian, 2316 MacArthur Blvd., Irving, Texas 75060)

**Lafayette Model KT100** AM-FM tuner. Schematic needed. (Leung Cho Ng, 305 Memorial Dr., Cambridge, Mass. 02139)

**Knight-Kit Model T-150** transmitter, 6-80 meters. Operating manual or schematic needed. (Tom Wood, 24 Roxbury Rd., Port Washington, N.Y. 11050)

**Philco Model 37-610** receiver. Schematic and any other available information wanted. (Ted Larson, 560 Central Ave., Milaca, Minn. 56353)

**Majestic Model A131593** radio receiver; tunes BC, SW 9.5-15.5 MHz, and FM; has 12 tubes. Schematic and parts source needed. (David S. Temple, 2245 James Ave., Ventura, Calif. 93003)

**Heathkit Model TC-1** tube checker. Manual needed. (Donald Scagel, 7 Woodside Dr., Bloomfield, Conn. 06002)

**Freed-Eisemann Model 46** radio-phonograph combination; tunes AM, FM, SW; has 23 tubes, separate power-amplifier unit. Schematic needed. (Arthur Warnes, 62 Chicago St., Salt Lake City, Utah 84116)

**NRI "Multitester."** Schematic needed. Schematic for tube-type theremin also needed. (Michael Boettcher, 2225B W. Lisbon Ave., Milwaukee, Wis. 53205)

**AN/AMT-6 (XE-1)** Army Signal Corps Parachute Radiosonde, manufactured by Melpar, circa 1950; transmits around 400 MHz. Schematic and operating instructions needed. (Mark Halliday, 24 Scott Rd., Doylestown, Pa. 18901)

**Electronics Tube Corp. Model H-21** oscilloscope. Schematic, parts list, new CRT, source for parts, and operating manual needed. (Robert Marzilli, 1487 Magnolia Rd., Vineland, N.J. 08360)

**Weston Model 664** capacity meter, Type III. Schematic needed. (Capt. W.A. Hopkins, Quarters Q, Naval Air Engineering Center, Philadelphia, Pa. 19112)

**Pyramid Model CRA-1** capacitor-resistor analyzer. Power transformer needed. (J.W. Landon, Wayne, W. Va. 25570)

**Bendix Radio Model PN-9-A** transmitter; circa WWII; U.S. Army Signal Corps. Any available information wanted. (Joseph Famularo, 43 Glen St., Rockland, Mass. 02370)

**Philco Model 41-616** radio-phonograph; tunes 4 bands; has 15 tubes. Schematic and operating instructions needed. (John W. Clayton S.A., B72-57-10 ET "A" School, Bldg. 520, 604/115 N.T.C., Great Lakes, Ill. 60088)

**Knight "Ocean Hopper,"** receiver, circa 1961; has 5 coils; tunes 165 kHz to 35 MHz. Coil socket needed. (Henry Gacy, 1715 Holden, Detroit, Mich.)

**Simpson "Giant" Model 320** tester. Operating manual needed. (Marvin Kershner, 22 Mile Rd., Paris, Mich. 49338)

**"Port-A-Phone" Model WI-100** portable wireless interphone; made by Feller Eng. & Mfg. Co. Schematic and instruction manual needed. (Alberto Lainez Lozada, Lord Cockrane 451-2, Miraflores, Lima, Peru, S.A.)

POPULAR ELECTRONICS



**Crosley Model 628-B** radio receiver, ser. 1669595, circa 1940. Schematic and parts values needed. (Jim Borrelli, 172 Phillip St., Throop, Pa. 18512)

**Philco Model 7008** visual alignment generator. Schematic and operating manual needed. (Robert Snell, 4031 Heyward, Cincinnati, Ohio 45205)

**RCA Model 210** receiver. Schematic, servicing data, and operating manual needed. (Alan J. Iverson, Rte. 2, Box 20, Albion, Nebr. 68620)

**Colonial Radio Corp. Model TBY-4** (U.S. Navy) portable transceiver, type CRI-43044. Operating manual and information about battery pack and/or required voltages and frequency coverage needed. (Alan Doyle, 5 Third Ave., Hawthorne, N.J. 07506)

**Royal Canadian Air Force AR-6** radio receiver, ref. 10D/1428, 1942; made by RCA Victor Co. Ltd. Schematic and alignment instructions needed. (J.M. Gauvreau, 1233 Forget, Quebec 6, Que. Canada)

**Zenith Model T825** radio receiver, 1955; chassis =8T01; 50 watts; AM/FM. Radio receiver needed. (George Spitzer, 17 W. 54 St., New York, N.Y.)

**Jackson Instruments Model OS1/AP** oscilloscope. Schematic, operating and servicing manual needed. (Berthold Bauer, 6987 Kulsheim, Bronnbacherstr, Germany)

**Crosley Model 48** radio receiver. Any available information wanted. (Vito F. Sgroi, 2321 Findlay Ave., Monterey Park, Calif.)

**Granco Products Model 720U** AM/FM receiver; has 7 tubes; selenium rectifier. Schematic and alignment instructions needed. (A. G. Rose, 123 Russell St., Kingston, Ont., Canada)

**RME-69** general-coverage receiver. 1938. Schematic needed. (Wayne Adams, 1988 S. Muskego Ave., Milwaukee, Wis. 53204)

**Halicrafters Model S-38A** receiver. Schematic, operating manual, alignment data, and parts list source needed. (Michael Adams, 1750 Caldwell Rd., S. Daytona, Fla. 32019)

-30-

# OUT OF TUNE

**Fuzz-Box For Electric Guitar** (*February*, 1968, page 42). In Fig. 1, the line between the wiper

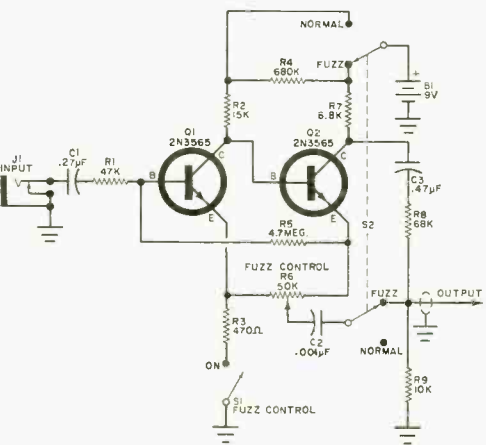

of *R6* and FUZZ/NORMAL switch *S2* should be broken and capacitor *C2* inserted as shown above.

-30-

# RCA has all-new FCC license training

**Get your license— or your money back!**

Now RCA Institutes Home Study Training has the FCC License preparation material you've been looking for — all-new, both the training you need and the up-to-date methods you use at home — at your own speed—to train for the license you want!

**Pay-As-You-Order**— lesson by lesson. You match your program and your budget to meet your own situation. Choose the FCC License you're interested in — third, second or first phone. Take the course for the license you choose. If you need basic material first, apply for the complete License Training Program.

**SPECIAL TO AMATEURS.** This course—while designed for Commercial license qualification, contains much of the new material called for by FCC Docket 15928—advanced and extra class you'll want to qualify for before November of 1969. *QRX* until you get the information.

Mail coupon today for full details and a 64-page booklet telling you how RCA Institutes Home Training can show you the way to a new career—higher income—and your FCC license.



RCA INSTITUTES, INC.  
Dep't PEC-38  
320 West 31 Street,  
New York, N.Y. 10001

Please rush me without obligation, information on your all-new FCC License training.

Name \_\_\_\_\_

Address \_\_\_\_\_

City \_\_\_\_\_ State \_\_\_\_\_ Zip \_\_\_\_\_

## PSYCHEDELIC STROBE

(Continued from page 48)

Ziff-Davis Service Division, Dept. ISH  
595 Broadway, New York, N. Y. 10012

Please send my copy of the 1968 ELECTRONICS INSTALLATION & SERVICING HANDBOOK as checked below:

- I am enclosing \$1.25 plus 15c for shipping and handling for the Regular Edition. (\$1.75 for orders outside U.S.A.)
- I am enclosing \$3.00. Please send me, postpaid, the Leatherflex-covered Deluxe Edition, (\$3.75 for orders outside U.S.A.) (Please allow 3 additional weeks for delivery of the Deluxe Edition.)

print name \_\_\_\_\_

PE-38

address \_\_\_\_\_

city \_\_\_\_\_

state \_\_\_\_\_

zip code \_\_\_\_\_

**HERE'S THE  
MOST IMPORTANT JOB  
TICKET YOU'LL WRITE UP  
THIS YEAR!**

**NOW—GET THE TRICKS OF THE TRADE FOR SERVICING EVERYTHING . . . FROM TV TO AM/FM . . . FROM CITIZEN'S BAND TO PUBLIC ADDRESS . . . FROM HOME INTERCOM TO TAPE CARTRIDGE UNITS. THEY'RE ALL IN THE NEW, 1968 ELECTRONICS INSTALLATION AND SERVICING HANDBOOK.**



You'll find the latest, most comprehensive technique advice, equipment information and step-by-step "how-to-do-it" hints that will aid you in your servicing (or save you costly outside repairs).

This 140-page "encyclopedia" of electronics servicing knowledge contains a special, full-color section on color TV maintenance . . . model numbers and prices of replacement parts . . . recommended tools for every operation . . . accessory information to help you turn an extra dollar. Plus up-to-the-minute reports from hundreds of manufacturers.

Whether you're a professional serviceman, weekend home hobbyist or spare time "Mr. Fixit," the 1968 ELECTRONICS INSTALLATION AND SERVICING HANDBOOK is essential for you. Essential for your profit, fun or both.

**GET THE HANDSOME LEATHERFLEX-COVERED EDITION FOR \$3 POSTPAID!**

The 1968 ELECTRONICS INSTALLATION & SERVICING HANDBOOK is also available in a splendid deluxe edition. Rugged Leatherflex cover provides lasting protection yet is softly textured and gold-embossed for the look of elegance. A collector's item—a superb addition to your electronics library. And it's yours, for just \$3 postpaid, when you check the appropriate box on the order form.



**ORDER YOUR COPY TODAY!**

with a loudspeaker voice coil, turn down the audio output, and adjust  $R10$  until the flash just stops firing. As the volume is turned up, the flash will start to follow the major beat of the music, producing one flash for each beat. When an audio amplifier is played at very loud volume, it may be necessary to bridge the audio output with a potentiometer to provide the strobe with enough signal to fire, but not enough to overload.

To use the strobe as an auto timing light, ground one of the audio leads to the engine and connect a 5-megohm resistor in series with the other one. Solder a small piece of insulated wire to the far end of the resistor, and wrap several turns around the number-one spark plug lead. Set  $R10$  until the flash just stops when the engine is not running. Now start the engine. Every time the number-one plug fires, it will cause the strobe to fire. If the strobe does not fire, it may be necessary to connect the far end of the resistor directly to the spark plug.

To use the strobe as a slave flash unit for your camera, connect one audio input to one side of the camera switch, and the other audio input to a 1½-volt flashlight cell in series with the other side of the camera switch. Set  $R10$  so that the strobe doesn't self-trigger. Every time the camera switch is operated the unit will flash. If the flash does not put out enough light for some photography purposes, the value of  $C5$  can be increased somewhat. This capacitance value should not be changed if the unit is being employed as a psychedelic strobe, as the higher light output will shorten the flashtube life.

To use the strobe as a mechanical motion stopper,  $R10$  can be adjusted until the motion being observed seems to be stopped. If major use of this mode of operation is desired, it is possible to remove  $R10$  from the circuit board and to replace it with a conventional potentiometer mounted on the metal enclosure as the speed control; the potentiometer shaft should have a pointer knob attached to it and a dial can be made and calibrated against known speeds. —30—

## MODULATION MONITOR

(Continued from page 35)

of wire and maintain the coil's shape (see photograph below).

After the parts are mounted in place, wire the components together, following the schematic of the monitor and the directions supplied with the amplifier module as guides. Then, mount an insulated pin jack in the top of the box, and solder the free end of  $L2$  to it. Snap battery  $B1$  in place, and secure the two parts of the metal box together. Finally,

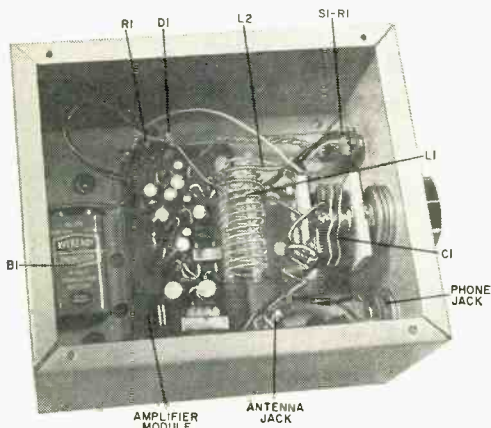

Use a metal chassis to house the monitor circuit and provide shielding against external noises and r.f. interference. Parts layout is not critical.

plug about a one-foot length of heavy wire into the pin jack to provide an antenna for the monitor.

With the parts specified, your monitor will tune very broadly from about 40 to about 60 MHz. Using a 25- or 35-pF variable capacitor for  $C1$  will allow the monitor to tune in the Citizens Band. Best results are obtained if the shortest antenna that provides good reception when the monitor's volume control is turned up is used. In some cases, no antenna is needed.

With the modulation monitor described above, you can readily detect signal distortion, over-modulation, under-modulation, and hum. The monitor is designed for use only with AM phone transmissions.

-30-

March, 1968

# Olson



\* **FREE**

Fill in coupon for a **FREE** One Year Subscription to **OLSON ELECTRONICS'** Fantastic Value Packed Catalog—Unheard of **LOW, LOW PRICES** on Brand Name Speakers, Changers, Tubes, Tools, Stereo Amps, Tuners, CB, and other Values. Credit plan available.

NAME \_\_\_\_\_  
 ADDRESS \_\_\_\_\_  
 CITY \_\_\_\_\_ STATE \_\_\_\_\_  
 GIVE ZIP CODE \_\_\_\_\_

If you have a friend interested in electronics send his name and address for a **FREE** subscription also.

**OLSON ELECTRONICS**  
 INCORPORATED

826 S. Forge Street, Akron, Ohio 44308

**CIRCLE NO. 21 ON READER SERVICE PAGE**

**Argos' new speaker technology creates a genuine price breakthrough in two-way system design.**

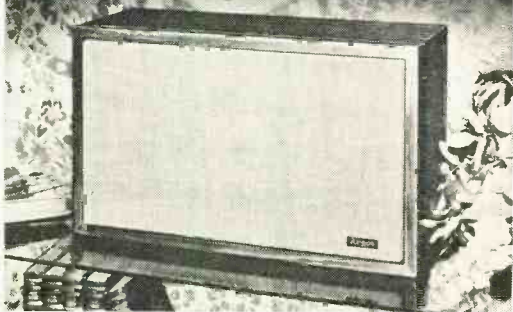

The new Argos TX-200 is a totally new dimension in high fidelity sound reproduction systems—a superb instrument offering fine-furniture construction, big-system performance and compactness for maximum versatility. The TX-200 matches a specially-designed high compliance, low-resonance woofer with a new high-compression horn-loaded driver component to produce distortion-free response from 30 Hz to the inaudibles at 18,000 Hz.

#### Specifications

Cabinet: Select walnut, Belgian linen grille. Size: 18 $\frac{3}{4}$ " x 11 $\frac{1}{8}$ " x 7 $\frac{7}{8}$ ".  
 Price: Audiophile net \$45.00.

**Argos**  
 Products Company

Genoa, Illinois 60135

**CIRCLE NO. 5 ON READER SERVICE PAGE**

# Valuable SAMS BOOKS

## USE THIS HANDY ORDER FORM JUST PUBLISHED! IMPORTANT!

- Tube Substitution Handbook, 11th Ed.** List over 10,000 direct substitutions. A complete guide to substitutions for receiving, picture tube, miniature, industrial and communications types; includes foreign tubes. Tells when and how to make proper substitutions. Order 20614, only..... \$1.75
- ABC's of Ham Radio, 3rd Ed.** Covers latest regulations, including new incentive licensing program. Tells how to learn the code, how to set up and operate your first station; includes study material to help you get your license. Order 20638, only..... \$2.50
- 101 Easy Audio Projects.** Complete instructions for building easy, low-cost projects, such as audio amplifiers, a-m and f-m tuners, reverb units, time-delay control boxes, eavesdropping amplifiers, and test equipment. Order 20608, only..... \$3.25
- Understanding Electronic Test Equipment.** Fully explains operating principles, functions, and applications of instruments most commonly used in electronic testing and troubleshooting. Includes solid-state equipment. Order 20613, only..... \$4.25
- ABC's of Transformers and Coils, 2nd Ed.** Helps you understand basic principles of inductance, transformer and coil construction, inductor applications, and methods of testing and measuring transformers and coils. Includes inductor components used in computers. Order 20612, only..... \$2.25
- Outboard Motor Service Manual, 4th Ed. (2 Vols)**
  - Vol. 1.** Full service data for motors under 30 HP; covers models made by 37 leading manufacturers. Order 20598, only..... \$4.95
  - Vol. 2.** Repair instructions for motors of 30 HP and over; covers models made by 21 manufacturers. Order 20599, only..... \$4.95
  - Both volumes. Order 20603, only..... \$9.50
- Second-Class Radiotelephone License Handbook.** New 3rd edition; complete study course for elements I, II and III of the latest FCC exams. Helps you earn the license you need for communications and two-way radio work. Order 20316, only..... \$4.95
- Color-TV Servicing Made Easy.** Full explanation of color principles, circuitry, setup adjustments and servicing of all color-TV sets. Takes the mystery out of servicing color-TV.
  - Vol. 1.** Order 20135, only..... \$3.25
  - Vol. 2.** Order 20523, only..... \$4.50
- How to Read Schematic Diagrams, 20568**..... \$2.95
- ABC's of Citizens Band Radio, 3rd Ed. 20019**..... 2.25
- Stereo/FM Know-How & Buying Guide, 50012**..... 1.25
- So You Want to Be a Ham, 4th Ed. 20607**..... 3.95
- Transistor Ignition Systems Handbook, 20238**..... 2.95
- TV Tube Symptoms & Troubles, 20476**..... 1.95
- Understanding Telemetry Circuits, 20518**..... 3.25
- 1st Class Radiotelephone License Handbook, 20086**..... 5.25
- Modern Dictionary of Electronics, 3rd Ed. 20600**..... 9.95
- Handbook of Electronic Tables & Formulas, 20230**..... 3.95
- Solving TV Tough-Dogs, 20403**..... 3.25

### FAMOUS ABC'S BOOKS

- |   |   |
|---|---|
| <input type="checkbox"/> Lasers & Masers, 20262..... \$2.25 | <input type="checkbox"/> Computers, 20012..... \$2.50     |
| <input type="checkbox"/> Tape Recording, 20395..... 2.25    | <input type="checkbox"/> Boolean Algebra, 20055..... 2.25 |
| <input type="checkbox"/> Transistors, 20440..... 2.25       | <input type="checkbox"/> Modern Radio, 20047..... 1.95    |

## — HOWARD W. SAMS & CO., INC. —

Order from any Electronic Parts Distributor, or mail to Howard W. Sams & Co., Inc., Dept. PE-3 4300 W. 62nd St., Indianapolis, Ind. 46268

Send books checked above. \$ \_\_\_\_\_ enclosed.

Send FREE Sams Book Catalog.

Name \_\_\_\_\_

PLEASE PRINT

Address \_\_\_\_\_

City \_\_\_\_\_ State \_\_\_\_\_ Zip \_\_\_\_\_

CIRCLE NO. 26 ON READER SERVICE PAGE

## "TRUE OR FALSE" ANSWERS

(Quiz appears on page 40)

- 1 **FALSE** Poor convergence frequently goes unnoticed during color programming but is most objectionable during black-and-white shows.
- 2 **FALSE** Hearing efficiency decreases gradually between the ages of 20 and 35. Until very old age, however, it does not change appreciably after 35.
- 3 **FALSE** Most TV receiver failures occur when the receiver is turned on and off.
- 4 **FALSE** Most home entertainment manufacturers now consider 117 volts a.c. to be average. It is not uncommon to find homes with 125 volts of a.c. line voltage.
- 5 **TRUE** Many spark gaps—some looking a good deal like disc capacitors—are found in modern TV receivers. They prevent possible high voltage build-up across the CRT elements.
- 6 **FALSE** A "glitch" is a low-frequency (slow-moving) vertical-interference line. Glitches are frequently caused by poor filtering and show up on non-synchronous-to-line broadcasts as a horizontal band or line moving vertically through the picture.
- 7 **FALSE** Sound reproduction always depends on speaker quality and speaker enclosure design, not on speaker quantity. Similarly, magnet weight alone is not a good criterion by which to judge speaker quality.
- 8 **FALSE** Color TV 25" rectangular and 21" round CRT tubes display pictures that are almost exactly the same height and width. The 25" color tube has about 40 square inches more viewing area which is picked up in the picture corners.
- 9 **TRUE** Left and right channel stereo record separation is based on vertical and horizontal stylus displacement. Consequently, rumble—a vertical movement—shows up readily in stereo record playback (equally in both channels). Old mono cartridges, on the other hand, were limited in vertical compliance to reduce possible resultant rumble.
- 10 **FALSE** Assuming the receiver was properly set up, OPERATING a vacuum cleaner could only degauss an already magnetized set. Turning a vacuum OFF in the area of a color set COULD cause poor purity, however.
- 11 **TRUE** For example, if the filament in the horizontal oscillator fails, the output tube and perhaps the flyback transformer would be damaged. In series-string receivers, the output tube would also be disabled when the failure occurred.
- 12 **FALSE** The SCR is being used as a stereo indicator switch in FM tuners and the reed relay as a spot killer switch in TV receivers.
- 13 **TRUE** Instant-on receivers stay warm by application of partial a.c. power. If a wall switch is employed, the standby power would be removed.
- 14 **FALSE** Although some radiation would be removed by the cage, its major function is to restrict fire from spreading outside the cage.
- 15 **FALSE** No system is presently available for automatic hue control, and none is in sight.
- 16 **TRUE** Power required to sweep a picture tube is proportional to angle of deflection.

## AMATEUR RADIO

(Continued from page 80)

regulations forbid transmitting that information.

(3) It is only necessary to send the call letters of the station you are working at the sign-off when you end a contact. This rule change will be particularly helpful in DX "pile-ups," where every operator on the frequency calls the same DX station, and the one who wastes time sending the DX call letters often misses the contact. Such contacts are usually very short, so it is easy to learn the call letters of the station being called by listening to the sign-off transmission of the last station that worked it.

**Long-Distance Communications.** If you have ever attempted to keep a regular DX schedule, the following items should impress you. In a recent issue, the San Francisco Radio Club *News* reported that WA6UNS, Oakland, Calif., and VK2NS, New South Wales, Australia, had worked each other on 765 consecutive nights in a still-continuing schedule at 0800 GMT on 7-MHz CW.

And *Short Wave Magazine* (London) told about what may be the granddaddy of all DX skeds. G5QA, England, and ZL2OU, New Zealand, have been holding daily schedules on 20-meter CW since 1936. Over this period of 31 years (subtracting the war years, about 9200 days), G5QA and ZL2OU have made over 10,000 successful 2-way contacts! The discrepancy between the number of days and the number of contacts is explained by the fact that they often work each other twice a day—as they were doing daily at time of writing.

While the number of contacts is not as high, the *VHFER Magazine's* report that Bill, W6DNG, had worked OH1NL, Finland, 24 times and F8DO, France, eight times on 144 MHz is quite impressive for a "local" band. Of course, they are bouncing their signals off the moon. Bill, by the way, is using a 48-element beam—containing 16 driven elements, 16 reflectors, and 16 directors—that gives a measured gain of just under 20 dB (100 times) compared to a dipole.

Incidentally, the news that the American Telephone and Telegraph Company has given up on microwave for long-distance communications may decrease the pressure on the amateur UHF/VHF bands. According to *Electronic News*, vandalism, cut power cables, and other "outages" have caused A.T. & T. to decide to use buried cable in place of microwaves from now on. The buried cable is immune to vandalism and even to small nuclear devices.

## Now it's easy to be an authority on tape recording- with HiFi/STEREO REVIEW'S all-new 1968 TAPE RECORDER ANNUAL

HiFi/STEREO REVIEW'S  
**TAPE RECORDER ANNUAL 1968**

How to Choose a Tape Recorder • The New Kinescope, Cartridge, and Reel-to-Reel • Battery-Operated Tape Recorders • Choosing a Recorder • How to Use a Recorder • How to Maintain Your Recorder • Directory of Manufacturers, Dealers, and Distributors



PHOTO: Pointers on How to Start Your Own Tape Club

This fact-filled volume contains over 130 pages, 19 complete features, covering every aspect of tape recording. You get expert tips by the dozen, on equipment — making better tapes — editing — copying — on everything you want and need to know about tape recording.

**FEATURING** a complete directory of the latest monaural and stereo recorders, players and transports — the only complete buyer's guide available in the tape recorder field! Hundreds of photos — full data on hundreds of models from portable units to professional rigs. All the model numbers, specifications, dimensions and prices . . . every vital statistic you need to compare the newest machines and select the finest one in your price range.

**Plus** — Complete Directories of cartridge machines . . . microphones . . . headphones . . . raw and pre-recorded tapes . . . accessories. **How-To** Articles on selecting the right recorder . . . recording off the air . . . editing . . . creative taping . . . starting your own tape club. **Special Reports** on taping and the law . . . new self-reversing tape recorders . . . having fun with home VTRs . . . home cartridge players . . . buying a battery portable.

The 1968 TAPE RECORDER ANNUAL is an indispensable guide for everyone who wants better performance, greater versatility and a lot more fun from his tape recorder . . . month after month . . . tape after tape. Order your copy today!

**GET THE DELUXE LEATHERFLEX-COVERED EDITION FOR \$3 POSTPAID!** THE 1968 TAPE RECORDER ANNUAL is also available in a splendid deluxe edition. Rugged Leatherflex covers provide lasting protection yet are softly textured and gold-embossed for the look of elegance. A collector's item — a superb addition to your permanent reference library. And it's yours, for just \$3 postpaid.

Ziff-Davis Service Division, Dept. TRA  
595 Broadway, New York, N.Y. 10012

Please send my copy of the 1968 TAPE RECORDER ANNUAL as checked below:

- \$1.25 enclosed, plus 15c for shipping and handling for the Regular Edition. (\$1.75 for orders outside U.S.A.)
- \$3.00 enclosed. Please send me, postpaid, the Leatherflex-covered Deluxe Edition. (\$3.75 for orders outside U.S.A.) (Please allow 3 additional weeks for delivery of the Deluxe Edition.)

print name \_\_\_\_\_ PE-38

address \_\_\_\_\_

city \_\_\_\_\_

state \_\_\_\_\_ zip code \_\_\_\_\_

— PAYMENT MUST BE ENCLOSED WITH ORDER —

**No dealer stocks everything.**

**No salesman knows everything.**

**But the 1968 STEREO/HI-FI DIRECTORY does!**



It's a giant 182-page buyer's guide to virtually every new audio component on the market today. Over 1600 products in all! From amplifiers to complete hi-fi systems to tape cartridge recorders and players for your home, car and boat. All the latest offerings from 176 manufacturers are fully detailed and illustrated for your "shop-at-home" convenience.

Every technical specification, dimension, special feature, optional accessory, price and model number is at your fingertips—to help you compare similar items, feature for feature, dollar for dollar and decide which is best for you. Before you buy!

Forget the guesswork, costly mistakes, store-to-store treks and "after-you-get-it-home" disappointments. With the 1968 STEREO/HI-FI DIRECTORY as your guide, you'll zero-in on the equipment you want, buy it with confidence—and know you're getting the greatest value for your money.

The price for this valuable "encyclopedia" of hi-fi information? Just \$1.25. A small investment, indeed, for such an essential component of your listening enjoyment. So don't delay. Use the coupon below to order your copy of the 1968 STEREO/HI-FI DIRECTORY today!

**CONTENTS INCLUDE**

**Special 8-page section on:** • How to choose components • How to compare prices, features, specifications • Exclusive state-of-the-art report on componentry • PLUS an incisive analysis of the controversial 8 track, 4 track and cassette tape cartridges. . . . Comments and clues on which design holds the most promise for the future.

Individual directories for amplifiers / changers / turntables / cartridges and tonearms / receivers / tuners / tape machines (including video recorders and cartridge units) / speakers / integrated systems / antennas / microphones / cabinets.

The 1968 STEREO HI-FI DIRECTORY is available in a splendid deluxe edition. Rugged Leatherflex cover provides lasting protection yet is softly textured and gold-embossed for the look of elegance. A collector's item—a superb addition to your permanent reference library. Just \$3 postpaid.

**ZIFF-DAVIS SERVICE DIVISION • DEPT. SD  
595 Broadway • New York, N. Y. 10012**

**YES: Send me the new 1968 STEREO/HI-FI DIRECTORY as checked below:**

\$1.25 enclosed, plus 15c for shipping and handling. Send me the regular edition. (\$1.75 for orders outside the U.S.A.)

\$3.00 enclosed. Send me the Deluxe Leatherflex-bound edition, postpaid. (\$3.75 for orders outside the U.S.A.) Allow three additional weeks for delivery.

print name \_\_\_\_\_

address \_\_\_\_\_ PE-38

city \_\_\_\_\_

state \_\_\_\_\_ zip code \_\_\_\_\_

**PAYMENT MUST BE ENCLOSED WITH ORDER**



Bill Wolverton, WN710K, Philomath, Ore., works 80, 40, and 15 meters with a Hallicrafters HT-40 transmitter and S-38B receiver. A home-built coupler end-feeds a 67'-long wire antenna, 20' high.

**New Antenna.** Hermann W. Ehrenspeck, a physicist at the Air Force Cambridge Research Laboratories, has developed an interesting "Short Backfire VHF Antenna" that may find considerable use in amateur installations because it is claimed to have high gain in a small space. Enough details should be available in the following description to permit experimenting with such an antenna.

The antenna consists of a 2-wavelength diameter disc with a ¼-wavelength rim spaced ¼-wavelength behind a ½-wavelength dipole. The dipole transmission line reaches it through a small hole in the center of the disc. Another disc is mounted ¼-wavelength in front of the dipole. Exact dimensions of the smaller disc are not available, but it appears to be between ¾- and ½-wavelength in diameter. Incidentally, the larger disc with its rim looks something like the lid of a huge coffee can.

In operation, the signal from the dipole radiator is reflected from the small disc backwards towards the large reflector (hence the name, backfire antenna). The large disc then reflects the signal forward again. Dr. Ehrenspeck says that short backfire antennas constructed of "chicken wire" should work well.

The original article from which this information has been condensed appeared in *Electronic Design* magazine.

**NEWS AND VIEWS**

**Forrest Hudspeth, WA3FAE**, 201 Carroll Rd, Glen Burnie, Md., has designed his QSL card with the idea that it should be the first one noticed on anyone's shack wall. You can judge how well he succeeded by working him and swapping cards with him. Forrest uses a Heathkit DX-40 transmitter and HG-10 VFO, plus a Lafayette HE-30 receiver. In conjunction with an 80-40 meter doublet, Hornet TB-500 beam, and home-brew, 20-15 meter vertical antennas. He concentrates mainly on 15-meter CW

with a solid, chrome-plated "original" Vibroplex bug but also gives the other bands a workout. Forty-five states and 31 countries worked and a 20-wpm code certificate are mementos of WA3FAE's activities . . . **Paul Pilzer, WN2DDR**, 104 Woodhill Lane, Manhasset, L.I., N.Y., works all Novice bands. A "Globe Scout Deluxe" transmitter and a Lafayette HA-225 receiver cover the lower frequencies, and a Heathkit "Twoer" covers 146 MHz. His antenna farm sprouts a 2-and-6 meter beam, 18-foot vertical, 2-meter "Squalo," converted TV antenna, and a 57-foot dipole. But Paul did not mention his "worked" record, except that he needs California and several mid-west states for WAS . . . Attention Heathkit SB-100 users. Via **Alex, VK2JZ**, Australia, Bill, FH3KJ, says that reducing the value of R-221 in the receiver second mixer from 470 ohms to 47 ohms increases "receive" sensitivity dramatically. Alex made the change and says that it did what Bill said it would.

**H. W. "Bucky" Crowley, WN5500/1**, 6 Phillip St. #4, Boston, Mass., broke his wrist the day after he got on the air; so he spent his first six weeks of operating sending code with his left hand and copying it with one finger on a typewriter. In spite of this handicap, Bucky has worked 30 states with an old 1953 "Globe Scout" transmitter and an Elmac PMR-6 receiver (total cost \$30). His antenna is a 40-meter dipole; a 15-meter Cubical Quad is in the making . . . **Greg Brown, WN9UDX**, 2208 Prairie St., Glenview, Ill., sticks to 15 meters almost exclusively. A 3-element, 15-meter beam may have something to do with it. A Heathkit T-60 transmitter and a Drake 2-B receiver also get into the act. With this combination, Greg's record is 40 states and 33 countries confirmed, and he works ZL3JO (New Zealand) almost every day . . .

**Al Guinn, WN4G55**, P.O. Box 3061, Bristol, Tenn., wishes that some of the DX he hears at the low end of the 21-MHz band would tune up to his frequency of 21.180 MHz once in a while, so that he could work it. Al's Heathkit DX-40 transmitter and Hallicrafters SX-110 receiver cooperate with 40- and 15-meter dipole antennas; he has worked 29 states and will skip anyone needing a Tennessee contact or looking for a Rag Chewer's Club (RCC) certificate.

**Vic Rosello, KP4CSZ**, C-13 Cypress St., Valle Arriba Hts., Carolina, Puerto Rico, runs 75 watts input to a Hallicrafters HT-40 transmitter feeding a 40-meter dipole antenna. A Lafayette HA-350 does the receiving. In six months as a Novice (signing WP4CSZ), Vic worked 53 countries and 16 states. In a couple of months as a General, he has added another nine countries and two states to his total—still crystal-controlled. When he "finds" some money, Vic plans to buy a VFO and a microphone. Until then, look for him on the magic frequency of 21.111 MHz, or on 14.074 MHz . . .

**Steve Watts, WN6YAR**, 1109 Highland Drive, Modesto, Calif., spends most of his time on 15

meters but sneaks off to 40 meters at times. His Heathkit DX-60 transmitter feeding a Mosley TD3 Jr. trap dipole has worked 35 states and five countries in three months. A Hammarlund HQ-150 does the receiving. With 38,000 hams in California, Steve doubts that many hams outside of the state need a California contact, but he is willing. He'll probably be signing a WE6 call, though, because he was just about ready to take his General exam when he wrote. Incidentally, the San Francisco Radio Club News claims that the FCC is almost out of WE6 call-signs and speculates that WC6's will appear soon . . . **Sanford Hutson, K5QHS**, 4423 A St., Little Rock, Ark., got back into the DX-chasing game six months ago; he is amazed how much easier it is to rack up new countries than it was on AM eight or nine years ago. Even though a wife, patients, and medical studies at the University of Arkansas do not allow him much time on the air, Sanford's Heathkit SB-100 SSB/CW transceiver, Heathkit "Warrior" amplifier, and Mosley CL-33 tri-band beam have racked up 130 new countries in six months—and most of the countries were worked before he got the amplifier! A Heathkit "Twoer" is used on the local 2-meter DX Club DX Net that alerts all the members when a "new one" appears over the DX horizon. If you happen to work E17AF, remember that K5QHS is his QSL manager. (See photo on page 80.)

Good luck in the second part of the ARRL DX Contest. Send us your "News and Views" and pictures, and please keep your club bulletins coming. Send them to: Herb S. Brier, W9EGQ, Amateur Radio Editor, POPULAR ELECTRONICS, P. O. Box 678, Gary, Ind. 46401.

73. Herb, W9EGQ

### How Fast Is Fast?

The speed at which a computer adds or subtracts is acknowledged to be faster than the human mind can conceive—but is there an ultimate limit in computational speed? Could a computer be so fast that the answer would appear before the arithmetical input was completed? Well, hardly, but IBM mathematician Shmuel Winograd has developed a formula that does spell out the ultimate limit in computational speed. The formula is so fundamental that it is valid for any computer numbering system—binary, decimal, or other. As an example, Mr. Winograd's formula shows that regardless of how clever a computer is designed in the future, it still must take 50 billionths of a second to add two 48-digit binary numbers!



## LISTEN TO: POLICE & FIRE REPORTS

FOR INDUSTRIAL, COMMERCIAL, UTILITY AND GOVERNMENT USE

CRYSTAL CONTROLLED • DUAL CONVERSION • LOW POWER DRAIN

Specifically designed for simplicity of operation and efficiently engineered for dependable service. Fits the smallest autos yet powerful enough to deliver a clean clear signal. Features: 6 crystal controlled frequencies, Dual Limiter, Quadruple tuned RF stage for greater image rejection, Noise Free squelch, PLUG IN crystals for instant freq. change. Compatible with all major continuous tone systems. Operates on 117VAC & 12VDC. Size: 6 7/8" x 2 3/8" x 8 1/2" / Wt: 3 lbs. 8 oz.

Perfect For  
POLICE • FIRE  
Other Law Agencies • Tow Trucks • Civil Defense •

Complete with AC and DC power cables, Mounting bracket, less crystals. Crystals \$5.00 ea.

FR-104 (25-50 MHz) **\$140<sup>00</sup>**  
FR-105 (150-175 MHz)

SONAR RADIO CORP., 73 Wortman Ave., Bklyn, N. Y. 11207  
Please send information on FR-104/105 FM Monitor Receivers. Dept. 609

Name \_\_\_\_\_  
Address \_\_\_\_\_  
City \_\_\_\_\_ State \_\_\_\_\_

CIRCLE NO. 28 ON READER SERVICE PAGE



## SAVE BIG MONEY ON ELECTRONICS

Buy from RADIO SHACK, America's biggest nationwide electronics store chain. Send now for your free copy of our new 1968 bargain-packed electronics catalog, available soon . . . plus a year of special bargain bulletins. Write to —

**RADIO SHACK®**  
2727 West 7th St., Dept. WW  
Fort Worth, Texas 76107

### FREE CATALOG AND BARGAIN BULLETINS

Name .....

Address .....

City ..... State ..... Zip .....

Radio Shack Corporation — subsidiary of Tandy Corp. • Over 190 stores coast to coast

CIRCLE NO. 24 ON READER SERVICE PAGE



Because you've got to SEE it to BELIEVE it... we will send you a FREE sample!

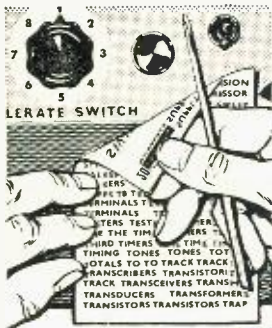

*instant lettering*  
**DATAMARK®**  
— the easy new way to label your projects!

Just rub over the pre-printed words or symbols with a ballpoint pen and they transfer to any surface — looks like finest printing! Label control panels, meter dials, letter on anything!

LOOK FOR *instant lettering*  
**DATAMARK** SETS . . . only \$1.25 each  
— at leading electronic distributors

#### DATAMARK SETS AVAILABLE FOR:

- Amateur Radio. CB
  - Audio, Hi-Fi, TV
  - Experimenter Home Intercom
  - Industrial Test Equipment
  - Switch & Dial Markings
  - Alphabets & Numerals in 1/8", 1/4" and 1/2"
- each set has black, white, and gold

SEND FOR FREE SAMPLE

**THE DATAK CORPORATION**  
85 HIGHLAND AVENUE • PASSAIC, N. J. 07055  
CIRCLE NO. 12 ON READER SERVICE PAGE

## SOLID STATE

(Continued from page 86)

**The Battle of the Giants.** A technical-philosophical tug of war is shaping up among semiconductor manufacturers on the relative merits of plastic (epoxy) vs. metal can packages.

On one side, General Electric has chosen to go all out for plastic packages, and all metal can silicon planar transistors are being eliminated from the GE line, with distributor stock returned and availability limited to factory inventory. Among the first to use the modern epoxy package, GE is now the first to obsolete the metal can.

On the other side, RCA is busy pushing its low-cost "PHP" line, which features hermetically sealed metal cans, claiming that this type of packaging offers the best combination of heat dissipation, temperature range, and shielding at economy prices.

Other firms, including TI, Motorola, and Fairchild, seem to be taking a "wait and see" middle course, offering devices in both packages, with many types having identical characteristics in both metal and plastic at almost identical prices.

How would you vote? Metal can or plastic package?

Until next month . . .

—Lou

## THE PRODUCT GALLERY

(Continued from page 74)

In keeping with the current trend toward simplicity in the operation of a tape deck, the TD-1030 is operated by a single rotary switch/lever linkage. This lever has five positions: fast rewind; all stop; playback or record (protected by a separate record button actuator); pause; and fast forward. The TD-1030 has dual (uncalibrated) vu meters for easy monitoring of recording level inputs, and automatic shutoff linkage. Most important, the TD-1030 is one of the few low-cost tape decks with tape lifters to protect the tape heads during rewind or fast forward operations.

All in all, if you're looking for a "best buy" in tape decks for 1968, you might do well to look into Allied's TD-1030 stereo tape deck. As far as cost, performance, and looks go, the TD-1030 deserves an "E" for excellence.

Circle No. 89 on Reader Service Page 15 or 115

POPULAR ELECTRONICS



## THE "FERRET"

(Continued from page 44)

near output capacitor *C7*. (The inner conductor goes to *C7* and the outer conductor is connected to the board ground pattern.)

Finally, attach the length of 300-ohm twin lead to the board points provided adjacent to coil assembly *L1-L2*, and solder a 4-inch length of hookup wire to the B+ point. The board is now complete, but should be given a final check before being installed in the box.

**Finishing Touches.** Insert four 4-40 screws (at least 3/4-inch in length) through the holes in the bottom of the box. Slip four 1/2-inch spacers over the screws. Then slip the assembled PC board into the box, guiding the shaft of variable capacitor *C2* through the hole in the front panel. Ease the board down until the screws pass through the board mounting holes and the board rests on the four spacers. Secure the board in this position by tightening four 4-40 nuts on the four mounting screws.

Next, attach the cables from the printed circuit board to the input and output terminal strips (*TS1* and *TS2*).

As the final wiring step, connect the length of hookup wire from the B+ point of the board to the (+) terminal of the dual battery holder. Apply decals to the front panel to give your *Ferret* a more finished appearance. It is also a good idea to install four rubber feet on the bottom of the box since, sooner or later, the *Ferret* will wind up sitting atop your short-wave receiver.

**Alignment.** Connect a length of RG-58/U coaxial cable to the output terminal strip (*TS2*) of the *Ferret*. The inner conductor attaches to the *H1* terminal and the outer conductor (shield) attaches to the *LO* terminal. Attach the other end of the cable to the input terminals of your receiver.

Using Fig. 5 as a guide, attach your antenna to the input terminals of the *Ferret*. Install batteries *B1* and *B2* in the dual battery holder, observing proper polarity. Then turn on your short-wave receiver.

(Continued on page 110)

March, 1968

# Space age minded ?

Look ahead to an exciting  
career in engineering.  
Start now. At

## MSOE

Residence study at the Milwaukee School of Engineering leads to B.S. degrees in Electrical and Mechanical Engineering and Engineering Technologies. Other courses lead to Associate in Applied Science degrees in these engineering technologies: computer... electrical power... electronic communications... air conditioning... fluid power... internal combustion engines... metallurgy... welding... chemical... architectural and building construction. Find out about financial aids, and job placements. Approved for G. I. Bill. Send for Your Career Booklet today.



MILWAUKEE SCHOOL OF ENGINEERING  
Dept. PE-368, 1025 North Milwaukee Street  
Milwaukee, Wisconsin 53201

Please send the "Your Career" booklet. I'm interested in:

Electrical fields  Mechanical fields

NAME \_\_\_\_\_ AGE \_\_\_\_\_

ADDRESS \_\_\_\_\_

CITY \_\_\_\_\_ STATE \_\_\_\_\_ ZIP \_\_\_\_\_

CIRCLE NO. 17 ON READER SERVICE PAGE

# 10 New Kits From Heath...

## New Deluxe Heathkit "227" Color TV

**Exclusive Heathkit Self-Servicing Features.** Like the famous Heathkit "295" and "180" color TV's, the new Heathkit "227" features a built-in dot generator plus full color photos and simple instructions so you can set-up, converge and maintain the best color pictures at all times. Add to this the detailed trouble-shooting charts in the manual, and you put an end to costly TV service calls for periodic picture convergence and minor repairs. No other brand of color TV has this money-saving self-servicing feature.

**Advanced Features.** Top quality American brand color tube... 227 sq. in. rectangular viewing area... 24,000 v. regulated picture power... improved phosphors for brilliant, livelier colors... new improved low voltage power supply with boosted B+ for best operation... automatic degaussing... exclusive Heath Magna-Shield to protect against stray magnetic fields and maintain color purity... ACC and AGC to reduce color fade and insure steady, flutter-free pictures under all conditions... preassembled & aligned IF with 3 stages instead of the usual 2... preassembled & aligned 2-speed transistor UHF tuner... deluxe VHF turret tuner with "memory" fine tuning... 300 & 75 ohm VHF antenna inputs... two hi-fi sound outputs... 4" x 6" 8 ohm speaker... choice of installation—wall, custom or optional Heath factory assembled cabinets. Build in 25 hours.

**Kit GR-227, (everything except cabinet)...** 114 lbs... \$42 dn., as low as \$25 mo. .... **\$419.95**

**GRA-227-1, Walnut cabinet.** 54 lbs. no money dn., \$6 mo. .... **\$59.95**

**GRA-227-2, Mediterranean Oak cabinet (shown above)** 70 lbs. .... no money dn.; \$10 mo. .... **\$94.50**



Kit GR-227  
**\$419.95** (less cabinet)  
\$25 mo.



Kit GRA-27  
**\$19.95**

### New Remote Control For Heathkit Color TV

Now change channels and turn your Heathkit color TV off and on from the comfort of your armchair with this new remote control kit. Use with Heathkit GR-227, GR-295 and GR-180 color TV's. Includes 20' cable.



Kit GR-295  
**\$479.95**  
(less cabinet)  
\$42 mo.

## Deluxe Heathkit "295" Color TV

Color TV's largest picture... 295 sq. in. viewing area. Same features and built-in servicing facilities as new GR-227. Universal main control panel for versatile in-wall installation. 6" x 9" speaker.

**Kit GR-295, (everything except cabinet),** 131 lbs... \$48 dn., \$42 mo. .... **\$479.95**

**GRA-295-4, Mediterranean cabinet (shown above),** 90 lbs... no money dn., \$11 mo. .... **\$112.50**

Other cabinets from \$62.95.



Kit GR-180  
**\$359.95**  
(less cabinet & cart)  
\$22 mo.

## Deluxe Heathkit "180" Color TV

Same high performance features and exclusive self-servicing facilities as new GR-227 (above) except for 180 sq. in. viewing area.

**Kit GR-180, (everything except cabinet),** 102 lbs. \$36 dn., as low as \$22 mo. .... **\$359.95**

**GRS-180-5, table model cabinet & mobile cart (shown above),** 57 lbs... no money dn., \$5 mo. .... **\$39.95**  
Other cabinets from \$24.95.

## New! Heathkit/Kraft 5-Channel Digital Proportional System with Variable Capacitor Servos

System Kit GD-47  
**\$219.95**  
\$21 mo.



This Heathkit version of the internationally famous Kraft system saves you over \$200. The system includes solid-state transmitter with built-in charger and rechargeable battery, solid-state receiver, receiver rechargeable battery, four variable capacitor servos, and all cables. Servos feature sealed variable capacitor feedback to eliminate failure due to dirty contacts, vibration, etc.; three outputs: two linear shafts travel 1/2" in simultaneous opposite directions plus rotary wheel. Specify freq.: 26.995, 27.045, 27.145, 27.195 MHz.

**System Kit GD-47, all of above,** 5 lbs. .... **\$219.95**

**Kit GDA-47-1, transmitter, battery, cable,** 3 lbs. .... **\$86.50**

**Kit GDA-47-2, receiver,** 3 lbs. .... **\$49.95**

**GDA-47-3, receiver rechargeable battery,** 1 lb. .... **\$9.95**

**Kit GDA-47-4, one servo only,** 1 lb. .... **\$21.50**

## New! Heath/Mitchell COLORVAL Dark-room Computer... Kit or Assembled

Kit PM-17  
**\$89.95**  
\$9 mo.

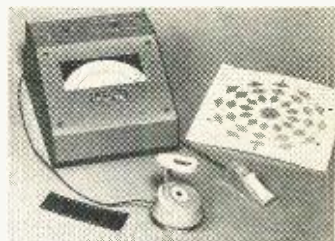

Colorval takes the work out of color printing, leaves the creativity to you. Colorval is easy to set up... you "program" the scan filter pack for the type of film, paper, and equipment you use... we show you how. Unique Color Probe allows visual determination of ideal enlarger filter combination. Color Wheel and table shows what filter changes are needed. Exposure Probe scans shadows and highlights; exposure scale on Computer indicates proper contrast for color and b/w printing. Get started in color the right way, quickly, easily.

**Kit PM-17, 6 lbs., no money dn.,** \$9 mo. .... **\$89.95**

**Assembled PMW-17, 6 lbs. no money dn.,** \$13 mo. .... **\$125.00**

# See 300 More in FREE Catalog

What would you expect to pay  
for a Vox "Jaguar" Combo organ  
with a 180-watt 3-channel amp?  
\$1000? \$1250? \$1500? More?

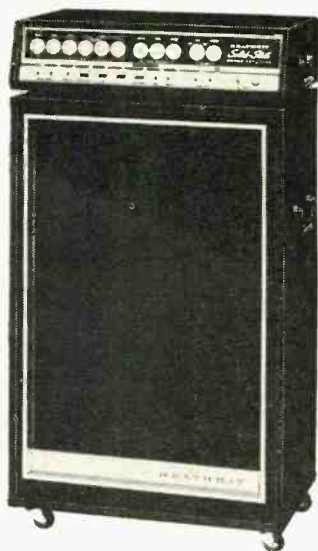

You can get both for only \$598  
during this Special Heathkit Offer!

Now you can get this famous professional combo organ with a versatile high-power piggy-back amp. and matching speaker system for just a little more than you'd expect to pay for the "Jaguar" alone! The Heathkit/Vox "Jaguar" is solid-state; two outputs for mixed or separated bass and treble; reversible bass keys for full 49 key range or separate bass notes; bass volume control; vibrato tab; bass chord tab; four voice tabs (flute, bright, brass, mellow); keyboard range C<sub>2</sub> to C<sub>6</sub> in four octaves; factory assembled keyboard, organ case with cover, and stand with case. Also available separately; you'll still save \$150 (order Kit TO-68, \$349.95).

The Heathkit TA-17 Deluxe Super-Power Amplifier & Speaker has 180 watts peak power into one speaker (240 watts peak into a pair); 3-chan-

nels with 2 inputs each; "fuzz", brightness switch; bass boost; tremolo, reverb; complete controls for each channel; foot switch; 2 heavy duty 12" speakers plus horn driver. Also available separately kit or factory assembled (Kit Amplifier TA-17, \$175; Assembled \$275; Kit Speaker TA-17-1 \$120; Assembled \$150; Kit TA5-17-2, amp. & two speakers \$395; Assembled TAW-17-2, amp. & two speakers \$545).

Kit TOS-1  
Organ, Amplifier  
& Speaker Kits (240 lbs.)  
**\$598.00**

Kit TOS-2  
Organ Kit, Assembled  
Amplifier & Speaker (240 lbs.)  
**\$698.00**

## New! Solid-State Portable

### Volt-Ohm-Meter

So Handy, So Low Cost we call it "every man's" meter. Just right for homeowners, hobbyists, boatowners, CBer's, hams ... it's even sophisticated enough for radio & TV servicing! Features 12 ranges... 4 AC & 4 DC volt ranges, 4 ohm ranges; 11 megohm input on DC, 1 megohm input on AC; 4 1/2" 200 uA meter; battery power; rugged polypropylene case and more. Easy 3 or 4 hour kit assembly. Ideal gift for any man! 4 lbs.

Kit IM-17  
**\$19.95**



## New! Heathkit Guitar Headphone Amplifier

Kit TA-58  
**\$9.95**



Now you can play and practice your electronic guitar in private! Just plug this miniature amplifier into the jack of your guitar and use a pair of headphones. Solid-state circuit has tailored response; automatic off-on switching; self-contained battery (not supplied); and capability of operating one or two pairs of mono or stereo headphones of 4 to 2 megohms. Ideal for practice or instruction. Easy to build.

Kit TA-58, 2 lbs. .... \$9.95



**NEW**  
**FREE 1968**  
**CATALOG!**

Now with more kits, more color. Fully describes these along with over 300 kits for stereo hi-fi, color TV, electronic organs, electric guitar & amplifier, amateur radio, marine, educational, CB, home & hobby. Mail coupon or write Heath Company, Benton Harbor, Michigan 49022.

**HEATHKIT**

HEATH COMPANY, Dept. 10-3  
Benton Harbor, Michigan 49022  
In Canada, Daystrom Ltd.

Enclosed is \$ \_\_\_\_\_, including shipping.

Please send model (s) \_\_\_\_\_

Please send FREE Heathkit Catalog.

Please send Credit Application.

Name \_\_\_\_\_

Address \_\_\_\_\_

City \_\_\_\_\_ State \_\_\_\_\_ Zip \_\_\_\_\_

Prices & specifications subject to change without notice.

CL-319



## ON THE CITIZENS BAND

(Continued from page 81)

of the state is KQM3135. Present officers are Maurice Porter, KMM5050, president; Jim Dobbins, KON0207, vice president; Theron Chewning, KMM2657, secretary; J.E. McAlister, KKN3114, treasurer, and Charles Cook, KNN2212, communications officer.

In an effort to stimulate courtesy and cooperation, and increase monitoring efficiency among members of emergency groups in Los Angeles County, Paul Carter, chairman of the *10-12 News-Break*, Whittier, Calif., has announced an Emergency Service Award of the month. The award consists of \$25 to be presented to the member of an emergency service organization whom area CB'ers must "vote in" in any given month. Twenty-three strict rules govern the nomination and final judgment. Send a note to the *10-12 News-Break* office at 11829 S. Louis Ave., Whittier, Calif., for more information. Better, yet, include \$1 for a one-year subscription to the *10-12 News-Break*, a well-written, news-worthy CB publication.

The Southeast REACT Emergency Aid Squad, Inc., Washington, D.C., has just completed an eight-week course of instruction

on Radiological Monitoring. The 16-hour course was given in conjunction with the Office of Civil Defense and Howard University's Extension Civil Defense Program. Participating squad members who completed the course received a Civil Defense I.D. card and a certificate qualifying them to work as radiological monitors under the guidance of a shelter manager.

Charles Pelaske, Maywood-Bell REACT, Bell, Calif., is convinced that the people who stole transceivers from autos in the California area over the last two years were part of an organized group. Pelaske believes the rigs were taken outside the area to be exchanged for other units which were then peddled in the areas where the heists were originally made. Since most manufacturers use only an easily removed gummed label to serialize their products, Pelaske advises that transceivers owners have their Social Security Numbers etched on the back of all equipment.

Other CB'ing Californians have not yet given up on the drive to promote CB call-signs on their vehicle license plates. The Trail Blazers, Lynwood, Calif., are sponsoring a petition for which they hope to obtain ten thousand signatures in five months. The drive was created after Assemblyman Wakefield of the Lynwood area had received a few thousand signatures and expressed an in-

# New Courier Traveller.



# A product of small thinking.

We put everything into the new Courier Traveller to make it the industry's smallest 23-channel CB transceiver. And the smallest thing of all is its price—\$149. Every feature you'd look for to assure total performance—honed down into a compact 5¾" W x 6¼" D x 1⅞" H. Start with silicon-transistors throughout. Exclusive incoming signal indicator, which lights up automatically when receiving S-6 or better signal. Super efficient transmitter designed to help pierce "skip." Add illuminated channel selector, auxiliary speaker jack, modulation indicator, and single-knob tuning. Plus exclusive Courier "Safety Circuit" to protect against mismatched antenna, incorrect polarity, and overload. Sorry. There's nothing small about Traveller's guarantee. It's so trouble-free, we had to guarantee it for 10 full years.

Just \$149  
Complete  
with crystals  
for all 23 channels



**COURIER COMMUNICATIONS, INC.** a subsidiary of **Whittaker Corporation**  
56 hamilton avenue • white plains • new york 10601

Yes. I'm thinking small.  
Tell me all about the new Courier Traveller.

Name \_\_\_\_\_  
Address \_\_\_\_\_  
City \_\_\_\_\_ County \_\_\_\_\_ PE-83  
State \_\_\_\_\_ Zip \_\_\_\_\_

CIRCLE NO. 11 ON READER SERVICE PAGE

www.americanradiohistory.com

Live Better Electronically With

# LAFAYETTE RADIO ELECTRONICS

## 1968 Catalog 680 FREE!



Now OFF PRESS  
BETTER THAN EVER  
Over 500 Pages

Stereo Hi-Fi • Citizens Band • Ham Gear • Tape Recorders • Test Equipment • TV and Radio Tubes and Parts • Cameras • Auto Accessories • Musical Instruments • Tools • Books

Featuring Everything in Electronics for  
• HOME • INDUSTRY • LABORATORY  
from the "World's Hi-Fi & Electronics Center"

LAFAYETTE Radio ELECTRONICS  
Dept. 1C-8 P.O. Box 10  
Syosset, L.I., N.Y. 11791

Send me the FREE 1968 LAFAYETTE Catalog 680 1C-8

Name .....

Address .....

City ..... State.....

Zip .....

(Please Give Your Zip Code No.)

CIRCLE NO. 16 ON READER SERVICE PAGE

# SYDMUR

The Last Word In Ignition Systems



**SAVE  
MONEY**  
on GAS! COILS!  
SPARK PLUGS!  
TUNE-UPS!

The most advanced solid state C.D. ignition systems available. Take advantage of the latest technology... Get the most out of your car's engine.

- Increased Mileage
- Greatly Extended Spark Plug Life
- Longer Battery Life
- Fewer Tune-ups

Rugged construction and conservatively rated components.

Every Sydmur unit is pre-tested and guaranteed. The easy to install Sydmur—is fully adaptable: 6 or 12 volt systems, positive or negative ground.

Available in either kit or assembled form.

Fly-away assembled .....\$60.00 prepaid\*

Fly-away kit ..... 44.50 prepaid\*

And the smaller "COMPAC" unit (12V. negative ground only) designed for automobiles, motorcycles, go karts, outboard motors, etc.

Compac assembled .....\$34.75 plus 75¢ handling\*

Compac kit ..... 24.95 plus 75¢ handling\*

(\*New York State residents add sales tax.)

Recommended by many of the world's leading automotive manufacturers. Send check or money order today.

For free literature, write:

**SYDMUR ELECTRONIC SPECIALTIES**

1268 East 12th Street Brooklyn, N.Y. 11230

CIRCLE NO. 34 ON READER SERVICE PAGE

terest in the matter. Wakefield stated that the proposal would be brought before the California legislature early this year, but told the sponsors that additional signatures would definitely be of influential value. Californians can request additional information by writing to License Plate Drive, P.O. Box 385, Lynwood, Calif. 90262.

**Continuing CB Call-Signs.** In a surprise reversal, on January 3, 1968, the Federal Communications Commission cancelled its 1964 rule change on CB call-signs. From now on, your present CB call will remain yours unless you let your license lapse (renewable every five years), or your license is suspended or revoked.

This action will be welcomed by all legitimate CB'ers. Heretofore, CB'ers were issued new call-signs upon each license renewal or modification.

I'll CB'ing you,

—Matt, KHC2060

## SHORT-WAVE LISTENING

(Continued from page 83)

as to the tenor of the propaganda being sent out. Current plans are for the station to continue to operate from Cairo but the new management will likely be headed by a non-Egyptian—if the 13 countries can agree on one.

**Confidential Frequency List.** A 34-page compilation of call-signs and frequencies used by out-of-the-way radio stations is being offered by Gilfer Associates, Inc. (Box 239, Park Ridge, N.J. 07656). This listing contains material abstracted from the ITU master frequency lists. Calls and commonly used frequencies are given for such radio services as Ships at Sea, Coastal Radiotelephone, the FCC Network, Royal Canadian Mounted Police, Zone and Interzone Police, Interpol, etc. Price, \$1.95, postpaid.

**The DX Awards Program.** Your Short-Wave Editor would like to remind those who are relative newcomers to the hobby, and to this column, that DX Awards seals are available which make attractive additions to your Monitor Registration Certificate. Awards are presented for reception and verification of 20, 30, 40, and 50 U.S. states; 6, 8, 10, and 12 Canadian provinces and territories; and 25, 50, 75, 100, and 150 countries. Letters of Certification are issued for each additional 10 countries (over 150) heard and verified.

If you would like a copy of the rules and

POPULAR ELECTRONICS

regulations for each of the three phases of the DX Awards Program to date, just send a postage stamp and/or return envelope with your request to: DX Award Rules, P.O. Box 333, Cherry Hill, N.J. 08034. You will also receive a copy of the official list of countries that you may claim to qualify for the Countries Awards.

Remember that you must have a Short-Wave Monitor Registration Certificate in your possession before you become eligible to apply for any of these awards. You'll find a Short-Wave Monitor Certificate application form on page 95 of the February 1968 issue of POPULAR ELECTRONICS.

**World Communications Club.** One of the younger SWL clubs, the W.C.C. of Great Britain, has an international membership of about 165 active DX'ers. Headquarters of the club is c/o 26, Tolhouse St., Great Yarmouth, Norfolk, England. The W.C.C. publishes a monthly 40-page newsletter/bulletin bearing the title *CONTACT*. Dues are \$4 per year if the bulletin is mailed via sea mail; dues and an airmail bulletin to North America, \$10.00.

### CURRENT STATION REPORTS

The following is a resume of current reports. At time of compilation all reports are as accurate as possible, but stations may change frequency and/or schedule with little or no advance notice. All times shown are Greenwich Mean Time (GMT) and the 24-hour system is used. Reports should be sent to SHORT-WAVE LISTENING, P.O. Box 333, Cherry Hill, N.J., 08034, in time to reach your Short-Wave Editor by the fifth of each month; be sure to include your WPE identification, and the make and model number of your receiver. We regret that we are unable to use all the reports received each month, due to space limitations, but we are grateful to everyone who contributes to this column.

**Albania**—Tirana has added two more frequencies to its schedule: 6135 kHz, with Eng. noted at 0435-0445; and 6190 kHz, closing in Eng. at 0155 and continuing in native language with orchestral music and a speaker.

**Argentina**—Station LRA, Buenos Aires, was noted at 0255 with Eng. commentary on 9682 kHz, down from its normal 9690-kHz channel. This station can also be heard on 11.710 kHz (down from 11.715 kHz) with Eng. and s/off at 2345, Monday through Friday.

**Bahamas**—Station ZNS, Nassau, 1540 kHz (medium waves) can be heard at 0300-0500, often overriding WPTR, Albany, N. Y., and KXEL, Waterloo, Iowa. Reports should be sent to Assistant Manager Jack Dodge, ZNS Radio, P. O. Box 1347, Nassau, Bahamas.

**Bolivia**—*R. Norte*, Monetro, Depto. Sta. Cruz, has moved up from 4940 to 4961 kHz, where it was

### SHORT-WAVE ABBREVIATIONS

anmt—Announcement	QRN—Station interference
BBC—British Broadcasting Corporation	R.—Radio
Eng.—English	s/off—Sign-off
ID—Identification	s/on—Sign-on
kHZ—Kilohertz	V—Varies
kW—Kilowatts	xmsn—Transmission
N.A.—North America	xintr—Transmitter

## Deluxe POPULAR ELECTRONICS MAGAZINE CASES

DESIGNED TO HOLD A FULL YEAR'S COPIES



These decorative, yet sturdily constructed cases are just what you've been looking for to keep your copies of Popular Electronics Magazine in easy-to-find order.

Constructed of reinforced fiberboard and covered in rich leatherette, these durable cases guard against soiling and tearing of your magazines while lending themselves handsomely to the decor of any room, whether it be a library, study, den, music room or pine-paneled garage. The magazine cases are available with embossed gold lettering in either all black or attractive maroon back with black sides.

Specially designed to hold a full year's copies of Popular Electronics Magazine, the cases are only

**\$3.50 each, 3 for \$10, 6 for \$19  
FULLY GUARANTEED**

Note: Magazine cases are also available for other of your favorite titles. For prompt shipment, use the coupon below.

Ziff-Davis Publishing Company, Dept. SD  
One Park Avenue, New York, N.Y. 10016  
Please send \_\_\_\_\_ Popular Electronics Magazine Cases.  
Also send cases for the magazine titles indicated below:

TITLE	QUANTITY
_____	_____
_____	_____

- All black, gold embossed  
 Maroon back, gold embossed/black sides

Enclosed is \$ \_\_\_\_\_ at \$3.50 per case, 3 for \$10, 6 for \$19 (Quantity prices apply for combination orders of more than one title). Orders outside U.S.A. \$4.50 ea., 3 for \$13, 6 for \$25.

Name \_\_\_\_\_

Address \_\_\_\_\_ PE-38

City \_\_\_\_\_

State \_\_\_\_\_ Zip Code \_\_\_\_\_

Payment must accompany order.

heard with Latin American pop tunes to 0300/closing. Do not confuse it with another Bolivian just 2 kHz lower. *R. Ibare*, Beni.

Station CP85, *R. Universidad*, Tarija, is drifting badly and can be found anywhere from 4720 to 4740 kHz (at press time, it was on 4723 kHz—Ed.) with s/off time at 0300. Programs are mostly cultural with classical music and few anmts. Again, do not confuse this station with *R. Progreso* of Loja, Ecuador, which is also currently drifting (presently on 4723 kHz—Ed.). The latter closes much later, however.

**Brazil**—Station ZYL20, *Emissora Rio Sao Francisco*, Alagoas, 4925 kHz, is noted at 0258 with music and an ID with chimes. *R. Cultura Guaiaba*, Guaiaba, 5055 kHz, is a rarely reported station; look for it around 2200-2337 with many commercials, news and some music, all-Spanish.

**Ceylon**—*Radio Ceylon* (Commercial Service), Colombo, 15,205 kHz, is noted from 0200 to 0210 with Eng. news, and to 0330 with the "Musical Clock Program." This broadcast is beamed to Asia.

**China**—*R. Peking* is operating a medium-wave xmtr on 1525 kHz which is rated at 2000 kW. It is

Africa and Far East areas. The 15,445-kHz outlet has French at 0500 and 0530, Eng. at 0515, all relayed from Paris. Brazzaville is also reported on 4795 kHz, a low-powered regional outlet, from 0500 s/on, and on 9610 kHz, with native drum beats at 0515 and infrequent ID's; in French.

**Cuba**—*R. Havana's* Eng. schedule until the end of March is: 2010-2140 to N. Europe on 15,230 kHz; 2050-2150 on 11,760 and 15,270 kHz, 0100-0450 on 9525



Larry Beat, WPE8JJX, Toledo, Ohio, does his DX-ing with a National NC-88 receiver. That's a Lafayette solid-state tape recorder on top of it. A member of the radio clubs of R. Canada, the BBC, R. Portugal, and R. Budapest, Larry presently has 48 countries verified out of a total of 56 heard.



Mike Kropotkin, WPE2PXJ, uses a Hallicrafters S-120 receiver, and his antenna is a Hy-Gain SW-9. Mike now has 20 countries and 20 states verified.

being heard in Central Europe daily at 1500-2200 but there have been no reports as yet from N. A. on this super station.

**Congo Republic**—*R. Brazzaville*, 15,190 kHz, is heard from 1730 to 1830; news in French is aired at 1805; then French until 1915 when Eng. news is given to 1930, beamed to Africa and Madagascar. Another Eng. xmsn is given at 1300-1330 beamed to

kHz, 0100-0600 on 11,760 kHz, 0330-0600 on 6135 kHz, and 0630-0800 on 9655 kHz, all to N. & S. America.

**Dominican Republic**—A new station is HIKZ, *R. Difusora Popular*, assigned 4980 kHz, but only being heard on its harmonic of 9960 kHz; the schedule is 1100-0200, and reports should go to Rafael Reyes, Administrator, Calle Modesto Diaz #28, Apartemento 3, San Cristobal. *Onda Musical*, Santo Domingo, has moved up to 4795 kHz, as noted around 0300 with time checks and Latin American programming in Spanish.

**Ecuador**—As noticed in various bulletins, there is confusion regarding the Latin American station operating on 4865 kHz. It is neither *R. Luz de America* of Quito, nor *R. Cemit* of Portoviejo (which has been on 4772 kHz for years) but is the Bahia de Caraquez outlet of *R. Cemit*, an Ecuadorian network with stations in various cities. Look for it after 0300 in Spanish.

## NEW SOLID STATE 5-BAND RECEIVER

SEND FOR FREE LITERATURE

MODEL R-5



- Continuous Coverage .54 to 54 mc
- Variable beat frequency oscillator
- Includes 6-meter ham band
- And the 30 to 50 mc police bands
- Fully transistorized — Bandsread
- Noise limiter — Optional battery pack

WIRED AND TESTED . . . . . \$79.95

AMECO

DIVISION OF AEROTRON



BOX 6527, RALEIGH, N. C. 27608

CIRCLE NO. 1 ON READER SERVICE PAGE



# POPULAR ELECTRONICS READER SERVICE PAGE

## free information service:

Here's an easy and convenient way for you to get additional information about products advertised or mentioned editorially (if it has a "Reader Service Number") in this issue. Just follow the directions below...and the material will be sent to you promptly and free of charge.

**1.** Print or type your name and address on the lines indicated. Circle the number(s) on the coupon below that corresponds to the key number(s) at the bottom of the advertisement or editorial mention(s) that interest you. (Key numbers for advertised products also appear in the Advertisers' Index.)

**2.** Cut out the coupon and mail it to the address indicated below.

**3.** This address is for our product "Free Information Service" only. Editorial inquiries should be directed to POPULAR ELECTRONICS, One Park Avenue, New York 10016; circulation inquiries to Portland Place, Boulder, Colorado 80302.

**POPULAR  
ELECTRONICS**

VOID AFTER APRIL 30, 1968

P.O. BOX 8391  
PHILADELPHIA, PA. 19101

1 2 3 4 5 6 7 8 9 10 11 12 13 14 15 16 17 18 19 20  
21 22 23 24 25 26 27 28 29 30 31 32 33 34 35 36 37 38 39 40  
41 42 43 44 45 46 47 48 49 50 51 52 53 54 55 56 57 58 59 60  
61 62 63 64 65 66 67 68 69 70 71 72 73 74 75 76 77 78 79 80  
81 82 83 84 85 86 87 88 89 90 91 92 93 94 95 96 97 98 99 100

NAME (Print clearly) \_\_\_\_\_

ADDRESS \_\_\_\_\_

CITY \_\_\_\_\_ STATE \_\_\_\_\_ ZIP CODE \_\_\_\_\_

3 b

# dynaco



World-renowned for excellence in stereo high fidelity components. Ready built, or economical easy do-it-yourself kits. A wide choice of prices and power outputs to suit your needs. One performance level—the best. Sophisticated engineering enables assembly by the novice with assurance of laboratory standards of excellence. Dynakits have been recommended by every major testing organization.

To: Dynaco Inc., 3060 Jefferson Street, Phila., Pa. 19121  
Please rush detailed information to:

Name.....

Address.....

City..... State..... Zip.....

PE368

CIRCLE NO. 13 ON READER SERVICE PAGE

**FIND BURIED TREASURE!**  
10-DAY MONEY BACK GUARANTEE  
**TREASURE PROBE**  
\$18.88 ppd  
ALL TRANSISTORIZED

3 ft. portable detector finds buried metal objects. Signals location with loud audible sound. Detects gold, silver, metallic ore and nuggets of all kinds. Find lost coins, jewelry, Indian artifacts, civil war souvenirs. Treasure probe guaranteed to equal detectors selling to \$150 or your money back. Absolutely complete, sensitive earphone, 9v battery, nothing else to buy. TO ORDER: Send check, cash or money order, \$5.00 deposit for COD in N.J. add 5% tax. TREASUREPROBE Dept. P.E.A. P.O. Box 228, Toms River, N.J. 08753

## LEARN Electronics Engineering AT HOME

Fix TV, design automation systems, learn transistors, complete electronics. College level Home Study courses taught so you can understand them. Earn more in the highly paid electronics industry. Computers, Missiles, theory and practical. Kits furnished. Over 30,000 graduates now employed. Resident classes at our Chicago campus if desired. Founded 1934. Catalog. "Vets—write for information about G I Bill Training."

AMERICAN INSTITUTE OF ENGINEERING & TECHNOLOGY  
1137 West Fullerton Parkway, Chicago, Illinois 60614

**Egypt**—Cairo has Eng. to Europe at 2145-2315 on 9475 and 12,005 kHz. News and commentary is given at 2200; news headlines at 2313. Other xmsns were noted on: 11,765 and 7075 kHz, both new frequencies and both heard at 0400 in Arabic; 11,665 kHz, very strong at 2300 with Arabic news; and 17,655 kHz, at 1654 with Eng. mailbag and at 1700 with "Arabic By Radio."

**Ethiopia**—Station ETLF, Addis Ababa, was found with Eng. on 11,920 kHz at 0434-0455 and from 0615;

### MEDIUM WAVES

Here is a listing of some of the medium-wave stations currently being heard. The number at the left is the frequency in kilohertz. Approximate times are given at right with type of program; the term "evenings" refers to about 2300-0400.

584	Madrid, Spain	2315; some music
725	Paramaribo, Surinam	Evenings; music and religious programs, some in English
764	Dakar, Senegal	2315-2330; native music
	Baghdad, Iraq	After 0500; difficult to log
780	Barbadoes	2230; BBC news, sports
830	Belize, Br. Honduras	Evenings; moved from 834 kHz
900	XEW, Mexico City	0230; music and talks in Spanish
1035	4VEH, Haiti	Evenings; Eng.-language lessons and religious programs
1043	Dresden, E. Germany	0245; weak, QRM from WHO, Des Moines, Iowa
1235	Hamilton, Bermuda	Evenings; music and talks in Eng.-weather for European cities
1466	3AM2, Monaco	0500; Trans World Radio, music and religious programs, native language
1586	West Germany	0500; often a good signal

on a later date, it had moved up to 11,940 kHz, with Eng. at 2320-2330. Reports go to Box 654.

**Finland**—Finnish B/C Corp., Helsinki, has Eng. to N. A. on 9585 kHz at 0200-0300.

**France**—Eng. xmsns from Paris are as follows: to Brazzaville on 7160 kHz at 0515-0530 and on 17,850 and 21,650 kHz at 1100-1115; to the Orient on 15,245, 17,740, and 21,580 kHz at 1300-1330; and to Africa (via Brazzaville relay) on 15,245 kHz at 1915-1930. There are no Eng. xmsns beamed to the United States.

**Guatemala**—Station TGN. 720 kHz, and TGNA, 5955 kHz, Box 601, Guatemala City, have Eng. at 0300-0430 with mostly religious programming. In some areas both stations are being heard.

**Haiti**—A station being heard on 5090 kHz from 0025 to 0055/close with pop music and annts in French is believed to be 4VAF. *La Voix de Grande-Anse*, Jeremie. Poor modulation made a definite ID impossible. The station reportedly had obtained new output tubes for its xmtr, which had been off the air for a lengthy period.

**Hungary**—R. *Budapest* has been logged on a new frequency of 7100 kHz at 2130 with ID and Eng. news, at 2140 with a repeat of the headlines, and at 2144 with a request for letters from listeners.

**India**—*All India Radio*, Delhi, is noted in many areas at 2145 in Eng. on 9915 kHz.

**Italy**—A new frequency for Rome is 6075 kHz, heard loud to 7275 kHz with Eng. news to the Mediterranean area, as announced, at 0425-0440.

**Japan**—*Nippon Hoso Kyokai* (NHK), Tokyo, was noted on 7140 kHz with several ID's and numerous musical selections from 1310, completely covering the Indonesian outlet in Ambon.

**Korea (North)**—R. *Pyeongyang*, 16,320 kHz, has Spanish from 0055 to 0150/close, with news at 0100. Eng. is noted on (as announced) 46.3 and 39.5

meters at 1145-1157 and 1415-1430. The wavelengths correspond to late readings of 6479 and 7580 kHz, respectively.

**Korea (South)**—*Voice of Free Korea*, Seoul, has extended its Eng. broadcast to a full hour, 0300-0400, as noted on 15,430 kHz. Spanish is heard on this channel from 0210 to 0300.

**Lebanon**—Beirut may be coaxed out from under London from 2005 to 2030 s/off in French with a variety program on 15,180 kHz. *Radio Lebanon's* latest schedule reads: to Africa on 15,350 kHz at 1830-1900 in Eng., at 1900-2000 in Arabic, and at 2000-2030 in French; to S. America on 15,340 kHz at 2300-2330 in Portuguese, at 2330-0030 in Arabic, and at 0030-0100 in Spanish; to N. A. and Europe on 11,785 kHz at 0130-0200 in French, at 0200-0230 and 0300-0330 in Arabic, at 0230-0300 in Eng., and at 0330-0400 in Spanish. Omnidirectional xmsns are

### SHORT-WAVE CONTRIBUTORS

Charles Washburn (WPE1FO), Machias, Maine  
 Stan Mayo (WPE1GMF), Portland, Maine  
 Robert Bovick (WPE1GPW), Worcester, Mass.  
 Conrad Baranowski (WPE1GXN), Boston, Mass.  
 Peter Simpson (WPE1HIC), Natick, Mass.  
 Craig Thompson (WPE1HJE), Cambridge, Mass.  
 Eric Lebowitz (WPE2JY), Jackson Heights, N. Y.  
 Robert Kaplan (WPE2MJK), Bronx, N. Y.  
 Robert Hejl (WPE2OMD), Farmingdale, N. Y.  
 Peter Macinta, Jr. (WPE2ORB), Kearny, N. J.  
 Andrew Jezioro (WPE2PCB), Cheektowaga, N. Y.  
 Edward Sobota (WPE2PKR), Fulton, N. Y.  
 Gary Ohlson (WPE2PNB), Red Hook, N. Y.  
 Brian Mc Mahon (WPE2POC), Fair Haven, N. J.  
 James Riviello (WPE2POK), Cherry Hill, N. J.  
 David Simon (WPE2POP), Brooklyn, N. Y.  
 Robert Kennicutt, Jr. (WPE2PKR), Port Crane, N. Y.  
 Thomas Wisser (WPE2PUA), Linwood, N. J.  
 Paul Jordano (WPE2PVK), Mount Vernon, N. Y.  
 Bret Schumacher (WPE2PWJ), Liverpool, N. Y.  
 William Via (WPE3FHB), Baltimore, Md.  
 Rudolph Menna (WPE3HIV), Philadelphia, Pa.  
 John Maruschak (WPE3HKP), Levittown, Pa.  
 Grady Ferguson (WPE4BC), Charlotte, N. C.  
 David Meisel (WPE4KS), Charlottesville, Va.  
 Ray Bacon (WPE5BFU), Baton Rouge, La.  
 Carlton Blake (WPE5ETX), Fort Smith, Ark.  
 W. W. Mosby (WPE6ENA), San Jose, Calif.  
 Trevor Clegg (WPE6FAF), Santa Cruz, Calif.  
 James Perley (WPE6GAL), Rededa, Calif.  
 Chester Siemon (WPE6MAO), Roseville, Mich.  
 Bill Ferguson (WPE6JMV), Elyria, Ohio  
 David Morrison (WPE6JSD), Grand Rapids, Mich.  
 Gary Makowski (WPE6JVT), Chicago, Ill.  
 Bill Vogt (WPE6JND), Tinley Park, Ill.  
 Craig Cook (WPE6JBI), Milwaukee, Wis.  
 A. R. Niblack (WPE6KAI), Vincennes, Ind.  
 John Beaver, Sr. (WPE6AE), Pueblo, Colo.  
 Jack Perolo (WPE6PIC), Sao Paulo, Brazil  
 Richard Lavolette (WPE6EM), Sayward, B. C., Canada

David Alpert, Morton Grove, Ill.  
 Werner Funkenhauser, Guelph, Ont., Canada  
 Nick Grasso, Cleveland Heights, Ohio  
 Kenneth Gregory, Jr., Meadowview, Va.  
 Glenn Hansen, Burton, Wash.  
 Glenn Jacobs, Philadelphia, Pa.  
 Calvin Kuehner, St. Charles, Ill.  
 Kenny Logsdon, Louisville, Ky.  
 Leslie Marcus, Eugene, Ore.  
 James Misner, San Diego, Calif.  
 Jimmy Morris, Dover, Del.  
 Rev. John Pejza, Ojai, Calif.  
 Mike Russell, St. Louis, Mo.  
 Jeff Utter, Carlsbad, Calif.  
 Robert White, San Francisco, Calif.  
 North American Short Wave Association, Altoona, Pa.  
*Radio New York Worldwide*, New York, N. Y.  
*Sveदन Calling DX'ers Bulletin*, Stockholm, Sweden

aired daily at 0430-0730 and 1625-1820 on 5980 kHz, and at 0925-1600 on 9545 kHz.

**Malaysia**—*Voice of Malaysia*, Kuala Lumpur, 6175 kHz, has seemingly retimed its Eng. session or eliminated it altogether; the broadcast previously in Eng. at 1115-1130 is now in an Asian language.

The editors of *Popular Photography* proudly present a dramatic, sophisticated and colorful tribute to the loveliest subject in the world...

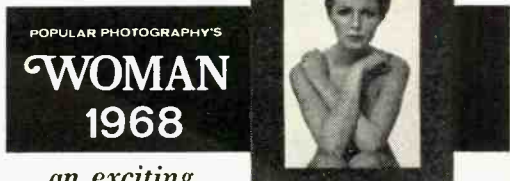

...an exciting insight into the world of beautiful women by the great photographers of our time!

**POPULAR PHOTOGRAPHY'S WOMAN 1968** is a collection of superb photographs—the finest, most searching works of leading professional photographers including Gowland, Steckler, Sokolsky and Lyon. They bring the woman into focus—her many moods, her countless expressions, her unpredictable reactions, as she plays her varied roles in modern life. From girl next door to girl friend. From movie queen to mother. From fashion model to temptress. And always — glamorous, subtle and enchanting.

Included in a 20-page *Playboy* feature section is a portfolio of never-before-published photos taken by 6 of *Playboy's* best photogs... another outstanding section analyzes *Blow-Up*—the motion picture that probes the relationships of a photographer with his cameras and models. To celebrate the 100th anniversary of *Harper's Bazaar*, a special photo album depicts *Harper's* stylish effects on the woman of today.

**POPULAR PHOTOGRAPHY'S WOMAN 1968**—a 128-page gallery of fine photography is essential as a reference work for every photographer. A section of the publication is devoted to technical data including camera, lighting, exposure time, film, filters and technique used for each photograph.

**POPULAR PHOTOGRAPHY'S WOMAN 1968** is a masterful study of the loveliest subject in the world. It is destined to become a collector's item for every person who appreciates great photography. Order your copy today!

**POPULAR PHOTOGRAPHY'S WOMAN 1968** is also available in a splendid LEATHERFLEX-BOUND deluxe edition. Rugged Leatherflex cover provides lasting protection yet is softly textured and gold-embossed for the look of elegance. A collector's item. **\$3 POSTPAID!**

ZIFF-DAVIS SERV. DIV., DEPT. WO • 595 Broadway, N.Y., N.Y. 10012  
 Please send me a copy of **POPULAR PHOTOGRAPHY'S WOMAN 1968** as checked below.

- \$1.25 enclosed, plus 15c for shipping and handling. Send me the regular edition. (\$1.75 for orders outside the U.S.A.)  
 \$3.00 enclosed. Send me the Deluxe Leatherflex-bound edition, postpaid. (\$3.75 for orders outside the U.S.A.) Allow three additional weeks for delivery.

print name \_\_\_\_\_  
 address \_\_\_\_\_ PE-38  
 city \_\_\_\_\_ state \_\_\_\_\_ zip code \_\_\_\_\_

PAYMENT MUST BE ENCLOSED WITH ORDER

FROM HiFi/STEREO REVIEW  
**DELUXE PADDED DUST-PROOF  
 RECORD and TAPE CASES**  
 plus FREE cataloging forms



**These decorative, yet sturdily constructed cases are just what you've been looking for**

to keep your records and tapes from getting tossed about and damaged, disappearing when you want them most and just generally getting the "worst of it" from constant handling. They're ideal too for those valuable old "78's" that always seem to get thrown about with no place to go.

Constructed of reinforced fiberboard and covered in rich leatherette in your choice of eight decorator colors, the HiFi/STEREO REVIEW Record and Tape Cases lend themselves handsomely to the decor of any room, whether it be your library, study, den, music room or pine-paneled garage. The padded leatherette back (in your color choice) is gold tooled in an exclusive design available only on HiFi/STEREO REVIEW Record and Tape Cases. The sides are in standard black leatherette to keep them looking new after constant use.

**Extra**

With each Record and Tape Case you order you will receive, free of charge, a specially designed record and tape cataloging form with pressure-sensitive backing for affixing to the side of each case. It enables you to list the record names and artists and will prove an invaluable aid in helping you locate your albums. The catalog form can be removed from the side of the case at any time without damaging the leatherette.



Record Cases are available in three sizes: for 7", 10" and 12" records. Each case, with a center divider that separates your records for easy accessibility, holds an average of 20 records in their original jackets. The Recording Tape Case holds 6 tapes in their original boxes.

• The Tape Cases or the 7" Record Cases (with catalog forms) are only \$3.25 each; 3 for \$9; 6 for \$17.

• The 10" or 12" Record Cases (with catalog forms) are \$3.50 each; 3 for \$10; 6 for \$19.

Add an additional 75c per order (regardless of number of cases ordered) for shipping and handling.

Ziff-Davis Publishing Company, Dept. SD  
 One Park Avenue, New York, N. Y. 10015

My remittance in the amount of \$ \_\_\_\_\_  
 is enclosed for the Cases indicated below.

**Quantity**

- \_\_\_\_\_ Tape Case at \$3.25 ea.; 3 for \$9; 6 for \$17
- \_\_\_\_\_ 7" Record Case at \$3.25 ea.; 3 for \$9; 6 for \$17
- \_\_\_\_\_ 10" Record Case at \$3.50 ea.; 3 for \$10; 6 for \$19
- \_\_\_\_\_ 12" Record Case at \$3.50 ea.; 3 for \$10; 6 for \$19

ADD 75c PER ORDER FOR SHIPPING AND HANDLING.  
 Check color choice for back of case (sides in black only):

- |  |                                      |                                     |
|--|--------------------------------------|-------------------------------------|
| <input type="checkbox"/> Midnight Blue | <input type="checkbox"/> Red         | <input type="checkbox"/> Saddle Tan |
| <input type="checkbox"/> Pine Green    | <input type="checkbox"/> Orange      | <input type="checkbox"/> Yellow     |
| <input type="checkbox"/> Grey          | <input type="checkbox"/> Spice Brown | <input type="checkbox"/> Black      |

Name \_\_\_\_\_

Address \_\_\_\_\_ FE-38

City \_\_\_\_\_ State \_\_\_\_\_ Zip Code \_\_\_\_\_

**PAYMENT MUST BE ENCLOSED WITH ORDER**

**Oman**—About the only way to log this country is to listen for *Ibri Radio* on 5710.5 kHz. This aero station broadcasts irregularly in air/ground service.

**Peru**—Station OAX8X, *R. Amazonas*, Iquitos, 4814 kHz, at times duals the 9770-kHz outlet and is audible after the Brazilian on 4815 kHz signs off, with typical Latin American programs until the close at 0500. Station OBX70, *R. Onda Imperial*, Cuzco, 5056 kHz, recently opened, fades in around 0000 with increasing strength until 0300 s/off; many ID's are given. Station OBX7U, *R. Maldonado*, Maldonado, 4980 kHz, verifies promptly but the card does not indicate xmitr power; this station closes daily at 0400.

**Poland**—*R. Warsaw* has begun a French service at 1100 on 9540, 11,800, 11,815, and 11,955 kHz; at 1215 on 9540, 11,800, and 11,815 kHz; at 1630 and 1730 on 11,800 and 11,955 kHz; at 2000 and 2130 on 5995 and 7145 kHz; and at 2200 on 5995 and 7285 kHz.

**Portugal**—A new French xmsn from Lisbon directed to Europe is given at 0545-0630 on 21,490 kHz. The service to Canada includes French at 0215-0300, and Eng. at 0300-0345 on 5985 kHz.

**South Africa**—*R. RSA*, Johannesburg, is now using 15,220 and 11,875 kHz (delete 9705 kHz) for broadcasts to N. A. in Eng. at 2330, 0030, and 0130. A xmsn to the Middle East in Eng. is presented at 0430 on 15,220 kHz.

In addition, a native-language xmsn has been noted from 1440 to 1550 s/off on 25,780 kHz. A xmsn in Eng. to Ireland and the United Kingdom was heard on 21,500 kHz at 1915. News in Eng. was being given, at press time, on unlisted 15,035 kHz at 2338-2343. Home Service xmsns are being noted on 11,735 kHz at 0610 in Eng., and on 6155 kHz from 2210 with the Commercial Service in Eng. and Afrikaans.

**Swan Island**—The clandestine station, *R. Americas*, has resumed xmsns on 6000 kHz, where it has been logged at 0625, 2150, and 0100, operating dual to the medium-wave outlet on 1157 kHz (V), all-Spanish except for an occasional Eng. ID.

**Sweden**—*R. Sweden*, Stockholm, 21,585 kHz, has Eng. to S. E. Asia ending at 1430, and followed by Swedish.

**Switzerland**—The low-powered HER22, Berne, is readable at times along the East Coast on 3985 kHz during the European Service xmsn at 0620-0705; Italian news is given at 0630, Eng. from 0700.

**Clandestine**—A station being heard on 10,031 kHz from 1145 is thought to be *Liberation Radio, The Voice of the South Vietnam National Front for Liberation* (Viet Cong). The programming includes considerable native-language talks and chorus singing followed by a theme melody DISsimilar to that used by *R. Peking*. —30—

**W.F. and I.P.**

The Electronics Industries Association has earmarked \$500,000 to "win friends and influence people" favorably. A program has been initiated to counteract the not-too-good publicity being given electronics service technicians, and to encourage more young people to seek a career in consumer electronics servicing. The first phase of this five-year program was a three-hour seminar on "Wanted: 230,000 Electronic Service Technicians—Who? When? Where?" at the annual convention of the American Vocational Association, an organization representing 45,000 vocational education teachers and counsellors. The EIA eventually intends to influence and improve electronics teaching at the high school classroom level.

# LETTERS (Continued from page 12)

60 QSL cards from 24 states and three provinces in Canada. Some of my better catches have been KNBR in San Francisco; CBK in Saskatchewan, Canada; and WROZ in Evansville, Ind. (which runs only 250 watts at night). I have even received an image frequency from the 2.5-MHz signal of WWV in Fort Collins, Colorado.

Since almost everyone today owns—or has access to—a broadcast band radio, it is possible for almost everyone to join in the fun of SWL'ing. All that is needed is a short outdoor antenna, and some patience.

D. LEE  
Kansas City, Mo.

## OPERATING INSTRUCTIONS WANTED

I have a Model 49 tube tester made by the Jackson Electrical Instrument Co., Dayton, Ohio, that I would like to use for checking early model tubes in my work for the Salvation Army. Unfortunately, I do not have the operating instructions, and the manufacturer of the tube tester could not help me. I would greatly appreciate any help either you or your readers can give me in locating the operating instructions.

ROBERT A. NEUMANN  
9611-102 Ave.  
Edmonton, Alberta, Canada

*Although we at POPULAR ELECTRONICS have no idea where you can obtain the information you want, some of our readers might know. We have given your full address so that anyone who may be able to help can contact you directly.*

## AM/FM STEREO TUNER PROJECT REQUESTED

My main hobby interest is hi-fi/stereo equipment, so I can appreciate the great pre-amplifier, amplifier, and speaker system projects you have published. Now, how about designing an FET and IC AM/FM stereo tuner?

STEPHEN H. HOFFMAN  
Atherton, Calif.

*A project on how to build a high-quality AM tuner is scheduled for our May, 1968, issue. We have no immediate plans for an FM tuner project, but it's a possibility.* —50—

## ANSWERS TO POLARITY QUIZ

*(Quiz appears on page 66)*

- |            |             |
|------------|-------------|
| 1 Positive | 6 Positive  |
| 2 Negative | 7 Negative  |
| 3 Positive | 8 Negative  |
| 4 Negative | 9 Negative  |
| 5 Negative | 10 Negative |

# POPULAR ELECTRONICS

MARCH 1968

## ADVERTISERS INDEX

READER SERVICE NO.	ADVERTISER	PAGE NO.
1	AMECO Division of Aerotron, Inc	114
2	Allied Radio	14
	American Institute of Engineering & Technology	116
3	Amperex Electronic Corporation	FOURTH COVER
4	Arcturus Electronics Co	121
5	Argos Products Company	99
32	Avanti Research & Development, Inc	26
6	B & K	11
7	Burstein-Applebee	96
	Capitol Radio Engineering Institute, The	36, 37, 38, 39
8	Cleveland Institute of Electronics	9
9	Cleveland Institute of Electronics	62, 63, 64, 65
10	Computer Usage Education	94
	Conar	96
11	Courier Communications, Inc	111
12	Datak Corporation, The	104
	DeVry Institute of Technology	5
13	Dynaco Inc	116
31	Electro-Voice, Inc	93
33	Finney Company, The	7
14	Heath Company	106, 107, 108, 109
15	Hy-Gain Electronics Corporation	10
16	Lafayette Radio Electronics	112
	McGee	110
17	Milwaukee School of Engineering	105
18	Mosley Electronics, Inc	95
19	Multi-Elmac Co	12
20	Multicore Sales Corp	14
	National Radio Institute	SECOND COVER, 1, 2, 3
	National Technical Schools	18, 19, 20, 21
21	Olson Electronics Incorporated	99
22	Pace Communications Corp	6
23	Pearce-Simpson, Inc	23
	RCA Electronic Components and Devices	THIRD COVER
	RCA Institutes, Inc	88, 89, 90, 91, 97
24	Radio Shack	104
25	Satch & Co., Herbert	94
26	Sams & Co., Inc., Howard W	100
27	Solid State Sales	123
28	Sonar Radio Corp	103
29	Squires Sanders, Inc	17
34	Sydmur Electronic Specialties	112
	Treasureprobe	116
	Valparaiso Technical Institute	110
30	Weller Electric Corporation	8

CLASSIFIED ADVERTISING 120, 121, 122, 123, 124

# ELECTRONICS MARKET PLACE

**COMMERCIAL RATE:** For firms or individuals offering commercial products or services. \$1.00 per word (including name and address). Minimum order \$10.00. Payment must accompany copy except when ads are placed by accredited advertising agencies. Frequency discount: 5% for 6 months; 10% for 12 months paid in advance.

**READER RATE:** For individuals with a personal item to buy or sell. 60c per word (including name and address). No Minimum! Payment must accompany copy.

## FOR SALE

**FREE!** Giant bargain catalog on transistors, diodes, rectifiers, SCR's, zeners, parts. Poly Paks, P.O. Box 942, Lynnfield, Mass. 01940.

**GOVERNMENT Surplus Receivers, Transmitters, Snooperscopes, Radios, Parts, Picture Catalog 25¢.** Meshna, Nahant, Mass. 01908.

**WEBBER LAB's Police—Fire Transistorized Converter kit 30-50 mc. & 100-200mc. (1 mc. spread) \$5.00 each.** 72 Cottage Street, Lynn, Mass. 01905.

**R.F. CONVERTERS.** World's largest selection. Also CCTV cameras, etc. Lowest factory prices. Catalog 10¢. Vanguard 196-23 Jamaica Ave., Hollis, N.Y. 11423.

**TELEPHONE VOICE SWITCH: (LS-500). ACTUATES AUTOMATICALLY AND UNATTENDED ANY TAPE OR WIRE RECORDER. PICTORIAL INSTALLATION INSTRUCTIONS INCLUDED. \$23.75. POST PAID USA, WJS ELECTRONICS, P.O. BOX 1508, LAS VEGAS, NEVADA 89101.**

**INVESTIGATORS: KEEP IN STEP WITH ADVANCEMENTS IN THE ART OF ELECTRONICS FOR THE PROFESSIONAL. SEND \$1.00 FOR EQUIPMENT BROCHURE.** WJS ELECTRONICS, P.O. BOX 1508, LAS VEGAS, NEVADA 89101.

**BUG DETECTOR: WILL DETECT AND LOCATE SURREPTITIOUS TRANSMITTING DEVICES IN CONFERENCE ROOMS, HOME AND OFFICES, ETC. WRITE FOR DETAILS.** WJS ELECTRONICS, 737 NORTH SEWARD, HOLLYWOOD, CALIF. 90038.

**DETECTIVES! Free Brochures! Electronics Surveillance Devices. SILMAR ELECTRONICS, 3476 N.W. 7th Street, Miami, Fla. 33125.**

**ROCKETS:** Ideal for miniature transmitter tests. New illustrated catalog, 25¢. Single and multistage kits, cones, engines, launchers, trackers, rocket aerial cameras, technical information. Fast service. Estes Industries, Dept. 18, Penrose, Colorado 81240.

**LOWEST Prices Electronic Parts. Confidential Catalog Free. KNAPP, 3174 8th Ave. S.W., Largo, Fla. 33540.**

**RADIO—T.V. Tubes—33¢ each. Send for free catalog.** Cornell, 4213 University, San Diego, Calif. 92105.

**CONVERT any television to sensitive, big-screen oscilloscope. Only minor changes required. No electronic experience necessary. Illustrated plans, \$2.00.** Relco-A33, Box 10563, Houston, Texas 77018.

**CRYSTALS . . . largest selection in United States at lowest prices. 48 hr. delivery. Thousands of frequencies in stock. Types include HC6/U, HC18/U, FT-241, FT-243, FT-171, etc. Send 10¢ for catalog with oscillator circuits. Refunded on first order.** Jan Crystals, 2400F Crystal Dr., Fort Myers, Fla. 33901.

**SURVEILLANCE EQUIPMENT—NEW HIGH PERFORMANCE SUBMINIATURE MODELS. ELECTRONIC COUNTERMEASURE DEVICES TO PROTECT PRIVACY. FREE DATA: SECURITY ELECTRONICS-PE, 15 EAST 43RD STREET, NEW YORK, N.Y. 10017.**

**FREE ELECTRONICS (new and surplus) parts catalog. We repair multimeters.** Bigelow Electronics, Bluffton, Ohio 45817.

**JAPANESE PRODUCTS CATALOG by air mail \$5, sea \$3.** Intercontinental, CPO 1717, Tokyo, Japan.

**TREASURE Hunters! Prospectors! Relco's new instruments detect buried gold, silver, coins. Kits, assembled models, transistorized. Weighs 3 pounds. \$19.95 up. Free catalog.** Relco-A33, Box 10836, Houston, Texas 77018.

**RECTIFIERS, transistors, other components. Catalog free.** Electronic Components Co., Box 2902C, Baton Rouge, La. 70821.

**DIAGRAMS—Radios \$1.00, Television \$2.50. Give make and model.** Diagram Service, Box 1151PE, Manchester, Conn. 06042.

**EUROPEAN and Japanese bargain catalogs. \$1 each.** Dee, 10639E Riverside, North Hollywood, Calif. 91602.

**GENERAL INFORMATION:** First word in all ads set in bold caps at no extra charge. Additional words may be set in bold caps at 10¢ extra per word. All copy subject to publisher's approval. Closing Date: 1st of the 2nd preceding month (for example, March issue closes January 1st). Send order and remittance to: Hal Cymes, POPULAR ELECTRONICS, One Park Avenue, New York, New York 10016.

**INVESTIGATORS, FREE BROCHURE, LATEST SUBMINIATURE ELECTRONICS SURVEILLANCE EQUIPMENT, ACE ELECTRONICS, 11500-L NW 7TH AVE., MIAMI, FLA. 33168.**

**JAPAN DIRECTORY.** Electronics products and parts. General merchandise and Asia trade information. Just \$1.00 today. Ippano Kaisha Ltd., Box 6266, Spokane, Washington 99207.

**TRANSISTORIZED CONVERTER KITS:** Two models, converts car radio. Receive 30-50mc or 100-200mc (one mc tuning) \$5.00 with simple instructions. Crystal \$2.50. Meshna, No. Reading, Mass. 01864.

**METAL—Treasure Detectors, most sensitive. Lowest priced. Free catalog.** Jetco Instruments, Box 2880-E, Huntsville, Texas 77340.

**REVERBERATION Springs—Data sheets and application information available. Send self addressed envelope to: Southwest Technical Products Corp., 219 W. Rhapsody, San Antonio, Texas 78216.**

**SIGNAL Tracing Trouble Shooter—Repairs radios, televisions, amplifiers. Money back guarantee, \$5.95.** United, P. O. Box 8690, Washington, D.C. 20011.

**MUSIC LOVERS, CONTINUOUS, UNINTERRUPTED BACKGROUND MUSIC FROM YOUR FM RADIO, USING NEW INEXPENSIVE ADAPTOR. FREE LITERATURE.** ELECTRONICS, 11500-Z NW 7th Ave., MIAMI, FLORIDA 33168.

**MECHANICAL, Electronic devices catalog 10¢. 1/16 laminated copper clad 2 sides, for printed circuits, 9 1/2 x 4 1/2, \$1.** Fertik's, 5249 'D' St., Philadelphia, Pa. 19120.

**PROXIMITY switch. Detects nearness of human body! Free information.** Claremont Products, 860 Reed, Claremont North, Calif. 91711.

**DESK nameplate 2" x 8" plastic, walnut background, white engraving, \$2.95. Print name. Three plastic holders frame and display 60 QSL or post cards \$1.00. Same day shipment. Postpaid and guaranteed.** Tepabco, Brown Blvd., Gallatin, Tennessee 37066.

**TV CAMERA KITS!** Television live pictures on any TV receiver without modification! Perfect for experimental, educational and industrial applications. Eight tube and transistor models to choose from—\$18.95 up. Plans available separately. **EASY-EDUCATIONAL-ECONOMICAL.** Informative catalog **FREE.** ATV RESEARCH, 13th & Broadway, Dakota City, Nebr. 68731.

**SONAR monitor Receivers unsurpassed. Fire, police, ambulance, taxi, highway patrol communications. Exceptional values.** Griffin's, 322 West State, Ithaca, New York 14850.

**LATEST TELEPHONE BUGGING COUNTERMEASURES: ENGINEERING LABORATORIES, BOX 1036, ANDERSON, INDIANA 46015.**

**LINEAR AMPLIFIERS: "Hornet"—50 watts output—\$98.50; "Raid-er"—100 watts—\$139.95; "Maverick-250"—250 watts—\$244.95. For AM and SSB. "BANDIT II"—12 V. mobile amplifier—\$169.95. Frequency range 20-35 megacycles (illegal for Class D 11 meters.) Dealer inquiries invited. D & A Manufacturing Co., 1217 Avenue C, Scottsbluff, Nebraska 69361.**

**LOOKING FOR SURVEILLANCE EQUIPMENT?** Write for information about Directory of Manufacturers and Distributors. T & G Publications, Box 28658, Memphis, Tenn. 38128.

**DRAKE SW-4 and speaker. Like new \$150.** Harrison, 501 Miami Terrace Park, Ohio.

**OUTDOOR TV Antennas now wholesale.** Jones, 1115 Rambler, Pottstown, Penna. 19464.

**ELECTROLUMINESCENT Night Light transistorized. 1 watt output. Good for camping. Completely portable \$29.95. Send money order only to: Lilly Electronics Co., 2744 Gladstone, Detroit, Mich. 48206.**

**VOLKSWAGEN Owners: Voltage booster, boosts 6 volts to 12 volts on Pre-1967 Volkswagens. Operate stereo, C.B. Etc. Kit \$11.95. Wired \$16.95.** Sulco Industries, Culver City, Calif. 90230.

**RELAYS**—Sigma 80030. Any quantities. **ALARM RELAY SUPPLY**, 20725 Burbank Blvd., Woodland Hills, Calif. 91364.

**JAPANESE or EUROPEAN DIRECTORY** 200 firms \$1.00. **SURVEILLANCE EQUIPMENT**, Catalog 25¢. Wireless **SNOOPERMIKE** \$25.00. **SUBMINNMIKE** 3/8 x 3/8 x 3/16 \$4.00. **SIERRATRONICS**, Box 7497, Las Vegas, Nev. 89101.

**POPULAR RESISTOR ASSORTMENT**. 150 American-Brand 1/2 watt resistors in handy folder. \$5.95. **C. E. WIRE CO.**, Box 665, Fort Wayne, Indiana 46801.

**WE SELL CONSTRUCTION PLANS. TELEPHONE:** Answering Machine, Speakerphone, Carphone, Phonevision, Legal Connector, Auto Dialer, Central Dial System. **TELEVISION:** \$35.00 Color Converter, Tape Recorder, 3DTV, \$25.00 Camera. **DETECTIVE:** Infinity Transmitter. Tail Transmitter, Police Radar Detector. **HOBBYIST:** Electron Microscope, 96 Hour Tape Music System, Ultrasonic Dishwasher, Radar-Oven, Electronic Tranquilizer. Plans \$4.95 each. **COURSES:** Telephone Engineering \$39.50, Detective Electronics \$22.50, Anti-Detective Electronics \$27.50. **SUPER HOBBY CATALOG** 25¢. Don Britton Enterprises, 7906 Santa Monica Blvd., Hollywood, Calif. 90046.

**CIRCUIT Boards, Parts for "Poptronics" projects.** Free catalog. S.W. Technical, Box 16297, San Antonio, Texas 78216.

**SURVEILLANCE EQUIPMENT, LATEST MINIATURE DEVICES, FREE 1968 catalog.** **FISHER ELECTRONICS**, Box 350, N. Miami Beach, Florida 33160.

**TRANSISTORIZED Kit, Converts A.M. Radio—receive police, fire—30-50 or 100-200 MC.** With perforated board \$5.00—With Printed circuit \$7.50—Instructions included. Crystal controlled, Crystal \$2.50. **MESHNER, NO. READING**, Mass. 01864.

**DRAKE SW-4 short-wave receiver.** Tunes 49, 41, 31, 25, 19, 16, 13 meter bands, plus 2 spare xtal positions. First \$190 check. J. Gillespie, **POPULAR ELECTRONICS Classified**, Box 117, 1 Park Avenue, New York, N.Y. 10016.

## PLANS AND KITS

**ALLWAVE RADIO KIT.** Tube, transistor included \$5.00. Headset \$2.50. **Ekeradio**, Box 131, Temple City, Calif. 91780.

**TESLA COIL—40" SPARKS!** Plans \$5.00. Information 50¢. **Huntington Electronics**, Box 9-P Huntington Station, Shelton, Conn. 06484.

**INTEGRATED CIRCUIT digital kit.** Contains IC, Mounting board, circuits. \$3.75. **Adams**, Box 399, Hazelwood, Missouri 63042.

**CRYSTAL, TRANSISTOR, TUBE kit catalog—25¢, refundable.** Laboratories, 12041-L Sheridan, Garden Grove, Calif. 92640.

**INTEGRATED CIRCUIT KITS; COMPUTER LOGIC; IC's;** others. Catalogue free. **KAYE ENGINEERING**, Box 3932-A, Long Beach, California 90803.

**ELECTRONIC** supplies, plans, kits, free literature. **Hazelton**, Box 163, Hazel Park, Michigan 48030.

## SHORTWAVE LISTENING

**1968 SWL PROGRAM GUIDE**, listings by the hour, \$2.00. **Antennas, Antenna Tuners. BOOKS** for SWLs, 218 Gifford, Syracuse, N.Y. 13202.

**YOUR** guide to better shortwave listening. How to buy, set up and operate a listening post. Send 25¢ for Booklet SWL-1, Dept. R., Hammarlund Manufacturing Company, Mars Hill, N.C. 28754.

**GUIDE TO BROADCASTING STATIONS.** New frequency list of AM, FM, and short-wave. 136 pages. Bargain price. \$1.95. **TRANSISTOR CIRCUIT HANDBOOK** now \$4.50. We have limited stock ITU lists. Catalog. **GILFER ASSOCIATES, INC.**, BOX 239, PARK RIDGE, N.J. 07656.

## HIGH FIDELITY

**FREE!** Send for money saving stereo catalog #P3E and lowest quotations on your individual component, tape recorder, or system requirements. **Electronic Values, Inc.**, 200 W. 20th St., New York, N.Y. 10011.

**HI-FI Components, Tape Recorders**, at guaranteed "We Will Not Be Undersold" prices. 15-day money-back guarantee. Two-year warranty. No Catalog. Quotations Free. **Hi-Fidelity Center**, 239 (P) East 149th Street, New York 10451.

**"LOW**, Low quotes: all components and recorders. **HiFi, Roslyn**, Penna. 19001.

# "ARCTURUS" SALE

\* **Tube Bargains, to name just a few:**

#6146	..... \$2.95	= 5725/6AS6	..... 59¢	#6A05	..... 56¢
= 6360	..... 3.50	= 5842/417A	..... \$2.50	= 6BQ7	..... 94¢
#6688	..... 3.50	= 5847/404A	..... 2.50	= 6CG7	..... 59¢
= 6939	..... 3.50	= 1A X 2	..... 49¢; 5 for 2.00	= 6J6	..... 49¢
#7025	..... .59	= 6K7	..... 39¢; 3 for 1.00	#6T8	..... 84¢
= 7788	..... 3.75	= 12BN6	..... 39¢; 3 for 1.00	#6U8	..... 77¢
#2D21	..... .49	= 25L6	..... 39¢; 3 for 1.49	= 12AU7	..... 39¢

Any unlisted receiving tube, 75% discount off RCA list prices.

- Tube Cartons: 6AU6 etc. size, \$1.75 per 100. 6SN7 etc. size, \$2.10 per 100. 5U3GB size, \$2.50 per 100. 5U4G size, .03¢ each.
- Obsolete Tubes: = UX200. \$1.69; #80. \$1.20; = 10Y, 69¢.
- 7 inch 90 degree TUV bench test Picture Tube with adapter. No inc trap needed. Cat. #7BP7, \$6.99.
- Silicon Rectifier octal-based long-range replacement for 5U4, 5Y3, 5AS4, 5AW4, 5T4, 5V4, 5Z4. With diagram. Cat. #Rect 1, 99¢ each.
- OZ4 Silicon Rectifier replacement, octal based. Cat. #Rect 2, 99¢ each.
- 10 Flangeless Rectifiers, 1 amp, 400 to 1000 p.i.v. Cat. #RS10, \$2.98.
- 10 Silicon Rectifiers, 750 MA, 50 to 300 p.i.v. Cat. #330F, 99¢ each.
- Condensers: 50-30 MFD at 150 v., 39¢ each. 3 for \$1.00. Cat. #30: 850-100-100-15 MFD at 16-16-4-115 v., 3 for 79¢ Cat. #82Y.
- 5 Transistor Circuit Boards containing up to 6 transistors, plus diodes, resistors, capacitors, etc. Cat. #TB10, 99¢.
- Needles: values such as #AS22 Sapphire. 39¢; Diamond, 99¢.
- Color Yokes. 70 Degree for all around color CRT's. Cat. #XRC70, \$12.95. 90 degree for all rectangular 19 to 25 inch color CRT's, Cat. #XRC90, \$12.95.
- Transistorized U.H.F. Tuners used in 1965 to 1967 TV sets made by Admiral, RCA, Motorola, etc. Removable gearing may vary from one make to another. Need only 12 volts d.c. to function. No filament voltage needed. Easy replacement units. Cat. #U.H.F. 567, \$4.95.
- Flyback Transformer in original carton. Made by Merit or Todd. Most with schematic drawing of unit. Please do not request specific type. Cat. #506, 99¢ each.
- Kit of 30 tested Germanium Diodes. Cat. #100, 99¢.

Send for our Free Catalog listing thousands of similar best buys in tubes, parts, kits, transistors, rectifiers, etc. Order under \$5.00, add 50¢ handling charge. Include 4% of dollar value of order for postage.

## ARCTURUS ELECTRONICS CORP.

502-22nd St., Union City, N.J. 07087 Dept. MPE  
Phone: 201-UN 4-5568  
CIRCLE NO. 4 ON READER SERVICE PAGE

**TAPE RECORDERS**, Hi-Fi, components, Sleep Learning Equipment, tapes. Unusual Values Free Catalog. **Dressner**, 1523R, Jericho Turnpike, New Hyde Park, N.Y. 11040.

**FINEST** portable recorders, radios, CB equipment. Free catalog. **Minitronics**, 1983E3 Via Del Rio, Corona, California 91720.

## WANTED

**CASH Paid!** Unused tubes, electronic equipment. **Barry**, 512 Broadway, NYC 10012.

**QUICKSILVER**, Platinum, Silver, Gold. Ores Analyzed. Free Circular. **Mercury Terminal**, Norwood, Mass. 02062.

**WANTED** to lease, then buy: **MECHANICAL MAN** for display. This August. Not complicated, but robot must do something. Appearance most important. Write: **H. Hagloch**, 814 N. Tusc., Dover, Ohio 44622.

**TECH MANUALS, SOLD ON MILITARY SURPLUS AND CIVILIAN ELECTRONIC EQUIPMENT. GIVE MAKE, MODEL FOR MANUAL QUOTE.** **SLEP ELECTRONICS, DRAWER 178-PE, ELLENTON, FLORIDA 33532.**

## TUBES

**TUBES "Oldies"**, latest. Lists free. **Steinmetz**, 7519 Maplewood, Hammond, Indiana 46324.

**RECEIVING & INDUSTRIAL TUBES, TRANSISTORS.** All Brands—Biggest Discounts. Technicians, Hobbyists, Experimenters—Request **FREE** Giant Catalog and **SAVE!** **ZALYTRON**, 469 Jericho Turnpike, Mineola, N.Y. 11501.

**TUBE** Headquarters of World! Send 10¢ for Catalog (tubes, electronic equipment) **Barry**, 512 Broadway, N.Y.C. 10012.

**RADIO & T.V. Tubes—33¢ each.** Send for free list. **Cornell**, 4213 University, San Diego, Calif. 92105.

**DON'T BUY TUBES—Radios TV-Xmitting, special-purpose types** until you get our price list! Lowest prices in U.S.A. 5,000 types—Guaranteed Brand New. Send postcard for TV—Special Purpose Price List. **UNITED RADIO COMPANY, P.O. BOX 1000, NEWARK, N.J. 07101.**

## TAPE AND RECORDERS

**BEFORE** Renting Stereo Tapes try us. Postpaid both ways—no deposit—immediate delivery. Quality—Dependability—Service—Satisfaction—prevail here. If you've been dissatisfied in the past, your initial order will prove this is no idle boast. Free Catalog. Gold Coast Tape Library, Box 2262, Palm Village Station, Hialeah, Fla. 33012.

**AUTOMATIC** telephone connection for Concord and other transistorized recorders. **SURVEILLANCE** and Privacy Protection Devices. Free Data: Security Electronics-PER, 15 East 43rd Street, New York, N.Y. 10017.

**HI-FI** Components. Tape Recorders, at guaranteed "We Will Not Be Undersold" prices. 15-day money-back guarantee. Two-year warranty. No Catalog. Quotations Free. HiFidelity Center, 239 (PT) East 149th Street, New York 10451.

**SCOTCH** Recording Tapes. Tape Recorders. Catalog 10¢. Tower, Lafayette Hill, Pa. 19444.

**RENT STEREO TAPES—75¢ WEEK. CATALOG. ART'S TAPE SERVICE,** 1613½ North Mariposa Ave., Hollywood, Calif. 90027.

**TAPE** transport. NAB recording studio quality. Build yourself for amazingly low cost. Detailed plans \$5.00. Free particulars. Pepke Laboratories, 309-B West 19 Street, New York, N.Y. 10011.

**RENT** Stereo Tapes—over 2,500 different—all major labels—free brochure. Stereo—Parti, 1616-PE Terrace Way, Santa Rosa, California 95404.

**TAPEMATES** makes available to you **ALL 4-TRACK STEREO TAPES—ALL LABELS**—postpaid to your door—at tremendous savings. For free brochure write: **TAPEMATES**, 5727 W. Jefferson Blvd., Los Angeles, California 90016.

**TAPE RECORDER SALE.** Brand new, nationally advertised brands, \$10.00 above cost. Special prices on HI-FI Components and color television. Arkay Sales, 1028C Commonwealth Avenue, Boston, Mass. 02215.

**STEREO TAPES,** Save 30% and up; no membership or fees required; postpaid anywhere U.S.A. Free 70-page catalog. We discount batteries, recorders, tape/accessories. Beware of slogans, "not undersold", as the discount information you supply our competitor is invariably reported to the factory. **SAXITONE**, 1776 Columbia Road, N.W., Washington, D.C. 20009

**WHOLESALE:** 4/8 Track Cartridge Tapes—Recorders, CB, AM/FM. **MUSICO**—Box 2705, Montgomery, Alabama.

## EQUIPMENT

**RELAYS** . . . Limited assortment of ten telephone relays as used in telephone work for \$5.95. Send check or money order to: Surplus Saving Center, Dept. CPE-3, Waymart, Penna. 18472.

**SOLDERLESS TERMINALS:** Kit 101 assorted, \$2.00 postpaid. McCanna Company, Woodstock, N.Y. 12498.

**HANDSETS** . . . Miscellaneous types and manufacturers \$2.95 each, two for \$5.00—Send check or money order to: Telephone Engineering Company, Dept. CPE-3, Simpson, Penna. 18407.

## REPAIRS AND SERVICES

TV Tuners rebuilt and aligned per manufacturers specification. Only \$9.50. Any make UHF or VHF. Ninety day written guarantee. Ship complete with tubes or write for free mailing kit and dealer brochure. JW Electronics, Box 51C, Bloomington, Indiana 47401.

**SPEAKER REPAIR.** Hi-Fi, guitar, organ speakers reconed good as new at fraction of new speaker price. For details write: Waldom Electronics, Inc., Dept. PE, 4625 W. 53rd St., Chicago, Ill. 60632.

## PERSONALS

**MAKE FRIENDS WORLDWIDE,** promote international understanding, join Europe's leading correspondence club. Illustrated brochure free. **HERMES**, Box 17/33, 1 Berlin 11, Germany.

**INVESTIGATORS, FREE BROCHURE, LATEST SUBMINIATURE ELECTRONIC SURVEILLANCE EQUIPMENT. ACE ELECTRONICS, 11500-K NW 7th Ave., MIAMI, FLA. 33168.**

**IF YOU ARE 30-60,** if you live in the N.Y.C. area, and if you are seeking interesting, stimulating companionship, write **TWOgether Associates**, Box 1, 38 East 57 St., N.Y.C. 10022.

**BILL PROBLEMS?** Poor credit no trouble. Not a loan company. Send for free application. Nationwide Acceptance, Dept. PE, 930 F St. N. W., Washington, D.C. 20017 or 307 Pocasset Ave., Providence, R. I. 02909.

## INSTRUCTION

**LEARN** While Asleep, hypnotize with your recorder, phonograph. Astonishing details, sensational catalog free! Sleep-Learning Association, Box 24-ZD, Olympia, Wash. 98501.

**LEARN ELECTRONIC ORGAN SERVICING** at home all makes including transistors. Experimental kit—trouble-shooting. Accredited NHSC, Free Booklet. **NILES BRYANT SCHOOL**, 3631 Stockton, Dept. A, Sacramento, Calif. 95820.

**ASSOCIATE** Degree in Electronics Engineering earned through combination correspondence-classroom educational program. Free brochure. Grantham Technical Institute, 1505 N. Western Ave., Hollywood, Calif. 90027.

**HIGHLY EFFECTIVE** home study course in Electronics Engineering Mathematics with circuit application. Earn your Associate in Science Degree. Free Literature. Cook's Institute of Electronics Engineering, P.O. Box 36185, Houston, Texas 77036. (Established 1945.)

**FCC** First Class License in six weeks—nation's highest success rate—approved for Veterans Training. Write Elkins Institute, 2603B Inwood Road, Dallas, Texas 75235.

**LEARN TECHNICAL WRITING**—at home. High paying prestige careers not requiring college. Growing demand, all industries for tech writers now. Low monthly tuition. Easy to understand. **FREE** career book, sample lesson. **APPROVED FOR VETERANS.** American Technical Writing Schools, Dept. PEC-38, 5512 Hollywood Blvd., Hollywood, Calif. 90028.

**R.E.I.'s** famous (5) week course for the first class radio telephone license is the shortest, most effective course in the nation. Over 98% of R.E.I. graduates pass F.C.C. exams for 1st class license. Total tuition \$350.00. Job placement free. Write for brochure Radio Engineering Institute of Electronics, 1336 Main Street, Sarasota, Florida 33577—or 3123 Gillman Road, Kansas City, Missouri 64109—or 809 Caroline Street, Fredericksburg, Virginia 22401.

**ELECTRONIC SURVEILLANCE, THEORY, INSTRUCTIONS, DIAGRAMS! \$2.00. ELECTROWEST, BOX 50313, CICERO, ILLINOIS 60650.**

**HOME** Electronics course only \$26.95. Free literature. Edu-Kits, Department 681D, Hewlett, New York 11557.

**WHO TEACHES ELECTRONICS?** Compiled information on over 200 correspondence courses from 55 schools teaching electronics. \$1. P. O. Box 562, Astoria, Oregon 97103.

## GOVERNMENT SURPLUS

**JEEPS** Typically From \$53.90 . . . Trucks From \$78.40 . . . Boats, Typewriters, Airplanes, Electronics Equipment, Photographic Equipment, used. 100,000 Bargains Direct From Government. Complete Sales Directory and Surplus Catalog \$1.00 (Deductible First \$10.00 Order). Surplus Service, Box 820-J, Holland, Mich. 49423.

**SURPLUS ELECTRONICS BONANZA.** Buy directly from Government. Don't Miss Out! All necessary information: \$2.00. Pacifico, Box 43485-F, Los Angeles, California 90043.

## AUTHORS' SERVICES

**AUTHORS!** Learn how to have your book published, promoted, distributed. **FREE** booklet "ZD," Vantage, 120 West 31 St., New York 10001.

**POEMS WANTED** for new song hits and recordings by America's most popular studio. Tin Pan Alley, 1650-ZD Broadway, New York 10019.

## MUSIC

**POEMS** wanted for new songs. Nashville Music Institute, Box 532-E, Nashville, Tennessee 37202.

## MUSICAL INSTRUMENTS

**ACCORDIONS, GUITARS, BAND INSTRUMENTS!** Save to 50%. Terms. Trades. Free Trial. Free catalog. Mention instrument. Music Mart, 5535-PE Belmont, Chicago 60641.



## INVENTIONS WANTED

**PATENT** Searches including Maximum speed, full airmail report and closest patent copies, \$6.00. Quality searches expertly administered. Complete secrecy guaranteed. Free Invention Protection forms and "Patent Information." Write Dept. 9, Washington Patent Office Search Bureau, 711 14th Street, N.W., Washington, D.C. 20005.

**INVENTORS.** We will develop, help sell your idea or invention, patented or unpatented. Our national manufacturer clients are urgently seeking new items for outright cash sale or royalties. Financial assistance available. 10 years proven performances. For free information, write Dept. 41, Wall Street Invention Brokerage, 79 Wall Street, New York, N.Y. 10005.

**INVENTORS!** Outright cash sale or royalties for your inventions. Patented. Unpatented. Active demand from our client manufacturers. Financial assistance available. Write Dept. 35, United States Invention Brokerage, 78 Wall Street, New York, N.Y. 10005.

**INVENTIONS** wanted. Patented; unpatented. Global Marketing Service, 2420-P 77th, Oakland, Calif. 94605.

**INVENTIONS—IDEAS** developed: **CASH/ROYALTY SALES.** Member: United States Chamber of Commerce, Raymond Lee, 230-GR PARK AVENUE, NEW YORK CITY 10017.

**PATENT SEARCHES \$6.00! FREE "INVENTION RECORD"/**Information. Miss Hayward, 1029HR Vermont, District of Columbia 20005.

**INVENTORS!** Sell your invention for cash or royalties! Our client manufacturers eagerly seek new items. Patented. Unpatented. Financial assistance if needed. 25 years proven performances. For free information, write Dept. 20, Gilbert Adams, Invention Broker, 80 Wall St., New York, N.Y. 10005.

**INVENTORS!** Don't sell your invention, patented or unpatented, until you receive our offer. Eagle Development Company, Dept. P, 79 Wall Street, N.Y., N.Y. 10005.

**INVENTORS! OUR FREE EXPERT ANALYSIS** of your invention can save valuable time, help you realize full sale value. Strictly confidential. **FREE INVENTION CERTIFICATE.** Write today: Pioneer Invention Service, Dept. 35, 150 Broadway, New York, N.Y. 10038.

## BOOKS

**FREE** catalog 950 aviation/electronic/space books. Aero Publishers, 329PE Aviation Road, Fallbrook, California 92028.

**UNUSUAL Books!** Catalog free! International, Box 7798(PE), Atlanta, Georgia 30309.

**ELECTRONICS, How-To-Do-It** books. Free catalog. Handyman Books, Box 52H, Westbury, N.Y. 11590.

**FREE** Book. Prophet Elijah Coming Before Christ. Wonderful Bible Evidence. PE Megiddo Mission, Rochester, New York 14619.

**FREE CATALOG.** Adult Books. **POSTAL PE,** 2217 Lackland, St. Louis, Missouri 63114.

**TERRIFIC,** new army written book, Basic Theory and Application of Transistors. \$1.40 postpaid. Devices, Box 136E, Bronx, New York 10463.

## HYPNOTISM

**FREE** Hypnotism, Self-Hypnosis, Sleep Learning Catalog! Drawer H400, Ruidoso, New Mexico 88345.

**"FEMALE HYPNOTISM"** Exposed, explained! "Secret Method"—they never know! \$2, rushed. Guaranteed! Isabella Hall, Silver Springs, Florida 32688.

**SELF-HYPNOSIS** for self-improvement. Safe, effective! Free literature. McKinley, Dept. T-4, Box 3038, San Bernardino, California 92404.

**HYPNOTIZE SUCCESSFULLY—**or money refunded! Complete illustrated course—including Self-Hypnosis \$1.00. Arthur Fowler, Box 4396, Woodbury, New Jersey 08096.

**FREE! AMAZING** hypnotic record-kit releases fantastic mental power. Trial offer expires soon. Write: Forum, AA3, 333 North Michigan, Chicago 60601.

**HYPNOTIZE FEMALES!**—Unnoticed! Instantly! Nerves! Exciting! Send \$2.25. Research Enterprises, 29-SN21 Samoset, Woburn, Mass. 01801.

**FEMALE HYPNOTISM!!** Easily! Instantly! Secret Nerve Centers! \$2.20. Brugenheimer Publishers, Box 158-E30, Lexington, Mass.

## INTEGRATED CIRCUITS



SR Flip Flops ..... \$ .90  
 SR Clocked Flip Flops ..... \$1.15  
 SRT Flip Flops ..... \$1.15  
 8 Input Nand Nor Gates ..... \$1.00  
 JK Flip Flops ..... \$1.15  
 Dual Nand Nor Gates ..... \$1.00  
 Dual and Gates ..... \$1.00  
 Dual Nand Nor Gates ..... \$1.00  
 TO-85 flat pack, with holder . . .  
 They come complete with schematic, elect. characteristics sheet and some typical applications. Guaranteed to operate.

## SILICON CONTROL RECTIFIER

PRV	3A	7A	20A
50	.35	.45	.70
100	.50	.65	1.00
200	.70	.95	1.30
300	.90	1.25	1.70
400	1.20	1.60	2.10
500	1.50	2.00	2.50
600	1.80	2.40	
700	2.20	2.80	

## Top Hat & Epoxy 1 AMP

PRV	
100	.07
200	.09
400	.12
600	.18
800	.22
1000	.35
1200	.50

## Silicon Power Rectifiers

PRV	3A	12A	20A	40A
100	.09	.30	.40	.75
200	.16	.50	.60	1.25
400	.20	.70	.80	1.50
600	.30	1.00	1.20	1.80
800	.40	1.25	1.50	2.30
1000	.55	1.50	1.80	2.70

## TRIACS TO-66 5 AMP

PRV	
100	.90
200	1.40
300	1.75
400	2.25
500	2.60

Terms: FOB Cambridge, Mass. Send check or Money Order. Include Postage. Average Wt. per package 1 1/2 lb. Allow for C.O.D. Min. Order \$3.00.



**POST OFFICE BOX 74F  
SOMERVILLE, MASS. 02143**

Featuring transistors, rectifiers and components  
**SEND FOR OUR SPRING CATALOGUE**  
 Business Address: 325 Elm St. Cambridge, Mass.

**CIRCLE NO. 27 ON READER SERVICE PAGE**

## REAL ESTATE

**FREE!!!** 184-page illustrated **SPRING 1968 CATALOG!** Describes hundreds of farms, ranches, town and country homes, businesses, vacation, retirement and waterfront properties coast to coast! Specify type property and location preferred. Zip code, please. **UNITED FARM AGENCY,** 612-EP West 47th St., Kansas City, Mo. 64112.

## PHOTOGRAPHY—FILM, EQUIPMENT, SERVICES

**MEDICAL** Film—Adults Only—"Childbirth"—1 reel 8mm \$7.50—16mm \$14.95. International-E, Greenvale, L.I., New York 11548.

**SCIENCE** Bargains—Request Free Giant Catalog "CJ"—148 pages—Astronomical Telescopes, Microscopes, Lenses, Binoculars, Kits, Parts. War surplus bargains. Edmund Scientific Co., Barrington, New Jersey 08007.

## RECORDS

**SPECIAL INTEREST RECORDS AVAILABLE, PRODUCED BY THE EDITORS OF THE WORLD'S LEADING SPECIAL INTEREST MAGAZINES. SEND FOR FREE CATALOG. RECORD CATALOG-PE, ZIFF-DAVIS PUBLISHING COMPANY, ONE PARK AVENUE, NEW YORK, N.Y. 10016.**

## EDUCATIONAL OPPORTUNITIES

**WANTED! TV—**Radiomen to learn aircraft electronics servicing. Numerous job openings everywhere. Write: Academy Avionics, Reno/Stead Airport, Reno, Nevada 89506.

**LEARN WHILE ASLEEP.** Miraculously build Mind Power, achieve Self-Confidence, improve Health, gain Success. Method 92% effective. Details free. ASR Foundation, Box 7021EG Henry Clay Sta., Lexington, Kentucky 40502.

## RUBBER STAMPS

RUBBER ADDRESS STAMP \$1.50. SIGNATURE \$3.50. FREE CATALOG. JACKSON, P.O. BOX 443-G, FRANKLIN PARK, ILL. 60131.

## PRINTING

OFFSET PRINTING—8 HOUR SERVICE—25 to 5,000 copies. Nationwide Printing, Atlanta, Illinois 61723.

FREE LITERATURE: 1000 Address Labels \$1.00, 1000 Business Cards \$4.95. Printing, Rubber Stamps. Jordan's, 552 West O'Connor, Lima, Ohio 45801.

LOW Cost Printing, Mimeographing, Business Cards, Envelopes, Free Brochures, Introductory offer. Seaview, 8115-T Avenue "L", Brooklyn, N.Y. 11236.

THERMOGRAPHED business cards, \$3.49—1,000, free samples. Gables—405B Clifton, Glenshaw, Pa. 15116.

## PLASTICS

CASTOLITE Liquid Plastic pours like water and hardens like glass without heat. Clear, Colors. Embed real flowers, butterflies, photos, coins. Also new molding formulas for perfect reproductions. Illustrated booklet shows HOW. Send 25¢—Dept. 68-103C. CASTOLITE, Woodstock, Ill. 60098.

## BUSINESS OPPORTUNITIES

INVESTIGATE ACCIDENTS: Earn to \$1000 monthly. Men urgently needed. Car furnished. Business expenses paid. No selling. No college education necessary. Pick own job location. Investigate full time or earn to \$8 hour spare time. Write for FREE information. No obligation. Universal Schools, CZ-3, 6801 Hillcrest, Dallas, Texas 75205.

RAISE Rabbits for us on \$500 month plan. Free details. White's Rabbitry, Mt. Vernon, Ohio 43050.

FREE CATALOGS. Repair air conditioning, refrigeration. Tools, supplies, full instructions. Doolin, 2016 Canton, Dallas, Texas 75201.

PIANO TUNING learned quickly at home. Tremendous field! Musical knowledge unnecessary. GI Approved. Information free. Empire School, Miami, Florida 33145.

ELECTROPLATING Equipment and supplies. All types for home workshops and industrial. Send \$1.00 (refundable) for equipment guide formulas, operating data, catalog. HBS Equipment Division 90, 3543 East 16th, Los Angeles, California 90023.

I MADE \$40,000.00 Year by Mailorder! Helped others make money! Start with \$10.00—Free Proof. Torrey, Box 318-N, Ypsilanti, Michigan 48197.

FREE Book "990 Successful little-known Businesses." Work home. Plymouth 245W, Brooklyn, N.Y. 11218.

SELL LIFETIME, Metal, Social Security Plates. Big profits! Sample and Sales Kit Free. Russell, Box 286-PE, Pulaski, Tennessee 38478.

EARN \$240.00 a Month at home, spare time, doing only two \$5.00 Invisible Mending jobs a day. Big money paid for service that makes cuts, tears disappear from fabrics. Steady demand. Details free. Fabrican, 1572 Howard, Chicago, Ill. 60626.

SELL HERTEL BIBLES—Part time. Finest reference Bible available. Demonstrator and supplies furnished. Excellent commissions. Write: International Book, Box 114PE, Wichita, Kansas 67201.

SELL America's Biggest value wedding line! Big 40% profit showing wedding invitations and over 50 exciting accessory items. Sideline for printing, Christmas card salesmen. Free display album. Elmcraft, 7201 S. Cicero, Dept. EW-187, Chicago, Illinois 60629.

## COINS

INDIAN Cents—Buffalo nickels, good clear dates (scarce). Buffalos 20 different \$3.95; 100 mixed \$12.95; Indians 20 different \$6.95; 100 mixed \$24.95; 50 mixed foreign coins \$1.95. Van's Coins, 168 Waiworth, Wisconsin 53184.

SPECIAL: Barber Quarter, Only 50¢. Bedrin, 250F Fulton. Hempstead, New York 11550.

## STAMPS

SURPRISE COLLECTION! Exotic mint British Colonials, absolutely free with approvals. VIKING, Great Neck 50, N.Y.

TEN British Africa 25¢ with recent British approvals. El Diablo Stamps, Box 141, Rheem Valley, Calif. 94570.

## MOTION PICTURES

JUST FOR FUN . . . TEACH YOURSELF MOVIES WITH TOP PRO INSTRUCTORS. 8/SUPER 8. FREE CATALOG. SPORTLITE FILMS-PE, 20 North Wacker Drive, Chicago, Illinois 60606.

## EMPLOYMENT INFORMATION

FOREIGN and USA job opportunities available now. Construction, all trades. Earnings to \$2,000.00 monthly. Paid overtime, travel, bonuses. Write: Universal Employment, Woodbridge, Connecticut 06525.

AUSTRALIA. New Life. Jobs. Opportunity. Government Shares Fare. Information \$1. Pacifico, Box 43485-R, Los Angeles, Calif. 90043.

OVERSEAS jobs openings all trades and professions. Free information. Write: National Employment Service, Box 2235 A.M.F., Miami, Florida 33159.

## MISCELLANEOUS

WINEMAKERS: Free illustrated catalog of yeasts, equipment. Simplex, Box 7203, Minneapolis, Minn. 55412.

SPARE TIME OPPORTUNITY—MONEY—WE PAY at the rate of \$10 hr. for NOTHING but your opinions, written from home about our clients' products and publications, sent you free. Nothing to buy, sell, canvass, or learn. NO SKILL. NO GIMMICKS. Just honesty. Details from RESEARCH, ZD2, Box 669, Mineola, N.Y. 11501.

BILLS PAID WITHOUT BORROWING—Nobody refused up to \$18,000.00. Bad credit no problem—Not a Loan Co. Write for FREE application—INTERNATIONAL ACCEPTANCE, Dept. 50A, 5133 N. Central Ave., Phoenix, Arizona 85012—119 Ann St., Hartford, Conn. 06103—507 Carondelet St., New Orleans, La. 70130—or 504 Victoria Ave., Windsor, Ontario, Canada.

VENTRILOQUISM! Information free! Dummy catalog 25¢. State age. Maher, Studio ZD2, Box 8536, Kensington Station, Detroit, Michigan 48224.

EMPLOYMENT Resumes. Get a better job & earn more! Send only \$2.00 for expert, complete Resume Writing Instructions. J. Ross, 80-34 Kent St., Jamaica, N.Y. 11432, Dept. PE.

STOP BURGLARS THE EASY WAY!! Affix authentic "Protected by Electronic Sentry Alarm" Decals to auto windows, doors & windows of home, retail stores, vending machines, etc. Whether you have an alarm or not—thieves stay away! Only \$1.00 each set of two. J. Ross, 80-34 Kent St., Jamaica, N.Y. 11432 Dept. PE.

TRANSISTORS for fun, profit. Learn easily. \$2.00. Money back. Transistor, Box 774, Devon, Pa. 19333.

MEN! Suits, sport coats, outerwear—\$15-\$25. Buy direct & save! Write for free catalog. Dept. E, Manufacturer's Discount Clothing Co., Box 253, Baltimore, Md. 21203.

STAMMER — Stutter — No more. (Dr. Young.) Write Gaucho, Box 9309-E8, Chicago 60690.

BEERS, PEACH BRANDY, WINES—Strongest Formulas, \$2.25. (complete brew supplies hydrometers catalog included)—Research Enterprises, 29-D Samoset, Woburn, Mass. 01801.

CLASSIFIED ADVERTISING IN POPULAR ELECTRONICS remains your best bet for outstanding mail order sales responses. These pages are read thoroughly each month by electronics hobbyists seeking those products and services found only in the ELECTRONICS MARKET PLACE. POPULAR ELECTRONICS readers respond readily because they know they can rely on the advertisers appearing in the pages of their favorite magazine. Your low cost ad will result in increased mail order responses for you! Try the next issue, May, which closes March 1st. Send copy and payment to: Hal Cymes, Classified Advertising Mgr., POPULAR ELECTRONICS, 1 Park Ave., New York, N.Y. 10016.

## We can't leave well enough alone...

...so we redesigned the RCA-6BK4A to improve its capability in shunt regulator circuits of high voltage power supplies in color TV receivers. Always the best tube to do the job, the RCA-6BK4B is now even better.

An improved plate provides highly efficient heat radiation and uniform temperature distribution...and permits a 40 W max. plate dissipation rating. This rating is especially important in present-day color receivers. An increased peak

negative heater-cathode voltage capability of 450 V max. results from better heater insulation and tighter processing controls. A redesigned top cap reduces strain on dome of the glass envelope for greater strength and reliability.

Innovations and improvements that make your service operation more reliable, efficient and profitable are our constant aim. So see your local Authorized RCA Tube Distributor for quality RCA receiving tubes.



# RCA

# Now...18 different professional-quality amplifiers, tuners & preamps

- completely assembled...
- solid state, printed circuits...
- priced lower than kits.

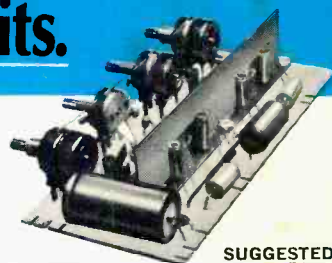

There are so many ways you will use these easy-to-install, printed-circuit assemblies; in hi-fi equipment, ham gear, P.A. and intercom systems, or as guitar and organ amplifiers. Employing the most advanced Complementary-Symmetry transistorized designs, these assemblies provide the ultimate in economical circuitry for reliable audio applications from one watt to twenty. They have already become the design standard for a large group of audio equipment manufacturers, as well as a basic teaching tool in many educational institutions.

TYPE	DESCRIPTION	SUGGESTED LIST PRICE
PCA-1-9	1W, 9V D.C. 4 Transistor Amplifier	\$7.20
PCA-1-14	2W, 14V D.C. 4 Transistor Amplifier	7.00
PCA-2-9	3/4W, 9V D.C. 3 Transistor Amplifier	5.90
PCA-2-14	1W, 14V D.C. 3 Transistor Amplifier	5.90
PCA-3B-18-1	4W/Channel Stereo Amplifier with Bass, Treble, Volume and Balance Controls	19.20
PCA-4-9	1W, 9V D.C. High Gain, 4 Transistor Amplifier for Radio, Ceramic or Crystal Phono Cartridge, etc.	8.30
PCA-4-9A	Same as PCA-4-9 with Tone Control Circuit	9.20
PCA-4-14	2W, 14V D.C. High Gain 4 Transistor Amplifier for Radio, Ceramic or Crystal Phono Cartridge, etc.	8.30
PCA-4-14A	Same as PCA-4-14 with Tone Control Circuit	9.20
PCA-4-18A	3W, High Sensitivity, 4 Transistor Amplifier with Volume and Tone Controls for use as Guitar, Radio or Phono Amplifier	9.52
PCA-5A-14	2W/Channel 14V D.C. Stereo Amplifier with Balance, Tone and Volume Controls	15.80
PCA-6A-25	8-10W/Channel Stereo Amplifier with Preamp for Ceramic Phono Cartridge and Bass, Treble, Balance, and Volume Controls	30.10
PCA-6A-25SCS	Same as PCA-6A-25 with Separate Control Assembly	31.80
PCA-7B-18	Tape Cartridge Stereo Preamp with Level Set Controls	12.00
PCA-7C-18	Same as PCA-7B-18 without Level Sets; 4 Transistor	9.50
PCA-8-36	20W Mono Basic Amplifier	18.85
PCA-9-18	3W/Channel, 10 Transistor Stereo Tape Playback Amplifier with Volume, Tone and Balance Controls	25.30
PCR-1-9	9V 2 Transistor AM Tuner	11.30

For brochure containing complete technical data on all 18 assemblies and for name of distributor nearest you, write: Amperex Electronic Corporation, Distributor Sales Dept., Hicksville, New York 11802.

## Amperex®

TOMORROW'S THINKING IN TODAY'S PRODUCTS

CIRCLE NO. 3 ON READER SERVICE PAGE