

BUILD POLICE SUPERHET RECEIVER

POPULAR ELECTRONICS

NOVEMBER
1967

50
CENTS

**Build Electronic
Voltmeter**

**Build Supply for
IC Experiments**

**Build 40-Meter
30-Minute Antenna**

**Broadcasting
Goes Underground**

**Build Solid-State
THEREMIN
Connect to
Your HI-FI
System**

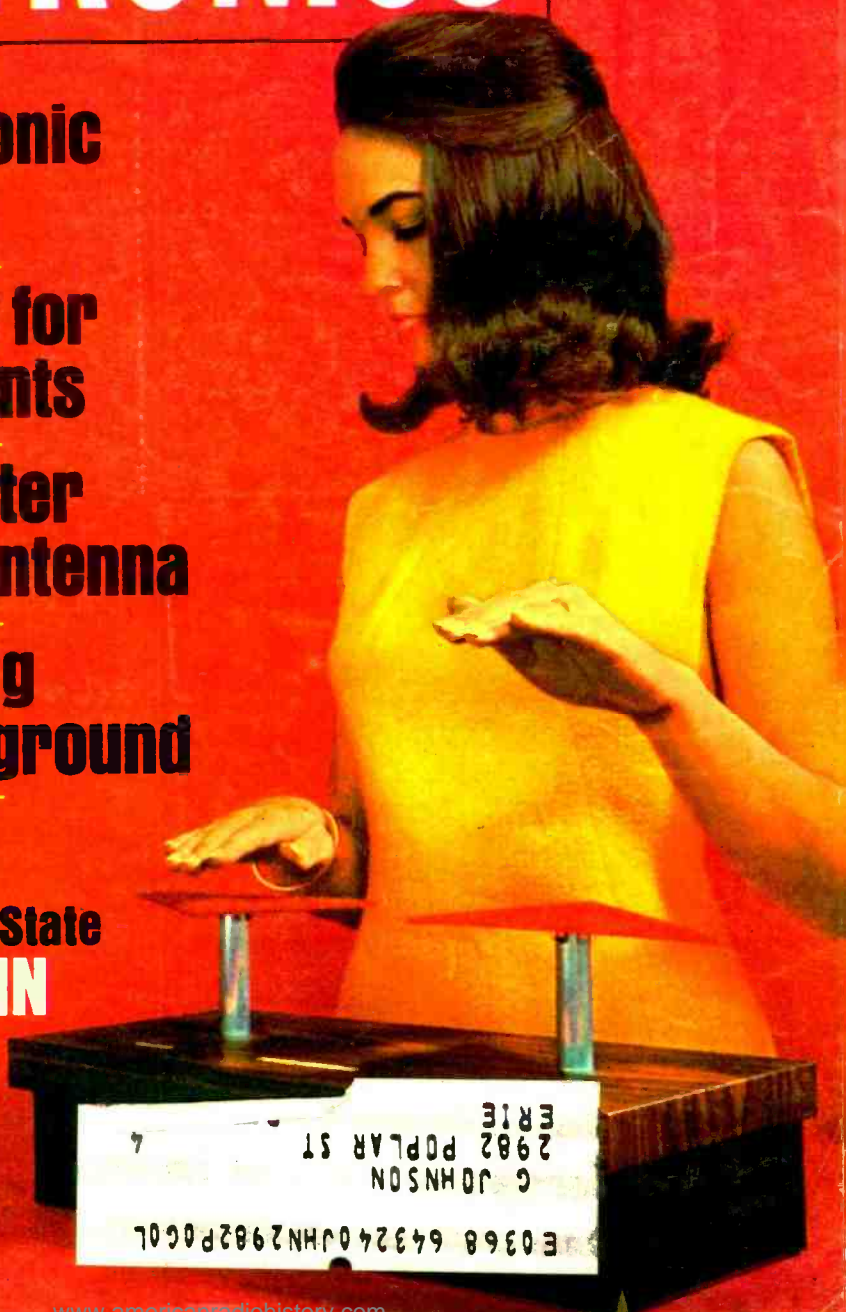

E 0368 643240JHN2982P0GOL
C JOHNSON
2982 POPLAR ST
ERIE



Discover the excitement of learning Electronics with training kits NRI sends you

New Achievement Kit Custom Training Kits "Bite Size" Texts

Only NRI offers you this pioneering method of "3-Dimensional" home-study training. It's the result of more than half a century of simplifying, organizing, dramatizing subject matter. As an ambitious man you can effectively learn the Electronics field of your choice the NRI way. But NRI training is more than kits and texts. It's personal services, too, which have made NRI a 50-year leader in the home-study field.

YOU GET MORE FOR YOUR MONEY FROM NRI

Everything that you see here is included in just one NRI course. Other courses are equally complete, yet you'll be surprised at the low cost. Text for text, kit for kit, dollar for dollar—your best home study buy is NRI.

Available Under NEW GI BILL

If you served since January 31,
1955, or are in service, check
GI line in postage-free card.



*Earn \$4 to \$6 an hour
spare or full time in*
**TV-RADIO
SERVICING**

Want to earn extra money? Looking for a good paying job? Interested in your own full-time business? Radio-TV Servicing is the branch of Electronics offering all these opportunities. In addition to teaching you the facts, NRI shows you how to earn while you learn.

You can learn quickly how to install, maintain and service tube and transistor home and auto radios, TV sets (including booming Color TV), hi-fi and stereo, public address systems. Like thousands of others, you can be earning \$4 to \$6 an hour in spare-time starting soon after you enroll.

*There's glamor and
success awaiting you in*
**BROADCASTING—
COMMUNICATIONS**

Good paying, fascinating positions await competent Communications Operators and Technicians. Broadcast stations, commercial stations, ships, aircraft, land vehicles all need men who know how to maintain and repair transmitting and receiving equipment. With closed-circuit TV, Facsimile, Microwave, Radar, Telemetry and all the communications needs of the Space Age, you can see how important training in this field has become. NRI training includes preparation for your First Class Radiotelephone FCC License. *And you must pass the FCC exam or NRI refunds your tuition in full!*

*Move ahead in America's
fast moving industry as an*
**ELECTRONICS
TECHNICIAN**

There is a serious shortage of qualified Electronics Technicians. Electronics has found its way into hundreds of areas not even dreamed of ten years ago: offices; manufacturing; medical and dental uses; transportation; space exploration; government and military equipment . . . there's no end of opportunity for trained men. This course stresses the basic principles around which most Electronic devices are built; prepares you for many current job openings. Prepare now. Learn Automation, computers, data processing, ultrasonics, telemetry. Whatever your interest in Electronics, you'll find an NRI training plan for you. Check the course of most interest to you on the postage-free card and mail it today for your free NRI Catalog. No obligation. No salesman will call. NATIONAL RADIO INSTITUTE, Washington, D. C. 20016.



**More than
50 years of leadership
in Electronics Training**

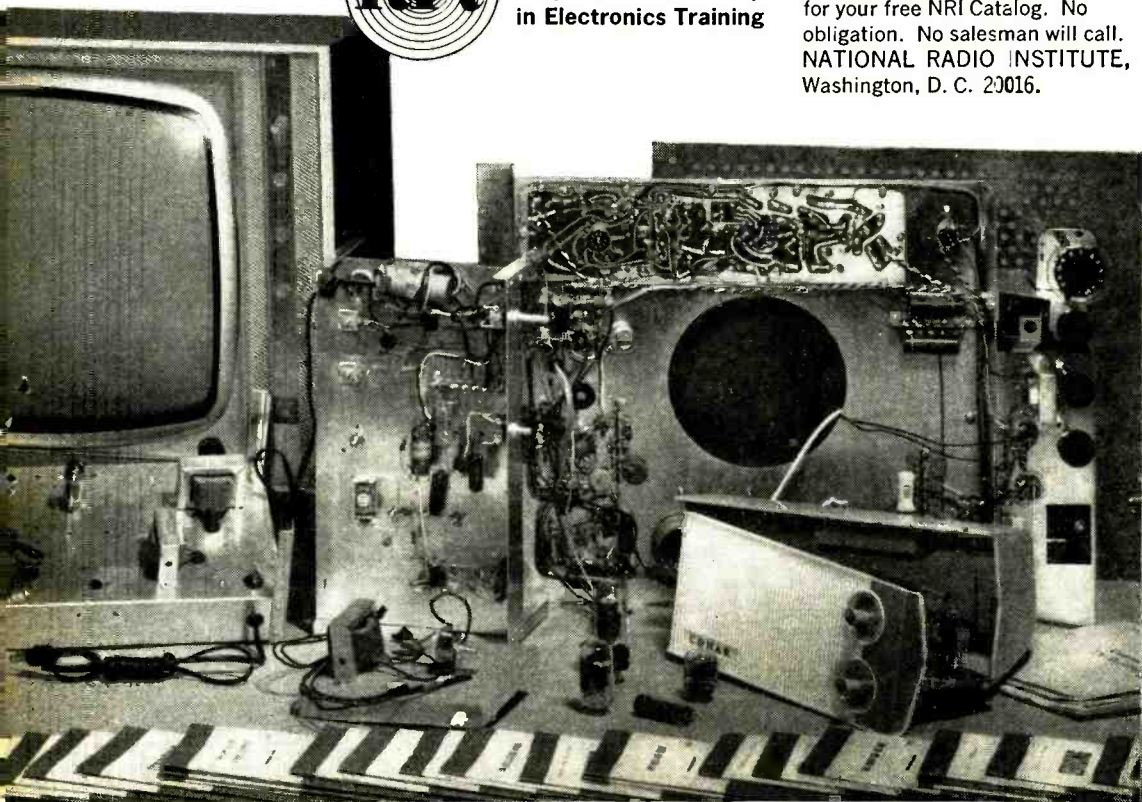

POPULAR ELECTRONICS

WORLD'S LARGEST-SELLING ELECTRONICS MAGAZINE

VOLUME 27

NOVEMBER, 1967

NUMBER 5

SPECIAL CONSTRUCTION FEATURE

GEORGE J. WHELAN, K2BIE **41 POLICE SPECIAL II**

Build self-contained no-nonsense superhet for 152-176 MHz

FEATURE ARTICLES

LOUIS E. GARNER, JR. **29 MUSIC A LA THEREMIN**

Solid-state version connects to hi-fi system

34 HI-FI SPEAKERS FOR SMALL ROOMS

A look at the Pioneer CS-24 and Wharfedale W20D

S. WALD **40 BATTERY-LESS DWELL METER**

THOMAS KENT **49 CLANDESTINE BROADCASTERS**

International short-wave broadcasting goes underground

DAVID B. WEEMS **53 INSTANT NON-FAT SPEAKER ENCLOSURE**

MATT P. SPINELLO, KHC2060 **55 ON THE CITIZENS BAND**

FRANK H. TOOKER **57 LOW-COST HIGH-QUALITY ELECTRONIC VOLTMETER**

Build your own test equipment for solid-state experiments

CHARLES J. SCHAUERS, W6QLV **66 INFORMATION CENTRAL**

69 POPULAR ELECOMICS

ROBERT P. BALIN **70 COLOR CODE QUIZ**

DON LANCASTER **71 EXPERIMENTER'S "PROFESSIONAL" POWER SUPPLY**

Dozens of IC experiments are coming up—get ready!

ROBERT LEGGE **74 FOREIGN-LANGUAGE BROADCASTS TO NORTH AMERICA**

HANK BENNETT, W2PNA **75 SHORT-WAVE LISTENING**

Tuning the medium waves

BILL LEGGE **76 ENGLISH-LANGUAGE BROADCASTS TO NORTH AMERICA**

HERB S. BRIER, W9EGQ **77 AMATEUR RADIO**

Upcoming contests

LOU GARNER **79 SOLID STATE**

ROBERT N. TELLEFSEN, W0KMF **82 THE "40-POLE"**

Simple vertical for 40-meter ham or 41-meter broadcast band

DAVID J. SWEENEY **83 PUT FM IN YOUR CAR**

FRANK H. TOOKER **84 THE R-MATCHER**

DEPARTMENTS

8 LETTERS FROM OUR READERS

14 TIPS & TECHNIQUES

15 READER SERVICE PAGE

22 NEW PRODUCTS

26 ELECTRONICS LIBRARY

96 NEW LITERATURE

100 OPERATION ASSIST

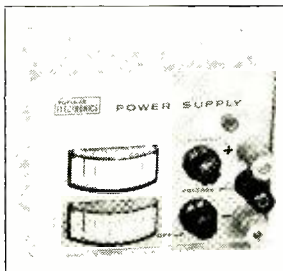

Short-circuit with safety

71

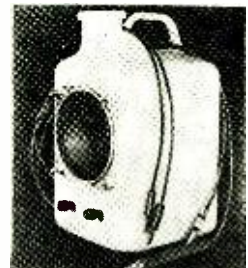

Familiar-looking jug?

53

POPULAR ELECTRONICS is indexed in the Readers' Guide to Periodical Literature

Copyright © 1967 by ZIFF-DAVIS PUBLISHING COMPANY. All rights reserved.

POPULAR ELECTRONICS, November 1967, Volume 27, Number 5. Published monthly at 307 North Michigan Avenue, Chicago, Illinois 60601. One year subscription rate for U.S., U.S. Possessions and Canada, \$5.00; all other countries, \$6.00. Second class postage paid at Chicago, Illinois and at additional mailing offices. Authorized as second class mail by the Post Office Department, Ottawa, Canada and for payment of postage in cash. Subscription service: Portland Place, Boulder, Colorado 80302. Editorial: One Park Ave., New York, N.Y. 10016.

This month's cover photo by Bruce Pendleton

GET YOUR **FREE** COPY!



*America's Largest
Electronics Store
Chain Brings You
The Only Catalog
That Isn't "Me Too"*

**NOW OVER 170 STORES
IN 34 STATES NATIONWIDE!**

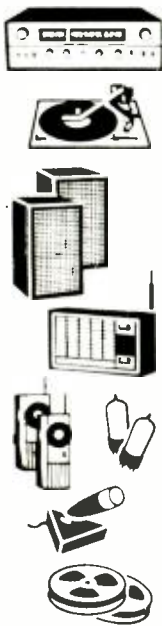

**See Hundreds of
Truly Exclusive**

<p>CB TAPE CARTRIDGES CASSETTES RADIOS PHONOS</p>	<p>KITS MICROPHONES SPEAKERS TUBES RECORDERS PARTS</p>
--	---

at "no middleman" prices!

ONLY RADIO SHACK'S CATALOG is principally confined to products of our own design. That's why we say it isn't "me too." That's why it's so eagerly awaited by thousands of pro's, hams, CB'ers, audiophiles, teachers, music lovers and electronics hobbyists! YOU NEED the new Radio Shack Catalog '68 to know what's really new in electronic parts and equipment. That's why you should SEND TODAY FOR YOUR FREE COPY, magnificently published in colorgravure on 8 1/2 x 11" stock. It's the finest effort, the biggest array of new products, in our 45 year history. Use handy coupon below.

**CUT
OUT
TODAY
AND
MAIL!**

Mail Today to: Radio Shack Mailing List Center,
2727 West 7th St., Fort Worth, Texas, 76107

Rush my FREE Radio Shack Catalog '68
via return mail to address below:

Name _____
Street _____
City _____
State _____ Zip _____

Dept. WD

CIRCLE NO. 29 ON READER SERVICE PAGE

FULLY EQUIPPED FOR
IMMEDIATE OPERATION
ON ALL **23** CHANNELS



**23-CHANNEL CB
mobile and base station
AM TRANSCEIVER**

GREATER RANGE POWER with the exclusive new DYNA-BOOST circuit that intensifies speech signals and extends the signal range. The new Cobra CAM-88 is rugged, handsome and field proven. Compare it, feature for feature, with other CB equipment and you'll be convinced that the Cobra CAM-88 is by far the best.

Outstanding Features

- Fully-Equipped for Immediate 23-channel Transmit and Receive
- Double Conversion Superheterodyne Receiver
- Transistorized 117V AC/12V DC Power Supply
- Speech Compression with Switch
- Delta-Tune Fine Tuning
- Squelch Control and Standby Switch
- Illuminated Dual-Purpose Meter Power-in (Receive)-Power-out (Transmit)
- Modulation Indicator
- Detachable Press-to-talk Microphone
- Convertible to a Public Address Amplifier

Carefully engineered design makes the Cobra completely reliable and easy to operate. Completely self-contained. *No additional crystals needed.* \$21495



DIVISION OF **DYNASCAN CORPORATION**
1801 W. BELLE PLAINE AVE. • CHICAGO, ILL. 60613

Made in U.S.A.

Export: Empire Exporters, 123 Grand St., New York 13, U.S.A. Also available in Canada
CIRCLE NO. 7 ON READER SERVICE PAGE

POPULAR ELECTRONICS

PHILLIP T. HEFFERNAN
Publisher

OLIVER P. FERRELL
Editor

LESLIE SOLOMON
Technical Editor

MARGARET MAGNA
Managing Editor

EDWARD I. BUXBAUM
Art Director

ALEXANDER W. BURAWA
Associate Editor

ANDRE DUZANT
Technical Illustrator

PATTI MORGAN
Assistant Editor

AURORA NARDOZZI
Editorial Assistant

H. BENNETT, W2PNA

H. S. BRIER W9EQG

L. E. GARNER, JR.

CHARLES J. SCHAUERS, W6QLV

M. P. SPINELLO, WC2060
Contributing Editors

LAWRENCE SPORN
Advertising Sales Manager

ARDYS C. MORAN
Advertising Service Manager

ZIFF-DAVIS PUBLISHING COMPANY

Editorial and Executive Offices
One Park Avenue, New York, New York 10016
212 679-7200
Eastern Advertising Manager, RICHARD J. HALPERN
Midwestern Office
307 North Michigan Avenue, Chicago, Illinois 60601
312 726-0892
Midwestern Advertising Manager, JAMES WEAKLEY
Western Office
9025 Wilshire Boulevard, Beverly Hills, California 90211
213 Crestview 4-0265; BRadshaw 2-1161
Western Advertising Manager, **BUD DEAN**

Japan: James Yagi
Ishikawa Mansion
〒4, Sakuragaoka
Shibuya-ku, Tokyo
462-2911-3

Circulation Office
Portland Place
Boulder, Colorado 80302

William B. Ziff, Chairman of the Board (1946-1953)
William Ziff, President
W. Bradford Briggs, Executive Vice President
Hershel B. Sarbin, Senior Vice President
Philip Sine, Financial Vice President
Walter S. Mills, Jr., Vice President, Circulation
Stanley R. Greenfield, Vice President, Marketing
Phillip T. Heffernan, Vice President, Electronics Division
Frank Pomerantz, Vice President, Creative Services
Arthur W. Butzow, Vice President, Production
Edward D. Muhlfeld, Vice President, Aviation Division
Irwin Robinson, Vice President, Travel Division

Ziff-Davis also publishes Airline Management and Marketing, Boatline, Business & Commercial Aviation, Car and Driver, Cycle, Electronics World, Fishing, HiFi/Stereo Review, Modern Bride, Popular Aviation, Popular Photography, Skiing, Skiing Area News, and Skiing Trade News. (Travel Weekly is published by Robinson Publications, Inc., a subsidiary of Ziff-Davis Publishing Company.)

All subscription correspondence should be addressed to POPULAR ELECTRONICS, Circulation Department, Portland Place, Boulder, Colorado 80302. Please allow at least six weeks for change of address. Include your old address, as well as new-enclosing if possible an address label from a recent issue.

EDITORIAL CONTRIBUTIONS must be accompanied by return postage and will be handled with reasonable care; however, publisher assumes no responsibility for return or safety of art work, photographs or manuscripts.



Member Audit Bureau of Circulations



SEE WHY so many DeVry-trained Men Step Into Electronics Jobs the Day after Graduation!

EVERY GRADUATE CAN ALSO RECEIVE EMPLOYMENT HELP THROUGH HIS ENTIRE CAREER, AT NO ADDED COST

DeVry's greatest claim to fame is the progress of its graduates. Our aim is to prepare a man so thoroughly that we can recommend him to employers . . . ready to step into a job the day after graduation. If we expect to continue to help employers, our graduates have to be good! That is why we provide top quality instruction—followed by career-long employment service at no added cost.

DeVry's educational programs are designed to prepare men 17-45 in their spare time at home or in any of our three well-equipped, modern resident schools in Chicago, Phoenix or Canada. Why not fill in and mail coupon for free facts today?

Approved for Veterans.

For FREE Information

Lack of technical experience is no barrier to the man who wants to prepare for a career in ELECTRONICS. Send coupon for two FREE booklets and find out why.



DeVRY INSTITUTE of TECHNOLOGY

4141 Belmont Avenue, Chicago, Ill. 60641, Dept. PE-11-X

Please give me your two free booklets, "Pocket Guide to Real Earnings," and "Electronics in Space Travel"; also include details on how to prepare for a career in Electronics. I am interested in the following opportunity fields (check one or more):

- | | |
|--|---|
| <input type="checkbox"/> Space & Missile Electronics | <input type="checkbox"/> Communications |
| <input type="checkbox"/> Television and Radio | <input type="checkbox"/> Computers |
| <input type="checkbox"/> Microwaves | <input type="checkbox"/> Broadcasting |
| <input type="checkbox"/> Radar | <input type="checkbox"/> Industrial Electronics |
| <input type="checkbox"/> Automation Electronics | <input type="checkbox"/> Electronic Control |

Name _____ Age _____

Address _____ Apt. _____

City _____ State or Province _____ Zone or Zip Code _____

Check here if you are under 16 years of age.

**HOME STUDY AND RESIDENT SCHOOL PROGRAMS
AVAILABLE IN CANADA. SEND FOR DETAILS.**

2106

Accredited Member of National Home Study Council

DeVRY INSTITUTE OF TECHNOLOGY

4141 BELMONT AVENUE, CHICAGO, ILLINOIS 60641

Weller®

...the soldering tools
professionals depend on



The original Dual Heat Soldering Guns

Preferred by technicians for their fast heating copper tips, exclusive trigger-controlled dual heat, and high soldering efficiency. Available in 3 wattage sizes, each with spotlight.

100/140-watt Model 8200, 145/210-watt Model D-440, and 240/325-watt Model D-550. Also in complete kits:

- **Model 8200PK** includes 100/140 watt gun, extra tips, tip-changing wrench, flux brush, soldering aid and solder
- **Model D-550PK** heavy-duty 240/325 watt gun kit with soldering, cutting and smoothing tips, wrench and solder

Dependable MARKSMAN Irons in a size for every job



Ideal for deep chassis work and continuous-duty soldering, Marksmann irons outperform others of comparable size and weight. All five feature long-reach stainless steel barrels and replaceable tips.

- 25-watt, 1 1/4-oz. Model SP-23 with 1/8" tip (In kit with extra tips, soldering aid, solder—Model SP-23K)
- 40-watt, 2-oz. Model SP-40 with 1/4" tip
- 80-watt, 4-oz. Model SP-80 with 3/8" tip
- 120-watt, 10-oz. Model SP-120 with 1/2" tip
- 175-watt, 16-oz. Model SP-175 with 5/8" tip

NOW a BATTERY OPERATED IRON for field servicing

Use this lightweight service tool for automotive wiring, model planes, or mobile communications. Works from any 12 volt battery or 12-14 volt AC/DC supply. Supplied complete with long-life patented "Temperature Sensing" tip, 12-ft. power cord and terminal clips. Model TCP-12—12 volt; Model TCP-24—24-28 volts.



Complete Weller Line includes replacement tips and solder at your Electronic Parts Distributor

WELLER ELECTRIC CORPORATION
Easton, Pa.

WORLD LEADER IN SOLDERING TECHNOLOGY
CIRCLE NO. 39 ON READER SERVICE PAGE

LETTERS

FROM OUR READERS

Address correspondence for this department to:
Letters Editor, POPULAR ELECTRONICS
One Park Avenue, New York, N. Y. 10016

KEEP IC PROJECTS COMING

I wish to point out an unprecedented erroneous flabbergastidity that appeared in the "Spots Before Your Eyes" article (September, 1967). On page 29 you show Oriental and Vermont Avenues each with a hotel on them, and Connecticut Avenue—in the same color group—with only three houses on it. Each hotel is equal to 5 houses, and the rules of "Monopoly" specifically state that a player must build evenly on each piece of property in a color group. Therefore, how can you show a hotel (equal to 5 houses) on two pieces of property and only 3 houses on the last lot? Connecticut Avenue must have 4 houses

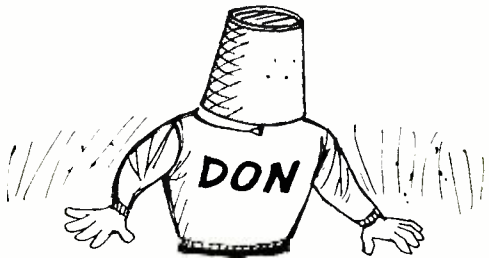

on it before Oriental and/or Vermont Avenues can have a hotel. Don Lancaster should be informed that errors like this can start riots.

However, I won't make any further issue of this point if POPULAR ELECTRONICS keeps these fantastic IC projects coming. They not only keep me updated on electronics, but also provide great sources of enjoyment and scientific interest.

HOWARD TARJEFT, JR.
Trenton, Mich.

Howard, you're perfectly correct about even building on each piece of property in a color group. We'll tell Don Lancaster, who no doubt will hang his head in shame. As for presenting more IC projects, keep reading POPULAR ELECTRONICS—you won't be disappointed.

ELECTRIC-SHOCK DOG TRAINING COLLAR

In the April, 1963, issue of POPULAR ELECTRONICS (page 8), you published a letter from Bruce Hannon requesting a construction project for an electric-shock dog training collar. At that time your answer was that you preferred not to publish details of a homemade electronic dog collar as it might

POPULAR ELECTRONICS

FREE!

Live Better Electronically With

LAFAYETTE RADIO ELECTRONICS

NOW OFF PRESS!

Latest Electronics Buying Guide

1968 CATALOG 680

Over 500 Pages



New!
23 Channel 2-Way
CB Radio
All Solid State
with IC's

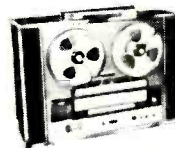

New!
Solid State Stereo
Tape Recorders
with Automatic Reverse



New!
Solid State FM-AM
Receivers
with "IC" & FET's

A complete buying guide to HI-FI, CB, Amateur gear,
Optics, Musical Instruments, Tools, and Auto Accessories



LAFAYETTE Radio ELECTRONICS
Dept. 1K-7 P.O. Box 10
Syosset, L.I., N.Y. 11791



SEND
FOR YOUR
FREE
COPY
TODAY!

Send me the Free 1968 Lafayette Catalog 680 1K-7

Name _____

Address _____

City _____ State _____ Zip _____

(Please Give Your Zip Code No.)

CIRCLE NO. 23 ON READER SERVICE PAGE

cause injury to the dog if improperly constructed or improperly used.

I was also interested in this idea but somewhat worried about the voltage drop to ground through the dog. I researched this nagging question and found that as little as



30 mA could cause fibrosis of the dog's heart. So, for the time being, I pursued the matter no further.

Now I also ask for construction details for an electric-shock dog training collar. I know that devices of this nature should not be used as punishment devices, but I could come up with a training schedule that would not be likely to ruin the dog's nature.

MORGAN KENNEDY, JR.
New York, N.Y.

Morgan, our original feelings about an electric-shock dog training collar are still very strong. Whether such a device is employed as a punishment inflicting medium or as a training aid is immaterial, especially where the dog is concerned. Even though the electric shock is restricted to the neck area of the dog—and is very unlikely to cause a dangerous shock to ground through the dog's body as you suggested—using an electric shock to train a dog is far from a humane way of treating an animal.

WHERE TO OBTAIN IC'S

The "Square Deal" Audio Generator (November, 1966) featured the use of IC's (integrated circuits). This was followed by two more projects using IC's in the December, 1966, issue. In all these projects, Fairchild Semiconductor was listed as the source for data sheets and distributor lists. I wrote to Fairchild, and they sent me data sheets but no distributor list. Can you tell me where I can buy these Fairchild Semiconductor IC's and approximately how much they cost?

L. M. STRYKER
Lieutenant, U.S.N.
Yorktown, Va.

Lieutenant, since we have had several inquiries like yours, we have endeavored to obtain a Fairchild Semiconductor distributor list. Space does not permit us to list all of the distributors here. However, project build-

Add LIFE to your color TV, stereo radio and electronic equipment



Whisper Fan®

- Made especially for cooling transistors, tubes and other heat generating components
- Helps guard against part failure
- Ensures trouble-free life — peak performance
- Costs only a few pennies to operate — saves dollars in repair bills
- So quiet and noise-free, you have to feel the breeze to know it is at work
- Quickly and easily installed



Only
\$14.85
Complete!

Ask your dealer to demonstrate how the Delwyn Whisper Fan will pay for itself in savings on just one heat-caused repair bill.



BOX 195 B, Route 28
Kingston, New York 12401



CIRCLE NO. 13 ON READER SERVICE PAGE

EXTRA POWER

with

FINCO

AMPLIFIERS

*For perfect color TV and
FM Stereo Reception*

FINCO MODEL #65-4
Antenna Amplifier
\$47.95 list VHF-TV
Two-transistor Antenna
Amplifier for 75 OHM
Downlead, and power
supply with built-in
single or dual 300 ohm
outputs. Provides 12
dB gain in the low band
and 14 dB gain in the
high band.



FINCO MODEL #65-1
Distribution Amplifier
\$29.95 list 2-tube 4-
output VHF-TV or FM
Distribution Amplifier
for 300 OHM Opera-
tion, providing 8 dB
gain at each 300 ohm
output to feed home or
commercial systems.



FINCO MODEL #65-5
Distribution Amplifier
\$44.95 list VHF-TV 75
OHM Single Outlet Dis-
tribution Amplifier for
deluxe home or com-
mercial use to feed
multiple sets through
line tap offs or split-
ters. Delivers 17 dB
Low Band and 14 dB
High Band.



FINCO MODEL #65-2
Distribution Amplifier
\$39.95 list 2-tube 4-
output VHF-TV or FM
Distribution Amplifier
for 75 OHM CO-AX
Operation, providing 6
dB gain at each 75 ohm
output to feed deluxe
home or commercial
systems.



FINCO MODEL #65-6
Amplifiers \$79.95 list.
VHF-TV Antenna Moun-
ted two-transistor pre-
amplifier with 75 OHM
two-tube Single Output
Distribution Post-am-
plifier up to 30 dB gain
for improved reception.
Used in home or com-
mercial installations to
feed multiple sets.



FINCO MODEL #65-3
Antenna Amplifier
\$44.95 list New VHF-
TV Antenna Amplifier
and Power Supply with
built-in single or dual
outputs to improve re-
ception of weak signals
in fringe areas. Pro-
vides 12 dB gain in the
low band and 14 dB
gain in the high band.



FINCO MODEL #65-7
FM Signal Amplifier
\$24.95 list. One-trans-
istor Indoor Behind-
the-set FM amplifier
with a passive filter in-
put circuit to reject sig-
nals outside the FM
band which cause in-
terference. Delivers 20
dB Gain



Sets "COME ALIVE" with Brilliant Sound and Color

A Finco high-gain, low-noise amplifier
will bring in the sharpest **COLOR** or
B & W TV picture and the finest sound!

**All FINCO Products are Engineered
For Color!**



Write for Color Brochure #20-411.

THE FINNEY COMPANY

34 W. Interstate Street • Dept. PE • Bedford, Ohio 44146



This is the booklet Popular Electronics' readers have been turning to since the beginning of high fidelity to see the most advanced developments in record playing equipment.

It's Garrard's Comparator Guide and an entirely new edition is just off the press.

In it, you'll read about Garrard's new Synchro-Lab Motor™ and the exciting new series of automatic turntables it powers . . . the Synchro-Lab Series.™

Write today for your complimentary copy.

Garrard®

Dept. AS-13, Westbury, N.Y. 11590.
Please send Comparator Guide.

Name _____
Address _____
City _____ State _____ Zip _____

British Industries Corp., a division of Avnet, Inc.

CIRCLE NO. 18 ON READER SERVICE PAGE

LETTERS (Continued from page 10)

ers who live in the West can contact Hamilton Electro Sales—North, 340 Middlefield Rd., Culver City, Calif. 94041; in the Central states, Semiconductor Specialists, Inc., 6154 Jefferson Ave., St. Louis, Mo. 63134; and in the East, Schweber Electronics, Westbury, L.I., N.Y. 11591. According to our latest information, the suggested list prices of the μ L900 and μ L914 are 80 cents and \$1.50, respectively.

READER CIRCUIT HANDBOOK—A POSSIBILITY

I agree with Tom Ordon ("Letters From Our Readers," August, 1967) that a handbook of the reader circuits that appear in your "Solid State" column would be desirable to the readers of POPULAR ELECTRONICS. I have



been copying many of the diagrams and placing them in a looseleaf binder. A handbook would be more compact, neater, and easier to follow.

JAMES L. BOCHANTIN
Du Bois, Ill.

Subsequent to the appearance of Tom's letter, we have had quite a response from our readers in favor of this idea—so much, in fact, that we are seriously considering the publication of such a handbook.

OLD AND OBSOLETE TUBES FOR SALE

I have noticed many requests for obsolete items in POPULAR ELECTRONICS—vacuum tubes, small parts, and out-of-date schematic diagrams. I have about 3000 old and obsolete tubes ranging from 01-A's to 117Z6's, and would like to reduce my inventory. About 40% of these tubes are new and still in their boxes; the others are not boxed and some are used, but all are in perfect working order. My stock also includes loctal types selling for about \$7 at the present time. Any of your readers who would like to obtain a stock of these tubes can have them at 10 cents each in lots of 100.

R. I. BEALE
6645 SW 73 Court
S. Miami, Fla. 33143

We've included your complete address, R.I., so that interested readers can contact you directly.

-30-

CIRCLE NO. 20 ON READER SERVICE PAGE →

MORE CBers ARE BUYING Hy-gain's NEW CLR 2 THAN ANY OTHER BASE STATION ANTENNA FOR CITIZENS BAND

*because they
work better*

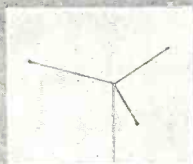

▲ Top Hat originally conceived by Hy-Gain effectively reduces static...offers low wind resistance.

19'10½" radiator is maximum legal height... provides maximum signal capture area

▲ Full sized ¼ wavelength radials insure maximum gain through lowering the angle of radiation

*because they're
built better*

Rugged double-grip mast bracket ▶

Taper-swaged seamless aluminum tubing ▼



▶ Unique full circumference compression clamp exerts vise-like grip to insure permanent protection against corrosion and mechanical failure. Hy-Gain exclusive.



▶ Solid State Matcher



AND...WE GUARANTEE 'EM!

HY-GAIN
Dept. EA-11

The Antenna Manufacturer

ELECTRONICS CORPORATION

8458 N.E. Highway 5 - Lincoln, Nebraska

with a Record of Engineering "FIRSTS"

When THIS Pioneer Speaks
...it's time to listen!

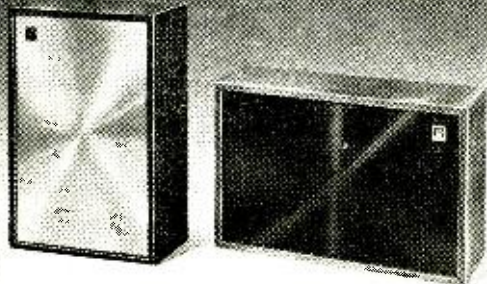

**Model CS-24 PIONEER
Full-Fidelity Compact
Slimline Speaker System**

...an incredible value at \$27⁵⁰ ea.

Listen . . . to the outstanding beauty, clarity and definition of this *slimline* Pioneer CS-24 speaker system. It's the ideal system for high fidelity vocal reproduction and total musical enjoyment. The CS-24 has been the "HIT" of Hi-Fi shows wherever shown.

A remarkable engineering achievement in a system of this kind, the CS-24 is a dual cone 8" speaker system. Decorator styled in jewelry polished silver or black metal grille and framed in superbly finished matched wood grain cabinet. Whether wall or shelf mounted, Pioneer Model CS-24 enhances the appearance of any office, living room, den or kitchen. Only the world's largest loudspeaker manufacturer can bring you such tonal pleasures at such an unbelievably low price of \$27.50 each, and guarantees it for 3 years, too. Size: 10 1/8" H. x 16 1/8" W. x 4 3/4" D.

SPECIAL OFFER

TO POPULAR ELECTRONICS READERS!

If not available at your nearest dealer you can order direct, and we will credit our nearest franchised dealer accordingly. Just complete coupon below and mail with your check to Pioneer. *No COD's please.*

FILL OUT & MAIL TODAY



PIONEER ELECTRONICS U.S.A. CORP.

140 Smith St., Farmingdale, N. Y. 11735

(516) 694-7720

Send me _____ Model CS-24 Speaker Systems @ 27.50 each
FOB Farmingdale, N. Y. I want the following finish

Silver Black. Check enclosed for \$ _____

(Add state/local taxes where applicable).

Name

Street

City/State Zip Code

CIRCLE NO. 41 ON READER SERVICE PAGE



**TIPS
&
TECHNIQUES**

**SIMPLE JIG IMPROVES
APPEARANCE OF PROJECTS**

When wiring several small parts to closely spaced terminals, you can give your project a neat, factory-wired appearance by bending component leads to a uniform shape. A simple jig, consisting of a block of wood and a few headless nails,

is all you need. Before driving the nails into the block of wood, bend the leads of a small component to the desired shape, then set the component on the block of wood, and drive the nails in at the bends as shown in the photo. For different size components, you may need several of these easy-to-make jigs. With the aid of a jig, you can speed assembly time, eliminate "kinked" and broken component leads, and reduce the possibility of unwanted short circuits.

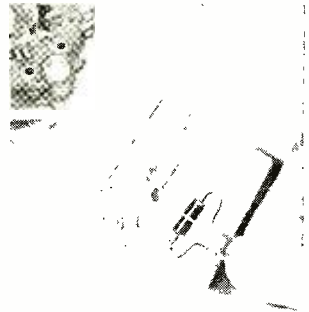

—Frank H. Tooker

**CANCEL MONO NOISE
ON STEREO RECORDS**

Rumble and record surface noise are common problems when mono records are played on a stereo record player. You can reduce or even

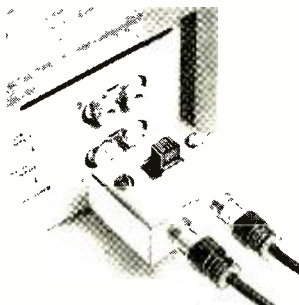

eliminate this noise if the two "signal" conductors from the phono pickup are shorted together. This can be quickly accomplished with a simple switching arrangement at the amplifier input. Mount a miniature

s.p.s.t. slide switch in a small metal case. Then mount two phono jacks on one side of the case and two phono plugs on the other side, using the case as a common ground for

READER SERVICE PAGE

free information service:

Here's an easy and convenient way for you to get additional information about products advertised or mentioned editorially (if it has a "Reader Service Number") in this issue. Just follow the directions below...and the material will be sent to you promptly and free of charge.

1. Print or type your name and address on the lines indicated. Circle the number(s) on the coupon below that corresponds to the key number(s) at the bottom of the advertisement or editorial mention(s) that interest you. (Key numbers for advertised products also appear in the Advertisers' Index.)

2. Cut out the coupon and mail it to the address indicated below.

3. This address is for our product "Free Information Service" only. Editorial inquiries should be directed to POPULAR ELECTRONICS, One Park Avenue, New York 10016; circulation inquiries to Portland Place, Boulder, Colorado 80302.

**POPULAR
ELECTRONICS**

VOID AFTER DECEMBER 31, 1967

P.O. BOX 8391
PHILADELPHIA, PA. 19101

1 2 3 4 5 6 7 8 9 10 11 12 13 14 15 16 17 18 19 20
21 22 23 24 25 26 27 28 29 30 31 32 33 34 35 36 37 38 39 40
41 42 43 44 45 46 47 48 49 50 51 52 53 54 55 56 57 58 59 60
61 62 63 64 65 66 67 68 69 70 71 72 73 74 75 76 77 78 79 80
81 82 83 84 85 86 87 88 89 90 91 92 93 94 95 96 97 98 99 100

NAME (Print clearly) _____

ADDRESS _____

CITY _____ STATE _____ ZIP CODE _____

INCOMPARABLE PACE 2300

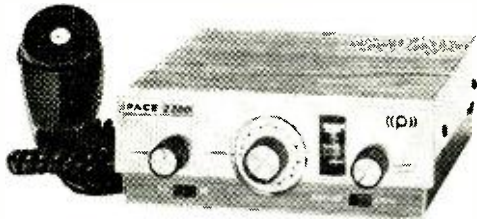

23 CHANNEL MOBILE CB RADIOTELEPHONE

Here is the ultimate in efficient, ultra-reliable solid state two-way Citizens Band radio communication, with more exclusive features than any other all-silicon transceiver.

Transmitter—equipped with heavy silicon diamond output transistor, rated at full authorized power (5 watts) • delivers 4 watts (typical) with 100% modulation • double conversion super-heterodyne receiver with narrow band, shaped audio response • custom styled to match interior auto decor—handsome walnut grain metal case and chrome bezel • all 23 channels installed and factory tuned • full size "S" meter installed and calibrated • local/distance receiver sensitivity control • exclusive noise limiting • Public Address and loud hailer facility with front panel control and separate speaker jacks • equipped for "Private Caller" selective call accessory • quick-snap power cord and bracket for easy transfer to other vehicle • new locking latch rack • full year guarantee on all parts, plus lifetime guarantee on glass fiber circuit board.

\$219.95

Write for complete information:

((P)) PACE

COMMUNICATIONS CORP.

24049 Frampton Ave., Harbor City, Calif. 90710

Export Div.: 64-14 Woodside Ave., Woodside, N.Y.
Also available in Canada

CIRCLE NO. 28 ON READER SERVICE PAGE

TIPS

(Continued from page 14)

the four parts. Wire the jacks, plugs and switch so that in one position the switch is open and provides normal stereo channel separation and in the other position both channels are combined. Plug the switch box into the inputs of your amplifier and the phono pickup cables into the switch box as shown in the photo. When playing mono records, just switch to the "combine" position.

—Art Trauffer

SIMPLE SPEED REDUCER FOR POWER TOOLS

Looking for a speed reducer for your portable power tools? You can build one for the cost of two chassis-mounting a.c. receptacles, a d.p.d.t. switch, and a power cord. A table lamp or other electrical appliance serves as a current limiter, and thus a speed reducer. (The speed of rotation of the power tool is proportional to the amount of current flowing. Therefore, if you want to reduce the speed of an electric drill appreciably, you would use a low wattage lamp in preference to a high wattage one.) Once the parts are mounted on a small utility box, wire them together so that in one position of the switch the receptacles are in parallel across the

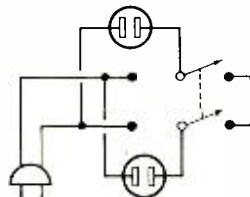

line (label this position *HI*), and in the other position both receptacles are in series (label this position *LO*), as shown. To use the speed reducer, plug the lamp or appliance into one receptacle and the power tool into the other. Set the switch to *LO* for reduced speed, to *HI* for full speed.

—James R. Oswald

MAKE QUICK AND ECONOMIC PHONE-TIP-TO-PHONE-PLUG ADAPTERS

With the aid of a pair of Fahnestock clips, you can easily mate headphone phone tips to a standard phone plug. Simply secure the Fahnestock clips to the appropriate terminals of the phone plug, using the screws supplied with the plug (see photo). The phone tips can then be connected to the plug, and held in place securely by spring action of the Fahnestock clips. If the need arises, the phone tips can be easily removed. This simple trick eliminates unsightly patch cords and does away with overly bulky temporary connections.

—Mark Bodian



LOOK!

A New Electronics Slide Rule with Instruction Course

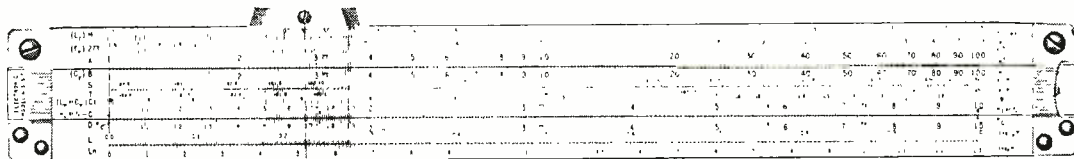

Front

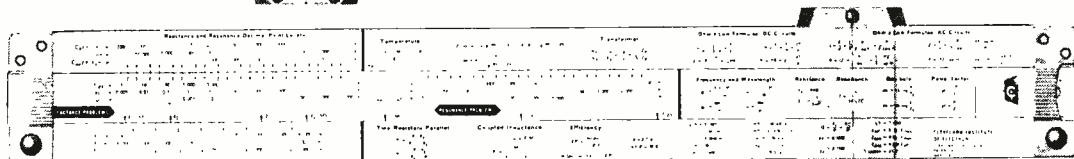

Back

This amazing new "computer in a case" will save you time the very first day. CIE's patented, all-metal 10" electronics slide rule was designed *specifically* for electronic engineers, technicians, students, radio-TV servicemen and hobbyists. It features special scales for solving reactance, resonance, inductance and AC-DC circuitry problems... an exclusive "fast-finder" decimal point locator... widely-used formulas and conversion factors for instant reference. And there's all the standard scales you need to do multiplication, division, square roots, logs, etc.

Best of all, the new CIE Slide Rule comes with an Instruction Course of four **AUTO-PROGRAMMED** lessons. It includes hundreds of illustrations, diagrams and practice problems. You'll learn ingenious short cuts... whip through exacting electronics problems quickly and accurately. This course alone is worth far more than the price of the entire package!

Electronics Slide Rule, Instruction Course, *and* handsome, top-grain leather carrying case... a \$50 value for less than \$25. Send coupon for **FREE** illustrated booklet and **FREE** heavy vinyl Pocket Electronics Data Guide. Cleveland Institute of Electronics, 1776 E. 17th St., Dept. PE-138, Cleveland, Ohio 44114.

*TRADEMARK



GET BOTH FREE!



**Send
coupon
today** →

Cleveland Institute of Electronics

1776 E. 17th St., Dept. PE-138, Cleveland, Ohio 44114

Please send **FREE** Illustrated Booklet describing your Electronics Slide Rule and Instruction Course.

SPECIAL BONUS! Mail coupon promptly... get **FREE** Pocket Electronics Data Guide too!

Name _____ (PLEASE PRINT)

Address _____ County _____

City _____ State _____ Zip _____

A leader in Electronics Training... since 1934.

CIRCLE NO. 9 ON READER SERVICE PAGE

**“Get more
education
or
get out of
electronics
...that’s my advice.”**





Founded 1927
CREI
 Accredited Member
 of the National Home Study Council

Ask any man who really knows the electronics industry.

Opportunities are few for men without advanced technical education. If you stay on that level, you'll never make much money. And you'll be among the first to go in a layoff.

But, if you supplement your experience with more education in electronics, you can become a specialist. You'll enjoy good income and excellent security. You won't have to worry about automation or advances in technology putting you out of a job.

How can you get the additional education you must have to protect your future—and the future of those who depend on you? Going back to school isn't easy for a man with a job and family obligations.

CREI Home Study Programs offer you a practical way to get more education without going back to school. You study at home, at your own pace, on your own schedule. And you study with the assurance that what you learn can be applied on the job immediately to make you worth more money to your employer.

You're eligible for a CREI Program if you work in electronics and have a high school education. Our FREE book gives complete information. Air-mail postpaid card for your copy. If card is detached, use coupon below or write: CREI, Dept. 1211E, 3224 Sixteenth Street, N.W., Washington, D.C. 20010.



40
Years of
 Home Study
 Education

The Capitol Radio Engineering Institute

A Division of McGraw-Hill, Inc.
 Dept. 1211E, 3224 Sixteenth Street, N.W.
 Washington, D.C. 20010

Please send me FREE book describing CREI Programs. I am employed in electronics and have a high school education.

NAME _____ AGE _____

ADDRESS _____

CITY _____ STATE _____ ZIP CODE _____

EMPLOYED BY _____

TYPE OF PRESENT WORK _____ G.I. BILL

- I am interested in Electronic Engineering Technology
 Space Electronics Nuclear Engineering Technology
 Industrial Electronics for Automation
 Computer Systems Technology

APPROVED FOR TRAINING UNDER NEW G.I. BILL



NEW PRODUCTS

Additional information on products covered in this section is available from the manufacturers. Each new product is identified by a code number. To obtain further details on any of them, simply fill in and mail the coupon on page 15.

23-CHANNEL 2-WAY CB RADIO

Unique IC "noise silencer" circuitry—claimed to be a first in CB radio—is incorporated in Lafayette Radio's imported Model HB-625 23-channel transceiver. The 5-watt transmitter section utilizes "range-boost" modulation

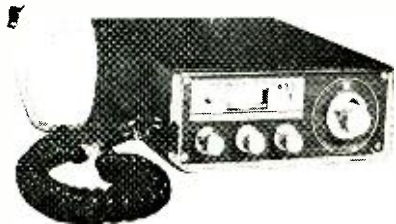

circuitry, while the dual-conversion receiver section features mechanical filtering, delta tuning, a variable squelch control, and an automatic noise limiter. The HB-625 will accept Lafayette's "Priva-Com" private tone caller, and it is equipped with internal public address facilities. Crystals for all channels are supplied.

Circle No. 75 on Reader Service Page 15

TV ANTENNA PREAMPLIFIER

Improved fringe area reception—on sets more than 15 miles from the nearest TV or

FM transmitter—is the purpose of Jerrold's "Powermate" Model CPM-107 antenna-signal preamplifier. By overcoming noise pickup and antenna down-lead losses, the CPM-107 permits weak signals to get through much better. With a 75-ohm input and output, the unit consists of a Jerrold CPM-1 single-transistor broadband preamplifier

for VHF/FM and a Model 107 remote supply for "color-perfect" reception at all frequencies. The housing is weatherproof (Cyclac) and universal mounting brackets are used.

Circle No. 76 on Reader Service Page 15

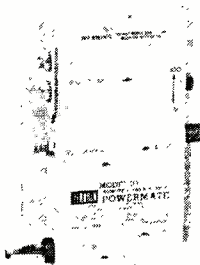

40-WATT AM/FM-STEREO TUNER RECEIVER

Pioneer's Model SX-300T transistor stereo receiver is an integrated system combining an AM tuner, an FM-stereo tuner and a 20-watts-per-channel stereo amplifier on a single chassis. The FM - stereo tuner utilizes time-switching demodulation to achieve better than 35 dB channel separation at 1 kHz.

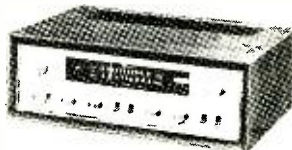

The FM section has 3- μ V sensitivity, 52 dB image rejection, and a 55 dB signal-to-noise ratio. The AM section employs a built-in ferrite loopstick antenna and features 28- μ V sensitivity, 33-dB image rejection. Frequency response is 20 to 20,000 Hz \pm 3 dB, harmonic distortion less than 1.0% at 1 kHz.

Circle No. 77 on Reader Service Page 15

DE-SOLDERING TOOL

Fast, safe, and efficient removal of micro-miniature components is the aim of Ungar's

"Princess" (turquoise blue handled) "de-Solderette" tool. The non-sticking and non-clogging tool is held in one hand, leaving the other one free for removal of IC chips and discrete devices during re-work and repair. The replaceable tip of the "Princess" has an 0.033" aperture, and the 18-



watt heat capsule delivers a tip temperature of 600°F. Easy pickup is accomplished by the red vacuum bulb which produces 5.5 ounces per square inch of vacuum at the tip.

Circle No. 78 on Reader Service Page 15

CRT TESTER

Automatic color tracking—fast and accurate—is possible with Sencore's new "CRT Champion" tester, Model CR143, eliminating the need for tedious logging and comparing of individual gun readings. With separate G2

screen grid controls, each color gun is set up and then automatically compared to the others for tracking. The "Champion" makes all standard color and black-and-white CRT tests, including shorts, emission, and

life tests, using pure d.c. A line-adjust control assures accuracy when you're checking

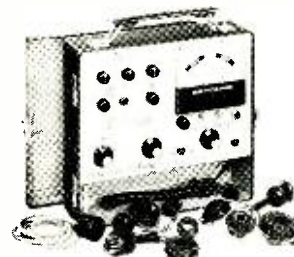

EICO Makes It Possible

Uncompromising engineering—for value does it!
You save up to 50% with Eico Kits and Wired Equipment.



Cortina Stereo

Engineering excellence, 100% capability, striking esthetics, the industry's only **TOTAL PERFORMANCE STEREO** at lowest cost.

A Silicon Solid-State 70 Watt Stereo Amplifier for \$89.95 kit, \$129.95 wired, including cabinet. Cortina 3070.

A Solid-State FM Stereo Tuner for \$89.95 kit, \$129.95 wired, including cabinet. Cortina 3200.

A 70-Watt Solid-State FM Stereo Receiver for \$159.95 kit, \$239.95 wired, including cabinet. Cortina 3570.



Eicocraft

The newest excitement in kits.

100% solid-state and professional. Fun to build and use. Expandable, interconnectable. Great as "jiffy" projects and as introductions to electronics. No technical experience needed. Finest parts, pre-drilled etched printed circuit boards, step-by-step instructions.



EICOCRAFT Electronic Siren \$4.95, Burglar Alarm \$6.95, Fire Alarm \$6.95, Intercom \$3.95, Audio Power Amplifier \$4.95, Metronome \$3.95, Tremolo \$8.95, Light Flasher \$3.95, Electronic "Mystifier" \$4.95, Photo Cell Nite Lite \$4.95, Power Supply \$7.95, Code Oscillator \$2.50, FM Wireless Mike \$9.95, AM Wireless Mike \$9.95, Electronic VOX \$7.95, FM Radio \$9.95, AM Radio \$7.95, Electronic Bongos \$7.95.



Two years ahead! Model 7923

All Solid-State 23-Channel 5W Transceiver. 4 exclusives: dual-crystal lattice filter for razor-sharp selectivity; efficient up-converter frequency synthesizer for advanced stability; precision series-mode fundamental crystals; Small: only 3"H, 8"W, 8 1/4"D. \$189.95 wired only.

The best buy in tube-type CB—"Sentinel-Pro" 23-channel dual conversion 5W Transceiver \$169.95 wired only.

EICO Trans/Match (Model 715) is a professional test set designed for complete checking of ham and CB equipment. Kit \$34.95; Wired \$49.95.

Citizen's Band

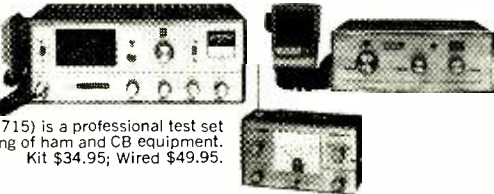

Truvohm

Professional Portable Multimeters by EICO.

The industry's greatest V-O-M values.

Designed, made to Eico's high standards of professionalism. Each complete with batteries & test leads.

Backed 100% by famous EICO warranty.

Model 100A4, 100,000Ω/V, \$34.95.

Model 30A4, 30,000Ω/V, \$19.95.

Model 30A3, 30,000Ω/V, \$15.95.

Model 20A3, 20,000Ω/V, \$12.95.

Model 4A3, 4,000Ω/V, \$8.95.

Model 1A1, 1,000Ω/V, \$5.95.



Automotive

EICO 888—Car/Boat Engine Analyzer.

For all 6V/12V systems; 4, 6, 8-cyl. engines.

Now you can keep your car or boat engine in tip-top shape with this solid-state, portable, self-powered universal engine analyzer. Completely tests your total ignition/electrical system.

Complete with a Tune-up & Trouble-shooting Manual. Model 888; \$44.95 kit, \$69.95 wired.

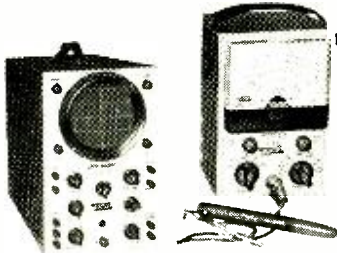
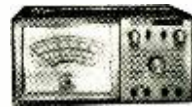

Model 232 Peak-to-Peak VTVM. A must for color or B&W TV and industrial use. 7 non-skip ranges on all 4 functions. With exclusive Uni-Probe. \$29.95 kit, \$49.95 wired.

Test Equipment EICO®

100 best buys to choose from.

"The Professionals" — 100% professional parts at lowest cost

Model 460 Wideband Direct-Coupled 5" Oscilloscope. DC-4.5mc for color and B&W TV service and lab use. Push-pull DC vertical amp., bal. or unbal. input. Automatic sync limiter and amp. \$109.95 kit, \$149.95 wired.

FREE 1968 CATALOG

PE-11

EICO Electronic Instrument Co., Inc.
131-01 39th Ave., Flushing, N.Y. 11352
 Send me FREE catalog describing the full EICO line of 200 best buys, and name of nearest dealer.

Name _____
Address _____
City _____
State _____ Zip _____

CIRCLE NO. 14 ON READER SERVICE PAGE

PRODUCTS (Continued from page 22)

critical tubes where line voltage fluctuations might cause incorrect readings, and an exclusive automatic rejuvenation circuit provides three positions for saving faulty tubes or equalizing gun currents in color tubes. The "Champion" is equipped with plug-in sockets for fast testing of all CRT's and easy updating.

Circle No. 79 on Reader Service Page 15

MOBILE POLICE/FIRE BAND RECEIVERS

Selective i.f. stages incorporate four IC's in *Lafayette Radio's* imported Models PB-50 and PB-150 solid-state mobile police and fire monitor receivers.

The PE-50 covers 30 to 50 MHz, while the PB-150 covers 152 to 174 MHz. Both models have provisions for crystal-controlled or tunable reception, and each features better than 1- μ V sensitivity with an audio output of 2.8 watts. Primarily designed for operation from 12-volt d.c. (negative ground) car electrical systems, they can also be operated from 117-volt a.c. line power with an optional power supply.

Circle No. 80 on Reader Service Page 15

70-WATT STEREO RECEIVER

Recently EICO mounted its "Cortina" 3070 amplifier and "Cortina" 3200 FM stereo tuner on a single chassis and came up with the 3570 FM/MPX stereo receiver. It's a power-



ful "all-in-one" 70-watt unit that should satisfy the tastes of all stereo buffs. In the front end, FM section, there are two r.f. stages, five tuned circuits, and four stages of double-tuned i.f. for reliable and interference-free performance. In the amplifier-control section are all the controls, inputs, and outputs you need to match any type of turntable cartridge and speaker system to the 3570 receiver. The 3570 comes both in kit form and factory wired.

Circle No. 81 on Reader Service Page 15

WIRELESS REMOTE CONTROL AND INTERCOM

Two time- and step-saving devices for use in the home have been announced by *Olson Electronics*. The Model SW-394 wireless remote control switch lets you turn on or off any electrical device that draws up to 500 watts of power from almost anywhere in your home. The Model AM-340 wireless (solid-state) intercom is a hand-held or wall-mount-

ing room-to-room communicator. Both utilize the existing house wiring to couple control signals or voice information from unit to unit, so there is no need to run unsightly and potentially hazardous cable.

Circle No. 82 on Reader Service Page 15

CB TRANSCEIVER FOR MOTORCYCLES

Motorcycle enthusiasts: now you can go on the air CB-style with a compact "Polly-Otter" two-way Citizens Band radio manufactured by *Polytronics*. There are two models of the Polly-Otter—one for luggage carrier mounting, and the other to fit into scooter and motorcycle saddlebags. Each model has a fully solid-state 7-channel transmitter and superhet receiver, resulting in a 5-watt transceiver that gives reliable two-way contact up to 15 miles or more away. These transceivers are fully waterproof and said to be immune to extreme temperatures. Various accessories are available.

Circle No. 83 on Reader Service Page 15

BUILT-IN FLEXIBILITY TURNTABLE

A new precision turntable, Model TD-150, has been released by *Thorens*. Designed to provide the serious hi-fi'er with the maximum amount of flexibility, the TD-150 lets the user select literally any tone arm-cartridge

combination. Features include a precision - balanced, non-magnetic 12" diameter platter, and two low-speed synchronous motors

that are connected to a single shaft to provide constant tracking speed at either 33 $\frac{1}{3}$ or 45 r/min. A spring-loaded suspension system supports the uni-suspension tone arm board and heavy platter so that vibrations and acoustic feedback are kept at a minimum.

Circle No. 84 on Reader Service Page 15

COMBINATION AM/MARINE BAND RECEIVER

A portable transistorized receiver designed for boat, car, and personal use, the Model 1305 AM/MB Marine Band Radio made by *Craig Panorama, Incorporated*, features an emergency direction finder, push-button illuminated dial, tone controls and AM and marine band switches. The receiver can be connected to any car or boat power system (6 or 12 volts), whether positive or negative ground. The 8-transistor circuit develops 400 milliwatts of peak power when operated on flashlight batteries and up to 2 watts peak when used in an optional power bracket. In the latter case, the built-in ferrite bar antenna connects to boat or car antenna automatically.

Circle No. 85 on Reader Service Page 15

SPECIAL 10th ANNIVERSARY ISSUE—

*All-new
Winter
1968
Edition!*

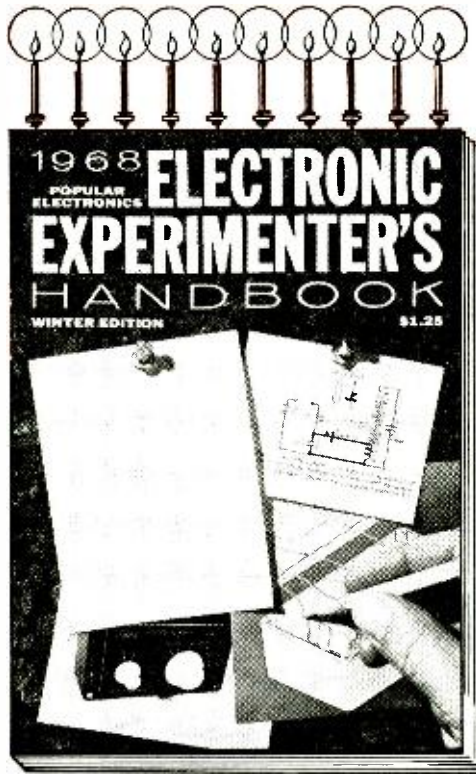

*Over 145
Pages!*

*50%
Discount!*

It's our anniversary . . . but you get the present: 250 fascinating, fun-filled hours with the all-new Winter 1968 ELECTRONIC EXPERIMENTER'S HANDBOOK! A big surprise package of 28 challenging do-it-yourself construction projects for • your home and auto • audio, stereo, hi-fi • SWL, CB and Ham • science fair projects • lab and test equipment.

You'll build such valuable units as . . . a solid-state CD ignition system . . . a sequence-operated lock . . . a metal locator . . . a two-by-two stereo preamplifier . . . a 70 watt per

channel hi-fi amplifier . . . a VOM range splitter . . . an IC binary counter . . . and Tesla's thermo-magnetic motor!

Each has complete schematics, illustrations, parts lists and easy-to-follow instructions that guarantee you perfect finished products. PLUS expert tips 'n techniques designed to build your electronics skill. You'll keep up with the latest advances in

the field, learn many professional methods and shortcuts . . . and develop that extra technical know-how you get only from practical, first hand experience.

In short, Happy Anniversary to us . . . means Happy Hobbying to you. For this big 10th Anniversary edition of the ELECTRONIC EXPERIMENTER'S HANDBOOK is the best yet—sure to be grabbed up by electronics enthusiasts everywhere. Use the coupon below to order your copy today!

GET THE DELUXE LEATHERFLEX-BOUND EDITION for just \$3 POSTPAID!

The Winter 1968 ELECTRONIC EXPERIMENTER'S HANDBOOK is also available in a splendid deluxe edition. Rugged Leatherflex cover provides lasting protection yet is softly textured and gold-embossed for the look of elegance. A collector's item — a superb addition to your electronics bookshelf. And it's yours, for just \$3 postpaid, when you check the appropriate box on the order form.

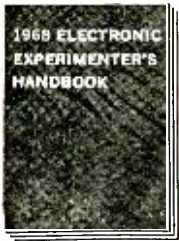

*Only
\$1.25*

ZIFF-DAVIS SERVICE

DIVISION, DEPT. EEHF

595 B'way, N.Y., N.Y. 10012

OK! Send me the all-new Winter 1968 ELECTRONIC EXPERIMENTER'S HANDBOOK.

\$1.25 enclosed, plus 15c for shipping and handling. Send me the regular edition. (\$1.75 for orders outside the U.S.A.)

\$3.00 enclosed. Send me the Deluxe Leatherflex-bound edition, postpaid. (\$3.75 for orders outside the U.S.A.) Allow three additional weeks for delivery.

name _____
 address _____ PLEASE PRINT
 city _____ PE-11
 state _____ zip code _____

I missed the big Spring 1967 edition. Please send me the regular edition Deluxe Leatherflex-bound edition. (Prices same as above.)

— PAYMENT MUST BE ENCLOSED WITH ORDER. —

Before you buy
a cheap changer,
read about this
inexpensive Dual.



The new Dual 1010S at \$69.50 is Dual's lowest priced model, yet it is in every respect a precision-engineered automatic turntable.

Its cueing system lowers the tonearm gently on your records instead of just dropping it and possibly damaging both stylus and groove. This is the identical auto/manual system as used on our most expensive models.

The 1010S also shares their feathertouch slide switches and Elevator-Action changer mechanism. Its Hi-Torque motor holds speed constant within 0.1% even when voltage varies $\pm 10\%$, and its low mass tubular tonearm tracks flawlessly at 2 grams.

Precision features like these make the difference between a Dual and a cheap record changer. And make the difference on your records.

United Audio Products, Inc.,
535 Madison Avenue, New York,
N. Y. 10022.



CIRCLE NO. 38 ON READER SERVICE PAGE

ELECTRONICS LIBRARY

HI-FI STEREO HANDBOOK, Third Edition

by William F. Boyce

The *Hi-Fi Stereo Handbook* will help answer almost any question an audio buff might have about modern hi-fi equipment. This edition covers the gamut of the equipment now on the market—from intricate tuner/amplifiers right on down to the type of stylus to look for in a cartridge. In addition, the book gives pointers on how to install a system, describes the various components, and explains how each component operates. Updated material includes new transistor circuits, latest recording techniques, and multipath-checking equipment. Whether you are planning to buy your first hi-fi system or replace the one you probably already have, you'll find this book to be a handy reference both before and after you buy.

Published by Howard W. Sams & Co., Inc.,
4300 West 62 St., Indianapolis, Ind. 46206. Soft
cover. 288 pages. \$4.95.



A MODERN TRANSISTOR WORKBOOK

Written directly for the hobbyist or experimenter by the Radio Shack staff, this book features construction details of 50 simple, solid-state projects each using easy-to-get, inexpensive parts.

Published by Radio Shack Corp., 730 Commonwealth Avenue, Boston, Mass. 02215. Soft cover. 80 pages. \$2.00.



DIODE CIRCUITS, Second Edition

by Rufus P. Turner

Diodes play important roles in every area of electronics. But because they are relatively simple devices, they are often misunderstood, and just as often improperly used. *Diode Circuits* gives more than 150 examples of commonly used diode circuits—60 of which did not appear in the first edition of this book. Operation of each circuit is explained in detail, and the types of diodes designated are up-to-date, with modern nomenclatures. The information presented in this book is practical and informative, for both the beginner and advanced technician. *Diode Circuits* also includes a section devoted to experimenter circuits, each of which was tested by the author and proved to work.

Published by Howard W. Sams & Co., Inc.,
4300 West 62 St., Indianapolis, Ind. 46206. Soft
cover. 160 pages. \$3.25.

—30—

If General Custer had used a Messenger 300

... things might have happened differently that day along the Little Big Horn River.

There's really no need to fight a battle every time you want to go on the air. The Johnson Messenger 300 protects your flanks at all times from adjacent channel interference with a precision crystal filter. Your voice carries authority thanks to the Messenger 300's speech compression circuit. It gives you more audio without splatter or overmodulation.



On the front lines the Messenger 300 operates up to 8 hours on the rechargeable Power Pack. At the command post, plug in the accessory AC power supply. You can even signal the troops with Tone Alert selective calling. It eliminates the need for constant monitoring and lets you concentrate on more important matters. FCC type accepted and DOT approved.

Don't win a price battle and get scalped on quality. Put yourself in command with a Johnson Messenger 300. Send for details today.

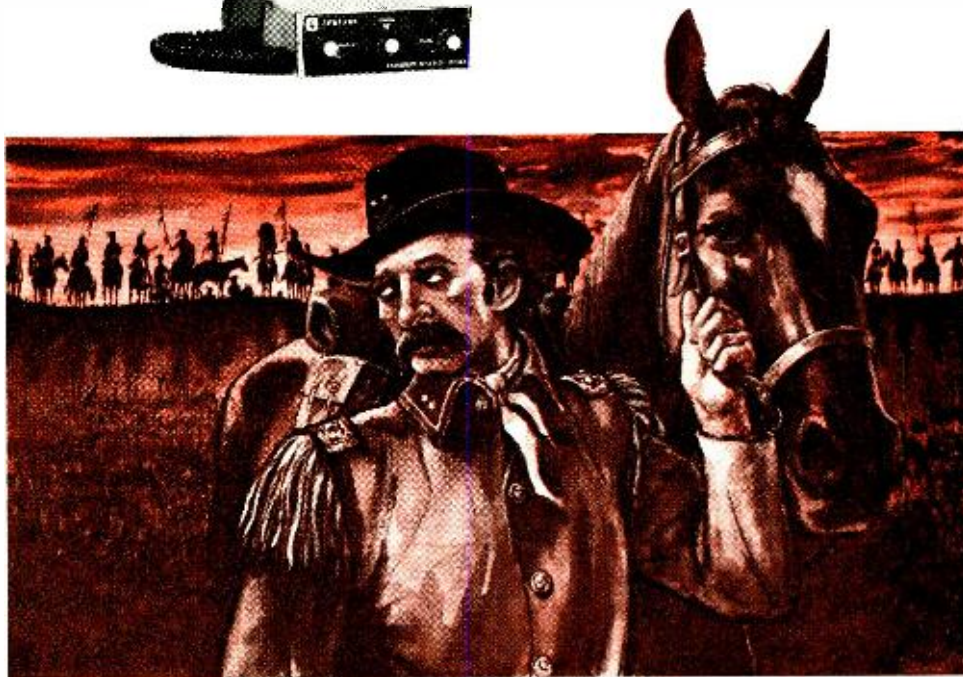

Johnson's Messenger 1, TWO, III, 100 and 300 are FCC type accepted and DOT approved. No other manufacturer gives you this assurance of quality and performance.



E. F. JOHNSON COMPANY

2424 Tenth Ave. S.W., Waseca, Minn. 56093

Providing nearly a half-century of communications leadership

Please send me information on the Messenger 300 and the complete Johnson CB line.

Name _____

Address _____

City _____ State _____ Zip _____

CB'ers...

SKIP IS LEGAL

ON THE HAM BANDS...

in fact, Amateur Radio is based on the intelligent use of natural phenomena to achieve distant communications with relatively low power. Increased sun-spot activity in the next couple of years will bring tremendous propagation opportunities — like worldwide contacts on ten meters . . . tropospheric bending (predictable from an ordinary weather map) brings exciting surprises on two meters . . . Sporadic E skip gets you miles and miles and miles with little power on six meters . . . and more! And that is not all that you have going for you . . . there are no time restrictions . . . less crowding . . . more frequency bands . . . more legal power . . . and greater satisfaction because your knowledge of propagation permits you to plan your contacts. It is all out in the open . . . you can give the man your right name and your call without getting a pink ticket for a chaser.

You can get into ham radio easily and quickly (our buck says it will take you only 30 days . . . 45 max.). The technical requirements for a Novice license are *simple*. The test can be administered by a qualified licensee in your own neighborhood. Available licensing booklets lay it all out on a silver platter for you. SURE, we know about the code test, but man, five words — 25 characters — a MINUTE . . . that's less than a minute's worth of notes in a dreamy waltz!

Start it off with a Squires-Sanders 22'er (two-way voice privileges on two meters for Novices) . . . for sixty days we will throw in a free license manual and a code learning record. If you want to go all out, apply for the Technician License . . . a little more complex technical test (you can do it) and the same easy five word code exam . . . permits privileges on other bands — like 6 meter two-way voice. 22'er — 20 watts of high quality two meter AM phone transceiver . . . only \$249.95. 66'er — 22 watts of same for six meters . . . same free manual and record . . . same price.

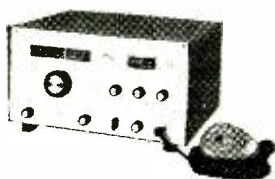

OK, OK . . . so your only interest is highly intelligible local communications for your personal business . . . your truck . . . your boat . . . your car . . . then go see the COMPLETE all transistor, twenty-three channel Squires-Sanders 5 watt CB line: the famous 23'er (\$235) . . . the beautiful new COMMANDER (\$200) . . . the hot little low cost SKIPPER . . . the fabulously plush ADMIRAL base station . . . and the 5 channel S-5-S. (\$185). But please, just talk to mamma . . . or the office . . . or call H.E.L.P.

Squires  Sanders

See your distributor or write today for details. SQUIRES SANDERS, INC., Box A, Liberty Corner, N. J. 07938
CIRCLE NO. 36 ON READER SERVICE PAGE

For that different sound... Music à la *Theremin*

COVER STORY



BY LOUIS E. GARNER, JR.

THE FIRST TRUE ALL-ELECTRONIC MUSICAL INSTRUMENT—BROUGHT UP TO DATE USING BIPOLAR TRANSISTORS AND FET'S

FOR ABOUT THE PRICE of an inexpensive guitar, plus a few hours assembly time, you can own and enjoy what is perhaps one of the most versatile of all musical instruments: the unique and amazing theremin. Named after its Russian-born inventor, Leon Theremin, its frequency range exceeds that of all other instruments, including theater pipe organs, while its dynamic range is limited only by the power capabilities of the amplifier and speaker system with which it is used. Above all, it is a *true* electronic instrument, not just an "electronic version" of a familiar string, reed, or percussion instrument. Its tone is unlike that of any conventional instrument.

A musician playing a theremin seems almost like a magician, for he can play a musical selection without actually touching the instrument itself! As he moves his hands back and forth near two metal plates, he seems to "conjure up" individual notes at any desired volume; he can "slide" from one musical note to another with ease, can produce tremolo and vi-

brato effects at will, and can even sound notes which fall outside the standard musical scale. He can play tunes or melodies, produce unusual sound effects, or can accompany a singer or another instrument—all by means of simple hand movements.*

The theremin is ideal for amateur as well as professional musicians and can be used for "fun" sound effects as well as for serious music. It makes a wonderful addition to the home recreation room, and can be used equally well by rock 'n' roll groups or larger bands. Theatrical groups find it just the thing for producing eerie and spine-tingling background effects to accompany mystery or horror plays, and for the budding scientist or engineer, it is an excellent Science Fair project.

*Nearly everyone who has ever watched television or attended a motion picture has heard music and background effects produced by a theremin, yet relatively few could recognize the instrument, and fewer still have had the chance to own or play one. With its astounding tonal and dynamic ranges, it has been used to produce background music and special effects in scores of science-fiction, fantasy, horror, and mystery shows.

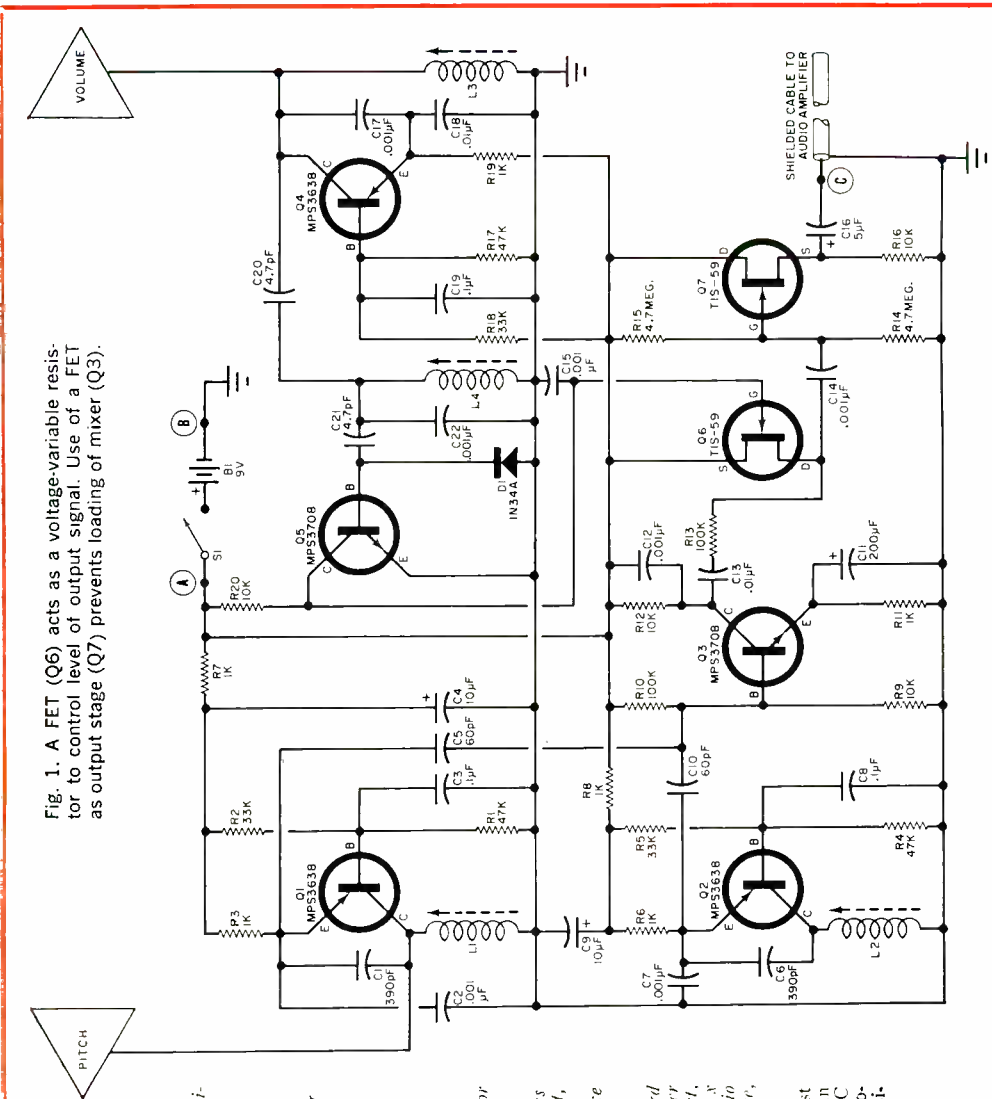

Fig. 1. A FET (Q6) acts as a voltage-variable resistor to control level of output signal. Use of a FET as output stage (Q7) prevents loading of mixer (Q3).

PARTS LIST

- B1—0.5-volt battery
- C1, C6—500-pf polystyrene capacitor
- C2, C7, C17, C22—0.001- μ f polystyrene capacitor
- C3, C8, C10—0.1- μ f disc ceramic capacitor
- C4, C9—10- μ f, 15-volt electrolytic capacitor
- C5, C11—60 pF polystyrene capacitor
- C11—200- μ f, 15-volt electrolytic capacitor
- C12, C14, C15—0.001- μ f disc ceramic capacitor
- C13—0.01- μ f disc ceramic capacitor
- C16—5- μ f, 15-volt electrolytic capacitor
- C18—0.01- μ f polystyrene capacitor
- C20, C21—4.7- μ f polystyrene capacitor
- D1—1N34A diode
- L1, L2, L3, L4—50-300 μ l adjustable coil
- Q1, Q2, Q4—MPS3638 transistor (Motorola)
- Q3, Q5—MPS3708 transistor (Motorola)
- Q6, Q7—TIS-59 n-channel FET transistor (Texas Instruments)
- R1, R4, R17—47,000 ohms
- R2, R5, R18—33,000 ohms
- R3, R6, R7, R8, R11, R19—1000 ohms, \pm 5% call, 10%
- R9, R12, R16, R20—10,000 ohms
- R10, R13—100,000 ohms
- R14, R15—4.7 megohms

All resistors \pm 5% call, 10% tolerance
 S1—S.p.s.t. slide or toggle switch
 Misc.—Etched circuit board, large circuit board (or metal) for control antennas, $\frac{3}{4}$ " diameter antenna pipe and mounting hardware—see text, wooden cabinet or case approximately 18" x 6" x 4", battery mounting clip, shielded audio cable, two small knobs, spacers, hookup wire, solder, etc.

The following are available from Southwest Technical Products Corp., 210 W. Rhapsody, San Antonio, Texas 78216: etched and drilled PC board, \$2.50; complete set of electronic components, including PC board, \$16.50; wooden cabinet and set of antennas, \$6.00.



(A)

The typical theremin has two r.f. oscillators, one having a fixed, the other a variable, frequency, with their output signals combined in a mixer/amplifier stage. At "tune-up," the oscillators are preset to "zero beat" at the same frequency. The frequency of the variable oscillator is controlled by an external tuning capacity—the "antenna"—which is a "whip" or simple metallic plate.

As the musician's hand is moved near this antenna, the variable oscillator shifts frequency and a beat note is set up between the two oscillators. The pitch is proportional to the difference in frequency between the two oscillators. This beat note, amplified, is the theremin's output signal. The more advanced theremin designs—such as the version presented here—use a third oscillator to control output volume, and two antennas. This theremin also uses a unique FET volume control, and a FET output stage. See Fig. 1.

Construction. Except for the two control antennas, power switch *S1*, and battery *B1*, all components are assembled on a printed circuit board as shown full-size in Fig. 2(a); the parts are assembled as shown in Fig. 2(b). An insulated jumper is required between *C15* and *R20* as shown in Fig. 2(b) and Fig. 3. Mount the PC board in a suitable cabinet with four spacers (see Fig. 3), making sure that suitable holes are drilled in the cabinet or through a dialplate to accept the tuning-slug screws of *L2* and *L4*. Coils *L1* and *L3* are mounted on small L-brackets; initially, these brackets should be adjusted so that *L1* is at right angles to *L2* and *L3* at right angles to *L4*. Switch

Fig. 2. Actual-size printed circuit board etching guide is shown at (A); dashed line in component layout guide (B) indicates insulated jumper wire.

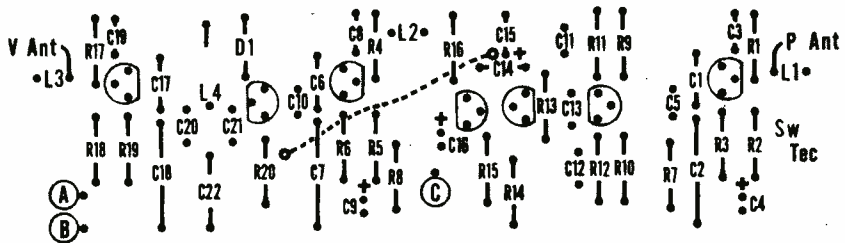

(B)

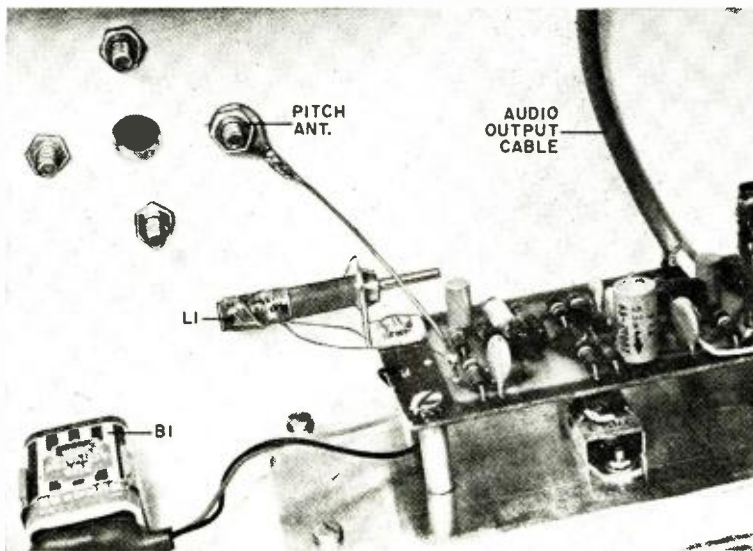

Fig. 3. Coils L1 and L3 should be mounted on L-brackets. Positions of these coils can be altered to change harmonic content (see "Tuning" instructions in text). Photo at far right demonstrates how insulated jumper wire between C15 and R20 should be routed.

S1 is also mounted on the cabinet or dialplate, in the area of the L2 and L4 slug screws, while the battery is secured to the cabinet wall.

Ordinary copper-clad circuit board can be used to make up the pitch and volume control antennas. Although the author's units are equilateral triangles approximately 9" on a side—almost any other design will do—shape is not critical. If desired, the upper surface of the antennas may be covered with a colorful material (see cover photo).

The antennas are mechanically mounted on an electrically conducting support. The ones used by the author, (see Fig. 4) were six-inch lengths of $\frac{3}{4}$ " aluminum pipe with appropriate mounting flanges. The antennas were attached to the pipe with conduit plug buttons soldered to the bottom of each antenna. The flanges of the buttons should make a good friction fit to the pipe. A solder lug for connection to the PC board is placed under one of the pipe support mounting screws as shown in Fig. 3.

Connect the negative lead of the battery to terminal B on the PC board; then connect the positive battery lead, via S1, to terminal A. The center lead of the audio output coaxial cable is connected to terminal C on the PC board, while the associated braid is soldered to the ground foil. Connect the volume control lead and one lead from L3 to the proper hole

HOW IT WORKS

Transistors Q1 and Q2 are the variable and fixed "pitch" oscillators respectively, while Q4 serves as the "volume" oscillator. Essentially similar circuits are used in all three oscillators, so only one (Q1) will be described here. Base bias is established by resistor voltage divider R1 and R2, with the former bypassed for r.f. by C3. Resistor R3 serves as the emitter (output) load. The basic operating frequency is determined by the tuned circuit of L1 and combination of C1 and C2.

In the case of Q1 and Q4, their tuned circuits are also connected to external "antennas." When these antennas are "loaded" due to body capacitance (the presence of a hand near the antenna), this "load" is reflected to the tuned circuits as a capacitive change which, in turn, alters the frequency of oscillation. Because Q2's circuit uses no "antenna," its frequency remains constant at all times.

In operation, Q1's r.f. output signal is coupled to mixer/amplifier Q3 via coupling capacitor C5—while Q2's signal is coupled to Q3 via C10. If these two oscillators (Q1 and Q2) are at the same frequency, then there will be no resultant "beat" present at the collector of Q3. However, since Q1's frequency is determined by how close the operator's hand is to the "pitch" antenna, the resultant beat frequency will vary as the distance between the hand and antenna varies. Because the mixing action of Q3 produces both r.f. and audio beats, capacitor C12 is used to bypass the r.f. components and prevent them from appearing at the collector of Q3. The resultant audio beat is passed, via the volume control circuit, to the FET output stage, Q7.

Oscillator Q4 (the "volume" oscillator), like "pitch" oscillator Q1, has its frequency of oscillation determined by the amount of hand capacitance near its "antenna." The r.f. signal at the collector is coupled via C20 to another tuned

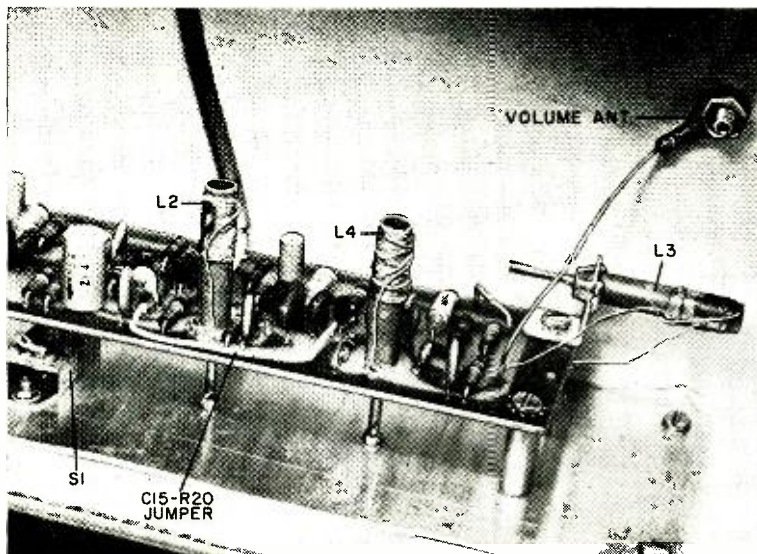

circuit consisting of $L4$ and $C22$. The r.f. signal across this second tuned circuit is rectified by diode $D1$ and applied to the base of d.c. amplifier $Q5$. Thus, the d.c. voltage level present at the collector of $Q5$ is a function of the amount of r.f. present on $L4-C22$. This level is at its maximum when the $L4-C22$ tuned circuit is at the same frequency as the $Q4$ collector tuned circuit.

In practice, however, the frequency of $Q4$'s tuned circuit is made to be slightly higher than the $L4-C22$ frequency. As a result, very little d.c. signal is passed to the base of $Q5$. This means that the voltage at the collector of $Q5$ is at a maximum. If the frequency of $Q4$'s tuned circuit is reduced, when a hand is placed near the "volume" antenna, the base current applied to $Q5$ increases, causing the collector voltage to drop.

The unique volume control consists of FET $Q6$, connected in shunt with the audio signal flow. The audio signal at the collector of $Q3$ passes through d.c. blocking capacitor $C13$ and is also isolated (for d.c.) from $Q7$ by $C14$. Resistor $R13$ and FET $Q6$ are arranged as a voltage divider. If the gate voltage of $Q6$ is highly positive, then the FET acts as a low resistance between $R13$ and ground, greatly reducing the signal level allowed to pass to $Q7$. As the gate of $Q6$ goes less positive, the effective resistance of $Q6$ increases and the level of audio signal to $Q7$ increases.

The voltage at the collector of d.c. amplifier $Q5$ is connected to the gate of $Q6$. As this voltage level is determined by the frequency of $Q4$, the operator can readily adjust the output volume by changing his hand capacitance to the "volume" antenna. The variable-pitch, variable-volume audio signal is coupled to an external audio amplifier via FET $Q7$. A FET is used for $Q7$ because its very high input impedance (a couple of megohms) will not affect operation of FET $Q6$. If desired, the source resistor of $Q7$ ($R16$) can be changed to a similar-valued potentiometer.

on the PC board (see Fig. 3), then connect the pitch control lead and one lead of $L1$ together and solder to the hole on the PC board. The other ends of both coils are soldered to the ground foil of the PC board.

Tuning. Although the theremin is used with an external audio amplifier and speaker, no special test equipment is needed for the tuning adjustments. The procedure is as follows.

(1) Temporarily short $Q6$'s gate and source electrodes together, using either a short clip lead, or a short length of hookup wire, tack-soldered in place.

(2) Preset the coil ($L1$, $L2$, $L3$ and $L4$) cores to their mid-position.

(3) Connect the theremin's output cable to the input jack of an audio amplifier (with speaker)—a guitar amplifier is ideal. Turn the amplifier on, volume up to nearly full.

(4) Turn the theremin on by closing $S1$ and adjust $L2$'s slug (keep hands or other parts of the body away from the pitch antenna) until a low frequency growl is heard from the speaker.

(5) Turn the theremin off and remove the short from $Q6$.

(6) Turn the theremin back on and adjust $L4$'s slug until a point is found where the growl is heard from the speaker. Then adjust $L3$'s stud until the sound

(Continued on page 102)

Hi-Fi Speakers for Small Rooms

SLIM-LINE SPEAKERS
GIVE WAY TO COMPACTS . . .

A REPORT ON
THE PIONEER CS-24
AND WHARFEDALE W20D

HOW LONG should a hi-fi speaker system last? Certainly five years is not uncommon, and if you were a reader of POPULAR ELECTRONICS in 1962, you may recall the large slim-line speaker system that was being installed in the downstairs living room shown at right.* Now it's time to place something a little more modern and up-to-date on that brick fireplace mantel—a compact system.

PIONEER CS-24 "LITTLE GEM"

Last spring, Pioneer Electronics U.S.A. Corp. (140 Smith St., Farmingdale, N.Y. 11735) introduced a compact slim-line speaker system at the price-breaking figure of \$27.50. Measuring only 10³/₈" high x 16" wide x 4¹/₄" deep, the CS-24 has an oiled walnut wrap-around and a front panel of spin-processed perforated metal. The panel is available in two color tones—black and silver. Spin-processing produces a visually pleasing reflection and light scattering pattern, similar to what you see when you look at a star sapphire jewel.

Manufactured in Japan, the Pioneer CS-24 was designed for full fidelity sound reproduction of background music in offices, restaurants, waiting rooms, etc. A typical response curve shows that the speaker system has a range of 120-11,000

Hz within plus-or-minus 5 dB. The response rolls off below 80 Hz and above 12,500 Hz.

As a background music speaker, the CS-24 is among the very best from the viewpoints of both sound and physical size. However, this speaker system need not be restricted to that use. Your reviewer was so impressed by the well-balanced sound output of the CS-24 that he decided to live with the CS-24 in his downstairs stereo setup.

Of course, the CS-24 does not produce thundering bass—it's not missed in this low ceiling room, anyhow—but neither do the highs tend to screech at you. The sound is clean, and this fact can be attributed to the 8" double cone speaker—a surprising lot of speaker for so little money. Power requirements for the CS-24 are modest, and the same good response was observed with an amplifier of only 0.5 watt output as with an amplifier rated at 30 watts. By the way, the maximum power to the CS-24 should be kept under 10 watts.



*"Slim Line Speaker Kit," POPULAR ELECTRONICS, July, 1962, page 70.

Mounting the CS-24 on a wall is easy, due to the mounting receptacles in the back of the speaker enclosure. Two round-head wood screws will hold the 7½-lb weight of the CS-24. The unit can be installed vertically or horizontally to suit your particular requirements.

The Pioneer CS-24 is a good investment (there's a 3-year guarantee), individually as an extension speaker, or in pairs for a good-sounding, very-low-cost stereo starter system.

WHARFEDALE W20D "MINORETTE"

Most people knowledgeable about hi-fi are aware that no two speaker systems sound alike. While testing and living with the Pioneer CS-24, it seemed like an ideal time to take a somewhat similar speaker system and run a side-by-side comparison. As this was also an opportunity to see if it's true that for a lot more money, you can get "better" sound—the British Wharfedale W20D "Minorette" speaker system was selected.

The Wharfedale W20D (Wharfedale is a division of British Industries Corp., Westbury, N.Y. 11590) is a two-unit speaker system with an 8" woofer and a 3" Mylar-domed pressure tweeter. The cabinet dimensions are 9¾" high x 14" wide x 8½" deep. Thus, the volume difference between the two enclosures is mostly in depth and amounts to another 250 cubic inches. Priced at \$49.95, the W20D has a removable grille for fabric coordination in your living room, and the wood veneer is oiled walnut.

Until you have experienced or witnessed a side-by-side demonstration of this particular nature, you may not be aware of the amazing differences that *do* exist between speaker systems. While the Pioneer CS-24 sound is balanced and pleasing, the Wharfedale W20D sound is distinctive. Possibly the stereo enthusiast would say that the W20D is more truly hi-fi. This is undoubtedly due to the acoustic suspension woofer (on the low end) and to the omnidirectional domed tweeter (on the high end). For the additional investment of \$22.45 more per speaker, you do get more low-frequency response and somewhat more highs.

Wharfedale was obviously aware that mounting an 8" woofer and a 3" tweeter in a small sealed enclosure could be fraught with danger—the highs can predominate and overpower the lows. To evade this problem, Wharfedale wired in what it calls an "acoustic compensation control." This continuously variable control permits the listener to match the speaker system to his amplifier, listening room, and musical tastes. In our tests, any tendency of the system to sound peaky in the highs could be eliminated by careful adjustment of the "compensation" control.

The W20D manufacturer recommends a minimum of 10 watts driving power (IHF) for each speaker. Although this may be optimum for the hi-fi enthusiast, it is not really a prime necessity. In fact, the W20D can be driven by almost any TV sound channel output transformer (the W20D accepts a 4- to 8-ohm input).

The latter application is where the small, fully enclosed speaker system really shines. If your TV receiver sounds thin, try hooking up a speaker system like the CS-24 or W20D and hear the TV sound come to life.

-30-

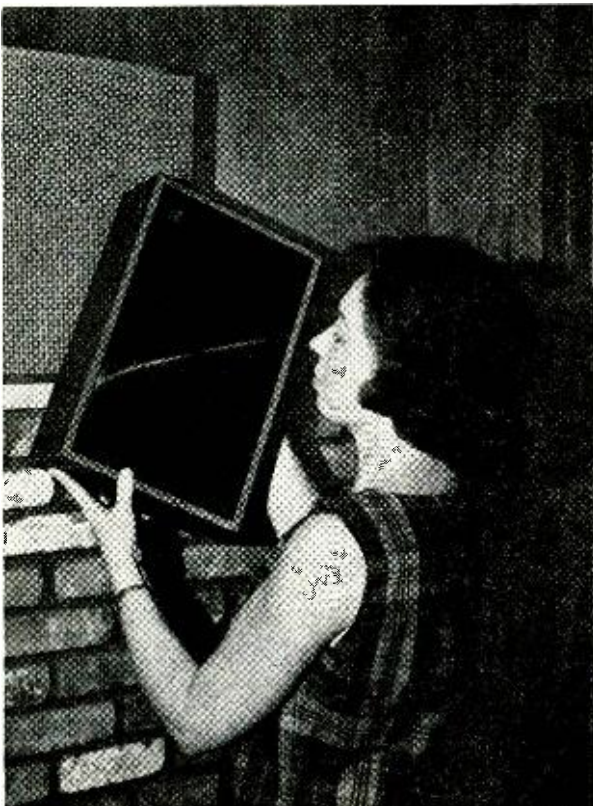

Gene Frost was “stuck” in low-pay TV repair work. Then two co-workers suggested he take a CIE home study course in electronics. Today he’s living in a new house, owns two good cars and a color TV set, and holds an important technical job at North American Aviation. If you’d like to get ahead the way he did, read his inspiring story here.

IF YOU LIKE ELECTRONICS—and are trapped in a dull, low-paying job—the story of Eugene Frost’s success can open your eyes to a good way to get ahead.

Back in 1957, Gene Frost was stilled in a low-pay TV repair job. Before that, he’d driven a cab, repaired washers, rebuilt electric motors, and been a furnace salesman. He’d turned to TV service work in hopes of a better future—but soon found he was stymied there too.

“I’d had lots of TV training,” Frost recalls today, “including numerous factory schools and a semester of ad-

vanced TV at a college in Dayton. But even so, I was stuck at \$1.50 an hour.”

Gene Frost’s wife recalls those days all too well. “We were living in a rented double,” she says, “at \$25 a month. And there were no modern conveniences.”

“We were driving a six-year-old car,” adds Mr. Frost, “but we had no choice. No matter what I did, there seemed to be no way to get ahead.”

Learns of CIE

Then one day at the shop, Frost got to talking with two fellow workers who were taking CIE courses... pre-

paring for better jobs by studying electronics at home in their spare time. “They were so well satisfied,” Mr. Frost relates, “that I decided to try the course myself.”

He was not disappointed. “The lessons,” he declares, “were wonderful—well presented and easy to understand. And I liked the relationship with my instructor. He made notes on the work I sent in, giving me a clear explanation of the areas where I had problems. It was even better than taking a course in person because I had plenty of time to read over his comments.”

Studies at Night

“While taking the course from CIE,” Mr. Frost continues, “I kept right on with my regular job and studied at night. After graduating, I went on with my TV repair work while looking for an opening where I could put my new training to use.”

His opportunity wasn’t long in coming. With his CIE training, he qualified for his 2nd Class FCC License, and soon afterward passed the entrance examination at North American Aviation. “You can imagine how I felt,” says Mr. Frost. “My new job paid \$228 a month more!”

“CIE training helped pay for my new house,”

says Eugene Frost
of Columbus, Ohio



Currently, Mr. Frost reports, he's an inspector of major electronic systems, checking the work of as many as 18 men. "I don't lift anything heavier than a pencil," he says. "It's pleasant work and work that I feel is important."

Changes Standard of Living

Gene Frost's wife shares his enthusiasm. "CIE training has changed our standard of living completely," she says.

"Our new house is just one example," chimes in Mr. Frost. "We also have a color TV and two good cars instead of one old one. Now we can get out and enjoy life. Last summer we took a 5,000 mile trip through the West in our new air-conditioned Pontiac."

"No doubt about it," Gene Frost concludes. "My CIE electronics course has really paid off. Every minute and every dollar I spent on it was worth it."

Why Training is Important

Gene Frost has discovered what many others never learn until it is too late: that to get ahead in electronics today, you need to know more than soldering connections, testing circuits, and

replacing components. You need to really know the fundamentals.

Without such knowledge, you're limited to "thinking with your hands" ... learning by taking things apart and putting them back together. You can never hope to be anything more than a serviceman. And in this kind of work, your pay will stay low because you're competing with every home handyman and part-time basement tinkerer.

But for men with training in the fundamentals of electronics, there are no such limitations. They think with their heads, not their hands. They're qualified for assignments that are far beyond the capacity of the "screw-driver and pliers" repairman.

The future for trained technicians is bright indeed. Thousands of men are desperately needed in virtually every field of electronics, from 2-way mobile radio to computer testing and troubleshooting. And with demands

like this, salaries have skyrocketed. Many technicians earn \$8,000, \$10,000, \$12,000 or more a year.

How can you get the training you need to cash in on this booming demand? Gene Frost found the answer in CIE. And so can you.

Send for Free Book

Thousands who are advancing their electronics careers started by reading our famous book, "How To Succeed In Electronics." It tells of the many electronics careers open to men with the proper training. And it tells which courses of study best prepare you for the work you want.

If you'd like to get ahead the way Gene Frost did, let us send you this 40-page book free. With it we'll include our other helpful book, "How To Get A Commercial FCC License." Just fill out and mail the attached card. Or, if the card is missing, write to CIE at the address below.

CIE
Cleveland Institute
of Electronics
1776 E. 17th St., Dept. PE-60
Cleveland, Ohio 44114

Accredited Member National Home Study Council

ENROLL UNDER G.I. BILL

All CIE courses are available under the new G.I. Bill. If you served on active duty since January 31, 1955, or are in service now, check box on reply card for G.I. Bill information.

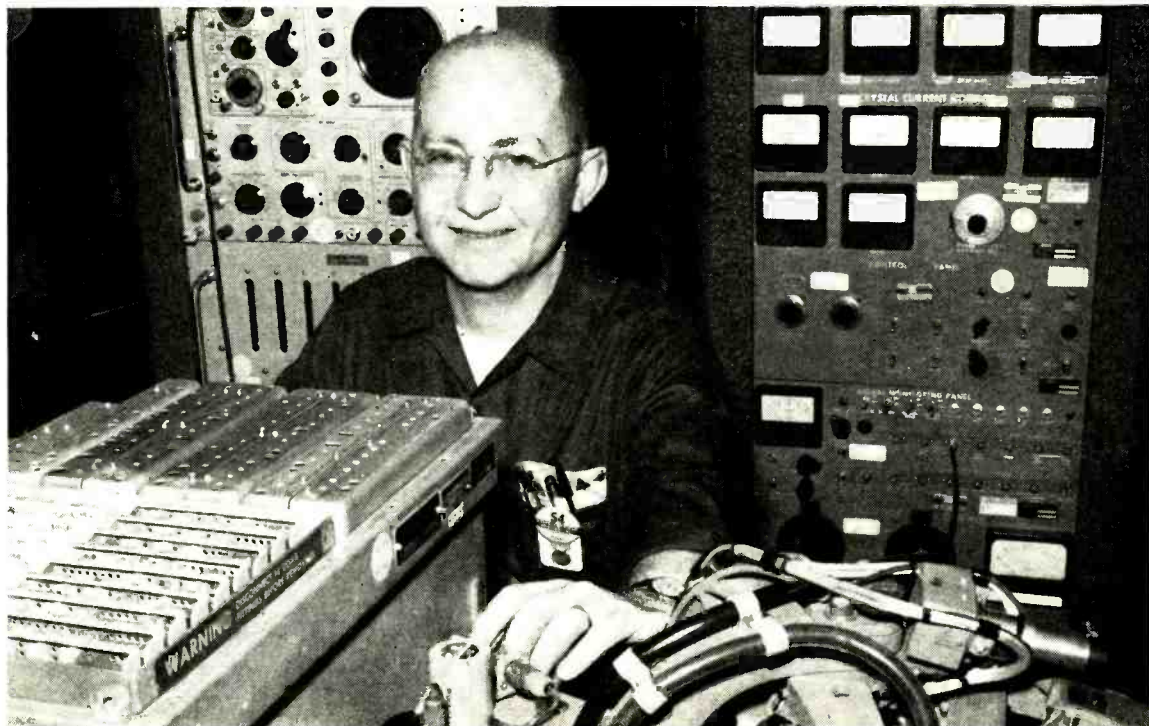

CIRCLE NO. 10 ON READER SERVICE PAGE

Build a Battery- less Dwell Meter

NO CAR TUNE-UP IS
COMPLETE WITHOUT PROPER
ADJUSTMENT OF IGNITION
POINT DWELL TIME

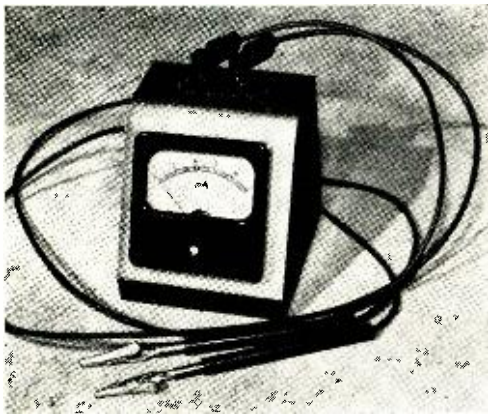

All parts mount conveniently inside a small meter case. Inputs to the circuit terminate in suitably insulated connector jacks on top of the meter case.

WITH JUST FIVE inexpensive parts, you can build a "Battery-less Dwell Meter" that will perform with about the same accuracy obtainable from most commercial units. It will provide accurate dwell angle measurements for any 4-, 6-, or 8-cylinder engine (both 6- and 12-volt battery systems). However, it may or may not work with transistorized or CD ignition systems.

All parts can be conveniently mounted inside a small meter case. The size of the case will be determined by the dimensions of the meter. Input to the dwell meter is through a pair of color-coded banana-type jacks or five-way binding posts which should be well insulated.

Prepare one black and one red test cable, both about 3' to 4' long. Connect an alligator clip to one end of each cable and a suitable plug to mate with the input jacks to the other ends.

Initial calibration of the dwell meter compensates for the internal resistance of the meter movement. Connect the test cables across your car's battery, being sure that the red cable goes to the positive side of the battery. Then adjust potentiometer $R3$ until the meter pointer deflects to exactly full scale. No other

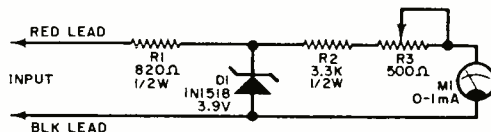

Heart of the dwell meter circuit is zener diode D1. Potentiometer $R3$ is used for calibration purposes.

adjustment is necessary—even if you switch from a 6-volt to a 12-volt system, or vice-versa.

When using the instrument, connect the black test cable to your car's chassis ground and the red cable to the points side of the distributor coil. (In a positive ground vehicle, reverse the two leads.)

To convert meter indications to "degrees dwell," use the following equations. For an 8-cylinder engine: $\text{mA} = 1 - (\text{degrees}/45)$; for a 6-cylinder engine: $\text{mA} = 1 - (\text{degrees}/60)$; for a 4-cylinder engine: $\text{mA} = 1 - (\text{degrees}/90)$.

Check the engine specifications of your vehicle to determine the required degrees dwell. Then calculate the respective current indication, and make a mark on the meter scale.

—S. Wald

HOW IT WORKS

The dwell meter circuit will indicate the ratio of "closed" to "open" time of the distributor breaker points. With the engine running, the voltage between the "hot" point and ground will be a square wave of 12 volts amplitude (or 6 volts in a 6-volt car) whose frequency is determined by the engine r/min . Once the square wave reaches zener diode $D1$, it is clipped at 3.9 volts, thus presenting a clean waveform to meter $M1$. Because of this 3.9-volt clipping, the dwell meter can be used on either 6- or 12-volt cars. The meter averages the "duty cycle" or "dwell time" of the square waves.

The values of resistors $R2$ and $R3$ are selected to provide a full-scale deflection of the meter pointer when 1 mA is flowing through the circuit (steady state). Simple equations are given in the text to convert the meter indications to dwell time.

Police Special II

LISTEN TO THE BAND THAT
CRACKLES WITH EXCITEMENT

BY GEORGE J. WHELAN, K2BIE

SOME of the most fascinating radio activity you will ever hear takes place 24 hours a day in the band of frequencies lying between 152 and 176 MHz. It is here where the listener can almost "ride along" with police and fire department patrol or emergency crews, or speed through the night with an ambulance driver as he races against time and death, hear movie companies at work, or listen to the animated conversations between fishing boats. If you live near the coast, 24-hour-a-day weather reports are yours, courtesy of your local weather bureau. If you live in a wooded mountain area, you can hear the forest rangers going about their business, or timber crews reporting in. The list of things to hear is long, but at all times, there is a feeling of participation on the part of the listener that no other band can match.

The original "Police Special"^{**} made lots of friends for the old 30 to 50 MHz Public Service band. However, in the past year or so, Public Service stations have rapidly been moving "upstairs" to the 152-176 MHz VHF Public Service band, and unique new classes of stations have

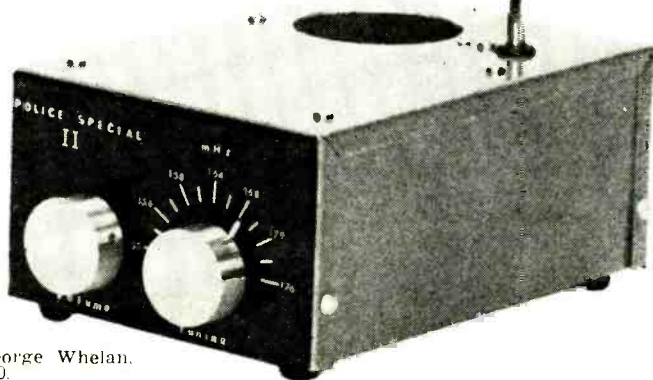

^{**}"Police Special Receiver," by George Whelan, POPULAR ELECTRONICS, July, 1959, p. 50.

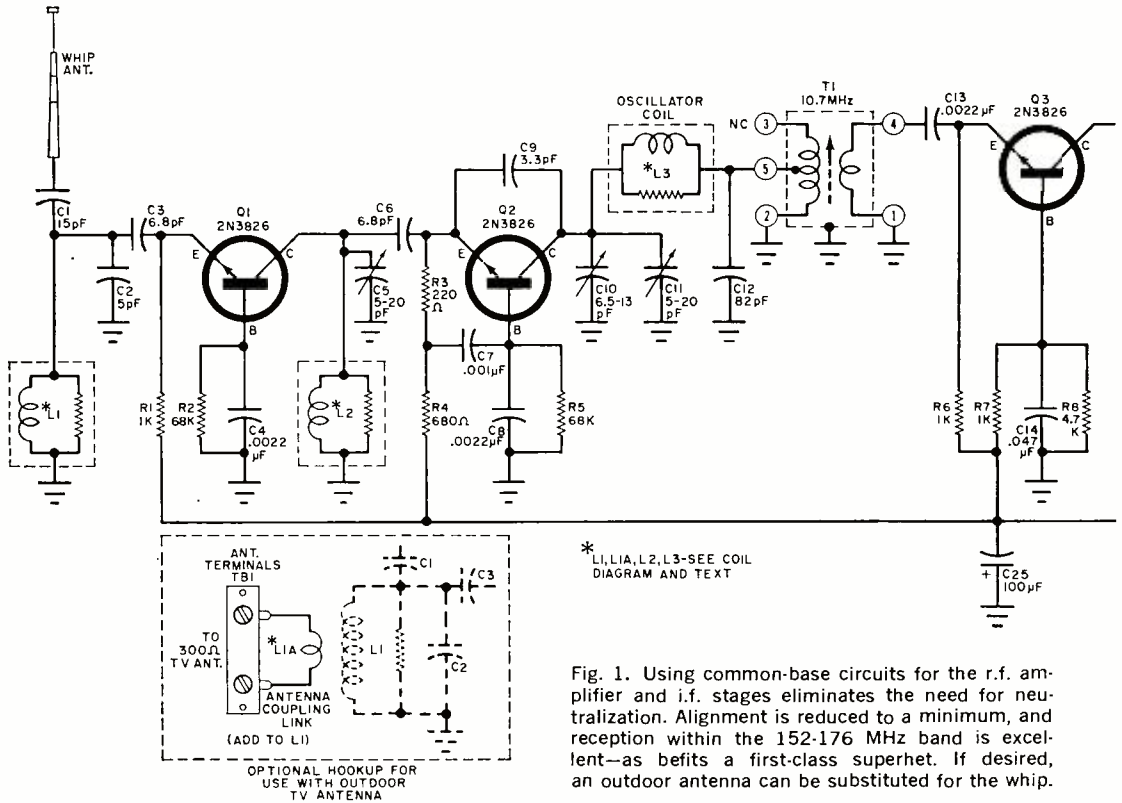

Fig. 1. Using common-base circuits for the r.f. amplifier and i.f. stages eliminates the need for neutralization. Alignment is reduced to a minimum, and reception within the 152-176 MHz band is excellent—as befits a first-class superhet. If desired, an outdoor antenna can be substituted for the whip.

come on the air, never heard in the old low-frequency band.

The "Police Special II" is a simple, single-conversion FM communications receiver that tunes the entire 152-176 MHz VHF Public Service band. It is entirely self-contained, in a 7" x 5" x 3" aluminum cabinet, and features a built-in audio amplifier, speaker, telescoping whip antenna, vernier-drive tuning, and portability gained through battery operation. The "heart" of the receiver is a printed-circuit r.f. module, featuring a grounded-base r.f. amplifier, stable VHF autodyne converter, two 10.7-MHz i.f. amplifiers, and a solid-state ratio detector circuit.

The transistorized r.f. module performs the work of amplifying, selecting, and detecting the desired signals. Boosting the detected signals to speaker volume is the job of the a.f. module, a prefabricated, imported four-transistor audio amplifier. The combination of these two modules produces an eight-transistor VHF receiver that is sensitive, stable,

low in noise, high in economy, and best of all, "buildable."

Circuit Details. The schematic is shown in Fig. 1 and contains a few surprises for those of you who thought a VHF receiver had to be complex to be good. For instance, the r.f. amplifier (Q1) and i.f.

PARTS LIST

- B1—9-volt battery (Burgess 2N6, or RCA VS-305)
- C1—15-pF disc ceramic capacitor
- C2—5-pF disc ceramic capacitor
- C3, C6—6.8-pF disc ceramic capacitor
- C4, C8, C13—0.0022-μF disc ceramic capacitor
- C5, C11—5-20 pF trimmer capacitor (Centralab 820-B, or similar)
- C7, C15—0.001-μF disc ceramic capacitor
- C9—3.3-pF NPO tubular ceramic capacitor (Centralab TCZ, or similar)
- C10—6.5-13 pF variable capacitor, fitted with reduction vernier drive (Lafayette 32 C 0917)
- C12—82-pF disc ceramic capacitor
- C14, C17—0.047-μF disc ceramic capacitor
- C16—0.033-μF disc ceramic capacitor
- C18—25-pF disc ceramic capacitor
- C19—56-pF disc ceramic capacitor
- C20, C21—390-pF disc ceramic capacitor
- C22—3-μF, 3-volt electrolytic capacitor
- C23—500-pF disc ceramic capacitor
- C24—0.033-μF disc ceramic capacitor

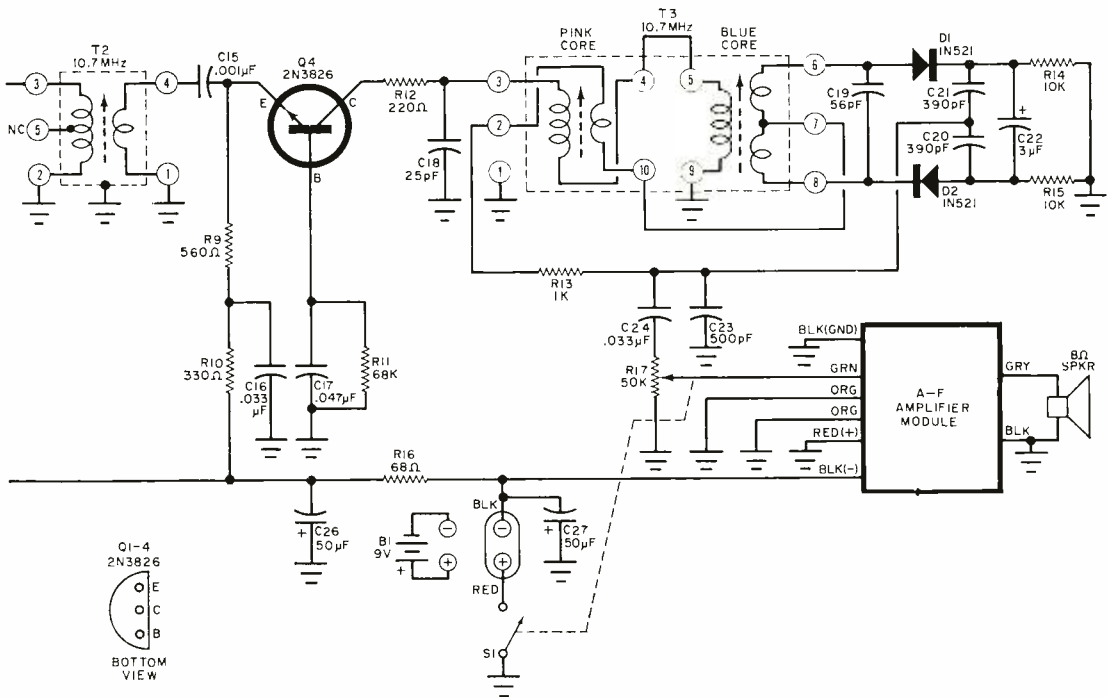

- C25—100- μ F, 12-volt electrolytic capacitor
 C26, C27—50- μ F, 15-volt electrolytic capacitor
 D1, D2—1N521 diode
 L1, L1-A, L2, L3—See text
 Q1, Q2, Q3, Q4—2N3826 transistor (Texas Instruments)
 R1, R6, R7, R13—1000 ohms
 R2, R5, R11—68,000 ohms
 R3, R12—220 ohms
 R4—680 ohms
 R8—4700 ohms
 R9—560 ohms
 R10—330 ohms
 R14, R15—10,000 ohms
 R16—68 ohms
 R17—50,000-ohm, $\frac{1}{2}$ -watt potentiometer, with s.p.s.t. switch (IRC Q11-123, with 76-1 switch)
 S1—S.p.s.t. switch (part of R17)
 T1, T2—10.7-MHz miniature i.f. transformer (J.W. Miller 2071)
 T3—10.7-MHz miniature ratio detector transformer (J.W. Miller 2073)
 TS1—Five-terminal tie lug strip (center ground)
 TS2—Three-terminal tie lug strip (center ground)

All resistors
 $\frac{1}{2}$ watt

- TS3—Antenna terminal strip (optional—see text)
 1—A.F. amplifier module (Lafayette 99 C 9042 or similar)
 1— $2\frac{1}{2}$ "-diameter permanent magnet speaker
 1— $7" \times 5" \times 3"$ metal box (Bud C'U-210S-1 or similar)
 1—Printed circuit board for r.f. module*
 Misc.—Telescoping whip antenna (Lafayette 99 C 3114), $\frac{1}{4}"$ to $\frac{1}{8}"$ shaft coupler (H.H. Smith 120), $\frac{1}{4}"$ -o.d. \times 1"-long brass spacer (H.H. Smith 2320), $\frac{1}{2}"$ -o.d. \times 1 $\frac{1}{2}"$ -long ceramic spacer (H.H. Smith 2647), $\frac{1}{4}"$ -o.d., $\frac{1}{8}"$ -i.d. \times $\frac{1}{4}"$ -long brass spacer (H.H. Smith 2100), 6-32 screws and nuts, 4-40 screws and nuts, $1\frac{1}{2}"$ -diameter knobs, battery hardware, ground lugs (3), antenna angle bracket—see text, rubber feet (4), perforated speaker grille, tin pointer, wire, solder, etc.

*An etched and drilled circuit board is available from Southwest Technical Products Corp., 219 W. Rhapsody, San Antonio, Texas 78216 for \$3.00. Order part number 142.

stages (Q3 and Q4) all operate in the common-base mode. Operating common-base pays dividends in this design, as it eliminates the need for tricky neutralization circuits and simplifies impedance-matching between stages. Moreover, the higher input and output impedances gained by using common-base circuitry

eliminate the need for tapped antenna, mixer and oscillator coils, and permit use of small coupling capacitors in the r.f. and converter stages which effectively reject unwanted i.f. signal "feed-through."

Tuning of the receiver is also surprisingly simple, since only oscillator coil L3

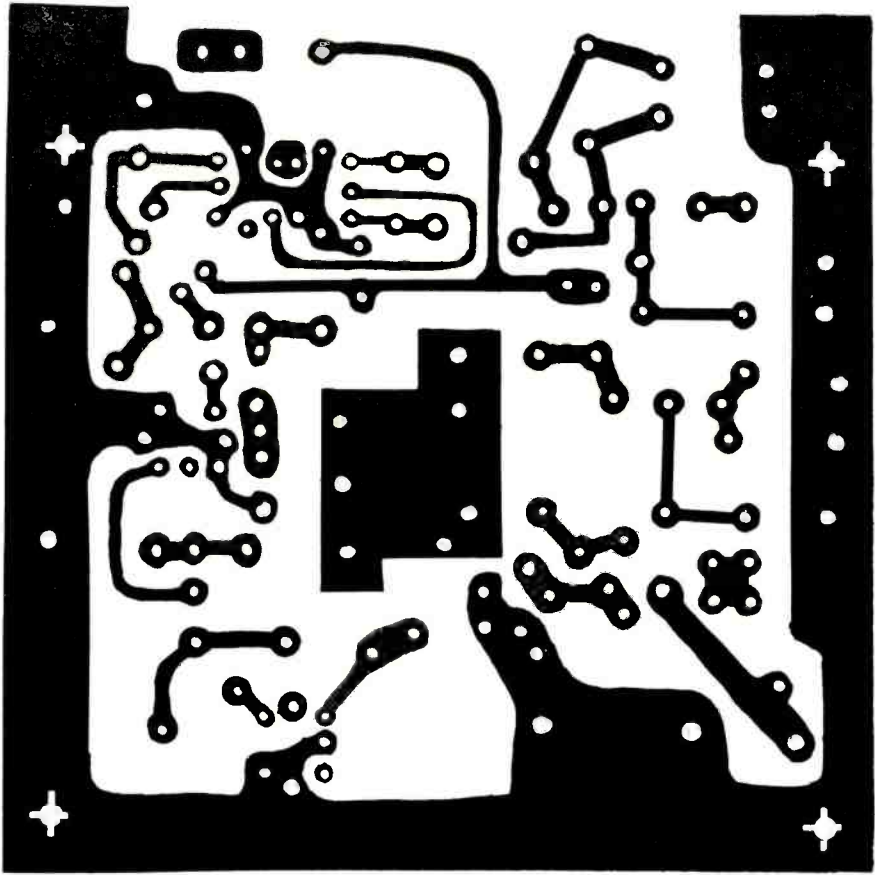

is tuned, by single-section variable capacitor *C10*. This method of tuning was arrived at after experiments which proved that the small increase in gain obtainable by tuning antenna coil *L1* and mixer coil *L2* along with oscillator coil *L3* was more than offset by the bulk and expense of a three-gang variable capacitor. Consequently, a "broad-band" approach was adopted in the antenna and mixer resonant circuits. Antenna coil *L1* is resonated at about 168 MHz by fixed capacitor *C2* while mixer coil *L2* is resonated at about 158 MHz by trimmer capacitor *C5*. This tuning arrangement yields nearly uniform front-end gain across the entire 154-174 MHz spectrum and considerably eases the problems of cost and alignment.

The preassembled a.f. module cuts the construction time considerably, and helps to keep costs down. However, assembling the printed-circuit r.f. module and hooking up the two modules in the cabinet

still calls for a fair investment of time and effort.

The printed circuit board for the r.f. module is a must in a project like this one, as the very high frequencies at which the circuit operates demand strict control over parts layout, lead lengths, and grounding. You can make your own board using the full-size layout shown in Fig. 2, or you can obtain it ready-to-go (see Parts List).

Cabinet Details. Lay out the cabinet as shown in Fig. 3. Be sure to measure accurately before you drill. (Since antenna terminal strip *TS3* is optional, the holes are also optional; they can be drilled now if you intend to use the receiver with an outdoor antenna.) Drill and punch the required holes, removing burrs and ragged edges with a tapered reamer or file.

When metal work has been completed, make up a panel plate (Fig. 4) and ce-

Fig. 2. For best results, copy exactly the actual-size printed circuit board etching guide (on the opposite page).

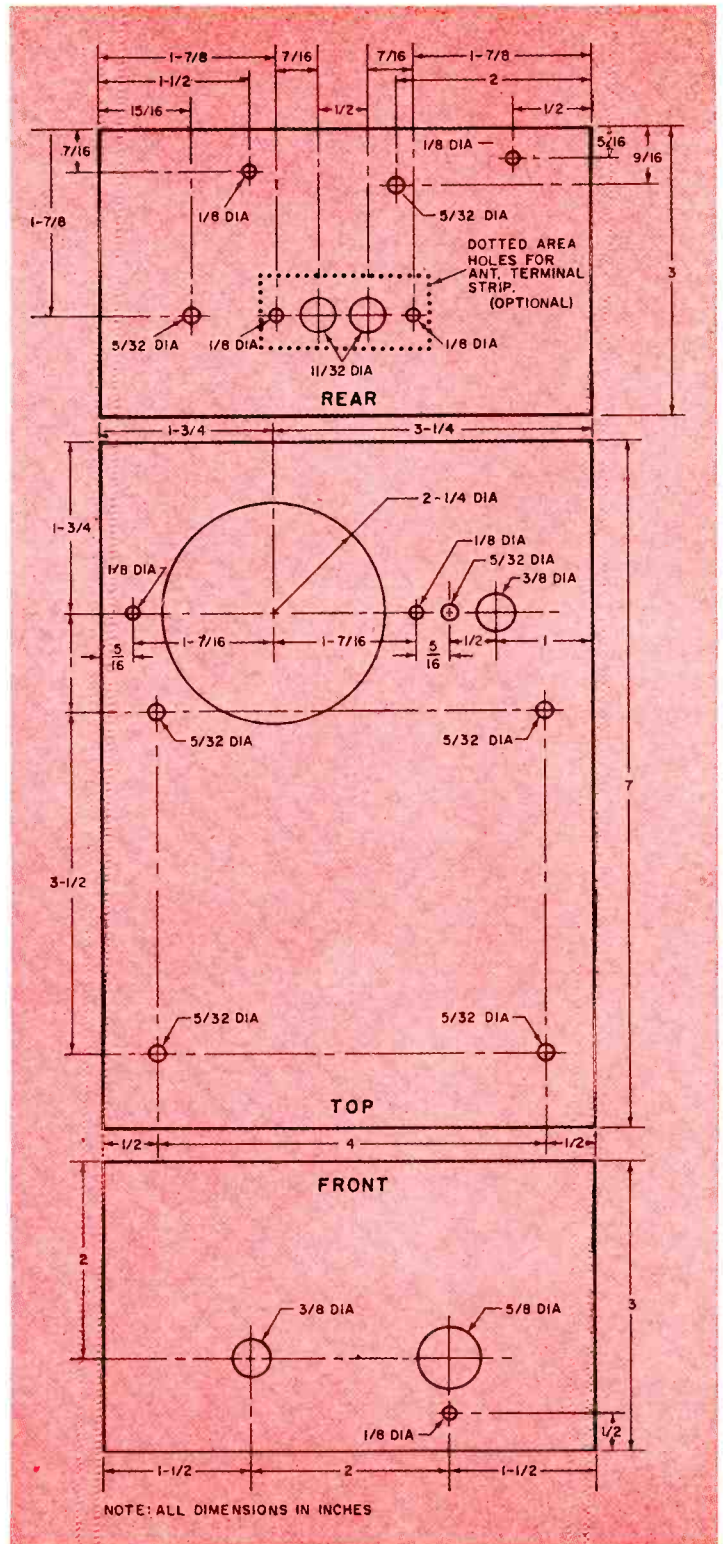

Fig. 3. To avoid unwanted interactions, mounting holes should be drilled to conform with dimensions and locations shown in the drawing (at right).



Fig. 4. Actual-size calibration guide can be copied or cut out and cemented directly on front panel.

ment it to the front panel of the cabinet using a good-quality adhesive cement. When the cement has dried, apply two coats of clear, acrylic spray to the panel plate to protect it from wear and tear. Allow the spray to dry, and cut out the panel plate portions covering the clearance holes for the tuning capacitor and volume control shafts, using a razor blade or sharp knife.

Install the six threaded metal spacers to support the r.f. module and a.f. amplifier module, and the threaded ceramic spacer to support the whip antenna (Fig.

5). Slip a ground lug under the spacer closest to the volume control. Insert a $\frac{3}{8}$ "-o.d. rubber grommet into the clearance hole for the whip antenna.

Cut a $2\frac{1}{2}$ "-diameter circular speaker grille from perforated sheet metal or phenolic material and paint it black to complement the gray hammertone finish of the cabinet. When dry, place the grille inside the cabinet, over the speaker mounting hole, with the speaker on top of it. Insert two 4-40 screws into the speaker mounting holes from the outside of the cabinet and slip a ground lug onto

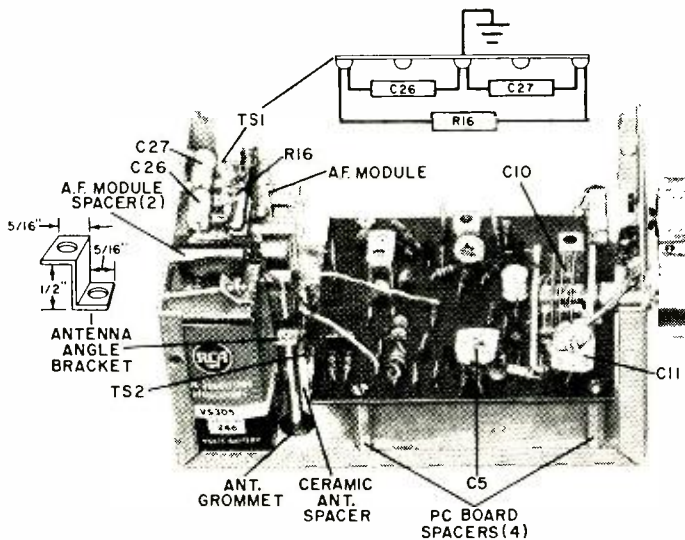

Fig. 5. Shown at left are construction details for the antenna mounting bracket and the parts arrangement on terminal strip TS1. Battery is held in place by a metal clamp.

each screw from inside the cabinet, placing each lug so that it bears against the mounting lip of the speaker. Fasten the lugs in this position with two 4-40 nuts, so that the speaker and grille are securely held against the cabinet.

Install volume control *R17* on the front panel, being careful not to tear the panel plate when tightening mounting hardware. Fasten terminal strip *TS1* to the rear panel of the cabinet and install resistor *R16* and capacitors *C26* and *C27* on it as shown in Figs. 5 and 6. Run two leads from the high side and center of the volume control to the two empty terminals of *TS1*, for later connection to the a.f. amplifier module. Connect the low side of the volume control to one contact of its on-off switch; then, con-

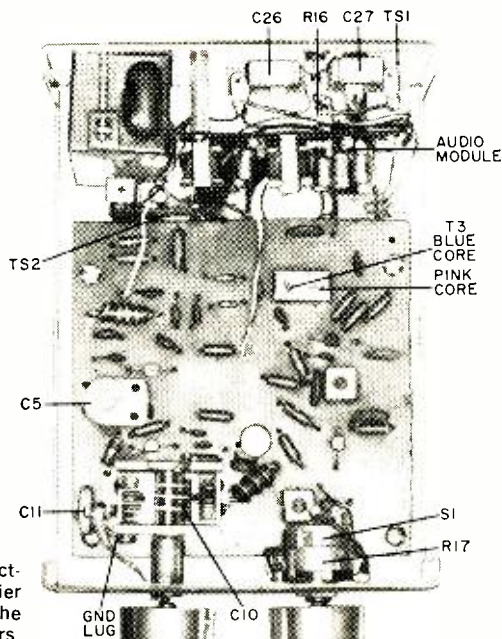

Fig. 6. Carefully orient detector transformer *T3* exactly as shown. Commercially available audio amplifier module should be mounted on the rear apron of the chassis using appropriate size hardware and spacers.

HOW IT WORKS

Signals intercepted by the self-contained whip antenna are capacitively coupled to antenna tuned circuit *L1* and *C2*. The desired signal induces a voltage across *L1-C2* which is coupled to the emitter of r.f. amplifier *Q1* by *C3*. The base of *Q1* is bypassed to ground by *C4*, with operative bias provided by *R2*, and emitter current stabilization furnished by *R1*. The minute signal current flowing into the emitter-base junction of *Q1* controls the flow of collector current through mixer tuned circuit *L2-C5*. The amplified signal voltage developed across this tuned circuit is coupled to the emitter of converter *Q2* by *C6*.

Converter *Q2* is an autodyne circuit; i.e., it is both an oscillator and a mixer. Oscillation is established by coil *L3* in series with the *Q2* collector (resonated by tuning capacitor *C10* and trimmer capacitor *C11*) feeding back a portion of the r.f. voltage to the emitter through *C9*. Since the feedback current is positive (in-phase), the circuit oscillates.

Frequency of oscillation is determined by the setting of *C10* and may be varied from 143.3 to 163.3 MHz. An incoming signal current appearing at the emitter of *Q2* mixes with the oscillator current, due to nonlinear detection in the emitter-base junction. This mixing process creates the familiar "sum" and "difference" signal frequencies. The important signal is the difference (or i.f.) signal, in this case, 10.7 MHz.

A portion of the primary of *T1* is resonated at 10.7 MHz by capacitor *C12*. Consequently, the 10.7-MHz energy in the collector current of *Q2* "sees" a high impedance across *T1-C12* and is induced into the secondary winding of *T1* and coupled to the emitter of i.f. amplifier *Q3* by *C13*. Transistor *Q3* amplifies the incoming i.f. signal, and applies its output across self-resonant i.f. transformer *T2*. The secondary of *T2* couples the amplified 10.7-MHz i.f. signal to the emitter of second i.f. amplifier *Q4*, which further amplifies

the signal, applying it to the primary of ratio detector transformer *T3* through "swamping" resistor *R12*. The effect of strong signals on the high primary inductance of *T3* is limited by *R12*, preventing "ringing" and oscillation in the circuit. The i.f. signal applied to the tuned primary of *T3* is induced into the tuned secondary through mutual coupling. Both the primary and secondary windings are resonant at 10.7 MHz, being tuned by *C18* and *C19* respectively.

Voltages across the primary and secondary tuned circuits of *T3* are 90° out-of-phase at resonance, but this phase difference changes as the frequency of the incoming i.f. signal varies. Therefore, the signal voltages applied to diodes *D1* and *D2* for peak detection also change, in step with the frequency variations of the incoming signal. Both diodes are placed "back-to-back", so that both conduct simultaneously during one-half of the signal frequency cycle. Thus, as the frequency of the i.f. signal varies, the diodes detect the peak voltage excursions, developing audio voltages in series across equal capacitors *C20* and *C21*. Capacitor *C23* bypasses residual i.f. voltages appearing in the audio signal after detection. Resistors *R14* and *R15* provide the d.c. load for the detector diodes. Capacitor *C22* prevents the diodes from responding to noise pulses or other amplitude-modulated interference by holding the rectified signal voltage constant across the load resistors. The audio recovered from the incoming signal is applied via *C24* to volume control *R17*.

The prefabricated a.f. amplifier module raises the audio signal to a comfortable listening level, through two cascaded audio amplifier stages and a push-pull, Class-B output stage, delivering a maximum of 100 milliwatts of audio to the speaker. Operating power for both the r.f. and a.f. modules is supplied by 9-volt battery *B1*, bypassed by decoupling capacitor *C27*. Additional decoupling is furnished by *R16* and capacitors *C25* and *C26*, to prevent audio modulation of the d.c. voltage applied to the r.f. module.

nect this contact to the ground lug under the nearby spacer.

Install terminal strip *TS2* and the whip antenna angle bracket on the tapped ceramic antenna spacer, securing them with a 6-32 bolt. Position the angle bracket so that it lines up under the grommeted clearance hole.

Wire the "hot" contact of the on-off switch to the right-hand terminal of *TS2*, but don't solder until the battery clip is installed. Wire the left-hand terminal of *TS2* to the left-hand side of resistor *R16* on *TS1*, but don't solder at *TS2* until the battery clip is installed.

A.F. Module. The prefabricated audio amplifier module has four pre-drilled mounting holes in its printed circuit board. However, only two of these holes are used. Hold the board in position on the rear panel spacers to check alignment of the board holes with the two tapped spacers. Drill out the two mounting holes matching the spacer positions to accept 6-32 screws. Install the a.f. amplifier module on the spacers as shown.

Next, remove the battery clip from the a.f. amplifier module, cutting the red and black leads about halfway along their respective lengths. Strip the leads attached to the battery clip and connect the black (negative) lead to the left-hand terminal of *TS2* and the red (positive) lead to the right-hand terminal of *TS2*. Solder both connections. The color-coded leads of the a.f. amplifier module should then be connected as shown in Fig. 1. When you've completed these steps, check your wiring carefully.

Mount the battery as shown in Fig. 5, then connect the battery clip to the battery, switch the set on, and turn the volume control to maximum gain (fully-clockwise). Touch the center terminal of the volume control with your finger and note if an audible 60-Hz buzz comes from the speaker, indicating that the a.f. amplifier module is working properly. If nothing happens, check the wiring again, and the battery, or look for a defect in the volume control, a.f. amplifier module, or speaker.

R.F. Module. First install tuning capacitor *C10* on the non-foil side of the printed circuit board, using two #6 self-tapping screws inserted through the board

into the holes on the underside of the capacitor frame (see Fig. 7). Tighten the screws securely to prevent vibration of the capacitor and to make good ground contact with the printed pattern on the underside of the board.

Now attach a ground lug to the tapped hole at the far left on the front of the tuning capacitor frame, using a short 6-32 machine screw. Bend the ground lug

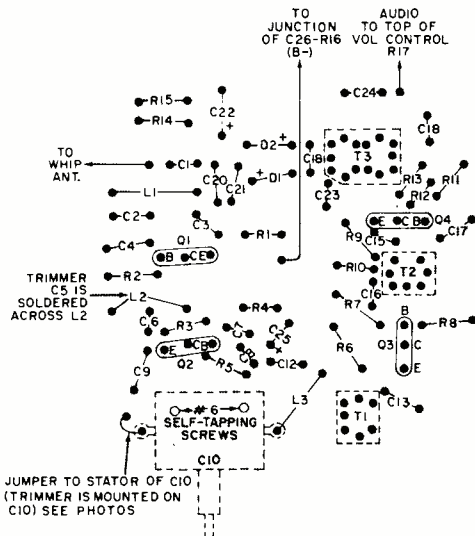

Fig. 7. When mounting capacitor *C10* on board, make good electrical contact between frame and foil.

around the left side of the capacitor. Remove the mounting clip from trimmer capacitor *C11*, and solder its rotor terminal to the ground lug of #14 tinned busbar down through the stator terminal of trimmer capacitor *C11* and through the printed circuit board, trimming off the excess busbar length after soldering.

Install i.f. and ratio detector transformers *T1*, *T2*, and *T3* in their respective locations on the printed circuit board (see Figs. 6 and 7), being careful not to bend the terminal pins in the process since you may break the micro-thin wire leads inside. The mounting tabs of each transformer should be bent flat and soldered to the foil ground conductor. Be careful to install ratio detector transformer *T3* properly. The blue core (output side) should be closest to diodes *D1*
(Continued on page 92)

CLANDESTINE Broadcasters



UNDERGROUND AND CLOAK-AND-DAGGER STATIONS
MAKE CHOICE EX'ING FOR RADIO LISTENERS

BY THOMAS KENT

CLANDESTINE broadcasters are the most fascinating and the most frustrating stations on the short-wave bands. Usually operated by deposed governments or groups in exile, these pirate stations encourage citizens to rise up in revolution against their new governments; they urge soldiers to desert their ranks; they broadcast coded messages to undercover agents; and they offer the SWL the thrill of hearing history in the making.

Because of their sensitive political positions, these broadcasters go to great lengths to conceal facts about themselves. They rarely provide mailing addresses and transmitter locations are usually well hidden. To avoid jamming, clandestine broadcasters change frequencies and schedules often and without notice. Much "information" about such stations is usually no more than

rumor, and the SWL must analyze each piece of evidence to learn the real facts.

In The Bahamas? Since the end of the *Radio Americas'* location controversy—it's definitely on Swan Island—the number one mystery station has been *Radio Libertad*. This broadcaster, which bills itself as "the anti-Communist voice of America," has been on the air for several years, beaming anti-Castro programs to Cuba. It is generally believed that the U.S. Government has an "interest" in the station's operations.

The biggest question about *Radio Libertad* is its true location. It is never mentioned, and the mailing addresses given over the air have all proved to be false. However, many DX'ers have long believed that the transmitter is on Andros Island, one of the southernmost islands in the Bahamas group.

To check this theory, a letter was sent to the Bahamas Broadcasting and Television Commission in Nassau asking if *Radio Libertad* operates from Bahamas territory. The station's operating schedule and frequencies were included with the letter. The reply, from H. R. Bethel, General Manager of Bahamas government station ZNS, was surprising: although *Radio Libertad's* BCB frequency was monitored for three days, said Bethel, *no signal was heard!* This is certainly peculiar since the station is easily received in Puerto Rico, even farther away than Nassau from Cuba, *Radio Libertad's* target area. Subsequent letters suggesting that *Radio Libertad's* short-wave frequencies be monitored were ignored. Is it possible that ZNS is not telling all it knows?

Direction-finding instruments and beam antenna headings indicate that the *Radio Libertad* transmitter is in the general vicinity of Andros Island. The Bahamas have always cooperated with U.S. Government operations. (It is believed that U.S. Armed Forces bases are located in the Bahamas, and it wouldn't be difficult to hide a radio station in the jungles of Andros Island.)



Small islands in the Caribbean have long been suspected as hiding places for clandestine broadcast stations. Radio Americas' transmitters are located on Swan Island, and two new transmitter facilities located on Navassa Island will soon be operational.

Radio Libertad is easy to log, though QSL's are obviously not available. Transmissions are from 1100 to 1645 and from 0000 to 0600 GMT on many frequencies. Among the most reliable frequencies are 15,050, 9295, 7308, 6250, 6000 kHz (a

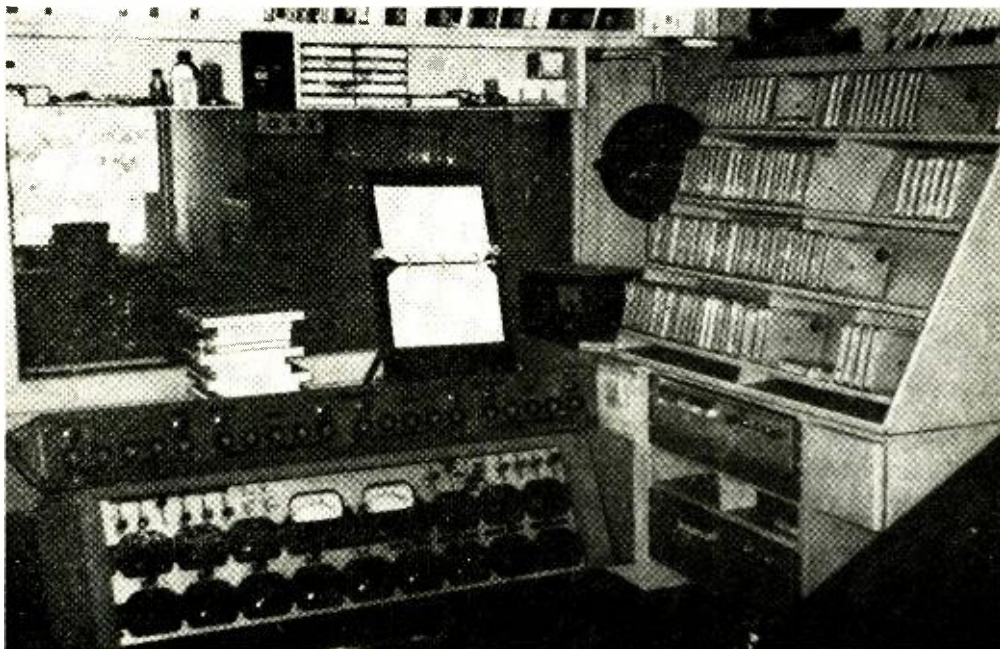

Operating at 1160 kHz on the standard broadcast band, and 6000 kHz on the international broadcast (short-wave) band, Radio Americas routes all program material through control console shown at lower left.

former *Radio Americas* channel), and 1400 kHz. Broadcasts begin with chimes and the same anthem used by *Radio Habana Cuba*. All programs are in Spanish; however, station identifications are also given in English.

Incidentally, as this story goes to press, there is considerable fanfare concerning a new station to be opened on Navassa Island, between Haiti and Cuba. This island is a U.S. Possession and apparently, up until quite recently, has been uninhabited. Transmitters are being shipped to Navassa for operation in the AM broadcast band, as well as in the short-wave broadcast bands. The BCB transmitter is rated at 50 kW, and the short-wave transmitter at 20 kW. Programming is reported to be similar to that of *Radio Americas*—all Spanish language broadcasts.

The "Numbers" Game. More mysterious than *Radio Libertad* are the short-wave "numbers stations"—some probably located in the Caribbean area. These stations begin their transmissions with musical signals, chimes, or the sound of buzzers. Then, without any other station identification, announcers read long lists of numbers in 4- or 5-digit groups. At the end of the lists of numbers, the stations abruptly leave the air—again with no identification. It is suspected that all of these numbers stations are somehow involved in espionage activities and are transmitting coded instructions to undercover agents.

Numbers stations have been heard in the German, Russian, English, and Czech languages, but the most interesting ones to North Americans are those that broadcast in Spanish. According to Cuban exile sources, the Spanish-speaking stations are used by the Federation of Cuban Workers in Exile, a Miami-based organization, to send coded instructions to anti-Castro guerrillas inside Cuba. The transmitter site is unknown, but is most likely located in the Florida Keys, where many Cuban exile activities have been based.

These Spanish numbers stations have been heard around 0400 and 0500 GMT in the 3-4 and 5-8 MHz bands. They change frequencies often, but among the channels most consistently in use are 7390, 7010, 5680, 5630, 3380, and 3205 kHz. The song "Besame Mucho" is fre-

quently employed for transmitter identification by some stations.

Besides *Radio Libertad* and the Spanish numbers stations, there is another important clandestine radio activity in our hemisphere. A number of unlicensed short-wave stations have suddenly begun operation in Bolivia, most of them in or near the 49-meter band. Communist insurgency in Bolivia has reached an all-time high, and it is possible that these



Radio Americas feeds these twin antennas in phase to produce a directional pattern aimed at Cuba.

stations are a part of the "liberation" movement, especially since they are all located in rebel-infested areas.

A partial listing of these stations includes: *Radio Mandez*, Huanuni, on 5790 kHz; *La Voz del Minero*, Llallagua, on 5850 kHz; *Radio Busch*, Uyuni, on 6500 kHz; and *Radio Copacabana*, Sucre, on 6600 kHz. There are also two stations known as *Radio Libertad* (no relation to the Andros Island station) operating from Santa Cruz and Sucre on 6200 and 6600 kHz respectively.

In Europe, Too. One of the more interesting clandestine stations in Europe is *Radio Euzkadi*, operated by the Basque resistance movement. The goal of this movement is to create an independent state for the million-odd Basques now living in northern Spain, though even among the Basques the idea has won little popular support. The movement claims to be strongly anti-Communist, and "wants only to re-establish Euzkadi, the Basque homeland."

As is the case with other clandestine stations, *Radio Euzkadi's* transmitter location is unknown. The unsuccessful attempts made by Spanish dictator Franco to silence the station indicate that the transmitter is probably not in Spain. The station may be in southern France, where there is a small Basque colony. Headquarters of the Basque resistance movement is in Paris and the Basques evidently operate freely in France.

It has been suggested by some DX'ers that *Radio Euzkadi* is in Latin America or in Cuba. *Radio Euzkadi* itself denies that it is associated with Communist Cuba "or with any other government." There really seems to be no reason why the Basques should want to set up high-powered—and therefore very expensive—transmitters in Latin America when they can operate safely and with low power from French territory.

Radio Euzkadi ("La Voz de la Resistencia Vasca") broadcasts in both the Basque and Spanish languages around 2145 GMT on 15,080 and 13,250 kHz. Reports are usually verified; they should be written in Spanish, if possible. The address is 48, rue Singer F-75, Paris 16e, France.

Less is known about two other European clandestine stations, *Radio Portugal Livre* and *Radio Espana Independiente*. They are both Communist operations whose targets are Generalissimo Franco and the Portuguese dictator, Premier Salazar. *Radio Portugal Livre* is rumored to operate from Rumania, though *Radio Bucharest* denies this rumor. The station is heard on 8333 kHz in Portuguese until sign-off at 2350 GMT. "A Portuguesa," the Portuguese national anthem, is played at the end of each transmission.

Radio Espana Independiente transmits on 6950, 7600, and 10,110 kHz around

1500 GMT and on 10,110, 11,260 and 12,140 kHz around 0600 GMT. The *World Radio Bulletin* gives as its address, P.O. Box 359, Prague, Czechoslovakia.

The Asiatics. The complex political situation in Southeast Asia has given rise to several new clandestine stations there. The most recent is the *Voice of the People of Thailand*, 9425 kHz, which signs on with Oriental chimes at 1430 GMT. It broadcasts only in Thai and is obviously Communist-supported.

The Associated Press reports from Saigon that a station identified as *Radio Liberation Army* or "Voice of the Sacred Sword of Patriotism" has been heard urging North Vietnamese soldiers to

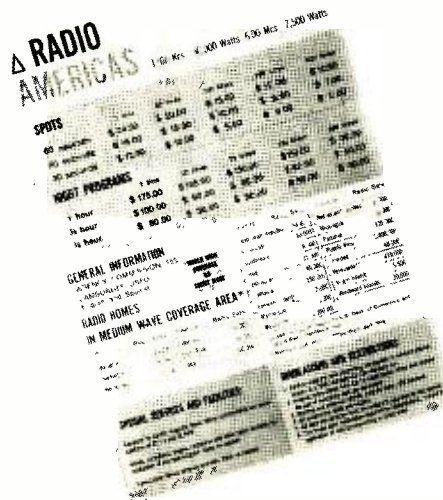

At one time, Radio Americas' operating expenses were paid by funds from a sympathetic government. Now sale of advertising time pays these expenses.

leave South Vietnam. It claims to be in Hanoi, but is almost certainly operated by American or South Vietnamese personnel in South Vietnam. Of course, there is no relation between this station and the various "Radio Liberation Army" stations operated by North Vietnam and Communist China. Transmissions are at 0500-0600 on 7225 and 7216 kHz (Hanoi also uses the latter channel) and at 1400 GMT on 9425 kHz. The interval signal is a drum and cymbal call, and the Vietnamese ID may begin "Guom Thienh Ai Quoc" or "Day la Tieng noi."

Instant Non-Fat Speaker Enclosure

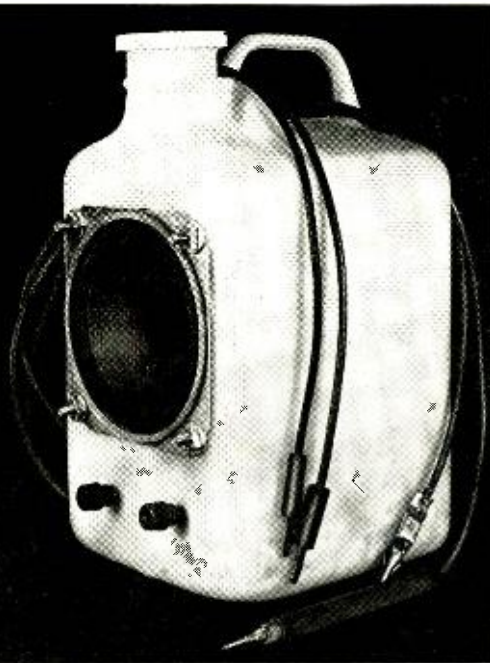

TEST SPEAKER FINDS A NEW HOME

IF NECESSITY is the mother of invention, ingenuity must be the father, or so the saying goes. Recently I needed two identical speaker enclosures and the only systems available were too large or too heavy. Rather than assemble enclosures from plywood scraps, I settled for two empty white plastic milk containers! I converted them into enclosures in just about an hour.

But you don't need plastic milk containers to build the "Instant Non-Fat Enclosure." Any cube-shaped, one-gallon jug—preferably with a large carrying handle, for portability—will do. If you buy milk or liquid detergents in bulk, the jug is a bonus; otherwise, you can pick one up at a hardware store for about 25 to 50 cents.

The finished enclosure can be dressed up with weird designs for the youngsters, or painted a solid color to match the decor of your game room. You also get a two-for-one deal with the jug-type enclosure: you can go from a sealed enclosure to a ported enclosure simply by removing the jug cap!

Any replacement-type 3.5- to 8-ohm impedance speaker up to 5" in diameter (or 4" x 6" oval) can be used. The speaker should be mounted on the outside of the jug, so the mounting hole must be just large enough to accommodate all but the flat mounting rim of the speaker basket—see the illustration on the next page. (For a typical 4"-diameter speaker, this hole will be approximately 3 $\frac{3}{8}$ " in diameter. For any other size speaker, carefully measure the hole size you need.)

Locate the speaker mounting hole so that when it is cut there will be enough room to mount a pair of banana jacks or 5-way binding posts along the bottom of the jug. After cutting the hole, temporarily set the speaker in place, and mark off the mounting screw holes. Remove the speaker, and punch or drill an $\frac{1}{8}$ " hole at each mark. Then screw a $\frac{3}{16}$ " x 1" binding-head machine screw (or regular machine screw and a lock-washer) into each hole. Use a short-handled screwdriver and orient the screws so that their heads are on the inside of the jug.

Solder a 12"-long piece of insulated stranded hookup wire to each of two chassis-mounting-type solder lugs. Then drill appropriate size holes and mount the banana jacks or binding posts in place, setting one of the solder lugs un-

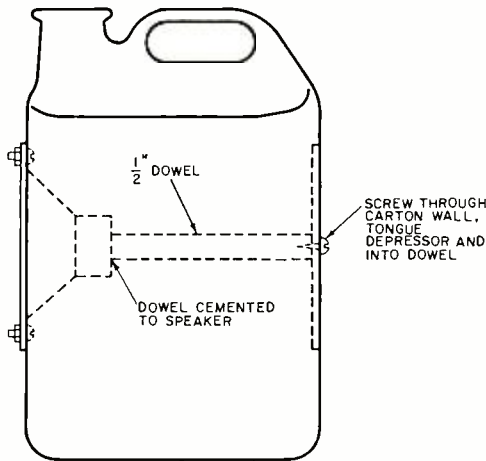

Dowel is cemented to speaker and screwed to rear wall of jug to insure maximum enclosure rigidity.

der each nut inside the jug before tightening the nuts.

To obtain the most acceptable sound from the "Instant Non-Fat Enclosure," the walls of the plastic jug must be made less flexible. This can be done by gluing two or three tongue depressors to the jug's side and rear interior walls. One tongue depressor should be oriented on the rear wall so that a wood screw can be driven through it and into the wood dowel as shown in drawing above. When

the glue sets, apply a heavy coat of floor-tile adhesive to all interior surfaces except the cap.

Set the jug aside and allow the adhesive to set. Meanwhile, determine the distance between the speaker magnet support and rear wall of the jug when the speaker is mounted in place. Cut a $\frac{1}{2}$ " x $\frac{1}{2}$ " piece of wood to this length, and glue one end of this wood dowel to the rear of the magnet support. Allow the glue to set at least six hours, or overnight.

Solder the hookup wires coming from the banana jacks or binding posts to the voice coil lugs on the speaker. When the adhesive on the jug walls and the glue holding the wood dowel to the speaker magnet support set, fill the jug with shredded cotton batting or kapok. Lower the speaker into its mounting hole, and screw it down. The adhesive covering the screw heads will hold the screws tight.

Finally, drill a hole in the rear wall of the jug, directly in line with the wood dowel on the speaker. Drive a 1"-long wood screw through the rear wall and into the dowel. Seal the mating surfaces between the speaker basket and jug with caulking compound or other suitable material. If necessary, mount a protective screen over the exposed speaker to prevent damaging the cone by rough handling.

—David B. Weems

World's Most Powerful Transistor



VERY HIGH POWER is now available in a single transistor—the Model 1401 being produced by Westinghouse Electric Corporation. The 1401 is rated at 625 watts and 250 amperes, making it the world's most powerful transistor at the present time. A diffused junction *npn* transistor, the 1401 employs a specially processed 1"-diameter by 0.01"-thick silicon wafer. A new method of mounting the silicon wafer was developed to minimize heat effects. The 1401 was designed mainly for voltage regulation, amplification, and switching of large blocks of power. However, it is also suitable for power switching in electrical distribution systems in aircraft and missiles, and as the control system for electric automobiles.

—30—



ON THE CITIZENS BAND

By MATT P. SPINELLO, KHC2060, CB Editor

WHENEVER Citizens Band users get together, enforcement of Federal Communications Commission regulations generally becomes the major topic of discussion; and as a result of this dialogue a distorted image of the FCC has grown in the minds of a great many law-abiding CB'ers. The distortion is attributable largely to two factors: (1) there are a few operators who willfully violate FCC rules, either out of ignorance of the true purpose of CB, or out of resentment at the Commission's "intrusion" on their "rights"; and (2) the same small group is eager to peddle its "gospel" to other CB'ers who have no ax to grind and whose only direct contact with the FCC comes through an application for a license.

In an effort to help CB'ers know the FCC better—and to better understand existing regulations—representatives of the Amphenol Corporation, manufacturer of CB radios, recently visited with E. J. Galins, engineer-in-charge of the Commission's 18th district Field Engineering Office in Chicago. Mr. Galins and his five assistants are responsible for a 5-state area comprised of Illinois, Indiana and parts of Iowa, Kentucky and Wisconsin. Here are some of his answers to questions about CB that were put to him during the interview.

Q. Mr. Galins, what has been the result of the new CB rules instituted in April, 1965?

A. First off . . . there really weren't any "new" rules, just a restatement of the old . . . The first rules, perhaps, were written too briefly and loosely, but it was never really even implied that anyone could use CB for hobbying. There's no longer any doubt that people who violate Part 95 (FCC rules for CB) do so deliberately. . .

Q. Did the FCC anticipate the great demand for CB licenses?

A. Yes, I think so—at least I did. After all, whenever you open up anything like this to the public without any strings to it except age, you're going to get a big response.

Q. What effect has the response had on you and your assistants?

A. With the increasing number of licensees, the number of violations has gone up rapidly . . . We have rather limited enforcement, five men and three monitoring vehicles . . . We have so many demands from more vital ser-

vices—like police and industrial bands—that we can't use even one man full time on CB violations.

Q. Does that mean you don't crack down very hard on CB violations?

A. Absolutely not . . . We have many notices going out of this office every week . . . which may cost CB'ers as much as \$100 and their licenses . . .

Q. Don't you have to crack down on a violator while he's on the air?

A. No. All we have to do is hear an infraction on the air and we can issue a Notice of Violation by mail. . . Often we hear stations in our district working CB'ers in Texas or California, so we write out citations for both parties.

Q. Do you ever call offending stations on the air?

A. No, never. In fact, our vehicles carry no Citizens Radio transmitting equipment. We get reports of people pretending on the air that they're the FCC—which, by the way, is illegal—but the real FCC just listens.

Q. What other violations do you make special efforts to stop?

A. We take special interest in stations with unusually strong signals . . . and (those) we observe with 100' towers. We can tell with field strength meters whether or not a given



Engineer-in-charge of the FCC's 18th district Field Engineering Office in Chicago, E. J. Galins (left) discusses current CB regulations with a representative of the Amphenol Corporation (right).

antenna can radiate a signal of a given strength with a legally powered transceiver. If we believe that the power is in excess of five watts input, we pay a call on the operator.

Q. *Do most violators break more than one law?*

A. Yes, unfortunately. It's not unusual to find the same violator using obscene language, not using call letters, running more than legal power limit with an antenna exceeding the 20' regulation . . . About one percent of CB'ers deliberately disobey FCC rules.

Q. *Many people have been talking recently about a program called HELP, the Highway Emergency Locating Plan. What enforcement problem do you think would be created by a program of this sort which would put two-way radio CB transceivers in the family car so the driver could call for help in case of trouble?*

A. I expect it would make our job more difficult, but any program that might reduce traffic hazards on our nation's highway system deserves deep study. That's exactly what the FCC is giving HELP right now—deep study.

Q. *The FCC recently charged that some CB set manufacturers are abetting violators by supplying transceivers that operate on proposed HELP channels and also on certain Business Band channels. From an engineering standpoint, does present CB equipment encourage CB operators to break the rules?*

A. Most equipment will meet Part 95 rules as long as an unqualified person doesn't tamper with it. The regulations clearly specify

that a person must have a Second Class Radiotelephone license in order to service the frequency and power-determining circuits of a CB transceiver. So far as equipment with features that encourage law-breaking is concerned, Rosel Hyde, FCC chairman, recently told CB manufacturers that the service would be in jeopardy if CB equipment and CB advertisements continue to "invite violations by the unsophisticated, careless licensee." Linear amplifiers for CB, transmitters that hint at possible modifications to higher-than-legal power limits, units with more than 23 channels, and those covering more than CB frequencies—when used by un-informed or irresponsible persons . . . contribute to an already infamous violations record.

Q. *In closing, what final thoughts would you like to leave the nation's Citizens Band users?*

A. I guess the first would be that, despite its limited staff, the FCC is listening. There's no future in breaking the law—especially a radio law which is so easy to enforce even a thousand miles from the scene of the violation.

Second, don't be tempted to break the law by answering calls from other licensees . . . Only seven of the 23 channels may be used for talking with other licensees.

Third, identify every transmission and don't permit family members to operate your equipment without identification in your absence. Omission of station identification is equivalent to driving a car without license plates.

Finally, I'd like to suggest that every CB user periodically review Part 95 rules and regulations to make sure that he isn't accidentally violating some rule that might result in a fine at some future date.

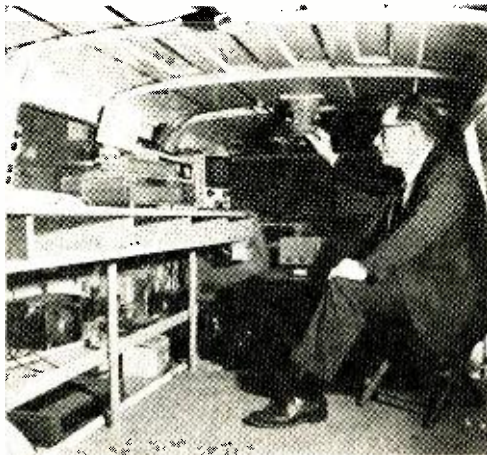

Monitoring engineers operating out of the Chicago FCC office have only three vehicles to check on CB communications in a five-state area. The vehicles are equipped as shown here; none has a transmitter since the FCC only LISTENS for violations.

CB Emergency Action. Jim Greer, Allied Louisiana Emergency Radio Team (ALERT) member, learned recently that completing a monitoring shift at midnight doesn't always signal the end of the ALERT day. On his way out of the Bellemont Motor Hotel, where ALERT's emergency control center is located, Greer learned that a woman at the motel was suffering from what appeared to be a heart attack, and that no ambulance was available to transport her to the hospital. Greer made available ALERT's two emergency vehicles, while George Weimer called police to inform them of the matter. Police met the ALERT mobiles en route and escorted them to the hospital. After analysis and treatment, the woman was found to have been suffering from food poisoning. ALERT members were commended for their quick thinking and action.

(Continued on page 118)

Low-Cost High- Quality Electronic Voltmeter

ALMOST NON-LOADING
VOLTMETER
MEASURES FROM
0.5 to 150 VOLTS
FULL SCALE, AND IS
IDEAL FOR TESTING
SEMICONDUCTOR
CIRCUITS

BY FRANK H. TOOKER

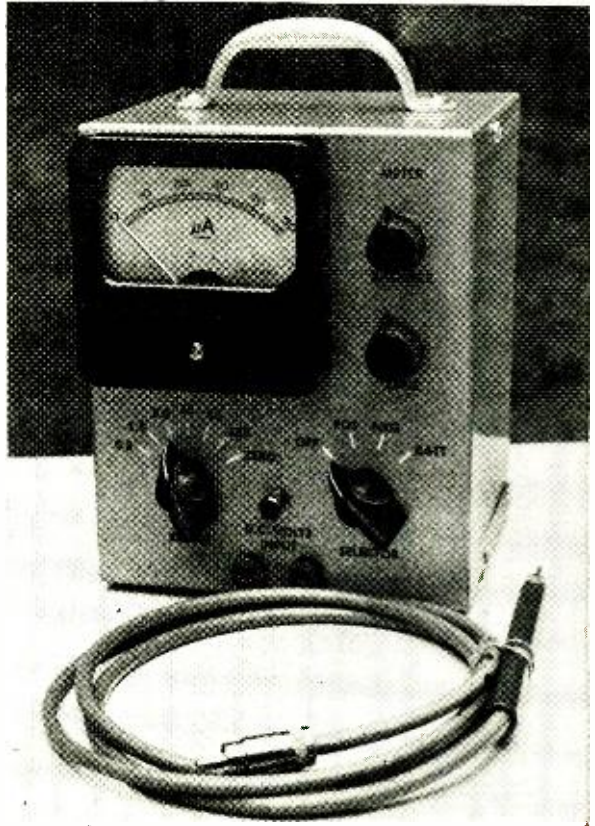

MEAASURING the very low d.c. voltages in a solid-state circuit is almost impossible with most VOM's. Why? Because of the shunting effect of the low input resistance of the VOM (it could be about 1000 ohms-per-volt) across what usually is a very low resistance within the circuit. The resulting parallel resistance produced by this combination is, in most cases, far below what the circuit needs to operate properly. The effect: improper operation due to wrong voltages, excessive current flow, and associated electrical changes within the circuit.

It was to remove this excessive loading that the VTVM was developed. Its very high input impedance (typically about 11 megohms) alleviated the parallel resistance problem, and in essence produced a non-loading measuring instrument. Unfortunately, most VTVM's in use have 1.5 volts as their lowest full-scale range—making it difficult to read many of the fractional voltages usually found within solid-state circuits.

The DCEV (direct-current electronic voltmeter) diagrammed in Fig. 1, combines the high input resistance of the VTVM with the portability of the VOM, uses a couple of low-cost transistors, and has the impressive specs shown in the table on page 59. Note that the DCEV has an input resistance of one megohm-per-volt over the four lowest ranges, making it an ideal voltmeter for solid-state checkout. The cost? Just about \$20, plus a few hours of work.

Basic Operation. The DCEV is, in a sense, a resistance multiplier. It may be visualized as taking the moderate resistance of a conventional voltmeter circuit and building it up by a factor of 50. It does so by current amplification. A voltmeter having a 50- μ A meter movement provides a resistance of 20,000 ohms-per-volt. When a 50- μ A meter is preceded by an amplifier having a fixed gain of 50, the resulting resistance becomes $50 \times 20,000 = 1$ megohm per volt.

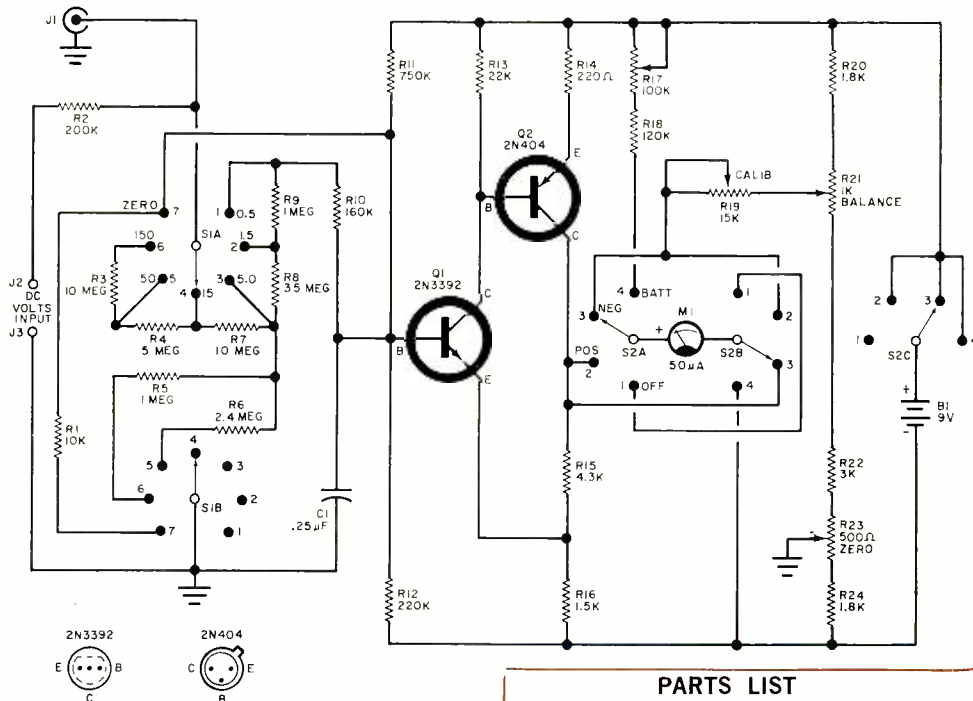

Fig. 1. The DCEV is basically a two-transistor TVM (transistor voltmeter) having the very high input impedance of the VTVM and the portability of a VOM. Unlike most VOM's, the DCEV has a 0 to 0.5 volt full-scale lower range, making it ideal for use with any type of semiconductor circuit including IC's.

Both the microammeter and the series resistor of the conventional voltmeter have a linear response, i.e., if sufficient voltage is applied to the combination to make $50 \mu\text{A}$ flow in the circuit, the meter deflects to full scale; if a voltage equal to one-half that required for full-scale deflection is applied, then $25 \mu\text{A}$ flows in the circuit and the meter deflects to half-scale.

When the voltmeter is incorporated in a DCEV, a similar order of linearity must be designed into the transistor amplifier, if the meter readings of the DCEV are to be reliably accurate. In fact, to measure both positive and negative voltages at high impedance and with equal accuracy for both, the transistor amplifier must be linear over the whole range of full-scale deflection of the meter with a *positive* input potential to full-scale deflection of the meter with a *negative* input potential—twice the range of the meter movement alone. The linearity of a DCEV in

PARTS LIST

- B1—9-volt transistor battery
- C1—0.25- μF , 200-volt Mylar capacitor
- J1—Probe jack (Lafayette 99 C 6234 or similar)
- J2—Banana jack, red
- J3—Banana jack, black
- M1—3" meter, 0-50- μA (Lafayette 99 C 5042 or similar)
- Q1—2N3392 transistor
- Q2—2N404 transistor
- R1—10,000 ohms, $\pm 10\%$
- R2—200,000 ohms, $\pm 5\%$
- R3, R7—10 megohms, $\pm 5\%$
- R4—5 megohms, $\pm 5\%$
- R5, R9—1 megohm, $\pm 5\%$
- R6—2.4 megohms, $\pm 5\%$
- R8—3.5 megohms, $\pm 5\%$
- R10—160,000 ohms, $\pm 5\%$
- R11—750,000 ohms, $\pm 5\%$
- R12—220,000 ohms, $\pm 5\%$
- R13—22,000 ohms, $\pm 10\%$
- R14—220 ohms, $\pm 10\%$
- R15—4300 ohms, $\pm 5\%$
- R16—1500 ohms, $\pm 5\%$
- R17—100,000-ohm potentiometer
- R18—120,000 ohms, $\pm 10\%$
- R19—15,000-ohm potentiometer, wire-wound
- R20, R24—1800 ohms, $\pm 5\%$
- R21—1000-ohm potentiometer, wire-wound, miniature (Mallory VW-1K, or similar)
- R22—3000 ohms, $\pm 5\%$
- R23—500-ohm potentiometer, wire-wound, miniature (Mallory VW, or similar)
- S1—2-pole, 9-position, non-shorting rotary switch (Mallory 3229J, or similar)
- S2—3-pole, 4-position, non-shorting rotary switch (Mallory 3234J, or similar)
- 1—6" x 5" x 4" utility cabinet
- Misc.—Handle, transistor sockets (2), rubber feet, $\frac{1}{2}$ "-long #8 spacers (2), pointer knobs for R21 and R23, $4\frac{3}{4}$ " x $2\frac{3}{4}$ " x $1\frac{1}{16}$ " insulated mounting board, battery clip, battery connector, small L-bracket, wire, solder, etc.
- Accessories—Test leads (1 red, 1 black) with banana plugs, isolating probe (see Fig. 3)

All fixed resistors $\frac{1}{2}$ watt

HOW IT WORKS

Transistors *Q1*, and *Q2* are connected as a high-gain, direct-coupled amplifier. Input is applied to the base of *Q1* and the resulting output at the collector of *Q2* is measured by microammeter *M1* in series with calibrating potentiometer *R19*. A current proportional to the deflection of *M1* flows in collector resistors *R15* and *R16*, and a voltage proportional to the current flowing in *R16* is fed to the emitter of *Q1* as negative feedback.

In addition to stabilizing the gain of the amplifier, this feedback accomplishes four other important functions: (1) it increases the input resistance of *Q1*; (2) it decreases the effective output resistance of *Q2*; (3) it makes the performance of the amplifier largely independent of the current gains of the transistors; and (4) it stabilizes the operating bias of *Q1* and *Q2* in the presence of temperature variations. Residual drift due to thermal activity is nulled out by adjustment of *Balance* potentiometer *R21*, which is connected in the conventional manner of a bridge. *Zero* potentiometer *R23* is adjusted to set the ground potential of the instrument equal to the base potential of *Q1*.

Amplifier *Q1-Q2* is preceded by a conventional resistive attenuator which enables the DCEV to measure from 0.5 volt full scale to 150 volts full scale in six settings of the *Range* switch. Reduction of the input resistance on the two higher ranges is limited to 20-plus megohms, which helps to keep the DCEV accurate during hot summer days when humidity percentages run high and insulation tends to behave like a very high

resistance. As it is, the input resistance of the DCEV on the 150-volt range is more than twice that of a VTVM.

Capacitor *C1* bypasses to ground any "hash" picked up on the test leads. The presence of this capacitor also increases the rise time of the input circuit to where very little overtravel of the meter needle occurs when a potential is suddenly applied to the DCEV's input terminals.

Selector switch *S2* not only makes provision for the measurement of either positive or negative voltages at the DCEV input, but it also has a position for accurately checking the battery while the amplifier is in operation. To calibrate this part of the circuit, set potentiometer *R17* at maximum resistance, then connect a VOM (so you can read 10 volts conveniently) in parallel with the battery. Set the *Selector* switch to *Batt*, and read the battery voltage on the VOM. Multiply the VOM reading by 5 and adjust *R17* until the meter of the DCEV reads this value. Thereafter, the DCEV battery can be checked at any time simply by setting *S2* to *Batt* and dividing the DCEV's meter reading by 5. When the battery voltage begins to drop, replace the battery. Power consumption of the DCEV is low, so battery life is long.

When the *Selector* switch is set to *Off*, the battery is disconnected and the terminals of the microammeter are simultaneously short-circuited. So doing damps the meter movement substantially, thus helping to protect the movement from damage and pivot wear while the DCEV is being handled or transported. This refinement is seldom, if ever, found even in instruments costing many times the DCEV.

this respect is termed its "turnover linearity," and in the instrument described in this article, turnover linearity is better than in many a VTVM.

The best way to obtain linearity in an amplifier is to provide means of automatically and continuously comparing the output level with the input level, and to maintain a fixed ratio between the two. In other words, it is essential to stabilize the gain of the amplifier over a wide range of current input. This has been done by designing a high-gain amplifier with a response that is as linear as possible and then employing negative feedback to bring the gain down to the required level. The linearity improves in the same ratio as the gain reduction. Thus, if an amplifier is linear within, say, 10%, without negative feedback, and a gain-reduction factor of 20 is obtained as a result of adding feedback, the linearity with feedback will be 10%/20, or 0.5%.

Construction. The DCEV can be assembled in a 4" by 5" by 6" aluminum utility box with room to spare. The at-

tractive appearance of the instrument depends in large measure upon how carefully and accurately the front panel is laid out and machined. Layout dimensions are given in Fig. 2. If the layout

SPECIFICATIONS

Range	0.5, 1.5, 5.0, 15, 50, and 150 volts d.c.
Input Resistance	1 megohm-per-volt on four lower ranges; 300,000 ohms-per-volt on 50-volt range; and better than 150,000 ohms-per-volt on 150-volt range
Linearity	1% from full scale to 1/5 full scale
Turnover Linearity	1% or better
Accuracy	± 5% with unselected resistors
Power Consumption	2 mA at 9 volts
Other Features	Special switching provides meter damping to avoid damage in transport, and also permits easy battery voltage check

lines are kept short, confined to the point of measurement, they will not show when the instrument is assembled. When all machine work is finished, deburr the panel by washing it thoroughly in a conventional detergent-water solution, rinse well, and dry.

Panel lettering can be done with either decals or dry-transfer labels. The important thing is to work slowly and carefully, keeping in mind that there is as much satisfaction to be had in the appearance of a good instrument as there is in its use. The switch positions will be

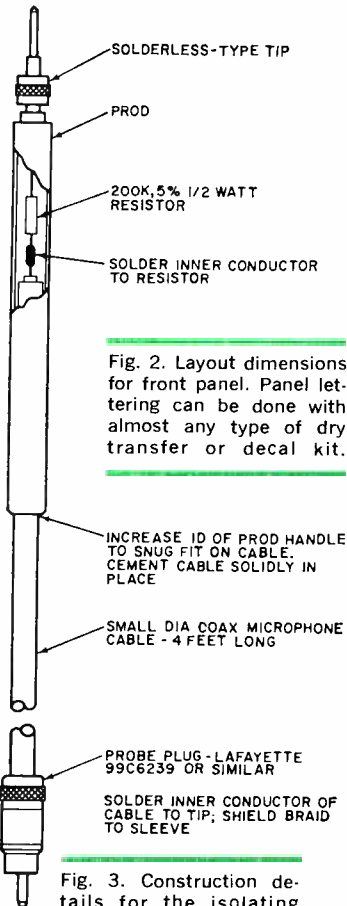
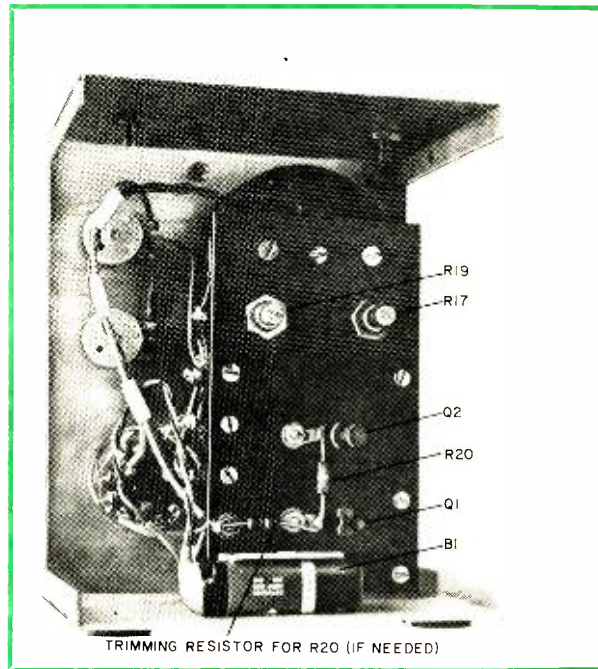
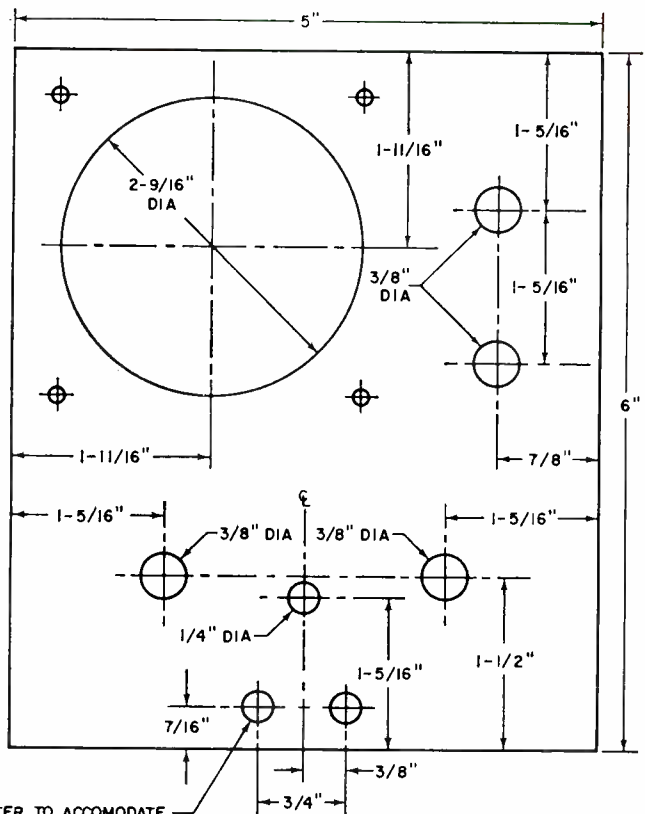
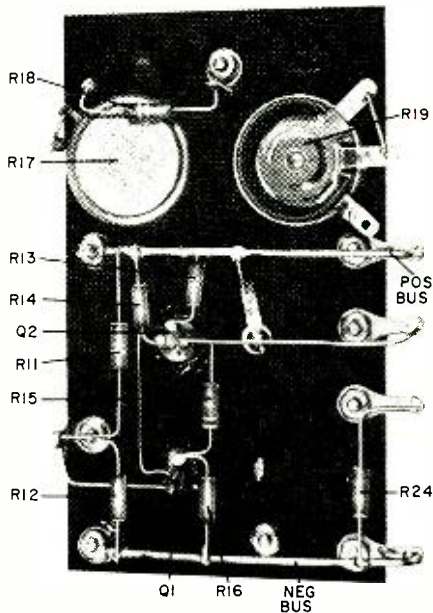
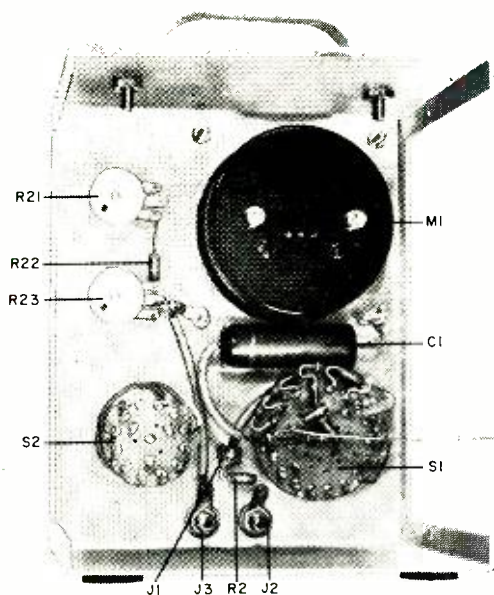

Fig. 2. Layout dimensions for front panel. Panel lettering can be done with almost any type of dry transfer or decal kit.

Fig. 3. Construction details for the isolating probe for use with the DCEV. These parts are not included in Parts List.



2 HOLES, DIAMETER TO ACCOMMODATE INSULATING WASHERS OF BANANA JACKS OR BINDING POSTS, AS DESIRED



The completely assembled DCEV (left, above) is made up of the front-panel assembly (center), and the insulated board assembly (above, right). Battery is clamped to bottom of case as shown. Note that R20 is mounted on the transistor side of the board (see text).

most legible and attractive if the lines are made in white and the legends in black.

Range switch *S1* is a 9-position unit, but only seven of the positions are used in the DCEV. The stop provided with the switch specified in the Parts List should be located so as to confine rotation to these seven positions. Rewire the Range switch with the multiplier resistors (*R2* through *R9*) before mounting it on the panel.

The accuracy of the readings obtained depends largely upon the accuracy of the multiplier resistors. Best accuracy will be achieved when the exact values specified in the Parts List are used. These resistors can be selected from 5% units tested on an accurate resistance bridge. If stock (unselected) 5% resistors are used, the DCEV will still be of considerable value in practical applications, however, for much of the electronic equipment to be tested with it will not require an accuracy greater than $\pm 5\%$ in operating voltages.

Most of the parts associated with the amplifier are assembled point-to-point on a $4\frac{3}{4}'' \times 2\frac{3}{4}'' \times \frac{1}{16}''$ insulated mounting board. Wire terminals are used where multiple connections are needed. In the author's model, resistor *R20* has been located on the outer surface of the board where it is easily accessible for trimming its value to obtain optimum initial centering of the *Balance* and *Zero* controls. If you are not interested in such splitting of hairs, this resistor can just as well be located below deck along with the others.

The board is mounted on the meter terminals with $\frac{1}{2}''$ spacers at the top and secured at the bottom by a small L-bracket under one of the screws holding the battery clip. Layout is not critical, and any other method of assembly—perforated mounting board and flea clips, or a printed circuit board—can be used instead, if desired.

Construction details of an isolating probe for the DCEV are given in Fig. 3.

(Continued on page 104)

10 Reasons why RCA Home Training is Your best investment for a rewarding career in electronics:



Performing transistor experiments on programmed breadboard – using oscilloscope

1 LEADER IN ELECTRONICS TRAINING

When you think of electronics, you immediately think of RCA... a name that stands for dependability, integrity and pioneering scientific advances. For over a half century, RCA Institutes, Inc., a service of Radio Corporation of America, has been a leader in technical training.

2 RCA AUTOTEXT TEACHES ELECTRONICS FASTER, EASIER, ALMOST AUTOMATICALLY

Beginner or refresher, AUTOTEXT, RCA Institutes' own method of programmed Home Training will help you learn electronics more quickly and with less effort, even if you've had trouble with conventional learning methods in the past.

3 THOUSANDS OF WELL PAID JOBS ARE NOW OPEN TO MEN SKILLED IN ELECTRONICS

RCA Institutes is doing something positive to help men with an interest in electronics to qualify for rewarding jobs in this fascinating field. Every year, literally thousands of high paying jobs in electronics go unfilled just because not enough men take the opportunity to train themselves for these openings.

4 WIDE CHOICE OF CAREER PROGRAMS

Start today on the electronics career of your choice. On the attached card is a list of "Career Programs", each of which starts with the amazing AUTOTEXT method of programmed instruction. Look the list over, pick the one best suited to you and check it off on the card.

5 SPECIALIZED ADVANCED TRAINING

For those already working in electronics or with previous training, RCA Institutes offers advanced courses. You can start on a higher level without wasting time on work you already know.

6 PERSONAL SUPERVISION THROUGHOUT

All during your program of home study, your training is supervised by RCA Institutes experts who become personally involved in your efforts and help you over any "rough spots" that may develop.

7 VARIETY OF KITS YOURS TO KEEP

To give practical application to your studies, a variety of valuable RCA Institutes engineered kits are included in your program. Each kit is complete in itself. You never have to take apart one piece to build another. At no extra cost, they're yours to keep and use on the job.

8 FROM RCA INSTITUTES ONLY - TRANSISTORIZED TV KIT, VALUABLE OSCILLOSCOPE

Those enrolled in RCA's television course or program receive complete transistorized TV Kit. All students receive a valuable oscilloscope—both at no extra cost and only from RCA Institutes.

9 UNIQUE TUITION PLAN

With RCA Home Training, you progress at the pace that is best for you! You only pay for lessons as you order them. You don't sign a long-term contract. There's no large down-payment to lose if you decide not to continue. You're never haddgered for monthly

bills. Even if you decide to interrupt your training at any time, you don't pay a single cent more.

10 RCA INSTITUTES GRADUATES GET TOP RECOGNITION

Thousands of graduates of RCA Institutes are now working for leaders in the electronics field; many others have their own profitable businesses. This record is proof of the high quality of RCA Institutes' training.

CLASSROOM TRAINING ALSO AVAILABLE

If you prefer, you can attend classes at RCA Institutes Resident School, one of the largest of its kind in New York City. Coeducational classroom and laboratory training, day and evening sessions, start four times a year. Simply check "Classroom Training" on the attached card for full information.

JOB PLACEMENT SERVICE, TOO!

Companies like IBM, Bell Telephone Labs, GE, RCA, Xerox, Honeywell, Grumman, Westinghouse, and major Radio and TV Networks have regularly employed graduates through RCA Institutes' own placement service.

SEND ATTACHED POSTAGE PAID CARD TODAY! FREE DESCRIPTIVE BOOK YOURS WITHOUT OBLIGATION! NO SALESMAN WILL CALL!

All RCA Institutes courses and programs are approved for veterans under the New G.I. Bill.

RCA INSTITUTES, INC. Dept. PE-N7
350 West 4th Street
New York, N.Y. 10014



Accredited Member National Home Study Council

The Most Trusted Name in Electronics

Construction of Multimeter.



Construction of Oscilloscope.

Temperature experiment with transistors.

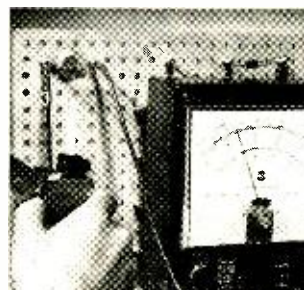



INFORMATION CENTRAL

By CHARLES J. SCHAUERS, W6QLV

EDITORIAL SPACE is always at a premium and you must excuse us if we paraphrase your questions and simultaneously make the answers as brief as possible. Obviously, many questions can be answered at great length, but not all readers are interested in the same questions. We try to strike a balance between the "no information" inquiries and the "sufficient for the purpose" published answers. At times, it may appear that we have oversimplified answers, but this is only because we credit our readers with the intelligence and ingenuity to supply any "missing" data needed in the solution of a problem.

We must once again reiterate that there are many questions that simply cannot be answered in this column—nor through the usual channels—for a variety of reasons. For example, sometimes the reader has not presented his problem with enough facts so that it can be understood. On other occasions, the questions flow so thick and fast that even the most superficial response would call for a three- or four-page personal letter.

Questions sent to *Information Central* should be brief, but complete. When you ask a question, please put it on a postcard (if at all possible) and be as concise as you can. This will save time here and may well expedite your answer.

Tone Reed Relay. *What is a tone reed relay and how does it work?*

A tone reed relay is usually referred to as a resonant relay and is constructed on the "tuning fork" principle. When a specific audio frequency is electrically applied to the armature coil of a reed relay, that tone causes the reed to vibrate. The vibration may actuate a number of devices including those used for CB selective calling, control of model aircraft, and many other purposes. Reed relays are sold in a variety of different resonant frequencies.

R/C Transmitter. *Is there any law that says I can't use a modified hand-held Class-D CB transceiver for model aircraft radio control?*

No, just make sure that you are on the proper channel and have the appropriate Class C license.

Mercury Vapor Tubes. *What is the purpose of a mercury-filled tube?*

Mercury tubes are really not filled up to the brim with mercury, but simply have a small amount that may be vaporized, or technically speaking, ionized. Mercury vapor tubes are generally used in rectifier or control circuit applications. The mercury vapor permits enormously greater current handling capacity. Most of these tubes are now being replaced by silicon solid-state rectifiers. The solid-state rectifiers are more efficient and eliminate the need for a filament transformer and various hash suppression components.

Coax Cable Choice. *I see different grades of coaxial cable being advertised and have been wondering which one I should buy. I plan to use coax to feed my new 3-element, 3-band beam antenna.*

Any of the top-grade "regular" coax cables will work with your new antenna. Of course, the cable impedance must match the antenna; since most beams are designed with a 50-ohm impedance, this should not be a problem. Practically all hams prefer RG-8/U cable. CB'ers, because of their lower power output, can safely use RG-58/U cable. I would suggest that you steer clear of some of the war surplus coaxial cable—make sure that your cable is "fresh" and not something that has been stored in a warehouse for the last ten years.

Hi-fi Jammer. *I live in an apartment house and my next-door neighbor plays his stereo hi-fi full-blast from early in the morning till late at night. We have courteously told him that it is annoying, but he continues right on with his ear-pounding music. Isn't there some way in which I can electronically jam his hi-fi set?*

Even with the paper-thin walls in the modern apartment houses, you and your family are entitled to a quiet and unmolested existence. The situation sounds like a police matter; we do not recommend your becoming involved in the operation of an electronic FM broadcast jammer.

CB TVI. *Since installing my new CB base station, my next-door neighbors have complained about television interference. I didn't*

think that a CB rig was powerful enough to create TVI.

The power of your CB rig is not the question—it's whether or not the transceiver has a built-in second harmonic filter. It sounds as though your rig doesn't, and I would suggest your adding a low-pass filter. Various electronics companies sell such filters and you might try one similar to the Lafayette #42 C 0123. This filter should clear up all of your TVI—unless one of your neighbors has an antique black-and-white TV receiver.

Dynamite Blasting Caps and R.F. *I understand that it is possible for my CB rig to cause an electric blasting cap to explode. Is this really true?*

Yes, you'd better believe it! The problem occurs because of the length of the wire leads to the blasting cap. These leads could have the same resonant wavelength as your CB signal and would therefore pick up enough r.f. to explode the cap. When you see the sign "No Transmitting—Blasting in This Area," turn off your CB transmitter.

Inoperative Tweeter. *I hooked up a new tweeter to my hi-fi speaker system and it cut out most of the sound. The tweeter has its own L-pad. What could be wrong?*

Either you have a short in the wiring, or you have left out the high frequency bypass capacitor. Re-read your wiring instructions and see if they don't recommend your inserting a bypass capacitor.

Transistor Substitution Guide. *Isn't there a complete cross-reference of transistors so that European, American, and Japanese transistors can be identified?*

There are several transistor substitution guides being published. Many technicians use the Howard Sams "Transistor Substitution Guide," but the handiest book I've seen is published in Holland. It is called "Transistoren" and will quickly tell you the American equivalent for such rarities as the SFT213 or HJ71. It sells for \$2.00 a copy and is available from Gilfer Associates, Inc., Box 239, Park Ridge, N.J.

Horizontal Oscillator Interference. *I am an SWL with what I consider to be reasonably good equipment. I have one major difficulty, which is that I pick up a sort of buzzing sound about every 15 kHz right through the broadcast band and up to about 3 MHz. What is all of this noise anyway?*

No doubt the signals you hear are radiated from the horizontal oscillator (15.75 kHz) of a nearby TV receiver. Getting rid of this kind of interference is sometimes a difficult problem. In the worst case, it will be necessary to shield the offending TV receiver with a piece of copper window screen.

On occasion, you can simply shield the open bottom of the TV receiver—making sure that the copper screen is well grounded to the chassis. In very stubborn cases, the copper screen must be extended along the sides, top, and back of the receiver. In a few instances, interference is coming along the a.c. power line and you can bypass the noise to ground through a pair of 0.005- μ F ceramic disc capacitors in series across the a.c. line (center-tap grounded to the receiver chassis).

Over-Voltage Warning. *I need a device that will sound off when a certain d.c. voltage is exceeded. Do you have any suggestions?*

Yes, try working up a simple circuit using Mallory's Sonalert[™] and a zener diode. In the diagram below, note that the zener diode

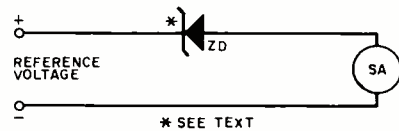

prohibits current flow until its rated voltage is exceeded. The Sonalert will sound off at any voltage from 6 to 28 volts d.c. and draws just a few milliamperes of current.

A.L.C.—Yes or No? *How does the usual automatic limiting control (a.l.c.) work in an SSB transceiver? Is it worthwhile having?*

The a.l.c. prevents flat-topping or overdriving of a linear final r.f. amplifier on peak signals, thus reducing or preventing splatter. Generally speaking, the circuit is simple and works like this: a small amount of r.f. is taken from the final r.f. stage by a diode circuit which applies this negative voltage to an intermediate driving stage grid, thus lowering the drive to that stage below the flat-topping limit. I would never own an SSB transceiver without an a.l.c., especially if a high-power linear amplifier is tied to it.

FM Tuner Distortion. *I have an old FM tuner that worked fine with my original hi-fi setup; but when I connected the tuner to my new stereo amplifier, the distortion was abominable. What could be wrong? I plugged the tuner into the jack marked "Tuner Input."*

One of two possible things could cause this excessive distortion. First, the output voltage from the tuner may be too high for the input of your new stereo amplifier. Check to see if this is true by reading the manufacturer's specifications for these two items. If necessary, insert some sort of resistance pad loading to cut down the tuner output.

Also, it is possible that the original amplifier and the new stereo amplifier do not have the same input impedance. Check out this possibility—although it is unlikely.

A.F. Signal Tracer. *I need a simple transistorized audio frequency signal tracer that will operate around 900 Hz. Can you help me?*

There has been a variety of tracer circuits published in the popular press, but the one I like and use is shown below. If oscillation

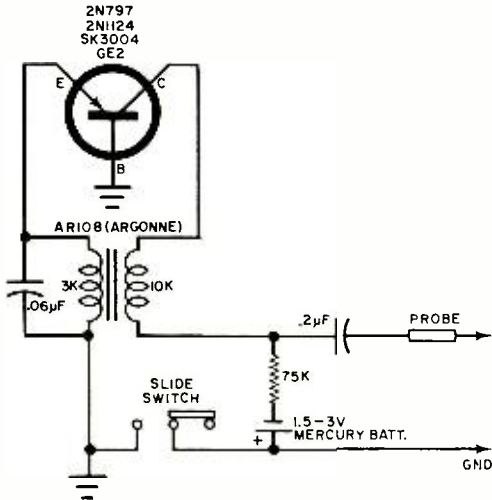

is not present when you build this circuit, simply reverse the secondary wiring connections of the transformer so that they are properly phased. This circuit is small enough to be mounted in a 35-mm. film can. The probe can be a single banana plug.

Collins 75A4 Improvement. *I understand that my old Collins 75A4 receiver can be improved by changing the second mixer tube (6BA7) to a 6U8A. Where can I obtain the necessary information to make this change?*

Details for making this change appeared in *CQ Magazine*, June, 1960, page 81. Reprints of the article are available from the publisher of *CQ Magazine* for \$1.00.

Replacing Electrodynamic Speakers. *How do I go about replacing the old electrodynamic speaker in my 1930 radio receiver with a modern-day permanent magnet speaker?*

Years ago, speaker magnets were so weak and efficiency so low that the magnets were excited by a field coil which really doubled in brass as a choke in the power supply. Most field coils can be replaced by substituting an 8-H coil with a current rating of at least 200 mA. Then, connect the permanent magnet voice coil to the output transformer.

Sometimes you must make sure that the new voice coil has the same impedance as the output transformer. If it doesn't, a substitute transformer is required at this point.

Using Surplus Transistors. *I am a sucker for surplus electronic bargains and recently bought a pound of different transistors for only \$1.00. How do I go about using them? Many of the transistors are unmarked and I can't even tell the pnp from the npn transistors, let alone decide whether any of them are silicon or germanium.*

Your *Information Central* department receives this question or its equivalent about three dozen times each month. As far as we are concerned, many of these unmarked transistors are not bargains. You need some sort of transistor tester to at least establish whether they are *pnp* or *npn* and to give you some idea of the possible gain characteristics. The Editors of *POPULAR ELECTRONICS* plan on publishing (in an early issue) a device that will enable you to determine the value of the various resistors to be used with an unknown transistor.

National 200 Improvement? *I have a National 200 transceiver and it seems to work fine, but now I would like to add a speech clipper to it. Do you have any ideas on this subject?*

Yes, I would suggest leaving well enough alone! The National 200 gives you maximum talk power and has a.l.c. Adding a speech clipper—a precarious procedure if impedances are not properly matched—could alter the speech transmission characteristics of this transceiver. All field reports concerning the National 200 that I have heard indicate that the speech is excellent.

Easy Diode Check. *I can buy a large number of silicon diodes of all kinds at a very low price. I can also pick and choose, but I don't have a diode checker. Is there some other method I can use in its place to check out these diodes?*

Yes, simply use your VOM on its high ohms scale. When the test prods of the ohmmeter are placed on a good diode, the meter will indicate a low value in one direction; reversing the leads will show a very high resistance reading in the other direction. If a diode is shorted, a low-resistance indication will be obtained in both directions. An open diode would be indicated by no reading in either direction.

Questions for *Information Central* should be directed to *POPULAR ELECTRONICS*, One Park Avenue, New York City, New York 10016. Every possible effort is being made to answer urgent reader inquiries within three to four weeks.

-30-

POPULAR ELEComics



"I hope Pop doesn't turn on his car radio today!"

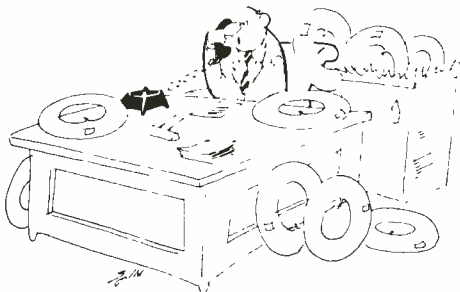
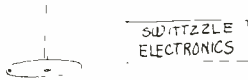

"Regarding our order of Oct. 16 for tubes . . ."

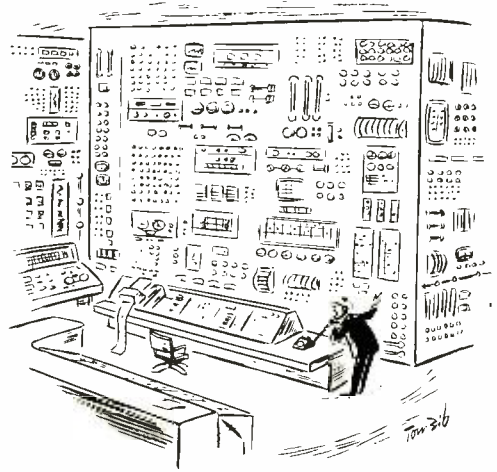

"I can't find the 'on' switch!"

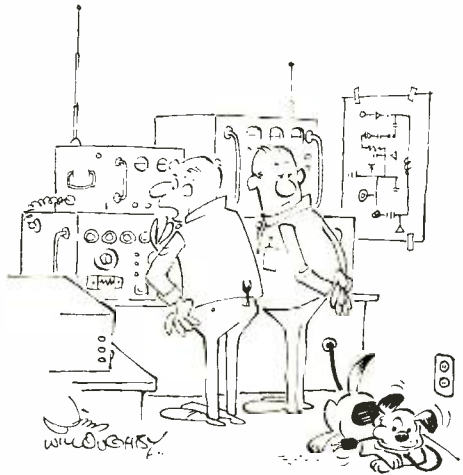

"That's funny, it was working a minute ago."

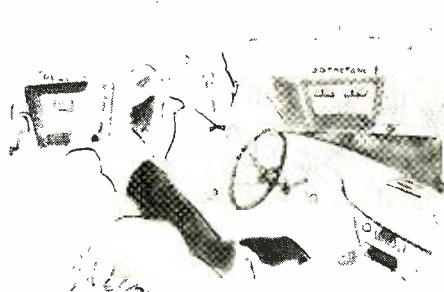

"Check your tape head?"

Color Code Quiz

By ROBERT P. BALIN

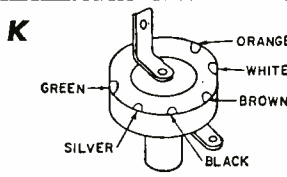
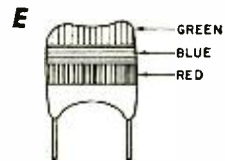
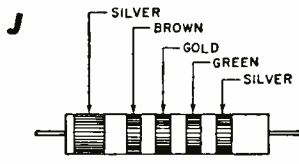
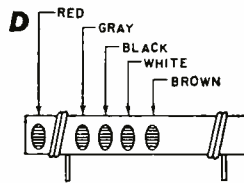
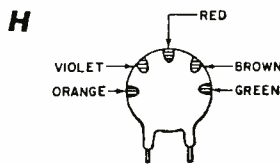
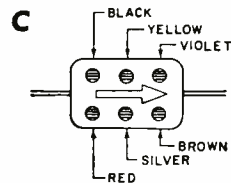
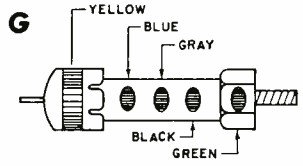
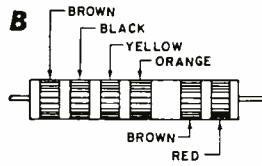
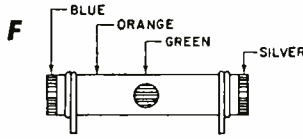
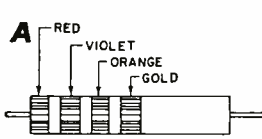

Color-coded bands and dots are commonly used to provide important rating data on resistors, capacitors, and inductors. It is necessary, therefore, that an electronic technician either memorize the color code and the numerical value of each band and dot, or have ready access to this information on charts. To test your ability to read color codes, pretend that you have found the components (A-K) shown at left in your spare parts box and want to identify them. Consult your charts and any other information that you may have available.

(Answers appear on page 110)

- A Axial Lead Resistor**
 Value _____ Tolerance _____
- B Molded Tubular Paper Capacitor**
 Value _____ Tolerance _____
 Voltage _____
- C Molded Flat Mica Capacitor**
 Value _____ Tolerance _____
 Code _____ Class _____
- D Temperature-Compensated Tubular Ceramic Capacitor**
 Value _____ Tolerance _____
 Temp. Coef. _____

- E Mylar/Polyester Film Capacitor**
 Value _____
- F Radial Lead Resistor**
 Value _____
 Tolerance _____
- G Standoff Ceramic Capacitor**
 Value _____
 Tolerance _____
 Temp. Coef. _____
- H Ceramic Disc Capacitor**
 Value _____
 Tolerance _____
 Temp. Coef. _____
- J Molded Choke Coil**
 Value _____
 Tolerance _____
 Code _____
- K Button Silver Mica Capacitor**
 Value _____
 Tolerance _____

Experimenter's "Professional" Power Supply

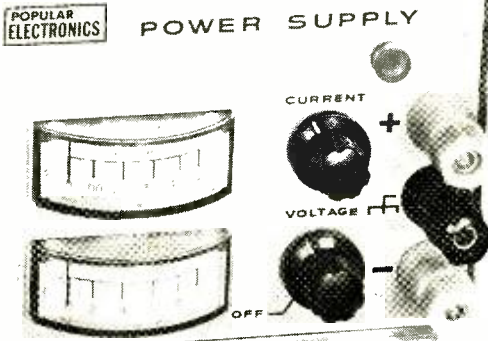

- ADJUSTABLE 0-10 VOLTS
- ADJUSTABLE 0-500 mA
- SHORT-CIRCUIT-PROOF
- ALL FOR ABOUT \$20

BY DON LANCASTER

LOOKING FOR a professional-quality low-voltage power supply? Here's one that puts out 0-10 volts at half an ampere or less, is fully regulated, and automatically protects both itself and your circuits from any possible damage. An adjustable current limiter sets the absolute maximum current that can possibly be delivered to the circuits—no high damaging currents are possible should an accidental short circuit or polarity reversal occur. The power supply can even run short-circuited overnight with no harm!

This power supply circuit (Fig. 1) is ideal for IC experiments, where you can easily set the 3.6 or 4.5 volts at the high-current levels you will need in multiple circuits. You'll also find it handy as a battery eliminator for transistor radio servicing, and a general replacement for "D" cells or similar batteries in bench experiments, and anywhere else you're working with transistor or IC circuitry.

The performance specs are very impressive: less than 1 millivolt of r.m.s. output ripple; regulation better than 300 millivolts, no load to full load. There are dual meters, one for voltage and one for current, with no confusion over what scale you are reading. Two controls are provided—one for adjusting voltage, the other to set the short-circuit current

limit. And the split output terminal design gives you either a positive or negative case ground. All this in a three-pound 3" x 4" x 5" package you can easily put together in several evenings for \$15 to \$30, depending upon how fancy you care to get.

Construction. The power supply will just fit in a 3" x 4" x 5" metal box. Holes for the meters are cut with a nibbling tool. Color-coded five-way binding posts are used at the output, red for +, yellow for -, and black for the case. If you use *exactly* 3/4" mounting centers between the binding posts, you can use a standard double banana plug connector to your experimental projects. Line switch *S1* mounts on the rear of voltage-adjust potentiometer *R6*.

Although not essential, a small printed circuit board greatly simplifies the wiring and makes all the small parts easy to mount. The board should be laid out and drilled as shown in Fig. 2. Component layout and interconnections are shown in Fig. 3. Be very careful of all circuit and component polarities. The PC board mounts on the chassis spacers with four #6 screws.

To bleed the heat from *Q3*, use a Wakefield NC623K heat sink drilled to suit the 2N3766 unit specified, and an insulated

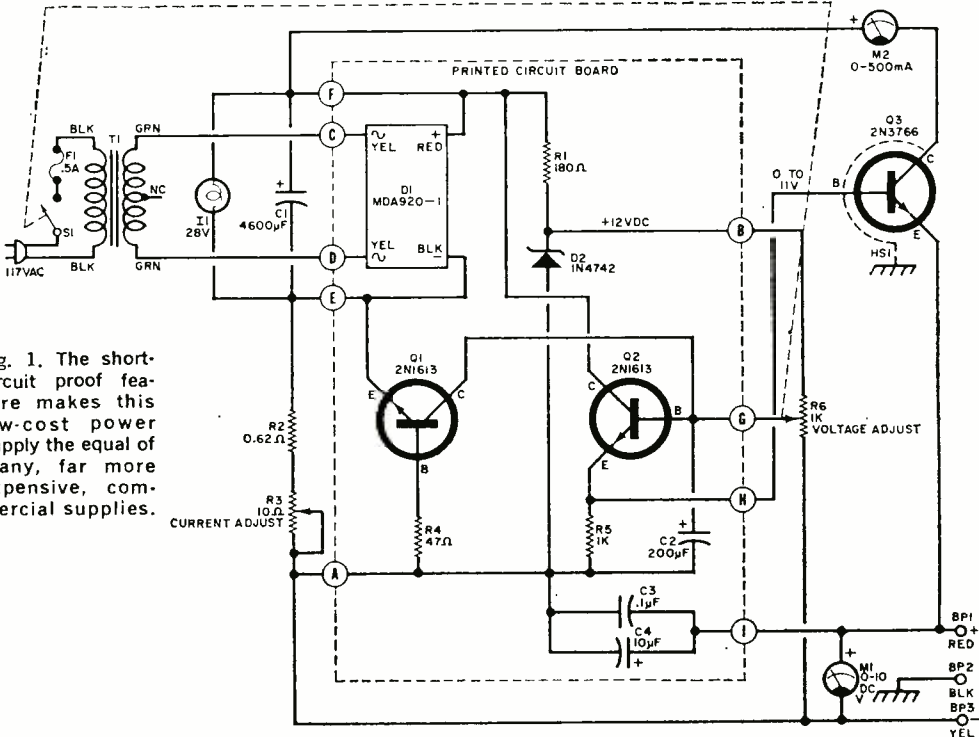

Fig. 1. The short-circuit proof feature makes this low-cost power supply the equal of many, far more expensive, commercial supplies.

PARTS LIST

- BP1, BP2, BP3—5-way binding post, one red, one black, one yellow
 C1—4600- μ F, 15-volt computer-grade electrolytic capacitor (Sprague 462G015AA, or similar)
 C2—200- μ F, 15-volt electrolytic capacitor
 C3—0.1- μ F, 50-volt miniature disc ceramic capacitor
 C4—10- μ F, 15-volt electrolytic capacitor
 D1—1.5-ampere, 50-volt, full-wave bridge rectifier (Motorola MDA930-1, or similar)
 D2—12-volt, 1-watt zener diode (Motorola 1N4742, or similar)
 F1—0.5-ampere fuse with holder
 HS1—3" x 4 7/16" flat-finned heat sink (made from Wakefield NC623K—see text)
 I1—28-volt, miniature pilot light assembly
 M1—0-10 d.c. voltmeter, edgewise-type (Emico Model 13, or similar)
 M2—0-500 d.c. milliammeter, edgewise-type (Emico Model 13 or similar)
 PC1—1 1/2" x 3" printed circuit board
 Q1, Q2—2N1613 transistor
 Q3—2N3766 transistor with mounting kit for TO-66 case

- R1—180-ohm, 1/2-watt carbon resistor
 R2—0.62-ohm, 1-watt carbon resistor
 R3—10-ohm, 5-watt miniature wire-wound potentiometer (Mallory VW-10, or similar)
 R4—47-ohm, 1/2-watt carbon resistor
 R5—1000-ohm, 1/2-watt carbon resistor
 R6—1000-ohm, 1/2-watt potentiometer (with s.p.s.t. switch S1)
 S1—S.p.s.t. switch (on R6)
 T1—12.6-volt, 2-ampere filament transformer (Allied Radio 54 D 1420 or similar)
 1—3" x 4" x 5" enclosure (Bud CU-2105-A, or similar)
 1—Hard anodized-aluminum dialplate, available from Reill's Photo Finishing, 4627 N. 11th St., Phoenix, Arizona 85014; in silver color for \$2.75, red or copper for \$3.25, postpaid in USA; stock #PSV-1 (optional)
 Misc.—Insulated mounting kit and #6 hardware for Q3, line cord and strain relief, 3/4" knobs (2), mounting clip for C1, ground strap for BP2, #10 nylon cup washers (4), TO-5 transistor pads (2), printed circuit terminals (9), solderless terminals (9), wire nut, #6 hardware, wire, solder, etc.

mounting kit. (As this heat sink is a \$1.50 item, you might prefer to build your own with 1/8" aluminum or some other low-priced material.) Use silicone grease on Q3, and check to be certain the transistor is insulated from the heat sink proper. The heat sink mounts on the rear of the case with pop rivets or #6 hardware.

Assembly. The various elements are assembled in the case in accordance with the layout selected. Figure 4 shows the author's unit before wiring. The printed board is mounted at the top, directly above the two meters, and the fuse holder is at the rear. The two potentiometers and three binding posts are also visible. The transformer (T1) and filter capaci-

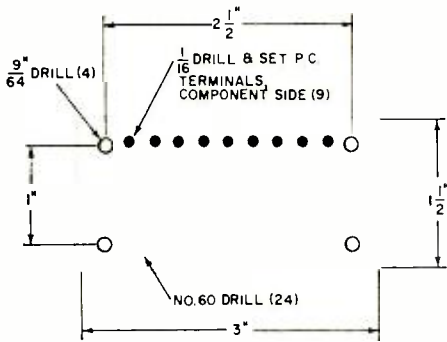

Fig. 2. Foil side of full-size PC board (right) is drilled as shown above and components mounted as shown in Fig. 3.

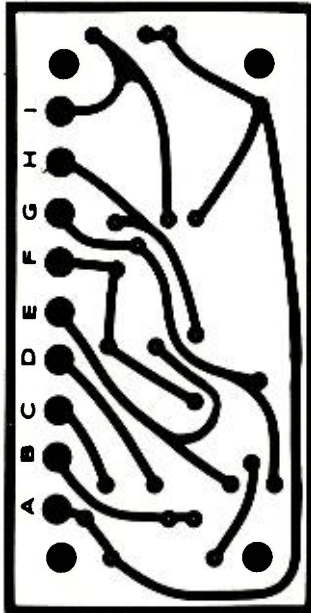

Fig. 3. Parts arrangement on component side of the printed board. Observe polarity of the capacitors.

HOW IT WORKS

The power supply circuit uses full-wave, capacitor-filtered, 16-volt, unregulated d.c. generated by 12.6-volt, 2-ampere filament transformer *T1*, rectifier bridge module *D1*, and filter capacitor *C1*. Transistors *Q2* and *Q3*, and 12-volt zener diode *D2* make up a voltage regulator. Together *Q1* and *Q2* have a gain of around 10,000, effectively "amplifying" the filtering effect of capacitor *C2*. Voltage-adjust potentiometer *R6* across *D2* permits setting the output voltage smoothly from zero to 10 volts. A heat sink is required for *Q3* as it will dissipate about 16 watts in the short-circuit mode.

A silicon transistor needs 0.6 volt between base and emitter before it will conduct current. To get short-circuit protection, a 0.62-ohm current sensing resistor (*R2*) is placed in series with the output, and transistor *Q1* is connected across this resistor. As long as the current is less than 1 ampere, the voltage drop across *R2* is less than 0.6 volt, and *Q1* stays off. If too much current flows, *Q1* immediately turns on, and robs the zener diode of its supply voltage; the output voltage, drops immediately, thus preventing any fault currents. A wire-wound control potentiometer (*R3*) connected in series with the 0.62-ohm resistor permits setting the maximum short-circuit current to be delivered to a load.

tor *C1* are mounted on the rear wall of the case. Long leads are used to interconnect these two components, and to wire *Q3* to the PC board.

Wiring should present no major problems. Use #18 wire on the high-current portions of the instrument—between the collector of *Q3* and meter *M2*, from *M2* to terminal F of the PC board, from the emitter of *Q3* to the red (+) binding post, and between the yellow (-) binding post and *R3*, *R3* to *R2* (*R3* can be soldered directly to *R2*), and *R2* to ter-
(Continued on page 105)

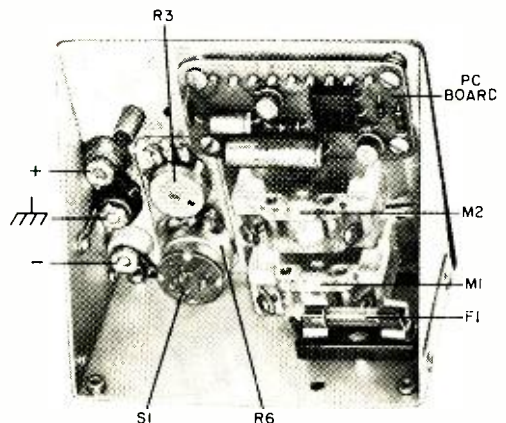
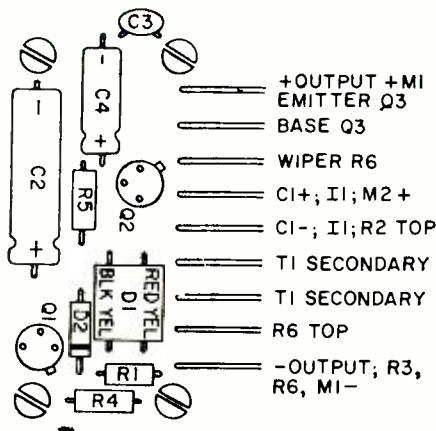



Fig. 4. Author's unit before wiring. Capacitor *C1*, transformer *T1*, and transistor *Q1* are on rear cover.

FOREIGN-LANGUAGE BROADCASTS TO NORTH AMERICA

Prepared by **ROBERT LEGGE**

LANGUAGE	STATION	TIME—EST	TIME—GMT	FREQUENCIES (MHZ)
ARABIC	Beirut, Lebanon	9-9:30 p.m.	0200-0230	11.785
	Cairo, U.A.R.	6:30-7:30 p.m.	2330-0030	9.475
BULGARIAN	Sofia, Bulgaria	8-8:30 p.m.	0100-0130	9.70
CHINESE	Peking, China	8-10 p.m.	0100-0300	12.01, 15.095, 17.795
		10-12 p.m.	0300-0500	9.48, 12.01, 15.08
CZECH/SLOVAK	Prague, Czechoslovakia	8:30-9 a.m. (Sun.)	1330-1400	15.448, 17.705, 21.45
DANISH	Copenhagen, Denmark	7-7:45 a.m.	1200-1245	15.165
		8-8:45 p.m.	0100-0145	9.52
DUTCH	Brussels, Belgium	6:15-8 p.m.	2315-0100	9.615
	Hilversum, Holland	9:30-10:50 p.m.	0230-0350	9.59
FINNISH	Helsinki, Finland	7:15-10:10 a.m.	1215-1510	15.185
FRENCH	Brussels, Belgium	6:15-8 p.m.	2315-0100	9.615
	Lisbon, Portugal	9:15-10 p.m.	0215-0300	5.985
	Paris, France	7-7:30 p.m.	0000-0030	9.755, 11.845
	Rome, Italy	8:20-8:35 p.m.	0120-0135	9.63, 11.81
	Vatican City	8:10-8:25 p.m.	0110-0125	7.27, 9.69, 11.76
GERMAN	Berlin, Germany	8:30-9:30 p.m.	0130-0230	6.16, 9.73
	Cologne, Germany	7-10 p.m.	0000-0300	6.10, 9.545, 11.795
		10 p.m.-1 a.m.	0300-0600	6.10, 9.64, 11.795
	Vienna, Austria	7-11 p.m.	0000-0400	9.77
HUNGARIAN	Budapest, Hungary	7-7:30 p.m.	0000-0030	6.235, 9.833, 11.91
		9-10 p.m.	0200-0300	6.235, 9.833, 11.91
ITALIAN	Rome, Italy	5:30-8 p.m.	2230-0100	9.63, 11.81
JAPANESE	Tokyo, Japan	7:15-7:30 a.m.	1215-1230	9.505
		8:30-9 p.m.	0130-0200	15.135, 15.235, 17.825
LITHUANIAN	Vilnius, U.S.S.R.	5:30-6:30 p.m.	2230-2330	7.29, 9.665
NORWEGIAN	Oslo, Norway	10-11:30 a.m.	1500-1630	17.825
		6-7:30 p.m.	2300-0030	9.61
PORTUGUESE	Lisbon, Portugal	7-9 p.m.	0000-0200	6.025, 6.185, 9.68
		9:45-11 p.m.	0245-0400	6.025, 6.185, 9.68
RUMANIAN	Bucharest, Rumania	6:15-7 p.m.	2315-0000	6.15, 9.57, 11.94
		10:30-11 p.m.	0330-0400	6.15, 9.57, 11.94
RUSSIAN	Moscow, U.S.S.R.	7 a.m.-1 p.m.	1200-1800	15.15, 17.78
		6:30-7 p.m.	2330-0000	7.15, 9.685
		8:30-9 p.m.	0130-0200	7.15, 9.685
SPANISH	Buenos Aires, Argentina	8-9 p.m.	0100-0200	9.69
		11-12 p.m.	0400-0500	9.69
	Havana, Cuba	6 a.m.-4 p.m.	1100-2100	6.135, 15.30
		5-11 p.m.	2200-0400	6.135, 11.93
	Quito, Ecuador	6-9 a.m.	1100-1400	9.745, 11.915, 15.115
		7:30-9 p.m.	0030-0200	9.745, 11.915, 15.115
SWEDISH	Stockholm, Sweden	8-8:30 p.m.	0100-0130	5.99
		11-11:30 p.m.	0400-0430	5.99
UKRAINIAN	Kiev, U.S.S.R.	6:30-7 p.m.	2330-0000	7.29, 9.665, 9.685
		7:30-8 p.m.	0030-0100	7.29, 9.685



SHORT-WAVE LISTENING

By HANK BENNETT, W2PNA / W2P7ST
Short Wave Editor

TUNING THE MEDIUM WAVES

ANOTHER DX season is under way, and many DX'ers will be concentrating on the medium-wave band (540-1600 kHz). The absence of summer static and the additional hours of darkness will enable many listeners to tune in overseas stations that were not heard during the warmer months. Also, broadcast-band-only receiver users will have a chance to log stations comparable, in some cases, to DX heard by short-wave listeners.

The AM broadcast-band listener should keep in mind that all broadcast stations in the U.S. and Canada operate on frequency separations of 10 kHz, starting at 520 kHz. Stations in Europe and other areas of the world operate with a 9-kHz separation. Thus, with luck, you may hear stations on

aire relay station on 800 kHz has been heard to within 35 miles of CKLW, Windsor, Ontario, Canada, which operates on the same frequency. Station HCJB, Quito, Ecuador, has been logged only 200 miles away from Cincinnati's WLW, with its 50,000-watt voice, on 700 kHz.

If you want to do some serious medium-wave DX'ing, tune for stations in countries south of the U.S.A. during the evening hours. The Europeans can often be heard in the late afternoon to early evening and again two or three hours before your local sunrise. DX'ers trying for stations in the Pacific and Far East areas should listen from about two hours before to two hours after local sunrise.

From Sunday evening to Monday morn-

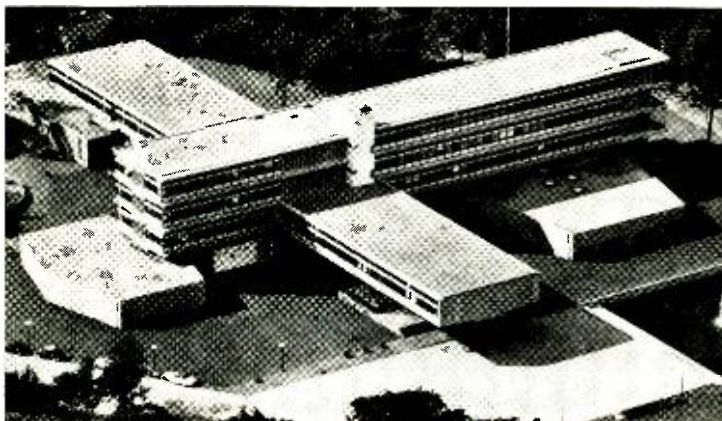

Housed in this modern building are the offices and studios of Radio Nederland, Hilversum, Holland. White star (left) pinpoints studio from which Eddie Startz conducts his well-known "Happy Station Program" on Sundays.

such odd frequencies as 566 kHz (Ireland), 647 kHz (England), 1043 kHz (East Germany), 1223 kHz (Sweden) or 1502 kHz (Poland). You won't find it easy to tune in these split-channel stations, however, unless you have a fairly selective receiver.

Stations in Central and South America will probably be coming through at times as well. Most of these stations operate on the same frequencies as the standard U.S. and Canadian stations although a few do operate on split channels. One of the easiest to log is *Radio Belize*, British Honduras, on 834 kHz. *Radio Nederland's* powerful Bon-

ing, local time, is generally considered best for DX'ing overseas BCB stations. Many of the North American stations are off the air then for servicing of their equipment, which can make a vast difference when you are trying to tune in a station operating on a split frequency between North American channels that are normally occupied by 24-hour-a-day broadcasters.

NASWA. The North American Shortwave Association (NASWA) recently celebrated its first anniversary as a strictly short-wave
(Continued on page 113)

ENGLISH-LANGUAGE BROADCASTS TO NORTH AMERICA

FOR THE MONTH OF NOVEMBER

Prepared by **BILL LEGGE**

TO EASTERN AND CENTRAL NORTH AMERICA				
TIME—PST	TIME—GMT	STATION AND LOCATION	FREQUENCIES (MHz)	
7:15 a.m.	1215	Melbourne, Australia	9.58, 11.71	
		Montreal, Canada	5.97, 11.72	
7:30 a.m.	1230	Stockholm, Sweden	15.24	
7:45 a.m.	1245	Copenhagen, Denmark	15.165	
6 p.m.	2300	London, England	6.11, 9.58, 11.78	
		Moscow, U.S.S.R.	7.15, 9.685	
6:45 p.m.	2345	Tokyo, Japan	15.135, 17.825	
7 p.m.	0000	Peking, China	15.06, 17.68	
		Sofia, Bulgaria	9.70	
		Tirana, Albania	7.263	
		Budapest, Hungary	6.235, 9.833, 11.91	
7:30 p.m.	0030	Johannesburg, South Africa	9.705, 11.97	
		Kiev, U.S.S.R. (Mon., Thurs., Sat.)	7.29, 9.685	
		Stockholm, Sweden	5.99	
		Vatican City	6.145, 7.27, 9.69	
7:50 p.m.	0050	Berlin, Germany	6.16, 9.73	
8 p.m.	0100	Havana, Cuba	6.17	
		Madrid, Spain	6.13, 9.76	
		Prague, Czechoslovakia	5.93, 7.115, 7.345	
		Rome, Italy	9.63, 11.81	
		Berne, Switzerland	6.12, 9.535, 11.715	
		Bucharest, Rumania	9.57, 11.94	
8:30 p.m.	0130	Cairo, U.A.R.	9.475	
		Cologne, Germany	9.64, 11.945	
		Hilversum, Holland	9.59 (Bonaire relay)	
		Copenhagen, Denmark	9.52	
		Lisbon, Portugal	6.025, 6.185, 9.68	
		Helsinki, Finland	9.585	
8:45 p.m.	0145	London, England	6.11, 7.13, 9.58	
		Moscow, U.S.S.R.	7.15, 7.205, 9.685	
		TO WESTERN NORTH AMERICA		
		TIME—PST	TIME—GMT	STATION AND LOCATION
7 a.m.	1500	Tokyo, Japan	9.505	
6 p.m.	0200	Melbourne, Australia	15.32, 17.84	
		Taipei, China	15.125, 17.72, 17.89	
		Tokyo, Japan	15.135, 15.235, 17.825	
6:30 p.m.	0230	Johannesburg, South Africa	9.705, 11.97	
7 p.m.	0300	Madrid, Spain	6.13, 9.76	
		Peking, China	9.457, 11.82, 15.095	
7:20 p.m.	0320	Yerevan, U.S.S.R. (Tues., Wed., Fri., Sat.)	11.755, 11.85	
7:30 p.m.	0330	Prague, Czechoslovakia	5.93, 7.115, 7.345	
		Stockholm, Sweden	11.705	
7:45 p.m.	0345	Berlin, Germany	6.16, 9.56	
8 p.m.	0400	Lisbon, Portugal	6.025, 6.185, 9.68	
		Moscow, U.S.S.R. (via Khabarovsk)	11.755, 11.85, 15.14	
		Peking, China	9.457, 11.82, 15.095	
8:30 p.m.	0430	Yerevan, U.S.S.R.	9.57, 11.94	
		Bucharest, Rumania	9.57, 11.94	
		Budapest, Hungary	6.235, 9.833, 11.91	
8:45 p.m.	0445	Cologne, Germany	9.735, 11.945	
9:15 p.m.	0515	Berne, Switzerland	6.12, 9.695	
10:30 p.m.	0630	Havana, Cuba	9.655	

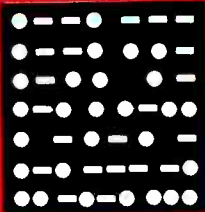

AMATEUR RADIO

By **HERB S. BRIER**, W9EGO
Amateur Radio Editor

UPCOMING CONTESTS

TRADITIONALLY, November offers two of amateur radio's major annual contests and a number of smaller ones. The big ones are the ARRL Sections Sweepstakes and the CQ World-Wide DX Contest. Here are the highlights.

ARRL Sections Sweepstakes. The 34th American Radio Relay League "SS" Contest will be held between 2100 GMT, Saturday, and 0300 GMT, Monday, November 11-13 (phone) and November 18-20 (CW). You use any of the authorized amateur frequencies to work and exchange "message preambles" with as many stations as you can in the United States and Canada. Each pre-

amble should contain the following information: contact number, station call-sign, signal report, ARRL section, GMT, operator's birthday (not the year of birth).

You earn a point for each preamble sent or received—a maximum of two points per station—and your final score is the sum of contact points multiplied by the number of sections worked, multiplied again by your power handicap. If your transmitter power is 150 watts or less, your power multiplier is 1.25 on CW and 1.5 on phone; for higher power, the multiplier is 1. Operating skill is more important than power in the "SS"; so most high scorers operate in the low-power bracket.

AMATEUR STATION OF THE MONTH



Milt Long, WA8LDR, of Wooster, Ohio, works 6 and 2 meters with Gonset transceivers and a Finco A62GMC beam antenna. For low-frequency MARS work, he uses a Johnson "Ranger-II" transmitter, a Hammarlund HQ-180A receiver, and a Hy-Gain 18-AVQ vertical antenna. Milt's main interest is Public Service. He is in Civil Defense, is President of the local Lions Club and Director of Communications for the Wayne County American Red Cross, and is a Major in the Army Reserve. WA8LDR will receive a one-year subscription for submitting the winner for November in our Amateur Station of the Month Photo Contest. To enter the contest, send a clear picture of your station with you at the controls and some details on the equipment you use and your ham career to Amateur Radio Photo Contest, c/o Herb S. Brier, Amateur Radio Editor, Box 678, Gary, Ind. 46401.

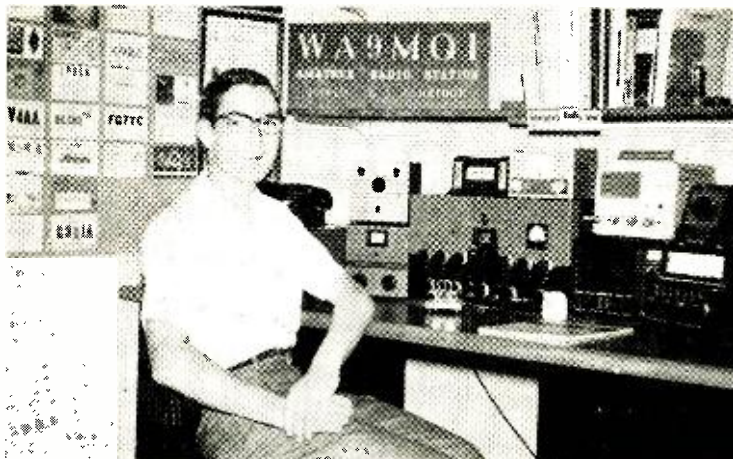

Dave Aldridge, WA9MQI, Indianapolis, Ind., likes to chase DX on CW and has 68 countries and a 30-wpm code certificate. He also works phone on all bands between 3.5 and 54 MHz.

High scorers in each section receive certificates of achievement; there are separate certificates for Novice winners. Write to the American Radio Relay League, Inc., 225 Main St., Newington, Conn. 06111, for Sweepstakes rules, ARRL section list, log sheets, and information on how to earn a 1000-point bonus.

CQ World-Wide DX Contest. The CW section of the CQ World-Wide DX Contest will be held between 0000 GMT, Saturday (Friday evening in the U.S.), November 25, and 2400 GMT, Sunday, November 26. You use any authorized amateur band to work as many DX stations as possible (each station may be worked once per band), exchanging signal reports and DX zone numbers with each station.

You can find your zone number in the *Radio Amateur Call Book*; or, better yet, write for a contest kit, which includes complete contest rules, a useful DX zone map, and official log sheets. Enclose a large, pre-addressed envelope with postage for two ounces with your request and send it to:



Bruce McNair, WB2NYK, Fords, N.J., works 80 to 10 meters CW and AM with a Knight-Kit T-150 transmitter. His favorite DX ing is done on 10-meter AM.

CQ World-Wide DX Contest, 14 Vanderventer Ave., Port Washington, L.I., N.Y. 11050.

If time permits, you might want to take a whirl at the phone section of the contest, October 21-22. The same rules apply.

Other Contests. On October 28-29, the Radio Society of Great Britain's 7-MHz Phone Contest will take place. Listen for the G's, GM's, etc., between 7.04 and 7.1 MHz



Pete Lipman, WN2YYL, De Witt, N.Y., says that all pictures of amateur stations look the same. Not his! Besides big feet, his shack features a Johnson "Adventurer" transmitter and a Hammerlund HQ-140X receiver. His record to date: 21 states worked.

and call them in the U.S. phone band. The CW half of the RSGB 7-MHz Contest is November 11-12; you will find most CW G's, etc., between 7.0 and 7.04 MHz.

Also from 0000 to 2400 GMT, November 12, is the Czechoslovakia International DX Contest (CW only). You work all countries except your own and send a signal report to

(Continued on page 111)

A MAJOR BREAKTHROUGH in semiconductor technology has once again proven that old adage . . . if at first you don't succeed, try, try again! Some time ago, theoretical studies predicted that a field-effect transistor (FET) using gallium arsenide (GaAs) alloy as its substrate should be superior to silicon-based units. But the mathematical analysis didn't show how to make such a device. For more than a decade scientists and engineers tried to produce practical GaAs transistors but, until a few months ago, they had little success.

With an eye towards possible military applications, the U.S. Air Force contracted with RCA's Princeton Research Laboratories to develop an operable and reproducible GaAs FET. As is common in such contracts, a definite "cut-off" date was included in the terms. Periodic reviews of the progress indicated that there wasn't any, despite concentrated efforts on the part of the research facility's top engineers. The Air Force finally allowed the contract to lapse.

But RCA's scientists kept working on the problem and—just a few months after the Air Force contract expired—realized that oxygen contamination of the substrate material might be a source of trouble. They hit upon the idea of using silicon nitride (SiN) rather than the more common silicon dioxide (SiO₂) as an insulating layer when fabricating the device. It worked!

The basic structure of the perfected GaAs *n*-channel insulated-gate field-effect transistor is shown in Fig. 1. The base material is

p-type GaAs, with its thin top layer doped by a modified vapor diffusion process to have *n*-type characteristics. Insulating layers of silicon nitride (SiN) and, finally, a sealing layer of silicon dioxide (SiO₂) are formed in a suitable pattern over the basic device and metallic contacts are then applied.

From a performance viewpoint, the new GaAs IGFET (insulated-gate FET) has a considerably higher transconductance at ultra-high frequencies than similar silicon devices and, in addition, can maintain its performance at much higher operating temperatures. It probably will be a number of months before GaAs transistors are available commercially, but with the basic fabrication problems solved, you may be able to obtain these superior devices before the end of 1968.

Solid-State Circuit Breaker. One of the big problems with fuses is that once they "work," they have to be physically replaced. When a circuit breaker opens, it has to be physically reset. Both of these factors can present quite a problem in a spacecraft. To circumvent this headache, NASA has now produced a solid-state circuit breaker called the "Thomas Fuse" which will temporarily disconnect a circuit during overload. The device is composed of a special epoxy resin impregnated with particles of metal. At normal operating temperatures, the metal particles are in contact and the resistance of the fuse is about 0.1 ohm. As the temperature increases, the epoxy expands, thus separating the metal particles and opening the circuit. Open resistance is about one megohm. When the fuse cools down, metallic contact is again resumed and the fuse closes.

The fuse cannot be physically damaged and it can be molded into any shape or size; in fact, it is even possible to make the actual interconnecting wiring out of this material. The operating temperature is a function of the epoxy-metal ratio.

Commercial applications appear almost unlimited. For example, the fuse could be molded into a screw and embedded in an automobile engine block for use as a low-cost thermostat. Or, it could be molded into all manner of fire detectors.

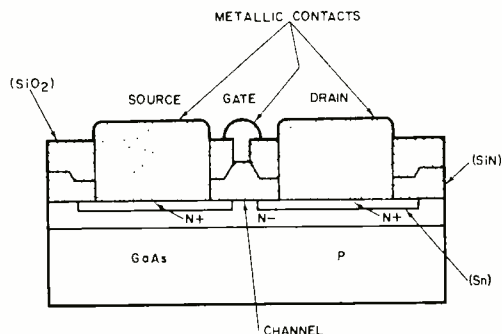

Fig. 1. The GaAs transistor—first of the new generation of FET's with much improved characteristics.

Reader's Circuits. Suitable for a variety of applications in the home, shop and office, or as a basis for a Science Fair project, the simple control circuits illustrated in Fig. 2 were submitted by reader William Shaw (19733 Denby, Detroit, Mich. 48240). One control circuit uses an SCR, the other a pair of transistors. They are inexpensive, non-critical components, and the projects can be assembled in a single evening.

Bill uses a low-voltage SCR—see Fig. 2(a)—to operate a relay which, in turn, switches an external circuit. In operation,

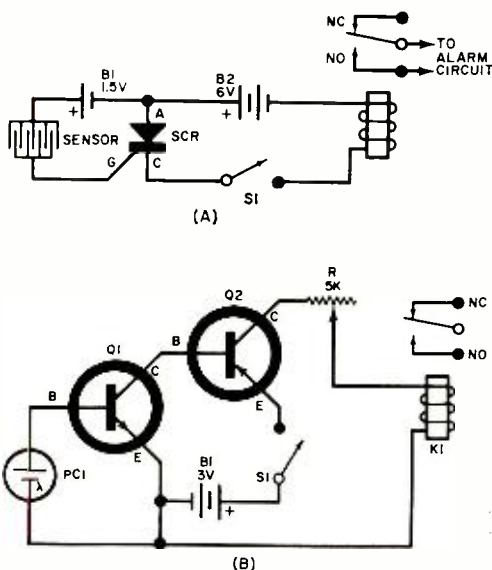

Fig. 2. Two circuits by Bill Shaw: (A) rain detector using low-voltage SCR; (B) two-transistor switch that operates when photocell is illuminated by a light.

B1 serves as the gate bias source, and *B2* as the anode power source. The sensor can be any of a variety of devices, including a microswitch, moisture sensor plate, reed switch, thermostat, thermistor or variable resistor, depending on the intended application. The SCR is normally in a high-resistance state and the relay is open. If the sensor is actuated—as by a rain drop falling on a moisture sensor plate, for example—gate bias is applied to the SCR, and this device switches to its low resistance (conducting) state, operating the relay.

Once triggered, the SCR continues to conduct even if the initial signal is removed. The relay remains closed, then, until the SCR's anode current is interrupted momentarily by opening the main power switch, *S1*, thus providing a "latch-type" operation requiring deliberate reset.

Bill employs an Olson RE-114 SCR in his model and an ordinary 6-volt d.c.,

s.p.d.t. relay. A GE X5 should be an acceptable substitute for the RE-114 and either a P&B RSSD or a Calectro 3-566P relay can be used.

In contrast to the SCR control, the transistor circuit shown in Fig. 2(b) operates *only* when a signal is applied to its sensing device. The design includes a photocell sensor, *PC1*, a two-stage direct-coupled complementary amplifier, *Q1-Q2*, a small relay, and a power supply.

In operation, light striking the photoelectric cell generates a small voltage which is applied to *Q1*'s base-emitter circuit. This bias current causes a corresponding, but amplified, increase in *Q1*'s collector current and, therefore, in *Q2*'s base current. Transistor *Q2* provides additional amplification, with its output current actuating the relay, which serves as a collector load. Series variable resistor *R1* is the sensitivity control.

Again, conventional parts are used: *PC1* is an International Rectifier B2M sun battery, *Q1* a general-purpose *npn* transistor such as a 2N35, 2N170 or TR-09, while *Q2* is a low-power *pnp* unit such as a 2N107, 2N109 or TR-05. Potentiometer *R1* is a 5000-ohm linear unit. The relay is a Lafayette "Little Jewel," and *B1* consists of two penlight cells connected in series to supply 3 volts.

Neither wiring nor parts arrangement is critical in either circuit. You can use chassis, perforated board, or etched circuit assembly methods, as preferred. A small metal box, plastic case, or small cigar box can serve as a cabinet. With either circuit, the relay contacts switch on an external device, such as a lamp, bell, buzzer, solenoid, fan, heating element, or motor, depending on the specific application.

As a general rule, the SCR control circuit would be used where "latch-on manual-reset" operation is needed, as, for example, in burglar, fire and rain alarms. The transistor control circuit, on the other hand, is intended for such applications as a remote control "commercial killer," a doorway annunciator, an automatic counter, a safety control for power tools, or as an automatic light switch. The only real limit on the applications of either circuit lies in the ingenuity of the user.

Manufacturer's Circuit. One of the circuits featured in the booklet included with Motorola's HANDYLab®, the 1-kHz RC audio oscillator shown in Fig. 3 can serve as a source for signal injection tests of audio equipment, as a CPO, as a modulation source for r.f. signal generators, as an a.c. test source for impedance bridges, as a tone generator for electronic musical instruments, or in virtually any application requiring a

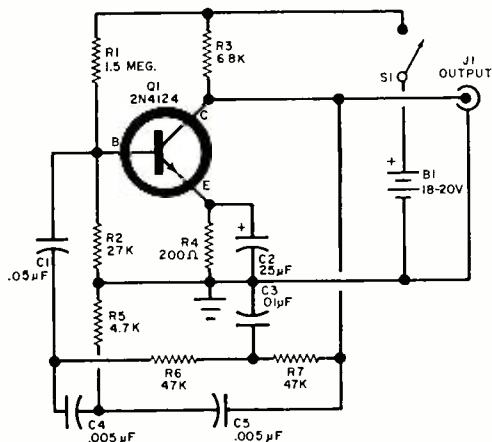

Fig. 3. Motorola suggests using this 1-kHz, twin-T audio oscillator as a clean sine-wave source for any application requiring a fixed-frequency signal.

fixed frequency audio signal. Among the other circuits included in the booklet are a UHF oscillator, an audio test oscillator, a multivibrator, a limiter/discriminator, and a complementary audio amplifier.

Incidentally, the HANDYLab itself is an exceptional "buy" for the serious experimenter and hobbyist. Although originally introduced as an item for industrial engineers, the HANDYLab is now available to anyone through all franchised Motorola distributors. It includes 25 each of 12 different general-purpose plastic transistors (both *pnp* and *nnp* types) and dual diodes—300 devices in all—yet sells for only \$49.50, including a 6-drawer, 31½" x 9¾" plastic cabinet and the circuit booklet. If you're quick with a slip-stick, you'll find that this figures out to only 16½ cents per device—NOT manufacturer's surplus, obsolete types, unmarked units, or off-tolerance rejects!

As shown in the schematic diagram of the audio oscillator, *nnp* transistor Q1 is used in the common-emitter configuration. Base bias is established by voltage-divider R1-R2 in conjunction with emitter resistor R4, bypassed by C2, while R3 serves as the collector load. The in-phase feedback needed to start and maintain oscillation is furnished through a Twin-T RC network, with R6-C3-R7 forming one branch of the "T," and C4-R5-C5 forming the other branch, and finally, C1 acting as a coupling capacitor. The circuit's frequency of operation is determined by the R and C values in the Twin-T network. Operating power is furnished by an 18- to 20-volt d.c. source, B1, controlled by s.p.s.t. switch S1.

Readily available components are used in the design. Transistor Q1 is a 2N4124. All resistors are half-watt types, although, for

best results, R5, R6, and R7 should have 5% tolerance. Capacitors C1, C3, C4, and C5 are paper or ceramic types, while C2 is a 25-volt electrolytic. The power source can be either a line-operated d.c. power supply or a pair of 9-volt batteries connected in series.

Neither layout nor lead dress is overly critical and, therefore, any conventional construction technique can be used in assembling a duplicate circuit. However, if you plan to use the circuit as a self-contained oscillator, you may prefer perforated or etched circuit board construction.

If desired, the circuit's output frequency can be changed by applying the following approximate design formulas and changing the appropriate R and C values accordingly: $f_o \approx 0.26 (1/R6C4)$ when $C3 = 2C4$, $R6 = 10R5$, and $C1 = 10C4$. If operation with a positive (to ground) source voltage is preferred, simply reverse C2's polarity and use a 2N4126 transistor.

Cordless Phones. Nearly every home and office has a telephone, and many have one or more extension phones. But all the units share two common limitations: dangling cords and limited areas in which they can be used.

How about an extension telephone that can be used anywhere? While working in the yard . . . in the garage . . . out by the backyard pool . . . or while participating in a lawn party or outdoor barbecue.

Don't scoff—it's not a wild idea from a futuristic TV spy thriller, nor a science-fiction story. It is, in one sense, "just around the corner," for Bell Telephone Laboratories is now conducting tests on an experimental cordless extension telephone.

The new unit is unlike push-to-talk walkie-talkies in that it provides simultaneous two-way conversation, as well as line connection and disconnect, dialing, and ringing. Designed to be carried on a belt or in an overcoat pocket, the telephone connects with the regular telephone network via a radio link to a local fixed station. The experimental model has a range of from 100 to 1500 feet from the fixed station, depending upon local conditions.

The test model is a 31-ounce, 9-inch long, solid-state, battery-powered unit which looks somewhat like the Bell System's popular "Trimline" handset, but eventual commercial models are likely to be substantially smaller and lighter.

The base station used with the cordless phone can be mounted on a wall, in a closet, or at a similar convenient location. It connects to the regular telephone line and is powered through an ordinary a.c. outlet.

That closes out our *Solid State* story for this month. Until December . . .

—Lou

The "40-Pole"

SIMPLE 40-METER
VERTICAL MONOPOLE
TUNES EITHER HAM OR
SWL 41-METER DX BANDS

A TRI-BAND ANTENNA is fine for working DX on the 10-, 15-, and 20-meter bands, but you need a separate antenna for the 40-meter band. The extra antenna need not be elaborate or expensive; in fact, you can make one in 30 minutes with essentially a 1:1 standing wave ratio (SWR) for less than a dollar. If you wish, you can also use the new antenna for the 41-meter short-wave international broadcast band.

The "40-Pole" is a 40-meter vertical monopole antenna. It is fashioned from conventional 300-ohm twin-lead cable. The finished antenna is lightweight, so it can be supported by simple hardware.

To construct the "40-Pole," simply ground one of the twin leads (see drawing at right), terminate the other lead with 52-ohm coaxial cable, and short together the leads at the upper end of the twin-lead cable. This done, the antenna is ready for mounting on a tower if you have one, or on the side of your house—if the house is tall enough.

For best results, the antenna must be vertical. The drawing shows how this can be done if you have a tower—a similar type of arrangement would be used for side-of-the-house mounting. The 1'-long dowels serve as stand-offs, but they should be mounted rigidly enough to serve as supports also. Otherwise, use some nylon cord to support the antenna as shown.

If you tower-mount the antenna, no ground radials are needed provided that the tower is well grounded and the shield of the coax cable is connected directly to the tower base at ground level. Of course, if you don't have a tower, or if your tower is not adequately grounded for r.f., ground radials are a necessity.

The very low SWR is attributable to the impedance step-up of the folded antenna element. The feed impedance of a vertical antenna is usually on the order of 10 to 15 ohms, and multiplying by 4 (for a 4:1 impedance step-up) puts the impedance between 40 and 60 ohms—thus neatly bracketing the 52-ohm impedance of the RG-8/U coaxial line for

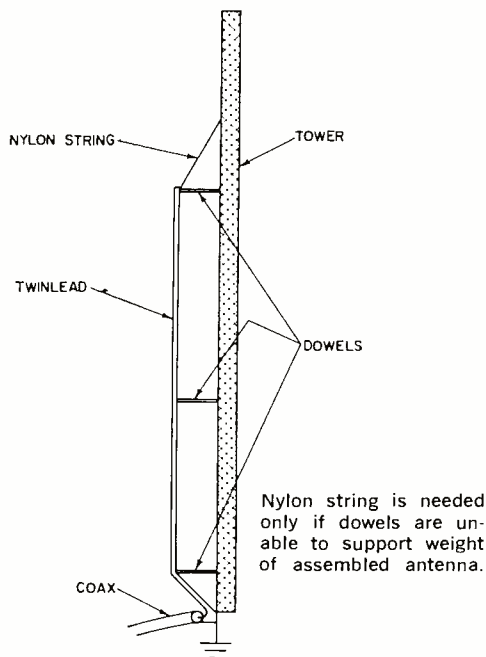

an almost perfect transmission line-to-antenna match.

Proximity of the tower has little effect on the length or performance of the "40-Pole." The length of the antenna is determined by dividing 234 by the frequency in MHz. If the antenna were to be cut to a frequency of 7.010 MHz, the length would be 33' 4½". Since the "40-Pole" is fairly broadband, cutting it to 7.150 MHz (approximately 32' 9") will allow coverage of the entire 40-meter band.

The results obtained with the "40-Pole" prototype have proved very satisfactory. You should be able to work all continents with a 100-watt transceiver, and even contact some of the rare DX stations that operate exclusively on 40 meters. The SWL will find that a vertical antenna is fine for DX'ing the 41-meter international broadcast band where the omnidirectional pattern is a great asset. —Robert N. Tellefsen, WOKMF

Put FM in Your Car

USE LOW-COST FM PORTABLE
FOR HI-FI ON THE ROAD

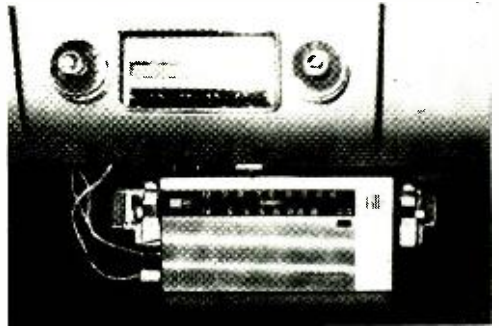

YOU CAN ENJOY all the programs on the FM broadcast band without paying a premium price for a new mobile FM radio or sacrificing your car's present AM radio. By installing a \$20-or-less FM or AM-FM transistor portable under the dashboard and piping it through the audio section of your AM radio, you save anywhere from \$30 to \$50.

If the connections are properly made, volume level and tone from both radios can be controlled through the AM radio. All you do to the FM radio when you get into your car is turn it on and set the volume level for distortionless sound through the AM radio.

The installation described here is not permanent. If you want to remove the FM radio and take it on hunting or fishing trips, to ball games, or just listen to it at home, you can do so in a few minutes.

The connections shown below represent the simplest approach to connecting a second radio to the one now in your car. The materials needed are a d.p.d.t.

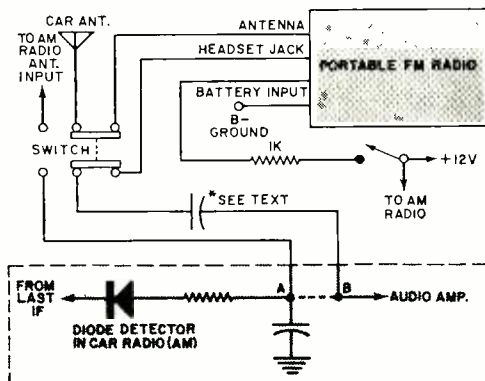

switch, a capacitor, a resistor, several cables and connectors, and a few pieces of hardware.

The switch must be wired to complete the AM circuit and connect the car's antenna to the AM radio in one position. In the other position, the switch routes the audio signal from the FM radio ear-phone jack into the AM radio's audio section and connects the antenna to the FM radio.

Power for the portable FM radio can be furnished by your car's electrical system or the battery already in the radio.

You can install the set in a single evening. First decide where you want to mount the switch and portable radio. Then remove the AM radio from the dashboard in your car, and look for the diode detector stage. This stage is located immediately after the last i.f. transformer (shown inside the dashed line box in the schematic). Cut the "signal" line at the output of the detector diode as indicated by the dashed line between points A and B.

Solder one lead of a coupling capacitor (any value between 0.01 μ F and about 1.0 μ F will do) to point B. Now connect appropriate-length stranded hookup wires to the free lead of the capacitor and point A, twist the wires together, and route them through a hole in the radio's case. Mount the radio back in the dashboard.

Wire the switch, using the schematic diagram as a guide. When connecting the coaxial cables to the antenna side of the

The d.p.d.t. switch selects AM or FM mode of operation and routes the car antenna to proper radio.

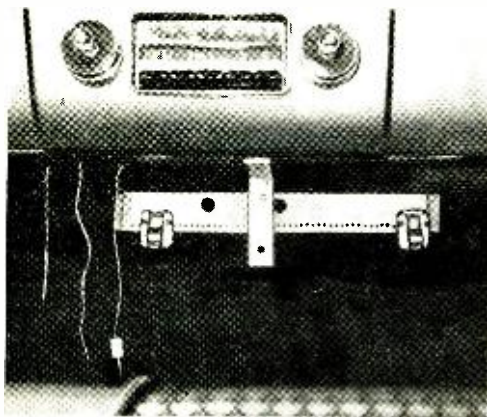

The FM radio mounting bracket can be conveniently bolted to underside of dash, just below AM radio.

switch, solder only the center conductors to the switch lugs. Then twist the mesh shields together and connect them to chassis ground *via* one of the switch mounting screws.

For a 12-volt, negative-ground electri-

cal system, connect a 1000-ohm, 1-watt resistor in series with the set's positive lead, and ground the negative lead. For 6-volt electrical systems, use the radio's regular battery supply.

The mounting bracket for the FM radio need not be as elaborate as the one shown at left. A simple L-shaped bracket and suitable clips to hold the radio firmly in place will suffice. After fashioning the bracket, glue several pieces of felt or rubber to the bracket to prevent marring of the radio's plastic case.

Mount the bracket in place, and clip the radio to it. Finally, use the correct types of cable connectors to plug the various cables into the FM radio.

That's all there is to it. You now have FM in your car for not much more than you would expect to pay for the installation of a new mobile FM radio, yet you have all the convenience of a carry-all portable.

—David J. Sweeney

Build The R-Matcher

THE "R-MATCHER" will allow you to compare, or match, resistance values with almost laboratory precision. It is accurate to within a fraction of an ohm from 1000 to 100,000 ohms, and on other resistances ranges well within the 1% generally specified for matched resistor pairs.

The circuit of the "R-Matcher" is essentially that of a Wheatstone bridge. Assuming that it is correctly balanced (switch *S1* depressed), a test resistor

connected between binding posts *BP1* and *BP2*, and another resistor from *BP3* to *BP4*, will cause meter *M1* to deflect if the values of the two resistors are not identical.

Initially, the device must be calibrated. Leave *BP1* through *BP4* open-circuited, and use a VOM or VTVM to measure the voltage drops from point *B* to point *A* and then point *C* while adjusting potentiometer *R2*. The unit is calibrated, or balanced, when the voltage drops on both sides of point *B* are exactly the same. Do not touch *R2* from this point on.

To use the "R-Matcher," connect the test resistors as explained above, set potentiometer *R1* for maximum resistance, and depress the switch. If no deflection is readable on *M1*, slowly reduce the setting of *R1* until there is a deflection, or until the setting is at a minimum. No deflection of *M1*'s pointer when *R1* is set to minimum resistance means both resistors are exactly matched; any deflection—no matter how slight—indicates that the resistors are not perfectly matched.

—Frank H. Tooker

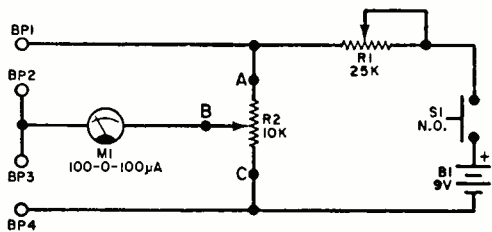

The circuit is essentially a Wheatstone bridge. Potentiometer *R2* must be set for the same voltage drop on both sides of point *B*; *R1* simply functions as a sensitivity control. Resistors to be matched are connected to *BP1*-*BP2* and *BP3*-*BP4*, respectively.

What In The World's Going On? Find Out With A Heathkit® SWL Radio

NEW! Professional 10-Band Shortwave Receiver... Slices Stations Down To The Last kHz

Covers 6 shortwave bands (49, 31, 25, 19 & 16 meters) . . . 80, 40 and 20 meter ham bands . . . 11 meter CB. Includes 5 kHz crystal filter for AM, SSB and CW listening. 1 kHz dial calibrations — 100 kHz per dial revolution . . . no more guessing station frequencies. Crystal-controlled front-end for same rate tuning on all bands. Prebuilt & aligned Linear Master Oscillator. Tuning dial to knob ratio 4 to 1. Calibrated "S" meter. Automatic noise limiter. Separate RF and AF gain controls. Headphone jack. Non-backlash vernier tuning dial. "Sub-pack" packaging for easy 20-hour kit assembly. Modern "low-boy" cabinet styling, plus many more "pro" SWL features. Optional crystal filters for optimum CW & SSB available.

Kit SB-310, 20 lbs. . . . no money dn., \$23 mo. **\$249.00**



Kit SB-310
\$249⁰⁰
\$23 mo.

(SB-600 8 ohm, 6" x 9" speaker \$18.95)

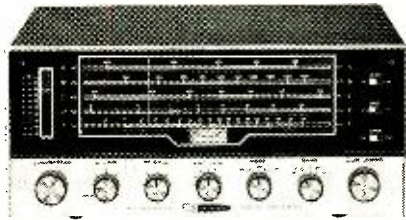

Kit GR-54
\$87⁹⁵
\$9 mo.

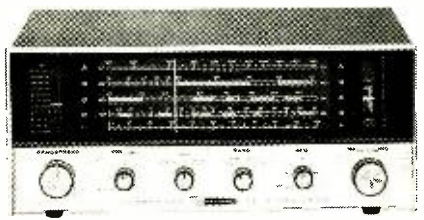

Kit GR-64
\$39⁹⁵
\$5 mo.

For The Seasoned SWL... Deluxe 5-Band Shortwave Receiver

Features 5 bands . . . 3 shortwave bands cover 2 MHz to 30 MHz, plus AM broadcast and 180 kHz to 420 kHz aeronautical & radio navigation bands. Tuned RF stage. Crystal filter for sharp selectivity. Separate product detector for SSB & CW. 6 diode, 6 tube superhet circuit. 4" x 6" speaker. Built-in code practice monitor. Switchable BFO, metal cabinet and more. Includes FREE SWL antenna.

Kit GR-54, 25 lbs. . . . no money dn., \$9 mo. **\$87.95**

Low-Cost 4-Band AM/Shortwave Receiver

Hear "live" broadcasts from around the globe, ham operators, Voice of America, ship-to-shore, CW, plus local AM on this single receiver. 4 bands . . . 3 shortwave bands cover 1 MHz to 30 MHz, plus AM broadcast. 5" speaker for crisp, bold sound. 7" slide-rule dial with logging scale. Lighted bandspread tuning dial. Relative signal strength indicator. BFO control. Headphone jack. Metal cabinet and more.

Kit GR-64, 15 lbs. . . . no money dn., \$5 mo. **\$39.95**

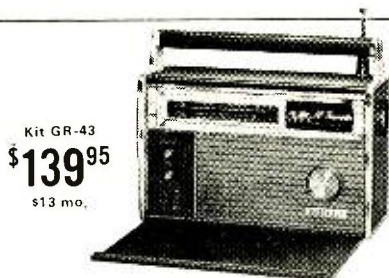

Kit GR-43
\$139⁹⁵
\$13 mo.

Deluxe 10-Band AM/FM/Shortwave Transistor Portable

10 bands tune Longwave, AM, FM and 2 MHz to 22.5 MHz shortwave. Separate AM & FM tuners and IF strips. 16 transistors, 6 diodes and 44 factory assembled and pretuned circuits. 4" x 6" speaker. Earphone, time zone map, listener's guide. Build in about 10 hours. Optional converter/charger for AC operation \$6.95.

Kit GR-43, 19 lbs. . . . no money dn., \$13 mo. **\$139.95**

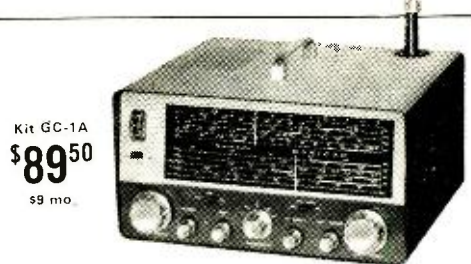

Kit GC-1A
\$89⁵⁰
\$9 mo.

Last Call For The "Mohican" Portable 5-Band Shortwave Receiver

Tunes 550 kHz to 32 MHz in 5 bands. Fixed-aligned IF ceramic "transmitters" for best selectivity. Self-contained for portability, yet can run on 117 v. AC with optional power supply @ \$9.95. 10 transistor, 6 diode circuit. Slide-rule dial, "S" meter, BFO control, electrical bandspread, 4" x 6" speaker, headphone jack, metal cabinet and more.

Kit GC-1A, 18 lbs. . . . no money dn., \$9 mo. **\$89.50**

Turn Page For More Heathkit Values!

CIRCLE NO. 19 ON READER SERVICE PAGE

Instant Gift-Solving Guide From Heath...

Now There Are 3 Heathkit Color TV's To Choose From

Introducing The NEW Deluxe Heathkit "227" Color TV

Exclusive Heathkit Self-Servicing Features. Like the famous Heathkit "295" and "180" color TV's, the new Heathkit "227" features a built-in dot generator plus full color photos and simple instructions so you can set-up, converge and maintain the best color pictures at all times. Add to this the detailed trouble-shooting charts in the manual, and you put an end to costly TV service calls for periodic picture convergence and minor repairs. No other brand of color TV has this money-saving self-servicing feature.

Advanced Performance Features. Boasts new RCA Perma-Chrome picture tube with 227 sq. in. rectangular viewing area for 40% brighter pictures... 24,000 v. regulated picture power and improved "rare earth" phosphors for more brilliant, livelier colors... new improved low voltage power supply with boosted B+ for best operation... automatic degaussing combined with exclusive Heath Magna-Shield that "cleans" the picture every-time you turn the set on from a "cold" start, and keeps colors pure and clean regardless of set movement or placement... automatic color control and gated automatic gain control to reduce color fade and insure steady, flutter-free pictures even under adverse conditions... preassembled & aligned 3-stage IF... preassembled & aligned 2-speed transistor UHF tuner and deluxe VHF turret tuner with "memory" fine tuning... 300 & 75 ohm VHF antenna inputs... two hi-fi sound outputs... 4" x 6" 8 ohm speaker... one-piece mask and control panel for simple installation in a wall, your custom cabinet or either optional Heath factory-assembled cabinets. Build in 25 hours.

- Kit GR-227**, (everything except cabinet) \$419.95
 ... \$42 dn., as low as \$25 mo.
- GRA-227-1**, Walnut cabinet... no money dn., \$6 mo. \$59.95
- GRA-227-2**, Mediterranean Oak cabinet (shown above),
 ... no money dn., \$10 mo. \$94.50



Kit GR-227
\$419.95

(less cabinet)
 \$25 mo.

Kit GRA-27
\$19.95



New Remote Control For Heathkit Color TV

Now change channels and turn your Heathkit color TV off and on from the comfort of your armchair with this new remote control kit. Use with Heathkit GR-227, GR-295 and GR-180 color TV's. Includes 20' cable.



Kit GR-295
\$479.95

(less cabinet)
 \$42 mo.

Deluxe Heathkit "295" Color TV

Has same high performance features and built-in servicing facilities as new GR-227, except for 295 sq. in. viewing area (industry's largest picture)... 25,000 volt picture power... universal main control panel for versatile in-wall installation... and 6" x 9" speaker.

- Kit GR-295**, (everything except cabinet), 131 lbs.... \$479.95
 \$48 dn., \$42 mo.
- GRA-295-1**, Walnut cabinet (shown above), 35 lbs....
 no money dn., \$7 mo. \$62.95
- Other cabinets from \$94.50



Kit GR-180
\$349.95

(less cabinet & cart)
 \$30 mo.

Deluxe Heathkit "180" Color TV

Same high performance features and exclusive self-servicing facilities as new GR-227 (above) except for 180 sq. in. viewing area.

- Kit GR-180**, (everything except cabinet), 102 lbs.... \$35 dn., \$30 mo. \$349.95
- GRA-180-5**, table model cabinet & mobile cart (shown above), 57 lbs.... no money dn., \$5 mo. \$39.95
- Other cabinets from \$24.95

Deluxe 12" Transistor Portable B&W TV - First Kit With Integrated Circuit

Unusually sensitive performance. Plays anywhere... runs on household 117 v. AC; any 12 v. battery, or optional rechargeable battery pack (\$39.95); receives all channels; new integrated sound circuit replaces 39 components; preassembled, prealigned tuners; high gain IF strip; Gated AGC for steady, jitter-free pictures; front-panel mounted speaker; assembles in only 10 hours. Rugged high impact plastic cabinet measures a compact 11 1/2" H x 15 1/2" W x 9 3/4" D. 27 lbs.

Kit GR-104
\$119.95
 \$11 mo.

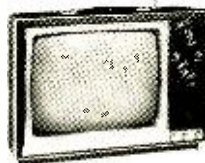

Kit GR-104, 27 lbs.... no money dn.,
 \$11 mo. \$119.95

No Money Down On \$25 to \$300 Orders — Write For Credit Form

Turn Page For 11 More Solutions

Enjoy The Sounds Of Christmas With A Heathkit Stereo System

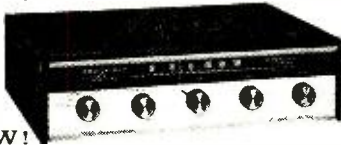

Kit AR-17
\$72⁹⁵
(less cabinet)
\$8 mo.

NEW! Lowest Cost Solid-State Stereo Receiver

Features wide 18-60,000 Hz response to -1 db at full 5 watts RMS power per channel... 14 watts music power... inputs for phono and auxiliary... automatic stereo indicator... outputs for 4 thru 16 ohm speakers... adjustable phase for best stereo... flysheed tuning... and compact 9 1/2" D x 2 7/8" H x 11 3/4" W size, 12 lbs. Optional factory assembled cabinets (walnut \$7.95, beige metal \$3.50).

Kit AR-17, (less cab.) 12 lbs... no money dn., \$8 mo. **\$72.95**

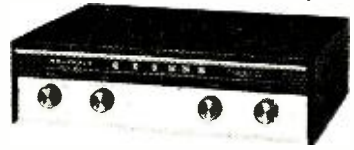

Kit AR-27
\$49⁹⁵
(less cabinet)
\$5 mo.

NEW! Low Cost Solid-State FM Mono Receiver

Features cool, solid-state circuit... 7 watts music, 5 watts RMS power... 18 to 60,000 Hz response to -1 db... inputs for phono and auxiliary... outputs for 4 thru 16 ohm speakers... flysheed tuning... front panel controls... pre-assembled & aligned FM front-end... and 9 1/2" D x 2 7/8" H x 11 3/4" W, bookshelf size, 9 lbs. Optional Heath factory assembled cabinets (walnut veneer \$7.95, beige metal \$3.50).

Kit AR-27, (less cab.) 9 lbs... no money dn., \$5 mo. **\$49.95**



Kit AR-15
\$329⁹⁵
(less cabinet)
\$28 mo.
Assembled ARW-15
\$499⁵⁰
(less cabinet)
\$43 mo.

World's Most Advanced Stereo Receiver ... Choose Kit Or Factory Assembled

Acclaimed by owners & audio experts for its advanced features like integrated circuits and crystal filters in the IF amplifier section; ultra-sensitive FET FM tuner; 150 watts dynamic music power; complete AM, FM and FM stereo listening; positive circuit protection; all-silicon transistors; "black magic" panel lighting; stereo only switch; adjustable phase control for best stereo and many more. 34 lbs. Optional wrap-around walnut cabinet \$19.95.

Kit AR-15 (less cab.), 34 lbs... \$33 dn., \$28 mo. **\$329.95**

Assembled ARW-15, (less cab.), 34 lbs... \$50 dn., \$43 mo. **\$499.50**

NEW! Heathkit Stereo Headphone Control Box



Kit AC-17
\$7⁹⁵

Now enjoy the convenience of switching from speaker to private headphone listening without leaving the comfort of your favorite chair. Connects to any headphone regardless of power, and has standard jacks to accommodate two sets of any impedance, 3 or 4 connector, stereo or mono headset. Tandem volume and balance controls. About the size of a pack of cigarettes. Includes 20' cable.

Kit AC-17, 3 lbs. **\$7.95**

NEW! Exclusive Heath Hi-Fi Furniture... Fully Assembled And Finished

Contemporary Walnut Stereo/Hi-Fi Cabinet Ensemble Complements Modern Furnishings

Masterfully crafted of fine veneers and solids with walnut finish. Statuary Bronze handles. Equipment cabinet features adjustable shelves to accommodate all makes of hi-fi components, record storage or tape recorder compartment, turntable compartment. Speaker cabinet features special Tubular-Duct Reflex design for matching 8" or 12" speakers, plus slot for a horn tweeter.

Model AE-37, equipment cabinet... **\$125.00**

no money dn., \$12 mo.

Model AEA-37-1, speaker cabinet... **\$59.50**

no money dn., \$6 mo. each

Early American Stereo/Hi-Fi Cabinet Ensemble

Early American richness with modern component layout. Constructed of specially-selected solids and veneers finished in popular Salem-Maple. Statuary Bronze handles. Equipment cabinet has adjustable shelves to accommodate any make hi-fi component, record storage or tape recorder compartment, turntable compartment. Speaker cabinet can be matched to any 8" or 12" speaker... has slot for horn tweeter.

Model AE-47, equipment cabinet... **\$135.00**

no money dn., \$13 mo.

Model AEA-47-1, speaker cabinet... **\$64.50**

no money dn., \$7 mo. each

Mediterranean Pecan Stereo/Hi-Fi Cabinet Ensemble

Beautifully constructed of fine furniture solids and veneers with Pecan finish. Statuary Bronze handles. Equipment cabinet has adjustable shelves to house any make hi-fi component, record storage or tape recorder compartment, turntable compartment. Speaker cabinet can be matched to any 8" or 12" speaker... has slot for horn tweeter.

Model AE-57, equipment cabinet... **\$150.00**

no money dn., \$14 mo.

Model AEA-57-1, speaker cabinet... **\$74.50**

no money dn., \$8 mo. each

Complete Ensemble
\$244⁰⁰



Complete Ensemble
\$264⁰⁰

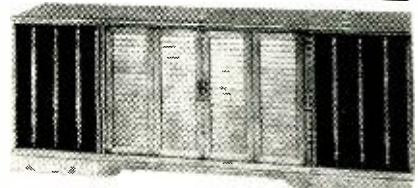

Complete Ensemble
\$299⁰⁰



CIRCLE NO. 19 ON READER SERVICE PAGE

Enjoy Widest Kit Selection, Easy Credit,

"Starmaker" Dual-Channel Solid-State Guitar Amplifier



Features 25 watts EIA, 60 watts peak power; two channels, each with two inputs; handles lead guitar, singer's mike; tremolo & reverb; two 12" speakers; line bypass reversing switch for hum reduction; foot switches; black vinyl-covered wood cabinet with aluminum front panel & chrome knobs. 52 lbs.

Kit TA-16 **\$134⁹⁵**
\$13 mo.

Assembled TAW-16 **\$199⁹⁵**
\$19 mo.

NEW! Single-Channel Solid-State Guitar Amplifier



Compare To Amps Costing \$175 & More! Boasts 20 watts EIA, 40 watts peak power; tremolo & reverb; two inputs for lead guitars, singer's mike; 12" speaker; line bypass reversing switch to reduce hum; foot switches; transformer power supply; black vinyl-covered wood cabinet with aluminum front panel & chrome knobs. 35 lbs.

Kit TA-27 **\$89⁹⁵**
\$9 mo.

Assembled TAW-27 **\$134⁹⁵**
\$13 mo.

NEW! Deluxe Solid-State Combo Amplifier & Speaker System ... Choose Kit Or Factory Assembled

Kit TA-17
Amplifier
\$175⁰⁰

\$17 mo.
(Wired TAW-17, \$275)

Kit TA-17-1
Speaker System
\$120⁰⁰

\$11 mo.
(Wired TAW-17-1, \$150)

Kit TAS-17-2
Special Combination Offer!
2 Speaker Systems &
Amplifier
Save \$20

\$395⁰⁰

\$40 dn.
\$34 mo.
(Wired TAW-17-2, \$545)

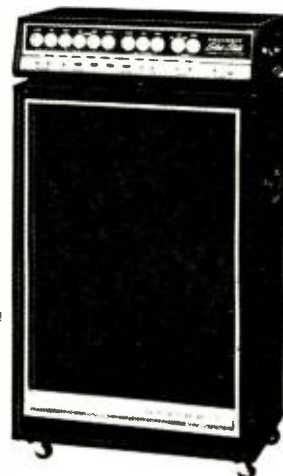

All the "big sound" features every combo wants . . . tremolo, built-in "fuzz", brightness, reverb, separate bass and treble boost and more. Delivers a shattering 120 watts EIA music power (240 watts peak power) through two TA-17-1 speakers . . . or 90 watts through one TA-17-1 speaker. Features 3 independent input channels, each with two inputs. Handles lead or bass guitars, combo organ, accordion, singer's mike, or even a record changer. All front panel controls keep you in full command of all the action.

Speaker system features two 12" woofers, special horn driver and matching black vinyl-covered wood cabinet with casters & handles for easy mobility.

Save Up To \$500 On This Heathkit® / Thomas "Paramount" Transistor Theatre Organ



Kit TO-67
\$995⁰⁰
(including bench)
Write for
credit details

All Genuine Thomas Factory-Fabricated Parts. Features 15 manual, 4 pedal voices, instant-play Color-Glo; all solid-state circuit; 200 watts peak power; two separate speaker systems . . . 2-speed rotating Leslie plus main system with two 12" speakers; two 44-note keyboards; professional horseshoe console with stop tablets; 28 notes of chimes; 13-note bass pedals; selective repeat & attack percussion; reverb; stereo headset outlet; assembled walnut finish hardwood cabinet and bench; and more. 265 lbs. 7", 33-1/3 rpm demonstration record 50c.

America's Lowest Cost Solid-State Organ

Save Up to \$205! Features instant-play Color-Glo; 10 organ voices, 13-note bass pedals, repeat percussion; two 37-note keyboards; 75 watt peak power; vibrato, matching preassembled walnut cabinet & bench; 5-year warranty on plug-in tone generators. 172 lbs. 7", 33-1/3 rpm demonstration record 50c.

Kit GO-325B
\$394⁹⁰
\$40 dn., \$34 mo.



NEW! Heathkit® / Thomas Organ Accessories

Exclusive Band Box Percussion

Automatically or manually, adds 10 percussion voices to any Heathkit/Thomas organ. Build & install in 12 hours.
Kit TOA-67-1, no money dn., \$14 mo. . . . \$145.00

Exclusive Playmate Rhythm Maker

Adds 15 fascinating rhythms to any Heathkit/Thomas Organ. Requires Band Box percussion boxes for operation.
Kit TOA-67-5, no money dn., \$18 mo. . . . \$189.90

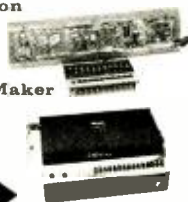

Order Now! Use The Handy Coupon Opposite Page

Direct-To-You Delivery From Heath



Kit TO-68
\$349⁹⁵

NEW! VOX "Jaguar" Transistor Combo Organ By Heathkit

Save Up To \$150 on the world's most popular combo organ with this new Heathkit version. Features the most distinctive sound of any combo organ. Has a special bass output that gives a brilliant stereo bass effect when played through a separate or multi-channel amplifier, 4 complete octaves, vibrato, percussive effects and reversible bass keys. Includes hand crafted orange and black cabinet, fully plated heavy-duty stand, expression pedal and waterproof carrying cover and case for stand. Requires a bass or combo amplifier like Heathkit TA-17 (opposite page).

Kit TO-68, 80 lbs.... \$35 dn., \$30 mo..... \$349.95

NEW! Amateur Novice CW Transceiver

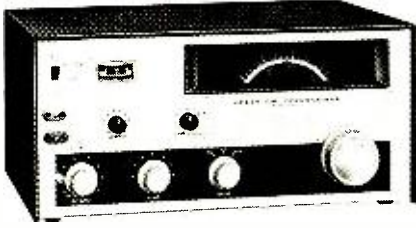

Kit HW-16
\$99⁵⁰
\$10 mo.

Novices! New Hams! Get on-the-air at lowest cost. Provides CW operation on the first 250 kHz of the 80, 40 & 15 meter bands. 75 watt CW input, up to 90 watts for general class operation. True "break-in" CW operation. Crystal control transmit with VFO receiver tuning. Built-in sidetone. Grid-block keying. Metal cabinet and simple assembly. 25 lbs.
Kit HW-16, 25 lbs.... no money dn., \$10 mo..... \$99.50

NEW! Heathkit Jr.® Solid-State Portable Phonograph

Kit JK-17
\$19⁹⁵



Perfect for the youngster in your family. Plays all 4 speeds, all record sizes. Crystal cartridge with sapphire stylus for all types of records; 4" speaker; built-in 45 rpm adaptor; preassembled turntable and hardboard cabinet. Build in 1 to 2 hours. 117 VAC, 60 Hz operation. 11 lbs.

Heathkit Jr.® Electronic Workshop "19"

Kit JK-27
\$13⁹⁵

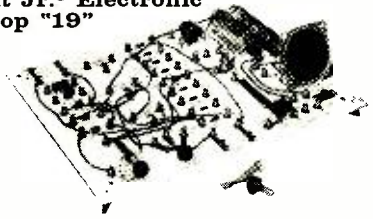

Ideal gift for any youngster who wants to learn electronics. Contains principles of operation & instructions for building 19 electronic projects . . . PA system, transistor radio, burglar alarm, etc. Spring-type connectors. Safe, flashlight battery operation. 4 lbs.

NEW! Heathkit Jr.® Guitar Amplifier



Kit JK-37
\$29⁹⁵
\$5 mo.

Ideal For Youngsters! Build in an evening. All solid-state. 9 watts music power. 8" speaker. Single channel, two inputs. Variable tremolo. Volume & tone controls. Red vinyl-covered wood cabinet with striped grille cloth and carrying handle. 12 lbs.



NEW FREE 1968 CATALOG!

Now with more kits, more color. Fully describes these along with over 300 kits for stereo/bi-fi, color TV, electronic organs, electric guitar & amplifier, amateur radio, marine, educational, CB, home & hobby. Mail coupon or write Heath Company, Benton Harbor, Michigan 49022.

HEATH COMPANY, Dept. 10-11
Benton Harbor, Michigan 49022
In Canada, Daystrom Ltd

Enclosed is \$_____ including shipping

Please send model (s) _____

Please send FREE Heathkit Catalog.

Please send Credit Application.

Name _____

Address _____

City _____ State _____ Zip _____

Prices & specifications subject to change without notice. CL-308

CIRCLE NO. 19 ON READER SERVICE PAGE

**Ask for
Turner's M+2/U...**

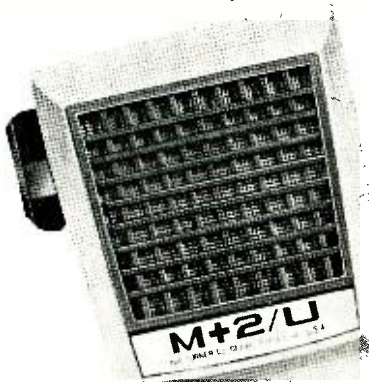

the LONG DISTANCE OPERATOR

The Turner M+2/U, a modified version of the famous Turner M+2, is here . . . and it gives you clear, distinct communication over distances which used to require a telephone!

The M+2/U uses a self-contained pre-amp and fingertip output control to let you dial the modulation you need . . . and it operates with any transceiver, tube or transistor! Wires quickly, easily . . . no matter what brand transceiver you have!

If you want new life for your old transceiver (or an unbelievable performance boost for a new one!) . . . ask for the new Turner M+2/U. It's the Long Distance Operator that's always on duty.



THE TURNER MICROPHONE COMPANY

946 17th Street N.E.
Cedar Rapids, Iowa

In Canada: Tri-Tel Associates, Ltd. Export: Ad Aur-
iema, Inc., 85 Broad Street, New York, N.Y. 10004

CIRCLE NO. 37 ON READER SERVICE PAGE

POLICE SPECIAL II

(Continued from page 48)

and $D2$, and the pink core (input side) closest to transistor $Q4$ (see Fig. 6).

Then install all resistors and capacitors on the board, as shown in Fig. 7.

When all components have been installed, check the parts layout and schematic to make sure that none were missed, or installed in the wrong position. If everything checks out, install transistors $Q1$ through $Q4$. Gently spread the leads of the transistors to fit the widely spaced mounting holes in the printed board, and be sure that the emitter and base leads are inserted into the proper holes. Bend leads flat against the printed conductor pattern and solder quickly to avoid heat damage. Clip off excess lead lengths when connections have cooled. Install diodes $D1$ and $D2$ (observing proper polarity), with the same care given the transistors.

Fabricate coils $L1$, $L2$, and $L3$, as shown in Fig. 8. The coil forms used in each case are standard 1-watt resistors. The exact values of resistance may be within $\pm 20\%$ of the specified values, as long as the diameter of the resistor body is the same. If you intend to use an outdoor antenna with the receiver, add coupling link $L1-A$ to antenna coil $L1$, as shown in Fig. 8. Install the finished coils on the printed board as shown in Fig. 7.

Remove the mounting clip from trimmer capacitor $C5$ and solder its rotor and stator terminals to the end leads of mixer coil $L2$ as shown. Then install a 5" length of hookup wire lead to the B-minus conductor pattern of the board, a 7" length to the output end of $C24$, and a 2" length to the input end of $C1$. Cut a 2" length of shield braid and solder it to the ground lug on tuning capacitor $C10$. Attach and solder a ground lug to the free end of the shield braid.

The r.f. module is now complete and ready for installation in the cabinet. Do a final check on all wiring and soldered connections and clean up any excess flux or solder splashes on the conductor side of the board.

Slip the assembled module into the cabinet and align the board properly on the four spacers. Secure the board to the

spacers using short 6-32 screws. Don't tighten the screws too much or you will crack the board.

Next, slip a short 4-40 screw through the front panel and slip the ground lug connected to the shield braid onto it—secure it with a 4-40 nut to make a good, solid ground connection. Attach the 7" hookup wire lead from output capacitor C24 to the high side of volume control R17, and connect the 5" hookup wire lead to the junction of resistor R16 and capacitor C26 on terminal strip TS2. The 2" antenna input lead connects to the center terminal of TS2.

Finishing Touches. Fabricate the pointer of the tuning dial as shown in Fig. 9. Sand the shaft coupling end to remove the plated finish. Then cut the pointer from sheet tin (a tin can is fine) and solder it to the sanded-end of the shaft coupling. When the solder has cooled, apply a coat of white enamel to the pointer and allow it to dry.

The 1/8"-diameter flattened shaft of tuning capacity C10 can be adapted to fit standard 1/4" knobs by soldering a 1/4"-

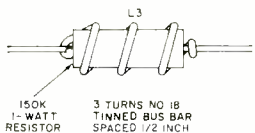
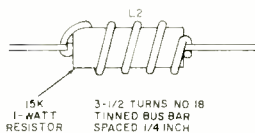
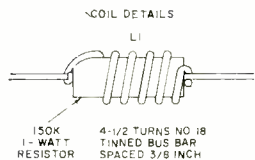
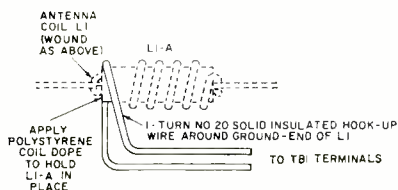

Fig. 8. Wind coils on 1-watt resistor bodies to provide solid support. If an outdoor antenna is used, antenna coupling coil L1-A must also be used.



Popular SAMS BOOKS



USE THIS HANDY ORDER FORM

RECENTLY PUBLISHED! TIMELY!

- Citizens Band Radio Handbook.** All-new third edition. Covers latest CB equipment and circuits, fixed and mobile installations, antenna systems, maintenance and repair, FCC rules, etc. Order 20569, only \$4.25
- ABC's of Radio & TV Broadcasting.** A fascinating explanation of what goes on at the transmitting end in radio and television broadcasting, in terms of both signal and equipment. Order 20575, only... \$2.25
- FET Circuits.** All about field-effect transistors (FET) and their practical application. FET's are now available at lower prices and their exciting uses will generate ideas for experimenters. Order 20585, only \$3.25
- Walkie-Talkie Handbook.** Describes all types available today; also covers specifications, accessories, maintenance, and licensing requirements. An invaluable guide. Order 20572, only... \$3.95
- ABC's of Hi-Fi and Stereo.** Provides a full understanding of basic principles of sound reproduction; explains monaural and stereo sound; tells how to select, operate, and maintain equipment; covers all system components in detail. Order 20539, only... \$2.25
- How To Read Schematic Diagrams.** Not only shows you how to read and interpret diagrams, but analyzes each component, its construction, and its circuit purpose and use. Order 20568, only... \$2.95
- TV Servicing Guide.** Tells you how to apply proper trouble shooting procedures based on analysis of symptoms, illustrated by picture tube photos. Packed with troubleshooting and servicing hints. Order 20361, only... \$2.50
- Color-TV Servicing Made Easy, Vol. 1.** Full explanation of color principles, circuitry, setup adjustments, and servicing of all color-TV sets. Takes the mystery out of servicing color-TV. Order 20135... \$3.25
- ABC's of Citizens Band Radio.** NEWLY REVISED & UPDATED. All you need to know about planning and setting up a CB 2-way radio system. Explains functions, principles, setup and operation, latest rules and regulations. Order 20019... \$2.25

- Transistor Ignition Systems Handbook, 20238... \$2.95
- TV Tube Symptoms & Troubles, 20476... 1.95
- Understanding Telemetry Circuits, 20518... 3.25
- 2nd-Class Radiotelephone License Handbook, 20316... 4.75
- Modern Dictionary of Electronics, 20151... 7.95
- Handbook of Electronic Tables & Formulas, 20230... 3.95
- Color TV Trouble Clues, 20120... 1.95
- Solving TV Tough-Dogs, 20403... 3.25

FAMOUS ABC'S BOOKS

- Lasers & Masers, 20262... \$2.25
- Computers, 20012... \$2.50
- Tape Recording, 20395... 1.50
- CB Radio, 20013... 2.25
- Transistors, 20440... 2.25
- Modern Radio, 20047... 1.95

— HOWARD W. SAMS & CO., INC. —

Order from any Electronic Parts Distributor, or mail to Howard W. Sams & Co., Inc., Dept. PE-11 4300 W. 62nd St., Indianapolis, Ind. 46268

Send books checked above. \$ _____ enclosed.

Send FREE Sams Book Catalog.

Name _____

PLEASE PRINT

Address _____

City _____ State _____ Zip _____

CIRCLE NO. 31 ON READER SERVICE PAGE

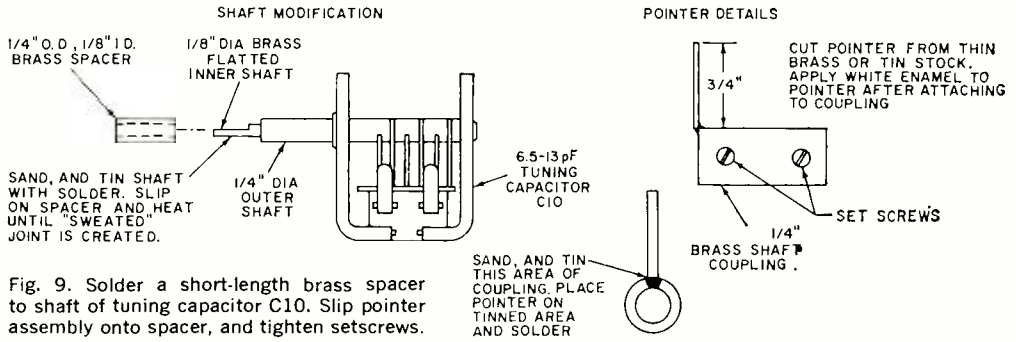

Fig. 9. Solder a short-length brass spacer to shaft of tuning capacitor C10. Slip pointer assembly onto spacer, and tighten setscrews.

o.d. x $\frac{1}{8}$ "-i.d. brass spacer to the existing shaft. Lightly sand the shaft and apply a thin coat of solder. Now slip the brass spacer onto the tinned shaft, heat the spacer until the solder on the shaft flows and allow the spacer-and-shaft-joint to cool.

Loosen the setscrews on the shaft coupling and slide the coupling onto C10's inner shaft, through the clearance hole in the front panel. Align the pointer with the rotor plates of the variable capacitor and tighten the rear setscrew to lock the shaft coupling to the outer shaft of the tuning capacitor. Install knobs on the adapted tuning capacitor inner shaft and the volume control shaft.

Install four rubber feet on the bottom half of the cabinet. For best results, use a good quality rubber or contact cement to attach the feet, rather than drilling holes and using hardware.

Alignment. Proper alignment of the completed receiver requires a fairly accurate signal generator, capable of producing tone-modulated 10.7-, 158-, and 168-MHz r.f. signals. To align the receiver, extend the antenna and rotate the volume control to the maximum position. Set the signal generator to 10.7 MHz, amplitude-modulated about 30%, and loosely couple the generator output to the receiver's antenna.

Then, using an insulated alignment tool, tune the slugs of T1, T2, and T3 for maximum output. When no further increase in output can be obtained, reset the signal generator to 158 MHz, amplitude-modulated about 30%, and place its output lead within six inches of the re-

ceiver's antenna. Set the tuning capacitor to a dial reading of 158 MHz and adjust oscillator trimmer capacitor C11, until the generator's signal is heard from the receiver speaker. Reduce the output of the generator to minimum and adjust mixer trimmer C5 for maximum output from the receiver. (You may have to readjust oscillator trimmer C11 to retune the receiver as the mixer trimmer is adjusted, since some interaction between the two adjustments is inevitable.)

When the receiver has been peaked at 158 MHz, retune the generator to 168 MHz, and tune in the signal on the receiver. Squeeze or stretch antenna coil L1 as necessary to peak the generator signal at this frequency. Check the tracking and tuning range of the receiver by setting the signal generator to 152 MHz and picking up the signal with the receiver. Tune progressively higher in the band in 2-MHz increments, to 176 MHz. If no parts substitutions were made and the coil specs were followed exactly, your receiver should easily tune from 152 to 176 MHz.

Now null the ratio detector for best reception of narrow-band FM signals. This adjustment can be performed on the bench and "touched-up" later using local Public Service signals. Tune the signal generator to 160 MHz, amplitude-modulated about 30%. Tune the receiver to the generator frequency, then adjust the blue core of ratio detector transformer T3 for a "null" in the received signal. As you make this adjustment, the signal should rise, drop off sharply, and rise again as the core is adjusted. The drop-off point is the correct null setting.

On-the-air "touch-up" of the receiver's

alignment requires patience and a steady hand. The adjustment calls for a slight de-tuning of the blue core of the ratio detector transformer to narrow the response for improved NBFM detection. To complete the "touch-up," tune across the band until you hear a Public Service station of medium signal strength. While the station is transmitting, adjust the blue core of transformer *T3* a fraction of a turn in each direction from null, "rocking" the tuning capacitor slightly across the signal frequency. Leave the blue core set at the position which yields maximum audio output.

After making this adjustment, install the bottom half of the cabinet and secure its four self-tapping screws.

Antennas. If you live in a fairly well-populated city or town, chances are the whip antenna will be all you'll need for good local reception (up to 10 miles) of VHF Public Service stations. However, if you're out in the country, you may need an outdoor antenna to boost reception. A roof-mounted TV antenna will give excellent results, expanding the pickup range by a considerable margin.

If you use your TV antenna, add the optional antenna terminal strip (*TS3*) and input coil *L1-A*, shown in the dashed box in Fig. 1. If you only want to use the whip antenna, omit the parts in the dashed box.

-30-



"Well, the surprise part is the price—they're 75 dollars . . ."

November, 1967

Thinking of college and a space age career?

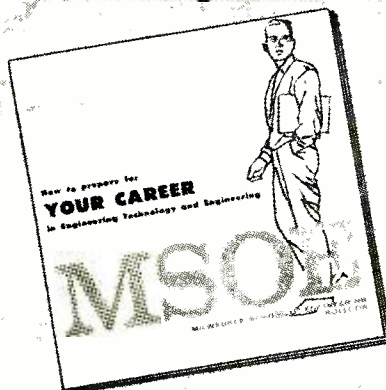

Send for this booklet on ENGINEERING TECHNOLOGY AND ENGINEERING

Learn how you can prepare for a dynamic career as an electrical or mechanical engineering technician or engineer in such exciting, growing fields as avionics, missiles, reliability control, fluid mechanics, data processing, metallurgy, microelectronics, and advanced aerospace research.

MSOE offers residence study programs leading to these degrees in engineering technology and engineering:

- 2 years — Associate in Applied Science
- 4 years — Bachelor of Science

Also get facts about scholarships and financial aids, job placement and other student services, plus photographs of MSOE technical laboratories and student activities. Courses approved for veteran training. For your copy, just mail the coupon — no obligation.

MSOE

Milwaukee, Wisconsin 53201

Milwaukee School of Engineering
Dept. PE-1167, 1025 N. Milwaukee Street
Milwaukee, Wisconsin 53201

Please send the "Your Career" booklet.
I'm interested in

- Electrical fields Mechanical fields

Name.....Age.....

Address.....

City.....State.....ZIP.....

CIRCLE NO. 24 ON READER SERVICE PAGE

MS-284

POPULAR ELECTRONICS SUBSCRIBER SERVICE

Please include an address label when writing about your subscription to help us serve you promptly. Write to: Portland Place, Boulder, Colo. 80302

CHANGE OF ADDRESS:
Please let us know you are moving at least four to six weeks in advance. Affix magazine address label in space to the right and print new address below. If you have a question about your subscription, attach address label to your letter.

TO SUBSCRIBE:

Check boxes below.

- New Renewal
- 5 years \$20
- 3 years \$13
- 1 year \$5

SPECIFY:

- Payment enclosed
—You get 1 extra issue per year as a BONUS!
- Bill me later.

AFFIX LABEL

If you have no label handy, print OLD address here.

please print

name

address

city

state

zip-code

[Add'l postage: \$1 per year outside U.S., its possessions & Canada.]

name please print 0246

address

city

state zip-code

NEW Vol. II of "For Shortwave Listeners" THE RAREST DX IN THE WORLD

New LP Record for SWL and shortwave hobbyists. Station I.D. announcements, Interval Signals, Music, Anthems, of seldom heard SW stations from around the World. Nepal, S. Vietnam, Fiji, Hong Kong, New Guinea, Cook Is., Gilbert & Ellice Is., and more. Most valuable in identifying those elusive DX signals when heard on your receiver. Recorded from source tapes supplied by the stations themselves for fine recorded quality. Postpaid \$3.95. Outside U.S.A. add \$1.00. Vol. I of "For Shortwave Listeners" also available. Same price. Specify Vol. I or Vol. II or BOTH for \$6.50. SWL RECORDS, Box 150, Culver City, Calif. 90230.



TUNAVERTERS
POLICE, FIRE, AIRCRAFT,
MARINE AND AMATEUR
CALLS ON YOUR BROADCAST RADIO!

Tunable RF converters. 6-1 reduction tuning. See complete listing in October Popular Electronics, Page 111.

HERBERT SALCH & CO., Woodsboro PE 12, Texas 78393

NEW LITERATURE

To obtain a copy of any of the catalogs or leaflets described below, simply fill in and mail the coupon on page 15.

Several new pieces of equipment built around integrated circuits are featured in *Lafayette Radio Electronics'* 512-page 1968 catalog, No. 680. Complete selections of hi-fi equipment, CB and marine radios, ham gear, tape recorders and test equipment, from almost every major manufacturer and Lafayette's own equipment are represented. Extras include electronic components, tools, optics, cameras, books, radios, TV sets, etc.

Circle No. 86 on Reader Service Page 15

Over 2000 dry transfer alphabet sheets and marking sets for electronic equipment, architectural drawings, etc., are fully described in the 1967 catalog released by *DataK Corporation*. Featured for the first time are sets of organic chemical symbols and logic diagram symbols, 14 new preprinted title sets, "Letra-tone" shading tints, and heat-resistant letters for drafting.

Circle No. 87 on Reader Service Page 15

TAD Products Corporation's 16-page, 1967-68 catalog contains detailed descriptions of slide- and rotating-type calculators, rules, comparators, nomographs, converters, reference books, and other time-saving devices for engineers, designers, and draftsmen.

Circle No. 88 on Reader Service Page 15

Complete information on the "Ampli-Vox Sound Cruiser Mobile Sound System" is contained in a specification brochure published by *Perma-Power Company*. The system is said to turn any car, bus, or truck into an instant sound truck, and is powered by the vehicle's 6- or 12-volt battery.

Circle No. 89 on Reader Service Page 15

Thyratron tubes and their applications are discussed thoroughly in a 19-page report available from *Amperex Electronic Corporation*. The fundamentals of thyratron operation, their characteristics, and circuit design, are covered first, followed by sections called "Installation of Thyratrons" and "Definitions of Ratings." Copies of this "Application Report #P-111" can be obtained by writing—on company stationery—to Amperex Electronic Corporation, Product Manager—Industrial Tubes, Hicksville, L.I., N.Y. 11802.

What in the world has the new Allied Catalog got for YOU?

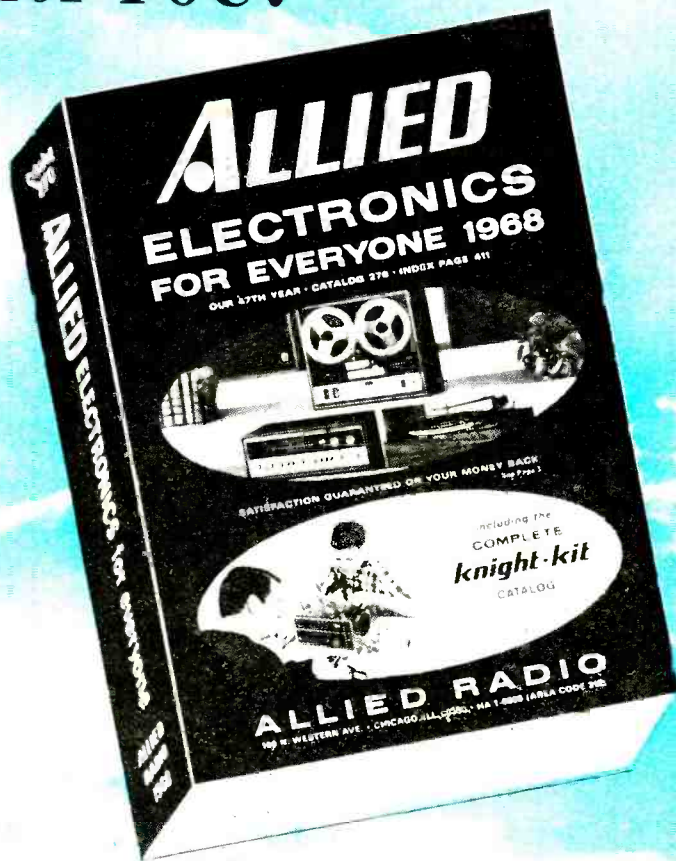

Everything!

EVERYTHING IN ELECTRONICS

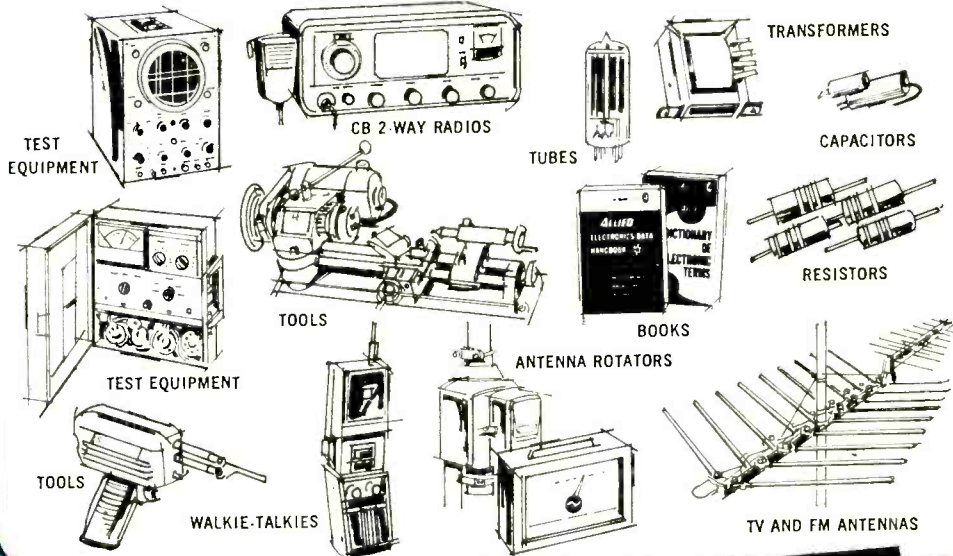

**EVERYTHING
TO BUILD, REPAIR, TEST OR
ENJOY ANYTHING ELECTRONIC**

EVERY FAMOUS NAME IN STEREO HI-FI

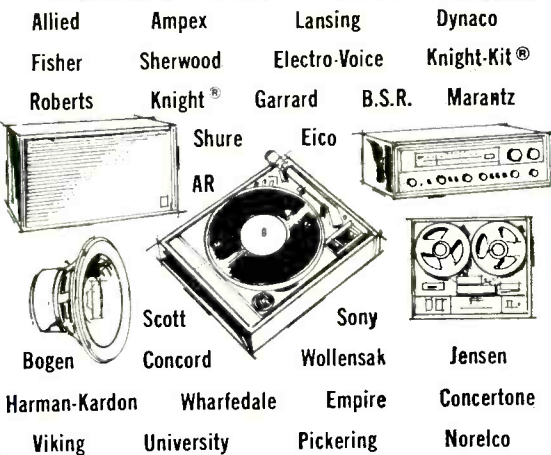

EVERYTHING IN KNIGHT-KITS

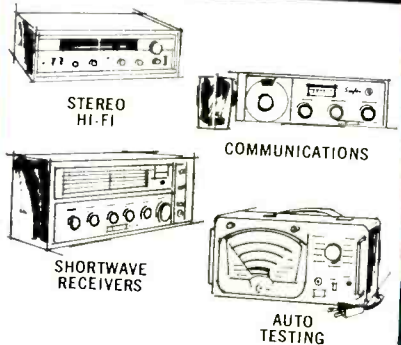

Discover the fun, enjoy the savings, gain the satisfaction of "building your own". Over 100 famous Knight-Kits to choose from.

ALLIED RADIO, DEPT. 3L, P.O. BOX 4398, CHICAGO, ILLINOIS 60680

WHY BUY BY MAIL FROM **ALLIED?**



Each year Allied fills more than a million orders by mail. That's because only the complete facilities of the world's largest electronics supply house can satisfy all the needs of hi-fi enthusiasts, CB users, engineers, Hams, and experimenters.

WORLD'S LARGEST SELECTIONS

Shop through the pages of this complete 518-page electronics buying guide. It gives you full descriptions and low prices on thousands upon thousands of items.

MANY PRODUCTS NOT AVAILABLE ANYWHERE ELSE

Allied stocks thousands of unusual and special items not available elsewhere. Many are specially designed and built to Allied's specifications to save you money.

FIRST WITH THE LATEST FOR 47 YEARS

Allied has always been the first to offer the latest developments in Electronics. See them now in Allied's new 1968 Catalog.

**No Money Down
Up to 2 Years to Pay**

WE QUALITY-TEST WHAT WE SELL

If it's from Allied—you can depend on it. Allied's own Quality Control Department must approve items of merchandise before they can be offered for sale.

COUNT YOUR SAVINGS AT ALLIED

Check Allied's lower prices. Look for the special values available only in the Allied Catalog.

IMMEDIATE SHIPMENT

Orders are filled promptly—usually the same day they're received.

**Satisfaction
Guaranteed
or Your Money Back!**



ENJOY "EASY CHAIR" SHOPPING

Shopping's easier at Allied. You always know exactly what you get. And, the selection of merchandise is so vast no single store could ever assemble and stock it all.

In all the world—there's
no other catalog quite
like ALLIED'S. . . .
WOULDN'T YOU LIKE
ONE FOR YOURSELF?

FREE



**ALLIED RADIO, Dept. 3L
P. O. Box 4398, Chicago, Ill. 60680**

Send me your 1968 Catalog.

NAME — PLEASE PRINT

ADDRESS

CITY

STATE

ZIP

CIRCLE NO. 2 ON READER SERVICE PAGE

**Discriminate Between
Desired Signal and
Unwanted Noise**

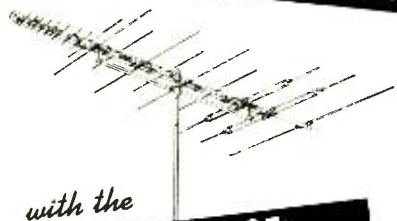

with the

**FREE SPACE
STANDING WAVE
MAGNETIC ANTENNA
UHF-VHF-FM-COLOR**

Investigate now!

S & A ELECTRONICS INC.

Manufacturers of the TARGET ANTENNA

228 W. FLORENCE STREET

TOLEDO, OHIO 43605

CIRCLE NO. 30 ON READER SERVICE PAGE

Audio-Color
Lets you see your music

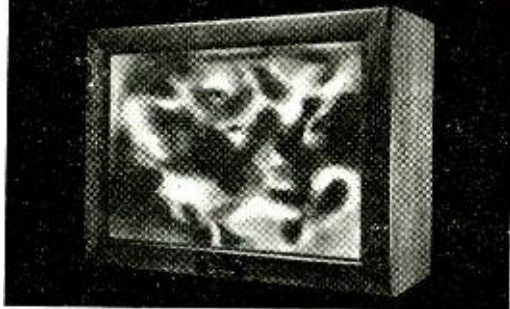

**ASSEMBLED
\$54.95**

**KIT FORM
\$44.95**

\$5 DOWN — \$5 MONTH

Walnut finished cabinet included / Shipped REA Collect

Easy to build, easy to install. All transistor AUDIO-COLOR adds a visual dimension to musical enjoyment. A brilliantly moving panorama of color casts dancing images on a soft frosted screen, reflecting rising and falling volume with each beat of the music. Here's a truly unique and exciting new musical experience. Make check or money order to CONAR.

SEND FOR FREE CONAR CATALOG

CONAR

Division of National Radio Institute,
Dept. MA7C 3939 Wisconsin Ave.,
Washington, D.C. 20016

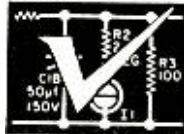

**OPERATION
ASSIST**

Through this column we try to make it possible for readers needing information on outdated, obscure, and unusual radio-electronics gear to get help from other P.E. readers. Here's how it works: Check the list below. If you can help anyone with a schematic or other information, write him directly—he'll appreciate it. If you need help, send a postcard to Operation Assist, POPULAR ELECTRONICS, One Park Avenue, New York, N.Y. 10016. Give maker's name, model number, year of manufacture, bands covered, tubes used, etc. State specifically what you want, i.e., schematic, source for parts, etc. Be sure to print or type everything legibly, including your name and address. Because we get so many inquiries, none of them can be acknowledged. POPULAR ELECTRONICS reserves the right to publish only those items not available from normal sources.

RCA-Victor Model SCP-3 automatic tape cartridge recorder. Servicing data needed. (E.J. Soniat, 15-A Colonial Manor, Ravenswood, W.Va. 26162)

Superior Model TV-11 tube tester. Schematic and operating manual needed. (Billy Schrock, Box 124, Garden City, Mo. 64747)

Philco tuning capacitor #31-2786. 2-gang, 5-25 pF unit needed. (R.B. Belanger, 7133 W. Warren, Detroit, Mich. 48210)

A-C Dayton Model XL-20-6 3-knob neodyne receiver; circa 1920-21. Schematic and source for tubes needed. (Dick Beery, 61 Curl Dr., Columbus, Ohio 43210)

RME Model 69. Schematic and technical data needed. (J.M. Kenley, 296 Cladon Dr., Cynthia, Ky. 41031)

Lincoln Model 2000A CB transceiver. Schematic and operating manual needed. (Jeff Corey, 6606 N. Ridge Blvd., Chicago, Ill. 60626)

Philco Model 40-516 radio-phono combination; has 3 bands; 13 tubes. Schematic and literature needed. (John P. Foster, 442 S. Hwy 168, Chesapeake, Va. 23320)

Hallicrafters HT-6 25-watt transmitter; circa 1941. Crystal adapter, tuning unit, and power amplifier tank coils needed for 160, 40 meters. Also crystal adapter for 20 meters and crystal adapter and crystals for 80 meters. (Glen Whitney, 6933 Fullbright Ave., Canoga Park, Calif. 91306)

E.H. Scott Model 800B-6 receiver, ser. 800 5127; tunes 550 to 1600 kHz and 6.0 to 18 MHz and 88 to 108 MHz on 3 bands; has 24 tubes. Schematic needed. (Edwin E. Spurr, 2806 J.F. Kennedy Dr., East Moline, Ill. 61244)

Zenith Model 6-S-819T receiver, ser. T686569; tunes 550 kHz to 22 MHz on 4 bands; has 6 tubes; circa late 1930's. Schematic and alignment data needed. (R.G. Paton, 125 Aotea St., Auckland 5, New Zealand)

Jackson Model 636 tube tester; also known as military R8. Schematic and adjustment information for tester needed. (John P. McDermott, Box 8, Stratford, Conn. 06497)

Neli Model GDP134 "Trans-Nition" system; circa 1965. Identification of 4 transistors or substitutes needed. (J.R. Shaw, 5015 Griffing Ct., Groves, Tex. 77619)

Sparton receiver, blue-mirrored case; tunes AM and s.w. (6-18 MHz). Schematic needed. (Burke Fort, 35 W. 53 St., Kansas City, Mo. 64112)

Starlite Model 700 tape recorder; made in England. Play record switch, or parts source, and schematic needed. (Dewitt C. Depuy, 70 Lexington Ave., Staten Island, N.Y. 10302)

POPULAR ELECTRONICS

Howard Model 118 receiver; circa 1937; tunes BCB and 2 s.w. bands; has 10 tubes and "magic eye." Schematic and parts list needed. (Zachary Widup, 115 Frederick St., Plainfield, Ill. 60544)

Crosley Model 02CA, 02CB, 02CP, or 02CQ receiver; has 10 tubes; tunes BCB, 5.5-18 MHz and 1.7-5.0 MHz. Service manual or schematic. 6AC5 tube, cabinet, knobs, and information on tuning setup needed. (Westley M. Ridgway, Jr., RR#1, South Shore, St. Charles, Mo. 63301)

Ferris Instrument external calibrator, 32XA5 \pm 72. Schematic, parts list, and operating manual needed. (Dave Patterson, 37 Wake Rd., Eatontown, N.J. 07724)

Hammarlund "Super Pro" receiver; tunes 100 kHz to 20 MHz on 5 bands; has 16 tubes. Schematic and operating manual needed. (Joe Hughart, Box 167, Sutter, Calif. 95982)

Wilcox-Gay Model 6A10 disc recorder. Operating manual needed. (Loring B. Quimby, Brookline, N.H. 03033)

Zenith 6-S-254 receiver; circa 1933. Four knobs, grille cloth, dial, and alignment information needed. (Floyd Dunlap, 14113 Stoneshire, Houston, Texas 77037)

Heathkit Model OM-2 5" oscilloscope. **Heathkit** Model S-3 electronic switch. Operating manuals needed. (Roger Bradford, 501 Meadowpark Lane, Media, Pa. 19063)

Olympic Model 21KB26 TV set, 1955. Rocket tuner strip to receive UHF channels needed, or any information on same. (Robert Bartels, RD 1 Box 266, Scranton, Pa. 18508)

RME Model 4350 receiver; tunes 160-10 meters. Operating manual and schematic needed. (Andrew Omori, P.O. Box 127, Mt. View, Hawaii 96771)

Erwood Sound Equipment Co. Model 4130 p.a. amplifier, ser. 3364; has 4 tubes. Schematic and all available information needed. (Bill Mac Culloch, C.K.E.C., New Glasgow, N.S., Canada)

Silvertone Model 1586 receiver, ser. 101425, circa 1936; covers American, s.w., and foreign frequencies. \pm 10128114352 coil, \pm 1013715050 band selector contact

plates 1 and 2. Schematic, and parts list needed. **Atwater Kent** Model 246 AM receiver, circa 1933. Schematic and parts list needed. (Bill Seward, Seward Junction, Liberty Hill, Texas 78642)

Gardiner electronic metal detector; has 4 tubes, uses 4 batteries. Schematic, and information on search coil and metering connection needed. (Bill Laxson, V.A. Center, Boise, Idaho 83707)

Doolittle Model PJZ-11 high-band transceiver; has 21 tubes; uses two 2-volt wet cells. Schematic, operating instructions, and new wet cells needed. (Duane G. Carley, 3017 Ustic Circle, Boise, Idaho 83704)

Wilcox-Gay Model 83IOU "Recordette," circa 1948. Power transformer needed. (John Antonelli, Mahopac Ave., Amawalk, N.Y. 10511)

GE Model 250 a.c.-d.c. portable 2-volt superhet receiver, circa 1950; tunes 540-1600 kHz. Schematic, operating instructions, and source of Willard Model 25-2 rechargeable wet cell for receiver needed. **Allen** Model E1223 12-volt ignition tuning light. Schematic and parts list needed. (Kenneth D. Bucklin, 1010 Harold Dr., S.W., Cedar Rapids, Iowa 52403)

Atwater Kent Model 30. Nameplate for inside lid and 3 condenser drive rims needed. (David Knepper, Box 43, Sidman, Pa. 15955)

Triplet Model 1210-A tube checker, ser. 108096. Schematic and operating manual needed. (Maurice E. Norton, Box 87, Dillard, Ga. 30537)

Link Type 1905 crystal-controlled FM receiver. Schematic, operating manual, and information on conversion to a.c. needed. (Eddie Joseph, 7278 Hollywood Blvd., Los Angeles, Calif. 90046)

War Department receiver, BC 342 series (N); tunes 1.5 to 18 MHz on 6 bands; set working but needs aligning for ham hand use. All mail will be answered. (B. Ahern, Leading Airman, L/FX 902079, R.N. Establishment, Seaford Park, Hillhead, Near Fareham, Hampshire, England)

National Model HRO-MX high-frequency receiver; has 9 tubes. Schematic, technical information, manual, and source for coils needed. (S. Pilacoutas, Box 1567, Nicosia, Cyprus)

-30-

Popular Science Top-Rates Scott's Stereo Tuner Kit

(THERE'S A SOUND REASON.)



Popular Science magazine's reviewer said, "I rate the LT-112-B as one of the finest FM tuners available — in or out of kit form." All of this fabulous tuner's critical circuitry comes pre-wired, pre-tested, and pre-aligned . . . and the full-size, full-color instruction manual makes the rest simple. In just eight hours, you'll have it completed. Again, in the reviewer's words: "Stereo performance is superb, and the set's sensitivity will cope with the deepest fringe area reception conditions . . . drift is non-existent." See your Scott dealer and review the new LT-112B-1 for yourself. Only \$199.95.

©Copyright 1967, H.H. Scott, Inc



H.H. Scott, Inc., Dept. 520-11, Maynard, Mass., Export: Scott International, Maynard, Mass. 01754
CIRCLE NO. 33 ON READER SERVICE PAGE

November, 1967

101

Cush
Craft

CB ANTENNAS

NEW *Ringo*

Now an improved model of the famous CR-1. Make Ringo your performance choice today!

3.75 db GAIN
BASE STATION
VERTICAL
MODEL CR-1
\$18.95



BALANCED BEAMS	
3 ELEMENT	\$29.50
4 ELEMENT	39.50
5 ELEMENT	59.50
6 ELEMENT DUAL	99.50
8 ELEMENT DUAL	119.50

TRIK STIK
ALL PURPOSE
Universal Antenna
Citizens Band • Monitor •
Ham • CD • FM • TV • Air-
craft • SWL • Business Radio
• Universal Mount

MODEL TS-1



\$6.45

PROTECT YOUR
EQUIPMENT

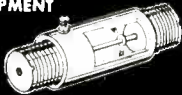

U. S. PATENT #2,922,913

BLITZ BUG
COAXIAL
LIGHTNING ARRESTER
over 250,000 in use
MODEL LAC-1 \$3.95
MODEL LAC-2 \$4.45

Cush
Craft

621 HAYWARD STREET
MANCHESTER, N. H. 03103

CIRCLE NO. 12 ON READER SERVICE PAGE

Olson



* **FREE**

Fill in coupon for a FREE One Year Subscription to OLSON ELECTRONICS' Fantastic Value Packed Catalog—Unheard of LOW, LOW PRICES on Brand Name Speakers, Changers, Tubes, Tools, Stereo Amps, Tuners, CB, and other Values. Credit plan available.

NAME _____
ADDRESS _____
CITY _____ STATE _____
GIVE ZIP CODE _____

If you have a friend interested in electronics send his name and address for a FREE subscription also.

OLSON ELECTRONICS
INCORPORATED

746 S. Forge Street, Akron, Ohio 44308

CIRCLE NO. 27 ON READER SERVICE PAGE

THEREMIN

(Continued from page 33)

is reduced to near zero. This setting, although somewhat critical, will be stable once obtained.

(7) Finally, adjust L_2 's slug until the growl becomes lower and lower in pitch, finally disappearing as "zero beat" is reached.

With the coils properly adjusted, no output signal will be obtained unless the operator's hands are moved near the *pitch* and *volume* control plates *simultaneously*. As the operator approaches the *pitch* control plate, a low-frequency note should be heard, increasing in pitch as the hand moves nearer and, finally, going higher and higher and beyond audibility as the hand almost touches the plate. As the operator puts his hand near the *volume* control, a low-level signal should be heard, increasing in amplitude until maximum volume is attained just before the plate is touched.

After the initial adjustments, L_2 and L_4 can be readjusted from time to time (using the front panel knobs) as needed to correct for minor frequency drift. In any case, a preliminary check of adjustment is always desirable whenever the theremin is to be used for a performance.

One further adjustment is optional. Coil L_1 's positioning with respect to L_2 will determine, to some extent, the shape of the output waveform and, hence, its

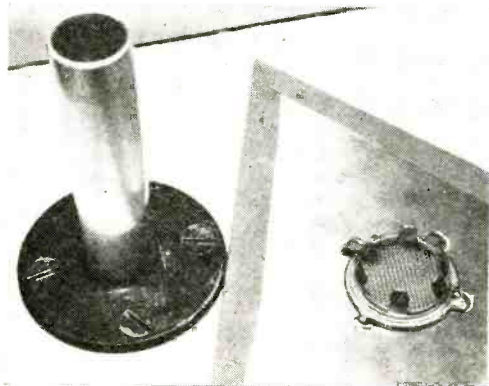

Fig. 4. Plug buttons soldered to metal plates that serve as antennas provide electrical coupling and mechanical support between antennas and pipes.

harmonic content. The mounting bracket supporting *L1* can be adjusted to reduce the mutual coil orientation to less than 90° if a greater harmonic content is desired. However, as the angle is reduced, low-frequency notes may tend to become pulse-like in character.

Installation. A guitar or instrument amplifier is an ideal companion unit for the theremin; either one allows bass or treble boost, as desired, and fuzz (distortion) or reverberation (if these features are incorporated in the amplifier's circuit). Simply provide a suitable cable plug and connect the theremin's output cable to the amplifier's input jack.

It is not necessary to purchase a special amplifier. The theremin's output signal level is sufficient to drive most power amplifiers to full output without additional preamp stages. The instrument can be used, for example, with a monaural version of the "Brute-70" amplifier described in the February, 1967, issue.

If the theremin is used in conjunction with a power amplifier which does not have a built-in gain (or volume) control, a "volume level" control should be added to its basic circuit to prevent accidental overdrive. This can be accomplished quite easily by replacing source load resistor *R16* (Fig. 1) with a 10,000-ohm potentiometer.

Operation. The results obtained depend more on the ability of the operator than on built-in limitations within the unit itself. A good "ear" for music is a must, of course, but, in addition, a moderate amount of skill is required, particularly

in finger or hand dexterity and movement. The latter is learned only through practice. For a start, here are the basic "playing" techniques.

To sound an individual note, first move the "pitch" control hand to the proper position near the *pitch* antenna (as determined by practice) to sound the desired pitch. Next, move the "volume" control hand *quickly* to the proper position near the *volume* antenna to sound the note at the desired level, then away after the proper interval to sound an eighth, quarter, half or full note.

To sustain a note, hold both hands in position. The note volume may be increased slowly by moving the "volume control" hand *slowly* nearer the *volume* antenna, reduced by moving it *slowly* away.

To "slide" from one note to another, hold the "volume hand" fixed in position and move the "pitch hand" nearer (or away from) the *pitch* antenna plate.

To produce a vibrato effect, hold the "volume hand" fixed in position and shake—or tremble—the "pitch hand" at the desired rate.

To create a tremolo effect, hold the "pitch hand" fixed in position and vibrate—or tremble—the "volume control" hand.

Tremolo and vibrato effects can be produced by simultaneously rapidly moving both hands back and forth.

If you've used triangularly shaped control plates in your instrument (as in the model shown), you'll find that a given hand movement has less effect on operation near the narrow (pointed) end of the triangle than near its broad base.

Practice is important!

-30-

Sonar SENTRY VHF MONITOR RECEIVERS

With Battery, Earphone, & Carrying strap less Crystals \$5.00 ea.

\$39.95



LISTEN TO: POLICE, FIRE, AIRCRAFT & WEATHER REPORTS!

for Industrial, Commercial, Utility & Govt. Use

2 CHANNELS • BROADCAST BAND • CRYSTAL CONTROLLED

Designed and engineered for simplicity of operation, compact enough to fit a shirt pocket yet powerful enough to deliver a clear clean signal—it's dependable • Operates on two crystal controlled VHF channels plus broadcast band • Completely solid state for long life use • Visible battery indicator to show battery condition at all times • Built in antenna • 5 7/8" H x 2 1/4" W x 1 3/16" D. Wt. 11 oz.

SONAR RADIO CORP., 73 Wortman Ave., Bklyn, N.Y. 11207

Please send information on VHF Monitor Receivers.

Model

FR-103 150-175 MHz	FR-106 25-50 MHz	AR-107 Aircraft 108-136 MHz
------------------------------	----------------------------	--

Name _____ Dept. 572

Address _____

City _____ State _____

CIRCLE NO. 35 ON READER SERVICE PAGE

Air.

Even your Hi Fi Components need it to survive.

You can minimize thermal drift and lengthen the life of Hi Fi sets, FM stereo receivers, communications and other equipment with this low noise fan. The Hi Fi Boxer was designed by engineers who have produced airmover designs for computers, broadcasting equipment, and the Minuteman Missile.

For more detailed information write the address listed below.

To obtain the Hi Fi Boxer see your local dealer or send a check* or money order for \$14.85 to:

Hi Fi Boxer, New Hampshire Division,
IMC Magnetics Corp., Route 16B
Rochester, New Hampshire

*Allow 10 days for personal checks to clear.

CIRCLE NO. 21 ON READER SERVICE PAGE

Argos' new speaker technology creates a genuine price breakthrough in two-way system design.

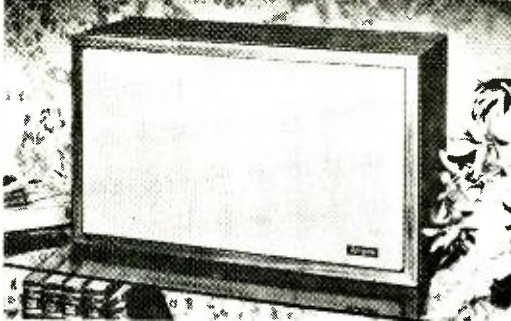

The new Argos TX-200 is a totally new dimension in high fidelity sound reproduction systems—a superb instrument offering fine-furniture construction, big-system performance and compactness for maximum versatility. The TX-200 matches a specially-designed high compliance, low-resonance woofer with a new high-compression horn-loaded driver component to produce distortion-free response from 30 Hz to the inaudibles at 18,000 Hz.

Specifications

Cabinet: Select walnut, Belgian linen grille. Size: 18 $\frac{1}{2}$ " x 11 $\frac{1}{2}$ " x 7 $\frac{1}{2}$ ". Price: Audiophile net \$45.00.

Argos
Products Company
Genoa, Illinois 60135

CIRCLE NO. 5 ON READER SERVICE PAGE

ELECTRONIC VOLTMETER

(Continued from page 61)

Calibration. After the instrument has been completely assembled, checked and rechecked to make certain there are no errors or omissions, set the *Selector* switch at *Off* and install the transistors and the battery. Then proceed as follows.

(1) Set the *Range* switch (*S1*) at any position except *Zero*; set calibration control *R19* at maximum resistance; set *Balance* control (*R21*) and *Zero* control (*R23*) at about mid-position.

(2) Set the *Selector* switch (*S2*) at *Pos* and adjust the *Balance* control for zero indication on the meter. When this control is properly set, moving the *Selector* switch from *Pos* to *Neg* and then back to *Pos* to *Neg* and then back to *Pos* again should produce no change in the zero indication of the meter.

(3) Set the *Range* switch at its *Zero* setting and adjust the *Zero* control (*R23*) for zero indication on the meter.

(4) Set the *Range* switch at 1.5 volts, apply an accurately known potential of this value to the input jacks, and adjust the calibration control (*R19*) until the meter indicates exactly full scale. If no other source is available, a fresh flash-light cell can be used for this purpose. Its potential will probably not be exactly 1.5 volts, but the accuracy so obtained will be sufficient for most practical purposes.

Maximum inaccuracy is likely to occur on the 0.5-volt range, since on this range the input resistance of the amplifier is a significant fraction of the multiplier resistance. In an individual instrument, some slight adjustment of the value of *R10* may be advantageous to improve the accuracy. Once the optimum value has been selected, it need not be changed thereafter.

Using the Meter. The original 0-50-microampere scale supplied with the meter is used. However, the microampere sign is ignored, and the meter reads in volts.

Thus, the meter indicates directly on the 50-volt range, and on the 150-volt range the indication is multiplied by three. On the lower ranges, the decimal

POPULAR ELECTRONICS

point is moved, mentally, one or two places to the left (as the setting of the *Range* switch requires) and, when necessary (on the 1.5- and 15-volt ranges), the reading is multiplied by three. -30-

POWER SUPPLY

(Continued from page 73)

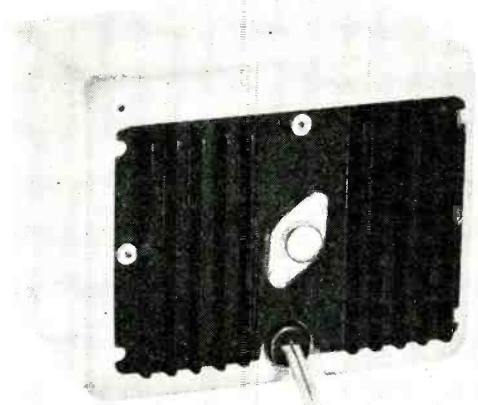

For good heat dissipation, mount transistor Q3 on a heat sink and bolt both to outside rear of cabinet.

minimal E of the PC board. Four #10 nylon cup washers serve as feet.

Current Limiting. The current limit can be preset from 50 to 500 mA. Up to about three-quarters of the current limit, the power supply produces a constant-
(Continued on page 110)

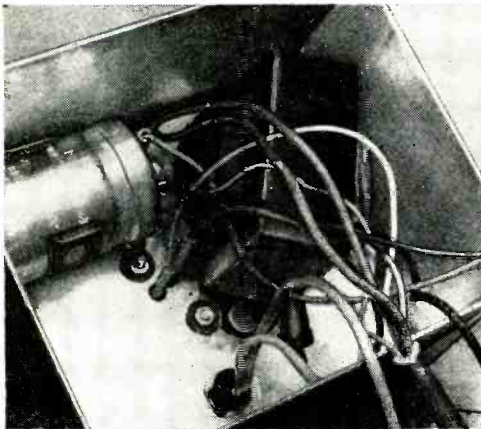

Use long leads when connecting transformer T1, capacitor C1, and power transistor Q3 in the circuit.

November, 1967

A swingin' new high-performance mobile CB antenna . . .

"the flipper"



**that clamps on
in seconds and adjusts
to 5 positions from
inside the vehicle!**

- Heavy duty, chrome-plated clamp mount with 5-position spring-loaded position adjustment. (0°, 45° or 90° mounted either side of vehicle.)
- Sleek black fiberglass whip, center-loaded for high efficiency.
- Ideal for portable operations, too.
- Mount only available—model M-179. Accepts 3/8-24 threaded antennas. (Not recommended for antennas longer than 5 ft.)

**"the flipper" Model M-180
mobile CB antenna**



Suggested CB
net price: **\$18.30**

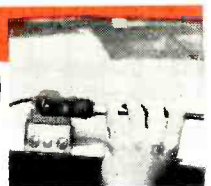

the antenna specialists co.

Div. of Anzac Industries, Inc.
12435 Euclid Ave., Cleveland, Ohio 44106

Export: 64-14 Woodside Ave.
Woodside, N.Y., 11377



"Stripes of Quality"®

CIRCLE NO. 4 ON READER SERVICE PAGE

NTS PUTS YOU WHERE THE MONEY IS ... FAST!



NTS Home-Study training is for men in a hurry to move up! NTS Electronics Courses are geared to the needs of the electronics industry. This is up-to-date training. As modern as tomorrow.

Our close working relationship with electronics companies all over the country is the key. They tell us what you need to know to be a top-flight technician. They

keep us informed of new, exciting career opportunities. With this information, we constantly revise our courses to keep our home-study students one step ahead. In an industry that moves so rapidly, advancement comes quickly to the man with NTS training.

Since 1905, NTS has been leading ambitious men to where the money is. Join them.

EXCLUSIVE! ONLY FROM NTS! ALL NEW KITS... MAKE IT FUN TO LEARN, EASIER TO EARN.

For the first time! The greatest lineup of electronics kits ever offered to train you for the space-age. Only NTS has them. Designed for tomorrow... each has all

the latest electronics advances built in. NTS trains you better. NTS makes it fun to learn, easier to earn more, TODAY.

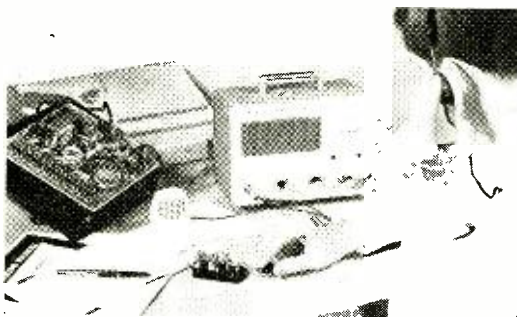
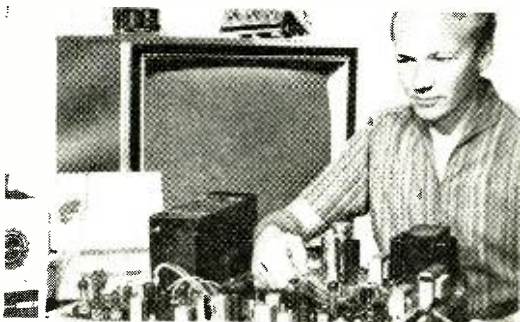

25" COLOR TV: Included in Color TV servicing courses ...to prepare you for the big demand for qualified service technicians. This is where the big money is. More than 16 million homes will have color TV by the end of this year. You can cash in on the boom. You can take a giant step ahead with professional training from NTS.

COMMUNICATIONS: Transceiver included in Communications Courses. This modern equipment is an important element in communications. You get it, you build it. With it you easily prepare for the F.C.C. License Exam. You become a fully trained man in communications, where career opportunities are unlimited.

**ALL
NEW KITS!
ALL NEW
COURSES!**

DESK-TOP COMPUTER: Professionally designed exclusively for NTS. Included with your Industrial and Computer Electronics Course. You can't get this computer kit, or anything like it, anywhere else. The special

computer and integrated circuitry of the training kits prepare you for a big career in this giant industry. These are the first kits offered by any school which include actual integrated circuits.

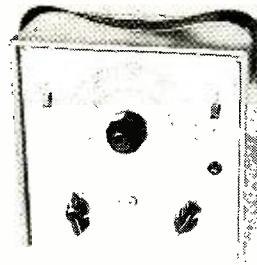
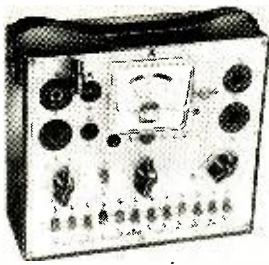

LEARN MORE, EARN MORE—IN ELECTRONICS

SIGNAL GENERATOR, VTVM, AND TUBE CHECKER INCLUDED WITH NTS ELECTRONICS COURSES. These are invaluable instruments for all kinds of Electronic and TV-radio servicing work. You learn to use them early in your training. Begin trouble-shooting work to earn money even before you've completed your course. Many of our students have more than paid for their NTS home-training this way—even before they graduated!

With these professional instruments, you are well-equipped to go into a business of your own. They're all you need to pinpoint most of the trouble spots in TV, Radio, or other electronic components. You get them at no extra cost—as part of your NTS training.

YOUR OWN BUSINESS

The big jobs belong to the men who prepare for them. You can earn money—learn how to start a business of your own—with NTS home training.

NTS starts you out right with the exclusive **Project Method Career Kit**. Contains everything you need to make your training easy. Keeps you organized. You learn faster. You move ahead that much sooner.

You can get all the details on the many advantages of NTS **Project Method** home training. It's all in the NTS catalog, along with pictures and information on all the equipment and exciting kits you receive and keep. Tells you all you need to know to get started.

CLASSROOM TRAINING AT LOS ANGELES:

You can take classroom training at Los Angeles in sunny southern California. NTS occupies a city block with over a million dollars in facilities devoted exclusively to technical training. Check special box in coupon.

HIGH SCHOOL AT HOME



National offers accredited high school programs. Take only subjects you need. Study at your own pace. Everything included at one low tuition. Check special high school box in coupon for full information and FREE catalog.

MAIL REPLY CARD OR COUPON FOR NEW COLOR CATALOG & SAMPLE LESSON. THEY'RE FREE!

We Have No Salesman - This Means Lower Tuition For You.



Accredited Member National Home Study Council
Member, National Association of Trade & Technical Schools

NATIONAL TECHNICAL SCHOOLS

WORLD WIDE TRAINING SINCE 1905

4000 So. Figueroa St., Los Angeles, Calif. 90037

9
TRAINING
PROGRAMS

NATIONAL TECHNICAL SCHOOLS

4000 S. Figueroa St., Los Angeles, California 90037

APPROVED
FOR
VETERANS

Please rush Free Color Catalog and Sample Lesson, plus detailed information on field checked below. No obligation.

- Master Course in Color TV Servicing
- Color TV Servicing for Qualified Technicians
- Master Course in TV & Radio Servicing
- Practical TV & Radio Servicing
- Master Course in Electronic Communications
- FCC License Course
- Industrial & Computer Electronics
- Stereo, Hi-Fi & Sound Systems
- Basic Electronics High School at Home

NAME _____ AGE _____

ADDRESS _____

CITY _____ STATE _____

Please fill in Zip Code for fast service

Check if interested in Veteran Training under new G. I. Bill. (Dept. 205-117)

Check if interested ONLY in Classroom Training at Los Angeles.

Move up to 30 watt Courier Business Band.



\$219.50!

FCC TYPE ACCEPTED

FLEET COURIER 30B. Powered for the business and commercial operator. Lowest price unit of its kind (FCC Type Accepted). Big power input (30 watts) and output. Greater range. Reduced interference. Increased antenna height. If you use CB for business communications—move up to Fleet Courier 30B!

COURIER COMMUNICATIONS, INC.

56 Hamilton Ave.,
White Plains, N. Y. 10601

a subsidiary of
Whittaker
CORPORATION

Yes! Tell me all about FLEET COURIER 30B.

Name _____

PE-711

Address _____

City _____

County _____

State _____

Zip _____

CIRCLE NO. 11 ON READER SERVICE PAGE

NOVICES! GENERALS!

A Money Saving — Two meter
5/8 wave omni-directional
Antenna.

THE MOSLEY DIPLOMAT 2
Built to handle any power amateurs
are permitted to use.

Special Do-it-Yourself . .
Customized features for 150 through
175 MCs.

Amateur
Net \$8.10

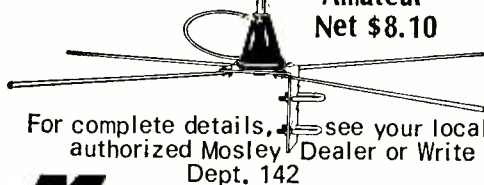

For complete details, see your local
authorized Mosley Dealer or Write
Dept. 142

Mosley Electronics Inc.

4610 N. LINDBERGH BLVD., BRIDGETON MO. 63042

CIRCLE NO. 25 ON READER SERVICE PAGE

voltage output. When the predetermined critical current value is reached, the regulator automatically switches over from constant voltage to constant current. For instance, suppose your circuit takes 60 mA of current under normal conditions. You would simply set your current limit about double, say 120 mA.

As long as the circuit is working properly, you get constant voltage out of the supply. Should a polarity reversal or a fault occur, the supply will provide no more than 120 mA, even to a short circuit, thus automatically protecting both itself and your circuits from a careless mistake or an inadvertent wiring error. The response time to a fault is measured in microseconds—much faster than any fuse or circuit breaker could possibly respond.

-50-

COLOR CODE QUIZ ANSWERS

(Quiz appears on page 70)

- A Axial Lead Resistor**
Value: 27,000 ohms Tolerance: $\pm 5\%$
- B Molded Tubular Paper Capacitor**
Value: 0.1 μF Tolerance: $\pm 30\%$
Voltage: 1200 volts
- C Molded Flat Mica Capacitor**
Value: 470 pF Tolerance: $\pm 10\%$
Code: JAN Class: C
- D Temperature-Compensated Tubular Ceramic Capacitor**
Value 8 pF Tolerance: $\pm 0.1 \text{ pF}$
Temp. Coef.: $-75 \text{ PPM}/^\circ\text{C}$
- E Mylar/Polyester Film Capacitor**
Value: 5600 pF
- F Radial Lead Resistor**
Value: 3.6 megohms Tolerance: $\pm 10\%$
- G Standoff Ceramic Capacitor**
Value: 68 pF Tolerance: $\pm 5\%$
Temp. Coef.: $-220 \text{ PPM}/^\circ\text{C}$
- H Ceramic Disc Capacitor**
Value: 720 pF Tolerance: $\pm 5\%$
Temp. Coef.: $-150 \text{ PPM}/^\circ\text{C}$
- J Molded Choke Coil**
Value: 1.5 μH Tolerance: $\pm 10\%$
Code: MIL
- K Button Silver Mica Capacitor**
Value: 391 pF Tolerance: $\pm 10\%$

POPULAR ELECTRONICS

AMATEUR RADIO

(Continued from page 78)

each station worked, also stating the number of years you have been a ham. Czechoslovakia (OK) contacts count three points, others one point. Total score: contact points multiplied by number of different prefixes worked. Scores go to: CCRC, P.O. Box 69, Praha 1, Czechoslovakia.

Halloween Patrols. Does your amateur radio club cooperate with local law enforcement agencies to control vandalism by over-enthusiastic Halloween "trick or treaters?" Among the clubs that do is the Michigan City Amateur Radio Club (Indiana). The club has a 6-meter transmitter at the police station to communicate with mobile stations assigned to patrol different sections of the city. When a mobile operator sees anything suspicious in his area, he reports to the control station at the police station, so that an official police car can be immediately dispatched to the scene.

Amateurs in Valparaiso, Ind., participate in a similar activity in conjunction with their Civil Defense organization. Authorities in both cities report that these programs giving local police "extra ears and eyes" cut down malicious mischief on Halloween. And one group of youths, foiled several times in carrying out some planned mischief by the sudden arrival of the police, bitterly complained that the police were shadowing them. Our thanks to the *Bison*, of the Indiana Radio Club Council, and the *Harbor Beam*, of the MCARC, for the above items.

"Inventor of Radio." In the book "Mahlon Loomis, Inventor of Radio" (Loomis Publications, 1967, Washington, D.C.), Thomas Appleby, W3AX, indicates that Marconi may have gotten the idea for using

an elevated antenna by reading Loomis's United States Wireless patent issued in 1872.

In 1866, Dr. Loomis, a dentist, had two copper gauze-covered kites on 600' copper wires flown from two Virginia mountaintops 18 miles apart to demonstrate the use of atmospheric electricity in a wireless telegraph system. Grounding and ungrounding one kite wire produced a detectable change of current in the other kite's ground connection. Dr. Loomis found that the system worked only when the kites were at the same heights, proving—he said—the necessity of tapping the same layer of atmospheric electricity at both ends of the path. In view of today's knowledge, however, it is more likely that, with his kite antennas at the same height, his transmitter and receiver were tuned to the same frequency.

A DX man at heart, Dr. Loomis tried unsuccessfully for years to raise enough money to prove that he could transmit from the United States to Japan on his wireless telegraph system. His best DX was a vague claim to have covered 400 miles in his experiments, but apparently he did not have a "QSL card" to prove it.

Incidentally, W3AX states in the book that the string of the kite Benjamin Franklin used to prove that natural and artificial electricity were the same had a resistance of 15 million ohms!

Interference Ended. A few months ago, the national press and TV published allegations that a West Coast amateur had been maliciously interfering with "phone patches" between wounded servicemen on a hospital ship in a Vietnam harbor and home, even though it was rumored that his own son was in Vietnam. Without judging his past conduct, we are glad to report that the same amateur's recent operating has been above reproach.

WCARS Log Via WB61ZF. WA6PTN, La Puente, Calif., called on the West Coast

NEW SOLID STATE 5-BAND RECEIVER

SEND FOR FREE LITERATURE

MODEL R-5

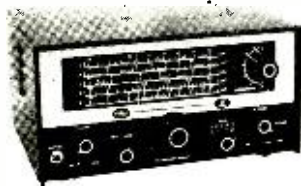

- Continuous Coverage .54 to 54 mc
- Variable beat frequency oscillator
- Includes 6-meter ham band
- And the 30 to 50 mc police bands
- Fully transistorized — Bandsread
- Noise limiter — Optional battery pack

WIRED AND TESTED \$79.95

AMECO

DIVISION OF AEROTRON



BOX 6527, RALEIGH, N. C. 27608

CIRCLE NO. 1 ON READER SERVICE PAGE

People who built their own Schober Organs wrote this ad

Here's what they say about the pleasure of assembling the Schober Electronic Organ from kits . . . and enjoying the magnificent sound of an instrument they've created in their spare time.



The NEW Schober THEATRE ORGAN
one of four models available

Building was fun
"Building it was at least as much fun as playing it!"
Mr. Lester F. Schwartz,
Somerset, N. J.

So proud I could pop
"I've done over 90 per cent of the work on this organ myself—and I'm so proud I could about pop!"
Mrs. V. P. Alibert,
Topeka, Kansas

Nothing as fine under \$4,000
"... I could not find any organ that sounded as fine as the Schober under \$5,000."
Mr. Jerome J. Fraenkel,
Franklin Square, N. Y.

Proud to own

"I am proud to own such a valuable instrument."

Mr. Jean J. Juteau, Montreal, Canada

Most cherished possession

"My spinet has become the most cherished possession in our home—fabulous, indeed."

Mr. Frank J. Marion, North Bergen, N. J.

Tremendous sound

"The sound is conservatively, tremendous."

Mr. Paul DeForest Wren, Westbrook, Conn.

Unbelievably easy to build

"When we ran out of instruction, the organ was finished . . . To me it was unbelievable!"

Mr. Ted Sowinski, Chicago, Illinois

Thousands of music lovers in every walk of life—from teen-agers to grandmothers, from people who are "all thumbs" to electronic engineers—have enjoyed the pleasure of assembling, playing and hearing the magnificent sound of the Schober organ. Whether you favor Bach or Bop, there is a Schober organ that gives you full range of expressional and tonal quality—so like a fine pipe organ that many listeners can't tell the difference. You can build a Schober organ for as little as \$645. And—even if you've never played a note before—Schober's enjoyable self-teaching courses give you immediate musical results.

Over 50% of Schober Organ owners never handled an electronic job before and didn't play a note, yet assembled some of the best organs ever designed and get a daily thrill from making their own music. Isn't it time for you to take this cost-saving road to greater musical pleasure—and enjoy the satisfaction of doing it yourself?

Free Information and Demonstration Recording

Send today for your free copy of Schober's 16-page, full color booklet, plus 7" free recording.

The Schober Organ Corp., Dept. PE-24
43 West 61st Street, New York, N. Y. 10023

- Please send me Schober Organ Catalog and free 7-inch "sample" record.
 Enclosed please find \$1.00 for 12-inch L.P. record of Schober Organ music.

NAME _____

ADDRESS _____

CITY _____ STATE _____ ZIP _____

CIRCLE NO. 32 ON READER SERVICE PAGE

Amateur Radio Service frequency of 7255 kHz with a message that a California girl traveling in the Far East was ill and that her previous medical history was needed to treat her. The information could not be sent expeditiously by commercial means; complicating the problem, international regulations forbid amateur third-party traffic to all Asiatic countries except Israel. But, after being alerted by K6KZI, W6QIE. South San Francisco, Calif., took the complicated medical message and put it into Thailand via Navy MARS and other channels within a few hours. The girl recovered.

NEWS AND VIEWS

Al Ward, WA9QZE, 309 Warwick, Barrington, Ill., went from SWL to Novice to General. He is the manager of the Barrington Amateur Radio Club station, WA9EDW. Using a Johnson "Valiant" transmitter, a Hallicrafters S-108 receiver aided by a Q-multiplier, and a Heathkit "Twoer." Al operates all amateur bands from 7 MHz through 148 MHz (except the 50-MHz band). His antennas include a home-brew vertical for 40 through 10 meters, a 40-meter dipole, and a Hy-Gain, 8-element, 2-meter beam. He has 49 states and 24 countries in five continents logged on the lower frequencies—Delaware is the hold-out state. Al's 2-meter record is five states and 130 miles—not bad for a five-watter . . . **Lee Hays, WN5PPF**, 426 S. Mockingbird Lane, Abilene, Texas, has a Novice record that many an old-time General would be proud of. How do "Worked All States" and "Worked All Continents" sound for starters? Then there is his Novice Round-Up score of 518 contacts in 72 sections in 34 hours of operation. Add these to 21 countries worked, membership in the Rag-Chewer's Club and QRP Club, NCS of two nets, and a 15-wpm code certificate, and you'll get the idea that Lee takes his amateur radio seriously. Doublet antennas for 40 and 15 meters and a "long wire" for 80 meters are driven by a Johnson "Viking" transmitter. Until recently, Lee's receiver was a Hallicrafters SX-140; now it is a Hallicrafters SX-100 . . . **Les Zaviski, WN7HEO**, Rt. 3, Box 236A, Enumclaw, Wash., works the three low-frequency Novice bands—"15" more than the other two. A Hy-Gain 14-AVQ vertical antenna abetted by a Hallicrafters HT-40 transmitter and S-129 receiver have put 24 states and three countries in the WN7HEO logbook.

Jack Bernath, Jr., W8FBP, 2825 Reynoldsburg-New Albany Rd., Blacklick, Ohio, has a busy schedule. He works for Bell Telephone Co. during the day and goes to the University of Ohio evenings; and in his spare time, he likes to home-brew equipment and modify surplus gear. An EICO 753 tri-band transceiver drives a home-brew linear amplifier using a pair of 813 tubes which excite either a 500' "long wire" antenna or a 3-element, 20-meter beam. The beam made a DX man out of Jack; he has worked 40 countries in the last three months to go with his 40 states worked. Oh, yes, Jack is also an active MARS member; he "plays with" radio-teletype and gardening, raises tropical fish; and strums a "blue grass" banjo . . . **Lloyd Simon, WA1FGK**, 120 Russell Rd., W. Newton, Mass., works 80, 40, 20, 15, and 10 meters with five dipole antennas all connected to a single feed line. Lloyd says the "spider web" works quite well, although it did take some pruning of lengths to make it work. The inside equipment includes an EICO 720 transmitter and 730 modulator combination and a Hallicrafters S-108 receiver. France and Scotland worked on 10 meters are Lloyd's latest DX—not too bad with 65 watts amplitude modulation.

Bruce McNair, WB2NYK, 79 Woodland Ave., Fords, N.J., runs 150 watts (peak) to a Knight-Kit T-150

transmitter to excite a Hy-Gain 14-AVS vertical antenna or a 10-, 15-, and 20-meter quad. The quad does especially well on "10," where Bruce worked 25 states and five countries on phone last spring. His total record is 45 states and 36 countries. Bruce recently became a certificate chaser and has 160 U.S. counties QSL'ed towards a Worked All Counties certificate. Already in hand are a 25-wpm code certificate and a "Real Ragchewer's Club" certificate commemorating a 7-hour contact! . . .

John R. Barlow, WA0JOA, 1610 Cottrell Ave., Iowa Falls, Iowa, is another ham who combines commercial and home-built equipment. A "Galaxy V" SSB/CW transceiver drives a home-brew linear amplifier on the lower frequency bands. John's favorite band is 75-meter phone, but he works 15 meters fairly frequently. His 75-meter antenna is a "bow tie," and his 15-meter antenna is a home-built, 2-element beam. They must work, because WA0JOA's record shows all states and 45 countries. John has much other equipment in the shack, including a Heathkit "Twoer," which drives a home-built beam 58' high . . . **Richard Dillman, WA2BJK**, 38 Emerson Ct., Westbury, N.Y., votes for the grounded (Marconi) antenna. On 80-meter CW, he says, the signal he puts out results in some of the fellows he works doubting that his power is only 50 watts. The secret is a good ground system. WA2BJK uses a Johnson "Adventurer" transmitter controlled by a Lafayette Radio VFO, and the receiver is a BC-453 surplus receiver plus a converter.

Your "News and Views" and a picture of your station would look fine on these pages; so let's have that letter you've been planning to write. We appreciate seeing your club bulletins. Mail all material to: Herb S. Brier, W9EGQ, Amateur Radio Editor, POPULAR ELECTRONICS, P. O. Box 678, Gary, Ind. 46401.

73, Herb, W9EGQ

SHORT-WAVE LISTENING

(Continued from page 75)

broadcast club. Their bulletin contains more than 50 pages devoted to short-wave broadcast tips, feature articles on various stations, QSL information, and other items of timely interest. Congratulations to Executive Editor Bill Eddings and his staff (Don Jensen, Del Hirst, Gregg Calkin, Dan Henderson, etc.) who have worked long and hard to build the NASWA bulletin up to its present fine caliber. If you would like to receive a sample copy of the bulletin, send 25 cents to: Bill Eddings, P.O. Box 989, Altoona, Pa. 16603.

CURRENT STATION REPORTS

The following is a resume of current reports. At time of compilation all reports are as accurate as possible, but stations may change frequency and/or schedule with little or no advance notice. All times shown are Greenwich Mean Time (GMT) and the 24-hour system is used. Reports should be sent to SHORT-WAVE LISTENING, P.O. Box 333, Cherry Hill, N. J., 08034, in time to reach your Short-Wave Editor by the fifth of each month; be sure to include your WPE identification, and the make and model number of your receiver. We regret that we are unable to use all the reports received each month, due to space limitations.

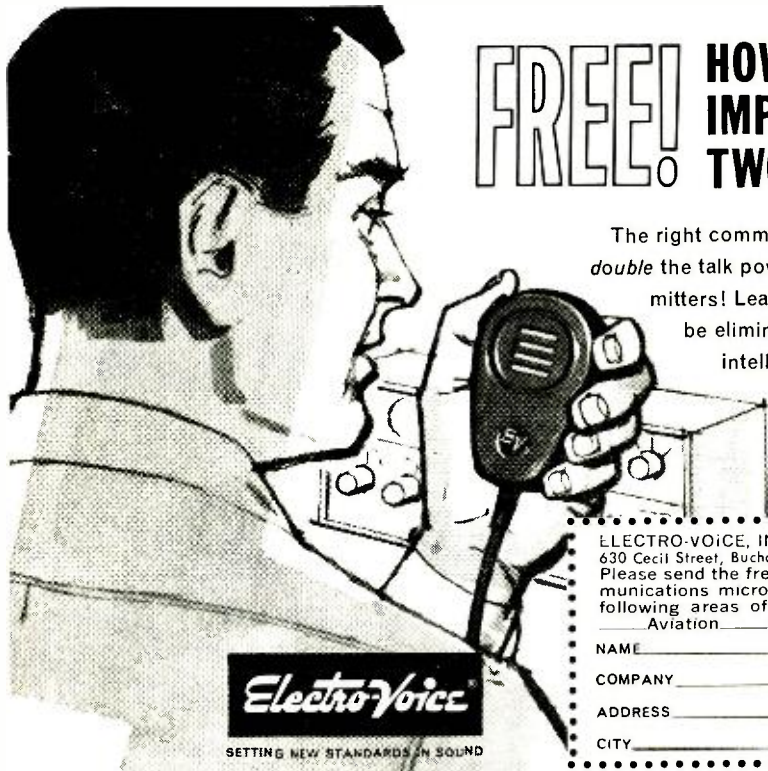

FREE! HOW TO IMPROVE YOUR TWO-WAY RADIO!

The right communications microphone may *double* the talk power of even the finest transmitters! Learn how unwanted noise can be eliminated—reliability improved—intelligibility increased by proper microphone selection.

Write for our helpful free booklet today!

Electro-Voice
SETTING NEW STANDARDS IN SOUND

ELECTRO-VOICE, INC., Dept. 1172P
630 Cecil Street, Buchanan, Michigan 49107
Please send the free E-V booklet on choosing communications microphones. I am interested in the following areas of two-way radio: Amateur Aviation CB Business.

NAME _____
COMPANY _____
ADDRESS _____
CITY _____ STATE _____

CIRCLE NO. 15 ON READER SERVICE PAGE

FREE!



BRAND NEW FALL AND WINTER RADIO-TV ELECTRONICS CATALOG



**YOUR BUYING GUIDE
FOR:** • Stereo & Hi-Fi
Systems & Components
• Tape Recorders • Elec-
tronic Parts, Tubes, Tools
• Phonos & Records
• Ham Gear • Test In-
struments & Kits • Cam-
eras & Film • PA • Cit-
izens Band • Radio & TV
Sets • Musical Instru-
ments

MAIL TODAY TO:

BURSTEIN-APPLEBEE

Dept. PEK 1012 McGee, Kansas City, Mo. 64106

Name _____
Address _____
City _____
State _____ Zip Code _____

CIRCLE NO. 8 ON READER SERVICE PAGE

but we are grateful to everyone who contributes to this column.

Afghanistan—*R. Afghanistan*, Kabul, has been heard at 1125 on 21.585 kHz with selections that sounded like a mixture of Arabic and Indian music; news in native language was given at 1130. The 15.255-kHz outlet was noted at 1645-1700 in native language and to 1715/fade in Russian.

Angola—*R. Commercial de Angola*, Sa da Bandeira, 7150 kHz, was on this measured frequency when noted at 0630 with pop music, Portuguese.

Argentina—One of the more unusual Argentinians is LRX1. *R. El Mundo*, Buenos Aires, heard on 6120 kHz with light music at 0215 and news and commentary at 0230, all-Spanish. This 10-kW xmsn comes through on the West Coast at this time with a fair-to-good signal.

Austria—Vienna is heard well at 1500 on 17.730 kHz, though sharing the channel with WNYW, New York. This station can be easily identified by its multilingual station annnt.

Barbadoes—DX'ers needing this country should try for *R. Barbadoes*, 780 kHz. Using 10 kW, they are often audible in the East (U.S.) over WEBM, Chicago. Try around 0200-0400. Reports should go to Caribbean B/C Corp., The Pine. St. Michael, Barbadoes.

Bolivia—*R. Pio XII, Siglo Viente*, was noted at 0904 with typical Bolivian music; new address for this 5955-kHz station is Correo Central, Llallagua. *R. Altiplano*, La Paz, now operates 24 hours daily on 5045 kHz. *R. Santa Cruz, La Voz de la Tierra Pampa*, Santa Cruz, is being widely heard around 0030 on 6140 kHz.

Brazil—Broadcasts from Brazil heard recently include: on 4765 kHz, *R. Feira de Santana*, ZYN37, Feira de Santana, with instrumental music to 0300 s/off; on 4795 kHz, *R. Tabajara*, Joao Pessoa, with music from 0901 to 0918/fade; on 4805 kHz, ZY58, *R. Difusora de Amazonas*, to 0303 s/off with some Herb Alpert records; on 4815 kHz, ZYH27, *R. Iracema de Fortaleza*, Fortaleza, from 0945 to 1021/fade with organ and accordian music; on 4915 kHz, ZYR60, *R. Cultura de Araraquara*, Araraquara, from 0902 to 0926/fade mostly with commercials but some music; on 4935 kHz, ZYI21, *R. Poti*, Natal, from 0901 to 0927/fade (this station verifies promptly in Eng.); on 4945 kHz, ZYE23, *R. Educadora de Braganca*, Braganca, from 0902 to 0925/fade and again at 1035-1100; and on 4955 kHz, PRF7, *R. Cultura de Campos*, Campos, from 0853

SMALL BUT POWERFUL

DON'T BE FOOLED BY
IMITATIONS!
Get the ORIGINAL



SYDMUR SOLID STATE "CD" IGNITION SYSTEM!

High Quality Components used throughout. Fiberglass Printed Circuit Board. Unitized Construction. Simplified Kit Assembly.

Construction Article in Nov. 1966 Popular Electronics

Thousands of satisfied customers.

Write for Free Literature TODAY.

COMPAC Assembled . . . \$34.75*

COMPAC KIT 24.95*

*Add 75c for mailing and handling

N.Y. State Residents add Sales Tax.

SYDMUR ELECTRONICS SPECIALTIES

1268 E. 12th St. Brooklyn, N.Y. 11230



At the controls of his Hallicrafters S-20R "Sky Champion" receiver is R. Leon Bridwell, WPE5ELW, Antlers, Okla. To date, he has 15 countries and 21 states verified. His antennas: twin 55' long-wires. If you would like to see YOUR installation on these pages, send a clear photo with you at the controls to Short-Wave Listening, P. O. Box 333, Cherry Hill, N.J. 08034, including some data on the equipment you use and your record as an SWL.

GET INTO ELECTRONICS

V.T.I. training leads to success as technicians, field engineers, specialists in communications, guided missiles, computers, radar, automation. Basic & advanced courses. Electronic Engineering Technology and Electronic Technology curricula both available. Associate degree in 29 months. B.S. obtainable. G.I. approved. Start February, September. Dorms, campus. High school graduate or equivalent. Catalog.

VALPARAISO TECHNICAL INSTITUTE
DEPARTMENT PE, VALPARAISO, INDIANA



to 0914/fade. All of the xmsns listed were in Portuguese and most of them (except where noted) had typical Brazilian music.

Cameroon—A station that we have not heard or had reported in N.A. is *R. Buca*. Yaounde, listed for 5984 kHz, with 1 kW, but widely reported in Europe as being on 3970 kHz and noted after 1930 (presumably in French—Ed.). Has anyone definitely logged it?

Chile—*R. Sociedad de Minería*, Santiago, was noted closing at 0410 after many commercials, "noticias," and variety programs, all-Spanish, on 9753 kHz.

Colombia—Station IJPT, *R. Colosal*, Neiva, listed for 6095 kHz, has appeared on 4947 kHz and should not be confused with *R. Nacional de Colombia* wandering around 4952 kHz. HJPT has been heard at 0300-0500 in Spanish. The station on 6097 kHz, mistakenly thought to be the above-mentioned *R. Colosal* is, in fact, HJIV, *La Voz del Centro*, Espinal, which opens at 1100.

Congo (East)—Lubumbushi (formerly Stanleyville) was recently noted in French from 2045 to 2100 s/off with African pop tunes on 11,865 kHz.

Congo (West)—Brazzaville has been heard on 15,445 kHz, at 0600-0615 in French, to 0630 in Eng., and from 0630 again in French; and on 15,280 kHz with news in Eng. at 2000-2030, then native language. All broadcasts were relay xmsns from Paris.

Cook Islands—*R. Rarotonga* has placed an order for three 5-kW xmtrs, one for the medium waves, the others for 3265 and 5045 kHz. Their present schedule is 2030-2330 and 0430-0900. Plans call for another xmsn at 1630-1930.

Egypt—Cairo now has Arabic at 1700 on a new frequency: 15,095 kHz. English can be heard at 2145-2230 on 11,995 kHz and at 0130-0300 on 9475 kHz.

Finland—Station OIX4, Pori, 15,185 kHz, is heard with IS at 1210, ID in native language at 1213,

and Eng. to past 1248; at 1500-1600 in Finnish, in Eng. at 1600 with "Finn Magazine," and back to Finnish at 1630, dual to 9555 and 11,805 kHz. The station has moved its 2300-0000 xmsn to N.A. to 15,155 kHz, and reception has improved.

SHORT-WAVE ABBREVIATIONS

anmt	Announcement	ORM	Station interior-
B C	Broadcasting	ence	
Eng.	English	R.	Radio
ID	Identification	s/off	Sign-off
IS	Interval signal	s/on	Sign-on
kHz	Kilohertz	VOA	Voice of America
kW	Kilowatt-	xmsn	Transmission
N.A.	North America	xmtr	Transmitter

France—Paris can be noted in Eng. at 1915-1930 and from 1120 s/on in French to Madagascar.

Guantanamo Bay—This relatively rare country can be logged on 1340 kHz evenings with Armed Forces Radio & Television Service programs of music and items of military interest.

Honduras—Station HRSY, *La Voz del Pacifico*, San Lorenzo, 4913 kHz, has been noted in Spanish relaying an earlier VOA Spanish program. They feature irregularly spaced ID's and many Latin American pop tunes. Try after 0230.

Indonesia—An Indonesian regional outlet, with pop music of the S. E. Asia type and a girl with a soft voice doing the announcing but with no Eng., was tentatively logged as YDH2, Semerang, 3935 kHz, at 1020-1030.

Iraq—*R. Baghdad* was noted on 15,400 kHz in the Home Service with talks in Arabic and chanting at 1105-1200.

Italy—Rome has Spanish to Latin America at 0305-0325 and Italian to the same areas at 2230-0000, both on 17,770, 15,410, 15,310, 11,905, and 11,810 kHz. Rome also transmits to N.A. on 15,400

Another Winner



News Service film crews and 500 mile race movie cameramen used 29 Regency CB radios for fast, reliable communications during the 1967 running of the world famous event. Our Bronco offers you the same low-priced communication reliability and versatility. With optional field-pack, and AC power supply, you can use it effectively for mobile, base or portable operation. And—the attractive price tag is unmatched by any other CB set. Try one today—you'll like the results.

at the
Indianapolis
500 Mile Race

the 
Bronco
only \$89.95



The Imperial

Range Gain II

Ranger

Pacer II

Charger

CIRCLE NO. 40 ON READER SERVICE PAGE

5 watts, 8 channels with channel 11 crystals
REGENCY ELECTRONICS, INC.
7900 PENDLETON PIKE
INDIANAPOLIS, INDIANA

GET



ACTION WITH

MULTI-ELMAC
PRECISION MADE,
POPULAR PRICED
CB UNITS!

FULL 23 CHANNEL

AC-DC Operation,
Illuminated Meter
& Channel Selector,
Triple Tuned RF,
"Noise Immune"
Squelch, Disable
Tuned IF's, Ready to Operate



\$16950

FULL 8 CHANNEL

AC-DC Operation,
Delayed AVC,
Electronic Switching,
2 Stage Pre-Amp,
Illuminated "S"
Meter, Complete
with Crystal for 1 Channel



\$9950

SOLID STATE

Transmitter-Converter

Compact 5/8" x
4 3/8" x 1 1/2", 9
Transistor, 2
Diodes, 5 Watt
Input (FCC Max.)
100% Modulation, 12 VDC
Operation, Complete with Crystal for
1 Channel



\$4995

Please send further information on Citi-Fone SS , 99 , II



MULTI-ELMAC CO.

21470 Coolidge • Oak Park, Michigan 48237

NAME _____

ADDRESS _____

CITY _____

STATE _____ ZONE _____

CIRCLE NO. 26 ON READER SERVICE PAGE

kHz at 0100-0120 in Eng., and from 0120 in French.

Lebanon—The xmitn at 2000 on 17.750 kHz to Africa listed last month as being in Arabic is actually in French. The 17.765-kHz outlet, listed for Spanish at 0030-0100, has been noticed running until 0125.

Mozambique—The Regional Service of *R. Clube de Mozambique* is testing a new xmitr in Nampula on 4985 kHz at 1700 with amnts in vernaculars, and on 7275 kHz at 0930 relaying the Portuguese service, dual to 7250 kHz. Other active Nampula outlets are 3355, 3376, 4945, 4955 and 1730 kHz. Active channels of regional service from Quelimane are 3210, 4895, and 7145 kHz. Porto Amelia is noted in Portuguese at 1030 on 7110 kHz. *R. Par*, Beira, is now on 4807 kHz and is scheduled for 0300-0600, 0900-1200, and 1800-2100.

Nigeria—*Voice of Nigeria*, Lagos, has been heard on two new frequencies: 21.645 kHz at 1540 in Eng. with pop music; and 11.715 kHz with "Listener's Choice" in Eng., closing at 2300.

Norway—*R. Norway*, Oslo, 11.735 kHz, has been noted at 2300-0000 with news, talks, and light music—all Norwegian except for Eng. ID and request for letters and reports. Tune carefully for this one: Holland on 11.730 kHz, and Mexico on 11.740 kHz, make reception difficult.

Portugal—Lisbon airs Eng. at 0730-0815 to Australia and New Zealand on 17.890, 17.880, and 11.840 kHz, at 0815-0900 to Japan and the Far East, at 1345-1430 to S. E. Asia and at 1815-1915 to Africa on 21.490, 17.890, and 17.880 kHz, at 2045-2130 to Europe on 9635, 7225, 7130, 6185, and 6025 kHz, at 2245-2330 to Europe on medium-wave 1061 and 755 kHz

SHORT-WAVE CONTRIBUTORS

Conrad Baranowski (*WPE1GXX*), Boston, Mass.
Paul Montelusco (*WPE1HDA*), Norwalk, Conn.
William Putney (*WPE2BGN*), Princeton, N.J.
William Graham (*WPE2LMU*), Binghamton, N. Y.
Robert Kaplan (*WPE2MIR*), Bronx, N. Y.
Richard Kline (*WPE2MUY*), Englewood, N. J.
Al Sauerbier (*WPE2NDA*), Washington, N. J.
John Zapisek (*WPE2OKD*), Wading River, N. Y.
Peter Macinta, Jr. (*WPE2ORB*), Kearny, N. J.
Craig Rice (*WPE2OXB*), Webster, N. Y.
William Cangemi (*WPE2PII*), Staten Island, N. Y.
Edward Sobota (*WPE2PJR*), Fulton, N. Y.
David Palfrey (*WPE2PKC*), Kearny, N. J.
John Hopkins (*WPE2PM*), Rockville Center, N. Y.
Marshall Brooks (*WPE2PQW*), Rochester, N. Y.
David Simon (*WPE2POP*), Brooklyn, N. Y.
William Via (*WPE2FHB*), Baltimore, Md.
Richard Spear (*WPE2SHE*), Baltimore, Md.
Marc Riddell (*WPE2HGG*), Williamsport, Pa.
Rudolph Menna (*WPE2HIV*), Philadelphia, Pa.
Grady Ferguson (*WPE2ABC*), Charlotte, N. C.
Edward Shaw (*WPE2JHP*), Roanoke, Va.
John Mayo (*WPE2JNG*), Oxford, N. C.
Trev Clegg (*WPE2FAE*), Fresno, Calif.
Alan Bender (*WPE2GGT*), Los Angeles, Calif.
Roger Treskunoff (*WPE2GGO*), San Francisco, Calif.
Mike Craig (*WPE2GPA*), Tustin, Calif.
Dave Frandin (*WPE2GTC*), San Diego, Calif.
Bruce Sebrian (*WPE2GTJ*), Bethel Island, Calif.
Steve Blanchard (*WPE2JIP*), Lansing, Mich.
Mark Ondrejko (*WPE2JIO*), Maple Heights, Ohio
Bill Vogt (*WPE2IND*), Tinley Park, Ill.
John Balzer (*WPE2IRS*), Greendale, Wis.
A. R. Niblack (*WPE2KAM*), Vincennes, Ind.
John Beaver, Sr. (*WPE2OAE*), Pueblo, Colo.
Jack Perolo (*WPE2PEIC*), Milwaukee, Wis.
Jeffrey Ace, Binghamton, N. Y.
David Alpert, Morton Grove, Ill.
Leo Alster, Rahway, N. J.
Floyd Dunlap, Houston, Texas
Henry Gac, Detroit, Mich.
Howard Glazer, Sharon, Mass.
Walter Karcheski, Jr., Worcester, Mass.
Ed Panich, Western Springs, Ill.
Curtis Phillips, Hellertown, Pa.
Michael Sutter, Palmetto, Ga.
Richard Wendt, III, Edgewood, Pa.
Robert White, San Francisco, Calif.
Roger Wink, Penfield, N. Y.
Sweden Calling DX'ers Bulletin, Stockholm, Sweden



Steven Celli, WPE2PSK, Freeport, N.Y., uses a Lafayette HA-63A receiver. There are 63 QSL cards in his shack. Steve's record: 34 countries verified.

(loggings are possible in Eastern N.A.) at 0300-0345 to Canada on 5985 kHz, and at 0200-0245 and 0400-0445 to N.A. on 9635, 6185, and 6025 kHz.

Rhodesia—Here is the revised schedule for the Rhodesia B/C Corp.: General Service on 3396 and 2425 kHz at 0355-0615 and 1500-2100 (Saturdays to 2200) and on 6020 kHz weekdays at 0620-1455 and Sundays at 0530-1200. The African Service is on 3306 kHz weekdays at 0330-0600 and daily at 1435-2015, and on 5975 kHz weekdays at 0605-1430 and Sundays at 0530-1430.

South Africa—The current schedule for *R. RSA*, Johannesburg is: European Service in French at 1756-1855 and in Eng. at 1856-1955 on 17.790 and 21.500 kHz; in German at 2026-2125 on 15.245 and 17.790 kHz; in Dutch at 2126-2225 and in Portuguese at 2226-2325 on 11.785 and 15.245 kHz. English to N.A. will be aired at 2326-0325 on 9705 and 11.970 kHz.

Sweden—*R. Sweden*, Stockholm, was noted with an Eng. DX program ending at 1430 and continuing in Swedish; additional Eng. was heard at 1600-1630, including Swedish-Eng. lessons, then Swedish from 1630; all on 17,840 kHz.

Syria—The present schedule from *R. Damascus* lists French and Eng. to Europe at 1600-1900 on 15.165 kHz and the same languages with omnidirectional antenna at 0500-0730 on 7145 kHz, mixed Hebrew, German, and Yugoslav at 1400-1500 on 7145 kHz and Turkish at 1500-1600 on 7145 kHz (omnidirectional); mixed Arabic, Spanish, and Portuguese at 2330-0100 to South America on 17.865 and 17.895 kHz and to N.A. on 15.165 kHz. Arabic xmsns are beamed to Europe at 1900-2300 on 15.165 kHz, to Egypt at 0400-0730 and 1000-1730 on 11.915 kHz and to N. Africa at 0400-0730 on 17.865 kHz, at 1000-1300 on 17.860 kHz, and at 1300-2300 on 11.915 kHz; omnidirectional broadcasts in Arabic are at 0730-1000 and 1900-2300 on 7145 kHz.

Thailand—Bangkok was noted with ID of *Overseas Service of R. Thailand* in Eng. at 1130, then chimes, on 7115 kHz.

U.S.S.R.—*R. Vilnius*, Lithuanian SSR, has been heard on a Sunday at 2255 with Eng. commentary and asking for reports on a new frequency: 11.790 kHz. *Govorit Kiyiv*, Kiev, Ukrainian SSR was noted with IS and ID at 2230, then programming on 11,980 kHz (new frequency), right alongside of *R. Moscow*, 10 kHz lower.

Venezuela—Station YVPP, *La Voz de la Frontera*, San Antonio del Tachira, reported last month on 4765 kHz, has been varying as low as 4755 kHz but at press time seems to have stabilized on 4760 kHz. The dual channel of 11.725 kHz has not yet been heard. S/off time is 0400.

NEW! ASTRO-COM WRIST TRANSMITTER FM 88-108 MC \$13.95

- TRANSMIT TO ANY STANDARD FM RADIO
- WORKS INDOORS OR OUT
- SPRING LOADED ANTENNA
- BATTERY AVAILABLE ANYWHERE



NEW! ASTRO-COM \$13.95

- DURABLE WATCH STRAP
- HIGH-IMPACT PLASTIC
- IT'S FUN! IT'S EFFECTIVE! IT'S POWERFUL!
- NO LICENSE REQUIRED

Discount Hobby Distributors
10977 Santa Monica Blvd.
Los Angeles, Calif. 90025

Name _____
Address _____
City _____
State _____ Zone _____

Send check, cash, or money order.
Calif. residents add 5% sales tax.

CIRCLE NO. 6 ON READER SERVICE PAGE

CRYSTAL GAZING

NO WAITING for the FUTURE



Buy The Best

PRECISION QUARTZ CRYSTALS
and ELECTRONICS for the
COMMUNICATIONS INDUSTRY

SENTRY MANUFACTURING COMPANY

1534 Linwood Boulevard—Oklahoma City, Oklahoma 73105
PHONE: 424-212-0331 — TELE: 871-3611 — TWE: 809 871-3176

CIRCLE NO. 34 ON READER SERVICE PAGE

**SAY YOU SAW
IT IN
POPULAR ELECTRONICS**

WRITE
NOW FOR
1968
SENT FREE

**McGEE'S
CATALOG**

1001 BARGAINS IN

SPEAKERS—PARTS—TUBES—HIGH FIDELITY
COMPONENTS—RECORD CHANGERS—
Tape Recorders—Kits—Everything in Electronics

1901 McGee Street, Kansas City, (PE), Missouri 64108

LEARN Electronics Engineering AT HOME

Fix TV, design automation systems, learn transistors, complete electronics. College level Home Study courses taught so you can understand them. Earn more in the highly paid electronics industry. Computers, Missiles, theory and practical. Kits furnished. Over 30,000 graduates now employed. Resident classes at our Chicago campus if desired. Founded 1934. Catalog. "Vets"—write for information about G I Bill Training.

AMERICAN INSTITUTE OF ENGINEERING & TECHNOLOGY
1137 West Fullerton Parkway, Chicago, Illinois 60614

R. Monagas, Caracas, normally on 11.770 kHz, has been testing around 11.749 kHz at 1715-1730 with music, ID's, and commercials.

Station YVKM, Caracas, 5030 kHz, is now announcing as *R. Reloj Continente* but the general format is unchanged. It was tuned recently from 0330 to 0400 s/off with Latin American music, commercials, and a newscast at 0355, all-Spanish.

Clandestine—*Liberation Radio, the Voice of the South Vietnam National Front for Liberation* (Viet Cong) is heard at good level but with poor modulation in Eastern N.A. at 1100 s/on operating on varying channels between 9980 and 10,100 kHz. (at press time it was on 10,070 kHz—Ed.). There is a dual channel operating on 8240 kHz. The only logged Eng. is heard on Saturday at 1315-1330 and is described as a "special broadcast for American servicemen in South Vietnam." The Vietnamese ID is *Dai Phat Thanh Giai Phong*.

Unidentified—An interesting station has been heard recently on 15,015 kHz, opening in Vietnamese at 1500 with a chime IS and an ID that begins *Day la Tieng . . . Vietnam . . .* A second program opens at 1530 and runs to 1600 using the same IS and ID. It is not known whether this is Saigon (unlikely), Hanoi (possible), or a Vietnamese program from Moscow or Peking—although neither the Moscow nor the usual Peking IS is used. Can anyone identify the station?

Utility—If you need Newfoundland, try for *Gander Radio*, Gander, 8828.5 kHz, with aero weather at 20 and 50 minutes past the hour. The Kennedy (New York) weather forecast precedes it by five minutes; Shannon (Ireland) follows it. —30—

ON THE CITIZENS BAND

(Continued from page 56)

Club Chatter. New York area CB'ers have been invited by the Metropolitan CB'ers Association, Inc., to register their CB gear (or any electronic equipment) through the club, by supplying the serial number of the equipment and 25 cents per unit to be listed. When compiled, the list will be forwarded to police, electronics distributors and dealers, and any others desiring the information, to be used for identification in case of theft or loss. Interested parties can obtain more information from the club at 900 Grand Concourse, Bronx, N.Y.

The Western Nova Scotia CB Club is buzzing with activity, according to press correspondent Louis Nickerson, XM63-1108. The club has had a weekly feature in local newspapers for several months. They also took time to publish, jointly with area CB clubs, a CB radio guide and information pamphlet for visitors to the area. The guide indicates which channels are in use, and the whereabouts of area clubs along individual routes. If you're planning a trip "that far," or would like one of the guides for a future excursion, contact Louis in care of the club at Woods Harbour, Shelburne Co., Nova Scotia.

I'll CB'ing you,

—Matt, KHC2060

ELECTRONICS MARKET PLACE

COMMERCIAL RATE: For firms or individuals offering commercial products or services. \$1.00 per word (including name and address). Minimum order \$10.00. Payment must accompany copy except when ads are placed by accredited advertising agencies. Frequency discount: 5% for 6 months; 10% for 12 months paid in advance.

READER RATE: For individuals with a personal item to buy or sell. 60c per word (including name and address). No Minimum! Payment must accompany copy.

GENERAL INFORMATION: First word in all ads set in bold caps at no extra charge. Additional words may be set in bold caps at 10¢ extra per word. All copy subject to publisher's approval. Closing Date: 1st of the 2nd preceding month (for example, March issue closes January 1st). Send order and remittance to: Hal Cymes, POPULAR ELECTRONICS, One Park Avenue, New York, New York 10016.

FOR SALE

FREE! Giant bargain catalog on transistors, diodes, rectifiers, SCR's, zeners, parts. Poly Paks, P.O. Box 942, Lynnfield, Mass. 01940.

GOVERNMENT Surplus Receivers, Transmitters, Snooper scopes. Radios, Parts, Picture Catalog 25¢. Meshna, Nahant, Mass. 01908.

INVESTIGATORS, FREE BROCHURE, LATEST SUBMINIATURE ELECTRONICS SURVEILLANCE EQUIPMENT, ACE ELECTRONICS, 11500-L NW 7TH AVE., MIAMI, FLA. 33168.

WEBBER LAB'S POLICE-FIRE KITS \$5.00 ALL SOLID STATE, SPECIFY FREQUENCY. 26-200MC ALWIRED CRYSTAL CONTROLLED LIFE TIME GUARANTEE \$23.00, KIT \$11.00. WRITE FOR METAL LOCATORS, REMOTE READING COMPASS, CATALOG 10¢, 72 COTTAGE STREET, LYNN, MASS. 01905.

R.F. CONVERTERS. World's largest selection. Also CCTV cameras, etc. Lowest factory prices. Catalog 10¢. Vanguard 196-23 Jamaica Ave., Hollis, N.Y. 11423.

TELEPHONE VOICE SWITCH: (LS-500). ACTUATES AUTOMATICALLY AND UNATTENDED ANY TAPE OR WIRE RECORDER. PICTORIAL INSTALLATION INSTRUCTIONS INCLUDED. \$23.75. POST PAID USA, WJS ELECTRONICS, 737 NORTH SEWARD, HOLLYWOOD, CALIF. 90038.

INVESTIGATORS: KEEP IN STEP WITH ADVANCEMENTS IN THE ART OF ELECTRONICS FOR THE PROFESSIONAL. SEND \$1.00 FOR EQUIPMENT BROCHURE. WJS ELECTRONICS, 737 NORTH SEWARD, HOLLYWOOD, CALIF. 90038.

BUG DETECTOR: WILL DETECT AND LOCATE SURREPTITIOUS TRANSMITTING DEVICES IN CONFERENCE ROOMS, HOME AND OFFICES, ETC. WRITE FOR DETAILS. WJS ELECTRONICS, 737 NORTH SEWARD, HOLLYWOOD, CALIF. 90038.

DETECTIVES! Free Brochures! Electronics Surveillance Devices. SILMAR ELECTRONICS, 3476 N.W. 7th Street, Miami, Fla. 33125.

CIRCUIT Boards, Parts for "Poptronics" projects. Free catalog. DEMCO, Box 16297, San Antonio, Texas 78216.

ROCKETS: Ideal for miniature transmitter tests. New illustrated catalog, 25¢. Single and multistage kits, cones, engines, launchers, trackers, rocket aerial cameras, technical information. Fast service. Estes Industries, Dept. 18, Penrose, Colorado 81240.

LOWEST Prices Electronic Parts. Confidential Catalog Free. KNAPP, 3174 8th Ave. S.W., Largo, Fla. 33540.

RADIO-T.V. Tubes - 33¢ each. Send for free catalog. Cornell, 4213 University, San Diego, Calif. 92105.

CONVERT any television to sensitive, big-screen oscilloscope. Only minor changes required. No electronic experience necessary. Illustrated plans, \$2.00. Relco-A33, Box 10563, Houston, Texas 77018.

CRYSTALS . . . largest selection in United States at lowest prices. 48 hr. delivery. Thousands of frequencies in stock. Types include HC6/U, HC18/U, FT-241, FT-243, FT-171, etc. Send 10¢ for catalog with oscillator circuits. Refunded on first order. Jan Crystals, 2400F Crystal Dr., Fort Myers, Fla. 33901.

FREE ELECTRONICS (new and surplus) parts catalog. We repair multimeters. Bigelow Electronics, Bluffton, Ohio 45817.

SURVEILLANCE EQUIPMENT - NEW HIGH PERFORMANCE SUBMINIATURE MODELS. ELECTRONIC COUNTERMEASURE DEVICES TO PROTECT PRIVACY. FREE DATA: SECURITY ELECTRONICS-PE, 15 EAST 43RD STREET, NEW YORK, N.Y. 10017.

JAPANESE PRODUCTS CATALOG by air mail \$5, sea \$3. Intercontinental, CPO 1717, Tokyo, Japan.

TREASURE Hunters! Prospectors! Relco's new instruments detect buried gold, silver, coins. Kits, assembled models. Transistorized. Weighs 3 pounds. \$19.95 up. Free catalog. Relco-A33, Box 10836, Houston, Texas 77018.

LINEAR AMPLIFIERS: "Hornet"—50 watts output—\$98.50; "Raider"—100 watts—\$139.95; "Maverick—250"—250 watts—\$244.95. For AM and SSB. Frequency range 20-35 megacycles (illegal for Class D 11 meters.) Dealer inquiries invited. D & A Manufacturing Co., 1217 Avenue C, Scottsbluff, Nebraska 69361.

RECTIFIERS, transistors, other components. Catalog free. Electronic Components Co., Box 2902C, Baton Rouge, La. 70821.

ELECTRONIC Ignition. Kits, components, systems. Diagrams. Anderson Engineering, Epsom, N.H. 03239.

DIAGRAMS—Radios \$1.00, Television \$2.50. Give make and model. Diagram Service, Box 1151PE, Manchester, Conn. 06042.

CLOSED CIRCUIT TV CAMERA KITS! \$18.95 (starter) to \$149.50 (complete). Both tube and transistorized models. Step-by-Step instruction manuals. Televisive live pictures on any standard TV receiver without modification. Quality performance! Perfect for industrial, educational and experimenter applications. FACTORY-DIRECT prices. Compare before buying. ATV RESEARCH, Thirteenth and Broadway, Dakota City, Nebr. 68731.

MUSIC LOVERS, CONTINUOUS, UNINTERRUPTED BACKGROUND MUSIC FROM YOUR FM RADIO, USING NEW INEXPENSIVE ADAPTOR. FREE LITERATURE. ELECTRONICS, 11500-Z NW 7TH AVE., MIAMI, FLORIDA 33168.

EXPERIMENTERS Latest Transistorized Projects Catalog 10¢. Hazleton Scientific, Box 163, Hazel Park, Michigan 48030.

ELECTRONIC, mechanical devices catalog 10¢. Transistor boards bonanza \$5.95. FERTIK'S, 5249 "D," Phila., Pa. 19120.

EUROPEAN and Japanese bargain catalogs. \$1 each. Dee, 10639E Riverside, North Hollywood, Calif. 91602.

ELECTRONIC SURVEILLANCE, THEORY, INSTRUCTIONS, DIAGRAMS \$2.00. ELECTROWEST, BOX 50313, CICERO, ILLINOIS 60650.

WEBBER ENGINEERING—Specialists in electronic projects or plans. Send \$1.00. Webber Engineering, Dept. 379, 109 Fays Ave., Lynn, Mass. 01905.

\$900. DUAL Trace Scopes from \$50. Signal generators to UHF. 5000 surplus items equally low priced. List \$2.00 (refundable). S & G Company, Box 51, Rochester, Mass. 02770.

NO telephone privacy? "Bug" on your line? Blow it off! ENGINEERING LABORATORIES, BOX 1036, ANDERSON, INDIANA 46015.

FOR Sale—Radio TV test equipment, tubes, photofacts. Write: Gayle Eckel, Circle Drive, Hartsville, Tenn. 37074.

POLICE RADIO. Hear all police calls, fire departments, Sheriffs, taxis, ambulances, Highway Patrol. New 5 Band portable radio and direction finder. Free Booklet. Nova-Tech, Dept. 303, Redondo Beach, Calif. 90278.

PRINTED circuit artwork and boards. Free lists. Dirck Spicer, 11 Ridgeland Road, Wallingford, Conn. 06492.

JAPAN DIRECTORY. Electronics products and parts. General merchandise and Asia trade information. Just \$1.00 today. Ippano Kaisha Ltd., Box 6266, Spokane, Washington 99207.

SUPER HOBBY CATALOG 25¢. WE SELL CONSTRUCTION PLANS. TELEPHONE: Ansaphone, Speakerphone, Legal Connector, Carphone, Central Dial System, Pushbutton Dialer, TELEVISION: \$35 all electronic Color Converter, Camera, Recorder, 3DTV. DETECTIVE: Tail Transmitter, Wireless Mike, Infinity Transmitter. Plans \$4.95 each. DYNAMITES ALL Eavesdroppers, silent jammer plans \$8.50. TELEPHONE ENGINEERING COURSE \$39.50. DETECTIVE ELECTRONIC COURSE \$22.50. ANTI-DETECTIVE ELECTRONIC COURSE \$27.50. TELEVISION FCC LICENSE COURSE \$97.50. Don Britton Enterprises, 7906 Santa Monica Blvd., Hollywood, Calif. 90046.

BUILD a laser—\$2.00 complete information. J. Canavan, 166 Embarcadero Street, San Francisco, Calif. 94105.

AUTOMATIC Burglar Alarm. Dials police. Construction Manual \$4.95. Catalog 10¢. Workshop, Box B393, Bethpage, New York 11714.

PARTS STORAGE—Three steel wall shelves, 10 drawers, \$12.95 Postpaid; **TOOLMASTERS**, Box 8092, Shawnee Mission, Kansas 66208.

FM WIRELESS MIC, Guitar Pickup, bug in case \$9.85. Board only with instructions \$6.75 COD. SCI Manufacturing Co., 3700 First National Bank, Dallas, Texas 75202.

FANTASTIC OPPORTUNITY Lite-Tronics now offers subminiature lamps at 60% off original price to stimulate new product applications. Less than 1/8" diam. and 3/16" long. 5 Volts, ultra bright. Send \$1.00 for sample and price list. Lite-Tronics, Box 203, Park Ridge, Ill.

ELECTRONIC Surveillance and security equipment. Latest devices. Free catalog: Fisher Electronics, Box 350, N. Miami Beach, Florida 33160.

STOP THROWING AWAY MONEY ON TRANSISTORS! Fabulous new book reveals how to use nickel-and-dime transistors in over 100 interesting projects. Explains amazingly simple methods for testing and identifying unmarked transistors. You get plans for ingenious bread-board to make building a breeze. **EXTRA:** Huge reference section gives inside story on over 3000 transistor types. You must save \$\$\$ with this 132-page goldmine of information or money cheerfully refunded. To prove it, we'll send one valuable transistor absolutely **FREE** (yours to keep) if you order now. Rush \$3.00 to: Capstone, 9 Danbury Rd., Wilton, Conn. 06897. Ask for "How to Use Bargain Transistors P-117." You'll be delighted.

ULTRA SENSITIVE WIRELESS MICROPHONE. Smaller than pack of cigarettes. Hear conversations up to 1/4 mile thru ordinary F.M. radio. Complete plans \$2.00. Albar Electronics, Box 115, Mt. Prospect, Ill. 60056.

SEND FOR FREE CATALOG, featuring rectifiers, zeners, SCR's, triacs, integrated circuits, and other semiconductor devices in large and small quantities. **ALL DEVICES ARE CHECKED AND GUARANTEED.** Solid State Sales, Box 74F, Somerville, Mass. 02143.

PROXIMITY switch. Detects nearness of human body! Free information. Claremont Products, 860 Reed, Claremont North, Calif. 91711.

JAPANESE or EUROPEAN DIRECTORY 200 firms \$1.00. **SURVEILLANCE EQUIPMENT,** wireless **SNOOPERMIKE** \$25.00, **SUBMINNIMIKE** 3/8 x 3/8 x 3/16 \$4.00, Brochure 25¢, **SIERRATRONICS**, Box 7497, Las Vegas, Nev. 89101.

TRANSISTORIZED CONVERTER KITS: Two models, converts car radio. Receive 30-50mc or 100-200mc (one mc tuning) \$5.00 with simple instructions. Crystal \$2.50. Meshna, No. Reading, Mass. 01864.

MUSETTE COLOR ORGAN. Unit performs as described in July, 1966 issue of PE. Will accept best offer over \$100.00. Mike Dinan, P. O. Box 1285, LIC, NY 11101.

PLANS AND KITS

ALLWAVE RADIO KIT. Tube, transistor included \$5.00. Headset \$2.50. Ekeradio, Box 131, Temple City, Calif. 91780.

MINI CIR-KITS, Oscillator Amplifier \$2.95. Others. Lectornix, Box 42, Madison Heights, Michigan 48071.

CLASSIFIED ADVERTISING ORDER FORM

Please refer to heading on first page of this section for complete data concerning terms, frequency discounts, closing dates, etc.

1	2	3	4	5
6	7	8	9	10
11	12	13	14	15
16	17	18	19	20
21	22	23	24	25
26	27	28	29	30
31	32	33	34	35

Words { @ 60¢ (Reader Rate) } = \$ _____
 { @ \$1.00 (Commercial Rate) }

Insert _____ time(s) Total Enclosed \$ _____

NAME _____

ADDRESS _____

CITY _____ STATE _____ ZIP _____

Signature _____

WORD COUNT: Include name and address. Name of city (Des Moines) or of state (New York) counts as one word each. Zone or Zip Code numbers not counted. (Publisher reserves right to omit Zip Code if space does not permit.) Count each abbreviation, initial, single figure or group of figures or letters as a word. Symbols such as 35mm, COD, PO, AC, etc., count as one word. Hyphenated words count as two words. PE-1167

"DISTANCE CRYSTAL SET CONSTRUCTION" Handbook -50¢. 10 Crystal plans-25¢. Catalog. Laboratories, 12041-L Sheridan, Garden Grove, Calif. 92640.

REVERB! FOR HI FI, GUITAR, ETC. COMPLETE KIT INCLUDING SPRING \$9.95. U.M.I. 77 TOLEDO ST., FARMINGDALE, N.Y. 11735.

INTEGRATED CIRCUIT KITS; COMPUTER LOGIC; Parts; others. Catalogue free. **KAYE ENGINEERING**, Box 3932, Long Beach, California 90803.

SHORTWAVE LISTENING

BUILD 2 Band set, tube and plan \$1.50. Ekeradio, Box 131, Temple City, Calif. 91780.

IMPROVE ANTENNA PERFORMANCE with Joymatch Antenna Tuning Unit, \$13.50. Books, Antennas. SWL Guide, 218 Gifford, Syracuse, N. Y. 13202.

HIGH FIDELITY

FREE! Send for money saving stereo catalog #P11E and lowest quotations on your individual component, tape recorder, or system requirements. Electronic Values, Inc., 200 W. 20th St., New York, N.Y. 10011.

HI-FI Components, Tape Recorders, at guaranteed "We Will Not Be Undersold" prices. 15-day money-back guarantee. Two-year warranty. No Catalog. Quotations Free. Hi-Fidelity Center, 239 (P) East 149th Street, New York 10451.

"**LOW**, Low quotes: all components and recorders. HiFi, Roslyn, Penna. 19001.

TAPE RECORDERS, Hi-Fi, components, Sleep Learning Equipment, tapes. Unusual Values Free Catalog. Dressner, 1523R, Jericho Turnpike, New Hyde Park, N.Y. 11040.

RADIO YESTERYEAR. Complete broadcasts of all the old favorites. One Hour sample tape \$5. Catalogue \$1 (refundable). C. Charmer, Box 11, Highbridge Station, Bronx, New York 10452.

WANTED

CASH Paid! Unused tubes, electronic equipment. Barry, 512 Broadway, NYC 10012.

QUICKSILVER, Platinum, Silver, Gold. Ores Analyzed. Free Circular. Mercury Terminal, Norwood, Mass. 02062.

WANTED—Harvey Wells X'Mit T-90, R'Cvr R-9A, APS-90 power supply. Need schematic and instruction manual. Robert Carpenter, 11597 Herman Way, Los Altos, California 94022.

RELAYS—Sigma 80030. Any quantities. **ALARM RELAY SUPPLY,** 20725 Burbank Blvd., Woodland Hills, Calif. 91364.

TUBES

TUBES "Oldies", latest. Lists free. Steinmetz, 7519 Maplewood, Hammond, Indiana 46324.

TUBE Headquarters of World! Send 10¢ for Catalog (tubes, electronic equipment) Barry, 512 Broadway, N.Y.C. 10012.

RADIO & T.V. Tubes—33¢ each. Send for free list. Cornell, 4213 University, San Diego, Calif. 92105.

RECEIVING & INDUSTRIAL TUBES, TRANSISTORS. All Brands—Biggest Discounts. Technicians, Hobbyists, Experimenters—Request **FREE** Giant Catalog and **SAVE!** **ZALYTRON,** 469 Jericho Turnpike, Mineola, N.Y. 11501.

DON'T BUY TUBES—Radio, TV-Xmitting, special-purpose types until you get our price list! Lowest prices in U.S.A. 5,000 types—Guaranteed Brand New. Send postcard for TV—Special Purpose Price List. **UNITED RADIO COMPANY, P.O. BOX 1000, NEWARK, N.J. 07101.**

SEMICONDUCTORS

HOBBYIST ASSORTMENTS

IC'S 70-5/FLAT PACK 50/\$5.95 100/\$9.95
 SAMPLE TESTED TO +50% IDENTIFICATION AND TEST INFO. INCLUDED WITH SCHEMATICS.
 FLAT PACK TEST SOCKETS AUGAT 8075-101 1.00
 MATCHING AMPHENOL CONNECTOR .95
 DIFF. AMPS. NPN/PNP 70-89 CASE 10/2.95
 SILICON DIODES 00-7 S.T. TO +80V 100/2.95
 MINIATURE SILICON DIODES 50PIV 100/2.95
 MINIATURE (PIN HEAD) THERMISTORS 5K OHMS 3/1.95
 TESTED AND MARKED DUAL IN LINE IC'S
 930 DUAL 4 INPUT BUFFER 1.10
 945 CLOCKED FLIP FLOP 1.50
 946 DUAL 2 INVERTER 2.00
 952 DUAL 2 INVERTER 2.00
 954 GATE, DUAL 4 INPUT 2.00
 956 BUFFER, DUAL 2 INPUT 2.00
 957 BINARY 3.00
 FULLY GUARANTEED, COME WITH SCHEMATIC.
 DARLINGTON AMPLIFIERS—MADE SPECIAL BY FSC FOR LMSD 3/4.95
 NEW WITH FACTORY SPEC. SHEET.

8 AMP SCR'S TO-59 CASE 100 PIV .60 200 PIV .90 300 PIV 1.40 400 PIV 1.60
 FULLY TESTED AND GUARANTEED.

ALL NEW AND BRANDED PRIME FAIRCHILD DEVICES
 2N871 NPN/H.V. AMP. OR OSC. .95
 2N996 PNP/ LOW NOISE 100 MC. SWITCH .95
 2N1132 PNP/ GENERAL PURPOSE AMPLIFIER 4/1.95
 2N1988 NPN/H.V. AF OR RF AMP. 2/1.95
 2N3120 PNP/VHF AMPLIFIER 3 WATT 2/1.95
 2N3304 PNP/ 500 MC. SWITCH 3/1.95
 2N3722 NPN/H.V. DRIVER 2/1.95
 2N3916 NPN/H.V. OUTPUT AF OR RF 2/1.95
 2N4019 PNP/DUAL AMPLIFIER 2/4.95
 FPR 300 CADMIUM SULFIDE CELLS 2/1.95
 905 HALF SHIFT TO-5 2/2.95
 911 GATE, 4 INPUT TO-5 1.50
 931 CLOCKED FLIP FLOP TO-5 1.75

MINIMUM ORDER \$5.00. CASH WITH ORDER, POSTAGE PREPAID. COD'S REMIT 25%.

ELECTRONICS COMPONENTS CO.
 715 LATHAM SQUARE BLDG.
 OAKLAND, CALIF. 94612
 (415) 836-3180

CIRCLE NO. 16 ON READER SERVICE PAGE

TAPE AND RECORDERS

BEFORE Renting Stereo Tapes try us. Postpaid both ways —no deposit—immediate delivery. Quality—Dependability —Service—Satisfaction—prevail here. If you've been dissatisfied in the past, your initial order will prove this is no idle boast. Free Catalog. Gold Coast Tape Library, Box 2262, Palm Village Station, Hialeah, Fla. 33012.

STEREO TAPES. Save up to 60% (no membership fees, postpaid anywhere U.S.A.). Free 60 page catalog. We discount batteries, recorders, tape accessories. Beware of slogans "not undersold," as the discount information you supply our competitor is usually reported to the factory. **SAXITONE,** 1776 Columbia Road, Washington, D.C. 20009.

TAPE RECORDER SALE. Brand new, latest models, \$10.00 above cost. Arkay Sales, 1028-C Commonwealth Ave., Boston, Mass. 02215.

AUTOMATIC telephone connection for Concord and other transistorized recorders. **SURVEILLANCE** and Privacy Protection Devices. Free Data: Security Electronics-PER, 15 East 43rd Street, New York, N.Y. 10017.

HI-FI Components. Tape Recorders, at guaranteed "We Will Not Be Undersold" prices. 15-day money-back guarantee. Two-year warranty. No Catalog. Quotations Free. HiFidelity Center, 239 (PT) East 149th Street, New York 10451.

SCOTCH Recording Tapes. Tape Recorders. Catalog 5¢. Tower, Lafayette Hill, Pa. 19444.

RENT STEREO TAPES—75¢ WEEK. CATALOG. ART'S, 1442 BLAZE, SIMI, CALIF. 93065.

TAPE transport. NAB recording studio quality. Build yourself for amazingly low cost. Detailed plans \$5.00. Free particulars. Pepke Laboratories, 309-B West 19 Street, New York, N.Y. 10011.

TAPES, RECORDS—Lowest Prices. No Fees or Obligations. LMS, 3415 SE 22, Des Moines, Iowa 50320.

INSTANT taping without rewinding—Plaque stores partly run tape, 7" feed, takeup reels. Plywood, unfinished, \$2.98 postpaid. Eryleen Products B-10, 361 Cambridge St., Burlington, Mass. 01803.

RENT Stereo Tapes—over 2,500 different—all major labels—free brochure. Stereo—Parti, 1616-PE Terrace Way, Santa Rosa, California 95404.

SPORTS FILMS

SPECTACULAR COLOR ACTION TITLES. CATALOG. SPORTLITE FILMS-PE, 20 North Wacker Drive, Chicago, Illinois 60606.

CUSTOM RECORDING

L.P. Hi-Fi Records made from any speed tape. Plan sixteen minutes per side. Three identical copies \$19.95. "RECORDS", Box 206, N. Wales, Penna. 19454.

REPAIRS AND SERVICES

TV Tuners rebuilt and aligned per manufacturers specification. Only \$9.50. Any make UHF or VHF. We ship COD. Ninety day written guarantee. Ship complete with tubes or write for free mailing kit and dealer brochure. JW Electronics. Box 51C, Bloomington, Indiana 47401.

PERSONALS

INVESTIGATORS, FREE BROCHURE, LATEST SUBMINIATURE ELECTRONIC SURVEILLANCE EQUIPMENT. ACE ELECTRONICS, 11500-K NW 7th Ave., MIAMI, FLA. 33168.

BORROW \$1,205 AIRMAIL! Repay \$47 for 36 months. State licensed. Postal Finance, Dept. 84-T, 200 Keeline Building, Omaha, Nebraska 68102.

"SLEEP THERAPY"—Send for free brochure, "What's It All About." Navon, Box 190-PE, Quincy, Massachusetts 02169.

BILL PROBLEMS? Poor credit no trouble. Not a loan company. Send for free application. Automatic Acceptance, 318PE Broadway Blvd., Reno, Nevada or 307PE Pocasset Ave., Providence, R. I.

MAKE FRIENDS, send your description and a stamp for bulletin "Introductions", P.O. Box 2471, Detroit, Mich. 48231.

MAKE FRIENDS WORLDWIDE, promote international understanding, join Europe's leading correspondence club. Illustrated brochure free. HERMES, Box 17/33, 1 Berlin 11, Germany.

INSTRUCTION

LEARN While Asleep, hypnotize with your recorder, phonograph. Astonishing details, sensational catalog free! Sleep-Learning Association, Box 24-ZD, Olympia, Wash. 98501.

LEARN ELECTRONIC ORGAN SERVICING at home all makes including transistors. Experimental kit—troubleshooting. Accredited NHSC, Free Booklet. NILES BRYANT SCHOOL, 3631 Stockton, Dept. A, Sacramento, Calif. 95820.

ASSOCIATE Degree in Electronics Engineering earned through combination correspondence-classroom educational program. Free brochure. Grantham Technical Institute, 1505 N. Western Ave., Hollywood, Calif. 90027.

HIGH SCHOOL DIPLOMA at home. Qualified instructors. Send age, highest grade completed, for free details. No salesman. SOUTHERN STATES ACADEMY, Westbury Square Professional Bldg., Dept. 5, Houston, Texas 77035.

REI First Class Radio Telephone License in (5) weeks Guaranteed. Tuition \$295.00. Job placement free. (KANSAS CITY) R.E.I., 3123 Gillham Road, Kansas City, Missouri, Telephone WE1-5444. (SARASOTA) R.E.I., 1336 Main Street, Sarasota, Florida 33577. Telephone 955-6922.

HIGHLY EFFECTIVE home study course in Electronics Engineering Mathematics with circuit application. Earn your Associate in Science Degree. Free Literature. Cook's Institute of Electronics Engineering, P.O. Box 36185 Houston Texas 77036. (Established 1945.)

FCC First Class License in six weeks—nation's highest success rate—approved for Veterans Training. Write Elkins Institute, 2603B Inwood Road, Dallas, Texas 75235.

PENMANSHIP Corrector. Improve poor penmanship quickly. Details free. Ozment, Box 665-23, St. Louis, Mo. 63188.

INVENTIONS WANTED

PATENT Searches including Maximum speed, full airmail report and closest patent copies, \$6.00. Quality searches expertly administered. Complete secrecy guaranteed. Free Invention Protection forms and "Patent Information." Write Dept. 9, Washington Patent Office Search Bureau, 711 14th Street, N.W., Washington, D.C. 20005.

INVENTORS! Outright cash sale or royalties for your inventions. Patented. Unpatented. Active demand from our client manufacturers. Financial assistance available. Write Dept. 35, United States Invention Brokerage, 78 Wall Street, New York, N.Y. 10005.

INVENTORS. We will develop, help sell your idea or invention, patented or unpatented. Our national manufacturer clients are urgently seeking new items for outright cash sale or royalties. Financial assistance available. 10 years proven performances. For free information, write Dept. 41, Wall Street Invention Brokerage, 79 Wall Street, New York, N.Y. 10005.

INVENTIONS wanted. Patented; unpatented. Global Marketing Service, 2420-P 77th, Oakland, Calif. 94605.

INVENTIONS—IDEAS developed: **CASH/ROYALTY SALES**. Member: United States Chamber of Commerce, Raymond Lee. 230-GR PARK AVENUE, NEW YORK CITY 10017.

PATENT SEARCHES \$6.00! FREE "INVENTION RECORD"/ Information. Miss Hayward, 1029HR Vermont, District of Columbia 20005.

INVENTORS! Sell your invention for cash or royalties! Our client manufacturers eagerly seek new items. Patented. Unpatented. Financial assistance if needed. 25 years proven performances. For free information, write Dept. 20, Gilbert Adams, Invention Broker, 80 Wall St., New York, N.Y. 10005.

INVENTORS! Don't sell your invention, patented or unpatented, until you receive our offer. Eagle Development Company, Dept. P, 79 Wall Street, N.Y., N.Y. 10005.

GOVERNMENT SURPLUS

JEEPS Typically From \$53.90 . . . Trucks From \$78.40 . . . Boats. Typewriters, Airplanes, Electronics Equipment, Photographic Equipment, used. 100,000 Bargains Direct From Government. Complete Sales Directory and Surplus Catalog \$1.00 (Deductible First \$10.00 Order). Surplus Service, Box 820-J, Holland, Mich. 49423.

BOOKS

FREE CATALOG. Adult Books. **POSTAL PE**, 2217 Lackland, St. Louis, Missouri 63114.

FREE Book. Prophet Elijah Coming Before Christ. Wonderful Bible Evidence. PE Megiddo Mission, Rochester, New York 14619.

FREE catalog 950 aviation/electronic/space books, Aero Publishers, 329PE Aviation Road, Fallbrook, California 92028.

UNUSUAL Books! Catalog free! International, Box 7798(PE), Atlanta, Georgia 30309.

AUTHORS' SERVICES

AUTHORS! Learn how to have your book published, promoted, distributed. FREE booklet "ZD," Vantage, 120 West 31 St., New York 10001.

POEMS WANTED for new song hits and recordings by America's most popular studio. Tin Pan Alley, 1650-ZD Broadway, New York 10019.

MUSIC

POEMS wanted for new songs. Nashville Music Institute, Box 532-E, Nashville, Tennessee 37202.

SONGWRITERS! Read "Songwriter's Review" magazine, 1697-P Broadway, N.Y.C. 10019. \$3, year (USA); 35¢, Sample. Guiding Light to Tin Pan Alley, Est. 1946.

MUSICAL INSTRUMENTS

ACCORDIONS, GUITARS, BAND INSTRUMENTS! Save to 50%. Terms. Trades. Free Trial. Free catalog. Mention instrument. Music Mart, 5535-PE Belmont, Chicago 60641.

SWISS Musical Movements. Electrical-Mechanical. Spielman, 131 West 42nd., New York 10036.

RUBBER STAMPS

RUBBER ADDRESS STAMP \$1.50. SIGNATURE \$2.88. FREE CATALOG. JACKSON PRODUCTS, 1433 WINNE-MAC, CHICAGO, ILL. 60640.

PHOTOGRAPHY—FILM, EQUIPMENT, SERVICES

MEDICAL Film—Adults Only—"Childbirth"—1 reel 8mm \$7.50—16mm \$14.95. International-E, Greenvale, L.I., New York 71548.

SCIENCE Bargains—Request Free Giant Catalog "CJ"—148 pages—Astronomical Telescopes, Microscopes, Lenses, Binoculars, Kits, Parts. War surplus bargains. Edmund Scientific Co., Barrington, New Jersey 08007.

REAL ESTATE

FREE!!! Big Illustrated 176-page. **FALL-WINTER CATALOG!** Describes hundreds of farms, ranches, town and country homes, businesses, vacation, retirement and waterfront properties coast to coast! Specify type property and location preferred. Zip code, please. **UNITED FARM AGENCY, 612-EP West 47th St., Kansas City, Mo. 64112.**

MAGNETS

MAGNETS. All types. Maryland Magnet Company, 5412-H Gist, Baltimore, Maryland 21215.

REMAILING SERVICE

SO. AMERICA Registered re-airmails, \$1.00. Confidential. Genaro, "Apartado" 360, Guayaquil, Ecuador.

EDUCATIONAL OPPORTUNITIES

WANTED! TV—Radiomen to learn aircraft electronics servicing. Numerous job openings everywhere. Write: Academy Avionics, Reno/Stead Airport, Reno, Nevada 89506.

LEARN WHILE ASLEEP. Miraculously build Mind Power, achieve Self-Confidence, improve Health, gain Success. Method 92% effective. Details free. ASR Foundation. Box 7021EG Henry Clay Sta., Lexington, Kentucky 40502.

PRINTING

FREE Booklet "Secrets of Cutting Printing Cost." Dept. 1, 305 S. 4th, Springfield, Illinois 62701.

THERMOGRAPHED business cards, \$2.99—1,000, free samples. Gables—405 Clifton, Glenshaw, Pa. 15116.

DO-IT-YOURSELF

SAVE! Build transistorized treasure finder. Details free! Del Research, Dept. A, West Barnstable, Mass. 02668.

FREE ARCTURUS CATALOG

A trusted name in electronics since 1925
Electronic parts, tubes. Wholesale.
Thousands of items. Unbeatable prices.

ARCTURUS ELECTRONICS CO.
502-22nd St., Dept. PE, Union City, N.J. 07087

BUILD your own telephone intercom—complete—less battery. Write Telephones, Box PE67, Simpson, Penna. 18407.

BUSINESS OPPORTUNITIES

INVESTIGATE ACCIDENTS! Earn up to \$1,000 and more a month in your own business. Work spare time with average earnings of \$5 to \$8 per hour. No selling. Send for Free booklet. No obligation. No salesman will call. Write: Universal Schools, CZ-11, 6801 Hillcrest, Dallas, Texas 75205.

RAISE Rabbits for us on \$500 month plan. Free details. White's Rabbitry, Mt. Vernon, Ohio 43050.

FREE CATALOGS. Repair air conditioning, refrigeration. Tools, supplies, full instructions. Doolin, 2016 Canton, Dallas, Texas 75201.

PIANO TUNING learned quickly at home. Tremendous field! Musical knowledge unnecessary. GI Approved. Information free. Empire School of Piano Tuning, Miami, Florida 33145.

ELECTROPLATING Equipment and supplies. All types for home workshops and industrial. Send \$1.00 (refundable) for equipment guide formulas, operating data, catalog. HBS Equipment Division 90, 3543 East 16th, Los Angeles, California 90023.

I MADE \$40,000.00 Year by Mailorder! Helped others make money! Start with \$10.00—Free Proof. Torrey, Box 318-N, Ypsilanti, Michigan 48197.

PROFITS to 50% fast: No inventory, no risk: Details 25¢. Moneysaver, Box 666Z, Aptos, Calif. 95003.

FREE Book "990 Successful little-known Businesses." Work home. Plymouth 145K, Brooklyn, N.Y. 11218.

ATTENTION CBERS—DEALERSHIPS OPEN IN ALL PARTS OF THE COUNTRY! SELL CB EQUIPMENT FROM YOUR HOME. WRITE FOR COMPLETE INFORMATION: RMD ELECTRONICS, 4151 N. WESTERN AVE., CHICAGO, ILLINOIS 60618.

HOW And Where To Get Capital. Launch or expand any electronics or photography business. Write: Counselor-48, Harlingen, Texas 78550.

FREE "Franchise Profit Letter" tells how unique NFR service is helping thousands seeking profitable businesses. Write today. National Franchise Reports, PE-528, 333 North Michigan, Chicago 60601.

100,000 PRODUCTS Wholesale! Terrific bargains! Wholesalers, 1265-PP, Broadway, New York, N.Y. 10001.

STAMPS

VALUABLE COLLECTORS' ITEM: Official Canadian 1st Day issue of the Queen Elizabeth Royal Visit to **EXPO 67** Postage Stamp mounted on commemorative envelope bearing beautiful portrait of Her Majesty. Postmarked with highly-prized first day cancellation! **ALSO INCLUDED** to introduce you to World's Most Rewarding Hobby: (2) Complete Set of 42 English Kings and Queens, (3) Big Collectors' Catalog, and (4) "How to Collect Postage Stamps" Booklet. Also, selections of Queen Elizabeth and other fine stamps from our approval service for Free Examination. You may return selections without buying and can cancel service anytime, but the Queen Elizabeth Commemorative Envelope, 42 English Kings and Queens, Big Collectors' Catalog, and Booklet "How to Collect Postage Stamps" are yours to keep **FREE!** Send 25¢ to cover postage and handling. **KENMORE STAMP COMPANY, B-225, MILFORD, NEW HAMP., 03055. USA.**

MICRO TUBES Large select stock
Dependable fast service

Not connected with any other
Mail Order Tube Co.

Send For FREE Tube List &
Special Purpose Tubes

35¢ ea. in lots of 100 | **37¢** per tube

ALL tubes sent postage pd. Send 35¢ handling chg. on orders under \$5. Send 25¢ on C.O.D.'s. Send approx. postage on Canadian & foreign orders.

WE HAVE PICTURE TUBES
MICRO Electron Tube Co.
110 Martin St., Paterson, N. J.

FREE Wonderful New United States Catalog! Postage and Airmails Complete, 786 Illustrations. Special offers. Bargains Galore—Everything! Send Today. H. E. Harris, Dept. FC-1, Boston, Mass. 02117.

450 FINE mixed U.S. 15¢. Wright, Box 753-X, Hagerstown, Maryland 21740.

COINS

SELLING 10 different S Lincoln cents, \$1.00; 7 small date 1960-D cents, \$1.00; 6 different S Jefferson nickels, \$1.00; 5 Barber dimes, \$2.00. Price list. Charles Lees, 2026 East Greenlee, Tucson, Arizona 85719.

LINCOLN CENT, 1943-S, 10¢. Free List. Bedrin, 250F Fulton, Hempstead, New York 11550.

EMPLOYMENT INFORMATION

FOREIGN and USA job opportunities available now. Construction, all trades. Earnings to \$2,000.00 monthly. Paid overtime, travel, bonuses. Write: Universal Employment, Woodbridge, Connecticut 06525.

HYPNOTISM

FREE Hypnotism, Self-Hypnosis, Sleep Learning Catalog! Drawer H400, Ruidoso, New Mexico 88345.

"FEMALE HYPNOTISM" Exposed, explained! "Secret Method"—they never know! \$2, rushed. Guaranteed! Isabella Hall, Silver Springs, Florida 32688.

FREE TRIAL!! Sensational! self-hypnosis record kit improves memory, concentration, personality. Results guaranteed! Forum, 333-AA11, Michigan, Chicago 60601.

HYPNOTIZE FEMALES!—Unnoticed! Instantly! Nerves! Exciting! Send \$3.00. Research Enterprises, 29-SN21 Samoset, Woburn, Mass.

FEMALE HYPNOTISM!! Easily! Instantly! Secret Nerve Centers! \$2.20. Brugenheimer Publishers, Box 158-E30, Lexington, Mass.

MISCELLANEOUS

WINEMAKERS: Free illustrated catalog of yeasts, equipment. Semplex, Box 7208, Minneapolis, Minn. 55412.

SPARE TIME OPPORTUNITY—MONEY—WE PAY at the rate of \$10 hr. for **NOTHING** but your opinions, written from home about our clients' products and publications, sent you free. Nothing to buy, sell, canvass, or learn. **NO SKILL. NO GIMMICKS.** Just honesty. Details from **RESEARCH**, ZD2, Box 669, Mineola, N.Y. 11501.

BILLS PAID WITHOUT BORROWING—Nobody refused up to \$18,000.00. Bad credit no problem—Not a Loan Co. Write for **FREE** application—**INTERNATIONAL ACCEPTANCE**, Dept. 50A, 5133 N. Central Ave., Phoenix, Arizona 85012—119 Ann St., Hartford, Conn. 06103—507 Carondelet St., New Orleans, La. 70130—or 504 Victoria Ave., Windsor, Ontario, Canada.

\$25.00 BLOCK MEERSCHAUM PIPE \$10.95. Free Literature. Northwestern Distributors, 1232 Market Street, San Francisco, California.

BEERS, PEACH BRANDY, WINES—Strongest Formulas, \$2.25. (complete brew supplies hydrometers catalog included)—Research Enterprises, 29-D Samoset, Woburn, Mass. 01801.

STAMMER — Stutter — No More. (Dr. Young.) Write: Gaucho, Box 9309-E8, Chicago 60690.

POPULAR ELECTRONICS

NOVEMBER 1967

ADVERTISERS INDEX

READER SERVICE NO.	ADVERTISER	PAGE NO.
1	Aerotron, Inc.	111
2	Allied Radio	97, 98, 99
	American Institute of Engineering & Technology	118
3	Amperex Electronic Corp	FOURTH COVER
4	Antenna Specialist Co., The	105
	Arcturus Electronics Co	123
5	Argos Products Company	104
6	Astro-Com	117
7	B & K	6
8	Burstein-Applebee	114
	Capitol Radio Engineering Institute, The	18, 19, 20, 21
9	Cleveland Institute of Electronics	17
10	Cleveland Institute of Electronics	36, 37, 38, 39
	Conar	100
11	Courier Communications, Inc	110
12	Cush Craft, Inc	102
13	Delwyn	120
	DeVry Institute of Technology	7
14	EICO Electronic Instrument Co., Inc	23
15	Electro-Voice, Inc	113
16	Electronics Components Co	121
17	Finney Company, The	11
18	Garrard	12
19	Heath Company	85, 86, 87, 88, 89, 90, 91
20	Hy-Gain Electronics Corporation	13
21	IMC Magnetics Corp	104
22	Johnson Company, E.F.	27
23	Lafayette Radio Electronics	9
	McGee	118
	Micro Electron Tube Co	124
24	Milwaukee School of Engineering	95
25	Mosley Electronics, Inc	110
26	Multi-Elmac Co	116
	National Radio Institute	SECOND COVER, 1, 2, 3
	National Technical Schools	106, 107, 108, 109
27	Olson Electronics Incorporated	102
28	Pace Communications Corp	16
41	Pioneer Electronics U.S.A. Corporation	14
	RCA Electronic Components and Devices	THIRD COVER
	RCA Institutes, Inc	62, 63, 64, 65
29	Radio Shack	5
40	Regency Electronics, Inc	115
30	S & A Electronics Inc	100
	SWL Records	96
	Salch & Co., Herbert	96
31	Sams & Co., Inc., Howard W	93
32	Schober Organ Corp., The	112
33	Scott, Inc., H.H.	101
34	Sentry Manufacturing Company	118
35	Sonar Radio Corp	103
36	Squires-Sanders, Inc	28
	Sydmar Electronics Specialties	114
37	Turner Microphone Company, The	92
38	United Audio Products	26
	Valparaiso Technical Institute	114
39	Weller Electric Corporation	8
CLASSIFIED ADVERTISING 119, 120, 121, 122, 123, 124		

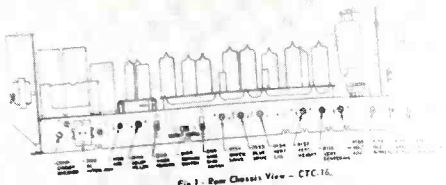

Fig. 1 - Rear Chassis View - CTC-16.

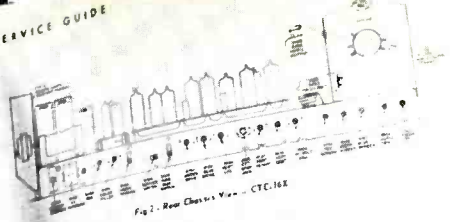

Fig. 2 - Rear Chassis View - CTC-16X

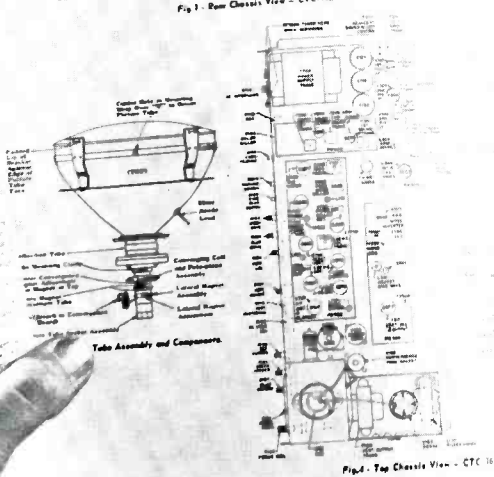

Fig. 3 - Top Chassis View - CTC-16

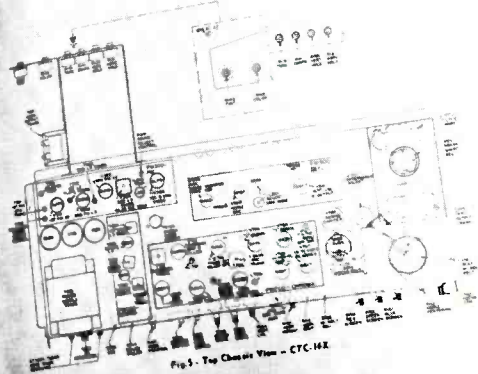
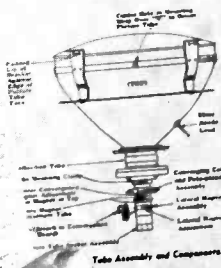

Fig. 4 - Top Chassis View - CTC-16X



Tube Assembly and Components

You need this guide for RCA Color Home Service Calls!

RCA'S NEW FIELD SERVICE GUIDE, ERT-200 helps you make all adjustments on all RCA color sets from 1955 to 1966 that can be performed in the home ... including step-by-step procedure for replacing a color picture tube.

Three part index lets you look up the set you are working on by model number, name or chassis number. You'll find the ERT-200 Field Service Guide indispensable. There's nothing like it on house calls for RCA color sets.

WHAT THIS GUIDE CONTAINS:

- Schematics on all RCA color sets from 1955 to 1966
- Field service adjustments (AGC, linearity, centering, etc.)
- Convergence, purity and black and white setup adjustments
- Parts lists
- Wave forms keyed to test points for majority of chassis
- Top and rear chassis views
- Photos of typical receivers
- Index of models from CTC2 through CTC20
- Separate section on tuner schematics
- Separate section on remote tuner schematics

FIELD-SERVICE GUIDE

RCA COLOR-TV RECEIVERS
1955-1966

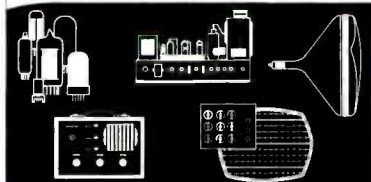
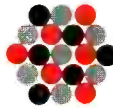

FEATURES

- Three-Service Adjustment - CTC-16 through CTC-20
- Top and Rear Chassis Views
- Isometric Diagrams
- Keyed Waveform Charts for Test Points
- Isometric Section on Tuner Schematics
- Parts Lists
- Component Parts of Model Number
- Model Name and Chassis Number

See your RCA Tube Distributor today and arrange to get your copy.

RCA Electronic Components and Devices, Harrison, N.J. 07029



The Most Trusted Name In Electronics



**One out of every five
professional servicemen
has switched to Amperex
TV replacement tubes**

It takes a lot of quality to change the buying habits of 20% of the most knowledgeable technicians in the business. These servicemen are following the pattern set by the leading TV manufacturers, who are designing more and more of their quality lines around tubes originated by Amperex. The Amperex line of popular types is expanding all the time. Look for the green and yellow cartons at your distributor's or write: Amperex Electronic Corp., Hicksville, L. I., N.Y. 11802.

Amperex

TOMORROW'S THINKING IN TODAY'S PRODUCTS

www.americanradiohistory.com

