

WHO HIRES ELECTRONICS TECHNICIANS?

POPULAR ELECTRONICS

SEPTEMBER
1967

50
CENTS

Build Automatic House Light
Dimmer for Stage Effects

The Magnetic Reed Switch
How It Works—How It Is Used

Build IC 100-kHz Standard

Advanced Project:
ELECTRONIC DICE

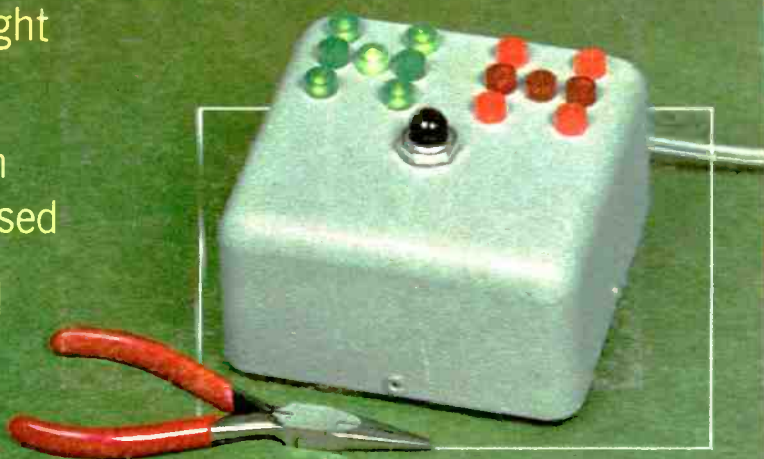

Schedules of all English-
Language Broadcasts from
Middle East and Africa

Build Multi-Waveform
Generator—Square, Pulse
or Sawtooth Patterns

Beginner's Project:
ALL-WAVE RECEIVER



**NRI GIVES YOU THE
RIGHT BALANCE...**

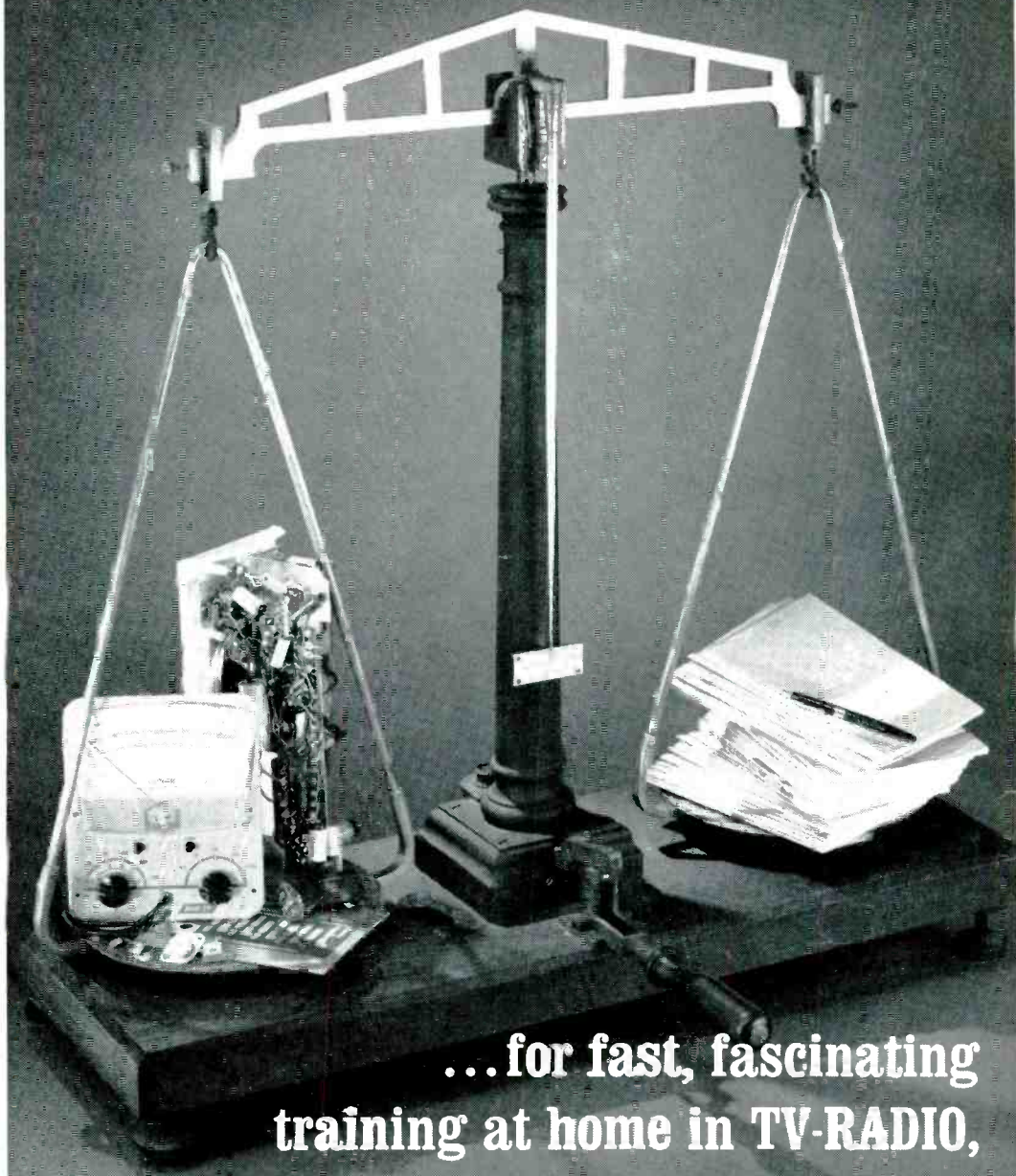

**...for fast, fascinating
training at home in TV-RADIO,
COMMUNICATIONS, ELECTRONICS**

Experience is still your best teacher

Here's how you get it with NRI job-simulated training

Ask any teacher, job counselor, engineer, technician or prospective employer about the need for "practical application of theory in Electronics. He'll tell you Electronics is as much a "hands on" profession as dentistry or chemistry. That's the way you learn at home with NRI. You put to work the theory you read in "bite-size" texts, using designed-for-learning lab equipment you build with professional components. You introduce defects into circuits, do experiments, until the "why" of circuitry and equipment operation comes clear through demonstration. You gain experience with transistors and solid-state designs as well as conventional tube circuits.

NRI lab equipment is designed and engineered from chassis up for education through practical experience — not for entertainment. The fact that the end results of your projects are usable, quality products is a personal bonus for you. Everything about NRI training has but one ultimate goal — to make you employable in your chosen field of Electronics by preparing you to prove your practical understanding of actual equipment; by giving you the equivalent of months, even years, of on-the-job training. There is no end of oppor-

tunity for the trained man in Electronics. You can earn extra money in your spare time, have your own full-time business, or qualify quickly for career positions in business, industry, government. Discover for yourself the ease and excitement of NRI training. Mail the postage-free card today for the new NRI Color Catalog. No obligation. No salesman will call. NATIONAL RADIO INSTITUTE, Electronics Div., Washington, D. C. 20016.

NRI has trained thousands



L. V. Lynch, Louisville, Ky., was a factory worker with American Tobacco Co., now he's an Electronics Technician with the same firm.

He says, "I don't see how the NRI way of teaching could be improved."



G. L. Roberts, Champaign, Ill., is Senior Technician at the U. of Illinois Coordinated Science Laboratory. In two years he received five pay raises.

Says Roberts, "I attribute my present position to NRI training."



Ronald L. Ritter of Eatontown, N.J., received a promotion before even finishing the NRI Communications course, after scoring one of the

highest grades in Army proficiency tests. He works with the U. S. Army Electronics Lab, Ft. Monmouth, N.J. "Through NRI, I know I can handle a job of responsibility."



Don House, Lubbock, Tex., went into his own Servicing business six months after completing NRI training. This former

clothes salesman just bought a new house and reports, "I look forward to making twice as much money as I would have in my former work."

APPROVED UNDER NEW GI BILL. If you served since January 31, 1955, or are in service, check GI line on postage-free card.

Accredited by the Accrediting Commission of the National Home Study Council

Over 50 Years of Leadership



in Electronics Training

YOU GET MORE FOR YOUR MONEY FROM NRI

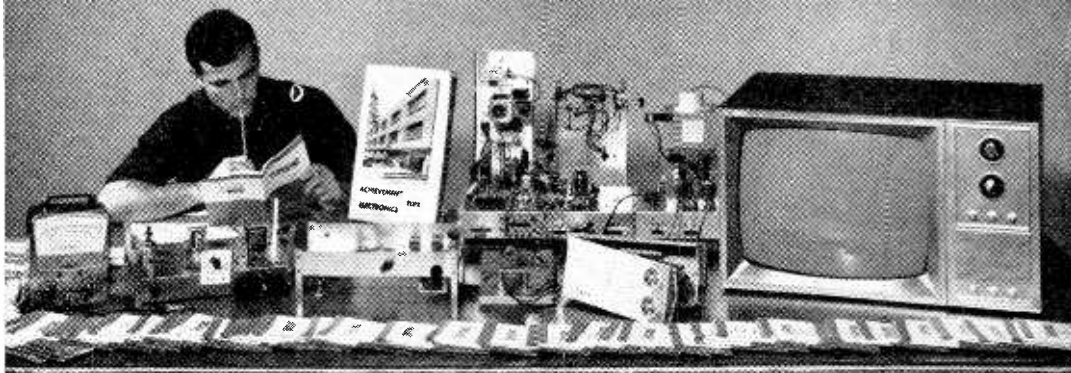

Everything you see here is included in one typical NRI home study course. Other courses are equally complete. Your training starts with the NRI Achievement Kit, sent the day you enroll. It contains the first of your "bite-size" texts which are programmed with

designed-for-learning professional lab equipment. Step-by-step, you learn with your hands as well as your head. You discover the "why" of circuitry as you acquire the professional's most valuable tool — practical experience in Electronics.

POPULAR ELECTRONICS

WORLD'S LARGEST-SELLING ELECTRONICS MAGAZINE

VOLUME 27

SEPTEMBER, 1967

NUMBER 3

SPECIAL CONSTRUCTION ARTICLES

- DON LANCASTER **29** SPOTS BEFORE YOUR EYES
A POPULAR ELECTRONICS exclusive all-electronic dice
- CHARLES CARINGELLA **40** THE BEGINNER'S FET REGEN RECEIVER
Just the project for the budding electronics genius

FEATURE ARTICLES

- TOM DUFFY and JERRY OLEKSY **35** THE POSSIBLE IMPRACTICAL IMPOSSIBLE CIRCUIT
- NEAL P. JENSEN **47** THE MAGNETIC REED SWITCH
Cut the cost of your next relay project
- and ALEXANDER W. BURAWA
- NEAL P. JENSEN **49** MAKE YOUR OWN REED SWITCH-RELAY
Wind reed switch solenoid to suit your circuit needs
- and ALEXANDER W. BURAWA
- MELVIN CHAN **52** MULTI-WAVEFORM GENERATOR
Palm-size device produces sawtooth, spike, and square waves
- ROBERT P. BALIN **55** ELECTRONIC ANGLE QUIZ
- RONALD L. IVES **56** THE ELECTRONICS TECHNICIAN SHORTAGE
An old-timer tells who does and who doesn't get the job
- 66** DON'T FRET—IT ONLY HERTZ
- IMRE GORGENYI **67** BUILD A 'MALF'
Automatic light control turns house into Broadway stage
- DON LANCASTER **70** L I L RICHIE
IC oscillator works with just about any crystal
- CHARLES J. SCHAUERS, W6QLV **74** INFORMATION CENTRAL
- BILL LEGGE **78** ENGLISH-LANGUAGE BROADCASTS TO NORTH AMERICA
- HANK BENNETT, W2PNA **79** SHORT-WAVE LISTENING
Are you listening to stations in the Far East?
- ROBERT LEGGE **80** BROADCASTS IN ENGLISH FROM MIDDLE EAST AND AFRICA
- HERB S. BRIER, W9EQO **81** AMATEUR RADIO
Transoceanic 50-MHz DX
- MATT P. SPINELLO, KHC2060 **83** ON THE CITIZENS BAND
Community Radio Watch
- LOU GARNER **85** SOLID STATE
- G. NEAL **87** LAFAYETTE "PRIVA-COM" IMPROVEMENT
- FRANK H. TOOKER **87** BLINKING DARKROOM TIMER

DEPARTMENTS

- 8** LETTERS FROM OUR READERS
- 15** READER SERVICE PAGE
- 22** NEW PRODUCTS
- 92** TIPS & TECHNIQUES
- 94** OPERATION ASSIST
- 96** ELECTRONICS LIBRARY
- 97** NEW LITERATURE
- 100** OUT OF TUNE



More jobs than technicians **56**

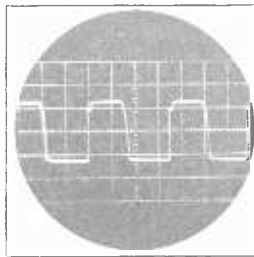

Multi-waveform generator **52**

POPULAR ELECTRONICS is indexed
in the Readers' Guide
to Periodical Literature

This month's cover photo by
Conrad Studios, Inc.

Copyright © 1967 by ZIFF-DAVIS PUBLISHING COMPANY. All rights reserved.

POPULAR ELECTRONICS, September 1967, Volume 27, Number 3. Published monthly at 307 North Michigan Avenue, Chicago, Illinois 60601. One year subscription rate for U.S., C.S. Possessions and Canada, \$5.00; all other countries, \$6.00. Second class postage paid at Chicago, Illinois and at additional mailing offices. Authorized as second class mail by the Post Office Department, Ottawa, Canada and for payment of postage in cash. Subscription service: Portland Place, Boulder, Colorado 80302. Editorial: One Park Ave., New York, N.Y. 10016.

GET YOUR

**FREE
COPY!**



*America's Largest
Electronics Store
Chain Brings You
The Only Catalog
That Isn't "Me Too"*

**NOW OVER 160 STORES
IN 33 STATES NATIONWIDE!**

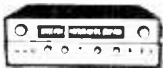

**See Hundreds of
Truly Exclusive**



**CB
TAPE
CARTRIDGES
CASSETTES
RADIOS
PHONOS**

**KITS
MICROPHONES
SPEAKERS
TUBES
RECORDERS
PARTS**

at "no middleman" prices!

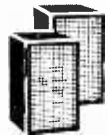

ONLY RADIO SHACK'S CATALOG is principally confined to products of our own design. That's why we say it isn't "me too." That's why it's so eagerly awaited by thousands of pro's, hams, CB'ers, audiophiles, teachers, music lovers and electronics hobbyists! YOU NEED the new Radio Shack Catalog '68 to know what's really new in electronic parts and equipment. That's why you should SEND TODAY FOR YOUR FREE COPY, magnificently published in colorgrature on 8 1/2 x 11" stock. It's the finest effort, the biggest array of new products, in our 45 year history. Use handy coupon below.



**CUT
OUT
TODAY
AND
MAIL!**

Mail Today to: Radio Shack Mailing List Center,
2727 West 7th St., Fort Worth, Texas, 76107



Rush my FREE Radio Shack Catalog '68
via return mail to address below:

Name _____

Street _____

City _____

State _____ Zip _____

Dept. TE

CIRCLE NO. 29 ON READER SERVICE PAGE

The CB-20 "Reacter" is one of seven solid state CB transceiver brands on the market selling for less than \$100. Even if their specifications were

comparable,*

doesn't it

make

sense

to buy yours

from the company that

has built more communi-

cations rigs by a country

mile than all

the others put

together?

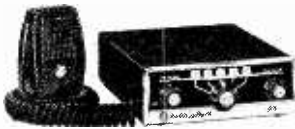

hallicrafters

A Subsidiary of Northrop Corporation
5th and Kostner Aves.
Chicago, Ill. 60624

*The CB-20's specs are a matter of conservative record: Channels: 5, crystal-controlled. Transistors: 12 plus 8 diodes, Zener voltage regulator. Sensitivity: One microvolt for 10 db S/N ratio. Audio power output: 3 watts. Power supply: 12 V. dc only. Modulation: high order. Microphone: push-to-talk ceramic. Maximum current drain: Receive, 0.75 amp.; Transmit, 1.4 amps. Dimensions: 7" x 6" x 2 1/4" LWH. Weight: 4 lbs. PS-20 AC pedestal power supply available as an accessory.

Export: Int'l. Div. Canada: Gould Sales Co.

CIRCLE NO. 12 ON READER SERVICE PAGE

POPULAR ELECTRONICS

PHILLIP T. HEFFERNAN

Publisher

OLIVER P. FERRELL

Editor

LESLIE SOLOMON

Technical Editor

WILLIAM GALBREATH

Art Director

MARGARET MAGNA

Associate Editor

ALEXANDER W. BURAWA

Assistant Editor

ANDRE DUZANT

Technical Illustrator

PATTI MORGAN

AURORA NARDOZZI

Editorial Assistants

H. BENNETT, W2PNA

H. S. BRIER W9EGQ

L. E. GARNER, JR.

CHARLES J. SCHAUERS, W6QLV

M. P. SPINELLO, KHC2060

Contributing Editors

LAWRENCE SPORN

Advertising Sales Manager

ARDYS C. MORAN

Advertising Service Manager

ZIFF-DAVIS PUBLISHING COMPANY

Editorial and Executive Offices

One Park Avenue, New York, New York 10016

212 679-7200

Eastern Advertising Manager, RICHARD J. HALPERN

Midwestern Office

307 North Michigan Avenue, Chicago, Illinois 60601

312 726-0892

Midwestern Advertising Manager, JAMES WEAKLEY

Western Office

9025 Wilshire Boulevard, Beverly Hills, California 90211

213 CRestview 4-0265; BRadshaw 2-1161

Western Advertising Manager, BUD DEAN

Japan: James Yagi

Ishikawa Mansion

#4, Sakuragaoka

Shibuya-ku, Tokyo

462-2911-3

Circulation Office

Portland Place

Boulder, Colorado 80302

William B. Ziff, Chairman of the Board (1946-1953)

William Ziff, President

W. Bradford Briggs, Executive Vice President

Hershel B. Sarbin, Senior Vice President

Philip Sine, Financial Vice President

Walter S. Mills, Jr., Vice President, Circulation

Stanley R. Greenfield, Vice President, Marketing

Phillip T. Heffernan, Vice President, Electronics Division

Frank Pomerantz, Vice President, Creative Services

Arthur W. Butzow, Vice President, Production

Edward D. Muhlfield, Vice President, Aviation Division

Irwin Robinson, Vice President, Travel Division

Ziff-Davis also publishes *Airline Management and Marketing*, *Boating*, *Business & Commercial Aviation*, *Car and Driver*, *Cycle*, *Electronics World*, *Flying*, *HIFI/Stereo Review*, *Modern Bride*, *Popular Aviation*, *Popular Photography*, *Skating*, *Skating Area News*, and *Skating Trade News*. (Travel Weekly is published by Robinson Publications, Inc., a subsidiary of Ziff-Davis Publishing Company.)

All subscription correspondence should be addressed to POPULAR ELECTRONICS, Circulation Department, Portland Place, Boulder, Colorado 80302. Please allow at least six weeks for change of address. Include your old address, as well as new-enclosing if possible an address label from a recent issue.

EDITORIAL CONTRIBUTIONS must be accompanied by return postage and will be handled with reasonable care; however, publisher assumes no responsibility for return or safety of art work, photographs or manuscripts.



Member Audit Bureau
of Circulations

POPULAR ELECTRONICS

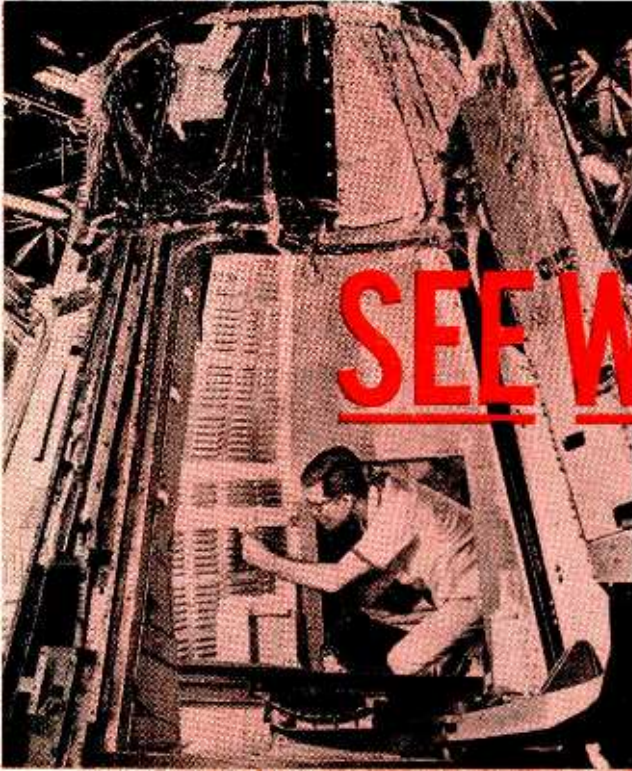

A SUBSIDIARY OF  BELL-HOWELL

SEE WHY so many DeVry-trained Men Step Into Electronics Jobs the Day after Graduation!

EVERY GRADUATE CAN ALSO RECEIVE EMPLOYMENT HELP THROUGH HIS ENTIRE CAREER, AT NO ADDED COST

DeVry's greatest claim to fame is the progress of its graduates. Our aim is to prepare a man so thoroughly that we can recommend him to employers . . . ready to step into a job the day after graduation. If we expect to continue to help employers, our graduates have to be good! That is why we provide top quality instruction—followed by career-long employment service at no added cost.

For FREE Information

Lack of technical experience is no barrier to the man who wants to prepare for a career in ELECTRONICS. Send coupon for two FREE booklets and find out why.



DeVry's educational programs are designed to prepare men 17-45 in their spare time at home or in any of our three well-equipped, modern resident schools in Chicago, Phoenix or Canada. Why not fill in and mail coupon for free facts today?

Approved for Veterans.

DeVRY INSTITUTE of TECHNOLOGY 4141 Belmont Avenue, Chicago, Ill. 60641, Dept. PE-9-X

Please give me your two free booklets, "Pocket Guide to Real Earnings," and "Electronics in Space Travel"; also include details on how to prepare for a career in Electronics. I am interested in the following opportunity fields (check one or more):

- | | |
|--|---|
| <input type="checkbox"/> Space & Missile Electronics | <input type="checkbox"/> Communications |
| <input type="checkbox"/> Television and Radio | <input type="checkbox"/> Computers |
| <input type="checkbox"/> Microwaves | <input type="checkbox"/> Broadcasting |
| <input type="checkbox"/> Radar | <input type="checkbox"/> Industrial Electronics |
| <input type="checkbox"/> Automation Electronics | <input type="checkbox"/> Electronic Control |

Name _____ Age _____

Address _____ Apt. _____

City _____ State or Province _____ Zone or Zip Code _____

Check here if you are under 16 years of age.

**HOME STUDY AND RESIDENT SCHOOL PROGRAMS
AVAILABLE IN CANADA. SEND FOR DETAILS.**

2106

Accredited Member of National Home Study Council

DeVRY INSTITUTE of TECHNOLOGY

4141 BELMONT AVENUE, CHICAGO, ILLINOIS 60641

BIGGER!

**BIGGER... BETTER
THAN EVER!**



**40th ANNIVERSARY
1967 CATALOG**



**YOUR BUYING GUIDE
FOR:** • Stereo & Hi-Fi Systems & Components. • Tape Recorders. • Electronics Parts, Tubes, Tools. • Phonos & Records. • Ham Gear. • Test Instruments & Kits. • Cameras & Film. • PA. • Citizens Band. • Radio & TV Sets. • Musical Instruments.

**SEND FOR
YOURS TODAY!**

BURSTEIN-APPLEBEE CO.

Dept. PE 1012 McGee, Kansas City, Mo. 64106
 Rush me the FREE 1967 B-A Catalog

Name _____

Address _____

City _____ State _____ Zip Code _____

CIRCLE NO. 5 ON READER SERVICE PAGE

**IT ONLY COSTS
1/100 OF 1¢ MORE
PER SOLDER JOINT
TO KNOW YOU ARE USING THE
WORLD'S FINEST CORED SOLDER**



New Easy Dispenser Pak
68/48
18 S.W.G.

Latest PG (Printed Circuit) Pak
68/48 Extra Thin
22 S.W.G.—028

each only 69¢ per package at your dealer



MULTICORE SALES CORP., WESTBURY, N.Y. 11590
CIRCLE NO. 21 ON READER SERVICE PAGE

LETTERS

FROM OUR READERS

Address correspondence for this department to:
Letters Editor, POPULAR ELECTRONICS
One Park Avenue, New York, N. Y. 10016

YOU CAN RECHARGE DRY CELLS

Although Fred Shunaman did not try to charge alkaline cells for his article ("Can Dry Cells Be Recharged," July, 1967), I would like to confirm the fact that they can indeed be recharged. I have used a battery charger identical to that described in the article, and I can add that if carbon-zinc cells prove to be outstanding performers, alkaline cells are even superior. I've used four "AA" cells every day for well over a year for more than an hour a day. These batteries charge back up to almost the initial voltage each time and no end appears in sight. I charge them about once every two weeks, and I only started recharging them six months after I started using them.

JULIAN M. GOKHALE
Washington, D.C.

IMPROVED AUTO THEFT ALARM

I would like to suggest an addition to the "Auto Sentinel" theft alarm ("Stamp Out Auto Theft," March, 1967). In my area, tow-in by overzealous local agencies is a greater threat than actual auto theft. They have ways of removing completely locked cars. If a mercury switch is added to the "Auto Sentinel,"



the alarm will go off if the car is moved bodily, or even bumped hard. The switch can be mounted in a universal joint and connected to the "trigger switch" and ground terminals of TSI. The universal joint is necessary to allow adjustments to be made when traveling over hilly ground.

FRANK S. REID, K4VHJ
Lexington, Ky.

PULSE COMMAND RESPONDER

I read with interest the article on the "Pulse Command Responder" (July, 1967), since a friend and I had built a similar device

CIRCLE NO. 9 ON READER SERVICE PAGE →

*If you have gone
as far as
CB can take you,
step up to the*
COURIER

CLASSIC

A new world of CB awaits you in the incomparable solid-state Courier Classic. In its magnificently simple housing, with rich front panel designed to compliment the finest automobile interior, is every known feature that could be built into a CB transceiver. Start with Classic's push-pull adjustable noise limiter. New, fail-safe relay. The best squelch in the business. Circuitry designed to help pierce "skip". Add every known feature you ever looked for in CB, plus total reliability. In a compact 6½"W x 8½"D x 2½"H. Then cap it with the industry's biggest guarantee—10 full years!

Ready to step up to the Courier Classic? See it now at your Courier dealer, or write today!

\$189
Complete with mobile mounting bracket and crystals for all 23 channels.

Use your Courier Classic as a Base Station with exclusive Courier POWER CHARGER, Model PS-1.

\$29.95



COURIER COMMUNICATIONS, INC.

56 Hamilton Avenue, White Plains, New York

Yes! I'm ready to step up to the Courier Classic.

Name _____

Address _____

City _____ County _____

State _____ Zip _____

FULLY EQUIPPED FOR
IMMEDIATE OPERATION
ON ALL 23 CHANNELS



**23-CHANNEL CB
mobile and base station
AM TRANSCEIVER**

GREATER RANGE POWER with the exclusive new DYNA-BOOST circuit that intensifies speech signals and extends the signal range.

The new Cobra CAM-88 is rugged, handsome and field proven. Compare it, feature for feature, with other CB equipment and you'll be convinced that the Cobra CAM-88 is by far the best.

Outstanding Features

- Fully-Equipped for Immediate 23-channel Transmit and Receive
- Double Conversion Superheterodyne Receiver
- Transistorized 117V AC/12V DC Power Supply
- Speech Compression with Switch
- Delta-Tune Fine Tuning
- Squelch Control and Standby Switch
- Illuminated Dual-Purpose Meter
Power-in (Receive)-Power-out (Transmit)
- Modulation Indicator
- Detachable Press-to-talk Microphone
- Convertible to a Public Address Amplifier

Carefully engineered design makes the Cobra completely reliable and easy to operate. Completely self-contained. *No additional crystals needed.* \$21495



**DIVISION OF DYNASCAN CORPORATION
1801 W. BELLE PLAINE AVE. • CHICAGO, ILL. 60613**

Export: Empire Exporters, 123 Grand St., New York 13, U.S.A. Also available in Canada
CIRCLE NO. 4 ON READER SERVICE PAGE

LETTERS (Continued from page 8)

for a science fair project. I would like to point out, however, that the Guardian IR-MC stepping relay called out in the project's Parts List is not equipped with electrical reset. The Guardian stepping relays that do have electrical reset are the MER-115AC, PER-115AC and RER-115AC.

JOHN KOZAKIEWICZ
Hudson Heights, P.Q.

You're absolutely right, John. The relay specified in the Parts List was actually supposed to be the Guardian IR-MER or similar relay. The relays you have specified fall into the "or similar" category.

COLOR ORGAN

Last summer I built the "Musette" Color Organ (July, 1966). Construction was simple and went very quickly. I did run into a problem when I tried to connect both channels of my stereo receiver to the audio input, however. I could not do so without mixing the outputs to my speakers. Rather than build another color organ, I decided to use the Musette with only one channel.

Then I encountered a second problem. When I turned up the volume on my receiver to a certain point, the color organ set up a feedback path to my receiver and shorted out the receiver's output transistors. I decided to put a diode into the input circuit to prevent the feedback.

It later occurred to me that if I put two diodes into the circuit (see drawing), I could

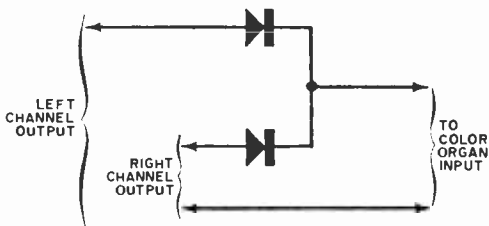

mix both channels from my receiver into the color organ and, at the same time, preserve the stereo effect at the speakers. The outputs to the speakers are tapped ahead of the diodes, before any mixing takes place.

WILLIAM J. CALL
Belmont, Mass.

LET'S HAVE PARTS CLEARLY IDENTIFIED

Recently I bought ten resistors and some other parts from two large electronic parts distributors, and every one of them was incorrectly packed. Eight of the resistors bore no resemblance to the ones I had ordered! If distributors cannot afford to employ people who have at least a basic knowledge of the products they deal in, then it should be the responsibility of the distributors to see to it

(Continued on page 14)

IN ELECTRONICS AND ELECTRICITY THIS AMAZING NEW SLIDE RULE SEPARATES THE MEN FROM THE BOYS!

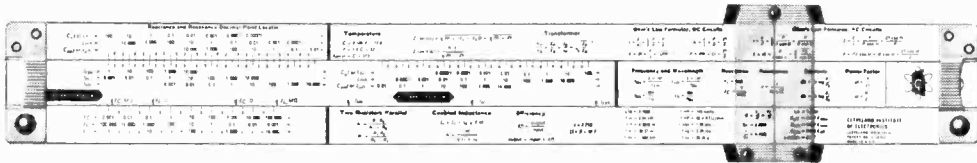

LOOK WHAT YOU GET...

YOU GET... a patented*, high-quality, all-metal 10" electronics slide rule. "Your computer in a case". Has special scales for solving sticky reactance and resonance problems... an exclusive "fast-finder" decimal point locator... widely-used electronics formulas and conversion factors. PLUS... all the standard scales you need for non-electronic computations such as multiplication, division, square roots, logs, etc.

YOU GET... a complete, "AUTO-PROGRAMMED" self-tutoring instruction course. Four fast-moving lessons with hundreds of easy-to-understand examples and diagrams. You'll learn how to find quick, accurate answers to complex electronics problems... soon be your outfit's slide rule "expert". Free examination and consultation service if you want it plus a Graduation Certificate! THIS COURSE ALONE IS WORTH FAR MORE THAN THE PRICE OF THE COMPLETE PACKAGE!

YOU GET... a sturdy, handsome carrying case. It's made of genuine top-grain leather, doubly reinforced at the "wear-spots", features heavy duty liner for extra slide rule protection, has a removable belt loop for convenient carrying. "Quick-Flip" cover makes it easy to get your rule in and out of the case. Stamps you as a real "pro" in electronics.

**A \$50.00 VALUE FOR LESS
THAN \$25.00**

*Under U. S. Patent #3,120,342

NOW... take full advantage of what you know about electronics and electricity... solve complex problems in seconds while others plod along the old-fashioned "pad and pencil" way!

READ WHY OTHERS CALL THIS REMARKABLE NEW SLIDE RULE PACKAGE TODAY'S BIGGEST BARGAIN IN ELECTRONICS.

The Editor of Popular Electronics, Mr. Oliver P. Ferrell says: "Why didn't someone think of this before. The convenience of having all relevant formulas imprinted right on the slide rule saved me time the very first day!"

A student, Mr. Jack Stegeman says: "Excellent, I couldn't say more for it. I have another higher-priced rule but like the CIE rule much better because it's a lot easier to use."

The Head of the Electrical Technology Dept., New York City Community College, Mr. Joseph J. DeFrance says: "I was very intrigued by the 'quikie' electronics problem solutions. Your slide rule is a natural!"

SPECIAL BONUS OFFER:

ANYONE WHO SENDS IN THIS COUPON WILL RECEIVE, ABSOLUTELY FREE, A HANDY POCKET ELECTRONICS DATA GUIDE.

It's a useful, pocket-sized electronics "encyclopedia"... jam-full of valuable facts, formulas and other helpful information. Carry it with you... when it comes to electronics, you'll be the "man-with-the-answer"!

**Cleveland Institute
of Electronics**
Dept. PE-136, 1776 E. 17th St., Cleve. Ohio 44114



ACT NOW! SEND SPECIAL "NO-RISK" COUPON TODAY!

CIE Cleveland Institute of Electronics
1776 E. 17th Street, Dept. PE-136, Cleveland, Ohio 44114

Please send FREE illustrated Slide Rule Booklet and FREE Pocket Electronics Data Guide.

NAME _____ (Please Print)

ADDRESS _____ COUNTY _____

CITY _____ STATE _____ ZIP _____

A leader in Electronics Training... since 1934

**GET
BOTH FREE!**

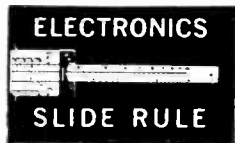

CIRCLE NO. 7 ON READER SERVICE PAGE

Look What's NEW In The

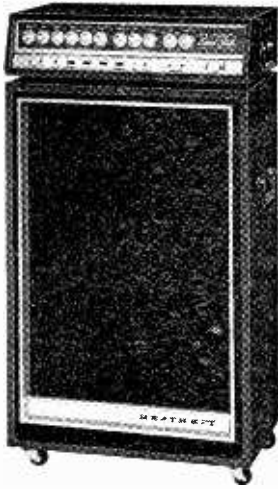

NEW! Deluxe Solid-State Combo Amplifier & Speaker System!

Kit TA-17
Amplifier
\$175⁰⁰
40 lbs.

Kit TA-17-1
Speaker System
\$120⁰⁰
100 lbs.

Special Combo Offer!

Kit TAS-17-2 Amplifier &
2 Speaker Systems
Save \$20.00
\$395⁰⁰
240 lbs.

All the "big sound" features every combo wants . . . tremolo, built-in "fuzz", brightness, reverb, plus a shattering 120 watts of EIA music power. Has 3 independent input channels each with 2 input jacks. Handles lead or bass guitars, combo organ, singer's mike, even a record changer. Speaker system features two special 12" woofers, special horn-driver and matching black vinyl-covered wood cabinet.

NEW! Low Cost Single-Channel Solid-State Guitar Amplifier



Kit TA-27
\$89⁹⁵

Boasts 20 watts EIA music power, 40 watts peak power; variable tremolo & reverb; two inputs that handle lead guitars; singer's mike; special heavy-duty 12" speaker; line bypass reversing switch that reduces hum; transformer-operated power supply; and handsome leather-textured, black vinyl covered wood cabinet with extruded aluminum front panel and chrome knobs. 35 lbs.

NOW Available Fully Assembled . . . Heathkit "Starmaker" Dual-Channel Guitar Amplifier

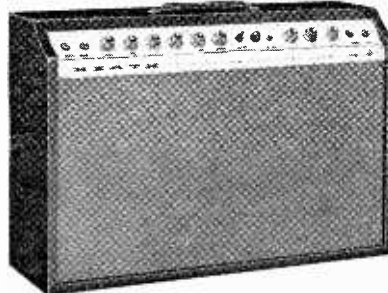

Assembled
TAW-16
\$199⁹⁵
(Kit TA-16
\$134.95)

Features all solid-state circuit; 25 watts EIA, 60 watts peak power; two channels, one for accompaniment, accordion or mike, the other for variable tremolo & reverb; two inputs each channel; two 12" heavy-duty speakers; line bypass reversing switch for hum reduction; leather-textured black vinyl covered wood cabinet with extruded aluminum front panel & chrome knobs. For extra savings, build the kit version in just 15 hours. 52 lbs.

NEW LOW PRICE On Heathkit "180" Deluxe Color TV

Now Save \$30 on this superb set. Features 180 sq. in. rectangular viewing area, plus exclusive built-in servicing facilities so you can converge and maintain the best color pictures at all times. Also has 24,000 volt picture power, automatic degaussing, rare earth phosphors for livelier colors, 3-stage IF, plus many more advanced features. Choice of installation . . . in a wall, your custom cabinet or an old black & white set cabinet, Heath assembled contemporary (Illust. \$49.95) or Early American (\$75.00) floor cabinets, or new Heath table model (\$24.95) cabinet. Build in 25 hours. 102 lbs.

Kit GR-180
Was \$379.95
Now Only
\$349⁹⁵
(less cab.)



'68 HEATHKIT® Catalog!

NOW Available Fully Assembled . . .
World's Most Advanced Stereo Receiver



Assembled
ARW-15
\$499⁹⁵
(less cab.)
Kit AR-15.
\$329.95

Boasts advanced features like integrated circuits and crystal filters in the IF amplifier; ultra-sensitive FET FM tuner; 150 watts dynamic music power; AM, FM and FM stereo; positive circuit protection; all-silicon transistors; "black magic" panel lighting; stereo only switch; adjustable phase control and many more. 34 lbs. Optional wrap-around walnut cabinet \$19.95

NEW! Professional 10-Band
Shortwave Listener's Receiver

Kit SB-310
\$249⁰⁰
(less speaker)



Covers 6 shortwave bands (49, 41, 31, 25, 19, & 16 meters) . . . 80, 40 & 20 meter ham bands . . . 11 meter CB. Has 5 kHz crystal filter for AM, SSB and CW; Selectivity that slices stations down to last kHz . . . no more guessing station identities; 11-tube circuit; crystal-controlled front-end; prebuilt & aligned linear oscillator; metal cabinet. Other crystal filters available. 20 lbs.

NEW! Amateur Novice CW
Transceiver

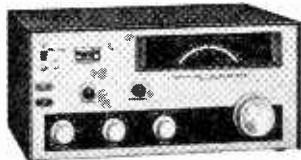

Kit HW-16
\$99⁵⁰

Novices! New Hams! Get on-the-air at lowest cost. Provides CW operation on the first 250 kHz of the 80, 40 & 15 meter bands. 75 watt CW input, up to 90 watts for general class operation. True "break-in" CW operation. Crystal control transmit with VFO receiver tuning. Built-in sidestone. Grid-block keying. Metal cabinet and simple assembly. 25 lbs.

NEW! Deluxe Solid-State Volt-Ohm
Meter

Kit IM-16
\$44⁹⁵

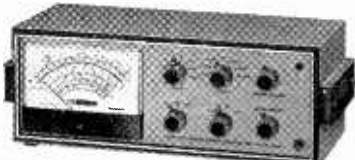

Features 8 DC and 8 AC voltage ranges from 0.5 v to 1500 v full scale; 7 ohmmeter ranges; 11 megohm input resistance on DC ranges; 1 megohm on AC ranges; internal battery or 120/240 v. 50/60 AC power for portable or "in-shop" operation; 6" 100 uA meter; single test probe for all measurements; new Heathkit "unitized" cabinet construction.

NEW! Heathkit Jr.
Solid-State Port-
able Phonograph

Kit JK-17
\$19⁹⁵



Perfect for the youngster in your family. Plays all 4 speeds. all record sizes. Crystal cartridge with sapphire stylus for all types of records; 4" speaker; built-in 45 rpm adaptor; preassembled turntable and hardboard cabinet. Build in 1 to 2 hours. 117 VAC, 60 Hz operation. 11 lbs.

NEW! Heathkit Soldering Iron

Kit GH-17
\$14⁹⁵



Ideal for kit-building or other electronic soldering jobs. Safe 6 volt, 25 watt GE midget iron with non-corroding tip. 3 heat ranges. Excellent heat recovery time. Quick warm-up . . . iron ready in 2 minutes. Protective metal cage. Build in an hour. 5 lbs.



NEW!

FREE 1968 CATALOG!

Now with more kits, more color. Fully describes these along with over 300 kits for stereo, hi-fi, color TV, electronic organs, electric guitar & amplifier, amateur radio, marine, educational, CB, home & hobby. Mail coupon or write Heath Company, Benton Harbor, Michigan 49022



HEATH COMPANY, Dept. 10-9
Benton Harbor, Michigan 49022
In Canada, Daystrom Ltd.

Enclosed is \$ _____, including shipping.

Please send model (s) _____

Please send FREE Heathkit Catalog.

Name _____

Address _____

City _____

State _____

Zip _____

Prices & specifications subject to change without notice.

CL-300

NEW

**mobile
performance
hand-held
convenience
incomparable
PACE
quality**



3-channel transmit /
receive • 2-watt
output • 18 silicon
transistors
• double
conversion
receiver
• automatic
noise
limiter
and squelch
• for mobile
and portable
use • only
\$99.95 complete
with antenna and
battery. Write
for information.

PACE-MATE CB transceiver

((P)) PACE

COMMUNICATIONS CORP.
24049 Frampton Ave., Harbor City, Calif. 90710
Export Div.: 64-14 Woodside Ave., Woodside, N.Y.
Also available in Canada

CIRCLE NO. 23 ON READER SERVICE PAGE

LETTERS (Continued from page 10)

that each part is marked with letters or numerals. I would also like very much to see all components with engraved or etched identifying marks so that the values of parts can be easily read after years of use.

W. SCHNEIDER, WB2ZXB
Franklin Square, L.I., N.Y.

"LIVING LETTERS"

I am an avid FM enthusiast and would like to make contact with someone in an eastern metropolitan area who would be interested in exchanging tapes of FM radio broadcasts, via the mail. Since I became an FM fan, I have not been out of California, and so have heard no FM stations from any other state. I would very much like to hear some FM stations

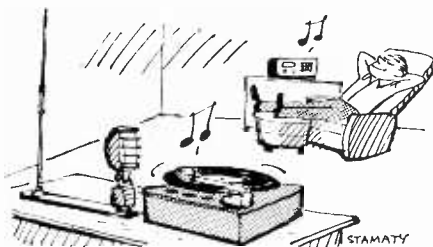

from other areas, and get acquainted with another FM fan via "Living Letters." I can supply tapes of all San Francisco stations, Sacramento stations, and many others.

PATRICK G. CONNOLLY
Electronics Technician Third
U. S. Naval Auxiliary Landing Field
Monterey, Calif. 93940

I would very much like a "tapespondent" in the U.S.A. I am an electronics enthusiast, and am working for my amateur radio "ticket" at the present time. Anyone interested in "tapesponding" should please write to me (don't send tapes because the cost of their return would be too high). All letters will be answered. I will tapespond on 3-inch tape spools at any speed desired by my tapespondent.

ANDY DERMONT
175 Moulsham Drive
Chelmsford, Essex,
England

I would like to have tape correspondence with people in different parts of the United States. Anyone interested in having a "tape pal," please write:

PHIL SALLEY
3140 Travis Ct.
Columbia, S. C. 29204

"APRIL FOOL"

Congratulations on "Announcing Unusually Adaptable Computer" (April, 1967, page 88). In our present world, surrounded by com-

POPULAR ELECTRONICS READER SERVICE PAGE

free information service:

Here's an easy and convenient way for you to get additional information about products advertised or mentioned editorially (if it has a "Reader Service Number") in this issue. Just follow the directions below... and the material will be sent to you promptly and free of charge.

1. Print or type your name and address on the lines indicated. Circle the number(s) on the coupon below that corresponds to the key number(s) at the bottom of the advertisement or editorial mention(s) that interest you. (Key numbers for advertised products also appear in the Advertisers' Index.)

2. Cut out the coupon and mail it to the address indicated below.

3. This address is for our product "Free Information Service" only. Editorial inquiries should be directed to POPULAR ELECTRONICS, One Park Avenue, New York 10016; circulation inquiries to Portland Place, Boulder, Colorado 80302.

**POPULAR
ELECTRONICS**

VOID AFTER OCTOBER 31, 1967

P.O. BOX 8391
PHILADELPHIA, PA. 19101

1 2 3 4 5 6 7 8 9 10 11 12 13 14 15 16 17 18 19 20
21 22 23 24 25 26 27 28 29 30 31 32 33 34 35 36 37 38 39 40
41 42 43 44 45 46 47 48 49 50 51 52 53 54 55 56 57 58 59 60
61 62 63 64 65 66 67 68 69 70 71 72 73 74 75 76 77 78 79 80
81 82 83 84 85 86 87 88 89 90 91 92 93 94 95 96 97 98 99 100

NAME (Print clearly) _____

ADDRESS _____

CITY _____ STATE _____ ZIP CODE _____

9N

New sound column

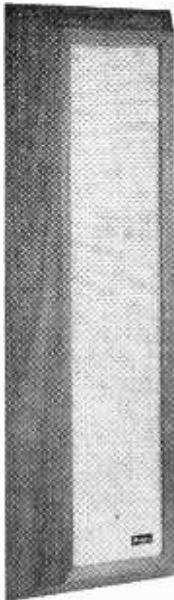

High Fidelity Speaker System

Looks beautiful, sounds excitingly different! Sound column design uses scientific focusing principle to add extra projection to high tones, re-create music with startling fidelity. Ideal for stereo. 33 1/4" h. x 10 1/2" w. x 4" d. 4 Jensen speakers — 2 specially-designed high compliance woofers, 2 direct radiator tweeters. 50 to 17,000 cps. Cabinet of genuine walnut with oiled finish . . . designed to hang on the wall like a picture.

The Astra

\$49.95 each
audiophile net

Write for free catalog showing Argos systems for every purpose

Argos

PRODUCTS COMPANY

Dept. C 600 S. Sycamore St., Genoa, Ill. 60135
CIRCLE NO. 3 ON READER SERVICE PAGE

Buy the best.



Our 1968 catalog of precision quartz crystals and electronics for the communications industry is now available.

It will cost you nothing.



SENTRY MANUFACTURING COMPANY
1634 LINWOOD BOULEVARD, OKLAHOMA CITY, OKLAHOMA 73106
PHONE: 405-232-1431 — TELEFAX: 071-361 — TWX: 910-831-3175

CIRCLE NO. 6 ON READER SERVICE PAGE

LETTERS (Continued from page 10)

puters, automation, and mechanization, we tend to forget about the most versatile, productive, and important unit of all, Man!

ROBERT P. PORTER
Section Supervisor
Small Computer Systems Test
Control Data Corp.
Arden Hills, Minn.

I think Lou Garner made a mistake in including the news of the "super-powered" transistor on pages 85 and 106 of the April '67



issue. This would have gone over beautifully if it were not for one minor complication: I received the magazine on MARCH 17!

JOHN HOMKO, JR.
Ansonia, Conn.

Bob, we couldn't agree more. John, hereafter we'll try to arrange to have you receive your subscription copy two weeks late.

A "SHOCKING" BOOK

I built a variation of the "Tickle Stick" (February, 1966). I stuck to the given specifications, but instead of using a tubular enclosure, I put the circuitry inside a hollow book. Then I covered the book with aluminum foil and made a 1/4" split in the backbone to form the two electrodes. Whenever an innocent victim is handed the book, he soon realizes that he has a "shocking" edition in his hands.

BILL HIGGS
San Marco, Texas

TROUBLESHOOTING AID

Why not include normal operating voltages at all junctions with your construction projects? These voltages could be neatly placed on the schematic drawing accompanying each project. I believe this addition would be helpful when someone has to analyze or troubleshoot a complicated circuit.

MIKE EATON
San Diego, Calif.

Mike, because electronic components are available in a wide variety of tolerances and because of possible substitution of parts
(Continued on page 100)

POPULAR ELECTRONICS

Up to 100 times more rejection

The Johnson Messenger 323 uses a precision crystal filter in the receiver to deliver up to 100 times more rejection of adjacent channel interference than other units. The frequency synthesizer is so accurate, there's no need for a "fine tuning" control. Speech compression in the transmitter provides more audio for greater range without distortion or splatter.

For even greater operating convenience there's an illuminated combination "S" meter /power output meter, a built-in PA system, a socket

for the Johnson Tone Alert selective calling system and optional base station and portable power supplies.

All solid state, the Messenger 323 isn't "just another" 23-channel CB rig. It has all of the same dependability, versatility and extra care built-in that make all Johnson Messengers the standard of the industry. At home, in the field or on the road, nothing surpasses Johnson . . . providing nearly a half-century of communications leadership.

NEW—23 channel



E. F. JOHNSON COMPANY
Providing nearly a half-century of communications leadership.

E. F. JOHNSON COMPANY

2497 Tenth Ave. S.W., Waseca, Minn. 56093

Please rush complete details on Messenger 323

Name _____

Address _____

City & State _____ Zip _____

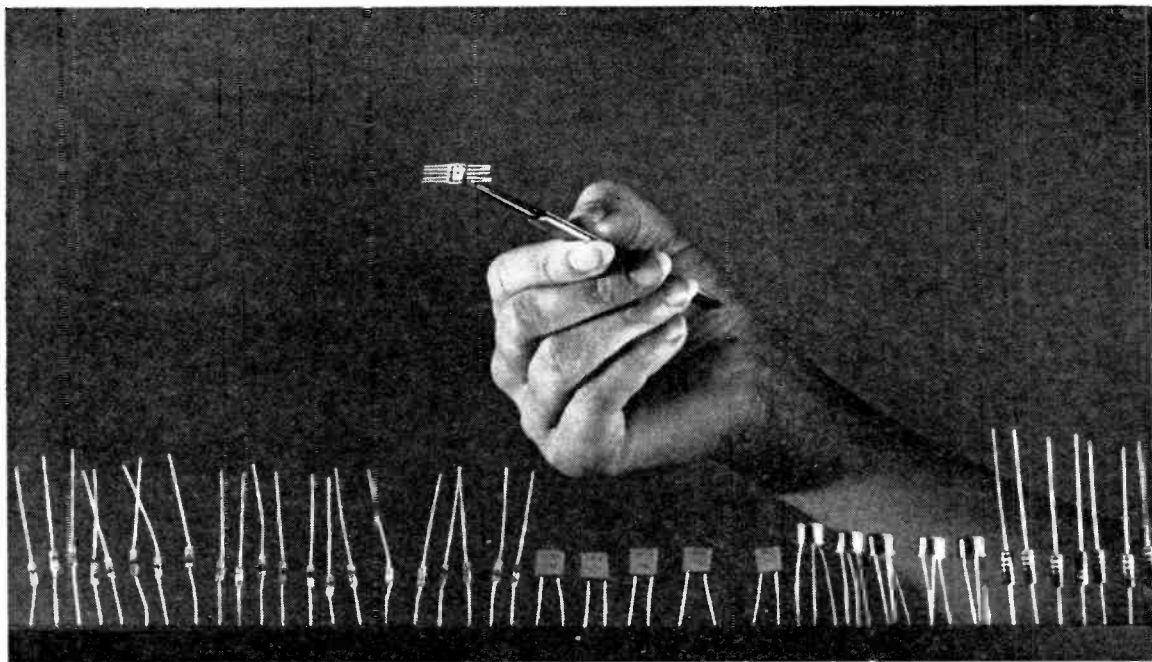

50 functions in a single chip. *The functions of 50 separate transistors, diodes, resistors and capacitors can now be formed by the tiny dot in the center of the integrated circuit held by the tweezers.*

The "Chip"

...will it make or break your job future?

THE DEVELOPMENT OF INTEGRATED CIRCUITRY is the dawn of a new age of electronic miracles. It means that many of today's job skills soon will be no longer needed. At the same time it opens the door to thousands of exciting new job opportunities for technicians solidly grounded in electronics fundamentals. Read here what you need to know to cash in on the gigantic coming boom, and how you can learn it right at home.

TINY ELECTRONIC "CHIPS," each no bigger than the head of a pin, are bringing about a fantastic new Industrial Revolution. The time is near at hand when "chips" may save your life, balance your checkbook, and land a man on the moon.

Chips may also put you out of a job...or into a better one.

"One thing is certain," said *The New York Times* recently. Chips "will unalterably change our lives and the lives of our children probably far beyond recognition."

A single chip or miniature integrated circuit can

perform the function of 20 transistors, 18 resistors, and 2 capacitors. Yet it is so small that a thimbleful can hold enough circuitry for a dozen computers or a thousand radios.

Miniature Miracles of Today and Tomorrow

Already, as a result, a two-way radio can now be fitted inside a signet ring. A complete hearing aid can be worn entirely inside the ear. There is a new desk-top computer, no bigger than a typewriter yet capable of 166,000 operations per second. And it is almost possible to put the entire circuitry of a color television set inside a man's wrist-watch case.

And this is only the beginning!

Soon kitchen computers may keep the housewife's refrigerator stocked, her menus planned, and her calories counted. Her vacuum cleaner may creep out at night and vacuum the floor all by itself.

Money may become obsolete. Instead you will simply carry an electronic charge account card. Your employer will credit your account after each week's work and merchants will charge each of your purchases against it.

When your telephone rings and nobody's home, your call will automatically be switched to the phone where you can be reached.

Doctors will be able to examine you internally by watching a TV screen while a pill-size camera passes through your digestive tract.

New Opportunities for Trained Men

What does all this mean to someone working in electronics who never went beyond high school? It means the opportunity of a lifetime—if you take advantage of it.

It's true that the "chip" may make a lot of manual skills no longer necessary.

But at the same time the booming sales of articles and equipment using integrated circuitry has created a tremendous demand for trained electronics personnel to help design, manufacture, test, operate, and service all these marvels.

There simply aren't enough college-trained engineers to go around. So men with a high school education who have mastered the fundamentals of electronics theory are being begged to accept really interesting, high-pay jobs as engineering aides, junior engineers, and field engineers.

How To Get The Training You Need

You can get the up-to-date training in electronics fundamentals that you need through a carefully chosen home study course. In fact, some authorities feel that a home study course is the best way. "By its very nature," stated one electronics publication recently, "home study develops your ability to analyze and extract information as well as to strengthen your sense of responsibility and initiative." These are qualities every employer is always looking for.

If you do decide to advance your career through spare-time study at home, it makes sense to pick an electronics school that specializes in the home study method. Electronics is complicated enough without trying to learn it from texts and lessons that were designed for the classroom instead of correspondence training.

The Cleveland Institute of Electronics has everything you're looking for. We teach only electronics—no other subjects. And our courses are designed especially for home study. We have spent over 30 years perfecting techniques that make learning electronics at home easy, even for those who previously had trouble studying.

Your instructor gives your assignments his undivided personal attention—it's like being the only student in his "class." He not only grades your work, he analyzes it. And he mails back his corrections and comments the same day he gets your lessons, so you read his notations while everything is still fresh in your mind.

Always Up-To-Date

Because of rapid developments in electronics, CIE courses are constantly being revised. Students re-

Tiny TV camera for space and military use is one of the miracles of integrated circuitry. This one weighs 27 ounces, uses a one-inch vidicon camera tube, and requires only four watts of power.

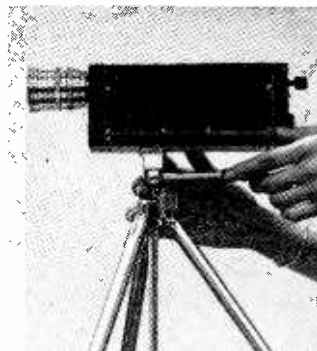

ceive the most recent revised material as they progress through their course. This year, for example, CIE students are receiving exclusive up-to-the-minute lessons in Microminiaturization, Logical Troubleshooting, Laser Theory and Application, Single Sideband Techniques, Pulse Theory and Application, and Boolean Algebra. For this reason CIE courses are invaluable not only to newcomers in Electronics but also for "old timers" who need a refresher course in current developments.

Praised by Students Who've Compared

Students who have taken other courses often comment on how much more they learn from CIE. Mark E. Newland of Santa Maria, California, recently wrote: "Of 11 different correspondence courses I've taken, CIE's was the best prepared, most interesting, and easiest to understand. I passed my 1st Class FCC exam after completing my course, and have increased my earnings \$120 a month."

Get FCC License or Money Back

No matter what kind of job you want in electronics, you ought to have your Government FCC License. It's accepted everywhere as proof of your education in electronics. And no wonder—the Government licensing exam is tough. So tough, in fact, that without CIE training, two out of every three men who take the exam fail.

But better than 9 out of every 10 CIE-trained men who take the exam pass...on their very first try!

This has made it possible to back our FCC License courses with this famous Warranty: you *must* pass your FCC exam upon completion of the course or your tuition is refunded in full.

Mail Card For Two Free Books

Want to know more? The postpaid reply card bound in here will bring you a free copy of our school catalog describing today's opportunities in electronics, our teaching methods, and our courses, together with our special booklet on how to get a commercial FCC License. If card has been removed, just send us your name and address.



CIE

Cleveland Institute of Electronics

1776 E. 17th St., Dept. PE-58, Cleveland, Ohio 44114

Accredited Member National Home Study Council
A Leader in Electronics Training... Since 1934



ENROLL UNDER NEW G.I. BILL

All CIE courses are available under the new G.I. Bill. If you served on active duty since January 31, 1955, or are in service now, check box on reply card for G.I. Bill information.

CIRCLE NO. 8 ON READER SERVICE PAGE



NEW PRODUCTS

Additional information on products covered in this section is available from the manufacturers. Each new product is identified by a code number. To obtain further details on any of them, simply fill in and mail the coupon on page 15.

ALL-WAVE RECEIVER

Continuous coverage from 0.54 to 54 MHz is claimed for *Ameco Equipment Corporation's* Model R-5 "all-wave" receiver. Its five continuous "bands" include: the standard broadcast band; all foreign broadcast bands; all amateur bands from 160 through 6 meters; all 27-MHz CB channels; and all two-way radio frequencies from 30 to 50 MHz. Fully transistorized, the Model R-5 has a BFO and

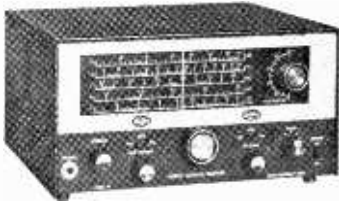

noise limiter, and a built-in power supply for a.c. operation; with an optional accessory, it can also be used as a portable. It is supplied both in kit form and wired and tested, with cabinet.

Circle No. 75 on Reader Service Page 15

TACHOMETER AND DWELL METER

Any car, foreign or domestic, 4 or 6 or 8 cylinders, can be tuned up with *Delta Products'* "Transitester" Model T-1000 tune-up tachometer and Model D-1000 dwell meter. Both instruments have 3½" meters and a rugged lightweight case, and will give correct readings on vehicles equipped with transistor ignition, capacitive discharge ignition, or conventional ignition. The tachometer has a range of 0 to 1200 r/min, and simple calibration and setting knobs let you read engine dwell degrees easily with the dwell meter. Each instrument comes with complete instructions for use, and color-coded leads to eliminate guesswork.

Circle No. 76 on Reader Service Page 15

SENSITIVE LOW-COST VOM

Measuring capabilities never before available in a low-cost VOM are claimed for *Amphenol Corporation's* Model 870 "Millivolt Com-

mander." A field effect transistor (FET) unit, it measures voltages as low as 0.1 volt d.c. full scale, and 0.01 volt a.c. full scale, with accuracies of $\pm 2\%$ and $\pm 3\%$, respectively. Input resistance on all d.c. ranges is 11 megohms, and input impedance on all a.c. ranges is 10 megohms. The 870 is a battery-powered instrument with a.c./d.c. test probe assembly and hinged front cover.

Circle No. 77 on Reader Service Page 15

AUTOMATIC VOLTAGE REGULATOR

Handling up to 400 watts, the new Model D-210 automatic voltage regulator from *Perma-Power* enables color TV sets to be used more efficiently in areas where line voltage regulation is poor. It eliminates picture distortion such as flutter, shrinking, flop-over and loss of brightness caused by low voltage. The Model D-210 boosts line voltage 10 volts when the line drops below 110 volts. When voltage is normal, it cuts out. It shuts off when the TV set (or any appliance) is not in use. There are no tubes, ballasts, or relays to wear out, and the unit is fully guaranteed for one year.



Circle No. 78 on Reader Service Page 15

AMPLIFIED HEADPHONE

Now you can start a stereo system with only a tuner or record changer and enjoy the full benefits of stereo listening, according to *Telex*. This company's new "Amplitwin" headphone features a speaker, miniaturized four-stage solid-state amplifier, battery, on-off switch, and volume control, as well as high and low level inputs incorporated in each ear cup. You can connect it directly to turntables, changers, tape transport, deck, or tuner. Acoustic response is 16-15,000 Hz. When the amplifiers are switched off, the "Amplitwin" operates as a conventional headphone with any stereo equipment having a headphone jack. Connecting cords and a heavily padded storage/carrying caddy come with the headphone.



Circle No. 79 on Reader Service Page 15

MARINE CB ANTENNA













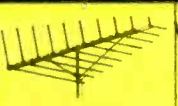

Boat owner CB'ers will be interested in the Model ASM-23 "Sea-Hook," an omnidirectional antenna from *Antenna Specialists* which has an exceptionally low angle of radiation

NEW FINCO[®] COLOR SPECTRUM[™] antennas are "signal customized" for better color reception...

"the ANTENNA that captures the RAINBOW"

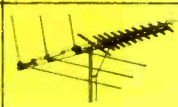
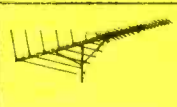
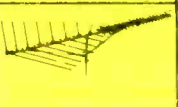
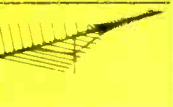
FINCO has developed the Color Spectrum Series of antennas— "Signal Customized" — to exactly fit the requirements of any given area. There is a model scientifically designed and engineered for your area.

Check this chart for the FINCO "Signal Customized" Antenna best suited for your area.

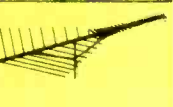
STRENGTH OF UHF SIGNAL AT RECEIVING ANTENNA LOCATION ▼	Strength of VHF Signal at Receiving Antenna Location				
	NO VHF ▼	VHF SIGNAL STRONG ▼	VHF SIGNAL MODERATE ▼	VHF SIGNAL WEAK ▼	VHF SIGNAL VERY WEAK ▼
NO UHF →		 CS-V3 \$10.95	 CS-V5 CS-V7 \$17.50 \$24.95	 CS-V10 \$35.95	 CS-V15 CS-V18 \$48.50 \$56.50
UHF SIGNAL STRONG →	 CS-U1 \$9.95	 CS-A1 \$13.95	 CS-B1 \$29.95	 CS-C1 \$43.95	 CS-C1 \$43.95
UHF SIGNAL WEAK →	 CS-U2 \$14.95	 CS-A2 \$22.95	 CS-B3 \$49.95	 CS-C3 \$59.95	 CS-D3 \$69.95
UHF SIGNAL VERY WEAK →	 CS-U3 \$21.95	 CS-A3 \$30.95	 CS-B3 \$49.95	 CS-C3 \$59.95	 CS-D3 \$69.95

NOTE: In addition to the regular 300 ohm models (above), each model is available in a 75 ohm coaxial cable downlead where this type of installation is preferable. These models, designated "XCS", each come complete with a compact behind-the-set 75 ohm to 300 ohm balun-splitter to match the antenna system to the proper set terminals.



THE FINNEY COMPANY
34 West Interstate Street
Dept. PE • Bedford, Ohio 44146

Send for free brochure
Name _____
Address _____
City _____ State _____ Zip _____

CIRCLE NO. 11 ON READER SERVICE PAGE

PRODUCTS (Continued from page 22)

for maximum potential overwater range. A full electrical half-wave radiator, the 27-MHz antenna is loaded for an overall length of 97 inches. Special feature: an exclusive pure-white cyclac base with built-in foldover to allow instant "retraction" of the antenna when negotiating bridges and other low obstacles. The impedance is 50 ohms, matching virtually all available CB transceivers, and VSWR is said to be better than 1.5 to 1.0.

Circle No. 80 on Reader Service Page 15

SOLID-STATE AMPLIFIED SPLITTER

Called the "Homer," the solid-state amplified splitter being manufactured by *Blonder-Tongue* improves TV or FM reception on up to four sets operating from a single antenna.

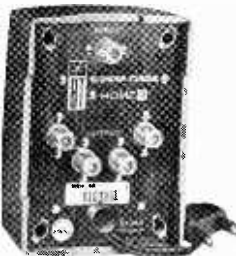

The splitter nearly triples TV or FM signals (9 dB) when operating two sets, doubles the signal (6 dB) gain with four sets. Featuring a new inductive-coupled emitter feedback circuit, it is said to be extremely effective in defeating crossmodulation, harmonic interference, wind-

shield wiper effect, hash, herringbone and beat patterns. Because it draws less power than an electric clock, the "Homer" remains "on" at all times. It can be mounted wherever there is an a.c. outlet, and is supplied with five coax connectors for RG-59 cable.

Circle No. 81 on Reader Service Page 15

"KITTEN" SPEAKER SYSTEM

It purrs . . . and it roars—from 30 to 18,000 hertz. *Empire Scientific* calls it "Kitten," otherwise known as the Empire Model 2000 speaker system. Designed primarily for young people with limited space and limited budgets, "Kitten" comes in three styles: walnut finish, walnut finish with contour cushion (shown in photo), and walnut finish with imported marble top. It contains a 10-inch high-compliance woofer with 2-inch voice coil, and a direct-radiator mid-range and tweeter with wide angle dispersion—the same two drivers used in the "Cavalier" speaker systems. Power-handling capacity: 60 watts of undistorted music power.



Circle No. 82 on Reader Service Page 15

BATTERY-LESS VTVM

The "professional" Model V-95 VTVM introduced by *Precision Apparatus* (a division of

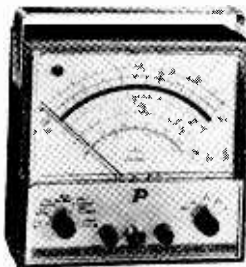

Dynascan Corporation) employs an exclusive solid-state power supply that eliminates the need for batteries to operate the ohm-meter section. Other features include a 7" meter movement which has a built-in mirror for reducing parallax, specially

calibrated 0.5-, 1.0-, 1.5- and 5.0-volt scales for transistor circuit analysis, and simplified peak-to-peak and dB scales. The meter's handle is designed to accommodate the owner's name plate.

Circle No. 83 on Reader Service Page 15

SIGNAL STRENGTH METER

Portable, lightweight, battery-operated, and housed in a rugged case, the *Jerrold AIM-718* solid-state signal strength meter was designed specifically for antenna installers. Reading directly in dBmV and microvolts, the meter shows exact antenna requirements. It's equipped with separate VHF and UHF tuners and provides continuous coverage of 54 to 216 MHz for VHF-TV/FM and 470 to 890 MHz for UHF-TV. Features include an audio output jack, crystal earphone, and two built-in dB attenuators—plus a safety switch that turns off the power when the cover is closed.



Circle No. 84 on Reader Service Page 15

"HAND-AND-STAND" MICROPHONE

Featured in *Electro-Voice's* Model 631 "hand-and-stand" entertainer's microphone is a "Uniseal" switch. Underneath the snap-on switch actuator is a magnetically operated reed relay switch, sealed away from dirt and corrosion. A magnet in the removable actuator closes or opens the switch contacts when it is moved forward or back on the case; and when the actuator is removed, the contacts remain in a fail-safe "on" position. There are no openings in the microphone case to leak or degrade bass response. And inside the Model 631 is an effective four-stage filter that traps dirt and magnetic particles before they can get to the element, and also provides "blast" and "pop" protection. Frequency re-

FREE!

Live Better Electronically With

LAFAYETTE RADIO ELECTRONICS

NOW OFF PRESS!

Latest Electronics Buying Guide

1968 CATALOG 680

Over 500 Pages



New!
23 Channel 2-Way
CB Radio
All Solid State
with IC's



New!
Solid State Stereo
Tape Recorders
with Automatic Reverse



New!
Solid State FM-AM
Receivers
with "IC" & FET's

A complete buying guide to HI-FI, CB, Amateur gear,
Optics, Musical Instruments, Tools, and Auto Accessories



LAFAYETTE Radio ELECTRONICS
Dept. II-7 P.O. Box 10
Syosset, L.I., N.Y. 11791



SEND
FOR YOUR
FREE
COPY
TODAY!

Send me the Free 1968 Lafayette Catalog 680

II-7

Name _____

Address _____

City _____ State _____ Zip _____

(Please Give Your Zip Code No.)

CIRCLE NO. 16 ON READER SERVICE PAGE

Olson



*** FREE**

Fill in coupon for a **FREE** One Year Subscription to **OLSON ELECTRONICS' Fantastic Value Packed Catalog—Unheard of LOW, LOW PRICES** on Brand Name Speakers, Changers, Tubes, Tools, Stereo Amps, Tuners, CB, and other Values. Credit plan available.

NAME _____
ADDRESS _____
CITY _____ STATE _____
GIVE ZIP CODE _____

If you have a friend interested in electronics send his name and address for a **FREE** subscription also.

OLSON ELECTRONICS
INCORPORATED

703 S. Forge Street Akron, Ohio 44308

CIRCLE NO. 22 ON READER SERVICE PAGE

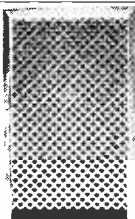

MODEL SP5A

Excellent music and voice reproduction needs a good speaker system derived from current state of art and classical design. Free of obsolescence. Patent applied for. Now offering two models with several styles to choose.

TANG INC. HI-FI SPEAKER

TANG SP5AX A new speaker with "controlled impedance" for transistorized amplifiers.

- 1) Linearized speaker impedance vs. frequency relationship.
- 2) 45 — 18500 Hz \pm 3 db at 16 ohms; system resonance 40 Hz.
- 3) Rear exit to couple to walls as low frequency horn.
- 4) Acoustical chamber and diffracting grill in front of speaker.
- 5) High efficiency 5" special speaker with heavy magnet enclosed in solid walnut cabinet 10" x 7" x 6" \$39.95 each

TANG SP5A Same as above except without impedance control, Response 45 — 18500 \pm 4 db at 8 ohms \$29.95 each

Style 2 with fluffy white grill cloth add \$5.00 each.

At your dealers or inquire direct

TANG INCORPORATED

P. O. Box 162

Framingham Center, Mass. 01701

Direct mailing service available if no dealer in your area.

CIRCLE NO. 27 ON READER SERVICE PAGE

PRODUCTS (Continued from page 24)

sponse is 100 to 13,000 Hz, and the microphone's output is -55 dB. A stand clamp is provided.

Circle No. 85 on Reader Service Page 15

REGULATED D.C. POWER SUPPLY

Allied Radio's Model KG-664 Knight-Kit is a three-in-one power supply: B+, filament, and d.c. bias. It delivers 0-400 volts of regulated d.c. power at up to 200 mA continuously; 0-100 volts d.c. at 1 mA regulated for line variation; plus 6.3 volts a.c. at 6 amperes and 12.6 volts a.c. at 3 amperes for filament supply voltage. Two front panel meters continuously monitor

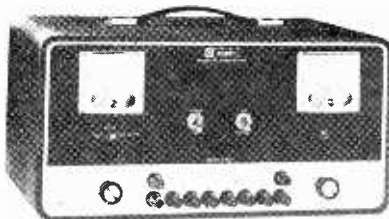

voltage and current. There is less than 1.0% variation in output voltage from no load to full rated load, and less than 1.0% variation in output for ± 10 volts variation in 120-volt a.c. input. Ten isolated 5-way binding posts on the front panel offer maximum versatility in ground polarity connections. The KG-664 is also available factory-assembled.

Circle No. 86 on Reader Service Page 15

CASSETTE-TYPE RECORDER-REPRODUCER

The *Ampex Corporation* recently introduced a cassette-type tape recorder-reproducer stereo system. Called the Ampex "Micro 85," it consists of a recorder-reproducer, stereo microphones, and a pair of speakers in

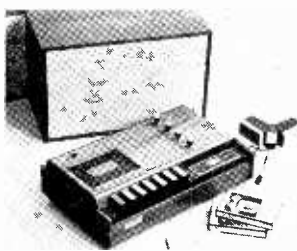

walnut enclosures. The recorder-reproducer comes in a smartly styled walnut cabinet, has piano-key-type push-button controls and takes up less space than

most turntables. It is equipped with all solid-state stereo amplifiers and preamplifiers, and the recording level is continuously monitored through the use of a built-in vu meter. Controls include record level, balance, volume, and tone. The tape passes the heads at a constant speed of $1\frac{1}{4}$ in/s, and up to 90 minutes of playing time is possible with a single tape cassette.

Circle No. 87 on Reader Service Page 15

POPULAR ELECTRONICS

new

HOWARD W. SAMS BOOKS

Current Bestsellers for Everyone in Electronics

How to Read Schematic Diagrams.

New 2nd edition. Enlarged and updated. Not only shows how to read and interpret diagrams, but analyzes each component, its construction, and its circuit application and function. **RSD-2**...\$2.95

Walkie-Talkie Handbook. Describes all types available today; also covers specifications, accessories, maintenance, and licensing requirements. An invaluable guide. **AWS-1**...\$3.95

Transistorized Amateur Radio Projects. Offers a complete selection of tried and proved transistorized construction projects for the beginning as well as the advanced amateur. Full building data for dozens of units. **TRP-1**...\$3.25

CB Radio Antennas. New edition. Tells how to set up a CB antenna system for maximum "reach" and how to get the most from your present CB antenna; includes data on maintenance. **CAH-2**...\$3.25

Tube Substitution Handbook. 10th Ed. Lists over 11,000 direct substitutions for receiving, picture tubes, subminiature, industrial, and communications types. Tells when and how to make proper substitutions. **TUB-10**...\$1.75

Know Your Oscilloscope New ed. Latest use of scopes for servicing and observing circuit action. New data on transistorized scope circuitry, triggered-sweep and dual-trace scopes. **KOS-2**...\$2.50

ABC's of Shortwave Listening. New ed. Describes the exciting world of shortwave radio—international broadcasts, ham, police, aircraft, marine, space signals. **SWL-2**...\$2.25

Troubleshooting With the Oscilloscope. New ed. Shows the practical use of the scope to isolate circuit troubles in any type of electronic equipment. Tells how to setup for tests, how to use probes, how to interpret waveforms, how to trouble-shoot. **TOS-2**...\$3.95

ABC's of Transistors. New ed. Helps anyone understand the structure and function of the transistor. Describes basic transistor circuits and testing procedures. **TRA-2**...\$2.25

ABC's of Citizens Band Radio New ed. All you need to know about planning and setting up a CB 2-way radio system. Explains functions, principles, setup and operation and regulations. **ACR-2**...\$2.25

Short-Wave Listener's Guide. 2nd Ed. Gives listings for over 300 short-wave stations by country, call letters, frequency, power, and broadcast time. Invaluable for the short-wave fan. **SLG-2**...\$1.75

101 Ways to Use Your VOM & VTVM. Shows you how to get the most from these popular instruments, how to make required connections, how to test properly, how to evaluate results. **TEM-3A**...\$2.95

Color TV Servicing Made Easy. Full explanation of color principles, circuitry, setup adjustments, and servicing of color TV sets. Takes the mystery out of servicing color TV. **CSL-1**...\$3.25

Tape Recorders—How They Work. New 2nd edition. Fully explains principles of magnetic recording, various types of recorders, mechanisms and components, testing procedures, etc. Best reference on the subject. **TRW-2**...\$3.95

PHOTOFACT® Guide to TV Troubles. 2nd Ed. Photos of actual TV picture defects indicate where to find the trouble source in minutes. **PFG-2**...\$3.95

Second-Class Radiotelephone License Handbook. New 3rd edition; complete study course for elements I, II and III of the latest FCC exams. Helps you earn the license you need for two-way radio work. **QAN-2**...\$4.75

Color TV Training Manual. 2nd Ed. Best guide for technicians preparing to service color TV. Detailed explanation of color principles, circuits, setup procedures, alignment, and troubleshooting; full-color illustrations. **TVC-2**...\$5.95

99 Ways to Improve Your CB Radio. Provides invaluable tips on how to operate, service, and maintain CB radio equipment to achieve optimum performance. **ICB-1**...\$2.50

Citizens Band Radio Handbook. New enlarged edition. Covers latest CB equipment and circuits, antenna systems, fixed and mobile installations, maintenance and repairs, FCC rules, etc. **CBH-2**...\$3.50



How to Build Speaker Enclosures. Provides a wealth of both practical and theoretical information for constructing high-performance speaker enclosures for music systems. **SEB-1**...\$3.25

Color TV Trouble Clues. Vol. 2. Field-tested guide to procedures for fast color TV receiver repair. Describes symptoms, troubleshooting techniques, proper use of test instruments. **COL-2**...\$1.95

ABC's of Lasers and Masers. 2nd Ed. Clearly explains the operation and applications of the laser, the amazing device which produces light radiations capable of performing astounding feats. **LAL-2**...\$2.25

Handbook of Electronic Tables & Formulas. New enlarged 2nd edition. Complete reference for all charts, math tables, formulas and laws, symbols, constants, and standards. Special color insert shows latest FCC frequency spectrum assignments. **HTF-2**...\$3.95

ABC's of Computers. Explains in simple terms how computers work and what they do. Covers analog and digital types; describes circuitry, memory devices, programming, etc. **ABC-2**...\$2.50

101 Questions & Answers About Transistors. Provides through pertinent questions and answers, a basic understanding of transistor theory and applications. **QTS-1**...\$2.50

HOWARD W. SAMS & CO., INC.

Order from your Sams Distributor today, or mail to Howard W. Sams & Co., Inc., 4300 W. 62nd St., Indianapolis, Ind. 46268 Dept. PE-9

Send me the books I have circled at right. \$_____ (check) (money order) enclosed.

Name_____

Address_____

City_____ State_____ Zip_____

- RSD-2 TRA-2 COL-2
- AWS-1 ACR-2 LAL-2
- TRP-1 SLG-2 QAN-2
- CAH-2 TEM-3A TVC-2
- TUB-10 CSL-1 ICB-1
- KOS-2 TRW-2 CBH-2
- SWL-2 PFG-2 HJF-2
- TOS-2 SEB-1 ABC-2
- QTS-1

Send FREE Sams Booklist

CIRCLE NO. 24 ON READER SERVICE PAGE

CB'ers...

SKIP IS LEGAL

ON THE HAM BANDS...

in fact, Amateur Radio is based on the intelligent use of natural phenomena to achieve distant communications with relatively low power. Increased sun-spot activity in the next couple of years will bring tremendous propagation opportunities — like worldwide contacts on ten meters . . . tropospheric bending (predictable from an ordinary weather map) brings exciting surprises on two meters . . . Sporadic E skip gets you miles and miles and miles with little power on six meters . . . and more! And that is not all that you have going for you . . . there are no time restrictions . . . less crowding . . . more frequency bands . . . more legal power . . . and greater satisfaction because your knowledge of propagation permits you to plan your contacts. It is all out in the open . . . you can give the man your right name and your call without getting a pink ticket for a chaser.

You can get into ham radio easily and quickly (our buck says it will take you only 30 days . . . 45 max.). The technical requirements for a Novice license are *simple*. The test can be administered by a qualified licensee in your own neighborhood. Available licensing booklets lay it all out on a silver platter for you. SURE, we know about the code test, but man, five words — 25 characters — a MINUTE . . . that's less than a minute's worth of notes in a dreamy waltz!

Start it off with a Squires-Sanders 22'er (two-way voice privileges on two meters for Novices) . . . for sixty days we will throw in a free license manual and a code learning record. If you want to go all out, apply for the Technician License . . . a little more complex technical test (you *can* do it) and the same easy five word code exam . . . permits privileges on other bands — like 6 meter two-way voice. 22'er — 20 watts of high quality two meter AM phone transceiver . . . only \$249.95. 66'er — 22 watts of same for six meters . . . same free manual and record . . . same price.

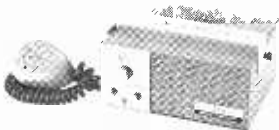
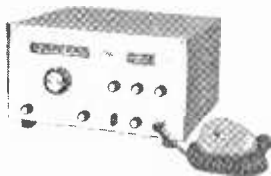

OK, OK . . . so your only interest is highly intelligible local communications for your personal business . . . your truck . . . your boat . . . your car . . . then go buy the 23'er all transistor 23 channel 5 watt CB transceiver for a modest \$235.00 or the 5 channel S5S for \$185.00. But, please, just talk to momma . . . or the office . . . or call H.E.L.P.

Squires  Sanders

See your distributor or write today for details. SQUIRES-SANDERS, INC., Box 319 A, Millington, New Jersey, 07946
CIRCLE NO. 26 ON READER SERVICE PAGE

INTEGRATED CIRCUITS
SIMPLIFY CONSTRUCTION
OF REAL ELECTRONIC DICE
FOR FUN,
PLEASURE, OR PROFIT,
AND PUT . . .

TECHNICALLY SPEAKING, this is a Mod 6 walking ring counter using six J-K flip-flops and lamp drivers. Decoding is reduced to four circuits and the readout is via a selective arrangement of 14 low-voltage bulbs. From a practical aspect, this is an electronic pair of dice that can't be loaded.

SPOTS BEFORE YOUR EYES

By **DON LANCASTER**

While intended primarily for use as a parlor-type family game, this gadget will also make a dandy science fair project for illustrating the basic principles of probability and computer counter circuitry, and will serve as an immediate attention-getting device at any exhibit or display. It measures 6¼" x 3¾" x 2", and should cost from \$18 to \$30, depending on how fancy you care to make your particular version. Complete kits and/or all special parts are readily available.

COVER STORY

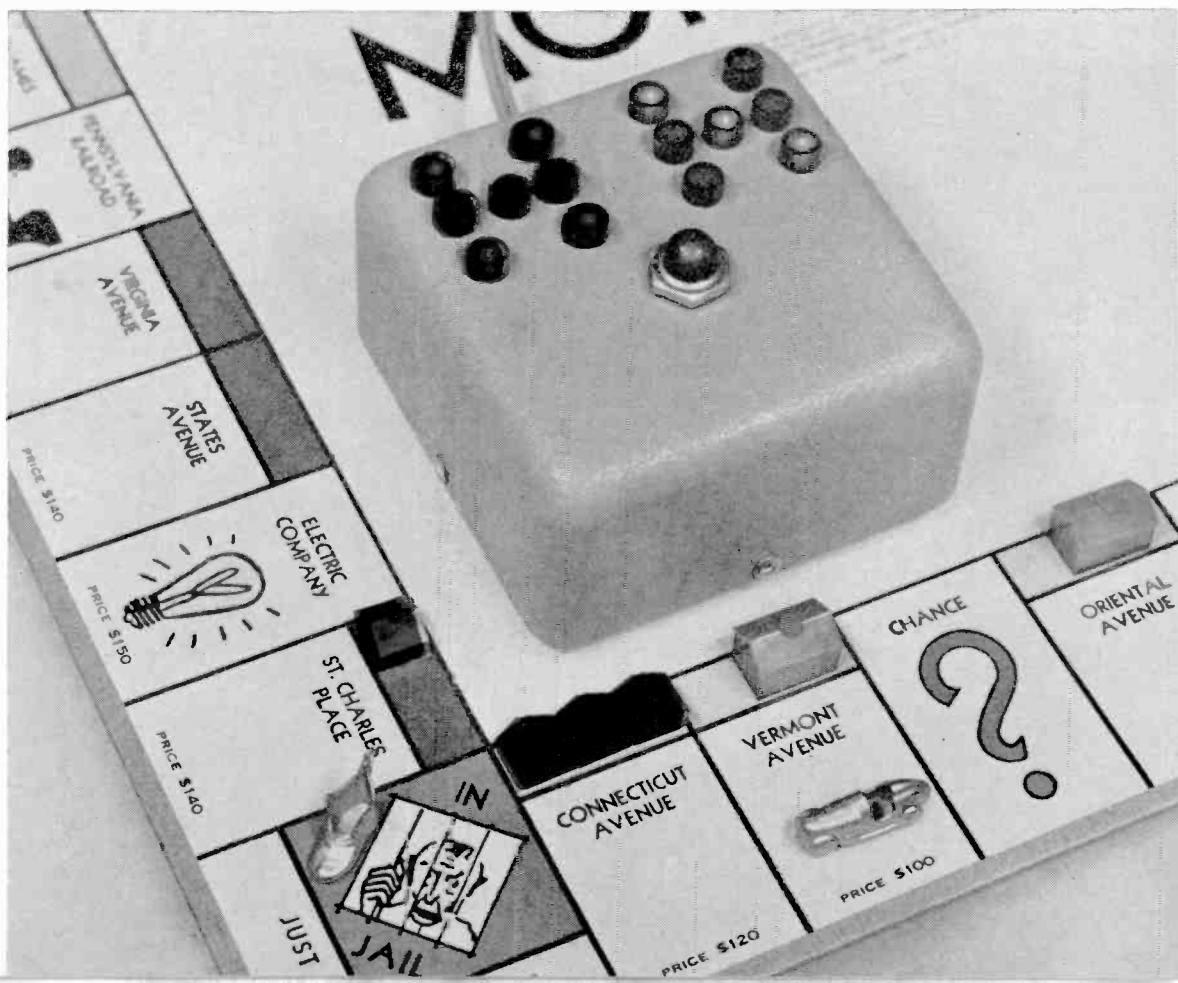

Fig. 1. When push-button switch S1 is depressed, the 3-kHz oscillator starts up. The first counter runs at this speed while simultaneously dividing by six, causing the second counter to run at 500 Hz. When S1 is released, both counters stop and the pertinent indicators light up.

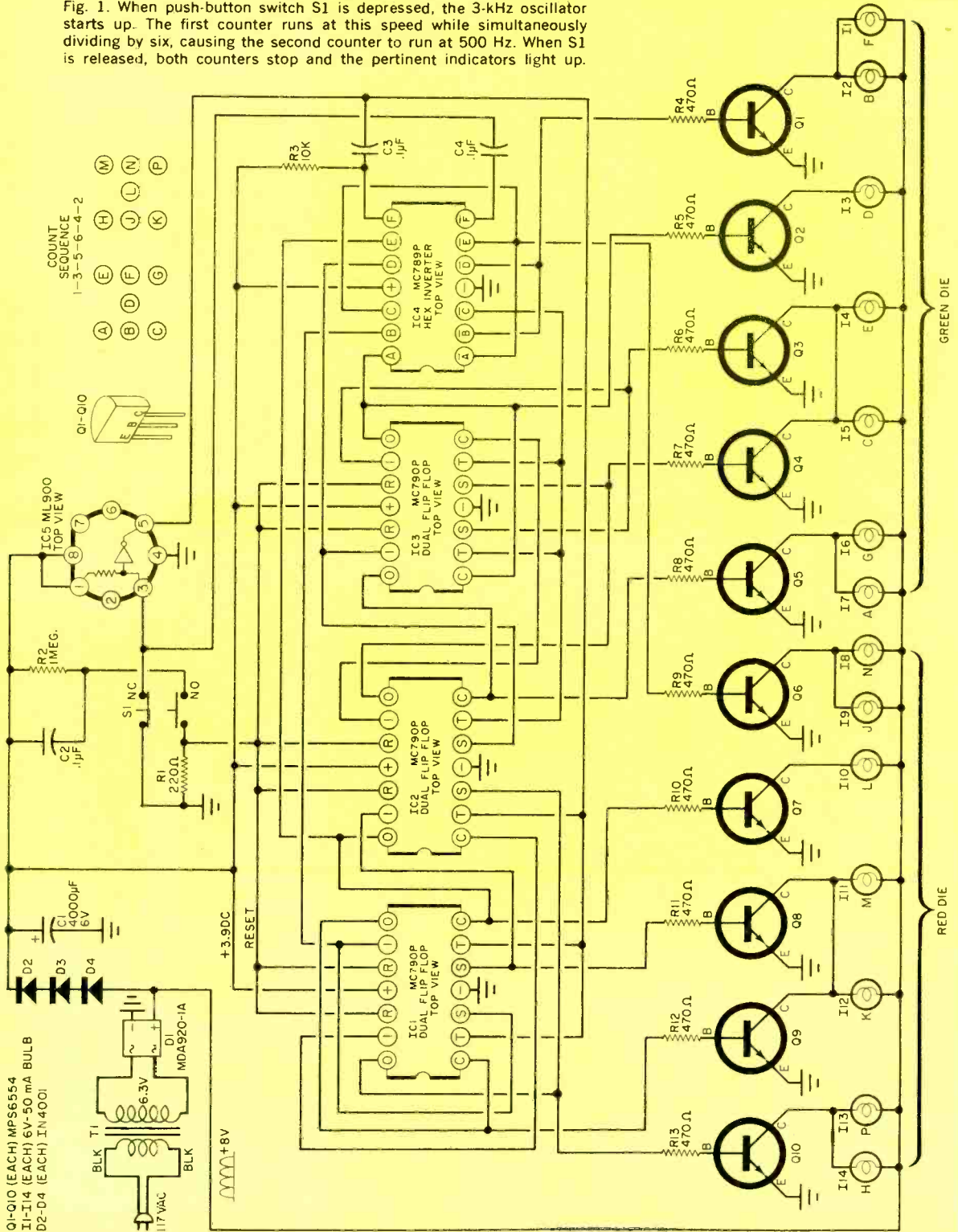
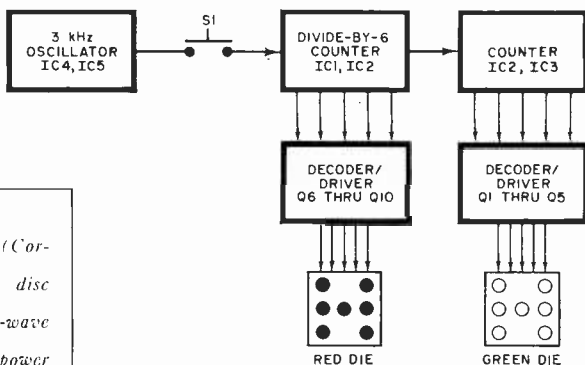

Fig. 2. Since each die is fed from a separate counter, and there is no fixed time during which the counters cycle through their stages, the final lamp indication is random, as with real dice.



PARTS LIST

- C1—4000- μ F, 6-volt electrolytic capacitor (Cornell Dubilier BR 4000-6, or similar)
- C2, C3, C4—0.1- μ F, 10-volt miniature disc ceramic capacitor
- D1—MDA920-1.1 1-ampere, 50-volt, full-wave bridge rectifier assembly (Motorola)
- D2, D3, D4—1N4001 or similar silicon power diode
- I1-I14—6.3-volt, 50-mA, pilot lamp assembly, 7 red, 7 green (Southwest Technical Products Corp. L-92, or similar)*
- IC1, IC2, IC3—MIC790P dual 1-K flip-flop (Motorola)
- IC4—MC789P hex inverter (Motorola)
- IC5—uL900 buffer (Fairchild)
- Q1-Q10—MPS6554 transistor (Motorola)
- R1—220-ohm, $\frac{1}{4}$ -watt carbon resistor
- R2—1-megohm, $\frac{1}{4}$ -watt carbon resistor
- R3—10,000-ohm, $\frac{1}{4}$ -watt carbon resistor
- R4-R14—470-ohm, $\frac{1}{4}$ -watt carbon resistor
- S1—Two-circuit "make one, break one" push button, snap-action
- T1—6.3-volt, 0.6-ampere miniature filament transformer (Knight 54D1416, or similar)
- 1—6 $\frac{1}{4}$ " x 3 $\frac{3}{4}$ " x 2" case and cover (Harry Davis #240, or similar)
- 1—3 $\frac{5}{8}$ " x 2 $\frac{1}{2}$ " x 1 $\frac{1}{16}$ " printed circuit board*
- Misc.—Line cord and strain relief, wire nuts (2), PC terminals (17), #6 x $\frac{3}{8}$ " threaded standoffs (4), #6 x $\frac{1}{4}$ screws (4), insulated wire jumpers (15), wire, solder, etc.

*The following are available from Southwest Technical Products Corp., 219 W. Rhapsody, San Antonio, Tex. 78216: etched and drilled circuit board, \$3.50; kit of 14 pilot lamp assemblies including 1 spare bulb, \$4.00; complete kit of all parts including fully punched and finished plastic case, \$30.00; postpaid in USA.

NOTE: Although a metal mounting box is shown both on the cover and in the photo on page 29, the construction details given in this article are for the plastic box called for above.

How It Works. Each of the two dies consists of seven pilot lamps that are lit or not lit dependent upon the commands of an electronic counter and decoder circuit. Figure 1 shows the circuit, while the block diagram in Fig. 2 illustrates basic operation.

There are two electronic counters, each of which has six possible states, just like the six sides of a die. Whenever the control push button (S1) is depressed, a 3-kHz oscillator is connected in the circuit, and both counters rapidly run through all of their states, the first at a 3-kHz rate; because of the divide-by-six

characteristic inherent in the first counter, the second counter operates at a 500-Hz rate. Since the push button will be held down a good fraction of a second, each counter runs through all of its states many hundreds of times.

When the push button is released, the counters stop in some random state—truly random, as the operator has no control whatsoever over which number is up on either counter when he releases the button. Since each die cycles at different rates and since the dwell time on any one "side" is identical, true dice odds result.

The six counter states are decoded to produce the familiar die combinations, with the center lamp lit only for a "one," the outside six for a "boxcar," etc. Although seven lamps are used, only those combinations of lit bulbs corresponding to the die patterns are permitted to light.

Each counter requires only four decoding circuits. The first decides "even," or "odd." If the count is "odd," the center bulb lights. The next decoder decides "not one" which lights two diagonally opposite bulbs *except* during a "one." A third decoder decides "four," "five," or "six" and lights the remaining two diagonally opposite bulbs on these counts. The final decoder selects "six" and lights the two remaining bulbs on this count. A bit of reflection will show that these four decodings automatically light the proper number of bulbs in the proper pattern for each die position.

A dual power supply and a special pulse circuit complete the unit. The latter feature resets the counter the instant the push button is depressed, guaranteeing that both counters always start off properly.

Fig. 3. Actual-size layout of printed board. Be careful if you make your own as wiring errors will be hard to find. A commercial board is available (see Parts List).

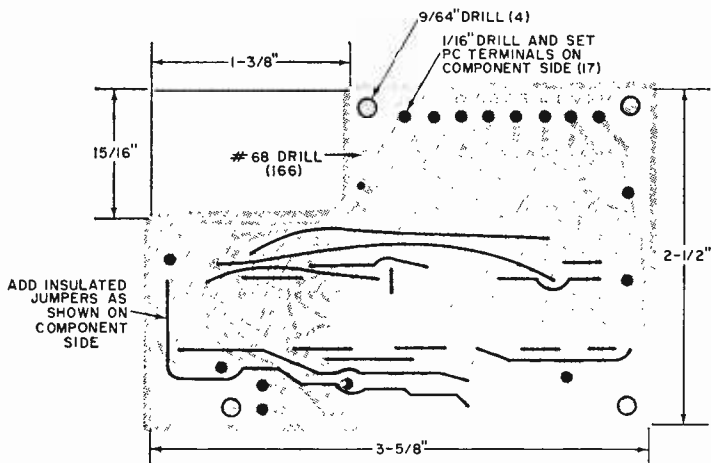
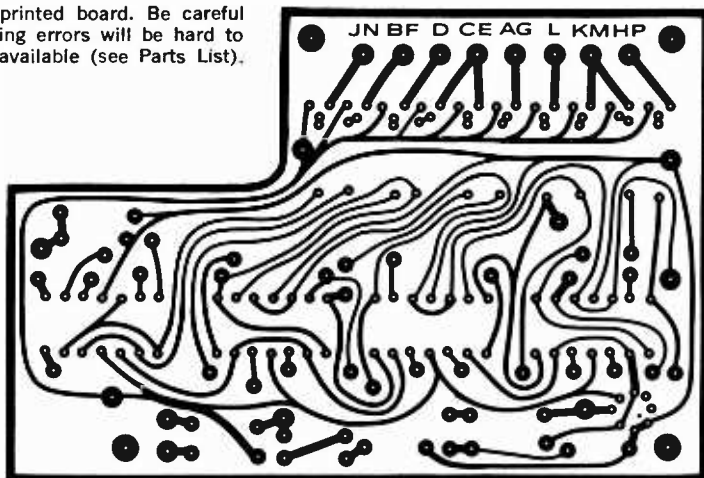

Fig. 4. Before installing components on the board, insert the 16 insulated jumpers as shown here. Observe caution when installing jumpers as errors can be troublesome.

Circuit Details. Integrated circuit *IC5* and part of *IC4* form a 3-kHz multi-vibrator that runs only when *S1*, a 2-circuit, snap-action push button, is depressed. This 3-kHz signal is routed to the two counters consisting of *IC1*, *IC2*, and *IC3*. Incidentally, the total cost of all the integrated circuits is slightly under \$8.00.

High-gain transistors (*Q1* through *Q10*) are used to amplify the low-level logic signals and light one or two bulbs each. Resistors *R4* through *R13* limit the base currents and prevent the bulbs and transistors from excessively loading the counters.

Fig. 5. Component layout and wiring interconnections. Note that *IC1*-*IC4* are identified by notches at one end while *IC5* has one flat side. Lettered bulbs are arranged as per Fig. 1.

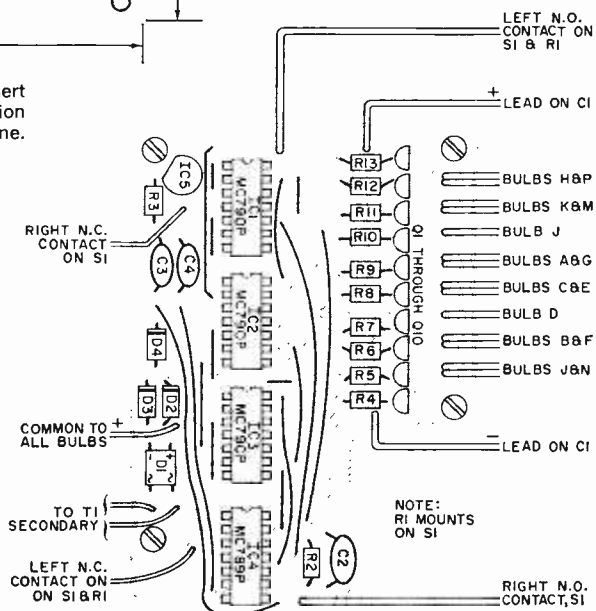

Fig. 6 (right). Finished layout with parts called out in Parts List. Other arrangements can be used if desired.

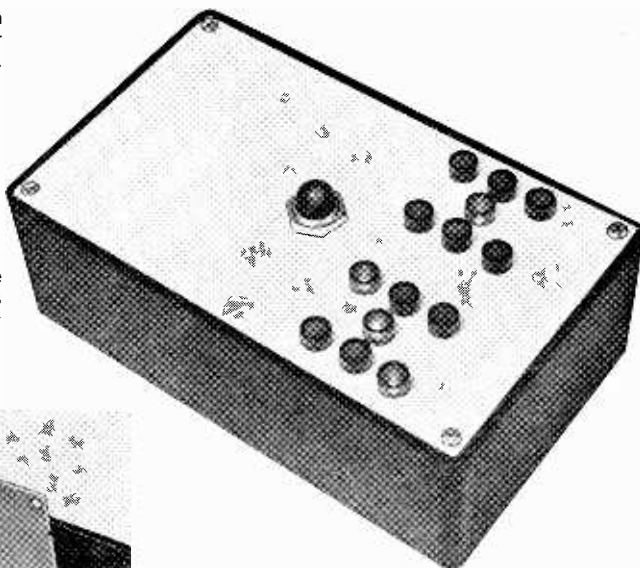
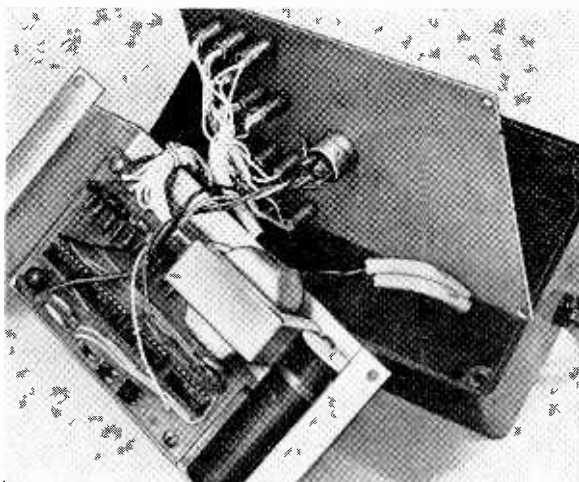

Fig. 7 (below). Internal view of the finished device. Note that $R1$ is mounted on $S1$ on the front cover plate along with indicator lamps. Construction details of the U-shaped frame, and the cover, are on page 34.



The bulbs consist of 6-volt, 50-mA units, available as complete, matched red or green panel lamp assemblies from the source listed. Use of higher-current bulbs is not recommended due to the requirement of a larger power transformer and the necessity of using power transistors with exceptionally high gain to obtain any reasonable brilliance and uniformity. Even the transistors selected for the 50-mA bulbs must have a *beta* well over 100, specified at a 100-mA current level. Bear this in mind if you make any substitutions. The particular bulbs and power levels selected are more than bright enough for use under normal viewing conditions, and the actual bulb current is purposely held low to gain a long bulb life.

The dual power supply consists of $T1$ and diodes $D1$ through $D4$. The bulbs and transistors run off the unfiltered, full-wave rectified low-voltage from $D1$. Di-

odes $D2$, $D3$, and $D4$ form a dynamic regulator that drops this voltage and feeds it to filter capacitor $C1$ and then to the oscillator and counter circuits. The normal level across $C1$ is 3.9 volts; this will vary a tenth of a volt or so with the different die combinations. The value of $C1$ selected is the smallest one that will allow the circuit to operate properly—do not substitute for $C1$ unless you increase its value.

Switch $S1$ is a “make one, break one” push button. A d.p.d.t. snap-action type can be substituted simply by not using the extra contacts. Network $R1$, $R2$, and $C2$ generates a brief reset pulse each time the push button is initially depressed.

Construction. A printed circuit board is an absolute must for this circuit, owing to the large number of connections and the mounting techniques required for the integrated circuits. You can buy the board already etched and drilled commercially (see Parts List). If you prefer, you can lay out, etch, and drill your own, by following the details in Fig. 3. Be exceptionally careful with your layout if you make your own, for a wiring error in the counter portion of the circuit is quite difficult to find.

Sixteen wire jumpers are required for the PC board. These are formed of insulated wire and mounted on the *compo-*

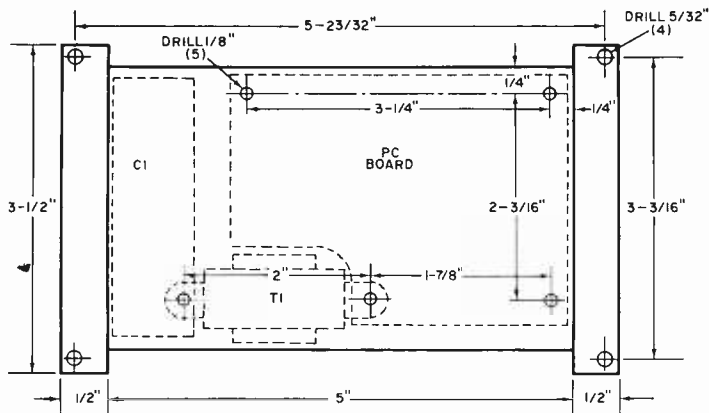

Mechanical details of the U-shaped frame. This frame supports the PC board, capacitor C1, and transformer T1. Note that the PC board uses 1/4-inch standoffs. The frame is designed to fit the plastic box specified.

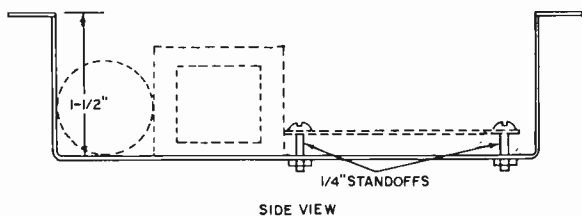
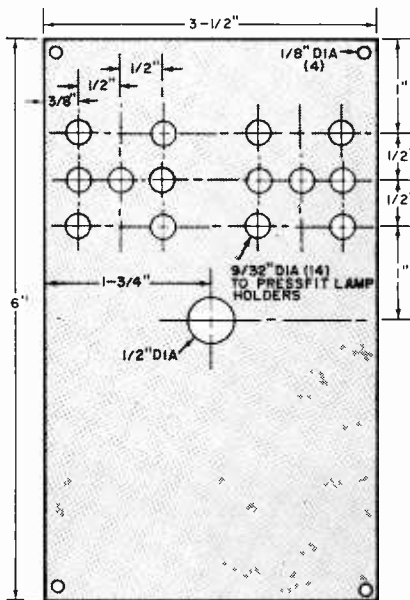

Fig. 8. Drilling details of the front cover. The lamp holes are drilled so that the lamps can be press-fitted.



ment side of the circuit board, before any other parts are inserted. Just follow the layout guide in Fig. 4. Be sure to connect the jumpers *exactly* as indicated.

All the circuit parts except T1, C1, R1, S1, and the bulb mount on the board. Use a very small iron and fine solder. Double-check all connections with a magnifying glass and remove all excess solder flux.

Component layout and wiring interconnections are shown in Fig. 5. Note that the integrated circuits may only be connected in one manner, and that they are identified by a notch on one end of the flat packs, and a flat beside lead #8 on IC5. (All IC's are shown *top view* in the schematic.) Each bulb has its die position identified by the code letters shown in the schematic. Use two contrasting colors of pilot lamp assemblies, one for each die.

The electronic dice may be built in virtually any small enclosure. You can use a deep-drawn aluminum box, a conventional chassis, or a plastic instrument case. Mounting details are shown in the photos (Figs. 6 and 7). The U-shaped frame supports the circuit board, transformer, and filter capacitor. The PC board should be spaced slightly above the bottom of

the metal support to avoid any short circuits. The entire assembly can then be mounted in its case.

Details of the lamp assembly drilling on the case cover are shown in Fig. 8. The cover supports the 14 lamp assemblies grouped according to the color and die patterns as well as S1 and R1 (mounted on S1).

The Possible Impractical Impossible Circuit

WOULD YOU BELIEVE A SINGLE-DIODE FULL-WAVE RECTIFIER?

By TOM DUFFY and JERRY OLEKSY

A ONE-DIODE full-wave rectifier? Impossible! Everyone knows you need at least two diodes for full-wave rectification. Or, should we say, everyone *assumes* that you need two diodes.

You can demonstrate one-diode full-wave rectification with the circuit shown below, left. The frequency of the input is relatively unimportant. Connect an oscilloscope across output terminals *D* and *C* and you should get one of the three waveforms shown, depending upon the position of the potentiometer arm.

With the potentiometer arm at the top, the waveform should be like the one at the extreme left. Rotating the arm to the other extreme should produce a waveform like the one in the middle photo. If you carefully balance the two waveforms (via the potentiometer), the output should become a typical full-wave rectification pattern (right).

The two theory schematics (center and

right) show what's happening. When terminal *B* is negative with respect to *A*, the current flow is indicated by the arrows. Note that current goes through the rectifier and through the load resistor. When the polarity of the input is reversed, current flow through the rectifier is blocked, but a new path is formed through resistor *R1* and current continues to flow through the load. Thus, no matter what the sine-wave excursions are, the direction of flow through the load resistor is the same—hence, you have full-wave rectification.

Why isn't this circuit used in practical everyday equipment? Well, in a conventional full-wave rectifier the efficiency can go up to 90%, but in this one-diode arrangement the efficiency is only about 25%. Also, all of the resistors are in series with the load and any voltage drop across them will subtract from the output. —30—

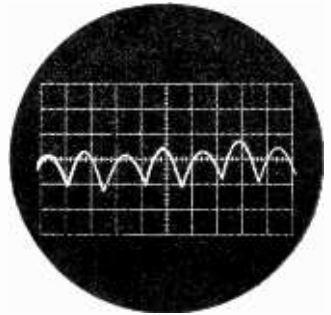
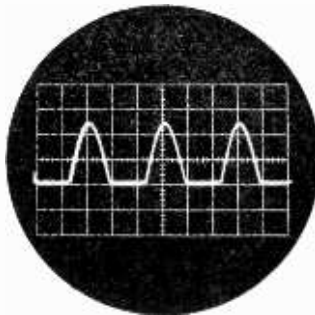
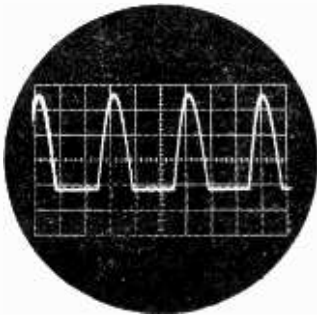

The test circuit diagram is shown below. You can easily duplicate this experiment as a science fair project. All of the scope photos above were taken off a Heathkit Model IO-14.

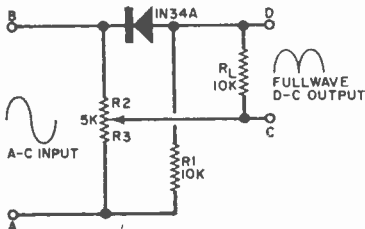

As potentiometer is rotated from one extreme to the other, traces show two different half-wave patterns (above left, and center).

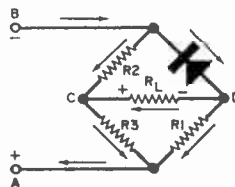

Balance the two half waves and the scope trace should look like the one above. The theory diagrams are shown below.

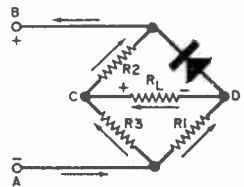

NTS PUTS YOU WHERE THE MONEY IS ...FAST!

NTS Home-Study training is for men in a hurry to move up! NTS Electronics Courses are geared to the needs of the electronics industry. This is up-to-date training. As modern as tomorrow.

Our close working relationship with electronics companies all over the country is the key. They tell us what you need to know to be a top-flight technician. They

keep us informed of new, exciting career opportunities. With this information, we constantly revise our courses to keep our home-study students one step ahead. In an industry that moves so rapidly, advancement comes quickly to the man with NTS training.

Since 1905, NTS has been leading ambitious men to where the money is. Join them.

EXCLUSIVE! ONLY FROM NTS! ALL NEW KITS... MAKE IT FUN TO LEARN, EASIER TO EARN.

For the first time! The greatest lineup of electronics kits ever offered to train you for the space-age. Only NTS has them. Designed for tomorrow... each has all

the latest electronics advances built in. NTS trains you better. NTS makes it fun to learn, easier to earn more, TODAY.

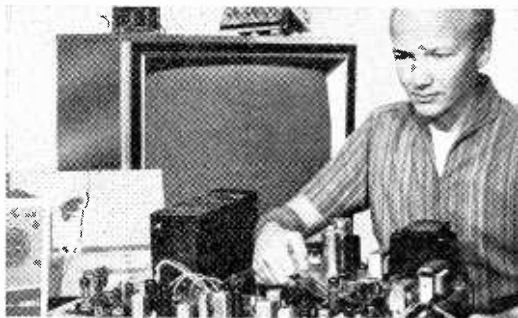

25" COLOR TV: Included in Color TV servicing courses ...to prepare you for the big demand for qualified service technicians. This is where the big money is. More than 16 million homes will have color TV by the end of this year. You can cash in on the boom. You can take a giant step ahead with professional training from NTS.

COMMUNICATIONS: Transceiver included in Communications Courses. This modern equipment is an important element in communications. You get it, you build it. With it you easily prepare for the F.C.C. License Exam. You become a fully trained man in communications, where career opportunities are unlimited.

**ALL
NEW KITS!
ALL NEW
COURSES!**

DESK-TOP COMPUTER: Professionally designed exclusively for NTS. Included with your Industrial and Computer Electronics Course. You can't get this computer kit, or anything like it, anywhere else. The special

computer and integrated circuitry of the training kits prepare you for a big career in this giant industry. These are the first kits offered by any school which include actual integrated circuits.

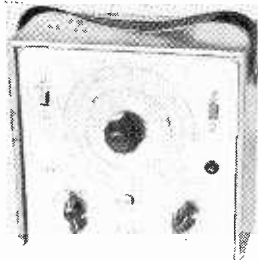
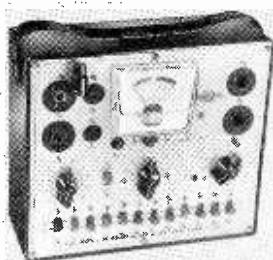

LEARN MORE, EARN MORE—IN ELECTRONICS

SIGNAL GENERATOR, VTVM, AND TUBE CHECKER INCLUDED WITH NTS ELECTRONICS COURSES. These are invaluable instruments for all kinds of Electronic and TV-radio servicing work. You learn to use them early in your training. Begin trouble-shooting work to earn money even before you've completed your course. Many of our students have more than paid for their NTS home-training this way—even before they graduated!

With these professional instruments, you are well-equipped to go into a business of your own. They're all you need to pinpoint most of the trouble spots in TV, Radio, or other electronic components. You get them at no extra cost—as part of your NTS training.

YOUR OWN BUSINESS

The big jobs belong to the men who prepare for them. You can earn money—learn how to start a business of your own—with NTS home training.

NTS starts you out right with the exclusive **Project Method Career Kit**. Contains everything you need to make your training easy. Keeps you organized. You learn faster. You move ahead that much sooner.

You can get all the details on the many advantages of NTS **Project Method** home training. It's all in the NTS catalog, along with pictures and information on all the equipment and exciting kits you receive and keep. Tells you all you need to know to get started.

CLASSROOM TRAINING AT LOS ANGELES:

You can take classroom training at Los Angeles in sunny Southern California. NTS occupies a city block with over a million dollars in facilities devoted exclusively to technical training. Check special box in coupon.

HIGH SCHOOL AT HOME



National offers accredited high school programs. Take only subjects you need. Study at your own pace. Everything included at one low tuition. Check special high school box in coupon for full information and FREE catalog.

MAIL REPLY CARD OR COUPON FOR NEW COLOR CATALOG & SAMPLE LESSON. THEY'RE FREE!

We Have No Salesman This Means Lower Tuition For You.



Accredited Member National Home Study Council
Member: National Association of Trade & Technical Schools



NATIONAL TECHNICAL SCHOOLS

WORLD-WIDE TRAINING SINCE 1905

4000 So. Figueroa St., Los Angeles, Calif. 90037

9 TRAINING PROGRAMS

NATIONAL TECHNICAL SCHOOLS

4000 S. Figueroa St., Los Angeles, California 90037

APPROVED FOR VETERANS

Please rush Free Color Catalog and Sample Lesson, plus detailed information on field checked below. No obligation.

- Master Course in Color TV Servicing
- Color TV Servicing for Qualified Technicians
- Master Course in TV & Radio Servicing
- Practical TV & Radio Servicing
- Master Course in Electronic Communications
- FCC License Course
- Industrial & Computer Electronics
- Stereo, Hi-Fi & Sound Systems
- Basic Electronics High School at Home

NAME _____ AGE _____

ADDRESS _____

CITY _____ STATE _____

Please fill in Zip Code for fast service

Check if interested in Veteran Training under new G. I. Bill. (Dept. 205-97)

Check if interested ONLY in Classroom Training at Los Angeles.

BUILD THE BEGINNER'S FET REGEN RECEIVER

MAKE THIS
YOUR FIRST PROJECT
USING
FIELD-EFFECT TRANSISTORS

By CHARLES CARINGELLA

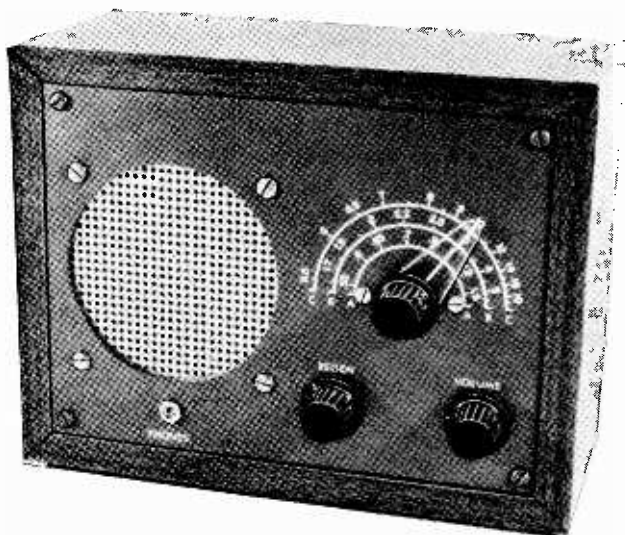

COVER STORY

PUT THE WORLD at your fingertips with a simple all-wave receiver that packs a lot of performance in a small package! Build this FET regenerative receiver and tune in DX as well as local broadcast stations. You'll be able to listen to hams, weather broadcasts, standard time signal broadcasts, maritime telephone operators, and many, many other stations on the short-wave bands.

Simplified printed-circuit construction and nominal cost make this receiver an ideal beginner's project. Three bands can be tuned by simply changing plug-in coils—the broadcast band from 0.55 to 1.5 MHz, as well as two short-wave bands from 1.7 to 5.5 MHz and 5.5 to 18 MHz.

Highlight of the all solid-state regenerative receiver is the FET (field-effect transistor) "front end" stage. This is followed by a 5-transistor complementary-symmetry audio amplifier that delivers a room full of audio power to a built-in loudspeaker. The completed receiver measures only 8¼" x 6¼" x 4".

A vernier drive mechanism, with a tuning ratio of 6:1, is used for easier tuning. An ordinary 9-volt transistor radio battery provides the necessary d.c. power, so the receiver can not only be used at home but is "portable" enough to go camping, on picnics, etc. The unit will also serve as an emergency standby receiver. Since power consumption is low, battery life is quite good.

The receiver will cost about 32 dollars to build if *all* new parts are purchased individually. A savings of about 7 dollars can be realized if the complete "kit" of parts specified in the "Parts List" is purchased.

How It Works. The schematic diagram of the FET regenerative receiver is shown in Fig. 1. Transistor *Q1* is of the Texas Instruments 2N3819 n-channel silicon field-effect variety. This is a new low-cost epoxy FET, used as a regenerative detector, which plays a large part in making the sensitivity of this circuit rival that of some superhet communications receivers.

Pre-wound slug-tuned plug-in coils, modified slightly by the addition of a feedback winding and a miniature mounting plug, are used for each of the three bands covered. R.F. signals from the antenna are coupled to the primary winding of *L1* through capacitor *C1*. Variable capacitor *C3* tunes the receiver by resonating with the secondary winding of coil *L1*. A third winding on *L1* provides the necessary feedback for regeneration.

Potentiometer *R1* serves as the regeneration control and determines the amount of a.c. voltage that is fed back through *C2* to the feedback winding on *L1*. For reception of AM signals, *R1* is

adjusted to the point just before the stage "pops" into oscillation. This is the point of maximum sensitivity and selectivity. CW signals, as well as SSB signals, are copied by adjusting *R1* so the stage just barely oscillates or regenerates.

The "front end" stage employing *Q1* is inherently stable because of the extremely low power dissipation and the rigid mechanical layout of components on the circuit board. Many of the frequency drift problems common to equivalent vacuum-tube circuits are non-existent in this FET circuit. The author has successfully copied "ham" SSB signals with this receiver, a trick that is often hard to perform with many superhets!

The output signal developed by the regenerative detector is a low-level audio voltage. It is direct-coupled through resistor *R4* to audio preamplifier stage *Q2*, a high-gain, low-cost RCA 40395 germanium *npn* transistor. Potentiometer *R8* is the volume control. Transistors *Q3* and *Q4* provide further amplification of the audio signal.

Transistors *Q5* and *Q6* operate as a push-pull complementary-symmetry Class B power amplifier. They are sold together as a matched pair and are designated as the RCA 40396. Output distortion is very low and fidelity is excellent. Over 200 milliwatts of audio power can be delivered to the speaker, more than enough to fill an average-size room with sound. D.c. stabilization is provided by the feedback path through resistor *R17*. The output of the audio amplifier is capacitively coupled through *C16* to a 3½"-diameter, 45-ohm speaker, and a miniature closed-circuit phone jack, *J1*, automatically disables the speaker when an earphone is used. Any impedance earphone can be employed.

Battery *B1* is a conventional 9-volt transistor radio battery. Since the d.c. power requirement is very modest, battery life should be quite good, with a single battery lasting for several months under normal operating and listening conditions. The idling current is a low 5 to 8 milliamperes with no signal, jumping to a high of 20 to 25 mA on audio peaks.

Construction. The entire receiver circuitry is constructed on a 4" x 2⅞" printed circuit board. The etched copper

foil side of the circuit board is shown in Fig. 2. The first step is to mount the coil socket in place with the retainer ring provided with the socket. The flat edge on the socket must face the direction indicated and the solder lugs on the socket should be on the copper foil side of the board.

Next, install variable capacitor *C3*. Use three 6-32 x ⅜" screws and three ¼"-long spacers. The spacers must be inserted between the capacitor bracket and the circuit board to space the capacitor away from the board.

The hole template of the front panel is shown in Fig. 3. The panel thickness should be ⅝", and it can be fabricated from aluminum, plastic, Bakelite, or any equivalent material. Mount the speaker with four 6-32 x ⅜" screws. At the two left-hand holes, use regular 6-32 nuts to fasten down the screws. Use 1"-long spacers that have been threaded for 6-32 screws at the remaining two locations; refer to Fig. 4 for the exact location of the spacers. Mount the vernier drive mechanism with 4-40 x ¼" screws and nuts. The two potentiometers and the phone jack go on last—mount them in the directions indicated in Fig. 5.

Now mount the circuit board on the front panel. (See Fig. 4.) The two circuit board mounting holes should line up with the 1" spacers, and the shaft on the variable capacitor should line up with, and fit into, the vernier drive. Attach the circuit board to the 1" spacers with two 6-32 x ⅜" screws. Make sure the board is exactly parallel to the panel, then tighten the setscrews to lock the tuning capacitor to the vernier drive. The circuit board should now be mounted rigidly in place. Attach a knob to the shaft of the vernier drive, and turn it back and forth from one stop to the other. The vernier drive and the variable capacitor should turn smoothly. If everything checks out properly, you can remove the circuit board assembly and proceed with the wiring.

Bend the solder lugs on the coil socket over and make the connections to them as shown in Fig. 2. Keep these leads as short as possible. Flip the circuit board over and solder the components in place as shown in Fig. 6. Mount all the transistors first. Space each transistor about ¼" away from the circuit board, making

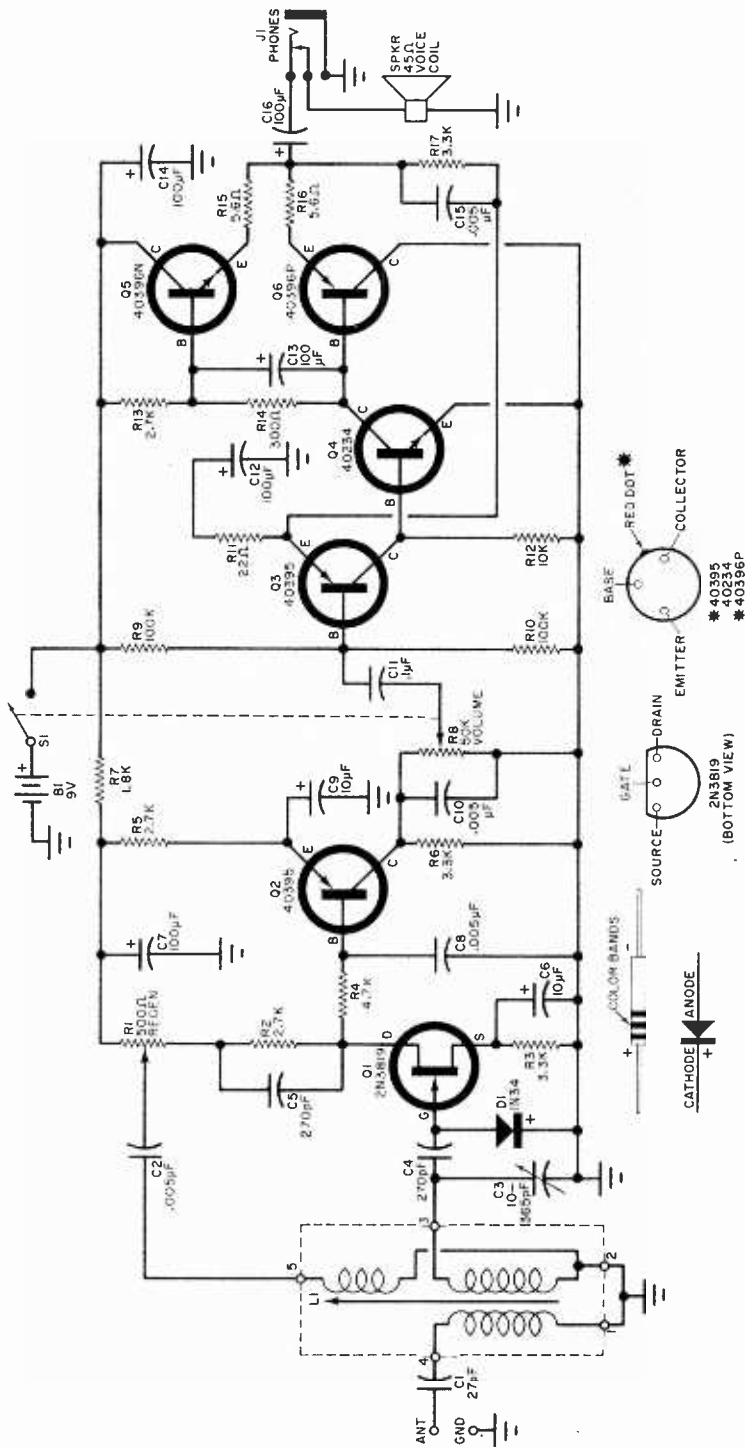

Fig. 1. Except for the number of transistors used, this circuit bears a remarkable resemblance to regenerative receivers of the 1930's. As POPULAR ELECTRONICS has often mentioned in print, the FET is a transistor that thinks and behaves as if it were a vacuum tube. However, many of the tube problems relating to drift and instability are absent.



(BOTTOM VIEW)



Fig. 2. "Same-size" outline of printed circuit board for readers who like to make their own. In drawing above, right, are notations on drilling of holes and making external connections to the printed circuit.

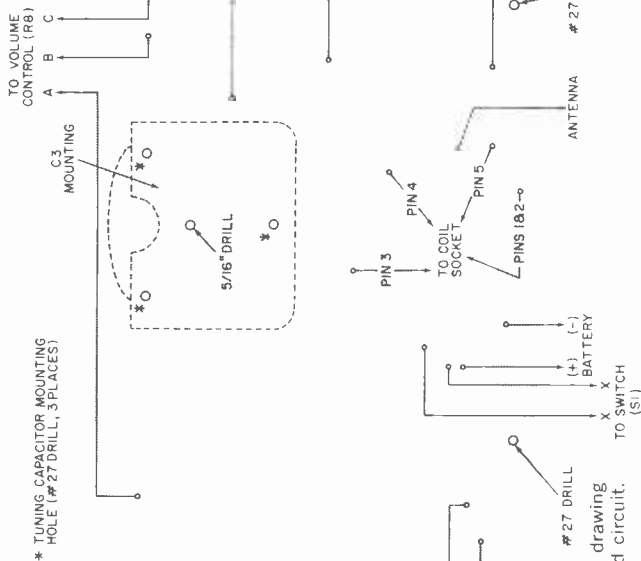

PARTS LIST

- B1—9-volt battery
 C1—27-pf ceramic capacitor
 C2, C8, C10, C15—0.005- μ f ceramic capacitor
 C3—10-10-365 pF variable capacitor (J. W. Miller 2111)
 C4, C5—270-pF ceramic capacitor
 C6, C9—10- μ F, 15-volt miniature printed circuit electrolytic capacitor
 C7, C12, C13, C14, C16—100- μ F, 15-volt miniature printed circuit electrolytic capacitor
 C11—0.1- μ F ceramic capacitor
 D1—1N34 germanium diode
 J1—Miniature closed-circuit phone jack
 J1—Coil for Band "A," 0.55-1.5 MHz (J. W. Miller A-5495-A); Band "B," 1.7-5.5 MHz (J. W. Miller B-5495-A); Band "C," 5.5-18 MHz (J. W. Miller C-5495-A)
 Q1—Texas Instruments 2N3810 transistor
 Q2, Q3—RC-1 40395 germanium pnp transistor

- O4—RC-1 40234 germanium npn transistor
 Q5—RC-1 40396Y germanium npn transistor
 Q6—RC-1 40396P germanium pnp transistor
 R1—500-ohm linear taper potentiometer
 R2, R5, R13—2700 ohms
 R3, R6, R17—3300 ohms
 R4—4700 ohms
 R7—1800 ohms
 R8—500,000-ohm, audio taper potentiometer with 5-p.s.l. switch S1
 R9, R10—100,000 ohms
 R11—22 ohms
 R12—10,000 ohms
 R14—300 ohms
 R15, R16—5.6 ohms
 S1 S.p.s.l. switch (part of R8)
 SPKR—3 1/2"-diameter P.M. speaker with .15-ohm voice coil (Quam 3A07Z45)
 1 Printed circuit board*

- 1—Ball-type center drive, 6:1 ratio (Jackson Bros. 4511, D1F)
 3—Miniature plugs, 5 pin (Amphenol 71-5S)
 1—Miniature socket, 5-pin (Amphenol 78-5S)
 Misc.—Knobs, plastic pointer, speaker grille, cabinet, panel, Faberstock clips, battery holder, battery clip, No. 28 enameled copper wire, 1" spacers, 1/4" spacers, screws, hookup wire, solder, etc.

* Etched and drilled printed circuit board is available for \$3 postpaid from Caringella Electronics, Inc., P. O. Box 327, Upland, Calif. 91786. A complete kit of parts (including above circuit board, pre-punched panel with printed dial, plastic pointer, all components, hardware and wire (but less cabinet and battery) is available for \$24.95 postpaid. California residents should add 4% sales tax to all orders.

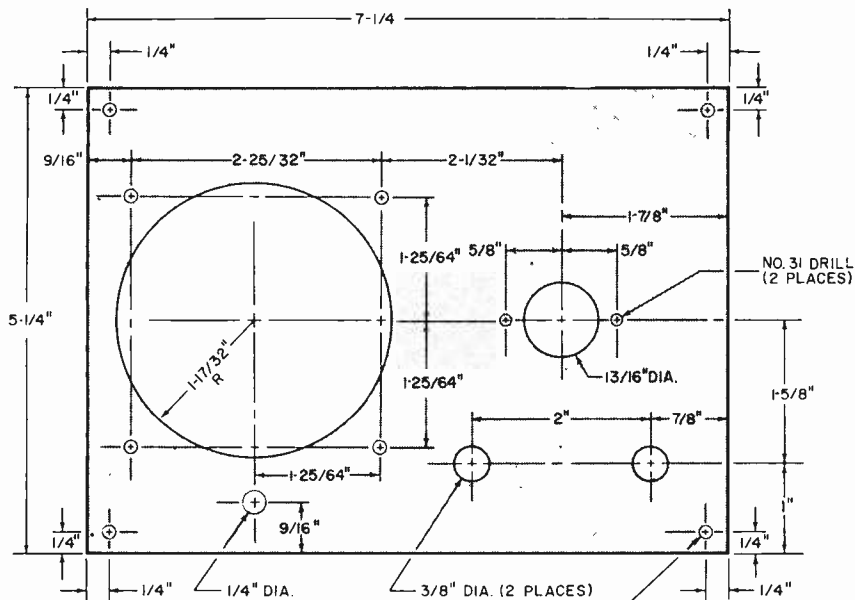
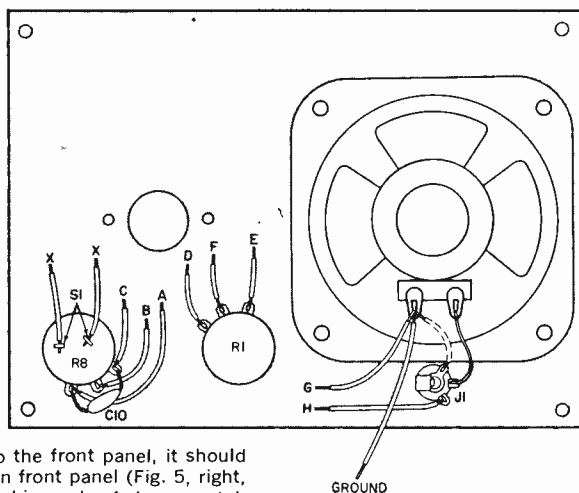
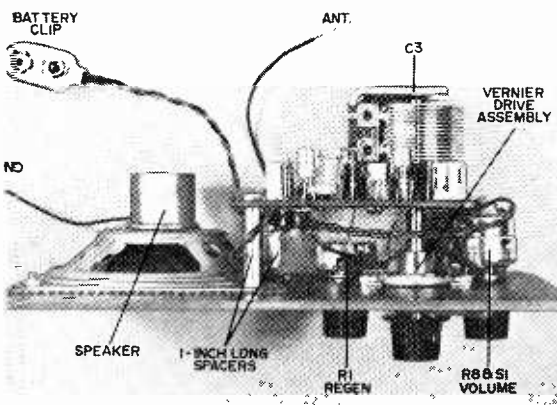

Fig. 3. This drawing shows the front panel arrangement of mounting holes in author's model. NO. 27 DRILL (8 PLACES)



Figs. 4 and 5. When printed circuit board is attached to the front panel, it should look like Fig. 4 above. A few components are mounted on front panel (Fig. 5, right, above) before printed circuit is put in place. Be sure panel is made of strong metal.

sure that each one is oriented properly! A heat sink should be used on each transistor lead while soldering to keep from damaging the transistor.

Next, install the capacitors. They should be flush-mounted against the board. Carefully observe the polarity of the electrolytics when installing them. Capacitor *C10* is the only one not mounted on the circuit board. It is soldered directly across volume control *R8*.

Mount diode *D1* vertically on the board.

Space the body of the diode about $\frac{1}{4}$ " away from the board, and carefully observe polarity of the diode when it is mounted. As with the transistors, the leads of the diode should also be held with a heat sink while soldering.

All of the resistors are installed vertically on the board. The connection to tuning capacitor *C3* is made from the "component" side of the board (see Fig. 6). All of the remaining connecting leads are soldered to the copper foil side of the

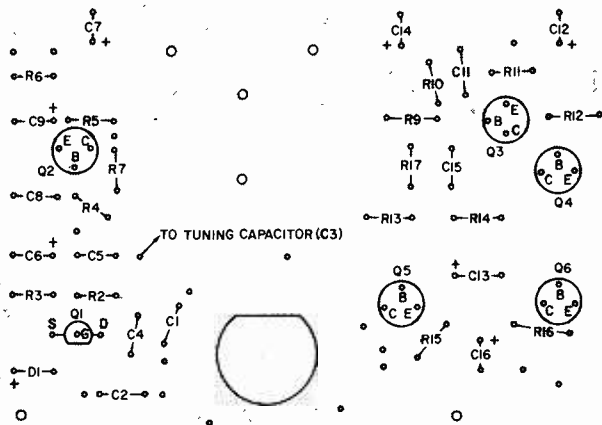

Fig. 6. Flip side of printed circuit board shown in Fig. 2. Note positions of the components, and, in particular, observe lead orientation of the various transistors. The center hole (shaft) for mounting C3 is eventually enlarged so that the shaft passes through freely without binding and C3 is rigidly supported by bolts through the 3 remaining small holes.

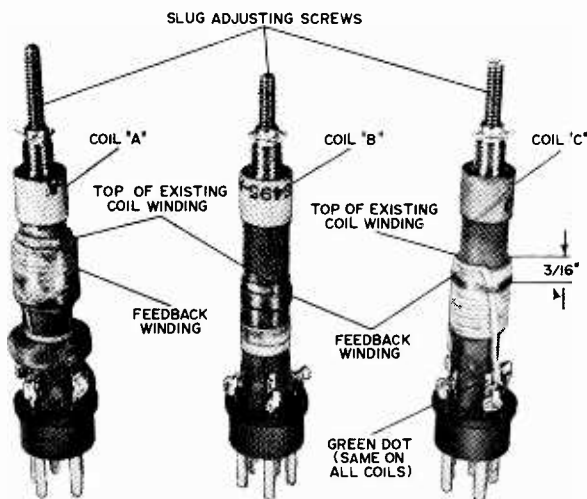

Fig. 7. Each of the plug-in coils is mounted on an Amphenol miniature 5-pin plug. Coil modification details appear in the text on the next page.

board. Flip the board over to the copper foil side (Fig. 2), and make these lead connections last. Leave these leads long; they will be trimmed to the proper length once the board is mounted in place.

Once again, mount the completed circuit board assembly on the front panel. Connect the leads from the board to the two potentiometers, the speaker, and the phone jack as illustrated in Fig. 5. Keep the leads to regeneration control R1 as

short as possible! The lead from J1 to the speaker lug (represented by the dotted lines) may be omitted if an aluminum panel is used. Recheck all wiring, transistors, electrolytic capacitors, and the diode polarities in accordance with Fig. 6.

Coil Modifications. A set of three plug-in coils will cover the frequency range from 0.55 MHz to 18 MHz. Three J. W. Miller pre-wound slug-tuned coils are used for the purpose. As furnished by the manufacturer, each coil consists of a primary winding which is connected to the external antenna and ground, and a secondary winding which is tuned by an external capacitor. A miniature 5-pin plug must be attached to each coil for "plug-in" capability. Also, a simple feedback winding must be added to each coil as shown in Fig. 7.

Heavy, tinned copper wire is used to hold the miniature plugs firmly against the bottom of each coil. The heavy wire connects the plug pins to the coil solder lugs. Solder a 1½" length of No. 18 tinned copper wire into pins 1, 2, 3 and 4 on each of the miniature plugs. Pin 5 will be left empty for the moment. The plug pins are hollow, and each lead should just barely stick out the bottom end of the pin. Make sure each connection has an adequate amount of solder within the pin, but avoid running any excess solder over the outside of the pins.

After all the pins have been soldered, test each plug in the socket on the circuit board to make sure they plug in and

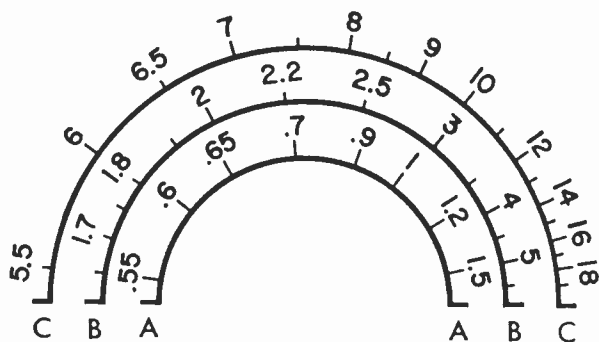

Fig. 9. If you use the coils and variable capacitor specified in the Parts List, the tuning range should be approximately 550-1500 kHz with coil "A"; 1.7-5.5 MHz with coil "B"; and 5.5-18.0 MHz with coil "C". The receiver should regenerate smoothly over this range.

out easily. If necessary, carefully trim away any excess solder. Place the plugs against each coil as shown in Fig. 7. Align the green dot on each coil between pins 2 and 3 on each plug, and attach each lead to the nearest solder lug on each coil. Run each lead through the loop on the solder lugs and cinch the leads tightly to make a rigid assembly out of the coil and plug, then solder each connection. Finally, cut off any excess leads.

Use No. 28 enameled copper wire for the feedback windings on all three coils. On each coil, start the winding by first soldering one end of the enameled copper wire to the coil solder lug which is connected to pin 2 on the miniature plug, then wind the wire as follows:

Coil "A"—0.55 to 1.5 MHz. With the plug pins pointed towards you, wind 30 turns close-wound across the existing top

coil, in a counterclockwise direction, starting from the bottom and winding towards the top.

Coil "B"—1.7 to 5.5 MHz. With the plug pins pointed towards you, wind 8 turns close-wound in a clockwise direction, starting about $\frac{3}{16}$ " down from the top of the existing winding, and winding towards the top.

Coil "C"—5.5 to 18 MHz. With the plug pins pointed towards you, wind 3 turns close-wound in a counterclockwise direction, starting about $\frac{3}{16}$ " down from the top of the existing winding, and winding towards the top.

Solder the end of each completed feedback winding to pin 5 of each plug. Then complete each coil assembly by coating the new feedback windings with coil dope.

A preliminary setting can be made on the tuning slug of each coil to get them in the right "ball park." Run the slug completely out of each coil by turning the adjusting screw counterclockwise until it stops. Then, for coil "A" run the slug in about 3 to 4 turns, for coil "B" run the slug in about 8 to 9 turns, and for coil "C" run the slug in about 3 to 6 turns. The coils can be more accurately aligned later.

The Cabinet. You can construct the cabinet to suit your own taste. The author used $\frac{1}{2}$ "-thick plywood.

The cabinet can be "finished" by covering it with self-sticking shelf paper, or painting it the color of your choice. The author used an imitation wood-grain shelf paper; however, there are many types and colors to choose from. Shelf paper is readily found in grocery stores, department stores, etc.

(Continued on page 114)

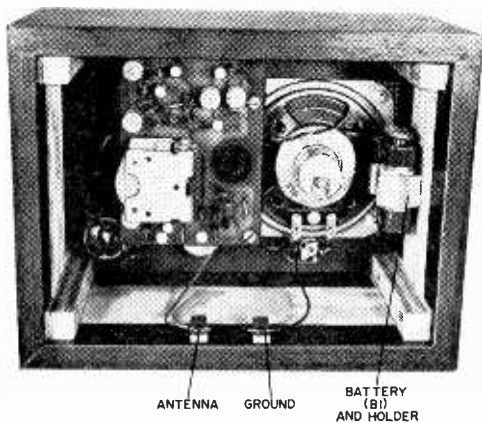

Fig. 8. Back view of the completed receiver in the cabinet designed by the author. You can either make your own cabinet or buy a ready-made metal box.

THE MAGNETIC REED SWITCH

WORLD'S
MOST-SENSITIVE
LOW-COST RELAY

By NEAL P. JENSEN
and
ALEXANDER W. BURAWA

HAVE YOU EVER DECIDED to build a project only to find that an expensive or hard-to-get sensitive relay was required? If you didn't forget the whole idea right then and there, you probably worked up an "easy-way-out" solution to your relay problem—probably adding an extra amplifying stage to develop enough power to energize a general-purpose relay. But all you would really accomplish with such a solution would be to cut down the cost of the relay and add the cost of the components needed for the extra circuit.

There is a far simpler solution to the problem, but one that many hobbyists and experimenters often overlook. Instead of using a general-purpose relay, you can substitute a magnetic reed switch. With a reed switch, you don't sacrifice sensitivity for price. You can realize up to 90% savings by using a reed switch instead of a conventional relay.

Most experimenters will question the suitability of reed switches in applications that call for a general-purpose relay—regardless of sensitivity. In this article the two devices will be compared, and you can make your own judgment. You will find that the reed switch—though a boon to electronics—will not obsolete the relay in all switching applications, just as the transistor has yet to replace all electron tubes.

Magnetic reed switches are second-generation relay-type switching devices. They were invented at the Bell Telephone Laboratories in 1940 to reduce the costs of maintaining and replacing conventional relays and to meet the needs for higher efficiency and greater sensitivity for switching devices used in complex telephone systems.

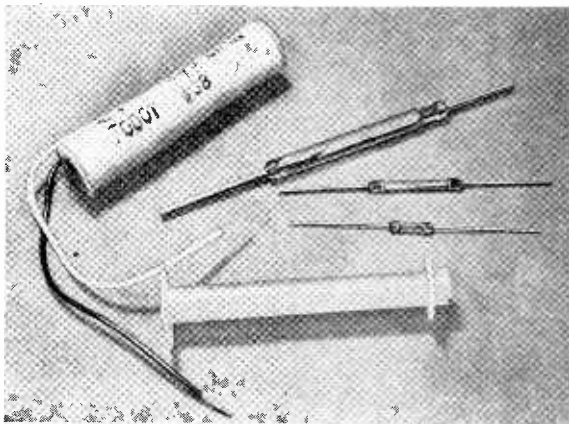

Partly because they were invented by Bell Telephone and partly because they combined high speed and uniform performance over long periods of time, reed switches played their first major role in telecommunications equipment. But because the reed switch is sensitive, compact, lightweight, and costs only a fraction of the price of a relay exhibiting the same characteristics, its use has extended to business, industry, and now to the experimenter.

Relays are comparatively heavy, bulky affairs. Because relay contacts are often open to the surrounding air—sometimes even corrosive atmospheres—periodic servicing is required to remove dirt and corrosion. By the nature of its construction, the relay is a low-efficiency device, generally insensitive to small energizing currents.

Conversely, the magnetic reed switch is compact and lightweight. Its contacts, sealed in an inert-gas-filled glass tube, never need servicing. And the inert gas in the tube retards arcing between the contacts—another problem with open relays.

Sensitivity not possible with even the best of conventional relays is a characteristic of a reed switch.* For example, it is possible to close a reed switch with less than 3 mA at 6 volts. A costly relay

*The sensitivity of a reed switch depends on the characteristics of its energizing solenoid and whether or not a permanent magnet is used to bias the switch—in much the same manner as biasing is used in an amplifier circuit.

would have to be custom-made to provide this sensitivity and current handling (at the contacts) capacity.

Relays are low-speed switching devices, almost totally inadequate at switching speeds exceeding approximately 150 open and-close actions per second. Reed switches, on the other hand, are high-speed devices, usable at switching frequencies up to 500 open-and-close operations per second. The average contact make-or-break response time of a reed switch is on the order of 1 millisecond.

The useful life of a typical reed switch will generally exceed 10-million operations. In circuits where current flows only after the contacts are closed, this figure can be as high as 500-million operations. No relay yet designed can compare with these figures.

Reed switches, of course, have certain disadvantages that make them unsuitable for some applications. Presently available reed switches can handle low to moderate power loads, up to about 50 voltamperes. Reed switches are also limited to a simple on/off action. Complex switching arrangements, however, can be obtained by "ganging" several reed switches and operating them with a common energizing power source.

Unlike some relays that can be energized from either an a.c. or a d.c. source, reed switches are restricted to d.c. sources only. If an a.c. source were used, the reed switch would open and close in step with the frequency of the applied power.

The most readily apparent difference between reed switches and conventional relays is in their respective construction (see photo at right). There is a significant difference in the proximity and orientation of the energizing solenoids. The relay's movable contacts are spring-returned to their passive position when no power is applied to the energizing solenoid. The only spring action in the reed switch is the slight amount built into the reeds.

What does this difference in construction mean in terms of sensitivity? In a nutshell, it means all the difference in the world. The relay action depends on the electromagnetic field (from one end of the solenoid) being strong enough to overcome the tension of the spring. This

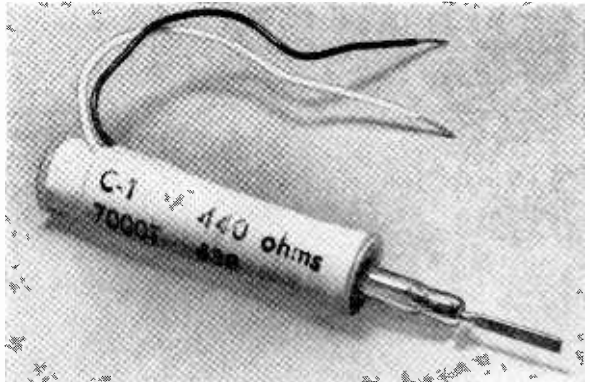

When a reed switch is used in place of a conventional relay, a solenoid is needed to close the reeds by means of electrical energy. The reed switch must be inserted in hollow core of solenoid.

is a waste of electromagnetic energy. The contacts of the reed switch form the core of the energizing solenoid and are at the center of the electromagnetic field.

Since the energizing solenoid extends from one end of the reed switch to the other end, an interesting phenomenon takes place when the solenoid is connected to a power source. The contacts become separate magnets with opposing magnetic poles. These low mass contacts, overlapping and closely spaced, are in-

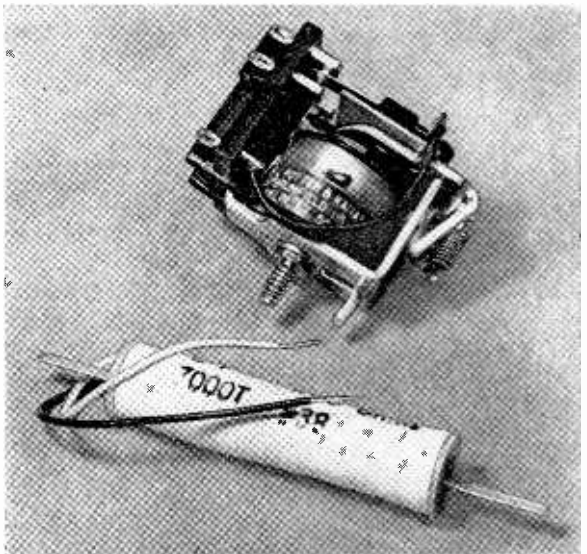

Different methods of construction used in conventional relay (top) and reed relay (bottom) account for wide variations in sensitivity between devices.

stantly attracted to each other. The density and strength of the magnetic field running through the center of the solenoid is considerably greater than that around the outside of the solenoid, so less power is required to close the reed-switch contacts than is required to close the relay's contacts—considerably less. Almost all the energizing current flowing through the solenoid is used to close the contacts of the reed switch, while less than 50% is used in the relay.

Where only a few milliamps of current are available for closing the contacts of a reed switch, a permanent magnet is often used to increase sensitivity. The permanent magnet biases the reed switch in such a way that its field and the field of the solenoid aid each other. As a result, the amount of current needed to close the contacts can be reduced to a level determined by the proximity of the permanent biasing magnet to the contacts of the reed switch.

In present-day electronics, where transistors are the building blocks for circuit designs and design concepts, sensitivity is a key feature. Transistors—generally low power devices when compared with vacuum tubes—require the use of high-sensitivity switching devices for proper switching action. Relays that are designed to energize with 4-mA

drain on the circuit generally cost more than \$10, whereas a reed switch, designed to operate at 2 mA, need not cost more than \$2—if the energizing coil is home-wound.

Perhaps the most important role the reed switch has played to date is in the "No. 1 Electronic Switching System"* (ESS) developed by the Bell Telephone Laboratories at a cost of some \$100-million for research alone. The No. 1 ESS is the world's most advanced switching system for telephone communications, and because of its high-speed/high-reliability requirements, reed switches are being used almost exclusively in place of relays.

The No. 1 ESS is so successful that over the next three decades it should become the telephone equipment standard throughout the United States. Solid-state devices and magnetic reed switches have made this new system possible.

The results obtained by Bell Telephone are just as easily applicable to your next relay project—if you use a reed switch. Immediately following are details for winding your own solenoid for a popular model of reed switch. —50—

**An article that goes into further detail about the "No. 1 ESS" appeared in the January, 1965, issue of POPULAR ELECTRONICS (The Great Immortal Machine, page 69).*

MAKE YOUR OWN REED SWITCH-RELAY

. . . AND GET "NEAR-ULTIMATE" OPERATING CHARACTERISTICS

By **NEAL P. JENSEN** and
ALEXANDER W. BURAWA

REED SWITCHES are available in a variety of sizes and contact ratings. The correct reed switch for a given application is determined by two factors: the energizing circuit and the power consumption of the load to be controlled.

While many manufacturers supply solenoid coils for different switch sensitivities, you might want to wind the coil to suit the needs of your particular circuit. This is not as difficult as it may sound. Aside from the monetary savings you realize by winding your own coil, your switching device may more nearly approach the "ultimate" in efficiency.

The Solenoid Coil. The data given in this article and the Coil Winding Table on page 50 are typical for the operation of the General Electric DR series of dry reed switches. This series includes the DR101 (rated at 15 volt-amperes) and the DR113 (rated at 50 volt-amperes). For other models of reed switches, consult the manufacturer for coil information.

The coil form must be made from non-magnetic materials, using the dimensioned drawing shown in Fig. 1 as a guide. The hollow tube that forms the core of the coil form can be a short length of aluminum or plastic tubing with an inner diameter just large enough to accept the reed switch. The coil form ends should be

cardboard, plastic, or phenolic board. Drill a small hole in one of the coil form ends to pass one end of the windings out for connection into the circuit. Glue the pieces together with epoxy cement.

Next, determine what sensitivity your circuit requires and whether or not a permanent (bias) magnet is needed. The Coil Winding Table will guide you. For example, if your circuit supplies 6 volts to the switch solenoid, and you want to close the contacts when 4.0 mA is flowing, you read down the columns under the headings "A" and "B" until you find both the voltage and current figures that come closest to your requirements. Keep in mind that the values in the columns under "A" are for use without a bias magnet, and those under "B" are for use with a magnet. A careful check will reveal that, in this case, your requirements can be met only by using the columns under "B" (6.0 volts and 2.8 mA) and that a bias magnet must be employed.

After locating this information from the voltage and current columns, read across the table to the left, and you will find how many turns of what number, or size, wire are needed. For the example given, 22,500 turns of #40 enameled wire are required.

After determining the number of turns needed, carefully chuck the coil form in a variable speed electric drill. Feed one

wire end through the small hole in the coil form end. Tape the wire to the hollow tube and begin winding at a slow speed, evenly, up and down the length of the coil form until you have an overall diameter of $\frac{3}{4}$ " (this overall diameter will yield the approximate number of turns indicated no matter what size wire is used).

After the coil is wound, tape down the free end. Then wrap a few layers of electrical tape over the entire winding to prevent unraveling. Solder appropriate hookup wires to each end of the switch, and slide the switch into the core of the coil form. Finally, center the switch in the coil form.

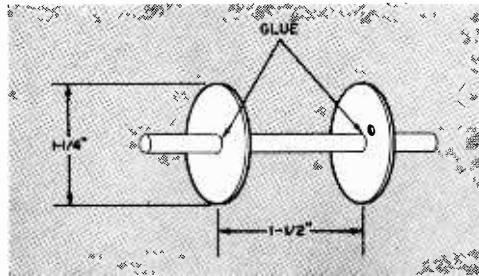

Fig. 1. The coil form used for a reed switch must be fabricated from nonmagnetic materials. Dimensions shown in this drawing are typical for the DR series of General Electric's dry reed switches. The inner diameter of coil form core should be $\frac{1}{4}$ ".

COIL WINDING TABLE

WIRE SIZE	TURNS	RESISTANCE IN OHMS	A		B	
			NO BIAS MAGNET		WITH BIAS MAGNET	
			VOLTS	CURRENT (mA)	VOLTS	CURRENT (mA)
18	311	0.38	0.13	335	0.08	210.0
20	460	0.9	0.2	228	0.12	140.0
22	700	2.0	0.3	150	0.2	85.0
24	1000	4.5	0.45	105	0.3	57.0
26	1600	11.0	0.7	66	0.4	43.0
28	2350	22.0	1.0	45	0.6	28.0
30	3500	50.0	1.5	30	0.9	19.0
32	5000	110	2.2	21	1.5	11.0
34	7000	200	3.0	15	2.0	8.5
36	10,000	450	4.5	10	3.2	5.0
38	15,000	1000	6.5	7	4.0	4.0
40	22,500	2000	9.0	5	6.0	2.8
42	34,000	5000	15.0	3	10.0	1.8
44	50,000	12,000	22.5	2	15.0	1.1

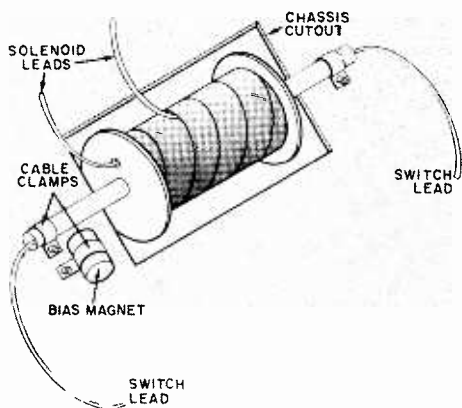

Fig. 2. If bias magnet is used, reed switch-relay assembly must be mounted over cutout in chassis to allow for positioning and orienting of the magnet.

Installation and Setup. If no bias magnet is used, the reed switch-relay can be simply mounted, using 1½"-long spacers and plastic cable clamps to support it on the chassis. Use of a bias magnet, however, requires that a hole be cut in the chassis and the reed switch-relay assembly located as shown in Fig. 2.

Locate the cable clamps as close to the coil form ends as possible to prevent them from interfering with the bias magnet. Bolt the switch assembly down tight, but leave the bias magnet loose to allow repositioning.

Now, connect an ohmmeter or other continuity indicating device to the switch leads. Determine what type of action you want from the switch assembly when an energizing voltage is applied to the solenoid—high sensitivity, normally-closed, or latching.

For high sensitivity, slowly move the biasing magnet close to the switch until the contacts close; then back off until the contacts just open again. Bolt the bias magnet down tightly in that position. (If the contacts do not close even when the magnet is touching the coil form, use a stronger magnet.) Apply power to the solenoid leads. If the closing action is not "snappy" or the contacts do not close, reverse the polarity of the connections.

A normally-closed action can be obtained with slightly more influence from the biasing magnet. Move the magnet close to the coil form until the switch just closes; then bolt it down. When the

energizing voltage is applied to the solenoid, the magnetic fields should oppose each other. Therefore, if the contacts do not snap open—and stay open—reverse the polarity of the solenoid connections.

To obtain a latching-type action, apply power to the solenoid, and then experiment with the proximity of the biasing magnet until the contacts remain closed when the power is removed. By the same token, the contacts should remain open if the polarity of the solenoid connections is reversed when power is removed. It may take several attempts to locate the appropriate proximity of the biasing magnet.

The final step is to connect the switch contacts to the load and the coil windings to the energizing circuit. Be sure, however, to connect the solenoid into the circuit with the proper polarity.

That's all there is to it. You now have an extremely sensitive relay, a simple latching relay, or a normally-closed relay at only a fraction of the cost of a conventional relay.

-30-

EXPERIMENTAL REED SWITCH KIT

Many hobbyists like to experiment with a new electronic device before they proceed to design a circuit in which it might be used. The Wabash "Engineering Design Kit" (No. 67-001) was assembled for those who want to practice using dry reed switches without spending a lot of money in the process.

The kit contains fifteen dry reed switches, three solenoids—one of which is a logic coil, four permanent magnets, and a "how" and "why" instruction booklet. The switches come in two sizes and three sensitivities, to give you a well-rounded idea of the versatility of reed switch-type relays and proximity switching devices.

With this kit, you can test and evaluate proximity and position detectors, demonstrate sensitivity, latching relays, logic circuits, and matrix or crosspoint latches. The particular reed switches supplied are said to respond to a frequency of up to 2000 counts per second. That's about an average 0.5-millisecond open-or-close response time.

You can obtain your experimental reed switch kit by sending \$10 to New Product Engineering, Incorporated, Wabash Magnetics, 812 Manchester Ave., Wabash, Ind. 46992.

BUILD MULTI-WAVEFORM GENERATOR

SIMPLIFY YOUR
HI-FI TESTING THROUGH
THE USE OF
THIS CONTINUOUS-COVERAGE
LOW-COST GENERATOR

By MELVIN CHAN

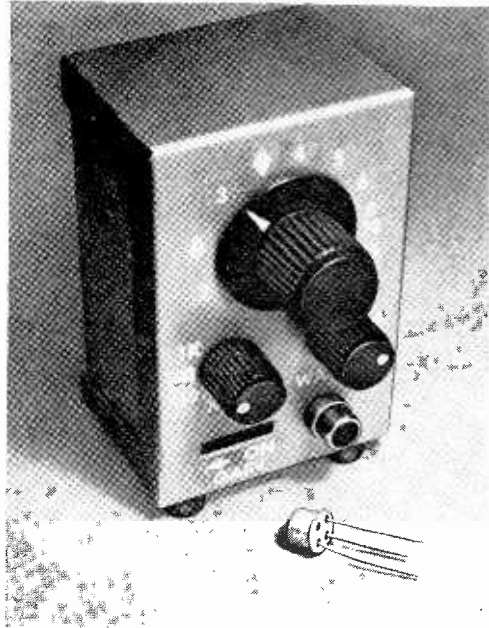

SERIOUS AUDIOPHILES with a good working knowledge of electronics are aware of the many types of test signal waveforms that can be used to check out audio amplifiers. Some signals, unlike sine waves, can perform a number of tests at one time. One of these signals is the square wave. This waveform will check out amplifier frequency response while simultaneously indicating any high- or low-frequency inadequacies, phase shift, and any ringing present in the system.

Some audio engineers prefer to use a sawtooth signal, instead of a square wave, to perform these tests, while others feel that a "spike" waveform is best. The use of these waveforms has been discussed in technical journals serving the hi-fi field. The simple, low-cost (under \$10) multiple waveform generator described in this article can deliver a square, sawtooth or spike waveform test signal, at any fundamental frequency between about 200 and 20,000 Hz.

How It Works. The circuit for the test set is shown in Fig. 1. Transistor *Q1* is a unijunction unit operating as a relaxation oscillator. The frequency of oscillation is determined by front panel potentiometer *R2*, in conjunction with a

charging capacitor (*C1*, *C2*, or *C3*) selected by switch *S1*. During oscillation, a sawtooth waveform will appear at the emitter of *Q1*, and a negative-going spike will appear at *B2* of *Q1*. The sawtooth and spike waveforms are directly fed to waveform selector switch *S2*, and on to emitter follower *Q3*.

The sawtooth signal is also fed, through *R4*, to the base of transistor *Q2*.

PARTS LIST

- B1*—9-volt battery
- C1*—0.02- μ F capacitor
- C2*—0.2- μ F capacitor
- C3*—2.2- μ F electrolytic capacitor
- C4*, *C5*—30- μ F, 6-volt electrolytic capacitor
- C6*—0.47- μ F capacitor
- J1*—Phono jack
- Q1*—2N2646 unijunction transistor
- Q2*, *Q3*—2N2712 transistor
- R1*—1500-ohm, $\frac{1}{2}$ -watt resistor
- R2*—25,000-ohm linear potentiometer
- R3*—2000-ohm, $\frac{1}{2}$ -watt resistor
- R4*, *R5*—10,000-ohm, $\frac{1}{2}$ -watt resistor
- R6*—50,000-ohm miniature potentiometer (Lafayette 99 R 6145 or similar)
- R7*, *R8*—100,000-ohm, $\frac{1}{2}$ -watt resistor
- R9*—5000-ohm potentiometer (with *S3*)
- S1*, *S2*—2-pole, 5-position switch
- S3*—S.p.s.t. switch (part of *R9*)
- Misc.—Small box (Premier 1001 or Bud CU-3001-A), printed circuit board, knobs, hardware, etc.

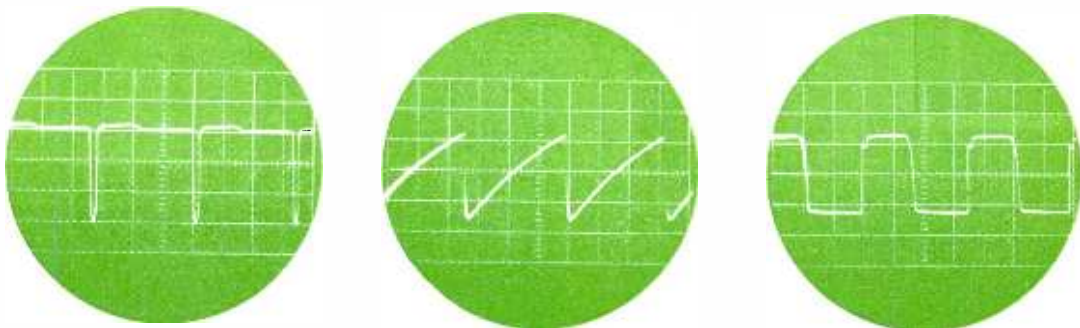

The pulse (left), sawtooth (center) and square wave (right) waveforms as seen on an oscilloscope. The little step on the leading edge of the square wave will vary dependent on the transistor used for Q2.

This transistor is biased by R6 so that it conducts only during a small portion of the sawtooth waveform. This produces a square wave at the collector of Q2. Transistor Q3 is an emitter follower which accepts the signal selected by S2 and supplies it, at relatively low impedance, through capacitor C6, to output jack J1.

Construction. Layout of the printed board is shown in Figs. 2 and 3, while Fig. 4 illustrates the method of mounting used by the author. The printed board is secured to the bottom of the case with three 2-56, 1/2"-long bolts, using nuts

to space the board far enough away from the case to preclude any possibility of shorting components. Figure 4 also illustrates one method of mounting the battery.

After mounting frequency control potentiometer R2, multiplier switch S1, waveform selector switch S2, and output jack J1, the printed board can be wired to these components as shown in Fig. 3. Looking at the rear of control R2 (as mounted), the left-hand terminal goes to the PC board (near R3), and the center and right-hand terminal are connected together. One lead from this

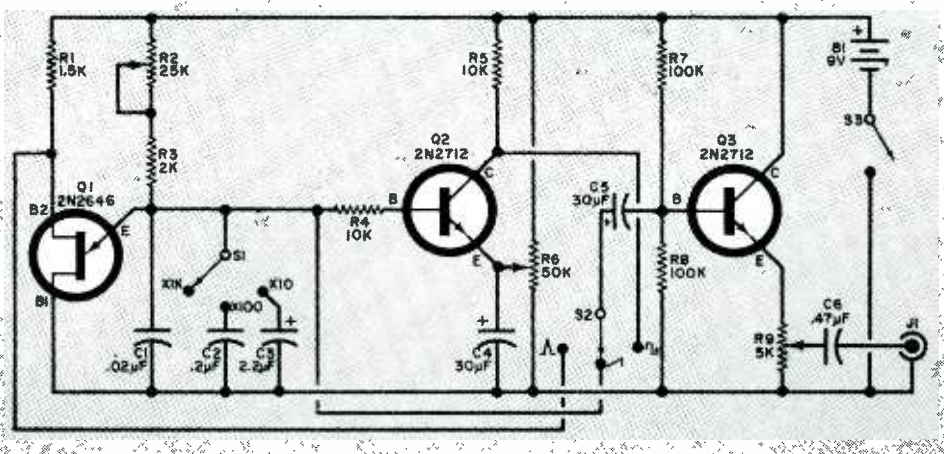

Fig. 1. As transistor Q1 oscillates, a pulse is generated at base-2 and a sawtooth waveform appears at the emitter. The sawtooth signal also produces a square wave via Q2. Signal choice is made by S2.

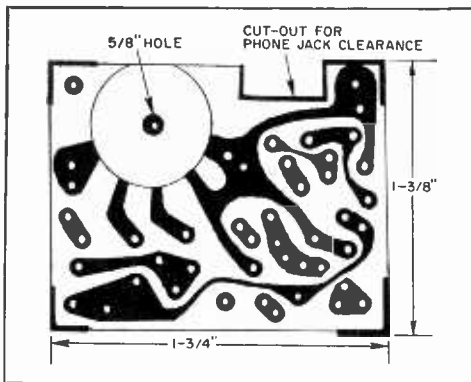

Fig. 2. Actual-size printed board. Potentiometer R9 (with S3 attached) is a printed circuit type (Lafayette 99 R 6019) and solders directly into board.

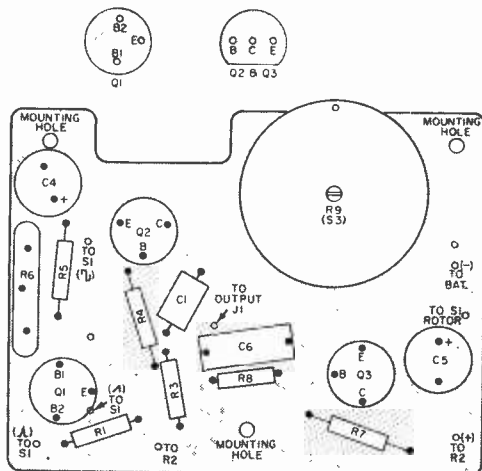

Fig. 3. Transistors Q2 and Q3 have in-line leads, although the PC board shows a triangular arrangement, so that other transistor types may be used. Drawing is oversized to show parts layout clearly.

pair goes to the PC board (near C5) and the other goes directly to the positive terminal of battery B1. The power switch (S3) is located in the negative lead of the battery.

Calibration. Connect an oscilloscope to the output jack, place S2 in the pulse setting, turn the generator on, and you should see a pulse-type signal on the scope. Switch S2 to the sawtooth position, and there should be a sawtooth waveform on the scope. Frequency of the

waveforms is dependent on the setting of R2 and S1.

When these waveforms are present, switch S2 to the square-wave position, and adjust R6 until a symmetrical square wave is obtained. Since this unit was not designed to rival precision instruments, there will probably be some discrepancy

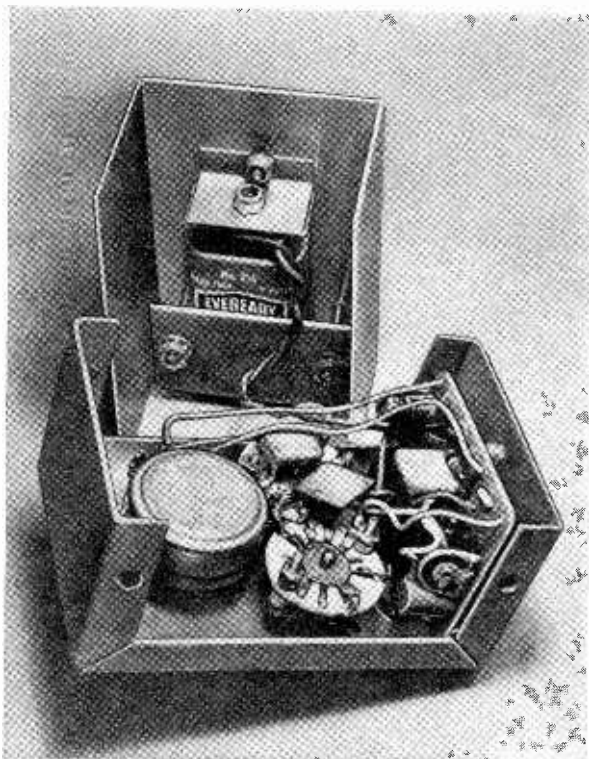

Fig. 4. In the author's unit, the battery is mounted on the rear cover so that, when the two sections are joined, it will not mechanically interfere with R2, S1, S2, or components mounted on printed board.

in the calibration scale for each range. However, as shown in the photo on page 52, exact scale markings are broad.

To calibrate the unit, a reasonably accurate audio generator as well as an oscilloscope is required. Start with the x10 range. Set S1 to x10 and S2 to square-wave output. Connect the external audio generator to the scope and set it for 20 Hz. Adjust the scope sync control until it locks and displays only one 20-Hz waveform. Now, without touching the scope,
(Continued on page 99)

ELECTRONIC ANGLE QUIZ

By **ROBERT P. BALIN**

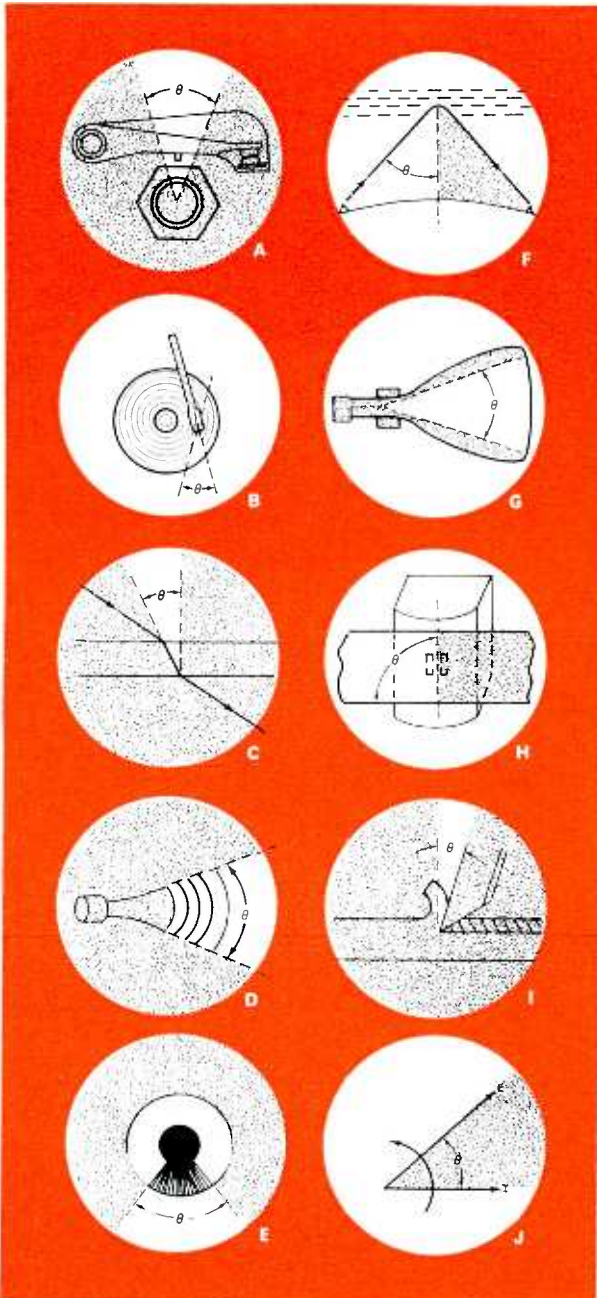

Electronics technicians use the term "angle" in a variety of fashions: it can describe the area of coverage, the shape of a mechanical component, or denote the phase relationship between voltage and current in an a.c. circuit. For example, you may have heard of the "firing angle" of a thyatron, or the "conduction angle" of a vacuum tube. To test your knowledge of electronic "angles," try matching the angles depicted in drawings A through J with the descriptive terms below (1-10).

(Answers appear on page 113)

- 1 Azimuth Angle _____
- 2 Critical Angle _____
- 3 Cutting Angle _____
- 4 Deflection Angle _____
- 5 Dispersion Angle _____
- 6 Dwell Angle _____
- 7 Phase Angle _____
- 8 Refraction Angle _____
- 9 Shadow Angle _____
- 10 Tracking Angle _____

A
STRAIGHT-FROM-THE-SHOULDER
DISCUSSION OF
HOW TO BE HIRED,
HOW TO STAY EMPLOYED,
AND WHO **THE**
DOESN'T GET ANYWHERE

ELECTRONICS TECHNICIAN SHORTAGE

THERE IS, according to almost any personnel manager, a serious shortage of electronics technicians. Perusal of the "Help Wanted" ads in almost any metropolitan newspaper reveals many openings for electronics technicians. Even such prestige employers as Bell Telephone Laboratories and Hewlett-Packard now seek out technicians whereas, not so many years ago, the waiting list for jobs at Bell Labs was longer than the personnel roster.

This shortage of electronics technicians is critical in many parts of the country. A few firms have even established training courses, tuition free, with guaranteed jobs for all who complete the course. Ads reading "Learn to be an Electronic Technician at our expense" offer a real opportunity to those with ambition, reasonable intelligence, and limited education, since some of these training courses are quite good.

Why a Shortage? The major cause of the electronics technician shortage is the enormous growth of the electronics industry. This growth includes not only the proliferation of the "amusement" part of the industry, but also the great expansion of military electronics, communication electronics, industrial controls, and the computer field. Medical

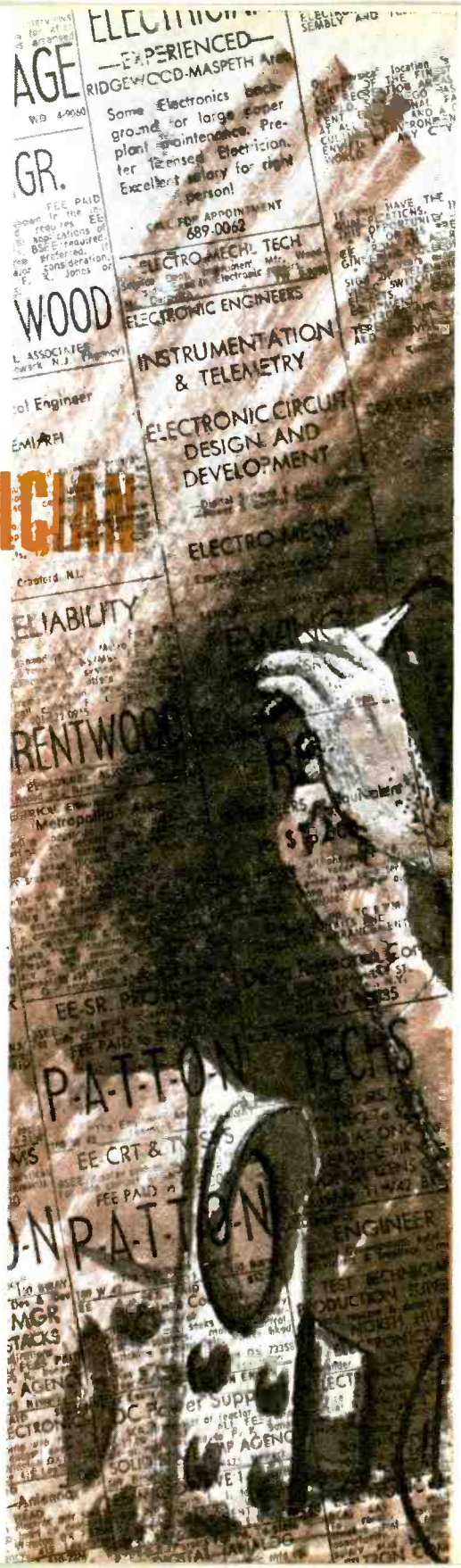

INTER
Sunday, June 17
10 AM-8 PM
Call

W. LAWSON
(516) PL 1-4500

Or send resume to:
5500 Canoga Avenue
Woodland Hills, Calif. 91364

Guidance & Control
Systems Division

LITTON
INDUSTRIES

Electronic
Technician

Hudson Laboratories
of
Columbia University
1408 PALSADE STREET
ROSBES FERRY, N.Y.
609-8860 Ext. 209

FOR INTERVIEW CALL
212 329-5100
28975 TIMES

ELECTRONIC
TECHNICIANS

FIELD SERVICE

ELECTRONIC
TECHNICIANS

Design Eng
Analog, digital, logic, memory
Circuits/Systems
\$9-\$22,000
Call or write in confidence to P.O.
Box 1000, All replies acknowledged.

SOLID STATE
4201 MA
560 BROAD ST. Newark

ELECTRONIC
TECHNICIANS

By RONALD L. IVES

electronics, geophysical electronics, navigational electronics, and meteorological electronics are other branches of the industry which are expanding at a rapid rate. Even law-enforcement agencies are now extensive users of electronics equipment.

But expansion of the electronics industry accounts for only part of the technician shortage. There is also continuous attrition in the ranks of electronics technicians. Most of the electronics and radio pioneers have now retired, died, or stepped up to administrative positions. Few, if any, of those who built the Paragon RA-10 receiver, once world-famous, are still working as technicians.

There is also a "loss off the bottom"—the lowest grade technicians, those who put the wires on the round gimmick with colored stripes through holes 6 and 7 of the printed-circuit board, work for a few months, or even a year, and then come down with "nerves," "the misery," etc., quit and go back on relief. Many of these jobs are being eliminated by automation.

The "loss off the top" is more serious, as it removes from the technician ranks some of the best workers. Often, these technicians, after working for a couple of years, leave to start businesses of their own. Some have saved up enough money to finish college; and some, after attending night classes for several years, earn a degree, and get hired as engineers by competitors. Also, many technicians graduate to better jobs as supervisors, field representatives, sales representatives, troubleshooters, computer programmers, etc.

... almost any competent technician can get a job ...

Although the combination of industry growth and the attrition of technicians gives the personnel office ulcers, it also keeps the pay of technicians at a healthy level and insures that almost any competent technician can get a job.

Who Gets Hired. When a firm advertises for electronics technicians, what do they actually want and who will they hire? Suppose the company of your choice has not advertised recently. Should you apply? If you belong to some minority group (almost everyone does), will it affect your chances of employment?

These questions are easy to ask but sometimes almost impossible to answer. Some companies have "secret" employment policies, interpreted by those in the personnel office. Although illegal, the department with the vacancy can be a closed corporation that will only accept applicants of a specific religion, race, political belief, or national origin. As a very general rule (there are exceptions), successful medium-sized to large companies have honest liberal employment policies. In many of them, you will find John Lowell, Seamus O'Hara, Ikey Cohenstein, Woe Sin Wong, Atanacio Tafoya, and Crispus Attucks Jones working harmoniously on the same project. In the Southwest, you may also find Luis Oacipicagigua on the project roster. He is familiarly called "Chief."

Despite stories that women are employed only on the production line and as equipment operators, many laboratories employ women as electronics technicians in all categories. Some of them do outstandingly good work.

Assuming that you have applied for a job, either directly at the personnel office or by mail, you will probably be interviewed by several people. The first interview will be quite short, in most instances, to determine only your general suitability for employment. If you look

like a dissappointed beatnik or have applied for a chief engineer's job when you are only qualified for a position as assistant janitor (trainee), the first interview is as far as you will get.

Following this first interview, many companies give some sort of a written test. Most of these tests are quite fair and provide a pretty good evaluation of a man's ability; others are badly off the beam, being loaded with questions about

TECHNOLOGICAL ASSOCIATES
 We need a...
 Soldering...
 Start...
 1283 W. El Cam...
 Sunnyvale
 An equal opportunity employer

TEMPO ASSOCIATES
 Link 1100...
 for secrets...
 abilities:
 * Typing
 * Short
 * Ability
 * Ability

ELECTRONICS ASSEMBLY
 EARN AS YOU LEARN — NO EXPERIENCE NECESSARY
 Our Moving View Manufacturing plant is hiring...
 We will train qualified applicants for various types of Assembly work. All openings are for permanent positions. Shifts are not rotated and excellent company benefits are provided.
 All applicants will be tested by us and must be at least 21 years of age. Citizenship is not necessary.
 If you are not previously employed, please call Employment Office 962-3201, between the hours of 8:00 a.m. and 9:00 a.m., and arrange for a test appointment.

Assignments:
 * Co
 * Pr
 * Er
 Interest at 321

variometers, gravity cells, electrolytic interrupters, and other pieces of radio equipment that are now relegated to the museum.

A few firms give what purports to be a psychological test, its aim being to eliminate "undesirable types" from among the applicants. Some of these tests are successful in eliminating the "lunatic fringe" but others are so loaded with "Hobson's choice" questions ("The lost books of Sennacherib state that Jehu was Constantine's charioteer, yes_____ no_____") which *must* be answered, that no ordinary person can get a pass-

... don't claim to know all about electronics ...

ing score. There is no place, on many of these questionnaires, for "don't know." If you get stuck with one of these, play it by ear, remembering that almost any statement containing *always* or *never* is likely to be false.

Because of Government contracts, most prospective employees must undergo a loyalty check of some sort, leading to a security clearance. This involves a fingerprint check and an investigation of the applicant's background. The loyalty "test" can be anything from a simple and straightforward outline of past experience and associations to a detailed questionnaire that might well make J. Edgar Hoover sweat. There is usually a lecture on security, sometimes given by an ex-FBI man who knows the score and at other times by a retired Army sergeant who "knows Communists."

After or while passing these hurdles, which may take from a few days to a few months, you will finally see the head of the department where the vacancy exists and get an idea of what the job will actually be. There may be a practical test at this stage of the game—soldering, reading wiring diagrams, using the oscilloscope, or something of the sort. Most of the questions are pretty straightforward and to the point, but watch out for a "stinker." If you are asked for the characteristics of an inverse bilateral frammistat or the circuit of a hypsometric depedicator, the correct answer might well be "I don't know." If you are qualified for the

specific opening, this interview may be the shortest and simplest of them all.

Smaller companies usually have a shorter procedure in hiring but are often pretty demanding when it comes to qualifications and experience. Many non-electronic concerns have a semi-autonomous electronics department which maintains electronics equipment and fills the recurring demand "make me a widget that—".

Who Doesn't Get Hired. Many applicants for electronics jobs don't get hired. Folklore has it that they are not hired because they aren't competent. Actual reasons for "no hire" do include lack of training or experience, but most "no hires" are due to other things.

One of the surest ways of not getting hired is to have an overinflated resumé. Be sure that your statements of education and experience will stand checking. Even if you are pretty good, don't claim to "know *all* about electronics."

If, when applying for a job, you look like an exhibit from an anthropology museum, a fugitive from the barber shop, or are several months estranged from the laundry and the bathtub, the personnel manager is not going to be favorably impressed. Unless you want to be a geek in the sideshow, a little attention to personal appearance will help chances of employment.

Most employers have had sad and costly experiences with alcoholics, so don't show up for an interview smelling like a brewery. Likewise, if you are a hophead, weedhead, or acidhead, stay out of the personnel office.

Too many grievances about previous employers impress most personnel men unfavorably. Unless you are out of a job because of a contract termination or a company merger, you left your previous employment because of some unsatisfactory condition. This is understood. But if you left each of the last six places you worked (for two months each) because

ABOUT THE AUTHOR

Ronald L. Ives is a prolific author and has published hundreds of articles on electronics. Mr. Ives is currently associated with Metronics, Inc., Palo Alto, Calif. Born in 1909, he has a doctorate in geography, geology and anthropology. His long career in electronics—dating back to 1926—has kept him in close contact with technicians.

... a technician's job is not usually a dead end ...

everyone there was a !\$#-//!! the interviewer is going to be a bit skeptical. Sometimes he knows the facts about your previous employer and if your tale of woe and injustice disagrees with his knowledge, he may have reservations about your employability.

Although most electronics employers are fairly sophisticated, an applicant whose vocabulary is overloaded with four letter words is likely to find himself on the street again. Save the "blue" words for when you spill the solder pot into your right-hand pocket.

Who Doesn't Stay Hired. In any newly hired group of electronics technicians, some, or many, work out satisfactorily, remain on the job, and in the course of time get raises and promotions. In some of the older companies, we find senior technicians with twenty or more years of service and paychecks that make the Internal Revenue Service very happy. Many technicians who were trained during WW II are now section heads. A few have become engineers, chief operators, traveling troubleshooters, and customer contact men. A few are now either in business for themselves or have graduated "upstairs" to the board of directors. A technician's job is not usually a "dead end."

But, in any newly hired group, there are a number of technicians who don't stay hired because they are technically incompetent in one way or another. One of the most common failings is the inability to use technical knowledge. The sufferer from this fault can pass every written test, fill blackboards with correct formulas and wiring diagrams, discuss theory impressively, and generally act like a genius (junior grade)—but he can not make anything work.

Some relatively new employees are called to the security office after a few weeks of work and are seen no more. The trouble could be false statements on

the employment application, concealment of a criminal record, or denial of security clearance for various reasons.

The technician who shows up for work under the influence of anything intoxicating or stupefying usually goes on permanent vacation rather suddenly. Absences every Monday morning, the day after every holiday, and the two days after each payday, usually make the section chief suspicious. So do shaky hands on return to work after each reported bout with "the virus." Filling your thermos full of "Old Bust Head" instead of coffee sounds like an excellent idea, but the foreman's grandfather knew about that one, too.

One sure way of getting plenty of leisure (without pay) is to try to force your religious or political beliefs on your fellow employees. If, while ostensibly employed by an electronics company, you spend a lot of time recruiting for the Charles Ash Society, organizing compulsory prayer sessions during coffee breaks, or bawling people out for not attending the Whoop and Holler Pentecostal Tabernacle, you are greasing the skids under your feet.

A related, but less serious evil, is taking off too many religious holidays. Most employers allow time off for religious observances, but if you take off on Good Friday, don't also take off for Yom Kippur and the first day of Ramadan.

Unreasonable friction on the job is a cause of many firings, as is intolerance of the reasonably normal traits of your fellow employees. A department where a number of the employees are "not speaking" is an unhealthy one and usually undergoes changes in personnel pretty regularly. Meddling in the personal affairs of your fellow workers just won't do, and loud personal criticism of the man at the next bench is completely out of line.

A very common employee trait, carried on the books as "stock shrinkage"

... "pilferage" causes a lot of technicians to lose jobs ...

or "pilferage," but more commonly known as stealing, causes a lot of technicians to change jobs involuntarily. This ranges from the occasional "borrowing" of a resistor to fix the home radio to wholesale thefts of expensive or scarce components for sale. Many employers are pretty liberal about a few

There is also the recurrent and disturbing condition of a sterling character, of unquestioned competence and laudable diligence, who just doesn't fit in a given department. Very often the reason for this cannot be determined and nobody seems to be at fault. Happily, most of these individuals recognize the situation, get jobs elsewhere before a crisis occurs, and frequently do well at the new job.

Where Employers Fail. Some "prestige" employers have an appreciable number of technical employees who stay with the company until retirement. However, a rather disturbing number of electronics employers have very high labor turnovers, so that anyone who has been on the job for as long as six months is regarded as a "veteran." Most of the stable electronics manufacturers and research laboratories fall somewhere between these extremes.

Almost any freshman student of economics can point out, with examples, an inverse relationship between company profits and labor turnover. But by the time he graduates, this student of economics will find that the situation isn't that simple; he will be firmly convinced that labor recruiting costs money and that excessive labor turnover indicates something wrong somewhere.

Many firms, usually the smaller and newer ones, start all applicants at minimum rate, regardless of training and experience; lay off whole departments indiscriminately at the termination of a contract; and then search madly for new help, a few weeks later, when they get a new contract. Such companies soon get a bad reputation in the community and the more competent and skilled workers will not apply there. New "hires," in consequence, are almost all from the bottom of the barrel—inexperienced, uneducated, or with bad records elsewhere.

(Continued on page 98)

LEARN TO BE AN ELECTRONIC TECHNICIAN AT OUR EXPENSE

This Sunnyvale electronics company produces equipment for research and development, production processes and other commercial applications. The company primarily manufactures electronic test equipment for steady and accurate performance. The company also produces an exciting line of receivers and transmitters which are used in space exploration and missile control.

HIGHEST STARTING RATES

The company seeks individuals who are interested in test and alignment of electronic communication equipment. They may be radio hams, or night school students, or individuals who have completed electronic classes, or individuals who have previously worked in radio or TV repair shops, or individuals with previous related service experience in the field of electronic equipment.

IMMEDIATE OPENINGS

TEST TECHNICIANS
Must have electronic production test experience using scopes, signal generators, counters, Q-meters, multimeters, etc. Will be trained to perform complete electronic tests on receivers, FM instruments, etc.

RF TECHNICIANS
Assist engineers in prototype assembly, trouble shoot electronic systems. Work from schematics and sketches. Excellent opportunity to work in well equipped lab with R & D engineers.

EARN WHILE YOU LEARN

... or call

... growing Coast. J soon to mult...

... modulators ... training ...

... atal circuits ... familiar with ...

... cathode ... and H-T ... tubes, amplifiers.

... be able to set up ...

... d be able to use ...

IS

riday

small parts but get downright "unreasonable" about recurrent disappearances of special integrated circuits, machine tool parts, or even oscilloscope plug-ins. Great care in keeping "company property" separate from "personal property" will not hurt your job tenure or chances for promotion.

**“Get more
education
or
get out of
electronics
...that’s my advice.”**



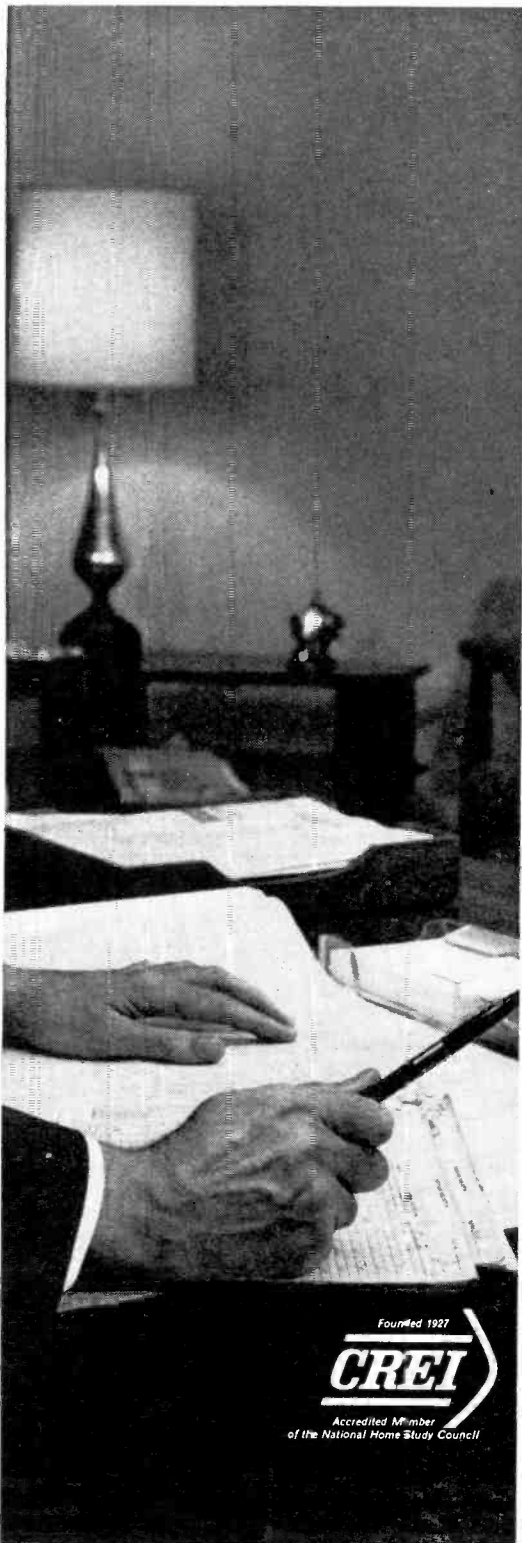

Founded 1927
CREI
 Accredited Member
 of the National Home Study Council

Ask any man who really knows the electronics industry.

Opportunities are few for men without advanced technical education. If you stay on that level, you'll never make much money. And you'll be among the first to go in a layoff.

But, if you supplement your experience with more education in electronics, you can become a specialist. You'll enjoy good income and excellent security. You won't have to worry about automation or advances in technology putting you out of a job.

How can you get the additional education you must have to protect your future—and the future of those who depend on you? Going back to school isn't easy for a man with a job and family obligations.

CREI Home Study Programs offer you a practical way to get more education without going back to school. You study at home, at your own pace, on your own schedule. And you study with the assurance that what you learn can be applied on the job immediately to make you worth more money to your employer.

You're eligible for a CREI Program if you work in electronics and have a high school education. Our FREE book gives complete information. Air-mail postpaid card for your copy. If card is detached, use coupon below or write: CREI, Dept. 1209E, 3224 Sixteenth Street, N.W., Washington, D.C. 20010.



The Capitol Radio Engineering Institute

A Division of McGraw-Hill, Inc.
 Dept. 1209E, 3224 Sixteenth Street, N.W.
 Washington, D.C. 20010

Please send me FREE book describing CREI Programs. I am employed in electronics and have a high school education.

NAME _____ AGE _____

ADDRESS _____

CITY _____ STATE _____ ZIP CODE _____

EMPLOYED BY _____

TYPE OF PRESENT WORK _____ G.I. BILL

- I am interested in Electronic Engineering Technology
 Space Electronics Nuclear Engineering Technology
 Industrial Electronics for Automation
 Computer Systems Technology

APPROVED FOR TRAINING UNDER NEW G.I. BILL

DON'T FRET

IT ONLY
HERTZ!



"Hello, boss? About this radio repair job you sent me on—HELP!"

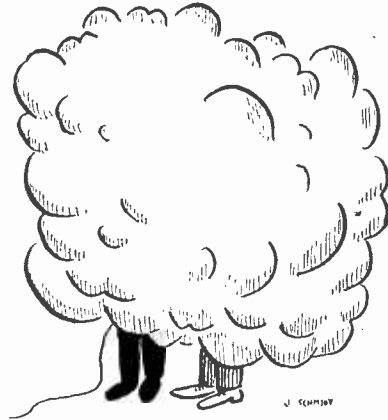

"There's your trouble!"



"Hey, Mom . . . place an ad in
POPULAR ELECTRONICS:
'Rig for sale, never been used over 3 wpm.'"

THE MYSTERY

THE MANY ENGINEERS who attended the electronics show said it was a great success. One reason for its success was the exhibit of an old weather-beaten passenger conveyance set up in the center of the hall. A sign explained that 100 years ago it had belonged to a short-lived company called the Rimrock Freight. Viewers could still see the faint company initials on the coach door.

But while the engineers looked at the initials, one song or musical selection after another could be heard coming from the passenger compartment. "I don't get it," said one mystified viewer.

"Of course, you do," commented his companion. "Think about what you're looking at."

"You mean," said the first man, "that this is a tuned R.F. stage!"

—"Doc" Hurtado

BUILD A "MAL"



... THE LIGHTING CONTROL WITH A DIFFERENCE!
EVERY HOME SHOULD HAVE
A MANUAL AND AUTOMATIC LIGHT FADER
FOR THAT
COZY LIVINGROOM FEELING

By **IMRE GORGENYI**

IT'S SHOW TIME . . . lights . . . action . . . Hold on! What kind of lights do you have in your home? Can you create a mood in keeping with the program you are about to present? Be it movies, slides, or live action, when the house lights go down, they should go down gradually, and when they come on again, they should come on gradually—if the show is to be performed in a professional manner.

There may be times when you want the lights to be on only partially to create a special effect, or to allow some one to move about the room without stumbling and without completely interrupting your show. Or, there may be times when you might like to watch a TV program in subdued lighting to help improve

picture contrast. There is much to be said for romantic settings for other occasions, too.

Whether you are dining or entertaining, you should find the *MALF*, a Manual and Automatic Light Fader, an interesting project to build and to use. Specifically, the *MALF* enables you to fade out your lights and to bring them on again in a gradual manner, either manually or automatically.

The values of the components that control the automatic timing provide about a 1-minute dimming cycle and about a 20-second brightening cycle. (You can change the values of some of the components to obtain different timing cycles.) In the manual mode you can obtain any level of brightness from mini-

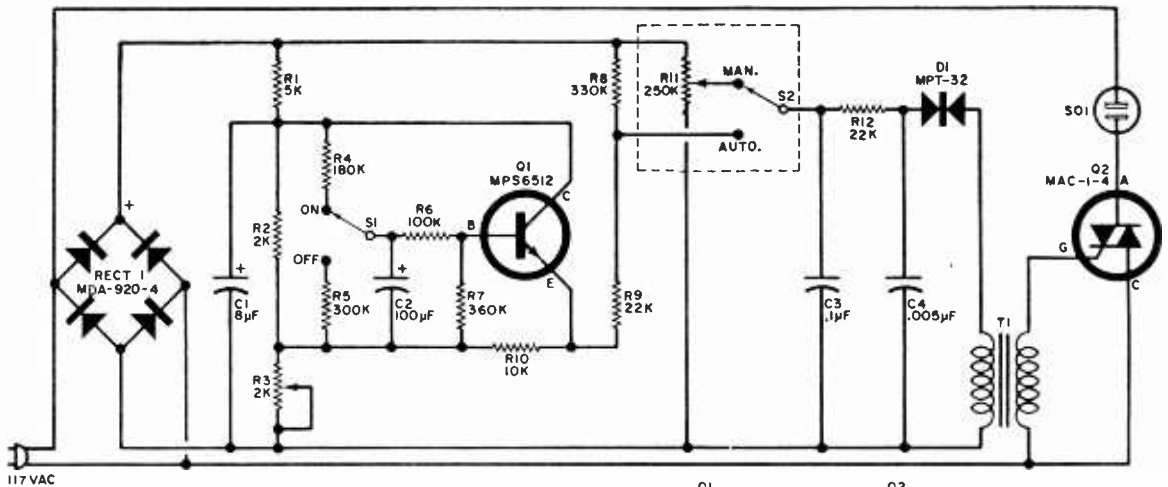
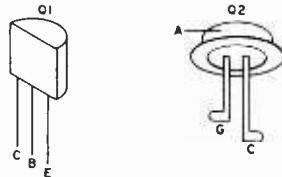

Fig. 1. When S2 is in the manual position, R11 controls the lighting. When S2 is in the automatic position, transistor Q1 has control. Lights up or down are then determined by the setting of S1.



imum to just about maximum from the lamps under control. And you can control any amount of lamp power up to more than 500 watts with this unit (Q2 is rated at 5 amperes), but loads not exceeding 300 watts leave an ample margin of protection against overload. The unit itself draws very little power and it costs about \$15 to build.

How It Works. In the manual mode, the 120-Hz ripple from the full-wave rectifier stack (RECT 1), in Fig. 1, is fed through potentiometer R11 to C3, which in turn charges up C4 via R12. A charge gradually builds up on C4 which is applied across trigger diode D1. When the voltage level on C4 reaches the breakdown voltage of D1 (about 32 volts), D1 conducts and produces a short-duration pulse across the primary winding of T1.

A pulse then appears across the secondary winding of T1 and triggers thyristor Q2, which turns it "on." When Q2 conducts, the lamps plugged into load socket SO1 will light. Lamp brightness depends upon the amount of time Q2 conducts during each alternation of the 120-Hz ripple voltage.

The sooner Q2 starts to conduct at the beginning of each alternation, the higher will be the power applied to the lamps, and the brighter the lamps will be. Potentiometer R11 varies this "timing" in

PARTS LIST

- C1—8- μ F, 150-volt electrolytic capacitor
- C2—100- μ F, 15-volt electrolytic capacitor
- C3—0.1- μ F, 200-volt paper or mylar capacitor
- C4—0.005- μ F, 200-volt ceramic capacitor
- D1—Trigger diode (Motorola MPT-32, or similar)
- Q1—Npn silicon transistor (Motorola MPS 6512, or similar)
- Q2—Thyristor (Motorola MAC-1-4, or similar)
- R1—5000-ohm, 4-watt resistor
- R2—2000-ohm, 1-watt resistor
- R3—2000-ohm, 2-watt wire-wound potentiometer (IRC-CTS 112-2000, Mallory MTC 23L1, or similar)
- R4—180,000 ohms
- R5—300,000 ohms
- R6—100,000 ohms
- R7—360,000 ohms
- R8—330,000 ohms
- R9, R12—22,000 ohms
- R10—10,000 ohms
- R11—250,000-ohm, 2-watt linear potentiometer (Ohmite CU-2541, or similar)
- RECT 1—200-volt PIV full-wave rectifier module (Motorola MDA-920-4, or similar)
- S1, S2—S.p.d.t. switch
- SO1—117-volt, a.c. panel-mounted outlet
- T1—1-to-1 pulse transformer (Sprague 11Z12, or similar)
- 1—3 $\frac{3}{4}$ " x 6 $\frac{1}{4}$ " x 2" box and metal cover
- Misc.—2 $\frac{1}{2}$ " x 4" perforated circuit board, push-in terminals (approx. 24), 6-32 x $\frac{3}{4}$ " threaded spacer, line cord, knob, solder, etc.

the manual mode, and can be set to provide the desired brightness level. This control can be rotated by hand in a continuous manner to fade the lights in or out.

Once $Q2$ is triggered, it will conduct until the voltage on either anode goes through zero. This is a full-wave type of control and functions on both negative and positive halves of the cycle. Transformer $T1$ also isolates the d.c. supply from the a.c. lines, and $C3$ serves as a d.c. filter, as does $C1$.

For automatic operation, transistor $Q3$ and its related components are substituted for $R11$ simply by the flick of switch $S2$. Transistor $Q1$ is hooked up like a series-type voltage regulator whose emitter-collector current flow depends upon its emitter-base voltage. However, the output voltage changes because the control voltage changes, and in this respect $Q1$ is more of a follower than a regulator.

The more positive the base is in an *npn* transistor (with respect to the emitter), the more current will flow. When $S1$ is in the *ON* position, a charge builds up on $C2$, gradually making the base more positive. More current flows through $R10$ and makes the top end (junction of $R9$ and $R10$) more positive. The higher the voltage at this point, the less time it takes to charge $C4$ up to trigger $D1$, and the brighter the lights.

The charging rate of $C2$ depends upon its value and that of $R4$ as well as the applied voltage, which can be varied by adjusting potentiometer $R3$. However, the adjustment of $R3$ affects the *ON* delay time. A different "turn-on" slope (Fig. 2) can be built into the unit by changing the values of either $R4$ or $C2$, or both. Higher values will make the

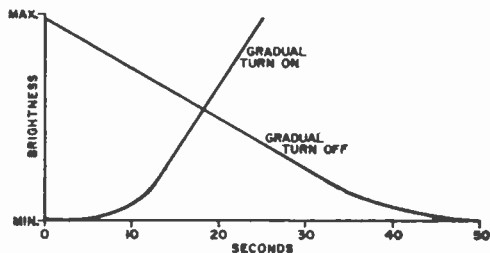

Fig. 2. Slopes of lamp turn on/off. The slopes can be altered by changing certain parts values.

slope less steep and the lights will go on more gradually. Conversely, lower values will quicken the action.

To reverse the action and cause the lights to fade out, flip $S1$ to the *OFF* position. This removes the voltage applied to $C2$ and permits $C2$ to discharge through $R5$, $R6$, and $R7$. When the voltage across $C2$ drops, the voltage across

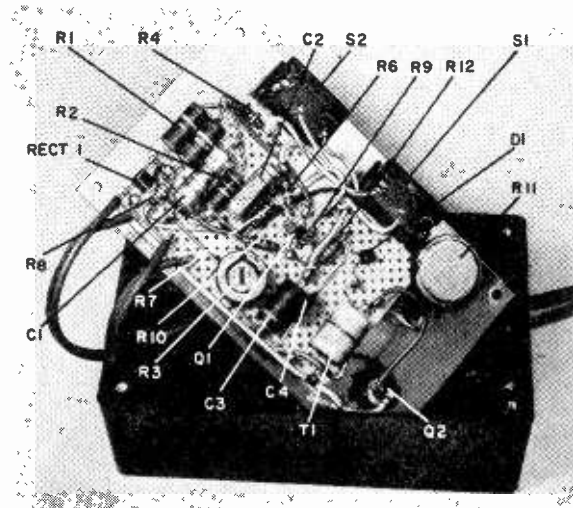

Fig. 3. As shown here, parts layout is not critical. However, make sure that $Q2$ is isolated from cover.

$R10$ drops accordingly, and the lights fade out. Resistor $R5$ is optional: its addition merely helps to speed the discharge action and cause the lights to fade out faster.

Construction. A Bakelite meter case and a metal cover were used to house the *MALF*. The metal cover serves as a heat sink for $Q2$. Use a nonconducting epoxy cement to attach $Q2$ to the cover mechanically, but not electrically. To be sure that $Q2$ does not make electrical contact with the cover, apply a thin layer of cement on the underside of the cover where $Q2$ is to be located, and let it dry. When the cement is dry, apply another coat and then set $Q2$ in place.

Use an ohmmeter to check the insulation of the epoxy joint. If you get a reading, remake the joint. An electrical contact at this point can put the cover on one side of the 117-volt a.c. line and
(Continued on page 102)

L'IL RICHIE

SIMPLE, STABLE,
HARMONIC-RICH
CRYSTAL OSCILLATOR
IS BUILT AROUND
A LOW-COST
INTEGRATED CIRCUIT

By **DON LANCASTER**

L'il Richie is a small one—it's shown here alongside a conventional "C" cell—but the crystal is a 100-kHz bar and is larger than most crystals.

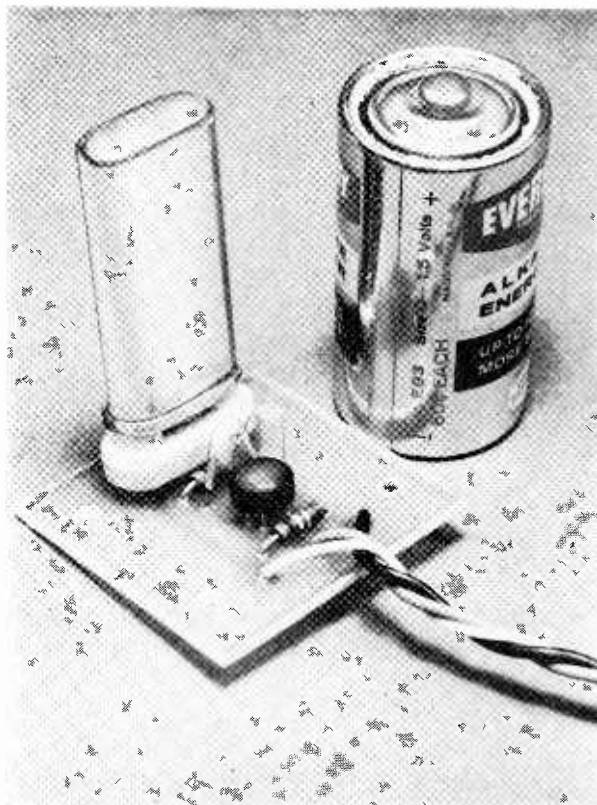

TAKE ONE low-cost integrated circuit, two resistors, one capacitor, and one crystal—combine properly—turn on the power, and you can generate crystal-controlled sine or square waves at any frequency between 100 kHz and 3 MHz, and, with slight modification, the 3- to 10-MHz range. Uses of the "L'il Richie" are as varied as the user's imagination.

Amateur radio operators will find the harmonic-rich output useful as 100-kHz or 1-MHz crystal calibrators. As a bonus,

the addition of an output tank circuit creates a flea-power transmitter for field days, antenna testing, and hidden-transmitter hunts.

For AM servicing, just insert a 455-kHz crystal, and you have an i.f. alignment generator. Switch to 500-, 1000-, or 1500-kHz crystals, and you have a handy signal generator for dial calibration, tracking adjustments, or antenna and r.f. stage tuning.

For TV or FM work, plug in the need-

ed crystal—3.58, 4.5, or 10.7 MHz—and you have a marker or signal generator all set to go. And, finally, the advanced experimenter can use the “L’il Richie” as a stable, crystal-controlled reference clock for electronic counting circuits.

How it Works. The two independent gates in IC1 (Fig. 1) are biased in their class A region using resistors R1 and R2. These two gates are cascaded with C1 to form a two-stage, RC-coupled r.f. amplifier. Feedback from output to input via XTAL produces the desired oscillation, in the form of a square wave very nearly equal to the crystal’s series-resonant frequency.

PARTS LIST

- C1—1000-pF disc ceramic capacitor—see text
 IC1— μ L914 epoxy micrologic dual gate (Fairchild)*
 R1, R2—10,000-ohm, 1/4-watt carbon resistor
 XTAL—Series resonant, first-overtone crystal, 100 kHz to 3MHz with C1 as listed; to 10.7 MHz with selected value for C1
 Misc.—1 1/2" x 1 3/8" single-sided PC board,** socket to fit XTAL with mounting screw, solder terminals (3), solder

*Data sheet and distributor list are available from Fairchild Semiconductor, 313 Fairchild Drive, Mountain View, Calif.

**Complete kit, including printed circuit board, but less crystal and socket, is available from Southwest Technical Products Corp., Box 16297, San Antonio, Texas 78216, for \$1.75, postpaid in the U.S.A.

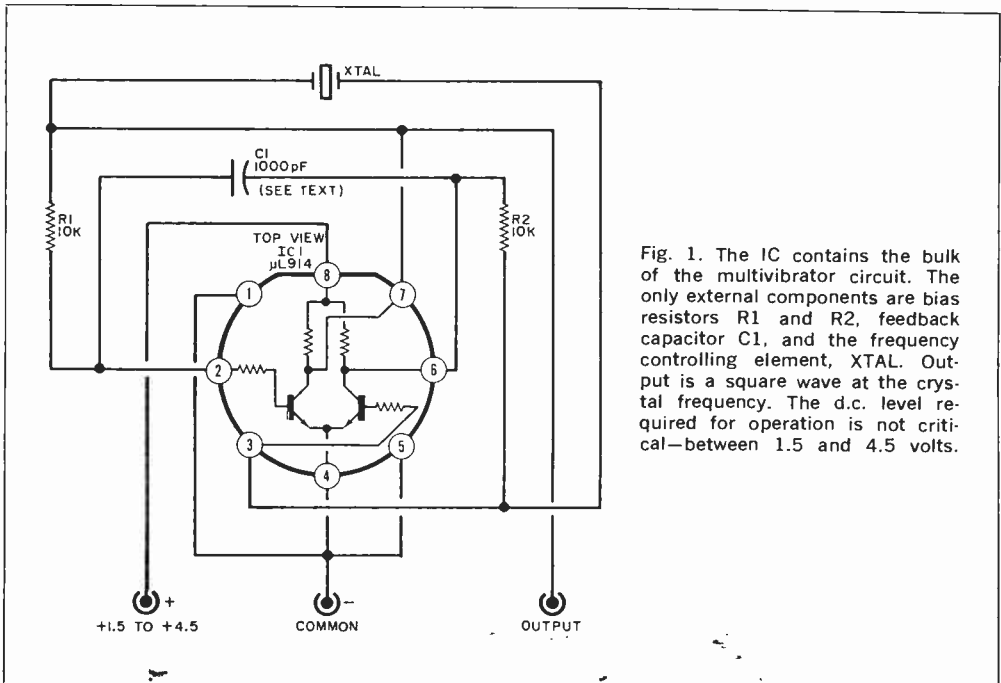
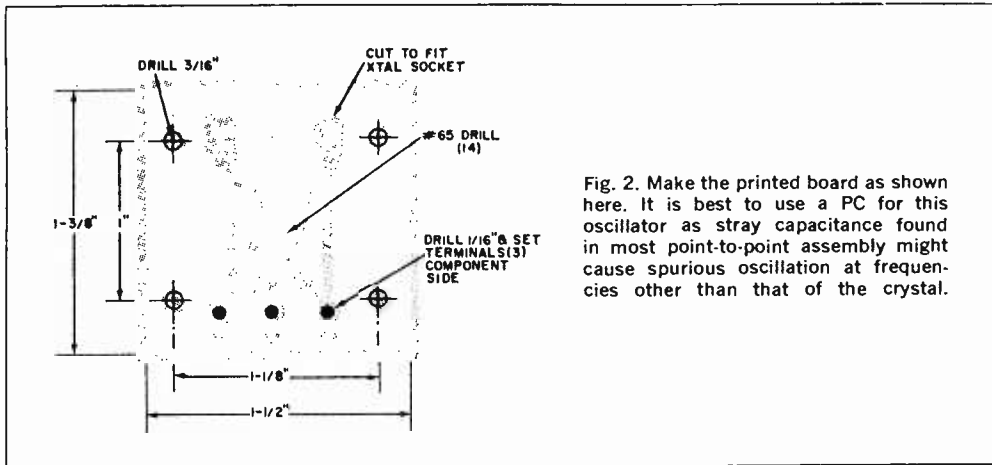

Fig. 1. The IC contains the bulk of the multivibrator circuit. The only external components are bias resistors R1 and R2, feedback capacitor C1, and the frequency controlling element, XTAL. Output is a square wave at the crystal frequency. The d.c. level required for operation is not critical—between 1.5 and 4.5 volts.



The entire circuit requires only five low-cost parts and can be powered by any convenient supply from a single penlight cell (1.5 volts) up to 4.5 volts d.c.

Construction. Any neat construction technique can be used for this circuit, but long leads or sloppy construction can produce a device whose frequency may not entirely depend upon the crystal used. A complete kit, including the printed circuit board, is available from the source indicated in the Parts List, but if

you want to do your own PC layout work, just follow Figs. 2 and 3.

Note that *IC1* is mounted with the positive power lead centered on the flat of its epoxy case (pin 8). And be sure that the crystal holder pins and the crystal socket match, as some older crystal holders have different pin diameters and spacings.

After assembly and inspection, insert a crystal of below 3 MHz, and perform an initial checkout using 3 volts from two flashlight cells. If you're planning on using crystals from 3 to 10 MHz, you'll have to experiment to get the value of *C1* just right to suit your particular crystal's drive requirements. Higher frequency generators will require values of from 20 to 100 pF.

Some capacitor tinkering is required at these higher frequencies and a generator tailored in this manner will most likely work best with one particular crystal, and over a more limited power supply range. You might like to try a trimmer, or padder, for *C1* if you're planning high-frequency operation with multiple crystals. A 0.01- μ F power supply bypass capacitor might also be required.

Occasionally, older surplus crystals or one with an unusual cut may take off on the second or third harmonic instead of the fundamental. Usually, a bit of capacitance shunting the crystal socket will settle things down. Values will be in the 50- to 200-pF range. Use discretion with

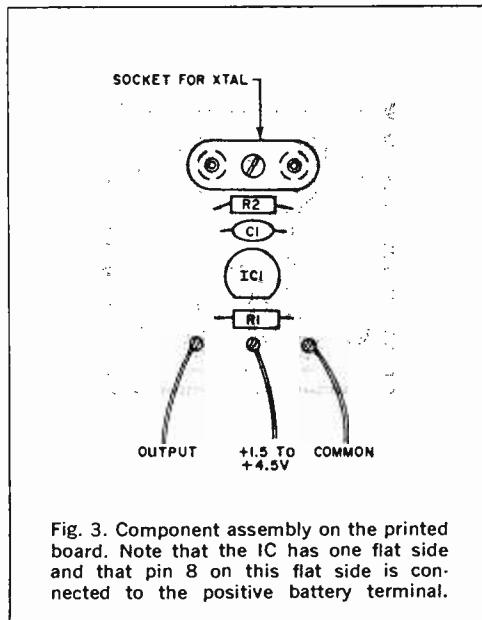

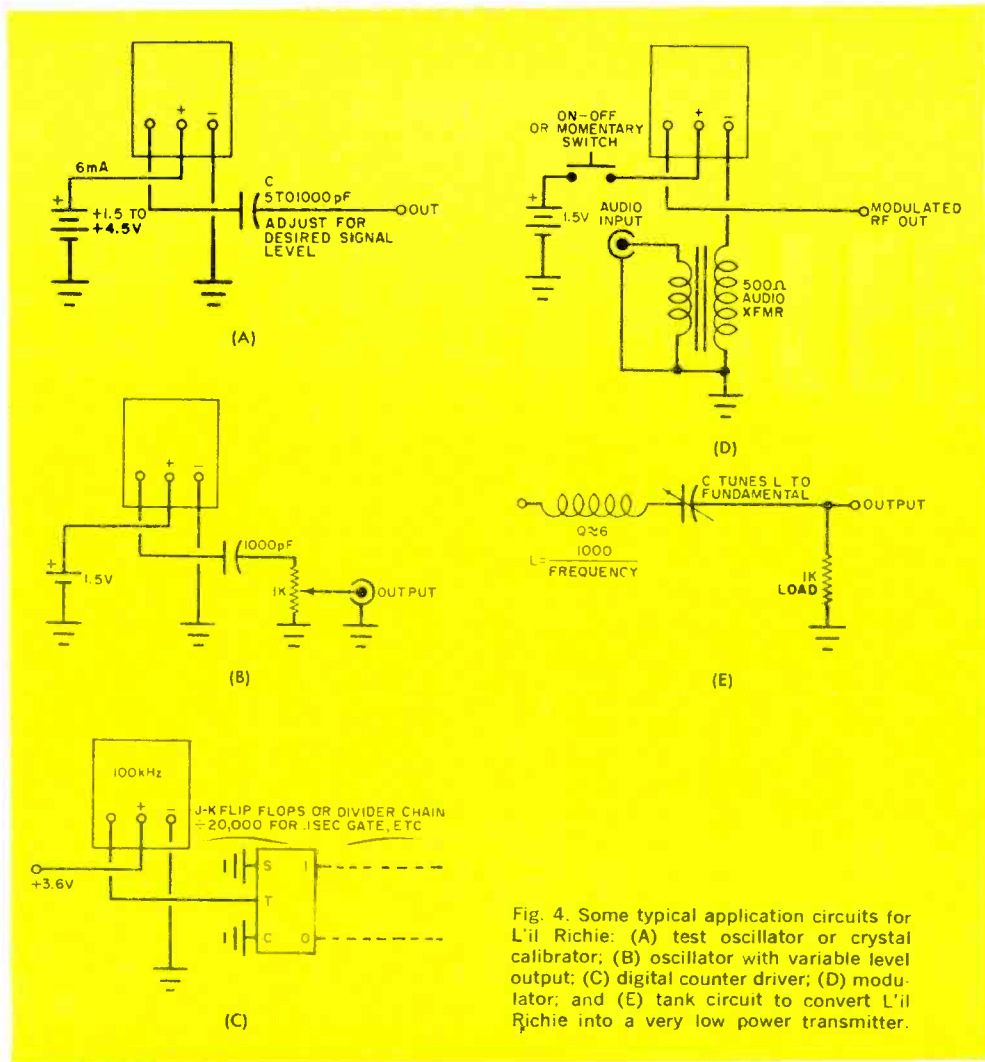

Fig. 4. Some typical application circuits for L'il Richie: (A) test oscillator or crystal calibrator; (B) oscillator with variable level output; (C) digital counter driver; (D) modulator; and (E) tank circuit to convert L'il Richie into a very low power transmitter.

this capacitive loading, for the generator will now oscillate either with or without the crystal in place.

Operating Hints. Figure 4 shows some circuits you might like to try. In the test oscillator or crystal calibrator in Fig. 4(A), an output capacitor (C) is selected to get the desired signal level. If you want a continuous output level adjustment range, use the circuit shown in Fig. 4(B). The digital clock and divider connection is shown in Fig. 4(C); a coupling capacitor is not required here.

On-off switching, keying, or audio modulation are added with the circuit in Fig. 4(D). Or, if you want a sinusoidal output instead of a square wave, just add a series-resonant tank circuit to the output, tuned to the crystal frequency, as shown in Fig. 4(E).

The generator's output voltage will be slightly less than the supply voltage. Expect around 1.2 volts peak-to-peak with penlight cell operation, and perhaps 4 volts for a 4.5-volt supply. Total circuit drain is less than 6 mA with the higher supply voltage.



INFORMATION CENTRAL

By CHARLES J. SCHAUERS, W6QLV

IF YOU INCLUDE pass-along readership, each issue of POPULAR ELECTRONICS is read by 900,000 to 1,000,000 electronics experimenters and hobbyists! You may find that hard to believe, but this columnist doesn't because incoming mail to *Information Central* is a veritable deluge!

Answering your questions takes time and people—not counting the man-hours spent opening and sorting the hundreds of postcards and letters. So far, *Information Central* has managed to keep abreast of the flood, but if your answer is delayed, don't be surprised. Also, please carefully consider your inquiry before putting it into the mail. Have you exhausted all of your local sources of information? If a project doesn't work, have you had a third party double-check the wiring?

If you want to modify a published project, please don't ask us to redesign it to your specifications—there just isn't time available for that sort of endeavor. Nor is there any method whereby *Information Central* can send you operating instruction books or construction manuals—please don't ask for them.

And please don't try to engage us in a long, involved correspondence exchange. Letters and postcards that are not returned to the sender—with our response—are destroyed; there just isn't enough space available to keep everything we receive.

Two final thoughts: first, you cannot reach this columnist by telephone—I am not based in the New York City editorial offices; second, don't put a “deadline” on your information request. Although everyone appreciates the fact that certain activities (school, business, etc.) must be completed within a given period, there is no guarantee that your letter will be at the top of the pile.

Be sure to address your request to the attention of *Information Central*.

Excessive Motor Noise. *I have a solid-state tape recorder and when I try to record signals on the VHF aircraft band the recorder motor noise ruins the recordings. Even placing the recorder 5'-6' away from the receiver produces the same results. What can I do to get rid of this noise?*

If you have a wiring diagram of the tape recorder, see if the motor leads are bypassed

to ground. If not—and they probably are not—try bypassing them with low-voltage 0.5- μ F capacitors. If this lessens the interference, but does not totally eliminate it, you may find it necessary to substitute coaxial capacitors in each motor lead—be sure that the case of the coaxial capacitor is grounded to the common ground terminal of the recorder. You might also try a pair of VHF-type r.f. chokes in series with each motor lead and then connect two 0.01- μ F ceramic capacitors in series across the motor leads with the center tap of the capacitors going to the common ground.

Walkie-Talkie On 10 Meters. *I have a pair of low-powered walkie-talkies and would like to convert them to the 10-meter ham band. I have seen your articles on converting 5-watt CB transceivers, but how do I go about it with walkie-talkies?*

Most of the hand-held CB walkie-talkies can be used on the lower part of the 10-meter band without too many modifications. First, change the crystals; but be sure that your substitute crystal is the type that the walkie-talkie requires (generally in a HC-18/U holder). Secondly, be prepared to remove up to three turns of wire from the coils associated with the receiver front end, oscillator, and the final r.f. tank of the transmitter. The loading coil in the antenna circuit may also need modification to handle the higher frequencies with the same whip antenna. I had an article in the December 1961 issue of *CQ Magazine* which covered the conversion of the popular Lafayette HE-29B hand-held transceiver—take a look at it if you have the opportunity.

Impedance Matching. *I have a transmitter with an 829B in the output which has a balanced output tank with a centered link coupling to a 300-ohm antenna. Is there any way to convert this link coupling so that I can use 52-ohm coaxial cable?*

One way would be to build an antenna tuner from the plans that are contained in any of the ham radio handbooks. Another, simpler method would be to prune down the number of turns on the antenna coupling link until it reaches 52 ohms and matches both the antenna and transmission line.

FM BCI. *I bought a modestly priced VHF receiver to tune the aeronautical band between 108 and 136 MHz. Unfortunately, not only do I receive the airports and airplanes, but I also receive a variety of FM broadcasting stations. The manufacturer told me that this is due to the design of the receiver and he is unable to suggest a remedy. Is there anything that I can do?*

I will not mention the model or manufacturer of the receiver you are using inasmuch as it is well known that this receiver will not operate where there are strong FM signals. The receiver has a grounded-grid input circuit and the selectivity and cross-modulation characteristics are far from the

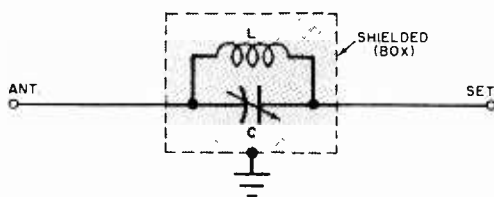

L=4 TURNS #12 BARE COPPER WIRE 1/2" DIA, 3/4" LONG
C=10pF MIDGET VARIABLE OR COMPRESSION TYPE CAPACITOR

best. You can try two things—although it is doubtful that they will completely cure your problem. Use a vertical antenna that has been cut to receive around 122 MHz, and use the trap shown above. Tune the trap for minimum FM interference.

Testing Electrolytics. *I have acquired several dozen electrolytic capacitors ranging in value from 8 to 100 μ F with voltage ratings between 150 and 450 volts. Is there any quick way I can check these capacitors?*

I would suggest the circuit shown below. Set the voltage of this tester to the working voltage printed on the side of the capacitor. If the neon bulb lights immediately and stays on, the capacitor is shorted. If there is no light whatsoever, the capacitor is open.

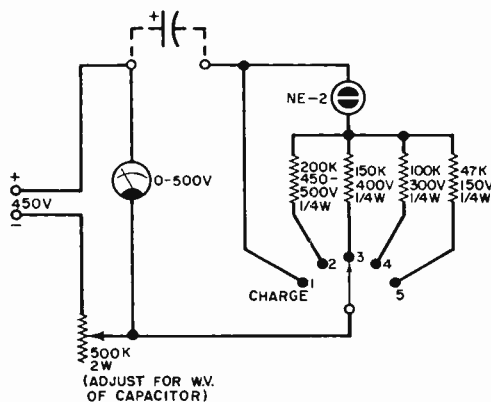

September, 1967

If the neon flickers, you can be sure there is some leakage. On good capacitors, the neon light should go on; and when the capacitor has reached its full charge, the neon light will go out. Even a weak dull glow indicates leakage. But be sure that there is no a.c. ripple in the d.c. voltage used for this tester. Any a.c. will make a capacitor appear leaky.

Standby-Receive Switch. *How do I add a standby-receive switch to my receiver?*

Very simply. Just insert a s.p.s.t. switch in the lead coming from the center tap of the high voltage secondary on the power transformer and ground. I am assuming that your receiver has a full-wave rectifier.

FM Tuning Indicator. *I have an early model FM receiver and would like to connect up a tuning indicator. How do I go about it?*

See the schematic below. The input to the indicator must come from the grid of the first limiter tube. The actual connection is

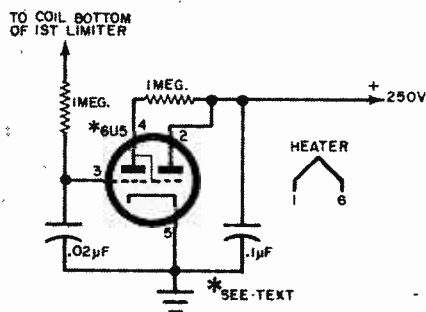

made at the bottom of the coil whose top is connected to the limiter grid. The 250 volts can be "stolen" from the final audio stage if you use a proper dropping resistor.

TV Photos. *When I take a photograph of a TV picture, my prints show a black diagonal bar which was not in the TV picture. Is this a hidden message?*

No, you're simply using the wrong type of camera—undoubtedly one with a focal plane shutter. You can take good TV photos with a leaf shutter camera, but not with a focal plane camera because the shutter opening will show the time the screen is dark with flyback. Try shooting with the speed at 1/15 second—it should help.

Viking "Ranger" TR Noise. *I am a new ham and have just acquired a used Viking "Ranger" transmitter. The unit seems to work okay, but when I wire in my electronic transmit-receive (TR) switch, the noise is terrible—when the transmitter is on standby.*

How do I get rid of this terrific hash?

I would suggest that you try increasing the bias on the final r.f. stage. If your "Ranger" has a biased rectifier, add the diode and resistor shown in the diagram below. This should cut off the diode noise being generated in the final amplifier tube.

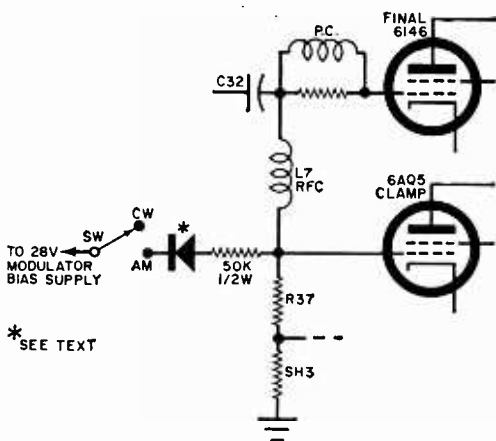

Open the switch for CW operation to permit the clamp tube to operate. Use any diode similar to the 1N647, and adjust the value of the series resistor for best operation. You could use a 22½-volt battery, but this is not as effective as obtaining the bias from the -28 volts available in many "Rangers."

GW-22A Squeal. *My Heathkit GW-22A transceiver has an intermittent squeal. Changing channels has no effect and I have tested all of the tubes. I can sometimes jiggle the mike switch to make the squeal stop, however. What's going on?*

It sounds like a poor connection in the microphone switch. This transceiver has an electronic push-to-talk circuit and the switch connection must be good and of very low resistance. You can double-check by substituting a new microphone.

Transistor Replacement. *I own a power supply that uses 2N1518 transistors which keep popping. There certainly must be a replacement with a higher rating—is there?*

Yes, there is; and I would suggest the Delco 2N1520. This transistor is of the same family as the 2N1518, but has a higher current rating and should work better in a power supply application where there are wide voltage input excursions. I presume the supply you have is for mobile use. If so, try to keep the input voltage down below 14 volts.

Walkie-Talkie Operation. *I have just heard that the FCC is going to change the frequencies of the walkie-talkie transceivers. If I*

buy a pair of new ones now, must I give them up in a few months when the Rules are changed?

No. The Rules change affecting walkie-talkie operation has not been finalized. Even so, the FCC will not curtail 27-MHz operation, but simply require manufacturers to build transceivers for the new channels.

R/C Model Control. *I have become interested in radio control of model boats and aircraft. Can I use the same frequency for controlling each of my models?*

As long as you have a Class C license, you can use any one of the six 27-MHz channels for model control. You don't need a separate channel for your airplane and a separate channel for the boat.

Head Alignment. *Why is there some spill-over on the second channel of my stereo tape recorder? Is there anything I can do to cure this problem?*

It sounds like tape head azimuth alignment misadjustment. Check the instruction manual that came with your tape recorder and unless you find a recommendation to the contrary in it, adjust the tape head while playing back a special test tape especially recorded for this purpose.

HT-46: No Audio. *I own a Hallicrafters HT-46 transmitter and it has always worked beautifully, but when I returned from vacation recently, I found that I could no longer use it on voice. The mike seems okay and the transmitter works on CW. Where do I start looking for the trouble?*

First, check the mike preamplifier tube (12AT7), since this is the most likely culprit. Simultaneously, check the mike connections under the chassis and see if the mike gain control is properly set and operative. You may also have a bad triode section in tube V2a (another 12AT7) which is the third audio amplifier.

BCB Station Guide. *I want to DX the BCB this coming winter. Where can I get a list of all AM broadcasting stations and their frequencies?*

There are several lists available, but the best is the "North American Radio Guide" written by Vane Jones and published by Howard Sams; it sells for \$2.50. All European BCB stations are listed in the "Medium Wave Guide" published in Denmark (but printed in English); this one sells for \$2.75. Both books are available in many radio parts stores or can be ordered from major suppliers (Allied Radio, Lafayette Electronics, Radio Shack, etc.). Books on SWL'ing can also be bought from Gilfer Associates, Box 239, Park Ridge, N.J. 07656.

Lightning Protection. Now that I have my Novice license, I'd like to get on 40 meters as soon as possible, but my father insists that any transmitting antenna I erect have "full lightning protection." I wanted to put up a simple dipole made of 300-ohm twin lead, but I guess that's out now. What do you suggest?

Afraid so, since it's much too inconvenient to safely ground a folded dipole. I would suggest a half-wave antenna center-fed with 75-ohm coax cable. This immediately grounds one-half of the antenna and the other half can be grounded through a commercial product called the "Blitz Bug." It's a lightning arrester made for ham stations and costs around \$5.00. The coax line and the "Blitz Bug" should more than satisfy your father's requirements.

HO Train Interference. I am a model train enthusiast and my engine motors radiate radio and TV interference. My next-door neighbor can just about see a TV picture when my trains are running. Can you tell me how to eliminate this awful electrical noise?

Your problem is similar to the first one in this month's installment (page 74). Try coaxial capacitors in the leads feeding the train track. Ground the capacitor jackets to a water pipe ground. If there is room in the engine model, put two 0.001- μ F ceramic capacitors in series across the motor and ground the center connection to a metal part of the model frame. Since the noise is coming from commutator arcing, you might try "arc suppressors" if all else fails. These suppressors are manufactured by International Rectifier Corp., but are not too commonly available. You can experiment making your own with two silicon diodes mounted back-to-back like the ceramics mentioned above.

Wireless Mikes. I've looked all over for plans to build a wireless mike but I can't locate any. How come?

The FCC has vetoed the publication of construction plans for wireless microphones—especially those transmitting in the FM broadcast band. They created too much interference.

Sticking S-Meter. My receiver S-meter appears to stick, or hang up. Is there anything I can do about it?

You probably have a defective meter, which can either be repaired or replaced. You shouldn't attempt to repair this meter unless you are familiar with its operation and you have all of the necessary tools. It would probably be cheaper in the long run to replace it with a new meter from the receiver manufacturer.

Automatic Rain Switch. I need a simple device that will sound an alarm bell or buzzer when it rains. Can you help me?

Try the circuit in the diagram shown below. The selection of the transistor is a minor detail and you should be able to use almost anything including a 2N216, 2N445, 2N446, 2N532, 2N595, SK-7, SK-3011, or GE-5. The relay can be one of the Lafayette Electronics "Little Jewel" units selling for just under \$2—it has a 5000-ohm coil.

Mount the closely spaced spiral coils on a wooden, plastic, or fiberboard base. When a raindrop "shorts" the coils, the collector current will flow and activate the relay. I suggest using an ordinary waterproof glue to hold the coils to the baseboard. After the

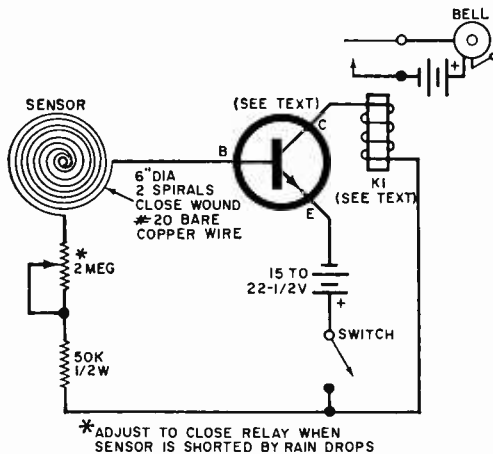

glue has set, lightly sandpaper the wire so that contact can be made by the raindrops between the conductors. You could also use two small pieces of copper screen assembled as a sandwich ($\frac{1}{16}$ inch air spacing) so that a raindrop might "short" out between the mesh.

TV Information. Although "Operation Assist" is of tremendous value to a guy looking for a rare schematic or instruction manual, there must be a simple way of getting routine TV servicing data.

Yes, there is. You can get radio and TV servicing information from two major sources. Try "Sams Photofacts" published by Howard W. Sams & Co., Indianapolis, Ind. 46206 for details on sets manufactured between 1946 and 1966. So-called "Sams Folders" are sold by most radio parts jobbers. Via mail order you can get diagrams of thousands of radio and TV receivers from Supreme Publications, 1760 Balsam Rd., Highland Park, Ill. The usual cost of a diagram is about \$1.50, but it may vary, and the publisher should be checked before ordering. —50—

ENGLISH-LANGUAGE BROADCASTS TO NORTH AMERICA

FOR THE MONTH OF SEPTEMBER

Prepared by **BILL LEGGE**

TO EASTERN AND CENTRAL NORTH AMERICA			
TIME—EST	TIME—GMT	STATION AND LOCATION	FREQUENCIES (MHZ)
6:15 a.m.	1115	Melbourne, Australia	11.71
7:15 a.m.	1215	Montreal, Canada	9.625, 11.72
7:45 a.m.	1245	Copenhagen, Denmark	15.165
9:30 a.m.	1430	London, England	15.105, 21.61
6 p.m.	2300	London, England	9.58, 11.78, 15.26
		Moscow, U.S.S.R.	9.685, 11.96, 15.21
6:45 p.m.	2345	Tokyo, Japan	15.135, 17.825
7 p.m.	0000	Peking, China	15.06, 17.68
		Sofia, Bulgaria	9.70
		Tirana, Albania	7.263
7:30 p.m.	0030	Budapest, Hungary	9.833, 11.91, 15.16
		Johannesburg, South Africa	9.705, 11.875
		Kiev, U.S.S.R.	9.665, 11.755, 11.90
		(Mon., Thurs., Fri.)	
		Stockholm, Sweden	11.805
7:50 p.m.	0050	Vatican City	9.69, 11.76, 15.285
8 p.m.	0100	Berlin, Germany	9.73, 11.89
		Havana, Cuba	6.17
		London, England	7.13, 9.58, 11.78
		Melbourne, Australia	15.32, 17.84
		Moscow, U.S.S.R.	9.685, 11.88, 11.96
		Prague, Czechoslovakia	7.345, 11.99, 15.368
		Rome, Italy	9.63, 11.81
8:30 p.m.	0130	Berne, Switzerland	6.12, 9.535, 11.715
		Bucharest, Rumania	11.94, 15.25
		Cairo, U.A.R.	9.475
		Cologne, Germany	9.64, 11.945
		Hilversum, Holland	9.59 (via Bonaire)
8:45 p.m.	0145	Copenhagen, Denmark	9.52
9 p.m.	0200	Lisbon, Portugal	6.025, 6.185, 9.68
9:30 p.m.	0230	Beirut, Lebanon	11.965
10 p.m.	0300	Budapest, Hungary	9.833, 11.91
		Madrid, Spain	6.13, 9.76
TO WESTERN NORTH AMERICA			
TIME—PST	TIME—GMT	STATION AND LOCATION	FREQUENCIES (MHZ)
6 p.m.	0200	Melbourne, Australia	15.32, 17.84
		Tokyo, Japan	15.135, 15.235, 17.825
7 p.m.	0300	Moscow, U.S.S.R.	15.14, 17.775, 17.88
		(via Khabarovsk)	
		Peking, China	9.457, 11.82, 15.095
7:30 p.m.	0330	Prague, Czechoslovakia	5.93, 7.345, 11.99, 15.368
		Stockholm, Sweden	11.805
7:45 p.m.	0345	Berlin, Germany	11.92
8 p.m.	0400	Lisbon, Portugal	6.025, 6.185, 9.68
		Sofia, Bulgaria	9.70
8:30 p.m.	0430	Bucharest, Rumania	9.57, 11.94, 15.25
		Budapest, Hungary	9.833, 11.91, 15.16
8:45 p.m.	0445	Cologne, Germany	9.735, 11.945
9 p.m.	0500	Berne, Switzerland	9.695, 11.715
		Moscow, U.S.S.R.	15.14, 15.18, 17.775
		(via Khabarovsk)	
10:30 p.m.	0630	Havana, Cuba	9.655



SHORT-WAVE LISTENING

By HANK BENNETT, W2PNA/WPE2FT
Short-Wave Editor

ARE YOU LISTENING TO STATIONS IN THE FAR EAST?

EVER SINCE the 1950's, the Far East has been of special interest to the American SWL. From Laos to Vietnam—here is where the news is made. Not only does this area abound with daily happenings, but it gives the DX'er a great chance to increase his "Countries Verified" list.

Some of the world's largest transmitters can be found in the Far East. *Radio Peking*, for example, operates on 6290, 7035, 9457, 9925, 9950, 11,600, 11,822, 12,015, 12,065, and 15,060 kHz. It can often be heard between 2000 and 0100 and around 1000 and 1300 GMT, and English is a regular part of the programming. Specifically, tune to 6290, 9950, and 12,065 kHz at 2000 (beamed to North America); 7035, 9457, and 9925 kHz at 1000; 11,600 kHz at 1300; and 15,060 kHz at 0000.

Another Communist-dominated station is *Radio Hanoi*, operating from North Vietnam. Although not as strong as its counterpart in Peking, it is being heard throughout the western area of North America and in some eastern areas as well. Programs in English are aired daily at 2300 on 9840 and 11,840 kHz, and at 1000, 1300, and 1530 on 9760 and 11,760 kHz. A new frequency reportedly also in use is 7215 kHz at 1000.

These are not, by any means, the only Far East stations that you can hear. English-language transmissions are beamed to North America by: *R. Australia* on 6140 and 6150 kHz at 1100 GMT; *R. Japan* on 9675 and 11,875 kHz at 1015 and 15,345 kHz at 1100; and *R. Thailand* on 6190 and 11,910 kHz at 0430. They are all "good bets."

The following stations also transmit in English: *Voice of Free Korea* on 9640 and 15,125 kHz at 0500; *Voice of America* relay in the Philippines on 7175 kHz at 1100; and the *Voice of Free China* in Taiwan on 7130, 7250, 11,825, and 15,345 kHz at 0230. And the Far East Broadcasting Company has transmissions beamed to North America on 9715, 11,890, 15,300, and 17,810 kHz at 0800. Happy listening!

Bootleggers Beware! From time to time your Short-Wave Editor receives reports that certain individuals are innocently (?) attempting to set up their own short-range

AM broadcast station. Some of these attempts may possibly be the result of said individuals thinking that the WPE Monitor Registration Certificate is a license to transmit. *IT IS NOT!* The Certificate is given only in recognition of proven ability to receive radio transmissions.

(Continued on page 114)



Bernard Hughes, G2PE6D, who does his SWL'ing in Worcester, England, is shown here with his Eddystone 840-C receiver. He has a newer RCA AR88D. Bernard's current record is impressive: 128 countries, 39 states, and six continents verified.



A QSL from the U.S. Navy submarine "Quillback" is the most prized verification received by Mickey Knapp, WPE6EOG, S. San Gabriel, Calif. This gentleman has been around since the days of the loose coupler, spark gap, and honeycomb coils. Currently his listening post features a National 183-D receiver backed up by a Hallicrafters SX-110 with RME preselector. He has 103 countries verified.

BROADCASTS IN ENGLISH FROM MIDDLE EAST AND AFRICA

Prepared by **ROBERT LEGGE**

In these days of rapidly changing foreign events, listeners may want to tune in broadcasts that originate directly from where the action is. Many countries transmit broadcasts in English intended for other areas than North America which can nevertheless be heard here with fair to good radio signals. Below is the schedule of broadcasts in English from the Middle East and Africa that can be heard in North America.

MIDDLE EAST				
COUNTRY	CITY	TIME—GMT	BEAM	FREQUENCIES (MHZ)
IRAN	Tehran	2000-2030	Europe	11.730, 15.122
IRAQ	Baghdad	1930-2020	Europe	6.030, 6.095
ISRAEL	Jerusalem	0545-0600	Europe	9.009, 9.625
		2105-2145	Europe	9.009, 9.625
LEBANON	Beirut	1830-1900	Africa	17.750
TURKEY	Ankara	1415-1445	Europe	17.822
		2200-2230	Europe	15.160
U.A.R.	Cairo	1300-1430	South Asia	17.690
		1930-2015	Central Africa	17.690
		2045-2215	West Africa	15.135
		2145-2315	Europe	9.475, 12.005

AFRICA				
COUNTRY	CITY	TIME—GMT	BEAM	FREQUENCIES (MHZ)
ALGERIA	Algiers	2200-2230	Europe	6.175
CONGO REPUBLIC	Brazzaville	0515-0530	Africa	11.725, 15.445
		0615-0630	Africa	11.725, 15.445
		1915-1930	Africa	11.930, 15.190
ETHIOPIA	Addis Ababa (ETLF)	1330-1400	South Asia	15.400
		1900-1945	West Africa	15.365
GHANA	Accra	1400-1430	Africa	17.910
		1500-1545	Africa	17.910, 21.545, 21.720
		1815-1900	Africa	15.285
		2100-2215	Europe	9.545
LIBERIA	Monrovia (ELWA)	1900-1930	Middle East	15.155
		2115-2145	North Africa	15.155
MOROCCO	Rabat	2030-2130	Africa	11.735
MOZAMBIQUE	Lourenco Marques	0400-0700	Africa	11.780
NIGERIA	Lagos	1700-1900	Africa	9.690, 11.915
		2100-2200	Africa	9.690, 11.915
RWANDA	Kigali	1200-1245	Africa	17.765
		1745-1830	Africa	17.765
SOUTH AFRICA	Johannesburg	0430-0445	Middle East	11.900, 15.220
		1700-1755	North Africa	17.735, 21.495
		1800-1855	East Africa	15.220, 17.805
		1900-1955	Europe	15.285, 17.735
		2100-2155	Africa	9.525, 11.900
TANZANIA	Dar-es-Salaam	1800-1810	Africa	15.410

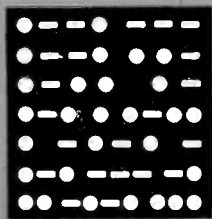

AMATEUR RADIO

By **HERB S. BRIER**, W9EGO
Amateur Radio Editor

TRANSOCEANIC 50-MHZ DX

ALL AMATEURS know that high-frequency radio propagation conditions are intimately related to the sunspot cycle—the higher the number of sunspots, the higher the maximum usable frequency. But how many know that we are rapidly nearing the peak of the present cycle?

This means that the 28- to 29.7-MHz band will be wide open from dawn to dusk almost daily starting early in the fall and continuing until next spring. In addition, the maximum usable frequency (MUF) should creep up to above 50 MHz to give alert 50-MHz operators a chance to work their share of transoceanic DX.

The big thing in working this kind of DX on 50 MHz is being in the right place at the right time. Keep an ear on 28 MHz; when 10 is especially hot, 6 may be open. Also, you might monitor the commercial frequencies between 35 and 45 MHz; when overseas stations start "clobbering" the locals, the chances are good that 6 is open to the same general area. And remember that this type of DX on 50 MHz is always a daylight proposition. Look for Europe and Africa in the morning and to the west in the afternoon. South Americans may come through either mornings or afternoons on good days.

AMATEUR STATION OF THE MONTH



Nils E. Segerdahl, W2UX, of East Patchogue, N.Y., has been an active amateur for over 40 years. Among the equipment he has accumulated are (from left to right) a home-built "mainliner" RTTY converter (on top of a home-built 1000-watt linear amplifier), Heathkit monitor scope, Collins 32S3 CW/SSB transmitter, station control unit, and Collins 75S3 receiver. His antennas include a Mosley TA-33 tribander, and a 5-element, 2-meter beam, both on a 65' tower. W2UX will receive a one-year subscription for submitting the winner for September in our Amateur Station of the Month photo contest. To enter the contest, send a clear picture of your station with you at the controls and some details on the equipment you use and your ham career to Amateur Radio Photo Contest, c/o Herb S. Brier, Amateur Radio Editor, Box 678, Gary, Ind. 46401.



Jim Roper, W9JSW, News Editor for Channel 32 TV station WFLD in Chicago, is shown here operating amateur radio station WA9RTP located in the studios of the TV station. In background is Patrick Muldowney, WFLD News Announcer. See text below.



Edwin Knox, WN7GNR, of Harrisburg, Oregon, has worked Japan and the U. S. East Coast with a Heathkit DX-60 transmitter and National NC-98 receiver.

According to W6SAI's *Amateur Radio Facts*, a good clue as to when the 28-MHz band is open to Japan and Asia is provided by the beacon transmitter of the Japanese Amateur Radio League, Tokyo. Its call letters are JA1IGY, its frequency is 28,997.5 kHz, and the station is on the air 24 hours a day.

Amateur Radio and Commercial TV. Amateur radio station WA9RTP, located in the studios of TV station WFLD, Chicago, is frequently used to bring on-the-spot re-

ports from amateurs in disaster areas to WFLD viewers. The first cooperative effort between the amateur radio station and the TV station occurred during the disastrous snowstorm in the Chicago area starting January 27, the second one in May when a series of tornadoes brought death and destruction to several communities in that area.

Station WFLD also features a prime-time TV program on amateur radio from 5 to 5:30 p.m. each Saturday afternoon.

Can Loose Lip Sink Ship? A recent item in the national press reported on the U.S. Navy's concern over amateurs operating on Navy ships sailing in or towards sensitive areas unintentionally jeopardizing ship se-



Walter J. Kania, WN8TKA, Dearborn, Mich., worked 29 states and Canada with his Heathkit DX-40 transmitter and RME-45 or Lafayette KT-340 receiver. Walt is probably signing his General call by now.

curity by mentioning ship positions, destinations, and arrival dates on the air. According to a knowledgeable Navy officer who has operated amateur stations on Navy ships all over the world, there is a dual problem involved here.

First, FCC regulations require maritime mobile stations to give the names of their ships and their positions when they sign their call letters, thereby revealing information that the Navy wants to keep quiet. Our informant admits that he "forgets" this regulation when in sensitive waters at the risk of receiving an FCC citation. He thinks, however, that the Navy and the FCC should get together and decide what they want instead of making the maritime mobile operator the "fall guy."

The other part of the problem shows up when members of the ship's crew talk back home over the ship's amateur station. The first things the home folks want to know are: "How are you? Where are you? Where are you going? When will you get there?"

(Continued on page 104)



ON THE CITIZENS BAND

By MATT P. SPINELLO, KHC2060, CB Editor

LAST MARCH Fred W. Hawe, driver for the Marathon Oil Company in the Detroit area, witnessed an accident in which two vehicles collided and a woman was thrown through the windshield of her auto. Hawe's truck was equipped with commercial two-way radio, and he immediately contacted his dispatcher, reporting both the nature of the accident and the location. An ambulance and patrol car were sent to the scene, and the woman was rushed to the hospital. She has since recovered, possibly owing her life to Hawe's quick thinking.

On April 19, three dangerous criminals who were being driven to a pre-trial meeting in Springfield, Virginia, overpowered their guards and drove off in the official vehicle. Alva D. Shillingburg, driver for the Alban Tractor Company, was flagged down by the guards as he came along in his truck, and Shillingburg used his two-way radio to report the incident to his dispatcher. Within minutes, police had sealed off all exits in the area. The escapees were captured about one mile from one of the exits.

On April 27, Fred Hawe was presented with the first Community Radio Watch Distinguished Service Award—a plaque and a \$200 U.S. Savings Bond—for helping the accident victim through the use of two-way radio. The award was presented by Detroit Mayor Jerome A. Cavanaugh and Police Commissioner Ray Girardin. Twenty-four hours later, Alva D. Shillingburg was presented with a duplicate Distinguished Service Award by his Congressman, Joel T. Broyhill of the 10th Virginia District.

These two awards were the first to be issued through the Community Radio Watch program, sponsored nationally by Motorola Communications and Electronics, Inc., Chicago, Ill. The program was initiated last December with the basic purpose of encouraging citizens, especially those who use two-way

radio, to support the police in their efforts to maintain law and order. It was designed to recruit drivers of radio-equipped vehicles to serve as "eyes and ears" for the police throughout their communities so that human life and property could be protected more effectively and the crime rate reduced substantially.

Cincinnati, Ohio, and Rockford, Illinois, were the first two communities to initiate the Community Radio Watch program in the country. From Motorola's public relations heads, Bruce Robertson and Herb Swan, your CB Editor learned that Citizens Radio users were quick to volunteer their services

to the program. As soon as the news media had announced the adoption of the program in both areas, more than 100 CB'ers asked to be included in the Cincinnati program, with 150 CB'ers eager to be of service in the Rockford area.

Since Community Watch was introduced, over 200 cities have started a local program, 37 of them with populations over 100,000, and representing 45 of the 50 states. As of May 1, an estimated 16,000 companies, with

over 200,000 personnel driving radio-equipped vehicles, had pledged their support. Examples of the support in individual communities are: Pittsburgh, Pa., 3000 members; Detroit, Mich., 4000; Atlanta, Ga., 5000; Tacoma, Wash., over 2000; and Fort Worth, Texas, 3500 members.

Community Radio Watch awards are given to any individual who makes an extraordinary contribution through the use of two-way radio. A statement of facts is made on a CRW award application, submitted by a participating company or governmental agency, within 90 days after the act has been performed. Anyone who uses two-way radio to report a situation which results in the saving of life or property (even though he may not be participating in the Community Radio





The first Community Radio Watch kit was presented by Col. Jacob Schott, Cincinnati Chief of Police, to Jerry Hurter of the Cincinnati Gas & Electric Company. Pictured (left to right) are: Ken Wisenbaugh, co-ordinator of the program; Col. Schott; William C. Wichman, Cincinnati City Manager; Mr. Hurter; John Kuhnell, Hamilton County Police Association; and John Dooley, Manager of Transportation for the CG&E Company.

Watch program) is eligible for an award. Motorola's CRW Award Committee reviews each application, makes any necessary investigation, and issues a final decision on the award.

Motorola suggests three plans for establishing and operating a Community Radio Watch on a local basis. The company proposes that the program be handled (1) through the mayor's office, or (2) by a mayor's committee (police chief, sheriff's department, etc.), or (3) by a local organization such as the Junior Chamber of Commerce.

The program is open to anyone who uses two-way radio. Licensed CB'ers, clubs, or emergency groups interested in participating should contact local authorities. If they are not familiar with the program, they can write for full details to Community Radio Watch, Motorola Communications and Electronics, Inc., 4501 W. Augusta Blvd., Chicago, Ill. 60651. They will receive a complete kit which explains the program and its objectives and how to put it to work. As a membership roster is established, Motorola will supply membership certificates for each participating company or group, bulletin board notices, instruction booklets for each driver, decals for each vehicle (see illustration on previous page), special dispatcher's cards, and driver I.D. cards. It is hoped that CB'ers throughout the U.S. will participate.

Hint to the Mobiles. One of the readers of this column, who occasionally repairs CB transceivers, has encountered a unique problem. He reports that several CB'ers have dispensed with an AM BCB/CB coupler and are connecting AM radios to the CB antenna—perhaps because the wife doesn't want so many antennas on the family car.

One lashup like this developed a parasitic (an unwanted radio signal) right in the middle of the broadcast band. This signal (with CB modulation) was being "broadcast" and, needless to say, the FCC frowns on that sort of thing.

If you use your CB antenna for your AM radio, do so with an appropriate coupler, or better yet, use one of those specialized combination BCB/CB mobile antennas.

CB Chatter. The Midwest CB'ers, The Channel 19 Horizontal Club, and The 11-Meter Channel Busters Club, Inc., will sponsor a CB Jamboree on September 10 at the Smith Auditorium Memorial Park, State Road 3, North. Trophies will be awarded the largest caravans and those that come from long distances, door prizes will be given all day, and there will be grand prizes consisting of a color TV set, a CB transceiver, etc. Overnight campsites are available. For more information, contact Mrs. Adelene Waters, R.R. 1, New Castle, Indiana.

The Citation, monthly publication of the Macomb CB'ers, Mt. Clemens, Mich., recently published a list of Michigan law enforcement agencies, complete with call-signs and monitoring channels, that are actively engaging CB radio facilities to supplement their own communications systems. Would you believe 12 city police departments, 15 sheriff departments, 19 state departments, and 2 fire departments? If your state boasts a heftier list, we'd like to see it!

REACT Metropolitan Squad Headquarters, 39-23 58th St., Woodside, N.Y. 11377, needs squad members to supplement the present team of 40. This group, which was organized three years ago, serves the Queens County area with search and rescue operations.

(Continued on page 112)

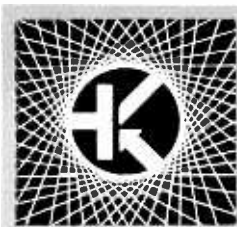

SOLID STATE

By LOU GARNER, Semiconductor Editor

QUITE A STORM has been blowing up around a miniature TV antenna which, it is claimed, can be built into a TV set and yet outperform antennas many times its size. The hullabaloo is about the SIA (sub-miniature integrated antenna) which uses a short vertical antenna and a built-in transistor stage. According to inventor Edwin Turner, who is conducting tests on SIA's at Wright-Patterson Air Force Base, and his associate, Hans Meinke of the Institute for High-Frequency Research, Technical University, Munich, integrating a transistor circuit into the antenna allows the system to operate over a wide frequency range—at least 2:1 and possibly up to 50:1, a feat beyond most current antennas.

Many competent antenna designers and manufacturers claim that the SIA is not much better than ordinary rabbit ears, while some question the SIA's ability to deal with such problems as signal-to-noise ratio, crossmodulation, and directivity. Still others claim that the transistor does not have to be built into the antenna, and that a low-noise outboard transistor amplifier will do the job.

To complicate the situation, Turner has demonstrated three different SIA's. One covers a wide frequency range with an omni-

directional beam pattern in the horizontal plane. The second is similar but operates over a narrow band; however, according to Turner, by controlling the transistor's d.c. current, the acceptance band could be moved over a wide range, making it possible to combine antenna and front end in one device. The third SIA operates over a 2:1 band and is designed to be used in an array to produce a controllable, directional beam pattern.

Reader's Circuit. Tom Studwell (42 Bethpage Drive, Bethel, Conn. 06801), who submitted the general-purpose audio pre-amplifier circuit shown in Fig. 1, says he developed the design by adapting and modifying a circuit he found in GE's popular "Transistor Manual." According to Tom, this circuit gives excellent results when used with ceramic phono cartridges and dynamic microphones. He suggests that it might be suitable for use with magnetic cartridges, although he hasn't tried it in this application.

The circuit features a common-emitter amplifier, *Q1*, direct-coupled to emitter-follower stage *Q2*. Two inputs are provided . . . one (*J1*) for a ceramic cartridge and the other (*J2*) for a dynamic microphone. Selector switch *S1* not only selects the desired

Fig. 1. Tom Studwell's general purpose preamplifier can be driven from either a ceramic phono cartridge or a dynamic microphone.

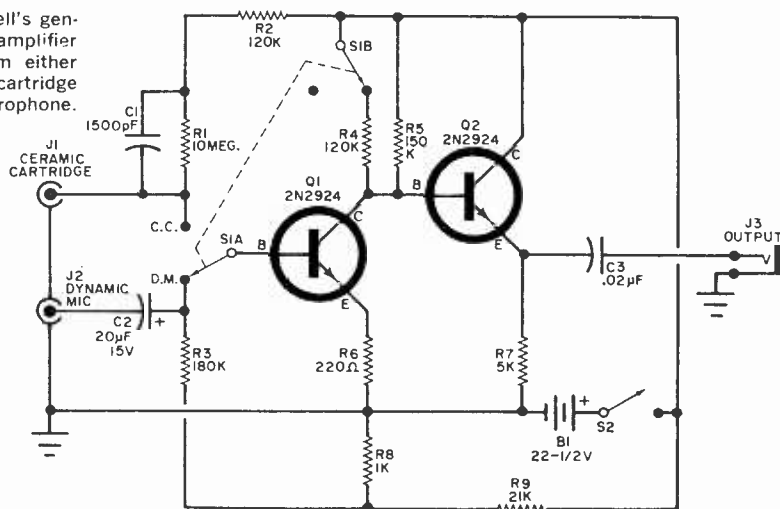

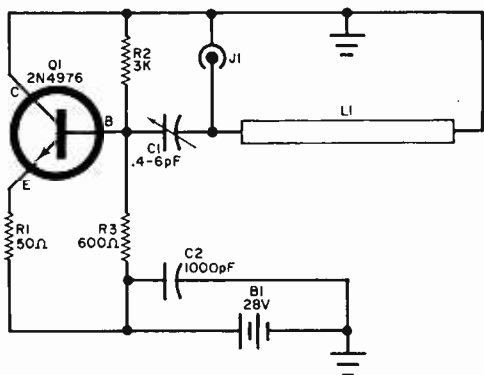

Fig. 2. TRW Semiconductors, Inc., claims operation at 1.6 GHz at 400 mW output for this oscillator.

input signal, but also adjusts $Q1$'s base bias and collector load for optimum performance.

When $S1$ is in the microphone (D.M.) position, the input signal is applied to $Q1$'s base through d.c. blocking capacitor $C2$, while base bias is obtained from voltage divider $R8$ - $R9$ and applied through isolation resistor $R3$. $Q1$'s load consists of parallel resistors $R4$ and $R5$. When $S1$ is switched to the cartridge (C.C.) position, the input signal (from $J1$) is applied directly to $Q1$'s base, while base bias is furnished through series resistors $R1$ and $R2$, with $R1$ bypassed by $C1$ to adjust overall frequency response. $R5$ serves alone as $Q1$'s collector load.

In either switch position, unbypassed emitter resistor $R6$ acts to stabilize amplifier operation, while $Q1$'s amplified output signal is coupled directly to $Q2$'s base. The final output signal is developed across $Q2$'s emitter load, $R7$, and applied to output jack $J3$ through coupling capacitor $C3$.

Tom has specified readily available components in his design. And, because neither parts arrangement nor wiring dress is overly critical, you can follow your own inclinations when assembling the circuit. For example, you might want to employ chassis-type construction, assembling the preamp for use as an "outboard" addition to an existing amplifier. Or you may wish to use the basic circuit as part of an overall amplifier design. Or you might prefer to assemble it on a perforated board, mounting the completed assembly in a small box as a self-contained accessory amplifier.

Manufacturer's Circuit. As a general rule, low-frequency r.f. oscillator circuits are comparatively simple. At higher frequencies, circuits may become somewhat more complex, as phase-compensated feedback arrangements and additional bypass and isolation networks may be required. At extremely high frequencies, however, the circuits may

once again become relatively simple, as, for example, the 1.6-GHz, 400-mW r.f. oscillator shown in Fig. 2.

Featuring a 2N4976 *npn* silicon planar power transistor, this circuit was abstracted from the transistor's specification sheet as issued by TRW Semiconductors, Inc. (14520 Aviation Blvd., Lawndale, Calif. 90260). The 2N4976 is a unique transistor. With a maximum power dissipation rating of 5.0 watts, and a maximum collector to emitter rating of 30 volts, the unit can deliver as much as 1.0 watt as a Class C common-emitter amplifier at 2 GHz. The device is assembled in a special UHF *stripline* package, with ribbon-like electrode leads and a heat-sink following stud.

Although the basic circuit shown is suitable for use in a variety of experimental and practical applications, it is definitely *not* a project for the beginner, or, perhaps, even the average hobbyist. It should be of interest, however, to advanced experimenters and hams, to engineering students, technicians, and practical engineers.

In Fig. 2, note that $Q1$ is used in a modified common-collector arrangement, with emitter isolation provided by $R1$ and stabilized base bias established by voltage-divider $R2$ / $R3$. There is a series-tuned circuit consisting of trimmer capacitor $C1$ and stripline inductance $L1$ (copper *stripline* 4-

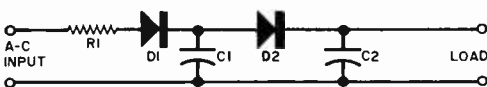

Fig. 3. George Garvin's filter uses an extra diode.

mm wide and 8-mm long). Feedback is provided through the tuned circuit as well as $Q1$'s interelectrode capacities. Coaxial output jack $J1$ is coupled to the $C1$ - $L1$ juncture point to provide a 50-ohm output impedance.

Filter Follow-Up. Our discussion of basic d.c. power supply ripple filters back in the May, 1967, issue (in the *Transitips* section) sparked a good deal of interest. A number of readers forwarded their comments and observations, and several even submitted "pet" circuits. Although most of these circuits were variations of standard designs, a few represented clever new approaches. One of the more interesting ones is shown in Fig. 3.

Submitted by reader George L. Garvin (10384 E. Jefferson, Osceola, Ind. 46561), this filter network features a *second* rectifier diode ($D2$) in place of a choke or resistor as part of a pi-filter. There are several ad-
(Continued on page 103)

CAPACITOR CHANGE REDUCES FALSE OPERATION OF SELECTIVE-CALLING SYSTEM

AS THE CB channels become more and more crowded, it is necessary to use better squelch circuits to screen out unwanted calls. One of the most successful methods devised is the selective-calling system which depends on the simultaneous reception of two audio tones (transmitted by the calling station), to open the squelch of the called station. An example of this kind of equipment is the Lafayette "Priva-Com III Dual-Tone Encoder/Decoder," sold as a matching unit for several Lafayette CB transceivers.

As good as this system is, there is an

LAFAYETTE "PRIVA-COM" IMPROVEMENT

insufficient time delay built into the "Priva-Com" to prevent beat frequencies between interfering stations on busy channels from opening the squelch. To solve this problem, change the values of capacitors *C7* or *C15* (each a 30- μ F, 6-volt unit) in the "Priva-Com" to at least 160 μ F. Raising the value to 320 μ F will completely prevent false squelch openings with no decrease in receiver sensitivity. The "turn on" time is increased to 2 seconds when a 160- μ F capacitor is used, and to 3.5 seconds when a 320- μ F capacitor is used. —G. Neal

BLINKING DARKROOM TIMER

FOR THE HARD OF HEARING,
OR THOSE WHO LIKE
MUSIC WHILE THEY WORK

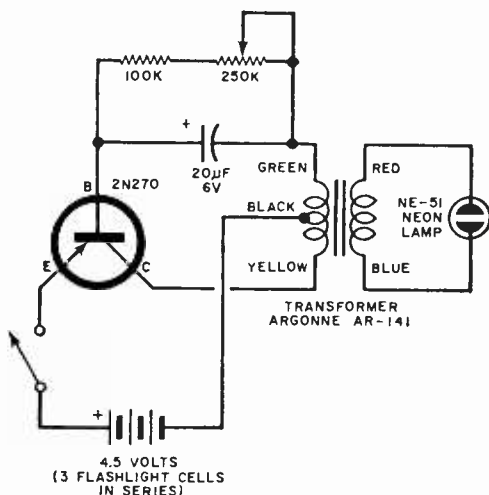

Adjust potentiometer until the blocking oscillator causes the neon lamp to glow once each second.

A METRONOME-TYPE timer, which produces an audible click at one-second intervals, is commonly used in the photographic darkroom for many developing and enlargement operations. While such a timer is useful, it is of little value to a photographer who is hard of hearing or one who likes to have a radio playing while he's working.

The timer shown in the schematic diagram at left uses pulses of light, rather than audible clicks, to mark the timing interval. The slight orange-red glow from the neon lamp will not affect most enlargement papers. However, always allow the unit to operate for several minutes before calibration and at least a minute before actual use.

Calibration consists of adjusting the potentiometer until the neon lamp flashes once per second. —Frank H. Tooker

There's more than one road to success.

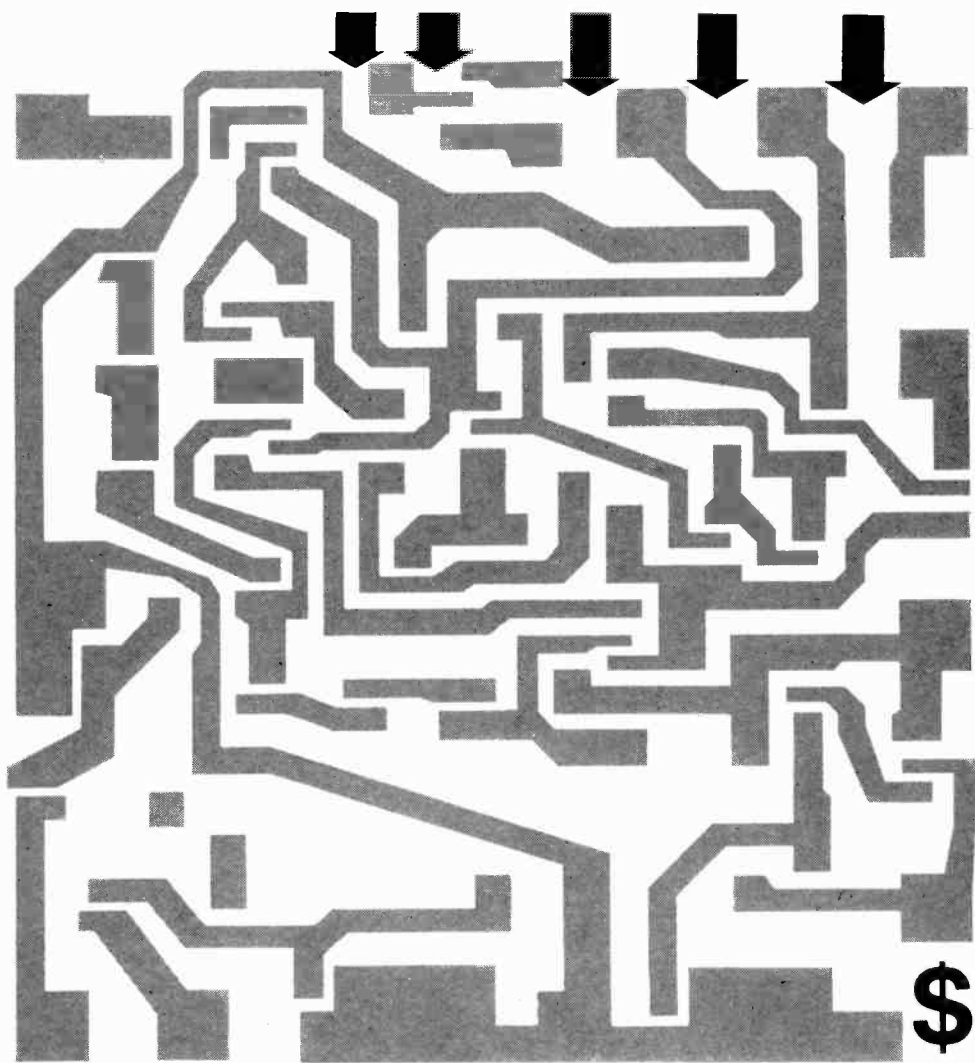

An integrated circuit enlarged several thousand times

RCA Institutes can help find the one best for you!

Are you trying to find your way through a maze of career possibilities? Find out how RCA Institutes can start you on your way toward a well paying job in electronics. Send the attached card today!

Learn electronics at home faster, easier, almost automatically— with RCA AUTOTEXT

Are you just a beginner with an interest in the exciting field of electronics? Or, are you already earning a living in electronics and want to brush-up or expand your knowledge in a more rewarding field of electronics? In either case, AUTOTEXT, RCA Institutes' own method of Home Training will help you learn electronics more quickly and with less effort, even if you've had trouble with conventional learning methods in the past.

THOUSANDS OF WELL PAID JOBS ARE OPEN NOW TO MEN SKILLED IN ELECTRONICS!

Thousands of well paid jobs in electronics go unfilled every year because not enough men have taken the opportunity to train themselves for these openings. RCA Institutes has done something positive to help men with an aptitude and interest in electronics to qualify for these jobs.

HOME STUDY CAN TRAIN YOU FOR REWARDING CAREER OPPORTUNITIES

To help fill the "manpower gap" in the electronics field, RCA Institutes has developed a broad scope of Home Training courses, all designed to lead to a well paying career in electronics in the least possible time. You also have the opportunity to enroll in an RCA "Career Program" exclusively created to train you quickly for the job you want! Each "Career Program" starts with the amazing AUTOTEXT Programmed Instruction Method. And, all along the way, your program is supervised by RCA Institutes experts who become personally involved in your training and help you over any "rough spots" that may develop.

VARIETY OF KITS ARE YOURS TO KEEP

To give practical application to your studies, a variety of valuable RCA Institutes engineered kits are included in your program. Each kit is complete in itself, and yours to keep at no extra cost. You get the new Programmed Electronics Breadboard for limitless experiments, including building a work-

ing signal generator, multimeter, and a fully transistorized superheterodyne AM receiver.

ONLY FROM RCA INSTITUTES — TRANSISTORIZED TV KIT— VALUABLE OSCILLOSCOPE

All students receive a valuable oscilloscope. Those enrolled in the Television program receive the all-new transistorized TV Kit. Both at no extra cost and only from RCA Institutes.

CHOOSE THE "CAREER PROGRAM" THAT APPEALS MOST TO YOU

Start today on the electronics career of your choice. Pick the one that suits you best and mark it off on the attached card.

- Television Servicing
- Telecommunications
- FCC License Preparation
- Automation Electronics
- Automatic Controls
- Digital Techniques
- Industrial Electronics
- Nuclear Instrumentation
- Solid State Electronics
- Electronics Drafting

ADVANCED TRAINING

For those already working in electronics, RCA Institutes offers advanced courses. You can start on a higher level without wasting time on work you already know.

UNIQUE TUITION PLAN

With RCA Institutes Training, you progress at your own pace. You only pay for lessons as you order them. You don't sign a long-term contract. There's

no large down-payment to lose if you decide not to continue. You're never badgered for monthly payments. Even if you decide to interrupt your training at any time, you don't pay a single cent more.

CLASSROOM TRAINING ALSO AVAILABLE

If you prefer, you can attend classes at RCA Institutes Resident School, one of the largest of its kind in New York City. Coeducational classroom and laboratory training, day and evening sessions, start four times a year. Simply check "Classroom Training" on the attached card for full information.

FREE PLACEMENT SERVICE, TOO

In recent years, 9 out of 10 Resident School students who used the Free Placement Service have been placed before or shortly after graduation. This Service is available to Home Study students.

**SEND ATTACHED POSTAGE PAID
CARD TODAY. FREE DESCRIPTIVE
BOOK YOURS WITHOUT OBLIGATION.
NO SALESMAN WILL CALL.**

All RCA Institutes courses and programs are approved for veterans under the New G.I. Bill.

RCA INSTITUTES, INC. Dept. ZPE-97
350 West 4th Street
New York, N.Y. 10014



The Most Trusted Name In Electronics

PARTS
METHODS
IDEAS
GADGETS
DEVICES

TIPS & TECHNIQUES

CABLE SHIELD SPEEDS AND SIMPLIFIES DESOLDERING

If you've ever soldered shielded cable into a circuit, you are aware of the fact that the shield absorbs quite a bit of solder before the job is done. This ability of the shield to soak up solder comes in handy when you're desoldering components from a printed circuit board, solder lugs, etc. When placed over the

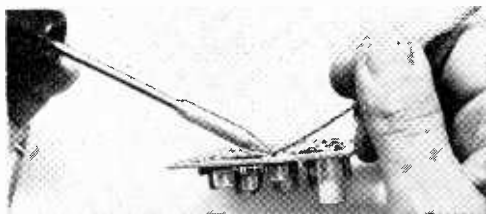

connection to be desoldered and heated with a soldering iron or gun, the shield will usually soak up all but a thin film of the solder. The residue of solder left on the connection will not hamper easy removal of the component.

—Donald E. Hammack

COLOR INDICATOR LAMPS AND LENSES WITH MODELER'S PAINT

In projects where several different color indicator lamps are used to indicate the unit's various functions or modes of operation, the glass envelopes of the bulbs can be colored to save time and money. A metal flake type of paint, used for painting model cars, is available in several colors (each costing about 15 cents) and makes an ideal coloring agent. Before you use the paint, however, let it stand undisturbed for a day or two to allow the metal flakes to settle to the bottom. Then all you need do is dip the envelope of the bulb into the upper layer of clear lacquer, being careful not to disturb the metal flakes. Let the first coat dry, and dip the bulb into the lacquer again. Two



At last—TTI removed the resistance to Electronics training at home!

New training method eliminates frustrations that slow down your progress—boredom, dry theory, lack of fun in doing, loss of interest or motivation











- No ordinary program—you set up a "learning laboratory" in your home. Step by step you build, test, troubleshoot the circuits you are studying. Smooth-flowing series of 63 projects makes each principle crystal clear. (You build 4 radios, not just one!)

Industrial-quality vector board with unique solderless circuits lets you put together, prove, revise or expand, and dismantle each circuit. You get full set of tools, test instruments and materials.



TECHNICAL TRAINING INTERNATIONAL, Dept. 1J7
10447 S. Torrence Ave., Chicago, Ill. 60617
Send me your free Career Selector, and information about the Solid State Demonstration Project.



Send for Career Selector Kit, with details of our Solid State Demonstration Project offer. With it you prove to yourself how much easier you can learn by our new training method. It also helps determine your level of interest in this fascinating career field.

name _____

address _____

city _____ state _____ zip _____

coats will suffice in most cases. If you prefer, you can paint the inside of clear lenses to obtain the same effect. —*Frank G. Palesh III*

COLOR-CODING SAVES TIME WHEN YOU'RE LOOKING FOR A SPECIFIC TOOL

Nutdrivers and screwdrivers often have similar sizes and shapes; so locating the correct tool for a given piece of hardware can be time-consuming. However, a simple color-code system, similar to that found on some nutdriver sets, will speed things up. All you need are several different colors of enamel paint. Select the tools that have been giving you trouble, dip their handles into different color paints, remove and let dry. Two or more color bands can be used to identify special features; one to identify the type of tool, another to identify its size, and a third to tell whether or not the tool is magnetized. Each successive band of color is produced by dipping the tool handle into the paints and varying the depths by about $\frac{1}{4}$ ". If three bands are desired, the first band would extend about 1" from the end of the handle, the second about $\frac{3}{4}$ ", and the third about $\frac{1}{2}$ " from the end.



—*Jerome B. Koons*

HIDDEN SWITCH PREVENTS UNAUTHORIZED USE OF ELECTRONIC DEVICES

If you are bothered by unauthorized people turning on your equipment, here is a way to hide the power switch so that it cannot be readily switched on. As shown in the drawing, mount the switch inside the device you want

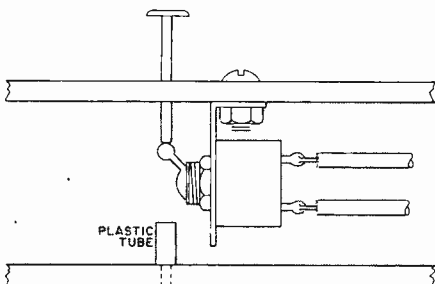

it to control the power to, and position the toggle (or slide) between two holes, one in the chassis cover and one in the chassis. A piece of plastic rod protrudes through the cover hole and rests on the toggle. To turn on the switch, insert another plastic rod through the hole in the chassis and the plastic tube and press until the switch clicks on; then remove this rod. The switch is easily turned off by depressing the permanently mounted plastic

rod on the chassis cover. Because this rod only touches the switch toggle, it cannot be used to reactivate the switch.—*Richard Rylander*

USE TWO ISOLATION TRANSFORMERS TO ELIMINATE SHOCK HAZARD

One isolation transformer eliminates much of the shock hazard so far as the electrical chassis ground in a given electrical device is concerned. But if two transformerless devices are plugged into the same outlet, the chassis of one can be 117 volts "hot" with respect to the other. This is true whether or not an isolation transformer is connected between the devices and the outlet. To completely eliminate electrical shock hazards between two transformerless devices that are plugged into the same outlet, each device should be powered by its own isolation transformer.

—*Frank H. Tooker*

PHONE JACKS PROVIDE EASY ACCESS FOR METERING ELECTRONIC CIRCUITS

Many electronic circuits require periodic metering to determine whether or not they are operating according to specifications. If you are tying up one or more meters for this purpose, or have to remove the cover from a chassis every time you make a current or voltage reading, try a few strategically wired phone jacks. If a standard phone jack is wired into a circuit for voltage readings (upper drawing) and a closed-circuit phone jack is

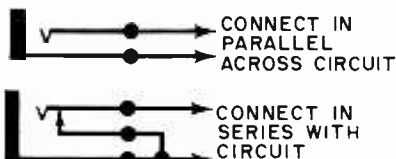

wired for current readings (lower drawing), only one ammeter and voltmeter are required (or a single VOM). Neither jack will affect the operation of the circuit. The closed-circuit jack allows the circuit to be interrupted momentarily and an ammeter placed in the circuit to make current checks. Mount the jacks in an easily accessible place—either on the front or the rear panel of the instrument case. —*Henry R. Rosenblatt*

HAM HISTORIANS MEET

Amateur radio historians and collectors will meet at the Ford Science Museum on September 23 for a full day of programming devoted to the early days of radio. Grote Reber, pioneer radio astronomer, is scheduled to speak, and the guest of honor will be Mrs. Edwin Armstrong, widow of the famous inventor. Climax of the event will be a swap session/auction of early broadcast sets, magazines, and books. For more information, write: Link Cundall, 69 Boulevard Parkway, Rochester, N.Y. 14612.

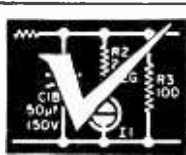

OPERATION ASSIST

Through this column we try to make it possible for readers needing information on outdated, obscure, and unusual radio-electronics gear to get help from other P.E. readers. Here's how it works: Check the list below. If you can help anyone with a schematic or other information, write him directly—he'll appreciate it. If you need help, send a postcard to Operation Assist, POPULAR ELECTRONICS, One Park Avenue, New York, N.Y. 10016. Give maker's name, model number, year of manufacture, bands covered, tubes used, etc. State specifically what you want, i.e., schematic, source for parts, etc. Be sure to print or type everything legibly, including your name and address. Because we get so many inquiries, none of them can be acknowledged. POPULAR ELECTRONICS reserves the right to publish only those items not available from normal sources.

Radio Craftsman Model RC200 TV receiver, circa 1951. Output and power transformers needed. (Wm. Strole, 1415 S. 49 Ct., Cicero, Ill. 60650)

C E S Electronic Products Model 402D "Micro Mixer." Schematic and operating manual needed. (David N. Amidon, 650 Moutectto, Sierra Madre, Calif. 91024)

Precision Model T60 tube tester. Roll chart and tube testing data needed. (Matthew J. Socha, Rt. 1, Box 420, Summerfield, Fla. 32691)

RCA Model 18 T receiver. R.F. coil needed. (Charles Durke, 103 W. Phoenix Ave., Normal, Ill. 61761)

LaSalle receiver, series B-52260; has 4 tubes. Schematic needed. (Larry Crail, Box 296, Kingsford Heights, Ind. 46346)

Western Electric Model 4B receiver, circa 1917. Type 215A tube needed. (Jim Hoffman, 105 Sherman Ave., Glen Ridge, N.J.)

Ampro Model YSA 16-mm. sound projector; has 6 tubes. Schematic and operating manual needed. (Jerry Raye, 413 N.E. 32, Grand Prairie, Tex. 75050)

BC-455-B receiver, made by Western Electric, ser. 88501. Schematic and operating manual needed. (Eugene Light, 15008 Stanleaf Dr., La Mirada, Calif. 90638)

Sonar Radio Corp. Model R9 receiver; tunes 27.25 to 30 MHz. Schematic needed. (Howard T. LaMunion, 1109 Mathews Ave., Utica, N.Y. 13502)

Silvertone Model 107-A-450-S receiver; tunes s.w. from 1.2 to 65 MHz on 6 bands; has 9 tubes. Schematic, operating manual, and alignment data needed. (K.J. Tucker, 1162 N. Viceroy Ave., Covina, Calif. 91722)

Waterman Model S-14-A "Pocketscope." Schematic and operating manual needed. (S. Curilly, 8115 Langley Ave., Chicago, Ill. 60619)

Wilcox Gay Model A 93 floor cabinet disc recorder and phono; has 10 tubes. Tube layout needed. **National** Model NC98 receiver. Narrow-band FM adapter needed. (L. K. Slama, 613 Barker St., Racine, Wis.)

Hallcrafters Model R15ARR7 receiver, circa 1945; tunes BC and s.w. from 550 kHz to 42 MHz. Operating manual for BC 1031 "Panadapter" needed. (Stewart H. MacKenzie, 16182 Ballad Ln., Huntington Beach, Calif. 92647)

APA-38 "Panoramic" adapter, surplus, circa 1953; input, 30 MHz. Technical manual needed. (Robert Laag, 7405 Kingsley Way, Riverside, Calif. 92504)

RCA "Radiola 25", circa 1935; has 6 tubes. Schematic and source for tubes needed. (Lewis W. Thompson, 33 Nichols, St., Lewiston, Me. 04240)

Link Model 1905 ED2A mobile radio receiver, ser. 71882; circa 1954; tunes 152-174 MHz. Crystal frequency information, schematic, tuning instructions, and service manual needed. (Richard D. Strosnider, 5316 Ivyhurst Dr., Columbus, Ohio 43227)

Atwater Kent amplifier, type TA; has 2 tubes. Operating manual needed. (Jeffrey Lee, 10 Foxcroft Rd., Albertson, N.Y. 11507)

R-105A/ARR-15 receiver, surplus; 26.5 volts d.c., 2 to 18 MHz. Schematic and operating manual needed. (Frank Calabrese, 477 N. Eagleberry St., Gilroy, Calif. 95020)

Moleo Insulation Co. Model T-435A/AMT-4B "Radio-sonde" transmitter. Schematic and operating manual needed. (Cliff Frommer, 251 Marcus Ave., New Hyde Park, N.Y. 11040)

Grunow Model 1171 receiver, chassis 11C, circa 1935; tunes 4 bands; has 11 tubes. Schematic needed. (Kenneth Pfitzer, 2700 Countryside Dr., Florissant, Mo. 63033)

Hickok Model 288X signal generator, circa 1947; tunes 100 to 110 MHz on 7 bands; has 6 tubes. Operating manual needed. (Robert L. Koffler, 3516 Courtleigh Dr., Baltimore, Md. 21207)

Western Air Patrol Model 377 receiver; tunes BC and s.w.; has 7 tubes. Schematic needed. (Bobby Ennis, 9322 Laurel, Fontana, Calif. 92335)

Webster-Chicago Model 18-11R "Electric Memory" (wire recorder). Schematic, operating manual, and source for parts needed. (Lee Kuperstein, 5503 Temple Rd., Philadelphia, Pa. 19150)

Goldak Model 203 scintillation counter, circa 1952. Schematic and operating manual needed. (J. Michael Phillips, 1420 Volney Dr., Los Angeles, Calif. 90063)

Zenith Model 9-8-365 receiver; tunes 550 kHz to 18 MHz on 3 bands; has 9 tubes. Schematic needed. (David W. DuBois, 22711 14 St., Apt. D, Newhall, Calif. 91321)

National Radio Institute "Multitester"; has 1 tube. Schematic and source for parts needed, especially AC-RF head. (Robert Margiotta, 4201 Taylor St., Hollywood, Fla. 33021)

Westinghouse Model H105A receiver; tunes on 2 bands; has 7 tubes. Schematic, operating manual, and parts list needed. (C. Douglas Towne, 5 Salt Box Lane E., Darien, Conn. 06820)

BC-348K receiver, ser. 1187, made by Belmont Radio; tunes 200 kHz to 18 MHz on 6 bands. Schematic and operating manual needed. (Robert Ganshirt, 48 Fletcher Ave., Lexington, Mass. 02173)

Akai Model M-5 tape recorder. Operating manual needed. (Harry C. Nance, 148 W. 10 St., New York, N.Y. 10014)

RCA "Radiola III" receiver; has 4 tubes. Schematic and source for tubes needed. (C.J. Lyman, 519 N. Summit Ave., Sioux Falls, S. D. 57104)

BC-639 receiver, surplus; tunes 100 to 155 MHz. Alignment and service data needed. (A.C. Lewis, Box 100, Humboldt, Tenn. 38343)

Challenger Model CH18 amplifier, series Q-24; has 7 tubes. Schematic needed. (Scott Flanagan, 115 Coolidge Ave., Columbus, Ohio 43228)

Majestic Model 8S473 receiver-phonograph combination; tunes BC and 5.7 to 17.2 MHz; has 8 tubes. Schematic, alignment data, and source for glass dial plate #117-69 needed. (Keith Christensen, Box 88, Vaughn, Mont. 59487)

National Model HRO-7 receiver; tunes 50 kHz to 30 MHz. Source for coils A, B, E, F, G, H, and J needed. (Louis H. VanLandingham, 650 N. Xenophon, Tulsa, Okla. 74127)

Howard Radio Corp. Model D-L receiver, circa 1935; tunes 550 to 1600 kHz; has 14 tubes. Schematic and source for parts needed. (Jeff Bush, 5 Peace Way, Reil Bank, N.J. 07701)

Link Model 1905A receiver and 1906A transmitter. Schematic needed. (Ed Lankford, 511 Purnell Dr., Nashville, Tenn. 37211)

Supreme Model TV-7/U tube tester. Schematic and current test data cards needed. **Dumont** Model 350-R oscillograph. Operating and maintenance manuals needed. (C.W. Thorn, 2028-B Hibiscus, APO, San Francisco, Calif. 96334)

Raytheon Model 2008 E fathometer; measures up to 120 fathoms; has 6 tubes. Schematic needed. (Jeffrey R. Loudon, Box 672, Friday Harbor, Wash. 98250)

BC-645 transceiver, surplus; tunes 460 to 490 MHz; has 15 tubes. Schematic, operating manual, and conversion data needed. (Allen Windhorn, Rt. 2, St. Peter, Minn. 56082)

RCA Model SC-88 receiver, ser. 233; tunes 540 kHz to 32 MHz. Schematic and operating manual needed. (Thomas M. Zane, 950 S. Garfield St., Apt. 30, Lodi, Calif. 95240)

Hickok Model 955 VOM. Selector switch or diagram of same needed. (Calvin Rossman, Box 127, Marcus, Iowa 51035)

Bendix radio compass, MN-26-Y, circa 1943, surplus; tunes 150 to 1500 kHz on 3 bands. Schematic and operating manual needed. (Bob Porter, Box 18 "E", Bolton, Ontario, Canada)

Philco Model 41-295 receiver, code 121, circa 1941; tunes BC and s.w. to 15 meters; has 11 tubes. Schematic and parts list needed. (Bruce D. Henderson, 3761 G Watkins Dr., Riverside, Calif. 92507)

Precision signal generator, series E-200, ser. 8646; covers 90 kHz to 44 MHz on 7 bands; has 3 tubes. Schematic and operating manual needed. (Allen Harmon, 4357 Park, Indianapolis, Ind. 46205)

Supreme Model 504A tube and set tester. Socket adapters needed. (John F. Chericco, 953 Rosewood Ave., Bricktown, N.J. 08723)

BC-669-C transceiver, surplus, circa 1944. Schematic, operating manual, and BC-669 crystals needed. (Dave Jacobs, 1172 N. 10 St., Corvallis, Oreg. 97330)

Hallicrafters SX-24 "Skyrider Defiant" receiver; has 9 tubes; tunes 540 kHz-43.5 MHz. Schematic, sources for parts and matching SX-23 speaker, and technical data needed. (Ian Caswell, Fanton Hill, Weston, Conn. 06880)

Link FM 1905A and **1906A** transmitter-receiver; hi-band taxicab unit. Schematic needed. (Ed Lanford, 511 Purnell Dr., Nashville, Tenn. 37211)

Hallicrafters SX-28 receiver. Source for bandswitch shaft and detent assembly needed. (Dow E. Evelyn, 6761 Bison St., Springfield, Va. 22150)

Harvey Wells Model R-9 "Bandmaster" receiver; circa 1955; tunes 10 to 80 meters on 5 bands; has 9 tubes. Schematic and operating manual needed. (William J. Bigoss, 81 Washington Ave., Hawthorne, N.J. 07506)

American Scientific Development Model TV20 tube tester, ser. A-8552. Tube testing and updating data needed. (Gene R. Mattozzi, Manito Radio, E. 1011 36 Ave., Spokane, Wash.)

Minerva Model W-11T "Tropic/Master" receiver; has 8 tubes; tunes BC and s.w. Schematic and technical data needed. (William C. Cathcart, 15713 Debyllyn Ave., Gardena, Calif. 90247)

Supreme Instruments Model 503 audio oscillator. Operating instructions and schematic needed. (Edward F. Sbardella, 4 Saint Louis Dr., Biloxi, Miss. 39531)

Sparton receiver, ser. 2701; has 8 tubes. Schematic needed. (Arne Hoff, 969 Walnut Ave., Sonoma, Calif. 95476)

Precision Radiation Model 117B "Scintillator." Operating manual needed. (L.A. Truetken, 10601 Dunkeld Circle, St. Louis, Mo. 63137)

Bell Model 2200B audio amplifier, ser. 4334. Operating manual needed. (Chuck Morton, 29-530 Tylehurst St., Winnipeg 10, Manitoba, Canada)

Waterman Model S-10 "Pocket Scope." Instruction book and schematic needed. (L. Olson, 1510 S. Dunsuir, Los Angeles, Calif. 90019)

Link 2975 transceiver. Schematic and/or source of parts needed. (M. Anthony, 308 Ege Ave., Jersey City, N.J. 07304)

Abbott Model MRT-3 short-wave receiver. Schematic and operating manual needed. (Cpl. T.F. Warren, 4 B Silver, MCB, 29 Palms, Calif. 92278)

Pierson KP-81 communications receiver; tunes 540 to 40,000 kHz on 5 bands. Schematic or tube type location diagram needed. (William J. Gyorgy, 1628 Van Buren Ave., San Mateo, Calif. 94403)

Philco Model 38-60 receiver; tunes BC and s.w. on 2 bands; has 5 tubes; code 125. Schematic and alignment data needed. **Zenith Model R959539** receiver; tunes BC and s.w.; has 14 tubes. Schematic needed. (George Bennett, Rt. 3, Box 27, Sumrall, Miss. 39482)

Stromberg-Carlson Model C362695 receiver; tunes 14 to 49 MHz, 520-4200 kHz on 4 bands. Schematic needed. (K. P. Becker, 319-B West Main St., Patchogue, N.Y. 11772)

GET MORE ACTION WITH

MULTI-ELMAC
PRECISION MADE,
POPULAR PRICED
CB UNITS!

*** CITI-FONE SS \$16950**

**FULL
23 CHANNEL**

AC/DC Operation,
Illuminated Meter
& Channel Selector,
Triple Tuned RF,
'Noise Immune'
Squelch, Double
Tuned IF's. Ready to Operate



*** CITI-FONE 99 \$9950**

**FULL
8 CHANNEL**

AC/DC Operation,
Delayed AVC,
Electronic Switching,
2 Stage Pre-Amp,
Illuminated "S"
Meter. Complete
with Crystal for 1 Channel



*** CITI-FONE II \$4995**

SOLID STATE

Transmitter Converter
Compact 5 1/4 x
4 1/4 x 1 1/2" 9
Transistor, 2
Diodes, 5 Watt
Input (FCC Max.)
100% Modulation, 12 VDC
Operation. Complete with Crystal for
1 Channel



Please send further information on Citi-Fone SS , 99 , II

 **MULTI-ELMAC CO.**
21470 Coolidge • Oak Park, Michigan 48237

NAME _____
ADDRESS _____
CITY _____
STATE _____ ZONE _____
CIRCLE NO. 20 ON READER SERVICE PAGE

ELECTRONICS LIBRARY

INTRODUCTION TO ELECTRONICS

by Lane K. Branson

This school text deserves considerable attention because of its realistic approach to basic electronics. Unlike many other books, *Introduction To Electronics* is as much interested in "why" as in "how." The student is thus able to obtain a better grasp of modern (1967) electronics—he is told "how", and is then shown "why" a circuit behaves as it does. Although the distinction may appear subtle, it is important in these days of hurry-up education. The book contains hundreds of typical problems and good appendices.

Published by Prentice-Hall, Inc., Englewood Cliffs, N.J. 07632. Hard cover. 594 pages. \$12.00.



A NEW WAY TO SERVICE COLOR TV

by Carl Babcock

In this straight-from-the-shoulder book on color TV servicing, the author has adopted a technician's approach to solving some of the "tough dogs." In doing so, he has fallen back on the old adage, "Look for the obvious—first." This is a good book to have if you're stumped by a tricky problem, or need something to stir up those soggy brain cells.

Published by Gernsback Library, 154 W. 14 St., New York, N.Y. 10011. Soft cover. 192 pages. \$3.25.



WORKED EXAMPLES IN BASIC ELECTRONICS

by P. W. Crane

In a text written solely for the engineering student, the author provides a variety of detailed examples illustrating the use of well-known formulas. The nomenclature is British, but this should not be a stumbling block to interested readers.

Published by Pergamon Press, Inc., 44-01 21 St., Long Island City, N.Y. 11101. Digest-size hard cover. 282 pages. \$7.00. (Also available in limited supply as a paperback for \$4.50.)



BASIC ELECTRICITY AND AN INTRODUCTION TO ELECTRONICS, Second Edition

by Howard W. Sams Engineering Staff

Written in easy-to-understand language, this revised edition is liberally supplemented with

all the drawings and photos necessary for a solid understanding of the text. The material is presented so simply and clearly that it dispels the popular belief that this is a difficult subject. The book begins with the fundamentals of electricity and progresses to more advanced material in electronics. Each chapter concludes with a summary of the subject covered and a series of review questions.

Published by Howard W. Sams & Co., Inc., 4300 West 62 St., Indianapolis, Ind. 46206. Soft cover. 192 pages. \$3.95.



HOW TO TEST ALMOST EVERYTHING ELECTRONIC

by Jack Darr

The author of this handy gem is best known by the reading public for his monthly column in *Radio-Electronics* magazine. If there ever was any doubt, this book will verify that Jack is one of the last of the great "innovators." While it is easy to test a circuit or component with the proper instrument—how do you do it if that particular piece of equipment is missing? What substitute test setup can you use? What results can you obtain with a jury-rig test bench? If you don't know—and plenty of us don't—you'll find this book a fountain of fascinating ideas.

Published by Gernsback Library, 154 W. 14 St., New York, N.Y. 10011. Soft cover. 160 pages. \$2.95 (also available in hard cover for \$4.60).



CIRCUIT PROBLEMS AND SOLUTIONS VOLUME 1: Elementary Methods

by Gerard Lippin

If you are studying electronics, your success or failure will depend upon your mastering certain fundamental formulas. While textbooks start you down the right path, many students need more "homework" and will welcome these 300 basic problems and their step-by-step solutions. The subject coverage is a.c., d.c., and series-parallel circuits.

Published by Hayden Book Company, Inc., 116 West 14 St., New York, N.Y. 10011. Soft cover. 190 pages. \$3.95.



HANDBOOK OF ELECTRONIC INSTRUMENTS AND MEASUREMENT TECHNIQUES

by Harry E. Thomas & Carole A. Clarke

This book should be classified as a "one source" reference guide. The authors have extracted all of the common factors pertaining to a particular test instrument or measurement—with the assistance of practically all of the major lab-style test equipment manufacturers. The "extract" is presented—notebook fashion—in a concise, concentrated format. Functioning of any one instrument is ignored, and only the basics of why and how are disclosed. The gamut extends from sim-

ple metering to microwave measurements. There are valuable appendices including tables, glossary, applications, symbols, etc.

Published by Prentice-Hall, Inc., Englewood Cliffs, N.J. 07632. Hard cover. 398 pages. \$16.00.



101 WAYS TO USE YOUR HI-FI TEST EQUIPMENT, Second Edition

by Robert G. Middleton

The new edition of this book emphasizes basic audio tests of hi-fi systems and associated test equipment. This is not a theory-ridden textbook but a practical working handbook designed for the professional audio technician, engineer, and serious audiophile. In addition to the more commonly used audio signal generators, oscilloscopes and VTVM's, such specialized test equipment as harmonic distortion meters, intermodulation distortion analyzers, wattmeters, tone-burst generators, and FM multiplex (stereo) generators are also covered. A "must" for any audio workbench or laboratory.

Published by Howard W. Sams & Co., Inc., 4300 West 62 St., Indianapolis, Ind. 46206. Soft cover. 160 pages. \$2.95.



SINGLE SIDEBAND: THEORY AND PRACTICE

by Harry D. Hooton, W6TYH

Interested in the insides of most of the ham SSB transmitters and transceivers? If so, this comprehensive analysis is your kind of book. Author Hooton has put together a package that first sets forth the various techniques of SSB generation and reception and then details how these techniques are put into practice. Literally "tons of information" have been jammed into this unusual book. Recommended for hams and any others installing or maintaining SSB gear.

Published by Editors and Engineers, Ltd., P.O. Box 68003, New Augusta, Ind. 46268. Hard cover. 352 pages. \$6.95.



ELECTRONIC DESIGNER'S HANDBOOK

by T. K. Hemingway

Devoted to transistor circuit design as analyzed by a British electronics consultant, this book is divided into three parts: (1) design principles; (2) unusual circuits; and (3) prototype testing. Mathematics is kept to a minimum, and considerable emphasis is placed on the effects of subtle circuit variations. Practical examples of the design parameters discussed illustrate special problems.

Published by Business Publications, Ltd. Distributed in the United States by TAB Books, 18 Frederick Rd., Thurmont, Md. 21788. Hard cover. 296 pages. \$8.95.

—50—

NEW LITERATURE

To obtain a copy of any of the catalogs or leaflets described below, simply fill in and mail the coupon on page 15.

Things you can do with a tape recorder, how to select a tape recorder, and how to select the proper microphone for your particular needs are the main subjects of "The Tape Recording Omnibook" published by *Elpa Marketing Industries, Inc.* In addition, tape splicing and editing is discussed, and the ReVox Mark III G-36 tape recorder is illustrated and described in detail in this 16-page, 2-color brochure.

Circle No. 88 on Reader Service Page 15

Hams and CB'ers will be interested in the new 6-page catalog put out by *Gold Line Connector, Inc.* It describes and shows the following special accessories: a direction-finding antenna, a 2-position and a 5-position coaxial switch, alternator filter, CB generator filter, antenna matching network, and a lightning arrester.

Circle No. 89 on Reader Service Page 15

Xcelite Incorporated's 2-page Bulletin N567 contains information and specifications on two sets of nutdrivers featuring special plastic cases which keep the tools properly organized for bench work and have tight-fitting, snap-lock covers. Set HS6-18 consists of ten hollow shaft nutdrivers, and Set 77 has seven drilled shaft nutdrivers.

Circle No. 90 on Reader Service Page 15

Entitled "A Microphone For Every Purpose," *Sonotone's* new 12-page catalog features its new dual-impedance, dynamic cardioid mike and the slim-line DM70 dynamic model. The catalog also lists Sonotone's complete line of ceramic microphones—low impedance and high impedance—for p.a. systems, talk sessions, home taping, emergency communications, and learning laboratories.

Circle No. 91 on Reader Service Page 15

More than 50 new items are offered for the first time in *Conar's* Summer 1967 Catalog. They include electronic organs, hi-fi tape equipment, multiplex auto radios, an adapter for channeling TV sound through a hi-fi amplifier, and a home intercom system. Also presented are several new pieces of test equipment, plus some automotive test gear.

Circle No. 92 on Reader Service Page 15

THE TECHNICIAN SHORTAGE

(Continued from page 61)

Some employers, as a matter of policy, regard all technicians as second-class citizens and flood them with advice and admonitions on the intellectual level of the third grade in a school for retarded children. They sometimes even meddle in the personal affairs of their employees, usually in the guise of "security." These policies often alienate the more competent and experienced employees who begin "looking around" and usually find jobs where there is no meddling.

Employing (and usually paying) technicians at levels far below their competence also accelerates labor turnover. A frozen table of organization, with promotions only by seniority (if at all), leads to employee losses "off the top."

Employee irritation is also increased by a book of company rules as thick as a telephone directory, worded by a shyster lawyer, so that no matter how hard the employee tries to do the job right, he is in hot water. If the supervisor also gives hourly public bawl-outs, he will soon be calling on personnel for more technicians.

Incompetent supervision of various sorts also reduces the effectiveness of the technician staff and leads to either less than optimum production or increased labor turnover, or both. One of the chief problems, in many places, is an administrative section head who doesn't know how long it takes to do a given job. This same man is also prone to giving vague and unclear instructions and then complaining about incompetence when he doesn't get what he thinks he might have wanted.

A surprising number of companies do not supply adequate work space, sufficient tools in good order, and proper materials for their technician staff. Although a good technician can produce pretty good equipment with a box full of junk and some garage-type tools, the work will be better done, at much lower cost, if the tools and equipment are adequate. Most technicians get heartily sick of unnecessary "Goldberging" and soon go looking for jobs in places which are better equipped.

What Can Be Done. The shortage of competent electronic technicians has been with us for some time and will worsen in coming years. There just aren't enough people entering the profession to make up for normal attrition and the expansion of the electronics industry. This shortage may retard industry growth and make maintenance and repairs of electronics equipment inordinately costly.

The electronics industry is not alone in having technician shortages. Good automobile mechanics, medical technicians, nurses, secretaries, engineers, etc. are also in short supply. As one personnel man remarked recently "there just aren't enough brains to go around." Lunkheads, it is true, are still plentiful, but there aren't many jobs available for the man who can't learn to pick up both handles of the wheelbarrow at the same time.

Part of the technician shortage can be alleviated by increasing training programs, provided people can be persuaded to respond. Most technician jobs today require high school graduation plus some additional training or experience. The Associate in Science (E.E.) programs in some of our junior colleges are a step in the right direction, but are hampered by a shortage of teachers. Some of the military training programs are quite good. Several of the correspondence schools give excellent theoretical background, but are unavoidably weak in practical applications. There are still a few self-taught electronics men of respectable competence, but most of them are not only already employed but are nearing retirement age.

There is a small reservoir of competent technicians which has not been tapped because of various company regulations and prejudices. For example, is it necessary for electronics technicians to pass an "Air Force" physical exam? This will eliminate the man with a wooden leg, but may not detect another man's wooden head. Does the use of bifocals bar a technician from employment? Why? Do all technicians have to be less than 35 years old? Should a minor juvenile record bar a man from employment permanently? Is the "male only" restriction valid? Should a "solid citizen" of a neighboring country, such as Canada or

Mexico, be barred from employment in most places because he is not a U. S. citizen? Is security being overused? Are the psychological tests given by a few companies valid or do they work against experienced personnel? Just how important is fluent English, especially in bilingual areas of the country?

Judicious relaxation of some of these regulations and prejudices could put a large number of technicians to work at all levels, not only ameliorating the technician shortage but reducing the relief rolls. In addition, company policies leading to upgrading of technical personnel would lessen the shortage at the upper levels, where it is reported to be most acute. A few manufacturers subsidize further study and profit by it in many instances. Company training programs also help in many cases.

There is, however, one "stinker" in the whole situation. Many of those who can become good technicians do so, but also have the ability to become good engineers, and do that too. The net result is that the economy has gained an engineer but lost a competent technician! -30-

MULTI-WAVEFORM GENERATOR

(Continued from page 54)

remove the audio generator from the vertical input, and apply the output from *J1* to the scope. Rotate *R2* until exactly one waveform is displayed. This position of *R2* can then be pencil-marked as the "2" position.

Repeat the above procedure for as many dial markings as desired. Then proceed to the other multiplier scales, and make sure that the calibration points are reasonably accurate for the higher frequencies. In the event of serious mis-tracking, select the multiplier range that is most accurate, and use it as a reference. Then either select, or trim, the capacitor values (*C1*, *C2*, or *C3*) until a reasonable accuracy is obtained.

If desired, the lower end can be reduced down to 2 Hz if a good-quality 20- μ F capacitor is used for *C3*. If this is done, the value of *C4* will have to be increased in order to produce a good square wave. -30-

TURNER +2 "Best CB Microphone



That's what many +2 owners say, and we're glad they're so enthusiastic. It's the only microphone on the market that actually increases the output of your microphone up to 50 times at the twist of a dial. It makes a world of difference on CB (and amateur), so why in the world don't you get one? List Price \$49.50

in the World!"

THE  MICROPHONE COMPANY
946 17th Street N.E.
Cedar Rapids, Iowa

In Canada: Tri-Tel Associates, Ltd.
Export: Ad Auriema, Inc. 85 Broad Street,
New York, N.Y. 10004

NOW! IMMEDIATE DELIVERY EVERYWHERE!

CIRCLE NO. 28 ON READER SERVICE PAGE

LETTERS (Continued from page 16)

specified in a project, the builder's test voltages may not conform to those obtained from an author's prototype. Where voltages are critical, the potential amplitudes and polarities are called out in the "Construction" section of the text. Cumulative deviations from specified values can in some cases cause as much as a 20% higher or lower voltage than might be specified.

"WAY OUT" GUITAR AMPLIFIER

I had been searching for a good guitar amplifier, and POPULAR ELECTRONICS came to the rescue. What I did was combine the mono version of the "Brute-70" amplifier (February, 1967), the "Two-By-Two" stereo preamplifier (March, 1967), the "Reverb For Your

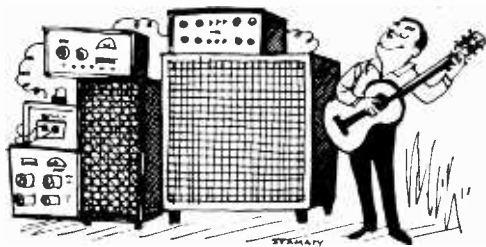

Car" (February, 1966), the "Mixed Twelve" speaker system (March, 1967), the "Fuzzbox" (January, 1967) and an Eico-Craft tremolo into one big amplifying system. It's quite a monster. But it cost less than \$150 and is comparable to a \$350 unit.

B. E. SOLOMON
Whittier, Calif.

A word of advice, B.E.; don't practice in a neighborhood where people like peace and quiet. Your "monster" should be able to produce some "interesting" sounds, though.

ADD 15-VOLT A.C. RANGE TO HEATHKIT VOM

In your "Tips & Techniques" column (April, 1966), you had an item about adding a 15-volt d.c. range to the Heath-kit Model MM-1 VOM. The author said nothing, however, about how to install a setup that can give a 15-volt d.c. range. The way to do this is to use a 50,000-ohm, ½-watt, 1% resistor in series with the 5-volt a.c. shunt resistor. Then terminate the added resistor at a suitable front-panel-mounted test jack.

SSgt. A. P. TIMMERMAN
APO San Francisco, Calif. 96274

"SEQUENCE OPERATED LOCK"

I was fascinated by the "Sequence Operated Lock" (January, 1967), but I discovered that the device could be tampered with. If you open S7 and depress each of the other switches in the circuit, you are bound to deliver power to the load when you eventually

press S6. However, if you eliminate S7 and S8 and connect only one s.p.s.t., normally-closed push-button switch in series with one of the input power lines and the relays, the lock will not only be tamperproof, but the new switch will also serve as a reset for K1 and K2.

SIDNEY WILSON
Santa Ana, Calif.

I made some changes in the "Sequence Operated Lock" circuit that I feel make it even more secure. First I placed only the switches outside the door, leaving the relays safely behind the locked door. Even if an intruder understood how to trace out a circuit, he wouldn't have access to the important parts.

Next, I put extra switches on the door. These switches play no part in the combination circuit, but if depressed they will energize lock-out relay K1. For a finishing touch, I used a double-pole relay for K1 with the extra contacts connected to a bright light. If the wrong combination is selected or one of the switches not in the combination circuit is depressed, the lock-out circuit comes into play and the bright light begins flashing.

FRED A. SMITH
El Paso, Texas

Your "Sequence Operated Lock" is good but not impossible to pick. If an intruder placed a flat piece of wood against the buttons and exerted pressure evenly—depressing all the switches simultaneously—power would be delivered to the load. But if you place two normally-closed push-button switches in series with each other and K2, the lock cannot be opened when all the switches are depressed at the same time.

DAVID LISSNER
Chicago, Ill.

Sid and Fred, you both came up with good, workable ideas for tamperproofing the "Sequence Operated Lock" circuit. Both of your suggestions, combined into one unit, would undoubtedly frustrate a would-be burglar. David, if someone were to place a flat piece of wood over all of the switches and apply pressure, no power could be delivered to the load. If this trick were tried, S8 would also be open and K2 could not be energized. If we assume that S8 is located in another place—say inside the door—then Fred's extra switches might be an even better idea than yours. —30—

OUT OF TUNE

Build \$6 Electronic Tachometer (April, 1967, page 61). To improve the stability and reading accuracy of this tachometer, replace R3 (listed as a 1000-ohm potentiometer) with a 10,000-ohm pot, and change R7 (listed as 120 ohms) to a 47-ohm, ½-watt resistor (R7 determines the Schmitt trigger point and the proper value may vary depending on the transistors used). —30—

Build your own motor speed control with RCA experimenter kits

Control Motors With Name Plate Ratings Up to 6 Amperes. Available from Your RCA Distributor

Now, using two RCA Silicon Controlled Rectifier Experimenter Kits (KD2105) together with additional passive components, you can build a motor speed control for ac/dc universal motors (series wound) with name plate ratings up to 6 amperes.

RCA's twin-kit circuits offer you flexibility in that you may control any one of many individual tools or appliances such as half-inch power drills, jigsaws, buffers, floor polishers, and mixers.

The RCA Experimenter Twin-Kits are part of a complete program fully explained and illustrated in the new 136-page Experimenter's Manual KM-71 on sale at your RCA Distributor. In it you'll find detailed information on more than 24 different and useful circuits you can build including 6- and 12-Volt battery chargers, lamp dimmers, audio frequency operated switches, and heat and light-operated switches.

Check with your RCA Distributor on RCA Experimenter's Kits. Select the kit or kits for the solid-state circuits you have in mind. Do it today.



Technical Series KM-71

RCA Electronic Components and Devices, Harrison, N. J. 07029



The Most Trusted Name in Electronics

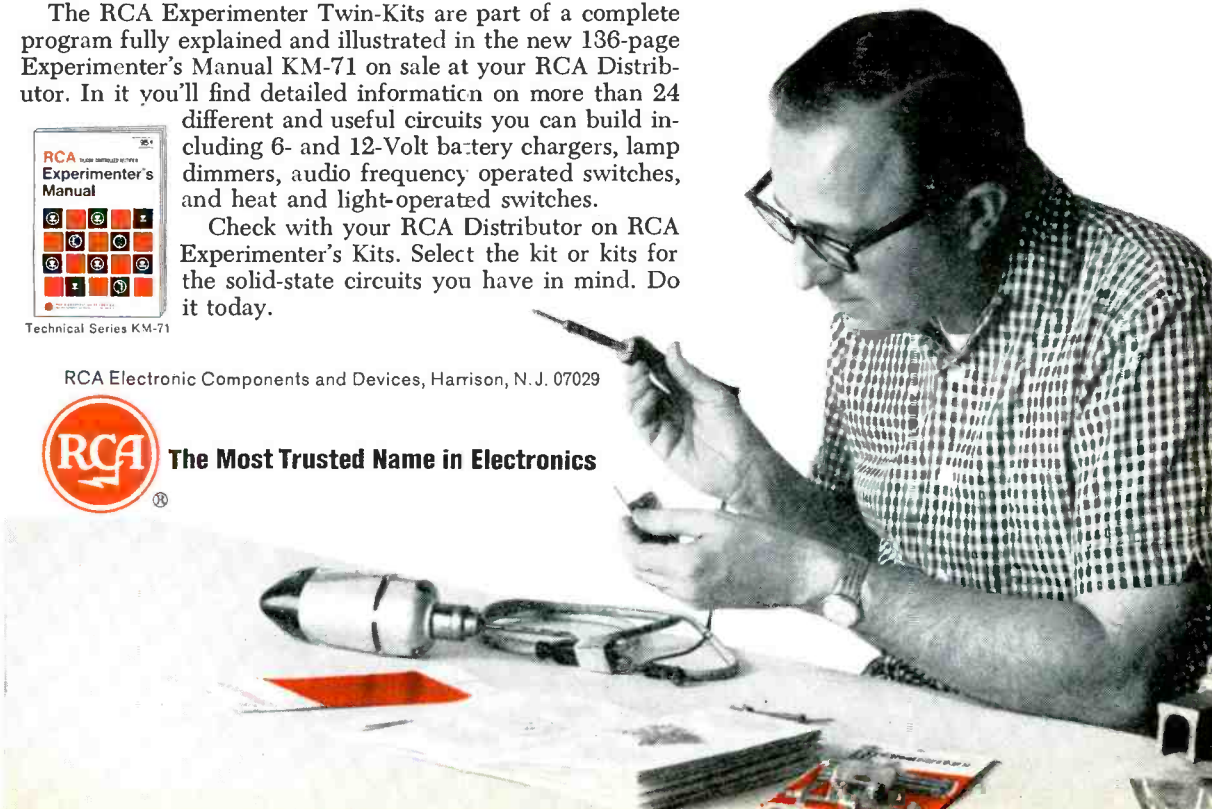
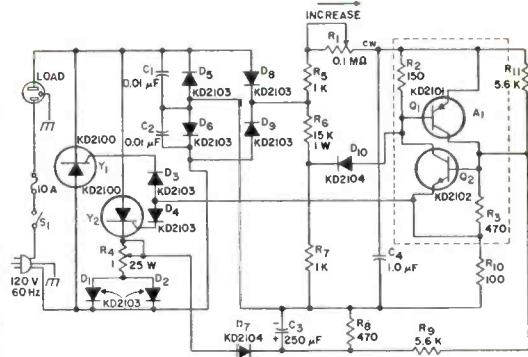

FROM HIFI/STEREO REVIEW
**DELUXE PADDED DUST-PROOF
 RECORD and TAPE CASES**
 plus FREE cataloging forms

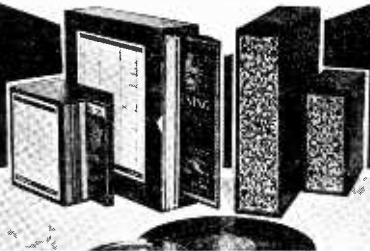

These decorative, yet sturdily constructed cases are just what you've been looking for

to keep your records and tapes from getting tossed about and damaged, disappearing when you want them most and just generally getting the "worst of it" from constant handling. They're ideal too for those valuable old '78's that always seem to get thrown about with no place to go.

Constructed of reinforced fiberboard and covered in rich leatherette in your choice of eight decorator colors, the HIFI/STEREO REVIEW Record and Tape Cases lend themselves handsomely to the decor of any room, whether it be your library, study, den, music room or pine-paneled garage. The padded leatherette back (in your color choice) is gold tooled in an exclusive design available only on HIFI/STEREO REVIEW Record and Tape Cases. The sides are in standard black leatherette to keep them looking new after constant use.

Extra

With each Record and Tape Case you order you will receive, free of charge, a specially designed record and tape cataloging form with pressure-sensitive backing for affixing to the side of each case. It enables you to list the record names and artists and will prove an invaluable aid in helping you locate your albums. The catalog form can be removed from the side of the case at any time without damaging the leatherette.



Record Cases are available in three sizes: for 7" 10" and 12" records. Each case, with a center divider that separates your records for easy accessibility, holds an average of 20 records in their original jackets. The Recording Tape Case holds 6 tapes in their original boxes.

● The Tape Cases or the 7" Record Cases (with catalog forms) are only \$3.25 each; 3 for \$9; 6 for \$17.

● The 10" or 12" Record Cases (with catalog forms) are \$3.50 each; 3 for \$10; 6 for \$19.

Add an additional 75c per order (regardless of number of cases ordered) for shipping and handling.

Ziff-Davis Publishing Company, Dept. SD
 One Park Avenue, New York, N. Y. 10015

My remittance in the amount of \$ _____
 is enclosed for the Cases indicated below.

Quantity

_____ Tape Case at \$3.25 ea.; 3 for \$9; 6 for \$17

_____ 7" Record Case at \$3.25 ea.; 3 for \$9; 6 for \$17

_____ 10" Record Case at \$3.50 ea.; 3 for \$10; 6 for \$19

_____ 12" Record Case at \$3.50 ea.; 3 for \$10; 6 for \$19

ADD 75c PER ORDER FOR SHIPPING AND HANDLING.

Check color choice for back of case (sides in black only):

- | | | |
|--|--------------------------------------|-------------------------------------|
| <input type="checkbox"/> Midnight Blue | <input type="checkbox"/> Red | <input type="checkbox"/> Saddle Tan |
| <input type="checkbox"/> Pine Green | <input type="checkbox"/> Orange | <input type="checkbox"/> Yellow |
| <input type="checkbox"/> Grey | <input type="checkbox"/> Spice Brown | <input type="checkbox"/> Black |

Name _____

Address _____ PE-97

City _____ State _____ Zip Code _____

PAYMENT MUST BE ENCLOSED WITH ORDER

BUILD A "MALF"
 (Continued from page 69)

create a possible shock hazard. Before you use cement on the cover, remove any grease, oil, or dirt with alcohol or other suitable cleaner.

Parts layout is not critical. However, the layout shown in Fig. 3 is easy to follow. A 2½" × 4" perforated phenolic board and about 24 push-in terminals will hold the components in place. If you cannot get a 5000-ohm, 4-watt resistor for R1, you can use two 10,000-ohm, 2-watt resistors in parallel as shown. A single ¾"-long centrally-located threaded spacer holds the board on the cover with adequate clearance. Observe the usual precautions when hooking up RECT 1, Q1, Q2, and the electrolytic capacitors for proper polarity or connections. Also, heat-sink the semiconductors when soldering. Excessive heat can destroy these components.

Drill a number of ¼" holes on the sides of the case to allow air to circulate in the unit while it is in operation. The only part mounted on the case is SO1. All other parts are either on the cover or on the perforated board.

Checking It Out. After you complete the construction, plug a load (one or more lamps totaling less than 500 watts) into SO1, and plug the MALF into a 117-volt outlet. First check for shock hazard . . . use an a.c. voltmeter (VOM on the 150-volt range) to see if there is an a.c. voltage between the cover and a suitable ground, such as a water pipe. You should get no voltage reading. Then reverse the plug and repeat the test.

To adjust the delay-on time, first set R3 in its mid-position and time the action. You can then increase or decrease the time simply by rotating the control in one direction or the other. The more resistance in the circuit, the longer it will take for the lights to come on.

Should you run into problems with radio interference on a nearby AM radio, such interference can be minimized by filtering and shielding, and by increasing the distance between the radio and the MALF. Interference on FM or TV isn't likely.

SOLID STATE

(Continued from page 86)

vantages to this arrangement. First, the d.c. drop across the series element (*D2*) remains essentially the same regardless of load. With a choke or resistor, the d.c. voltage drop increases as load current increases. Second, space requirements are reduced, for a high-current rectifier diode is generally much smaller than a choke or resistor capable of handling similar currents. And finally, costs are reduced, as a typical diode is less costly than a high-power resistor or heavy-duty filter choke.

From a performance viewpoint, the "diode filter" circuit is, perhaps, less effective than a resistor or choke arrangement. However, a considerable reduction in ripple voltage is possible, even where the network (*D2-C2*) is added to an existing well-filtered power supply circuit. In practical tests in our lab, we found that ripple voltages could be cut approximately in half (under full load) by adding a diode and shunt capacitor as an "outboard" filter to a commercial power supply. Further reductions in ripple might be achieved by cascading additional sections.

Product News. Named, appropriately, the "Twilite Sentry," a new transistorized auto accessory offered by Dynamic Development (P.O. Box 2084-D, Pasadena, Calif. 91105) automatically turns auto headlights ON when ambient light levels fall below a preset value, as at twilight or during inclement weather, and OFF when light levels are normal. Designed for operation on 12-volt systems, the unit also turns the headlights OFF automatically when the ignition switch is opened, reducing the chances of a "dead" battery caused by forgetfulness. With a list price of \$32.95, the "Twilite Sentry" is being offered, for a limited time, for only \$19.95 on a direct order basis.

Solid-state devices for operating fluorescent lamps on low-voltage d.c. power sources are being manufactured by The Bodine Company, Inc. (P.O. Box 67, Germantown, Tenn. 38038). Dubbed "TRANS-BALS," the new units consist of a d.c./a.c. inverter and current-limiting ballast combined into a single package. Models are available for all conventional fluorescent lamps and for d.c. supplies from 12 to 48 volts.

Readers in the medical and biological research fields may be interested in a new line of implantable transmitters now offered by The Barrows Company (465 Calderon, Mountain View, Calif. 94040). With a useful

September, 1967

HAMS! CBERS! W9IOP PUTS THE WORLD AT YOUR FINGER TIPS!

\$1.00



NEW
4th Edition
"SECOND OP"

Essential DX operating aid, provides vital data like: beam headings; list of world QSL bureaus; includes logging space. See needed prefixes at a glance, increase your odds of a QSO because you have full information instantly.

\$1.00

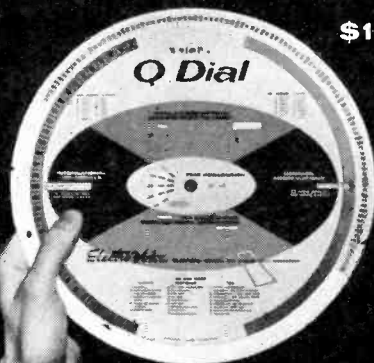

NEW "Q" DIAL

A must for every active operator, ham or C.B. Over a dozen vital information tables including: Q-signals, 10-signals, abbreviations, all U.S. radio districts and prefixes, time conversion, logging space for CW-SSB-CB. Saves time for efficient operation.

At your E-V microphone headquarters, or send coupon.

ElectroVoice

Dept. 973P, 630 Cecil Street, Buchanan, Michigan 49107
Please send _____ Second Op, _____ Q Dial. I enclose
\$1.00 for each item ordered.

Name _____

Address _____

City _____

State _____ Zip _____

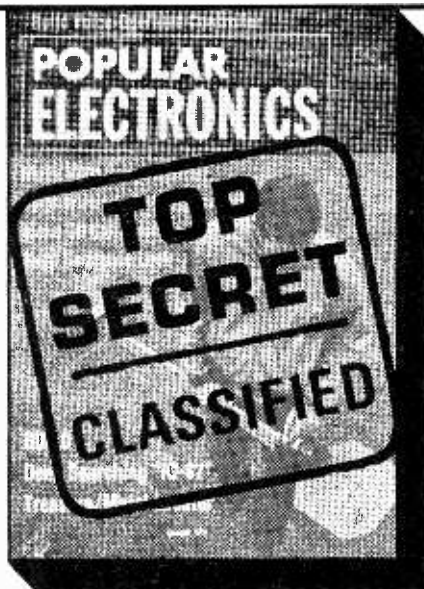

*...not by a long
shot it isn't !!*

There's certainly nothing top secret about the classified pages in Popular Electronics Magazine. They're wide open to the searching eyes of every buyer who's in the market for the product or service that he knows can be found in Popular Electronics' Electronics Market Place.

The more than 400,000 buyers of Popular Electronics, largest readership of any electronics magazine in the world, are your guarantee of knowing that your ad is being read by people who are constantly looking for and buying electronics products. It is these people to whom you **MUST** direct YOUR advertising as do the many key advertisers appearing in this issue and in each issue throughout the year.

No doubt about it—there's a vast market of buyers searching the classified advertising pages of Popular Electronics and it's important that your ad be exposed to this prime buying audience. Prove to yourself that the leading electronics magazine **MUST ALSO** be the leader in sales responses to the many classified ads presently enhancing its pages—it makes a great deal of sense—give it a try.

There's complete rate information for your convenience in the classified section of this issue. Or, if you'd like a little personal service, it's right up our alley. Just write to

HAL CYMES

Classified Advertising Manager

ZIFF-DAVIS PUBLISHING COMPANY

One Park Avenue • New York, New York 10016

transmitting range of about 3 feet, these units are compact enough to be implanted in animals as small as a 200-gram rat, and will permit remote monitoring of body temperature and EKG.

Transitips. Disappointed by short battery life? Perhaps you are abusing your batteries . . . or perhaps you are choosing them on the basis of size and voltage, rather than by current rating and service life.

No matter how efficient your circuit, you must put in *more power* than is delivered. An audio amplifier furnishing, say, 100 mW, requires at least 14 mA at 9 volts d.c. (126 mW). This is nearly 75% greater than the recommended discharge rate for the popular 2U6 (or 216) transistor battery. A CB transceiver with a 100-mW rating may require 20 mA, or more, when used as a transmitter.

If you want a reasonable battery service life, first determine the d.c. drain of your equipment, then choose your battery type accordingly. Afterwards, *take care* of your batteries, observing the following tips:

Don't store your equipment (or batteries) where very high temperatures may develop, as, for example, in the glove compartment of a car during the summer.

Do turn your equipment off when it is not in active use. A battery will provide more hours total service when used intermittently than when subjected to continuous discharge.

Don't allow moisture or corrosion to accumulate on battery terminals or connectors, for this may establish a leakage path, causing a steady current drain.

Do keep the volume control adjusted for the *minimum* level needed for comfortable listening. A Class AB or B audio amplifier requires more (d.c.) power as the output level is increased.

Don't try to operate pilot lamps with ordinary "transistor" batteries. These batteries are not designed to furnish the relatively high currents required by lamp bulbs.

Do remove the batteries if you plan to store your equipment for an appreciable period.

—Lou

AMATEUR RADIO

(Continued from page 82)

Forgetting that he is talking over the air, the sailor usually answers the questions and "blows" security. But on shipboard or anywhere else, the operator is responsible for what goes out over the air from his station. He does this by keeping his hand on the control switch, and cutting the trans-

mitter off the air whenever necessary to keep forbidden material inside the radio room.

Incidentally, this year's annual International Amateur Radio Club (4U1ITU) Convention in Geneva, Switzerland, will take place on September 23 and 24. It is timed to coincide with the "World Administrative Radio Conference to deal with matters relating to the maritime mobile service" at the International Telecommunications Union headquarters in Geneva. For details, contact IARC, 1211, Geneva 20, Switzerland.

VHF QSO Party. If you operate on the amateur bands above 50 MHz, ARRL's annual VHF QSO Party is for you. The Party starts at 2 p.m., local standard time, Saturday, September 9, and continues until 10 p.m., September 10. You earn one point per contact on 50 and 144 MHz, two points per contact on 220 and 420 MHz, and three points per contact on the higher frequencies. Multiply your contact points by the sum of the different ARRL sections worked on each band to get your score.

The American Radio Relay League, Inc., will award certificates to the winners in each ARRL section, with separate certificates for Novice winners in any section with three or more Novice participants. Obtain official score sheets from the ARRL Communications Department, 225 Main St., Newington, Conn. 06111, and send your score to the same address after the Party.

Colorado Amateurs On the Job. With the recent move of WWV to Boulder, Colorado, it is no news that the National Bureau of Standards and ESSA (its parent organization) have several important research facilities located in the state. According to the *Round Table* bulletin of the Denver Amateur Radio Club, House Bill #1570 was introduced in the Colorado General Assembly to protect the ESSA Research Facility on Table Mountain from radio interference.

Claude Maier, WØIC, saw the bill on the house calendar and realized that it was so broadly written that the radiation from almost any piece of electronic gear was above the maximum level permitted by the bill. In addition, almost any organization could classify itself as a communications research facility and would be entitled to the protection of the bill. Claude alerted Carl Smith, WØBWJ, ARRL Rocky Mountain Division Director, and other Colorado amateurs, as well as representatives of commercial and government services of the inherent dangers of the bill.

Representatives of these groups were in almost daily attendance at the Colorado Statehouse for the next several weeks, as the
(Continued on page 110)

September, 1967

HERE'S The Place To Buy Your Electronic Components!

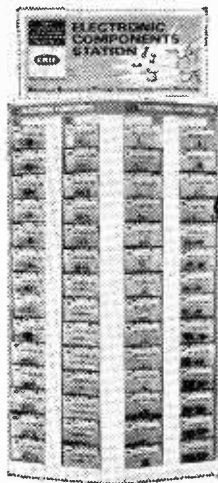

LOOK FOR...
**ERIE'S
ELECTRONIC
COMPONENTS
STATION**

Every Component
Neatly Packaged and
Clearly Identified...
Ready to Use in
Your Circuit

112 QUALITY COMPONENTS



CERAMIC DISC CAPACITORS

Voltages — 12, 25, 200 and 1000 V.
Capacitance — 5 pF thru 220,000 pF
(.22 μ F)



CERAMIC TUBULAR CAPACITORS

Voltages — 100 V. and 500 V.
Capacitance — 1 pF thru 1000 pF (.01 μ F)



MYLAR FILM CAPACITORS

Voltages — 200, 400, and 600 V.
Capacitance — .01 pF thru .1 μ F



TRIMMER CAPACITORS (Variable)

Ceramic — Plastic — Glass
Ranges to suit your needs



RECTIFIERS and DIODES

Industry's Most
Popular Types



Erie, Pennsylvania



FREE 6-PAGE COMPONENTS CATALOG

Send To:
ERIE TECHNOLOGICAL PRODUCTS
Distributor Sales
644 WEST 12TH STREET, ERIE, PA.

PLEASE SEND ME YOUR FREE CATALOG LISTING ALL 112 COMPONENTS ON THE ERIE ELECTRONIC COMPONENTS STATION.

NAME _____

STREET _____

CITY _____ STATE _____

CIRCLE NO. 10 ON READER SERVICE PAGE

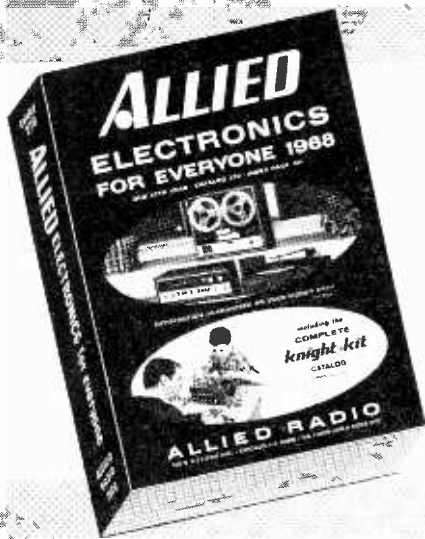

What has this new
1968 ALLIED catalog got
for you?

everything!

send for your **FREE** copy



WHY BUY BY MAIL FROM *ALLIED*?

Each year Allied fills more than a million orders by mail. That's because only the complete facilities of the world's largest electronics supply house can satisfy all the needs of hi-fi enthusiasts, CB users, engineers, Hams, and experimenters.

WORLD'S LARGEST SELECTIONS

Shop through the pages of this complete 518 page electronics buying guide. It gives you full descriptions and low prices on thousands upon thousands of items.

MANY PRODUCTS NOT AVAILABLE ANYWHERE ELSE

Allied stocks thousands of unusual and special items not available elsewhere. Many are specially designed and built to Allied's specifications to save you money.

FIRST WITH THE LATEST FOR 47 YEARS

Allied has always been the first to offer the latest developments in Electronics. See them now in Allied's new 1968 Catalog.

COUNT YOUR SAVINGS AT ALLIED

Check Allied's lower prices. Look for the special values available only in the Allied catalog.

IMMEDIATE SHIPMENT

Orders are filled promptly—usually the same day they're received.

**Satisfaction
Guaranteed
or Your Money Back!**

**No Money Down
Up to 2 Years to Pay**

WE QUALITY-TEST WHAT WE SELL

It it's from Allied — you can depend on it.

ENJOY "EASY-CHAIR" SHOPPING

Shopping's easier at Allied. You always know exactly what you get. And, the selection of merchandise is so vast no single store could ever assemble and stock it all.



ALLIED RADIO, DEPT. 3-J, P.O. BOX 4398, CHICAGO, ILL. 60680

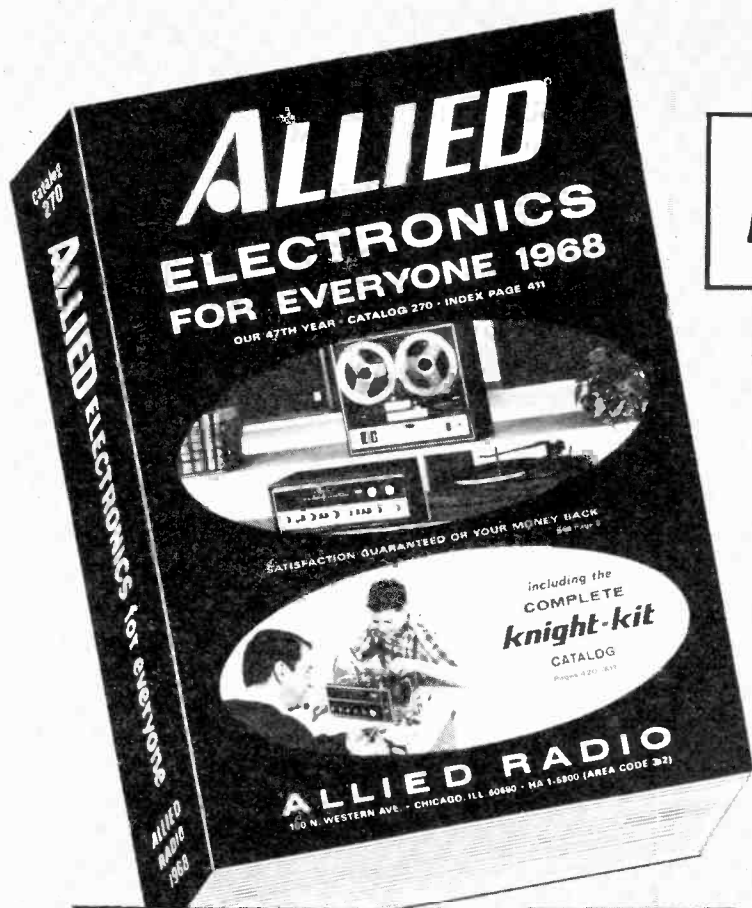

new!

518 PAGES

- Stereo Hi-Fi
- Famous Knight-Kits
- Tape Recorders & Tape
- CB 2-way Radios
- Walkie-Talkies
- FM-AM & AM Radios
- Short Wave Receivers
- Portable TV
- Phonographs
- Amateur Gear
- Intercoms & PA
- Automotive Electronics
- Test Instruments
- TV Antennas & Tubes
- Power Tools, Hardware
- Tubes, Transistors
- Parts, Batteries, Books

FREE

**1968
ALLIED
CATALOG**

MAIL THIS
COUPON
IF CARD
HAS BEEN
REMOVED

ALLIED RADIO, DEPT. 3-J, P.O. BOX 4398
CHICAGO, ILLINOIS 60680

Send me your free 1968 Catalog

NAME (Please Print) _____

ADDRESS _____

CITY _____

STATE _____ ZIP _____

bill was rewritten and amended until a workable bill was placed on the Governor's desk for his signature. The final bill excludes amateur radio and some other services from its provisions.

Snow Rescue in Sunny California. In his amateur radio column in the Los Angeles *Herald-Examiner* for April 29, Ray Meyers, W6MLZ, described how Alvin Lewison, W6KAO, and his wife, Ruth, K6KLN, used amateur radio to escape from a nasty predicament. The Lewisons were traveling in their automobile last April 1 on State Highway 2 in the California foothills near Mt. Wilson, when suddenly a snow avalanche tore down the mountainside and buried three cars, including the Lewisons'.

Calling the West Coast Amateur Radio Service Net on 7255 kHz over his mobile station, Al reported the problem to the highway department. W6KAO kept in contact with the net for six hours before the rescue snow plow and sheriff's unit reached the stranded group. But after traveling a few miles further, the whole party—including the rescuers—was again stalled in snow banks. All good things must come to an end, however, and twelve hours after they started out, Al and Ruth were back in their own home—in sunny southern California.

News and Views

Dennis Hennigan, WN1HOG, 226 Pollard St., N. Billerica, Mass., has worked 12 states—11 confirmed—in four weeks. His 80-40 meter dipole is driven by an EICO 720 running 75 watts, and he receives on a National NC-98. In the process of assembly is a Heathkit "Twoer." In addition, Denny is studying hard for his General Class ticket. . . . **Stan DePue, WN9TCW**, 497 Brookside Rd., Barrington, Ill., works the three low-frequency Novice bands with a Knight-Kit T-150A transmitter. His record so far is 42 states and 13 countries. Stan rates New Zealand and the Cape Verde Islands as his best DX. A Hy-Gain 18-V vertical antenna and a 40-meter doublet do the radiating at WN9TCW, and a Hallicrafters SX-101A receiver and a Knight-Kit R-55A split the receiving chores. . . . **Allan Rabinowitz, WN2AOT**, 575 East 79th St., Brooklyn, N.Y., receives on a Hallicrafters SX-110 and transmits on a Heathkit DX-40. A Hy-Gain 14-AVQ vertical antenna does the yard work and has radiated a signal into 14 states and Canada on the 7- and 21-MHz Novice bands. Allan is a member of the RagChewer's Club, too. He is a photographer by trade, but wouldn't you know it? He has no pictures of his station. Maybe this will encourage him to take some.

Gary L. Carlson, KL7FRZ, P. O. Box 185, Haines, Alaska, started out as WN7WPR back in August, 1954, and got his General three months later. Gary has been at Haines, Alaska, since June, 1966, and needs Vermont for his Worked All States certificate. He hopes to make DXCC some day, even though he has a long way to go. His all-time record is 66 countries worked; and from Haines, he has 15 worked. An EICO 753 CW, SSB transceiver driving a Heathkit SB-200 amplifier, a Windom antenna, and a Hammarlund SP-600 receiver cover all the amateur phone and CW bands from 80 through 10 meters. He reaches 15 and 10 meters by multiplying frequency in the amplifier. . . . **Terry Tyrone Steeden, WN5RLC**, 1919 Currie Lane,

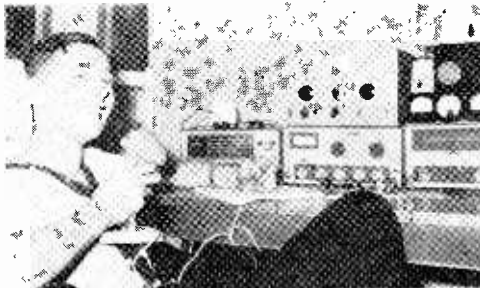

Keith Densmore, VE3CEM, operates out of Toronto, Canada. For details on equipment, see text below.

Amarillo, Texas, is using a 1940 regenerative receiver, a home-built, 12-watt transmitter, and a 40-meter "inverted-V" antenna. Total cost to him: \$8.73. He has worked 20 states on 40 meters in two months. Terry is a college student studying for the ministry and will sked you for any reason. . . .

Randy Drescher, WN4FGW, 3520 Monica Parkway, Sarasota, Fla., has worked 26 states, four Cubans, two Hawaiians, and Bermuda in four weeks—all on 40 meters. Not bad for a Johnson "Ranger" transmitter exciting a 40-meter dipole only 12 feet high. Randy's receiver is a war-surplus BC-348J.

Steve Brandt, WB6VVS, 4384 Bel Aire Drive, La Canada, Calif., had to visit the FCC twice to convince the "man" that he could copy the code at 13 wpm. He had no trouble the second time, because he copied WIAW's code-practice transmissions until he could copy 15 wpm "solid." Steve now works 20 meters with a home-brew transmitter running 300 watts to a pair of 1625 tubes. (A 4:1 overload!) A converted "Command-Set" transmitter serves as a VFO, and a Hallicrafters SX-111 does the receiving. A home-brew, "all-band" vertical antenna completes the installation, except for the station log, which shows 20 states and Canada worked. . . . Talking about code-practice transmissions, the Philmont Mobile Radio Club, in cooperation with the Franklin Institute, Philadelphia, Pa., transmits code practice at 2000. local time, Monday through Friday, on 29,626 kHz.

Keith Densmore, VE3GEM, 1806 Queen St., East, Toronto 8, Ont., Canada, was first licensed in August, 1965. He started with a Heathkit DX-60 transmitter running 90 watts, a Heathkit HG-10 VFO, and a Heathkit HR-10; to this gear he has now added a 300-watt, home-brew amplifier. The VE3GEM antenna farm sprouts horizontal dipoles for 80, 40, and 20 meters, plus a ground-mounted Hy-Gain V-27 vertical. For the past year or so, Keith has divided most of his time between rag-chewing on 80-meter phone and 80- and 40-meter CW. Nevertheless, he has 47 states, 9 Canadian provinces and 19 countries worked. Keith's future plans include SSB phone—when his pocketbook can stand the strain (amateur gear is much more expensive in Canada than it is in the U.S.A.) . . .

Edwin Knox, WN7GNR, Route 2, Box 104, Harrisburg, Ore., splits his operating time between the 80-, 40-, and 15-meter Novice bands. Eighty- and 40-meter dipoles fed from the same transmission line insert his signals into space and capture incoming signals. A Heathkit DX-60 transmitter supplies the outgoing signals, and a National NC-98 receiver processes the incoming ones. Together they have put 17 states and Japan into the WN7GNR logbook.

Will we read your "News and Views" or see your picture in next month's column? The first step is up to you and the mailman. Write to Herb S. Brier, W9EGQ, Amateur Radio Editor, POPULAR ELECTRONICS, P. O. Box 678, Gary, Ind. 16401.

73, Herb, W9EGQ

Now-it's easy to make recordings of children

WITH POPULAR PHOTOGRAPHY'S UNIQUE NEW RECORD ALBUM

"TONY SCHWARTZ ON HOW TO RECORD—THE SOUND OF CHILDREN"

To instruct you in the techniques of recording children's voices, the editors of Popular Photography asked famed sound authority Tony Schwartz to prepare this special record, available exclusively and by mail only through Popular Photography magazine and other Ziff-Davis publications. By listening to it you can quickly acquire the skills needed to make top-quality recordings of youngsters—thus preserving permanently the sound of their voices.

YOUR TEACHER: AN EXPERT'S EXPERT

You couldn't have a better instructor than Tony Schwartz. A pioneer in the use of portable tape recorders, he has been capturing the sounds of actuality for 23 years. You've read his monthly column in Popular Photography. Now hear him explain and illustrate in provocative recorded demonstrations the working methods that have helped him to become the world's No. 1 sound collector.

SIMPLE, COMPLETE INSTRUCTIONS

HEAR ACTUAL DEMONSTRATIONS OF

- A tape recording before and after editing
- The sound of a battery operated recorder at three (3) inch per second, 1 1/2, 3 1/2, and 7 1/2 inches per second
- The improvement in fidelity when a quality microphone replaces the mic supplied as a recorder's standard equipment
- How to reduce unwanted noise while recording
- Accusies: the sound of sound in the living room, kitchen, hallway, and street
- Improving sound quality by re-recording a tape

In addition to the tips on selecting and using equipment, you learn how to create complete sound stories with children—even recreate a situation that has already taken place! Actual sound demonstrations enable you to hear the effects of various tape speeds, microphones, and acoustical conditions. You also learn how to eliminate unwanted noise and to improve your tapes by re-recording them. In less than one hour, you get the benefit of years of experience and recording know-how!

EXTRA!

You'll be intrigued and thoroughly entertained by Side II of this superb new album. It's devoted entirely to three of Tony Schwartz's most famous sound essays, all acclaimed as "works of great artistry that will surely be enjoyed by anyone who enjoys and appreciates the sounds of children."

"CHILDREN AND GOD"—a fascinating composite of thoughts expressed by youngsters of various religious faiths. Their naively reverent concepts of God, heaven, good and bad, and prayer will be a revelation to you. This unique presentation is unlike anything you have ever heard before!

"NANCY GROWS UP"—a remarkable sound portrait of a girl's developing personality. In just two minutes, you hear her voice from 20 minutes after her birth, through the years until she's 13—when she reveals: "I've discovered boys!"

"SOUND SNAPSHOTs"—a potpourri of chuckles . . . once-in-a-lifetime sayings that could come only from the mouths of babes. These uproarious remarks, all said in the innocence of childhood, include delightfully ingenuous observations like these:

"I'm so hot I'd like to take my skin off!"

"I had growing pains yesterday."

"You go up in heaven when you die. You don't have to pay taxes, or anything—I'm positive."



A high fidelity 12 inch, 33 1/3 RPM long playing vinyl album manufactured by the Custom Services Division of Capitol Records.

. . . plus many more that will make you howl with laughter! You and your friends will enjoy listening to all of these entertaining essays in sound again and again.

Free INSTRUCTION BOOKLET WITH EACH RECORD ALBUM

Packed with valuable facts, it contains scores of helpful tips you can use to make better, more interesting recordings—information that supplements the instructions in the record. And it's yours if you place your order now for "Tony Schwartz on How To Record—The Sound Of Children."

Get the most out of your recording equipment by discovering the easy way to make tapes that you'll always treasure. This instructive and entertaining album should be owned by everyone within the sound of a child's voice and laughter. The special low price is:

only \$4.98 postpaid

ORDER YOUR ALBUM TODAY

"The Sound of Children"

P.O. Box 3112
Church Street Station, New York, N.Y. 10008

Please send "Sound of Children" albums at \$4.98 each, postpaid.

My check (or money order) for \$_____ is enclosed.
(Outside U.S.A. please send \$7.00 per record ordered.)
N.Y. State residents please add local sales tax.

PE-97

Name _____

Address _____

City _____

State _____ Zip Code _____

PAYMENT MUST BE ENCLOSED WITH ORDER

Deluxe
POPULAR ELECTRONICS
MAGAZINE CASES
 DESIGNED TO HOLD A FULL YEAR'S COPIES



These decorative, yet sturdily constructed cases are just what you've been looking for to keep your copies of Popular Electronics Magazine in easy-to-find order.

Constructed of reinforced fiberboard and covered in rich leatherette, these durable cases guard against soiling and tearing of your magazines while lending themselves handsomely to the decor of any room, whether it be a library, study, den, music room or pine-paneled garage. The magazine cases are available with embossed gold lettering in either all black or attractive maroon back with black sides.

Specially designed to hold a full year's copies of Popular Electronics Magazine, the cases are only

\$3.50 each, 3 for \$10, 6 for \$19
FULLY GUARANTEED

Note: Magazine cases are also available for other of your favorite titles. For prompt shipment, use the coupon below.

Ziff-Davis Publishing Company, Dept. SD
 One Park Avenue, New York, N.Y. 10016

Please send _____ Popular Electronics Magazine Cases.
 Also send cases for the magazine titles indicated below:

TITLE	QUANTITY
_____	_____
_____	_____
_____	_____

- All black, gold embossed
 Maroon back, gold embossed/black sides

Enclosed is \$ _____ at \$3.50 per case,
 3 for \$10, 6 for \$19 (Quantity prices apply for combination orders of more than one title). Orders outside U.S.A. \$4.50 ea., 3 for \$13, 6 for \$25.

Name _____
 Address _____
 City _____
 State _____ Zip Code _____

Payment must accompany order.

ON THE CITIZENS BAND

(Continued from page 84)

mobile patrols, and 24-hour monitoring, and is negotiating with the City of New York to further aid N.Y.C. police and their auxiliary units. Interested CB'ers should contact director Richard T. Moran at the address given above.

Cook County CB Civil Defense Director Robert Lorenz needs volunteers in the Chicago area. Bob says that his group has too much ground to cover and too few operators. For more information and an application blank, midwesterners can contact him at 4316 Home Avenue, Stickney, Ill. 60405.

A Fall Festival CB Jamboree sponsored by the Emergency Citizens Band Monitors, Inc., will be held on September 16 and 17 at the Madison County Coliseum in Huntsville, Alabama. The grand prize will be a 7-day trip for two to the Bahama Islands, or a 1968 national brand 23" color TV set—winner's choice; and there will be more than \$3000 worth of other prizes. Camping facilities are available; also special CB motel rates. For additional information, write to R. M. Lewis, KDD7237, Jamboree Chairman, Emergency Citizens Band Monitors, Inc., P.O. Box 1542, Huntsville, Alabama 35807.

Sergeant Robert P. "Bob" Holmes, and several other CB'ers stationed in Vietnam, would like to hear from stateside communicators. How about sending them a copy of your club publication with a note attached? Write Bob in care of Headquarters, Force Logistic Command, c/o FPO, San Francisco, Calif. 96602.

The Allied Louisiana Emergency Radio Team, Inc. (ALERT), Baton Rouge, La., was called into action last April when the area was threatened by the worst flood conditions to plague Louisiana since 1953. Monitor stations handled communications traffic for two and a half days. At least 45 mobile units were put into operation, patrolling the area to give assistance where needed and making reports on flood conditions. By early evening of the first day, 14 inches of rain had been recorded. ALERT Control, operating on channels 1 and 21, manned Red Cross Headquarters communications between eight shelters that had been set up. The ALERT members were highly commended for their help—many of them worked day and night.

Congress Asked to Review CB Radio.

Four Congressmen (F.T. Bow, F. Clark, H.R. Kornegay, and J.W. Stanton) have submitted a resolution to the House of Representatives asking that the Congress direct the FCC to review CB radio. The resolution advocates

the expansion of CB and the provision for more frequencies for personal use.

Congressman Bow is well known for his intense interest in CB and has been a staunch critic of the FCC. The fate of this resolution is an unknown quantity at press time, but very probably—as in the past—it will be sidetracked into “committee” and therein die a slow death. At least, the interest on the part of the four Congressmen is appreciated.

I'll CB'ing you,

—Matt, KHC2060

ANGLE QUIZ ANSWERS

(Quiz appears on page 55)

- 1 — H The AZIMUTH ANGLE of a tape recorder is the angle between the running axis of the tape and the gap in the recording head.
- 2 — F The CRITICAL ANGLE of a transmitted radio signal is the minimum angle which the wavefront, as it enters the ionosphere, can make with a line extending to the center of the earth, and still be reflected back to earth.
- 3 — I The CUTTING ANGLE of a recording stylus is the angle between the longitudinal axis of the stylus and a line perpendicular to the plane of the disc.
- 4 — G The DEFLECTION ANGLE of a cathode-ray tube is the angle swept by the maximum peak-to-peak deflection of the beam.
- 5 — D The DISPERSION ANGLE of a speaker defines the limits of sound radiation possible from a given cone design.
- 6 — A The DWELL ANGLE of an automobile distributor cam and point assembly is the number of degrees through which the cam rotates while the ignition points are closed.
- 7 — J The PHASE ANGLE of an alternating current is the number of electrical degrees by which the current leads or lags the applied voltage in an a.c. circuit.
- 8 — C The REFRACTION ANGLE is the angle which a light ray traveling through two different mediums makes with a line perpendicular to the interface of the mediums.
- 9 — E The SHADOW ANGLE of an electron ray (tuning eye) tube defines the target area (shaded) present under minimum signal conditions.
- 10 — B The TRACKING ANGLE of a phonograph is the angle between the longitudinal axis of the cartridge and a tangent to the needle groove.

Thinking of college and a space age career?

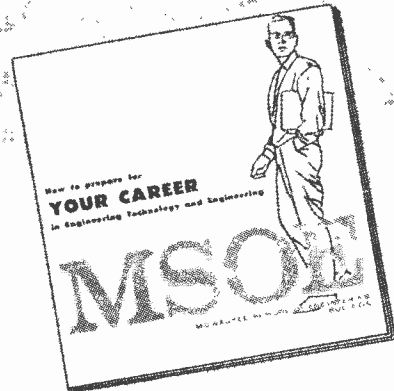

Send for this booklet on ENGINEERING TECHNOLOGY AND ENGINEERING

Learn how you can prepare for a dynamic career as an electrical or mechanical engineering technician or engineer in such exciting, growing fields as avionics, missiles, reliability control, fluid mechanics, data processing, metallurgy, microelectronics, and advanced aerospace research.

MSOE offers residence study programs leading to these degrees in engineering technology and engineering:

2 years — Associate in Applied Science

4 years — Bachelor of Science

Also get facts about scholarships and financial aids, job placement and other student services, plus photographs of MSOE technical laboratories and student activities. Courses approved for veteran training.

For your copy, just mail the coupon — no obligation.

MSOE

Milwaukee, Wisconsin 53201

Milwaukee School of Engineering
Dept. PE-967, 1025 N. Milwaukee Street
Milwaukee, Wisconsin 53201

Please send the "Your Career" booklet.
I'm interested in

Electrical fields Mechanical fields

Name.....Age.....

Address.....

City.....State.....ZIP.....

CIRCLE NO. 17 ON READER SERVICE PAGE

MS-284

FET REGEN RECEIVER

(Continued from page 46)

The back view of the completed receiver is shown in Fig. 8. The battery holder is mounted on the side of the cabinet with small wood tacks, while small brass wood screws are used to mount the Fahnestock clips. One clip is used for the antenna connection and the other for the ground connection.

Alignment and Operation. For best reception, use an end-fed antenna between 50 and 75 feet long, mounted as high as possible, and a good ground. But the receiver will operate satisfactorily on shorter lengths of antenna because of its excellent sensitivity. For camping, picnics, and other portable applications, a short length of insulated wire tossed into the nearest tree will suffice.

If you have never played with a regenerative receiver, it will not take you long to get the "feel" of tuning it for best results. Control *R1* will have to be reset from one end of each band to the other. When scanning large segments of the band, it is best to "back off" on *R1* until a station or group of stations is found. Then advance the control to the point just before the receiver "pops" into regeneration. At this point, the received signal will increase in strength and selectivity.

If you duplicate the receiver exactly as outlined here, the calibration markings shown in Fig. 9 will fall right into place. The receiver can be calibrated precisely by adjusting the tuning slugs on the plug-in coils and tuning in on stations of known frequency. This is easy enough to do on the broadcast band—if the station frequencies are unknown, you can always use another broadcast radio to correlate the frequencies. On the short-wave bands, the WWV time-signal stations can be used as "frequency standards." WWV stations will be found on 2.5, 5.0, 10, and 15 MHz.

On the short-wave bands, reception will usually be very limited and spotty during the day. It will begin to improve late in the afternoon, however, and by evening the bands will be "crawling" with stations!

SHORT-WAVE LISTENING

(Continued from page 79)

Also, I have been receiving mail from a person, or persons, allegedly living in the Greater New York area, giving frequency, schedule, and sketchy location of "a new broadcast station." They even had QSL cards printed. All of this information has been turned over to the Federal Communications Commission.

VOA QSL Cards. Last month we mentioned that the *Voice of America* had discontinued issuing QSL cards to U. S. listeners ("It is diverting staff funds and time from our basic mission which is to provide programming for audiences in foreign countries"). One of our readers, dismayed at having been refused a QSL for his logging of the Tangier relay, wrote a polite note to one of the QSL card signers requesting more detailed information on the new policy of the VOA. His reply: the Tangier relay QSL!

CURRENT STATION REPORTS

The following is a resume of current reports. At time of compilation all reports are as accurate as possible, but stations may change frequency and/or schedule with little or no advance notice. All times shown are Greenwich Mean Time (GMT) and the 24-hour system is used. Reports should be sent to SHORT-WAVE LISTENING, P.O. Box 333, Cherry Hill, N. J., 08034, in time to reach your Short-Wave Editor by the fifth of each month; be sure to include your WPE identification, and the make and model number of your receiver. We regret that we are unable to use all the reports received each month, due to space limitations, but we are grateful to everyone who contributes to this column.

Albania—*R. Tirana* is heard well in Eng. at 0230 on 9715 kHz. and from 0000 to 0025 to close on a new frequency of 11.905 kHz.

Austria—*Austrian Radio*, 15.360 kHz. was logged at 2315-2345 with light opera. to 2350 with pop music. The ID's are generally multilingual.

The current schedule to N. A. (all xmsns to Eastern N.A. only) is: 6155 kHz (Deutsch Alterburg—10 kW) at 2300-0430; 9770 kHz (Moosbrunn—100 kW) at 2300-0200; and 9770 kHz (Fleckenendorf—20 kW) at 0200-0400.

Bolivia—A new station is *R. Guayaramerin*, Guayaramerin, operating on 4964 kHz with the usual Latin American programming around 0100. Verification is by letter.

Brazil—*R. San Carlos*, 2420 kHz. was noted weakly at 0201 in Portuguese. This is a difficult one to log.

Canada—The latest CBC schedule to N.A. is: 1215-1313 on 11,720 and 9625 kHz (Eng.), and 1316-1342 on 11,720 kHz (French). Other loggings include: CKZU, 6160 kHz. Vancouver, at 2330 and at 0500-0600 relaying CBU; CFVP, 6030 kHz. Calgary, noted at 2214 with music and commentary.

Cape Verde Islands—Station CR4AC. *R. Barlavento*, Sao Vicente, 3910 kHz. is often noted around 2300-0000 when the channel is clear of ham radio xmsns.

Cuba—The current schedule for Eng. from Havana is: to Northern Europe at 2010-2140 on 15.285

kHz; and to N. and S. America at 2050-2150 on 15,270 and 15,300 kHz, at 0100-0450 on 6170 kHz, at 0100-0600 on 11,760 kHz, at 0330-0600 on 6135 kHz, and at 0630-0800 on 9655 kHz.

Czechoslovakia—R. Prague has Eng. to N.A. at 0100-0155 on 7345, 11,990, 15,368, and 17,840 kHz, and at 0330-0425 on 5930, 7345, 11,990, and 15,368 kHz. "Magazine of the Air" is broadcast on Sundays at 1400-1455 on 15,448, 17,705, and 21,450 kHz.

Denmark—Eng. from Copenhagen is broadcast: to N.A. at 0145-0215 on 9520 kHz; to the Far East at 0745-0815, to N.A. at 1245-1315, to S. Asia at 1445-1515, and to Africa at 1915-1945, all on 15,165 kHz. The weekly DX bulletin is now given on Wednesday instead of Tuesday during the Eng. half hour on weekdays at 0145 on 9520 kHz, and at 0745, 1245, 1445, and 1915 on 15,165 kHz. There are also tests in Eng. on Saturdays at 1015 on 9520 kHz.

Dominican Republic—Station HIMS. R. *Cristal*, Santo Domingo, continues to hold to 5007 kHz, and is heard in Spanish from 0150 to 0405 s/off, with Latin American pop tunes and time checks. Station HIRL, R. *Exitos*, listed as inactive, is being heard on 3365 kHz at 0200. The address, not positively copied, seems to be Apartado 70, Santiago de los Caballeros.

Egypt—Cairo is being reported on 11,695 kHz at 0415, on 15,048 kHz at 1350-1500, and on 17,865 kHz



The listening post of Victor Lipinski, WPE4HTV, Alexandria, Va., is well equipped with (left to right) an RCA cartridge recorder, on top of a Garrard 1000 symphonicon stereo; a Conar audio-color, on top of a Lafayette HA-520 FM receiver, on top of a Hallicrafters S-118; a Lafayette "Comstat-25" (for CB), on top of a Lafayette HA-230; and an RCA AM-FM receiver, on top of a Voice of Music speaker. Under the desk: an Airline amplifier. His record to date is 50 states and 60 countries verified.

SHORT-WAVE ABBREVIATIONS

annt—Announcement	QRN—Atmospheric disturbance
B/C—Broadcasting	QSL—Verification
CBC—Canadian Broadcasting Corporation	R.—Radio
Eng.—English	s/off—Sign-off
GMT—Greenwich Mean Time	s/on—Sign-on
ID—Identification	V—Voice
kHz—Kilohertz	VOA—Voice of America
kW—Kilowatts	xmsn—Transmission
N.A.—North America	xmtr—Transmitter

with news from 2350 to 0000 s/off; all-Arabic, Eng. is scheduled to N.A. at 0130-0300 on 9475 kHz, and to N. Africa at 0630-0700 on 7075 kHz.

England—London's World Service to N.A. is now on 17,790 kHz at 2115-2315, on 15,260 kHz at 2115-0030, on 11,780 kHz at 2300-0330, on 9580 kHz at 2300-0330, and on 6110 kHz at 0000-0330. Another new and unlisted xmsn to N.A. has been noted at 1600-1630 on 15,300 kHz. Plans call for the BBC to have its own "World Radio Club" with a quarter hour weekly program; more details will be forthcoming when available.

Finland—Pori is strong to N.A. in Eng. at 2300-2315 and in Finnish to 0000 on 15,185 kHz.

Formosa (Taiwan)—V. of *Free China*, Taipei, has Eng. at 0250-0350 on 7130, 11,825, 15,125, 15,345,

17,720, 17,775, and 17,890 kHz; at 1800-1900 on 9685, 9765, 11,725, 11,825, 15,125, and 17,890 kHz; and at 1030-1100 ("The Dragon Show") on 7130, 9655, 9685, 11,825, and 17,890 kHz.

Germany (West)—The VOA's low-powered xmtrs in Munich are scheduled at 0300-0730 and 1400-2345 to Europe on 3980 kHz and at 1645-1730 to the Middle East on 11,880 kHz, both using 8 kW.

Deutsche Welle, Cologne, is scheduled to N. A. in Eng. at 0130-0250 (with some French) on 9640 and 11,945 kHz, at 0445-0545 on 9735 and 11,945 kHz, at 1045-1055 on 11,905 and 15,315 kHz, and at 1900-1910 on 15,245 and 17,785 kHz.

Guatemala—Station TGNA. R. *Cultural*, Guatemala City, is audible on the West Coast on both 5955 and 720 kHz in Eng. from 0300 to 0400 s/off. Another station, on 6100 kHz, is believed to be TGOA. *La Voz de las Americas*, noted at 2330-0000 with "Pepsi" commercials and constant mention of "America Central."

Haiti—Station 4VHW. R. *Haiti*, Port-au-Prince, can be heard in French at 2120-2140 on 6195 kHz, with pop music.

Hungary—R. *Budapest* is beamed to Europe in Eng. at 1930-2230 on 21,685, 17,890, 15,160, 11,910, 9833, 7220, 7100, 6234, and 3995 kHz; and to N.A..

Sonar SENTRY VHF MONITOR RECEIVERS

With Battery, Earphone, & Carrying strap
less Crystals
Crystals \$5.00 ea.

\$39⁹⁵

Model

FR-103 150-175 MHz	FR-106 25-50 MHz	AR-107 Aircraft 108-136 MHz
-----------------------	---------------------	-----------------------------------

LISTEN TO: POLICE, FIRE, AIRCRAFT & WEATHER REPORTS!

for Industrial, Commercial, Utility & Govt. Use

2 CHANNELS • BROADCAST BAND • CRYSTAL CONTROLLED

Designed and engineered for simplicity of operation, compact enough to fit a shirt pocket yet powerful enough to deliver a clear, clean signal—it's dependable • Operates on two crystal controlled VHF channels plus broadcast band • Completely solid state for long life use • Visible battery indicator to show battery condition at all times • Built-in antenna • 5 1/4" H x 2 1/2" W x 1 1/4" D. Wt. 11 oz.



SOLID STATE

POCKET SIZE

SONAR RADIO CORP., 73 Wortman Ave., Bklyn, N.Y. 11207

Please send information on VHF Monitor Receivers.

Name _____ Dept. 556

Address _____

City _____ State _____

CIRCLE NO. 25 ON READER SERVICE PAGE

POPULAR ELECTRONICS SUBSCRIBER SERVICE

Please include an address label when writing about your subscription to help us serve you promptly. Write to: Portland Place, Boulder, Colo. 80302

CHANGE OF ADDRESS:

Please let us know you are moving at least four to six weeks in advance. Affix magazine address label in space to the right and print new address below. If you have a question about your subscription, attach address label to your letter.

TO SUBSCRIBE:

Check boxes below.

- New Renewal
 5 years \$20
 3 years \$13
 1 year \$5

SPECIFY:

- Payment enclosed
 —You get 1 extra issue per year as a BONUS!
 Bill me later.

← AFFIX LABEL →

If you have no label handy, print OLD address here.

name _____

address _____

city _____

state _____

zip-code _____

please print

[Add postage: \$1 per year outside U.S., its possessions & Canada.]

name _____ please print _____ 0228

address _____

city _____

state _____ zip-code _____



SMALL BUT POWERFUL

**DON'T BE FOOLED BY
IMITATIONS!**

Get the ORIGINAL

SYDMUR SOLID STATE "CD" IGNITION SYSTEM!

High Quality Components used throughout. Fiberglass Printed Circuit Board. Unitized Construction. Simplified Kit Assembly.

Construction Article in Nov. 1966 Popular Electronics
Thousands of satisfied customers.
Write for Free Literature TODAY.

COMPAC Assembled . . . \$34.75*

COMPAC KIT . . . 24.95*

*Add 75c for mailing and handling

N.Y. State Residents add Sales Tax.

SYDMUR ELECTRONICS SPECIALTIES
1268 E. 12th St. Brooklyn, N.Y. 11230

LEARN Electronics Engineering AT HOME

Fix TV, design automation systems, learn transistors, complete electronics. College level Home Study courses taught so you can understand them. Earn more in the highly paid electronics industry. Computers, Missiles, theory and practical. Kits furnished. Over 30,000 graduates now employed. Resident classes at our Chicago campus if desired. Founded 1934. Catalog. "Vets—write for information about G I Bill Training."

AMERICAN INSTITUTE OF ENGINEERING & TECHNOLOGY
1137 West Fullerton Parkway, Chicago, Illinois 60614

Australia, and New Zealand at 0030-0130, 0300-0400, and 0430-0500 on 15,160, 11,910, 9833, 7220, and 6234 kHz.

Iraq—*R. Baghdad* has Eng. to Europe at 1730-1820 on 6030 and 6095 kHz according to their schedule. Can anyone confirm?

Kuwait—This country, broadcasts in Eng. at 1600-1900 on 4967.5 kHz, with 10 kW. Some reports also indicate that there is Eng. at 0500-0600 on the same frequency although this time is listed only for medium-wave service on 1130 kHz.

Lebanon—A registered mail schedule gives the following new information; to N.A., U.S.A., Canada, Mexico, Antilles, and Europe in French at 0130-0200; to Western U.S.A. in Arabic at 0200-0230 and in Eng. at 0230-0300; to Eastern U.S.A. in Arabic at 0300-0330 and in Spanish at 0330-0400; all on 11,965 kHz.

Malawi—Malawi B/C Corp., Blantyre, has been unusually good from 0345 s/on with drums and a cock crowing; the broadcasts include pop and native music with vernacular anmts. Despite a good signal, however, the 3380-kHz frequency used is likely to have plenty of late summer QRN.

Mauritania—*R. Mauritanie*, Nouakchott, has the following schedule, according to a recent QSL: weekdays at 0700-0800, 1300-1530, and 1800-2230; Sundays at 0800-1400 and 1700-2300. Frequencies: 1349 kHz, with 1 kW, all times; 7245 kHz, with 4 kW and 9610 kHz, 30 kW, at 1330-1530; 3222 or 4855 kHz, 30 kW, at 0700-0800 and 1700-2300.

Mexico—Station XEQM, *R. Frecuencia Juventud*, Merida, 6105 kHz, is noted at 2030-2100 with few ID's but frequent mention of Yucatan and some beer commercials. You may hear a cuckoo clock on the half hour. This broadcast is all-Spanish, and the power rating is only 250 watts.

Navassa Island—This island, located between Haiti and Jamaica, and thought by some to be the actual location of *R. Swan*, will soon have a commercial station with a 50-kW xmtr on the medium waves and a 20-kW xmtr on the short waves, according to an overseas source. No specific frequencies have been given as yet.

Nepal—*R. Nepal*, Kathmandu, was heard on the East Coast with Eng. and pop music at 1245 on 4600 kHz. Very weak, this station should prove exceptionally difficult for most monitors to log.

Netherlands—*R. Nederland*, Hilversum, has a special news xmsn in Eng. and Spanish at 2310, followed by another in Dutch at 2330, on 15,320 kHz.

Norway—Here is *R. Norway's* complete Eng. schedule, with all xmsns listed being 30 minutes in length and on Sundays only except as noted: at 0800 to the Pacific, Far East, Australia, and Africa on 11,850, 15,175, 17,775, 21,655, and 21,730 kHz; at 1200 to N. Europe, Australia, New Zealand, the Far East, and W. Africa, on 7240, 15,175, 17,825, 21,655, and 21,730 kHz; at 1400 to the Americas, Indonesia, Australia, and S. Africa on 15,345, 17,825, 21,655, 21,670, and 21,730 kHz; at 1600 to the Americas, Middle East, and S. Africa on 15,345, 17,825, 21,655, 21,670, and 21,730 kHz; at 1800 to U. S. West Coast, the Pacific, Africa, and S. America on 11,850, 17,825, 21,655, 21,670, and 21,730 kHz; at 2000 to N. and S. America and E. Africa on 15,345, 17,825, 21,655, and 21,730 kHz; at 2200 to W. Europe, Caribbean, and S. America on 15,345, 17,825, 21,655, and 21,730 kHz; Mondays at 0000 to the Americas and N. Europe on 11,735, 15,175, 15,345, and 21,655 kHz; and Mondays at 0400 to N. and C. America, the Pacific, and N. Europe on 9645, 11,735, and 11,850 kHz. The last two xmsns are also on 1578 kHz.

Paraguay—Station ZPA5, *R. Encarnacion*, Asuncion, was good at times as noted on 11,947 kHz at 2245-2330 and 0015-0030, with Latin American music, home and world news, talks, and many commercials, all-Spanish.

Philippines—The VOA's low-powered xmsns in Malolos are scheduled to S. China on 7275 kHz at 1315-1600, on 11,850 kHz at 2145-0200 and on 11,865

kHz at 0845-1630; to S. Asia at 2200-0200 on 15.165 kHz; to S. E. Asia at 1000-1300 on 15.335 kHz; and to Indonesia and N. E. Asia at 0900-1630 on 15.345 kHz. The 7275- and 15.335-kHz xmtrs operate with 7.5 kW, the others with 15 kW.

The Far East B/C Co., Manila, is using 11.770 kHz at 1630-1736 for Russian religious programs to the Soviet Union, dual with 11,890 kHz. The former channel evidently has replaced the usual frequency of 11.855 kHz.

Rumania—Eng. to N. A. is scheduled at 0130-0230 on 15,250, 15,225, 11,940, 11,810, 11,725, and 9590 kHz, and at 0300-0330 and 0430-0500 on the same channels plus 9570 kHz.

Ryukyu Islands—The VOA, Okinawa, has a 15-kW xmtr on 15,240 kHz at 1000-1600 beamed to S. E. Asia.

Sweden—Here is R. Sweden's complete Eng. schedule: to Europe at 0900-0930 and 1100-1130 on 9625 kHz and at 2015-2045 on 6065 kHz; to the Middle East at 0900-0930 and 1900-1930 on 21,690 kHz; to the Far East at 1100-1130 and 1230-1300 on 15,240 kHz and 2245-2315 on 11,810 kHz; to Africa at 1230-1300 on 21,690 kHz and at 1900-1930 on 15,240 kHz; to S. Asia at 1400-1430 on 21,585 kHz and at 0515-0545 on 17,840 kHz; to S. America at 2245-2315 on 11,705 kHz; to Eastern N. A. at 1400-1430 and 1600-1630 on 17,840 kHz and at 2015-2045, 0030-0100, and 0200-0230 on 17,840 kHz; and to Western N. A. at 1600-1630 on 15,240 kHz and at 0330-0400 on 11,705 kHz.

Tanzania—Dar-es-Salaam was noted briefly on 5050 kHz with soft African music mixed with a few U.S. pop tunes at 0325-0355. The Interna-



The listening post of Philip Horkin, WPE6GXA, Sherman Oaks, Calif., contains a National NC-77X receiver, preselector, a Roberts 1040 tape recorder, home-built transmitting equipment, and an intercom connected to the shack of another SWL in his area.

tional Service has been picked up on a new frequency of 4915 kHz with Eng. and Swahili to Nigeria, Ethiopia, and E. Africa around 1755; Eng. has also been heard at 1600 on 4785 kHz. Has anyone definitely heard either of R. Tanzania's Swahili networks operating at 0300-2000 on 5985 kHz and at 0900-1500 on 9550 kHz?

Vietnam (South)—Saigon's complete overseas schedule reads: Vietnamese at 2200-0000 on 6165 and 9620 kHz and at 0000-1600 on 4877 kHz; Cantonese at 0000-0115, 0500-0615, and 1430-1530 on 7245 kHz; Mandarin at 0115-0200 and 1400-1430 on 7245 kHz; French at 1100-1200, Eng. at 2330-0000 and 1230-1300, Cambodian at 0430-0500 and 1015-1100, and Thai at 0000-0030, all on 9755 kHz. Reports go to The National Broadcasting System of Vietnam, 3, Phan-Dinh-Phung Str., Saigon.



ASSEMBLED
\$54.95

KIT FORM
\$44.95

\$5 DOWN — \$5 MONTH

Walnut finished cabinet included / Shipped REA Collect

Easy to build, easy to install. All transistor **AUDIO-COLOR** adds a visual dimension to musical enjoyment. A brilliantly moving panorama of color casts dancing images on a soft frosted screen, reflecting rising and falling volume with each beat of the music. Here's a truly unique and exciting new musical experience. Make check or money order to **CONAR**.

SEND FOR FREE CONAR CATALOG

CONAR

Division of National Radio Institute,
Dept. JA7C 3939 Wisconsin Ave.,
Washington, D.C. 20016

TELEVISION RADIO
COLOR TV

MAIL COUPON FOR FREE BOOK

Coyne Electronics Institute Dept. 67-C2
1501 W. Congress Pkwy., Chicago, Ill. 60607

Send information as checked below

- HOME TRAINING in TV • Radio • Color TV • Electronics
- RESIDENT SCHOOL COURSES in Electronics, Electricity, Engineering, Radio-TV, Color TV, Refrigeration, and FCC

Name.....
Address.....
City..... State..... Zip.....
Phone..... Age.....

VA Approved—GI Bill



NOW AVAILABLE!
THE FIRST SOLID-STATE CCTV CAMERA KIT!

VIDICON * 400 line resolution * AUTOMATIC light compensation * Video or RF output (ch. 2-6) * Connects without modification to any TV receiver

ONLY \$149⁹⁹

LIGHTS! ACTION! CAMERA!

OUTPERFORMS old-fashioned tube model cameras yet COSTS LESS! Field and lab tested for thousands of hours. Perfect for amateur, industrial and educational applications. Designed to run continuously. Completely self-contained, single printed circuit board construction. Get all the details (including pictures) in our BRAND NEW 20 page closed-circuit TV catalog. It's FREE—Write TODAY! Also included is a full complement of tube and transistor "starter" kits, focus-deflection coils, lenses, vidicons, tripods and other essential TV items. **FACTORY-DIRECT** prices save you money.

P. O. BOX 396-P8

ATV RESEARCH

SO. SIOUX CITY, NEBR. 68716

NEW Mosley

CB STACK 'IT Beam

Extra gain for nearly 1/2 the previous cost of stacking Mosley beams.

4610 N. Lindbergh Blvd.
Mosley Electronics Inc. Bridgeton Missouri 63042

Please send me FREE of charge and obligation, literature on the STACK 'IT beams.

Name _____

Address _____

City/State _____

Zip Code No. _____

Mosley Electronics Inc. #108

4610 N. Lindbergh Blvd. Bridgeton Mo. 63042

CIRCLE NO. 18 ON READER SERVICE PAGE



NEW MOSLEY NOVICE

A completely Do-It-Yourself beam for 15 meters. Priced to fit your budget.

X-15 rated for Full Power (Novice or General). Readjust for 10 meters, if desired, when you become a General.

Please send FREE info. on X-15 Beam.

Name _____

Address _____

City/State _____

Zip Code No. _____

Mosley Electronics Inc. #121

4610 N. Lindbergh Blvd. Bridgeton Mo. 63042

CIRCLE NO. 19 ON READER SERVICE PAGE

Yugoslavia—R. *Belgrade* can be heard in Eng. at 1830-1900 and 2200-2215 on 6100 kHz and in Spanish at 0000-0030 and 0100-0130 on 7200 kHz.

Zambia—R. *Zambia* now broadcasts its General Service on 3295, 4911, 6165, 7240, and 9505 kHz, and the Home Service on 3346, 4965, 6060, and 7220 kHz. This station is also testing on 9505 kHz with low power at 0700-1400 and would welcome reports—send them to the Chief Engineer, Mr. J. Allerton.

Clandestine—*Peyk-ye-Iran* (the station frequently jammed by another clandestine station more popularly known as the "Kiss Me Honey" station

SHORT-WAVE CONTRIBUTORS

Bill Scholz (WPE1GKK), Ansonia, Conn.
Stan Mayo (WPE1GMF), Port-and, Me.
Conrad Baranowski (WPE1GXX), Boston, Mass.
William Gilbert (WPE1HBO), Hamden, Conn.
Bob Klatskin (WPE1HEX), Hamden, Conn.
Eric Lebowitz (WPE2JY), Jackson Heights, N. Y.
William Graham (WPE2LMU), Binghamton, N. Y.
Robert Kaplan (WPE2JMR), Bronx, N. Y.
Ken Coyne (WPE2XFC), Long Beach, N. Y.
Paul Mayo (WPE2XJG), Brooklyn, N. Y.
Peter Macinta, Jr. (WPE2ORB), Kearny, N. J.
Morey Goldstein (WPE2PGR), East Meadow, N. Y.
Dave Palfrey (WPE2PKC), Kearny, N. J.
John Hopkins (WPE2PM), Rockville Centre, N. Y.
Walter Horowitz (WPE2PVS), Bayside, N. Y.
James Rivie'n (WPE2POK), Cherry Hill, N. J.
Alec Slater (WPE2PQM), Little Neck, N. Y.
Robert Kennicutt, Jr. (WPE2PRR), Port Crane, N. Y.
Howard Silverstein (WPE3GVL), Philadelphia, Pa.
Mark Maersch (WPE3HEK), Severna Park, Md.
John Seiler (WPE3HIC), Pittsburgh, Pa.
Robert Wilkner (WPE1ACP), Pompano, Fla.
Grady Ferguson (WPE1BC), Charlotte, N. C.
Dan Henderson (WPE1GH), Laurel, Md.
John Ethridge (WPE4HC), Martin, Tenn.
Kirk Randall (WPE4IO), McLean, Va.
David Meisel (WPE4IRS), Charlottesville, Va.
Paul Hill (WPE4JCV), Virginia Beach, Va.
Ed Shaw (WPE4JHP), Roanoke, Va.
Ronald Curtis (WPE5ERM), Edmond, Okla.
Charles Rickman (WPE5GQ), Warrenton, Va.
W. W. Mosby (WPE6EAX), San Jose, Calif.
Trevor Clegg (WPE6FAF), Fresno, Calif.
Joseph Courville (WPE6GIL), South Gate, Calif.
Richard Ripley (WPE6GOX), Glendale, Calif.
Tim Vanderelli (WPE6GUF), Picoima, Calif.
Juris Burkevics (WPE7CJJ), Firecrest, Wash.
Charles Milhans (WPE7COE), Tacoma, Wash.
Donald Cheney (WPE7COO), Corvallis, Ore.
Fred Wright (WPE8GDK), APO, San Francisco, Calif.
Richard Pistek (WPE9HQA), Chicago, Ill.
Steve Brimmer (WPE9HAM), Eau Claire, Wis.
Bill Vogt (WPE9ND), Tinley Park, Ill.
A. R. Niblack (WPE9KMI), Vincennes, Ind.
John Beaver, Sr. (WPE9AE), Pueblo, Colo.
Walt Green (WPE9EVK), Davenport, Iowa
Jack Perolo (WPE9PEY), Milwaukee, Wis.
Mike Wilson (WPE9EAX), Calgary, Alta, Canada
Leo Alster, Rahway, N. J.
Bruce Horlick, Los Angeles, Calif.
Paul Jordano, Mt. Vernon, N. Y.
Nelson Maylone, Detroit, Mich.
Roger Tre-kunoff, San Francisco, Calif.
Ricky Weber, Levittown, N. Y.
Canadian Broadcasting Corp., Montreal, Que. Canada
Deutsche Welle, Cologne, Germany
International Short-Wave Club, London, England
R. Sweden, Stockholm, Sweden
Sweden Calling DX'ers Bulletin, Stockholm, Sweden

although the latter no longer uses that particular recording) is the *Voice of the Communist Party of Iran* (TUDEN). The station gives a mailing address of Box 4176, Stockholm 4, Sweden (although its actual location is reportedly East Berlin), has a mailing list, and dispenses Marxist literature. Listeners' letters are answered on Wednesdays. When last heard, this station was operating on 11,695 kHz around 1600-1740.

An overseas source states that the Kurds of northern Iraq also have a xmitr operating on 11,695 kHz but that it cannot be heard in Europe (and presumably not in N.A. either.—Ed).

—30—

ELECTRONICS MARKET PLACE

COMMERCIAL RATE: For firms or individuals offering commercial products or services. \$1.00 per word (including name and address). Minimum order \$10.00. Payment must accompany copy except when ads are placed by accredited advertising agencies. Frequency discount: 5% for 6 months; 10% for 12 months paid in advance.

READER RATE: For individuals with a personal item to buy or sell. 60¢ per word (including name and address). No Minimum! Payment must accompany copy.

GENERAL INFORMATION: First word in all ads set in bold caps at no extra charge. Additional words may be set in bold caps at 10¢ extra per word. All copy subject to publisher's approval. Closing Date: 1st of the 2nd preceding month (for example, March issue closes January 1st). Send order and remittance to: Hal Cymes, POPULAR ELECTRONICS, One Park Avenue, New York, New York 10016.

FOR SALE

FREE! Giant bargain catalog on transistors, diodes, rectifiers, SCR's, zeners, parts. Poly Paks, P.O. Box 942, Lynnfield, Mass. 01940.

GOVERNMENT Surplus Receivers, Transmitters, Snooperscopes, Radios, Parts, Picture Catalog 25¢. Meshna, Nahant, Mass. 01908.

INVESTIGATORS, FREE BROCHURE, LATEST SUBMINIATURE ELECTRONICS SURVEILLANCE EQUIPMENT, ACE ELECTRONICS, 11500-L NW 7TH AVE., MIAMI, FLA. 33168.

CB-WPE-QSL CARDS. Same High Quality, Beautiful, Glossy multi-color cards. New **LOW PRICES. SAMPLES, 25¢.** Dick, W8VXK, 19QA0625, Gladwin, Mich. 48624.

R.F. CONVERTERS. World's largest selection. Also CCTV cameras, etc. Lowest factory prices. Catalog 10¢. Vanguard 196-23 Jamaica Ave., Hollis, N.Y. 11423.

TELEPHONE VOICE SWITCH: (LS-500). ACTUATES AUTOMATICALLY AND UNATTENDED ANY TAPE OR WIRE RECORDER. PICTORIAL INSTALLATION INSTRUCTIONS INCLUDED. \$23.75. POST PAID USA, WJS ELECTRONICS, 737 NORTH SEWARD, HOLLYWOOD, CALIF. 90038.

INVESTIGATORS: KEEP IN STEP WITH ADVANCEMENTS IN THE ART OF ELECTRONICS FOR THE PROFESSIONAL. SEND \$1.00 FOR EQUIPMENT BROCHURE. WJS ELECTRONICS, 737 NORTH SEWARD, HOLLYWOOD, CALIF. 90038.

BUG DETECTOR: WILL DETECT AND LOCATE SURREPTITIOUS TRANSMITTING DEVICES IN CONFERENCE ROOMS, HOME AND OFFICES, ETC. WRITE FOR DETAILS. WJS ELECTRONICS, 737 NORTH SEWARD, HOLLYWOOD, CALIF. 90038.

DETECTIVES! Free Brochures! Electronics Surveillance Devices. SILMAR ELECTRONICS, 3476 N.W. 7th Street, Miami, Fla. 33125.

CIRCUIT Boards, Parts for "Poptronics" projects. Free catalog. DEMCO, Box 16297, San Antonio, Texas 78216.

ROCKETS: Ideal for miniature transmitter tests. New illustrated catalog, 25¢. Single and multistage kits, cones, engines, launchers, trackers, rocket aerial cameras, technical information. Fast service. Estes Industries, Penrose 18, Colorado 81240.

LOWEST Prices Electronic Parts. Confidential Catalog Free. KNAPP, 3174 8th Ave. S.W., Largo, Fla. 33540.

RADIO-T.V. Tubes - 33¢ each. Send for free catalog. Cornell, 4213 University, San Diego, Calif. 92105.

CONVERT any television to sensitive, big-screen oscilloscope. Only minor changes required. No electronic experience necessary. Illustrated plans, \$2.00. Relco-A33, Box 10563, Houston, Texas 77018.

MUSIC LOVERS, CONTINUOUS, UNINTERRUPTED BACKGROUND MUSIC FROM YOUR FM RADIO, USING NEW INEXPENSIVE ADAPTOR. FREE LITERATURE. ELECTRONICS, 11500-Z NW 7th AVE., MIAMI, FLORIDA 33168.

EXPERIMENTERS Having trouble understanding TRANSISTOR Terminology? Our pamphlet can help you. Includes **FIELD EFFECT.** Only \$1.00. Williams, Box 2131, Lehigh Valley, Penna. 18001.

SURVEILLANCE EQUIPMENT - NEW HIGH PERFORMANCE SUBMINIATURE MODELS. ELECTRONIC COUNTERMEASURE DEVICES TO PROTECT PRIVACY. FREE DATA: SECURITY ELECTRONICS-PE, 15 EAST 43RD STREET, NEW YORK, N.Y. 10017.

CRYSTALS . . . largest selection in United States at lowest prices. 48 hr. delivery. Thousands of frequencies in stock. Types include HC6/U, HC18/U, FT-241, FT-243, FT-171, etc. Send 10¢ for catalog with oscillator circuits. Refunded on first order. Jan Crystals, 2400F Crystal Dr., Fort Myers, Fla. 33901.

FREE ELECTRONICS (new and surplus) parts catalog. We repair multimeters. Bigelow Electronics, Bluffton, Ohio 45817.

JAPANESE PRODUCTS CATALOG by air mail \$5, sea \$3. Intercontinental, CPO 1717, Tokyo, Japan.

TREASURE Hunters! Prospectors! Relco's new instruments detect buried gold, silver, coins. Kits, assembled models. Transistorized. Weighs 3 pounds. \$19.95 up. Free catalog. Relco-A33, Box 10836, Houston, Texas 77018.

SEND FOR FREE CATALOG, featuring transistors, rectifiers, zeners, SCR's, biswitches and other semiconductor devices in large and small quantities. **ALL DEVICES ARE CHECKED AND GUARANTEED. INTEGRATED CIRCUITS (JK, SR, SRT FLIP FLOPS AND GATES),** with checked inputs and diagrams are available. Solid State Sales, Box 74F, Somerville, Mass. 02143.

LINEAR AMPLIFIERS: "Hornet"—50 watts output—\$98.50; "Raider"—100 watts—\$139.95; "Maverick—250"—250 watts—\$244.95. For AM and SSB. Frequency range 20-35 megacycles (illegal for Class D 11 meters.) Dealer inquiries invited. D & A Manufacturing Co., 1217 Avenue C, Scottsbluff, Nebraska 69361.

ELECTRONIC PARTS! Components, transistors, diodes, kits, relays, and many special items. Guaranteed. Send 25¢ for 100 page catalog. General Sales Co. P.O. Box 2031 D, Freeport, Texas 77541.

MESHNA'S TRANSISTORIZED CONVERTER KIT. Converts car radio to receive police and fire. 30-50MHz and 100-200 MHz (one MHz Tuning). \$5.00 with easy to follow step instructions. Meshnas, No. Reading, Mass. 01864.

WEATHERCASTER—Portable crystal controlled radio receiver for U.S. Weather Bureau's new instant weather channel (162.55 MHz). New York, Chicago, Honolulu, Kansas City, Miami and New Orleans now broadcasting. Inquire at other local Weather Bureaus before ordering. \$39.95. Shaw Electronics, Roper Building, Miami, Florida 33131.

ELECTRONIC, MECHANICAL DEVICES CATALOG 10¢. Gear Bonanza, \$2.50 FERTIK'S, 5249 "D," Phila., Pa. 19120.

PRINTED circuit artwork and boards. Free lists, Dirck Spicer, 11 Ridgeland Road, Wallingford, Connecticut 06492.

RECTIFIERS, transistors, other components. Catalog free. Electronic Components Co., Box 2902C, Baton Rouge, La. 70821.

TELETYPE test set, surplus, like new. Loaded with useful parts. (Cost Gov't \$600.00). \$14.95. F.O.B. Harrisburg, Pa., Telemethods International, Box 18161, Cleveland, Ohio 44118.

ELECTRONIC Ignition. Kits, components, systems. Diagrams. Anderson Engineering, Epsom, N.H. 03239.

DIAGRAMS—Radios \$1.00, Television \$2.50. Give make and model. Diagram Service, Box 1151PE, Manchester, Conn. 06042.

CLOSED CIRCUIT TV CAMERA KITS! \$18.95 (starter) to \$149.50 (complete). Both tube and transistorized models. Step-by-Step instruction manuals. Televisive live pictures on any standard TV receiver without modification. Quality performance! Perfect for industrial, educational and experimenter applications. **FACTORY-DIRECT** prices. Compare before buying. **ATV RESEARCH**, Thirteenth and Broadway, Dakota City, Nebr. 68731.

COURSES: TELEPHONE ENGINEERING \$39.50; Detective Electronics \$22.50; **SECURITY ELECTRONICS** \$27.50. We **SELL CONSTRUCTION PLANS**. Telephone: Ansaphone, Speakerphone, Legal Connector, Carphone, Central Dial System, Pushbutton Dialer. Detective: Tail Transmitter, Wireless Mike. Hobbyist: Electron Microscope, Police Radar Detector with Legal Jammer, All Electronic \$35 Color TV Converter, TV Camera, TV Recorder; Plans \$4.95 each. "Dynamites All Mikes, silent jammer," "Olive Mike," "Know your Telephone Rights," plans \$8.50 each. **SUPER HOBBY CATALOG** 25¢. Don Britton Enterprises, PO Drawer G, Waikiki, Hawaii 96815.

WEBBER LAB'S POLICE-FIRE KITS \$5.00 ALL SOLID STATE, SPECIFY FREQUENCY. 26-200MC **ALWIRED CRYSTAL CONTROLLED LIFE TIME GUARANTEE \$23.00, KIT \$11.00. WRITE FOR METAL LOCATORS, REMOTE READING COMPASS, CATALOG 10¢, 72 COTTAGE STREET, LYNN, MASS.**

DIAGRAMS, SERVICE MANUALS, \$1. Technical Services Associates, Box 1167, Berkeley, California 94701.

CIGARETTES 12¢ a pack—Improved roller makes 20 filter-tip or plain, king or regular for 12¢. Facts free. Moberly, Box 961, Owensboro, Kentucky 42301.

EUROPEAN and Japanese bargain catalogs. \$1 each. Dee, 10639E Riverside, North Hollywood, Calif. 91602.

JAPANESE or EUROPEAN DIRECTORY 200 firms \$1.00. **SURVEILLANCE EQUIPMENT**, wireless **SNOOPERMIKE** \$25.00, **SUBMINNIKIKE** 3/8 x 3/8 x 3/16 \$4.00, Brochure 25¢, **SIERRATRONICS**, Box 7497, Las Vegas, Nev. 89101.

LOWEST prices. LP records. All labels. Harvey's, Box 1402, Newport News, Va. 23601.

PLANS AND KITS

ALLWAVE RADIO KIT. Tube, transistor included \$5.00. Headset \$2.50. Ekeradio, Box 131, Temple City, Calif. 91780.

ULTRA MINIATURE CB TRANSMITTER. Under 2" long. Easy and inexpensive to build. Complete Plans—\$2.00. Electronics, Box 262-B, Stuyvesant Station, New York, N.Y. 10009.

INTEGRATED CIRCUIT KITS; COMPUTER LOGIC; Parts; Others. Catalogue free. **KAYE ENGINEERING**, Box 3932, Long Beach, California 90803.

"DISTANCE CRYSTAL SET CONSTRUCTION" Handbook—50¢. Catalog. Laboratories, 12041-L Sheridan, Garden Grove, Calif. 92640.

GIANT TESLA COIL—FORTY-INCH SPARKS! Complete plans \$5.00. Details, color photo 50¢ (deductible). Huntington Electronics, Inc., Box 9-P, Huntington Station, Shelton, Conn. 06484.

TUBES

TUBES "Oldies", latest. Lists free. Steinmetz, 7519 Maplewood, Hammond, Indiana 46324.

TUBE Headquarters of World! Send 10¢ for Catalog (tubes, electronic equipment) Barry, 512 Broadway, N.Y.C. 10012.

RADIO & T.V. Tubes—33¢ each. Send for free list. Cornell, 4213 University, San Diego, Calif. 92105.

RECEIVING & INDUSTRIAL TUBES, TRANSISTORS. All Brands—Biggest Discounts. Technicians, Hobbyists, Experimenters—Request **FREE** Giant Catalog and **SAVE!** **ZALYTRON**, 469 Jericho Turnpike, Mineola, N.Y. 11501.

DON'T BUY TUBES—Radio, TV-Xmitting, special-purpose types until you get our price list! Lowest prices in U.S.A. 5,000 types—Guaranteed Brand New. Send postcard for TV—Special Purpose Price List. **UNITED RADIO COMPANY, P.O. BOX 1000, NEWARK, N.J. 07101.**

CLASSIFIED ADVERTISING ORDER FORM

Please refer to heading on first page of this section for complete data concerning terms, frequency discounts, closing dates, etc.

1	2	3	4	5
6	7	8	9	10
11	12	13	14	15
16	17	18	19	20
21	22	23	24	25
26	27	28	29	30
31	32	33	34	35

Words { @ 60¢ (Reader Rate) } = \$ _____
 { @ \$1.00 (Commercial Rate) }

Insert _____ time(s) Total Enclosed \$ _____

NAME _____

ADDRESS _____

CITY _____ STATE _____ ZIP _____

Signature _____

WORD COUNT: Include name and address. Name of city (Des Moines) or of state (New York) counts as one word each. Zone or Zip Code numbers not counted. (Publisher reserves right to omit Zip Code if space does not permit.) Count each abbreviation, initial, single figure or group of figures or letters as a word. Symbols such as 35mm, COD, PO, AC, etc., count as one word. Hyphenated words count as two words. PE-967

SHORTWAVE LISTENING

ANTENNA SPACE PROBLEMS? Solve with **JOTSTICK!** Mosley SWL-7. All Books for SWLs. SWL Guide, 218 Gifford, Syracuse, N.Y. 13202.

HIGH FIDELITY

FREE! Send for money saving stereo catalog #P9E and lowest quotations on your individual component, tape recorder, or system requirements. Electronic Values, Inc., 200 W. 20th St., New York, N.Y. 10011.

Hi-Fi Components, Tape Recorders, at guaranteed "We Will Not Be Undersold" prices. 15-day money-back guarantee. Two-year warranty. No Catalog. Quotations Free. Hi-Fidelity Center, 239 (P) East 149th Street, New York 10451.

"**LOW**, Low quotes: all components and recorders. Hi-Fi, Roslyn, Penna. 19001.

TAPE RECORDERS, Hi-Fi, components, Sleep Learning Equipment, tapes. Unusual Values Free Catalog. Dressner, 1523R, Jericho Turnpike, New Hyde Park, N.Y. 11040.

WANTED

CASH Paid! Unused tubes, electronic equipment. Barry, 512 Broadway, NYC 10012.

QUICKSILVER, Platinum, Silver, Gold. Ores Analyzed. Free Circular. Mercury Terminal, Norwood, Mass. 02062.

\$1.00—SENDS your name to wholesalers, importers, etc. Many **FREE SAMPLES**. Shopper, 1727 State, Santa Barbara, Calif. 93101.

TAPE AND RECORDERS

TAPE RECORDER SALE. Brand new, latest models, \$10.00 above cost. Arkay Sales, 1028-C Commonwealth Ave., Boston, Mass. 02215.

TAPE transport. NAB recording studio quality. Build yourself for amazingly low cost. Detailed plans \$5.00. Free particulars. Pepke Laboratories, 309-B West 19 Street, New York, N.Y. 10011.

BEFORE Renting Stereo Tapes try us. Postpaid both ways—no deposit—immediate delivery. Quality—Dependability—Service—Satisfaction—prevail here. If you've been dissatisfied in the past, your initial order will prove this is no idle boast. Free Catalog. Gold Coast Tape Library, Box 2262, Palm Village Station, Hialeah, Fla. 33012.

RENT 4-TRACK STEREO TAPES—Dependable service our keynote—**ALL MAJOR LABELS**—**FREE CATALOG** (48 States)—**TRIMOR** Company, P.O. Box 748, Flushing, N.Y. 11352.

STEREO TAPES. Save up to 60% (no membership fees, postpaid anywhere U.S.A.). Free 60 page catalog. We discount batteries, recorders, tape accessories. Beware of slogans "not undersold," as the discount information you supply our competitor is usually reported to the factory. **SAXITONE**, 1776 Columbia Road, Washington, D.C. 20009.

AUTOMATIC telephone connection for Concord and other transistorized recorders. **SURVEILLANCE** and Privacy Protection Devices. Free Data: Security Electronics-PER, 15 East 43rd Street, New York, N.Y. 10017.

RENT Stereo Tapes—over 2,500 different—all major labels—free brochure. Stereo—Parti, 1616-PE Terrace Way, Santa Rosa, California 95404.

Hi-Fi Components. Tape Recorders, at guaranteed "We Will Not Be Undersold" prices. 15-day money-back guarantee. Two-year warranty. No Catalog. Quotations Free. HiFidelity Center, 239 (PT) East 149th Street, New York 10451.

EXCHANGE, rent Stereo Car Tapes. Autotapes, Box 19086-D, Indianapolis, Ind. 46219.

MICRO-TUBES Large select stock
Dependable fast service

Not connected with any other
Mail Order Tube Co.

Send For **FREE** Tube List &
Special Purpose Tubes

35¢ ea. in lots of 100
37¢ per tube

All tubes sent postage pd. Send 35¢ handling chg. on orders under \$5
Send 25¢ on C.O.D.'s. Send approx postage on Canadian & foreign orders

WE HAVE PICTURE TUBES
MICRO Electron Tube Co.
119 Martin St., Paterson, N. J.

FREE Booklet—How to Start a Small Business with your Tape Recorder. Angel Sound, P. O. Box 109, New York, N.Y. 10034.

NEW SONY PR-150 TAPE \$3.00 per 1800', 7" reel; \$17.00 for 6. Shipping 60¢ plus 10¢ per reel; \$1.00 for 6. Clay Webb, 101 N. Hyland, Ames, Iowa 50010.

REPAIRS AND SERVICES

TV Tuners rebuilt and aligned per manufacturers specification. Only \$9.50. Any make UHF or VHF. We ship COD. Ninety day written guarantee. Ship complete with tubes or write for free mailing kit and dealer brochure. JW Electronics, Box 51C, Bloomington, Indiana 47401.

MICROPHONES rebuilt to manufacturers response curve. All brands, all types expertly repaired. All Audio Service, Box 16, Deer Park, New York 11729.

POWER Transformers wound to your specifications. **BECO**, 1006 Riverside Dr., Salem, Virginia 24153.

INSTRUCTION

LEARN While Asleep, hypnotize with your recorder, phonograph. Astonishing details, sensational catalog free! Sleep-Learning Association, Box 24-ZD, Olympia, Wash. 98501.

LEARN ELECTRONIC ORGAN SERVICING at home all makes including transistors. Experimental kit—trouble-shooting. Accredited NHSC, Free Booklet. **NILES BRYANT SCHOOL**, 3631 Stockton, Dept. A, Sacramento, Calif. 95820.

ASSOCIATE Degree in Electronics Engineering earned through combination correspondence-classroom educational program. Free brochure. Grantham Technical Institute, 1505 N. Western Ave., Hollywood, Calif. 90027.

HIGHLY—effective home study course for FCC commercial phone exams. Free literature! Cook's School of Electronics, P.O. Box 36185, Houston, Texas 77036.

HIGH SCHOOL DIPLOMA at home. Qualified instructors. Send age, highest grade completed, for free details. No salesman. **SOUTHERN STATES ACADEMY**, Professional Bldg., Dept. 5, Decatur, Ga. 30000.

REI First Class Radio Telephone License in (5) weeks Guaranteed. Tuition \$295.00. Job placement free. (KANSAS CITY) R.E.I., 3123 Gillham Road, Kansas City, Missouri, Telephone WE1-5444. (SARASOTA) R.E.I., 1336 Main Street, Sarasota, Florida 33577. Telephone 955-6922.

HIGHLY EFFECTIVE home study course in Electronics Engineering Mathematics with circuit application. Earn your Associate in Science Degree. Free Literature. Cook's Institute of Electronics Engineering, P.O. Box 36185 Houston Texas 77036. (Established 1945.)

FCC First Class License in six weeks—nation's highest success rate—approved for Veterans Training. Write Elkins Institute, 2603B Inwood Road, Dallas, Texas 75235.

FCC LICENSE THROUGH TAPE RECORDED LECTURES at home plus one week personal instruction in Washington, Memphis, Minneapolis, Seattle or Hollywood. Bob Johnson Radio-telephone License Training, 1060D Duncan, Manhattan Beach, Calif. 90266.

PERSONALS

INVESTIGATORS, FREE BROCHURE, LATEST SUBMINIA-TURE ELECTRONIC SURVEILLANCE EQUIPMENT. ACE ELECTRONICS, 11500-K NW 7th AVE., MIAMI, FLA. 33168.

BORROW \$1,205 AIRMAIL! Repay \$47 for 36 months. State licensed. Postal Finance, Dept. 84-N, 200 Keeline Building, Omaha, Nebraska 68102.

BILL PROBLEMS? Poor credit no trouble. Not a loan company. Send for free application. Automatic Acceptance, 318PE Broadway Blvd., Reno, Nevada or 307PE Pocatset Ave., Providence, R. I.

INVENTIONS WANTED

PATENT Searches including Maximum speed, full airmail report and closest patent copies, \$6.00. Quality searches expertly administered. Complete secrecy guaranteed. Free Invention Protection forms and "Patent Information." Write Dept. 9, Washington Patent Office Search Bureau, 711 14th Street, N.W., Washington, D.C. 20005.

INVENTORS! Outright cash sale or royalties for your inventions. Patented. Unpatented. Active demand from our client manufacturers. Financial assistance available. Write Dept. 35, United States Invention Brokerage, 78 Wall Street, New York, N.Y. 10005.

INVENTORS. We will develop, help sell your idea or invention, patented or unpatented. Our national manufacturer clients are urgently seeking new items for outright cash sale or royalties. Financial assistance available. 10 years proven performances. For free information, write Dept. 41, Wall Street Invention Brokerage, 79 Wall Street, New York, N.Y. 10005.

INVENTIONS wanted. Patented; unpatented. Global Marketing Service, 2420-P 77th, Oakland, Calif. 94605.

INVENTIONS-IDEAS developed: **CASH/ROYALTY SALES.** Member: United States Chamber of Commerce, Raymond Lee, 230-GR PARK AVENUE, NEW YORK CITY 10017.

PATENT SEARCHES \$6.00! FREE "INVENTION RECORD"/ Information. Miss Hayward, 1029HR Vermont, District of Columbia 20005.

INVENTORS! Sell your invention for cash or royalties! Our client manufacturers eagerly seek new items. Patented. Unpatented. Financial assistance if needed. 25 years proven performances. For free information, write Dept. 20, Gilbert Adams, Invention Broker, 80 Wall St., New York, N.Y. 10005.

INVENTORS! Don't sell your invention, patented or unpatented, until you receive our offer. Eagle Development Company, Dept. P, 79 Wall Street, N.Y., N.Y. 10005.

INVENTORS Needing Help with any problem, financial, development, securing manufacturer, obtaining patent. Write the organization that delivers action and results—not promises. Pioneer Invention Service, Dept. 79, 150 Broadway, New York, N.Y. 10038.

GOVERNMENT SURPLUS

JEEPS Typically From \$53.90 . . . Trucks From \$78.40 . . . Boats, Typewriters, Airplanes, Electronics Equipment, Photographic Equipment, used. 100,000 Bargains Direct From Government. Complete Sales Directory and Surplus Catalog \$1.00 (Deductible First \$10.00 Order). Surplus Service, Box 810-J, Holland, Mich. 49424.

BOOKS

FREE CATALOG. Adult Books. **POSTAL PE,** 2217 Lackland, St. Louis, Missouri 63114.

FREE Book. Prophet Elijah Coming Before Christ. Wonderful Bible Evidence. PE Megiddo Mission, Rochester, New York 14619.

FREE catalog 950 aviation/electronic/space books, Aero Publishers, 329PE Aviation Road, Fallbrook, California 92028.

UNUSUAL Books! Catalog free! International, Box 7798(PE), Atlanta, Georgia 30309.

UNUSUAL Books—Catalog Free—Starlight Press, 170-05 Baisley Boulevard, Jamaica, New York 11434.

AUTHORS' SERVICES

AUTHORS! Learn how to have your book published, promoted, distributed. **FREE** booklet "ZD," Vantage, 120 West 31 St., New York 10001.

POEMS WANTED for new song hits and recordings by America's most popular studio. Tin Pan Alley, 1650-ZD Broadway, New York 10019.

MUSIC

POEMS wanted for new songs. Nashville Music Institute, Box 532-E, Nashville, Tennessee 37202.

SONGS, POEMS WANTED! For publishing, recording at our expense! Ted Rosen, 17PE Longwood Road, Quincy, Mass.

RECORDS MADE FROM YOUR TAPE RECORDINGS. For information write: Angel Sound, P. O. Box 109, New York, N.Y. 10034.

MUSICAL INSTRUMENTS

ACCORDIONS, GUITARS, BAND INSTRUMENTS! Save to 50%. Terms. Trades. Free Trial. Free catalog. Mention instrument. Music Mart, 5535-PE Belmont, Chicago 60641.

STAMPS

VALUABLE COLLECTORS' ITEM: Official Canadian 1st Day issue of the Queen Elizabeth Royal Visit to **EXPO 67** Postage Stamp mounted on commemorative envelope bearing beautiful portrait of Her Majesty. Postmarked with highly-prized first day cancellation! **ALSO INCLUDED** to introduce you to World's Most Rewarding Hobby: (2) Complete Set of 42 English Kings and Queens, (3) Big Collectors' Catalog, and (4) "How to Collect Postage Stamps" Booklet. Also, selections of Queen Elizabeth and other fine stamps from our approval service for Free Examination. You may return selections without buying and can cancel service anytime, but the Queen Elizabeth Commemorative Envelope, 42 English Kings and Queens, Big Collectors' Catalog, and Booklet "How to Collect Postage Stamps" are yours to keep **FREE!** Send 25¢ to cover postage and handling. **KENMORE STAMP COMPANY, B-225, MILFORD, NEW HAMP., 03055. USA**

HYPNOTISM

FREE Hypnotism, Self-Hypnosis, Sleep Learning Catalog! Drawer H400. Ruidoso, New Mexico 88345.

"FEMALE HYPNOTISM" Exposed, explained! "Secret Method"—they never know! \$2, rushed. Guaranteed! Isabella Hall, Silver Springs, Florida 32688.

FREE TRIAL!! Sensational! self-hypnosis record kit improves memory, concentration, personality. Results guaranteed! Forum, 333-AA9, Michigan, Chicago 60601.

HYPNOTIZE FEMALES!—Unnoticed! Instantly! Nerves! Exciting! Send \$2.25. Research Enterprises, 29-SN21 Samoset, Woburn, Mass.

FEMALE HYPNOTISM!! Easily! Instantly! Secret Nerve Centers! \$2.20. Brugenheimer Publishers, Box 158-E30, Lexington, Mass.

SPORT FILMS

NON-STOP ENTERTAINMENT IN SPARKLING COLOR—SUPER 8 OR REGULAR 8. Catalog. **SPORTLITE FILMS-PE**, 20 North Wacker Drive, Chicago, Illinois 60606.

RUBBER STAMPS

RUBBER ADDRESS STAMP \$1.50. SIGNATURE \$2.88. FREE CATALOG. **JACKSON PRODUCTS**, 1433 WINNE-MAC, CHICAGO, ILL. 60640.

PHOTOGRAPHY—FILM, EQUIPMENT, SERVICES

MEDICAL Film—Adults Only—"Childbirth"—1 reel 8mm \$7.50—16mm \$14.95. **International-E**, Greenvale, L.I., New York 71548.

SCIENCE Bargains—Request Free Giant Catalog "CJ"—148 pages—Astronomical Telescopes, Microscopes, Lenses, Binoculars, Kits, Parts, War surplus bargains. **Edmund Scientific Co.**, Barrington, New Jersey 08007.

EDUCATIONAL OPPORTUNITIES

WANTED! TV—Radiomen to learn aircraft electronics servicing. Numerous job openings everywhere. Write: **Academy Avionics**, Reno/Stead Airport, Reno, Nevada 89506.

LEARN WHILE ASLEEP. Miraculously build Mind Power, achieve Self-Confidence, improve Health, gain Success. Method 92% effective. Details free. **ASR Foundation**, Box 7021EG Henry Clay Sta., Lexington, Kentucky 40502.

PRINTING

FREE Booklet "Secrets of Cutting Printing Cost." Dept. 1, 305 S. 4th, Springfield, Illinois 62701.

CB-WPE-QSL CARDS. Fast service. Low prices. Free samples. **JERRY**, Box 9363, Austin, Texas 78756.

THERMOGRAPHED business cards, \$2.99—1,000, free samples. **Gables—405T Clifton**, Glenshaw, Pa. 15116.

COINS

LINCOLN CENT, 1955-S, 25¢, free list. **Bedrin**, 250F Fulton, Hempstead, N.Y. 11550.

SELLING 10 different S Lincoln cents, \$1.00; 7 small date 1960-D cents, \$1.00; 6 different S Jefferson nickels, \$1.00; 5 Barber dimes, \$2.00. Price list. **Charles Lees**, 2026 East Greenlee, Tucson, Arizona 85719.

DO-IT-YOURSELF

BUILD your own telephone intercom—complete—less battery. Write **Telephones**, Box PE67, Simpson, Penna. 18407.

SAVE! Build transistorized treasure finder. Details free! **Del Research**, Dept. A, West Barnstable, Mass. 02668.

AUTOMOTIVE EQUIPMENT

NEW! New! Portable Electronic auto and marine engine analyzer \$24.95. Free Literature. **Colette Electric Co.**, 15024 Harper, Detroit, Michigan 48224.

FREE ARCTURUS CATALOG

A trusted name in electronics since 1925

Electronic parts, tubes. Wholesale.

Thousands of items. Unbeatable prices.

ARCTURUS ELECTRONICS CO.
502-22nd St., Dept. PE, Union City, N.J. 07087

BUSINESS OPPORTUNITIES

INVESTIGATE ACCIDENTS! Earn up to \$1,000 and more a month in your own business. Work spare time with average earnings of \$5 to \$8 per hour. No selling. Send for Free booklet. No obligation. No salesman will call. Write: **Universal Schools**, CZ-9, 6801 Hillcrest, Dallas, Texas 75205.

RAISE Rabbits for us on \$500 month plan. Free details. **White's Rabbitry**, Mt. Vernon, Ohio 43050.

FREE CATALOGS. Repair air conditioning, refrigeration. Tools, supplies, full instructions. **Doolin**, 2016 Canton, Dallas, Texas 75201.

PIANO TUNING learned quickly at home. Tremendous field! Musical knowledge unnecessary. GI Approved. Information free. **Empire School of Piano Tuning**, Miami, Florida 33145.

ELECTROPLATING Equipment and supplies. All types for home workshops and industrial. Send \$1.00 (refundable) for equipment guide formulas, operating data, catalog. **HBS Equipment Division 90**, 3543 East 16th, Los Angeles, California 90023.

ELECTRICAL REPAIR—Washers, dryers, motors, stoves, clocks, toasters. Free details. **Industrial Training Institute**, Dept. 65118, 815 E. Rosecrans, Los Angeles 90059.

EMPLOYMENT INFORMATION

FOREIGN and **USA** job opportunities available now. Construction, all trades. Earnings to \$2,000.00 monthly. Paid overtime, travel, bonuses. Write: **Universal Employment**, Woodbridge, Connecticut 06525.

FOREIGN EMPLOYMENT. Construction, other work projects. Good paying overseas jobs with extras, travel expenses. Write only: **Foreign Service Bureau**, Dept. D, Bradenton Beach, Florida 33510.

AUSTRALIA Wide-open. Jobs. Opportunity. Government-assisted passage. Information: \$1. **Pacifico**, Box 43485R, Los Angeles, California 90043.

REAL ESTATE

FREE!!! New Illustrated **FALL-WINTER CATALOG!** Describes hundreds of farms, ranches, homes, businesses, vacation, retirement and waterfront properties coast to coast! Specify type property and location preferred. Zip code, please. **UNITED FARM AGENCY**, 612-EP West 47th St., Kansas City, Mo. 64112.

MISCELLANEOUS

WINEMAKERS: Free illustrated catalog of yeasts, equipment. Samples, Box 7208, Minneapolis, Minn. 55412.

SPARE TIME OPPORTUNITY—MONEY—WE PAY at the rate of \$10 hr. for **NOTHING** but your opinions, written from home about our clients' products and publications, sent you free. Nothing to buy, sell, canvass, or learn. **NO SKILL. NO GIMMICKS.** Just honesty. Details from **RESEARCH**, ZD2, Box 669, Mineola, N.Y. 11501.

TEN Winemaking Recipes and Winemaking Supplies catalog 10¢. **Country Winemaker**, Box 243EGA, Lexington, Massachusetts 02173.

EMPLOYMENT Resumes. Get a better job & earn more! Send only \$2.00 for expert, complete Resume Writing Instructions. J. Ross, 80-34 Kent St., Jamaica, N.Y. 11432, Dept. PE.

BEERS, PEACH BRANDY, WINES—Strongest Formulas, \$2.25. (complete brew supplies hydrometers catalog included)—Research Enterprises, 29-D Samoset, Woburn, Mass. 01801.

STAMMER — Stutter — No More. (Dr. Young.) Write: Gaucho, Box 9309-E8, Chicago 60690.

STOP BURGLARS THE EASY WAY!! Affix authentic "Protected by Electronic Sentry Alarm" Decals to auto windows, doors & windows of home, retail stores, vending machines, etc. Whether you have an alarm or not—thieves stay away! Only \$1.00 each set of two. J. Ross, 80-34 Kent St., Jamaica, N.Y. 11432 Dept. PE.

BILLS PAID Without Borrowing—Nobody refused up to \$18,000. Bad credit no problem—Not a loan co. Write for **FREE** Application—**INTERNATIONAL ACCEPTANCE CO.**, Dept. 50A-5133 N. Central, Phoenix, Arizona 85012, or 119 Ann St., Hartford, Conn. 06103.

CLASSIFIED ADVERTISING IN POPULAR ELECTRONICS remains your best bet for outstanding mail order sales responses. More than 400,000 monthly buyers of **POPULAR ELECTRONICS** read these pages thoroughly as they eagerly await the offering of products and services found only in each issue's **ELECTRONICS MARKET PLACE**. **POPULAR ELECTRONICS** readers respond readily because they know they can rely on the advertisers appearing in the pages of their favorite magazine. **INCREASE YOUR MAIL ORDER RESPONSE** substantially by placing a low cost ad (\$1.00 per word—minimum \$10.00) in these columns. Forward advertising copy with your payment today in order to be certain of inclusion in the next issue, November (Closing September 1st, on sale October 19th). Send to: Hal Cymes, Classified Advertising Manager, **POPULAR ELECTRONICS**, One Park Avenue, New York, N. Y. 10016.



not by a long shot it isn't !!

There's certainly nothing top secret about Popular Electronics' classified pages. They're wide open to every buyer in the market for the product or service he knows can be found in Electronics Market Place.

More than 400,000 buyers of Popular Electronics, largest readership of any electronics magazine in the world, guarantee that your ad is being read by people constantly looking for and buying electronics products. It is these people to whom you **MUST** direct **YOUR** advertising as do the many key advertisers appearing in this issue and in each issue throughout the year.

No doubt about it—there's a vast market of buyers searching the classified advertising pages of Popular Electronics and it's important that your ad be exposed to them. Prove to yourself that the leading electronics magazine **MUST ALSO** be the leader in sales responses to the many classified ads presently enhancing its pages—it makes a great deal of sense—give it a try.

See classified section for rate information or write to **HAL CYMES**, *Classified Advertising Manager*
ZIFF-DAVIS PUBLISHING COMPANY
One Park Avenue, New York, N. Y. 10016

POPULAR ELECTRONICS

SEPTEMBER 1967

ADVERTISERS INDEX

READER SERVICE NO.	ADVERTISER	PAGE NO.
	ATV Research	117
1	Allied Radio	106, 107, 108, 109
	American Institute of Engineering & Technology	116
2	Amperex Electronic Corp	FOURTH COVER
	Arcturus Electronics Co	123
3	Argos Products Company	16
4	B & K	10
5	Burstein-Applebee Co	8
	Capitol Radio Engineering Institute, The	62, 63, 64, 65
7	Cleveland Institute of Electronics	11
8	Cleveland Institute of Electronics	18, 19, 20, 21
	Conar	117
9	Courier Communications, Inc	9
	Coyne Electronics Institute	117
	DeVry Institute of Technology	7
	Electro-Voice	103
10	Erie Technological Products	105
11	Finney Company, The	23
12	Hallcrafters	6
13	Heath Company	12, 13
14	Hy-Gain Electronics Corporation	125, 126, 127, 128
15	Johnson Company, E.F.	17
16	Lafayette Radio Electronics	25
	Micro Electron Tube Co	121
17	Milwaukee School of Engineering	113
18	Mosley Electronics, Inc	118
19	Mosley Electronics, Inc	118
20	Multi-Elmac Co	95
21	Multicore Sales Corp	8
	National Radio Institute SECOND COVER , 1, 2, 3	
	National Technical Schools	36, 37, 38, 39
22	Olson Electronics Incorporated	26
23	Pace Communications Corp	14
	RCA Electronic Components and Devices	THIRD COVER
30	RCA Electronic Components and Devices	101
	RCA Institutes, Inc	88, 89, 90, 91
29	Radio Shack	5
24	Sams & Co., Inc., Howard W	27
6	Sentry Mfg. Co	16
25	Sonar Radio Corp	115
26	Squires-Sanders, Inc	28
	Sydur Electronics Specialties	116
27	Tang, Inc	26
	Technical Training International	92
28	Turner Microphone Company, The	99
	CLASSIFIED ADVERTISING 119, 120, 121, 122,	
	123, 124	

MEANS A LOT!

Hy-Gain has always been first with new developments in basic antenna design — the kind that make a difference in performance. We introduced the first full $\frac{5}{8}$ " wave base station antenna with the first static removing "top hat". The first duo-beams were introduced by Hy-Gain. We have led the field in mobile antennas with the "mark of distinction" top loaded design, which gives unparalleled performance.

Being first is not all — we have made more improvements to every basic antenna design. WE HAVE MORE EXPERIENCE! Because of more experience, because of superiority of basic antenna knowledge, because of the world's best antenna test range, all Hy-Gain BIG SIGNAL antennas are better, electrically and mechanically!



Hy-gain's

DUO-BEAMS

GET GREATEST RANGE POSSIBLE

Uniquely designed directional antennas that compress pattern into a beam that reaches out farther than all the others.



ANOTHER
HY-GAIN
FIRST!



Hy-gain's

MOBILE "TOPPERS"

It can be seen! ...when your mobile topper has the "Mark of Distinction" — the Hy-Gain TOP-LOADED antenna — the most efficient made.



...and you will find a difference

BASE STATION

Hy-Gain's
WORLD FAMOUS
CLR 2

12.55 Watts
"Talk Power"

Has electrically
extended
5/8 wavelength
radiator

Model CLR 2
\$3295 Net

SPECIFICATIONS

ELECTRICAL

Effective Input Power..... 12.55 Watts
Typical SWR..... Less than 1.5:1
Coaxial Feedline..... 52 ohm
Omni-directional pattern

MECHANICAL

Overall Height of Radiator..... 19'10"
Diameter of Radiator
(Tapers)..... 1-1/4" to 7/16"
Length of Radials..... 9'
Radial Diameter
(Tapers)..... 5/8" to 5/16"
Mast Bracket Accepts..... up to 1-5/8"
Wind Survival..... 100 MPH

GCLR2

FOR COMMERCIAL APPLICATIONS -
MARINAS - COASTAL AREAS

Entire Antenna Gold Iridite Treated to Mil-Spec for lasting durability.

Model GCLR 2 \$4450 Net

Same Operational Specs as CLR 2 with 120 MPH Wind Survival. (See other side for illustration)

MOBILE ANTENNAS

Hy-Gain's MOBILE TOPPERS with the "MARK 1"

All Hy-Gain Mobile Toppers have stainless steel radiator and



ROOF MOUNTS

All except TQRMB MAGNA TOPPER have single 3/8" dia. hole mount. All come complete ready to install with antenna, shock spring, mount, coax cable and PL-259 connector.

DX ROOF TOPPER

Guaranteed to outperform ANY other mobile antenna; 50" overall height.

Model TQRDX.....\$16.95 Net.

SHORTY ROOF TOPPER

Guaranteed to outperform any base loaded mobile antenna; only 19" overall height. **Model TRQS.....\$15.50 Net.**

MAGNA TOPPER

Magnet base installs instantly - no holes to drill - Holds firmly at speeds over 80 MPH. Capacitively grounded. You don't remove car finish! 28" overall height.

Model TQRMB.....\$15.95 Net.

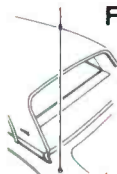

FENDER & COWL MOUNTS

Complete with antenna, single-hole chrome mount, coax cable and PL-259 connector.



TMCQ TOPPER

50" overall height. **Model TMCQ.....\$14.95 Net.**

COMBINATION CB-AM/FM "DUO-TOPPER"

Replaces AM broadcast whip 50" overall height - chrome plated brass radiator - coupler precision tuned for CB; adjustable to optimum performance on AM/FM.

Model TTMPQ.....\$15.95 Net.

Non-telescoping Model with Stainless Radiator. **Model TMPQ.....\$15.95 Net.**

in **Hy-gain's** COMPLETE LINE of CB ANTENNAS AND ACCESSORIES

Hy-gain's ROTATABLE DUO-BEAMS

DUO-BEAM 10 MODEL 1110DB

120 Watts
"Talk Power"



\$119.95 Net

DUO-BEAM 6 MODEL 116DB

93 Watts
"Talk Power"



\$74.95 Net

DUO-BEAM 4 MODEL 114DB

42 Watts
"Talk Power"

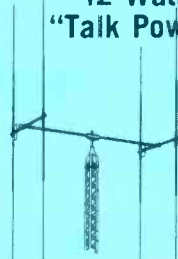

\$44.95 Net

- ALL HY-GAIN DUO-BEAMS HAVE THESE SPECIFICATIONS:**
- SWR at Resonance—Less than 1.4:1
 - Accept 52 ohm Coaxial Feedline
 - Maximum Wind Survival—80 MPH

SPECIFICATIONS	1110DB	116DB	114DB
ELECTRICAL: Front-to-Back Ratio	26 db	23 db	18 db
MECHANICAL: Boom Length	18 ft.	12'2"	3'1"
Cross Boom Length	24 ft.	14'	9'
Longest Element	18'9¾"	18'6½"	17'11"
Turning Radius	15'6"	9'6"	5'2"

OF DISTINCTION" Hy-Q loading coil.

d lifetime adjustable tuning rod.

TRUNK DECK JIFFY TOPPER

Guaranteed performance. Easy trunk lid installation. Mounts on trunk lip—no exterior holes to drill. 50" overall height. Complete with adjustable stainless steel mount, antenna, PL-259 connector and coaxial cable. Model TJCQ.....\$15.95 Net.

MARINE TOPPER

Guaranteed 1.5db Gain. Most efficient marine antenna available. Mounts on any wood or fiberglass boat. Quick disconnect. Weather resistant throughout. 59" overall. With 12' coax and PL-259 connector. Model TQMA.....\$24.95 Net.



SEND FOR
LITERATURE
TODAY
OR

SEE YOUR
HY-GAIN
DEALER OR
DISTRIBUTOR

HY-GAIN ELECTRONICS CORPORATION

N.E. Highway 6 at Stevens Creek, Lincoln, Nebraska 68501

a little difference...M

Your "S"-meter may not measure it; but when a hill, tall buildings or other obstructions COME BETWEEN YOU AND SATISFACTORY RESULTS, you need an antenna that's just a little bit better.

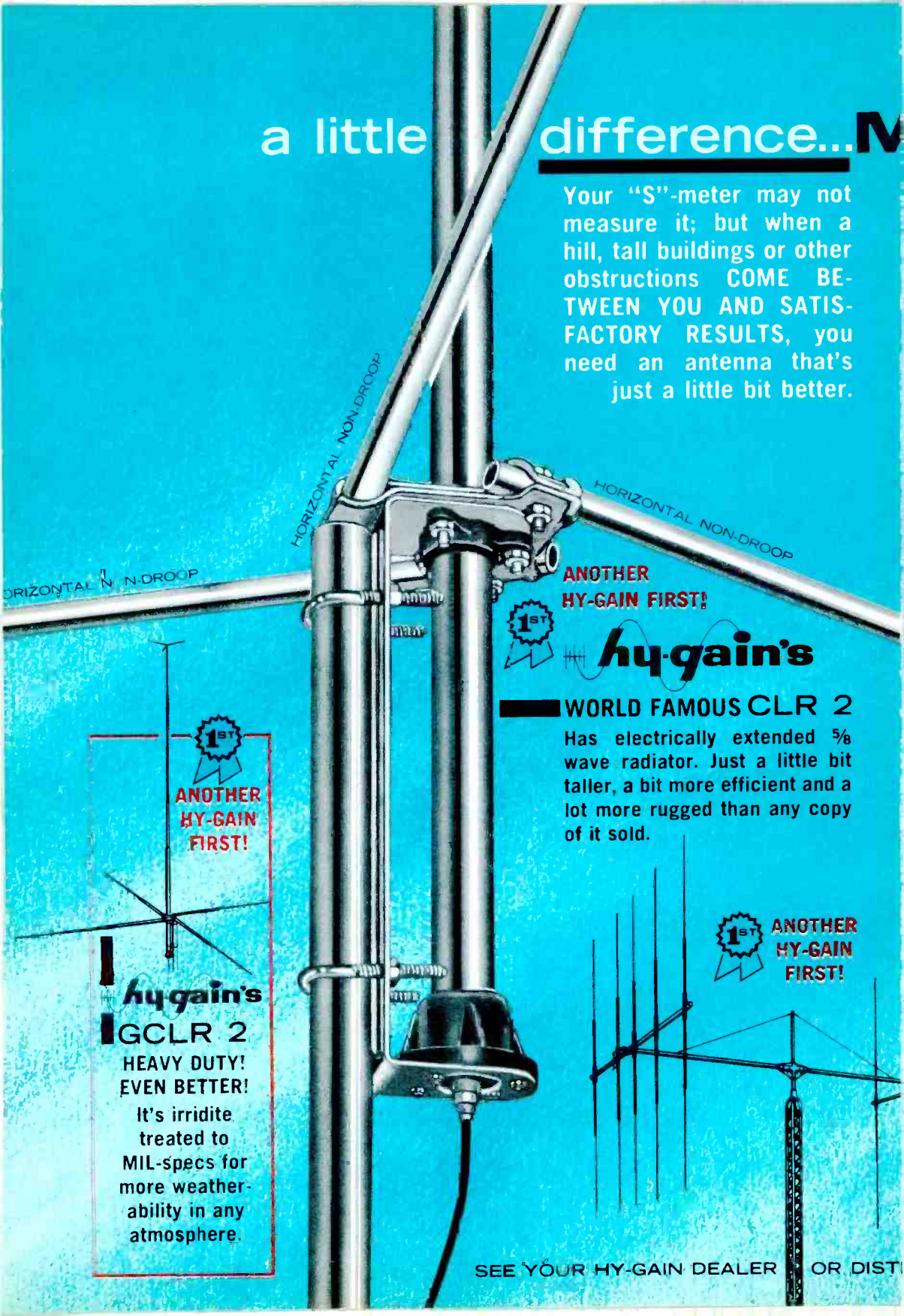

HORIZONTAL NON-DROOP

HORIZONTAL NON-DROOP

HORIZONTAL NON-DROOP

ANOTHER
HY-GAIN FIRST!



hy-gain's

WORLD FAMOUS CLR 2

Has electrically extended $\frac{5}{8}$ wave radiator. Just a little bit taller, a bit more efficient and a lot more rugged than any copy of it sold.



ANOTHER
HY-GAIN
FIRST!

hy-gain's

CLR 2
HEAVY DUTY!
EVEN BETTER!

It's irridite treated to MIL-specs for more weatherability in any atmosphere.



ANOTHER
HY-GAIN
FIRST!

SEE YOUR HY-GAIN DEALER OR DIST



How else but with RCA HI-LITE color picture tubes
can you bring today's color to your customers?

Your service reputation is the cornerstone of your business. That's why there's no room to compromise with quality in the components you install.

RCA HI-LITE picture tubes enable you to offer your customers TODAY'S COLOR... incorporating the latest technology of the world's most experienced picture tube manufacturer. They're the same tubes that go into today's original equipment sets.

RCA's new Perma-Chrome process for rectangular picture tubes, for example, means locked-in color purity from the moment the picture comes on. Faster servicing for you. Added customer satisfaction.

Install an RCA HI-LITE and you literally "up-date" your customer's set while, at the same time, enhancing your service reputation.

RCA Electronic Components and Devices, Harrison, N.J.



The Most Trusted Name in Electronics

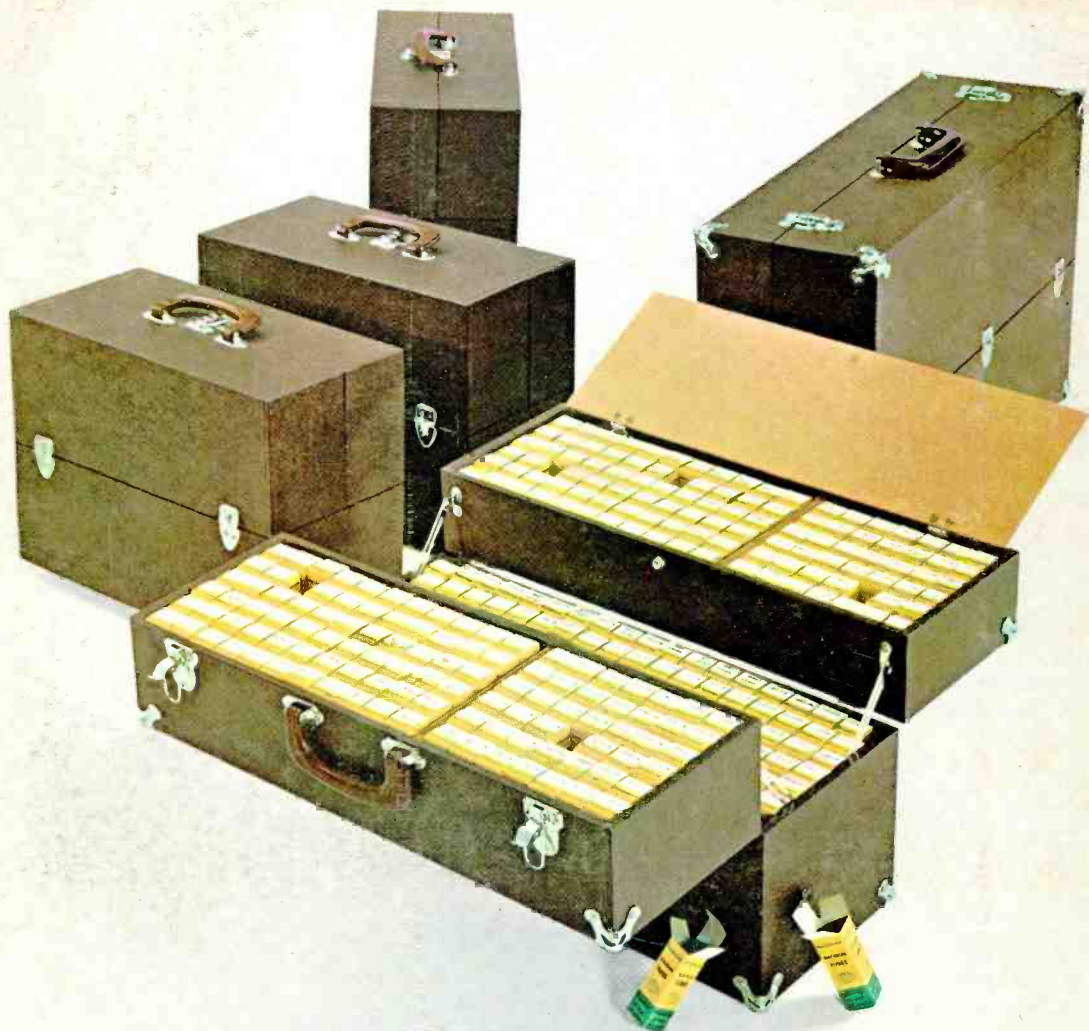

**One out of every five
professional servicemen
has switched to Amperex
TV replacement tubes**

It takes a lot of quality to change the buying habits of 20% of the most knowledgeable technicians in the business. These servicemen are following the pattern set by the leading TV manufacturers, who are designing more and more of their quality lines around tubes originated by Amperex. The Amperex line of popular types is expanding all the time. Look for the green and yellow cartons at your distributor's or write: Amperex Electronic Corp., Hicksville, L. I., N.Y. 11802.

Amperex

TOMORROW'S THINKING IN TODAY'S PRODUCTS

