

LASERS--The Light Fantastic

POPULAR
ELECTRONICS

JULY
1963

35
CENTS

▲
7

BUILD SIGNAL STETHOSCOPE
ARE SLIM HI-FI SPEAKERS OK?
RIP AM RECEIVER OF TV SYNC-BUGS



NEW
HULA-HOOP
ANTENNA for
Ham or CB
Mobiles



Where You Train Is As Important As Your Decision To Train



Electronics is a growing and expanding industry. That's why so many ambitious men are deciding to train for careers in this exciting field. They recognize the opportunities to advance and prosper. But, where a man trains and how the school of his choice teaches Electronics

... how it encourages him to reach his goals and realize his ambitions ... is most important to his success.

This is a fast changing world. A school offering Electronics courses must keep pace. That's why NRI—with nearly 50 years of specialized experience—now offers eight choices of training within the one field of Electronics. Select the course of most interest to you and receive the kind of home-study training that prepares you for a specialized career. NRI's large staff of specialists is always on the job keeping course material up-to-date ... helping you earn your way while training ... assisting you with job placement when ready. In short, whatever branch of Electronics you select, NRI is qualified through knowledge and experience to help you grow.

SPECIAL TRAINING

EQUIPMENT INCLUDED

NRI "learn by practice" method is the time-proved way to learn easier, faster, better. Most NRI courses include—at no extra cost—special training equipment to give shop and laboratory experience in your own home. All equipment is yours to keep.

Projects you build, experiments you perform, make NRI lessons come to life. Complex subjects become interesting, easy to grasp. Your first projects are measuring voltage and current in circuits you build yourself. You use a Vacuum Tube Voltmeter which you construct. Later on, you progress into more involved experiments. If you like working with your hands, you'll enjoy learning Electronics with NRI.



THE PROVEN WAY TO BETTER PAY

Best of all, NRI provides training right in your own home and in your spare time. No time wasted getting to school. You fit study hours to your own schedule. You go as fast or as slow as you like. Check the training of most interest to you; cut out and mail the postage-free card now. Read about Electronics opportunities, NRI courses, the NRI trial plan, convenient terms.



Pick the **ELECTRONICS** CAREER You Want

1 INDUSTRIAL ELECTRONICS

Learn Principles, Practices, Maintenance of Electronic equipment used today in business, industry, defense. Covers Electronic controls and measurement, computers, servos, telemetry, multiplexing, many other subjects.

2 RADIO-TELEVISION SERVICING

Learn to service AM-FM Radios, black and white and color TV sets, Stereo Hi-Fi, PA systems, etc. A profitable, interesting field for part-time or full-time business of your own.

3 COMPLETE COMMUNICATIONS

A comprehensive training course for men seeking careers operating and maintaining transmitting equipment in Radio-TV Broadcasting or mobile, marine, aviation communications. Prepares you for FCC License.

4 FCC LICENSE

Prepares you quickly for First Class License exams. Every communications station must have one or more FCC-licensed operators. Also valuable for Service Technicians. You train at home.

5 MOBILE COMMUNICATIONS

Training in installation and maintenance of mobile equipment and associated base stations like those used by fire and police, taxi companies, etc. Prepares you for First Class FCC License exams.

6 MARINE COMMUNICATIONS

Shipboard transmitting equipment, direction finders, depth indicators, radar are all covered in this course. You prepare for your First Class Radiotelephone License with Radar Endorsement.

7 AVIATION COMMUNICATIONS

For men who want careers working with and around planes. Covers direction finders, ranges, markers, loran, shoran, radar, landing systems, transmitters. Prepares you for FCC License exams.

8 MATH FOR ELECTRONICS

From basic arithmetic review to graphs and electronic formulas in one complete "short course" package of five carefully prepared texts. Quick, complete and low in cost.



America's Oldest and Largest Radio-TV
Electronics Home-Study School

MAIL POSTAGE-FREE CARD NOW

JOIN THE THOUSANDS WHO TRAINED FOR NEW CAREERS WITH NRI

Thousands of NRI graduates throughout the U.S. and Canada are proof that it's practical to train at home. NRI graduates have found success in many kinds of Electronic work: inspectors, maintenance men, research and development, testers, broadcast operators in the fields of communications, Radio-TV servicing, or in essential military and government posts. Catalog tells more of what NRI graduates do and earn. Mail postage-free card.



"I want to thank NRI for making it all possible," says Robert L. L'Heureux of Needham, Mass., who sought our job consultant's advice in making applications and is now an Assistant Field Engineer in the DATAmatic Div. of Minneapolis-Honeywell, working on data processing systems.

"Everything I now have is due to my success through NRI training," writes Wallace G. Baptist, who has developed a large and profitable wholesale Radio Electronics business in Jacksonville, Ill. His business now requires 14 employees.



"If I had failed to enroll with NRI, I may never have gotten anywhere." That's how Van W. Workman, Wauchula, Fla., explains his success in broadcasting. Now an engineer/announcer for WAUC, he was with WBOB when only 19. "I think this is proof for any young man that his future can be secure if he will give a few minutes a day to prepare for it."

"I can recommend the NRI course to anyone who has a desire to get ahead," states Gerald L. Roberts, whose Communications training helped him become an Electronics Technician at the Coordinated Science Laboratory U. of Illinois, working on naval research projects. He also holds a First Class FCC License with Radar Endorsement.



**Cut Out and Mail NOW
FREE 64-PAGE
CATALOG**

**NO STAMP NECESSARY
NRI PAYS POSTAGE**

**NRI TRAINING
Washington 16, D.C.**

3GD4

**The Amazing
Field of
Electronics**

Please send 64-page catalog on how to train at home for new careers in Electronics. I am interested in course checked below (No representative will call):



- | | |
|-----------------------------------------------------|--------------------------------------------------|
| <input type="checkbox"/> Industrial Electronics | <input type="checkbox"/> Mobile Communications |
| <input type="checkbox"/> Radio-Television Servicing | <input type="checkbox"/> Marine Communications |
| <input type="checkbox"/> Complete Communications | <input type="checkbox"/> Aviation Communications |
| <input type="checkbox"/> FCC License | <input type="checkbox"/> Math for Electronics |

Name _____ Age _____
(PLEASE PRINT)

Address _____

City _____ Zone _____ State _____

ACCREDITED MEMBER NATIONAL HOME STUDY COUNCIL

www.americanradiohistory.com

NOW 8 WAYS

To Assure Advancement Or Turn Your Hobby Into A New, Profitable Career

**TRAIN AT HOME
WITH THE LEADER**



NRI is America's oldest, largest home-study Electronics, Radio-Television school. For nearly half a century NRI has maintained the confidence and respect of students, graduates and the Electronics Industry for constantly providing the best possible home-study training at a cost most everyone can afford. No matter how much or how little education you have, one of NRI's eight courses can help you toward a more interesting, more profitable career. Mail the postage-free card.

FIRST CLASS
PERMIT
NO. 20-R
(Sec. 34.9, P.L.&R.)
Washington, D.C.



BUSINESS REPLY MAIL

NO POSTAGE STAMP NECESSARY IF MAILED IN THE UNITED STATES

POSTAGE WILL BE PAID BY



**3939 Wisconsin Avenue
Washington 16, D.C.**

"One of the most sensitive FM tuners on the market."

—POPULAR ELECTRONICS

"We found that with only about three inches of wire connected to the antenna terminals we could get every one of the important stations in the New York area."

—AUDIO

"In addition to fine electrical performance, it has the smooth flywheel tuning and general 'feel' of factory-wired Fisher tuners."

—ELECTRONICS WORLD

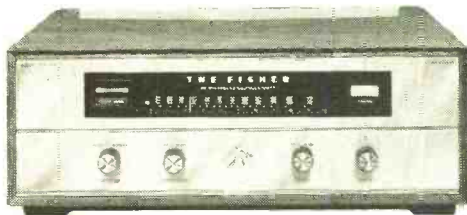

And you can build it yourself for \$169.50*—with the Fisher KM-60 StrataKit!

The StrataKit method of kit construction is a unique Fisher development. Assembly takes place by simple, error-proof stages (Strata). Each stage corresponds to a *separate* fold-out page in the instruction manual. Each stage is built from a *separate* transparent packet of parts (StrataPack). Major components are *pre-mounted* on the extra-heavy-gauge steel chassis. Wires are *pre-cut* for every stage—all work can be checked stage-by-stage, page-by-page.

Front-end and Multiplex stages come fully assembled and pre-aligned. The other stages are also aligned and require only a 'touch-up' adjustment by means of the tuner's laboratory-type d'Arsonval signal-strength meter.

The ultra-sophisticated wide-band Fisher circuitry of the KM-60 puts it in a spectacular class by itself. Its IHF Standard sensitivity of 1.8 microvolts makes it the world's most sensitive FM tuner kit. Capture ratio is 2.5 db; signal-to-noise ratio 70 db. Enough said.

Another outstanding feature of the Multiplex sec-

tion is the exclusive STEREO BEAM,** the Fisher invention that shows if an FM station is broadcasting in stereo.

The Fisher KM-60 StrataKit is very close to the finest FM Stereo Multiplex tuner that money can buy and by far the finest that you can build.

FREE! \$1.00 VALUE! Write for The Kit Builder's Manual, a new, illustrated guide to high fidelity kit construction.

Fisher Radio Corporation
21-52 44th Drive
Long Island City 1, N.Y.

Please send me without charge The Kit Builder's Manual, complete with detailed specifications on all Fisher StrataKits.

Name _____
Address _____
City _____ Zone _____ State _____

The
Kit Builder's
Manual

10713

The Fisher

*FACTORY-WIRED (KM-61), \$219.50. WALNUT OR MAHOGANY CABINET, \$24.95. METAL CABINET, \$15.95. PRICES SLIGHTLY HIGHER IN THE FAR WEST.
EXPORT: FISHER RADIO INTERNATIONAL, INC., LONG ISLAND CITY 3, N.Y. CANADIAN TRI-TEL ASSOCIATES, LTD., WILLOWDALE, ONT. **PAT. PENDING

POPULAR ELECTRONICS



POPULAR ELECTRONICS is Indexed
in the Readers' Guide
to Periodical Literature

Cover photo by Morgan S. Gassman, Jr.

VOLUME 19

JULY 1963

NUMBER 1

Special News Feature

- The "Light" Fantastic.....Ed Nanas 33
*Status report on LASERS, the most exciting development
in electronics in the past few years.*

Special Construction Feature

- The Hula Hoop—A New Ham or CB Antenna....Roy E. Pafenberg, W4WKM/KCG1046 25
*At last—a mobile antenna that can be mounted horizontally
on a roof top and radiates better than a quarter-wave whip.*

Electronic Construction Projects

- Nonsense Box.....Alan L. Danziss 47
Double-Duty EICO 772.....Robert Clark-Duff, W2OMM/KBG2857 49
Exterminate TV Sync-Bug Interference!.....William I. Orr, W6SAI 52
Snap-In Breadboard.....Luis Vicens 54
Signal Stethoscope.....Lyman E. Greenlee 59
What What's Light.....Art Trauffer 62

Amateur, CB, and SWL

- Satellites on the Air..... 12
SWL, QSL Bureau..... 22
Short-Wave Broadcast Predictions.....Stanley Leinwolf 66
Short-Wave Report: VOA Greenville-on-the-Air, DX Awards....Hank Bennett, W2PNA 67
On the Citizens Band.....Matt P. Spinello, 18W4689 70
Across the Ham Bands: Make Your Signal Reports More Accurate
Herb S. Brier, W9EGQ 73

Electronic Features and New Developments

- Breakthroughs 31
A Few Winning Words on Hi-Fi.....Bob Tupper 32
Dynaquad Touch Control..... 40
Slim Silhouette Speaker Systems.....Hans H. Fantel 41
Transistor Topics.....Lou Garner 56
Extracurricular Education (a Carl and Jerry Adventure).....John T. Frye, W9EGY 63

Departments

- Letter Tray 6
POP'tronics Bookshelf 14
Tips and Techniques..... 18
Coming Next Month..... 78

Copyright © 1963 by ZIFF-DAVIS PUBLISHING COMPANY. All rights reserved.

3 More Big Training Advantages



DeVRY Tech Exclusive!

WITH TRANSISTORIZED METER . . . PLUS NEW "MODULAR CIRCUITS" TO BUILD AT HOME!

Now Prepare for GOOD JOB OPPORTUNITIES IN ELECTRONICS Faster—with

1. **METER** — Transistorized, Portable, AC-DC Multimeter
2. **SCOPE** — 5-inch New Streamlined Commercial-Type Oscilloscope
3. **ELECTRO-LAB*** — For 3-Dimension Circuit Building

To help you get ready F-A-S-T-E-R . . . and THOROUGHLY . . . for good-paying job opportunities in the fast growing Electronics field, DeVry Technical Institute now presents the newest and finest training advantages in its over 30 years of experience. Now . . . AT HOME . . . in your spare time, you prepare with "industry-type" home laboratory equipment. To provide real PRACTICAL EXPERIENCE, you build a quality Transistorized Meter and a 5-inch industrial-type Oscilloscope . . . work with small, 3-dimensional circuits on DeVry's new Design Console . . . use highly instructive home training movies . . . and follow up-to-date lessons with many time-saving fold-out diagram sheets.

Little wonder DeVry men qualify for such fine opportunities in Space-Missile Electronics, Automation, Computer Work, Radio-TV, Industrial Controls, and other fields.

You learn PRACTICAL techniques important in today's Space Age industry, because you build many compact circuits with the streamlined Electro-Lab, using exclusive solderless "modular connectors." You perform over 300 construction and test procedures in all! Your self-built test equipment has function-grouped controls, meter scales color-keyed to the panel markings—much like instruments used on today's jobs. What's so important, the home laboratory and the test equipment are YOURS TO KEEP!



OSCILLOSCOPE

DESIGN CONSOLE

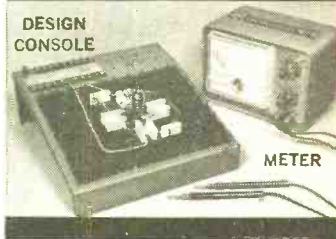

METER

* Trademark ®

INDUSTRY NEEDS TRAINED MEN

Through this remarkable 3-way method, DeVry Tech has helped thousands of ambitious men prepare for good jobs or their own profitable full-time or part-time service shops. It is the newest in a long series of PRACTICAL training aids that we have pioneered and developed in more than three decades of experience. Sound interesting? Then see how DeVry Tech may help YOU. Mail the coupon today.

From RADIO to SPACE-MISSILE ELECTRONICS

DeVry's training goes all the way from radio repair . . . to space-missile electronics. That's the range of subjects covered in its programs AT HOME or in its well-equipped training centers in Chicago and Toronto. You learn up-to-date techniques, working with new equipment, modern texts, movies—one of today's finest combinations of training equipment . . . geared for RESULTS!

EMPLOYMENT SERVICE

When you complete the program, DeVry's efficient Employment Service is ready to help you get started. There is no extra charge—ever—for this aid. ACCREDITED MEMBER, NATIONAL HOME STUDY COUNCIL.

DeVRY TECHNICAL INSTITUTE
CHICAGO • TORONTO

MAIL COUPON FOR FREE FACTS

DEVRY TECHNICAL INSTITUTE
4141 Belmont Ave., Chicago 41, Ill., Dept. PE-7-T 2082

Please give me your two free booklets, "Pocket Guide to Real Earnings" and "Electronics in Space Travel"; also include details on how to prepare for a career in Electronics. I am interested in the following opportunity fields (check one or more):

- | | |
|------------------------------------------------------|-------------------------------------------------|
| <input type="checkbox"/> Space & Missile Electronics | <input type="checkbox"/> Communications |
| <input type="checkbox"/> Television and Radio | <input type="checkbox"/> Computers |
| <input type="checkbox"/> Microwaves | <input type="checkbox"/> Broadcasting |
| <input type="checkbox"/> Radar | <input type="checkbox"/> Industrial Electronics |
| <input type="checkbox"/> Automation Electronics | |

Name _____ Age _____

Address _____ PLEASE PRINT Apt. _____

City _____ Zone _____ State _____

Check here if you face military service.

Canadian residents: Write DeVry Tech of Canada, Ltd.
970 Lawrence Avenue West, Toronto 19, Ontario

ONLY
\$995
EACH

NEW! Fun-to-Build

knight-kit®

WALKIE-TALKIE

C-100 ALL-TRANSISTOR
2-WAY TRANSCEIVER KIT

Now! Enjoy real on-the-go communication between two or more stations up to ¼ mile! Just press the button and you're "on-the-air." No license or exam required, no age limit. Operates up to 75 hours on low-cost battery. Handsome blue case, only 5 7/8 x 2 7/8 x 1 3/4"; telescoping 40" antenna. A breeze to build. Includes all parts, solder, wiring instructions (less battery). Wt., 9 oz.

83 Y 804FA Walkie-Talkie Kit. \$995 Each only.

83 Y 013. Leatherette Carrying Case... 98c
83 Y 002. 9-Volt Battery..... 21c



ALLIED RADIO

100 N. Western Ave., Chicago 80, Ill.

ORDER TODAY

Ship me: Walkie-Talkie Kit(s) 83 Y 804FA.

Carrying Case(s) 83 Y 013 9-V. Battery(ies) 83 Y 002

\$.....enclosed check money order

Name
PLEASE PRINT

Address

City _____ Zone _____ State _____

CUBA?

History reports itself while it is happening, in English, from the Caribbean . . . Moscow . . . New Delhi . . . London . . . Laos . . . Little America . . . and very soon, the Moon. Be there tonight on a hallicrafters.



Model S-118
WORLD RANGE RADIO

professional communication receiver for short wave and local broadcast

For 64-pg. miniature book, "Guide to Short Wave Listening," send 35¢ to Dept. 4-G.

hallicrafters

5th & Kostner Aves., Chicago 24, Ill.



POPULAR ELECTRONICS

World's Largest-Selling Electronics Magazine

Publisher **PHILLIP T. HEFFERNAN**

Editor **OLIVER P. FERRELL**

Feature Editor **W. STEVE BACON, W2CJR**

Technical Editor **L. JEROME STANTON, W2WHM**

Art Editor **JAMES A. ROTH**

Associate Editor **MARGARET MAGNA**

Technical Illustrator **ANDRE DUZANT**

Amateur Radio Editor **H. S. BRIER, W9EGQ**

CB Editor **M. P. SPINELLO, 18W4689**

Semiconductor Editor **L. E. GARNER, JR.**

Short-Wave Editor **H. BENNETT, W2PNA**

Contributing Editor **J. T. FRYE, W9EGV**

Radio Propagation Editor **STANLEY LEINWOLL**

Editorial Consultant **OLIVER READ, W4TWW**

Advertising Manager **WILLIAM G. McROY, 2W4144**

Advertising Service Manager **ARDYS C. MORAN**

ZIFF-DAVIS PUBLISHING COMPANY

Editorial and Executive Offices (Oregon 9-7200)
One Park Avenue, New York 16, New York

William B. Ziff, Chairman of the Board (1946-1953)
William Ziff, President

W. Bradford Briggs, Executive Vice President

Hershel B. Sarbin, Vice President and General Manager

M. T. Birmingham, Jr., Vice President and Treasurer

Robert P. Breeding, Circulation Director

Charles Housman, Financial Vice President

Stanley R. Greenfield, Vice President

Phillip T. Heffernan, Vice President

Midwestern and Circulation Office (Wabash 2-4911)

434 South Wabash Avenue, Chicago 5, Illinois

Midwestern Advertising Manager **JAMES WEAKLEY**

Western Office (Crestview 4-0265)

9025 Wilshire Boulevard, Beverly Hills, California

Western Advertising Manager, **WILLIAM J. RYAN, 11Q3002**

Foreign Advertising Representative

D. A. Goodall Ltd., London, England



Member
Audit Bureau of
Circulations



POPULAR ELECTRONICS is published monthly by Ziff-Davis Publishing Company at 434 South Wabash Avenue, Chicago 5, Illinois, July, 1963, Volume 19, Number 1. (Ziff-Davis also publishes Popular Photography, Electronics World, HiFi/Stereo Review, Popular Boating, Car and Driver, Flying, Modern Bride, Amazing, and Fantastic.) Subscription Rates: One year United States and possessions, \$4.00; Canada and Pan American Union Countries, \$4.50; all other foreign countries, \$5.00. Second Class postage paid at Chicago, Illinois, and at additional mailing offices. Authorized as second class mail by the Post Office Department, Ottawa, Canada, and for payment of postage in cash.

PAYMENT MAY ALSO BE REMITTED in the following foreign currencies for a one-year subscription: Australian pounds (2/6/10); Belgian francs (260); Danish kroner (36); English pounds (1/17/6); French francs (26); Dutch guilders (19); Indian rupees (26); Italian lire (3300); Japanese yen (1750); Norwegian kroner (38); Philippine pesos (21); South African rands (3.80); Swedish kronor (28); Swiss francs (23); or West German marks (21).

Always say you saw it in—POPULAR ELECTRONICS

What Job Do You Want In Electronics?

Whatever it is, Cleveland Institute can help you get it!

Yes, whatever your goal is in Electronics, there's a Cleveland Institute program to help you reach it *quickly and economically*. Here's how: Each CIE program concentrates on electronics theory as applied to the solution of practical, everyday problems. Result . . . as a Cleveland Institute student you will not only learn electronics but *develop the ability to*

use it! This ability makes you eligible for any of the thousands of challenging, high-paying jobs in Electronics. Before you turn this page, select a program to suit your career objective. Then, mark your selection on the coupon below and mail it to us *today*. We will send you the complete details . . . without obligation . . . if you will act **NOW!**

Electronics Technology



A comprehensive program covering Automation, Communications, Computers, Industrial Controls, Television, Transistors, and preparation for a 1st Class FCC License.

First Class FCC License

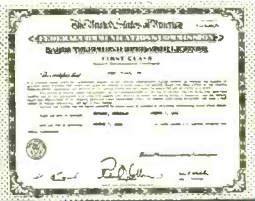

If you want a 1st Class FCC ticket quickly, this streamlined program will do the trick and enable you to maintain and service all types of transmitting equipment.

Industrial Electronics & Automation

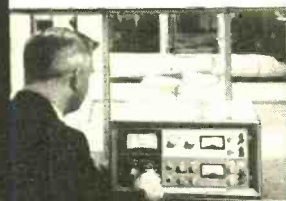

This exciting program includes many important subjects as Computers, Electronic Heating and Welding, Industrial Controls, Servomechanisms, and Solid State Devices.

Electronic Communications



Mobile Radio, Microwave, and 2nd Class FCC preparation are just a few of the topics covered in this "compact" program . . . Carrier Telephony too, if you so desire.

Broadcast Engineering



Here's an excellent studio engineering program which will get you a 1st Class FCC License and teach you all about Program Transmission and Broadcast Transmitters.

Mail Coupon TODAY For FREE Catalog

Cleveland Institute of Electronics

1776 E. 17th St., Dept. PE-6
Cleveland 14, Ohio

Please send FREE Career Information prepared to help me get ahead in Electronics, without further obligation.

CHECK AREA OF MOST INTEREST—

- | | |
|-------------------------------------------------|----------------------------------------------------|
| <input type="checkbox"/> Electronics Technology | <input type="checkbox"/> First Class FCC License |
| <input type="checkbox"/> Industrial Electronics | <input type="checkbox"/> Electronic Communications |
| <input type="checkbox"/> Broadcast Engineering | <input type="checkbox"/> _____
other |

Your present occupation _____

Name _____ Age _____
(please print)

Address _____

City _____ Zone _____ State _____

Approved for Veteran's Training under Korean GI Bill. PE-6

How to Succeed in Electronics

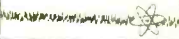

Cleveland Institute of Electronics

1776 E. 17th St., Dept. PE-6
Cleveland 14, Ohio



Accredited Member

SUBSCRIPTION SERVICE: All subscription correspondence should be addressed to POPULAR ELECTRONICS, Circulation Department, 434 South Wabash Avenue, Chicago 5, Illinois. Please allow at least six weeks for change of address. Include your old address as well as new—enclosing if possible an address label from a recent issue.
EDITORIAL CONTRIBUTIONS must be accompanied by return postage and will be handled with reasonable care; however, publisher assumes no responsibility for return or safety of art work, photographs or manuscripts.

BUILD YOUR AMATEUR TRANSMITTER from these easy-to-build kits!



ADVENTURER — 50 watts CW input rugged 807 transmitting tube, instant bandswitching 80 thru 10 meters. Crystal or VFO control, wide range pi-network output.

VALIANT II—275 watts input CW and SSB (P.E.P.) with auxiliary SSB exciter, 200 watts phone; instant bandswitching 160 thru 10 meters. Crystal or VFO control, wide range pi-network output, timed sequence keying.

RANGER II — 75 watts CW, 65 AM. Also serves as RF audio exciter. Self-contained bandswitching 160 thru 6! VFO or crystal control. Timed sequence keying, wide range pi-network output.



Adventurer



Valiant II



Ranger II

Write today — FREE 30-page amateur catalog!



E. F. JOHNSON COMPANY

2403 Tenth Ave. S.W. Waseca, Minn.

Name _____

Address _____

City _____ State _____



Teleset Headset delivers Marginal Signals with Maximum Intelligibility

Here is the new quality headset designed by Telex to meet the special requirements of Ham operation. Same top performance magnetic driver element used in the more expensive Magna-Twin Mark III. Ruggedly constructed, yet lightweight—only 8 oz.—and completely adjustable for comfort. Single-cord design for more freedom of movement. Excellent sensitivity and broad response to 10,000 cps pulls those weak signals in through the QRM. Handsome beige and brown styling. You'll be surprised at the economy price. Write for descriptive literature today.

TELESET...

A Product of Sound Research



TELEX / Acoustic Products

COMMUNICATIONS ACCESSORIES DIVISION

3054 Excelsior Blvd. • Minneapolis 16, Minn.

ults To apply in...
LETTER TRAY
on, we changed L2 to 7 or 8 turns of #22
on a 1/4" glass base... Constructive

Address correspondence for this department to:
Letters Editor, POPULAR ELECTRONICS
One Park Avenue, New York 16, N. Y.

More Time on Tape

■ Congratulations to Fred Blechman for a clear, concise presentation of an increasingly popular subject ("A Buyer's Guide for Portable Tape Recorders," April, 1963). Your readers might also be interested in another Sarkes Tarzian, Inc. tape, advertised on page 15 in the same issue but not listed in the article—#1411-06. This is a 3/4" reel containing 600' of 0.5-mil Mylar tape, and provides more than twice as much recording time at the tape mentioned for Tarzian (two hours vs. 45 minutes at 1 7/8 ips). It certainly helps prevent the frustration of running out of tape in the middle of a recording session.

WILLIAM C. BISHOP
Chicago, Ill.

Robots: Dumb Monsters?

■ I enjoyed reading "Our Heartless Friends the Robots" by D. S. Halacy, Jr. (May, 1963).

On page 100 in the second column, however, Mr. Halacy uses the Hebrew word "golem," a transliteration, as "early-day robots run amuck." The *Dictionary and Thesaurus of the Hebrew Language*, by Eliezer Ben-Yehuda, defines this word as "an ignorant person."

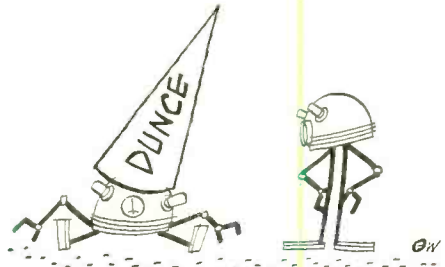

It would be interesting to know on what basis Mr. Halacy understands "golem" to mean "robot"; also where it is so used in the Old Testament.

PAUL L. CONANT, SR.
Richardson, Texas

An interesting point. Webster's defines "golem" as "Adam in the shapeless state of his creation, a monster . . . In Jewish legends, an artificial man . . . hence, an automaton." One Biblical source referred to is Psalms CXXXIX.16.

Automatically Automatic Automaton

■ Your article on robots (Halacy) in the May, 1963, issue was a real goody. Let's have more in

Always say you saw it in—POPULAR ELECTRONICS

A NEW WORLD OF OPPORTUNITY AWAITS YOU WITH N.T.S. ALL-PHASE HOME TRAINING IN ELECTRONICS



You can install and maintain electronic circuitry in missiles and rockets... specialize in micro-waves, radar and sonar.

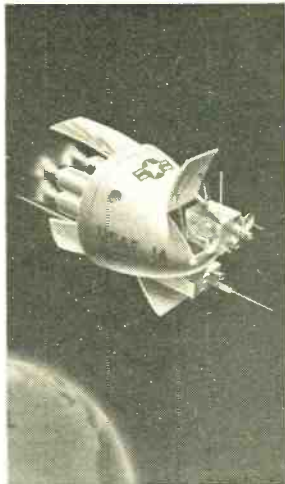

You can succeed in TV-Radio Communications... prepare for F.C.C. License, service advanced satellites for industry and defense.



You can service and repair the electronic "brains" of industry—computers, data processing, and other automation equipment.

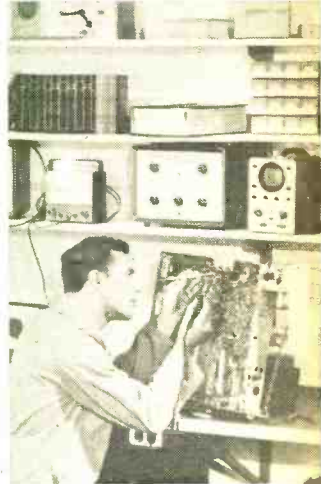

You can become a highly-paid TV-Radio Technician, an electronics field engineer, or succeed in your own sales & service business.

The N.T.S. Master Course enables you to do more, earn more in ELECTRONICS • TELEVISION • RADIO

Yet N.T.S. Training costs no more than other courses far less complete

There's a good reason why N.T.S. Master-Training opens a wide new world of opportunity for you in Electronics, Television, Radio.

Everything you learn, from start to finish, can be applied directly to all phases of the Electronics Industry.

As a result, the N.T.S.-Trained Technician can move ahead faster, in any direction — from TV-Servicing to Radio Communications to Space-Missile Electronics and Automation for industry and defense. You can go wherever pay is highest and opportunity unlimited.

Electronic circuitry, for example, is one of science's miracles that is basic to the entire field of Electronics. It is used in satellites, computers and space capsules as well as in today's television sets and high fidelity equipment. N.T.S. shows you how to service and repair electronic circuitry for all electronic applications.

YOU WORK ON MANY PRACTICAL JOB PROJECTS.

You build a short-wave, long-wave superhet receiver, plus a large-screen television set from the ground up. N.T.S. training kits contain all the parts you need, at no extra cost. (See box at right.) You also receive a professional Multitester to use during training and on the job.

ONE LOW TUITION. You need training related to all phases of Electronics. Industry demands it. Only N.T.S. provides it... in ONE Master Course at ONE low tuition.

RESIDENT TRAINING AT LOS ANGELES

If you wish to take your Electronics-TV-Radio training in our famous Resident School in Los Angeles — the oldest and largest school of its kind in the world — write for special Resident School catalog and information, or check coupon.



NATIONAL TECHNICAL SCHOOLS
WORLD-WIDE TRAINING SINCE 1905
4000 So. Figueroa St., Los Angeles 37, Calif.



YOU ENROLL BY MAIL AND SAVE MONEY. No salesmen means lower costs for us, lower tuition for you.

START NOW. A whole new world of opportunity awaits the man with Electronic Home-Training from National Technical Schools — a recognized leader in technical training for 58 years.



19 BIG KITS
YOURS TO KEEP



MAIL COUPON NOW FOR FREE BOOK AND ACTUAL LESSON!

NO OBLIGATION.
NO SALESMAN WILL CALL.

NATIONAL TECHNICAL SCHOOLS
WORLD-WIDE TRAINING SINCE 1905

National Technical Schools, Dept. R2G-73
4000 S. Figueroa St., Los Angeles 37, Calif.

Please Rush **FREE** Electronics-TV-Radio "Opportunity" Book and Actual Lesson. No Salesman Will Call.

Name _____ Age _____

Address _____

City _____ Zone _____ State _____

Check if interested **ONLY** in Resident Training at L.A.
High school home study courses also offered. Check for free catalog.

from Scott . . .

FREE STEREO KIT CATALOG

Have fun . . . save money . . . build the best! Now world-famous Scott stereo components come in easy-to-build kit form. You can build an FM Multiplex tuner, your choice of an 80 watt or 48 watt stereo amplifier, a preamp, power amplifier, and a speaker. Write for complete details.



SCOTT® Dept. 520-07

H. H. Scott, Inc. 111 Powdermill Road, Maynard, Mass.

RUSH ME COMPLETE INFORMATION ON SCOTTKITS.

Name _____

Address _____

City _____ State _____

Export: Morhan Exporting Corp., 458 Broadway, N.Y.C.
Canada: Atlas Radio Corp., 50 Wingold Ave., Toronto

NEW - - by KUHN SHORT WAVE MOBILE CONVERTER

Listen to overseas short wave stations around the world while you drive. Hear news direct from London, Paris, Moscow, Cologne, etc. Covers 19, 25, 31 and 49 Meter Bands plus extra Band for 40 Meters and Canadian Time Signals. Works with any standard 12 volt transistorized car radio. Can be installed in minutes. Complete with Mtg. bracket. Works with your present antenna. Nothing else to buy.

351A

\$34.95



AIRCRAFT • POLICE • FIRE



348A
Complete
\$34.95

Transistorized, directly tunable Converter. Powered with self-contained mercury cell. Excellent sensitivity and stability. Designed for car, home or portable receivers. Two types available: Aircraft VHF 116-130 MC or 150-162 MC.



345A
Complete
\$29.95

Crystal controlled Mobile Converter, highly efficient. Operates directly from 12 volt auto system. For 150-174 MC or 30-50 MC.

A low cost turntable converter for any 10 MC area of: 26-54 MC, Aircraft VHF, or 150-160 MC. Easily installed. For use with home or auto sets.

\$14.95

315A

Tuner same ranges as above but for use with small table model radios

325C



Order today or send for free catalog on full line of converters and receivers for every application.



20 GLENWOOD
CINCINNATI 17,
OHIO

Letter Tray

(Continued from page 6)

the same vein. One criticism, however, is that you forgot to mention that in order for a machine to be truly automatic, the automatic feedback must be automatically variable.

G. H. MORGAN
Vallejo, Calif.

As with human beings, for instance?

TV DX: South America

■ On Sunday, April 28, at about 3:15 P.M., I was trying to watch a baseball game on channel 3 from Savannah, 125 miles away. Some interference showed up about this time, and I turned my rotatable antenna a few degrees south to pinpoint the source. Lo and behold, a perfect test pattern showed up, a much better picture than that from Savannah.

The unusual thing about this was that the test pattern was from TGBOL-TV in Guatemala. It was as good as any picture I have ever seen. Will you please explain how this could happen?

CHAN HERRINGTON, WPE4GOY
Alma, Ga.

Congratulations on a rare bit of DX, Chan. Actually, cases of TV DX occurring in the spring and summer are not uncommon, but they're usually dismissed as local interference. What happens, for reasons unknown, is that scattered patches of relatively dense ionization appear at about the same height as the E layer in the ionosphere. This phenomenon, called sporadic-E ionization, occurs in the early spring and lasts through August, reaching a peak during June and July. The patches of ionization reflect TV and other high frequency signals back to earth.

No "Hobby Class" Say Hams, Others

■ I would like to express my disagreement with the proposal to establish a "hobby class" amateur license (See "On the Citizen's Band," May, 1963, for news of this proposal).

Although industry benefits a great deal from the efforts of radio amateurs, amateur radio is not in existence specifically for this purpose . . . The requirements for an amateur license are not strict . . . any move to ease them would tend to lower standards. To place an amateur station on the air and operate it consistent with good engineering practices requires technical know-how . . . The establishment of a proposed "hobby class" license would be an invitation to those (who lack this knowledge) to buy packaged equipment and use it for play.

It must be assumed that . . . other amateur licensees would be barred from this allocation. This portion of 10 meters now finds much use for emergency nets such as Civil Defense, RACES, and AREC, not to mention international amateur communications. May I suggest that the crowded conditions on the Citizens Band be alleviated by stiffer penalties for misuse and abuse, such as the complete removal of offenders . . . The proposal serves no national purpose other than to provide

Always say you saw it in—POPULAR ELECTRONICS

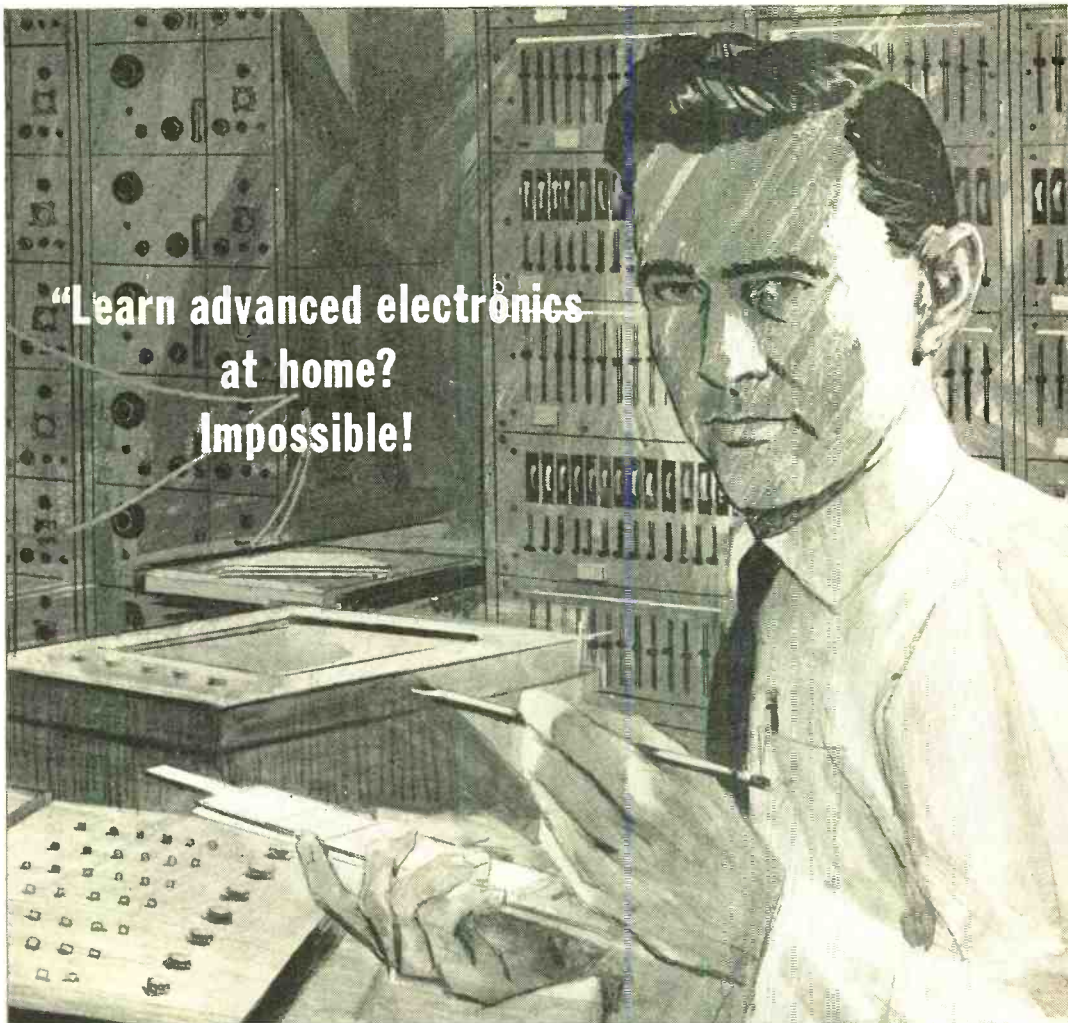

**“Learn advanced electronics
at home?
Impossible!”**

A CREI Program helped Edward W. Yeagle advance to project engineer at Barnes Engineering Co., Stamford, Conn.

...that's what I thought until I found out about CREI”

“Sure, I knew that home study programs were fine for a man who wanted to learn basic electronics. But, I needed to study advanced electronics to put myself in line for a better job. Thought I couldn't do it without quitting my job and going back to school. But then my supervisor told me about CREI. I've had two salary increases since I enrolled—and my company recognizes the value of this education.”

This man is one of the thousands of men in every phase of electronics who are moving ahead with the help of CREI Home Study Programs. If you are employed in electronics, CREI can help you, too. For complete information, send for FREE book. Use coupon or write: CREI, Dept. 1207-A 3224 Sixteenth St., N.W., Washington 10, D. C.



CREI

Founded 1927
Accredited Member of the
National Home Study Council



The Capitol Radio Engineering Institute
Dept. 1207-A, 3224 16th St., N.W., Washington 10, D. C.

Please send me FREE Book describing career opportunities and CREI Programs in advanced electronics. I am employed in electronics and have a high school education.

Name _____ Age _____

Address _____

City _____ Zone _____ State _____

Employed by _____

Type of Present Work _____

Check: Home Study Residence School G. I. Bill

53

Letter Tray

(Continued from page 8)

additional recreation to a few at the expense of many.

ALBERT T. WALTERS, JR., K4QIP/4
Eau Gallie, Fla.

■ . . . If they're going to have a "hobby class" license, why can't they put it on 2-3.25 mc., 4.5-6.75 mc., 8-13 mc., 15-20 mc., or even 31-49 mc.? They say that a simplified license will start a large group pursuing electronics . . . Like the Novice license, for instance?

CRAIG MCCLUSKEY, WPE6EFG
Los Angeles, Calif.

■ . . . It has a commercial aim behind it . . . In a month anyone can get their code speed up to 5 wpm . . . As the ARRL suggests, it would ruin 10 phone for all hams . . . please don't suggest that any such license be called an *amateur radio license!*

JOHN ZURIS
Chicago, Ill.

Versatile Receiver

■ I have obtained excellent results with the receiver ("One Receiver—All Bands," January, 1963), and even pulled-in some 40-meter DX that my brother's ham set didn't do as well on.

There did seem to be discrepancies between the schematic and pictorial in the article, however. For example, the pictorial shows the filament supply grounded, while the schematic doesn't. These little things make it hard if you're building your first project.

I plan to calibrate the receiver by getting it to oscillate and tuning in the squeal on a well-calibrated receiver. Also, what do you think of the idea of using the receiver as a signal generator by winding a coupling coil?

RICHARD SPAULDING
Cayuta, N. Y.

Thanks for the letter, Richard. Sorry you had difficulty in building this project. The schematic and pictorial were substantially correct, but we agree that some things might have been clearer. In answer to your question, you should be able to use the receiver as a signal generator by turning up the regeneration control just slightly past the point of oscillation, and simply coupling to the antenna coil winding through a small capacitor, say about 100 μ f. Reduce the coupling as much as possible, working with a minimum amount of signal. A tight coupling will tend to "pull" the compactron off frequency.

In Defense of CB

■ A letter in the May issue referred to CB'ers as common telephone users. This is wrong, as many CB'ers are hams, and many more hold first or second class commercial licenses. It is also possible to be interested in radio as a hobby and not be a ham.

I cannot deny the value of ham radio's many

years of disaster work, research, and development, but the CB service, open for only a few years, has racked up a few achievements in this area also. The point is that we all have one common goal: better communications.

Looking in the front of my ARRL Handbook, I find the "Amateur Code of Ethics;" the amateur is gentlemanly, loyal, progressive, friendly, balanced, and patriotic. With this in mind, as a CB'er, SWL, hobbyist, and possibly one day a ham, I ask all hams to help us, don't knock us. We're only a few years old, and you have so many years of knowledge to share . . .

ROBERT JONES, 12W1009
Sacramento, Calif.

More WPE Clubs?

■ I find that the WPE Club idea is catching. Would you ask WPE8's interested in joining an SWL club to send me their names, addresses, WPE registrations, information on their equipment, and any comments they might have on starting a club? 73!

RAY WEBER, WPE8EZX
3839 Willys Pky.
Toledo 12, Ohio

■ I would like to get a WPE4 SWL club started here in Puerto Rico. Those interested should send me their names, addresses, WPE registrations, information on equipment, and any suggestions.

SERGIO PEREZ, WPE4GMF
Carmen Buzello St. 1104
Urb. Country Club
Rio Piedras, Puerto Rico

■ Could you publish my letter asking if any WPE6's are interested in joining an SWL club, and have them send me their names, addresses, equipment, and WPE registrations?

GUY MAZZA, WPE6E00
2871 Almaden Rd.
San Jose 35, Calif.

Other readers who would like to form WPE clubs in their respective call areas (letters received at the last moment) are: Bruce Merritt, WPE6EQC, Rt. 1, 8872 Yosemite Blvd., Modesto, Calif., and John Wotysiak, WPE8FJT, 2204 Clifton Ave., Lansing 10, Mich.

Radio in a Bottle?

■ The acid test for the radio hobbyist is building a radio in a bottle. I have seen only a few attempts, all of which ended in failure.

DENNIS MULLENIX
Mattoon, Ill.

We'd like to see one, Dennis, just one.

Variable Voltage With 1625's

■ The power supply in the January, 1963 issue ("Variable Voltage . . . You Pick It") was just what I had been looking for. Instead of the more expensive KT-66, I used a 1625 transmitting tube, the 12-volt-filament version of the 807. The I.C.A.S. plate dissipation is 30 watts, and it costs just 20 or 25 cents at most surplus stores.

JAMES ZACHER, WA9DLT
Des Plaines, Ill.

Makes
soldering
a cinch!

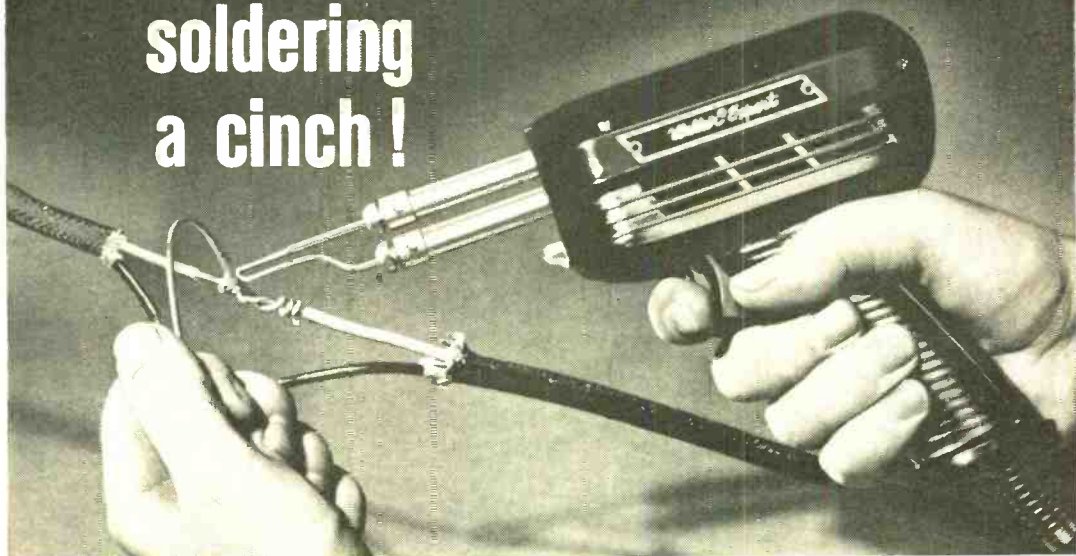

Weller® Dual Heat Soldering Gun

There's no tool like a Weller Dual Heat Gun for quick, easy soldering and scores of household repairs. Pull the trigger—tip heats instantly and spotlight illuminates work. 2 trigger positions give you a choice of two tip temperatures. You can switch instantly to the heat best suited for the job. And by using high heat only when necessary, you prolong tip life.

Tip is made of copper for superior heat transfer and premium-plated for rigidity and long life. Accessory tips

are available for heat sealing, cutting and smoothing.

Over 5 million Weller guns have been sold. They're used by professional servicemen and homecrafters the world over. All Weller guns are UL approved and guaranteed one year against defects in material and workmanship.

Weller dual heat guns are available in many models with wattage ratings to suit your needs. They are also supplied in plastic case kits that include accessories.



A must for hi-fi kit building. Assures noise-free connections. Use low heat when soldering near sensitive components, high heat for chassis connections.



Saves on electrical repairs. Enables you to do many appliance and electrical repair jobs yourself. Also useful for many different crafts and hobbies.



Mends metal. Whether patching holes, sealing seams or joining metal parts, your Weller gun will pay for itself on scores of repair jobs around your home.



Does more than soldering. With cutting and smoothing tips you can cut plastic tile, repair plastic toys, seal plastic bags, repair furniture dents, etc.

WELLER ELECTRIC CORP., 601 STONE'S CROSSING ROAD, EASTON, PA.

FREE GIANT NEW 1963 CATALOG



BURSTEIN-APPLEBEE CO.

Dept. PE, 1012 McGee St., Kansas City 6, Mo.
 Rush me FREE 1963 B-A Catalog.

SEND FOR IT TODAY

FREE

Name

Address

City State



SELL YOUR USED EQUIPMENT Through POPULAR ELECTRONICS' Classified Columns!

The 400,000 readers of **Popular Electronics** are interested in your used electronic gear or components. If you have something to sell, let the readers of **Popular Electronics** know about it through the classified advertising columns. It costs very little—**60 cents a word**, including your name and address. Minimum message—10 words.

For further information write:

Martin Lincoln
POPULAR ELECTRONICS
 One Park Avenue
 New York 16, N. Y.



The following satellites, launched by the United States, were reported to have beacon and telemetry transmissions as of May 14, 1963. The satellites are listed by their code names, according to frequency; because some transmit on more than one frequency, they appear more than once.

Transit 4A	54.000 mc.
Vanguard 1*	108.023 mc.
Telstar 2	136.000 mc.
Relay 1	136.140 mc.
Transit 4A	136.200 mc.
Explorer 16**	136.200 mc.
Tiros 4	136.230 mc.
Tiros 6	136.233 mc.
Tiros 5	136.234 mc.
Explorer 17**	136.317 mc.
Ariel	136.407 mc.
Explorer 14	136.440 mc.
Explorer 17	136.560 mc.
Alouette	136.593 mc.
Relay 1	136.620 mc.
OSO I	136.744 mc.
Anna 1B	136.815 mc.
Explorer 16	136.860 mc.
Injun 3**	136.860 mc.
Tiros 6	136.922 mc.
Tiros 5	136.923 mc.
Anna 1B	136.975 mc.
Alouette**	136.979 mc.
Transit 4A	150.000 mc.
Anna 1B	162.000 mc.

*Transmits only while satellite is in sunlight—no battery power

**Transmits only upon command from ground stations—not during every pass

Satellites of the Soviet Union have telemetry and tracking transmissions in the 19.990-20.010 mc. band. Whenever a Cosmos series satellite is launched, check Radio Moscow for an announcement of tracking frequencies. Most Cosmos series satellites re-enter the atmosphere in 60-90 days. Cosmos 2, 5, and 8 are in orbit at press time, but do not seem to be transmitting.

If you're interested in eavesdropping on satellites, and missed our June 1962 article on the NASA-136 converter, we recommend that you look it up. Easy to construct, this sensitive converter can intercept the satellites operating in the 136-137 mc. band.

Always say you saw it in—POPULAR ELECTRONICS



New RAY-TEL TWR 3... features Revolutionary Frequency Synthesizer

Space age technology has advanced a new concept in frequency control. Now, the new Raytheon Ray-Tel TWR3 employs a solid state frequency synthesizer which enables a single crystal to control both the transmitter and the receiver for the same channel. This reduces crystal costs by one half!

Also the "3" features ten channels • Tunable receiver for "spotting" clear channels and for general band monitoring • 3.2 watts output • Sensitive RF stage • Exceptionally low internal noise level • Dual conversion • And an "S" meter which also indi-

cates power output, modulation, and is an "on-off" indicator.

The rugged "3" design expresses true power . . . performance . . . and reliability. Here is the finest available in 2-way communications. Suggested Retail Price \$219.95. For full particulars write Raytheon Company, Distributor Products Division, P. O. Box 602, Westwood, Massachusetts.



LATEST SAMS BOOKS FOR EVERYONE IN ELECTRONICS



USE THIS HANDY ORDER FORM

- CB Radio Construction Projects.** Complete details for building valuable CB devices, such as S-meter, portable antenna, pocket monitor receiver, selective call system, field strength meter, modulation monitor, SWR meter, remote listening unit, etc. Order **CBG-1, only** **\$2.50**
- ABC's of Hi-Fi and Stereo.** Fully describes sound and stereo; covers consoles vs. components; details anatomy of a sound system, kit-building for pleasure and savings, how to get the most from hi-fi. Order **H5F-1, only** **\$1.95**
- Amateur Radio Construction Projects.** Shows how to build 40-80 meter band novice transmitter, 30-watt 15, 40, 80 meter transmitter, balun antenna matching unit, crystal-controlled converters, etc. Full building instructions. Order **ARP-1, only** **\$2.50**
- Dictionary of Acronyms & Abbreviations.** Know the meaning of ACNO, BCD, CAV, DAI? This book gives you all the answers—defines over 3,200 acronyms and abbreviations. Invaluable reference for engineers, technicians, students. Hardbound. Order **DAG-1, only** **\$4.95**
- Science Projects in Electricity.** Uniquely planned science projects easily teach the facts about electric current flow; electrical units, terms, and circuits; magnetism; DC & AC; inductors & transformers; capacitors, etc. Order **SPE-1, only** **\$2.95**
- TV Troubleshooter's Reference Handbook.** Brings you the practical experience of experts in analysis and repair of TV problems. Covers all circuitry. Unique step-by-step charts for quickly solving virtually any TV troubles. Order **TVH-1, only** **\$2.95**
- Communications Equipment Schematic Manual.** Complete schematics and specs for leading commercial 2-way systems, including Bendix, Comco, DuMont, GE, Link, Motorola, RCA. Order **CEM-1, only** **\$3.95**
- TV Service Pricing Manual.** For the TV service operator who wants to improve his profit picture. Tells how to determine charges for various jobs, how to figure cost of operation, how to stay competitive yet make a reasonable profit, how to boost repair output. Order **PRM-1, only** **\$1.50**
- International Code Training System, CTG-1** **\$6.95**
- How to Read Schematic Diagrams, RSD-1** **1.50**
- Handbook of Electronic Tables & Formulas, HTF-2** **3.95**
- Modern Dictionary of Electronics, DIC-1** **6.95**
- ABC's of Short-Wave Listening, SWL-1** **1.95**
- TV Servicing Guide, SGS-1** **2.00**
- Radio Receiver Servicing, RS-2** **2.95**
- Transistor Substitution Handbook, SSH-4** **1.50**



FREE! Ask for the Sams Booklist, describing over 200 important books.

FREE! Index to Photofact, world's finest circuit data on 53,000 TV & radio models.

HOWARD W. SAMS & CO., INC.

Order from any Electronic Parts Distributor or mail to Howard W. Sams & Co., Inc., Dept. G-93 4300 W. 62nd St., Indianapolis 6, Ind.

Send books checked above. \$_____ enclosed.

Send **FREE** Booklist. Send Photofact Index.

Name _____

Address _____

City _____ Zone _____ State _____

IN CANADA: A. C. Simmonds & Sons, Ltd., Toronto 7

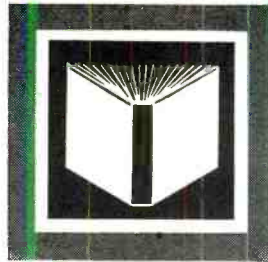

Pop'tronics Bookshelf

PROFITABLE TELEVISION TROUBLESHOOTING, Second Edition

by Eugene A. Anthony

After the first edition of this book was published some six years ago, it gradually came to be regarded as the TV serviceman's "Bible." Between 1957 and 1963, literally hundreds of other books on TV repairs have been printed. However, as a thorough-going background reference work, few—if any—come close to this volume by Eugene Anthony. *Profitable TV Troubleshooting* is in a class by itself. The writing is clear and concise, the explanations are down to earth, and the flow of material is logically arranged chapter by chapter. The new edition includes many revisions which bring the whole book up to date. The chapters on color television have been almost completely rewritten, and a separate chapter has been added on remote controls. The step-by-step tables in chapter 12 will be helpful in solving 90% of the TV troubles a serviceman is likely to encounter.

Published by McGraw-Hill Book Co., Inc., 330 West 42nd St., New York 36, N.Y. Hard cover. 407 pages. \$7.25.



CAREERS AND OPPORTUNITIES IN ELECTRONICS

by John M. Carroll

There is certainly a crying need for a well-thought-out, revealing book on the topic of careers in electronics. Unfortunately, this particular effort is more of a summary and condensed history of electronics than an informative guide of value, say, to a career-conscious high-school senior. True, it could excite a reader's interest in electronics and induce him to explore further in the field, but it doesn't tell him how to go about it. Your reviewer's impression is that the author has obviously been involved in elec-

Always say you saw it in—POPULAR ELECTRONICS



In today's world...

What does it take to feel like a man?

It takes action to feel like a man. Takes pride and courage. But in today's modern world *it also takes training. Technical training.* Ask any mechanic. Ask any missile man.

In today's modern Army all units are fast-moving. Flexible. Men and machines are closely interlocked. And since the machines are complex, men have to be extra skilled to handle them. The Army *makes* men like this—technically skilled, competent, confident.

You can be expert in areas like engineering, missiles, electronics, motor mechanics—or any of 150 other fields!

And of course, if you are qualified, you can receive extensive training in other fields like Combat Arms—Infantry, Armor or Artillery. You will be proud to be a member of any one of them. And you'll end up proud of yourself too. Find out how to feel like a man in today's fast-changing world. See your local Army recruiter today.

CLASSROOM TRAINING COURSES IN
LOS ANGELES AND NEW YORK CITY

START YOUR CAREER IN ELECTRONICS NOW AT RCA INSTITUTES...

Choose from this list

	Course	Qualifications	Length of Course
A	Electronics Technology (T-3)	High School Grad, with Algebra, Geometry, Physics or Science	Day 2¼ yrs. (N.Y., L.A.) Eve. 6¾ yrs. (N.Y.)
B	Industrial and Communications Electronics (V-7)	2 yrs. High School with Algebra, Physics or Science	Day 1½ yrs. (N.Y., L.A.) Eve. 4½ yrs. (N.Y.) Eve. 3 yrs. (L.A.)
C	Electronics and Receivers (V-3)	2 yrs. High School with Algebra, Physics or Science	Day 9 mos. (N.Y., L.A.) Eve. 2¼ yrs. (N.Y.) Eve. 1½ yrs. (L.A.)
D	Electronic Drafting (V-11, V-12)	2 yrs. High School with Algebra, Physics or Science	Eve. Basic: 1 yr. (N.Y.) Advanced: 2 yrs. (N.Y.)
E	Automation Electronics (V-14)	Radio Receiver and Transistor Background	Sat. 44 wks. (N.Y.) Eve. 9 mos. (N.Y.)
F	Digital Computer Electronics (V-15)	Radio Receiver and Transistor Background	Sat. 30 wks. (N.Y.) Eve. 6 mos. (N.Y.)
G	Fundamentals of Computer Programming (CP-1)	College Grad. or Industry Sponsored	Sat. 15 wks. (N.Y.) Eve. 3 mos. (N.Y.)
H	RCA 301 Computer Programming (CP-2)	CP-1 or Equivalent	Sat. 15 wks. (N.Y.) Eve. 3 mos. (N.Y.)
I	RCA 501 Computer Programming (CP-4)	CP-1 or Equivalent	Sat. 15 wks. (N.Y.) Eve. 3 mos. (N.Y.)
J	IBM 1401 Computer Programming (CP-3)	CP-1 or Equivalent	Sat. 15 wks. (N.Y.) Eve. 3 mos. (N.Y.)
K	Color Television	Television Background	Eve. 3 mos. (N.Y., L.A.)
L	Transistors	Radio Background	Eve. 3 mos. (N.Y., L.A.)
M	Technical Writing	Electronics Background	Eve. 3 mos. (N.Y.)
N	Preparatory (P-1)	1 yr. High School	Day 3 or 6 mos. (N.Y.) Day 3 mos. (L.A.)
O	Preparatory Mathematics (P-0A)	1 yr. High School	Eve. 3 mos. (N.Y.)

RCA Institutes is one of the largest technical institutes in the United States devoted exclusively to electronics. Free Placement Service. Applications now being accepted for next term classes in Los Angeles and New York.



The Most Trusted Name
in Electronics
RADIO CORPORATION OF AMERICA



Send to the school nearest you -

RCA Institutes, Inc. Dept. PER-73

Pacific Electric Building 350 West Fourth Street
610 S. Main St., L.A. 14, Calif. New York 14, New York

Please send me your FREE catalog. I am interested in the courses circled below.

A B C D E F G H I J K L M N O

Name _____ (please print)

Address _____

City _____ Zone _____ State _____

For Home Study Courses See Ad On Opposite Page

tronics so long himself that he doesn't quite succeed in communicating the excitement that the field should hold for a newcomer; nor does the book live up to the promise of its title.

Published by E.P. Dutton & Co., Inc., 201 Park Ave. S., New York 3, N.Y. 190 pages. Hard cover. \$3.95.



HAM ANTENNA CONSTRUCTION PROJECTS

by J. A. Stanley

Here is a book that lives up to its title with a vengeance. It's jam-packed with hundreds of practical ideas on antenna designs, mountings, radiation patterns, tuners, matching problems—anything you can think of that relates to antennas and antenna construction. Antennas are described that can fit anywhere and do just about anything. They are fabricated in special shapes for apartment dwellers, made out of TV conicals, rain gutters, aluminum tubing, or just about any piece of metal that comes to hand. If you are in that group of 19 out of 20 hams that doesn't have enough green stuff for a 5-element, 20-meter beam, this book is for you. About the only mystery attached to it is the author's ghost name—we're sure that many POP'tronics readers will realize that J. A. Stanley is really a very capable ham from Denver, Colorado.

Published by Howard W. Sams & Co., Inc., 4300 West 62nd St., Indianapolis, Ind. 160 pages. Soft cover. \$2.95.



DIODE CIRCUITS HANDBOOK

by Rufus P. Turner

One of our favorite authors, Rufus Turner, has come up with a valuable addition to any experimenter's bookshelf. This is a handbook in every sense of the word—it contains nearly 100 circuits using germanium and silicon, tunnel and varactor, zener and varistor diodes. Name a circuit in which it's possible to employ a crystal diode and, in all probability, you'll find a description of it. According to the press release on the book, there are 23 receiver, 9 transmitter, 6 audio, 15 power supply, 28 instrumentation, 9 computer, 6 control, and 4 miscellaneous circuits. We didn't count them, but it certainly looks like they're there. *Diode Circuits Handbook* is a must for the electronics gadgeteer.

Published by Howard W. Sams & Co., Inc., 4300 West 62nd St., Indianapolis 6, Ind. 128 pages. Soft cover. \$2.50.

RCA introduces a new easy way to learn electronics at home

Learn faster, remember more with this revolutionary new "learning method". And RCA Institutes, Inc. is first to bring it to you!

Forget all your old ideas about learning! The newest method, RCA "Autotext", uses the latest scientific development in the field of home training! RCA "Autotext" is a system of programmed instruction, accurately planned so that as you read a series of statements, questions, and answers, you learn almost without realizing it! It's fun to learn this new RCA way!

We'll prove it to you! ... RCA Institutes now offers you a complete Home Training Course using RCA "Autotext" called "Introduction to Electronics." In addition, you get a complete set of experiment lessons, service practice lessons, and all the kits you need. You learn electronics theory faster with less effort.

WIDE CHOICE OF HOME TRAINING COURSES: In addition to Introduction to Electronics, RCA Institutes offers this complete selection of Home Training Courses:

- Electronics Fundamentals*
- TV Servicing
- Color TV
- Transistors
- Electronic Drafting
- Communications Electronics
- FCC License Preparation
- Mobile Communications
- Automation Electronics
- Computer Programming

**Also available in Spanish*

All RCA Institutes Home Training Courses are complete step by step easy-to-understand units. You get prime quality equipment in the kits furnished to you to keep and use on the job. In addition, RCA's liberal tuition plan affords you the most economical possible method of home study training. You pay for lessons only as you order them. If you should wish to interrupt your training for any reason, you do not owe one cent. Licensed by the N.Y. State Department of Education. Approved for Veterans.

CLASSROOM TRAINING AVAILABLE IN NEW YORK CITY, LOS ANGELES, AND CHERRY HILL (NEAR CAMDEN) NEW JERSEY. Check "Classroom Training" and we will rush information.

FREE OFFER!

We'll send you complete information on the amazing new RCA "Autotext", along with a FREE SAMPLE of a Home Training lesson to prove to you how easy it is to learn this new way. Check "Autotext", and information will be rushed to you.

RCA INSTITUTES, INC., Dept. PE-73

A Service of Radio Corporation of America
350 West 4th St., New York 14, N. Y.
Pacific Electric Bldg., 610 S. Main St., Los Angeles 14, Calif.



The Most Trusted Name
in Electronics

RCA Institutes, Inc. Dept. PE-73
350 West 4th St., New York 14, N. Y.
Pacific Electric Bldg., 610 S. Main St., Los Angeles, Calif.

Please rush me FREE illustrated book with information checked below. No obligation. No salesman will call.

"Autotext" _____ Home Training _____

Classroom Training (choice of city) _____

Name _____ Age _____

Address _____

City _____ Zone _____ State _____

CANADIANS: Take advantage of these same RCA Institutes Courses at no additional cost. No postage, no customs, no delay. Fill out this coupon and send in envelope to: RCA Victor Ltd., 5581 Royal Mount Ave., Montreal 9, Quebec.

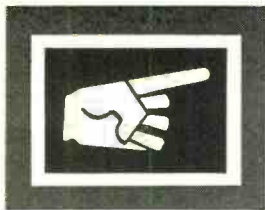

Tips and Techniques

WORKING WITH STRANDED WIRE

Most experimenters know that stranded wire is called for where there's much flexing or bending to be expected. But getting all of the wires through small holes in tube socket or terminal strip wiring tags, or into the cup of military type connector pins can be a very frustrating job. Do it the easy way by first making the end effectively into a solid wire for the short length that must enter the hole. Cut the wire to length, carefully strip the ends, clean the strands if necessary, and tin the end portions, shaking off the excess solder before it solidifies. The tinned ends can now be bent and squeezed

into just the right shape to enter a tight hole. Once in place, you'll find the freshly tinned wire much easier to solder, too.

—Arthur L. Jennings

STEPPING UP PHONO SPEED

Those children's phonographs are great until they start losing speed and 33-rpm records play at 29-30 rpm, or 45's at 40 rpm. The cause is usually due to wearing of the rubber rim on the idler wheel. You can make a temporary repair by building up the worn



surface with plastic tape, but the best way to handle this situation is to increase the diameter of the rubber from the *inside*. Just slip the rubber "tire" off the idler wheel and place a single layer of plastic tape along the bottom of the groove in the

(Continued on page 20)



IN ACTION!

10-33, Mayday
or
S.O.S.

they all mean the same thing . . . an emergency.

And this is when CB really swings into action.

There is no civic group in this country that can claim a better record of helping when it counts, than CB'ers and their clubs.

Whether it be rescuing a distressed motorist, helping the police locate lost persons, or aiding the injured, CB is on the spot — and "In Action" around the clock.

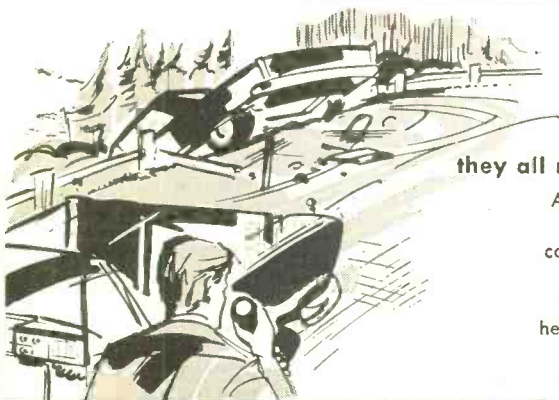

"Sound" Reasons for Buying the "Companion"

- Channels—5, plus front panel crystal socket for use on any channel.
- Transistorized Power Supply—5 watts input. 3 watts into 50 ohms output.
- Adjustable squelch control. Modulation—high level limited to 95%.
- Pre-set automatic noise limiter, gated squelch.
- Ultra-sensitive Superhet receiver — ½ microvolt.

See your authorized Pearce-Simpson dealer or write us for his name.

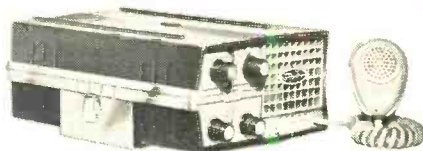

"Companion" Citizens Band Transceiver



PEARCE-SIMPSON INC.

2295 N.W. 14th STREET
MIAMI 35, FLORIDA

Here's what they're saying about Sarkes Tarzian's free new booklet, "Lower the Cost of Fun with Tape Recording"...

"The vigor of this presentation proves that Tarzian is interested in getting this country (and tape recording) moving again...everyone should walk to their nearest tape store and request a copy...or walk to Bloomington"
 ...(name withheld on request)

"Contains a modest but penetrating analysis of why Tarzian Tape is perhaps the least-known superior product in the United States today"
 ...Committee for Truth in Tape Promotion

"'Invite Tape to Your Party' is the chapter that puts the bright light of public inspection on those 'friendly get-togethers' in suburbia"
 ...Chipman Report

"The chapter dealing with recording of short wave broadcasts blatantly lays bare more capitalistic tricks for spying on peaceful communications of our people's democracies"
 ...Havana Times

"The chapter entitled 'Use Tape in Your Business' is a bold statement of Tarzian confidence in traditional American enterprise"
 ...Hall Street Journal

"I agree" ... Harry Goldwater



The editors of Esquire helped us write it. We think it's stimulating, helpful, and fun. Best of all, it's yours free—from your hi-fi or photo dealer, or by writing to the address below.

AND DON'T FORGET TO BUY A REEL OF TARZIAN TAPE. It's professional quality tape at a really practical price—choose 1½-mil or 1-mil acetate, 1-mil or ½-mil Mylar*, all reel sizes.

*DuPont Trademark



SARKES TARZIAN, Inc.

World's Leading Manufacturers of TV and FM Tuners • Closed Circuit TV Systems • Broadcast Equipment • Air Trimmers • FM Radios • Magnetic Recording Tape • Semiconductor Devices

MAGNETIC TAPE DIVISION • BLOOMINGTON, INDIANA

Export: Ad Auriema, Inc., N.Y. • Canada: E. J. Piggott Enterprises Ltd., Toronto, Ont.



XMAS IN JULY

FREE GIFT
PAKS **\$50.00** WORTH OF
RADIO & TV
PARTS
25c for handling
PLUS ANY \$1 ITEM IN THIS AD

BOTH FREE WITH ANY \$10 ORDER

WORLD FAMOUS POLY PAK KITS—BRAND NEW PARTS

- | | |
|------------------------------------------------------------------------------------------------------------------------------------------------------------------------------------------------------------------------------------------------------------------------------------------------------------------------------------------------------------------------------------------------------------------------------------------------------------------------------------------------------------------------------------------------------------------------------------------------------------------------------------------------------------------------------------------------------------------------------------------------------------------------------------------------------------------------------------------------------------------------------------------------------------------------------------------------------------------------------------------------------------------------------------------------------------------------------------------------------------------------------------------------------------|-----------------------------------------------------------------------------------------------------------------------------------------------------------------------------------------------------------------------------------------------------------------------------------------------------------------------------------------------------------------------------------------------------------------------------------------------------------------------------------------------------------------------------------------------------------------------------------------------------------------------------------------------------------------------------------------------------------------------------------------------------------------------------------------------------------------------------------------------------------------------------------------------------------------------------------------------------------------------------------------------------------------------------------------------------------------------------------------------------------------------------------------------------------------------------------------------------------------|
| <ul style="list-style-type: none"> 15 PNP TRANSISTORS CK722, 2N107 equals 15 NPN TRANSISTORS 2N35, 2N170, 2N377 4 SURFACE BARRIER 100mc transrs, npn 15 GERMANIUM DIODES 1N34, 1N18, 1N60 3 20-WATT TRANSISTORS 2N1321 4 GE 2N43 TRANSISTORS PNP, hi-gain, audio 4 RAYTHEON WORLDS smallest npn transrs 4 SYLVANIA NPN 2N35 4 GE 2N170 RPN NPN 4 GE 2N107 PNP 4 TRANSISTOR TRANSFORMERS, worth \$25 40 1% PRECISION RESISTORS, 1/2, 1, 2W 3 UTC "SOUNDINGERS" TRANSISTOR TRANSFORMERS 10 ELECTROLYTICS to 500mf to 450V 10 TRANSISTOR ELECTROLYTICS, asst values 60 SOCKETS, plugs, rect, power, audio 35 TWO WATERS, Allen Bradley, 5% too 40 WORLD'S SMALLEST RESISTORS, 5% too 10 RCA PLUG-IN JACK sets for phono, tuners 50 TERMINAL STRIPS 1 to 6 lug types \$25 RADIO-n-TV SURPRISE transistors, etc. 10 VOLUME CONTROLS to 1 meg, switch too 50 ONE WATERS, IRC, Allen Bradley, 5% too 100 CERAMIC TUBULAR CONDENSERS | <ul style="list-style-type: none"> 4 SUN BATTERIES 1 1/2", lite sensitive 5 2N155 TYPE POWER TRANSISTORS, TO3 case 25-PC SEMI "BANK" transrs, diodes, rectrs 25 AMP TRANSISTOR car ignition, etc. 2 40-WATT TRANSISTORS, threaded case 20 SILICON RECTIFIERS -diodes, top hat, etc. 10 2-amp STUD RECTIFIERS, silicon, power 10 ZENER DIODES, asst, silicon, 1 watt 6 750-MIL 600V SILICON TOP HATTERS 100 HALF WATERS, 5% too, 100ohm to 1meg 40 DISC CAPACITORS 27 mmf to .05mf 30 POWER RESISTORS, 1/2 to 24K ohms 10 TRANSISTOR SOCKETS for PNP and NPNs 10 SWITCHES, rotary micro toggle, slide 60 CERAMIC COND discs, tubular to .05mf 60 TUBULAR CONDENSERS, .0002 to .1mf to 1KV 40 SUBMINI CONDENSERS .0002 to .05mf 60 RADIO-n-TV KNOBS, asst, shapes-colors-etc. 60 COILS-n-CHOKES, rf, osc, if, peaking, etc. 60 MICA CONDENSERS, asst, silvers too 60 CARBON RESISTORS, 1/2, 1, 2W to 2meg, 5% too 100 PARTS SURPRISE, worth \$50 30 CORNING magnetic-film Low-noise resistrs |
|------------------------------------------------------------------------------------------------------------------------------------------------------------------------------------------------------------------------------------------------------------------------------------------------------------------------------------------------------------------------------------------------------------------------------------------------------------------------------------------------------------------------------------------------------------------------------------------------------------------------------------------------------------------------------------------------------------------------------------------------------------------------------------------------------------------------------------------------------------------------------------------------------------------------------------------------------------------------------------------------------------------------------------------------------------------------------------------------------------------------------------------------------------|-----------------------------------------------------------------------------------------------------------------------------------------------------------------------------------------------------------------------------------------------------------------------------------------------------------------------------------------------------------------------------------------------------------------------------------------------------------------------------------------------------------------------------------------------------------------------------------------------------------------------------------------------------------------------------------------------------------------------------------------------------------------------------------------------------------------------------------------------------------------------------------------------------------------------------------------------------------------------------------------------------------------------------------------------------------------------------------------------------------------------------------------------------------------------------------------------------------------|

INCLUDE POSTAGE. AVERAGE WEIGHT PER PAK 1 lb. Send 10c for bargain flyer on semiconductor, paks, parts

POLY PAKS

P. O. BOX 942E
So. Lynnfield, Mass.

NEVER FAIL— ZONE YOUR MAIL

The Post Office has divided 106 cities into postal delivery zones to speed mail delivery. Be sure to include zone number when writing to these cities; be sure to include your zone number in your return address—after the city, before the state.

Tips

(Continued from page 18)

metal center. A single layer of tape may do the trick, but if not, experiment with additional layers until you reach the proper speed. Put a thin layer of cement over the tape (after the proper amount has been determined) so that the rubber tire and plastic base will not slip.

—Homer L. Davidson

PIN-PLUG PLASTIC INSULATORS

Sometimes it's necessary to have insulating covers on pin-plugs. There are plugs on

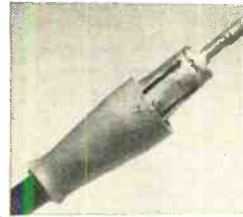

the market with such insulators over the ground caps, but if you need one of these plugs in a hurry, you can whip one up right on the spot. Just take a rubber or flexible plastic insulator—

the type used on test clips—and cut about 1/2" or 3/4" off the narrow end. When you slip this short insulator over a plain pin-plug, you'll have an insulated one.

—Charles Lang

FLUORESCENT STARTER REPAIR

The starters in fluorescent light fixtures seldom outlive the fluorescent tubes. This is almost invariably due to the failure of the poor-grade capacitor used in the starter. When the starter goes, the tube blinks on and off, or doesn't light at all. To repair the starter, open its case by bending back the lugs holding the aluminum shell to the fiber base. Clip out the paper-foil capacitor and discard it. Substitute a 600-volt., 01- μ f. ceramic disc capacitor for the original capacitor if the light uses a 15-20 watt fluorescent tube. For a light using a 30-40 watt tube, install a .005- μ f., 600-volt ceramic disc capacitor. Then reassemble the starter, making sure that the capacitor leads do not short to the aluminum shell.

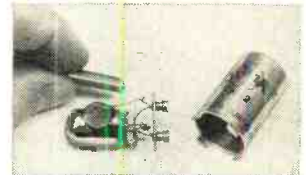

—Bert Isbell, K5IBZ

(Continued on page 22)

The power saw you've been looking for, at the price you never hoped to find!

SLOAN-ASHLAND
7 1/2" POWER SAW

POWERED BY GENERAL ELECTRIC

BIG CAPACITY!
 Whips through Rough
 2x4's at 45°

POWERFUL!
 10 Amp. Burnout-Proof Motor
 develops 2 H.P.

DEPENDABLE!
 General Electric High-Torque Motor

RUGGED!
 UL Approved for
 Industrial Use

1. 4800 RPM High Torque G E Motor develops 2 H.P.—115V AC-DC—10 Amp.
2. Oversize Fan keeps motor cool. Blows sawdust straight down
3. Safety Cutter—no "kickbacks", gear damage, burn out
4. Self-lubricating bearings, gears sealed in grease chamber
5. Angle cut adjusts 0° to 45°—cuts rough 2 x 4 at 45°
6. Adjustable Rip Guide
7. Extra Large 7 1/4 x 12 3/4" Base Plate—for stability
8. 7 1/2" Hardened Cominat on Rip and Cross Cut Blade
9. Retractable Safety Swing Blade Guard
10. Aluminum Die Cast Mirror Finish
11. Depth of cut adjusts from 0" - 2-8/16"—Calibrated Guide
12. 3-wire reinforced rubber cord and plug
13. Automatic Safety Release Switch

From base plate to safety switch, this SLOAN-ASHLAND Power Saw is built for heavy duty use on the job, in the home, on the farm. The General Electric motor drives the big 7 1/2" blade through the toughest wood without the slightest hesitation—and it keeps doing it all day long. The safety clutch helps insure longer life, easier use because it does away with hand-jarring "kickbacks", costly gear damage and motor burnout. Yes! Feature for feature, you'll agree this is the greatest power saw value you've ever enjoyed.

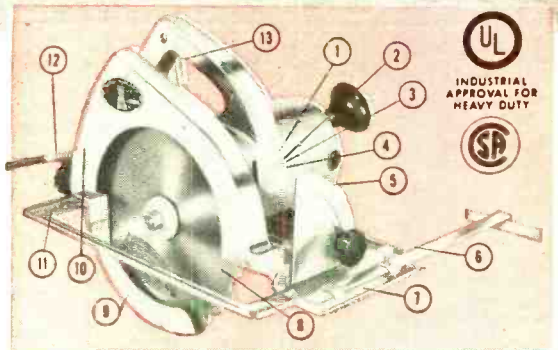

SLOAN-ASHLAND
7 1/2" POWER SAW

\$39.95

WARNING BLINKER & FLASHLIGHT FREE!



FINGERHUT PRODUCTS CO., 3104 W. Lake St., Minneapolis 16, Minn.

Send me your new Sloan-Ashland 7 1/2-inch power saw, plus the free warning blinker and flashlight.

Fingerhut Products guarantees that the \$5 down payment I have enclosed will be returned to me if I am dissatisfied for any reason, and return the power saw to you within 10 days of receipt.

If I do agree to keep the Sloan-Ashland power saw, I will send you only \$5.00 a month until I've paid the balance of the low \$39.95 total price (plus shipping and handling). The blinker and flashlight is mine to keep whether or not I decide to keep the power saw.

Name _____ (please print)
 Street _____
 City _____ Zone _____ State _____
 Where employed _____
 Home phone number _____ 1405

Tips

(Continued from page 20)

EXTRA "LAMP HANDEE"

Here's an old trick, but one so useful that it's worthwhile rehashing. It's easy to see into those dark chassis corners if you have a spare Ungar "Standard Line" soldering iron. This is the type of iron that comes equipped with several screw-on heating units of different wattages. The thread is the same as that for the base of a standard 7-watt decorative light bulb. For less eye strain, all you have to do is to screw one of these bulbs into the soldering iron, in place of a heating unit.



—Steve Brant, K8VII

WATER COLORS IDENTIFY TERMINALS

Ever remove a component—such as a re-

sistor—from a piece of equipment, and then waste precious minutes trying to locate the terminals from which it was unsoldered when you went to replace it? You can avoid this stumbling block by identifying the terminals beforehand with children's water color paint. Put a dab of paint on the two terminals from which you remove the part, and you can't miss them when you're ready to resolder.

—John A. Comstock

HOMEMADE SPAGHETTI

There's no need to be caught short when you want some spaghetti to insulate the leads of a component. If regular spaghetti isn't readily available, take some hookup



wire—the plastic insulated type is best—and strip off a length of insulation equal to the desired length of spaghetti. For large diameter spaghetti, use larger insulated wire—plastic mike cable insulation serves very well.

—Homer L. Davidson

SWL/QSL BUREAU

THE SWL/QSL Bureau is a non-sponsored organization operating with the cooperation of the ARRL QSL Bureau and the Newark News Radio Club. Its purpose is to handle incoming overseas SWL and QSL cards destined for W, K, and VE SWL's. When cards arrive with a complete address, the SWL is notified by post card and requested to send a 9½ x 4¼ inch SASE (legal size, self-addressed, stamped envelope), with an extra stamp enclosed, to the Bureau so that cards may be forwarded to him. Many SWL and QSL cards arrive incompletely addressed, however, or addressed only to a WPE call-sign. Cards are held for the call-signs listed.

If your call-sign appears in this list, and you have not already filed your name, address, and WPE call-sign with the Bureau, send an SASE to: LeRoy Waite, WPE2AK, Manager, SWL/QSL Bureau, 39 Hannum St., Ballston Spa, N. Y. Upon receipt of the SASE, your card/cards will be forwarded to you.

WPE1DIA	WPE2KK	WPE6UD
WPE1DKI		
WPE1EHJ	WPE3AGB	WPE7AKB
WPE1TV	WPE3BDV	WPE7AQB
	WPE3CCM	WPE7AQQ
WPE2AAK	WPE3CFW	
WPE2ADW	WPE3DAA	WPE8BAU
WPE2AQO	WPE3MC	WPE8BCY
WPE2AWP	WPE3UY	WPE8BGP
WPE2BJV		WPE8BXY
WPE2BWW	WPE4CIA	WPE8CBC
WPE2BCP	WPE4CVN	WPE8CBG
WPE2CFP	WPE4EDP	WPE8CCL
WPE2CRL	WPE4EEJ	WPE8CMQ
WPE2CSD	WPE4FBO	WPE8DQF
WPE2CSE	WPE4RX	WPE8EET
WPE2CSL		WPE8ETY
WPE2CT	WPE5ACB	WPE8IED
WPE2DDZ	WPE5AWK	WPE8PH
WPE2DEY	WPE5AWV	
WPE2DNL	WPE5CFE	WPE9ATR
WPE2DXA	WPE5RJ	WPE9BOJ
WPE2EAA		WPE9CFZ
WPE2EC	WPE6AQT	WPE9CQV
WPE2EGX	WPE6BJW	WPE9CXR
WPE2EMG	WPE6CBQ	WPE9EQI
WPE2FEN	WPE6CRJ	WPE9NA
WPE2GJD	WPE6CJW	WPE9OAB
WPE2HIH	WPE6DJW	WPE9OAJ
WPE2HKT	WPE6OT	WPE9OBK

RAD-TEL'S

1 for 1 TUBE SALE!

Your Choice

29
each

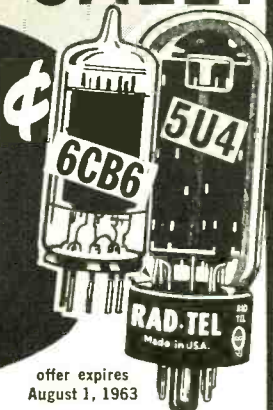

offer expires
August 1, 1963

*RAD-TEL'S SPECIAL OFFER

For every Rad-Tel quality Brand New Tube you buy, as advertised—Rad-Tel will give you your choice of a Brand New 5U4 or 6CB6 tube for only 29¢ each!!

LIMITED TIME OFFER—ORDER NOW!

ONE YEAR GUARANTEE

ONE DAY SERVICE—OVER 500 TYPES IN STOCK

up to **75% OFF****

Rad-Tel's Quality
BRAND NEW TUBES

*Manufacturers
Suggested List Price

• FREE! Send For New Tube & Parts Catalog Send For Trouble Shooting Guide

Be your own TELEVISION REPAIRMAN

The Original NOW YOU CAN

FIX YOUR OWN TV SET BOOK

You can fix your own TV if you have TV Fixit Book . . . because 80% of troubles are caused by tubes. This book explains, illustrates trouble and what tubes cause this trouble. Pinpoints in over 3000 layouts by model number, position and type tube causing trouble.

\$1.00

No. 170



CHEATER CORD

Easy to work on
set while panel is off.

6 ft., No. 154 29¢ ea. Lots of 3—25¢ ea.



RAD-TEL TUBE CO.

TV, RADIO
AND HI-FI

Dept. PE-7 55 CHAMBERS STREET, NEWARK 5, NEW JERSEY

TERMS: 25% deposit must accompany all orders, balance C.O.D. Orders under \$5: add \$1 handling charge plus postage. Orders over \$5: plus postage. Approx. 8 tubes per 1 lb. Subject to prior sale. No C.O.D.'s outside continental U.S.A.

EACH TUBE ATTRACTIVELY BOXED & BRANDED RAD-TEL

Qty.	Type	Price	Qty.	Type	Price	Qty.	Type	Price	Qty.	Type	Price
—	0Z4	.79	—	6AU8	.87	—	6K6	.63	—	12CU5	.58
—	1AX2	.62	—	6AV6	.41	—	6S4	.52	—	12CU6	1.06
—	1B3	.79	—	6AW8	.90	—	6SA7GT	.99	—	12CX6	.54
—	1DN5	.55	—	6AX4	.66	—	6SH7	1.02	—	12D4	.69
—	1G3	.79	—	6AX5	.74	—	6SJ7	.88	—	12DE8	.83
—	1J3	.79	—	6BA6	.50	—	6SK7GT	.95	—	12DL8	.88
—	1K3	.79	—	6BC5	.61	—	6SL7GT	.84	—	12DQ6	1.04
—	1R5	.77	—	6BC8	1.04	—	6SN7	.65	—	12DS7	.84
—	1S5	.75	—	6BE6	.55	—	6SQ7GT	.94	—	12DT5	.76
—	1T4	.72	—	6BF5	.90	—	6T4	.99	—	12DT7	.79
—	1U5	.65	—	6BF6	.44	—	6T8	.85	—	12DT8	.78
—	1X2B	.82	—	6BG6	1.70	—	6U8	.83	—	12DW8	.89
—	2AF4	.96	—	6BH8	.98	—	6V6GT	.54	—	12DZ6	.62
—	3AL5	.46	—	6BJ6	.65	—	6W4	.61	—	12E05	.62
—	3AU6	.54	—	6BJ7	.79	—	6W6	.71	—	12EG6	.62
—	3AV6	.42	—	6BK7	.85	—	6X4	.41	—	12EK6	.62
—	3BC5	.63	—	6BL7	1.09	—	6X8	.80	—	12EL6	.50
—	3BN6	.75	—	6BN6	.74	—	7A8	.68	—	12EZ6	.57
—	3BU8	.78	—	6BQ6	1.12	—	7AU7	.65	—	12F8	.66
—	3BY6	.58	—	6BQ7	1.00	—	7EY6	.75	—	12FA6	.79
—	3BZ6	.56	—	6BU8	.70	—	7Y4	.69	—	12FM6	.50
—	3CB6	.56	—	6BX7	1.11	—	8AU8	.90	—	12FR8	.97
—	3CS6	.58	—	6BZ6	.55	—	8AW8	.93	—	12FX8	.90
—	3DG4	.85	—	6BZ7	1.03	—	8BQ5	.60	—	12GC6	1.06
—	3DK6	.60	—	6C4	.45	—	8CG7	.63	—	12J8	.84
—	3DT6	.54	—	6CB6	.55	—	8CM7	.70	—	12K5	.75
—	3GK5	.99	—	6CD6	1.51	—	8CN7	.97	—	12L6	.73
—	3Q4	.63	—	6CG7	.61	—	8C57	.74	—	12SF7	.69
—	3S4	.75	—	6CG8	.80	—	8EB8	.94	—	12SK7GT	.95
—	3V4	.63	—	6CL8	.79	—	8FQ7	.56	—	12SL7	.80
—	4BQ7	1.01	—	6CM7	.69	—	9CL8	.79	—	12SN7	.67
—	4CS6	.61	—	6CN7	.70	—	11CY7	.75	—	12SQ7GT	.91
—	4DT6	.55	—	6CQ8	.92	—	12A4	.60	—	12U7	.62
—	4GM6	.60	—	6CR6	.60	—	12AB5	.60	—	12V6	.63
—	5AM8	.79	—	6CS6	.57	—	12AC6	.55	—	12W6	.71
—	5AN8	.90	—	6CS7	.69	—	12AD6	.57	—	12X4	.47

RAD-TEL TUBE CO. NOT AFFILIATED WITH ANY OTHER MAIL ORDER TUBE COMPANY

—	5AQ5	.54	—	6CUs	.58	—	12AE6	.50	—	17AX4	.67
—	5AT8	.83	—	6CU6	1.08	—	12AF7	.94	—	17DQ6	1.06
—	5BK7	.86	—	6C5	.70	—	12AF3	.73	—	18FW6	.49
—	5BQ7	1.01	—	6C7	.71	—	12AF6	.67	—	18FX6	.53
—	5BR8	.83	—	6DA4	.68	—	12AJ6	.62	—	18FY6	.50
—	5CG8	.81	—	6DE6	.61	—	12AL5	.47	—	19AU4	.87
—	5CL8	.76	—	6DG6	.62	—	12AL8	.95	—	19BG6	1.39
—	5CQ8	.84	—	6DJ8	1.21	—	12AQ5	.60	—	19EA8	.79
—	5EA8	.80	—	6DK6	.55	—	12AT6	.50	—	19T8	.85
—	5EU8	.80	—	6DN6	1.59	—	12AT7	.76	—	21EX6	1.49
—	5J6	.72	—	6DG6	1.10	—	12AU6	.51	—	25AX4	.70
—	5T8	.86	—	6DT5	.81	—	12AU7	.61	—	25C5	.53
—	5U4	.60	—	6DT6	.53	—	12AV6	.41	—	25CA5	.59
—	5U8	.84	—	6DT8	.94	—	12AV7	.82	—	25CD6	1.52
—	5V6	.56	—	6EAB	.79	—	12AX4	.67	—	25CUE	1.11
—	5X8	.82	—	6EB5	.73	—	12AX7	.63	—	25DN6	1.42
—	5Y3	.46	—	6EB8	.94	—	12AY7	1.44	—	25EH5	.55
—	6AB4	.46	—	6EM5	.77	—	12AZ7	.86	—	25L6	.57
—	6AC7	.96	—	6EM7	.92	—	12B4	.68	—	25W4	.68
—	6AF4	1.01	—	6EU8	.79	—	12B6	.50	—	32E75	.55
—	6AG5	.70	—	6EV5	.75	—	12B6E	.53	—	35C5	.51
—	6AH4	.81	—	6EW6	.57	—	12B76	.60	—	35L6	.60
—	6AH6	1.10	—	6EY6	.75	—	12BH7	.77	—	35W4	.42
—	6AK5	.95	—	6FG7	.69	—	12BK5	1.00	—	35Z5	.60
—	6AL5	.47	—	6FV8	.79	—	12BL6	.56	—	36AM3	.36
—	6AM8	.78	—	6GH8	.80	—	12BQ6	1.16	—	50B5	.69
—	6AQ5	.53	—	6GK5	.61	—	12BR7	.74	—	50C5	.53
—	6AS5	.60	—	6GK6	.79	—	12BT7	.76	—	50EH5	.55
—	6AT6	.49	—	6GN8	.94	—	12BZ7	.77	—	50L6	.61
—	6AT8	.86	—	6H6	.58	—	12BZ7	.86	—	70L7	.97
—	6AU4	.85	—	6J5GT	.51	—	12CNS	.56	—	117Z3	.85
—	6AU6	.52	—	6J6	.71	—	12CR6	.67	—	807	.75

ORDER FORM MAIL TODAY

RAD-TEL Tube Co. Total
Dept. PE-7 Tubes \$ _____
55 Chambers Street Total \$ _____
Newark 5, New Jersey Part(s) \$ _____
Grand \$ _____
Total \$ _____

ENCLOSED IS \$ _____ Please rush order.

SEND: _____ Book(s) Be Your Own TV Repairman @ \$1.00 ea #170
_____ Cheater Cord 29c ea. Lots of 3 - 25c ea. #154

Orders under \$5.00 - Add \$1.00 handling charge - plus postage.

FREE! Send FREE Tube and Parts Catalog
 Send FREE Trouble Shooting Guide

NAME _____

ADDRESS _____

CITY _____ ZONE _____ STATE _____

BEST BUYS IN STEREO AND MONO HI-FI

Transistorized Stereo/Mono 4-Track Tape Deck RP100 Semikit (electronics in kit form) \$299.95 Wired \$399.95



New Stereo FM Multiplex Tuner ST97 Kit \$99.95* Wired \$149.95*



70-Watt Integrated Stereo Amplifier ST70 Kit \$99.95 Wired \$149.95

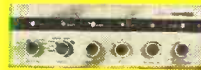

FM-AM Stereo Tuner ST96 Kit \$89.95* Wired \$129.95* *Incl. FET

40-Watt Integrated Stereo Amplifier ST40 Kit \$79.95 Wired \$129.95



28W Integrated Stereo Amplifier HF81 Kit \$69.95 Wired \$109.95

FM Tuner HFT90 Kit \$39.95 Wired \$65.95 Incl. FET Metal Cover \$3.95



Stereophonic Dual Preamplifier ST84 Kit \$95.95 Wired \$89.95

AM Tuner HFT94 Incl. FET Kit \$39.95 Wired \$65.95

Stereo Power Amplifiers



	Kit	Wired
70W HF87A:	\$74.95	\$114.95
100W HF89A:	\$99.50	\$139.50
28W HF86:	\$43.95	\$74.95



FM-Multiplex Autodaptor MX99 Kit \$39.95 Wired \$64.95 Cover Optional, \$2.95 (Patents Pending)



Bookshelf Speaker System HFS1 Kit \$39.95 Wired \$47.95

BEST BUYS IN CITIZENS TRANSCEIVERS, HAM GEAR, RADIOS

Citizens Band Transceivers 770 Series from Kit \$79.95 Wired \$109.95



U. S. Pat.



60W CW Transmitter #723 Kit \$59.95 Wired \$89.95

Walkie-Talkie Citizens Band Transceiver #740 Kit \$54.95 Wired \$79.95. Complete with rechargeable battery & charger.



BEST BUYS IN TEST EQUIPMENT

Metered Variable Auto-Transformer AC Bench Supplies



Model 1073 (3 amps) Kit \$35.95 Wired \$47.95

Model 1078 (7½ amps) Kit \$42.95 Wired \$54.95

Peak-To-Peak VTVM = 232 & Uni-Probe® (U.S. Pat.) Kit \$29.95 Wired \$49.95



VTVM = 221 Kit \$25.95 Wired \$39.95

DC-5 MC 5" Scope #460 Kit \$89.95 Wired \$129.50



General Purpose 5" Scope #427 Kit \$69.95 Wired \$109.95

Tube Tester #625 Kit \$34.95 Wired \$49.95



RF Signal Generator #324 Kit \$28.95 Wired \$39.95



1000 Ohms/Volt V-O-M #536 Kit \$14.95 Wired \$18.95



6- & 12V Battery Eliminator & Charger #1050 Kit \$29.95 Wired \$38.95



Extra-filtered for transistor equipment. =1060 Kit \$39.95 Wired \$49.95

AC Volt-Watt Meter #261* Kit \$49.95 Wired \$79.95



*Formerly called #260

Multi-Signal Tracer #145A Kit \$23.95 Wired \$32.95



EXCELLENCE IN CREATIVE ELECTRONICS

Over 2 MILLION EICO instruments in use throughout the world. Compare, take them home — right "off the shelf" — from 2000 neighborhood dealers, most of whom offer budget terms.



EICO, 3300 N. Blvd., L.I.C., N.Y. PE-7
 Send free Catalog describing over 106 top-quality products, free Stereo Hi-Fi Guide, free Short Course for Novice License, name of nearest EICO dealer. Send new 36-page GUIDEBOOK TO HI-FI for which I enclose 25¢ for postage & handling.

Name.....
 Address.....
 City..... Zone..... State.....
 Add 5% in the West

THE HULA HOOP

*Superior mobile
performance without
that tree-limb-slapping
quarter-wave whip*

-A New Ham or CB Antenna

COVER STORY

By ROY E. PAFENBERG, W4WKM, KCG1046

The superstructure shown on the top of the station wagon on this month's cover is not a new-style luggage rack. It is a brand-new and highly efficient ham or CB antenna that you can install on your car—provided it's not a convertible. Properly known as the Directional Discontinuity Ring Radiator (DDRR) and commonly called the "Hula-Hoop," this antenna is a big performer in a small package. The Hula-Hoop is a recent invention* and

*"Hula-Hoop Antennas: A Coming Trend?" J. M. Boyer, *Electronics*, pp. 44-46, Jan. 11, 1963.

THE HULA HOOP

The Hula-Hoop can be held to the roof of your car with suction cups. For a tight installation, the cups and rooftop must be very clean. Apply a liberal coating of glycerin to the inside of the cups to make them waterproof and airtight.

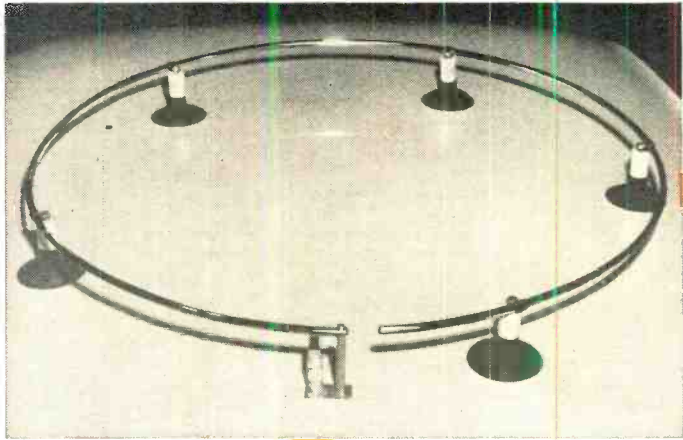

is not as yet manufactured commercially. However, you can construct this antenna yourself, easily and economically, from readily available materials.

Exhibiting most of the desirable characteristics of the full quarter-wave vertical antenna, the Hula-Hoop packs all of this performance into a unit that projects only three inches above the roof of a car. The full quarter-wave vertical whip has set the performance standard for mobile antennas, and the usual loaded or shortened designs rarely perform as well. Unfortunately, the quarter-wave whip is an ungainly and not exactly handsome item of hardware. If all the bent, broken and lost CB antennas that have been mangled by overhead obstructions were placed end-to-end, they would easily reach from New York to Chicago!

The Hula-Hoop is a more efficient radiator than most quarter-wave whip installations. The whip is usually mounted on the rear bumper or fender so that the car body absorbs a healthy portion of the radiated signal. The whip, mounted in this fashion, also has pronounced directional effects. The Hula-Hoop, on the other hand, is mounted in the center of the car roof, which serves as a very effective ground plane. Since this location is unobstructed, little energy is absorbed by the car, and the radiation pattern is almost perfectly circular.

There are other advantages. At high road speeds, a whip antenna will vibrate

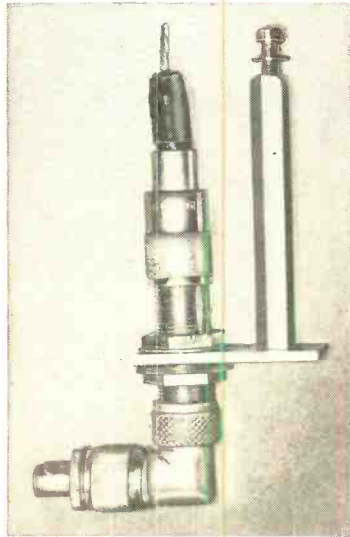

Completed rooftop r.f. feed-through is shown in the photo above. The connector is put together using the following Amphenol parts (left to right, below): 83-1SP, 83-22F, 83-1AP, 83-1SP with 83-185 adapter.

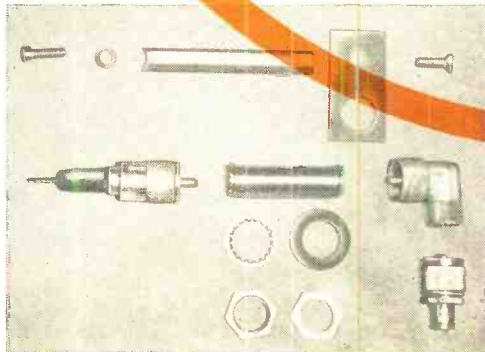

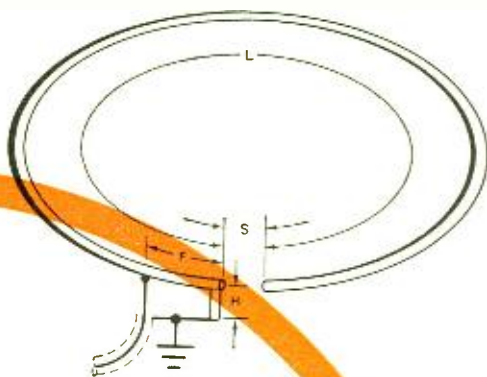
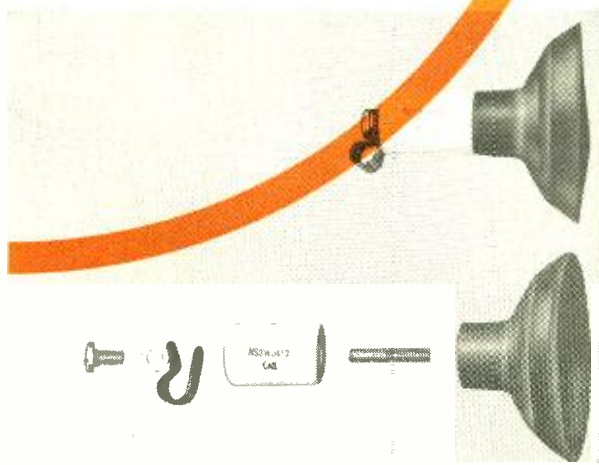

Fig. 1. Dimensions of Hula-Hoop antenna are keyed in drawing above and detailed in table below. Cut element "L" 1-1½" longer than specified and then tune up the antenna as described in text.

Band	Frequency (mc.)	"L"	"H"	"F"	"S"
CB Channel 1	26.965	104.8"	3"	See text	2"
CB Channel 9	27.065	104.4"	3"	See text	2"
CB Channel 23	27.255	103.7"	3"	See text	2"
10 Meters	28.000	100.9"	3"	See text	2"
10 Meters	29.000	97.4"	3"	See text	2"
10 Meters	29.700	95.1"	3"	See text	2"
6 Meters	50.000	55.8"	2"	See text	1"
6 Meters	52.000	53.7"	2"	See text	1"
6 Meters	54.000	51.7"	2"	See text	1"

Fig. 2. Insulator assemblies (5 required) are made of luggage rack suction-cups. Replace bolt supplied with cup with one 1½" long having ¼-20 threads. Insulator is available as a surplus item, or use Birnbach #731 for assembly.



or flutter in the wind. This flutter causes rapid variations in the strength of both transmitted and received signals. Since the Hula-Hoop is rigidly mounted to the top of the car, the antenna will not flutter at any speed. Another positive factor is that one end of the Hula-Hoop antenna element is grounded so that static charges are quietly bled off. This results in a pronounced reduction in receiver noise level when operating at high road speeds.

The Hula-Hoop has a relatively narrow bandwidth. This can be a blessing or a disadvantage depending on your mode of operation. If you normally operate on a single frequency or on a number of closely spaced frequencies, the Hula-Hoop will reduce receiver interference by rejecting signals from widely removed CB channels and other communications services. On the other hand, if you normally jump from one end of the band to the other, the Hula-Hoop will require retuning.

How It Works. The Hula-Hoop antenna consists of a quarter-wave length of conductor bent into a circle with the ends separated by a small gap. The hoop is supported by insulators above a ground plane (the car roof) at a height which is a small fraction of a wavelength. One end of the hoop is grounded by a grounding stub which doubles as an antenna element support post. The antenna is fed by an unbalanced, coaxial transmission line with the shield grounded to the ground plane and the center conductor connected to the antenna element a short distance from the grounding stub. This feed point is adjusted to obtain a proper impedance match between the transmission line and the antenna. Fig. 1 shows the basic design.

While it is impossible to present all of the theoretical considerations relating to the Hula-Hoop antenna, the following explains the basic idea. The ring conductor, or hoop, forms a single wire transmission line with the ground plane surface. Radio frequency energy traveling down this transmission line is radiated as both horizontally and vertically polarized waves. This radiation, at right angles to the conductor, occurs along the full length of the antenna element. The horizontally polarized wave is cancelled by the current flowing in the



ground plane. Vertically polarized radiation occurs because the curvature of the ring radiator introduces an infinite series of electrical discontinuities in the transmission line. This vertically polarized wave is not cancelled, and is radiated into space. It is this predominantly vertically-polarized radiation that makes the Hula-Hoop antenna ideal for CB use.

Construction. Building the Hula-Hoop antenna is not at all difficult. The photographs show construction and assembly details. Figure 1 gives the critical dimensions, and Figs. 2, 3, and 4 show the details of the simple metal parts required.

You will need five of the antenna insulator assemblies shown in Fig. 2. Drill or ream the clearance hole in the plastic cable clamp to pass a $\frac{1}{4}$ " - 20 screw. Mount the cable clamp to the top of the insulator but do not tighten the screw.

The antenna element is made from $\frac{3}{8}$ " copper tubing. When you buy the tubing, try to get a length from a roll that is not bent or kinked. Also, handle the tubing carefully to avoid extra work later on. Cut a length of tubing a couple of inches longer than the dimension shown in Fig. 1 for the frequency you desire to work. Dress the ends smooth and then carefully form the tubing into a perfect circle, leaving a gap of about an inch. Select a short length of metal rod or a stud cut from a $\frac{5}{16}$ " screw and force it into one end of the tubing. File this insert flush with the end of the tubing. Using a #10 drill, drill a hole $\frac{1}{4}$ " in from the end of the reinforced section of tubing and perpendicular to the plane of the hoop.

The grounding stub support post, shown in Fig. 3, is made from a length of $\frac{3}{8}$ " round or hexagonal, aluminum or brass rod. Carefully file one end of the

rod to match the contour of the copper tubing.

Now fabricate the grounding stub mounting plate shown in Fig. 4. Secure the post-plate assembly to the antenna element, using a #10 - 32 machine screw, with lock washer, through the hole previously drilled in the antenna tubing. Now slide the cable clamps of the insulator assemblies on the antenna element with the insulators positioned to the inside of the hoop. Position the insulators evenly around the hoop and tighten the cable clamp screws. The photos show these assembly details and the antenna ready for installation.

Installation. Details of the installation will depend to a large degree on the construction of your car. Although the gap in the Hula-Hoop may face toward either the front or the back, the antenna should be centered on the roof for maximum efficiency. Ideal as this may be, it does not always result in a practical location for bringing the transmission line through the roof. On most station wagons and many sedans, the antenna feed point may be positioned near the dome light. Temporary removal of the light will give access to the desired portion of the roof with little or no removal of upholstery.

In any event examine the construction



Fig. 3. Grounding stub post is made of brass or aluminum rod. Both ends are drilled and tapped to 1" to accept 10-32 screw.

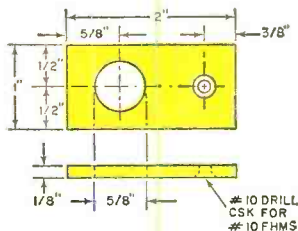

Fig. 4. Grounding stub mounting plate can be fabricated from either brass or aluminum.

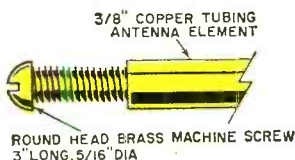
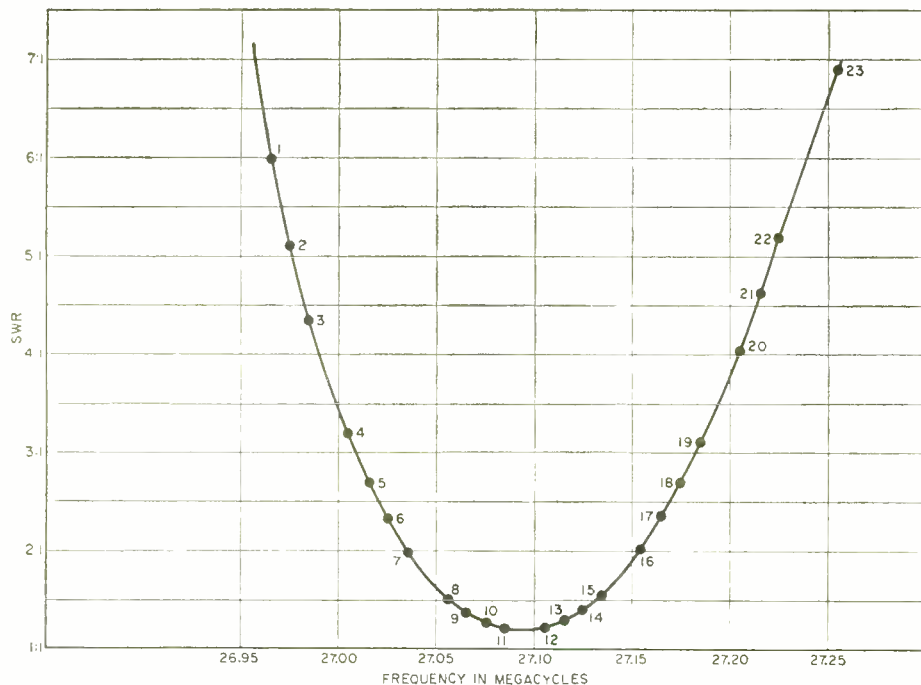

Fig. 5. Tuning adjustment screw is helpful in loading Hula-Hoop.



The sharp tuning characteristics of the Hula-Hoop are amply demonstrated in this VSWR graph covering the Citizens Radio band.

of your car. Remove the dome light and determine how the upholstery is secured to the roof. Since you will need to reach only one hand to the feed point, perhaps you can work your arm through to the desired location. If you are still in doubt, consult your car dealer or an automotive body shop to determine the best approach.

After the antenna feed point is located, carefully drill a 1/4" hole in the roof of the car. Have a helper hold the bottom part of a 5/8" punch under this hole while you position the top part and insert the drive screw from the top of the roof. The transmission line feed-through adapter should now be assembled.

Run one of the 83-22F mounting nuts flush against the 83-1AP adapter coupling nut. Smear a 3/8" fiber washer with automotive sealing compound and place it over the body of the adapter. From the inside of the car, feed the body of the 83-22F adapter through the hole in the roof and through the hole in the antenna stub mounting plate. To insure a leakproof installation, apply automotive sealing compound between the

body of the adapter and the holes in the roof and the mounting plate. Slide a lock washer over the body of the adapter and run down the second mounting nut. Carefully align the antenna with the body of the car and securely tighten the mounting nut. Moisten the bottoms of the suction cups and fully collapse them by pushing down firmly on the insulator assemblies.

Temporarily connect the transmission line to the antenna by soldering a 6" length of #16 or larger, solid conductor, insulated copper wire to the center conductor of a PL-259 connector. Strip the insulation from approximately 4" of the free end of the wire and connect the PL-259 to the top of the 83-22F feed-through adapter. Wrap this bare wire around the copper tubing antenna element at a point about 2" from the grounding stub.

Routing of the coaxial cable from the roof feedthrough adapter to the transceiver will depend strictly on the construction of your car. You can probably save a lot of work by following the routing of the dome light wiring. In some cars, this wiring is made fully accessible

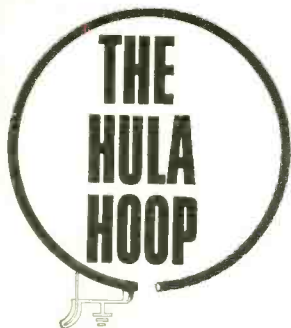

by removing the center post trim strip. Use a length of solid copper wire as a combination probe and fish line to pull the cable under the upholstery to the desired location.

To finish the inside work, terminate the coaxial cable with a fitting to match the connector used on your transceiver, and replace the dome light assembly.

Adjustment. Although tuning the Hula-Hoop antenna is not difficult, there are a number of adjustment steps, and these must be accomplished in the indicated sequence. Also, the use of a SWR meter is almost mandatory for the initial adjustments. This should not be a major problem since a wide selection of inexpensive SWR meters are made by various manufacturers and are available in both kit and wired form. If you do not care to make such an investment at this time, you may be able to borrow an instrument from an obliging ham or CB'er.

Since transmitter tuning and antenna adjustments can interact, the best procedure is to adjust the transmitter for operation into a 50-ohm load and then leave it alone until the antenna tuning is completed. To initially tune the transmitter, simply hook two 100-ohm, 2-watt composition resistors in parallel and connect between the antenna terminal and chassis ground. Tune the transmitter into this dummy load in accordance with the manufacturer's instructions. Remove the resistors and connect a short length of coaxial cable between the transceiver antenna connector and the SWR meter input connector. Use RG-8/U or RG-58/U coaxial cable fitted with appropriate connectors for this purpose. Connect the Hula-Hoop transmission line to the output connector of the SWR meter.

Inspect the antenna to insure that the

suction cups are fully collapsed and that the gap between the ends of the hoop is approximately that shown in Fig. 1. *Shifting of the ring radiator with respect to the car top during or following adjustment will detune the antenna.* Readjust the gap to that shown in Fig. 1 following any significant alteration in the length of the antenna element.

Switch the SWR meter to read forward power, apply power to the transceiver, switch to transmit and calibrate the SWR meter for a full-scale meter reading. Switch the SWR meter to read reflected power and transmit. Keep all test transmissions very short and identify your station during each transmission. The SWR reading should be quite high at this stage.

Move your hand close to the ungrounded end of the ring radiator and the SWR reading should increase. This increase indicates that the antenna is too long and that the hand capacity is resonating the antenna to a still lower frequency—the expected result, since we initially cut the copper tubing a bit too long.

The antenna radiator must now be cut to the proper length and there are two possible methods of doing so. You can alternately shorten the antenna in $\frac{1}{8}$ " increments and conduct resonance tests, or you can install the tuning adjustment screw shown in Fig. 5. The latter course is highly recommended, since it simplifies initial tuning and permits easy adjustments to other channels.

Cut 2" off the ungrounded end of the copper tubing antenna element, file the end square, and readjust the gap between the ends of the tubing. Recalibrate the SWR meter, switch to read reflected power, and again conduct the hand-capacity resonance test. As your hand approaches the antenna you should note a pronounced dip in the reflected power reading as the antenna passes through resonance, and an increase as you move your hand still closer to the antenna. If these effects do not occur, cut another inch from the end of the copper tubing, file the end square, readjust the gap and again conduct the test.

When the hand capacity test indicates resonance, temporarily thread a 2" long, $\frac{5}{16}$ " brass machine screw into the end of

(Continued on page 88)

BREAKTHROUGHS

Brief news flashes on important developments in the field of electronics

TWENTY-FOUR MEGAWATT KLYSTRONS, the most powerful amplifier tubes ever to go into production, by Sperry. Generating 360 pulses a second, 240 of the tubes will be arrayed along the two-mile-long atom smasher being built by Stanford University. The amplifiers will boost the energy of electrons 40,000 times as they zip through a 10,000-foot pipe.

TRANSPARENT "GLASS" WIRES by Corning, .0025-inch fibers of glass coated with an electrically-conductive film of metal oxide and covered with transparent insulation. The wires are for use in electroluminescent coordinate display panels.

ELECTRONIC NURSE continually monitors heart and respiration rates, temperature and blood pressure, presents these factors at a central location, and records them on a chart. ITT is the manufacturer.

SOLID STATE ELEMENTS

that combine the best properties of transistors and vacuum tubes are displayed here in a silicon wafer held with tweezers. There are hundreds of the devices, known as insulated-gate field-effect transistors, in 20 complete circuits within the wafer. The new elements may make possible circuits that are cheaper, simpler, and more reliable than anything to date.

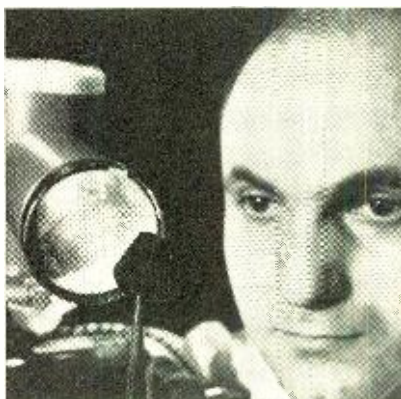

LOW NOISE UHF SILICON TRANSISTOR by RCA is said to extend the frequency of silicon devices to over 1,000 megacycles. So small that its working area would fit within the cross-section of a human hair, the device achieves VHF-UHF performance thus far possible only with a few germanium transistors and some special purpose vacuum tubes.

ELECTRONIC VIBRATION DETECTOR that is immune to airborne sound yet so sensitive that it can pick up minuscule vibrations. About the size of a pocket watch, the Honeywell device serves as a burglar alarm when taped to safes, showcases, etc.

HIGH-SPEED TUNNEL DIODE MEMORY by IBM which can modify computer instructions at a rate at least three times as fast as other types. Making use of the tunnel diode's ability to switch from one voltage state to another in a split-billionth of a second, the memory unit has a 200 nanosecond cycle and can process 45 million letters or numbers a second—equivalent to 90 full-length novels.



FUEL CELLS that produce electricity by combining air with inexpensive fuels such as propane, natural gas, and even gasoline are a new development from General Electric. Here, Dr. Leonard Niedrach (left) and Dr. Thomas Grubb demonstrate one of the cells which may one day revolutionize the production of electricity.

MICROBALANCE by Westinghouse is so sensitive that it measures the tars and other residue from cigarette smoke blown at it by an engineer. The heart of device is a quartz crystal.





I guess I started collecting records the day I first noticed the covers on some of the albums.

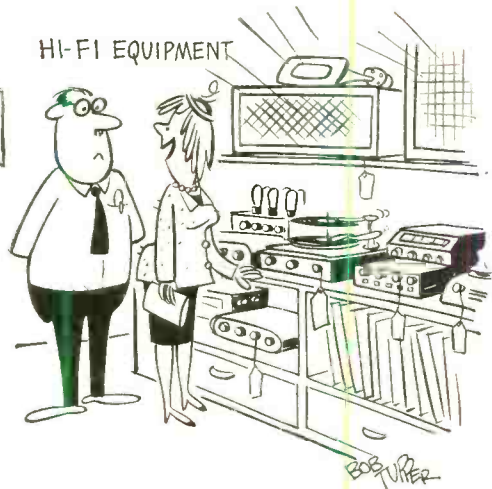

No thank you—I'm just listening around.

A Few Winning Words on Hi-Fi

From **BOB TUPPER**



It's one of those Make-It-Yourself records from your mother.

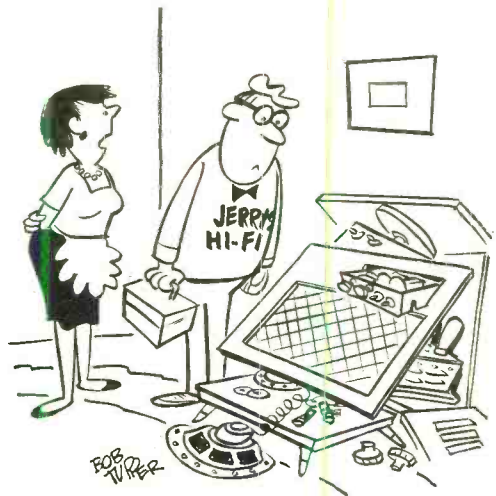

Could it be a tube?

THE "LIGHT" FANTASTIC

LASER STATUS REPORT

One development follows another in rapid succession

By ED NANAS

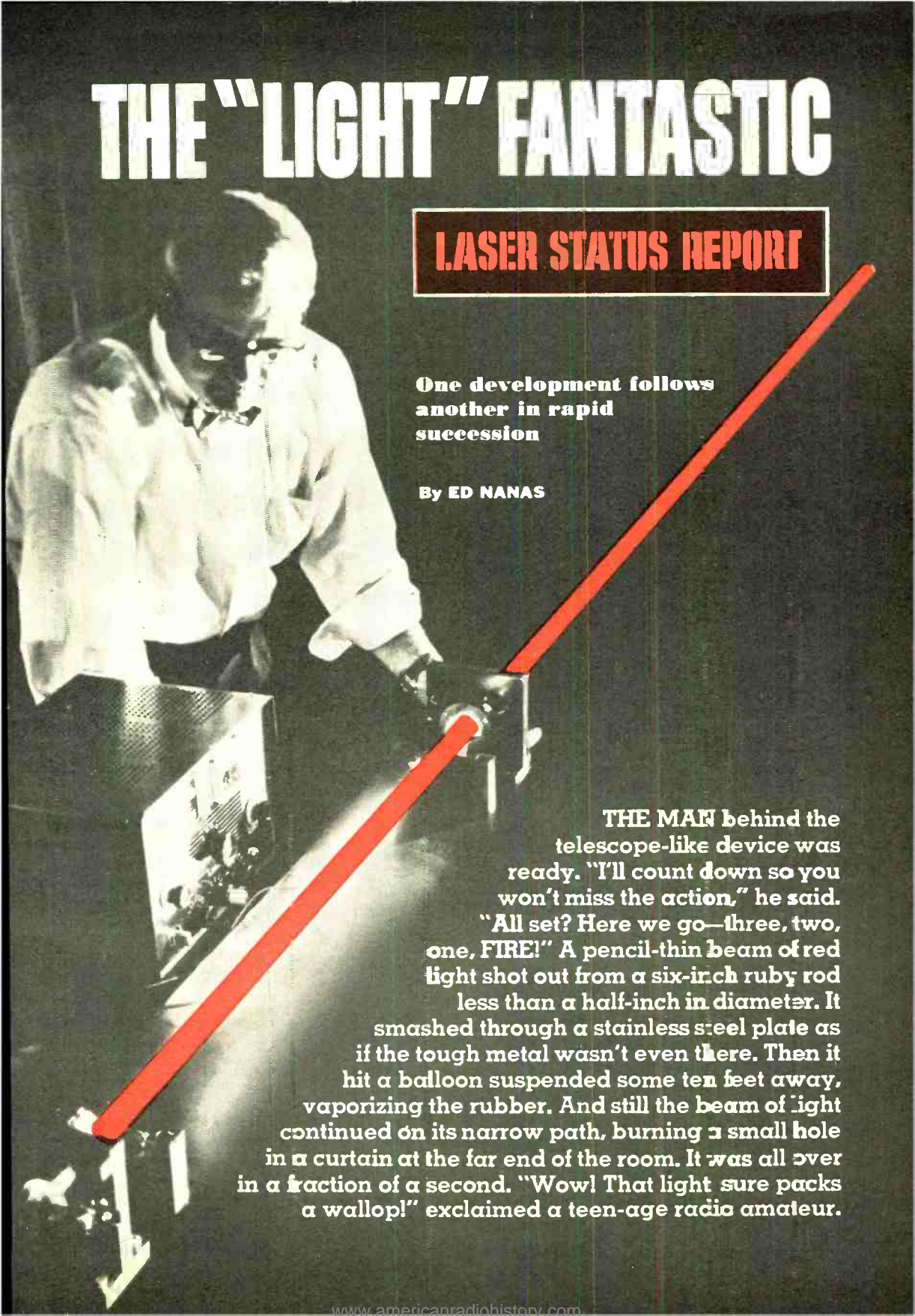
A black and white photograph of a man in a white lab coat and safety glasses, looking down at a piece of equipment. A thick red beam of light is shown originating from the equipment and extending diagonally across the page. The background is dark.

THE MAN behind the telescope-like device was ready. "I'll count down so you won't miss the action," he said. "All set? Here we go—three, two, one, FIRE!" A pencil-thin beam of red light shot out from a six-inch ruby rod less than a half-inch in diameter. It smashed through a stainless steel plate as if the tough metal wasn't even there. Then it hit a balloon suspended some ten feet away, vaporizing the rubber. And still the beam of light continued on its narrow path, burning a small hole in a curtain at the far end of the room. It was all over in a fraction of a second. "Wow! That light sure packs a wallop!" exclaimed a teen-age radio amateur.

LASER STATUS REPORT

Page 33: A c.w. gas laser recently demonstrated by Sylvania. An r.f. field excites gas mixture to self-sustaining oscillation.

He was standing at the rear of the hall with his father, an electronics engineer. "I've never seen anything like it!"

Until three years ago, *nobody* had seen anything like it!

The boy and his father had just witnessed a demonstration of one of the most promising and fastest developing technological devices ever conceived by man—the laser. In only three whirlwind years, the laser—which gets its name from the initials of *Light Amplification by Stimulated Emission of Radiation*—has moved out of the theory stage, out of the laboratory curiosity category, and into a whole new, exciting world of applications.

The laser has the unique ability to generate and amplify light waves at specific wavelengths just as radio waves are generated and amplified at specific wavelengths. Light generated by a laser is known as *coherent* light because it is "pure," or predominantly of one frequency. Making the sun seem like a hand-held flashlight by comparison, the thin beams of coherent light, which have already vaporized steel and, in a recent experiment, illuminated the moon, can be used to:

- Transmit a billion simultaneous telephone conversations on a single thread of light one millimeter in diameter—without interference;
- Build laser radar systems, including portable range finders, having resolutions more than 1000 times better than conventional narrow-beam radars;
- Perform micro-surgery—delicate eye surgery has already been demonstrated—precise enough to allow cutting of a single human cell;
- Reach billions of miles into space with a beam powerful enough to guide a spaceship, communicate with life on planets in other solar systems;
- Construct ultra-precise clocks, guidance systems, and laboratory instruments;
- Devise practical underwater communications and ranging systems using recently developed techniques for generating green or blue coherent light;
- Build new battlefield weapons, includ-

ing an anti-missile device and a form of "death ray";

- Greatly speed up the functioning of complex computers by using lasers in conjunction with fiber optic paths to transmit great masses of information within a computer or from one machine to another;
- Investigate the possibility of transmitting electric power through space;
- Speed up chemical processes thousands of times, such as those that take place during photosynthesis.

Fantastic? Not at all; and the list is by no means complete. The laser is indeed creating a revolution, and new discoveries relating to the generation and application of coherent light are being announced almost daily. Let's take a closer look at the phenomenon of laser light and the mechanisms used to generate it.

Coherent vs. Incoherent. Light waves coming from the sun or from incandescent or fluorescent lamps consist of a broad band of frequencies all mixed together. In addition, light from these sources can be considered as having been emitted from an infinite number of sources, all of which have random phases and polarizations with respect to one another. We call this kind of light *incoherent*.

A similar thing happens in the radio bands when lightning is discharged. A whole host of frequencies are generated, and they can be heard as noise or static on a radio receiver. As another example, incoherent water waves on the surface of a pond can be created by throwing in a handful of pebbles; coherent waves by dropping in a single large size rock.

Both a radio transmitter and a laser generate coherent radiation that is predominantly of one specific frequency. The difference between the two is that the radiation produced by the laser is very much higher in frequency (and, therefore, much shorter in wavelength), so that it falls within the optical portion of the electromagnetic spectrum.

The electromagnetic spectrum ranges from extremely low frequencies where wavelengths (the distance between two

TV via laser is an accomplished fact. Image of the young lady is relayed (in this experiment) to an optical modulator which impresses it on a c.w. laser beam. The beam strikes a photocell in a telescope-like receiver (right, rear) and is converted to the TV signal seen on monitor.

Highest power laser to date, the 350-joule Raytheon model below may soon be dwarfed by powers as high as 3000 joules. Intense beam of light is shown blasting its way through a steel girder a quarter-inch thick.

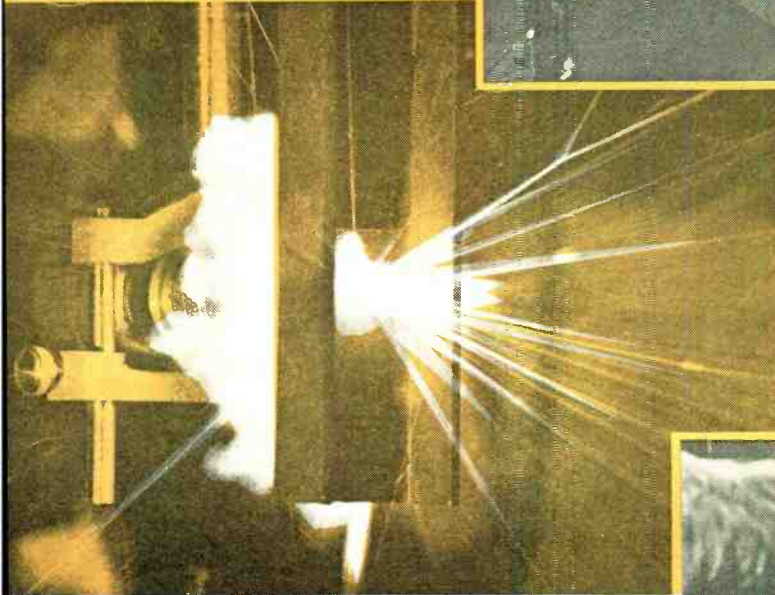
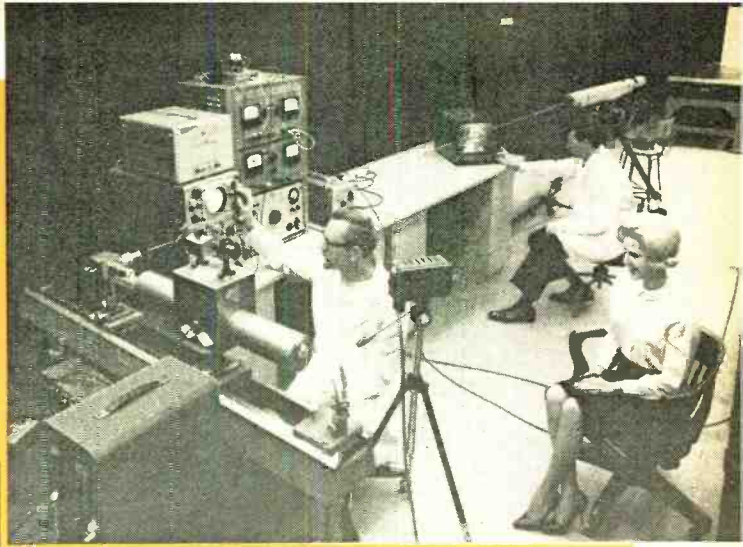

Continuous wave (c.w.) lasers have reached powers of 9 watts and are expected to go higher in the near future. Many of these types use a dysprosium-doped calcium fluoride crystal as does the RCA model below. The whole apparatus is enclosed by two hemispherical mirrors which focus light on the crystal. The crystal itself is obscured by the light source next to it.

specific crests or two troughs in a given wave) can be measured in miles or meters, to frequencies far above the visible band where wavelengths are measured in microns (one-thousandth of a millimeter) and angstrom units (one ten-thousandth of a micron). In terms of cycles per second, light waves vibrate at an extremely rapid rate— 10^{15} cps would be a rough figure.

At visible frequencies, radiation must be generated on an *atomic* level—as in a laser. This is made possible by the fact that the atoms of certain materials, when excited by large doses of energy, emit light at one frequency or group of frequencies. Thus, a *substance* (ruby, for example) made up of atoms which can be excited, and which will, at a certain point, emit coherent light, are used

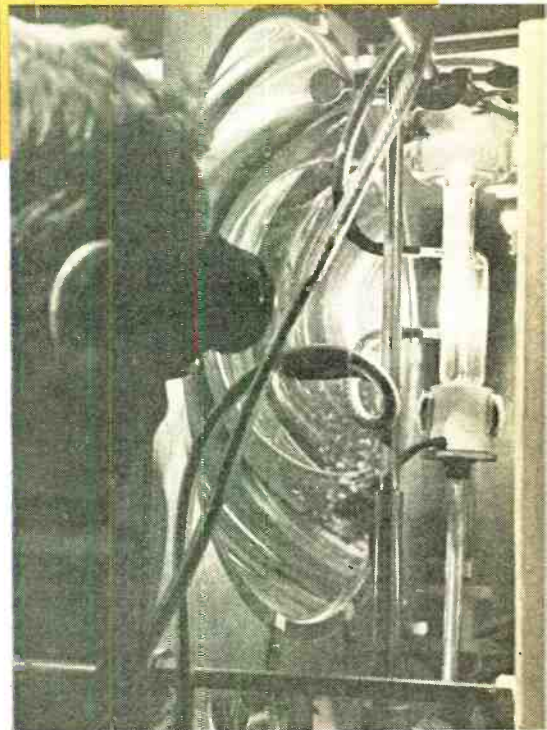

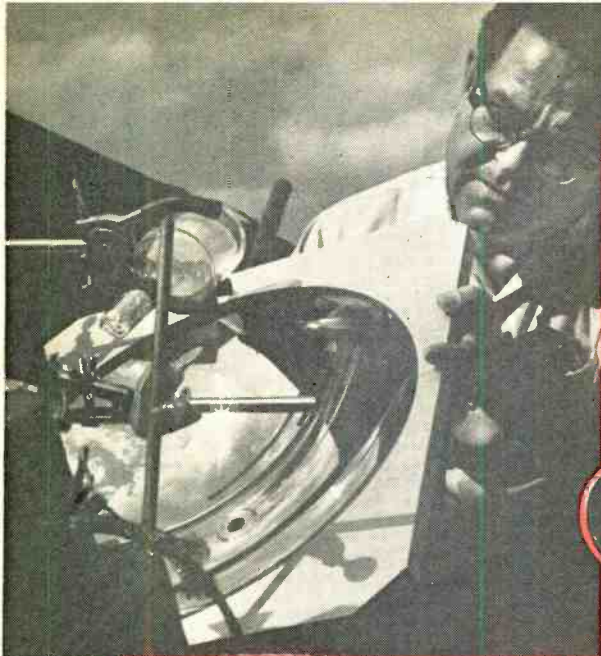

Sunlight pumping of a solid-state laser is a new development which may soon make it possible to put sun-powered lasers aboard satellites for communications, tracking, and geodetic measurements. This device, designed by RCA, uses a 12" hemispherical mirror to focus sun on calcium fluoride crystal rod.

Laser rifle is actually a compact rangefinder which fires a pulse of coherent light, collects the light reflected back from the target, and indicates exact distance to the target by computing the elapsed time for pulse's round trip. The device has measured up to seven miles.

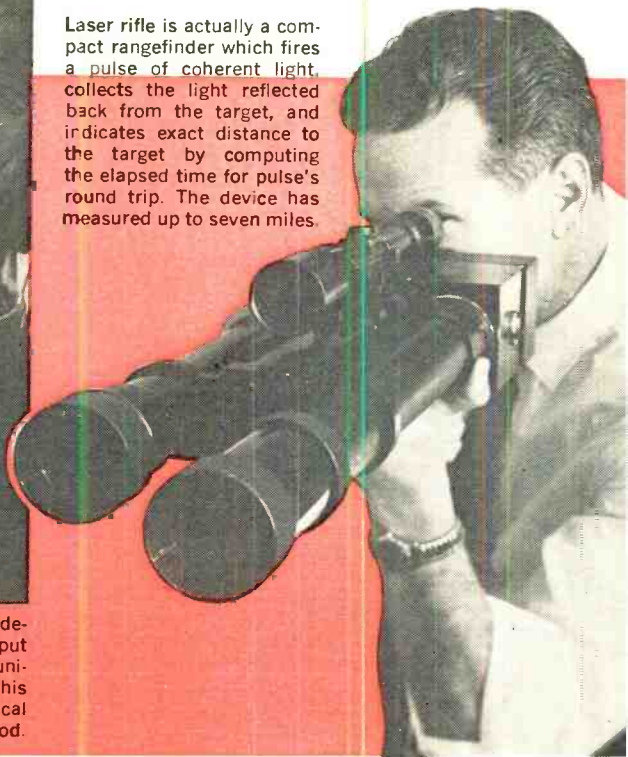

in lasers instead of the *electron tubes* used at lower frequencies.

The Amazing Laser. The properties exhibited by laser beams are much more startling than the foregoing explanation indicates. Like ordinary light, they can be focused and modulated, but there the similarity ends. A laser beam, because of its extremely short wavelength and because it is generated at the atomic level with all of the light energy in phase, is a *very narrow beam of extremely high energy*. This energy, concentrated at a single point, can burn through steel.

The fact that a laser beam can be modulated is expected to be of great importance in future applications. The reason is easy to understand. The transmission of a voice by radio requires a band of frequencies several thousands of cycles wide. The transmission of a television signal complete with sound takes up *six million cycles* of the available spectrum. By and large, the radio portion of the spectrum is now overcrowded, and the situation is expected to get progressively worse.

The use of optical frequencies for communications opens up great new vistas. In the visible white-light portion of the spectrum alone, the number of frequencies available is fantastic—250 million megacycles! This figure represents thousands of times more frequency space than in all the radio frequency bands combined. One or two laser beams, relayed as microwaves are now, could carry all of the communications traffic in America from coast to coast—telephone calls, television programs, computer data, and facsimile!

Optical Powerhouses. The first successful pulsed optical maser (laser) generated a peak power of about 10 kilowatts for very short intervals. The newer lasers have now climbed much higher—recently one was announced by the Korad Corporation with a peak of 500 megawatts (500,000,000 watts)—all concentrated in one narrow beam of 7-nanosecond duration. For the 500-megawatt pulse, it was calculated that the electric field in the focused electromagnetic beam was on the order of 10^7 volts per centimeter. The beam was observed

LASER STATUS REPORT

A "Colidar" (for Coherent Light Detecting and Ranging), produced by Hughes Aircraft Co., operates on the same principle as the laser "rifle" opposite. Research is underway on other laser ranging devices.



to cause ionization of the air in its focal path with a brilliant blue flash, and spectacular damage was done to materials placed at the focal point. Since these gigantic pulses of energy were for extremely short intervals, the total pulse energy was only about 5 joules.

In only one year, the output energies of pulsed lasers have spiraled up from 1 or 2 joules (one watt for one second) to 350 joules. A thousand joules is just around the corner and may be achieved by the time you read this. A glass laser with a pulsed output of somewhere between 2000 and 3000 joules is under development by American Optical Company, and may be announced as early as August, 1963. Theoretically, there is no limit. Ten-thousand-joule-outputs are predicted within the next year.

What do all these figures mean? Just one joule—about the same amount of energy you get from a flashlight bulb in several seconds of operation—is enough to vaporize a hole through a $\frac{1}{32}$ -inch-

THE BASIC LASER

The essential ingredients of a laser are:

A resonant cavity: Usually formed by two reflecting surfaces, such as precisely parallel mirrors, one slightly less opaque than the other;

An active medium: Positioned inside the cavity with its axis perpendicular to the reflecting surfaces. It may be a (1) gas—a noble gas such as helium, mixed with neon, and contained in a glass or a quartz tube; (2) crystal—a rod of high purity ruby, glass or a rare earth material such as calcium tungstate; (3) liquid—an organic liquid, such as benzene or pyradine; (4) semiconductor—the newest of the lasers, a gallium-arsenide diode.

Pumping power: Applied to the active medium to excite its atoms. It may consist of: (1) high-power lamps—used with crystal lasers; (2) concentrated sunlight—also used with crystal lasers; (3) electrical or radio frequency discharge—used with gas lasers; (4) direct electric current—10,000 to 20,000 amperes injected directly into the junction of a diode laser.

The basic principles of laser light generation are similar to those of the microwave maser. Atoms in the active medium can possess different amounts of energy. Ordinarily, an atom will occupy the lowest of several energy levels, and is said to be in the ground state. But when "pumping" power is applied, they get excited. That is, the atoms absorb some of the photons (particles or "quanta" of light) from the power source and jump to a higher energy level, like water being pumped into a tank atop a standpipe.

At this higher energy level, usually two steps above the ground state, the atoms begin to relax. They fall to an intermediate energy level, but still above the original lowest level. This intermediate level is called the metastable condition, because the atoms are more reluctant to leave it than they were to leave the higher level to which they were originally excited. In order to make their departure they must give up the light they absorbed. The important thing is that the light they give up in dropping back to the ground state is of a specific wavelength.

Sooner or later, (within a few microseconds), the first atoms begin to drop from the metastable level. They are put to work in the resonant cavity of the laser. Without the reflecting surfaces, the light they emit would be mere fluorescence, like that of a neon sign. But inside the resonant cavity of the laser, they are bounced back and forth. With each pass parallel to the axis of the active material, they stimulate other excited atoms in the metastable level to give off their absorbed light much more quickly than they would ordinarily. The stimulated light moves in the same direction as the light stimulates it. With each pass, the light gains more energy in an effect akin to a chain reaction.

In only 200 microseconds or so, the released light waves, traveling in parallel and in phase back and forth between the reflecting ends of the laser—you might call it "feedback"—build up to an intensity great enough to escape through the one end of the laser which is only partially opaque. This output beam of light has almost all of its intensity in a very narrow cone. All its waves are in step; of the same phase and frequency. It is coherent light.



Brightest stars of recent research are semiconductor and liquid laser devices. At top, left, is a liquid "frequency converter" that can change the frequency or color of a laser beam. At left is one of the first gallium arsenide lasers produced by G.E. (others were made by I.B.M. and M.I.T.). It is suspended in liquid nitrogen to keep it cool when large excitation currents are passed through it. Above, I.B.M. scientists examine a brand-new semiconductor laser announced very recently: an indium phosphide type.

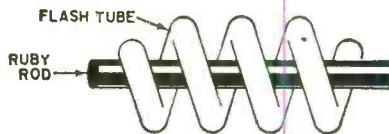
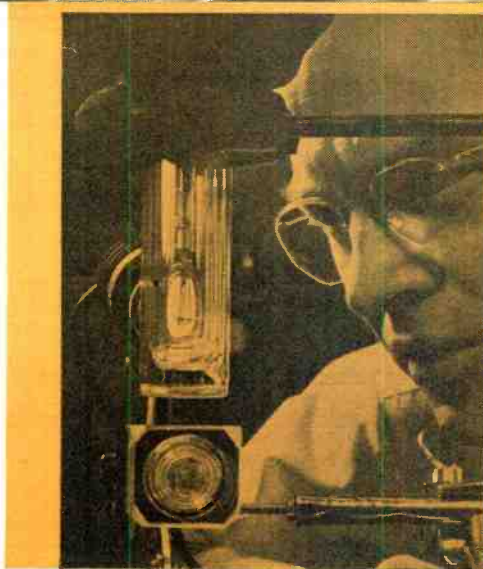

The drawing, the basic ruby laser, illustrates in a general way the setup used with most crystal types.

Basic configuration of a low-power c.w. gas laser. The reflecting plates reflect back a large percentage of energy; result is a small, continuous output.

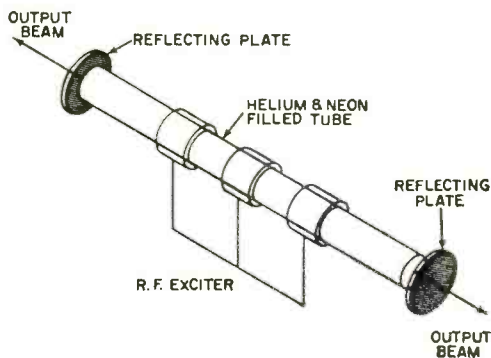

thick sheet of steel if it is transmitted in a concentrated burst of about a millisecond.

A 10-joule ruby laser, which is fairly common today, operating at a wavelength of 0.7 micron, has a power density at the center of the beam of about 10^{16} watts per square meter. The power density at the surface of the sun is less than 10^8 watts per square meter. Thus, this rather modest laser is capable of producing a power density 100-million times that of the surface of the sun!

Continuous-Wave Lasers. A little over a year ago, the first crystal laser was made to operate *continuously* (the high-power devices we have been discussing are *pulsed*) at Bell Laboratories with power outputs of a few milliwatts. Gas lasers and semiconductor lasers also

LASER STATUS REPORT

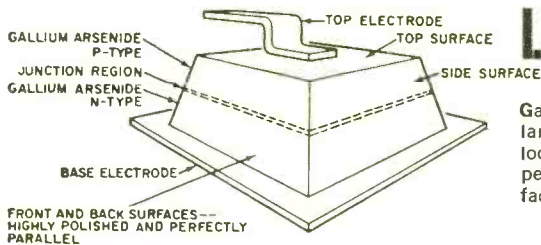

Gallium arsenide laser, greatly enlarged and shown in schematic form, looks like this. Coherent light is emitted perpendicular to the front and back surfaces and along the junction of device.

have been made to operate continuously with comparative power outputs. As **POPULAR ELECTRONICS** goes to press, however, a new 9-watt continuous-wave (c.w.) laser is about to be introduced for use in research related to welding and other machine tool uses.

A 45-watt c.w. laser may be another major development to be announced in 1963. Both this unit, which is being researched at M.I.T.'s Lincoln Laboratory, and the 9-watt c.w. laser use dysprosium-doped calcium fluoride crystals rather than gases or semiconductors.

Although c.w. lasers are somewhat

be set up with the star *Altair* (16.5 light-years away) with only 10 watts from a laser. Already, General Electric has designed a burst communications system using a rapid laser pulse of great power (rather than a continuous wave) to carry vast amounts of data.

Power Transmitters? In the vacuum of space, attenuation is slight, governed primarily by the degree of beam spread. Recently, Sperry Rand Corporation has been able to achieve the minimum theoretical beam spread of a point source of light— 0.005° , or 10^{-4} radians—without the use of external lenses. Previously,

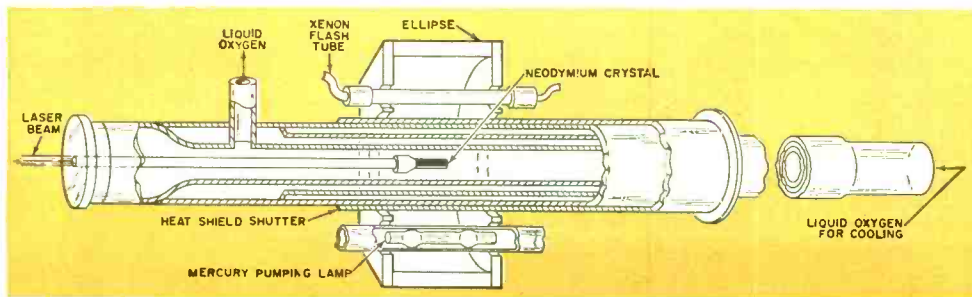

Continuous wave crystal lasers use configurations somewhat like this Bell telephone design. The neodymium crystal is at one focus of an elliptical cavity, and the mercury lamp at the other to concentrate pumping light.

puny in their power outputs compared to the pulsed type, they have immense advantages as carriers for communications purposes. At optical frequencies and with narrow beam angles concentrating all the radiated energy into a small cone, a television channel could be established between the earth and Saturn with only about 600 watts, while a voice channel to the most distant planet, Pluto, could be maintained with as little as five watts.

Dr. Donald S. Bayley, of General Precision, Inc., one of some 400 organizations conducting laser research, has said that an interstellar information channel carrying one binary bit per second could

the already narrow laser beams, on the order of 0.05° , were further focused down by what amounts to an inverted telescope.

The ultra-small beam spread of concentrated optical-frequency energy indicates that it will be possible to transmit power over great distances with very little loss; power for spaceships, for instance. It is now possible to construct optical antennas, nothing more than a series of lenses, to transmit laser beams which would lose only $\frac{1}{30}$ th of one percent in a 20-mile hop—far less than present-day transmission lines. Thus, if

(Continued on page 76)

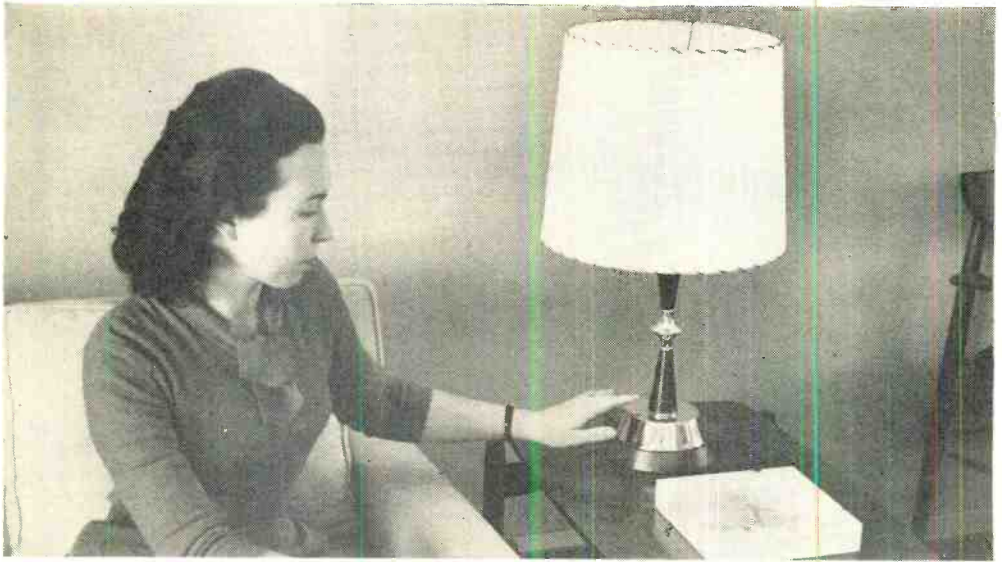

Dynaquad Touch Control

IF you're looking for an interesting household gadget using a modern-day semiconductor, you might investigate the Dynaquad Touch Control Lamp. Marketed by Tung-Sol Electric Inc. (545 N. Arlington Ave., East Orange, N.J.) as a do-it-yourself kit listing for \$19.95 but available to electronics hobbyists at most jobbers for under \$15.00, the lamp incorporates a body-capacity switching system built around a TS1595 *pnpn* transistor. The kit can be assembled in about 30 minutes. Hidden in the base of the lamp is a touch control switch using the special *pnpn* transistor in a neon bulb oscillator circuit. Body capacity—which acts when you touch the metal base of the lamp—triggers a relay which turns on the light. A second touch—at the ring on the center post of the lamp—releases the relay through a second oscillator circuit. Tung-Sol plans on making just the *pnpn* transistor, or the touch control switch, available to experimenters for alarm systems and computer projects.

The touch control switch consists of two neon oscillator circuits, a relay, and a *pnpn* transistor. The antenna trimmer adjustments are made at the factory and rarely need correcting.

Wiring of the lamp is so simple that it can be assembled in 30 minutes. No soldering is required since all of the leads to and from the lamp are held together with so-called "wire nuts."

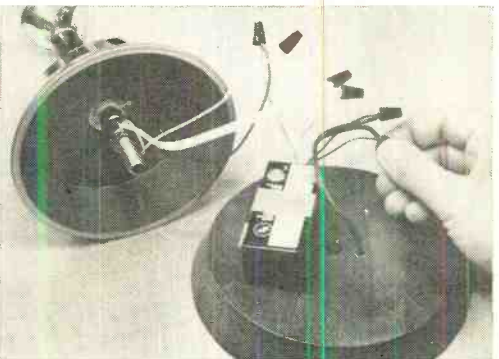
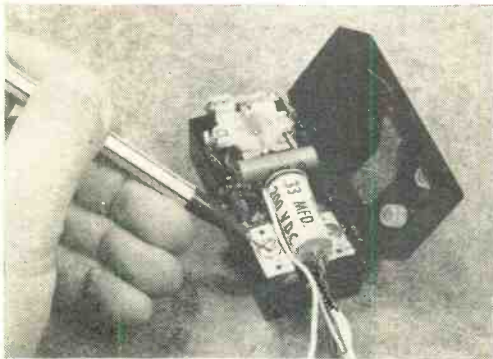

SLIM

SILHOUETTE SPEAKER SYSTEMS

*Originally conceived to appeal to
the eye, they sound good, too*

By HANS H. FANTEL

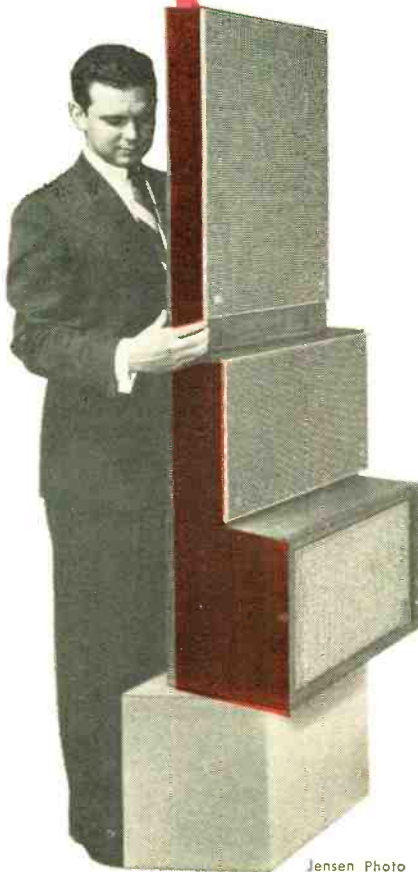

Jensen Photo

IF an audio fan tells you his speakers are flat, it's no longer a safe bet that he's talking about frequency response. Nowadays he might be referring to his speakers' *shape*.

The new look in loudspeakers—the flat panel—is undoubtedly handsome, but simply mentioning it is a sure way to start an argument. “Just put it down as a furniture fashion—nothing more,” scoffs a veteran hi-fi'er who resolutely sticks to his bulky baffles.

“It's a design challenge with interesting possibilities,” says Dick Shahinian, the audio engineer who developed the Paco L-4, one of the latest entries in the field.

Behind this conflict of opinions are the unresolved questions posed by any new development: How does it work? *Does* it work? And, should you buy one? The engineers involved in this development don't beat around the bush. They admit outright that good looks and space-saving compactness are the chief reasons for the slim-down. None would claim that the slim speakers are superior in principle to their chunky counterparts.

In sum, slim speakers are not a natural technical development. They were conceived as an innovation to spur sales. And the furniture stylists tossed the challenge to the engineers: “Make the thin ones as good as the fat ones!” The surprise is that it's being done—almost.

SLIM

SILHOUETTE SPEAKER SYSTEMS

"We're fighting all the rules in the book," admits Shahinian. "Like any engineering challenge, it's a battle against the laws of nature. Normally, good bass reproduction requires an ample amount of air space in the baffle. When you slim down the box, you've got to make it up in other ways."

Each manufacturer, it seems, is finding his own ways of doing so.

Multiple Woofers. To compensate for the small air space in the slim enclosure, some designers enlarge the active area from which the sound radiates. Paco, for instance, crams four small woofers into its slim box. Pumping air in unison, these multiple woofers create a broad wave front that transfers low-frequency energy more effectively to the listening room. Goodman's "Slimline" Series and Lafayette's "Decorette" and "Slenderette" systems follow the same principle. The idea is to set enough air in motion with the woofer cones alone so that bass projection becomes largely independent of the cabinet.

Going all the way with this line of logic, the Audax "Sonoteer" got rid of the cabinet entirely. This speaker is simply an open panel with four woofers and a tweeter, radiating sound both front and back, and seems to be in open defiance of the old principle that the back of a loudspeaker must always be enclosed to keep the back wave from canceling out the front wave at low frequencies.

When Saul J. White, the designer of the Sonoteer speaker system, was asked how he avoided bass cancellation in an open-back design, he had a ready answer: "You'd get bass cancellation all right if the speaker stood out in the open. But in a normal-size living room not all the bass gets away. You get enough bass bouncing back from the walls to make up for the cancellation loss. Multiple reflections in the room may cancel the bass in some spots, but they reinforce

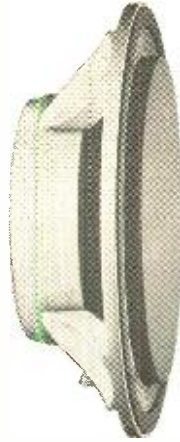

One answer to the problem of putting speaker systems on reducing diets was the ceramic magnet. The one here, at the back of a Jensen 3-P woofer, is molded into a pancake to reduce depth. Note also flat-head piston cone.

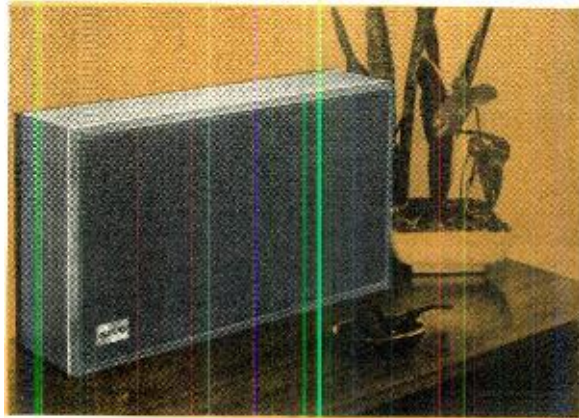

EICO's HFS-6, above, is a slim, compact system which crams a 10" woofer, an 8" midrange unit and a dome-radiator tweeter into this enclosure. Opposite, center is the HFS-10, a low-cost, compact two-speaker system by the same company.

it in others—depending on whether they are in or out of phase in any particular part of the room."

To elaborate on White's answer, you have to find the right spot in the room for a backless baffle because it relies on wall reflections for bass reinforcement. But once you have found it, the front-plus-back radiation provides a pleasant, spacious kind of sound. Of course, you can't push such speakers flat against a wall—the rear needs breathing space.

Ceramic Magnets. The Jensen people took another tack. Their efforts centered on making a fairly large woofer shallow enough to fit into a narrow enclosure.

Radiating both front and rear the Audax Sonoteer has no back. Bass is augmented by the wall reflections.

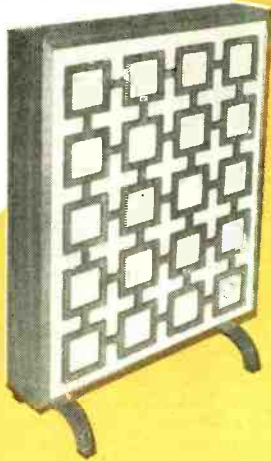

To accomplish this, they took advantage of ceramic magnet materials which had been developed shortly before. These are suspensions of metal particles in a ceramic binder, and they permit magnets to be molded into flat shape and still concentrate plenty of magnetic flux around the voice coil.

Jensen engineers succeeded in making a powerful speaker magnet in the form of a flat pancake with a hole in the middle. Around this magnet they were able to produce a 10" deep-swinging woofer less than 3" in depth (Model 3P/W1). This woofer, also unconventional in its use of a cone with a flat piston head, is the core of Jensen's 3-P and TR-9 slim-line systems, which measure from 3 $\frac{3}{8}$ " to 5 $\frac{1}{2}$ " deep, reach down to 30 cps, and handle up to 25 watts of power.

Inverted Magnets. Still another way to reduce the depth of a woofer is to invert the magnet. Instead of sticking out in back, the magnet is turned around so that it projects into the hollow of the cone, taking up no additional space. Utah Electronics Corporation built its "Sorcerer" speaker system (5" deep) around an 8" woofer of this type.

One drawback of this design is that the magnet located "inside" the cone cannot be directly supported by the speaker frame but must be cantilevered from it. It is difficult to suspend heavy magnets in this manner, and the power-handling capacity of such speakers is limited. However, the Utah "Sorcerer" handles 12 watts which suffices for one channel of a medium-power stereo system.

Coneless Speakers. By far the most radical slim-down exercises were performed by audio designer Abraham Cohen of Advanced Acoustics, who cut out the cone altogether. Instead, he uses a thin wood panel as the vibrating element.

Flexibly suspended by its edge, the panel is activated by a voice coil and functions, in effect, as a depthless cone; its large area makes up for the shallow swing of the panel and enables it to move a sufficient amount of air. Like the backless Audax Sonoteer described above, the panel puts out sound both front and back, and hence works best at some distance from the nearest wall. The frequency output of the open panel



Paco's L-4, a floor-standing slim-line design, gets good base boost from extra woofers—four 6" units.

SPEAKER COMPARISON CHART

MODEL	SOURCE	DIMENSIONS (w. x h. x d.)	SPEAKER COMPLEMENT	POWER RATING (watts)	FREQUENCY RESPONSE (cps)	IMPEDANCE (ohms)	DESIGN PRINCIPLE	FURNITURE FINISH	PRICE
ADVANCED ACOUSTICS WAFAIRE, BI-PHONIC COUPLER	A	13½ x 21¾ x 3½	panel woofer, 2" tweeter	25	30—beyond audibility	8	coneless panel	walnut	\$ 69.50 124.50 (pair)
ADVANCED ACOUSTICS MINI, BI-PHONIC COUPLER	A	13¾ x 17¼ x 2	panel woofer, 2" tweeter	20		8	coneless panel	walnut or teak	42.50 79.50 (pair)
ARGOS PETITE PHF-1S	B	18 x 12 x 3¼	1 woofer, 1 tweeter	6	50-17,000	8	vented enclosure	walnut	24.95
ARGOS SPACE SAVER HFVB-8S	B		8" woofer, 3½" tweeter			8	vented enclosure	walnut or birch	17.95
AUDAX SONOTEER CA-70	C	21 x 25 x 4	2 woofers, 2 mid range, 1 tweeter	45	40-18,000	8	open back	fruitwood, walnut, ebony	89.95 79.95 89.95
EICO HFS-6	D	23½ x 13½ x 5¼	10" woofer, 8" mid range, dome-radiator tweeter	40	50-20,000	8	vented enclosure	walnut	62.50 (wired) 52.50 (kit)
ELECTRO-VOICE REGINA 200	E	16¾ x 24½ x 5½	10" woofer, 5" tweeter	40	50-15,000	8	sealed enclosure	walnut	89.50
FISHER KS-1	F	18 x 24 x 5¼	10" woofer, 5" mid range, 3" tweeter	60	40-18,500	8	sealed enclosure	birch walnut	84.50 89.50
FISHER KS-1 (KIT)	F	18 x 24 x 5¼	10" woofer, 5" mid range, 3" tweeter	60	40-18,500	8	sealed enclosure	unfinished birch unfinished walnut	59.50 64.50
GOODMAN G-1	G	17 x 25 x 5¼	8" woofer, 6" mid range, 3½" tweeter	20	40-17,000	16	vented enclosure	walnut	56.50
GOODMAN G-2	G	17 x 25 x 6¼	10" woofer, 6" mid range, 3½" tweeter	20	40-17,000	16	vented enclosure	walnut	59.50
GOODMAN G-3	G	17 x 25 x 5¼	3 8" woofers, 6" mid range, 3½" tweeter	45	40-17,000	16	vented enclosure	walnut	79.50
GOODMAN G-4	G	20 x 28 x 6¼	3 10" woofers, 6" mid range, 3½" tweeter	60	40-17,000	16	vented enclosure	walnut	89.50
HEATH PROFILE AS-22 (KIT)	H	19½ x 25 x 5	10" woofer, 6" mid range, 3½" tweeter		55-12,000 ± 5 db	8	inverted magnet	walnut, unfinished	54.95 49.95
JENSEN 3P/1	I	25 x 13¾ x 5½	10" woofer, 8" mid range, 2 3½" tweeters, dome-radiator super tweeter	25	20—beyond audibility	8	vented enclosure	walnut	119.50 97.50 (kit)
JENSEN 3P/2	I	21¼ x 26½ x 3½	10" woofer, 8" mid range, 2 3½" tweeters, dome-radiator super tweeter	25	20—beyond audibility	8	vented enclosure	walnut	139.50

JENSEN TR-9	I	22 3/4 x 13 1/2 x 5 5/8	10" woofer, 8" mid range, super-tweeter	25	30—beyond audibility	8	vented enclosure	walnut	89.50
JENSEN X-20	I	15 1/8 x 12 7/8 x 2 3/8	1 woofer, 2 tweeters	6		4, 8 or 16	vented enclosure	walnut	39.95
KNIGHT KN-281	J	23 3/4 x 13 1/2 x 6 1/2	10" woofer, 2 3 1/2" tweeters	30	35-15,000	8	vented enclosure	walnut	49.95 94.90 (pair) 44.95
KLH MODEL NINE	K	23 1/2 x 70 x 2 7/8	full-range electrostatic	75		16	electro-static	—	1140.00 (pair)
LAFAYETTE DECORETTE SK240WX	L	17 x 25 x 4 3/4	2 8" woofers, 1 8" mid range, 1 3 1/2" cone tweeter, 1 horn tweeter	60	40-20,000	8	sealed enclosure	walnut	59.95
LAFAYETTE SLENDERETTESK235WX	L	20 x 24 x 5	2 6" woofers, 1 8" mid range, 2 3 1/2" tweeters	20	50-15,000	8	sealed enclosure	walnut	39.95
LANSING TRIMLINE CS4	M	23 3/4 x 20 x 5 1/8	8" full-range speaker, 8" passive cone	25		8	parasite cone	walnut	117.00
PALCO L-4	N	20 x 26 3/4 x 6 3/16	3 6" woofers, 1 3 1/2" tweeter	30	45-18,000	8	multiple woofers	walnut	99.95
UNIVERSITY MINI	O	18 x 13 3/8 x 2	panel woofer, 1 tweeter	20	50-17,000	8	coneless panel	walnut	44.49
UNIVERSITY SYL-O-ETTE	O	23 x 29 x 4	8" woofer, 6 1/2" midrange-tweeter	30	40-20,000	8		walnut	99.95
UTAH SORCERER SH-4W	P	20 x 12 x 5	8" woofer, 5" tweeter	12	45-17,000	8	inverted magnet	walnut unfinished birch	49.95 46.95
UTAH PT3	P	18 x 12 x 3	8" woofer, 3 1/2" tweeter	10	-18,500	8	inverted magnet	walnut	33.25
V-M SILHOUETTE	Q	20 1/2 x 26 3/4 x 4 3/4	10" woofer, 6" midrange, 3 1/2" tweeter	25	30-16,000	8	vented enclosure	walnut	68.00
V-M MODEL 42	Q	15 x 20 x 4	6" woofer, 3 1/2" tweeter	15	50-14,000	8	vented enclosure	walnut	49.95

A—Advanced Acoustics Co.
67 Factory Place
Cedar Grove, N.J.

B—Argos Products Co., Inc.
301 Main St.
Genoa, Ill.

C—Audax Div. Rek-O-Kut Co. Inc.
38-19 108th St.
Corona 68, N.Y.

D—EICO (Electronic Instrument Co.)
33-00 Northern Blvd.
Long Island City 1, N.Y.

E—Electro-Voice, Inc.

Buchanan, Mich.
F—Fisher Radio Corp.
21-21 44th Drive
Long Island City 1, N.Y.

G—Goodmans Loudspeakers
Rockbar Corp.
650 Halstead Ave.
Marmaroneck, N.Y.

H—Heath Company
Hilltop Rd.
Benton Harbor, Mich.

I—Jensen Manufacturing Co.
6601 S. Laramie Ave.
Chicago 38, Ill.

J—Allied Radio Corp.
100 N. Western Ave.
Chicago 80, Ill.

K—KLH Research & Development Corp.
30 Cross St.
Cambridge 39, Mass.

L—Lafayette Radio Electronics
111 Jericho Turnpike
Syosset, L.I., N.Y.

M—James B. Lansing Sound, Inc.
3249 Cosmos Ave.
Los Angeles 39, Calif.

N—Pacotronics, Inc.
70-31 84th St.
Glendale, L.I., N.Y.

O—University Loudspeakers, Inc.
80 S. Kensington Ave.
White Plains, N.Y.

P—Uph. Electronics Co.
1124 East Franklin St.
Huntington, Ind.

Q—V-M Corporation
Benton Harbor, Mich.

covers bass and midrange; the top end is provided by a 2" cone tweeter. Sold under the name of "Bi-Phonic Coupler," this design is available in various sizes, the largest ("Wafaire") going down to 30 cps. The same idea is followed in University Loudspeakers' "Mini" model which has been shaved down to a mere 2" in over-all thickness.

Undisputed king of the coneless speakers is KLH's Model Nine, a large panel less than 3" thick. Being a full-range, all-electrostatic speaker (in fact, the only American speaker of this type), its slimness is not the result of compromise but is inherent in its electrostatic principle. This puts the KLH Nine in a class by itself, not really comparable to the rest of the slim speaker tribe. So is the price tag: \$1140 for a matched stereo pair.

Ports and Parasites. Most thin speakers rely on some variant of the familiar bass-reflex principle to scoop more lows out of the shallow box. In many designs, the bass port (the hole through which the lows are let out) has an internal duct attached to it. This provides acoustic loading and keeps the opening of the port from being too close to the woofer cone. The Jensen, Knight, Paco, Argos, Heath, Goodmans, and EICO models are all slim speakers with such duct-loaded ports.

J. B. Lansing uses a different method of port loading in its C54 "Trimline"—a driverless 8" speaker cone is tacked across the bass opening. This "parasite cone" or "passive cone" shakes with the air pressure waves built up by the bass in the box (generated by a regular 8" speaker), and thus transmits the low frequencies into the room.

Exceptions to the rule of vented enclosures are the Electro-Voice Regina 200, the Fisher KS-1, and the Lafayette "Decorette" and "Slenderette." These systems employ hermetically sealed enclosures, presumably to avoid the resonance problems sometimes encountered in vented baffles. The loss of bass reinforcement through the port is made up in those designs by woofers with long voice-coil travel and very compliant cone suspensions capable of pumping more air with each stroke.

Family Resemblance. With designers going off in so many directions, it is hard to evaluate slim speakers as a group.

But a certain family resemblance is evident despite the differences. Except in the open-back designs, there is a possibility that the rear panels may vibrate excessively because of their large area and the high back-pressure building up in the narrow enclosures. Such vibration may lead to distortion in loud passages. One way to test a speaker of this kind is by banging the rear panel with your fist. If you hear a hollow bong, it indicates that the panel has a tendency to vibrate. A toneless thud tells you that the panel is tightly braced, as it should be, and that the speaker won't honk if a strong bass note comes along.

As a rule, the bass you get from slim speakers is not as fat and sassy as the bottom notes from standard enclosures. The specifications may rightly claim response down to, say, 30 or 40 cps. What the specs usually don't tell you is just how much response drops off from the "flat" level in those lower reaches. Only rarely is the deviation from flat response given with a \pm db rating for the extreme frequencies. Of course, you can fill in some lows with bass boost from your amplifier, and in most cases you wind up with pleasantly balanced sound. Don't expect orchestral thunder or low organ notes to shake the walls, but most kinds of music come across convincingly.

Slim speakers sound best in moderate-size rooms (less than 20' long) where their bass output is not too greatly dissipated and extreme lows are not practical, anyway. (Even with the best of speakers, it takes a large room to let those bottom notes of the pipe organ roll out properly.) As a group, slim speakers are quite efficient. They put out plenty of sound at low wattage, and amplifiers rated between 10 and 25 watts per channel drive them easily. In fact, a blast from a powerhouse amplifier in the 50-watts-per-channel class would probably shatter most of the slim speakers.

Medium-power amplifiers are thus natural companions to the slim speakers, and smallish rooms their natural habitat. And it is in just such rooms that the space-saving feature really counts. If you can't find a place to put them, you can easily hang the backless speakers from the ceiling. And the others you can hang on the wall—like a picture. —~~30~~

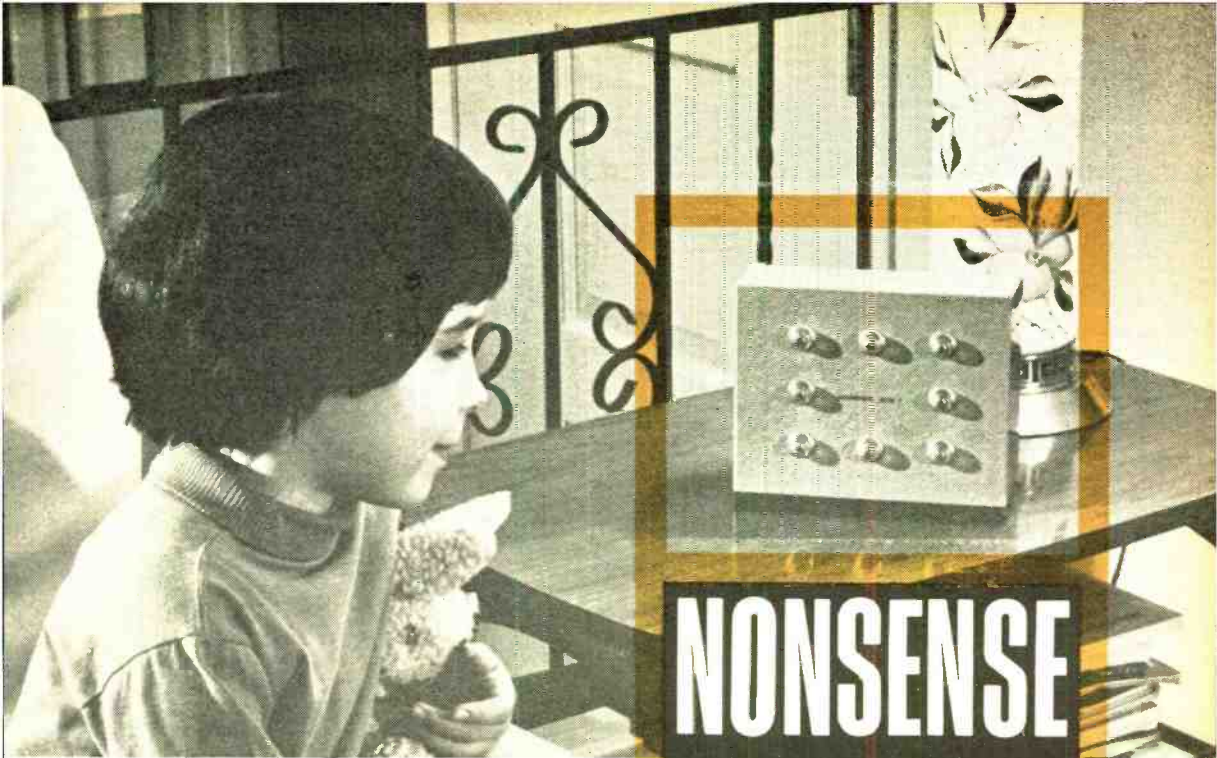

**The most useless thing ever published,
but your children will think it's great**

NONSENSE BOX

By ALAN L. DANZIS

YOU MIGHT tell your kids it's a scintillation counter detecting cosmic messages from outer space. Or, you casually can mention to friends the fact that it's a miniaturized digital computer reading out answers in binary computations. Chances are they'll believe every word you say; only you will know that this box is actually "nonsense."

The "Nonsense Box" consists of eight neon lamp flashing circuits flashing at various independent time rates, and all powered by a single 90-volt battery. The current drain imposed by this circuit is around 65 microamperes and the battery should last well over a year. Of course, this is one of the *advantages* (?) of the Nonsense Box—there is no switch to turn it off.

How It Works. Each flashing circuit consists of a neon glow lamp, a 0.5 μ f. 200-volt capacitor and a resistor of one of four specified values from 4.7 to 8.2 megohms. Take a look at the first flashing circuit (*NE1*, *C1*, and *R1*). Since

there is no current flowing in the circuit, there is no voltage drop across *R1*, or the resistor *R9* in series with the battery. This permits *NE1* to fire (conduct) setting up a voltage drop across *R1* and charging *C1*. As the charge across *C1* rises, the voltage across the neon bulb drops, and *NE1* is extinguished. Now *C1* slowly discharges through *R1* (the old *R/C* time constant effect) until sufficient voltage builds up across the neon bulb to fire it and cause the whole process to repeat itself.

Even though the flashing circuits are doubled up (*C1/R1* and *C5/R5* have the same values), small capacitor and resistor mismatches insure that no two flashing circuits have the same time constant. Resistor *R9* helps insure the random nature of the firing pattern.

Construction. The Nonsense Box can

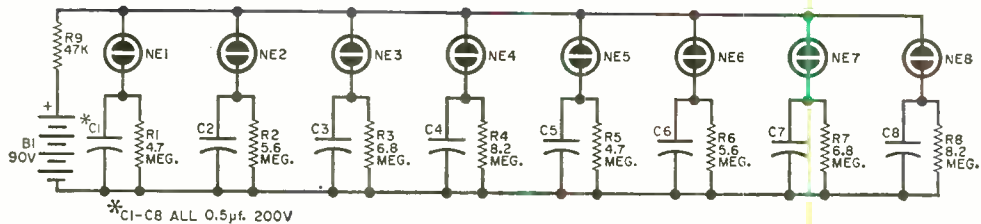

The neon lamps can be arranged in any pattern desired—circle, square, etc.

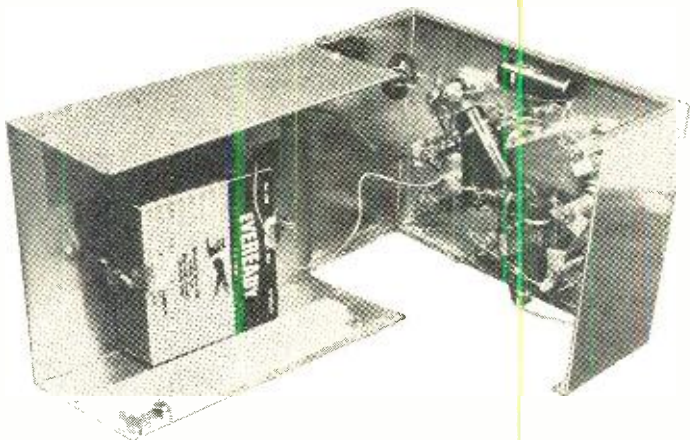

PARTS LIST

- B1—90-volt "B" battery (Burgess type V60 or Eveready type 479)
- C1-C8—0.5 μ f., 200-volt paper capacitors (eight required)
- NE1-NE8—NE-51 type neon bulb (eight required)
- R1, R5—4.7 megohms
- R2, R6—5.6 megohms
- R3, R7—6.8 megohms
- R4, R8—8.2 megohms
- R9—47,000 ohms
- S—Neon lamp socket (Dialco type 810-B with clear plastic lens)
- Misc.—Mounting box, battery retaining clamp, wire, solder, etc.

All resistors
1/2-watt

be made of either metal or wood. It should have sufficient space inside to comfortably hold the neon bulb sockets and permit the battery to be mounted rigidly in place. The latter measure is especially necessary since many people will try to shake the Nonsense Box to make it turn off.

Care should be exercised in laying out the holes for mounting the neon lamps. The spacing is not critical, but uniformity is desirable. The lamps could be arranged to make a person's initial, or

The interior wiring of the Nonsense Box can be as haphazard as you want. Be sure to clamp the battery in place to prevent it being shaken loose.

in the square fashion shown in the photos.

Wiring is noncritical—even the battery polarity may be reversed. It is suggested that one terminal of each of the eight lamp sockets be wired together. Solder one end of R9 to this common connection and leave the other end temporarily free. Now solder one end of resistors R1-R8 and capacitors C1-C8 to each of the unused lamp socket terminals according to the wiring schematic. Bring all 16 free leads from these capacitors and resistors to a common bus bar and solder. The two leads from the battery connect to the free end of R9 and the common bus bar.

The Nonsense Box should start flashing immediately—and only you will know that it's all "nonsense."

-30-

Double-Duty EICO 772

Combination CB and amateur installation? A few simple changes put this transceiver on both 10 and 11 meters

MANY CB'ers, introduced to the fascinating world of two-way radio via the 11-meter band, are qualifying for ham tickets. And why not? How else can you rag-chew on the air to your heart's content, contact rare DX stations in such exotic locales as Sarawak and Sumatra, or maybe just talk to the hams in your home town?

On the other hand, many already-licensed hams are finding a CB ticket a handy thing to have. With it, you can operate a low-cost, two-way utility radio system—and the units that make up your system can be operated by a friend, business associate, or your wife.

The inescapable conclusion is that it would often be desirable to have a *dual-purpose* rig that could be used for both hamming and CB, especially in the case of mobile installations where space for equipment is strictly limited. You can, of course, convert CB equipment to the 10-meter ham band (see POPULAR ELECTRONICS, June, 1961, page 64). A still better idea, however, is to add a 10-meter crystal-controlled amateur channel to your CB rig *and keep the unmodified CB channels for CB use*. The modifications are usually easy to make; and, when completed, you have a double-duty rig that switches quickly back and forth between 10 and 11 meters.

The changes outlined here refer to the EICO 772 CB transceiver, but the basic ideas are ap-

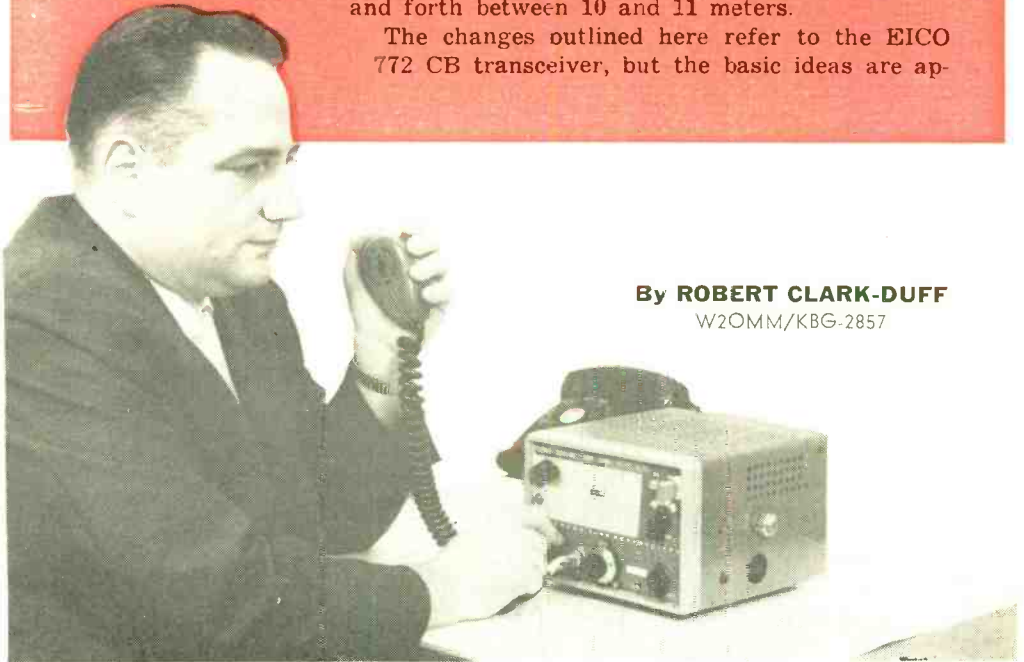

By **ROBERT CLARK-DUFF**
W2OMM/KBG-2857



This is the author's version of a "Double-Duty" EICO Model 772. The nameplate shows his original CB call—2A4148. New control functions are indicated in the photo on the facing page.

plicable to most CB rigs having both "tunable" and "fixed-tune" receiver functions. From the operator's seat, the 772 is actually two sets in one, sharing a lot of common parts. The author decided to convert the "tunable-receive" half of the set to 10-meter operation and use the "fixed-tune" half for CB operation.

Putting the 772 on 10. All that is involved in converting the receiver to ham-band operation is resetting the slug of the tunable oscillator coil. With this one simple adjustment, it is possible to make the unit cover any 500 kc. portion (approximately) of the 10-meter band. At first glance, the fact that coverage is limited to 500 kc. might seem like a disadvantage (the 10-meter band extends from 28 to 29.7 mc.—1700 kc.), but actually most activity on 10 meters tends to be concentrated approximately in the center of the band. In view of this fact, 500-kc. coverage is quite adequate.

The only necessary requirement for putting the transmitter section on 10 meters is a third overtone crystal cut for the frequency desired, plus a bit of tuning up.

Although the 772 can be put on 10 meters practically "as is," a number of mechanical modifications were made in the author's unit for more operating flexibility. These included the addition of a ten-position rotary selector switch to make available up to ten CB receive channels on fixed tune, an external socket for CB transmit crystals—making

it possible to change them by hand, and a vernier dial for the tunable 10-meter receiver.

Three of the four original transmit crystal sockets were used for 10-meter crystals. Since this left room for only one CB channel, another socket was connected in parallel to the fourth and installed on the front panel.

The end result is a 10-meter amateur receiver and a 10-meter transmitter which operates at 5 watts input with a selection of three transmit crystals. In addition, the rig can still put out a legitimate signal on any CB channel, plus receive on ten preselected crystal-controlled channels. And all this comes in one transceiver measuring 6" x 8½" x 9"!

Modifications. Although it is not necessary to make all of the modifications described, they are well worthwhile, and do not involve extensive wiring changes. The ten-position rotary selector switch is "sandwiched in" by mounting a bracket in approximately the center of the chassis and then mounting the switch on it.

This control is made accessible by mounting a bushing and shaft in a new hole drilled at the upper left of the front panel, and connecting it to the switch assembly with a flexible shaft and two couplers.

The new CB receive crystals are mounted directly on the switch. The only circuit change necessary with this arrangement is to remove the original receive crystal and insert two leads in the socket. One lead goes to a common ground (one leg of each crystal mounted on the switch is grounded), and the other lead goes to the common terminal

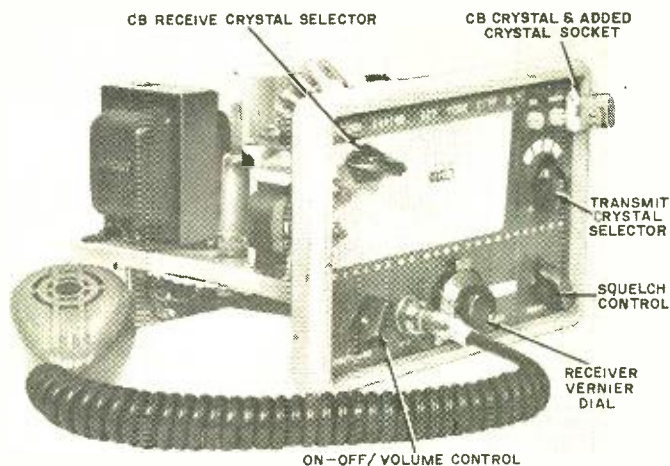

Front panel additions for greater flexibility include a CB receive crystal selector, a CB transmit crystal socket, and a vernier dial.

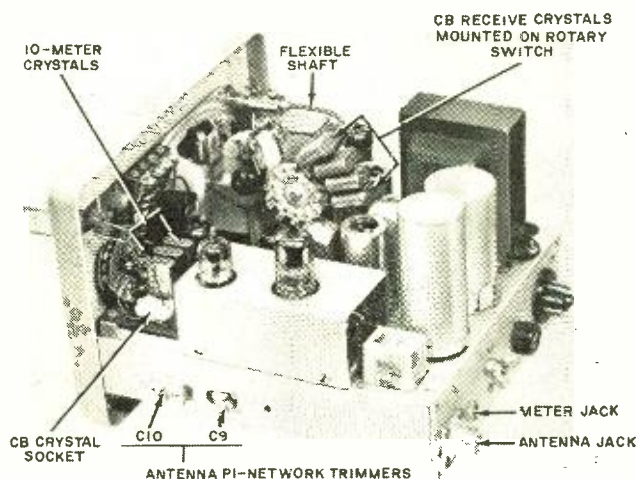

The CB receive crystals and switch are mounted on bracket at center of chassis. Trimmers C9 and C10 are peaked to change bands.

of the new switch to complete circuit.

The socket for CB transmit crystals is mounted on the front panel at the upper right as shown in the photographs. Simply extend two leads from the fourth crystal socket and connect them to the new socket. And the last modification is to mount the vernier dial on the front panel to "bandspread" the tunable 10-meter receiver.

With the modifications complete, the 772 is ready for tuning up. All that's needed for this operation are 10-meter transmit crystals and a signal generator or other accurate r.f. source for aligning the receiver.

Adjustments. To put the tunable receiver in the 10-meter band, set the r.f.

alignment source for 28.5 mc. With the plates of the tuning capacitor (*C21*) fully meshed, adjust the tunable oscillator coil (*L6*) until the signal is heard. It will be found necessary to bring *L6*'s slug, which is adjusted from the top of the chassis with a hex alignment tool, upward.

To put the transmitter section on 10 meters, insert a third overtone crystal in one of the three inside crystal sockets. Connect a dummy load to the antenna jack (a #47 pilot light), and, while pressing the transmit switch, adjust the antenna pi-network trimmers for maximum output as indicated by bulb brilliance. Adjust *C9* and *C10* in that order, and

(Continued on page 80)

Exterminate TV

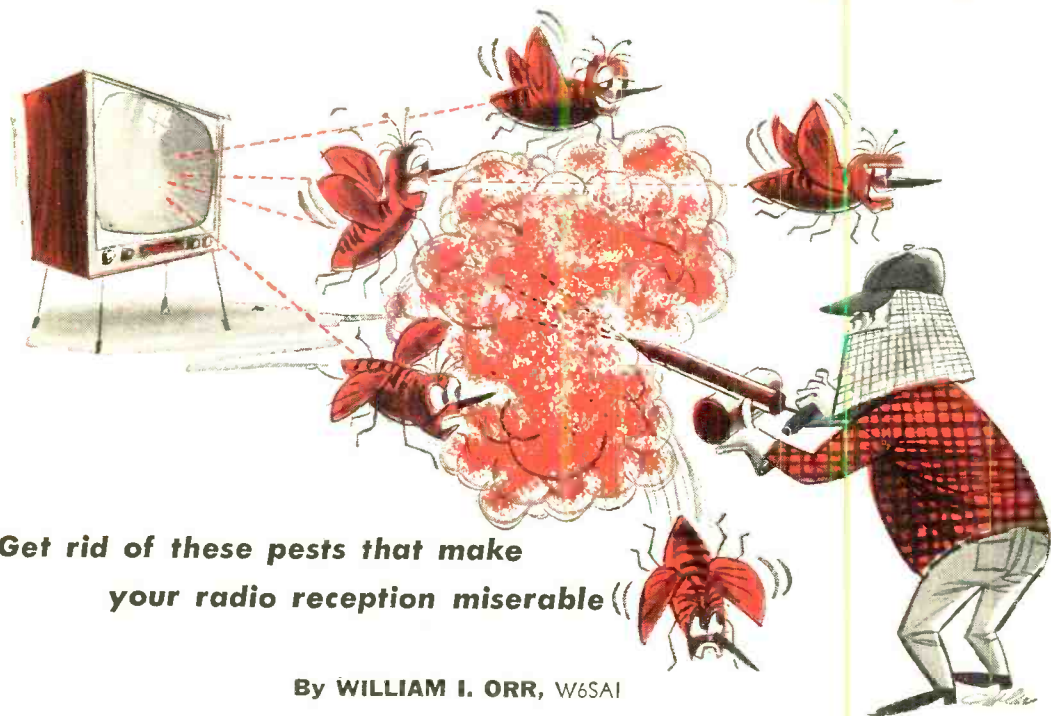

**Get rid of these pests that make
your radio reception miserable**

By **WILLIAM I. ORR**, W6SAI

ARE YOU plagued by TV "sync-bugs?" Many amateurs and SWL's hear this persistent nuisance, which is threatening to make a shambles of the radio spectrum, as rough, unstable signals found at close points across the dials of their short-wave receivers.

Sync-bugs creep across the bands with a slow, measured tread, uncanny in their instinct for squatting directly atop the signal you're trying to listen to. The broadcast listener hears them in the form of "birdies" and "whistles" across the dial that turn Toscanini and Fabian into a cacophony of howls and catcalls.

Where do these "insects" come from? The truth of the matter is that they are generated by a nearby TV set (which is probably operating quite normally). The 15 kc. horizontal oscillator, which possesses about as much stability as a hundred-foot antenna mast made of "two-by-four's," generates powerful pulses of energy rich in harmonics which can be radiated for hundreds of yards. You can identify the sync-bugs by the fact that they appear every 15 kc. across

the dial; check to see if it's your TV set you're hearing by turning it on and off.

TV Set Radiation. Sync-bugs can reach your receiver in three different ways: they can be radiated by the TV lead-in and antenna system, they can travel down the power cord and into the a.c. line to be "piped" to your receiver, or they can be radiated directly by the wiring of the TV set. Since you can't eliminate the *source* of the radiation (without, that is, eliminating your TV viewing), the answer is to prevent the interference from being radiated beyond the immediate vicinity of the set.

The first step is to effectively trap the sync-bugs that are radiated by the antenna system of the television receiver. This can be accomplished by shunting the radiations to ground (the chassis) while permitting the TV signals to pass down the antenna to the set without appreciable attenuation. A simple linear trap made of a length of 300-ohm TV "ribbon" lead-in affixed to the antenna terminals will do the job.

To make the trap, cut a length of

Sync-Bug Interference!

300-ohm line 25" long. Strip 1½" of insulation from each end and tin the leads; twist the wires at one end together. Trim both leads of a .01 μf., 1000-volt ceramic capacitor to ½" and connect one of them to the shorted end of the 300-ohm line as in Fig. 1.

Connect the other capacitor lead to ground by fastening it under a self-tapping screw on the TV chassis, or by soldering it to any convenient grounding point. Connect the opposite end of the trap across the TV antenna terminals. The trap can be conveniently draped about the rear of the cabinet, taking care that it doesn't touch tubes or other parts.

Wiring and Power Line Problems. The next step is to prevent unwanted sync-bugs from reaching your receiver via the a.c. cord of the TV set and the house wiring. To block this exit from the set, two .01 μf., 1000-volt ceramic capacitors are placed across the a.c. line to ground at the point where the line leaves the TV chassis. With most TV sets, the power connection is made through a simple interlock mounted at the rear. It may be possible to solder the capacitor leads to the back of the plug pins (see Fig. 2), or a bit of insulation can be removed from the power wires and the leads soldered to them. Tape the wires securely. Solder or bolt the other two capacitor leads to the chassis.

Radiation is especially apt to take place from the wires running from the chassis to the socket of the picture tube, since these wires carry the 15 kc. signal generated by the horizontal oscillator. The cure for this problem is a simple shield made from heavy aluminum foil, such as "Reynolds Wrap." Form the wires into a bundle, and wrap them with a covering of electrical tape. Trim the foil to size and carefully wrap it over the tape. Smooth the foil and form the rough edges back on themselves until the wires are substantially shielded. *Do not shield the high voltage lead going to the bulb of the picture tube.* Finally, wrap several turns of wire around the foil, twist it tight, and connect the other end to the chassis.

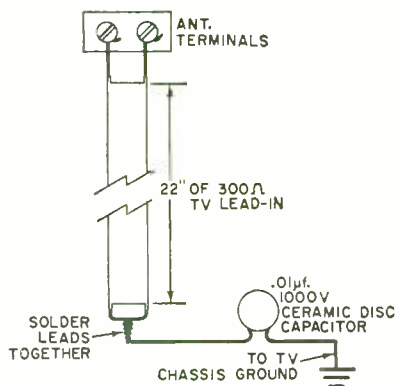

Fig. 1. Simple trap for eliminating sync-bugs from antenna system consists of 22" of TV lead-in and a .01 μf. bypass capacitor.

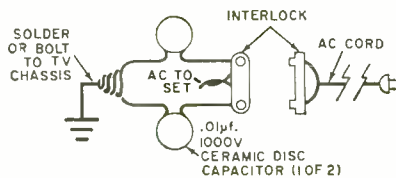

Fig. 2. Radiation into power line can be cured by bypassing to ground (the chassis) both sides of the a.c. line with capacitors.

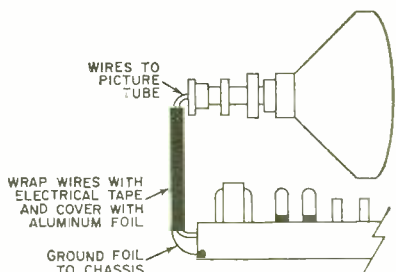

Fig. 3. To stop the set's wiring from radiating, shield the wires running from the chassis to the picture tube socket; see text.

The results of all this? In the author's case, the sync-bugs almost vanished, going from S9 to S3 in strength on 80 meters. On an a.c.-d.c. receiver, the sync-bugs had almost obliterated a local station; after "exterminating" them, they were unnoticeable.

HERE'S a new kind of "breadboard" that enables you to assemble and disassemble experimental hookups in a jiffy. Although it uses a metal chassis, it virtually eliminates the machine work needed for individual circuit assembly. In addition, it reduces "wear and tear" on parts, permitting the same components to be used time and again.

The secret here is that a variety of components, mounted on various "plug buttons," can be snapped in or out of a chassis hole in a second. And this feature is also responsible for the unusual name—"Snap-In Breadboard"—which is exactly what this is. "Plug buttons," circular pieces of metal with flanges, are ordinarily used to fill unwanted chassis holes. Here, they allow components to be snapped "in" or "out" at will.

A standard 7" x 13" x 2" aluminum chassis was used by the author, although either smaller or larger bases can be employed to suit specific needs. The size

low the chassis plane), or at the bottom. This arrangement also permits two or three chassis to be "stacked" vertically for assembly of more complex circuits.

Finally, appropriate terminal strips are premounted across the center of the chassis and lengths of #12 tinned bus-bar soldered in position, the latter to serve as connection strips for filament. B+, bias, ground, and other common wiring.

Once the chassis is completed, assemble a basic stock of "snap-in" components, and you're off to the races. The initial stock can include tube sockets of various sizes, "L" brackets, selenium rectifiers, variable capacitors, terminal strips, stand-off insulators, variable resistors, switches, and similar components. Individual parts are mounted on appropriate plug buttons, with machine screws, nuts, and lock washers—or, where feasible, simply by soldering them in position.

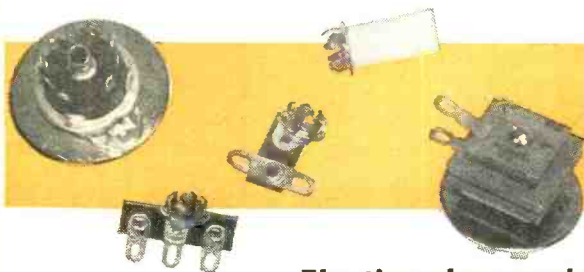

SNAP-IN

***The time-honored breadboard is back again—
in an updated, improved version***

shown is suitable for assembling not only single-stage circuits and simple networks but complete receivers and multi-stage amplifiers. For larger and more complex circuits, a number of basic chassis may be bolted together horizontally or "stacked" vertically.

Holes are drilled and punched in a symmetrical pattern. Only four hole sizes are used— $\frac{1}{8}$ ", $\frac{3}{8}$ ", $\frac{1}{2}$ ", and $1\frac{1}{4}$ "—the smallest for machine screws; the $\frac{3}{8}$ " and $\frac{1}{2}$ " holes for potentiometers, switches, and similar controls; and the $1\frac{1}{4}$ " holes for tube sockets.

Extruded aluminum angle is used for the four legs. These are drilled so the chassis may be mounted either at the top (as shown), in the middle (providing "leg" extensions both above and be-

The classic breadboard of days gone by looked a little like this. Commercial receivers of yesteryear also used this convenient wiring technique.

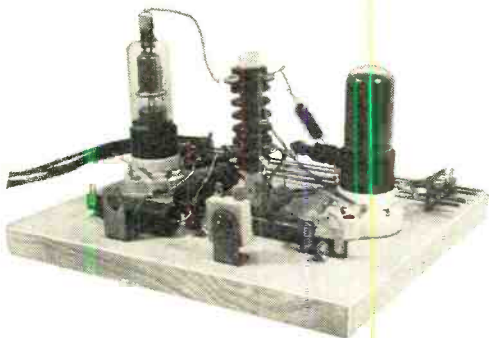

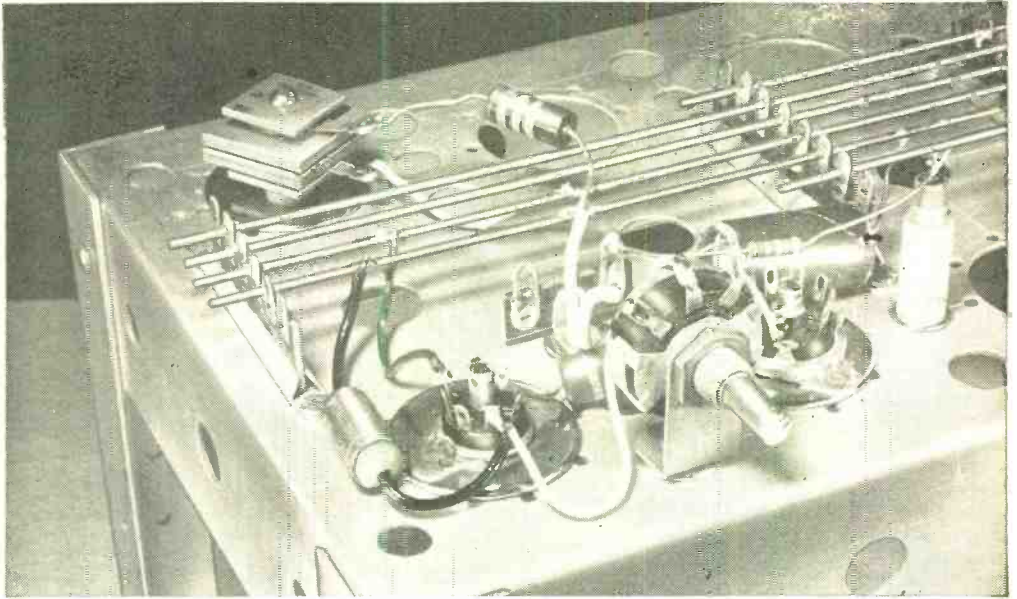

Thanks to "snap-in" feature, experimental circuits can be assembled and disassembled in a jiffy. Wiring is point-to-point; resistors, capacitors, and similar components are supported by their own leads.

BREADBOARD

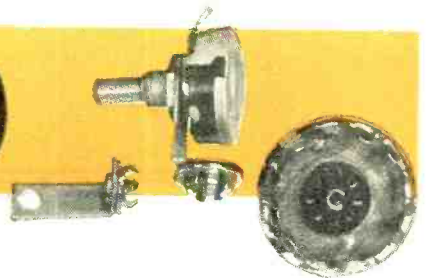

By **LUIS VICENS**

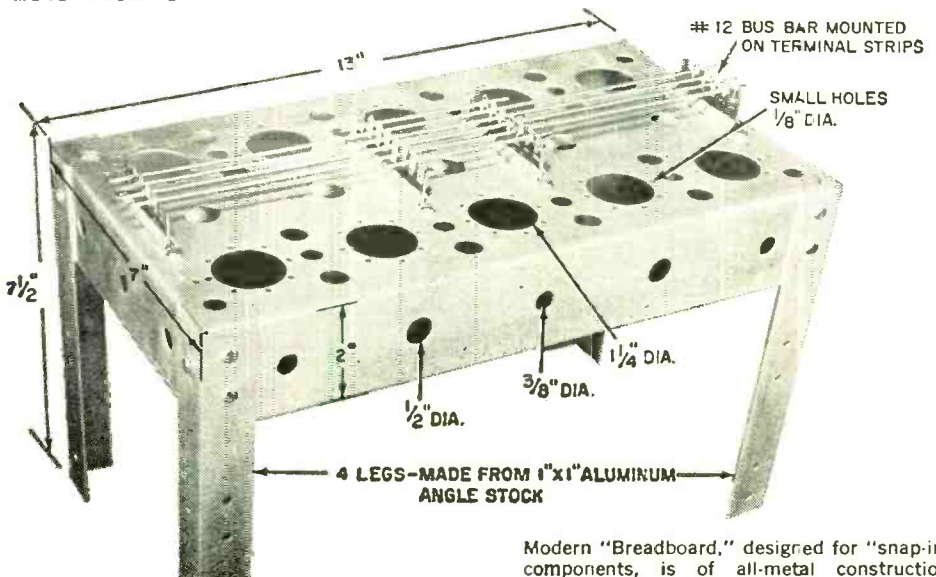

Modern "Breadboard," designed for "snap-in" components, is of all-metal construction.

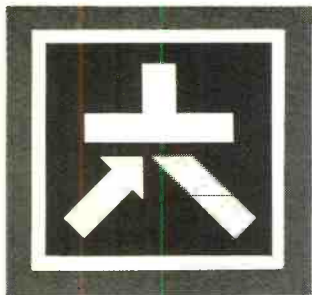

Transistor Topics

By LOU GARNER, Semiconductor Editor

IN PAST COLUMNS, we've discussed many new types of semiconductor devices. Some of these—the Spacistor, for example—haven't, as yet, reached the production stage. Others, such as the field-effect transistor, have only recently become available to hobbyists and experimenters. Still others . . . the tunnel diode and SCR are prime examples . . . have become "staples" on the shelves of many home laboratories and workshops. The time-lag between the announcement of a new device and its general availability at competitive prices may be from as little as a few months to as much as several years, depending on the production problems encountered and upon general industrial demand for the device.

The newest semiconductor device that has come to our attention is the *optical transistor*. Developed by scientist Richard F. Rutz of IBM's Thomas J. Watson Research Center (Yorktown, N. Y.), it can be operated at very high frequencies

and is relatively easy to fabricate. Although dubbed a "transistor" and performing similar functions, the new device operates on a completely different principle. The basic unit is manufactured of gallium arsenide and, like a conventional transistor, consists of alternate layers of *p* and *n* type material, as illustrated in Fig. 1. In operation, however, the recombination of holes and electrons at the base-emitter junction causes the emission of light energy. This light passes across the base region and creates electron-hole combinations when it is absorbed at the base-collector junction. Thus, energy is transferred from the emitter to collector by light waves rather than by the movement of electrons and holes. An external signal applied to the base-emitter junction varies the number of electrons and holes available and thus the amount of light emitted, permitting the device to be used as an amplifier.

Since light travels at much higher



Researchers at IBM's Thomas J. Watson Research Center study a greatly enlarged picture of the newly developed light-operated gallium arsenide transistor.

Fig. 1. Speed of light travel across base region from emitter junction to collector junction is cause of gallium arsenide transistor's faster response.

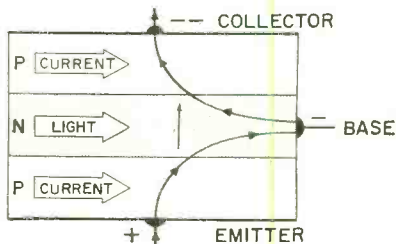

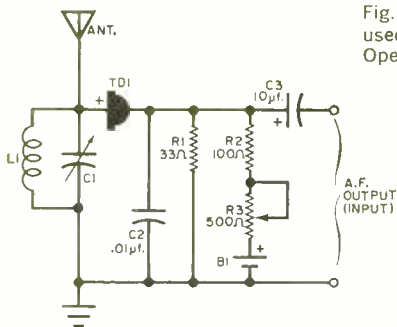

Fig. 2. Richard Mattos' tunnel diode circuit can be used for FM reception or as a wireless microphone. Operating mode is determined by circuit adjustment.

speeds than conventional current carriers (holes and electrons), the optical transistor can be used at extremely high frequencies without the need for the hard-to-make ultra-thin base regions required by standard high-frequency transistors. Laboratory models of the new device have been operated as oscillators at frequencies of one megacycle, but, theoretically, it should be possible to build units capable of handling signals in the kilomegacycle range.

As this is written, the optical transistor is still an experimental device. In future months, however, when production units become available, this new device should be ideal for home-built VHF and UHF gear, including transceivers, mobile transmitters, FM receivers, UHF-TV converters, and similar projects.

Readers' Circuits. The tunnel diode is one of the most versatile of semiconductor devices. As an example of its versatility, the basic circuit illustrated in Fig. 2, submitted by reader Richard J. Matos (603 Edgewater Drive, Pensacola, Fla.), may be used without modification either as a simple *FM broadcast-band receiver* or as an *FM wireless microphone*, depending on bias adjustment.

Referring to the schematic diagram, the tunnel diode, *TD1*, is used either as a regenerative detector or oscillator, with its frequency of operation determined by tuned circuit *L1-C1*. Operating power is furnished by battery *B1*, with the critical bias needed for detector or oscillator action determined by voltage-divider *R1-R2-R3*. Capacitor *C2* serves as an r.f. bypass, while *C3* is used as a d.c. blocking and a.c. coupling capacitor.

Standard components are used. The diode is a Philco T 1925 general-purpose unit or equivalent type. Coil *L1* is made up of five turns of #16 or #18 wire on a

$\frac{1}{4}$ " dia. by $\frac{1}{2}$ " form. Capacitor *C1* is a 3-25 μf . trimmer capacitor, *C2* a 0.01 μf . mica. or ceramic unit, and *C3* a 10 μf ., 3 to 10 volt electrolytic. Resistors *R1* and *R2* are $\frac{1}{2}$ -watt units, while *R3* is a small potentiometer. The power supply, *B1*, is a standard 1.5-volt zinc-carbon or mercury cell.

Assembling the tunnel diode circuit is a straight-forward procedure. Either etched wiring, conventional chassis, or breadboard wiring techniques may be used. Neither layout nor lead dress is overly critical, but good VHF wiring practice should be observed, with signal-carrying leads kept as short and direct as is practicable.

According to Dick, there are two critical factors: antenna length and adjustment of *R3*. He suggests the use of a quarter-wave vertical antenna and reports good results with the 20" whip used in his model. Potentiometer *R3* must be readjusted for optimum performance each time the operating frequency is changed.

The circuit may be used as an FM receiver by connecting a high-gain audio amplifier and suitable output device (such as earphones or a loudspeaker) to the audio terminals. If the circuit is to be used as a wireless microphone, the amplifier is replaced by an audio signal source . . . such as a dynamic earphone used as a microphone. In either mode of operation, *R3* must be adjusted for best performance.

Suitable for use at either CB or 10-meter ham band frequencies, the *super-regenerative receiver circuit* shown in Fig. 3 was submitted by Norman Dick, WN2EHB (241 East 169th St., Bronx 56, N. Y.). Norm reports that he has received 5-watt CB stations at distances of up to three miles and has picked up out-of-state 10-meter stations quite regularly. He indicates, however, that while the circuit is very sensitive, it is not overly selective.

Turning to the schematic diagram, we find that Norm has used a *pnp* transistor in the common-base configuration as a simple oscillator/detector. The circuit's

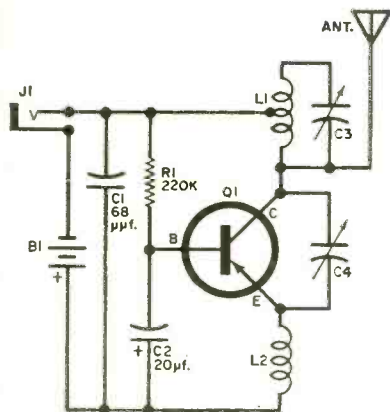

Fig. 3. Norman Dick's receiver circuit is a super-regenerative type covering CB and ten meter band frequencies. Sensitivity at low cost is its main appeal.

operating frequency is determined by tuned circuit $L1-C3$, while $C4$ provides the necessary collector-emitter feedback. Coil $L2$ serves as the emitter load. Operating power is obtained from a 9-volt battery, $B1$, with base bias supplied through $R1$, bypassed by $C2$.

Norm's circuit may be duplicated easily from readily available components. Transistor $Q1$ is a Lafayette SP271 or Sylvania 2N247; $L2$ is a 73- μ h. TV peaking coil, while $L1$ consists of 24 turns of #22 wire, center-tapped, on a $\frac{1}{4}$ "-diameter form (air core); $C1$ is a 68- μ f. silver mica capacitor, $C2$ a 20- μ f., 12-volt electrolytic, $C3$ a 180- μ f. trimmer, and $C4$ a 2.5-13 μ f. trimmer. Resistor $R1$ is a $\frac{1}{2}$ -watt unit; $J1$ is a standard open-circuit 'phone jack (3000-ohm impedance magnetic 'phones are used); while $B1$ may be any 9-volt transistor battery (typically, types 2N6 or 2U6). A 38" whip antenna is employed.

Point-to-point wiring, a circuit board, or any standard construction technique can be employed when assembling the receiver, provided a reasonably "clean" layout is used, with signal leads kept short and direct. Norm assembled his original model in a plastic box measuring 3" by 2" by 1".

In operation, receiver tuning is determined by adjustment of $C3$, while feedback capacitor $C4$ serves as a *sensitivity* control. For best performance, $C4$ should be adjusted until a clean "hiss" is obtained when not tuned to a

This month we are inaugurating "Transitips," a new feature which, as with "Readers' Circuits," we plan to make a regular section of the column. In it we'll pass on practical information on circuit design and modification, test techniques, and application tips which should help you to obtain maximum performance from your home-assembled experimental circuits, and to trouble-shoot balky projects. The material offered will be based on the practical experiences of your Semiconductor Editor, upon contributions by readers, and upon suggestions offered by semiconductor manufacturers. This month we'll discuss some of the problems encountered in assembling wireless microphones.

station. Replace $C4$ with a larger (or smaller) capacitor value if necessary for good operation. Bear in mind when operating the unit that any superregenerative receiver can cause serious interference in other nearby receivers operating in the same band.

Transitips. In terms of general popularity, the AM wireless microphone or "home broadcaster" probably ranks second only to the simple broadcast-band receiver as a hobbyist project. Despite its popularity, however, this type of project seems to be one of the most troublesome for the average experimenter, and many hobbyists have tried literally dozens of circuits before they've found a satisfactory design.

The wireless microphone is basically nothing more than a modulated oscillator, and, therefore, any standard r.f. oscillator circuit *should be* capable of satisfactory performance as a wireless microphone *provided* reasonable modulation can be obtained. One typical circuit . . . a tickler feedback oscillator . . . is illustrated in Fig. 4.

Referring to the schematic diagram, a *pnp* transistor, $Q1$, is used in the common-emitter configuration. An *nnp* unit may be used in the same circuit if the battery ($B1$) polarity is reversed. The circuit's operating frequency is determined by tuned circuit $L1-C1$, while the feedback needed to start and sustain oscillation is furnished by $L2$, coupled to
(Continued on page 81)

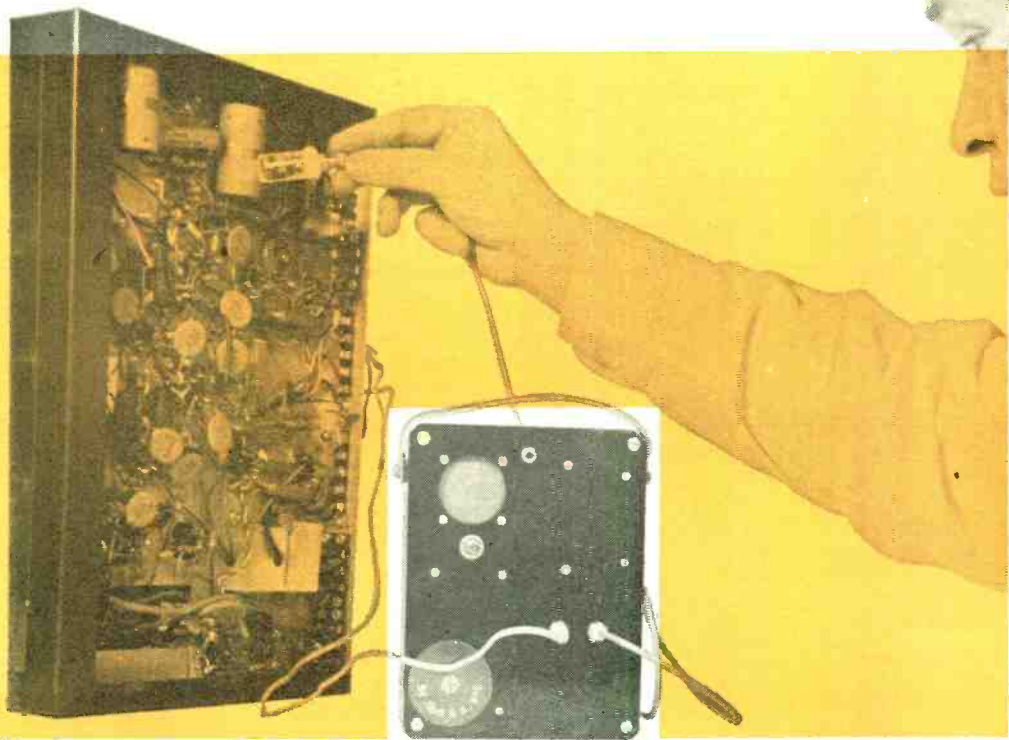

THE SIGNAL STETHOSCOPE

It's a combination radio, signal tracer, hum finder, tuner, amplifier—and the cost is low

By **LYMAN E. GREENLEE**

ONE OF THE most useful pieces of equipment on any service technician's bench is a good signal tracer, and this one more than fills the bill. With it you can easily trace or inject a signal through most stages of any amplifier or AM receiver. You'll also find the "Signal Stethoscope" excellent for checking such things as phono cartridges or speakers, tracking down hum, and even locating concealed a.c. wiring. But that's not all. When you don't need the unit for service work, you can use it for play! A twist of the switch turns the Signal Stethoscope into a sensitive portable radio, or an AM tuner for a p.a. system. What's more, as the following paragraphs reveal, building this seemingly-complicated instrument is a snap.

About the Circuit. This unit is designed around two preassembled circuit boards which are available at very reasonable cost. One of these is a three-transistor AM tuner, the other a four-transistor audio amplifier (see the Parts List). The wiring, shown in the schematic on page 61, is simple. The tuner output (red wire) is con-

nected to the amplifier input (green wire) through closed-circuit jacks *J1* and *J2* and volume control *R1*. Amplifier output (gray wire) is fed to the speaker through closed-circuit jack *J3*.

Battery *B1*'s positive terminal is wired to the ground leads (gray and black, respectively) of the tuner and amplifier. Switch *S1*, connected between the negative terminal of *B1* and the negative leads of the tuner and amplifier (blue and orange, respectively) controls the power.

A plug inserted into *J1* will break the connection between tuner and amplifier, receiving the output of the tuner. The connection will also be broken by a plug inserted into *J2*, and this plug will feed a signal to the input of the amplifier. Similarly, a plug inserted into *J3* will break the amplifier-speaker connection and receive the output of the amplifier. With no plugs inserted and *S1* in position 2, the unit works as a radio.

Two special probes, both of which plug into the amplifier input, were constructed for signal tracing and detecting hum. In the signal tracing probe, *D1* acts as a detector and demodulates r.f. signals. The hum-detecting probe contains *L1*, a winding and core from a

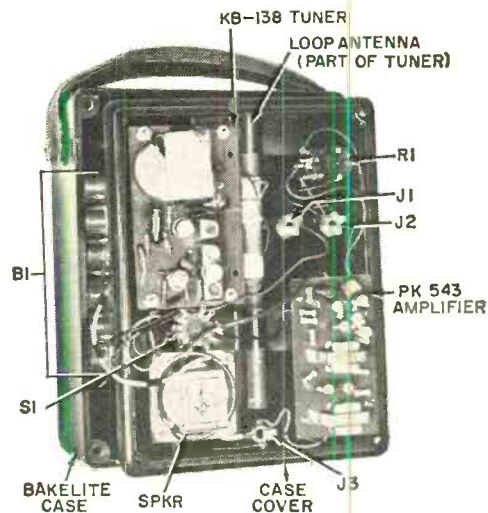
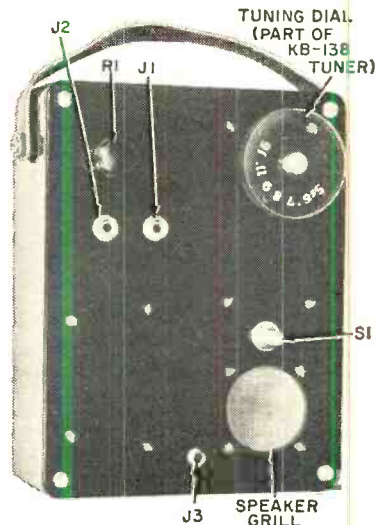

PARTS LIST

- B1*—Six penlight cells in series
- C1*—250 μf . miniature mica or ceramic capacitor (Aerovox type 1468LS or 1469)
- C2*—500 μf . miniature mica or ceramic capacitor (Aerovox type 1468LS or 1469)
- D1*—1N34A germanium diode or equivalent
- J1, J2, J3*—Miniature closed-circuit phone jack (Switchcraft 42A or equivalent)
- L1*—Winding and core from discarded i.f. transformer (see text)
- R1*—50,000-ohm miniature audio taper potentiometer (Lafayette VC-31; switch not used)
- R2*—10,000 ohms, $\frac{1}{4}$ -watt
- R3*—27,000 ohms, $\frac{1}{4}$ -watt
- S1*—2-pole, 5-position miniature rotary switch (Lafayette SW-78 or equivalent)
- SPKR*— $1\frac{1}{2}$ " PM speaker with 8- to 10-ohm voice coil (Lafayette SK-61 or equivalent)
- 1—Transistorized AM tuner (Olson KB-138)
- 1—Transistorized amplifier (Lafayette PK-543)
- 1— $6\frac{3}{4}$ " x $5\frac{1}{4}$ " x $2\frac{3}{4}$ " Bakelite case (Lafayette MS-218 with MS-219 cover or equivalent)
- 2—3-cell battery holders (Keystone 171 or equivalent)
- 3—Miniature phone plugs (Switchcraft 740 or equivalent)
- 1—Miniature panel connector, male (Switchcraft 5501 MP or equivalent)
- 1—Miniature cable connector, female (Switchcraft 5501F or equivalent)
- Misc.—Ball-point pen, pill vial, hardware, shielded cable, alligator clips, knobs, etc.

Parts layout is noncritical; the components fit nicely into a Bakelite case of convenient bench size.

discarded i.f. transformer. When this probe is plugged into *J2*, any hum picked up by *L1* will be fed to the amplifier input.

Construction Hints. The Signal Stethoscope is built into a $6\frac{3}{4}$ " x $5\frac{1}{4}$ " x $2\frac{1}{4}$ " Bakelite case. All of the components, except the six penlight cells composing *B1*, are mounted on the case cover. The cells (installed in two holders) are fastened inside the case proper.

Since the two major components of the Signal Stethoscope, the KB-138 AM tuner and the PK-543 transistorized amplifier, are preassembled, construction is rela-

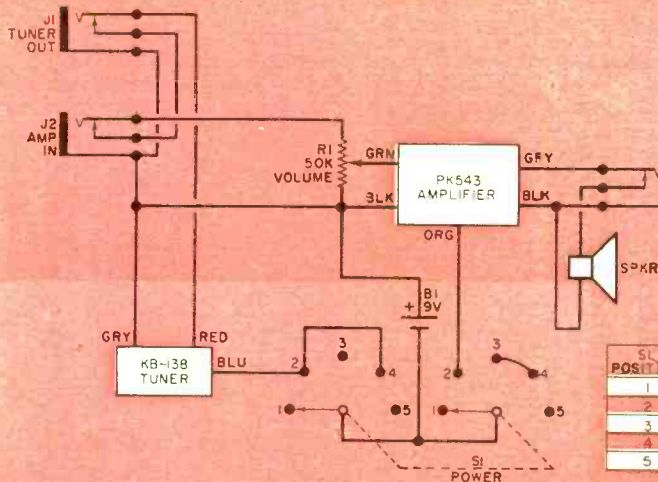

Wiring the Signal Stethoscope is simply a matter of connecting preassembled units as indicated here.

SL POSITION	FUNCTION
1	TUNER & AMP OFF
2	TUNER & AMP ON
3	AMP ON, TUNER OFF
4	TUNER ON, AMP OFF
5	TUNER & AMP OFF

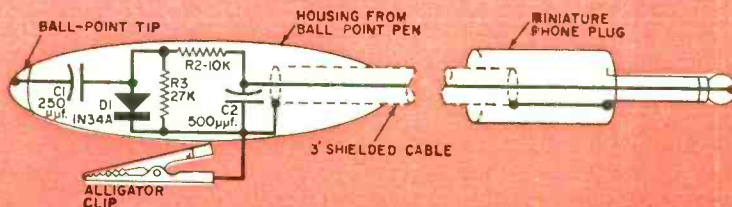

The signal-tracing probe (left) requires a bit of ingenuity. Miniature components are installed in a ball-point pen housing.

The hum probe (right) is part of a discarded i.f. transformer and a miniature connector installed in a plastic pill vial.

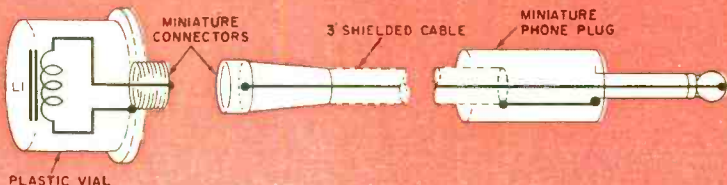

tively easy. The loopstick antenna with the tuner comes disconnected; this is mounted and wired in after the tuner is in place. Discard the tuner battery holder and snip off the battery leads and connector supplied with the amplifier.

The amplifier's two orange leads are meant to be connected to a volume control-mounted, on-off switch. Since a different arrangement is used, cut off the orange lead running to one of the (now disconnected) battery leads and leave the other one intact. Five amplifier leads remain: one green, one gray, one orange, and two black. The black leads are both grounds; it's convenient to use one for the speaker circuit and the other for the input and power circuits (see the schematic). The tuner has three leads (gray, red, and blue) which are con-

nected as shown in the diagram above.

Mechanical Assembly. Parts layout is not at all critical; you should have no trouble fitting everything in the case specified. Both the tuner and amplifier boards are mounted with 4-40 screws and nuts. Fiber or rubber washers are slipped over the screws to provide clearance between the circuit boards and the panel of the Bakelite case.

A grille for the speaker can be made by simply drilling a series of holes in the front panel. The author cut one large hole and covered it with a section cut from a wire mesh gasoline filtering element (available at most auto supply houses). Drill holes for the three jacks, R1, and S1, and mount them. Position the loopstick antenna near the radio;

(Continued on page 78)

WHAT'S a "What's What Light?" As far as your friends are concerned, it can be anything; a mechanical fortune teller, a lie detector, a mystery light, or just a handy switchless flashlight—only *you* know the secret of its operation, and, "what's what."

There are no protruding switches, no holes in the case. How does it work? Simple. Just turn it on its side and the light shines brightly. "Ah-ha," someone says, "a mercury switch." Let him think he has discovered the secret, and then turn the box *upright*. Bring your hand

close to the box—without touching it—and light the bulb a second time!

In the first case, the actuating device is, of course, a small mercury switch (Burstein-Applebee Cat. No. 17A994 or equivalent). In the second example, the switch is of the magnetic proximity type—a glass-enclosed reed switch which closes when a small magnet, hidden in the palm of your hand, is brought near the side of the box. Reed switches complete with magnets are available from several suppliers (Radio Shack Cat. No. 27K95L486 is one) for under \$2.00.

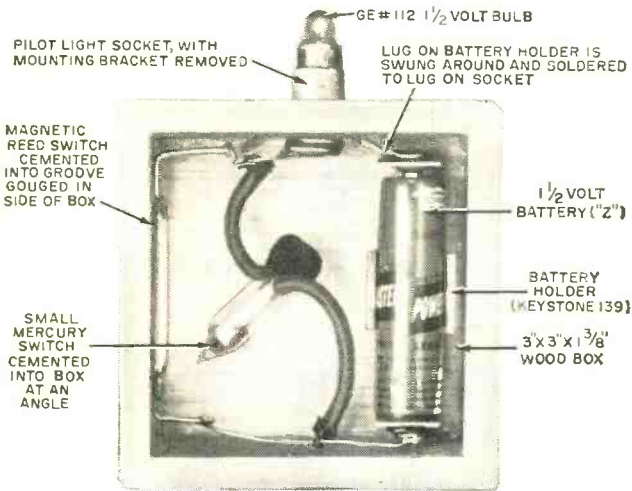

What's What Light

By ART TRAUFFER

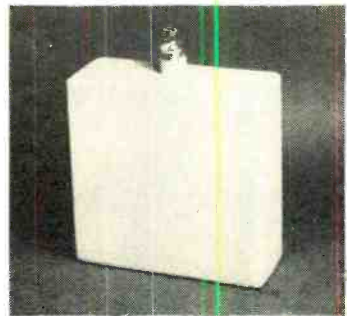

The secret? Let friends try to guess, then prove them wrong. When box is placed on its side, the light shines as shown at right. When box is upright, the light remains off unless a small magnet is brought near side of box (photo below).

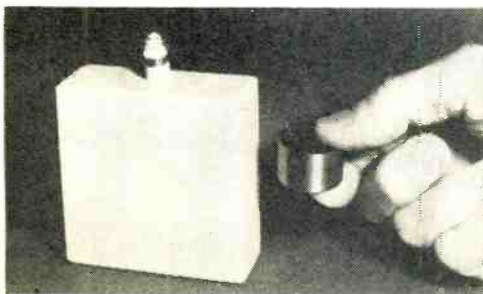
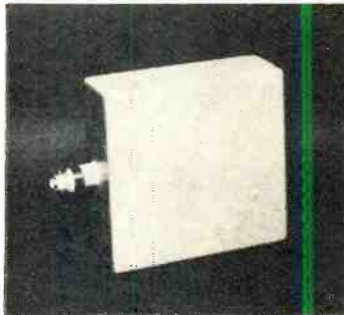

The light shown here was built in a 3" x 3" x 1 3/8" wooden box made of 1/4" stock, but almost any housing can be used. Gouge a groove in the side of the box for the reed switch and position the mercury switch as shown. The two switches are wired in parallel, and in series with battery and bulb. Fasten the box together with small brads, sand and finish, and you'll have your own "What's What Light."

-30-

Extracurricular Education



a Carl and Jerry Adventure

By
JOHN T. FRYE
W9EGV

ON A WARM, moonlit July evening, Carl and Jerry were enjoying a couple of cold root beers at a drive-in when a rakish white convertible with the top down pulled up alongside. The two young men sitting on the red upholstery of the front seat hailed them with boisterous friendliness.

"Look, Phil," said the driver to his companion; "it's the Wireless Boys. Hiya, Carl; hiya, Jerry. How are the prides of Old Parvoo?"

"Humbly grateful to be recognized by the driver of a dreamboat like that," Carl retorted, recognizing Phil Briggs and Dave Hayden, friends home from an Eastern college for the summer. "You must have saved a lot of trading stamps for that set of wheels, Dave."

"Nope, my uncle gave it to me for making the dean's list," Dave answered. "Come on. Get in and live a little. All I need is a chance to show it off."

Carl and Jerry needed no second invitation. They pulled their car around behind the root beer stand and piled into the back seat of the convertible.

"Hey, Dave, what's that bright little white light I noticed in the middle of your grille?" Jerry wanted to know as they rolled out into the street.

"That's a 'running light,'" Dave ex-

plained. "Lots of drivers are putting them on as a safety feature since they were written up in the *Indianapolis Star*. It's just a twenty-one candlepower white light like the truck marker lights. You mount it in the middle of the grille and as near on a line with the headlights as possible, and wire it into the ignition switch so that it comes on whenever you start the car. It really shows the other guy that you're moving or getting ready to."

The boys covered the town in the next hour. First they circled all the drive-in eating places. Next they followed a carload of girls in another convertible, exchanging flirtatious quips with them until a train at a crossing separated the cars. Finally Dave demonstrated how his car could screech the tires while rounding a corner at high speed and how the tires could make two long black marks on the pavement when the accelerator was suddenly floored.

Carl and Jerry, who had great respect and even affection for anything mechanical, winced at this abuse but said nothing. After all, it was Dave's car, and if he wanted to drive it like a member of the teen-age Silly Set, that was his misfortune.

Then Dave drove out of town onto the

highway and really stuck his foot into the fan.

"Ease off, Dave!" Jerry shouted when the speedometer was touching 95 miles per hour. "You've convinced us your car can really roll. Carl and I have to get home."

"Aw, Dave, let's take them out on that old abandoned river road and show them how this car can take the bumps," Phil suggested.

"Yeah, fellows, this won't take long," Dave said as he pulled off the highway onto a mile-long lane that ran to a stretch of road along the river. The road had been abandoned ever since the new highway had gone through a few years before, and, without maintenance, the pavement had cracked, had been heaved up by the frost, and had developed huge chuckholes. Fishermen parked their cars on it occasionally; otherwise it was not used.

"Fasten your seat belts, men," Dave said when they reached the broken pavement. "I won't need mine because I have the wheel to hang on to. Now watch how this sweet little buggy keeps an almost even keel while I make like the mad driver in the TV commercial."

Carl and Jerry barely had time to fasten their belts as the car leaped ahead along the rough roadway. It swayed crazily from side to side as Dave tried to miss the deepest of the holes.

Gaining speed, the heavy car shot over the crest of a sharp rise and for a sickening moment was actually air-borne and spinning at the same time. It came down with a tremendous thud and started rolling over. Carl and Jerry just had time to duck down and wrap their arms around their knees when the car rolled off the road and down over a steep bank toward the river. End-over-end, side-over-side it went, and finally came to rest upside down amid a shower of glass from the broken windshield.

THERE was a deathly silence after the deafening noise. Carl found himself hanging upside down by his seat belt. Cautiously he loosened the buckle and eased himself down on a flinty-hard surface. "Jerry . . . Jerry," he called into the darkness, "are you all right?"

"I will be if you get your big feet out of my face," Jerry answered, slipping

out of his belt and crouching on the ground beside Carl.

"How about you, Dave and Phil?" Carl said. "You guys okay?"

"Does having a broken leg disqualify me?" Dave's voice, with a note of hysteria evident in it, came faintly from somewhere outside the car.

"Forget the wise-cracking and tell us what kind of shape you're in," Carl demanded.

"So who's wise-cracking? I was thrown out when the car rolled over, and my right leg's broken just below the knee. You better shut off the ignition and cut the light switches. We don't want a fire."

It was hard to orient one's self in pitch darkness beneath an upside-down car, but Carl finally managed to crawl forward underneath the bucket seat on the driver's side and turn off the switches. As he started to back out, his hand brushed a limp body hanging head down in a seat belt. A cold chill ran up his spine, but he forced himself to feel Phil's lifeless-looking wrist. The pulse was weak, but it was beating.

Working carefully in the cramped quarters, Carl loosened Phil's seat belt and eased him down onto the hard limestone that bordered the road along the river. As his hand touched the unconscious youth's head, he felt something warm and sticky that he was sure was blood.

"Phil's hurt and unconscious," he reported between grunts while he delivered lusty kicks against the closed doors of the inverted car. "Dave, why can't I get these doors open? How is the car resting?"

"It's wedged in the bottom of a kind of pocket in the limestone," Dave answered. "The slanting sides are holding the doors shut. The hood's torn off, and the whole front end is sticking out over the edge of a ledge. I'm lying under the front looking up at the motor. If the car had gone over the ledge, I'd have been squashed. Why aren't you and Jerry mashed?"

"There's more room under here than you'd think," Jerry said as he explored their prison with his hand. "We're resting right on top of a hollow in the limestone, and I'm sitting up without my head touching the floor, but the only

opening I can find is a little space about two inches high and a foot long between the middle of the cowl and the ground."

"See if you can find a penlight in the glove compartment," Dave suggested.

When Carl opened the glove compartment, the light inside came on and illuminated the interior of the car. It showed Phil's pale face and closed eyes and a deep cut on his forehead from which blood was oozing. The penlight was passed out through the narrow slit to Dave down below.

"Suppose you could hobble to get help?" Carl asked Dave. "Phil needs a doctor pretty badly from the looks of him."

"I'll try," Dave's voice answered. They heard him moving around, and then there was the sound of a body falling heavily to the ground. Only after they called to him a number of times did he finally answer weakly: "Sorry, you guys, I passed out. It's no go with this leg. I just conk out when I try to move on it."

"Just lie still," Jerry told him. "We'll think of something. Maybe we can attract attention with the horn." But when he pushed the horn button there was no sound except the clicking of the relay.

"That's no good; the horn is smashed," Dave said, his voice quavering. "So are the headlights. No one would see or hear them anyway. I know they'd never see this little flashlight. You guys can't get out. I'm out, but I can't go anywhere. It may be days before we're found. Phil is hurt..."

"Let's not waste time punching the panic button," Jerry said crisply. "I've got an idea, but it'll take a few feet of wire. Do you see any we can get?"

"The running light has about ten feet," Dave replied. "You can cut it loose from the switch inside and I can cut it loose out here."

Jerry whipped out his pocket knife and cut the wire loose from the switch. Three feet was cut off and the insulation stripped from both ends. One end of this short piece was shoved out to Dave.

"Strip insulation from the low-voltage lead going from the ignition coil to the distributor and wrap the end of this wire around the bare spot," he directed. "Then pull the high-tension lead out of

the coil and stick the bared end of the long piece of wire into the socket. Scrape the insulation off this wire at a place close to the coil and fasten this bared spot so that it's about an eighth of an inch from the motor block or the metal car frame. Fasten it so it'll hold and throw the loose end of the wire on top of some bushes so it doesn't touch the ground. Can you do everything?"

"I will do it!" Dave promised. "I got us into this mess, and I can certainly help get us out."

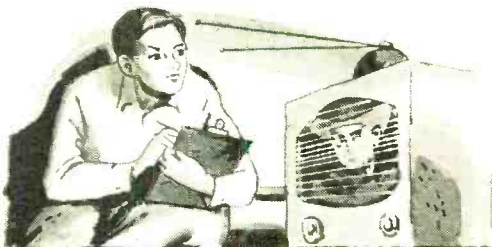

SOS . . . trapped under wrecked car on river road

"Mind telling me what you've got in mind?" Carl asked Jerry as they heard Dave fumbling around the front of the car.

"I'm going to try to make a spark transmitter with the ignition coil," Jerry answered. "The battery current from the ignition switch goes through the primary of the coil back to ground through the points inside the distributor. When I rub the end of this short wire against the metal body of the car, the contact will be in parallel with the points and the voltage-boosting capacitor across them. The current surge through the primary will induce a high voltage in the secondary that will arc across the spark-gap Dave is fixing up. The rest of the wire will act as an antenna to radiate the r.f. energy in the arc."

"Why not use the high-tension lead to make your spark gap?"

"It's probably the resistance type designed to reduce ignition interference to radio and TV and would keep us from getting out."

"How are you going to key it?"

Jerry was busy cutting a series of close-spaced notches through the paint

(Continued on page 89)



Short-Wave Broadcast Predictions

JULY 1963

By **STANLEY LEINWOLL**
Radio Propagation Editor

FROM May through August, and particularly during June and July, there is a considerable increase in the number of sporadic-E clouds formed in the ionosphere—even more so in low-sunspot years like this one. Sporadic-E clouds are regions of extremely high ionization density which can reflect frequencies much higher than the ionosphere's normal F-layers are capable of returning to earth. Last summer record numbers of E-skip interference cases were reported on the lower television channels, and this type of interference is expected to be just as bad this summer. Because of the ionospheric activity, short-skip openings from *Voice of America* transmitters beamed overseas on 15 and 17 mc. should occur frequently during daylight hours up to about 1000 miles from the major transmitting sites in New Jersey, North Carolina, Ohio, and California.

		TIME (EST)												
Between Eastern USA and:		00	02	04	06	08	10	12	14	16	18	20	22	24
Western Europe		7	7	9	9	15	15	15	15	15	15	11	9	
Eastern Europe		7	7	9	9	9	15	15	15	15	11	11	9	
South & Central America		11	11	11	15	17	17	17	17	17	17	15	11	
Near East		7	7	9	11	11	15	15	15	15	15	11	9	
North Africa		7	9	9	15	15	15	15	15	15	15	11	11	
South & Central Africa		9	9	11	15	17	17	17	17	15	15	11	9	
Australia & New Zealand		11	11	11	11	11	9	*	17	21	21	21	15	

		TIME (CST)												
Between Central USA and:		00	02	04	06	08	10	12	14	16	18	20	22	24
Western Europe		7	7	9	11	15	15	15	15	15	11	9	9	
Eastern Europe		7	7	9	11	11	11	15	15	11	11	11	9	
South & Central America		11	11	9	15	17	17	17	17	17	17	15	11	
North Africa		9	9	9	11	15	15	15	15	15	15	11	9	
South & Central Africa		9	9	11	15	15	15	15	15	15	11	11	9	
Far East		9	9	7	9	11	11	15	15	15	15	15	11	
Australia & New Zealand		11	11	11	11	11	11	*	21	21	21	21	15	

		TIME (PST)												
Between Western USA and:		00	02	04	06	08	10	12	14	16	18	20	22	24
Western Europe		7	7	9	11	11	15	15	15	11	9	9	9	
Eastern Europe		9	7	9	11	11	11	15	11	11	11	11	9	
South & Central America		9	9	9	11	15	17	17	17	17	17	15	11	
Africa		9	9	11	15	15	15	15	15	15	11	9	9	
Far East		11	9	9	9	11	11	15	15	15	15	15	15	
South Asia		11	9	9	9	11	11	11	15	15	15	15	11	
Australia & New Zealand		11	11	11	11	9	15	17	21	21	21	21	15	

To determine the frequencies and times for best short-wave reception in the United States, select the table for the area you are located in, read down the left-hand column to the region you want to hear, then follow the line to the right until you are under the figures indicating your approximate local time. The boxed numbers will tell you the frequency band (in megacycles) to listen to during any 2-hour interval. Asterisk (*) indicates that signals will probably not be heard.



Monthly Short-Wave Report

By **HANK BENNETT**, W2PNA/WPE2FT
Short-Wave Editor

VOA GREENVILLE—ON THE AIR

THE WORLD'S largest and most powerful long-range radio facility is on the air. Operated by the U. S. Information Agency from the vicinity of Greenville, North Carolina, it is broadcasting America's story to the world. The power output—4.8 million watts—is equivalent to that of 96 of America's 50,000-watt medium-wave commercial stations!

The Greenville site covers nearly 6200 acres, broken into three separate areas: one for receiving, and the other two for transmitting facilities. The two transmitting sites each occupy some 2800 acres. To maintain full operations at Greenville requires the services of 100 people who work in shifts around the clock.

Thanks to Greenville, some 21 years after the *Voice of America* was born the U. S. can broadcast with a "loud and clear" voice to Latin America, Europe, and Africa. In addition, the new receiving-transmitting complex provides *VOA* stations in Europe, the Mediterranean, and Africa with more reliable and higher quality programs for relay to their respective target areas.

Over-All Picture. There are numerous ways to communicate with foreign countries, some of which are newspapers, pamphlets and magazines, motion pictures and photographs, telephones and teletype machines, exhibits, and personal verbal contacts. However, radio broadcasting is a unique means of communication in that radio waves cannot be stopped at national boundaries.

Even the 2000-odd jamming transmitters that are used by Communist-bloc countries fail to effectively block the *VOA* or defeat its basic purpose—to spread the truth to all corners of the

earth. Such a tremendous job of jamming, if attempted by the U. S., would cost in the area of \$150,000,000 yearly. Compare this with the \$22,000,000 which is the annual operating cost of the entire *VOA* network, of which some \$2,500,000 is budgeted for operation of the Greenville station. A considerable portion of that annual cost will be offset by the retirement of obsolete *VOA* stations at Wayne, N. J., and Brentwood and Schenectady, N. Y.

The Greenville station boasts six transmitters rated at a half-million watts

Directional antennas at transmitter site at Greenville. Utilizing specially designed equipment, programs are fed through various antennas from one transmitter.

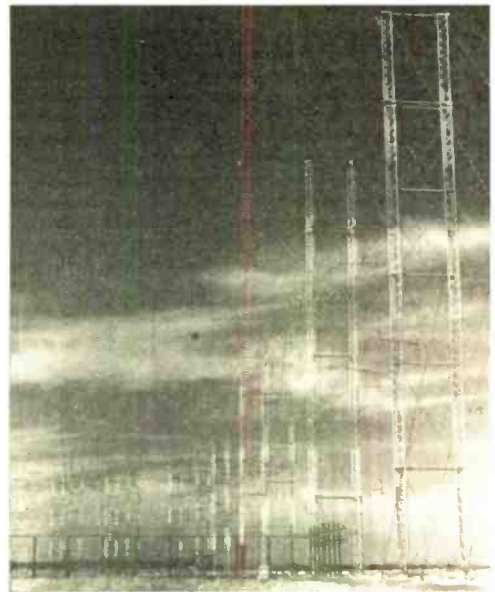

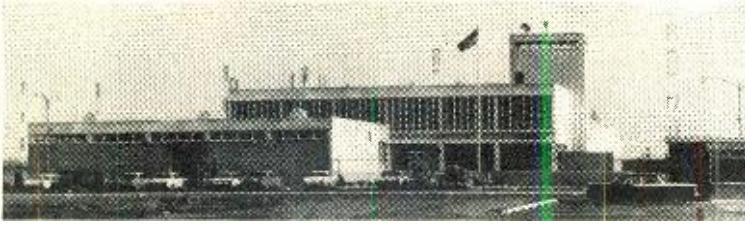

This is one of the two transmitter buildings at Greenville. A separate building houses the receiving facility. VOA in Greenville has 22 transmitters and 96 directional antennas.

each, six quarter-million-watt units, six 50-kilowatt transmitters, and four little 5000-watt'ers. Broadcasts are beamed through 96 directional antennas. But the new equipment at Greenville by no means makes up the entire picture of the VOA's current expansion in broadcasting.

Existing VOA stations in Dixon and Delano, Calif., and in Bethany, Ohio, are being modernized. New antennas have been constructed for the U. S. Information Agency's station in Free Berlin to enable that station to increase its effective power by five times for night broadcasts to blanket East Germany. Six transmitters leased by the VOA from the British Broadcasting Corporation in Wooferton, England, are being increased

in power to 250,000 watts each. A major relay station is being built near Monrovia, Liberia, the site of a currently operating mobile station. The U. S. Coast Guard Cutter *Courier*, anchored off Rhodes in the Mediterranean, will have its transmitters replaced by more efficient land-based stations.

Other mobile units are now in operation in Marathon Key, Florida, and beamed strongly toward Cuba—tune for them on 1180 kc. in the medium-wave band. Three other medium-wave outlets (rated at *one million watts* each!) are located in Munich, Germany; the Philippines; and Okinawa.

Programming. The VOA was born on February 24, 1942, to "tell the truth" to the world, and has never deterred from

ENGLISH-LANGUAGE NEWSCASTS TO NORTH AMERICA

All of the stations below specifically beam English-language newscasts to the U.S.A. The times may vary a few minutes from day to day.

COUNTRY	STATION	FREQUENCY (kc.)	TIMES (EST)
Australia	Melbourne	17,840, 15,315, 9580	2030, 2130, 2230, 0745
Bulgaria	Sofia	6070	1900, 2000, 2300
East Congo	Leopoldville	11,755	1630, 2100, 2230
West Congo	Brazzaville	11,725	2015
Czechoslovakia	Prague	11,990, 9795, 9550, 7345, 5930	2000, 2330
Denmark	Copenhagen	9520	2100, 2230
West Germany	Cologne	15,405, 11,795 9640, 6160	1010 2035
		11,795, 9735, 6145	0000
Hungary	Budapest	11,890, 9833, 7220 9833, 7220, 5960	1900 2230
Italy	Rome	11,905, 9575	1930, 2205
Netherlands	Hilversum	9715, 11,710 6035, 9630	1625 (exc. Sun.) 2030 (exc. Sun.)
Portugal	Lisbon	6185, 6025 (or 9740)	2105, 2305
Spain	Madrid	9360, 6130	2215, 2315, 0015
Sweden	Stockholm	17,840, 7270	0900, 2045, 2215
Switzerland	Berne	11,865, 9535, 6165	2030, 2330
U.S.S.R.	Moscow	(announced) 9650, 9570, 7320, 7250, 7150, 7130, (also monitored) 7230, 7200, 7110, 7070, 7030	1700, 1900, 2000, 2100, 2300, 0000 0040
Vatican City	Vatican City	9645, 7250	1950

DX Awards Presented

Awards have been issued for 25 countries verified to the following DX'ers, in the order in which they appear. Congratulations to all of you!

David Zuehlke (WPE9FPL), West Bend, Wisc.	Jerry McMahan (WPE0SS), Cedar Rapids, Iowa
C. McKinstry (WPE6CXS), San Bernardino, Calif.	Andrew Kasparson (WPE1DFW), Auburn, Mass.
Irwin Belofsky (WPE2BYZ), Brooklyn, N. Y.	Gary Frankeberger (WPE9DBO), Normal, Ill.
Robert E. Jewell (WPE9EX), Crown Point, Ind.	Richard Mills (WPE2HOZ), New York, N. Y.
Henry Mendenhall (WPE3BQX), Glenolden, Pa.	Arthur S. Mullins (WPE9FUW), Oak Park, Ill.
Thomas Bell (VE4PE4Q), Winnipeg, Man.	Jack Elias (WPE3CKI), Philadelphia, Pa.
Bill Harrison (WPE4FSJ), Nashville, Tenn.	Paul Lange (WPE8FGN), Flint, Mich.
Amedeo Calviello (WPE2FAE), Brooklyn, N. Y.	Joseph Liberatore (VE7PE4R), Victoria, B. C.
C. T. Langlais (WPE0CRH), Grand Junction, Colo.	James Coston (WPE5CEP), Corpus Christi, Texas
Charles Matterer (WPE6DGA), San Leandro, Calif.	Gerry Klinck (WPE2FAH), Buffalo, N. Y.
Charles Morrissey (WPE2IIT), Bellerose, N. Y.	Emil Lenchak (WPE3AIR), Hazleton, Pa.
Robert Davis (WPE5AUR), San Antonio, Texas	Philip Cutler (WPE9EFL), Barrington, Ill.
Michael Schieman (WPE4DNI), Decatur, Ga.	John Harvey (WPE2EG), Lewiston, N. Y.
John Otey (WPE5DV), Tulsa, Okla.	Bernard Bastura (WPE1EID), Middletown, Conn.
R. Force (WPE2AWH), Berkeley Heights, N. J.	Otto Barz (WPE2HWV), Flushing, N. Y.
Russell Anderson (WPE8DFW), Muskegon, Mich.	Pete Mondron (WPE8CES), Mt. Vernon, Ohio
Serge Nuemann, II (WPE6AKA), Culver City, Calif.	Glen Fornwalt (WPE3COM), Lancaster, Pa.
Marshall Hopper (WPE2EYT), Syracuse, N. Y.	W. Chapman (WPE1DRZ), Middletown, Conn.
Dave Siddall (WPE1EBN), Hyannis, Mass.	William Fields, Jr. (WPE4EPP), Macon, Ga.
James Albrinck (WPE8AZJ), Reading, Ohio	Donald Reinholz (WPE8CRH), Detroit, Mich.
John Berg (WPE7BGF), Seattle, Wash.	Ronald Walsh (VE3PE1BQ), Kingston, Ont.
Jim Phelps (WPE0CGE), Davenport, Iowa	Bruce Orcutt (WPE4ENZ), Brandon, Fla.

that policy. It has been estimated that the daily number of listeners is in the tens of millions and at times may run well into the hundreds of millions, especially during periods of world crises. In 1962, the VOA received over 200,000 letters from foreign listeners.

The U.S.I.A. has arranged VOA programming so that it will be heard in homes around the world at peak audience listening times, usually in mornings and/or evenings. In addition to the regular broadcasts, some 260 stations in 15 Latin American countries rebroadcast VOA programs by direct pickup or by taping them for future use. The high power of the new Greenville station will give such pickups better clarity.

Newscasts from the VOA are given in 35 languages, although as many as 60 languages may be used in the preparation of taped programs for rebroadcast over thousands of medium-wave local stations. The total broadcasting time, at the end of 1962, was 740 hours weekly.

The VOA's broadcasting time is topped only by Red China (787 hours) and Moscow (1205 hours). Communist-controlled stations, as a whole, broadcast approximately 3800 hours of weekly international programs, but this figure is misleading since it also includes all of their own national and satellite countries' trans-

mitters as well as clandestine radio transmitters that mask their identities with various pseudonyms.

The Greenville Station. The city of Greenville, which has a population of about 23,000, is 265 miles south of Washington, D. C., in the fertile coastal plain

(Continued on page 84)



The Master Control Panel at the receiving station of the USIA's new broadcast complex at Greenville.



On the Citizens Band

with **MATT P. SPINELLO**, 18W4689, CB Editor

LEGALLY and quite conveniently (and probably to the surprise of many readers), hobby-type two-way radio has been permissible between 26.965 and 27.275 mc. ever since the birth of CB in 1938. The legal scope of this type of operation includes such goings-on as working "skip" stations, unlimited length of transmissions, ham-type communications (CQ's included), and the use of c.w.—all allowed by the FCC and without a license!

CB PACKAGE FOR THE HOBBYIST

We're referring to 100-milliwatt handie-talkie type equipment, of course. For what used to be obvious reasons, 100-mw. units have rarely been utilized for anything other than short-distance communications, mostly line-of-sight operation. Under the Federal Communication Commission's rulings contained in Part 15, this equipment lent itself to a number of applications right from the start, but was never as practical as higher-powered 5-watt CB equipment—at least not until recently.

While it doesn't seem likely that 100-milliwatt gear will replace the 5-watt units, the fact remains that interest in the lower-powered equipment has been increasing, and much of this interest might easily lead towards the procurement of amateur radio licenses—as farfetched as that may seem!

We're constantly on the lookout for methods and measures that might be instituted to take the pressure off the Citizens Band, yet still allow the self-appointed hobbyist a place to "hobby," and the serious-minded rule-abiding CB'er a place to communicate without interference. Without a doubt there is a need for such a separation, and at this stage of the game each type of operator is deserving of his own distinctive "corner to communicate"!

In the May issue of **POPULAR ELECTRONICS**, we mentioned International Crystal Manufacturing Company's petition to the FCC that a hobby class license be established in the 29.405-29.595 mc. region,

carrying a maximum power input limitation of 10 watts. While this pot brews, International Crystal has taken a step in another direction by creating a 100-mw. "Part 15 package" that legally permits the hobbyist to practice ham-style communications without getting in anybody's hair, and with much more range than might be expected.

Obviously a big question here would be how anyone could possibly derive as much "communicativity" from one-tenth of a watt as with 5 watts. It stands to reason that a handie-talkie at ground level is not going to put a New Jersey "Jaunter" directly in touch with a Connecticut Clam-bake. But if conditions were right, the New Jersey talkie might "skip" all the way to Illinois, and quite legally!

Better still, if the New Jersey talkie were

The roof-mounted portion of International Crystal's 100-mw. Model 1500 includes transmitter, antenna, and receiver preamplifier. No license is needed for either phone or c.w. operation on the 11-meter band.

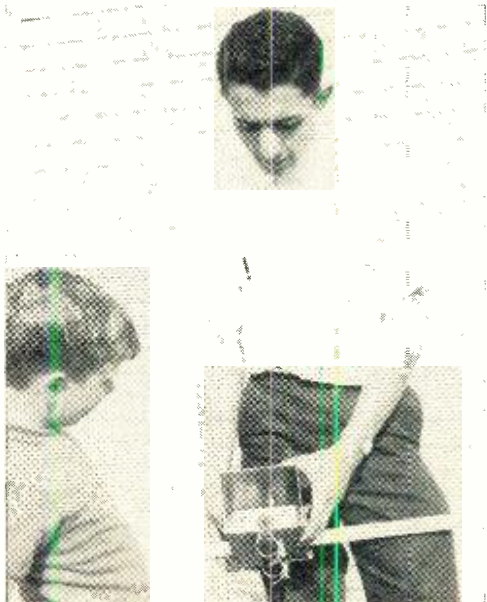

POPULAR ELECTRONICS

perched atop a roof, the operator might be surprised to find that he could chatter almost as far with a hand-held unit as with his 5-watt rig. Granted, 5 watts on the roof would give greater range, but considering the huge ball of coax that has to be unwound from the output of the 5-watt rig to the rooftop, the operator is lucky as he has 1 watt left fighting its way out of the antenna. Furthermore, if an efficiently selective receiver is made part of the 100-mw. Lilliputian system, a whale of a lot of communicating can result.

International Crystal's Model 1500 "Executive" transceiver, which permits phone and c.w. operation on 11 meters without a license, may well be the outcome of this line of thought. Since the transmitter and antenna are combined for rooftop mounting, maximum power goes into the antenna. In the house, a second unit contains a super-sensitive receiver/exciter. A receiving preamp at the antenna boosts weak signals for better reception.

To round out this Part 15 package, the Model 1500 comes complete with eight sets of crystals plus a special socket on top of the unit for adding a chosen ninth channel. A key for c.w. operation is also included, providing the potential ham with an opportunity to put the code to actual on-the-air use.

Perhaps this type of equipment will ease

The flea-power output of the 1500 is surprisingly effective: there are no transmission line losses. The part of the unit that goes on the roof can be mounted on a chimney, or on a tri-mount and mast.



July, 1963



Your CB Editor, shown here with the control part of the 1500, installed the unit in his back yard temporarily, and worked a moving handie-talkie for several blocks before a 5-watter QRM'ed him out.

the CB pains of yesterday and today by allowing the future communications expert the chance to get his foot in the door without kicking anyone in the process. Most important, he won't be hobbing illegally and can still enjoy a type of two-way communications to his heart's content.

Tech Tips. With summer weather luring the out-of-doors man to every conceivable type of sporting pleasure, it's a sure bet that several thousand CB units will be installed in all types of boating and camping equipment during the next few months. The Champion Spark Plug Company has published a useful list called "10 Tips for Good Marine Reception." If you're a boating enthusiast, take heed. They're definitely worth considering!

(1) Use a marine-type approved antenna—not an automotive type—and one that has proper electrical characteristics for the frequency on which it is to operate.

(2) Install the antenna on the opposite side of your remote control engine panel and as far forward in the bow as possible.

(3) Use a shielded lead-in wire. Ground the metal braid to the radio cabinet.

(4) Fiberglass and wooden boats will require at least a 12 sq. ft. under-hull ground plate or a commercially available radio ground plate for best results.

(5) Plate should have only one (≠10) grounding wire connected to the negative battery post.

(6) All pieces of electronic and electrical equipment should terminate their grounds at the negative side of the battery, not directly to the plate.

(7) Interference from small electric motors (windshield wipers, bait wells, bilge pumps, etc.) can be eliminated by installing

71



Through a CB setup with "Mom," young Joey Guy has a guide as he crosses busy intersections on his way to school each day. See "Walkie-Talk" below.

a generator capacitor from the hot input lead to ground. The capacitor should be installed as near the offending device as possible.

(8) Metal boats do not require a ground plate, provided the electrical system is grounded to the hull. If possible, route all wiring under the metal rails of the boat.

(9) Check all boat wiring—be certain no wires run through a leaky bilge.

(10) Do not handle radio equipment, especially transmitting equipment, when standing in bilge water or when wearing water-soaked shoes. It is best to disconnect the hot lead or remove the line fuse when working on electrical equipment.

Tips 5 and 6 protect your boat and engine from electrolysis. Tips 9 and 10 protect you from electric paralysis!

Walkie-Talk. Last winter we mentioned that a couple of midwestern youngsters would be in instant contact with their homes while trekking through heavy snow and cold and crossing busy intersections. In the accompanying photo, Joseph Guy is shown proudly displaying his "direct-line-to-Mom." We understand the picture was taken on a 22-below-zero day just before Joey was camouflaged with heavy scarf, Russian-type headgear and mittens.

Standing by at the base station 5-watt CB unit, Joey's Mom audibly guided him across busy intersections by reminding him to look both ways before crossing and having him call back as soon as he had reached the other side. The CB system also enabled her to prod him along his path, lest he become an ice cube, until he finally reassured

her that he had entered the heated school building.

The only problems encountered with the operation were in getting Joey to remember to turn the unit off (thank Heaven for rechargeable batteries), and the time spent answering phone calls each morning from mothers wanting to know if their children had arrived at school safely; children that were last seen following a little guy who was "holding something in his hand with a long wire sticking out of one end!"

CB Jamboree's. On July 14, The Wabash Valley Citizens Radio League will hold its annual Citizens Band Jamboree at Turkey Run State Park, located north of Terre Haute, Indiana. Last year's event drew some 2500 CB enthusiasts. This year the WVCRL offers a bundle of prizes along with huge displays from many manufacturers.

The Southern Tier CB Radio Club of Binghamton, N.Y., will hold its first Jamboree on Saturday, August 3, at Ross Park. A well-rounded program and prizes are promised. For more information, contact Robert T. Reagan, 86 South Washington St., Binghamton, N.Y.

Basil F. Petty informs us of the South Western Ohio Citizens Band Association's sponsorship of its First Annual Nationwide CB Jamboree to be held Sunday, August 25, 1963, at Lebanon Fairground, Lebanon, Ohio. The club has announced an *exclusive* premier showing of the newest concept in CB equipment. There will be \$500 in prizes, food, entertainment, exhibits and displays. Proceeds of the event will be turned over to a national charity. For more information, Basil may be contacted at P.O. Box 231, Mason, Ohio.

Two other coming events are: The Cereal City C-B Radio Club Jamboree, Kellogg Airport Hangar #4, Battle Creek, Mich. to be held on July 27; and the 1963 Round-Up of the Maumee Valley C-B Radio Association, Inc., Hessen Cassel Hall, Fort Wayne, Ind., on September 22.

Club News. The Chateaugay General Radio Club of Canada finds itself with a membership of 20 after only two weeks of existence. While this is basically a suburban organization, Moe Edwards states that a few member stations are located in Montreal. The club monitors all channels, but keeps channel 20 available for pertinent club activities. They have already drawn up their rules and operating procedure and are presently working towards a network of communications to provide constant service for those in need. The CGRC will also publish its own news bulletin shortly. Interested

(Continued on page 90)

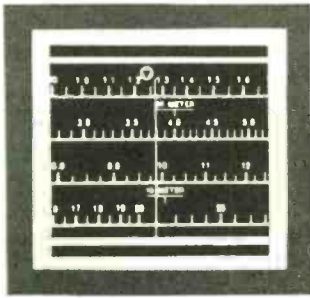

Across the Ham Bands

By **HERB S. BRIER**, W9EGQ
Amateur Radio Editor

MAKE YOUR SIGNAL REPORTS MORE ACCURATE

HOW CLOSELY does your communications receiver S-meter agree with the standard amateur R-S-T signal reporting system? On 80 meters, for example, does the S-meter pointer hover well up on the meter scale even when no signal is tuned in, and do fairly strong signals pin the meter? But on 10 and 15 meters, are all meter readings much lower? If so, you have a typical S-meter.

Most S-meters are subject to large errors, as communication receiver operating manuals usually state. Fortunately, however, these errors can be practically eliminated—without modifying the receiver or S-meter in the slightest. Here's how to do it:

Adjust the receiver in the normal manner at a time when static and other external noises are low, tune it to a spot where no signals are being received at the moment, and write down the S-meter reading. This will be your true S_0 point, no matter what the actual meter

reading is. Next, locate a signal you can just barely hear, and note the new S-meter reading. This will be your new S_1 point.

To establish your true S_9 , refer to your logbook and copy the S-meter readings of the strongest 10% of the signals you have logged over a period of random listening until you have compiled a list of about 20 reports. (Exclude the extra-strong signals of your immediate ham neighbors from the list.) Convert "db-over-9" reports into equivalent S-units by dividing the number over 9 by six; then add the answers to 9; 30 db over 9, for example, would be equivalent to S_{14} . (Convert any fraction to the nearest whole number.)

Next, add the reports together and divide the sum by the number of reports you used, to get the average value. If the answer is greater than 9, subtract 9, and divide the remainder by 6. This puts the answer back into the conventional

.....Novice Station of the Month.....

This month's free subscription goes to John B. Becker, KN3VGR for his well equipped, efficiently organized station layout. Notice that transmitter and receiver are raised off the desk enough to put the controls and dial at a comfortable operating height; a "must" if fatigue is to be kept to a minimum during those long hours chasing elusive DX. John's big real complaint is that someone didn't steer him into amateur radio forty years ago. The General exam is his next objective.





Ron Ferris, KN1ZSY, of 18 Whittemore St., Concord, Mass., son of notable DXer W1HZ, bagged 41 states and seven DX QSO's in his first 10 weeks on the air.

db-over-9 form. This final answer will determine the new S9 point on your S-meter.

Finally, divide the number of divisions on your S-meter scale between your new S1 and S9 points by 7 to locate your new S2 through S8 points. Then put all this information into neat chart form, preparing a separate chart for each ham band of interest to you.

Your S-meter will now be accurately calibrated for your location and antenna system. As a result, your signal strength reports will be true evaluations of the strengths of the signals you hear, whether they are weak or strong.

Incidentally, if the meter turns out to be excessively "scotch" on some bands, resulting in weak signals not registering on the S-meter, use the signal-strength table to evaluate the strength of readable signals too weak to register on the meter.

FCC Notes. Mobile logging rules have been simplified. Effective March 21, 1963, the Federal Communications Commission modified section 12.136(a) of its amateur rules to provide that, during a period of continuous mobile operation, the mobile operator need only log call-signs of stations worked (and CQ's) at his first opportunity, such as a stop for service or refreshment, *provided that* he also logs the date and the starting and ending times of each period of continuous mobile operation.

Also, the FCC has finally revoked the license of a K8 and issued orders to show cause why the licenses of a W1 and a WA4 should not be revoked. The rea-

Delores Y. Hovendick, K1VGH, 164 Lois St., Manchester, N.H., shares this rig with husband Jim, K1TLT. Having nothing else to do (except raise four children, bowl in two leagues, teach Sunday School, and sing in the choir), De worked most states as a novice before pausing to acquire her General ticket.



son for the action in each case was the *failure to reply* to official notice of violation of FCC regulations. In other words, these misguided hams probably moved and neglected to have their licenses modified for their new addresses. As a result, they never received their mail from the FCC.

If you move, be sure to have your license modified for your new address immediately—even if you don't plan on getting on the air from the new location right away. Some one else might "borrow" your call letters, or your call could be miscopied by a monitoring station; in either event, *you* would be in trouble if you didn't reply to the notice, even though you were innocent of the violation.

NUVISTOR Q-MULTIPLIER

Regular readers of our "News and Views" section have undoubtedly noticed that many equipment descriptions include something like "I use a 'you-name-it' receiver, *plus* a Q-multiplier for additional selectivity." A Q-multiplier is a regenerative circuit connected to the i.f. amplifier of a superheterodyne receiver to modify its selectivity characteristics. The simple Q-multiplier described here, which utilizes a nuvistor, will increase the ability of an inexpensive communications receiver to separate signals up to 10 times or more.

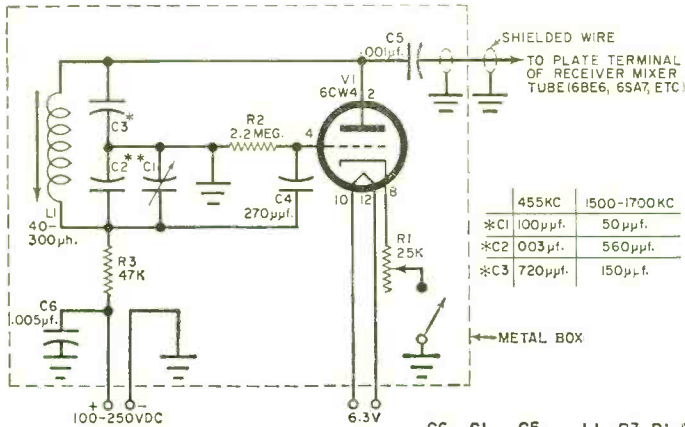

As with other Q-multipliers, the nuvistor version makes use of controlled regeneration to boost selectivity.

	455 KC	1500-1700 KC
*C1	100 μf.	50 μf.
*C2	0.003 μf.	560 μf.
*C3	720 μf.	150 μf.

Construction in the type of box shown permits parts layout for good electronic function and easy assembly.

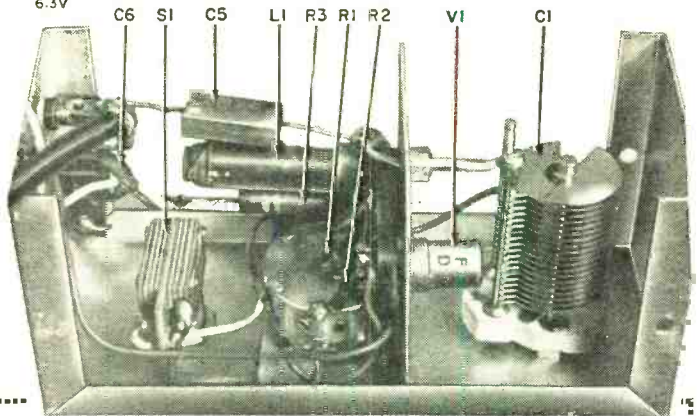

PARTS LIST

- *C1—100-μf. (50-μf.) midget variable capacitor
- *C2—0.003-μf. (560-μf.) mica or silver mica capacitor
- *C3—720-μf. (150-μf.) mica or silver mica capacitor
- C4—270-μf. mica or paper capacitor
- C5—0.001-μf. mica or paper capacitor
- C6—0.005-μf. mica or paper capacitor
- L1—40-300 μh. slug-tuned coil (Miller #2002 ferrite rod loop antenna or equivalent)
- R1—25,000-ohm potentiometer, linear taper
- R2—2.2-megohm, ½-watt resistor

- R3—47,000-ohm, ½-watt resistor
- P1—Single-contact "phono" plug or equivalent
- S1—S.p.s.t. switch
- V1—6CW4 nuvistor
- 1—2¼" x 2¼" x 5" aluminum box (Bud #2104A or equivalent)
- Misc.—Insulated tie points, shielded wire (RG-59U or equivalent), etc.

*First values are given for 455-kc. i.f. amplifiers; values in parenthesis are for i.f.'s in the 1600-kc. range.

Construction notes. The frequency range of the Q-multiplier must match the receiver intermediate frequency; therefore, part values are included in the parts list for units to operate in both the 455-kc. and 1600-kc. i.f. ranges. The unit is built in a 5" x 2¼" x 2¼" aluminum, utility box; the small size of the nuvistor permits uncrowded construction. Although parts placement is not critical, the general arrangement shown in the photograph is recommended.

Refer to your receiver instruction manual in connection with the following step. The 6.3 volts at 0.135 amperes and

100—250 volts, d.c., at a few milliamperes required to power the Q-multiplier can be obtained from the receiver's accessory socket (if it has one), or from a convenient spot in the receiver, such as the heater and screen terminals of the output tube socket. The power may also be obtained from a small external power supply. In fact, with an a.c./d.c. type of receiver, an external supply is required; a Q-multiplier may not give completely satisfactory results on c.w., however, when used with inexpensive a.c./d.c. receivers.

(Continued on page 91)

The "Light" Fantastic

(Continued from page 39)

you had a laser putting out one million watts, a hundred miles away you would receive 997,500 watts: still quite a bit of power.

Laser Radar. One of the immediately attainable applications of the laser is in a radar-like system for measuring distance and velocity, and for tracking. Several such systems already have been built or are in the works, including those of Hughes, RCA, General Electric, and Sperry. For example, the RCA tracking system, using a two-inch corner reflector, is expected to achieve a range accuracy of six feet over 70 miles. The Sperry system, using the Doppler effect, can measure the frequency shift of vehicles traveling at 18,000 miles per hour, or as slowly as 0.2-inch per hour!

Such systems on the moon or in a satellite hold tremendous promise for guiding spacecraft and rendezvousing in space. By 1965, laser radars are expected to provide high-resolution maps of the moon and Mars, yielding new information about their surfaces that will make landing a man a fairly safe procedure. A laser ranging and telescope system will go into operation this year at Cloudcroft, N. M., to track satellites such as the new Discoverer series; in that area of the country, the weather is generally clear and lasers can be beamed into space from the ground.

Even the heavy-wheel gyroscope may be on its way out as a result of laser technology. Sperry Gyroscope—the organization which invented the gyro—has come up with a closed-circuit ring of lasers which can be used as an automatic device for guiding ships, planes, missiles and space vehicles.

New Laser Types. One of the most important developments in the rapidly changing field of laser technology came late last year when three organizations, I.B.M., General Electric, and M.I.T., announced almost simultaneously the development of a semiconductor laser.

The advantages of this type of laser—a gallium arsenide (GaAs) diode—are impressive when compared to crystal and

gas lasers. Semiconductor lasers approach efficiencies of 100 percent as compared to a few percent for other types; they are excited directly by electric current while other lasers require bulky optical pumping apparatus; because they are excited by an electric current, they can be easily modulated by simply varying the excitation current.

Gallium arsenide diodes (research models are already available as relatively low-cost, off-the-shelf items) consist of a layer of *p*-type gallium arsenide and a layer of *n*-type gallium arsenide. When electrons in an intense electric current, about 20,000 amperes per square centimeter, are applied to the device, it emits coherent or incoherent light, depending upon the diode type, from the junction between the two layers of gallium arsenide.

Current research is concerned with improving the efficiency of semiconductor lasers, modulating them, and, in a new twist, using them as "pumps" to improve greatly the efficiency of other types of lasers.

Developed in a number of forms are lasers which use rare earth *chelates*—molecules which completely enclose each atom of a rare earth element such as europium. Chelates, combined with plastic, a liquid or other medium, can be pumped to produce laser action.

One of the most important new laser techniques is a method for generating light of different frequencies or colors from a single laser beam. By beaming coherent light through a liquid such as nitrogen, light of other frequencies is obtained. Laser frequencies can also be altered by heterodyning two beams by mixing them within a crystal. These developments make it possible to convert intense laser beams to any frequency; green, blue, or from far infrared to near ultraviolet regions.

Also within the year we have seen lasers operating at room temperatures rather than having to be immersed in expensive cryogenic environments to keep them cool. Lasers pumped by the sun, by cathode-ray fluorescence, and by exploding wires, as well as by directly applied electric current, have come into being in the past twelve months. Raytheon and M.I.T. have bounced a laser beam off the moon. Whereas early last

year you had to build your own laser if you wanted one—an expensive and delicate process even for the most advanced electronics engineer—you can now buy a wide variety of laser types.

The Modulation Problem. While predictions on the future usefulness of laser beams in communications are highly optimistic, much work remains to be done on developing practical methods of modulation. Communications—including television signals—have already been transmitted by laser in laboratory setups, but thus far, only a small fraction of the fantastically large available bandwidth in a laser beam has been utilized.

The various approaches to modulation can be divided into two groups: internal modulation applied while the coherent light is being generated, and external modulation applied to the light beam after it leaves the laser. As we noted earlier, the gallium arsenide laser is relatively easy to modulate using an internal technique. The excitation current can be simply varied to produce modulation.

Another method of internal modulation, used with other types of lasers, involves changing the *Q* of the laser cavity with an electro-optical shutter between the laser material and a reflecting end plate of the cavity. This introduces a variable loss which causes large changes in the level of operating power akin to amplitude modulation.

A third approach is Stark-effect modulation, achieved by sending a strong transverse electric field into the laser material. This field causes line-splitting and frequency modulation of the output. A similar technique, using a magnetic field, has also been used. It is called Zeeman-effect modulation.

External modulation of the laser output can be accomplished using the Pockels effect, in which the beam is passed through a piezoelectric crystal which can be “strained” by an electrical field. Other external modulation approaches include the Kerr effect (plane-polarization), varying the pumping power, and mechanical means, such as the use of shutters, gratings, lenses, reflectors and ultrasonics.

For demodulation, the radiation must be converted to electrical energy in most cases. New phototubes, photomultiplier detectors, and photodiodes have been

developed for this purpose within the last six months. With coherent radiation, the same techniques will work with light beams that will work with microwaves, so it boils down to a difference in detail, not principle. Superheterodyne techniques can be used to convert the light into lower frequency signals, such as microwaves; microwave detection equipment can then be employed. “Heterodyning” is accomplished by “beating” one laser beam with another. The result is a frequency equal to the difference between the two falling in the microwave region.

Lasers, Present and Future. As indicated earlier, it isn't only the communications people who are taking a close look at the laser. At Columbia-Presbyterian Medical Center in New York, ophthalmologists already have used a ruby laser beam to coagulate a human eye retina to prevent it from becoming detached. Such an operation can be completed in less than 0.001 second, eliminating the possibility of damage due to eye motion during the exposure.

The machining and welding potential of the laser has already been demonstrated in certain applications. At G.E., the surfaces of industrial diamonds have been vaporized the instant the high-energy light beam strikes them. Production lines are now being set up to use the laser beam in cutting “components” to size for use in microcircuits, and to weld leads to semiconductors.



“It has a built-in memory.”

The laser also holds the potential of becoming the ultimate anti-missile weapon. One proposal is to use high-power beams of several lasers focused on the enemy missile with sufficient energy to vaporize it. This would be a "clean" weapon compared to anti-missile rockets with nuclear warheads and their attendant radioactive fall-out.

A new laser scheme which theoretically could generate a billion joules or more is under development now. It involves the separation and sorting of hydrogen spins, the physics of which are too complex to go into in this article. Such a powerful laser could transmit its beam through the atmosphere and earth cloud cover and still deliver enough power at the impact point to vaporize a missile.

Power requirements could be sharply reduced, however, by orbiting an anti-missile laser above the atmosphere. Laser light could also be used as a spotlight from space for photography at long distances.

The laser is less than three years old,

yet we have already come a long way. The experts say that this is one field in which we are well ahead of the Russians. To understand the laser is to understand an important facet of the future of communications, medicine, machining for industry, and the practical equivalent of the legendary death ray.

Whatever use the laser is put to, its impact on mankind will be great—comparable, perhaps, to the discovery of atomic energy. When and how will the impact be felt? Only time will tell. —30—

The Signal Stethoscope

(Continued from page 61)

pieces of plastic tape can be used to hold it in place. After you mount the battery holders for *B1* inside the case, you're ready to start wiring.

Keep all leads reasonably short. Remember to hook up the loopstick, and to observe the proper battery polarity when connecting *B1*. You may find it necessary to align the KB-138 tuner when the wiring is completed. The instructions that come with this unit tell you how to do so, both with and without instruments. If you should notice any feedback or motorboating after the tuner has been aligned, experiment with the dress of the interconnecting wires to clear it up.

If you live in a metropolitan area, you may find that the output of the tuner on local stations overdrives the input of the amplifier. If this is a problem, add a 47,000-ohm, 1/2-watt resistor in series between the tip connection of *J2*, and the "hot" ungrounded end of potentiometer *R1*.

Probes for the Stethoscope. As indicated in the schematic, the signal-tracer probe is built into a large ball-point pen housing. Holes are drilled in the end and side of the case for the connecting leads, and the ball-point pen tip is retained for use as a probe tip. Cut off all but about 1/2" of the ink cartridge, clean out the remaining ink, and solder *C1* to the inside of the tip. Both *C1* and *C2* should be coaxial lead ceramic or small mica capacitors so that they will fit

COMING NEXT MONTH

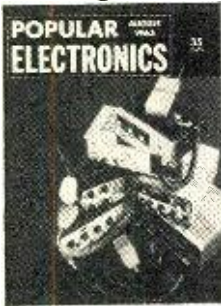

What is the state of the art when it comes to CB gear? Time has rolled around to take another look at transceivers, antennas, mikes, test equipment, and miscellaneous accessories. Our Third Annual CB Buyer's Guide will contain complete specifications of all equipment currently marketed for the CB'er.

- **THE TUBE FAMILY TREE, PART III**
In the final installment of this series, we take up the history of the vacuum tube where we left it in the June issue. The discussion centers around the unusual special purpose tubes used in research, radar, and industrial applications.
- August will be a **BIG ISSUE** month for **POPULAR ELECTRONICS**. Presently scheduled are a variety of construction projects and features of interest to hams, SWL's, and experimenters, plus all regular departments.

Get Your First Class Commercial F.C.C. License In a Hurry — Or at Your Own Pace!

Is the Course Proven?

A high percentage of Grantham *resident* students get their 1st class FCC licenses in the short period of 12 or even 8 weeks from the time they start the course. Many others choose *home study*, completing the course and getting their licenses at their own convenience.

Is the Course Complete?

Not only does the Grantham course cover all required subject matter completely; it grows and changes and expands in phase with change and expansion in the electronics field generally. With the Grantham course, you are assured of modern, up-to-the-minute instruction.

Is the Course "Padded"?

The streamlined Grantham course is designed specifically to prepare you to pass FCC examinations and examinations given by electronics firms. What you need to know to achieve these goals, you are taught completely and in detail. The course is not "padded" with information you will not need.

Is It a "Coaching Service"?

The weakness of the "coaching service" or "Q & A" method employed by some schools and individuals is that it presumes the student already has a knowledge of basic electronics.

The Grantham course is presented from the viewpoint that you have no prior knowledge of the subject; nothing is taken for granted where your training is concerned. We "begin at the beginning" and progress in a logical, step-by-step manner from one point to another, with the necessary math taught as an integral part of the course. Every subject is covered simply and in detail; the emphasis is on making the subject easy to understand.

With each lesson you receive an FCC-type test so that you can discover after each lesson just which points you do not understand and clear them up as you go along. In addition to the lesson tests, ten comprehensive Review Exams are given throughout the course.

For further details concerning F. C. C. licenses and our training, send for our FREE booklet

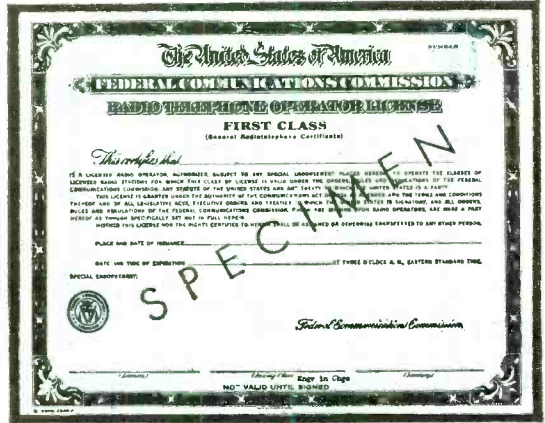

Is the School Accredited?

Grantham School of Electronics is accredited by the Accrediting Commission of the National Home Study Council.

Is It a "Memory Course"?

Grantham School has never endorsed the "memory" or "learn by rote" approach to preparing for FCC license exams. This approach may have worked in the early days of broadcasting, to the extent that a man could get his license that way; but, Heaven help the employer who expected this man to be able to demonstrate abilities implied by possession of the license!

Fortunately for all concerned, it is no longer possible for a man to pass FCC exams by spilling out memorized information which is essentially meaningless to him. Advances in the field of electronics—and the desire of the FCC to have the license really mean something — have caused upgrading of the exams to the point where only the man who is able to *understand* and *reason* electronics can acquire the 1st class FCC license.

Learn to thoroughly understand basic electronics from the school whose graduates are successfully employed by virtually every major electronics firm in the United States. Why not join them through Grantham training?



GRANTHAM



SCHOOL OF ELECTRONICS

Train through home study or at one of our four convenient resident locations shown below:

1505 N. Western Ave.
Los Angeles 27, Calif.
(Phone: HO 7-7727)

408 Marion Street
Seattle 4, Wash.
(Phone: MA 2-7227)

3123 Gillham Road
Kansas City 9, Mo.
(Phone: JE 1-6320)

821 - 19th Street, N. W.
Washington 6, D. C.
(Phone: ST 3-3614)

(Mail in envelope or paste on postal card)

TO: GRANTHAM SCHOOL OF ELECTRONICS
NATIONAL HEADQUARTERS OFFICE
1505 N. Western Ave., Hollywood 27, Calif.

Gentlemen:

Please send me your free booklet telling how I can get my commercial F.C.C. license quickly. I understand there is no obligation

Name _____ Age _____

Address _____

City _____ State _____

I am interested in:

Home Study, Resident Classes 33-K

inside the case. Wire in the diode and other components. Use care (and a heat sink!) while soldering to avoid heat damage.

The hum probe is built into a plastic pill vial: you can get one the right size at your local drugstore. Coil *L1* is one winding of a discarded i.f. transformer. Remove the winding (it's a good idea to check for continuity) and cut down its ferrite core so that only about 1/4" extends out at each end. Install it and a miniature panel connector in the pill vial as shown in the schematic on page 61.

One other type of "probe" will come in handy for signal-injecting work and a variety of other applications. Nothing but a set of clip leads wired to a miniature phone plug, it is a convenient device for tapping off outputs from *J1* and *J2*, or feeding an input into *J3*.

The use of the signal-tracing probe is fairly obvious, but a few words might be said about the hum probe. To check it, plug it into *J2* and turn the volume control up full. When placed in the vicinity of an operating soldering iron, you should hear a loud hum with the probe 2' away. You can use the hum probe to trace concealed a.c. wiring as long as the wiring is carrying current (the more the better). Just move the probe along the wall and listen for hum. A similar technique can be used (at a lower gain setting) with electronic equipment such as hi-fi amplifiers.

A final word of advice: When tracing signals, keep the tuner section turned off. Otherwise, the tuner's oscillator may interfere. -30-

Double Duty EICO

(Continued from page 51)

then repeak *C10*.

The only step remaining is to tune the rig into your antenna using a field strength meter. Simply adjust *C9* and *C10* as before for maximum output. The two antenna trimmers must be adjusted whenever the 772 is switched between 10 and 11 meters in order to load the antenna properly. This is no great problem, however, since the trimmers are accessible through holes in the side of the cabinet.

How Does It Work? Conversion of the EICO 772 proved highly successful. On 10 meters, good signal reports were received over a surprisingly wide area considering the low power and the fact that the unit was being operated within the confines of New York City. While many people attempt to "hop up" the power of CB transceivers from 5 to 7 or 10 watts for ham use, the legal CB maximum proved to be perfectly adequate for the author's purposes.

Other advantages in converting this CB rig to ham use are the effective noise limiter and the high audio level—many times the guy on the other end will report no S-meter reading, but will still be able to copy perfectly.

As for CB operation, it is the same as before—good. But now 10 crystal receive channels make the rig more convenient to use than ever. -30-

ALL TAPE HEADS WEAR OUT! HERE'S HOW AND WHY!

Magnetic tape itself is the real cause of head wear—its abrasive action as it passes over the head face gradually wears away the *depth of metal* (see at right). Wear is nearly always uneven with craters or ripples forming on the face making it impossible to achieve good contact between the head gap and signal recorded on the tape! Severe high frequency losses and erratic output result from such poor tape-to-gap contact—the outstanding fidelity of tape reproduction is lost!

Head wear should *not* be permitted to reach this point—much less go beyond it to the limit where the gap actually begins to open up.

Examine your heads for wear or have your Hi Fi dealer, Radio/TV serviceman or camera store check them. Insist on Nortronics replacement heads and "Quik-Kit" mounting hardware; both correctly matched to your recorder.

Write for **FREE NORTRONICS Tape Head Replacement Guide**



*"Music sounds best on tape—
Tape sounds best with Nortronics heads!"*

Nortronics 
8135 10th Ave., N. • Minneapolis 27, Minn.

Transistor Topics

(Continued from page 58)

L1. Base bias is supplied through R1. Audio modulation is injected into the emitter circuit by a carbon microphone (Mic) shunted by r.f. capacitor, C3.

Our experience indicates that most of the problems encountered with this type of circuit can be resolved into two general troubles: (a) improper feedback and (b) incorrect base bias. Unfortunately, either (or both) of these conditions may be present *even* when the project is assembled from a tested circuit

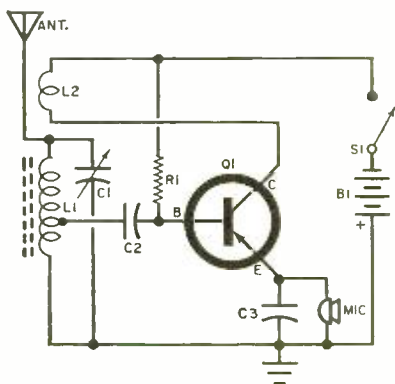

Fig. 4. Typical wireless microphone. Parts values are not given as they differ with frequency.

published in a magazine article or book, for specified component values are based on average transistor characteristics. If the individual builder happens to use a high (or low) gain transistor, some readjustment of either feedback or bias may be necessary for best performance.

If feedback is of incorrect polarity, the circuit will not oscillate. In practice, this can be corrected by reversing the connections to the feedback coil (L2, Fig. 4).

If too little feedback is used, the circuit will oscillate weakly . . . little output may be obtained, and oscillation may stop when modulation is applied. A similar condition may be caused by a low-gain transistor. This condition can be corrected by adding turns to the feedback coil (L2) or by increasing the coupling to the tuning coil.

If too much feedback is used, the output signal will be distorted and rich in



it can't happen to me!

What makes you think so? Cancer can strike anyone. Estimates are that cancer will "happen" to more than half a million Americans this year.

You can't just push cancer away. But you can do something to protect yourself against it. Many cancers are curable when detected early and treated promptly. So be sure to have a health checkup regularly—at least once a year. Also, be alert to Cancer's 7 Danger Signals. If you don't know what they are, contact your local American Cancer Society office. Do it today!

AMERICAN CANCER SOCIETY

This space contributed by the publisher

NEW MERRELL KITS

40 WATT STEREO AMPLIFIER W/PRE-AMPS



WILLIAMSON TYPE
20-20,000 CPS
MAGNETIC INPUTS
\$49.95
SA-40
5% higher
W. of Rockies

MANY MERRELL KITS FROM \$19.95 FREE Write for Brochure
MERRELL KITS, 519-E Hendrix St., Brooklyn 7, N. Y.

OPERATE A FIX-IT SHOP

Earn Big Money. Repair household appliances, rewind motors, sharpen mowers, saws, do house wiring, etc. Every neighbor, stranger a prospect. We show you how to make repairs, secure business, what to charge, buy needed parts wholesale, etc. FREE BOOK.

CHRISTY TRADES SCHOOL
3214 W. Lawrence Chicago 25

MOVING?

ATTACH LABEL HERE

If you've recently changed your address or plan to in the near future, be sure to notify us at once. Place magazine address label here and print your new address below.

NEW ADDRESS:

Name _____

PLEASE PRINT

Address _____

City _____ Zone _____ State _____

PLEASE FILL IN MOVING DATE BELOW:

If you have any other questions about your subscription be sure to include your magazine address label when writing us.

Mail to: POPULAR ELECTRONICS,
434 So. Wabash Ave., Chicago 5, Ill.

EARN Electronics Engineering DEGREE

You can earn an A.S.E.E. degree at home. College level HOME STUDY courses taught so you can understand them. Continue your education, earn more in the highly paid electronics industry. Missiles, computers, transistors, automation, complete electronics. Over 27,000 graduates now employed. Resident school available at our Chicago campus—Founded 1934. Send for free catalog.

AMERICAN INSTITUTE OF ENGINEERING & TECHNOLOGY
1137 West Fullerton Parkway, Chicago 14, Ill.

ASSEMBLE THIS ALL BAND BATTERY SHORT WAVE RADIO FOR \$9.95!



LISTEN AROUND THE WORLD—UP TO 12,000 MILES AWAY! Ships, Aircraft, Voice of America, Russia, London, Australia, Amateur, Citizens, Police—Also USA Broadcast. 5 WAVE BANDS, 5 to 40 MC. Calibrated tuning dial. Wt. only 3 lbs. WONDERFUL FOR EVERYONE—NOW HEAR THE WHOLE WORLD TALKING DAY OR NIGHT! SEND ONLY \$2.00 (cash, e.k. mo.) and pay postman \$7.95 COD postage or send \$9.95 for P.P. delivery. Complete Basic Kit includes all parts and instructions. Order Yours Now. Available only from Western Radio, Dept. BEL-7, Kearney, Nebr.

ELECTRONICS

Train in the new shop-labs of the world famous
COYNE ELECTRICAL SCHOOL on a quarter of a million dollars worth of equipment. Est. 1899—Non-Profit Institute. Courses: Electronics • Electricity • TV-Radio.

Use this coupon to get our free book
"YOUR OPPORTUNITIES IN ELECTRONICS"

COYNE ELECTRICAL SCHOOL Educ. Serv. Dept. B3-M
1501 W. Congress Parkway, Chicago 7, Ill.

NAME _____

ADDRESS _____

CITY _____ STATE _____

Unlike most other schools, we do not employ salesmen.

harmonics. Under some conditions, blocking and "self-modulation" may occur, which may result in a squeal or tone signal superimposed on the voice modulation. Similar complaints may be caused by a high-gain transistor. Proper correction procedure is to reduce the turns on the feedback coil (L_2) or to reduce the coupling to the tuning coil.

If too low a base bias is used, the circuit may still oscillate, but will deliver a distorted signal. In addition, operation may be sporadic. Some of the complaints encountered may approximate those caused by excessive feedback. The remedy is to increase the base bias by reducing the size of the base resistor (R_1 , Fig. 4).

If too high a base bias is used, the transistor will operate near saturation. Again, distortion can occur and the output signal may contain spurious harmonics. Excessive power consumption will result. Under some conditions, the transistor may overheat and be damaged. The condition may be corrected by reducing the bias current . . . that is, increasing the size of the base resistor (R_1).

Optimum base bias for oscillation may not permit adequate modulation. Here, the circuit will emit a strong r.f. signal, but the modulation percentage will be low, even when a sensitive microphone is used. This condition results when the transistor is biased for linear class A operation—nonlinear operation is essential for adequate modulation. Again, the solution is to readjust the base bias current, generally to a lower value (by increasing the value of R_1).

A useful technique for determining the optimum bias value is to install a potentiometer in place of R_1 . This control is then adjusted (gradually) until best performance is obtained. Finally, the control is replaced with a fixed resistor of approximately the same value. Typical bias resistor values will range from 50,000 to 500,000 ohms, depending on battery voltage, transistor characteristics, amount of feedback used, and similar factors.

July is a good month to dream of the day when you'll be able to buy (or build) an all-electronic air conditioner. Until next month, then . . . keep cool!

—Lou



NOW...GET THE FINEST STEREO TEST RECORD

ever produced

for just...\$4.98

Featuring Tests Never Before Available
To The Hobbyist

Why We Make the Model 211 Available Now

Although there are many stereo test records on the market today, most critical checks on existing test records have to be made with expensive test equipment.

Realizing this, HiFi/STEREO REVIEW decided to produce a record that allows you to check your stereo rig, accurately and completely, just by listening! A record that would be precise enough for technicians to use in the laboratory—and versatile enough for you to use in your home.

The result: the HiFi/STEREO REVIEW Model 211 Stereo Test Record!

Stereo Checks That Can Be Made With the Model 211

- ✓ Frequency response — a direct check of eighteen sections of the frequency spectrum, from 20 to 20,000 cps.
- ✓ Pickup tracking — the most sensitive tests ever available to the amateur for checking cartridge, stylus, and tone arm.
- ✓ Hum and rumble — foolproof tests that help you evaluate the actual audible levels of rumble and hum in your system.
- ✓ Flutter—a test to check whether your turntable's flutter is low, moderate, or high.
- ✓ Channel balance — two white-noise signals that allow you to match your system's stereo channels for level and tonal characteristics.
- ✓ Separation—an ingenious means of checking the stereo separation at seven different parts of the musical spectrum—from mid-bass to high treble.

ALSO: ✓ Stereo Spread
Speaker Phasing
Channel Identification

PLUS SUPER FIDELITY MUSIC!

The non-test side of this record consists of music recorded directly on the master disc, without going through the usual tape process. It's a superb demonstration of flawless recording technique. A demonstration that will amaze and entertain you and your friends.

UNIQUE FEATURES OF HiFi/STEREO REVIEW'S MODEL 211 STEREO TEST RECORD

- Warble tones to minimize the distorting effects of room acoustics when making frequency-response checks.
- White-noise signals to allow the stereo channels to be matched in level and in tonal characteristics.
- Four specially designed tests to check distortion in stereo cartridges.
- Open-air recording of moving snare drums to minimize reverberation when checking stereo spread.

All Tests Can Be Made By Ear

HiFi/STEREO REVIEW's Model 211 Stereo Test Record will give you immediate answers to all of the questions you have about your stereo system. It's the most complete test record of its kind—contains the widest range of check-points ever included on one test disc! And you need no expensive test equipment. All checks can be made by ear! *Note to professionals: The Model 211 can be used as a highly efficient design and measurement tool. Recorded levels, frequencies, etc. have been controlled to very close tolerances — affording accurate numerical evaluation when used with test instruments.*

DON'T MISS OUT—SUPPLY LIMITED

The Model 211 Stereo Test Record is a disc that has set the new standard for stereo test recording. Due to the overwhelming demand for this record, only a limited number are still available thru this magazine. They will be sold by POPULAR ELECTRONICS on a first come, first serve basis. At the low price of \$4.98, this is a value you won't want to miss. Make sure you fill in and mail the coupon together with your check (\$4.98 per record) today.

FILL IN AND MAIL TODAY!

Stereo Test Record
Popular Electronics—Dept. SD
One Park Ave., New York 16, N.Y.

Please send me _____ test records at \$4.98 each. My check (or money order) for \$_____ is enclosed. I understand that you will pay the postage and that each record is fully guaranteed.

Name _____
(Please Print)

Address _____

City _____ Zone _____ State _____

SORRY—No charges or C.O.D. orders!

PE 73

Short-Wave Report

(Continued from page 69)

section. The VOA installations are located west, northeast, and southeast of the city, in a triangular pattern. The receiving site is the area to the west of the city. All of the sites have modern buildings made of cement and glass.

Notably visible outside of the buildings at the western site are the receiving antennas and the microwave tower to which programs are relayed from the main studios in Washington, D. C. Inside are the impressive master control room, the receiver room, and the teletype area. In addition, the receiving site is completely equipped with a bunkroom, food storage space, kitchen, and offices.

The transmitter sites have identical, although larger, buildings. On the cleared, level ground stand the orange and white "curtain antennas" some 400 feet high. Each of the transmitter buildings houses eleven transmitters, three in each of the larger power categories, and two 5000-watt units. They flank the master controls which are on an open dais.

The transmitters, receivers, and related devices were installed at Greenville by LTV's Continental Electronics Systems, Inc., and the construction was done by the Alpha Corp. of Texas, Inc. Work on the \$23-million project originally began in November, 1960.

Current Station Reports

The following is a resume of current reports. At time of compilation all reports are as accurate as possible, but stations may change frequency and/or schedule with little or no advance notice. All times shown are Eastern Standard and the 24-hour system is used. Reports should be sent to P.O. Box 254, Haddonfield, N.J., in time to reach your Short-Wave Editor by the eighth of each month; be sure to include your WPE Monitor Registration and the make and model number of your receiver. We regret that we are unable to use all of the reports received each month, due to space limitations, but we are grateful to everyone who contributes to this column.

Belgium—Brussels has discontinued the Eng. language program to the African continent. A short Eng. section will be included as the last part of the "Horizon" program which is broadcast on 21,510 and 9720 kc. at 1505-1600 with Eng. on Mondays and Thurs-

days only; the remainder of the broadcast is in Dutch and French.

Brazil—*Radiodifusora do Amazonas*, Manaus, 17,795 kc., listed as inactive, was tuned recently from 1510 with pop records. Further monitoring requested.

China—Peking is noted on 6270 kc. from 1653 to 1657 s/off with Oriental music and language; on 12,055 kc. with news at 1203 and s/off at 1256; on 15,040 kc. with s/on at 1930 in native language, talks and music. An ID for *R. Tirana* is given just prior to the 1957 s/off. This xmsn. supposedly from Tirana (Albania), is widely believed to be aired over Peking's xmters. English to N.A. is given on 9480 kc. from 2000 to 2055 s/off.

Colombia—*Ecos de Pasto*, Pasto, formerly a medium-wave station only, is now on 865 kc. where it was tuned from 2230 to 0007 s/off mostly with records and talks and a few commercials. An Eng. message is given just after s/on and before s/off requesting air-mailed reports.

Horizonte! Emissora Colombiana, Bogota, presumably a new station, was noted only once on 5610 kc. from 2045 to 2200 s/off with eastern European and international pop tunes. The IS was a horse race bugle call. All Spanish. Reports requested.

Cuba—Havana's most recent schedule reads: 0600-1330 on 15,135 kc.; 0600-0730 and 1700-2200 on 6135 kc.; 0750-1030 on 17,855 kc.; 1050-1330, 1700-1800, 1900-2100, and 2130-0100 on 15,340 kc.; 1700-0100 on 9765 kc.; and 2200-0100 on 6060 kc. Bear in mind that this schedule is subject to frequent changes. Late reports also indicate reception on 11,865 kc. to Europe around 1540 in Eng., and on 6110 kc. in Spanish around 0215.

Egypt—Cairo has been monitored on 9475 kc. at 1645 daily with Eng. news; on 9795 kc. from 2134 to 2145 s/off with music; on 11,720 kc. at 1100-1230 with Arabic music—Italian followed, with a newscast at 1400; on 17,690 kc. at 1300 with *Voice of Africa* program (may run dual to or operate only on 17,875 kc.); and on 17,910 kc. at 0813-0912 with native music and an Eng. newscast at 0845.

Finland—The latest schedule for *R. Finland*, Helsinki, reads as follows: to Europe on 15,190, 11,805, and 9555 kc. at 1100-1130 on Mondays and Fridays, and a repeat on 6120 kc. at 1600-1630 on Fridays only; to N.A. on 15,190, 11,805, and 9555 on Tuesdays and Saturdays at 0630-0700. A DX program is given on the first and third Saturday of the month.

Formosa—Taipei has Eng. xmsns daily at 2150-2250 on 6095, 7130, 11,860, 15,345, 17,785, and 17,890 kc.; at 0510-0555 on 6095, 7130, 9720, and 11,860 kc.; and at 1000-1115 on 6095, 7130, 9685, and 11,825 kc. The "Dragon Show" is aired at 0730-0800 (to 0825 on Sundays) on 6095, 7130, 9720, and 11,860 kc. The ID is *The Voice of Free China*. Reports are welcomed and should be sent to 53, Sec. III, Jen Ai Road, Taipei, Taiwan.

France—The only Eng. listing in the newest schedule from Paris is at 0800-0815 to the Far East on 15,245, 17,765, and 21,620 kc., although the French lesson at 0245 to England on 7160 kc. may be partially in English.

Gabon—*Radiodiffusion Nationale Gabonaise*, Libreville, operates—according to their

WHY BUY A TRANSISTOR AMPLIFIER?

IT MAKES MUSIC SOUND BETTER!

Shimmering cymbals, thundering tympani, blaring trumpets, abrupt, bursting piano . . . each with its characteristic sound, unmodified . . . this is the sound of realism . . . the quick, natural sound of transistor amplifiers. "Transient Response" . . . the ability of an amplifier to provide instantaneous bursts of power as the music demands . . . an ability so superior in transistor equipment that it has already created the term, "transistor sound". To this greater realism, add Longer Life, Lower Power Consumption, Cooler, Faster Operation . . . these are the reasons why you should move up to a Transistor Amplifier!

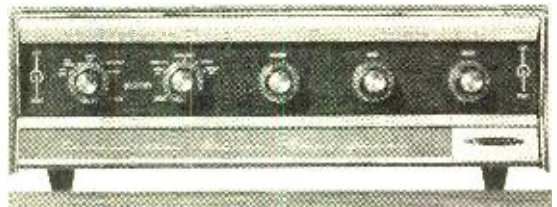

WHY BUY A HEATHKIT TRANSISTOR STEREO AMPLIFIER? • IT IS BETTER!

The first of the high power transistor stereo amplifiers to live up to its specifications! A full 70 watts continuous power, 100 watts music power, plus or minus one db at all frequencies from 13 to 25,000 cycles! No faltering, no compromising, just the most satisfying, solid stereo sound you've ever heard. You choose the latest in electronic circuitry with the Heathkit AA-21 . . . 28 transistors, 10 diodes, and complete controls. Easy to build, too, with circuit boards and encapsulated component modules. Order it now; kit or assembled, it's better!

Kit AA-21, 28 lbs., \$13 mo. **\$139.95**
Assembled AAW-21, \$16 mo. **\$167.95**



FREE HEATHKIT CATALOG
100 pages of the world's most famous do-it-yourself electronic kits . . . over 250 in all . . . for stereo/hi-fi, marine, amateur radio, test and lab., automotive, electronic organ, television, home and hobby . . . easy to build equipment which requires no special skills and saves you up to 50%.

HEATH COMPANY, Benton Harbor 10, Michigan

- Enclosed is \$_____ plus postage, please send Heathkit Model_____ Transistor Amplifier.
 Please send FREE Heathkit Catalog.

NAME _____

ADDRESS _____

CITY _____

ZONE _____

STATE _____

Prices and specifications subject to change without notice. Dealer and export prices slightly higher.

schedule—weekdays at 0000-0130, 0500-0800, and 1200-1600 (to 1800 on Saturdays) and on Sundays at 0200-1600 on 4777 kc. mornings and evenings (local time) and 7270 kc. afternoons (local time).

Germany (West)—*The Voice of Germany*, Cologne, has made quite a few changes in broadcasts to the Western Hemisphere. The schedule now reads: to South America at 1710-1800 in Portuguese and to South and Central America at 1800-1850 in Spanish on 6145, 11,795, and 15,295 kc.; to Eastern N.A. at 2035-2115 in Eng. and at 2115-2155 in French on 6160 and 9640 kc.; to Western N.A. at 2355-0035 in Eng. on 6145, 9735, and 11,795 kc., plus a new xmsn at 1010-1050 in Eng. on 11,795 and 15,405 kc. The latter broadcast replaces the 1530-1610 xmsn on 9735 and 11,795 kc. Other Eng. xmsns: to Australia and the Far East at 0345-0440 on 15,375, 17,845, and 21,705 kc., and at 1610-1700 on 7205 and 9735 kc.; to Indonesia at 0745-0825 on 15,405 and 17,815 kc.; to S. Asia at 0230-0340 on 15,275, 17,845, and 21,705 kc. and at 1050-1120 on 15,295 and 17,875 kc.; to Africa at 0105-0135 and 1115-1210 on 15,275 and 17,845 kc. and at 1520-1550 on 11,785 and 15,275 kc.

Greece—*Radio Athens* has reportedly suspended all foreign-language programs without notice. It is known that the station was "weak" due to heavy QRM. A new 100-kw. short-wave xmttr has been proposed as well as increased coverage domestically with a network of 38 xmttrs.

Guinea—Conakry has been found on 6160 kc. around 0215-0245 with African rhythms and French language.

Haiti—*La Voix Evangelique*, Cap Haitien, is scheduled daily at 0600-0900 and 1200-2015 (to 2300 on Fridays, Saturdays, and Sundays) on 11,835 kc. (no call); 9770 kc. (4VEH); 6120 kc. (4VE); 2450 kc. (no call); and 1035 kc. (4VEF). Reports are welcomed.

India—Delhi has been noted at 1745 in native language on 11,740 and 11,920 kc.; from 0715 to 0730 s/off with Indian music on 11,720 kc.; at 1205 with Indian music and Hindi and Eng. announcements on 3925 kc.; and at 0900-1000 with Eng. talks, news, and music on 15,225 kc. The latter xmsn is not heard on Saturdays or Sundays.

Japan—The Far East Network, Tokyo, has been noted on 6165 kc. at 0700 with time, news, sports, and feature stories; all English.

Korea (South)—HLK52, Seoul, 6035 kc., has been noted at 0631 with talks in Korean. An ID is given at 0659.

Lebanon—New frequencies in use from Beirut are 11,785 kc. to S. Africa at 1330-1500 and 11,755 kc. to S. America at 1515-1615.

Netherlands—The "Happy Station Program" is broadcast Sundays only as follows: to Australia, New Zealand, and Pacific areas on 21,480 and 9630 kc. at 0100-0225; to Europe, Far East, and Pacific areas on 21,665, 21,480, 6020, and 5980 kc. at 0530-0700; to Africa, Middle East, and Europe on 17,775 kc., and to the Near East, S. Asia, Africa, Antarctica, and Europe on 15,425 and 620 kc. at 1100-1225; to S. America on 11,730 kc., Spain and Portugal on 7165 kc., and Central Europe on 6020 kc. at 1600-1730; and to N.A. on 9630 and 6035 kc. at 2100-2230.

Netherlands West Indies—The xmttrs for *Trans-World Radio's* Curacao outlet are to be completed by October, 1963. The medium-wave outlets are rated at 50 kw., the short-wave units at 260 kw.

Philippines—The latest schedule for the Far East B/C Co. reads: to Australia, New Zealand, and Malaya on 17,810 and 15,300 kc. at 1655-1930; to Formosa on 15,370 kc. and to Hong Kong on 7230 kc. at 1830-1930; and to Formosa and S. Asia on 15,380 kc. at 2000-2100. Other xmsns: 17,810, 15,300, 11,920, and 9730 kc. at 2100-2200 (Sundays to 0900, and 11,850 kc. from 0030 on Sundays); 17,810,

SHORT-WAVE CONTRIBUTORS

Edward Manfredi (WPEIDNA), Providence, R. I.
 John Maher, Jr. (WPE1DUN), Darien, Conn.
 David Siddall (WPE1EBN), Hyannis, Mass.
 Thomas Walsh (WPE1EGZ), Quincy, Mass.
 Paul Brenner (WPE1EMD), Chestnut Hill, Mass.
 Michael Bugaj (WPE1EZZB), Middletown, Conn.
 Bernard Langley (WPE1FV), Auburn, Mass.
 Irwin Belofsky (WPE2BYZ), Brooklyn, N. Y.
 Amedeo Calviello (WPE2FAE), Brooklyn, N. Y.
 Harley Rutstein (WPE2HKK), Englewood, N. J.
 Michael Flomp (WPE2LXH), Valley Stream, N. Y.
 Ronald Steinberg (WPE2JGR), Brooklyn, N. Y.
 Michael Hromoko (WPE2JLG), Newark, N. J.
 William Dickerman (WPE3BEB), Williamsport, Pa.
 Chuck Pearce (WPE3DSC), King of Prussia, Pa.
 Norman Willner (WPE3DUJ), Bethesda, Md.
 Frank Sippel (WPE3EGJ), Sharon Hill, Pa.
 Harry Mayhew (WPE3EVI), Harrisburg, Pa.
 George Cox (WPE3NF), New Castle, Del.
 W. G. Bussard (WPE3PU), Baltimore, Md.
 Grady Ferguson (WPE4BC), Charlotte, N. C.
 Chuck Edwards (WPE4BNK), Fort Lauderdale, Fla.
 John Brunst (WPE4BQ), Neptune Beach, Fla.
 William Pate, Jr. (WPE4CIR), Lawrenceville, Ga.
 Kenneth Alyta, Jr. (WPE4FXB), Charlotte, N. C.
 David Brodsky (WPE4GNZ), Arlington, Va.
 William Bing (WPE5AG), New Orleans, La.
 Jack Keene (WPE5BMP), Houston, Texas
 Eddie Burchfield (WPE5CLL), Gulport, Miss.
 Stewart Mac Kenzie, Jr. (WPE6AA), Huntington Beach, Calif.
 Bill Lund (WPE6CJ), Manhattan Beach, Calif.
 Gary Payne (WPE6DHU), Fresno, Calif.
 Ron Reiring (WPE6EJG), Madera, Calif.
 Edward Swift (WPE7AVQ), Corvallis, Ore.
 Tim Shaw (WPE8BUV), Bay Village, Ohio
 James Jenny (WPE8EOL), Cincinnati, Ohio
 D. N. Williamson (WPE8EVI), Dayton, Ohio
 William Montague (WPE8FUG), Dayton, Ohio
 Dan Schonberg (WPE8FVH), Shaker Heights, Ohio
 Dale Wendell (WPE8GCY), Detroit, Mich.
 Mike Kander (WPE8MS), Dayton, Ohio
 Don Allen (WPE9EIR), Covington, Ind.
 Charles Signer (WPE9FSG), Elmwood Park, Ill.
 John Beaver, Sr. (WPE9AE), Pueblo, Colo.
 Bill Holscher (WPE9ATE), Webster Groves, Mo.
 Owen Williamson (WPE9BSL), Minneapolis, Minn.
 Ron Hocking (WPE9CPE), Hastings, Nebr.
 Ernie Emmerton (WPE9OCS), Point Lookout, Mo.
 George Henley (G2PE3Y), Watford, England
 Jack Perolo (PY2PEIC), Sao Paulo, Brazil
 Claes Lindblad (SM7PE1AB), Karlskrona, Sweden
 John Yokoff (TA3PE11), Diyarbakir, Turkey
 Gregg Calkin (VE1PE3L), Saint John, N. B.
 Ron Walsh (VE3PE1BQ), Kingston, Ont.
 Gary Cooper (VE3PE1MX), St. Catharines, Ont.
 Bob Wood (VE3PE1SM), Tilbury, Ont.
 Glenn Lindsey (VE3PE1UY), Willowdale, Ont.
 Margaret Hinkson (VP4PE1B), Port of Spain, Trinidad & Tobago
Radio Australia, Melbourne, Australia
Radiodiffusion-Television Francaise, New York, N. Y.
Radio Nederland, Hilversum, Netherlands
 Bernard Brown, Derby, England
 D. W. Day, Bakersfield, Calif.
 Philip De Lillis, Brooklyn, N. Y.
 Wallace Glavich, Eureka, Calif.
 Joe Piechuta, Meriden, Conn.
 Bill Pollard, Vienna, Va.
 Mike Ryan, Redwood City, Calif.
 Miriam Stockton, 4VEH, Cap Haitien, Haiti
 Steve Wilhelm, Philadelphia, Pa.

15,300, 11,850, and 9730 kc. at 0330-0900 (15,380 kc. from 0400 to 0500, 7230 kc. from 0545 to 0830). All English.

Portugal—Lisbon is currently scheduled to N.A. at 2100-2145 (Sundays to 2130) and at 2245-2330 (Sundays from 2300) on 6025 and 6185 kc.; to S. E. Asia at 0815-0845 on 15,125 kc.; to Africa on 11,935 and 15,380 kc. and to Europe on 6025 kc. at 1315-1430. Medium-wave stations noted include: *Voice of the West* on 755 kc. at 1815-1833 (Eng. to 1830); and CSB9 on 782 kc. at 1845-1930, with all-Portuguese language and a mixture of recorded music including some U.S. tunes.

Portuguese Guinea—CQM, Bissau, has moved from 4782 kc. to 4947 kc. and was noted at 1635 with pop tunes; s/off at 1802. The 7947-kc. xmsn appears to have been discontinued.

Sierra Leone—Freetown, 5980 kc., is noted at 0159 with an ID and a short Eng. xmsn, then a London news relay. The dual 3316-kc. outlet is heard better.

Spratly Island—A previous listing for this country can be ruled off; it has proven to be a hoax perpetrated by two or more European listeners. The island itself does exist, however.

St. Pierre and Miquelon—DX'ers needing this country, especially those living in the northeast, should try for the medium-wave outlet on 1375 kc. around 0500. Virtually all of the xmsns from *R. St. Pierre* are in French.

Sweden—*R. Sweden* now operates on 7270 kc. to Eastern N.A. at 2000-2115 (Eng. from 2045) and to Western N.A. at 2130-2245 (Eng. from 2215). Spanish to Central America is given at 2300-2330. The 0900-0930 xmsn to N.A. on 17,840 kc. is unchanged.

Tunisia—*R. Tunis* has been noted on 6204 kc. (a move from 6113 kc.) at 1600 in Arabic; also at 0000. It may close around 1827. The medium-wave outlet on 629 kc. has been tuned in dual.

Uganda—*R. Kampular* has Eng. daily at 1445-1500 on 4976 kc. with news and weather.

USSR—*R. Khabarovsk* is a new outlet on 6195 kc. The ID is given three minutes before the hour and/or half hour. The station was noted around 0530 with orchestral music.

Vietnam (South)—The latest schedule from Saigon reads: Vietnamese on 11,920, 7245, 6165, and 4877 kc. at 0100-1900, and on 7265 kc. at 0100-0215, 0630-0800, and 1200-1530; Eng. on 7265 kc. at 0215-0245, 0800-0845, and 1600-1715; Thai on 7265 kc. at 0245-0315 and 1530-1600; French at 0200-0300, 0730-0800, and 1400-1730, Chinese at 0300-0415, 0800-0945, and 1200-1300, and Cambodian at 1300-1400, all on 9620 kc.

Clandestine—*R. Libertad, La Voz de Anti-Communita de America* gives the announced schedule of 0700-1100 and 1800-0100 on 4005, 5075, 6240, 7308, 7804, 9325, and 15,050 kc. Other unlisted xmsns have been tuned on 4030 kc. at 0130-0146 and on 6750 kc. at 2030.

—30—

TV-RADIO Servicemen or Beginners...

Send for Coyne's 7-Volume Job-Training Set on 7-Day FREE TRIAL!



The First
Practical
TV-RADIO-
ELECTRONICS
Shop
Library!

Answers ALL Servicing Problems QUICKLY...
Makes You Worth More On The Job!

Put money-making, time-saving TV-RADIO-ELECTRONICS know-how at your fingertips—examine Coyne's all-new 7-Volume TV-RADIO-ELECTRONICS Reference Set for 7 days at our expense! Shows you the way to easier TV-Radio repair—time saving, practical working knowledge that helps you get the BIG money. How to install, service and align ALL radio and TV sets, even color-TV, UHF, FM and transistorized equipment. New photo-instruction shows you what makes equipment "tick." No complicated math or theory—just practical facts you can put to use immediately right in the shop, or for ready reference at home. Over 3000 pages; 1200 diagrams; 10,000 facts!

SEND NO MONEY! Just mail coupon for 7-Volume TV-Radio Set on 7-Day FREE TRIAL! We'll include the FREE BOOK below. If you keep the set, pay only \$3 in 7 days and \$3 per month until \$27.25 plus postage is paid. Cash price only \$24.95. Or return set at our expense in 7 days and owe nothing. Either way, the FREE BOOK is yours to keep. Offer limited, so act NOW!

FREE DIAGRAM BOOK!

We'll send you this big book, "150 Radio-Television Picture Patterns and Diagrams Explained," ABSOLUTELY FREE just for examining Coyne's 7-Volume Shop Library on 7-Day FREE TRIAL! Shows how to cut servicing time by reading picture-patterns, plus schematic diagrams for many TV and radio sets. Yours FREE whether you keep the 7-Volume Set or not! Mail coupon TODAY!



"LEARNED MORE FROM THEM THAN FROM 5 YEARS WORK!"

"Learned more from your first two volumes than from 5 years work."
—Guy Bliss, New York
"Well set for either the serviceman or the beginner. Every service bench should have one."
—Melvin Masbruch, Iowa.

Coyne Educational Book Publishing Division
ELECTRICAL SCHOOL
1455 W. Congress Parkway, Dept. 73-PE Chicago 7, Illinois

Like Having An Electronics Expert Right At Your Side!

- VOL. 1—EVERYTHING ON TV-RADIO PRINCIPLES! 300 pages of practical explanations; hundreds of illustrations.
- VOL. 2—EVERYTHING ON TV-RADIO-FM RECEIVERS; 403 pages; fully illustrated.
- VOL. 3—EVERYTHING ON TV-RADIO CIRCUITS! 336 pages; hundreds of illustrations, circuit diagrams.
- VOL. 4—EVERYTHING ON SERVICING INSTRUMENTS! How they work, how to use them. 368 pages; illustrated.
- VOL. 5—EVERYTHING ON TV TROUBLESHOOTING! Covers all types of sets. 437 pages; illustrations, diagrams.
- VOL. 6—TV CYCLOPEDIA! Quick and concise answers to TV problems in alphabetical order, including UHF, Color TV and Transistors; 868 pages.
- VOL. 7—TRANSISTOR CIRCUIT HANDBOOK! Practical Reference covering Transistor Applications; over 200 Circuit Diagrams; 410 pages.

BOOKS HAVE BRIGHT, VINYL CLOTH WASHABLE COVERS!
FREE BOOK—FREE TRIAL COUPON!

Educational Book Publishing Division

COYNE ELECTRICAL SCHOOL
1455 W. Congress Parkway, Dept. 73-PE, Chicago 7, Ill.
Yes! Send me COYNE'S 7-Volume Applied Practical TV-RADIO-ELECTRONICS Set for 7-Days FREE TRIAL per offer. Include "Patterns & Diagrams" book FREE!

Name Age

Address

City Zone State

Check here if you want Set sent C.O.D. Coyne pays postage on C.O.D. and cash orders. 7-Day Money-Back Guarantee.

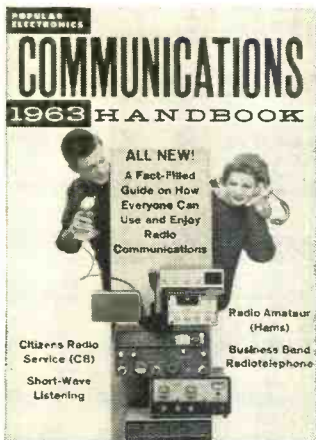

THE 1963 COMMUNICATIONS HANDBOOK

is the unique new publication that completely covers the specialized field of communications. It brings you 148 pages that cover:

- Citizens Band
- Short Wave Listening
- Ham Radio
- The Business Radio Service

The 1963 COMMUNICATIONS HANDBOOK is now on sale. Pick up a copy at your favorite newsstand or electronics parts store. Or use the handy coupon below. Just PRINT your name and address clearly and enclose \$1.00, the cost of the HANDBOOK, plus 15¢ to cover mailing and handling charges (Canada and foreign countries, \$1.25 plus 25¢ postage).

Ziff-Davis Publishing Company PE73
 Dept. CH3
 One Park Avenue, New York 16, New York

Name _____
 Address _____ (please print)
 City _____
 Zone _____ State _____

ERSIN Multicore
 5-CORE SOLDER
 WETS FASTER - MELTS FASTER
 SOLDERS BETTER!

MULTICORE SALES CORP. • PORT WASHINGTON, N. Y.

GET INTO ELECTRONICS

V.T.I. training leads to success as technicians, field engineers, specialists in communications, guided missiles, computers, radar, automation, basic & advanced courses, Electronic Engineering Technology, an ECFD accredited Technical Institute curriculum. Associate degree in 24 months. B.S. obtainable. G.I. approved. Start September, February. Dorms, campus. High school graduate or equivalent. Catalog.

VALPARAISO TECHNICAL INSTITUTE
 DEPARTMENT PE, VALPARAISO, INDIANA



Hula-Hoop Antenna

(Continued from page 30)

the tubing. By threading the screw in and out of the tubing, adjust for minimum reading on the reflected power scale of the SWR meter. Measure the exposed length of screw, remove the screw and lightly tin the inside of the copper tubing to afford a better bite for the screw threads. Replace the 2" screw with a 3" screw and adjust for the same exposed length. As you make the final adjustments, close the car doors and stand well back from the car. It will probably take several attempts to secure the minimum SWR reading.

With the antenna resonated, adjust the antenna feed point for a further reduction in SWR. Slide the transmission line connection to the antenna element back and forth between the top of the grounding stub and a point about 4" from this stub. After the minimum SWR point is found, touch up the antenna length-adjustment screw and again touch up the feed point adjustment for minimum SWR. Now replace the temporary antenna feed wire with a length of the insulated conductor removed from a piece of RG-8/U coaxial cable and solder the connections.

Wrap the PL-259 connector with plastic tape to keep water out of the coaxial fittings. Loosen the suction cups and thoroughly clean the inside of the cups and the roof of the car. Then apply a liberal coating of glycerin to the entire inner surface of the cups and fully collapse the cups in their original position. And once again touch up the antenna element length adjustment screw for minimum SWR.

Now touch up the tuning of the transmitter in accordance with the manufacturer's instructions. Little change of the tuning and loading adjustments should be required and the standing-wave ratio should not increase. Page 29 shows the on and off resonance standing-wave ratios that may be expected.

Remove the SWR meter, connect the antenna, and prepare yourself for some of the best mobile ham or CB operation you have ever experienced.

-50-

Always say you saw it in—POPULAR ELECTRONICS

Extracurricular Education

(Continued from page 65)

on the edge of the bottom of the dash. "When I drag the contact wire across these notches," he said, "the rapid make-and-break of the primary current will produce an almost continuous arc across the gap."

AFTER Dave finished his job, Jerry turned on the switch and dragged his wire across the notches. But there was no sparking to indicate the presence of current. "The points must be closed," he said. "Gig the starter a bit and see if we can't get them to open."

Carl did, and at the second try the motor stopped with the points open. Dave reported that a fat blue spark leaped across the gap when Jerry's contact wire stroked the serrated rim of the dash.

Very deliberately, over and over, Jerry brushed the wire along the dash so as to spell out in slow International Morse: "SOS SOS TRAPPED UNDER WRECKED CAR ON OLD RIVER ROAD." When he grew tired, Carl spelled him. There was no talking. The only sounds came from the night insects, the rhythmic hissing of the spark, and an occasional low moan from Phil.

They had been at this for a good hour when Dave suddenly shouted, "Hey! I see headlights coming down the road. Help! Help!"

A few seconds later they heard a car stop and the sound of someone sliding down the bank. When he spoke, they recognized the voice of the deputy sheriff:

"So it wasn't a hoax! Who's under the car? What's wrong with the leg?"

Dave quickly explained the situation, and the officer climbed back up the bank to radio for an ambulance and a wrecker.

"Listen, you guys," Dave called. "I've been lying here thinking what a stupid jerk I am, dean's list or not. My driving got us into this, and then I panicked. You kept your heads and figured a way out. It's not the brains you're supposed to have that count, it's the ones you use when you really need them. I want you to know I'm sorry."

BECOME A RADIO TECHNICIAN
For ONLY \$26.95

BUILD 20 RADIO CIRCUITS AT HOME

With the New
Progressive Radio "Edu-Kit"®
ALL Guaranteed to Work!

only
\$26.95
Reg. U.S.
Pat. Off.



A COMPLETE HOME RADIO COURSE

- BUILD**
- 12 RECEIVERS
 - 3 TRANSMITTERS
 - SIGNAL TRACER
 - SIGNAL INJECTOR
 - CODE OSCILLATOR
 - SQ. WAVE GENERATOR
 - AMPLIFIER

- No Knowledge of Radio Necessary
 - No Additional Parts or Tools Needed
 - Excellent Background for TV
- Training Electronics Technicians Since 1946

FREE Set of Tools, Pliers-Cutters, Tester, Soldering Iron, Alignment Tool, Wrench Set.

WHAT THE "EDU-KIT" OFFERS YOU

The "Edu-Kit" offers you an outstanding PRACTICAL HOME RADIO COURSE at a rock-bottom price. You will learn radio theory, construction and servicing. You will learn how to build radios, using regular schematics; how to solder and wire in a professional manner; how to service and trouble-shoot radios. You will learn how to work with punched metal chassis as well as the new Printed Circuit chassis. You will learn the principles of RF and AF amplifiers and how to use detectors, receivers, test equipment. You will learn and practice code, using the Progressive Code Oscillator. You will build 20 Receiver, Transmitter, Code Oscillator, Signal Tracer, Square Wave Generator, Amplifier and Signal Injector circuits, and learn how to operate them. You will receive an excellent background for TV. In brief, you will receive a basic education in Electronics and Radio, worth many times the small price you pay—only \$26.95 complete.

PROGRESSIVE TEACHING METHOD

The Progressive Radio "Edu-Kit" is the foremost educational radio kit in the world, and is universally accepted as the standard in the field of electronics training. The "Edu-Kit" uses the Modern educational principle of "Learn by Doing." You begin by building a simple radio. Gradually, in a progressive manner, and at your own rate, you construct more advanced multi-tube radio circuits, learn more advanced theory and techniques, and do work like a professional radio technician. These circuits operate on your regular AC or DC house current.

THE KIT FOR EVERYONE

You do not need the slightest background in radio or science. The "Edu-Kit" is used by young and old, schools and clubs, by Armed Forces Personnel and Veterans Administration for training and rehabilitation. One of the most important aspects of the "Edu-Kit" is the Consultation Service which we provide. We welcome students to send us their problems, whether related to any of the material covered in the "Edu-Kit" course, or encountered in other experiences in the field of electronics.

THE "EDU-KIT" IS COMPLETE

You will receive all parts and instructions necessary to build 20 different radio and electronic circuits, each guaranteed to operate. Our kit contains tubes, tube sockets, variable electrolytic, mica, ceramic and paper dielectric condensers, resistors, tie strips, coils, hardware, tubing, punched metal chassis, instruction Manual, switches, etc. In addition, you receive Printed Circuit materials, including Printed Circuit Chassis, special tube sockets, hardware and instructions. You also receive a useful set of tools, pliers-cutters, an alignment tool, professional electric soldering iron, wrench set, and a self-powered, dynamic Radio and Electronics Tester. The "Edu-Kit" also includes Code Instructions and the Progressive Code Oscillator. You will also receive lessons for servicing with the Progressive Signal Tracer and the Progressive Signal Injector, a High Fidelity Guide, FCC Amateur License Training Book, and a Quiz Book.

All parts, components, etc., of the "Edu-Kit" are 100% unconditionally guaranteed, brand new, carefully selected, tested and matched. Everything is yours to keep. The complete price of this practical home Radio and Electronics course is only \$26.95.

TROUBLE-SHOOTING LESSONS

You will learn to trouble-shoot and service radios, using the professional Signal Tracer, the unique Signal Injector, and the dynamic Radio and Electronics Tester. Our Consultation Service will help you with any technical problems.

J. Stasulis, of 25 Poplar Pl., Waterbury, Conn., writes: "I have repaired several sets for my friends, and made money. The 'Edu-Kit' paid for itself. I was ready to spend \$240 for a course, but I found your ad and sent for your kit."

FREE EXTRAS

- Set of Tools • Radio Book • Radio and Electronics Tester • Electric Soldering Iron • Pliers-Cutters • Alignment Tool • Tester • Instruction Book • Hi-Fi Book • Quiz Book • Membership in Radio-TV Club • Consultation Service • FCC Amateur License Training • Printed Circuitry • Certificate of Merit • Valuable Discount Card • Wrench Set

"UNCONDITIONAL MONEY-BACK GUARANTEE"

ORDER FROM AD—RECEIVE FREE BONUS RESISTOR AND CONDENSER KITS WORTH \$7.00

- "Edu-Kit" Postpaid, Enclosed full payment of \$26.95.
- "Edu-Kit" C.O.D. I will pay \$26.95 by check or money order.
- Send me FREE additional information describing "Edu-Kit."

Name

Address

PROGRESSIVE "EDU-KITS" INC.

1186 Broadway Dept. 606D Hewlett, N. Y.

POPULAR ELECTRONICS

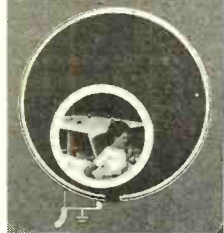

Send
POPULAR ELECTRONICS
Every
Month

NAME.....

ADDRESS.....

CITY..... ZONE..... STATE.....

3 years for \$10

Check one: 2 years for \$7

1 year for \$4

In the U. S., and possessions.

Payment Enclosed Bill Me

Foreign rates: Canada and Pan American Union countries, add .50 per year; all other foreign countries, add \$1 per year.

New Renewal

Mail to: **POPULAR ELECTRONICS**

Dept. 1-8183, 434 S. Wabash Ave., Chicago 5, Ill.

B. S. DEGREE IN 36 MONTHS

INDUSTRY AND GOVERNMENT NEED 50,000 NEW ENGINEERS EACH YEAR!

Accelerated year-round program puts you in the job-market a whole year early! Accredited. Aerospace, Chemical, Civil, Electrical, Mechanical, Electronics, Math, Chemistry, Physics. Also diploma in Engineering in 27 months. Quality instruction; widely recognized. Graduates employed from coast to coast. Self-help program. Moderate rate. Start Sept., Jan., March, June. Catalog: 1614 E. Washington Blvd., Fort Wayne 2, Indiana.



WALKIE TALKIE RADIO SENDING SET



YOUR OWN POCKET SIZE RADIO STATION
Talk to any house or car radio without wires or hookups of any kind! Built-in antenna. Self-contained flashlight batteries—Power transistor! Talk to radios nearby or hocks away and to cars or between cars up to one block or more away—depending on local conditions.
No license or permit needed! SEND ONLY \$2.00—(cash, ck, mo) and pay postman only \$7.99 plus COD postage or send \$9.99 for postpd delivery. Shipped complete ready to operate. Order yours now—Today! Available only from:
WESTERN RADIO, Dept. VEL-7, Kearney, Nebr.

engineering degree in 27 months

Enjoy better income . . . advancement. Major corporations visit us regularly to interview and employ seniors. BACHELOR OF SCIENCE IN 27 MONTHS in Electrical, Mechanical, Aeronautical, Chemical, Civil Engineering. IN 36 MONTHS in Business Administration. Small classes. More professional class hours. Well-equipped labs. Campus. Modern dorms. New library. Moderate costs. Founded 1884. Enter Sept., Jan., Mar., June. Write J. D. McCarthy for Catalog and "Your Career" book.

TRI-STATE COLLEGE 3673 College Avenue
Angola, Indiana

"Knock it off," Carl said gruffly. "No one twisted our arms to make us go on this ride. We're in it together. It took a lot of guts to wrestle around and do what you did with that broken leg. I guess we all got a lesson tonight."

The deputy came back and explained that the distress call had been picked up by a 13-year-old boy watching TV directly across the river. The boy had been studying the code to get a ham license, and he noticed that the flashing of his screen had a dot-dash rhythm to it. Laboriously he wrote out the message, getting a few more letters each time it was repeated. He called the sheriff's office, and the deputy was sent to investigate.

"That kid's going to have some grateful help in studying for his license," Jerry promised, "and I'll never gripe again about ignition interference."

The wrecker and ambulance soon arrived. The end of the car was carefully winched up until Carl and Jerry could slide Phil out and get out themselves.

Just as Phil was being loaded into the ambulance alongside Dave, he opened his eyes and grinned feebly.

"That last bump was a doozy!" he observed.

On the Citizens Band

(Continued from page 72)

parties may contact Moe at 1 St. Francis Blvd., Chateaugay P.Q., Canada.

Jack Leach, KHG1227, publicity chairman of the South-Lynd Radio Club of Lyndhurst, Ohio, forwarded us a copy of this club's first newspaper—a clean-cut, neatly organized effort which should net the group a lot of respect as an organized association. While a few clubs have jammed their pages with cartoons and uninformative chatter, possibly to create an impression of might, the South-Lynders must be commended for definitely starting out on the right "channel." Their three-page bulletin makes interesting reading front-to-back, and leaves no doubt of the clubs' aims.

The Dixie Five Watters CB Club of Alabama has announced the election of new officers; Curtis Pope, president; Eddie Blackwelder, vice president; and Benny Bangs, secretary-treasurer. Now in its second

year, this organization points to the installation of a CB unit in the City Hall as its most recent major achievement. The purpose of the installation was to create a control point for local CB units in times of emergency.

Our sincere thanks go to the hundreds of CB clubs who are mailing their newspapers and bulletins to *On the Citizens Band* each month. This is *your* column; its success depends on *your* information. Help us tell CB'ers throughout the United States and Canada what's happening in your neck of the woods. While space limitations prevents our squeezing in *everything* that's going on, we'll certainly try to get the most interesting items printed on these pages. And don't forget the pictures!

I'll CB'ing you,

Matt, 18W4689

Across the Ham Bands

(Continued from page 75)

Install a shielded wire between the plate terminal of the receiver's mixer tube (6BE6, 6SA7, etc.) and a connector on the rear of the receiver chassis or to an unused terminal on the receiver accessory socket, to accommodate the output terminal (P1) of the Q-multiplier. After the lead is installed, tune in a steady signal on the receiver, and carefully retune the primary winding of the first i.f. transformer for maximum signal strength. This must be done to compensate for the capacity added to the primary tuned circuit of the i.f. transformer by the shielded lead.

Then plug in the Q-multiplier, adjust capacitor *C1* and resistor *R1*, and adjust coil slug *L1* for maximum signal strength. Retard control *R1* as necessary during this operation to prevent the Q-multiplier from breaking into sustained oscillation (indicated by a steady squeal from the loudspeaker or by the receiver suddenly going dead). Also, the value of resistor *R3* may be increased or decreased if necessary to give resistor *R1* full control.

Operation. In operation, receiver selectivity is maximum when resistor *R1* is adjusted just below the oscillation point. Capacitor *C1* acts as a vernier tuning control, permitting the desired signal to be picked out of a mess of interference.

July, 1963

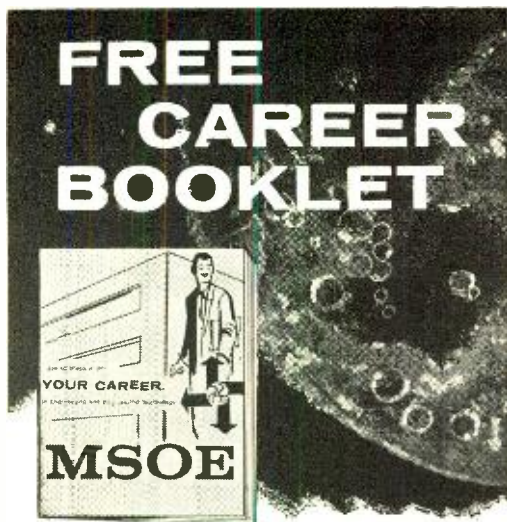

To guide you to a successful future in

ELECTRONICS RADIO-TV COMPUTERS ELECTRICAL ENGINEERING

This interesting pictorial booklet tells you how you can prepare for a dynamic career as an Electrical Engineer or Engineering Technician in many exciting, growing fields:

**MISSILES • AVIONICS • AUTOMATION
SALES • DEVELOPMENT
ELECTRICAL POWER • ROCKETRY
RADAR • RESEARCH**

Get all the facts about job opportunities, length of study, courses offered, degrees you can earn, scholarships, part-time work — as well as pictures of the Milwaukee School of Engineering's educational and recreational facilities. No obligation — it's yours free.

MILWAUKEE SCHOOL OF ENGINEERING

MAIL COUPON TODAY!

Milwaukee School of Engineering

Dept. PE-763, 1025 N. Milwaukee St., Milwaukee, Wis.

Please send FREE "Your Career" booklet

I'm interested in

Electronics Radio-TV Computers

Electrical Engineering Mechanical Engineering

Name..... Age.....

Address..... PLEASE PRINT

City..... Zone..... State.....

I'm eligible for veterans education benefits.

Discharge date..... MS-117

News and Views

Francis M. Muter, KN7URC, 116-15th Ave., S., Nampa, Idaho, must like radio. He works for broadcast station KATN and operates a 100-milliwatt AM and FM station with a range of about 50 yards—which covers an old folks home and a couple of apartment buildings; and as a radio amateur, he operates on 80, 40, and 2 meters! His ham gear includes a Globe Chief 90A transmitter, and a Hallicrafters S-43 receiver, plus a Q-multiplier for the lower frequencies; and a 30-watt FM unit covers 2 meters. . . . A few weeks ago, your Amateur Radio Editor had his first experience with amateur television. The occasion was the dedication of the \$10,000 amateur radio station, W9DVJ, and electronics clinic installed for the use of the patients at the Veterans Administration Research Hospital in Chicago. W9EGQ made



Mounted on a mobile tower truck, this parabolic dish is relaying a ham TV broadcast to Chicago from the QTH of W9EGQ, Gary, Ind. Herb participated in the dedication of W9DVJ via this TV remote pickup.

the dedication address to the guests at the hospital from his home in Gary via amateur television—an airline distance of 27 miles. Bob Gill, W9JEC, and Bill Craig, W9ZZS, engineered the TV circuits and supplied the equipment, which included two complete TV stations. Other hams helping in the project included Beverley, K9HGY, George, K9HGZ, Darryl, K9OGE, "Kap," W9QKE, and Jim, W9TKW. . . . **Sheldon Traeger**, 2128 Cedarview, Beachwood, Ohio, reports that he memorized the alphabet in 35 minutes with the aid of the code chart in our March column; he is now copying code at a speed of 5 wpm.

Bill Thompson, WA8FLM, 3075 Hyannis Drive, Cincinnati 39, Ohio, is a week-old General. As a Novice, he worked 35 states, all on 40 meters, using a slightly modified version of

the simple transmitter described in our January, 1962, column, feeding an antenna 12 feet high. Bill's first receiver was a "surplus" BC-455; his present one is a Lafayette KT-320. . . . **Bruce MacClements, KN1ZWF**, 4 Bourn Ave., Hampton, N.H., cranks his Heathkit DX-20 transmitter up to 50 watts to drive an off-center-fed antenna. He receives on a Knight-Kit Span Master. Eleven states and 45 contacts in two months compose his "brag list." Bruce would like to be nominated for the Rag Chewers' Club. . . . **Craig Blaine, WN2FVE**, 41 Sergeant St., Johnson City, N.Y., is also WPE2HUB. This fact led to his getting his ham ticket, when a local ham, to whom he had sent an SWL card, offered to help him study for his ham license. In turn, Craig and his dad, Pete, WN2GFM, now offer their help to other prospective hams. Craig and Pete share a Johnson Ranger transmitter feeding a 40-meter dipole about 20 feet high, and a Hallicrafters SX-110 receiver. Both receiver and transmitter were bought used, and Craig recommends used gear for those with expensive tastes and small pocketbooks.

Larry Meyers, WV2ZOF, 222 Frankhauser Rd., Buffalo, N.Y., looks back to his year as a Novice and finds that he made 667 contacts in 42 states, Canada, Puerto Rico, and Bahrain Island near Saudi Arabia. All this was done with an EICO 720 transmitter feeding a 40' end-fed antenna. Two receivers, a Hallicrafters S-108 and a National NC-60, sit on Larry's operating desk; he SWL's as WPE2GPC while waiting for his General Class license.

. . . **Tom Watson, WN5FAA**, 223 College St., Pittsburgh, Texas, has really been making his station earn a return on his license in the three months he has had it. Thirty-four states (32 confirmed), Mexico, and several Canadian hams appear in the pages of his logbook. For the lower frequencies, Tom's antenna is a dipole 30 feet high, his receiver is a Lafayette HE-30, and his transmitter is an EICO 720; for two meters, he has a Heathkit Twoer. . . .

Raymond Theis, WN0CVA, 1010 Elm, Burlington, Iowa, was hoping to pick up the missing three states for his Novice WAS before the Novice ticket expired. Even if he didn't quite make it, 47 states, all confirmed, Canal Zone, Mexico, Puerto Rico, and Canada is a Novice record to be proud of. A Heathkit DX-35 transmitter, Lafayette KT-200 receiver, helped along by a Q-multiplier and some audio filters, and a Hy-Gain doublet all contributed to Ray's good results. . . . In an interesting letter to your Amateur Radio Editor, **Carl C. Drumeller, W5EHC**, 5824 N. W. 58th St., Oklahoma City, Okla., objects very strongly to the practice of calling licensed radio amateurs "hams." He says the term has derogatory implications, and he can't understand why many radio amateurs are proud to be called "hams." Obviously, Carl doesn't go along with William Shakespeare's idea that a rose by any other name will smell as sweet.

Once again, we've used up all our space. As always, we invite you to send your "News and Views," station photos, ideas for construction projects, etc., to *Across the Ham Bands*. Until next month, 73,

Herb, W9EGQ

ELECTRONICS MARKET PLACE

RATE 60¢ per word. Minimum 10 words prepaid. September issue closes July 5th. Send order and remittance to Martin Lincoln, POPULAR ELECTRONICS, 1 Park Ave., New York 16, N. Y.

FOR SALE

TV Tuners—Rebuilt or Exchanged \$9.95 complete—all types—fast, guaranteed service. Send tuner with all parts to: L.A. Tuner Exchange, 6411 West Jefferson Blvd., Los Angeles 16, California.

GOVERNMENT Surplus Receivers, Transmitters, Snooper-scopes, Parabolic Reflectors, Picture Catalog 10¢. Meshna, Malden 48, Mass.

DIAGRAMS for repairing Radios \$1.25, Television \$2.50. Give make, model. Diagram Service, Box 672-PE, Hartford 1, Conn.

WPE-CB-QSL cards—Brownie-W3CJ1—3110A Lehigh, Allentown, Pa. Catalogue with samples 25¢.

CB WPE QSL Cards, Samples Free. Radio Press, Box 24, Pittstown, New Jersey.

"SPECIAL! WPE-SWL-CB-QSL cards, 3 colors, \$2.50 per 100—Free Samples, Garth, Jutland, New Jersey."

SAVE dollars on radio, TV-tubes, parts at less than manufacturer's cost. 100% guaranteed! No rebrands, pulls. Request Bargain Bulletin. United Radio, 1000-E, Newark, N. J.

EMBOSSED Business Cards, 1,000 \$4.00. Card Service, Box 2131, Tulsa, Oklahoma.

TRANSISTORIZED Products Importers catalog, \$1.00, Intercontinental, CPO, 1717, Tokyo, Japan.

INVESTIGATORS, free brochure, latest subminiature electronic listening devices. Ace Electronics, 11500-L NW 7th Ave., Miami 50, Fla.

CANADIANS—GIANT Surplus Bargain Packed Catalogs. Electronics, Hi-Fi, Shortwave, Amateur, Citizens Radio. Rush \$1.00 (Refunded). ETCO, Dept. Z., Box 741, Montreal, CANADA.

TELEPHONE Voice Switch (LS-500). Actuates automatically and unattended any tape or wire recorder. Pictorial installation instructions included. \$23.75. Post Paid US. WJS Electronics, 1525 No. Hudson, Hollywood 28, Calif.

JUNK your distributor and voltage regulator. Improve automobile mileage and performance. Construction details for transistorized distributor and voltage regulator \$4.75. No moving parts. DB Enterprises, 8959 Wonderland Ave., Hollywood 46, Calif.

TV Camera. Build for less than \$50. Construction details \$4.75. DB Enterprises, 8959 Wonderland Ave., Hollywood 46, Calif.

POLICE Radar Detector and legal jammer. Stop before those radar speed traps. Easy to build for less than \$10; used with your car radio. Complete construction details \$3.75. C. Carrier Co., 6311 Yucca St., Hollywood 28, Calif.

COLOR TV. Convert your black and white TV to color. Completely Electronic. No mechanical gadgets. Costs about \$35. Complete construction details \$4.75. DB Enterprises, 8959 Wonderland Ave., Hollywood 46, Calif.

RECORD TV Programs at home. Easy to construct. Watch your favorite TV Shows whenever you wish. Complete construction details \$4.75. DB Enterprises, 8959 Wonderland Ave., Hollywood 46, Calif.

CONVERT any television to sensitive, big-screen oscilloscope. Only minor changes required. No electronic experience necessary. Illustrated plans, \$2.00. Relco Industries, Box 10563, Houston 18, Texas.

EAVESDROP with a pack of cigarettes. Miniature transistorized FM radio transmitter. Complete diagrams and instructions \$2.00. C. Carrier Co., 5880 Hollywood Blvd., Hollywood 28, Calif.

BE a spy. Correspondence course on wire tapping, bugging, telescopic sound pickup, recording techniques, microphotography, and invisible photography. Lessons in surveillance, tailing, and use of equipment. Complete course \$22.50. C. Carrier Co., 6311 Yucca St., Hollywood 28, Calif.

CB-QSL Cards—45 Designs, Free Brochure. Woody, 2611 Shenandoah, St. Louis 4, Mo.

GOVERNMENT Sells Surplus: Electronics; Oscilloscopes; Transceivers; Test Equipment; Radar; Sonar; Walkie-Talkies; Boats; Jeeps; Aircrafts; Misc.—Send for "U.S. Depot Directory & Procedures"—\$1.00—Brody, Box 425(PE), Nanuet, New York.

INVESTIGATORS! Do your own sound work. Send \$1.00 for brochure of latest electronic equipment. WJS Electronics, 1525 No. Hudson, Hollywood 28, Calif.

TRANS-NITION electronic ignition parts kit. Negative ground \$25.00. Coil, Manual special \$8.50. Manual \$2.00. Anderson Engineering, Wrentham, Massachusetts.

TRANSISTORIZED treasure finder kits, assembled models from \$19.95. Free catalog. Relco, Box 10563, Houston 18, Texas.

MILITARY Discount—Name Brands Free Recording Tape and Stereo Handbook. Include Rank and Serial Number. Electronics International Inc. Box 3066, Charlottesville, Virginia.

FREE literature keeping you informed on the latest work-saving, money-making test equipment. Learn how Easy Budget Payment Plan lets you pay out of increased earnings. Top engineered test instruments are priced for tremendous value. Write today. Century Electronics, 352 Maple Ave., Westbury, N.Y.

TELEPHONE Extension In Your Car. Answer your home telephone by radion from your car. Complete diagrams and instructions \$2.00. C. Carrier Co., 5880 Hollywood Blvd., Hollywood 28, Calif.

SUPERSENSITIVE directional microphone picks up faint sounds at 300 feet. Detects sound through ordinary walls. Easily built for \$7.00. No electronic experience necessary. Plans, \$2.00. Dee Company, Box 7263-F, Houston 8, Texas.

CB-QSL-SWL cards. Samples 10¢. Include your personal picture on cards. No extra Cost. Signal, Adams County, Manchester, Ohio.

TRANS-Flash Transistor Ignition, Kits, Components, Special 400/1 Coil \$9.50, Manual \$2.00. Associated Electronics Engineering Co., 11 South Fullerton Avenue, Montclair, New Jersey.

COMPUTER sections, electrolytics, relays, switches, resistors, batteries, tubes, capacitors, speakers, microphones, fuses, transistors. All new gigantic assortment \$5. Baker Electronics, R.R. 1, Greencastle, Indiana.

TRANSISTORS—brand new, NPN units that can be used as the basis for many experiments and transistorized projects. Similar in specifications to the 2N229, these transistors are not seconds or pulls but fully tested and guaranteed units fresh from the factory. Will replace any general purpose NPN or PNP transistor. Order several at five for only \$1. Baker Electronics, R.R. 1, Greencastle, Indiana.

14 Weather instrument Plans \$1.00. Saco, Box 2513B, South Bend, Indiana.

TELETYPE: Build your own for less than \$50. Copy Wireless News. Hams. Construction Plans \$4.75. DB Enterprises, 8959 Wonderland Ave., Hollywood 46, Calif.

DIAGRAMS, servicing information. Television, Radio, \$1.00. Supreme Publications, Highland Park, Illinois.

"LISTEN-in-coil" picks up any telephone conversation in vicinity. No connection to telephone necessary. Easily concealed. \$2.98 complete. United Acoustics, 1302A Washington St., Hoboken, N. J.

NOV cards of distinction, for the discriminating, CB-QSL-WPE. Your photo on cards from snapshot, also send your ideas and design for custom work by professional artist, samples 25¢. Dick McGee Advertising, 1444 Home St., Jacksonville 7, Fla.

PRINTED Circuit Boards. Hams, Experimenters, CB, FM Multiplex, \$4.50. 100KC Crystal Calibrator, \$1.00. Free Catalog. P/M Electronics, Box 6288, Seattle 88, Washington.

15 Distance One-tube plans—25¢; One-tube Handbook—50¢. Includes Transistor experiments, catalog. Laboratories, 1131-L Valota, Redwood City, California.

CB-WPE-QSL's, New Designs. Free catalogue. Longbrook, Box 393, Quakertown, New Jersey.

CBERS' triple your range. Repeater method used by Common Carriers. Complete instructions 50¢ coin. Federal Electronics, Box 278, Oklahoma City, Okla.

PARTS and accessories for transistor ignition systems. Build your own for peak performance. Catalogue available. Write: Al-Mar Associates, 73 Constant St., Manchester, N. H.

"SLEEP Machine. Easy and inexpensive to build all electronic device guaranteed safe and effective. Eliminates dangerous drugs. Sell all you can make for enormous profits. Plans, schematic and university clinical report—\$5.00. American Science Associates, Inc., 8228 Southwest Station, Washington 24, D. C."

CB transmitters \$6.00. Many other unbeatable bargains; send 10¢ for list. Vanguard, 190-48—99th Ave., Hollis 23, N.Y.

CB QSL Cards. New, kute, clever, komical designs. Some low as \$1.80 per 100. Samples 10¢. R. Hellwig, Box 425, Lake Wales, Florida.

HAM EQUIPMENT

CBERS' Hams: Compact AAA-1 Clipper-Filter kit triples talk-power, fits any CB transceiver, improves selectivity; \$10.99. Double reception with SK-3 Preselector for GW-10, GW-11, SK-4 Preselector fits GW-12 internally! Kit, \$8.99; wired, \$11.99. SK-20 Preselector, tunable 3.5-30 megacycles, kit \$18.98. Noisejector, NJ-7, \$4.49. Prices Postpaid! (Free kit, antenna list.) Holstrom Associates, P.O. Box 8640-E, Sacramento 22, California.

BARGAINS! Ham transmitters, receivers. Interesting lists 10¢. Brand's, Sycamore, Illinois.

CONVERT CB transceivers to 6 meter amateur band. Converters from \$6.00, details 10¢. Vanguard, 190-48 99th Ave., Hollis 23, N. Y.

WANTED

CASH Paid! Unused tubes, electronic equipment. Barry, 512 Broadway, N.Y.C. 12.

QUICKSILVER, Platinum, Silver, Gold. Ores Analyzed. Free Circular. Mercury Terminal, Norwood, Mass.

TRANSISTORS, Tubes, all types Test Equipment. PRC, GRC, TS, URM, UPM. Aircraft Communications or Navigation Equip., Write or Phone V & H Radio, 2053 Venice, LA 6, Calif. RE 50215.

HIGH-FIDELITY

PRICES? The Best! Factory-Sealed Hi-Fi Components? Yes! Send for free catalog. Audion, 25P Oxford Road, Massapequa, N. Y.

DISGUSTED with "Hi" Hi-Fi Prices? Unusual discounts on your High Fidelity Requirements. Write Key Electronics, 120 Liberty St., New York 6, N. Y. DI 6-4191.

HI-FI Components, Tape Recorders at guaranteed "We Will Not Be Undersold" prices. All brands in stock. 15-day money back guarantee. 2 year warranty. Write your requirements for quotation. No Catalog. Hi-Fidelity Center, 1797-P 1st Ave., New York 28, N.Y.

"LOW, Low quotes: all components and recorders. HiFi, Roslyn 9, Penna."

RECORDERS, Components. Free wholesale catalogue. Carston, 125-P East 88, N. Y. C. 28.

WRITE for lowest quotations, components, recorders. No Catalogs. Hi-Fidelity Supply, 2817-QC Third, New York City 55.

HI-FIDELITY factory closeout below cost! Precise, stereo 14 watt amplifiers, regular wholesale \$59.95, now \$33.50. Precise 40 watt monaurals with output meters regular wholesale \$89.95, now \$49.50. VM 4 speed changers \$19.50. Shelf speaker systems Mahogany wood 18 x 10 x 9 complete with woofer and tweeter \$18.00. All merchandise fully guaranteed. Sy Luba, 254-27 Long Island Expressway, Little Neck 62, N. Y.

BI-Plex 8" Speakers. Complete Spectrum. Best for stereo. 12 for \$100.00. Two samples \$20.00. Caravelle, 916 McLean Avenue, Yonkers, N. Y.

TAPE AND RECORDERS

TAPE Recorders, Hi-Fi, components, Sleep Learning Equipment, tapes. Unusual Values Free Catalog. Dressner, 1523PE, Jericho Turnpike, New Hyde Park 11, N. Y.

4/TR Stereo Tapes—bought, sold, rented, traded! Bargain closeouts! Catalog/Columbia, 9651 Foxbury, Rivera, California.

SELF-Hypnosis may help you many ways. New Tape or LP-record teaches you quickly, easily! Free literature. McKinley Company, Box 3038, San Bernardino, California.

SAVE 30% Stereo music on tape. Free bargain catalog/blank tape/recorders/Norelco speakers. Saxitone, 1776 Columbia Road, Washington, D. C.

RENT Stereo Tapes—over 2,500 different—all major labels—free catalog. Stereo—Parti, 811-G Centinela Ave., Inglewood 3, California.

CONCORD 400, one of world's finest professional 4-track stereo recorders. Complete with recording and playback pre-amplifiers. Two VU meters. Remote control. Carrying Case. For portable use or built-in installation. Brand new in original cartons. Incredibly priced at \$159.50. Caravelle, 916 McLean Avenue, Yonkers, N. Y.

RECORDING tape, top quality by major U. S. manufacturer. 1800 feet, 1 mil, 7 inch reel, \$1.95 each, 10 for \$17.70 postpaid. Moneyback guarantee. Western Magnetics, Box 3722, Portland 8, Oregon.

TUBES

"FREE Catalog—name brand tubes 65% discount, phono needles 80% or more discount, phono cartridges, picture tubes 75¢ inch parts, parts kits, silicon and selenium rectifiers, transmitting tubes, 7" T.V. test tube \$6.99, improved batteries, tube testers, etc. Want to swap or sell tube inventory? Send us your offering. Arcturus Electronics Corp., Dept. Z.D., 502—22nd St., Union City, N. J.

BEFORE You Buy Receiving Tubes, Test Equipment, HiFi Components, Kits, Parts, etc. . . . send for your Giant Free Zalytron Current Catalog, featuring Standard Brand Tubes: RCA, GE, etc.—all Brand new Premium Quality Individually Boxed, One Year Guarantee—all at Biggest Discounts in America! We serve professional servicemen, hobbyists, experimenters, engineers, technicians. Why Pay More? Zalytron Tube Corp., 461 Jericho Turnpike, Mineola, N. Y.

TUBE Headquarters of The World! Free Catalog (tubes, electronic equipment) write! Barry, 512 Broadway, N.Y.C. 12.

TOOLS

CUT Holes Fast With Greenlee Chassis Punches—Make accurate, finished holes in one and one-half minutes or less in metal, hard rubber, and plastics. No tedious sawing or filing—a few turns of a wrench does the job. All standard sizes . . . round, square, key, or "D" shapes for sockets, switches, meters, etc. Available at your electronic parts dealer. Write for free literature. Greenlee Tool Co., 2028C Columbia Avenue, Rockford, Illinois.

REPAIRS AND SERVICING

TV Tuners rebuilt and aligned per manufacturers specification. Only \$9.50. Any make UHF or VHF. We ship COD. Ninety day written guarantee. Ship complete with tubes or write for free mailing kit and dealer brochure. J Electronics, Box 51C, Bloomington, Indiana.

METERS—Multimeters Repaired and calibrated. Free estimates—catalog. Bigelow Electronics, Box 71-E, Bluffton, Ohio.

METERS—multimeters, panel instruments, V.T.V.M.'s, repaired and calibrated. Free estimates. R & S Instrument Repair Service, 175 Fifth Avenue, New York 10.

WHATEVER your needs, Popular Electronics classified can solve them. Simply place an ad in these columns and watch your results pour in.

PATENTS

PATENT Searches. \$6.00! Free "Invention Record"/Information.—Miss Hayward, 1029 Vermont, Washington 5, D. C.

INVENTIONS WANTED

INVENTIONS wanted. Patented; unpatented. Global Marketing Service, 2420-P 77th, Oakland 5, Calif.

BOOKS

HORROR books—Buy direct from publishers! Bargains! Free details. Trans-International, P.O. Box 2942, Paterson, N. J.

AUTHORS! Learn how to have your book published, promoted, distributed, FREE booklet "ZD," Vantage, 120 West 31 St., New York 1.

BOOK 200 Electric Stunts \$1.00. Cutziff, 875 Arastradero, Palo Alto, Calif.

DIGITAL Computers Simplified: Basic, concept level introduction, clearly illustrated. Advent Editions, P. O. Box 124A, Sarasota, Florida. \$3.00. 25¢ postage.

WHATEVER your needs. Popular Electronics classified can solve them. Simply place an ad in these columns and watch your results pour in.

GOVERNMENT SURPLUS

GOVERNMENT Surplus direct from Government. Jeeps \$264.00, Radios \$2.53. Typical prices. Guns, Typewriters, Cameras, Tools, thousands more Amazing low prices. How, where to purchase. Merchandise available, etc. Only \$1.00 to: Surplus, P.O. Box 50512, Dept. R, New Orleans 50, Louisiana.

GOVERNMENT Surplus Sales Bulletin—"Directory-Procedure"—50¢—Industrial, Box 770(A), Hoboken, N. J.

SURPLUS: Save 95% and more. Jeeps \$101.28, Airplanes \$65.70, Electronic Equipment 5¢ per pound. Everything imaginable. "Locations and Procedures" plus "Profits from Surplus". Only \$1.00. Surplus. Dept. E-7, Box 6091, Dallas 22, Texas.

JEEPS \$111.68, boats \$6.20, airplanes, recorders, radios, electronics equipment, thousands of items typically at 90% savings or better. For complete information send \$1.00 to Surplus Service, Box 820, Holland 10, Michigan.

IF you have something to sell, let the readers of Popular Electronics know about it through the classified advertising columns. It costs very little—only 60¢ a word, including your name and address. Your ad will be seen by more than 400,000 active buyers of electronic gear and components. Act now! Write your classified ad today, enclose payment and mail to: Martin Lincoln, Popular Electronics, One Park Avenue, New York 16, New York. September issue closes July 5th.

LEATHERCRAFT

FREE "Do-It-Yourself" Leathercraft Catalog. Tandy Leather Company, Box 791-Q49, Fort Worth, Texas.

INSTRUCTION

LEARN While Asleep, hypnotize with your recorder, phonograph. Astonishing details, sensational catalog free! Sleep-Learning Association, Box 24-ZD, Olympia, Washington.

FCC License in 6 Weeks, First Class Radio telephone. Results Guaranteed. Elkins Radio School, 2603B Inwood, Dallas, Texas.

FCC 2nd Class License. Results Guaranteed. Build your future now. Total cost \$35.00. Write for free information. Federal Electronics, Box 278, Oklahoma City, Okla.

TROUBLE getting homemade equipment to work? Read "Introduction to Electronic Servicing" (Sams BSJ-1) \$2.95 at parts jobbers—or postage free from Electronic Books, Box 8433-A University Park Station, Denver 10, Colorado. 10 Day Money-Back Guarantee.

HIGHLY-Effective home study review for FCC commercial phone exams. Free literature! Wallace Cook, Box 10634, Jackson 9, Miss.

LEARN Electricity, slide-rule calculations, and appliance repair in 32 compact lessons. Dept. PE 1, World-Wide Institute, 2555 Shelley Drive, Indiana, Pa.

BASIC Mathematics. Algebra, Calculus, Trial first 4 easy lessons \$1. Mathco, Cincinnati 17, Ohio.

STAMPS AND COINS

TERRIFIC Stamp Bargain! Israel-Iceland-Vatican Assortment—plus exotic triangle set—also fabulous British Colonial Accumulation—Plus large stamp book—All four offers free—Send 10¢ to cover postage. Empire Stamp Corp. Dept. Z2, Toronto, Canada.

TOPS! Free illustrated booklet "How To Collect Coins." Approvals. Littleton Coin Co., Littleton E12, N. H.

100 Foreign coins for \$2.95. Tony's, Box 6350PE, Phoenix 5, Arizona.

PHOTOGRAPHY-FILM, EQUIPMENT, SERVICES

MEDICAL Film—Adults Only—"Childbirth"—1 reel 8mm. \$7.50—16mm \$14.95. International, Greenvale, L. I., New York.

SCIENCE Bargains—Request Free Giant Catalog "CJ"—144 pages—Astronomical Telescopes, Microscopes, Lenses, Binoculars, Kits, Parts. War surplus bargains. Edmund Scientific Co., Barrington, New Jersey.

WANT to buy good equipment, and accessories? Place a low-cost classified ad in this space. For information, write: Martin Lincoln, Popular Electronics, One Park Avenue, New York 16, N. Y.

EDUCATIONAL OPPORTUNITIES

ENGINEERING Education for the Space Age. Northrop Institute of Technology is a privately endowed, nonprofit college of engineering offering a complete Bachelor of Science Degree Program and Two-Year accredited technical institute curricula. Students from 50 states, many foreign countries. Outstandingly successful graduates employed in aeronautics, electronics, and space technology. Write today for catalog—no obligation. Northrop Institute of Technology, 1179 West Arbor Vitae Street, Inglewood 1, California.

DETECTIVE Profession. Home Study. Lapel pin, Certificate, Future. Box 41197-AG, Los Angeles 41, Calif.

COMPLETE your High School at home in spare time with 66-year-old school. Texts furnished. No classes. Diploma. Information booklet free. American School, Dept. XA36, Drexel at 58th, Chicago 37, Illinois.

COLLEGE Home Study courses from leading universities. Full credit towards Bachelor's or Master's degree. 5,000-course directory \$2.00. College Research, Box 3404, Tucson 3, Arizona.

BUSINESS OPPORTUNITIES

INVESTIGATE Accidents—Earn \$750 to \$1,000 monthly. Men urgently needed. Car furnished. Business expenses paid. No selling. No college education necessary. Pick own job location. Investigate full time. Or earn \$6.44 hour spare time. Write for Free Literature. No obligation. Universal, CZ-7, 6801 Hillcrest, Dallas 5, Texas.

BUY Direct from factories. Appliances, cameras, watches! Free details! Cam Co., 436 PE Bloomfield Ave., Verona, N. J.

VENDING Machines—No Selling. Operate a route of coin machines and earn amazing profits. 32-page catalog free. Parkway Machine Corporation, 715PE Ensor Street, Baltimore 2, Md.

ELECTROPLATING equipment and supplies. All types for home work shops. Free Catalog. HBS Equipment Division, 3445 Union Pacific, Los Angeles 23, Calif.

MAKE \$25-\$50 week clipping newspaper items for publishers. Some clippings worth \$5.00 each. Particulars free. National, 81 Knickerbocker Station, New York City. \$100 Weekly possible. Compile Mailing lists and address envelopes for advertisers. Home—spare time. Particulars free. National Service, 81 Knickerbocker Station, New York City.

I MADE \$40,000.00 Year by Mailorder! Helped others make money! Start with \$10.00—Free Proof. Torrey, Box 3566-N, Oklahoma City 6, Oklahoma.

ASSEMBLE artificial lures at home for stores. Materials supplied free. Profitable! Write: Lures, Fort Walton Beach 1, Florida.

PIANO Tuning learned quickly at home. Tremendous field! Musical knowledge unnecessary. Information Free. Empire School of Piano Tuning—PE, Champaign, Ill. (Founded 1935).

EARN extra money! No investment required. Part-time selling; brand name hi-fi components at discount prices. Exclusive territories. To qualify you must be a hi-fi enthusiast or knowledgeable in field. Give full info, by letter including 3 business refs. & bank. Greatest opportunity for extra earnings ever offered. Write: I F A Electronics, P. O. Box 559, Encino, Calif.

MONEY in Mail-order. Catalogs, Appliances, Jewelry, Toys, Formulas, T.V. Repairs. Special. One Arm Bandits. Spar Products, 601E S. Vermont, Los Angeles 5, Calif.

\$100 per day—work at home—details \$1.00—Dow, Box 1624A, New York 1.

FREE Franchise Profit Letter tells how unique NFR service is helping thousands seeking profitable businesses. Write today. National Franchise Reports, PE-528, 333 North Michigan, Chicago 1.

MISCELLANEOUS

INVESTIGATORS, free brochure, latest subminiature electronic listening devices. Ace Electronics, 11500—K NW 7th Ave., Miami 50, Fla.

INDEPENDENT Thinkers—investigate Humanism, the scientific personal philosophy! Free literature. American Humanist Association, Dept. PE2, Yellow Springs, Ohio. **"HOMEBREW Formulas!"** Beer, Ale, Liquors, Wines! Easily made! Thousands sold! Manual, \$2.00 postpaid. Research Enterprises, 29-D Samoset Road, Woburn, Massachusetts.

"FAMILY Wine Formulas!"—Elderberry, Concord, Blackberry, others. Manual, \$2.00. Brugenheimer Company, Box 201-3, Lexington, Massachusetts.

NEW Vortex theory with a unique structural explanation for elementary particles and forces. Nuclear theory challenged. New 1963 edition. 25 cents postpaid. C. F. Krafft, 4809 Columbia Road, Annandale, Va.

PORTABLE Still—Complete plans and instructions. Distill two pints each fill. \$2.00. Bande Enterprises, Box 784, Wilmington, Delaware.

HYPNOTIZE Unnoticed, quickly, effortlessly, or refund! Thousands delighted! \$2.00. Minter, Box 244-D, Cedarburg, Wisconsin.

HYPNOTIZE unnoticed! Patented new hand device makes you a Hypnotist first day or refund! Hypnotist's handbook included! \$2.00. Hypnosis Foundation, Box 487, La Mesa 9, California.

"HYPNOTIZE . . . One word . . . One fingersnap," on stage. Satisfaction—or refund. \$2. Hypnomaster, Box 9309-E8, Chicago 90.

SIGNS, indoor or outdoor types. Aluminum, Brass, Bronze. Send for brochure. R. T. A. Service, Box 522, New York 8, N. Y.

PERSONAL Data Record Book \$1.79. Rosen, Box 3920, Chicago 54.

IF you have something to sell, let the readers of Popular Electronics know about it through the classified advertising columns. It costs very little—only 60¢ a word, including your name and address. Your ad will be seen by more than 400,000 active buyers of electronic gear and components. Act now! Write your classified ad today, enclose payment and mail to: Martin Lincoln, Popular Electronics, One Park Avenue, New York 16, New York. September issue closes July 5th.

POPULAR ELECTRONICS

July 1963

Advertisers Index

ADVERTISER	PAGE NO.
Allied Radio	4
American Institute of Engineering & Technology	82
Burstein-Applebee Co	12
Capitol Radio Engineering Institute, The	9
Christy Trades School	81
Cleveland Institute of Electronics	5
Coyne Electrical School	82, 87
DeVry Technical Institute	3
EICO Electronic Instr. Co. Inc	24
Fisher Radio Corporation	1
Grantham School of Electronics	79
Hallicrafters	4
Heath Company	85
Indiana Institute of Technology	90
Johnson Company, E.F.	6
Kuhn Electronics Inc	8
Lafayette Radio Electronics	THIRD, FOURTH COVER
Merrell Kits	81
Milwaukee School of Engineering	91
Multicore Sales Corp	88
National Radio Institute	SECOND COVER
National Technical Schools	7
Nortronics	80
Pearce-Simpson Inc	18
Poly Paks	20
Progressive "Edu-Kits" Inc	89
RCA Institutes, Inc	16, 17
Rad-Tel Tube Co	23
Raytheon Company	13
Sams & Co., Inc., Howard W	14
Sarkes Tarzian, Inc	19
Scott Inc., H. H.	8
Telex, Inc	6
Tri-State College	90
U.S. Army	15
Valparaiso Technical Institute	88
Weller Electric Corp	11
Western Radio	82, 90

LAFAYETTE

"WORLD'S HI-I

BIG Transistor RADIO VALUES



**24-WATT
PHONO**

**OUTSTANDING PERFORMANCE
AT A BUDGET PRICE**

Here is a stereo system any budget. Featured is a 24-watt stereo amplifier of control facilities to as capability and flexibility, outstanding amplifier are carefully selected Lafayette audio specialist.



Garrard Autoslim



880
EMPIRE



SK-124

LS-225WXM . . .

MATCHED COMPONENTS

Lafayette LA-224 Amplifier
Garrard Autoslim 4-4 Changer
Wood Base for Chango, Walnut or B Empire 880 Diamond Cartridge
2 Lafayette SK-124 Systems



SK-236WX Shpg. wt. 22 lbs.

**NEW
"SLENDER
SPEAKERS"**

FEATURES JENSEN SPEAKERS AND UNIVERSAL WOODCRAFTERS CABINETS

Designed and engineered exclusively for a slender 4 1/4" deep yet incorporates superb deep rich sound and latest advanced ac signs. Contains Jensen 3-way 3-speaker system finished on all four sides in finest walnut veneer—ideal for shelf, floor or wall mount.



49.95
No Money Down

**LAFAYETTE
12-TRANSISTOR 4-BAND
PUSHBUTTON RADIO**

tune in on the world

- Tunes LM and 3 SW Bands
- 2 Dynamic Speakers
- 3 Built-in Antennas

- Large Slide Rule Dial
- Complete with Batteries and Earphone

FS-252L . . . Shpg. wt., 5 lbs.

AC Adapter (optional)



49.95
No Money Down

**LAFAYETTE 12-TRANSISTOR FM/AM
SHORTWAVE PORTABLE RADIO**

- 3-Bands: FM, AM plus SW
- 12 Transistors, 4 Diodes & Varistor
- Big 3x5" Speaker
- Tuned RF Stage

- Automatic Frequency Control, AGC
- Tone Control
- Precise Slide Rule Tuning
- Includes Earphone & Batteries

FS-251L . . . Shpg. wt., 5 1/2 lbs.

AC Adapter (optional)



7.95
FS-255

LAFAYETTE AC ADAPTER

Converts FS-251 and 252 to AC house current. Saves Batteries.

CUT HERE AND PASTE ON POST CARD

LAFAYETTE Radio ELECTRONICS
Dept. IG-3, P. O. BOX 10
Syosset, L. I., N. Y.



Rush FREE 388 p. Giant Size 1963 Catalog

Send me stock No.

Shipping charges collect. \$..... enclosed.

Name
(Please Print)

Address

City Zone State

LAFAYETTE... HEADQUARTERS FOR CB AND AMATEUR EQUIPMENT

NEW! 12-Transistor "WALKIE-TALKIE" with Squelch

Features separate microphone and speakers for better sending and receiving, positive push-to-talk action and 46" telescoping antenna. May be operated on AC with optional 117VAC power pack. Includes crystals, earphone, leather carrying case and batteries.

39.95 2 for 78.88
No Money Down

HE-100

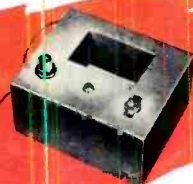

HE-97

7.45

NEW AC POWER PACK

Converts 117V AC to 9V DC. Plugs into HE-100.



HE-20C

HE-20C LAFAYETTE'S DELUXE CITIZENS BAND TRANSCEIVER.

Now officially approved for use in Canada by the Dept. of Transport. New quality features include 8 crystal Receive Positions, 8 Crystal Transmit Positions, and Built-in Power Supply.

109.50 No Money Down



HE-80WX

149.50

No Money Down

NEW! LAFAYETTE Professional Quality 14-TUBE COMMUNICATIONS RECEIVER

For today's congested amateur bands. Features dual conversion 6 meters. Calibrated electrical band-spread on 80 thru meters. 1 uv sensitivity for 10 db S/N ratio; built-in electronic S-meter, product detector circuit for SSB and reception, separate B-O and Q-Multiplier circuits. Voltage regulator.

HE-15B LAFAYETTE'S 2-WAY CITIZENS BAND TRANSCEIVER.

Improved with 8 Crystal Transmit Positions, increased selectivity in IF's, attractive modern styling. Officially approved for use in Canada by the Dept. of Transport.



HE-15B

54.50

No Money Down

LAFAYETTE "SQUELCHER"



10.95

• Provides Full Squelch and Noise Limiting action
HE-55 10.95

NEW! LAFAYETTE "PRIVA-COM"



32.50

2 for 62.50

• Top Notch Selective Call System for Private Communications
HA-100 32.50

LAFAYETTE CEILING MOUNTED GROUND PLANE ANTENNA



8.80

• Low Cost HE-E94WX 8.80
• Lightweight Aluminum

MAIL ORDER & SALES CENTER



120,000 Square Feet Designed with You in Mind

LAFAYETTE RADIO ELECTRONIC

"The Symbol of Quality"

111 Jericho Turnpike, Syosset, L.I., New York