

WHERE IS TRANSISTORIZED STEREO?

# POPULAR ELECTRONICS

JULY  
1961

35  
CENTS

9

Projects  
in this  
issue

- Cubical Quad Beam
- Universal Tester
- 6-Meter Mobile
- CB Power Meter
- Starved Amplifier
- Signal Generator
- Field Strength Meter
- Hi-Fi Speaker System
- VOM to VTVM Adapter



# This is ..... CADRE 2-Way Radio

developed by **CADRE INDUSTRIES CORP.**  
for the **27 Mc CITIZENS BAND OPERATION**

These CADRE units are built to the highest standards of the electronics industry, by a company that has been long established as a prime manufacturer of precision electronic research equipment and computer assemblies. CADRE transceivers are 100% transistorized — compact, lightweight . . . engineered for unparalleled performance and reliability.

The CADRE 5-Watt Transceiver, at \$199.95, for example, for offices, homes, cars, trucks, boats, aircraft, etc. measures a mere 11 x 5 x 3", weighs less than 6 pounds! Nevertheless, it offers 5 crystal-controlled transmit/receive channels (may be used on all 22), and a range of 10 miles on land, 20 over water!

The CADRE 100-MW Transceiver, \$124.95, fits into a shirt pocket! Weighs 20 ounces, yet receives and transmits on any of the 22 channels . . . efficiently, clearly . . . without annoying noise. A perfect "pocket telephone"!

For the time being, it is unlikely that there will be enough CADRE transceivers to meet all the demand. Obviously, our dealers cannot restrict their sale to the fields of medicine, agriculture, transportation, municipal services, etc. However, since these CADRE units were engineered for professional and serious commercial applications—and cost more than ordinary CB transceivers — we believe that as "water finds its own level," CADRE transceivers will, for the most part, find their way into the hands of those who really need them.

*Write for complete information and detailed specifications.*

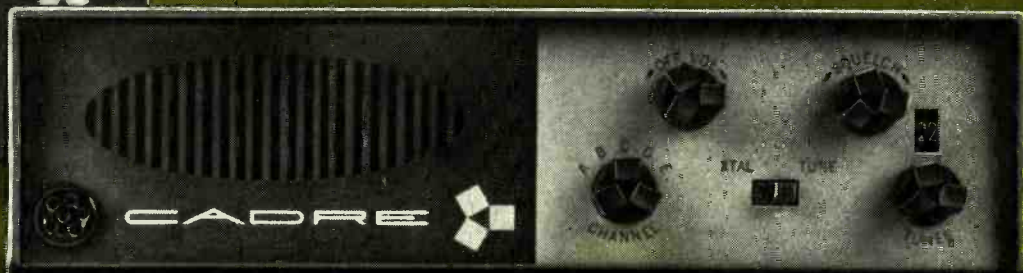

**CADRE INDUSTRIES CORP., Endicott, N. Y.**

*Prices appearing in this advertisement are suggested retail prices*



# SELECTIVE

## SSB/AM/CB/Recording/PA ... Improved with Electro-Voice Model 729

Now! A low-cost microphone that offers the enormous advantage of true cardioid directional pickup, plus a virtually indestructible ceramic element! This design, by rejecting surrounding noises from the sides and rear, provides substantially improved voice pickup at greater working distance and with less room-noise pickup.

Smooth response assures natural reproduction without boominess or "peaked" sound, for better intelligibility and maximum power output. High output is ample for any inputs, and does not change with high humidity or temperature. The 729 can be comfortably hand-held, and slips easily into the

desk stand or the floor stand adapter provided. You get all this, and more, in the new 729 at a list price of only \$24.50, with normal trade discounts applying. For equipment requiring a relay-control switch on the microphone, select the Model 729SR, (illustrated) for only \$26.50 list. Either way you get traditional E-V quality, plus a money-back guarantee. Write for full information and list of Electro-Voice microphone specialists.

**SPECIFICATIONS:** • Polar Pattern: Cardioid • Frequency Response: 60-8,000 cps • Output Level: -55 db • Impedance: Hi-Z • Size: 7-3/4 in. long • Weight: 1 lb. • Cable: 8-1/2 ft. shielded.

ELECTRO-VOICE, INC., Commercial Products Division  
Dept. 712P, Buchanan, Michigan

**Electro-Voice**®

# POPULAR ELECTRONICS

VOLUME 15

NUMBER 1

JULY

1961



POPULAR ELECTRONICS is indexed  
in the Readers' Guide  
to Periodical Literature

## Special Feature

English-Language Voices from the Orient.....	Stewart West	41
Short-wave broadcasts beamed to North America provide hours of informative and interesting listening		

## Electronic Construction Projects

6 Meters and Mobile.....	Len Buckwalter, K1ODH	47
Sensitive Field Strength Meter.....	Herbert Friedman	51
VTVM Adapter for Multimeters.....	Philip E. Hatfield, W9GFS	54
Universal Workshop Tester.....	Frank A. Parker	57
SWR Power Meter for CB.....	James G. Lee, W6VAT	61
FM Power Lead Antenna.....	Art Trauffer	64
Fixed-Frequency Signal Generator (Advanced Experimenter's Corner) John J. Sury, K8NIC/5		76
Headphone "Ear Saver".....	Herb S. Brier, W9EGQ	95

## Audio and High Fidelity

Hi-Fi Showcase.....		18
Transistors in Hi-Fi.....	Richard A. Flanagan	65
Starved Circuit Amplifier.....	Howard Burgess	69
Space-Saver Speaker System.....	David B. Weems	72

## Amateur, CB, and SWL

FCC Report.....	Robert E. Tall	10
Cubical Quad for CB.....	William I. Orr, W6SAI	79
On the Citizens Band.....	Tom Kneitel, 2W1965	85
New SWL Antenna.....		87
Across the Ham Bands: How to Pass General Class Code Test.....	Herb S. Brier, W9EGQ	93
Short-Wave Report: Questions and Answers.....	Hank Bennett, W2PNA	99
Short-Wave Monitor Certificate.....		100

## Electronic Features and New Developments

POP'tronics News Scope.....		6
Space Electronics.....	Oliver P. Ferrell	82
Diode Quiz.....	Robert P. Balin	88
How to Become a Ham.....	Donald L. Stoner, W6TNS	89
Transistor Topics.....	Lou Garner	96
Hobnobbing with Harbaugh: Always Problems Yet! Dave Harbaugh		101
Carl and Jerry: Treachery of Judas.....	John T. Frye, W9EGV	102

## Departments

Letters from Our Readers.....		16
POP'tronics Bookshelf.....		24
Tips and Techniques.....		26
New Products.....		35

Copyright © 1961 by ZIFF-DAVIS PUBLISHING COMPANY. All rights reserved.

POPULAR ELECTRONICS is published monthly by Ziff-Davis Publishing Company, William B. Ziff, Chairman of the Board (1946-1953) at 454 N. Wabash Ave., Chicago 5, Ill.; second-class postage paid at Chicago and additional mailing offices. Authorized by Post Office Department, Ottawa, Canada, as second-class matter. **SUBSCRIPTION RATES:** One year U.S. and possessions, and Canada \$4.00; Pan-American Union Countries \$4.50; All other foreign countries, \$5.00.

# THE A.E.S. Gigolo

## ONE OF THE MOST SOUGHT AFTER PRODUCTS IN THE HIGH FIDELITY INDUSTRY

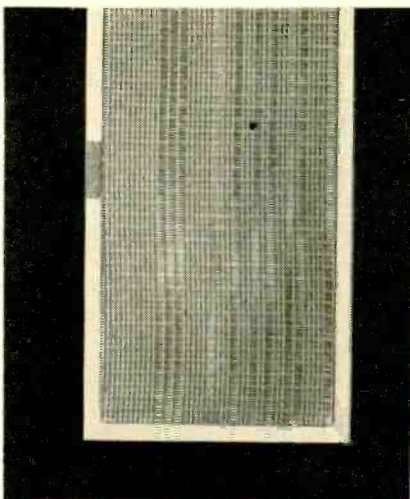

At our present rate of sales and production, A. E. S. will sell nearly 100,000 Gigolos this year.

Imagine, now you can own a speaker with this quality for only \$15.00.

**TRY IT—WE GUARANTEE IT  
100,000 PEOPLE CANNOT BE WRONG**

### DESCRIPTION

The Gigolo is constructed with a resonant resistant all wood product of at least 3/4" thickness throughout. Its outside dimensions are 24" long, 12" high, 9 1/2" deep. The heavy construction and the fine workmanship suggest a value far exceeding its low, low price. All units sold on 100% MONEY BACK GUARANTEE.

Price \$15.00. Unfinished only.  
F.O.B. Factory

### SPECIFICATIONS:



Frequency response 500 Tone bursts 3500  
 Maximum frequency response 19-21000 cps  
 Frequency response  $\pm 8$  db 45-18000 cps  
 Harmonic distortion less than 3% 70-21 Kc  
 Impedance curve within  $\pm 200\%$  of 8 ohms  
 20-20000 cps  
 Flux density 11000 gauss  
 Frequency response curve run at continuous 10 watts.  
 Power handling capacity, the Gigolo may be used with small economy amplifiers of very low wattage, as well as with the highest power-component amplifier with satisfactory results.

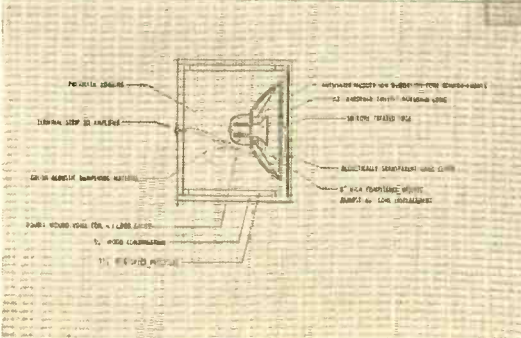

A.E.S., Inc.  
 3338 Payne Avenue, Cleveland, Ohio  
 Gentlemen please ship \_\_\_\_\_ GIGOLOS.  
 I understand these units are guaranteed and if I am not satisfied I may return for a full refund of sales price, \$15.00 each.

Name \_\_\_\_\_  
 Address \_\_\_\_\_  
 City and State \_\_\_\_\_  
 Enclosed find check \_\_\_\_\_ money order \_\_\_\_\_

# POPULAR ELECTRONICS

World's Largest-Selling Electronics Magazine

Average Net Paid Circulation Over 357,000

This month's cover photo by Joe Petrovec

**Publisher**

**PHILLIP T. HEFFERNAN**

**Editor**

**OLIVER P. FERRELL, 2W1665**

**Managing Editor**

**JULIAN M. SIENKIEWICZ  
WA2CQL**

**Art Editor**

**JAMES A. ROTH**

**Associate Editors**

**RICHARD A. FLANAGAN  
MARGARET MAGNA**

**Assistant Editor**

**MARC E. FINKEL**

**Editorial Assistants**

**MARY ANNE O'DEA  
MARIA SCHIFF**

**Draftsman**

**ANDRE DUZANT**

**Editorial Consultant**

**OLIVER READ, W4TWV**

**Contributing Editors**

**H. BENNETT, W2PNA  
H. S. BRIER, W9EGQ  
J. T. FRYE, W9EGV  
L. E. GARNER, JR.  
T. KNEITEL, 2W1965**

**Advertising Manager**

**WILLIAM G. McROY, 2W4144**

## COMING NEXT MONTH



(ON SALE JULY 27)

- **"COMPACTRON" FM TUNER**  
Here's a single-tube FM tuner that features a grounded-grid r.f. stage, a superregenerative detector, and an audio stage—all in one envelope!
- **HYBRID CATHODE MODULATOR**  
One tube and two inexpensive transistors form the heart of this easy-to-build gadget, designed for use with transmitters having class "C" keyed finals.
- **TRANSISTORIZED A.C. VOLTMETER**  
Construction details on a pocket-sized test unit with five ranges from 0.05 to 500 volts, and input impedances from 200,000 ohms to 3 megohms.

ZIFF-DAVIS PUBLISHING COMPANY,  
One Park Ave., New York 16, N. Y.  
William B. Ziff, Chairman of the Board  
(1946-1953); William Ziff, President;  
W. Bradford Briggs, Executive Vice  
President; Hershel B. Sarbin, Vice  
President and General Manager;  
Michael Michaelson, Vice President  
and Circulation Director; M. T. Bir-  
mingham, Jr., Vice President and  
Business Manager; Richard Kislik,  
Treasurer; Charles Hausman, Finan-  
cial Vice President.



BRANCH OFFICES: Midwestern Office,  
434 S. Wabash Ave., Chicago 5, Ill.,  
Jim Weakley, Advertising Manager;  
Western Office, 9025 Wilshire Blvd.,  
Beverly Hills, Calif., William J. Ryan,  
Western Manager.

Foreign Advertising Representatives:  
D. A. Goodall Ltd., London; Albert Mil-  
hado & Co., Antwerp and Dusseldorf.

**SUBSCRIPTION SERVICE:** Forms 3579 and all subscription correspondence should be addressed to Popular Electronics, Circulation Department, 434 South Wabash Avenue, Chicago 5, Illinois. Please allow at least four weeks for change of address. Include your old address as well as new—enclosing if possible an address label from a recent issue.

**CONTRIBUTORS:** Contributors are advised to retain a copy of their manuscripts and illustrations. Contributions should be mailed to the New York Editorial Office and must be accompanied by return postage. Contributions will be handled with reasonable care, but this magazine assumes no responsibility for their safety. Any copy accepted is subject to whatever adaptations and revisions are necessary to meet the requirements of this publication. Payment covers all author's, contributor's and contestant's rights, titles, and interest in and to the material accepted and will be made at our current rates upon acceptance. All photos and drawings will be considered as part of material purchased.

**MEN 17 to 55**



# DeVry Tech's Electronic Training

*has helped Men like these Get Better Jobs or Shops of their own...*

# How about YOU?



**No Advanced  
Education  
Required**

## **NO PREVIOUS TECHNICAL EXPERIENCE NEEDED!**

Men from practically every walk of life have won better jobs or businesses of their own through DeVry Tech's program. Many of these men, like thousands of others, had no previous technical experience. They prepared either in our well-equipped Toronto or Chicago laboratories, or at home in their spare time without interfering with their regular jobs.

The "Electronic Age" is here! Opportunities for men 17 to 55 are great! Fill in coupon below for FREE details! Act now!

### **LIVE-WIRE EMPLOYMENT SERVICE**

DeVry Tech's Placement Department is in contact with some of the best-known employers in the Electronics field. The service is free to all graduates — and DeVry Tech's record in helping to place men has been outstanding.

Get  
**FREE**  
Facts!

Here are some of the many Electronic opportunities DeVry Tech's program will fit you for:

- COMMUNICATIONS • TELEVISION • RADIO • GUIDED MISSILE CONTROL
- COMPUTERS • RADAR • MICRO-WAVES • INSTRUMENTATION
- AUTOMATION ELECTRONICS

*"One of North America's Foremost Electronics Training Centers"*



**DeVRY TECHNICAL INSTITUTE**  
CHICAGO • TORONTO



We'll give you free copies of interesting booklets, "Pocket Guide to Real Earnings" and "Electronics in Space Travel." See for yourself how you may take advantage of the opportunities in this growing field.

**DRAFT AGE?** We have valuable information for every man of draft age; so if you are subject to military service, be sure to check the coupon.

Accredited Member of National Home Study Council

### **MAIL COUPON TODAY!**

**DeVRY TECHNICAL INSTITUTE**  
4141 Belmont Avenue • Chicago 41, Illinois • Dept. PE-7-R

Please give me your two free booklets, "Pocket Guide to Real Earnings" and "Electronics in Space Travel"; also include details on how to prepare for a career in Electronics. I am interested in the following opportunities (check one or more):

- Space & Missile Electronics
- Television and Radio
- Microwaves
- Radar
- Automation Electronics
- Communications
- Computers
- Broadcasting
- Industrial Electronics
- Special "Short Courses"

Name \_\_\_\_\_ Age \_\_\_\_\_

Address \_\_\_\_\_ Please Print \_\_\_\_\_ Apt. \_\_\_\_\_

City \_\_\_\_\_ Zone \_\_\_\_\_ State \_\_\_\_\_

2036  Check here if you face military service.  
Canadian residents: Write DeVry Tech of Canada, Ltd.,  
970 Lawrence Avenue West, Toronto 19, Ontario

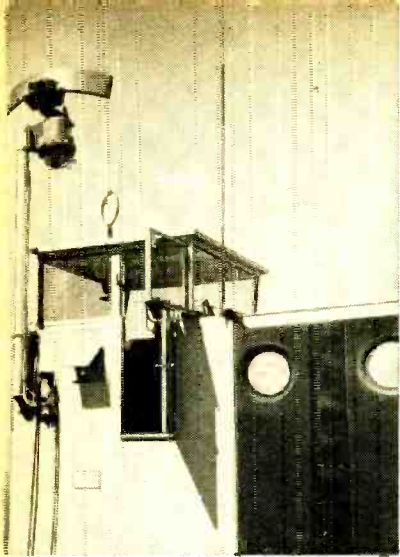

◀ **PHFFT!!! A DECKHOUSE**—A rubber and steel kit which inflates to become an electronically equipped deckhouse can convert a landing craft into a control boat or an open beach site into a living-room-sized command post. Developed by Raytheon and the U.S. Army Transportation Corps, the lightweight unit expands to a 14-foot-square structure that houses a marine radar, a radio direction finder, a depth sounder, a gyrocompass, and high-powered radiotelephones, as well as a glass-walled lookout tower. The self-contained package has inflatable bunks for six men and even includes a galley. Imagine, soldiers at sea, thanks to air force!

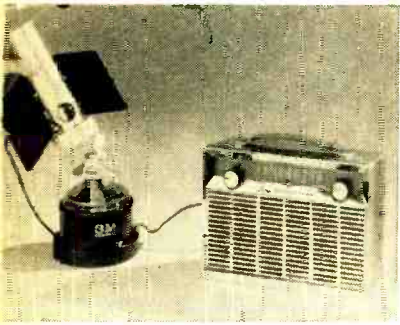

◀ **HOT ELECTRONS**—A portable thermoelectric generator capable of powering a transistor radio from the heat of a kerosene flame will provide a simple emergency power source. Developed by Minnesota Mining and Manufacturing Co., primarily for operating radio sets in home fallout shelters, the generator could also be used in the event of power failure caused by tornadoes, ice storms or other natural disasters, or in remote areas where electrical power is not available and battery supplies are limited. The generator and a supply of fuel can be stored indefinitely and still provide full power in less than one minute after the wick has been lighted. If no kerosene is available, it can be powered by two candles held beneath its chimney. A built-in transistorized converter changes the generator output to the 3 to 9 volts d.c. required by most transistor portables.

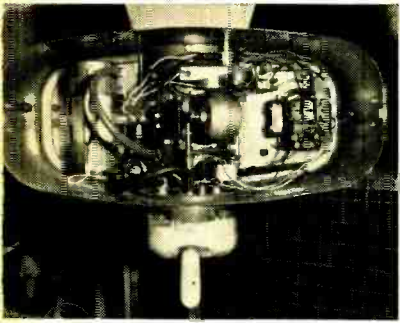

◀ **SOMETHING TO MOO ABOUT**—Modern cow mothers no longer have to tend their calves, thanks to an electronic calf feeder produced by K & K Manufacturing in Minneapolis. The feeder, called Nurs-ette, automatically mixes a formula of milk-replacer powder and warm water, then feeds it to the calf, dispensing the formula in four-minute intervals. "Brains" of this non-mooing cow mother are four precision switches made by the Micro Switch division of Minneapolis-Honeywell.

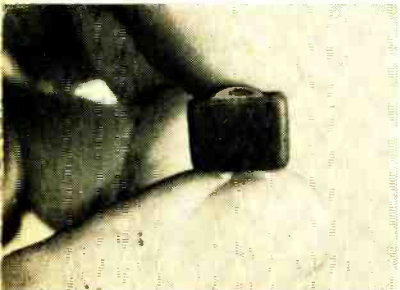

◀ **BITE-SIZED TRANSMITTER**—A microminiature transmitter, so compact that the entire unit including its battery can be mounted as a tooth in a dental bridge, has been designed by Varo, Inc., Garland, Texas, for the U.S.A.F. Aerospace Medical Center. Scientists there are monitoring the number of closures, grinding, and tooth pressures of astronauts in order to measure degrees of stress during simulated space tests. In addition, since the transmitter is small enough to be enclosed in a capsule and swallowed, medical research scientists will be able to monitor the digestive processes of the human body. Dimensions of the unit are .39" x .22" x .30" plus .04" allowed for battery protrusion; weight—only 1.3 grams with battery.



# YOUR TICKET TO A BETTER JOB

Learn  
Electronics

for  
**FREE**  
**Booklet**  
**CLIP**  
**COUPON**  
and mail in  
envelope or  
paste on  
postal  
card.



## WHICH LICENSE FOR WHICH JOB?

The **THIRD CLASS** radiotelephone license is of value primarily in that it qualifies you to take the second class examination. The scope of authority covered by a third class license is extremely limited.

The **SECOND CLASS** radiotelephone license qualifies you to install, maintain and operate most all radiotelephone equipment except commercial broadcast station equipment.

The **FIRST CLASS** radio telephone license qualifies you to install, maintain and operate every type of radiotelephone equipment (except amateur) including all radio and television stations in the United States, its territories and possessions. This is the highest class of radiotelephone license available.

## GRANTHAM TRAINING PREPARES YOU

The Grantham course covers the required subject matter completely. Even though it is planned primarily to lead directly to a first class FCC license, it does this by **TEACHING** you electronics. Some of the subjects covered in detail are: Basic Electricity for Beginners, Basic Mathematics, Ohm's and Kirchhoff's Laws, Alternating Current, Frequency and Wavelength, Inductance, Capacitance, Impedance, Resonance, Vacuum Tubes, Transistors, Basic Principles of Amplification, Classes of Amplifiers, Oscillators, Power Supplies, AM Transmitters and Receivers, FM Transmitters and Receivers, Antennas and Transmission Lines, Measuring Instruments, FCC Rules and Regulations, and extensive theory and mathematical calculations associated with all the above subjects explained simply and in detail.

## OUR GUARANTEE

If you should fail the F. C. C. exam after finishing our course, we guarantee to give additional training at **NO ADDITIONAL COST**. Read details in our free booklet.



## Upgrade Your Income

To get ahead in electronics—first, you need the proper training; then, you need "proof" of your knowledge. Your first class commercial F. C. C. license is a "diploma" in communications electronics, awarded by the U. S. Government when you pass certain examinations. This diploma is recognized by employers. Grantham School of Electronics specializes in preparing you to **earn** this diploma.

Grantham training is offered in resident classes or by correspondence. Our free booklet gives complete details. If you are interested in preparing for your F. C. C. license, mail the coupon below to the School's home office at 1505 N. Western Ave., Hollywood 27, California—the address given in the coupon—and our free booklet will be mailed to you promptly. No charge—no obligation.

# Grantham School of Electronics

HOLLYWOOD  
CALIF.

SEATTLE  
WASH.

KANSAS CITY  
MO.

WASHINGTON  
D. C.

## RESIDENT CLASSES HELD IN FOUR CITIES

If you are interested in attending day or evening classes mail the coupon for free information to our home office in Hollywood, Calif.

(Mail in envelope or paste on postal card)



To: **GRANTHAM SCHOOL OF ELECTRONICS**  
1505 N. Western Ave., Hollywood, Calif.

Gentlemen:

Please send me your free booklet telling how I can get my commercial F.C.C. license quickly. I understand there is no obligation and no salesman will call.

Name \_\_\_\_\_ Age \_\_\_\_\_

Address \_\_\_\_\_

City \_\_\_\_\_ State \_\_\_\_\_

I am interested in:  Home Study,  Seattle classes

Hollywood classes,  Kansas City classes,  Washington classes

13k

MAIL COUPON NOW — NO SALESMAN WILL CALL →

# NEWS SCOPE

*Continued*



UPI

◀ **RADAR YARDSTICK**—This gadget may look like a movie camera, but it is really a tellurometer. When it is aimed at a similar device located hundreds of yards away, the exact distance between the two devices can be computed electronically, thanks to radar. “Down under” surveyors are using the tellurometers to map Tauranga Harbor, New Zealand, with the aid of marker beacons. Eventually, the marker beacons will be used to position depth sounding equipment, and engineers in England will be able to construct a three-dimensional scaled-down model of the harbor for dredging purposes. Electronics has provided the means for a low-cost across-the-world engineering study that otherwise would have taken considerably more time at excessive cost.



UPI

◀ **ELECTRONIC MASQUERADE**—No, this odd-ball machine does not count your eyes. Since insomnia knows no national boundaries, Russian scientists have introduced this sleep-inducing apparatus and its elaborate eye-relaxing mask to the Western world. In the Russian pavilion at the Utrecht Spring Fair, Netherlands, a hapless Dutchwoman is given a dose of Soviet “peasant” dreams.



◀ **ELECTRIC BUGS BUNNY** paces Japan’s Olympic trackmen as they train for the 1964 Olympic games in Tokyo. Donated and installed at Tokyo’s National Athletic Stadium by the Tokyo Shibaura Electric Co., this 15-million-yen “Electronic Coach” is a product of modern electronic technology. Very much like the rabbit used in dog races, it runs on a rail laid along the inside of the track. Speed can be set in advance and controlled by magnetic tape or changed during the run by remote control from a central control room under the stadium’s stands. And just in case the runner lags too far behind, a real live coach can bark commands from the “rabbit” through a one-way radio.

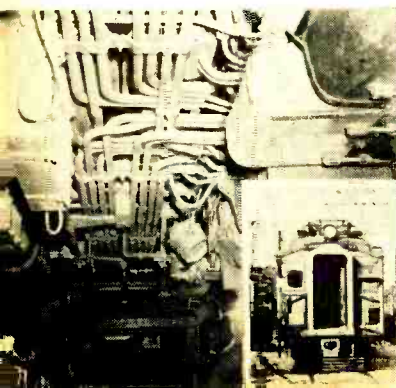

◀ **BOTTOMS UP**—The aluminum electrical conduit of a regular passenger railroad car—as seen from an inspection pit—shows no sign of aging or damage in spite of 875,000 miles of service since 1926, when it was manufactured by the Aluminum Company of America. Used by the Illinois Central Railroad Company on one of the nation’s busiest passenger lines, the conduit evidenced virtually no deterioration after 35 years of continual exposure to Chicago’s corrosive atmosphere, and to rain, snow, and heat, as well as the constant wear and tear of regular service. Recently inspected by engineers of Alcoa’s Rome Cable Division, it was declared ready for another 35 years of service—surely beyond the life of the car.

**AT  
LAST!**

**RADIO-TV and  
ELECTRONICS TRAINING**

**.... AT A PRICE  
YOU CAN AFFORD!**



**\*21 INCH**  
Receiver Kit included

Yes, this great course costs far less than any training of its kind given by other major schools! Radio-Television Training School will train you for a good job in Television or Industrial Electronics — **AT HOME IN YOUR SPARE TIME.**

*Think of it—* a complete training program including over 120 lessons, Fourteen Big Radio-Television Kits, Complete Color-TV Instruction, Unlimited Consultation Service . . . **ALL at a really big saving to you.** How can we do this? Write to us today . . . and find out!

And what's more — you can (if you wish)

**OPEN YOUR OWN RTS-APPROVED AND FINANCED RADIO-TV SERVICE SHOP**

*We Want Many More Shops This Year*

This 38 year old training organization — called RTS, that's Radio-Television Training School — wants to establish a string of Radio-TV Repair Shops in principal cities throughout the U. S. So far, a great many such shops are **NOW IN BUSINESS AND PROSPERING.** We are helping and training ambitious men to become future owners and operators of these shops in all areas.

**FOR UNSKILLED  
INEXPERIENCED MEN ONLY —  
WE TRAIN YOU OUR WAY!**

We must insist that the men we sign up be trained in Radio-TV Repair, Merchandising and Sales by our training methods—because **WE KNOW** the requirements of the industry. Therefore, we will **TRAIN YOU . . .** we will show you how to earn **EXTRA CASH**, during the first month or two of your training period. **YOU KEEP YOUR PRESENT JOB. TRAINING TAKES PLACE IN YOUR OWN HOME, IN YOUR SPARE TIME!**

**COMPLETE  
COLOR TV  
INSTRUCTION  
INCLUDED**

*you build these  
and other units*



MULTITESTER KIT INCLUDED!

\*tubes excluded

**RADIO-TELEVISION  
TRAINING SCHOOL**

815 EAST ROSECRANS AVENUE  
LOS ANGELES 59 CALIFORNIA

Est. 1922



**ACT  
NOW!**

**RTS  
APPROVED  
SERVICE  
SHOP**

Get your free book on the  
**FAMOUS RTS BUSINESS PLAN**  
find out how you can open  
**A REPAIR SHOP OF YOUR OWN**

*We supply and finance your equipment*

When you are ready and qualified to operate one of our RTS-Approved TV Repair Shops **WE WILL SUPPLY AND FINANCE EVERY BIT OF EQUIPMENT YOU NEED TO GET STARTED** plus an inventory of parts and supplies. In other words we will stake you **— AN OFFER NEVER MADE BEFORE BY ANY TRAINING ORGANIZATION.** Under the RTS Business Plan you receive:

1. An electric sign for the shop front.
2. Complete laboratory of test equipment.
3. Letterheads, calling cards, repair tickets, etc.
4. Basic inventory of tubes, parts, supplies.
5. Complete advertising and promotional material.
6. Plans for shop arrangement.
7. Instructions on how to go into business.
8. Continuous consultation and help.
9. The right to use RTS Seal of Approval, and the RTS' Credo.
10. The right to use the Famous Trade Mark.

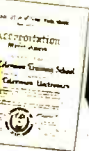

**ALL  
THESE  
FREE!**

RTS' Membership in The Association of Home Study Schools is your assurance of Reliability, Integrity, and Quality of Training.



**CUT OUT AND MAIL — TODAY!**

**RADIO-TELEVISION TRAINING SCHOOL**

815 EAST ROSECRANS AVE Dept. PE-71  
LOS ANGELES 59 CALIFORNIA

**SEND ME FREE —** all of these big opportunity books — "Good Jobs in TV-Electronics," "A Repair Shop of Your Own" and "Sample Lesson." I am interested in:

- Radio-Television       Industrial Electronics (Automation)

Name \_\_\_\_\_ Age \_\_\_\_\_

Address \_\_\_\_\_

City & State \_\_\_\_\_

To: \_\_\_\_\_

**Mail This Coupon Now—No Salesman Will Call**



# FCC Report

☆☆☆☆☆ ☆☆☆☆☆☆☆☆☆☆☆☆☆☆☆☆☆☆☆

By **ROBERT E. TALL**  
Washington Correspondent

**T**HE most concentrated drive for Congressional action on a non-broadcast piece of radio legislation is being put on by the Federal Communications Commission this year to get a "punishment to fit the crime" in cases of minor violations of its rules. Changes in the Communications Act asked of Congress would give the FCC power to fine CB, amateur, and other types of radio licensees between \$100 and \$500 for violation of 12 specific rules, including the ones on which CB'ers are getting caught off base most often.

Under the existing law, the FCC can revoke licenses or start criminal proceedings, through the Justice Department, against those who scoff at its rules; but the Commission feels that these steps are a little too drastic in the case of most non-broadcast rule violations. Besides, it told Congress, the procedures involved are too "cumbersome" and take too much time.

The new FCC proposal is identical to a request sent to the last session of Congress. While the Senate passed the bill in the summer of 1959, the House of Representatives let it die by inaction during the Congressional rush to recess before elections last year. Since the new Congress has both this year and next to act on the current bill, and since the Senate has already gone on record in support of the measure, the proposed legislation could well be a reality by or before next year.

In sizing up the various changes in the Communications Act it was planning to ask Congress for this year, the FCC ranked the "small forfeitures" plan as its number one priority item—even be-

## ◆ EVOLUTION OF A FAMOUS TAPE RECORDER



(MODEL EL 3536)

- ◆ Four-track stereophonic or monophonic recording and playback
- ◆ Three speeds—7½, 3¾ and 1½ ips
- ◆ Completely self-contained, including dual recording and playback preamplifiers, dual power amplifiers, two Norelco wide-range loudspeakers (second in lid) and stereo dynamic microphone (dual elements)
- ◆ Can also be used as a quality stereo hi-fi system with tuner or record player.

**PLUS**—'Sound-on-Sound'...for adding sound over previously recorded sound, without any danger of erasure!  
**PLUS**—Mixing facilities...for recording any two sources of sound simultaneously!

Complete with dual-element microphone and two matched Norelco loudspeakers: **\$399.50**

the *Norelco*<sup>®</sup>  
**CONTINENTAL '400'**  
a new 4-track stereo-record/  
stereo-playback tape recorder  
guild-crafted for you by  
**Philips of the Netherlands**

For complete descriptive literature write to:  
North American Philips Co., Inc.  
High Fidelity Products Division  
230 Duffy Avenue  
Hicksville, L. I., N. Y.

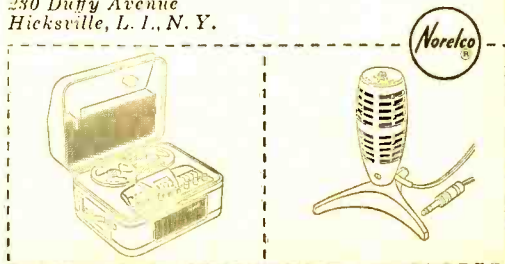

Always say you saw it in—POPULAR ELECTRONICS

# BREAK THROUGH TO HIGHER PAY

# in ELECTRONICS

# TV-RADIO

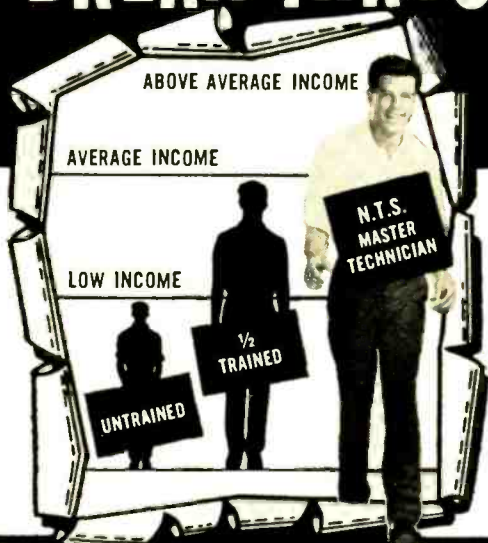

**START NOW!** Break through the Earning Barrier that stops half-trained men. N.T.S. "All-Phase" training prepares you — at home in spare time — for a high-paying CAREER in Electronics — TV — Radio as a **MASTER TECHNICIAN**. One Master Course at One Low Tuition trains you for unlimited opportunities in All Phases: Servicing, Communications, Preparation F.C.C. License, Broadcasting, Manufacturing, Automation, Radar and Micro-Waves, Missile and Rocket Projects.

A more rewarding job... a secure future... a richer, fuller life can be yours! As an **N. T. S. MASTER TECHNICIAN** you can go straight to the top in industry... or in your own profitable business.

You work on actual job projects

## SUCCEED IN MANY HIGH-PAYING JOBS LIKE THESE...

- TV-Radio Sales, Service and Repair
- Profitable Business of Your Own
- Communications Technician — F.C.C. License
- Hi-Fi, Stereo & Sound Recording Specialist
- TV-Radio Broadcasting Operator
- Technician in Computers & Missiles
- Electronics Field Engineer
- Specialist in Microwaves & Servomechanisms
- Expert Trouble Shooter
- All-Phase Master Technician

## 19 BIG KITS YOURS TO KEEP



Free book gives you all the facts

## NATIONAL TECHNICAL SCHOOLS

WORLD-WIDE TRAINING SINCE 1905

4000 SO. FIGUEROA ST., LOS ANGELES 37, CALIF., U.S.A.

Write Dept. R2G-71



N.T.S. Shop-Tested HOME TRAINING is **Better, More Complete, Lower Cost**... and it is your key to the most fascinating, opportunity-filled industry today!

### YOU LEARN QUICKLY AND EASILY THE N.T.S. SHOP-TESTED WAY

You get lessons, manuals, job projects, unlimited consultation, graduate advisory service.

You build a Short Wave-Long Wave Superhet Receiver, plus a large-screen TV set from the ground up, with parts we send you at no addi-

tional cost. You also get a Professional Multiester for your practical job projects.

### EARN AS YOU LEARN... WE SHOW YOU HOW!

Many students pay for entire tuition — and earn much more — with spare time work they perform while training. You can do the same... we show you how.

**SEND FOR INFORMATION NOW... TODAY! IT COSTS YOU NOTHING TO INVESTIGATE.**

### RESIDENT TRAINING AT LOS ANGELES

If you wish to take your training in the Resident School at Los Angeles, the world's TV capital, start NOW in our big, modern Shops, Labs, and Radio-TV Studios. Here you work with latest Electronic equipment — professionally installed — finest, most complete facilities offered by any school. Expert friendly instructors. Personal attention. Graduate Employment Service. Help in finding home near school — and part time job while you learn.

WRITE FOR SPECIAL RESIDENT SCHOOL CATALOG AND INFORMATION



ACCREDITED MEMBER... the only nationally recognized accrediting agency for private home study schools.

### N.T.S. HOME TRAINING is

- Classroom Developed
- Lab-Studio Planned
- Shop-Tested
- Industry-Approved
- Specifically Designed for Home Study

### ACTUAL LESSON



**MAIL COUPON NOW for FREE BOOK and ACTUAL LESSON**

**NO OBLIGATION! NO SALESMAN WILL CALL**

## NATIONAL TECHNICAL SCHOOLS

WORLD-WIDE TRAINING SINCE 1905

Mail Now To National Technical Schools, Dept. R2G-71 4000 S. Figueroa St., Los Angeles 37, Calif.

Please rush **FREE** Electronics-TV-Radio "Opportunity" Book and Actual Lesson. No Salesman will call.

Name \_\_\_\_\_ Age \_\_\_\_\_

Address \_\_\_\_\_

City \_\_\_\_\_ Zone \_\_\_\_\_ State \_\_\_\_\_

Check here if interested **ONLY** in Resident Training at Los Angeles. **VETERANS:** Give date of discharge.

## YOUR BEST CITIZENS BAND BUY!

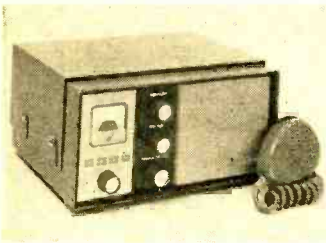

**NEW**

**KAAR  
TR327  
Radiotelephone  
the  
Deluxe  
"D" Phone**

Once again, Kaar's quarter century of progress in 2-way radio communications offers you MORE!

### MORE PRACTICAL, USABLE FEATURES

New, Universal Power Supply... New, Illuminated Signal Level Meter... New, Sealed Relay... New, Snap-In, Snap-Out Mounting... 4 Crystal-Controlled Channels... Front Panel Power Output Peak Control... 5-Watt Input... Highly Effective Noise Limiter... Positive Squelch... Lots of Audio... Big 4 1/2" Speaker.

### PLUS...TWO TREMENDOUSLY IMPORTANT OPTIONAL FEATURES

**Tunable Citizens Band**...flexibility and convenience you've never before enjoyed on Citizens Band.  
**Tunable Standard Broadcast Band**...for music, news, and entertainment wherever you go. **\$179.00**  
Always MORE for YOU from KAAR!

(BASIC MODEL)

For complete information on the new, KAAR TR327 send coupon to:  
**KAAR Engineering Corp.**  
2981 Middlefield Road, Palo Alto, California

NAME \_\_\_\_\_  
ADDRESS \_\_\_\_\_  
CITY \_\_\_\_\_ STATE \_\_\_\_\_

**Strictly for SWL's  
who want Better Listening!**

**2 Multi-band Antennas**  
by **MOSLEY**

Experienced Short Wave Monitors know that a resonant antenna at any one band of frequencies is much more efficient than a random length of wire.

Here are two MOSLEY Dipole Antennas designed to provide the utmost in antenna performance because each is resonant at a number of short wave frequency bands!

Each antenna comes in easy-to-assemble kit form and is complete with wire, weather-proof trap assemblies, center connector, end insulators and 100 feet of 75 ohm lead-in. A pair of wire-cutting pliers will be all you need to quickly assemble either antenna. Attach end insulators to convenient supports, connect lead-in to receiver... and tune in new horizons of exciting short wave listening!

Model SWL-7 - Covers 11, 13, 16, 19, 25, 31 & 49 Meter Short Wave Broadcast Bands. SWL Net Price, \$14.75

Model RD-5 - Covers 10, 15, 20, 40 & 80 Meter Amateur Bands. SWL Net Price, \$15.75

See your favorite SWL and Ham Equipment Dealer Today!  
Beams and Verticals are fine for SWL DX-ing, too! MOSLEY makes 'em all! Write for free literature.

**Mosley Electronics, Inc.**  
BRIDGETON,  
MISSOURI

## FCC Report

(Continued from page 10)

fore Congress got under way in January. It's a sure thing that the agency will move quickly to put the program into effect when and if it clears Congress—which could be any time now—and is signed by the President.

In support of the measure, and with an eye toward CB operations, the Commission told Congress flatly that the "marked increase" in the number of relatively minor violations of its rules in "some of the newer private radio services" represents a "very real menace" to the "orderly use of the radio spectrum and to efficient regulation by the Commission," and that "existing sanctions are inadequate to handle the situation."

As proposed by the FCC, the new "forfeiture" authority would apply to all types of radio stations except broadcast stations and several classes of marine radio stations which are already covered by similar provisions. The fines would apply separately to both the operator and the licensee of any station which: (1) is operated by any person not holding a valid radio operator license of the type prescribed, where one is required; (2) is operated without proper identification; (3) transmits a "false" call-sign; (4) is operated on an unauthorized frequency; (5) transmits unauthorized communications on a distress or calling frequency; (6) interferes with any distress communication; (7) does not curb spurious emissions to the extent required; (8) uses higher power than that authorized; (9) renders an unauthorized communication service; (10) uses an unauthorized type of emission; (11) uses unauthorized transmitting equipment; or (12) "willfully or repeatedly fails to respond to official communications from the Commission."

Under the plan, the FCC would have to notify you within 90 days of an alleged violation, and you would then have an opportunity to explain why you felt you shouldn't be fined. You would be given the first crack back at the Commission in writing, and then, if you wish, be granted a personal interview with an FCC field official at the agency's clos-



Accredited by the National Home Study Council

good training  
doesn't cost . . .  
it pays!

# How To Get an



# FCC License (Commercial)

## An FCC License Or Your Money Back!

Completion of the Master Course (both Sections) will prepare you for a First Class Commercial Radio Telephone License with a Radar Endorsement. Should you fail to pass the FCC examination for this license after successfully completing the Master Course, you will receive a full refund of all tuition payments. This guarantee is valid for the entire period of your enrollment agreement.

## Increase Your Technical Knowledge

Get a government license plus an understanding of such electronic applications as computers . . . industrial electronics . . . radar . . . communications . . . and many more.

## Get This Handy Pocket Electronics Data Guide

# Free...

Puts all the commonly used conversion factors, formulas, tables, and color codes at your fingertips. Yours absolutely free if you mail the coupon today. No further obligation.

## Not for Beginners!

Please inquire only if you really want to get ahead and to add to what you have already learned in school, in the service, or on the job. Some previous schooling or experience in electronics, electricity, or related fields is necessary for success in Cleveland Institute programs.

## Cleveland Institute of Electronics

1776 E. 17th Street Desk PE 79 Cleveland 14, Ohio

July, 1961

## Get All 3 Booklets Free!



### Cleveland Institute of Electronics

1776 E. 17th Street, Desk PE 79, Cleveland 14, Ohio

Please send Free Career Information Material prepared to help me get ahead in Electronics and a free copy of your "Pocket Electronics Data Guide." I have had training or experience in Electronics as indicated below:

- |   |   |
|---|---|
| <input type="checkbox"/> Military           | <input type="checkbox"/> Broadcasting       |
| <input type="checkbox"/> Radio-TV Servicing | <input type="checkbox"/> Home Experimenting |
| <input type="checkbox"/> Manufacturing      | <input type="checkbox"/> Telephone Company  |
| <input type="checkbox"/> Amateur Radio      | <input type="checkbox"/> Other.....         |

In what kind of work are you now engaged?

In What branch of Electronics are you interested?

.....

.....

Name.....Age.....

Address.....

City.....Zone.....State.....

PE 79

**hallicrafters' new s-120  
short wave receiver  
has the clean look of  
precision performance**



**\$69.95**

Where there's danger and excitement . . . where men of adventure are making history . . . *you can be in on the action* with this rugged, super-sensitive short wave receiver!

Here's the very latest Hallicrafters advanced design, a compact beauty that's professionally styled, precision engineered to pull in the best of short wave—*ships, planes, foreign stations, amateurs, police, emergency and military stations*—from all over the world. All this, and it's a fine *standard broadcast* receiver too!

Latest features, including electrical *bandspread* for precision tuning . . . *slide-rule dial* (shows you where to listen for what) . . . telescoping "*whip*" antenna . . . front panel jack for *headphones*. Set up your own private listening post for adventure *today!*

The new ideas in communications  
are born at . . .

**h hallicrafters**  
DEPT. 21, CHICAGO 11, ILL.



Want to hear exciting examples  
of short wave? Send us 25¢  
and we'll rush you our limited edition  
record, "The Amazing World of  
Short Wave Listening".

**FCC Report**

(Continued from page 12)

est office to your home, to try to talk him out of it.

The schedule of forfeitures calls for \$100 for violation of any one of the 12 points, no matter how many times the provision is violated during the three months before you are cited; it has a ceiling of \$500 for any number of violations of all of the 12 points during the same 90-day period. And if the bill is passed, the Commission would be permitted to set the money penalty at a lower figure, or to wipe it out entirely, at its discretion. The agency told Congress that the fines would be applied "only for a willful, or negligent, or repeated violation."

On another subject that could cost CB'ers and other radio users some money, FCC Chairman Newton N. Minow has gone on record in support of long-discussed proposals which would permit the Commission to charge "filing fees" for the processing of applications.

This proposal is a perennial favorite as a means of defraying some of the cost of government, and for paying the cost of the government's providing special services to some members of the public in cases where the entire public may not be involved. Mr. Minow said he feels that there is "no reason why public funds should have to be appropriated for the operation of the FCC."

A formal petition to raise the allowable height of CB antennas over the present 20-feet-above-existing-objects limit has again been received by the Commission. The petition said that an increase in the limit to 30 feet would encourage the use of directional antennas, and would tend to reduce interference.

-50-

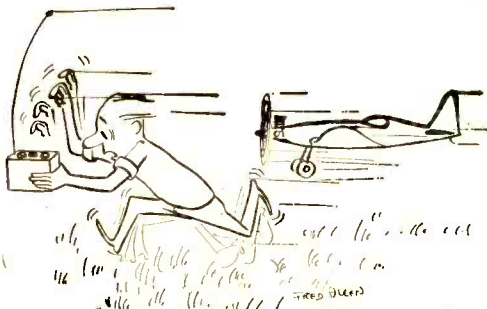

Always say you saw it in—POPULAR ELECTRONICS



**For serious-minded men desiring higher income and status-**

CREI has developed a program of home study that is comparable in technological content to advanced residence courses in electronics. The program was developed hand-in-hand with leading companies and Government agencies contributing to the Nation's efforts in electronics, communications, missiles, and space exploration.

This CREI program in Electronics Engineering Technology may be completed in 2 to 4 years, depending on how much of your spare time you can devote to study. The courses are presented in easy-to-understand form. Our instructors will give you personal attention and assist you when you need help.

To qualify CREI graduates for advancement to key technical positions, CREI offers a complete program in electronics, including—

Automation • Instrumentation • Industrial Electronics  
 Aeronautical Electronics • Guided Missiles • Radar  
 Servo-mechanisms • Computers • Astronautics • Telemetering • Communications • Electronics Manufacturing • Field Engineering • Nuclear Engineering

# A COLLEGE-LEVEL EXTENSION PROGRAM IN ELECTRONICS

There is a drastic need in the electronics industry for well-educated engineers and technical personnel. Although the great majority of students find ample opportunity for advancement with their present companies, CREI maintains a Placement Bureau to assist graduates and advanced students in finding more desirable positions. For many years, the demand for CREI graduates and advanced students has far exceeded the supply.

A few of the private companies and government agencies whose officials approve CREI for their own personnel:

U. S. Navy (5,240 enrolled in extension program)

Army, Air Force, Marine Corps, Coast Guard

Columbia Broadcasting System

National Broadcasting Company

Federal Electric Corporation

Florida Power & Light

Pan American Airways

United Airlines

The Martin Company

All America Cable & Radio

Voice of America

... and many others

**QUALIFICATIONS FOR CREI.** You qualify if you have a high school diploma or equivalent, and if you have had basic electronic training and practical experience in electronics. Available to Veterans.

**CREI's Extension Division offers you a college-level home study program in electronics comparable in technological content to advanced residence courses.**

**Mail this coupon . . . today!**

**CAPITOL RADIO ENGINEERING INSTITUTE**

ECPD Accredited Technical Institute Curricula • Founded 1927  
 Dept. 1207-M, 3224 16th St., N.W., Washington 10, D. C.

England: CREI London, Granville House, 132-135 Sloane Street, London S.W. 1, England

Please send me your course outline and FREE 56-Page Book "Your Future in Electronics and Nuclear Engineering Technology" . . . describing opportunities and CREI home study courses in Advanced Engineering Technology.



- Check field of greatest interest**
- Radar, Servo and Computer Engineering Technology
  - Electronic Engineering Technology
  - Communications Engineering Technology
  - Television Engineering Technology
  - Aeronautical Electronic Engineering Technology
  - Automation and Industrial Electronics Engineering Technology
  - Nuclear Engineering Technology

Name \_\_\_\_\_ Age \_\_\_\_\_  
 Street \_\_\_\_\_  
 City \_\_\_\_\_ Zone \_\_\_\_\_ State \_\_\_\_\_

Check:  Home Study     Residence School     Korean Veteran

To obtain fast, immediate service and to avoid delay, it is necessary that the following information be filled in:

Employed by \_\_\_\_\_

Type of Present Work \_\_\_\_\_

Education: \_\_\_\_\_

Years of High School \_\_\_\_\_

Other \_\_\_\_\_

Electronics Experience \_\_\_\_\_



### Microphones designed for the ham

Turner's 250 Series Microphones give you the ultimate in operating convenience. Transmit by simply lifting the microphone or depressing the push-to-talk bar. For longer transmissions, simply pull the lever-lock switch forward.

Engineered to satisfy the communication requirements of any ham, the 250 Series is available in six different models ranging in price from \$9.60 net to \$29.70, depending on switching arrangement, finish and interior. Dynamic response is 60-10,000 c.p.s. — Level —52 db. Crystal response is 60-8,000 c.p.s. — Level —48 db.

See the versatile, easy-to-operate Turner 250 Series microphones at your nearest distributor's, or write direct for complete information and specifications.

**THE TURNER MICROPHONE COMPANY**  
 946 17th St. N.E., Cedar Rapids, Iowa  
 EXPORT: Ad Auriema, Inc., 85 Broad St., New York 4, N.Y.

# Letters

from our  
**readers**

### Happy Over Flip-Flops

■ Your recent articles on flip-flop computers ("Flip-Flop Circuits," March, 1961, and "Flip-Flop Computer," April, 1961) were like water in the desert. I've been searching for this type of information for five years, ever since I became a member of the Association for Computing Machinery. Please continue to publish material on this subject, and give us more articles with theory and practical construction information.

HARRY C. VOORHOEVE  
 N. Vancouver, B. C., Canada

■ I believe there is an error in the schematic on page 62 of the March 1961 issue. The 1.5-volt reset battery is shown hooked up in reverse for proper circuit operation. The positive—rather than the negative—terminal should be connected to reset switch S<sub>2</sub>.

DALE S. McCLANAHAN  
 Florissant, Mo.

■ I constructed the circuit shown on page 62 of the March 1961 article entitled "Flip-Flop Circuits." Since I had no 2N554 transistors on hand, I substituted two 2N107's, making appropriate changes in the resistor values. The low maximum current of the 2N107's made it impossible for me

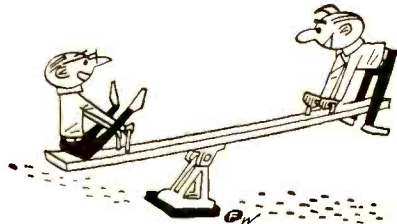

to use small bulbs in the collector circuits, so I used milliammeters instead. It works fine—and thanks for the informative article.

R. S. CLARK  
 Morton Grove, Ill.

*Judging by the mail we've received on the subject, reader interest in computers is at an all-time high. We'll be happy to oblige with more computer articles in the near future. Reader McClanahan is right, incidentally—the reset battery was shown connected in reverse on page 62 of the March article but corrected in the April issue.*

### SWL's Comment

■ Being an SWL, I really enjoy reading "Short-Wave Report." I can honestly say that with the

Always say you saw it in—POPULAR ELECTRONICS

help of the current station reports, it is much easier to tune to points on the dial where I can expect to find good listening. Some day, I hope to discover a rare station or two myself that I can pass on to the column.

JACK CONNELLY, WPE3BMU  
Baltimore, Md.

### Transistor Tester

■ The parts list for the "In-Circuit Transistor Tester" (February, 1961) indicates that C2 is a 0.068- $\mu$ f., 400-volt disc capacitor. I haven't been able to find such a capacitor in any of the catalogs. Can you tell me who makes this unit?

WILLIAM R. LUSBY  
Washington, D. C.

*Your confusion was caused by a misprint; C2 should be a 0.0068- $\mu$ f. capacitor.*

### San Antonio SWL Club

■ We POPtronics Monitors here in San Antonio have been trying, without much success, to find members for a local short-wave club. Our organization ("The Alamo DX Club," Dave Rhodes, President) has just received the call sign WPE5BJR. San Antonio, however, is a city of over 700,000 people and it's difficult for us to locate other SWL's who might like to join. Any help you can give us will be appreciated.

BOB STEPHENS, WPE5AYM  
GARLAND WOODS, WPE5QW  
DAVE RHODES, WPE5AYH  
WAYNE BEDGOOD, WPE5QK

*All San Antonio area SWL's interested in joining this new organization should contact The Alamo DX Club, % Dave Rhodes, WPE5AYH 907 Shemya St., San Antonio 21, Texas.*

### Radar "Slip"

■ I have just finished my first reading of your March 1961 issue. Since I am a prospective radar



technician, I was very much interested in the article on "Then Danger of Radar Waves" by Ken Gilmore—I found it a useful supplement to my Air Force classes. But there seems to be an error on page 106. The author states: "... the Air Force plays it extra safe by specifying that personnel shall be exposed to radiation fields no greater than one-twentieth that amount, or 0.1 watt/sq. cm." Shouldn't this be 0.01 watt/sq. cm.?

A/3C WILLIAM F. AULL  
Lowry A.F.B., Colorado

*You're right, reader Aull. Please excuse the slip, and good luck with your radar classes.*

### Part Needed

■ I'm restoring an ancient Crosley "Magnetune" radio (Model 729) and need a push-button assem-

bly to complete the job. The Crosley part number is G8-48762. I'd even consider buying a complete 729 receiver in order to get this part, and would appreciate hearing from any reader who can help.

WELTON L. GEORGE  
221 Palmyra Drive  
Orlando, Fla.

### Darkroom Meter

■ Enclosed is a picture of the "Darkroom Meter" (April 1961 issue) which I have just completed. I had some trouble with shorted photocell leads at



first, but now the unit's working fine and I expect it to be a great help in my work.

MYRON S. SHEPARD  
440 East 91 St.  
New York, N. Y.

*That's a good-looking piece of equipment, Mr. Shepard. We notice from your letterhead that you're a professional photographer, but apparently you're no novice at electronic construction either.*

### Conflict of Interests

■ I have been reading POPULAR ELECTRONICS for three years, and think it is the "best." It amuses me to see the hi-fi and ham radio fans trying to eliminate each other in your "Letters from Our



Readers" column. I'd like to know what would happen if they all got together and tried to run your excellent magazine for just one issue.

GEORGE OLSEN, WPE1ABV  
East Lyme, Conn.

*We try to please as many readers as possible, George—and that includes CB'ers, SWL's, and just plain experimenters. When the amateur radio and hi-fi fans come in to run the magazine, we hope you'll be willing to act as referee.*

SPARTAN TEACHES  
**ELECTRONIC  
 TECHNICIANS**  
 THE EASY  
 WAY

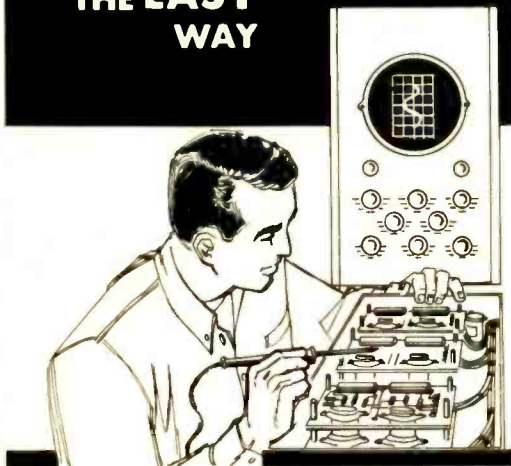

Spartan teaches Electronic Technicians the easy way . . . by scientific methods and with ultra modern equipment. Write today for FREE brochure on methods and equipment. You learn by doing! If you really want to earn more money, get into the electronics field—NOW—where earnings are higher, jobs are plentiful. Ask about our Extended Payment Plan and Job Placement service. **YOUR FUTURE IS AT STAKE!**

Classes open to men and women . . . day and night courses available.

**SPARTAN SCHOOL OF ELECTRONICS**

Director of Admissions  
 Spartan School of Electronics  
 Dept. PE-71  
 Municipal Airport / Tulsa, Okla.

NAME .....

ADDRESS .....

CITY ..... STATE .....

**Hi-Fi** | 



**Showcase**

*A quick look at new products in the stereo/hi-fi field\**

**A**LTHOUGH extremely compact (measuring only 2<sup>5</sup>/<sub>8</sub>" x 9<sup>3</sup>/<sub>4</sub>" x 7<sup>5</sup>/<sub>8</sub>" ), the Knight KN-141 FM tuner from *Allied Radio* boasts features of larger, more expensive units, as well as some special ones of its own. For lock-in, drift-free tuning, there's a bar-type 6FG6 electronic tuning eye, plus automatic frequency control (a.f.c.). A built-in line-cord antenna fills the bill for local reception, and there are provisions for adding an external antenna. Even more important, the KN-141's small size means it can be used almost anywhere: plug its line cord into any wall outlet, its output cord into any amplifier's tuner or phono jack, and listen. Price, complete with beige and gray case, \$49.95. . . . Another new product from Allied is the KN-611 monophonic amplifier for low-cost home music systems. A perfect match for the KN-141 FM tuner with its beige and gray color styling, the KN-611 is also small in size (4" x 9<sup>1</sup>/<sub>2</sub>" x 7<sup>1</sup>/<sub>2</sub>" ). With inputs for tape, tuner, or phono cartridge, the KN-611 can easily form the heart of a budget-priced home music system. Push-pull EL84/6BQ5 output tubes deliver 10 watts, and individual bass and treble tone controls allow you to adjust the sound to suit your taste. Price, \$39.95.

From *Benjamin Electronic Sound* comes an automatic turntable/changer with a hysteresis motor and a dynamically balanced, 7-lb. non-ferrous 12" turntable for excellent speed accuracy. Not only do push buttons change the automatic turntable to a record-changer and vice versa, but the buttons can also be used to place the pickup in the record groove, thus eliminating hand-lifting entirely. The four-speed "Studio-H" is priced at \$99.50; another model, "the Studio," uses a shaded-pole induction

\*Write to the manufacturers listed at the end of this column for more data on products mentioned



# THIS COULD HAPPEN TO YOU... UNLESS THE KIT YOU BUILD IS A PACO

COMPARE THESE PACO FEATURES:

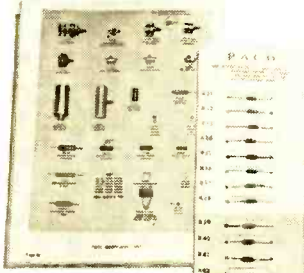

No mistaken identity or endless searching. Parts are clearly pictured and labeled; resistors are neatly mounted and identified!

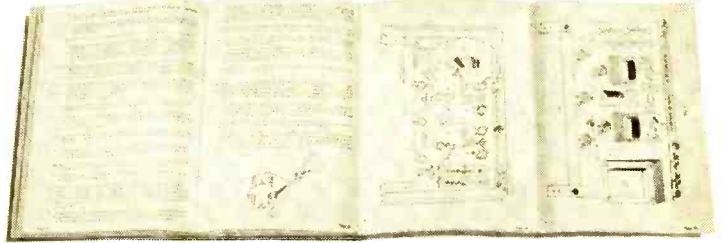

Step-by-step instruction book makes assembling a Paco Kit foolproof! Paco gives you giant, fold-out diagrams on corresponding instruction pages so you can see both at the same time.



### PACO Model C-25 IN-CIRCUIT CAPACITOR TESTER KIT

Reveals dried out, shorted, or open electrolytics—in the circuit—with Paco's exclusive Capacity Dial. Instantly finds open or direct shorted capacitors without removing from circuit. Great time saver!

**Specifications:**

**SIMPLE SEQUENTIAL TEST:** reveals open or shorted capacitors, including electrolytic types.  
**ELECTROLYTIC DIAL:** indicates actual electrolytic values while capacitor is in circuit; any electrolytic which yields a capacity reading on Electrolytic Dial is automatically revealed as not open or shorted.

**ELECTROLYTIC TEST:** indicates in-circuit electrolytic capacity from 2 mfd to 400 mfd in two ranges; condenser is automatically proved non-short and not open if Capacity Reading can be obtained.

**Model C-25:** Kit, complete with PACO-detailed assembly-operating manual. **Kit Net Price: \$19.95**  
**Model C-25W:** Factory-wired, ready to operate. **Net Price: 29.95**



### PACO Model DF-90 TRANSISTORIZED DEPTH FINDER KIT

Protect your boat against shoals and underwater hazards with this compact, easy-to-read depth finder. Transistors prolong battery life, provide utmost accuracy and portability. A boon to fishermen—locates hard-to-find schools of fish. A low cost safety device for every boat owner.

**Specifications:**

**FULLY TRANSISTORIZED:** 5 transistors, with a low battery drain for extremely long battery life.  
**HIGH INTENSITY INDICATOR:** for sensitive, accurate response under all conditions.

**FAST, EASY READINGS:** made possible by means of over-sized scale calibrated at one-foot intervals from 0 to 120 feet.

**Model DF-90:** Kit, complete with PACO-detailed assembly-operating manual. **Kit Net Price: \$84.50**  
**Model DF-90W:** Factory-wired, ready to operate. **Net Price: \$135.50**



### PACO Model SA-40 STEREO PREAMP-AMPLIFIER KIT

Assemble a superb home music system with this true 40 watt stereo preamp-amplifier. Unmatched flexibility, less than 0.5% distortion, and handsome design make this the ideal component for music lover and audiophile alike!

**Specifications:**

**MUSIC WAVEFORM POWER OUTPUT:** 25 watts per channel (50 watts total).  
**RESPONSE:** 30 cps to 90Kc.  $\pm 1.0\%$  db  
**HARMONIC DISTORTION:** less than 0.5% at 20 watts per channel output.

**Model SA-40:** Kit, complete with black and gold case and PACO-detailed assembly-operating manual. **Kit Net Price: \$79.95**  
**Model SA-40W:** Factory-wired, with black and gold case, ready to operate. **Net Price: \$129.95**

Paco Electronics Company, Inc., Dept PE7  
70-31 84th Street, Glendale 27, L. I., N. Y.  
Please send me your complete illustrated catalog.

Name .....

Address .....

City ..... Zone ..... State .....

© PACOTRONICS, INC. 1961

## FREE! COMPLETE ILLUSTRATED CATALOG

Mail this coupon for the complete Paco catalog of electronic equipment kits, including test instruments, measuring instruments, and high fidelity components.



# EARN \$10,000 A YEAR

- DIESEL       ELECTRONICS  
 AUTO         AUTOMATION

The average starting salary of students, completing our FCC License, Electronics Technician Course, and those completing our Diesel Automotive Training, is \$4,300 per year.

After becoming familiar with the industry, their salary usually increases to \$6,000 or \$7,000 per year.

After they become senior technicians, or master mechanics, they can earn \$8,000 to \$10,000 per year.

When they become specialists, or a part of management . . . or start their own business . . . they can earn considerably more.

**RESIDENT SHOP TRAINING** is easier and costs less than you may think! We provide you with housing and part-time jobs while in school, plus free nation-wide placement service for graduates.

Check subject above in which you are interested and mail for

◀ **FREE BOOKLET** ▶

**BAILEY**  
Technical Schools

Veteran Approved  
1626 S. Grand, Rm. 28, St. Louis 4, Mo.

Your Future  
IN  
ELECTRONICS  
AND  
AUTOMATION

Your Future  
in  
DIESEL and  
AUTO  
MECHANICS

---

Name \_\_\_\_\_ Age \_\_\_\_\_  
 Street \_\_\_\_\_  
 Town \_\_\_\_\_ Zone \_\_\_\_\_ State \_\_\_\_\_

## SAVE \$75

Assemble your own high quality Citizens Band and 10 meter amateur band radiophone with the all-new SPRINGFIELD TR-28 chassis

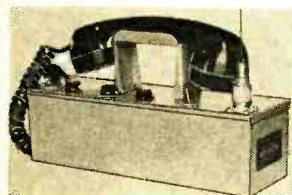

**Complete electronic chassis—only**

**\$24.98**  
post-paid

100 milliwatt 23 channel transmitter with 4 channel selector switch.

23 channel supersensitive receiver with noise limiting and AVC action plus extended frequency range for 10 meter amateur band.

Electronic chassis is complete with all transistors plus crystal for 1 channel.

Meets FCC requirements for both unlicensed and licensed operation. No age restrictions for unlicensed operation.

Complete instructions for quick assembly. No knowledge of electronics necessary as chassis is factory wired, tested and guaranteed.

Accessories for completing the walkie-talkie as illustrated are available at low cost.

Requires only 8 standard flashlight batteries. Battery life 1,000 hours.

Range from 1/2 to 10 miles depending on conditions.

New sectional construction for easy maintenance and repair if ever required. Transmitter and receiver may be detached and used separately as each contains its own audio and RF circuits.

FREE R. F. power indicator kit with each order

### SPRINGFIELD ENTERPRISES

Dept. E-7 196-23 Jamaica Ave., Hollis 23, N.Y.

## Showcase

(Continued from page 18)

motor and sells for \$79.95. . . . From *Dynaco* comes a 16" professional arm-and-cartridge combination produced by Denmark's Bang and Olufsen. Based on the "Isodyne" principle, the TA-16 arm maintains precisely equal pressures on each side of the record groove regardless of frictional forces. As a result, it is not subject to skipping when jarred, does not require accurate turntable leveling, yields lower record wear, low distortion, uniform channel balance, precise phase relationships, and uniform channel separation. Tracking at pressures as low as 1 gram, the TA-16's cartridge has a frequency response from 30 to 15,000 cycles,  $\pm 2$  db. Price of the TA-16 arm-and-cartridge combination: \$59.95.

A stereo/mono four-track tape deck from *EICO* (Model RP-100) is equipped with a 14-transistor record/playback amplifier and push-pull bias/erase oscillator. Not only does the RP-100 incorporate such professional features as a hysteresis synchronous capstan-drive motor and two heavy-duty induction reel motors, but separate record and play heads and amplifiers permit monitoring while recording. Simple to operate, the RP-100 has all-electric push-button controls, and its "record" button is interlocked with its "run" button to prevent accidental erasure. The RP-100 is available in two models, both with speeds of  $3\frac{3}{4}$  and  $7\frac{1}{2}$  ips. One model, fully wired and tested, sells for \$395.00; a second (a "semi-kit") consists of a fully wired and tested tape deck with tape electronics in kit form and sells for \$289.95. An optional carrying-case designed to hold the RP-100 and two 7" reels is priced at \$29.95. . . . From *Eric Electronics* comes a 50-watt stereo amplifier/preamp combination that makes use of transistorized preamps. The result is a better match to magnetic pickups and tape heads, no hum or microphonics, and better signal-to-noise ratio. Delivering 25 watts per channel at less than 1% total harmonic distortion, the 3560T features a center-channel output which effectively eliminates the "hole in the middle" effect.

Two kits just introduced by the *Heath Company* are an AM/FM tuner (Model

Always say you saw it in—POPULAR ELECTRONICS

# LAFAYETTE is America's Citizens Band Headquarters

Complete Portable Communications for Everyone



Ship to Shore



On the Farm



Construction Work

NO LICENSES, TESTS OR AGE LIMITS

HE-29



LAFAYETTE  
**9** TRANSISTOR  
CITIZENS  
BAND  
"WALKIE TALKIE"

**42.95**  
2.00 Down  
**2 for 82.95**

PORTABLE—  
POCKET SIZE  
Only  
6 3/4 x 3 1/4 x 1 3/8"

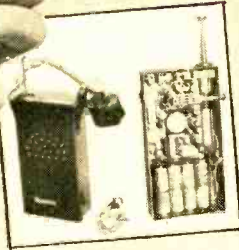

• Completely Wired—Ready to Operate • Fully Transistorized—9 Transistors plus 1 Diode • Uses Inexpensive Penlight Batteries • No License, Tests or Age Limits • Comes with Leather Carrying Case, Earphone, Antenna, Batteries and Crystals  
As simple and easy to use as the telephone—and twice as handy. Receives and transmits up to 7-miles under favorable conditions, or 1.5 miles under average conditions. Weighs only 18-oz. and slips into your pocket. Push-to-talk button operates built-in speaker as sensitive microphone.

LAFAYETTE HE-20A  
DELUXE  
Citizens Band  
TRANSCEIVER

**109.50** 5.00 Down



Made in U.S.A.

Now With Added Deluxe Features—

• Pi-Network for Greater Power Output • Calibrated "S" Meter • 14 Tube Performance, 3 Diodes • Built-in 12 Volt Power Supply for Mobile Use • Complete with Matched Crystals for Channel 9  
A highly efficient 2-way communications system operating over a distance of up to 20 miles or more depending on terrain. Features

4 crystal-controlled transmit positions and 4 crystal-controlled receive positions. Tuneable superhet receiver covers all 23 assigned channels. Other highlights include dependable push-to-talk ceramic mike & relay, adjustable squelch control, automatic series gate noise limiter and illuminated dial.

LAFAYETTE HE-15A

Made in U.S.A.



ONLY  
**59.50**  
5.00 Down

SUPERHET

Citizens Band TRANSCEIVER

NOT A KIT

• Completely Wired—Not A Kit • 5 Crystal-Controlled Transmitting Positions • Tuneable Receiver Over Full 23 Channels • High Output Crystal Microphone • Complete with Transmitting Crystal for Channel 9  
A compact, precision transmitter and receiver covering up to a 20 mile or more radius, depending upon conditions. The HE-15A features an effective full-wave variable noise limiter, RF jack on front panel, planetary vernier tuning, 5-prong microphone jack for easy relay addition, and 12 tube performance from 4 dual-function tubes, 2 single-function tubes, 2 rectifiers.

HE-19 Telescoping Whip Antenna ..... Net 3.95  
HE-16 Power Supply for 12 Volts ..... Net 10.95  
HE-18 Power Supply for 6 Volts ..... Net 10.95

LAFAYETTE All-in-One  
CITIZENS BAND  
MOBILE ANTENNA

HE-800WX  
**6.95**

• Chrome Swivel Base • Stainless Steel Spring  
• 102 1/2" Stainless Steel Whip for Optimum 11-Meter Performance

Chrome swivel ball mount base designed for mounting on any surface. Stainless steel spring holds rod in properly adjusted position and prevents rod damage from shocks and blows. Stainless steel whip for maximum resiliency and strength.



NEW! LAFAYETTE  
RADIO FIELD INDICATOR

TM-14  
**6.95**

• Continuously Indicates Transmitter Output • Rugged 200 ua Meter Movement • Requires No Electricity, Batteries or Transmitter Connection  
Check the performance of marine, mobile or fixed transmitter. Features a 200 ua meter movement with variable sensitivity control. Earphones can be plugged in for an aural check of output. Antenna extends from 3 1/4" to 10 3/4". Magnet on bottom plate allows easy mounting on car dash or metal surfaces. Size, less antenna, 3 1/4"W, 2 1/4"H, 2"D.



**LAFAYETTE**  
RADIO

PLEASE INCLUDE SHIPPING CHARGES WITH ORDER

165-08 LIBERTY AVENUE, JAMAICA 33, N. Y. • OTHER LOCATIONS

NEW YORK, N. Y.  
100 6th Avenue

NEWARK, N. J.  
24 Central Avenue

BRONX, N. Y.  
547 W. Endham Road

PARAMUS, N. J.  
180 Rte. 17

BOSTON, MASS.  
110 Federal Street

PLAINFIELD, N. J.  
139 W. 2nd Street

RESIDENT SCHOOL COURSES IN  
LOS ANGELES AND NEW YORK CITY

# START YOUR CAREER IN ELECTRONICS NOW AT RCA INSTITUTES...

Choose from this list

	Course	Qualifications	Length of Course
A	Advanced Electronic Technology (T-3)	High School grad, with Algebra, Physics or Science	Day 2 1/4 yrs. Eve. 6 3/4 yrs. (N.Y.) 4 1/2 yrs. (L.A.)
B	Television and General Electronics (V-7)	2 yrs. High School, with Algebra, Physics or Science	Day 1 1/2 yrs. Eve. 4 1/2 yrs. (N.Y.) 3 yrs. (L.A.)
C	Radio and Television Servicing (V-3)	2 yrs. High School, with Algebra, Physics or Science	Day 9 mos. Eve. 2 1/4 yrs. (N.Y.) 1 1/2 yrs. (L.A.)
D	Transistors	Radio background	Eve. 3 mos.
E	Electronic Drafting (V-11 V-12)	2 yrs. High School, with Algebra, Physics or Science	Eve. Basic: 1 yr. Advanced: 2 yrs.
F	Color Television	Television background	Eve. 3 mos.
G	Audio-Hi Fidelity	Radio background	Eve. 3 mos.
H	Computer Programming (C-1)	College Graduate or Industry sponsored.	Eve. 24 weeks
I	Technical Writing (V-10)	High School Graduate	Eve. 2 1/4 yrs. (N.Y.) 1 1/2 yrs. (L.A.)
J	TV Studio Production (S-1)	High School Graduate	Day 15 weeks Eve. 45 weeks
K	Digital Computers	Electronics background	Eve. 3 mos. (L.A.)
L	Preparatory Math & Physics (P-0)	1 yr. High School	Day 3 mos.
M	Preparatory Mathematics (P-0A)	1 yr. High School	Eve. 3 mos.
N	Home Study Courses	Choose from: Radio and Electronic Fundamentals, TV Servicing, Color TV, Transistors, and Automation Courses. Catalog free on request.	

RCA Institutes is one of the largest technical institutes in the United States devoted exclusively to electronics. Free Placement Service. Applications now being accepted for next term classes in Los Angeles and New York.



The Most Trusted Name  
in Electronics  
RADIO CORPORATION OF AMERICA



Send to the school nearest you!

RCA Institutes, Inc., Dept. PER-71

Pacific Electric Building 350 West Fourth Street  
610 S. Main St., L.A. 14, Calif. New York 14, N. Y.

Please send me your FREE catalog. I am interested in the courses circled below.

A B C D E F G H I J K L M N

Name \_\_\_\_\_ (please print)

Address \_\_\_\_\_

City \_\_\_\_\_ Zone \_\_\_\_\_ State \_\_\_\_\_

For Home Study Courses, See Ad On Opposite Page

## Showcase

(Continued from page 20)

AJ-11) and a 28-watt stereo amplifier (Model AA-151). Housed in matching cabinets (both are luggage-tan, vinyl-clad steel, measuring 15 3/4" x 5 1/4" x 11"), the units form an ideal basis for a low-cost stereo system. In the AJ-11 tuner, separate "magic-eye" tuning indicators let you "zero in" on both AM and FM stations with ease and accuracy. And while there are built-in antennas for both AM and FM, terminals are also provided for attaching external antennas. As for controls, there's a 3-position a.f.c. switch, an AM fidelity switch, and individual flywheel tuning for both AM and FM. In the AA-151 amplifier, four dual inputs and five controls (source, volume, bass, treble, and mode) provide "fingertip" command of every stereo and mono function. Price of the AJ-11 tuner kit is \$69.95; fully wired, it is designated the AJW-11 and sells for \$129.95. The Model AA-151 stereo amplifier, incorporating clutched volume controls for single- or dual-channel adjustment, is available only in easy-to-build kit form and carries a price tag of \$59.95.

Two new speaker systems—the S-2 and S-3—from **H. H. Scott, Inc.** achieve unusually smooth response over the entire audio spectrum. Both are three-way units, employing built-in crossovers, and both have nominal impedances of 16 ohms. The more elaborate of the two (the S-2) employs a high-compliance 12" woofer, two dual-cone mid-range speakers, and a wide-dispersion, spherical tweeter. The Model S-3, in contrast, has a 10" woofer, one mid-range speaker, and a wide-range tweeter. Both models carry a two-year guarantee. The S-2, measuring 23 3/4" x 14 1/2" x 12 1/2", is priced at \$199.95; the S-3 (23 1/2" x 11 3/4" x 9 3/4") sells for \$129.95. -30-

Allied Radio Corp. (Knight), 100 N. Western Ave., Chicago 80, Ill.  
Benjamin Electronic Sound Corp., Corona, N.Y.  
Dynaco Inc., 3912 Powelton Ave., Philadelphia 4, Pa.  
Electronic Instrument Co., Inc. (EICO), 33-00 Northern Blvd., Long Island City 1, N.Y.  
Eric Electronics Corp., 1823 Colorado Ave., Santa Monica, Calif.  
Heath Co., Benton Harbor, Mich.  
H. H. Scott, Inc., Dept. P, 111 Powdermill Rd., Maynard, Mass.



# RCA training at home can be the smartest investment you ever made

Look what you get in the Course in Radio and Electronic Fundamentals

**40 Fascinating THEORY LESSONS**



Containing all the basic principles of radio and electronics in easy-to-understand form.

**40 EXPERIMENT LESSONS**



Each containing absorbing, practical experiments bound together in 20 books.

**40 SERVICE PRACTICES**



Full of practical, time-saving and money-saving servicing tips, bound into 20 books.

**PLUS ALL THIS AT NO EXTRA COST...**

**15 KITS**

to build a Multimeter, AM Receiver and Signal Generator. Kits contain new parts for experiments, integrated so as to demonstrate what you learn in the lessons and to help you develop technical skills. Each kit is fun to put together!



**MULTIMETER**

A sensitive precision measuring instrument you *build* and use on the job. Big 4½" meter with 50 micro-amp meter movement. 20,000 ohms-per-volt sensitivity d-c, 6,667 a-c.



**AM RECEIVER**

Have the satisfaction of building your own radio receiver with this high-quality 6-tube superheterodyne set. Big 5" speaker, fine tone!



**SIGNAL GENERATOR**

A "must" for aligning and trouble-shooting receivers. Build it for your own use. 170 KC to 50 MC fundamental frequencies for all radio and TV work.

Also, comprehensive, fully-integrated home study courses in • *Television Servicing* • *Color Television* • *Electronics For Automation* • *Transistors*. Stake out your future in electronics with any one of this wide variety of courses. Practical work with the very first lesson! Pay-only-as-you-learn! No long-term contracts to sign! No monthly installments required. Pay only for one study group at a time, if and when you order it!

**SEND FOR FREE HOME STUDY CATALOG TODAY!**

RESIDENT SCHOOL COURSES in Los Angeles and New York City offer comprehensive training in Television and Electronics. Day and Evening classes. Free Placement Service. Catalog free on request.



**RCA INSTITUTES, INC.**  
A Service of Radio Corporation of America • 350 W. 4th St., New York 14, N. Y. • 610 S. Main St., Los Angeles 14, Calif.

**RCA INSTITUTES, INC.** Home Study School, Dept. PE-71  
A Service of Radio Corporation of America  
350 West Fourth Street, New York 14, N. Y.

Without obligation, rush me the FREE 64-page illustrated booklet "Your Career in Electronics" describing your electronic home study training program. No salesman will call.

Name.....  
Address.....  
City.....Zone.....State.....  
Veterans: Enter discharge date.....

**CANADIANS**—Take advantage of these same RCA courses at no additional cost. No postage, no customs, no delay. Send coupon to: RCA Victor Company, Ltd., 5581 Royalmount Ave., Montreal 9, Quebec.



The Most Trusted Name in Electronics

For Resident School Courses See Ad On Opposite Page.

# NEW ANTENNAS

## Short Wave Listening

Amazing new indoor short wave antenna system reaches out for those far away signals and greatly increases the performance of any short wave receiver. Covers frequencies from 5 through 30 megacycles including all the important short wave and amateur bands. . . . Easy to operate—simply attach cable (6 foot furnished) to receiver, extend telescoping ears and adjust "match" and "tune" controls for maximum signal strength. Attractively housed in unbreakable modernistic plastic case with chrome plated antennas. Completely factory wired.



Price \$14.75 EACH

### OUTDOOR HIGH EFFICIENCY

MODEL SWO

Peaked for  
11-13-16  
19-24-31  
40m

High efficiency outdoor antenna. Only 40 feet long. Mounts quickly and easily under eaves, in attic space, etc. Peaked for top performance on the important short wave bands with 8 trap assemblies. Complete kit includes 100 feet of lead in cable.

**4u-gain** antenna products  
1135 No. 22nd St. Lincoln, Nebr.

# POPtronics Bookshelf

## ABC'S OF COMPUTERS by Allan Lytel

This basic introduction to electronic computers explains in simple language what computers are, how they operate, and what they can be expected to do. The general circuitry and special circuit devices used in the two basic types of computers (digital and analog) are discussed, followed by an explanation of computer numbering systems — including binary notation—and computer logic circuits. Binary, decade and ring counters are covered, and the book concludes with comprehensive data on calculating circuits, information storage, input-output devices, and programing.

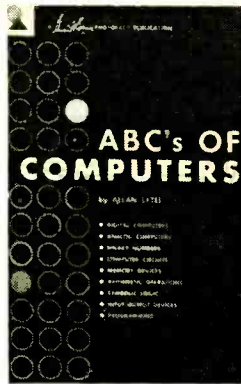

Published by Howard W. Sams & Co., Inc., 1720 E. 38th St., Indianapolis 6, Ind. 128 pages. Soft cover. \$1.95.



## MOST-OFTEN-NEEDED 1961 RADIO DIAGRAMS compiled by M. N. Beitman

All popular 1961 home radios, FM and stereo units, transistor portables, and auto sets are covered in this latest addition to Supreme Publications' Radio Diagram Series. The book contains every bit of information required for quicker servicing, including extra-large schematics, alignment data, printed-board diagrams, voltage readings, trimmer locations and dial-stringing guides. This factory-prepared data is "complete, authoritative, and accurate."

Published by Supreme Publications, 1760 Balsam Rd., Highland Park, Ill. 192 pages. Soft cover. \$2.50.

## KUHN

"LEADERS IN SPECIALIZED RECEIVING EQUIPMENT"

### MOBILE FIXED CONVERTERS

- POLICE
- FIRE
- COMMERCIAL
- CITIZEN'S BAND

**331B** Crystal controlled. Requires no high voltage supply. For transistor car radios. Can be connected in moments for emergency use. 2-54 MC

Complete \$24.95  
Other models for 108-162 MC available.



**315A**

A practical converter for emergency use with home or auto sets. Easily installed. Tunable over 12 MC in 26-54 MC or 30 MC in 108-174 MC band.

COMPLETE \$13.95



**315AC** Crvstal controlled up to 54 MC. COMPLETE \$18.95  
Crystal controlled up to 165 MC. COMPLETE \$22.95

**315AD** Crystal controlled. For use with transistor car radios. 2-54 MC. COMPLETE \$17.95  
**315A** VARIABLE CONVERTER. Front panel tuning permits rapid change between separated signals over 10 MC range in 26-54 MC or 108-174 MC band. COMPLETE \$19.95

CONVERTERS ALL EQUIPPED WITH SELF CONTAINED SWITCHING AND LEADS FOR RAPID CHANGE-OVER

ORDER TODAY or SEND FOR FREE CATALOG . . . containing complete information on a full line of: CONVERTERS AND RECEIVERS FOR EVERY APPLICATION



**326B** SUPER CONVERTER. Crystal controlled. For transistor car radios. Ultra high gain. Self contained ANL. 2-54 MC. Complete \$44.95



20 GLENWOOD CINCINNATI 17, OHIO

## TUNNEL DIODE MANUAL

Intended as a reference source for circuit designers in the relatively new field of tunnel diode applications, General Electric Company's "Tunnel Diode Manual" is similar in pattern to its well-known "Transistor Manual." Four chapters cover amplifier, oscillator, switching and logic circuits; and tunnel diode ratings, characteristics, and test circuits are described in the other chapters.

*Published by the General Electric Co., Kelley Bldg., Liverpool, N. Y. Soft cover. 96 pages. \$1.00.*



## SECOND-CLASS RADIOTELEPHONE LICENSE HANDBOOK by Edward M. Noll

Everyone who services two-way mobile radio equipment—and some who operate it—must take the FCC second-class radiotelephone license examination. This volume provides all of the information needed to pass it, and explains the duties and responsibilities of the license holder. Six chapters contain over 650 questions and answers, based on past FCC examinations, which allow the reader to progress logically from topic to topic. Six additional chapters supply a comprehensive background in two-way radio communications theory and practice.

*Published by Howard W. Sams & Co., Inc., 1720 E. 38th St., Indianapolis 6, Ind. 240 pages. Soft cover. \$3.95.*



## INTERNATIONAL TRANSISTOR SUBSTITUTION GUIDEBOOK by Keats A. Pullen, Jr., Eng. D.

This guidebook is designed to provide accurate, reliable information on transistor substitution. The author based his recommendations on a comparison of

the electrical and physical characteristics of transistors manufactured in the United States and in six foreign countries. His evaluation of comparable electrical ratings was extremely conservative, and doubtful substitutes were not included in the listings. Dimensions and case styles of both the original and the substitute are indicated beside the type numbers, and a special effort has been made to correlate type numbers no longer in use with their current equivalents.

*Published by John F. Rider Publisher, Inc., 116 W. 14th St., New York, N. Y. 64 pages. Soft cover. \$1.50.*

## New Literature

An eight-page "New Products Catalog" introduces the latest audio/stereo items made by Audiotex. Featured equipment includes a pocket-sized circuit tester, a kit of phono record accessories, volume and speaker controls, and a series of exact replacement record changer knobs. Copies are available from Audiotex Mfg. Co., 400 S. Wyman St., Rockford, Ill. Ask also for the more complete Catalog AD-60, which lists their full line of high-fidelity audio accessories.

International Crystal's 1961 catalog covers its complete line of radio crystals and accessories for all applications. Also illustrated and discussed are a variety of crystal-controlled amateur and CB converters, oscillators, transmitters, and transceivers, as well as modulators and power supplies; some of these units are available in kit form. Write to the International Crystal Mfg. Co., Inc., 18 N. Lee, Oklahoma City, Okla., for your copy of the catalog.

A new "short-form" catalog of mechanical and electronic components for missile and satellite tracking systems and antenna pattern range instrumentation has been published by Antlab, Inc., 6330 Proprietors Rd., Worthington, Ohio. The 20-page booklet lists over 30 new products, including a series of 60,000 foot-pound antenna mounts, a series of totally enclosed servo and electro-manual antenna mounts, and a microwave receiver.

# FREE CAREER BOOKLET

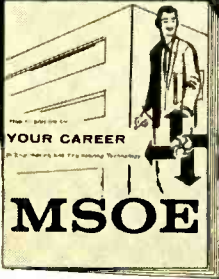

To guide you to a successful future in

## ELECTRONICS RADIO-TV COMPUTERS ELECTRICAL ENGINEERING

This interesting pictorial booklet tells you how you can prepare for a dynamic career as an Electrical Engineer or Engineering Technician in many exciting, growing fields:

**MISSILES • AVIONICS • AUTOMATION  
SALES • DEVELOPMENT  
ELECTRICAL POWER • ROCKETRY  
RADAR • RESEARCH**

Get all the facts about job opportunities, length of study, courses offered, degrees you can earn, scholarships, part-time work — as well as pictures of the Milwaukee School of Engineering's educational and recreational facilities. No obligation — it's yours free.

### MILWAUKEE SCHOOL OF ENGINEERING

#### MAIL COUPON TODAY!

**Milwaukee School of Engineering**  
Dept. PE-761, 1025 N. Milwaukee St., Milwaukee, Wis.

Please send FREE "Your Career" booklet  
I'm interested in

Electronics     Radio-TV     Computers  
 Electrical Engineering     Mechanical Engineering

Name \_\_\_\_\_ Age \_\_\_\_\_

PLEASE PRINT

Address \_\_\_\_\_

City \_\_\_\_\_ Zone \_\_\_\_\_ State \_\_\_\_\_

I'm eligible for veterans education benefits.

Discharge date \_\_\_\_\_ MS-117

## Tips



## and Techniques

### MOUNTING MINIATURE COMPONENTS

Miniature components such as diodes, small resistors, etc., can be transferred easily from one experimental circuit to another by means of fuse clips if they are mounted in glass casings from blown cartridge fuses. Loosen the caps of a



glass fuse with heat, remove them, and discard the burned-out element. The leads of the component to be mounted are cut to the proper size and one lead is soldered to one of the caps. Slip the glass tube over the component and into the attached cap. Then deposit a drop of solder inside the remaining cap and replace it on the other end of the glass so that the second lead is in contact with the solder. The cap is now heated with a soldering iron, melting the drop of solder and thus making a connection to the second lead.

—Gregory Moline

### SQUEEZE-TYPE DISPENSER DUSTER

Use an empty squeeze-type mustard or catsup dispenser to blow dust and dirt

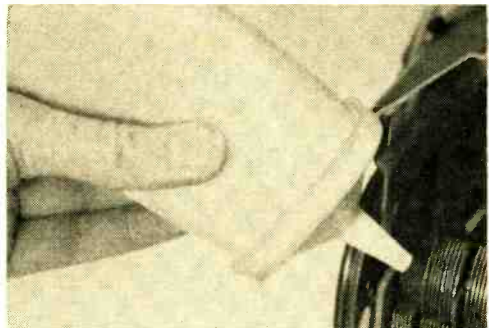

from your radio or TV chassis parts. A concentrated air blast which easily reaches into tight corners is produced by the small nozzle. Such a dispenser will

Always say you saw it in—POPULAR ELECTRONICS

# NEW—simply great **knight-kits**<sup>®</sup>

A PRODUCT OF ALLIED RADIO

talk of the kit world...only at **ALLIED**

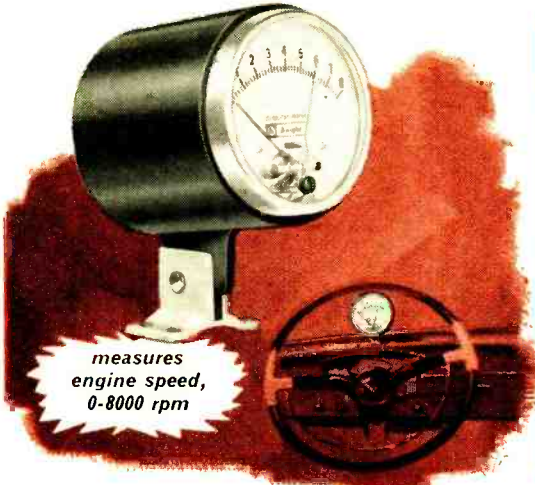

measures engine speed, 0-8000 rpm



it's **WIRELESS**—just plug in and **TALK!**

## New Money-Saving Electronic Tachometer Kit

3% Accuracy Regardless of Temperature or Voltage Variations

Until Aug. 1

**\$19.95**

No Money Down

Another **KNIGHT-KIT first**—a precision tachometer in money-saving, easy-to-build form. Helps you drive at your best engine speed efficiency, like the professionals. Transistor switching and Zener diode regulator contribute to exceptional 3%-of-full-scale accuracy, regardless of voltage or temperature changes. Operates with 4, 6 or 8 cylinder automotive engines; simple installation. Ideal also for outboard marine engines using battery or magneto ignition system from 2 cycle 2 cylinder and up. Big illuminated D'Arsonval meter; 0-8000 rpm scale; separate reference pointer may be preset to any desired speed. For 12-volt systems only. With cables, mounting hardware, wire and solder. Shpg. wt., 2 lbs.

**83 Y 944.** For negative ground systems (American cars).

**83 Y 980.** For positive ground systems (Foreign cars).

No Money Down. Introductory Price..... **\$19.95**

## Deluxe Wireless Intercom System Kit at Lowest Cost

Works Anywhere Without Wires — No Installation!

This easy-to-assemble intercom operates without installation or wiring—just plug into any AC or DC wall outlet for step-saving communication! Change locations easily—anywhere. Ideal for home, office or store. In the home, you can communicate with nursery, garage, basement or patio. In office or shop, provides time-saving communication. Will operate between adjacent buildings that are on same electric-company line transformer. Perfect for baby sitting. Features power-line noise silencing circuit for absolutely quiet "standby"; premium quality throughout. Has Talk-Listen switch, with lock-on feature for constant listening. Handsome cream-toned plastic cabinet, 9 x 5½ x 5½". Can be used in systems consisting of 2 or more units, as desired. Shpg. wt., 3½ lbs.

PAIR

**\$37.90**

No Money Down

**20 YX 272-2.** Complete 2-Station System. NET..... **\$37.90**

**83 Y 941.** Additional Station. NET EACH..... **\$18.95**

SEE DOZENS OF GREAT

**knight-kit** BUYS IN

**Allied's Summer Sale Book!**

Make your money-saving selections from page after page of great **KNIGHT-KIT** values and special offers! Save most on the best in build-your-own Stereo, hobby, instrument and Ham kits. Also see terrific closeouts on tape recorders, phonos, records and tape; specials in radios, cameras, TV accessories, Citizens Band radio, amateur gear, P.A., test instruments, tools and electronic parts. Send coupon today!



SEND FOR IT NOW!

**free**

**SAVE AS NEVER BEFORE** on everything in Electronics—hundreds of special bargains—dozens of new products! Write for this big value-packed Sale Book today!

**ALLIED RADIO, Dept. 38-G1**  
100 N. Western Ave., Chicago 80, Ill.

Send **FREE** Allied Sale Book No. 205

Ship me the following:

83 Y 944 Tachometer Kit.  20 YX 272-2 Intercom System  
 83 Y 980 Tachometer Kit.  83 Y 941 Intercom Station

\$..... enclosed

Name.....  
PRINT

Address.....

City..... Zone..... State.....

**ALLIED RADIO**

# CB Owners: IT'S WHAT GOES OUT ON THE AIR THAT COUNTS!

Get maximum amplifier output and outstanding performance from your 5-watter by using famous PR CRYSTALS. These high-active crystals get greater distance than ordinary sluggish crystals. Clearer reception too. Put PR Crystals in your set today, and get the STRONGEST SIGNALS POSSIBLE WITHIN POWER LIMITS.

## SWITCH TO A BETTER CHANNEL

Be smart... have several sets of PR Crystals... two or three sets at least. Then you can switch channels at will, to avoid jamming. PR CRYSTALS ARE AVAILABLE IN ALL 23 CITIZENS BAND CHANNELS.

Type Z-9R, Calibrated .005%, \$2.95 each. EVERY PR CRYSTAL IS UNCONDITIONALLY GUARANTEED.

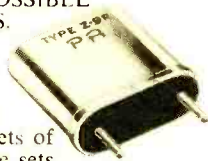

Get PR's Now From Your Jobber.



**PETERSEN RADIO CO., INC.**

2800 West Broadway  
Council Bluffs, Iowa

## PURCHASING A HI-FI SYSTEM?

TIME PAYMENTS AVAILABLE  
Up to 2 Years to Pay!

Send Us  
Your List of  
Components  
For A Package  
Quotation

YOU CAN BUY WITH  
CONFIDENCE AT AIREX

All merchandise is brand new,  
factory fresh and guaranteed.

Free Hi-Fi Catalog

**AIREX  
RADIO  
CORPORATION**

85-PE Cortlandt St., N. Y. 7 WO 4-1820

Jim Lansing\*  
Altec Lansing  
Electrovoice  
Jensen • Hartley\*  
University • Viking  
Acoustic Research  
Janszen • Superscope  
Wharfedale  
USL Citizen Band  
Gonset • Hallicrafter  
Texas Crystals  
Concertone  
Bell • G.E.  
Weathers  
Harman-Kardon  
Eico • Pilot • Fisher  
ESL • Roberts  
Bogen • Leak • TEC  
Dynaklit • H. H. Scott  
Thorens\* • Sherwood\*  
Dual Changer  
DeWald  
Sony • Challenger  
Wollensak • Pentron  
Garrard • Frazier  
Miracord • Pickering  
Glaser-Steers  
Components  
Rek-O-Kut • Tandberg\*  
Audio Tape • Conrac  
Norelco • Magnecord\*  
Fairchild • Gray  
Artizan Cabinets  
Rockford Cabinets

\*Fair Traded

## Tips

(Continued from page 26)

do a much better job than blowing with your breath will, and you won't get a face full of dust.

—Charles Lang

### BLOWN FUSE INDICATOR

Add this little circuit to a piece of equipment and you'll be able to tell at a glance whether or not you have a blown fuse. As long as the fuse is good, no current will pass through resistor *R1* and the NE-2 neon bulb. If the fuse

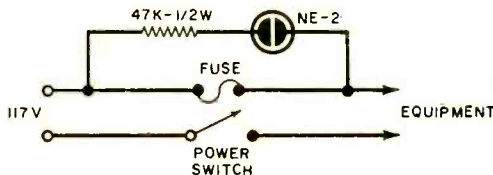

should blow, the current takes the alternate path through the indicator circuit, causing the neon lamp to glow. A 47,000-ohm, 1/2-watt unit, *R1* is a current-limiting resistor and is required for 117-volt operation of the NE-2.

—James Romelfanger, K9PKQ

### MAKE SWITCH FROM PHONE JACK

Either a "push-pull" or a rotary s.p.s.t. switch can be easily improvised with a closed-circuit phone jack. For a push-pull switch, cut a 1 3/4" length of 1/4" diameter Bakelite or plastic rod. Fasten a setscrew knob at one end and smooth

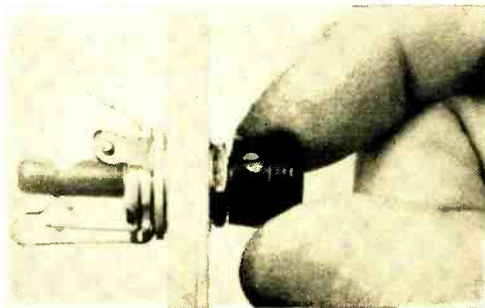

the other end with a file. You'll find that pushing the rod all the way into the jack will open the contacts, pulling it out slightly will close them. For a rotary

Always say you saw it in—POPULAR ELECTRONICS

small and

# MIGHTY

32" of Dynamic CB Antenna



Can be mounted  
on top, fenders  
or trunk lid.

patent pending.

## INTRODUCING THE **Stinger** Mobile Whip

Completely out performs and outmodes more expensive cumbersome conventional whips and loaded coil antennae . . . The 32" STINGER antenna is MONEY BACK GUARANTEED to equal or surpass any 102" whip transmitting and will give approximately 30% better reception than any other CB antenna on the market.

- \* Is the only CB Antenna on the market with a money back performance guarantee.
- \* Is adaptable to Marine and Aircraft applications with equal GUARANTEED results.
- \* Costs less to buy . . . easier to install.
- \* Increases receiving and transmitting distances, on both high and low wattage sets.
- \* Makes signal more audible over natural CB channel noises.
- \* Is easy to install on either top, fenders or trunk lid . . . installation is through a single hole and enhances the appearance of any automobile.

The STINGER mobile whip is the only CB Antenna on the market designed for the Class D, 27 mc, frequency band . . . it is only 32" long and is not of the loaded coil design. The Stinger is designed on the RF (radio frequency), inductive, transformer coupled, high gain theory . . . bringing about higher transmission efficiency extra high gain reception and relatively equal transmission/reception characteristics in all directions no matter where it is mounted.

For further information on the fabulous mighty mite "STINGER" or for your nearest STINGER DEALER, send this coupon to:

INTERNATIONAL COMMUNICATIONS CO.  
26330 So. Western Ave., Lomita, California

Name \_\_\_\_\_

Address \_\_\_\_\_

City \_\_\_\_\_ Zone \_\_\_\_\_ State \_\_\_\_\_

DISTRIBUTION INQUIRIES INVITED



## 2-WAY RADIO

from \$13495

• Anyone can operate—  
license issued on request!

Used by thousands of businessmen, salesmen, farmers, doctors, construction crews and sportsmen! Finest Citizens' Transceiver available—excellent range. Covers 23 channels. Maximum legal power—dozens of features—easy to install anywhere!



Delivery or servicing



Building or contracting



Boat-to-boat or ship-to-shore



Car-to-office or home

SEND FOR FREE COLOR BROCHURE!



Send full details on the "Messenger"

NAME \_\_\_\_\_

ADDRESS \_\_\_\_\_

CITY \_\_\_\_\_ STATE \_\_\_\_\_

VIKING  
*Messenger*



**E. F. JOHNSON CO.**

2401 10 Av. SW, Waseca, Minn.

## QUICKLY CUT HOLES

in metal, plastics,  
hard rubber...



ROUND



SQUARE



KEY



"D"



### GREENLEE CHASSIS PUNCHES

Make smooth, accurate openings in 1½ minutes or less . . . for sockets, plugs, controls, meters, panel lights, etc. Easy to use . . . simply turn with wrench.

Many sizes and models.

Write for literature.



**GREENLEE**

GREENLEE TOOL CO., 1915 Columbia Ave., Rockford Illinois

## Tips

(Continued from page 28)

switch, the same rod and knob arrangement is used but a "V" is filed into the rod to match the tip wiper of the phone jack. (See photo.) When the rod is placed so that the tip wiper falls into the "V," the contacts will close. To open them, you turn the knob 180 degrees.

—Art Trauffer

### TR-1A OR AD-70 SPEED CHANGE

It's not necessary to remove the front panel in order to change tape speed on the Heathkit Series TR-1A tape recorders or the AD-70 tape player if an access hole is made in the panel to expose the drive pulley. Use a 1" or 1½"

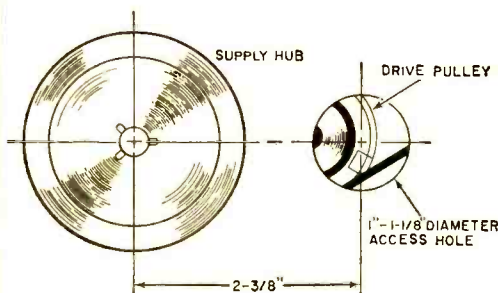

chassis punch, positioning the hole as shown in the diagram. To change speeds, turn off the motor and place the mechanism in the "rewind" position. Slowly rotate the supply hub to turn the drive pulley while using a hook bent from a stiff iron wire to guide the belt into the proper groove. During operation, the hole is covered by the supply reel and does not detract from the appearance of the machine.

—H. Edwin Boesch, Jr.

### SPEAKER PROTECTION

It pays to protect the loudspeaker of a piece of equipment under construction or repair. If you cut a piece of stiff cardboard to the proper size and fasten it to the front of the speaker with masking tape, there will be no danger of your plunging a screwdriver through the cone. Particularly "unlucky" people can also cover the openings in the back frame of the speaker.

—Ronald S. Newbower

Always say you saw it in—POPULAR ELECTRONICS



# BUILD YOUR OWN RADIO

## CIRCUITS AT HOME

with the New

### PROGRESSIVE RADIO "EDU-KIT"®

A Practical Home Radio Course

Reg. U. S.  
Pat. Off.



Training Electronics Technicians Since 1946

- Now Includes
- ★ 12 RECEIVERS
  - ★ 3 TRANSMITTERS
  - ★ SQ. WAVE GENERATOR
  - ★ SIGNAL TRACER
  - ★ AMPLIFIER
  - ★ SIGNAL INJECTOR
  - ★ CODE OSCILLATOR
- ★ No Knowledge of Radio Necessary
  - ★ No Additional Parts or Tools Needed
  - ★ EXCELLENT BACKGROUND FOR TV
  - ★ SCHOOL INQUIRIES INVITED
  - ★ Sold In 79 Countries

ONLY  
**\$26.95**

### YOU DON'T HAVE TO SPEND HUNDREDS OF DOLLARS FOR A RADIO COURSE

The "Edu-Kit" offers you an outstanding PRACTICAL HOME RADIO COURSE at a rock-bottom price. Our Kit is designed to train Radio & Electronics Technicians, making use of the most modern methods of home training. You will learn radi theory, construction practice and servicing. THIS IS A COMPLETE RADIO COURSE IN EVERY DETAIL. You will learn how to build radios, using regular schematics; how to wire and solder in a professional manner; how to service radios. You will work with the standard type of punched metal chassis as well as the latest development of Printed Circuit chassis.

You will learn the basic principles of radio. You will construct, study and work with RF and AF amplifiers and oscillators, detectors, rectifiers, test equipment. You will learn and practice code, using the Progressive Code Oscillator. You will learn and practice trouble-shooting, using the Progressive Signal Tracer, Progressive Signal Injector, Progressive Dynamic Wave Generator and the accompanying instructional material.

You will receive training for the Novice, Technician and General Classes of F.C.C. Radio Amateur License. You will receive 20 Receiver, Transmitter, Square Wave Generator, Code Oscillator, Signal Tracer and Signal Injector circuits, and learn how to operate them. You will receive an excellent background for television, Hi-Fi and Electronics.

Absolutely no previous knowledge of radio or science required. The "Edu-Kit" is the product of many years of teaching and engineering experience. The "Edu-Kit" will provide you with a basic education in Electronics and Radio, worth many times the complete price of \$26.95. The Signal Tracer alone is worth more than the price of the entire Kit.

### THE KIT FOR EVERYONE

You do not need the slightest background in radio or science. Whether you are interested in Radio & Electronics because you want an interesting hobby, a well paying business or a job with a future, you will find the "Edu-Kit" a worth-while investment.

Many thousands of individuals of all

ages and backgrounds have successfully used the "Edu-Kit" in more than 79 countries of the world. The "Edu-Kit" has been carefully designed, step by step, so that you cannot make a mistake. The "Edu-Kit" allows you to teach yourself at your own rate. No instructor is necessary.

### PROGRESSIVE TEACHING METHOD

The Progressive Radio "Edu-Kit" is the foremost educational radio kit in the world, and is universally accepted as the standard in the field of electronics training. The "Edu-Kit" uses the modern educational principle of "Learn by Doing." Therefore you construct, learn schematics, study theory, practice trouble shooting—all in a closely integrated program designed to provide an easily-learned, thorough and interesting background in radio.

You begin by examining the various radio parts of the "Edu-Kit." You then learn the function, theory and wiring of these parts. Then you build a simple radio. With this first set you will enjoy listening to regular broadcast stations, learn theory, practice testing and trouble-shooting. Then you build a more advanced radio, learn more advanced theory and techniques. Gradually, in a progressive manner, and at your own rate, you will find yourself constructing more advanced multi-tube radio circuits, and doing work like a professional Radio Technician.

Included in the "Edu-Kit" course are twenty Receiver, Transmitter, Code Oscillator, Signal Tracer, Square Wave Generator and Signal Injector circuits. These are not unprofessional "breadboard" experiments, but genuine radio circuits, constructed by means of professional wiring and soldering on metal chassis, plus the new method of radio construction known as "Printed Circuitry." These circuits operate on your regular AC or DC house current.

### THE "EDU-KIT" IS COMPLETE

You will receive all parts and instruction necessary to build 20 different radio and electronics circuits, each guaranteed to operate. Our kits contain tubes, tube sockets, variable, electrolytic, mica, ceramic and paper dielectric condensers, resistors, tie strips, hardware, wiring, punched metal chassis, instruction Manuals, hook-up wire, solder, selenium rectifiers, volume controls and switches, etc.

In addition, you receive Printed Circuit materials, including Printed Circuit chassis, special tube sockets, hardware and instructions. You also receive a useful set of tools, a professional electric soldering iron, and a self-powered Dynamic Radio and Electronics Tester. The "Edu-Kit" also includes Code Instructions and the Progressive Code Oscillator. In addition to F.C.C. questions and answers for Radio Amateur License training. You will also receive lessons for servicing with the Progressive Signal Tracer and the Progressive Signal Injector, a High Fidelity Guide and a Quiz Book. You receive Membership in Radio-TV Club, Free Consultation Service, Certificate of Merit and Discount Privileges. You receive all parts, tools, instructions, etc. Everything is yours to keep.

### FREE EXTRAS

#### • SET OF TOOLS

- SOLDERING IRON
- ELECTRONICS TESTER
- PLIERS-CUTTERS
- ALIGNMENT TOOL
- WRENCH SET
- VALUABLE DISCOUNT CARD
- CERTIFICATE OF MERIT
- WIRE CUTTING INSTRUCTIONS MANUAL
- HIGH FIDELITY GUIDE • QUIZZES
- TELEVISION BOOK • RADIO TROUBLE SHOOTING BOOK
- MEMBERSHIP IN RADIO-TV CLUB: CONSULTATION SERVICE • FCC AMATEUR LICENSE TRAINING
- PRINTED CIRCUITRY

### SERVICING LESSONS

You will learn trouble-shooting and servicing in a progressive manner. You will practice repairs on the sets that you construct. You will learn symptoms and causes of trouble in home, portable and car radios. You will learn how to use the professional Signal Tracer, the unique Signal Injector and the dynamic Radio & Electronics Tester. While you are learning in this practical way, you will be able to do many a repair job for your friends and neighbors, and charge fees which will far exceed the price of the "Edu-Kit." Our Consultation Service will help you with any technical problems you may have.

### FROM OUR MAIL BAG

J. Stataitis, of 25 Poplar Pl., Waterbury, Conn., writes: "I have repaired several sets for my friends, and made money. The "Edu-Kit" paid for itself. I was ready to spend \$240 for a course, but I found your ad and sent for your Kit."

Ben Valerio, P. O. Box 21, Magna, Utah: "The Edu-Kits are wonderful. I am sending you the questions and also the answers for them. I have been in Radio for the last seven years, but like to work with Radio Kits, and like to build Radio Testing Equipment. I enjoyed every minute I worked with different kits; the Signal Tracer works fine. Also like to let you know that I feel proud of becoming a member of your Radio-TV Club."

Robert L. Shuff, 1534 Monroe Ave., Huntington, W. Va.: "Thought I would drop you a few lines to say that I received my Edu-Kit, and was really amazed that such a bargain can be had at such a low price. I have already started repairing radios and phonographs. My friends were really surprised to see me get into the swing of it so quickly. The Trouble-shooting Tester that comes with the Kit is really swell, and finds the trouble, if there is any to be found to

### PRINTED CIRCUITRY

At no increase in price, the "Edu-Kit" now includes Printed Circuitry. You build a Printed Circuit Signal Injector, a unique servicing instrument that can detect many Radio and TV troubles. This revolutionary new technique of radio construction is now becoming popular in commercial radio and TV sets.

A Printed Circuit is a special insulated chassis on which has been deposited a conducting material which takes the place of wiring. The various parts are merely plugged in and soldered to terminals.

Printed Circuitry is the basis of modern Automation Electronics. A knowledge of this subject is a necessity today for anyone interested in Electronics.

### UNCONDITIONAL MONEY-BACK GUARANTEE

### ORDER DIRECT FROM AD—RECEIVE FREE BONUS RESISTOR AND CONDENSER KITS WORTH \$7

- Send "Edu-Kit" postpaid. I enclose full payment of \$26.95.
- Send "Edu-Kit" C.O.D. I will pay \$26.95 plus postage.
- Rush me FREE descriptive literature concerning "Edu-Kit."

Name .....

Address .....

### PROGRESSIVE "EDU-KITS" INC.

1186 Broadway, Dept. 582-D, Hewlett, N. Y.

# Can You IDENTIFY

any of these three

CB transceivers?

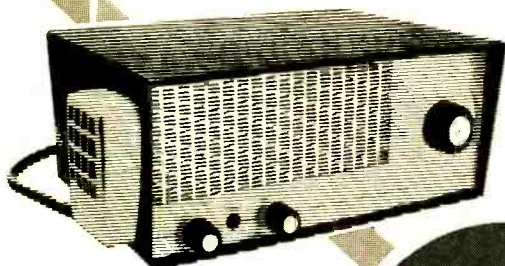

6 channels, crystal-controlled on both transmit and receive; universal power supply (117, 12 and 6 volts); 10-tube function superhet (one r.f. and two 1650-kc. i.f. stages); shunt noise limiter; adjustable squelch; un-metered; ceramic mike; 12 lb.; 4 $\frac{1}{8}$ " x 10 $\frac{1}{8}$ " x 7 $\frac{3}{8}$ ". Accessories include mounting bracket, cables, r.f. power meter, 50-ohm dummy load.

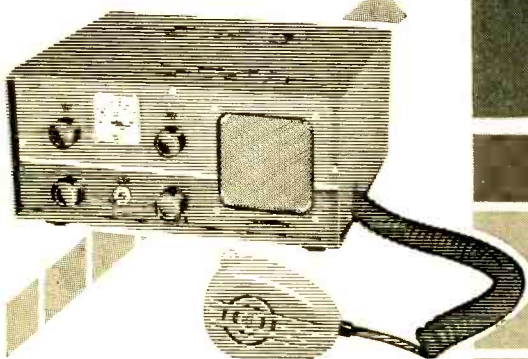

5-channel transmitter with tunable receiver, plus 1 crystal-controlled receive channel; universal power supply (117, 12 and 6 volts); 13-tube function double-conversion superhet; series noise limiter; adjustable squelch; metered; ceramic mike; 5 $\frac{1}{2}$ " x 11 $\frac{1}{4}$ " x 9 $\frac{3}{8}$ ". Also available with 5 crystal-controlled channels on both transmit and receive (same price). Either model available with special noise limiting/squelch circuit (TNS) for \$20.00 more.

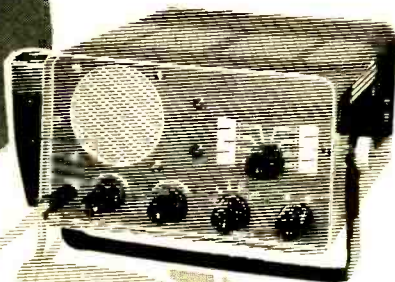

8-channel transmitter with 8-channel crystal-controlled or tunable receiver; universal power supply (117, 12 and 6 volts); 8-tube function receiver (one r.f. and two 455-kc. i.f. stages) —plus 2 diodes; series noise limiter; adjustable squelch; un-metered; ceramic mike; 9 lb.; 4 $\frac{1}{4}$ " x 9 $\frac{1}{4}$ " x 11 $\frac{1}{4}$ ". 5-meter available as accessory (\$24.95).

You can after you see the AUGUST issue of POPULAR ELECTRONICS

It contains a complete up-to-the-minute catalog of CB equipment including transceivers, antennas, microphones, accessories

**DON'T MISS THE AUGUST ISSUE—ON SALE JULY 27**

# Learn RADIO, TELEVISION AND ELECTRONICS by Practicing at Home in Your Spare Time

At No Extra Cost you get specially developed Electronic Training Kits for practical experience. Shop and laboratory practice at home make learning easier, interesting, faster. You do not need a high school diploma or previous experience.

## Increasing Demand for Trained Men

This is the Electronics age. Men with Electronic know-how are in demand. They enjoy high pay and growing opportunities for advancement. Satellites, Radar, Automation in Industry, Missiles, Rockets, Planes, Stereo, TV, Radio, Two Way Communications for transportation are a few of the fantastic developments in the fast growing Electronics industry. If you are not completely satisfied with your work; if you are doubtful about your future, investigate Electronics.



## High Pay, Prestige, Bright Future

What branch of Electronics interests you? Thousands of successful NRI graduates prove that NRI's learn-by-practice method is the way to success. You start in your chosen career way ahead of the man who only learns from books. You do not need to give up your job. You do not need to go away to school. You learn at home, get practical knowledge from training kits NRI provides.

## Train With the Leader

NRI is the world's oldest and largest home study Electronics school. You benefit from the experience NRI has gained from training men for 45 years. NRI offers you proven courses of home study in Electronics; Principles, Practices and Maintenance—Radio Television Communications—Radio Television Servicing.

## Start Soon, Earn More

Soon after enrolling NRI shows you how to apply your knowledge to earn extra money doing Electronic repairs or servicing Radio and Television sets for friends and neighbors. Take the first step toward success now. Find out what NRI offers you. Mail the postage-free card. No obligation. Cost of



NRI training is low. Monthly payment plan available. NATIONAL RADIO INSTITUTE, Washington 16, D.C.

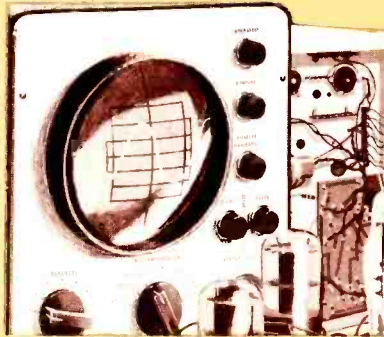

## NRI Has Trained Thousands for Success



"I get over twice the salary I made before enrolling. NRI training gave me a thorough understanding." H. ATKINSON, Austin, Tex.

"Now in charge of sound effects for CBC. NRI opened doors to greater opportunity for me." F. TUDOR, Toronto, Ontario.

"Averaged \$150 a month spare time before I graduated. Now have my own full time business." F. W. COX, Hollywood, Cal.

## NEW COURSE IN ELECTRONICS TURN PAGE

Cut Out and Mail—No Stamp Needed

# 64-PAGE FREE CATALOG

No Salesman will call. (Please PRINT) Dept. IED-4

Name \_\_\_\_\_ Age \_\_\_\_\_

Address \_\_\_\_\_

City \_\_\_\_\_ Zone \_\_\_\_\_ State \_\_\_\_\_

**NRI** National Radio Institute  
Washington 16, D.C.

ACCREDITED MEMBER NATIONAL HOME STUDY COUNCIL

The amazing field of

How to  
for its

National  
Radio  
Institute

WASHINGTON, D.C.

**PREPARE NOW—  
Electronic  
Technicians  
Are In  
Demand**

# New NRI Home Study Courses in **ELECTRONICS** PRINCIPLES—PRACTICES MAINTENANCE



Fast growing use of Electronics in industry, business and the military is creating good career opportunities everywhere. 4 to 7 Electronic **TECHNICIANS** are needed for every graduate engineer. This

is the age of Automation, Missiles, Rockets, Computers, Radar, Microwave, hundreds of other devices where Electronics plays the key role now.

## **Job Counselors Advise Learning Electronics**

Job counselors know the untrained man is last to be hired and the first to be fired. In this Electronics Age *you must be trained* to qualify for high earnings and advancement. To meet this growing demand for Technicians, NRI has developed a comprehensive course in Electronics—Principles, Practices, Maintenance. This training stresses fundamentals . . . the basic principles on which all Electronic equipment is developed, now or in the future.

## **Learn More to Earn More—Mail Card**

NRI Electronics training gives you both theory and experience in an interesting, practical way. Train at home, at your own pace. Keep your present job until you are ready for a better one. Get complete information now. Move up soon to higher pay and a brighter future in Electronics—the growth industry of the '60's. Mail postage-free card.

## **SPECIAL TRAINING EQUIPMENT**

*At no extra cost* NRI includes special training equipment. You get practical experience with Thyatron Tube circuits; Multivibrators; build a D'Arsonval type Vacuum Tube Voltmeter; work with pentode tubes, selenium rectifiers, oscillators, transistors, magnetic amplifiers; get practical experience in telemetry circuits used in earth satellites



and basic circuits used in digital and analog computers. You perform more than 100 experiments. You "learn-by-practice" from beginning to graduation.

## **Oldest and Largest School of its Kind**

Get **FREE** 64-page catalog from NRI—oldest and largest home-study Electronics—Radio-Television School. It gives facts about careers in Industrial and Military Electronics, also tells about other NRI courses in Broadcasting and Communications, Radio-TV Servicing. **NATIONAL RADIO INSTITUTE**, Washington 16, D. C.

**SEE OTHER SIDE**

**FIRST CLASS**  
Permit No. 20-R  
(Sec. 34.9, P. L. & R.)  
Washington, D.C.

**BUSINESS REPLY MAIL**

No Postage Stamp Necessary if Mailed in the United States

**POSTAGE WILL BE PAID BY**

**NRI** National Radio Institute  
3939 Wisconsin Avenue  
Washington 16, D.C.



**POSTAGE FREE CARD  
MAIL NOW**

# NEW products

## ISOLATION TRANSFORMER KIT

Features of the latest Heathkit isolation transformer include a high power rating



(300 watts continuous duty, 500 watts intermittent), improved meter accuracy ( $\pm 1$  volt), and new styling. The IP-10 completely isolates equipment under test from the a.c. line. Output is variable from 90

to 130 volts in .75-volt steps, and the built-in meter monitors either input or output voltage at the flick of a switch. Price, \$54.95. (Heath Co., Benton Harbor, Mich.)

## VEST-POCKET RADIO

Channel Master has announced a new 7-transistor vest-pocket radio. Said to have unusual sensitivity for its  $4\frac{1}{2}$ " x  $2\frac{7}{8}$ " size, the Model 6516 is equipped with a  $2\frac{1}{2}$ " speaker, a vernier fine-tuning dial, and a built-in ferrite antenna. Operating on a standard 9-volt battery, the set is housed in an unbreakable nylon case; a dual-purpose carrying handle also acts as an easel stand. Included in the \$34.95 price are a cowhide carrying case and a magnetic earphone (with its own leather case) for private listening. (Channel Master Corp., Ellenville, N. Y.)

## MOBILE MIKE

The Raytheon "Elucidator," a good-looking press-to-talk hand microphone packaged in a high-impact plastic case, is suitable for use with mobile and marine transmitters, p.a. systems, tape recorders and intercom equipment. Employing a standard F1-type carbon but-

ton which is bypassed for r.f., the microphone has a nominal impedance of 35 ohms and operates on currents ranging from 15 to 120 milliamperes. Voice intelligibility is said to be excellent. The Elucidator weighs only four ounces and

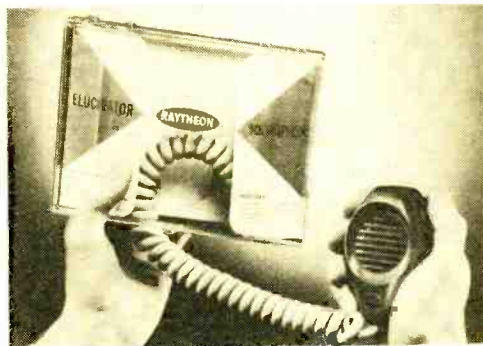

has an 11'-60" retractable coiled cord. Price, \$19.95. (Raytheon Co., Distributor Products Div., 411 Providence Highway, Westwood, Mass.)

## POCKET FLASHLIGHT

The "Flex-Lite," a handy pocket flashlight, has a flexible neck which allows



the beam to be turned to any position desired. Ideal for getting light into odd corners, the unit is also equipped with a locking pocket or belt clip so that both hands may be free. The case is made of anodized aluminum, and a convenient twist

switch is built into the light head. Price, \$4.95. (Aero-Motive Mfg. Co., Kalamazoo, Mich.)

## HI-FI TV KITS

A line of high-fidelity TV-set kits has been designed by Transvision to meet the demands of sophisticated video-audiophiles. The sets have ultralinear sweep circuits, d.c. restoration, and wideband i.f. and video amplifiers. Push-pull distortion-free audio stages and woofer-

# 2 NEW KITS from H. H. Scott

Revolutionary H. H. Scott Techniques  
Make Kit Building Easier . . . More Fun!

Now, for the first time, H. H. Scott engineering leadership, H. H. Scott quality and H. H. Scott experience are available to you in a massive 130 watt power amplifier kit and a feature-packed pre-amplifier kit — two new expertly designed kits that utilize the time-saving, labor-saving kit techniques pioneered by H. H. Scott. Why settle for less than the best? See these new H. H. Scott kits at your dealer *now*.



**LK-150 130 Watt Power Amplifier Kit**  
Conservative design, huge transformers, consistent top performance. Amplifier absolutely stable even without load. A top-quality H. H. Scott kit. **\$169.95\***

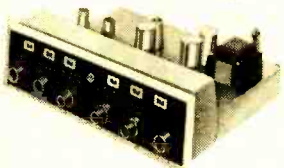

**LC-21 Pre-Amplifier Kit**  
Easy-to-build, extremely versatile pre-amp kit with 16 front panel controls, amazing frequency response from 8 to 50,000 cps! Handsome styling. Takes only 6-8 hours to build. A terrific, feature-packed stereo control center! **\$99.95\***



**LT-10 FM Tuner Kit**  
Professional H. H. Scott Wide-Band tuner with pre-aligned, pre-mounted silver-plated front end. Uses Ez-A-Line alignment system . . . no special tools. Highly rated by experts. Sensitivity 2.2  $\mu$ V (IHF M) **\$89.95\***



**LK-72 72 Watt Integrated Stereo Amplifier Kit**  
A complete stereo pre-amp power-amp combination. Plenty of power for any speaker system. Fabulous H. H. Scott features never before available in a kit: 36 watts/channel; separate bass, treble and center channel controls; tape recorder monitor; many more! **\$149.95\***



H. H. Scott, Inc., 111 Powdermill Rd., Maynard, Mass. Dept. 520-07

Rush me complete specifications on your new kits, and your new "1961 Guide to Custom Stereo."

Name.....

Address.....

City..... Zone..... State.....

\*Cage or case extra. Slightly higher West of Rockies  
Export: Morlan Exporting Corp., 548 Broadway, N. Y. City

## products

(Continued from page 35)

tweeter speakers are standard, but models without the audio sections can be supplied for use with existing hi-fi systems. Either a 23", 24" or 27" picture

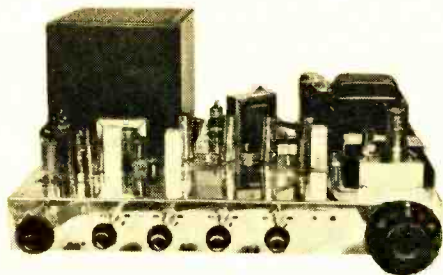

tube may be selected. Prices (with 23" tube) range from \$179.00 to \$199.00. The same sets are available factory-wired for \$259.00 to \$299.00. (*Transvision*, New Rochelle, N. Y.)

### GARAGE DOOR OPENER KIT

The receiver and mechanical section of the Heathkit electronic garage door

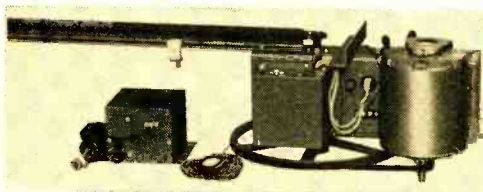

opener can be installed on any overhead-track-type garage door up to eight feet

### RECHARGEABLE BATTERY

The Gould "NICAD" rechargeable battery, designed to fit any standard two-cell flashlight, promises 250 charging cycles. To recharge it, you just remove the cap at one end and plug the battery into any 117-volt a.c. outlet. The hermetically sealed cells are of nickel-cadmium construction. Price of the battery (incorrectly given as \$18.75 in the May 1961 issue) is \$9.95. (*Gould-National Batteries, Inc.*, 931 Vandalia St., St. Paul 14, Minn.)

high; the transmitter mounts under the hood of your car. Special features of the Model GD-20 include a safety device to stop the operation should the moving door meet an obstruction; a switch to activate the door from inside the house; and a light that goes on automatically when the door is opened. The complete kit is priced at \$109.95; extra transmitter kits for additional cars are available for \$24.95. (*Heath Co.*, Benton Harbor, Mich.)

### TAPE STROBE KIT

Tape recorder owners can check the speed of their drive systems with a

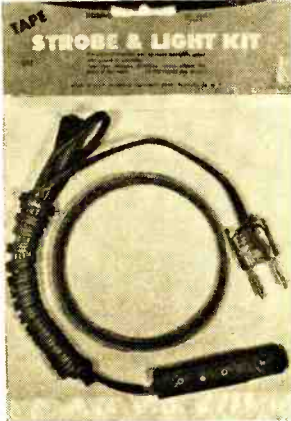

“Tape Strobe and Light Kit” produced by *Robins Industries Corp.*, Flushing, N. Y. Model TK-5 consists of five lengths of 25” non-magnetic leader tape with stroboscopic markings and a small neon light which

flickers at the rate of 120 times per second. The “Strobetape” is spliced into a tape reel at some convenient point and exposed to the flickering light as it passes through the machine. Capstan speed can be checked separately with an endless loop of the Strobetape. Price, \$2.00.

### PHONO JACK ADAPTER

To facilitate mounting a phono jack in an extra-thick panel, *Switchcraft, Inc.* (5555 N. Elston Ave., Chicago 30, Ill.) has introduced its No. 371 adapter. De-



signed for use with the Switchcraft 3501 FP standard phono jack, the adapter makes it convenient to use mounting

panels up to 1¼” thick. The No. 371 comes complete with diagram, mounting nut, and washers. Price, 95 cents.

### “ELECTRONIC LABORATORY”

Transistor radios, code-practice oscillators, and solar-powered devices are among the 18 different projects that can

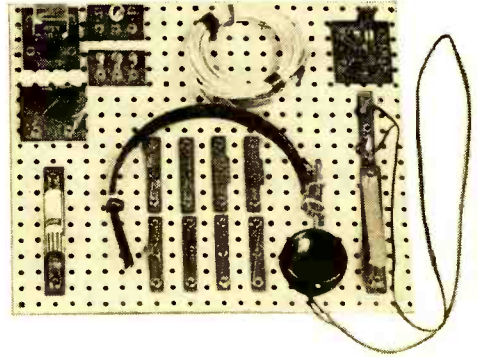

be built with the “Electronic Laboratory” manufactured by *Superelex Electronics Corp.* (4 Radford Place, Yonkers, N. Y.). All the parts are provided—the only extra equipment you’ll need is a screwdriver, since the pre-mounted components are equipped with solderless screw connections and all connecting leads are pre-cut. Price, \$11.95.

### SOLAR MOTOR KIT

Intended for science students, schools, and others interested in the direct conversion of light

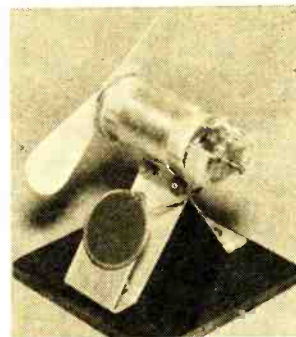

to electricity, the solar motor, available in kit form from *Linwood Products Co.* (Box 186, Wollaston 70, Mass.), operates on either sunlight or artificial light.

The kit contains a precision ball-bearing motor, plastic base, hardware and a silicon cell. When light strikes the cell, electricity is generated which operates the motor, turning a small propeller on the motor shaft. Easy to assemble, the complete kit sells for \$19.75 postpaid; the motor and cell are also obtainable separately.

# FROM **ELECTRONICS BOOK SERVICE**—BOOKS ON CONSTRUCTION, COMPUTERS, ADVANCED THEORY ...YOURS FOR A 7-DAY FREE EXAMINATION

Here is a comprehensive selection of books covering the fields of electronic theory and construction—for your use and profit! You'll find basic reference books, practical guides, construction manuals, and advanced texts to give you excellent guidance in the why's and how's of electronic theory. Each book is filled with descriptive illustrations and diagrams.

And you can have one or more of these top notch bestsellers for 7 days FREE.

Simply write your choices on the coupon below and mail it today. Read and enjoy your books for seven full days. If, after that time, you do not agree that they are everything you want, return them and owe nothing. Otherwise, send along your payment of our bill plus a small charge for postage and handling.

Here is the perfect way for every electronic experimenter to build the library he must have. Order now!

## CONSTRUCTION



### 2350 WORKING WITH THE OSCILLOSCOPE, Saunders

New block-o-matic diagrams show you how to master electronics' most versatile instrument quickly and easily.

Step by step demonstrations of the 'scope's actual uses in radio, TV, transistors, other work; written from 40 years of oscilloscope experience. \$3.00

### 2353 THE CONSTRUCTION OF LIVING ROBOTS, Berkeley and Assoc.

What are the properties of living beings, and how can they be imitated by simple machinery? Here are accessible projects, detail of how to make them and circuit diagrams. \$1.00



### 3171 DIRECT CURRENT FUNDAMENTALS, 2nd Edition, DeFrance

Starting with a simple approach which calls for no previous training, this text develops Direct Current knowledge up to the engineering level. \$7.00



### 2357 BRAINIACS—201 SIMPLE ELECTRIC BRAIN MACHINES AND HOW TO MAKE THEM, Berkeley and Assoc.

Operating on one flashlight battery, these machines can reason logically, compute, solve puzzles, play games, encipher and decipher. Includes the Geniacs and Tyniacs; and Boolean algebra, with directions for going from these machines to automatic computers. All construction details. \$4.95

### 2702 INTRODUCTION TO ELECTRONIC ANALOG COMPUTERS, Warfield

This is the book on computers for professionals engaged in engineering research and development. Simple signal flow graphs stress the topological aspects of analog computers. Basics of the subject and their application. \$6.00



### 2351 RADIO PROJECTS, Warner

10 easy-to-construct radios described in this new book covering the field thoroughly and completely, progressing in complexity from the simple crystal detector to the superheterodyne receiver. Clearly and fully illustrated. \$3.85

plexity from the simple crystal detector to the superheterodyne receiver. Clearly and fully illustrated. \$3.85

### 2359 CONSTRUCTING ELECTRIC BRAINS, Berkeley and Jensen

Thirteen articles from Radio Electronics which together explain how to make machines that carry out arithmetical operations, solve problems, etc. Relays, tubes and various devices may be used. \$2.20



### 2359 MECHANICS VEST POCKET REFERENCE BOOK

Over 200 fact-filled pages including tables, charts, formulas, for every aspect of mechanical work. Also includes logarithm table, conversion factors on gears, U.S. versus foreign measurements, etc. \$2.50

## ADVANCED THEORY



### 3106 ELECTRONIC CIRCUITS, Martin

This is more extensive in scope than any other book on electronic circuits in print. Includes the vacuum tube, transistor, magnetic amplifier circuits, and multistage amplifiers. \$13.00



### 3124 PRINCIPLES OF COMMUNICATIONS SYSTEMS, Horshberger

This book explains the characteristics of channels useful in communication—and describes human and other factors that determine the design and limit of any given system. Three kinds of systems are considered in detail: (1) audio systems, (2) television, (3) radar. \$8.00

## COMPUTERS AND OTHER

### 2700 FUNDAMENTALS OF DIGITAL COMPUTERS, 3rd Edition

The first book to present a comprehensive, understandable coverage of digital computers—fast becoming an indispensable factor in modern business and industry. Illustrated. \$7.95

### 3620 TRANSISTORS HANDBOOK, Bevlitt

The first handbook in the transistor field. This is a non-mathematical treatment, designed not only for the professional engineer, but also for the technician in the electrical communications field. \$10.00





**2017 ELECTRONIC EXPERIMENTER'S HANDBOOK 1961, Ziff-Davis**

A do-it-yourself goldmine! Includes 40 all-new projects—20 data charts and tables on circuits, resistors, transformers, capacitors, ham and citizens band radio, sound levels—and more. Projects for your shop, for your hi-fi and audio systems, for the ham and SWL and for fun. \$1.00



**2703 HIGH SPEED COMPUTING, Methods and Applications, Hollingdale**

The first all-inclusive manual for the machine user, without specialized training. Describes the computer parts, sections, and organization; shows you how to organize and program a problem; discusses computer types, mathematics and logic, engineering and commerce, and uses in many specific fields. \$5.00



**2006 ELECTRONIC EXPERIMENTER'S MANUAL, Findlay**

With a few dollars worth of basic tools and this book to guide you, you can explore the wonderworld of electronics experimentation more completely than ever before. 10 big sections, including exciting projects you'll build and use. \$4.95

**2704 AUTOMATION AND COMPUTING, Booth**

How modern computing fits in with 20th century automation. Offers history of automation and of calculators, achievements, particularly in automatic process control, machine tool control and assembly, the present-day practical possibilities from a mathematical and electronic point of view. \$5.00



**2012 JOBS & CAREERS IN ELECTRONICS 1961, Ziff-Davis**

Your key to a top-paying position in electronics! Describes interesting jobs for engineers, technicians, technical writers. Includes five big sections on opportunities in electronics, planning a career, testing your aptitude, case histories of careers and spare time electronics. \$1.00



**2007 COMPUTERS AND HOW THEY WORK, Fabnestock**

A fact-filled guidebook to electronic computers. Covers the history of computers and explains the workings of every major computer system ever used. Must reading for career-minded students and electronics pros who want a more complete knowledge of this important field. \$4.95



**2011 STEREO & HI-FI DIRECTORY 1961, Ziff-Davis**

New! Over 1200 component listings, 800 photos; latest models, prices! Entire sections on every phase of stereo and monaural high fidelity. \$1.00

**2710 A PICTORIAL MANUAL ON COMPUTERS, Workley and Assoc.**

Computers and their internal parts in pictures, designed to show you what the thinking machines are and how they are made. \$1.25

**2711 LINEAR PROGRAMMING AND COMPUTERS, Davis**

This book is the ideal introduction to linear programming, explaining the motivations and illustrating them by the techniques. Offers a good start in the field. \$1.20



**2008 CLASS D CITIZENS RADIO, Sands**

Now, with more than a million vehicles equipped for its use, Citizens Radio is a major phase of the electronics field. Here's the story on the whole field—its history, rules, and everything about how it works. Learn exactly what Citizens Radio is, its applications, what you need, FCC rulings, etc. \$4.95

**FREE!**

ENCLOSE PAYMENT NOW WITH YOUR ORDER AND YOU WILL GET AS A FREE BONUS A COPY OF THE HARD-COVER EDITION OF THE 1960 ELECTRONIC EXPERIMENTER'S HANDBOOK—



A \$1.95 VALUE

**FREE!**

**ELECTRONICS BOOK SERVICE**  
One Park Avenue, New York 16, N. Y.

Please send me the book(s) I have listed below for a FREE 7-Day Trial Examination. I understand that if I am not completely satisfied, I may return my selection(s) and I'll owe you nothing. Otherwise, I will send you payment for the book(s) of my choice, plus postage and handling.

NUMBER	TITLE	PRICE
*TOTAL		

\*New York City Residents, please add 3% sales tax.  
(If you need more space for other titles, attach a sheet of paper with addl. list.)  
 **SAVE MONEY!** Enclose payment in full for the book(s) of your choice and we will pay shipping charges. Same return privileges and prompt refund guaranteed.  
 Please send me FREE CATALOG, when published. EF558

NAME \_\_\_\_\_ PLEASE PRINT CLEARLY  
ADDRESS \_\_\_\_\_  
CITY \_\_\_\_\_ ZONE \_\_\_\_\_ STATE \_\_\_\_\_

(7-day free trial offer good only in U.S.A. and Canada. Foreign customers must enclose payment in full. Satisfaction guaranteed or money refunded.)

## BEST BUYS IN STEREO AND MONO HI-FI

New Transistorized Stereo/Mono 4-Track Tape Deck RP100 Semikit (electronics in kit form) \$289.95 Wired \$395.00



New FM-AM Stereo Tuner ST96  
Kit \$89.95 Wired \$129.95  
Incl. FET

New 70-Watt Integrated Stereo Amplifier ST70  
Kit \$94.95 Wired \$149.95



New 40 Watt Integrated Stereo amplifier ST40  
Kit \$79.95 Wired \$129.95



28W Integrated Stereo Amplifier HF81  
Kit \$69.95 Wired \$109.95

FM Tuner HFT90  
Kit \$39.95 Wired \$65.95  
Incl. FET Metal Cover \$3.95



AM Tuner HFT94 Incl. FET  
Kit \$39.95 Wired \$65.95



Stereo Preamplifier HF85  
Kit \$39.95 Wired \$64.95

Stereo Power Amplifiers



	Kit	Wired
100W HF89:	\$99.50	\$139.50
70W HF87:	\$74.95	\$114.95
28W HF86:	\$43.95	\$ 74.95



Stereo/Mono Changer/Player 1007 with stereo cartridge and dual sapphire styli \$49.75



Bookshelf Speaker System HFS1  
Kit \$39.95 Wired \$47.95

## BEST BUYS IN CITIZENS TRANSCEIVERS, HAM GEAR, RADIOS

Citizens Band Transceivers from Kit \$59.95 Wired \$89.95



New 60W CW Transmitter #723  
Kit \$49.95 Wired \$79.95



Transistor Portable Radio RA6  
Kit \$29.95 Wired \$49.95  
Incl. FET

## BEST BUYS IN TEST EQUIPMENT

New Metered Variable AC Bench Supplies Model 1073 (3 amps) Kit \$35.95 Wired \$47.95 Model 1078 (7 1/2 amps) Kit \$42.95 Wired \$54.95



Peak-To-Peak VTVM = 232 & Uni-Probe® Pat. = 2,790,051 Kit \$29.95 Wired \$49.95



VTVM = 221  
Kit \$25.95 Wired \$39.95

DC-5 MC 5" Scope = 460  
Kit \$79.95 Wired \$129.50



5" Push-Pull Scope = 425  
Kit \$44.95 Wired \$79.95

Tube Tester = 625  
Kit \$34.95 Wired \$49.95



RF Signal Generator #324  
Kit \$26.95 Wired \$39.95



1000 Ohms/Volt V-O-M #536  
Kit \$12.90 Wired \$14.90



6- & 12V Battery Eliminator & Charger #1050  
Kit \$29.95 Wired \$38.95



Extra-filtered for transistor equip. = 1060  
Kit \$38.95 Wired \$47.95

R-C Bridge & R-C-L Comparator #950B  
Kit \$19.95 Wired \$29.95



Multi-Signal Tracer #145A  
Kit \$19.95 Wired \$28.95



# EICO

# EXCELLENCE IN CREATIVE ELECTRONICS

Over 2 MILLION EICO instruments in use throughout the world. Compare, take them home — right "off the shelf" — from 1500 neighborhood dealers, most of whom offer budget terms.



EICO, 3300 N. Blvd., L.I.C. I, N.Y. PE-7  
 Send free Catalog describing over 80 top-quality products, free Stereo Hi-Fi Guide, free Short Course for Novice License, name of nearest EICO dealer.  Send new 36-page GUIDEBOOK TO HI-FI for which I enclose 25¢ for postage & handling.

Name.....  
 Address.....  
 City..... Zone... State.....  
 Add 5% in the West

Listen to the EICO Hour, WABC-FM, N. Y. 95.5 MC, Mon.-Fri., 7:15-8 P.M.

© 1961 by EICO, 33-00 N. Blvd., L. I. C. I, N. Y.

# VOICES FROM THE

# ENGLISH LANGUAGE



# ORIENT

By  
STEWART WEST

**Short-wave broadcasts from the Far Eastern and Pacific areas can provide you with many hours of pleasant and interesting listening**

**W**ANT an opportunity to learn more about people with different customs and religions from ours? You have one—in your short-wave receiver!

Dozens of fascinating English-language broadcasts from the Orient speed across the Pacific Ocean every day. Some are interesting Oriental and Polynesian programs, while others originate from such English-speaking countries as Australia and New Zealand. But whatever your interest in the Orient and the lands "Down Under," chances are you'll find what you're looking for among the signals waiting to be "tapped" on the short-wave bands.

Listeners in the Western part of North America are almost ideally situated to hear most of these broadcasts, since the signals travel over water and are well clear of the auroral zones near the poles. But SWL's in Eastern North America also pick up many signals from the Orient. Although some can be heard only when conditions are particularly favorable, a good antenna coupled to a sensitive (not necessarily expensive) receiver will pull in many a distant broadcast.

The comprehensive, as up-to-date-as-possible charts on the next four pages list English-language broadcasts from  
*(Continued on page 46)*

# ENGLISH-LANGUAGE SHORT-WAVE BROADCAST STATIONS FROM

TIME: EST (PST)	CITY, COUNTRY (NAME)	FREQUENCIES (kc.)
1400-1500 (1100-1200)	Djakarta, Indonesia (Voice of Indonesia) News—1415 (1115)	11710, 9865
1445-1545 (1145-1245)	Delhi, India (All India Radio) News—1445 (1145)	15105, 11955, 11890, 9635
1525-1550 (1225-1250) —except Wednesday	Tokyo, Japan (Radio Japan) News—1525 (1225)	15135, 11800, 9675
1600-1830 (1300-1530)	Manila, Philippines (Far East Broadcasting Co.) News—1645 (1345)	21515, 15300
1745-0045 (1445-2145)	*Wellington, New Zealand (Relay of 2YA) News—1933-2000 (1633-1700) Monday—Friday	15280
1830-2000 (1530-1700)	Manila, Philippines (Far East Broadcasting Co.) News—1830 (1530) (News also on 1780.5, 1385.5)	21515, 15385
1830-0315 (1530-0015)	Melbourne, Australia (VLH15)	15230
1915-0100 (1615-2200)	*Melbourne, Australia (Radio Australia)	21540, 17840, 25735 (experimental)
1915-0515 (1615-0215)	Perth, Australia (VLX15 and VLW9)	15425, 9610
1930-2020 (1630-1720)	**Tokyo, Japan (Radio Japan) News—1930 (1630) Mailbag—Tuesday 2005 (1705) (Includes DX program each fort- night)	21520, 17725, 15135
2000-2200 (1700-1900)	**Peking, China (Radio Peking) News—2000, 2100 (1700, 1800)	17720, 15115, 11945, 9480
2030-2100 (1730-1800)	**Taipei, Taiwan (Voice of Free China) News—2130 (1730)	17785, 11860
2030-2230 (1730-1930)	Colombo, Ceylon (Commercial Service)	15265
2130-2145 (1830-1845)	Karachi, Pakistan (Radio Pakistan)	11885, 9645
2130-2145 (1830-1845)	Delhi, India (All India Radio)	15300, 11710
2200-0000 (1900-2100)	**Peking, China (Radio Peking) News—2200, 2300 (1900, 2000)	17745, 15060, 11820, 9460
2200-0500 (1900-0200)	Tokyo, Japan (FEN—Far East Network)	15257, 11750

# FAR EASTERN AND PACIFIC AREAS HEARD IN NORTH AMERICA

TIME: EST (PST)	CITY, COUNTRY (NAME)	FREQUENCIES (kc.)
2315-0000 (2015-2100)	**Tokyo, Japan (Radio Japan) News—2315 (2015) Mailbag—Friday 2345 (2045) (Includes DX program each fortnight)	21520, 17725, 15135, 11800
2315-0015 (2015-2115)	**Bangkok, Thailand (HSK9) News—2325 (2025)	11910
0030-0100 (2130-2200)	**Seoul, Korea (Voice of Free Korea)	15125, 11925
0100-0145 (2200-2245)	Port Moresby, New Guinea (VLT9)	9520
0100-0345 (2200-0045)	*Wellington, New Zealand (Radio New Zealand) News—0100, 0230 (2200, 2330) Mailbag—Friday 0200 (2300) DX Program—1st Wed. of each month \$140 (2240)	11780, 6080
0100-0415 (2200-0115)	*Melbourne, Australia (Radio Australia) News—0100, 0400 (2300, 0100) Mailbag—Sunday 0145 (2245) DX Program—Sunday 0215 (2315)	11710
0200-0530 (2300-0230)	Suva, Fiji (Fiji Broadcasting Commission)	5980, 3980
0200-0830 (2300-0530)	Port Moresby, New Guinea (VLT6) News—0400, 0730, 0800 (0100, 0430, 0500)	6130
0400-0615 (0100-0315)	Honiara, Solomon Islands (VQ02)	5960
0400-0830 (0100-0530)	Melbourne, Australia (VLR9 and VLR6)	9680, 6150
0400-0645 (0100-0345)	*Wellington, New Zealand (Radio New Zealand) News—0430 (0130), Sunday 0403 (0103) Mailbag—Friday 0500 (0200) DX Program—1st Wed. of each month 0530 (0230)	11780, 6080
0400-0830 (0100-0530)	Brisbane, Australia (VLQ9 and VLM4)	9660, 4920
0410-0630 (0110-0330) —except on 9725 and 7110 kc.	Singapore (BBC Far East Station) News—0600 (0300) and at 0415 (0115, on 17755, 11955, 9690)	17755, 11955, 11820, 9725, 9690, 7110
0430-0445 (0130-0145)	Karachi, Pakistan (Radio Pakistan)	21590, 17745

# ENGLISH-LANGUAGE SHORT-WAVE BROADCAST STATIONS FROM

TIME: EST (PST)	CITY, COUNTRY (NAME)	FREQUENCIES (kc.)
0430-0530 (0130-0230)	Tokyo, Japan (Radio Japan) News—0430 (0130) Mailbag—Friday 0515 (0215) (Includes DX program each fort- night)	15235, 11875
0500-0830 (0200-0530)	Sydney, Australia (VLI6)	6090
0500-1000 (0200-0700)	Tokyo, Japan (FEN—Far East Network)	15257, 11750, 6160
0500-1230 (0200-0930)	*Melbourne, Australia (Radio Australia)	9565, from 0800 (0500) 11740
0505-0550 (0205-0250)	Taipei, Taiwan (Voice of Free China) News—0515 (0215)	17785, 17890, 15225, 6095
0525-0630 (0225-0330)	*Bangkok, Thailand (Overseas Broadcasting Station) News—0530 (0230)	11910, 7300
0530-1030 (0230-0730)	Perth, Australia (VLX9 and VLW6)	9610, 6140
0600-0700 (0300-0400)	Djakarta, Indonesia (Voice of Indonesia) News—0615 (0315)	11795, 9585
0600-0900 (0300-0600)	*Melbourne, Australia (Radio Australia) News—0600, 0700, 0800 (0300, 0400, 0500) Mailbag—Sunday 0630 (0330)	11810 to 0700 (0400), 9580
0630-0845 (0330-0545)	Singapore (BBC Far East Station) News—0800 (0500) (News also on 11955, 9725)	15435, from 0800 (0500) 11820 & 9690
0700-0730 (0400-0430)	Tashkent, USSR (Radio Tashkent) News—0700 (0400)	11695
0700-0800 (0400-0500)	*Peking, China (Radio Peking) News—0700 (0400)	15095, 11820
0714-0815 (0414-0515)	**Melbourne, Australia (Radio Australia) News—0745 (0445) Mailbag—Sunday 0730 (0430) DX Program—Sunday 0800 (0500)	11710
0730-0825 (0430-0525)	Taipei, Taiwan (Voice of Free China) The Dragon Show	17890, 17825, 9720, 9660, 7130, 6095
0730-0800 (0430-0500)	Pyongyang, North Korea (Radio Pyongyang)	6250

# FAR EASTERN AND PACIFIC AREAS HEARD IN NORTH AMERICA

TIME: EST (PST)	CITY, COUNTRY (NAME)	FREQUENCIES (kc.)
0730-0830 (0430-0530)	Manila, Philippines (Call of the Orient) News—0800 (0500)	21515, 11920, 9730
0730-0900 (0430-0600)	Jesselton, North Borneo (Radio Sabah)	4970
0730-1145 (0430-0845)	Colombo, Ceylon (Commercial Service)	9520
0745-0915 (0445-0615)	Saigon, South Vietnam (VTVN)	9625
0800-0830 (0500-0530)	*Tokyo, Japan (Radio Japan—General Service) News—0800 (0500)  <i>The frequencies given are also used for English News at 0600, 0700, 1000 (0300, 0400, 0700)</i>	15235, 11815, 11780
0800-0930 (0500-0630)	Kuching, Sarawak (Radio Sarawak)	4950
0830-0900 (0530-0600)	Hanoi, North Vietnam (Voice of Vietnam)	11840, 9840
0830-1000 (0530-0700)	Delhi, India (All India Radio)	17705, 15365
0900-0930 (0600-0630)	Tashkent, USSR (Radio Tashkent) News—0900 (0600)	11695
0900-1150 (0600-0850)	Singapore (BBC Far East Station) News—1100 (0800)	11955, 9690 (News on 9725)
0930-1000 (0630-0700)	**Seoul, Korea (Voice of Free Korea)	11925
0930-1030 (0630-0730)	Djakarta, Indonesia (Voice of Indonesia) News—0945 (0645)	11795, 9585
0945-1000 (0645-0700)	Karachi, Pakistan (Radio Pakistan) News—0945 (0645)	15195, 11725, 11674
1000-1130 (0700-0830)	Manila, Philippines (FEBC, Call of the Orient) News—1000 (0700)	21515, 11920, 9730
1014-1115 (0714-0815)	**Melbourne, Australia (Radio Australia) News—1016 (0716) Mailbag—Sunday 1030 (0730) DX Program—Sunday 1100 (0800)	11710
1030-1045 (0730-0745)	Karachi, Pakistan (Radio Pakistan)	15145, 11672
1100-1130 (0800-0830)	Seoul, Korea (Voice of Free Korea)	11925

\*Stations usually heard with a good signal in North America  
 \*\*Broadcasts especially beamed for listeners in North America



David Liu (at right), chief of VOFC's English desk, chats with visitor on weekly "Chatter Box" program.



Voice of Free China transmitter room, near Taipei, on Formosa.



"Songs of the Maori People," featuring typical native songs and dances, can be heard twice weekly on Radio New Zealand.

Bell-bird's chime-like call is interval signal for Radio New Zealand.



Eddie Tan is popular disc-jockey/MC for Voice of Free China's hour-long, English-language "Dragon Show."

Graham Hutchins is the Editor of "DX'ers Calling" for Radio Australia.



Keith Glover (left) is the "Overseas Mailman" heard Sundays on Radio Australia.

New 100-kw. transmitters for Radio Australia. Located at Shepparton, units handle programs for stations VLB and VLE.



short-wave stations in South and East Asia, Australia, and various South Sea islands. Frequencies and times may vary somewhat, however, because of changing conditions or interference on the listed channel.

Many stations listed on the 4-, 6-, and 7-mc. bands will fade out soon after the sun rises in your area, while those on the 9- and 11-mc. bands will gradually fade out later in the morning. For the most part, signals from stations in the Far East and Pacific areas will travel across the Pacific Ocean to your listening post. Occasionally, though, they will come the long way round—across Europe and Africa—usually in the late afternoon and early evening, when listeners in the Eastern states will get their strongest signals.

When more than one frequency is listed, check them all to see which one will give the best reception at your particular listening post—since short-wave conditions are constantly changing, there is no one "best" station.



# 6 METERS and MOBILE

**I** NTEREST in the 6-meter band has been running high ever since the FCC opened the band to Technicians. The remarkable performance of even low-power transmitters on 50 mc. makes a mobile rig especially attractive. There's plenty of opportunity for local contacts, with an occasional taste of DX when the band "opens up."

The transmitter described here offers several advantages, especially for the new ham who is anxious to abandon the code key in favor of a microphone. For one thing, it's a self-contained rig, complete with power supply. Then, too, there's a relay for switching from "Send" to "Receive." Further, chassis layout is "open" (you'll find no "rat's nest" of wires), thus easing the problems of critical wiring at the high (50-mc.) frequency. And finally, the circuit is easily wired for either 6- or 12-volt cars. In fact, the only other components needed to round out a mobile station are a receiving converter and a whip antenna.

**Construction.** After drilling and punching the chassis, make certain that the major parts are oriented properly before fastening each one in place. The lugs on

*Thinking of  
going mobile?  
Then make  
this compact,  
self-contained  
transmitter  
the heart  
of your rig*

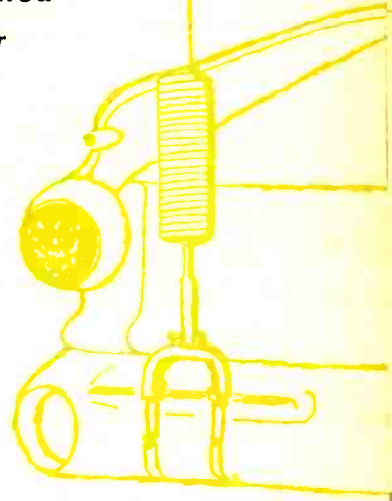

**By LEN BUCKWALTER, K1ODH**

Inexpensive transmitter puts out approximately five watts with power supply shown. Crystal-controlled, the rig can be constructed for either 6- or 12-volt cars.

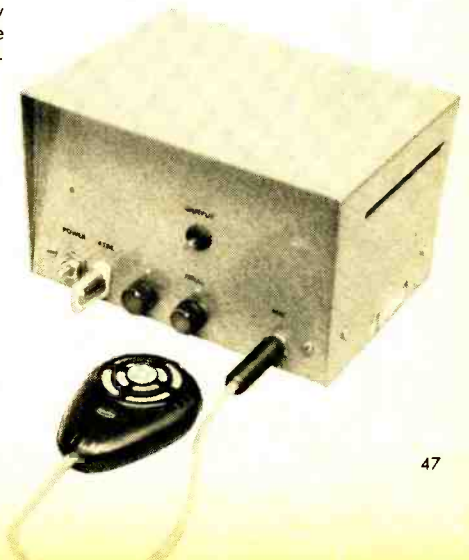
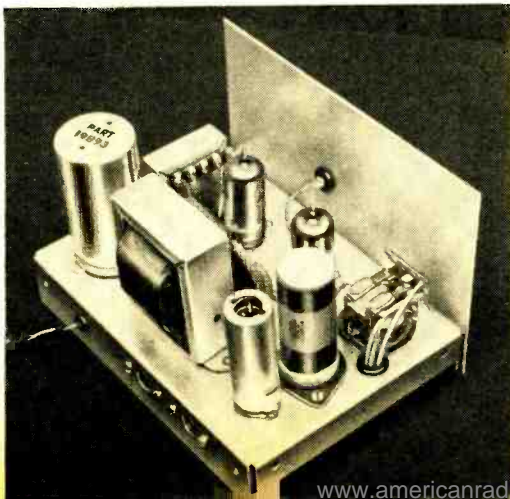

the tube sockets, for example, should be positioned as shown in order to keep leads short. Note that the center lugs on the two large terminal strips serve as both mounting feet and grounds.

The neon bulb (*I1*) is simply pushed through a rubber grommet on the front panel and held in place by friction. Be sure to install a ground lug on top of the chassis under one screw which holds the socket for tube *V1* (this screw is nearest the front panel). The lug re-

Two views of underside of chassis, showing location of principal parts. All leads should be kept as short as possible.

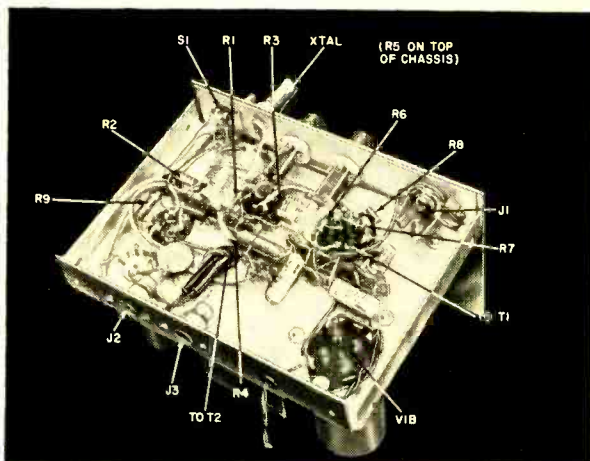

ceives one lead of resistor *R5*; the other lead is soldered directly to one of the leads on neon bulb *I1*.

Standard #20 hookup wire is suitable for most of the wiring, although coil *L3* in the antenna circuit is a 1½-turn pick-up link fashioned from a short piece of #20 enameled magnet wire. Wind it around a ½"-form (the author used a tubular capacitor), slip it off, and solder it in place. When properly mounted, it should *almost* touch *L2*.

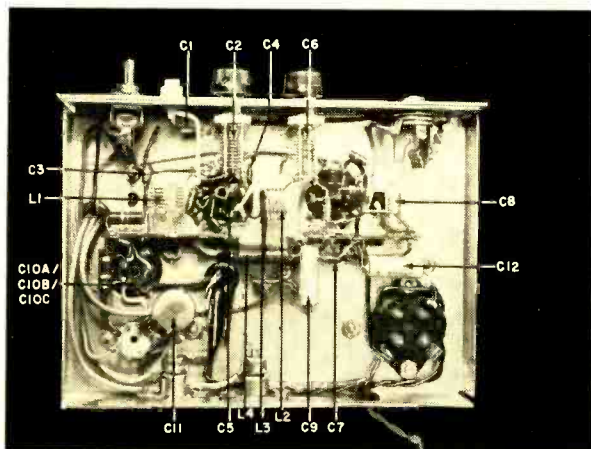

Almost any carbon microphone equipped with a press-to-talk switch is satisfactory, but its plug must be wired to match jack *J1*. Due to switching by relay *K1*, only one antenna is needed.



The three cables coming from relay *K1* are shielded; ordinary phono cable will serve very nicely. Note that in each case the shield grounds at only one end of the cable (at the underside of the chassis).

**6 or 12 Volts.** The rig as shown is wired for a 6-volt auto ignition system. The alternative, 12 volts, is achieved by one wiring and four component changes—simply substitute the parts given under the heading "For 12-Volt Operation" in the Parts List. The wiring change is to connect the heaters of tubes *V1* and *V2* in series instead of in parallel (see schematic). Otherwise, everything remains the same—pin numbers, layout, etc.

**Checkout and Tune-Up.** After checking carefully for possible wiring errors, plug in the crystal and microphone. The circuit is designed for a carbon mike

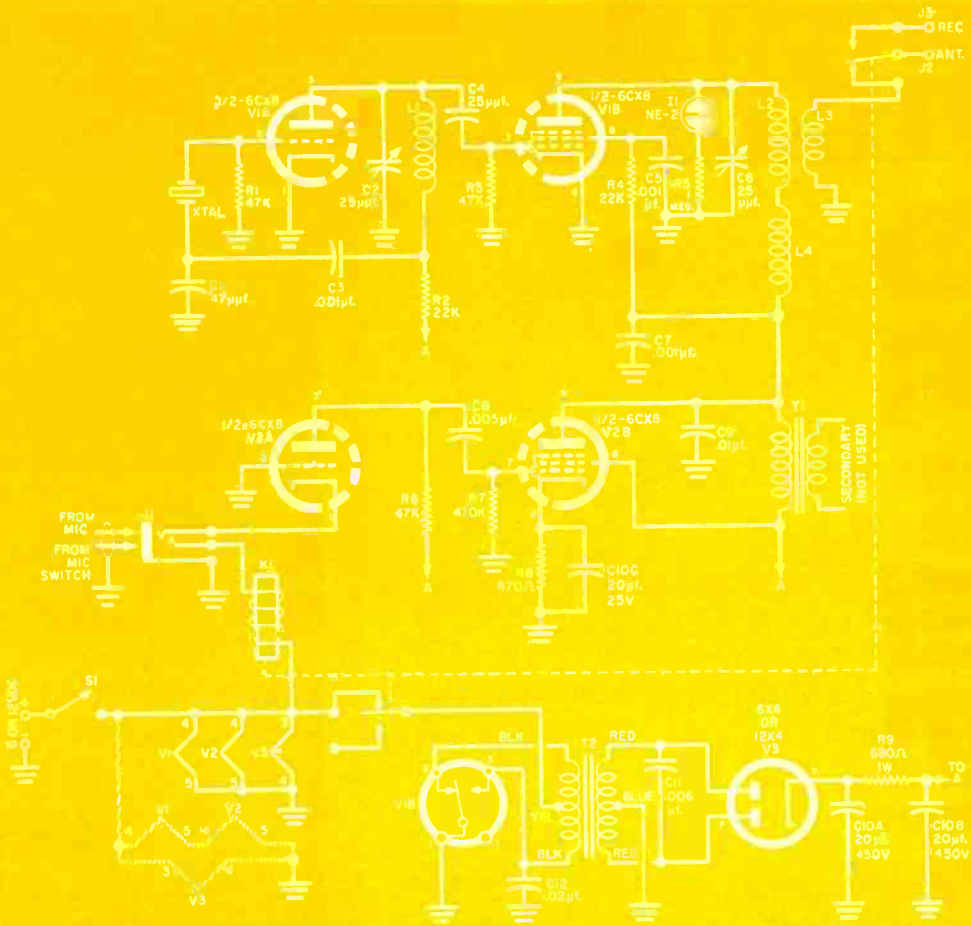

### PARTS LIST

- C1—47- $\mu$ f., 600-volt disc capacitor
- C2, C6—25- $\mu$ f., variable capacitor (Johnson 20M11 or equivalent)
- C3, C5, C7—0.001- $\mu$ f., 600-volt disc capacitor
- C4—25- $\mu$ f., 600-volt disc capacitor
- C8—0.005- $\mu$ f., 600-volt paper capacitor
- C9—0.01- $\mu$ f., 600-volt paper capacitor
- C10a/C10b/C10c—20/20/20  $\mu$ f., 450/450/25 volt d.c. electrolytic capacitor (Mallory FP345.8 or equivalent)
- C11—0.006- $\mu$ f., 2000-volt disc capacitor
- C12—0.02- $\mu$ f., 600-volt paper capacitor
- I1—NE-2 neon bulb
- J1—2-circuit phone jack
- J2, J3—Auto-type antenna jack
- K1—D.p.d.t., 6-volt d.c. antenna switching relay (Potter & Brumfield KT11D-6VDC or equivalent)
- L1—6 turns of B & W 3003 coil stock
- L2—5 turns of B & W 3003 coil stock
- L3—1½ turns of #20 enameled wire, ½" diameter—see text
- L4—7- $\mu$ h. r.f. choke (Ohmite Z-50 or equivalent)
- R1, R3, R6—47,000 ohms      All resistors
- R2, R4—22,000 ohms, 1 watt      ½-watt unless
- R5—1 megohm                      otherwise noted
- R7—470,000 ohms
- R8—470 ohms

- R9—680 ohms, 1 watt
- S1—S.p.s.t. toggle switch
- T1—Universal output transformer (secondary not used) (Lafayette TR-12 or equivalent)
- T2—Vibrator transformer; primary, 6 volts d.c. CT; secondary, 200 volts CT @ 55 ma. (Lafayette TR-77 or equivalent)
- V1, V2—6CX8 tube
- V3—6X4 tube
- XTal—6-meter crystal, overtone type
- 1—6-volt, 4-prong vibrator (Lafayette MS-14 or equivalent)
- 1—7" x 5" x 4½" aluminum utility enclosure (LMB W-1A or equivalent)
- 1—Carbon microphone—see text
- 1—2-lug terminal strip, one lug grounded
- 1—5-lug terminal strips; center lug grounded
- Misc.—Shielded cable, tube and vibrator sockets

### Alternate Parts for 12-Volt Operation

- K1—D.p.d.t., 12-volt d.c. antenna switching relay (Potter and Brumfield KT11D-12VDC or equivalent)
- T2—Vibrator transformer; primary, 12 volts d.c. CT; secondary, 200 volts CT @ 55 ma. (Lafayette TR-78 or equivalent)
- V3—12X4 tube
- 1—12-volt, 4-prong vibrator (Lafayette MS-128 or equivalent)

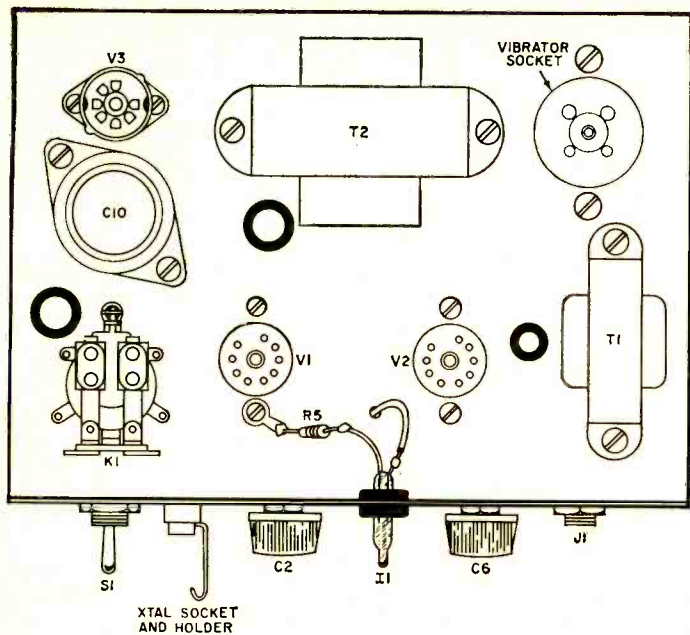

Drawing of top of chassis, with case removed. Neon bulb I1 serves as a tuning indicator and is held in place by a rubber grommet; R5 is soldered directly to one lead and attached to a solder lug under a screw at V1's socket.

## HOW IT WORKS

The 6-meter mobile transmitter is comprised of three sections—a transmitter, a modulator, and a power supply. In the transmitter section, tube *V1a* oscillates at the crystal frequency due to feedback through capacitor *C3*; tuned circuit *C2/L1* selects the fifth overtone of the crystal output, which, with a "6-meter" overtone crystal, falls in the 6-meter band. Tube *V1b* is an r.f. amplifier, boosting the oscillator output and delivering it to tuned circuit *C6/L2*. The *L2/L3* combination matches the high impedance of the plate circuit to the low impedance of the antenna.

In the modulator section, tube *V2a* amplifies the weak signals generated by the carbon microphone. Since the microphone is in series with the cathode of the tube, current passing through the tube supplies excitation current for the microphone. In addition, this hookup eliminates the

necessity of using an impedance-matching transformer.

The audio signal is further amplified by tube *V2b*. Inasmuch as modulation "transformer" *T1* is in series with the B+ voltage to the r.f. amplifier *V1b*, audio voltage in *T1* will affect the output of the r.f. amplifier. This creates the characteristic envelope of amplitude modulation.

In the power supply, the vibrator interrupts the d.c. input, enabling transformer *T2* to step it up to about 200 volts; rectifier tube *V3* and a filter network consisting of *C10a*, *R9*, and *C10b* furnish a smoothed B+. The vibrator is powered when relay *K1* returns the *T2* primary center-tap to the battery, and this occurs whenever the microphone button is depressed, energizing the relay coil. The remaining relay contacts switch the external antenna from "receive" to "transmit."

equipped with a push-to-talk button. A Monarch MC-63 is shown here, but there are numerous bargains to be had in army surplus units—the T-17, for example. Just be certain that the button connects the relay coil to ground (through the shield of the mike cable) when it is depressed.

Next, hook a 54" piece of wire to the jack marked *Ant* and apply power. The most important aspect of the initial tune-up is to determine the approximate positions of the two tuning capacitors; unless this is done, you might find yourself operating on the wrong overtone of the crystal. A grid-dip meter is valuable for tuning up, but a nearby receiver

equipped with an S-meter will also do the trick.

Tune the receiver to your transmitting crystal frequency, press the mike button, and rotate the oscillator capacitor (*C2*) for a peak on the S-meter. Now tune the final for peak output.

With the vibrator transformer listed, input power of the transmitter is five watts (B+ at *C10a* is about 200 volts). If desired, power input can be boosted by selecting a transformer with a higher rating—up to about 270 volts. No other parts changes are necessary.

Once you are assured of proper operation on the crystal frequency, mark the  
(Continued on page 120)

# SENSITIVE

# Field Strength Meter

**Transistor-amplified unit, bandswitched from 20 to 2 meters, measures field strength, tests for harmonics, and checks transmitter audio quality**

**By HERBERT FRIEDMAN**



The FSM has headphone output jack for use in checking transmitter's audio quality. Plugging in headphones does not change sensitivity of instrument.



**A** FIELD STRENGTH METER (FSM) is one of the handiest instruments you can have around your ham shack—it can be used for tuning up and checking transmitters and antennas, or hunting for those TVI-producing harmonics. This transistor-amplified unit combines many of the features most desired in a field strength meter. In addition, its tuned input—which is bandswitched from 20 through 2 meters—makes for high sensitivity and eliminates interference from the transmitter's fundamental frequency when you're checking for harmonics.

**The Circuit.** A standard tuned circuit with a diode detector picks up and rectifies the r.f. signal. The rectified r.f. is then fed to the base of a common emitter transistor amplifier whose gain is such that a base current of 10 to 20 microamperes, depending on manufacturing variations in the transistor, causes full-scale deflection of the 0-1 ma. meter (*M1*).

This gain is more than adequate for general testing. If greater sensitivity is desired, such as for antenna checking at relatively large distances from the transmitter, a 0-50 or 0-100  $\mu$ a. meter can be substituted for *M1*. No circuit changes

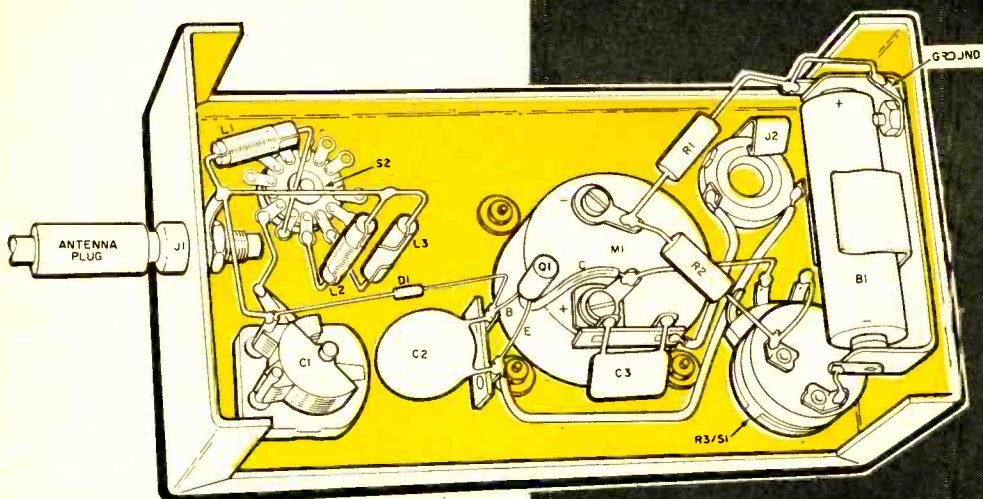

Small metal utility box houses and shields FSM parts. The leads of coils L1, L2 and L3 should be as short and direct as possible. Notice that the polarity of mercury battery B1 is unusual; the casing is positive and the insulated center disc is negative.

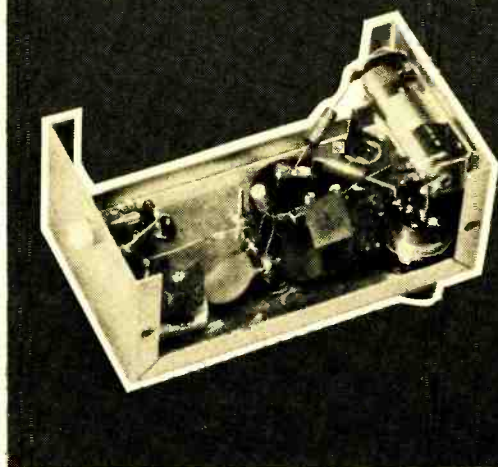

would be necessary as a result of the substitution.

The 2N217 transistor (*Q1*), like all transistors, has a normal leakage current which would ordinarily cause a constant meter indication. This leakage indication is avoided by using the collector-emitter resistance of *Q1* as one arm of a balanced bridge circuit. The bridge is balanced with potentiometer *R3* so that current does not flow through *M1* when no signal is being picked up.

When a signal does enter the instrument, however, rectified r.f. from diode *D1* is fed to *Q1*'s base circuit, and the effective collector-emitter resistance of *Q1* decreases. This unbalances the bridge, causing current to flow in the milliammeter.

Since the transistor amplifies the audio as well as the d.c. component of the rectified r.f., a high sound level is available at the headphone output (*J2*). Isolated from the d.c. circuit, by capacitor *C3*, this output permits the use of crystal headphones for better sound reproduction when checking a transmitter's audio

quality. Neither the reading of meter *M1* nor the sensitivity of the instrument changes when the headphones are plugged in.

**Construction.** The field strength meter is built in a hand-sized (5¼" x 3" x 2⅛") aluminum box; a plastic box should not be used since it would not provide the necessary shielding. The antenna is a 12" piece of stiff wire soldered to a banana plug.

Follow the parts layout in the photograph and pictorial diagram, making sure that antenna jack *J1* is mounted near the rear of the top of the box. This insures that there will be enough room to mount coils *L1*, *L2* and *L3*.

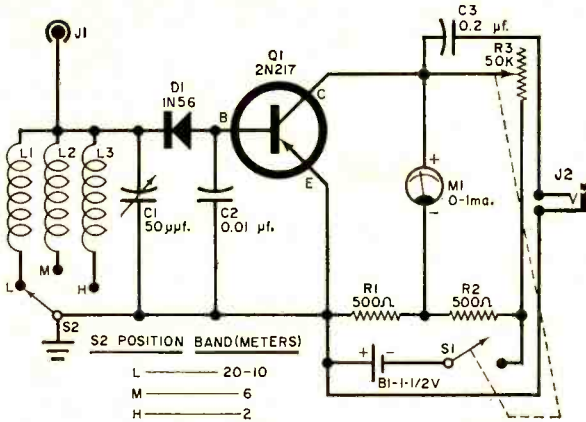

### PARTS LIST

- B1—1.4-volt mercury transistor battery (Mullory #ZM-9 or equivalent)  
 C1—50-µf. trimmer capacitor (Hammerlund MAPC-50-B or equivalent)  
 C2—0.01-µf., 75-volt ceramic disc capacitor  
 C3—0.2-µf., 75-volt ceramic disc capacitor  
 D1—1N56 diode  
 J1—Nylon-insulated banana jack (H. H. Smith #221 or equivalent)  
 J2—Open-circuit phone jack  
 L1—2.4-µh. miniature r.f. choke (Miller 4606 or Stancor RTC-8517) } modified  
 L2—0.47-µh. miniature r.f. choke } —see  
 L3—0.1-µh. miniature r.f. choke } text  
 (Miller 4580 or Stancor RTC-8511)  
 M1—0-1 ma. d.c. milliammeter (Lafayette TM-400 or equivalent)  
 Q1—2N217 transistor  
 R1, R2—500-ohm, ½-watt resistor  
 R3—50,000-ohm potentiometer (with switch S1)  
 S1—S.p.s.t. switch (on R3)  
 S2—1-p.3.t. switch (appropriate sections of Lafayette SW-78 or equivalent)  
 1—5¼" x 3" x 2½" aluminum box (Bud #CU-2106A or equivalent)  
 1—Battery holder (Keystone #139 or equivalent)

The coils are commercial miniature r.f. chokes (see Parts List) which are modified by removing turns. Remove five turns from the Miller 4606 to make L1, three turns from the 4588 for L2, and two turns from the 4580 for L3.

Wire coils L1, L2, and L3 to switch S2 so that they are placed in the circuit in that order as S2 is moved from its extreme counterclockwise position through its first two clockwise positions. Be sure to place the coils so that their leads are as short as possible, especially the 2-meter coil (L3).

Use a heat sink, such as a copper alligator clip, to protect the diode and transistor while soldering them in place. The clip, if placed on a lead close to the joint being soldered, will serve to dissipate the excess heat.

**Labeling and Calibration.** Mark the extreme counterclockwise (L1) position of range switch S2 with an "L" for "low band" (20 through 10 meters). The first clockwise (L2) position is marked with an "M" for "middle band" (6 meters), and the second clockwise (L3) position with an "H" for "high band" (2 meters).

Before proceeding further, check the balancing circuit. First rotate balance control R3 to the "off" position and insert the battery; then turn the control just enough to switch on S1. Meter M1's needle will move off the zero mark to some positive or negative value. If the needle moves in the negative direction, disconnect the wire at the end terminal of R3 and move it to the terminal at the other end. The balance control is now rotated until M1 reads zero, and the unit is ready for calibration.

(Continued on page 121)

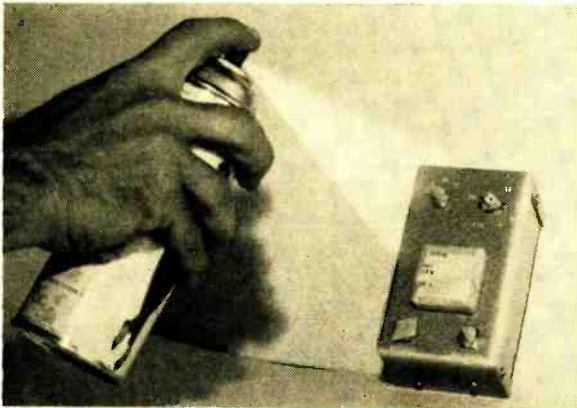

A clear plastic spray such as Krylon is used to protect the panel decals. Front panel parts are covered with tape and cardboard while spraying.

# VTVM

# Adapter for Multimeters

**Low-cost adapter converts any good-quality VOM  
to a sensitive, high-input-resistance d.c. VTVM**

By PHILIP E. HATFIELD, W9GFS

**I**F YOU NEED a vacuum-tube voltmeter but hesitate to buy one because you already own a good standard multimeter, the little adapter described here may be the answer to your problem. It will convert your meter to a d.c. VTVM having an input resistance of 11 megohms. Since the only connections to the multimeter are made through the existing input jacks, the unit can easily be removed whenever you wish.

The adapter provides d.c. ranges of 0 - 4, 0 - 40, and 0 - 400 volts, and—with the help of a specially built probe—the two lower ranges can also be used on r.f. voltages at frequencies up to about 10 megacycles. The cost of the unit is low, and you'll be able to check sensitive circuits in which voltages would literally disappear under the load of an ordinary multimeter.

**Construction.** The parts are housed in a 3" x 4" x 5" metal utility box. Start construction by drilling all the mounting holes and installing all parts except

"range" switch *S1* and power transformer *T1*.

Resistors *R3*, *R4* and *R5* are then mounted on *S1*, the terminal for one of the unused sections of this switch serving as a tie point for the grounded end of *R5*. The switch is now installed and all wiring in the box, except for the transformer connections, may be completed. Finally, mount and connect the transformer.

Before the VTVM adapter can be used, the proper probes must be provided. The d.c. probes are a set of ordinary test leads with one modification: a 1-megohm resistor (*R1*), wired in series with the test lead, is installed in the handle of the positive probe. The r.f. probe circuit is built into the plastic case of a nasal inhaler, in the following manner.

Remove the interior sleeve from the plastic case, and drill holes for the leads and banana plug in the outer shell and threaded cap respectively. Diode *D1*, resistor *R2* and capacitor *C1* are then

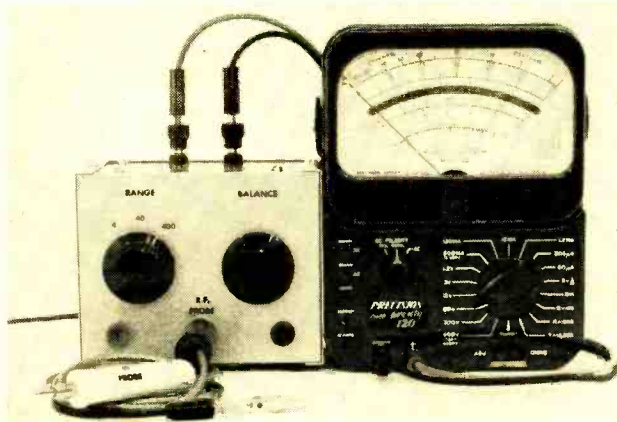

The adapter connects to the multimeter's existing input jacks as shown at left. It can be removed at any time if you want to use the multimeter in the normal way.



Completed unit (below, right) fits in 3" x 4" x 5" utility box with space to spare. Switch used for S1 (see pictorial diagram, right) has two extra positions. The terminal of one of these was used as tie point for the grounded end of R5.

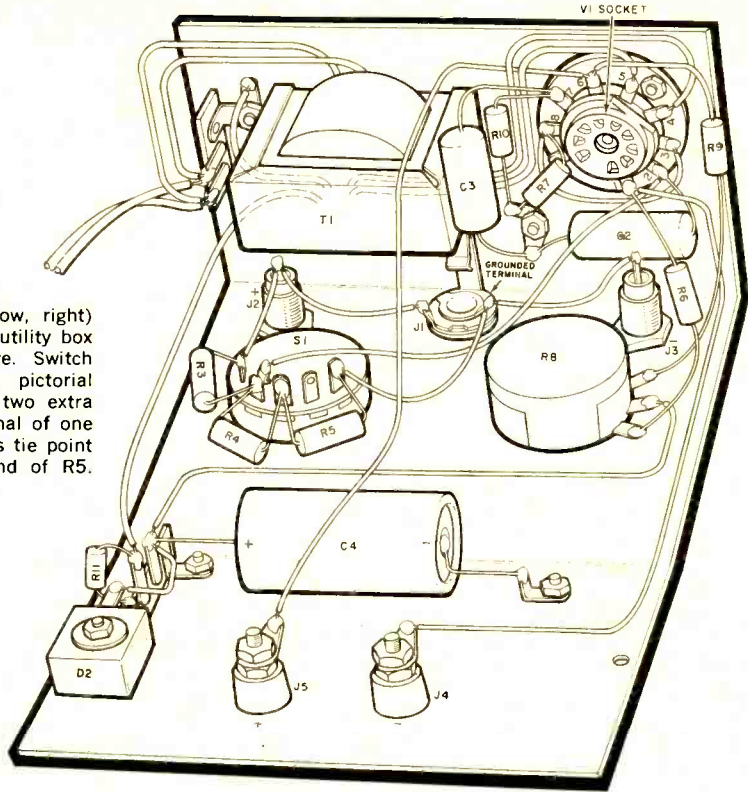

wired in; these components will be slipped into the shell when the case is closed. Finally, install a phone plug (P1) and an alligator clip on the free ends of the appropriate leads. The banana plug may be used as a test prod, or it may be slipped into an alligator clip for attachment to a circuit point.

**Checking and Operation.** Set your multimeter to 50, 75 or 100 volts d.c., connecting its negative lead to J4 and its positive lead to J5. The adapter is plugged in and, after it has warmed up, balance control R8 is set for a zero reading on the multimeter. Connect the adapter's d.c. test leads across a 1.5-volt flashlight cell, then several cells in series, and finally a variable voltage power supply—checking several points on the three ranges.

The voltage indicated on the meter will be 10 times the voltage across the adapter's test leads on the 0-4 volt range. On the 0-40 volt range, the meter will indicate the same voltage which is across the leads; while on the 0-400 volt range,

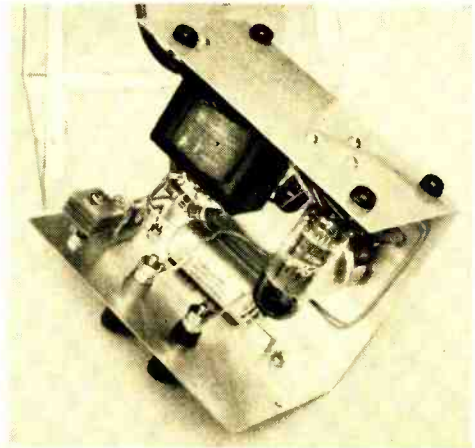

the meter reading will be one-tenth that of the voltage across the leads.

The most accurate readings will be obtained when the resistance of the multimeter used is greater than 50,000 ohms. For this reason, the higher voltage ranges of the multimeter should be employed where possible.

To use the r.f. probe, plug in its cable

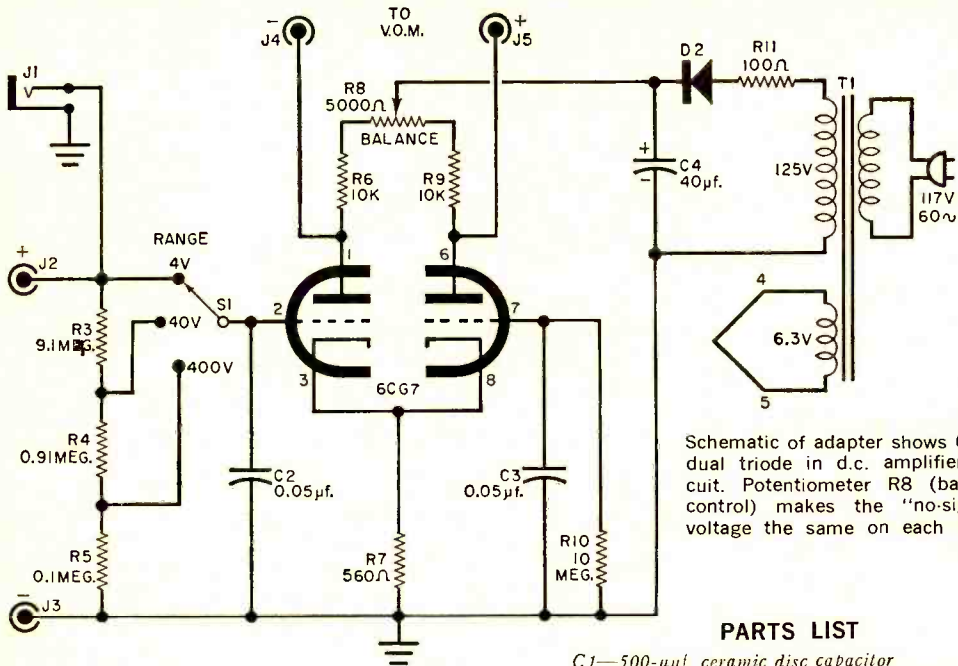

Schematic of adapter shows 6CG7 dual triode in d.c. amplifier circuit. Potentiometer R8 (balance control) makes the "no-signal" voltage the same on each plate.

### PARTS LIST

- C1—500- $\mu$ f. ceramic disc capacitor
  - C2, C3—0.05- $\mu$ f., 200-volt paper capacitor
  - C4—40- $\mu$ f., 150-volt electrolytic capacitor
  - D1—1N48 diode
  - D2—150-volt, 20-ma. selenium rectifier (International Rectifier #1159A or equivalent)
  - J1—Open-circuit phone jack
  - J2, J3—Tip jack (one red, one black)
  - J4, J5—Banana jack and binding post combination (one black, one red)
  - P1—Phone plug
  - R1—1.0 megohm
  - R2—3.3 megohms
  - R3—9.1 megohms
  - R4—0.91 megohm
  - R5—0.1 megohm
  - R6, R9—10,000 ohms
  - R7—560 ohms, 1 watt, 10%
  - R8—5000-ohm wire-wound potentiometer
  - R10—10 megohms, 1 watt, 10%
  - R11—100 ohms, 1/2 watt, 10%
  - S1—Single-pole, 3-position rotary switch (3 positions of Mallory #32151, or equivalent)
  - T1—Power transformer: primary, 115 volts; secondaries, 115 volts @ 15 ma., 6.3 volts @ 0.6 amp. (Triad R-54X or equivalent)
  - V1—6CG7 tube
  - V1—9-pin miniature breadboard tube socket (Pomona XS-9 or equivalent)
  - V1—3" x 4" x 5" utility box (Bud CU-2105-A or equivalent)
  - Misc.—D.c. test probes; banana plug, alligator clip and plastic inhaled case for r.f. probe; hardware; knobs
- All resistors  
1 watt, 5%,  
unless otherwise  
specified

and disconnect the d.c. test leads. The probe's clip lead is attached to a ground point in the circuit and its tip is touched or clipped to the point where r.f. voltage is to be read. As mentioned previously, the probe should be used only on the 4- and 40-volt ranges of the adapter; voltages much higher than 40 will exceed the ratings of D1.

**How It Works.** The adapter uses a 6CG7 dual triode as a d.c. amplifier. With no input signal, the two sections of the tube draw currents which are dependent on their own characteristics and the values of the resistances in their cathode and plate circuits. If one section draws more current than the other, it will have a greater voltage drop in its plate resistor, and a voltmeter connected across jacks J4 and J5 will show this voltage difference.

(Continued on page 110)

The circuit for the r.f. probe is housed in a plastic nasal inhaler case. The positive d.c. probe is a standard test prod having a 1-megohm resistor in series with its lead.

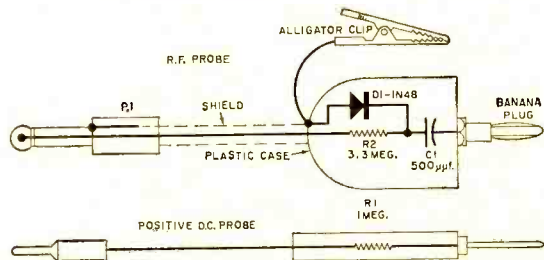

# UNIVERSAL WORKSHOP TESTER

*Versatile instrument measures  
capacitance and resistance,  
checks tuning and modulation,  
also acts as a signal generator*

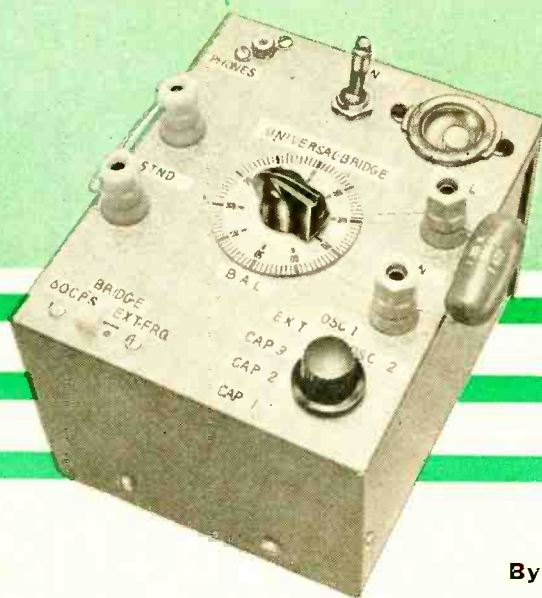

By FRANK A. PARKER

**H**ERE IS an audio generator, resistance-capacitance bridge, and a tuning and modulation indicator all rolled into one. Small in size, this universal tester will take up little room on your workbench and should save you hours in building and adjusting home-brew projects.

With the aid of this instrument, you can easily find values of capacitors from 10  $\mu\mu\text{f.}$  to 40  $\mu\text{f.}$  with ratings as low

as 10 volts. Finding a matched pair of resistors also becomes quite easy. The tuning-eye feature gives you an accurate tuning indicator for AM and FM tuners and tells you the amount of modulation present in the received signal. Added to this, you have an audio generator which puts out a 10- and a 1000-cycle tone for testing audio amplifiers or for signal tracing.

Parts for the tester should cost about

Bottom of chassis, showing placement of parts. Author paralleled two smaller units for both C2 and C3.

\$20, but this price can drop drastically if you're lucky enough to have some of the components in your spare parts box.

### CONSTRUCTION

As indicated in the Parts List, the unit is housed in a 4" x 5" x 6" aluminum box; a 4 $\frac{3}{8}$ " x 5 $\frac{7}{8}$ " x 1" chassis cut from a piece of scrap aluminum fits inside the box and holds most of the components. If you wish, you can use a larger box and chassis—wiring and layout will be easier with the added benefit of a larger and easy-to-read bridge scale.

The entire instrument is built into the front half of the box; the back half serves as a cover. Mount jack *J1*, balance control *R1*, switches *S1*, *S2*, and *S3*, and binding posts *BP1* through *BP4* on the box's front panel, as shown in the photos. Capacitor *C4* should be placed just behind the front panel; all the remaining components, including the tubes, fixed resistors, and capacitors, are mounted on the chassis.

The socket assembly for tube *V2* is supplied with a mounting bracket and escutcheon plate which are attached to the front panel of the box; the tube itself clamps onto the bracket. Wire *V2*'s socket to the chassis subassembly using about 7" of the color-coded leads provided (see schematic diagram). Save the excess lengths of wire cut off the socket; they will be handy for connecting the front panel controls to the chassis.

Balance potentiometer *R1* can be any 2000- to 5000-ohm, 2-watt, linear taper unit; the exact resistance will not affect calibration. Use a standard potentiometer with a 270° rotation or buy a surplus 360° pot of the same value and rating for a longer balance scale; a 360° pot was employed in the model.

Be sure to use the values specified in the Parts List for capacitors *C1*, *C2* and *C3*; these are the "standard" capacitors and determine the tester's calibration and ranges. Leads between these capacitors and function switch *S1* should be as short as possible. The connecting leads between the binding posts (*BP1*

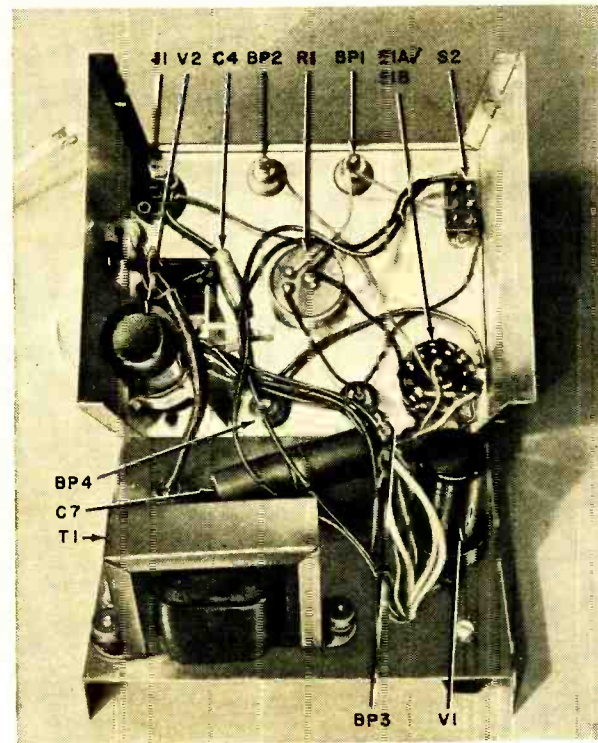
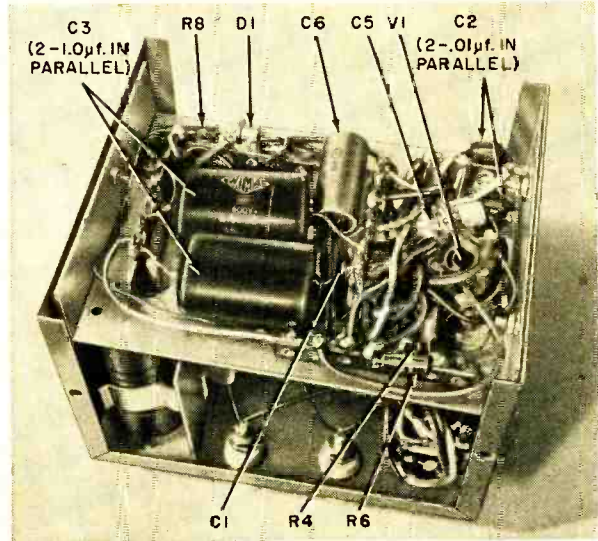

View of aluminum box with chassis removed. Operating controls are mounted on top of box, with tube *V1*, transformer *T1*, and most small components on chassis.

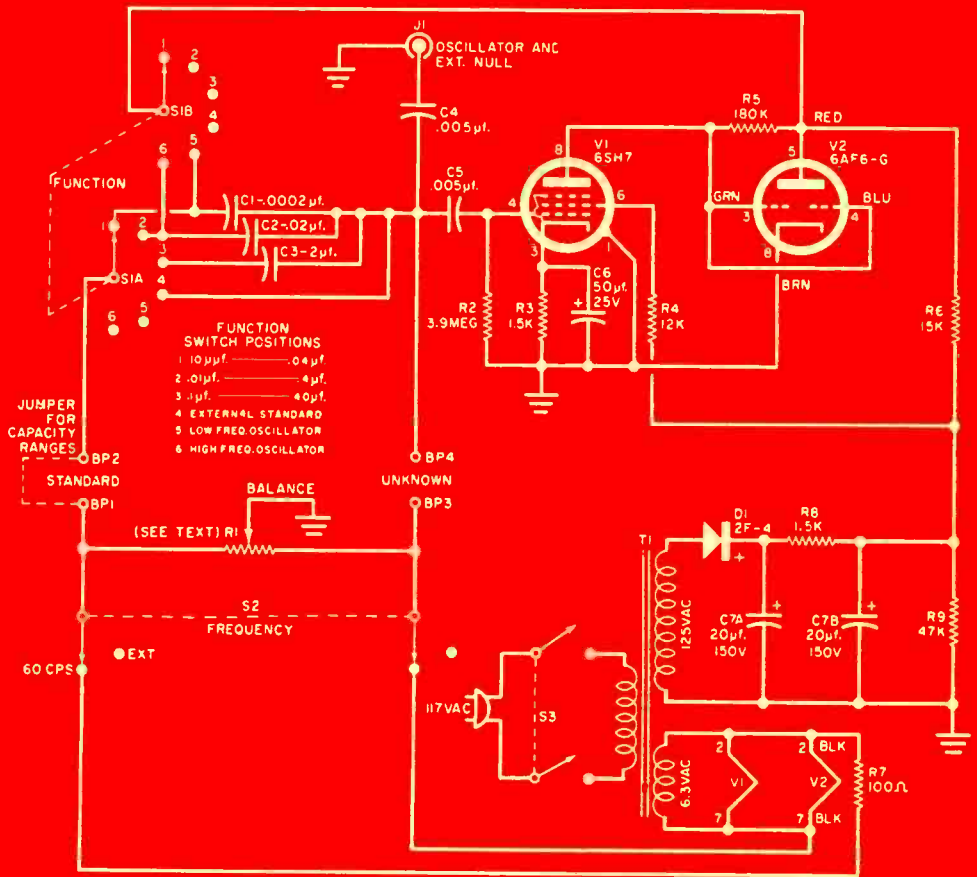

Schematic diagram of tester. Potentiometer R1 can be almost any 2000- to 5000-ohm unit.

## PARTS LIST

BP1, BP2—Universal binding post (yellow)  
BP3, BP4—Universal binding post (blue)  
C1—0.0002-μf. silver mica capacitor, 5% tolerance  
C2—0.02-μf., 200-volt Mylar capacitor, 10% tolerance  
C3—2-μf., 200-volt Mylar capacitor, 10% tolerance  
C4, C5—0.005-μf., 600-volt paper capacitor  
C6—50-μf., 25-volt electrolytic capacitor  
C7a/C7b—20/20 μf., 150-volt electrolytic capacitor  
D1—Silicon diode (Sarkes-Tarzian 2F-4 or equivalent)  
J1—RCA-type phono jack  
R1—2500-ohm, 2-watt linear potentiometer—see text  
R2—3.9 megohms  
R3—1500 ohms

R4—12,000 ohms  
R5—180,000 ohms  
R7—100 ohms, 2 watts  
R8—1500 ohms  
R9—47,000 ohms, 1 watt  
S1—Two-pole, six-position rotary switch  
S2—D.p.d.t. slide switch  
S3—D.p.s.t. toggle switch  
T1—Power transformer; primary, 117 volts; secondaries, 125 volts @ 15 ma., 6.3 volts @ 0.6 amp. (Stancor PS-8415 or equivalent)  
V1—6SH7 tube  
V2—6AF6-G tube  
1—6" x 5" x 4" aluminum box (Bud CU-2107A or equivalent)  
1—4 $\frac{3}{8}$ " x 5 $\frac{7}{8}$ " x 1" chassis—see text  
1—Tuning eye assembly (Amphenol 58-MEA-8 or equivalent)  
Misc.—Knobs, hardware, octal socket, wire

All resistors  
 $\frac{1}{2}$  watt unless  
otherwise noted

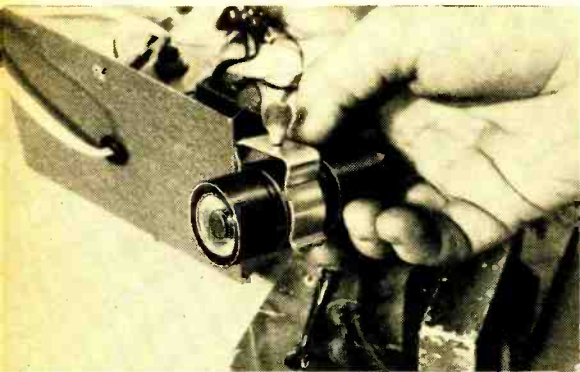

Socket assembly for tube V2 in the workshop tester includes mounting bracket and escutcheon plate.

through *BP4*) and balance potentiometer *R1* should also be kept short. Other wiring is not critical.

### CALIBRATION

Before applying power to the instrument, check the resistance across resistor *R9* with an ohmmeter. The meter should fall to zero ohms and then slowly climb to about 47,000 ohms; any lower final reading indicates a wiring error or a shorted or leaky filter capacitor (*C7a* or *C7b*). Now disconnect the meter and switch on the unit; tube *V2* should light with a green glow. If *V2* doesn't light, check for about 125 volts d.c. on the plate of *V2* and for 6.3 volts a.c. on *V2*'s heater.

Next, jumper the "standard" binding posts (*BP1* and *BP2*) and set function switch *S1* to capacitance range 1 (*Cap 1*). Rotate balance potentiometer *R1* through its range. The eye of *V2*—the null indicator—should open at one end of *R1*'s range and close at the other end. If the eye doesn't open and close, check for plate and heater voltage on amplifier tube *V1*. When everything checks out, the bridge's balance potentiometer (*R1*) is ready for calibration.

Make a scale for *R1* by marking *V2*'s eye-open position "0" and the eye-closed position "100." This scale is then divided equally, every five units, as shown in the Calibration Chart. You can buy a ready-made scale (such as the Croname 905, designed for 270° rotation pots) or you can make your own scale. If you use a 360° rotation pot and make your own scale, as the author did, you'll find

### CALIBRATION CHART

Balance Pot (R1)	Range 1 (uf.)	Range 2 (uf.)	Range 3 (uf.)
0	—	—	—
5	.00001	.001	.1
10	.00002	.002	.2
15	.00004	.004	.4
20	.00005	.005	.5
25	.00006	.006	.6
30	.00007	.007	.7
35	.0001	.01	1.0
40	.00015	.015	1.5
45	.00017	.017	1.7
50	.0002	.02	2.0
55	.00025	.025	2.5
60	.0003	.03	3.0
65	.0004	.04	4.0
70	.0005	.05	5.0
75	.00065	.065	6.5
80	.0008	.08	8.0
85	.001	.1	10.0
90	.002	.2	20.0
95	.004	.4	40.0
100	—	—	—

that the "0" and "100" points coincide.

The "0" to "100" scale marked on *R1*'s dial now corresponds to the values of capacitance given in the Calibration Chart, which is valid only if the values of capacitors *C1*, *C2*, and *C3* correspond to the values given in the Parts List. As mentioned earlier, different values for *R1* will not affect the calibration.

### OPERATION

Once calibrated, the universal tester is ready to go to work in any one of a number of applications.

**Capacitance Bridge.** Connect a wire jumper across "standard" binding posts *BP1* and *BP2* and rotate function switch *S1* to a capacity range (*Cap 1*, *Cap 2*, or *Cap 3*). Next, connect the unknown capacitor across the "unknown" binding posts *BP3* and *BP4*. The capacitor's polarity need not be observed and its working voltage can be as low as 10 volts d.c.

(Continued on page 116)

**Running into  
too much tumult  
and turmoil on  
the Citizens Band?  
Then build this . . .**



**By JAMES G. LEE**  
W6VAT

# SWR/POWER METER FOR CB

**L**ET's face it," groaned one CB'er to another a few weeks ago, "it's getting so I can almost never cut into that hubbub on 11 meters!"

The other nodded knowingly. "I had the same trouble," he returned, "until I built a little SWR/power meter for my rig."

CB'er number two had a point: with the five-watt input allowed by the FCC, every CB'er needs some means of insur-

ing that he's getting peak efficiency from his transmitter. And one of the best ways of doing so is to provide some means of measuring actual power delivered to the antenna.

You can leave the SWR/power meter described here in the line at all times to measure actual power. In addition, it can be used for initial transmitter and antenna tuning adjustments for best standing-wave ratio (SWR). The circuit

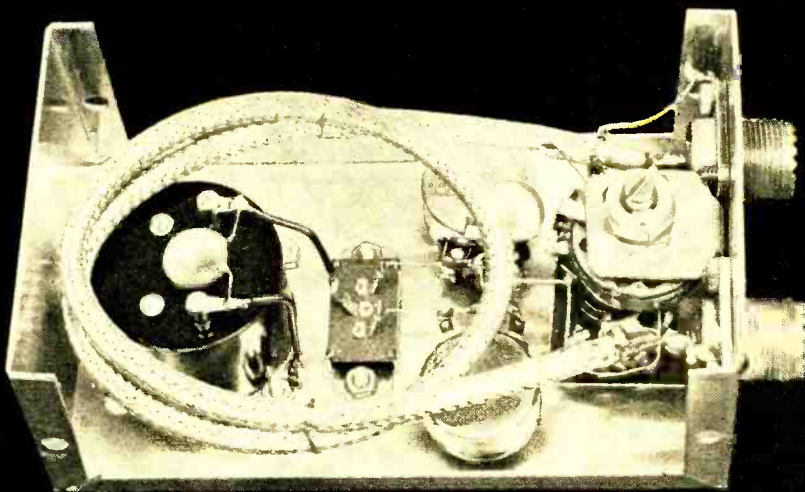

Parts layout of power meter is highly symmetrical and reflects arrangement of schematic diagram on page 64 very closely. See text for details of pickup loop.

consists of a directional coupler which is switched to sample either forward or reflected voltage, and a voltmeter on which these voltages are measured.

Although this meter can be used on other than CB frequencies, keep in mind that its power-handling capability is sufficient only for transmitters rated at 5 watts input or less.

**Construction.** The unit is housed in a Bud CU-3006-A Minibox. Photo above shows the general layout and should answer any questions regarding parts placement.

The coax directional coupler is made from an 18" length of RG-58/U. Slit the outer covering lengthwise with a knife and peel it off. Bunch the woven braid toward the center to loosen it so that a length of #28 enameled wire can be threaded between the braid and the inner insulation. The enameled wire is then brought out through the braid about 1" from each end.

Next, smooth the braid back to its original position on the inner insulation without scratching the enameled wire.

With this done, a few turns of #20 tinned wire should be wrapped around the braid about  $\frac{1}{2}$ " from each end of the cable.

About 1" of this tinned wire should be left free on each end; then solder the wire to the braid and trim off any excess braid. Finally, cut the inner insulation so as to expose about  $\frac{3}{16}$ " of the inner conductor at each end. The coax line and coupler can now be set aside, and the rest of the meter assembled.

Note that the metal cover on potentiometer *R1* is removed to lower circuit capacity and the potentiometer carefully positioned for shortest leads. Diode *D1* requires special handling when soldering—a pair of long-nose pliers held close to the rectifier will serve as an effective heat sink. The last item to be soldered in place is the coax coupler—avoid scratching the enamel insulation where the wire comes out of the braid.

**Calibration.** Although there are a number of ways to calibrate the unit, the simplest involves your CB transmitter and a suitable dummy load. (If you use



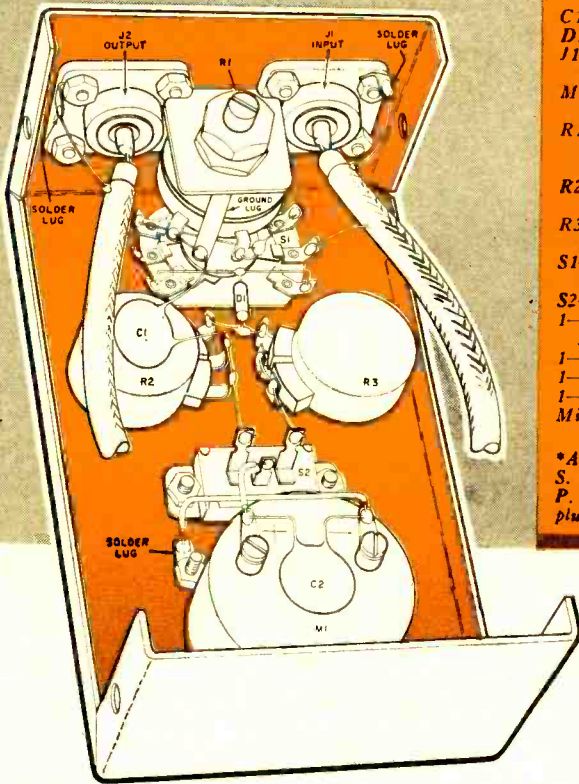

### PARTS LIST

- C1, C2—005- $\mu$ ., 1000-w.v.d.c. ceramic capacitor
  - D1—1N66 diode
  - J1, J2—Coaxial jack, chassis-mounting (Amphenol 83-1R or equivalent)
  - M1—0-200  $\mu$ a. meter (Monarch PM-4\* or equivalent)
  - R1—250-ohm potentiometer, linear taper, screwdriver adjustment, with locking shaft (Ohmite CLU2511 or equivalent)
  - R2—100,000-ohm potentiometer, linear taper (IRC PQ11-128 or equivalent)
  - R3—100,000-ohm potentiometer, linear taper, screwdriver adjustment (IRC RQ11-128)
  - S1—2-pole, 2-position rotary switch (Centralab 1462 or equivalent)
  - S2—S.p.d.t. slide switch
  - 1—5 $\frac{1}{4}$ " x 3" x 2 $\frac{1}{8}$ " aluminum box (Bud #CU-3006-A or equivalent)
  - 1—18" length of RG-58/U coaxial cable
  - 1—20" length of #28 enameled wire
  - 1—12" length of #20 bare copper wire
  - Misc.—Wire, solder, plugs to match J1 and J2
- \* Available from Arrow Electronics, Inc., 2534-38 S. Michigan Ave., Chicago, Ill., or RPJ Sales, P. O. Box 1252, Studio City, Calif., for \$4.95, plus postage.

Top half of box holds all components; wiring is point-to-point, with small parts supported by their own leads. Solder lugs should be mounted at jacks J1, J2, and at meter M1, as indicated.

an r.f. source other than your CB rig, make sure its frequency is between 25 and 30 mc.) The easiest dummy load to make is a 2-watt, 50-ohm resistor mounted in a male coax plug; all leads should be as short as possible, and the resistor should ideally be of the non-inductive type.

With the back off the unit, attach the dummy load to output jack J2 and set S2 to Sensitivity, S1 to Fwd, and R2 at its maximum resistance position. Next, attach the transmitter (or other r.f. source) to the input connector with a short length of coax and turn on the transmitter. Adjust Sensitivity potentiometer R2 until a full-scale reading is obtained on the meter. Now, switch S1 to Ref; this should result in a lower reading on the meter.

Potentiometer R1 should then be ad-

justed for a minimum meter reading. Using the above dummy load, you will not get a complete null, but the meter should read 30  $\mu$ a. or less with full-scale Fwd deflection. Once the null is obtained, the locking nut on R1 can be tightened and the Minibox cover replaced.

For Power calibration, a VTVM with a high-frequency detector probe is necessary—the author used a Heathkit V7-A. Replace the dummy load with a T-connector and screw the load on one arm of the T. Set S2 to Power and R3 at its maximum resistance position. Now apply power and measure the voltage at the open arm of the T with the VTVM and probe.

Once the voltage is known, the power can be calculated from the standard  $E^2/R$  formula. For example, 10 volts across 50 ohms equals 2 watts; R3 can

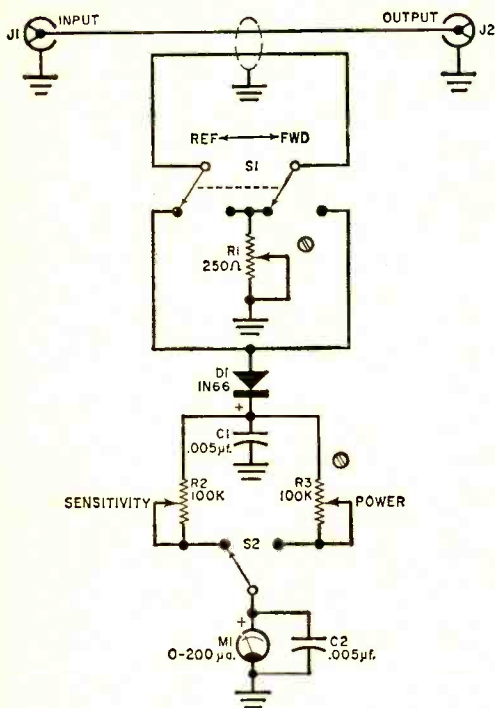

Schematic diagram of CB meter. Note that potentiometers R1 and R3 should have screwdriver adjustment.

switch *S1* to *Ref* and read the current.\* The SWR can be calculated from the following equation:

$$SWR = \frac{I_{Fwd} + I_{Ref}}{I_{Fwd} - I_{Ref}}$$

For example, let  $I_{Fwd} = 200 \mu\text{a.}$  and  $I_{Ref} = 30 \mu\text{a.}$  Then

$$SWR = \frac{200 + 30}{200 - 30} = \frac{230}{170} = 1.36 : 1$$

If precise SWR is not needed, relative indications can be used. Simply keep the *Fwd* reading at a constant value and tune for minimum reading in the *Ref* position. The SWR can then be calculated using the lowest *Ref* value.

To measure r.f. power, you need to know only the load resistance and the voltage impressed across this resistance. With switch *S1* set to *Fwd* and switch *S2* set to *Power*, potentiometer *R3* can be adjusted for a given *Fwd* voltage representing a given power, since the load resistance will be a fixed value. Potentiometer *R3* has a screwdriver adjustment—once calibrated for a given load, it need not be touched again. —30—

be adjusted to give whatever meter deflection is desired—100  $\mu\text{a.}$ , say.

**Operation.** The meter is now ready for use and can be inserted in the line between the antenna and the transmitter at any convenient point. For SWR measurements, switch *S1* to *Fwd* and *S2* to *Sensitivity*. Turn on the transmitter and adjust *R2* for full scale; then

\*A known voltage (or power) is not really necessary for making SWR measurements. Assuming you have enough "forward" (*Fwd*) voltage available to obtain a half- to full-scale reading, it is only necessary to switch *S1* to *Ref* to obtain a reflected voltage; the ratio between these two readings can then be used to compute the SWR.

## FM POWER LEAD ANTENNA

If your landlord won't allow you to put up a roof-top antenna for your FM tuner or receiver, try this efficient "built-in" line-cord antenna—it should provide good reception within the normal service area of most broadcast stations. To install the antenna, just substitute a three-wire line cord for the set's original two-wire cord, and cut off the extra lead (preferably the center one) before it enters the line plug. Connect the other end of this lead through a coupling capacitor (a 1000- $\mu\text{f.}$  unit for a line cord about 65" long) to a tap on the set's r.f. coil; the best place to tap into the coil

is determined by experimentation. Try the plug in the outlet socket both ways to see which gives the best results.

—Art Trauffer

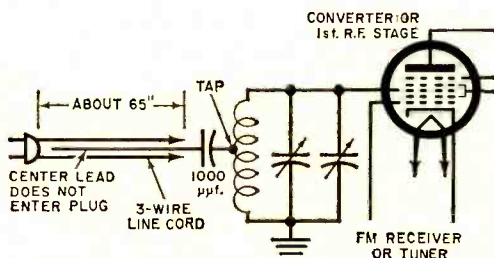

POPULAR ELECTRONICS

# TRANSISTORS IN HI-FI

Long the mainstay of hearing aids and personal portables, transistors are now challenging tubes in the race for quality sound reproduction

By RICHARD A. FLANAGAN

Associate Editor

IS ANOTHER hi-fi "revolution" in the offing? Can we expect transistors to edge out vacuum tubes in the same manner that stereo moved in on monophonic hi-fi? Will power transistors—the 2N553, for instance—become as renowned in hi-fi amplifiers as vacuum power output tubes are—the KT-88 or the EL-34, for example?

A good many industry spokesmen say "Yes" to such questions—at least in part. To be sure, most of them won't go so far as to "see" transistors outdistancing the vacuum tube in the way that long-playing records replaced 78-rpm discs back in the late forties and early fifties; there are still too many problems on hand for any such pronounced change. The hi-fi vacuum tube, most of them think, will still be around ten years from now, and in good strength. But the transistor, they reason, will also be very much in the hi-fi picture.

**Sizing Them Up.** What does the transistor have to offer over its more common vacuum-tube rival? Smaller size and lighter weight are two "advantages," and both result from the fact that the transistor requires no power-consuming, heat-producing heater current.

Whether these properties are truly relevant in hi-fi is a matter of opinion. But space savings of up to 50% are possible with transistors, clearly a feather in the transistor's cap in view of the ever-present trend toward greater and greater miniaturization. And while weight is seldom significant in hi-fi equipment, the fact remains that transistorized amplifiers weigh up to 75% less than their vacuum-tube counterparts.

Such weight savings may seem relatively unimportant, but they do make handling much less of a problem all

All-transistor stereo amplifier/preamplifier made by Transis-Tronics, Inc. Due to transistor circuitry, "no-signal" power consumption is only 2 watts.



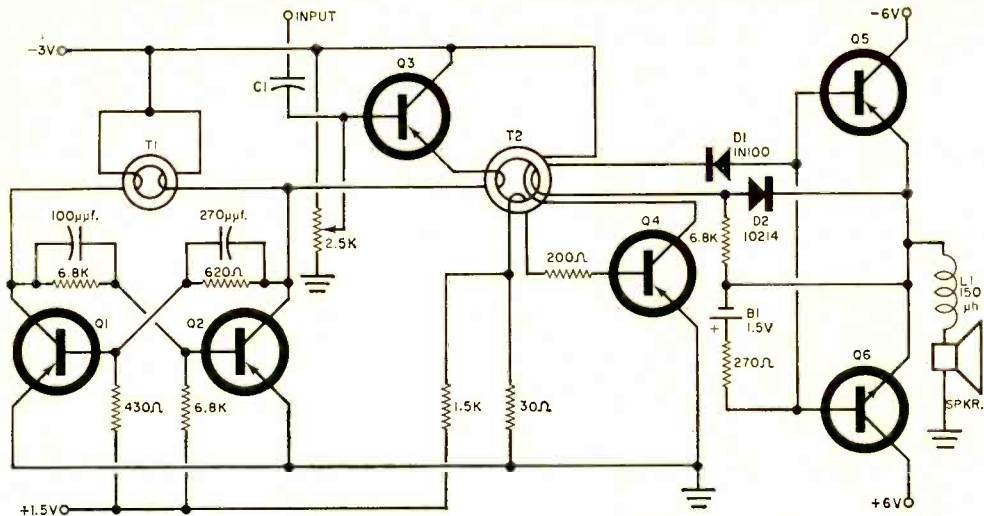

Partial schematic of experimental transistorized amplifier designed by H. D. Crane and P. E. Merritt of Stanford Research Institute is shown above. Unit employs pulse-width modulated carrier to turn output transistors on and off, resulting in efficiencies approaching 100%. Fed into an Altec-Lansing 604D speaker (at right), the amplifier exhibited response within 2 db from 0 through 15,000 cycles.

around—even the Mrs. of the hi-fi household is able to shift transistorized amplifiers and related components about at will. In addition, there is the added attraction that shipping costs can be markedly reduced, with savings passed along to consumers.

Another advantage of using transistors is freedom from microphonics. Pre-amplifier tubes, for example, are frequently shock-mounted to prevent annoying “pings,” but the transistor suffers from no such ills. Theoretically, it would be possible to house a transistorized amplifier immediately adjacent to a low-frequency woofer with no detrimental results whatever. And since transistors develop comparatively little heat, they can easily be housed in out-of-the-way places and in cabinetry where tubes could not operate safely.

**Two “Horses.”** Although there is a strong tendency to think of the transistor in the same light as the vacuum tube, the two devices really have very little in common; while related, they are two “horses” of decidedly different colors. Of course, both tubes and transistors amplify. But *what* and *how* they amplify makes the tube as different from the transistor as a dynamic speaker is from an electrostatic speaker.

Since the vacuum tube is primarily a voltage amplifier, many people have become accustomed to thinking in terms of voltage whenever they think of ampli-

fication. And, in the case of tubes, they’re right. Power output tubes—the KT-88 we mentioned a little earlier, for instance—are purposely designed with big cathode and plate areas, so that the tubes are capable of handling the large amounts of power required to drive a speaker. But such design doesn’t change the basic operation of the tube. Regardless of its structure, it is still primarily a voltage-amplifying device.

The transistor, by contrast, amplifies current. And its circuitry differs markedly from tube circuitry for this very reason. For example, although there is a great deal more flexibility in transistor than in vacuum-tube circuitry, a transistor generally has low input and high output impedances. As any “tube man” knows, this is diametrically opposed to the usual arrangement with vacuum tubes.

A typical hi-fi tube—a 12AU7—may have an input or grid resistor of 470,000 ohms, and inverse feedback may raise the effective input resistance to an even higher value. But a transistor—a 2N190,



for example—may have an input resistance of only approximately 1250 ohms.

Obviously, between tube and transistor, we *do* have two horses of different colors which must be treated in an entirely different manner. A low-impedance source—a magnetic phono cartridge or a cathode-follower output from an FM tuner—could be made quite happy feeding an input resistance of 1250 ohms. But a high-impedance source such as a crystal microphone would require a matching transformer in order to work satisfactorily at all.

**Many "Gaits."** As we've hinted, however, the transistor has some tricks up its sleeve which enable it to perform with much greater flexibility than the vacuum tube. Actually, a transistor can be hooked up in a number of ways, each with characteristics suited to the job at hand. In one—the common base arrangement we were actually referring to in the 2N190 example above—it has a low input and a high output impedance, ideal for matching such low-impedance devices as magnetic phono cartridges.

Connected in another way—in the common collector arrangement—the transistor has characteristics which are almost exactly opposite. In fact, the resulting high input and low output impedances are ideally suited to matching low-impedance devices such as speakers.

The low-output impedance of the transistor's emitter-follower arrangement explains its growing application in a circuit which has long plagued designers of vacuum-tube amplifiers—the power-output stage. Although the tube has a low output impedance in contrast to its input impedance, its output impedance is still far too high for direct connection to hi-fi speakers.

Over the years, a number of circuits have been devised in an attempt to give output tubes lower impedance characteristics and perhaps even eliminate the expensive, heavy, space-consuming output transformer. In cases where the output transformer is retained, heavy inverse feedback is ordinarily employed, both to cut overall distortion arising within the feedback loop and to reduce the otherwise high output impedance to improve speaker damping.

Where the output transformer has been eliminated, it has usually been at a price. In some cases, a special speaker has been used with a voice-coil impedance higher than usual—500 ohms, say; to match this impedance, a battery of tubes was hooked up in parallel or push-pull parallel to reduce the output impedance to the required value. In still other instances, a special arrangement known as the "single-ended push-pull circuit" has been successfully employed to match speakers of relatively low impedances.

But the transistor is basically a low-voltage, high-current device and is thus "ready-made" for driving low-impedance speakers. The emitter-follower arrangement—a cathode-follower in equivalent vacuum-tube terminology—offers greatest promise, both because of its low inherent distortion and its extremely low output impedance.

Another proof of the transistor's greater flexibility lies in the so-called "complementary" circuits involving both *npn* and *pnp* types. While the vacuum tube finds its counterpart in the *npn* transistor, there is no vacuum-tube

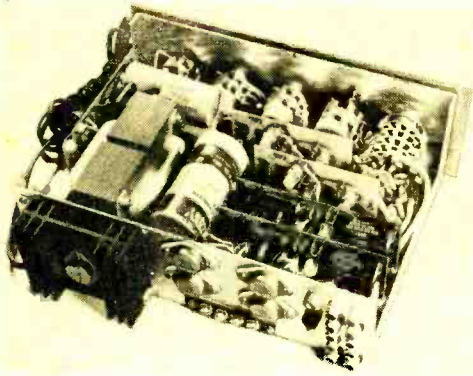

Compact parts placement and small physical size are readily apparent in prototype model of transistorized amplifier/preamplifier built by Texas Instruments. Circuit develops only 0.4% harmonic distortion at 1000 cycles and 20 watts output.

equivalent for the *pnp* type (no tube can amplify with a plate voltage which is negative). In short, the complementary relationship between *pnp* and *npn* transistors permits many circuits which simply would not be possible with vacuum tubes.

**Who's Ahead?** Although the vacuum tube is currently way out in front of the transistor in the hi-fi field—in number, at least—this is only to be expected. After all, the vacuum tube has been around for many decades, while the transistor is just entering the race.

First employed in hearing aids and portable radios, the transistor today is only beginning to come into its own in hi-fi. One firm—Transis-Tronics, Inc., of Santa Monica, California—has entered the hi-fi field with a completely transistorized hi-fi amplifier/preamplifier. Another firm—Texas Instruments, in Dallas, Texas, already producing a wide range of semiconductors—recently designed a dual 20-watt transistorized stereo amplifier/preamplifier; one of the two prototype models has response to 50,000 cycles and beyond. A third manu-

facturer—Johnson Electronics of Casselberry, Florida—is producing transistorized background music systems. In fact, transistorized hi-fi equipment is cropping up all over. By fall, a good number of hi-fi manufacturers expect to have transistorized equipment on the market.

Most designers admit that presently available output tubes can deliver more power than the power transistors now in production. But Transis-Tronics' S-15 amplifier—typical of current transistor amplifier practice—carries a music-power rating of 20 watts per channel, adequate for most home stereo installations. Taking advantage of the transistor's low output impedance, the output of the S-15 is direct-coupled to the speaker, thus eliminating the output transformer. The manufacturer proudly states that "hum, heat, and microphonics" are absent, and the compact size of the S-15 (it measures only 2" x 10 $\frac{1}{8}$ " x 8 $\frac{1}{2}$ " ) means that it can be put just about anywhere.

As suggested earlier, the design of transistorized equipment follows quite different lines from vacuum-tube apparatus. In the case of the S-15, Transis-Tronics' engineers have come up with a stereo amplifier/preamplifier package that is far more compact than any comparable tube unit, as you would expect. And, being transistorized, it has a "personality" which is characteristic of transistorized equipment.

For one thing, the S-15 needs no warm-up time; turn it on, and it's ready to play. Then, too, there's the matter of life expectancy. Since transistorized equipment can last indefinitely, the manufacturer offers a two-year guarantee on materials and workmanship.

Another noteworthy feature results from the fact that transistors draw peak current only under "signal" conditions. Although the S-15 is equipped with an on-off switch, the switch could actually be dispensed with. Input power under no-signal conditions is an all but unbelievable 2 watts, rising to 60 watts under maximum signal conditions.

Somewhat hard to get used to is the fact that there is no need to connect the usual resistor across the output of one channel when it is not in use. Not only is there no output transformer to heat

*(Continued on page 110)*

# STARVED CIRCUIT AMPLIFIER

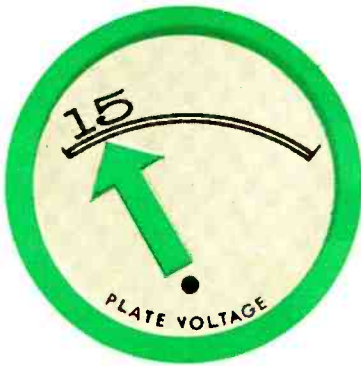

**Oversized load resistor reduces both plate voltage and current, yet gives gain of almost 2000 times**

By HOWARD BURGESS

**H**AVE you ever put an amplifier on a starvation diet? It's almost unbelievable how much gain an ordinary tube can turn out when it gets really "hungry." Special circuits, sometimes known as "starved circuits" because of their very low plate voltages, have been designed for just this purpose and are among the oddities of electronics.

Few other types of amplifier circuits can do so much with so few parts. For example, a two-tube audio amplifier using "starved" circuitry can give voltage gains in excess of 50,000 with only 4 resistors and 2 capacitors; this probably qualifies it as one of today's best bargains. The little starved-circuit amplifier to be described here will give you a good idea of what can be done.

**Theory.** Those who like to know the "why" before they build should start by

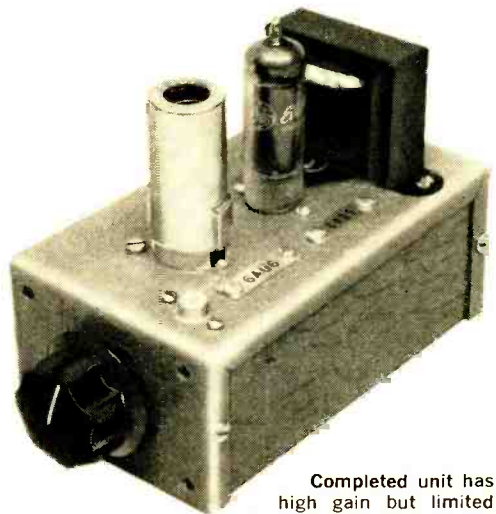

Completed unit has high gain but limited frequency response, a useful combination for signal tracing and speech amplification.

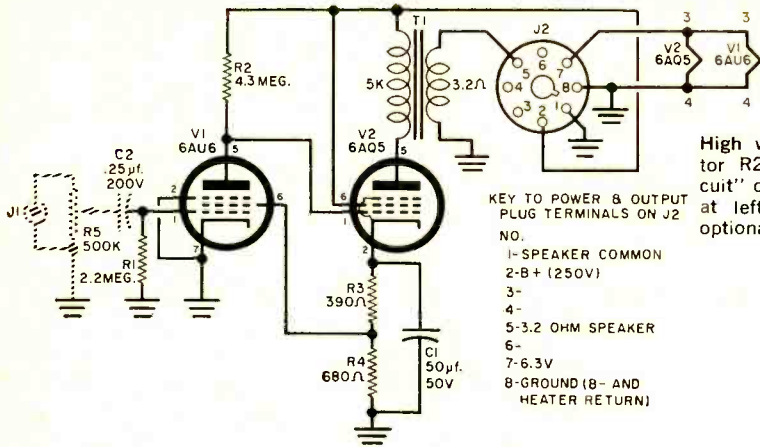

High value of plate load resistor R2 is key to "starved circuit" of V1. Shaded components at left in schematic comprise optional gain control circuit.

KEY TO POWER & OUTPUT PLUG TERMINALS ON J2  
NO.  
1- SPEAKER COMMON  
2-B+ (250V)  
3-  
4-  
5-3.2 OHM SPEAKER  
6-  
7-6.3V  
8-GROUND (8- AND HEATER RETURN)

PARTS LIST

- C1—50-µf., 50-volt electrolytic capacitor
- C2—0.25-µf., 200-volt paper capacitor
- J1—Phono jack
- R1—2.2-megohm, ½-watt resistor
- R2—4.3-megohm, ½-watt resistor
- R3—390-ohm, 1-watt resistor
- R4—680-ohm, 1-watt resistor
- R5—500,000-ohm potentiometer, audio taper
- T1—Output transformer; primary, 5000 ohms; secondary, 3.2 ohms (Knight 62G064 or equivalent)
- V1—6AU6 tube
- V2—6AQ5 tube
- 1—5¼" x 3" x 2⅜" aluminum box (Bud CU-3006A or equivalent)
- Misc.—Hardware, tube sockets, etc.

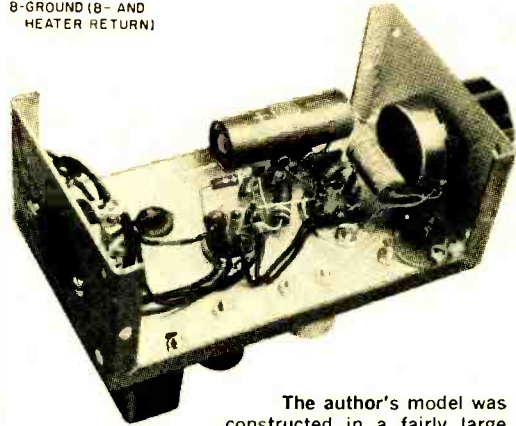

The author's model was constructed in a fairly large box, with standard-sized components. Your version can be smaller, if you wish.

looking at the data sheets for a 6AU6 pentode. This tube gives a gain of about 300 with a 250-volt plate supply; and if the voltage is reduced to 100, the gain may fall as low as 110. If the screen and plate voltages are reduced to about 15 volts, however, the gain may go up to well over 2000 under the right circuit conditions.

One of the secrets of achieving this high gain is the use of a very large plate resistor. The signal voltage de-

veloped across a 10-megohm plate resistor, for instance, becomes quite high for even a very small plate current.

Starved circuits should not be confused with circuits using 12-volt plate tubes, by the way. The gain of a true starved circuit depends on the use of several hundred volts dropped across the plate load resistor.

**The Circuit.** The schematic diagram shows the extreme simplicity which can be designed into a starved-circuit amp-

Two possible applications for starved circuit amplifier: modulating low-powered transmitter (left, below); and amplifying output of small crystal receiver (right).

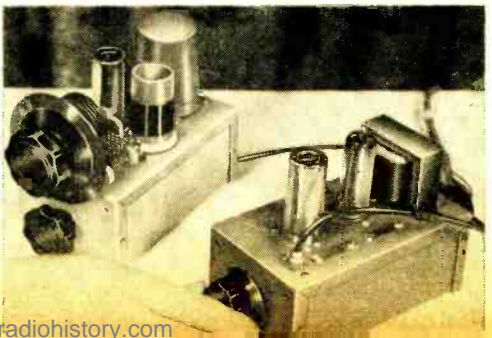
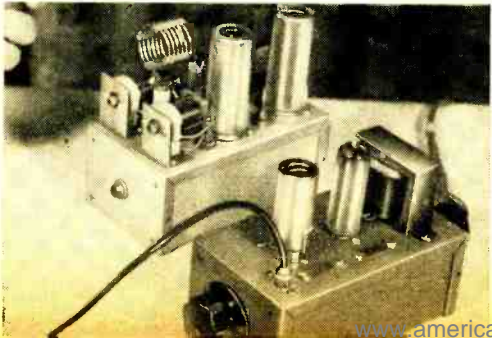



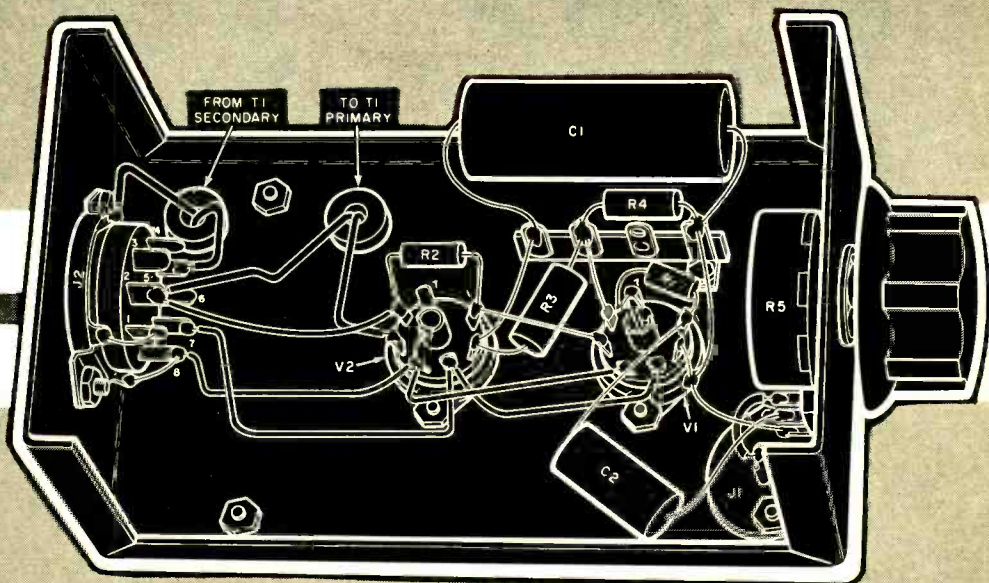

lifier. Almost any of the common tubes can be used if slight changes in circuit values are made; some tubes, of course, will give more gain than others. Two very common types are used here—the 6AU6 pentode (*V1*) and the 6AQ5 beam power audio tube (*V2*).

One of the main points of interest in this circuit is the direct coupling from the plate of the 6AU6 to the control grid of the 6AQ5. It is possible to eliminate the usual coupling capacitor and grid resistor because the plate of *V1* is only about 17 volts above ground. The grid of *V2* has a comfortable value of negative bias—even though it is tied to the plate of *V1*—because *V2*'s cathode is about 32 volts above ground.

It was found by experiment that *V1* works very well with about 20 volts on its screen. This voltage could have been taken from the plate supply, in the ordinary way, with a dropping resistor and bypass capacitor. Instead, however, the screen grid is tied to a point on the cathode resistance of *V2* about 20 volts above ground—so no bypass capacitor is needed for the screen grid.

The schematic diagram shows two

fixed resistors (*R3* and *R4*) with a total value of 1070 ohms in the cathode circuit of *V2*. If you like to experiment however, you might replace these resistors with a 1000-ohm, 2-watt potentiometer. The screen grid of *V1* could be connected to the slider arm. Adjusting this arm would vary the value of the screen voltage on *V1*, which in turn could be used to control the amount of plate current in *V2*.

Control grid bias for *V1* is furnished by the so-called "contact" potential which is developed across resistor *R1*. This allows the cathode of *V1* to be grounded, eliminating another resistor and bypass capacitor which are usually necessary.

Potentiometer *R5* and capacitor *C2* constitute an optional gain control circuit; the capacitor must be used even if the gain control circuit is not, in order to avoid loss of bias on *V1*.

We have now "thrown away" almost as many resistors and capacitors as we have kept. With fewer components, the amplifier circuit is easier to manipulate. It would be no problem now for the ex-

*(Continued on page 115)*

# SPACE-SAVER SPEAKER SYSTEM

By DAVID B. WEEMS



Side view of enclosure, showing its perforated resistive panel. All joints are screwed and glued.



***Resonant bass cavity coupled with  
wide treble dispersion  
explain this small speaker system's  
truly amazing performance***

**T**WO OBJECTS, physicists tell us, can't occupy the same space at the same time. Personally, I've never bothered to find out just *why*, but I'm certain they're right.

You see, the speakers didn't look especially large at the hi-fi showroom—just a little closer to Airedales than Pekinese. At home, the situation boiled down to this: if we moved out of the living room, then the two stereo speakers could move in. But if we stayed . . . well, two objects can't occupy the same space at the same time, like we said!

Looking over the "bookshelf" speaker systems back at the hi-fi showroom, I stumbled across what I think is a rather significant fact: most of them were pretty much the same size, and most of them

were designed to rest on a "bookshelf" or a table of sorts. As it happened, I had no available space of either kind at the moment.

Further, I reasoned, a bookshelf or table doesn't really add to the performance (although it does raise the speaker to a better level for dispersing sound). What's more, I thought, a speaker/table combination can take up more space than a full-sized enclosure with improved characteristics.

Scratching the old noggin a bit, I finally came up with the solution you see pictured here. It's a speaker-and-baffle combination that occupies only about  $\frac{3}{4}$  sq. ft. of floor space, needs no supporting "table," and yet sounds good from "top to bottom." The basic design is actually

British, but it has been reworked to fit an ultra-smooth little speaker sold in the United States (the Lafayette type SK-128).

If you like your bass with a built-in boom (some people do, and that's their privilege), this cabinet may not appeal to you. In fact, like most good speaker systems, your first impression may be that it's a little "shy" at both the low- and high-frequency extremes. But it's not the first impression that counts; it's how well the sound "wears." Lack of boom can be deceptive, and this little system can accept boosting at either end of the spectrum without pain.

**Familiar Features.** You will note that there are some familiar features in an unusual setting. For one thing, the speaker is pointed upward to avoid "beam" effects at high frequencies and to disperse the sound better. In addition, an angled panel directly behind the speaker is drilled with a number of small holes and offers a resistive path between the speaker cavity and the closed chamber at the bottom. This chamber, incidentally, is intended to

counteract resonances in the bass; otherwise, the baffle acts as a conventional ducted-port bass reflex.

Together, these features add up to extremely smooth bass and treble response in a unit whose cost is nominal. The cabinet, for example, is made of  $\frac{1}{2}$ " plywood costing less than \$3.00, plus about 50 cents worth of foam plastic and some scraps of lumber.

The price of a square yard of grille cloth will vary according to the kind you choose, or you may want to eliminate the cloth altogether and try for a different effect. Another change you might consider is the use of an open grille for the top instead of the closed wood top shown here—more on this possibility later.

The foam plastic used for "padding" the speaker compartment is of the flexible kind. Apparently this material goes under a variety of names, but the warehouse which provided ours called it "poly-ether" foam. It's similar to foam rubber and is used in upholstery work. If you can find a firm which supplies it for that purpose, you can probably get

Materials for cabinet are readily available at lumber yards and supply houses. Funnel construction is explained in text.

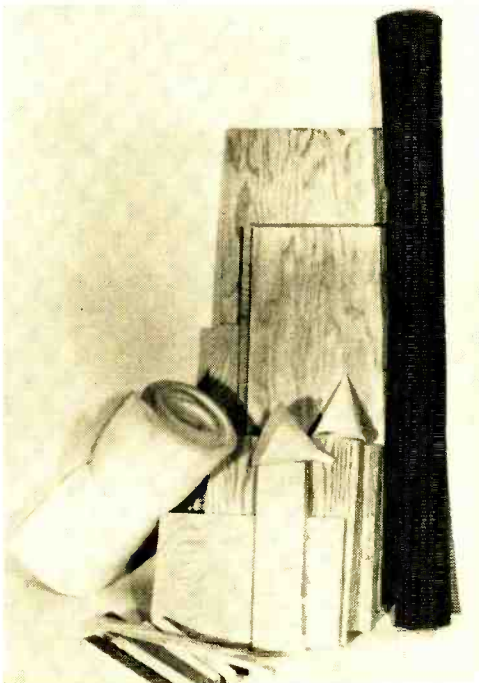

## BILL OF MATERIALS

### Lumber

- A— $\frac{1}{2}$ " x 12" x 29 $\frac{1}{2}$ " plywood (back)
- B, C— $\frac{1}{2}$ " x 8 $\frac{1}{2}$ " x 23 $\frac{1}{2}$ " plywood (sides—2 required)
- D— $\frac{1}{2}$ " x 11" x 17" plywood (front)
- E— $\frac{1}{2}$ " x 11" x 10 $\frac{1}{4}$ " plywood (resistive panel)
- F— $\frac{1}{2}$ " x 11" x 7 $\frac{1}{2}$ " plywood (duct panel)
- G— $\frac{1}{2}$ " x 11" x 2 $\frac{1}{4}$ " plywood (sloping panel)
- H— $\frac{1}{2}$ " x 11" x 8 $\frac{1}{2}$ " plywood (bottom)
- I— $\frac{1}{2}$ " x 8 $\frac{1}{2}$ " x 12" plywood (speaker board)
- J— $\frac{3}{4}$ " x 9 $\frac{1}{8}$ " x 12 $\frac{1}{16}$ " plywood (top)
- K— $\frac{1}{2}$ " x 7 $\frac{1}{4}$ " x 10 $\frac{1}{16}$ " plywood (sub-top—optional)
- L— $\frac{3}{4}$ " x  $\frac{3}{4}$ " x 12" pine (top/front framing)
- M— $\frac{3}{4}$ " x  $\frac{3}{4}$ " x 7 $\frac{3}{4}$ " pine (top/side framing—2 required)
- N, O— $\frac{3}{4}$ " x  $\frac{3}{4}$ " x 4 $\frac{3}{4}$ " pine (front corner framing—2 required)
- I—Length of  $\frac{3}{4}$ " x  $\frac{3}{4}$ " pine (to be cut for cleats)
- I—6' length of door stop (top and bottom trim)

### Other Parts

- 1—Plastic funnel, 4" diameter
- 1—Plumb bob, small (conical plug at bottom of funnel)
- 1 lb.—Plaster of Paris
- 5 doz.—Wood screws, #6 x 1"
- 1 yard—Plastic grille cloth
- 4 sq. ft.—Plastic foam,  $\frac{1}{2}$ " thick (acoustical padding in speaker compartment—see text)
- Misc.—Glue, carpet tacks, etc.

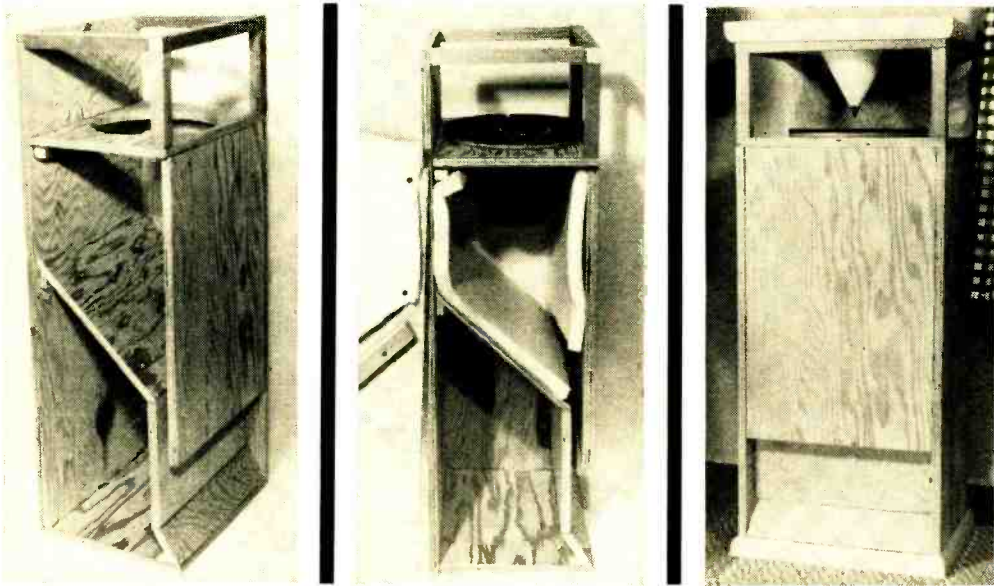

Constructing enclosure is actually rather simple, if you follow the step-by-step instructions outlined in text. One side was removed (left and center) to show the internal layout better.

their left-over cuttings for a fraction of what you'd have to pay in most stores.

**Basic Enclosure.** There are several angled cuts to be made on the pieces of plywood. If you have access to a power saw, you've no problem; but if you don't, it's best to have the parts cut to size at a lumber yard or cabinet shop. You

can save some time and material by keeping the pieces left over from cutting the resistive panel and the bottom sloping panel and using them for glue blocks on the back and bottom. And don't forget that for a cut of  $30^\circ$  the saw blade should be set at  $60^\circ$ , which is  $30^\circ$  from a vertical setting.

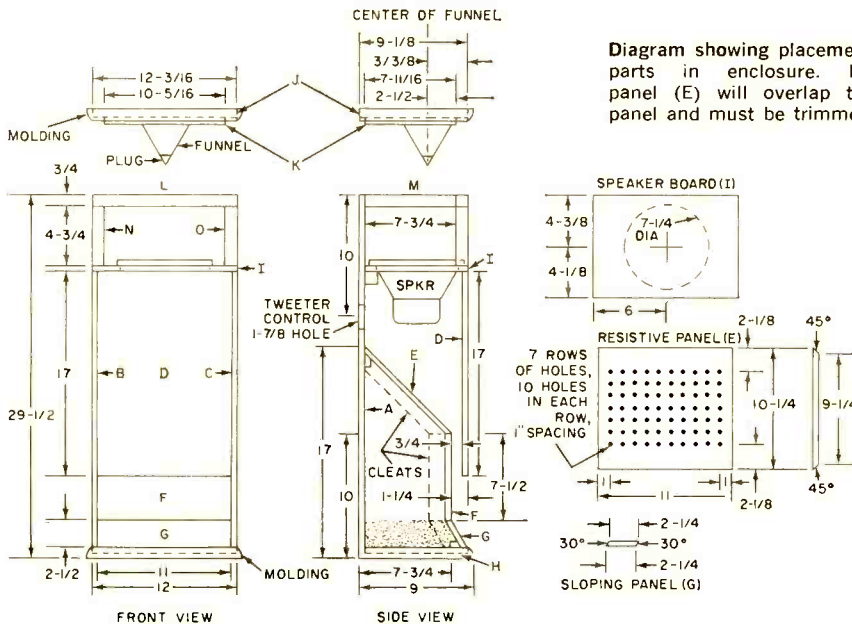

Diagram showing placement of all parts in enclosure. Resistive panel (E) will overlap the duct panel and must be trimmed to fit.

Plaster of Paris "funnel" serves as a reflector for high frequencies. Author used empty peanut-butter jar as holder.



Begin assembly by fixing the cleats in position on the back, bottom, and sides, using plenty of glue and screws. Join these parts and then add the resistive panel, having first drilled it with seventy  $\frac{1}{4}$ " holes according to the pattern shown. This panel will require trimming from its original  $10\frac{1}{4}$ " dimension to prevent its overlapping the duct panel and obstructing the duct.

Next, the duct panel and the bottom sloping panel can be placed in position. By coating the sloping panel edges heavily with glue and putting in its bottom screws last, as shown, the top edge will be forced up against the bottom edge of the duct panel for a good seal.

Now the front panel can be set in place, using some small pieces of  $\frac{3}{4}$ " stock to insure proper spacing from the duct panel. Place the foam plastic so that it covers the interior surface of the speaker compartment. Last of all, put on the speaker board and the top framework, and the basic enclosure is finished.

**Inverted Cone.** The reflector for the high frequencies can now be prepared. There are several acceptable means of reflecting highs, including a single convex "mirror," a set of multiple convex surfaces, or an inverted cone. The latter method is used here.

The cone is easily constructed from a funnel by cutting off the narrow tube at the bottom, fitting in a cheap plumb bob for a plug, and filling the funnel with plaster of Paris. Don't mix the latter until you are ready for it.

After the funnel is filled with the plaster of Paris, it should be put aside to harden—preferably overnight. Meanwhile, you might want to try out the



Completed "Space-Saver" assembly rests on floor, can be placed almost anywhere in listening room.

speaker to make sure everything is working all right and to decide what kind of top you are going to have.

**Open or Closed?** Connect the speaker leads (it's unnecessary to wire in the tweeter control at this point) and set the speaker in the opening made for it. Now try several kinds of music, both with the top open and with a board across the framework. There will be fewer highs without the reflector in place, of course, but the thing to listen for is the change of quality in the overall sound of the speaker when the board is in place and when it is removed.

If you like the sound with the board in place, go ahead with the plans as shown here. If, on the other hand, you dislike the slight coloration caused by the top (remember, sound quality is largely a matter of individual taste),

*(Continued on page 111)*

**ADVANCED  
EXPERIMENTERS  
CORNER**

*Crystal-controlled and transistorized,  
this battery-powered test instrument  
provides three radio frequencies  
and a 455-kc. intermediate frequency  
for ready receiver alignment*

# FIXED-FREQUENCY SIGNAL GENERATOR

**T**HINK you could use a highly accurate, fixed-frequency r.f. signal generator having optional a.f. modulation? Sure you could—it's just the test instrument for aligning amateur and SWL receivers, FM tuners, and TV sets.

Hand-tailored for construction by the advanced experimenter, the inexpensive signal generator described here delivers fixed frequencies of 100 kc., 455 kc., 1 mc., and 10 mc. In addition, the 455-kc., 1-mc., and 10-mc. signals can be modulated with a 700-cycle square wave from a self-contained generator. The basic circuits are highly flexible—for FM i.f. alignment, for example, a 10.7-mc. crystal could be substituted for the 10-mc. crystal shown.

Fully transistorized and battery-operated, this simple piece of test equipment is built around three low-cost *npn* transistors, one moderately priced *pnp* transistor, and four crystals. The rest of the parts are normally found in any spare parts box. Long battery life is assured—with everything "on," total current is only about 4.5 ma.

**Construction.** The unit is built in the bottom half of a 5" x 4" x 3" aluminum

box as shown in the photos. Most of the components are mounted on a circuit board which is inserted as a shelf midway between the 3" x 5" sides of the box. A few components are mounted directly on the box itself; these are switches *S1*, *S2*, and *S3*; battery *B1*; audio level control *R6*; and output jacks *J1*, *J2*, and *J3*.

Begin by drilling all holes for the box-mounted components as well as two holes at each 3" x 4" end of the box for mounting the circuit board—a 4 $\frac{7}{8}$ " x 2 $\frac{3}{4}$ " x

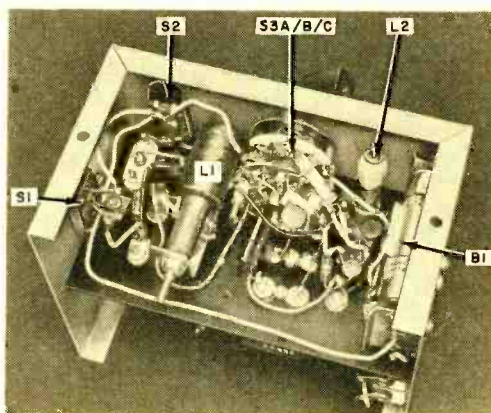

By **JOHN J. SURY**, K8NIC/5

Completed unit (below) is compact, completely self-contained, and easy to operate. Standard RCA phono jacks serve as output connectors.



### HOW IT WORKS

Three separate oscillators—one switchable—make up the signal generator. In the 100-kc. oscillator, transistor *Q1* oscillates at a frequency determined by crystal *X1* and tank circuit *L1/C1*. Capacitor *C3* feeds the 100-kc. signal to output jack *J1*; s.p.s.t. switch *S1* turns the oscillator "on" and "off."

In the second oscillator, transistor *Q4* oscillates at frequencies of 455 kc., 1 mc., or 10 mc., according to whether crystal *X2*, *X3*, or *X4* has been switched into the collector-to-base feedback path. As in the 100-kc. oscillator, output is taken from the collector of the transistor to an output jack (*J3*) through an isolating capacitor (*C11*). Switch *S3* selects the required crystal and also serves to turn this section "on" and "off."

The third oscillator employs two transistors (*Q2* and *Q3*) in a simple multivibrator circuit, producing a relatively symmetrical square wave at a frequency of approximately 700 cycles. The output from this section is fed via audio level control *R6* into transistor *Q4* and (through isolating capacitor *C6*) to audio output jack *J2*. Switch *S2* controls the operation of this oscillator.

1/16" Bakelite or perforated phenolic sheet. Sockets will be required for both the transistors and crystals to prevent damage to these heat-sensitive components when soldering. In wiring the

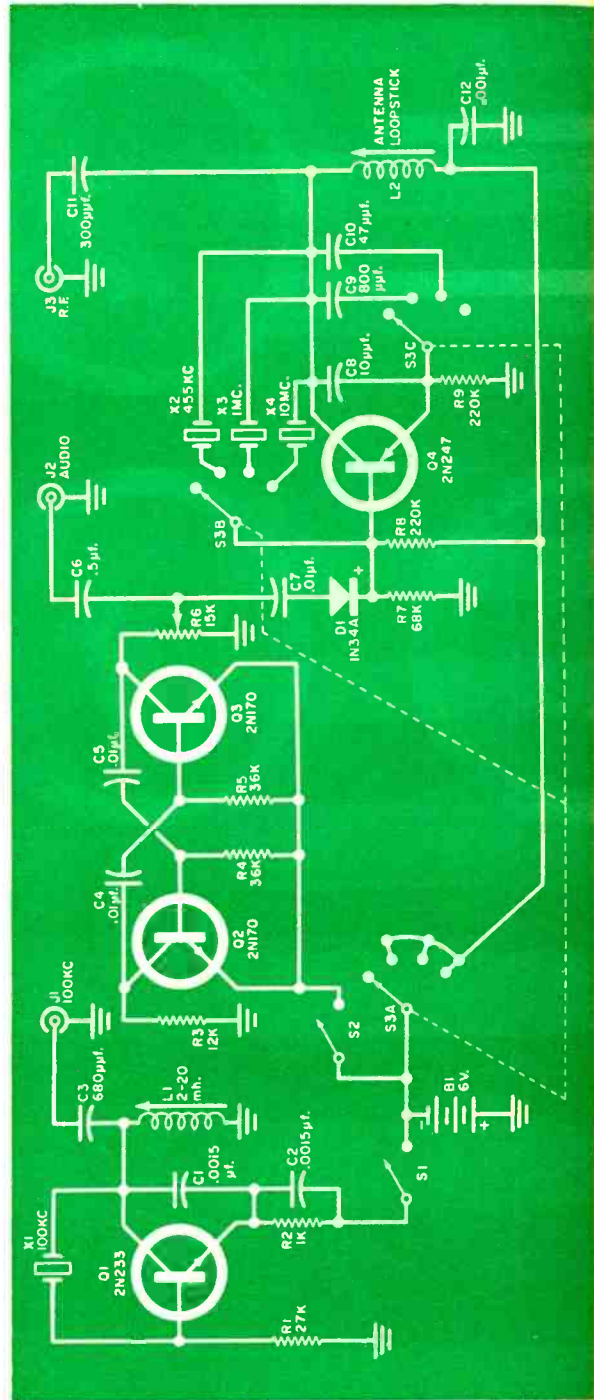

board, be sure that leads leaving the board are long enough for easy hookup to the box-mounted components.

The audio generator subassembly should be wired separately, then mounted

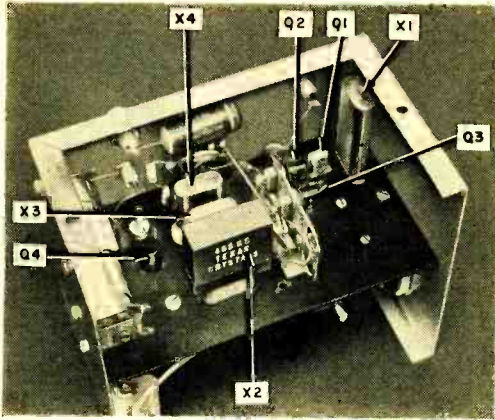

Audio oscillator subassembly (vertical strip in center of board which holds transistors Q2 and Q3) should be wired separately, then mounted.

on the circuit board. When the board has been completely wired, double-check your work against the schematic diagram. Then wire the four flashlight cells in the box to form the 6-volt battery. Connect jumpers and leads to the three switches (S1, S2, and S3), and solder capacitors C9 and C10 directly to switch S3. Finally, fasten the circuit board to

### PARTS LIST

- B1—6-volt battery (four Eveready 915 penlight cells or equivalent in series)  
 C1, C2—0.0015  $\mu$ f. All capacitors  
 C3—680  $\mu$ f., 600 volts 150 w.v.d.c.  
 C4, C5, C7—0.01  $\mu$ f. ceramic  
 C6—0.5  $\mu$ f., 200 volts, paper unless  
 C8—10  $\mu$ f., mica otherwise  
 C9—800  $\mu$ f. specified  
 C10—47  $\mu$ f., mica  
 C11—300  $\mu$ f., 600 volts  
 C12—0.001  $\mu$ f.  
 D1—1N34A diode  
 J1, J2, J3—RCA phono jack  
 L1—2-18 mh. slug-tuned coil (Miller 6314 or equivalent)  
 L2—Antenna loopstick (Lafayette MS-11 or equivalent)  
 Q1—2N233 transistor  
 Q2, Q3—2N170 transistor All resistors  
 Q4—2N247 transistor  $\frac{1}{2}$  watt unless  
 R1—27,000 ohms otherwise  
 R2—1000 ohms specified

- R3—12,000 ohms  
 R4, R5—36,000 ohms  
 R6—15,000-ohm miniature potentiometer (Lafayette VC-35 or equivalent)  
 R7—68,000 ohms  
 R8, R9—220,000 ohms  
 S1, S2—S.p.s.t. slide switch  
 S3—Miniature 4-pole, 4-position non-shorting rotary switch—one pole not used (Centralab PA-1013 or equivalent)  
 X1—100-kc. crystal  
 X2—455-kc. crystal  
 X3—1-mc. crystal  
 X4—10-mc. crystal  
 1—5" x 4" x 3" aluminum box (Bud CU-2105A or equivalent)  
 1—4 $\frac{7}{8}$ " x 2 $\frac{3}{4}$ " x  $\frac{1}{16}$ " Bakelite or plastic board  
 2—Dual penlight-cell battery holders (Lafayette MS-181 or equivalent)  
 Misc.—Transistor sockets, crystal sockets, wire, hardware, etc.

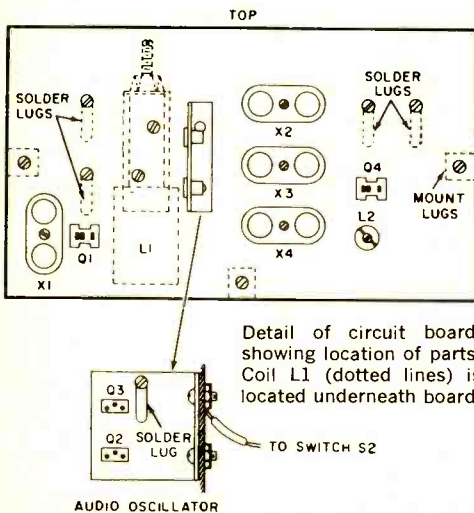

the box and connect the board to the box-mounted components.

**Checking It Out.** Although an oscilloscope is ideal for checking operation of the unit, it is by no means mandatory. In the author's case, a very loose coupling sufficed to feed a suitable 10-mc. signal into his receiver, and only the center conductor had to be connected to the antenna on the 1-mc. and 100-kc. outputs. For i.f. alignment, both leads from the unit had to be connected to the receiver.

As a check on the generator's accuracy, the author zero-beated the 100-kc., 1-mc., and 10-mc. outputs against his receiver. When the unit was turned off, Station WWV came in smack on the nose!



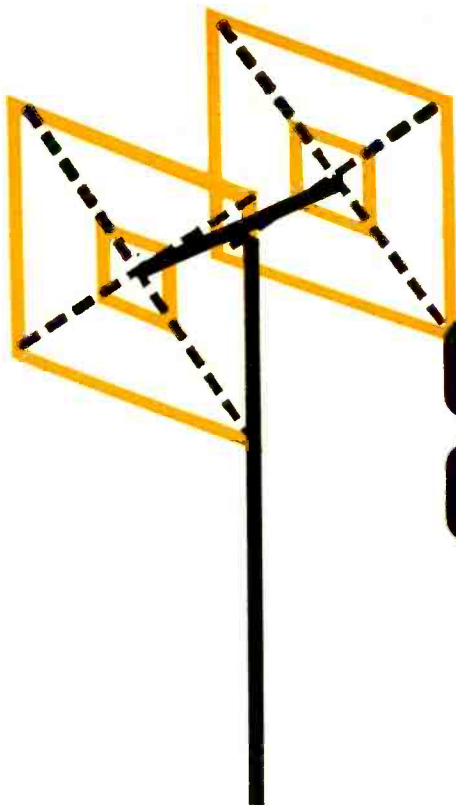

# CUBICAL QUAD for CB

**I**NTERFERENCE on the crowded Citizens Band channels in urban and industrial areas is often so high that the efficiency of the CB service is severely impaired. The use of a good, directional beam antenna will do much to reduce or eliminate the interference.

First, the beam antenna will concentrate the transmitted r.f. energy in one direction. Secondly, the beam will improve reception by picking up signals from one direction only and greatly attenuating all others, thus providing a bonus feature over nondirectional antennas such as the simple ground plane. Two CB stations employing beam antennas can enjoy reliable communications over distances far beyond the usual range of single-element antennas.

An efficient and inexpensive beam antenna that has enjoyed great popularity among radio amateurs is the "Cubical Quad" array. The Quad is simple to construct, made of easily obtainable components, and provides a power gain of approximately 6 db (four times). No tuning adjustments are necessary; you

**Popular directional antenna  
makes its Citizens Band debut**

By **WILLIAM I. ORR**, W6SAI

build it, put it up, and *it works!* If you are a good "scrounger," you should be able to construct the Quad for ten dollars or less!

**Framework Assembly.** The Quad consists of two square loops of #14 enameled wire (a 100' roll cut into two equal lengths) supported on a simple lightweight bamboo frame. (See Fig. 1.)

One loop of wire is coupled to the CB equipment via a twin-line lead-in, while the second loop acts as a parasitic reflector element requiring no connections to the lead-in. The antenna can be supported by a center pole and rotated by a heavy-duty "TV-type" antenna rotor. Directivity—the direction in which the antenna beams transmitted waves and

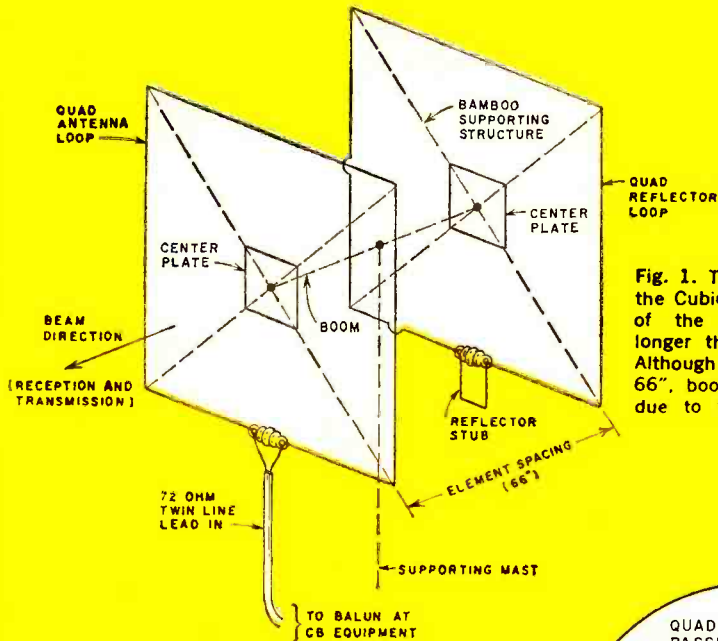

Fig. 1. The designer's "eye view" of the Cubical Quad antenna. Each side of the square loops is slightly longer than one-quarter wavelength. Although spacing between loops is 66", boom will be about 1" shorter due to thickness of center plates.

### BILL OF MATERIALS

- 8—10'-long bamboo poles—see text
- 1—100' roll of #14 enameled wire—see text
- 2—12" x 12" plywood plates,  $\frac{5}{8}$ " thick
- 1—65" section of dry 2" x 2" lumber
- 8—4" galvanized steel angle brackets
- 16—Galvanized U-bolts with nuts and washers
- 1—Random length of TV-type 72-ohm "ribbon" line (Belden #8222)
- 2—2" glass or ceramic insulators
- 1—99" length of  $\frac{3}{8}$ "-diameter braided shield (Belden #8661 shielded loom)
- 1—Coaxial plug (to mate with CB antenna jack)

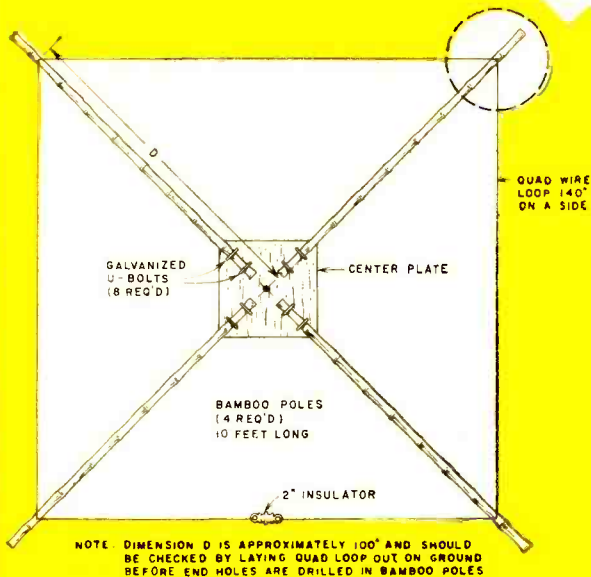
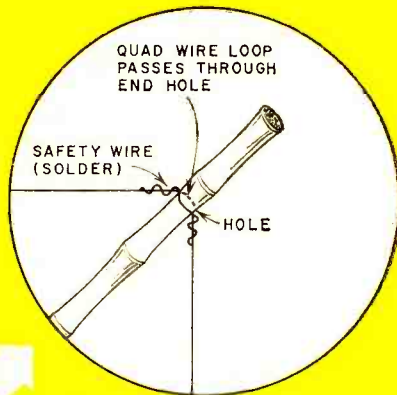

Fig. 2. Two square loops are necessary. Quad wire is strung through holes in ends of poles and secured with safety wire. (See details above.) To eliminate wire slack, loosen U-bolts and extend the poles.

best picks up r.f. signals—is in a plane at right angles to the plane of the loops and *through* the driven element.

A suitable framework can be made up of bamboo "arms" and a wooden supporting structure. (See Fig. 2.) Four poles are required for each Quad loop, and are bolted to a wooden center plate with galvanized U-bolts, commonly used in TV installations. The center plates in turn are bolted to opposite ends of a wooden boom. Choose bamboo poles that are clean, straight, and free of splits and cracks between the rings; use 10'-long poles so that the small tips may be cut off and discarded to provide an overall length of 9 feet. The poles should be wrapped firmly with electrical vinyl tape between the joints to retard splitting

Galvanized or plated hardware is used in the assembly to retard rust and corrosion, and the butt ends of the poles are wrapped with electrical tape for added strength at the points where the U-bolts contact the bamboo. Two U-bolts are required for each pole, and the poles are positioned so that there is a gap of about 1½" between the butt ends. Washers are placed under all nuts to prevent them from digging into the soft surfaces of the plywood.

The boom is made of a 65" section of dry 2" x 2" lumber, well painted to protect it from moisture. ("Green" lumber would tend to warp as it gradually dries out, imparting a nasty twist to the symmetrical Quad design.) Sand the boom before you paint it, as this precaution will protect you from splinters and splinters during the assembly process.

The center plates are attached to the ends of the wooden boom by means of eight galvanized steel angle brackets. (Refer to Fig. 3.)

**Wiring the Quad.** You'll find that the bamboo framework is a flimsy and unwieldy structure, having as much stability as a jellyfish. However, once the antenna wires are strung in position, the assembly will magically become neat and amazingly rigid.

The next job is to string the wires on the bamboo frameworks. (See Fig. 2.) Remove the frameworks from the boom and lay them on the ground. Since the Quad loops are 140" on a side, you cannot take up slack by shortening the wire loops. Rather, the slack in the wires (if any) must be absorbed by expanding the bamboo framework until the wires are under tension. Final tension may be adjusted by spreading the poles equally apart at the center plate before the U-bolts are tightened.

Begin by cutting the two wire loops; there will be enough extra wire on each loop to make the end connections and the reflector stub. Make one loop assembly first.

When everything is "ship-shape," wire each bamboo pole to the loop. Scrape the enamel covering from the loop wire for an inch on each side of the poles and pass a short piece of copper wire over each pole, wrapping it securely about the Quad wire. Then solder the joints.

(Continued on page 117)

BOOM ASSEMBLY

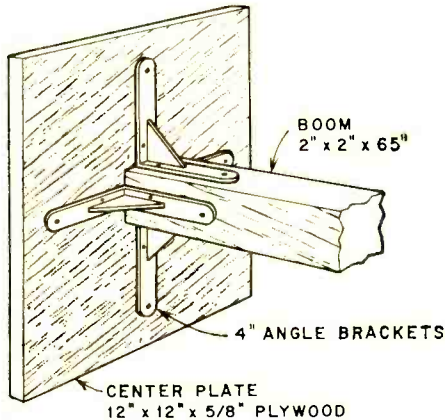

Fig. 3. Weakest parts of Cubical Quad are at junctions of center plates to boom, so be sure plates are securely mounted before installing the antenna.

and then given two coats of outdoor varnish or shellac to protect them from the weather.

Plywood is ideal material to use for the two center plates, which measure 12" on each side and are cut from 5/8" stock. (See Fig. 3.) It is necessary to seal the plate edges against moisture to prevent the plywood from cracking or splitting—two liberal coats of outdoor house paint will do the job. The center plates are drilled to pass U-bolts which clamp the bamboo poles along the diagonals of the plates.



# SPACE ELECTRONICS

By **OLIVER P. FERRELL**, Editor



NASA Photograph

Lift off! The Juno II rocket carrying NASA's S-15 satellite lifts at 0917 hours from Cape Canaveral. With an active life of about one year, the S-15 (now called Explorer XI) counts and measures gamma rays.

**T**HE BIG NEWS for experimenters in space science was the successful launching of NASA's S-15 satellite in late April. The S-15 (now called Explorer XI) is a gamma-ray astronomy telescope satellite being used to detect and measure cosmic and gamma radiation from space. Explorer XI is swinging around the earth once every 108 minutes in an orbit that extends from 310 miles to 1100 miles above the surface.

A photo and description of Explorer XI appeared in last month's column (page 68). This satellite will not only detect gamma rays but also will enable the source of these high-energy particles to be mapped. It is felt that gamma rays come from our own galaxy and possibly neighboring galaxies. A special sensing mechanism in Explorer XI, similar to a Geiger counter, measures the gamma and cosmic rays, and the information is tape-recorded. As the satellite passes over a

A huge space center is planned by AT&T in Rumford, Maine. This model antenna is similar to one used by Bell Labs in its series of Echo I balloon experiments.

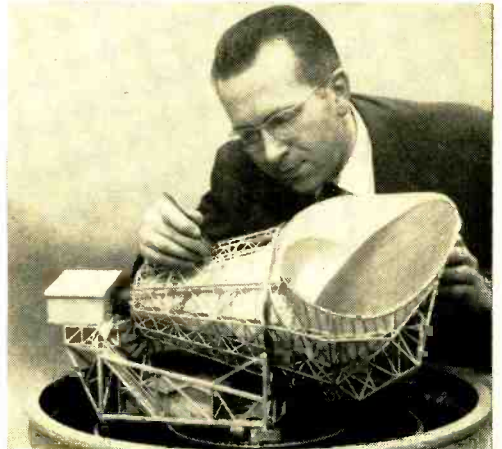

POPULAR ELECTRONICS

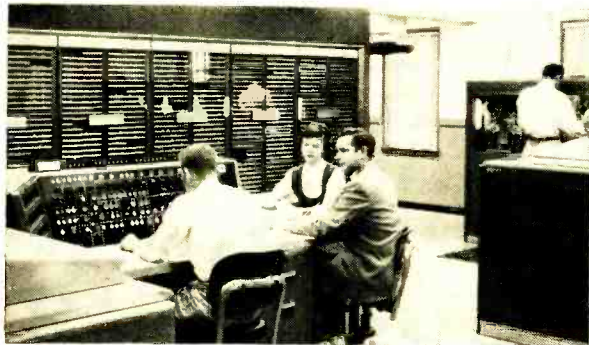

Official Photograph  
U. S. Navy

The U.S. Navy maintains a space surveillance system (NAVSPASUR) which has been in operation since 1959. It detects, tracks, identifies and determines the orbits of all non-transmitting space objects. Orbit computations are performed by the Naval Ordinance Research Calculator (NORC) at Dahlgren, Va.

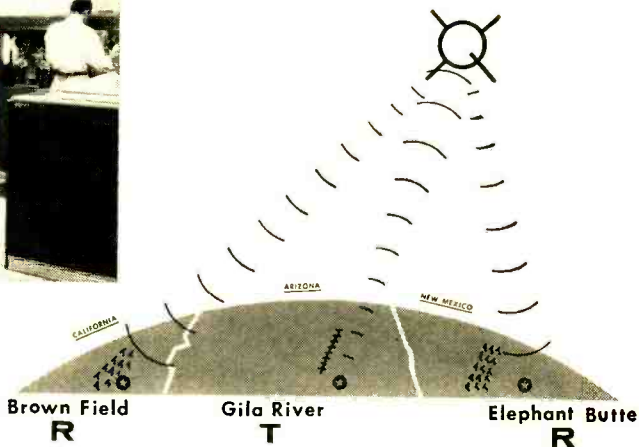

NAVSPASUR operates with two 50,000-watt transmitters and four gigantic receiving stations. The western complex shown above has the receiving stations in Brown Field, Calif., and Elephant Butte, near Truth or Consequences, New Mexico; the transmitter is at Gila River, near Phoenix, Arizona. An eastern complex has stations in Mississippi, Alabama and Georgia. Each transmitting station radiates a fan-shaped pattern of 108-mc. energy. A satellite or rocket body passing through this beam reflects a weak signal that is picked up by the two corresponding receivers. Direction and position are determined by triangulation methods.

ground tracking station, a "command signal" activates the recorder, broadcasting the information on 107.97 megacycles. Rated at 125 milliwatts, the 107.97-mc. signal should be heard without difficulty on an average FM tuner.

A 20-milliwatt tracking signal is being radiated continuously by Explorer XI on 108.06 megacycles. Rechargeable batteries are used in this satellite. The estimated life of Explorer XI is about three

years in orbit and one year transmitting gamma- and cosmic-ray data.

**Another Try for S-45.** In our first *Space Electronics* column (April, 1961, page 65), we commented at considerable length on the ionospheric sounding satellite called NASA S-45. The first try at launching the S-45 failed—apparently due to a mechanical malfunction in one of the upper stages. This defect has been cured, NASA believes, and they are now getting ready—as this column is being written—to launch the "back-up" S-45 satellite.

This satellite will be another one in the "Explorer" series. It will radiate strong signals on 20.005, 40.01, 41.01 and 108.27 megacycles; the 20-megacycle signal should be sufficiently strong to be heard on the average short-wave receiver.

The best time to listen for satellites using 20-megacycle transmitters is between midnight and dawn. Many listeners experience considerable difficulty with

A unique antenna having a width of 120 feet is now being built by the U.S. Air Force in Tyngsboro, Mass. Ultra-sharp beams from this antenna will be used to test satellite-relay communication systems.

Official Photograph U. S. Air Force

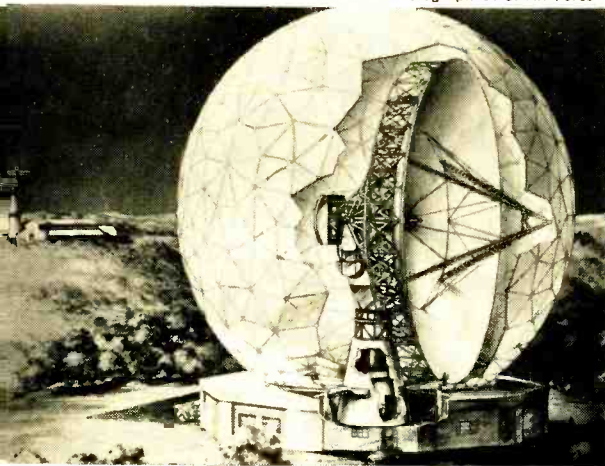

interference from the WWV 20-mega-cycle standard frequency broadcast. Mark the WWV 20-mc. spot on your dial and then tune in after midnight.

By the way, Explorer VII, launched on October 13, 1959, continues to send a weak signal out on 19.99 megacycles.

**Radio Signal Status.** Two new satellites have started transmitting since our last column was written: Explorer XI (discussed above) and Discoverer XXIII. Although the latter is on the air—so to speak—the U. S. Air Force has not re-

Also, because of the speed of the satellite in its orbit, a trailing wire “cuts” the earth’s magnetic field and induces an undesirable voltage into the communications equipment.

Canadian experimenters have been working on an extendable ribbon antenna for their NASA S-27 shot. We hope to have photos and more details on this unusual antenna design next month.

Meanwhile, researchers have pointed out that the exhaust gases from a rocket engine could also be used as an antenna;



Official Photograph U. S. Navy

Hub of the Navy’s space surveillance system is the Dahlgren, Va., operations center. Here the data from receivers in the two complexes are evaluated and space objects identified as known or unknown.

leased information on the frequencies it is using.

Of the 27 satellites now in space, 24 are American (nine still transmitting) and three are Soviet (none transmitting). At this writing, the Russians still act as though they were receiving signals from their Venus probe; however, after loss of the signal in early March, it seems doubtful that anything more will ever be heard. The Soviet Lunik I has gone into a solar orbit, leaving only Spacecraft I in an earth orbit. The Americans have two satellites in solar orbit (Pioneer IV and V), all others in earth orbits.

**Antennas in Space.** A great variety of suggestions have been made in recent months for the construction of short-wave antennas to be unfolded once a satellite is in orbit. Lead-weighted trailing wires are the current favorites, although they have an effect on the spin and tumble of the satellite—sometimes favorable and desirable, sometimes not.

such gases are ionized and are to all means and purposes a good electrical conductor. Employing exhaust gases would permit antennas to be operated up in the low- and medium-frequency bands (between 200 and 10,000 kc.).

Heretofore, antennas have been restricted in size and efficiency. Loaded whips, loops, etc., are not efficient radiators. Now that the LOFTI satellite (see last two *Space Electronics* columns) has shown that low frequencies can pass through the ionosphere, we may reasonably expect to see additional satellite transmissions in the long-wave and short-wave bands.

**At Minus One:** A group of radio amateurs is now actively pursuing the possibility of installing a miniature transmitter in a NASA satellite. Called “Project OSCAR,” the transmitter would operate in the 144-megacycle (2-meter) ham band. Hopes are high that they will be able to get a transmitter aloft in late 1961 or early 1962.

-30-

# On the Citizens Band



By TOM KNEITEL, 2W1965

**T**HIS is the wildest! Remember when we told you (back in March) about "Bermuda Belle," the YL taxi dispatcher with the British accent who was busting up CB communications? Well, the Racine CB Club (Wisconsin) knows her as "Happy Valley Sally," and it turns out that she's practically the club "sweet-heart."

When a friend of one of the club's members went to Bermuda on his vacation, they asked him to find out "Sally's" name. Sure enough, a little digging turned up The City Taxi Service in Hamilton, and its radio operator—Helen Richardson.

When the Racine gang got the information, they started sending her QSL cards. In return, they received beautiful picture post cards of Bermuda, with a little personal greeting on each. Now they have her picture, and are car-



rying on pretty much of a regular correspondence with her.

Our thanks go to Don Jensen, 18W6098, editor of "The Heterodyne," the Racine Club paper, for this item. If you're interested in the club, write to Don at 1832 Ridge Drive, Racine, Wis.

A new gizmo which should prove handy around a rig has been announced by SECO—the Model 510 transmitter tester. In addition to being useful for CB rigs, it will also serve low-power transmitters in other services operating below 160 mc.

Weighing only two pounds, the 510 has a 3" meter calibrated for direct reading for both positive and negative AM modulation peaks. It also measures 0

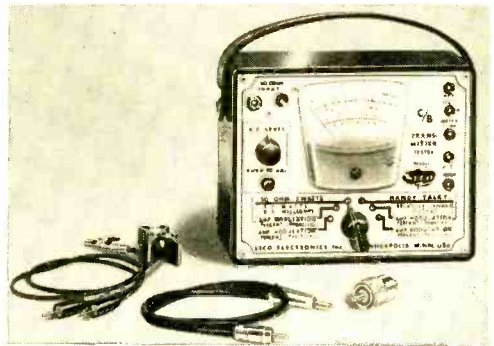

to 5 watts r.f. and has a 0-400-ma. scale. You can check to see how much power you are losing in your transmission line—read the meter and weep!

**While we're on the subject** of new products, it occurs to us that we devote too little space to CB antennas. This is due primarily to the fact that we hardly ever receive sufficient information on a new antenna to do a write-up. But this month Mark Mobile has filled us in on its new Model CSM-11.

Real snappy looking, the CSM-11 is intended to be used on the side of existing TV, broadcast or communications towers (to keep within FCC regulations). It can be used in a single bay or (as Model CSM-11-2) stacked with units on either side of the tower to narrow the vertical pattern and produce a 3-db gain (in effect, doubling the trans-

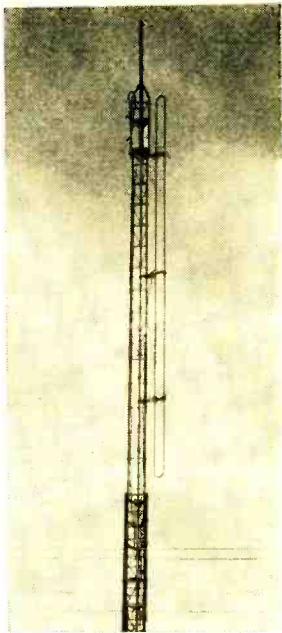

mitter power) over a half-wave dipole.

If you want the full scoop on this antenna, drop a note to Mark Mobile, 5441 W. Fargo Ave., Skokie, Ill. Tell 'em your Uncle Tom sent you and ask about their Heliwhip CB antennas—which are “the most!”

We couldn't believe our ears when a local CB'er told us that a number of 2W-area CB'ers had been stopped in their cars by “FCC investigators” who wanted to see their 452-C cards (mentioned in last month's column). The 2W'ers were also asked to flip on a dead carrier for a few seconds while the “investigators” took field intensity measurements with all sorts of devilish-looking meters.

We didn't believe it, that is, until several readers wrote in to say that the same thing had happened to them outside the 2W area. So we called Bill Kiser, top man at the FCC's New York field office, and found that the FCC has *absolutely nothing to do with these goings-on*. Mr. Kiser said that he had heard about it, too, and was just as “shocked” as we were.

It's Mr. Kiser's guess that a few CB'ers have simply gone “over the hill” with the gung-ho bit and fancy themselves as FCC inspectors. Legit FCC investigators do not operate in this man-

ner. For one thing, they would show *their* Gov't. ID cards to *you* before asking to see any of your equipment.

Mr. Kiser suggests that CB'ers who are stopped on the road by an “FCC investigator” ask to see his ID card. If none is forthcoming, or if the ID card looks like a phony, get the license number of his car and immediately report the incident to the Department of Justice. As you might imagine, impersonating a federal officer is agin' the law.

**Speaking of goings-on**, there's a character on the air who has been heard bragging that he has contacted 23 CB areas, managing the feat without once receiving a thumping from the FCC. I can't understand this—I know CB'ers who have gotten citations for working adjacent call areas.

**Have you ever been bothered** by a low-frequency howl in your transceiver which pops up between periods of modulation? Several readers have, so here's a suggestion to help clear up the situation.

The howl is probably caused by r.f. feedback, and adding the circuit shown in the diagram below to your rig should

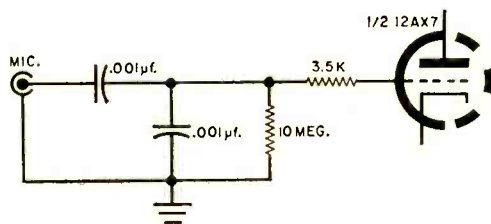

rid you of the problem. An alternate method is to place a 330- $\mu$ f. capacitor across the mike.

**Here are some quotes** from the band. (Is it possible that you are guilty of any of them?)

*You're coming in loud and clear—will you repeat your last transmission?*

*After talking for 12 minutes: Well, I guess we've had our nickel's worth, so let's clear this channel. Meet you down on channel 5 as soon as I plug the crystal.*

*Wanna be my unit 4? . . . I asked for four units, but I only got a base station. Frank and Tony are gonna be units 2 and 3.*

We must confess that these quotes  
(Continued on page 119)



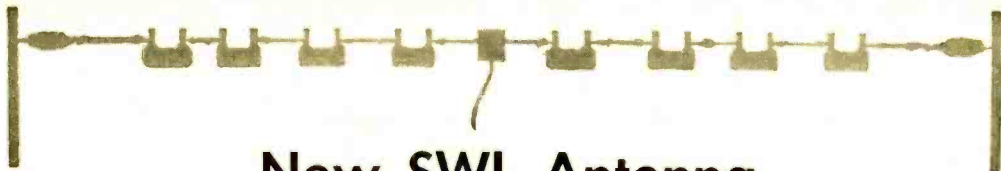

## New SWL Antenna

**Mosley SWL-7 kit: a 7-band dipole for \$14.75**

**Y**OU can always get some sort of short-wave reception by throwing a hank of wire out of the window, or even using bedsprings for an antenna. But what a difference it makes if the antenna is resonating on the short-wave broadcast band you want! Signal strength improves by three or more S-units (18-24 db), signal-to-noise ratio improves, and the antenna directionality can be used to discriminate against unwanted stations.

The new Mosley SWL-7 antenna (available in kit form from Mosley Electronics, Inc., 4610 N. Lindbergh, Bridgeton, Mo.) does all of the above—it resonates on seven different short-wave broadcast bands—all with the same dipole. This minor miracle is accomplished by cutting each of the two legs of the dipole antenna into five pieces (all carefully measured in length) and then introducing a “trap” between each length.

Small LC combinations on rigid forms, the traps are dipped in a plastic to protect them from the weather. Eight of them (four to a dipole leg) are fastened between the cut sections of the antenna wire. This array is strung in the air and the appropriately placed coils cause the single dipole to resonate on five bands.

The theory behind this multiple-resonating dipole is quite simple. On five of the bands—13, 19, 25, 31, and 49 meters—the antenna acts as a quarter-wave dipole, tuned by the appropriate resonators for each band. And on 11 and 16 meters, the resonators cut each antenna leg to  $\frac{3}{4}$  wavelength. For six of the seven short-wave bands, a pair of resonators behave as insulators, cutting the antenna to the correct length; the re-

maining resonators act as short circuits in each case.

On the other side of this first set of traps is a two-foot length of wire and another pair of traps. At 13 meters, the 11-meter traps have negligible impedance and, with the additional length of wire, effectively place the antenna in the 13-meter band. And so on through the 49-meter band.

The Mosley SWL-7 can be assembled in just under an hour, and it works like a charm. Like any good SWL antenna, it should be installed at least 25 feet in the air and about 40 feet away from surrounding structures.

-30-

Kit is supplied with eight color-coded traps, 45 feet of antenna wire, 100 feet of 75-ohm lead-in, and a pair of porcelain insulators.

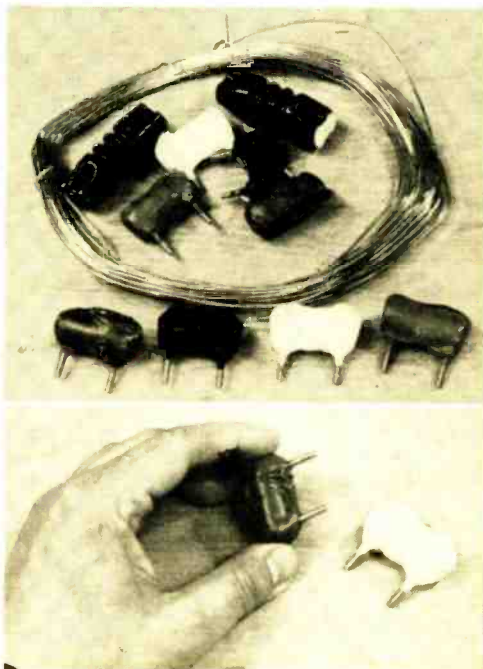

Ends of the traps are brass bolts. The antenna wire is wrapped around the bolts and fastened tightly in place with nuts and lock washers.

# DIODE QUIZ

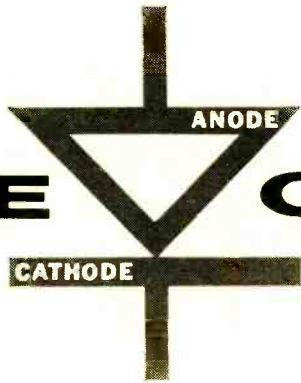

By ROBERT P. BALIN

Keeping in mind that a diode can pass current in one direction only, see if you can find the effective resistance across the battery in the circuits below. Assume that every resistor measures six ohms, and that the diodes have zero resistance in the forward direction, infinite resistance in the reverse direction.

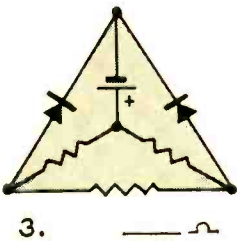
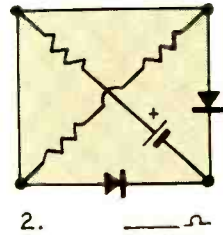
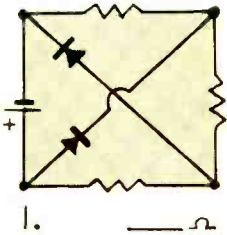

Answers  
appear  
on  
page 109

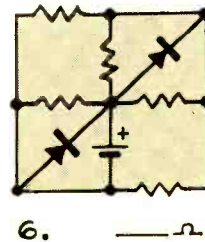
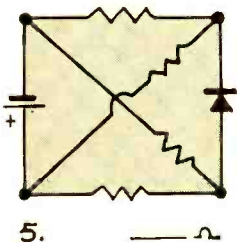
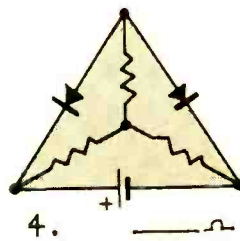

# HOW TO BECOME

*Although the road to hamdom may look difficult, any U. S. citizen can become a ham—over 200,000, many of them ex-CB'ers, already have!*



## A HAM

By DONALD L. STONER, W6TNS

**A**MATEURS tend to paint a rosy picture of how easy it is to obtain an amateur license. Looking back, it doesn't seem difficult at all. However, from the beginner's point of view, the requirements may look formidable. It's true that it's not particularly easy to acquire the skills needed to pass the examinations. But the "reward" of being able to communicate with any amateur in the world is more than adequate compensation for the time and effort needed to qualify for a license.

Contrary to some popular opinion, an amateur license is not simply "obtained." It must be *earned*. And to earn an amateur license, you must prove your proficiency and knowledge of the hobby to the satisfaction of the Federal Communications Commission. Such "proof" takes the form of a code and theory test administered by the FCC. As with other tests, you must exceed a certain mini-

mum "standard" in order to qualify.

The important thing to remember is that anyone—any U. S. citizen, that is—can earn a license, even you! If you want support for this statement, remember that eight-year-old children, 96-year-old great-grandfathers, and handicapped people hold amateur licenses. The only requirements are citizenship, a certain amount of your time, and an unswerving interest in the hobby.

Condensed to nutshell size, the requirements for an amateur license are (1) the ability to send and receive radiotelegraph code at prescribed speeds, and (2) a firm grasp of radio theory. The code speed and the complexity of the theory test are determined by the class of license desired. The amateur ranks are currently populated with amateurs holding four major types of licenses—Novice, Technician, General, and Extra Class. Naturally, the easiest one to earn

Both of the hams shown above have been heard around the world. At left is Dorothy Strauber, K2MGE, who talks regularly with OQ5IE in the Congo; and at right is John Alvares, CR9AH, who lives on Macau Island.

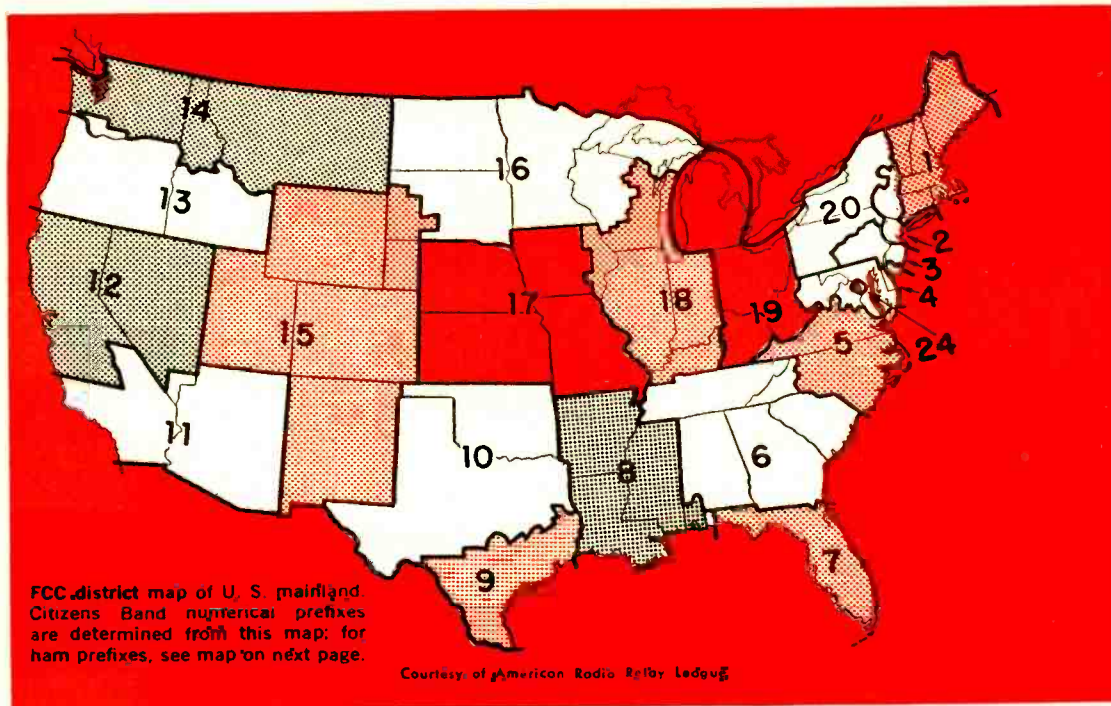

—the Novice class license—carries the most restricted privileges.

**The Novice License.** Several years ago, the American Radio Relay League—an organization by and for amateurs—pointed out that the big stumbling-stone on the road to becoming an amateur was the code speed requirement. It was necessary to send and receive 13 words per minute to qualify for a license.

However, the code had long been the symbol of amateur radio and the elimination of this part of the test was almost unthinkable. In addition, the code is an effective means of separating the person who wants to dabble with transmitters and antennas from the serious experimenter.

As a result of the ARRL suggestion, the FCC introduced the Novice license in 1951. The requirements for this class are a code speed of only 5 words per minute (letters, no numerals) and a 20-question examination appropriate for the beginner.

When issued a Novice license, you are allowed to use radiotelegraph in a small segment of the 80-, 40-, and 15-meter bands. You are also allowed to transmit radiotelephone signals in a slice of the 2-meter band. Since this is a begin-

ner's license, it is valid for only one year and is not renewable. In all operations, Novices are limited to 75 watts input power (about the same power as is consumed by a small table lamp), and the operating frequency of the transmitter must be controlled by a quartz crystal.

Although understandably rather severe, these limitations do not hold back the Novice, for he can still communicate with other amateurs all over the world. Several Novices have the outstanding accomplishment of contacting 100 or more countries within their one-year tenure.

The purpose of the Novice Class is to provide an opportunity to "practice" the code. Learning the code is *not* considered "difficult" because it must be memorized, or because you must have the manual dexterity to thump out a message on a key, or write the answer down on a piece of paper. It is "difficult," however, for the simple reason that it's hard to find time in a busy day to practice. Getting on the air, and "talking" (by code) with other hams like yourself, makes learning the code "almost fun"—like the commercial says.

**The "Technician."** Along with the Novice license, the FCC instituted another

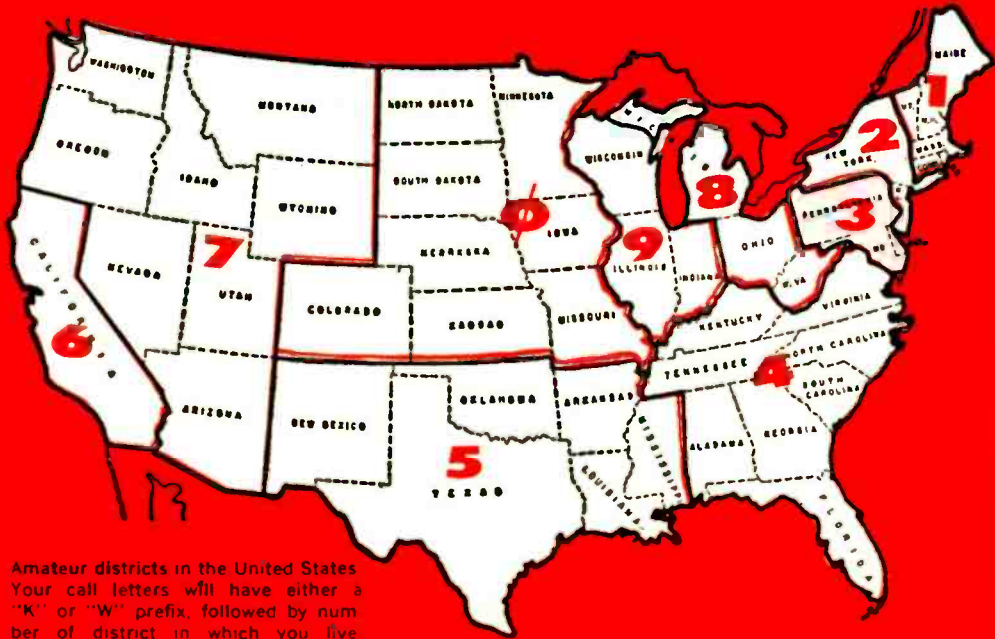

Amateur districts in the United States  
Your call letters will have either a  
"K" or "W" prefix, followed by num-  
ber of district in which you live

er beginner's license to promote interest and activity on the higher frequency bands. The code requirement is the same as for the Novice (5 wpm), but the written examination is more comprehensive, and hence more difficult—it is nearly identical to the test given for the General Class license.

Permitted the maximum power input of 1000 watts, the "Technician" can operate using either voice or code. But since the purpose of this license is to promote interest in the very high frequencies, he is confined to the 6-meter band and higher frequencies.

Both the Novice and Technician examinations can be taken by mail. When you feel that you are qualified, send a post card to your district FCC office requesting the examination papers. Any local amateur can give you the examination—he will send and receive for your code test. If you pass this part of the exam, you then proceed to the written section. When the test has been completed, the examiner signs the papers and forwards them to the FCC district office for grading. If all goes well, you will be assigned a call.

**General Class.** The majority of amateurs fall into this category. They are

The International Morse Code is used by radio amateurs everywhere. Some helpful short cuts to learning the code are discussed in text

THE RADIOTELEGRAPH CODE

A . . . . .	U . . . . .
B . . . . .	V . . . . .
C . . . . .	W . . . . .
D . . . . .	X . . . . .
E . . . . .	Y . . . . .
F . . . . .	Z . . . . .
G . . . . .	1 . . . . .
H . . . . .	2 . . . . .
I . . . . .	3 . . . . .
J . . . . .	4 . . . . .
K . . . . .	5 . . . . .
L . . . . .	6 . . . . .
M . . . . .	7 . . . . .
N . . . . .	8 . . . . .
O . . . . .	9 . . . . .
P . . . . .	0 . . . . .
Q . . . . .	.
R . . . . .	-
S . . . . .	+
T . . . . .	=
DOUBLE DASH . . . . .	END OF MESSAGE . . . . .
ERROR . . . . .	INVITATION TO TRANSMIT . . . . .
WAIT . . . . .	END OF WORK . . . . .



### BOOKS ON AMATEUR RADIO

**Amateur Radio Theory Course** (\$3.95)  
**Amateur Questions and Answers—  
 License Guide** (50 cents)  
 American Electronics Co.  
 1203 Bryant Ave., New York 59, N. Y.

**QST Magazine** (\$5.00 per year)  
 —including ARRL membership  
**The Radio Amateur's Handbook** (\$3.50)  
**A Course in Radio Fundamentals** (\$1.00)  
**How to Become a Radio Amateur\*** (50 cents)  
**The Radio Amateur's License Manual\*** (50 cents)  
**Operating an Amateur Radio Station\*** (25 cents)  
**Learning the Radiotelegraph Code\*** (50 cents)  
 \*These four books are available for \$1.50.  
 American Radio Relay League (ARRL)  
 38 LaSalle Rd., W. Hartford, Conn.

**CQ Magazine** (\$5.00 per year)  
**Amateur Radio License Guide** (\$2.50)  
 Cowan Publishing Corp.  
 300 W. 43rd St., New York 36, N. Y.

**The Radio Handbook** (\$7.50)  
 Editors and Engineers  
 Summerlund, Calif.

**G-E Ham News**  
 (available free at distributors)  
 General Electric Company

**RCA Ham Tips**  
 (available free at distributors)  
 Radio Corporation of America

**Better Shortwave Reception** (\$2.85)  
**Novice and Technician Handbook** (\$2.85)  
 Radio Publications  
 Box 149, Wilton, Conn.

**Sound-n-Sight Code Course**  
 Complete Course, 0-20 wpm (\$15.95)  
 Novice Course, 0-8 wpm (\$9.50)  
 John F. Rider, Publisher, Inc.  
 116 W. 14th St., New York 11, N. Y.

**Electronic Experimenters Handbook** (\$1.00)  
**POPULAR ELECTRONICS Magazine**  
 (\$4.00 per year)  
 Ziff-Davis Publishing Co.  
 1 Park Ave., New York 16, N. Y.

permitted all the privileges granted U. S. hams and have unlimited access to the amateur bands. They operate at inputs up to 1000 watts (affectionately known as a "full gallon"), and the frequency-determining element in their transmitter can be variable. Thus, they can "move around" to duck interference or to "zero in" on another amateur. Licenses in this class may be renewed every five years.

The General Class examination is usually taken at the nearest FCC district office, but invalids unable to travel as well as persons located far from an examining office can take the General Class examination by mail under the direction of another amateur. When this is done, they receive a Conditional license, but it is otherwise identical to the General "ticket."

**Extra Class.** This is the most advanced amateur class and its purpose is to promote self-advancement and increased knowledge of electronics and amateur operation. The code requirements are stepped up to 20 wpm, and the written test is more difficult. The amateur must hold a General Class license for two years before he can apply for the Extra Class license. At the present time there are no additional privileges connected with this class.

**The Bands.** Our lowest frequency and longest wave-length band is *160 meters*. It is just above the spot where you hear police calls on your radio. This band is shared with Loran navigation stations and is broken up into several subdivisions. During the daylight hours there is little or no activity, and even at night one can usually operate without interference from other stations.

The *80-meter band* is located on your short-wave radio dial between the marine and aircraft bands and has a frequency of 3.5 to 4.0 mc. (megacycles). During the day it is sparsely populated because signals at this frequency usually do not travel more than 100 miles. At night, however, it comes to life like a tomcat, and contact with stations halfway across the continent is common. On rare occasions, transmissions in excess of 5000 miles occur.

On the *40-meter band*, 7.0-7.3 mc., you can establish contact with most of the  
 (Continued on page 108)



# Across the Ham Bands

By  
**HERB S. BRIER**  
W9EGQ

## HOW TO PASS THE GENERAL CLASS CODE TEST

**T**HERE ARE TWO periods of crisis in the life of the average ham. The first occurs when he faces the fact that wanting to be a ham is not enough. He knows that he must study to pass the code and theory examinations. He knows, too, that the booklets, "How to Become a Radio Amateur," "Learning the Radiotelegraph Code," "The Radio Amateur's License Manual", and "Operating an Amateur Radio Station" are available in a packet entitled "Gateway to Amateur Radio" for \$1.50, postpaid, from any amateur supply house. So he gets the packet and begins studying.

Once the decision to study is made, the would-be ham memorizes the code alphabet in a week or so. Within a month, his copying speed is usually up to around 8 words per minute—more than enough for the 5-wpm Novice code test. A few more weeks of study, using the "License Manual" as a guide, makes passing the

technical part of the Novice exam equally easy.

The second crisis occurs when the Novice, in order to enjoy all amateur operating privileges, takes the 13-wpm code test and the more comprehensive technical examination required for a General Class license. And what a crisis it is! As many as three out of four applicants for a General Class license fail the code test the first time. Many fail it several times before finally passing, and others settle for the more restrictive Technician Class license (same technical exam as for General Class, but only 5-wpm code required).

**Proper Preparation.** The high failure rate does not mean that learning to copy code at 13 wpm is a fearfully complicated task. After all, hundreds of thousands of people from the age of seven up have done it. It does show, however, that too many applicants for the General Class

### Novice Station of the Month

Gary Yantis, KNØBHM, will receive a one-year free subscription to P.E. for submitting this picture of himself and his Novice station. Gary's shack, located in the attic of his home at 10809 Johnson Dr., Shawnee, Kansas, boasts a Globe Chief 90A transmitter and a Hallicrafters SX-99 receiver. His antenna is an "end-fed" wire. Just 13, Gary made 90 contacts in his first two weeks on the air. Congratulations, KNØBHM!

This is the first winning entry in our monthly photo contest. Why don't you try your luck? Send a picture of yourself and your Novice station to Herb S. Brier, W9EGQ, % POPULAR ELECTRONICS, P.O. Box 678, Gary, Ind., and you will be eligible for a free subscription. Photographs not chosen as prize winners will also be published as space permits.



license are really not prepared for the examination.

For many years, would-be hams have been trying to find an effortless way to master the code, but the only effective way is to practice steadily and often—thirty minutes to an hour every day will do it. The right kind of practice is important, though. If you have been on the air as a Novice for several months and your code speed is not improving, you are probably in a rut. Most Novices send around 8 wpm and repeat everything important several times. Sending or re-

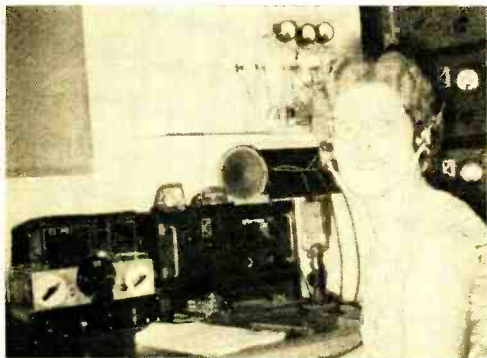

Mavis Stafford, VK3KS, operates this ham station with her husband, Ivor, VK3XB, in Victoria, Australia, using completely home-built equipment. Mavis has worked more than 120 countries (confirmed), Ivor over 170. Incidentally, Ivor is famous for being the first VK for hundreds of Novices on 7 mc.; he needs only a state or two for WAS/Novice.

ceiving this brand of code is *not* good practice.

Listen in the General Class sections of the c.w. bands for stations sending a little faster than you can copy comfortably. Write down every letter you recognize; what you copy "in your head" means nothing. And don't worry about letters you miss; you'll hear them again.

**W1AW Code Sessions.** Listen also for the nightly code-practice transmissions of W1AW, the ARRL Headquarters Station, at 9:30 p.m., Eastern Standard Time; 8:30 p.m., Central Standard Time; 7:30 p.m., Mountain Standard Time; and 6:30 p.m., Pacific Standard Time. These sessions are broadcast on 3555, 7080, 14,100, 21,075, and 28,080 kc.; choose the frequency which comes through best in your locality.

You can identify W1AW by its transmission of "QST QST QST DE W1AW W1AW W1AW," repeated for several minutes before every half hour. On Sunday, Tuesday, Thursday, and Saturday, the transmitted speeds are 5 to 13 wpm. On Monday, Wednesday, and Friday, they are 15 to 35 wpm.

When you can copy the 13-wpm transmissions "solid," skip the "slow" nights but continue practicing on the "fast" nights until you can easily copy the 15-wpm speed. At this point, you should be making fair copy at 20 wpm and be more

Ron Slattery, K9TOF, (below), shares a station with his Dad, K9UFN, in Lake Forest, Ill. The Heath DX-20 transmitter is modulated with the cathode modulator described in our April 1959 column. The receiver is a Hallicrafters S-53A with Q-multiplier and preamp, the antenna a 245' long "Windom."



than ready to try the General Class code test.

Interference from other stations may make it difficult to copy W1AW unless you have a very selective receiver, but don't give up. The interference is seldom there continuously, and you can almost always find other hams sending at the desired speeds.

Code lessons on phonograph records, magnetic recording tape, and punched paper tapes (used on special machines) are also excellent for improving your receiving ability. The one disadvantage is that, after playing and replaying a lesson a number of times, you become so familiar with it that you no longer get good practice.

**Sending.** Practice your sending, too, because you will have to pass a trans-



mitting as well as a receiving test. Imagine the heartbreak of passing the receiving test only to fail in sending! This does happen, and some of the sending heard on the ham bands makes you wonder why it doesn't happen more often.

### HEADPHONE "EAR SAVER"

As most old-timers know, using headphones makes it easier to copy weak signals through heavy noise and interference. If you're using phones and have the receiver volume turned way up to hear a weak signal, however, a strong signal opening up on the same frequency can really vibrate your ear drums. The

#### PARTS LIST

- B1, B2—1½-volt "D" cell
- C1—0.1- $\mu$ f., 200-volt paper capacitor
- C2—0.05- $\mu$ f., 200-volt paper capacitor
- D1, D2—1N34 diode
- J1—Open-circuit phone jack
- L1—215-mh. coil (Stancor WC-14 or WC-14A television width coil with slug screwed all the way in, or equivalent)
- P1—Phone plug
- R1—10,000-ohm, 1-watt resistor
- R2—2200-ohm, 1-watt resistor
- S1—D.p.s.t. toggle switch
- 1—Battery holder, 2-cell type (Keystone #176 or equivalent)
- 1—4" x 2¼" x 2¼" aluminum utility box (Bud CU-2103-A or equivalent)
- Misc.—Terminal strips, solder lugs, grommets, shielded cable, etc.

"Ear Saver" uses a pair of germanium diodes in an audio limiting circuit to cut these strong signals, static crashes, ignition noises, etc., down to size. In addition, a 900-cycle low-pass filter adds some effective selectivity to ham receivers deficient in this quality.

**Construction.** The unit is built in a 4" x 2¼" x 2¼" aluminum utility box. A suitable parts layout is shown in the photograph.

Drill a ⅜" hole in front of and behind the battery holder and line each one with a rubber grommet; these holes will accommodate the battery leads. An insulated terminal strip and a solder lug is placed under each of the two battery holder mounting nuts. The shielded input lead passes through a grommeted ¼" hole in the rear lip of the box.

Resistor *R1* is wired across the two insulated terminals, and the center con-

ductor of the input cable goes to one end of *R1*; the cable shield is connected to the adjacent ground lug. When wiring in the diodes, grasp the leads being worked on between the diode body and the solder joint with a pair of long-nose pliers or other heat sink to prevent these

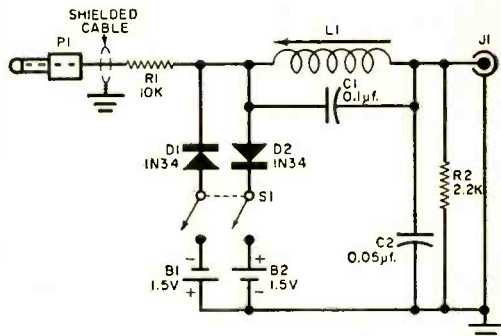
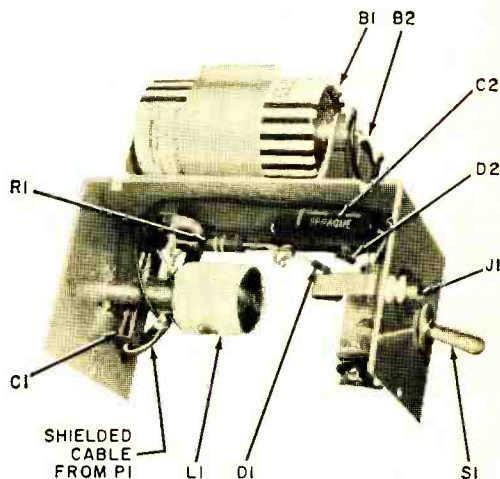

Placement of parts and wiring details for the "Ear Saver" are shown above. Capacitor C2 can be increased to 0.1  $\mu$ f. to reduce high-frequency background noise on c.w. signals. Experiment with the value of resistor R2; with some headphones, this value should be changed, or the resistor eliminated.

delicate semiconductors from being damaged by the heat.

**Operation.** Screw the slug on coil *L1* all the way in, and install batteries *B1* and *B2* in the holder with the polarities shown on the diagram. Insert plug *P1* into the receiver phone jack and plug your phones into jack *J1*, leaving switch *S1* in the "off" position.

The receiver volume control is ad-  
(Continued on page 112)

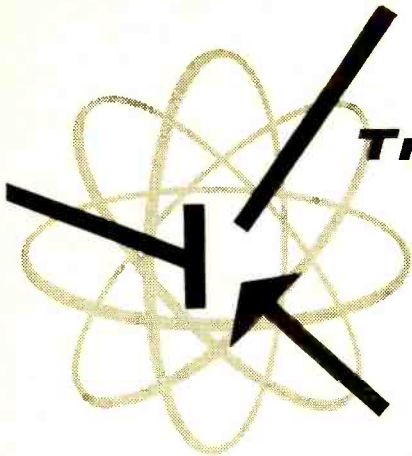

## Transistor Topics

By LOU GARNER

**I**N THE EARLY DAYS of transistors, each manufacturer had his own pet ideas as to what constituted optimum packaging. As a result, there were more shapes and sizes of transistors than there were manufacturers. A single firm, for example, may have produced similar units in a half-dozen different cases—all different from those used by any other manufacturer.

Today, however, a majority of small signal transistors are packaged in a relatively small number of standard enclosures. Accepted by most producers, these standard cases are made in several different sizes, each with its own specification number. A "TO-5" case, for ex-

Integrated circuit components developed by Philco's Lansdale Division include a three-diode array in a TO-18 package (left); an eight-diode array in a TO-5 package (center); and a transistor-diode logic circuit consisting of a silicon transistor and five silicon diodes housed in a TO-5 package (right).

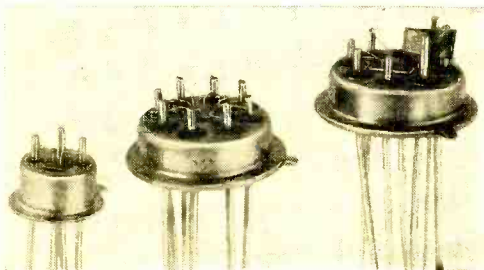

ample, is a cylindrical enclosure approximately  $\frac{1}{4}$ " high by a little over  $\frac{1}{3}$ " in diameter. A "TO-18" case, also cylindrical, has about the same height as its diameter, measuring close to  $\frac{1}{8}$ " in each dimension.

These standard enclosures have proven popular with other component manufacturers as well as with transistor firms: relays, crystals, pulse transformers, resistors, capacitors, diodes, and photocells have all been packaged in the "TO" series of cases. Now comes news that at least two major manufacturers are packaging *complete circuits* in these small enclosures—the Lansdale Division of Philco (Lansdale, Pa.) and the Fairchild Semiconductor Division (545 Whisman Rd., Mountain View, Calif.).

As of this writing, Philco's production is still in the pilot plant stage, although engineering samples are available on special order. The Philco program is an outgrowth of the company's microelectronics developmental work and resulted from recognition of the fact that there are recurring circuit patterns in many types of equipment—computers and counters, for example. As we've discussed in earlier columns, a "flip-flop" or logic circuit is frequently repeated hundreds or even thousands of times in a typical computer.

According to Dr. C. G. Thorton, Philco's director of semiconductor research and development, these new circuit packages offer several advantages over conventional designs—smaller size, lighter weight, lower cost, and improved reliability. In addition, with fewer components to handle and a smaller number of connections to make, there should be a corresponding drop in the labor costs of assembling complex equipment.

Philco currently plans to produce diode arrays of from 3 to 8 diodes per package, and logic circuits incorporating a transistor and up to 5 diodes. In the

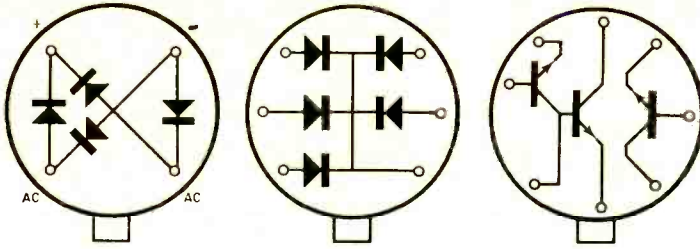

Fig. 1. Schematic diagrams of typical circuit packages produced by Fairchild Semiconductor Division. Four diodes at left are connected in bridge rectifier circuit, while five diodes in center have common cathode connection for use in logic circuits; three transistors at right (two in cascade) are intended for use in subminiature amplifiers. Diodes at left are assembled in a TO-18 package, other two circuits in TO-5 case.

future, the Lansdale Division expects to make up special assemblies of resistor-transistor "Nor" logic circuits, binary flip-flops, and transistorized inverters on special order.

On the West Coast, Fairchild's Semiconductor Division is producing a broad range of circuits packaged in transistor cases, including diode bridges, diode logic circuits, reference modules, Darlington amplifiers, and special combinations of two or more transistors and diodes. The circuit arrangements in some of these units are illustrated in Fig. 1.

Among the other circuit assemblies produced by Fairchild is an interesting r.f. power amplifier. Made up of four high-voltage r.f. transistors connected in parallel within a single power transistor enclosure, it is designed for use as an amplifier or power oscillator in a transmitter.

Fairchild's circuits are made using the exclusive *planar* manufacturing process, a technique permitting the production of high-frequency silicon diodes and transistors of consistent quality. The units are generally built on special order to meet customer specifications. However, a few of the more popular arrangements are in mass production and are available through regular distributors.

The moral to our story? In the future, don't jump to conclusions when you see something which *looks* like a transistor—it might be a resistor, capacitor, or perhaps even a complete amplifier!

**Reader's Circuit.** This month, our reader's circuit was contributed by B. E. Henry, W8QBJ (1120 Elberson Ave., Cincinnati 5, Ohio), a member of the

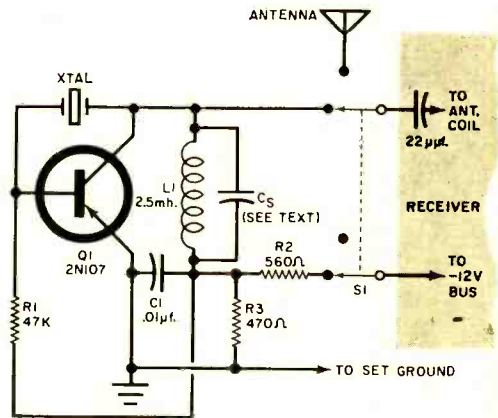

Fig. 2. Circuit of 1-mc. crystal calibrator submitted by reader B. E. Henry. Power for the device is supplied by the receiver, as explained in text.

Greater Cincinnati Amateur Radio Association. He has designed a 1-mc. crystal calibrator intended for use with transistorized communications receivers such as Heath's popular "Mohican." The circuit appears in Fig. 2.

As you can see, a *pn*p transistor is used in the common-emitter arrangement. Collector and base bias voltages are obtained from the receiver with which the circuit is used, through voltage-divider  $R2$ - $R3$ , bypassed by  $C1$ . Series resistor  $R1$  serves to limit base bias current to an optimum value. A r.f. choke,  $L1$ , serves as the collector load, with the feedback necessary to start and maintain operation supplied through the quartz crystal ( $Xtal$ ). In operation, d.p.d.t. switch  $S1$  serves both to apply power to the crystal calibrator and to

transfer the receiver's "input" lead from its antenna to the calibrator's output circuit.

All the parts are standard and should be readily available through regular parts distributors and the larger mail order outlets. Resistors *R1*, *R2*, and *R3* are ½-watt units; *C1* is a 0.01- $\mu$ f. ceramic or paper capacitor—its working voltage is not critical. Choke *L1* is any standard 2.5-mh. unit—W8QBJ didn't indicate the type of crystal used in his

terminated by experiment. W8QBJ indicates that its value is reasonably critical, varying with circuit wiring, the individual characteristics of the transistor used, the type of crystal, and other factors. He used a 51- $\mu$ f. capacitor here. Either a mica or ceramic unit can be used, with its value probably falling somewhere between 25 and 150  $\mu$ f.

The finished instrument provides test signals at 1-mc. intervals to check the receiver's calibration and dial reading. Some experimenters and hams prefer to use a 100-kc. oscillator for this job, but—as W8QBJ points out—100-kc. signals are pretty close together on the dial when checks are made at around 28 mc. With a 1.0-mc. source, there is less chance of error.

**Summer Fun.** With winter's chill breezes dispelled by the warmth of the summer sun, one naturally feels more inclined to outdoor rather than indoor activity. If, like most of us, you'd like

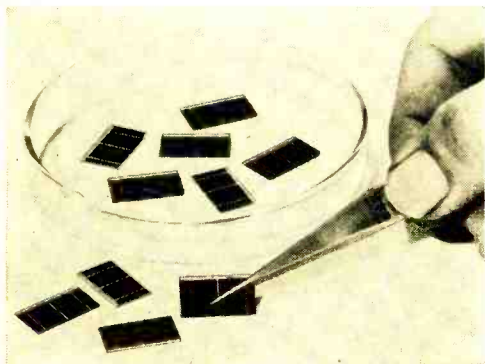

Solar cells manufactured by the International Rectifier Corp. are "gridded" for efficiencies up to 20% greater than ordinary cells.

Transistor portable (P870) from General Electric features an adjustable whip antenna as well as a camera-like case and carrying strap.



model, but any standard quartz crystal should give satisfactory results.

The instrument can be assembled in a metal or plastic case. Neither parts layout nor lead dress is especially critical, but all signal leads should be kept as short and direct as possible, as is customary when wiring r.f. circuits. Since W8QBJ assembled his unit primarily for use with his Mohican receiver, he mounted *S1* on the set's rear chassis apron. You may prefer to assemble the crystal calibrator as a self-contained unit with its own built-in power source. A pair of Burgess Z4 batteries wired in series to supply 12 volts should be satisfactory for most work.

When the wiring is completed and checked, shunt capacitor *Cs* can be de-

to enjoy the outdoors without giving up your interest in transistors, you'll find this is a good season for trying out sun-powered transistor receivers, amplifiers, and other projects.

Don't feel limited to projects having only one or two transistors. Sun batteries, like chemical cells, can be connected in series or parallel to furnish higher voltages or greater currents than can be obtained from a single unit. With enough units, you could conceivably even power a small p.a. system or medium-range transmitter.

There's good news, too, from a prominent solar cell manufacturer. Sunlight-to-electricity conversion efficiencies as high as 13% are possible with solar cells

*(Continued on page 113)*

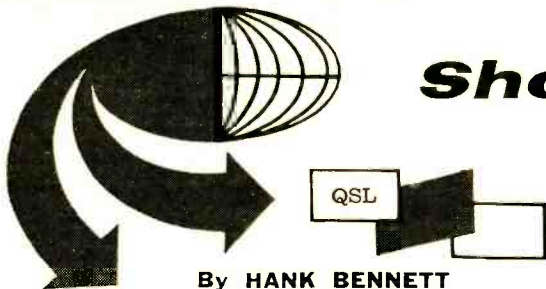

By **HANK BENNETT**  
W2PNA/WPE2FT

# Short-Wave Report

## QUESTIONS AND ANSWERS

**E**VERY MONTH, letters and cards from SWL's all over the world pour across your Short-Wave Editor's desk. Most of them include some question about one phase of short-wave listening or another. So many of these questions crop up time and again that this month we're going to reply to the most common ones in print. Perhaps you will find the answer to something that's been bothering *you* in the following list.

**Q:** I'm new at short-wave listening.

Where can I obtain a book that will tell me all about SWL'ing in general?

**A:** Very few books are available on the hobby, and practically none will be found in public libraries. One of the best around is "How To Listen To The World," which is published by the *World Radio Handbook* and is available for \$1.00 from Gilfer Associates, P. O. Box 239, Grand Central Station, New York 17, N. Y. Also, your Short-Wave Editor has several leaflets available on various phases of DX'ing which may be obtained for return postage.

**Q:** What kind of receiver should I purchase?

**A:** We try to maintain a policy of not recommending specific receivers. Rather, we suggest that the SWL obtain specifications of various receivers from their manufacturers so that he can determine for himself just which one will best meet his needs and budget. In addition, many amateur parts shops in the larger cities maintain areas where prospective customers may actually try out different receivers.

**Q:** If a station announces its frequency in meters, how does one convert to kilocycles and megacycles?

**A:** The key to this problem is the figure "299820." To convert meters to kilocycles, divide the meters into 299820. Conversely, dividing the frequency in kilocycles into 299820 will give you the wavelength in meters. To change kilocycles to megacycles, simply divide by 1000; for example, 17,895 kc. is 17.895 mc., 6040 kc. is 6.040 mc.

**Q:** How does one identify foreign stations which rarely, if ever, announce in English?

**A:** If you don't know the language, this can be a rough one! I suggest that you obtain a copy of the *World Radio Handbook* (\$2.70 from Gilfer Associates). The *WRH* lists interval signals, slogans, frequencies, schedules, and other items of interest. Try to memorize some of the slogans and interval signals. But bear in mind that



Philip Wittlin, WPE2CVH, Flushing, N. Y., listens on a Hallicrafters S-38E; the attachment on the right of the receiver is a switch for his two antennas. Philip's wall is papered with veries.



Frank Winstan, VE2PE7A, Montreal, Quebec, DX'es with a Hallicrafters S-38E receiver. To date he has logged 30 countries.

the announcer may pronounce the station names in a way other than you think he should. For instance, *Radio Rumbos* (YVLK, Caracas, Venezuela, 4970 kc.) comes out more like "Rahd'yo Room-boase" than it does like "Radio Rum-bows." Some of the Arabic slogans can be copied easily: *Radio Cairo*, for instance is *Huna Kahira*. One term widely used is "Ici" (pronounced ee-see), the French word

for "Here is," and it usually precedes the actual name or location of the station (*Ici Londres; Ici Brazzaville; Ici Paris*, etc.).

**Q:** I have very few stations logged; am I eligible to be one of your reporters?

**A:** Certainly! Reports from anyone with a genuine interest in DX'ing will be welcomed.

**Q:** Why don't you acknowledge reports?

**A:** I do—I send out two to three hundred acknowledgments monthly. Please bear in mind that you have one Short-Wave Editor; I have several thousand reporters.

**Q:** I've reported for months on end.

You never use my reports, yet a certain few DX'ers are always well represented in your column. How come?

**A:** A report may not warrant publication for any of several reasons. It might be inaccurate, incomplete, or a duplication of material used the previous month. Often, the reason is simply

(Continued on page 122)

## Short-Wave Monitor Registration

If you haven't registered for your Short-Wave Monitor Certificate and call letters, fill out this form and mail it with ten cents in coin to: Monitor Registration, POPULAR ELECTRONICS, One Park Ave., New York 16, N. Y. Include *stamped, self-addressed* envelope so we can mail your certificate at once. If you live outside the United States, send two International Reply Coupons or equivalent value postage stamps. Canadians may send fifteen cents in coin.

(Please Print)			
Name			
.....			
Address		City	State
.....		.....	.....
Receiver	Make	Model	
	.....	.....	
Receiver	Make	Model	
	.....	.....	
Principal SW Bands Monitored		Number of QSL Cards Received	
.....		.....	
Type of Antenna Used			
.....			
Signature		Date	
.....		.....	

# Hobnobbing with Harbaugh

Always Problems Yet!

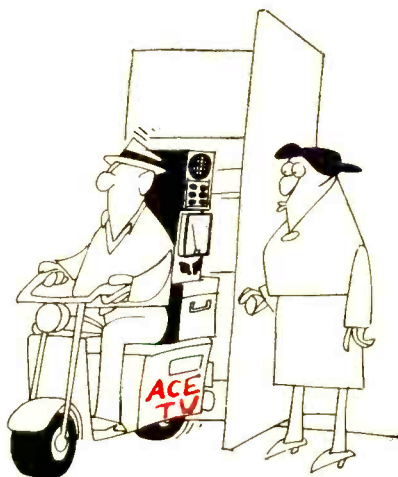
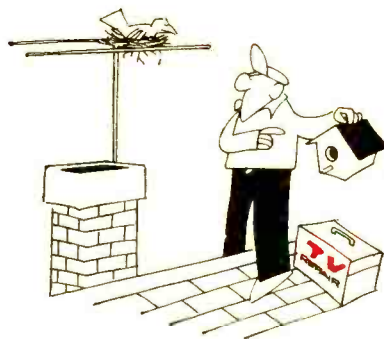



## **Carl and Jerry**

### **Treachery of Judas**

**O**UTSIDE it was a sizzling hot day, but Carl and Jerry were sitting in the comparative coolness of their basement laboratory boning up on algebra. Although this might seem like a strange activity for a couple of boys who had graduated from high school only a month before, there was a good reason for it. Older boys drifting back from college for summer vacation had passed the "word."

"Sharpen up your algebra! College math," they said, "is really tough. Assignments there are three or four times as long as high school assignments, and you'll have no time to catch up on fuzzy fundamentals. But nine times out of ten when you draw a blank in analytic geometry or calculus, you'll find that your trouble is caused by weakness in algebraic manipulation."

Carl and Jerry immediately dug out their algebra books and started going through them right from the beginning, each working the exercises independently. When their answers did not match, they examined their respective solutions until the mistake was found. They both pledged to complete the review before leaving for college in the fall.

But the boys were only human; so they dropped their books with alacrity when they heard a knock at the outside door and saw the outline of a visitor looming through the screen. A huge man, well over six feet, stepped inside at Jerry's invitation and stood in the middle of the floor mopping his brow.

"My name is Cody," he announced slowly in a deep voice as though he had rehearsed every word. "I work for an agency of the federal government—it's not necessary for you to know which

one. . . . I have a problem, and Police Chief Morton thinks you may be able to help me. I doubt it; but if you will come with me, I'll show it to you." He was already walking back through the doorway as he finished speaking.

Jerry and Carl, exchanging puzzled glances, followed him to a small foreign car standing at the curb. He was so big and the car so tiny that it seemed he did not so much get into the car as put it on. After a glance at the well-occupied front seat, the boys got in the back; and the stranger drove silently and rapidly out of town along the highway leading west.

About five miles from town he pulled off on a seldom-traveled side road and stopped beside a heavy growth of trees. "We have to go through the woods on foot," he announced, displaying surprising agility as he climbed over the rail fence bordering the road. He began to walk so swiftly that the boys almost had to trot to keep up with him; yet those big square-toed shoes never snapped a twig or dislodged a noise-making pebble.

After a twenty-minute trek, the stranger motioned the boys to be silent and tested the wind direction with a moistened forefinger. Then he led them in a big semicircle, dropped to his knees, and crawled toward the top of a small knoll. Carl and Jerry, becoming more intrigued by the moment, slithered along beside him.

**F**INALLY the big man stopped, and pointed down through some low bushes at a small tar-paper shack standing in a clearing not more than a hundred feet away. A short, fat, bearded man was sitting on a low bench beside



the open door playing a guitar; and lying at his feet was the reason the government man wanted the wind to be blowing from the cabin toward them. It was the largest, roughest-looking Saint Bernard dog the boys had ever seen. A stout chain went from the dog's broad leather collar to an iron stake driven into the earth near the door.

"There's my problem," Mr. Cody said in a hoarse whisper. "The man is the leader of a communist-backed group trying to overthrow a government friendly to us. I have information that two of his lieutenants may arrive at any hour for an important meeting. It's most essential that I hear what's said at that meeting; but how? No one can bug the shack with that dog on guard, and he and the man are always together. Even if I could hide a mike in the shack, the conversation might take place outside where it's cooler."

"I always thought Saint Bernards were kindly dogs that brought you a keg of brandy when you were lost in the snow," Carl muttered.

"This one probably never saw those cartoons," the big man said with a trace of a grin. "He's as mean as they come. When the man hears anything suspicious, he turns the dog loose; and I'd as soon have a timber wolf after me."

"Wish I could see a little better," Jerry whispered. "I'm getting an idea."

Silently Mr. Cody took a small telescope from his pocket and handed it to Jerry. The latter focused it carefully on the dog for a few seconds, then handed it back. "If you'll take us back to town to pick up some equipment. I think we can fix you up," he said confidently.

The large man looked at the youth steadily for a moment, then turned around and started crawling down the slope. On the way to the car, Jerry outlined his plan.

"My idea is to conceal a tiny FM transmitter inside the dog's collar. That collar fits loosely, and there's plenty of room for the transmitter I have in mind. You know what I'm talking about, Carl. It's that little tunnel-diode job we built from plans in the fifth edition of G.E.'s *Transistor Manual*. In addition to the diode and a transistor, all it uses are a few resistors and capacitors, a mike, and a coil. We'll pick up the transmitter



on Carl's transistorized FM receiver. Since you say the dog and the man are always together, we should be able to overhear the conversation no matter where it takes place."

"I'll have to take your word about what will work electronically—Morton claims you know your stuff," the federal man said as they got into the car; "but aren't you forgetting something? How are you going to get the collar off the dog to install the transmitter? I'd rather try to change the rattles on a diamond-back snake."

"That's why I want to go see Doc Andrews, the veterinarian, first," Jerry declared, with an enigmatic look. Two could play at this close-mouthed business!

**B**ACK IN TOWN, Jerry asked Doctor Andrews if he had a Cap-Chur pistol. When he said he did, Jerry asked if they could borrow it and a couple of charges that would immobilize a hundred-pound dog. The doctor balked at this, but the federal man took him over into a corner and showed him something in his wallet. From that moment on, the veterinarian cooperated fully. He charged a couple of syringes with 300 milligrams each of a nicotine alkaloid drug and explained how the pistol was to be used.

Mr. Cody then dropped Carl and Jerry off at their laboratory, saying that he would be back in half an hour. The first thing the boys did was to arrange their tunnel-diode transmitter on a flat metal sheet that could be fastened inside the dog's collar. By the time they had collected Carl's transistor FM receiver, Jerry's battery-operated tape recorder, a leather punch and some soft brass

rivets, the little car was standing at the curb again.

Their impatience made the trip to the edge of the woods seem much longer this time. When they arrived, the federal man lifted a grain sack—which contained something alive that squealed and grunted—out of the luggage compartment under the hood.

"What's with the little pig?" Carl asked.

"You'll see—maybe," the big fellow replied as he slung the sack over his shoulder and headed into the woods. When they arrived at their former vantage point, both the fat little man and his dog were apparently dozing.

"I'll stay here," Mr. Cody stated. "You two go around to the other side of the clearing and take care of the dog. When he scents you, he'll make a fuss



and the man will turn him loose. Let him chase you back into the woods out of sight before you shoot him."

"I like that," Carl said as they started working their way around the clearing. "We do the dirty work. What's the dope on this Cap-Chur pistol, anyway?"

"The projectile is actually an automatic hypodermic syringe. When compressed CO<sub>2</sub> shoots it from the barrel of the pistol, a brass plug sealing an opening at the back of the hollow rubber plunger is dislodged by inertia, exposing gas-generating tablets inside the plunger to the action of water. A collar on the syringe needle allows it to penetrate the

skin of the animal to just the right depth; then the gas generated by the tablets forces the plunger forward and injects the drug into the muscular tissues. The pistol and a similar longer-range rifle are used a lot by veterinarians, stock raisers, dog-catchers, and so on.

"Try to hit the dog right behind his rib cage," was Jerry's final instruction. "Above all, don't miss!"

**W**HEN they reached the edge of the clearing, the dog had awakened and was gnawing on some bloody beef ribs. Every time he cracked one of the bones with his powerful jaws, Carl winced. Suddenly the animal rose to his feet, sniffed the air suspiciously, and began to growl.

"What's wrong, Judas? Somebody out there?" the little man asked as he reached over and unsnapped the chain. "Go get 'em!"

Carl and Jerry were already fading back into the woods, and the dog came bounding straight toward them. Each boy scrambled up into the branches of a small tree. As the dog stopped beneath them, raised his blood-stained muzzle into the air, and peered at them with bloodshot eyes, Carl took careful aim with the pistol and pulled the trigger.

There was a little "ph-t-t-t" of sound, the dog jumped, and a tuft of yarn fastened to the back of the Cap-Chur projectile to keep it flying point-foremost appeared in the dog's coat a hand-span ahead of his hip bone. Almost at once his head sank; he staggered drunkenly about, and then rolled over on his side.

Quickly Jerry slid out of his tree and gingerly started unfastening the collar from the unconscious dog.

"Oh, oh!" Carl exclaimed from his vantage point in the tree. "Fatso is getting worried about Judas. Here he comes out of the shack with a double-barreled shotgun. Now we're in a pickle. We'd better scram. Wait a minute. . . Do you hear that?"

From the other side of the clearing there was a great rustling of leaves. The little fat man, who had started to follow the dog, turned around and began cautiously climbing the incline toward the federal agent's hiding place.



When the man with the shotgun had almost reached the bushes at the top of the knoll, a squealing little pig burst out of them and ran toward him. "So, my little rascal, you were the one making all that racket, were you?" he commented aloud, with obvious relief, as he turned around.

Jerry had been working feverishly, punching holes in the collar, riveting the transmitter in place, and arranging the  $4\frac{3}{4}$ "-length of black enameled wire that served as an antenna for the 100-megacycle transmitter so it could function without being noticed. He buckled the collar back in place and removed the Cap-Chur hypodermic needle. Even as he did so, the dog began to stir.

The boys left hurriedly, but as they looked back over their shoulders, they saw the huge beast get to his feet and—standing with his paws wide apart—shake his head vigorously.

"Here, Jude; here, Judas!" his master called. The dog turned around obediently and started lumbering toward the shack. At the same instant there was the sound of an automobile motor, and a car came bouncing out of the woods into the clearing. Two dapper men stepped out and shook hands with the fat man.

Without waiting to see more, the boys returned to the place where they had left Mr. Cody.

"That pig came in real handy," Carl admitted as he stretched out beside the federal agent.

"I thought it might," Mr. Cody grunted, handing the FM receiver and the portable tape recorder to Jerry. The latter turned on the receiver with the volume down low, and instantly the voices of the three men came in faintly but clearly; and well they might. The fat man, with a visitor on either side of him, was sitting on the bench fondling the dog's ears. The hidden mike could not have been in a better position to pick up what was being said.

The conversation being taken down by the little portable recorder didn't make much sense to the boys. It was all about automatic rifles, landing strips, beaches, grenades, and "our agents." Dates and places were mentioned, and the whole thing seemed intensely interesting and important to the big federal man, who scarcely breathed as he listened.

Finally the two men shook hands with  
*(Continued on page 114)*



Only Heath offers  
Top Quality at the  
Lowest Price, and....



**NOW**—*we guarantee you*

**At your service . . .**

**THE NEW HEATHKIT AUTOMATIC GARAGE DOOR OPENER!**

Compare price, compare features, and you'll buy this latest Heathkit labor-saving wonder! Opens and closes all overhead track-type doors up to 8' high automatically! Garage light turns on when door is open, stays on for short period after door closes! Safety release device. Adjustable operating force! Tone-coded "hi-power" 6 or 12 v transmitter and special receiver prevents interference. Easy one-man assembly. All parts included. 65 lbs.

- Kit GD-20 (mechanism, transmitter, receiver) . . . \$109.95
- \$11 dn., \$10 mo. . . . .
- Kit GDA-20-1 (extra transmitter) . . . \$2.50 dn., \$5 mo. . . . \$24.95



**BIG-BUY PORTABLE 4-TRACK STEREO TAPE RECORDER**

All-in-one monophonic or 4-track stereo tape record and playback! Two tape control levers; individual tone balance and level controls; monitoring switch for listening while recording; "pause" button for editing; two "eyes" to check recording levels. Also functions as "hi-fi stereo center" for record players, etc., or to feed tape music to separate hi-fi system. Parts for all amplifiers and speakers included; turquoise and white cabinet and 3 1/4" — 7 1/2" speed tape deck are assembled. Less mic.

- Kit AD-40 . . . 49 lbs. . . \$18 dn., \$16 mo. . . . . \$179.95
- Assembled ADW-40 . . . 49 lbs. . . \$30 dn., \$26 mo. . . . \$299.95



**NEW HIGH FIDELITY PA AMP.**

Heath exclusive; 20 watt hi-fi rated PA amp. Two inputs; equalization switches; electrical mixing; sealed "pads"; tape recorder, line, and voice coil output. Plug-in, low-Z mic. Xformers separate. 24 lbs.

- Kit AA-31 . . . \$59.95
- \$6 dn., \$6 mo. . . . . \$11.95
- Mic. Xformers, AN-11

**"LEGATO-COMPACT"**

All Altec Lansing speakers! 2-12" hi-compliance woofers; exponential horn and driver; range 30-22,000 cps; assembled. 800 cps network. 30 watts program; 16 ohm Z. Assembled, finished cabinets: 32" x 19" d x 32 3/4" h 132 lbs.

- Kit AS-21U, unfin. \$224.95
- Kit AS-21W, wal. . . \$229.95
- Kit AS-21M, mahog \$229.95

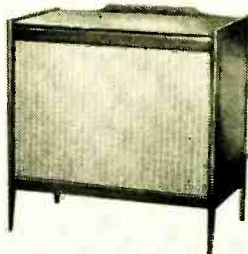

**HEATH COMPANY** Benton Harbor, Michigan





Introducing a new styling concept in two popular Heathkit Stereo Units



Here's a handsome matching pair for your new Heathkit stereo system! Both have new louvered wrap-arounds of luggage-tan vinyl-clad steel with contrasting charcoal-grey front panels framed with polished aluminum bezels... a regal new look to Heath's medium-price stereo line.

### HEATHKIT AJ-11 AM/FM TUNER

Successor to the popular AJ-10, this new version features fly-wheel tuning, two "magic-eye" tuning indicators, adjustable FM automatic frequency control, AM "fidelity" switch for max. selectivity or fidelity, dependable 12 tube circuit, built-in power supply. 21 lbs.

Kit AJ-11... \$7 dn., \$7 mo. **\$69.95**  
 Assembled AJW-11... \$13 dn., \$11 mo. **\$129.95**

### HEATHKIT AA-151 28-WATT STEREO AMPLIFIER

Here's the popular SA-2 model all dressed up in brand-new styling. Delivers 28 hi-fi rated watts (14 per channel) for plenty of power. Has clutched volume controls, ganged tone controls, 4 dual inputs. 28 lbs.

Kit AA-151... \$6 dn., \$6 mo. **\$59.95**  
 Assembled AAW-151... \$12dn., \$11mo. **\$119.95**

*can build any Heathkit!*



**IGNITION ANALYZER**  
 Switch to primary, secondary, parade or superimposed patterns. See condition of plugs, points, wiring, coil & condenser. Plug-in ID-11 Timing Light available. 15lbs.  
 Kit IO-20... \$9 dn. **\$89.95**  
 Assembled IOW-20 **\$169.95**



**NEW TELEPHONE AMPLIFIER!**  
 Hands-free phone chats! Ideal for conferences, dictation, etc. Place handset on cradle, unit turns on, instantly ready! All-transistor; long-lasting battery power. Easy to build. Ivory color.  
 Kit GD-71... 4 lbs. **\$19.95**



**LOW COST DEPTH SOUNDER**  
 Best value in marine electronics. Detects fish, submerged objects, and bottom depth. Big 4 3/4" dial calibrated from 0-100'. 6-transistor circuit, battery powered. Corrosion & splash-resistant aluminum cab. Transducer included. 9 lbs.  
 Kit MI-10 \$7 dn., \$7 mo. **\$69.95**



**LOW COST 3-BAND MARINE RDF**  
 Deluxe features at minimum cost. Covers 200-400kc beacons, 550-1600 kc broadcast, 1700-3400 kc marine band. Loop and "sense" antennas eliminate double null. 9-transistor circuit, battery powered. Pre-assembled tuning unit.  
 Kit DF-3 12 lbs. \$10 dn. **\$99.95**

### You get guaranteed success with Heathkit!

Never before has a manufacturer of do-it-yourself kits guaranteed your success in completing a project. Heath does so and backs it up with an iron-clad, money-back guarantee! By making this guarantee, we hope to banish any doubt you may have about your ability to build a kit. How is such a guarantee possible? The careful planning that goes into the design of Heathkit equipment revolves around this paramount thought—anyone, regardless of background or experience, must be able to build any Heathkit. This same thought guides the writing of the detailed Heathkit assembly instructions with the world famous "check-by-step" system. These attributes plus the experience of a million customers attests to the fact that anyone can build a Heathkit. Order your favorite Heathkit today. Enjoy top quality equipment with savings of up to 50% and the satisfaction of doing it yourself. Get guaranteed success with Heathkit!

### MONEY BACK GUARANTEE

The Heath Company unconditionally guarantees that you can build any Heathkit product and that it will perform in accordance with our published specifications, by simply following and completing our check-by-step instructions, or your purchase price will be cheerfully refunded.

### FREE Catalog!

Contains complete descriptions and specifications on all of the above new models plus more than 200 other famous Heathkit items. Send for your free copy, use the coupon below; see how you can enjoy top quality equipment with savings of up to 50% with Heathkit!

Ordering Instructions: Fill out the order blank. Include charges for parcel post according to weights shown. Express orders shipped delivery charges collect. All prices F.O.B. Benton Harbor, Mich. A 20% deposit is required on all C.O.D. orders. Prices subject to change without notice. Dealer and export prices slightly higher.

Please send the following items:

Item	Model No.	Price

Order direct by mail or see your Heathkit dealer.

Ship  Parcel Post  Express  C.O.D.  Best Way



**HEATH COMPANY**  
 Benton Harbor 10, Michigan

PLEASE SEND MY FREE COPY OF THE 1961 HEATHKIT CATALOG

Name \_\_\_\_\_

Address \_\_\_\_\_

City \_\_\_\_\_ Zone \_\_\_\_\_ State \_\_\_\_\_

## How to Become a Ham

(Continued from page 92)

United States. In the evening the transmission range increases, but many foreign radio stations are so strong that they tend to blot out amateur broadcasters. When radio conditions are excellent, contact with stations 10,000 miles away is entirely possible.

The 20-meter band has a frequency of 14.0 - 14.35 mc. and it is probably the most popular of all amateur allocations. During the day and evening you can often contact hams halfway around the globe. In the early morning hours, an unusual condition—called a “long-path opening”—may result in signals being propagated well in excess of 12,000 miles (half the circumference of the earth). Generally speaking, the radio transmissions on 20 meters seem to travel with greatest ease during the interval between daylight and darkness.

The 15-meter band, 21.0 - 21.45 mc., is similar to the 20-meter band but usually does not stay “open” at night. The Novice segment lies between 21.1 and 21.25 mc. It is on this band that Novices work the majority of overseas DX stations. The band is usually open between 10 a.m. and 4 p.m. to Europe, and around sunset it will propagate to South America and the South Pacific.

Ten meters (28.0 - to 29.7 mc.) is a rather amazing band. As an old saying goes, “when it’s good, it’s terrific!” Signals from Europe, Africa, and the Far East often come booming in stronger than on any other band. Unfortunately, it is seldom open in the evening and is influenced more by seasons and the sun than most other bands.

The 6-meter band can be found between 50 and 54 mc. It is usually considered a “rag-chew” band for local contacts. However, unusual things happen in the summer and fall. For part of the day, signals from great distances can often be heard, just as you can sometimes pick up out-of-state television stations on your TV set. When this happens, the 6-Meter-ites have an exciting time working as many stations as they can, while optimum conditions exist. By taking advantage of the situation, many hams have been able to work all states

on 6 meters, and some with high-power stations have contacts of over 5000 miles under their belts.

Normally, the 2-meter band (144-148 mc.) and the higher bands (220, 440, and so on) are “line-of-sight” propositions. Distances in excess of 300 miles generally cannot be worked by anyone but the most dedicated and persevering high-frequency operator.

**Getting Started.** The first hurdle to overcome, of course, is learning the code. It is necessary to memorize the letters and the corresponding sounds that represent the code. The letter “A,” for example, is not heard as “dot-dash,” but rather as “di-dah” and should be pronounced this way during practice sessions. An “F” would sound like “di-di-dah-di,” and “X” would be “dah-di-di-dah,” and so on.

It doesn’t really matter what method you use to memorize the code as long as you learn to recite it without hesitation. One good way is to make up a set of 3” x 5” cards with letters (numerals and punctuation, too, if you wish) written in India ink with a script-type pen on one side. On the reverse side of the card, print the symbol representing the letter.

The idea is to have someone “flash” these cards for you while you recite the answers. Since he will be viewing the back of the card, he will know if you have given the correct answer, even without knowledge of the code. Then your “flasher” should turn the cards over and have you reel off the letters representing the symbols you see. After you can correctly identify either side without pauses, he should mix the cards up so you will not know if a letter or a symbol is coming up next.

As for electronics theory, there is no simple way to acquire the knowledge necessary to become an amateur. But read and study all the magazines and handbooks you can get your hands on—you’ll find POPULAR ELECTRONICS especially helpful. The monthly P. E. column, “Across the Ham Bands,” by Herb Brier, W9EGQ, provides lots of useful information to smooth your path to the amateur license. So, too, do such ARRL books as *The Radio Amateur’s Handbook*.

**Equipment Needed.** Amateur radio is not a rich man’s hobby, and the cost of setting up a station can be as expensive as you wish to make it. You

may be surprised to learn that it's possible, by rebuilding war-surplus equipment, to get on the air for less than \$50, including antenna, key, crystal, and even a log book! However, such a receiver will not separate stations very well and the transmitter will be in the "peanut-whistle" category. In addition, the equipment can only be used on one amateur band. But the fact remains that you will be able to communicate with many other stations for this minimum figure.

A more practical way to do it would be to construct transmitter and receiver kits. A transmitter with world-wide capabilities (in the neighborhood of 50-watts input) might cost as little as \$40.00 or as much as \$200.00.

The reason for the big spread in the cost of the transmitter is this: with the inexpensive units, you are limited in your operations; with the more expensive types, you can shift your frequency electronically (not permitted with Novice Class operation) and practice phone operation on the bands below 6 meters (also not permitted Novices). If you think you would like to have these features when your General "ticket" arrives, such a transmitter might be a better buy. You would not have to trade in the "old clunker" when you are finally allowed variable frequency operation and use of the voice mode.

**The Road Ahead.** All in all, the quicker you set your sights on the goal of becoming a full-fledged ham, the sooner you'll reach your destination. Thousands of others have met the challenge and, far from finding the road difficult, they have actually discovered it to be an extremely rewarding undertaking.

Like these others, you'll find your reward in the world-wide fellowship open only to hams. "Hello, OM (old man)," you'll be saying some night, as your voice rings out over the airwaves. "The handle is. . ."

-50-

### Diode Quiz Answers

(Questions on page 88)

- |   |        |   |        |
|---|--------|---|--------|
| 1 | 2 ohms | 4 | 9 ohms |
| 2 | 6 ohms | 5 | 6 ohms |
| 3 | 3 ohms | 6 | 2 ohms |

# Learn Electronics Fast and Right...

AT SENSIBLE PRICES!

## COMPLETE BASIC TRAINING

written so you can  
really understand it!



The most important  
training of all—  
BECAUSE IT'S BASIC!

These two big, down-to-earth manuals help you train for a well paid career in ANY phase of Television-Radio, communications, hi-fi, industrial electronics, etc.—at only a small fraction of what you might expect to pay for such clear, complete training.

First, the 396-page **BASIC ELECTRICITY** Manual gives you a full working knowledge of the electrical theories, principles, components, instruments, measurements, etc. on which all Electronics is based. Then, the 402-page **BASIC ELECTRONICS** Manual teaches you just how these are applied.

Set-up diagrams, practical problem solutions, and over 700 pictures in the two manuals help make everything perfectly clear. Complicated electronic devices are vastly simplified by dividing them into 3 easily understandable groups. Nothing is omitted or condensed. Backed with this basic training you'll deal with circuits, components or equipment, and approach technical problems with a firm background of understanding.

**BASIC ELECTRICITY**—A big 396-page guide to underlying electrical principles and their applications. Includes details on currents; circuits; electro-magnetism; phase relations; instrumentation; measurements; power factor; components; motors; batteries; tubes; transistors; amplifiers; oscillators; sound reproduction and dozens more. Price only \$6.25 separately—or see money-saving offer in coupon.

**BASIC ELECTRONICS**—Just out! This 402-page complete understanding of electronic components of all sorts and how they work; basic circuits and how and why they are used; electronic applications in both communications and industry and hundreds of related subjects. A "must" for those who want to really get ahead in the fast-growing electronics field! Price \$6.25.

### STUDY 10 DAYS FREE!

Dept. PE-71, Technical Division, HOLT, RINEHART and WINSTON, INC. 62390  
383 Madison Ave., New York 17, N.Y.

Send following manuals for 10-day FREE EXAMINATION. I will then promptly remit price indicated (plus postage) or return books postpaid and owe nothing.

**BASIC ELECTRICITY** (price \$6.25) = 708859  **BASIC ELECTRONICS** (price \$6.25) = 708974

**MONEY-SAVING COMBINATION** = 709196

Both manuals at only \$11.00 for the two. (You save \$1.50)

SAVE: Send money with order and we pay postage. Same 10-day return privilege with money promptly refunded.

Name .....

Address .....

City, Zone, State .....

OUTSIDE U.S.A.—Either book \$6.75, both for \$12. Cash with order but 10-day return privilege with money refunded.

Above offers expire Feb. 1, 1962

## Transistors in Hi-Fi

(Continued from page 68)

up or burn out, but the unused channel won't even draw appreciable power!

**On the Track.** In preamps—just as in amplifiers—transistors show great promise. The so-called “hybrid” circuits, employing both transistors and tubes, have much to offer, although some designers feel it is simpler to employ either one or the other.

In the case of tape, the standard NAB replay characteristics call for a bass boost in excess of 30 db at low “hum” frequencies. Getting this out of a tube without excessive hum and distortion can mean rather elaborate circuitry, even to the extent of d.c.-operated heaters. With a transistor, however, there is no heater, and thus virtually no hum problem. A single transistor placed between the tape head and the equalizing tube can boost output sufficiently to remove almost all traces of hum.

Perhaps the greatest promise of the transistor lies in tuners. Transis-Tronics currently produces an all-transistor FM tuner (Model FM-15), which has the very obvious advantage of almost permanent alignment. Ultra-compact and extremely lightweight, the FM-15 boasts little hum or drift, since there are no heaters to warm up and cause frequency shift.

**The Race Continues.** Not only is the number of transistorized hi-fi products increasing rapidly, but new circuits are constantly coming from engineers. H. D. Crane and P. E. Merritt of the Stanford Research Institute, for example, have designed and built a novel transistorized amplifier based on a modulated carrier principle. Their amplifier, as you might guess, eliminates the output transformer, but not in the manner you might think. Working along lines quite different from the more or less stereotyped vacuum-tube circuits, Crane and Merritt use a transistor much like an on-off switch. Their reasoning goes something like this.

Since a transistor is very efficient when employed in an on-off fashion, controlling the ratio of on-time to off-time can produce an amplified output signal to drive a speaker at a very low imped-

ance. In the Crane and Merritt design, the transistor is “controlled” (i.e., modulated) by use of a square-loop ferrite core.

Several experimental models of this amplifier have been tested, and each shows uniform frequency response throughout the audio range down to d.c. As Crane and Merritt predicted, distortion is very low, even without the use of inverse feedback circuits. And efficiency is very high, with little input power required. In fact, about the only drawback in their design is the high cost of the switching transistors in the output stage. But as transistor technology improves, there is every reason to believe that prices will come down.

Thus, as we have seen, the transistor is making significant inroads in hi-fi. This doesn't signal the end of the vacuum tube in hi-fi, of course, since improvements can be expected in tubes just as in any other hi-fi component. But the transistor already occupies a very significant place in the hi-fi field. And the race has barely started. -50-

## VTVM Adapter

(Continued from page 56)

To zero the meter, the balance control (*R8*) is used to change the relative amounts of resistance in the two plate circuits so the same voltage appears at each plate.

When the positive voltage applied to the grid approaches 4 volts, a linear plate voltage change is no longer obtained. For this reason, a voltage divider has been incorporated to allow higher voltages to be measured without applying more than 4 volts to the grid of the tube.

The r.f. probe uses diode *D1* as a shunt rectifier. The diode develops a d.c. voltage across the input voltage divider when r.f. energy is coupled to it through capacitor *C1*. This voltage causes the meter to operate in the same manner as with a d.c. voltage applied to the test leads. -50-

---

*This VTVM adapter is patterned after one described in the July and August 1954 issues of the "G.E. Ham News." The author wishes to extend his thanks to the General Electric Company for permission to use the idea.*



## Space-Saver Speaker System

(Continued from page 75)

then mount the funnel on a single  $\frac{3}{4}$ " brace and locate it above the tweeter.\*

**Finishing it.** To finish the cabinet, cover the top as well as the sides with grille cloth. Note that the top has about  $\frac{1}{8}$ " overhang at the front and on each side, allowing space for the grille cloth. A piece of  $\frac{1}{2}$ " plywood is cut to fit inside the top framework of  $\frac{3}{4}$ " material. It holds the funnel and provides a guide to hold the top in position.

The top and bottom of the enclosure are trimmed with ordinary door stop (pine molding) and finished to match the top board. Door stop has a width of about  $1\frac{1}{8}$ " and so extends down far enough to cover the edge of the cloth. At the bottom it can be positioned so that it doesn't interfere with the opening of the duct.

The tweeter control is mounted in the back through the  $1\frac{7}{8}$ " hole. Speaker leads are passed through the back panel by means of two  $\frac{1}{8}$ " brass bolts, placed just above the control. When mounting the speaker, follow the instructions supplied with it for hooking up the tweeter control, and don't forget to place the tweeter at the front of the enclosure.

One possible change could be made in the enclosure if you find it too high for your particular installation. The back could be cut  $5\frac{1}{2}$ " shorter and the entire top eliminated. A  $\frac{3}{4}$ " frame around the outside of the top would provide the necessary elevation of a top grille (sub-top) to cover the speaker. This would cut about 6" from the height, but would leave the speaker without a positive method of treble dispersion. Perhaps a plant in an egg-shaped tripod-held pot would provide the answer, if you can bear the thought of water being carried that near an upturned, unprotected speaker cone.

But however you finish it and however you use it—for monaural or for stereo—this little speaker system will do its job uncomplainingly. And unlike some of its prima donna competitors, it performs well in any location.

-30-

\*If you use the  $\frac{3}{4}$ " brace, be sure to put it in with removable screws after the speaker is mounted, or access to the speaker will be limited.

## MAKE MONEY servicing C/B equipment with **SECO**

### 2-WAY RADIO TEST SET

Combination Crystal Checker, RF Signal and Field Strength meter, 0-50 ma. meter for final amplifier tuning. Use as RF output indicator. Checks activity on third overtone transmitter crystals—checks fundamental and high overtone crystals at fundamental frequency. Powered by two 1.5 V. "C" cells.



Model 500—wired and factory tested  
\$29.95 Net

### TRANSMITTER TESTER

For low power transmitters up to 160 MC. Calibrated for direct percentage reading of amplitude modulation: 0-5 watts RF output: 0-400 ma. RF output. Connection provided for headphones or scope. Optional "T" pad attenuator adapts to transmitters rated up to 50 watts.



Model 510—complete with all necessary cables and adaptors  
\$46.95 Net

### ANTENNA TESTER

For 50 ohm coaxial line applications. Simplified direct reading scales for SWR Antenna System Efficiency (read in percent and a Good-Poor scale), Forward Power and Reflected Power. Instrument insertion loss is negligible up to 160 mc. Power ranges are 0-10, 0-100 and 0-1000 watts maximum.



Model 520—complete with instructions  
\$42.95 Net

### ATTENU-LOAD

Dual purpose 50 ohm-50 watt unit—ten db "T" pad attenuator reduces power levels by 10 to 1 ratio . . . plus fully shielded 50 ohm termination for coaxial cable applications. Noninductance resistance load bank for low frequencies as well as VHF to 160 mc. With SO-239 coaxial jacks for input and output.



Model 511A  
\$21.50 Net

### SECO TUBE TESTERS

GRID CIRCUIT TUBE TESTER—full TV tube coverage—MODEL GCT-9  
\$32.95 net

GRID CIRCUIT AND TUBE MERIT TESTER—full TV tube coverage—Model 78  
\$69.50 net

COMPLETE TUBE TESTER—tests Dynamic Mutual Conductance, Cathode Emission and Tube Merit—includes Grid Circuit Test—MODEL 107 \$139.50 net

DYNAMIC TRANSISTOR CHECKER—tests PNP and NPN types—Model 100 \$19.95 net

BATTERY ELIMINATOR—for transistor equipment—yields 0 to 15 V.DC from 105-125V. 60 cycle AC—Model PS-2 \$13.95 net

See your dealer or send coupon.



SECO ELECTRONICS INC.

5015 Penn Ave. S., Minneapolis 10, Minn.

Please send me full information on Model

500  510  520  511A  107  78  
 GCT-9  100  PS-2

FREE Selling and Installing Citizens Band Equipment Bulletin

Name \_\_\_\_\_

Address \_\_\_\_\_

City \_\_\_\_\_ State \_\_\_\_\_

## Across the Ham Bands

(Continued from page 95)

vanced until the weaker signals have the desired volume in the phones. The stronger signals will now be too loud for comfort, but snapping on *S1* will level off all signals and noise to the same maximum volume.

Capacitor *C2* may be increased in value to 0.1  $\mu$ f. to reduce higher frequency background noise. This technique is probably useful for c.w. only, since it may make phone signals sound too "boomy." With some headphones, changing the value of resistor *R2* or omitting this resistor entirely may give improved results.

If your receiver now gives just adequate volume on the phones, there will not be sufficient audio voltage developed to permit the limiter section of the "Ear Saver" to work most efficiently. Try connecting the input cable to the 500-ohm output terminals of the receiver.

### News and Views

**Jim Weitzman, KN9YTJ/K9YTJ**, 5535 Roosevelt Dr., Milwaukee, Wis., operates on 80, 40, 15, and—once in a while—on 6 meters. His states total is 48 worked, 47 confirmed, and he has worked 12 other countries. Jim transmits on a Heathkit DX-40 feeding a 40-meter dipole, 35' high, and receives on a Hallcrafters SX-101A. He has a 15-wpm code certificate and hopes to receive his General Class license shortly. . . . **Joe Hannigan, KNØFNL**, 1915 White, Grand Junction, Colo., worked 20 states and Canada his first 20 days on the air. A Globe Chief 90A transmitter, feeding a Hy-Gain 14-AVS vertical antenna, and a National NC-109 receiver are his weapons to fight QRM on 40 and 15 meters. Joe will be glad to help prospective Novices obtain their licenses. . . . **Larry Cruise, KN3MKK**, 660 N. Price St., Pottstown, Pa., believes that his most unusual contact was VE3QE in Ontario, Canada, on SSB (single sideband) phone in the 40-meter Novice band. In addition, Larry has worked 37 states, including Alaska. He transmits via a Heathkit DX-20 and a 40-meter dipole, 12 feet high. He receives on a Hallcrafters SX-110, to which he has added a Q-Multiplier.

**Roger "Rozy" D. Rozelle, K4AIP**, 164 King Spring Rd., Smyrna, Ga., thinks his nickname has helped him get a lot of QSL cards. And the Novices have been very generous with their 88's (love and kisses)! In 6½ months, 4½ of them as a Novice, Rozy has worked 44 states (all confirmed), many Canadians, and 10 other countries—all on 40 meters. He transmits on a DX-40 feeding a 40-meter dipole, 40' high. Rozy's receiver

makes his record even more outstanding—he uses only a Knight 2-tube regenerative Space-Spanner! Ask him to sked you for the Rag Chewers Club. . . . **Carlton Carlson, WA2LYP**, 28 Country Club Drive, Mount Marion, N. Y., is proud of having built a 6-tube ham receiver, which works fine. He spends his time on 40 and 80 meters with a Knight T-50 transmitter feeding either a "long wire" or a 40-meter dipole. Carl has worked 30 states in three months on the air.

**Jeff Rounce, KN7MYN**, 121 7th Ave., S.W., Sydney, Montana, has worked 21 states on 40 and 15 meters, using a Heathkit DX-20 transmitter and a "surplus" BC-779B Super Pro receiver. Jeff reports that there are 16 hams in Sydney, Montana: 12 of them are graduates of the Novice course taught by W7CGG and K7AHU, who are now giving General Class instruction. Jeff also tells us about a DX operator who would be just as thrilled to work you as you would be to work him. He is. . . . **Kenneth Shields, HS1F**, C/O Sgt. Starr, OARMA, U. S. Embassy, APO 146, San Francisco, Calif. Ken got his license January 28, and in five weeks of operating in Thailand worked CR7, ZS6, VS6, KG6, UH8, VQ3, PY4, KA2, and W6! HS1F runs 50 watts to a DX-20 and receives on a Hallcrafters S-38E.

**Chuck M. Hall, KN5FNU**, 1526 West 10th St., Laurel, Miss., uses a Heathkit DX-100 cranked down to 75 watts to transmit and receives on a Hallcrafters SX-99. In three months he worked 40 states, all confirmed. His best DX is Northern Rhodesia. Chuck will sked you if you need Mississippi, especially if you operate in Hawaii or Alaska. . . . **Mike Maloney, K5ZFC**, 1528 S. Trenton, Tulsa, Okla., became a General with a Novice score of 29 states. He receives on a Heathkit AR-3 plus a Q-Multiplier, and transmits on a DX-40 coupled to the ionosphere through a 25'-high 40-meter dipole. If you chat with him for a half hour or longer, he will nominate you for your Rag Chewer's Club Certificate. Look for Mike on 15 and 40 meters. . . . **Gerhardt Martens, KNØAQC**, Box 335, Frazee, Minn., in five months as a Novice, has cranked out 425 contacts on five continents. A Globe Chief 90A transmitter, 15-meter beam, 15-meter dipole, multi-band trap dipole, and a surplus RCA AR-88F receive and transmit the educated electrons. . . . **Bob, KNØYBX**, Box 420, Sturgis, S. D., proves that equipment isn't everything. He started out with a 15-watt transmitter and a Hallcrafters S-38B receiver without a beat oscillator, and worked 78 stations. Then, with a S-53A receiver, he worked VE8 and KL7, getting RST-599 reports. He now has a Heathkit DX-20 transmitter and a Collins 75A-4 receiver—his best DX with this combination is Maine!

Remember that we are giving a new or renewal subscription to POPULAR ELECTRONICS to the sender of the best Novice station picture published in this column each month. And no matter what grade of license you have, we are always anxious to receive your reports, pictures, and suggestions for construction projects. Send them to: Herb Brier, W9EGQ, POPULAR ELECTRONICS, P. O. Box 678, Gary, Indiana. 73,

*Herb, W9EGQ*

## Transistor Topics

(Continued from page 98)

made using a new collector strip process developed by the International Rectifier Corp. (1521 E. Grand Ave., El Segundo, Calif.). The cells are manufactured with a number of secondary collector strips protruding from the main or primary strip, affording a better collection of current from the active cell area; they are called "gridded" cells, because the collectors form a grid network over the active area. The higher operating voltage and lower impedances resulting from the new process give an increase in cell output power over conventional cells of up to 20% under similar light and load conditions. In small quantities, the new units sell for \$2.00 to \$6.00 each.

If your ideas for summer fun lead to the water, with skin diving your particular fancy, you'll be interested in a transistorized device manufactured by Electro-Voice, Inc. (Buchanan, Mich.). Called the "SCUBACOM," the instrument is designed for underwater voice communications. It has an effective range of up to 150 feet at operational depths of up to 120 feet, and consists of a mask/microphone, power supply, and speaker/amplifier. No receiver is needed. This unit sells for \$210.00.

**From Overseas.** Philips G.m.b.H., the Austrian subsidiary of the giant Dutch Philips organization, is building three factories near Klagenfurt, Austria, for the manufacture of transistors and capacitors. They are said to be the first transistor manufacturing plants in Austria. Current plans call for the production of over seven million dollars worth of components by 1964, with about 80% of the output scheduled for export.

An institute for basic research in electronics, with particular emphasis on semiconductors, has been set up under the sponsorship of 16 Japanese electronics firms. The facility will be built near Sendai, Japan, and will be headed by Yasushi Watanabe, professor-emeritus of Tohoku University.

**Product News.** From Japan comes word of a new ultra-miniaturized video tape recorder small enough to be used in the home. Manufactured by the world-famous Sony firm, the Model SV-201

Here's the Most Sensational Tape Recorder Ever Made!

# PORTABLE TRANSISTOR 2-TRACK TAPE RECORDER!

NO PLUG-IN ELECTRICITY

PLAYS ANYWHERE! INDOORS OR OUT

SAVE BY MAIL

1st TIME BELOW THE FORBIDDEN \$70 FOR A 2-TRACK RECORDER



IT'S NEW! MODERN! SAVE UP TO 43%

COMBINES ALL TOP SPECS!

- 2-Tracks—3 1/2 and 1 1/2 ips!
- Battery Operation Built-in!
- All Transistorized—Compact!
- Built-in Amplifier & Speaker!
- Up to ONE Hour of Recording!
- Record Level! Battery Indicator!
- Modern Push Button Control!
- Separate Volume Control!
- Separate Speed Control!
- Dual-Tape Mike—use as standard & also record phone conversations with switch!
- Fast Forward, Rewind, Record, Playback—in vertical or horizontal position!
- records anywhere!

With handsome unbreakable portable case (size 8x6x2 1/2"). Includes 3" reel of tape, take-up reel, dual mike, earphone. Uses standard batteries.

EXTRA 300-FT. OF RECORDING TAPE . . . . .99c

ALL AT ONE LOW PRICE  
**\$39.95**  
POSTAGE PREPAID

## POLY PAK SPECIALS—THIS MONTH ONLY

- |   |     |                    |
|---|-----|--------------------|
| <input type="checkbox"/> 30 CRYSTAL DIODES, germanium, glass-sealed | \$1 | <b>\$1 PER PAK</b> |
| <input type="checkbox"/> 2 POWER TRANSISTORS                        | \$1 |                    |
| <input type="checkbox"/> 4 NPN TRANSISTORS                          | \$1 |                    |
| <input type="checkbox"/> 3 PNP TRANSISTORS                          | \$1 |                    |
| <input type="checkbox"/> 50, PRECISION RESISTORS                    | \$1 |                    |
| <input type="checkbox"/> 4 "Top Hat" 500 MIL SILICON RECTIFIERS     | \$1 |                    |
| <input type="checkbox"/> 100 CERAMIC CONDENSERS                     | \$1 |                    |
| <input type="checkbox"/> 50 DISC CONDENSERS                         | \$1 |                    |
| Postage Prepaid   |     |                    |

## NEW SILICON 750MA\* RECTIFIERS "TOP HAT"

*CAPACITOR INPUT DERATE 20%			
rms/div 17/25 14c	rms/div 35/50 19c	rms/div 70/100 29c	rms/div 140/200 34c
<input type="checkbox"/>	<input type="checkbox"/>	<input type="checkbox"/>	<input type="checkbox"/>
rms/div 210/300 43c	rms/div 280/400 55c	rms/div 350/500 70c	rms/div 420/600 \$1.00
<input type="checkbox"/>	<input type="checkbox"/>	<input type="checkbox"/>	<input type="checkbox"/>

(Lekttron prepays the postage in U.S.A.)



Send for 2-Year Subscription

**FREE**

**BIGGEST & BEST BARGAINS IN ELECTRONICS**

- Amateur & C-B
- Electronics
- Radio & TV
- Hi-Fi & P.A.
- Kits & Poly Paks
- Do-It-Yourself
- Hobby-Tool-Crafts

CLIP OUT AND MAIL THIS AD

CUT OUT AND MAIL

**LEKTRON** 245 EVERETT AVE. CHELSEA 50, MASS. Write for Free Catalog

HOW TO ORDER: Avg. wt. per pak 1 lb. Return ad with check or M.O. including postage; excess returned. C.O.D. orders, 25% down; rated, net 30 days. Include Postal Zone in address.



## Starved Circuit Amplifier

(Continued from page 71)

perimentally minded builder to alter the characteristics of the unit with a few simple resistor changes.

**Frequency Response.** Of course, no amplifier offers everything, and starved circuit units are no exception. Though these amplifiers are long on gain, they are somewhat short on high-frequency response.

In this particular circuit, the gain is between 25,000 and 30,000, but the upper frequency limit is between 2500 and 3000 cycles. Although a frequency range of 50-2500 cycles may not appeal to the hi-fi enthusiast, it covers the most common voice frequencies and is ideal for communications or intercom work. Under certain circuit conditions it will be found that the audio level is almost self-limiting, and no clipping is introduced.

The upper frequency limit of the amplifier can be increased by reducing the resistance of  $R_2$ , though the gain will suffer. Since direct coupling is used between the tubes, just about the only limits to the low-frequency response are the sizes of  $C_1$  and  $C_2$  and the characteristics of the output transformer ( $T_1$ ).

**Uses.** The starved-circuit amplifier can be used as a very sensitive signal tracer or voice amplifier. It has sufficient gain to operate from a low-level microphone and can serve as a low-power modulator, a driver for a higher power modulator, or an intercom amplifier. Since the circuit is adaptable to miniaturization, many other uses will suggest themselves. The minimum of construction involved won't upset anybody's time or parts budget.

-30-



July, 1961

## BUILD YOUR OWN Concert Quality ELECTRONIC ORGAN SAVE 50%



- Step by step instructions
- Pay as you build
- Over 14 models

THE *Artisan* ELECTRONIC ORGAN

Send for free literature

### ELECTRONIC ORGAN ARTS

4949 YORK BLVD., LOS ANGELES 42, CALIF.

Please send me free information



NAME \_\_\_\_\_  
ADDRESS \_\_\_\_\_  
CITY \_\_\_\_\_ ZONE \_\_\_\_\_  
STATE \_\_\_\_\_  
DEPT. P \_\_\_\_\_

### Experimenters • Amateurs • Hobbyists

Extraordinary values await you in government surplus electronic components. Don't buy anything until you have our "Bargain Bulletin"; new material for mere dimes on the dollar. Remember, everything is brand new; here are typical values:

Stancor P-4004 power transformer, \$21 list	9 lbs.	\$4.44
Cornell-Dubilier T-JL-15100, 10 mfd./1500 v oil	4 lbs.	3.19
BC-610 tuning units, specify TU number	4 lbs.	3.45
6V6GY vacuum tubes, a dozen for	3 lbs.	6.95
5 vct fil xfmr, 15 KV ins, 220-240/60 pri	19 lbs.	6.45
Auto xmr, 110/60 to 220/60, 90 watts	7 lbs.	2.29
Sealed 115 v/60 cyc relay, DPDT rated 5 amps	10 oz.	1.95
Astatic 400-D tone arm with dual sapphires, cer	1 lb.	7.45
455 KC IFS, National or equal	10 oz.	.79
Electrolytic, 3 x 20/400 volts—8 oz. 59¢	10 for	4.95

WRITE TODAY FOR FREE GOVERNMENT SURPLUS BARGAIN BULLETIN

**JOE PALMER** P.O. Box 6188 CCC, Sacramento, California

### engineering degree in 27 months

You know the advantages college graduates have in industry . . . more income, rapid advancement. Important firms like Tri-State graduates . . . regularly interview seniors on campus. Become an Electronics Engineer. Quality faster here.

### Bachelor of Science Degree in 27 Months

in Electrical (Electronics or Power major), Mechanical, Chemical, Aeronautical, Civil Engineering. IN 36 MONTHS B.S. in Business Administration (General Business, Accounting, Motor Transport Management majors). For earnest, capable, mature students. Small classes. More professional class hours. Beautiful campus. Well-equipped labs, modernized buildings, new dorms. Year-round operation. Enter Sept., Jan., Mar., June. Founded 1884. Write J. D. McCarthy, Director Admissions, for Catalog and "Your Career in Engineering and Commerce" Book.

**TRI-STATE COLLEGE** 3671 College Avenue  
Angola, Indiana

115

# RCA-DEPENDABLE Citizens' Band Radios to keep you in touch!

**IN YOUR HAND  
ONLY  
\$129.95\***



## RCA PERSONAL-COM

Ideal unit for business, farm and personal uses. No tests, license or age requirements for unit-to-unit operation. Mercury battery. Completely transistorized.



**IN YOUR CAR  
ONLY  
\$189.95\***

## RCA MARK VII RADIO-PHONE

Operates from car, home, office, boat. Can be used at any location having 6 or 12 volt DC or standard AC power source. Stable reception, solid transmission. A tremendous value!

\*Manufacturer's Nationally Advertised Price (optional with dealer)

RADIO CORPORATION OF AMERICA  
Telecommunication Center, Dept. X-420  
Meadow Lands, Pa.

Please send me FREE literature on:

- RCA Personal-Com
- RCA Mark VII Radio-Phone

NAME \_\_\_\_\_

ADDRESS \_\_\_\_\_ PHONE \_\_\_\_\_

CITY \_\_\_\_\_ ZONE \_\_\_\_\_ STATE \_\_\_\_\_



The Most Trusted Name  
in Electronics

RADIO CORPORATION OF AMERICA

## Universal Workshop Tester

(Continued from page 60)

Set bridge frequency switch  $S2$  to "60 cps" and switch on the unit.

When the null indicator eye ( $V2$ ) lights, rotate  $R1$  until  $V2$  gives an "eye open" indication. If the point where the eye opens is at either end of  $R1$ 's scale (0 or 100), set  $S1$  to the next higher or lower scale until an eye-open indication is found somewhere between the extremes of  $R1$ 's range. When the eye-open indication is observed, check  $R1$ 's reading against the Calibration Chart for the unknown capacitor's value.

**Resistance Bridge.** To find a matched pair of resistors among a group marked with the same value, connect one resistor across "standard" binding posts  $BP1$  and  $BP2$ . Connect any resistor you want to match to the "standard" resistor across "unknown" binding posts  $BP3$  and  $BP4$ . Set  $S1$  to *Ext* and place  $S2$  in the 60 cps position. Now, rotate  $R1$  in the vicinity of 50 on its scale, and switch on the tester. If the unknown resistor is exactly the value of the standard, null indicator  $V2$  will give an eye-open indication at "50." Should the unknown resistor be a lower value than the standard,  $R1$  will read above 50. In the same way, unknown resistors with a higher value than the standard resistor will give readings on  $R1$  below 50.

**Audio Generator.** As previously stated, two fixed audio frequencies are available from the tester. Setting  $S1$  to *Osc 1* and  $S2$  to the *Ext Freq* position produces a very low frequency (on the order of 5 to 10 cycles) at jack  $J1$ . Null indicator  $V2$  will flicker on and off with the low-frequency oscillation. Switching  $S1$  to *Osc 2* changes the output frequency to about 1000 cycles. (No jumper should be connected across binding posts  $BP1$  and  $BP2$  in either position.)

**Tuning Eye.** To use the instrument as a tuning eye for an AM or FM tuner, simply connect a shielded cable between jack  $J1$  and the tuner's auxiliary or tape output jack. Set  $S1$  to *Ext* and place  $S2$  in the *Ext Freq* position. No jumper should be connected across binding posts  $BP1$  and  $BP2$ . When a station is tuned in properly, the eye of  $V2$  will open widest. Modulation on the received signal will

cause the eye to flicker and wink in accordance with audio peaks.

**External Null Detector.** The instrument will also work with an external null detector when you want to employ it as a capacitance or resistance bridge. Use a pair of medium- to high-impedance phones for the null detector. Connect the phones (or the crystal phono input of an audio amplifier) to jack *J1*. Whenever a balance is achieved in a capacitance or resistance test, the 60-cycle buzz in the phones or the amplifier's speaker will be at a minimum. Null indicator eye *V2* will also operate in the usual manner.

**External Frequency Tests.** When you want to test a capacitor with a frequency other than 60 cycles, set *S2* to *Ext Freq*. Connect a low-voltage audio source of about 7 volts in series with a 100-ohm resistor across binding posts *BP1* and *BP3* (NOT *BP2*). For an audio source, use the low-impedance output of an audio amplifier fed by an audio generator; keep the amplifier's gain down so as not to damage the capacitor under test.

Next, place a jumper across binding posts *BP3* and *BP4*. Now, set *S1* to the estimated capacity range and rotate *R1* for a null on *V2* in the usual manner (an eye-open indication on *V2* means that the bridge is balanced). Refer to the Calibration Chart for the capacitor's value.

-30-

### Cubical Quad for CB

(Continued from page 81)

This safety wire will prevent the loop from shifting about on the framework. (Refer to Fig. 2.)

The second loop assembly may be made by laying its components atop the first one and making a "Chinese copy." When it is completed, the reflector stub (Fig. 4) should be soldered across the center insulator of one of the loop assemblies.

Finally, mount the bamboo frameworks to the center boom with the angle brackets.

**Feed System.** The Quad is a symmetrical, balanced antenna, and for best results should be fed with a balanced transmission line. Two-wire, 72-ohm "TV-type" transmission line (Fig. 5) is used at a considerable savings in cost over common coaxial line. The line may

**NOW** **TOP** **4** **NEW** **4u-gain** **Mobile Citizens Band** **with the** **Top Loaded Whips**

**LOADING FOR EFFICIENCY**

in

**STAINLESS STEEL**

New auto whip design uses top loading to raise radiating portion of antenna. Radiation resistance also raised to 52 ohms for perfect match. All these, plus higher mounting position add up to brilliant performance. Available now in half-size (50" overall) stainless steel whip. Top loading coil capsule same dia. as whip; fused to stainless steel section. Extremely rugged. Complete with chrome-plated, single hole mounting body mount and coax receptacle. Model TLW-M **\$1195** list

for fitting most auto mounts. Model TLW **\$895** list

**TELESCOPING**

Same as Model TLW-M but with telescoping sections (from 50" 28"), stainless steel and chrome plated brass. May be used with CPR Coupler as high efficiency antenna for AM Radio and Citizens Band. Model TLWT-M **\$1195** list

Same as above but fitted with std. 3/8" x 24 stud mounts. Model TLWT **\$995** list

Write for complete literature and specifications direct to

**4u-gain** antenna products

1135 NO. 22nd ST.

LINCOLN, NEBRASKA

find new adventure in amateur radio...

with **Viking** 1st choice of amateurs the world over!

loaded with features... kit or wired!



<b>ADVENTURER</b> —50 watts CW input 80 through 10 meters. 240-181-1... Kit Am. Net... \$54.95	<b>RANGER</b> —75 watts CW input; 65 watts phone—160 through 10 meters. 240-161-2... Kit Am. Net... \$229.50	<b>VALIANT</b> —275 watts CW and SSB; 200 watts AM—160 through 10 meters. 240-104-2... Kit Am. Net... \$349.50
	240 161-1... Wired Am. Net... \$329.50	240-104-2... Wired Am. Net... \$439.50



**E. F. JOHNSON CO.**  
2433 10th Ave. S.W. • Waseca, Minn.

Complete specifications and schematics on all Johnson transmitters, amplifiers, station accessories, keys and practice sets!

NAME \_\_\_\_\_

ADDRESS \_\_\_\_\_

CITY \_\_\_\_\_ STATE \_\_\_\_\_

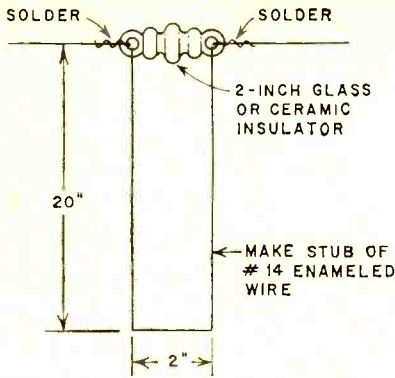

Fig. 4. Shorted stub on reflector loop serves to tune the element for maximum rejection of CB signals at the rear of the Quad antenna. Inspect soldered joints at insulator before installing antenna.

be of any length required to reach from the antenna to the CB equipment. Most CB rigs are designed for use with an unbalanced (coaxial) transmission line. Therefore, some sort of balance-to-unbalance device must be placed near the CB rig's antenna jack for a correct impedance match between the lead-in line and the equipment. A *balun sleeve* made of flexible, metal braid will do the job.

A 99" length of braid is slipped over the line and trimmed to the correct dimension. (See Fig. 6.) Tape the braid's free end to prevent unraveling; the opposite end is tinned, and a wire lead is soldered to it.

Now affix a coaxial plug to the end of the line. The leads from the balun sleeve and one side of the transmission line are

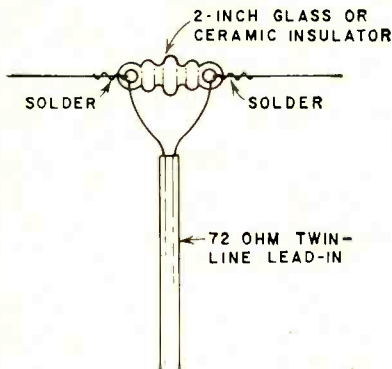

Fig. 5. Install 72-ohm line as you would a TV twin-lead. Fix lead-in to mast a few feet below the connections, to prevent wire's weight from bending loop.

connected to the outer shell of the plug. The remaining lead of the transmission line is soldered to the center pin of the plug. Make the connections from the line and balun to the plug as short as possible.

**Using the Antenna.** The pattern of the Quad is quite broad (about 60 degrees), requiring only that the antenna be pointed in the general direction of desired communication. Power gain is about four, so that your transmitter power will be boosted to an equivalent

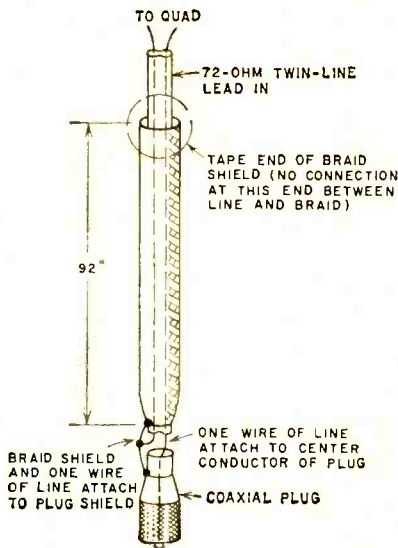

Fig. 6. Neatness counts when wiring up the simple balun. Poor solder joints and incorrect lengths will lessen power gain of the Cubical Quad. So do it right!

of 20 watts input (about 12 watts output); the same power gain is provided on received signals. Signals from the back of the beam are attenuated by a factor of 10 to 15.

The antenna should be mounted high and in the clear, free of telephone wires or utility lines. It may be rotated by a heavy-duty TV rotor if communication in various directions is desired.

Taking into consideration the price of materials and assembly time, this simple, rugged antenna design is hard to beat for everyday use on the Citizens Band. Build a Quad yourself and enjoy more consistent contacts and a longer operational range!



## On the Citizens Band

(Continued from page 86)

were lifted from the fine and funny paper of the Citizens Radio League (Chicago).

The CRL gang passes along this helpful tip to CB mobileers: leave your car window open slightly. Instantaneous air pressures created when you slam a door with all the windows closed can damage a pressure-sensitive microphone.

**They're getting smaller** all the time—Part 15 walkie-talkies, that is. We understand that Ross Laboratories in Seattle has one 5 1/4" high, 2 5/15" wide, and 1 3/8" deep. It weighs only 8 1/2 ounces! But small as it is, it has five transistors with an r.f. stage in the signal inhaled.

**It seems funny** to talk about sleet and snow in July (when you're probably taking deep breaths from air-conditioners) but we have just received word about a worthwhile effort last February on the part of the 27 Meggers CB Club of South Euclid, Ohio.

It was during one of those blizzards which made 1960-61 infamous. At 8:30 p.m. on the night of the storm, the city officials requested the aid of the club members in guarding downed electrical wires, directing traffic away from danger zones, and investigating complaints from local citizens. They helped gladly, many working while soaked to the bone in the sub-freezing weather. They were on duty until 4:00 a.m. the following day.

As a result of the fine work of the members, the club has received official commendation letters from the South Euclid Police Department and from the executive director of the city. Also, the American Red Cross has asked the "27 Meggers" to accept the responsibility of maintaining all disaster communications for them in the "six-city" area around South Euclid.

The club is looking for new local members to help in this important work. If you live in the area, you are requested to contact Leslie H. Marks, 19A6473, President, The 27 Meggers CB Club, 1553 Algiers Drive, Mayfield Heights 24, Ohio.

-30-



### HEADS YOU WIN!

Yes, you'll be a winner every time by saving "heap plenty" on all of your high fidelity requirements. Write us and see! Ask too for audio discount catalog A-12.

**KEY ELECTRONICS**  
120 Liberty St., N. Y. 6, N. Y.

### TV PICTURE TUBES

All Aluminized Glass Types

BUY DIRECT AND SAVE

- 12LP4 . . . \$8.95 • 21AL/ATP4 . . . \$16.75
- 17BP4 . . . \$9.95 • 24DP4 . . . \$24.50 • 27EP4 . . . \$39.95

ALL TYPES AVAILABLE

These tubes are made from reprocessed glass. All materials including electron gun are brand new.

All Prices with old tube F.O.B. Chicago

FREE . . . Write for complete Picture Tube list.

PICTURE TUBE OUTLET • 2922 MILWAUKEE, Chicago 18

## PORT ARTHUR COLLEGE ELECTRONICS COMMUNICATIONS

AM FM Television Broadcast Engineering  
Industrial Electronics—Automation

CHECK THESE FEATURES: Tuition \$36 per mo., room & board \$52 per mo. in dorm on campus. College operates 5 KW broadcast station. Students get on-the-job training at studios on campus. FCC license training with all courses. Well equipped classrooms & lab., am fm transmitters, radar & marine eqmt., television camera chain, experiment lab test eqmt. & other training aids. Our graduates in demand at good salaries. Free placement service. Have trained men from all 50 states. Approved for GI. Write to Dept. P-761 for Free Booklet.

**PORT ARTHUR COLLEGE** Port Arthur Texas  
Established in 1909

## Hear 'Em — Work 'Em Better with BROWNING CB Equipment

R-2700 CB RECEIVER  
\$149.00

S-NINE CB TRANSMITTER  
\$119.50



Also Available  
R-2700 Receiver PLUS  
T-2700 Transmitter  
SPECIAL PACKAGE PRICE

Send for Free Literature



**browning**  
101 UNION AVE., LACONIA, N.H.

Make your CB base station a real communications center with this Browning team. Highly sensitive and selective R-2700 Receiver delivers sharp, noise-free reception on all CB channels. Overcomes even the most severe atmospheric and man-made interference. Browning S-NINE Transmitter allows full power transmission on all channels — introduces new features and advanced design never previously utilized in CB communications.

SATISFACTION GUARANTEED FOUR CONVENIENT PURCHASE PLANS

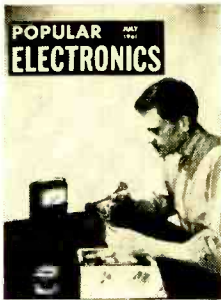

Send  
**POPULAR  
ELECTRONICS**  
Every Month

NAME.....

ADDRESS.....

CITY..... ZONE... STATE.....

3 years for \$10

Check one:  2 years for \$7

1 year for \$4

Payment Enclosed     Bill Me

In the U. S., its possessions and Canada.  
Foreign rates: Pan American Union countries, add .50 per year; all other foreign countries, add \$1 per year.

Mail to:

**POPULAR ELECTRONICS**

Dept. PE-761H, 434 S. Wabash Ave.

CHICAGO 5, ILL.

## 6 Meters and Mobile

(Continued from page 50)

knob positions on the front panel. They will act as reference points for future tune-ups and help prevent off-frequency operation. Changing crystals should involve only a slight re-tuning.

Neon bulb *II* gives two simultaneous indications of the transmitter's performance. The first is a steady orange glow on one of its electrodes, showing the presence of B+ voltage each time the push-to-talk button is depressed. The other electrode serves as an r.f. indicator and should have an orange-purple glow. After the initial settings of both tuning capacitors have been determined and marked on the panel, you can touch up the settings by slowly tuning the knobs for maximum brilliance of *II*.

Since oscillator tuning is quite broad, and the oscillator is peaked for maximum r.f. output, the circuit may not oscillate each time the rig is switched to "Transmit." The remedy is to choose a compromise setting. Output will be down slightly, but instability shouldn't prove troublesome. Flick the push-to-talk button several times to check for any sign of instability. The receiver S-meter should always peak at the same point during this procedure.

**Installation.** Two L-brackets bolted to the sides of the transmitter's case provide a secure mounting arrangement. Match the brackets with two holes drilled under the car's dashboard. The power source can be a terminal on the rear of the ammeter. Choose the one that indicates when the transmitter is drawing power (drain during "Transmit" will be about 5 amperes for 6-volt systems, 2.5 amperes for 12-volt systems). The ground lead can be routed to any nearby bolt at car-chassis ground; be certain to determine whether your car has a negative or positive ground, and wire accordingly.

Installation is completed when the antenna cable of a 6-meter receiving converter is plugged into the transmitter jack labeled *Receiver*. Pushing the press-to-talk button automatically causes the relay to switch the whip antenna (at jack *J2*) between converter input (jack *J3*) and transmitter output. -30-

## Sensitive Field Strength Meter

(Continued from page 53)

To calibrate the FSM, rotate tuning capacitor *C1*'s plates to full mesh and place a pointer knob on the capacitor shaft with the pointer at the nine o'clock position. The range switch is set to "L" and a 20-meter signal from the transmitter or a grid-dip meter is fed to the instrument. Rotate *C1* clockwise until the indicating meter "peaks" and mark this position of *C1*'s pointer "20." Do the same for 15 and 10 meters, marking the appropriate positions "15" and "10."

Range switch *S2* is now set to "M" and a six-meter signal is fed to the field strength meter. Again adjust *C1* for a peak and mark the new pointer position "6."

Finally, set switch *S2* at "H" and repeat the operation for 2 meters.

If panel decals are used for labeling, they should be protected with a coating of clear plastic spray such as Krylon. Use masking tape to protect the components while spraying.

**Operation.** To check field strength, turn on and balance the FSM as described above, setting *S2* and *C1* to the transmitter's operating frequency. Meter *M1* will now indicate field strength and can be used to take comparative readings around the transmitter and antenna.

The FSM can be used to test for harmonics by rotating *C1* on the "L," "M" and "H" positions of *S2*. The settings at which *C1* "peaks" meter *M1* show the bands being picked up; the peak readings of *M1* are indications of relative signal strength.

No gain control is provided, since it is unnecessary. The 1-ma. meter can take a considerable overload without damage—but if you want to operate in a high-signal-strength area for more than a few seconds, detune *C1* until the needle rests on scale. Capacitor *C1* may also be used to set meter *M1* at some convenient reference point for comparative signal strength measurements.

When using the headphone output to check the audio quality of a transmitter, adjust *C1* for a meter reading of 0.5 - 0.9 ma. When *M1* is set at this value, the transistor is biased on the linear portion of its operating curve. —30—

July, 1961

# RADIOCOM



## Citizens Band Transceiver

NEWEST DESIGN OF PROVEN UNIT  
DUAL NOISE LIMITER  
HIGHEST SENSITIVITY AND SELECTIVITY  
TRANSISTOR POWER SUPPLY  
MOST COMPACT — ONLY 3 1/2" HIGH

Yours with easy terms.

**15.95 down — 12 months to pay**

Now you can own the finest transceiver on the market. The RADIOCOM has been designed, tested, and proven by the thousands in service over a two and half year period to be the ultimate in citizen band design. It is available to you for only 159.50, on easy payment terms of 15.95 down and 12 monthly payments of 12.95. Quantity discounts available for dealers.

Let us prove this is the one for you.

Send NOW for FREE color catalog

RADIOCOM, P. O. BOX 147, Garland 7, Texas

BUILD THE  
PROJECTS  
DESCRIBED  
IN THIS  
ISSUE OF

WITH THESE



PRODUCTS

## POPULAR ELECTRONICS

### UNIVERSAL BRIDGE

Uses BUD CU-2107A ..... \$1.50

### SENSITIVE FIELD STRENGTH METER

Uses BUD CU-2106A ..... \$1.02

### FIXED FIELD STRENGTH METER

Uses BUD CU-2105A ..... \$1.20

### SWR/POWER METER FOR CB

Uses BUD CU-3006A ..... 82c

### STARVED CIRCUIT AMPLIFIER

Uses BUD CU-3006A ..... 82c

### VTVM ADAPTER FOR MULTIMETER

Uses BUD CU-2105A ..... \$1.20

### ACROSS THE HAM BANDS

"EAR SAVER" FOR HEADPHONE LISTENING  
Uses BUD CU-2103A ..... 90c

All Bud products are available for immediate delivery from your authorized Bud Distributor. They are the best for applications described in these projects.

WATCH FOR THESE LISTINGS EVERY MONTH  
IN POPULAR ELECTRONICS

## BUD RADIO, INC.

2118 East 55th Street Cleveland 3, Ohio  
Dept. PE

**FREE** **GIANT 1961 204 PAGE CATALOG**

**B-A 1961**  
ANNUAL CATALOG #11

Since 1927

A Complete Buying Guide for Everything in

**RADIO TV ELECTRONICS**

**BURSTEIN-APPLEBEE CO.**

Dept. PE, 1012 McGee St., Kansas City 6, Mo.

Send Free 1961 B-A Catalog No. 611

Name .....

Address .....

City..... State .....

**SAVE UP TO 50% ON 8-A SELECTED KITS**

**HI-FI AND STEREO SYSTEMS & COMPONENTS**

**TOP VALUES IN POWER AND HAND TOOLS**

**30 PAGES OF BARGAINS NOT IN ANY OTHER CATALOG**

**SEND FOR IT TODAY**

**GET INTO ELECTRONICS**

V.T.I. training leads to success as technicians, field engineers, specialists in communications, guided missiles, computers, radar, automation. Basic & advanced courses in theory & laboratory. Assoc. degree in 20 mos. B. S. obtainable. ECFM accredited. G. I. approved. Graduates with major companies. Start Sept., Feb. Dorms, campus. H. S. graduates or equivalent. Catalog.

**VALPARAISO TECHNICAL INSTITUTE**

Dept. PE VALPARAISO, INDIANA

**POLICE, CITIZENS BAND, AIRCRAFT**

Monitor these and other signals from any auto radio using the inexpensive and dependable Model 107 transistorized converter. Any SINGLE frequency between 25-50 and 108-175 mcs. Fully miniaturized, it can be installed in seconds. Designed to give years of dependable, trouble free service. Order now, or send for free information. State frequency. Guaranteed for one full year.

Model 107 . . . . . \$14.95

ROBIN RADIO CO. 2408 Hemphill Greenville, Texas

**SCIENCE ENGINEERING**

B. S. Degree—36 mos. • B. E. degree—27 mos.

Accelerated year-round program. Aero., Chemical, Civil, Elec., Mech., Metallurgical; Math., Chemistry, Physics. Modest rate. Earn board. New classes start July, Sept., Jan., March, June. Catalog. 2371 E. Washington Blvd., Fort Wayne 2, Indiana.

**INDIANA TECHNICAL COLLEGE**

**Short-Wave Report**

(Continued from page 100)

lack of space; we make every effort to use material from as many different reporters as we possibly can, but some reporters are known experts, and their information benefits a large number of DX'ers.

- Q:** Why do you publicize Iron Curtain stations? This seems contrary to the policies of some clubs, particularly the International Shortwave Club.
- A:** The ISWC has for years advocated a complete ban on reports to Iron Curtain stations, as well as a ban on any publicity, with the hope that this might cut down on jamming practices. However, I'm an editor, not a censor; if there is interesting news concerning stations behind the Iron Curtain, we will try to publish it for you. Should future developments warrant a ban on these items, we'll change our policy accordingly.

**Current Station Reports**

Here is a resume of the current station reports. All times shown are Eastern Standard and the 24-hour system is used. At time of compilation all reports are as accurate as possible, but stations may change frequency and/or schedule with little or no advance notice.

**Australia**—The Home Service from Perth is scheduled as follows: VLX15, 15,425 kc., and VLW9, 9610 kc., at 1915-0515 daily; VLX9, 9610 kc., at 0530-1030 and 1700-1900 Sunday through Friday; and VLW6, 6140 kc., at 0530-1100 and 1730-1900 on Saturday. VLX is 10 kw.; VLW is 2 kw. (WPEOAE)

Frequency changes include the moving of the 0458-1230 Eng. xmsn to S., S.E., and S.W. Asia from VLD9, 9580 kc., to VLE9, 9565 kc., and the 0458-0900 Eng. and Japanese xmsn to N.E. Asia and Japan from 9570 to 9580 kc. (WPE2DYC, WPE4BC, WPE6AXD, WPE6BZM, WPE6CAS, WPE8BVQ, WPE8CPE, WPE8CUK, WPE8MS, RL)

**Austria**—A new schedule from Vienna reads: 6155 kc. at 0000-0300, 0400-1100, and 1300-1600; 7155 kc. at 0300-0500 and 0700-0900; 7200 kc. at 0500-0700; 9770 kc. at 1100-1300. (WPE2AXS)

**Belgium**—Brussels operates in Eng. at 1515-1550 to Africa on 15,335, 11,850, and 9745 kc.; to N.A. at 1615-1800 on 15,335 kc. and 1815-2000 on 11,850 kc. (replacing 9765 kc.); to Africa at 1900-2000 (Monday and Friday only at 1945-2000) on 11,850, 11,720, and 9745 kc. There is a mailbag program on Saturdays at 1545 and 1930. (WPE4FI, WPE8CKW, WPE8MS, WPE9ACQ)

**Brazil**—PSF, *Agencia Nacional, Ministerio da Justica e Negocios Interiores*. Rio de Janeiro, is noted on 14,690 and 10,220 kc. at 1700-1800 with music to 1730 and "A Voz do Brasil" to 1800, in Portuguese. Another parallel channel is 7935 kc., but this has not been heard as yet. (WPE6BPN, WPE9AGK)

**Canada**—Montreal has moved from 21,600 to 21,595 kc. for the 0630-0930 xmsn. (WPE4FI)

**Costa Rica**—TIDCR, *La Voz de la Victor*, San Jose, has finally moved to its announced frequency of 9615 kc. after being on 9619 kc. for years. (WPE4FI)

TIFC, San Jose, has moved from 6037 to 6031 kc. and is noted at 0700 s/on. Both the 6031- and 9645-kc. channels carry Eng. at 1400-1500 and 2300-0000. (WPE4CVS, WPE4FI, WPE8BAG, WPE9AGB, WPE0AWU, WPE0BCT)

**Cuba**—*La Onda Corta Experimental Cubano*, Havana, appears to be operating at 1900-2100 on 11,760 kc., and at 2100-2300 on 11,770 kc. All Spanish, the programs consist mostly of music and news, with no commercials. Reports go to Apartado 7026, Havana. (WPE2ENN, WPE6AA, WPE6BPN, WPE6EZ, WPE8CAY, WPE8CXT, WPE8MS, WPE9CMO, CB, JM, DP)

**Ecuador**—Schedule changes for HCJB, Quito: Swedish at 0530-0600 and German at 0000-0030 on 9745 kc.; Spanish at 1530 (replacing Russian) and Eng. at 1700 (replacing Spanish) on 15,115 and 11,915 kc. A new program for DX'ers, "The DX Party Line," is being aired on the first Monday of each month at 2100-2200 on 9745, 11,915, and 15,115 kc. DX'ers might also carefully check for the medium-wave outlet on 700 kc., which has been heard (even in WLW territory!) riding in on twilight skip around local sunset time. (WPE1BZY, WPE2AXS, WPE2CGG, WPE3CCB, WPE4BWM, WPE4CRZ, WPE4CVJ, WPE6BPN, WPE6BPV, WPE8CQH, WPE8CTZ, WPE8CUC, VE5PE2H, CB, HCJB)

**Galapagos Islands**—If you have never logged this country, look for the radiotelephone station on 8450 kc., heard irregularly. This is not a broadcasting station but can be added to your "Countries Heard" log. (VE7PE2M)

**Gilbert and Ellice Islands**—Additional non-broadcasters you might like to log are the Ocean, Canton, Christmas, Fanafuti, and Arorae Islands. Tune for them on the 4413.8-kc. coastal 'phone channel. (VE7PE2M)

**Goa (Portuguese India)**—*Emissora de Goa*. 21,580 kc., has been noted at fair strength at

#### SHORT-WAVE REPORTERS!

Your reports will be read and processed faster if you send them directly to:

Hank Bennett, Short-Wave Editor  
POPULAR ELECTRONICS  
P. O. Box 254  
Haddonfield, N. J.

Make sure you include your WPE call letters with your report.

**FREE**

**ALLIED**

**SPECIAL MONEY-SAVING  
ELECTRONIC SALE BOOK**



**SAVE**

**HUNDREDS OF  
BARGAINS!**

SAVE MOST on Allied Summer Specials! Terrific closeouts on quality Stereo hi-fi systems and components, tape recorders, phonos, records and tape. Top values in Allied's own KNIGHT® products and exciting build-your-own KNIGHT-KITS®. Hundreds of specials in radios, cameras, TV accessories, Citizens Band radio, amateur gear, P.A. systems, test instruments, tools and electronic parts. Dozens of new products. Write today!

**NO MONEY  
DOWN**  
on Allied's  
Easy Terms

**FREE**

**SEND FOR VALUE-PACKED SALE BOOK**

**ALLIED  
RADIO**

ALLIED RADIO, Dept. 54-G1  
100 N. Western Ave., Chicago 80, Ill.

Send FREE Allied Sale Book No. 205

Name \_\_\_\_\_

PRINT

Address \_\_\_\_\_

City \_\_\_\_\_ Zone \_\_\_\_\_ State \_\_\_\_\_

## GROVE CB SALE!!

Closing out our stock of CB kits. Nationally advertised at \$39.95 up. Complete with power supply, tubes, crystal, cabinet, coils, etc., less mike. Kit sales final. Rush your order today!!

- 110 VOLT CB TRANSCEIVER KITS ..... \$19.95
- 12 VOLT CB TRANSCEIVER KITS ..... \$22.95
- 6 VOLT CB TRANSCEIVER KITS ..... \$22.95

#### GET THE GROVE PRICE ON ANTENNAS!

- 3-ELEMENT HORIZONTAL BEAM ANTENNA (Reg. \$29.95) SALE PRICE ..... \$11.99
- GROUND PLANE ANTENNA (Reg. \$15.95) SALE PRICE ..... \$8.99
- BUMPER MOUNT + 102" WHIP + SPRING (Reg. \$12.00) SALE PRICE ..... \$8.99
- HELIWHIPS BY MARK MOBILE (includes FREE \$4.95 JK XMTG CRYSTAL) ..... \$7.20
- 11-PC. MOBILE NOISE SUPPRESSION KIT (includes tunable Generator Filter) SALE PRICE ..... \$3.99
- FIELD STRENGTH METER KIT (fantastically priced!!) SALE PRICE ..... \$6.99
- FAMOUS MAKE CB XMTG CRYSTALS (Reg. \$3.95) (EACH) SALE PRICE ..... \$1.99

Lots of 3—\$1.89 each; Lots of 6—\$1.79 each

Check items wanted. Return ad w/check or M.O. Include Postage. Excess returned. C.O.D. orders 25% down (Note: Large Antennas must be shipped railway express or freight)

**GROVE ELECTRONIC SUPPLY COMPANY**  
4103 W. Belmont Ave., Chicago 41, Ill.

- Rush items checked
- Send FREE catalog of giant CB Values

Name \_\_\_\_\_ (please Print)

Address \_\_\_\_\_

City \_\_\_\_\_ Zone \_\_\_\_\_ State \_\_\_\_\_

1130-1330 in Indian languages and Portuguese, with some pop records. (WPE4BC, WPE4FI)

**Greece**—Two private stations on the air are Karpenission, 6525 kc. (300 watts, 1000-1400 daily), and Chios, 6590 kc. (100 watts, 1000-1330). Has anyone heard either of these stations? (VE7PE2M)

**India**—The External Service of *All India Radio*, Delhi, may be heard on 15,240 kc. to W. Africa at 1445-1545 and on 9525 and 11,895 kc. to S.E. Asia at 1930-1940. Both xmsns are in English. (WPE8MS)

**Ireland**—According to *Sweden Calling DX'ers*, the Irish Army is going to have its own short-wave station at the Curragh for test xmsns in Eng. to Irish troops in the Congo. No other information is available at the moment. (WPE9ARA)

**Israel**—Jerusalem is noted on 11,920 kc. at 1515-1545 in Eng. and from 1600 in Arabic. The 9009-kc. outlet is heard well with a new 2315-2330 xmsn in Yiddish. (WPE2CCI, WPE4FI, WPE5AG, WPE9AGB, WPE0AE)

**Italian Somaliland**—R. *Mogadiscio* operates on 7150 and 4970 kc. at 0130-0300 in Somali, at 0600-0715 in Arabic, and at 0830-1100 in Italian. An Eng. program may be forthcoming in the near future. (VE7PE2M)

**Italy**—Rome has replaced 6010 kc. with 11,905 kc. to N.A. at 1730-2225, dual to 9575 kc. English is aired at 1930-1950 and 2205-2225. (WPE2EMJ, WPE2EVQ, WPE4FI, WPE5BDG, WPE9AGB, WPE0BAN, JB)

**Japan**—Tokyo's new schedule reads in part as follows: to Eastern N.A. at 1930-2030 on

21,520, 17,725, and 15,135 kc. in Eng. and Japanese; to Western N.A. and L.A. at 2200-0000 on the same channels, plus 11,800 kc., in Spanish, Eng., and Japanese; to Hawaii at 0030-0200 on 17,725 and 15,235 kc. in Eng. and Japanese; to Europe at 0230-0330 on 21,610, 17,725, and 15,135 kc. in Eng. and Japanese; to Africa at 1430-1530 on 11,705 and 9525 kc. in Eng., French, and Japanese; to Europe (II) at 1400-1600 on 15,135, 11,800, and 9675 kc. in Russian, German, French, Eng., Italian, Swedish, and Japanese; to Middle East and N. Africa at 1145-1345 on 15,135, 11,800, and 9525 kc. in Arabic, French, Eng., and Japanese; to Australia and New Zealand at 0430-0530 on 11,875 and 15,235 kc. in Eng. only. The General Service is now aired at 0600-0630, 0700-0730, 0800-0900, and 1000-1030 on 11,815, 11,780, and 15,235 kc.; at 1930-2030, 2100-2130, 2200-2230, 2300-2330, 0000-0030 on 21,610, 17,795, and 15,115 kc.; at 0100-0200, 0300-0330, and 0400-0430 on 11,815, 15,105, and 17,755 kc.; and at 0500-0530 on 11,815, 15,105, and 15,235 kc. (WPE1CLM, WPE2BRH, WPE2CXO, WPE2DLT, WPE2LP, WPE6BPN, WPE6BZM, WPE8MS, WPE9AGK)

**Jordan**—The Hashemite B/C Service, Amman, was testing for a few days on 7155 and 11,710 kc. at 2030-0100 (to Europe and N.A.) and 0900-1700; and on 9530 and 11,710 kc. at 0115-0305 and 0600-0805. All xmsns were in Arabic. This may be a forerunner of regular service. (WPE2CCI, WPE4BVK, WPE5AG, and many others)

**Mali Republic**—R. *Mali*, Bamako, has been

#### SHORT-WAVE CONTRIBUTORS

Frank Fulchiero (WPE1AXH), Niantic, Conn.  
Richard Leverone (WPE1BZV), Norfolk, Mass.  
Thomas Cardullo (WPE1CIS), Somerville, Mass.  
Don Rieger (WPE1CLM), Hamden, Conn.  
Jeffrey Trevas (WPE2ANX), Kew Gardens, N. Y.  
Robert Newhart (WPE2AXS), Merchantville, N. J.  
James Bauer (WPE2BAZ), Forest Hills, N. Y.  
Albert Mencher (WPE2BRH), Bayside, N. Y.  
Richard Phillips (WPE2CCI), Forest Hills, N. Y.  
Billy Hudzik (WPE2CGG), Plainfield, N. J.  
Mike Stafford (WPE2CXO), Jamestown, N. Y.  
Joseph Eggert (WPE2DID), Newark, N. J.  
Burt Lee (WPE2DLT), Bergenfield, N. J.  
Edward Jones (WPE2DVC), Bronx, N. Y.  
Larry Garutti (WPE2EAW), Newark, N. J.  
Mrs. Ida Hill (WPE2EMJ), Ontario, N. Y.  
Alfred Tejada (WPE2ENV), Brooklyn, N. Y.  
Charles Linter (WPE2EVQ), Larchmont, N. Y.  
Grover White (WPE2LP), Baldwin Harbor, N. Y.  
Michael Serdy, Jr. (WPE3BSI), Duquesne, Pa.  
Robert Lyon (WPE3CCB), Levittown, Pa.  
Grady Ferguson (WPE4BC), Charlotte, N. C.  
Johnny Futch (WPE4BMR), Nashville, Ga.  
Jack Meyers (WPE4BVK), Norfolk, Va.  
Mike Vanacor (WPE4BWM), Tampa, Fla.  
Dan Meeks (WPE4CEX), Birmingham, Ala.  
Robert Heller (WPE4CIC), Clemson, S. C.  
William Pate, Jr. (WPE4CIR), Lawrenceville, Ga.  
John White (WPE4CRZ), Birmingham, Ala.  
Dick Snyder (WPE4CSZ), St. Petersburg, Fla.  
David Robertson (WPE4CVJ), Milton, Fla.  
Leland Stark (WPE4CVS), Mobile, Ala.  
Roger Legge (WPE4FI), McLean, Va.  
William Bing (WPE5AF), New Orleans, La.  
Robert Ragsdale (WPE5BDG), Dallas, Texas  
Stewart MacKenzie, Jr. (WPE6AA), Long Beach, Calif.  
Dennis Nunez (WPE6AXD), Del Paso Heights, Calif.  
Shael Hanisch (WPE6BPN), Pasadena, Calif.  
Keen Anderson (WPE6BPV), Eureka, Calif.  
Lee McVey (WPE6BNC), Bakersfield, Calif.  
Matt Collins (WPE6BZM), Los Angeles, Calif.

Herbert Neff, Jr. (WPE6CAS), Lakeside, Calif.  
J. Art Russell (WPE6EZ), San Diego, Calif.  
Gene Alward (WPE7AN), Pullman, Wash.  
Ronald Luyster (WPE8AG), Flushing, Ohio  
Kent Shaffer (WPE8BAG), Dayton, Ohio  
John Kennedy (WPE8BO), Shelby, Ohio  
John Porter (WPE8BVQ), Grosse Ile, Mich.  
Louis Horacek (WPE8CAV), Morgantown, W. Va.  
Joseph Bose (WPE8CKW), Norwood, Ohio  
Mike Eisenstot (WPE8CPB), Youngstown, Ohio  
William Goff, Jr. (WPE8COH), Bridgeport, Ohio  
Albert Quader, Jr. (WPE8CTZ), Cleveland, Ohio  
Bob Hill (WPE8CUC), Wyandotte, Mich.  
Trevor Hilfer (WPE8CUL), Maple Heights, Ohio  
Leroy Gruber (WPE8CYT), Deer Park, Ohio  
Dan Wilt (WPE8HF), Ingleswood, Calif.  
Mike Kander (WPE8MS), Dayton, Ohio  
Dennis Hallstrom (WPE9ACQ), Arlington Heights, Ill.  
Earl Kinmonth (WPE9AGB), Joliet, Ill.  
Bill Berghammer (WPE9AGK), Lombard, Ill.  
Robert Klein (WPE9ARA), Beaver Dam, Wis.  
Bob Bensen (WPE9CEW), Joliet, Ill.  
Joseph Cecchi (WPE9CMO), Chicago, Ill.  
Robert Frey (WPE9IP), Niles, Ill.  
John Beaver, Sr. (WPE9JAE), Pueblo, Colo.  
Bill Holscher (WPE9JATE), Webster Groves, Mo.  
Paul Marshall (WPE9AWU), Colorado Springs, Colo.  
Tommy Stock (WPE9BAN), Boonville, Mo.  
Don Stitt (WPE9BCT), Hastings, Nebr.  
Donald Golding (VE3PE6D), Oshawa, Ont.  
Jim Roik (VE4PE2U), Winnipeg, Man.  
Morley Brownstein (VE5PE2H), Regina, Sask.  
Richard Lavolette (VE7PE2M), Richmond, B. C.  
Charles Boehnke (CB), Reno, Nev.  
Joe Brown (JB), Endicott, N. Y.  
Tom Herde (TH), Lone Branch, N. J.  
Robert Laginess (RL), Detroit, Mich.  
Joseph Montoya (JM), West Covina, Calif.  
Dave Prichard (DP), Springfield, N. J.  
*Radio HCJB*, Quito, Ecuador  
*World Radio Handbook (WRH)*

noted on 7075 kc. at 0200-0300 in French with news at opening. (WPEOAE)

**Mexico**—A new station is *R. Universidad Potosina*, San Luis Potosi, operating on 6045 kc., relaying XEXQ, 1460 kc. Other details are lacking. (WRH)

**Netherlands**—Hilversum has been testing recently on 15,445 and 17,810 kc. at 1455-1515 to N.A.; taped reports were requested. Schedule changes: to Australia, New Zealand, and Pacific Areas at 0200-0250 (replacing 0500-0550) on 11,730 and 9590 kc.; to S. Asia at 0900-0950 on 21,565 and 15,445 kc.; to Africa and Europe at 1430-1520 on 17,775 and 15,425 kc. (also on 6020 kc. for Europe only); to Europe and N.A. at 1630-1720 (replacing 1610-1705) on 15,220 and 11,730 kc. (also 6020 kc. for Europe only); to N.A. at 2030-2120 on 11,730 and 6025 kc. (with 9590 kc. as an alternate channel). (WPE1AXH, WPE2BRH, WPE2EAW, WPE3BSI, WPE4BC, WPE4CIC, WPE4CSZ, WPE8AGY, WPE8BOI, WPE8BVQ, WPE8HF, WPE9AGB, WPEOAE, VE3PE6D, VE4PE2U)

**New Zealand**—A new schedule, superseding the one given last month, from *Radio New Zealand*, Wellington, reads as follows: to Pacific Islands at 1200-1945 on 9540 kc. (also to 1730 on 15,280 kc.), at 1745-0045 on 15,280 kc., at 0100-0345 (Sundays to 0300) on 6080 and 11,780 kc.; to Australia at 1500-1730 on 11,780 kc., at 1745-0045 on 15,280 kc., and at 0400-0645 on 6080 and 11,780 kc.; to Antarctica at 0315-0345 (Sundays only) on 11,780

### SHORT-WAVE ABBREVIATIONS

B/C—Broadcasting  
Eng.—English  
ID—Identification  
IKC—International  
Reply Coupon  
IS—Interval signal  
kc.—Kilocycles  
kw.—Kilowatts

L.A.—Latin America  
N.A.—North America  
R.—Radio  
s/off—Sign-off  
s/on—Sign-on  
veri—Verification  
xmsn—Transmission  
xmt—Transmitter

kc.; to Samoa at 1540-1555 (Mondays) and at 0200 (Tuesdays), and to Cook Islands and Niue at 0210-0225 (Wednesdays) and at 0300-0315 (Saturdays) on the same channels used in the Pacific Service. (WPE2DLT, WPE2EMJ, WPE4CIR, WPE6BPN, WPE6BXC, WPE7ANY, WPE9IP, WPEOATE, WPEOECT)

**Peru**—*R. Nacional del Peru* operates OAX4R, 9562 kc., OAX4Z, 6082 kc., and OAX4T, 15,150 kc. in Lima; OAX8C, 9610 kc., Iquitos; OAX6L, 9530 kc., Tacna; and OAX1Z, 9550 kc., Tumbes. They verify by registered letter. (WPE2ANX)

**Poland**—A rarely heard station is the *Polish Pathfinders Station*, Warsaw, 6850 kc., 350 watts. Their schedule: 0400-1100, in Polish. (VE7PE2M)

**Sao Tome**—CR5SC, *R. Clube de Sao Tome*, operates at 1400-1600 in Portuguese on 4807 kc. (VE7PE2M)

**Senegal**—*R. Mauretanie* verified with card and letter and stated that all correct reports will be verified but that listeners must send

# TRU-VAC 1-YEAR GUARANTEED RADIO and TV TUBES

**\$33**  
Per 100 TUBES

Factory Used or Factory Second Tubes! TRU-VAC will replace FREE any tube that becomes defective in use within 1 year from date of purchase! All tubes individually boxed, code dated & branded in TRU-VAC Partial Listing Only—Thousands More Tubes In Stock!

**SPECIAL! 6SN7GT . . . . .30¢ 6W4GT . . . . .30¢**

024	4BS8	6AH6	6BC5	6CD6G	6J7	6W6GT	7F8	12AV7	12K7
1A7GT	4BZ7	6AK5	6BC8	6CF6	6KG6T	6X4	7G7	12AX4GT	12L6
1B3GT	4CB6	6AL5	6BD6	6CG7	6K7	6KS5GT	7H7	12AX7	12Q7
1H5GT	6AMB	6AN8	6BE6	6CH6	6N7	6X6	7N7	12AZ7	12R5
1R5	5AN8	6AN8	6BF5	6CH8	6Q7	6Y6G	7Q7	12B4	12SA7
1S5	5AT8	6AQ5	6BG6G	6CL6	6S4	7A4/XXL	7S7	12BA6	12SJ7
1T4	5AV8	6AQ6	6BH6	6CM6	6S6T	7A6	7X6	12B7	12SK7
1U4	5AZ4	6AQ7	6BJ6	6CM7	6S7	7A6	7X7	12B6	12SN7GT
1U5	5CG8	6AR5	6BK5	6CN7	6SD7GT	7A7	7Y4	12BE6	12SQ7
1V2	SR4	6AS5	6BK7	6CQ8	6S8	7A5	7Z4	12BF6	12W6GT
1X2	STR	6AT6	6BL7GT	6CR6	6S67	7B5	12A8	12BH7	12W6GT
2AF4	SU4	6AU4GT	6BN6	6C57	6SH7	7B6	12AB5	12BQ6	12X4
2BN4	SUB	6AU5GT	6BQ6GT	6C65	6S17	7B7	12AQ5	12BR7	19AU4GT
2CY5	SV4G	6AU6	6BQ7	6C66	6S47	7B8	12AT6	12B7	19BG6G
3AL5	SV6GT	6AU8	6BR8	6D6	6SL7	7C4	12AT7	12CA5	19T8
3BC5	5X8	6AV5GT	6BS8	6DE6	6SQ7	7C5	12AUG	12CN5	25Z6GT
3BN6	5Y3	6AV6	6BY6G	6DG6GT	6SR7	7C6	12AU7	12D4	35A5
3BZ6	6AB4	6AW8	6BZ6	6DQ6	6T4	7C7	12AV6	12F8	35B5
3CB6	6AC7	6AX4GT	6BZ7	6F6	6T8	7E5	35U4	12K5	35C5
354	6AF4	6AX5GT	6C4	6H6	6U5	7E6			35D4
3V4	6AG5	6BR	6C4B	6J5	6R8	7E7			
4BQ7A	6AH4GT	6BA6	6CB6	6J6	6V6GT	7F7			

**BRAND NEW 1-YEAR GUARANTEED TV PICTURE TUBES**  
Below Listed prices do not include divl. Add Additional \$5.00 Deposit on tube size to 20" on 21" and 24" tubes—\$7.50. Deposit refunded immediately when divl is returned prepaid. Aluminized tubes—\$4.00 extra. Picture tubes shipped only to continental USA and Canada—All tubes F.O.B. Harrison, N. J.

10BP4	7.99	17CP4	16.99	21AMP4	17.99	21KP4	18.39
16CP4	16.09	17TP4	16.99	21WP4	18.79	21YP4	18.39
16RP4	11.99	20CP4	15.89	21AWP4	17.49	21WP4	17.49
17AVP4	15.49	20HP4	17.89	21EP4	17.29	21YP4	18.39
17BP4	13.49	21ALP4	18.79	21FP4	18.39	24CP4	21.79

**ATTENTION QUANTITY USERS!** Big Discounts Are Yours... Call or Write For Our 1000 Tube "Private Label" Special!  
**Money cheerfully refunded within five (5) days, if not satisfied!**  
**SHIPPING INSTRUCTIONS: TRU-VAC® PAYS YOUR POSTAGE** on orders of \$5 or more in USA and Territories. Send approximate postage on Canadian and foreign orders. Any order less than \$5 requires 25¢ handling charge. Send 25¢ on C.O.D.'s!  
**ANY TUBE NOT LISTED ALSO AVAILABLE AT 35¢ EACH!**

**Sensational Offer!**  
"Self Service"  
**TUBE CHECKERS**  
**\$37.95** FOB Our Warehouse

Let your customers test their own tubes! These reliable, checkers will test your investment in return your investment in one week or less with little or no effort on your part! Handsome, field-PLATE WITH KEY FOR LIGHTED DOOR AND NEON-RED HEAD!

## TRU-VAC

Harrison Avenue • Box 107 • Harrison, N. J. Humboldt 4-9770

# POPULAR ELECTRONICS

## Advertisers' Index

July 1961

ADVERTISER	PAGE
Airex Radio Corporation.....	28
A.E.S., Inc. ....	3
Allied Radio .....	27, 123
Bailey Technical Schools.....	20
Browning .....	119
Bud Radio, Inc. ....	121
Burstein-Applebee Co. ....	122
Cadre Industries Corp. ....	SECOND COVER
Capitol Radio Engineering Institute.....	15
Cleveland Institute of Electronics.....	13
DeVry Technical Institute.....	5
EICO .....	40
Electro-Voice, Inc. ....	1
Electronic Organ Arts.....	115
Electronics Book Service.....	38, 39
Grantham School of Electronics.....	7
Greenlee Tool Co. ....	30
Grove Electronic Supply Company.....	123
Hallicrafters .....	14
Heath Company .....	106, 107
Holt, Rinehart and Winston, Inc.....	109
Hy-gain Antenna Products.....	24, 117
Indiana Technical College.....	122
International Communications Co. ....	29
Johnson Co., E. F. ....	30, 117
Kaar Engineering Corp. ....	12
Key Electronics .....	119
Kuhn Electronics Inc. ....	24
Lafayette Radio .....	21
Lektron .....	113
Milwaukee School of Engineering.....	26
Mosley Electronics Inc. ....	12
Moss Electronic, Inc. ....	3rd, 4th, COVER
National Radio Institute.....	33, 34
National Technical Schools.....	11
North American Philips Co., Inc.....	10
Paco Electronics Company, Inc.....	19
Palmer, Joe .....	115
Petersen Radio Co., Inc. ....	28
Picture Tube Outlet.....	119
Port Arthur College.....	119
Progressive "Edu-Kits" Inc.....	31
RCA Institutes, Inc. ....	22, 23
Rad-Tel Tube Co. ....	130
Radio Corporation of America.....	116
Radio-Television Training School.....	9
Radiocom .....	121
Robin Radio Co. ....	122
Scott, Inc., H. H. ....	36
Seco Electronic Inc. ....	111
Spartan School of Electronics.....	18
Springfield Enterprises .....	20
Tri-State College .....	115
Tru-Vac .....	125
Turner Microphone Company, The.....	16
Valparaiso Technical Institute.....	122

an IRC. The veri was for 9610 kc., although their schedule shows only 7245 kc. (WPE4BMR)

**Seychelles**—ZCQ3, *Seychelles B/C Service*, Mahe, is scheduled at 0515-0615 daily in Eng. on 4990 kc. Tune very carefully for this one! (VE7PE2M)

**Spanish Guinea**—R. *Calatrava*, Calatrava, Rio Muni, operates on 6670 kc. at 1100-1455 in the Home Service. The IS is "Ave Maria." DX'ers will have a rough time trying to log this, although it has been done. (VE7PE2M)

**Sudan**—Khartoum s/on at 2315 with Arabic ID as *Huna Omdurman* on 11,855, 9600, and 5039 kc. World news is given to 2330. S/off at 0130. (WPE9AGK)

**Sweden**—Changes in the schedule given last month: 0730-0800 to Far East on 17,845 and 15,420 kc.; 0945-1015 to S. Asia on 17,845

### FREE LEAFLET

Leaflet M. entitled "Call-Sign Allocations of the World," is now ready for distribution by your Short-Wave Editor. Send your request—with return postage—to Box 254, Haddonfield, N. J.

and 15,240 kc.; 1245-1315 to Africa on 15,240 kc.; 2215-2245 to Western N.A. and 0900-0930 and 2045-2115 to Eastern N.A. on 11,805 and 7240 kc. (WPE2BRH, WPE3BSI, WPE4FI, WPE6AA, WPE8BOI, WPE9CEW, WPE0AE, TH)

**Tahiti**—A meteorological station at Papeete broadcasts weather bulletins in French on 7125 kc. at 0010 and 1715. (VE7PE2M)

**Turkey**—The latest complete schedule from Ankara reads: Eng. at 0845-0915 to Asia on 17,820 kc., at 1645-1730 to Europe on 7285 kc. and at 1815-1900 to N.A. on 9515 kc.; Turkish at 0600-0700 and 1100-1115 on 17,820 kc. and at 1545-1645 on 7285 kc.; Arabic at 0000-0045, 1030-1100, and 1230-1300, Persian at 0830-0845 and at 1000-1030. Spanish at 1745-1800, Peshtu at 0800-0830, and Urdu at 0845-0915, all on 17,820 kc.; Serbo-Croat at 1130-1145, Romanian at 1145-1200, Bulgarian at 1200-1215, Greek at 1315-1345, Hungarian at 1345-1400, Polish at 1400-1415, German at 1415-1445, Italian at 1445-1515, and French at 1515-1545, all on 7285 kc. Reports go to Turkish Press, Broadcasting, and Tourist Department, Shortwave Service, Ankara, Turkey. Three IRC's should be sent with your report. (WPE1CHS, WPE2BAZ, WPE2DJD, WPE4BVK, WPE4CEX, WPE5AG, WPE8BOI, WPE8CXT)

**Uruguay**—According to the World Radio Missionary Fellowship, Inc., HCJB, Quito, Ecuador, is in the process of purchasing *La Voz del Pueblo*, Montevideo, for use in reaching the southern countries of South America via the long waves. (WPE8AGY)

**Venezuela**—YVKO, *Radio Nacional de Venezuela*, Caracas, is again active on 6170 kc. after a long absence; it is heard at 0600-0700 and 1900-0000. YVKP, *R. Tropical*, Caracas, has moved from 4900 to 4870 kc. where it is heard at 1900-2330. (WPE4BMR, WPE4FI)

-30-





# ELECTRONICS MARKET PLACE

RATE: 60¢ per word. Minimum 10 words prepaid. September issue POPULAR ELECTRONICS, 1 Park Ave., New York 16, N. Y.

closes July 10th. Send order and remittance to Martin Lincoln.

## FOR SALE

**AUTO** Radio Distributor, Selling, Servicing, Becker Blaupunkt, FM-AM, other European, American Sets. Save 30% + Square Electronics, 150-60 Northern Blvd., Flushing, N. Y.

**CITIZENS' BAND!** Add a Hushpuppy noise suppressor to your Heathkit, Lafayette, Globe, etc. transceiver. Squelch Action! Completely Wired. Guaranteed, \$4.98. Western Mass. Electronics, Great Barrington 1, Mass.

**GOVERNMENT** Sells Surplus: Electronics; Oscilloscopes; Transceivers; Test Equipment; Radar; Sonar; Walkie-Talkies; Boats; Jeeps; Aircrafts; Misc.—Send for "U.S. Depot Directory & Procedures"—\$1.00—Brody, Box 425(PE), Nanuet, New York.

**TV Tuners—Rebuilt or Exchanged** \$9.95 complete—all types—fast, guaranteed service. Send tuner with all parts to: L.A. Tuner Exchange, 4611 West Jefferson Blvd., Los Angeles 16, California.

**GOVERNMENT** Surplus Receivers, Transmitters, Snooper-scopes, Parabolic Reflectors, Picture Catalog 10¢. Meshna, Malden 48, Mass.

**WPE-SWL-CB-QSL** Cards — Samples 10¢ — "Brownie" W3CJ1, 3110A Lehigh, Allentown, Penna.

**DIAGRAMS** for repairing radios \$1.00. Television \$2.00. Give make, model. Diagram Service, Box 672-PE, Hartford 1, Conn.

**BEFORE** You Buy Receiving Tubes or Hi-Fi Components send now for your giant Free Zalytron current catalog—featuring nationally known Zalytron First Quality TV-Radio Tubes, Hi-Fi Stereo Systems, Kits, Parts, etc. All priced to Save You Plenty—Why Pay More? Zalytron Tube Corp., 220 W. 42nd St., NYC.

**CITIZENS** Band—Amateurs! Add squelch action to your transceivers. OZCO "Snoozer" quiets beyond belief! Compact, completely wired, guaranteed. Easily installed! Only \$2.00 each, \$3.95 pair, postpaid, tax included. OZCO Sales, Canaan, Connecticut.

**UNUSUAL** Electrical Devices Wholesale. Literature 25c. Wellco Products, Box 3055, North Hollywood, California.

**CB—WPE.** Send Your Call and \$1.00 for Three giant 11"x7" Call Signs. New! Cbers Business Cards, Samples Free. P.O. Box 933Q, Aurora, Ill.

**10** Distance Crystal Set plans—25¢; 20 different—50¢, including Transistor experiments, catalog. Laboratories, 1131-L Valota, Redwood City, California.

**PHOENIX** Experimenters. Surplus Components. Beacon Electronics. Open Saturdays. 1226 S. 26th St., Phoenix, Arizona.

**CITIZEN**-Band Crystals—Direct From Manufacturer. Guaranteed .005% Tolerance. Send Only \$1.75 For Each Crystal With Equipment Mfg. Name, Model No. And Channel No. To Michigan Crystal Co., Inc., Box 413, Lansing, Michigan.

**SOUND** Operated Relay—For Dictating or Private use—Actuate recorder only when sound is present—literature and price. WJS Electronics, 1130 North Highland Ave., Hollywood 38, Calif.

**TELETYPE.** Build your own for less than \$50. Copy wireless News Service, Government, Hams. Construction Plans...\$4.75. DB Enterprises, 8959 Wonderland Ave., Hollywood 46, Calif.

**CODE** By Sleep Teaching. Guaranteed. 4 taped lessons to 18 WPM: \$12.95 each. Electrosleep, 8959 Wonderland Ave., Hollywood 46, Calif.

**MORSE** Code Copier. Automatic like Teletype. Costs less than \$45 to build. Complete Construction details. \$4.75. DB Enterprises, 8959 Wonderland Ave., Hollywood 46, Calif.

**BRASS** Rivets and Eyelets: 500 Piece Assortment—includes diameters 1/16", 3/32", 1/8",—Various Lengths. Some Nickel and Tin Plated. Send only \$1.00, Postpaid. Ace Industrial Supply Co., 186 East 2nd St., New York 9, New York.

**CB QSL's**—\$1.75 per 100 postpaid. Glossy, red and green. Free sample. Hobby Print Shop, Umatilla, Fla.

**RARE,** hard to get Tubes. State your needs. Airway, 10144 W. Jefferson, River Rouge 18, Michigan.

**"TV Life-Saver"** eliminates 3 out of 4 TV breakdowns. Saves you money. Just plug in. Pat. #2,914,637. Send only \$1.00, pay postman \$3.95 plus COD postage, or send \$4.95 for postpaid delivery. TV Life-Saver, Box 66, Hallandale, Florida.

**PRINTED** Circuit Preamp! Square wave tested response 5-40 kc. Master control center. Volume, bass, treble, selector, equalization, speaker selector. Six inputs, extra recording output. We supply completed printed circuit board, schematic, pictorials, complete parts list, step-by-step instructions. Simple enough for beginners, yet professional quality. \$4.95. Avant Research, 95 Rolling Lane, Needham 92, Mass.

**HEAT** Sinks—For diamond shaped transistors. 2/\$1.00 Ppd. Zimco, Box 77, Barton, Wisconsin.

**TELEPHONE** Extension in your Car. Answer your home telephone by radio from your car. Complete diagrams and instructions \$2.00. C. Carrier Co., 5880 Hollywood Blvd., Hollywood 28, Calif.

**EAVESDROP** with a pack of cigarettes. Miniature transistorized FM Radio Transmitter. Complete diagrams and instructions \$2.00. C. Carrier Co., 5880 Hollywood Blvd., Hollywood 28, Calif.

**POLICE** Radar Detector. Stop before those radar speed traps. Fool proof, legal system. Complete diagrams and instructions \$2.75. C. Carrier Co., 5880 Hollywood Blvd., Hollywood 28, Calif.

**BE A Spy.** Correspondence course on wire tapping, bugging, telescopic sound pickup, recording techniques, microphotography, and invisible photography. Lessons in surveillance, tailing, and use of equipment. Complete course \$22.50. C. Carrier Co., 5880 Hollywood Blvd., Hollywood 28, Calif.

**TV** Tape Recorder. Build your own Video Recorder. Complete correspondence course and construction details. \$22.50. C. Carrier Co., 5880 Hollywood Blvd., Hollywood 28, Calif.

**COLOR TV.** Convert your black and white TV to color. Completely Electronic. No mechanical gadgets. Costs about \$35. Complete construction details \$4.75. DB Enterprises, 8959 Wonderland Ave., Hollywood 46, Calif.

**JUNK** your Distributor and Voltage Regulator. Improve automobile mileage and performance. Construction details for transistorized distributor and voltage regulator \$4.75. No moving parts. DB Enterprises, 8959 Wonderland Ave., Hollywood 46, Calif.

**TV** Camera. Build for less than \$50. Construction Details \$4.75. DB Enterprises, 8959 Wonderland Ave., Hollywood 46, Calif.

**TELEPHONE** Voice Switch (LS-500). Actuates automatically and unattended any tape or wire recorder. Pictorial installation instructions included. \$23.75. Post Paid US. WJS Electronics, 1130 N. Highland Ave., Los Angeles 38, Calif.

**INVESTIGATORS!** Do your own sound work. Write for free brochure of latest electronic equipment. WJS Electronics, 1130 N. Highland Ave., Los Angeles 38, Calif.

**"CITIZEN** Band Power Output Meter 0.5 Watts. Quality American Made Power Output Meter For Getting Peak C-B Performance. \$18.75 Free Literature. SWECO, Box 226, Bakersfield, Calif."

**"ROCKETRY,** Electronics. Parts, Plans. Pricelist 10c (Refundable). AMSEC, Jeffersonton, Kentucky."

**TINY** Radio. No Tubes—Batteries or Transistors. Works forever. Send stamp for catalogue. Midway Radio, Dept. 7E, Kearney, Nebr.

**WORLDWIDE** All-Wave Low-Cost Portable Radio. Send stamp for catalogue. Western Radio Dept. 7E, Kearney, Nebr.

**TALK** from House to Car or to any Radio with Walkie Talkie. Send stamp for catalogue. Western Radio, Dept. 7E, Kearney, Nebr.

**WORLD'S** Tiniest Transistor Radio—Many others. Send stamp for catalogue. Western Radio, Dept. 7E, Kearney, Nebr.

**TALK** to others—Miles Away with Low-Cost Radio-phone—No license. Send stamp for circular. Western Radio, Kearney, Nebr.

**HEAR** Russia—Europe—the Whole World! Short-Wave Adapter works on any radio—no hookups. Send stamp for catalogue. Western Radio, Dept. 7E, Kearney, Nebr.

**"SPECIAL!** WPE-SWL-CB-QSL cards, 3 colors, \$2.50 per 100—Free Samples, Garth, Jutland, New Jersey."

**MOST** Television, radio engineers, performers and other personnel started without previous experience. Thousands more needed for high pay, on the job training. Don't waste time and money on useless courses. Start right now. No license required. We supply list of job types available for beginners. Details on who to see, where to go, what to say etc. \$5.00. Nothing else to pay. Broadcasting Placement Services, Box 7263, Houston 8, Texas.

**DIRECTIONAL** microphone picks up a whisper at great distances. Used by detectives, broadcasters. Build for \$6.00 in one evening. No technical skill required. Complete plans \$2.50. Dee Company, Box 7263, Houston 8, Texas.

**EMERGENCY** Power Convert auto type generator for 120v 60cy output to 750w instructions \$2.50 winding kit less generator \$7.95. W. H. Houck, Box 8331, Orlando, Fla.

**CITIZENS' Band Operators**—New "Noistop" eliminates ignition interference from nearby vehicles—no suppression needed your car either! Boosts range by hearing weak signals without jamming from trucks! For all but super-regen types. Complete with instructions for Eico, Elmac, Globe, Gosset, Johnson, Lafayette, Polycomm, Utica. \$15.95. Others send your unit and additional \$5.00 we'll install "Noistop". Business Radio, Box 5652, Minneapolis 17, Minnesota.

**ADULT Party Record and Catalog:** \$1.00. DRC-11024 Magnolia No. Hollywood, Calif.

**LIGHTING Kit** . . . For designers, inventors, hobbyists. Contains 29 different lampholders, 8 lamp varieties, lamp shields, jumpers, resistors, power cord. \$15.00, Leecraft Mfg. Co., 60 Greene St., NYC.

**ELECTRONIC-Scientific Kits** by Kit-tronics. Metal Detector, SW Radio, Experimental kits. Catalog and Discount Certificate 10c. Kit-tronics Corporation, Dept. B-11, 6509 Whitman Avenue, Van Nuys, California.

**DETECT** police radar traps before they detect you, ingenious! Plans and instructions \$1. Universal electric tachometer plans with calibration instructions \$1. Wardell Smith, Electronic Design, 65 Glenwood Rd., Upper Montclair, N. J.

## WANTED

**QUICKSILVER**, Platinum, Silver, Gold. Ores Analyzed. Free Circular. Mercury Terminal, Norwood, Massachusetts.

**WANTED** Circulated Indian Cents, Liberty V-Nickels And Buffalo Nickels Before 1936. 10¢ each In Large Quantities No Mutilated Coins Send To John J. Firpo, 2107 Van Ness, San Francisco 9, California.

**TRIGGER**—W9IVJ. We Buy Shortwave Equipment For Cash. 7361 W. North, River Forest, Ill., Phone PR 1-8616. Chicago TU 9-6429.

## HIGH-FIDELITY

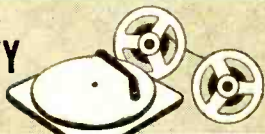

**DISGUSTED** with "Hi!" Hi-Fi Prices? Unusual discounts on your High Fidelity Requirements. Write Key Electronics, 120 Liberty St., New York 6, N. Y. Cloverdale 8-4288.

**DON'T** Buy Hi-Fi Components, Kits, Tape, Tape Recorders until you get our low, low return mail quotes: "We Guarantee Not To Be Undersold." Wholesale Catalog Free. Hi-Fidelity Center, 220 PC-E.23 St., New York 10, N. Y.

**PRICES?** The Best! Factory-Sealed Hi-Fi Components? Yes! Send for free catalog. Audion. 25P Oxford Road, Massapequa, N. Y.

**RECORDERS**, Components. Free wholesale catalogue. Carston. 125-P East 88. N. Y. C. 28.

**PROMPT** Delivery. We Will Not Be Undersold. Amplifiers, Tape Recorders, Tuners, Etc. No Catalogs, Air Mail Quotes. Compare. L. M. Brown Sales Corp. Dept. P, 239 E. 24 St., N.Y. 10, N.Y.

**SOUNDTASTIC!** That's what our customers are saying upon receiving our prices on our latest High Fidelity Stereo and Monaural, Amplifiers, tuners, turntables, speakers, tape recorders, kits. All brand new with factory guarantee. Individual quotations only. No catalogues. Audio World, 2057 Coney Island Avenue, Brooklyn 23, New York. Dept. HR.

## TAPE & RECORDERS

**TAPE Recorders**, Hi-Fi, components. Sleep Learning Equipment, tapes. Unusual Values. Free Catalog. Dressner. 1523PE, Jericho Turnpike, New Hyde Park, N. Y.

**RENT** Stereo Tapes—over 2,000 different—all major labels—free catalog. Stereo—Parti. 811-G Centinela Ave., Inglewood 3, California.

**BUILD** This Stereo Hi-Fi Magnetic Tape Playback, Equivalent in Essentials to \$1000. Instrument. Complete Plans and Instructions Available. Send 10¢ For Description and Specifications. Merlyn Company (PE-7) Box 3053-A, Pasadena, Calif.

**NEW** self-hypnosis tape or LP record teaches you quickly, easily. Free literature. McKinley Co., Box 3038, San Bernardino, California.

## INSTRUCTION

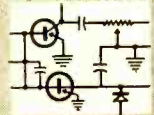

**ENGINEERING** Education for the Space Age. Northrop Institute of Technology is a privately endowed, nonprofit college of engineering offering a complete Bachelor of Science Degree Program and Two-Year accredited technical institute curricula. Students from 50 states, many foreign countries. Outstandingly successful graduates employed in aeronautics, electronics, and space technology. Write today for catalog—no obligation. Northrop Institute of Technology, 1179 West Arbor Vitae Street, Inglewood 1, California.

**EXPERIMENT** with nature's electronics. Instructions—Stillwater, Box 337E, Morris Plains, New Jersey.

**PHOTOGRAPHY** For Pleasure or profit. Learn at home. Practical basic training. Long established school. Free booklet. American School of Photography, 835 Diversey Parkway, Dept. 253B, Chicago 14, Illinois.

**EARN** \$150 Week as Electronics Draftsman. Send \$2 first lesson, or \$25 complete home study course. Prior, Inc., Dept. 12, 23-09 169 Street, Whitestone 57, New York.

**LEARN** Calculus, Easy, Practical, Trial 4 lessons \$1. Mathco, 4256-8 Minmor, Cincinnati 17, Ohio.

## REPAIRS and SERVICING

**LET** us wire and test any kit for you. Naczas Kit Service, 18 Wolfe Street, Manchester, New Hampshire.

## INVENTIONS WANTED

**INVENTIONS** wanted. Patented; unpatented. Global Marketing Service, 2420-P 77th. Oakland 5, Calif.

**INVENTIONS** Wanted for immediate promotion! Patented, unpatented. Outright cash; royalties! Casco, Dept. BB. Mills Building, Washington 6, D.C.

## BUSINESS OPPORTUNITIES

**I WANT A MAN** who wants a business of his own. I will train you, supply the equipment, help finance you, start you rolling. This is not a risky get-rich-quick scheme. It is a legitimate business, exclusive protected franchise, proved successful by hundreds throughout the country. Send name, address and phone number to Marion Wade, 2117 North Wayne, Dept. 145M, Chicago 14, Illinois.

**SELL** Champion, A-C sparkplugs, Reconditioned. Guaranteed 10,000 miles. 100% profit. Cisco 3302-P La-Branch, Houston 4, Texas.

**DRAFTED**, Must Sell Business. Quick. Dave's T.V. Renville, Minnesota.

**ELECTROPLATING** equipment and supplies. All types for Home work and shops. Free catalog. HBS Equipment Division, 1624 East First Street, Los Angeles 33, California.

**SOMEONE** "borrowing" your personal copy of Popular Electronics each month? You ought to be taking advantage of Popular Electronics' convenient re-sale plan. Sell copies in your store . . . perform a good service for your customers . . . with no risk involved. For details, write: Direct Sales Department, Popular Electronics, One Park Avenue, New York 16, New York.



## SHOPPING GUIDE

### Classified

A HANDY REFERENCE TO PRODUCTS AND SERVICES NOT NECESSARILY ELECTRONIC, BUT OF WIDE GENERAL INTEREST

### PHOTOGRAPHY—FILM EQUIPMENT, SERVICES

**SCIENCE Bargains**—Request Free Giant Catalog "CJ"—144 pages—Astronomical Telescopes, Microscopes, Lenses, Binoculars, Kits, Parts. War surplus bargains. Edmund Scientific Co., Barrington, New Jersey.

**PHOTOMURALS** Individually Made Any Size or Color Your Negative Or Choose From Our Thousands. Brochure 50¢. Al Greene Associates, 1333 South Hope Street, Los Angeles 15, California.

### STAMPS & COINS

**TERRIFIC Stamp Bargain!** Israel—Iceland—Vatican Assortment—plus exotic triangle set—also of fabulous British Colonial Accumulation—Plus large stamp book—All four free—Send 10¢ to cover postage. Empire Stamp Corp., Dept. Z2, Toronto, Canada.

200 Different U.S. Stamps \$1.00 Approvals included. Shelron, Box 907-H, New York 8, N. Y.

**TRUNKFUL** 25,000 Indian—Lincoln Cents mixed (from the 1920's & some much older). Will pack "grab-bag" style. 800 mixed for \$50. Sample bag of 22—\$2. Money Back Guar. Mrs. Fischer, 5 Centre St., Hempstead 94, N. Y.

**GIGANTIC Collection Free!** Includes triangles, early United States, animals, commemoratives, British Colonies, high value pictorials, etc. Complete collection plus big illustrated magazine all free. Send 5¢ for postage. Gray Stamp Company, Dept. Z2, Toronto, Canada.

**SELLING** entire personal stamp collection. All foreign. Good condition. Assorted packets of 50—25¢ and self-addressed, stamped envelope. Popular Electronics, Box 107, One Park Avenue, New York 16, New York.

### EDUCATIONAL OPPORTUNITIES

**DETECTIVE Profession.** Home Study. Badge. Certificate. Future. 4563 AG York, Los Angeles 41, Calif.

### LEATHERCRAFT

**FREE "Do-It-Yourself"** Leathercraft Catalog. Tandy Leather Company, Box 791-W-41, Fort Worth, Texas.

**FREE!** New 1961 catalog of all photographic books available. For your copy, send postcard with name and address to Catalog Popular Photography Book Service, One Park Ave., New York 16, N. Y.

### BOOKS

**BOOKS**—All 10¢. 2000 titles, all subjects, catalog free. Cosma, Clayton, Ga.

**THOUGHT** books; 300 titles. Catalogue free. Truth Seeker Co., 38 Park Row, New York 8.

### EMPLOYMENT INFORMATION

**HIGH Paying Jobs in Foreign Lands!** Send \$2.00 for complete scoop! Foreign Opportunities, Box 172, Columbus 16, Ohio.

**EARN** Extra money selling advertising book matches. Free samples furnished. Matchcorp, Dept. MD 71, Chicago 32, Illinois.

### BUSINESS OPPORTUNITIES

**BUY** Direct from factories. Appliances, cameras, watches! Free details! Cam Co., 6810PE 20th Ave., Brooklyn 4, N. Y.

**VENDING** Machines—No Selling. Operate a route of coin machines and earn amazing profits. 32-page catalog free. Parkway Machine Corporation, Dept. 12, 715 Ensor St., Baltimore 2, Md.

**FREE** Book "990 Successful, Little-Known Businesses." Work home! Plymouth—455R, Brooklyn 4, New York.

**GROW** Mushrooms. Cellar, shed and outdoors. Spare, full time, year round. We pay \$4.50 lb. dried. We have 29,000 customers. Free Book. Mushrooms. Dept. 334, 2954 Admiral Way, Seattle, Wash.

**MAKE** \$25-\$50 Week. clipping newspaper items for publishers. Some clippings worth \$5.00 each. Particulars free. National. 81-DG, Knickerbocker Station, New York.

**A Second Income From Oil Can End Your Toil!** Free Book And Oilfield Maps! National Petroleum, Panamerican Bank Bldg.—PE, Miami, Florida.

**AMERICA'S** leading franchise firms are listed in the new 1961 NFR Directory of Franchisors. Use it as your guide to franchise profits. Send one dollar today. National Franchise Reports, ZD-528, 333 North Michigan, Chicago 1.

**EXCLUSIVE** Employment Information free. Nationwide—Worldwide. Box 12, Detroit 13, Mich.

### MISCELLANEOUS

**"WINEMAKING," "Beer, Ale"** Strongest methods. Illustrated. \$2.20. Eaton Bookstore (Supplies), Box 1242-C, Santa Rosa, California.

**UNDERPAID?** Technical Writers Earn \$240.00 Up Week, Easy Condensed course. \$2.00 Tweco, P.O. Box 155, Indio, Calif.

**"COLLEGE** Home Study Manual." 1961 Edition, lists and explains over 6000 Degree-credit Home Study courses offered by fifty leading American Universities. Send \$2 today! College Research Society, North Highlands 3, California.

**"HOMEBREW** Guide" Complete Illustrated Instructions, \$2.00. Hydrometers Available. Cal Brew Supplies, 1225-V Luzern, Seaside, California.

IT'S EASY TO ORDER FROM RAD-TEL

UP TO **75% OFF** ON

RAD-TEL'S FIRST QUALITY

**BRAND NEW TUBES**

**ONE FULL YEAR GUARANTEE**

**SERVICEMEN:** Now speedy one-day service. BUY DIRECT FROM RAD-TEL! YOU'LL SAVE PLENTY. YOUR ORDER SHIPPED WITHIN 24 HOURS AFTER RECEIVING AND PROCESSING. RAD-TEL SELLS ONLY BRAND NEW TUBES. NOT USED.

THE SIGN OF RAD-TEL'S RELIABILITY



**GUARANTEED RAD-TEL TRANSISTORS SET TESTED**

All Transistors Germanium PNP

**AF** ST\* AF Driver. Use as: Driver Low Power Output, Code Osc., DC Amp., Control, Test Instr., Pre-Amp., Timers, Organ, etc. **39c ea.**

**RF** ST\* as Converter in an American set. Use as: Converter Sq. Wave Gen., RF Osc., Amp. Regen. Det., etc. **49c ea.**

**IF** ST\* as 455kc IF in an Amer. set. Use as: IF Amp., Grid Dip Osc., Electronic Computer, RF Osc., Switch, Amp., etc. **49c ea.**

**AUTO OUTPUT** ST\*\* as Audio Power Output into Speaker. 90% of Auto Radios so Powered. Use as Power Amp., Mobile Power Supply, Voltage Regulator, Osc., DC to DC Converters. **79c ea.**

**HI POWER** ST\*\* as Hi Power AF Output. Ideal as DC to DC Converter, Multivibrator replaces Vibrator supply. **\$1.39 ea.**

\* SET TESTED IN AMER. TRANSISTOR RADIO OF CURRENT MFR. \*\* SET TESTED IN AMER. AUTO RADIO OF CURRENT MFR. AT 16 VOLT BATTERY SUPPLY.

Rad-Tel eliminates complicated characteristics and numbers with their "SET-TESTED" Transistors. Transistors Tested to Rad-Tel's specifications—available on request. 100% Satisfaction Guaranteed. Substitute or replace with Rad-Tel Transistors on the basis of similar operating characteristics . . . at Low, Low Prices.

NOT AFFILIATED WITH ANY OTHER MAIL ORDER TUBE COMPANY

SEND FOR FREE TROUBLE SHOOTER GUIDE AND NEW TUBE & PARTS CATALOG

**RAD-TEL TUBE CO.**

DEPT. PE-701 55 CHAMBERS STREET, NEWARK 5, N. J.

TERMS: 25% deposit must accompany all orders, balance C.O.D. Orders under \$5: add \$1 handling charge plus postage. Orders over \$5: plus postage. Approx. 8 tubes per 1 lb. Subject to prior sale. Prices subject to change. No C.O.D.'s outside continental USA.

EACH TUBE INDIVIDUALLY & ATTRACTIVELY BOXED

Qty.	Type	Price	Qty.	Type	Price	Qty.	Type	Price
	0Z4M	.79		6AX7	.64		12AF6	.49
	1AX2	.62		6BA6	.50		12AJ6	.46
	1B3GT	.79		6BC5	.61		12AL5	.45
	1DN5	.55		6BC7	.94		12AL8	.95
	1G3	.79		6BC8	.97		12AQ5	.52
	1J3	.79		6BD6	.51		12AT6	.43
	1K3	.79		6BE6	.55		12AT7	.76
	1LN5	.59		6BF6	.44		12AU6	.50
	1R5	.62		6BG6	1.66		12AU7	.61
	1S5	.51		6BH6	.65		12AV5	.97
	1T4	.58		6BH8	.87		12AV6	.41
	1U4	.57		6BJ6	.62		12AV7	.75
	1U5	.50		6BK7	.85		12AX4	.67
	1X2B	.82		6BL7	1.00		12AX7	.63
	2AF4	.96		6BN4	.57		12AZ7	.86
	3AL5	.42		6BN6	.74		12B4	.63
	3AU6	.51		6BQ5	.65		12BA6	.50
	3AV6	.41		6BQ6GT	1.05		12BD6	.50
	3BA6	.51		6BQ7	1.00		12BE6	.53
	3BC5	.54		6BR8	.78		12BF6	.44
	3BE6	.52		6BU8	.70		12BH7	.77
	3BN6	.76		6BY6	.54		12BL6	.56
	3BU8	.78		6BZ6	.55		12BQ6	1.06
	3BY6	.55		6BZ7	1.01		12BY7	.77
	3BZ6	.55		6C4	.43		12BZ7	.75
	3CB6	.54		6CB6	.55		12C5	.56
	3CF6	.60		6CD6	1.42		12CN5	.56
	3CS6	.52		6CF6	.64		12CR6	.54
	3DK6	.60		6CG7	.61		12CU5	.58
	3DT6	.50		6CG8	.77		12CU6	1.06
	3Q5	.80		6CM7	.66		12CX6	.54
	3S4	.61		6CN7	.65		12DB5	.69
	3V4	.58		6CR6	.51		12DE8	.75
	4BC8	.96		6CS6	.57		12DL8	.85
	4BN6	.75		6CU5	.58		12DM7	.67
	4BQ7	1.01		6CU6	1.08		12DQ6	1.04
	4BS8	.98		6CY7	.71		12DS7	.79
	4BU8	.71		6DA4	.68		12DZ6	.56
	4BZ6	.58		6DB5	.69		12EL6	.50
	4BZ7	.96		6DE6	.58		12EG6	.54
	4CS6	.61		6DGG	.59		12EZ6	.53
	4DE6	.62		6DQ6	1.10		12F8	.66
	4DK6	.60		6D15	.76		12FM6	.45
	4DT6	.55		6D16	.53		12K5	.65
	5AM8	.79		6EU8	.79		12SA7M	.92
	5AN8	.86		6EAB	.79		12SK7GT	.74
	5AQ5	.52		6HGGT	.58		12SN7	.67
	5AT8	.80		6JSGT	.51		12SQ7M	.78
	5BK7A	.82		6J6	.67		12U7	.62
	5BQ7	.97		6K6	.63		12V6GT	.53
	5BR8	.79		6S4	.51		12W6	.69
	5CG8	.76		6SA7GT	.76		12X4	.38
	5CL8	.76		6SK7	.74		17AX4	.67
	5EA8	.80		6SL7	.80		17BQ6	1.09
	5EU8	.80		6SN7	.65		17C5	.58
	5J6	.68		6S07	.73		17CA5	.62
	5T8	.81		6T4	.99		17D4	.69
	5U4	.60		6U8	.83		17DQ6	1.06
	5U8	.81		6V6GT	.54		17L6	.58
	5V6	.56		6W4	.60		17W6	.70
	5X8	.78		6W6	.71		19AU4	.83
	5Y3	.46		6X4	.39		19B6G	1.39
	6AB4	.46		6X5GT	.53		19T8	.80
	6AC7	.96		6X8	.80		21EX6	1.49
	6AF3	.73		7AU7	.61		25BQ6	1.11
	6AF4	.97		7A8	.68		25C5	.53
	6AG5	.68		7B6	.69		25CA5	.59
	6AH6	.99		7Y4	.69		25CD6	1.44
	6AK5	.95		8AU8	.83		25C06	1.11
	6AL5	.47		8AW8	.93		25DN6	1.42
	6AM8	.78		8B05	.60		25EH5	.55
	6AQ5	.53		8C67	.62		25L6	.57
	6AR5	.55		8CM7	.68		25W4	.68
	6AS5	.60		8CN7	.97		25Z6	.66
	6AT6	.43		8CX8	.93		35C5	.51
	6AT8	.79		8EB8	.94		35L6	.57
	6AU4	.82		11CY7	.75		35W4	.42
	6AU6	.52		12A4	.60		35Z5GT	.60
	6AU7	.61		12AB5	.55		50B5	.60
	6AU8	.87		12AC6	.49		50C5	.53
	6AV6	.41		12AD6	.57		50DC4	.37
	6AW8	.90		12AE6	.43		50EH5	.55
	6AX4	.66		12AF3	.73		50L6	.61
							11Z73	.61

# SHIPPED ON APPROVAL NO MONEY WITH ORDER — NO C. O. D.

Superior's New  
Model 82A

## A truly do-it-yourself type TUBE TESTER

TEST ANY TUBE IN 10 SECONDS FLAT!

- ① Turn the filament selector switch to position specified.
- ② Insert it into a numbered socket as designated on our chart (over 600 types included).
- ③ Press down the quality button —

**THAT'S ALL! Read emission quality direct on bad-good meter scale.**

### FEATURES:

- Tests over 600 tube types. • Tests OZ4 and other gas-filled tubes. • Employs new 4" meter with sealed air-damping chamber resulting in accurate vibrationless readings. • Use of 22 sockets permits testing all popular tube types and prevents possible obsolescence. • Dual Scale meter permits testing of low current tubes. • 7 and 9 pin straighteners mounted on panel. • All sections of multi-element tubes tested simultaneously. • Ultra-sensitive leakage test circuit will indicate leakage up to 5 megohms.

Production of this Model was delayed a full year pending careful study by Superior's engineering staff of this new method of testing tubes. Don't let the low price mislead you! We claim Model 82A will outperform similar looking units which sell for much more—and as proof, we offer to ship it on our examine before you buy policy.

Model 82A comes housed in handsome, portable, Saddle-Stitched Texan case. Only... **\$36.50** Net



Model 82A—Tube Tester  
Total Price **\$36.50**  
Terms: \$6.50 after 10 day trial, then \$6.00 monthly for 5 months if satisfactory. Otherwise return, no explanation necessary.



Model 77—VACUUM TUBE VOLT-METER... Total Price... **\$42.50**  
Terms: \$12.50 after 10 day trial, then \$6.00 monthly for 5 months if satisfactory. Otherwise return, no explanation necessary.

Superior's  
New  
Model 77

## VACUUM TUBE VOLTMETER WITH NEW 6" FULL-VIEW METER

Compare it to any peak-to-peak V. T. V. M. made by any other manufacturer at any price!

- Extra large meter scale enables us to print all calibrations in large easy-to-read type.
- Employs a 12AU7 as D. C. amplifier and two 9006's as peak-to-peak voltage rectifiers to assure maximum stability. • Meter is virtually burn-out proof. The sensitive 400

AS A DC VOLTMETER: The Model 77 is indispensable in Hi-Fi Amplifier servicing and a must for Black and White and color TV Receiver servicing where circuit loading cannot be tolerated.

AS AN ELECTRONIC OHMMETER: Because of its wide range of measurement leaky capacitors show up glaringly. Because of its sensitivity and low loading, Intermittents are easily found, isolated and repaired.

AS AN AC VOLTMETER: Measures RMS values if sine wave, and peak-to-peak value if complex wave. Pedestal voltages that determine the "black" level in TV receivers are easily read.

micro-ampere meter is isolated from the measuring circuit by a balanced push-pull amplifier. • Uses selected 1% zero temperature coefficient resistors as multipliers. This assures unchanging accurate readings on all ranges.

### SPECIFICATIONS

- DC VOLTS—0 to 3/15/75/150/300/750/1,500 volts at 11 megohms input resistance.
- AC VOLTS (RMS)—0 to 3/15/75/150/300/750/1,500 volts. • AC VOLTS (Peak to Peak)—0 to 8/40/200/400/800/2,000 volts.
- ELECTRONIC OHMMETER—0 to 1,000 ohms/10,000 ohms/100,000 ohms/1 megohm/10 megohms/100 megohms/1,000 megohms. • DECIBELS: -10 db to +18 db, +10 db to +38 db, +30 db to +58 db. All based on 0 db = 006 watts (6 mw) into a 500 ohm line (1.73v). • ZERO CENTER METER—For discriminator alignment with full scale range of 0 to 1.5/7.5/37.5/75/150/375/750 volts at 11 megohms input resistance.

Comes complete with operating instructions, probe leads, and streamlined carrying case. Operates on 110-120 volt 60 cycle. Only... **\$42.50**

We invite you to try before you buy any of the models described on this page and the following page. If after a 10 day trial you are completely satisfied and decide to keep the Tester, you need send us only the down payment and agree to pay the balance due at the monthly indicated rate.

**NO INTEREST  
OR FINANCE  
CHARGES ADDED!**

If not completely satisfied, you are privileged to return the Tester to us, cancelling any further obligation.

**SEE OTHER  
SIDE**

CUT OUT AND MAIL TODAY! ▶

MOSS ELECTRONIC, INC.

Dept. D-890 3849 Tenth Ave., New York 34, N. Y.

Please send me the units checked on approval. If completely satisfied I will pay on the terms specified with no interest or finance charges added. Otherwise, I will return after a 10 day trial positively cancelling all further obligation.

Model 77 Total Price \$42.50  
\$12.50 within 10 days. Balance  
\$6.00 monthly for 5 months.

Model TV-50A Total Price \$47.50  
\$11.50 within 10 days. Balance  
\$6.00 monthly for 6 months.

Model 82A Total Price \$36.50  
\$6.50 within 10 days. Balance  
\$6.00 monthly for 5 months.

Model 70 Total Price \$15.85  
\$3.85 within 10 days. Balance  
\$4.00 monthly for 3 months.

Name: \_\_\_\_\_  
Address: \_\_\_\_\_  
City: \_\_\_\_\_ Zone: \_\_\_\_\_ State: \_\_\_\_\_

All prices net, F.O.B., N. Y. C.

# SHIPPED ON APPROVAL NO MONEY WITH ORDER — NO C.O.D.

Superior's New Model 70 UTILITY TESTER®

## FOR REPAIRING ALL ELECTRICAL APPLIANCES and AUTOMOBILE CIRCUITS



As an electrical trouble shooter the Model 70:

- Will test Toasters, Irons, Broilers, Heating Pads, Clocks, Fans, Vacuum Cleaners, Refrigerators, Lamps, Fluorescents, Switches, Thermostats, etc.
- Measures A.C. and D.C. Voltages, A.C. and D.C. Current, Resistances, Leakages, etc.
- Will measure current consumption while the appliance under test is in operation.
- Incorporates a sensitive direct-reading resistance range which will measure all resistances commonly used in electrical appliances, motors, etc.
- Leakage detecting circuit will indicate continuously from zero ohms to 5 megohms (5,000,000 ohms).

As an Automotive Tester the Model 70 will test:

- Both 6 Volt and 12 Volt Storage Batteries • Generators • Starters • Distributors • Ignition Coils • Regulators • Relays • Circuit Breakers • Cigarette Lighters • Stop Lights • Condensers • Directional Signal Systems • All Lamps and Bulbs • Fuses • Heating Systems • Horns • Also will locate poor grounds, breaks in wiring, poor connections, etc.

**INCLUDED FREE** This 64-page book—practically a condensed course in electricity. Learn by doing.

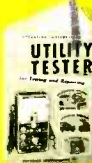

Just read the following partial list of contents: What is electricity? • Simplified version of Ohms Law • What is wattage? • Simplified wattage charts • How to measure voltage, current, resistance and leakage • How to test all electrical appliances and motors using a simplified trouble-shooting technique. • How to trace trouble in the electrical circuits and parts in automobiles and trucks.

Model 70 comes complete with 64 page book and test leads

**\$15<sup>85</sup>**  
Only

Model 70—UTILITY TESTER  
Total Price...\$15.85—  
Terms: \$3.85 after 10 day trial,  
then \$4.00 monthly for 3 months,  
if satisfactory. Otherwise return, no  
explanation necessary.

Superior's New Model TV-50A

## GENOMETER

### 7 Signal Generators in One!

- ✓ R.F. Signal Generator for A.M.
- ✓ R.F. Signal Generator for F.M.
- ✓ Audio Frequency Generator
- ✓ Marker Generator
- ✓ Bar Generator
- ✓ Color Dot Pattern Generator
- ✓ Cross Hatch Generator

This Versatile All-Inclusive GENERATOR Provides ALL the Outputs for Servicing:

- A.M. RADIO • F.M. RADIO • AMPLIFIERS • BLACK AND WHITE TV • COLOR TV

**R. F. SIGNAL GENERATOR:** 100 Kilo-cycles to 60 Megacycles on fundamentals and from 60 Megacycles to 180 Megacycles on powerful harmonics.

**VARIABLE AUDIO FREQUENCY GENERATOR:** Provides a variable 300 cycle to 20,000 cycle peaked wave audio signal.

**MARKER GENERATOR:** The following markers are provided: 189 Kc., 262.5 Kc., 456 Kc., 600 Kc., 1000 Kc., 1400 Kc., 1600 Kc., 2000 Kc., 2500 Kc., 3579 Kc., 4.5 Mc., 5 Mc., 10.7 Mc., (3579 Kc. is the color burst frequency)

**BAR GENERATOR:** Pattern consists of 4 to 16 horizontal bars or 7 to 20 vertical bars.

**DOT PATTERN GENERATOR (FOR COLOR TV):** The Dot Pattern projected on any color TV Receiver tube by the Model TV-50A will enable you to adjust for proper color convergence.

**CROSS HATCH GENERATOR:** The pattern consists of non-shifting horizontal and vertical lines interlaced to provide a stable cross-hatch effect.

Complete with shielded leads

**\$47<sup>50</sup>** Net



Model TV50-A—Genometer  
Total Price \$47.50  
Terms: \$11.50 after 10 day trial,  
then \$6.00 monthly for 6 months  
if satisfactory. Otherwise return,  
no explanation necessary.

## TRY FOR 10 DAYS BEFORE you buy! THEN if satisfactory

pay in easy, interest free, monthly payments. See coupon inside.

We invite you to try before you buy any of the models described on this and the preceding page. If after a 10 day trial you are completely satisfied and decide to keep the Tester, you need send us only the down payment and agree to pay the balance due at the monthly indicated rate. (See other side for time payment schedule details.)

**NO INTEREST  
OR FINANCE  
CHARGES ADDED!**

If not completely satisfied, you are privileged to return the Tester to us, cancelling any further obligation.

**SEE OTHER  
SIDE**

CUT OUT AND MAIL TODAY!

FIRST CLASS

Permit No. 61430

New York, N. Y.

VIA AIR MAIL

BUSINESS REPLY CARD

No Postage Stamp Necessary if Mailed in the U. S.

POSTAGE WILL BE PAID BY —

MOSS ELECTRONIC, INC.

3849 TENTH AVENUE

NEW YORK 34, N. Y.