

Hi-Fi Loudspeakers — Why They Sound Different

POPULAR ELECTRONICS

OCTOBER
1960

35
CENTS

HI-FI • HAM & CITIZENS RADIO

You can make:

- Transistors Eliminate Auto Vibrators
- Converter to Pull In Short Waves
- Antenna Stubs to Pep Up CB Reception

Also:

- Why Satellites Use Pulse Modulation

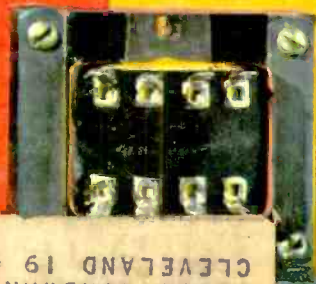
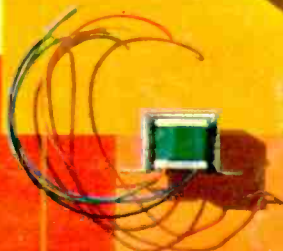
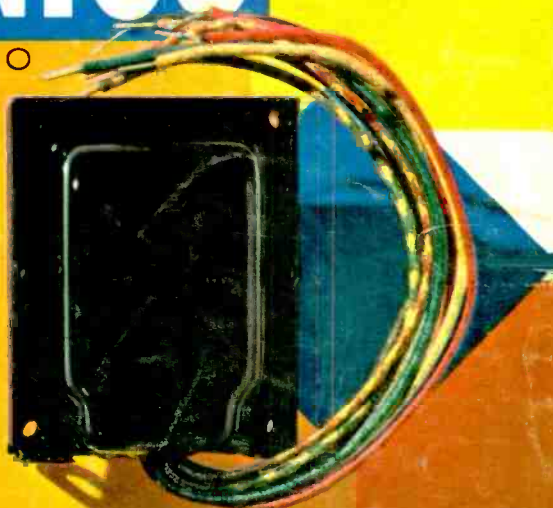

Spe
16 Pa

20S106811
LOUIS HOFFART
18108 WINDWARD
CLEVELAND 19 OHIO



CLASSICS THAT MADE THE HIT PARADE

— a new bonus reel from Audiotape

DETAILS OF THE PROGRAM

"Classics that Made the Hit Parade" includes these popular symphonic themes:

Borodin	Polovtsian Dances from Prince Igor (Stranger in Paradise)
Tchaikovsky	Symphony No. 5 in E (Moon Love)
Waldteufel	Espana Waltz (Hot Diggity)
Chopin	Polonaise No. 6, in Ab Major (Till the End of Time)
Tchaikovsky	Symphony No. 6 in B (The Story of a Starry Night)
Rachmaninoff	Piano Concerto No. 2 in C Minor (Full Moon and Empty Arms)
Chopin	Fantasia Impromptu in C= Minor (I'm Always Chasing Rainbows)
Tchaikovsky	Romeo and Juliet Overture (Our Love)

DETAILS OF THE OFFER

This exciting recording is available in a special bonus package at all Audiotape dealers. The package contains one 7-inch reel of Audiotape (on 1½-mil acetate base) and the valuable "Classics that Made the Hit Parade" program (professionally recorded on Audiotape). For both items, you pay only the price of two reels of Audiotape, plus \$1. And you have your choice of the half-hour two-track stereo program or the 55-minute monaural or four-track stereo versions.

See your Audiotape dealer now.

Some of our greatest popular songs — hits like "Full Moon and Empty Arms," "Till the End of Time," "Stranger in Paradise" — took their melodies from the classics. Eight of these lovely themes — in their original classical setting — are the basis for "Classics that Made the Hit Parade," a program with strength, variety, and, of course, rich melodic beauty.

This unusual program, professionally recorded in sparkling full fidelity on Audiotape, is available RIGHT NOW from Audiotape dealers everywhere. (And only from Audiotape dealers.) Ask to hear a portion of the program, if you like. Then, take your choice of a half-hour of two-track stereo, or 55 minutes of four-track stereo or dual-track monaural sound — all at 7½ ips. Don't pass up this unique opportunity.

"Classics that Made the Hit Parade" makes an ideal addition to Audio's first two bonus reels, "Blood-and-Thunder Classics" and "High Spirits." still available at Audiotape dealers.



audiotape "It speaks for itself!"

AUDIO DEVICES, INC., 444 Madison Ave., N. Y. 22, N. Y.
in Hollywood: 840 N. Fairfax Ave. • In Chicago: 5428 N. Milwaukee Ave.

NOW READY

The NEW NRI Home Study Course in

ELECTRONICS

PRINCIPLES — PRACTICES — MAINTENANCE

SPECIAL TRAINING EQUIPMENT

No extra cost. In NRI Electronics training especially developed training kits bring to life theory you learn in easy, illustrated lessons. You get practical experience with Thyatron Tube circuits, Multivibrators, Capacitors, Diodes, Transistors, Telemetry, Computer Circuits and other basic circuits and components.



KIT 1 Get practical experience measuring voltage, current, building circuits.

KIT 2 Build d'Arsonval type Vacuum Tube Voltmeter. Test power line frequencies, high audio, radio frequency signals, resistances.

KIT 3 Practice with resistors, capacitors, coils. Work with half, full-wave, bridge, voltage doubler and pi-type filter circuits.

KIT 4 Build circuits with pentode tubes, selenium resistors, transistors. Build oscillator, check signal phase shift with oscilloscope.

KIT 5 Experiment with thyatron tube circuits, Lissajous patterns. Study basic amplitude detector circuits, modulation, demodulation.

KIT 6 Get practical experience with magnetic amplifiers, learn to use modified Prony brake; determine motor torque. Use strobe disc to measure motor speed.

KIT 7 Learn effects of positive and negative feedbacks (used in analog computers). Practice varying polarizing voltage and illumination.

KIT 8 Experiment with multivibrators used as timing generators in binary counters, and as frequency dividers. Learn to use blocking oscillators, thermistors.

KIT 9 Practical experience in telemetry circuits used in earth satellites, remote control devices. Work with basic circuits used in digital and analog computers.

KIT 10 Assemble circuits in electrical and electro-mechanical systems, make valuable practical electronic circuits.

MAIL COUPON—New 64-Page Catalog pictures and describes Training Kits, explains what you learn.

NRI is America's oldest, largest home study Radio-Television-Electronics school. For over 45 years NRI has been training men without previous experience for success in Radio-Television Servicing and Communications. Now, expanded uses of Electronics in industry, business and defense are increasing the demand for Electronic Technicians. Four to seven Technicians are needed for every engineer. To meet this demand NRI announces a complete, comprehensive course in **ELECTRONICS—Principles, Practices, Maintenance.**

This training stresses basic fundamentals because so many Electronic devices are built around identical Electronic principles. It is for beginners, or for Technicians who wish to expand their knowledge.



This is the Electronic Age. Electronic Equipment is already being used to count, weigh, control flow of liquids, solids,

gases. Control exposure in photography, detect fumes, or fire. Inspect at remote points. Supervise traffic. Survey land areas and ocean contours. Search for oil, miles beneath the surface. Measure radiation and control power levels in atomic installations. Control air traffic. Translate one language into another. The **MILITARY** applications of Electronics . . . particularly in space rockets and missiles, tracking devices, etc., . . . probably equal all of the uses above. Electronic equipment is used to machine parts through complex cycles. It is used in business to process data, control inventory, prepare payrolls, post, calculate, and in medicine for electrodiagnosis, measure body characteristics, electro-surgery.



Job Counselors Recommend
Right today a career in Electronics offers

unlimited opportunity. Job Counselors know the pay is high, jobs interesting, advancement opportunities great. They advise ambitious, aggressive men who want higher pay now and a better future: "For an interesting career, get into Electronics."

Learn More to Earn More

Simply waiting and wishing for a better job won't get you ahead. You have to decide you want to succeed and *you must act*. NRI can provide the training you need at home in spare time. No need to go away to school. You don't need a high school diploma or previous Electronic experience. This course is planned to meet the needs of beginners. You work and train with components and circuits you will meet throughout your Electronics career. You get especially developed training kits for practical experience that make Electronics easy, simple to learn.



Oldest and Largest School

Training men to succeed, is the National Radio Institute's *only* business. The NRI Diploma is respected and recognized. NRI graduates are everywhere throughout U.S. and Canada. Mail the coupon today. New, FREE 64-page Catalog gives facts, opportunities about careers in Industrial and Military Electronics, also shows what you learn, facts about NRI's other courses in Radio-Television Servicing and Radio-Television Communications. Monthly payments available.

OLDEST & LARGEST HOME STUDY RADIO-TV SCHOOL
National Radio Institute
WASHINGTON 16, D.C. ESTABLISHED 1914

MAIL THIS COUPON NOW

NATIONAL RADIO INSTITUTE
Washington 16, D. C. OKD4A

Send me full information without cost or obligation. No salesman will call. (Please print.)

Name Age

Address

City Zone State

ACCREDITED MEMBER NATIONAL HOME STUDY COUNCIL

POPULAR ELECTRONICS is published monthly by Ziff-Davis Publishing Company, William B. Ziff, Chairman of the Board (1946-1953), at 431 S. Wabash Ave., Chicago 5, Ill. Second-class postage paid at Chicago, Illinois. Authorized by Post Office Department, Ottawa, Canada, as second-class matter. **SUBSCRIPTION RATES:** One year U.S. and possessions, and Canada \$4.00; Pan-American Union Countries \$4.50, all other foreign countries, \$5.00.

POPULAR ELECTRONICS

OCTOBER

1960

VOLUME 13

NUMBER 4



"Bonus" Feature

- The Transformer.....Ken Gilmore 67
Here's the full story of this useful coupling device—from its inception to its present-day uses—complete in a special 16-page "bonus" section

Electronic Construction Projects

- Mobile Short-Wave Converter.....J. A. Stanley 57
Kill Those Harmonics.....Kent A. Mitchell, W3WTO 60
Vibrator Substitute.....Patrick A. Gainer 64
Citizens Band Transceiver Kit.....87
Diode Noise Generator.....Herb S. Brier, W9EGQ 95

Audio and High Fidelity

- Hi-Fi Showcase.....36
Living with Loudspeakers.....John Milder 48
Keeping Your Hi-Fi on the Level.....Art Trauffer 62
AM/FM Stereo Tuner.....101
Super Stereo.....102

Amateur, CB, and SWL

- FCC Report: CB and Amateur News.....Robert E. Tall 8
Amateur Radio—The King of Hobbies.....Donald L. Stoner, W6TNS 41
On the Citizens Band.....Tom Kneitel, 2W1965 86
Across the Ham Bands: Substituting Parts.....Herb S. Brier, W9EGQ 93
Short-Wave Report.....Hank Bennett, W2PNA 105
Short-Wave Monitor Registration.....106

Electronic Features and New Developments

- Notes from the Editor: Reader Services.....Oliver P. Ferrell 6
Language Laboratories.....George Lesko 46
Pulse Modulation.....Herbert Kondo 53
Circuit Quiz.....Robert P. Balin 66
Test Instruments—Bridges (Part 1).....G. H. Harrison 83
The Radar Man.....Educated G.I. 88
X Rays (After Class Feature).....Fred E. Ebel, W9PXA 89
Keep Those Contacts Clean.....Ken Murray 96
Transistor Topics.....Lou Garner 98
Transmitters on the Move.....104
Carl and Jerry: The Crazy Clock Caper.....John T. Frye, W9EGV 112
Pity the Poor Customer.....Charles Rodrigues 114

Departments

- Letters from Our Readers.....12
POP'tronics Bookshelf.....20
New Products.....28
Tips and Techniques.....32

ALLIED value-packed 1961

444-PAGE ELECTRONICS CATALOG

including products available only from Allied



complete
up-to-date

free
send for it today!

SAVE MOST ON EVERYTHING IN ELECTRONICS

- Newest Stereo Hi-Fi Systems— Everything in Hi-Fi Components
- Money-Saving, Build-Your-Own KNIGHT-KITS* for Every Need
- Best Buys in Recorders & Supplies
- Newest Public Address Systems, Paging and Intercom Equipment
- Amateur Receivers, Transmitters, and Station Gear
- Citizen's Band 2-Way Radio
- Test and Laboratory Instruments
- TV Tubes, Antennas, Accessories
- Huge Listings of Parts, Tubes, Transistors, Tools, Books

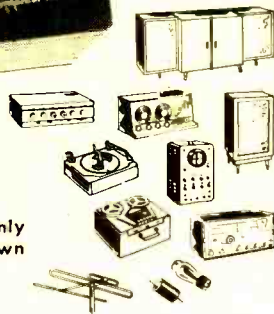

BUY ON EASIEST TERMS ONLY \$2 DOWN

Yes, only \$2 down on orders up to \$50; only \$5 down on orders up to \$200; only \$10 down over \$200. Up to 24 months to pay.

ALLIED Exclusives:

MONEY-SAVING KNIGHT-KITS®—the very best in build-your-own electronic equipment—designed to save you money, easiest to assemble—the only kits offered with Free Inspection Privilege. See the complete selection of Stereo hi-fi kits, Hobbyist kits, Test Instrument and Amateur kits. KNIGHT-KITS are an exclusive ALLIED product.

KNIGHT® STEREO HI-FI—comparable to the best in quality and performance, yet priced far lower in cost. Select super-value KNIGHT components or complete systems and save most. Also see the largest selection of famous-name stereo hi-fi components and money-saving ALLIED-recommended complete hi-fi systems.

ALLIED RADIO

our 40th year

SATISFACTION GUARANTEED
OR YOUR MONEY BACK

World's Largest Electronic Supply House

free

the most complete
electronics catalog!

ALLIED RADIO, Dept. 109-K
100 N. Western Ave., Chicago 80, Ill.

Send FREE 1961 ALLIED Catalog.

Name _____

Address _____

City _____ Zone _____ State _____



POPULAR ELECTRONICS

World's Largest-Selling Electronics Magazine

Average Net Paid Circulation Over 320,000

This month's cover photo by Bruce Pendleton
Equipment courtesy of Chicago Standard
Transformer Corp. and Lafayette Radio

Editor

OLIVER P. FERRELL, 2W1665

Managing Editor

JULIAN M. SIENKIEWICZ, WA2CQL

Art Director

ALFONS J. REICH

Associate Editors

**RICHARD A. FLANAGAN
MARGARET MAGNA
PERRY WINTER, K2VLR**

Editorial Assistants

**FRANCIS PARDO
MARIA SCHIFF**

Editorial Consultant

OLIVER READ, W1ETI

Contributing Editors

**H. BENNETT, W2PNA
H. S. BRIER, W9EGQ
J. T. FRYE, W9EGV
L. E. GARNER, JR.
T. KNEITEL, 2W1965**

Art Associate

J. A. ROTH

Art and Drafting Dept.

**K. W. PAUL, JR.
W. K. VAHLSING, WV2GYL**

Advertising Director

JOHN A. RONAN, Jr., 1W6455

Advertising Manager

WILLIAM G. McROY, 2W4144

COMING NEXT MONTH

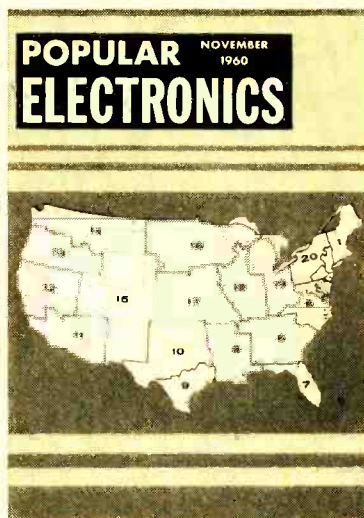

(ON SALE OCTOBER 25)

ZIFF-DAVIS PUBLISHING COMPANY,
One Park Ave., New York 16, N. Y.
William B. Ziff, Chairman of the Board
(1946-1953); William Ziff, President;
W. Bradford Briggs, Executive Vice
President; Michael Michaelson, Vice
President and Circulation Director; Her-
shel B. Sarbin, Vice President; J. Leonard
O'Donnell, Treasurer.



BRANCH OFFICES: Midwestern Office,
434 S. Wabash Ave., Chicago 5, Ill.,
Jim Weakley, Advertising Manager;
Western Office, 9025 Wilshire Blvd.,
Beverly Hills, Calif., Dan Cena, Western
Manager.

Foreign Advertising Representatives:
D. A. Goodall Ltd., London; Albert Mil-
hado & Co., Antwerp and Dusseldorf.

SUBSCRIPTION SERVICE: Forms 3579 and all subscription correspondence should be addressed to Circulation Department, 434 South Wabash Avenue, Chicago 5, Illinois. Please allow at least four weeks for change of address. Include your old address as well as new—enclosing if possible an address label from a recent issue.

CONTRIBUTORS: Contributors are advised to retain a copy of their manuscripts and illustrations. Contributions should be mailed to the New York Editorial Office and must be accompanied by return postage. Contributions will be handled with reasonable care, but this magazine assumes no responsibility for their safety. Any copy accepted is subject to whatever adaptations and revisions are necessary to meet the requirements of this publication. Payment covers all author's, contributor's and contestant's rights, titles, and interest in and to the material accepted and will be made at our current rates upon acceptance. All photos and drawings will be considered as part of material purchased.

- **CITIZENS BAND RADIO**
All the information you need to become a CB operator—on licensing, equipment, and procedures—complete in a special 16-page bonus section
- **PRINTED CIRCUITS**
The low-down on printed circuits—which are gradually finding their way into virtually every piece of equipment now on the market.
- **LOAD LINES**
How to plot the load lines that give us much useful data on tubes under operating conditions
- **TRANSCEIVER MODIFICATIONS**
Making a few simple modifications on your Heath 6- or 10-meter transceiver will result in easier tuning and peak efficiency of operation

**GET FULL FACTS
FREE!**

Prepare for a
Profitable, Exciting Future

as an **Electronics
Technician!**

**No Previous Technical Experience
Required!**

Opportunities were never greater for the man who wants to get someplace and be somebody than they are today in the fast-expanding, profitable field of Electronics.

Let us tell you without cost or obligation how you may prepare for a real career in one or more branches of Electronics, either in our well-equipped Chicago or Toronto laboratories—or at home without interfering with your present job. Send coupon for **FREE** facts today!

**AN EXCELLENT OPPORTUNITY
FOR MEN 17-55!**

Even if you haven't an advanced education, find out how you may prepare in your spare time at home, to enter the **BIG OPPORTUNITY** field of Electronics. Mail coupon **TODAY!**

FREE! Sample Booklet!

We'll give you a free copy of an interesting booklet, "Electronics and YOU." See for yourself how you may take advantage of the opportunities in this growing field.



MAIL COUPON TODAY!

DeVRY TECHNICAL INSTITUTE
4141 Belmont Ave., Chicago 41, Ill., Dept. PE-10-Q

Please give me your **FREE** booklet, "Electronics and Space Travel," and tell me how I may prepare to enter one or more branches of Electronics as listed above.

Name _____ Age _____

Street _____ Apt. _____

City _____ Zone _____ State _____

Check here if subject to Military Training.

Canadian residents address: DeVry Tech of Canada, Ltd.
2032 970 Lawrence Avenue West, Toronto, Ontario

**NO ADVANCED
EDUCATION NEEDED!**

Prepare now for Electronic job opportunities in —

Radar
Guided Missile
Control
Computers
Radio
Television
Broadcasting
Communications

Remote Control
Systems
Automation
Electronics
Industrial
Electronics
Your Own
Service Shop

Free Employment Service

DeVry Tech's Placement Department is in contact with some of the best-known employers in the Electronics field. The service is free to all graduates — and DeVry Tech's record in helping to place men has been outstanding.

Draft Age?

We have valuable information for every man of draft age; so if you are subject to military service, be sure to check the coupon.

Accredited Member of National Home Study Council



"One of North America's
Foremost Electronics
Training Centers!"

**DeVRY TECHNICAL
INSTITUTE**

4141 Belmont Avenue • Chicago 41, Illinois

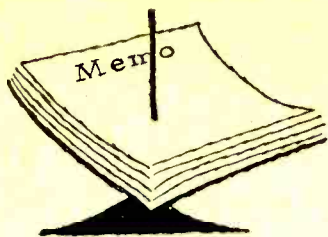

Notes from the Editor

READER SERVICES. My first month as editor of POPULAR ELECTRONICS has certainly not contained a dull moment. It has been a very busy month—during which the staff has lined up some marvelous things for the future. Among them are informative and newsworthy feature stories and some of the best do-it-yourself construction material I've ever seen. In this editorial, however, I want to concentrate on an important problem--the matter of reader inquiries and correspondence.

As last month rolled by, I was literally astounded at the mounting stack of reader inquiries that flooded the P.E. offices. In less than four weeks, nearly 600 cards and letters requiring an answer crossed my desk. Many of these inquiries were not simple and uninvolved by any stretch of the imagination. To answer them properly would have required exhaustive research. Approximately 80% did not even deal with material published in POPULAR ELECTRONICS, but instead ran the gamut of requests from career advice to how to repair TV receivers.

An editor would be the last NOT to expect reader mail, but I do think that this is an opportune moment for me to spell out just what we can, and cannot do, for our readers. It goes without saying that we will attempt to answer all inquiries pertaining directly to published material in any issue of our magazine. However, we cannot possibly answer requests for:

- new designs or original engineering involving material or ideas that have no direct bearing on articles which have been published in POPULAR ELECTRONICS
- information on material published in other magazines
- help in finding a job or planning your career in electronics
- help in selling your old equipment or estimating its value
- ''advance'' information on one of next month's construction articles, so you can be first in your neighborhood to build it
- the design of a ''sure winner'' for the next science fair

If you write to POPULAR ELECTRONICS and your letter requires an answer, be sure to include your correct mailing address. If our reply to your letter seems unduly delayed, please understand that the pressure of putting out a monthly magazine consumes much of our time.

POPULAR ELECTRONICS

Do you WISH you were EMPLOYED in ELECTRONICS?

F.C.C. LICENSE—THE KEY TO BETTER JOBS

An F.C.C. *commercial* (not amateur) license is your ticket to higher pay and more interesting employment. This license is Federal Government evidence of your qualifications in electronics. Employers are eager to hire *licensed* technicians.

WHICH LICENSE FOR WHICH JOB?

The **THIRD CLASS** radiotelephone license is of value primarily in that it qualifies you to take the second class examination. The scope of authority covered by a third class license is extremely limited.

The **SECOND CLASS** radiotelephone license qualifies you to install, maintain and operate most all radiotelephone equipment except commercial broadcast station equipment.

The **FIRST CLASS** radio telephone license qualifies you to install, maintain and operate every type of radiotelephone equipment (except amateur) including all radio and television stations in the United States, its territories and possessions. This is the highest class of radiotelephone license available.

GRANTHAM TRAINING PREPARES YOU

The Grantham course covers the required subject matter completely. Even though it is planned primarily to lead directly to a first class FCC license, it does this by **TEACHING** you electronics. Some of the subjects covered in detail are: Basic Electricity for Beginners, Basic Mathematics, Ohm's and Kirchhoff's Laws, Alternating Current, Frequency and Wavelength, Inductance, Capacitance, Impedance, Resonance, Vacuum Tubes, Transistors, Basic Principles of Amplification, Classes of Amplifiers, Oscillators, Power Supplies, AM Transmitters and Receivers, FM Transmitters and Receivers, Antennas and Transmission Lines, Measuring Instruments, FCC Rules and Regulations, and extensive theory and mathematical calculations associated with all the above subjects explained simply and in detail.

OUR GUARANTEE

If you should fail the F. C. C. exam after finishing our course, we guarantee to give additional training at **NO ADDITIONAL COST**. Read details in our free booklet.

Get Your First Class Commercial F.C.C. LICENSE QUICKLY!

Learn by Correspondence or in Resident Classes

Grantham training is offered by correspondence or in resident classes. Either way, we train you quickly and thoroughly---teach you a great deal of electronics and prepare you to pass the F. C. C. examination for a first class license. Get details now. Mail coupon below.

This booklet **FREE!**

This free booklet gives details of our training and explains what an F. C. C. license can do for your future. Send for your copy today.

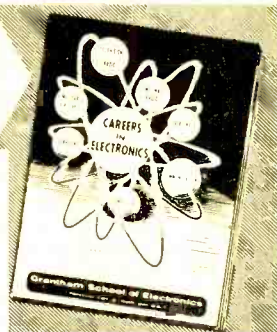

To get ahead in electronics—first, you need the proper training; then, you need "proof" of your knowledge. Your first class commercial F. C. C. license is a "diploma" in communications electronics, awarded by the U. S. Government when you pass certain examinations. This diploma is recognized by employers. Grantham School of Electronics specializes in preparing you to **earn** this diploma.

Grantham training is offered in resident classes or by correspondence. Our **free** booklet gives complete details. If you are interested in preparing for your F. C. C. license, mail the coupon below to the School's home office at 1505 N. Western Ave., Hollywood 27, California—the address given in the coupon—and our free booklet will be mailed to you promptly. No charge—no obligation.

Grantham School of Electronics

HOLLYWOOD CALIF.

SEATTLE WASH.

KANSAS CITY MO.

WASHINGTON D. C.

RESIDENT CLASSES HELD IN FOUR CITIES

If you are interested in attending day or evening classes mail the coupon for free information to our home office in Hollywood, Calif.



(Mail in envelope or paste on postal card)

To: **GRANTHAM SCHOOL OF ELECTRONICS**
1505 N. Western Ave., Hollywood, Calif.

Gentlemen:

Please send me your free booklet telling how I can get my commercial F.C.C. license quickly. I understand there is no obligation and no salesman will call.

Name _____ Age _____

Address _____

City _____ State _____

I am interested in: Home Study, Seattle classes

Hollywood classes, Kansas City classes, Washington classes

03 R

MAIL COUPON NOW—NO SALESMAN WILL CALL →

October, 1960

7

New Sylvania
**"Transistor Circuit
 Handbook for the
 Hobbyist"** gives you
 30 performance-tested
 circuits using
 low-cost transistors!

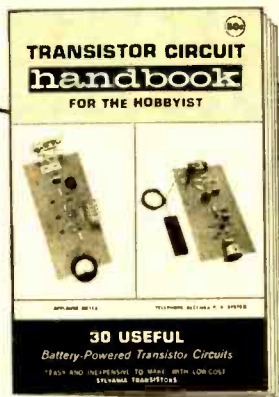

Interesting new "gadgets" and useful equipment for every electronic experimenter, "ham" or student. Handbook is divided into four circuit-packed chapters.

- I Test Equipment Circuits
- II High Frequency Circuits
- III Audio Frequency Circuits
- IV Utility Circuits

**NOW AT YOUR LOCAL
 SYLVANIA SEMICONDUCTOR
 DISTRIBUTOR'S. Only 50¢.**

Get a copy today!

Sylvania Semiconductor Division, Woburn, Mass.

SYLVANIA
 Subsidiary of GENERAL TELEPHONE & ELECTRONICS



CB and Amateur News

CITIZENS BANDERS who have been waiting anxiously for the FCC to raise the permissible power input for Class D stations to 25 watts can relax—at least for a while. So, too, can CB'ers looking forward to the day when FM transmissions will be permitted on the Citizens Band. The earliest the Commission can be expected to make any final changes in Class D regulations is two or three months after an initial notice of proposed rule-making—and then only if the agency feels that it can go along with the proposed changes.

The Commission has been receiving a hefty volume of correspondence concerning the possibility of such rule changes ever since a petition for a new 25-watt limit came in earlier this year from the Connelly Sales Co. of La Mirada, Calif. One big drawback to boosting the power of CB stations is the fact that any increase in permissible power would almost surely have to be accompanied by an increase in technical specifications for CB equipment. And this would almost certainly bring about an unwanted increase in the price of the units.

Prior to the August recess of the Commission, it appeared that favorable action—if any—on the Connelly request would not come before October. Allowing time for comments from interested CB'ers and other procedural steps, final action could not be expected before the end of the year.

The California company also posed the question of single-sideband operation in the Citizens Band. Since present regulations limit operation to double sideband (A1) only, this seems to be another matter for the Commission to consider.

Major revisions in application forms for the amateur radio fraternity—for renewal of licences with or without modifi-

HOW TO BREAK INTO RADIO-TV-ELECTRONICS

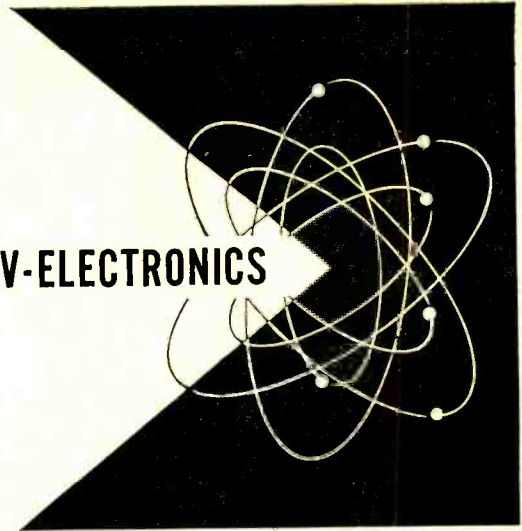

A good paying career in Radio-TV-Electronics may be closer than you think—regardless of your age, education or present job experience.

You know about the tremendous demand for radio-TV and electronics technicians. But something perhaps you didn't know is how easy it is to get the training that will qualify you for this vital work, and how quickly you can advance.

From the very beginning you will find that your I.C.S. course is preparing you thoroughly—at your own pace—for an exciting new career. I.C.S. Radio-TV-Electronics courses make electronic fundamentals clear, easy to follow. You get *personalized* guidance from people who know—and can tell you—what it takes to succeed along every step of the way.

The I. C. S. method makes it possible to learn while you earn. You study at home—in your spare time. Everything you learn is practical, usable. Your mastery of Radio-TV-Electronics assures you of top

pay and real job security in one of today's fastest growing fields.

So if you would like to break into Radio-TV-Electronics—your first step is to send for your **FREE I.C.S. Career Kit**. There's no obligation... and there's a whole new future to gain.

Send coupon below for your free I.C.S. Career Kit!

1
2
3

"How to Succeed" career guide

"Career Catalog" of job opportunities in your field of interest

"Sample Lesson" (math) to demonstrate the famous I.C.S. method



For Real Job Security—Get an I.C.S. Diploma!

I. C. S., Scranton 15, Penna.

Accredited Member,
National Home Study Council

INTERNATIONAL CORRESPONDENCE SCHOOLS



BOX 45868J, SCRANTON 15, PENNA.

In Hawaii reply P.O. Box 418, Honolulu

(Partial list of courses)

Without cost or obligation, send me "How to Succeed" and the opportunity booklet about the field BEFORE which I have marked X (plus sample lesson):

RADIO TELEVISION ELECTRONICS

- General Electronics Tech.
- Industrial Electronics
- Practical Radio-TV Eng'r'g
- Practical Telephony
- Radio-TV Servicing

BUSINESS

- Cost Accounting
- Managing a Small Business
- Purchasing Agent

DRAFTING

- Electrical Drafting

HIGH SCHOOL

- High School Diploma
- Good English
- High School Mathematics

ELECTRICAL

- Electrical Engineering
- Elec. Engr. Technician
- Elec. Light and Power
- Practical Electrician
- Professional Engineer (Elec.)

LEADERSHIP

- Industrial Foremanship
- Industrial Supervision
- Personnel-Labor Relations
- Supervision

Name _____ Age _____ Home Address _____

City _____ Zone _____ State _____ Working Hours _____ A.M. to _____ P.M. _____

Occupation _____ Canadian residents send coupon to International Correspondence Schools, Canadian, Ltd., Montreal, Canada. . . . Special low monthly tuition rates to members of the U. S. Armed Forces.

"I put it together with
my Wen Solder Gun"



Burt Weston

The Wen 100K Solder Gun Kit consists of a feather-light slim gun with 100 watts power. It heats in 2½ seconds. A built-in spotlight focuses on the work. In addition you get extra tips for hot cutting and smoothing as well as a supply of rosin core solder . . . all in a strong metal box for neat compact storage. It's perfect for every home soldering job. C-1ly

\$7.95

YOU CAN ALWAYS DEPEND ON
NEWER AND FINER PRODUCTS FROM



FINE FINISH SANDER — Light, handy and quiet. Powerful motor delivers 14,400 straight-line-action strokes per minute. Perfect for fine finishing and polishing. Strong black plastic case. Comes complete with 6 assorted abrasive sheets and 2 polishing pads. **\$13.95**



MULTI-PURPOSE ½ HP "ALL-SAW"—Makes "one-job" saws obsolete. Does everything a Pattern Saw will do . . . more than a circular saw . . . many things normally done by a hand saw or nibbler—and many things that, until now, only a chain saw could do. UL "Industrially Rated," it cuts anything from a 6" log to intricate patterns in wood, metal, etc. Complete with 7 blades. **\$44.95**



3/8" 2-Speed Power Drill **\$29.95**
Lightweight Sabre Saw **\$26.95**

WEN PRODUCTS, INC., 5810 Northwest Hwy., Chicago 31, Ill.

cations—are to be put into effect by the FCC early next year. The Commission wants to abolish the present Form 405-A—used for renewal of an amateur operator license without modification, and the present Form 602—used for stations at military posts.

The reasons given for the change are that the 405-A renewal form has been improperly used in the past. In addition, it has been causing administrative difficulties, since sufficient information has not been included in many cases.

Both forms are to be replaced with new Form 610-A, which will cover additional stations, club stations, or stations for recreation under military auspices. The regular amateur application Form 610 will be retained.

A "Kilocycle Kops" episode concerning the FCC and CB'ers took place in Los Angeles recently. During the afternoon traffic rush, the Commission's district office there received a report that an unidentified Citizens Band station had been on the air continuously for some three hours. Although hampered by one-way streets, no turns, no stopping, no parking, and other traffic restrictions, an investigative car manned by an FCC engineer tried hard to determine where the signal was strongest.

As the search narrowed, according to the Commission, the FCC engineer heard a fragment of a conversation in which someone was telling a customer that his account with a certain piano company was overdue. After the engineer managed to find a parking space, he visited the piano company's office. There, a very flustered woman explained that she was confused by the controls on a Citizens Radio set and didn't know how to turn it off.

Courteously, the engineer flipped the switch for her, and the carrier left the air. The woman said she thought she could handle it in the future!

At the end of the FCC's 1960 fiscal year, on June 30, there was a total of 126,034 Citizens Radio station licenses on the Commission's books, representing an increase of 79,965 since the same date a year ago. Of the total, more than 105,000 are in the Class D service. Of the new stations added since July 1, 1959, more than 70,000 are Class D stations. The Commission has estimated that 90% of its incoming Citizens Band applications are now for Class D stations.

Opportunities in Electronics

- Radar
- Guided Missiles
- Broadcasting
- Aeronautical Electronics
- Industrial Electronics
- Home Electronics
- Computers
- Automation

Thousands of interesting well-paid jobs in electronics must be filled. To fill such jobs, you need sound technical training. An FCC license is convincing proof of technical skill. Send for the three Cleveland In-

Are you interested in learning how you can have a profitable career in any or all of the above fields?

Find out how modern technical training and a Government License (FCC) can lead to profitable employment in any branch of electronics.

stitute booklets offered here. They explain how you can prepare for an interesting and profitable career in electronics. Mail the coupon today—no obligation.

good training doesn't cost—it pays!

Send For These 3 FREE Booklets

GET THIS HANDY POCKET ELECTRONICS DATA GUIDE

Free . . .

Puts all the commonly used conversion factors, formulas, tables, and color codes at your fingertips. Yours absolutely free if you mail the coupon in 30 days. No further obligation!



TO GET THIS FREE GIFT, MAIL COUPON Within 30 Days!

Please send **FREE** Booklets prepared to help me get ahead in Electronics. I have had training or experience in Electronics as indicated below:

- | | |
|---|---|
| <input type="checkbox"/> Military | <input type="checkbox"/> Broadcasting |
| <input type="checkbox"/> Radio-TV Servicing | <input type="checkbox"/> Home Experimenting |
| <input type="checkbox"/> Manufacturing | <input type="checkbox"/> Telephone Company |
| <input type="checkbox"/> Amateur Radio | <input type="checkbox"/> Other |

In what kind of work are you now engaged?..... In what branch of Electronics are you interested?.....

Name..... Age.....

Address

City..... Zone..... State.....

Desk PE-70

Cleveland Institute of Electronics

4900 Euclid Ave., Desk PE-70
Cleveland 3, Ohio



Accredited by the
National Home Study Council

Letters

from our
readers

Supersonic Presses

■ I am interested in some of the problems that the Tacoma Newprint Corporation must have had in learning how to run its printing presses at Mach 5! The brand of paper that can travel at that speed should be used for ICBM nose cones.

CHESTER E. CLAFF, JR.
Brockton, Mass.

The caption in Ken Gilmore's article on magnetic amplifiers (July, 1960, p. 71) pertaining to printing presses said 5000 feet per second—when it should have said 5000 feet per minute. But the presses are still some of the fastest in the world.

Rebuilding the Relics

■ I found your article on rebuilding relics very informative. I have two such pre-war receivers

that I now use for SWL'ing. In addition to your suggested alterations I have added an antenna tuner. One thing seems to be missing, though, and that is bandspread—what would be the easiest way to add it to one of these relics?

JOHN F. ZIMA, WPE2CAA
New Hyde Park, N. Y.

■ Mr. Wicks' article was one of the best I have ever read. I'm out looking for old relics that can be rebuilt.

NORMAN BANDER
New York, N. Y.

■ I fixed up an old RCA 17K and Philco 610; the 17K is now my main short-wave receiver. As you suggested, some old manuals can be

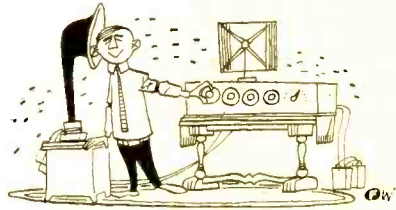

obtained from manufacturers—I got the RCA manual for 25 cents.

DAVID DRÜCKER
Newport News, Va.

"Rebuild the Relics for SWL'ing" (August, 1960, p. 76) has been attracting considerable reader in-

MICRO

ELECTRON TUBE

INTRODUCES FOR THE FIRST TIME
ANYWHERE A SELECT STOCK OF USED
TUBES AT A FABULOUS LOW PRICE

37¢

ea.

FOR any TUBE LISTED

Jan Surplus Tubes!

\$35 PER HUNDRED ASSTD.

ALL TUBES SENT POSTAGE PAID
Please send 25¢ handling for orders under \$5. Send 25% deposit on C.O.D. orders. Send approximate postage on Canadian and foreign orders.

MICRO

ELECTRON TUBE CO.

P. O. Box 55, Dept. PE10, Park Sta., Paterson 3, N. J.

- Each and every tube is tested in our own laboratory for mutual conductance and life test.
- We guarantee FREE replacement for one year of any tube purchased from us which fails to function efficiently under any or all operating conditions. Prompt refunds are made on any defective merchandise.
- The advertised tubes are not necessarily new, but may be electrically perfect factory seconds or used tubes—each is clearly so marked.

0A2	6X6	6BM6	6SF5	7Z4	19BG6G
024	5Y30T	6BJ6	6SF7	12A8	1916
1A7GT	5Y4Q	6BK5	6SJ7	12A05	1978
1B30T	6AT	6BK7	6SK7	12AT7	24A
1H4G	6AB	6BL7GT	6SL7GT	12AU6	25AV5
1H9GT	6AB4	6BN6	6SN7GT	12AV7	25BQ6
1L4	6AC7	6BQ6GT	6SQ7	12AV6	25ON6
1L8	6AF4	6BZ6	6S7	12AV7	25L6GT
1H8GT	6AG7	6C4	6S7	12AX4GT	25W4GT
1Q5GT	6AQ5	6C5	6V6	12AX7	25Z5
1R5	6A07	6C6	6V6GT	12AZ7	25Z6
1R5	6A07	6C6B	6V6GT	12B6	26
1S5	6AN4GT	6C6B	6V6GT	12BA6	35A5
1T4	6AN5	6C6C	6V6GT	12BA7	35B5
1U4	6AN5	6C6D	6V6GT	12BE6	35C5
1U8	6AL5	6C6E	6V6GT	12BF6	35L6GT
1V2	6AL7	6C6F	6V6GT	12BH7	35W4
1X2	6AN6	6C6G	6V6GT	12BQ6	35Y4
2A3	6AN6	6C6H	6V6GT	12BR7	35Z5GT
2AF4	6AQ5	6C6I	6V6GT	12B7	37
3BC5	6AQ6	6C6J	6V6GT	12CA5	39/44
3BN6	6AQ6GT	6C6K	6V6GT	12CA5	42
3C26	6AR5	6C6L	6V6GT	12K7	43
3CB6	6AS5	6C6M	6V6GT	12L6	45
3CF6	6AT8	6C6N	6V6GT	12M7	50A5
3C5	6AT8	6C6O	6V6GT	12N7	50B5
3L4	6AU4GT	6C6P	6V6GT	12P6	50C5
3Q4	6AUSGT	6C6Q	6V6GT	12Q7	50L6GT
3S4	6AU8	6C6R	6V6GT	12R7	50X6
3V4	6AU8	6C6S	6V6GT	12S7	56
4B27	6AUSGT	6C6T	6V6GT	12T7	57
4B7A	6AV5	6C6U	6V6GT	12U7	58
5A58	6AW6	6C6V	6V6GT	12V7	59
5A78	6A4GT	6C6W	6V6GT	12W7	60
5A8	6A4GT	6C6X	6V6GT	12X4	75
5A44	6B8	6C6Y	6V6GT	12Z3	76
5B7	6BA6	6C6Z	6V6GT	14A7/12B7	77
5T8	6BC8	6C7	6V6GT	14B7	78
5U4G	6BD6	6C7	6V6GT	14C7	80
5U8	6BE6	6C7	6V6GT	14D7	84/6Z4
5V4G	6BF6	6C7	6V6GT	14E7	117Z3
5V6GT	6BGG	6C7	6V6GT	14F7	117Z6
		6C7	6V6GT	14G7	
		6C7	6V6GT	14H7	
		6C7	6V6GT	14I7	
		6C7	6V6GT	14J7	
		6C7	6V6GT	14K7	
		6C7	6V6GT	14L7	
		6C7	6V6GT	14M7	
		6C7	6V6GT	14N7	
		6C7	6V6GT	14O7	
		6C7	6V6GT	14P7	
		6C7	6V6GT	14Q7	
		6C7	6V6GT	14R7	
		6C7	6V6GT	14S7	
		6C7	6V6GT	14T7	
		6C7	6V6GT	14U7	
		6C7	6V6GT	14V7	
		6C7	6V6GT	14W7	
		6C7	6V6GT	14X7	
		6C7	6V6GT	14Y7	
		6C7	6V6GT	14Z7	
		6C7	6V6GT	15A7	
		6C7	6V6GT	15B7	
		6C7	6V6GT	15C7	
		6C7	6V6GT	15D7	
		6C7	6V6GT	15E7	
		6C7	6V6GT	15F7	
		6C7	6V6GT	15G7	
		6C7	6V6GT	15H7	
		6C7	6V6GT	15I7	
		6C7	6V6GT	15J7	
		6C7	6V6GT	15K7	
		6C7	6V6GT	15L7	
		6C7	6V6GT	15M7	
		6C7	6V6GT	15N7	
		6C7	6V6GT	15O7	
		6C7	6V6GT	15P7	
		6C7	6V6GT	15Q7	
		6C7	6V6GT	15R7	
		6C7	6V6GT	15S7	
		6C7	6V6GT	15T7	
		6C7	6V6GT	15U7	
		6C7	6V6GT	15V7	
		6C7	6V6GT	15W7	
		6C7	6V6GT	15X7	
		6C7	6V6GT	15Y7	
		6C7	6V6GT	15Z7	
		6C7	6V6GT	16A7	
		6C7	6V6GT	16B7	
		6C7	6V6GT	16C7	
		6C7	6V6GT	16D7	
		6C7	6V6GT	16E7	
		6C7	6V6GT	16F7	
		6C7	6V6GT	16G7	
		6C7	6V6GT	16H7	
		6C7	6V6GT	16I7	
		6C7	6V6GT	16J7	
		6C7	6V6GT	16K7	
		6C7	6V6GT	16L7	
		6C7	6V6GT	16M7	
		6C7	6V6GT	16N7	
		6C7	6V6GT	16O7	
		6C7	6V6GT	16P7	
		6C7	6V6GT	16Q7	
		6C7	6V6GT	16R7	
		6C7	6V6GT	16S7	
		6C7	6V6GT	16T7	
		6C7	6V6GT	16U7	
		6C7	6V6GT	16V7	
		6C7	6V6GT	16W7	
		6C7	6V6GT	16X7	
		6C7	6V6GT	16Y7	
		6C7	6V6GT	16Z7	
		6C7	6V6GT	17A7	
		6C7	6V6GT	17B7	
		6C7	6V6GT	17C7	
		6C7	6V6GT	17D7	
		6C7	6V6GT	17E7	
		6C7	6V6GT	17F7	
		6C7	6V6GT	17G7	
		6C7	6V6GT	17H7	
		6C7	6V6GT	17I7	
		6C7	6V6GT	17J7	
		6C7	6V6GT	17K7	
		6C7	6V6GT	17L7	
		6C7	6V6GT	17M7	
		6C7	6V6GT	17N7	
		6C7	6V6GT	17O7	
		6C7	6V6GT	17P7	
		6C7	6V6GT	17Q7	
		6C7	6V6GT	17R7	
		6C7	6V6GT	17S7	
		6C7	6V6GT	17T7	
		6C7	6V6GT	17U7	
		6C7	6V6GT	17V7	
		6C7	6V6GT	17W7	
		6C7	6V6GT	17X7	
		6C7	6V6GT	17Y7	
		6C7	6V6GT	17Z7	
		6C7	6V6GT	18A7	
		6C7	6V6GT	18B7	
		6C7	6V6GT	18C7	
		6C7	6V6GT	18D7	
		6C7	6V6GT	18E7	
		6C7	6V6GT	18F7	
		6C7	6V6GT	18G7	
		6C7	6V6GT	18H7	
		6C7	6V6GT	18I7	
		6C7	6V6GT	18J7	
		6C7	6V6GT	18K7	
		6C7	6V6GT	18L7	
		6C7	6V6GT	18M7	
		6C7	6V6GT	18N7	
		6C7	6V6GT	18O7	
		6C7	6V6GT	18P7	
		6C7	6V6GT	18Q7	
		6C7	6V6GT	18R7	
		6C7	6V6GT	18S7	
		6C7	6V6GT	18T7	
		6C7	6V6GT	18U7	
		6C7	6V6GT	18V7	
		6C7	6V6GT	18W7	
		6C7	6V6GT	18X7	
		6C7	6V6GT	18Y7	
		6C7	6V6GT	18Z7	
		6C7	6V6GT	19A7	
		6C7	6V6GT	19B7	
		6C7	6V6GT	19C7	
		6C7	6V6GT	19D7	
		6C7	6V6GT	19E7	
		6C7	6V6GT	19F7	
		6C7	6V6GT	19G7	
		6C7	6V6GT	19H7	
		6C7	6V6GT	19I7	
		6C7	6V6GT	19J7	
		6C7	6V6GT	19K7	
		6C7	6V6GT	19L7	
		6C7	6V6GT	19M7	
		6C7	6V6GT	19N7	
		6C7	6V6GT	19O7	
		6C7	6V6GT	19P7	
		6C7	6V6GT	19Q7	
		6C7	6V6GT	19R7	
		6C7	6V6GT	19S7	
		6C7	6V6GT	19T7	
		6C7	6V6GT	19U7	
		6C7	6V6GT	19V7	
		6C7	6V6GT	19W7	
		6C7	6V6GT	19X7	
		6C7	6V6GT	19Y7	
		6C7	6V6GT	19Z7	
		6C7	6V6GT	20A7	
		6C7	6V6GT	20B7	
		6C7	6V6GT	20C7	
		6C7	6V6GT	20D7	
		6C7	6V6GT	20E7	
		6C7	6V6GT	20F7	
		6C7	6V6GT	20G7	

AT LAST!

RADIO-TV and ELECTRONICS TRAINING

... AT A PRICE YOU CAN AFFORD!

***21 INCH**
Receiver Kit included

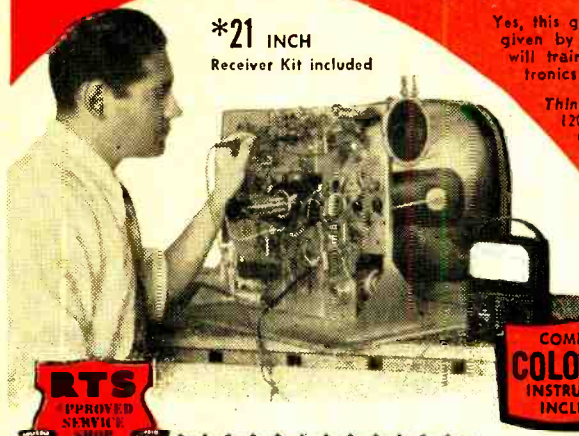

Yes, this great course costs for less than any training of its kind given by other major schools! Radio-Television Training School will train you for a good job in Television or Industrial Electronics — AT HOME IN YOUR SPARE TIME.

Think of it—a complete training program including over 120 lessons, Fourteen Big Radio-Television Kits, Complete Color-TV Instruction, Unlimited Consultation Service ... ALL at a really big saving to you. How can we do this? Write to us today ... and find out!

And what's more — you can (if you wish)
OPEN YOUR OWN RTS-APPROVED AND FINANCED RADIO-TV SERVICE SHOP

We Want Many More Shops This Year

This 38 year old training organization — called RTS, that's Radio-Television Training School — wants to establish a string of Radio-TV Repair Shops in principal cities throughout the U. S. So far, a great many such shops are NOW IN BUSINESS and PROSPERING. We are helping and training ambitious men to become future owners and operators of these shops in all areas.

FOR UNSKILLED INEXPERIENCED MEN ONLY — WE TRAIN YOU OUR WAY!

We must insist that the men we sign up be trained in Radio-TV Repair, Merchandising and Sales by our training methods—because WE KNOW the requirements of the industry. Therefore, we will TRAIN YOU ... we will show you how to earn EXTRA CASH, during the first month or two of your training period. YOU KEEP YOUR PRESENT JOB. TRAINING TAKES PLACE IN YOUR OWN HOME, IN YOUR SPARE TIME!

ACT NOW!

COMPLETE COLOR TV INSTRUCTION INCLUDED

you build these and other units



MULTIMETER KIT INCLUDED!

*tubes excluded

RADIO-TELEVISION TRAINING SCHOOL

815 EAST ROSECRANS AVENUE
LOS ANGELES 59 CALIFORNIA

Est. 1922



Get your free book on the **FAMOUS RTS BUSINESS PLAN** find out how you can open **A REPAIR SHOP OF YOUR OWN**

We supply and finance your equipment

When you are ready and qualified to operate one of our RTS-Approved TV Repair Shops **WE WILL SUPPLY AND FINANCE EVERY BIT OF EQUIPMENT YOU NEED TO GET STARTED** plus an inventory of parts and supplies. In other words we will **take you ... AN OFFER NEVER MADE BEFORE BY ANY TRAINING ORGANIZATION.** Under the RTS Business Plan you receive:

1. An electric sign for the shop front.
2. Complete laboratory of test equipment.
3. Letterheads, calling cards, repair tickets, etc.
4. Basic inventory of tubes, parts, supplies.
5. Complete advertising and promotional material.
6. Plans for shop arrangement.
7. Instructions or how to go into business.
8. Continuous consultation and help.
9. The right to use the RTS Seal of Approval and the RTS Credo.
10. The right to use the Famous Trade Mark.



RTS' Membership in The Association of Home Study Schools is your assurance of Reliability, Integrity, and Quality of Training.

ALL THESE FREE!



CUT OUT AND MAIL — TODAY!

RADIO-TELEVISION TRAINING SCHOOL
815 EAST ROSECRANS AVE Dept. PE-100
LOS ANGELES 59 CALIFORNIA

SEND ME FREE — all of these big opportunity books — "Good Jobs in TV-Electronics," "A Repair Shop or Your Own" and "Sample Lesson." I am interested in:

- Radio-Television Industrial Electronics (Automation)

Name _____ Age _____

Address _____

City & State _____

30¢ **Mail This Coupon Now—No Salesman Will Call**

for

LOWEST
microphonics...

hum...

noise

in a high- μ
dual triode



the

Amperex

ECC83 A PLUG-IN

REPLACEMENT FOR THE 12AX7

MICROPHONICS:

Negligible in amplifiers requiring an input voltage of at least 50 mv for an output of 5 watts. No special precautions against microphonics necessary even though the tube is mounted in the near vicinity of a loudspeaker with 5% acoustical efficiency.

HUM AND NOISE LEVEL:

Better than -60 db relative to 50 mv when the grid circuit impedance is no greater than 0.5 megohms (at 60 cps), the center tap of the heater is grounded and the cathode resistor is by-passed by a capacitor of at least 100 mfd.

OTHER **Amperex TUBES** FOR
HIGH-FIDELITY AUDIO APPLICATIONS:

- EL84/6BQ5** 9-pin power pentode; 17 W PP
- 6CA7/EL34** High-power pentode; 100 W PP
- EF86/6Z67** Low-noise high- μ pentode
- ECC81/12AT7** Low-noise medium- μ dual triode
- ECC82/12AU7** Low-noise low- μ dual triode
- ECC85/6AQ8** High- μ dual triode for FM tuners
- GZ34/5AR4** Cathode-type rectifier; 250 ma.
- EZ80/6V4** 9-pin rectifier; cathode; 90 ma.
- EZ81/6CA4** 9-pin rectifier; cathode; 150 ma.

At All Leading Electronic Parts Distributors



Amperex
ELECTRONIC CORP.

230 Duffy Ave., Hicksville, Long Island, N.Y.

Letters

(Continued from page 12)

terest. If you missed this article, it tells how to pick out an old receiver worth rejuvenating, how to get the wiring schematic, and how to add a BFO and phone jack. Copies of this issue are available from our Circulation Department, 434 South Wabash Ave., Chicago 5, Ill., for 35 cents.

To answer reader John Zima's question, adding bandspread is very simple. You just wire a 15- μ f. variable capacitor in parallel with the oscillator tuning capacitor and attach a vernier dial. Keep in mind that the extra capacity will throw the main dial calibration off unless you realign the oscillator.

"Strange Inhabitants"

■ I enjoyed James Van Detta's article "The Strange Inhabitants of 75-Meter Phone" (July, 1960, p. 66), although I wondered why he restricted it to that band. Oddballs, such as the types described, can be found on all ham bands—phone and c.w. Personally, I think the most unusual characters are the CB'ers. Half of them don't seem to know the difference between a microphone input and an antenna output, yet they are on the air trying desperately to change frequencies with their send-receive switches.

STEVEN MELTZER
New York, N. Y.

Although we are inclined to agree with reader Meltzer, the caliber of the CB operator has been improving as the novelty of CB wears off. Characters we will always have on any band anywhere.

Power Line Grounding

■ Harking back to your article in August 1959 titled "Shocking But True," it would seem to me that most people are electrocuted because they connect themselves between a hot power line and



ground. Why should the power companies ground one side of the power line? Why not completely isolate power lines, keeping both sides "above" ground?

ALYNN ROTHMAN
Syosset, L. I., N. Y.

Abbott's National Electrical Code Handbook: states "Circuits are grounded for the purpose of limiting the voltage upon the circuit which might otherwise occur through exposure to lightning or other voltages higher than that for which the circuit is designed; or to limit the maximum potential to ground due to normal voltage." In other words, power line circuits are safer when one side of the line is grounded than they would be if both

(Continued on page 18)



FREE!

Lafayette Radio's 324 PAGE 1961 Catalog

America's "Electronics & Hi-Fi Shopping Center"

40 years of service to Audiophiles, Experimenters, Hobbyists, Engineers, Technicians, Students, Servicemen and Dealers. **HERE IT IS** — the biggest, best and most comprehensive catalog you can ask for. Choose from thousands of items, all available for immediate delivery at the lowest, money-saving prices. And, as always, **SATISFACTION GUARANTEED OR MONEY REFUNDED.**

"The Best Buys In The Business"

- Stereophonic Hi-Fi Equipment
- Public Address Systems
- Tape Recorders
- Radio and TV Tubes and Parts
- Citizen Band Equipment
- Amateur Equipment
- Industrial Supplies

Exclusive at Lafayette. Lafayette Kits: Build a path to a new world of entertainment. Created, designed and engineered for top quality at top performance — there's more fun in doing it yourself, especially when it's so easy. An exclusive product of Lafayette Electronics — easily the best value for your money any day.

PLUS Hundreds of "specials" you'll find only at Lafayette.

Easy Pay Plan. The simplest, and quickest way to get what you want, when you want it. As little as \$2 down . . . up to 24 months to pay.

Mail the coupon today for your **FREE** copy of Lafayette Radio's 1961 catalog.



KT-350 FM Tuner Kit
54.50



TE-15 Tube Checker
19.95

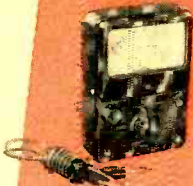

RW-60 20,000 Ohms Per Volt Multimeter
13.50



RK-40J 2-Speed Portable Tape Recorder
49.50



Stereo Control Center
KT-600, Kit
79.50

LA-600 Wired
134.50



Communications Receiver
KT-200, Kit
64.50

HE-10, Wired
79.95



Lafayette Radio Electronics Corp.

Dept. 11-6, P.O. Box 190
Jamaica 31, N. Y.

Send me the FREE Lafayette 324 page
1961 catalog 610

Name _____

Address _____

City _____ Zone _____ State _____

NEW! LAFAYETTE HE-15A 2-WAY SUPERHET CITIZENS BAND TRANSCEIVER!



NOT A KIT
Made in U.S.A.



57⁵⁰

ONLY 5.00 DOWN

- **5 Crystal Controlled Transmitting Positions:** Operates at a maximum FCC legal power input of 5 watts fully modulated.
- **Superheterodyne Tuneable Receiver Over Full 23 Channel Band:** RF stage in both Transmitter and receiver, 3 watts audio output plus large 4" speaker.
- **Complete with Transmitting Crystal:** Removable front plate for easy accessibility of crystals. Channel 9 crystal supplied.
- **4 Dual Function Tubes, plus 2 Single Function Tubes, plus 2 Rectifiers for 12 Tube Performance:** Compares with units costing 3 times as much. Unexcelled reception on land and sea with coverage up to 20 or more miles depending on antenna height and terrain.
- **Planetary Vernier Tuning:** Controls include 3 position function switch (transmit, receive, plus transmit with spring return) and effective Full-Wave Variable Noise Limiter.
- **High Output Crystal Microphone:** 2 position push to talk slide switch plus 5-prong microphone jack makes conversion to a push-to-talk relay a cinch.

- **Adapts for use Anywhere:** Modern compact styling. Brackets are supplied for easy mounting of unit in auto, truck or boat. Addition of 6 or 12 volt power supply (separately supplied) adapts transceiver for mobile operation. Only 10 $\frac{3}{4}$ "x6 $\frac{1}{2}$ "x5 $\frac{7}{8}$ "H. Shpg. wt., 11 lbs.

Anyone Can Operate - No examination or technical knowledge required - Any citizen 18 years or older is eligible for a license. Simply fill out FCC application supplied with HE-15A Transceiver.

HE-15A Factory Wired and Tested (less antenna)	\$5.00 Down	Net 57.50
HE-19 Whip Antenna		Net 3.95
HE-16 Power Supply for 12 Volts		Net 10.95
HE-18 Power Supply for 6 Volts		Net 10.95
Use in the Home	Boating - Ship to Shore	On the Farm
	Business - Trucking	

SENSATIONAL LAFAYETTE CITIZENS BAND MOBILE ANTENNA

6.95

- Includes—
- CHROME SWIVEL BASE
 - STAINLESS STEEL SPRING
 - 102 $\frac{1}{2}$ " STAIN-LESS STEEL WHIP FOR OPTIMUM 11 METER PERFORMANCE

THE SCOOP BUY FOR CITIZENS BAND MOBILES

Chrome swivel ball mount base designed to be mounted on any surface. Stainless steel spring holds rod in properly adjusted position and prevents rod damage from shocks and blows. Stainless steel whip for maximum resiliency and strength. Shpg. wt., 4 lbs.

HE-800WX Net 6.95

NEW! LAFAYETTE TELESCOPIC CITIZENS BAND WHIP ANTENNA

3.95

- Chrome Plated
- Telescopes From 16 $\frac{1}{2}$ to 40"
- Mounts Vertically or Right Angle

An outstanding antenna value. This high quality three section telescoping antenna is designed for attachment directly to your citizens band transceiver. Ideal for point to point service over short distances. Molded base loading coil has a threaded stud with a PL-259 plug-connector for vertical or right angle mounting. Shpg. wt., 1 lb.

HE-19 Net 3.95

10,000 OHMS PER VOLT MULTITESTER

NEW! 9.95 Outperforms Instruments Many Times Its Size

- Extra Large 3 $\frac{1}{2}$ " Meter Face
- Completely Wired and Tested
- All Accessories Included

Convenient pocket size with single range selector switch. First capacity range requires 120V AC, second range requires 6V AC. Durable Bakelite case and panel. Complete with leads and battery. 4 $\frac{1}{2}$ "x3 $\frac{1}{2}$ "x1 $\frac{1}{8}$ ". Shpg. wt., 1 $\frac{1}{2}$ lbs.

TE-10 Net 9.95

TE-14 Pigskin Carrying Case, Shpg. wt., 8 oz. Net 1.95

NEW! LAFAYETTE RADIO FIELD INDICATOR

7.95

- Provides a Continuous Indication of Transmitter Output
- Rugged 200ua Meter Movement with Variable Sensitivity Control
- Requires No Electricity, Batteries or Transmitter Connection

Measures the RF field generated by any marine, mobile or fixed transmitter. Rear phone jack accepts ear-phones. Antenna extends from 3 $\frac{1}{4}$ " to 10 $\frac{3}{4}$ ". Bottom plate magnet allows mounting on any metal surface. Measures 3 $\frac{3}{8}$ "x2 $\frac{1}{4}$ "x2 $\frac{1}{2}$ "D (less antenna). Shpg. wt., 2 lbs.

TM-14 Net 7.95

PLEASE INCLUDE SHIPPING CHARGES WITH ORDER

LAFAYETTE RADIO
165-08 LIBERTY AVENUE JAMAICA 33, N. Y.

NEW YORK 13, N. Y.
100 6th Avenue

BOSTON 10, MASS.
110 Federal Street

PLAINFIELD, N. J.
139 W. 2nd Street

BRONX 58, N. Y.
542 E. Fordham Rd.

NEWARK 2, N. J.
24 Central Avenue

PARAMUS, N. J.
182 Route 17

LAFAYETTE HI-FI KITS

Build A Path to A New World of Entertainment

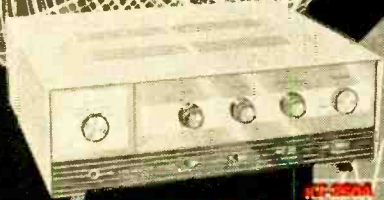
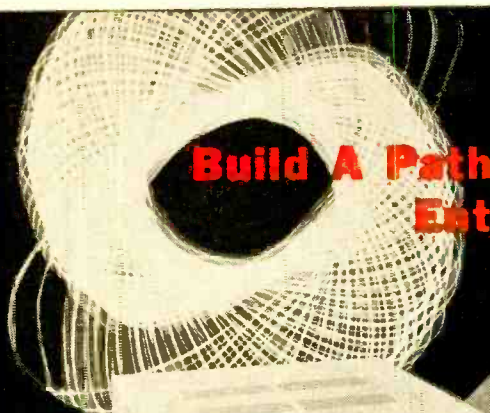

**KT-3500A
50-WATT STEREO AMPLIFIER... 24.00**



**KT-500A
FM-AM STEREO TUNER... 14.50**



**KT-600A
STEREO PREAMPLIFIER... 79.50**



KT-650 FM TUNER... 34.00



**KT-350A
50-WATT STEREO AMPLIFIER... 59.50**



**KT-350 100-WATT
BASIC STEREO AMPLIFIER...**

ENGINEERING:

Created with the non-technical builder in mind. There's much more fun in assembling your own kit... and it's so easy.

DESIGN:

Each kit has the fine professional-looking touch. Styled to blend with every decor.

VALUE:

You can't get better units at these money-saving prices.

QUALITY:

Top performance due to high quality parts and engineering.

MONEY-BACK GUARANTEE

Lafayette Kits are exclusive products of Lafayette Electronics. Each Lafayette Kit must meet or exceed its published specifications, or your money is refunded in full.

All Lafayette Kits are Available on the Easy Pay Plan.



Lafayette Radio Dept. 1J-6
P.O. Box 190 Jamaica 31, N. Y.

Send me the FREE 324-Page
1961 Catalog No. 610

CUT OUT AND PASTE ON POST CARD

Name _____

Address _____

City _____ Zone _____ State _____

Dependable Power



BURGESS BATTERIES

CHROME PROTECTED
SEALED-IN-STEEL
SELF RECHARGEABLE
GUARANTEED LEAKPROOF



Radar-Lites

CORROSION PROOF
separated head and
battery design

BURGESS BATTERY COMPANY

DIVISION OF SERVEL, INC.
FREEPORT, ILLINOIS • NIAGARA FALLS, CANADA

Letters

(Continued from page 14)

sides were "floating" or "isolated." Accidental grounding of the present distributing system is either harmless or blows a fuse; accidental grounding of a "floating" system could not be easily detected and could be very dangerous.

"Tiny Mite" Modifications

■ When I built the three-transistor miniature amplifier described in your June 1960 issue, I found that I could obtain better gain and low frequency

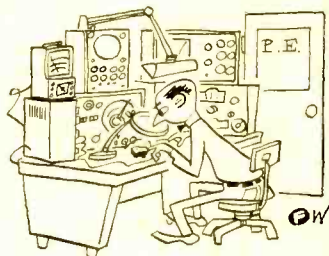

response by using a 10- μ f. capacitor for C_1 . And instead of the dynamic microphone, I used a crystal equivalent with a miniature 200,000- to 1000-ohm matching transformer (Triad SP-7).

GARBIS SAATJIAN
Venice, Calif.

■ I built the "Tiny Mite" amplifier described in your June issue and am very happy with the results. I substituted 2N1265 transistors for the 2N207's suggested in the diagram and used a two-inch speaker in place of the microphone. The amplifier is so sensitive that I can hear a ball of cotton hit a table.

NORMAN B. WORTHEM
Chicago, Ill.

The "Tiny Mite" amplifier turned out to be one of our "Mighty Mite" projects—it seems that everyone was waiting for this circuit. If other readers have made modifications, we will be interested to hear about them.

The 240-Volt Problem

■ We have one problem here, "Down Under," that we'd like you to help us with. The voltage rating in Australia is 240 volts, unlike the 117 volts in the United States. How do we go about altering a circuit so it will work with 240 instead of 117 volts?

Y. SHALIA
Edgecliff, N.S.W.
Australia

Although our circuits are designed for American and Canadian readers, it's usually not much of a problem to convert to 240 volts. If there's a power transformer in the circuit, just obtain a similar unit with a 240-volt primary. Circuits without transformers can also be converted, but you'll need a suitable 240- to 117-volt step-down transformer which will increase the overall cost somewhat.

—30—

YOUR KEY TO A TOP-PAYING POSITION IN ELECTRONICS!

Choose a career in **ELECTRONICS**! It's wide open...with interesting jobs for engineers, technicians, technical writers. And the all-new 1961 edition of **JOBS AND CAREERS IN ELECTRONICS** is your perfect guide to this big, exciting field!

Five Giant Sections Covering: **OPPORTUNITIES IN ELECTRONICS**

Where are the jobs in electronics today? This section pinpoints the best areas in the country in which to look for a job... gives you a comprehensive list of companies on the lookout for trained personnel.

CASE HISTORIES OF CAREERS IN ELECTRONICS

What kind of jobs are available in electronics? Here are 11 actual accounts of people at work in various branches of electronics...including an engineer, an inventor, a weatherman, and a computer expert.

HOW TO PLAN A CAREER IN ELECTRONICS

How do you start out in electronics? This section is devoted to training—includes information on the military, correspondence schools, courses to study, advisability of a degree, plus a complete directory of electronics schools.

TESTING YOUR ELECTRONICS APTITUDE

Do you qualify for an electronics career? This special testing section gives you an accurate picture of your ability to qualify for a technical job.

SPARE TIME ELECTRONICS

Want to earn money in your spare time? Here's a rundown on spare time radio repair, complete with a listing of the tube types you'll need.

THE 1961 JOBS AND CAREERS IN ELECTRONICS



**NOW
ON
SALE
ONLY
\$1.00**

Buy your copy at your favorite newsstand or electronics parts store—or order by handy coupon below.

Ziff-Davis Publishing Company, Department PE-106
434 S. Wabash Avenue, Chicago 5, Illinois

Please send me a copy of the 1961 **JOBS AND CAREERS IN ELECTRONICS**. I enclosed \$1.00, the cost of **JOBS AND CAREERS IN ELECTRONICS**, plus 10¢ to cover mailing and handling charges. (Canada and Foreign, \$1.25 plus 10¢ postage).

NAME _____

ADDRESS _____

CITY _____ ZONE _____ STATE _____

FREE **GIANT 1961 204 PAGE CATALOG**

BA 1961
ANNUAL CATALOG #11

SAVE UP TO 50% ON B-A SELECTED KITS

HI-FI AND STEREO SYSTEMS & COMPONENTS

TOP VALUES IN POWER AND HAND TOOLS

30 PAGES OF BARGAINS NOT IN ANY OTHER CATALOG

RADIO TV ELECTRONICS

BURSTEIN-APPLEBEE CO.

Dept. 1E, 1012 McGee St., Kansas City 6, Mo.

Send Free 1961 B-A Catalog No. 611

Name

Address

City

State

SEND FOR IT TODAY

Introducing the New ...

BUTOBA MT-5

Not just a battery-powered tape recorder ...

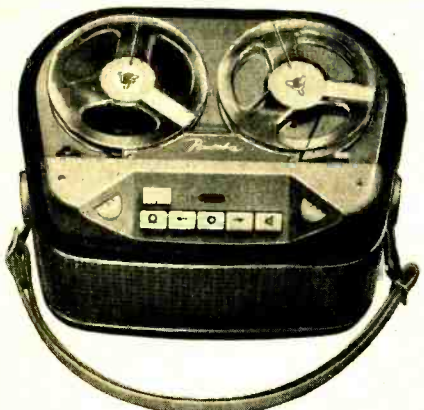

But ... a precision West German high fidelity tape recorder powered by 8 ordinary flashlight batteries ... frequency response 50-13,000 cps. on 3 3/4 ips ... dual track & dual speed—1 1/2 & 3 3/4 ips ... 5" reels, max. recording time of 4 hours ... push-button controls—fast forward & rewind ... operates on 110 to 260V AC & 6V DC with converter ... many other attractive features ...

Write for further details and nearest dealer
BUTOBA DIV., TURNING CORP. OF AMERICA
 34 Park Row New York 38, N. Y.

POP'tronics Bookshelf

"RADIO SERVICING," Third Edition, by Abraham Marcus. Published by Prentice-Hall, Inc., Englewood Cliffs, N. J. 649 pages. Hard cover. \$7.95.

As the author states in his introduction, he believes that a person is better equipped to trouble-shoot receivers if he has a good understanding of radio theory than if he simply studies individual sets in detail. Beginning with an intensive review of basic electrical and radio theory, Mr. Marcus follows through with an explanation of the electron tube and its many functions, plus specific service notes on possible defects. Servicing procedures, techniques, and instruments are covered. Numerous charts, diagrams, graphs, and other illustrations are provided, as are listings of electrical terms, and formulas, symbols, units and abbreviations. Recommended as a useful guide for budding servicemen and as a general reference book for the more established technician.

"TUBE SUBSTITUTION HANDBOOK," published by Howard W. Sams & Co., Inc., 2201 E. 46th St., Indianapolis 6, Ind. 96 pages. Soft cover. \$1.50.

Substituting tubes, either American or European, in a variety of circuits is simplified by the data in this handbook. American substitutes for European tubes are listed, as are European substitutes for American tubes, industrial substitutes for receiving tubes, and possible picture-tube substitutions. Any serviceman or electronic experimenter will find the book of value and will probably make frequent reference to it.

"DIGITAL COUNTERS AND COMPUTERS" by Ed Bukstein. Published by Rinehart & Company, Inc., 232 Madison Ave., New York 16, N. Y. Hard cover. 248 pages. \$7.00.

Written to meet the demand for in-

NOW!
at a price
you can afford!

MAKE MORE MONEY in TELEVISION RADIO-ELECTRONICS

**BETTER...MORE COMPLETE...LOWER COST...
WITH NATIONAL SCHOOLS SHOP-METHOD
HOME TRAINING!**

BETTER... Training that is proved and tested in Resident School shops and laboratories, by a School that is the **OLDEST** and **LARGEST** of its kind in the world.

MORE COMPLETE... You learn **ALL PHASES** of *Television-Radio-Electronics*.

LOWER COST... Other schools make several courses out of the material in our **ONE MASTER COURSE**... and you pay more for less training than you get in our course at **ONE LOW TUITION**



These
two FREE books will
show you how!

You get all information
by mail... You make
your own decision... at
home! **NO SALESMAN
WILL CALL**

TOP PAY... UNLIMITED OPPORTUNITIES LIFETIME SECURITY CAN BE YOURS!

You are needed in the Television, Radio, and Electronics industry! Trained technicians are in growing demand at excellent pay—in **ALL PHASES**, including Servicing, Manufacturing, Broadcasting and Communications, Automation, Radar, Government Missile Projects.

NATIONAL SCHOOLS SHOP-METHOD HOME TRAINING, with newly added lessons and equipment, trains you in your spare time at home, for these unlimited opportunities, including many technical jobs leading to supervisory positions.

YOU LEARN BY BUILDING EQUIPMENT WITH KITS AND PARTS WE SEND YOU. Your National Schools course includes thorough *Practical* training—**YOU LEARN BY DOING!** We send you complete standard equipment of professional quality for building various experimental and test units. You advance step by step, perform more than 100 experiments, and you build a complete TV set from the ground up, that is yours to keep! A big, new TV picture tube is included at no extra charge.

EARN AS YOU LEARN. We'll show you how to earn extra money right from the start. Many of our students pay for their course—and more—while studying. So can you!

RESIDENT TRAINING AT LOS ANGELES

If you wish to take your training in our Resident School at Los Angeles, the world's TV capital, start **NOW** in our big, modern Shops, Labs and Radio-TV Studios. Here you work with latest Electronic equipment... professionally installed... finest, most complete facilities offered by any school. Expert, friendly instructors. Personal attention. Graduate Employment Service. Help in finding home near school... and part time job while you learn. Check box in coupon for full information.

LESSONS AND INSTRUCTION MATERIAL ARE UP-TO-DATE, PRACTICAL, INTERESTING. Every National Schools Shop-Method lesson is made easy to understand by numerous illustrations and diagrams. All instruction material has been developed and tested in our own Resident School Shops, Laboratories and Studios.

SEND FOR INFORMATION TODAY... it can mean the difference between **SUCCESS** and failure for you! Send for your **FREE BOOK** "Your Future in Television-Radio-Electronics" and **FREE Sample Lesson**. Do it **TODAY**, while you are thinking about your future. It doesn't cost you anything to investigate!

GET THE BENEFITS OF OUR OVER 50 YEARS EXPERIENCE

Approved for
GI Training



NATIONAL SCHOOLS

Los Angeles 37, Calif.

YOU GET...

- 19 Big Kits—**YOURS TO KEEP!**
- Friendly Instruction and Guidance
- Job Placement Service
- Unlimited Consultation
- Diploma—Recognized by Industry
- **EVERYTHING YOU NEED FOR SUCCESS!**

SHOP-METHOD HOME TRAINING COVERS ALL PHASES OF INDUSTRY

1. Television, including Color TV
2. Radio AM & FM
3. Electronics for Guided Missiles
4. Sound Recording and Hi-Fidelity
5. FCC License
6. Automation and Computers
7. Radar & Micro-Waves
8. Broadcasting and Communications

NATIONAL TECHNICAL SCHOOLS

WORLD-WIDE TRAINING SINCE 1905

MAIL NOW TO
NATIONAL TECHNICAL SCHOOLS, Dept. RZG-100
4000 S. FIGUEROA ST. LOS ANGELES 37, CALIF.
Rush free TV-Radio "Opportunity" Book and sample
lesson. No salesman will call.

NAME _____ AGE _____
ADDRESS _____
CITY _____ ZONE _____ STATE _____
 Check if interested **ONLY** in Resident School training at Los Angeles
VETERANS: Give date of Discharge _____

new

from H. H. SCOTT EASY TO BUILD fm tuner kit

Write for details



H. H. SCOTT

H. H. Scott Inc., Dept. PE-10
111 Powdermill Rd., Maynard, Mass.

Rush me complete information on your Wide-Band FM Tuner Kit and your complete stereo component catalog.

Name _____

Address _____

City _____

State _____

QUICKLY CUT HOLES

in metal, plastics,
hard rubber...



ROUND



SQUARE



KEY



"D"



GREENLEE CHASSIS PUNCHES

Make smooth, accurate openings in 1½ minutes or less... for sockets, plugs, controls, meters, panel lights, etc. Easy to use... simply turn with wrench.

Many sizes and models.

Write for literature.



GREENLEE TOOL CO., 1915 Columbia Ave., Rockford Illinois

Bookshelf

(Continued from page 20)

telligible technical information in the growing field of computer technology, this book contains much information never before published in book form. Prepared in a clear, easily understandable style and supplemented with numerous illustrations and study questions for each chapter, it should fulfill the needs of the technically inclined layman, the student, and others interested in the science of computation.



"UNDERSTANDING RADIO," Third Edition, by Herbert M. Watson, Herbert E. Welch, and George S. Eby. Published by the McGraw-Hill Book Company, Inc., 330 W. 42nd St., New York 36, N. Y. 706 pages. Hard cover. \$6.20.

Written for the student with little background in electronics, this revised textbook combines both the theoretical and practical aspects of radio. Several introductory chapters explaining sound, radio waves, electricity, and magnetism are followed by chapters on the theory, building, and operation of short-wave sets, transmitters, crystal receivers, and—new with this edition—a public address unit. Ending each chapter are two study aids: technical term definitions, and questions. Thoroughly illustrated with diagrams, pictorials, and schematics, the book also makes effective use of its inside covers and fly-leaves. The latter contain charts which show the standard RETMA color code, drawings of resistors and capacitors, and a list of tube characteristics.



"PRACTICAL TRANSISTOR SERVICING," by William C. Caldwell. Published by Howard W. Sams & Co., Inc., 2201 E. 46th St., Indianapolis 5, Ind. 192 pages. Soft cover. \$2.95.

(Continued on page 26)

Why be satisfied with less when:

this College-level program of home study in Electronic Engineering Technology

—can help you achieve new levels of income and success



Mail This Coupon Today

CAPITOL RADIO ENGINEERING INSTITUTE
 ECPD Accredited Technical Institute Curricula • Founded 1927
 Dept. 1210-G, 3224 16th St., N.W., Washington 10, D. C.
 Please send me your course outline and FREE 44-Page Book
 "Insurance for Your Future in the New World of Electronics"
 . . . describing opportunities and CREI home study courses
 in Advanced Electronic Engineering Technology.



- Check field of greatest interest**
- Radar, Servo and Computer Engineering Technology
 - Electronic Engineering Technology
 - Communications Engineering Technology
 - Television Engineering Technology
 - Aeronautical Electronic Engineering Technology
 - Automation and Industrial Electronics Engineering Technology

Name _____ Age _____

Street _____

City _____ Zone _____ State _____

Check: Home Study Residence School Korean Veteran

CREI OFFERS COLLEGE-LEVEL OPPORTUNITY to the man who wisely realizes that the recognition and rewards in electronics are now going to other men—especially the man with modern advanced education.

WITHIN TWO TO FOUR YEARS, depending on the courses selected and amount of stick-to-itiveness brought to bear, you can complete this program in electronics, which is comparable in technological content to advanced residence courses. You study during hours chosen by you. You have plenty of time to do your best.

THIS ADVANCED PROGRAM IS THE CULMINATION of 33 years of working closely with leading companies and Government agencies in the critical field of electronics, where demand for engineering and technical personnel far exceeds the supply. The courses are presented in easy-to-understand form, and our experienced instructors guide your progress step by step.

YOU QUALIFY FOR CREI if you have a high school diploma or equivalent, and if you have had basic electronic training and practical experience in electronics.

PLEASE WRITE US NOW FOR DETAILED, ILLUSTRATED, 44-PAGE CATALOGUE, which gives complete information on home study program and registration procedure. CREI also offers a Residence School Program, where graduates earn AAS degree. Day and evening classes start at regular intervals. Electronics experience is not required for admittance to the Residence School.

CREI PROFESSIONAL STANDING

U.S. Office of Education lists CREI as "an institution of higher education."

CREI was a co-founder of the National Council of Technical Schools.

CREI was among the first three technical institutes whose curricula were accredited by the Engineers' Council for Professional Development.

More than 20,500 students are enrolled in CREI Home Study and Resident Programs.

America's leading electronics, communications, missiles and space exploration companies and Government agencies recognize CREI. Many of these organizations actually pay the tuition for their employees studying with CREI.

To obtain fast, immediate service and to avoid delay, it is necessary that the following information be filled in:

Employed by _____

Type of Present Work _____

Education: _____

Years of High School _____

Other _____

Electronics Experience _____

ELECTRONICS

BOOK SERVICE

will send you your choice of the world's greatest electronics books for a **7-DAY FREE EXAMINATION**

Here are some of the world's greatest electronics books...chosen carefully by Ziff-Davis Electronics Book Service as among the best in their fields. You'll find top-notch texts and manuals on theory and instruction...important volumes covering radio and TV servicing, transistors and tubes...reference books to help you understand such fields as computers, citizens band, communications, and electronics experimentation.

Each volume is designed to help you get more know-how, greater enjoyment from your electronics specialty—and each is yours for 7 days FREE! Simply write your choices on the coupon below and mail it today. When your books arrive, read and enjoy them for seven full days. If, after that, you don't agree that they are everything you want, return them and owe nothing. Here is the perfect way to build the library every man in electronics must have.

THEORY AND INSTRUCTION

RADIO AND TV SERVICING

TRANSISTORS AND TUBES

Get started in radio, TV, communications, by using these simple basic guides to electronic principles, functions, and operations!

Save time and labor in radio and TV maintenance by referring to professional handbooks!

Keep abreast of the latest designs and concepts in both transistors and tubes by using the charts, diagrams, and photographs in these practical books!



2500. BASIC ELECTRONICS, Grob

An introductory text on the fundamentals of electricity and electronics for technicians in radio, television and industrial electronics. \$9.25

2501. ELEMENTS OF ELECTRONICS, Hikey and Villines

This basic electronics text offers an excellent course for training radio and electronics technicians and for students in television, radar and sonar. \$6.95



2511. UNDERSTANDING RADIO, Watson, Welch and Eby

For those with little or no technical knowledge who wish to know the fundamentals of radio theory and servicing. \$7.95

2412. TELEVISION AND FM ANTENNA GUIDE, Noll & Mandl

Two antenna experts tell you their secrets of antenna choice and installation for best reception in any area. Loaded with useful tips on improving reception in fringe and difficult areas. \$5.25

2407. HOW TO GET AHEAD IN THE TELEVISION AND RADIO SERVICING BUSINESS, Marcus

Shows the easy way to get started as a TV-Radio repairman, how to earn while you learn, how to get and keep customers. \$3.50



2415. MANDL'S TELEVISION SERVICING, Mandl

This standard text book in the T.V. servicing field provides clear descriptions of the fundamentals of T.V., and practical instruction on the diagnosis and correction of typical troubles. \$6.95

2408. ESSENTIALS OF ELECTRICITY FOR RADIO AND TELEVISION, Slurzburg and Osterheld

Provides necessary background of principles for understanding T.V., FM and radio circuits. \$8.00



2404. FM RADIO SERVICING HANDBOOK, King

A practical guide to FM V.H.F. receivers, their design, construction, alignment and repair. \$5.00



2600. TRANSISTORS, Gillie

Describes and analyzes semi-conductors and transistors and how they behave. 300 pages, illustrated. \$7.95

2604. BASIC ELECTRON TUBES, Geppert

A text for a first course in electronics. It covers the tubes themselves, not the circuit applications. Basic principles governing operation of specialized tubes are explained. \$7.50



2601. TRANSISTORS IN RADIO, TELEVISION AND ELECTRONICS, Kiver

A descriptive, non-mathematical text for radio, television, electronics technicians and for those who need to gain a working knowledge of transistors and transistor circuits. \$7.95

2606. ELECTRON-TUBE CIRCUITS, Seely

A clear analytical method in the study of electron-tube circuits. Provides a broad background in preparing for work in radio and electronic engineering. \$10.50

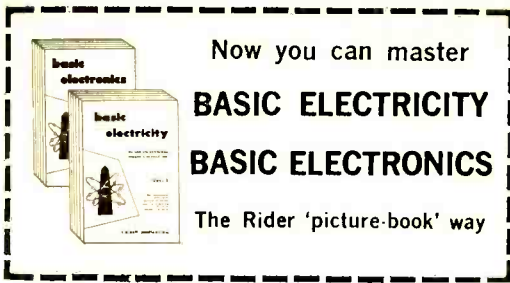

Now you can master
BASIC ELECTRICITY
BASIC ELECTRONICS

The Rider 'picture-book' way

Fabulous illustrated training course now used by
 U. S. Navy—No Other Books Like Them!

A Complete Idea on Every Page

Here's how this easy, illustrated course work: every page covers one complete idea! There's at least one big illustration on that same page to explain it! What's more, an imaginary instructor stands figuratively at your elbow, doing "demonstrations" that make it even easier for you to understand. Then, at the end of every section, you'll find review pages that highlight the important topics you've just covered. You build a thorough, step-by-step knowledge at your own pace—as fast as you yourself want to go! Sponsored by the Navy to turn out trained technicians in record time, this modern course presents Basic Electricity and Basic Electronics in a simple way that everyone can grasp—regardless of previous education!

10 Complete Volumes

BASIC ELECTRICITY—Volumes 1 and 2 cover DC components and circuits; Volumes 3 and 4 cover AC components and circuits; Volume 5 covers AC and DC motors and machinery.

BASIC ELECTRONICS—Volume 1 covers Diodes and Power Supplies; Volumes 2 and 3 cover Amplifiers and Oscillators; Volumes 4 and 5 cover Transmitters and Receivers.

Home Study Without Correspondence

This course is so different, so complete—there's no need for the usual letter writing, question and answer correspondence! Learn at home—at your own pace!

10 Day Examination — Money Back Guarantee

Send today for these exciting new training courses — you risk nothing! When you receive the volumes, examine them in your own home for 10 full days. If, at the end of that time, you're not completely satisfied, simply return the books to us and we'll gladly refund your full purchase price! Total cost for either 5-volume course is only \$10.00!

BASIC ELECTRICITY #169, 5-vols. soft covers, \$10.00; #169H, all 5 vols. in one cloth binding, \$11.50.

BASIC ELECTRONICS #170, 5-vols. soft cover, \$10.00; #170H, all 5 vols. in one cloth binding, \$11.50.

JUST PUBLISHED

VOLUME 6 BASIC ELECTRONICS by Van Valkenburgh, Nooger & Neville Inc. We are pleased to announce the publication of Volume 6, BASIC ELECTRONICS by Van Valkenburgh, Nooger & Neville. Volume 6 is a companion volume to the present five volume course on Basic Electronics by the above authors. It is intended to enable you to expand into the areas of semiconductors, transistors and frequency modulation after the content of the first five volumes has been completed. Volume 6 utilizes the same famous "picture-book" technique used in the present highly successful five volume course.

The original five volume course in BASIC ELECTRONICS is available as heretofore as five individual volumes in paper covers and as all five volumes in one cloth binding. Vol. 6 #170-6 paper cover, \$2.90; #170-6H, cloth \$3.60.

at electronics parts jobbers or bookstores, or order direct:
 DEPT. PE-10

JOHN F. RIDER PUBLISHER INC.
 116 West 14th Street, New York 11, N. Y.
 Canadian prices same as U.S.
 add city & state taxes. All prices subject to revision.

Bookshelf

(Continued from page 22)

The growing popularity of transistor radios requires that the serviceman know the theory and function of transistors, and how servicing techniques and procedures for transistor sets differ from those for tube radios. The author simplifies transistor theory by presenting only what he considers necessary for the serviceman's major needs. Using his experience as an instructor and as a service engineer, he explains the techniques of isolating trouble to a stage, checking voltages, and testing transistors. One chapter outlines case histories of actual troubles and the test procedures used to solve them. For those who want a practical guide to servicing transistor radios and already have experience with tube radios, this book will effectively bridge the gap.

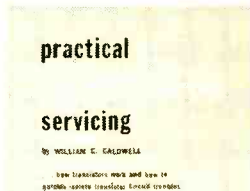

instructor and as a service engineer, he explains the techniques of isolating trouble to a stage, checking voltages, and testing transistors. One chapter outlines case histories of actual troubles and the test procedures used to solve them. For those who want a practical guide to servicing transistor radios and already have experience with tube radios, this book will effectively bridge the gap.

Free Literature

■ Lafayette's 1961 electronic equipment catalog is now available. In addition to Lafayette equipment and kits, it lists the latest stereo and hi-fi equipment of most major manufacturers. It also covers Citizens Band equipment, public address systems, and a virtually endless variety of standard radio and TV components. To obtain this free, 320-page catalog, write to Lafayette Radio Electronics Corp., 165-08 Liberty Ave., Jamaica 33, N. Y.



■ A 60-page handbook of data pertaining to space exploration, titled "Space Facts," can be obtained on request from Product Information, Missile and Space Vehicle Department, General Electric Company, 3198 Chestnut St., Philadelphia 4, Pa. —30—



... symbol of
RAD-TEL
FIRST QUALITY

INSIST ON RAD-TEL FOR EVERY
 TELEVISION AND RADIO TUBE NEED

Super-Special! **KIT OF 100**

**Bi-Pass
 CONDENSERS**

Over 50% Are 600V
 Others 400 V And 200V

at LESS
 THAN
 4¢ each

Goodall
 Semi-Molded
 Paper and
 MYLAR

Values
 .001 to 1 mf

\$ 3.95

**GUARANTEED
 ONE FULL
 YEAR!**

Up to 75% OFF on BRAND NEW TUBES

You Can Rely On Rad-Tel's Speedy One Day Service!

Not Used — Not Pulled Out Of Old Sets • Each Tube Individually and Attractively Boxed!

Qty.	Type	Price	Qty.	Type	Price	Qty.	Type	Price	Qty.	Type	Price	Qty.	Type	Price	Qty.	Type	Price
—	024M	.79	4B27	.96	6AV6	.40	6DE6	.58	12AE6	.43	12CR6	.54	—	1704	.69		
—	1AX2	.62	4C56	.61	6AW8	.89	6DG6	.59	12AF3	.73	12CU5	.58	—	17DQ6	1.06		
—	1B3GT	.79	4DE6	.62	6AX4	.65	6DQ6	1.10	12AF6	.49	12CU6	1.06	—	17L6	.58		
—	1DN5	.55	4DK6	.60	6AX7	.64	6DT5	.66	12AJ6	.46	12CX6	.54	—	17W6	.70		
—	1G3	.73	4DT6	.55	6BA6	.49	6DT6	.53	12AL5	.45	12DB5	.69	—	19AU4	.83		
—	1J3	.73	5AM8	.79	6BC5	.54	6EU8	.79	12AL8	.95	12DE8	.75	—	19BG6	1.39		
—	1K3	.73	5AN8	.86	6BC7	.94	6EA8	.79	12AQ5	.52	12DL8	.85	—	19T8	.80		
—	1L6	1.05	5A05	.52	6BC8	.97	6HG6T	.57	12AT6	.43	12DM7	.67	—	21EX6	1.49		
—	1LN5	.59	5AT8	.80	6BD6	.58	6J5GT	.51	12AT7	.76	12DQ6	1.04	—	25BQ6	1.11		
—	1R5	.62	5BK7A	.82	6BE6	.55	6J6	.67	12AU6	.50	12DS7	.79	—	25C5	.53		
—	1S5	.51	5BQ7	.97	6BF6	.44	6K6	.63	12AU7	.60	12DZ6	.56	—	25CA5	.59		
—	1T4	.58	5BR8	.73	6BG6	1.66	6S4	.48	12AV5	.97	12EL6	.50	—	25CD6	1.44		
—	1U4	.57	5CG8	.76	6BH6	.65	6SA7GT	.76	12AV6	.41	12EG6	.54	—	25CU6	1.11		
—	1U5	.50	5CL8	.78	6BH8	.87	6SK7	.74	12AV7	.75	12EZ6	.53	—	25DN6	1.42		
—	1X2B	.82	5EA8	.80	6BJ6	.62	6SL7	.80	12AX4	.67	12F5	.66	—	25EH5	.55		
—	2AF4	.96	5EU8	.80	6BK7	.85	6SN7	.65	12AX7	.63	12F8	.66	—	25L6	.57		
—	—	—	5I6	.68	6BL7	1.00	6SQ7	.73	12AZ7	.86	12FM6	.45	—	25W4	.68		
—	3AL5	.42	5T8	.81	6BN4	.57	6T4	.99	12B4	.63	12K5	.65	—	25Z6	.66		
—	3AU6	.51	5U4	.60	6BN6	.74	6U8	.78	12BA6	.50	12SA7M	.86	—	35C5	.51		
—	3AV6	.41	5U8	.81	6BQ5	.65	6VG6T	.54	12BD6	.50	12SK7GT	.74	—	35L6	.57		
—	3BA6	.51	5V6	.56	6BQ6GT	1.05	6W4	.57	12BE6	.53	12SN7	.67	—	35W4	.52		
—	3BC5	.54	5X8	.78	6BQ7	.95	6W6	.69	12BF6	.44	12SQ7M	.73	—	35Z5GT	.60		
—	3BE6	.52	5Y3	.46	6BR8	.78	6X4	.39	12BH7	.73	12U7	.62	—	50B5	.60		
—	3BN6	.76	6AB4	.46	6BU8	.70	6X5GT	.53	12BL6	.56	12V6GT	.53	—	50C5	.53		
—	3BU8	.78	6AC7	.96	6BV6	.54	6X8	.77	12BQ6	1.06	12W6	.69	—	50DC4	.37		
—	3BY6	.55	6AF3	.73	6BZ6	.54	7AU7	.61	12BY7	.74	12X4	.38	—	50EH5	.55		
—	3BZ6	.55	6AF4	.97	6BZ7	.97	7A8	.68	12BZ7	.75	17AX4	.67	—	50L6	.61		
—	3CB6	.54	6AG5	.65	6C4	.43	7B6	.69	12C5	.56	17BQ6	1.09	—	117Z3	.61		
—	3CF6	.60	6AH6	.99	6CB6	.54	7Y4	.69	12CA5	.59	17C5	.58	—	—	—		
—	3CS6	.52	6AK5	.95	6C06	1.42	8AU8	.83	12CN5	.56	17CA5	.62	—	—	—		
—	3CY5	.71	6AL5	.47	6CF6	.64	8AW8	.93	—	—	—	—	—	—	—		
—	3DK6	.60	6AM8	.78	6CG7	.60	8BQ5	.60	—	—	—	—	—	—	—		
—	3DT6	.50	6AN4	.95	6CG8	.77	8CG7	.62	—	—	—	—	—	—	—		
—	3Q5	.80	6AN8	.85	6CM7	.66	8CM7	.68	—	—	—	—	—	—	—		
—	3S4	.61	6AQ5	.50	6CN7	.65	8CN7	.97	—	—	—	—	—	—	—		
—	3V4	.58	6AR5	.55	6CR6	.51	8CX8	.93	—	—	—	—	—	—	—		
—	4BC5	.56	6AS5	.60	6CS6	.57	8EB8	.94	—	—	—	—	—	—	—		
—	4BC8	.96	6AT6	.43	6C5U5	.58	10DA7	.71	—	—	—	—	—	—	—		
—	4BN6	.75	6AT8	.79	6CU6	1.08	11CY7	.75	—	—	—	—	—	—	—		
—	4BQ7	.96	6AU4	.82	6CY5	.70	12A4	.60	—	—	—	—	—	—	—		
—	4BS8	.98	6AU6	.50	6CY7	.71	12AB5	.55	—	—	—	—	—	—	—		
—	4BU8	.71	6AU7	.61	6DA4	.68	12AC5	.49	—	—	—	—	—	—	—		
—	4BZ6	.58	6AU8	.87	6DB5	.69	12AD6	.57	—	—	—	—	—	—	—		

Not a Kit, but Completely Wired

**STEREO AMPLIFIER
 CHASSIS \$4.95**

- Lots of 3 ea.
- Single, \$5.95 ea.
- Set of tubes: 2-35C5; 1-12AX7; 1-35W4 \$1.15
- Set of 3 grey 1/2" knobs 30c



SEND FOR FREE TROUBLE SHOOTER GUIDE AND NEW TUBE & PARTS CATALOG

RAD-TEL TUBE CO.

55 Chambers St
 Newark 5, N. J.

PE-1060

TERMS: 25% deposit must accompany all orders — balance C. O. D. Not Affiliated With
 \$1 HANDLING CHARGE FOR ORDERS UNDER \$5. Subject to prior sale. Any Other Mail
 Please add postage. No C. O. D.'s outside continental U. S. A. Order Tube Co.

**BUILD THE
PROJECTS
DESCRIBED
IN THIS
ISSUE OF**

POPULAR ELECTRONICS

WITH THESE



PRODUCTS

Build a Vibrator Substitute

Use BUD AU-1083—\$1.29

Across The Ham Bands

Use BUD CU-3003A—72¢

All Bud products are available for immediate delivery from your Authorized Bud Distributor. They are the best for applications described in these projects.

WATCH FOR THESE LISTINGS EVERY MONTH
IN POPULAR ELECTRONICS

BUD RADIO, INC.

2118 East 55th Street Cleveland 3, Ohio
Dept. P.E.

**To build the
projects in
this
issue
of**

**POPULAR
ELECTRONICS**

Use these
**STANCOR
TRANSFORMERS**

"Build a Vibrator Substitute"

T1—Driver Transformer
use Stancor TA-16
Net Price \$1.73

They are available from any Stancor Distributor . . . and have been verified for their application in the construction projects listed.

LOOK FOR this helpful listing every month. It appears regularly in Popular Electronics.

CHICAGO STANDARD
TRANSFORMER CORPORATION
3501 W. Addison St. Chicago, Illinois

NEW products

TV TUBE REACTIVATOR

Here's an item for that budding television servicershop—a Mercury CRT Tester-Reactivator. Designed to take the guesswork out of TV cathode-ray tube testing, the Model 800 will check for picture-tube quality, life expectancy, possible shorts, and

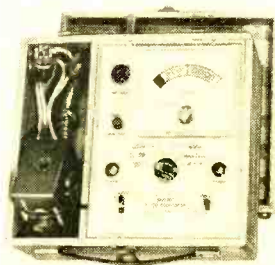

leakage. In addition, it can be used to reactivate either black and white or color picture tubes—a controlled high-voltage pulse is fed to the tube without "stripping" the emitting surface of the cathode. Shorts can be burned out and welds can be made with this special high-voltage pulse circuit. \$49.95. (Mercury Electronics Corp., 77 Searing Ave., Mineola, N. Y.)

FM CAR TUNER

Latest addition to the growing line of FM converters for cars is the Eric Model 100 FM tuner. Like other auto converters, the Model 100 feeds signals directly to your regular AM auto radio. Quite compact (it



measures 2 $\frac{7}{8}$ " x 8 $\frac{1}{4}$ " x 7 $\frac{3}{4}$ "), the Model 100 is claimed to have high sensitivity. An accessory FM antenna is available, although the converter will work with most automobile antennas if they are set to a height of about 30". Price, \$79.95. (Eric Engineering Co., 1823 Colorado Ave., Santa Monica, Calif.)

STEREO SPEAKER SWITCH

If you're wiring up another pair of stereo speakers, say in the den or patio, keep the

We'd like to send you these important new books for a 7-DAY FREE TRIAL EXAMINATION

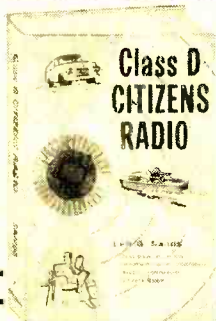

CLASS D CITIZENS RADIO

Leo G. Sands

Here is the first complete book on Citizens Radio Operation. Ever since the initial use of 2-way radiotelephone by police departments, this field has been growing in importance and application. Now, with more than a million vehicles equipped for its use, Citizens Radio is a major phase of the electronics field. This important new volume covers every aspect of the field—its history, rules, and everything about how it works—in seven big chapters with one hundred major sections. You'll learn exactly what Citizens Radio is, its applications, what equipment you need, the full story on receiver circuits and transmitters, antennas, installation, and maintenance, full FCC rulings, how to apply for licenses, etc. Many illustrations.

\$4.95

COMPUTERS AND HOW THEY WORK by James Fahnestock

Here is a fact-filled exciting guidebook to the wonderworld of electronic computers, with more than 120 illustrations and easy-to-follow tables in 10 big chapters. Step by step, you'll see and understand the workings of every type of computer ever used. This important new book illustrates the basic principles of computers in methods that require no knowledge of electronics. You'll learn all about computer memories, flip-flops and the binary counting system. You'll learn the mathematical language of computers where $1 + 1 = 10$. Other chapters show you how computers use tubes and transistors to make complex logical decisions in thousandths of a second. **COMPUTERS AND HOW THEY WORK** is must reading for career minded students and for electronics pros who want a more complete knowledge of this field.

\$4.95

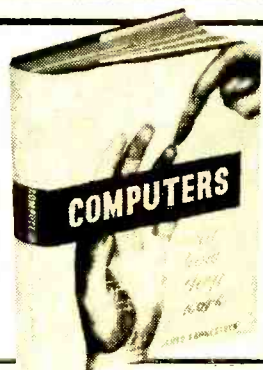

THE ELECTRONIC EXPERIMENTER'S MANUAL

by David A. Findlay

With a few dollars worth of basic tools, and this book to guide you, you can explore the magic of electronics experimentation more completely than ever before. In a few short hours, you'll start your first project. You'll learn about every component used in experimentation, every tool, its function and why it is used. There are 10 big sections, each covering a specific phase of construction. There's a giant section of projects you can build, test equipment you'll construct and use in your future work. **THE ELECTRONIC EXPERIMENTER'S MANUAL** will give you the professional know-how you must have no matter what phase of electronics is your specialty.

\$4.95

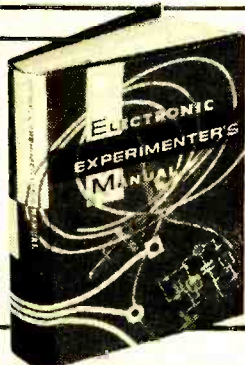

USE THIS CERTIFICATE FOR 7 DAY FREE EXAMINATION

7 DAY FREE EXAMINATION

When your books arrive, read and enjoy their diversity of contents, the thoroughness of their coverage. Then after seven days examination, if you decide that they are not everything you want, send them back and receive a complete refund of the purchase price.

ELECTRONICS BOOK SERVICE •

One Park Avenue, New York 16, N. Y.



Please send me..... copies of **CLASS D CITIZENS RADIO** and bill me at only \$4.95 a copy plus postage and handling.

Please send me..... copies of **COMPUTERS AND HOW THEY WORK**, and bill me at only \$4.95 a copy plus postage and handling.

Please send me..... copies of **THE ELECTRONIC EXPERIMENTER'S MANUAL**, and bill me at only \$4.95 a copy plus postage and handling.

If I don't agree that this is one of the best electronics investments I've ever made, I may return the book(s) within seven days and get a full refund.

\$..... enclosed. (SAVE MONEY! Enclose payment with your order and we'll pay the postage.)

Name

Address

City Zone State 507

products

(Continued from page 28)

Centralab 1486 switch in mind. It permits operating either speaker pair individually, or simultaneously—a real switching convenience. Measuring approximately 1" x 1½", the switch is supplied with a push-on knob. (Centralab, 900 E. Keefe Ave., Milwaukee 1, Wis.)

TUBE TESTER

One of the smallest, lowest-priced tube testers on the market today, the EMC

Model 211 checks all octal, loctal, 7- and 9-pin miniature tubes for shorts, leakages, opens, and intermittents as well as for emission. Magic eye and voltage regulator tubes can also be checked. Size, 6¾" x 5¼" x 2¼" deep. Price: \$22.90 wired; \$14.90 in kit form. (Electronic Measurements Corp., 625 Broadway, New York 12, N. Y.)

ELECTRONIC ORGAN TUNER

Another gadget to ease the job of the radio/TV/hi-fi serviceman, the Schober "Auto-tuner AT-1" enables even a serviceman with a tin ear to tune electronic organs.



Replace improper equipment with the only microphone designed specifically for citizen's band

THE TURNER 350C

This reasonably priced, mobile-type ceramic microphone is the perfect replacement for the many improper, tape recorder-type microphones now being used on CB equipment. Has DPST switch wired for relay operation with easily reversible terminals to allow modifications (if necessary); wiring diagram enclosed with each microphone; hanger button and standard dash bracket for mobile rig mounting; and an 11" retracted (five foot extended), plastic-jacketed, coiled cord. Response: 80-7,000 cps. Output: -54 db. List price: \$16.50 complete. See your Turner Distributor, listed below, he has the 350C in stock.



THE TURNER MICROPHONE COMPANY
934 17th St. N.E.
Cedar Rapids, Iowa

ARKANSAS

Little Rock: Southern Radio Supply
Texarkana: Lavender Radio & T.V. Sup.

CALIFORNIA

Downey: Net Electronics
Hemer: Gil Severns
Hollywood: Pacific Radio Exchange
Los Angeles: Radio Product Sales
The Sound Foyer

Oakland: Elmar Electronics
Sacramento: Selectronics
San Francisco: Market Radio Sound Dept.
San Pedro: Marine Radio Service

DISTRICT OF COLUMBIA

Washington: Electronic Wholesalers

FLORIDA

Miami: East Coast Radio & TV
Tampa: Kinkade Radio Supply

GEORGIA

Atlanta: Specialty Distributing

ILLINOIS

Chicago: Nationwide Radio
La Salle: La Salle Electronics

INDIANA

Anderson: Seybert's Radio Sup.
Bloomington: Stansifer Radio Co.
Evansville: Hutch and Son, Inc.

Ohio Valley Sound

Fort Wayne: Pemberton Laboratories
Indianapolis: Brown Distributing Co.

Graham Electronic Sup.

Van Sickle Radio Supply

Kokomo: George's Electronic Sup.

Michigan City: Tri-State Electrical Sup.
Portland: Buck's Hi-Fi

Richmond: Fox Electronics Company
Terre Haute: Midwest Supply Company

IOWA

Cedar Rapids: Iowa Radio Supply
Des Moines: Radio Trade Supply Co.

KANSAS

Topeka: Acme Radio Supply

KENTUCKY

Lexington: Radio Equipment Co.
Louisville: Archby Electronics

P. I. Burks Company

LOUISIANA

Baton Rouge: Davis Electronics Sup.
New Iberia: Brooks Electronics

MASSACHUSETTS

Boston: A. W. Mayer Company
Radio Shack Corp.

Lowrence: Alco Electronics

MICHIGAN

Ann Arbor: Purchase Radio Supply
Detroit: High Fidelity Workshop

Lansing: Offenauer Company

MINNESOTA

Minneapolis: Schoak Electronics

MISSOURI

St. Louis: Radonics

NEW JERSEY

Berlin: Midstote Radio Supply
Jersey City: Nidisco-Jersey City

Mountainside: Federated Purchaser

NEW YORK

Buffalo: Radio Equipment Corp.
Formingdale, L.I.: Gem Electronics
Forest Hills: Beam Electronics
Mt. Vernon: Davis Electronics
New York: Harvey Radio Company
Acme Electronics

OHIO

Cleveland: Pioneer Electronic Sup.
Columbus: Whitehead Radio Company
Mansfield: Wholesaling, Inc.
Toledo: Lifetime Electronics

OKLAHOMA

Oklahoma City: Johnson Wholesale

OREGON

Portland: United Radio Supply

PENNSYLVANIA

Lancaster: George D. Barbey Co.
Lebanon: George D. Barbey Co.
Philadelphia: Radio Electric Service Co
Pottstown: George D. Barbey Co.
Reading: George D. Barbey Co.
Wilkes-Barre: General Radio & Electr
York: Radio Electric Service Co.

TEXAS

Houston: Sound Equipment Inc.

VIRGINIA

Arlington: Rucker Electronic Products
Falls Church: The Television Workshop

WISCONSIN

Chippewa Falls: Bushland Radio Spec.
Eau Claire: Bushland Radio Spec.

products

(Continued from page 30)

Picking up organ notes through a microphone, the "Autotuner" user varies 13 organ frequencies (in turn) until the appropriate built-in strobe disc pattern stands still. The gadget is usable with almost all electronic-oscillator organs; its cost is said to be less than one-third that of comparable models—\$69.50 (\$49.50 in kit form). (The Schober Organ Corp., 43 West 61st St., New York 23, N. Y.)

DUAL TRACK TAPE RECORDER

A dual-track, two-speed tape recorder introduced by Radio Shack Corp., 730 Commonwealth Ave., Boston 17, Mass., will be marketed for less than \$50. Operating at

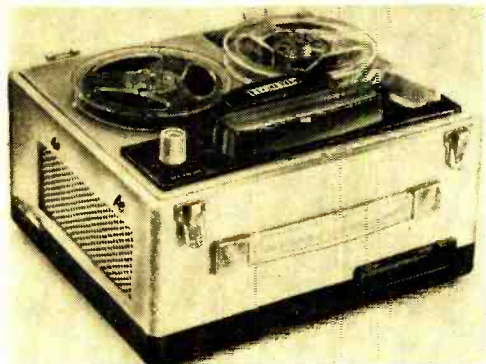

either 3¾ or 7½ ips, it measures 11¾" x 10" x 7", weighs a full 17 lbs. There are external jacks for microphone, radio-phono and external speaker; accessories include a microphone, a radio cord, and a standard 5" reel.

REVERBERATION SYSTEM

If you want to make your living room sound like Carnegie Hall, try the new

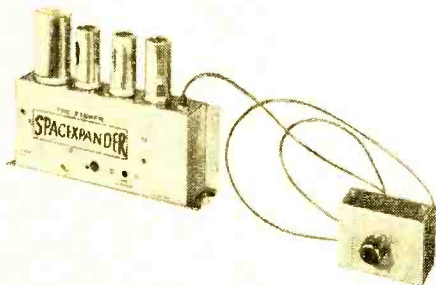

Fisher Model K-10 Dynamic "Spacexpander." Added to a stereo hi-fi system, the Spacexpander gives sparkle to "dead"

recordings by introducing a small time delay or reverberation effect in one channel. It may also be connected to a stereo center-channel amplifier and speaker. \$59.50. (Fisher Radio Corp., 21-21 44th Drive, Long Island City 1, N. Y.)

ADJUSTABLE "LOCK" END WRENCH

Have you ever felt frustrated because you accidentally changed the gap size on your adjustable end wrench? The "Select-O-

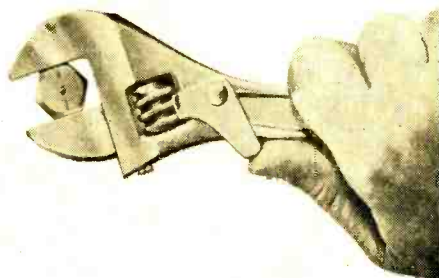

Lock" wrench is being offered by Utica Drop Forge & Tool Division (Kelsey-Hayes Co., Utica, N. Y.) to solve that problem. Built into the wrench is a device which guarantees no slipping or re-setting. The wrench is available in sizes ranging from 4 through 12 inches.

MULTI-PURPOSE TOOL KIT

Interested in a small tool kit that you can carry in a tackle box or glove compartment? The Shelton "Super Socketool" may

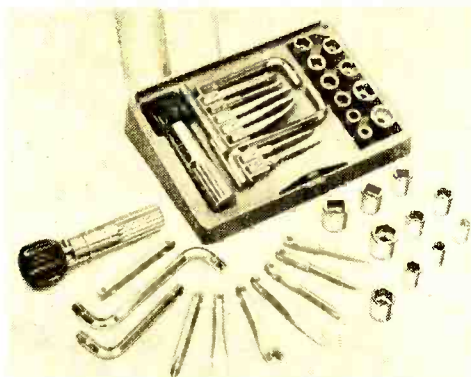

be the answer. Designed around a universal ratchet handle, the kit includes a wide variety of open-end sockets, screwdriver bits, awl attachments, and a handy tack lifter. It makes an ideal gift for any do-it-yourself'er. \$4.98. (Shelton Products Co., Shelton, Conn.)

-50-

1,000,000 have sent for it!

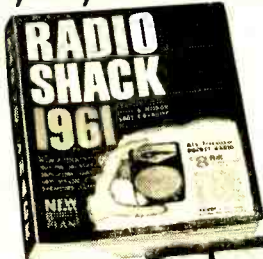

Mail
Coupon
for
Your

FREE

SAVE
on over
30,000
famous-make
items

**1961 Electronics
CATALOG**

plus full year's FREE SUBSCRIPTION to
all other Radio Shack catalogs!

See the latest and best in electronics

- Stereo
- Hi-Fi
- Ham Radio
- Transistors
- Test Equipment
- Kits & Parts
- Related Items

Radio Shack Corp. Dept. 6CK7
730 Commonwealth Ave., Boston 17, Mass.

Send latest Electronics Catalog plus
every new issue for one year, FREE.

Name _____

Address _____

Post Office _____

or City _____ Zone _____ State _____

WHO NEEDS

MILES OF WIRE?

GET HOME ELECTRICITY

ANYWHERE

WITH A

**terado POWER
CONVERTER**

Change 6 or 12 volt D.C. to 110
volt, 60 cycle A.C.

No installation—just plug into ciga-
rette lighter of car, truck, or boat,
and it's ready to go!

Operate lights, electric shav-
ers, dictation machines, rec-
ord players, small electric
tools, portable TV, and testing
equipment.

Models from 15 to 200 watts,
priced as low as \$12.95

See Your Electronic Parts
Dealer or Jobber

TERADO COMPANY

1057 RAYMOND AVE., ST. PAUL 8, MINNESOTA
In Canada: ATLAS RADIO CORPORATION LTD., TORONTO



Tips



and

Techniques

ANTENNA COIL PROTECTOR

If you own both a receiver and a trans-
mitter, you can prevent your receiver's an-
tenna coils from going up in smoke because
of stray r.f. from your transmitter. Simply
connect two NE-2 neon lamps to your re-
ceiver as shown. Solder the lamps in place
by their leads on the under-the-chassis side

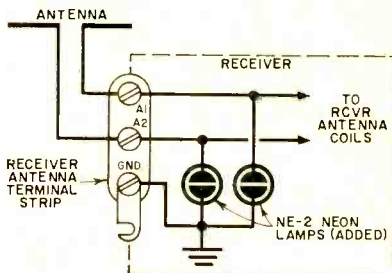

of the receiver's antenna terminal strip;
you will note that one lamp is connected
between lug A1 and Gnd., the other be-
tween A2 and Gnd. Although the lamps
will not affect normal reception, they will
fire and prevent damage to the antenna
coil if you accidentally jolt your receiver
with r.f. from your transmitter.—Carl
Wright, Tucson, Ariz.

SOLDERING IRON FILE

Before soldering small parts such as termi-
nal lugs, clean and brighten them with a
small file taped to your soldering iron's

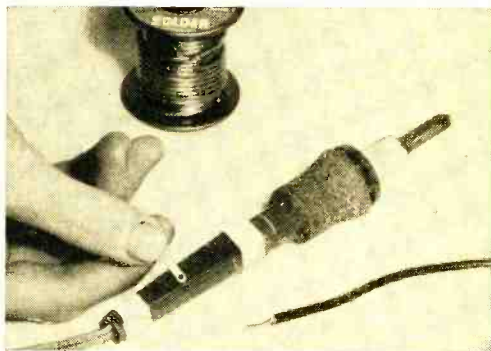

handle. Any small file will do, but an old
nail file is ideal. Don't rub the file against
the part as you might accidentally burn

(Continued on page 35)

Learn RADIO, TELEVISION AND ELECTRONICS by Practicing at Home in Your Spare Time

At No Extra Cost you get specially developed Electronic Training Kits for practical experience. Shop and laboratory practice at home make learning easier, interesting, faster. You do not need a high school diploma or previous experience.

Increasing Demand for Trained Men

This is the Electronics age. Men with Electronic know-how are in demand. They enjoy high pay and growing opportunities for advancement. Satellites, Radar, Automation in Industry, Missiles, Rockets, Planes, Stereo, TV, Radio, Two Way Communications for transportation are a few of the fantastic developments in the fast growing Electronics industry. If you are not completely satisfied with your work; if you are doubtful about your future, investigate Electronics.



High Pay, Prestige, Bright Future

What branch of Electronics interests you? Thousands of successful NRI graduates prove that NRI's learn-by-practice method is the way to success. You start in your chosen career way ahead of the man who only learns from books. You do not need to give up your job. You do not need to go away to school. You learn at home, get practical knowledge from training kits NRI provides.

Train With the Leader

NRI is the world's oldest and largest home study Electronics school. You benefit from the experience NRI has gained from training men for 45 years. NRI offers you proven courses of home study in Electronics; Principles, Practices and Maintenance—Radio Television Communications—Radio Television Servicing.

Start Soon, Earn More

Soon after enrolling NRI shows you how to apply your knowledge to earn extra money doing Electronic repairs or servicing Radio and Television sets for friends and neighbors. Take the first step toward success now. Find out what NRI offers you. Mail the postage-free card. No obligation. Cost of



NRI training is low. Monthly payment plan available. NATIONAL RADIO INSTITUTE, Washington 16, D.C.

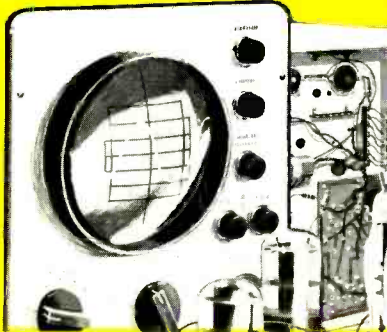

NRI Has Trained Thousands for Success



"I get over twice the salary I made before enrolling. NRI training gave me a thorough understanding." H. ATKINSON, Austin, Tex.

"Now in charge of sound effects for CBC. NRI opened doors to greater opportunity for me." F. TUDOR, Toronto, Ontario.

"Averaged \$150 a month spare time before I graduated. Now have my own full time business." F. W. CCX, Hollywood, Cal.

NEW COURSE IN ELECTRONICS TURN PAGE

Cut Out and Mail—No Stamp Needed

64-PAGE CATALOG FREE

No Salesman will call. (Please PRINT) Dept. JKD-4

Name _____ Age _____

Address _____

City _____ Zone _____ State _____

OLDEST & LARGEST HOME STUDY RADIO-TV SCHOOL
National Radio Institute
WASHINGTON 16, D. C.

ACCREDITED MEMBER NATIONAL HOME STUDY COUNCIL

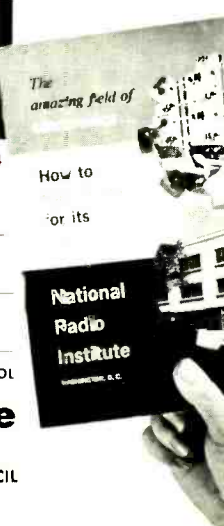



JOB COUNSELORS ADVISE LEARN ELECTRONICS

NEW Home Study Course in **ELECTRONICS** Principles-Practices-Maintenance **NOW READY**

This is the El-ctronic Age. Electronic equipment is already being used to count and control flow of liquids, solids, gases. Electronics is employed to search for oil, make surveys, control traffic, machine complex parts and in atomic installations. Military uses of Electronics are great and expanding rapidly. In business, Automation with Electron cs plays an important part, prepares payrolls, calculates engineering formulas.

Learn More to Earn More

Now, to meet the growing demand for trained Electronic Technicians NRI has developed a comprehensive, complete course in Electronics Principles, Practices, Maintenance. This training stresses fundamentals. It is a course specially prepared for beginners and for Technicians. You get both theory and practical experience in an interesting, exciting way.

Ten Special Training Kits Give Practical Experience

You get practical experience with Thyratron Tube circuits, Multivibrators, build a D'Arsonval type Vacuum Tube Voltmeter (Kit 2); work and experiment with pentode tubes, selenium resistors, oscillators, transistors, magnetic amplifiers; and get practical experience in telemetry circuits as used in earth satellites, digital and analog computers (Kit 9).

NRI Oldest, Largest School

Wishing for success won't bring success. You must act. Get FREE 64-page Catalog from America's oldest and largest home study Electronic-Radio-Television school. It gives facts, opportunities in Industrial and Military Electronics careers, also shows what you learn, tells about NRI's other courses in Radio Television Servicing and Radio Television Communications. Monthly payments plan. Mail Postage Free Card for 64-page Catalog. NATIONAL RADIO INSTITUTE, Washington 16, D.C.



SPECIAL TRAINING KITS NO EXTRA COST

SEE OTHER SIDE

FIRST CLASS

Permit No. 20-R

(Sec. 34.9, P. L. & R.)

Washington, D.C.

BUSINESS REPLY CARD

No Postage Stamp Necessary if Mailed in the United States

POSTAGE WILL BE PAID BY

National Radio Institute

3939 Wisconsin Avenue

Washington 16, D.C.



POSTAGE FREE CARD
MAIL NOW

Tips

(Continued from page 32)

yourself on the iron. Instead, rub the part against the file as shown.—*Jerome Cunningham, Chicago, Ill.*

KIT BUILDING AID

To speed up the building of kits and other construction projects, take a few minutes to arrange all parts in a corrugated cardboard carton, as shown, separating the var-

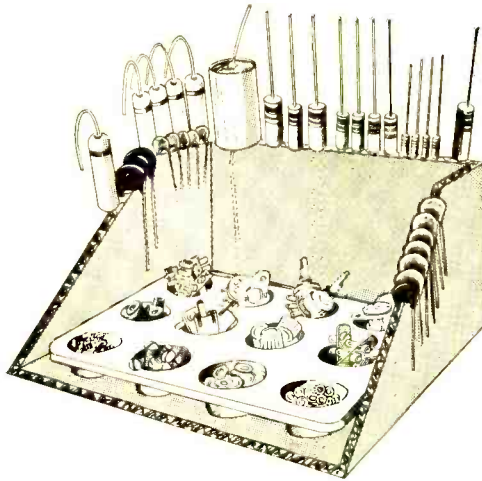

ious parts into convenient categories. Resistor and capacitor leads can be inserted in the edge of the cardboard with values written on the cardboard next to each component. Muffin tins or molded egg cartons make handy trays for smaller parts.—*Courtesy of the Heath Company, Benton Harbor, Mich.*

TROUBLE-SHOOTING PRINTED CIRCUITS

Tracing the printed wiring on a circuit board can be difficult if the board must be turned over constantly to follow the wiring. If you place a strong light behind the board, the shadow of the printed wiring will show through the board and eliminate the necessity of turning it over. The reduced handling will also prevent unnecessary wear and tear on leads connected to the circuit board.—*Ernie Harrison, Tuscaloosa, Ala.*

MINIATURE HEX-HEAD WRENCH

You can easily make a miniature hex-head wrench out of a wing nut and a pair of recessed hex-socket screws. For a $\frac{1}{4}$ " sock-

et wrench, simply take a wing nut with a $\frac{1}{2}$ "-diameter threaded opening and screw in two Allen-type, $\frac{1}{2}$ "-diameter recessed head screws as shown. When both Allen screws are in place, their bottoms will lock

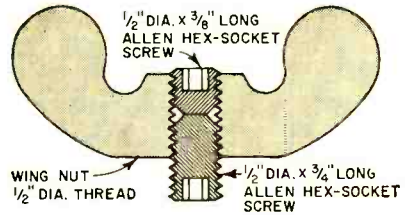

so that they won't turn when used as a wrench. Other size wing nuts and recessed Allen screws can be used in the same way.—*Sam Lissauer, Los Angeles, Calif.*

EMERGENCY CONTINUITY CHECKER

A pair of high-impedance headphones can be used as a continuity checker by simply connecting a $1\frac{1}{2}$ -volt flashlight cell and a

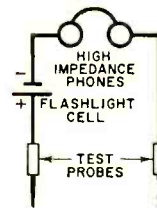

couple of test probes to the phones as shown. Unless the circuit is open, you'll hear a loud click in the phones whenever the probes are effectively short-circuited. You'll find this checker helpful for testing continuity of vacuum-tube filaments, switches, fuses, household appliances, etc.—*Robert McFeely, Indianapolis, Ind.*

COAT-HANGER INSTRUMENT STAND

A convenient stand for a multimeter or vacuum-tube voltmeter can be easily formed from a wire coat hanger. Shape the

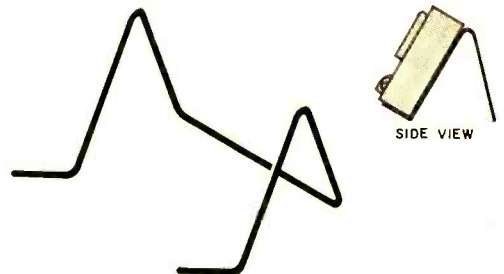

wire to fit the meter, and tape the ends of the wire to prevent scratching or marring the meter. The stand will hold the meter securely and at a convenient reading angle.—*Rudolf F. Graf, New York, N. Y.* —30—



RATED "Best Buy"
NOW EVEN BETTER



\$110.50

only for those who want the ultimate

SHERWOOD S-3000 III

FM/MX STEREO TUNER

The FM tuner that has everything... 0.95 μ v sensitivity, Interchannel Hush noise muting system, "Acro-Beam" tuning eye, cascode balanced input, automatic frequency control, "local-distant" switch... now brings you the only

FM TUNER with "CORRECTIVE" INVERSE FEEDBACK

Every high fidelity amplifier today incorporates "corrective" inverse feedback for lower distortion and improved response. Now, Sherwood brings the same performance benefits to the S-3000 III FM Tuner; these include reduction of distortion due to over-modulation by the FM station and better quality long-distance reception.

READY FOR FM STEREO

Stereo via FM multiplex broadcasting is just around the corner. The S-3000 III contains chassis space and all control facilities to plug in a stereo multiplex adapter. Other features include flywheel tuning, plus 7" expanded slide rule tuning scale, cathode-follower output, and front panel output level control. Sherwood Electronic Laboratories, Inc., 4300 N. California Ave., Chicago 18, Ill.

(*) Other fine Sherwood Tuners:
S-2000 II AM-FM Tuner \$145.50
S-2200 AM-FM MX Stereo Tuner \$179.50

FOR BROCHURE WRITE DEPT. PE-10

Hi-Fi

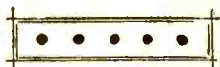

Showcase

THINGS are hopping at hi-fi salons these days as a result of some exceptional hi-fi/stereo demonstrations during recent audio shows. Here are short descriptions of a few new products that may capture your interest. Further information is generally obtainable at any store handling hi-fi components; you can also write the individual manufacturers—see addresses on page 38.

Birmingham Sound Reproducers Ltd. prefers to call itself BSR and reckons that in a few years this abbreviation will be as familiar as RCA, GE, IRC, etc. Its stock in trade is record changers and it claims that 25% of all stereo phonograph combinations now being sold use its "Monarch" changers. BSR is currently emphasizing the UA14 model which has been life-tested to exceed 550,000 plays... *Eric Sound*, only a few years back, was a small producer of FM tuners. Although its prices were low, quality and workmanship seemed to be above average and the tuners sold well in west coast markets. Eric continues to expand and now offers a variety of hi-fi/stereo components. Its most recent addition is a stereo receiver/amplifier with 10 watts output per channel; the west coast price of \$169.50 is \$5.00 cheaper than the east coast price—quite a switch!

The *Gray Manufacturing Co.* has had a rebirth of interest in the hi-fi field. To refresh your memory, the Gray people are best known for a viscous-damped tone arm that gained considerable recognition in the days prior to stereo discs. Now they are back with a re-engineered model of the same arm but one that does not interfere with the vertical compliance requirements of stereo discs. Both kit and pre-wired versions are available... *Lafayette Radio* continues to offer a variety of unusual hi-fi products under its own brand name. Our attention has been drawn to a "Trihelix" 10-inch 3-way speaker that looks like a "natural" for any do-it-yourself bookshelf system. The "Trihelix" actually consists of three mechanically independent speakers with crossover points at 1500 and 5000 cps. Frequency range is within ± 3.0 db from

2W1665 Calling All CB'ers!

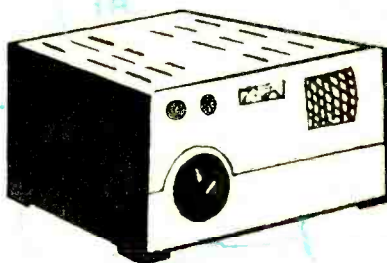

These call letters are those of POPULAR ELECTRONICS' Editor, Perry Ferrell—and he's inviting all of you to take a look at next month's exciting issue!

It features a special giant 16 page bonus section on CITIZENS BAND—the radio service now sweeping the country from coast to coast! In addition to a special full-color cover map of the United States giving you all the FCC Citizens Band call area prefixes—you'll find out how Citizens Band operates... how you can use it for business or private purposes... how to get your license.

There's valuable information on CB equipment... what antennae to use... and much more in this big section of November POPULAR ELECTRONICS.

Also in November POPULAR ELECTRONICS:

- **PRINTED CIRCUITS**—the new development in electronics that has finally come of age. You'll find out what they are... types used in different equipment... how they are made.
- **LOAD LINES**—how to draw and use them to design your own vacuum tube circuits. They're used with vacuum tube characteristic curves found in every tube manual.
- **MODIFYING YOUR TRANSCEIVER**—is easy with this November POPULAR ELECTRONICS feature. Tells you how to add a tuning vernier dial, plate current meter and other modifications to your CB or amateur transceiver to increase operating ease.

Don't miss the informative, entertaining November issue of
POPULAR ELECTRONICS!

Subscription Rates:

one year \$4

two years \$7

three years \$10

POPULAR ELECTRONICS, 434 South Wabash Avenue, Chicago 5, Illinois



Showcase

(Continued from page 36)

from **EICO**® ... a completely new

CITIZENS BAND TRANSCEIVER

that meets **FCC regulations***



Model 760: 117 VAC
Kit **\$59.95** Wired **\$89.95**

Model 761: 117 VAC & 6 VDC kit **\$69.95**
Model 762: 117 VAC & 12 VDC including mounting bracket wired **\$99.95**

*EICO premounts, prewires, pretunes, and seals the ENTIRE transmitter oscillator circuit to conform with FCC regulations (Section 19.71 subdivision d). EICO thus gives you the transceiver in kit form that you can build and put on the air without the supervision of a Commercial Radio-Telephone Licensee!

Highly sensitive, selective SUPERHET (not regenerative) receiver with 5½ dual function tubes and RF stage. Continuous tuning over all 23 bands. Exclusive Super-Hush® noise limiter. AVC. 3" x 5" PM speaker. Detachable ceramic mike. 5 Watt crystal-controlled transmitter. Variable "pi" network matches most popular antennas. 12-position Posi-Lock® mounting bracket. 7 tubes and 1 crystal (extra xtals available). Covers up to 20 miles. License available to any citizen over 18—no exams required.

SAVE with these famous VALUE LEADERS!



All-Transistor Portable RA-6: Kit **\$29.95** Wired **\$49.95**
High sensitivity & selectivity. Plug-in transistors. 4" x 6" speaker; push-pull audio. Prealigned RF & IF transformers. Less batt., incl. FET.



New! 60-Watt CW Transmitter #723: Kit **\$49.95** Wired **\$79.95**
Ideal for novice or advanced ham needing low-power, stand-by rig. 60W CW, 50W external plate modulation. 80 through 10 meters.



90-Watt CW Transmitter* #720: Kit **\$79.95** Wired **\$119.95**
"Top quality"—ELECTRONIC KITS GUIDE. Ideal for veteran or novice. 90W CW, 65W external plate modulation. 80 through 10 meters.
*U.S. Pat. No. D-184,776



High-Level Univ. Mod.-Driver #730: Kit **\$49.95** Wired **\$79.95**
Delivers 50W undistorted audio. Modulates transmitters having RF inputs up to 100W. Unique over-modulation indicator. Cover E-5 \$4.50.



Grid Dip Meter #710: Kit **\$29.95** Wired **\$49.95**
Includes complete set of coils for full band coverage. Continuous coverage 400 kc to 250 mc. 500 ua meter

For FREE CATALOG, fill out coupon on Page 40

EICO® 3300 N. Blvd., L.I.C. 1, N. Y.
Add 5% in the West

30 to 12,000 cps; overall response is 20 to 20,000 cps. Priced at \$32.50, this unit represents an unusual buy . . . Another mail-order house with its own brand is *Radio Shack*. Its popular "Realistic" 4-speed turntable (with hysteresis motor) has been redesigned and an all-new stereo tone arm added; the combination is being labeled the "Mark VIIIa." A special mounting board is furnished with it which measures 13" deep, 15" wide, and requires 3½" clearance above and 4" below the mounting plate. Price, \$59.95.

Rek-O-Kut has come to the obvious conclusion that some audiophiles just don't like to be bothered with the soldering and shielding of tone arm leads. The result is the *Rek-O-Kut* "Micropoise" tone arm which incorporates two color-coded plug-in leads; a ground wire is permanently anchored to the base of the arm. The "Micropoise" is also dynamically-balanced (calibrated from 0 to 6 grams), a departure from the statically-balanced arms produced heretofore. Prices are \$29.95 (12") and \$34.95 (16") . . . Have you noticed that cartridge manufacturers are not forgetting the 78-rpm libraries? *H. H. Scott* now sells a special cartridge for its British-made Model 1000 stereo integrated arm and cartridge. The 78-rpm head has a 3-mil stylus and just the right weight to play at 3.5 grams. By the way, *H. H. Scott* will replace—apparently free of charge—any of the original London-Scott 1000 cartridges with a ruggedized version not susceptible to stylus damage . . . *Audio-Empire* has a new turntable—the Empire 208—featuring all three record speeds and a belt drive! One other manufacturer has a hybrid turntable (part idler-drive and part belt-drive), but we're pretty sure that Herb Horowitz's crew has come up with something extra special. In fact, they measure rumble vibration amplitude in millionths of an inch. Price, \$87.50.

—30—

Audio-Empire (Dyna-Empire, Inc.), 1075 Stewart Ave., Garden City, N. Y.

BSR (USA) Ltd., College Point, Long Island, N. Y.

Eric Engineering Co., 1823 Colorado Ave., Santa Monica, Calif.

Gray High Fidelity Div., 16 Arbor Street, Hartford 1, Conn.

Lafayette Radio, 165-08 Liberty Ave., Jamaica 33, N. Y.

Radio Shack Corp., 730 Commonwealth Ave., Boston 17, Mass.

Rek-O-Kut Co., Inc., Corona, N. Y.

H. H. Scott, Inc., 111 Powdermill Road, Maynard, Mass.

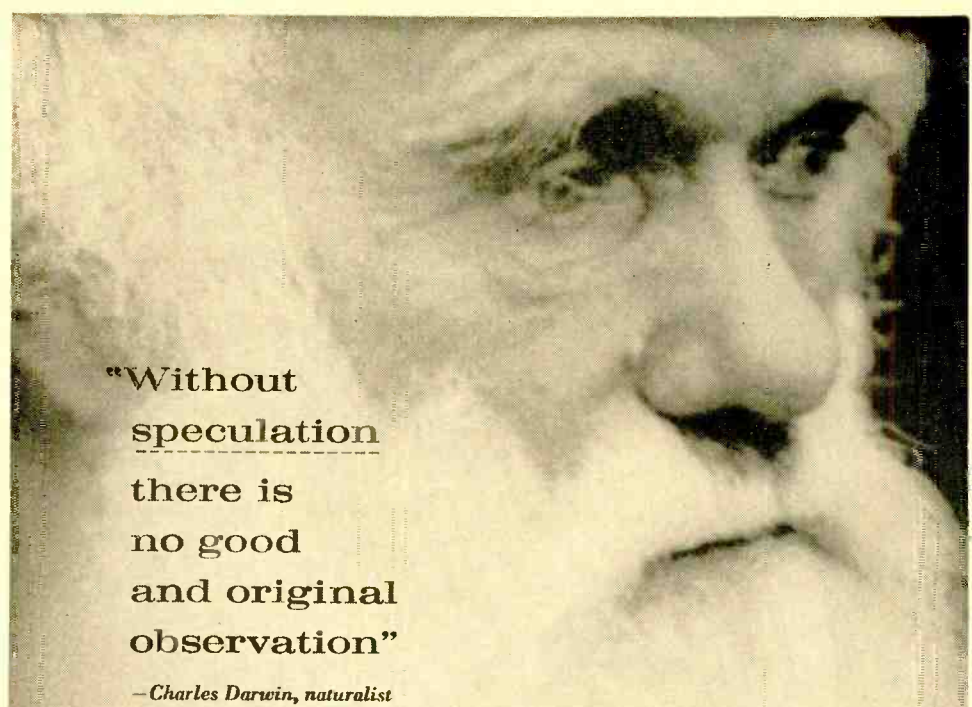

**“Without
speculation
there is
no good
and original
observation”**

—Charles Darwin, naturalist

Man’s search for scientific knowledge and understanding has its tap-roots in the above thought expressed by Darwin in a letter to his distinguished contemporary, Alfred Russel Wallace, in 1857.

Speculation—intuitive contemplation guided by past discoveries—led Darwin to his famous observations set forth in *Origin of Species*. Similarly, it led Alexander Graham Bell to the invention of the telephone—and has since led to dozens of major advances in the field of electrical communications.

At Bell Telephone Laboratories, the puzzling flow of current in semiconductors provoked speculation which yielded the transistor—and a Nobel Prize. Speculation about the behavior of the electron led to experimental proof of its wave nature—and another Nobel Prize. “Brains” capable of guiding missiles and space probes first took form in the bold speculations of Bell Laboratories scientists.

Today, Bell Laboratories scientists and engineers are more keenly aware than ever of the importance of speculative thinking. The far-reaching scientific and technological developments of tomorrow are already the subject of advanced research. Among them are radically new materials and devices—basically new switching systems, transmission via satellites, and waveguide networks able to carry hundreds of thousands of voices simultaneously.

Through informed speculation about Nature’s laws, Bell Laboratories will continue to search for the “good and original observations” which are so vital to the ever-improving Bell Telephone System.

BELL TELEPHONE LABORATORIES

WORLD CENTER OF COMMUNICATIONS RESEARCH AND DEVELOPMENT



the experts say
your BEST BUY
 is **EICO**...

EICO, 3300 N. Blvd., L.I.C. 1, N.Y. PE-10

Show me HOW TO SAVE 50% on 70 models of top-quality: HI-FI TEST INSTRUMENTS
 "HAM" GEAR Send FREE Stereo Hi-Fi Guide. Send FREE Short Course for Novice License. Send FREE Catalog & name of neighborhood EICO dealer.

Name.....
 Address.....
 City..... Zone..... State.....

ADD 5% IN THE WEST

...in
STEREO and MONO HI-FI



STEREO Dual Amplifier-Preamplifier HF81
 Kit \$69.95.
 Wired \$109.95.
 "Excellent" —

SATURDAY REVIEW:
 HI-FI MUSIC AT HOME.



STEREO Dual Preamplifier HF85
 Kit \$39.95.
 Wired \$64.95.
 "Extreme flexibility... a bargain" — HI-FI REVIEW



STEREO Dual Power Amplifiers: New
 100W HF89: Kit \$99.50
 Wired \$139.50
 70W HF87: Kit \$74.95. Wired \$114.95.
 28W HF86: Kit \$43.95. Wired \$74.95.



NEW!
 STEREO-Mono Player/Automatic Changer complete with dual stereo cartridge and "Magnadaptor" \$49.75 incl. F.E.T.



Mono Power Amplifiers (60, 50, 35, 30, 22, 14-Watt; use 2 for Stereo) from Kit \$23.50. Wired \$41.50.



Mono Integrated Amplifiers: (50, 30, 20, 12-Watt; use 2 for Stereo) from Kit \$34.95. Wired \$57.95.



FM Tuner HFT90
 Kit \$39.95*.
 Wired \$65.95*.
 Cover \$3.95.

*Less Cover, F.E.T. incl.

AM Tuner HFT94
 Kit \$39.95. Wired \$65.95, incl. Cover & F.E.T.



2-Way Bookshelf Speaker System HFS1 complete with factory-built cabinet: Kit \$39.95
 Wired \$47.95



NEW!
 COMPLETE STEREO DUAL AMPLIFIER AF-4
 Kit \$38.95
 Wired \$64.95

TRUE Hi-Fi quality to drive hi efficiency speakers to concert volume.

...and in
TEST INSTRUMENTS



New Transistorized Power & Bias Supply #1020
 Kit \$19.95.
 Wired \$27.95.



Miniaturized Multi-Signal Tracer #145A
 Kit \$19.95.
 Wired \$28.95.



Vacuum Tube Voltmeter #221
 Kit \$25.95.
 Wired \$39.95.



New Battery-Powered Filament Continuity Tester #612
 Kit \$3.95.
 Wired \$5.95.



1000 Ohms/Volt V-O-M #536
 Kit \$12.90.
 Wired \$14.90.



5" Push-Pull Scope #425
 Kit \$44.95
 Wired \$79.95.



Peak-to-Peak VTVM #232 & Uni-Probe (pat. pend.)
 Kit \$29.95.
 Wired \$49.95.



RF Signal Generator #324
 Kit \$26.95.
 Wired \$39.95.



Series/Parallel R-C Combination Box #1140
 Kit \$13.95. Wired \$19.95
 1350 Combinations!



6V & 12V Battery Eliminator & Charger #1050
 Kit \$29.95. Wired \$38.95.
 Extra-filtered for transistor equip. #1060
 Kit \$38.95. Wired \$47.95



Tube Tester #625
 Kit \$34.95.
 Wired \$49.95.



R-C Bridge & R-C-L Comparator #950B
 Kit \$19.95.
 Wired \$29.95.

MOST EICO DEALERS OFFER BUDGET TERMS

IN STOCK! Compare, take them home — right "off the shelf" — from 2000 neighborhood dealers. Over 2 MILLION EICO instruments in use throughout the world.

© 1960 ELECTRONIC INSTRUMENT CO., INC., 33-00 N. BLVD., L.I.C. 1, N.Y.

Amateur Radio

The king of hobbies

By DONALD L. STONER, W6TNS

WHAT is a radio amateur? To his non-amateur friends, he is the slightly whacky character who lives in a little world all his own. To his wife he is the lunkhead who gets solder on her carpets and is responsible for enormous electric bills. His neighbors sometimes consider him a member of a vast organization dedicated to the violent overthrow of television. All will agree that he seems to speak in a foreign tongue. But to his fellow "hams," a radio amateur is simply a person with the

Corbis/Bettmann Archive



most interesting, unusual, and rewarding hobby in the world.

Birth of the Hobby. Although amateur radio is strictly a twentieth-century hobby, the birth of an infant called "wireless" occurred long before the turn of the century. In 1887, when the chief interest of most of the population was attending a band concert, a brilliant young German scientist named Heinrich Hertz was experimenting with electricity. Hertz discovered that a spark could be made to jump a gap some distance from the source of power—with no connecting wires! He correctly deduced that electromagnetic waves traveled between the source and the spark gap at the speed of light. The units could be separated by only a few feet, however, or no spark could be detected. Nevertheless, Heinrich Hertz might well be called the world's first radio amateur.

The Italian genius Marconi carried Hertz's simple experiment further by connecting one side of the "sending" spark gap to wires buried in the ground; the other side of the gap was connected to a "sky-wire" or antenna. Equally important, Marconi applied the telegraph code, devised by Samuel Morse for telegraph lines, to his new invention. With this setup, electromagnetic waves generated by the crackling spark traveled more than a mile to a receiving station (see page 41). Practical wireless telegraphy had arrived on the scene; the year was 1895.

Marconi worked ceaselessly to increase the range of his equipment, and more sensitive devices were invented to reproduce the sound of the code. By the time practical distances had reached 200 miles, many government and commercial companies were beating on Marconi's door in their search for wireless equipment. By late 1901, Marconi had thrust his signals 1800 miles from Wales to Newfoundland, in one great leap.

Mushrooming events in the wireless field created more public interest than had ever been known. Experimenters found that they could listen in on this new marvel by building their own receiving stations; amateur transmitting stations followed in short order. The English end of the transatlantic circuit stimulated a similar interest in that country—the amateur experimenters, or "am's" as they were called, built receiving gear with a frenzy.

Keep in mind that there were no tubes,



Heinrich Hertz, a brilliant German scientist, discovered the principle of electromagnetic radiation in 1887. Although Hertz died before he succeeded in transmitting waves more than a few feet, he was the world's first "radio amateur." (*Culver Pictures photo*)

capacitors, resistors, megacycles, or meters. And there were no government regulations, frequency allocations, or organizations for amateurs. Anyone who wanted to experiment built the necessary parts and plunged into the construction of his station.

Important Milestone. Then the rotary spark gap was invented. Rather than use a fixed gap for the spark, this device used many gaps which rotated at high speed. It produced pleasant-sounding oscillations at the then fantastic rate of 50,000 cps. Even more important, the oscillations could be modified by the human voice.

Many experimenters feared insanity when voices, rather than the whine of the spark-set, leapt out of their headsets. But once again amateurs scrambled, this time to hurl their voices across space. The art of radiotelephone transmission had been created; the year was 1906.

Publications describing all kinds of devices for the experimenter were numerous. The papers described feats of distance and



Guglielmo Marconi, an Italian, was first to transmit signals across the 1800-mile span of the Atlantic Ocean. (Culver Pictures photo)

Hiram Percy Maxim (right), co-founder of the American Radio Relay League, was instrumental in the repeal of the war-time ban on radio amateurs. (QST photo)



“heroism” by wireless stations almost daily. The tiny stream of fire created by Hertz and Marconi had become a tremendous blaze in the eyes of experimenters everywhere.

With the increased activity came an ever-rising tide of interference between stations. With no regulations, all stations—amateur, commercial, and government—were intermingled. The interference culminated in the Wireless Act of 1912, with the adoption of the rules which provide the framework under which amateurs operate today. Most important, the government was to control all wireless transmissions, all operators had to be licensed, and amateurs were relegated to a no-man’s land of wavelengths shorter than 200 meters (near the high end of the present broadcast band). Commercial and government stations were the only wireless stations allowed below this frequency, except by special permit.

Amateurs protested violently, for they

felt that this regulation effectively slashed the wrists of their sending hands. The new wavelengths were uninhabited and incapable of propagating energy across a small village, or so they thought. The more progressive experimenters soon discovered that their range had been increased, rather than decreased, and with no additional transmitting power! The better stations could communicate over distances in excess of 30 miles.

Formation of ARRL. In 1914 another great event occurred. The Radio Club of Hartford, Conn., formed a league of amateur stations. This group, as the American Radio Relay League, still represents U. S. amateurs in all official matters. The purpose of the League was to band amateurs together so that they could relay messages from one point to another as commercial stations did.

An early network of amateurs was attempted between Boston and Denver, with the eventual hope of spanning the conti-

ment. Soon, with the leadership of League co-founder Hiram Percy Maxim, messages were flying back and forth. By 1921, with improved equipment and techniques, a message and answer could make the round trip between coasts in six minutes! Although the League suffered severe financial troubles in the beginning, it was able to publish the first issue of its official organ in December, 1915—a magazine still known as "QST."

During the First World War, two-thirds of the 6000 amateurs trooped off to the battlefield, and all amateur transmissions ceased. During the war, and with the help of amateurs, the government discovered how valuable the wavelengths shorter than 200 meters were. These frequencies became the exclusive property of the Navy; and after the shooting had died down, the Navy was hesitant to return them. Under the pressure of League president Maxim and secretary Warner, however, the government relented. In October of 1919, amateur radio was restored. Call letters, consisting of a number and two letters, were again assigned by area to amateurs. (It was much later before the W and K prefixes were added.)

The war also made a commercial item out of a device that was once a laboratory curiosity. It was called a valve (vacuum tube) and could be used to make receivers more sensitive. Even more important, this magic bottle could be used to generate radio signals electronically, with no moving parts whatever. The glow of the vacuum-tube filament cast a shadow over the spark gap and helix coil which signaled the end of a great era. With a mighty whoosh of ozone, King Spark shuddered and died!

New Vistas. Armed with this electronic invention, the ARRL sent Paul F. Godly, 2ZE, to Europe for transatlantic tests. During the experiments, thirty American amateurs were heard on the continent. Finally, after many months of preparation, the first two-way amateur contact flashed across the Atlantic.

In the course of these tests, it was discovered that the shorter wavelength provided superior propagation of electromagnetic energy. Later it was found that the wavelengths between 40 and 10 meters were optimum for long-distance contacts. A mass exodus to the "short wavelength" bands began which made the California Gold Rush seem like a school fire drill.

From then on improvements in equipment and techniques appeared in rapid succession. Today, with modern advances, we think nothing of speaking with amateurs on the other side of the globe—it happens daily! In fact, the amateur radio hobby has literally soared through the ionosphere and far out into space. For ex-

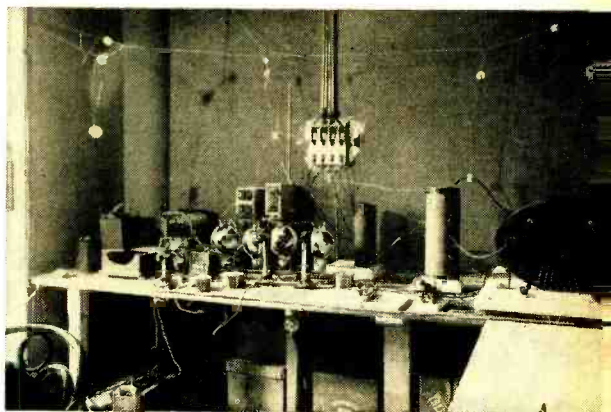

First transatlantic two-way communication between amateurs took place 37 years ago. In November, 1923, stations IMO and IXAM (now W4CF and K6BJ) in the United States worked station F8AB in France. Photo shows F8AB as it looked then.

ample, early in 1953, two outstanding radio amateurs, Ross Bateman (W4AO) and Bill Smith (W3GKP), succeeded in bouncing amateur signals from the surface of the moon back to earth. Although they used the legal maximum power for amateurs—1000 watts—theirs was truly a marvelous technical accomplishment.

Of equal merit was the transmission between John Chambers, W6NLZ, and Ralph Thomas, KH6UK, in 1957. In that year they communicated between California and Hawaii on the 144-mc. band. Frequencies this high, like TV signals, are usually confined to short distances, and covering the 2540-mile path was thought impossible. Later, these same two pioneers repeated the feat on the 220-mc. band—again confounding the experts.

Facets of the Hobby. Amateur radio is actually a large group of hobbies within a hobby, for amateurs have many methods of communication. Some prefer to use the telegraph code system, claiming it is more

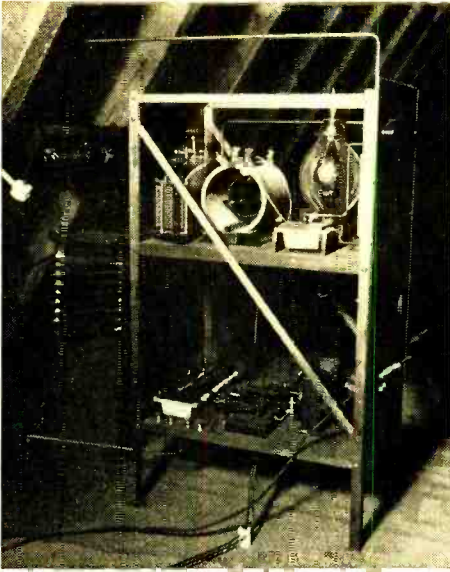

Amateur station 3OT (left) in the year 1925. Object in center is a tapped coil; a large transmitting tube is on the right. (QST photo)

Ham of the Year (1959) Walter Ermer, Sr., W8AEU (below, right), helped provide Cleveland, Ohio, with a 300-man emergency corps.

Homemade station W4AO (below, left) in the basement of Ross Bateman's home was used to bounce signals off the moon. (QST photo)



reliable and less expensive. Others insist that talking over the air is more personal. Still other hams do their "talking" with rattling teletype machines. And a few hardy souls even have their own TV stations. In all, there are more facets to the hobby than to the Hope diamond! Let's look at a few of the activities that occupy the time of almost 200,000 people.

Chatting, or "rag-chewing," is by far the most popular diversion, for hams love to talk! As soon as the first cigarette of the morning is lit, Sam Ham will flick on his receiver and transmitter, even before putting the coffee pot on the stove. Other hams are doing the same thing. More often

than not, a group of these early birds collect in a "round-table," and the microphone is passed around via the air waves until it is time for the various members to dash off to work. The scene is repeated after supper by some of the more rabid members of the clan.

"What do you find to talk about?" hams are often asked. The simplest answer is that sex, religion, and politics are frowned upon, but virtually everything else goes. Generally, the conversation drifts around to technical subjects, new equipment, the latest circuits, and so on.

Sam Ham might also be interested in an-
(Continued on page 134)



Instructors at New York University's language lab, left, walk around the classroom, keeping tabs on each student's progress and straightening out any problems that may arise.



Student's booth contains a tape recorder, a microphone, and a set of headphones. The student listens to a prerecorded lesson and repeats it phrase by phrase into his tape recorder. In playback, he hears the two tracks one after the other and is able to compare his pronunciation with that of the instructor.

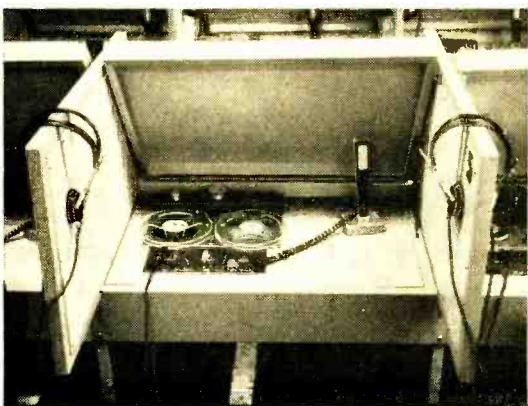

Language Laboratories

The electronic answer to the language-teaching problem

By **GEORGE LESKO**

WHEN it comes to foreign languages, Americans have traditionally been among the most poorly educated people in the world. This is unfortunate and perhaps even dangerous. With modern technology making the world smaller every month, it is becoming increasingly apparent that a knowledge of foreign tongues is important in the pursuit of world peace.

To facilitate the teaching of languages in our schools, educators are turning to electronics—more specifically, to the magnetic tape recorder. "Language laboratories"

which center around the use of tape recorders are springing up in high schools and colleges all over the country.

How does a "language laboratory" work? As an example, let's consider the one recently installed at New York University.

Dual Recording. In a classroom measuring 100' x 100', there are 177 semi-enclosed booths. Each booth is lined with sound-absorbing material and contains a microphone, headphones, and a tape recorder. A bank of 11 "master" tape recorders located in the front of the classroom permits

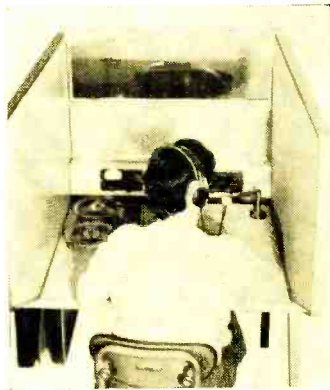

The success of the language-lab concept has led to production of commercial equipment specifically designed for this application. At left above is the control console for the "Medallion" 50-student, 4-language system, produced by the DuKane Corp., St. Charles, Ill. Directly above is one of the "Medallion's" listening booths. At left, a high-school class in Russian is finding out that the language-lab method of learning is quick and easy.

11 languages to be taught simultaneously.

As a student sits at his booth, he listens to a prerecorded lesson. After the instructor's voice speaks a word or phrase, the student repeats it into his microphone, and both voices are recorded on tape. In playback, the new recording allows the student to compare his pronunciation with that of the instructor.

The progress of the students is noted in two ways. First, the instructor can walk from booth to booth, plugging in his headphones to listen to a single student; this gives the student a feeling of personal attention and provides a means of solving individual problems. In addition, the instructor can plug his headphones into the master control at the head of the classroom and listen to students without their knowledge.

"Electronic" Education. How does the electronic language laboratory advance education? It frees the instructors from

the drudgery of routine teaching, practice drill, and pronunciation problems. One instructor becomes 30 teachers at the same time, and is capable of giving individual attention to any single student without holding up the others.

Also, the students get much more practice in the language lab. In a conventional language class, a student averages perhaps one minute of active participation during a session. The language lab enables him to have forty minutes of speaking time per session.

The future for language laboratories looks exceedingly bright. In the New York City school system alone, about twenty language labs are expected to be in operation by the end of the 1961 school year. Other educational centers throughout the country are also planning to make full use of this revolutionary new electronic teaching tool.

EVER since the beginning of the hi-fi era, loudspeakers—like every other component in the sound-reproducing chain—have been fuel for heated arguments between audiophiles. But unlike amplifiers and preamps, speakers have managed to hold on to their very audible personalities. The bumpy response curves of even the most expensive speaker systems are some-

By JOHN MILDER

Living with

There are good reasons for the differences you hear between speaker systems. Understanding the differences is the key to finding the right speaker for you



Loudspeakers

how unimpressive in comparison with those straight-as-an-arrow graphs drawn for quality amplifiers. Fortunately, most speaker systems sound a lot better than their response charts look.

Thanks to the individuality of speakers and the people who listen to them, listening tests and reports on speaker systems have never been easy to make. All things considered, there are good reasons for relying on *your* ears as the ultimate judges of speaker quality. But to make your ears reliable test instruments, it's important to understand the reasons for those hard-to-describe differences between speakers and your reactions to them.

Speaker Coloration. Despite traditional yardsticks like frequency response and distortion measurements, most audiophiles rely on the term "coloration" to describe the differences between a pair of speaker systems. Classifying the kind of sound from any speaker usually calls for words like "mellow," "brilliant," "crisp," and so on. But the ultimate praise for the speaker an audiophile picks to take home to his living room is the word "uncolored."

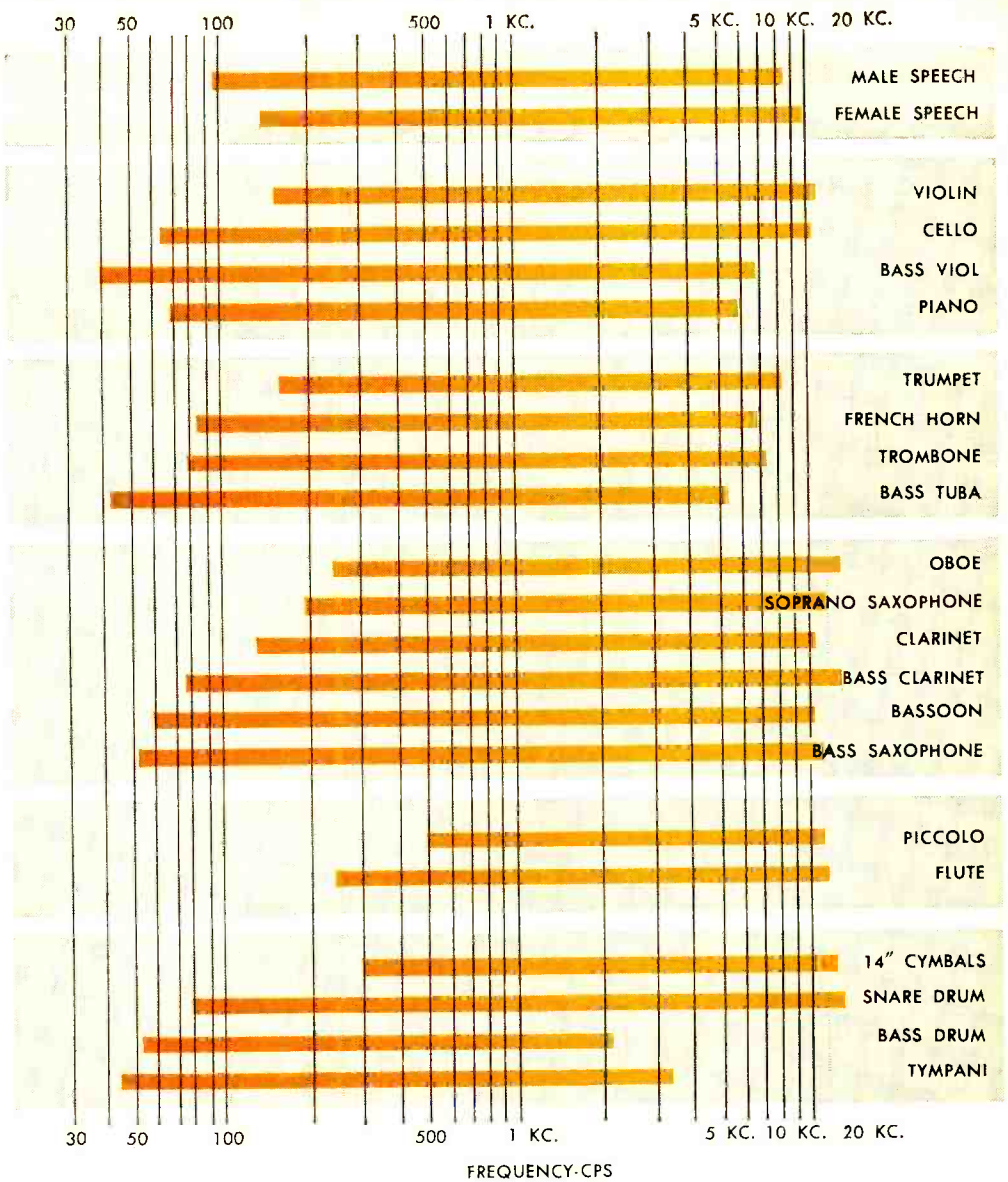

Frequency ranges of human speech and typical musical instruments. Organ (not shown) extends to 30 cps.

Since "coloration" gets a real workout in the lingo of hi-fi showrooms, let's take a closer look at it and see what it really means.

Although you may not know enough about the world of hi-fi music to tell a score from a schematic, you're buying a musical instrument when you select a speaker system. Like a violin or a bass drum, a speaker vibrates to set air in motion and produce sound. A violin gets its orders from the

man behind the bow, while a speaker obeys electronic directions from an amplifier.

Each instrument in a symphony orchestra sounds different because of the varying harmonics they produce along with their fundamental frequencies. Without their distinctive harmonics, all instruments would act like sine-wave generators and sound exactly like each other. The harmonics themselves get their start in life from the construction of the instruments,

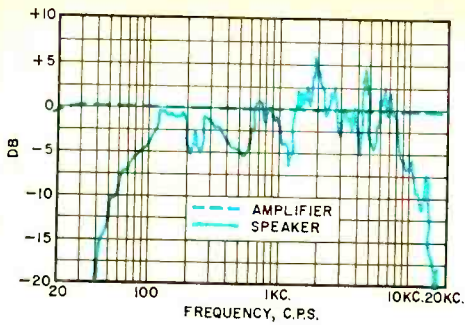

On-axis response of a high-quality speaker compared to response curve for a typical hi-fi amplifier. Note pronounced dropping off of speaker response at upper and lower limits.

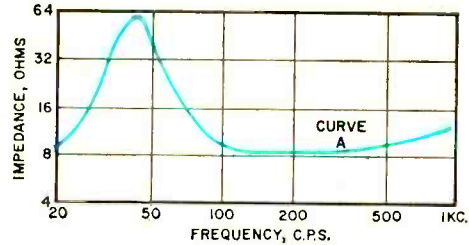

Impedance increases at speaker's resonant frequency (curve A, above). However, a properly designed bass-reflex enclosure will substantially reduce this rise (curve B, below).

the materials used, and the way the instruments are played. Everything about a violin, for instance, down to the glue used to put it together, helps to decide its "coloration" and musical personality.

Speaker coloration follows the same rules. Speakers are made from many materials—from paper pulp to plastics—and any material that's part of a speaker's vibrating mass will add harmonics which color the speaker's sound. Since only one of today's speakers—Electro-Voice's "Ionovac" tweeter—creates sound with an ionized air "diaphragm," virtually any speaker you buy will have some degree of coloration.

Coloration and Distortion. When we call a speaker harsh or muddy, the speaker itself is overshadowing the sound it's trying to reproduce. On test instruments, excessive coloration will show up both as distortion and as very uneven frequency response.

When a speaker won't let you forget for a minute that it's only a speaker, it's having a field day with its harmonics and paying little attention to an amplifier's directions. Often the reason is the use of too "live" a material for a speaker cone; the closest musical equivalent would be banging on an oil drum instead of a tympani. But even a cone of good inert material can go off on its own. If the cone isn't properly designed or isn't adequately controlled by the magnetic field which surrounds its voice coil, it can vibrate independently or flex at the wrong points along its surface. A speaker with all these faults sounds as musical as Jack Benny's violin.

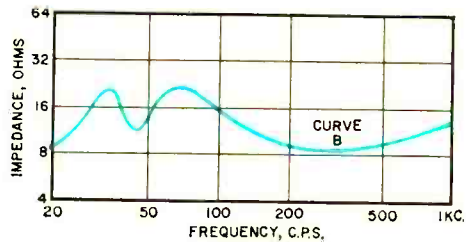

Most speaker manufacturers go to great lengths to avoid excessive coloration. They test cone materials and experiment with suspensions and magnetic structures. And they do their best to make sure that speakers don't assert their own character at the expense of the music they are called upon to reproduce.

The acid test of the manufacturer's success is your ability to "hear through" a speaker system without being distracted by its over-all sound quality. It's worth remembering, though, that the subtle differences you can hear between quality speakers are unavoidable. Whether it's a moving-coil or an electrostatic unit, every speaker has its trademark in sound, yours to like or dislike.

Speaker Enclosures. While speakers provide enough problems to keep any engineer from getting bored, the enclosures in

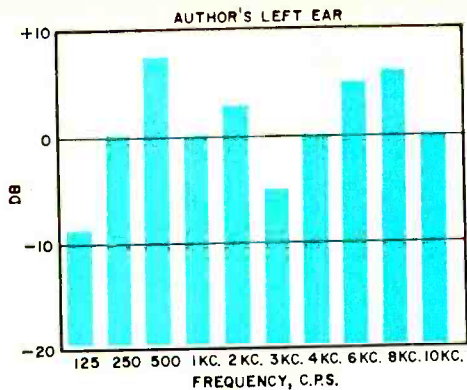

The author, male and under 30, found that his right ear was more uniform in sensitivity than his left ear, as shown in the charts above and below. Sensitivity varies with age and sex.

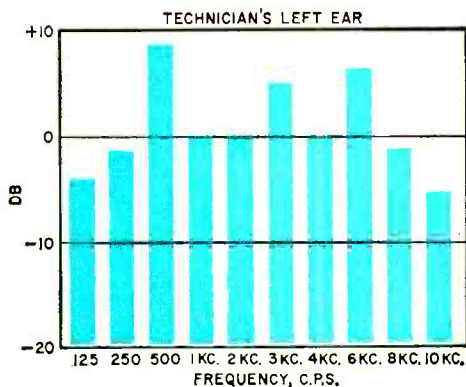
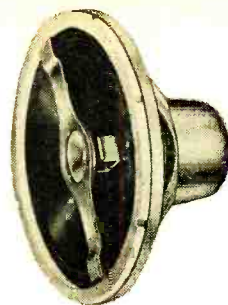
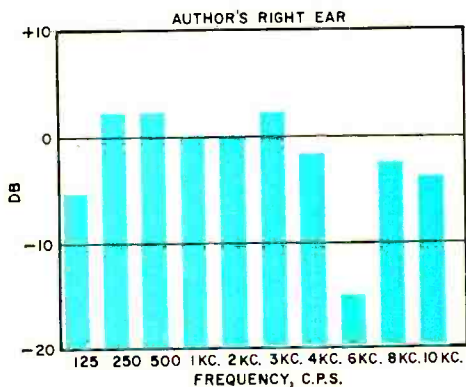

A lab technician, female and also under 30, was generally more sensitive to middle and higher frequencies. Most tests indicate that women have better "ears" than men do.

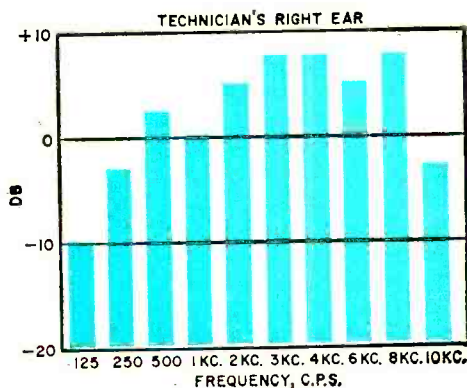

which they are mounted also have their say as musical instruments. The role of an enclosure can be as important as the sound chamber of a Stradivarius violin. The part played by an enclosure in the overall sound of a speaker system depends to a large extent on what we ask it to do. Its general sound quality will also depend in part on how well it's made.

A bass reflex cabinet, usually designed to cancel out a speaker's resonant frequency and extend its bass response, adds its own distinct flavor to a speaker's sound. Depending on its design, it can make for a juicy resonance in the base response by adding harmonics at intervals above the speaker's resonant frequency. Other resonant enclosures—those designed along the lines of an organ pipe, for example—also color a speaker's sound. There's nothing particularly unmusical about this type of coloration.



tion, but a badly tuned or poorly built enclosure adds boominess or rattling which makes for uneasy listening.

An infinite baffle, intended primarily to keep a speaker's back-wave from cancelling out its front-wave at low frequencies, also adds its own kind of coloration. Overall sound from an infinite baffle can be distinctly unpleasing as a result of panel resonance from poor construction.

Horn enclosures, too, have the job of boosting a speaker's ability to move air at low frequencies. But a badly designed or constructed horn can add a very annoying coloration, and using a horn enclosure with a speaker intended for infinite baffling can produce a muddy, bass-heavy sound.

Since any enclosure is meant to be a partner—ideally a silent one—for its speaker, it's always smart to follow the instructions of a speaker's manufacturer to a "T" when you build your own cabinet. But whether or not you're a do-it-yourself'er, make sure that you judge a speaker only in an enclosure specifically designed for it.

Listener Response. In any listening test, our own listening habits affect our judgments as much as anything that a manufacturer builds into his speaker systems. By hi-fi standards, though, the quality control with which we're turned out as listeners is pretty poor, and the "frequency response chart" of an average pair of ears is much more uneven than the graph for a mediocre full-range speaker (see charts on p. 51). Medical standards for "normal" hearing ability permit almost a 25-db variation in our response from 125 to 10,000 cps; audio equipment with that kind of tolerance would put a manufacturer out of business.

Although your own frequency response chart would make any speaker's chart look good in comparison, the up's and down's in your "response curve" are important for judging a speaker system. If one person has trouble hearing a frequency at which a speaker is peaking or distorting badly, he may be able to listen comfortably to a speaker which would drive another person

—with better hearing at that frequency—out of the room.

In addition to our individual hearing abilities, there's also the matter of listening habits. After some experimentation, one listener discovered that speaker systems which sound right to a violinist friend of his sound very harsh and unnatural to him. His friend is used to the piercing, gutty quality of a violin at close range, while he is used to the string tone heard from the back rows of a balcony. Many similar listening habits help to shape our preference in recorded sound.

Our imperfections as hi-fi listeners ought to keep us from being arbitrary in our judgments of speaker systems. They are also our best defense against critical friends who find our speaker systems too tinny or too dull for their tastes. If a

speaker passes the objective tests we can give it, there's no reason to cringe under criticism from a neighbor with "golden ears."

Use Your Ears.

There are several reliable tests for judging a speaker, and today's range of speaker systems makes it easy to find one for your particu-

lar tastes. The job will be even easier, though, if you trust your common sense and avoid arbitrary standards which don't take *you* into account.

If you have any fixed ideas on how wide a speaker's frequency response must be for hi-fi listening, don't insist on them. Trust your ears to tell you which speaker in your price range comes closest to live sound as you know it; and make sure that a speaker's response at one end of the frequency range is balanced by its performance at the other end. A speaker with very good highs but weak lows will wind up sounding thin and unsatisfying in your living room, and a system with solid lows and missing highs will leave you thinking that an orchestra has too many bass fiddles and drums.

Many authorities feel that the product of the lowest and highest notes your system will handle should equal 400,000; others have picked totals as high as 600,000. This

(Continued on page 137)

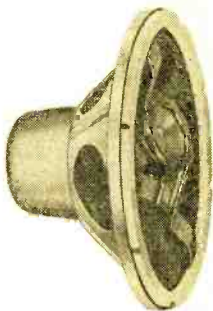

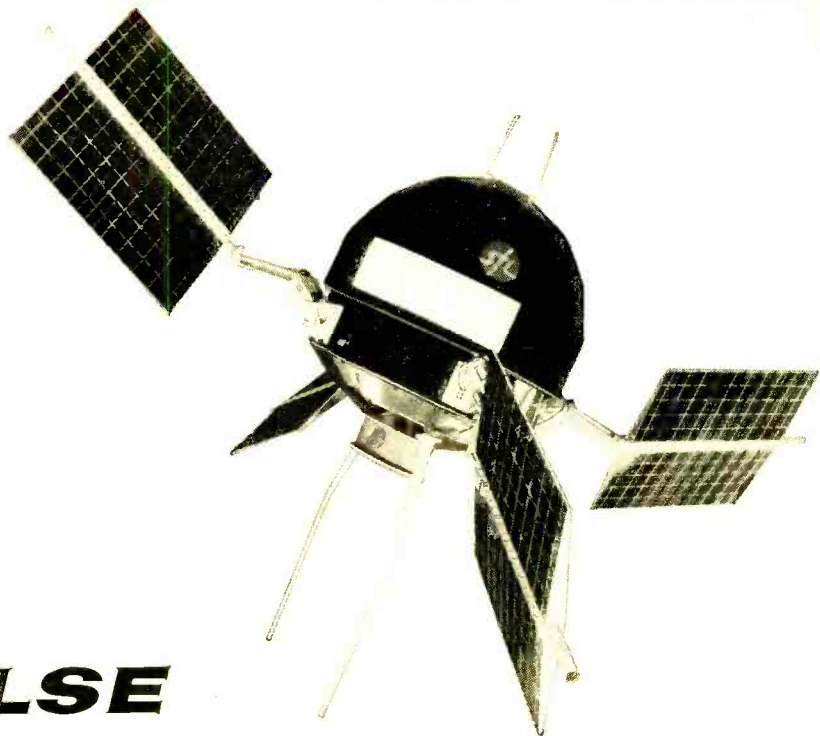

PULSE MODULATION

FROM SATELLITE 1959-*delta* the message came loud and clear: a huge belt of electrons circles the planet earth thousands of miles out in space. Our 1959-*delta* had further jolting news: the outer Van Allen radiation belt, once thought to expand after a solar eruption, actually shrinks. Even more striking was the news that there is a huge interplanetary "atom smasher" centered about the sun.

Satellite 1959-*delta*, commonly known as "Explorer VI," had a lot more to say. But how it said it is just as interesting as what it said. A great deal of Explorer VI's information was sent by a five-watt transmitter that used pulse modulation, the most sophisticated modulation system known today. So important is this new communications system that it is already used for telegraphy, radar, multi-channel microwave transmission, and telemetry, as well as space communications.

Basic Theory. The idea of pulse modulation has been around a long time. In telegraphy, the familiar "dots and dashes" of the Morse code are pulses produced with a switch or key. Ham operators have long been using a form of pulse modulation when they key their high-frequency transmitters to send out pulses of electromagnetic energy in code. Television servicemen come across a form of pulse modulation in the gated-beam tube.

The principle behind the pulse modulation system is actually ridiculously simple: information is impressed on a train of pulses instead of directly on a continuous-wave carrier. But

***This exciting
method of
communication
is reaching out
beyond
the frontiers
of space***

**By
HERBERT KONDO**

if it's as simple as that, why all the excitement about it? What does pulse modulation have that more familiar forms of modulation—AM and FM—don't have?

For one thing, pulse modulation offers practically noise-free transmission and reception—even more so than FM. To visualize this concept, let's consider a train of ideal pulses—pulses with vertical sides, as shown in (A) of Fig. 1. Noise is picked up during transmission, resulting in the waveshape shown in (B). With suitable clipping and limiting circuits, we can reproduce only that part of the pulse signal between the dotted lines, as shown in (C). Having done this, we can then re-transmit this new signal free of noise.

Pulse modulation has another outstanding advantage. It uses transmitter energy more efficiently than either AM or FM because of the simple "on-off" nature of the pulses. This means that a pulse transmitter will have a longer range than an AM transmitter of the same power.

All pulse modulation systems boil down to two basic principles:

- (1) A message signal modulates a train of pulses which are applied to a subcarrier.
- (2) The subcarrier then modulates a high-frequency carrier.

The relation of a subcarrier to a carrier can be made clear by an analogy. Let's suppose that there are five messenger boys on the same subway train in New York City. Each boy is carrying a message to a different destination (receiver). If we think of the subway as the carrier, then each messenger boy is a subcarrier. The message each boy carries is the modulated signal.

Sampling. The most important idea in pulse modulation is sampling, a concept which we come across almost every day. For example, if you've never heard a stereophonic recording, you can listen to a "stereo sample" record and get a good idea of what stereo is like. Another widely known use of sampling is the public-opinion poll which bases its findings on selective sampling techniques.

If we want to transmit a conversation by pulse modulation, we take samples of the conversation—thousands of samples each second—and then transmit them in the same order in which they were spoken. Each pulse is actually a single sample; its height, width, or position indicates the instantaneous value of the sound sent.

For good reproduction, it has been shown

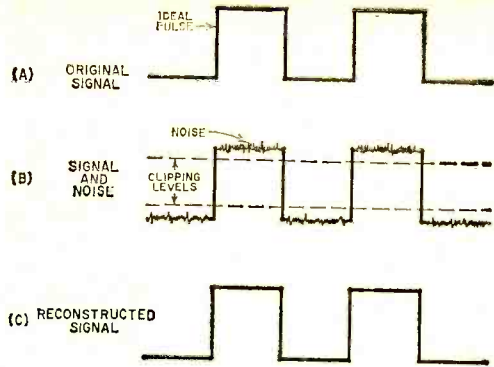
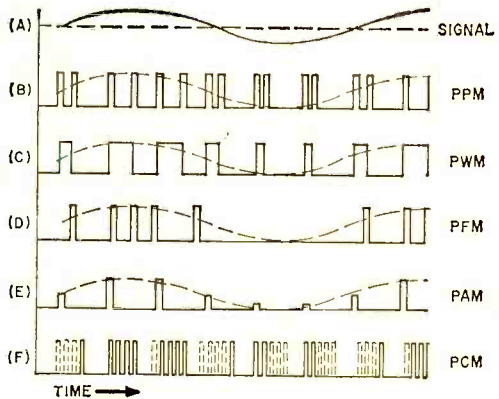

Fig. 1. Original signal amplitude of pulses (A) is affected by noise in transmission (B). Electronic clipping restores original signal (C).

Fig. 2. Information contained in the modulating signal in (A) is shown as it would appear using the various pulse transmission methods (B through F). Binary numbers corresponding to signal amplitudes can be transmitted in the PCM system.



that the number of samples per second must be greater than twice the highest frequency of the signal we wish to send. Thus, if the highest frequency in a telephone conversation is 4000 cps, we must take at least 8000 samples each second.

Types of Modulation. Another basic concept in pulse modulation is the modulation itself. When we modulate a carrier wave, we ordinarily alter its amplitude (AM), its frequency (FM), or its phase (PM). The nice thing about a pulse is that there's another characteristic we can use for modulation, namely, *time*.

If we alter the timing of the pulses, we are effectively changing their position rela-

tive to one another—this is actually done in pulse position modulation (PPM). In pulse width modulation (PWM), we alter the width of the pulses; in pulse frequency modulation (PFM), the frequency of the pulse changes. We can also alter the amplitude of the pulses to produce pulse amplitude modulation (PAM). And we can even code the pulses, as is done in pulse code modulation (PCM).

Let's take a closer look at all of these pulse modulation techniques and find out

somewhat similar to ordinary FM, except that the basic carrier consists of equally spaced pulses rather than a sine wave. The occurrence of the pulses varies with the amplitude of the modulating signal, as in Fig. 2(D).

PAM. In pulse amplitude modulation, the height of the pulses varies directly in accordance with the modulating signal, much like the amplitude modulation of a continuous-wave (c.w.) carrier. In Fig. 2(E), the *positive-going* portion of a sine wave in-

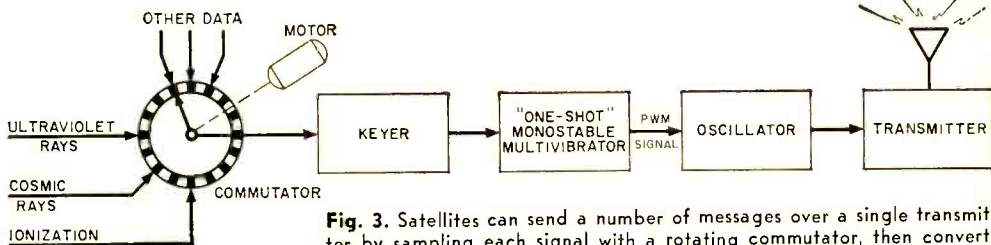

Fig. 3. Satellites can send a number of messages over a single transmitter by sampling each signal with a rotating commutator, then converting the sampled information to PWM signals for transmission to earth.

how a sine wave—see Fig. 2(A)—is transmitted in each system. Later, we'll see how pulse width modulation and pulse code modulation are used in transmissions from satellites and in multi-channel telephone communications.

PPM. Pulse position modulation, widely used in radar and in microwave relays, depends on a modulating signal varying the position of the pulses. A separate generator produces a series of marker pulses which act as reference points. With PPM, the relative position of the signal pulse and the marker pulse are important, as shown in Fig. 2(B).

PWM. In pulse width modulation, the width or duration of the pulses varies directly in accordance with the modulating signal, as shown in Fig. 2(C). Also known as pulse duration modulation (PDM), PWM varies either the leading or the trailing edges, or perhaps even both edges, of the pulses. For example, if the leading edges of the pulses were spaced at equal time intervals, the trailing edges could then be varied (displaced in time) in accordance with the amplitude of the modulating signal. Since pulse width modulation requires relatively simple circuitry, it is the ideal type of pulse modulation for use in outer space vehicles.

PFM. Pulse frequency modulation is

increases the height of the pulse train, while the *negative-going* portion of the signal decreases the height.

PCM. Pulse code modulation uses the presence or absence of a pulse to convey information. In the sample shown in Fig. 2(F), the code makes use of a group of four positions, which may be "filled" with either a pulse or a space (absence of a pulse).

PWM in Outer Space. If we were to make a block diagram of the telemetry system used in the Vanguard rocket, it would break down into the five simple blocks shown in Fig. 3. (See "Telemetry—Vital Link to the Stars," in the November 1959 issue of *POPULAR ELECTRONICS* for a complete discussion of telemetry.)

In Fig. 3, a rotating sampling switch—called a commutator—samples a number of contacts which are connected to devices that measure outer space data (cosmic and ultraviolet rays, X-rays, etc.). Information from the contacts is then sent to the keyer which triggers a one-shot multivibrator (itself a special type of PWM generator). With this arrangement, the multivibrator produces pulse signals whose width varies in accordance with the information (voltage) supplied to it by the commutator and keyer. The PWM signals are fed to the oscillator, which modulates the

transmitter that sends satellite performance information to earthbound receiving stations.

"Explorer I," which discovered the Van Allen radiation belt, also used pulse width modulation. The initial output of the cosmic ray channel, which carried the Van Allen radiation information, was a pulse width signal which then frequency-modulated a subcarrier oscillator. The subcar-

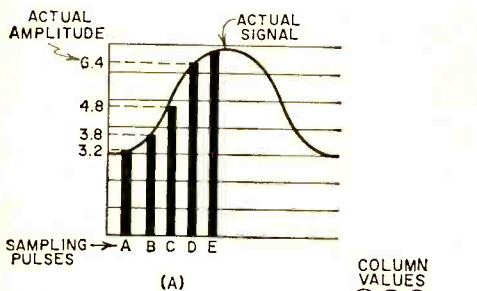
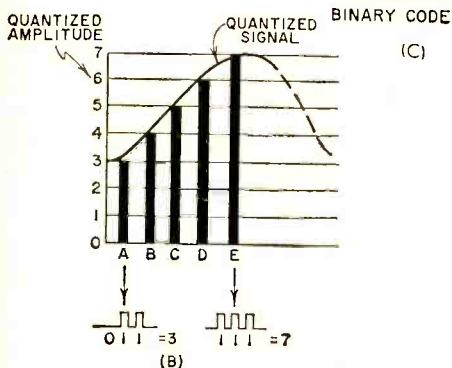

Fig. 4. In the PCM system, amplitude of actual signal (A) is sampled at regular intervals. The samples are rounded off into whole-number pulse amplitudes—a quantized signal (B)—and then converted to binary numbers. Binary code chart (C) gives decimal value of binary numbers.

COLUMN VALUES			
④	②	①	
1	1	1	= 7
1	1	0	= 6
1	0	1	= 5
1	0	0	= 4
0	1	1	= 3
0	1	0	= 2
0	0	1	= 1



rier, in turn, phase-modulated the carrier of the satellite's transmitter. This rather complex sequence of modulation techniques also occurred on the cosmic dust transmissions from Explorer I.

PCM in Communications. Of all forms of pulse modulation, the most exciting is pulse code modulation. Says a one-time Bell Telephone Laboratories scientist: "It's the most sophisticated communication technique around. It has the advantage of an extremely high signal-to-noise ratio, plus the added element of secrecy. PCM

is statistical in nature, and it's hard to jam any statistical communication system—the less predictable the system, the harder it is to design electronic countermeasures against it."

Suppose you bought a VTVM kit for \$29.17, tax included. If a friend asked you how much you paid for it, you might tell him that it cost \$30.00. Would you be lying? Not at all—you are perfectly justified in rounding off the numbers to the nearest easily remembered figure. People are doing this sort of thing all the time. The same technique is used in pulse code modulation.

For example, if the amplitude of the signal we wish to send is 4.7 volts, PCM would send it through as 5 volts; if the signal amplitude is 2.37 volts, PCM would transmit it as 2 volts. This simplification is necessary because the signal has to be coded, and the code uses only whole numbers.

Let's suppose we want to send the signal shown in Fig. 4(A). Sampling pulses sense the amplitude of the signal to be transmitted. Pulse A, which has a value of 3.2 volts, is changed to an amplitude of 3 volts as shown in Fig. 4(B). Pulse B, which has a value of 3.8 volts, is changed to an amplitude of 4 volts. This process of simplifying the original signal in terms of whole numbers is called *quantizing* the signal; the result is known as a *quantized signal*—see Fig. 4(B).

Once the signal is quantized, it must be coded for transmission (hence the name, pulse code modulation). For this, the binary code is used (see "The Language of Digital Computers," POPULAR ELECTRONICS, January 1958, p. 68).

Each quantized pulse representing the amplitude of the signal at a given point must be changed into a group of pulses in the PCM binary code. Always keep in mind this distinction between the quantized pulse and the pulse group: the quantized pulse is a sampling pulse, whose value will be determined by its *amplitude*; the pulse group represents the original signal in binary language.

In a binary pulse group, only the presence or absence of a pulse has meaning. If the code is a three-pulse group, as shown in Fig. 4(C), then the far-right position has a value of 1 if a pulse is present, or 0 if the pulse is absent. The middle position would have double the first position's value, or 2, if a pulse were present, but would

(Continued on page 124)

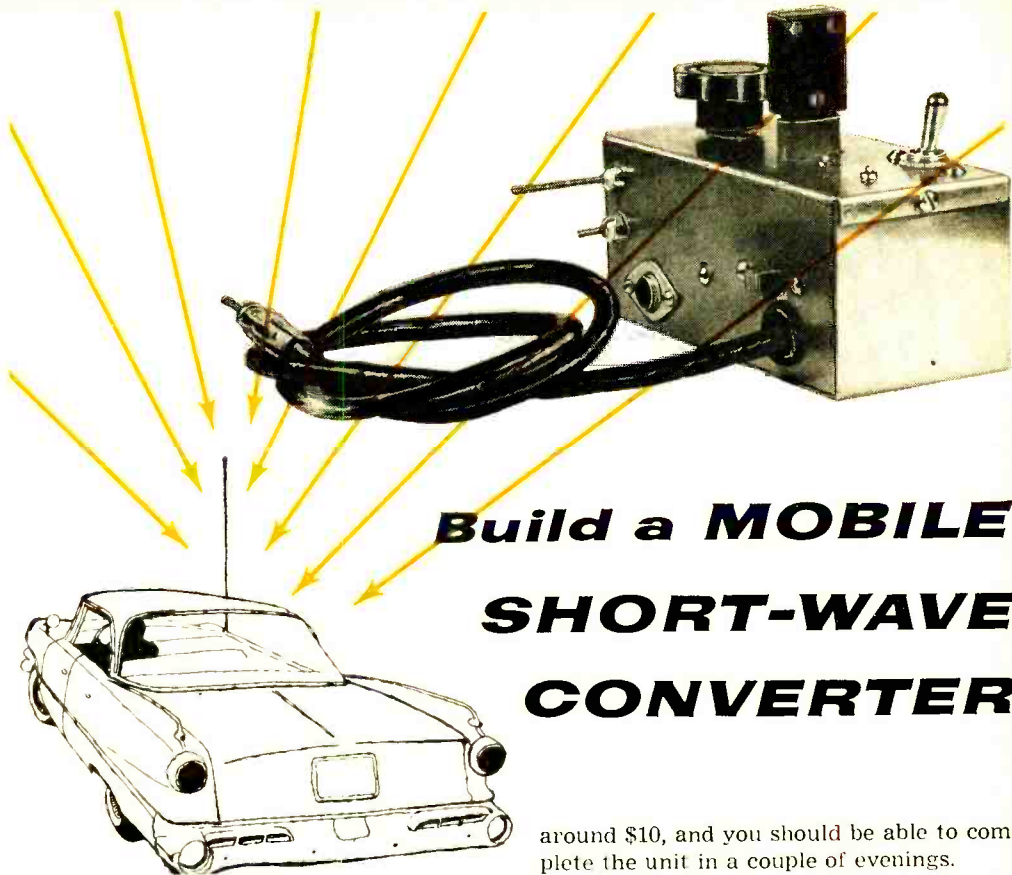

Build a **MOBILE SHORT-WAVE CONVERTER**

By **J. A. STANLEY**

*Self-powered unit pulls in
short-wave and ham broadcasts
while you drive*

TUNING IN short-wave or ham stations on your auto radio is easy with this crystal-controlled converter. A small, self-powered unit, it can be quickly connected to any auto radio by simply inserting it between the radio and the antenna. Although the converter uses only one transistor, it will pull in foreign short-wave broadcasts easily. You'll be able to tune all frequencies between 30 and 49 meters (about 5 to 10 mc.), using only five different crystals.

Since the converter runs on its own battery, you won't have to break into your car's electrical system. Parts will cost

around \$10, and you should be able to complete the unit in a couple of evenings.

Construction. The complete converter is built into a 5" x 2¼" x 2¼" aluminum box as shown. Using a slightly larger box will make assembly easier, but take care to keep tuned-circuit leads short.

Of the five coils (*L1* through *L5*) in the converter, only two (*L3* and *L4*) are hand-wound. Coil *L4* consists of 22 turns cut from a section of Barker and Williamson 3016 coil stock. Any similar coil stock can be used as long as it has a spacing ratio of 32 turns to the inch and a 1" diameter. Note that *L4* is tapped 2½ turns from the ground end, as shown in the pictorial detail.

Antenna coil *L3* consists of nine turns of No. 22 solid insulated hookup wire wound directly over *L4*. A turn or two of plastic tape around *L4* separates the two coils.

Coils *L1* and *L2* are the "garden" variety of broadcast-band antenna loopsticks. If you have a couple of these in your junk box, so much the better, but keep in mind that they have to be short enough to fit into the box you select for the converter. The r.f. choke (*L5*) should have a value of about 2.5 mh., as shown in the parts list;

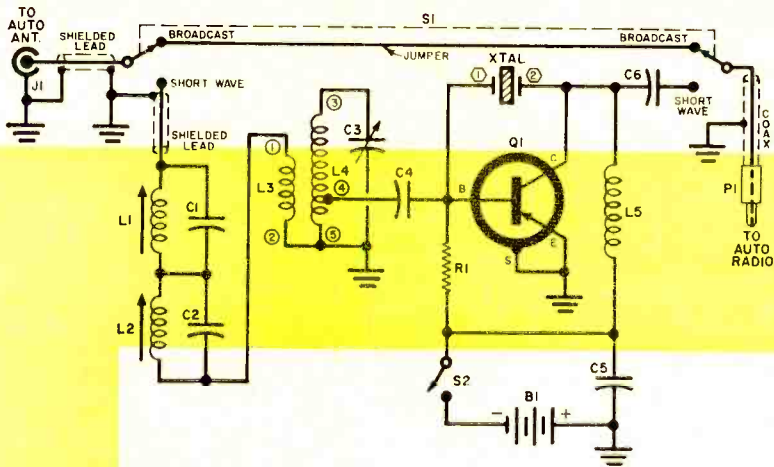

PARTS LIST

- B1—3-volt battery (two penlight cells in series, Burgess Type Z or equivalent)
 C1—500- μ f. ceramic capacitor
 C2, C4—100- μ f. mica or ceramic capacitor
 C3—100- μ f. midjet variable capacitor (Hammarlund APC-100B or equivalent)
 C5, C6—.001- μ f. ceramic capacitor
 J1—Auto antenna jack (Motorola 1207 or equivalent)
 L1, L2—Ferrite broadcast-band loopstick (Lafayette MS-11 or equivalent)
 L3—Antenna coil (see text)
 L4—Tuning coil (see text)
 L5—2.5-mh. r.f. choke (National R-100 or equivalent)
 P1—Auto antenna plug (Motorola 1200 or equivalent)
 Q1—2N247 transistor (see text)
 R1—390,000-ohm, $\frac{1}{2}$ -watt resistor
 S1—D.p.d.t. slide switch (Lafayette SW-17 or equivalent)
 S2—S.p.s.t. slide switch (Lafayette SW-14 or equivalent)
 Xtal—5- to 8-mc. crystal (James Knight H-73 or equivalent—see text)
 1—5" x 2 $\frac{1}{4}$ " x 2 $\frac{1}{4}$ " aluminum box (Bud CU3004A or equivalent)
 Misc.—Hardware, battery holder, sockets

Schematic diagram of converter shows a p-n-p transistor for Q1. Battery polarity should be reversed if an n-p-n transistor is used.

tal will do, as will the surplus FT-243 units.

The converter will tune from 550 to 1600 kc. *higher* than the frequency of the crystal you select. For example, if you select a 6450-kc. crystal, you will be able to tune from 7000 to 8050 kc. on your auto radio dial. This range takes in the 40-meter ham band and the 39-meter international short-wave band.

If you want to pick up other frequencies in the converter's 5- to 10-mc. range, simply select a crystal *near* the frequencies shown in the following table.

Crystal Frequency (kc.)	Frequency Covered by Auto Radio (kc.)
5000	5550 to 6600
6000	6550 to 7600
7000	7550 to 8600
8000	8550 to 9600

current rating isn't important, but the d.c. resistance should be as low as possible.

Any number of transistors will work in the converter; a 2N247 (RCA) was used in the model, but the AO-1 and 2N344/SB101 (Philco) will serve as well. The converter will even work with the low-cost 2N170 (G.E.), if you reverse the battery polarity shown on the schematic. With the 2N170, though, the converter's tuning range may be limited from 5.5 to 6 or 7 mc., depending on how well your 2N170 oscillates.

Frequency Coverage. Select a crystal with a fundamental frequency between 5 and 8 mc. Any 40-meter ham-band crys-

Operation. Once the crystal has been selected, it's an easy matter to fire up the converter. Simply unplug the antenna lead from the auto radio and plug it into jack J1 on the converter. Then insert plug P1 from the converter into the auto radio's antenna jack.

Now switch on the converter and the auto radio. Set bandswitch S1 on the converter to "short wave," and tune the car radio. Instead of the usual broadcast sta-

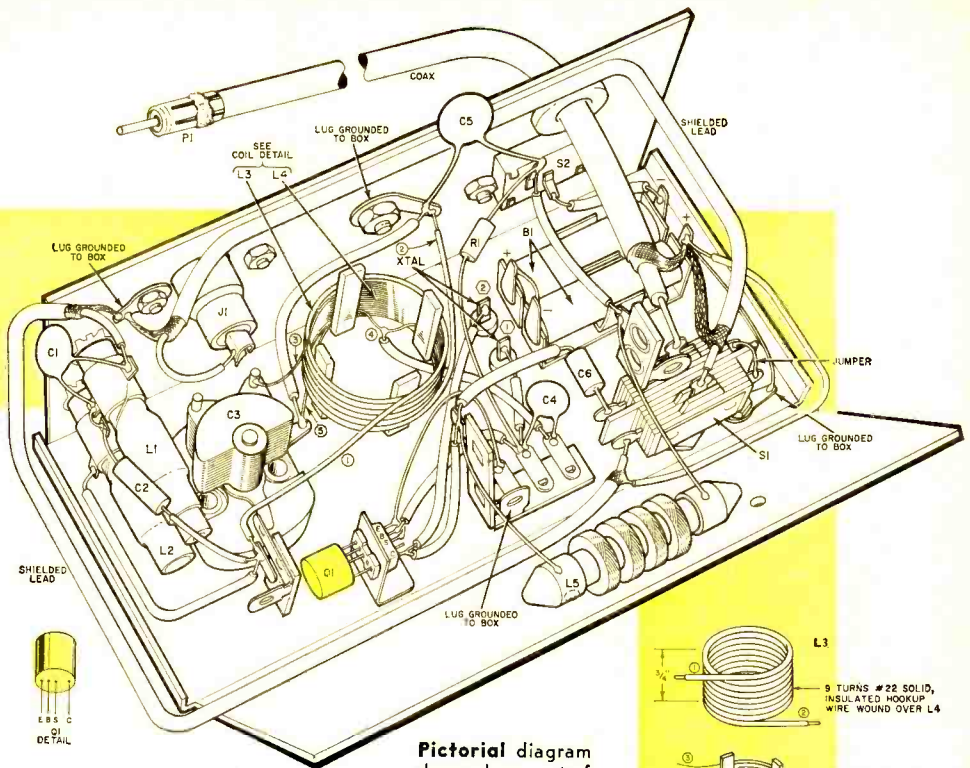

Pictorial diagram shows placement of all parts. If you use a three-terminal transistor, disregard shield connection.

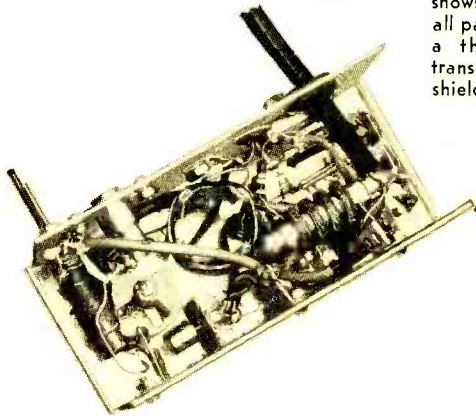
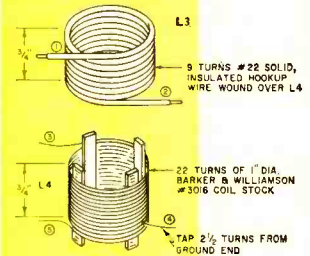

HOW IT WORKS

The converter is basically a self-oscillating mixer. With switch *S1* in the short-wave position, signals picked up by the auto antenna are fed into jack *J1* and pass through the switch contacts. Short-wave signals pass through both broadcast-band traps consisting of tuned circuits *L1-C1* and *L2-C2*, while unwanted broadcast-band signals are eliminated. The short-wave signals are then induced into tuning coil *L4* from antenna coil *L3*; capacitor *C3* tunes *L4* to the frequency of the short-wave signal.

Transistor *Q1* operates as an untuned crystal oscillator and an r.f. mixer. The desired signal is applied to the base of *Q1* through capacitor *C4* and is mixed with the frequency of the crystal. The difference frequency (signal frequency minus crystal frequency), which falls on the standard broadcast band, appears at the collector of *Q1*. This signal is applied to the auto radio via capacitor *C6*, switch *S1*, and plug *P1*. Resistor *R1* supplies base bias to *Q1*, choke *L5* serves as a collector load, and *C5* serves as an r.f. bypass capacitor. Transistor *Q1* is powered by battery *B1* through on-off switch *S2*.

When the converter is not in use, handswitch *S1* is placed in the broadcast position. With this setting of *S1*, broadcast-band signals are fed through jack *J1* and plug *P1* directly to the auto radio.

tions, you should hear short-wave stations. You can now adjust tuning capacitor *C3* on the converter for best results.

If there are one or two broadcast stations that still "ride through," adjust the slugs on coils *L1* and *L2* to eliminate them. Otherwise, just set one slug "in" and one "out" to trap broadcast stations equally well across the band.

For normal broadcast-band reception on your car radio, switch off *S2* on the converter and set bandswitch *S1* to "broadcast band."

Kill Those Harmonics

Inexpensive, easy-to-make tuned stubs will eliminate harmonics from your CB or ham rig

By **KENT A. MITCHELL**, W3WTO

WHETHER you're a Citizens Bander or a ham operator, harmonics from your transmitter can ruin your neighbor's TV pleasures and bring him pounding on your door. Likewise, the FCC takes a dim view of anyone who clutters up the bands with spurious radiations.

One sure way to help clean up your signal is to connect a stub filter to your an-

tenna transmission line. Although relatively simple and inexpensive, quarter-wave stub filters are very effective in eliminating even-order harmonics (2nd, 4th, 6th, etc.) from the output of a transmitter feeding a single-band antenna. Although relatively simple and inexpensive, quarter-wave stub filters are very effective in eliminating even-order harmonics (2nd, 4th, 6th, etc.) from the output of a transmitter feeding a single-band antenna. Since the stub is a quarter wavelength of the signal frequency, it presents a very high impedance to the transmitted signal, and the signal passes on to the antenna with little or no loss in power. Even-order harmonics, however, are confronted with a virtual short circuit, since the stub

Fig. 1. Quarter-wave stub filters can be of either the "shorted end" (A) or "open end" (B) types. Both types eliminate even-order harmonics.

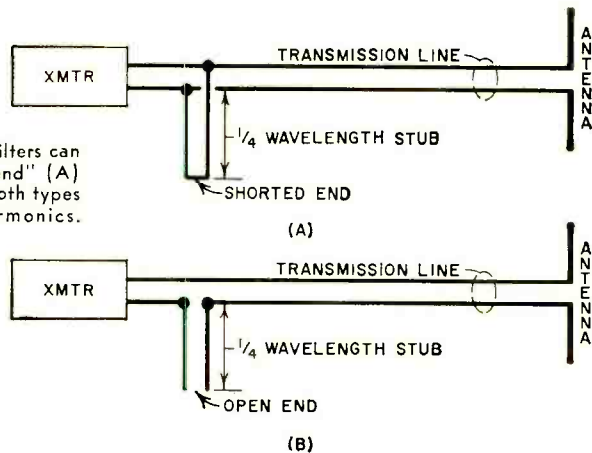

tenna transmission line. Although relatively simple and inexpensive, quarter-wave stub filters are very effective in eliminating even-order harmonics (2nd, 4th, 6th, etc.) from the output of a transmitter feeding a single-band antenna.

There are two types of quarter-wave stub filters. In one case, a quarter-wave stub with a shorted end is connected in parallel with the transmission line; in the other, a quarter-wave stub with an open end is hooked up in series with either leg of the transmission line. Let's see how these two types of stubs work and how they are used.

Figure 1(A) shows a shorted quarter-

offers a very low impedance at these frequencies. The parallel shorted stub is easily connected to coaxial transmission lines as well as twin-lead and open-wire lines.

Figure 1(B) shows an open-end quarter-wave stub hooked up in series with the transmission line. The stub offers little or no resistance to the fundamental frequency, allowing it to pass to the antenna. Even harmonics, on the other hand, "see" some multiple of one-half wavelength—a near-infinite impedance for these frequencies—which prevents them from reaching the antenna. Open-end series stubs are not suitable for coaxial transmission lines since

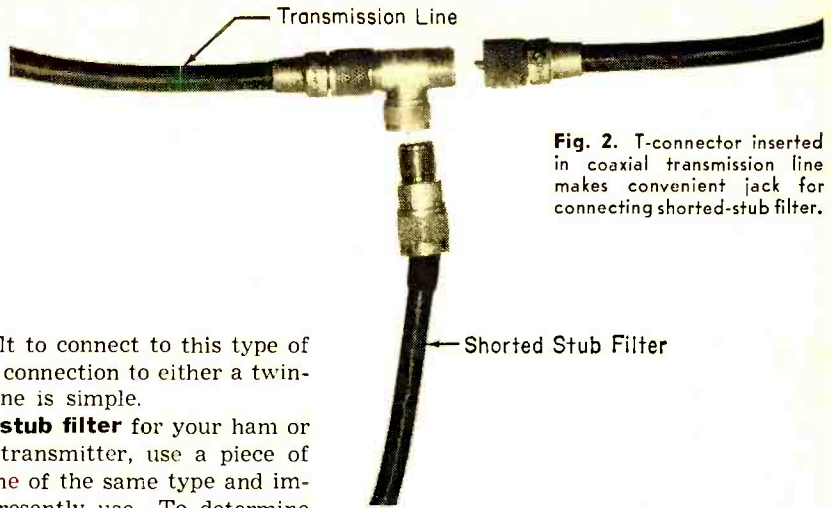

Fig. 2. T-connector inserted in coaxial transmission line makes convenient jack for connecting shorted-stub filter.

they are difficult to connect to this type of line. However, connection to either a twin-lead or open line is simple.

To make a stub filter for your ham or Citizens Band transmitter, use a piece of transmission line of the same type and impedance you presently use. To determine the length of the stub, substitute the fundamental frequency of your transmitter in the following formula:

$$\text{Length of stub (feet)} = \frac{246}{\text{Freq. of xmtr. (mc.)}} \times \text{Velocity factor of stub}$$

Incidentally, coaxial cables such as RG-8/U, RG-58/U, RG-11/U, and RG-59/U have a velocity factor of 0.66; flat 300-ohm TV twin-lead has a velocity factor of 0.82; tubular 300-ohm line is rated at 0.84; and the popular 450-ohm open-wire transmission line at 0.90.

As an example, let's say we are going to cut a shorted stub filter for the 6-meter

just attach a male coax connector (Amphenol 83-851 or equivalent) to the stub so that it can be easily connected to the T-connector. For twin-lead or open-wire stubs, solder the stub directly to the line as shown in Fig. 3.

Keep in mind that a stub filter is not intended to replace a low-pass filter but rather to supplement one. A stub filter is more efficient in attenuating troublesome even harmonics which can be a cause of TVI, while a low-pass filter attenuates all harmonics very effectively.

-30-

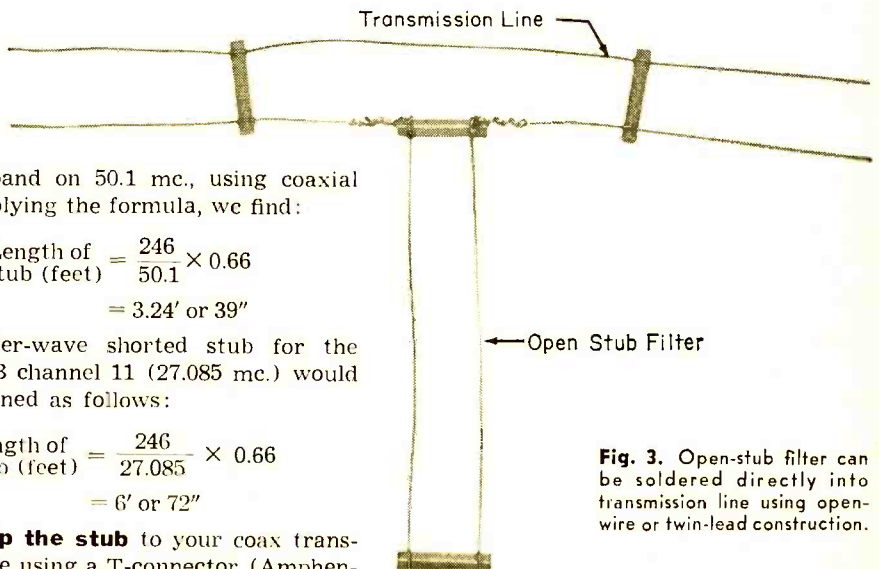

Fig. 3. Open-stub filter can be soldered directly into transmission line using open-wire or twin-lead construction.

amateur band on 50.1 mc., using coaxial cable. Applying the formula, we find:

$$\begin{aligned} \text{Length of stub (feet)} &= \frac{246}{50.1} \times 0.66 \\ &= 3.24' \text{ or } 39'' \end{aligned}$$

A quarter-wave shorted stub for the popular CB channel 11 (27.085 mc.) would be determined as follows:

$$\begin{aligned} \text{Length of stub (feet)} &= \frac{246}{27.085} \times 0.66 \\ &= 6' \text{ or } 72'' \end{aligned}$$

Hook up the stub to your coax transmission line using a T-connector (Amphenol 82-36 or equivalent) as in Fig. 2. Then

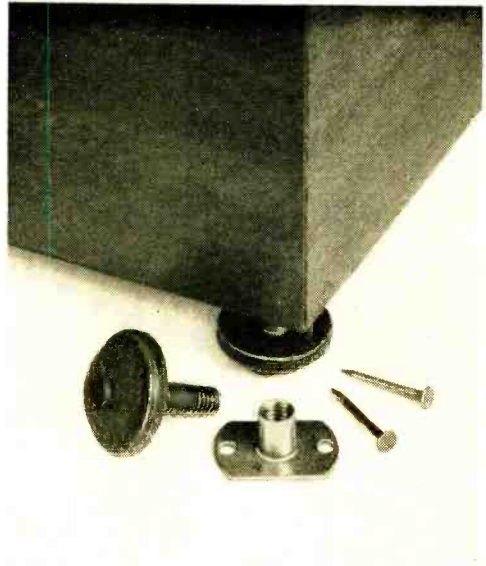
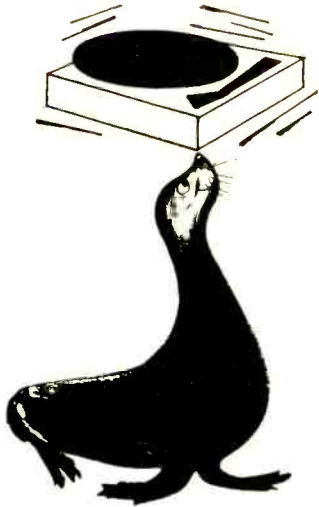

Various manufacturers sell adjustable leveling feet for turntable or record-changer bases. Unit shown above replaces the customary felt corner pad.

Keeping your Hi-Fi on the Level

Simple adjustments can prolong life of stereo records

By ART TRAUFFER

TOP stereo disc performance is possible only when your turntable, tone arm, and cartridge are perfectly level. If the turntable and/or tone arm are not exactly level, the cartridge may jump grooves and slide across the face of the record. Even if this doesn't happen, the stylus and record grooves will wear more rapidly on one side than on the other. In addition, tilting causes unbalanced response and distortion. Accurate leveling of turntable and cartridge is the only way to insure correct tracking.

If your turntable and tone arm are mounted on a wood platform, the best way to level the turntable is to install adjust-

able leveling feet on the bottom corners of the base. Lay either a tubular level or round level on the turntable and adjust the leveling feet screws until the turntable is exactly level. The round level is preferable since it indicates unbalance in any direction without the necessity for repositioning it on the turntable.

If your turntable and tone arm are mounted in a console cabinet, you can tilt the turntable by making adjustments in the mounting board, or by placing thin metal shims under the feet of the console legs. If your console cabinet is not too heavy, you may be able to install adjustable leveling feet on the bottoms of the legs.



Circular bubble level costs about 90 cents, can be placed anywhere on turntable, and will reveal even small amounts of slope without repositioning.



Top surface of most professional tone arms should be parallel to the record surface. Check this with a level and adjust height of the arm accordingly.



Adjusting cartridge shell to make it parallel with record surface is easy with a circular level. Some pickups can also be adjusted from side to side.

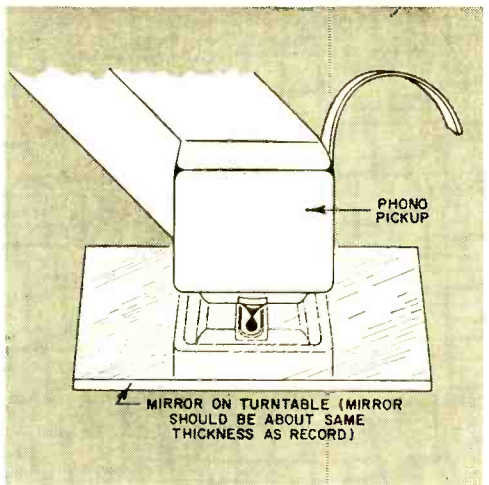

Pocket mirror provides simple method of checking vertical alignment of the cartridge stylus. Equal force should be exerted on both sides of groove.

After the turntable has been leveled, the next step is to level the tone arm from front to back. First place a record on the turntable and set the stylus on the record. Then set a tubular level on top of the pickup arm. If your particular tone arm calls for it, adjust the height of the arm until it

is exactly horizontal from front to back.

A novel way to align the stylus from side to side is to use a small mirror of about the same thickness as your records and adjust the tone arm from side to side until the stylus and its reflection in the mirror are in a vertical line.

CAR OWNERS bothered with car-radio vibrator replacement from time to time can try this transistorized plug-in substitute. Although it costs about \$8 to build—somewhat more than a replacement vibrator—the unit will probably outlive the car and give years of service free from annoying vibrator buzz. It will work with any 6- or 12-volt automobile electrical system that has a *negative* ground.

Less than ten standard parts are needed to build the vibrator substitute. One of the parts, the transformer, needs a bit of unwinding, but this is easily done.

Construction. Since the parts used in the vibrator substitute, mainly transistors *Q1* and *Q2* and transformer *T1*, take up a little more room than the vibrator they replace, the unit is housed separately in a 4" x 4" x 2" aluminum chassis box. Mount *Q1* and *Q2* on one of the box's cover plates after carefully scraping the surface of the plate in that area; the scraped surface will make a good heat sink for the transistors and provide electrical contact for their collectors.

Transformer *T1* has two windings—a primary and a center-tapped secondary; only the secondary—the outermost winding—need be unwound. Note that the primary is color-coded with a red and a blue lead; the secondary is color-coded with a yellow and a green lead, and the black lead is the secondary's center-tap. The secondary actually comprises two separate coils, one using a light-color enameled wire and the other a darker enamel, wound side-by-side.

Remove *T1*'s metal frame, and push the coil off the laminated core, being careful not to damage the coil. Now slowly take off the outer layers of insulation until the outermost winding is reached. Disconnect only the light enameled wire from the black lead, and start unwinding it together with the dark enameled wire which is connected to the yellow lead. Remove 60 turns of each for 6-volt cars, or 90 turns for 12-volt cars. Be careful not to break any of the other leads or transformer windings.

After unwinding the proper number of turns, leave about four inches of each color enameled wire for leads. Fasten down the leads with plastic tape and reassemble the transformer. Hook up the new light and dark enameled leads and the rest of the color-coded leads as shown.

Wire up the four-prong vibrator adapter plug (*P1*) to the circuit using a couple of

Build a Vibrator Substitute

*Transistorized unit features
long life and noise-free operation*

By **PATRICK A. GAINER**

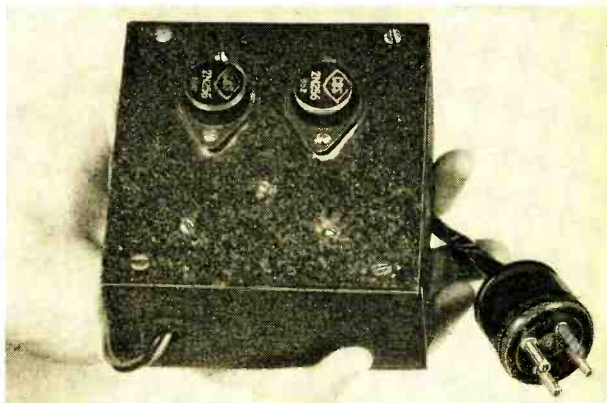

PARTS LIST

- P1*—Four-prong plug (Amphenol 86-PM4 or equivalent)
- Q1, Q2* 2N256 transistor (for 12-volt cars) or 2N677 transistor (for 6-volt cars)
- R1, R3* 220-ohm, 1-watt resistor
- R2, R4* 10-ohm, 1-watt resistor
- T1* Feedback transformer (Stanco TA-16 see text)
- 1—4" x 4" x 2" aluminum chassis box (Bud AU-1083 or equivalent)
- Misc.—Hardware, transistor sockets, terminal lug, etc.

HOW IT WORKS

The vibrator substitute accomplishes electrically what the vibrator does mechanically by generating an output similar to the output of the vibrator. Transistors *Q1* and *Q2* are connected in a push-pull oscillator circuit with transformer *T1* providing feedback at the proper voltage and phasing to sustain oscillation; resistors *R1*, *R2*, *R3*, and *R4* maintain the correct base bias for *Q1* and *Q2*.

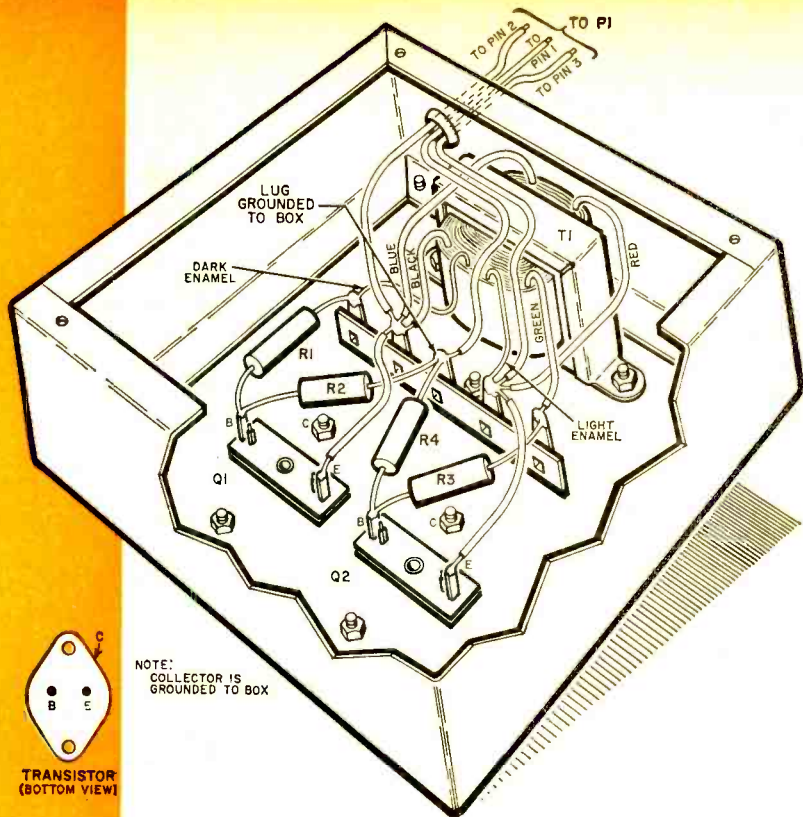

TRANSISTOR (BOTTOM VIEW)

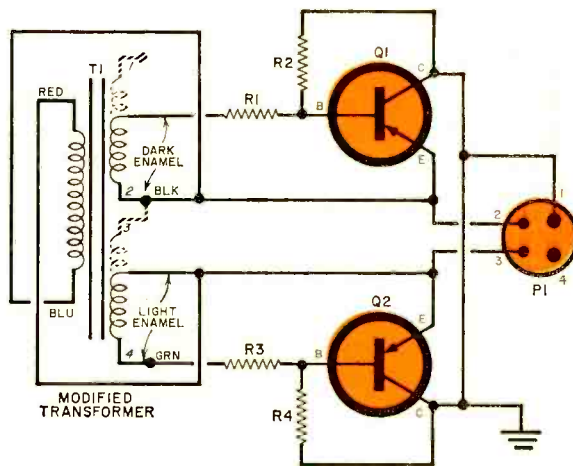
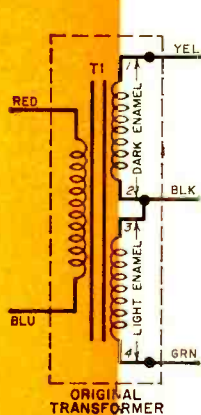

feet of wire for each lead. Now tape the leads together to form a cable.

Operation. Mount the vibrator substitute near the radio in a cool place under the dash, then plug the unit into the vibrator socket and switch on the radio. If you don't hear a faint buzz from transformer *T1*, check all wiring and the radio's fuse. If the buzz is too loud, *T1*'s laminations are probably loose.

If the radio is turned off for a few seconds and then on again, the starting load may be great enough to prevent oscillation. In this case, just leave the radio off for about 15 seconds until the tube filaments have had a chance to cool.

POPULAR ELECTRONICS

Quiz

In all of electricity and electronics, there are only three basic properties: resistance, inductance, and capacitance. These properties, or combinations of them, can give us complete control over current, voltage, phase, and power in any electric circuit.

Since resistive, inductive, and capacitive circuits operate on entirely different principles, each type of circuit has a distinctive character of its own. But regardless of where or how these three basic properties are used, they retain their individual characteristics. From the descriptions of their behavior given below, can you identify the type of circuit referred to?

Circle **R** if you think the circuit is resistive; **L**, if inductive; and **C**, if capacitive. Answers will be found on page 127.



Resistive?



Inductive?



or Capacitive?

By

ROBERT P. BALIN

- | | | | | |
|----|---|---|---|---|
| 1 | Electrical energy can remain stored in this type of circuit even after the source of energy is removed | R | L | C |
| 2 | The current in this type of circuit is always in phase with the source of voltage | R | L | C |
| 3 | Arcing is likely to occur between the contacts when this circuit is opened | R | L | C |
| 4 | Electrical energy is stored in the magnetic fields found in this type of circuit | R | L | C |
| 5 | This circuit tries to keep its voltages constant | R | L | C |
| 6 | The flywheel effect is characteristic of this type of circuit | R | L | C |
| 7 | Electrostatic fields are used in this circuit | R | L | C |
| 8 | This type of circuit always has unity power factor | R | L | C |
| 9 | This circuit acts almost like a short circuit to a.c. voltages | R | L | C |
| 10 | Voltage across this circuit builds up to a high potential instantaneously when the circuit is opened | R | L | C |
| 11 | If the frequency of the source voltage for this circuit is increased, the current goes down | R | L | C |
| 12 | The current in this circuit leads the source voltage | R | L | C |
| 13 | This type of circuit can act almost like an open circuit at the instant that power is applied | R | L | C |
| 14 | No electrical energy is stored in this type of circuit at any time | R | L | C |
| 15 | Because of the surge currents in this circuit, its fuse may blow when power is applied | R | L | C |
| 16 | Conductor or component insulation may be damaged when power is removed from this circuit | R | L | C |
| 17 | This type of circuit tries to keep its current constant | R | L | C |
| 18 | Current never actually flows through this type of circuit | R | L | C |
| 19 | In this circuit the current remains the same regardless of changes in the frequency of the source voltage | R | L | C |
| 20 | This type of circuit has a lagging power factor | R | L | C |

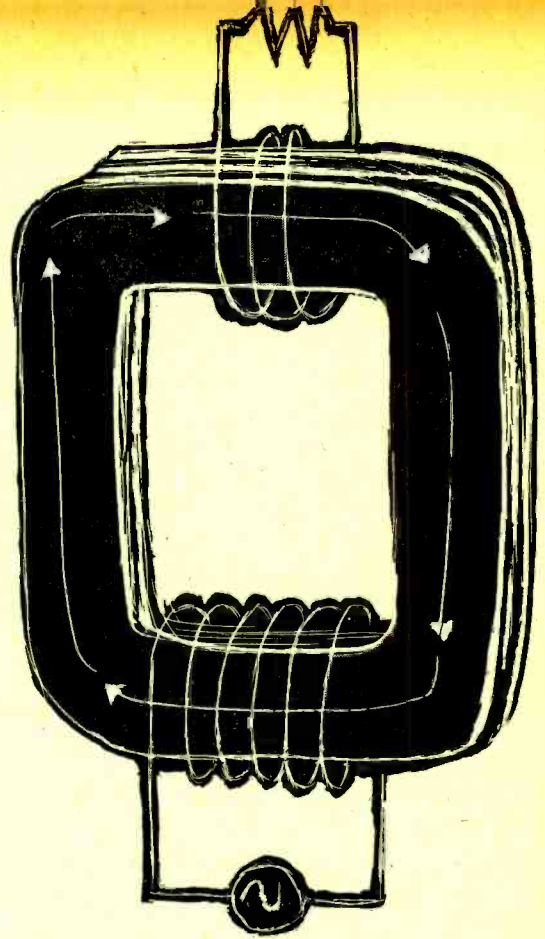

the transformer

a fundamental coupling device,
the transformer is one of electronics'
most capable magicians—here's what's behind
its electrical sleight-of-hand and how
it performs its multitude of valuable tricks

by ken gilmore

what the transformer does

The electrical power that makes your light bulbs glow, runs your refrigerator, and operates your hi-fi set comes into your home at a potential of about 115 volts. Yet if you were to climb the utility pole outside and measure the voltage there, it could turn out to be as high as 6000 volts. If you kept on climbing poles at other places around town, you might find voltages as high as 120,000 volts!

Even in your home, some appliances—air conditioners, clothes dryers, electric ranges, and other heavy-duty equipment—may operate at 230 volts instead of the usual 115 volts. And if you probe into your television set, you'll find an even wider voltage range. For although your TV draws its power from the wall plug—and power there is at 115 volts—your set has the ability to change this voltage into a number of different values, so that each tube and circuit can operate under the exact conditions it likes best. Consequently, in some places, you will find values as low as one or two volts; in others, values as high as 15 or 20 *thousand* volts.

Electric power, one of our most useful servants, becomes tremendously *more* useful when we can change it at will to dozens, or even hundreds, of different voltages. Fortunately, we can make these changes easily and economically with a device known as the transformer.

Transformers are all around us. One—the gadget about the size of a large garbage can hanging near the top of utility poles—changes the 6000-volt transmission-line power into the 115 and 230 volts you need. Another—this one about as big as a flashlight—takes 6 or 12 volts from your car's battery, and changes it into the 10,000 or more volts needed to fire your spark plugs. Still another—a square can a little bigger than your fist—channels

high-fidelity electrical signals into the speakers of your hi-fi set.

We'll talk more about these special applications—and others like them—a little later. Right now, let's get down to the business of seeing just how a transformer goes about performing this valuable electrical sleight-of-hand—changing one voltage into another.

how the transformer works

When an electric current flows in a wire, a weak magnetic field is set up around it. If we twist the wire into a coil, the weak field around each turn of the wire is reinforced by the fields around the other turns; the result is a much stronger field.

If an a.c. current flows in the coil, the magnetic field builds as the current flows in one direction; dies down, or decays, as the current returns to zero; then builds in the opposite polarity as the current flows in the other direction. You can think of the building and decaying magnetic field as a pulsing, invisible force, expanding and contracting as the current reverses its direction of flow. As the field builds and decays, the magnetic flux lines (the circular lines in the diagram) cut back and forth through the coil.

Now suppose we put another coil of wire next to and in line with the first, although not actually touching it. As the magnetic field expands and contracts, the flux lines will cut back and forth through the second coil as well as through the first one, and a voltage will be *induced* in the second coil. This is called "mutual induction," and is the basis of all transformer action. Because of this property, a simple transformer can be made—and many are—simply by placing two coils of wire

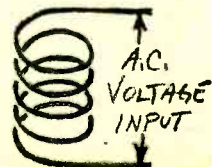
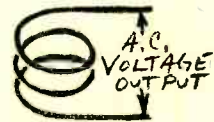
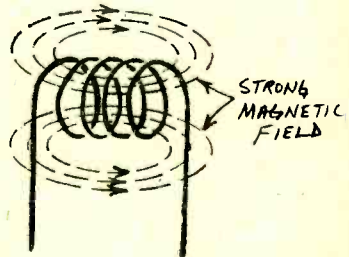
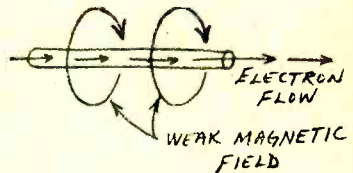

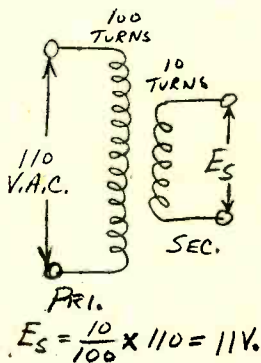
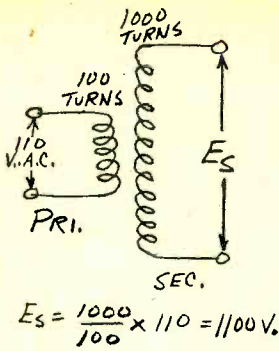

close together and applying an alternating current to one of them.

The main value of a transformer lies in the fact that the ratio of the voltages in the two coils can be controlled by the number of turns of wire in each. To put it another way, if the secondary (the coil into which voltage is induced) has ten times as many turns of wire as the primary (the coil across which the original voltage is applied), then the secondary voltage will be ten times the primary voltage. In such a case we have a *step-up* transformer.

On the other hand, if the secondary has only one-tenth as many turns as the primary, the secondary voltage will be one-tenth the primary voltage, and we have a *step-down* transformer.

efficiency

In the above calculations, we have assumed that *all* magnetic lines of flux, as they expand and contract, cut *all* turns of the transformer. The magnetic coupling in such a case would be 100%. Of course, in practical transformers a few lines of force manage to stray outside the useful area. But by careful design, engineers are able to produce transformers with efficiencies of 80%, 90%, and even more. In fact, for the purposes of most calculations, transformer efficiency can be considered to be virtually 100%.

voltage vs. current

Even though we can get a higher voltage from a transformer than we put into it, the transformer is not capable of creating power. What we gain in voltage, we lose in current. On the other hand, if we step down the voltage, we get more current.

If the current flowing in the primary of the step-up transformer in the diagram above is 5 amperes and the voltage 110 volts, the power consumed in the primary is 550 watts. Since the output voltage is 1100 volts, or ten times as much, we would have

available only one-tenth the current, or 0.5 ampere. Thus, even though we can juggle voltages and currents at will, the output power is 550 watts—the same as the primary input. (Actually, the output power would be slightly less than 550 watts, due to the small losses in efficiency mentioned earlier.)

iron cores

So far, we have described a transformer as two coils of wire, placed close together along a common axis. Although some transformers are actually built this way, most use other types of construction. Instead of being placed side by side, the two coils are usually arranged with one coil inside the other; this gives much closer and more efficient magnetic coupling.

For use at low frequencies, designers wind the two coils around a common iron core. Since iron is a much more efficient conductor than air, the magnetic field built up is much stronger. That is, almost all the magnetic lines of force developed by the primary winding are gathered up by the iron core and shaped so that almost all cut through the secondary winding. Therefore the efficiency of the transformer is greatly increased.

The diagrams at left show the three principal types of iron-core transformers. First is the open-core transformer which, while possible, is never used because of its relative inefficiency—a large part of the magnetic field would still have to be in air, rather than in iron. The closed-core transformer is considerably more efficient; and the shell core transformer is most efficient of all. The shell-core type has another advantage: since the flux path is almost entirely contained in the iron core, it is less subject to disturbances by external magnetic fields than other types, and it doesn't disturb other nearby circuits as much.

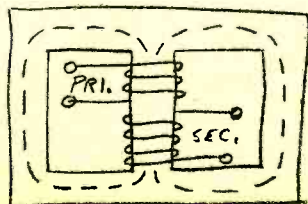
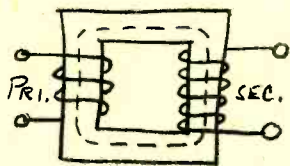
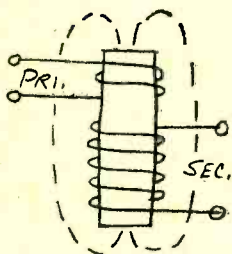

transformer losses

The first transformer ever made was simply an iron ring with two 2-layer coils of wire wrapped around it. Its inventor was Michael Faraday, the great English electrical pioneer. He discovered electromagnetic or mutual induction—the principle upon which the transformer works—in 1831. When he connected his primitive ironing transformer as shown, the galvanometer needle jumped as the switch was closed.

Although Faraday's device was a true transformer, its losses were high. Today's modern, refined transformers have assumed a wide variety of sizes, shapes, and characteristics as engineers have attempted to minimize the losses that are a part of every transformer's operation.

Transformer losses come from many different sources. First, not every magnetic flux line cuts the secondary—some simply travel out into space, consuming energy from the primary, but doing no useful work. This loss is called *flux leakage*. Designers minimize it by careful physical arrangement of the coils and core. Sometimes the primary is wound on the core first, then the secondary applied on top. At other times the secondary is split into two layers with the primary in between.

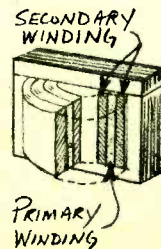
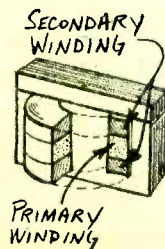
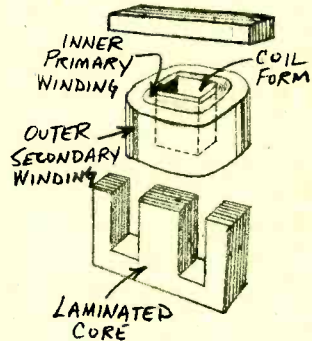
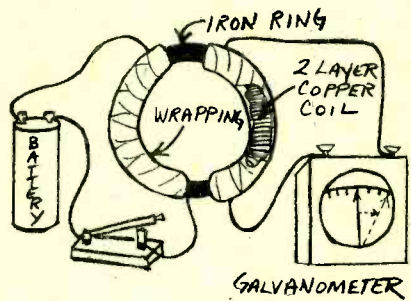

copper losses

The so-called copper losses are caused by the electrical resistance of the transformer windings. Although copper is a good conductor, it has a measurable resistance, as does any conductor. When current flows through this resistance, heating takes place and power is wasted. As a result, almost any transformer will feel warm to the touch when operating normally, and some are actually hot.

core losses

Since the iron core itself, as well as the coils, is cut by the expanding and contracting magnetic field, a current is induced here, too. As this *eddy current* flows in the core, it steals energy from the primary circuit and dissipates it as useless heat. The eddy current flows at right angles to the magnetic flux. It can be reduced by substituting several thin layers of iron for the solid core. These thin layers—laminations—are separated by layers of glue which electrically insulate the laminations from each other. In practice, a small eddy current is set up separately in each lamination, but the total loss is much less than for a solid-core transformer.

Still another core loss is caused by the alternating current itself. Since this current reverses its direction 120 times a second, the iron core—in effect, an electromagnet—must continually reverse its polarity. And since the minute magnetic elements in the core tend to resist this change, power must be expended to realign them. This is called *hysteresis loss*. Engineers reduce it by building transformer cores of steels which change magnetic polarity with comparative ease, so that less power is consumed in making the switch.

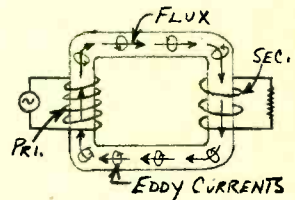

miscellaneous losses

Since the turns of wire in a transformer are close together, there is some distributed capacitance between the turns, between different layers of windings and between separate windings. This

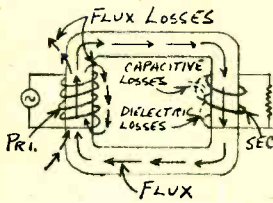

capacitance, though small, is cumulative. Like a small capacitor connected across the transformer, it shorts out some of the voltage developed across the windings. At low frequencies (the usual 60 cps of house current, for example) this loss is unimportant, but at higher frequencies engineers must go to great lengths to minimize it.

Another small loss is caused by the imperfection of transformer insulation. A small leakage current will flow through almost any insulator, and thus absorb some of the transformer's power. This is known as *dielectric loss*.

Then, too, particularly at high frequencies, a transformer can begin to act as a small but efficient radio transmitter, and actually radiate power like a broadcast antenna. This is called *transmission loss*.

Most of these losses, under normal conditions, are minor, but at times they become serious. For example, eddy current losses are small at power-line frequencies, but at the high end of the audio spectrum—say around 20,000 cps—they become significant. This means that a poorly designed transformer in the output stage of a hi-fi amplifier will operate much less efficiently at 20,000 cps than at 1000 cps; the result is poor frequency response.

To minimize eddy currents designers specify thinner laminations. Where laminations 20 to 25 thousandths of an inch thick are used in power transformers designed to work at 60 cps, audio transformers rarely have laminations thicker than 10 or 15 thousandths of an inch. For really good hi-fi reproduction, lamination thicknesses may range from ten thousandths of an inch all the way down to only one thousandth of an inch.

higher and higher frequencies

As frequencies go still higher, even one thousandth of an inch is too much, and eddy current losses become excessive. Consequently, r.f. transformers frequently have cores made of minute grains of iron suspended in an insulating material

and compressed under high pressure into a solid mass. Since the grains are insulated from each other, they break up the eddy current path and help reduce eddy current losses.

As might be expected, the size of the iron granules becomes important as the frequency increases, since at high frequencies eddy currents are even set up within the individual granules. Granules several thousandths of an inch thick are satisfactory below 100,000 cps, but as the frequency goes higher the particles cannot be larger than several millionths of an inch thick.

A new type of magnetic core made of iron ferrite has recently allowed designers to build iron-core transformers to operate at frequencies higher than ever before. These ferrites—varieties of iron oxide, or rust—are valuable because they have magnetic properties, and yet are insulators and do not conduct current. Because of the unusual construction of these transformers, no eddy currents form.

If you have bought an ultra-portable radio recently, you are benefiting from ferrite-improved transformers. Miniature radios of even a few years ago had loop antennas at least 8 to 10 inches long and almost as high to collect enough signal to operate. Now ferrite-core antennas, far more efficient because of their magnetic core but not susceptible to eddy current ills, can be built as small as a short pencil. As a result, portable radios can now be produced smaller than they have ever been produced before.

In many applications, particularly for very high frequencies, air-core transformers are used. The coils are wound on a non-magnetic form such as Bakelite or polystyrene. The coils may be concentric, or end to end. Frequently one is movable, so that the degree of coupling between them is adjustable.

One of the biggest problems in high-frequency transformer design, particularly where multiple layers of winding are involved, is stray capacitance. If a regular winding were used, with adjacent layers lying parallel to each other, this capacitance could become intolerable. Consequently, layers are frequently spiraled back and forth as in the transformer shown in the drawing at right. This makes adjacent layers cross each other almost at right angles instead of being parallel, and stray capacitance is materially lowered as a result.

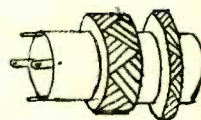
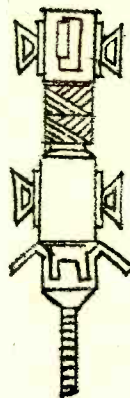

how the transformer is used

The transformer invented in the 1830's wasn't put to work outside the laboratory until 1885 when William Stanley, an engineer who worked for George Westinghouse, designed and tested a transformer power-distribution system. He used a 500-volt generator and fed the power directly into a 4000-foot transmission line. A transformer to step down the voltage to 100 volts was used at the other end of the line.

Westinghouse wasted no time in putting Stanley's superior transmission system into operation. That same year he built the first plant especially designed for transformer power distribution in Buffalo, N. Y. It went into use on November 30, 1886. His generator produced a 1000-volt, 133-cps output which was fed directly into the transmission line, and stepped down at the customer's home.

In spite of its obvious superiority, however, high-voltage transmission with transformers did not gain immediate acceptance. Thomas Edison, for one, was violently opposed to a.c. power, and he used his tremendous prestige to gain support for his own d.c. system. Consequently, it was not until many years later—after the turn of the century—that high-voltage a.c. power distribution became common. Even today there are a few places—some areas of New York City, for example—still receiving Edison's legacy of d.c. power.

But giant power transformers and their complex distribution stations now dot the landscape all over the country. The one shown on the next page, one of the largest ever built, can handle enough electric power for a city of 500,000 inhabitants.

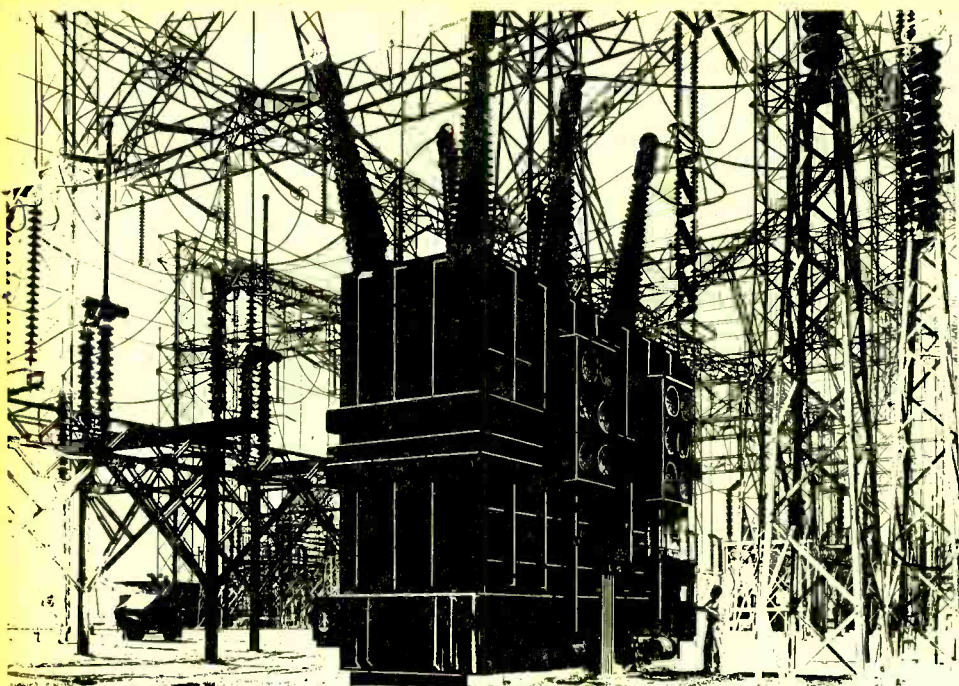

power distribution

Why use transformers for power distribution? The efficiency of transmission is tremendously increased by stepping up the voltage to as much as several hundred thousand volts. Also, a given size of wire can carry far more power at high voltage than low, saving money in transmission costs. Let's see why.

As an example, let's take a transmission line of No. 1 wire 10 miles long—that's a conductor about the size of your little finger. The resistance of one such wire 10 miles long is about 7 ohms. (Actually, the resistance of each wire in the transmission pair is 7 ohms but for the sake of illustration let's consider just one.) Now let's say that we transmit a current of 120 amperes at 120,000 volts (a common transmission-line voltage) over the 10 miles. The total power fed into the line at the generating station is 14,400,000 volt-amperes.

With 120 amperes flowing in the 7-ohm line, the voltage drop over the ten miles will be 840 volts. Thus, the output voltage will be 119,160 volts; 120 amperes at 119,160 volts gives a 14,299,200 volt-ampere output. Along the line we have lost 100,800

volt-amperes, dissipated by the resistance of the transmission line. This seems like a lot of power, but if we figure it in terms of percentage, the loss amounts to a negligible 0.7% of the total fed into the line.

Now let's see what happens if the supply voltage is reduced to only 12,000 volts. The power input is now 1,440,000 volt-amperes. We will assume that the transmission line is still carrying 120 amps—its maximum load under any conditions. Since the current and resistance are the same, the voltage drop over the 10 miles will also be the same—840 volts. The loss in the transmission line will still be 100,800 volt-amperes, but now this represents a whopping 7% of the total fed into the transmission line.

Obviously, the high-voltage transmission is far more efficient. As also demonstrated in this example, the transmission line can carry far more power under high-voltage conditions. For these reasons, all transmission lines operate at higher voltages than those delivered to your electric meter by the power companies.

At Niagara Falls, N. Y., for example, hydroelectric generators produce power at 6000 volts. It is immediately stepped up by transformers to 120,000 volts and fed to long-distance transmission lines. At various points it is stepped back down to 6000 volts for distribution over local areas, then stepped down once again to 230 and 115 volts for home use.

power transformers

Although a power-distribution transformer is more spectacular, you're much more likely to be familiar with the ordinary power transformer used in radios, amplifiers, and TV sets. Such devices have a primary winding and usually several secondary windings to meet the various voltage and current requirements of a receiver or amplifier; a drawing of a typical power transformer is shown at right, above. The primary is usually designed for 115 volts; the high-voltage secondary may produce anywhere from 250 to as high as 600 or 700 volts (higher for some purposes). The other

secondaries, usually rated at 5.0 and 6.3 volts, are for tube filaments.

Power transformers are available with a wide variety of windings and current capabilities. They may have four, five, six, or even more windings, each rated at a different voltage for some specific purpose. The high-voltage winding of a light-duty power transformer may be capable of producing perhaps only 30 or 40 ma., while a heavy-duty unit may turn out 300, 400, or even 500 ma. Transformers for high-power transmitters produce voltages and currents far in excess of these values, but for such applications separate transformers are generally used for high-voltage and filament supplies.

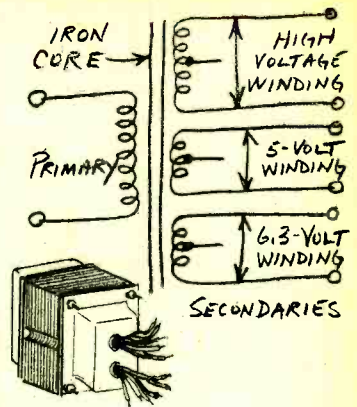

audio transformers

So far, all the transformers we have talked about in detail are designed for use in power circuits which operate at 60 cps. But transformers can operate on a wide variety of frequencies—every audio amplifier uses at least one transformer of this sort, and many include several such transformers.

Although the same basic principles of step-up and step-down are used in audio transformers, this is usually of secondary importance to the transformer's ability to serve as an impedance-matching device. Take, for example, an input transformer. Here it may be necessary to match a phonograph pickup, a microphone, or other input source of as little as 200 or 300 ohms (even less, in some cases) to a grid circuit of as much as several hundred thousand ohms. If the pickup or microphone were connected directly to the grid, a serious *mismatch* would occur, which would not only reduce the efficiency of the circuit but upset frequency response as well. The input transformer matches the components so that each operates properly.

The interstage transformer is another variety of the audio transformer and performs much the same kind of job: matching the output tube—sev-

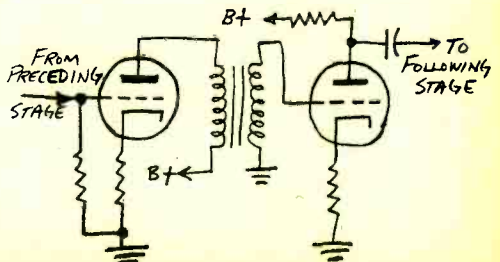
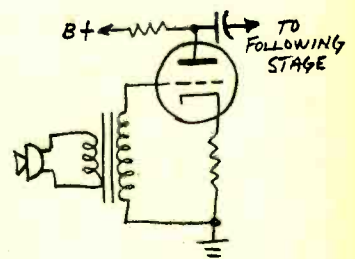

eral thousand ohms—to a grid circuit of a much higher impedance.

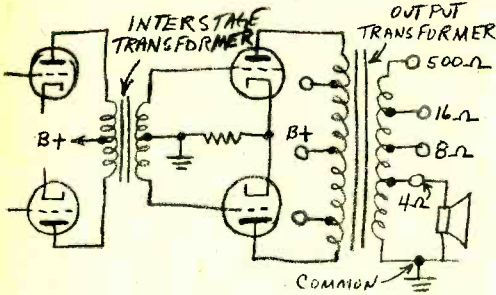

A third variety is the output transformer, whose main task is again impedance-matching. The plate circuit of the output tubes may have an impedance of many thousands of ohms, while most loudspeakers are 4, 8, or 16 ohms. To accommodate various tube-speaker combinations, most output transformers have a series of "taps" on the secondary winding, and

perhaps on the primary as well, so that windings of the proper impedance can be selected. Only the part of the transformer windings actually used (in the diagram, the portion between the first and second terminals) affects the circuit's impedance values. One form of output transformer—known as a "universal" type—is so designed that it is capable of matching virtually any possible tube and speaker combination.

better and better design

Great progress has been made recently in audio-transformer design. Just a few years ago it was difficult to get a transformer with any appreciable output above, say, 10,000 to 15,000 cps. Today, transformers with flat outputs up to 20,000 cps are common, while units flat to 50,000 or even 100,000 cps are available.

Tremendous problems had to be overcome to produce today's outstanding transformers. In addition to the losses mentioned earlier, a transformer has inductive reactance which varies according to frequency (remember that a transformer is also a coil). At frequencies of 100 and 1000 cps, the inductive reactance of the primary will be 10 and 100 times, respectively, its value at 10 cps. The inductive reactance appears to the output tube's plate as a load resistance, and thus various amounts of amplification take place at various frequencies. As a result, the gain of the amplifier is about two-and-a-half times higher at 200 cps than at 10 cps. At 3000 cps it would be three times higher. At still higher

frequencies, distributed capacitance becomes an important factor, and gains fall off rapidly.

Engineers go to great lengths to compensate for these effects; by means of special core materials, unique coil designs, special wrapping patterns, interlaced layers, and other techniques, they have produced a variety of audio transformers with unbelievably even response over an extremely wide range of frequencies.

r.f. circuits

As mentioned earlier, transformers are also widely used in r.f. circuits. Even the simplest five-tube a.c.-d.c. radio will usually have as many as four transformers, in addition to its audio output transformer. A typical radio, for example, might have an antenna coil (actually a small transformer which couples the antenna's output into the grid of the first amplifying tube), an oscillator coil (a transformer which supplies feedback for the oscillator), and two i.f. transformers which couple the various stages.

These transformers are likely to be air, powdered-iron, or ferrite-core transformers, since a regular iron core would cause intolerable eddy-current losses. The windings will also probably be of a special spiral design calculated to minimize capacitance effect.



special-purpose transformers

Although the transformers we have been discussing make up the bulk of those used, there are many other types, all of which perform their useful, specialized jobs.

The *autotransformer*, for example, uses only one winding instead of two, but accomplishes an effect similar to that of a regular transformer. If the whole coil is used as the primary and only a portion as the secondary, then it is a step-down unit. Hooked in reverse, it is a step-up device. This transformer, of course, cannot be used in circuits

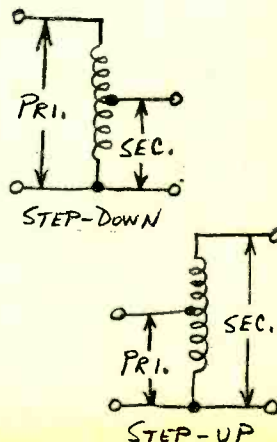

which must be electrically isolated from each other. But it serves very well in your automobile where it draws current from the 6- or 12-volt battery or generator and puts out the 10,000 or more volts needed to fire your spark plugs.

While we're on the subject of your automobile, let's take a look at the car radio which uses another kind of specialized device, the *vibrator transformer*. This device effectively "transforms" d.c. As the vibrator element moves back and forth touching each contact in turn, current flows through each half of the primary alternately, with each pulse going in a different direction. With the proper turns ratio, the output from the original 6- or 12-volt d.c. source can be as much as several hundred volts a.c.

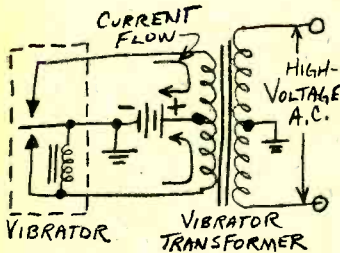

Photoflash transformers, used to operate photographer's electronic flash or "strobe" units, are also vibrator-operated. They can take the vibrator-interrupted output from a 1½-volt battery and turn it into several thousand volts a.c.

Pulse transformers are used primarily in radar. They range from tiny units (several of which can fit in a thimble) that put out a few millionths of a watt to huge, multi-ton giants that transmit powerful million-watt pulses. These transformers are designed to step up odd-shaped waveforms without changing the waveshape.

One of the newest types—*transistor transformers*—are similar to those used in regular r.f. and a.f. circuits except that their impedances and voltage ratings are calculated to match the operating requirements of transistors. Some of these units, by the way, can fit in a cube three-eighths of an inch square, and they weigh only a fraction of an ounce.

Thus, through the ingenuity of the design engineer, the transformer—though always operating on the same simple principle discovered by Faraday—can be adapted to perform hundreds of useful and important services.

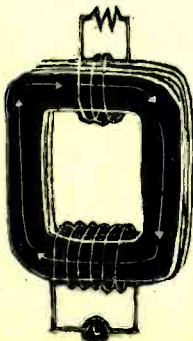

Test Instruments

BRIDGES

Part 1

The Wheatstone

and Its Variations

By G. H. HARRISON

WHEN a chemist or pharmacist wants to measure chemicals to the highest possible degree of accuracy, he uses his delicate balance scale to weigh each ingredient. For rough work, the ordinary spring scale will do. But for precision, there is no substitute for the balance.

In electronics, an ordinary volt-ohm-milliammeter is good enough for most work. Like the spring scale, it is reasonably accurate. But when the scientist or engineer must measure resistance, capacitance, or inductance with the utmost accuracy, he—like the chemist—turns to the balance. The electronic balance he uses is known as “the bridge.”

How the Bridge Works. As might be expected, the bridge does its job by carefully balancing an unknown resistor against a known one, an unknown capacitor against a known one, and so on. Its accuracy is limited only by the component which it uses as a standard; and thus extremely precise measurements are possible.

The bridge is even relatively independent of the inaccuracies of the meter used to indicate when the bridge is “in balance.” The meter acts only as a null detector, indicating when *no current* is flowing. Its inaccuracies, therefore, whatever they may be, do not appreciably affect the actual measurement.

Although there are dozens or perhaps scores of variations on the basic bridge circuit, they all spring from the original *Wheatstone* bridge, devised by S. H. Christie in 1833 and first used by Sir Charles Wheatstone in 1847. The basic Wheatstone circuit, still the most accurate means of measuring resistance known to modern science, is shown in Fig. 1.

Let's assume that the battery supplying current to the bridge is 12 volts, R_1 is 40 ohms, R_2 is 80 ohms, and that R_3 is a variable resistor. Indicator G_1 is a center-reading galvanometer; with no current flowing, its needle will come to rest in the center of the scale. Current of one polarity causes

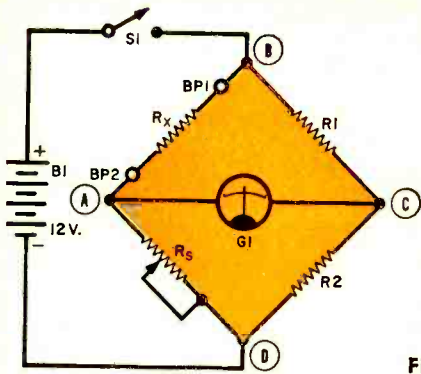

Fig. 1.

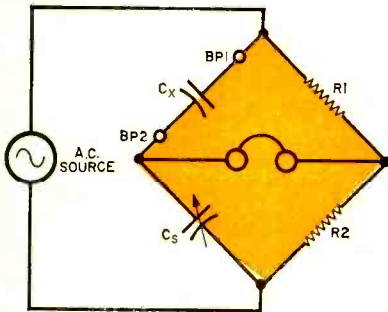

Fig. 2.

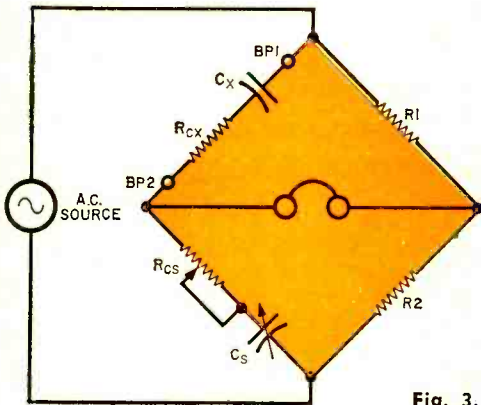

Fig. 3.

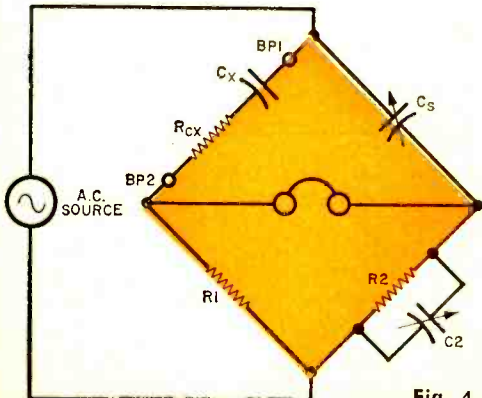

Fig. 4.

it to move to the right; the opposite polarity, to the left.

Measuring Resistance. Now, with the constants as given above, let's connect an unknown resistor (R_x) across the test terminals $BP1$ and $BP2$ and find its resistance. When switch $S1$ is closed, the galvanometer needle swings off center. We adjust R_s until it again reads zero. This means that no current is flowing through the galvanometer in either direction. Since no current is flowing through GI , the voltage at point A must equal the voltage at point C. Resistor R_s —which is calibrated—reads 100 ohms. With the information we now have about the circuit, let's calculate the value of R_x . As you might guess, we'll call on Ohm's law.

The voltage from point B to point D is 12 volts, and the sum of $R1$ and $R2$ is 120 ohms. Since $I = E/R$, the current through this leg of the circuit ($R1 + R2$) is 100 ma. Going one step further, the voltage drop across $R1$ can now be calculated: $E = IR = 0.1 \times 40 = 4$ volts. The drop across $R2$ is: $E = 0.1 \times 80 = 8$ volts.

Since point C is 8 volts positive with respect to point D, and since the bridge is balanced, point A must also be 8 volts positive with respect to point D. Thus, the current through R_s must be: $I = E/R = 8/100 = 80$ ma.

Since R_s and R_x are in series, the current through R_x is also 80 ma., and its voltage drop is 4 volts. Its resistance, then, is: $R = E/I = 4/0.08 = 50$ ohms.

As Ohm's law shows in this example, the ratio of the voltage drops across R_x and R_s must equal the ratio of the drops across $R1$ and $R2$. We can express this relationship as: $E_x/E_s = E1/E2$; or $IR_x/IR_s = R1/IR2$, or, cancelling, $R_x/R_s = R1/R2$.

Transposing algebraically gives the formula most widely used for calculating the value of the unknown resistor: $R_x = (R_s \times R1)/R2$.

In most practical bridges, calculations are frequently simplified even further by the careful selection of $R1$ and $R2$. For example, if $R1$ and $R2$ are equal—say, each is 100 ohms—then R_s and R_x will be equal when the bridge is balanced. The value of R_x will equal the dial reading of R_s . If $R1$ is 100 ohms and $R2$ is 50 ohms, then R_x will be twice the R_s dial reading, and so on.

Measuring Capacitance. We have considered only d.c. bridges so far, but in practice many bridges use alternating current.

Capacitance, for example, is measured with an a.c. bridge; the basic circuit, shown in Fig. 2, uses the same principle as the basic Wheatstone bridge. The ratio of the reactance of C_x to C_s must equal the ratio of the resistance of R_1 to R_2 . To put it mathematically: Reactance C_x / Reactance $C_s = R_1/R_2$. Since Reactance C_x / Reactance $C_s = C_x/C_s$, then $C_x/C_s = R_1/R_2$, or $C_x = (C_s \times R_1) / R_2$.

Incidentally, the headphones shown in this circuit are frequently used in a.c. bridge circuits as null detectors. If the frequency of the a.c. supply voltage is between 500 and 5000 cps, where the human ear is most sensitive, then the bridge can be very accurately balanced by simply tuning until the tone has completely disappeared.

When working with very low voltages, an amplifier is sometimes used in conjunction with the headphones or loudspeaker as a null indicator. At higher frequencies, an oscilloscope, vacuum-tube voltmeter, a wave analyzer, or an ordinary radio receiver can be used. Actually, any circuit or instrument which will accurately detect a null meets the requirements.

Some a.c. bridges are constructed with R_2 , rather than C_s , as the variable component, but the principle is the same. Once the bridge is balanced, the ratio $R_1:R_2$ is noted, and the ratio $C_x:C_s$ will be the same. To put it another way, with the formula $C_x = (C_s \times R_1) / R_2$, the unknown can always be calculated, no matter which element is varied to balance the bridge.

In practice, the unknown capacitor will not be purely capacitive, but will contain some resistance as well. Even though the value of resistance will be low, it can affect the accuracy of the reading. Consequently, this resistive component (R_{Cx}) is usually balanced out with a small variable resistor (R_{Cs}) in series with C_s (Fig. 3).

In most conventional capacitor bridges, this circuit usually appears as the Schering bridge (Fig. 4). Here, the resistance of C_x (R_{Cx}) is cancelled out by adjusting C_2 . The adjustable capacitor, C_s , is calibrated directly in microfarads or micro-microfarads, depending on circuit constants.

Measuring Inductance. Inductance can be measured on another a.c. variation of the Wheatstone bridge (Fig. 5). This circuit, however, is seldom used because of the difficulty and expense of manufacturing

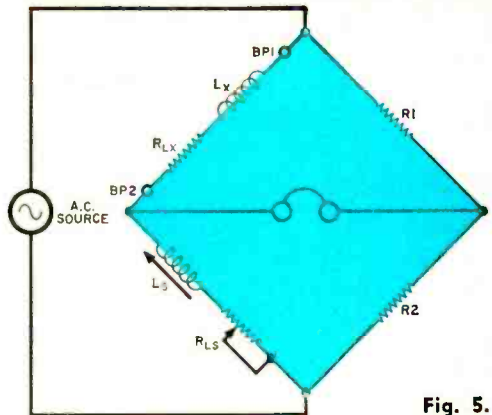

Fig. 5.

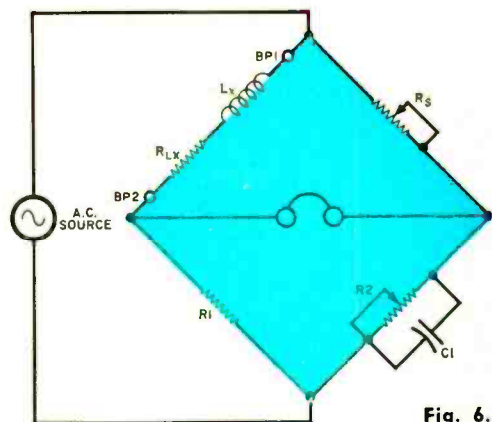

Fig. 6.

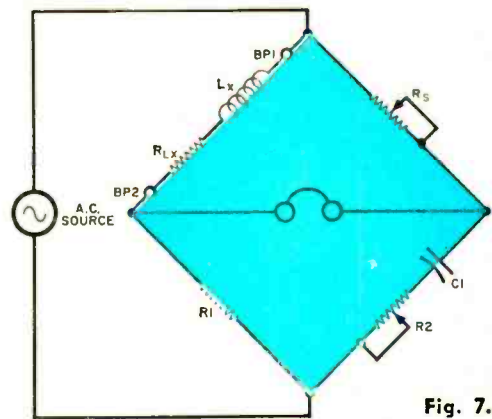

Fig. 7.

high-quality accurately-calibrated variable inductors.

Instead, most commercial induction bridges use either the Maxwell bridge (Fig. 6), or the Hay bridge (Fig. 7). In both circuits the inductive reactance of the unknown inductance L_x is balanced against

(Continued on page 126)

On the Citizens Band



By TOM KNEITEL, 2W1965

AMONG the new equipment making news in CB circles, perhaps the most talked about is the Philmore "station" consisting of the CT-1 transmitter kit, CC-1 converter kit, and CPA-1/CPM-1 power supply.

The CT-1 transmitter is a six-channel job which, although tiny (3" high, 9" wide, 8" deep), weighs seven pounds and has a lot of hair on its chest. It features a 6CX8 in the final, a 12AX7 mike preamp and driver, and a 6AQ5A modulator. It has a pi output network to match any antenna, and it's fully neutralized to squelch parasites. The CT-1 also boasts a push-to-talk switch and a panel meter which instantly indicates

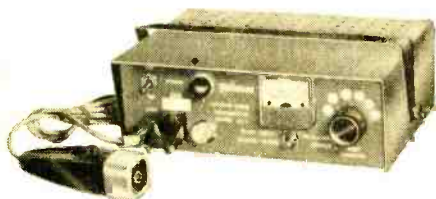

plate input power in watts or relative output and modulation.

The CC-1 converter will hook into any receiver, mobile or base. If you want to use it with a receiver that already tunes the 11-meter band, you can change the CC-1 to a preamplifier and add two more r.f. stages to your receiver by merely removing the crystal from the converter.

The transistorized mobile and base power supplies deliver 300 volts d.c. at 100 ma., choke-filtered.

Abuses of the CB Service seem to be growing as the Service itself grows. A number of areas are suffering from "VFO artists," poor sports with variable frequency oscillators. They seem to get a kick out of jamming CB communications by running their carrier back and forth across the band.

There is also a varied assortment of wise-crackers without call letters who like to add their own insipid comments to every-

one else's conversations. And then there are the guys with the itchy mike fingers—they seem so anxious to get on the air that—before they get their license—they either swipe someone else's call or make up their own.

Needless to say, such operations are against federal laws, and the violators are subject to appropriate governmental action when they are caught.

Another new entry in the CB equipment field, going along with the component, or "modular," theory of putting together a station made up of separate units, is Browning Laboratories' R-2700 receiver.

This rig has a dual-conversion circuit with 0.2-microvolt sensitivity. In addition to being tunable, the R-2700 has five crystal positions and gives adjacent-channel selectivity better than -40 db. Other features



include a noise limiter, an "S" meter, squelch, a.v.c., and 55 db image rejection.

We're waiting for news of the T-2700, companion transmitter to the R-2700.

Wrist-watch CB is on the way—the Longines-Wittnauer Watch Company recently received U. S. Patent No. 2,937,271 for a wrist-watch-housed, CB-activated alarm device. When the owner's code signal is transmitted, a bell inside the watch rings, letting him know that someone is trying to reach him. Although the device is not being manufactured as a separate item, it will be part of a complete two-way unit of the future. It measures about 1" square and $\frac{3}{8}$ " thick.

-50-

**POPULAR
ELECTRONICS**

builds a Citizens Band Transceiver Kit

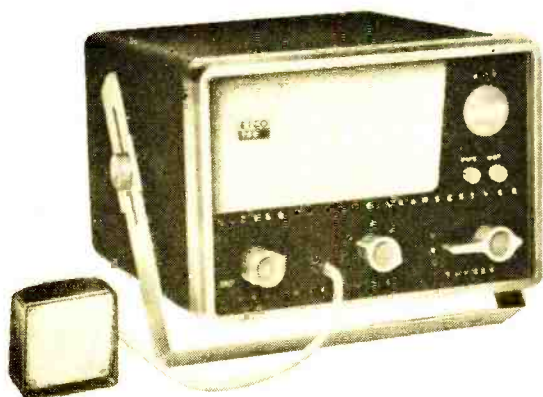

Rugged construction and quick-disconnect features make EICO Models 761 and 762 ideal for shared mobile fixed-station operation

AS MORE AND MORE mobile Citizens Band transceivers hit the air, the need for ruggedized equipment becomes increasingly apparent. With mobile operation in mind, EICO (33-00 Northern Blvd., Long Island City 1, N. Y.) has released a new Citizens Band transceiver which meets this requirement. There are three versions, each of which comes in both kit and factory-wired form.

Two mobile versions, Model 761 and 762, work on 6 and 12 volts respectively, and each also works on 117 volts a.c. The kits are priced at \$69.95, the factory-wired models at \$99.95. A third version, Model 760, operates only on 117 volts a.c. (\$59.95 for the kit, \$89.95 for the factory-wired model). Otherwise, all three versions are identical.

Encased in a steel cabinet and using only solid steel chassis and brackets, the transceiver is literally built like a battleship. You can mount either of the mobile versions under the dash of your car quickly and easily with the universal mounting bracket supplied, and—if desired—it can be quickly removed for use in the house.

Circuitry. The transceiver is divided into four basic circuits as shown in the block diagram below. In the superheterodyne tuner section, you'll

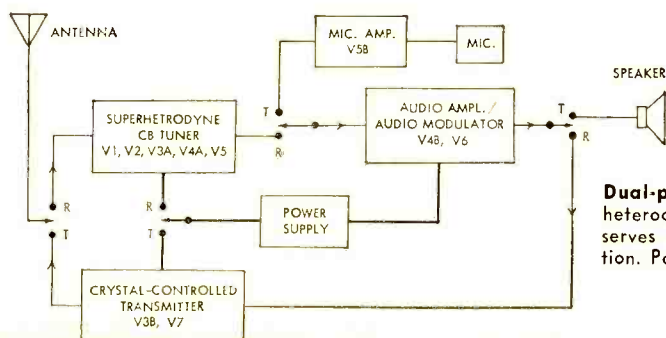

Dual-purpose audio amplifier in superheterodyne tuner section of transceiver serves as modulator for transmitter section. Power supply is common to all sections.

find an r.f. amplifier, a mixer, two 1750-kc. i.f. amplifiers, a detector and a noise limiter. A single knob provides for continuous tuning over the entire Citizens Band (26.965 to 27.255 mc.). Sensitivity is 1 microvolt for a 10-db signal-to-noise ratio. The audio amplifier section for the receiver also doubles as a modulator for the transmitter section.

When transmitting, an audio preamplifier stage is added to the modulator circuit to boost the signal from the crystal microphone. Crystal control is used in the transmitter which consists of an oscillator stage and a final r.f. amplifier operating at the 5-watt maximum permitted by the FCC. A variable "pi" network matches the transmitter's final to 50- and 75-ohm antennas. The power supply uses a pair of silicon diodes for rectifiers; this keeps cabinet temperature down.

Special Features. The outstanding feature of the transceiver kit models is the factory-wired and sealed transmitter circuit. With this much of the work done for you by the manufacturer, you can legally tune up your antenna system while on the air without an FCC commercial license. However, if you tamper with the seal in any way, this antenna tuning privilege is voided.

Mobile operation in crowded urban areas with their multitude of man-made noise generators usually makes for unfavorable reception. The EICO people have licked this problem by incorporating a diode noise limiter in the transceiver which takes the bite out of the noise. You won't have dead silence between transmissions but rather a gentle murmur to tell you that the set is alive.

Another small, but thoughtful, design feature is the provision of two antenna jacks. One is a standard auto antenna jack and the other is a coax jack which makes for quick connect-disconnect when you change from mobile to fixed-station operation. Incidentally, no changes are necessary when you switch from battery operation to house current— you just unplug the battery and plug in the a.c. power. —30—

The Radar Man

If ever you saw upon the street
A man who walked with dipole feet
With a lagging train of pips behind—
He was a radar man with a micromind.

With microseconds and microwaves
And microvolts, he filled his days;
And thus in the course of passing time
His brain had shrunk to a micromind.

His eyes gave out with a neon gleam,
His nose lit up like a radar screen,
His ears worked like an electronic gate,
And his heart pumped blood at a video rate.

This man obtained, in passing years,
Infinite impedance between his ears.
At last he succumbed to a heavy jolt
When he probed what he thought was a microvolt.

The Doc looked up from his microscope
And said to the nurse, "Behold this dope!
Since of his brain not a trace can I find,
He was a radar man with a micromind."

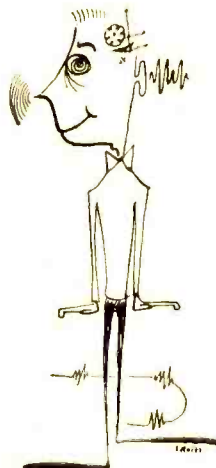

Educated G.I.

POPULAR ELECTRONICS
AFTER CLASS
feature

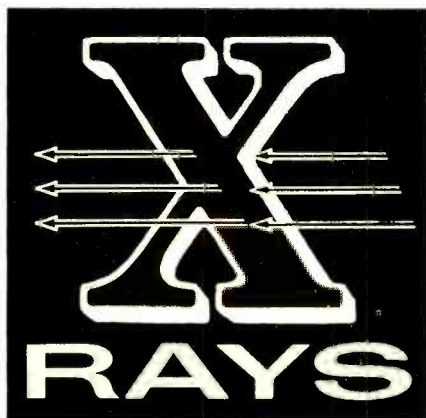
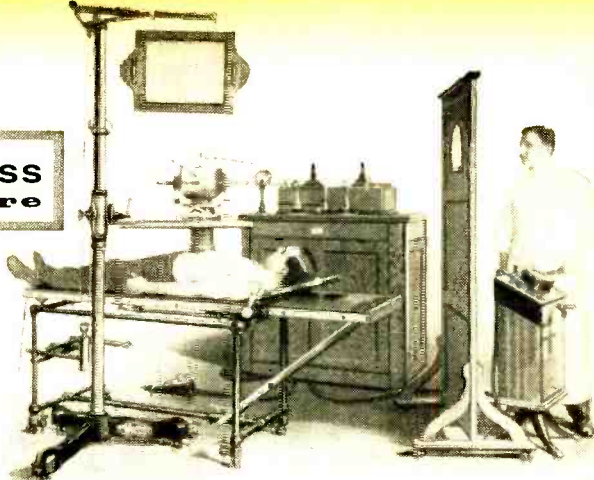

By **FRED E. EBEL**, W9PXA

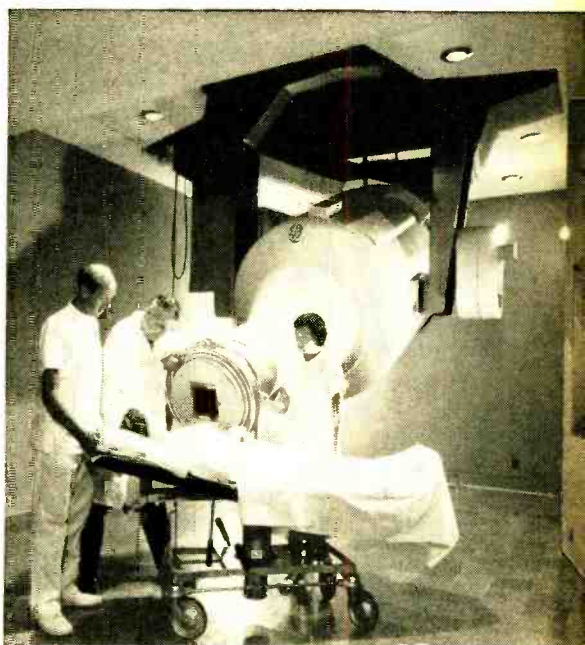

Is it light?
No.
Is it electricity?
Not in any known form.
What is it?
I don't know.

With such scientific frankness did physics professor Wilhelm Konrad Roentgen relate his discovery of a mysterious new ray to a newspaper reporter. Stumbled upon by accident during a routine laboratory experiment on the night of November 8, 1895, the new ray was dubbed an "X ray" by Roentgen. "X," then as now, was the mathematical symbol for the unknown.

Much of the "X" has been taken out of X rays since the modest German physics professor demonstrated this startling radiation and its power to penetrate tin,

**Discovered by chance
only 65 years ago,
X rays are one of our most
valuable research tools**

paper, wood, and even the human body. When X-rays were first put into use, you ordinarily had to visit a hospital to see them in action. Today, unlimited industrial applications make X rays far more than just a diagnostic and therapeutic tool of medical science.

Chance—or Fate? Just what did happen on the night of November 8, 1895? Call it fate, fortune, or chance, but there were a number of conditions that conspired to make this night one to remember. First, Roentgen had completely covered the Crookes tube he was using with a black cardboard, making it light-tight. Secondly, his laboratory itself was plunged in darkness. Finally, the *piece de resistance*—a sheet of paper painted with crystals of barium platinocyanide—lay on a bench some distance from the tube.

The barium platinocyanide screen was the “chance” that nature gave Roentgen to unlock one of her secrets. For when the crystals glowed with a shimmering yellow-green fluorescence, Roentgen’s keen scientific mind became curious. True, cathode rays could make the crystals glow—but at this distance? He placed the crystal screen at an even greater distance from the tube than the range cathode rays were known to penetrate. Still the strange fluorescence!

Heart pounding, he grabbed a book and placed it between the Crookes tube and the screen. The crystals continued to glow. Whatever it was, it was coming through the book! Next, he tried metals—and found that the rays penetrated in varying degrees, although lead and platinum stopped them completely.

Now came the most dramatic test of all. Roentgen exposed his hand, and—his heart must have almost stopped—saw the shadows of his bones. As Roentgen made photographs of his findings, it was obvious that he had found something far more exciting than cathode rays—X rays!

How X Rays Are Formed. How was Roentgen able to produce these powerful rays with his crude apparatus—a modified

Crookes tube, mercury interrupter, and a Ruhmkorff induction coil that furnished a bare 20,000 volts? The simple fact is this: X rays are relatively easy to generate. You simply speed up electrons and let them collide with a target. The electrons cause disturbances within the atoms of the target, releasing X rays. Any material, even a gas or liquid, will release X rays when bombarded by high-velocity electrons.

Obviously, then, glass can be a target, as it was in the Crookes tube Roentgen used—see Fig. 1. Here a gas-type tube, consisting

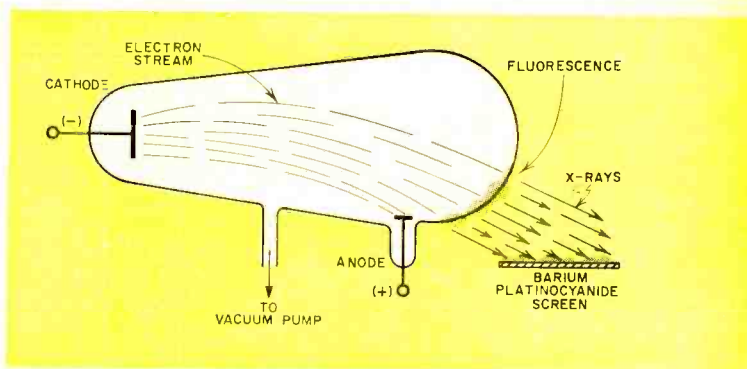

of an anode and cold cathode, was connected to a high-tension induction coil. Heavy positive ions in the residual gas were drawn to the negative cathode (unlike charges attract), striking with such force that they knocked electrons from the cathode metal. It was this positive-ion bombardment that created and maintained a source of electrons, the “work horses” for X-ray generation.

The negatively charged electrons, in turn, were drawn toward the high-voltage positive anode. The resultant stream of electrons, actually cathode rays, traveled so fast—about 30,000 miles per second—that most of them could not “turn the corner” to reach the anode. Instead, they smashed into the glass wall of the tube. The glass, therefore, was the target, providing the barrier for the sudden stoppage of electrons. The result: radiation of X rays, and, of course, the glow of fluorescence of the glass that Roentgen observed.

Nature of X Rays. X rays are electromagnetic rays similar to visible light rays,

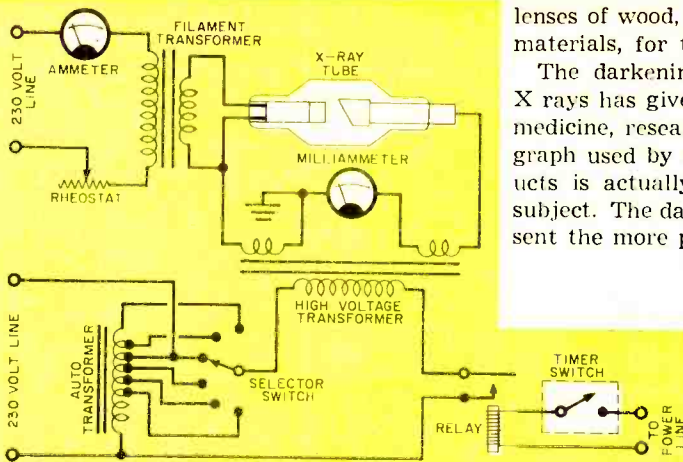
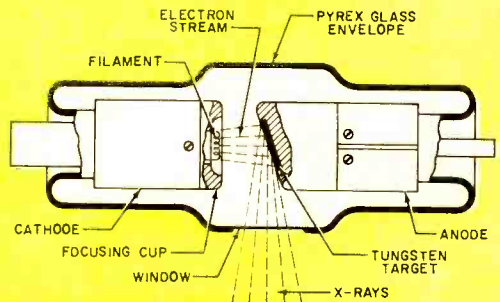

Fig. 2. Basic X-ray unit includes X-ray tube and high-voltage supply.

Fig. 1. Crookes tube used by Roentgen produced X rays when electrons flowing from its cathode to its anode bombarded the glass tube.

Fig. 3. X-ray tube detail. The focusing cup concentrates electron stream from cathode and directs it toward tungsten target material.



with this important exception—their wavelength is very small, about 1/10,000th that of light. These tiny wavelengths are measured in angstroms, units so small that you can line up 254,000,000 of them between the one-inch marks on a ruler. The X-ray region in the electromagnetic spectrum ranges from about 0.006 to 1000 angstrom units. Interestingly enough, it is this exceedingly short wavelength of X rays that makes possible their penetration of matter, and which enables the researcher to delve into the vast voids of molecular inner space.

Unlike the cathode ray generated in your TV picture tube, X rays are non-electrical. Thus, they are unaffected by electrostatic and magnetic fields. This can be proved by placing a magnet or charged plate near X rays; they will be neither attracted nor repelled as in the case of cathode rays.

Traveling at the same speed as light and radio waves—186,000 miles per second, X rays can be reflected and refracted only at very small angles. (Roentgen failed to focus X rays, despite many experiments with

lenses of wood, glass, aluminum, and other materials, for this reason.)

The darkening of photographic film by X rays has given them wide application in medicine, research, and industry. A radiograph used by makers of cast-metal products is actually a shadow picture of the subject. The dark regions of the film represent the more penetrable parts—gas pock-

ets in a weld, for example; the lighter regions identify the more opaque areas.

How X Rays Work. A basic X-ray unit is comprised of filament, high-voltage transformer and timing circuits—see Fig. 2. The heart of the unit is the X-ray tube. Like Roentgen's original tube, the modern tube also has a cathode and an anode, but with tremendous improvements. Now the tube is evacuated to an extremely high vacuum. The cathode structure contains a coil of tungsten wire—the filament—which "boils off" electrons when heated to incandescence. A metal reflector or focusing cup on the cathode directs the electron beam toward the target—as shown in Fig. 3.

Tungsten is ordinarily used for the target material, since it can withstand high temperatures without melting. This is important because less than 1% of the energy in the electrons is converted to X rays upon bombardment with the target; most of the energy is converted to heat. To help dissipate the heat, the tungsten is imbedded in a

large mass of copper which conducts the heat into air or into oil, as in the case of the oil-immersed tube.

It is desirable to have the focal spot—the area of the target that receives the electron bombardment—as small as possible. The smaller the focal spot, the better the detail of the radiograph. But a small focal spot means an intense blast of electrons in a tiny area; even tungsten melts under such grueling treatment. This problem can be solved by simply rotating the anode target. The target constantly turns another “face” to the electron stream, area—see Fig. 4.

An induction motor provides the rotating power in an ingenious way. The stator surrounds the outside of the evacuated glass bulb tube and provides the rotating magnetic field that turns the rotor in the tube at approximately 3000 rpm. The rotor in the “neck” of the tube is, of course, con-

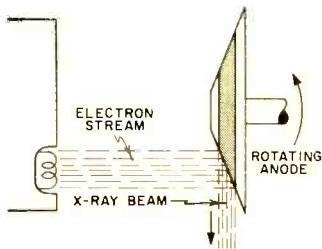

Fig. 4. Rotating anode in target constantly turns new face to electron stream in order to distribute heat over a wide area.

nected to the target. The entire moving assembly is located inside the evacuated tube.

The high-voltage circuit consists of a step-up transformer and its controls; an autotransformer supplies voltage to the primary winding of the high-voltage transformer. Any change of the autotransformer voltage produces a corresponding change in the high-voltage output which is applied to the X-ray tube. Changes in voltage are made with a selector switch; increasing the tube voltage results in a decrease in wavelengths of X rays, accompanied by an increase in penetrability.

If “soft” X rays of low penetrability and longer wavelengths are desired, the selector switch is set at about 20,000 volts. But if

“hard” X rays of high penetrability and shorter wavelengths are desired, the switch is set for several hundred thousand volts.

Rectification of the high-tension alternating current to the tube can be very simple—in fact, the circuit can be made self-rectifying. Current will flow through

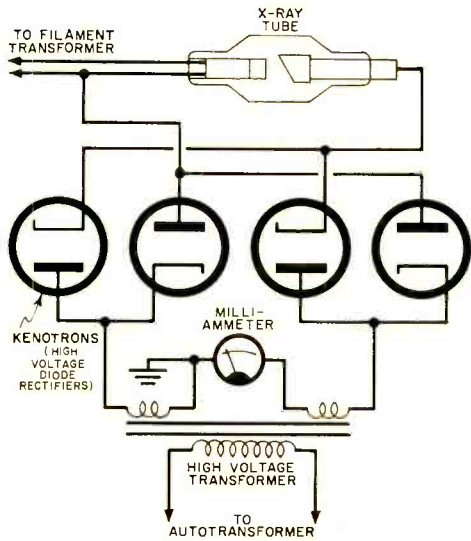

Fig. 5. High-voltage rectifier circuit used in some X-ray systems.

the tube only on the half cycle when the anode is on its negative half cycle, since the anode now repels the negative electrons. Some X-ray systems use a high-voltage full-wave rectifier circuit, permitting conduction of current through the tube on each half cycle of alternating current—see Fig. 5.

Present-Day Uses. Quality control in manufacturing makes extensive use of the non-destructive quality of X rays in the inspection of casting and weldments for such defects as cracks and gas pockets. X-ray devices in beverage plants “look into” opaque cans moving rapidly on a conveyor line and give the signal for automatic rejection of under-filled cans.

Similar devices reveal foreign bodies in food stuffs; detect the hollow heart of potatoes; separate pithy from juicy oranges; and reveal the improper assembly of electronic tubes, switches, and small electrical assemblies. X rays also gauge the thick-

(Continued on page 128)



Across the Ham Bands

By
HERB S. BRIER
W9EGQ

SUBSTITUTING PARTS IN CONSTRUCTION PROJECTS

YOU'VE probably noticed that construction articles often suggest digging into your "junk box" for parts. Most hams go for this idea to help preserve well-rounded pocketbooks. Unfortunately, the parts in their junk boxes are seldom the exact parts specified in the parts list for the gear they want to build. This brings up the question of how far you can deviate from specified values without degrading the performance of the finished product.

Obviously, this is not an easy question to answer without having all the facts. But with a little knowledge of what's involved, you should be able to experiment with other values intelligently.

Overall Considerations. First, read the construction article carefully, and take a close look at the diagrams, pictures, and parts list. The writer of the article has probably pointed out the critical components—don't change them. On the other

.....Ham of the Month.....

Yair Ben-Nissim, 4X4GB, of Kfar Ganim, Petah Tikva, Israel, says that he much prefers a long rag-chew with a strong station to digging out and working a weak one in a new country. But we wonder if he means it—in a worldwide DX contest last fall, Yair racked up the world's highest phone score. Not only has he rag-chewed with fellow hams in over 185 countries on phone, but he has confirmations from 160 of them.

Now 28 years old, Yair Ben-Nissim earned his call letters back in 1952. The present equipment at 4X4GB's station is a 250-watt transmitter (a pair of 813's modulated by 805's) and a Hallicrafters SX-28 receiver. For antennas, Yair has a 50' high "Christmas tree," consisting of separate three-element wide-spaced rotary beams for 10, 15, and 20 meters, spaced four feet apart. He uses simple dipoles for 80 and 40 meters.

Until last year, 10 meters was 4X4GB's favorite band. But the influx of so many Russian hams with frequency-modulated signals on this band has spoiled it for DX work in much of the Middle East. So Yair currently spends most of his time hamming on 15 meters.

Even when he isn't hamming, Mr. Ben-Nissim's not far from ham radio. He's a radio technician for the Israeli government, working in the engineering service, radio section, of the Israeli Post Office. In this position, he handles amateur license examinations and issues the licenses.

For an interesting DX rag-chew, look for Yair Ben-Nissim, 4X4GB, on the air.

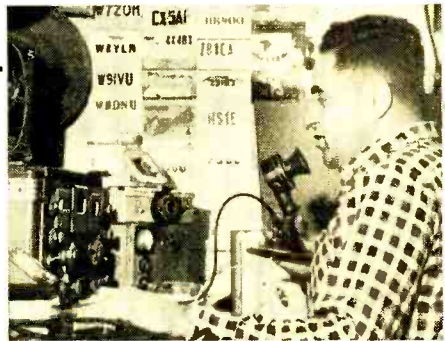

hand, feel reasonably free to call on your junk box for the less critical ones.

The parts list will probably name the manufacturers of the major parts used in the original model followed by "or equivalent." When using equivalent parts, it's a good idea to gather them together before beginning construction. Otherwise, you may discover that your parts differ physically from the specified ones, and you may have to change the parts arrangement to make the equivalent parts fit. Such rearranging is easier to do if you plan it ahead of time than after you have most of the parts mounted.

It's also a good idea to weed out defective junk box parts with your VOM. Check resistors for changes in resistance; capacitors for shorts and leakage; and chokes, transformers, and coils for open windings.

Resistors. Because fixed resistors and fixed capacitors are the most numerous components in the average piece of electronic gear, they offer the greatest opportunity for using spare parts. Unless otherwise specified, fixed resistors commonly have a tolerance of 10% or 20%. Consequently, you can substitute any resistor whose measured resistance is within the tolerance rating of the resistor specified.

You can also connect resistors in series or in parallel to produce a specified resistance. For example, two 22,000-ohm resistors in *series* or two 100,000-ohm resistors in *parallel* can be substituted for a 10% or 20% tolerance, 47,000-ohm resistor. Use the following formulas to calculate the effective resistance (R_t): for resistors in series, $R_t = R_1 + R_2 + \dots$; for two resistors in parallel, $R_t = R_1 \times R_2 / R_1 + R_2$.

You can always substitute a higher-wattage resistor if you have room for it. For economy, composition resistors are normally specified in sizes up to 2 watts; higher-wattage units are usually wire-wound. The two types are generally interchangeable, but never substitute a wire-wound resistor for a composition type in r.f. circuits.

Capacitors. Fixed capacitors come in a wide variety of types—mica, silver-mica, paper, ceramic, oil-filled, electrolytic, and so on. In spite of the great number of types available, however, it's not really hard to remember how each is used.

Mica capacitors (especially silver-mica capacitors) and zero-temperature-coefficient ceramic capacitors are specified where low losses and high stability are required.

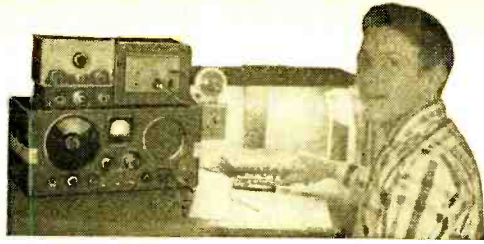

Here's proof of what low power can do. Keith B. MacAdam, K2RX1, (above), worked 23 states on 40 meters with a nine-watter. And Matthew Blanding, K4FNX, (below), racked up 300 contacts using 15 watts output as a Novice; now a General, his record includes 41 states and 14 countries.



Normally, you shouldn't substitute other types for them. On the other hand, you can ordinarily substitute mica capacitors for other types.

The standard tolerance rating for paper and ceramic capacitors is 20%, although the tolerance rating for some general-purpose ceramic capacitors is as wide as -30% to +100%. Obviously, the exact capacitance is relatively unimportant in many bypassing and coupling applications, and you can usually deviate up to 50% from the specified value without trouble.

Where lots of capacitance in a small, low-cost package is required, the electrolytic capacitor is king. However, if you have some oil-filled capacitors on hand—war surplus units, for example—you can substitute them for electrolytic capacitors of the same ratings. Usually, the exact capacitance of electrolytics is not too important; in a pinch, you can use the nearest available capacitance—preferably on the high-capacitance side.

Don't assume from the above that the

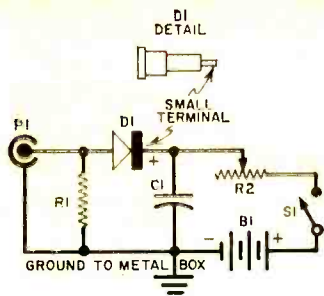
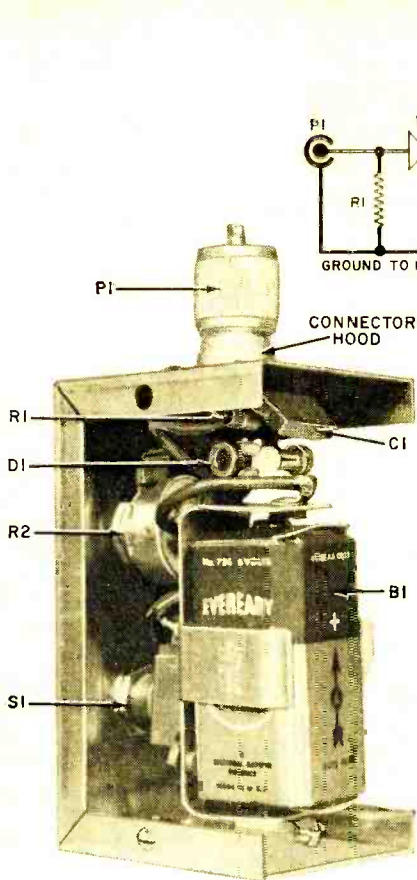

PARTS LIST

- B1—6-volt battery (Eveready 724 or equivalent)
- C1—0.005- μ f. mica or ceramic capacitor
- D1—1N21B or 1N23B silicon diode (Sylvania)
- P1—Coaxial connector plug or jack (see text)
- R1—51- or 300-ohm, 5%, 1/2-watt composition resistor (see text)
- R2—25,000-ohm audio taper potentiometer (Mallory U-28A or equivalent)
- S1—S.p.s.t. toggle switch
- 1—2 1/4" x 2 1/4" x 4" aluminum box (Bud CU-3003A or equivalent)
- 1—Battery holder (Keystone 175 or equivalent)
- Misc.—Hardware, terminal strip, wire, solder, etc.

Test your receiver's sensitivity with this easy-to-build noise generator. Although a coaxial plug (with hood) is used here for P1, a coaxial jack may be substituted if you wish.

parts list accompanying a construction article isn't important—the designer undoubtedly had good reasons for specifying the values he did. Nevertheless, it is helpful to know that you can do a little changing in experimental circuits and still get satisfactory results. But when in doubt, always follow the book.

DIODE NOISE GENERATOR

Just how sensitive is your receiver on the higher-frequency ham bands? Does your buddy hear weak signals that you miss on 21 and 28 mc. because he has a more sensitive receiver or because he's in a better location? This simple diode noise generator will quickly answer these and similar questions.

The one critical component in the generator is the silicon diode, D1. Either a 1N21B or a 1N23B silicon diode works well, but a general-purpose germanium diode, such as the 1N34A, is *not* suitable. Fortunately, both the 1N21B and 1N23B are

available at reasonable cost both in new and "surplus" stocks.

Construction. The noise generator is housed in a 2 1/4" x 2 1/4" x 4" aluminum box. Output connector P1 can be either a coaxial plug (Amphenol 83-1SP or equivalent) or a coaxial jack (Amphenol 83-1R or equivalent). If you choose the plug, as shown in the photo, you must also use a coaxial hood (Amphenol 83-1H or equivalent) to insure proper shielding. In either case, mount the connector at one of the 2 1/4" x 2 1/4" ends of the box's cover.

If the hood-and-plug combination is used, insert the round end of the hood in back of the plug and solder them together. Then, mount the hood-and-plug combination to the box by means of the four mounting holes in the hood. No soldering is required if you use the coaxial connector jack—the jack is simply attached to the box by its four mounting holes.

Silicon diode D1 has a different diameter terminal on each end. Use a 1/8" cartridge—
(Continued on page 131)

Keep Those Contacts Clean

Dirty contacts in switches and other types of controls are a perennial source of trouble—here are ways to keep them clean

By KEN MURRAY

HIGH-RESISTANCE CONTACTS, one of the hidden causes of poor performance on the part of electrical appliances, can be found almost everywhere. Dirt and dust, as well as various forms of corrosion, can reduce or even stop the flow of electricity through the contacts of switches, relays, thermostats, and other types of control devices.

Cleaning and polishing low-voltage contacts is easy if you follow the recommendations of furnace-control manufacturers. Most of them suggest passing a strip of clean white paper between the closed contact points. If such contacts give trouble frequently, look inside the housing for dust accumulations. Trouble can often be prevented by blowing the unit out periodically.

A piece of sandpaper or a file both make good cleaning agents. Or you can use a flat typewriter eraser for a light cleaning. Even a pencil eraser will help remove corrosion, but remember to brush or wipe off any rubber particles which might be left be-

Wiring a capacitor across switch contacts will reduce sparking. Installation above, right, employs a 0.1- μ f. unit.

Prepared contact cleaner dissolves corrosion (right) as well as lubricating and preserving all types of contacts.

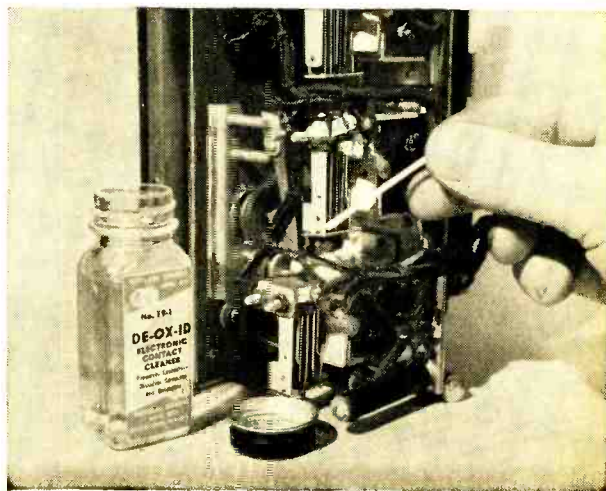
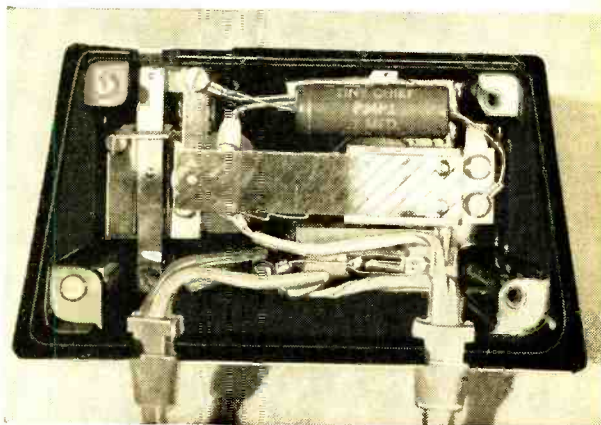

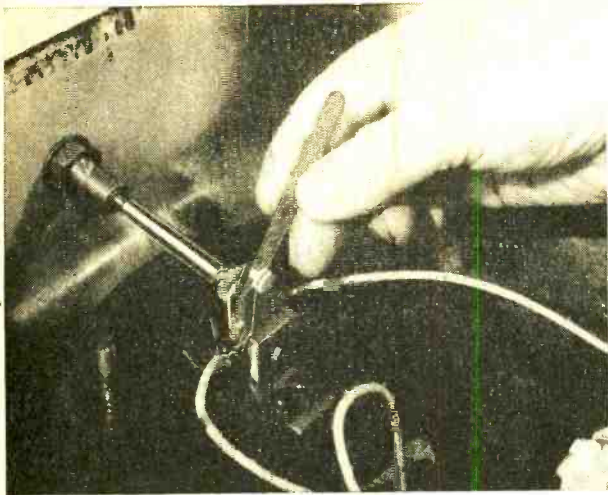

Light filing will clean up contacts that are pitted from heavy service, as in the 1300-watt electric plate shown at left.

Badly worn contacts can be cleaned with a piece of sandpaper (center). Be sure to blow out all abrasive particles.

Plain white paper can be used to clean low-voltage contacts (bottom) by simply drawing the paper between the points,

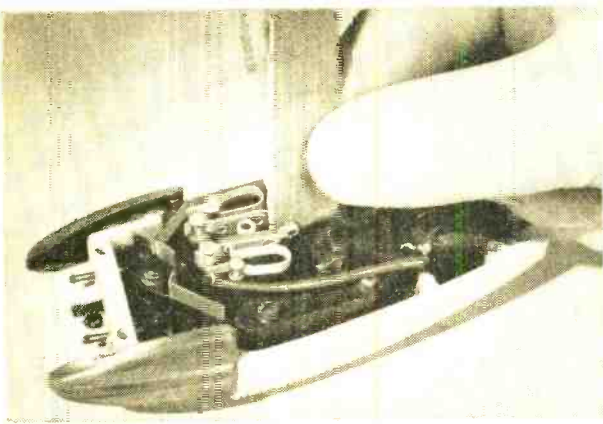

hind. Neither an ordinary cloth nor an emery cloth should be used because of the possible residue of lint or emery particles.

When there are many contacts to keep clean, you may want to use one of the radio repairman's aids—a commercial "contact cleaner." It's sold in small bottles. Apply it with a toothpick (or medicine dropper), and—like magic—blackened contacts will be brightened in a second or two while you watch.

Excessive pit-causing sparking at contacts can be reduced by wiring a small capacitor across the points. Its capacitance should not be large enough to eliminate sparking altogether; a weak spark will help burn off dust and grease as they accumulate.

When switches, plugs, relays, etc., are located where damp air or moisture can get at them, they need frequent attention. Knife switches in such locations can be kept clean with a thin coating of petroleum jelly (Vaseline).

In a car, corrosion of electrical contacts can be the cause of dim and fluctuating lights. The thing to do here is check the condition of fuse contacts, switches, sockets, and ground connections. Auto repairmen know that almost all trouble encountered with generator regulators is due to burned contact points—they use a special fine-cut file for cleaning.

—30—

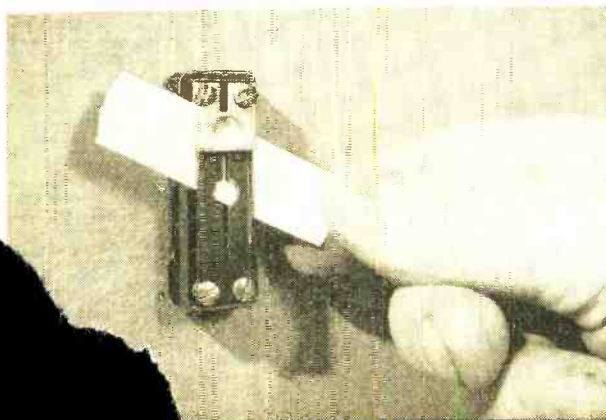

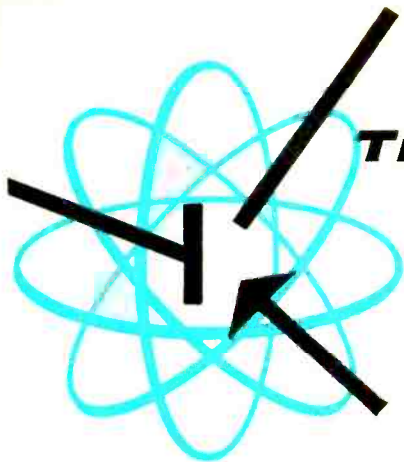

Transistor Topics

By LOU GARNER

WITH Election Day not far off, we can look forward to an increasing deluge of political news, including a barrage of public opinion polls and "predictions" of the election results by electronic computers. If past performances are any criteria, all the major radio-TV networks will have batteries of computers warmed up and waiting to give minute-by-minute predictions as early returns come in.

Our favorite semiconductor components—transistors and diodes—will play an important role in all of this activity, for most modern computers use transistorized circuits. Compared with vacuum tubes, transistors offer the advantages of smaller physical size, lower power consumption, less heat dissipation, and improved reliability, particularly when thousands of units are in use simultaneously.

To many, the giant electronic computers—some of which employ tens of thousands of transistors—are complex almost beyond understanding. In actual fact, however, their complexity lies in the multiplication of rather simple circuits. In this respect, they are much like a tremendous building erected with millions of concrete blocks or bricks—taken by itself, each individual block is a relatively simple object.

In one sense, an ordinary superheterodyne short-wave receiver is more complex than a basic computer, for it is apt to employ a larger variety of basic circuits: r.f. amplifier, mixer, local oscillator, i.f. amplifiers, crystal filters, beat frequency os-

cillator, demodulator, audio and power amplifiers. By contrast, a computer may consist of only three or four basic switching circuits—each multiplied a thousand times.

Typical basic transistor circuits used in computers are shown in simplified form in Fig. 1: a "logic" circuit in Fig. 1(A), a "flip-flop" or switching circuit in Fig. 1(B).

A logic circuit is one that performs simple reasoning operations—if either of several conditions are true, then an output signal is developed. Or the circuit may be arranged so that a signal is developed only



if several conditions are true at the same time. Let's see how this can be done.

Figure 1(A) shows a simple one-stage amplifier using a *p-n-p* transistor (*Q1*) in the common-emitter arrangement. Resistor *R3* serves as a collector load, *C1* as an output coupling capacitor, and *R2* as a base resistor. Collector bias is furnished by battery *B2*. Under normal conditions, no signal is developed by the stage, since there is no base bias applied to *Q1*.

Suppose, now, that s.p.s.t. switch *S1*

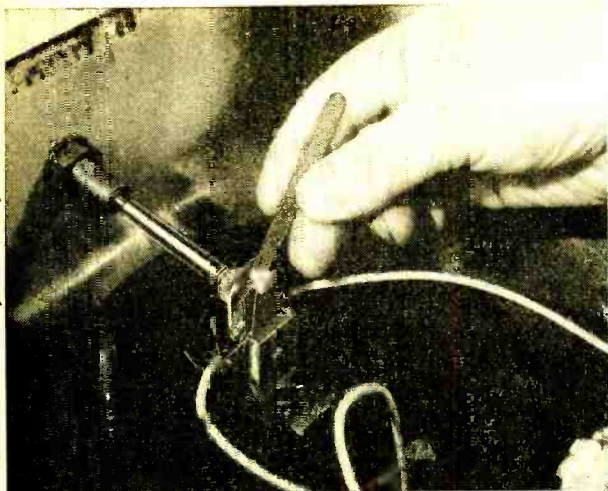

Light filing will clean up contacts that are pitted from heavy service, as in the 1300-watt electric plate shown at left.

Badly worn contacts can be cleaned with a piece of sandpaper (center). Be sure to blow out all abrasive particles.

Plain white paper can be used to clean low-voltage contacts (bottom) by simply drawing the paper between the points.

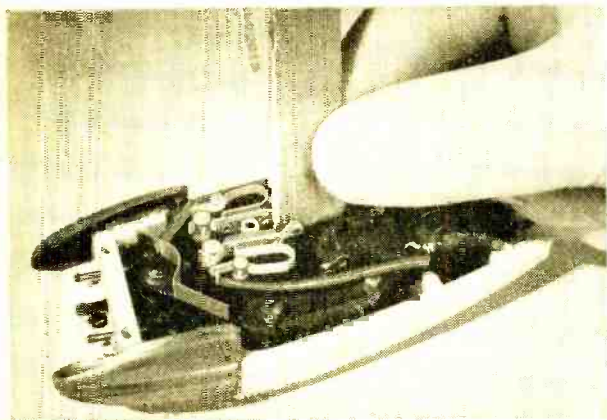

hind. Neither an ordinary cloth nor an emery cloth should be used because of the possible residue of lint or emery particles.

When there are many contacts to keep clean, you may want to use one of the radio repairman's aids—a commercial "contact cleaner." It's sold in small bottles. Apply it with a toothpick (or medicine dropper), and—like magic—blackened contacts will be brightened in a second or two while you watch.

Excessive pit-causing sparking at contacts can be reduced by wiring a small capacitor across the points. Its capacitance should not be large enough to eliminate sparking altogether: a weak spark will help burn off dust and grease as they accumulate.

When switches, plugs, relays, etc., are located where damp air or moisture can get at them, they need frequent attention. Knife switches in such locations can be kept clean with a thin coating of petroleum jelly (Vaseline).

In a car, corrosion of electrical contacts can be the cause of dim and fluctuating lights. The thing to do here is check the condition of fuse contacts, switches, sockets, and ground connections. Auto repairmen know that almost all trouble encountered with generator regulators is due to burned contact points—they use a special fine-cut file for cleaning.

—50—

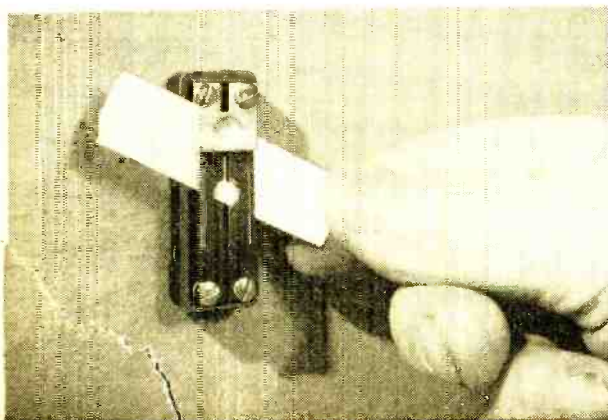

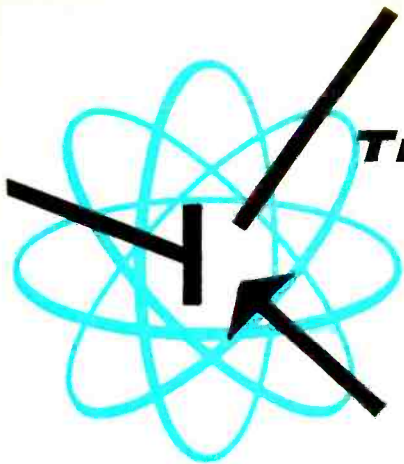

Transistor Topics

By LOU GARNER

WITH Election Day not far off, we can look forward to an increasing deluge of political news, including a barrage of public opinion polls and "predictions" of the election results by electronic computers. If past performances are any criteria, all the major radio-TV networks will have batteries of computers warmed up and waiting to give minute-by-minute predictions as early returns come in.

Our favorite semiconductor components—transistors and diodes—will play an important role in all of this activity, for most modern computers use transistorized circuits. Compared with vacuum tubes, transistors offer the advantages of smaller physical size, lower power consumption, less heat dissipation, and improved reliability, particularly when thousands of units are in use simultaneously.

To many, the giant electronic computers—some of which employ tens of thousands of transistors—are complex almost beyond understanding. In actual fact, however, their complexity lies in the multiplication of rather simple circuits. In this respect, they are much like a tremendous building erected with millions of concrete blocks or bricks—taken by itself, each individual block is a relatively simple object.

In one sense, an ordinary superheterodyne short-wave receiver is more complex than a basic computer, for it is apt to employ a larger *variety* of basic circuits: r.f. amplifier, mixer, local oscillator, i.f. amplifiers, crystal filters, beat frequency os-

cillator, demodulator, audio and power amplifiers. By contrast, a computer may consist of only three or four basic switching circuits—each multiplied a thousand times.

Typical basic transistor circuits used in computers are shown in simplified form in Fig. 1: a "logic" circuit in Fig. 1(A), a "flip-flop" or switching circuit in Fig. 1(B).

A logic circuit is one that performs simple reasoning operations—if either of several conditions are true, then an output signal is developed. Or the circuit may be arranged so that a signal is developed only

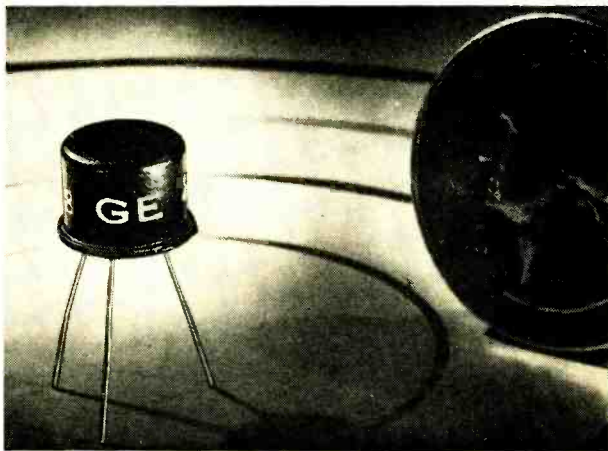

if several conditions are true at the same time. Let's see how this can be done.

Figure 1(A) shows a simple one-stage amplifier using a *p-n-p* transistor (*Q1*) in the common-emitter arrangement. Resistor *R3* serves as a collector load, *C1* as an output coupling capacitor, and *R2* as a base resistor. Collector bias is furnished by battery *B2*. Under normal conditions, no signal is developed by the stage, since there is no base bias applied to *Q1*.

Suppose, now, that s.p.s.t. switch *S1a* is

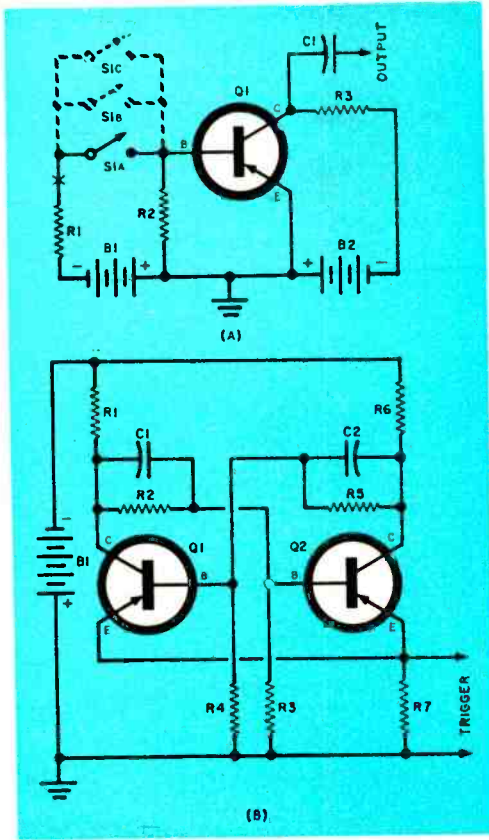

Fig. 1. Simplified versions of two basic transistor circuits employed in electronic computers: a "logic" circuit (A), and a "flip-flop" circuit (B).

Typical high-speed germanium switching transistor of the type used in modern computer circuits is shown at left. This is a General Electric unit.

closed. A bias current can be delivered by battery *B1* through limiting resistor *R1*. This, in turn, permits a flow of collector current, developing an output pulse across *R3*. Thus, we have obtained a basic logic function, i.e., a signal is developed if a switch is closed.

We can extend this basic operation to cover other situations by connecting other switches in parallel with *S1a*, as shown by the dotted lines. With this arrangement, the basic circuit can perform logic calculations involving several situations.

A signal is developed if *S1a* or *S1b* or *S1c* is closed; such an arrangement, for obvious reasons, is called an "or" circuit. By breaking the lead at point "X" and inserting an-

other s.p.s.t. switch, we can change the circuit function to perform another basic operation; with this connection, the stage becomes an "and" circuit, for it will deliver an output signal only if *S1a* and our new series switch are closed simultaneously. If we use signal polarity as an indication of function, the same basic circuit can be used to perform the negative logic functions "nor" and "and not." These four functions are basic to all reasoning.

In practice, the simple switches are generally replaced by electronic circuits which perform the same function, but much faster. A typical circuit is shown in Fig. 1(B). Here, two *p-n-p* common-emitter stages are cross-coupled as a basic electronic switch. Resistors *R1* and *R6* serve as collector loads, *R3* and *R4* as base resistors, and *R2* and *R5* (bypassed by *C1* and *C2*) as coupling resistors. Common emitter resistor *R7* permits the application of a control signal or "trigger" to initiate circuit operation, and d.c. bias is supplied by *B1*.

In operation, either *Q1* or *Q2* conducts, with the other acting as essentially an "open" circuit. Their roles can be interchanged by applying a trigger signal across *R7*. Let us assume that *Q1* is conducting. The d.c. drop across its load resistor, *R1*, is such that little or no bias voltage is available to be applied through *R2* and across *R3* to *Q2*'s base. Since *Q2* is operating with little or no base bias, it acts as a high resistance or open circuit. There is virtually no d.c. drop across its collector load, *R6*, and adequate base bias is applied through *R5* to keep *Q1* conducting.

Now suppose that a negative pulse is applied across *R7*. It has no effect on *Q2*, since this stage is operating as an "open" circuit. As far as *Q1* is concerned, however, a negative pulse applied to its emitter effectively reduces the base-emitter bias, thereby reducing the collector current flow, and reducing the d.c. drop across *R1*. This drop, in turn, is reflected as an increase in *Q2*'s base bias, causing the second stage to start conducting. The action is cumulative and rapid, with *Q1* transferred to a non-conducting state, and *Q2* conducting heavily. A second input pulse applied to *R7* will "flip" the circuit back to its original condition—and so on.

While these two circuits are not the only ones found in electronic computers, most computers employ variations of basic logic and switching circuits. If you understand

how these simple typical circuits operate, you'll be in a good position to study—and to understand—more advanced computer circuits.

Reader's Circuit. Not long ago we received an interesting letter from reader T. L. Clayton aboard the U.S.S. "Hornet" in Pearl Harbor. With the letter was the circuit of a two-transistor receiver he had designed in his spare time and a tape recording as "proof" of the receiver's performance. His circuit has a number of off-beat features which should prove worthy of further experimentation.

Referring to Fig. 2, r.f. signals are picked up by loop antenna *L1* and selected by a

sistor *Q2*'s base bias is supplied by voltage-divider *R6-R7*.

Except for the coils used, all components are standard. Transistor *Q1* is a type 2N94A r.f. unit, *Q2* a type 2N35. Capacitor *C1* is a dual 365- μf . tuning capacitor with both sections connected in parallel; *C6* is a single 365- μf . variable capacitor; *C2*, *C3*, and *C4* are 0.005- μf . ceramic, mica, or paper capacitors; *C5* and *C7* are 25- μf . electrolytics; and *C8* is a 0.05- μf . ceramic or paper unit. Except for the electrolytics, which should be rated at 25 volts, capacitor working voltages are non-critical.

All resistors are half-watt units except the 5000-ohm bias control, *R1*, and 15,000-

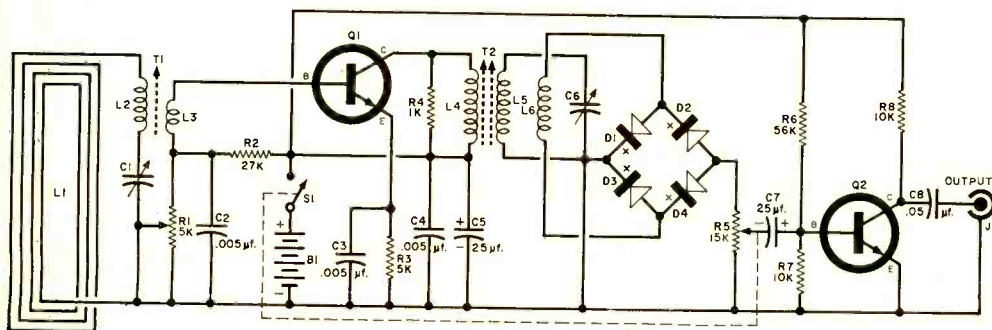

Fig. 2. Reader T. L. Clayton's two-transistor receiver circuit has a number of unusual features. See text for details.

tuned circuit which includes the loop, *L2*, and variable capacitor *C1*. Step-down winding *L3* matches the high impedance of the tuned circuit to the moderate impedance of the common-emitter r.f. amplifier, *Q1*. From *Q1*, the amplified r.f. signal appearing across collector load *R4* and *T2*'s primary winding *L4* is coupled to the tuned secondary *L5-C6* and to impedance-matching secondary *L6*. The signal is detected by a full-wave bridge rectifier (*D1*, *D2*, *D3*, *D4*), with an audio signal appearing across *Gain* control *R5*. From here, the audio signal is coupled through *C7* to a common-emitter audio amplifier, *Q2*, with the amplified output signal developed across collector load *R8* coupled through d.c. blocking capacitor *C8* to the set's output terminals.

Both stages use *n-p-n* transistors, with *Q1*'s base bias furnished by voltage-divider *R1-R2*, bypassed by *C2*, in conjunction with emitter resistor *R3*, bypassed by *C3*. Tran-

ohm *Gain* control, *R5*, which are standard potentiometers. The bridge-type detector is made up of four type IN34A diodes, but other general-purpose diodes will serve as well. Power switch *S1* is ganged to *R5*, while battery *B1* may be a single 15-volt assembly or ten flashlight or penlight cells connected in series.

Coil *L1* consists of three turns of standard hookup wire around the outer edge of a 2' x 3' piece of cardboard. Transformer *T1* is made up by winding a single layer of litz wire over the paper sleeve covering a Grayburne ferrite loopstick; this extra winding serves as *L3*. Transformer *T2* consists of two loopsticks (*L4* and *L5*) placed on a common axis with the coils end-to-end, and with a single layer of litz wire over *L5*'s paper sleeve. This last winding serves as coil *L6*.

Layout is not especially critical, but Clayton points out that *Q1*'s input and output circuits should be kept well separated to prevent feedback, and that *T1* and *T2* should be mounted at right angles to each other to prevent r.f. oscillation.

(Continued on page 129)

NEW AM/FM STEREO TUNER

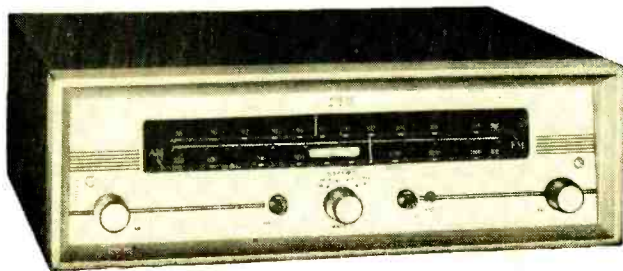

PACO's Model ST-45 comes as a kit, semi-kit, or factory-wired

A good-looking and good-sounding unit, the Model ST-45 AM/FM stereo tuner is available in three forms: as a kit (\$84.95), as a semi-kit (\$99.95), or factory-wired (\$134.95). It's made by PACO Electronics Company, Inc., 70-31 84th St., Glendale 27, N. Y.

If you decide to get the complete kit, you'll find that the assembly instructions are practically "built in." Two printed-circuit boards are used, one for the seven-tube FM section (shown at right) and another for the three-tube AM section. The detailed instruction manual covers the special techniques of soldering to a printed-circuit board. With the pre-aligned transformers, no alignment for either section is necessary—the set will play the moment it is plugged in.

Two tubes use conventional wiring: the power rectifier and the dual AM-FM cathode-follower triodes. Both are in a non-critical part of the circuit and will not affect the alignment of the set. The tube line-up is rounded off with an electronic tuning eye which provides accurate tuning on AM and FM.

The semi-kit is identical to the kit except that both FM and AM circuit boards are completely wired. All tuned circuits are aligned and tested at the factory. You just wire the audio and power sections, and you're in business. Even if you've never assembled a kit before, you should have no trouble with the semi-kit.

Now let's take a look at the circuits of the Model ST-45 and see what you get for

your money. In the r.f. stage of the FM section is a 6AQ8, one half operating as a grounded grid amplifier and the other half as a mixer. A separate dual triode is used for the local oscillator and for a.f.c. operation. In the 10.7-mc. i.f., two full stages of amplification are followed by two limiter stages. A standard Foster-Seeley discriminator is used to detect the FM signal and the resultant audio is fed into a cathode-follower triode. There are separate audio level controls for both FM and AM on the front panel. Overall sensitivity of the FM section is 2 microvolts for 30 db of quieting; the i.f. bandwidth is over 200 kc.

You probably won't need an outdoor antenna for FM reception, since the set is quite sensitive. However, if you live in a FM fringe area, a good directional antenna will be helpful on weak signals.

Featured in the AM section is a tuned r.f. stage, followed by a heptode converter and a single stage of i.f. A crystal diode is used as a detector which feeds the cathode follower audio output. There is also a rotatable ferrite antenna in the AM section, and a 10-kc. whistle filter eliminates the interference which unfortunately is inherent to AM broadcasts on a very crowded band that exists today.

The power supply uses a standard full-wave rectifier with an electrostatically shielded transformer. You'll find that the shielding will help eliminate noise pickup from the power line—especially important for good AM reception.

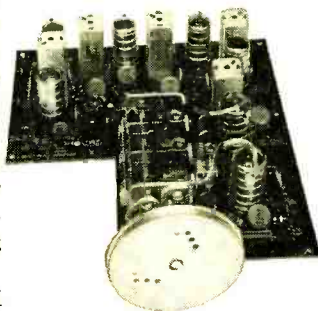

Super

Six-channel high-fidelity sound accurately follows action of wide-screen movie with no "hole-in-the-middle" effect

Huge VU meters connected to each of six stereo channels enable Todd-AO technicians to "track" screen action with dialogue, music, sound effects.



Minnesota Mining and Manufacturing Co. photos

EVER wonder why big movie productions—such as "South Pacific" and "Porgy and Bess"—don't end up with a stereophonic "hole in the middle?" The answer, according to the sound department of Todd-AO, is the use of *six*-channel stereo.

Getting the cumulative mixture of sound effects, solo singing voices, speech, choruses and background music properly oriented on six stereo tracks is no easy matter. In fact, the actual filming time of "Porgy and Bess" took only 93 days, while the time

spent in perfecting the multi-channel sound came to five months—60 days of pre-recording vocals, choruses and music, plus another 90 days to cut, edit and re-record for final finished prints ready to be shown at your local theater.

Of greatest interest to the stereophile is the technique of "panning" or "swinging" the sound back and forth across the movie screen to follow the action. After the film has been satisfactorily edited (for showing time, flow of story action, etc.), the music

POPULAR ELECTRONICS

Stereo



score is recorded and edited to fit. Then all of the individual sound tracks are blended and mixed in the first re-recording phase; this step involves making the dialogue tracks coincide with the action—especially important due to the immense size of the screen. Next, the sound effects are “swung” in the same manner, and, occasionally, even the choruses must be made to follow screen action.

Todd-AO technicians have devised an unusual way of accomplishing the “swinging” process. Sitting at four consoles, the sound engineers mix music, dialogue and sound effects by watching the edited version of the film and simultaneously observing six VU meter readings. Each VU meter is fed from one of the six channels and pertains to a certain area of the movie screen. As the action moves about, the engineers “track” the dialogue from channel to channel.

Over three million feet of magnetic film—“Scotch” No. 125—was used in the production of “Porgy and Bess.” The frequency response of the six magnetic tracks exceeds that of an optically recorded sound track in an ordinary motion picture by a wide margin: 40 to 12,000 cps for the magnetic film strip compared to only 100 to 8000 cps for the optical recording. —30—

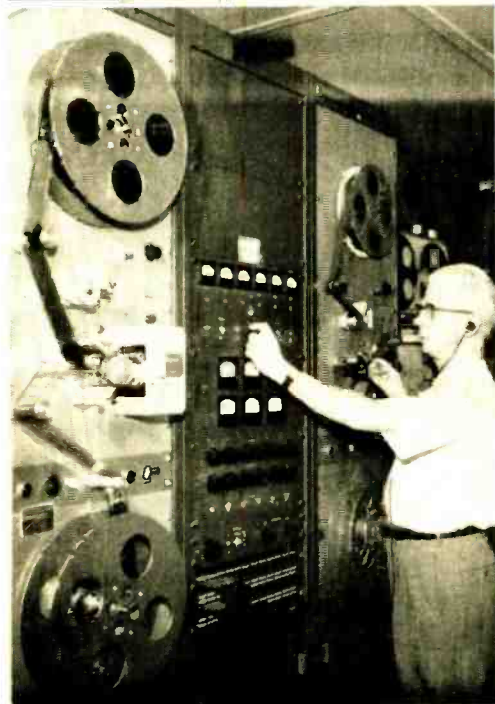

Sound tracks from bank of 35-mm. tape playback machines (above left) are fed through a console to a pair of six-track recorders. Final version of “Porgy and Bess” consisted of 14 reels.

Magnetic oxide strip on ultra-wide 70-mm. motion picture film (left) has synchronized audio dubbed in from 35-mm. six-channel audio tape. Operator shown here is monitoring the VU meters.

Transmitters on the Move

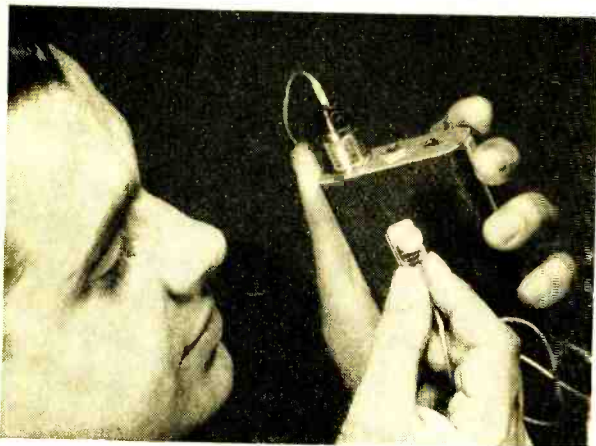

"WALK AND TALK" operation is possible with this miniature transmitter and ultra-miniature dynamic microphone. Developed by Telefunken, and tabbed the "Mikroport," the unit puts out low-power FM signals on 37 mc. Intended for voice transmissions only, the microphone has a frequency range of from 100 to 1500 cps. The shielded wire on the 30" microphone cable eliminates audio hum pickup and serves as the antenna as well.

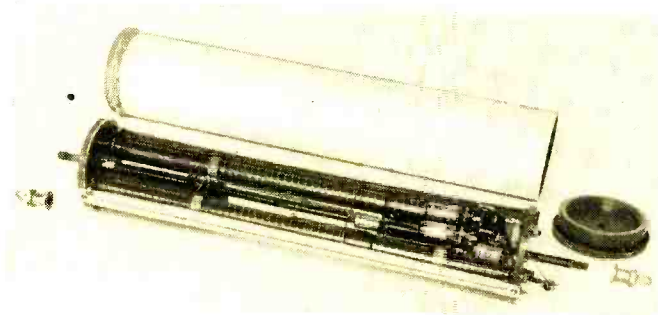

SHIPWRECKED SAILORS or passengers on planes forced down in uninhabited areas or in the ocean will benefit from the emergency self-powered transmitter shown above. When this new Telefunken unit is assembled in its cylindrical housing, it is completely waterproof and insensitive to shock. Even when the transmitter is floating in water, its special ferrite antenna radiates enough of a signal on the 2.182-mc. distress frequency for an accurate radio fix miles away.

A LITTLE RED WAGON provides the action in this mobile radio setup, used for surveying operations at Monterey, Calif. With it, surveyor Don Kjelstrup gives directions for the precise placement of piles for a small craft dock to the barge in the background. Another surveyor, out on the wharf, has his own red wagon unit. (UPI photo)





Short-Wave Report

By **HANK BENNETT**
W2PNA/WPE2FT

HOW many DX'ers can lay claim to the ability to do housework while listening to the British Broadcasting Corporation? Or to wash the dishes and mop up the kitchen floor while tuned to the morning broadcast from *Radio Australia*? Our Featured DX'er this month, Mrs. Ira Kalish, of 2537 Dock Rd., Bellmore, N. Y., is one of those who can.

While DX'ers of the feminine sex are few and far between, Ruth Kalish can proudly boast of being one of the really active "Lady DX'ers" at the present time. In 18 months, Ruth has logged stations in 47 countries, 33 of which have been verified. Her veries from *All India Radio* and *Radio Omdurman* (Sudan) are the most highly prized; her favorite stations are the BBC for newscasts, *Deutsche Welle* (Germany) and Lisbon for their excellent musical programing.

A former code operator on analog computers, Ruth has found that a combination of housework and DX'ing can and does work. Her Hallicrafters S-85 receiver is located in the kitchen, and her present antenna can be found somewhere between the kitchen cabinets and the window screen.

Daytime DX'er Ruth Kalish combines short-wave listening and housework. In 18 months, she has logged 47 countries (33 verified) with her Hallicrafters S-85.

Ruth began DX'ing in May, 1959, when she was presented with her receiver as a Mother's Day gift (her son Conrad is almost three years old—she's 27). An inveterate radio fan but bored with the ever-present commercial advertising, she went into the shorter waves. She soon found that many highly enjoyable hours could be spent in just listening, if not tuning for DX.

With daytime DX'ing the rule, Ruth usually monitors the 16- and 19-meter bands. During the evening, husband Ira often takes over the listening post for a session of code practice from W1AW, the American Radio Relay League's headquarters station in West Hartford, Conn.; and from latest



reports, he is doing nicely at around 13 words per minute. Baby Conrad is the only member of the Kalish household not yet engaged in SWL'ing.

The Kalishes just recently moved to their home in Bellmore. Future plans call for expansion of the antenna system into a long-wire or doublet type; previously they had little space for an antenna. However, Ruth has asked us to point out that a fancy antenna is not a necessity for DX'ing. She and Ira were slow in starting their hobby because someone had told them a beam antenna was almost a must for foreign station reception. A random length of wire and a good ground is all that is necessary to hear the larger stations; for those real rough catches, of course, you have to get down to the finer points, antennawise.

Our housewife-DX'er also wants to pass along a tip that she noticed in the March, 1960, "Across the Ham Bands" on using a 6AC7 tube in place of the 6SG7 as r.f. amplifier in the S-85 receiver. Ruth made the substitution and is highly satisfied with the increase in sensitivity. She suggests that others might find it worth trying.

Engraved Desk Plate. If you want to show off your WPE call letters, here's an item that will enhance any listening post. It's an engraved desk plate made of five-ply plastic laminate with a mahogany finish. There is no paint filling, the finish

will never fade, and an occasional waxing will keep it sparkling. Priced at \$3.20, the desk plate comes with a rubberized bottom section so that it won't slide. Orders may



be sent directly to your Short-Wave Editor (P.O. Box 254, Haddonfield, N. J.); checks or money orders should be included rather than the actual cash to avoid any possible loss.

If you haven't yet registered for your Monitor Certificate and call letters, fill out the form below and mail it to: Monitor Registration, POPULAR ELECTRONICS, One Park Ave., New York 16, N. Y. Please include a dime to help cover handling costs, and a stamped, self-addressed business envelope.

If you live outside of the United States, send either two International Reply Coupons (IRC) or postage stamps of equivalent IRC value. Canadians may send either two IRC's, stamps, or 10 cents in coin. To help us speed up the processing of overseas applications, let us know the amateur prefix used in your area.

(Continued on page 138)

Short-Wave Monitor Registration

(Please Print)

Name		
.....		
Address	City	State
.....
Receiver	Make	Model
.....
	Make	Model
.....
Principal SW Bands Monitored	Number of QSL Cards Received	
.....	
Type of Antenna Used		
.....		
Signature	Date	
.....	

BUILD 20 RADIO

Reg. U. S.
Pat. Off

CIRCUITS AT HOME

with the New
PROGRESSIVE RADIO "EDU-KIT"®

ONLY
\$26.95



A Practical Home Radio Course

Now Includes

- ★ 12 RECEIVERS
- ★ 3 TRANSMITTERS
- ★ SQ. WAVE GENERATOR
- ★ SIGNAL TRACER
- ★ AMPLIFIER
- ★ SIGNAL INJECTOR
- ★ CODE OSCILLATOR
- ★ No Knowledge of Radio Necessary
- ★ No Additional Parts or Tools Needed
- ★ EXCELLENT BACKGROUND FOR TV
- ★ School Inquiries Invited
- ★ Sold in 79 Countries

**YOU DON'T HAVE TO SPEND
HUNDREDS OF DOLLARS FOR A RADIO COURSE**

The "Edu-Kit" offers you an outstanding PRACTICAL HOME RADIO COURSE at a rock-bottom price. Our Kit is designed to train Radio & Electronics Technicians, making use of the most modern methods of home training. You will learn radio theory, construction practice and servicing. THIS IS A COMPLETE RADIO COURSE IN EVERY DETAIL.

You will learn how to build radios, using regular schematics; how to wire and solder in a professional manner; how to service radios. You will work with the standard type of punched metal chassis as well as the latest development of Printed Circuit chassis.

You will receive training for the Novice, Technician and General Classes of F.C.C. Radio Amateur Licenses. You will build 20 Receiver, 20 Transmitter, Square Wave Generator, Code Oscillator, Signal Tracer and Signal Injector circuits, and learn how to operate them. You will receive an excellent background for television, Hi-Fi and Electronics.

Absolutely no previous knowledge of radio, or any other science, therefore you construct the product of many years of teaching and engineering experience. The "Edu-Kit" will provide you with a basic education in Electronics and Radio, worth many times the complete price of \$26.95. The Signal Tracer alone is worth more than the price of the entire Kit.

THE KIT FOR EVERYONE

You do not need the slightest background in radio or science. Whether you are interested in Radio & Electronics because you want an interesting hobby, a well paying business or a job with a future, you will find the "Edu-Kit" a worth-while investment. Many thousands of individuals of all

ages and backgrounds have successfully used the "Edu-Kit" in more than 79 countries of the world. The "Edu-Kit" has been carefully designed, step by step, so that you cannot make a mistake. The "Edu-Kit" allows you to teach yourself at your own rate. No instructor is necessary.

PROGRESSIVE TEACHING METHOD

The Progressive Radio "Edu-Kit" is the foremost educational radio kit in the world, and is universally accepted as the standard in the field of electronics training. The "Edu-Kit" uses the modern educational principle of "Learn by doing." Therefore you construct, learn schematics, study theory, practice trouble-shooting—all in a closely integrated program designed to provide an easily-learned, thorough and interesting background in radio.

You begin by studying the pricing radio parts of the "Edu-Kit." You then learn the function, theory and wiring of these parts. Then you build a simple radio. With this first set you will enjoy listening to regular broadcast stations, learn theory, practice testing and trouble-shooting. Then you build a more advanced radio, learn more advanced theory and techniques gradually, and in a progressive manner, and at your own rate, you will find yourself constructing more advanced multi-tube radio circuits, and doing work like a professional Radio Technician.

Included in the "Edu-Kit" course are twenty Receiver, Transmitter, Code Oscillator, Signal Tracer, Square Wave Generator and Signal Injector circuits. These are not unprofessional "breadboard" experiments, but genuine radio circuits, constructed by means of professional wiring and soldering in metal chassis, plus the new method of radio construction known as "Printed Circuitry." These circuits operate on your regular AC or DC house current.

THE "EDU-KIT" IS COMPLETE

You will receive all parts and instructions necessary to build 20 different radio and electronics circuits, each guaranteed to operate. Our Kits contain tubes, tube sockets, variable electrolytic mica, ceramic and paper dielectric condensers, resistors, tie strips, coils, hardware, tubing, punched metal chassis, Instruction Manuals, hook-up wire, solder, selenium rectifiers, volume controls and switches, etc.

In addition, you receive Printed Circuit materials, including Printed Circuit chassis, special tube sockets, hardware and instructions. You also receive a useful set of tools, a professional electric soldering iron, and a self-powered Dynamic Radio and Electronics Tester. The "Edu-Kit" also includes Code Instructions and the Progressive Code Oscillator, in addition to F.C.C.-type Questions and Answers for Radio Amateur License training. You will also receive lessons on servicing with the Progressive Signal Tracer and the Progressive Signal Injector, a High Fidelity Guide and a Quiz Book. You receive Membership in Radio-TV Club, Free Consultation Service, Certificate of Merit and Discount Privileges. You receive all parts, tools, instructions, etc. Everything is yours to keep.

PRINTED CIRCUITRY

At no increase in price, the "Edu-Kit" now includes Printed Circuitry. You build a Printed Circuit Signal Injector, a unique servicing instrument that can detect many Radio and TV troubles. This revolutionary new technique of radio construction is now becoming popular in commercial radio and TV sets.

Printed Circuitry is a special insulated chassis on which has been deposited a conducting material which takes the place of wiring. The various parts are merely plugged in and soldered to terminals.

Printed Circuitry is the basis of modern Automatic Electronics. A knowledge of this subject is a necessity today for anyone interested in Electronics.

FREE EXTRAS

- SET OF TOOLS
- SOLDERING IRON
- ELECTRONICS TESTER
- PLIERS-CUTTERS
- ALIGNMENT TOOL
- WRENCH SET
- VALUABLE DISCOUNT CARD
- CERTIFICATE OF MERIT
- TESTER INSTRUCTION MANUAL
- HIGH FIDELITY GUIDE & QUIZZES
- TELEVISION BOOK & RADIO TROUBLESHOOTING BOOK
- MEMBERSHIP IN RADIO-TV CLUB: CONSULTATION SERVICE & FCC AMATEUR LICENSE TRAINING
- PRINTED CIRCUITRY

SERVICING LESSONS

You will learn trouble-shooting and servicing in progressive manner. You will practice repairs on the sets that you construct. You will learn symptoms and causes of trouble in home, portable and car radios. You will learn how to use the professional Signal Tracer, the unique Signal Injector and the dynamic Radio & Electronics Tester. While you are learning in this practical way, you will be able to do many a repair job for your friends and neighbors, and charge fees which will far exceed the price of the "Edu-Kit." Our Consultation Service will help you with any technical problems you may have.

J. Statales, of 25 Poplar Pl., Waterbury, Conn., writes: "I have repaired several sets for my friends, and made money. The "Edu-Kit" paid for itself. I was ready to spend \$240 for a Course, but I found your ad and sent for your Kit."

FROM OUR MAIL BAG

Ben Valerio, P. O. Box 21, Magna, Utah: "The Edu-Kits are wonderful. Here I am sending you the questions and also the answers for them. I have been in Radio for the last seven years, but like to work with radio parts, and like to build Radio Testing Equipment. I enjoyed every minute I worked with the different kits; the Signal Tracer works fine. Also like to let you know that I feel proud of becoming a member of your Radio-TV Club."

Robert L. Shuff, 1534 Monroe Ave., Huntington, W. Va.: "Thought I would drop you a few lines to say that I received my Edu-Kit, and was really amazed that such a bargain can be had at such a low price. I have already started repairing radios and phonographs. My friends were really surprised to see me get into the swing of it so quickly. The Trouble-shooting Tester that comes with the Kit is really swell, and finds the trouble, if there is any to be found."

UNCONDITIONAL MONEY-BACK GUARANTEE

**ORDER DIRECT FROM AD—RECEIVE FREE BONUS
RESISTOR AND CONDENSER KITS WORTH \$7**

- Send "Edu-Kit" postpaid. I enclose full payment of \$26.95.
- Send "Edu-Kit" C.O.D. I will pay \$26.95 plus postage.
- Rush me FREE descriptive literature concerning "Edu-Kit."

Name

Address

PROGRESSIVE "EDU-KITS" INC.

1186 Broadway, Dept. 573D, Hewlett, N. Y.

FROM HEATH...

14 NEW KITS



AA-50 \$79⁹⁵

HI-FI RATED 25/25 WATT STEREO AMPLIFIER-PREAMPLIFIER KIT

A complete 25/25 watt stereo power and control center (50 watts mono) . . . 5 switch-selected inputs for each channel . . . new mixed center speaker output . . . stereo reverse and balance controls . . . special channel separation control . . . separate tone controls for each channel with ganged volume controls . . . all of these deluxe features in a single, compact and handsomely styled unit! Five inputs for each 25 watt channel are provided: stereo channel for magnetic phono cartridge (RIAA equalized); tape head input; three high level auxiliary inputs for tuners, TV, etc. There is also an input for monophonic magnetic phono cartridge, so switched that monophonic records can be played through either or both amplifiers. The automatically mixed center speaker output lets you fill in the "hole-in-the-middle" found in some stereo recordings, or add extra monophonic speakers in other locations. Nearly all of the components are mounted on three circuit boards, simplifying assembly and minimizing possibility of wiring errors. 30 lbs.

New Heathkit Stereo Hi-Fi Components . . .

plus Exciting New Kits for the Ham, Technician,

Boating Fan and Hobbyist



AD-10

\$33⁹⁵

MANUAL STEREO RECORD PLAYER KIT

Made by famous Garrard of England, the AD-10 is a compact 4-speed player designed to provide trouble-free performance with low rumble, flutter and wow figures. "Plug-in" cartridge feature. Rubber matted heavy turntable is shock-mounted, and idler wheels retract when turned off to prevent flat spots. Powered by a line-filtered, four-pole induction motor at 16, 33 $\frac{1}{3}$, 45 and 78 rpm. Supplied with Sonotone STA4-SD ceramic stereo turn-over cartridge with .7 mil diamond and 3 mil sapphire styli. Mechanism and vinyl covered mounting base preassembled, arm pre-wired; just attach audio and power cables, install cartridge and mount on base. With 12" record on table, requires approximately 15" W. x 13" D. x 6" H. Color styled in cocoa brown and beige. 10 lbs.



a subsidiary of
DAYSTROM, INCORPORATED



AA-20 \$34⁹⁵



AA-30 \$45⁹⁵

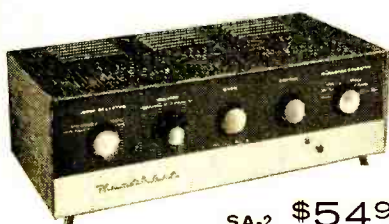

SA-2 \$54⁹⁵



SA-3 \$29⁹⁵

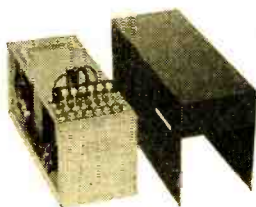

AN-10 \$19⁹⁵

ECONOMY STEREO PREAMPLIFIER KIT

Although these two new Heathkit models are designed as companion pieces, either one can be used with your present stereo system. The preamplifier (AA-20) features 4 inputs in each stereo channel and gives you a choice of 6 functions. It will accommodate a magnetic phonograph (RIAA equalized), a crystal or ceramic phonograph, and two auxiliary sources (AM-FM tuners, TV, tape recorders, etc.) and is completely self-powered. The six-position function selector switch gives you instant selection of "Amplifier A" or "Amplifier B" for single channel monophonic; "Monophonic A" or "Monophonic B" for dual channel monophonic using both amplifiers and either preamplifier; "Stereo" and "Stereo Reverse". 8 lbs.

HI-FI RATED 14/14 WATT BASIC STEREO AMPLIFIER KIT

Two 14-watt high fidelity amplifiers, one for each stereo channel, are packaged in the single, compact, handsomely styled amplifier (AA-30). Suitable for use with any stereo preamplifier or with a pair of monophonic preamplifiers, it features individual amplifier gain controls and speaker phase reversal switch. Output terminals accommodate 4, 8 and 16 ohm speakers. 21 lbs.

HI-FI RATED 14/14 WATT STEREO AMPLIFIER KIT

A tremendous dollar value in the medium power class, this top-quality stereo amplifier-preamplifier combination delivers full 14 watts per stereo channel (28 watts monophonic) to drive your stereo system with ease, while versatile controls give you fingertip command of its every function. In addition to "stereo" and "stereo reverse" functions, the SA-2 provides for complete monophonic operation. Inputs on each stereo channel accommodate "magnetic phono" (RIAA equalized), "crystal phono", "tuner" and high level auxiliary input for tape recorder, TV, etc. Other features include a speaker phase-reversal switch, clutched volume controls, ganged tone controls, filament balance controls, and two AC outlets to accommodate accessory equipment. Handsomely styled in black with inlaid gold design. 23 lbs.

UTILITY RATED 3/3 WATT STEREO AMPLIFIER KIT

Your least expensive route to stereo, the SA-3 delivers 3 watts per stereo channel (6 watts monophonic), adequate for average living-room listening. The high level preamplifier has two separate inputs for each channel and is designed for use with ceramic or crystal cartridge record players, tuners, tape recorders, etc. Featured are ganged bass and treble tone controls, clutched volume controls, channel reversing switch, speaker phase reversal switch and mono-stereo function selector switch. Attractively styled with satin-black cabinet. 13 lbs.

MIXED LOWS STEREO CROSSOVER NETWORK KIT

The AN-10 makes it possible for you to convert to stereo or improve your present stereo system by using just one bass "woofer"; saves buying a second bass speaker, permits using more economical "wing" speakers, improves the bass response of any stereo system. Delivers the non-direction bass frequencies of both channels below 250 cps to a single woofer and passes the higher frequency stereo channels to a pair of wing speakers. Rated at 25 watts per channel. Matches 8 or 16 ohm woofers, 8 ohm high frequency speakers, or Heathkit SS-1-2-3 speaker systems. 10 lbs.

TURN PAGE FOR MORE HIGH QUALITY DO-IT-YOURSELF KITS



HEATHKIT® GIVES YOU MORE IN THESE TEN WAYS:

- 1. Building a Heathkit is easy**—Check-by-step instruction manuals make it virtually impossible for you to fail.
- 2. Building a Heathkit is quick**—No complicated, technical jargon for you to decipher; at most, a Heathkit takes only a few evenings to assemble.
- 3. Building a Heathkit is economical**—Mass production and purchasing economies are passed directly along to you, our customers.
- 4. Building a Heathkit is educational**—As you build, you learn . . . more about electronics, more about the component units and when and where to add them.
- 5. Building a Heathkit is fun**—Nothing quite equals the sense of achievement you receive when you successfully complete a Heathkit unit and "tune-in" for the first time.
- 6. Your Heathkit is Guaranteed**—Every Heathkit unit is guaranteed to meet advertised performance specifications . . . or your money will be cheerfully refunded.
- 7. Your Heathkit is available on Convenient Credit**—Our time payment plan makes it possible for you to order now . . . pay later.
- 8. Your Heathkit is Tops in Quality**—The very finest in electronic equipment comes to you in kit form from the Heath Company.
- 9. Heathkit Dealers can Serve you Locally**—Carefully selected Heathkit representatives are available in most localities.
- 10. Heathkit Service is Customer Service**—Our staff of technical experts is always ready to answer your questions or help you if you have any difficulty.



GC-1
\$109⁹⁵
\$11.00 dn., \$10.00 mo.

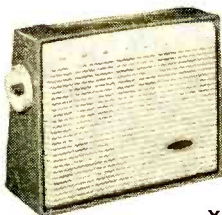

XR-2P
\$29⁹⁵
(6 lbs.)



XR-2L
\$34⁹⁵
(7 lbs.)

TEN-TRANSISTOR "MOHICAN" GENERAL COVERAGE RECEIVER KIT (GC-1)

An excellent portable or fixed station receiver. Many firsts in receiver design. Ten transistor circuit, flashlight battery power supply and new ceramic IF transformers. The amazing miniature transformers used in the GC-1 replace transformer, inductive and capacitive elements used in conventional circuits for shaping bandpass; offer superior time and temperature stability, never need alignment, provide excellent selectivity. Telescoping 54" whip antenna, tuning meter, fly-wheel tuning and large slide-rule dial also featured. Covers 550 kc to 30 mc in five bands. Electrical bandspread on five additional bands cover amateur frequencies from 80 through 10 meters. Operates up to 400 hours on 8 standard size "C" batteries. Sensitivity: 10 uv, broadcast band; 2 uv, amateur bands, for 10 db signal-to-noise ratio. Selectivity: 3 kc wide at 6 db down. Measures 6½" x 12" x 10". 20 lbs.

HEATHKIT XP-2 Plug-in power supply for 110 VAC operation of GC-1. 2 lbs. \$9.95



HD-19
\$34⁹⁵



HD-20
\$14⁹⁵

6-TRANSISTOR PORTABLE RADIO KIT (XR-2 Series)

Unsurpassed quality and styling are combined in these handsome sets to provide you with superb and dependable portable entertainment wherever you are—wherever you go! Choose the gleaming, two-tone molded plastic model or the handsome simulated leather-and-plastic combination—both feature a gracefully curved grille in smart beige plastic. The XR-2P complements the handsome grille with a mocha colored case of high-impact plastic, while the XR-2L encases the beige grille in suntan color Sur-U-Lon simulated leather. Vernier tuning control gives you smooth, precise station selection. Six Texas Instrument transistors are used for quality performance and long life; a large 4" x 6" PM speaker with heavy magnet provides "big set" richness of tone. Ready to play after simple assembly—transformers prealigned. Six flashlight batteries used for power (500—1,000 hrs.) (Batteries not included).



HW-19 (10 meter)
HW-29 (6 meter)

\$39⁹⁵
each

ORDERING INSTRUCTIONS

Fill out the order blank below, giving us your name and address in the space provided at right. Include charges for parcel post according to weights shown. Express orders are shipped delivery charges collect. All prices F.O.B. Benton Harbor, Mich. A 20% deposit is required on all C.O.D. orders. Prices subject to change without notice. Dealers and export prices slightly higher.

QUAN.	ITEM	MODEL NO.	PRICE

Ship via Parcel Post Express C.O.D. Best Way

FREE CATALOG!

Over 150 items of stereo, marine, amateur and test equipment are illustrated and described in the complete Heathkit Catalog.



HEATH COMPANY Benton Harbor 10, Mich.
Please send my free copy of your complete catalog.

NAME _____

ADDRESS _____

CITY _____ ZONE _____ STATE _____

New! One switch operation

"HYBRID" PHONE PATCH KIT (HD-19)

Transfer calls from ham rig to telephone by flipping a single switch! Allows voice control (VOX) or manual operation. VU meter monitors output to 600 ohm line and serves as null depth indicator. Separate receiver and transmitter gain controls. Provides better than 30 db isolation between receive and transmit circuits. All leads filtered to minimize RF feedback. Matches receivers with 3 to 16 ohms impedance. 4 lbs.

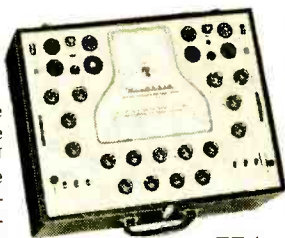

TT-1

\$13495

\$13.50 dn., \$12.00 mo.

NEW 100 KC CRYSTAL CALIBRATOR KIT (HD-20)

This versatile ham aid provides marker frequencies every 100 kc between 100 kc and 54 mc. Use to align all types of communications equipment. Features transistor circuit dependability, battery power portability, and crystal control accuracy. .005% crystal supplied. 1 lb.



Two brand new models

HEATHKIT 10 & 6 METER TRANSCEIVERS

Complete ham facilities at low cost! Ideal for beginning and veteran hams for local net operations. Transmitter and receiver are combined in one easy-to-use instrument. Features neat, modern styling, press-to-talk transmit/receive switch, built-in AC power supply, variable receiver tuning, variable gain control, and amplifier metering jack. Operates mobile using vibrator power supply. Microphone and two power cables included. Handsomely styled in two-tone mocha and beige. Less crystal.

VIBRATOR POWER SUPPLIES: VP-1-6 (6 volt), VP-1-12 (12 volt). 4 lbs. Kit; \$8.95 each. Wired; \$12.95 each.



EK-1

\$1995

MUTUAL CONDUCTANCE TUBE TESTER (TT-1)

The impressive list of its features make this tube tester a fine value. Tests Gm (amplifiers) from 0-24,000 micromhos. Emission, Leakage, Grid current ($\frac{1}{4}$ microampere sensitivity), Voltage regulators (built-in variable DC power supply), Low power Thyatron and Eye tubes. Features 300, 450, and 600 ma constant current heater supplies, life test, Hybrid tube test, built-in switch operated calibration circuit. Large easy-to-read meter, and constant tension free-rolling roll chart mechanism. Individual selector switches allow testing any tube type, regardless of basepin connections, protecting against obsolescence. Assembly simplified by 7 wiring harnesses and transformer terminal board. Assembly skill of technician or higher recommended, time 40 hours average. Black leatherette case with white trim, nylon feet, removable top. 27 lbs.

EDUCATIONAL KIT (EK-1)

Teaches, as you build, the basic "yardsticks" of electronics—opens up fascinating areas of study for youngsters and adults alike. The combination kit and text-workbook gives you a practical demonstration of the principles of voltage, current and resistance; the theory and construction of direct current series and parallel circuits, voltmeter, ammeter and ohmmeter circuits and the application of ohms law to these circuits. The completed meter is used to verify ohms law and the maximum power transfer theorem, one of the most important theorems in electronics. The finished kit, a practical volt-ohm-milliammeter, may be used in a variety of applications. Procedures for checking home appliances and automobile circuits included with the kit. The EK-1 will serve as a prerequisite to following Heathkit Educational kits. Get started NOW in this new and exciting series of "learn-by-doing" educational kits. 4 lbs.

See Your Heathkit® Dealer*

*The convenience of Local Heathkit Sales and Service costs but a few dollars more.



By
JOHN T. FRYE
W9EGV

Carl and Jerry

The Crazy Clock Caper

IT WAS almost the end of an exasperatingly beautiful, warm, sunny school day. Carl and Jerry were sitting in class listening impatiently to the voice of the Latin teacher droning on and on about the second conjugation. Their eyes were on the clock over the door.

Suddenly the voice of the principal issued from the intercom speaker: "Miss Manders, will you please have Jerry Bishop and Carl Anderson come to my office at once?"

The boys rose from their seats at a nod from Miss Manders and started for the door. They could feel the backs of their necks growing hot under the concentrated questioning stares of their classmates.

"Now what've we done?" Carl muttered as they walked along the hall.

"Rather: what have they caught us at?" Jerry whispered.

Jerry knocked at the office door, and the sight of the principal's smiling face banished their worries.

"Boys, this is Mr. Stoner from Center City," he said. "Mr. Stoner is here to straighten out a little trouble we're having with our new automatic clock and bell system."

Tall, thin, bespectacled Mr. Stoner stopped his nervous pacing about the office long enough to shake hands.

"He needs a couple of boys to help him with his testing," the principal explained. "I suggested you two because of your interest in electricity and electronics. I have to leave for a board meeting, but I'm sure you three can get along without my help—especially since my wife says I can't even plug in the electric toaster and do it right!"

As the principal closed the door behind him, Mr. Stoner slumped into a chair. Nervously tugging at his ear, he stared

searchingly into the faces of the two boys. Finally he spoke:

"Boys, I'm going to level with you. I'm in a spot. Actually, I'm an electric typewriter serviceman. The man who is supposed to take care of these clocks is on vacation, and I'm pinch-hitting for him. I know just a little about the system, but that little doesn't seem to be enough to find the trouble. I've spent three days on it, and my boss is beginning to ride me. He thinks a man who can fix electric typewriters should be able to fix anything. On top of

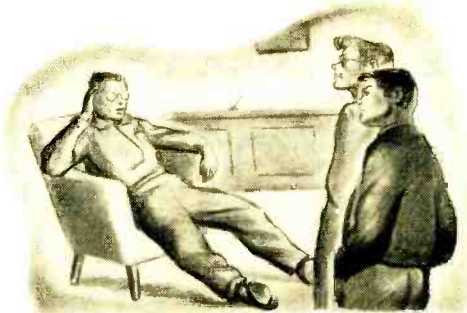

that, my wife called last night and said that my little boy is sick—I should be home with them.

"The principal tells me you two are sharp on electronics. I hope he's right, for I certainly could use some help."

"What's wrong?" Jerry asked.

"All the clocks in the building are supposed to keep in step with the master clock here in the office," Mr. Stoner replied, as he sprang up and renewed his pacing. "Every fifty-ninth minute this master clock causes an audio tone of a certain frequency to be fed into a power amplifier located there in the closet. The signal is built up to about

forty watts and fed into the 117-volt a.c. line. It goes out over the power lines to the electric clocks plugged in in the various rooms.

"Inside each clock is a transformer with tuned windings. The primary in series with a capacitor is connected directly across the a.c. line. The coil and capacitor are series-resonant at the audio frequency, so maximum current flows in the primary. Audio voltage developed across the parallel-tuned secondary fires a cold-cathode thyratron tube. Current through this thyratron actuates an electric clutch that causes the sweeping second hand to pick up the minute hand and carry it to the vertical position before dropping it. Every twelve hours a similar arrangement corrects the hour hand.

"In some installations the correction takes place at 6 a.m. and 6 p.m., but the hour hand is corrected at noon and midnight in this setup. Different audio frequencies are fed into the line by the clock at preset times. These signals are picked up by other tuned transformers with thyratrons that close relays and ring bells in the classrooms. By using different frequencies, the bells of different rooms can be rung at different times so a complex time schedule can be accommodated.

"Every morning several of the room clocks indicate the wrong hour. Others are on time. Different clocks are incorrect on different mornings. At noon they are all automatically corrected, and they stay on time until school is out. But the next morning it's the same old story."

“WHAT have you done so far?" Carl wanted to know.

"I've checked the tone generator and the power amplifier thoroughly. All the tones are on frequency, and there's no parasitic oscillation or noise in the amplifier. I've checked the tuning of the transformers in the clocks to make sure they're right on frequency. I've gone over the wiring. And I've measured the clock-setting signal at all the clocks—it's supposed to be in excess of 0.8 volt, and it is.

"Incidentally, the coupling between the primary and secondary of each tuned transformer is variable so that the voltage delivered to the thyratrons can be kept uniform in spite of different audio voltage levels present across the wall sockets into

(Continued on page 120)



WITH VOCALINE 4-CHANNEL COMMAIRE ED-27M CITIZENS BAND RADIO

**Ranked first for
dependability • distance • clarity**

The difference between Vocaline Commaire ED-27M and ordinary Citizens band radios can be as substantial as the difference between the two photos above. For distance, reliability, flexibility and uniform clarity on the entire 22 channel citizens band . . . you have only to hear the Commaire to convince yourself that this is the one unit that is unmatched by any other in its class. Specifications and features: Finished to pass U.S. Navy 500 hour salt spray test! "Silent-Aire" squelch with exclusive noise suppression. Double conversion superheterodyne single crystal receiver — accepted as the finest. Transistorized power supply. 5 watts input — 3 watts output. 6 and 12 VDC — 115 VAC. Only 5¼" x 9¼" x 8¼".

\$189.50 each, list.

Also available in single channel model—Commaire ED-27M—proven as the world's finest-performing class D Citizens Band Radio! Only \$179.50 each, list.



VOCALINE

COMPANY OF AMERICA

121 Coulter Street Old Saybrook, Conn.

Send complete literature to:

Name _____

Address _____

City _____ Zone _____ State _____

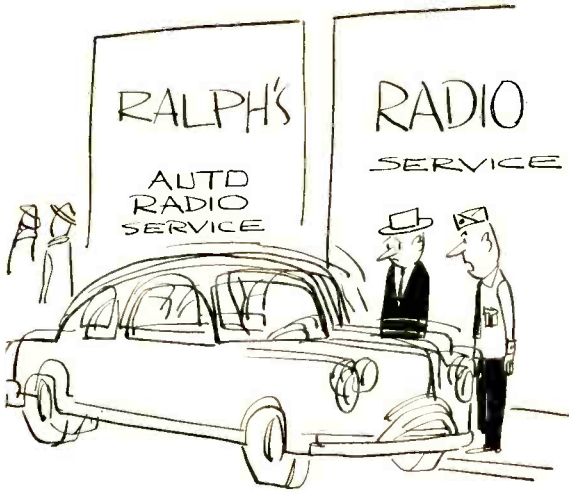

"It looks to me like you need a new vibrator."



"No! No! No! You still haven't got it right. It's 6 12BA6's, 12 6J6's, 6 6U6's, and 12 12AU6's."

Pity The Poor Customer

By Charles Rodrigues



"Most of these selections can be found in your country under the Folkways label."

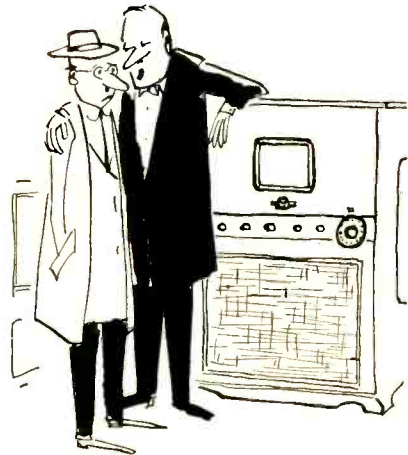

"Look at it as a tried and true TV receiver."

**Courses in Radio and
Electronic Fundamentals –
TV Servicing – Color TV –
Electronics for
Automation –
Transistors**



**SEND FOR THIS FREE
64 PAGE BOOK TODAY!**

Check Home Study!

RCA Institutes Home Study School offers a complete program of integrated courses for beginners and advanced students . . . all designed to prepare you for a rewarding career in the rapidly expanding world of electronics. Practical work with your very first lesson. And you get top recognition as an RCA Institutes graduate!

CANADIANS — take advantage of these same RCA courses at no additional cost. No postage, no customs, no delay. Send coupon to:
RCA Victor Company, Ltd., 5581
Royalmount Ave., Montreal 9, Que.

SEE OTHER SIDE

CUT OUT AND MAIL THIS POSTAGE-FREE CARD TODAY!

RCA INSTITUTES, INC., DEPT. PE-XO

350 W. Fourth St. • New York 14, N. Y.

Please rush me your FREE illustrated 64-page book describing your electronic training programs. No obligation. No salesman will call.

Home Study Book Resident School Book

Name _____ Age _____

Address _____

City _____ Zone _____ State _____

Korean Vets: Enter Discharge Date _____

HOME STUDY SCHOOL

RESIDENT SCHOOL



START YOUR CAREER IN ELECTRONICS NOW AT RCA INSTITUTES in Los Angeles-New York City

CHOOSE FROM THIS LIST...

RCA TRAINING CAN BE THE SMARTEST INVESTMENT YOU EVER MAKE

With RCA Institutes Home Study training you set your own pace in keeping with your own ability, finances and time. You get prime quality equipment as a regular part of the course... and you never have to take apart one piece to build another. Perhaps most important, RCA's liberal Pay-As-You-Learn Plan is the most economical home study method *because you pay only for lessons as you order them*... one study group at a time! If you drop out at *any* time, for *any* reason, you do not owe RCA one penny! No other obligations! No monthly installment payments! Licensed by New York State Education Department.

	Course	Qualifications	Length of Course
A	Advanced Electronic Technology (T-3)	High School grad, with Algebra, Physics or Science	Day 2 1/4 yrs. Eve. 6 3/4 yrs.
B	TV and General Electronics (V-7)	2 yrs. High School, with Algebra, Physics or Science	Day 1 1/2 yrs. Eve. 4 1/2 yrs.
C	Radio & TV Servicing (V-3)	2 yrs. High School	Day 9 mos. Eve. 2 1/4 yrs.
D	Transistors*	V-3 or equivalent	Eve. 3 mos.
E	Electronic Drafting (V-9)*	2 yrs. High School, with Algebra, Physics or Science	Eve. 3 yrs.
F	Color TV	V-3 or equivalent	Day 3 mos. Eve. 3 mos.
G	Audio-Hi Fidelity*	V-3 or equivalent	Eve. 3 mos.
H	Video Tape*	V-3 or equivalent	Eve. 3 mos.
I	Technical Writing (V-10)	V-3 or equivalent	Eve. 3-18 mos.
J	Radio Telegraph Operating (V-5)*	2 yrs. High School, with Algebra, Physics or Science	Day 9 mos. Eve. 2 1/4 yrs.
K	Radio Code (V-4)*	8th Grade	Eve. as desired
L	Preparatory Math & Physics (P-0)	1 yr. High School	Day 3 mos.
M	Preparatory Mathematics (P-0A)	1 yr. High School	Eve. 3 mos.

*Courses to be added to Los Angeles Curriculum

SEE OTHER SIDE

First Class

Permit No. 10662
New York, N. Y.

BUSINESS REPLY CARD

No Postage Stamp Necessary if Mailed in U. S.

Postage will be paid by—

RCA INSTITUTES, INC., DEPT. PE-XO

350 West Fourth Street

New York 14, N. Y.

RCA Institutes is one of the largest technical institutes in the United States devoted exclusively to electronics. Co-educational Day and Evening classes. Free Placement Service. Applications now being accepted.



SEND FOR THIS FREE ILLUSTRATED BOOK TODAY. Fill in the other side of the postage-free card and check Resident School.

RCA INSTITUTES, INC. A Service of Radio Corporation of America • 350 W. 4th St., New York 14, N.Y. • 610 S. Main St., Los Angeles 14, Calif.



The Most Trusted Name in Electronics

\$25.00
WORTH OF
RADIO-TV PARTS

OVER 100 PIECES

FREE

PLUS \$1 PAK OF YOUR CHOICE LISTED BELOW FREE WITH EVERY \$10 ORDER

SPRAGUE 40-40-40 MFD @ 450WV

Electrolytic, twist lock. Most pop top power supply replacements. Fresh stock! Reg. \$2.50.

40 TUBE SOCKETS

4 to 12 prongs, mica filled top & mini types. Worth \$8.

60 PLUGS & RECEPTACLES

Incl: power, audio, battery, etc. Worth \$8.

6 115VAC PANEL SWITCHES

Toggle type. SPST, DPDT, etc. A shop must.

40 TRANSISTOR RESISTORS

Asst. to 3 meg. 5 watt rating. Color coded. Worth \$1.85.

4 TRANSISTOR OSC. COILS

For 456 kc superhet ckts; found in trans. radios. Mini-size. Worth \$1.

3 TRANS'R POWER CHOKES

For making mini transistor power supplies. Only 3/4" x 7/8" x 7/8". Open frame, leads. Worth \$3.

4 I.F. TRANSFORMERS

456 kc. Only 1 1/2" x 1/4". Transistor ckts. Worth \$3.

4 PILOT LITE ASSEMBLIES

With 1 1/2" neon jewel. Fits mini bay, bulbs. Dialco type. Worth \$3.50.

13-IN-1 PAK

Diodes; carbon, W.W., precision, 1/4W resistors; disc, ceramic, molded, oil, paper, mica condensers; socket; coils. Worth \$8.

20-PC. TWIST DRILL SET

In case. 1/16 thru 1/4". For all types of drills. Worth \$3.

SOLDERING IRON

115VAC/DC, with cord & plug. Nifty hobby unit. Worth \$1.85.

20 TRANSISTOR DISCS

Condensers, incl: .02, .03, & .05 mfd. @ 30 to 100V. Worth 25¢ ea.

30 MOLDED CONDENSERS

Oils, too! Lasts for life. Worth \$8.

"POLY" WIRE PAK

Asst. colors, 0-25 ft. rolls; plastic ins. #18 thru #24. Worth \$4.

8 SILICON 'N' XTAL DIODES

1N21, 1N31, etc. Some \$1.10 worth \$10.

10 VOLUME CONTROLS

Asst. to 1 meg. Some with switch. Worth \$15.

60 TERMINAL STRIPS

1 to 10 tie points. Used in every type of prod. Worth \$5.

4 SELENIUM RECTIFIERS

115VAC/DC half wave. To 350 mls. Nifty shop pak.

4 CBS SEMI-CONDUCTORS

1N82A silicon diodes. Reg. \$1.05¢ ea.

70 COILS & CHOKES

RF, ant. osc. slug-tuned, I.F. Wonderful shop asst. Worth \$18.

10 PANEL SWITCHES

Asst. micros, power, rotary types. Exc. variety. Worth \$10.

70 ONE-WATT RESISTORS

Incl: precisions, W.W., carbon-film, 1/4 & 5/8 watt.

70 INSULATED RESISTORS

IIC, Allen Bradley, Stackpole makers. 1/2, 1W, 100 ohms to 1 meg. 1%, 5% too. Worth \$15.

4 OUTPUT TRANSFORMERS

501.6, etc. Open frame types. Worth \$8.

2 500-MIL RECTIFIERS

Silicon diat. with long axial leads. Worth \$1.

CRYSTAL MIKE

Sensitive 100 to 7,000 cps. Worth \$2.98.

40 TWO-WATT RESISTORS

Incl: 1/2 watt. Asst. values. Worth \$1.

4 AC & DC CHOKES

Power & radio types; to 300 mls. Open frame types. Worth \$10.

1500 PCS. HARDWARE

Nuts, bolts, etc.; wide variety. Handy shop asst. Worth \$1.

50-FT. ZIP CORD

For solder, extns. AC/DC 2-cond panel. Worth \$3.

\$25 SURPRISE PAK

Wide variety of usable radio-TV, hobby parts. Worth \$2.

3 FERRITE LOOPSTICKS

Adjustable, 540 to 1600 kc. Worth \$2.

TRANSISTOR RADIO BASIC

Incl: transistor, socket, loopstick, diode, case. Worth \$1.

4 TRANSIRON POWER DIODES

W/long axial leads. For sub-mini & transistor semi-cond. ckts. Worth \$2.

50 PRECISION RESISTORS

1/2 watt. Various types too. Worth \$1.

50-PC. COBALT MAGNET SET

100's of uses for schools, tool shops, for the experimenter or magnetic properties. Worth \$1.

80 TUBULAR CONDENSERS

Papers, molded, oils, ceramic; .0001 to 1 mf to 600V. Worth \$16.

100 HALF WATT RESISTORS

Asst. values. Some 1/2 watt. Worth \$18.

10 INSTRUMENT KNOBS

Pointer types, black, brass insert & set screws. Worth \$1.

35 POWER RESISTORS

Asst. 5 to 50W to 10,000 ohms. Various types too. Worth \$12.

6 TRANSISTOR* RADIO

KIT! *Basic 20 pcs. incl. I.F.'s, osc. coils, var. cond. in-and-out trans., var. cond. sockets, instructions \$5.88

\$1 HEADLINERS

3 HOBBY TRANSISTORS . . . \$1

15 "POLY" BOXES to 4" . . . \$1

125 CERAMIC CONDENSERS . . . \$1

12 GERMANIUM DIODES . . . \$1

7 SIL. DIODES 1N21, 1N22 . . . \$1

15 ROTARY SWITCHES . . . \$1

\$15-Radiation DETECTORS . . . \$1

125 ASST. RESISTORS . . . \$1

\$30 RELAY SURPRISE

Popular lab and shop asst. Worth \$1.

70 MICA CONDENSERS

Incl: silvers tool .00015 to .01 to 600V. Worth \$20.

10 ELECTROLYTIC COND'N'S

Incl: can & paper types. Duals too! To 1000 mfd to 450V. Worth \$12.

15 AC-DC LINE CORDS

2-conductor, with molded plugs, rubber insulated, cut \$1 lengths.

2-PC. NUTDRIVER SET

Plastic handle, 3/16 thru 7/16 nutdrivers in handy case. Worth \$3.

3 TRANSISTOR RECTIFIERS

Selenium; designed for sub-mini ckts. Only 5/16 x 4/16"! 1/2 wave, plugs in.

\$30 PRINTED CKT SURPRISE

Includes printed circ, transformer, chokes, resistors, condensers, sockets, boards (transf. alone worth \$15).

24 ARTISTS BRUSHES

100% pure bristles. Sizes 1 to 5.

60 RESISTOR SPECIAL

Carbons, precisions, hi-Q, W.W. carbon-film, to 50W. 1% too. Worth \$10.

2 PNP TRANSISTORS

By Western Electric. Worth \$1.85 ea.

8 NEON INDICATORS

For 110 VAC; mini. bay types. Worth \$3.

10 RCA PLUG-N-JACK SETS

For amps, tuners, recorders, etc. Worth \$3.

NEEDLE & STAMP CHECKER

Battery-operated. Checks needles, stamps, etc. Worth \$3.

60 RADIO 'N' TV KNOBS

Asst. colors, sizes, shapes; some \$1 ea.

50 CONDENSER SPECIAL

Incl: discs, ceramics, molded, mica, papers, oils, etc. Worth \$12.

5 MICRO-SWITCHES

Ultra-sensitive for burglar alarms, photo-electric ckts., etc. For 115VAC. SPST. Worth \$1.50 ea.

300-FT. HOOKUP WIRE

Asst. colors, insulation, sizes. Worth \$5.

6 SPOOLS OF SOLDER

Rosin core type. Handy shop pak. Worth \$1.

40 SMALLEST RESISTORS

Only 4/16" long; with long axial leads. For transistor ckts. color-coded. World's Smallest. Worth \$1.

\$1 HEADLINERS

2000-ohm PHONE, cord & plug . . . \$1

XTAL PHONE, cord & plug . . . \$1

CRYSTAL RADIO SET . . . \$1

10-3-sec. TIM'G DEVICES . . . \$1

40 ASST. SILVER MICAS . . . \$1

50 DISC CONDENSERS . . . \$1

5 IN34 CRYSTAL DIODES . . . \$1

30 PANEL LITE BULBS . . . \$1

\$1 HEADLINERS

2 PNP TRANSISTORS

By Western Electric. Worth \$1.85 ea.

8 NEON INDICATORS

For 110 VAC; mini. bay types. Worth \$3.

10 RCA PLUG-N-JACK SETS

For amps, tuners, recorders, etc. Worth \$3.

NEEDLE & STAMP CHECKER

Battery-operated. Checks needles, stamps, etc. Worth \$3.

60 RADIO 'N' TV KNOBS

Asst. colors, sizes, shapes; some \$1 ea.

50 CONDENSER SPECIAL

Incl: discs, ceramics, molded, mica, papers, oils, etc. Worth \$12.

5 MICRO-SWITCHES

Ultra-sensitive for burglar alarms, photo-electric ckts., etc. For 115VAC. SPST. Worth \$1.50 ea.

300-FT. HOOKUP WIRE

Asst. colors, insulation, sizes. Worth \$5.

6 SPOOLS OF SOLDER

Rosin core type. Handy shop pak. Worth \$1.

40 SMALLEST RESISTORS

Only 4/16" long; with long axial leads. For transistor ckts. color-coded. World's Smallest. Worth \$1.

FREE GIANT BARGAIN CATALOG WRITE FOR YOURS!

OVER 1000 SOLD THE 1st MONTH—NOT ONE RETURNED TO DATE!

JUMBO PAKS! RADIO-TV PARTS by the POUND

500-1000 pcs. per pound

BUY 4* pick the 5th FREE

COMPLETE SATISFACTION—MONEY BACK GUARANTEE

- ONE POUND Precision Resistors Worth \$100, NOW
- ONE POUND Disc Condensers Worth 50, NOW
- ONE POUND Ceramic Condensers Worth 85, NOW
- ONE POUND Discs & Ceramics Worth 75, NOW
- ONE POUND Discs, Ceramics, Precisions Worth 70, NOW
- ONE POUND Carbon Resistors Worth 60, NOW
- ONE POUND "Tiny" Paper Condensers Worth 60, NOW

\$25.00 per pound

LEKTRON 135 EVERETT AVE. CHELSEA 50, MASS.

HOW TO ORDER ORDER BY "BLACK-TYPE" HEADLINES i.e. 40 TUBE SOCKET—\$1 **MINIMUM ORDER \$2**

AVG. WT. 1 lb. per pak. State price with each item. Send check or M.O. including sufficient postage; excess returned. C.O.D. orders, 25% down; rated, net 30 days. Include Postal Zone No. in address. (Canada postage, 48¢ 1st lb.; 28¢ ea. add'l lb.)

see the exciting **1961**

knight-kits®

A PRODUCT OF ALLIED RADIO

in this value-packed **ALLIED** catalog

free

**444 pages
most complete**

send for it!

use coupon
on next page

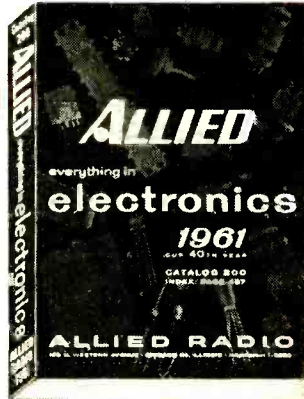

knight-kits—Best by Design

FUN TO BUILD Building it yourself is always satisfying fun—it's fun at its best when you build Knight-Kits—they're so beautifully engineered, so much easier, more pleasurable to work with...

YOU SAVE You save substantially because you buy direct from Allied at our money-saving big-volume-production prices—and because you do the easy building yourself...

YOU OWN THE BEST You'll be glad you built a Knight-Kit, because you'll own and enjoy with pride a true custom-built product, professionally engineered and styled—designed for superior performance...

EASIEST TO BUY **only \$2 down** on orders up to \$50; \$5 down up to \$200; \$10 down over \$200—up to twenty-four months to pay...

exclusive knight-kit

MONEY BACK GUARANTEE

Every Knight-Kit is unconditionally guaranteed to meet our published specifications for performance or your purchase price is refunded in full.

**Buy Any Knight-Kit!
...Build and Use It!
It Must Perform
Exactly as Claimed!**

Your Satisfaction is Guaranteed

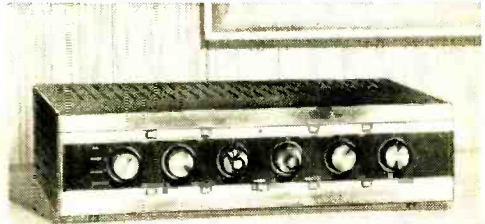

**70-Watt
Super-Power
Stereo!**

DELUXE 70-WATT STEREO AMPLIFIER

Super-power to drive any of today's speakers; the ultimate in control flexibility and functions 83 YU 934 **\$119.95** **only \$5 down**

see many more great **HI-FI KITS**

- | | |
|--------------------------|-------------------|
| Stereo Preamp | 18-Watt Amplifier |
| 60-Watt Stereo Amplifier | 12-Watt Amplifier |
| Stereo Control | FM Tuner |
| 25-Watt Amplifier | Speaker Systems |



ALL-BAND SUPERNET RECEIVER

Covers 540 kc to 36 mc, plus 6 meters; general coverage tuning and calibrated Amateur bandspread tuning. 83 YU 935 **\$67.50** **only \$5 down**

see many other **HOBBYIST KITS**

- | | |
|--|------------------------|
| "Space Spanner" TM Receiver | Transistor Radios |
| "Ocean Hopper" TM Radio | Intercom Systems |
| Radio-Intercom | Electronic Lab Kits |
| Clock-Radio | Photoelectronic System |

◀ **BEST VTVM VALUE**

High sensitivity general-purpose VTVM; 11 meg input resistance; balanced-bridge circuit; 4½" meter. 83 Y 125 **\$25.75**

only **\$2 down**



only **\$2 down**

From original concept to final design, each Knight-Kit is produced by and comes directly to you from **ALLIED**

sold exclusively by

ALLIED

knight-kits: best in build-your-own electronic equipment



STEREO TAPE RECORD/PLAY PREAMP

Professional quality; permits tape monitoring, sound-on-sound and echo effect; use with any tape transport. 83 YX 929 (less case) \$79.95

only \$5 down



DELUXE 40-WATT STEREO AMPLIFIER

Full frequency center channel. Finest amplifier available anywhere in this price range. 83 YU 774 \$76.95

only \$5 down

Only \$39.95 For Full 20 Watts Stereo!

SUPER-VALUE STEREO HI-FI AMPLIFIER

20-Watt Stereo Hi-Fi Amplifier, with special clutch-type dual-concentric level control; biggest bargain in Stereo hi-fi. 83 YX 927 \$39.95

only \$2 down

DELUXE FM-AM STEREO HI-FI TUNER

Dynamic Sideband Regulation, variable AFC, "Magic Eye" slide-tuning, multiplex add-in. 83 YU 731 \$87.50

only \$5 down



SUPERHET CITIZENS BAND TRANSCEIVER

Dual-conversion receiver for highest sensitivity and selectivity; 2-channel crystal-controlled 5-watt transmitter. 83 YX 712-2 \$79.95

only \$5 down



\$39.95 For This Citizen's Band Transceiver

only \$2 down



FM-AM HI-FI TUNER BUY

Outstanding FM-AM Hi-Fi Tuner; with AFC and tuned RF stage on FM; includes multiplex jack. 83 YX 928 \$49.95

only \$2 down

SENSATIONAL 4-BAND "SPANMASTER" RECEIVER

For thrilling world-wide reception; exciting Short-wave and Broadcast; band-switching, 540 KC to 80 MC. With cabinet. 83 YX 258 \$25.95



only \$2 down

TOP VALUE CITIZENS BAND TRANSCEIVER

Lowest-priced complete Citizens Band Transceiver. Tunable 22-channel super-regenerative receiver; 5-watt transmitter. 83 Y 713-2 \$39.95



32-WATT STEREO AMPLIFIER VALUE

Money-saving 32-Watt Stereo Hi-Fi Amplifier; high power at low cost; full frequency center channel. 83 YU 933 \$59.95

only \$5 down



only \$2 down

"600" TUBE CHECKER

Checks over 700 types; illuminated roll-chart; obsolescence-proof design. 83 YX 143 . . . \$32.95

RF SIGNAL GENERATOR

Output to 112 mc on fundamentals; 400-cycle modulation. 83 Y 145 . . . \$19.75

full selection of INSTRUMENT KITS

- 5" Oscilloscopes
- AC VTVM
- Tube Checkers
- Signal Tracer
- Audio Generator
- Sweep Generator
- Battery Eliminator
- Capacity Checker
- Transistor Checker
- R/C Tester,
- plus many others



free

SEND FOR THE 444-PAGE 1961 ALLIED CATALOG

Write today for the world's biggest electronics catalog, featuring the complete KNIGHT-KIT line. See the big news in quality electronic kits—save on everything in Electronics. Send for your FREE copy.

send for it today!

ALLIED RADIO, Dept. 163-K
100 N. Western Ave., Chicago 80, Ill.

Send FREE 1961 ALLIED Catalog

Name _____

Address _____

City _____ Zone _____ State _____

RADIO

Pioneer in electronic kit development



*** FREE**

*
Fill in coupon for a FREE One Year Subscription to
OLSON RADIO'S Fantastic Bargain Packed Catalog
— Unheard of LOW, LOW, WHOLESALE PRICES
on Brand Name Speakers, Changers, Tubes, Tools, Hi-
Fi's, Stereo Amps, Tuners and other Bargains.

NAME _____
ADDRESS _____
CITY _____ ZONE _____ STATE _____

If you have a friend interested in electronics send his
name and address for a FREE subscription also.

**OLSON RADIO
CORPORATION**

812 S. Forge St. Akron 8, Ohio

SERVICE MASTER... EVERY TOOL YOU NEED 99% OF THE TIME

Complete 23-piece kit for radio, TV, and electronic service calls. Includes 2 interchangeable handles (Regular and Stubby), 9 snap-in regular nutdrivers . . . 3 stubby, 3 screwdrivers (2 slotted, 1 Phillips), 2 reamers, 7" extension. Plus "Cushion Grip" long nose plier, diagonals, and adjustable wrench. Durable, plastic-coated case.

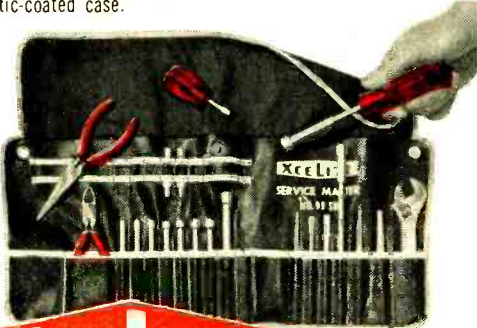

XCELITE

XCELITE, INC., ORCHARD PARK, N. Y.
Canada: Charles W. Pointon, Ltd., Toronto, Ont.

ask your
distributor
to show you
Kit 99 SM.

Carl and Jerry

(Continued from page 113)

which the clocks are plugged. Since the audio signal must thread its way through the maze of a.c. wiring and be subjected to various bypassing actions of different loads on different parts of the wiring, it is understandable that these levels would be different."

"It's kind of funny that nothing happens during the day," Jerry mused. "Maybe something the janitors do at night upsets the clocks."

"I thought of that. The only electrical apparatus they use regularly is a power vacuum sweeper. When the vacuum is running, it produces some noise on the line, but this noise only measures .2 volt—far too low to trip the clock-setting mechanism. Oh, yes, there's one odd thing the principal noticed: more clocks seem to go crazy when it rains. That would point toward humidity as the cause of our trouble, but I can't imagine how."

"Do you have any other ideas?" Carl wanted to know.

"Just one. Today I figured that line voltage variation occurring at night might somehow upset things, so I borrowed this variable-voltage transformer from a TV shop. I'll crank the voltage applied to the signal generator and the power amplifier up and down while you two check the clocks in various rooms to see if anything happens."

Carl and Jerry went from room to room inspecting the clocks while Mr. Stoner raised and then lowered the line voltage applied to the clock-regulating equipment by ten percent. The clocks never budged.

"Well, there goes my last idea," Mr. Stoner said dispiritedly as the boys came back into the office. "I just don't know—"

He was interrupted by the ringing of the telephone on the desk. He answered it, and the boys could see him becoming more and more agitated as he talked.

"My little boy has just been taken to the hospital for an emergency appendectomy," he reported as he hung up the telephone. He began gathering up his tools and throwing them into his tool box. I must go home at once. Have the janitor lock the office. I don't know when I'll get back." This last sentence was shouted back over his shoulder as he dashed out the office door.

Carl and Jerry hunted up the janitor and

delivered the message, then started for home.

"You know," Carl remarked, "I feel sorry for Mr. Stoner. He really has trouble. I wish we could help him."

"Maybe we can," Jerry answered. "Let's go to school a half hour early tomorrow and check those clocks ourselves. We just might get lucky and stumble onto something."

THE NEXT MORNING the boys found only seven of the forty-one clocks with the incorrect time. Two were in the basement, three on the first floor, and two on the top floor.

Shortly before noon it began to rain, so Carl and Jerry ate lunch in the school cafeteria. As they ate, they puzzled over their problem. "It simply has to be something that happens between midnight and morning," Jerry finally decided. "Suppose we ask the principal to let us snoop around here tonight and see what goes on."

The principal readily agreed to the plan and gave the boys a pass key that would let them into any of the classrooms. The sensible thing would have been for the boys to

go to bed right after supper and get some sleep before midnight, but what did our heroes do? They stayed up and watched the late show until a quarter of twelve! Then they set out for the school, Jerry



carrying an a.c. voltmeter, and Carl a pair of binoculars.

Quietly, they let themselves into the dimly-lit building. There was something spooky and a little sinister about the empty halls and the closed doors of the classrooms. From somewhere in the building

TV-RADIO Servicemen or Beginners...

Send for *Coyne's*
7-Volume Job-Training Set
on 7-Day **FREE TRIAL!**



The First
Practical
TV-RADIO-
ELECTRONICS
Shop
Library!

**Answers ALL Servicing Problems QUICKLY...
Makes You Worth More On The Job!**

Put money-making, time-saving TV-RADIO-ELECTRONICS know-how at your fingertips—examine Coyne's all-new 7-Volume TV-RADIO-ELECTRONICS Reference Set for 7 days at our expense! Shows you the way to easier TV-Radio repair—time saving, practical working knowledge that helps you get the BIG money! How to install, service and align ALL radio and TV sets, even color TV, UHF, FM and transistorized equipment. New photo-instruction shows you what makes equipment "tick." No complicated math or theory—just practical facts you can put to use immediately right in the shop, or for ready reference at home. Over 3000 pages; 1200 diagrams; 10,000 facts!

SEND NO MONEY! Just mail coupon for 7-Volume TV-Radio Set on 7-Day FREE TRIAL! We'll include the FREE BOOK below. If you keep the set, pay only \$4 in 7 days and \$4 per month until \$27.25 plus postage is paid. Cash price only \$24.95. Or return set at our expense in 7 days and owe nothing. Either way, the FREE BOOK is yours to keep. Offer limited. So act NOW!

"LEARNED MORE FROM THEM THAN FROM 5 YEARS WORK!"

"Learned more from your first two volumes than from 5 years work."

—Guy Bliss, New York

"Sweet set for either the serviceman or the beginner. Every service bench should have one."—Melvin Masbruch, Iowa.

FREE DIAGRAM BOOK!

We'll send you this big book, "150 Radio-Television Picture Patterns and Diagrams Explained!" **ABSOLUTELY FREE!** just for examining Coyne's 7-Volume Shop Library on 7-Day FREE TRIAL! Shows how to cut servicing time by reading picture-patterns, plus schematic diagrams for many TV and radio sets. Yours FREE whether you keep the 7-Volume Set or not! Mail coupon TODAY!



Like Having An Electronics Expert Right At Your Side!

VOL. 1—EVERYTHING ON TV-RADIO PRINCIPLES! 300 pages of practical explanations; hundreds of illustrations.

VOL. 2—EVERYTHING ON TV-RADIO-FM RECEIVERS; 403 pages; fully illustrated.

VOL. 3—EVERYTHING ON TV-RADIO CIRCUITS! 336 pages; hundreds of illustrations, circuit diagrams.

VOL. 4—EVERYTHING ON SERVICING INSTRUMENTS! How they work, how to use them. 368 pages; illustrated.

VOL. 5—EVERYTHING ON TV TROUBLESHOOTING! Covers all types of sets. 437 pages; illustrations, diagrams.

VOL. 6—TV CYCLOPEDIA! Quick and concise answers to TV problems in alphabetical order, including UHF, Color TV and Transistors; 868 pages.

VOL. 7—TRANSISTOR CIRCUIT HANDBOOK! Practical Reference covering Transistor Applications; over 200 Circuit Diagrams; 410 pages.

BOOKS HAVE BRIGHT, VINYL CLOTH WASHABLE COVERS

FREE BOOK—FREE TRIAL COUPON!

Educational Book Publishing Division
COYNE ELECTRICAL SCHOOL
1455 W. Congress Parkway, Dept. AO-PE, Chicago 7, Ill.

Yes! Send me COYNE'S 7-Volume Applied Practical TV-RADIO-ELECTRONICS Set for 7-Days FREE TRIAL per your offer. Include "Patterns & Diagrams" book FREE!

Name _____ Age _____

Address _____

City _____ Zone _____ State _____

Check here if you want Set sent C.O.D. Coyne pays shipping charges. 7-Day Money-Back Guarantee.

Coyne

Educational Book Publishing Division
ELECTRICAL SCHOOL
1455 W. Congress Parkway Dept. AO-PE Chicago 7, Illinois

came a faint humming sound, and they moved softly about in their sneakers until they located it. The hum was coming from the large tank of an industrial vacuum sweeper which was sitting on a low cart in front of an open door.

As the boys peered around a corner, the janitor came out of the room and piled the

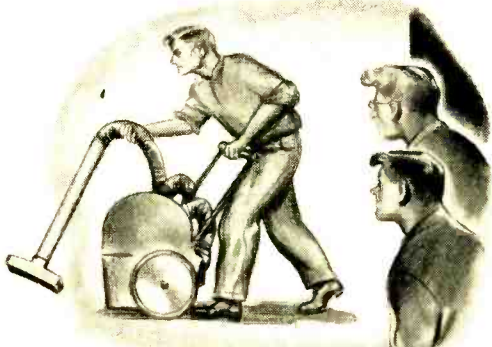

long flexible hose of the vacuum cleaner on the cart, recovered the line cord that had been plugged into a socket in the room, and pushed the cart to the next door.

It took the janitor only a few minutes to vacuum this room, but he apparently neglected that the floor of the next one was too dirty to be dry-cleaned. First he sloshed sudsy water over the floor and gave it a quick going-over with a rotary wet mop. Then he used the vacuum to suck up the excess water. As he did this, the boys could hear the motor of the cleaner slowing down in protest. Finally, he went over the floor with a clean mop and clear water.

Jerry silently beckoned Carl into a classroom across the hall. The floor was still damp, and the clock was four hours fast!

"I've got an idea," Jerry whispered. "You take the key and get into that wing across the way where you can see the clocks in the rooms the janitor is cleaning. Don't let him see you. I'll be doing some checking here. We'll meet in this room in half an hour."

Carl waited until the janitor had started on another room and then slipped away.

Jerry tiptoed across the hall to a baseboard outlet socket just outside the room in which the janitor was working. There he plugged in his own version of a tuned transformer he had made from an old TV

TRU-VAC 1-YEAR GUARANTEED RADIO and TV TUBES

Factory Used or Factory Second Tubes! TRU-VAC will replace FREE any tube that becomes defective in use within one year from date of purchase! All tubes individually boxed, code dated & branded "TRU-VAC." Partial Listing Only — Thousands More Tubes in Stock!

SPECIAL! 65N7GT 30¢												6W4GT 30¢											
024	4858	6AH6	6BC5	6CD6G	6J7	6W6GT	7F8	12AV7	12K7	1A7GT	48Z7	6AK5	6BC8	6CF6	6K6GT	6X4	7G7	12AX4GT	12L6				
183GT	4C86	6AL5	6BD6	6C67	6K7	6X5GT	7H7	12AX7	12Q7	1H5GT	5AW8	6AN8	6BE6	6C6R	6N7	6X8	7N7	12AZ7	12R5				
1R5	5AN8	6AN8	6BF5	6CH8	6Q7	6Y6G	7Q7	12B4	12SA7	155	5AT8	6AQ5	6BG6G	6CL6	654	7A4	XKL7S7	12BA6	12S17				
1T4	5AV8	6AQ6	6BH6	6CM6	688GT	7A5	XKL7S7	12B6A	12S17	1U4	5AZ4	6AQ7	6BJ6	6CM7	65A7	7A6	7X6	12B7	12S17				
1U5	5CG8	6AR5	6BK5	6CN7	6SD7GT	7A7	7Y4	12BE6	12S07	1V2	5R4	6AS5	6BK7	6CB8	6F5	7B4	7Z4	12BF6	12V6GT				
1X2	5T8	6AT6	6BL7GT	6CR6	65G7	7B5	12A8	12BH7	12W6GT	2AF4	5U4	6AU4GT	6BN6	6CS7	65H7	786	12AB5	12BQ6	12X4				
2BN4	5U8	6AU5GT	6BQ6GT	6CU5	65J7	787	12AQ5	12BR7	18AU4GT	2CY5	5V4G	6AU6	6B07	6C6U	65K7	788	12AT6	12BY7	19BG6G				
3AL5	5V6GT	6AU8	6BR8	6D6	65L7	7C4	12AT7	12CA5	19T8	3BC5	5X8	6AV5GT	6BS8	6DE6	65Q7	7C5	12AU6	12CN5	25Z6GT				
3BN6	5Y3	6AV6	6BY5G	6DQ6GT	65T7	7C6	12A7	12D4	35A5	3CB6	6AC7	6AX4GT	6BZ7	6F6	6T8	7E5	12AU7	12D4	35A5				
3C86	6AF4	6AX5GT	6C4	6G6	6U5	7E6	12AV6	12F8	35B5	3V4	6AG5	6BR	6CA8	6J5	6U8	7E7	12K5	35S5	35W4				
4BQ7A	6AH4GT	6BAG	6CB6	6J6	6V6GT	7F7																	

35

EACH

\$33

Per 100 TUBES

BRAND NEW 1-YEAR GUARANTEED TV PICTURE TUBES

Below Listed prices do not include duct. Add. Additional \$5.00 Deposit on tube sizes to 20" on 21" and 24" tubes—\$7.50. Deposit refunded immediately when duct is returned unused. Aluminized tubes—\$4.00 extra. Picture tubes shipped only to continental USA and Canada—All tubes F.O.B. Harrison, N. J.

10BP4	7.99	17CP4	16.99	21AMP4	17.99	21KP4	18.39
16CP4	16.99	17TP4	16.99	21AVP4	18.79	21YP4	18.39
16RP4	11.99	20CP4	15.89	21AWP4	17.49	21WP4	17.49
17AVP4	15.49	20HP4	17.89	21EP4	17.29	21YP4	19.39
17BP4	13.49	21ALP4	18.79	21FP4	18.39	24CP4	27.79

ATTENTION QUANTITY USERS! Big Discounts Are Yours... Call or Write For Our Tube "Private Label" Special!

Money cheerfully refunded within five (5) days, if not satisfied!

SHIPPING INSTRUCTIONS: TRU-VAC PAYS YOUR POST-AGE on orders of \$5 or more in USA and Territories. Send approximate postage on Canadian and foreign orders. Any order less than \$5 requires 2% handling charge. Send 25¢ on C.O.D.'s.

ANY TUBE NOT LISTED ALSO AVAILABLE AT 35¢ EACH!

Sensational Offer!

"Self Service" TUBE CHECKERS

\$37.95 FOB Our Warehouse

Let your customers test their own tubes! These reliable, reconditioned 22-socket tube checkers will return your investment in one week or less with little or no effort on your part! Handsome, field-tested console models. **PLEASE WITH KEYS FOR BOTTOM DOOR AND NEON-LIGHTED HEAD!**

TRU-VAC

Harrison Avenue • Box 107 • Harrison, N. J. Humboldt 4-9770

LOOK! 1000 USED TV'S

Costly, famous make console models with little or no tube replacement! Perfect for resale, or as your own second set! 10", 12" and 19" screens... none smaller! Note shipped FOB, Harrison, N. J.

\$1695 (As Is)

flyback transformer. Placing his voltmeter across the secondary of this transformer enabled him to read the voltage of any

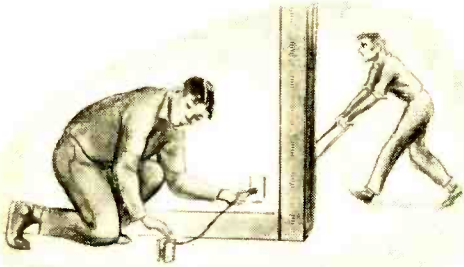

clock-setting signal on the line without interference from the 60-cycle a.c. current.

When the janitor switched on the vacuum cleaner, Jerry got a reading that represented 0.2 volt; but when the sweeper began to suck up water, this reading quadrupled! With a smile of satisfaction, Jerry unplugged his apparatus and returned to the rendezvous room to await Carl.

The latter soon appeared, his eyes wide with excitement, and his uncased binoculars dangling about his neck. "When that vacuum sweeper begins to suck up water, the clock in the room goes crazy," Carl reported.

They did not discuss the matter further. It was two o'clock, and both boys were growing very sleepy. They slipped out of the building and went straight home to bed.

WHEN Carl and Jerry arrived at school the next morning, Mr. Stoner was standing on the steps, smiling and relaxed. "The little boy is getting alone fine," he said, "and I feel like a new man. I guess I needed a shock to show me what was really important. Now that my son is going to be all right, nothing else bothers me. We'll lick this clock thing in time, and I refuse to get worked up about it again."

Excitedly, both boys talking at once, Carl and Jerry told him what they had observed the previous night.

"That's it!" Mr. Stoner exclaimed. "The vacuum cleaner was only sucking air when I checked it. When it sucks water, the motor works harder and produces a noise of the right amplitude and frequency to trip the clock-setting mechanism in the room where the vacuum sweeper is being used. It's too weak to bother more distant clocks, and even the clock in the room isn't dis-

prepare for your career in
ELECTRONICS
ELECTRICAL
ENGINEERING
RADIO-TV
COMPUTERS

At MSOE, you can equip yourself for a career in many exciting, growing fields:
MISSILES • RADAR • AVIONICS
AUTOMATION • RESEARCH
DEVELOPMENT • ELECTRICAL
POWER • ROCKETRY

When you graduate from the Milwaukee School of Engineering, you are prepared for a dynamic career as an Electrical Engineer or Engineering Technician. Under a faculty of specialists, you gain a sound technical education in modern, completely equipped laboratories and classrooms. As a result, MSOE graduates are in great demand and highly accepted by industries nationally.

At MSOE, you will meet men from all walks of life and all parts of the country — some fresh out of high school or prep school, others in their twenties — veterans and non-veterans.

You can start school in any one of four quarters and begin specializing immediately. Engineering technicians graduate in 2 years with an Associate in Applied Science degree. For a Bachelor of Science degree in Engineering, you attend 4 years. A 3-month preparatory course also is available.



FREE CAREER BOOKLET!

If you're interested in any phase of electronics, radio or television, be sure to look into the programs of study offered by the Milwaukee School of Engineering. Just mail the coupon.

MILWAUKEE SCHOOL OF ENGINEERING

Dept. PE-1060, 1025 N. Milwaukee St.
 Milwaukee, Wisconsin

Please send FREE Career Booklet. I'm interested in
 Electronics Electrical Power Radio-TV
 Mechanical Engineering Computers Electrical Engineering Industrial Electronics Preparatory

PLEASE PRINT

Name..... Age.....

Address.....

City..... Zone..... State.....

I'm eligible for veterans education benefits

SAVE on everything in
STEREO HI-FI
and **ELECTRONICS**



FREE SEND FOR THE BIG
444-PAGE 1961
ALLIED CATALOG

Value packed! World's largest selection! See products and values you get only from ALLIED. Save on:

- Everything in Stereo Hi-Fi Music Systems & Components • Biggest Selection of Hi-Fi Cabinetry • Exclusive Knight® Super-value Stereo • Knight-Kits®—Best in Build-Your-Own Hi-Fi • Tape Recorders & Phono Equipment • Everything in Electronic Parts, Tubes, Transistors, Test Equipment, TV Accessories, Tools, Books.

ONLY \$2 DOWN
on orders up to \$50; only \$5 down up to \$200; \$10 down over \$200.

Save most at ALLIED. Write today!

FREE SEND FOR VALUE-PACKED CATALOG



ALLIED RADIO, Dept. 108-K
100 N. Western Ave., Chicago 80, Ill.

Send FREE 1961 ALLIED Catalog

Name _____

Address _____

City _____ Zone _____ State _____

\$1 ELECTRONIC SALE

Buy one at the low price listed and get the second for only \$1.00 more. Price includes postage and insurance.

All merchandise is new, tested, guaranteed, and meets FCC specifications where required. Tubes, transistors, and crystals are included. Power supplies and cabinets are not.

- TRANSMITTER**, Code #253275, 5 watt, 27 mc. crystal controlled citizens band. \$14.99 ea. 2 for \$15.99.
- TRANSMITTER**, Code #253505, 5 watt, 50 to 54 mc., crystal controlled, amateur band. \$14.99 ea. 2 for \$15.99.
- TRANSMITTER**, Code #925827, 100 milliwatt, 27 mc., crystal controlled, citizens band, completely transistorized. Shirt pocket size. \$18.99 ea. 2 for \$19.99.
- CONVERTER**, Code #260270, adapts any broadcast radio to 27 mc. citizens band. Tunes all 22 channels. \$14.99 ea. 2 for \$15.99.
- CONVERTER**, Code #926027, similar to above except uses 3 high frequency transistors. Operates on 6 or 12 volts. \$24.99 ea. 2 for \$25.99.
- NOISE SILENCER**, Code #113300, for superhet radio receivers. A superior circuit using 2 dual tubes which provides the most effective noise clipping and adjustable squelch without audio distortion or loss of gain. \$14.99 ea. 2 for \$15.99.
- RECEIVER**, Code #715271, frequency range 27 to 29 mc. citizens band and 10 meter amateur band. Sensitivity better than 4 microvolts. Battery operated. \$9.99 ea. 2 for \$10.99.
- RECEIVER**, Code #971527, 27 mc. citizens band, Pocket size, completely transistorized. Operates on 4 pen-light cells. \$16.99 ea. 2 for \$17.99.

Limited Quantity—no catalogs or literature available. All merchandise on display at our retail store at 196-23 Jamaica Ave., Hollis 23, N. Y.

Mail your order direct to our factory below.

VANGUARD ELECTRONIC LABS, Dept. E-10
190-48 99 Ave., Hollis 23, N. Y.

turbed during the dry-cleaning process. Well, installing a noise filter inside the motor housing will stop the noise in a jiffy."

"Only one thing bothers me," Carl said slowly. "Why did more clocks get out of synch when it rained?"

"That's easy," Jerry broke in. "When it rained, the kids tracked in more mud, making it necessary to scrub more rooms that night. So more clocks were off the next morning."

"I don't know how to thank you fellows," Mr. Stoner said sincerely.

"Well," Carl suggested slyly, "you could say you needed us to help you install that noise filter during the Latin period. We're due to have a quiz, and—"

"Say no more!" Mr. Stoner interrupted with a chuckle. "I'm sure I need you more than Caesar does today." -30-



Pulse Modulation

(Continued from page 56)

again have a value of 0 if there were no pulse. The far left position would have double the value of the middle position, or 4, if a pulse were present, but a value of 0 if no pulse were there.

Suppose our quantized pulse has a value of 3. Then, in a three-pulse binary code, there would be a pulse in the far right (1) and middle (2) positions only (1 + 2 = 3). If the quantized pulse has a value of 7, then all three pulses in the group would be needed (1 + 2 + 4 = 7).

With a three-pulse binary group, we can send out the waveshape shown in Fig. 4(B) using any of seven values. For greater "fidelity" in reproducing the waveshape, we would need a large number of samples, and larger binary pulse groups would be required. A five-pulse group, for example, gives 32 different amplitudes; a seven-pulse group gives 128 different amplitudes.

The binary-coded signal is ultimately fed to an r.f. transmitter, which is turned alternately on and off by the binary pulses.

Multiplexing and PCM. Bell Telephone Laboratories has many plans for pulse code modulation. For example, they envision a 24-voice-channel PCM telephone system which would allow 24 people to talk at the same time over a single line.

If you've had any experience with present-day "party lines," you know it's impossible for two people to talk over the

same line at the same time. How, then, can 24 people do it? The answer is multiplexing, a kind of sampling technique. The type used in telephony is time-division multiplexing.

Let's consider a case where six people are sharing a single telephone line. Three of them are talking in city A and three are listening in city B. By means of a rotating commutator in city A, each speaker is rapidly hooked up to the line in succession. At the same time a second commutator in city B, synchronized with the commutator in city A, samples the line and distributes each speaker's voice to the intended listener in city B. It's possible to have as many as 176 simultaneous conversations over a single line using PCM.

Multiplexing, incidentally, is the method used by earth satellites to transmit different types of information back to earth. Instead of hooking up 24 talkers in sequence, we can hook up 24 transducers which give information about temperature, cosmic ray density, magnetic field strength, etc. Each transducer modulates a subcarrier oscillator, which in turn modulates the regular high-frequency carrier. Both time-multiplexing and PCM were used in the Explorer VI.

PCM offers great possibilities as a television transmission system, and Bell Labs is actively at work on this idea also. In microwave radio, PCM promises practically interference-free transmission. And since a PCM signal is easily applied to magnetic tape, it is ideal for missile and satellite telemetering as well.

Compared to other forms of pulse modulation, PCM has the sole disadvantage of a wider bandwidth requirement. But as telemetry systems move from the lower megacycle bands to the 2200-mc. region, this disadvantage becomes less and less important.

An Exciting Future. Pulse modulation is no longer just theory—it is a reality. Young as it is, pulse modulation is the giant behind the front-page news of space exploration.

As we explore the frontiers of outer space, and as we search for ways to improve and increase the information-handling capacity of our existing communications systems, it becomes increasingly evident that pulse modulation is one of the most exciting developments of modern electronics.



It takes more learning for a modern job but you earn more right from the start! You'll live better and happier with a career job as a pilot!



- Pilots of all types are needed! Commercial, Business or Executive!
- Train in beautiful Tulsa on modern equipment!

YOUR FIRST STEP TO THE BIG PAYCHECK

MAIL THIS COUPON!

WHICH CAREER INTERESTS YOU

- Commercial Pilot
- Co-Pilot Engineer
- Avionics
- Jet Mechanic
- Link Trainer
- Instrument Mechanic

DEPT. — P100



Director of Admissions
Spartan School of Aeronautics
Municipal Airport • Tulsa, Okla.

Name _____

Address _____

City _____ Age _____

Zone _____ State _____

We will welcome a letter. Give us more information about your ideas or plans.

MOBILE-FIXED CONVERTER

POLICE • FIRE • CITIZENS' BAND



For Use with
12 V. Transistor Type
Car Radios
26-50 MC

#311B—Complete with crystal and tubes. Requires no high voltage supply. Operates on 12 V. DC. Self installed in seconds. **\$24.95**
Other models for 108-162 MC available.



#315A is a practical converter for emergency use. Easily installed. Tuning range approximately 12 MC in the 26-50 MC band—30 MC in the 108-174 MC band. Designed for mobile or home use. **\$13.95**

Available crystal controlled up to 54 MC. **\$19.95**
Also available crystal controlled up to 165 MC. **\$22.95**



#316A VARIABLE CONVERTER. Front panel tuning permits rapid change between separated signals over 10 MC range in 26-54 or 108-174 MC bands. **\$19.95**

#311A CITIZENS BAND TUNEABLE CONVERTER. This universal converter covers the entire Citizens Band and is designed for use with home, car or communications sets—AC-DC or standard models. Also available: 200-400 KC Aircraft, 2-3 MC Marine, 4.5 MC-CAP, or 2-174 MC. **\$24.95**

Full line of converters and receivers for every application.

ORDER TODAY or WRITE for LITERATURE

KUHN ELECTRONICS
20 GLENWOOD CINCINNATI 17, OHIO

IT'S FUN TO BE AN ARMCHAIR ADVENTURER



With a NATIONAL NC-60 SPECIAL Shortwave Radio Receiver you can cross the six continents in the comfort of your favorite chair, visit foreign lands, eavesdrop on aircraft, ships at sea and radio hams. Enjoy standard broadcast too, with its powerful new radio receiver. Suggested price only \$59.95. Write for literature and name of nearest dealer.

JOIN THE NATIONAL ASSOCIATION OF ARMCHAIR ADVENTURERS

SEND 50c for membership certificate and exciting new book on Shortwave Listening. Tells when, where, how to listen, provides log for listing countries you hear. SEND 50c to:

National RADIO CO., INC.

MELROSE 76, MASS.

A wholly owned subsidiary of National Co., Inc.



Export: AD AURIEMA, INC. 85 Broad St., New York, N.Y., U.S.A.
In Canada: CANADIAN MARCONI CO., Toronto 17

Test Instruments

(Continued from page 85)

the capacitive reactance of $C1$. Resistor $R2$ in each case is used to cancel out the resistance of the inductor (RLx), and then Rs is used to balance the bridge.

Figure 8 shows a commercial multi-range Maxwell bridge. Although at first glance it may seem to bear little resemblance to the bridge circuits shown so far, a closer investigation will reveal that it is simply the Maxwell bridge circuit arranged so that different components can be switched in to allow measuring a wider range of values. The unknown inductance and $R1$, $R2$, or $R3$, depending on which one is in the

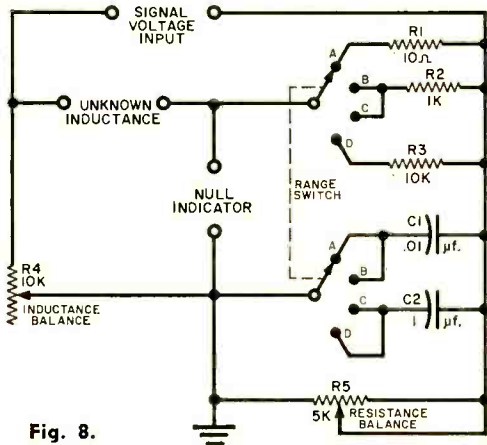

Fig. 8.

circuit at any given time, form the leg comparable to Lx and $R1$ in Fig. 6. Resistor $R4$ and the parallel network, $R5$ and $C1$ or $C2$, correspond to Rs and the network $R2-C1$ in Fig. 6.

In such a circuit, $C1$, $C2$, $R1$, $R2$, $R3$, and $R4$ serve as the standards against which the unknown values are measured, and must, therefore, be of the highest precision; $R4$ is a decade resistor for this reason. Actually, all precision bridges use decade resistors rather than the variable potentiometer type shown for the sake of clarity in all of the diagrams so far.

The decade resistor ($R4$), as illustrated in Fig. 8, is simply a series of precision resistors combined with a switching arrangement so that any value of resistance can be easily and quickly set from the front panel by turning the knobs of the rotary switches.

Incidentally, with the circuit constants

shown, the inductance ranges are: Position A, 10 to 1000 μ h.; Position B, 1 to 100 mh.; Position C, 0.1 to 10 henrys; Position D, 1 to 100 henrys. Usually, a low-distortion audio signal generator set for 400 or 1000 cps is used as the voltage source. The lowest voltage which will produce a clearly audible signal should be used, since too much current flowing in the bridge components can heat them and cause them to change values.

Some inductance bridges are arranged so that the C_1 - C_2 , R_5 network can be switched into either a series or parallel arrangement, changing the bridge from Maxwell (parallel) to Hay (series). This is a highly desirable feature because the Maxwell bridge is more efficient at measuring the inductance of low- Q coils, while the Hay bridge does a better job on high- Q inductances. Some commercial testers are even arranged so that Hay, Maxwell, Schering, and Wheatstone bridges can all be set up by manipulating the panel controls.

Bridge Accuracy. Just how accurate are the measurements made with bridge circuits? Most laboratory-type bridges are accurate to within 1 or 2% of the resistance measured, and some extremely fine instruments measure to within a fraction of 1%. These figures compare with normal ohmmeter accuracy of 5 to 10% for typical service instruments.

Regular laboratory capacitance and inductance bridges do even better, usually achieving an accuracy of 0.2 to 1%, as compared with 5 to 10% for other types of capacitance- and inductance-measuring instruments and circuits.

Next month we will examine some other types of versatile bridge circuits and see how they are used in harmonic-distortion meters, oscillators, and other specialized instruments.

High School Grads! Earn An A. S. DEGREE IN 2 YEARS!

Join the ranks of high-salaried ELECTRONIC ENGINEERING TECHNICIANS in MISSILES...RADIO-TV...COMMUNICATIONS

You, too, can get started NOW in America's most exciting, fastest-growing industry—ELECTRONICS! Stepped-up programs in missiles and satellites, plus expansion in scientific research, opens thousands of high-pay career opportunities for qualified, trained men. Central Tech offers home study and resident courses at college level. Fully-recognized ECPD-accredited technical institute program. Easy pay-as-you-advance plan. FREE PLACEMENT SERVICE! Your future depends on YOU! Don't wait! Get FREE book now!



Get THE TRUTH ABOUT ELECTRONICS! This free book tells full facts about your opportunity in the fascinating field of electronics. How to train quickly for high-salary positions. Various job availabilities. Success of past graduates from Central Tech. Easy payment plan. Work-while-learning plan. Gives 32-year history of the Institute. Shows choices of studies to fit your greatest interests. Tells how to select most profitable courses. Get your FREE copy. Fill in coupon and mail today sure!

FREE! Check and MAIL TODAY!

ELECTRONICS DIVISION — Central Technical Institute

Dept. A-1001644 Wyandotte St., Kansas City 8, Mo.

(Offering engineering technician curricula accredited by Engineers' Council for Professional Development)

Tell me more about how Central Training can qualify ME for a high-pay Electronics career. Check special interest below:

- | | | |
|---|---|---|
| <input type="checkbox"/> Radio | <input type="checkbox"/> Space Satellites | <input type="checkbox"/> Technical Drafting |
| <input type="checkbox"/> Television | <input type="checkbox"/> Nuclear Power | <input type="checkbox"/> Armed Forces |
| <input type="checkbox"/> Electronics | <input type="checkbox"/> Radar | <input type="checkbox"/> Civil Service |
| <input type="checkbox"/> Guided Missile | <input type="checkbox"/> Aviation | <input type="checkbox"/> Own Business |
| <input type="checkbox"/> Other _____ | | |

Home Study with 14 Kits of Equipment.

Resident Training in Kansas City.

Name _____ Age _____

Address _____

City _____ Zone _____

State _____ County _____

ANSWERS TO CIRCUIT QUIZ

appearing on page 66

- | | |
|------|------|
| 1 C | 11 L |
| 2 R | 12 C |
| 3 L | 13 L |
| 4 L | 14 R |
| 5 C | 15 C |
| 6 L | 16 L |
| 7 C | 17 L |
| 8 R | 18 C |
| 9 C | 19 R |
| 10 L | 20 L |

**A
SQUARE
DEAL
HAS
SIX
SIDES!**



This six-sided symbol is proof of a square deal! A square deal for our readers...for the advertisers whose products you see on these pages...and for us here at POPULAR ELECTRONICS.

It's the hexagon of the ABC—the Audit Bureau of Circulations. The ABC is the governing body among publishers that sets circulation standards and audits the official figures on magazine sales.

We are proud to display the ABC Symbol in POPULAR ELECTRONICS each month because it proves to our readers and advertisers alike through unchallengeable figures that our magazine is the established circulation leader in its field. It proves too, that Ziff-Davis' seven other special-interest magazines are also number one in circulation in their respective fields.

The ABC symbol establishes the true worth of a magazine. It cannot be purchased...it must be earned. We take pride in the overwhelming acceptance by you, our readers. We take pride in offering this acceptance to our advertisers. The ABC has made all this possible by guaranteeing a square deal on all sides.

FREE Catalog
OF THE WORLD'S FINEST
ELECTRONIC GOV'T
SURPLUS BARGAINS



**MAGNAVOX AUDIO
AMPLIFIER**

Mfg. for the Navy for intercommunication and amplification of radio signals. Uses 2 12A6 tubes in push-pull; also high quality input transformer for carbon microphone, and Receiver input-output transformer has variable control for headset or speaker. Also mounting for 12 Volt Dynamotor, and instruction book. Voltage required for operation 12 VDC and 250 VDC 60



MA. Can be used for mobile or home use. Size: 7 1/2 x 7 x 10". Wt. 1 1/2 lbs. Navy # CMX-50128. Price—Complete with 3/12A6 Tubes **\$2.95** (1 spare), less Dyn. \$6.95 Price—With 12 Volt Dynamotor. \$6.95

Address Dept. PE—Prices F.O.B., Lima, Ohio.
25% Deposit on All C.O.D. Orders

FAIR RADIO SALES
2133 ELIDA RD. • Box 1105 • LIMA, OHIO

X Rays

(Continued from page 92)

ness of electroplating, as well as that of hot steel strip racing along at 4000 feet per minute in a rolling mill.

Dramatic applications abound in X-ray diffraction. Here, X rays are made to bounce off mirror-like atomic planes of crystalline substances to reveal secrets of inner structure. Nylon, magnetic TV tape, synthetic rubber, high-temperature alloys, high-test gasolines, and penicillin are just a few of the products X-ray diffraction has helped to develop or improve.

Art museums use X rays to examine the authenticity of old paintings. In other applications, X rays distinguish real diamonds and pearls from their imitations.

Biologically Speaking. It is now well known that X rays as well as gamma rays can mutate or change the genes (hereditary units) of our bodies. Excessive X-radiation can also affect flesh, bone, and blood destructively. For these reasons, it is of utmost importance that exposure to radiation be kept at a minimum.

What can be done in this respect? So far as background radiation is concerned, even Adam and Eve had to contend with the small amount of gamma radiation from radioactive material which occurs naturally in soil, rocks, and even plants. In fact, there are radioelements in our bodies that give each of us a daily unavoidable radiation dose of 0.0001 roentgen. (The roentgen is the unit of X- and gamma-ray dose.) In addition, cosmic rays from interstellar space add to our daily dose of background radiation.

In essence, X rays are simply a form of man-made radiation, but new techniques and advancements greatly reduce the effects of their exposure to patients. Diagnostic voltages now up to 150 kv. permit much shorter exposure times, as do faster films. Significant, too, are collimators that confine the X-ray beam to the exact area desired.

All in all, few would deny that the tremendous diagnostic and therapeutic benefits of X rays far outweigh any possible deleterious effects. In fact, many a man, woman, and child is alive today because of Roentgen's startling discovery. Since that eventful night in 1895, these once strange and unknown rays have done much to alter the nature of the world we live in. —30—

Transistor Topics

(Continued from page 100)

When the wiring is completed, *L1* should be connected to the receiver proper with a short length of twisted hookup wire. A local station is tuned in by adjusting both *C1* and *C6*; the trimmers on these units should be adjusted for best alignment and tracking. Potentiometer *R1* is adjusted for maximum gain and left fixed in position unless *Q1* is replaced. Good results should be obtained with moderate-impedance (4000 to 10,000 ohms) magnetic or high-impedance crystal earphones, although Clayton indicates that he uses his receiver as a tuner for an audio installation.

The Sun At Work. Sun-powered devices continue to make news. The International Rectifier Corporation (1521 E. Grand Ave., El Segundo, Calif.) has developed a series of silicon solar cells for use in space vehicles, satellites, and related applications. The cells are covered with a thin, optically-coated glass which provides: (a) reduced cell temperature and higher efficiency; (b) protection of the cell's surface from micrometeorite bombardment and abrasion; (c) reflection of that portion of the solar spectrum not effective in electrical conversion; and (d) an anti-reflection surface to improve the transmission of desired radiation. Many of these silicon solar cells are already in use.

Switching from outer space back to earth, the Hoffman Electronics Corporation, another California firm, has developed a highway-emergency call system powered by solar energy. The transmitter consists

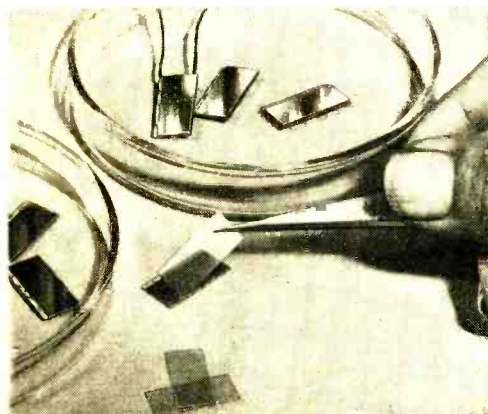

Glass-topped silicon solar cells developed by International Rectifier Corp. for space applications. October, 1960

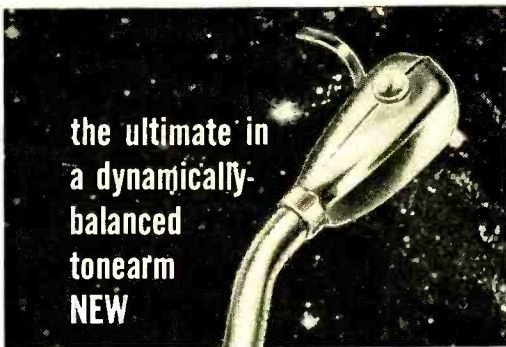

the ultimate in
a dynamically-
balanced
tonearm
NEW

REK-O-KUT

Micropoise™

STEREO TONEARM

Model S-220
12" arm

\$29.95
net

Model S-260 16" arm
34.95 net

Extra Stereo Shell—
Model PS-20L
5.95

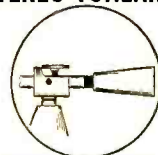

MICROPOISE DYNAMIC BALANCE CONTROL—By dialing the Control, arm is dynamically balanced and set for accurate stylus pressure.

PERMANENTLY ATTACHED PLUG-IN CABLE—fully shielded, anchored to the arm—includes two color-coded plug-in leads, shields and ground. No soldering! No hum problem!

FAST SINGLE-HOLE MOUNTING: Arm base mounts through single hole by tightening of single locknut.

Exclusive precision low friction Silicone damped horizontal bearing—eliminates horizontal oscillation—plus many other advanced features... from Rek-O-Kut... world's leading producer of high fidelity tonearms.

Revolutionary automatic control accommodating the S-220 will soon be announced!



Rek-O-Kut Company, Inc., Dept. PE-10
38-19 108th St., Corona 68, N. Y.

Please send me free brochure:

Name _____

Address _____

City _____ Zone _____ State _____

Export: Morhan Exporting Corp. 458 Broadway, N. Y. 13.
Canada: Atlas Radio, 50 Wingold Ave., Toronto 19.

RK 60

NEW CITIZENS' BAND TEST SET . . .



Combination Crystal Checker, RF Signal and Field Strength Meter

Compact, portable . . . cuts servicing and installation time on Citizens' Band and *all* other types of crystal controlled transmitters and receivers! Checks crystal activity—indicates output—checks for "on channel" operation—use for final amplifier tuning, adjusting squelch, or peaking. The perfect "assist" instrument for technicians, communications engineers, or radio amateurs.

Fully transistorized, complete with 15 ft. remote cable. **\$29.95 NET**

SEND COUPON TODAY



SECO ELECTRONICS, INC. E-5
5015 Penn Ave. So.—Minneapolis 19, Minn.

Please send free literature on all Seco Test Equipment.

NAME _____

ADDRESS _____

CITY _____ ZONE _____ STATE _____

**EAST CANADA: Daveco Agencies, Ltd., Montreal, Quebec
WEST CANADA: Ron Merritt Co., Vancouver 1, B. C.**

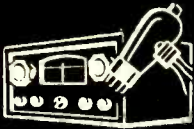

SELL YOUR USED EQUIPMENT Through POPULAR ELECTRONICS' Classified Columns!

The 320,000 purchasers of POPULAR ELECTRONICS are always interested in good used equipment or components. So, if you have something to sell, let PE readers know about it through our classified columns. It costs very little: just 50¢ a word, including name and address. Minimum message : 10 words.

For
further
information
write:

Martin Lincoln
POPULAR ELECTRONICS
One Park Avenue
New York 16, N. Y.

of a push-button operated call box, designed for mounting on a pole or lamp post. Pushing a button will summon the fire department, police, an ambulance, or service truck. Operating power is furnished by a rechargeable nickel-cadmium power pack kept charged by five silicon solar cells. According to the manufacturer, five minutes of full sunlight supplies enough current for one message.

Product News. A new series of high-voltage silicon cartridge rectifiers has been announced by the General Instrument Semiconductor Division (65 Gouverneur St., Newark 4, N. J.). Available with axial lead or fuse clip mounting arrangements, these units can supply currents up to 250 ma. and can handle voltages from 600 to 16,000 PIV. Typical applications are in high-voltage supplies for cathode-ray and Geiger counter tubes.

Of the more than 4,000,000 portable radio receivers sold in 1959, over 90% were transistorized. This year, an even higher percentage will be tubeless.

Sylvania (Woburn, Mass.) has introduced a new "pancake" type of packaging for sub-miniature transistors. Types SYL-1986 and SYL-1987, *p-n-p* and *n-p-n* units, respectively, with cutoff frequencies of several megacycles and maximum dissipation ratings of 100 mw. are the first to be so housed; overall dimensions are only 0.070" high by 0.270" wide, exclusive of leads.

From the Stoddart Aircraft Radio Co. (6644 Santa Monica Blvd., Hollywood 38, Calif.) comes news of a pocket-sized transistorized v.l.f. receiver. Designed as a standard receiver for aircraft, shore stations, and mobile units, as well as for personal use, it is crystal-controlled and tunes to five stations between 14 and 20 kc. The set's bandwidth is 500 cps, sensitivity is 0.005 microvolt, and power output is 10 milliwatts. Measuring 1" x 3 3/4" x 4" overall, it weighs only 10 oz. and will operate up to 100 hours on its self-contained 4-volt mercury battery.

Two bidirectional transistors have been announced by RCA (Somerville, N. J.). Designed primarily for medium-speed switching applications, Types 2N1169 and 2N1170 have cutoff frequencies of 7 mc. Their emitter and collector electrodes may be used interchangeably.

That does it for now. I'll be back next month with more circuits and news.

—Lou

Across the Ham Bands

(Continued from page 95)

type fuse clip for the larger diode terminal, and a pin from a wafer-type octal socket for the smaller terminal. Using a two-lug insulated terminal strip, solder the fuse clip to one lug and the socket pin to the other lug; do not insert the diode until you've completed the soldering.

Together, the clip, pin, and terminal strip make the diode holder which is mounted behind *P1*. Connect the large clip of the diode holder to the center terminal of *P1*.

Terminating resistor *R1* should have a resistance equal to the input impedance of the receiver under test. This impedance is usually 50 or 300 ohms; check the manufacturer's specifications to be sure. Use a 51- or 300-ohm, 5%, ½-watt composition resistor for *R1*, depending on the resistance you need. Now mount *R1* and capacitor *C1* close to *P1*, keeping all leads short.

Location and lead length of all other components is not critical. Mount potentiometer *R2* and toggle switch *S1* on the 2¼" x 4" side of the box; the battery holder can be mounted wherever convenient.

Operation. First, connect the noise generator to your receiver antenna terminals using a length of coaxial cable. If you selected the coaxial plug for *P1*, you can plug the generator right into the receiver's antenna jack.

Next, connect a low-range a.c. voltmeter



"It's the bank—they say that when you endorse a check you should stop adding your call letters to your name."

COMPLETE SERVICE TRAINING

... written so you can understand it!

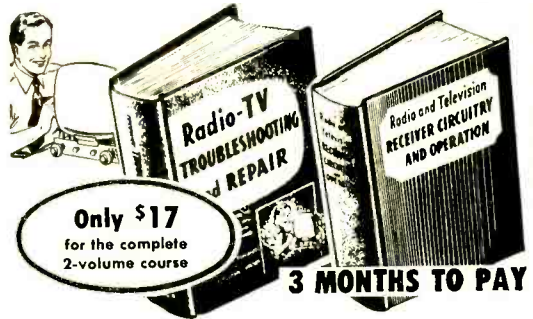

Fix any TV or Radio Ever Made

EASIER-BETTER-FASTER!

No complicated theory or mathematics! These famous Ghirardi books get right down to brass tacks in showing you how to handle all types of AM, FM, and TV service work by approved professional methods. Almost 1500 pages and over 800 clear illustrations show how to handle every phase of troubleshooting and servicing. Each book is co-authored by A. A. Ghirardi whose manuals have helped train more servicemen than any other books or courses of their kind!

1—Radio and Television Receiver TROUBLESHOOTING AND REPAIR

A complete guide to profitable professional methods. For the beginner, it is a comprehensive training course. For the experienced serviceman, it is a quick way to "brush up" on specific jobs, to develop improved techniques or to find fast answers to puzzling service problems. Includes invaluable "step-by-step" troubleshooting charts that show what to look for and where. 820 pages, 417 illustrations, price \$10 separately.

2—Radio and Television Receiver CIRCUITRY AND OPERATION

This 669-page volume is the ideal guide for servicemen who realize it pays to know what really makes modern radio-TV receivers "tick" and why. Gives a complete understanding of basic circuits and circuit variations; how to recognize them at a glance; how to eliminate guesswork and useless testing in servicing them. 417 illus. Price separately \$9.00.

Special low price . . . you save \$2.00

If broken into lessons and sent to you as a "course," you'd regard these two great books as a bargain at \$100 or more! Under this new offer, you buy both books for only \$17.00 . . . you save \$2.00—and have the privilege of paying in easy installments while you use them! No lessons to wait for. You learn fast—and right!

STUDY 10 DAYS FREE!

Dept. PE-100, HOLT, RINEHART & WINSTON, INC.,
Technical Div., 383 Madison Ave.,
New York 17, N. Y.

Send books below for 10-day FREE EXAMINATION. In 10 days I will either remit price indicated (plus postage) or return books postpaid and owe you nothing.

Radio & TV Receiver TROUBLESHOOTING & REPAIR (Price \$10.00 separately)

Radio & TV CIRCUITRY & OPERATION (Price \$9.00)

Check here for MONEY-SAVING COMBINATION OFFER . . . Save \$2.00! Send both of above big books at special price of only \$17.00 for the two. (Regular price \$19.00 . . . you save \$2.00.) Payable at rate of \$8 plus postage after 10 days if you decide to keep books and \$3 a month for 3 months until the total of \$17.00 has been paid.

SAVE! Send cash with order and we pay postage. Same return privilege with money promptly refunded.

Name

Address

City, Zone, State

Outside U.S.A.—\$10.50 for TROUBLESHOOTING & REPAIR; \$9.50 for CIRCUITRY & OPERATION; \$18.00 for both. Cash only, but money refunded if you return books in 10 days.

**POPULAR
ELECTRONICS**

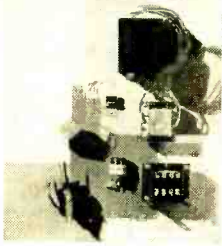

Send
**POPULAR
ELECTRONICS**
Every
Month

name _____

address _____

city _____ zone _____ state _____

Check one: 3 years for \$10
 2 years for \$7
 1 year for \$4

Payment Enclosed Bill Me

In the U. S., its possessions and Canada.
Foreign rates: Pan American Union countries,
add .50 per year; all other foreign countries,
add \$1 per year.

Mail to: **POPULAR ELECTRONICS**
Dept. PE-106, 434 S. Wabash Ave., Chicago 5, Ill.

or multimeter across the voice coil of the receiver's speaker. Turn the receiver's a.v.c. and BFO off and the r.f. gain control full on. Now, adjust the audio volume control for a convenient reference reading on the meter. Turn on *S1* on the noise generator, and advance *R2* for a 3-db increase on the meter. If your meter is not calibrated in db, 1.4 times the *reference* meter reading will equal a 3-db increase.

The less you have to advance *R2* for a 3-db increase in receiver output, the *better* your receiver sensitivity. On frequencies below 14 mc., only a slight advance of *R2* should be necessary. But on the 14-mc. and higher-frequency bands, even advancing *R2* full on may not do the job. In the latter case, check your tubes and receiver alignment. Try a "hotter" tube in the first r.f. amplifier tube socket, or build a "signal booster" (see "Across the Ham Bands," March, 1960). -30-

News and Views

Ron Slattery, K9TOF, 5029 West 157th St., Oak Forest, Ill., shares his ham station with his dad, KN9UFN. The rig is a Heathkit DX-20 feeding either a 245' long-wire or a 137' Windom antenna. Their receiver is a Hallcrafters S-53A helped along by a Heathkit QF-1 Q-Multiplier and the 14- to 29-mc. signal booster described in our March, 1960, column. For local phone contacts, Ron modulates the DX-20 with the cathode modulator described in the April, 1959, column; although he admits making many substitutions in building it, he gets excellent quality reports.

... **Alan Garfinkle, KN4WMW**, 54 Chadwick Dr., Charlestown, S. C., has worked only nine states in two months on the air. But he expects to do better now that he has repaired the break in the coaxial feedline to his beam antenna (see the May, 1959, issue of POPULAR ELECTRONICS). Someone drove a nail through the coax—accidentally, of course. Alan pushes with a Heathkit DX-40 and pulls with a Hallicrafters S-85. He's currently constructing a 2-meter rig.

W5AYV is owned by the Grace Methodist Church, 400 N. Carolina Dr., El Paso, Texas, with Ross A. Sheldon, K5UCH, as trustee. The pastor, Rev. D. L. Hinkle, believes that the station gives the young people of the church an introduction to the importance of communications and electronics in the space age. Also, he says, "it is an indirect effort in Christian evangelism." W5AYV uses a Heathkit AT-1 transmitter, an end-fed antenna, and a war-surplus RAL-7 receiver. Bigger and better things are hoped for in the future, but being on a "scrounge budget," it will be a slow process. This station operates in the Novice bands only, because most of its operators are Novices. They are more anxious to send you their card than to receive yours; make a sked on any Novice band between

PACO
WANTS
YOUR
NAME...



... for their permanent mailing list to receive advance information on all new electronic kit developments—

**TEST and MEASURING INSTRUMENTS/
HI-FI STEREO COMPONENTS/HI-FI SPEAKER
SYSTEMS/MARINE INSTRUMENTS/
AUTOMOTIVE EQUIPMENT**



For NEW 1961
PACO Catalog,
WRITE:



PACO ELECTRONICS COMPANY, INC.
70-31 84th Street, Glendale 27, L. I., New York
Kit Division of **PRECISION Apparatus Co., Inc.**
a subsidiary of **Pacotronics, Inc.**

2:00 and 4:00 p.m., MST, on Sundays. . . . Gary Yantis, KNØBHM, 10809 Johnson Dr., Shawnee, Kansas, has been on the air for two weeks and already has made 90 contacts in ten states. His transmitter is a Globe Chief 90A at 75 watts, which feeds a long-wire antenna; he receives with a Hallicrafters SX-99. His favorite band is 80 meters, although he has been known to make a few contacts on 40 and 15 meters.

By the time you read this, Bill Watts, K4JQV, ETN-3, USN, Lorac Support Team #3, C/O Fleet Post Office, N. Y., should be operating portable from Newfoundland. Then, for the next two years, he expects to operate from Bermuda, The Bahamas, Grand Turks, and other islands—if he can get licenses to operate from them. If you have any information about how he should go about getting the permission, drop him a line. Bill calls himself a "General-Class-type Novice," and spends most of his ham time in the Novice bands. . . . WV2??? is 15 and lives at 117 Center St., Hamburg, N. Y., but he forgot to tell us his name or call letters. He uses a Heathkit DX-40 transmitter, a Gonset G-43 receiver, and has worked 21 states, including Alaska, plus Puerto Rico, with a 12' high antenna. WV2??? expects to have knocked the "V" out of his call by the time he writes again—let's hope he tells us who he is at the same time.

Bill Clements, K4GMR, 1712 Temple Ave., Nashville 12, Tenn., was a Novice for just about a month and has been a General for a bit over a year. Bill uses a DX-40 driven by a VF-1 VFO. It feeds 40-, 20-, 10-meter dipoles through a single coaxial feedline, permitting him to work 40 through 10 meters. On 80 meters, he loads the antenna as a random-length wire with an antenna coupler. Bill's favorite activity is plain old-fashioned rag-chewing, mostly on c.w., and he spends half his time in the Novice bands. Nevertheless, his station record is 47 states worked, all QSL'ed, and 51 countries worked, 37 confirmed. A Hammarlund HQ-145 separates the wanted signals from the interference.

Ray Mote, Jr., 1110 E. Caesar, Kingsville, Texas, who expects to get his Novice license soon, says you can tune in sideband signals on the Knight-Kit "Ocean Hopper" and similar regenerative receivers by advancing the regeneration control to beyond the oscillation point—the same setting used for code reception—and very carefully tuning in the signal. At one critical setting, the received voice will quit sounding like "Donald Duck" and become perfectly readable. . . . Darrel Booth, K5THS, Route 3, Box 151, Emerson, Ark., really has an antenna farm—it consists of an 800' long-wire; an 80-meter doublet; a home-built 10- and 15-meter beam; a 10-, 15-, and 20-meter vertical; and a 75' long-wire. Darrel modulates a Globe Chief 90A with an EICO 730 modulator and drives it with a Meissner VFO; he receives on a Hallicrafters S-38E. He works all the phone and c.w. bands from 3.5 to 29.7 mc., but 75-meter phone is his favorite.

How about sending us your ham shack pictures, news, and construction projects? 73,
Herb, W9EGQ

BIG MONEY

IN THE 4 CORNERS OF THE WORLD!

in TELEVISION, RADIO, ELECTRONICS, RADAR, SONAR

ONLY CHRISTY OFFERS COMPLETE TRAINING!

Investigate the Christy Complete Course. Why be satisfied with less? CIS Shop Method, Home Training makes learning easy. You learn by working with actual equipment. You receive Comprehensive training from the start. Can EARN AS YOU LEARN. You become qualified to open your own Electronics Repair business or to gain high pay as a TV, Radio, Electronics, etc., Technician.

17 TRAINING KITS INCLUDED! You receive a Multi-Tester, Oscillator, Signal Tracer, Oscilloscope, Signal Generator, Electronic Timer, Regenerative Radio, 24" TV set (optional) and other valuable testing equipment. FREE BOOK and TWO FREE LESSONS yours for the asking! No obligation.

CHRISTY TRADES SCHOOL
3214 W. Lawrence Ave., Dept. T-514
Chicago 25, Ill.



CHRISTY TRADES SCHOOL, Dept. T-514
3214 W. Lawrence Ave., Chicago 25, Ill.

Please send me the 3 FREE BOOKS and Special Form for PAYING LATER from EARNINGS MADE WHILE LEARNING.

NAME AGE.....

ADDRESS

CITYZONE.....STATE.....

PURCHASING A HI-FI SYSTEM?

Send Us Your List of Components For A Package Quotation

WE WON'T BE UNDERSOLD

All merchandise is brand new, factory fresh and guaranteed.

AIREX RADIO

CORPORATION

64-PE Cortlandt St., N. Y. 7

PARTIAL LIST OF BRANDS IN STOCK

Jim Lansing*
Altec Lansing
Electrovoice
Jensen • Hartley
University
Acoustic Research
Janszen
Wharfedale
USL Citizen Band
Gonset • Hallicrafters
Texas Crystals
Concertone • Viking
Bell • G.E.
Weathers
Harman-Kardon
Eico • Pilot • Fisher
Acrosound • Roberts
Bogen • Leak
Dynakit • H. H. Scott
Thorens* • Sherwood*
Dual Changer
Ampex • DeWald
Sony • Challenger
Wollensak • Penfron
Garrard • Quad*
Fairchild • Gray
Artizan Cabinets
Rockford Cabinets

*Fair Traded

CO 7-2137

CITIZEN BAND CLASS "D" CRYSTALS



3rd Overtone: Hermetically Sealed
.005% tolerance—Meet F C C require-
ments. 1/2" pin spacing—.050 pin diam-
eters. (.093 pins avail-
able, add 15¢ per crys-
tal.)

\$2.95
EACH

ALL 22 FREQUENCIES
IN STOCK!

(add 5¢ per crystal for postage and handling)

The following Class "D" Citizen Band frequencies in stock (frequencies listed in megacycles): 26.965, 26.975, 26.985, 27.005, 27.015, 27.025, 27.035, 27.055, 27.065, 27.075, 27.085, 27.105, 27.115, 27.125, 27.135, 27.155, 27.165, 27.175, 27.185, 27.205, 27.215, 27.225.

Matched crystal sets for Globe, Gonset, Citi-Fone and Halliercrafters Units . . . \$5.90 per set. Specify equipment make.

RADIO CONTROL CRYSTALS in HC6/U HOLDERS—SIX FREQUENCIES

In stock for immediate delivery (frequencies listed in megacycles): tolerance .005%, 1/2" pin spacing, .050 pin diameter. (.093 pins available, add 15¢ per crystal.) Specify frequency desired.

26.995, 27.045, 27.095, 27.145, **\$2.95**
27.195, 27.255 EACH

(add 5¢ per crystal for postage and handling)

Send for **FREE CRYSTAL CATALOG #860**
WITH OSCILLATOR CIRCUITS

ASK YOUR PARTS DEALER FOR TEXAS CRYSTALS

See big red display . . . if he doesn't stock them, send us his name and order direct from factory.

All orders Shipped *1st Class Mail*
from Our New Florida Plant
Rush your order to:

TEXAS CRYSTALS

Dept. P-100, 1000 Crystal Drive, Fort Myers, Fla.
For even faster service, Phone WE 6-2100

**COLLEGE-LEVEL STUDY ÷
ELECTRONICS ÷ WORK ÷
ASSOCIATE DEGREE ÷ PLAY ÷
2-YR. RESIDENCE IN
STUDY for CAREER BEAUTIFUL
in Industrial Field COLORADO**

- MISSILES
- COMPUTERS
- RADAR
- AUTOMATION
- MICROWAVE
- TRANSISTORS
- SERVOMECHANISMS
- CO-EDUCATIONAL
- DORMITORIES
- AT FOOT OF ROCKIES

MAIL NOW FOR FREE INFORMATION

NAME _____ AGE _____

ADDRESS _____

CITY _____ ZONE _____ STATE _____

INTERESTED IN RESIDENT HOME STUDY

COLORADO TECHNICAL INSTITUTE
P. O. BOX 7757 DENVER 15, COLO.

Amateur Radio

(Continued from page 45)

other phase of the hobby—*mobile operation*. If he is, he probably has a miniature duplicate of his home station built into the family car. As Sam threads his way to the office, he can once again participate in the "round-table" by transmitting the words "break-break" over his rolling radio station. Or, should Sam elect to, he can switch the frequency of his equipment and join in the conversation with a similar group of hams clear across the country.

Before you get the idea that radio amateurs are a bunch of chattering magpies, remember that the original intent was public service and the *handling of messages*. The majority of amateurs today carry on in the same tradition.

A device to assist amateurs in handling messages is known as a "phone patch." It connects the receiving and transmitting equipment to the phone lines so that telephone conversations can be transmitted over the air. As a result of this device, American servicemen stationed overseas can talk directly to their loved ones via ham radio.

"Ham of the Year." Each year one amateur is selected, from all the others, to receive an award for meritorious service to the community or country. The award is granted by the Edison Radio Amateur Award Committee of General Electric Company; the group screens hundreds of nominations and selects the amateur with the most outstanding service accomplishment.

The 1957 award was presented to James E. Harrington, K5BQT, of Lake Charles, La. In June of that year, Harrington provided emergency communications from hurricane-stricken Cameron, La. With the help of two other amateurs, he gathered emergency equipment and supplies and traveled 40 miles by boat through the swollen Calcasien River. At Cameron, Harrington and his helpers waded through waist-deep water to reach the court house. Once there, he operated continuously for three days and handled some 1500 messages.

The 1958 Edison Award was presented to an 18-year-old high school student, Julius Madey, K2KGJ, of Clark, N. J. Julius was chosen from a large field of worthy candidates because of his outstanding public

service in handling more than 12,000 messages and phone patches for isolated South Pole personnel.

And Walter Ermer, Sr., W8AEU, won the 1959 award for his outstanding organizational and administrative ability in providing Cleveland, Ohio, with a 300-man voluntary amateur radio emergency corps. During the year this corps handled vital communications on 23 occasions, including storm and tornado emergencies, and floods.

Thrills of DX'ing. The DX-minded ham is an unusual variation of the typical amateur. Like Sam Ham, our inveterate DX'er rises before dawn. He turns on the station and starts the coffee brewing almost at the same time. However, DX Dan does not head pell-mell into a round-table. Instead, he squashes a pair of headphones on his ears and intently tunes the receiver dial to and fro. Several days may come and go without so much as a peep out of Dan's powerful transmitter.

Then one morning Dan flushes his quarry and a look of grim determination settles across his face. He is listening to the faint rolling dots and dashes of HS1A in Thailand! Suddenly, as HS1A stands by, Dan's

powerful "rig" springs to life and his measuring instruments swing to and fro. Less than one minute later, Dan pushes the telegraph key away and writes down this new contact in his log book.

Most amazing, perhaps, is that DX Dan probably heard many other rare and exotic stations while searching the band for HS1A. On a typical morning he may have heard 15 out of the 19 districts of the Soviet Union, Sarawak, Brunei, Mauritius, Orkney Island, Qatar, Trucial Oman, and of course the more common countries such as Burma, Malaya, Australia, or New Zealand. But Dan ignored their CQ calls in favor of the more elusive Thai amateur, for he had talked to these other stations long ago. As our DX'er prepared to dash off to work, he checked off number 261 on his list of the almost 300 countries in the world.

In addition to the thrill of having "hooked" a new one, Dan will get a material reward also. Hams exchange postcard-sized QSL cards which confirm their contacts; each card carries details such as date and time heard, mode of transmission (voice or code), and a signal strength re-

OVER 1300 HI-FI COMPONENTS

at your fingertips in the

1961 STEREO & HI-FI DIRECTORY

The world's most comprehensive hi-fi reference gives you facts, data, prices, illustrations, performance analysis on virtually every piece of hi-fi equipment manufactured. Entire sections on:

TUNERS / RECORD PLAYERS / TAPE RECORDERS / CARTRIDGES / TONE ARMS / TURNTABLES / AMPLIFIERS / PREAMPS / LOUDSPEAKER SYSTEMS / RECORD CHANGERS / ENCLOSURES AND CABINETS

On sale at your newsstand or electronics parts store October 4th, or order by coupon today.

**ONLY
\$1.00**

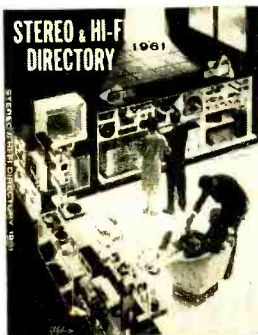

Ziff-Davis Publishing Company
Department PE 106
434 S. Wabash Avenue, Chicago 5, Illinois

Please send me a copy of the 1961 STEREO AND HI-FI DIRECTORY. I enclose \$1.00, the cost of the DIRECTORY, plus 10¢ to cover mailing and handling charges. (Canada and foreign, \$1.25 plus 10¢ postage.)

NAME _____

ADDRESS _____

CITY _____ ZONE _____ STATE _____

port. Thus, a few months after his contact, Dan will receive a card that he can proudly display.

An interesting variation of the DX-minded ham is Ambassador Al. Al "gets his kicks" by conversing with overseas amateurs, but only to gain friends and exchange ideas. Although he may never meet one of these hams, he is truly a man of the world. He can tell you what the temperature was yesterday in Kuala Lumpur, Malaya, or who is winning the tennis matches in Melbourne, Australia. Al has two or three favorites overseas and maintains weekly schedules with them. Often they exchange inexpensive gifts, and once in a while they have the opportunity of meeting each other. Needless to say, our "ambassadors of the air waves" have created more good will for this country than John Q. Public realizes.

The YL's. Although we have used the male gender in describing the various types of amateurs, men are far from having a monopoly on the hobby. There is no accurate tabulation, but approximately one out of every thirty hams is a woman!

Probably the first woman ham was Miss

Cecil Powell, secretary to the ARRL co-founder, Hiram Percy Maxim. In 1915, she constructed her own station, learned the code, and became an active amateur.

What do they talk about? Well, what do women talk about when they get together? There are DX'ers, public-service spark plugs, and ambassadresses among the skirt and sweater brigade also. A YL can even do her ironing, or other household chores, while exchanging recipes with an XYL (married young lady) 2000 miles away.

How About You? Think you'd like to be a ham? Amateur licenses are issued by the Federal Communications Commission to any citizen of the United States who can pass the radiotelegraph code and written examination.

If you already hold a license and toss your call letters across the ether, you're probably as sold on the hobby as any of your 200,000 fellow hams. But if you have yet to experience the thrill of world-wide communication or the satisfaction of an around-the-state round-table, your fun has not yet begun. Why not join the crowd of enthusiastic hams—come on in, the ether's fine!

-30-

ELECTRONICS

Train in the new shop-labs of the world famous
COYNE ELECTRICAL SCHOOL on a quarter of a million dollars worth of equipment or learn at home in your spare time with Coyne's modern television training.

Use this coupon to get our free book
"GUIDE TO CAREERS"

COYNE ELECTRICAL SCHOOL
1501 W. Congress Pkwy.
Chicago 7, Ill., Dept. of Electronics 5C

training at Coyne training at home

NAME _____

ADDRESS _____

CITY _____ STATE _____

Unlike most other schools, we do not employ salesmen.

CODE

TELEPLEX METHOD trains you to hear Code signals just as you hear spoken words—because it teaches Code SOUNDS and not dots and dashes. Thirty words with ease . . . fifty words not unreasonable! Starts beginner or advances your present speed. Try it for yourself and compare with anything else. 40 years experience teaching Code have made the Teleplex Method far superior to all the cheap "gimmicks" on the market. Write today for details and free trial. You be the Judge! (Improved cabinet allows new low cost.)



TELEPLEX CO.

739-C Kazmir Court, Modesto, Calif.

Canadian Representative: THE HAM SHACK
1269 Granville St.—Vancouver, B. C.

new! 7-Band SWL/DX Dipole Kit for 11·13·16·19·25·31·49 meters

Here's a low cost 7-band receiving dipole antenna kit that will pick up those hard-to-get DX stations. Everything included . . . just attach the wires and you're on the air! Weatherproof traps enclosed in Poly-Chem for stable all-weather performance. Overall length of antenna - 40 feet.

Complete with

8 Trap Assemblies

Transmission Line Connector
Insulators

45 ft. No. 16 Tinned Copper Wire
100 ft. of 75 ohm twin lead

WRITE FOR NAME OF NEAREST DISTRIBUTOR

SWL-7 \$14.75

Mosley Electronics, Inc. 4610 N. Lindbergh • Bridgeton, Missouri

Living with Loudspeakers

(Continued from page 52)

means that if 40 cps is the lowest note your system can deliver, any response much over 10,000 or 15,000 cps will result in an unbalanced overall sound (40 x 10,000 equals 400,000; 40 x 15,000 equals 600,000). Keep in mind, too, that the real extremes in bass and treble response cost plenty of money, and that smooth and balanced response in a moderately priced unit will beat wide-range distortion every time.

Watch out for speakers which seem to project one part of an orchestra—trumpets, for instance—into your lap. No matter how sensational they sound in a showroom, speakers with this kind of coloration will set your nerves on edge in your living room, and leave you with an advanced case of listening fatigue. Any system which draws your attention to one part of the frequency range is suspect.

Perhaps the most important thing you can listen for in a speaker's performance is good transient response—the ability of a speaker to follow the amplifier's directions without sluggishness. Good transient performance will show up in the sharp impact of musical instruments, in the crisp definition of a drum roll, or the slow dying out of a piano chord. It will also give you a good idea of the kind of hall in which a recording was made—from a small, acoustically dead studio to a large, reverberant concert hall. A speaker with good transient response provides a more genuine kind of "presence" than a speaker which puts one section of an orchestra in your lap.

Don't be too quick to condemn a speaker that seems to have poor transient response, however. The speaker is only part of the reproducing chain and can't be expected to do any better with transients than the other elements that make up the chain do.

Pick up all the advance information you can, from specification sheets to magazine test reports, before you settle down for your own listening tests. But keep an open mind when the writer of a test report sounds off with his opinion of a speaker's coloration. And remember that a speaker with a modest-looking response curve may turn out to be more than realistic enough for your ears. If a friend tells you that the speaker you've chosen sounds "tinny," give him a smile and take him down for an audiometer test.

-30-

Special Offer 25¢

Hear these authentic recordings of dramatic events from

"The Amazing World of Short Wave Listening"

narrated by Alex Dreier, Radio-TV "Man on the Go"

- President's voice from outer space!
- Actual capture of a desperate criminal!
- Radio amateur at Little America!
- Ships at sea . . . aircraft in action!

S-38E
receiver
\$59.95

3 short wave bands plus standard broadcast. Built-in speaker, headset output.



MAIL COUPON TODAY!



hallicrafters...
DEPT. 21, CHICAGO 11, ILL.

- Gentlemen: Please rush by return mail my recording, "The Amazing World of Short Wave Listening." 1 enclosure 25c.

NAME _____

ADDRESS _____

CITY _____

STATE _____

TUBE REPLACEMENT GUIDE

EVERYONE who uses vacuum tubes NEEDS this new 1960 Expanded Edition TUBE GUIDE.

Contains over 2700 substitutes for over 1500 tubes, including radio & TV receiving tubes, tubes used in Hi-Fi & Stereo, foreign tubes and TV picture tubes.

All tubes suggested for substitution have characteristics similar to those they are to replace. FIT INTO SAME SOCKET & NEED NO WIRING CHANGE.

Two chapters cover complete listing of TV Pix tube replacements including newest 110° tubes.

Substitutes given for over 225 foreign tubes. Last chapter lists transistor substitutes. The

only complete GUIDE featuring all receiving tube substitutions WITHOUT SOCKET CHANGING OR REWIRING. This valuable book will save you TIME & MONEY and permit operation of your set even though original tubes are unobtainable.

Guaranteed Money Back in 5 Days if Not Satisfied

RUSH COUPON NOW!

H. G. CISIN, Consulting Engineer—Dept. P-43
Amagansett, N. Y.

Enclosed find \$1. Rush TUBE REPLACEMENT GUIDE.

Name _____

Address _____

City _____ Zone _____ State _____

\$1 Post-paid

Short-Wave Report

(Continued from page 106)

The following is a resume of the current station reports. All times shown are Eastern Standard, and the 24-hour system is used. At time of compilation all reports are as accurate as possible, but stations may change frequency and/or schedule with little advance notice.

Albania—*R. Tirana* currently has its Eng. program at 1730-1800 on 7157 kc. (WPE8MS)

Argentina—LRA, Buenos Aires, has moved to 11,725 kc. and was noted around 1800 opening the Eng. feature. The 15,345-kc. outlet has not been heard and presumably 11,725 kc. has replaced it. (WPE9KM)

Belgium—"Belgian Magazine" in Eng. is scheduled from Brussels on Sundays, Tuesdays, and Thursdays at 1730-1800 on ORU3, 11,850 kc., and ORU4, 15,335 kc. (to N.A. and S.A.) and on ORU5, 6000 kc. (to Southern Europe); on Sundays, Mondays, Tuesdays, Thursdays, and Fridays at 1930-2000 on ORU3, 11,855 kc. (to N.A.) and on OTC (Leopoldville) on 9655 kc. (to N.A. and S.A.); on Saturdays at 1815-2000 on ORU3 (to N.A.) and OTC (to N.A. and S.A.). All reports go to P. O. Box 26, Brussels-1, Belgium. (WPE3ALZ, WPE3AYB)

Brazil—Listed as inactive, PRG9, *R. Nacional de Sao Paulo*, has been noted on 6125 kc. at 1928-1930 with news and a talk. PRN9,

Rio de Janeiro, 9295 kc., was heard with a special Eng. xmsn at 1920, cut up by QRM. (WPE3DS)

ZYC7, *R. Tupi*, Rio de Janeiro, 6015 kc., can be heard at 2000 with a regular show in Portuguese. *R. Dijusora do Maranhao*, Maranhao, 2370 kc., is noted at times around 1930-2000 with ads, talks, and music, all-Portuguese. (WPE1HC)

On 2420 kc., try for Anapolis around 2145 with Latin-American vocals and instrumentals. You'll have to dig deep for this one. If you tune in prior to 2145 you may pick up Martinique. (WPE3NF)

Ceylon—*R. Ceylon*, in a letter, asks that reports be sent to them at either G.P.O. 1510, Colombo (preferably) or Torrington Square, Colombo. Do not combine the addresses. Clifford Dodd is the man to whom your reports should be sent. (WPE2YS)

Congo—Former *R. Congo Belge* outlets are now identifying as *Ici Leopoldville, Radiodiffusion de la Republique du Congo*. (WPE1BM)

Cuba—The largest Cuban network, *Radio Progreso*, has been taken over by the government. This network has an s.w. outlet on 9362 kc. (WPE1AGM)

Curacao—*R. Curom* has moved to 9750 kc.; a good signal was noted from 2215 to 2232 s/off, with programs of varied music and all-Dutch anmts. (WPE9KM)

Dahomey—With careful tuning, *Radiodiffusion du Dahomey*, Cotonou, can be heard on

LEARN THE SHORT-CUTS

Professional TELEVISION All-Practice TRAINING

Jump your earnings fixing black-and-white and color sets. Get into the top-pay bracket. NRI's concentrated spare time, low-cost training can do it for you. You'll fix sets faster, easier. Special course for Radio and TV servicemen—not for beginners. Full information free. Mail coupon now: NATIONAL RADIO INSTITUTE, Dept. OKD4T, Wash. 16, D.C.

NATIONAL RADIO INSTITUTE
Dept. OKD4T, Washington 16, D. C.

Without cost or obligation send me facts about your Professional All-Practice TV Course.

Name.....Age.....

Address.....

City.....Zone.....State.....

ACCREDITED MEMBER NATIONAL HOME STUDY COUNCIL

TV PICTURE TUBES AT LOWEST PRICES

NEW TUBES 14RP4-\$16.95 14W/ZP4-\$16.95 17BP4-\$19.95
17BP4-\$19.95 21CEP4-\$22.95 21DEP4-\$22.95
ALL ALUMINIZED: 24AEP4-\$26.95 24AMP4-\$26.95

10BP4	\$ 7.95	16WP4	\$12.00	17TP4	\$17.00	21EP4	\$13.50
12LP4	8.50	16PT4	9.95	19AP4	16.00	21FP4	14.50
14B/CP4	9.95	17AVP4	12.50	20CP4	13.50	21WP4	14.00
16DP4	12.00	17BP4	9.95	20MP4	14.50	21YP4	14.50
16EP4	12.75	17CP4	17.00	21AP4	22.10	21ZP4	13.50
16GP4	14.50	17GP4	17.60	21ALP4	15.75	24CP4	23.50
16KP4	9.95	17HP4	12.50	21AMP4	15.75	24DP4	24.50
16LP4	10.95	17LP4	11.50	21ATP4	15.75	27EP4	39.95
16RP4	9.95	17QP4	9.95	21AUP4	15.75	27RP4	39.95

1 YEAR WARRANTY

Aluminized tubes \$3.00 for 21"; \$5.00 for 21" and 27" additional. Prices include the return of an acceptable similar tube under vacuum. These tubes are manufactured from reprocessed used glass bulbs. All materials including the electron gun are brand new.

ALL PRICES FOB CHICAGO, ILLINOIS. Deposit required, when old tube is not returned, refundable at time of return. 25% deposit required on COD shipments. Old tubes must be returned prepaid. Tubes shipped Rail Express. We ship to the Continental U. S. and Canada, only.

WRITE FOR COMPLETE LIST

—PICTURE TUBE OUTLET—
2922 MILWAUKEE AVE., CHICAGO 18, ILLINOIS
Dickens 2-2048

BUY DIRECT
Importer-to-You



ACCORDIONS! SAVE UP TO 1/2

SAVE UP TO 50% OFF RETAIL PRICES

of comparable accordions! Buy Direct from World's Largest Dealer! 5-Day Free Trial! Low Importer-to-You Prices! Over 30 models—finest Italian makes. New easier terms! Bonus gifts FREE. Rush coupon for Free Color Catalogs and Direct Importer-to-You prices! Write today!

ACCORDION CORPORATION OF AMERICA,
Dept. PE-100, 2003 W. Chicago Ave., Chicago 22, Ill.
Rush Free catalog and Importer-to-You prices.

FREE Color Catalog

Name.....

Address.....

City.....State.....

4870 kc. at 0045; native chants are followed by talks in a native language. News in French is given at 0100. (WPE(VB))

Dominican Republic—HIX, Ciudad Trujillo, 9505 kc., has been noted at 0635, 0930, and at 2300/closing. Programs consist of music and frequent talks in Spanish; ID's are prefaced by "Dios, Patria, and Libertad." The ID is given as HIX, *Radio Nacional Dominicana*. (WPE4BC)

El Salvador—According to word received from the station, they have a new outlet on 4800 kc. with a slogan of *R. Tropical*. Reports should be sent to Apartado Postal 1006, San Salvador, E. S. (WPE6CJ)

Fiji Islands—A colorful veri from *R. Suva* lists these outlets: VRH4, 3980 kc., VRH5, 5980 kc., and VRH6, 6005 kc., each 250 watts, plus three medium-wave outlets. The 6005-kc. outlet is believed to be inoperative at present. VRH5 is noted at 0150-0300, all Eng., with news at 0200. (WPE1ANK, WPE0AE)

Gilbert Islands—VSZ10, Tarawa, 6050 kc., is noted at 0300-0320 with native language talks and native music but with an Eng. ID at 0305. (WPE0AE)

Honduras—A new station is *La Voz de Suyapa*, 9705 kc., Tegucigalpa, noted with religious program at 0647-0705, news in Spanish to 0718, religious program to 0731, concert music to 0800; again from 2025 to 2200 s/off with pop records. The call letters are not certain; various reports claim them to be HRBA (or HRVA) or HRCF (or HRCS). Do not confuse with *R. Suyapa* on 4940 or 6125 kc. (WPE3DS, WPE9KM)

Hungary—*R. Budapest* operates twice daily in Eng. to N.A. at 1900-2000 and 2230-2330 on 11,910, 9833, and 7220 kc. Reports go to: North American Service, *R. Budapest*, Budapest, Hungary. (WPE1ARV)

India—*All India Radio*, Delhi, is heard at 1445-1515 in Eng. beamed to the United Kingdom and Western Europe on 11,710 kc. News is given at 1445-1455. Delhi also has Eng. news at 1930-1950 on 17,820 kc., and at 2130-2145 on 17,765 and 17,825 kc. (WPE8HF, WPE0AE)

Iran—*R. Teheran* operates its External



Listening post of John Rushton, WPE1ARV, Providence, R. I. His equipment includes a Hallicrafters S-38E receiver, a Webcor "Regent" tape recorder, a Firestone 17" TV set, and a 101' long-wire antenna.

October, 1960

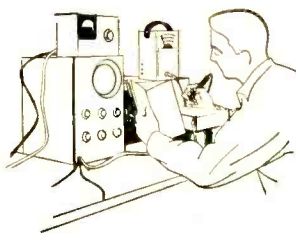

The Perfect
Workshop
Companion For
The Advanced
Audiophile

THE 1961 AUDIO YEARBOOK

Over 25 projects and features covering stereo, hi-fi, components, acoustics—every phase of audio! Advanced discussions and instructions on:

- CONSTRUCTING THE BI-PHONIC COUPLER
- STEREO MICROPHONE TECHNIQUES
- FINDING FAULTS IN HI-FI SYSTEMS
- WIDE SPACE STEREO
- MULTIPLEXING MUSIC ON ONE RECORDER
- ROOM ACOUSTICS FOR STEREO
- Plus many other authoritative articles

Now on sale at your newsstand or electronics parts store or order by coupon today.



ONLY
\$1.00

Ziff-Davis Publishing Company, Dept. PE 106
434 S. Wabash Avenue
Chicago 5, Illinois

Please send me a copy of the 1961 AUDIO YEARBOOK.
I enclose \$1.00 plus 10¢ to cover mailing and handling charges. (Canada and Foreign \$1.25 plus 10¢ postage.)

NAME _____

ADDRESS _____

CITY _____ ZONE _____ STATE _____



use the solder
that most
set makers
use!

KESTER SOLDER

Make sure your soldering's the best... use the best - KESTER SOLDER. Send for FREE 16-page book that tells you how!

KESTER SOLDER COMPANY

4275 Wrightwood Avenue • Chicago 39, Illinois

OVER 60 YEARS' EXPERIENCE IN SOLDER AND FLUX MANUFACTURING

SAY YOU SAW IT IN
POPULAR ELECTRONICS



LOOK

NO FURTHER... IF YOU'RE UNHAPPY WITH "HI" HI-FI PRICES. WRITE FOR OUR UNUSUAL AUDIO CATALOG. KEY ELECTRONICS CO. 120-B Liberty St., N. Y. 6

RENT stereo tapes

- OVER 1500 DIFFERENT ALBUMS
- POSTPAID TO AND FROM YOUR HOME

SEND FOR FREE BROCHURE | stereo-parti 

811-AZ Centinela Ave., Inglewood 3, Calif.

engineering degree in 27 months

Grasp your chance for a better life. Rapid advancement. Better income. BACHELOR OF SCIENCE DEGREE IN 27 MONTHS in Elect. (Electronics or Power major), Mech., Civil, Aero., Chem., Engineering. IN 36 MONTHS in Business Administration (General Business, Acctg., Motor Transport Mgt. majors). Small classes. More professional class hours. Well-equipped labs. Campus. Downs. Modest costs. Year-round operation. Founded 1884. Enter Jan., Mar., July, Sept. Write J. D. McCarthy, Director of Admissions, for Catalog and "Your Career in Engineering and Commerce" Book.

TRI-STATE COLLEGE 36100 College Avenue
Angola, Indiana

LEARN TO DRAW; READ BLUEPRINTS, SCHEMATICS, WIRING DIAGRAMS; and to render any Mechanical, Electronics, Architectural & Art Drawing or Painting.

SELF STUDY COURSES & Drafting Room Essentials available in simplified form. Plan 1: Send \$2.25 for any one of the above desired "Individual" chapters. Plan 2: Send \$9.00 for the "Special Main Chapters" of our book entitled, "Encyclopedia of Drawing & Design" (for Home Study or School Text). Publisher: (Author's experience: Chief Draftsman, Art Director, Engineer.) Louis D. Prior, Inc., 23-09 169th Street, Whitestone 57, New York, N.Y.

Service as follows: at 1230 in Kurdish and at 1330 in Arabic on EPB7, 7288 kc.; at 0700 in Urdu on 9680 and 3750 kc. (EQO); at 1500 in Russian, at 1515 in Turkish, at 1530 in French, and at 1545 in Eng. on EQC, 9680 kc. All broadcasts are non-directional and xmtr power is 100 kw. (WPE8MS)

Italy—Rome is noted on 3995 kc. from 1730 to 1800 closing. A veri letter states that it belongs to the Home Service. There is also the "Programma Nazionale" daily on 6060 kc. (dual to 9515 kc.) and the "Second Programma" on 7175 kc. The "Notturmo d'Italia" is broadcast daily at 1705-0030 on 9515 kc. (GP)

Japan—The Japan B/C Corp., NHK, to mark its 25th year of international broadcasting service, is sending letters of appreciation and small souvenirs to listeners who have regularly submitted reception reports covering the various transmissions. The letter, 8 1/2"x11" in size and suitable for framing, is nicely printed on fine Japanese paper (certificate style) and signed by Ichiro Matsui, Director of the Int'l. Broadcasting Dept. (WPE6EZ)

Liberia—ELWA, Monrovia, was noted on 15,082 kc. at 1125 with native language; French

SHORT-WAVE ABBREVIATIONS

anmt—announcement	kc.—Kilocycles
BBC—British Broadcasting Corp.	kw.—Kilowatts
Eng.—English	N.A.—North America
FM—Frequency modulation	QRM—Interference
ID—Identification	R.—Radio
IRC—International Reply Coupon	S.A.—South America
IS—Interval signal	s/off—Sign-off
	s/on—Sign-on
	xmsn—Transmission
	xmtr—Transmitter

later. The programs had the usual religious content. S/off is at 1301 with the Liberian National Anthem. (WPE3NF)

Mali Federation—Brazzaville's current Eng. schedule reads: 0015-0100 on 15,445, 11,970, 9730, 7105, 5970, and 21,500 kc.; 0330-0400 on 21,500 and 15,445 kc.; 0700-0745 on 15,445 and 11,970 kc.; 0930-1000 on 17,720 and 21,500 kc.; 1200-1230 on 21,500, 11,970, 9770, and 5970 kc.; 1330-1400 and 1430-???? on 15,190 kc.; and 2015-2100 and 2115-2130 on 11,970 and 9625 kc. (WPE6AA)

Mauretanie—Radiodiffusion de la Republique Islamique de Mauretanie, Saint Louis, operates at 0200-0300 and 1455-1845 on 4855 kc. and at 0715-0830 on 9610 kc. Power is 4 kw. They appreciate reports and will verify all correct ones; an IRC must be included (WPE8MS)

Mexico—XERR, Radiodifusoras Comerciales, is a new outlet for XERH and XEHH (1500 and 11,880 kc.) according to their verification. (WPE2AXS)

XEDF, Mexico City, 9535 kc., is heard from 0650 to 0700 fade-out with music, commercials and anmts. (WPE3DS)

Morocco—The previously thought-to-be Amman, Jordan, station is definitely located at Sebaa-Aioun (announcing as Rabat) on 11,735 kc. News in Eng. is given at 1315-1330. Arabic to past 1645. (WPE3DS, WPE3NF, WPE9KM)

Sebaa-Aioun is down to 9502 kc. around 1313 in Arabic. Another new outlet is on 5985 kc. at 2335 with Arabic chanting. (WPE1BM, WPE3NF)

Mozambique—*R. Clube de Mozambique*, Lourenco Marques, gives the following schedule. Portuguese—3250 kc. at 1200-1530; 4924 kc. at 1030-1530; 9656 kc. at 2345-0100 and 0430-0700 (0045-0700, 0800-1030 Sundays); 15,152 kc. at 1030-1300, 2345-0100, and 0430-0700 (0045-0700 Sundays). English and Afrikaans—3221 kc. at 2230-2300 and 1230-1600 (to 1700 Saturdays); 4840 kc. at 2230-0100 and 1000-1600; 7254 kc. at 2230-1200; 9620 kc. at 0000-1000; 11,760 kc. at 2230-1400 (2355 Saturday to 1400 Sunday); and 15,097 kc. at 0400-0800. Try for them in the East African xmsn on 4840 kc. around 2330-0000 with Eng. and pop records. (WPE8FV, WPE0VB)

Nicaragua—A letter from Miguel Angel Solis, Jr., manager of *R. Philips*, YNRS, 7660 kc., 150 watts, stated that they do not have printed schedules or veri cards, and indicated that a formal log of the station showing minute details of the xmsns is not kept. He gave the schedule as 0700-2300. (WPE0AKR)

Niger—*R. Niger*, Niamey, has moved to 4785 kc.; s/on 0028 with a flute IS, ID in French, then native chanting. A good signal and dual to 5050 kc. (WPE3NF)

North Borneo—*R. Sabah*, Jesselton, operates on 5980 kc. in Eng. at 2330-0000 (Saturdays at 2200-2300), at 0600-0615 with BBC and local news, and at 0730-0900. "Radio Sabah Calling"

is issued every two weeks in Eng., Chinese, Malay, and Kadazan; the price is 30 cents per issue, \$8.00 yearly. (WPE8MS)

Pakistan—Karachi is noted weakly at 1030-1045 with dictation news on 15,275 kc. (WPE4AIX)

Peru—Definite channel changes include: OAX8C, *R. Nacional del Peru*, Iquitos, on 9335 kc. (from 9610 kc.) at 1830-2045; OAX6L, *R. Nacional del Peru*, Tacna, on 9350 kc. (from 9374 kc.) at 1830-2045; and OAX4W, *R. America*, Lima, on 9455 kc. (from 9510 kc.) also at 1830-2045; all with Spanish music, talks, commercials, and variety shows. The "International Service" from Lima on 15,150 kc. is carried on Monday, Wednesday, and Friday, with Eng. at 1600-1700. (WPE8NE, WPE9KM, WPE0AE)

Philippines—The Far East B/C Co., Manila, carries Eng. at 1600-1830 on 17,805 and 21,515 kc., at 1830-1930 on 15,385 and 21,515 kc., at 0230-0400 on 9730, 11,920, 15,300, 17,805, and 21,515 kc., at 0400-0500 on 6030, 11,855, and 21,515 kc., and at 0500-0730 on 11,920 and 21,515 kc. News is given at 1645, 1830, 0430, and 0700. (WPE6OU, WPE8MS)

Puerto Rico—WKYN, Rio Piedras, can often be noted on 26,310 kc. This is an FM link between studios and xmtrs; the basic station being on 630 kc. Reports may be sent to P. O. Box 816, San Juan, care of Quality B/C Co. (WPE9MV)

Saudi Arabia—Djeddah was logged at new s/on time of 2313 with IS and march on 11,950

New Isotronic Training Method

LEARN TV REPAIR IN ONE SHORT WEEK!

Now, after 5 year's research—a streamlined training system that *obsoletes all others!* In just 7 days you may earn \$150 weekly, without paying up to \$250 for training, studying long months! Developed by electronic scientists in cooperation with major TV mfr's., the new Isotronic method is the most practical ever devised! For conclusive proof, write for details and FREE SAMPLE LESSON. Use it on your own set or a friend's — repair it — convince yourself you can make big money immediately in your own TV business! Hurry — Free Lesson supply limited. Write: TV Servicing Systems, Dept. D-74A 1038 So. La Brea Ave., Los Angeles 19, Calif.

ADD TO YOUR INCOME

Learn at Home to Fix APPLIANCES

FREE SAMPLE LESSON

Tester Furnished—No Extra Charge. National Radio Institute trains you at home. Every service customer is worth more when you can fix his electrical appliances. Mail coupon for Lesson and Catalog.

National Radio Inst., Dept. D4K0 Washington 16, D.C.
Please send me Electrical Appliance Sample Lesson and Catalog FREE (No salesman will call).

Name..... Age.....
Address.....
City..... Zone..... State.....
ACCREDITED MEMBER NATIONAL HOME STUDY COUNCIL

Double YOUR EFFECTIVE Citizens Band Power!

The cardioid pattern of the Mosley VGR-27 antenna will multiply your effective power by two, giving a forward gain of 3 db.

This 100% rust proof antenna is ideal for point-to-point communication and is easily rotated for working mobile stations. The VGR-27 offers increased range and reliability with decreased interference from sides and rear.

WRITE FOR INFORMATION

Mosley Electronics Inc. 4610 N. Lindbergh • Bridgeton, Missouri

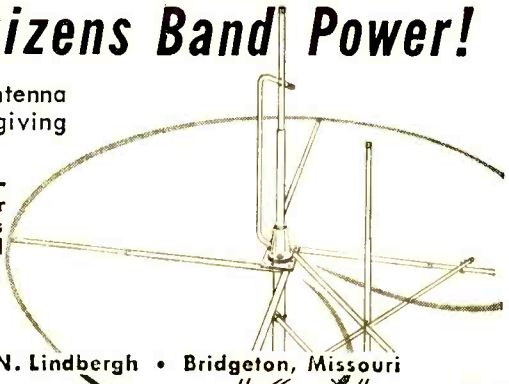

EASIEST TO BUILD**LAYER BUILT
COLOR GUIDE**

Grommes

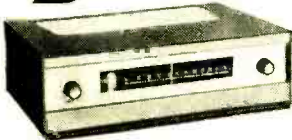
**DE LUXE HI-FIDELITY
KITS****101GTK
FM TUNER**

Finest tuner kit offered! "Standard Coil" tuning unit is pre-wired, pre-aligned and can be tuned-in as soon as completed, without professional adjustments. Better reception than tuners costing 2 or 3 times as much. Latest circuits, matched crystal diode detector, Foster Seeley Discriminator, AFC, Electronic Tuning Eye, Quiet, drift-free. Simply and successfully assembled by anyone with screwdriver, pliers and soldering iron. Step-by-step instructions. Model 101GTK, only..... **\$59.50**

20 WATT STEREO AMP.

De Luxe stereo at half the cost! Two 10 watt channels with 2 pre-amps. 40 watts peak. Fre. Res. ± 0.5 DB. 20-20,000 CPS. Complete controls. 20LJK..... **\$59.50**

10 WATT AMPLIFIER

With built-in pre-amp. 20 watts peak. Fre. Res. ± 1 DB. 20-20,000 CPS. 4 inputs. Output: 4, 8, 16 ohms. Automatic Loudness Control. 1L6K..... **\$24.95**

Many other kits available—
At dealers or sent prepaid with check or M.O.

FREE!

GROMMES Div. of Precision Electronics, Inc.
9101-P King Ave., Franklin Park, Ill.
Please rush details on Grommes Kit Line.

Name _____
Address _____
City _____ State _____

SCIENCE ENGINEERING

Bachelor's degree in 27 or 36 months

Accelerated year-round program: Aero, Chemical, Civil, Elec., Mech., Metallurgical, Mathematics, Chemistry, Physics, Modest rate. Earn board. New classes start Jan., March, June, Sept. Catalog, 2310 E. Washington Blvd., Fort Wayne 2, Indiana.

INDIANA TECHNICAL COLLEGE

GET INTO ELECTRONICS

V.T.I. training leads to success as technicians, field engineers, specialists in communications, guided missiles, computers, radar, automation. Basic & advanced courses in theory & laboratory. Assoc. degree in 29 mos., B.S. obtainable. ECPD accredited, G.I. approved. Graduates with major companies. Start Feb., Sept. Dorms, campus. H. S. graduates or equivalent. Catalog.

VALPARAISO TECHNICAL INSTITUTE
Dept. PE VALPARAISO, INDIANA



BIG MONEY OR EXTRA INCOME Home Appliance Repair

Wide-open field for men of all ages. Millions of Home Appliances need fixing. . . . Every home is your market for Full-Time Career or Spare-Time "Second Income" opportunities. Save on your own repairs. N.T.S. Shop-Tested HOME TRAINING is streamlined, modern, low-cost, practical. Qualifies you fully and you start earning early in your course. Includes Tools and Appliance Tester. Send for FREE Opportunity Book and actual lesson. No Obligation. No Salesman Will Call!

NATIONAL TECHNICAL SCHOOLS H2G-100
Los Angeles 37, California

Name _____ Age _____
Address _____
City _____ Zone _____ State _____

FREE BOOK

kc., and then into Arabic at a weak level. (WPE9KM)

Sudan—Omdurman gives this schedule: Arabic at 2315-0030 (Fridays to 0600) and 0930-1600; Southern Sudan program at 0900-0930; English at 0730-0800. Channels listed: 5039 kc. (20 kw.); 9600 kc. (7.5 kw.); and 11,750 and/or 7200 kc. Reports go to Box 572, Omdurman, Sudan. (WPE1BM)

Swan Island—While *R. Swan* is not a short-wave station, DX'ers will now have a chance

SHORT-WAVE CONTRIBUTORS

Jim Silk (WPE1AGM), Madison, Conn.
Dave Swedock (WPE1ANK), Meriden, Conn.
John Rushton (WPE1ARV), Providence, R. I.
Jerry Berg (WPE1BM), W. Hartford, Conn.
Alan Roth (WPE1BY), Bridgeport, Conn.
Bud Barto (WPE1HC), Naugatuck, Conn.
Dave Quintin (WPE1ZR), New Britain, Conn.
Robert Newhart (WPE2AXS), Merchanville, N. J.
Michael Mattes (WPE21S), E. Williston, N. Y.
C. Vernon Hyson (WPE3AGZ), Kensington, Md.
Bill Plack (WPE3ALZ), Pittsburgh, Pa.
Walter J. Schulz (WPE3AYB), Philadelphia, Pa.
Dan Metro (WPE3DS), McKeesport, Pa.
George Cox (WPE3VF), New Castle, Del.
Gene Pearson (WPE4AIX), Birmingham, Ala.
Grady Ferguson (WPE4BC), Charlotte, N. C.
Stewart Mac Kenzie, Jr. (WPE6AA), Long Beach, Calif.
Bill Lund (WPE6CT), Santa Monica, Calif.
J. Art Russell (WPE6EZ), San Diego, Calif.
Laurence Hansford (WPE6OU), Modesto, Calif.
Richard England (WPE6VF), Columbus, Ohio
Dan Wilt (WPE6WF), Akron, Ohio
Mike Kander (WPE6MS), Dayton, Ohio
Ronald Beitman (WPE6NE), Amelia, Ohio
Dan Brintlinger (WPE6BGC), Decatur, Ill.
Robert Frey (WPE9IP), Niles, Ill.
Ron Rende (WPE9KL), Stickney, Ill.
A. R. Niblack (WPE9KM), Vincennes, Ind.
Ron Kozor (WPE9MV), Fort Wayne, Ind.
John Beaver, Sr. (WPE9AE), Pueblo, Colo.
Richard E. Davis (WPE9AKR), Englewood, Colo.
Dick Schreiber (WPE9EII), Wheat Ridge, Colo.
George Buchanan (WPE9VB), Webster Groves, Mo.
Fred Baines (VE1PE2C), New Glasgow, N. S.
Giacomo Perolo (GP), Bauru, Brazil!

to log this rarely-heard island in the Caribbean. The Gibraltar Steamship Co. of New York is operating the station on 1160 kc., 50-kw. power, beamed to Cuba. Look for *R. Swan* evenings but beware of QRM from WJJD, Chicago, on the same frequency. (Ed.)

Sweden—Stockholm has an Eng. mailbag every other Wednesday at 0900-0930 on 17.840 kc. (WPE1ZR, WPE8HF, WPE9BGC, WPE9IP)

Thailand—*R. Thailand* s/on at 0525 on 11,910 kc., Eng. news at 0530. English to N.A. is heard at 2215-2315, with news at 2225. The Home Service (Arabic) is heard on 6240 and 7140 kc. at 0700-1020. Return postage is not required with your report. (WPE1BM, WPE1BY, WPE3-AGZ, WPE9KL, VE1PE2C)

USSR—*R. Ulan Bator*, Outer Mongolia, has been noted on 10,380 kc. at 1830-1930 with many talks and chanting with instrumental music; no English. (WPE9AE)

R. Baku, Azerbaijan, has verified for 9840 kc. Their schedule runs: 2300-2315 in Azerbaijani; 2330-2345 in Persian. (WPE9EH)

Venezuela—*R. Rumbos*, Caracas, has apparently moved into the 25-meter band. A definite ID was noted at 2200 on 11,970 kc. Much checking indicates that this is a fundamental frequency rather than a harmonic. (WPE9KM)

-30-

**POPULAR
ELECTRONICS**

BARGAIN BASEMENT

SAVE ON THESE SPECIAL BUYS OF THE MONTH

Experimenters • Amateurs • Hobbyists

Extraordinary values await you in government surplus electronic components. Don't buy anything until you have our "Bargain Bulletin"; new material for mere dimes on the dollar. Remember, everything is brand new; here are typical values:

Stancor P-4004 power transformer, \$21 list, 9 lbs.	\$4.44
Cornell-Dubilier TJJL-15100, 10 mid 1500 v oil, 4 lbs.	3.19
BC-610 tuning units, specify TU number, 4 lbs.	3.45
6V6CTY vacuum tubes, a dozen for	6.95
5 vet fil xfmr, 15 KV ins, 220-240/60 pri, 19 lbs.	6.45
Auto xfmr, 110/60 to 220/60, 90 watts, 7 lbs.	2.29
Sealed 115 v 60 cyc relay, DPDT rated 5 amps, 10 oz.	1.95
Astatic 400-D tone arm with dual sapphires, cer., 1 lb.	7.45
455 KC IFS, National or equal	1.10
Electrolytic, 3 v, 400 volts—8 oz, 59c	4.95

WRITE TODAY FOR FREE GOVERNMENT SURPLUS BARGAIN BULLETIN

JOE PALMER P.O. Box 6188 CCC, Sacramento, California

NEW SILICON 750 MA RECTIFIERS*

GENERAL PURPOSE
SPECIAL 2 FOR \$1

400 PIV AT 300 MA
39c EA. 25 FOR \$8.

rms / piv 35 / 50 19c	rms / piv 70 / 100 29c	rms / piv 140 / 200 34c	rms / piv 210 / 300 43c
rms / piv 280 / 400 50c	rms / piv 350 / 500 62c	rms / piv 420 / 600 80c	rms / piv 490 / 700 95c
rms / piv 560 / 800 \$1.05	rms / piv 630 / 900 \$1.25	rms / piv 700 / 1000 \$1.70	rms / piv 770 / 1100 \$2.00

Use in F.W. Bridge or F.W.C.T. up to 1A DC or mtg 2' sq
Fins for 1.5Amp. (orders \$5 or more we pay postage 48 states.)

*Derate 20% for Capacitor Input Send 25c for catalogue
"TAB" 111N Liberty St. N. Y. 6, N. Y.

NEVER FAIL— ZONE YOUR MAIL

The Post Office has divided 106 cities into postal delivery zones to speed mail delivery. Be sure to include zone number when writing to these cities; be sure to include your zone number in your return address—after the city, before the state.

ALL BAND TRAP ANTENNA!



Reduces Interference and Noise on All Makes Short Wave Receivers, Makes World Wide Reception Stronger, Clearer on All Bands!

For ALL Amateur Transmitters. Guaranteed for 500 Watts Power for Pi-Net or Link Direct Feed. Light, Neat, Weatherproof

Complete as shown total length, 102 ft. with 87 ft. of 72 ohm balanced feedline, Hi-impact molded sealed automatic frequency resonant traps (WL 3 oz. P x 7" long). You just tune to desired band for henlike results. Excellent for ALL world wide short wave receivers and amateur transmitters. For NOVICE AND ALL CLASS AMATEURS! Use as Inverted V for All Band power gain! Eliminates 5 resonance antennas with better performance guaranteed. NO HAYWIRE HOUSE APPEARANCE! EASY INSTALLATION!

80-40-20-15-10 meter bands, Complete	\$14.95
40-20-15-10 meter bands, 54 ft antenna (best for worldwide swl)	\$13.95
20-15-10 meter bands, Dual Trap, 24 ft. Antenna	\$19.95

SEND ONLY \$3.00 (cash, ck., mo) and pay postman balance COD plus postage on arrival or send full price for postpaid delivery. Available only from:
WESTERN RADIO Dept. AEL-10 Kearney, Nebraska

TELEPHONE



HANDSETS

Use as inter-house phone, talk house to garage, as loud speaker system, etc. You receive transmitter, receiver, 3 conductor cord and simplified, illustrated installation diagrams. Handsets are guaranteed to be the same as used in our great National Telephone System. Price delivered \$2.95. Two for \$5.00!

TELEPHONE REPAIR AND SUPPLY CO.
DEPT. PE-10 1760 Lunt Ave., Chicago 26

WALKIE TALKIE RADIO SENDING SET



YOUR OWN POCKET SIZE RADIO STATION
Talk to any house or car radio without wires or hookups of any kind! WL only 1/2 lb. Size 1 1/2" x 2 1/2" x 4 1/2". Built-in antenna. "Break-in" on regular radio broadcasts with "Dial Setter" and "Push-to-Talk" switch. Self-contained flashlight batteries—Power transistor! Talk to radios in the same building and to cars or between cars up to one block or more away—depending on local conditions. No license or permit needed! Practical and real fun in a million ways. Guaranteed to work—1 year service guaranteed. **SEND ONLY \$3.00** (cash, ck., mo) and pay postman only \$8.99 plus COD postage or send \$12.99 for postpaid delivery. Shipped complete ready to operate with instructions for all kinds of operation. New 1961 Model Radio Talkie is now Super-powered! Order yours now—Today! Available only from:
WESTERN RADIO, Dept. TEL-10, Kearney, Nebr.

ONE CENT SALE Buy One At Our Regular Low Price And Get The Second For Only 1c More

CITIZENS BAND TRANSMITTER (27 MC) 5 watt class, complete with crystal \$14.99 each, two for \$13.00

CITIZENS BAND RECEIVER chassis tunable through all 22 channels. Complete with audio amplifier, \$9.99 ea., two for \$10.00

AMATEUR BAND TRANSCIEVER (144-148 MC) chassis with dual VHF triodes for walkie-talkie radiophone, \$9.99 ea., two for \$10.00

SIGNAL BOOSTER chassis for 27 MC. High gain (20dB) double tuned RF pentode amplifier. Improves performance of any Citizen Band receiver. Complete with tube \$11.99 each, 2 for \$12.00

KIT OF PARTS for AM-FM-VHF radio receiver. Tunable from 80-200 mc. which includes USG match line frequencies, \$6.99 ea., two for \$7.00

CONVERTER (Crystal Controlled) for 27 MC Citizens Band. Adapts any standard broad-band radio to 27 MC band. Tunes all 22 channels. Complete with tubes and crystal, \$14.99 each, 2 for \$15.00

LIMITED QUANTITY—NO LITERATURE OR CATALOG
Remit in full. Include sufficient postage. No C.O.D.'s

VANGUARD ELECTRONIC LABS. Dept. E-10
Factory & Mail Order, 130-48 99th Ave., Hollis 23, N. Y.
Retail Store, 196-23 Jamaica Ave., Hollis 23, N. Y.



RES
WELL DEFINED
PAPER, 100



Send for FREE list of more than 40 models

Let's "kit" Together
Use YOUR Parts & PAPPY'S wiring



IRVING ELECTRONICS CO.
POST OFFICE BOX 3222 SAN ANTONIO, TEXAS

SENDING A BILL?

It'll get there quicker if you give your postal delivery zone number with your address.

The Post Office has divided 106 cities into postal delivery zones to speed mail

delivery. Be sure to include zone number when writing to these cities; be sure to include your zone number in your return address—after the city, before the state.

THE SECRET OF A GOOD BUY IS
**KNOWING
 EXACTLY**

WHAT YOU'RE LOOKING FOR!

And when it comes to photo equipment, there's one sure source for the facts and figures that will help you make a decision before you buy!

THE NEW

PHOTOGRAPHY
 DIRECTORY



Complete listings on over 5,000 pieces of photo equipment...data, prices, illustrations and comparisons of:

- Still Cameras • Accessories • Movie Cameras & Projectors • Lenses • Underwater Gear • Lighting Equipment • Darkroom Supplies • Stereo • Films and Papers — plus new Comparison Charts on Tape Recorders, Slide Projectors, Filters, and Electronic Flash.

PLUS:

GIANT 16 PAGE BONUS INSERT ON:

HOW TO BUY PHOTOGRAPHIC EQUIPMENT —a complete handbook on how to buy wisely—what to look for—how to check out quality, prices, models—compare features—eight chapters covering every type of photo equipment!

The 1961 PHOTOGRAPHY DIRECTORY AND BUYING GUIDE is on sale October 25th at your favorite newsstand—or order by handy coupon below today.

ONLY \$1.00

Ziff-Davis Publishing Co., Dept. PE106
 434 South Wabash Ave., Chicago 5, Ill.

Please send me a copy of the 1961 PHOTOGRAPHY DIRECTORY AND BUYING GUIDE. I enclose \$1.00, the cost of the DIRECTORY, plus 10¢ to cover mailing and handling charges. (Canada and Foreign \$1.25 plus 10¢ postage)

NAME _____

ADDRESS _____

CITY _____ ZONE _____ STATE _____

**POPULAR ELECTRONICS
 Advertiser's Index
 OCTOBER 1960**

ADVERTISER	PAGE
Accordion Corporation of America	138
Airex Radio Corporation	133
Allied Radio	3, 118, 119, 124
Amperex Electronic Corp.	14
Audio Devices, Inc.	2nd Cover
Bell Telephone Laboratories	39
Bud Radio, Inc.	28
Burgess Battery Company	18
Burstein-Applebee Co.	20
Capitol Radio Engineering Institute	23
Central Technical Institute	127
Chicago Standard Transformer Corporation	28
Christy Trades School	133
Cisin, H. G.	137
Cleveland Institute of Electronics	11
Colorado Technical Institute	134
Coyne Electrical School	121, 136
DeVry Technical Institute	5
EICO	38, 40
Fair Radio Sales	128
Grantham School of Electronics	7
Greenlee Tool Co.	22
Grommes Div. of Precision Electronics, Inc.	142
Hallicrafters	137
Heath Company	108, 109, 110, 111
Holt, Rinehart and Winston, Inc.	131
Indiana Technical College	142
International Correspondence Schools	9
Irving Electronics Company	142
Kester Solder Company	140
Key Electronics Co.	140
Kuhn Electronics	126
Lafayette Radio	15, 16, 17
Lektron	117
Micro Electron Tube Co.	12
Milwaukee School of Engineering	123
Mosley Electronics, Inc.	136, 141
Moss Electronic Inc.	3rd, 4th Cover, 148
National Radio Co., Inc.	126
National Radio Institute	1, 33, 34, 138, 141
National Technical Schools	21, 142
Olson Radio Corporation	120
Paco Electronics Company, Inc.	132
Palmer, Joe	143
Picture Tube Outlet	138
Popular Electronics Book Service	24, 25, 29
Prior, Louis D.	140
Progressive "Edu-Kits" Inc.	107
RCA Institutes, Inc.	115, 116
Rad-Tel Tube Co.	27
Radio Shack Corp.	32
Radio-Television Training School	13
Rek-O-Kut Company, Inc.	129
Rider Publisher Inc., John F.	26
Scott, Inc., H. H.	22
Seco Electronics, Inc.	130
Sherwood Electronic Laboratories, Inc.	36
Spartan School of Aeronautics	125
Stereo-Parti	140
Sylvania Semiconductor Division	8
TV Servicing Systems	141
"TAB"	143
Telephone Repair & Supply Co.	143
Telex Co.	136
Terado Company	32
Texas Crystals	134
Tri-State College	140
Tri-Vac Electric Company	122
Turner Company	30
Turning Corp. of America	20
Valparaiso Technical Institute	142
Vanguard Electric Labs	124, 143
Vocaline Company of America	113
Wen Products, Inc.	10
Western Radio	143
Xcelite, Inc.	120



ELECTRONICS MARKET PLACE

RATE: 50¢ per word. Minimum 10 words prepaid. December issue closes October 7th. Send order and remittance to Martin Lincoln, POPULAR ELECTRONICS, 1 Park Ave., New York 16, N. Y.

FOR SALE

15 Distance One-tube plans—25¢, with Transistor experiments, catalog. Laboratories, 1131-L Valota, Redwood City, California.

CAPACITOR Decades—calibrated .001 to 10 M.U.F.—500 V.D.C.—limited quantity—\$38 each—Foster, 2812 Trenholm Road, Columbia, S. C.

GOVERNMENT Surplus Receivers, Transmitters, Snooper scopes, Parabolic Reflectors, Picture Catalog 10¢. Meshna, Malden 48, Mass.

CITIZEN'S Band! Add a Hushpuppy noise suppressor to your Heathkit, Lafayette, Globe, etc. transceiver. Squelch Action! Completely Wired, Guaranteed. \$4.98. Western Mass. Electronics, Great Barrington 1, Mass.

TV & Radio Tubes—All top Name Brands—R.C.A., etc.—60%-10%-5%. Full replacements—regularly boxed. No Joblots or closeouts. (Representatives wanted for all states). Radio Tube Specialists, 397—7th Ave., Brooklyn 15, N. Y.

GOVERNMENT Sells: Surplus Electronics; Test Equipment; Oscilloscopes; Transceivers; Jeeps; Boats; Aircrafts; Misc.—Send for U.S. Depot Directory & Procedure \$1.25. Brody Surplus, Box 425-PE, Nanuet, N. Y.

TELEVISION Sets \$11.95 plus Shipping—Jones TV, Sanatoga, Pa.

WPE-SWL-CB-QSL Cards—Samples 10¢. "Brownie," W3CJI, 3110A Lehigh, Allentown, Penna.

DIAGRAMS for repairing radios \$1.00. Television \$2.00. Give make, model. Diagram Service, Box 672-PE, Hartford 1, Conn.

CITIZENS Band Chll monitor decal for automobile. Colorful, Neat, Four for dollar. Clubs inquire. Harris, 114 Danray Drive, Richmond 27, Virginia.

SOMETHING for sale? Place a classified ad in this section. Low-cost, fast results. It's easy.

BE A Spy. Correspondence course on wire tapping, bugging, telescopic sound pickup, recording techniques, microphotography, and invisible photography. Lessons in Surveillance, tailing and use of equipment. Complete course \$22.50. C. Carrier Co., 5880 Hollywood Blvd., Hollywood 28, Calif.

COLOR TV—Convert your black and white TV to color. Completely Electronic. No mechanical gadgets. Costs about \$35. Complete construction details \$4.75. DB Enterprises, 8959 Wonderland Ave., Hollywood 46, Calif.

JUNK Your Distributor and Voltage Regulator. Improve automobile mileage and performance. Construction details for transistorized distributor and voltage regulator. No moving parts. \$4.75. DB Enterprises, 8959 Wonderland Ave., Hollywood 46, Calif.

NEW! Electric soldering gun with internal solder feed. Leaves one hand free for manipulating work. Low price. Free literature. Arnies Electronics, McNeal, Arizona.

20 Watt 80-40 CW transmitters \$19.95, postpaid. Jackson Electronics, 1605 South Raleigh, Denver 19, Colorado.

PUBLIC Address and Intercom Equipment, used. Write for free list, condition and prices. Selbee, 34 W. Merchant St., Audubon, N. J.

CITIZENS Band Log. Keep a neat record of your calls. Only \$1.98. Send check or money order to H Enterprises, P.O. Box 867, Brooklyn 1, N. Y.

BEFORE You Buy Receiving Tubes or Electronic Components, send Now for your Giant Free Zalytron Catalog No. 162—featuring nationally known Zalytron First Quality TV-Radio Tubes, plus all types of Components, Kits, Amplifiers, Transceivers, etc. All priced to Save You Plenty—Why Pay More? Zalytron Tube Corp., 220 W. 42nd St., N.Y.C.

SPECIAL! QSL'S 3 color's padded, \$2.50 per 100. Send name, address, call letters, ARRL?, Garth, Jutland, New Jersey.

Whatever your needs, Popular Electronics Classified can solve them. Simply place an ad in these columns and watch your results pour in.

TUBES—TV and Radio tubes, Guaranteed—Save up to 80%—Write: Emkay Electronics, P.O. Box 142, Blythebourne Station, Brooklyn 19, N. Y.

TV Tuners—Rebuilt or Exchanged \$9.95 complete—all types—fast, guaranteed service. Send tuner with all parts to: L. A. Tuner Exchange, 4611 West Jefferson Blvd., Los Angeles 16, California.

AUTO Radio, Distributor, Selling, Servicing. Becker Blaupunkt, FM-AM, other European, American Sets. Save 30%+! Square Electronics, 150-60 Northern Blvd., Flushing, N. Y.

CITIZEN'S Band! Add squelch action to your Heathkit CB-1 or other superregenerative transceivers! Ozco Hissmaster effectively reduces annoying hiss. Completely wired, \$2.00. Kit, \$1.00. Ozco Sales, Canaan, Conn.

CITIZEN'S band handy-talkie. Kit \$29.95. Wired \$49.95. Information 10¢. Electronics, 16103 Biltmore, Detroit 35, Michigan.

BASIC theory and application of transistors—263 page Army electronic technician training manual. Send \$2.75. Technical Publications, Box 562, Sarasota, Florida.

TELEPHONE Voice switch (LS-500). Actuates automatically and unattended any tape or wire recorder. Pictorial installation instructions included. \$23.75 Post Paid U.S. WJS Electronics, 1130 N. Highland Ave., Los Angeles 38, Calif.

INVESTIGATORS! Do your own sound work. Write for free brochure of latest electronic equipment. WJS Electronics, 1130 N. Highland Ave., Los Angeles 38, Calif.

EAVESDROP with a pack of cigarettes. Miniature transistorized FM Radio Transmitter. Complete diagrams and instructions \$2.00. C. Carrier Co., 5880 Hollywood Blvd., Hollywood 28, Calif.

TELEPHONE Extension In Your Car. Answer your home telephone by radio from your car. Complete diagrams and instructions \$2.00. C. Carrier Co., 5880 Hollywood Blvd., Hollywood 28, Calif.

POLICE Radar Detector. Stop before those radar speed traps. Fool proof, legal system. Complete diagrams and instructions \$2.75. C. Carrier Co., 5880 Hollywood Blvd., Hollywood 28, Calif.

COMPLETE diagrams plus failure chart to repair television \$2.00, radio \$1.00, recorders \$1.00. Give make, model. Handee, Box 146, Brooklyn 19, New York.

TRANSISTOR Portable radio kits, \$6.95. TV's console models, 16", 17", 19", used, \$14.95. Heavy duty solder gun, free extra tip, solder, \$5.95. Channel Master conical antenna, \$6.95. Switch-type indoor antenna, \$2.99, 6 for \$2.49 ea. Parallel picture tube brightener, 99¢, series type, \$1.39. Auto vibrators, 6V 4 prong Universal, \$1.59, 12V 3 prong Standard, \$1.79; 12V 4 prong Standard, \$1.99. Fiber fuse clips, 15¢ ea., 12 for \$1.65. RCA cheater cords, 39¢ ea., 6 for \$1.95. Write for free catalog of tubes, parts. All postpaid except used TV and channel master antenna. F.O.B. Harrison, N. J. Teltron Electric Co., Dept. PE10, 428 Harrison Ave., Harrison, N. J.

TV Cameras, Panadaptors, Receivers, Transmitting Tubes, SSB Gear, Citizen Band Radios, Transistors Spear Electronics, 37-10 33 St., Long Island City, N. Y.

YOUR own space station, radicom germanium stereophonic radio combined with intercommunication, \$5.48. Mauthner, 839 Newington, Duarte, California. Two sets for \$9.98.

Over 320,000 buyers and sellers will read your ad when placed in this space. It costs 50¢ per word; minimum of ten words including your name and address.

WANTED

CASH paid for short-wave ham receivers and transmitters. Treger W91VJ-2023B N. Harlem Ave., Chicago 35, Tuxedo 9-6429.

Want to buy good equipment and accessories? Place a low-cost classified ad in this space.

HIGH-FIDELITY



PRICES? The Best! Factory-sealed Hi-Fi Components? Yes! Send for free catalog. Audion, 25P Oxford Road, Massapequa, N. Y.

COMPONENTS—best quotations—sale items. Bayla Co., Box 131-P, Wantagh, N. Y.

DISGUSTED with "Hi" Hi-Fi Prices? Unusual discounts on your High Fidelity Requirements. Write Key Electronics, 120 Liberty St., New York 6, N. Y. Cloverdale 8-4288.

RECORDERS, Components. Free wholesale catalogue. Carston, 125-P East, 88. N.Y.C. 28.

DON'T Buy Hi-Fi Components, Kits, Tape, Tape Recorders until you get our low, low return mail quotes. "We Guarantee Not To Be Undersold." Wholesale Catalog Free. Hi-Fidelity Center, 1797PC First Avenue. New York 28, N. Y.

TAPE & RECORDERS

AMPEX, Concertone. Magnecord, Presto, Bogen, Tandberg, Penton, Sherwood, Rek-O-Kut, Scott, Shure, Dynakit, others. Trades. Boynton Studio, Dept. PE, 10 Pennsylvania Ave., Tuckahoe, N. Y.

LOW quotes on everything HiFi & Stereo Tapes. Bargain List: HiFi, Dept. P3, Roslyn, Pa.

TAPE Recorders, Hi-Fi, components, Sleep Learning Equipment, tapes. Unusual Values. Free Catalog. Dressner, 69-02F, 174 St., Flushing 65, N. Y.

NEW Self-Hypnosis tape! Free literature. McKinley Co., Box 3038, San Bernardino, Calif.

RECORDING Tape—1200' \$1.35. Check our prices on Scotch, Irish and others. Pacific Magnetic Tape Supply, 3715 Monroe Street, Riverside, California.

RENT Stereo Tapes—over 1500 different—all major labels—free catalog. Stereo-Parti, 811-P Centinela Ave., Inglewood 3, California.

INSTRUCTION

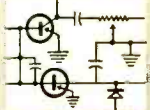

BE A Memory Machine! Earn to \$3,700 yearly extra! Research Center, 520 E. Fewel, El Paso 7, Texas.

COMPLETE Your High School at home in spare time with 63-year-old school. Texts furnished. No classes. Diploma. Information booklet free. American School, Dept. X736, Drexel at 58th, Chicago 37, Illinois.

DETECTIVE Profession. Home Study. Badge, Certificate, Future. Box 41197-AG, Los Angeles 41, California.

BE A Survival Specialist! New correspondence course for staying alive, land, sea, air. Valuable to all! Lessons on emergency radio; signalling; practical navigation; parachute jumping; aerial drops; mountain climbing; stalking, snaring, skinning game; desert travel; beverage plants; edible snakes, insects; poisonous plants; etc. Complete! Only \$19.95. "Lock Picking Secrets!" Fully illustrated, \$9.95. Commando fighting tricks (186 illustrations), \$1.98. Special! All three, \$25.00. Satisfaction guaranteed. Wilford's, 7400 Benjamin Franklin Station, Washington 4, D. C.

LEARN Code. Qualify for Amateur or Commercial License. Free Book. Candler System, Dept. PE-10, Box 9226, Denver 20, Colo.

WRITE Martin Lincoln, Popular Electronics, 1 Park Avenue, New York 16, N. Y. for information on how to place a classified ad in this section.

FREE literature on Radio Announcing! Magazines, Beginner's Books! DeeJay, Box 802, Aberdeen, South Dakota.

TELEVISION-radio service diagrams with complete voltages, waveforms and service adjustments. Any US radio or TV since 1920 model. TV \$2. Radio \$1. No C.O.D. Give make and model. Teleradio Service Labs, P. O. Box 8042, Sacramento 18, California.

CALCULUS, Easy, Practical! Lessons, Trial \$1, Guaranteed. Mathco, 4256-8 Minnor, Cincinnati 17, Ohio.

FREE Antenna with instructions. Experiment with Nature's electronics. Stillwater, Box 317-H, Morris Plains, New Jersey.

PASS 1st Class Radiotelephone Examination first time with help of new study guide. based on Element 4 of latest FCC publication. 280 multiple choice questions, arranged for subject study. Formulas, diagrams, and math the easy way. Send \$3.00 to Hilger Enterprises, Box 2798, Dept. A, Long Beach, California.

CONVERT your present T.V. Set to either 6 or 12 volt. Use in your car—free antenna adapter with complete information \$2.95. B. & E.—Box 84, Bellflower, California.

LEARN while asleep (methods 92% effective). Develop will power and dynamic personality, control weight and tension through electronically proven transitional sleep techniques. Details free. A.S.R. Foundation, Box 21-eg., Henry Clay Station, Lexington, Kentucky.

LEARN while asleep, hypnotize with your recorder, phonograph. Astonishing details, unusual catalog free! Sleep-Learning Association, Box 24-ZD, Olympia, Washington.

INVENTIONS WANTED

INVENTIONS wanted. Patented, unpatented. Global Marketing Service. 2420-P 77th, Oakland 5, Calif.

INVENTIONS Wanted. Patented, unpatented. J. T. Invention Sales Company, 25 Fayette St., Brooklyn 6, N. Y.

PLASTICS

NEW Liquid Casting Plastic, clear, colors. Embed real flowers, butterflies, photos, coins. Send 25¢ for two handbooks "How to Cast Liquid Plastics" and "How to Make Extra Money at Home." Castolite, Dept. L-108, Woodstock, Illinois.

BUSINESS OPPORTUNITIES

EARN big money. Self service tube checkers, console model, 22 sockets. Customers test own tubes. Includes neon lighted head, key for bottom door. \$39.95, F.O.B. warehouse. Teltron Electric Co., Dept. HR10, 428 Harrison Ave., Harrison, N. J.

EMPLOYMENT INFORMATION

OVERSEAS Employment. American Firms and United States Government. Comprehensive job information \$2.00. Foreign Opportunities, Box 172, Columbus 16, Ohio.

DETECTIVES—Experience unnecessary. Detective Particulars. Wagoner, 125-Z West 86th, N. Y.

AMERICAN—Overseas jobs. Land—sea—air. Higher pay. Transportation—benefits. Men—Women. All occupations. Details—Write: Employment Headquarters, 79 Wall Street, Dept. GE-2, New York 5.

EARN Extra money selling advertising book matches. Free samples furnished. Matchcorp, Dept. MD-100, Chicago 32, Illinois.

Always say you saw it in—POPULAR ELECTRONICS



SHOPPING GUIDE

Classified

A HANDY REFERENCE TO PRODUCTS AND SERVICES NOT NECESSARILY ELECTRONIC, BUT OF WIDE GENERAL INTEREST

MISCELLANEOUS

NEW and Unusual devices for home and shop. Literature 10¢. Wellsco, Box 3055, North Hollywood, California.

PHOTOGRAPHY—FILM EQUIPMENT, SERVICES

OPTICAL—Science-Math Bargains. Request Free Giant Catalog "CJ." 128 Pages. Astronomical Telescopes, Microscopes, Lenses, Binoculars, Kits, Parts, Amazing war surplus bargains. Edmund Scientific Co., Barrington, New Jersey.

FREE! Blackhawk's big sale catalog 8mm, 16mm movies, 2"x2" color slides. Biggest selection anywhere! Projectors, cameras, supplies—big discounts! Get free, every three weeks. 12-page newspaper size bargain list! Blackhawk Films, Davenport 24, Iowa.

FREE! New 1960 catalog of all photographic books available. For your copy, send postcard with name and address to Catalog Popular Photography Book Service, One Park Avenue, New York 16, N. Y.

STAMPS & COINS

105 Different U.S. Stamps 25¢, Approvals included. Sheiron, Box 907-J, New York 8, N. Y.

OVER 320,000 buyers and sellers will read your ad when placed in this space. It costs only 50¢ per word; minimum of 10 words including your name and address.

50 World Wide Stamps, many exciting commemoratives, for only 10¢ and stamped self-addressed envelope. No approvals will be sent. Popular Electronics, Box 105, One Park Avenue, New York 16, N. Y.

MUSIC

SONGPOEMS AND LYRICS WANTED! Mail to: Tin Pan Ailey, Inc., 1650 Broadway, New York 19, N. Y.

SONGS into Dollars! Share 33 million dollars yearly for New songwriters, songpoets. Any subject, songs composed, published, promoted by largest firm. Information, appraisal Free. Send Nordyke Music Publishers, 6000 Sunset, Hollywood 283, California.

LEATHERCRAFT

FREE "Do-It-Yourself" Leathercraft Catalog. Tandy Leather Company, Box 791-R36, Fort Worth, Texas.

MAGNETS

ALNICO Permanent Magnets. Hobbyist, Surprise Assortment. \$2 (refundable). Postpaid. Magnetics, 7777 Sunset, Dept. PA, Los Angeles 46.

WHATEVER your needs, Popular Electronics classified can solve them. Simply place an ad in these columns and watch your results pour in.

BUSINESS OPPORTUNITIES

GROW Mushrooms. Cellar, shed and outdoors. Spare, full time, year round. We pay \$4.50 lb. dried. We have 29,000 customers. Free Book. Mushrooms, Dept. 334, 2954 Admiral Way, Seattle, Wash.

MAKE \$25-\$50 Week, clipping newspaper items for publishers. Some clippings worth \$5.00 each. Particulars free. National, 81-DG, Knickerbocker Station, New York.

VENDING Machines—No Selling. Operate a route of coin machines and earn amazing profits. 32-page catalog free. Parkway Machine Corporation, Dept. 12, 715 Ensor St., Baltimore 2, Md.

RADIO Parts Stores and Hi-Fi Salons: Someone "borrowing" your personal copy of Popular Electronics each month? You ought to be taking advantage of Popular Electronics' convenient re-sale plan. Sell copies in your store . . . perform a good service for your customers . . . with no risk involved. For details, write: Direct Sales Department, Popular Electronics, One Park Avenue, New York 16, New York.

BUY Direct from factories. Appliances, cameras, watches! Free details! Cam Co., 6810PE-20th Ave., Brooklyn 4, N. Y.

MISCELLANEOUS

SKYSCRAPER—Heel Shoes, Wasp-waisted Corsets! Photo Catalogs, \$2.00. Pinecraft, Box 442-P, Hollywood 28, Calif.

DIESEL injector parts and fuel pumps wanted GM51-53-71-110. Ted, 2093 East 19 Street, Cleveland 15, Ohio.

"HOMEBREW," Make it yourself. Complete instructions \$1.75. Homecrafts, Box 587-A, Bellevue, Nebraska.

GUARANTEED quality processing, 35mm, 8mm Kodachrome \$1.00. Send for free mailers, photographic discount catalogue. Carterchrome, Box 645, Utica 1, New York.

"WINEMAKING," "Beer, Ale Brewing." Highest powered methods. Illustrated. \$2.20. Eaton Bookstore, Box 1242-C, Santa Rosa, California.

POCKET Rubber Stamps—special offer any three lines, with ready inked pad, \$1.00. Cloutier's Rubber Stamp Shop, 95 Thaddeus St., Chicopee Falls, Mass.

BIZARRE Fashions! Illustrated Catalogue, \$1.00. Renee, Box 2804-P, Hollywood 28, Calif.

FREE Illustrated, Hypnotism Catalogue. Write: Powers, 8721 Sunset, Hollywood 46, California.

EXAMINE ANY OF THESE TESTERS

BEFORE YOU BUY!!

Yes, we offer to ship at our risk one or more of the testers described on these pages.

The Model 88.... A New Combination

TRANSISTOR RADIO TESTER and DYNAMIC TRANSISTOR TESTER

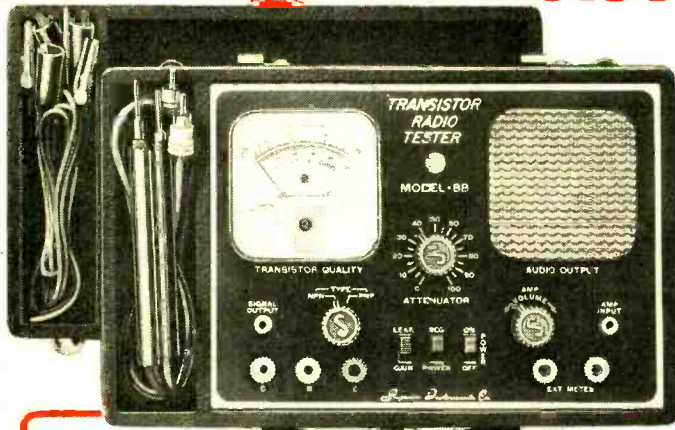

The Model 88 is perhaps as important a development as was the invention of the transistor itself, for during the past 5 years, millions of transistor radios and other transistor operated devices have been imported and produced in this country with no adequate provision for servicing this ever increasing output.

The Model 88 was designed specifically to test all transistors, transistor radios, transistor recorders, and other transistor devices under dynamic conditions.

Model 88 TRANSISTOR RADIO TESTER & TRANSISTOR TESTER... Total Price... \$38.50
Terms: \$8.50 after 10 day trial, then \$6.00 monthly for 5 months if satisfactory. Otherwise return, no explanation necessary.

AS A TRANSISTOR RADIO TESTER

We feel sure all servicemen will agree that the instruments and methods previously employed for servicing conventional tube radios and TV have proven to be impractical and time consuming when used for transistor radio servicing. The Model 88 provides a new simplified rapid procedure — a technique developed specifically for radios and other transistor devices.

An R.F. Signal source, modulated by an audio tone is injected into the transistor receiver from the antenna through the R.F. stage, past the mixer into the I.F. Amplifier and detector stages and on to the audio amplifier. This injected signal is then followed and traced through the receiver by means of a built-in High Gain Transistorized Signal Tracer until the cause of trouble whether it be a transistor, some other component or even a break in the printed circuit is located and pin-pointed. The injected signal is heard on the front panel speaker as it is followed through the various stages. Provision has also been made on the front panel for plugging in a V.O.M. for quantitative measurement of signal strength.

The Signal Tracing section may also be used less the signal injector for listening to the "quality" of the broadcast signal in the various stages.

Model 88 comes housed in a handsome portable case. Complete with a set of Clip-On Cables for Transistor Testing, an R.F. Diode Probe for R.F. and I.F. Tracing; an Audio Probe for Amplifier Tracing and a Signal Injector Cable. Complete — nothing else to buy! Only **\$38.50**

AS A TRANSISTOR TESTER

The Model 88 will test all transistors including NPN and PNP, silicon, germanium and the new gallium arsenide types, without referring to characteristic data sheets. The time-saving advantage of this technique is self evident. A further benefit of this service is that it will enable you to test new transistors as they are released!

The Model 88 will measure the two most important transistor characteristics needed for transistor servicing; leakage and gain (beta).

The leakage test measures the collector-emitter current with the base connection open circuited. A range from 50 ohms to 100,000 ohms covers all the leakage values usually found in both high and low power transistor types.

The gain test (beta) translates the change in collector current divided by the base current. Inasmuch as the base current is held to a fixed value of 50 microamperes, the collector current calibrated in relative gain (beta), is read directly on the meter scale.

DID YOU EVER?

Order merchandise by mail, including deposit or payment in full, then wait and write . . . wait and write?

Purchase anything on time and sign a lengthy complex contract written in small difficult-to-read type?

Purchase an item by mail or in a retail store then experience frustrating delay and red tape when you applied for a refund?

Obviously prompt shipment and attention to orders is an essential requirement in our business . . . We ship at our risk!

PRINTED IN U.S.A.

NO

**CONTRACT TO SIGN
CO-MAKERS
EMPLOYER
NOTIFICATION**

The simple order authorization included in this offer is all you sign. We ask only that you promise to pay for or return the goods we ship in good faith.

**EXAMINE ANY ITEM YOU SELECT
IN THE PRIVACY OF YOUR OWN HOME**

Then if completely satisfied pay on the interest-free terms plainly specified. When we say interest-free we mean not one penny added for "interest" for "finance" for "credit-checking" or for "carrying charges." The net price of each tester is plainly marked in our ads—that is all you pay except for parcel post or other transportation charges we may prepay.

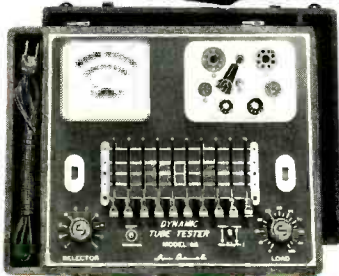

Model 85—Trans-Conductance Tube Tester. Total Price—\$52.50.

Terms: \$12.50 after 10 day trial, then \$8.00 monthly for 5 months if satisfactory. Otherwise return, no explanation necessary.



Model TW-11—Tube Tester Total Price \$47.50

Terms: \$11.50 after 10 day trial, then \$6.00 monthly for 6 months if satisfactory. Otherwise return, no explanation necessary.

We invite you to try before you buy any of the models described on this page, the preceding page and the following pages. If after a 10 day trial you are completely satisfied and decide to keep the Tester, you need send us only the down payment and agree to pay the balance due at the monthly indicated rate.

**NO INTEREST
OR FINANCE
CHARGES ADDED!**

If not completely satisfied, you are privileged to return the Tester to us, cancelling any further obligation.

**SEE OTHER
SIDE**

CUT OUT AND MAIL TODAY! ▶

Superior's New Model 85—a **DYNAMIC** type **TRANS-CONDUCTANCE**

TUBE TESTER

• Employs latest improved TRANS-CONDUCTANCE circuit. Tests tubes under "dynamic" (stimulated) operating conditions. An in-phase signal is impressed on the input section of a tube and the resultant plate current change is measured as a function of tube quality. This provides the most suitable method of simulating the manner in which tubes actually operate in radio, TV receivers, amplifiers and other circuits. Amplification factor, plate resistance and cathode emission are all correlated in one meter reading.

• **SYMBOL REFERENCES:** For the first time ever in a trans-conductance tube tester, Model 85 employs time-saving symbols (★, +, ●, ▲, ■) in place of difficult-to-remember letters previously used. Repeated time studies proved to us that use of these scientifically selected symbols speeded up the element switching step. As the tube manufacturers increase the release of new tube types, this time-saving feature becomes more necessary and advantageous.

• **THE "FREE-POINT" LEVER TYPE ELEMENT SWITCH ASSEMBLY** marked according to RETMA basing, permits application of test voltages to any of the elements of a tube. The addition of an extra switch position permits the application of the necessary grid voltage needed for dynamic testing and insures against possible obsolescence due to changes in basing design.

• **NEW IMPROVED TYPE METER** with sealed air-damping chamber provides accurate, vibrationless readings.

• **FREE FIVE (5) YEAR CHART DATA SERVICE.** The chart provided with Model 85 includes easy-to-read listings for over 1,000 modern tube types. Revised up-to-date subsequent charts will be mailed to all Model 85 purchasers at no charge for a period of five years after date of purchase.

• **SPRING RETURN SAFETY SWITCH** guards Model 85 against burn-out if tube under test is "shorted."

• **7 AND 9 PIN TUBE STRAIGHTENERS** have been included on the front panel to eliminate possibility of damaging tubes with bent or out-of-line pins.

• **AN ULTRA-SENSITIVE CIRCUIT** is used to test for shorts and leakages up to 5 megohms between all tube elements.

Model 85 comes complete, housed in a handsome portable cabinet with slip-on cover. Only.....

\$52.50

Superior's **STANDARD PROFESSIONAL**
New Model **TUBE TESTER**
TW-11

• Tests all tubes, including 4, 5, 6, 7, Octal, Lockin, Hearing Aid, Thyatron, Miniatures, Sub-miniatures, Novals, Subminisures, Proximity Fuse Types, etc.

• Uses the new self-cleaning Lever Action Switches for individual element testing. All elements are numbered according to pin-number in the RMA base numbering system. Model TW-11 does not use combination type sockets. Instead individual sockets are used for each type of tube. Thus it is impossible to damage a tube by inserting it in the wrong socket.

• Free-moving built-in roll chart provides complete data for all tubes. Printed in large easy-to-read type.

NOISE TEST: Phono-jack on front panel for plugging in either phones or external amplifier detects microphonic tubes or noise due to faulty elements and loose internal connections.

EXTRAORDINARY FEATURE
SEPARATE SCALE FOR LOW-CURRENT TUBES Previously, on emission-type tube testers, it has been standard practice to use one scale for all tubes. As a result, the calibration for low-current types has been restricted to a small portion of the scale. The extra scale used here greatly simplifies testing of low-current types.

Housed in handsome, portable, Saddle-Stitched Texon case. **\$47.50 Net**
Only.....

MOSS ELECTRONIC, INC.

Dept. D-811 3849 Tenth Ave., New York 34, N. Y.

Please send me the units checked on approval. If completely satisfied I will pay on the terms specified with no interest or finance charges added. Otherwise, I will return after a 10 day trial positively cancelling all further obligation.

Model 88 Total Price \$38.50
\$8.50 within 10 days. Balance \$6.00 monthly for 5 months.

Model 77 Total Price \$42.50
\$12.50 within 10 days. Balance \$6.00 monthly for 5 months.

Model TV-50A Total Price \$47.50
\$11.50 within 10 days. Balance \$6.00 monthly for 6 months.

Model 85 Total Price \$52.50
\$12.50 within 10 days. Balance \$8.00 monthly for 5 months.

Model TW-11 Total Price \$47.50
\$11.50 within 10 days. Balance \$6.00 monthly for 6 months.

Name

Address

City Zone State

All prices net. F.O.B., N. Y. C.

SHIPPED ON APPROVAL NO MONEY WITH ORDER — NO C. O. D.



Model TV50-A—Genometer
Total Price \$47.50
Terms: \$11.50 after 10 day trial,
then \$6.00 monthly for 6 months
if satisfactory. Otherwise return,
no explanation necessary.

Superior's New Model TV-50A **GENOMETER** 7 Signal Generators in One!

- ✓ R.F. Signal Generator for A.M.
- ✓ R.F. Signal Generator for F.M.
- ✓ Audio Frequency Generator
- ✓ Marker Generator
- ✓ Bar Generator
- ✓ Color Dot Pattern Generator
- ✓ Cross Hatch Generator

This Versatile All-Inclusive GENERATOR Provides ALL the Outputs for Servicing:
• A.M. RADIO • F.M. RADIO • AMPLIFIERS • BLACK AND WHITE TV • COLOR TV

R. F. SIGNAL GENERATOR: 100 Kilocycles to 60 Megacycles on fundamentals and from 60 Megacycles to 180 Megacycles on powerful harmonics.

VARIABLE AUDIO FREQUENCY GENERATOR: Provides a variable 300 cycle to 20,000 cycle peaked wave audio signal.

MARKER GENERATOR: The following markers are provided: 189 Kc., 262.5 Kc., 456 Kc., 600 Kc., 1000 Kc., 1400 Kc., 1600 Kc., 2000 Kc., 2500 Kc., 3579 Kc., 4.5 Mc., 5 Mc., 10.7 Mc., (3579 Kc. is the color burst frequency)

BAR GENERATOR: Pattern consists of 4 to 16 horizontal bars or 7 to 20 vertical bars.

DOT PATTERN GENERATOR (FOR COLOR TV): The Dot Pattern projected on any color TV Receiver tube by the Model TV-50A will enable you to adjust for proper color convergence.

CROSS HATCH GENERATOR: The pattern consists of non-shifting horizontal and vertical lines interlaced to provide a stable cross-hatch effect. **\$47.50 Net**
Complete with shielded leads



**Model 77—VACUUM TUBE VOLT-
METER.** Total Price . . . \$42.50
Terms: \$12.50 after 10 day trial, then
\$6.00 monthly for 5 months if satis-
factory. Otherwise return, no explana-
tion necessary.

Superior's New Model 77 **VACUUM TUBE VOLTMETER** WITH NEW 6" FULL-VIEW METER

Compare it to any peak-to-peak V. T. V. M. made by any other manufacturer at any price!

- Extra large meter scale enables us to print all calibrations in large easy-to-read type.
- Employs a 12AU7 as D. C. amplifier and two 9006's as peak-to-peak voltage rectifiers to assure maximum stability. • Meter is virtually burn-out proof. The sensitive 400

AS A DC VOLTMETER: The Model 77 is indispensable in Hi-Fi Amplifier servicing and a must for Black and White and color TV Receiver servicing where circuit loading cannot be tolerated.

AS AN ELECTRONIC OHMMETER: Because of its wide range of measurement leaky capacitors show up glaringly. Because of its sensitivity and low loading, Intermittents are easily found, isolated and repaired.

AS AN AC VOLTMETER: Measures RMS values if sine wave, and peak-to-peak value if complex wave. Pedestal voltages that determine the "black" level in TV receivers are easily read.

micro-ampere meter is isolated from the measuring circuit by a balanced push-pull amplifier. • Uses selected 1% zero temperature coefficient resistors as multipliers. This assures unchanging accurate readings on all ranges.

SPECIFICATIONS

- DC VOLTS—0 to 3/15/75/150/300/750/1,500 volts at 11 megohms input resistance.
- AC VOLTS (RMS)—0 to 3/15/75/150/300/750/1,500 volts. • AC VOLTS (Peak to Peak)—0 to 8/40/200/400/800/2,000 volts.
- ELECTRONIC OHMMETER—0 to 1,000 ohms/10,000 ohms/100,000 ohms/1 megohm/10 megohms/100 megohms/1,000 megohms. • DECIBELS: -10 db to +18 db, +10 db to +38 db, +30 db to +58 db. All based on 0 db = .006 watts (6 mw) into a 500 ohm line (1.73V).
- ZERO CENTER METER—For discriminator alignment with full scale range of 0 to 1.5/7.5/37.5/75/150/375/750 volts at 11 megohms input resistance.

Comes complete with operating instructions, probe leads, and stream-lined carrying case. Operates on 110-120 volt 60 cycle. Only **\$42.50**

TRY FOR 10 DAYS BEFORE you buy! THEN if satisfactory

pay in easy, interest free, monthly payments. See coupon inside.

We invite you to try before you buy any of the models described on this and the preceding pages. If after a 10 day trial you are completely satisfied and decide to keep the Tester, you need send us only the down payment and agree to pay the balance due at the monthly indicated rate. (See other side for time payment schedule details.)

**NO INTEREST
OR FINANCE
CHARGES ADDED!**

If not completely satisfied, you are privileged to return the Tester to us, cancelling any further obligation.

**SEE OTHER
SIDE**

CUT OUT AND MAIL TODAY!

FIRST CLASS

Permit No. 61430

New York, N. Y.

VIA AIR MAIL

BUSINESS REPLY CARD

No Postage Stamp Necessary if Mailed in the U. S.

POSTAGE WILL BE PAID BY —

MOSS ELECTRONIC, INC.

3849 TENTH AVENUE

NEW YORK 34, N. Y.